

BYTE[®]

DECEMBER 1982 Vol. 7, No. 12
\$2.95 in USA
\$3.50 in Canada/£1.85 in U.K.
A McGraw-Hill Publication

the small systems journal



ROBERT
82 TIMNEY

GAME PLAN 1982

Powerful.

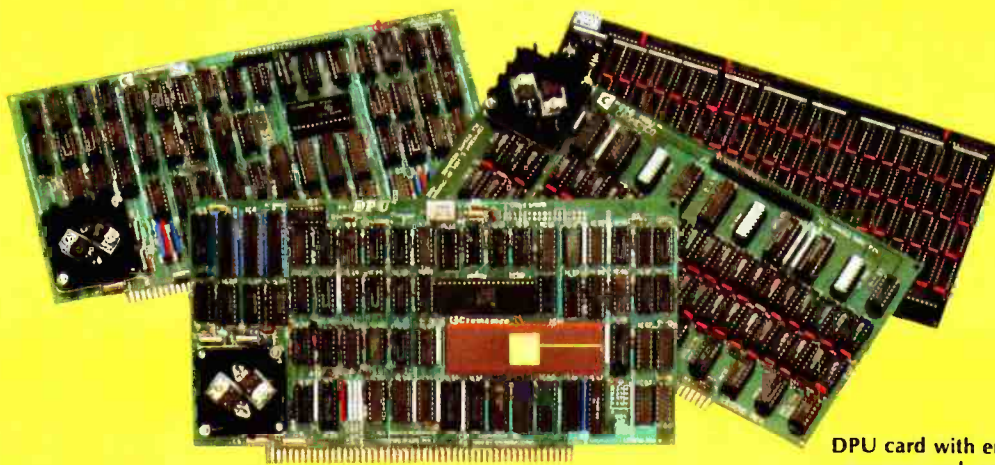

DPU card with error-correcting memory and controller cards

68000-Powered for tomorrow

Once again you get a big stride forward with Cromemco. This time it's our new DPU Dual Processor Unit. It gives enormous power to Cromemco computer systems such as our System One shown here.

Compares with mainframes

With the new DPU you get the almost unbelievably powerful 68000 processor and its 32-bit data-handling capabilities combined with its **16 Megabyte** address space.

In other words with the System One/DPU combination you get a small machine that's the equal of superminis and mainframes in some areas.

8-Bit and 68000 software

The dual part of the DPU refers to its on-board Z-80A processor. With this you have access to existing CP/M* software.

But besides being compatible with this wealth of existing 8-bit software, the System One/DPU has available a whole family of new 68000 system software. This includes a wide range of high-level software such as our 68000 Assembler, FORTRAN 77, Pascal, BASIC, COBOL, and C.

Beyond all this there's a version for the 68000 of our widely admired CROMIX† Operating System. It's like UNIX‡ but has even more features and gives multi-tasking and multi-user capability. In fact, one or more users can run on the Z-80A processor while others are running on the 68000. Switching between the Z-80A and 68000 is automatically controlled.

The System One itself is a bus-oriented machine that has options for color graphics, for 390K or 780K of floppy storage, a 5 MB hard disk option, communications capability, and multi-processor capability using our I/O processor card.

Powerful new micro. Powerful software.



System One CS-1H

3715 Printer

3102 Terminal

Highly expandable

With the System One/DPU combination, you get tremendous expandability. Right now you can have up to 2 MB of RAM storage. You get this with our new Memory Storage cards and our Memory Controller. The Controller fully supports the 16 MB storage space of the 68000, allowing you vast future expansion capability.

Further, the memory has built-in **error detection and correction**, a feature normally found only in much more costly systems.

Present customers can field-upgrade their Cromemco systems to use the DPU and still be able to run their present software using the Z-80A on the DPU. It's one more

instance of Cromemco's policy of providing obsolescence insurance for Cromemco users.

Low priced

With all this performance you might not be ready for the low price we're talking about. With 256K of RAM and 780K of floppy storage, the price of the System One/DPU is only \$5495. That's hard to beat.

So contact your rep now. He'll fill you in on the many more features that this outstanding and powerful machine offers.

*CP/M is a trademark of Digital Research
†CROMIX is a trademark of Cromemco, Inc.
‡UNIX is a trademark of Bell Telephone Laboratories

 **Cromemco**™
i n c o r p o r a t e d
280 BERNARDO AVE., MOUNTAIN VIEW, CA 94040 • (415) 964-7400
Tomorrow's computers today
Circle 156 on Inquiry card.

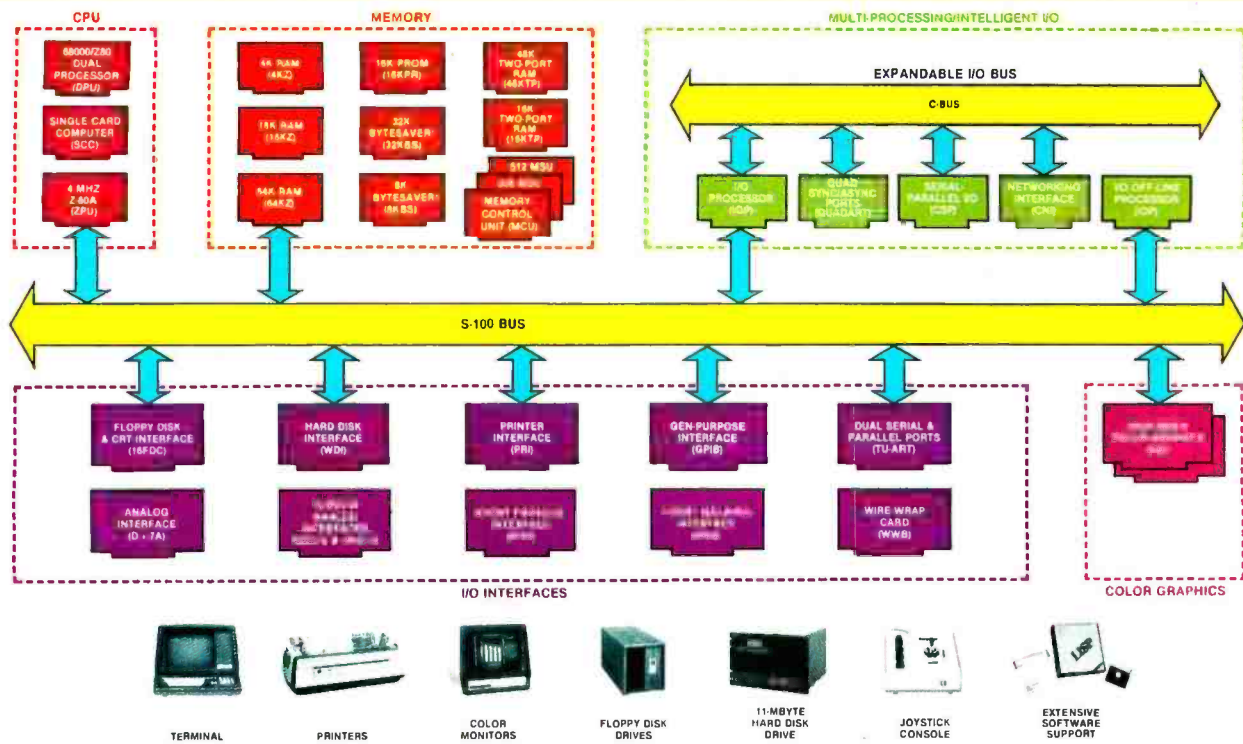

What Cromemco computer card capability can do for you

The above diagram shows in a functional way one of the most complete lines of computer cards in the industry.

Look it over carefully. It could be well worth your while.

These are all cards that plug into our S-100 bus microcomputers.

You can also assemble them into a custom system in convenient Cromemco card cages.

MULTI-PROCESSING AND INTELLIGENT I/O

The range of capabilities and versatility you can draw upon is enormous.

In processors, for example, you have a choice of CPU's including our extremely useful new I/O Processor. This can be used as a satellite processor to do off-line processing, multi-processing, and to form intelligent I/O. It opens the door to a whole new group of applications and tasks. Ask us about it.

HIGH RESOLUTION COLOR GRAPHICS

Again, you can have beautiful high-resolution color graphics with our color graphics interface. You can select from over 4000 colors and have a picture with a resolution at least equal to quality broadcast-TV pictures.



You have an unprecedented selection of memory including our unusual 48K and 16K two-port RAMs which allow high-speed color graphics.

LOTS OF STORAGE

These days you often want lots of disk storage. So you can select from our disk controller card which will operate our 5" and 8" floppy disk drives (up to 1.2 megabytes). Or select our WDI interface to operate our 11-megabyte hard disk drives.

POWERFUL SOFTWARE AND PERIPHERAL SUPPORT

There's much more yet you can do with our cards. And, of course, there's an easy way to put them to work in our 8-, 12-, and 21-slot card cages. Our PS6 power supply makes it simple to get the system into operation.

Finally, Cromemco offers you the strongest software support in the industry

with languages like FORTRAN, C, COBOL, ASSEMBLER, LISP, BASIC and others. There is also a wide choice from independent vendors.

To top it all off, you can draw from a substantial array of peripherals: terminals, printers, color monitors and disk drives.

There is even more capability than we're able to describe here.

NOW AT HALL-MARK AND KIERULFF

For your convenience Cromemco products are now available at Hall-Mark Electronics and Kierulff Electronics. Contact these national distributors for immediate product delivery.

CROMEMCO COMPUTER CARDS

- PROCESSORS — 4 MHz Z-80 A CPU, single card computer, I/O processor
- MEMORY — up to 64K including special 48K and 16K two-port RAMs and our very well known BYTESAVERS® with PROM programming capability
- HIGH RESOLUTION COLOR GRAPHICS — our SDI offers up to 754 x 482 pixel resolution.
- GENERAL PURPOSE INTERFACES—QUADART four-channel serial communications, TU-ART two-channel parallel and two-channel serial, 8PIO 8-port parallel, 4PIO 4-port isolated parallel, D+7A 7-channel D/A and A/D converter, printer interface, floppy disk controller with RS-232 interface and system diagnostics, wire-wrap and extender cards for your development work.



Cromemco™
i n c o r p o r a t e d

280 BERNARDO AVE., MOUNTAIN VIEW, CA 94040 • (415) 964-7400
Tomorrow's computers today

Circle 157 on inquiry card.

www.americanradiohistory.com

Features

42 Build the Circuit Cellar MPX-16 Computer System, Part 2 by Steve Ciarcia / A continued description of an 8088-based system that shares its principles of operation with the IBM Personal Computer.

83 Game Plan 1982 / A section devoted entirely to games and gaming begins here.

84 The Coinless Arcade—Rediscovered by Pamela Clark and Gregg Williams / With so many games available for microcomputers and cartridge systems, you can play forever.

92 The Vectrex Arcade System by Pamela Clark / A vector-display game system brings true arcade adventures into the home—all for less than \$200.

94 Board to Death / Can you tell an Apple from a TRS-80 when they're stripped of their outer trappings? Find out by taking this quiz that tests your skill in recognizing printed-circuit boards.

96 Design Techniques and Ideals for Computer Games by Chris Crawford / Atari's prized and prolific creator of games discusses some of the special techniques he uses.

112 Chargel by C. Anthony Ray / A trajectory game that shoots electrons through stationary ions. It's the second-place winner in the BYTE Game Contest.

124 Cosmic Conquest by Alan Sartori-Angus / The first-place winner in the BYTE Game Contest is a real-time space strategy game.

142, 150, 160, 162 BYTE Game Grid: Ricochet by Gregg Williams; Action Games for the VIC-20 by Russell Kavanagh; Deadline by Chris Morgan; Penetrator by Stan Wszola

167 Character Editor for the Atari by Tim Kilby / Explore the Atari's ANTIC 4 and 5 modes.

222 User's Column: A Slew of Languages, a Slap at Documentation, and a Curse at Keyboards by Jerry Pournelle / Unaccustomed as he is to voicing his opinions, Jerry drops just a few hints.

260 The Soundchaser Computer Music Systems by Robert A. Moog / Two new synthesizers make headway in the evolutionary process toward the ultimate computer music system.

278 A Brief Introduction to Electronic Music Synthesizers by Robert A. Moog / Modern-day synthesizers are direct descendants of analog computers.

288 The 8051 One-Chip Microcomputer: A Most Powerful Microcontroller by Howard Boyet and Ron Katz / Hardware-intensive applications can show off the power of hardware.

314 Problem Oriented Language, Part 1: A New Method of Input by Mark Finger / Data entry can be shortened and simplified by using Problem Oriented Language.

372 Practical Dynamic-Memory System Design by Rob Belics / A straightforward look at design with dynamic devices.

414 Test Your Memory Using the Barber-Pole Algorithm by H. R. Pinnick Jr. / Useful diagnostic information is not hard to obtain, as an example coded for the 8080 processor shows.

486 A Versatile Low-Cost Microprocessor Controller Module by David L. Craig / Add intelligence to your latest project at minimal expense.

Reviews

206 Microshell and Unica: Unix-Style Enhancements for CP/M by Christopher Kern

250 Autocontrol's AC-85: A CP/M System on One Board by JoAnne Benedict

392 Multidos: A New TRS-80 Disk Operating System by Rowland Archer

404 Condor Series 20 DBMS by Jack L. Abbott

Nucleus

6 Editorial: The Play's the Thing

14 Letters

38, 202, BYTE's Bits

182, 390 Product Description: Lotus Development Corporation's 1-2-3; The Lobo Max-80

202, 389 Book Reviews: PET/CBM BASIC; 8080/Z80 Assembly Language: Techniques for Improved Programming

389, 403 BYTE's Bugs

398, 448 System Notes: GRPRINT: An Apple Utility Program for Dot-Matrix Printers; A Little Apple SOS with Your Pascal

500 BYTELINES

505 Clubs and Newsletters

506 Ask BYTE

508 Software Received

512 Books Received

514 Event Queue

518 Cumulative Index Update

532 What's New?

589 Unclassified Ads

590 BOMB, BOMB Results

591 Reader Service



Page 84



Page 92



Page 96



Page 150

Editor in Chief

Christopher P. Morgan

Managing Editor

Mark Haas

Technical Editors

Gregg Williams, Senior Editor;
Richard S. Shulford, Curtis P. Feigel,
George Stewart, Arthur Little,
Stanley Wszola, Pamela Clark, Richard Malloy,
Phillip Lemmons, West Coast Editor; Steve
Ciarcia, Mark Dahmke, Consulting Editors;
Jon Swanson, Drafting Editor

Copy Editors

Beverly Cronin, Chief;
Faith Hanson, Warren Williamson, Anthony J.
Lockwood, Hilary Selby Polk, Elizabeth Kepner,
Nancy Hayes, Cathryn Baskin, Tom McMillan;
Margaret Cook, Junior Copy Editor

Assistants

Faith Kluntz, Beverly Jackson, Lisa Jo Steiner

Production

David R. Anderson, Assoc. Director;
Patrice Scribner, Jan Muller, Virginia Reardon;
Sherry McCarthy, Chief Typographer;
Debi Fredericks, Donna Sweeney,
Valerie Horn

Advertising

Thomas Harvey, Director;
Marion Carlson, Rob Hannings, Deborah
Porter, Vicki Reynolds, Cathy A. R. Drew, Lisa
Wozniak, Jacqueline Earnshaw, Reader
Service Coordinator; Wai Chiu Li, Advertising/
Production Coordinator; Linda J. Sweeney

Circulation

Gregory Spitzfaden, Manager;
Andrew Jackson, Asst. Manager;
Agnes E. Perry, Barbara Varnum, Louise
Menegus, Jennifer Price, Sheila A. Bamford,
James Bingham, Dealer Sales;
Deborah J. Cadwell, Asst; Linda Ryan

Marketing Communications

Horace T. Howland, Director;
Wilbur S. Watson, Coordinator;
Timothy W. Taussig, Graphic Arts Manager;
Michele P. Verville, Research Manager

Controller's Office

Daniel Rodrigues, Controller,
Mary E. Fluhr, Acct. & DIP Mgr.; Karen
Burgess, Jeanne Cilley, Linda Fluhr,
Vicki Bennett, L. Bradley Browne,
Vern Rockwell

Traffic

N. Scott Gagnon, Manager;
Scott Jackson, Kathleen Reckart

Receptionist

Jeanann Waters

Publishers

Virginia Londoner, Gordon R. Williamson;
John E. Hayes, Associate Publisher;
Cheryl A. Hurd, Publisher's Assistant



In This Issue

Video games are taking the country by storm. They provide thousands of youngsters and adults alike with hours of exciting play. Their attraction forms a complex web of challenge, high-speed action, and intrigue. Video games offer a temporary alternative to workaday problems and worries. And, as Robert Tinney's cover suggests, they transport you into another world. Swiftly moving out of the arcades and into the homes, video games for microcomputers have grown into a booming industry of their own. In keeping with this national game wave and the playful spirit of the holiday season, we have put together a section devoted exclusively to games (see page 83). Game Plan 1982 includes "The Coinless Arcade—Rediscovered" by Pamela Clark and Gregg Williams; reviews of four games in BYTE's new Game Grid; the first- and second-place Game Contest Winners, "Cosmic Conquest" by Alan Sartori-Angus and "Charge!" by C. Anthony Ray, respectively; an article by Chris Crawford of Atari on "Design Techniques and Ideals for Computer Games," a quiz called "Board to Death" that will test your skill in recognizing printed-circuit boards; and more. We have our first annual update of the BYTE Cumulative Index. We present the second part of Steve Ciarcia's three-part article "Build the Circuit Cellar MPX-16 Computer System." Gregg Williams describes "Lotus Development Corporation's 1-2-3." And we have Jerry Pournelle's User's Column plus our regular features and reviews.

BYTE is published monthly by BYTE Publications Inc, 70 Main St, Peterborough NH 03458, phone (603) 924-9281, a wholly-owned subsidiary of McGraw-Hill, Inc. Office hours: Mon-Thur 8:30 AM - 4:30 PM, Friday 8:30 AM - Noon, Eastern Time. Address subscriptions, change of address, USPS Form 3579, and fulfillment questions to BYTE Subscriptions, POB 590, Martinsville NJ 08836. Second class postage paid at Peterborough, N.H. 03458 and additional mailing offices. USPS Publication No. 528890 (ISSN 0360-5280). Canadian second class registration number 9321. Subscriptions are \$19 for one year, \$34 for two years, and \$49 for three years in the USA and its possessions. In Canada and Mexico, \$21 for one year, \$38 for two years, \$55 for three years. \$43 for one year air delivery to Europe, \$35 surface delivery elsewhere. Air delivery to selected areas at additional rates upon request. Single copy price is \$2.95 in the USA and its possessions, \$3.50 in Canada and Mexico, \$4.50 in Europe, and \$5.00 elsewhere. Foreign subscriptions and sales should be remitted in United States funds drawn on a US bank. Printed in United States of America.

Address all editorial correspondence to the editor at BYTE, POB 372, Hancock NH 03449. Unacceptable manuscripts will be returned if accompanied by sufficient first class postage. Not responsible for lost manuscripts or photos. Opinions expressed by the authors are not necessarily those of BYTE. Entire contents copyright © 1982 by BYTE Publications Inc. All rights reserved. Where necessary, permission is granted by the copyright owner for libraries and others registered with the Copyright Clearance Center (CCC) to photocopy any article herein for the base fee of \$1.00 per copy of the article or item plus 25 cents per page. Payment should be sent directly to the CCC, 21 Congress St, Salem MA 01970. Copying done for other than personal or internal reference use without the permission of McGraw-Hill is prohibited. Requests for special permission or bulk orders should be addressed to the publisher.

BYTE® is available in microform from University Microfilms International, 300 N Zeeb Rd, Dept PR, Ann Arbor MI 48106 USA or 18 Bedford Row, Dept PR, London WC1R 4EJ England.

Subscription questions or problems should be addressed to:

BYTE Subscriber Service
P.O. Box 328
Hancock, NH 03449



Officers of McGraw-Hill Publications Company: Paul F. McPherson, President, Executive Vice President; Gene W. Simpson, Senior Vice President-Editorial; Ralph R. Schulz, Vice President; R. Bernard Alexander, Kemp Anderson, Business Systems Development; Shel F. Asen, Manufacturing; Harry L. Brown, Special Markets; Robert B. Doll, Circulation; James E. Hackett, Controller; Eric B. Herr, Planning and Development; H. John Sweger, Jr., Marketing. Officers of the Corporation: Harold W. McGraw Jr., Chairman and Chief Executive Officer; Joseph L. Dionne, President and Chief Operating Officer; Robert N. Landes, Senior Vice President and Secretary; Ralph J. Webb, Treasurer.



Add Multi-Transparency Color Graphics to Your S-100 or Multibus System

The system builder's best choice for color graphics is a CS5000 color system from SCION. Its basic component is MicroAngelo[®], the single board graphics display computer that has revolutionized monochrome display capability with low cost 512x480 pixel graphics resolution and 40 line by 85 character text capacity.

When MicroAngelo boards are combined, they create high resolution color graphics that have a unique advantage. The displayed image is a combination of transparencies. So you can add, modify or delete images by transparency rather than as an entire image.

SCION's Series CS5000 builds an image with up to 8 bit planes, each generated by a MicroAngelo board. You select the assignment of those bit planes to transparencies. Each transparency can display $2^n - 1$ colors where n is the number of bit planes it uses... 2 bit planes would make a three color transparency, 8 bit planes would make a 255 color transparency. Once each transparency has been defined, your host can work with it independently, generating and modifying its graphics and text without interacting with the others. The independent transparencies are combined by the Color Mixer board which also assigns one of 16.8 million possible colors to each color of each transparency.

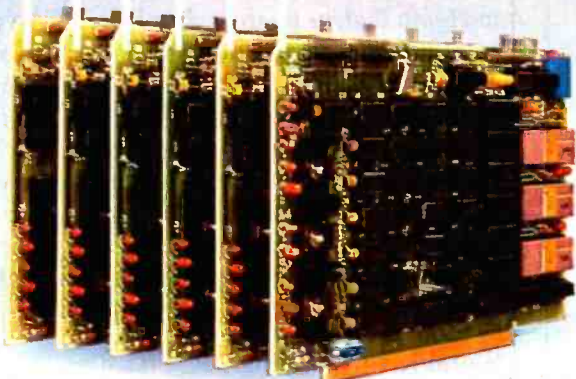

Your computer talks to the SCION Color System in SCREENWARE[™], SCION's high level display firmware language. SCREENWARE commands are used by the computer in each MicroAngelo bit plane to generate graphics and text primitives. User interface is made simple with prompted system set-up using SCION's ColorPak.

MicroAngelo based color graphics systems are easy to use. Just plug the boards into your Multibus or S-100 host. Or use the freestanding work station configuration with its RS-232 interface. In each case, you get high resolution color graphics for such a low price you can't afford to design your own.

Think SCION for your graphics display needs. Think MicroAngelo. Call us at (703) 476-6100.

System shown is a Model CS5050S.
*A trademark of Intel Corp.

SCION

if the image is important.

12310 Pinecrest Rd./Reston, VA 22091
(703) 476-6100 TWX: 710-833-0684

Circle 510 on Inquiry card for Multibus Information, Circle 511 on Inquiry card for S-100 Information, Circle 512 on Inquiry card for representative to call.

MAINTAIN PROJECT CONTROL WITH MILESTONE®



Put your microcomputer to work...

As a project manager, you know the value of careful planning. An oversight here, a miscalculation there, and in no time, you could be in a lot of trouble.

Now, thanks to MILESTONE, it's easy to obtain and keep complete project control.

MILESTONE is an easy-to-use computer program that puts your desktop microcomputer to work using the same proven "critical path" techniques previously available only on big, expensive computers. Now, regardless of your type of project, you can plan and control manpower, dollars and time - with MILESTONE.

The price is \$295. (\$395. for the CP/M-86 version.) Manual alone is \$30.

Requires 56K RAM and CP/M, CP/M-86 or UCSD Pascal. Specify 8080/85, Z80, 8086 or UCSD version. Formats 8" single density IBM soft-sectored, 5 1/4" NorthStar OD, Micropolis Mod II, Superbrain 3.0, Apple II with CP/M, 5 1/4" and 8" Xerox 820, IBM Personal Computer with CP/M-86 and IBM DisplayWriter with CP/M-86.

See your computer dealer for
details or contact us directly.

SOFTWARE
SOFTWARE
DIGITAL MARKETING
DIGITAL MARKETING™



DIGITAL MARKETING CORPORATION

2670 CHERRY LANE • WALNUT CREEK • CALIFORNIA • 94596
(415) 938-2880 • Telex: 17-1852 (DIGMKTG WNCR)

Milestone is a registered trademark of Organic Software
CP/M and CP/M-86 trademarks of Digital Research
UCSD Pascal trademark of Regent of University of California

Editorial

The Play's the Thing

Pamela Clark, Technical Editor

Each year, we mark December's arrival by the visions of toys and games that fill store windows, newspaper ads, television screens, and, of course, children's heads. And each year, many of us remain aloof, choosing instead to concentrate our energies on work. At least that was the case until 1982.

This year, not only the children are thinking about games, reading about games, talking about games, buying games, and even playing games. Prime-time television documentaries focus on the game invasion and its origins. Communities around the country picket arcade parlors in an attempt to keep the young from electronic clutches. Video-game commercials appear almost as frequently as pitches for laundry detergent. Games magazines fill the racks at supermarkets. Will 1982 be remembered as the Year the Games Got Us?

What's the Attraction?

Accompanying this newfound passion for arcade games is the inevitable quest to understand their fascination. Theories abound: games provide tension release, an escape from reality, and a techno-mystical high, to name a few. In addition to sounding vaguely like claims for snake oil, these explanations ignore the fundamental relationship of people and play. As John Huzinga writes in *Homo Ludens* (man as the player), "We play and know that we play, so we must be more than rational beings, for play is irrational."

Play, of course, is nothing new. Throughout history people have played games, sometimes with great abandon but more often furtively, as if playing is something we shouldn't admit we do, much less enjoy. Perhaps this very ambivalence has relegated the activity to the young. Most adults have done little more than smile wistfully at youth's antics before resuming more serious activities. The microcomputer, however, gives play an aura of respectability and therefore makes games playing an acceptable adult pastime.

Suitable for Gaming

Although the microcomputer can do many things, it is uniquely suited to game playing. For many of us, it represents a mature approach to play in the privacy of our homes. A variety of skill levels, a large selection of games, and the ability to be programmed to a vow of silence make the machine a perfect play companion. It spares us the dilemma of finding worthy opponents and the anguish of having our pet strategies revealed to friends and relatives. And because we play in private, no one need ever discover our secret passion.

For better or for worse, many of us equate a fondness for arcade games with a craven longing for the *National Enquirer*—a weakness we shouldn't admit to in polite company. But that attitude is changing. Those of us who want to game without shame may soon find strength in numbers. As more people own microcomputers, the ranks of game players multiply. In fact, playing games could become a worldwide pastime. After all, if robots do all the work, we'll need *something* to do.



We're Expanding Your Personal Computer With Reliable Hard-Line Thinking

Let's cut through all the "compu-babble" about hard-disk systems with some hard-line thinking.

If you own an IBM-PC*, Apple II* or TRS-80* Model III, and want to expand to a hard-disk system, you want some fairly basic things from Winchester technology:

- More storage capacity than your present system
- Faster retrieval and storage of information
- Accurate processing with reliable hardware and software

PERCOM DATA was pioneering critical, reliable data separation functions for micro systems long before many of today's companies even began. PERCOM DATA's solid industry reputation is your promise of hard-disk performance, from a drive with specifications equal to or superior to your own system.

PERCOM DATA 5¼ inch PHD's™ are your easy, hard-line answer. These units are available in 5, 10, 15 and 30 megabyte models. The First Drive unit has a micro-processor-based drive controller, permitting you to add up to 3 more hard-disk PHD's. And PHD series prices are more than competitive, whether your system is an IBM-PC, Apple II, or TRS-80 Model III.

So, if you're ready to expand your system, do it with PERCOM DATA's PHD. Our hard-line thinking of more than half a decade means you get a reliable, high-quality PERCOM DATA peripheral, backed by the PERCOM DATA Performance Promise.

Take a hard-line of your own today! Call one of our Sales Consultants for more information and specifications or for the name of your close-by PERCOM DATA Dealer.

PERCOM DATA's Hard-Line Hotline is 1-800-527-1222

PERCOM DATA

C O R P O R A T I O N

Expanding Your Peripheral Vision

DRIVES • NETWORKS • SOFTWARE

11220 Pagemill Road Dallas, Texas 75243 (214) 340-7081

1-800-527-1222

*IBM is a registered trademark of International Business Machines

*Apple is a registered trademark of Apple Computer, Inc.

*TRS-80 is a registered trademark of Tandy Radio Shack Corporation

The Best In Price, Selection and Delivery

Call Now TOLL FREE 800-368-3404 (In VA, Call Collect 703-237-8695)

AMPEX • INTERTEC • TEXAS INSTRUMENTS • GENERAL DATA
COMM. • ANDERSON JACOBSON • C. ITOH • QUME • BEEHIVE •
DATASOUTH • DIABLO • CENTRONICS • NEC • PRENTICE

MICROS

INTERTEC SUPERBRAIN II
64K DD* **ONLY \$1895**
64K QD* **ONLY \$2295**
64K SD* (96TPI) **ONLY \$2695**
*(includes M/Soft BASIC)
DDS-10 Meg
(Hard Disk) **ONLY \$3195**

DYNABYTE Call

PRINTERS

NEC

7710 \$2196
7715 Call for Special Price
7730 \$2196
7720 Call for Special Price
7725 Call for Special Price
Std. Forms Tractor \$ 200
3510 \$1390
3510EX Call for Special Price
3515 \$1395

DATASOUTH

DIABLO 630-R102 \$1995
630-R110 \$1795
630-R153* \$1745
*(for IBM P.C., Apple II, TRS-80)

630-R155 Call
630-K104 (KSR) \$2385
620-SPI \$1149

QUME

Sprint 9/45 ROFP \$1795
Sprint 9/55 ROFP \$2120
Sprint 9/55 ROFP
Exp. Mem. \$2186
Sprint 9/55 ROLP
Exp. Mem. \$2095
Sprint 11/40-130 Call
Bi-Dir. Forms Tractor \$ 199
CENTRONICS: 34/38 Call

TERMINALS

AMPEX

Dialogue 80 \$ 699
Dialogue 80 (4 pgs.) \$ 939

BEEHIVE (SMART DISPLAY)

DM5 Call
DM5A Call
DM310 (3101 Emulator) Call
DM 3270 (3270 Emulator) Call
Protocol Converter Call

C. ITOH
CIT 101 \$1350
TEXAS INSTRUMENTS
745 Standard \$1390
745 Std. (Reconditioned) Call
765 Bbl M'my Call
785 Standard Call
810 Basic \$1249
810 Package \$1439
820 Package RO Package \$1610
820 KSR Package Call
840 RO Basic \$ 795
840 RO Tractor Feed Pkg. \$1059
940 Video Ed'tr \$1570

MODEMS

PRENTICE STAR 300 Bd. \$ 124
GDC 1035JL \$ 169
1200-9600 Baud Call
Stat Muxes Call

DISC DRIVES

QUME

Data Trak 5 \$300 or 2 for \$549
Data Trak 8 \$525 or 2 for \$999

SOFTWARE

BISYNC-3780 \$ 769
Wordstar Call
Data Star Call
Mail Merge Call
Spell Guard \$ 229
Plan 80 \$ 249
Plan 80 Revised \$ 319
Super Calc \$ 249
Wordstar (IBM P.C.) \$ 289
Mail Merge (IBM P.C.) \$ 99
d Base II \$ 529
CalcStar Call
SuperSort Call
Nevada Cobol \$ 176
CIS Cobol \$ 749
Forms II \$ 159

Special! While They Last!

SOROC TERMINALS

IQ 120 **ONLY \$625**

NOTE: IBM and Burroughs compatible terminals available. Please inquire.

In addition, we can make EIA RS 232 or RS 449 cables to your order, and supply you with ribbons, printer stands, print wheels, thimbles for all printers listed. And many, many more items. CALL NOW.

All items shipped freight collect either motor freight or UPS unless otherwise specified. All prices already include 3% cash discount. Purchase with credit card does not include discount. Virginia residents, add 4% Sales Tax. For fastest delivery send certified check, money order or bank-wire transfer. Sorry, no C.O.D. orders. All equipment is in factory cartons with manufacturers' warranty (honored at our depot). Prices subject to change without notice. Most items in stock.

TERMINALS TERRIFIC



Terminals Terrific, Inc., P.O. Box 216, Merrifield, VA 22116
Phone: 800-368-3404 (In VA, Call Collect 703-237-8695)

Editorial

The Game's the Same

In 1982, few games broke new ground in either design or format. Regrettably, the trend toward uniformity may continue to be characteristic of computer gaming. There are two primary reasons for this: commercial marketing trends and the design imbalance of most games.

The microcomputer game industry is subject to the same forces that shape other industries, the primary one being to make money. If the public really likes an idea, it is milked for all it's worth, and numerous clones of a different color soon crowd the shelves. That is, until the public stops buying or something better comes along. Companies who believe that microcomputer games are the hula hoop of the 1980s only want to play Quick Profit. And when companies measure their success by quarters (both the calendar and coin variety), designing innovative games is low on the list of priorities.

Microcomputer games are now part of the mammoth entertainment industry that focuses on your play time and how much you will spend on it. Companies view games in terms of their knock-off potential, the same trend that affects television and movies. Look at *Raiders of the Lost Ark*, *Tales of the Gold Monkey*, and *Pitfall*—the movie, the TV show, and the game.

Ironically, in industry's rush to respond to demand, the original creative concept always seems to get copied rather than improved. Just as the birth of the microcomputer spawned a seemingly endless succession of similar machines, the instant popularity of video games will beget generations of imitative software. While the industry isn't totally saturated with look-alikes, this year has seen more money poured into promotion and advertising than into developing new and innovative games.

The Limits of Game Design

The second reason for uniformity, the design imbalance of games, has to do with the background of computer game designers. Most of the current designers acquired their computer skills before they began tinkering with games. Their games still reflect that orientation; they make the game fit the machine. Thus the microcomputer severely limits game design. Ideally, a computer game is composed of the same elements as any other game: the players' roles, the setting, and the plot (the sequence of events and their consequences). For believable roles, designers apply an extensive knowledge of behavior. For engaging settings, they draw on their imagination and experience. By combining these elements with a suitable plot, a designer can create a particular mood.

Unfortunately, in many computer games, some elements are not as well developed as others. Because the plot can easily be reduced to a series of numbers and instructions, it is well suited to the microcomputer. Thus most computer game designers manipulate the plot rather than the roles or setting. Consider the following sequence

FROM ATHENA TO YOU

Climb your own mountains with the
ATHENA I™ Computer

- Small (3 $\frac{3}{8}$ " x 11 $\frac{7}{8}$ " x 14 $\frac{1}{2}$ ")
- Battery Powered
- Truly Portable (15 pounds)
- Typewriter Style Keyboard
- Four Line by 80 Character Liquid Crystal Display
- CP/M® Operating System
- Network Capability (up to 15 units)
- Room for Future Expansion
- Dual Processors (2.5 Mhz NSC-800)
- 68K Bytes High Speed RAM
- 6K Bytes ROM
- 512K Bytes Solid State Mass Storage
(emulates floppy disk drive,
expandable to one megabyte)
- Two RS-232 Ports (for printers, screen
terminals & communication devices)
- Base Unit Consisting of 5 $\frac{1}{4}$ inch Floppy
Disk Drive & Recharger
- 12 Volt Power Cable (for operation from
car cigarette lighter receptacle)
- \$3,950.00 Complete

Additional accessories are available

ATHENA I's features speak for themselves.
You decide.

For further information (including a list of dealers in
your area) write or call:



ATHENA

Computer & Electronic Systems

31952 Camino Capistrano
San Juan Capistrano, CA 92675
(714) 661-2276

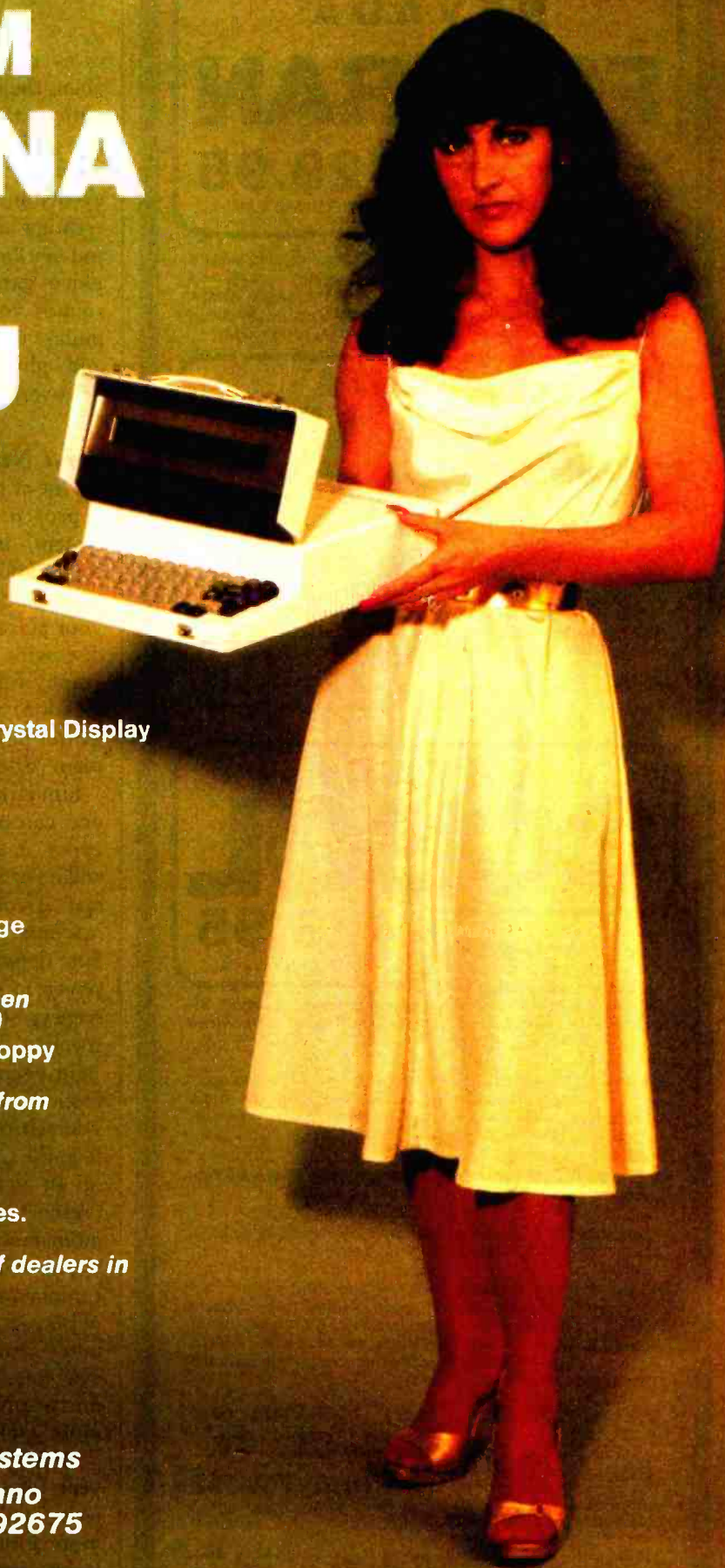

NEVADA FORTRAN

\$29.95

DISKETTE AND MANUAL

Just a beautiful compiler that's a pleasure to use! Perfect for Teaching Fortran. Perfect for Learning Fortran. Perfect for Scientists and Engineers. Advanced features include IF.. THEN.. ELSE.. constructs, COPY statement, a very nice TRACE style debugging, and 150 verbal error messages. What's more, you can intermix in-line Fortran and Assembly Language statements for those special Micro needs! Get yours, today!

NEVADA PILOT

\$29.95

DISKETTE AND MANUAL

Why has Nevada PILOT become so popular? It's definitely easier to learn than Basic. The documentation (146 pages) by Professor Starkweather is exceptional! And, it meets all the PILOT—73 standards with many new features.

You can quickly write user-interactive programs much easier than with Basic. Order yours now! Diskette and manual comes with 10 FREE programs.

NEVADA COBOL

\$29.95

DISKETTE AND MANUAL

Nevada COBOL is based upon the ANSI—74 standards with many advanced features. It's field-proven with thousands of users world-wide in Business, Government and Education. The excellent documentation (153 pages) is used as a classroom text at a number of colleges.

Because of Nevada COBOL's superior design, it requires about half the memory of competitive COBOL compilers. This major advantage is just one reason many business programmers are switching to Nevada COBOL.

And, lots of students are using Nevada COBOL because it's the affordable, easy to use COBOL! Order yours now!

Also available: COBOL Application Packages Book 1...\$9.95
Nevada EDIT...\$29.95

All our software requires the CP/M operating system, 32K RAM, one disk drive, CRT or video display and keyboard. Available on 8" standard single density or 5 1/4" diskettes for Apple II, Osborne I, North Star, Micropolis Mod II, Superbrain, TRS—80, IBM—PC and many other microcomputers. Dealer, Distributor, O.E.M inquires invited.



ELLIS COMPUTING

600 41st Avenue,
San Francisco, CA 94121

COD'S WELCOME



(415) 751-1522

Trademarks: CP/M, Digital Research; TRS—80, Tandy Corp.; Apple II, Apple Computer Inc.; Osborne I, Osborne Computer Corp.; IBM, International Business Machines © 1982 Ellis Computing

Editorial

of events: if Player A fires the laser pistol and hits the alien, the score will increase by 1000 and the sky will fill with swarms of attacking spaceships. (Quick: how many of you have already translated this into the appropriate code?) Programming a computer to keep a record of events and generate consequences is clearly easier than creating a complex integration that incorporates roles and settings. If you experience déjà vu while playing a video game, it's because, underneath the colors and sounds, most computer games are just the same old formulas. Creating games with a balance of roles, setting, and plot may require the skills of designers who discovered games before computers.

Brave New Games

One way to balance the elements of game design is to approach the microcomputer as part of an overall system, incorporating videodiscs and holography to create your own game. You might, for example, become the hero of a life-size battlefield projected on the walls of your playroom. All you'd have to do is select the videodisc with the appropriate scenery and push the holography function key. When you tired of battling in one location, you could choose another: capture the Eiffel Tower in Paris, run with the Cossacks on a vast Tibetan plain, or engage in a warp-drive duel in another galaxy.

Similarly, if you find a game design you really enjoy, you can personalize it; descending aliens could become gypsy moths, next-door neighbors, ring-around-the-collar, or whatever nemesis you want to blast away at. In fact, if you use the microcomputer as a game-generating machine, you can create your very own game world. First determine the size of your visual display, from one screen to six—which would fill the room with pulsating scenery. Route the sound through strategically located speakers and select your setting—30,000 bc, a couple of light-years down the road, or anywhere in between. Decide whether your player image will be a projection of yourself or a symbolic playing token you create. If you like, the game machine can compute your handicap based on an algorithm of your previous experience and your present mental and physical condition. After a few moments you'd have a game to call your own.

The computer's ability to communicate means that you can even share your game with a worldwide contingent of players. As we communicate through play, microcomputer gaming could become the Esperanto of the future. The possibilities are endless if we strive to make the microcomputer a game machine instead of just making more games for the microcomputer.

Where does that leave us? This hasn't been a banner year for innovation, but during 1982 lots of us finally went public playing games. That event alone may have more influence on the look of future games than any technological breakthrough, marketing strategy, or designer's revelation. ■

NOW: A COMPLETE CP/M PASCAL FOR ONLY

\$29.95!

HERE'S THE PASCAL YOU'VE BEEN READING ABOUT. AND, WITHOUT EXCEPTION, THE REVIEWS CALL JRT PASCAL A SUPER PRODUCT FOR AN AMAZING PRICE!

InfoWorld
Software Report Card

JRT Pascal
Version
2.0

	Poor	Fair	Good	Excellent
Performance	<input type="checkbox"/>	<input type="checkbox"/>	<input type="checkbox"/>	<input checked="" type="checkbox"/>
Documentation	<input type="checkbox"/>	<input type="checkbox"/>	<input checked="" type="checkbox"/>	<input type="checkbox"/>
Ease of Use	<input type="checkbox"/>	<input type="checkbox"/>	<input type="checkbox"/>	<input checked="" type="checkbox"/>
Error Handling	<input type="checkbox"/>	<input type="checkbox"/>	<input type="checkbox"/>	<input checked="" type="checkbox"/>

From INFOWORLD magazine, August 16, 1982

we think all software is overpriced. We want to build volume with the booming CP/M market, and our overhead is low, so we're passing the savings on to you.

AND AT NO RISK!

When you receive JRT Pascal, look it over, check it out. We invite you to compare it with other systems costing ten times as much. If you're not completely satisfied, return the system—with the sealed diskette unopened—within 30 days and your money will be refunded in full! *THAT'S RIGHT—COMPLETE SATISFACTION GUARANTEED OR YOUR MONEY BACK!*

In addition, if you want to copy the diskette or manual—so long as it's not for resale—it's o.k. with us. Pass it on to your friends! **BUT ACT TODAY—DON'T DELAY ENJOYING PASCAL'S ADVANTAGES—AT \$29.95, THERE'S NO REASON TO WAIT!**

Goodbye BASIC, PL/1, COBOL—hello PASCAL! Now, to make this most advanced language available to more micro users, we've cut our price—to an amazing \$29.95! This astonishing price includes the complete JRT Pascal system on diskette and the new, comprehensive user manual. Not a subset, it's a complete Pascal for CP/M.* Check the features below.

THIS IS THE SAME SYSTEM WE SOLD FOR \$295!

So how can we make this offer?—why the unbelievable deal? Very simply,

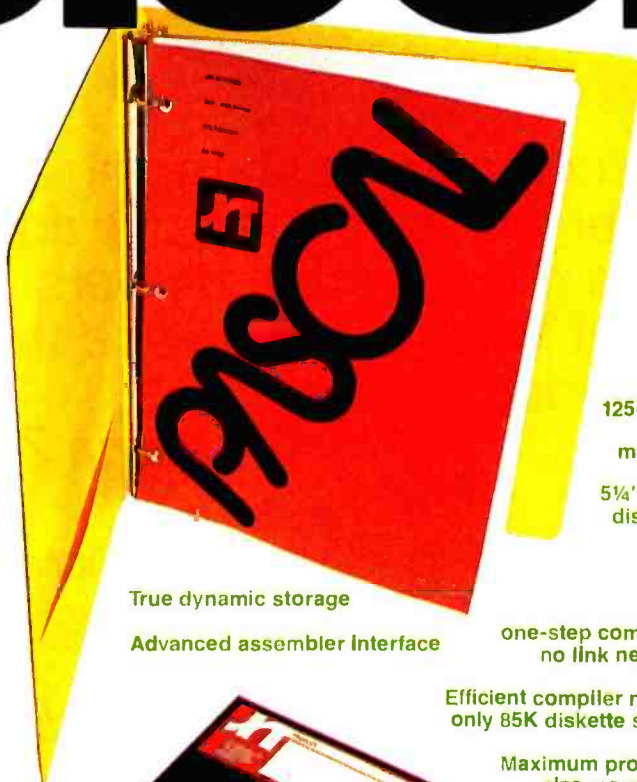

New 125-page user manual and 5 1/4" or 8" diskette

True dynamic storage

Advanced assembler Interface

Fast one-step compiler; no link needed

Efficient compiler needs only 85K diskette space

Maximum program size more than 200,000 lines

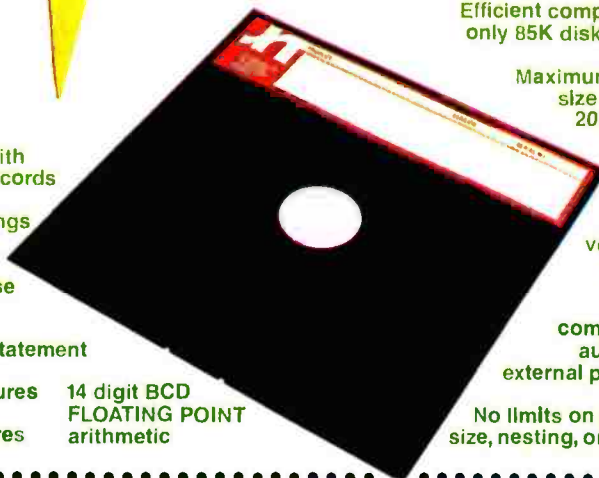

Random files to 8 megabytes with variable length records

64K dynamic strings

Activity analyzer prints program use histogram

Extended CASE statement

Graphing procedures

Statistic procedures

14 digit BCD FLOATING POINT arithmetic

More than 200 verbal error messages

Separate compilation of auto-loading external procedures

No limits on procedure size, nesting, or recursion



Send to
JRT SYSTEMS
1891—23rd Avenue
San Francisco, CA 94122

Phone
415/566-5100

I need the 5 1/4" diskette for Northstar Osborne Apple-CP/M
 Heath, Hard Sector Heath, Soft Sector Superbrain.
I need the 8" SSSD diskette.

Name _____ Address _____

City _____

State _____ Zip _____

Check C.O.D. MasterCard VISA
(CA residents add sales tax. Add \$6 for shipping outside North America.)

Card # _____ Exp. _____

Signature _____

*CP/M is a Digital Research TM. A 56K CP/M system is required.

This is what the pros have said about Perfect Writer:™

“Perfect Writer lives up to its name . . . It would be my choice for a word processor in my home.”

John Ford, Infoworld

“The company is stamping a giant footprint in the market with an aggressive advertising campaign—and with a program that delivers what the ads promise . . . Perfect Writer will likely be the tool I use to construct future documents.”

Dona Z. Meilach, Interface Age

“It does things I’ve seen nowhere else.”

James Fallows, Atlantic Monthly

“Capabilities like those in Wangwriter and other sophisticated systems.”

Softalk

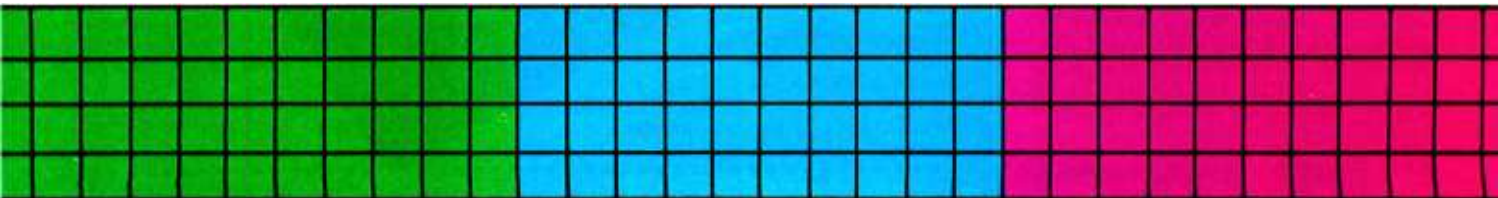

Perfect Writer™

The revolutionary word processing program with split-screen editing.

Perfect Speller™

The spelling checker program designed to work with Perfect Writer.

Perfect Filer™

The most powerful and easy-to-use file management and report-generator program fully integrated with Perfect Writer.

Perfect Calc™

The most powerful spreadsheet program you can buy—up to seven spreadsheets in memory at one time. Fully integrated with Perfect Writer.

This is how many orders for Perfect Calc™ were received before it was even released:

~~5,000~~

~~10,000~~

~~15,000~~

25,000*

Perfect Software™
The revolution in software.

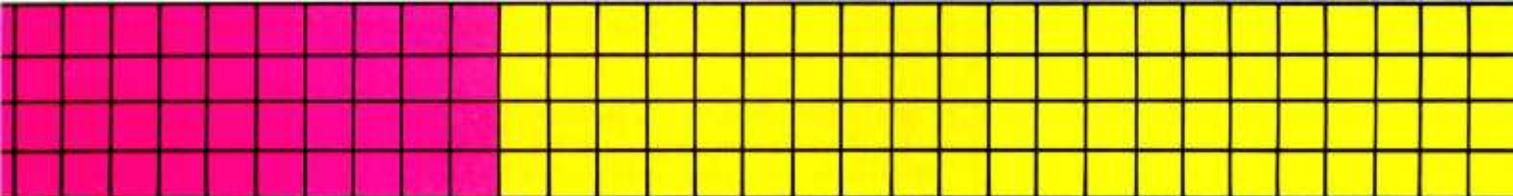

The Perfect Software team is available for: Apple with CPM, HP-125 and HP-87, Heath/Zenith, IBM PC, North Star, Osborne, Sharp, Superbrain, Televideo, TRS Model 2 and 16, Vector, Xerox 820 and most 5¼ and 8" CPM and MSDOS.

**MICROHOUSE HAS JUST BECOME
A MAJOR PERFECT DEALER/DISTRIBUTOR.**

*As of September 30, 1982.
Scheduled release November, 1982.

For the dealer nearest you call
800-227-5488
(in California 415-644-3001)

1400 Shattuck Ave.
Berkeley, CA 94709

DEALER INQUIRIES INVITED

Perfect Writer, Perfect Speller, Perfect Filer, Perfect Calc and Perfect Software are trademarks of Perfect Software, Inc.
CP/M is a trademark of Digital Research.
MS is a trademark of MicroSoft Corp.

Logo Draws Enthusiastic Responses

Congratulations on the August 1982 BYTE theme issue describing Logo, a most interesting language and computer-based learning environment.

Daniel Watt's excellent article, "Logo in the Schools" (page 116), as well as others in that issue, states that the Logo environment improves a student's learning ability. But from the research presented in BYTE, it is not clear that Logo, per se, is really the panacea its enthusiastic sponsors claim it to be.

Many factors influence a student's ability to learn and a teacher's ability to evaluate student performance. Increased training of the teachers, increased time spent individually with students, greater availability of modern equipment, special-interest group meetings after school and on weekends, and the special recognition that a child gets for being part of the study may have had a greater impact than that of Logo.

That the student knows that he or she is participating in a study can skew the test results tremendously. This problem was demonstrated long ago in psychological research and is known as the "Hawthorne effect."

The Edinburgh study (page 117) showed that the quantitative improvement in mathematical skills was small, while the teachers *perceived* the students to have better reasoning abilities. In this case, it appears that the outcome of the test was influenced by what the teachers expected to find.

If teachers *think* that Logo-based education is good for the students, then they will tend to find mostly positive results. Nicknamed the "Rosenthal effect," this problem has also been called a self-fulfilling prophecy.

The notion of a self-fulfilling prophecy applies to students as well. Children branded as "below average" often perform at a low level because they lack the confidence to succeed. When they are specially selected for a research study, they are labeled as someone unique. That label, in turn, becomes a self-fulfilling prophecy, giving them the impetus to succeed because someone *expects* them to.

The solution is to conduct a double-blind experiment. The person who evaluates student ability should have no knowl-

edge whatsoever of the experimental conditions applied to the student groups.

Education is a *system* with many subparts; Logo is only one part of that system and is merely the *catalyst* for all the other factors. Logo solves the problems associated with the computer (e.g., Logo is highly interactive and more user-friendly than previous systems). But Logo research projects seem to ignore all other influential forces.

When Logo systems go into the field, will classes be small enough for individual instruction? How many teachers will be given additional instruction and training in the use of Logo? Will funding be provided for teachers to supervise after-hours special-interest groups? Will schools really have enough machines to make Logo use meaningful? (Even if Apple donates a computer to every school, one computer per school doesn't provide much machine time for each student.)

Like the researchers, I also believe that the use of Logo systems will have a positive effect on learning ability. But more thorough research than that reviewed in BYTE must be done before we Logo-ize all of our schools.

Edward Mitchell, Software Development Engineer
720-A Independence Ave.
Mountain View, CA 94040

I read with interest the Logo articles in the August BYTE. I would, however, like to make two observations. First, the claim that modern program-language designers advocate the use of data typing in order to (1) discourage the use of a single variable for various purposes (see page 174 of Brian Harvey's "Why Logo?") and (2) to simplify the work of a compiler (see page 88 of "Harold Abelson's "A Beginner's Guide to Logo") are not quite accurate.

It is true that these goals can be attained by typing variables and declaring all variables used; however, the major gain is that the *information required for a precise understanding of a program from its text* is made available. A data type is a set of values and a group of operations; a variable is a named object declared to be of some type. A variable can have as value any element of the set of values of its declared type, and the operations of that type are the only ones that may be applied to the variable. Thus, the declaration

```
var i: integer
```

in Pascal supplies the following information: the program will be using a variable named "i," the values it may take on are in the range $-maxint$ to $+maxint$, and the only operations that may be applied to "i" are the arithmetic, comparison, and evaluation operations defined for integers in the Pascal-language definition. The gain is less in automatic compiler checking than in the increase of human understandability of a program.

This brings up my second point about Logo: it appears to be an excellent tool for the sorts of exploratory learning for which it was intended. In my opinion, however, it is totally inadequate as a medium for the development of certifiable product software which efficiently uses the resources of a machine to perform a computational task. In particular, the system does not lend itself to the development of *large* software systems by a group of software engineers; note that this is precisely the situation in which complete accurate information about the structure of the software and its functional and performance properties must be available to personnel other than the original developer. I suspect that Logo vendors would not want to develop, modify, and maintain the Logo processor software (interpreter, editor, I/O routines, etc.) *in Logo*. The development and maintenance of software products should be an engineering rather than an experimental enterprise; Logo was designed for experimental rather than engineering use.

Bill Wood
St. Louis Park, MN 55426

I would like to make a few comments on Daniel Watt's article "Logo in the Schools." It only reinforces my belief that schools are *not* the best place to educate children.

Several points brought forth in Watt's discussion of the Brookline Logo project (page 120) deserve special emphasis. "The surprising success of students with learning disabilities. . ." seems a contradiction. One wonders if "learning disability" is not an educator's term to describe a teaching *inability*. Information presented in a way acceptable to each individual child will virtually eliminate this national epidemic—learning disability.



PrintMate™ 150

THE MOST ADVANCED PRINTER IN ITS CLASS.

Good news for microsystem and personal computer users! MPI offers four wide carriage printers with excellence in price and performance. The two "A" versions of PrintMate™ 150 feature a factory installed "SoftSwitch™" front panel keypad, with a 4K buffer on PrintMate™ 150 model A1 and a 16K buffer on model A2. PrintMate™ 150 models B1 and B2 are factory equipped with a 2K and 16K buffer, respectively. PrintMate™ 150 models have an exceptional set of outstanding graphics and font capabilities, optional expansion, and other advanced features that differentiate the PrintMate™ 150 from its competitive rivals as the superior performer. A bold claim? The strong and widespread acceptance of the excellent PrintMate™ 150 is based on outstanding user features:

HIGH SYSTEM THRUPUT—150 characters per second advanced logic seeking impact printing with an accelerated print head slew rate and turnaround makes PrintMate™ 150 a high speed performer.

WIDE CARRIAGE VERSATILITY—The PrintMate™ 150's wide carriage can accommodate print lines from 136 to 231 characters in length and can easily handle forms from 3 to 15 inches wide and as long as 31 inches.

LARGE SELECTION OF PRINT CAPABILITIES—The 7x9 dot matrix allows user selection

of 10, 12, 15 or 17 characters per inch or the 11x9 serif font provides document quality printing at 10 characters per inch.

"SoftSwitch™" FRONT PANEL CONTROL—The PrintMate™ 150 A models have SoftSwitch™ front panel keypads for externally changing forms length, print density, horizontal and vertical tabs, baud rate and character set. A simple "SoftSwitch™" entry will display the operating mode you have selected and PrintMate™ 150 responds to every entry with a pleasant tone of confirmation. With the "SoftSwitch™", you can turn off the printer—even unplug it—and PrintMate™ 150 will retain every detail in its non-volatile memory. The "SoftSwitch™" may be added to the PrintMate™ B models.

EXPANDABLE PRINT BUFFER—PrintMate™ 150 models A2 and B2 have a factory installed 16K buffer. Both the 4K buffer model A1 and the standard 2K buffer model B1 are optionally expanded in increments to 16K. The PrintMate™ 150's expanded buffer allows application extensions for high speed interleaved printing and spooling, greatly improving the host computer's performance in applications that are print bound.

DOWNLINE LOADABLE FONTS—The powerful microprocessor based command set of the PrintMate™ 150 allows a custom character set to be developed in the host computer and downloaded to any Print-

Mate™ 150 model with a 4K or larger buffer.

GRAPHICS—The standard graphics capabilities of all PrintMate™ 150 models allow printing of up to 6,120 individually addressable dots per square inch giving exceptional resolution for graphics and special characters.

PrintMate™ APPLICATIONS PACKAGES—Turn-key graphics and display fonts can be implemented with an extensive line of MPI supported and maintained AP-PAK™ applications packages providing specialized fonts, custom graphs, tables, and picture graphics. Specialized characters such as logos may be easily defined and edited for printing directly from your computer.

CONSIDER THE FEATURES—Only PrintMate™ 150 offers so many ways to get your message across: graphics; display fonts; downline loadable character sets; high print speed; advanced logic seeking; 15 inch wide carriage; a variety of forms and paper capabilities and; friendly "SoftSwitch™" interaction. The PrintMate™ 150 is the responsive performer that perfectly mates with your microsystem or personal computer. With prices beginning at \$995, it is evident that the PrintMate™ 150 is the superior performer in function and price.



Micro Peripherals, Inc.
4426 South Century Drive
Salt Lake City, UT 84107
Phone 1-800-821-8848

Circle 331 on inquiry card.

The Brookline project rejected standardized tests to measure the stated goal "to observe and document what [the children] actually learned." To me, this means that tests may be designed to evaluate the system (e.g., an educator's pre-planned objectives) and not to determine a child's knowledge. One should think about this very carefully.

Watt said that a "limitation of the project was that it required an extremely sensitive and knowledgeable teacher, with a great deal of time to consider the needs of each student." To me, this is the ultimate limitation of *all* schools.

A final comment directed at Watt's conclusion. He said that "teachers need to understand the value of exploratory learning and student interaction." It seems to me that professional educators have been promoting just the opposite because, with student/teacher ratios of 30 and more, rigid discipline is mandatory. Watt should have said that "teachers need to unlearn their own training to limit individuality and interstudent communications." Paraphrasing the Computer in the Schools project coordinator, maybe practicing this will "turn kids on" and provide further "striking changes in kids' relationships to schools and learning."

Please continue the efforts to present a wide variety of information in BYTE so that those of us who choose to educate our children at home may learn. I found the August issue particularly supportive of my endeavor.

James O. Mayor
26824 Howard Chapel Dr.
Damascus, MD 20872

I agree with Mr. Mayor that many of the points raised in my article, "Logo in the Schools," could be taken as criticism of prevailing classroom practices. I am delighted that he found the August issue helpful in supporting his decision to educate his children at home. On the other hand, millions of children who are in schools are also entitled to experience the kinds of benefits that a Logo learning experience can offer. I believe that Logo can help schools broaden and deepen the kinds of learning experiences that they offer and that our schools will be more likely to do so if the issues highlighted by Mr. Mayor are clearly faced and understood by educators who choose to use Logo in their classrooms. . . . D. W.

What a pleasure it was to devour the August 1982 BYTE from cover to cover! Logo is becoming a significant part of our "computer culture," and BYTE's outstanding treatment of its many aspects and levels of subtlety certainly affirms that fact. I especially appreciated the articles by Daniel Watt ("Logo in the Schools," page 116) and Cynthia Solomon ("Introducing Logo to Children," page 196). From these articles, the average reader can get an excellent overview of the tremendous practical potential for Logo in our classrooms.

The National Logo Exchange, a newsletter for Logo teachers, is dedicated to facilitating the exchange of successful Logo teaching tips, techniques, and strategies among teachers using Logo in their classrooms. As editor, I applaud BYTE's efforts to educate the general public to Logo, and I look forward to the effects of the August issue being felt in many school board meetings across the country.

Again, thank you for the efforts on behalf of Logo. The children of today will benefit from the August BYTE for many years.

Tom Lough, Editor
The National Logo Exchange
POB 5341
Charlottesville, VA 22905

Excellent edition—August 1982. The articles on Logo were very good. As an educator who has been using Logo for several months with children of a variety of ages (2nd to 10th grades) and with a variety of results, I thoroughly enjoyed the issue (I wanted to write to compliment BYTE even before I finished the last article).

I would also like to comment on Chris Morgan's editorial "Keeping Our Technological Edge." While I echo Mr. Morgan's thoughts about providing a greater chance for children to learn computing skills by making hardware available through tax breaks, I would like to point out what many consider a more serious problem: the dramatic shortage of qualified teachers of math and science. The reason for this shortage is clear: salary. A beginning programmer earns more than one and a half times the salary of a beginning teacher. Further, there is little job security in teaching. The National Science Teachers Association found

that 50.2% of the teachers assigned to math and science classes last year had inadequate backgrounds. And the problem is getting worse. A recent article in the *New York Times* pointed out that during the last decade production of secondary school teachers has declined 78% in math and 64% in science.

Although numerous solutions have been proposed, including getting industry involved on various levels, the main thrust will have to come from a commitment to education on a national basis. We are dangerously close to falling behind Japan, West Germany, and the Soviet Union in technological fields, and we will certainly fall behind if we continue to follow this path of cutting back for today and sacrificing our future.

Again, I applaud BYTE on the August issue and for its awareness of the problems that are evolving.

John Reynolds, Computer Coordinator
Lenox School
170 East 70th St.
New York, NY 10021

More on Logo

I have just returned from buying two additional copies of the special Logo issue of BYTE. These will remain our references, as have some other issues of BYTE.

BYTE's consulting editor, Phil Lemmons, concluded his "Logo Update" by citing the lack of hardware to teach Logo (page 334). In the YPLA (Young People's Logo Association) we have faced that problem by devising methods of teaching turtle geometry off the computer. Most certainly we don't ignore the computer. Rather, we take the geometric concepts carried out on the screen and place them into real-life situations with which young people can very easily relate. Thus, when they get their turn at the keyboard, they can use that precious time to better advantage.

Our program is quite simple. We use body geometry, arts and crafts projects, graph paper, cut-outs made from screen-dumped programs, worksheets, activities with Big Trak, and other devices to help provide a visual reference to the educational concepts presented by the turtle.

Also, Gregg Williams in his comparative article on the implementations of Logo overlooked what I have found to be

BASF QUALIMETRIC™ A TOTALLY NEW DIMENSION OF QUALITY.



From BASF comes a totally new level of excellence in magnetic media—the Qualimetric standard, a standard so advanced that BASF FlexyDisks® are confidently backed by the industry's only lifetime warranty. The Qualimetric standard is maintained without compromise through every step of BASF design, production, inspection, and testing...reflecting an unwavering BASF commitment to media fidelity and durability.

Our FlexyDisk jacket, for example, incorporates a unique two-piece liner that not only traps damaging debris away from the media surface, but also ensures precise media-to-head alignment. The result—certified 100% error-free performance, backed by BASF's exclusive lifetime warranty.*

For information security, tomorrow and beyond, look for the distinctive BASF package with the Qualimetric seal. Call 800-343-4600 for the name of your nearest supplier.

ENTER TOMORROW ON BASF TODAY



*Contact BASF for warranty details. © 1982, BASF Systems Corporation, Bedford, MA

IBM personal computer UCSD p-System™ IV.1 includes 8087

Network Consulting has added many features that the professional programmer will find useful. These features are not available from any other sources.

- Hard disk support for Corvus, Tall Grass Technology, Davong and others
- 25% more floppy storage, without adding or modifying hardware, retaining compatibility with standard IBM diskettes
- 8087 Numeric Processing Unit increases speed of Floating Point Operations 20-40 times.
- Up to 800K on each mini-diskette
- RAM disk support (a pseudo-floppy volume that uses up to 512k RAM)
- 8086/87/88 macro assembler
- Extended memory support
- Adaptable system support available for adding custom I/O drivers
- 8087 Native Code Generator allows full use of 8087.
- A library of program modules
- Disk write verification

Standard p-System features include:

- Standard I/O redirection (including command files)
- Dynamic program overlays
- Support for asynchronous processes and concurrency primitives in Pascal
- Fast Pascal p-code compiler
- Fast FORTRAN and Basic p-Code compilers also available
- A powerful screen oriented editor
- A filer for handling both files and volumes
- A Native Code Generator that processes your Pascal, Fortran and Basic programs to convert parts of them to native machine code
- Dynamic runtime binding of separately compiled programs and units
- Turtlegraphics for easy graphics displays
- Print spooler for background printing
- Symbolic debugger

UCSD p-SYSTEM from Network Consulting

The only serious choice for business

TM The Regents of the University of California



Network Consulting Inc.

A106 - 1093 W. Broadway
Vancouver, B.C.
Canada V6H 1E2
(604) 738-3500

Letters

a very important undocumented TI Logo command. (See "Logo for the Apple II, the TI-99/4A, and the TRS-80 Color Computer," page 230.) To the best of my knowledge, *Turtle News* is the only publication to fully describe the JOY1 and JOY2 commands. These are extremely useful for inputting numerical code to the computer.

I have enjoyed working with cerebral-palsied patients using adapted joysticks as the input devices. And the ease with which Logo can be learned, coupled with its efficiency as a general-purpose language, make it very well suited for teaching these people what can be done with the computer.

Given the confidence quickly gained through Logo, these people can, will, and do gain the confidence to go on and learn what they need to do to become productive citizens. All they need is someone to show them that they can indeed do it.

Again, thanks for a marvelous issue. It will become a most permanent and useful part of our library.

James H. Muller, President
Young Peoples' Logo Association
1208 Hillside Dr.
Richardson, TX 75081

Congratulations on the August issue devoted to Logo. I can hardly imagine a better job of covering both the language and the culture. I have one complaint, however, concerning Gregg Williams's otherwise top-notch article comparing four different versions of Logo. (See "Logo for the Apple II, the TI-99/4A, and the TRS-80 Color Computer," page 230.)

His contrast between the relatively black box, user-proof character of Apple Logo and the relatively greater user access to the Terrapin/Krell version is right on the mark. But does it follow that "Apple Logo is better for situations involving nontechnical users and . . . Terrapin Logo is oriented more toward the sophisticated programmer"? I suppose that depends on one's image of the typical new user of Logo.

For the past few months, I have been giving workshops for educators interested in learning about Logo. As a group, these are overwhelmingly nontechnical users. Nevertheless, given a choice between Apple Logo and Terrapin Logo, they consistently express a preference for the Terrapin version (after overcoming some initial bias in favor of the Apple name).

The single difference that most accounts for this preference is one factor that wasn't even mentioned explicitly in the article: what the user can do with pictures in the two systems. Although it is possible to get a printer copy of the graphics screen in Apple Logo, one must "crash" Logo to do so. In Terrapin/Krell Logo, the user may save and read pictures from files that are accessible not only from within Logo but also within Apple DOS. As a result, for example, one can create and save pictures using public-domain Applesoft-based utilities and then use them freely from inside Logo programs.

To a teacher just getting started with a new language, this kind of compatibility across systems has a powerful appeal. So does a tutorial manual (from Terrapin) that is both "geared for the novice" and "does a very good job of introducing some advanced Logo concepts." Teachers also appreciate the tutorial demonstration programs and the shape-editing utility from MIT and the text-editing utilities from Terrapin. By contrast, as Mr. Williams states, "Apple Logo's greatest strength is its advanced programming commands." The applications for these commands are, of course, over the heads of the teachers in my introductory workshops.

Except for that, I could find nothing in the whole issue that didn't make sense to me. Thanks for a superb job.

David Greene
3144 David Ave.
Palo Alto, CA 94303

Thanks for pointing out a difference between the two systems that is obviously important to a large body of users. When I made those comments on Apple and Terrapin Logo, I was thinking of Apple Logo's BURY and STARTUP-file features (for the benefit of nontechnical users, Terrapin Logo doesn't have these) and Terrapin's tracing and assembler features (to be used by the advanced user; Apple Logo doesn't have these). But your evaluation is equally valid—and I certainly won't argue with experience gained in the field. Thanks for writing. . . . G. W.

The August 1982 BYTE devoted to the Logo language was very interesting, but all the writers missed the existence of the hidden (and dare I say subversive) message "RESIST THE DRAFT," which is to be found on sector 8, track 8, of Apple Logo. With this product going into so

**When you're looking for
a heavyweight performer
at a low price,
IBC outweighs the competition.**



IBC MIDDI CADET™

Maximum Users	9
Disk Storage	20 MB
Memory	256 KB * *
CPU Speed	6 MHz
Benchmark (Elapsed time)	1:44 Minutes*
List Price	\$7495.00

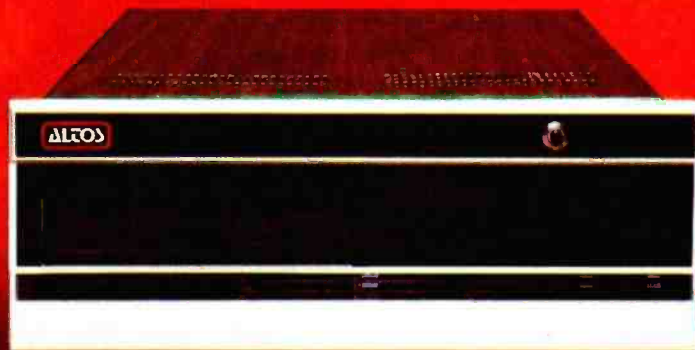

ALTOS™ ACS 8000-10

Maximum Users	4
Disk Storage	10 MB
Memory	208 KB
CPU Speed	4 MHz
Benchmark (Elapsed time)	5:03 Minutes*
List Price	\$7995.00

The IBC MIDDI Cadet is better, faster and less expensive than the ALTOS ACS-8000-10 and others. That's why we call it the heavyweight performer.

Because the MIDDI is completely software compatible with ALTOS, ONYX™, Dynabyte™ and others using CP/M™ 2.2, MP/M™ II or OASIS™, you can transport your applications software to the MIDDI without modification. So why not take the benchmark test yourself.

If you are an OEM, system integrator, multiple end user, or dealer for any of our competitors, send a copy of your application program to IBC. We will run your software on the MIDDI without modification and give you the elapsed time in minutes. You be the judge. If it really is faster than your current hardware and it is, then you owe it to yourself and your customers to switch to IBC.

So remember! When you want a heavyweight performer at a low price, contact:

OUTSIDE THE USA

IBC/Integrated Business Computers

21592 Marilla Street
Chatsworth, CA 91311
(213) 882-9007 TELEX NO. 215349

WITHIN THE USA

IBC/ DISTRIBUTION

4185 Harrison Blvd., Suite 301
Ogden, UTAH 84403
(801) 621-2294

*Four users under OASIS

** Upgradable to 512 K Bytes

ALTOS is a trademark of ALTOS Computer Systems; ONYX is a trademark of Onyx Systems, Inc.; DYNABYTE is a trademark of Dynabyte Business Computers; CP/M & MP/M are trademarks of Digital Research; and OASIS is a trademark of Phase One Systems.



many of our schools, it seems that Apple Computer is making an early start on 1984.

Dr. John S. Kallend
011 Life Sciences Building
Illinois Institute of Technology
Chicago, IL 60616

**Everyone Can Know
the Real Chips**

As Steve Ciarcia pointed out in his article "Everyone Can Know the Real Time," National Semiconductor's MM58167A real-time clock chip greatly simplifies the implementation of a time-of-day clock. (See the May 1982 BYTE, page 34.) However, the chip is manufactured using an extremely slow CMOS (complementary metal-oxide semiconductor) process that can cause designers some unforeseen problems. Most notably, chip access can take up to 1 microsecond, necessitating the use, in some systems, of the ready line (RDY/pin 4) to force the processor into

extra wait states until data is valid.

On the positive side, while the manufacturer seems to indicate that interrupts faster than 10 Hz are not possible, in fact interrupts at speeds over 500 Hz can be implemented. This involves using the alarm-clock function and incrementing the setting by values as small as 2 microseconds after each interrupt in software. Again, the slow CMOS process keeps the user from programming faster interrupts due to the long propagation delays in the 48-bit comparator. Within a year, National plans to release a new version of the chip using a higher-speed CMOS process that should eliminate the access problem and allow interrupts at rates up to 1 kHz. The MM58167A (and other chips by Motorola and Oki) will certainly increase the use of time-of-day clocks in small systems.

Bob Rumer
Beckman Instruments Inc.
200 South Kraemer W-172
Brea, CA 92621

A Reasonable Request

Can we please quit squabbling over which operating system is the best, or at least set up some ground rules for comparisons? I am very tired of the watermelon versus kumquat comparisons of Unix and CP/M that have been raging in BYTE this year. (See "Unix Feedback," August 1982 BYTE, page 20.)

To begin with, there are many different types of operating systems, including:

- single-user systems such as CP/M and RT-11
- real-time systems such as RSX-11M
- timesharing systems such as Unix, VMS, RSTS, and MP/M

It is a waste of time to fight over members of different groups. The only thing that really matters is if you are using an operating system that is suited to the task at hand. This can be illustrated quite well with Digital Equipment Corporation's PDP series of computers. At least four choices of operating systems are available

Circle 252 on inquiry card.

**The Most Promising Duet
For An Orchestra.**

**Our duet is perfect for a single user system.
The same duet performs even better in a multi-user orchestra.**

MCM ★ 80:

- S-100 Single Board Computer
- Single or multi processor capability
- Programmable master or slave selection
- Redundant processor manipulation
- 4MHz Z80A or 6MHz Z80B CPU
- 64K RAM and 2K EPROM with monitor
- 2 serial, 2 parallel, 4 timer ports
- Bi-directional inter-processor channel
- Dual mode serial ports interface
- Multi-layer PCB construction.

\$495.



DCM ★ 80:

- S-100 Disk Controller Module
- 8" and/or 5 1/4" floppy disk controller
- SASI (ANSI, SCSI) hard disk host adapter
- Single and double density, single and double side
- Software implementation on CP/M¹ 2.2 and TurboDOS²

¹ TM of Digital Research, Inc.
² TM of Software 2000, Inc.

\$345.



JC SYSTEMS

1075 Hiawatha Ct.
Fremont, CA 94538
(415) 657-4215

the Apple-IBM connection

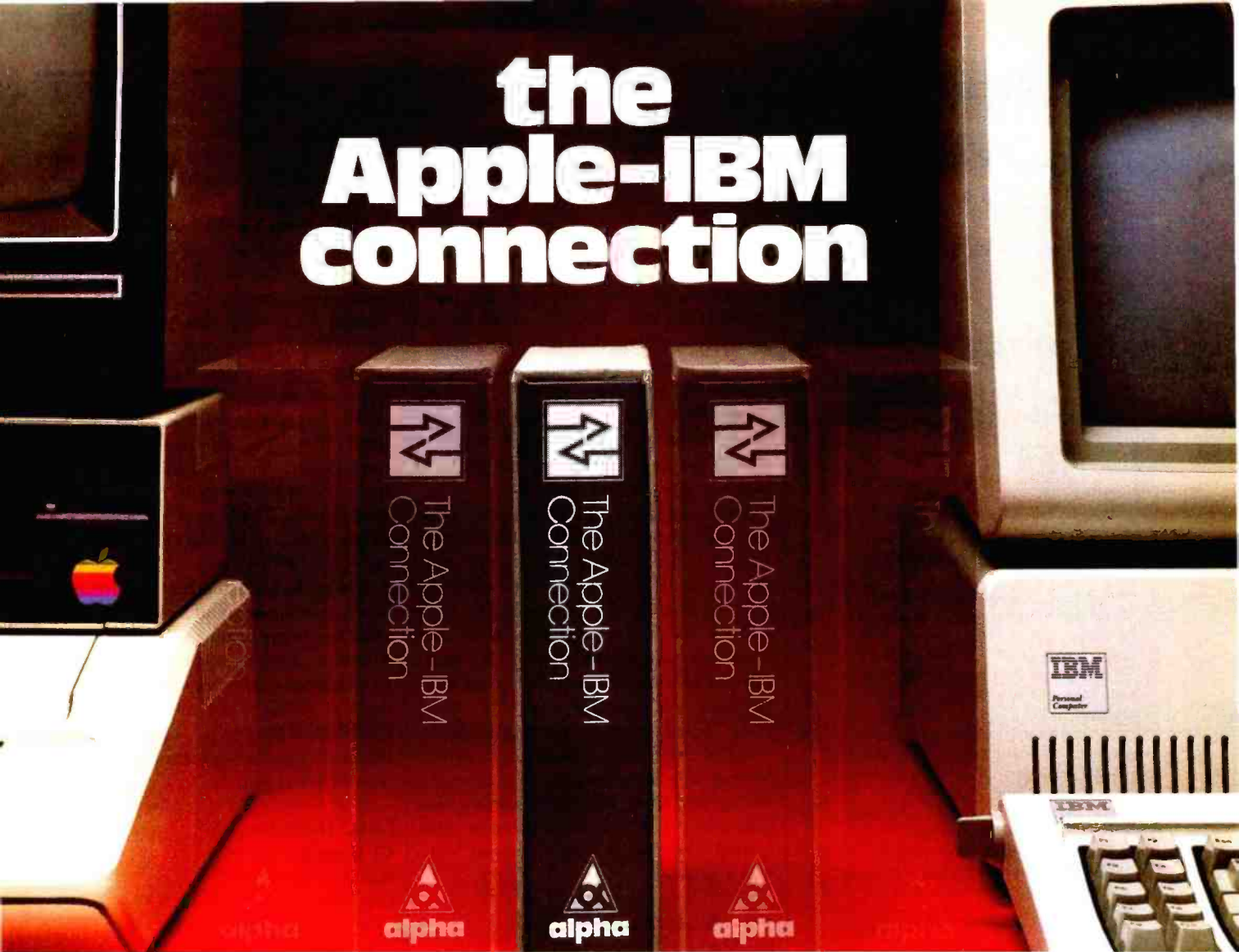

Transfers any file back and forth!

Increase **VisiCalc** and **Wordstar** power by transferring files from the **Apple II** to the **IBM Personal Computer**—with **no retyping and no errors!**

CONNECT Apples to IBMs, Apples to Apples, or IBMs to IBMs. Transfer information from **any** file thousands of miles—in minutes.

UPGRADE your 64K Apple VisiCalc to 256K IBM VisiCalc power. Your worksheets can be larger.

INCREASE your Apple Wordstar 130K floppy capacity to IBM DOS Wordstar 320K floppy capacity. Over twice the space on disk.

CONTROL communication from either side in either direction with **Master/Slave** operation.

COMMUNICATE with people using the **Electronic Mail** mode. The Apple-IBM Connection can be used to send messages to Apples or IBMs.

Designed for the non-technical user, the Apple-IBM Connection comes with a disk for the Apple and a disk for the IBM. Connect the two computers with a cable or a telephone modem and insert the disks.

Turn on the computers and the software does all the work, asking you for the name of the file being transferred, the transfer speed, and the type of connection you are using.

Less than one minute after powering up, the transfer starts. The software checks to make sure that no errors occur during transmission.

Alpha Products for the IBM Personal Computer

All Alpha products come with **spoken instructions**. Alpha Software—professional, innovative, and easy to use.

Data Base Manager **Type Faces**
Question **Mailing List**

Call us for participating Computerlands and other dealers at (617) 229-2924.



REQUIREMENTS

Apple II—1 Disk, 64K Memory. D.C. Hayes Micro-modem II or Mountain Hardware CPS Card.

IBM P.C.—1 Disk, 96K (Compiled Version) or 64K (BASIC Version). Any RS-232 Card.

Circle 26 on Inquiry card.

 **alpha**
SOFTWARE CORP

12 NEW ENGLAND EXECUTIVE PARK BURLINGTON, MASS. 01803

Apple is a trademark of Apple Computer Company. IBM is a trademark of International Business Machines Corp. VisiCalc is a trademark of VisiCorp. Wordstar is a trademark of MicroPro Corp.

www.americanradiohistory.com

**AVAILABLE
TODAY!**

\$195.00

INTELLIGENT PRINTER INTERFACE

Free Your Computer from the
Mundane Task of Printing



Imagine being able to use your computer seconds after beginning an extensive printout.

Visualize your printout with page breaks, page numbering and titles, margins of your choice, indented carryover lines, on any size paper!

Appreciate the time and money you will save by not waiting for your printer.

SooperSpooler, a buffered printer interface, maintains control over your printer while you go on using your computer for more productive activities. Eliminate waiting while your printer pecks through a long document. SooperSpooler accepts information from your computer at up to 3000 characters per second and feeds it to your printer as fast as it can handle it—without using any of your computer's memory or time!

SooperSpooler features include:

- 16K Memory (62K optional)
- Buffer Status Readout
- Space Compression
- Pagination
- Single Sheets
- Headers and Page Numbering
- Indentation on Carryover Lines
- Self Test Routine
- Features also Software Controllable
- Plugs into Most Computer Systems
- ★ 16K Parallel I/O Unit—\$349.00!
- ★ Serial I/O Option—\$95.00
- ★ 46K Memory Option—\$159.00

**SooperSpooler by Compulink—
The missing link that gives your
microcomputer mainframe printing.**

COMPULINK CORPORATION

1840 Industrial Circle
Longmont, CO 80501 (303) 651-2014

Send for brochure
Dealer inquiries welcome
Call for information: 800-525-6705

Letters

for it: RT-11, RSX-11M, RSTS, and Unix. For various tasks and under different conditions, any one may be the better choice. On a single machine, I have, at various times, used RT-11 to run diagnostics, RSX-11M to run a statistical package that required it, and Unix for all in-house daily processing. If I ever encountered a package that ran under RSTS, I would be glad to try to accommodate that system too.

As a matter of interest, my machine can handle one user under RT-11, about four under RSX-11M, and about ten under Unix. Because CP/M is a near double of RT-11 for 8-bit machines, the folly of direct comparisons is obvious.

If you let them, operating systems can become religions instead of tools to get your job done. More than enough religious fanatics are battling in the world today; we don't need a holy war over Unix and CP/M. If you are happy with your operating system, that is fine. But don't blind yourself to the fact that some tasks (perhaps even yours) might be much easier to perform in another environment. It is one thing to be locked into a system because of a large investment in time and money and quite another to use the fact that *you are locked in* to promote antiquated and low-powered systems onto new machines.

Tom Slezak, Computer Scientist
Bio-Medical Sciences Division
Lawrence Livermore National
Laboratory
POB 808 L-452
Livermore, CA 94550

Bug In FORTRAN-80 Goes Uncorrected

I have been putting Microsoft FORTRAN-80 to quite heavy use for more than four years and have been very satisfied with its general performance. Because Microsoft is regarded as a leader in microcomputer software, one might expect it to have a reasonable approach to handling bug reports. It does not, as the following example illustrates.

About three years ago, a bug appeared in FORTRAN-80 in which it failed to correctly repeat group format specifications. (For those interested in the specifics, FORTRAN-80 will not correctly perform the READ on page 153 of Harry Katzan Jr.'s FORTRAN 77 [New York: Van Nostrand Reinhold, 1978]. The structure

is common to both '66 and '77 FORTRAN.) I reported the bug at that time, and Microsoft acknowledged its presence. When I bought the next update, the bug had not been fixed. I reported it again, this time being assured that no one had reported it before (I had reported it previously, myself!). Again, when I bought the next update, the bug was still there.

After three years and several more repeats of the above, I sent a certified letter to the president of Microsoft that outlined my experience to him and asked him for a clear statement of Microsoft's intentions. What I got was an endorsement of the following: "Microsoft has no intention of fixing the bug in FORTRAN-80 regarding FORMAT re-use."

Having been in the business for many years, I can understand a certain degree of aloofness when dealing with the user, but Microsoft advertises FORTRAN-80 to be in compliance with the "full ANSI Standard FORTRAN X3.9-1966 except the COMPLEX data type." It is not, and Microsoft has known for some three years now that it is not.

David Dunthorn
CF Systems
908 West Outer Dr.
Oak Ridge, TN 37830

IBM FORTRAN's Quality Questioned

Caveat emptor: IBM Personal Computer FORTRAN "... is provided 'as is' without warranty of any kind... including... implied warranties of merchantability and fitness for a particular purpose. The entire risk as to the quality and performance of the program is with you." The quotation is from the IBM Program License Agreement.

Why worry? The compiler was developed by Microsoft and is supported by IBM. With names like that behind the product, it must be pretty good... right?

Wrong. During my evaluation, I encountered one problem after another, ranging from disappointing omissions to outright bugs. In my opinion, this product is fundamentally unusable.

I didn't expect it to be perfect. I have worked with at least 15 different FORTRAN compilers during my career, and none of them has ever been perfect. But consider what I found.



Strobe brings professional computer graphics down to earth

Picture an Apple II Computer, an Apple Graphics Tablet or Symtec Light Pen, a Strobe 100 Plotter, and Stoneware Graphics Processing Software. With this new low-cost system, you can now create professional level graphics in an extraordinary variety of formats.

Applications from CAD to pie charts

This powerful but easy-to-use system produces isometric drawings for architectural renderings with the same high precision as it does engineering drawings and personal artwork. The resulting multicolor, high-resolution graphics have truly unlimited applications for architects, engineers, scientists, interior designers, art directors, teachers and all business applications.

Images can be accurately drawn to scale, altered in proportion both vertically and horizontally, and automatically enlarged or reduced to scale. Portions of the image may be modified or erased without starting over from scratch and any portion may be enlarged 4 or 16 times for greater detail and resolution. Images may be rotated to any new position up to a full 360 degrees.

The system easily handles text for captions and titles and produces large, decorative characters for special emphasis and clarity. The Strobe 100 Plotter brings all this to your next meeting, your next presentation, or your next class—directly on your choice of transparency film or paper.

Strobe, Inc.—Your Single Source

Call or visit Strobe today to learn more about the capabilities of this remarkable new system. In minutes you will see how professional-level computer graphics have been brought down to earth at a very affordable price.



Apple II and Apple Graphics Tablet are trademarks of Apple Computer, Inc. Stoneware Professional Graphics Processing System and Symtec Light Pen are trademarks of Stoneware Corporation and Symtec, Inc., respectively.



Strobe Inc.
897-5A Independence Avenue
Mountain View, CA 94043
Telephone 415/969-5130

The Strobe Graphics System

Seeing is believing

**ARE YOU STILL
PRINTING
WITHOUT USING
A MICROBUFFER?**

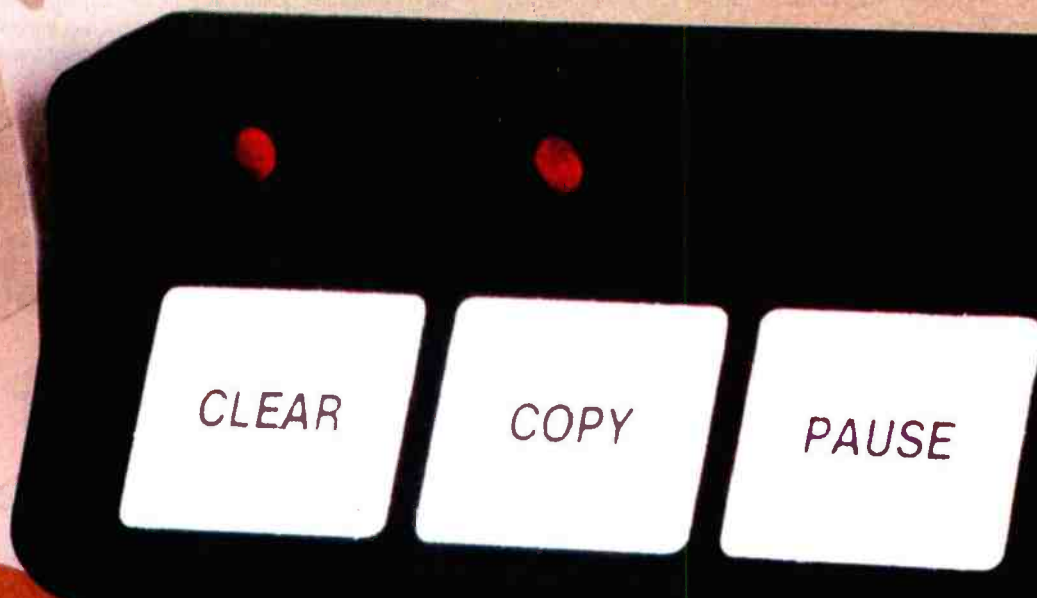

WHY?

USING YOUR COMPUTER TO DRIVE YOUR PRINTER IS A WASTE OF TIME.

While your printer is running, your computer is tied up. All you can do is twiddle your thumbs until the program is finished.

MICROBUFFER ALLOWS YOU TO PRINT AND PROCESS SIMULTANEOUSLY.

You just dump your printing data directly to Microbuffer, whoosh!, and continue processing.

Microbuffer accepts data as fast as your computer can send it. It first stores the data in its own memory buffer, then takes control of your printer.

It's that easy.

THERE IS A MICROBUFFER FOR ANY COMPUTER/PRINTER COMBINATION.

Microbuffers are available in Centronics-compatible parallel or RS-232C serial versions.

FOR APPLE II COMPUTERS, Microbuffer II features on-board firmware for text formatting and advanced graphics dump routines. Both serial and parallel versions have very low power consumption. Special functions include Basic listing formatter, self-test, buffer zap, and transparent and maintain modes. The 16K model is priced at \$259 and the 32K, at \$299.

FOR EPSON PRINTERS, Microbuffer is \$159 in either an 8K serial or a 16K parallel version. The serial buffer supports both hardware handshaking and XON-XOFF software handshaking at baud rates up to 19,200. Both interfaces are compatible with Epson commands including Graftrax-80 and Graftrax-80+.

ALL OTHER COMPUTER/PRINTER COMBINATIONS are served by the in-line, stand-alone Microbuffers. (Pictured here, twice actual size.)

Both serial and parallel versions are expandable up to 256K.

The serial stand-alone will support different input and output baud rates and handshake protocol. The 32K model starts at \$299, \$349 for 64K, and 64K add-ons (for up to a total of 256K) are just \$179.

SIMPLE TO INSTALL.

Microbuffer II is slot-independent. It will fit directly inside the Apple II in any slot except zero.

Microbuffer for your Epson mounts easily in the existing auxiliary slot directly inside the Epson printer.

The stand-alone Microbuffer is installed in-line between virtually any printer and any computer.

MICROBUFFER FROM PRACTICAL PERIPHERALS.

When you think of how much time Microbuffer will save, can you afford to *not* have one?

PRACTICAL PERIPHERALS, INC.™
31245 LA BAYA DRIVE
WESTLAKE VILLAGE, CA 91362
(213) 991-8200

Circle 378 on Inquiry card.



POWER



MICROBUFFER

What if you're having to clean floppy drive heads too often?



Ask for SYNCOM diskettes, with burnished Ectype® coating and dust-absorbing jacket liners.

As your floppy drive writes or reads, a Syncom diskette is working four ways to keep loose particles and dust from causing soft errors, dropouts.

Cleaning agents on the burnished surface of the Ectype® coating actually remove build-up from the head, while lubricating it at the same time.

A carbon additive drains away static electricity before it can attract dust or lint.

Strong binders hold the signal-carrying oxides tightly within the coating.

And the non-woven jacket liner,

more than just wiping the surface, provides thousands of tiny pockets to keep what it collects.



- Liner collects and "pockets" loose particles
- Tightly bonded milled ferrous oxides
- Head-cleaning and anti-static agents

To see which Syncom diskette will replace the ones you're using now, send for our free "Flexi-Finder" selection guide and the name of the supplier nearest you.

Syncom, Box 130,
Mitchell, SD 57301.
800-843-9862; 605-996-8200.

SYNCOM

Manufacturer of a full line of flexible media

Letters

Suppose you declare a character variable CHARACTER *64 LINE and then READ into LINE with a simple "A" format. If you do not supply 64 characters of input, the program terminates with fatal error number 1252: "Not enough input to satisfy IOlist. . ." This means you have to type the trailing blanks when entering input from the keyboard. It also means that you can't write a program to read a text file one line at a time. The I/O package does not provide the trailing blanks that conventional compilers do.

Now suppose, to compensate for this problem, you add error detection and recovery logic to your program using a READ statement of the form READ(*,10,ERR=50) LINE. The first time you enter a line which is too short, the program transfers to the specified error statement (50). However, the system can't seem to forget that it detected an error, so every subsequent attempt to READ results in an immediate transfer back to the error statement without reading a thing!

Well, instead of using a formatted READ, how about using a "list directed" (sometimes called "free format") READ? Sorry to say, that feature is not provided. The IBM Personal Computer FORTRAN conforms only to the Subset FORTRAN 77 standard, and the subset does not include list-directed I/O. Never mind the fact that this is a personal computer language that will most often be used interactively . . . you still have to count your spaces!

The ANSI (American National Standards Institute) standard for FORTRAN notes that the subset language is intended to make a minimum demand on storage requirements, particularly during execution. Implementing only the subset sure didn't minimize the size of this version. You have to have 128K bytes to run the compiler. Even at that, it requires two floppy disks to hold the compiler and a third one to hold the linker and library.

Memory used during execution is just as bad. A 12-line program with no arrays that does nothing more than READ from the keyboard and WRITE to the display requires 32,655 bytes of memory. (For comparison, I ran the same program on a Digital Equipment Corporation PDP-11/70 under RSTS/E and F77—a full implementation of the language—and it required only 18,048 bytes.) Add to this the 12K bytes of DOS and you find that it takes more than 44K of memory to run a trivial program. The executable file on

THE BEST PRICED 256K RAM CARD ONLY HAS 64K.

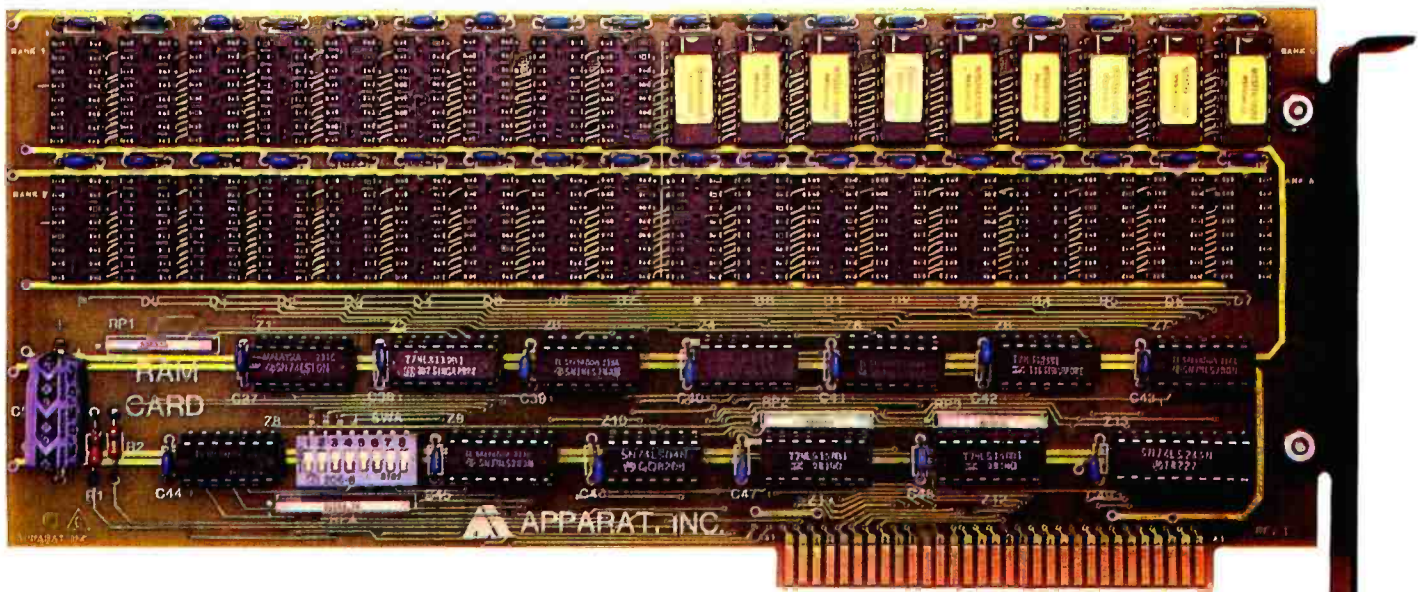

BUT YOU CAN GET ANOTHER 192K ANY TIME.

Apparat's RAM card, priced at **\$149**, is the most economical way to add memory to your IBM PC today. And have the ability to add-on tomorrow.

The RAM card, with sockets for up to 256K bytes of RAM, and parity, gives you an additional 64K of RAM for your IBM for a total of 128K. As the price of RAM chips



comes down further or your needs go up, you can add to it easily. Additional RAM is available today at \$79 per 64K increments if you need it now. If not, wait and buy it in the future. Either way, your RAM

card is fully warranted for 1 year. Add Apparat's COMBO card to the RAM card and get three additional functions; parallel printer, RS232 async communications and clock/calendar for only \$199.

Apparat's 64K RAM card gives you memory and economy. To order yours, write Apparat, Inc., 4401 S. Tamarac Parkway, Denver, Colorado 80237, 303/741-1778. Or to speed up your order, call us toll free at

800/525-7674

IBM PC is a trademark of IBM



 **Apparat, Inc.**

Circle 35 on Inquiry card.

disk (which you must create) is 35,200 bytes long—more than 20 percent of the capacity of a single-sided disk.

The memory usage is due to a large (apparently monolithic) run-time library. So what do you get with the library? It's hard to tell: the library's contents are not documented. It appears that you get standard FORTRAN intrinsic functions and I/O support and nothing else. No mention is made of the library routines to get the date or time, or to control cursor position and video attributes such as color and intensity; you have to write your own in assembly language. And no tools are provided for library maintenance. For example, there is no way to build a single library consisting of both FORTRAN and assembly-language subroutines.

What about speed? This is a compiler that produces machine language that is optimized for the 8088 processor. If you avoid the use of library subroutines, you can achieve speeds up to 4 times faster than a similar program using interpreted BASIC. But the mathematical library is terribly slow. A program that sums the

square roots of the numbers from 1 to 1000 takes 38 seconds using this FORTRAN; the same process using interpreted BASIC takes only 11 seconds! Incredible . . . the people who wrote the FORTRAN math library apparently didn't take advantage of the much faster routines already in read-only memory for BASIC.

The list goes on, but you should see the light by now. My advice to anyone considering the purchase of a FORTRAN compiler for the IBM Personal Computer is simple: don't buy version 1.00 of this product.

T. M. Putnam
157 Ivy Hill Dr.
West Lafayette, IN 47906

User's Column Fan

Like Karim Alim, we too have enjoyed Jerry Pournelle's User's Column. (See "What's the Story, Jerry?", August 1982 BYTE, page 30.) Perhaps because we also read Dr. Pournelle's science fiction, we

are not surprised to learn that he is on speaking terms with Arthur C. Clarke, Larry Niven, and Isaac Asimov. In any field, top professionals tend to know each other.

Jerry Pournelle uses his equipment professionally. Therefore, he can justify owning more of it than I can. Because of this, and because he knows people in the field, he can risk trying it out sooner than I can. Good. When I am ready to buy more equipment, I will review his experiences. And if in the meantime, he's told Bill Godbout his troubles, what I get may be all the better.

As a result of Jerry's reviews, we have picked up Ashton-Tate's dBase II and Oasis Systems' The Word and have been very pleased with them. If Jerry has written software that scratches an itch we share with him, we are willing to pay him for it.

We also had a systems engineer guide us in our selection of components for our system. The result is an S-100 system that has run for nearly two years with a minimum of problems. The engineer has been working with Compupro equipment for some time now. He says that the Godbout people have been most responsive to his questions and complaints. In fact, he would love to upgrade our system with all Godbout boards.

Maybe very few people can duplicate all of what Jerry Pournelle is doing with computers, but there are a lot of us who aspire to some of it.

Laura H. Wise
611 Fourth Place SW
Washington, DC 20024

Seeing Double

The August 1982 BYTE illustrated the latest application for publishers: the "Article Generator." What a delightful sense of irony BYTE has, using it to generate identical articles on the subject of program generators in both BYTE (see George Stewart's "Program Generator," page 38) and the September issue of *Popular Computing* (see page 112).

Charles H. Porter
14226 95th Ave. NE
Bothell, WA 98011

Several readers, Mr. Porter included, wrote to complain about our simultaneous publication of George Stewart's arti-

BYTEWRITER®

DAISY WHEEL
PRINTER



\$795
plus shipping

FEATURES

- Typewriter operation with nothing to disconnect • 10, 12 or 15 characters per inch switch selectable • Portable with carrying case • Entire interface mounted internally in the Olivetti Praxis 30 typewriter • Underlining • Cables available for most computers • Service from Olivetti dealers • Centronics compatible parallel input • Built in self test • Carriage ribbon • 2nd keyboard switch selectable.

BYTEWRITER

125 NORTHVIEW RD., ITHACA, N.Y. 14850
(607) 272-1132

CompuStar™



CompuStar's 255-User Controller
shown with a 96MB Disk Storage System.

The Best Made Better

When we unveiled our CompuStar™ multi-user terminal system just over a year ago, we thought we had created the most powerful, lowest-priced multi-user computer we would ever manufacture. We were wrong. Today, we've made our best even better!

Our newly redesigned CompuStar™ boasts the same performance statistics that made its predecessor such an overnight success, plus a host of exciting *new* features. CompuStar users now get the added benefits of dual character set capability, an expanded library of visual attributes including reverse video, underlining and below-the-line descenders, an enhanced disk operating system and Microsoft® BASIC — all at no extra cost! And single-user systems now start at as little as \$2995.

There are four types of CompuStar™ workstations (called Video Processing Units or VPU's) that can be connected into a variety of central disk systems with 10 to 96 megabytes of multi-user storage.

Up to 255 VPU's can be tied together to form a massive multi-user network. Or, you can start with only a single VPU and easily expand your system as your processing needs become more sophisticated. But whether you start with one or one-hundred VPU's, you'll probably never outgrow your CompuStar. Unlike other systems, you configure the CompuStar the way *you* want it . . . connecting any combination of VPU's in a "daisy chain" fashion into the central disk system. And since each VPU has its own twin Z80 processors, its own CP/M® operating system and a full 64K of internal memory, (not to mention disk capacities of up to 1½ million bytes), overall system response time remains unbelievably fast! And that's a claim most of the other multi-user vendors just can't make.

Inside our new CompuStar you'll find a level of design sophistication that's destined to establish a new standard for the industry. A series of easy-to-service modular components has been

engineered to yield the most impressive reliability figures we've ever seen. But CompuStar users are not only thrilled with our system's performance (and the miserly few dollars they spent to get it), they also have the peace of mind of knowing that Intertec's comprehensive customer protection and field service programs will insure their total after-the-sale satisfaction.

For more information on what just may be the last multi-user microcomputer you'll ever (have to) buy, ask your dealer today about our all new CompuStar™ system. Or, contact us at the number and address below. We'll gladly explain how we've made our best . . . even better!



2300 Broad River Rd. Columbia, SC 29210
(803) 798-9100 TWX: 810-666-2115

Circle 246 on inquiry card.

®Microsoft is a trademark of Microsoft Corporation. ®Registered trademark of Digital Research.

**Rana's disk drive was
twice as good as Apple's
with one head.**

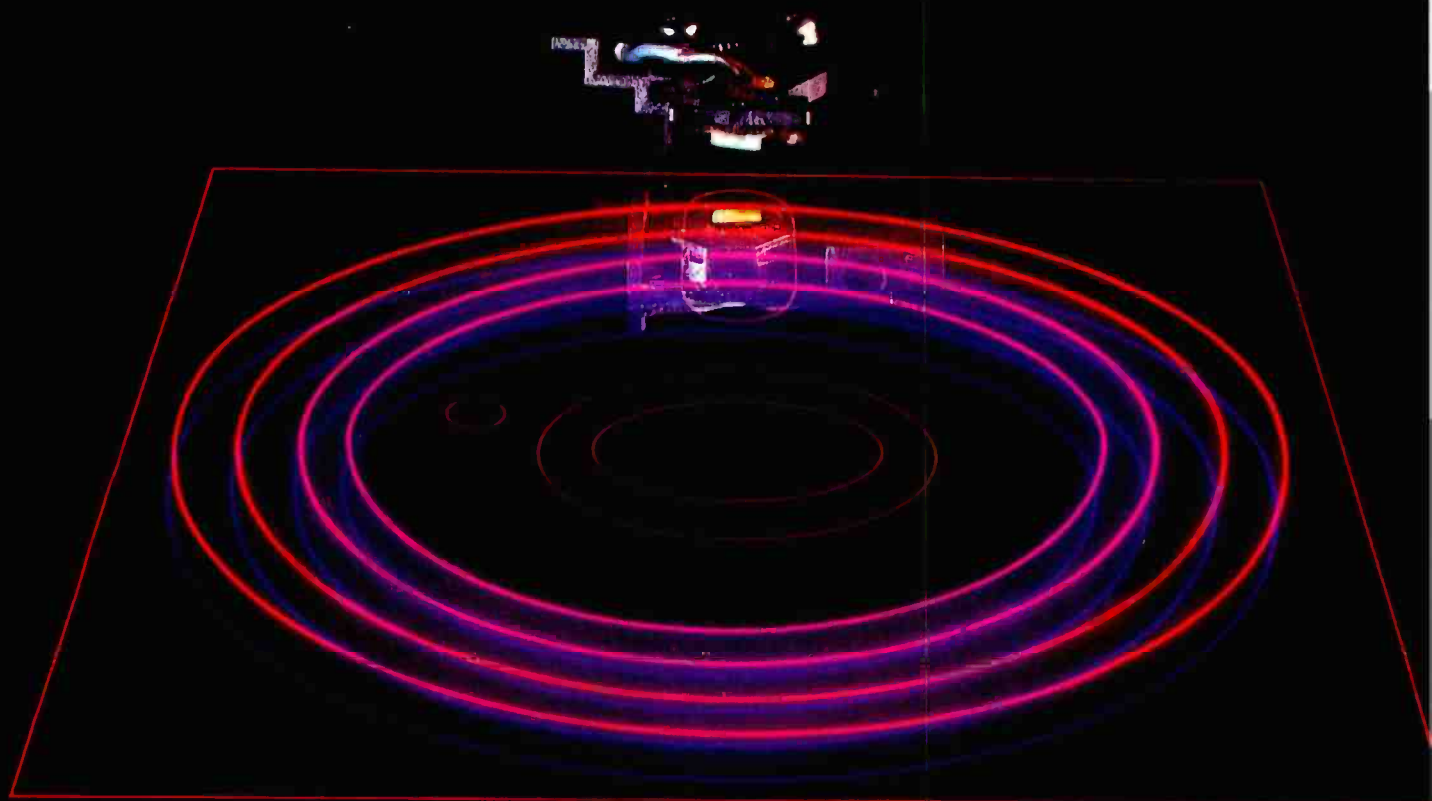

Now we have two.

We added another head so you won't have to buy another disk.

That's the beauty of a double sided head. A floppy disk which allows you to read and write on both sides. For more storage, for more information, for keeping larger records, and for improved performance of your system.

That's what our new Elite Two and Elite Three offers. It's the first double headed Apple® compatible disk drive in the industry. And of course, the technology is from Rana. We're the company who gave you 163K bytes of storage with our Elite One, a 14% increase over Apple's. And now with our high tech double sided heads, our Elite Two and Three offers you two to four times more storage than Apple's. That's really taking a byte out of the competition.

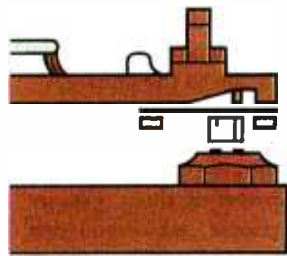

Rana's double sided heads give Apple II superior disk performance power than second generation personal computers such as IBM's.



They've come to expect it from us. Because Rana has always been a leader. We were the first with a write protect feature, increased capacity,

We put our heads together to give you a superior disk drive.

We designed the Elite Three to give you near hard disk capacity, with all the advantages of a minifloppy system. The double sided head operates on 80 tracks per side, giving you a capacity of 652K bytes. It would take 4½ Apples to give you that. And cost you three times our Elite Three's reasonable \$849 pricetag.

It takes 4½ Apples to equal the capacity of our superior Elite Three.

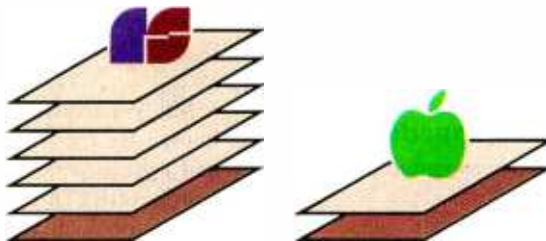

Your word processor stores 5 times as many pages of text on an Elite Three diskette as the cost ineffective Apple.

and accurate head positioning. A first with attractive styling, faster access time, and the convenience of storing a lot more pages on far fewer diskettes. We were first to bring high technology to a higher level of quality.

So ask for an Elite One, Two, or Three. Because when it comes to disk drives, nobody uses their head like Rana.

The Elite Two offers an impressive 326K bytes and 40 tracks on each side. This drive is making a real hit with users who need extra storage, but don't require top-of-the-line capacity. Costwise, it takes 2½ Apple drives to equal the performance of our Elite Two. And twice as many diskettes. Leave it to Rana to produce the most cost efficient disk drive in the world.

We've always had the guts to be a leader.

Our double sided head may be an industry first for Apple computers, but nobody was surprised.

RanaSystems



20620 South Leapwood Avenue, Carson, CA 90746 213-538-2353. For dealer information call toll free: 1-800-421-2207. In California only call: 1-800-262-1221. Source Number: TCT-654

Circle 401 on inquiry card.

Available at all participating Computerland stores and other fine computer dealers. See us at the Comdex Show, Booth 685.

© Apple is a registered trademark of Apple Computer, Inc.



If you use a Word Processor, you need

GRAMMATIK™

Beyond Spelling Checking

Grammatik can find **over 15 different** kinds of common errors missed by simple spelling checkers alone, including punctuation and capitalization errors, overworked and wordy phrases, and many others. Use Grammatik with Aspen Software's spelling checker Proofreader, featuring the Random House Dictionary®, or with your current spelling checker for a complete document proofreading system.

Read what the experts say:

"The perfect complement to a spelling checker."

Alan Miller, Interface Age, 5/82

"A surprisingly fast and easy tool for analyzing writing style and punctuation."

Bob Loudon, InfoWorld, 12/81

"Anyone involved with word processing in any way is encouraged to get this excellent program."

A.A. Wicks, Computronics, 6/82

"A dynamic tool for comprehensive editing beyond spelling corrections."

Dona Z. Meilach, Interface Age, 5/82

"A worthy and useful addition to your word processing software."

Stephen Kimmel, Creative Computing, 6/82

Works with CP/M®, IBM-PC®, TRS-80®

**Grammatik \$75.00
Proofreader \$50.00**

Order directly from Aspen Software, or see your local dealer. Specify your computer system configuration when ordering! Visa, Mastercard accepted.

Random House is a registered trademark of Random House, Inc. Other registered trademarks: CP/M: Digital Research -- TRS-80: Tandy Corp. -- IBM: IBM -- Proofreader, Grammatik: Aspen Software Co.

Aspen Software Co.

P.O. Box 339-B Tijeras, NM 87059
(505) 281-1634



Letters

cle, "Program Generators" in BYTE and Popular Computing. It was done intentionally. We reprinted the article in Popular Computing because George had done such an excellent job of reporting on program generators that we wanted to get the word out to Popular Computing's readers, too. . . . C. M.

The Power of Print Strikes Again

The July 1982 BYTE contained an excellent review of Joseph Weizenbaum's book *Computer Power and Human Reason* (page 402).

More than three years ago, I saw this book in a store and passed it by after looking at a few pages. But Nancy Robertson's review prompted me to buy it and read it from cover to cover. I learned a lot.

Mr. Weizenbaum has put wisdom and knowledge together in a field where hype and pseudoscience dominate. If the editors of BYTE could do an entire issue on this book, it would be a great public service.

John B. Palmer
POB 23
Boonville, CA 95415

Setting the Record Straight

We were dismayed by the inaccuracies contained in an advertisement that appeared in the August 1982 BYTE and by the false impressions it may have left among readers. The advertised product was I-Protect, a shield which purports to protect VDT (video-display terminal) operators from "the equivalent of a chest X-ray every 12 days." To support the erroneous claim that VDT operators are exposed to significant X-ray emissions, and thus need such protection, the advertisement misinterprets VDT radiation studies that were performed by the FDA (Food and Drug Administration) and NIOSH (National Institute for Occupational Safety and Health).

For the sake of readers who may have been misled by the advertisement, let us set the record straight.

Measurements performed under normal VDT operating conditions by the FDA and NIOSH have *never* shown X-ray emissions significantly above the natural background radiation to which we are all

exposed. In order for our laboratories to produce any higher levels of X-radiation, they had to resort to extreme conditions, including maximum misadjustments of both user and service controls, excessive line voltages, and intentionally induced component failure—conditions which in some cases led to illegible video displays and permanent damage to the units.

Based on our measurements of ionizing and nonionizing radiation, we do not believe that VDTs should pose a radiation risk to those who operate them. We are concerned that people who read the I-Protect advertisement may have been led to believe otherwise.

John C. Villforth, Director
Bureau of Radiological Health
Department of Health & Human Services
Food and Drug Administration
Rockville, MD 20857

Pournelle Taken to Task

In Jerry Pournelle's July 1982 BYTE User's Column, he discusses what he terms overpriced documentation. (See "Ada, MINCE, CP/M Utilities, Overpriced Documentation, and Analiza II," page 290.) It is common knowledge that most of the hardware and software documentation allied to currently available microcomputer products is of a depressingly low standard. Few suppliers seem to appreciate that the majority of end-users have nowhere near enough knowledge to make immediate and confident use of their hard-copy guides and manuals. It is unfortunate that documentation continues to be viewed by many machine and program producers as an evil necessity, and one can only hope that an increasingly competitive marketplace will result in higher overall standards.

However, I must take Jerry Pournelle to task over his comments on the cost of documentation. Actual printing costs comprise a very small proportion of the total cost of writing, editing, typesetting, reproducing, packaging, and distributing hard-copy publications. Assuming that the cost of employing qualified staff to write technical copy together with the appropriate overheads is included in the price of the software (and this is not always the case), the following considerations pertain:

1. Processing an order. This includes postage, packing, subsequent dispatch,

MORE BYTES PER DOLLAR*

It's true! The AVT-2 personal computer - fully Apple™ compatible - gives you more bytes per dollar than the market leader.

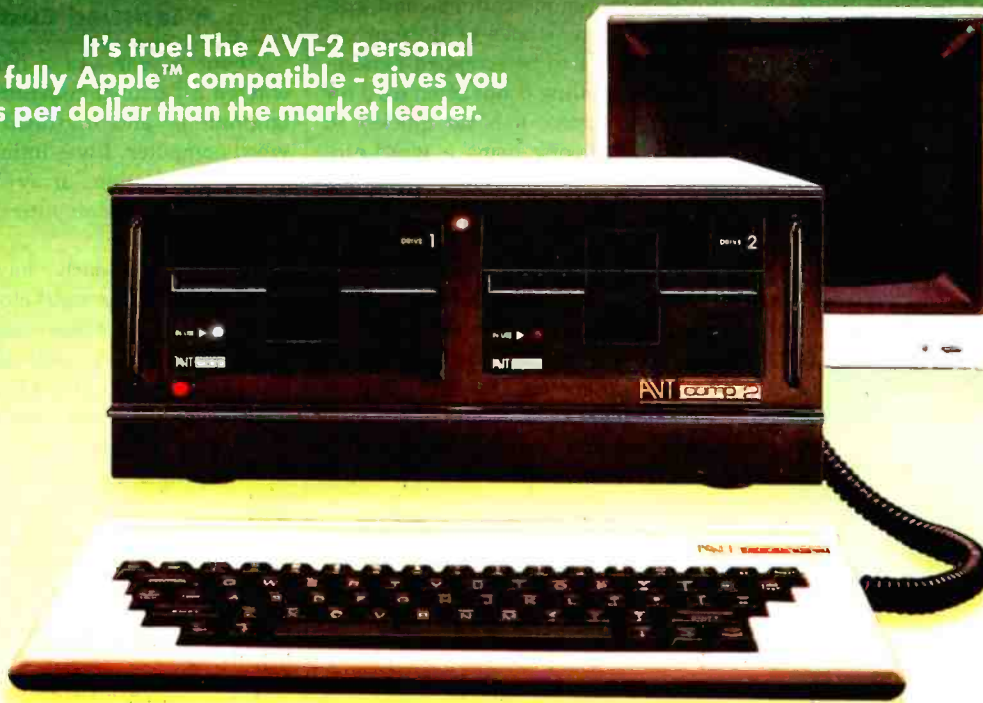

Check the Specs . . .

- Basic 64 K byte RAM memory upward expandable in 256 K byte cards to a maximum of four cards giving 1 M byte potential.
- 6502 Central microprocessor.
- 16 K byte ROM memory.
- EPROM-resident software.
- Composite B/W video output.
- Optional board generator for PAL, NTSC or RGB color signal.
- 40 col. x 24 line character display in B/W or color system.
- B/W graphic display 280 x 192 or 280 x 160 with 4 text lines.
- 16 Color graphic display 40 x 48 or 40 x 40 with 4 text lines.
- 6 Color graphic display 280 x 192 or 280 x 160 with 4 text lines.
- Full-feature detached keyboard with 65 keys and cursor steering.
- Seven Apple™ compatible slots for plug-in peripherals.
- Additional slot for color generation card, or programmable CTR control card or light pen interface card or 80 char. x 24 line generation card.
- Double 5¼ inch floppy disk drives, optional.
- Cassette and utility strobe output.
- 4 Annunciator outputs.

* The AVT-2 has a basic 64 K memory compared to 48 K of standard Apple II™. To find out how much cheaper the AVT-2 is, write or telex for a personal quote: AVT Trading A.G., Chamerstrasse 50, CH 6300 Zug, Switzerland. Telex 865267 GSAG.

Apple and Apple II are trademarks of Apple Computer Inc.

Circle 52 on inquiry card.

AVT **comp 2**

ERG/68000 MINI-SYSTEMS

- Full IEEE 696/S100 compatibility

HARDWARE OPTIONS

- 8MHz or 10 MHz 68000 CPU
- Memory Management
- Multiple Port Intelligent I/O
- 64K STATIC RAM (70 nsec)
- 256K Dynamic RAM, with full parity (150 nsec)
- 8" D/D, D/S floppy disk drives
- 5MB-32MB hard disk drives
- Full DMA host adaptor
- 20MB tape streamer
- 10 to 20 slot backplane
- 30 amp power supply

SOFTWARE OPTIONS

- 68KFOR¹ systems language with MACRO assembler and META compiler
- Fast Floating Point package
- Motorola's MACSBUG
- IDRIS² operating system with C, PASCAL, FORTRAN 77, 68K-BASIC¹ compilers
- CP/M—68K³ O/S with C, Assembler, 68K-BASIC

Trademark ¹ERG, Inc.

²Whitesmiths ³Digital Research
30 day delivery
with valid Purchase Order
OEM prices available
For CPU, Integrated Card Sets
or Systems.



Empirical Research Group, Inc.
P.O. Box 1176
Milton, WA 98354
206-631-4855

Letters

- and, possibly, the preparation of an invoice, for which a realistic commercial charge would be between \$5 and \$20.
2. Stocking and storing. To avoid delays in servicing an order, a busy organization will have to print a substantial number of documents and store them at some cost.
 3. Revision and amendment. The nature of products related to computing implies frequent changes due to improvements, modifications, and corrections. Thus, stocks of documentation will have to be scrapped periodically. Typesetting is not often used for reasons of speed; it is far quicker to modify hard copy using a word-processor that can look very professional when litho-printed.

Let us hope that the technology in which we are so interested and which causes us to read *BYTE* will overcome, through the advent of inexpensive digital typesetters, laser and ink-jet printing, FAX, and high-speed communications, some of these practical difficulties. Let us hope that the suppliers improve *their* communications!

C. J. Clifton, Head, Computer Products Design Engineering Software Centre
Engineering Sciences Data Unit Ltd.
251-259 Regent St.
London, W1R 7AD, England

Something Went Wrong

Jerry Pournelle's July 1982 *BYTE* User's Column contained two errors with regard to Digital Research products that I would like to correct. ("See Ada, MINCE, CP/M Utilities, Overpriced Documentation, and Analiza II," page 290.)

The article listed two different prices for Digital Research's symbolic instruction debugger SID: \$195 and \$295. Mr. Pournelle later commented that although it was an excellent product, the price was a bit high. The actual price of SID is only \$75.

The article also listed CP/M at \$180, when the actual price is \$150.

Also, our Japanese representatives, Microsoft Associates, have notified us that *BYTE* listed its old address, telephone, and Telex numbers in a recent article. The new location, telephone, and Telex number are:

Microsoft Associates
6th Floor A. Y. Building

3-2-2, Kitaayama, Minato-Ku
Tokyo 107, Japan
tel: 03-497-0381
Telex: 2427080

Patricia Lucas, Public Relations Manager
Digital Research
POB 579
Pacific Grove, CA 93950

A Satisfied Customer

About a year and a half ago, I first entered a personal computer store. I was ignorant of and mystified by the very word computer. I was intimidated by the seemingly nebulous array of the various brands of microcomputers, peripherals, and software.

But for previously having acquired shrewdness in the marketplace the hard way, I would have been easy prey for less scrupulous dealers and sales personnel. But I knew that I did not know enough to even begin to make intelligent choices about what, for me, is a major purchase—one with which I must live for a long, long time.

I approached the marketplace eager to learn everything I could about microcomputers. I avidly read various literature and *BYTE* magazine. I availed myself of the University of Minnesota's public service Microcomputer Helpline (call (612) DR MICRO). And I sought considerable clarification from numerous dealers.

In the marketplace, however, I experienced a number of possibly manipulative ploys: I was misled with incomplete information, I was intentionally misadvised, and (because I did not present the instant sale), perhaps the most irksome to me, I frequently experienced the cold shoulder from impatient or greedy sales personnel.

The manager and staff of only one computer store showed me the consistent patience and constant willingness to take the time to help educate me. They never misadvised me, nor have I ever felt manipulated by them. They have been customer-friendly even if this meant foregoing the sale of any item if a competitor's product was in my best interest. These days, that kind of ethics means more to me than money.

Perhaps, as was at issue in *BYTE* magazine several months ago, Computerland does ask somewhat more for products than some, especially mail-order competition. But if my very rewarding association

A Complete Graphics Department For Just \$1995



Realize day-in and day-out solid performance from a quiet and capable desktop plotter. It's true. For only \$1995* the Houston Instrument HIPLØT™ DMP-29 will provide you with world-class multi-color hard copy graphics, and deliver a level of quality and performance that you would expect in a plotter costing three times as much.

It's a hard worker. The DMP-29 goes about its job with amazing speed and precision. Unbeatable resolution and repeatability are yours in both 8½" x 11" and 11" x 17" formats, and 8-pen capability assures you of fast attention-free flexibility when multi-color output is required. High pen speed combined with an addressable resolution of 0.001" assures fast, accurate and stepless traces.

It's friendly. You can call 21 different functions directly from the front-panel membrane keyboard. It's tolerant too. The DMP-29 will modestly protect itself from user

errors, as when attempting to place a pen in an already occupied stall.

And it's smart. An extensive set of firmware routines makes life easier for the user. A small sampling of the built-in talent inherent in the DMP-29 includes character generation, circle, arc and ellipse synthesis, line type variations, viewport/windowing, clipping and scaling.

For more information on the hard working, friendly and smart DMP-29 plotter, contact Houston Instrument, P.O. Box 15720, Austin, Texas 78761. (512) 835-0900. For rush literature requests, outside Texas call toll free 1-800-531-5205. In Europe, contact Houston Instrument, Rochesterlaan 6, 8240 Gistel, Belgium. Telephone 059/27-74-45.

BAUSCH & LOMB

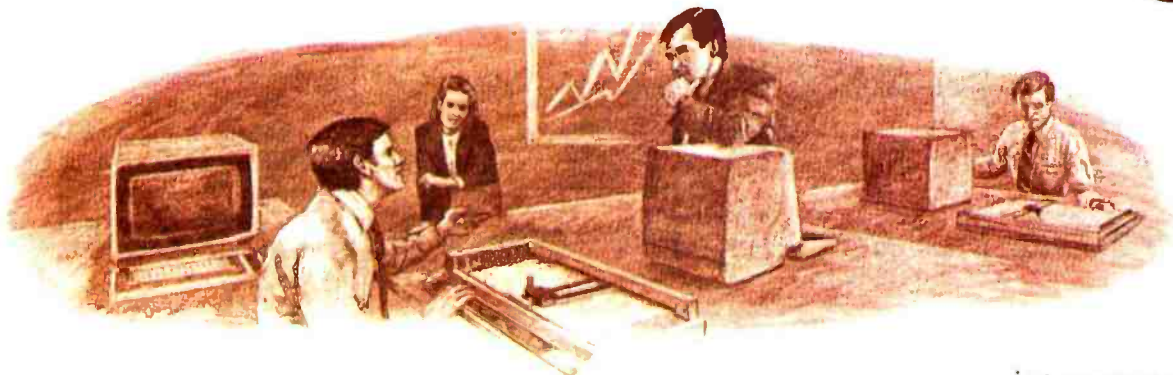

Circle 60 for literature.

Circle 61 to have representative call.

* U.S. Domestic price only
™ Trademark of Houston Instrument

4PO05

PRICE BREAKTHRU—

BULL!

IT'S A MIRACLE!!

TRS-80 Mod I and III hardware

16K RAM upgrade \$13.50

External Disk Drives inc. p.s. & enclosure**

40tk 1 side \$215.00
 40tk 2 sides \$295.00
 80tk 2 sides \$425.00

Signal extender cable for ext. drive \$12.50

2 drive expansion cable (Mod I or III) \$20.00

4 drive expansion cable (Mod I) \$25.00

Bare Drives—

40tk 1 side \$180.00
 40tk 2 sides \$245.00

Drive Service Manuals \$25.00

Single drive p.s. & enclosure \$49.95

Hard Disk (Winchester) for Mod I, LNW— Includes DOSPLUS 4.0

6.3 meg \$1649.00
 9.6 meg \$1849.00
 19 meg \$2449.00
 2 x 6.3 meg \$2449.00
 2 x 9.6 meg \$2849.00
 2 x 19 meg \$3949.00

Hard Disk 6.3 + 40tk floppy combination \$1995.00

Percom Doubler— \$149.00

LNW products

TRS-80 Mod III

16K L III Basic \$899.00
 16K upgrade \$13.50
 48K—1 disk \$1349.00
 48K—2 disk \$1549.00

2 sided disk upgrade \$70.00 ea

VR RS232C—upgrade \$70.00

Direct Connect 300 baud modem upgrade \$275.00

Hard Disk for Mod III—IBM-PC

6.3 meg \$1599.00
 9.6 meg \$1799.00
 19.0 meg \$2399.00
 2 x 6.3 \$2399.00
 2 x 9.6 \$2799.00
 2 x 19.0 \$3899.00

Coming Soon—Internal Hard Disk for Mod III

Floppy Disk III kits for Mod III include p.s. controller & cables

40tk—1 side \$440.00
 40tk—2 side \$510.00
 2nd—40tk 1 side \$190.00
 2nd—40tk 2 side \$250.00

**We use VR Data hardware upgrades exclusively They are the best around!

Printers—

C Itoh F-10 40CPS letter quality \$1399.00

C.Itoh F-10 55CPS letter quality \$1699.00

C.Itoh tractor for F10-40 \$200.00
 F10-55 \$225.00

Ribbons for above printers \$4.50 ea

Sheet feeder \$1300.00

C.Itoh Pro-writer parallel \$475.00
 serial \$575.00

Okidata 80 82A \$375.00
 83A \$479.00
 \$749.00

Okigraph \$65.00

NEC—7710 RS232 55 CPS \$2495.00
 NEC—7730 parallel \$2495.00
 NEC—7720 KSR \$2895.00

Vertical Tractors \$229.00

BiDirectional Tractors \$325.00

Sheet Feeder \$1175.00

Twin Feeder \$1595.00

Smith Corona—TP1 pitch 10/12 pitch—Serial/parallel interface

Super Deal \$595.00

Standard Cable \$25.00

Tabletop Printer stand—12" (holds up to 50 lbs.) \$17.95

Tabletop Printer stand—16" (holds up to 50 lbs.) \$24.95

Diskettes—10 per box

Verbatim—

5 1/4" SSDD \$23.95
 5 1/4" DSDD \$39.95

Maxell—5 1/4" \$34.95

Elephant by Leading Edge \$22.95

Disk head cleaners—VR Data (5 1/4") \$14.95
 Verbatim 5 1/4" or 8" \$29.95

5 1/4" plastic library case \$27.50

8" plastic library case \$27.50

Paper & Labels

9 1/2 x 11 Fanfold—2700 ct \$27.50

14 1/2 x 11 Fanfold—2700 ct \$35.00

3 1/2 x 5 1/2 labels—5M \$15.00

Modems

Hayes

Smartmodem \$229.00
 Micromodem II \$278.00
 Micromodem 100 \$305.00

Novation

Auto cat \$229.00
 D Cat \$165.00
 Cat \$155.00

4202B—1200 baud half duplex \$475.00

Apple Cat II \$339.00

Lexicon

Lex—II \$124.00

Monitors—

BMC 12" Mean Green \$89.00
 BMC 13" Composite Color \$325.00

Mod III software*

DOSPLUS 3.4 Mod I \$87.50
 DOSPLUS 3.4 Mod III \$87.50
 LDOS 5.1 Mod I, III \$117.50
 Micro Term (Best yet) \$75.00
 Super utility (Best yet) \$45.00

Micro Soft—

Adventure \$25.00
 Fortran-80 \$80.00
 A.L.D.S. \$80.00
 Basic Compiler \$159.00
 TRS-80 Mumath \$69.00

Hayden Software—

Sargon II \$32.00
 Blackjack master \$27.00
 Finplan \$69.00

Big Five Software

Super Nova \$17.00
 Attach Force \$17.00
 Cosmic Fighter \$17.00
 Meteor Mission II \$17.00
 Defense Command \$17.00
 Galaxy Invasion \$17.00
 Robot Attack \$17.00
 Stellar Escort \$17.00

Broderbund—

Galactic Trilogy \$35.00

Inc—Galactic Empire.
 Trader. Revolution—available separately \$17.00 ea

Acorn Software—

Gammon Challenger \$18.00

Pigskin \$17.00
 Tenpins \$18.00
 Invaders \$18.00
 Quad \$18.00
 Basketball \$18.00
 Duel-N-Droids \$18.00
 Astroball \$17.00
 Spacerocks \$17.00
 Everest Explorer \$17.00
 Elec. Handicapper \$80.00
 Basketball \$80.00

*All software listed is on disk—Cassettes may be available please inquire

Books—

TRS80 Disk & other mysteries \$15.95

Microsoft Basic Decoded \$20.00

The Custom TRS-80 Microsoft Basic faster & better \$20.00

The Custom Apple \$17.00

Letters

of the past is any measure, the staff at Computerland of Downtown Minneapolis is well worth the investment.

Larry E. Johnson
 Building 9, Room 225
 Minnesota Veterans Home
 Minnehaha Ave. and East 51st St.
 Minneapolis, MN 55417

Bug Fix

I use Wordstar with an IDS (Integral Data Systems) Prism 80 printer. Until recently, I could not print subscripts or superscripts. After many long-distance phone calls and letters to IDS, Micropro, and everyone else I could think of, I found the solution to be a simple matter of changing 8 bytes in Wordstar.

Specifically, to get superscript capability, you must change ROLUP: through ROLUP: +3 to 3, 1B, 19, and 19 (hexadecimal), respectively. To get subscript capability, you must change ROLDOW: through ROLDOW: +3 to 3, 1B, 14, and 14 (hexadecimal), respectively. I hope this information saves some readers the time and money I invested.

Leo J. Scanlon
 7708 East Allen Dr.
 Inverness, FL 32650

Shedding Light on Battery-Powered Displays

I read with interest Chris Morgan's editorial "The Briefcase Computer Market Heats Up" (July 1982 BYTE, page 6). On page 7, he states that "electroluminescent (EL) displays consume a lot of power—so much that they cannot be battery operated as can LCDs [liquid-crystal displays]."

EL-display technology is the most power-efficient of all the emitting technologies, except for CRTs (cathode-ray tubes). We at Aerojet have developed an EL display for a battery-operated portable terminal. This work has been under the sponsorship of the Army (ERADCOM). The display is being installed in the Digital Message Device terminal manufactured by Magnavox. The terminal will be evaluated in the U. S. Army's TACFIRE system.

LCDs are inherently the lowest power-consuming display technology ever conceived by man. However, they are not matrix-addressable in large panels of 320

Terms—COD or Prepaid Only
 F.O.B. Shipping Point
 (215) 461-5437

Prices Subject to Change Without Notice.
 TRS-80 Trademark of Tandy Corp.

DISK SUPPLY CO.

Suite 439 111 S. Olive St.
 Media, PA 19063

Check The Chart Before You Choose Your New 16-Bit Computer System.

**Columbia Data Products'
New Multi-Personal® Computer,
Featuring IBM-PC® Compatibility,
Excels In Professional, Business
And Industrial Applications.
Check it out.**

Columbia Data Products' MULTI-PERSONAL® COMPUTER can use software and hardware originally intended for the IBM® Personal Computer . . . while enjoying the flexibility and expandability of all Columbia Data's computer systems.

Available operating system software includes single-user MS-DOS® or CP/M 86® or multi-user, multi-tasking MP/M 86® or OASIS-16®, with XENIX® available soon, providing users with a host of compatible software packages for personal and professional business and industrial applications. A large selection of higher level languages are also available, including BASIC, FORTRAN, COBOL, PASCAL and MACRO Assembler.

Our standard 16-Bit 8088 hardware configuration provides 128K RAM with parity, two RS-232 serial ports, Centronics parallel printer port, interrupt and DMA controllers, dual floppy disks with 640K storage, Winchester disk and keyboard interfaces, and eight IBM-PC compatible expansion slots . . . and lists for only \$2995. Winchester hard disk configurations, featuring cache buffer controllers for enhanced disk access performance are also available, starting at \$4995.

So, when you need to grow, why gamble and hassle with independent third party hardware and operating system vendors which may or may not be compatible . . . not to mention the hidden expense and frustration of implementing peripheral drivers in the different operating systems and upgrades? Who needs the finger-pointing when things don't work out?

After you review our chart, you will agree . . . for overall 16-Bit microprocessor superiority, expandability, flexibility, compatibility and real economy, Columbia Data is your total source.

Our Multi-Personal Computer . . . the 16-Bit system born to grow!

Get yours now!

Circle 94 on inquiry card.



MAIN FEATURES	CDP-MPC	IBM-PC*	OTHERS
Microprocessor	16-Bit 8088 8-Bit Z-80 (Opt)	16-Bit 8088	?
USER Memory	128K-1 Mbytes	16K-256 Kbytes	?
IBM-PC Compatible Expansion Slots Beyond Professional Configuration ¹	8 Slots	0	?
Resident Floppy Disk Storage	Dual 320K (std)	Dual 160K (Opt) Dual 320K (Opt)	?
Resident Cache Buffer Hard Disk Storage	5M/10M	—	?
OPTIONAL OPERATING SYSTEMS (Supported by Company)²			
MS-DOS (PC-DOS)	Yes	Yes	?
CP/M 86	Yes	Yes	?
MP/M 86	Yes	—	?
OASIS-16	Yes	—	?
XENIX	Soon	—	?
OPTIONAL HARDWARE EXPANSION BOARD (Supported by Company)			
RS-232 Communications	Yes	Yes	?
B/W and Color Display Controller	Yes	Yes	?
Expansion Memory	Yes	Yes	?
Z-80 CP/M-80 Board	Yes	—	?
Cache Buffer Hard Disk	Yes	—	?
Time/Calendar Board	Yes	—	?
IEEE Bus Controller	Yes	—	?
8" Floppy Disk System	Yes	—	?
8" Hard Disk System	Up to 40 Mbytes	—	?
Tape Cartridge System	Yes	—	?

¹For comparison purposes, typical professional configurations consist of 16-Bit 8088 Processor, 128K RAM with Parity, Dual 320K 5-inch Floppies, DMA and Interrupt Controller, Dual RS-232 Serial-Ports Centronics Parallel Port and Dumb Computer Terminal or Equivalent.

²Columbia Data Products also supports CP/M 80* with an optionally available Z-80 CP/M Expansion Board.

*As advertised in BYTE Magazine, August 1982

COLUMBIA

DATA PRODUCTS, INC.

Home Office:
8990 Route 108
Columbia, MD 21045
Telephone 301-992-3400
TWX 710-862-1894

West Coast:
3901 MacArthur Blvd,
Suite 211
Newport Beach, CA 92653
Telephone 714-752-5245
Telex 277778

Europe:
P.O. Box 1418
450 Moenchengladbach 1
West Germany
Telephone 0216-33759
Telex 852452



IBM is the trademark of International Business Machines. CP/M and MP/M are trademarks of Digital Research. OASIS is the trademark of Phase One. MS-DOS and XENIX are trademarks of MICROSOFT.

columns by 192 rows or more. Additional power must be consumed to make them matrix-addressable, such as thermal addressing. When provided with thermal addressing, LCDs consume more power than EL displays.

Larry E. Tannas Jr., Engineering Manager
Thin Film Device Laboratory
Aerojet Electro Systems
1100 West Hollyvale St.
POB 296
Azusa, CA 91702

Actually, just about any electrical or electronic device can be run by batteries. The question is, would the batteries be too bulky for use with a portable computer? I've heard from a number of companies who are working on that very problem. Many thanks to Mr. Tannas and the other readers who noted that electroluminescent displays can indeed be run by batteries.
... C. M.

Sorry, Wrong Number

A pin number is incorrect in "MPI Disk Drives Meet IBM" in the September 1982

BYTE Letters (page 20). When following the procedure to use MPI B51 drives in the IBM Personal Computer, reference to pin 34 should be to pin 32, Side Select. Also, pins 7 and 8 (head load connecting to motor) can be jumper-connected on the shunt socket of the MPI drives instead of pins 1 and 14 (head load connecting to drive select). Either way will work.

Kim B. Lignell
649 South Harvard Ave.
Addison, IL 60101

Adventures Paid Off

In response to Hans Strasburger's request in the August 1982 BYTE (page 32) for "real" adventures like the original, we, too, were starved for adventure after getting 350 points. So we wrote our own and now offer three additional adventure-type programs. A Remarkable Experience is a cave-exploration game with passwords to unravel, unique locations to investigate, new treasures to find, and unusual actions to take. A Galactic Experience is a space-

exploration adventure with a murder mystery to analyze and a planet to save (by far our largest and most complex adventure). A Physical Experience is another space adventure where the user, Captain Player, must reverse the experiments of a group of scientists, prevent a supernova, and save the universe.

These are assembly-language programs with playing styles similar to the original Adventure; the computer recognizes and responds to one- or two-word sentences of four or five letters each. They are available in HDOS for Heath/Zenith computers and for standard 8-inch CP/M version 2.2 or higher. Further information can be obtained by writing to the address below.

Janet C. Hoyle, Business Manager
Hoyle and Hoyle Software
716 South Elam Ave.
Greensboro, NC 27403 ■

BYTE's Bits

Intel and Microsoft Ink Xenix Pact

Intel Corporation and Microsoft have signed an agreement making the Xenix operating system available for Intel's iAPX 86 microprocessor family. Under the terms of the agreement, Xenix for the iAPX family will be marketed by Intel. Intel began shipping the first iAPXs running Xenix in July. The company also announced plans to have the iAPX 286 outfitted with the operating system by the first half of 1983, which will make Unix-derived software available for 8086 system users.

Xenix is Microsoft's fully licensed 16-bit microprocessor adaptation of Bell Laboratories' Unix version 7 operating system.

Quarterly Calls for Papers

The editors of *The Journal of Computers Reading & Language Arts* have issued a call for papers dealing with the interdisciplinary theme of computers and their relationship to the reading and language arts. Papers or requests for information should be sent to George H. Block, *Journal of Computers Reading & Language Arts*, POB 13039, Oakland, CA 94661. ■

THE MULTI-USER FRIENDLY MEMORY BOARD WITH

NO COMPROMISE



- 256 Kilobytes
- 6 MHz with no wait states—most processors
- Designed to operate in any S-100 System IEEE or Non-IEEE
- 16-bit addressing option: Powerful Macrotech Memory Mapping (M³) bank select architecture allows each 4K block of the 16 bit (64K) logical addresses to be dynamically translated to any 4K block of the 256K on board physical memory.
- 24-bit direct addressing option

- "Educated" cycle control module generates all timing on board asynchronously for maximum access speed and uniform operation
- Comprehensive technical manual with complete installation guide and source listings for MP/M II™ and "Virtual Disk" solid state disk applications.
- DMA operation fully supported in strict accordance with IEEE 696 standard
- 8/16 data transfer protocol
- Parity error detection

- Multilayer board and bus signal filtering for noise-free operation.
 - Full one year warranty
- If you wish, send a check or money order for \$1,379 (In California add 6% sales tax where applicable). Manual available at \$25.00 each refundable with order.

*Registered Trademark of Digital Research Corp.
OEM & Dealer Inquiries Invited



MACROTECH International Corp.
22133 Cohasset St., Canoga Park,
California 91303
(213) 887-5737
In the U.K. call "0821" 828-763

GREAT IDEAS... Down to Earth Products

SIERRA DATA SCIENCES

(AVAILABLE SOON)



SDS-S100 CHASSIS

6 Slot Motherboard
Complete power supply
Utilize regular or Thinline drive



SDS-MULTIPLEXER/DISPLAY

Three RS232C 1 to 2 Switches
Two Seven Segment Status Display
(Can be used as a line monitor for data communications link)
(route RS232 to one of two devices)



NEC-FLOPPY DISK DRIVE

Double Sided
Single Density/Double Density
Up to 2.4 Megabyte
SPECIAL PRICING



SDS-HARD DISK INTERFACE

Micropolis 1220 Series
Interface Adapter

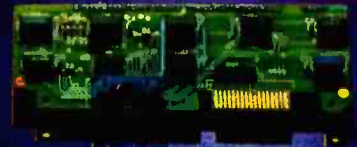

SDS-SLAVE



SDS-ZSIO



SDS-MASTER



SDS-SINGLE BOARD COMPUTERS

Z80A CPU 64K Bank Switch Memory
2 RS232 Channels 4 Timers IEEE 696 Bus Interface
4 Parallel ports
NEC 765 FDC with PLL to all Shugart compatible drives (SDS-Master only)

HARDWARE
SOFTWARE



SIERRA DATA SCIENCES

Fresno CA / Marketing Division, 21162 Lorain Ave., Fairview Park, Ohio 44126

(216) 331-8500 Telex. 980131 WDMR

SEE US AT COMDEX BOOTH 986.

Circle 419 on Inquiry card.

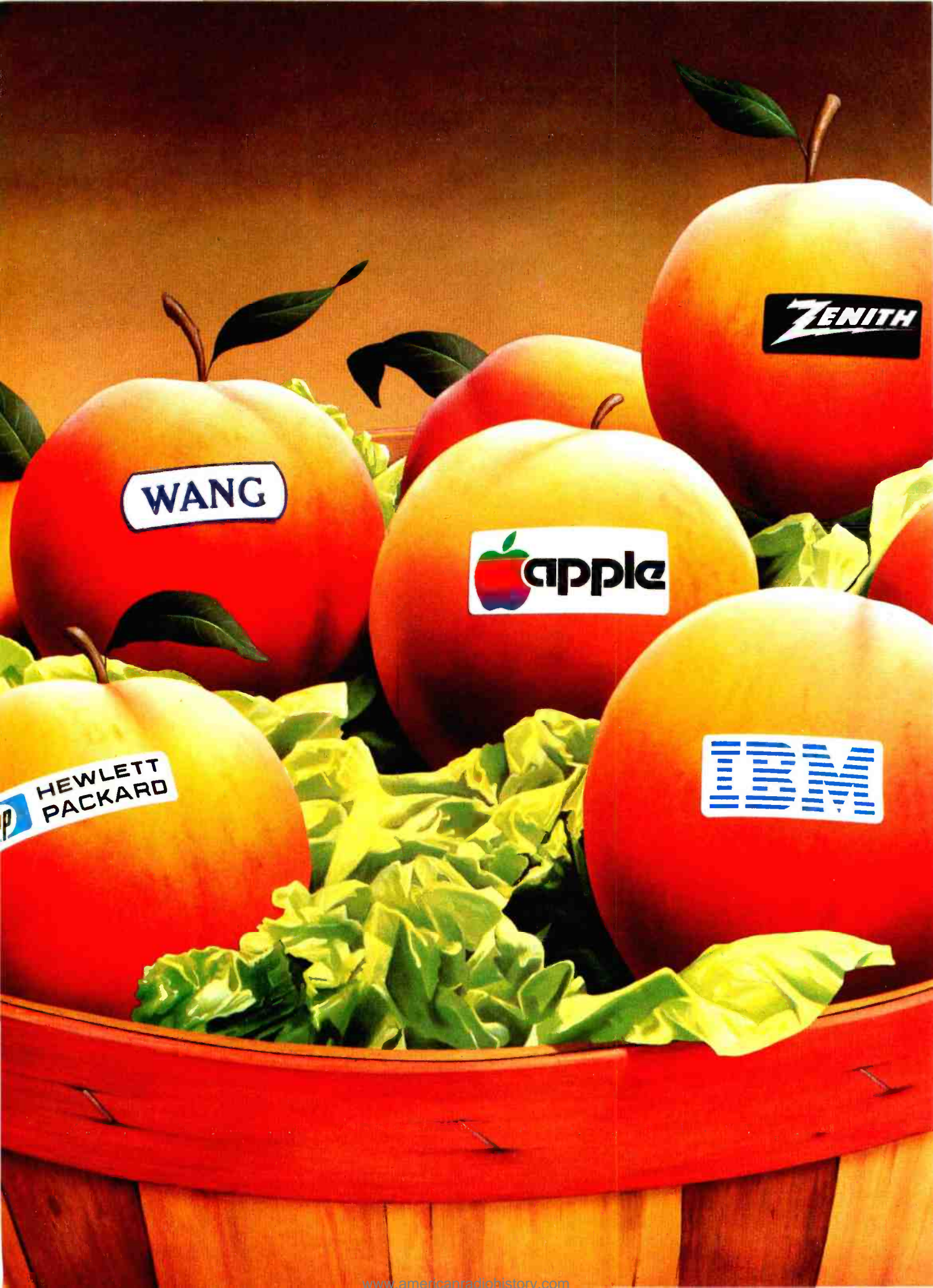

WANG

apple

ZENITH

HEWLETT
PACKARD

IBM

Look Who Picked the Peach. Did You?

They did.

And perhaps you did too. If you own an IBM Personal Computer,[™] an Apple III,[™] a Zenith Z-89[™] or a Hewlett-Packard HP-87,[™] you've had the chance to pick Peachware.[™] All these companies chose Peachtree Software[™] to get the most out of their machines for you.

And with good reason. Peachtree Software is the recognized leader in business software for microcomputers, with a reputation for comprehensive, well-designed packages, easy-to-use documentation and Peachcare[™] — our own array of support services unmatched in the industry.

With integrated systems like the Peachpak[™] 8 Accounting Series — General Ledger, Accounts Payable, Accounts Receivable, Sales Invoicing, Inventory Control and PeachPay[™] Payroll — Peachtree offers the manager unprecedented control over his critical accounting activities. And the Peachpak 9 Office Productivity Series, based on the PeachText^{™*} word

processor and including the PeachCalc[™] Electronic Spreadsheet, Spelling Proofreader, Mailing List Manager and Telecommunications, expands the power of Peachtree Software to all areas of the office.

Those qualities made our software the natural choice of these big manufacturers. But they're not the only ones who've picked a peach. So have tens of thousands of individual users of the better CP/M[™] — compatible microcomputers.

If you haven't picked the Peach, isn't it about time you did?



Circle 372 on inquiry card.

*We improved Magic Wand,[™] and it's so good we put our name on it.

IBM is a trademark of International Business Machines Corp.

Apple III is a trademark of Apple Computer Inc.

Z-89 is a trademark of Zenith Corporation.

HP-87 is a trademark of Hewlett-Packard Company.

CP/M is a trademark of Digital Research Inc.

Peachware, Peachtree Software, Peachcare, Peachpak, PeachPay, PeachText and PeachCalc are trademarks of Peachtree Software Incorporated, an MSA Company.

Copyright © 1982 Peachtree Software Incorporated, an MSA Company.

Please send me information on Peachware[™] by Peachtree Software.

B1282

Name: _____

Company: _____

Address: _____

City: _____ State: _____ Zip: _____

I am a: prospective dealer user of software

Peachtree Software Incorporated an MSA company

3445 Peachtree Road, N.E. / 8th Floor / Atlanta, Georgia 30326 / (404) 266-0673

www.americanradiohistory.com



Build the Circuit Cellar MPX-16 Computer System Part 2

A continued description of an 8088-based system that shares its principles of operation with the IBM Personal Computer.

Steve Ciarcia
POB 582
Glastonbury, CT 06033

This article is the second of three describing the design and operation of my most ambitious construction project to date: the Circuit Cellar MPX-16 computer system. I've written these articles with the intent of giving you a grasp of the basic functional parts of a complicated piece of electronic equipment and how these parts work together.

Because the MPX-16 is somewhat more complex than the projects I normally write about, I've had to simplify the presentation of many details to fit them into the magazine, but if you're interested in building an MPX-16, you can get all the details you need from the *MPX-16 Technical Reference and User's Manual*, which comes with the printed-circuit board available from The Micromint (see the text box on page 78). This book includes timing diagrams and listings

of the MPX-16's special software.

Last month I presented an overview of the system and a discussion of the coprocessors and bus structures. This month, I'd like to continue by explaining memory, interrupts, the expansion bus, and I/O (input/output) decoding. But first, here's a recap of the MPX-16's features.

System Features

The Circuit Cellar MPX-16 computer system fundamentally consists of a single 9- by 12-inch five-layer printed-circuit board (containing 120 integrated-circuit packages), to which various peripheral devices are attached. It has nine expansion slots and is completely compatible with the I/O-expansion bus of the IBM Personal Computer.

The MPX-16 uses the Intel 8088 microprocessor and the optional 8087 numeric coprocessor; the main circuit board has room for 256K bytes of user memory and contains two serial and three parallel I/O ports, a floppy-disk controller, and EPROMs (erasable programmable read-only memories) containing the BIOS (basic I/O system) module of Digital Research's CP/M-86 16-bit disk operating system. The MPX-16 can be

readily expanded to provide a full 1 megabyte of user memory and several megabytes of hard-disk mass storage. A more detailed list of characteristics appears in table 1.

The MPX-16 was initially designed to run CP/M-86, but eventually Microsoft's MS-DOS operating system will be available for it, making it possible to run most software written for the IBM Personal Computer on the MPX-16, except software that uses unique features of the IBM PC. The principal difference is this: with the present BIOS, the MPX-16 communicates with the user through a serially interfaced display terminal instead of a memory-mapped video display. (You could theoretically install an IBM Color Graphics Display Adapter and a serial IBM-type keyboard for exact hardware emulation.)

The MPX-16 is well suited for use as a low-cost 8088-based computer for integration into a complete hardware/software package, chiefly because it combines so many functions on a single printed-circuit board. Putting together the hardware of a complete system, you need only add a power supply, a serial video-display or printing terminal, and one floppy-disk drive (either 5¼- or

Copyright © 1982 by Steven A. Ciarcia.
All rights reserved.

IBM and IBM Personal Computer are trademarks of International Business Machines Corporation.

CP/M-86 is a trademark of Digital Research Inc.

IS THIS LEVEL OF RELIABILITY REALLY NECESSARY?

ACCUTRACK

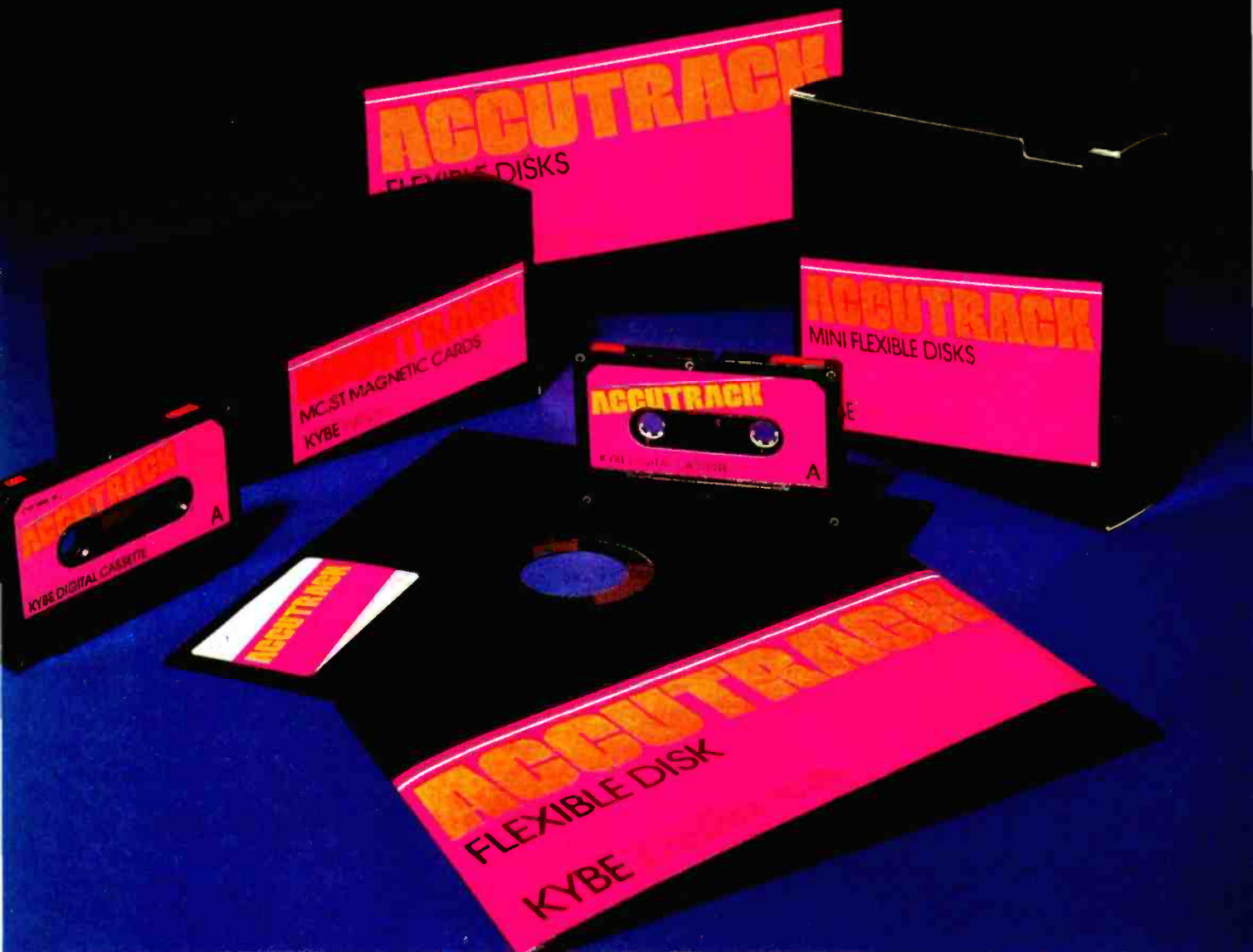

If you've ever lost data due to a faulty disk, you know how important reliability can be.

That's why Accutrack disks are critically certified at 2-3 times the error threshold of your system. Why they're precision fabricated for higher signal quality, longer life and less head wear. And why we take such extra steps as testing single-density mini disks at double-density levels. So you don't have to worry about the reliability of your media.

Accutrack disks. OEMs have specified them for years. You can trust them for your data. Call toll-free (800 225-8715) for your nearest dealer.



ACCUTRACK
Dennison KYBE Corporation

82 Calvary Street, Waltham, Mass. 02254
Tel. (617) 899-0012; Telex 94-0179
Outside Mass. call toll free (800) 225-8715
Offices & representatives worldwide

Circle 175 on inquiry card.

Dealers: Give your customers a choice—Accutrack's OEM performance as well as your heavily advertised brand. We have the industry's only complete line of disks, cassettes and mag cards, including virtually all special formats. If you want a quality line, small minimums, the ability to mix and match, private labeling, fast delivery and great price, call today. Find out how responsive a media supplier can be.

1. designed to use a 5-MHz Intel 8088 microprocessor, which combines a 16-bit architecture with an 8-bit bus interface and has 20-bit addressing capability for up to 1 megabyte of system memory, operating in maximum mode to support multiprocessing
2. optional Intel 8087 math coprocessor
3. onboard space for four 64K-byte banks of dynamic RAM for a total of up to 256K bytes, with parity generation and error detection
4. sockets for up to 64K bytes of JEDEC 24- or 28-pin standard ROM or EPROM devices
5. two RS-232C serial I/O ports
6. two 8-bit general-purpose parallel I/O ports with handshaking control lines
7. one Centronics-compatible parallel printer port
8. four programmable timers (one for a real-time clock, two for data rates, one for memory-refresh requests)
9. four independent DMA (direct memory access) channels
10. sixteen levels of vectored, prioritized interrupt control
11. single- or double-density floppy-disk controller for controlling up to four 5¼-inch or 8-inch single- or double-sided drives
12. five 62-pin I/O-expansion-channel connectors (hardware compatible with the IBM Personal Computer) with space for four more
13. five-layer 9- by 12-inch printed-circuit board
14. BIOS for CP/M-86 in EPROM

Table 1: Major characteristics of the MPX-16 computer system.

Start Address		Bank	Function
Decimal	Hexadecimal		
0	00000	0	64K to 256K bytes of R/W memory on system board
64K	10000	1	
128K	20000	2	
192K	30000	3	
256K	40000	4	up to 704K bytes of expansion memory in I/O channel
320K	50000	5	
384K	60000	6	
448K	70000	7	
512K	80000	8	
576K	90000	9	
640K	A0000	10	
704K	B0000	11	
768K	C0000	12	
832K	D0000	13	
896K	E0000	14	
960K	F0000	R	64K bytes of system ROM/EPROM

Figure 1: Map of memory-address-space allocation in the MPX-16, in 64K-byte increments.

8-inch). Turn on the power, insert a CP/M-86 disk, and go. And by the time you read this, an enclosure for the circuit board should be available. Many applications need nothing more.

System Memory

The stars of the show in November's article were the Intel 8088 microprocessor and the 8087 numeric processor extension (NPX),

with supporting roles played by the Intel 8284 clock generator/driver, the 8288 bus controller, and the 8237A-5 DMA (direct memory access) controller. This month we look at some less glamorous but equally necessary components, starting with a type of component so prosaic as to be called a commodity by the semiconductor industry: the memory.

The MPX-16 system circuit board contains both read-only and

read/write memory. In addition to the possible 64K bytes of ROM, the MPX-16 circuit board contains sockets for up to 256K 9-bit words (an 8-bit byte plus a parity bit) of dynamic RAM (random-access read/write memory). Furthermore, to augment the onboard memory, as much as 704K bytes of expansion RAM or ROM can be added in the I/O-expansion slots using readily available memory-expansion boards such as the Quadram Quadboard or the Seattle Computer RAM-Plus card. A memory map of the 8088's 1-megabyte (1,048,576-byte) address space in 64K-byte increments is shown in figure 1. Two of the five sections of the schematic diagram are included in this article; section 2 appears as figure 2 on pages 48, 49, and 50; section 3 as figure 3 on pages 52, 53, and 54. A table of integrated circuits, giving their type, location, and power connections, appears on pages 56 and 60 as table 2.

ROM Configuration

Four integrated-circuit sockets, designated IC82 through IC85 in section 3 of the schematic diagram, are provided for holding ROM (read-only memory) chips, which most often are EPROM devices. These four JEDEC- (Joint Electron Device Engineering Council) standard 28-pin sockets can contain several sizes of EPROMs, any of the various "byte-wide" (8-bit word size) devices such as the 2716 (16K bits or 2K bytes), the 2732 (4K bytes), the 2764 (8K bytes) or the 27128 (16K bytes). EPROMs with 24-pin packages, such as the 2716s and 2732s, are plugged into the lower 24 pins of the sockets, with certain jumper connections set accordingly.

For proper operation, the MPX-16 circuit board must contain a ROM or EPROM device in the highest address space (socket IC85) and a bank of RAM in the lowest address space because the 8088 processor fetches its first instruction after a power-up reset from location hexadecimal FFFF0 (usually a jump instruction branching to an initialization routine) and uses interrupt vectors in the range hexadecimal 00000 to 003FF.

The Ultimate Add-On Cards for PC.

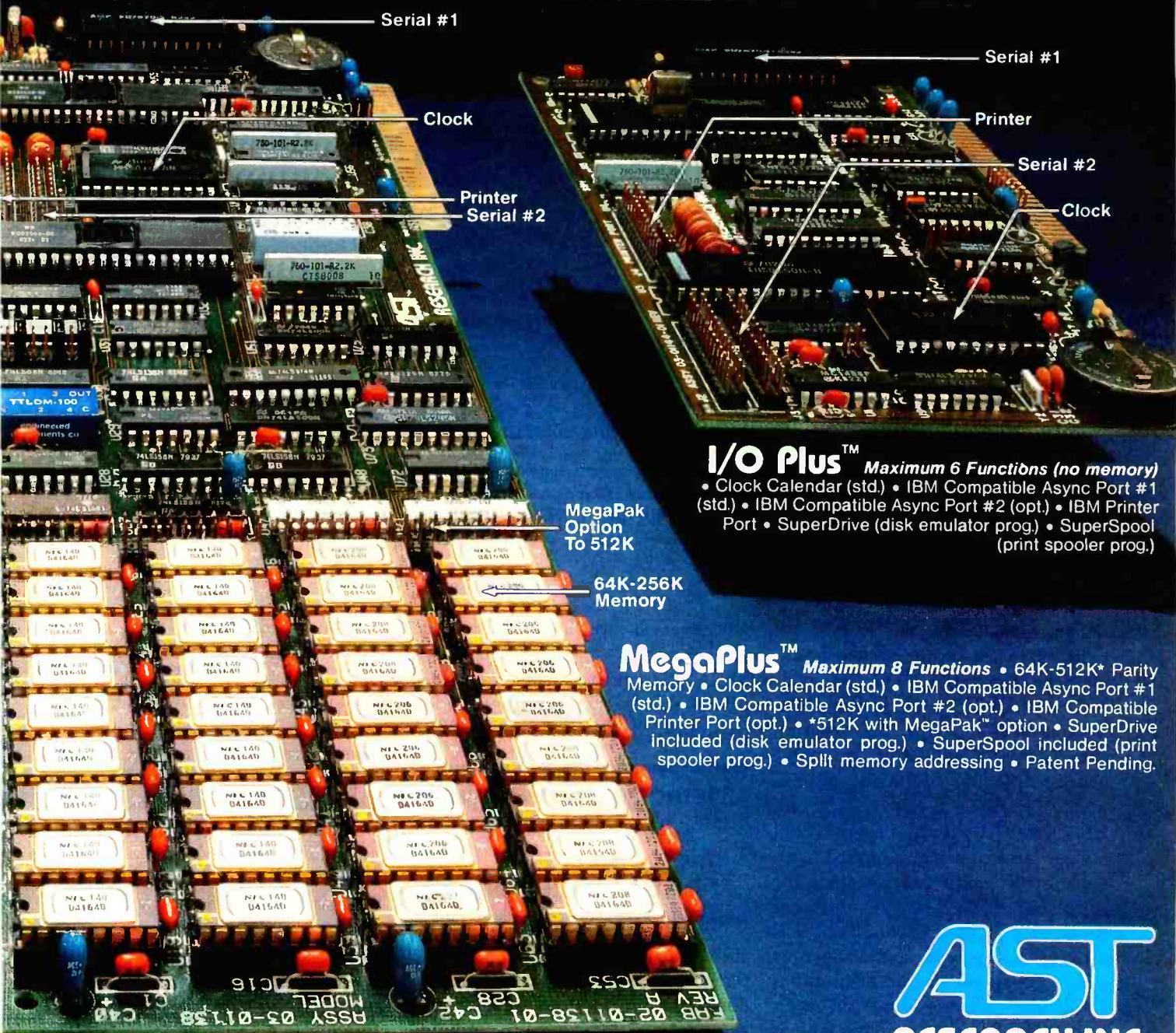

Serial #1

Serial #1

Clock

Printer

Printer
Serial #2

Serial #2

Clock

MegaPak
Option
To 512K

64K-256K
Memory

I/O Plus™ *Maximum 6 Functions (no memory)*
 • Clock Calendar (std.) • IBM Compatible Async Port #1 (std.) • IBM Compatible Async Port #2 (opt.) • IBM Printer Port • SuperDrive (disk emulator prog.) • SuperSpool (print spooler prog.)

MegaPlus™ *Maximum 8 Functions* • 64K-512K* Parity Memory • Clock Calendar (std.) • IBM Compatible Async Port #1 (std.) • IBM Compatible Async Port #2 (opt.) • IBM Compatible Printer Port (opt.) • *512K with MegaPak™ option • SuperDrive included (disk emulator prog.) • SuperSpool included (print spooler prog.) • Split memory addressing • Patent Pending.

AST

RESEARCH INC.

2691 Richter Ave., Suite 104
Irvine, California 92714

Telephone: (714) 540-1333

Dealer inquiries welcome.

Other products available for IBM PC: 1) ComboPlus™ (clock, serial, printer & max. 256K); 2) 3760/3780 Bisync Emulation Package; 3) Advance Communication Card (Async, Bisync, SDLC, HDLC); 4) Expansion Parity Memory (64K-256K now with SuperDrive™); 5) Disk++ (memory, Async & disk host adaptor); 6) Original Memory Combo; 7) Async Communication Card (1 or 2 ports); 8) Wire Wrap Card (13.1" x 4"); 9) Extender Card; 10) 527X Emulation. AST products are now available from your local Computerland stores and selected dealers throughout the U.S.

Nov. 29-Dec. 2, 1982
Las Vegas Convention Center
Las Vegas, Nevada



See Us At Booth
Numbers 584-586

COMDEX

IBM is the registered trademark of International Business Machines.

www.americanradiobistory.com

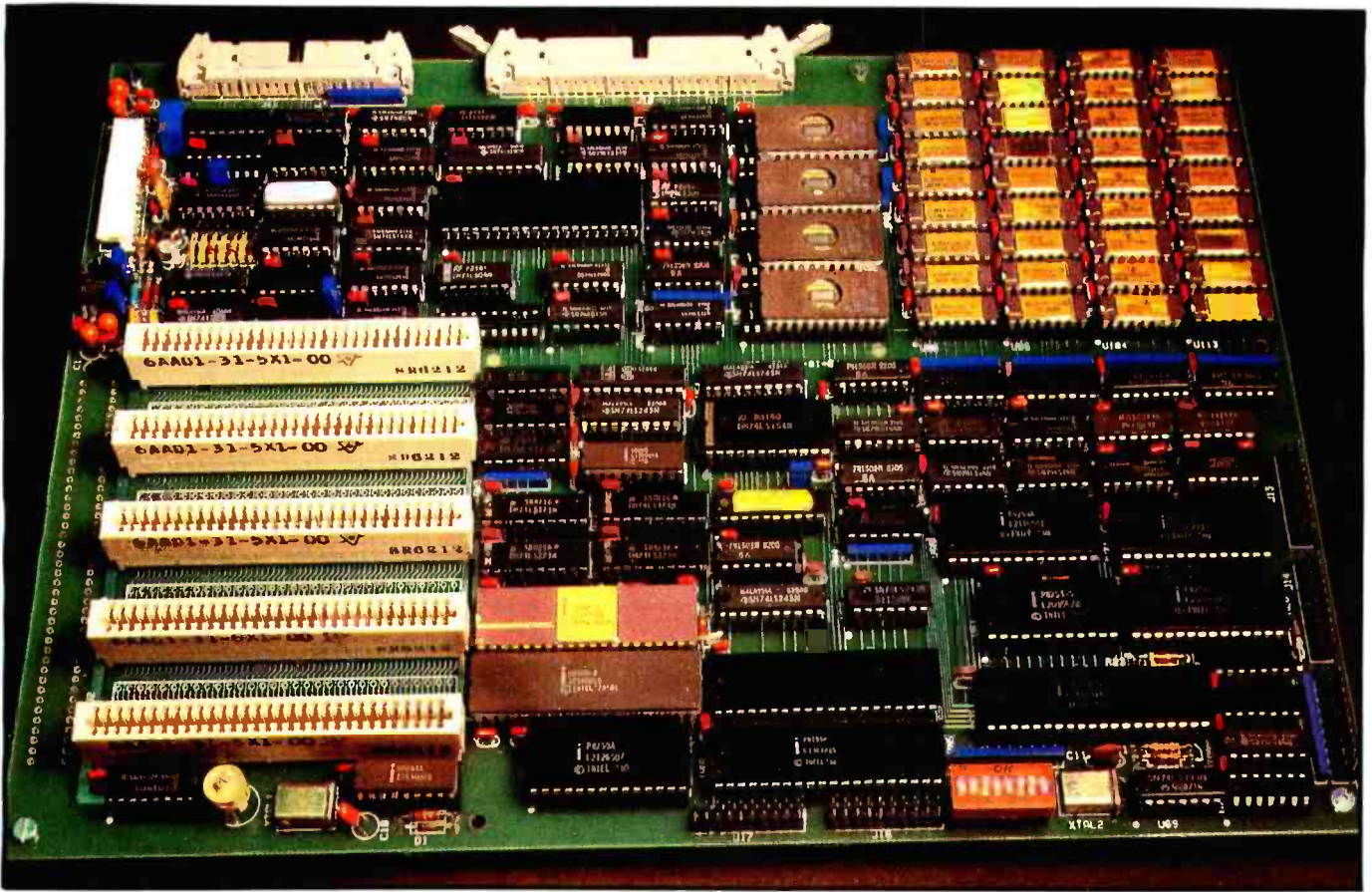

Photo 1: The Circuit Cellar MPX-16 single-board computer system, which uses the latest technology to provide lots of low-cost computing power. The five-layer printed-circuit board contains 120 integrated circuits including most common peripheral-device interfaces; furthermore, any peripheral-device card intended for use with the IBM Personal Computer can be plugged into one of the I/O-expansion slots. There are nine slot positions, but only five sockets are installed initially.

The capacity of the ROMs (or EPROMs) used on the system board must be compatible with the configuration of onboard jumpers JP1 through JP6 and with the program stored in the 32-word by 8-bit address-decoding PROM (programmable ROM) device IC45, an HM7603. The PROM program and jumper arrangements supplied with the system board are intended for type-2732 EPROMs. A different decoding PROM is needed for other memory-device types so that the four ROM sockets may be decoded into a contiguous address space in each case. (A PROM-programming table is included in the MPX-16 documentation.) The ROM-decoding logic and memory organization are respectively shown in sections 2 and 3 of the schematic diagrams.

The ROM-address-space-decoding logic for the system board is enabled

whenever all three high-order system address bits, SYSA17 through SYSA19, are high, causing the output of a NAND gate (IC30) to go low. If five PROM-address bits SYSA11

Memory chips are less glamorous than microprocessors, but just as necessary.

through SYSA15 or SYSA12 through SYSA16 (depending on the jumper configuration) address one of the programmed locations, the selected ROM-chip-enable line (one of PROMSEL0 through PROMSEL3) is also driven low, selecting that memory device. The ROMSEL signal at IC28 pin 5 (a two-input OR gate in section 2) also enables a wait-state-generation circuit if jumper JP7

is connected. After one of the PROMSELx lines has been driven active-low, a $\overline{\text{SYSTEMERD}}$ (system memory read, active-low) signal from the system bus master will initiate the memory-read cycle and generate a single wait state if JP7 is connected. Valid data from the ROMs is available on the data bus after $\overline{\text{SYSTEMERD}}$ goes low.

Normally, the MPX-16 requires ROM or EPROM devices with an access time of 350 ns (nanoseconds) or faster. The optional wait-state feature afforded through JP7 allows use of slower ROM devices with 450-ns access times. If faster devices are used, then JP7 should not be installed and the MPX-16 can operate with no wait states.

The EPROMs on the standard MPX-16 system board contain a power-on self-test routine and I/O drivers, including the CP/M-86 BIOS

INTRODUCING

SAVVY™



... the **PERSONAL LANGUAGE™** system
that mirrors your commands using
your own words!

What SAVVY is —

- SAVVY is a miraculous new information handling system.
- SAVVY is an automatic database management system.
- SAVVY is a new level of machine intelligence.
- SAVVY, part hardware, part software, is the beginning of truly "Personal Computing".
- SAVVY comes with: General Ledger, Accounts Receivable, Accounts Payable, Payroll, Mailing List, Document Writer and Inventory Control.



What SAVVY does —

Through SAVVY, you and your computer talk to each other in your own natural, conversational English (or Spanish, or French, etc.).

It learns from you what you want done in your own personal language.

Once SAVVY learns your language it can create any file you wish. Input, output, additions, changes and deletions are arranged for you.

SAVVY's "Robot Programmer" has been trained to write 100% of the programs needed to manage your database information.

SAVVY runs CP/M™ and Apple DOS.

What YOU discover —

You'll discover that SAVVY recognizes your personal words, even if misspelled, or even if you use a phrase never used before!

SAVVY continues to grow through use to become better and better at understanding your commands.

Eventually, you will see SAVVY as a mirror to your own way of thinking and working. It is a re-definition of "user-friendly".

SAVVY, it's the first system that truly means "personal computing".

SAVVY is like no other system on earth.

SAVVY cost \$950.

Seeing is believing. SAVVY is on display at selected computer retail locations. Call for the name of your nearest dealer.

CP/M is a trademark of Digital Research Corp.

Apple is a trademark of Apple Computer Inc.

Trademark: SAVVY, Robot Programmer: Excallbur Technologies Corporation.

Personal Language: SAVVY Marketing International.

100 South Ellsworth Street, 9th Floor, San Mateo, CA 94401 (415) 340-0335

SAVVY

MARKETING INTERNATIONAL

Circle 415 on inquiry card.

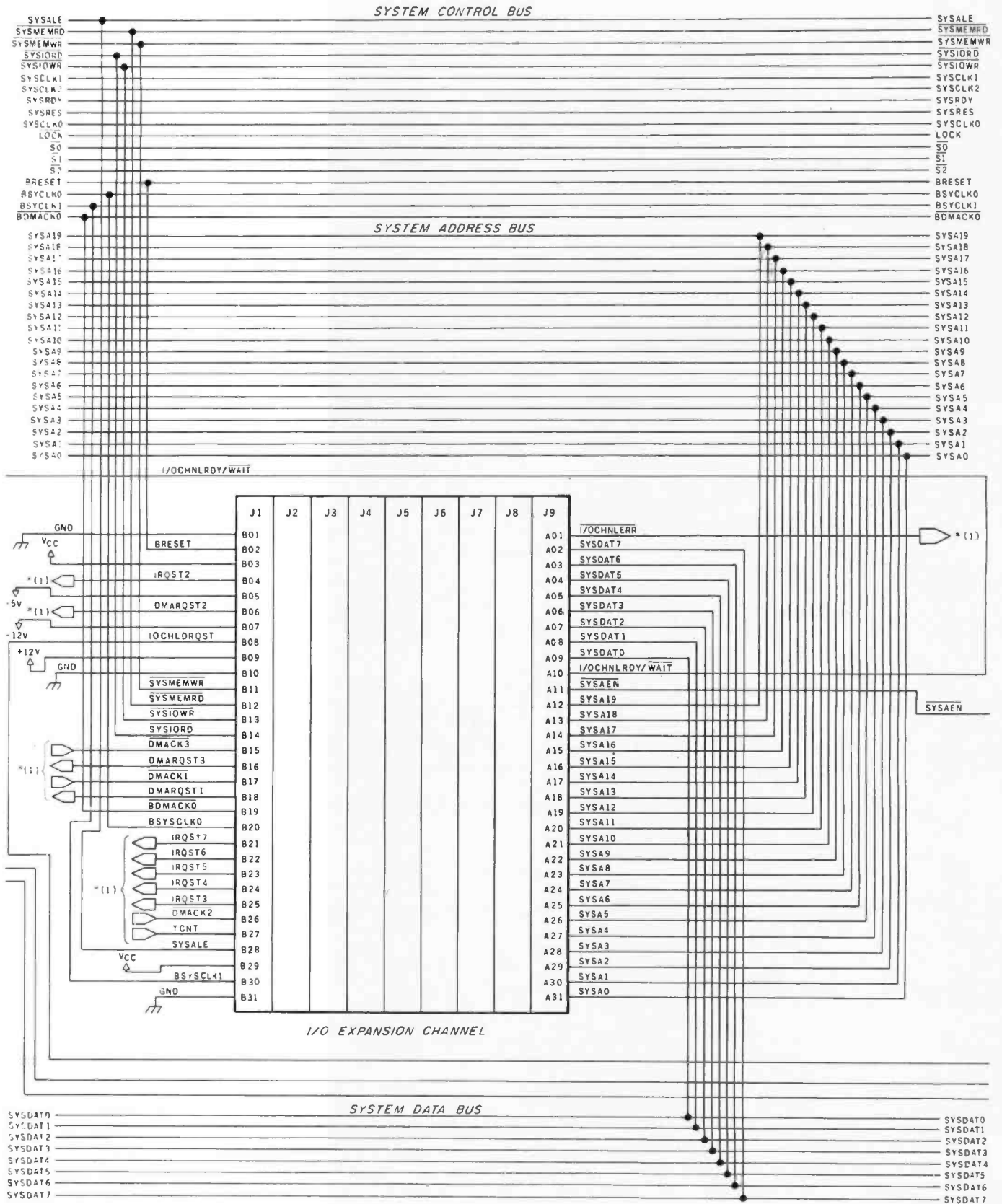

tion/figure location, and power connections. Connections to the I/O-expansion-channel slots are of course made to each individual slot. Possible substitutes for the HM7603 are the 74S288, the 82S123, and the AM27S09, although it's best to use the HM7603. (The diagram is continued on page 50.)

Figure 2: Continued from page 49.

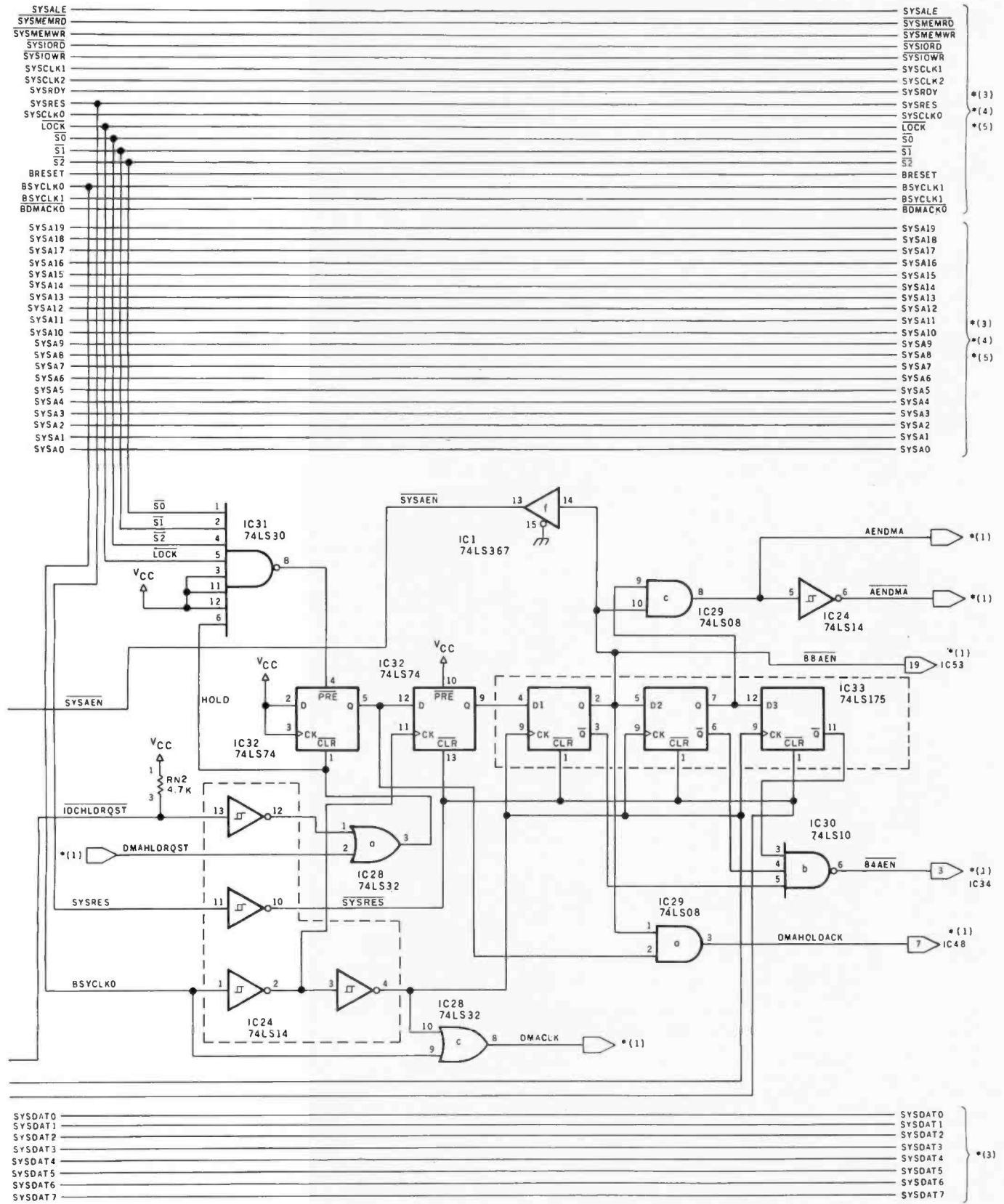

TO ORDER CALL:
1-800-451-2502
617-641-1241

Technical Support
617-641-1235



SoftwareBanc

661 Massachusetts Ave. Arlington, Ma. 02174

Everyone Wants To Sell You dBASE II™ Only We Teach You How To Use It!

dBASE II™ User's Guide FREE with BASE II™ \$29
140 pages of original material, perfect for beginning and advanced dBASE II™ users. Written by SoftwareBanc.

dBASE II™ Classes \$100 per day
Taught by SoftwareBanc Seminars

Los Angeles	Miami	Washington D.C.
Jan. 7, 8, 9	Dec. 28, 29	Jan. 21, 22, 23

dBASE II™	with FREE dBASE II™ User's Guide and 60 day money back guarantee!	\$495
ABSTAT	Statistics for dBASE II™ files	\$379
dUTIL	dBASE II™ programmer's utility	\$ 69
QUICKCODE	dBASE II™ program generator	\$229

Software includes FREE SoftwareBanc technical support.

**Only SoftwareBanc can offer this level of dBASE II™ expertise.
Is it any wonder that crowds are forming?**



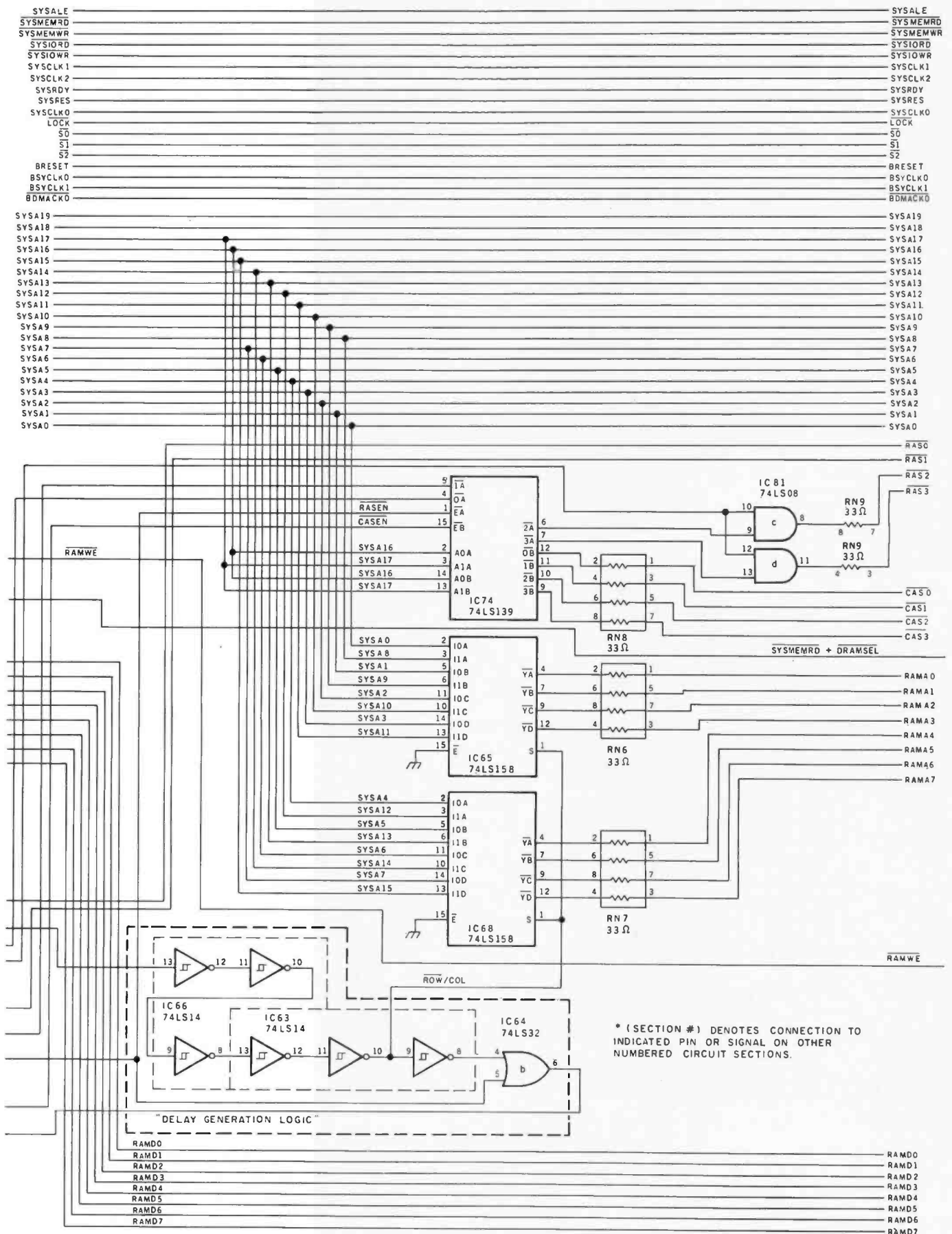

capacitors, not shown, should be installed adjacent to most integrated circuits between +5 V and ground. A table of all the MPX-16's integrated circuits appears as table 2 on pages 56 and 60, giving each device's number, type, section/figure location, and power connections. (The diagram is continued on page 54.)

Figure 3: Continued from page 53.

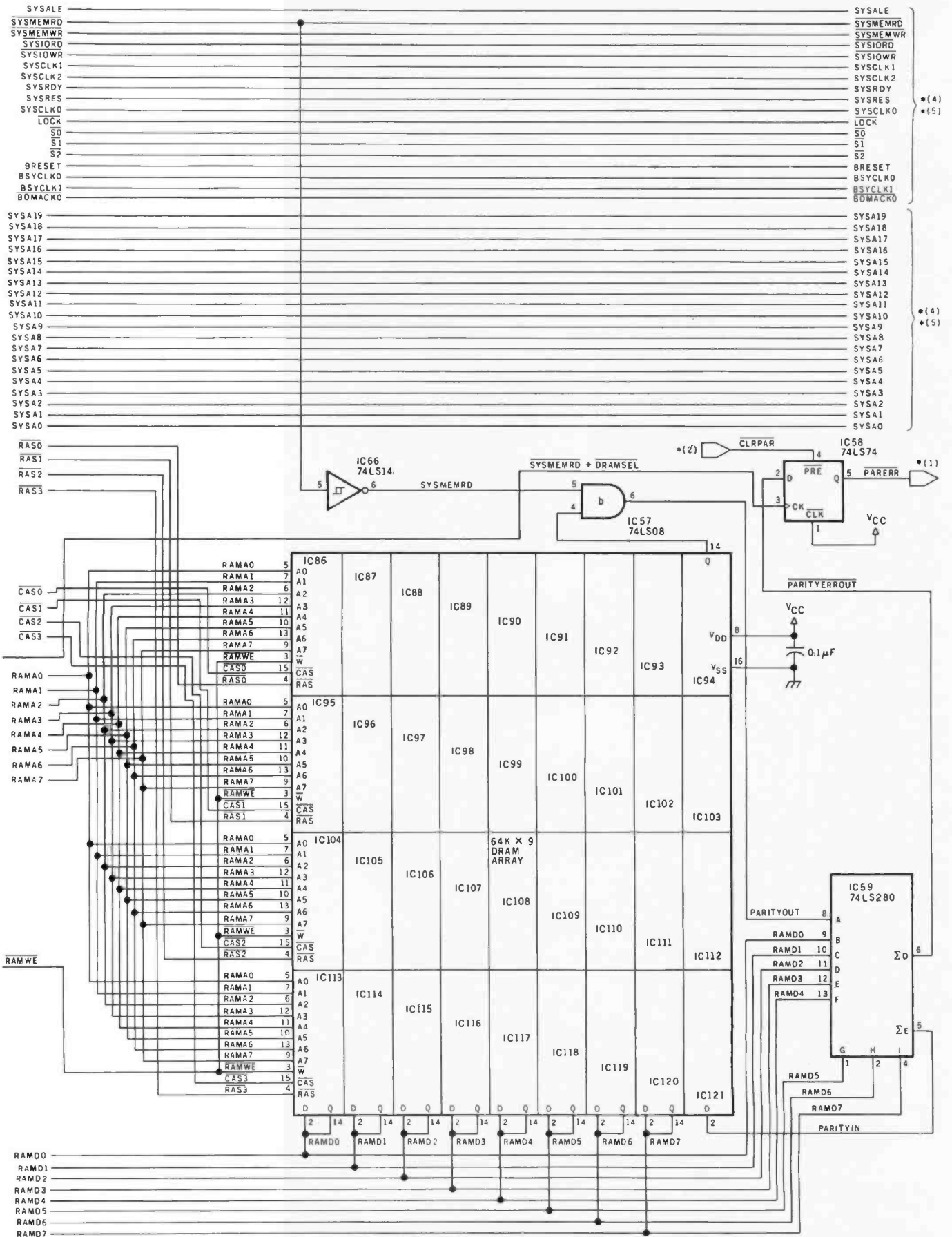

Bored Waiting?

Here's The Board You've Been Waiting For.



Teletek's HD/CTC

A hard disk and cartridge tape controller together on one board? Magic? Not really. It's Teletek's HD/CTC. The hard disk and cartridge tape drive controller provide the support necessary to interface both a rigid-disk drive and a cartridge tape deck to the S-100 bus.

A colorful addition to Teletek's already impressive line of S-100 boards, the HD/CTC's specifications include:

- A Z-80A CPU providing intelligent control of the rigid-disk and cartridge tape drives.
- Support of 5 1/4" rigid-disk drives with transfer rates of 5 megabits per second. Minor changes in on-board components allow the support of other drive types/sizes and transfer rates up to 15 megabits per second. (Interface to disk drive is defined by software/firmware on board.)
- Controller communications with the host processor via 2K FIFO at any speed desirable up to the limit of 2 megabytes per second for a data block transfer. Thus the controller does not constrain the host processor in any manner.
- Two 28-pin sockets allowing the use of up to 16k bytes of on-board EPROM and up to 8k bytes of on-board RAM.
- Individual software reset capability.
- Conforms to the proposed IEEE-696 S-100 standard.
- Controller can accommodate two rigid-disk drives and one cartridge tape drive. Expansion is made possible with an external card.

Teletek's HD/CTC Offers A Hard Disc Controller, Plus Cartridge Tape Controller, All In One Board.

TELETEK

9767F Business Park Drive Sacramento, CA 95827 (916) 361-1777 Telex #4991834. Answer back-Teletek

**INCOME TAX
ACCOUNTING**

Quick Tax[®]

has the finest
software
I've ever seen
for the
**Accounting
and Tax
Professional.**

"The programs are so well designed and supported, we had no start-up problems."—Ronald Braun, C.P.A.

1040 TAX PROGRAM \$995

- ALL MAJOR FORMS & SCHEDS.
- PRINTS ON IRS FORMS, MULTI-PART FORMS, OR OVERLAYS.
- INDIVIDUAL OR BATCH PROCESSING.
- AUTOMATIC CARRY-FORWARD OF PRIOR YEAR DATA.
- DIAGNOSTIC REPORTS.
- LETTER OF INSTRUCTION.
- AUTOMATIC CLIENT BILLING.
- MAILING LISTS/LABELS & ENVELOPES.
- UNLIMITED SUPPORTING SCHEDULES.

Simple and easy to use!

PLUS:
PROFORMA/TAX ORGANIZER
STATE MODULES AVAILABLE
TAX PLANNING
DEPRECIATION SCHEDULE

ALSO AVAILABLE:
GENERAL LEDGER
CLIENT WRITE-UP
AFTER THE FACT PAYROLL
AMORTIZATION SCHEDULE
TIME AND BILLING

ALL QUICK TAX PROGRAMS COME WITH ONE YEAR WARRANTY & SUPPORT.

See your nearest computer dealer.
Or, call or write for more information.

Quick-Tax Software is available for Xerox 820, IBM, PC, Radio Shack, DEC, Vector Graphic, Northstar, and other CP/M based computers.

CP/M is a registered trademark of Digital Research, Inc.
DEALER DISCOUNTS AVAILABLE.

Quick Tax[®] Ltd 319 Clawson St., Dept. BM
S.I., N.Y.C., N.Y. 10306
(212) 351-6143

IC Number	Type	Schematic Section	+ 5 V	GND	+ 12 V	-12 V
VR1	LM7905	5 (3-2)	(voltage regulator)			3
IC1	74LS367	1 (1-3b), 2 (2-2)	16	8		
IC2	74LS123	5 (3-2)	16	8		
IC3	74LS157	5 (3-2)	16	8		
IC4	74LS124	5 (3-2)	16	8		
IC5	74LS175	5 (3-2)	16	8		
IC6	74LS173	5 (3-2)	16	8		
IC7	74LS393	5 (3-2)	14	7		
IC8	74LS10	5 (3-2)	14	7		
IC9	74LS74	5 (3-2)	14	7		
IC10	M1116-8M	5 (3-2)	14	7		
IC11	74LS153	5 (3-2)	16	8		
IC12	74LS14	5 (3-2)	14	7		
IC13	74LS74	5 (3-2)	14	7		
IC14	74LS74	5 (3-2)	14	7		
IC15	74LS74	5 (3-2)	14	7		
IC16	74LS74	5 (3-2)	14	7		
IC17	74LS175	5 (3-2)	16	8		
IC18	7406	5 (3-2)	14	7		
IC19	spare socket					
IC20	74LS04	1 (1-3ab), 5 (3-2)	14	7		
IC21	8272	5 (3-2)	40	20		
IC22	74LS240	5 (3-2)	20	10		
IC23	7407	5 (3-2)	14	7		
IC24	74LS14	2 (2-2)	14	7		
IC25	74LS74	2 (2-2)	14	7		
IC26	74LS139	5 (3-2)	16	8		
IC27	7407	5 (3-2)	14	7		
IC28	74LS32	2 (2-2), 4 (3-1)	14	7		
IC29	74LS08	2 (2-2)	14	7		
IC30	74LS10	1 (1-3a), 2 (2-2)	14	7		
IC31	74LS30	2 (2-2)	14	7		
IC32	74LS74	2 (2-2)	14	7		
IC33	74LS175	2 (2-2)	16	8		
IC34	8284A	1 (1-3a)	18	9		
IC35	8259A	1 (1-3a)	28	14		
IC36	8088	1 (1-3a)	40	1,20		
IC37	8087 (option)	1 (1-3a)	40	1,20		
IC38	74LS373	1 (1-3a)	20	10		
IC39	74LS373	1 (1-3b)	20	10		
IC40	74LS173	1 (1-3b)	16	8		
IC41	74LS173	1 (1-3b)	16	8		
IC42	74LS173	1 (1-3b)	16	8		
IC43	74LS245	1 (1-3a)	20	10		
IC44	74LS373	1 (1-3a)	20	10		
IC45	HM7603-5	2 (2-2)	16	8		
IC46	74LS245	1 (1-3a)	20	10		
IC47	8155H-2	4 (3-1)	40	20		

Table 2: Integrated circuits in the MPX-16. Here are shown each device's number, type, section/figure location, and power connections.

The location of each chip in the five-part schematic diagram is listed by schematic section; the characters in parentheses show in which article the section appeared and which figure the device appears in. Some integrated circuits containing multiple gates appear in more than one schematic section. (The table is continued on page 60.)

**Be Wise.
Be Thrifty.
Be A
Night Owl.**



Your Own University Library Online At Home!

If you're free between the hours of six and midnight, make a date with one of the world's fastest, most powerful online information services — at a fraction of what it would cost during the business day. All you pay is a \$50 registration fee to receive your classified user's password. Then, any evening, you can summon up a wealth of information for as little as \$6 per hour.

Technical and scientific abstracts. Medical journals. Government studies. Business indexes. Major newspapers. BRS/AFTER DARK gives you access to the same comprehensive data files used by BRS Search Service subscribers, which include major corporations and reference libraries throughout the world. All instantly accessible with simple, interactive language.

Of course, BRS/AFTER DARK also gives you valuable peripheral services like a home-computer Newsletter and nationwide communication via electronic mail. Plus, shop-at-home services and instant software delivery programmed for the very near future.

Don't let another evening go by without BRS/AFTER DARK. All you need is your phone and any dial-up system or terminal. For more information about BRS/AFTER DARK, just fill out the coupon.

Circle 64 on inquiry card.

BRS



AFTER DARK

Sign me up as a BRS/AFTER DARK subscriber for a one-time subscription fee of \$50. (Basic user's rate as low as \$6 hour.)

BY 1/83

Charge to MASTER CARD/VISA (circle one)

Acct. No. _____ Expires _____

Send more information

Signature _____

NAME _____

ADDRESS _____

CITY _____ STATE _____ ZIP _____

Mail to: BRS • 1200 RT. 7 • LATHAM, NY 12110 • (518) 783-1161

Our "almost wholesale" prices just got 2% lower.

Take an additional 2% off our listed prices, until December 24.

Have a merry computer and a happy software.

16K RAM KITS.....13.95

Set of 8 NEC 4116 200 ns Guaranteed one year

DISKETTES

ALPHA DISKS.....21.95

Single sided, certified Double Density 40 Tracks, with Hub-ring Box of 10 Guaranteed one year

SCOTCH 3M

S S D DEN 40 TRK 23 50
D S D DEN 40 TRK 36 50

VERBATIM DATALIFE

MD 525-01, 10, 16 26 50
MD 550-01, 10, 16 44 50
MD 557-01, 10, 16 45 60
MD 577-01, 10, 16 34 80
FD 32 or 34-9000 36 00
FD 32 or 34-8000 45 60
FD 34-4001 48 60

DISKETTE STORAGE

5 1/4" PLASTIC LIBRARY CASE 2 50
8" PLASTIC LIBRARY CASE 3 50
PLASTIC STORAGE BINDER w/ Inserts 9 95
PROTECTOR 5 1/4" (50 Disk Capacity) 21 95
PROTECTOR 8" (50 Disk Capacity) 24 95
DISK BANK 5 1/4" 5 95
DISK BANK 8" 6 95

NEC PERSONAL COMPUTERS

Call Alpha Byte for our low NEC prices

ALTOS COMPUTER SYSTEMS

Call Alpha Byte for our low Altos prices

ATARI COMPUTERS

SIGNALMAN MODEM 85 00
ATARI 800 659 00
ATARI 400 (16K) \$CALL
ATARI 810 DISK DRIVE 445 00
ATARI 850 INTERFACE 169 00
ATARI 410 PROGRAM RECORDER 75 00
EPSON CABLE 35 00
MEMORY MODULE (16K) 89 95
JOYSTICK CONTROLLER 10 00
PADDLER CONTROLLERS 17 50
STAR RAIDERS 35 00
MISSILE COMMAND 35 00
ASTERIODS 35 00
PACMAN 35 00
CENTIPEDE 35 00

INTEC PERIPHERALS RAM MODULES

48K FOR ATARI 400 199 00
32K FOR ATARI 800 85 00

PRINTERS

ANADEX 9501A 1390 00
RIBBONS FOR MX-80 8 95
RIBBONS FOR MX-100 24 00
C-I-TOM F-10 40 CPS PARALLEL 1390 00

C-I-TOM F-10 40 CPS SERIAL 1390 00
C-I-TOM PROWRITER PARALLEL 480 00
C-I-TOM PROWRITER SERIAL 590 00
EPSON MX-80 W/GRAFTRAX PLUS \$CALL
EPSON MX-80 F/T W/GRAFTRAX PLUS \$CALL
EPSON MX-100 W/GRAFTRAX PLUS \$CALL
EPSON GRAFTRAX PLUS 60 00
COMREX CR-1 PARALLEL 839 00
COMREX CR-1 SERIAL 859 00
COMREX TRACTOR FEED 109 00
IDS PRISM 80 859 00
IDS PRISM 80 W/ COLOR/OPTIONS 1599 00
IDS MICROPRISM 480 \$CALL
NEC 8023A 485 00
NEC SPINWRITER 3530 P RO 1995 00
NEC SPINWRITER 7710 S RO 2545 00
NEC SPINWRITER 7730 P RO 2545 00
NEC SPINWRITER 7700 D SELLUM 2795 00
NEC SPINWRITER 3500 SELLUM 2295 00
OKIDATA MICROLINE 80 389 00
OKIDATA MICROLINE 82A 460 00
OKIDATA MICROLINE 83A 700 00
OKIDATA MICROLINE 84 1170 00
OKIGRAPH 82 49 95
OKIGRAPH 83 49 95
MICROBUFFER IN-LINE 32K 299 00
MICROBUFFER IN LINE 64K 349 00
MICROBUFFER 64K EXPANSION MOD 179 00

CORVUS

FOR S-100, APPLE OR TRS-80 MOD I, III

Controller, Case/P S, Operating System, A & T
5 MEGABYTES 2755 00
10 MEGABYTES 3699 00
20 MEGABYTES 4299 00
MIRROR BACK-UP 700 00

BOOKS

THE CUSTOM APPLE 24 95
BASIC BETTER & FASTER DEMO DISK 18 00
THE CUSTOM TRS-80 24 95
MICROSOFT BASIC FASTER & BETTER 24 95
CUSTOM I/O MACHINE LANGUAGE 24 95
TRS-80 DISK & MYSTERIES 16 95
MICROSOFT BASIC & DECODED 24 95

APPLE HARDWARE

APPLEMATE DRIVE 275 00
SUPER CLOCK II 129 00
VERSA WRITER DIGITIZER 259 00
ABT APPLE KEYPAD 119 00
SOFTCARD PREMIUM SYSTEM 575 00
MICROSOFT Z-80 SOFTCARD 249 00
MICROSOFT RAMCARD 125 00
VIDEX 80x24 VIDEO CARD 260 00
VIDEX KEYBOARD ENHANCER II 129 00
VIDEX ENHANCER REV. 0-6 99 00
VIDEX FUNCTION STRIP 74 00
M & R SUPERTERM 80x24 VIDEO BD 315 00
M & R COOLING FAN 44 95
T/G JOYSTICK 44 95
T/G PADDLER 29 95
T/G SELECT-A-PORT 54 95
VERSA E-Z PORT 21 95
THE MILL-PASCAL SPEED UP 270 00
PROMETHEUS VERSACARD 180 00
LAZAR LOWER CASE + 59 00
MICROBUFFER II; 16K W/GRAPHICS 259 00

MICROBUFFER II; 32K W/GRAPHICS 299 00
SUPERFAN II 62 00
RANA CONTROLLER 104 00
RANA DRIVES 335 00
SNAPSHOT 119 00
GRAPPLER + 145 00
7710A ASYNCHRON SER INTERFACE 149 00
7712A SYNCHRON SER INTERFACE 159 00
7742A CALENDAR CLOCK 99 00
7728A CENTRONICS INTERFACE 105 00
APPLE VISION 80-80 COL CARD 329 00
APPLE 8" DISK DRIVE CONTROLLER 549 00

MONITORS

U S I AMBER 12" 179 00
NEC 12" GREEN MONITOR 174 00
NEC 12" COLOR MONITOR 399 00
SANYO 12" MONITOR (B & W) 198 00
SANYO 13" COLOR MONITOR 402 00
BMC GREEN MONITOR 89 00
AMDEK COLOR I 365 00
AMDEK RGB COLOR II 774 00
AMDEK RGB INTERFACE 169 00
COMREX 12" GREEN MONITOR 115 00

MOUNTAIN HARDWARE

CPS MULTIFUNCTION BOARD 154 00
ROMPLUS W/ KEYBOARD FILTER 165 00
ROMPLUS W/O KEYBOARD FILTER 125 00
KEYBOARD FILTER ROM 49 00
COPYROM 49 00
MUSIC SYSTEM 369 00
ROMWRITER 149 00
A/D + D/A 299 00
EXPANSION CHASSIS 580 00
RAMPLUS 32K 160 00

S-100 HARDWARE

Alpha Byte is your new S-100 headquarters! We've expanded our line of S-100-compatible hardware. Here's just a few of the lines we carry

CALIFORNIA COMPUTER SYSTEMS

2200A MAINFRAME 459 00
2065C 64K DYNAMIC RAM 539 00
2422 DISK CONT & CP/M 359 00
2710 4 SERIAL I/O 279 00
2718 2 SERIAL / 2 PARALLEL I/O 269 00
2720 4 PARALLEL I/O 199 00
2810 Z-80 CPU 259 00

QT COMPUTER PRODUCTS

18 SLOT M/F W/P S 430 00
12 SLOT M/F W/CUTOUTS FOR 2-5 1/4 500 00
12 SLOT M/F W/CUTOUTS FOR 2-8 600 00
8 SLOT M/F W/CUTOUTS FOR 2-8 550 00

COMREX THE TIMEPIECE S-100 CLOCK 125 00

SIERRA COMPUTER PRODUCTS

S 100 PROM PROGRAMMER A T 240 00
S 100 PROM PROGRAMMER KIT 195 00
S 100 PROTOTYPE MODULE SEMI KIT 90 00

STATIC MEMORY SYSTEMS

LAST MEMORY BOARD 64K 500 00
LASTING MEMORY PROM PROG 299 00

ADVANCED MICRODIGITAL SINGLE S-100 BOARD COMPUTER

SUPERQUAD-8 820 00
SUPERQUAD-5 820 00

MODEMS

NOVATION CAT ACOUSTICS MODEM 135 00
NOVATION D-CAT DIRECT CONNECT 156 00
NOVATION AUTO-CAT AUTO ANS 219 00
NOVATION APPLE-CAT (300 Baud) 310 00
NOVATION APPLE-CAT (1200 Baud) 605 00
UDS 212 LP (1200 Baud) 429 00
UDS 103 JLP AUTO ANS 209 00
HAYES MICROMODEM 289 00
HAYES 100 MODEM (S-100) 325 00
HAYES SMART MODEM (300 BAUD) 227 00
HAYES SMART MODEM (1200 BAUD) 540 00
HAYES CHRONOGRAPH 199 00
LEXICON LEX-11 MODEM 119 00
SIGNALMAN MODEM W/RS-232C 85 00

TERMINALS

TELEVIDEO 920C 830 00
TELEVIDEO 950C 995 00
AODS-VIEWPOINT 599 00
HAZELTINE ESPRIT 510 00
VISUAL-50 GREEN 690 00

TRS-80 MOD I HARDWARE

PERCOM DATA SEPARATOR 27 00
PERCOM DOUBLER II W/DOS 3.4 159 00
TANDON 80 TRK DISK DRIVE W/P S 345 00
TANDON 40 TRK DISK DRIVE W/P S 289 00
LNW DOUBLER W/DOSPLUS 3.3 138 00
LNW 5/8 DOUBLER W/DOSPLUS 3.4 171 00
MOD III DRIVE KIT W/DRIVES 875 00

IBM HARDWARE

SEATTLE 64K RAM + 370 00
QUADBOARD 64K 464 00
64K MEMORY UPGRADE 80 00

ALPHA BYTE IBM MEMORY EXPANSION BOARDS

256K W/RS-232C 349 00
256K W/RS-232C & SUPERCALC 529 00
512K W/RS-232C 599 00
512K W/RS-232C & SUPERCALC 749 00

BARE DRIVES

TANDON 5 1/4 INCH
100-1 SINGLE HEAD 40 TRK 195 00
100-2 DUAL HEAD 40 TRK 269 00
100-3 SINGLE HEAD 80 TRK 250 00
100-4 DUAL HEAD 80 TRK 369 00

TANDON THINLINE 8 INCH

848-1 SINGLE SIDE 379 00
848-2 DUAL SIDE 490 00

IBM DISK DRIVES

Alpha Byte's add-on drive kits for the IBM-PC — each kit includes installation instructions
 1 Tandon TM100-1 Single head 40 trk 195.00
 1 Tandon TM100-2 Double head 40 trk 269.00

HARD DISK DRIVE SPECIAL MEDIA DISTRIBUTORS

5 1/4" Winchester, cabinet, P.S. controller assembled and tested. Attaches to your Z-80 CPU system in minutes. Runs on Northstar, Heath/Zenith, TRS-80 Mod II, Apple w/ CP/M[®], CCS and others. Hardware must be Z-80/CPM[®] system. The included self-installing software attaches to your CP/M[®] system. 6-month warranty. No effect on your present floppy disk system. Includes all cables and installation instructions
 10 MEGABYTES 2370.00
 20 MEGABYTES 3180.00

ISOLATORS

ISO-1 3-SOCKET 53.95
 ISO-2 6-SOCKET 53.95

MICRO PRO

APPLE CP/M[®]
 WORDSTAR*† 199.00
 SUPERSORT*† 109.00
 MAILMERGE*† 60.00
 DATASTAR*† 162.00
 SPELLSTAR*† 109.00
 CALCSTAR*† 109.00

MICROSOFT

APPLE
 FORTRAN* 150.00
 BASIC COMPILER* 296.00
 COBOL* 550.00
 Z-80 SOFTCARD 249.00
 RAMCARD 125.00
 TYPING TUTOR 17.95
 OLYMPIC DECATHLON 24.95
 TASC APPLESOFT COMPILER 130.00
 ALDS 95.00

IBM SOFTWARE

PEACHTREE SERIES 4 269.00
 VOLKSWRITER 145.00
 WRITE ON 90.00
 EASYWRITER II 247.00
 HOME ACCOUNTANT+ 105.00
 VISICALC / 256K 189.00
 SUPERCALC 189.00
 WORDSTAR 235.00
 MAILMERGE 79.00
 DATASTAR 220.00
 SPELLSTAR 150.00
 SUPERSORT 160.00
 d BASE II 429.00
 SPELLGUARD 230.00

Call for additional IBM software prices

APPLE SOFTWARE

MAGIC WINDOW 79.00
 MAGIC SPELL 59.00
 MAGIC MAILER 59.00
 DB MASTER 169.00
 DB MASTER UTILITY PACK 69.00
 DATA CAPTURE 4 0/80 59.95
 PFS GRAPH 89.95
 PFS (NEW) PERSONAL FILING SYSTEM 85.00
 PFS REPORT 79.00
 Z-TERM* 89.95
 Z-TERM PRO* 129.95
 ASCII EXPRESS 63.95
 EASY WRITER-PRO 199.00
 EASY MAILER-PRO 79.00
 EXPEDITER II APPLESOFT COMPILER 73.95
 A-STAT COMP STATISTICS PKG 129.00
 BEAGLE BROTHERS UTILITY CITY 23.00
 APPLE MECHANIC 23.00
 TIP DESK#1 15.95
 SUPER TEXT II 129.00
 LISA 2 5 59.95
 TRANSCEND II 115.00
 PEACHTREE SERIES 4 / 40 269.00
 SCREENWRITER II 99.00
 DICTIONARY 79.00

CONTINENTAL SOFTWARE

G/L 165.00
 A/R 165.00
 A/P 165.00
 PAYROLL 165.00
 PROPERTY MGMT 399.00

MACRO 80 185.00
 mu MATH/mu SIMP 200.00
 mu LISP/mu STAR 165.00

TRS-80 GAMES

INVADERS FROM SPACE 17.95

Save 33%

FRANKLIN ACE	MICROBUFFER 32K.....299.00
1000.....1595.00	NEC 12" GREEN
RANA DISK DRIVE.....449.00	MONITOR.....200.00
RANA DRIVE	VERBATIM DISKS.....45.00
CONT. CARD.....135.00	LIBRARY CASE.....5.00
C.I.TOH 8510	
PRINTER.....795.00	

\$3523

Now \$2352

THE HOME ACCOUNTANT 59.95
 FIRST CLASS MAIL 55.00
 VISICORP
 DESKTOP PLAN II 189.00
 VISIPILOT 158.00
 VISITRENO/VISIPILOT 229.00
 VISIDEX 189.00
 VISITERM 79.00
 VISICALC 189.00
 VISIFILES 189.00

CP/M[®] SOFTWARE

We carry CP/M[®] software in all popular disk formats. Call for availability and price. Most software also available on IBM

SUPERFILES 170.00
 THE WORD PLUS 117.00
 d BASE II 429.00
 QUICKCODE 230.00
 DUTIL 91.00
 SUPER CALC 189.00
 SPELLGUARD 230.00
 P & T CP/M[®] MOD 2 & 16 TRS-80 175.00
 COMMX TERMINAL PROG 82.50
 PASCAL Z 349.00
 PASCAL MT+ 439.00
 PASCAL/M 295.00
 SOFTWARE DIMENSIONS
 G/L A/R/A/P/P/R 1799.00
 CONDOOR I 579.00
 CONDOOR II 849.00
 BADLIM 62.00

DIGITAL RESEARCH

MAC 89.00
 SID 69.00
 ZSID 97.00
 PL / 1-80 439.00
 C BASIC 2 96.00

SUPERSOFT

DIAGNOSTIC I 69.00
 DIAGNOSTIC II 89.00
 C COMPILER 179.00
 UTILITIES I 59.00
 UTILITIES II 59.00
 RATFOR 89.00
 FORTRAN 239.00
 DISK DOCTOR 78.00

MICROPRO

WORDSTAR 265.00
 SUPERSORT 160.00
 MAILMERGE 95.00
 DATASTAR 220.00
 SPELLSTAR 150.00
 CALCSTAR 195.00
 WORDPAK 455.00

MICROSOFT

BASIC 80 249.00
 BASIC COMPILER 299.00
 FORTRAN 80 359.00
 COBOL 80 419.00

PINBALL 17.95
 MISSILE ATTACK 18.95
 STAR FIGHTER 24.95
 SCARFMAN 17.95

TRS-80 SOFTWARE

NEWDOS/80 2 0 MOD I.III 139.00
 LAZY WRITER MOD I.II 165.00
 PROSOFT NEWSRIPT MOD I.III w/labels 109.00
 SPECIAL DELIVERY MOD I.III 119.00
 X TRA SPECIAL DELIVERY MOD I.III 199.00
 TRACKCESS MOD I 24.95
 OMNITERM SMART TERM MOD I.III 89.95
 MICROSOFT BASIC COMP FOR MOD I 165.00
 LDOS 5 1 MOD I.III 119.00

APPLE & ATARI GAMES

BRODERBUND
 APPLE PANIC 23.61
 MIDNIGHT MAGIC 27.26
 CHOPFLIFTER 27.20

AUTOMATED SIMULATIONS

INVASION ORION 20.95
 STAR WARRIOR 31.35
 CRUSH, CRUMBLE AND CHOMP 24.95
 TEMPLE OF APSHAI 31.35
 HELLFIRE WARRIOR 31.35
 RESCUE AT RIGEL 23.36

ON-LINE SYSTEMS

WIZARD AND PRINCESS 27.26
 SOFT PORN ADVENTURE 23.36
 THRESHOLD 31.16
 JAW BREAKER 23.36
 CROSSFIRE 24.95
 ULYSSES & GOLDEN FLEECE 25.95

EDU-WARE

COMPU READ 24.95
 COMPU-MATH FRACTIONS 34.95
 COMPU-MATH DECIMALS 34.95

MORE GREAT APPLE GAMES

GALAXY WAR 20.95
 ALIEN TYPHOON 20.95
 ARCADE MACHINE 32.95
 TUES MORNING QUARTERBACK 25.95
 THE DRAGON'S EYE 20.95
 COMPUTER QUARTERBACK 31.16
 SEA FOX 24.00
 THE SHATTERED ALLIANCE 49.95
 POOL 1 5 27.26
 ULTIMA 31.16
 RASTER BLASTER 23.36
 FLIGHT SIMULATOR 26.61
 INTERNATIONAL GRAND PRIX 25.95
 SARGON II 28.95
 SHUFFLE BOARD 29.95
 SPACE KADETT 28.00
 SNACK ATTACK 23.36
 THIEF 24.95
 WARS CARS 23.00
 KAMIKAZI 27.26

THE WARP FACTOR 31.16
 COSMO MISSION 23.36
 WIZARDRY 37.95
 ZORK I 28.00
 ZORK II 28.00
 DEADLINE 35.00

SIRIUS SOFTWARE

SPACE EGGS 23.36
 GORGON 31.16
 SNEAKERS 23.36
 PHANTOMS FIVE 22.00
 BANDITS 25.00

EDU-WARE

PERCEPTION PKG 19.95
 COMPU-MATH ARITHMETIC 39.95
 COMPU-SPELL (REQ DATA DISK) 24.95
 COMPU-SPELL DATA DISKS 4-8, ea 17.95
 RENDEZVOUS 28.50

ON-LINE SYSTEMS

ULTIMA II 42.00
 MISSILE DEFENSE 27.26
 SABOTAGE 20.95
 TIME ZONE 77.96
 CRANSTON MANOR 25.95
 CANNON BALL BLITZ 25.95

MUSE SOFTWARE

ROBOT WARS 32.95
 THREE MILE ISLAND 31.61
 A B M 19.46

CALL OUR MODEM LINE FOR DAILY CHRISTMAS SPECIALS IN DECEMBER.

To order or for information call

**In New York:
(212) 509-1923**

**In Los Angeles:
(213) 706-0333**

**In Dallas:
(214) 744-4251**

**By Modem:
(213) 883-8976**

Alpha Byte

COMPUTER PRODUCTS

Circle 23 on inquiry card.

31245 LA BAYA DRIVE
 WESTLAKE VILLAGE, CA 91362

We guarantee everything we sell for 30 days — no returns after 30 days. Defective software will be replaced free, but all other software returns are subject to 15% restocking fee and must be accompanied by RMA slip. No returns on game software, unless defective. We accept VISA and MasterCard on all orders. COD orders, up to \$300. Shipping charges: \$3 for all prepaid orders, actual shipping charges for non-prepays; \$3 for COD orders under 25lbs. (\$6 for over) plus a \$4 surcharge, add 15% for foreign. FPO and APO orders. Calif. add 6% sales tax in LA County add 6 1/2%. Prices quoted are for stock on hand and are subject to change without notice.

DEC. SPECIAL SALE ON PREPAID ORDERS
(CHARGE CARDS, C.O.D OR P.O.'S NOT AVAILABLE)
MUST MENTION AD FOR SPECIAL PRICES

XMAS SPECIAL SALE.
5% OFF ON SSM KITS, WAMECO BARE BOARDS, WAMECO BARE BOARDS WITH MIKOS PARTS, EXTEK KITS.



CALIFORNIA COMPUTER SYSTEMS

\$100

2032 32K STATIC RAM A & T 200 NSEC	\$468.00
2065 64K DYNAMIC RAM A & T	\$351.00
2200 S-100 MAIN FRAM A & T	\$500.00
2422A FLOPPY DISC WITH CP/M 2.2™	\$372.50
2810A Z80 CPU A & T	\$281.25
2710A 4 SERIAL I/O A & T	\$291.95
2501A 12 SLOT MOTHER BOARD	\$180.00
2720A 4 PARALLEL A & T	\$214.95
PROTO BOARDS WW	\$39.95

APPLE PRODUCTS

7114A 12K ROM/PROM	\$99.95
7424A CALENDAR/CLOCK	\$106.95
7440A PROGRAMMABLE TIMER	\$106.95
7470A A TO D CONVERTER	\$105.95
7490A GPIB (IE 488) INTERFACE	\$182.00
7710A ASYNC SERIAL	\$125.95
7712A SYNC SERIAL	\$148.50
7720A PARALLEL STANDARD	\$105.00
7720B PARALLEL CENTRONICS	\$105.00
7811B ARITHMETIC PROCESSOR W/DISC	\$325.00
7811C ARITHMETIC PROCESSOR W/ROM	\$325.00
7520A EXTENDER	\$23.50
7300A APPLE CLIP	\$8.00



MICROCOMPUTER PRODUCTS

\$100 PRODUCTS

CB-2 280 PROCESSOR BOARD	
KIT S198.95. A & T	\$269.95
VBIC 64 x 16 VIDEO. PCBD	\$ 36.95
KIT S153.95. A & T	\$199.95
VB3 80 CHARACTER VIDEO 4MHZ	
KIT S345.95. A & T	\$425.95
IO4 2 PARALLEL 2 SERIAL. PCBD	\$ 36.95
KIT \$160.95. A & T	\$199.95
PB-1 2708 2716 PROGRAMMER BOARD	
KIT \$140.95. A & T	\$189.95

APPLE PRODUCTS

AIO - II SERIAL/PARALLEL INTERFACE.	
A & T	\$178.00
ASIO SERIAL I/O	
A & T	\$115.95
APIO PARALLEL IO W/O CABLES	
A & T	\$87.95



WAMECO INC.

BOARDS WITH MIKOS PARTS

MEM-3 32K STATIC RAM. PCBD	\$36.95
KIT LESS RAM S95.95 A & T	\$135.95
CPU-2 Z80 PROCESSOR. PCBD	\$32.95
KIT LESS ROM S109.95 A & T	\$149.95
CRT-1 36 OR 24 x 80 VIDED BOARD. PCBD	\$38.95
KIT	\$249.95. A & T. \$299.95
FPB-1 FRONT PANEL. PCBO	\$48.50
KIT S144.95. A & T	\$184.95
MEM-4 65K RAM/ROM BOARD. PCBD	\$38.95
KIT LESS MEMORY	\$99.95. A & T LESS MEMORY \$129.95



MONDAY-FRIDAY, 8:00 TO 12:00. 1.00 TO 5.30
THURSDAYS, 8:00 TO 9:00 P.M.

(415) 728-9121

P.O. BOX 955 • EL GRANADA, CA 94018

PLEASE SEND FOR IC XISTOR AND COMPUTER PARTS LIST
VISA or MASTERCHARGE. Send account number, interbank
number, expiration date and sign your order. Approx. postage will
be added. Orders with check or money order will be sent post paid
in U.S. If you are not a regular customer, please use charge,
cashier's check or postal money order. Otherwise there will be a
two-week delay for checks to clear. Calif. residents add 6.5% tax.
Money back 30-day guarantee. We cannot accept returned IC's
that have been soldered to. Prices subject to change without
notice.\$20.00 minimum order. \$2.00 service charge on orders less than
\$20.00.

IC Number	Type	Schematic Section	+ 5 V	GND	+ 12 V	-12 V
IC48	8237A-5	1(1-3b)	31	20		
IC49	74LS245	1(1-3a)	20	10		
IC50	74LS373	1(1-3a)	20	10		
IC51	8288	1(1-3a)	20	10		
IC52	74LS154	2(2-2)	24	12		
IC53	74LS245	3(2-3)	20	10		
IC54	74LS243	1(1-3b)	14	7		
IC55	74LS08	1(1-3ab),5(3-2)	14	7		
IC56	74LS32	1(1-3a)	14	7		
IC57	74LS08	3(2-3)	14	7		
IC58	74LS74	3(2-3),4(3-1)	14	7		
IC59	74LS280	3(2-3)	14	7		
IC60	8255A-5	4(3-1)	26	7		
IC61	8253-5	4(3-1)	24	12		
IC62	8259A	1(1-3a)	28	14		
IC63	74LS14	1(1-3a),3(2-3)	14	7		
IC64	74LS32	2(2-2),3(2-3)	14	7		
IC65	74LS158	3(2-3)	16	8		
IC66	74LS14	3(2-3)	14	7		
IC67	74LS32	3(2-3)	14	7		
IC68	74LS158	3(2-3)	16	8		
IC69	74LS393	4(3-1)	14	7		
IC70	8251A	4(3-1)	26	4		
IC71	8251A	4(3-1)	26	4		
IC72	1489	4(3-1)	14	7		
IC73	1489	4(3-1)	14	7		
IC74	74LS139	3(2-3)	16	8		
IC75	74LS00	1(1-3b)	14	7		
IC76	74LS14	4(3-1)	14	7		
IC77	7407	4(3-1)	14	7		
IC78	7407	4(3-1)	14	7		
IC79	1488	4(3-1)		7	14	1
IC80	1488	4(3-1)		7	14	1
IC81	74LS08	3(2-3)	14	7		
IC82	EPROM	3(2-3)	28,1*	14		
IC83	EPROM	3(2-3)	28,1*	14		
IC84	EPROM	3(2-3)	28,1*	14		
IC85	EPROM	3(2-3)	28,1*	14		
IC86	4164	3(2-3)	8	16		
↓	↓	↓	↓	↓		
IC121	4164	3(2-3)	8	16		

* depends on type of EPROM used

Table 2: Continued from page 56.

and a floppy-disk bootstrap-loader routine.

RAM Configuration

The onboard user-programmable memory of the MPX-16 consists of one to four 64K-byte banks of nine type-4164 64K-bit dynamic RAM devices. Within the 8088 processor's 1-megabyte address space, the

MPX-16 must have at least the lowest 64K-byte bank of RAM (bank 0) installed from hexadecimal addresses 00000 to 0FFFF so that interrupt-routine pointers can reside in the locations from hexadecimal 00000 to 003FF. The RAM chips are required to have an access time of no more than 200 ns and a cycle time of 335 ns. Single-bit parity generation and

SHARED WINCHESTER DISK!

The *NEXT STEP* from **TECMAR**

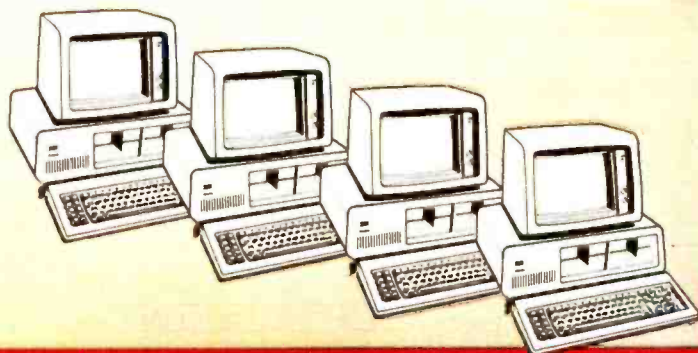

Now, Up to FOUR IBM Personal Computers Can Share the Same PC-MATE Winchester Disk System.

Give each Personal Computer a complete logical device for total READ/WRITE freedom, or they can all share a device for READ Only applications.

All PC-MATE WINCHESTER/5™ and WINCHESTER/10™ disk systems now feature the new ultra fast GT DMA disk controller. This new controller not only provides superior performance, it can serve as the base unit for the Shared Disk Facility.

The WINCHESTER/5™ is \$2995 and WINCHESTER/10™ is only \$3995. Each additional PC to share the disk needs only a PC-SHARE™ adapter at just \$495.

An Expansion Chassis, Five or Ten Megabyte Winchester Disk, Superior performance and Disk Sharing are just a few reasons why the PC-MATE™ Winchester Disk System should be your next step.

ALL IN ONE™ EXPANSION FOR THE IBM PERSONAL COMPUTER. Memory, Serial, Parallel, Clock/Calendar with Battery and more!!!

PC-Mate™ by TECMAR, the first and only complete line of expansion options for the IBM Personal Computer, now brings you the ultimate expansion product, the ALL IN ONE™ Board.

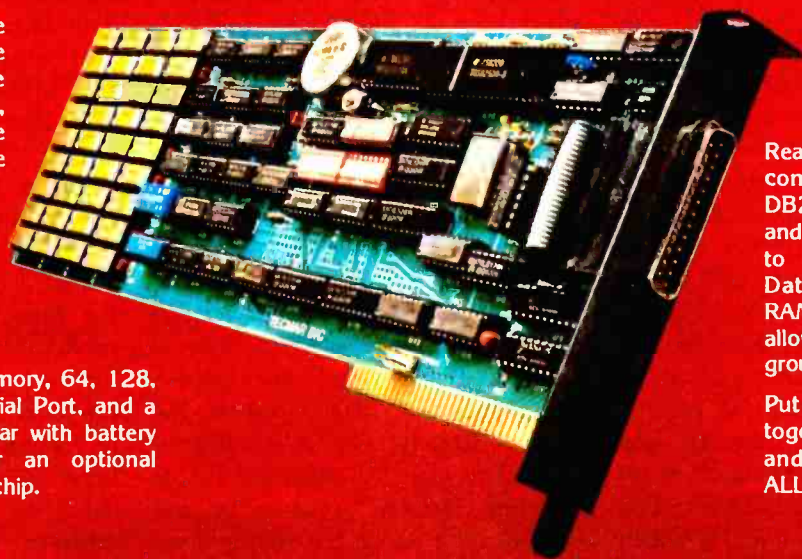

ALL IN ONE™ gives you memory, 64, 128, 192 or 256K bytes, a Serial Port, and a Parallel Port, Clock/Calendar with battery backup and circuitry for an optional Programmable Array Logic chip.

Ready to use, ALL IN ONE™ comes complete with the DB25 connectors on Serial and Parallel Ports, Software to set system Time and Date, and the popular RAMSPooler™ utility to allow printing as a background task.

Put all of these features together with these prices, and you really have it ALL IN ONE™

\$565. - 64K Bytes \$735. - 128K Bytes \$875. - 192K Bytes \$975. - 256K Bytes

Tecmar is currently shipping over thirty different expansion products including Memory, Winchester Disks, Communications Interfaces, Laboratory/Scientific/Industrial products and more!

*For IBM Personal Computer Expansion,
The Next Step . . . TECMAR.*

Call or write for product specifications and the name of your nearest participating Computerland and other fine PC-Mate Retailer internationally.

Tecmar Inc.

PERSONAL COMPUTER PRODUCTS DIVISION
23600 Mercantile Road, Cleveland, Ohio 44122
Telephone: (216) 464-7410 Telex: 241735

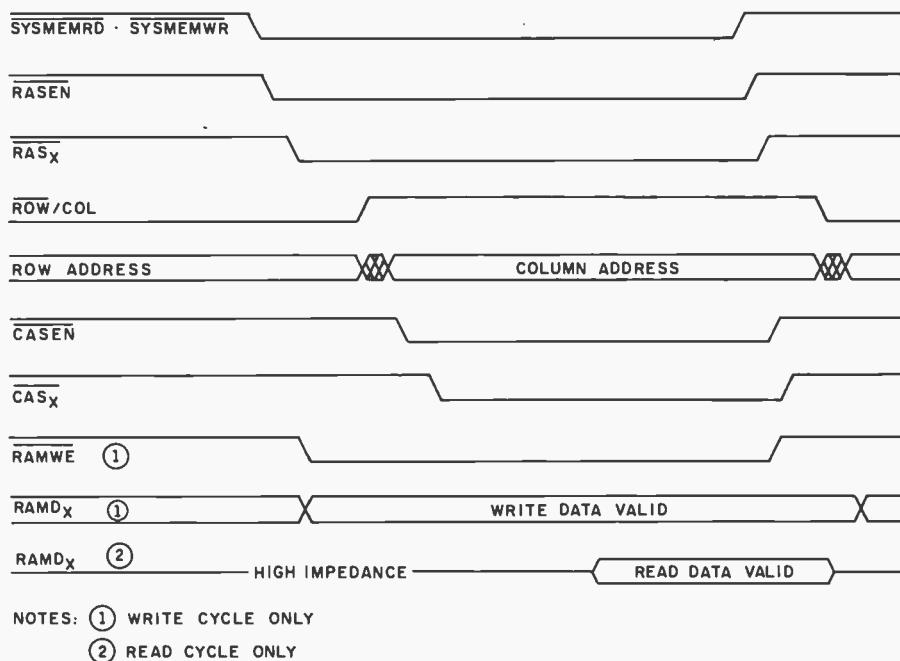

Figure 4: Timing diagram for the memory operation of the MPX-16.

error detection are provided for all of the 256K-byte onboard memory.

The RAM address-decoding logic is shown in section 2 of the schematic diagram (figure 2), and the read/write control logic, address multiplexers, RAM array organization, and parity-generation/error-detection logic are shown in section 3 (figure 3). The onboard RAM address space is selected when two conditions are met: the two high-order address bits SYSA18 and SYSA19 are both low and a memory-refresh cycle is not in progress (shown by DMACK0, the DMA-channel-0-acknowledge signal, being low). Because of this decoding scheme and the fact that the MPX-16 power-on self-test routine automatically clears memory and determines its size, the full 256K bytes of onboard RAM should be installed before you put in additional RAM in the I/O-expansion slots.

Dynamic Memory Refresh

Because dynamic RAM devices are used for the MPX-16's programmable memory, a memory-refresh circuit is necessary to prevent data stored in them from being lost. The 64K-bit dynamic RAMs require that all 256 rows be addressed every 4 ms (milli-

seconds) to maintain the integrity of the data (the columns need not be individually addressed); one row must be addressed for refreshing approximately every 15 μ s (microseconds). To eliminate having a separate bus-arbitration circuit for this purpose, memory refresh is carried out by executing a DMA (direct memory access) read cycle in a "RAS-only" manner—that is, using only the row-address-strobe inputs of the memory chips. Because refresh is controlled by the DMA circuit, there can never be a conflict between the refresh operation and the processor's memory references.

The DMACK0 signal goes active-low to indicate to the rest of the system that a refresh cycle is in progress. This signal disables the RAM-decoding circuitry, prevents the generation of a CAS (column-address-strobe) signal, and enables the REFRESHRAS input at IC64 pin 2 (in section 3, figure 3). When the system bus master, the 8237A DMA controller (IC48 in section 1, printed last month), drives the SYSMEMRD or SYSMEMWR (system memory write) line low, the output at IC 64 pin 3 also goes low. This causes the outputs of the four two-input gates (sections

of IC81: positive AND gates used as negative ORs), whose other input comes from IC74, to go low. These outputs form the RAS inputs for each of the four RAM banks. (The 33-ohm series resistors in the RAS control lines are there to reduce ringing on the lines, which might latch a new row address during the middle of the memory cycle.) The DMA controller is set up by the system-initialization software to automatically increment the address counter after each refresh-memory cycle.

Memory Operation

A diagram of typical timing cycles for normal memory-read and write operations is shown in figure 4. For either type of memory cycle, the read/write-control logic is enabled when the DRAMSEL signal is low, indicating that two conditions have both been fulfilled: a valid address (lower than hexadecimal C0000) has been latched on the system bus and the DMACK0 signal (from IC63, pin 6) is low (indicating that a refresh cycle is not in progress).

A memory cycle is initiated when the output of an AND gate (IC57 pin 3 in section 3) goes low, indicating that either the SYSMEMRD or the SYSMEMWR control signal has been driven low by the system bus master. The RASEN (RAS enable) signal at IC67 pin 11, produced from the output of IC57 ORed with DRAMSEL, enables the 1-of-4 (2- to 4-line) decoder IC74 to select one of the four lines RAS0, RAS1, RAS2, or RAS3 (row-address-input enable for each of the four banks—which one is selected depends on the logic levels of the SYSA16 and SYSA17 address lines) and sets up the row address on the multiplexed memory-address lines RAMA0 through RAMA7. A chain of Schmitt-trigger inverter sections, IC63 and IC66, delays the active-low output from IC57 pin 3 by five gate-delay periods, holding the row-address condition until the type-4164 memory chips have had sufficient time to latch the address bits.

When the ROW/COL signal goes high (column addressing active), the

CHAMPIONSHIP PERFORMER..

The PERSYST SPECTRUM[®] MULTI-FUNCTION BOARD

Whether it's getting the most out of a down hill run or getting the most out of your IBM[®] PC, performance counts...and PERSYST's SPECTRUM is the champion performer.

Up to 256 KBytes RAM, two Async Serial ports and a Parallel printer port...all on one IBM PC-compatible board. And, all four options are upgradable with low-cost field expansion kits.

SPECIAL HOLIDAY OFFER!!! **\$100 worth of Software FREE.**

Buy a SPECTRUM board between Nov. 26 and Dec. 31 and get PERSYST's INSTA-DRIVE[®] memory resident disk simulator and WAIT-LESS PRINTER[®] software print spooler programs FREE! (Retail value is \$100.)

Take advantage of this special Holiday offer. Simply present the coupon to your local participating computer dealer. He'll do the rest.

PERSYST

PERSONAL SYSTEMS TECHNOLOGY, INC.
15801 Rockfield, Ste. A, Irvine, CA 92714
714-859-8871

Circle 375 on inquiry card.

PERSYST HOLIDAY SPECIAL



FREE INSTA-DRIVE[®] and WAIT-LESS PRINTER[®] Software
with every SPECTRUM[®] Multi-function board purchased between Nov. 26 and Dec. 31, 1982.

multiplexers change the contents of RAMA0 through RAMA7 to the column address derived from the system-address-bus lines SYSA8 through SYSA15. The CASEN signal enables the B outputs of the 1-of-4 decoder IC74, which drives the CAS-control line for one of the memory banks.

The data-input and data-output lines of each RAM chip are tied together onto a common bidirectional memory-data line. The entire RAM array is isolated from the system data bus by bus transceiver IC53, which is enabled by the DRAMSEL signal during nonrefresh memory cycles, allowing data to pass between the RAM array and the system data bus.

The direction of data flow is controlled by the output of IC67 pin 6, a logical OR of DRAMSEL and SYSTEMMRD. During memory-read cycles, this signal is low, causing the data on the memory data bus to be transferred to the system data bus. During memory-write cycles, the

direction signal is high and the data flow is from the system data bus to the memory data bus.

Parity Checking

Until the introduction of the IBM Personal Computer, memory with parity checking was rare in personal computers but had been used for years in larger computers. IBM did well to copy this feature of larger machines, since the constant decreases in memory prices have made it more and more cost-effective. The MPX-16 also incorporates parity memory for increased system reliability and user confidence. Parity generation and checking in the MPX-16 are provided by a 74LS280 parity generator (IC59) and a type-D flip-flop (IC58), shown in figure 3 on page 54.

During a memory-write cycle, the PARITYOUT signal presented to pin 8 of IC59 is low, because the output of IC57 (an AND gate) is disabled by the low state of the active-high

SYSTEMMRD signal. The parity bit computed by IC59 from the eight RAM data lines is written into the parity-bit memory chip (the ninth one of each bank) for the bank being addressed.

When a memory-read cycle occurs, the output of IC57 is enabled, and the parity bit that was previously written for each byte is routed to IC59 and used to check for an error in the parity value. When the rising edge of the signal from IC67 pin 6 (DRAMSEL OR SYSTEMMRD) is detected by the flip-flop IC58, it latches parity value.

When no parity error is present, the odd-parity output (ΣO) of the 74LS280 will be a logic high state. When an error does occur, the odd-parity output will be low. The PARERR signal from IC58 is sent to the NMI (nonmaskable interrupt) logic and will remain set until the next memory-read cycle for which no parity error occurs, or until the flip-flop is preset by a low state on the CLRPAR (clear parity) line, IC58

Circle 386 on inquiry card.

Porta Sys™ - A Z8 Microprocessor System

by  ProtoSys

Development System, General Purpose Controller,
OEM Dedicated Controller

- Zilog Z8 with built in tiny basic interpreter, low power
- 24 programmable I/O lines
- RS 232 - compatible with most terminals
- 110 - 9600 band switch selectable
- Memory selectable for 4K by 8 RAM, 2716 EPROM (5V) or 2732 EPROM
- Memory capacity up to 36K on board - 480K expandable
- All expansion lines buffered for system Buss operations
- 72 pin double row (36 pin per side) .100 in. spacing gold plate over nickel
- Mainframe - 3 card capacity, +5 VDC, ±12 VDC
- AC input 120V 60Hz; 220V 60Hz available

Z8 CPU Card w/4K RAM (4.5 in. x 6.75 in.)	PR-1000	\$195.00
Memory Expansion ICs for the CPU Card(Per 4K)	EX-6132	35.00
Mainframe	PR-1001	149.00
Eprom Zapper	PR-1002	79.00
Optional Zero Insertion Socket		8.00
9 Slots Motherboard (5 in. x 12 in.) with 18 slots expansion capability	PR-1003	149.00
Ram-Eprom Expansion Board with 16K Ram	PR-1004	249.00
16K Cmos Ram Expandable to 32K with battery Backup	PR-1005	195.00
Expansion of Cmos Ram board to 32K	EX-6116	99.00
AD/DA Converter-Amplifier with I/O Board	PR-1006	149.00
Switching Power Supply with (SIZE: 1 in. H x 2.5 in. W x 3.5 in. D) +5v @ 5amps, +12v @ 1amp, -12v @ 1amp	PR-1010	99.00
Linear Power Supply with 5 outputs (Size: 4.5 in. W x 4.5 in. H x 10 in. D) +5v @ 3A, -5v @ 3A, +12v @ 1A, -12v @ 1A, +12v @ 1A	PR-1015	99.00

Availability-Stock to 2 weeks, California Residents-
please add 6.5% Sales Tax, Shipping and Handling Charges: UPS - \$5.00 UPS Blue Label - \$8.00
C.O.D. - Add \$5.00 in addition to above

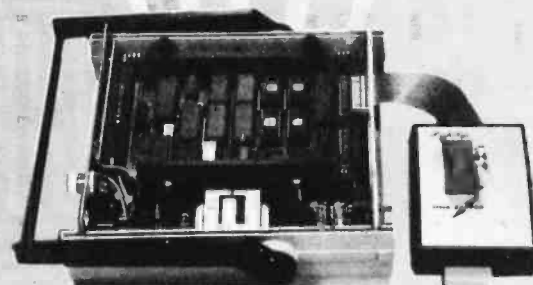
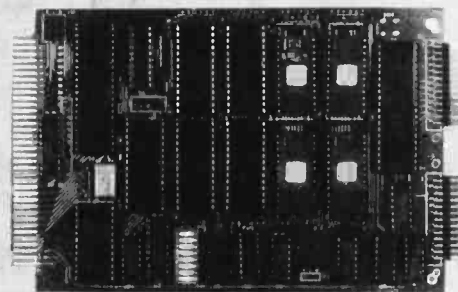

 ProtoSys

P.O. Box 23698 • San Jose, CA 95123 • Tel: (408) 226-2131



Vista Da Vinci

GREAT INNOVATORS



In Italy in the 15th century Leonardo Da Vinci was a multi-talented genius. Leonardo's ideas and designs were endless. He was always creating new devices to solve the world's problems. Pictured here are many studies for military arms and armor and battlements.

Today Vista is developing many high technology computer peripherals for use with IBM™ and Apple Computers. The final evolutionary stage in Apple disk storage, Quartet offers you the capacity of 4 Apple Disk Drives in the volume of one. Quartet's low profile styling has been developed to blend in with the profile and style of your Apple II Computer.

Quartet uses 2 Double Sided Thinline disk drives to give you over 640K of storage. With the included Quartet Controller & Software, your Computer can handle much larger tasks

than before. When using protected software, the Quartet operates just like 2 Apple Disk Drives, and will operate with ALL Apple compatible software.

The Quartet system is the COMPLETE, one-stop solution to your storage requirements on the Apple or Apple Compatible Computer. No other two-drive package offers as much value at any price. And the Quartet offers all this with a price comparable to single drive, single sided systems.

Features: • Thinline Drives for low profile • 2 Double Sided Drives for 640K Storage • Quartet Controller for Single/Double Sided Operation • Emulates Apple Disk II under a single sided mode • Boots & Runs All Apple Software • Double Sided, 40 track Patch software for DOS, CP/M*, & Pascal • Full Vista 120 Day Warranty

Contact Your Local Vista Dealer or Call our Vista Hotlines.

Vista

COMPUTER
COMPANY, INC.

1317 East Edinger / Santa Ana, CA 92705
(714) 953-0523 / (800) 854-8017

DISTRIBUTORS / REPRESENTATIVES

Western - Group 3 Wholesale
(213) 973-7844 (408) 732-1307
South Central - M.P. Systems
(214) 385-8885
UK - Haj Computers Ltd.
(0252) 517175 / TWX: 858404

Northeast - Computers & Peripherals Inc.
(315) 476-6664
Florida - Audio Marketing (REP)
(305) 322-8327
Central - Wyatt & Associates
(317) 773-4791

Circle 485 on Inquiry card.



Vista Quartet

* CP/M is a trademark of Digital Research, Inc.

™ IBM is a registered trademark of International Business Machines.

board the bus

INDUSTRIAL QUALITY BOARDS FOR THE IEEE-696/S-100 BUS

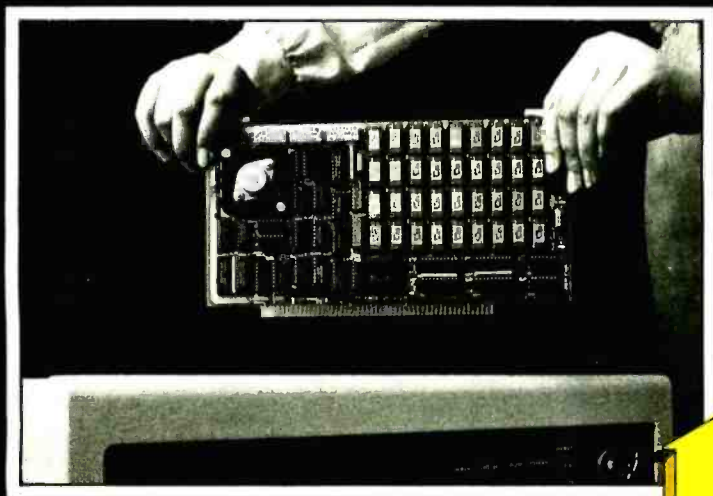

CPU GROUP

CPU 68000

- MC68000 processor
- 8 MHz operation
- 16-Mbyte addressing
- Single-user

CPU 68000M

- MC68451 MMU
- Segmented memory management
- Multi-user

MEMORY GROUP

EPROM

- 32/64K ROM
- 16-bit data paths
- 24-bit addressing

CMEM

- 8K/16K/32K CMOS
- 6 MHz for 8/16-bit
- Non-volatile with Li battery

DMEM

- 256K dynamic RAM
- 24-bit addressing
- 230 ns access

I/O GROUP

CLK-24C

- Real time clock
- LSI CMOS chip
- Li battery backup

SIO4

- 4-port serial I/O
- 256 bytes of FIFO
- DMA transfers
- 24-bit memory addr.

ANALOG GROUP

VIC 4-20

- 4 channels
- 20 mA outputs
- 12-bit performance
- Accepts AOM-12 inputs

AOM-12 (D-to-A)

- 12-bit $\pm 1/2$ L.S.B.
- 0-10V, $\pm 5V$, $\pm 10V$ jumper select outputs

AIM-12 (A-to-D)

- 32 S.E. channels
- 25 μ -sec conversion
- 12-bit resolution

IEEE-696/S-100 BUS



Sales representatives in most metropolitan areas.

OEM and Dealer pricing is available.

system reliability/system integrity

2530 San Pablo Avenue • Berkeley • CA 94702 • (415) 549-3854 • 172029 SPX

pin 4. Software called through the interrupt vector then notifies the user of a memory error.

Interrupt Advantages

The versatility of any computer system is enhanced if its processing can be interrupted by outside events so that it doesn't have to continually keep track of what is going on in the outside world. The MPX-16 supports an interrupt system with 16 levels of interrupt priority, for a high degree of versatility in dealing with the external environment.

Perhaps the major advantage to using interrupts is the increase in throughput resulting from their use in handling the system I/O functions. Instead of the processor's spending a great deal of time checking to see if I/O devices are ready to transfer data or waiting for them to be ready, in an interrupt-driven system the processor can continue executing its application program, only suspending execution to attend to an I/O device when the device signals that it is actually ready for data transfer.

Although it can be tougher to debug, interrupt-driven software is generally more compact and efficient than that which must explicitly check I/O devices by polling or waiting. But we don't have space here to discuss the software aspects at length.

MPX-16 Interrupt Logic

The interrupt structure of an 8088-based system revolves around an interrupt-vector lookup table located low in system memory from location hexadecimal 00000 through 003FF. Each interrupt vector in the table consists of 4 bytes that point to the address of an interrupt-service routine. Up to 256 interrupt vectors, numbered from decimal 0 to 255, can be used to specify starting addresses of interrupt routines anywhere in the 8088's 1-megabyte address space. Each of the interrupt vectors is assigned an interrupt-type number that points to its location in the lookup table. The type number multiplied by 4 equals the offset of the vector from location 00000.

The highest priority interrupt is the

Now for Concurrent CP/M-86

VEDIT - The Clear Choice for Programmers

Plus Features for Fast & Efficient Word Processing

Increasing your productivity is what a good text editor is all about. VEDIT excels by giving you a unique combination of extensive and easy to use editing features, customizability and complete hardware support. So compare VEDIT. You'll find everything you expect in a good editor plus a variety of time saving features which only VEDIT offers.

VEDIT is fully user oriented. You can use the function keys on any keyboard, or a layout you are already familiar



with - simplifying your usage and easing your learning. While most editors lose text if you run out of disk space, VEDIT lets you delete files or change disks. VEDIT is the result of continuous en-

hancement and feedback from our nearly four thousand licensed users.

For program development it surpasses any other editor - with more extensive file handling, important command macro capability and special features for Pascal, PL/1, 'C', Cobol, Assembler and others. With VEDIT you will reduce your program editing time by 30% as compared to the best word processor.

For word processing, VEDIT has word wrap, adjustable margins, reformatting of paragraphs, word and paragraph functions and simple printing with imbedded printer control characters.

Command macros let you perform editing tasks you might otherwise not even attempt. Time consuming tasks for other editors (such as translations or extensive search/replace on many files), can be done by VEDIT without your intervention, even overnight if you choose.

VEDIT supports all of the new CRT terminals, video boards and 8080, Z80 and 8086 computers. We have been consistently first to support new computers - first for CP/M-86, first for MSDOS. And we will support you with any technical assistance you may need.

For the full story, purchase VEDIT risk free. Evaluate the 125 page manual and if you are not satisfied, return the package (disk unopened) for a courteous refund.

CP/M and MP/M are registered trademarks of Digital Research Inc. WordStar and WordMaster are registered trademarks of MicroPro International Corporation. Apple II is a registered trademark of Apple Computer, Inc. MS-DOS and Softcard are trademarks of Microsoft. TRS-80 is a trademark of Tandy Corporation. IBM is a trademark of International Business Machines.

Circle 130 on inquiry card.

COMPARE VEDIT

Feature	VEDIT	WordMaster	WordStar
True Full Screen Editing	Yes	Yes	Yes
Edit files one disk in length	Yes	Yes	Yes
Compact and fast	Yes	Yes	No
Display of line and column #	Yes	No	Yes
Set/Goto text markers	Yes	No	Yes
'Undo' key to restore line	Yes	No	No
Automatic Indent/Undent	Yes	No	No
Adjustable tab positions	Yes	No	Yes
Repeat function key	Yes	Yes	No
Text move and copy	Yes	Yes	Yes
Scratchpad buffers	10	Only 1	No
Load/Save buffers on disk	Yes	No	No
Flexible command mode	Yes	Yes	No
Multiple command macros	Yes	No	No
Directory display	Yes	No	Yes
Edit additional (small) files simultaneously	Yes	No	No
Insert another disk file	Yes	Yes	Yes
Unlimited file handling	Yes	No	No
Automatic disk buffering	Yes	Yes	Yes
Recovery from 'Full Disk'	Yes	No	Some
Change disks while editing	Yes	No	No
Startup command file	Yes	No	No
Program CRT function keys	Yes	No	No
Word Wrap and reformatting	Yes	No	Yes
Printing	Simple	No	Extensive
Print formatting	No	No	Yes
Menu driven installation	Yes	No	Yes
Support newest CRT terminals	Yes	No	No
Support smart CRT functions	Yes	No	Some
Customizable keyboard layout	Yes	No	No
Available for CP/M-86	Since 1981	?	?
Available for MSDOS	Since 1981	?	Yes

Please specify your microcomputer, video board or the CRT terminal version, 8080, Z80, or 8086 code, operating system and disk format.

VISA & MasterCard

VEDIT - Disk and Manual	
For 8080, Z80 or IBM PC	\$150
For CP/M-86 or MSDOS	\$195
Manual only	\$18

Zenith Z100 and Z89 • DEC VT180 • Televideo 802
 TRS-80 I, II and 16 • Xerox 820 • Apple II Softcard
 SuperBrain • NorthStar • Cromemco • Altos • Vector
 MP/M • CP/M-86 • MP/M-86 • MSDOS • PCDOS

IBM Personal Computer and IBM Displaywriter

CompuView

PRODUCTS, INC.

1955 Pauline Blvd., Suite 200 • Ann Arbor, Michigan 48103 • (313) 996-1299

IN AUSTRALIA DISTRIBUTED BY SOFTWARE SOURCE PTY. LTD.
 89 OXFORD ST., BONDI JUNCTION, SYDNEY - (02) 389-6388

nonmaskable-interrupt (NMI) input at pin 17 of the 8088 microprocessor, IC36. This signal is an internally synchronized edge-triggered input which causes a predefined "type-2" interrupt that "vectors" (passes control) to the location identified by the eighth position in the table. Although the 8088's NMI input is not directly maskable by software, the MPX-16 contains extra hardware that can mask the interrupt signal before it gets to the 8088, given proper setup by the soft-

ware. The NMI input is used to report system memory-parity errors and errors from the I/O-channel expansion slots.

The next 15 levels of interrupts are implemented by two Intel 8259A programmable interrupt controllers (PICs), IC35 and IC62 in section 1 of the schematic diagram, which was printed in last month's article. One of the programmable interrupt controllers, IC35, serves as the master and resides on the multiplexed local

bus shared with the processors. The other, IC62, is a slave device to IC35 and resides on the system bus. The master/slave configuration is set up during the initialization process by software.

All of the peripheral devices residing on the system board, such as the serial and parallel I/O-port controllers, are supported by interrupt-request lines on the 8259A PICs. Interrupt requests from the PICs drive the INTR input of the 8088 (pin 18). This signal is a level-triggered input that can be internally masked by a software instruction. Interrupts requested by the INTR input do not have predefined vector types as does the nonmaskable interrupt. In the case of the 8259A PIC, a consecutive block of eight interrupt types, one for each of the eight interrupt-request input pins, is programmed into the device by the system software as part of the initialization process when the power is turned on.

Handling Interrupts

When an interrupt signal is received on the 8088's INTR pin, the processor enters an interrupt-acknowledge cycle that is used to determine the interrupt type. First the processor preserves what it was doing when interrupted: the state of the machine is saved by pushing the contents of the flag register, code-segment register, and instruction pointer onto the stack. In addition, the interrupt flag is cleared, disabling further interrupts from occurring until the processor is ready for them. (If nested interrupts are desired, the interrupt-service routine must re-enable the processor to receive interrupts, while ensuring that the most crucial tasks are not delayed until too late. The programming is not easy.)

In the next step, the 8288 bus controller (IC51) issues two interrupt-acknowledge pulses on the INTA line. The first pulse signals the 8259A PICs that the interrupt request is being granted. When the second INTA pulse is issued, the 8-bit code for the interrupt type is placed onto the data bus. The value of the interrupt type is multiplied by 4 (simply by being shifted left 2 places) to determine the

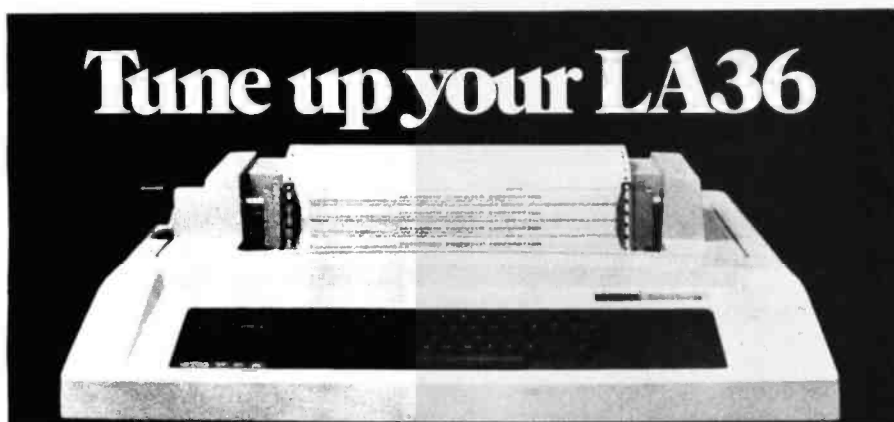

The DS120 Terminal Controller makes your LA36 perform like a DECwriter® III.

The Datasouth DS120 gives your DECwriter® II the high speed printing and versatile performance features of the DECwriter® III at only a fraction of the cost. The DS120 is a plug compatible replacement for your LA36 logic board which can be installed in minutes. Standard features include:

- 165 cps bidirectional printing
- Horizontal & Vertical Tabs
- Page Length Selection
- 110-4800 baud operation
- 1000 character print buffer
- X-on, X-off protocol
- Self Test
- RS232 interface
- 20 mA Current Loop interface
- Top of Form
- Adjustable Margins
- Double wide characters
- Parity selection
- Optional APL character set

Over 5,000 DS120 units are now being used by customers ranging from the Fortune 500 to personal computing enthusiasts. In numerous installations, entire networks of terminals have been upgraded to take advantage of today's higher speed data communications services. LSI microprocessor electronics and strict quality control ensure dependable performance for years to come. When service is required, we will respond promptly and effectively. Best of all, we can deliver immediately through our nationwide network of distributors. Just give us a call for all the details.

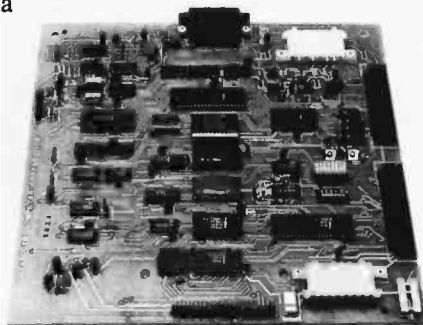

datasouth computer corporation

4216 Stuart Andrew Blvd. • Charlotte, North Carolina 28210 • 704/523-8500

Memory Loss is Now Just a Memory

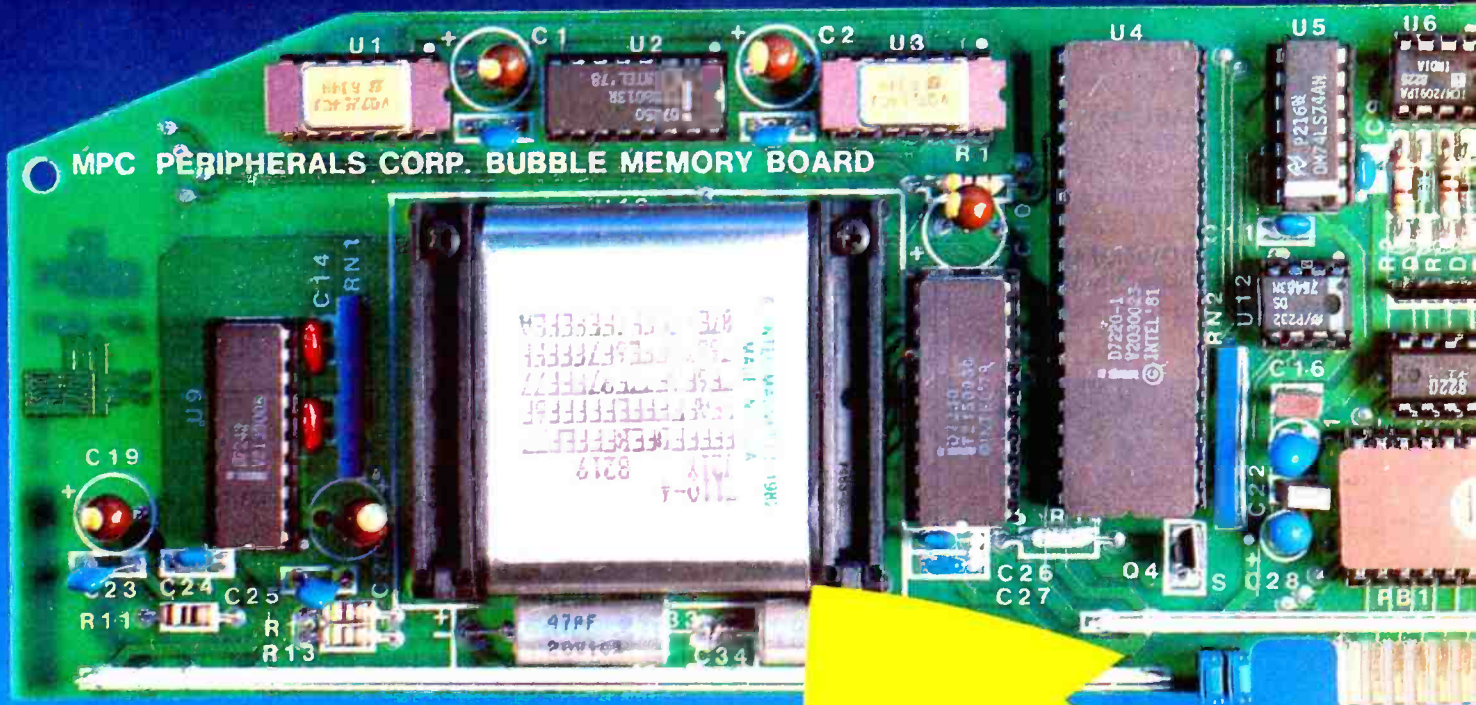

- 128K NON-VOLATILE MEMORY
- NOT AFFECTED BY ENVIRONMENTAL HAZARDS
- 3 TIMES FASTER THAN FLOPPY DISK
- 1000 TIMES MORE RELIABLE THAN DISK
- BOOTS DIRECTLY FROM BUBDISK™
- REPLACES THE DISK DRIVE
- TWO YEAR "NO HASSLE" WARRANTY

The BUBDISK™ executes DOS commands three times faster than a standard floppy disk drive and uses less power. It operates quietly, efficiently and error free in any hostile environment.

The rugged, solid state bubble is totally non-volatile and unlike disk, there are no moving parts to wear. Error correction circuitry plus automatic power down in the event of brown-out or outright power failure ensures absolute data storage reliability.

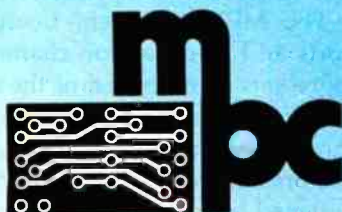

MPC Peripherals Corp.
9424 Chesapeake Drive
San Diego, CA 92123
619-278-0630
TWX 910-335-1177

Circle 330 on Inquiry card.

BUBDISK is a trademark of MPC Peripherals.

intel®
Bubbles

Nothing
Moves but
Information

THE ULTIMATE IEEE/S-100 MEMORY WOULD...

- BE NONVOLATILE**, holding data for up to eight years with the power off.
- RUN AT 6MHZ** without wait states.
- HAVE EXTENDED 24-BIT ADDRESSING** and bank select.
- HAVE DYNAMICALLY MOVABLE WRITE PROTECT AREAS** to prevent accidental erasure of programs and critical data.
- GENERATE POWER-FAIL** interrupts for orderly system shutdown & power failure recovery.



CMEM

AVAILABLE NOW FROM DUAL SYSTEMS, the CMEM memory boards combine high-speed CMOS memories with a new 5-8 year lithium battery. The CMEM offers the nonvolatility of an EPROM board while retaining the instant writability of a high-speed read/write RAM. These industrial grade boards are subjected to a 168-hour burn-in and a 1000-cycle power interruption test to insure data retention and the highest degree of reliability possible.

- CMEM-32K, 32K Bytes \$695
- CMEM-16K, 16K Bytes \$595
- CMEM- 8K, 8K Bytes \$495



DUAL SYSTEMS CORPORATION
 2530 San Pablo Avenue • Berkeley
 CA 94702 • (415) 549-3854 • 172029 SPX

Priority Level	Source	Signal Name	Description
0	NMI	PARERR or IOCHNLERR	memory-parity or I/O-channel errors
1	master	TIMEINTR	real-time clock
2	slave	SIO0RXRDY	serial-channel-A receive ready
3	slave	SIO1RXRDY	serial-channel-B receive ready
4	slave	SIO0TXRDY	serial-channel-A transmit ready
5	slave	SIO1TXRDY	serial-channel-B transmit ready
6	slave	PRINTRDY	printer-port ready
7	slave	FDCINT	floppy-disk-controller interrupt
8	slave	NPXINT	numeric-processor-extension (8087) interrupt
9	slave	PIOINT	parallel-I/O-port interrupt
10	master	IRQST2	I/O-channel interrupt
11	master	IRQST3	I/O-channel interrupt
12	master	IRQST4	I/O-channel interrupt
13	master	IRQST5	I/O-channel interrupt
14	master	IRQST6	I/O-channel interrupt
15	master	IRQST7	I/O-channel interrupt

Table 3: *Interrupt signals in the MPX-16, listed in order of priority. Priority-0 errors go through the 8088's NMI input, while the rest go through either the master or the slave 8259A interrupt controller.*

address of the interrupt vector. Program control is then transferred to the address contained in the 4 bytes of the interrupt vector. Note that the first 2 bytes are used as the new instruction pointer (lower 16 bits of the address) and the second 2 bytes are used to form the new code-segment register (upper 16 bits). When the interrupt-service routine has completed execution, control is returned to the main program via an IRET instruction, which pops the original flag and address information off the stack into the active registers. The main program then resumes execution where it left off, with the interrupts reenabled.

Interrupt Priorities

The organization of the system-board interrupt-priority scheme is shown in table 3. The highest priority hardware interrupt, as we've seen, is the NMI, which is caused by memory-parity or I/O-channel errors. The highest priority maskable interrupt is from the IR0 input of the master 8259A PIC, which is generated by the real-time clock. The next eight interrupts in priority come from peripheral devices attached to the slave 8259A PIC, which is in turn attached to the IR1 input of the master 8259A.

The last six interrupts come from the I/O-expansion-channel connectors. These interrupts drive the IR2 through IR7 inputs of the master 8259A.

Two other points concerning the 8259A PICs should be noted. Although a priority has been assigned to each interrupt-request input of the 8259A PICs, these can be changed by the system software. In addition, the 8259A PICs can even be used to implement a polled I/O system. (These devices provide considerable flexibility for handling I/O servicing at a relatively low hardware cost.) And finally, all of the interrupt-service routines in the MPX-16 system can be invoked via a software-interrupt instruction that specifies the interrupt type. This can be useful in starting an I/O device and in debugging the interrupt routines.

I/O-Expansion Channels

The MPX-16 system board supports an I/O-expansion channel that represents an extension of the system bus. Peripheral devices are connected through several 62-pin card-edge connectors like those used by peripherals designed for the IBM Personal Computer. The MPX-16 computer system

Performance Breakthrough...

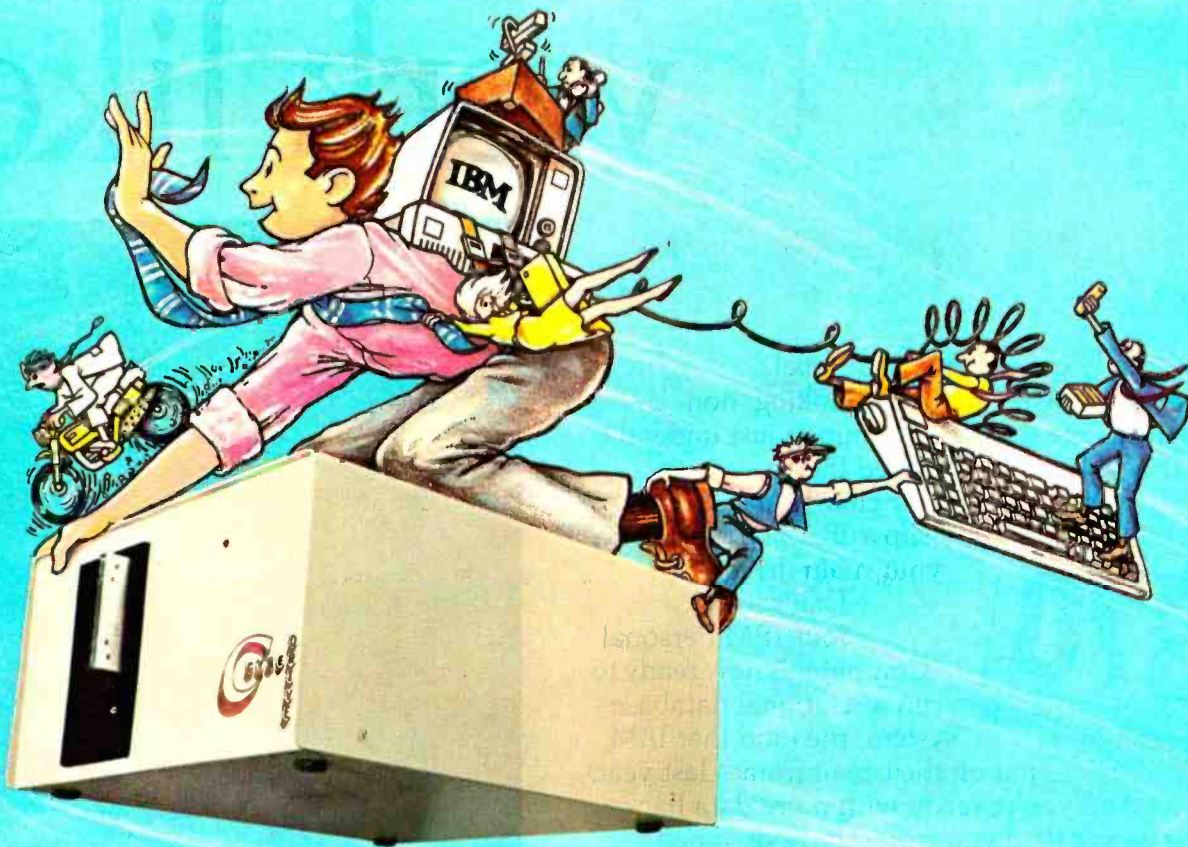

... the **CYBERDRIVE™** for the IBM Personal Computer

13.5 or 27 million bytes of disk capacity in a single cabinet with an integrated mini-cartridge tape for secure data backup.

Setting an exciting new microcomputer standard, the **CYBERDRIVE**¹ combines a full package of features.

It offers new, higher performance levels, with an integrated business-oriented backup device.

As the **CYBERDRIVE** is made available for other systems, media transfer is assured regardless of the host hardware or Operating System.

The **CYBERDRIVE** slashes the seek time dramatically—e.g. the usual 5 Megabyte stepper-motor Winchester disk offers average seek time typically in the range of 100 to 200 milliseconds (incl. head settling).

With the **CYBERDRIVE**, the average seek time across more than five times as much data is only 33 milliseconds (incl. head settling).

This basic speed, coupled with disk cache buffering and a peak transfer rate of 1 million bytes per second, make the **CYBERDRIVE** a performance champ!

The integrated mini-cartridge tapes used for backup of data allow dumping of (for example) 10 million bytes of data in about 10 minutes... much faster than other tape or floppy disk backup techniques. Hardware read-after-write error checking is incorporated in the tape device.

... And don't fail to ask about our superb lineup of serious business software (also offered in **CYBERDRIVE** format) including:

RM/COBOL² compiler—the micro industry standard.

MBSI³ **RM/COBOL** general business applications (derived from **MCBA**⁴ minicomputer packages)... thousands in use... money back guarantee... source program license.

CRT!⁵ from Cybernetics (COBOL Reprogramming Tool!)- Program generator for **RM/COBOL** to ease program development and maintenance... an alternative to a Data Base System.

CBASIC2⁶ & **CBASIC86**⁶ compilers... for aficionados of a useful BASIC.

The software is available on a variety of industry-standard Operating Systems including **CP/M**⁵-**MP/M**⁵ (both -80 & -86), **OASIS**⁶, **PCDOS**, and **UNIX**⁷. Inquire for specific details and prices.

Trademarks of:

1 - Cybernetics, Inc. 2 - Ryan-McFarland Corp. 3 - Micro Business Software, Inc.
4 - Mini-Computer Business Applications, Inc. 5 - Digital Research, Inc. 6 - Phase One Systems, Inc. 7 - Bell Laboratories

CYBERNETICS
INC.

8041 NEWMAN AVE., SUITE 208
HUNTINGTON BEACH, CA 92647
714/848-1922

© Copyright 1982 by Cybernetics Inc. All right reserved.
Prices and specifications subject to change without notice.

How to make work like a

First, neatly cut out the "370" label.

Now, when nobody's looking, nonchalantly tape it to your terminal, just under the "IBM," as if it really belonged there.

Then wait for your chance and quickly slip a dBASE II™ disk into your main drive.

That's it.

Your IBM Personal Computer is now ready to run a relational database system, the kind that IBM put on their mainframes last year.

And you're ready with more data handling power than you would have dreamed possible before dBASE II.

You'll wonder how you managed without it.

You'll find that dBASE II, because it's a relational database management system (DBMS), starts where file handling programs leave off.

dBASE II handles multiple databases and simplifies everything from accounting to department staffing to monitoring rainfall on the Upper Volta.

With a word or two, you CREATE databases, APPEND new data instantly, UPDATE, MODIFY and REPLACE fields, records and entire databases. Organize months worth of data in minutes with the built-in REPORT. Do sub-field and multi-field searches, then DISPLAY some or all of the data for any condition you want to apply.

And you've just begun to tap the power of dBASE II.

Easy to look at, easy to use.

Input screens and output forms couldn't be easier—just "paint" your format on the CRT and what you see is what you'll get.



You can do automatic calculations on fields, records and databases, accurate to 10 digits.

And you can use dBASE II interactively for answers right now. Or save your instructions, then repeat everything with two words: DO Manhours, DO ProjectX, DO whatever has to be done.

Use dBASE II to help make your choice:

If you've got a 96k IBM PC, send us \$700 and we'll send you a copy of dBASE II to use free for 30 days.

e your micro mainframe.



Instead of just poring over a manual, run it and make sure that it does what you need done.

Then if you find it isn't right for you, send it back and we'll return your money, no questions asked.

But if you do that, you'll have to remove that label. Because nothing short of a mainframe works like dBASE II.

Call (213) 204-5570 today or drop by your local computer store for the rest of the story.

Ashton-Tate, 9929 Jefferson Blvd.,
Culver City, CA 90230.

Ashton-Tate

©1982 Ashton-Tate
CP/M is a registered trademark of Digital Research

Pin	Signal Name	Pin	Signal Name
A01	$\overline{\text{IOCHNLERR}}$	B01	GND
A02	SYSDAT7	B02	BRESET
A03	SYSDAT6	B03	V _{cc}
A04	SYSDAT5	B04	IRQST2
A05	SYSDAT4	B05	- 5 V DC
A06	SYSDAT3	B06	DMARQST2
A07	SYSDAT2	B07	- 12 V DC
A08	SYSDAT1	B08	$\overline{\text{IOCHLDRQST}}$
A09	SYSDAT0	B09	+ 12 V DC
A10	$\overline{\text{IOCHNLRDY/WAIT}}$	B10	GND
A11	$\overline{\text{SYSAEN}}$	B11	$\overline{\text{SYSTEMMWR}}$
A12	SYSA19	B12	$\overline{\text{SYSTEMMRD}}$
A13	SYSA18	B13	$\overline{\text{SYSIOWR}}$
A14	SYSA17	B14	$\overline{\text{SYSIORD}}$
A15	SYSA16	B15	$\overline{\text{DMACK3}}$
A16	SYSA15	B16	DMARQST3
A17	SYSA14	B17	$\overline{\text{DMACK1}}$
A18	SYSA13	B18	DMARQST1
A19	SYSA12	B19	$\overline{\text{BDMACK0}}$
A20	SYSA11	B20	BSYSCLK0
A21	SYSA10	B21	IRQST7
A22	SYSA9	B22	IRQST6
A23	SYSA8	B23	IRQST5
A24	SYSA7	B24	IRQST4
A25	SYSA6	B25	IRQST3
A26	SYSA5	B26	$\overline{\text{DMACK2}}$
A27	SYSA4	B27	TCNT
A28	SYSA3	B28	SYSALE
A29	SYSA2	B29	V _{cc}
A30	SYSA1	B30	BSYSCLK1
A31	SYSA0	B31	GND

Table 4: Pin/signal relationships in the I/O-expansion connectors. These assignments are compatible with those in the expansion slots of the IBM Personal Computer. Many of the system control signals are buffered before being fed to these connectors.

can potentially contain 1 megabyte of memory and still have spare expansion slots for special-purpose I/O modules, which might include videotex decoders, process-control or data-acquisition interfaces, or local-network interfaces.

The standard MPX-16 system board has five expansion connectors installed in alternating positions, effectively located on 1-inch center-to-center spacings. An additional four connectors can be installed between them, if needed; the resulting nine connectors will be on half-inch center-to-center spacing. Spacing on 1-inch centers is usually required for disk controllers and I/O boards. Memory boards, on the other hand, will generally fit in half-inch spacing.

The I/O-expansion channel has been designed to be pin-for-pin hardware-compatible with the IBM

Personal Computer (model 5150). The IBM PC bus was chosen, as I explained last month, to take advantage of the expected proliferation of IBM-PC-compatible peripheral-adaptor modules and expansion memories. However, because the MPX-16 system board already supports most of the peripheral I/O functions that would ordinarily be added to the IBM computer, the I/O-expansion slots are available for new uses.

Table 4 lists the signal connections to the pins of the I/O-expansion connectors. All signal lines in the I/O channel are compatible with LS-TTL (low-power Schottky-diode-clamped transistor-transistor logic) signals. Brief descriptions of each group of lines follow.

Oscillator Clock (BSYSCLK1): This is a buffered version of the main

system timing clock. It runs at a frequency of either 14.31818 MHz or 15.0 MHz, depending on which crystal is installed. It has a 50 percent duty cycle.

System Clock (BSYSCLK0): This is a buffered version of the system processor clock. It runs at a frequency that is one-third that of SYSCLK1. It has a 33 percent duty cycle (high for one-third of the cycle, low for two-thirds).

System Reset (BRESET): This is a buffered version of SYSRES, which is active on power-up. It is synchronized to the falling edge of the SYSCLK0 waveform and is used for initialization of all system hardware components.

Address Latch Enable (SYSALE): This signal is used to indicate the presence of a valid address on the system bus. The falling edge of SYSALE is normally used to latch the address. This signal is generated by the 8288 bus controller during bus cycles initiated by one of the local-bus masters. The system-address enable signal, $\overline{\text{SYSAEN}}$, should be used to enable this signal in the I/O channel.

System Address Enable (SYSAEN): This line, when active-low, indicates that one of the system coprocessors (either the 8088 or the 8087) has control of the system bus. When $\overline{\text{SYSAEN}}$ is high, the 8237A-5 DMA controller has control of the system bus and drives the system address, system memory, and I/O-read/write lines.

I/O Channel Ready (IOCHNLRDY/WAIT): This line is normally high. When a slow I/O device or expansion memory board decodes a valid address, this line should be driven low, causing the flip-flops IC25 and IC33 to insert wait states into the bus cycle until the slow device has completed its cycle. (To avoid conflict with memory refresh, this line should never be held low for more than 1 or 2 μs .)

System Memory Read (SYSTEMMRD): This control line is used to gate the memory-device data buffers onto the system data bus during memory-read cycles initiated by either the processor or DMA controller.

Alspa

ZERO

ANNOUNCING THE HIGH SPEED, LOW COST NETWORK

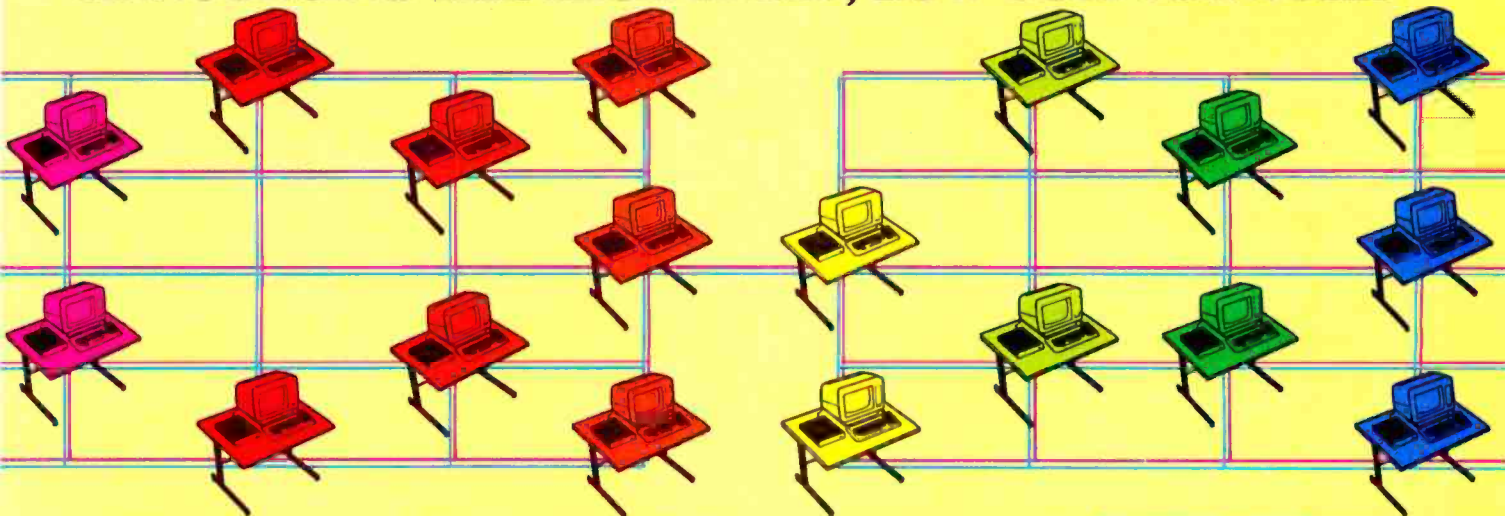

The **ZERO** is designed to bring high performance LOCAL AREA NETWORKING to users at budget prices.

The **ZERO** and **ZERO-NET** are unique. Any **ZERO** station can be a Network Master or Network Remote, permitting, for the first time, a low cost **non stop** network.

The **ZERO-NET** features a High Level Data Link Controller (message synchronous) at 400K bps carried over a simple twisted pair cable. To achieve maximum speed and reliability we use collision detection/avoidance circuitry and automatic CRC error detection/retransmission.

Each **ZERO** computer in the net can have Floppy Disk and/or Winchester Drives. The **ZERO** itself is a Z80 based Micro-computer with 64K Ram, 2K to 16K of EPROM, 2 Serial ports, 2 parallel ports, floppy disk controller, Z80CTC counter-timer and Z80DMA direct memory access.

The **ZERO** hardware design was optimized for **TURBODOS***, (CP/M**, MP/M** compatible) including such enhancements as console type-ahead (buffering), 1.416 Mbytes per 8 inch double-sided floppy, multi-processing (background processing) such as print spooling, etc.

KEY PARAMETERS

- Local Area Networks up to 256 nodes per NET, with any mix of Master and Remote stations. Each station may support up to 16 logical drives, local or remote.
- Local Area Networks may be linked through gateways.
- Per Node — 0 to 2 floppies and 0 to 4 hard disks with appropriate Driver Modules.
- Per Node — parallel and/or serial printer.
- Each user can control print routing and/or spooling.
- Each node may reference a file system and/or printer on any other node.
- Each node may have an Autostart Log-on with security access protection.
- Each node may have a FIFO type Electronic Mailbox.

- Each node may operate with MP/M compatible file/ record interlocks, or with special **TURBODOS** relaxation rules.
- Maximum recommended bus length of 4,000 L.Ft.
- Full CP/M and MP/M compatibility.
- The **TURBODOS** operating system can support up to one GIGA Byte (1,000 Mega Bytes) per logical drive.



The **ZERO-NET** product family — the **ZERO**, the **ZERO/FD**, the **Z-DRIVE** and the **ZNT** terminal — all the components required to configure an entire system are available for immediate delivery. The **ZERO** provides a microcomputer network that **OUTPERFORMS** many multi-user minicomputer systems at substantially lower cost. While the competition is still studying it, **ALSPA** has done it!

ZERO-NET

 **Alspa Computer, Inc.**

300 Harvey West Boulevard, Santa Cruz, CA 95060
(408) 429-6000 Telex 176279



BOOTH 3009/3011
Nov. 29-Dec. 2, 1982
Las Vegas Convention Center
Las Vegas, Nevada

*TURBODOS is a trademark of Software 2000, Inc.

**CP/M and MP/M are trademarks of Digital Research, Inc.

System Board Peripheral Device	Base Address (hexadecimal)
8237A-5 DMA controller	000
8272 floppy-disk controller	020
DMA page registers 0 and 1	040
DMA page register 2	060
DMA page register 3	080
floppy-disk-drive motor-on register	0A0
parity-error flip-flop clear	0C0
spare (reserved)	0E0
spare (reserved)	100
8259A interrupt controller—slave	120
8259A interrupt controller—master	140
console serial I/O port	160
auxiliary serial I/O port	180
8255A-5 parallel I/O	1A0
8155H-2 parallel I/O and timer	1C0
8253-5 counter-timers	1E0

Table 5: Base addresses of the I/O-device-control registers.

System Memory Write (SYSMEMWR): This control is used to store the data present on the system data bus into the selected memory location during memory-write cycles initiated by either the processor or DMA controller.

System I/O Read (SYSIORD): This control line is used to gate the selected I/O device to accept the data present on the system data bus during I/O-read cycles initiated by either the processor or the DMA controller.

System I/O Write (SYSIOWR): This control line tells the selected I/O device to accept the data present on the system data bus. It is active in I/O-write cycles initiated by either the processor or DMA controller.

I/O-Channel (Parity) Error (I/OCHNLERR): This signal, when enabled by the system software, will cause an interrupt via the NMI input of the 8088 processor. It is normally used to alert the processor to a parity error in memory devices residing in the I/O channel.

System Address Bus (SYSA0 through SYSA19): These lines form a 20-bit system address bus, which can

address up to 1 megabyte of memory. SYSA0 represents the least significant address bit (LSB), and SYSA19 represents the most significant address bit (MSB). These lines can be driven either from the processor or from the DMA controller and are considered to be active-high.

The MPX-16 computer system can potentially contain 1 megabyte of memory and still have spare expansion slots.

System Data Bus (SYSDAT0 through SYSDAT7): These lines form the 8-bit system data bus and can be driven by the processor, memory devices, or I/O devices. They are bi-directional and are considered to be active-high. SYSDAT0 is the LSB, SYSDAT7 the MSB.

I/O Channel Interrupt Requests (IRQST2 through IRQST7): These lines are prioritized interrupt-request lines, with IRQST2 having the highest priority and IRQST7 the

lowest priority. The lines are edge-triggered and active-high; however, the request signal must be maintained in the high state until the interrupt request has been acknowledged. The interrupt-service routine written for each particular device in use must usually do this.

DMA Requests (DMARQST1 through DMARQST3): These lines are prioritized DMA-request lines, with DMARQST1 having the highest priority and DMARQST3 the lowest priority. The lines are active-high and must be held high until the corresponding $\overline{\text{DMACK}}_x$ line goes active-low. DMARQST2 is used by the system-board floppy-disk controller and is included in the I/O channel only for compatibility with the IBM Personal Computer. These lines are typically used by peripheral devices such as disk controllers to request DMA service.

DMA Acknowledge Lines ($\overline{\text{DMACK}}_1$ through $\overline{\text{DMACK}}_3$): These lines are used to acknowledge DMA requests generated by the DMARQST $_x$ lines.

DMA Acknowledge 0 ($\overline{\text{BDMACK}}_0$): This is a buffered $\overline{\text{DMACK}}_0$ line and signifies that a DMA-controlled dynamic-memory-refresh cycle is in progress.

DMA Terminal Count (TCNT): This signal is active-high when any of the four DMA channels reaches a terminal count. The corresponding DMA-acknowledge line should be used in conjunction with the TCNT signal.

Peripheral Power: +5 volts (V) DC $\pm 5\%$, logic ground, +12 V DC $\pm 5\%$, -12 V DC $\pm 10\%$, and -5 V DC $\pm 10\%$ power connections are all provided in each expansion connector.

I/O-Decoder Logic

The MPX-16 computer system contains a variety of onboard, high-performance peripheral devices: direct support for all of the major I/O functions needed to form a complete microcomputer system, as listed in table 1 on page 44.

All of the system-board I/O peripherals are addressed or selected by the 4-to-16 decoder IC52 (shown in

SOFTech MICROSYSTEMS



The Universal Operating System.* Finally, once and for all.

The UCSD p-System* from SofTech Microsystems isn't like any other operating system you've ever used.

Why?

Because the p-System is the *only* truly portable, universal operating system ever developed, that's why. It's equally at home with all popular personal computers. Such as an IBM PC or Displaywriter, an Apple, a DEC, an HP, an Osborne, a Philips, a Sage, a Tandy, a TI, you name it. It lets you develop applications that are portable to 8-bit as well as 16-bit micros.

And we don't mean portable just at the source code level, either.

We mean you can develop your program on virtually any micro, compile to object code, and it's totally transportable. So you can design programs once, and you've designed for the entire market.

The p-System then actually broadens your potential customer base. With no significant reinvestment in programming time. You can reuse program components

from one application to another, and even create your own library of utilities. What's more, the p-System's universality allows you to get your software up and running on new hardware as soon as it hits the market.

It's about time.

At SofTech Microsystems, we saw an industry-wide need for an efficient OS that could honestly call itself universal. So, in 1979, we delivered just that. The UCSD p-System. And we've been delivering ever since.

As an applications developer, we think you owe yourself an OS that lets you broaden your market base and develop higher quality applications faster, less expensively, more dependably and more efficiently than ever before.

All at the same time. All on one micro.

Thanks to the p-System, finally, once is enough.

For product information or information on how to get a copy of the p-System Application Catalog, call or write to us at SofTech Microsystems.

Finally, Once is Enough.

SEE US AT COMDEX BOOTH #636.

Circle 424 on inquiry card.

SofTech Microsystems • 16885 West Bernardo Drive • San Diego, Calif. 92127 • (714) 451-1230

*Universal Operating System is a trademark of SofTech Microsystems Inc.. UCSD p-System is a trademark of the Regents of the University of California

section 2, figure 2 on page 48). This decoding logic maintains addressing compatibility with IBM Personal Computer peripherals by using the system-address-bus line SYSA9 to determine whether the peripheral device being selected is on the main circuit board or off it. A low state on the SYSA9 line enables one of the strobe inputs of the decoder; the other strobed input is enabled if one of the local bus masters has control of the system bus, indicated by a low state on 88AEN. When an I/O-device interface chip is selected by this decoded address and either the SYSIORD or SYSIOWR line is active, an I/O bus cycle is performed. During DMA cycles the I/O decoder is disabled.

The base address for each of the system-board I/O devices is shown in table 5 on page 76. The total number of address-space locations used by each peripheral device varies; this will be discussed in more detail next month in part 3.

Next Month:

If you've followed everything in this second installment on the Circuit

Cellar MPX-16 computer system, you're doing well. In the January article I'll fill you in on the serial and parallel I/O ports, counters, floppy-disk controller, and operating-system BIOS, among other topics. ■

Acknowledgments

Thanks to Jim Norris, George Martin, and Linda Spencer of Owl Electronic Laboratories for their contributions to this project.

Thanks to Mark Dahmke and Gordon Heins for their help with the documentation.

Thanks to Bill Morello and his staff at Techart Associates for their careful work in drawing the schematic diagrams.

Editor's Note: Steve often refers to previous Circuit Cellar articles as reference material for each month's current article. Most of these past articles are available in reprint books from BYTE Books, McGraw-Hill Book Company, POB 400, Hightstown, NJ 08520.

Ciarcia's Circuit Cellar, Volume I, covers articles that appeared in BYTE from September 1977 through November 1978. Ciarcia's Circuit Cellar, Volume II, contains articles from December 1978 through June 1980. Ciarcia's Circuit Cellar, Volume III, contains the articles that were published from July 1980 through December 1981.

To receive a complete list of Ciarcia's Circuit Cellar project kits available from the Micromint, circle 100 on the reader service inquiry card at the back of the magazine.

References

1. Cantrell, Thomas. "An 8088 Processor for the S-100 Bus." Part 1, September 1980 BYTE, page 46. Part 2, October 1980 BYTE, page 62. Part 3, November 1980 BYTE, page 340.
2. Ciarcia, Steve. "Build the Circuit Cellar MPX-16 Computer System, Part 1." November 1982 BYTE, page 78.
3. Ciarcia, Steve. "Ease into 16-Bit Computing." Part 1, March 1980 BYTE, page 17. Part 2, April 1980 BYTE, page 40. Reprinted in Ciarcia's Circuit Cellar, Volume II. Peterborough, NH: BYTE Books, 1981, page 171.
4. Ciarcia, Steve. "The Intel 8086." November 1979 BYTE, page 14. Reprinted in Ciarcia's Circuit Cellar, Volume II. Peterborough, NH: BYTE Books, 1981, page 120.
5. Component Data Catalog. Santa Clara, CA: Intel Corporation, 1981.
6. iAPX Book. Santa Clara, CA: Intel Corporation, 1981.
7. iAPX 86,88 User's Manual. Santa Clara, CA: Intel Corporation, 1981.
8. Morgan, Christopher L. and Mitchell Waite. 8086/8088 16-bit Microprocessor Primer. Peterborough, NH: BYTE Books, 1982.

The following items are available from:

The Micromint Inc.
561 Willow Ave.
Cedarhurst, NY 11516
(516) 374-6793

(for technical information)

(800) 645-3479

(for orders only)

1. MPX-16 single-board computer system: assembled, tested, and burned-in. Includes 64K bytes of RAM, Digital Research CP/M-86 operating system on 8-inch or 5¼-inch floppy disk, CP/M-86 BIOS in EPROM, MPX-16 Technical Reference and User's Manual. Requires power supply and floppy-disk drive.

Single-quantity price.....\$1895

2. MPX-16 single-board computer system, as above, but with 256K bytes of RAM installed.

Single-quantity price.....\$2135

3. MPX-16 single-board computer

system, with 64K bytes of RAM.
In OEM quantities of 100 \$1200 each

4. Complete MPX-16 disk-based system: includes MPX-16 single-board computer, assembled, tested, and burned-in, with 256K bytes of RAM installed, CP/M-86 operating system on 5¼-inch floppy disk, CP/M-86 BIOS in EPROM, power supply, one 5¼-inch single-sided floppy-disk drive, connecting cables, MPX-16 Technical Reference and User's Manual. Enclosure sold separately.

Single-quantity price.....\$2895

5. Unpopulated (blank) printed-circuit board for the MPX-16 computer system: five-layer, screened, and solder-masked. Includes CP/M-86 BIOS in EPROM, MPX-16 Technical Reference and User's Manual.

Single-quantity price.....\$300

6. Digital Research CP/M-86 User's Manual (three-volume set), sold separately.....\$40

7. MPX-16 Technical Reference and User's Manual, sold separately...\$50

8. Enclosure for MPX-16 circuit board.....call for price

* * *

When it becomes available for the MPX-16, Microsoft's MS-DOS operating system may be optionally substituted for CP/M-86.

The MPX-16 is available to OEMs in large quantities either as a circuit board or as a complete system with floppy-disk drives and enclosure. Call the Micromint for prices and delivery information.

For orders within the continental United States, please include \$10 for shipping; overseas orders please include \$30. Residents of New York please include 7 percent sales tax.

WHEN WE ANNOUNCED THE COMMODORE 64 FOR \$595, OUR COMPETITORS SAID WE COULDN'T DO IT.

THAT'S BECAUSE THEY COULDN'T DO IT.

The reason is that, unlike our competitors, we make our own IC chips. *Plus* all the parts of the computer they go into.

So Commodore can get more advanced computers to market sooner than anybody else. And we can get them there for a lot less money.

WHAT PRICE POWER?

For your \$595,* the Commodore 64™ gives you a built-in user memory of 64K. This is hundreds of dollars less than computers of comparable power.

Let's you think that the Commodore 64 is some stripped-down loss leader, a look at its available peripherals and interfaces will quickly convince you otherwise.

SOFTWARE THAT WORKS HARD.

The supply of software for the Commodore 64 will be extensive. And with the optional plug-in Z80 microprocessor, the Commodore 64 can accommodate the enormous amount of software available in CP/M.®

Add in the number of programs available in BASIC and you'll find that there are virtually no applications, from word processing to spreadsheets, that the Commodore 64 can't handle with the greatest of ease.

PERIPHERALS WITH VISION.

The Commodore 64 interfaces with all the peripherals you could want for total personal computing: disk drives, printers and a telephone modem that's about \$100, including a free hour's access to some of the more popular computer information services. Including Commodore's own Information Network for users.

RUN YOUR BUSINESS BY DAY.

SAVE THE EARTH BY NIGHT.

At the end of a business day, the Commodore 64 can go into your briefcase and ride home with you for an evening's fun and games.

Because of its superior video quality (320x200 pixel resolution, 16 available colors and 3D Sprite graphics), the Commodore 64 surpasses the best of the video game machines on the market. Yet, because it's such a powerful computer, it allows you to invent game programs that a game machine will never be able to play; as well as enjoy Commodore's own video game cartridges.

ATTACK, DECAY, SUSTAIN, RELEASE.

If you're a musicologist, you already know what an ADSR (attack, decay, sustain, release) envelope is. If you're not, you can learn this and much more about music with the Commodore 64's music synthesizing features.

It's a full-scale compositional tool. Besides a programmable ADSR envelope generator, it has 3 voices (each with a 9-octave range) and 4 waveforms for truly sophisticated composition and playback—through your home audio system, if you

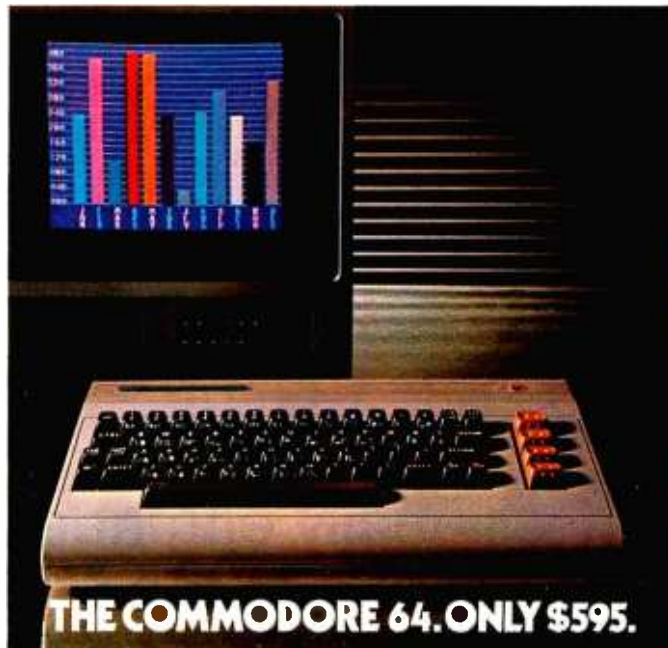

wish. It has sound quality you'll find only on separate, music-only synthesizers. And graphics and storage ability you won't find on any separate synthesizer.

DON'T WAIT.

The predictable effect of advanced technology is that it produces less expensive, more capable products the longer you wait.

If you've been waiting for this to happen to personal computers, your wait is over.

See the Commodore 64 soon at your local Commodore Computer dealer and compare it with the best the competition has to offer.

You can bet that's what the competition will be doing.

Commodore Business Machines
Personal Systems Division
P.O. Box 500, Conshohocken, Pennsylvania 19428

Please send me more information on the Commodore 64™

Name _____ Title _____

Company _____

Address _____

City _____ State _____

Zip _____ Phone _____

 **commodore**
COMPUTER

BT-12

*Manufacturer's Suggested Retail Price: July 1, 1982. Disk drives and printers are not included in prices. The 64's price may change without notice. CP/M® is a registered trademark of Digital Research, Inc.

Circle 95 on inquiry card.

BYTE December 1982 79



INFORMA

INFORMA X is the FIRST Information Management System professionally engineered ... from its inception ... to operate in the Multi-user, Multi-tasking, Multi-processing environment.

INFORMA X is not just another DBMS. It is a **practical necessity** for the business initiating computerization. As needs expand, systems invariably expand, so why be forced to reinvent the wheel just because of future growth? Any expansion you plan will need INFORMA X. Remember, a **single-user today** will be a **multi-user tomorrow**.

Almost invariably, a business begins computerization on a single application, single-user system which immediately requires expansion. Multi-user, multi-tasking and multi-processing systems become necessary. Unfortunately, software designed for the single-user system can not satisfy the needs of the multi-user environment. In fact, single-user software is inherently dangerous to precious records in the multi-user situation. Multi-processing and multi-tasking require professionally engineered software solutions for **mutual exclusion record lockout, deadly embrace conditions, asynchronous event conditions, and run away lockout conditions**, as well as other frightening technical problems. The concepts necessary to solve these problems must be designed into the system from its inception... **not as an addition or afterthought**. INFORMA X is

the **first** micro DBMS professionally engineered for multi-user, multi-tasking and multi-processing.

INFORMATION MANAGEMENT
INFORMA X is an Information Management System which provides the structure for information (data) organization and filing to allow for quick, efficient storage and retrieval of that data. In effect, it provides the most sophisticated framework for an elegant **computer filing system**. Traditionally, database management systems are structures designed to assist system programmers in their programming tasks. But the achievement of INFORMA X is to provide a **programmer-less** environment that allows even **first-time users** to achieve **professional results** in creating programs that store information, retrieve that information, and report on that information **in the formats the user personally desires**. INFORMA X uses neither "cryptic statements" nor "English type" statements and requires no "computereze", or other computer languages.

No "Computereze"
like: B:XPNW = MAIL

No "English type commands"
like: Find record 5 on drive D:
in database mail

No "Cryptic Commands"
like: pip d:=c:*.??v

INFORMA X IS FOR THE USER!
That's why ABACUS DATA will only deliver systems fully customized to the equipment. **Full keyboard functions, cursor control**, etc. Since the Security System requires a User Name, the system provides **individualization of function keys, screen displays, and keyboard actions** for each operator.



```
F MAIL
NAME;  _____
ADDRESS; _____
CITY; _____
STATE; __ ZIP _____

Fill in data blank or blank and Press
RETURN
THAT'S ALL !!
```

MORE THAN USER-FRIENDLY
Through the use of **menu driven, screen oriented**, tutorial response techniques the **first-time** computer user can create, modify or customize programs. Through the **innovative template** (screen) system, user acceptance is immediate. Each of the system's five components: THE DATA-

BEYOND DBMS

X



BASE, THE REPORTER, THE APPLICATION WRITER, THE SECURITY SYSTEM, and THE MENU MAKER has been designed to minimize operator inputs. **Single keystroke command structure** has been used throughout.

The INFORMA X is an **Information System**.

Beyond a database management system it has **lightning fast** storage and retrieval. To be useful for business it must be fast.

Beyond a reporter, it converts data into the **information** necessary to make business decisions.

Beyond an application writer, it will create, modify, expand, any application... up to 42 math calculations permitted for each record.

Beyond an automatic programming system, it is almost totally transparent to the user, requires no programming skill, yet achieves professional results.

Beyond a security system, (a necessity for business) it separately secures The System, The Applications, The Records, The Items and The Commands.

Beyond a menu maker, the user designs his own help pages for the INFORMA X programs and others.

Beyond an accounting system, it allows your total processing to be **AUTOMATED, ORGANIZED, INDIVIDUALIZED, and MODIFIABLE.**

All and much more!

INFORMA X is the only database software you will ever need.

Without INFORMA X all applications and programs are disjointed bits and pieces. INFORMA X will organize your automation. INFORMA X is currently delivered with an Accounting Package which includes:

- PAYROLL SYSTEM
- ACCOUNTS RECEIVABLE
- ACCOUNTS PAYABLE
- INVENTORY SYSTEM
- GENERAL LEDGER

Not just examples but operational programs and **more!**

PROFESSIONAL SUPPORT

INFORMA X is not merely a database management system but it is a method of automating information, storage, retrieval, and transmittal that should mean a **new way of business life.** We at ABACUS DATA, INC. are committed to supplying software that will enhance your business today and tomorrow. We encourage

your questions and comments and for that reason we maintain toll free numbers to service you.

1-800-874-8555.

In Florida **904-398-8547.**

Dealer and distributor inquiries welcomed.



abacus data, inc.

1920 San Marco Boulevard
Jacksonville, Florida 32207

CURRENT EQUIPMENT SPECIFICATIONS

Z80, 8085, 8080A
Minimum Memory 52K
CP/M® Operating System
Current delivery customized for all **TeleVideo®, Osborne®, and Action® Computer Systems** (Call for others)

Circle 6 on Inquiry card.

Let's get serious, folks.



After all this time, we're going to show you the real us.

We know that you think we're the serious, buttoned-down distributor that can ship you more different kinds of CP/M business and utility software than anybody else.

That we have software for the newest computers, like the IBM PC, almost before they're announced.

That we deliver more different formats, everything from Apple to Zenith, so that you don't have to turn down a sale.

And that we give you the healthy discounts and rapid delivery you need to make a decent profit.

But behind all that we've got our fun-loving side, too, you know.

And we're just as strong in computer games.

We know that games are serious business, and that if you don't have them, you can't sell them. So we've filled our shelves with games for Apple, Atari, the TRS-80 and more. Games from Avalon Hill, Broderbund, Gebelli, Microsoft, On Line, Sirius, whoever—just name it and it's yours.

All with the same deep

discounts, the same great delivery and the the same friendly service as we're giving you on your CP/M software.

So if you're ready for fun and games with a distributor, give us a call.

Software Distributors, 10023 Jefferson Boulevard, Culver City, CA 90230.

We're not just clowning around.

SOFTWARE DISTRIBUTORS

213-204-6620 • 800-252-4025 (CA)
Telex 182362 ATT: Soft USA Culv
800-421-0814

CP/M is a registered trademark of Digital Research



GAME PLAN 1982

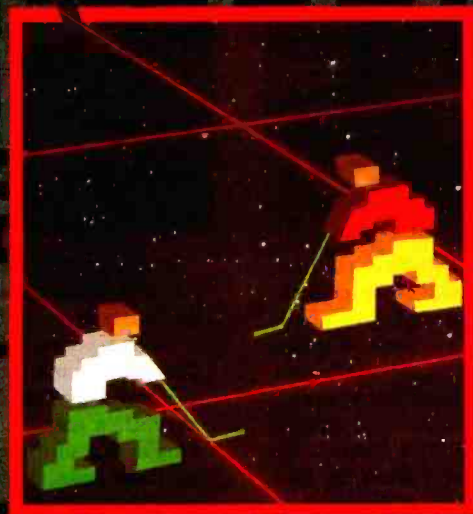

The Coinless Arcade — Rediscovered

Pamela Clark, Technical Editor
and Gregg Williams, Senior Editor

A faceless stranger gave you directions the first time you came to The Coinless Arcade. After a glorious night of gaming, you came away retaining a pocket full of quarters and not a few new friends. Everyone met together the next night, ready for more gaming, but you could not find the arcade—anywhere! Night dampness chilled your bones as the search continued, and, for a while, you combed the town every night: still, no arcade. You kept in touch with your new friends, if only to prove that you hadn't imagined it all.

A year has passed. You walk out the alley exit of a theater and, surprised, hear faint arcade noises. You follow them through the alleyways, only distantly aware that you never cross a main street. And there it is: the neon facade declaring "The Coinless Arcade" with festive colors, the air alive with electronic sounds. Once inside, you see a familiar face,

then another. Soon everyone has arrived. Laughing, you run to the nearest empty machine, reach for some quarters—and realize there's no need. You wish your friends good luck and press the flashing red button labeled START. The fun begins again.

Another computer gaming year has passed. Game designers continue to squeeze more than we've ever seen before from a given machine, and we applaud their efforts. In fact, some of the most exciting programming this year has been done for the cartridge game systems. That's why we're including two pages of games for the Atari (or Sears) Video Computer System and the Mattel Intellivision Game System.

Luckily for you players, The Coinless Arcade exists in your imagination and in your microcomputer. We've brought you these games from our Coinless Arcade. Put them in your microcomputer (or cartridge game system) and they're yours forever.

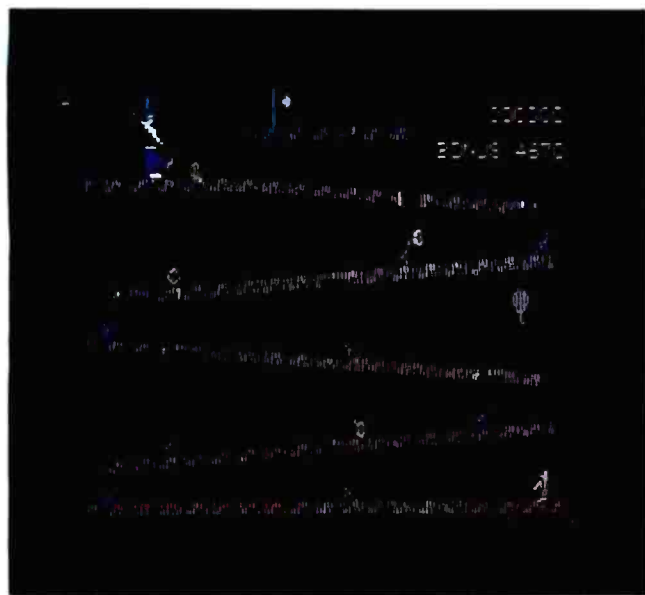

Playing Cannonball Blitz can provide entertainment for you and chuckling enjoyment for a crowd of onlookers. The object of the game is to get the rebel soldier up Nutcracker Hill and destroy the castle. The poor soldier, however, must contend with a barrage of cannonballs and constant trips and obstacles. It becomes hard not to laugh as you try to outrun or jump over cannonballs, or just plain get out of the way. **Cannonball Blitz** by Olaf Lubeck for the Apple II or II Plus, \$34.95 (disk), from Sierra On-line Inc., 36575 Mudge Ranch Rd., Coarsegold, CA 93614.



Want a challenge with a bizarre twist? First, you take a job with the ASPCA and are put in charge of controlling the lemming population. All you have to do is lock them in a room so they won't breed. Sounds easy until you try it. There are lemmings running everywhere, breeding faster and faster and getting run over by trucks. If you're not real careful, a mass suicide occurs as they march to the sea. This is one of the strangest topics for an arcade game that we have seen. **Lemmings** by Jerry Jewell, Terry Bradley, and Dan Thompson for the Apple II or II Plus, \$29.95 (disk), from Sirius Software Inc., 10364 Rockingham Dr., Sacramento, CA 95827.



The city is under attack, and it's up to you to rescue the only remaining inhabitants. Pilot your Needlefighter and swoop in, picking up each of the 18 survivors and transport them through a hazard-filled sky to temporary safety. Once you have saved all of the people, you must risk your life and theirs once again, as you move them to permanent quarters. It isn't easy—hero stuff never is. **Protector** by Mike Potter for the Atari 400/800, \$34.95 (cassette), from Synapse Software, 820 Coventry Rd., Kensington, CA 94707. (Also available on disk.)

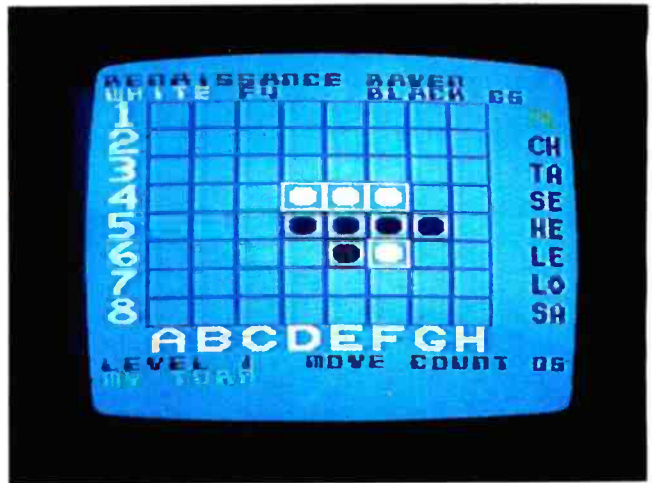

If you love playing two-person strategy games but can't always find a willing opponent, Renaissance may be the answer. This is a computer version of the board game Othello (trademark of Gabriel Industries) that is designed to let you challenge the machine, although it may be used with two human players. You can choose from eight levels, set up special games, and save and recall games from tape. **Renaissance** by Louis X. Savain for the VIC-20, \$49.95 (cartridge), from United Microware Industries Inc., 3503-C Temple Ave., Pomona, CA 91768.



As the commander of a nuclear submarine, you guide your vessel through a subterranean obstacle course, avoiding mountains, twisting through passages, and staying away from the webs of explosive mines rising from the sea floor. And if that wasn't enough to make a hazardous trip, watch out for the enemy attack stations, falling stalactites and mines, and, of course, lasers. The scrolling seabottom gives you the equivalent of 24 screens laid end-to-end, and the game also offers a two-player option. **Sea Dragon** by Wayne Westmoreland and Terry Gilman for the TRS-80 Models I and III, \$24.95 (disk), from Adventure International, POB 3435, Longwood, FL 32750. (Also available for the Apple and the Atari 400/800.)



Amid the sounds of explosions and the sight of burning buildings, you must maneuver your helicopter and rescue the 64 kidnapped delegates to the United Nations Conference on Peace and Child Rearing. Watch out for jet fighters and air mines and try to get as many of the hysterical hostages back to safety as you can. It's great fun manipulating the helicopter with a joystick acting as the throttle; and the little folks on the ground really wave to you! **Choplifter!** by Dan Gorlin for the Apple II or II Plus, \$34.95 (disk), from Broderbund Software, 1938 Fourth St., San Rafael, CA 94901. (Requires joystick with two buttons; also available for the Atari 400/800.)

COINLESS ARCADE

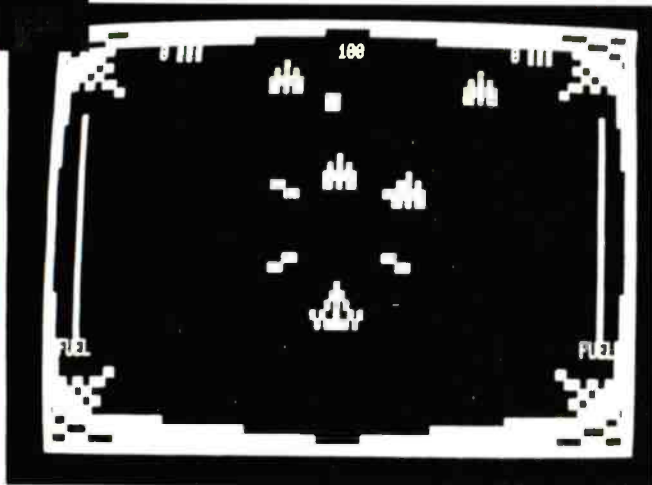

Escorting and defending cruisers through front-line battle zones becomes a hazardous task when Cretonian forces try to destroy your protective field. Your fuel supply is limited, so your mission must be completed rapidly, while you fight off three waves of Cretonian ram craft, energy torpedoes, and Kilr mines. **Stellar Escort** by Jeff Zinn for the TRS-80 Models I and III, \$19.95 (disk), from Big Five Software, POB 9078-185, Van Nuys, CA 91409. (Also available on cassette.)



If you suffer from nightmares of being caught in a snake-filled maze, don't play **Serpentine** before bedtime. Not only must you try to keep your nice blue serpents alive, but you must also make their lives long enough to lay eggs and raise new serpents. You can't merely avoid predator serpents: you must eat them in order to grow. Big serpents always swallow little serpents, so growing up fast can be a real advantage. **Serpentine** by David Snider for the Apple II or II Plus, \$34.95 (disk), from Broderbund Software, 1938 Fourth St., San Rafael, CA 94901.

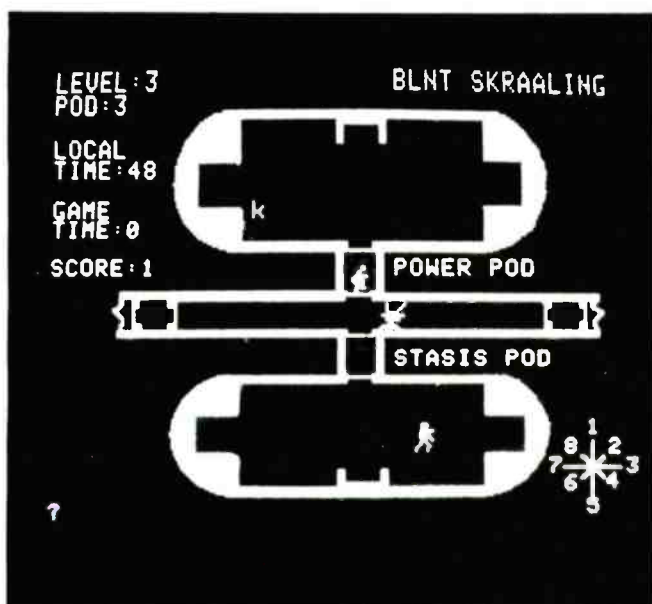

Use your problem-solving skills in a science-fiction scenario that makes you race against the clock in a simulation of an emergency situation aboard a biological survey spaceship. After a mid-space accident, your ship begins to malfunction. The crew must locate the main computer console, access the plans to the multipod vessel, and repair the damage before time runs out. During the search, you must look out for dangerous biological specimens and attacking robots. While the game can be played as solitaire, it can also incorporate up to seven players in a cooperative effort to save the ship (and your lives!). **Wreck of the B. S. M. Pandora** by Stephen Abrams for the Apple II or II Plus, \$50 (disk), from Apple Computer Inc., 20525 Mariani Dr., Cupertino, CA 95014.

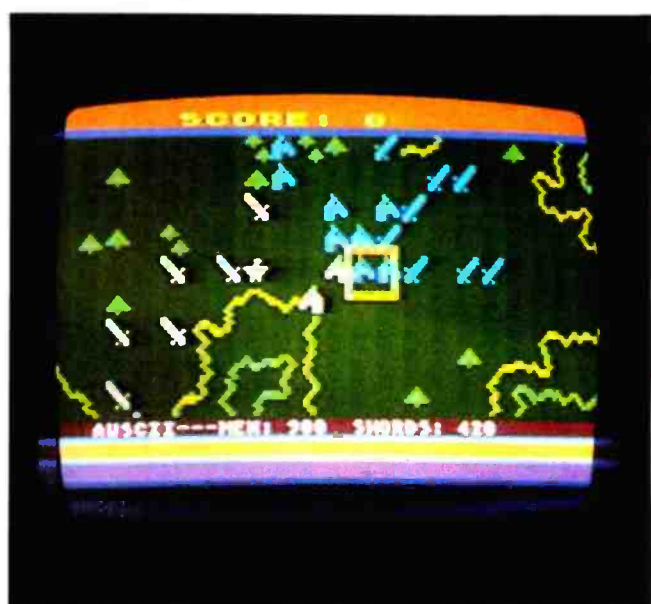

If you always had a secret desire to conquer barbarian hordes, **Legionnaire** is the game for you. High-resolution graphics, sound, and real-time combat combine to create a live-action battlefield. You command the Roman Legions of Julius Caesar, while the computer controls the Gaulish barbarian hordes. With up to ten legions to command, you select any two of 16 barbarian tribes to fight. The game provides you with a topological map, which must be mastered to defeat the most vicious of the barbarians. Don't let the cover art deter you (the worst we've seen this year!)—the game is great entertainment, even for those who haven't been war-game fans before. **Legionnaire** by Chris Crawford for the Atari 400/800, \$35 (cassette), from Avalon Hill Game Co., 4517 Harford Rd., Baltimore, MD 21214. (Also available on disk.)

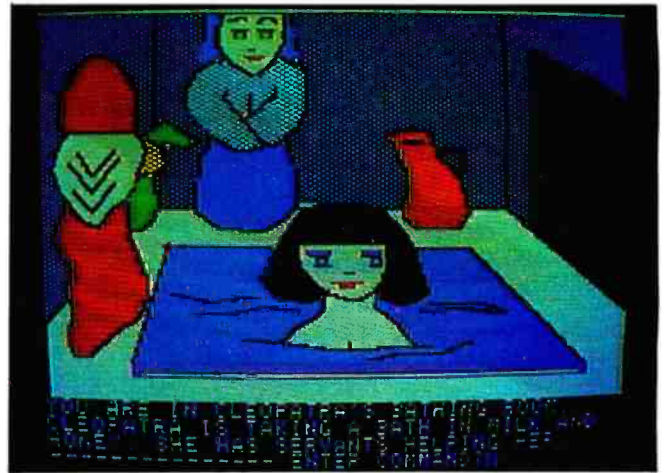

The Guinness Book of World Records must be getting ready for a computer games category, if Time Zone is any indication of things to come. Without a doubt, it is the longest adventure to date with more than 1400 color graphic pictures and six floppy disks packed (front and back!) with this challenging game. Not only do you become a time traveler, but you must be able to solve puzzles built into the game. This ultimate adventure is already a legend in its own time. **Time Zone** by Ken and Roberta Williams for the Apple II or II Plus, \$99.95 (disk), from Sierra On-line Inc., 36575 Mudge Ranch Rd., Coarsegold, CA 93614.



The award (if we had one) for the most arcade-like game of the year would go to Bandits. In this spectacular contest, every new wave of aliens has a different strategy and a different weapon to challenge you. And, of course, the more you manage to blast them off your screen, the faster they attack. Good graphics and great action make this game a must for arcade fans. **Bandits** by Tony and Benny Ngo for the Apple II or II Plus, \$34.95 (disk), from Sirius Software Inc., 10364 Rockingham Dr., Sacramento, CA 95827. (Also available for the Atari.)



If you have always been a fan of the old Saturday matinee monster movies, here is a game that allows you to create your own interactive version. Choose your favorite locale to be devoured: Washington, Tokyo, New York, or San Francisco. Next, from a choice of six killer creatures, select the monster you would most like to be when you grow up. With more than 100 possible scenarios, you can wreak havoc to your heart's content. Watch out for the National Guard and the mad scientist, though, because they are determined to eliminate your monster at any cost. **Crush, Crumble, and Chomp!** by Jon Freeman, J. W. Connelley, Michael Farren, and Toni Thompson for the Apple II or II Plus, \$29.95 (disk), from Epyx/Automated Simulations Inc., 1043 Kiel Court, Sunnyvale, CA 94086. (Also available on disk for the TRS-80 Models I and III and the Atari 400/800 and on cassette for the VIC-20.)



For an added thrill, try using two joysticks with **Cyborg**. Move your human/machine hybrid with one joystick and fire with the other as you battle robots, killer hyper-spheres, and giant spiders in a series of arenas. Each arena or wave may contain all of one type of opponent or a mixture of all, with each new arena harder to get through than the one before. **Cyborg** by Simon Smith for the Atari 400/800, \$29.95 (disk), from Med Systems Software, POB 2674, Chapel Hill, NC 27514.

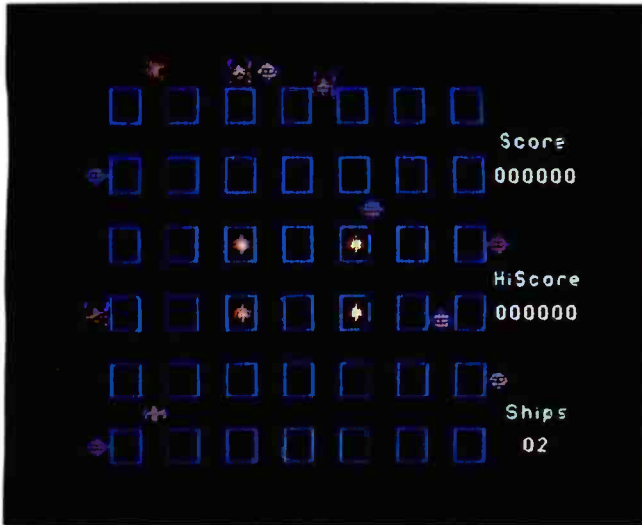

By allowing you to independently shoot and move in four directions, *Crossfire* emerges as one of the most difficult and challenging arcade games to play. Surrounded by aliens, with laser shots flying at you from all directions, you are confined in a grid. Instead of the freedom of the skies, you must exercise tight control over the movement of your ship, firing missiles at the same time. The reflexes take a long time to master, but, once you get the hang of it, it's addictive. *Crossfire* by Jay Sullivan for the Apple II or II Plus, \$29.95 (disk), from Sierra On-line Inc., 36575 Mudge Ranch Rd., Coarsegold, CA 93614. (Also available on disk, cassette, or cartridge for the Atari 400/800.)



As Dakota Smith, adventurer, treasure hunter, you must locate the golden Mask of the Sun to halt the deterioration of your body brought on by a mysterious amulet. You begin your quest for this solid gold mask with a face-to-face meeting with Professor de Perez in the Aztec ruins of Mexico. This graphics adventure uses a special animation and graphics language to draw full-screen graphics quickly enough to give the illusion of movement: people walk toward you and your jeep cruises down a country road. *The Mask of the Sun* by Alan Clark, Larry Franks, and Christopher and Margaret Anson for the Apple II or II Plus, \$39.95 (disk), from Ultrasoft Inc., 24001 Southeast 103rd St., Issaquah, WA 98027.

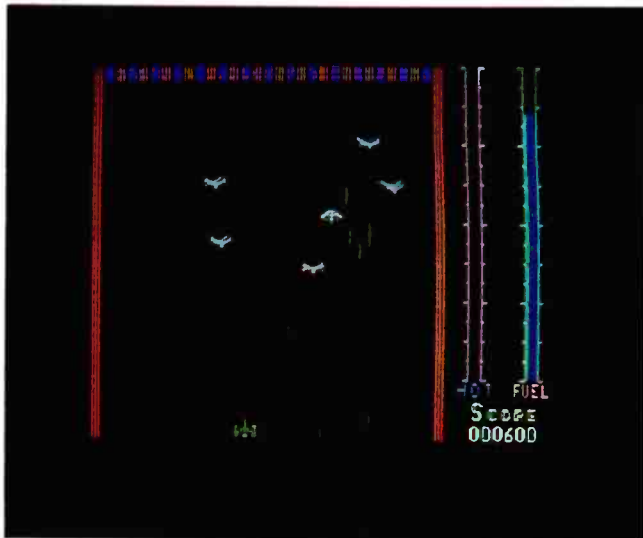

Endless waves of aliens (what else?) fill the skies. They are programmed to destroy you. You shoot at them, but if you shoot too quickly, your guns overheat and it's doomsday once again. The graphics are stunning, with each wave bringing a new variety of alien invader. *Threshold* by Warren Schwader and Ken Williams for the Apple II or II Plus, \$39.95 (disk), from Sierra On-line Inc., 36575 Mudge Ranch Rd., Coarsegold, CA 93614. (Also available for the Atari 400/800.)

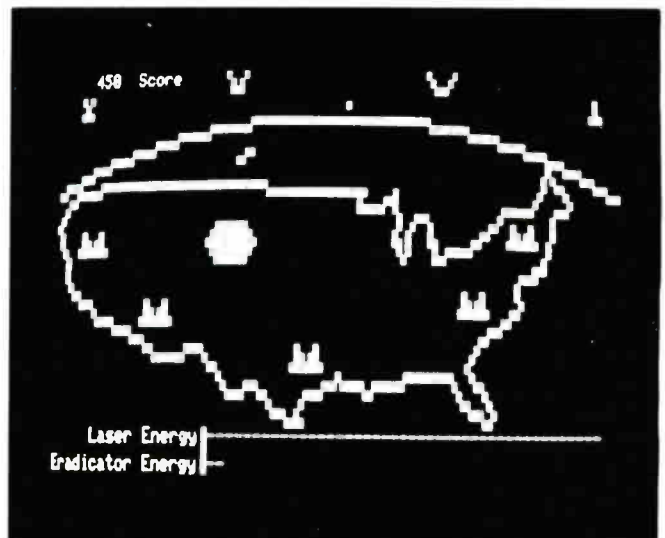

You're in control of the strategic defense satellites of the United States and, looking through your viewfinder, you can see nuclear rockets being launched from the Soviet Union. Quickly, you must intercept the rockets and destroy all of the Soviet missile sites as well. But the missiles keep coming, and now even your satellites are under attack. A graphic arcade experience awaits. *Laser Defense* by Simon Smith for the TRS-80 Models I and III, \$18.95 (disk), from Med Systems Software, POB 2674, Chapel Hill, NC 27514.

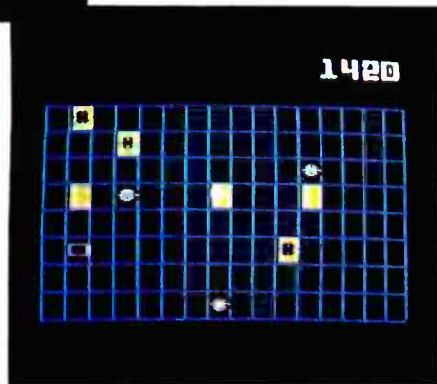

SPECIAL EFFECTS

As the game loads, a voice announces the title, *Space Spartans*. This is the first cartridge designed for use with the Intellivoice Voice Synthesis Module. Four voices are generated, but only two are used with regularity: the ship's computer and your central computer. The game is designed to be a reenactment of the Battle of Thermopylae in space. Because the voices provide vital information, the game isn't playable without the synthesis module. *Space Spartans* for Intellivision, \$45 (cartridge; Voice Module, \$80), from Mattel Electronics, 5150 Rosecrans Ave., Hawthorne, CA 90250.

Phasor Patrol is included when you purchase a Supercharger for your Atari VCS. (The Supercharger plugs into the cartridge slot on your machine and adds enough memory to give games increased action and more graphic detail. The games, available on cassette, load rapidly from any cassette player.) *Phasor Patrol* lets you use a sector map to warp hop from one section of the galaxy to another. The hyperdrive simulation is very impressive. Using the second screen, you locate enemy forces and use the torpedo sight to lock-in on your target. Scoring well in this game is a combination of skill and strategy. *Phasor Patrol* for the Atari VCS (video computer system), \$69.95 (cassette; includes the Supercharger), from Starpath Corp., 324 Martin Ave., Santa Clara, CA 95050.



OLD FAVORITES

A graphics version of an old computer game, *Utopia* lets you rule your own island state. One or two players can compete by scoring points that reflect the overall well-being of the people you rule. By controlling agriculture, housing, education, the military, industry, and hospitals, you alone are responsible for the people. Just remember to keep an eye out for the rebels and pirate ships. *Utopia* for Intellivision, \$40 (cartridge), from Mattel Electronics, 5150 Rosecrans Ave., Hawthorne, CA 90250.

Although not a new entry, *Tennis* is a favorite here at BYTE. Not only is this game engaging, the winning feature is that the ball carries a shadow underneath it. Try it when you can't get outdoors for your exercise at the net. *Tennis* by Alan Miller for the Atari VCS, \$22.95 (cartridge), from Activision, Drawer 7286, Mountain View, CA 94042.

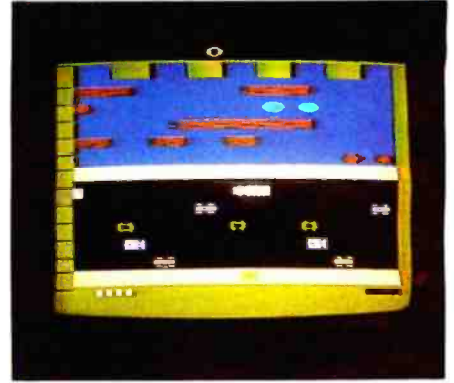
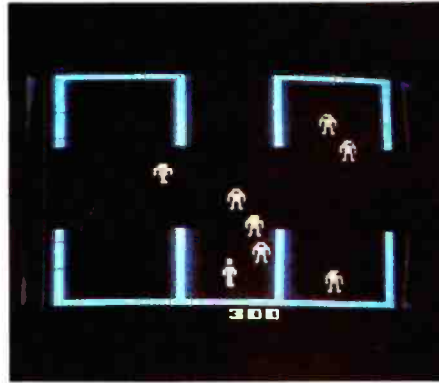

RE-CREATIONS

An implementation of one of the most successful arcade games, *Defender* is now available for you to play at home. You are the commander of a spaceship trying to blast the aliens from the skies and rescue the kidnapped humanoids before they are transformed into flying mutants. An excellent adaptation of the original. *Defender* for the Atari VCS, \$37.95 (cartridge), from Atari Inc., POB 427, Sunnyvale, CA 94086.

Another favorite of the commercial arcades is ready to challenge you at home. In *Berzerk*, you are trapped in an electronic maze, hounded by robots and the Evil Otto. Use the joystick to move through the maze and hit the button to fire your laser at the robots. Several playing options let you choose between armed and unarmed robots, characteristics for Otto, and the number of bonus lives available. *Berzerk* for the Atari VCS, \$31.95 (cartridge), from Atari Inc., POB 427, Sunnyvale, CA 94086.

One of the favorites for all ages, *Frogger* is a faithful implementation of the coin-operated video game with an extra bonus: an easy option that lets the frog stay on the moving log when it wraps around to the other side of the screen. Trying to get the poor frog to hop across the busy highway can be quite a trick. *Frogger* by Ed English for the Atari VCS, \$30 (cartridge), from Parker Brothers, POB 1012, Beverly, MA 01915.



NEW!

Pitfall Harry has three chances and 20 minutes to find gold and silver bars, money bags, and diamond rings. But on his way to discover all of these treasures, he must avoid crocodile-infested swamps, vicious cobras, disappearing tarpits, and deadly scorpions in the underground passage. One of the trickiest moves you have to learn is how to make Harry jump up and catch the swinging vine. *Pitfall* by David Crane for the Atari VCS, \$31.95 (cartridge), from Activision, Drawer 7286, Mountain View, CA 94042.

The Imperial Walkers are on the march, and you must use your fleet of Snowspeeders to destroy them before they reach the power generator on the ice planet Hoth. Using a joystick to maneuver your craft, you fly over, around, and under the lumbering army of Walkers. Your battlefield is eight television-screens-wide, and the enemy will approach you in single file from left to right. When the lead Walker reaches the right end of your radar band, the power generator is a lost cause. A surprisingly strong entry for a first attempt in the video-game market. *The Empire Strikes Back* by Rex Bradford for the Atari VCS, \$30 (cartridge), from Parker Brothers, POB 1012, Beverly, MA 01915.

The Vectrex Arcade System

A VECTOR-DISPLAY GAME SYSTEM FOR \$200 BRINGS TRUE ARCADE ADVENTURES INTO THE HOME.

Pamela Clark
Technical Editor

Here is one of the greatest game machines we have seen this year. With superb *vector* graphics, excellent sound, cartridges for some of the best coin-operated arcade games, and a suggested retail price of \$200, the Vectrex Arcade System is a good bet to score big with the consumer. Developed and distributed by General Consumer Electronics (GCE), a subsidiary of the Milton Bradley Company, the Vectrex comes closer to duplicating a real arcade game than any other game system on the market.

Because the Vectrex is a stand-alone system, you won't have to fight other people for use of the television set. Just take your Vectrex and plug it in wherever you have an electrical outlet. The system uses a Motorola 68A09 microprocessor chip in order to offer more speed and power than is available in most video games. You have a detachable control panel with a self-centering joystick and four buttons to play the games. You can plug in an additional optional control panel if you want to play



Games Available

GCE has obtained licensing rights and produced versions of the following coin-op arcade games: from Cinematronics Inc., *Armor Attack*, *Space Wars*, *Star Hawk*, *Rip Off*, and *Solar Quest*; from Konami Industry, *Scramble*; and from Stern Electronics Inc., *Berzerk*.

Several games have been developed in-house by GCE, including the *Star Trek* game, modeled after the movie; *Mine Storm*, the resident space game; *Blitz*, an action football game; *Cosmic Chasm*, a space action game; *Clean Sweep*, an action maze game; and *Hyper Chase*, an auto race adventure. In *Clean Sweep*, you try to clean up your bank after a burglary. The bank robbers, in trying to blow open the vault, have scattered money through the bank corridors. Use the joystick to move your vacuum cleaner through the maze, sucking up all of the loose money. But be careful, the robbers want the money too and will be trying to destroy you at every turn.

If you dream of being a formula-one race driver, then *Hyper Chase* is your game. The vector graphics are superb, as you use the controls to drive a grueling grand prix. All of these cartridges will retail for about \$30.



with a friend (or foe). The realistic sound, produced by a General Instrument AY38912 chip, includes music, explosions, and crowd cheers. And the display—well it almost has to be seen to be believed; imagine playing games at home (or in the office) using vector graphics with three-dimensional rotation and zoom.

Not only does this machine look and sound like its coin-operated counterparts, but it already has cartridges for seven of the more popular arcade games (see box).

One game, *Mine Storm*, was created by GCE and is resident in the 64K-byte ROM (read-only memory). GCE has also developed additional game cartridges, each with a screen overlay to provide color and detail to the 9-inch black-and-white display, and a complete player's reference manual. It is unusual and refreshing to see a product appearing on the market with its software ready to run. But enough of these words, just look at what it can do. ■

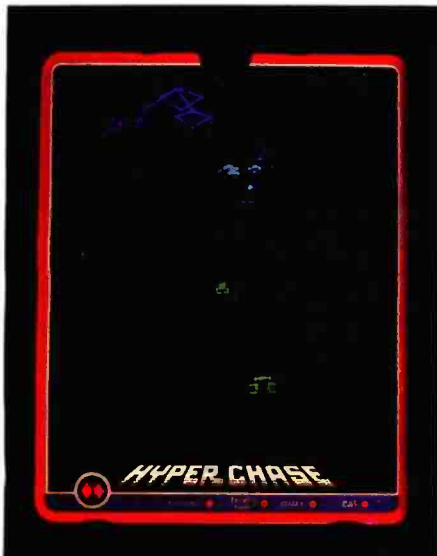

Board to Death

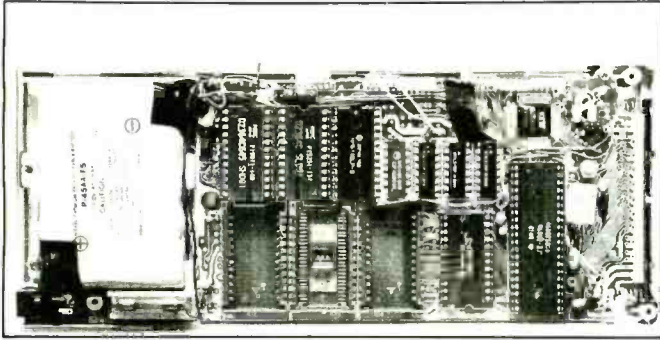

Photo 1: *All sounds.*

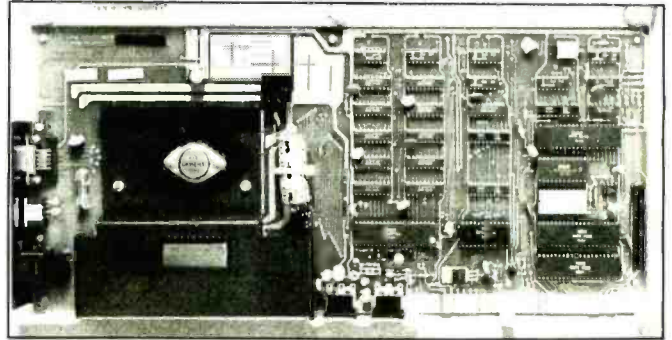

Photo 2: *German obscenity.*

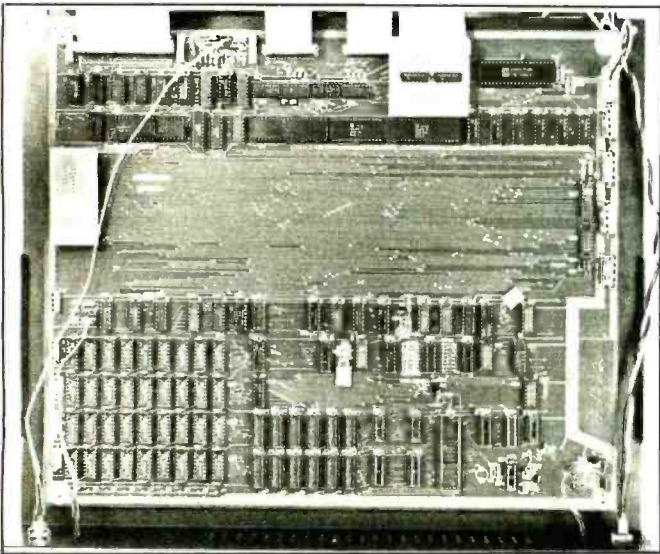

Photo 3: *George Washington's diary.*

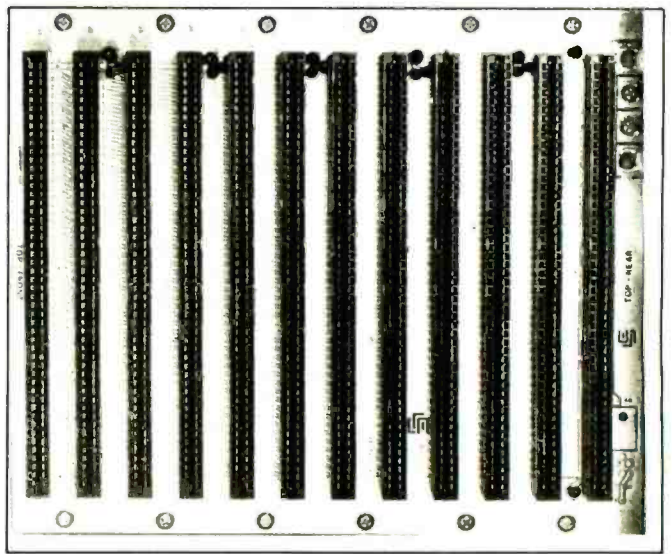

Photo 4: *Gold rush state.*

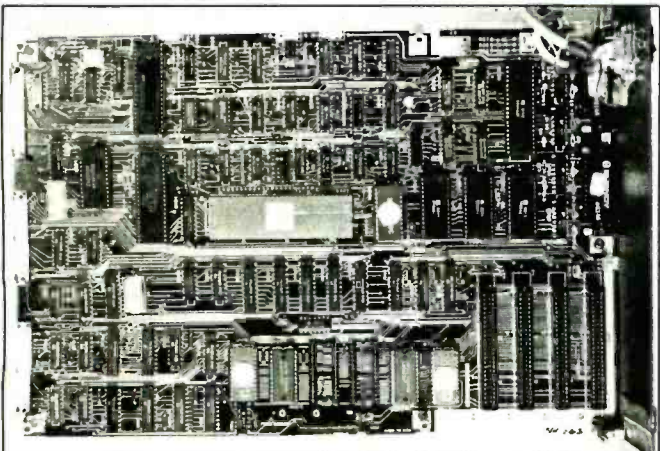

Photo 5: *Five-star idea.*

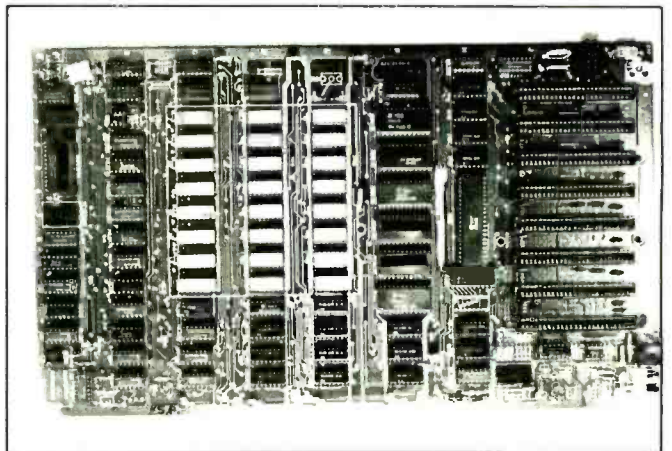

Photo 6: *Born in a garage.*

Test your hardware savvy. Presented here are 12 microcomputer system boards (sometimes referred to as motherboards). See how many you can recognize using just the photos (if you are really good), or read the clues under each photo for help. You may turn to page 590 for the answers only out of desperation. Don't feel too bad if you can't guess them all. Steve Ciarcia got only 8 out of 12. . . . J. N. S.

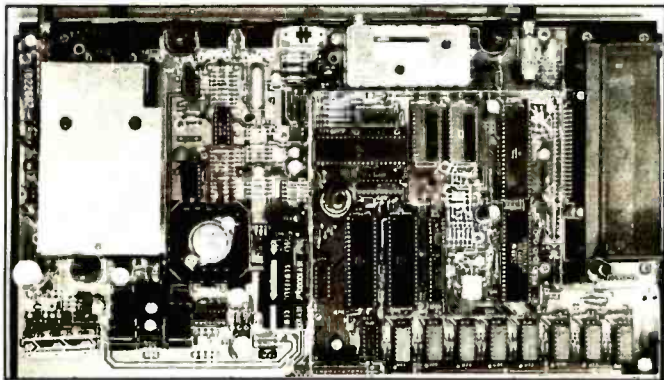

Photo 7: Tandy dandy.

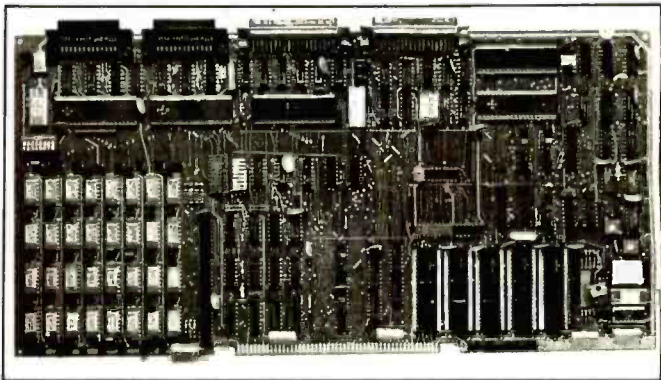

Photo 8: A very small motor.

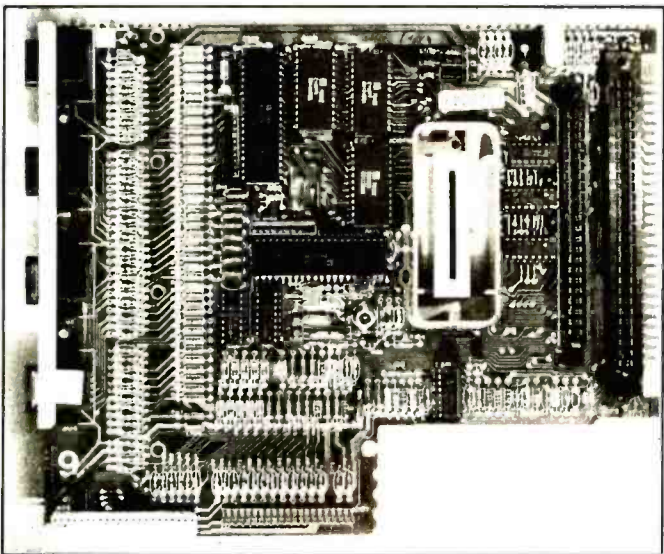

Photo 9: Go players beware.

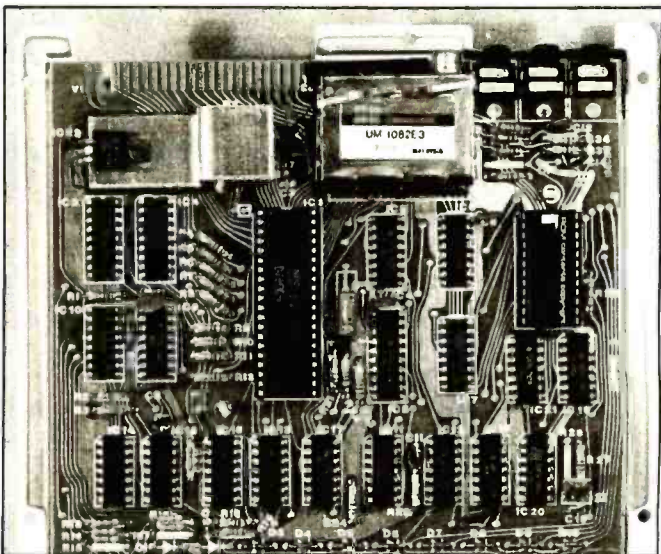

Photo 10: Surrogate promotion.

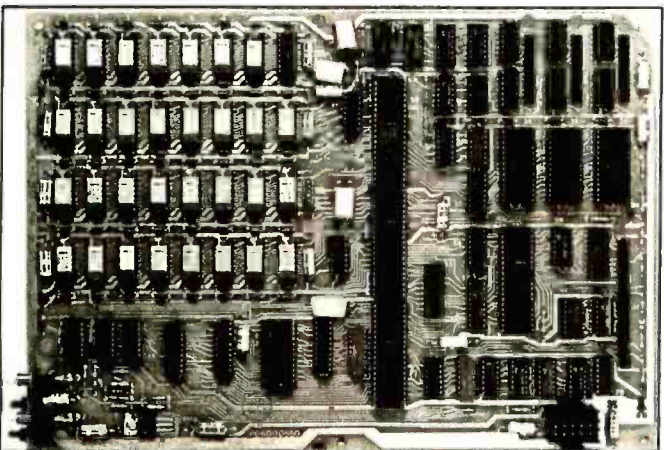

Photo 11: Control your car?

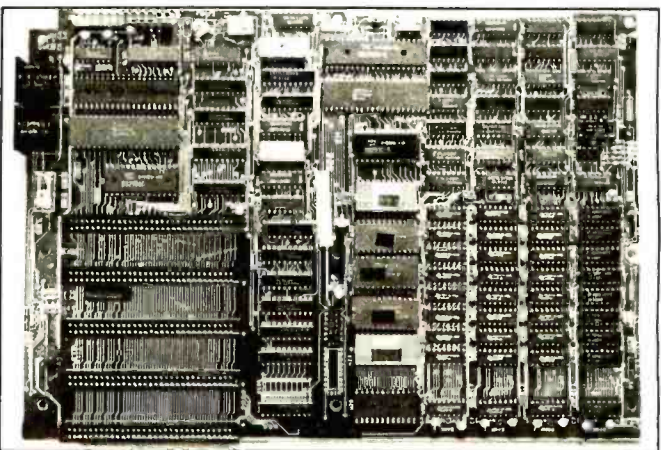

Photo 12: A little blue.

Design Techniques and Ideals for Computer Games

Chris Crawford
Atari Inc.
1265 Borregas Ave.
POB 427
Sunnyvale, CA 94086

Why are some computer games better than others? Game manufacturers and authors constantly try to answer this million-dollar question. Many factors contribute to the appeal of a computer game, including technical quality, graphics, sound, pace, game play, and action. Yet we cannot merely list the properties of a given game and expect the length of the list to tell us whether that game will be a success. Game design is an art form, and like any art form the individual components are less important than the manner in which they are put together, the overall technique.

All artists develop their own special techniques and ideals for the execution of their art. The painter worries about brushstrokes, mixing of paint, and texture; the musical composer learns procedures of orchestration, timing, and counterpoint. The game designer also acquires a variety of specialized skills, techniques, and ideals for the execution of the craft. In this article I will describe some of the techniques I use in my games. I don't understand my own art well enough to present my techniques in a hierar-

chical or logical sequence; instead, I'll simply offer a potpourri of interesting ideas grouped under the concepts of balance, relationships, monotonicity (having a positive monotonic learning curve), and winnability.

Balancing Solitaire Games

A solitaire game pits the human player against the computer. The computer and the human are very different creatures; where human thought processes are diffuse, associative, and integrated, the machine's thought processes are direct, linear, and arithmetic. This difference causes a problem. A designer creates a computer game for the benefit of the human, and therefore the game is played in the intellectual territory of the human, rather than in the intellectual territory of the computer. The computer is thus at a natural disadvantage. Although the computer could easily whip the human in games involving computation, sorting, or similar functions, such games would be of little interest to the human player in most cases. The computer must play on the human's home turf, which it does with great difficulty. How, then, do we design a game to enable the computer to compete with and challenge the human? Four techniques are available: *vast resources*, *artificial reckoning*, *limited information*, and *pace*.

Vast Resources

In what is by far the most heavily used technique for balancing a game, the designer provides the computer with immense resources that it uses stupidly. These resources may consist of large numbers of opponents that operate with only the most rudimentary intelligence. Many games use this ploy: *Space Invaders*, *Missile Command*, *Asteroids*, *Centipede*, and *Tempest*, for example. It is also possible to equip the computer with a small number of opponents more powerful than the human player's units, such as the super-tanks in *Battlezone*. The effect in both cases is the same: the human player's advantage in intelligence is offset by the computer's material advantages.

The vast-resources technique has a number of benefits. First, the conflict between the human and the computer assumes a David-versus-Goliath air. Most people would rather win as an apparent underdog than as an equal. Second, this technique is the easiest to implement. Providing intelligence for the computer's players can be difficult, but making hordes of computer players repeat a single process takes little more than a simple loop. Of course, the ease of implementation carries a disadvantage: everybody can do it. We are knee-deep in such games. Laziness and lack of determination have far more to do with

About the Author

Chris Crawford leads the Games Research Group at Atari. He has designed several microcomputer games and has written articles and books about computers and programming.

the prevalence of this technique than game-design considerations.

Artificial Reckoning

The obvious alternative to giving the computer player an advantage of sheer numbers is to provide it with intelligence adequate to meet the human player on equal terms. Unfortunately, artificial intelligence techniques are not understood well enough to be useful in this context. The development of tree-searching techniques allows us to produce passable chess, checkers, and Othello computer players. Any other game that can be expressed in direct tree-searching terms can also be handled with these techniques. Very few games, however, are appropriate for this treatment.

An alternative is to develop ad hoc artificial intelligence routines for each game—the method I have used in *Tanktics*, *Legionnaire*, and *Eastern Front 1941* with varying degrees of success. Although this strategy demands great effort from the game designer, the routines are so primitive that referring to them as artificial intelligence is misleading and almost arrogant. Instead, I use the less ambitious term artificial reckoning.

The first aim of any artificial reckoning system is to produce reasonable behavior. The computer should not drive its tanks over cliffs, crash spaceships into each other, or pause to rest directly in front of the human's guns. In other words, the artificial reckoning system must not allow obviously stupid moves. This requirement tempts us to list all possible stupid moves and write code that tests for each such stupid move and precludes it. This is the wrong way to handle the problem because the computer can demonstrate unanticipated creativity in the stupidity of its mistakes. A better (but more difficult) method is to create a more general algorithm that obviates the most absurd moves.

A second requirement of an artificial reckoning routine is unpredictability. The human player should never be able to second-guess the

behavior of the computer, for this would shatter the illusion of intelligence and make victory much easier. This second condition seems to contradict my first requirement of reasonable behavior because reasonable behavior follows patterns that should be predictable. We can resolve this apparent contradiction through a deeper understanding of the nature of interaction in a game. To arrive at such an understanding, we must combine three premises. First, a reaction to an opponent is in some ways a reflection of that opponent. A reasonable player tries to anticipate an opponent's moves by assessing the opponent's personality. Second, interac-

tiveness is a mutual reaction—both players attempt to anticipate each other's moves. Third, the level of interactivity is a measure of the quality of the game. We can combine these three premises in an analogy. Think of a game in terms of two mirrors facing each other, with each player looking out from one mirror. A weakly interactive game is analogous to two mirrors *almost* aligned toward each other; each player can see and interact at one or two levels of reflection. An ideal, perfectly interactive game is analogous to two highly reflective mirrors aligned *precisely* toward each other; each of the two players recursively exchanges

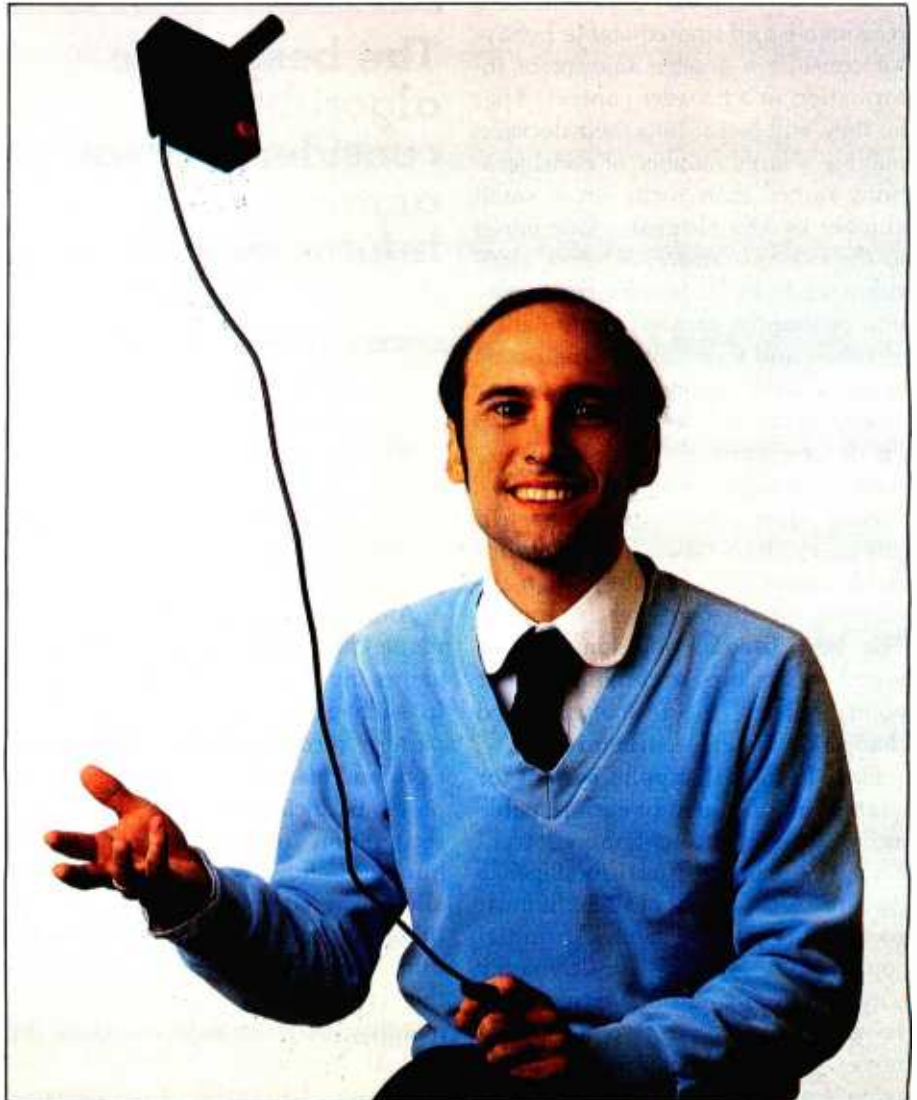

Photo 1: Chris Crawford, computer-game artist, uses a variety of design techniques to create new, stimulating games for the microcomputer. Photo by Franklin L. Avery.

places in an endless tunnel of reflected anticipations. No matter how reasonable the behavior, the infinitely complex pattern of anticipation and counter-anticipation defies prediction. The pattern is reasonable yet unpredictable, and thus satisfies the requirements of artificial reckoning.

Experience has shown me that game algorithms are most predictable when they are particular, emphasizing a single element of the overall game gestalt. For example, in war games, algorithms such as "determine the closest enemy unit and fire at it" are particular and yield predictable behavior.

I find that the best algorithms for reasonable and unpredictable behavior consider a greater amount of information in a broader context. That is, they will factor into their decision making a large number of considerations rather than focus on a small number of key elements. Compared to the example above, a better algorithm might be "determine the enemy unit posing the greatest combination of threat and vulnerability (based on range, activity, facing, range to other computer tanks, cover, and sighting); fire on unit if probability of killing exceeds probability of being killed."

How does one implement such principles into specific, programmable algorithms? I doubt that an all-purpose system can ever be found. The best general solution I have found so far uses a combination of point systems, field analysis, and changes in the game structure.

First, I establish a point system for quantifying the merit of each possible move. This is a time-honored technique for many artificial intelligence systems. A great deal of thought must go into the point system. An initial complication is one of dynamic range: the designer must ensure that the probability that two accessible moves will each accumulate a point value equal to the maximum value allowed by the word size (8 bits) approaches zero. In other words, we

can't have two moves each getting a score of 255 points or we have no way of knowing which is truly the better move.

Another problem with the point system is the balancing of factors against each other. Suppose we have a tank game in which we know that climbing on top of a hill is good, but we also know that moving onto a road is good. Which is better? If a hilltop position is worth fifteen points, what should a road position be worth? Ten points? Twenty? You really need a deep familiarity with the play of the game to answer these questions. Unfortunately, such

The best game algorithms consider a great amount of information in a broad context.

familiarity is impossible to attain with a game not yet completed. Instead you have to rely on broad experience, a thorough understanding of the situation being represented, painstaking analysis, and lots of experimenting.

Another artificial reckoning technique, field analysis, applies only to games involving spatial relationships. In such games the human relies on pattern recognition to analyze positions and plan moves. The microcomputer is incapable of true pattern recognition on the same level as humans; however, field analysis allows the computer to attain something approaching pattern recognition. The key effort for the designer is the creation of a calculable field quantity that correctly expresses the critical information needed by the computer to make a reasonable move. For example, in several of my war games I've used safety and

danger fields to tell a unit the level of risk in a given situation. Danger is calculated by dividing each enemy unit's strength by its range and summing the quotients of the different units; thus large or close units are very dangerous, and small or distant units are only slightly dangerous. A similar calculation with friendly units yields a safety factor. A unit decides whether to exhibit bold or timid behavior by comparing the danger and safety values at its position. Once this decision is made, the unit looks around and measures the net danger minus safety in each position it could move to. If the unit is feeling bold, it moves toward the danger; if it is feeling timid, it moves away. In this particular case, I find a vector field to be more informative than a scalar field; in some cases the scalar field is adequate. The vector field tells the magnitude and direction of danger; the scalar field tells only the magnitude. If the algorithm is intelligent enough to use the direction information, the vector field is more useful.

Coordinating the moves of the many units under computer control is a special dilemma. How is the computer to assure that the different units move in a coordinated way and that traffic jams don't develop? Usually the game designer's response is to use a sequential planning system coupled with a simple test to determine the position of other units. Thus, unit #1 moves first, then #2, followed by #3, with each one avoiding collisions. I can assure you from my own experience that this system serves only to replace collisions with the most frustrating traffic jams. A better method uses a virtual-move system in which each unit plans a virtual (hypothetical) move based on the virtual positions of all other units. Here's how it works: we begin with an array of real positions of all computer units. We create an array of virtual positions and initialize all virtual values to the real values. Then each unit plans its move, avoiding colli-

Explore the Frontiers of Intelligence

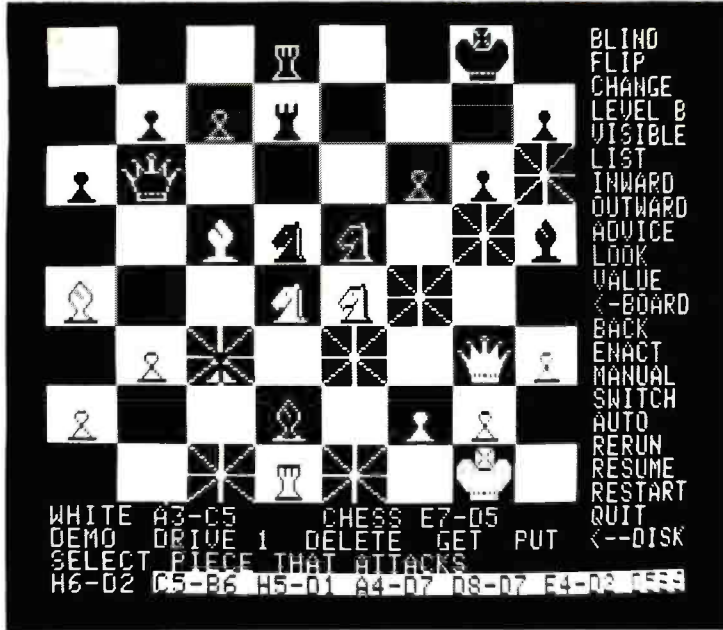

- ◀ Variations of blind-fold play—camouflaged or invisible pieces
 - ◀ Invert board to play black on bottom
 - ◀ Change pieces on board during game, or set up position
 - ◀ Change between 15 levels of play, plus postal and mate-finder modes
 - ◀ Show move that Chess is thinking about
 - ◀ List played moves for each side
 - ◀ Lines of force in: attacks and defenses on a square
 - ◀ Lines of force out: squares attacked and defended
 - ◀ Chess suggests a move
 - ◀ Show moves Chess thinks you will make, and its responses
 - ◀ Evaluation of a position
 - ◀ Return to board or switch to command menu
 - ◀ Take back a move (repeatable)
 - ◀ Play move suggested by look-ahead search
 - ◀ Chess plays neither side
 - ◀ Switch sides
 - ◀ Chess plays against itself—one level against another
 - ◀ Replay through most advanced position
 - ◀ Skip to most advanced position
 - ◀ Start new game
 - ◀ Leave program
 - ◀ Save, get, and delete games to and from disk
- All features self-documented; all choices cursor-controlled
Screen shows "outward" and "look" features being used

THE PEOPLE BEHIND THE PROGRAMS:

Larry Atkin & David Slate: Authors of the Northwestern University Chess 4.7 program—World Computer Chess Champion, 1977-1980

Peter Frey: Northwestern University professor
Editor: Chess Skill in Man and Machine
One of U.S. Othello Assoc.'s top-ranked players

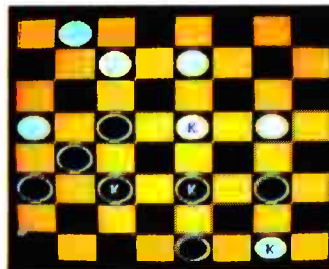
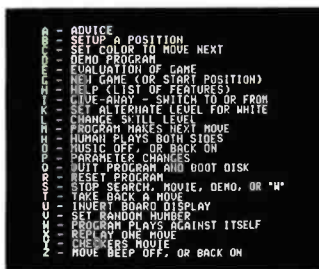
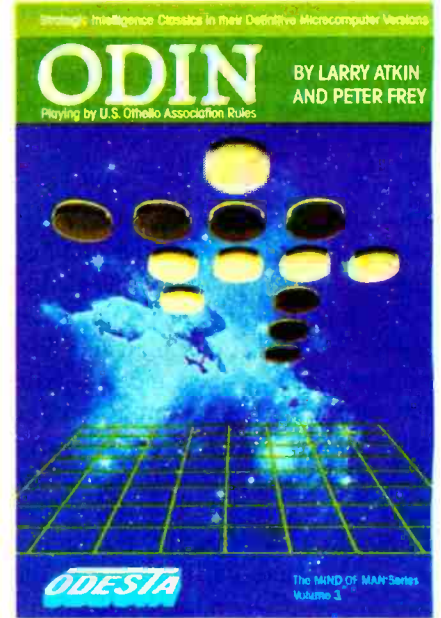
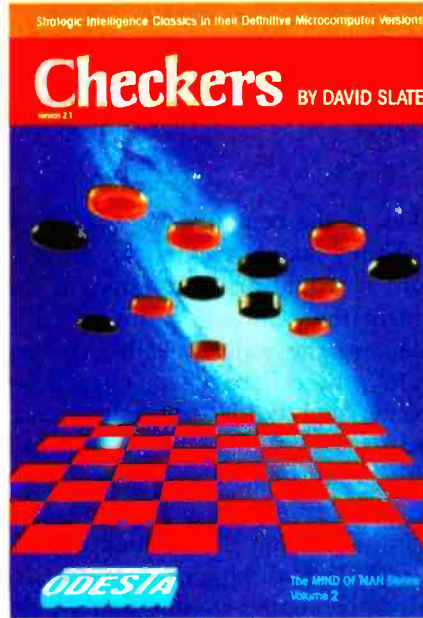

Black to move and win
(From Checkers documentation)

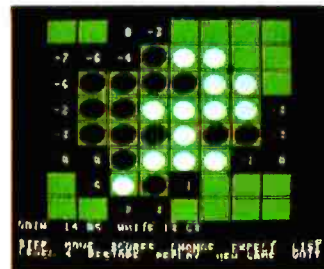

"Scores" feature in Odin

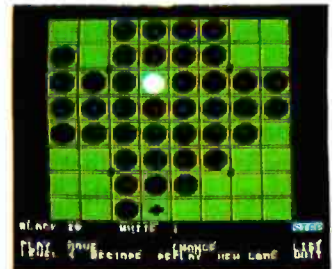

A clue to the secret of Odin:
Black is destined to lose.



930 Pitner
Evanston, IL 60202
(U.S.A.)

Chess: \$69.95
Checkers: \$49.95
Odin: \$49.95

See your local software dealer, or order
(Mastercard or Visa):
800-323-5423
(in Illinois, call 312-328-7101)

For Apple II, Apple II Plus 48K disk systems, and Atari 48K disk systems.
Odin is also available for TRS-80 Model 1 & 3 32K disk systems.

CHRIS CRAWFORD ON DESIGN



Photo 2: *Legionnaire*, a recently released war game about Caesar and the barbarian hordes, is a good example of a refined attack algorithm. Chris tried several strategies before the single advance-to-attack algorithm emerged.

sions with the virtual positions. After the unit plans its move, the planned final position is put into the virtual array. Other units then plan their moves. After all units plan one virtual move, the process repeats, with each unit planning its move on the basis of the interim virtual-move array. This huge outer loop should be convergent; after a sufficient number of iterations the routine terminates and the virtual positions form the basis of the moves made by the computer's units. This technique is useful for coordinating the moves of many units and preventing traffic jams.

Another technique for achieving reasonable and unpredictable algorithms is so simple that it seems like cheating: change the game. If a crucial element of the game is not tractable with artificial reckoning, remove it. If you can't find a good way to use a feature, you really have no choice but to delete it. For example, while designing *Tanktics*, I encountered a problem with certain

lakes. If the computer approached a U-shaped lake from the wrong direction, it would drive its tanks to the end of the peninsula formed by the lake, see the water blocking its forward progress, back up, change direction slightly, and drive back into the peninsula, only to be blocked again by the lake. The U-shaped lake created a trap for my artificial reckoning algorithm. I expended a great deal of time working on a smarter artificial reckoning routine that would not be trapped by such lakes and yet would retain desirable economies of motion. After much wasted effort I discovered a better solution: delete U-shaped lakes from the map. Ideally, the experienced game designer has enough intuitive feel for algorithms to sense game factors that are intractable and avoid them during the design stages of the game. However, most of us must discover these things the hard way and retrace our steps to modify the design.

No matter how good an algorithm

is, its applicability is limited. The odds are that a specific algorithm will work best under a narrow range of conditions. To be truly interesting, a good game design must offer a broad range of conditions. Thus with many games the designer must create a number of algorithms and switch from one to another as conditions change. The transition from one algorithm to another is fraught with peril; if you don't maintain continuity across the transition, the computer units may exhibit highly unreasonable behavior patterns. I well remember a frustrating algorithm transition in *Legionnaire*. The computer barbarians were controlled by three algorithms that caused them to either run for safety, approach to contact, or attack. Under certain conditions a barbarian operating under the approach-to-contact algorithm would decide on bold behavior, dash forward to make contact with the human, and make the transition to the attack algorithm, which would declare an attack unsafe. The barbarian would thus balk at the attack and convert to the run-for-safety algorithm, which would direct it to turn tail and run. The human player was treated to a spectacle of ferociously charging and frantically retreating barbarians, none of whom ever bothered to actually fight. I eventually gave up and redesigned the algorithms, merging all three into a single advance-to-attack algorithm with no transitions.

The artificial reckoning techniques I have described so far are designed for use in games involving spatial relationships. Many games are non-spatial and require other reckoning techniques. A common type of non-spatial game is a complex system simulation, often involving coupled differential equations. *Lunar Lander*, *Hammurabi*, *Energy Czar*, and *Scram* are examples of this type of game. In such games the primary problem facing the designer is not so much to defeat the human as to accurately model system behavior. I advise the game designer to be particularly

DON'T GET LOCKED IN



Pascal
Basic
Cobol
Forth
Pilot
Fortran
Spread Sheet
Inventory
Logo
"C"

Data Base Management
Word Processor
Communication Utility
Accounts Receivable
Accounts Payable
Engineering Utility

General Ledger
Mailing List
Macro Assembler
Education



TRSDOS*



CP/M**

Open your doors to a world of SOFTWARE with LNW computers. You'll get **MORE PERFORMANCE¹** than with the IBM PC², the Apple II³, TRS80 MODEL II or TRS80 MODEL III⁴ along with software support of TRSDOS or CP/M, the TWO MOST WIDELY USED OPERATING SYSTEMS. This means you, the user, can select from the largest base of business or personal software.

Standard Features: A serial RS232 communication port, parallel printer port. Hi-Resolution (480x192) B/W and COLOR graphics, an 80 character-per-line screen display along with Quad-density interface for 5" or 8" floppy disk storage offering immediate access to 3.5 million characters, or optional Hard disk

interface to 5 or 10 million characters.

Standard Software: LNW BASIC and DOS PLUS operating system packages, commanding all the above features, are included.

The LNW computer will be the key to your success with the starting price at **\$1695.00**, along with a full 6 month warranty.

Dealers: You too can open the door to a successful product. Call for our special dealer programs: (714) 544-5745.



LNW Computers
2620 Walnut Avenue
Tustin, California 92680
(714) 544-5744

*TRSDOS is a trademark of Tandy Corp.

**CP/M is a trademark of Digital Research Corp.

1. Performance is based on bench mark test in the JAN 1982 issue of BYTE magazine, pg. 54, with LNW80 II as the comparison.

2. IBM PC is a trademark of IBM CORP

3. APPLE II is a trademark of APPLE COMPUTERS

4. TRS80 is a trademark of Tandy Corp.

Circle 269 on inquiry card.

International orders please inquire for pricing/shipping cost.

CHRIS CRAWFORD ON DESIGN

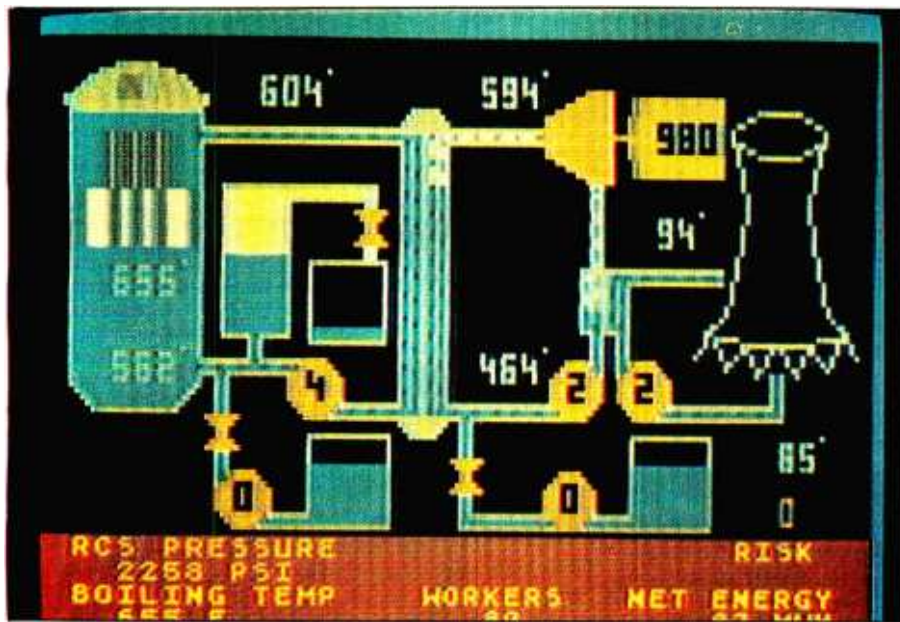

Photo 3: *Scram* is a nuclear-power-plant simulation that uses coupled differential equations to model complex behavior. Photo by Franklin L. Avery.

careful with games involving large systems of coupled differential equations. *Hammurabi* uses three coupled first-order differential equations, and most programmers find that number easy to manage. But the complexity of the problem rises very steeply with the number of differential equations used. *Energy Czar* used the fantastic sum of 48 differential equations, a feat made believable only by the fact that many constraints were imposed on them. In general, be wary of more than four coupled differential equations. If you must use numerous differential equations, try to use parallel equations in which the same fundamental equation is applied to each element of an array of values.

Each differential equation should have a damping factor that must be empirically adjusted:

$$\text{new value} = \text{old value} + \frac{\text{driving factor}}{\text{damping factor}}$$

A small damping factor produces lively simulated systems that bounce around wildly. A large damping factor yields sluggish systems that change slowly. Unfortunately, recourse to simple damping factors can backfire when a relationship of

negative feedback exists between the new value and the driving force. In this case, a large damping factor inhibits the negative feedback, and one of the variables changes erratically. The behavior of systems of differential equations is complex; I suggest that designers interested in these problems familiarize themselves with the mathematics of overdamped, underdamped, and critically damped oscillatory systems. For more general information on solving systems of differential equations, any good textbook on numerical analysis will serve as a useful guide.

The application of all these methods may well produce a game with some intelligence, but your expectations should not be too high. Even great effort is not enough to produce truly intelligent play. To date, none of my three attempts play with adequate intelligence to tackle a human player on equal terms. Indeed, they still need force ratios of at least 2 to 1 to stand up to the human player.

Limited Information

Another way to make up for the computer's lack of intelligence is to

limit the amount of information available to the human player. If the human does not have the information to process, he cannot apply his superior processing power to the problem. Applying this technique to excess can reduce the game to one of chance. Used with discretion, however, limited information can equalize the odds between the player and the computer. If the information is withheld in a reasonable context (e.g., the player must send out scouts), the restrictions on information not only seem natural, but they add to the realism and excitement of the game.

Game designers often overlook or misunderstand the value of limited information. Limited information can tickle the imagination of the player by suggesting details without actually confirming them. You must artfully choose the limitations on the information, however. Randomly assigned gaps are confusing and frustrating rather than tantalizing.

Pace

Controlling the pace of the game provides another way to even the balance between human and computer. The human may be smart, but the computer is much faster at performing simple computations. If the pace is fast enough, human players will not have enough time to apply their superior processing skills and will be befuddled. This is a very easy technique to apply, so it comes as no surprise that many designers of skill and action games use it heavily.

These four techniques—vast resources, artificial reckoning, limited information, and pace—are never used in isolation; every game uses some combination of the four. Most games rely primarily on pace and vast resources for balance, with very little artificial reckoning or limited information. The reason for this emphasis is simple: pace and vast resources are easy to implement, while artificial reckoning and limited information are more difficult. Economy of effort

Four times faster than any 300 bps modem, to be precise. With Hayes Smartmodem 1200, any computer with an RS-232C connection — such as the IBM Personal Computer, TRS-80[®] or Apple[®] III — can communicate over telephone lines with other computer terminals or printers. Smartmodem 1200 connects directly to any standard telephone jack in the USA. Dialing can be Touch-Tone[®] pulse or both. It can even operate over multiline phone systems (PBX) to dial numbers, receive and transmit data, and disconnect — automatically. An internal speaker lets you hear the call being made and monitor its progress. That way you'll know immediately if the line's busy or you reach a

wrong number. And indicator lights keep you posted on the current operating status: modem ready, terminal ready, carrier detect, auto-answer and high speed.

Smartmodem 1200 is two modems in one. Like the original Hayes Smartmodem, it can communicate with other Bell 103 type modems at up to 300 bps. Plus it's a 1200 bps modem for communicating with the faster Bell 212A type modems. Unlike many 1200 bps modems, Smartmodem 1200 lets you select full or half duplex, for compatibility with time-sharing services or any other system you choose. Smartmodem 1200 allows you to access The Source,SM communicate with

your branch offices, or exchange programs with other computer users. In fact, it performs just about any communication function you can imagine, and can be program controlled using any language.

Smartmodem 1200. Another product in the Hayes Stack[™] series that stands for quality and dependability. And all

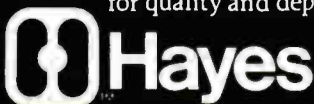

you need for communicating... fast! Available at computer stores

nationwide. For the name of your nearest dealer write: Hayes Microcomputer Products, Inc., 5835 Peachtree Corners East, Norcross, Georgia 30092; or call (404) 449-8791.

Smartmodem 1200. Gets you moving fast!



Hayes

[®] Trademark of Hayes Microcomputer Products, Inc. ©1982 Hayes Microcomputer Products, Inc. Sold only in the U.S.A. TRS-80 is a registered trademark of Tandy Corporation. Apple is a registered trademark of Apple Computer, Inc.

Touch-Tone is a registered trademark of American Telephone and Telegraph. The Source is a service mark of Source Telecomputing Corporation, a subsidiary of The Reader's Digest Association, Inc.

is no longer justifiable in the lucrative market for games. There's no reason why a game could not incorporate all four techniques; indeed, this should make the game all the more successful, for by using small amounts of each method, the game need not strain the limitations of any one method. The designer must decide the appropriate balance of each for the goals of the particular game.

Relationships Between Opponents

The concepts I've discussed so far apply primarily to computer games. Now let's consider some general game theory. Every game establishes a relationship between opponents that each player strives to exploit to maximum advantage. The fundamental architecture of this relationship, *symmetric* or *asymmetric*, plays a central role in the game. The simplest architecture establishes a *symmetric relationship* between the two players. Both possess the same properties, the same strengths and weaknesses. Symmetric games have an obviously desirable feature: they are automatically balanced. Because the same processes are applied to each player, symmetric computer games tend to be easier to program. Finally, these games are easier to learn and understand. Examples of symmetric games include Combat for the Atari 2600, Basketball, and Dog Daze.

Symmetric games suffer from a variety of weaknesses, the greatest of which is their relative simplicity. Any strategy that promises to be truly effective can and will be used by both sides simultaneously. In such a case, success derives not from planning but from execution. Alternatively, success in the game turns on very fine details. Chess provides an example: an advantage of but a single pawn can be parlayed into a victory.

Because of the weaknesses of symmetric games, many game designers attempt to establish an *asymmetric relationship* between the opponents. Each player has a unique combina-

tion of advantages and disadvantages. The game designer must somehow balance the advantages so that both sides have the same likelihood of victory, given equal levels of skill. The simplest way of doing this is with plastic asymmetry. Games incorporating this relationship are formally symmetric, but the players select initial traits according to some set of restrictions. For example, in the board game Wizard's Quest the players have the same number of territories at the beginning of the game, but they choose their territories in sequence. Thus, what was initially a symmetric relationship (each player is entitled to n territories) becomes an asymmetric one (player A has one

Symmetric games suffer from their relative simplicity.

combination of n territories while player B has a different combination). The asymmetry is provided through the choices of the players themselves at the outset of the game, so if the results are imbalanced, the players are responsible.

Other games have a more explicitly asymmetric relationship. Almost all solitaire computer games establish an asymmetric relationship between the computer player and the human player because the computer cannot hope to compete with the human in matters of intelligence. Thus, the designer gives resources to the human player allowing the use of his or her superior planning power, while the computer gets resources that compensate for its lack of intelligence.

The advantage of asymmetric games lies in the ability to build nontransitive or triangular relationships into the game. Nontransitivity is a well-defined mathematical property. In this context, it is best illustrated with the rock-scissors-paper game. Two players play this game; each secretly

selects one of the three pieces; they simultaneously announce and compare their choices. If both make the same choice the result is a draw and the game is repeated. If they make different choices, then rock breaks scissors, scissors cut paper, and paper enfolds rock. This relationship, in which each component can defeat one other and can be defeated by one other, is a nontransitive relationship; the fact that rock beats scissors and scissors beat paper does not mean that rock beats paper. This particular nontransitive relationship only produces clean results with three components so that each component relates to only two other components; it beats one and loses to the other. A rock-scissors-paper game with binary outcomes (win or lose) cannot be made with more than three components. You could make a game with multiple components if several levels of victory (using a point system, perhaps) were included.

Nontransitivity is an interesting mathematical property but it does not yield rich games if we hew to the strict mathematical meaning of the term. Its value to game design lies in the generalization of the principle into less well-defined areas. I use the term "triangular" to describe such asymmetric relationships that extend the concepts of nontransitivity beyond its formal definition.

A simple example of a triangular relationship appears in the game Battlezone. When a saucer appears, the player can pursue the saucer instead of an enemy tank. In such a case, there are three components: player, saucer, and enemy tank. The player pursues the saucer (side one of the triangle) and is pursued by the enemy tank (side two). The third side of the triangle (saucer to enemy tank) is not directly meaningful to the human—the computer maneuvers the saucer to entice the human into a poor position. This example is easy to understand because the triangularity assumes a spatial form as well as a structural one.

SEIKOSHA
GP-100A



GP-100A: US\$389

COMMAND PERFORMANCE.

Seikosh gives you all the best features—including economy and super-clear graphics.

Unlike some graphic printers, Seikosh's new GP-100A Uni-Hammer Graphic Printer puts full dot addressable graphics at your command. The GP-100A lets you repeat a column of data as many times as needed with just one command. Software control enables double-width character output, and the positioning is both character and dot addressable. Designed for simple operation, it ranks among the most cost-efficient graphic printers on the market. Command performance technology that not only works for you now, but takes you well into the future.

Other valuable features:

- Graphics, regular and double width character modes can be intermixed on the same line.
- Automatic printing. When the text exceeds the maximum line length, there is no loss of data due to overflow.
- Self-test printing is a standard feature.
- Centronics type parallel interface.
- Paper width is adjustable up to 10 inches.
- Optional Interface: RS232C, IEEE488, apple II, etc.

Graphic Printer  Series

Available at COMPUTERLAND and other fine stores in your area

Distributed by **AXIOM CORPORATION** 1014 Griswold Avenue San Fernando, Calif. 91340 Phone (213) 365-9521 TWX (910) 496-1746
Manufactured by **SEIKOSHA SYSTEM EQUIPMENT DIV.** 4-1-1 Taihei Sumida-ku Tokyo Japan. Phone: 03-623-8111 Telex: 262-2620

Circle 418 on Inquiry card.

www.americanradiohistory.com

CHRIS CRAWFORD ON DESIGN



Photo 4: *Eastern Front 1941* is a World War II game whose design incorporates one major trick. Once you learn the trick, mastery of the game becomes possible.

Triangularity is most often implemented with mixed offensive-defensive relationships. In any conflict game, players must make offensive and defensive actions. Some games concentrate the bulk of a certain activity on one side, making one player the attacker and the other player the defender. This game design is risky, for some people do not enjoy playing a single role, especially that of defender, throughout an entire game. After all, the defender can only lose status and never gain any. Much more entertaining are games that mix offensive and defensive strategies for each player. This way, each player gets to attack and to defend. What is more important, players can trade off defensive needs against offensive opportunities. Triangular relationships automatically spring from such situations.

The essential value of triangularity lies in its indirection. A binary relationship makes direct conflict unavoidable; the antagonists must approach and attack each other through direct means. These direct approaches are obvious and expected

and such games often degenerate into tedious exercises following a narrow script. A triangular relationship allows each player indirect methods of approach. The indirect approach always creates a far richer and subtler interaction.

Positive Monotonic Curve

An important trait of any game is a positive monotonic curve of results as a function of effort. Although my lumbering expression of the idea sounds imposing, its meaning is far simpler: as players work with a game, their scores should reflect steady improvement. Beginners should be able to make some progress, intermediate people should get intermediate scores, and experienced players should get high scores. If I were to make a graph of a typical player's score as a function of time spent with the game, that graph should show a curve sloping smoothly and steadily upward. I describe such a game as having a positive monotonic curve.

A variety of learning curves can arise. A game that has a relatively flat curve is hard to learn. If the curve is

steep, the game is easy to learn. If the curve has a sharp jump in it, apparently there is just one trick to the game, mastery of which guarantees mastery of the game. (*Eastern Front 1941* is a good example of such a game.) If the game has many sharp jumps, we say that there are many tricks. In all cases, the most desirable trait is a positive monotonic learning curve.

The designer works a positive monotonic curve into a game by providing a smooth progression from the beginner's level to an expert level. To do this, the game designer must create not one game but a series of related games. Each game must be intrinsically interesting and challenging to the level of player for which it is targeted. Ideally, the progression is automatic; players start at the beginner's level and the advanced features are brought in as the computer recognizes proficient play. More commonly, players must declare the level at which they desire to play.

Games without a positive monotonic curve frustrate players by failing to provide them with reasonable opportunities for bettering their scores. Players feel that the game is either too hard or too easy. Positive monotonic games challenge players at all levels and encourage continued play by offering the prospect of new discoveries. *Tempest* is an excellent example of such a game.

The Illusion of Winnability

An important trait of any game is the illusion of winnability. If a game is to provide a continuing challenge to players, it must also provide a continuing motivation to play. The game must appear to be winnable to all players, beginners and experts, but it must never be truly winnable or it will lose its appeal. This illusion is very difficult to maintain. Some games maintain it for the expert but never achieve it for the beginner; these games intimidate all but the most determined players. The most successful game in this respect is *Pac-*

COMPU-CART®

SECURELY TOGETHER

ERGONOMICALLY DESIGNED



PAT. PEND.

If you have an I.B.M. computer from their largest 3081 to their smallest Personal Computer, we have the right workstation for you. The CompuCart is the first ergonomically designed, fully lockable, mobile computer/terminal workstation.

The CompuCart's ERGONOMIC design means that not only is the keyboard at the correct height for comfortable interactive entry, but it is adjustable both horizontally (back and forth) and vertically to accommodate both the user and the hardware. The design further means that the keyboard, the work and the screen are all in your comfortable LINE OF SIGHT. The CompuCart is engineered to minimize fatigue and to improve the user-computer interface.

ONLY the CompuCart offers SECURITY by returning the computer to the closed position when not in use or running unattended, the double walled tambor door is closed and the whole workstation is secured with one lock. For a terminal user it means that you can comfortably step away from your desk while you are logged on and access to your terminal is restricted.

The CompuCart is mobile to allow multiple users to take full advantage of the multifunction features of modern computers and NETWORKS. Mobility also means BACKUP for a terminal or workstation that is down.

The CompuCart, even with all its features, requires minimum floor space (about 4 sq. ft.) and is the engineered workstation that suits both you and the hardware to conserve the human resource and keep your HARDWARE and SOFTWARE...SECURELY TOGETHER FOR YOU!



COMPU-CART

201 North Rome Ave. P.O. Box 2095 Tampa, FL 33601-2095
Ph. (813) 251-2431 (in Florida) Call Toll Free 1-800/237-9024

See us at Comdex
booth #1972
Circle 550 on Inquiry card.

CHRIS CRAWFORD ON DESIGN

Man, which appears winnable to most players, yet is never quite winnable. Tempest, on the other hand, intimidates many beginners because it appears to be unwinnable.

The simplicity or cleanliness of the game is the most important factor in creating the illusion of winnability. A dirty game intimidates its beginners with an excess of details. Many beginners never overcome the inhibiting suspicion that somewhere in the game lurks a "gotcha," some complicating detail or hidden factor that they haven't yet discovered. By contrast, a clean game encourages all players to experiment with the game as it appears.

Another key factor in maintaining the illusion of winnability arises from a careful analysis of the source of player failure. In every game the players are expected to fail often. What trips up the players? If they

believe their failure is caused by some flaw in the game or its controls, players become frustrated and angry with what they rightly judge to be an unfair and unwinnable situation. If players perceive their failure to be a result of their own limitations and decide that winning the game requires superhuman performance, they reject the game as unfair and unwinnable. But if players perceive failures to be attributable to correctable errors on their own part, then they believe the game to be winnable and play on in an effort to master the game.

Summary

In this article I have described a number of design factors and ideas that I have used in developing several games. These should not be used in grab-bag fashion, for taken together they constitute the elusive element we call technique. Technique is part of

an artist's signature, as important as theme. When we listen to Beethoven's majestic Fifth Symphony, the rapturous Sixth, or the ecstatic Ninth, we recognize in all the identifying stamp of Beethoven's masterful technique. If you would be a computer game designer, you must establish and develop your own technique. ■

Asteroids, Basketball, Battlezone, Centipede, Combat, Energy Czar, Missile Command, Scram, and Tempest are trademarks of Atari Inc.

Dog Daze is a trademark of Gray Chang.

Eastern Front 1941 is copyrighted by Chris Crawford.

Legionnaire, Tanktics, and Wizard's Quest are trademarks of The Avalon-Hill Game Company.

Pac-Man is a trademark of Namco.

Space Invaders is a trademark of Taito America.

BYTE Back issues for sale

	1976	1977	1978	1979	1980	1981	1982
Jan.				\$2.75	\$3.25	\$3.25	
Feb.			\$2.75	\$2.75	\$3.25	\$3.25	\$3.70
March			\$2.75	\$2.75	\$3.25	\$3.25	\$3.70
April			\$2.75	\$2.75	\$3.25	\$3.25	\$3.70
May		\$2.00	\$2.75	\$2.75	\$3.25	\$3.25	\$3.70
June		\$2.00	\$2.75	\$2.75	\$3.25	\$3.25	\$3.70

	1976	1977	1978	1979	1980	1981	1982
July	\$2.00	\$2.00	\$2.75	\$2.75	\$3.25	\$3.25	\$3.70
Aug.		\$2.00	\$2.75	\$2.75	\$3.25	\$3.25	\$3.70
Sept.		\$2.75	\$2.75	\$2.75	\$3.25	\$3.25	\$3.70
Oct.			\$2.75	\$2.75	\$3.25	\$3.25	
Nov.		\$2.75		\$3.25	\$3.25	\$3.25	\$3.70
Dec.		\$2.75	\$2.75	\$3.25	\$3.25	\$3.25	\$3.70

Circle and send requests with payment to:
BYTE Back Issues
P.O. Box 328
Hancock, NH 03449

Please allow 4 weeks for domestic delivery and 8 weeks for foreign delivery.

name _____
 address _____
 city _____
 state _____ zip _____

The above prices include postage in the US. Please add \$.50 per copy for Canada and Mexico; and \$2.00 per copy to foreign countries.

Check enclosed

Payments from foreign countries must be made in US funds payable at a US bank.

VISA Master Card
 Card # _____ Exp. _____

Signature _____

At last... a better way to find that article on computing!

An indexing service to locate source material in specific subject areas.

LAMP is a bi-monthly index to approximately 100 computer publications. An outstanding feature is the Subject Index, cross-referenced to provide the most comprehensive listing and ease of retrieval. All articles are read for subject content and then listed with as many cross references as required to retrieve the article.

An Author Index lists individual names as well as each contributor in jointly written articles. Another section is the Review Index which covers book reviews, hardware, software and educational courseware. It lists the source of the review and translates the written review into a One-Star to Five-Star rating.

LAMP eliminates the hit or miss method of finding articles of interest to you. Each bi-monthly issue contains approximately 200 pages.

A year-end issue is cumulative and includes the information from the previous 5 issues. Send for your subscription today.

BONUS FOR CHARTER SUBSCRIBERS

Subscribe now for the inaugural issue to be published in January 1983 and receive the LAMP pilot program which indexed periodicals from June through October, 1982. In effect, 5 months of LAMP free for ordering now.

To order by phone, call 800-526-9042 and use your Visa or MasterCard.

To order by mail, send your check for \$69.95 to Soft Images, 200 Route 17, Mahwah, N.J. 07430.

LAMP

Literature Analysis of Microcomputer Publications

Soft Images
DIVISION OF DECISION SYSTEMS INC.

Circle 423 on Inquiry card.



The Choice of

Computer Exchange — The Supply Center for the IBM-PC

SOFTWARE for the IBM-PC BUSINESS

	LIST PRICE	OUR PRICE
ASHTON-TATE, dBase II, CP/M-86	\$ 700	\$459
DENVER SOFTWARE, Easy (Executive Accounting System)	\$ 725	\$545
HOWARDSON, Real Estate Analyzer	\$ 250	\$189
INFORMATION UNLIMITED, Easywriter II (a WPS)	\$ 350	\$259
EasySpeller (88K Words)	\$ 175	\$129
Easyfilter (a DBMS)	\$ 400	\$299
Easy Planner	\$ 250	\$189
INNOVATIVE SOFTWARE, T.I.M. III (a DBMS)	\$ 495	\$369
IBSOFT, Data Design (a powerful easy-to-use DBMS) NEW!	\$ 225	\$169
INNOVATIVE, Spell Guard	\$ 295	\$220
IGA, Spell Guard	\$ 295	\$195
ISM, MatheMagic	\$ 90	\$ 69
LEXISOFT, Spellbinder (a versatile WPS in CP/M-86)	\$ 495	\$249
MICRO LAB, The Tax Manager	\$ 250	\$189
WORDSTAR plus free WordStar Training Manual	\$ 495	\$365
MICROPRO, MailMerge™	\$ 250	\$185
SpellStar™	\$ 250	\$185
Special! All Three Above, WordPac	\$ 895	\$695
WordStar Training Manual	—	\$ 25
NORTH AMERICAN BUS. SYSTEM, The Answer	\$ 250	\$169
PEACHTREE, Inventory Series 40	\$ 600	\$399
Peach Pak 40 (GL, AR & AP)	\$ 595	\$395
PERFECT SOFTWARE, Perfect Writer™	\$ 389	\$239
Perfect Speller™	\$ 189	\$119
Perfect Filer™	\$ 289	\$179
SELECT INFO., Select (a WPS)	\$ 595	\$375
SORCIM, SuperCalc	\$ 295	\$199
SuperWriter, call on availability	\$ 395	\$269
Spell Guard, call on availability	Call	Call
SUPERSOFT, Disk Doctor (CP/M-86)	\$ 100	\$ 75
Diagnostics II (CP/M-86)	\$ 125	\$ 95
Scratch Pad (CP/M-86 and MS-DOS)	\$ 295	\$225
VISICORP, VisiCalc®/256K	\$ 250	\$179
VisiDex	\$ 250	\$199
VisiTrend/Plot	\$ 300	\$219
VisiFile	\$ 300	\$239
Deskold Plan	\$ 300	\$239

UTILITY

WAGY SYSTEM, Copy/PC, Backup Copier and Utilities	\$ 35	\$ 29
NOBELL DATA,™™ System-Backup, Bit Copier	\$ 50	\$ 39
NORTON, Norton Utilities, 14 powerful programs, 3 disks	\$ 80	\$ 65

HOME & EDUCATIONAL

ACORN, Lost Colony	\$ 30	\$ 24
AUTOMATED SIMULATIONS, Temple of Apsah	\$ 40	\$ 29
Upper Reaches Apsah	\$ 20	\$ 15
JabberTalky	\$ 30	\$ 22
Curse of Ra	\$ 20	\$ 15
AVALON HILL, Galaxy	\$ 25	\$ 20
Midway Campaign	\$ 21	\$ 17
Computer Stocks and Bonds	\$ 25	\$ 20
Voyager	\$ 25	\$ 20
Draw Poker	\$ 21	\$ 17
BRODERBUND, Apple Panic	\$ 30	\$ 22
CONTINENTAL, The Home Accountant Plus	\$ 150	\$112
DATABOST, Write-On	\$ 130	\$110
Pig Pen	\$ 30	\$ 22
Space Strike	\$ 30	\$ 22
CONTINENTAL, The Home Accountant Plus	\$ 150	\$112
DAVIDSON, The Speed Reader	\$ 75	\$ 55
INFOCOM, Deadline	\$ 50	\$ 39
Zork I	\$ 40	\$ 29
Zork II	\$ 40	\$ 29
ON-LINE SYSTEMS, Frogger	\$ 35	\$ 26
Ulysses & The Golden Fleece	\$ 35	\$ 25
PBL CORP, Personal Investor	\$ 145	\$ 99
SENTIENT, Cyborg, (Call on availability)	\$ 35	\$ 29
SIRIUS, Conquest	\$ 30	\$ 23
Call to Arms	\$ 30	\$ 23
SPINNAKER, Snooker Troops, #1 or #2	\$ 45	\$ 35
Story Machine	\$ 35	\$ 25
Face Maker	\$ 35	\$ 25
STRATEGIC, The Warp Factor	\$ 40	\$ 30
VERSA COMPUTING, Graphics Hardcopy System	\$ 25	\$ 19



HARDWARE for the IBM-PC

	LIST PRICE	OUR PRICE
AST RESEARCH, Combo Plus, 64K with one option	NEW! \$ 495	\$379
Combo Plus, 256K with one option, NEW!	\$1095	\$729
Options: Async Comm Port, Para Printer Port., Clock/Calendar		
Add \$50 for second option and \$35 for third.		
Parity Memory Card, 64K	\$ 395	\$279
256K	\$ 995	\$659
Note: All of above cards are memory upgradeable.		
BYAO INC., DS1, Z80B for CP/M-80	\$ 660	\$570
DS2, above with serial port.	\$ 760	\$660
CORVUS, Hard Disk System. See Corvus Section This Page.		
CURTIS, PC Pedestal,™™ for Display on PC	\$ 80	\$ 65
3 Foot Cable for IBM Mono Display	\$ 50	\$ 39
DAVONG, DS1-501 Hard Disk, 5 Meg	\$1995	\$1595
MICROSOFT, 64K RAM Card w/Parity, RAM Drive & Utility	\$ 350	\$259
128K RAM Card w/Parity, RAM Drive & Utility	\$ 525	\$395
256K RAM Card w/Parity, RAM Drive & Utility	\$ 875	\$659
64K RAM Chips™™	\$ 175	\$129
QUADRAM CORPORATION		
Quadboard, 64K, expandable to 256K, 4 function board	\$ 595	\$445
Quadboard, 128K, expandable to 256K, 4 function board	\$ 775	\$575
Quadboard, 192K, expandable to 256K, 4 function board	\$ 895	\$645
Quadboard, 256K, four function board	\$ 995	\$685
Memory Board, 512K, with Serial Port, #6512	\$1295	\$995
Memory Upgrade Kit, 64K (9 chips), #B260	\$ 150	\$ 95
Microfazer, Snap-on, 8K, Par/Par, Epson, #ME8	\$ 159	\$129
Microfazer, Snap-on, 64K, Par/Par, Epson, #ME64	\$ 299	\$219
Microfazer, same as #ME8 except with copy, #MPPB	\$ 169	\$139
Microfazer, same as #MPPB except 128K	\$ 445	\$345
Power Supply for Microfazer, (9V, 25A) #PS1	\$ 20	\$ 15
TG PRODUCTS, Joystick	\$ 65	\$ 49
Disk Drives		
Tandon TM100-1 Single Sided 160K	\$ 280	\$229
TM100-2 Double Sided 320K	\$ 350	\$279
VISTA COMPUTER, 576K Mascard	\$1395	\$1195

QUADRAM CORPORATION

Quadboard, 64K, expandable to 256K, 4 function board	\$ 595	\$445
Quadboard, 128K, expandable to 256K, 4 function board	\$ 775	\$575
Quadboard, 192K, expandable to 256K, 4 function board	\$ 895	\$645
Quadboard, 256K, four function board	\$ 995	\$685
Memory Board, 512K, with Serial Port, #6512	\$1295	\$995
Memory Upgrade Kit, 64K (9 chips), #B260	\$ 150	\$ 95
Microfazer, Snap-on, 8K, Par/Par, Epson, #ME8	\$ 159	\$129
Microfazer, Snap-on, 64K, Par/Par, Epson, #ME64	\$ 299	\$219
Microfazer, same as #ME8 except with copy, #MPPB	\$ 169	\$139
Microfazer, same as #MPPB except 128K	\$ 445	\$345
Power Supply for Microfazer, (9V, 25A) #PS1	\$ 20	\$ 15
TG PRODUCTS, Joystick	\$ 65	\$ 49

Tandon Disk Drives
 TM100-1 Single Sided 160K \$ 280 \$229
 TM100-2 Double Sided 320K \$ 350 \$279
 VISTA COMPUTER, 576K Mascard \$1395 \$1195

XEDEX baby glue
 64K plus CP/M-80 operation \$ 600 \$495

PRINTERS, Impact

EPSON, See Epson section below.		
IDS, Prism 132, Color w/Graphics	\$1995	\$1549
Prism 80, Color, w/Graphics	\$1795	\$1450
Pager Tiger 440, w/Graphics & 2K Limited Special!	\$1295	\$495
Microprism 480, near letter quality	\$ 799	\$699
NEC, 8023 Printer f/T	\$ 695	\$525
OKIDATA, Microline 82A, 120 Cps, 80 Col. Para & Serial PAPER, Tractor Feed. Varies in stock, call for price.	\$ 649	\$495

CORVUS SYSTEMS

	LIST PRICE	OUR PRICE
* 6 Meg Hard Disk	\$2995	\$2495
11 Meg Hard Disk	\$4795	\$3995
20 Meg Hard Disk	\$5795	\$4795
IBM PC Interface (IBM DDS), Manual & Cable 5'	\$ 300	\$239
Mirror built-in for easy backup	\$ 790	\$649
Apple Interface, Manual & Cable 5'	\$ 300	\$239
Other Interfaces, Omni-Net, Constellation, Mirror. All in Stock.		

HEWLETT PACKARD

	LIST PRICE	OUR PRICE
H/P 7470A Graphics Plotter	\$1550	\$1195
H/P 41C Calculator	\$ 250	\$210
H/P 41CV Calculator with 2.2K Memory	\$ 325	\$275
H/P 41 Card Reader	\$ 215	\$179
H/P 41 Optical Wand	\$ 125	\$105

Wide variety of software and accessories available. Call

8" CP/M-80 BUSINESS & SYSTEM SOFTWARE

	LIST PRICE	OUR PRICE
ADVENTURE, Adventure's #1 to #12 inclusive, 8"	\$ 129	\$ 95
ASHION-TATE, dBase II, 8"	\$ 700	\$459
COMSHARE TARGET, Target PlannerCalc	\$ 50	\$ 39
Masterplanner	\$ 325	\$225
PlannerCalc Applications Pkg	\$ 50	\$ 40
PlannerCalc Combo Pkg	\$ 90	\$ 65
INFOCOM, Deadline, 8"	\$ 60	\$ 45
Zork I, 8"	\$ 50	\$ 39
Zork II, 8"	\$ 50	\$ 39
INNOVATIVE, Spellguard, 8"	\$ 295	\$199
ISM, MatheMagic	\$ 100	\$ 75
MICROCRAFT, Legal Billing & Time Keeping — Verdict	\$ 750	\$395
Prof. Billing & Time Keeping — Billkeeper	\$ 750	\$395
MICROPRO, WordStar® plus free WordStar Training Manual	\$ 495	\$365
MailMerge™	\$ 250	\$185
SpellStar™	\$ 250	\$185
Special! All Three Above, WordPac	\$ 895	\$695
WordStar Training Manual	—	\$ 25
DataStar™	\$ 295	\$199
SuperSort™	\$ 250	\$175
CalcStar™	\$ 145	\$ 99
Special! All Three Above, DataPac	\$ 695	\$449
MICROSOFT, Multiphan	\$ 275	\$199
Fortran-80, 8"	\$ 500	\$325
BASIC Compiler, 8"	\$ 395	\$295
COBOL-80, 8"	\$ 750	\$545
BASIC-80, 8"	\$ 350	\$275
multiSp/muStar-80	\$ 200	\$145
M-Soft-80	\$ 195	\$145
Edit-80	\$ 120	\$ 80
Macro-80	\$ 200	\$145
DASIS, The Word Plus (a WPS)	\$ 150	Call
PEACHTREE, GL, AR & AP, Series 40, all three	\$ 595	\$395
Inventory, Series 40	\$ 600	\$399
Peach Text, Spell & Mail, all three	\$ 595	\$395
Call on Series 8, each	\$ 750	\$499
PERFECT SOFTWARE, Perfect Writer™	\$ 389	\$239
Perfect Speller™	\$ 189	\$119
Perfect Speller™	\$ 289	\$179
QUALITY, GBS with 3 generators, (a DBMS)	\$ 700	\$525
SELECT INFO., Select (a WPS)	\$ 595	\$375
SORCIM, SuperCalc	\$ 295	\$199
Super Writer, call on availability	\$ 395	\$269
Spell Guard, call on availability	\$ 295	Call
SUPERSOFT, Disk Doctor (CP/M-80)	\$ 100	\$ 75
Diagnostics II (CP/M-80)	\$ 125	\$ 95
Scratch Pad (CP/M-80)	\$ 295	\$225

MONITORS

	LIST PRICE	OUR PRICE
NEC, 12" Green	\$ 249	\$159
12" Color, Composite	\$ 450	\$349
SANYO, 9" B&W	\$ 190	\$149
9" Green Special truckload sale	\$ 200	\$119
12" B&W	\$ 250	\$199
12" Green	\$ 260	\$199
13" Color, Composite	\$ 470	\$349
13" Color RGB	\$ 995	\$795
ZENITH, 12" Green	\$ 150	\$119
AMDEK, 12" Green #300	\$ 200	\$159
13" Color I, Composite	\$ 449	\$359
13" Color IIA, RGB, Hi Res. (Ap II, III & IBM-PC)	\$ 999	\$799
13" Color III, RGB, Commercial, (Ap II, III)	\$ 569	\$469
DVM, Color II or III to Apple II Interface	\$ 199	\$175
Note: Color II and III come with cable for IBM-PC.		

DISKETTES

*Control Data Corporation 12 for 10 Special. Limited Time!

CDC, 120 each, 5 1/4 with ring, SS, SD (Apple, IBM, etc.)	\$ 450	\$195
12 each, 5 1/4 with ring, SS, SD (Apple, IBM, etc.)	\$ 40	\$22
12 each, 5 1/4 with ring, SS, DD (H/P, IBM 320K, etc.)	\$ 51	\$ 28
12 each B, SS, SD	\$ 51	\$ 28
10 each, 5 1/4 with ring, DS, DD (IBM)	\$ 50	\$ 39
IBM, 10 each, 5 1/4, SS, SD (Apple, IBM, etc.)	\$ 60	\$ 45
10 each, 5 1/4, SS, DD (H/P, IBM 320K, etc.)	\$ 65	\$ 49
VERBATIM, 10 each 5 1/4, with ring, SS, SD or SS, DD	\$ 50	\$ 28
MANELL, 10 each 5 1/4, SS, SD	\$ 55	\$ 35
DYSAN, 10 each 5 1/4, SS, SD	\$ 55	\$ 39
10 each 5, DS, DD	\$ 65	\$ 49

EPSON PRINTERS & ACCESSORIES

MX80 F/T III, with Graftrax*	\$ 745	\$525
MX100 F/T III, with Graftrax*	\$ 995	\$695
IBM-PC to Epson Cable	\$ 60	\$ 45
Apple Interface and Cable for MX80 or MX100	\$ 120	\$ 95
Graptrax* by Orange Micro, specify your computer	\$ 165	\$119
Apple Graphics Dump	\$ 15	\$ 9
Artat to Epson Cable	\$ 40	\$ 30
TRS-80 to Epson Cable	\$ 40	\$ 30
Other cables, interfaces, ribbons, heads and paper in stock	Call	Call

NATIONAL ORDER DESK TOLL FREE
 (800) 547-1289
 OTHER ORDERS: 772-3256

Hot Line For Information
 On Your Order
 (503) 772-3803



Portland, OR, Cash & Carry Outlet, 11507-D SW Pacific Hwy., Terrace Shopping Center, Tigard, OR, Over-the-counter sales only. On 99W between Rte. 217 and Interstate 5, Call 245-1020.

ORDERING INFORMATION AND TERMS: All mail to P.O. Box 1380, Jacksonville, OR 97530. All items usually in stock. We ship immediately on Cashiers Checks, Money Orders, Fortune 1000 Checks and Government Checks. Personal, Certified or Company Checks allow 20 days to clear. No C.O.D. Add 3% for VISA or MC. Include telephone number. Add 3% for shipping, insurance and handling (S, I&H) with \$5 minimum. UPS ground is standard so add 3% more for UPS Blue with \$10 minimum. Add 12% total for S, I&H for US Postal. APO or FPO with \$15 minimum. For Hawaii, Alaska and Canada, UPS is in some areas only, all others are Postal so call, write, or specify PO. Foreign orders except Canada for S, I&H add 18% or \$25 minimum except for monitors add 30% or \$50 minimum. Prices subject to change and typo errors, so call to verify. All goods are new, include factory warranty and are guaranteed to work. Due to our low prices, all sales are final. Call before returning goods for repair or replacement. Orders received with insufficient S, I&H charges will be returned. ORDER DESK HOURS 8 to 6 PST, M-F and 10 to 4 Sat. 1 PM here is 4 PM in NY.

OUR REFERENCES: We have been a computer dealer since 1978 and in mail order since 1980. Banks: First Interstate Bank, (503) 776-5620 and Jefferson State Bank, (503) 773-5333. We belong to the Chamber of Commerce, (503) 772-6293, or call Dun & Bradstreet if you are a subscriber. Computer Exchange is a division of O'Tech Group, Inc.

Professionals

Manufactured
Exclusively for



Bell & Howell by

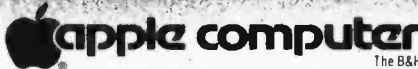

The B&H Apple II+ differs from the Apple II+ only in that it is in black hammetone color and its warranty is longer. Warrantly. Factory warranty is by Bell and Howell (not by Apple) and is one year parts plus 90 day labor. Warrantly service available at Bell and Howell service centers or return to Computer Exchange.

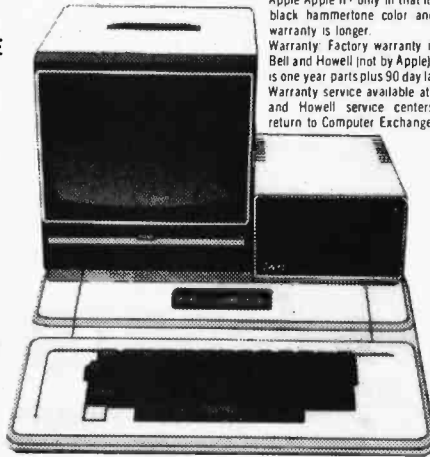

B&H Apple II+

	LIST PRICE	OUR PRICE	SAVE
64K (48K + ALS 16K)	\$1725	\$1195	\$530
DISK II w/3.3 Cont.	\$645	\$520	\$125
DISK II Only	\$525	\$450	\$75

OR: **SAVE OVER \$350** on a pair of drives.
Buy a pair of Micro-Sci A2 Drives.
See opposite page.

apple II/II+ supply center

HARDWARE

for Apple II/II+

	LIST PRICE	OUR PRICE
RAM CARDS:		
Microsoft, 16K RAM Card	\$ 195	\$ 149
* ALS, 16K AddRAM	\$ 149	\$ 59
* OCP, 16K RAM Card		
SUPER SPECIAL		
Saturn Systems, 32K	\$ 249	\$ 169
64K	\$ 425	\$ 319
128K	\$ 599	\$ 459
Axlon, 320K RAM Disk system	\$1395	\$995
80 COLUMN VIDEO CARDS:		
ALS, Smarter	\$ 345	\$ 249
Videx, Videoterm	\$ 345	\$ 249
See more ALS and Videx below.		
Vista, Vision 80	\$ 395	\$ 249
M&R, Sup R term	\$ 375	\$ 319
MISCELLANEOUS:		
ALS, Smarter 80 Col. Card Special	\$ 345	\$ 199
7 Card (Z-80) W/CPM Special	\$ 269	\$ 199
* 16K AddRAM Special	\$ 149	\$ 59
* Synergizer Pack Special	\$ 749	\$ 450
Synergizer Pack includes above 3, + CP/M book.		
Note: Above is a limited time offer.		
Apple Computer.		
Silentype II Printer	\$ 395	\$ 335
Graphics Tablet	\$ 795	\$ 675
Joystick II	\$ 50	\$ 39
Game Paddle	\$ 30	\$ 19
Numeric Keypad	\$ 150	\$ 119
Axlon, 320K RAM Disk System	\$1395	\$995
CDS, Serial Interface 7710A	\$ 150	\$ 125
Other CDS Cards in stock		
Dan Paymar, Lower Case Chups	\$ 50	\$ 39
Hayes, Micromodem II	\$ 379	\$ 275
Smartmodem	\$ 279	\$ 229
Kensington, System Saver	\$ 90	\$ 69
Keyboard Company.		
Joystick II	\$ 50	\$ 39
Game Paddle	\$ 30	\$ 23
Numeric Keypad	\$ 150	\$ 119
M&R, RF Modulator	\$ 30	\$ 25
Sup R lan	\$ 50	\$ 39
* Microsoft, 280 Softcard	\$ 399	\$ 269
16K RAM Card	\$ 195	\$ 149
Softcard Premium Pack	\$ 775	\$ 579
Mountain.		
CPS Multifunction Card	\$ 239	\$ 209
* Clock/Calendar	\$ 280	\$ 245
Novation, Applect Modem	\$ 389	\$ 299
Orange Micro, Grappier	\$ 165	\$ 119
Practical Peripherals.		
MBS 8K Serial (Epson)	\$ 159	\$ 129
MBP 16K Para (Epson)	\$ 159	\$ 129
* Microbiller II 16K (specify)	\$ 259	\$ 209
Microbiller II 32K (specify)	\$ 299	\$ 229
RH Electronics, Super Fan II	\$ 75	\$ 59
SSM, AIO-II, Serial/Para Interface	\$ 225	\$ 169
TG Products, Game Paddles	\$ 40	\$ 29
Joystick	\$ 60	\$ 45
Select-A-Port	\$ 60	\$ 45
* Videx, Videoterm 80 col.	\$ 345	\$ 249
Soft Video Switch	\$ 35	\$ 25
Enhancer II	\$ 149	\$ 99
Enhancer (Rev 6)	\$ 129	\$ 99
Function Strip	\$ 79	\$ 59
AppleWriter II preboot disk	\$ 20	\$ 15
Visicalc to 64K preboot disk	\$ 50	\$ 39
Visicalc to 176K preboot disk	\$ 90	\$ 69
Full Videx Line, Call, up to 35% off		

SOFTWARE

on disk for Apple II/II+

OUR BEST SELLERS —
CALL ON OTHERS

BUSINESS

	LIST PRICE	OUR PRICE
Apple Computer, Inc.		
The Controller (Accounting)	\$ 625	\$ 499
Apple Writer II	\$ 150	\$ 119
Apple Pascal	\$ 250	\$ 199
Apple Fortran	\$ 200	\$ 159
OOS Tool Kit	\$ 75	\$ 59
OOS 3.3 Upgrade Kit	\$ 75	\$ 59
Apple Pilot	\$ 150	\$ 119
DJ Portfolio Evaluator	\$ 50	\$ 45
How! How!	\$ 50	\$ 39
Microcourier	\$ 250	\$ 199
Micro Telegram	\$ 250	\$ 199
Time Manager	\$ 150	\$ 119
Apple Logo	\$ 175	\$ 139
Applied Soft Tech., VersaForm	\$ 389	\$ 265
Artsci, Magic Window II	\$ 100	\$ 69
Ashion-late, dBase II (CP/M)	\$ 700	\$ 439
Continental, GL, AR, AP or PR, ea.	\$ 250	\$ 169
1st Class Mail	\$ 75	\$ 49
Home Accountant	\$ 75	\$ 49
Hayden, Pie Writer (Specify brd.)	\$ 170	\$ 99
High Tech., Job Control Sys.	\$ 750	\$ 350
Info Master	\$ 189	\$ 119
Howard Soft.		
Creative Financing	\$ 195	\$ 129
Real Estate Analyzer II	\$ 195	\$ 129
Tax Preparer	\$ 150	\$ 99
Info. Unlim., Easywriter (PRD)	\$ 150	\$ 99
* Innovative, Spellguard (CP/M)	\$ 295	\$ 150
Lexisoft, Spellbinder (a WPS)	\$ 495	\$ 269
* Micro Craft, (CP/M)		
Professional Billkeeper	\$ 750	\$ 395
Legal Billing & Timekeeping	\$ 750	\$ 395
Micro Lab, Invoice Factory	\$ 200	\$ 129
Tax Manager	\$ 150	\$ 99
Micro Pro, (all CP/M)		
WordsStar + Training Manual	\$ 495	\$ 365
MailMerge™	\$ 250	\$ 185
SpellStar™	\$ 250	\$ 185
SPECIAL! All 3 above	\$ 895	\$ 695
Data Star™	\$ 295	\$ 199
CalcStar™	\$ 145	\$ 99
SuperSort™	\$ 250	\$ 175
SPECIAL! All 3 above	\$ 690	\$ 449
Muse, Super Text II	\$ 150	\$ 113
Super Text 40/80	\$ 175	\$ 129
Super Text 40/56/70 New!	\$ 125	\$ 95
Form Letter	\$ 100	\$ 75
On-Line, ScreenWriter II	\$ 130	\$ 89
General Manager	\$ 150	\$ 115
Oasis System, The Word	\$ 150	\$ 119
Osborne/C.P. Soft., (Disk and Book)		
* Some Common Basic Programs.		
75 Business, Statistics and Math programs for the Apple II	\$ 100	\$ 49
Practical Basic Programs.		
* 40 more very valuable programs beyond "Some Com. Basic Prog" \$ 100 \$ 49		

Peachtree, (CP/M), specify Videoterm or 40 column.		
3 Pak 40, (GL, AR & AR)	\$ 595	\$ 395
Inventory, Series 40	\$ 400	\$ 275
Peachpay, Series 40	\$ 400	\$ 275
3 Pak 9, (Text, Spell & Mail)	\$ 595	\$ 395
Perfect, Perfect Writer	\$ 389	\$ 239
Perfect Speller	\$ 189	\$ 119
Perfect Filter	\$ 289	\$ 179
Quality, GBS w/3 gen. (a DBMS)	\$ 650	\$ 475
Sensible, Sensible Speller	\$ 125	\$ 85
Silicon Valley, Word Handler	\$ 250	\$ 139
Soft/Sys, Executive Secretary	\$ 250	\$ 169
Executive Speller	\$ 75	\$ 55
Solidus/Softech		
* Stockfile	\$ 600	\$ 350
Stockseller	\$ 700	\$ 450
Software Publishing.		
PFS II	\$ 125	\$ 85
Report	\$ 95	\$ 65
Graph	\$ 125	\$ 85
Sourcm, SuperCalc, (CP/M)	\$ 295	\$ 219
Southeastern		
Data Capture 4.0, specify brd.	\$ 90	\$ 69
Stoneware, DB Master	\$ 229	\$ 159
DB Utility I or II	\$ 99	\$ 69
Systems Plus.		
Accgl, Plus, General Ledger	\$ 425	\$ 295
Accgl, Plus, GL, AP and A/R	\$ 995	\$ 595
Accgl, Plus, above + Inventory	\$ 1395	\$ 775
VisiCorp/Personal Software.		
Visicalc 3.3	\$ 250	\$ 179
VisiDex Special!	\$ 250	\$ 175
VisiFile	\$ 250	\$ 179
Desktop Plan II	\$ 250	\$ 179
Desktop Plan III	\$ 300	\$ 219
Visiplot	\$ 200	\$ 149
VisiSchedule	\$ 300	\$ 219
VisiTrend & VisiPlot Special!	\$ 300	\$ 179
VisiTerm	\$ 100	\$ 79

UTILITY & DEVELOPMENT

Beagle, Utility City	\$ 30	\$ 22
DOS Boss	\$ 24	\$ 18
Central Point Software:		
Filter, DOS Utility	\$ 25	\$ 18
Copy II Plus (bit copier)	\$ 40	\$ 35
* Comp. Appl., Nibbles Away II	\$ 70	\$ 59
Epson, Graphics Dump	\$ 15	\$ 9
Inssoft.		
GrafORTH by Paul Lutus	\$ 75	\$ 59
ALD System II by Paul Lutus	\$ 75	\$ 59
TransFORTH II by Paul Lutus	\$ 125	\$ 99
Microsoft.		
A.L.D.S.	\$ 125	\$ 75
BASIC Compiler	\$ 395	\$ 299
Cobol 80	\$ 750	\$ 559
Fortran 80	\$ 195	\$ 149
Olympic Decathlon	\$ 30	\$ 24
TASC Compiler	\$ 175	\$ 159
* Omega, LockSmith (bit copier)	\$ 100	\$ 75
On-Line, Expediter II, Compiler	\$ 100	\$ 69
LISA 2.5	\$ 80	\$ 60
Penguin, Comp. Graphics Sys. New!	\$ 70	\$ 53
Phoenix, Zoom Grafik	\$ 40	\$ 29
Quality, Bag of Tricks New!	\$ 40	\$ 29
Southwestern, ASCH Express	\$ 80	\$ 59
Sensible, Back It Up, (bit copier)	\$ 60	\$ 49

B & H APPLE II+ 64K STARTER SYSTEM

SPECIAL

\$1,795
SAVE \$ 765

- 48K B&H Apple II+
- ALS 16K RAM Card
- Disk II with 3.3 DOS & Controller
- Sanyo 9" Green Monitor

U-SCI FOR THE APPLE II/II+ III DIRECT SUBSTITUTES for APPLE DRIVES

Micro Sci A2 drives and/or controllers are direct plug compatible substitutes for Apple drives and controllers.

	LIST PRICE	OUR PRICE
• For Apple II		
A2, 5 1/4", 143K Disk Drive	\$ 479	\$ 369
Controller Card for A2 Drive	\$ 100	\$ 79
A40, 5 1/4", 160K Disk Drive	\$ 449	\$ 359
A70, 5 1/4", 286K Disk Drive	\$ 599	\$ 479
Controller for A40 or A70	\$ 100	\$ 79
Filter, Disk Utility Software	\$ 20	\$ 15
NEW!		
• For Apple III		
A3, 5 1/4", 143K Drive	\$ 449	\$ 359
A73, 5 1/4", 286K Drive	\$ 649	\$ 529
A143, 5 1/4", 572K Drive	\$ 799	\$ 669

OVERSTOCK SPECIALS FOR APPLE II/II+

ALS 16K AddRAM Card	\$ 149	\$ 59
ALS ZCard, 280 CP/M Card	\$ 269	\$ 199
ALS Smarter 80 Col. Card	\$ 345	\$ 249
ALS Synergizer Pack, 3 above	\$ 749	\$ 450
ALS Synergizer + Supercalc	\$ 749	\$ 490
ALS Synergizer + Condor Jr.	\$ 749	\$ 490
ALS Synergizer + Supercalc + Condor	\$ 749	\$ 560
DCP 16K RAM Card Special	\$ 179	\$ 59
Saturn Systems, 32K RAM Card	\$ 249	\$ 169
Videx, Videoterm, 80 column card	\$ 345	\$ 249

HOME & EDUCATION

Broderbund.		
Apple Panic	\$ 30	\$ 21
Arcade Machine (call first)	\$ 45	\$ 40
Chopfliter	New!	\$ 35 \$ 26
Many others		
Budgete, Raster Blaster	\$ 29	\$ 22
Continental, Home Accountant	\$ 75	\$ 48
Edu-Ware, Several in stock	Call	Call
Hayden, Sargon II (Chess)	\$ 35	\$ 29
Incom, Deadline	\$ 50	\$ 38
Inssoft, Electric Duet by Lutus	\$ 30	\$ 25
Zargs	New!	\$ 35 \$ 27
Spider Raid	New!	\$ 30 \$ 24
Lightning, Masterlype	\$ 40	\$ 29
Microsoft, Olympic Decathlon	\$ 30	\$ 24
Typing Tutor II	\$ 25	\$ 19
Muse, Robot War	\$ 40	\$ 29
Castle Wollenstein	\$ 30	\$ 23
Dn-Line.		
Ultima II	\$ 55	\$ 40
Threshold	\$ 40	\$ 30
Softporn (X Rated)	\$ 30	\$ 22
Cannonball Blitz, New!	\$ 35	\$ 26
Quality, Bag of Tricks	\$ 40	\$ 30
Sirius, Gorgon	\$ 40	\$ 29
Sir-Tec, Wizardry	\$ 50	\$ 39
Knight of Diamonds, New!	\$ 35	\$ 26
Sub Logic, Flight Simulator	\$ 34	\$ 25
Pinball	\$ 30	\$ 23
Strategic, Southern Command	\$ 60	\$ 30
OTHER BRANDS IN STOCK, CALL.		

800 Computer 16K	\$ 899	\$ 665
800 Computer 48K	\$ 1099	\$ 777
810 Disk Drive	\$ 600	\$ 499
850 Interface	\$ 220	\$ 169
410 Recorder	\$ 100	\$ 79
32K RAM, Microtek	\$ 100	\$ 85
32K RAM	\$ 200	\$ 109
Call for other software and accessories.		

LIMITED SPECIAL		
8001 32K Computer	\$ 995	\$ 699
286K Total, Dual Drive PC803L	\$ 995	\$ 699
32K add-on and I/O Unit PC8012	\$ 649	\$ 485
Call for other software and accessories.		

THE WORLD'S LARGEST COMPUTER MAIL ORDER FIRM

Computer Exchange

TM

AD #945

A Division of
OTECH

* Means a BEST buy.

Circle 112 for IBM Peripherals
Circle 113 for Apple
Circle 114 for all others

ALL MAIL: P.O. Box 1380, Jacksonville, OR 97530

WAREHOUSE AND OFFICES: BY APPOINTMENT AT 6791 UPPER APPLGATE ROAD.

www.americanradiohistory.com

BYTE GAME CONTEST

SECOND-PLACE WINNER

Charge!

C. Anthony Ray
39 Carriage Place
Urbana, IL 61801

One long, cold winter evening when I was in need of some amusement I decided to write a computer program to simulate the trajectory of a free electron through a sparse lattice of stationary ions. I placed symbols for positive and negative ions on the screen and assigned an initial speed and direction to an electron originating in the upper left corner of the field. As the electrons began to fly across the screen, my family clamored for a chance to play what looked like a game to them. I did some additional work on the program and Charge! came into being.

Object of the Game

The object of Charge! is to give a direction to an electron launched from the upper left corner of the playing field that will cause it to travel to the lower right corner of the field. You specify the direction by entering an x, y coordinate pair that corresponds to the point you would

like to hit. But there's a catch. For each round of the game, a random-number generator places ions on the screen that, depending on their charge (positive or negative), exert a push or pull on the electron. (See figure 1.) The influence of these ions alters the trajectory in ways that become more predictable as your experience with the game increases. When the electron impacts the border of the field, your score is the product of the x and y coordinates of that point. The closer your electron comes to the lower right corner, the higher your score. (I have kept the Applesoft screen-coordinate system, where the coordinates for the upper left corner are 0,0 and those for the lower right corner are 279,159.)

Although solitary play is possible, the game is more interesting as a competition for two to four players. Five different playing fields are displayed and each player is given a turn on each. To keep any one player from gaining an advantage, the computer varies the order of

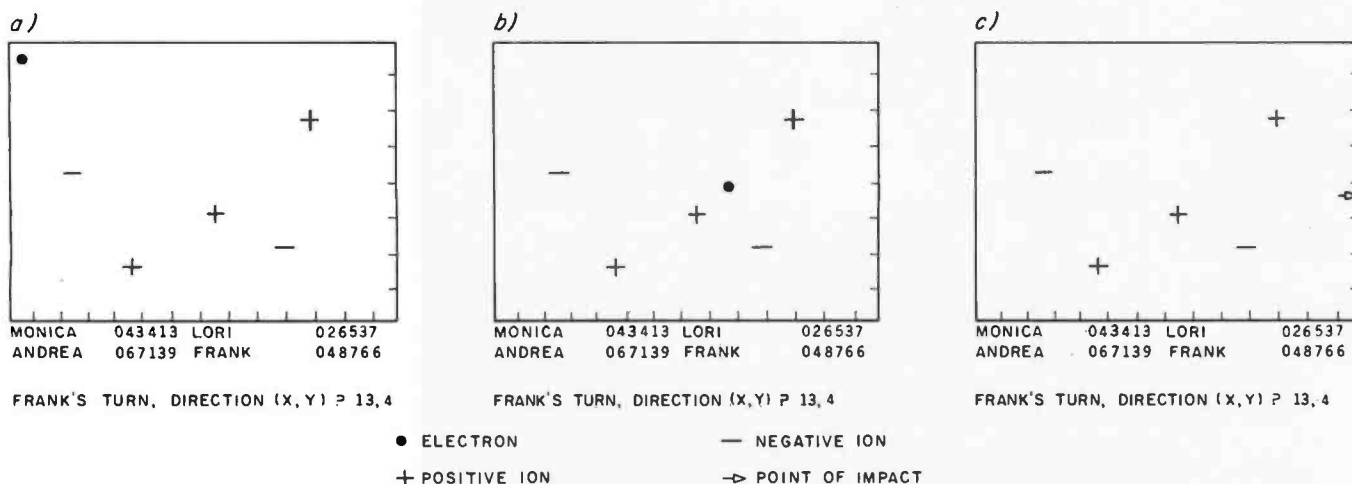

Figure 1: The electron is launched and proceeds according to the direction specified by the player. Its path is influenced by the pull and push of the ions, and the final point of impact is marked with an arrow.

indigo
data systems, inc.



PC MultiBoard

Up to 256K bytes of reliable parity checked system memory plus an IBM compatible RS-232 serial communications port and a real time clock/calendar. Three of the most frequently desired functions are integrated on a single board to keep your budget in line and your expansion slots free. And the PC MultiBoard™ is the perfect mate for Spool-It™ and Drive-It™. One year warranty. 64K-\$495, 128K-\$640, 192K-\$775, 256K-\$895.



Spool-It™

Utilize up to 64K of extra memory as a printer buffer and eliminate valuable time spent waiting on the printer. Works with Visi-Calc®, Super-Calc™ WordStar™, Easy-Writer™, Peachtree, BPI, BASIC, and most other PC DOS software. \$44.95

Drive-It™

Eliminate time spent waiting on disk drives by converting 32K to 320K of extra memory into an ultra-fast drive. Supports all standard DOS functions. \$59.95

Print-It™ (IBM/Epson printers)

The graphics screen print capabilities that IBM omitted are provided by this unique screen print utility which dumps either monochrome or color screen images (text and graphics) to IBM/Epson printers (with graphics installed). Other features include full IBM special character set support, shading, and print abort. Expanded, rotated, and inverse modes are available. \$44.95

Color-It™ (Prism/IDS printers)

Color printing has never been easier. Color-It™ provides the same screen print capabilities as Print-It™, but for the IDS Prism color printer. Up to 8 colors will be reproduced as displayed on the screen. Also supports the noa-color IDS 460/560 and Microprism printers. \$49.95

Software by M.A.P. Systems Inc.

The It series of software can be used individually or in combination to get the most out of your application software.

Indigo Data Systems, Inc. is dedicated to making USEFUL and USEABLE products for the IBM PC. Each product is designed with performance, compatibility, value, and quality in mind. We insist on it - So should you.

Indigo Data Systems, Inc. 100 E. NASA Rd. 1 Suite 107 Webster, Tx. 77598 (713) 488-8186.

HOLIDAY SPECIAL
256K PC MULTIPAK
FOR THE PRICE OF 192K
Reg. \$895 **\$775**

Offer good thru Jan. 31, 1983



Putting it together...

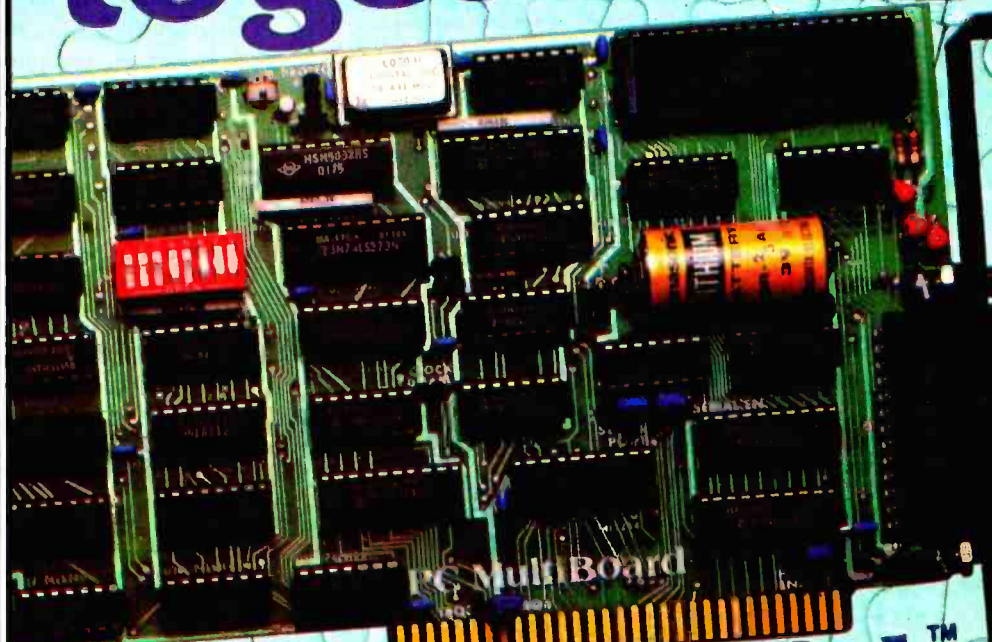

the PC MultiPak™

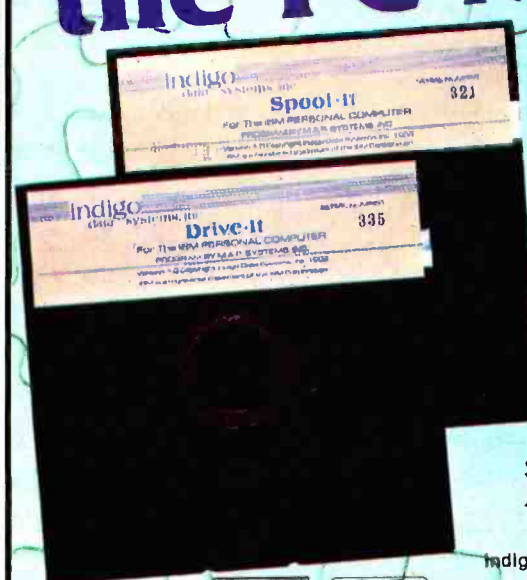

Put the expansion potential of your IBM PC to work for you today with this value packed combination of hardware and software. The PC MultiPak combines the PC MultiBoard with Spool-It and Drive-It - two software products designed to convert your extra money into free time. 64K-\$495, 128K-\$640, 192K-\$775, 256K-\$895 (May be ordered without clock option for \$40 less) 64K Memory Expansion Kit-\$150

includes:

- PC MultiBoard™
- 64K-256K RAM • SERIAL COMMUNICATIONS PORT
- CLOCK/CALENDAR
- Drive-It™
- RAM BASED DISK DRIVE EMULATION SOFTWARE
- Spool-It
- RAM BASED PRINT BUFFERING SOFTWARE

A \$600 VALUE

\$495

indigo
data systems, inc.

indigo products may be found at ComputerLand and other fine computer stores.

Dealer And Customer Inquiries call TOLL FREE 1-800-231-9480
In Texas Call Collect (713) 488-8186



BYTE GAME CONTEST

players' turns with each new playing field. The scores are cumulative and the person with the highest score at the end of five rounds is the winner.

Law of Motion

In life, the force or magnitude of the push or pull exerted upon an electron by an ion is inversely proportional to the square of the distance from the electron to the ion. For Charge!, however, I adapted this law of physics and used an inverse-distance (as opposed to an inverse-distance-squared) force algorithm. This change gives distant ions more influence over the electron and provides more dynamic action.

The Program

The primary features of Charge! are in straightforward BASIC and could be converted easily for use with other computers, including those with only low-resolution graphics (see listing 1). Some embellishments incorporated in the program take advantage of the Apple's unique characteristics, but these features could be deleted without significantly altering the game. For example, lines 8000 through 8180 contain a subroutine that causes the scores to be clicked up in pinball-machine fashion, complete with sound effects. A simple print statement could replace the entire routine. Another embellishment appears in the title display (lines 6030 through 6190). When the program starts, a flashing marquee appears on the screen, followed by a musical fanfare (generated by the subroutine in lines 9000 through 9290), and finally the title and the copyright notice are displayed. The fanfare is also played at the end of each game. (See listing 2 for an assembly-language version of the fanfare routine.) Further enhancements that could be left out include the sound effects sprinkled throughout the program. These can be recognized easily in the listing because they contain the variable SS.

The rest of the program is regular BASIC. Lines 7000 through 7170 keep track of the skill level, the number of players, and the players' names. Lines 4000 through 4140 register the score for each player, the number of electrons fired, and the number of people who have played in the current round. This information is used to determine which player goes next. The routine that draws the field and the scale markings and places the ions on the field appears in lines 2000 through 2170 and uses the shape table information in listing 3. This section also assigns a positive or negative value to each ion. Movement of the electron is handled in lines 1000 through 1090. Using the directional input provided by the player, the program translates the pair of coordinates into a velocity vector of magnitude SO. A new velocity vector is then computed based on the position and charge of each of the ions. Lines 3000 through 3050 contain the impact sequence. If the electron has gone outside the field, its position vector is set to the nearest field position, and an arrow is drawn indicating the point of impact. This position determines the player's score. The ending sequence for the game is provided in lines 5000 through 5150. The primary function of this sequence is to determine if another game is requested and, depending on that determination, either exit or set the parameters for the new game.

Charge! is a game that can be enjoyed by players of all ages. My engineering friends find it to be a challenge to their professional vanity and yet the game is simple enough that my 4-year-old daughter is an enthusiastic player. ■

The author has offered to make copies of his program available to BYTE readers for \$8. Send a blank disk and a self-addressed stamped envelope to:

C. Anthony Ray
39 Carriage Place
Urbana, IL 61801

Listing 1: The BASIC program for Charge!

```
10 REM *****
20 REM *
30 REM * CHARGE! *
40 REM *
50 REM * COPYRIGHT (C) 1982 *
60 REM * BY C. ANTHONY RAY *
70 REM *
80 REM *****
90 REM
100 GOSUB 6010: DIM SG(5,2): GOTO
    7010
1000 REM * CHARGE MOVE ROUTINE *
1010 HP = SQR(XO * XO + YO * YO):
    IF HP = 0 THEN HP = 1
1020 XO = XO * S0 / HP:YO = YO *
    S0 / HP
1030 FOR I = OE TO FV: IM = PEEK
    (SS):IM = PEEK(SS):NEXT
1040 DRAW TR AT XP,YP
1050 XN = XO:YN = YO
1060 FOR I = ZE TO SL:X = SG(I,ZE)
    - XP:Y = SG(I,OE) - YP:HP =
```

Listing 1 continued on page 116

NEC's new letter-quality printer gets personal with IBM.

The Spinwriter™ 3550 lets the IBM PC get down to business.

NEC's new Spinwriter letter-quality printer is the *only* one plug-compatible with the IBM Personal Computer. So you get the business applications you've been wishing for. Letter-quality output for word and data processing. Multi-language, scientific, and technical printing. Simple forms handling. Quiet operation. And the reliability of the industry's most popular printer line.

NEC designed the new Spinwriter especially for the IBM PC. It comes complete with documentation and training materials to fit your PC user's handbook. Just plug the Spinwriter in and your PC instantly becomes more versatile and flexible.

More than 8 forms handlers and 50 print thimbles boost PC versatility.

NEC designed the Spinwriter's 8 modular forms handlers to accommodate a wide range of paper and document sizes and types. The easily mounted handlers let your computer print out the forms you

need for data processing, word processing, graphics, accounting or other business applications.

The Spinwriter's 50 print thimbles can more than triple your PC's usefulness. They come in both constant pitch and proportional-spaced fonts, plus in foreign language, technical and scientific versions. They snap in and out in seconds, and let you print up to 203 columns on 16-inch paper. They each last for more than 30 million impressions.

This printer's special features make everything look better on paper.

The Spinwriter's software-invoked features include automatic proportional spacing; bidirectional, bold and shadow printing; justification; centering; under-scoring; and sub/super scripting, all at speeds up to 350 words per minute.

That big extra, Spinwriter reliability.

Spinwriters have the industry's best mean-time-between-failure rating, in excess of 3,000 hours. In terms of average personal computer usage, that's more than five years.

The Spinwriter 3550 is available at **ComputerLand** stores, **Sears Business Systems Centers** and **IBM Product Centers** nationwide.

NEC Information Systems, Inc. BE1282 5 Militia Drive, Lexington, MA 02173		
Send me more information on the Spinwriter 3550.		
Name _____		
Title _____	Telephone _____	
Company _____		
Address _____		
City _____	State _____	Zip _____

NEC

NEC Information Systems, Inc.

Spinwriter is a trademark of Nippon Electric Co., Ltd.

Circle 339 on inquiry card.

We're Made

for Each Other.



BYTE GAME CONTEST

Listing 1 continued:

```
X * X + Y * Y: XN = XN - CG *
SG(I,TW) * X / HP: YN = YN -
CG * SG(I,TW) * Y / HP: NEXT
1070 XDRAW TR AT XP,YP: XP = XP +
XN: YP = YP + YN
1080 IF XP < ZE OR XP > TN OR YP <
ZE OR YP > O9 THEN GOTO
3010
1090 XDRAW TR AT XP,YP: GOTO 1060
2000 REM * DRAWS IONS *
2010 HGR : SCALE = OE: ROT = ZE
2020 HPLLOT ZE, ZE TO 279, ZE TO 279,
159 TO ZE, 159 TO ZE, ZE
2030 FOR I = OE TO 13: HPLLOT 20 *
I, 157 TO 20 * I, 159: NEXT
2040 FOR I = OE TO 7: HPLLOT 277,
20 * I TO 279, 20 * I: NEXT
2050 HC = FV: SP = TW
2060 PO = - OE: PI = OE
2070 FOR I = OE TO SL
2080 SG(I, ZE) = 2 * INT (125 * RND
(1)) + 15
2090 SG(I, OE) = 2 * INT (65 * RND
(1)) + 14
2100 SG(I, TW) = - PI
2110 PI = PI * PO
2120 HC = HC - PI: SP = SP + PI
2130 HCOLOR = HC
2140 DRAW SP AT SG(I, ZE), SG(I, OE)
2150 NEXT
2160 HCOLOR = 7
2170 RETURN
3000 REM * IMPACT SEQUENCE *
3010 IF XP > 279 THEN XP = 279: ROT =
48
3020 IF YP > 159 THEN YP = 159: ROT =
0
3030 IF XP < 0 THEN XP = 0: ROT =
16
3040 IF YP < 0 THEN YP = 0: ROT =
32
3050 DRAW FR AT XP, YP: FOR I = OE
TO 50: IM = PEEK (SS) - PEEK
(SS): NEXT
4000 REM * SCOREKEEPING & WHOSE
TURN *
4010 FOR I = OE TO HM
4020 IF I = MC THEN S(I) = S(I) +
INT(XP * YP)
4030 NEXT
4040 IF INT(XP * YP) = 0 THEN
PRINT : GOTO 4070
4050 GOSUB 8010
4060 HOME
4070 C = C + 1
4080 IF C = FV * HM GOTO 5010
4090 IF M = HM THEN IF H = HM THEN
H = OE: M = OE: MC = OE: GOSUB
2010: GOTO 7150
4100 IF H = HM THEN M = M + OE: MC
= M: H = OE: GOSUB 2010: GOTO
7150
4110 MC = MC + 1
4120 H = H + 1
4130 IF MC > HM THEN MC = 1
4140 GOTO 7150
5000 REM * ENDING SEQUENCE *
5010 POKE 34, 0
5020 HTAB 1: VTAB 24: GOSUB 9060:
PRINT "ANOTHER GAME? (Y/N)";
5030 GET Y$: IF Y$ < > "Y" THEN
GOTO 5150
5040 H = 1: M = 1: MC = 1: C = 0
5050 FOR I = OE TO HM: S(I) = ZE:
NEXT
5060 VTAB 21: HTAB 1: PRINT SPC(
80)
5070 HOME
5080 VTAB 24: HTAB 1: PRINT "SAME
SKILL LEVEL? (Y/N) ";: GET
Y$
5090 IF Y$ < > "Y" THEN HOME:
VTAB 24: HTAB 1: INPUT "SKILL
LEVEL (1-5) ? "; SL
```

Listing 1 continued on page 118

FASTER THAN A FLYING HEAD!

The flying head of a hard disk is fast. **M-Drive™** is faster. And now, the originators of the **M-Drive** concept introduce **M-Drive/H™**, the most cost-effective solid state disk drive available.

M-Drive/H is a 512K memory board (cascadable up to 4 Megabytes for even more storage) which emulates disk drive operation and runs under CP/M® or MP/M™. You have to see the increase in operating speed and power to believe it; as *Byte* magazine said, "M-Drive makes a microcomputer . . . run like a big minicomputer. Highly recommended."

When time is of the essence, **M-Drive/H** is essential. For operation that's faster than a flying head, look into **M-Drive/H**—another leap forward from the leader in high performance systems and components. \$1895 suggested list.



M-DRIVE/H SUPPORT TEAM: OPERATING SYSTEMS

M-Drive/H is supported by popular operating systems such as CP/M 2.2, CP/M-86, MP/M-816, MP/M-86, and CP/M-68K.

M-DRIVE/H SUPPORT TEAM: CPUs

CompuPro makes a complete line of high-speed CPU boards recommended for use with the above operating systems and **M-Drive/H**.

CPU Z is a Z80 workhorse which operates under CP/M 2.2. \$295, \$395 CSC.

CPU 8085/88 executes both 8 and 16 bit software, and is compatible with CP/M 2.2, CP/M-86, MP/M-816, and MP/M-86. \$425, \$525 CSC.

CPU 86/87 is a 16 bit CPU (with 8087 math processor option) that works under CP/M-86, MP/M-816, and MP/M-86. \$695 (8 MHz), \$850 CSC (10 MHz). Factory installed 8087, add \$300 (clock speeds limited to 5 MHz with 8087).

CPU 68K (compatible with CP/M-68K) is the most advanced 68000 based board available. Includes sockets for **Memory Management Unit** and up to 8K X 16 (16 Kbytes) of EPROM. \$695 (8 MHz), \$850 CSC (10MHz).

CP/M and MP/M are trademarks of Digital Research. M-Drive and M-Drive/H are trademarks of CompuPro.

See **M-Drive/H**, and its support team of operating systems and CPUs, at your **Authorized CompuPro Systems Center** or **Sales Center**.



CompuPro division, Godbout Electronics, Box 2355, Oakland Airport, CA 94614

BYTE GAME CONTEST

Listing 1 continued:

```
5100 IF SL < OE OR SL > FV GOTO
    5090
5110 HOME
5120 VTAB 24: HTAB 1: PRINT "SAME
    PLAYERS? (Y/N) ";: GET Y$
5130 IF Y$ = "Y" THEN C = 0: GOSUB
    2010: GOTO 7140
5140 GOTO 7040
5150 HOME: TEXT: END
6000 REM * HEADING *
6010 PRINT CHR$(4)"BLOOD CHARGE
    SHAPES": POKE 232,0:POKE
    233,96
6020 ZE = 0: OE = 1: TW = 2: C = 0:
    TR = 3: FR = 4: FV = 5: S0 + 10:
    CG = 25: SS = -16336: TN = 279:
    O9 = 159
6030 TEXT
6040 FLASH
6050 PRINT "*****"
    *****"
6060 FOR I = OE TO 21: PRINT "*"
    ;: HTAB 39: PRINT "*": NEXT
6070 PRINT "*****"
    *****"
6080 NORMAL
6090 GOSUB 9010
6100 VTAB 3: HTAB 14: PRINT "---
    -----";
6110 FOR I = OE TO TR: VTAB TR + I:
    HTAB 14: PRINT "!"
    !";: NEXT
6120 VTAB 7: HTAB 14: PRINT "---
    -----";
6130 VTAB 5; HTAB 17: PRINT "CHARGE!";
6140 VTAB 10: HTAB 12: PRINT "A
    GAME FOR UP TO";
6150 VTAB 12: HTAB 14: PRINT "FOUR
    PLAYERS";
6160 VTAB 16: HTAB 11: PRINT "CO
    PYRIGHT (C) 1982";
6170 VTAB 18: HTAB 11: PRINT "BY
    C. ANTHONY RAY";
6180 FOR I = 1 TO 1500: NEXT I
6190 RETURN
7000 REM * START INFO *
7010 HOME : HGR
7020 VTAB 22: INPUT "SKILL LEVEL
    (1-5) > "; SL
7030 IF SL < 1 OR SL > 5 THEN 7010
7040 GOSUB 2010
7050 HOME : VTAB 22: INPUT "HOW
    MANY PLAYERS? ";HM
7060 H = 1: M = 1: MC = 1
7070 IF HM < 1 OR HM > 4 THEN GOTO
    7050
7080 FOR I = 1 TO HM
7090 HOME : VTAB 22: INPUT "WHAT'S
    YOUR NAME? "; NAME$(I)
7100 PRINT "HI, ";NAME$(I)
7110 FOR J = 1 TO 500: NEXT J
7120 HOME
7130 NEXT I
7140 VTAB 21:HTAB 1: PRINT NAME
    $(1): IF HM > 1 THEN VTAB 21:
    HTAB 20: PRINT NAME$(2); IF
    HM > 2 THEN VTAB 22: HTAB 1:
    PRINT NAME$(3): IF HM > 3 THEN
    VTAB 22: HTAB 20: PRINT NAME$(
    4)
7150 XP = 7: YP = 7: POKE 34,23
7160 VTAB 24: HTAB 1: PRINT NAME
    $(MC);"S TURN. DIRECTION (X
    ,Y) ";
7170 INPUT XO,YO: GOTO 1010
8000 REM * TICKS UP SCORE *
8010 IF MC = 1 THEN HT = 12:VT =
    21
8020 IF MC = 2 THEN HT = 32:VT =
    21
8030 IF MC = 3 THEN HT = 12:VT =
    22
8040 IF MC = 4 THEN HT = 32:VT =
    22
```

Listing 1 continued on page 120

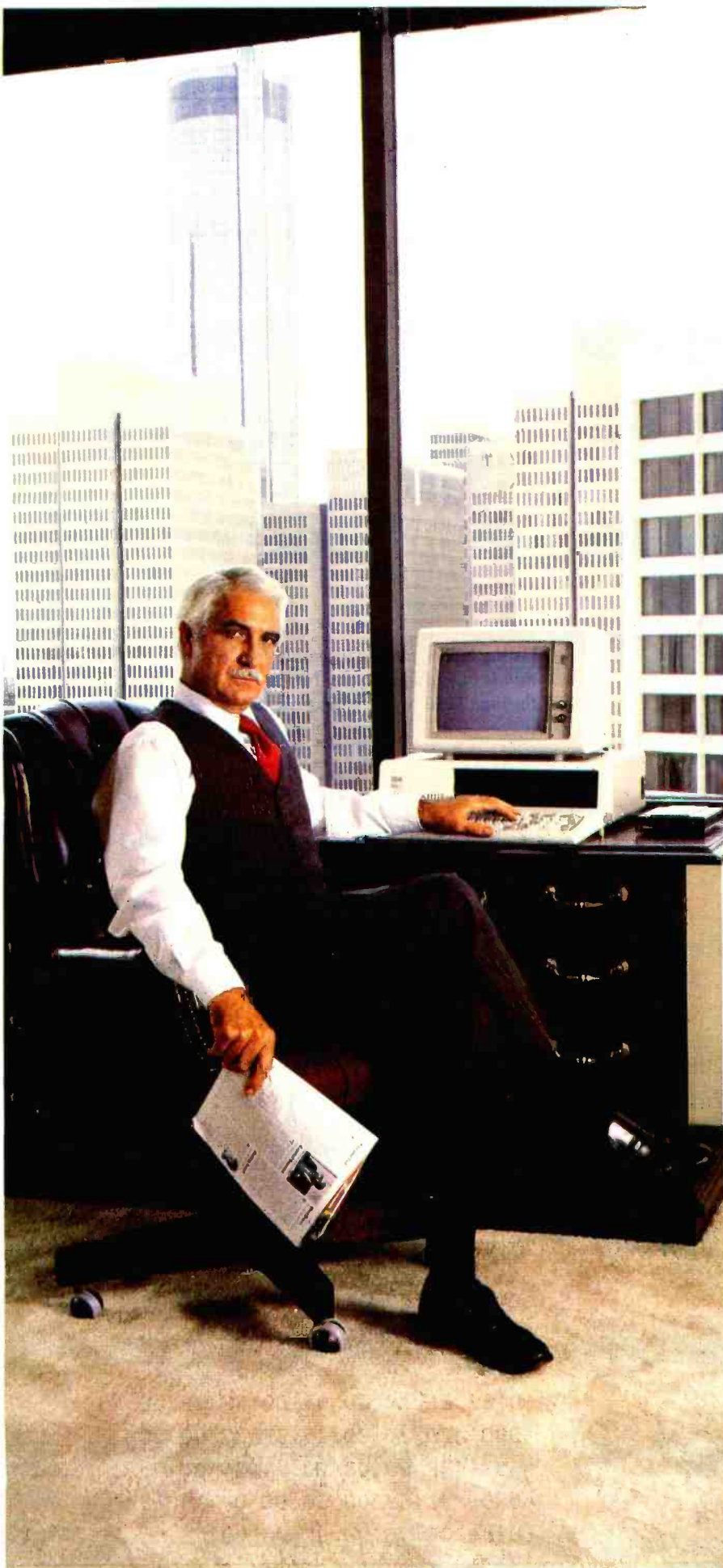

Now I can get the information I need. From anywhere. Immediately.

To do business, I need information from a lot of places.

Sales figures from Cincinnati.

Production costs from Philadelphia.

Personnel levels from our administrative offices three blocks away.

And — sometimes — I need up to the minute market prices from The Source. Whatever I need, I get it. Immediately. That means that I don't waste time waiting. And I don't have to make decisions based on old information. Even if it's just a day old.

Information from anywhere. Immediately. With

CROSSTALK™

Crosstalk allows your CP/M or MS-DOS based computer system to access almost any dial-up computer, capture and store the data, and transfer files between any two Crosstalk systems with complete error checking. Even when disk formats are incompatible.

To get your information, Crosstalk can automatically dial any dial-up system, capture on-line data for analysis off-line.

Crosstalk saves you and your computers time. It saves you money. And, best of all, it gets you the information that you need, when you need it. Ask your local dealer about it.

Now available for IBM PC



Microstuf, Inc.
1845 The Exchange
Suite 205
Atlanta, GA 30339
(404) 952-0267

DEALER INQUIRES WELCOME

CROSSTALK is a trademark of Microstuf, Inc.
CP/M is a registered trademark of Digital Research Inc.
The Source is a servicemark of Source Telecomputing, Corp.
a subsidiary of The Readers Digest Association, Inc.
MS-DOS is a trademark of Microsoft, Inc.

Circle 319 on inquiry card.

BYTE GAME CONTEST

Listing 1 continued:

```

8050 AM = S(MC)
8060 D%(1) = AM/1000000:AM = AM -
      D%(1) * 1000000
8070 D%(2) = AM/100000:AM = AM -
      D%(2) * 100000
8080 D%(3) = AM/10000:AM = AM -
      D%(3) * 10000
8090 D%(4) = AM/1000:AM = AM -
      D%(4) * 1000
8100 D%(5) = AM/100:AM = AM - D%
      (5) * 100
8110 D%(6) = AM
8120 FOR J = 6 TO OE STEP -1
8130 FOR I = ZE TO D%(J)
8140 HTAB HT + J: VTAB VT: PRINT
      I;
8150 IM = PEEK(SS) - PEEK(SS)
      + PEEK(SS) - PEEK(SS) +
      PEEK(SS) - PEEK(SS)
8160 NEXT I
8170 NEXT J
8180 RETURN
9000 REM * FANFARE *
9010 FOR I = 0 TO 18
9020 READ X
9030 POKE 768 + I,X
9040 NEXT
9050 DATA 173,48,192,136,208,
      4,198,1,240,8,202,208,246,
      166,0,76,0,3,96
9060 S = 768
9070 POKE 1,50
9080 POKE 0,91
9090 CALL S
9100 FOR I = 1 TO 3: NEXT I
9110 POKE 1,33
9120 POKE 0,82
9130 CALL S
9140 FOR I = 1 TO 3: NEXT I
9150 POKE 1,33
9160 POKE 0,75
9170 CALL S

```

```

9180 FOR I = 1 TO 3: NEXT I
9190 POKE 1,130
9200 POKE 0,66
9210 CALL S
9220 FOR I + 1 TO 30: NEXT I
9230 POKE 1,50
9240 POKE 0,75
9250 CALL S
9260 POKE 1,255
9270 POKE 0,66
9280 CALL S
9290 RETURN

```

Listing 2: The fanfare assembly-language routine. This information is placed in memory by the POKE statements in lines 9010 through 9050 of the main program.

0300:	1	ORG	\$300
0300:AD 30 C0	2	START	LDA \$C030
0303:88	3	B1	DEY
0304:D0 04	4	BNE	B2
0306:C6 01	5	DEC	\$1
0308:F0 08	6	BEQ	B3
030A:CA	7	B2	DEX
030B:D0 F6	8	BNE	B1
030D:A6 00	9	LDX	\$0
030F:4C 00 03	10	JMP	START
0312:60	11	B3	RTS

Listing 3: The game shape table, including the positive ion, negative ion, electron, and arrow (in that order).

```

6000- 04 00 0A 00 1D 00 27 00
6008- 2A 00 24 24 37 36 36 36
6010- 25 24 2D 2D 3C 3F 3F 3F
6018- 3F 2E 2D 05 00 3F 3F 2E
6020- 2D 2D 2D 25 3F 3F 00 2C
6028- 3E 00 08 20 24 24 24 95
6030- 92 62 0C 0C DC DB DB 13
6038- 0E 0E 0E 0E 06 00

```



MORE THAN EVER, ATARI HOME COMPUTERS ARE SPEAKING YOUR LANGUAGE.

With more program languages than ever to choose from, you now have more opportunities than ever to utilize the amazing capabilities of the ATARI 800™ Home Computer.

Whether you're a beginning programmer, or at the forefront of the art, you'll find an ATARI programming language that can make your task quicker and simpler than ever before. Just look at what ATARI has to offer:

ATARI Microsoft BASIC—Now we offer the industry standard, the most powerful Microsoft BASIC yet. With simple commands, it allows you to take advantage of unique ATARI hardware features such as our well-known player/missile graphics. For ease of programming, it includes n-dimensional arrays for numerics and string handling. And importantly, conversion procedures are simple.

ATARI Macro Assembler—Faster and more powerful than any ATARI language before, the ATARI Macro Assembler also allows you to access more memory space. And it's excellent for I/O interface and manipulation of such features as: player/missile graphics, sound registers and peripherals. In addition, the macro processor and "include" file library features speed-up program development considerably.

Fig-FORTH*—For specialized programming needs, such as educational or game applications, ATARI Fig-FORTH is uniquely effective. Fig-FORTH combines power and simplicity in an efficient 10K size, with characteristics of an interpreter and the speed of machine language code.

ATARI BASIC—An affordable and easy to use BASIC that requires only 8K of memory. It allows you to take advantage of the spectacular ATARI graphics and sound capabilities.

And its immediate mode error messages greatly simplify debugging.

ATARI Assembler Editor—An excellent tool to assist the assembler-programmer in creating, editing and debugging assembly programs.

PILOT—ATARI PILOT is an exceptional learning language, with built-in "turtle" graphics to let you create spectacular designs and pictures with very short programs. Simple one or two-letter commands allow you to create a dialogue with the computer. And a single "match" command can perform complex text evaluation and pattern-matching instantly.

ATARI Pascal*—An excellent high-level language for teaching structured programming, and for developing and maintaining programs. In addition to offering all the features of the ISO Pascal standard, ATARI Pascal offers unique extensions that allow you to take advantage of ATARI graphics and sound capabilities.

ATARI is constantly developing new ways to help you get more out of your ATARI 800 Home Computer. So watch for more innovative and exciting programming languages from ATARI in the future.

For more information, write to ATARI, Inc., Dept. C1Z, P.O. Box 16525, Denver, CO 80216.

© 1982 ATARI, Inc. All Rights Reserved.
*Available from the ATARI Program Exchange



ATARI HOME COMPUTERS

We've Brought The Computer Age Home.™

Circle 46 on inquiry card.

The Panasonic portable computer We've improved the way



THE **Link** by **Panasonic**™

It will improve the way you solve problems. And the solutions come from the portable computing power you have at your fingertips. You can take it with you on planes, cars, boats, anywhere, because it fits into a suitcase. You can be more cost effective in the field, because you'll have access to more information for making on-the-spot decisions. You'll have the incredible advantage of being able to telecommunicate from anywhere you are. It gives you a whole new world of computing. Portable computing.

Software Solutions — Now there's an exciting new software system for the 6502 microprocessor that gives you more solutions to your problems.

The popular language software for the portable computer includes Extended Basic Compiler/Interpreter, SnapFORTH and Microsoft Basic.®

The Panasonic portable computer also has a wide range of specific software programs for your specific problems, such as:

The Scientific Calculator — An incredibly powerful tool that solves mathematical problems for the scientist, engineer, and professional wherever they go.

Portabudget — It's your portable personal financial manager. It gives you up-to-the-minute personal control. It allows you to be your own record keeper, savings advisor, accountant, bill manager, credit and charge account guide, investment counselor, portfolio keeper, and tax assistant. Overall, it helps plan your personal financial life, portably.

Portacalc — Gives you the portability and the flexibility to automatically analyze numerical problems wherever and whenever they arise. You can assess "what if" alternative business problems, comprehend key variables in business, and dynamically analyze problems on engineering projects.

Portawriter — It allows you to write, edit, and format information. And, you can telecommunicate the information from wherever you are. Whether you're in the boardroom, hotel room, or even on a golf course, Portawriter gives you full editing and formatting capability for notes, reports, letters, news copy, tables, lists, forms, orders, you name it.

Portalog — It is an easy, precise tool for time-billing professionals without a minute to lose. Whether you're on the road or in the office, you can log time, compile bills, generate billing reports, and track the work of your highly paid employees. Portalog gives you improved timekeeping productivity.

Telecomputing 2™ — It lets you telecommunicate with your data base. You can establish communications between headquarters and field forces. Exchange files and programs between remote stations. Access timesharing services and store data in a large computer's mass storage. You can also upload and download program data.

with a wide range of new software. you solve problems.

Portaflex — A master program that allows you to create solutions for applications, such as:

- Inventory Control* — Analysis and control of inventory while you're on the job.
- Order Entry* — A customized system for any sales order entry. It offers you productivity, and the advantage of faster order entry.
- Field Service* — Retrieve, diagnose, and analyze your field service data wherever you are in the field.
- Auditing and Accounting* — Custom auditing and accounting, anywhere you are in the field.
- Estimating* — Versatility for flexible bidding and estimating at your job site.

Software Development Tools for the Customizer — Create your own custom programs and burn them into your EPROM so your program is recorded in nonvolatile form.

Simply take a desk top microcomputer,* insert the software development discs, create your own program, de-bug that program, compile the program, then "burn-in" your problem-solving EPROM.

*Presently offered for Apple II Plus.

Hardware Specifications —

The Panasonic portable computer offers 6502 microprocessor (1 MHz) technology.

- It offers 4K or 8K internal nonvolatile RAM
- 48K internal ROM
- Built-in Ni-Cad rechargeable battery pack
- External AC adapter/recharger
- 26-character liquid crystal display
- 65-key completely redefinable keyboard

Introducing Peripherals for Additional Solutions —

Modular peripherals let you customize your system.

- Multiple RS-232C serial interfaces
- Asynchronous modem with cassette interface (110 or 300 baud)
- 40-character microprinter (thermal dot matrix printing)
- 8K or 16K RAM memory expansion packs
- X-Y, four-color plotter (up to 80 characters per line)
- TV adapter (32 characters X 16 lines with color and graphics)

The Panasonic portable computer. It's improved the way you solve problems. Because we believe its portable modules and multiple software applications can vastly improve your productivity. And that can be an important solution to your profit problems.

The portable computer from Panasonic. We've improved the way you solve problems.

THE Link_™ Panasonic. It's changing the way the world uses computers.

Please send me more information.

Dealer Inquiries Invited

Panasonic Company, Hand-Held Computers
One Panasonic Way, Secaucus, New Jersey 07094

Name (PLEASE PRINT) _____

Title & Company _____

Type of Business _____

Address _____

City _____ State _____ Zip _____

Phone Number () _____

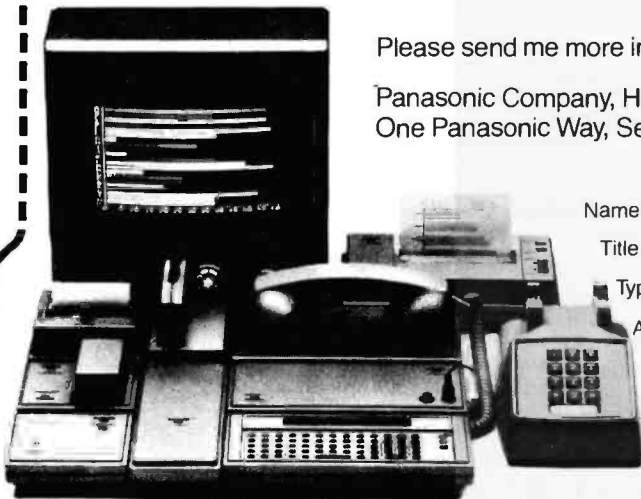

B-S

Panasonic®
just slightly ahead of our time.

Circle 368 on Inquiry card.

FIRST-PLACE WINNER

Cosmic Conquest

Alan Sartori-Angus
 Professor of Computer Science
 University of Natal
 Durban, South Africa

As you move your battle fleets through the galaxy, you try to strengthen your planet empire at the expense of your opponent, an Apple microcomputer. Planets are attacked and occupied, battle fleets fight to the death, high taxes spawn revolutions, and black holes swallow entire fleets. Welcome to Cosmic Conquest, where you must expand your empire, stave off insurrection, and destroy the enemy or lose the game.

The action takes place in a 30- by 30-unit galaxy that may be thought of as the surface of a sphere. While your view of the galaxy appears limited by the confines of the screen display, there are no boundaries: if you move off the top of the galaxy, you will reappear at the bottom; leaving from one side will cause you to reenter on the other. The size of your galaxy may be changed by altering the SIZE constant in the program.

The Cosmic Arena

The primary graphics display is the battle-fleet scan, the part of the galaxy immediately surrounding your current fleet (see figure 1). The battle-fleet symbol is in the center of the display, surrounded by the stars, the planets, the colonies, and the enemy battle fleets. The scan remains centered on the battle fleet currently under your control, and when you make a move the planets,

stars, etc., appear to move past your fleet. The x and y values displayed below the scan are coordinates that identify the present position of your battle fleet in the galaxy. The number of fighting ships available in your current fleet is also listed below the scan display, as well as the number of troop legions on board the fleet. Other information displayed includes the number of credits you have available and your score so far.

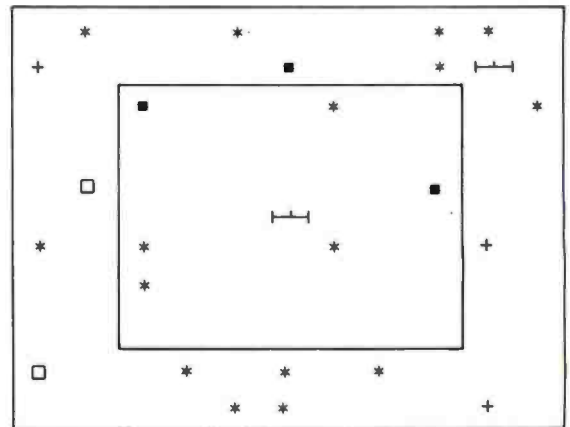

X = 16 Y = 12
 NO. OF SHIPS = 58
 LEGIONS = 85

SCORE = 570
 CREDITS 348

LEGEND

- * A STAR
- A PLANET THAT IS NOT A COLONY OF YOURS
- A COLONY OF YOUR EMPIRE
- |— ONE OF YOUR BATTLE FLEETS
- + ONE OF THE ENEMY BATTLE FLEETS

About the Author

Alan Sartori-Angus is Professor of Computer Science at the University of Natal, Durban, South Africa. He has been involved with computing since 1976 and specializes in data communications and operating systems, especially as applied to microcomputers. His interests include both standard and computer chess, war-gaming, and sports. He is presently involved in the design and construction of a FORTH engine using bit-slice components.

Figure 1: An example of the screen display during the game. Use the legend to identify the game symbols.

The IMS Family

IMS Computer products not only fulfill the requirements of stand alone applications, they are designed to be cost effective, intelligent nodes in a total network environment! Each product fulfills a particular requirement of the

network with a conservative functional overlap of the system above and below in the Family Tree. The IMS family is growing rapidly—keeping pace with technology and the ever increasing needs of industry.



The Ever Expanding IMS Product Line

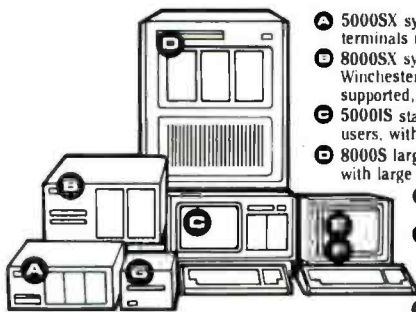

- Ⓐ 5000SX systems computer. S100 based archival node to which six user terminals may be connected, each with its own processor and memory.
- Ⓑ 8000SX systems computer. S100 based archival node with dual floppy. Winchester and tape back up capability. Six user terminals may be supported, each with its own processor and memory.
- Ⓒ 5000IS stand alone intelligent node. S100 based. May support up to four users, with up to 25 MByte Winchester with dual floppies.
- Ⓓ 8000S large system computer. S100 based. Can support up to 16 users with large disk and tape back up capability.
- Ⓔ Stand-alone intelligent CRT with high resolution monitor and removable typist keyboard.
- Ⓕ Expanded CRT to be used as Intelligent Note Processor. Includes Micro Processor. 64K of memory and four serial ports—two of which are to be used to connect into high speed network communication.
- Ⓖ Portable cartridge tape back up. Stores 17.5 Mbytes of data. Operates in start stop or streamer modes.

For complete information and specifications plus the location of your nearby IMS International dealer, call or write today! (714) 978-6966 or (702) 883-7611

IMS
INTERNATIONAL

2800 Lockheed Way
Carson City, NV 89701

Telex: 910-385-6051

We Build Computers As If Your Business Depended On Them.

See Us At
COMDEX '82
Nov. 29 - Dec. 2, 1982 • Booth 1144
Las Vegas Convention Center, Las Vegas, NV
Circle 228 on inquiry card.

BYTE GAME CONTEST

You begin the game with 250 credits, which can be used to purchase more ships or enlist additional legions. Although you don't have control of any colonies at this point, you have two fleets, each consisting of 20 ships and 50 legions. In addition, you have no idea what the galaxy looks like and no clues to what the enemy (the computer) is up to. Using one of the several commands available (see the text box on page 128), you can begin to create a powerful empire.

Your score indicates the strength of your empire, which you can increase by adding to the number of planets you control and the number of legions and ships you have. However, the strength of your empire is reduced by the strength of the computer's empire. You therefore have two methods of gaining strength: first, colonize as many planets as possible, and keep your troop numbers high; second, reduce the enemy's strength by taking over its colonies and destroying its battle fleets.

In determining your strategy, you will be faced with several difficult decisions. Do you place large garrisons on your planets to make them secure from the enemy and from internal revolt, or do you use those legions to colonize more planets? Do you spend your credits on ships that can help you destroy enemy battle fleets, or do you

pay to enlist more legions? It's highly unlikely that you'll find a clear winning combination of strategy and tactics. In fact, you may be well on the way to a high score when your fleet disappears from the screen upon being swallowed by a black hole.

Design Decisions

Cosmic Conquest is designed to be a single-player game of real-time action and strategic decision making. I wanted the game to be played in real time but to be more than just a game to test quick reactions in the manner of Space Invaders. I also decided that each play of the game should be different and that the game would use the precept of offering incomplete information to create a game for which there is no consistent winning strategy.

These design decisions are important to the play of Cosmic Conquest. The use of real time adds to your sense of tension as you play. Having to make split-second decisions all the time, some of which may cost you the game, is what I wanted Cosmic Conquest to be about. If you have all day to make decisions, it becomes too easy to win. The program further challenges you by never producing the same game twice. Not only is the galaxy different each time, but the winning tactics also change.

THE GIFT OF GAB

ECHO SPEECH SYNTHESIZERS

Whatever you type on the keyboard, your computer can say. It's as simple as that.

Our text-to-speech system gives your computer an unlimited vocabulary while using a minimum of memory. With nearly 400 grammatical rules contained in the ECHO, your computer can properly pronounce most any word, phrase, or sentence. Simple commands allow you to select from:

- Entire words pronounced or spelled letter by letter
- Words spoken monotonically or with intonation
- Spoken punctuation if desired
- 63 different pitch levels
- Fast or slow speech output
- Different volumes

Applications are unlimited, ranging from phone answering, educational and training programs, to games and aiding the sight and speech impaired. The ECHO is a complete stand alone unit which is compatible with most any computer; it sells for \$299.95. The ECHO II, which plugs into the Apple II, is priced at \$149.95.



STREET ELECTRONICS CORPORATION

1140 Mark Avenue, Carpinteria, CA 93013 (805) 684-4593

Two of mankind's greatest treasures

TIME & ART



Reflected in two outstanding peripherals for your APPLE II

The MBI™
APPLETIME™ Card
\$9900*

- Fully Mountain Software compatible
- Disk included with all software
- Includes Datebook™ - a complete desk calendar
- Time of day
- Calendar date
- Day of week
- Program timer
- International time-keeping ability
- Recharging battery backup
- Complete software formatting
- Offset time/date/day readout

The MBI™ VIP Card
VIP™ Card - "Versatile Interface Peripheral"
(Available for EPSON, NEC, C-ITOH, IDS PRISM, OKIDATA
and other graphic printers soon) **\$14900***

VIP™ Card - The Ultimate Graphics Card
A Centronics Parallel Interface with a Serial Port and
Cables featuring:

- Text and graphics screen dump routine
- Graphics with inverse & emphasized modes
- Enlarged picture mode
- Variable line length with left & right margins
- Block graphics
- 90° picture rotation
- Chart Recorder Mode
- A serial port with full RS232 capability
- Software baud rate control from 110 to 9600 baud

*Suggested List Price

MICROCOMPUTER
BUSINESS
INDUSTRIES
CORPORATION

MBI

ADMINISTRATIVE OFFICES: 1019 8TH STREET, GOLDEN, COLORADO 80401 (U.S.A.)
TELEPHONE: (303) 279-8438

TWX: 910-934-0191

Circle 310 on Inquiry card.

Apple is a trademark of Apple Computer, Inc. MBI, Appletime, VIP, and Datebook are trademarks of Microcomputer Business Industries Corporation.

www.americanradiohistory.com

Cosmic Commands

The following commands are available to you during the course of a game:

Move: The current battle fleet (the one shown in the center of the scan) can be moved up, down, left, and right merely by pressing the W, Z, A, and S keys, respectively.

Other Fleet: To make your other battle fleet your current fleet, press the O key. The display will change to show the area around your new current fleet. You can move, fight, colonize, etc. only with your current fleet.

Information: Additional information about the current state of the game can be obtained at any time by hitting the I key. This information includes the number of planets in your empire and the number of both planets and battle fleets in the computer's empire.

Fire: You can attack an enemy battle fleet in an adjoining square to your current battle fleet by pressing the F key. Casualties are inflicted on both fleets in proportion to the strength of the enemy fleet. (A rough guide is that a fleet will inflict a casualty rate of 40 percent of its strength upon the enemy fleet.) Battles may continue as long as you wish or until either one of the fleets is destroyed.

Tax: You may tax all the planets in your empire at any time by pressing the T key. The amount of tax provided by a planet is in proportion to the class of the planet. A larger-class planet will generally provide more taxes. However, because planets do not like being taxed it's possible that one or more will revolt. The likelihood that this will occur increases each time the planets are taxed. When a revolution occurs, you are told which planet revolted and whether or not the revolt was successful.

Land: You can attempt to land on any planet adjacent to your current battle fleet. The display prompts for the direction of the planet relative to the fleet and you indicate your choice by using the MOVE keys. When you land on the planet, you are faced with one of three situations: the planet is already a member of your empire, the planet is uncolonized, or the planet is garrisoned by enemy forces.

If the planet is already a member of your empire, you are

told the class of the planet and the size of the local garrison and are given a choice from five options: (1) leave legions on the planet, (2) gather legions from the planet, (3) buy ships, (4) enlist troops, and (5) leave.

Option 1 lets you transfer legions from the fleet to the planet to strengthen local garrison. This garrison puts down revolts when they occur and wards off attacks by the enemy. With option 2, you can reduce the strength of the local garrison in order to increase the number of legions with the fleet. The fleet legions are needed when you attack the enemy and capture other planets. By choosing option 3, you can purchase additional ships for your fleet. The planet will tell you the cost per ship, and you can buy as many ships as your credits will cover. If you choose option 4, you can raise new legions from the inhabitants of the planet. However, the planet is only capable of producing a limited number of legions and the cost of enlistment is an important factor. The planet will inform you as to the number of legions available and what they cost. The larger the class of a planet, the more legions it will be able to produce and the higher the cost will be for raising them. With both options 3 and 4, a built-in safeguard prevents you from repeating your request to buy in an effort to overcome the limitations on the numbers available. To leave the planet, you must choose option 5.

If the planet is uncolonized, you will be told the class of the planet and asked whether you wish to attack. A rough estimate of the strength of the planet can be made from the class; a planet is capable of having legions numbering the same as its class. If you decide to attack, the computer calculates the result of the battle and tells you either that your forces are now in control or that your forces have retreated. Whatever the outcome of the battle, you will also receive a report of losses.

When the enemy controls the planet, you are told the class of the planet and the size of the garrison. You are asked if you wish to attack, and if you respond affirmatively the computer calculates the result of the battle and displays it along with the number of losses.

Additionally, at any moment in time you can see only the portion of the galaxy that immediately surrounds the battle fleets. You have to cope with incomplete information, not knowing where the computer's fleets are nor which planets the computer has under control.

Programming the Action

I wrote the game program in FORTH for several reasons. The real-time aspect required that the speed of the display be as fast as possible, and the intended complexity of the game seemed to require a high-level language. FORTH satisfied both of these criteria. Another factor was the continued growth and development of the game program. Because the game has been

growing and changing since its conception, it was important for me to use a language that would allow fundamental changes to the program with a minimum of time and effort.

The information for the game is stored mainly in the three 30 by 30 arrays called GALAXY, INFO1, and INFO2 (see listing 1). The GALAXY array registers the contents (planets, battle fleets, etc.) of each square unit of the galaxy. For each of these squares that contains a planet, the corresponding array, INFO1, has two pieces of information about the planet. The least significant three bits contain the alliance factor for the planet, which is randomly set at the beginning of the game and decremented each time the planet is taxed. When the fac-

THE \$595* SMART TERMINAL

The Heath 19 Smart Video Terminal gives you all the important professional features you want in a terminal, all for under \$600.* You get the flexibility you need for high-speed data entry, editing, inquiry and transaction processing. It's designed to be the backbone of your system with heavy-duty features that withstand the rigors of daily use.

Standard RS-232C interfacing makes the 19 compatible with DEC VT-52 and most computer systems. And with the 19, you get the friendly advice and expert service that makes Heath/Zenith a strong partner for you.

Sold through Heathkit Electronic Centers† nationwide (see your white pages for locations). Stop in today for a demonstration of the Heath 19 Smart Video Terminal. If you can't get to a store, send for the latest Heathkit® Catalog. Write Heath Co., Dept. 334-964, Benton Harbor, MI 49022.

HEATH/ZENITH

Your strong partner

Completely addressable blinking cursor lets you edit anywhere on screen.

Reverse video by character lets you emphasize words, phrases or paragraphs.

High resolution CRT gives you sharp, easy-to-read image, reduces eye-strain.

Z-80 microprocessor-control makes the 19 capable of multitude of high-speed functions. It's the only terminal with ROM source code readily available.

Complete ASCII character set including upper case, lower case with descenders, and special graphic symbols.

80 character by 24 line format, plus 25th line for operator messages and prompts.

Professional quality keyboard, standard typewriter layout, 72 keys, including 12 special function keys.

Insert and delete character or line plus erase to end of line and end of screen make the 19 ideal for sophisticated editors like WORD-STAR.

Cursor and special functions are accessible by keyboard or computer, using either DEC VT-52 or ANSI Standard protocols.

Keypad in calculator format permits fast, easy entry of numeric data.



*In kit form, F.O.B. Benton Harbor, MI. Also available the completely assembled Zenith Z-19 at \$895. Prices and specifications are subject to change without notice.

†Heath Company and Veritechnology Electronics Corporation are wholly-owned subsidiaries of Zenith Radio Corporation. The Heathkit Electronic Centers are operated by Veritechnology Electronics Corporation.

BYTE GAME CONTEST

tor reaches zero, the planet revolts. The most significant five bits hold the class of the planet. The array INFO2 has various pieces of data. If the corresponding entry in the GALAXY array is a planet, then INFO2 holds the size of the local garrison. If the corresponding GALAXY entry shows an enemy fleet, then INFO2 gives the number of ships in that fleet.

The primary game loop is contained in the FORTH word RESTART. The program loops here and while waiting for you to press a key determines if the computer should be taking any action. The game program is written so that the computer will continue to play even if you do nothing. When you do press a key, that command is decoded by the FORTH word OBEY-COMMAND and is subsequently executed.

Another point of interest is the method by which the program handles the screen display. The graphics symbols are defined in shape tables, but in my initial use of them I discovered that the processor updated the main

display too slowly. To make the display update faster, I defined a small array, SCREEN, which at any moment during the game contains the description of the contents of the main graphics display on the screen. When the display is updated, the program first checks in SCREEN to see what is already there. If the display is already showing the symbol in question, no update takes place. The only time the screen is updated is when a different symbol has to be placed at a position on the screen. Although this method involves more calculation, it increases the speed of the display considerably because fewer symbols are written to the Apple high-resolution area on each update.

So with a limited amount of time, you must capture and keep as many planets as possible, avoid black holes, stamp out revolutions, and hold the enemy at bay by destroying opposing fleets. With over 2500 possible scenarios, Cosmic Conquest should keep you occupied for some time. ■

Listing 1: The FORTH program for Cosmic Conquest.

```

COSMIC CONQUEST: THE LISTING
( constants)
30 CONSTANT SIZE ( the size of the galactic array)
SIZE 2 * CONSTANT NO-OF-STARS ( no. of stars in galaxy)
SIZE 3 * 2 / CONSTANT NO-OF-PLANETS ( planets in galaxy)
4 CONSTANT NO-OF-B-HOLES ( no. of black holes)
200 CONSTANT W1 ( weight value assigned to planets in score)
5 CONSTANT W2 ( weight assigned to ships and troops)
10 CONSTANT W3 ( weight assigned to computers troops)
20000 CONSTANT SPEED ( how quickly computer moves)

( variables)
0 VARIABLE TEMP1 ( a temporary storage variable)
0 VARIABLE VTAX ( tax collected)
0 VARIABLE C-LEGIONS ( no. of computer legions for attacks)
0 VARIABLE CLASS-TOTALS ( computers planets classes totals)
0 VARIABLE C-FLEETS ( no. of computer fleets)
0 VARIABLE LEN ( no. of moves remaining in game)
0 VARIABLE TROOPS ( no. of computers troops in game)
0 VARIABLE RAND1 ( first random number seed)
0 VARIABLE RAND2 ( second random number seed)
0 VARIABLE X ( temporary storage for X position)
0 VARIABLE Y ( temporary storage for Y position)
0 VARIABLE BUY-V ( count to stop player buying every move)
0 VARIABLE LEG ( the no. of legions available to buy)
0 VARIABLE NEW ( how often new fleet created)
0 VARIABLE COMP-START ( how quickly computer plays)
0 VARIABLE COMPUTER ( how quickly computer plays)
0 VARIABLE DIFF ( difficulty of game 1-4)
0 VARIABLE C-PLANETS ( no. of computer planets)
0 VARIABLE PLANETS ( no. of players planets)
1 VARIABLE FLEET-FLAG ( no. of players current fleet)
250 VARIABLE CREDIT ( players credit in taxes)
0 VARIABLE START ( starting score in the game)

( defining words)
: ARRAY ( 2D array)
  <BUILDS DUP C, * ALLOT DOES>
  ROT 1 - OVER C@ * + + ;

( arrays)
SIZE SIZE ARRAY GALAXY ( the galactic array)
SIZE SIZE ARRAY INFO1 ( planetary array)
SIZE SIZE ARRAY INFO2 ( strength array)
11 11 ARRAY SCREEN ( the screen array)
2 6 ARRAY FLEETS ( players fleets info.)

( the case statement)
: CASE
  ?COMP CSP @ !CSP 4 ; IMMEDIATE

: OF
  4 ?PAIRS COMPILE OVER COMPILE = COMPILE 0BRANCH HERE 0 ,
  COMPILE DROP 5 ; IMMEDIATE

: ENDOF
  5 ?PAIRS COMPILE BRANCH HERE 0 , SWAP 2 <<COMPILE>>
  ENDF 4 ; IMMEDIATE

: ENDCASE
  4 ?PAIRS COMPILE DROP BEGIN SP@ CSP @ = 0= WHILE 2
  <<COMPILE>> ENDF REPEAT CSP ! ; IMMEDIATE

( general utility words)
: DELAY ( delay a fixed amount of time)
  5000 0 DO LOOP ;

: CLEAR-MSGE ( clear message area on text screen)
  10 10 DO
    1 0 UHTAB 35 SPACES
  LOOP ;

: XY@
  X @ Y @ ;

: CLEAR-SCREEN ( clear hires screen 1)
  HI HCLR ;

: CLEAR-DISP ( fill screen array with FF's)
  1 1 SCREEN 121 255 FILL ;

: CLEAR-GALAXY ( fills galactic array with NULLS)
  1 1 GALAXY SIZE SIZE * 0 FILL ;

: CLEAR-INFO ( fills info arrays with NULLS)
  1 1 INFO1 SIZE SIZE * 0 FILL
  1 1 INFO2 SIZE SIZE * 0 FILL ;

: RANDOM1 ( --- ran ) ( random number in range 1-SIZE)
  RAND1 @ 37 * 651 + DUP RAND1 ! ABS SIZE MOD 1+ ;

: RANDOM2 ( --- ran ) ( random number in range 1-SIZE)
  RAND2 @ 53 * 773 + DUP RAND2 ! ABS SIZE MOD 1+ ;

: EDGE-CHECK ( n --- ng )
  ( calculates wrap around of galaxy)
  SIZE 1 - + SIZE MOD 1+ ;

: INPUT ( --- nI ) ( number input routine)
  0 BEGIN ( start with zero total)
  KEY DUP EMIT DUP 0 = ( is it backspace?)
  IF
    DROP 10 / 0 ( get rid of last digit)
  ELSE
    DUP 57 > ( check if char. is digit)
    IF DROP 1
    ELSE DUP 48 (
      IF DROP 1
      ELSE 48 - SWAP 10 * + 0
      ENDF
    ENDF
  UNTIL ;

: F ( n1 --- add1 ) ( indexes current fleet array)
  FLEET-FLAG @ SWAP FLEETS ;

```

Listing 1 continued on page 132

Which Spreadsheet lets you:

- Use every cell (never see "out of memory")
- Consolidate multiple spreadsheets
- Split the screen as often as you want

VisiCalc NO
SuperCalc NO
CalcStar NO



ScratchPad . . . YES

The Ultimate Spreadsheet

ScratchPad features include:

- Virtual Memory (never see "out of memory")
Every cell on the spreadsheet can be used. Don't be misled, other spreadsheets tell you how "big" the matrix is, but you can only use a very small portion. With ScratchPad's virtual memory feature you can use EVERY CELL!
- Consolidation (not just merging but also combining spread-sheets) This makes ScratchPad almost three dimensional.
- Unlimited Screen Splitting
- If/Then
- Merge
- Unlimited Title Locking
- Long Strings Supported
- Help file
- Variable column width
- Built in financial functions

- Built in math functions
- Variable formats
- Automatic and selective recalc
- Interface to Stats-Graph graphic package
- More

For virtually all CP/M, CP/M-86, and MS DOS compatible systems, including the IBM PC.

Available from fine dealers everywhere, or directly from SuperSoft.

Requires:	44k
ScratchPad:	\$295.00
Manual Only:	\$ 15.00

Japanese Distribution:
ASR Corporation International
3-23-8, Nishi-Shimbashi, Minato-Ku,
Tokyo 105, Japan
Tel. (03) 437-5371
Telex. 0242-2723

CP/M is a registered trademark of Digital Research. VisiCalc is a registered trademark of Visi-Corp. SuperCalc is a registered trademark of Sorcim. CalcStar is a registered trademark of Micropro.

SuperSoft®

FIRST IN SOFTWARE TECHNOLOGY P.O.Box 1628 Champaign, IL 61820 (217) 359-2112 Telex 270365

BYTE GAME CONTEST

Listing 1 continued:

```

: TEXT ( selects text screen )
0 -16303 C! ;

: END-MSGE ( end of game message )
TEXT 12 0 UHTAB ." END OF GAME COMMANDER" ;

( graphics shapes and utilities )

0 VARIABLE SPACEFIG 00 ALLOT ( shape tables )

: C% ( loads 8-bit value into table )
OVER C! 1+ ;

: % ( loads 16-bit value into table )
OVER ! 2+ ;

SPACEFIG ( load shape tables )
12 % 31 % 41 % 47 % 63 % 74 % HEX
( space shape )
24 C% 3F C% 37 C% 36 C% 2E C% 24 C% 2C C% 36 C% 2E C% 2C C%
2E C% 25 C% 24 C% 3C C% 37 C% 2E C% 34 C% 36 C% 00 C%
( colony shape )
12 C% 2D C% 24 C% 24 C% 3F C% 3F C% 36 C% 36 C% 2D C% 00 C%
( planet shape )
2C C% 36 C% 3F C% 24 C% 05 C% 00 C%
( star shape )
3C C% 36 C% 2D C% 24 C% 1C C% 1F C% 16 C% 16 C% 0D C% 0D C%
1C C% 2C C% 1C C% 0C C% 04 C% 00 C%
( players fleet shape )
3C C% 1B C% 36 C% 26 C% 08 C% 2D C% 2D C% 25 C% 36 C% 36 C%
00 C%
( computers fleet shape )
36 C% 07 C% 28 C% 29 C% 32 C% 00 C%

DECIMAL DROP FORGET C% ( we don't need C% and % any more )

: SKETCH ( n --- ) ( sketch shape n at current position )
2 * 0 SWAP SPACEFIG + 2 SPACEFIG + DRAW ;
( into the main game words )

: SET-UP-GALAXY
NO-OF-STARS 0 DO 2 RANDOM1 RANDOM2 GALAXY C!
LOOP ( set up stars in galaxy )
NO-OF-PLANETS 0 DO RANDOM1 RANDOM2 2DUP 4 ROT ROT
GALAXY C! ( set up planets )
RANDOM1 4 * 8 + ROT ROT INFO1 C!
( set up class of planet )
LOOP
NO-OF-B-HOLES 0 DO 8 RANDOM1 RANDOM2 GALAXY C!
( set up black holes )
LOOP ;

: INITIALISE ( initialise all variables and arrays )
CR CR
BEGIN
." WHAT LEVEL OF DIFFICULTY (1-4) " INPUT DUP
5 ( IF ( correct response ) 1
ELSE ( incorrect response ) DROP CR 0
ENDIF
UNTIL
DIFF ! ( store difficulty )
HOME CR CR
." DO YOU WANT* CR ." 1. SHORT* CR ." 2. MEDIUM* CR
." 3. LONG* CR ." GAME*
KEY 127 AND ( pick up reply )
CASE
49 ( 1 ) OF 350 LEN ! ( 350 moves ) ENDOF
50 ( 2 ) OF 700 LEN ! ( 700 moves ) ENDOF
1500 LEN ! ( 1500 moves otherwise )
ENDCASE
HOME ." INITIALISING*
CLEAR-GALAXY CLEAR-DISP CLEAR-INFO SET-UP-GALAXY
1 FLEET-FLAG ! ( make fleet 1 current fleet )
250 CREDIT ! ( players credit )
0 PLANETS ! ( no planets )
0 C-PLANETS ! ( none for computer either )
20 1 3 FLEETS ! 20 2 3 FLEETS ! ( fleets start with 20 ships )
50 1 5 FLEETS ! 50 2 5 FLEETS ! ( fleets have 50 legions each )
DIFF 2 4 * 0 DO ( position computers fleets )
RANDOM1 RANDOM2 2DUP 17 ROT ROT GALAXY C!
15 ROT ROT INFO2 C!
LOOP
16 22 18 GALAXY C! 16 18 22 GALAXY C! ( position fleets )
22 1 1 FLEETS C! 18 1 2 FLEETS C!
18 2 1 FLEETS C! 22 2 2 FLEETS C!
29 3 DIFF 2 * - NEW ! ( how often computer creates fleets )
15 DIFF 2 4 * * TROOPS ! ( initial no. of computer troops )
20 DIFF 2 * C-LEGIONS ! ( no. of spare computer legions )
DIFF 2 4 * C-FLEETS ! ( no. of computer fleets )
SPEED DUP COMPUTER !
COMP-START ! ( how often computer moves )
1 BUY-V ! ;

: DRAW-BORDERS ( draw borders of display and headings )
CLEAR-SCREEN
7 HCOLOUR ( colour white )
17 5 HPOSN
230 5 HLINE 230 126 HLINE 17 126 HLINE 17 5 HLINE
57 27 HPOSN
198 27 HLINE 198 104 HLINE 57 104 HLINE 57 27 HLINE
HOME
." PLAYER*
2 0 UHTAB ." PLANETS ="
4 0 UHTAB ." EMPIRE"
6 0 UHTAB ." FLEETS"
6 21 UHTAB ." PLANETS"
20 0 UHTAB ." X="
20 7 UHTAB ." Y="
21 0 UHTAB ." NO. OF SHIPS ="
22 0 UHTAB ." LEGIONS ="
20 25 UHTAB ." SCORE ="
22 21 UHTAB ." CREDITS" ;

: FIND-DIRECTION ( --- X Y )
( find out which square player means )
23 0 UHTAB ." WHICH DIRECTION?"
2 SPACES KEY 127 AND
CASE
07 ( up ) OF -1 0 ENDOF
90 ( down ) OF 1 0 ENDOF
03 ( right ) OF 0 1 ENDOF
65 ( left ) OF 0 -1 ENDOF
0 0
ENDCASE
23 0 UHTAB 35 SPACES ( clear message )
2 F C2 + EDGE-CHECK SWAP
1 F C2 + EDGE-CHECK SWAP ;

: PRINT-IT ( c --- )
( shape determined by c is printed on screen at )
( position in X,Y )
DUP X 2 1+ Y 2 1+ SCREEN C2 =
IF ( display is already showing this shape so don't bother )
DROP
ELSE
DUP X 2 1+ Y 2 1+ SCREEN C! ( remember what screen has )
0 HCOLOUR ( colour black )
X 2 20 * 27 + Y 2 1+ 11 * HPOSN
0 SKETCH ( blank out char. there )
7 HCOLOUR ( colour white )
X 2 20 * 27 + Y 2 1+ 11 * HPOSN
CASE ( draw shape )
2 ( a star ) OF 3 SKETCH ( draw star ) ENDOF
4 ( empty planet ) OF 2 SKETCH ( a planet ) ENDOF
5 ( enemy planet ) OF 2 SKETCH ( a planet ) ENDOF
132 ( players planet ) OF 1 SKETCH ( a colony ) ENDOF
16 ( players fleet ) OF 4 SKETCH ( players fleet ) ENDOF
17 ( enemy fleet ) OF 5 SKETCH ( enemy fleet ) ENDOF
ENDCASE
ENDIF ;

: DRAW-SCAN ( draw the screen display )
1 F C2 5 - 2 F C2 5 -
11 0 DO
11 0 DO
OVER EDGE-CHECK OVER EDGE-CHECK
J Y ! I X ! GALAXY C2
PRINT-IT 1+
LOOP
11 - SWAP 1+ SWAP
LOOP
DROP DROP ;

: DRAW-FIGURES ( draw the totals in the display )
2 10 UHTAB PLANETS 2 5 .R
20 33 UHTAB PLANETS 2 C-PLANETS 2 - W1 *
1 3 FLEETS 2 2 3 FLEETS 2 + W2 * +
1 5 FLEETS 2 2 5 FLEETS 2 + W2 * +
TROOPS 2 W3 * - 6 .R
6 8 UHTAB C-FLEETS 2 5 .R
6 29 UHTAB C-PLANETS 2 5 .R
20 2 UHTAB 2 F C2 2 .R
20 9 UHTAB 1 F C2 2 .R
21 15 UHTAB 3 F 2 4 .R
22 10 UHTAB 5 F 2 6 .R
22 31 UHTAB CREDIT 2 6 .R ;

: DRAW-DISPLAY
1 SCALE H1 DRAW-SCAN DRAW-FIGURES ;

: NEW-FLEET ( fleet destroyed for some reason )
0 1 F C2 2 F C2 GALAXY C! ( remove fleet symbol )
0 3 F ! ( no ships left )
0 5 F ! ; ( no legions left )

: MOVE-FLEET ( X Y --- )
2DUP
0 1 F C2 2 F C2 GALAXY C! ( remove old symbol )
16 ROT ROT GALAXY C! ( position fleet )
2 F C! 1 F C! ; ( update fleet array )

: CHECK-POSITION ( X Y --- )
( check if move to position X Y is possible )
( and take appropriate action )
EDGE-CHECK SWAP EDGE-CHECK SWAP 2DUP GALAXY C2
CASE
0 ( space ) OF MOVE-FLEET ENDOF
8 ( black hole ) OF 23 0 UHTAB ." FLEET IN BLACK HOLE"
MOVE-FLEET DELAY NEW-FLEET
23 0 UHTAB 35 SPACES ENDOF

```

Listing 1 continued on page 134

Keep Your Computer Healthy...

with the Industry Standard in System Maintenance Programs.



Diagnostics II

Diagnostics II is the finest set of system maintenance routines available for microcomputers. It thoroughly checks all five areas of your computer system, pinpointing hardware problems to help keep your computer in perfect working order. The areas of your computer which are tested include: Memory, Printer, Terminal, Disk, and CPU.

In addition to being extremely thorough, every test in Diagnostics II is also "submit"-able. The output of the tests can be logged to disk for later review.

(Requires 32k CP/M)
Diagnostics II: \$125
Manual only: \$ 15

Disk Doctor

Disk Doctor automatically recovers otherwise unrecoverable information from "crashed" diskettes. It also un-erases files.

Maybe it was a lightning storm, static from the rug, or just too late at night to be working. Whatever the cause, when the diskette "crashes" or a file is accidentally erased, valuable data or programs can be permanently lost.

Disk Doctor was designed to recover this "lost" information. It consists of five wards, each performing a specific recovery operation.

- Ward A: Verifies diskettes and locks out bad sectors.
- Ward B: Places copyable information from "crashed" file in a good file.
- Ward C: Copies diskettes without stopping for bad sectors.
- Ward D: Un-erases files.
- Ward E: Displays a directory of recoverable erased files.

Disk Doctor was not designed for use with double-sided hard disks.

(Requires: 48k CP/M, two drives for complete operation)

Disk Doctor: \$100
Manual only: \$ 15

Available from fine dealers everywhere, or directly from SuperSoft.

Japanese Distribution:
ASR Corporation International
3-23-8, Nishi-Shimbashi, Minato-Ku
Tokyo 105, Japan
Tel. (03) 437-5371, Telex 0242-2723

Diagnostics II available for virtually all CP/M, CP/M-86, and MS DOS compatible systems.

Disk Doctor available for virtually all CP/M, and CP/M-86 compatible systems.

CP/M and CP/M-86 are registered trademarks of Digital Research.

SuperSoft®

FIRST IN SOFTWARE TECHNOLOGY P.O. Box 1628 Champaign, IL 61820 (217) 359-2112 Telex 270365

BYTE GAME CONTEST

Listing 1 continued:

```

DROP DROP
ENDCASE
DRAW-DISPLAY ;
: OTHER-FLEET ( make other fleet current fleet)
FLEET-FLAG @ 1 =
IF 2 FLEET-FLAG !
ELSE 1 FLEET-FLAG !
ENDIF
DRAW-DISPLAY ;
: MOVE-LEFT
1 F C@ 2 F C@ 1 - CHECK-POSITION ;
: MOVE-RIGHT
1 F C@ 2 F C@ 1+ CHECK-POSITION ;
: MOVE-DOWN
1 F C@ 1+ 2 F C@ CHECK-POSITION ;
: MOVE-UP
1 F C@ 1 - 2 F C@ CHECK-POSITION ;
: ENLIST ( enlisting legions on a planet)
BUY-U @ @ =
IF ( it's ok to buy)
.5 BUY-U ! ( can't buy for 5 more moves)
( calculate cost of legions)
RANDOM1 8 / XY@ INFO1 C@ 7 / + DUP TEMPI !
10 0 UHTAB ." COST PER LEGION = " 3 .R
( calculate no. of legions available)
XY@ INFO1 C@ 6 / DUP LEG !
12 0 UHTAB ." NO OF LEGIONS AVAILABLE = " 3 .R
( take the order)
14 0 UHTAB ." HOW MANY DO YOU REQUIRE?" INPUT
LEG @ MIN DUP TEMPI @ * CREDIT @
IF ( not enough money)
16 0 UHTAB ." NOT ENOUGH CREDIT"
ELSE
5 F @ OVER + 5 F ! ( update legions)
TEMPI @ * CREDIT @ SWAP - CREDIT ! ( update credit)
ENDIF
ELSE
10 0 UHTAB ." NO TROOPS AVAILABLE"
ENDIF ;
: BUY ( purchasing of ships at planet)
BUY-U @ @ =
IF ( it's ok to buy)
5 BUY-U ! ( stop continous buying)
RANDOM1 5 / XY@ INFO1 C@ 10 / + 1+ DUP TEMPI !
10 0 UHTAB ." COST PER SHIP = " 2 .R
12 0 UHTAB ." HOW MANY DO YOU WANT?" INPUT
CREDIT @ TEMPI @ / MIN ( no more than he can afford)
DUP 3 F @ + 3 F ! ( update ships in fleet)
TEMPI @ * CREDIT @ SWAP - CREDIT ! ( update credit)
16 1 F C@ 2 F C@ GALAXY C! ( make sure fleet symbol there)
ELSE
10 0 UHTAB ." NO SHIPS AVAILABLE"
ENDIF ;
: GATHER ( pick up legions from garrison onto fleet)
10 0 UHTAB ." HOW MANY DO YOU WISH TO TAKE?" INPUT
XY@ INFO2 C@ MIN TEMPI ! ( no more than are there)
5 F @ TEMPI @ + 5 F ! ( update legions on fleet)
XY@ INFO2 C@ TEMPI @ - XY@ INFO2 C! ; ( update on planet)
: LEAVE ( leave legions from fleet on planet as garrison)
10 0 UHTAB ." HOW MANY DO YOU WISH TO LEAVE?" INPUT
5 F @ MIN TEMPI ! ( no more than you have)
5 F @ TEMPI @ - 5 F ! ( update legions on fleet)
XY@ INFO2 C@ TEMPI @ + 255 MIN ( no more than 255)
XY@ INFO2 C! ; ( update on planet)
: FRIENDLY-PLANET ( options upon landing at colony)
BEGIN
10 0 UHTAB ." CLASS " XY@ INFO1 C@ 8 / 2 .R
." PLANET" 16 SPACES CR ( give class of planet)
." LOCAL GARRISON IS " XY@ INFO2 C@ 3 .R ." LEGIONS"
( give size of local garrison)
12 0 UHTAB ." DO YOU WISH TO: " 12 SPACES ( give options)
CR ." 1. LEAVE LEGIONS ON PLANET"
CR ." 2. GATHER LEGIONS FROM PLANET"
CR ." 3. BUY SHIPS"
CR ." 4. ENLIST TROOPS"
CR ." 5. LEAVE" CR
KEY 127 AND
CLEAR-MSGE ( get repl)
CASE
49 ( 1) OF LEAVE @ ( leave legions) ENDDF
50 ( 2) OF GATHER @ ( gather legions) ENDDF
51 ( 3) OF BUY @ ( buy ships) ENDDF
52 ( 4) OF ENLIST @ ( enlist troops) ENDDF
1 ( the default: leave planet)
ENDCASE DELAY
UNTIL
HI CLEAR-MSGE DRAW-DISPLAY ;
: COLONISE ( attack an uncolonised planet)
CLEAR-MSGE
XY@ INFO1 C@ 8 / RANDOM1 1 - 5 / 7 + * 10 / DUP TEMPI !
( calculate relative strength of planet)
5 F @
IF ( planet drives off your forces)
10 0 UHTAB ." YOUR FORCES RETREAT"
12 0 UHTAB ." YOUR LOSSES = "
5 F @ 2 / DUP 3 .R 5 F @ SWAP - 5 F !
DELAY DELAY
ELSE ( you capture planet)
10 0 UHTAB ." PLANET CAPTURED"
12 0 UHTAB ." YOUR LOSSES = "
TEMPI @ 3 .R
5 F @ TEMPI @ - 5 F ! ( update legions in fleet)
1 PLANETS +! ( increment no. of planets)
132 XY@ GALAXY C! ( colony symbol in galaxy)
DELAY DELAY
FRIENDLY-PLANET
ENDIF ;
: EMPTY-PLANET ( in orbit round uncolonised planet)
CLEAR-MSGE
10 0 UHTAB ." UNCOLONISED CLASS " XY@ INFO1 C@ 8 / 2 .R
." PLANET"
12 0 UHTAB ." DO YOU WISH TO ATTACK?" KEY 127 AND 89 =
IF
COLONISE
ENDIF
HI CLEAR-MSGE ;
: NOT-PLANET ( there isn't a planet where he's trying to land)
10 0 UHTAB ." NO PLANET THERE"
DELAY HI CLEAR-MSGE ;
: ATTACK ( attack a planet controlled by the computer)
CLEAR-MSGE
XY@ INFO2 C@ RANDOM1 1 - 5 / 7 + * 10 / DUP TEMPI !
( calculate enemy garrisons effective strength)
5 F @
IF ( enemy garrison wins)
10 0 UHTAB ." YOUR FORCES RETREAT"
12 0 UHTAB ." YOUR LOSSES = "
XY@ INFO2 C@ 5 F @ * TEMPI @ / 2 / XY@ INFO2 C@ SWAP
- XY@ INFO2 C!
5 F @ 2 / DUP 3 .R 5 F @ SWAP - 5 F !
ELSE
0 XY@ INFO2 C! ( reduce legions on planet to 0)
10 0 UHTAB ." PLANET CAPTURED"
12 0 UHTAB ." YOUR LOSSES = "
TEMPI @ 3 .R
5 F @ TEMPI @ - 5 F ! ( update legions with fleet)
132 XY@ GALAXY C! ( put colony in galaxy)
1 PLANETS +! ( increment planets)
-1 C-PLANETS +! ( decrement computer planets)
XY@ INFO1 C@ 8 / MINUS CLASS-TOTALS +!
DELAY ( reduce classes of comp. pints)
FRIENDLY-PLANET
ENDIF
DELAY HI CLEAR-MSGE ;
: ENEMY-PLANET ( player orbits enemy planet)
XY@ INFO1 C@ 8 /
10 0 UHTAB ." CLASS " 2 .R ." PLANET" CR CR
." ENEMY GARRISON OF STRENGTH "
XY@ INFO2 C@ 3 .R CR CR
." DO YOU WISH TO ATTACK?" KEY 127 AND 89 =
IF
ATTACK
ENDIF
HI CLEAR-MSGE ;
: LAND ( land on adjacent planet)
FIND-DIRECTION
2DUP Y ! X ! TEXT GALAXY C@
CASE
4 ( uncolonised planet) OF EMPTY-PLANET ENDDF
5 ( computers planet) OF ENEMY-PLANET ENDDF
132 ( players colony) OF FRIENDLY-PLANET ENDDF
NOT-PLANET ( otherwise it's not a planet)
ENDCASE ;
: REVOLT? ( planet at X,Y revolts)
12 0 UHTAB ." PLANET AT " Y @ . X @ ." REVOLTS" DELAY
XY@ INFO1 C@ 8 / XY@ INFO2 C@ 2DUP )
IF ( revolt succeeds)
DROP 4 XY@ GALAXY C! ( place planet symbol)
8 * 7 + XY@ INFO1 C! ( set revolt factor 7)
0 XY@ INFO2 C! ( set legions to 0)
-1 PLANETS +! ( reduce no. of planets)
7 EMIT ( ring bell)
14 0 UHTAB ." SUCCEEDS"
ELSE ( revolt fails)
SWAP 2 / - XY@ INFO2 C! ( reduce legions)
XY@ INFO1 C@ 7 OR XY@ INFO1 C! ( set revolt factor 7)
14 0 UHTAB ." FAILS"
ENDIF
DELAY
12 0 UHTAB 30 SPACES
14 0 UHTAB 12 SPACES ; ( clear messages)

```

Listing 1 continued on page 136

Developing Quality Software for Microcomputers



FORTRAN IV

SuperSoft makes full WATFIV FORTRAN IV available for microcomputers. SuperSoft/SSS FORTRAN meets and exceeds the ANSI 1966 standard. The compiler supports many advanced features including variable length character strings and recursive subroutines with static variables and complex variable types. Fully compatible RATFOR is also available.

Features:

Code generation:	"COM" FILES. External routines may be called. Relocatable format.
Data types:	Byte, integer, real, double precision, complex, logical, character and varying length strings.
Operations:	All standard operations plus string comparisons, assignments, and .XOR.
Constants:	Hexadecimal, decimal, and character literals with features to imbed control characters.
Statements:	ANSI 1966 standard with multiple statement lines.
Controls:	Map, List, and Symbol table output options.
I/O:	Read, Write, Append, Rewind, Close, Delete, Rename, Search, Sequential and Random I/O on disk files. Supports all CP/M devices.

For virtually all CP/M (Z-80 only), CP/M-86, and MS DOS compatible systems. This includes the IBM PC. Available from fine dealers everywhere, or directly from SuperSoft.

FORTAN (Z80):	\$375.00
FORTAN (8086):	\$425.00
RATFOR:	\$100.00
FORTAN Manual Only:	\$ 25.00

CORRECTOR

The Spelling Corrector That's Three Ways Better Than The Rest!

Corrector is the best spelling correction system available.

- It is the most powerful
- It has the most complete dictionaries
- It is the easiest to use

Most Powerful

Corrector doesn't just proofread text—it analyzes misspelled words, suggests correct spellings, produces correct spellings directly in the text, and automatically corrects misspellings each time they appear.

Also, Corrector allows full dictionary manipulation: creating, renaming, merging, transferring to other disks, printing out entries, deleting words, or eliminating a dictionary.

Most Complete Dictionaries

Corrector comes complete with its own 20,000 word dictionary. You can create dictionaries or expand current ones. Corrector allows up to nine separate dictionaries.

The entries in Corrector's dictionaries are compacted to give you the greatest number of entries and to increase the speed of operation. Corrector is VERY FAST.

Easiest To Use

Corrector takes less than ten minutes to learn. All commands are listed in rows. To invoke a command you simply type an "X". A complete HELP file is included which explains all commands.

Corrector works with virtually all CP/M editors and word processors using ASCII files. This includes Star-Ed, Word-Star, Magic Wand, Ed, and most others.

Requirements: Z-80 only, CP/M, 48k (more recommended)
 Corrector \$250.00
 Manual Only \$ 15.00

Japanese Distribution:
 ASR Corporation International
 3-23-8 Nishi-Shimbashi, Minato-Ku,
 Tokyo 105, Japan
 Tel. (03)437-5371
 Telex 0242-2723.

CP/M is a registered trademark of Digital Research.
 SSS-FORTAN is the copyright of Small-Systems Services.

SuperSoft®

FIRST IN SOFTWARE TECHNOLOGY P.O. Box 1628 Champaign, IL 61820 (217) 359-2112 Telex 270365

BYTE GAME CONTEST

Listing 1 continued:

```

: TAX      ( collect taxes on players planets)
0 UTAX !      ( set tax to 0)
TEXT          ( select text page)
10 0 VHTAB ." TAX COLLECTED ="
10 17 VHTAB 0 .
SIZE 1+ 1 DO
  SIZE 1+ 1 DO
    I J GALAXY C@ 132 =
    IF ( it's a colony)
      I J INFO1 C@ 3 * 5 / ( tax from planet)
      UTAX @ + DUP UTAX ! ( update tax)
      10 17 VHTAB 5 .R
      I J INFO1 C@ 7 AND -DUP
      IF ( doesn't revolt)
        I J INFO1 DUP C@ 1 - SWAP C!
      ELSE ( revolt)
        I X ! J Y ! REVOLT?
      ENDIF
    ENDIF
  LOOP
LOOP
CREDIT @ UTAX @ + CREDIT !      ( update credit)
HI CLEAR-MSGE DRAW-DISPLAY !
: COMPUTER-TURN ( computers turn to do something)
-1 NEW +!      ( decrement NEW)
NEW @ 0=
IF ( computer creates new fleet)
  7 EMIT      ( ring bell)
  1 C-FLEETS +!      ( update comp. fleets)
  29 4 DIFF @ * - NEW !      ( reset NEW)
  CLASS-TOTALS @ 8 / DUP C-LEGIONS +!
  DUP TROOPS +!
  BEGIN
  ,RANDOM1 RANDOM2 2DUP GALAXY C@ 0=
  IF ( empty space in galaxy)
    2DUP 17 ROT ROT GALAXY C! ( place fleet symbol)
    INFO2 C! 1      ( plus legions)
  ELSE
    DROP DROP DROP 0
  ENDIF
  UNTIL
ENDIF
DIFF @ 0 DO ( see if computer colonises planet)

RANDOM1 RANDOM2 2DUP GALAXY C@
CASE
4 OF ( empty planet)
  2DUP 2DUP 5 ROT ROT GALAXY C! ( place colony)
  C-LEGIONS @ 2 / DUP C-LEGIONS !
  ROT ROT INFO2 C!
  1 C-PLANETS +!
  INFO1 C@ 8 / CLASS-TOTALS +! ENDOF
132 OF ( players planet)
  2DUP Y ! X ! INFO2 C@ C-LEGIONS @ 2 / <
  IF ( captures planet)
    C-LEGIONS @ 3 / C-LEGIONS !
    5 XY@ GALAXY C!
    XY@ INFO1 C@ 8 / CLASS-TOTALS +!
    1 C-PLANETS +!
    -1 PLANETS +!
    5 0 DO 7 EMIT LOOP ENDIF ENDOF
  DROP DROP
ENDCASE
LOOP
DRAW-FIGURES ;

: FIRE ( players fleet attacks computer fleet)
0 X !
TEXT
2 F C@ 2 + DUP 3 - DO
  1 F C@ 2 + DUP 3 - DO
  1 EDGE-CHECK J EDGE-CHECK GALAXY C@ 17 =
  IF ( there's a fleet in range)
    1 EDGE-CHECK X ! J EDGE-CHECK Y !
  ENDIF
  LOOP
  LOOP
  X @ 0=
  IF
    10 0 VHTAB ." NO ENEMY FLEET IN RANGE"
  ELSE
    3 F @ XY@ INFO2 C@ OVER 4 * 10 /
    OVER 4 * 10 / DUP
    10 0 VHTAB ." FLEET HIT BY * 5 .R ." UNITS"
    ROT ROT - 0 MAX DUP 0=
    IF ( computers fleet destroyed)
      DROP TROOPS @ XY@ INFO2 C@ - TROOPS !
      ( reduce computers troops)
    ENDIF
  ENDIF

```

Listing 1 continued on page 138

"The Perfect Pair"

A DYNAMITE PAIR: ARBA and Accounting Plus*. Topnotch twins for real time Inventory control. The great ARBA Register and the dynamic ARBA Point of Sale software in tandem with Accounting Plus** Inventory Control Software.

ARBA Register. The affordable, dependable RS232 cash register. Designed to interface with virtually ANY computer on the market.

The ARBA Point of Sale module. Interfaces to Accounting Plus* Inventory Control with up to 65,000 items. Does real time price look up, updates Accounting Plus* Inventory transaction files, allows 99 departments. Generates daily reports, processes goods received, prints price labels. Accounting Plus* Inventory Control integrates with G/L, Payables, Receivables, Payroll, Purchase Order Entry. Under CP/M** or MP/M**.

*TM Software Dimensions, Inc. **TM Digital Research, Inc.

ARBA Register and Accounting Plus*.



ARBA Register—\$1295.00—Suggested Retail



ARBA

ARBA Fine Business Computing Corporation
890 E. Roosevelt Road
Lombard, Illinois 60148
(312) 620-8566

Dealer inquiries welcome
Circle 40 on inquiry card.

Now! A 60 MHz Tektronix scope built for your bench.

Wide-range vertical sensitivity:
Scale factors from 100 V/div (10X probe) to 2 mV/div (1X probe). Accurate to $\pm 3\%$. Ac or dc coupling.

Two high-sensitivity channels: dc to 60 MHz bandwidth from 10 V/div to 20 mV/div; extended sensitivity of 2 mV/div at > 50 MHz.

Sweep speeds: from 0.5 s to 50 ns. To 5 ns/div with X10 magnification.

Delayed sweep measurements: Accurate to $\pm 3\%$ with single time-base 2213; to $\pm 1.5\%$ with dual time-base 2215.

Complete trigger system. Includes TV field, normal, vertical mode, and automatic; internal, external and line sources; variable holdoff.

Probes included. High-performance, positive attachment 10-14 pF and 60 MHz at the probe tip.

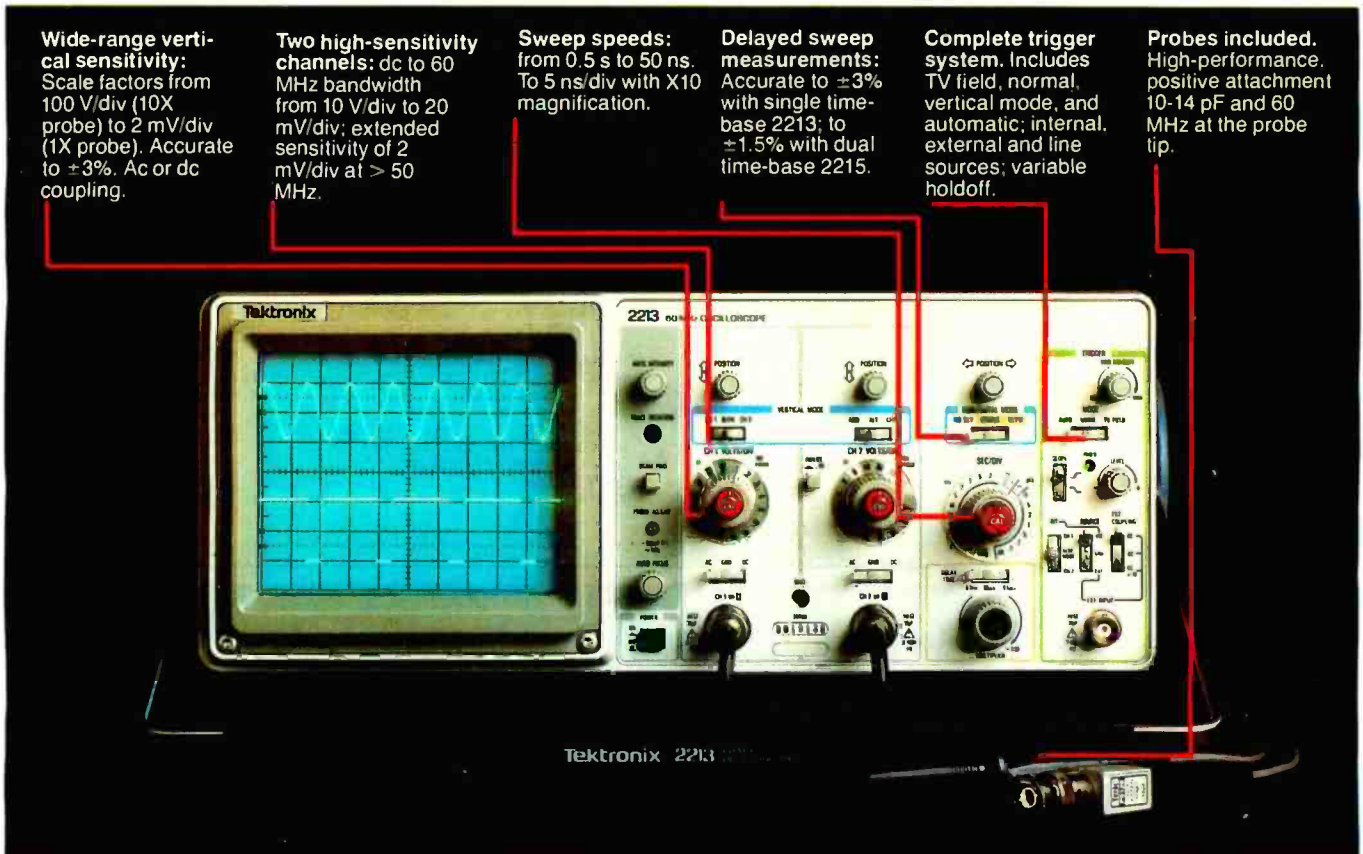

In 30 years of Tektronix oscilloscope leadership, no other scopes have recorded the immediate popular appeal of the Tek 2200 Series. The Tek 2213 and 2215 are unapproachable for the performance and reliability they offer at a surprisingly affordable price.

There's no compromise with Tektronix quality: The low cost is the result of a new design concept that cut mechanical parts by 65%. Cut cabling by 90%. Virtually eliminated board electrical connectors. And obviated the usual cooling fan.

Yet performance is written all over the front panels. There's the bandwidth for digital and analog circuits. The sensitivity for low signal measurements. The sweep speeds for fast logic families. And delayed sweep for fast, accurate timing measurements.

The cost: \$1200* for the 2213. \$1450* for the dual time base 2215. You can order, or obtain more information, through the Tektronix National Marketing Center, where technical personnel can answer your questions and expedite delivery. Your direct order includes

probes, operating manuals, 15-day return policy and full Tektronix warranty.

For quantity purchases, please contact your local Tektronix sales representative.

**ORDER TOLL FREE
1-800-426-2200**

Extension 04
in Oregon call collect:
(503) 627-9000

*Price F.O.B. Beaverton, OR. Price subject to change.

BYTE GAME CONTEST

Listing 1 continued:

```

0 XY@ GALAXY C!      ( destroy fleet symbol)
-1 C-FLEETS +!      ( reduce comps fleets)
ELSE
XY@ INFO2 C@ OVER - TROOPS @ SWAP - TROOPS !
( reduce spare troops)
XY@ INFO2 C!      ( reduce legions in fleet)
ENDIF
- @ MAX DUP @=
IF ( players fleet destroyed)
DROP NEW-FLEET
ELSE
3 F !
ENDIF
ENDIF
DELAY DELAY DRAW-DISPLAY H! CLEAR-MSGE ;

: INFORMATION ( display the text screen information)
TEXT KEY H! ;

HEX

: OBEY-COMMAND
BUY-V @ -DUP
IF
1 - BUY-V !
ENDIF
C@01 C@      ( pick up keyboard character)
CASE
( A) 41 OF MOVE-LEFT  ENDOF
( S) 53 OF MOVE-RIGHT ENDOF
( W) 57 OF MOVE-UP    ENDOF
( Z) 5A OF MOVE-DOWN  ENDOF
( O) 4F OF OTHER-FLEET ENDOF
( I) 49 OF INFORMATION ENDOF
( L) 4C OF LAND       ENDOF
( T) 54 OF TAX        ENDOF
( F) 46 OF FIRE       ENDOF
ENDCASE SP! ;

: COMPUTER? ( is it the computers turn or not)
COMPUTER @ 1 - DUP @=
IF
COMP-START @ COMPUTER ! DROP !
ELSE
COMPUTER ! @
ENDIF ;

: GAME-END?
LEN @ 0= ; ( game end if LEN is zero)

: RESTART ( restarts the stopped game)
CLEAR-DISP
HOME DRAW-BORDERS DRAW-DISPLAY
BEGIN
?TERMINAL
IF ( player has pressed a key)
OBEY-COMMAND
-1 LEN +!
COMPUTER-TURN
ENDIF
COMPUTER?
IF
COMPUTER-TURN
ENDIF
GAME-END?
UNTIL
END-MSGE ;

: CONQUEST ( the main game word)
HOME ." HIT ANY KEY" KEY RAND1 ! CR ( random number seed)
." AND AGAIN " KEY RAND2 ! ( random number seed)
HOME CR CR CR
." WELCOME TO COSMIC CONQUEST" CR CR
." DEvised AND WRITTEn BY" CR CR
." ALAN SARTORI-ANGUS"
INITIALISE
RESTART ;

```



*Step Up The Pace...
Higher Technology at Lower Cost.*

- Bell 212 compatible—1200 Baud
- Full duplex
- 120 CPS over any standard phone line

Microprocessor design has invaded the modem world. Our new 1200 baud modems pack Bell 212 compatibility into 10 integrated circuits—by far the lowest parts count of any 212 modem available. The extremely low parts count translates directly into long life, outstanding reliability and low production costs—savings passed on to you in a lower price.

The Micro Link 1200 features originate and answer capability. The Auto Link 1200 includes these features plus auto-answer. Both units are FCC certified for direct connection to the phone lines via a standard RJ11C phone jack and include RS232, Self-Test, and a one year limited warranty.

Take advantage of higher technology at lower cost. Call for full product specifications and pricing today.

Micro Link 1200 \$449* Auto Link 1200 \$499*

*Suggested list price, quantity one



U.S. ROBOTICS INC.

1035 WEST LAKE STREET, CHICAGO, ILLINOIS 60607
1(312) 733-0497

Circle 475 on Inquiry card.

There is a word that describes your choices in flexible disks today. That word is "ordinary." The woods seem to be full of offerings of middling quality, neither good nor bad, not necessarily cheap but not overly expensive for the most part, products that are just so-so, just average, just...well, just ordinary.

But now there's a new word in flexible disks. Ultra Magnetics. A word that redefines the state-of-the-art in flexible disk price performance rather than reinforcing the current state-of-the-marketplace. By itself, *Ultra* means "extra ordinary." And by itself is where you'll place the Ultra Magnetics product when you have a chance to compare it to others.

The superb engineering and meticulous manufacturing of each Ultra Magnetics disk clearly shows. A proprietary jacket provides more consistent jacket dimensions and lower torque that result in better auto-loading and longer life. A special lubricant built into each disk surface enhances both disk and head durability. And

100% surface testing of each and every Ultra Magnetics disk ensures the highest data reliability. Our Ultra Magnetics product line currently includes single- and double-sided 5.25-inch disks. Soon, it will feature 8-inch disks as well. For a fact, they are more expensive than some of the garden variety alternatives. But considering the performance and the reliability, Ultra Magnetics is a surprisingly attractive value.

Here's the bottom line. You no longer have to put up with what you may have sadly come to expect from flexible disks. And we encourage you to take the next logical step from the usual to the remarkable—from the ordinary to the extraordinary. Call your local supplies distributor and ask for Ultra Magnetics.



Ultra Magnetics Technology, Inc.
7 Hangar Way
Watsonville, CA 95076
(408) 728-7777

EXTRA ORDINARY



What if
“what if”
isn't
enough?



Just when the business world is up to its white collars in visiclones, calcalikes and other spreadsheet packages, Apple's* come out with something entirely different.

Introducing Senior Analyst.

Like other financial modeling packages, it allows managers and professionals to ask all those proverbial "What If?" questions.

Unlike the others, this powerful financial planning tool was designed to be used in a corporate environment, by lots of people. So you get lots of advantages.

For example, you can transfer data (across diskettes) from one financial model to another. Or consolidate many models into one.

So sales, manufacturing, administration and any number of other departments (even in other cities) can easily share information. Giving each the power to create comprehensive and



Senior Analyst lets different departments share and consolidate data. That way the company doesn't make more pitchforks than it can sell.

Analyst, you can do it. And even print out a formatted report that includes only the information you need.

A report that anyone can understand. Because the headings are in English, not in code.

even allows you to continue working while a model is being printed.)

To complement all these accommodating features, you'll also find built-in functions for depreciation, linear regression forecasting, and other powerful virtues not found in most financial software packages.

All of which we'd like you to experience in person, at any of our 1300 authorized full-support dealers (they also offer a vast library of other quality software distributed by Apple for Apples).

And don't ask for just any spreadsheet package. Tell them you need to see an analyst.



With Senior Analyst, you can now cultivate forecasts by merging reports from distant divisions.



Easy to follow commands allow employees to create models without learning a second language.

flexible financial projections, budgets, cash flow statements and the like.

Want to combine selected data (such as important subtotals) from six different divisions? With Senior

You can also document and print out all those assumptions used to create your model, to give others a concrete understanding of how you reached your conclusion. (The program



The most personal software.

Call (800) 538-9696 for the location of the authorized Apple dealer nearest you, or for information regarding corporate purchases through our National Account Program. In California (800) 662-9238. Or write Apple Computer Inc., Advertising and Promotion Dept., 20525 Mariani Ave., Cupertino, CA 95014. © 1982 Apple Computer Inc.

Circle 36 on inquiry card.

Ricochet

Gregg Williams
Senior Editor

Given the unique resources of microcomputers, you'd think someone would come up with an entirely new approach to game playing. Unfortunately, design innovations in video games are all too rare; we see new maze games, new shoot-'em-up games, and new adventure games, but seldom anything that stretches the imagination. There's a reason for this: adapting an existing, commercially proven idea and then programming for six months is much easier than agonizing over a new concept, programming for six months, and hoping for the best. Fortunately, a few brave souls thrive on the challenge of charting new territory. Thanks to two of them, we have a game called Ricochet.

I cannot find enough good things to say about Ricochet. It's easily the most original game I've seen this year, it's fun to play, and on top of that it's very modestly priced (under \$20, often discounted to about \$16). Available for three of the most popular microcomputers—the Apple II, the Atari 400/800, and Radio Shack TRS-80 Models I and III—the game has graphics, sound, and (on the Apple and Atari versions) color. You can choose from five game variations and play against a human or one of four computer opponents. And one of Ricochet's most interesting features is that it dynamically handicaps the more skillful of the two players to keep the game challenging even with players of widely varying skills. What more could you possibly want?

Before you rush out to buy Ricochet, you should know that it's not likely to be the favorite of the arcade set. Although it has arcade-like elements in it, Ricochet is primarily a game of strategy. Let's take a look at it.

Playing Ricochet

The Atari game board for Ricochet is shown in photo 1; the Apple and TRS-80 versions look somewhat different but play almost the same. The two players, Left and Right, start the game with two bumpers (the hourglass-shaped pieces at the left and right edges of the

screen) and two launchers each (one in each corner of the screen). The launcher can fire a launch (ball) that ricochets off the pieces (straight bars) and both players' bumpers; a launch is complete when it veers off the screen or hits any launcher. Pieces deflect the launch by 90 degrees, then immediately turn 90 degrees themselves. A move consists of firing a launcher or moving one or more pieces in the same direction (up, down, right, or left). You gain points for hitting any pieces or your opponent's launchers or bumpers; you lose points for hitting your own launchers or bumpers.

Although there are a few more rules I'll explain later, the paragraph above covers the behavior of most of the game. But no amount of rules can possibly convey how

Photo 1: Ricochet in progress. Photos 1a through 1c show the state of the board before, during, and after activation of the launcher in the lower left-hand corner. See the article for further details.

1a



much fun Ricochet is to play. The word that best describes my reaction to it is "delight." Rarely have I played a game that pleased me as much as Ricochet. No matter how good you are at visualizing what certain launches will do, some of them may remain in play much longer than you expect or hit an unexpected target. But even when the surprise costs you points, it's so much fun that you don't really mind.

Photos 1a through 1c show a simple example of a Ricochet launch in action. At the beginning of the move, the board is as shown in photo 1a. Left shoots his lower launcher; the launch bounces off pieces C and E (increasing Left's score by two points), hits the top wall of the game field, and ricochets into Right's top bumper. Photo

No matter how good you are at visualizing what certain launches will do, some of them may remain in play much longer than you expect.

1b shows the game board just as the launch hits the top right bumper; notice that pieces C and E have rotated 90 degrees. Left then scores 10 points for hitting the bumper, and the launch hits pieces H and J (which rotate and contribute two more points) before exiting off the right edge of the screen. Photo 1c shows the final result. And that's a *simple* shot in Ricochet. I've seen shots that ricochet 25 or even 50 times before ending and have launched shots that accumulate 20 points only to hit my own bumpers and disable the original launcher.

1b



Ricochet in the Long Run

The sequence of Ricochet described above is a match; it ends when one player can no longer shoot or if both launchers are either temporarily disabled or empty. The player with more points wins the match, and in the basic version of the game, play continues until one player wins two matches.

Now comes the fun part: Ricochet has a self-handicapping feature that enables players of different skill levels to compete as equals. The player who loses a match has a bumper removed in the next one; because the winning player has half as many bumpers to score from (one instead of two), winning the next game is harder for him. And if the winning player wins by a substantial margin, the value of his bumpers and launchers increases to a number *above* 10, which makes it easier for the losing player to win the next game. Ricochet also uses a "smart clock" that penalizes a player for playing more slowly than his opponent. These handicaps are all fine-tuned to make the players an equal match for each other even if they start at different skill levels. The more matches they play together, the more players become evenly matched. To carry the handicapping into future games, the computer issues a handicap rating to each player at the end of a game. If these values are typed in at the beginning of the next game, the players start the game more evenly matched.

Ricochet has a total of five variants, all of which are sufficiently different to warrant different strategies. You can play opposite a human opponent—in which case the program acts as a scorekeeper and referee—or against one of four computer "opponents," each of which has a distinct playing style. I found the computer players very difficult to beat, so you don't have to have a human op-

1c



DECADES OF SERVICE

Washington Computer Services

97 Spring St., New York, NY 10012 an affiliate of ((WASHINGTON ELECTRIC COMPANY)) est. 1912

TO ORDER: Call our toll-free number: (800) 221-5416. In N.Y. State and for technical information: (212) 226-2121. Hours: 9 AM-5:30 PM (EST) Monday-Friday **TELEX: 12-5606 CABLE: WASHCOMP NYK**



NEC APC

8086, 16 bit processor; Two 8" DSDD disk drives; 128K RAM (to 256K); 12" screen, green or color; 1024 x 1024 graphics; CP/M-86, MS-DOS; BENCHMARK word proc.; DBASE II data base; CHANG LABS microplan; IBM emulations; ACCOUNTING PLUS.

This new state-of-the-art workstation out-performs all others near its price range.

PRICES START BELOW
\$3300.00

The Professional's Workstation

NEC PC-8000 Personal Computer







On N.Y.S. Contract #P-07220

NEC COMPUTERS AND MONITORS

PLEASE! Do not confuse us with mail order dealers. We are a full service distributor serving the data processing & installation needs of business & industry from micros to mainframes. System houses, educational institutions & governmental agencies given special consideration. Leasing available. N.Y. State agencies, municipalities, and schools—call us for information on our O.G.S. term contracts on hardware & software. Please call to make an appointment for demonstration of this extraordinary computer at our showroom. Prices subject to change without notice; call for latest prices. Prices include 3% cash discount. N.Y. residents add sales tax. Accounting Plus is a trademark of Software Dimensions. CP/M® is a trademark of Digital Research. All sales subject to our standard sale conditions (available on request). Above prices do not include customization or installation.

From Computer Plus to YOU...

PLUS after PLUS after PLUS

 Model 16 128K 1 Drive \$4199 2 Drive \$4799	 Color Computer 16K \$249 w/16K Ext. Basic \$335 w/32K Ext. Basic \$449	 Model III 16K \$799 Model III 48K 2 Disk & RS232 c \$1699
 Okidata 80 \$325 Okidata 82A \$425 Okidata 84 \$1029	 Color Computer Disk Drive Drive 0 \$470 Drive 1 \$315	 Smith Corona Daisy Wheel \$599

BUY DIRECT Here are just a few of our fine offers... call TOLL FREE for full information.

COMPUTERS	MODEMS	DISK DRIVES
Model II 64K 52999	Lynx Direct Connect MII/III 235	R.S. Model III 15T-Drive 679
Model III 4K LEV I 599	Hayes Smart Modem II 235	Tandon 40 Track MI 289
MODEL III 16K 799	R.S. Acoustic Coupler AC-3 134	Color Computer Drive 1 315
MODEL III 32K 856.50	R.S. Modem I D.C. 130	Color Computer Drive 0 470
*MODEL III 32K 831.50	R.S. Modem II D.C. 210	Primary Hard Disk Mill 3999
MODEL III 48K 914	PRINTERS	Primary Hard Disk Mill 1999
*MODEL III 48K 864	Daisy Wheel II 1715	ETC.
Model III 48K 864	DWP-410 1335	CC-B1 recorder 52
2 Disk & RS232 c 1899	Smith Corona TPI Daisy Wheel 599	C. C. Joysticks 22
Color Computer 16K 249	Epson MX80 599	16K RAM N.E.C. 200 N.S. chips 25
Color Computer 16K w/extended basic 335	Epson MX80 FT 549	64K Ram Chips 75
Color Computer 32K w/extended basic 449	Epson MX100 735	Color Computer Flex D.O.S. 99
Color Computer 32K-64K w/extended basic 510	CGP-115 199	Brand Name Software * Send for listing.
Portable Computer 2 230	DMP-100 315	R.S. Software 10% off list
Model 16 1DR 128K 4199	DMP-200 599	<small>*Computer Plus New Equipment, with NEC RAM installed. 180 Day Computer Plus Warranty. 1Color Computer uses requires Disk 0 and Flex D.O.S.</small>
Model 16 2DR 128K 4799	DMP-400 1029	
DI-1 Data Terminal 599	DMP-500 1569	
PI-210 Portable Terminal 779	Microline 80 325	
	Microline 82A 425	
	Microline 83A 679	
	Microline 84 Parallel 1029	
	P. C. Plotter Printer 199	

We have the lowest possible Fully Warranted Prices AND a full complement of Radio Shack Software.

Prices subject to change without notice. Not responsible for typographical errors. TRS-80 is a registered trademark of Tandy Corp.



TOLL FREE 1-800-343-8124

computer plus

P.O. Box 926
480 King Street
Littleton, MA 01460
617-486-3193

Write for your free catalog

BYTE GAME GRID

ponent to enjoy playing Ricochet. The 20 different games (5 variants multiplied by 4 possible computer opponents) available for solitaire play are sufficiently varied to keep you interested in the game.

Versions of Ricochet

Ricochet is available in both cassette and floppy-disk versions for the TRS-80 and Atari and in a floppy-disk version for the Apple II. I played the game on all three computers (disk-based versions for the TRS-80 and Apple II, cassette version for the Atari). The Apple version requires Applesoft BASIC and 48K bytes of memory, the other two disk versions require BASIC and 32K bytes of memory, and the cassette versions require BASIC and 16K bytes of memory. The Atari cassette version loads in two steps to help prevent unauthorized copying and takes an excruciatingly slow 10 minutes to load; prospective cassette-based users are hereby warned.

Although it has very little sound and color, the Apple version has the smoothest graphics. The TRS-80 and Atari versions, on the other hand, use character-sized graphics that don't create an illusion of continuous movement. The Atari version has the best sound and color, but

At a Glance

Name
Ricochet

Type
Strategy game

Manufacturer
Automated Simulations
1043 Kiel Court
Sunnyvale, CA 94086

Price
\$19.95

Authors
Bernie De Koven and Jeff Connelley

Format
Cassette tape or floppy disk

Language
BASIC

Computer Needed
Radio Shack TRS-80 Models I or III with 16K bytes of memory (cassette) or 32K bytes of memory (disk), Apple II with Applesoft or Apple II Plus with 48K bytes of memory (disk), Atari 400 or 800 with BASIC cartridge and 16K bytes of memory (cassette) or 32K bytes of memory (disk)

Documentation
8-page instruction manual and separate loading instructions

Audience
Strategy game enthusiasts, any age

CHART-MASTER™

Business Graphics Software

Professional-Quality Graphics from Personal Computers

CHART-MASTER works with Apple® II, Apple® III and IBM personal computers to create full-color business graphics on Hewlett-Packard plotters, including the new low-cost H-P 7470A.

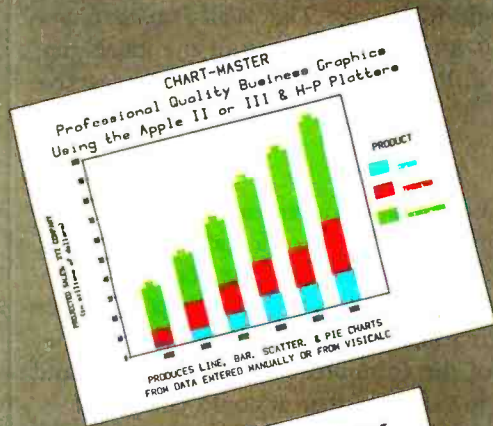

POWERFUL

CHART-MASTER produces bar charts, line charts, scatter diagrams and pie charts, as well as text pages and signs, on paper or acetate (transparencies). Data can be entered manually or automatically from Visicalc® and other programs. Charts can be edited, stored and retrieved.

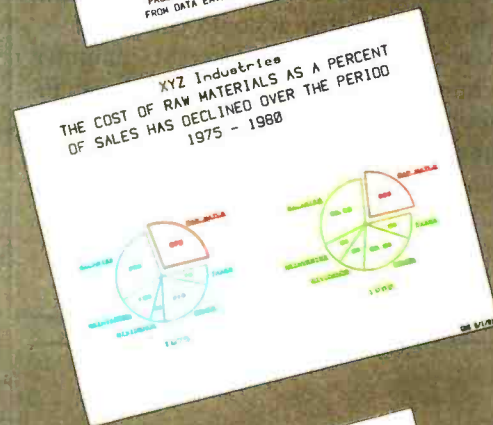

FLEXIBLE

CHART-MASTER allows you to select from a broad range of options to create the chart that best communicates your data. Options include producing up to nine charts per page, footnote and framing capabilities, left and right y-axes, a variety of hatching and line types, exploded pie segments, linear regression and curve-fittings, logarithmic axes and much more.

EASY TO USE

CHART-MASTER is an interactive, menu-driven program that allows users, whether managers or secretaries, to produce presentation-quality charts immediately with little or no training. It is easy for you to enter data, choose options, select a chart format ... and let CHART-MASTER do the rest.

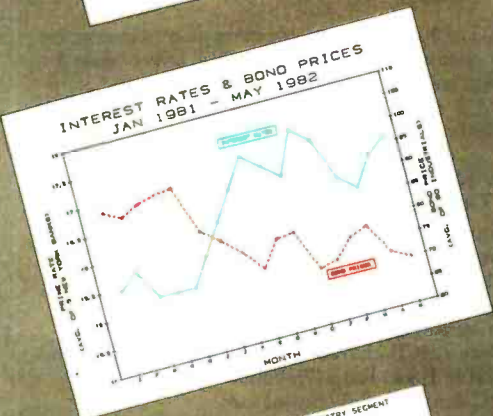
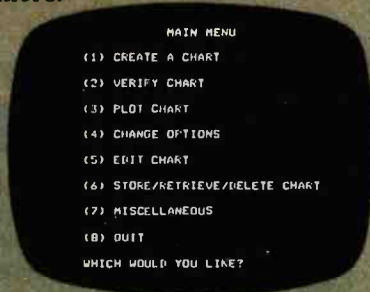

COST-EFFECTIVE QUALITY

To get the same high quality that CHART-MASTER delivers, you would have to use expensive time-sharing services, commissioned graphic artists or costly dedicated graphics systems. Thus, CHART-MASTER, especially when teamed with the new Hewlett-Packard 7470A plotter, represents a price/performance breakthrough. Users of these more costly methods will find that a CHART-MASTER/Hewlett-Packard combination pays for itself in just a few months. And, because CHART-MASTER also offers convenience, speed, user control and versatility, you will find that you will increase your use of business graphics at no marginal cost.

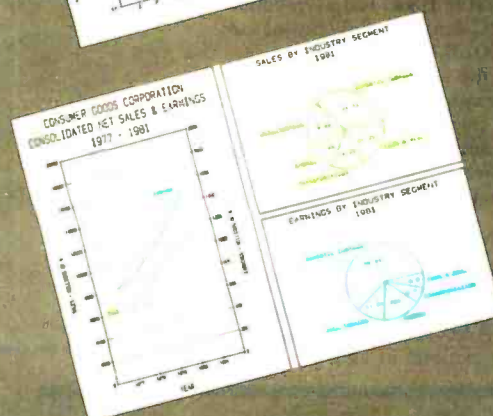

CHART-MASTER is available through your local computer dealer for \$375. A complete graphics plotting package, consisting of CHART-MASTER, H-P 7470A plotter and interface for your Apple or IBM personal computer, costs as little as \$2000. For further information and the name of your nearest dealer, call or write:

Decision Resources Professional software tools

PO Box 309, Westport CT 06880, 203/222-1974

Apple is a trademark of Apple Computer, Inc.
Visicalc is a trademark of Personal Software, Inc.

Circle 174 on Inquiry card.

BYTE GAME GRID

it plays more slowly than the Apple version and, paradoxically, penalizes you more quickly for not moving. (These differences are probably due to the idiosyncrasies of the different versions of BASIC in each machine; Ricochet is written in BASIC.) The TRS-80 version has the coarsest graphics and no color, but it makes some sound available through the cassette port (the sound is available even though the TRS-80 documentation doesn't mention it). Incidentally, the limitations of TRS-80 graphics make the pieces appear shorter when they are vertical than when they are horizontal, which, until you get used to it, may lead you to believe a path is blocked by pieces when it really isn't.

The Philosophy of Ricochet

I can tell from my own experience with game development that Ricochet was well designed and then polished for maximum playability. Such attention to detail is rare; most people release a game as soon as the program is free of programming errors—of course, that accounts for the countless mediocre games that are being sold today. As a result, you enjoy playing Ricochet even if you lose; you leave the game feeling satisfied instead of embittered.

That Ricochet is a game player's delight is really no surprise, because it was designed by Bernie De Koven and Jeff Connelley, both experienced game designers. De Koven's wonderful book, *The Well-Played Game* (Anchor Press, 1978), expresses many of the ideals that are implemented in Ricochet. It's a must for prospective game designers.

Conclusions

Ricochet is not only a fantastic strategy game but a reasonably priced one as well. (Arcade-game enthusiasts, take note: it is neither visually stunning nor the conventional arcade variety.) Automated Simulations should be commended for creating a totally new kind of game that takes advantage of the computer's unique strengths and for selling it at a lower price than it could command.

Ricochet has five variations, four different computer opponents, and a human-versus-human option. It can be played as a casual or a serious game, and in either case it is delightful. Interactive handicapping makes the game a challenge regardless of your relative skill level. If Ricochet is indicative of Automated Simulations' offerings, I eagerly await the company's next release. ■



Unlimited Vocabulary

64 Programmable levels of inflection

Built-in 6K text-to-speech algorithm

INTEX-TALKER brings a new dimension to interactive computer communications with a new high level of speech intelligibility and voice quality. Available as a stand alone peripheral or at the board level. Custom versions for OEM accounts.

At Only \$295.00 INTEX-TALKER Offers These Features:

- Phoneme based speech synthesizer chip
- 64 crystal controlled inflection levels - digitally programmable
- 6K text-to-phoneme algorithm
- 750 character buffer (3,000 character optional)
- Complete ASCII character set recognition and echo
- Adjustable Baud Rate (75-9600)
- RS232C and Parallel connectors
- X-on/X-off handshaking
- Phoneme access modes
- User expandable memory
- Music and sound effects capability (programming language for notes included)
- Onboard amplifier and power supply $\pm 12V$; +5V
- Spelling output mode

Order Now

Call the number below to order or request additional information. Master Charge or Visa accepted. Charge to your credit card or send a check for \$295.00 plus \$4.00 delivery. Add 4% sales tax in Michigan.

Dealer inquiries invited

INTEX™

Intex Micro Systems Corporation
755 West Big Beaver Road - Suite 1717
Troy, Michigan 48084
Telephone: 313/362-4280

Introducing

2,295⁰⁰
5 Megabytes



Simply plugs
into your
I.B.M.

Model
X5P

Talk about user friendly...

GENIE™ X5™

Comprehensive system utilities package. Allows eight-character names to be assigned to virtual volumes. User Can back-up to any Genie REMOVABLE Cartridge Drive, or to diskettes. Mix & Match different system file types on the same disk. System status screen messages. Up to 16 volumes on-line at a time.

5.25" Removable GENIE Winchester Cartridge Drive

IBM • APPLE II PLUS • RADIO SHACK

The Genie X5 is a REVOLUTIONARY new 5 Megabyte REMOVABLE WINCHESTER CARTRIDGE DRIVE. The cartridge Drive system simply plugs into your computer, and includes all necessary software and hardware. Genie drives are compatible with most popular software, and each cartridge replaces over 30 double-density floppy disks.

Removable Cartridge. Imagine, 5 Megabytes in the palm of your hand. These small Winchester cartridges are only .75 inch thick and 5.50 inches square. The disk itself is completely sealed from the outside and all its hazards by a sliding door that opens only once the cartridge is firmly seated inside the drive. Long term availability of this cartridge is assured by its adoption by several well known manufacturers including **Dysan** and **Memorex**, the world leaders in computer mass storage media.



Model X5A
\$2,695⁰⁰

FEATURES

- 5 Megabytes of on-line storage.
- File sizes to 5 Megabytes.
- Power-on self-test.
- No preventative maintenance required.
- Average access time 50 ms.
- Easy back-ups in minutes.
- System expandable to eight drives.
- Built-in error detection and correction.
- Comes complete with all necessary software and hardware.
- MTBF 11,000 hours.
- Built-in fan.
- Operates 110/220 VAC 50-60 Hz.
- One year warranty.

IBM	APPLE II PLUS	AVAIL. SOON
<ul style="list-style-type: none"> • Supports IBM-DOS, CP/M-86, PASCAL, P. SYSTEM, CON-CURRENT CP/M-86 	<ul style="list-style-type: none"> • Supports DOS 3.3, CP/M, and PASCAL 	RADIO SHACK S-100
<ul style="list-style-type: none"> • Ultra High Speed DMA data transfers • Only uses one slot in your IBM-PC • Allows you to run with up to four floppy disk drives 	<ul style="list-style-type: none"> • Boot from Hard Disk • Can assign Hard Disk volume to any slot or drive number in the system 	APPLE III

Available at your local computer dealer

Manufacturer's suggested retail price. Includes all required components. Concurrent CP/M-86 is a registered trade mark of Digital Research. IBM Personal Computer is a registered trademark of IBM Corporation. Apple is a registered trademark of Apple Computer, Inc. Radio Shack is a registered trademark of Tandy Corporation. Dysan is a registered trademark of Dysan Corp.

GENIE COMPUTER CORPORATION

31125 Via Colinas #908 • Westlake Village, CA 91362 • (213) 991-6210

Introducing GENIE™

5-10-15-20

Megabyte 5.25" GENIE Winchester Drives

I.B.M. • APPLE II PLUS • RADIO SHACK

5 MEGABYTES
\$2295⁰⁰

10 MEGABYTES
\$2595⁰⁰

15 MEGABYTES
\$2895⁰⁰

20 MEGABYTES
\$3195⁰⁰



Talk about user friendly...

Comprehensive system utilities package.

Allows eight-character names to be assigned to virtual volumes.

User can back-up to either our 5 + 5™ removable Cartridge Drive or to diskettes. Mix & match different system file types on the same disk. System status screen messages.

Up to 16 volumes on-line at a time.

FEATURES

- Precision Manganese-zinc heads
- Average access time 77 ms.
- File sizes 5-20 megabytes
- Power-on self test
- Built-in error detection and correction
- System expandable to eight drives
- Comes complete with all necessary software and hardware
- No preventative maintenance required
- Built-in fan
- Operates 110/220 VAC 50-60 Hz
- One year warranty

Excellence in Engineering

GENIE Drives were built with the user in mind. A design backed by many years of experience, the GENIE Drive is everything a user ever wanted in a hard disk. We offer the ultimate in hard disk mass storage systems that money can buy.

IBM	APPLE II PLUS	RADIO SHACK
<ul style="list-style-type: none"> • Supports IBM-DOS, CP/M-86, PASCAL • Ultra High Speed DMA data transfers • Only uses one slot in your IBM-PC • Allows you to run with up to four floppy disk drives 	<ul style="list-style-type: none"> • Supports DOS 3.3, CP/M, and PASCAL • Boot from Hard Disk • Can assign Hard Disk volume to any slot or drive number in the system 	<p>available soon</p> <hr/> <p>S-100</p> <hr/> <p>available soon</p>

*Manufacturer's suggested retail price. Includes all required components. IBM DOS Personal Computer is a registered trademark of IBM Corporation. Apple is a registered trademark of Apple Computer, Inc. Radio Shack is a registered trademark of Tandy Corporation. CP/M and CP/M-86 are registered trademarks of Digital Research.

Available at your local computer dealer

GENIE COMPUTER CORPORATION

31125 Via Collinas #908 • Westlake Village, CA 91362 • (213) 991-6210

Circle 210 on inquiry card.

Introducing

GENIE™



5.25" Removable GENIE Winchester Cartridge Drive IBM • APPLE II PLUS • RADIO SHACK • S-100

The **Genie Cartridge Drive** is a revolutionary new 10 Megabyte Hard Disk Drive that includes a 5 Megabyte removable Winchester cartridge. The cartridge Drive system simply plugs into your computer, and includes all necessary software and hardware. Genie Drives are compatible with most popular software, and each cartridge replaces over 30 double-density floppy disks.



FEATURES

- 10 Megabytes of on-line storage.
- File sizes to 5 Megabytes.
- Power-on self-test.
- Easy back-ups in minutes.
- System expandable to eight drives.
- Built-in error detection and correction.
- No preventative maintenance required.
- Comes complete with all necessary software and hardware.
- MTBF 8000 Hours.
- Built-in fan.
- Operates 110/220 VAC 50-60 Hz.
- One year limited warranty.

Only \$3995⁰⁰*

GENIE COMPUTER CORPORATION

31125 Via Colinas #908 • Westlake Village, CA 91362 • (213) 991-6210

Circle 210 on inquiry card.

Removable Cartridge. Imagine, 5 Megabytes in the palm of your hand. These small Winchester cartridges are only .75 inches thick and 5.50 inches square. The disk itself is completely sealed from the outside and all its hazards by a sliding door that opens only once the cartridge is firmly seated inside the drive. Long term availability of this cartridge is assured by its adoption by several well known manufacturers including Dyan and Memorex, the world leaders in computer mass storage media.

Talk about user friendly • • •

Comprehensive system utilities package. Allows eight-character names to be assigned to virtual volumes. User can back-up to any Genie REMOVABLE Cartridge Drive, or to diskettes. Mix & Match different system file types on the same disk. System status screen messages. Up to 16 volumes on-line at a time.

Available at your local computer dealer

Manufacturer's suggested retail price. Includes all required components. Concurrent CP/M-86 is a registered trademark of Digital Research. IBM Personal Computer is a registered trademark of IBM Corporation. Apple is a registered trademark of Apple Computer, Inc. Radio Shack is a registered trademark of Tandy Corporation. Dyan is a registered trademark of Dyan Corp.

Action Games for the VIC-20

Russell Kavanagh
16921 Lakefront Circle, #47
Huntington Beach, CA 92647

The Commodore VIC-20 computer has been available in the United States for more than a year now, but until fairly recently very little software was available for it. Creative Software, however, is one firm that provided software early on. Eager to do something with my new VIC-20, I mail-ordered a copy of the company's "Action Games" package, which includes VIC Trap, Seawolf, and Bounce Out.

I received the games in surprisingly short order and rushed to the VIC to try them out. To my chagrin, I experienced a few minutes of frustration because I had difficulty loading the programs. Fortunately, past experience with the VIC cassette interface had taught me that it's a bit flaky, but nothing that a little reorientation of the cassette drive and cabling can't fix. Sure enough, that did it, and I was able to load the first program.

I haven't had any trouble loading any of the games since then, and I suspect the problem I had was the VIC's fault. Inspection of the cassette cable indicates that it could use some attention to grounding and shielding . . . but that's another article. On to the matter at hand: playing games.

VIC Trap

Like the other two games in this package, VIC Trap

makes good use of the VIC's color and sound capabilities and can be played using either a joystick or the keyboard. Of the three games, it is the only one written in BASIC. To play, you guide a character around the screen, leaving a trail behind it. At the same time, the VIC does the same thing with its own character. The object is to try to trap the VIC by surrounding its character with your trail and/or the screen borders. The first player to collide with either the trail or the border loses. A point goes to the victor, and the process starts over again.

I didn't find VIC Trap very challenging, so I soon grew tired of it. The game is very slow moving and does not require you to develop a real strategy. The younger set might enjoy it, but I think even they would soon want to move on to the other games in this package. Still, VIC Trap is an interesting demonstration of the VIC color graphics and sound, and as such it might serve as a simple introduction of your computer to friends.

Seawolf

The second game in the package is written in machine language and is run through the use of a BASIC statement that jumps to the machine-language program. In this game you are the skipper of a "swift and dangerous submarine" that is positioned along the bottom of the screen.



Scenes from the Action Games package for the Commodore VIC-20 microcomputer. Left to right: VIC Trap, Seawolf, Bounce Out.

TMP software The computer's mind.™



Regardless of what brand of microcomputer you own, the key to its productivity is the software you use. And more and more companies and individuals are relying on TMP Software to get out more work, faster.

Software so advanced it's simple.

With TMP, Total Management Planning Systems, you and your computer communicate in English. Simply follow instructions displayed on the screen to quickly and efficiently enter, save and retrieve information. And unique "Help" screens allow you to ask questions and get answers, in process, without turning to instruction manuals or erasing information you're working on.

Combine packages, maximize results.

Perhaps more importantly, once you learn the operation of one TMP Software Package, you've learned the basics of our entire sophisticated system: TMP/FreeForm™ (electronic index cards); TMP/Calc™ (electronic spread sheets and more); TMP/Manager™ (structured data base management); TMP/Writer™

(word processing/document retrieval); TMP/Front-End™ (combines packages). Each package can stand alone, or they can be integrated to form a complete, powerful system — increasing productivity and minimizing the opportunity for error.

On-going support and innovation.

TMP Software is available for most popular desk-top computers and supermicros. And new software packages are being added monthly. Videotape training programs are available on VHS, Beta and U-Matic formats.

Contact your nearest TMP Software dealer or order direct. Either way, get on line with TMP, and improve your computer's mind. Dealer inquiries invited. The United Software Company, 2431 East Douglas, Wichita, Kansas, 67211, (316) 684-5281. MasterCard, Visa and American Express.

The computer's mind.

Total Management Planning Systems

Circle 506 on inquiry card.

TMP, TMP/FreeForm, TMP/Calc, TMP/Manager, TMP/Writer, and TMP/Front-End are trademarks of The United Software Company

When one terminal is not enough

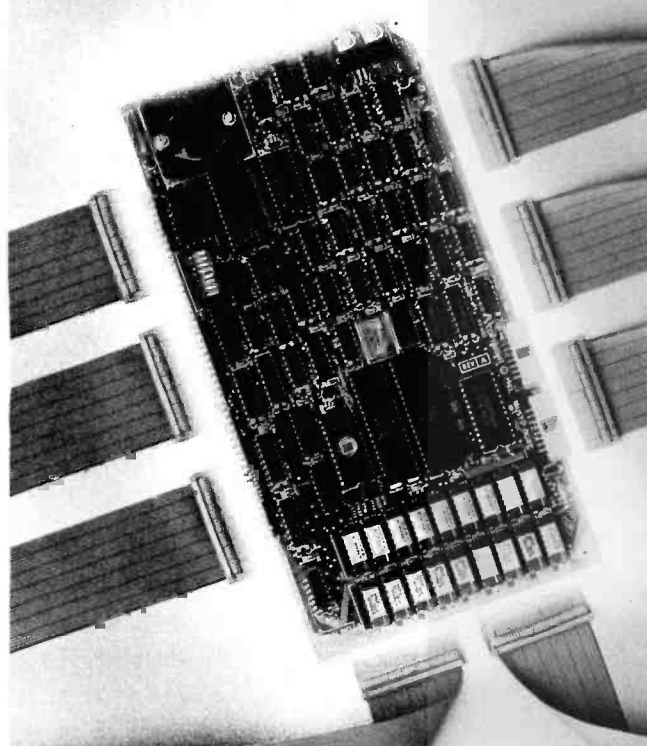

Add a MuSYS Slave!

Expand your Z80A/S-100 based micros with MuSYS slaves and TurboDOS*. Our NET/82 slave board has everything you need for another station: Z80A CPU, up to 128K bytes of RAM, two serial ports, a priority interrupt controller, memory parity checking, and many other features. There isn't a more cost-effective way to add complete, hardware-isolated network slaves to your system. And TurboDOS makes it even better. It's faster than CP/M®* for systems functions, supports larger files (134 MB) and disks (1048 MB), and unlike CP/NET* it's compatible with nearly all 2.2 applications software. Many features which are optional, extra-cost, or not available at all in CP/M® are standard with TurboDOS. Call today for all the details. Generous dealer/OEM discounts available.

*TurboDOS is a trademark of Software 2000, Inc.; CP/M and CP/NET are trademarks of Digital Research, Inc.; NET/82 is a trademark of MuSYS Corp.

MUSYS
CORP
Specialists in Multi-user Microsystems

1752 B Langley
Irvine, CA 92714
(714) 662-7387
TWX: 910-595-1967
CABLE: MUSYSIRIN

BYTE GAME GRID

At a Glance

Name Action Games; includes VIC Trap, Seawolf, and Bounce Out	Format Cassette tape
Type Game	Language BASIC and machine language
Manufacturer Creative Software 201 San Antonio Circle, No. 270 Mountain View, CA 94040 (415) 948-9595	Computer Commodore VIC-20 with 5K bytes of memory
Price \$24.95 plus \$1.50 shipping and handling	Documentation Six-page pamphlet
	Audience Game players

You can control motions to the left and right and fire torpedoes up through the water.

Above you are three levels of enemy ships, which you try to sink with your torpedoes. The ships move at different speeds; the one closest to you is the slowest and largest—easiest to hit and worth the least number of points. Ships enter the screen randomly from either side. Mines float between you and the ships above, and although they do you no damage, they will block your torpedo—in effect, running interference for the ships.

The play lasts for 60 seconds, during which you try to score as many points as possible. If you score enough points, you get a bonus of 30 seconds' more playing time. When your time is up, your new score is displayed along with your previous high score. Two levels of play enable you to change the speed and point values of the passing ships.

Seawolf has an arcade look to it; the graphics are fast and colorful, and the sound effects are good. There is no noticeable delay in controlling the submarine, although the instructions do warn you that your crew requires some time to "reload" a torpedo after a shot. I found the game reasonably entertaining, although the instructions overestimate the skill required to score that extra 30 seconds of play. I earned some of my highest scores by merely parking the sub and holding down the Fire button. That strategy works because you have an unlimited supply of torpedoes. I think Seawolf could be improved by limiting the torpedo supply and providing more rewards after the first bonus of 30 seconds. Maybe there are more rewards, but I never found them. Nonetheless, this game should be a popular one, especially for newcomers to the computer-game domain.

Bounce Out

The third and final game is a colorful and challenging version of the well-known video game Break Out. You

QDP-300

The peace of mind computer.

Introducing our third generation computer... the all-new QDP-300. Now, you can rest assured you've found the most advanced microcomputer on the market today. The QDP-300 is a user-friendly system - its on-line "Help" system gives even untrained operators access to its full power. It uses CP/M* and MP/M* operating systems that assure the user of an abundance of compatible software. The QDP-300 even has a dual voltage system that allows worldwide operation (115 or 220 volts) at the flick of a switch. For word processing, financial forecasting, engineering design and manufacturing, inventory, payroll, bookkeeping and more, the QDP-300 will work hard for you for years and years to come. It's also comforting to know that the QDP-300 is fully expandable and readily upgradeable as your computer needs grow. There's even more. It might make you sleep better to know that the QDP-300 is backed by one year, on-site warranty with service provided by General

Electric Apparatus and Engineering Services, with more than 50 service locations nationwide. If these features and all of the others we've built into the QDP-300 don't bring you peace of mind, then the low price tag will.

- **More Flexibility** - Easily upgradeable to 16 bit capability which gives the user 8 or 16 bit operation. IEEE 696/S-100 Bus.
- **More Speed** - Unique "cache memory" disk operation makes the QDP-300 one of the fastest operational 8 bit systems on the market.
- **More Power** - Advanced single board design utilizing Z80B** CPU operating at 6 MHz.
- **More Storage** - Dual 8" floppy disk drives provide a total of 2.4 MB of formatted storage (10 MB and 15 MB internal hard disk system optional; 30 MB external hard disk system also available.)

Call or write for complete specifications and literature.

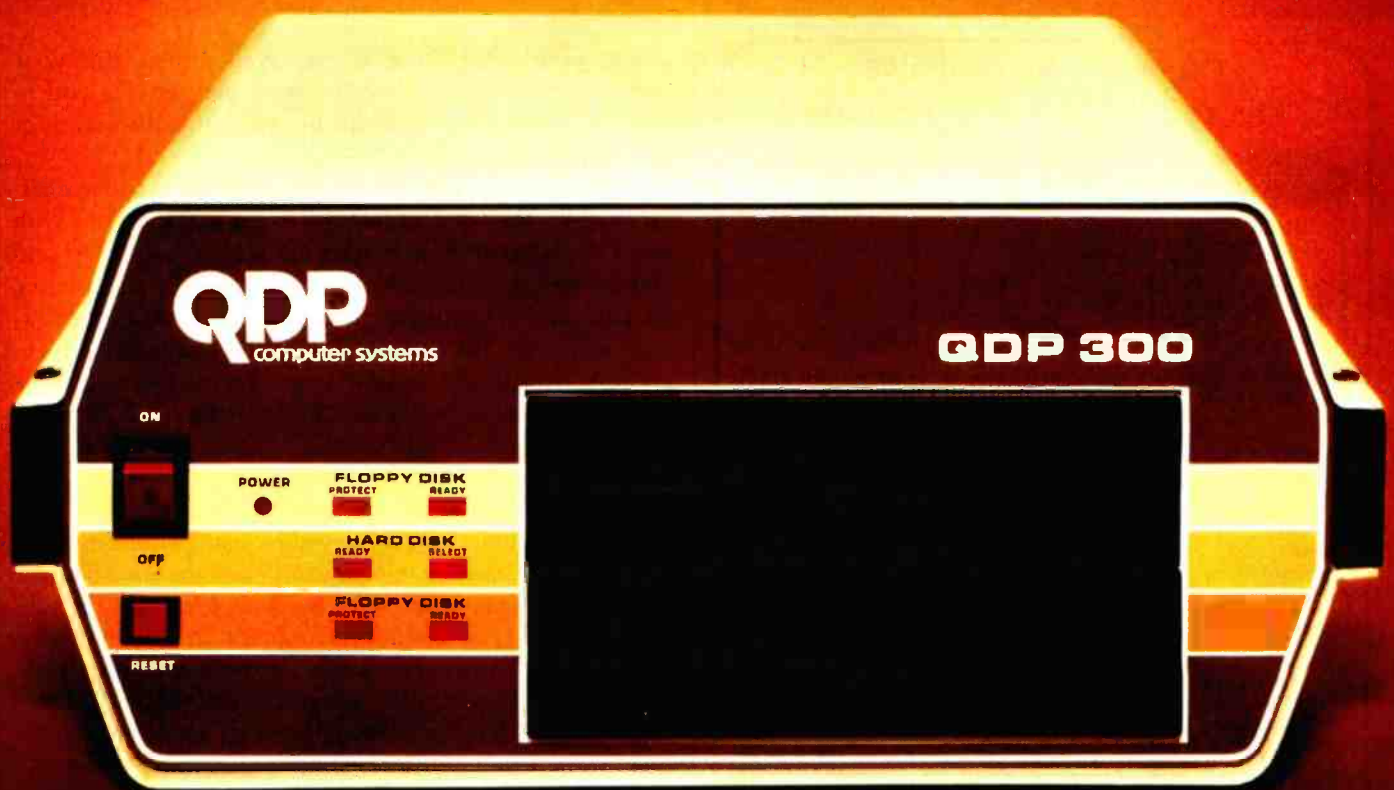

QUASAR DATA PRODUCTS

QDP
computer systems

10330 Brecksville Road, Cleveland, Ohio 44141
(216) 526-0838, Telex: 241596

Specifications subject to change

*CP/M and MP/M are trademarks of Digital Research Corp.

**Z80B is a trademark of Zilog Corp.

PROGRAMMERS FLIGHT SIMULATOR Apple II Plus DOS 3.3 48K



This total IFR System disk features gobs of menu selectable flight programs each with breath taking realistic picture graphics, moving scenery, airport approaches, holding patterns and much much more.

\$50.00 At your Computer Store or direct from
 Visa Mastercard
Programmers Software
 2110 N. 2nd Street
 Cabot, Arkansas 72023
 (501) 843-2988

BYTE GAME GRID

are given 10 balls at the start, and your goal is to knock out a wall of bricks. Your paddle moves along the bottom of the screen, and the bricks are positioned in three colored layers near the top of the screen. The bricks in each layer are worth successively more points. Each brick you hit with the ball disappears, and you add its value to your score. The ball bounces off the brick wall and the side boundaries and returns for you to hit with the paddle. The value of the bricks is also determined by how many balls you've used; you'll score more points if you clear the screen with only one ball instead of all of them. If you miss a ball with your paddle, you lose it. You continue playing until all 10 balls are gone. If you clear the screen, a new set of bricks appears. As the score adds up, the ball speed increases, and your paddle size may even change—it will be smaller, of course. At the end of the

Of the three games, Bounce Out is the winner, the one I usually go to for a quick game with my VIC.

game, your final score is displayed along with your previous high score. Two levels of play enable you to select the size of your paddle, but all of the other features remain the same.

Of the three games, I think Bounce Out is the winner. At least it's the one I usually go to for a quick game with my VIC. It's written in machine language, so it's fast and responsive. And because the ball speeds up, anticipating its path and returning it takes quite a bit of concentration. All in all, the game is sufficiently challenging to encourage you to try to beat your highest score. Bounce Out should be a welcome addition to your VIC game library.

Joystick Versus Keyboard

All of these games can be played by using either the keyboard or the joystick/pushbutton combination. Because many readers may not own a joystick, I thought the subject deserved some attention. Commodore does not sell a joystick, but Atari-compatible joysticks will plug right in. Of course, computer hobbyists of the old school can build one from scratch. How-to information is available in the Commodore VIC-20 Programmer's Reference Guide, which is now available.

If you don't have a joystick, don't worry, because you can play the games very well without one. In fact, I think VIC Trap and Bounce Out are a little easier when you use the keyboard. That's partly due to the fact that the movement of the character or the paddle can be controlled in

Powerful Lab Graphics For Your Apple II +[®] Computer

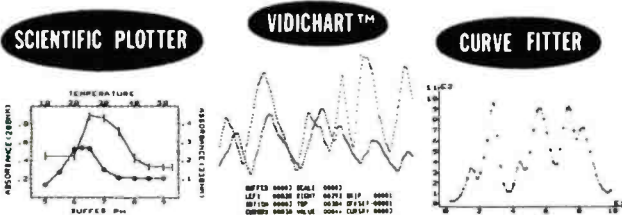

SCIENTIFIC PLOTTER **48K APPLE II +, \$25**
 Draws professional-looking graphs of your data. EASIER, FASTER, NEATER and more ACCURATE than handplotting. You choose data format, length and position of axes, 20 symbols, error bars, labels anywhere in 4 orientations, etc. Includes 5 DEMOS on disk with 30-PAGE MANUAL.

CURVE FITTER **48K APPLE II +, \$35**
 Selects the best curve to fit your data. SCALE, TRANSFORM, AVERAGE, SMOOTH, INTERPOLATE (3 types), LEAST SQUARES FIT (3 types), EVALUATE UNKNOWNNS from fitted curve. Includes 5 DEMOS on disk with 33-PAGE MANUAL.

VIDICHART™ **48K APPLE II +, \$75**
 NEW tools for lab data management. FAST plots of 4 data sets with SCROLLING in 4 directions, ZOOM scaling on X and Y axes, 2 types of graphic CURSORS and on-screen STATUS REPORT. PLOTS A/D INPUT while sampling. ADD, SUBTRACT, MULTIPLY, DIVIDE, INTEGRATE, DIFFERENTIATE, AVERAGE or NORMALIZE data sets with SIMPLE COMMANDS. Ideal for spectra, chromatograms, rate curves, etc. Includes SAMPLE DATA on disk with 28-PAGE MANUAL.

SPECIAL! All 3 programs on one disk, only \$120. Since each program uses the same data format on disk, data may be shared.

BUY THESE PROGRAMS AT YOUR LOCAL DEALER OR ORDER DIRECT. For more information, ask for FREE brochure or send \$5 for any manual (\$12 for all 3), deductible with purchase. Add \$1.50 shipping on all orders. For fastest service, call in your VISA or Master Card order.



INTERACTIVE MICROWAVE, INC.
 P.O. Box 771, Dept. B State College, PA 16801
 CALL (814) 238-8294 for IMMEDIATE ACTION

* Trademark of Apple Computer, Inc.

TIME-PROVEN PERFORMANCE



While new printers with impressive specifications are introduced on an almost daily basis, only time will tell the true quality of the product. Over the past 2 years our customers have continued to buy the DS180 printer, not only because of its impressive performance and competitive price, but also because of our outstanding track record for product reliability and customer support.

We have continually improved on the performance of the DS180 by incorporating such enhancements as dot addressable graphics, 6 user-selectable print sizes and a 2000 character buffer. These features coupled with 180 cps printing, parallel and serial interfaces, adjustable tractor feed and over 40 other programmable features, make the DS180 one of the most versatile matrix printers available today.

Before you select your next printer, why not take a look at a time-proven performer—the Datasouth DS180.

The DS180 printer is available nationwide through our network of sales/service distributors.

datasouth computer corporation

P.O. Box 240947 • Charlotte, NC 28224 • 704/523-8500

Telex: 6843018 DASOU UW

Circle 172 on inquiry card.

www.americanradiohistory.com

Ride the

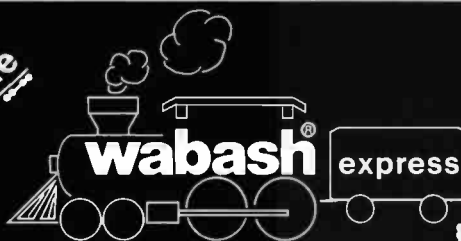

5 1/4" \$1.99*

SINGLE SIDE
SINGLE DENSITY
WHUB RING
SOFT,
10 OR 16
SECTORS
100% CERTIFIED
2 YEAR WARRANTY

8" \$1.99*

SINGLE SIDE
SINGLE DENSITY
SOFT
OR 32
SECTORS
100% CERTIFIED
2 YEAR WARRANTY

5 1/4" \$2.19*

SINGLE SIDE
DOUBLE DENSITY
WHUB RING
SOFT,
10 OR 16
SECTORS
100% CERTIFIED
2 YEAR WARRANTY

8" \$2.49*

SINGLE SIDE
DOUBLE DENSITY
SOFT
OR 32
SECTORS
100% CERTIFIED
2 YEAR WARRANTY

5 1/4" \$2.99*

DOUBLE SIDE
DOUBLE DENSITY
WHUB RING
SOFT,
10 OR 16
SECTORS
100% CERTIFIED
2 YEAR WARRANTY

8" \$3.09*

DOUBLE SIDE
DOUBLE DENSITY
SOFT
OR 32
SECTORS
100% CERTIFIED
2 YEAR WARRANTY

- * Minimum order 10
- * Packed 10 boxes of 10 diskettes with sleeves and labels
- * Quantity discounts - 100 deduct 5%, 1,000 deduct 7%, 5,000 deduct 10%
- * Add \$5.00 per case 5 1/4", \$7.00 per case 8" (case of 100) For shipping and handling Continental U.S.A., U.P.S. ground.

VINYL STORAGE PAGES

5 1/4" or 8" **10/\$5**
SNAP-IT POWER CENTER
Turn one outlet into six
• Shock-safe
• Unbreakable
• 15 Amp Circuit Breaker
• Lighted On-Off Switch **\$19.95**

DISK DRIVE HEAD CLEANING KITS

Prevent head crashes and ensure error-free operation
5 1/4" or 8" **\$19.50**

HARDHOLE DISK PROTECTORS

Reinforcing rings of tough mylar protect disk hole edge from damage.
Applicators **\$3 \$4**
Hardhole Rings (50) **\$6 \$8**

SFO C-10 CASSETTES... 10/\$7

(All cassettes include box and labels)
Get 8 cassettes, C-10 Sonic, and Cassette/8 Library-Album, as illustrated, for only **\$8**

LIBRARY CASES

8" Kas-sette/10 **\$2.99**
5 1/4" Mini Kas-sette/10 **\$2.49**

MAXELL 3M OYASAN BASF OPUS

Floppies, Tape, Data Cartridges, Data Cassettes, and Disk Packs

• Written purchase orders accepted from government agencies and well rated firms for net 30 day billing. • International orders accepted with a 15.00 surcharge for handling, plus shipping charges. • C.O.D. requires a 10% deposit. • We accept Visa, Mastercharge, Money Orders, and Certified checks. • Checks require bank clearances. • All shipments F.O.B. San Diego. • Minimum shipping and handling 2.00, minimum order 10.00. • California residents add 6% sales tax. Prices and terms subject to change without notice. • All sales subject to availability, acceptance, and verification. • All sales are final. • Satisfaction guaranteed or full refund.

We also offer printer ribbons, printwheels, type elements, equipment covers, power consoles, paper supplies, storage and filing equipment, furniture and many other accessories for word and data processing systems. Write for our free catalog.

ABC
DATA PRODUCTS
(FORMERLY ABM)

Toll Free Order Only
800-854-1555
For Information
or California Orders
(714) 268-3537

8868 CLAIREMONT MESA BLVD.
SAN DIEGO, CALIFORNIA 92123

BYTE GAME GRID

discrete steps with the keyboard; each time you push a key and release it, only one direction change (in VIC Trap) or one movement of the paddle (in Bounce Out) occurs. With the joystick, however, split-second timing and precise positioning are difficult. Note that if you push a key down and do not release it, the command will be read continuously, just as if you were holding the joystick in a given direction.

I also found the keyboard easier to use because my joystick required fairly accurate positioning, and if the stick was slightly off the mark, the command did not register. Seawolf is much better suited to the joystick, not only because it gives the game that arcade feel but because you can shoot and maneuver at the same time. In fact, games that have Fire buttons and the like are probably better played with pushbuttons instead of the keyboard, because people tend to get carried away (read "violent")

Games like Seawolf are best played with a joystick — which also saves wear and tear on your computer.

pushing keys. Watching the neighborhood kid trying to push the space bar through the bottom of your computer may convince you to get a joystick.

Conclusions

Of these three games, Bounce Out is my favorite. It combines a colorful playing field, fast action, and sound effects for a challenging game. Seawolf is also entertaining, but it's somewhat easily mastered. It has more of an arcade look than the others, and it's especially enjoyable when you use a joystick. VIC Trap is . . . well, the other game. Enough said.

Creative Software's documentation is good, and the cassette appears to be of good quality. Unfortunately, any attempt to save a program results in a locked-up VIC. I dislike this policy; I always feel better when I have an extra copy safely stored away. There are few worse sensations than when you see a LOAD ERROR message flash on your screen but don't have another copy of that program. No mention is made in the documentation of a replacement policy in the event that your copy is damaged, so I don't know how that would be handled. With good care, at any rate, the tape should last.

The Action Games package should be a welcome addition to your VIC-20 game collection. It is reasonably priced (three games for \$26.45 is about \$9 a game), and you might even find it for less through some of the mail-order software distributors. ■

Apple Polishing.



New software for your Apple* III. Only from Quark.

Now you can add three **new** Quark software products to your Apple III.

Advanced programs which offer you the technical sophistication you need. With the simplicity of operation you want. All at intelligent prices.

Case-in-point: Catalyst[™]. With this hard disk program, you'll only have to boot your system once. Which means you may not have to touch another floppy disk all day. And the price, to coin a phrase, is user-friendly. Only \$149.

You'll also be delighted with Discourse[™]. A spooler that saves you a lot of time. Because it lets you use your computer while you're printing other reports. Plus, you can queue up to 14 documents. The price is \$125.

And if you need an automated appointment calendar, the answer is Quark's new Vigil[™]. No matter what your Apple III is doing, Vigil will alert you to the next event on your busy schedule. The price is attention-getting, too. Just \$95.

Your dealer wants to show you these exciting new programs today. And while you're there, be sure to ask for our free brochure: Apple Polishing.

Or write us directly.

You'll discover how to put Quark's unique line of software to work for you. And then your Apple III can really shine.

* Apple is a registered trademark of Apple Computer, Inc.

Quark[™]

1433 Williams, Suite 1102 Denver, CO 80218
(303) 399-1096

CompuPro Systems



Performance. CompuPro systems run 8 and 16 bit programs - fast! "The (8 bit) 8085 was more than a third faster than any 8 bit micro we have tested to date. . . the (16 bit) 8088 (was) almost twice as quick as the identically-engined IBM Personal Computer. . ." - *Interface Age* magazine. And, there's so much memory you can even treat it as a pseudo-disk drive. "This technique makes a microcomputer. . . run like a big minicomputer." - *Byte* magazine.

Quality. What other machines sell as expensive add-ons come standard with CompuPro. All systems include over 2.4 million bytes (characters) of fast floppy disk storage, 8 and 16 bit operating systems, and powerful business software such as SuperCalc-86™ and dBase™. Plus, CompuPro's modular approach means that ". . . people who've invested in (CompuPro) systems in the past won't be left hung out to dry when new technology overtakes them. . ." - *Byte* magazine.

Deliver the Gift of Time.



CompuPro's family of 8/16 bit systems delivers the gift of time through performance, quality, and reliability. Time to plan. . .to create. . .to manage. . .time to do that which people do best, freed from repetitious and tedious work.

Reliability. When you depend on your computer, don't settle for anything less than the best: CompuPro Systems are as reliable as they are fast, and are backed by one of the best warranties in the business. "(The CompuPro System is) built like a Mack truck. You couldn't hurt it with a nine-pound sledge. When it comes to rugged reliability, (CompuPro) is *the* way to go. . ." - *Byte* magazine.



CompuPro division, Godbout Electronics,
Box 2355, Oakland Airport, CA 94614

Your CompuPro Authorized Systems Center has systems which deliver the performance, quality, and reliability you need in demanding business applications.

Circle 104 on Inquiry card.

Deadline

Chris Morgan
Editor in Chief

The eternal dilemma of the reviewer of mysteries is how to discuss the plot without revealing the ending. But that's not a problem with *Deadline*, a fascinating new program from Infocom, the creators of the Zork family of adventure games.

Deadline puts you in the role of the detective, plants you firmly in the cliché-ridden trappings of a thirties murder mystery, and challenges you to discover the culprit. Naturally, this involves your wandering in and around a large mansion, the scene of the recent murder—apparently by poisoning—of the master of the house.

In classic adventure style, the game begins when you arrive at the front gate of the property, where you are given a typically elaborate description of your immediate surroundings. But *Deadline* is quite a different animal from traditional adventures. For one thing, it's much less deterministic. Your actions have definite, if sometimes

unpredictable, effects on the various characters who inhabit the mansion (all are suspects, incidentally). In fact, if you get too nosy in your clue-hunting, you may be threatened or, in some cases, killed. In these respects *Deadline* resembles the other programs in the Zork family of adventure games.

Deadline's radical departure from the prototypical mystery is that it has more than one ending. The denouement depends on your actions and possibly on randomizing factors I haven't detected yet.

As the detective, you have a varied repertoire of strategies. Among other things, you can gather objects, analyze them for fingerprints at the lab, test them for a specific substance, arrest people (for that you should wait until you're quite sure of yourself!), ask people to tell you about each other or about objects you show them, accuse and even *kill* a suspect in the event that one threatens your life, wait for someone to arrive at a particular place, and so on. You can also use relatively complicated sentences. For instance, "Put the wrapper, the ticket, and the nail file on the dresser" is syntactically acceptable.

The game takes 12 hours (*Deadline* hours, that is) to play. You begin at 8 a.m. and have until 8 p.m. to solve the mystery. As with other adventure-style games, you can save your position at any time if you want to restart the game and try a new approach. One thing I discovered (and it's not giving too much away) is that in many cases events in the game occur at prearranged times. For instance, a phone that rings at 9:06 a.m. on your first pass through the game will probably ring at 9:06 in future passes—something to keep in mind if you miss an opportunity during the first pass (a common occurrence, I assure you).

Philosophically, I found I was playing the game like an old detective inspired by Edgar Allan Poe. And like Poe's



character, I concentrated on the myriad clues rather than the characters. But the real key to success in this game, as I discovered, is to monitor both the clues and the characters with equal diligence. And watch out for red herrings: there are many more of them than I initially suspected.

Deadline's documentation is useful, complete, and even witty—surely a rarity in personal computer soft-

ware. With its clever, dossier-like folder for printed material, 8 by 10 glossy of the scene of the crime, actual plastic packet of crushed tablets "found near the body," and the like, I felt like Lord Peter Wimsey arriving at the police commissioner's office to pick up the official file. A mystery addict couldn't ask for more.

Deadline is more than mere escapism, however; it's not for the player who prefers vicarious to actual experience. You're the one who'll do the work, and that includes solving the case. But in this case the work is great fun.

I do have one quibble: the beginning Deadline player deserves a few clues at the outset. After all, this is a very tricky game. For starters, it would be helpful to be present at the reading of the will. Rather than risk infuriating potential players by continuing, I have printed some pertinent clues upside down at the bottom of the page. Play the game for a few hours (real time, that is) before you glance at the clues. They don't give away too much, but they'll spare you a lot of make-work. ■

At a Glance

Name

Deadline

Type

Interactive mystery game

Manufacturer

Infocom Inc.
55 Wheeler St.
Cambridge, MA 02138

Price

\$49.95 (\$59.95 for the CP/M and PDP-11 versions)

Computer

Any of the following with 32K bytes of read/write memory and one disk drive: Apple II or II Plus, Atari 400/800, any CP/M-based system with 8-inch disk drives, IBM Personal Computer, DEC PDP-11

Author

Marc Blank

Language

Interlogic Machine Language (an Infocom language)

Documentation

A computer reference card, an inspector's casebook, and a dossier that includes transcripts of interviews with witnesses, lab reports, letters, memos, an 8 by 10 glossy of the scene of the crime, and a small bag of pills "found near the body"

Audience

Game players

Clues for Deadline

1. Find out what's bothering the gardener. The way you phrase your questions is important here as well as throughout Deadline.
2. Watch out for tricky wording in the game's description of the newspaper when it arrives.
3. George is a key character. Get his reactions to people and objects.
4. The library is a particularly important room for several reasons. Examine it and its contents.
5. Be sure to examine things carefully when appropriate.
6. It's instructive to follow certain characters around at times. But be careful!
7. Show the same clues to various people and compare their reactions.
8. Don't get preoccupied with clues at the expense of the suspects.

C compilers

HOST	6809 TARGET	PDP-11*/LSI-11* TARGET	8080-(Z80) TARGET	8088/8086 TARGET
FLEX*/UNIFLEX* OS-9*	\$200.00 \$350.00	500.00	500.00	500.00
RT-11*/RSX-11* PDP-11*	500.00	200.00 350.00	500.00	500.00
CP/M* 8080/(Z80)	500.00	500.00	200.00 350.00	500.00
PCDOS*/MSDOS* 8088/8086	500.00	500.00	500.00	200.00 350.00

*PCDOS is a trademark of IBM CORP. MSDOS is a trademark of MICROSOFT. UNIX is a trademark of BELL LABS. RT-11/RSX-11/PDP-11 is a trademark of Digital Equipment Corporation. FLEX/UNIFLEX is a trademark of Technical Systems consultants. CP/M is a trademark of Digital Research. OS-9 is a trademark of Microware & Motorola.

• FULL C

• UNIX* Ver. 7 COMPATABILITY

• NO ROYALTIES ON GENERATED CODE

• GENERATED CODE IS REENTRANT

• C AND ASSEMBLY SOURCE MAY BE INTERMIXED

• UPGRADES & SUPPORT FOR 1 YEAR

408-275-1659

TELECON SYSTEMS

1155 Meridian Avenue, Suite 218
San Jose, California 95125

At a Glance

Name

Penetrator

Type

One- or two-player arcade-style game

Manufacturer

Melbourne House
6917 Valjean Ave.
Van Nuys, CA 91406
(213) 272-8456

Price

\$24.95

Author

Phillip Mitchell

Format

Cassette or 5¼-inch floppy disk. The game package includes both Model I and Model III versions.

Language

Z80 machine language

Computer

TRS-80 Model I or Model III with 48K bytes of memory and one disk drive. You will need a speaker amplifier to hear the sound effects, and the program is compatible with the Alpha (Atari-type) joystick.

Documentation

16-page booklet

Audience

Game players

Four Defensive Rings

The game is divided into four stages that increase in difficulty, so progressing through them requires constant concentration. Each stage demands a different strategy. In stage 1 you merely shoot enemy missiles and destroy every radar station in your path (see photo). The radar stations must be destroyed because they pass along information about your course and tactics; unless you destroy them, they increase the level of danger for your ship and make successive stages more difficult.

Stage 2 increases your chances of crashing by forcing you to fly in a cavern (see photo). The low ceilings, ground obstructions, and flying missiles greatly limit your maneuverability. Of course, you still must fire your missiles and drop bombs to score points.

Stage 3 tests your reflexes because it requires a coordinated use of the thrust and braking controls (see photo) to maneuver through narrow vertical and horizontal corridors. Missiles are located at the bottom of silos. Destroying a missile requires braking over the target,

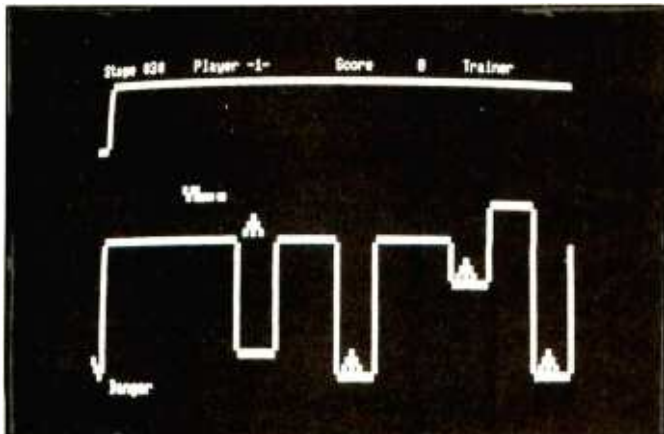

Stage 3: The enemy missiles are located in concrete silos, which makes them very difficult targets for your bombs.

dropping a bomb, and quickly maneuvering away in case you missed.

Stage 4 is the toughest of all. Not only does it incorporate features from all the previous stages, it adds alien parachutists (see photo). The aliens have a limited ability to maneuver themselves, so you can outmaneuver them even if you can't shoot them with your missiles.

If you manage to survive all four levels, you can destroy the neutron bombs at the center of the alien defensive rings and then try to fly back home through the four stages once more.

Game Features

If that were all there was to Penetrator, it would be a good game. But Mitchell gives us more: a training-simulation option and the ability to customize the game.

The training simulation lets you start at the beginning of any of the four stages with an unlimited number of ships at your disposal. The game will automatically

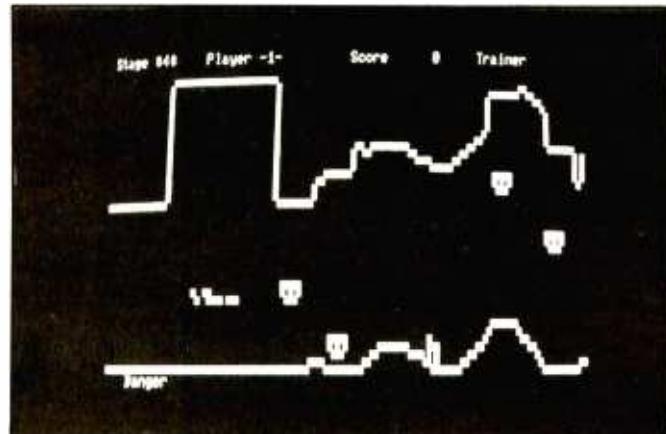

Stage 4: Alien parachutists fall from the ceiling of the cavern. Beyond this stage is the neutron bomb cache.

BYTE GAME GRID

repeat any stage until you successfully complete it, and only then can you move on to the next higher stage. This is a nice feature if you want to practice mastering one particular stage.

The ability to tailor the game to suit your tastes is one of Penetrator's most attractive features. You can alter the shape of the landscape and change the number and position of the missiles and radar bases. The changes in the game may be saved to disk or cassette, and the game will prompt you at the start to load a previously saved landscape. This ensures that the game will always be fresh even to an experienced player. The feature also enables you to simplify the game for very young children or make it more challenging for battle-hardened players.

Conclusion

My only complaint with Penetrator concerns the methods you must use to control the fighter. When you control the game from the keyboard, using the arrow keys is awkward. The Alpha joystick is a better alternative because it offers greater control; unfortunately, it makes controlling missile fire tricky. If you jiggle the stick to the right too slowly, you get thrust instead of missile fire.

Penetrator is a perfect example of how "less is more." The game shows what an inspired programmer can do with the limited graphics of TRS-80 Models I and III. Because it is eminently playable and it can be customized, Penetrator will be on my game shelf for a long time. ■

68000 DISASSEMBLER

An easy to use program to create source files from Motorola S-format files

The DISASSEMBLER runs on:
EXORmacs under VERSAdos

VAX under VMS
and IDRIS
and UNIX
NORD under SINTRAN

8" SD diskette **\$ 200**

Pascal source on request

NorSoft Consultants

Veungdsalsveien 1
3600 Kongsberg
Norway

Circle 343 on inquiry card.

Got a computer?

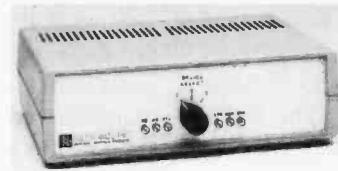

Get a Giltronix Selector Switch.

Eliminate unplugging and re-plugging your GPU's, peripherals, and modems. Eliminate expensive duplication of interconnection hardware. Connect three components to Giltronix Selector Switch #S8AB. Then select your connection with a simple turn of the dial. Only \$79 in OEM quantities. Monitoring options available. Full 5 year warranty on all Giltronix units.

SWITCH TO GILTRONIX.



970 San Antonio Ave., Palo Alto, CA 94303

Circle 212 on inquiry card.

FLOPPY DISKS

ALL DRIVES
PRETESTED BY METAVAN

NEW Shugart SA400L	\$229.00
NEW Shugart SA450	333.00
NEW Shugart SA801R	390.00
NEW Shugart SA851R	540.00
NEW Shugart SA410	345.00
NEW Shugart SA460	431.00
NEW Shugart SA810	627.00
NEW Shugart SA860	730.00
Enclosure—desk—2/8"—no power—unwired	75.00
Enclosure—desk—2/8"—w/power/wired—refurb	299.00

DISKETTES

1 Year warranty, 10 per plastic library case	
8" single side-single density	29.40
8" single side-double density	40.90
8" double sided-double density	46.70
5 1/4" Reinforced hub 10/plastic library case soft structured, 10 or 16 holes	
single side-single density	30.70
single side-double density	37.10
double sided-double density	44.90

TRACTOR FEED PAPER

9 1/2"x11 Blank, 3700 Sheets, perf	28.22
8 1/2"x11 Blue bar, 3700 sheets	25.72



METAVAN, INC.
1805 East Dyer Rd, Suite 307
Santa Ana, CA 92705
(714) 540-2427

Circle 294 on inquiry card.

ELIZA IS HERE!

AT LAST! A FULL IMPLEMENTATION of the original ELIZA program is now available to run on your microcomputer!

Created at MIT in 1966, ELIZA has become the world's most celebrated artificial intelligence demonstration program. ELIZA is a non-directive psychotherapist who analyzes each statement as you type it in and then responds with her own comment or question — and her remarks are often startlingly appropriate!

Designed to run on a large mainframe, ELIZA has hitherto been unavailable to personal computer users except in greatly stripped down versions lacking the sophistication which made the original program so fascinating.

Now, our new microcomputer version possessing the FULL power and range of expression of the original is being offered at the introductory price of only \$25. And if you want to find out how she does it (or teach her to do more) we will include the complete Source Program for only \$20 additional.

Order your copy of ELIZA today and you'll never again wonder how to respond when you hear someone say "Okay, let's see what this computer of yours can actually do!"

ELIZA IS AVAILABLE IN THE FOLLOWING DISK FORMATS:

- Standard 8 inch single density for all CP/M based computers \$25 for ELIZA COM - add \$20 for Microsoft BASIC-80 Source
- 5 1/4 inch CP/M for Apple II equipped with Z-80 SoftCard \$25 for ELIZA COM - add \$20 for Microsoft BASIC-80 Source
- 5 1/4 inch for IBM Apple II with Applesoft ROM and DOS 3.3 \$25 for Protected File - add \$20 for Applesoft Source
- 5 1/4 inch for IBM Personal Computer \$25 for Protected File - add \$20 for IBM Disk BASIC Source
- 5 1/4 inch for Osborne I Microcomputer \$25 for Protected File - add \$20 for Microsoft BASIC-80 Source

ARTIFICIAL INTELLIGENCE RESEARCH GROUP

921 NORTH LA JOLLA AVENUE
LOS ANGELES, CALIFORNIA 90046
(213) 656-7368 (213) 654-2214
MC, VISA and CHECKS ACCEPTED

Circle 43 on inquiry card.

Verbatim®

Floppy Discs
CALL NOW — TOLL FREE
1-800-328-DISC

Dealer inquiries invited. C.O.D.'s and charge cards accepted.

All orders shipped from stock, within 24 hours. Call toll FREE.



North Hills Corporation

3564 Rolling View Dr.
White Bear Lake, MN 55110
1-800-328-DISC
MN Call Collect 1-612-770-0485

Circle 344 on inquiry card.

www.americanradiohistory.com

RELATIONAL DBMS IN BASIC SOURCE

FOR SYSTEM INTEGRATORS

- CB-80 & RMAC Source & REL Files for easy development of CP/M Application Systems
- Separate overlays perform: RETRIEVE, STORE OPEN, DELETE, REPLACE & MODIFY operations, leaving more memory for application programs
- RETRIEVE dynamically joins more than one relation and sorts the results; no secondary links to reconstruct after storing data
- Numeric data is maintained in binary format providing more capacity and flexibility than typical all-ASCII systems
- 24 BIT internal record numbers allow up to 16 MILLION DBMS records per relation
CP/M, CB-80 & RMAC
Trademark of Digital Research, Inc.

Basic System & Administration Pkg - \$350
Query & Aggregation Languages - \$150
Manual for All Software - \$25 (refundable)

Telephone for Complete Brochure

Applied Business Concepts, Inc.
PO Box 22664 / Rochester, NY 14692
(716) 262-3999

Circle 38 on inquiry card.

BHART

The "B" in our name means **BUSINESS!**
Computers for: Business, Home Applications, Resource Management, Technology & Science

6 REASONS YOU SHOULD BUY FROM BHRT:

- BEST VALUE**—Progress in the computer industry never stops. Last year's top performer has already been surpassed by newer products. Our continuing search gives YOU, the buyer, endless bargains.
- LOWEST COST**—Big volume means **Lowest Possible Prices**. (We will pass on the latest price cuts. Check with us—we try to meet or beat any advertised price!!!)
- TECHNICAL EXPERTISE**—We have been handling computers for 20 years. Our experts are knowledgeable and responsive to your inquiries before and after your purchase.
- FINANCIAL INTEGRITY**—In 20 years not even a single check issued us has been returned "Non Sufficient Funds"! Need we say more? Check with our bankers!!!
- SERVICE**—Orders taken around the clock. Technical inquiries dealt with promptly (even weekends!). At your request we will test-run and "burn" your equipment to eliminate "dead on arrival" situations!!!
- FASTEST DELIVERY**—All prepaid orders for stock items shipped within 1 working day!

FREE COMPUTER



On Display
In Our NEW
Showroom
12210
Michigan
Ave., Grand
Terrace, CA!

Would you believe this deal? Buy the basic business software needed to get started at below List, and get FREE a COMPLETE HIGH QUALITY COMPUTER SYSTEM: Morrow Designs, renown for superb floppy drives, hard disks and computers, offer a real price breakthrough with their brand-new MICRO-DECISION: Z-80 CPU (4 MHz) in attractive cabinet, built-in 200KB floppy (room for 1 extra floppy upgrade), 2 serial ports, matched intelligent terminal (detachable keyboard). You get FREE CP/M 2.2, WordStar, Spell Checker, Electronic Spreadsheet, Microsoft Basic-80, BAZIC—everything you need to get going immediately upon receiving your computer. The software package alone lists over \$1,800. Yet, Morrow offers BOTH COMPUTER AND SOFTWARE at \$1,790 (extra floppy \$350). **BUT, the REAL SURPRISE is our SPECIAL INTRODUCTORY DEAL \$CALL!! on this tremendous bargain**

BUSINESS SOFTWARE

For IBM-PC (MS-DOS), CP/M-86, All CP/M, TRS-80, NorthStar! Although always on the lookout for hardware bargains, we urge against being "Penny wise and Dollar foolish" when it comes to Software. CYMA Business Software has been previously offered mainly to large institutional users. We are proud to be first to offer it to the end-user. Convince yourself of this Software's superiority. Get the outstanding hardbound CYMA Software Manuals and you will become as enthusiastic as we are!!! Manual for each CYMA module listed (credited to future CYMA module purchase) **\$39.95 ppd.**
Custom Forms for CYMA packages now carried at all MOORE BUSINESS FORMS outlets!
General Accounting Package: General Ledger/Accounts Payable/Accounts Receivable/Payroll
Your Choice ONLY **\$895**
SPECIAL OFFER: All 4 modules for Operating System of your choice.
ONLY **\$1,995**
Inventory **\$895**
Construction Management **\$2,295**
Small Business System **\$845**
Client Accounting System for CPA's **\$1,395**
Professional Practice Packages: Medical/Dental/Orthodon./Chiropractic Your Choice **\$1,495**
(Professional/CPA modules may be combined with Small Business System/General Accounting System for further savings.)

PRINTERS

DOT MATRIX
OKIDATA 82A: 80 col. bidirectional 120 CPS (faster than most), parallel AND serial input (interface not only your present computer, but any future replacement), die-cast frame (not stamped steel—compare!). Friction & pin feed/Adjustable tractor option. Block graphics/Dot-addressable graphics option.
LIST **\$649**
Exceptional Buy \$434
OKIDATA 83A similar to above but 132 col. LIST **\$995** **\$CALL**
OkiGraph dot graphics/Tractor Your Choice **\$59**
NEC 8023A 100 CPS, friction/tractor, 2K Buffer, graphics, parallel input. LIST **\$695** **\$479**
STAR MICRONICS 80 col., 80 CPS bidire., friction/adjust. tractor, specify serial OR parallel input LIST **\$464** **\$379**
AXIOM GP100 80 col., 30 CPS, graphics, parallel input. LIST **\$389** **\$299**
CORRESPONDENCE/LETTER QUALITY
BROTHER DaisyWriter 2000 serial/parallel **\$CALL**
MANNESMAN-TALLY heavy-duty 200 CPS Parallel input: LIST **\$930** ONLY **\$779**
Serial: LIST **\$1,075** ONLY **\$879**
NEC SpinWriter 3510/3530 ONLY **\$1,849**
7710/7730 ONLY **\$2,539**

ZENITH 100 has Everything:



If you are looking for a computer to run existing CP/M programs, but accept also IBM-PC/other 16-bit software, outstanding color graphics and great expansion potential, the Z100 is your choice! **Twin Processors** run 16-bit software (fully compatible with IBM-PC!!) AND 8-bit (all CP/M programs!). Truly outstanding graphics (Color/Monochrome): control 144,000 individual points on screen in 8 colors! **128K RAM standard** (internal expansion to 768K—run largest 16-bit programs!) **1 or 2 floppies standard**; plug-in Hard Disk soon available! 5 slots for S-100 cards: no planned obsolescence here! 1 parallel/2 serial ports make interfacing a cinch! With Zenith "The quality goes in before the name goes on"; but service is available nationwide through over 400 Zenith Service Centers. 3 configurations available:

ZF-100 128K RAM 8/16 bit, 1 floppy (+ room for Hard Disk), monochrome graphics (use your own monitor) LIST **\$3,249** ONLY **\$CALL**
ZF-110 Similar to above, but COLOR GRAPHICS, 2 floppies LIST **\$3,999** ONLY **\$CALL**
ZF-120 128K RAM, 8/16 bit, 2 floppies, monochrome graphics with integral display LIST **\$4,099** ONLY **\$CALL**
COLOR option for #1,3 above ONLY **\$CALL** Expansion to 192K RAM ONLY **\$CALL**
Color Monitor, RGB, High Resolution, 13" ONLY **\$CALL**
SOFTWARE: System Package, 16-bit & 8 bit Operating Systems, 16-bit COLOR Basic, 8-bit Basic, Microsoft MultiPlan. Total cost, \$900 ONLY **\$CALL** See our Software Section for additional software for CP/M, CP/M-86, MS-DOS All will run on the Z100!!!

SUPPLIES:

3M Diskettes, the highest quality your money can buy:
5 1/4" hard/soft, s.s., d.d. 10/box ONLY **\$20.99** d.s., d.d. 10/box ONLY **\$31.99**
8" hard/soft, s.s., d.d. 10/box ONLY **\$26.99** d.s., d.d. 10/box ONLY **\$37.49**
RIBBONS: EPSON MX-80 cartridges (Min. order 6)/EA. ONLY **\$ 9.49**
OKIDATA 82/83/84 nylon/DOZ. ONLY **\$19.95** NEC SpinWriter 5500-7700/DOZ. ONLY **\$44.95**
Full line of COMPUTER FURNITURE, SUPPLIES, DISKETTES at bargain prices; outstanding quantity discounts: Call our Technical Inquiry No. for details.

TeleVideo

FINALLY AVAILABLE FOR IMMEDIATE DELIVERY! Would have been incredible 1 year ago: Complete Business Computer with 10M HARD DISC built-in, 1 floppy for backup, 2 serial ports, detachable keyboard, priced below many "personal computers"! Traditional TeleVideo reliability, brilliant display, striking finish and appearance, are combined with extensive business software supported by TeleVideo. On-site Nationwide Service by TRW! IBM 2780/3780 emulation, and multiple 802's can form networks!



TeleVideo 802H LIST \$5,995 Our price too low to list **\$CALL**
TeleVideo 802 2 floppies, no hard disk but otherwise identical and upgradeable to 802H. Same software. LIST **\$3,495** ONLY **\$2,645**

SOFTWARE for 802H/802:
WordStar List \$495 **\$275** MailMerge List \$150 **\$99**
SpellStar List \$250 **\$159** CalcStar List \$300 **\$189**
DataStar List \$350 **\$229** SuperSort List \$250 **\$149**
SPECIAL: TeleSolutions (WordStar + CalcStar) **\$299**
TurboDos Will speed your operation x4 **\$339**
RM/CODOL: Multi-user, transparent records, file locking;
Full Compiler \$649 Run-time module only \$249 Manual \$49



NEC COMPUTER

NEC lets you keep your cake and eat it too! Extensive, inexpensive business software, but also many tutorials, beautiful color, game packages. We offer 2 NEC systems identical except for the display, at same bargain price:

8001A CPU, 32K RAM, 24K ROM Basic: 8012A I/O w/additional 32K RAM, real-time clock, interrupts, 8 slots: 8031A Dual Floppies, 286KB AND: Your Choice of 12" green monitor OR Color Converter for super color with your own TV. System List \$2,894 **\$2,099** (\$CALL for individual components)

NEC provides outstanding values in Business Software:
A/R, G/L, Payroll, Inventory, Job Costing, List \$395/module. Only **\$259**
NEC Word Processor incl. Spell Guard, List \$495 Only **\$389**
Report Manager Spread Sheet/Term II Communicator, Each **\$169**
NECDOS w/Multi-Key-Sort & ISAM, All 3 **\$349**
Creative Programming Tutorial Set, **\$59.95**
NEC Game Pack 1 & 2 (Alien, Space War, UFO, Galaxian, Bomber) **\$49**

ATARI

Ultimate Home Computer: Buy it for Games, and before your kids know it, they will learn their ABC, Geography, Mathematics, Music, Foreign Languages, And, Home Finances, Dow-Jones, Investment, Bookkeeping even Telemail Banking! Hooks to any TV, so can be used as soon as you get home! AND, TO MAKE ATARI EVEN A BETTER BUY, WE INTRODUCE 2 NEW PLANS:
• Buy ATARI 400, 16K RAM, by 12/31/82 at ONLY **\$209** (You pay \$269 and receive \$60 Coupon giving \$10 rebate on each ATARI Program/Game)
• Buy ATARI 800, 16K RAM, and receive SPECIAL DISCOUNT on additional 32K (This is ATARI RAM, not ???) ATARI 800-16K ONLY **\$638.95** ATARI 800-48K ONLY **\$CALL**
ATARI PERIPHERALS: 810 Disk Drive \$439 850 I/O \$164.95
ATARI SOFTWARE:
EDUCATOR: 410 Program recorder, Basic, States & Capitals. **\$129.95**
ENTERTAINER: Joysticks Star Raiders, Missile Command, **\$71.99**
GAMES: Space Invaders/Missile Command/Asteroids/Basketball/Chess/Super Breakout/Video Ease! Your Choice **\$29.99**
PAC-MAN/Centipede/Star Raiders/Caverns of Mars Your choice **\$35.99**
MILLIKEN Children's Games: AlienCounter/Jar Game/Golf Classic/Frenzy/Battling Bugs Your Choice **\$28.99**/cassette. **\$31.99**/diskette
Personal Finance: Data Mgmt./Cash Flow/Family Budget Each **\$20.99**
Write for our brochure of additional ATARI software at bargain prices!
SUPER SPECIAL: Atari 800/48K, 810 Disk, Axiom GP100 printer w/Interface. ONLY \$1,399

See Below for Special Introductory Offer to California Residents. Write for our information brochure.
ORDER DESK open 24 hours (800) 845-5555

CA, AK, HI call (714) 781-6566; TELEX: 472-0127 ATTN: EMD
Technical Inquiries: Mon.-Fri. 9-5 PST (714) 783-1363; Sun. 9-2 PST (714) 781-6566
BANK REFERENCE: BARCLAYS BANK OF CALIFORNIA (213) 892-7244

VISA MASTERCHARGE
APO, FPO, INTERNATIONAL ORDERS ACCEPTED.
P.O. Box 3791, Riverside, CA 92519

TERMS: Prices apply to prepaid orders only; include 3% cash discount. Personal checks allow 2 weeks to clear. Universities/Fortune-500 Companies ONLY 20 day net. California residents add 6% tax. This ad supersedes all prior offerings. Prices subject to change. Orders may be withdrawn without notice. All items new in original factory cartons and with full manufacturer's warranty. Software not warranted for suitability for specific usage. 15% restocking charge on all returned items. Absolutely no return on used or damaged items. Software returnable ONLY in UNOPENED original wrapping. Add 3% for Handling, Shipping & Insurance (\$3.95 min.) Non-UPS items (large computers/printers) shipped AIRFREIGHT COLLECT WITHIN CALIFORNIA ONLY. Non-UPS items shipped PREPAID to nearest commercial airport/route outlet! 10% handling charge on foreign orders; packing charges additional if needed.
CP/M is a registered trademark of Digital Research. Microsoft, MultiPlan are trademarks of Microsoft Corp. CYMA is trademark of CYMA Corp. TurboDOS is trademark of Software 2000. Z80A is registered trademark of Zilog Inc. WordStar, SpellStar, CalcStar, DataStar, MailMerge are trademarks of MicroPro Company.

computers wholesale

315-472-3055
Box 91 Brewerton, N.Y. 13029

**We pay UPS shipping charges
on prepaid orders.**

-SYSTEMS-

ALTOS..... 20% OFF LIST	
ACS-8000-2.....	\$2920
ACS-8000-10.....	6799
ACS-8000-12.....	7189
ACS-8000-14.....	8790
ACS-8000-15.....	3990
MTU-1.....	2000
MTU-2.....	2000
Series 5-15D.....	2390
Series 5-5D.....	4790

ATARI	
800 (48K).....	\$659
400 (16K).....	259
810 Disk Drive.....	449
850 Interface.....	169

CROMEMCO	
CS-0.....	\$1035
CS-1.....	3195
CS-1H.....	4795
CS-2.....	3755
CS-3.....	7995
ZPU.....	315
64KZ.....	799
TuArt.....	249
16FDC.....	475

The complete CROMEMCO line is available.

INTERTEC	
Superbrain II Jr.....	\$1969
Superbrain II QD.....	2349
Superbrain II SD.....	2650

MORROW DESIGN	
Decision I.....	\$1335

Micro Decision w/Terminal	
1 Drive.....	1435
2 Drives.....	1715
Discus 2D.....	830
Dual Discus 2D.....	1385

Call us for prices on the full MORROW line.

NORTHSTAR	
Advantage.....	\$2895
Horizon 2Q-64K.....	2685
HD 18 Mg. Disk.....	3879
G CP/M® for Advantage.....	119

We carry the complete NorthStar line—Call!

TELEVIDEO	
TS-801.....	\$2650
802.....	2795
802H.....	4755

ZENITH	
Z-89-80 CP/M® or H/DOS.....	\$2075
Z-89-82 CP/M® or H/DOS.....	2115
Z-90-80 CP/M® or H/DOS.....	2115
Z-90-82 CP/M® or H/DOS.....	2299

Advertised prices reflect a cash discount on prepaid orders only. Most items are in stock for immediate delivery in factory sealed cartons with full factory warranties.

-TERMINALS-

ADDS	
Viewpoint.....	\$559

HAZELTINE	
Esprit.....	435
Esprit II.....	515
Esprit III.....	1350
1420.....	589
1500.....	845
1520.....	1350
Executive 80-20.....	Savel 975

INTERTEC	
Intertube III.....	725

SOROC.....	Call!
-------------------	-------

TELEVIDEO	
910.....	\$559
912.....	659
920.....	719
925.....	719
950.....	899
X-tra Page Memory.....	80
Integral Modem.....	
(Must be ordered w/Terminal).....	335

ZENITH	
Z-19.....	\$685

-PRINTERS-

ANADEX	
DP9500.....	\$1290
2K Buffer.....	80
9501.....	1290
9620.....	1475

CENTRONICS	
704-9 Ser.....	\$1589
704-11 Par.....	1689
730-1 Ser.....	Savel 299
730-3 Ser.....	479
737-1 Par.....	689
737-3 Ser.....	Savel 299

C.ITOH	
Prowriter 8510A Par.....	\$425
Prowriter 8510A Ser.....	609
Starwriter F10 Par.....	1370
Starwriter F10 Ser.....	1370
Printmaster F10 Par.....	1920
Printmaster F10 Ser.....	1920
C.ITOH Starwriter F10-Tractor.....	200

DIABLO	
620 RO 25CPS.....	\$1275
630 RO 40CPS.....	1949
Tractor.....	275

EPSON	
MX-80.....	\$425
MX-80FT.....	510
MX-100.....	665
Serial RS232 w/2K.....	120

INTEGRAL DATA SYSTEMS

Prism 80 Basic.....	\$625
Prism 132 Basic.....	1075
Prism 80 Package.....	1299
Prism 132 Package.....	1465
Prism 80 All but color.....	1065
Prism 132 All but color.....	1260
Paper Tiger 445G.....	599
Micro Prism.....	639

NEC	
3510.....	\$1515
3515.....	1540
3530.....	1650
7710.....	2295
7715.....	2495
8023.....	465

OKIDATA	
80.....	\$300
82A.....	395
83A.....	595
84S.....	989
84P.....	989
Tractor for 80/82A.....	50

SMITH-CORONA TP-1.....	Call
-------------------------------	------

TEXAS INSTRUMENTS	
TI-810 Basic.....	\$1289
TI-810 VCO/Full.....	1549
TI-820 RO Basic.....	1545
TI-820 KSR Package.....	1739

-MONITORS-

AMDEK	
100G.....	141
Color I.....	310
Color II.....	689
Color III.....	419
300G.....	149

BMC	
Green Phos.....	\$99

SANYO	
9" Green Phos.....	\$159
12" Green Phos.....	209
13" Color.....	439

ZENITH	
Z-121.....	115

-HARD DISKS-

CORVUS	
5MB.....	\$2555
10MB.....	3995
20MB.....	4795
*Please specify what type of computer used	
Mirror Backup.....	629

MAEZON	
5Mg.....	\$2235
10 Mg.....	2760
15 Mg.....	3020
CP/M®s 100.....	75

-MODEMS-

HAYES	
Micro Modem 100.....	279
Micro Modem II.....	279
Smartmodem 300.....	215
Smartmodem 1200.....	520
Chronograph.....	199

NOVATION	
4102D 300/1200.....	\$269
D-Cat.....	145
Apple Cat II.....	310
Nov-212 1200 Baud.....	549

-SOFTWARE-

ASHTON-TATE	
D Base II.....	\$593

COMPU-View	
V-Edit.....	125

MICROAP	
Select III.....	155
Select IV.....	245
Select V.....	455
Glector.....	245

MICAH	
CP/M® 2.X.....	225
Expand.....	85

MICROPRO	
Supersort I.....	165
Supersort II.....	155
WordStar.....	295
Mailmerge.....	115
DataStar.....	245
CalcStar.....	225

MICROSOFT	
Z-80 Soft Card.....	295
Apple 16K RAM Card.....	165
Edit 80.....	85
Macro 80.....	165
Basic 80.....	275
Bascom.....	305
Fortran 80.....	335
Cobol 80.....	565
Softcard Premium Pack.....	625

MICRO TECH	
CALL	

OSBORNE	
Business Pack.....	285
General Ledger.....	59
Payroll, Cost Accounting.....	59
Accs. Payable / Accs. Receivable.....	59

SORCIM	
Supercalc.....	225

BLANK DISKS—Call for prices
—MEMOREX, MAXELL,
SCOTCH, VERBATIM—

*If you can't find what you
need listed here, just call for
the best prices on the items
you require.*

N.Y. residents, add appropriate sales tax. Shipping is not included (unless otherwise stated) C.O.D.s require a 25% deposit. All prices and offers may be changed or withdrawn without notice.

Character Editor for the Atari

DESIGN SPECIAL CHARACTERS
OR GRAPHICS SYMBOLS WHILE EXPLORING
THE ATARI'S ANTIC 4 AND 5 MODES.

Tim Kilby
RR 1, Box 288-B
Sperryville, VA 22740

One of the most powerful features of the Atari 400 and 800 computers is that they allow you to redefine the character set. Thus a creative programmer can design foreign-language alphabets, special symbol tables, or unique graphics characters for custom screen displays. This feature uses less memory than alternative Atari graphics modes and allows easy manipulation of characters in the form of text strings. Many of your favorite computer games use character graphics in BASIC mode 1 or the

hardware-only ANTIC 4 mode. In this article I shall explain how to use the elusive five-color ANTIC 4 mode because it offers the greatest graphics resolution and design challenge.

In brief review, the Atari computers support three text modes (GRAPHICS 0 through 2) and six graphics modes (GRAPHICS 3 through 8) accessible through Atari BASIC. (The new GTIA-chip-equipped computers have three additional graphics modes: GRAPHICS 9, 10, and 11.) But five more modes are available to BASIC programmers only through display-list modification. The display list is that set of instructions that determines how data found in screen memory will be displayed. Its beginning location in memory varies but can always be found in the pointers at memory locations 560 and 561 (230 and 231 hexadecimal). Both the display list and screen memory are subject to programmable modification.

While you may have heard of these hidden modes, few programmers take advantage of their unique features. The ANTIC 4 mode is very easy to

establish by means of a simple display-list modification, which can be accomplished by the program in listing 1. However, if you try to print text characters on the screen while in this mode they will be distorted and unreadable because in this mode character data is interpreted differently than in other text modes. The first time you use the ANTIC 4 or ANTIC 5 mode you will immediately see that normal character sets such as the one supplied with your computer just won't work. The best way to design a new character set, one that will work in ANTIC 4 mode, is to use a character-set editor, a program that will assist you in quickly designing a custom character set and saving it for future use. While several character editors are available commercially, none are specifically designed for use with ANTIC 4 and ANTIC 5 modes. The Character Graphics Editor will work with these modes.

Interpreting Character Data

A character set consists of 128 characters, each having an identifying character number and 8 bytes of

Editor's Note: *The Atari personal computers incorporate several sophisticated features that allow tremendous flexibility in the design of computer-generated graphics. Readers who want more background information on display lists and character modification should consult the following articles: "An Introduction to Atari Graphics," (January 1981 BYTE, page 18); "The Atari Tutorial, Part 1: The Display List," (September 1981 BYTE, page 284); and "The Atari Tutorial, Part 2: Graphics Indirection," (October 1981 BYTE, page 70). Other aspects of the Atari computers are covered in further articles in the Atari Tutorial series that appeared in BYTE from November 1981 through June 1982.*

ATARI GRAPHICS

Listing 1: The ANTIC 4 Display-List Modifier program. Any text characters entered on the screen while this program is running will be unreadable.

```
10 REM ANTIC 4 Display List Modifier
20 GRAPHICS 0
30 DL=PEEK(560)+256*PEEK(561)
40 POKE DL+3,4+64
50 FOR I=0 TO 22
60 POKE DL+6+I,4
70 NEXT I
```

data that determine its shape. The character numbers, from 0 to 127 (called ATASCII numbers by Atari) are each stored as one byte in a program. The shape data for each character is stored permanently in the ROM (read-only memory) inside the computer. When you call GRAPHICS 0 mode and print text to the screen, the computer fetches 8 bytes of shape data for each character; each byte represents 8 bits of information for a total of 64 bits per character. Each byte of shape data is converted into an 8-bit binary number containing zeros and ones. A bit that is "on" (a number one) displays a dot. A bit that is "off" (a number zero) does not. In figure 1 you can see that the letter X has 24 on bits and 40 off bits. The computer dutifully displays the 24 on dots, which you perceive as the X character.

In ANTIC 4 mode, however, the 64 bits of character data are interpreted differently. The computer takes one byte at a time. Instead of breaking

down each byte into 8 separate bits, it takes 2-bit units, or bit pairs, and interprets each pair as a single dot in one of four colors (see figure 2). If neither bit in the pair is on, then the background color (whatever is in color register 4) is chosen and no dot appears on the screen. If a right-hand bit is on, the dot will be the color in register 0. If the left-hand bit is on, the dot will be the color in register 1. If both bits are on you will see a colored dot from register 2. (COLOR 1 comes from register 0, COLOR 2 from register 1, and so forth, except for COLOR 0, which comes from register 4.)

So, where the computer reads four bit pairs, four dots could be displayed for each byte with a choice of three colors, four if you count the background color. Characters are still 8 bytes tall, so you have 32 dots (or pixels, as they should be called) per character instead of 64, but the letters are not tall and skinny as you might expect. Each pixel in ANTIC 4 mode is twice as wide as in GRAPHICS 0 mode. The physical dimensions of the displayed character will be the same in either mode, and the screen still displays 40 characters per line by 24 lines.

Figure 3 is the ANTIC 4 mode interpretation of figure 2 showing how some dots in a character would be COLOR 1, some COLOR 2, and some COLOR 3. Such characters look confusing on the screen. We

have to redesign them if we are to use them in this mode.

Designing ANTIC 4 Characters

Usually redesigning an alphabetic character to read properly in ANTIC 4 mode requires working with one color at a time. Referring back to figure 1, use only bits in columns 0, 2, 4, and 6 for characters with register 0 color, and columns 1, 3, 5, and 7 for characters with register 1 color. If both bits of a pair are on, then a third color, from register 2, will be used. But with the Character Graphics Editor program, you won't have to worry about bit columns or register numbers. By choosing a color, either 1, 2, or 3, the editor automatically plots points in the right position. If the letter X were redesigned, it might look like one of the versions illustrated in figures 4 and 5. Each variation produces the same character (except for color) in ANTIC 4. Notice that bit pair 0-1 on the right was not used in these cases; the right bit-pair column was left blank for spacing between text characters. This is not necessary when designing graphics symbols, especially when combining two or more characters to make one large character. For example, you could redefine the letters C, A, and R to be the front, midsection, and back of an automobile. Multiple colors could be incorporated for detail and realism.

A fifth color can be achieved by de-

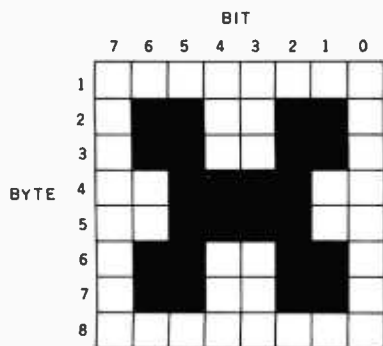

Figure 1: GRAPHICS 0 mode bit map for the X character. A character is composed of 64 bits, with selected bits turned on to display the character.

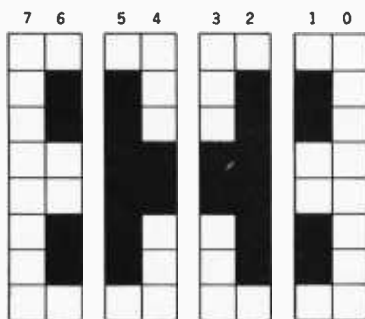

Figure 2: ANTIC 4 bit map for the X character. The bit map is divided into bit pairs for use by ANTIC 4 and 5 modes.

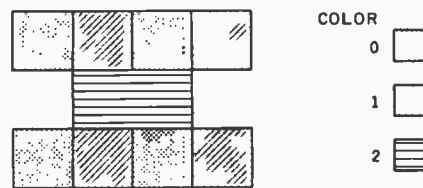

Figure 3: ANTIC 4 mode interpretation of figure 2. The configuration of the bit pairs determines the color on the screen.

GOOD NEWS

Have you put aside buying a color monitor because it's too expensive? But, have you looked at the new TAXAN RGBvision color monitor? Would you be excited at a suggested retail price of \$399.00 for the RGBvision I, and \$599 for the RGBvision II?



DO WE HAVE GOOD NEWS FOR YOU!

For those low prices, you can have:

- Full compatibility with Apple III and IBM PC without interface modules
- Compatible with Apple II through the TAXAN "RGB-II" card
- RGBvision I medium resolution - 380(H) lines
- RGBvision II high resolution - 510(H) lines
- Unlimited colors through linear amplifier video circuit and 16 colors for Apple III and IBM PC
- 12-inch, 90° deflection CRT display

Can you really afford to turn all that down without looking at the TAXAN RGBvision monitors? See your local dealer for a demonstration.



TAXAN 12" green phosphor monitor, model KGI2N, features an 800 line resolution at center, 2000 character display.



TAXAN

TSK ELECTRONICS CORPORATION

1524 Highland Avenue
Duarte, California 91010
A subsidiary of Kaga Denshi

Apple II and III are trademarks of Apple Computer, Inc.
IBM PC is a trademark of International Business Machines, Inc.

ATARI GRAPHICS

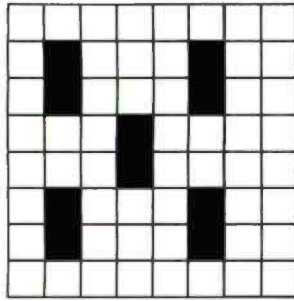

A

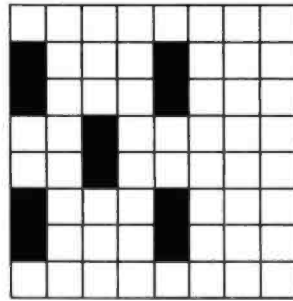

B

Figure 4: Alternative configurations for bit pairs. If all the right-hand bits are on, as in A, the X would be the color in register 0, while the X in figure B would be the color in register 1.

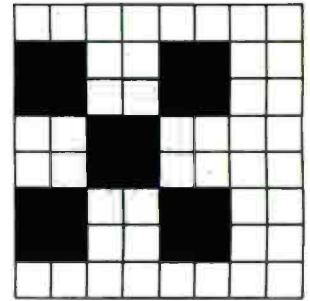

Figure 5: Inverse video character. By having all the bits in the bit pairs on and printing the character as an inverse video character you can obtain the color in register 3.

signing the character to have both bits in a bit pair on *and* printing the character as an inverse-video character (setting the most significant name bit). The X in figure 5, for example, if printed inverse, would be printed in the register 3 color. A single on bit, either left or right in a bit pair, will

not be affected by inverse video; only when both bits are on will the color switch with inverse printing. Using this technique you can have a total of four character colors plus the background color, just like GRAPHICS modes 1 and 2. ANTIC 4 mode allows the use of all 128 characters at

one time, whereas GRAPHICS 1 and 2 allow only 64 characters at a time.

ANTIC 5 mode is another hardware-only mode, just like ANTIC 4 except the characters are twice as tall. Twelve lines of ANTIC 5 mode characters will fit onto a full video display screen. The same redefined character

A unique experience for those who love a challenge ... SPITFIRE SIMULATOR...

- Fly a 360 mph Spitfire fighter • Pursue and attack 3-D target aircraft • Eight target types (Me 109, Fw 190, etc.) • Scores for targets hit and successful mission completion
 - Aerobatic (loops, rolls, stalls, etc.)
 - AIRSIM-I pilots: SPITFIRE SIMULATOR can use AIRSIM-I scenery!



\$40.00

Mass. residents add 5% sales tax. Overseas shipping add \$3.00. For Apple II or II+ with 48 K RAM. Applesoft ROM or equivalent. One disk. Game paddles or joystick.

See your dealer or contact us directly.

Apple is a Trademark of Apple Computer, Inc.
AIRSIM is a Trademark of Mind Systems Corporation



Mind Systems Corporation

P.O. Box 506
Northampton, MA 01061
(413) 586-6463

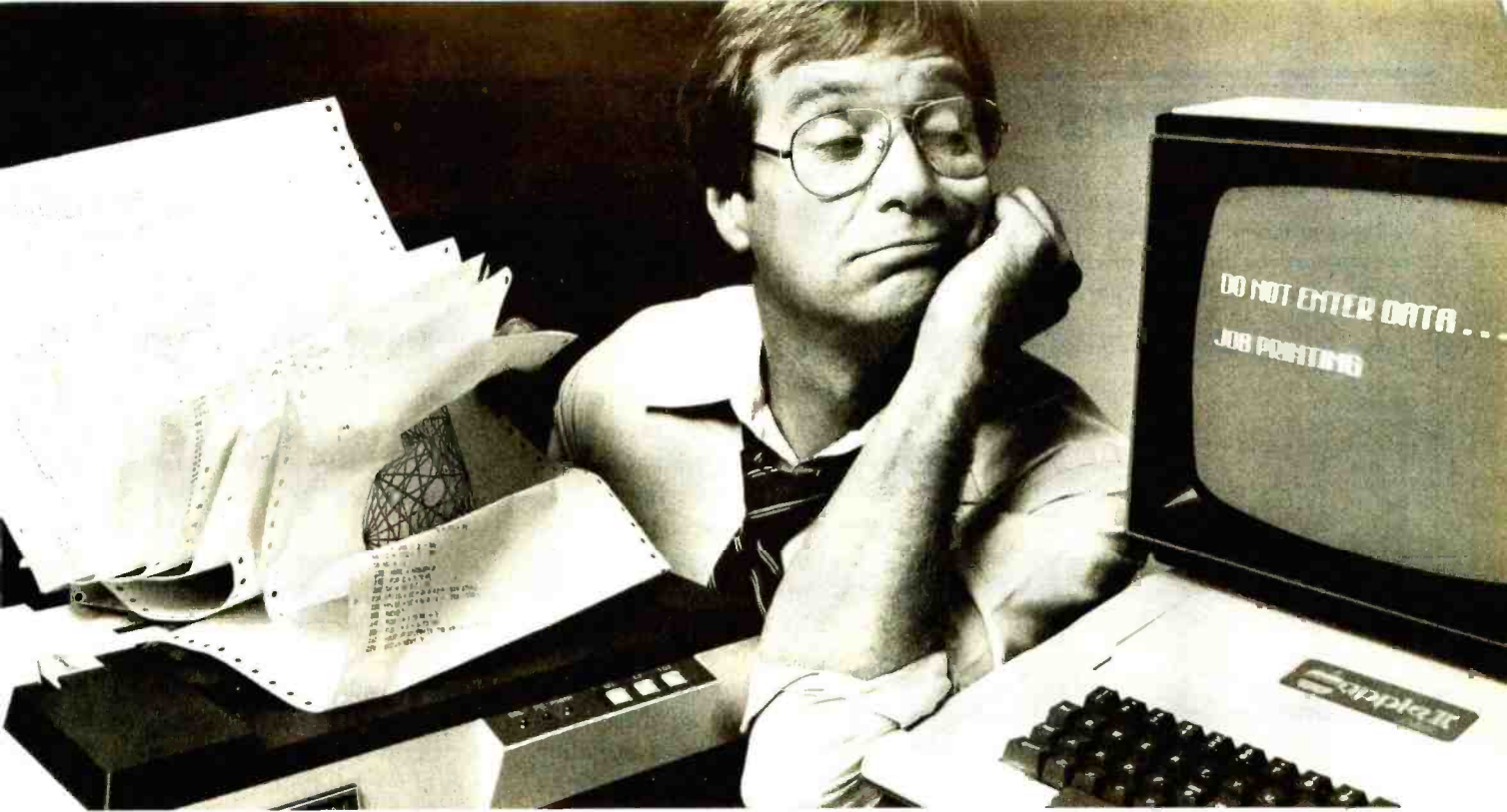

If your printer uses your Apple[®] more than you do, you need The Bufferboard[™].

If your Apple is locked into the "PRINT" mode so much that you've taken up solitaire to kill the boredom, you need a buffer. And if your computer is the Apple II or III, the only buffer for you is The Bufferboard. Expandable to 64K of storage, The Bufferboard stores an instantaneous bucketful of print data from your computer. Then it feeds the data to your printer at its own printing rate. Your Apple is set free from driving your printer and is ready for more data from you.

or expensive power supplies are needed because The Bufferboard fits right into your Apple—and docks onto your existing printer interface. The result is convenient

memory chips. This "bucket" will hold up to 20 pages of a print job, allowing you freedom to use your Apple.

The Bufferboard—designed exclusively for the Apple Computer.

Specifications:

- Versions for Grappler + interface, Epson interface, Apple interface, and other popular printer interfaces
- 16K buffer standard
- Upgradeable to 32K or 64K
- Automatic memory configuration
- Automatic self test
- Includes interface docking cable.

The Bufferboard is made by Orange Micro, Inc.; the same people who brought you the popular Grappler + printer interface. Both the Grappler + and The Bufferboard are now available at your local Apple dealer.

Apple is a registered trademark of Apple, Inc. Epson is a registered trademark of Epson America, Inc.

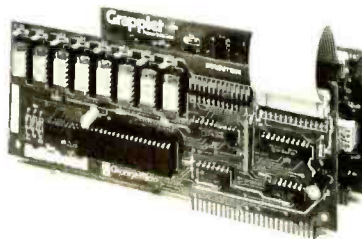

and economical buffering of most popular printer interfaces, including the Grappler +[™] interface, Epson interface, and Apple printer interface. Thirty seconds and a single hook-up are all you need to end the printer waiting game forever.

Up to 20 letter-size pages stored at a time.

The Bufferboard comes standard with 16K, and is expandable to 32K or 64K of buffering capacity with the addition of

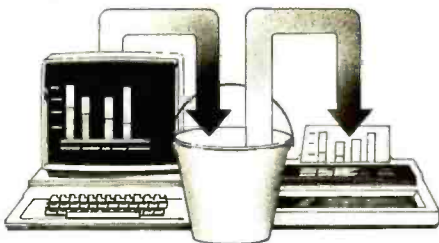

Take your existing interface—and buffer it!

Only The Bufferboard has a simple Interface-Docking System. No bulky boxes

Orange Micro inc.

3150 E. La Palma #G, Anaheim, CA 92806
(714) 630-3620, TELEX: TX 183511 CSMA

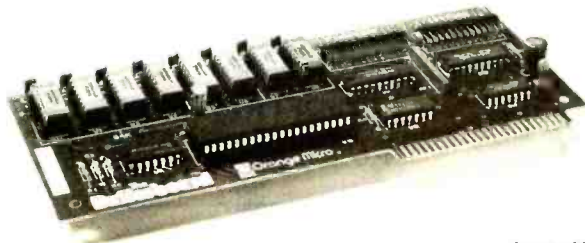

The Bufferboard[™]
For Apples and Printers

Circle 354 on inquiry card.

© Orange Micro, Inc. 1982

ATARI GRAPHICS

Listing 2: *The ANTIC 5 Display-List Modifier program. Characters entered on the screen will be displayed twice as tall as normal, again making them unreadable.*

```
10 REM ANTIC 5 Display List Modifier
20 GRAPHICS 0
30 DL=PEEK(560)+256*PEEK(561)
40 POKE DL+3,5+64
50 FOR I=0 TO 10
60 POKE DL+6+I,5
70 NEXT I
80 POKE DL+17,65;POKE DL+18,PEEK(560);
POKE DL+19,PEEK(561)
```

set used in ANTIC 4 mode may be used for ANTIC 5 mode. The display-list modification is similar to that for ANTIC 4 mode (see listing 2). Although I have never seen ANTIC 5 mode used in a practical program, the tall text characters do offer exciting potential.

Listing 3 demonstrates multicharacter, multicolored graphic symbols; the special characters are incorporated into the program in the form of DATA statements. The program displays GRAPHICS 0, ANTIC 4,

and ANTIC 5 modes with five colors of characters. Look for the inverse video characters (underlined> in lines 110 and 140.

Character Graphics Editor

One way to design a character set is by hand. With lots of graph paper, colored pens, and imagination, you can design a set in an hour or so. Then you must convert the graphic data into numerical data and code it in a program as DATA statements. This isn't difficult, but it is very time consuming. With the Character Graphics Editor program, the Atari computer can handle all these tasks, except for supplying the imagination, so let it do the work. Type in listing 4, using inverse characters whenever you see an underlined character. Line 140 has an Escape/Control key sequence in braces that will cause a down arrow to appear on the screen during the program run. The pro-

gram requires 13K bytes of free RAM (random-access read/write memory).

If you've used other character editors before, you'll probably find this one different visually and operationally. You will need to understand how ANTIC 4 and ANTIC 5 modes interpret data, as previously explained, because you will be working with three colors in a 4-by-8-dot grid.

When you run the editor, the screen will be divided into five windows, each for a different mode. The top window (GRAPHICS 3) displays an enlarged character in two grids. The left grid is the working grid; the right grid is an 8-by-8-dot interpretation of the left grid. Below these is the instruction window; watch for prompts and the menu here.

Next is a mode-switchable window containing the entire 128-character set, and below that are two windows, ANTIC 4 mode and ANTIC 5 mode

The Ultimate For dBASE II Users



dNAMES®

**DOCTORS REALTORS CONTRACTORS DENTISTS
LAWYERS MAIL ORDER SERVICE COMPANIES CONSULTANTS**

If you deal with people, these are features that make dNAMES® invaluable.

- Totally menu driven, error checking, taking full advantage of the power of dBASE II/2.31B.
- Pick from up to 9 primary and up to 40 secondary user supplied classification names. (WE THINK YOU'LL BE IMPRESSED.)
- Option of 5 report formats: single column or 3 across AVERY 33 labels, single line, 2-6 lines, or mailmerge data file. These are based on your choice of classifications, date range, zip range, letter range and/or sorted on your choice of fields in seconds.
- Transfer old or unused records to Archive backup disk.
- The most sophisticated edit program available for dBASE II. No more searching for individual records to edit. Display for instant editing only records that fall within your choice of ranges.
- Automatically checks file first to see if that record name is already on file. If so it displays all current information including date entered and last update) from up to three different files. At which point you can skip, edit, add a record, delete or recall, mark for future transfer, check for other similar names, or even address an envelope.
- Fast find a record by name or phone number instantly.
- Keep track of name, salutation, add, city, state, zip, phone, 2 different classifications, entry date and last update, and up to 4 lines of comments, all dispersed into 3 files for speed and efficiency.
- Although the uses for this program are endless, source code is included providing a base for limitless additional customizing.

C. ITOH, ALTOS, TELEVIDEO, EPSON, AND HAYES.
BEATS ANY PRICE IN THIS ISSUE.

dNAMES	129.00
dBASE II™	469.00
QUICKCODE™	219.00
dUTIL™	65.00
DB HELP ON LINE HELP	20.00
PAYROLL	350.00

CALL OR SEND FOR FREE COPY OF CURRENT DTIPS

TERMS - NO COD OR TERMS - CWO ONLY
PAYMENT - CASHIERS CK/M.O. - BANK TRANSFERS
ACCEPTED - Allow 20 days for personal checks
MASTERCARD/VISA ACCEPTED



TECHNICAL HOTLINE
619-272-5556
CONSULTATIONS AVAILABLE
ORDER DESK ONLY
619-272-5874



LEARN VISICALC™ THE EASY WAY USING OUR TEMPLATES

First load Visicalc, then load the Template diskette and key in the numbers. You will enjoy the power of Visicalc instantly!

DO YOUR:

ESTIMATING IN CONSTRUCTION Job Cost \$49.95

The Building Site • Preliminary Costs • Site Clearing, Excavation, & Fill • Footings • Foundation • Floor System • Super Structure • Roofing • Electrical, Plumbing, Heating & Air Conditioning • Brickwork • Energy Saving Materials • Interior Wall & Ceiling Finish • Exterior Trim • Concrete Floors, Walks, & Terrace • Interior Trim • Painting, Floor Covering & Appliances • Gutters. Onsite Improvements & Misc. • Overhead Contingency & Profit.

ANALYSIS IN FINANCE \$49.95

Break-Even Analysis • Cash Budget • Pro-Forma P & L • Pro-Forma Balance Sheet • Ratio Analysis • Depreciation Tables (5) • Net Present Values.

PROJECTIONS IN REAL ESTATE \$49.95

NIREB Forms: CID B — Property Analysis • CID C — Comparative Investment Analysis • CID D — Individual Tax Analysis • CID G — Excess Depreciation • Net Proceeds • CID I-A — Internal Rate of Return.

BUDGETS for the HOME \$29.95

Personal Budget • Shopping List • Mortgage & Loan • Individual Retirement Account • IRS Schedule A.

Future Templates — Retailing • Energy Audit • Engineering • Statistics • Multi-Level Marketing. Customize Templates \$30.

Specify which one: Apple II • TRS-80 I, II, III • IBM PC • Atari 400, 800 • Commodore

ORDERS AND INQUIRIES

(714) 338-5075
COD — Cashiers Check or Money Order Only. Prepaid — Personal Check O.K.
UPS — Add \$2.50 shipping or handling, street address required. Calif. — add 6.5% sales tax.

SOFTWARE MODELS

"The Template People"
P.O. Box 1029 • Crestline, CA 92325

SUPER BARGAINS

ACE 1000 COLOR COMPUTER! List \$1545
SHARP COMPUTER 249

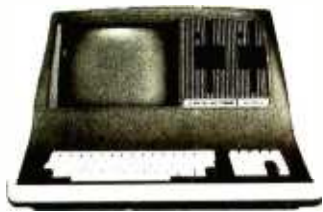

SUPERBRAIN II

Double Density 1894
 Quad Density 2274
 Super Density SD 2649
COMPUSTARS
 TO DEALERS CALL & SAVE

Advanced Micro Digital S-100 Super-Quad Single Board Computer. Z80 64K RAM, Disk Controller, RS-232 Only 699

ALTOS — single and multi-user
 ACS-8000-15D List 5990
 Only 4699

ATARI 400 289
 800 655

PRINTERS

OKIDATA 82A 489
 CENTRONICS 739-1 499
 IDS PRISM 80 743

EPSON MX-80 FT 547
 MX-80 459
 MX-100 749

ANADEX 9501A 1345
 Silent Scribe 1689
 NEC #3510 Letter Quality 1399
 C. ITOH F10 Letter Quality 648
 Smith Corona TP-1

TRAXX 5 1/4" Add-on Drives 249

Memory Merchant 16K static 159
 Central Data RAM S-100 64K 299
 Systems Group
 RAM S-100 64K 449
 Microangelo Video Graphics 715

AMERICAN SQUARE COMPUTERS is organizing a World Wide Association of Computer Dealers. Open a Store or Start Work Out of Your Home! We Charge NO FRANCHISE FEE! (Our Competitors charge a FRANCHISE FEE of from \$15,000.00 to \$45,000.00.) Be a Winner! Let US help YOU get started MAKING MONEY by HELPING PEOPLE to put COMPUTERS to WORK. Write or Phone today.

Which Computers are Best? ... Free

Insured Shipping at Low Rates.



TELEVIDEO

Televideo 910+ 518
 Televideo 925 718
 Televideo 950 899
 Televideo Computers Call

ADDS VIEWPOINT A-1B 525
 ZENITH Z-19 Terminal 649
 Z-89 48K Computer 2119
 Z-90 64K DD 2399
 ZVM-121 ZENITH
 Green Screen monitor 125

INTERTUBE III
 or EMULATOR \$710
 AMDEK Color Monitor \$329

GODBOUN COMPUPRO
 Super Sixteen 8085/8088. The fastest 8-16 bit computer! Runs 8 and 16 bit code! 128K Static RAM, 6MHz CPU's
L1ST 3440 SPECIAL 2569

New: Systems 816/A, B, and C with enclosure and drives.
 816/A List 5495 Only 4729

SEATTLE pure 16 bit computer is the fastest microcomputer by actual test! S-100. 128K Static RAM, 8 MHz 8086. 22 slot Mainframe
 Model #2 List 3785 Only \$3028
 #1 as above
 but 64K List 2990 Only \$2392

IBM PC memory made by SEATTLE.
 Now with "Flash Disk." 192K = 697
 64K = 427

CALIFORNIA COMPUTER 2210A
 List \$1995 Only \$1595
 Z80, 64K, I/O, Disk controller + CPM.
 California main frame 484

SYSTEMS GROUP computers run FRIENDLY OASIS Call SAVE

QUAY COMPUTER
 Two drives + CPM \$1745
 Four user MPM 208K +
 Hard Disk \$5945

TARBELL'S
 Empire I & II have two 8" disk drives. The I is single sided, the II is double sided.

FREE Business Software
 Empire I List 4888 Only 3495

Corvus Hard Disk SAVE
 SSM Video BRD VB3 kit 361
 Spectrum Color ASM 326



NORTH STAR

ADVANTAGE 64K Green Phosphor. The Best Business Graphics, 2 Disks, Serial Port. Options CPM — Business programs \$2894



NORTH STAR Horizon

Powerful North Star BASIC Free
 Superb for Business & Science

Horizon Standard is now HRZ-2-64K Quad

Factory Assembled & Tested Only
 Horizon-2-64K-Quad \$2649
 Horizon-1-64K-QHD 5 3795
 Horizon RAM 64K 594
 Big Sale on Multi-User

Time-Sharing SAVE
 North Star Hard Disk 18Mb 3995
 English to Basic Translator 75
 Zbasic 2 to 5 times faster! 325
 Secretary Word Processor 69
 Wordstar Word Processor 278
 Floating Point Board 699
 Oasis 699
 CPM for N* - Extra features 147
 Micro Mike Software CALL
 MICROSTAT \$265
 Pascal-80 539
 Extra Precision BASIC 49
 Northword 179
 Infomanager 329
 General Ledger 399
 Accounts Receivable 399
 Accounts Payable 399
 Inventory 399
 Order Entry 399
 PROPAC 1299
 DOS + BASIC 5.2 28

INTEGRAND main frames S-100. Many models to choose from
 Only 200 & UP

MODEMS

DC HAYES — S-100 \$329
 POTOMAC MICRO MAGIC 369
 SIGNALMAN 97
 CAT NOVIATION 159
 AUTOCAT 215



MICRO DECISION

"A DEAL YOU CAN'T REFUSE"

64K RAM, Z80, 4MHz, 2 Serial Ports, Disk Controller. FREE SOFTWARE: CPM — Microsoft BASIC — BaZic — Wordstar — Calcstar — Spellstar.

List Only
 with 1 5 1/4" Disk .. \$1195 \$ 999
 with 2 5 1/4" Disks .. 1545 1299



DECISION I

"The IBM-360 on the Z-80 & S-100 BUS!"

Sixteen Programs running simultaneously! Free CPM, Microsoft BASIC, and WORDSTAR with complete system!

DECISION 1 + 65K Static +
 8" Disks DMA 3403
 DECISION 1 + 65K Static +
 2 5 1/4" Disks 2795
 DECISION 1 + 65K Static +
 5" Disk + 5 Mb Hard Disk 4235
 DECISION 1-2user 256K Static +
 5" Disk + 5 Mb Hard Disk +
 MICRONIX 5830
 DECISION 1 — Z-80 + I/O + 65K 1915
 DECISION 1 — Rackmount + 20 Mb
 HD - 8" DRV Reg. 6235
 Inventory Sale 5415

MORROW Hard Disks

up to 26 MEGABYTES

HDC-M26 \$3333
 HDC-M20 3333
 HDC-M10 2955
DMA-M5 Reg. 1775
 Inventory Sale 1400
 DMA-M10 2235
 DMA-M16 2795

MORROW 8" Disk

Discus 2D + CPM 600K Only \$834
 Discus 2 + 2 + CPM 1.2 Mb 1068
 Add Drives 2D = 599 2 + 2 = 1795
 Discus 2D dual + CPM Only 1384
 Free Microsoft BASIC from MORROW with Discus system or hard disk.

FAST FIGURE — Most powerful spread sheet. 5 1/4" or 8" 99

Wordstar 278
 All MicroPro Software for IBM, Apple, North Star, Morrow, etc. SAVE! CALL

Call for latest prices & availability

Factory Guarantees

We Beat Prices

AMERICAN



COMPUTERS

919-889-4577

4167 Kivett Dr.

Jamestown N.C. 27282

919-883-1105

ATARI GRAPHICS

respectively, that will show actual-size samples of your design singularly, in inverse video, and in a multiple string. Plug a joystick into port 1, and you're ready to design.

Using the Editor

The character set initially loaded is the Atari standard set. The first character displayed, the letter A, doesn't look like a letter at all. Press C for clear. Your joystick movements will reposition the red cursor. Press the Fire button and a yellow dot will be plotted behind the cursor. (I know you'll want to move the cursor just to see if the dot is really there.) Press the button again and the dot will be erased. Select a color by pressing 1, 2, or 3. Atari's default colors (1 equals orange, 2 equals light green, and 3 equals blue) will be used for now. If you plot blue dots in the top window, the character's inverse color will be color 4, red. Using the SETCOLOR command, you can choose any character and background colors you wish in your own programs.

Press E to edit a different character. The Escape key, normally required to display some characters, isn't needed. The down arrow, for example, is displayed by pressing the Control and = keys simultaneously.

To save your character set as a data file, press S and enter a filename (casette users should enter C: as a file-

name). Load a previously saved data file by pressing L and entering a filename. Pressing the Select key alters the display list so that the entire character set in the third window switches from GRAPHICS 0 to ANTIC 4 mode. Test any letter or character combination by pressing T and the inverse (Atari logo) key, if you wish.

Now that you have the tool to make a proper character set, put it to use in a practical program of your own. Type in either listing 1 for an ANTIC 4 screen or listing 2 for ANTIC 5. Add the following lines and you will be able to load and use your newly created graphics character set:

```
10 RAMTOP=PEEK(106):  
   POKE 106,RAMTOP-8:  
   CHBASE=RAMTOP+4  
20 OPEN #1,4,0,"filename":  
   REM change filename to  
   the one you used.  
200 FOR I=0 TO 1023:  
   GET #1,D:  
   POKE CHBASE*256+I,D:  
   NEXT I  
210 POKE 756,CHBASE
```

Special Features

The Character Graphics Editor program uses several features that greatly enhance the program execution speed and could be used in your own BASIC

programs. A machine-language display-list interrupt (DLI) service routine is loaded into page 6 of the computer's memory at initialization. It allows the use of the standard character set in the menu window while displaying custom characters in the lower half of the screen display. The service routine is called 60 times per second by the DLI instruction located in the modified display list. Without this feature the menu would be unreadable.

A second machine-language routine, only 6 bytes long, saves and loads the character set in a fraction of the time it would take if the program used PUT and GET commands in loops. It too is located in page 6 and is initiated by a USR call.

String manipulations are used to transfer the standard character set from ROM to RAM, where it can be altered. String manipulations are also used to transfer a string containing zeros into screen memory, thus clearing displays with machine-language speed.

Player-missile graphics, an extremely powerful feature of the Atari computers, is used for the cursor and the two grid patterns of the Character Graphics Editor screen display. The cursor is moved via another string manipulation that is so fast that a delay loop was necessary to slow it down to a usable speed.

If you need some ideas to get you

AS
A-SYSTEMS CORPORATION

Job costing reports with bonding reports, Multi-state/multi-union/variable-rate payroll with certified reports, Sub-contract management, Accounts payable, Equipment costing, Accounts receivable, General ledger, Estimating and Critical path.

ACCOUNTING PACKAGE FOR CONSTRUCTION

Fully integrated. Excellent audit trail. Source code supplied nationwide. Installed four years available. Multi-user.

We are seeking representatives nationwide who understand computers, accounting, construction and sales.

Five Points Mall
1610 So. Main - Suite H
Bountiful, Utah 84010
801-298-0052

Verbatim Datalife™ flexible disks now come in a bold, new storage box. But more important, they now come to you with a five year warranty.*

We can give you a warranty this long because we're confident the way we make Datalife disks will make them perform better, last even longer.

All of our Datalife disks feature seven data-shielding advances for greater disk durability, longer data life. To protect your data from head-to-disk abrasion. To shield your data against loss due to environmental conditions. To insure a longer lifetime of trouble-free data

recording, storage and retrieval.

Every Datalife disk is extensively tested under the most extreme conditions. Critically-certified to be 100% error-free. Assuring you an added margin of performance, no matter what the operating conditions.

And we back it up with a five year warranty. Five times longer than the industry standard. Because Verbatim is the standard of excellence.

For flexible disks you can depend on—a lot longer—call (800) 538-1793. In California, or outside the U.S. call (408) 737-7771

collect for the name of your Verbatim dealer.

If you want longer data life, keep all your data on Verbatim Datalife. Our name is the promise. Our warranty is the proof.



Verbatim®

Here's the most exciting part of Verbatim's new packaging.

5 Year Warranty

©1987 Verbatim Corp. Datalife is a trademark of Verbatim Corp.
*See Verbatim's warranty policy for details.

ATARI GRAPHICS

started using ANTIC 4 or ANTIC 5, try to design a character set to graph molecular structures, a set of architectural symbols used in house-plan designs, or maybe a set of terrain symbols for a board game. The Character Graphics Editor can open two new modes for you, so let your creativity flow. ■

Listing 3: The Demo program demonstrates the GRAPHICS 0, ANTIC 4, and ANTIC 5 modes with multicharacter, multicolored graphics symbols.

```
5 REM ANTIC 4 & 5 Demo Program
10 GOSUB 1000
20 DIM ORCH1$(3),ORCH2$(3)
30 GRAPHICS 0
40 SETCOLOR 0,4,6:SETCOLOR 2,0,14:SETC
OLOR 1,8,6:SETCOLOR 3,14,12:SETCOLOR 4
,0,10
50 DL=PEEK(560)+256*PEEK(561)
60 POKE DL+3,68
70 FOR I=0 TO 6:POKE DL+I+6,4:NEXT I
80 FOR I=0 TO 3:POKE DL+I+15,5:NEXT I
90 POKE DL+24,65:POKE DL+25,PEEK(560):
POKE DL+26,PEEK(561)
100 POKE 756,CADR/256
110 ORCH1$="ab":ORCH2$="cd"
120 FOR R=0 TO 3:FOR I=0 TO 11:ORCH1
$;NEXT I: "" :FOR I=0 TO 11:ORCH2$;
:NEXT I: "" :NEXT R
130 POSITION 8,8:CHR$(27);CHR$(28);"
THIS IS ANTIC 4 MODE ";CHR$(27);CHR$(
28)
140 POSITION 16,11: "eeeeffff":POSI
TION 16,12: "99999999"
150 POSITION 8,14:CHR$(27);CHR$(28);
" THIS IS ANTIC 5 MODE ";CHR$(27);CHR$(
28)
160 END
1000 POKE 106,PEEK(106)-5:GRAPHICS 0:P
RINT "Transferring characters from ROM
to RAM . . ."
1010 CADR=256*(PEEK(106)+1)
1020 FOR I=0 TO 1023:POKE CADR+I,PEEK(
```

```
57344+I):NEXT I
1030 ? 4? "Redefining 7 characters . .
. . ."
1040 FOR I=0 TO 55:READ X:POKE 776+CAD
R+I,X:NEXT I
1050 DATA 3,63,247,255,255,61,223,61
1060 DATA 240,124,252,223,253,255,252,
244
1070 DATA 3,3,3,15,63,0,0,0
1080 DATA 192,192,192,240,252,0,0,0
1090 DATA 0,170,187,170,187,170,187,17
0
1100 DATA 0,85,255,85,255,85,255,85
1110 DATA 255,85,255,85,255,85,255,85
1120 RETURN
```

Listing 4: The Character Graphics Editor program. It allows you to design your own character set of graphics for use in the ANTIC 4 and 5 modes.

```
10 REM CHARACTER GRAPHICS EDITOR
20 REM (C) Copyright 1982 Tim Kilby
50 DIM A$(1),O$(1),CLEAR$(1),ZERO$(1)
,CLEAR1$(1),CLEAR4$(1),FILE$(15),A(7,8
)
60 GOTO 1600
80 SOUND 0,Y/2+100-X/4,10,4:FOR D=1 TO
8:NEXT D:SOUND 0,0,0,0:RETURN
100 REM MENU
110 GOSUB 180:POSITION 1,0
120 ? "Edit Load Set C
lear"
130 ? "Color 1,2,or 3 Save Set T
est"
140 ? "SELECT <ESC-ESC-ESC-CTRL-=>=3mod
e<ESC-ESC-ESC-CTRL-=> * CHOOSE
ONE *":RETURN
180 CLEAR$(1)=ZERO$(1,120):RETURN
200 REM SCREEN MEMORY ORIENTATION
210 POKE 87,3:POKE 88,PEEK(DL+4):POKE
89,PEEK(DL+5):RETURN
220 POKE 82,1:POKE 87,0:POKE 88,HOME+1
00-INT((HOME+100)/256)*256:POKE 89,INT
((HOME+100)/256):RETURN
230 POKE 82,4:POKE 87,0:POKE 88,HOME+2
20-INT((HOME+220)/256)*256:POKE 89,INT
((HOME+220)/256):RETURN
240 POKE 82,2:POKE 87,0:POKE 88,HOME+3
80-INT((HOME+380)/256)*256:POKE 89,INT
((HOME+380)/256):RETURN
250 POKE 82,2:POKE 87,0:POKE 88,HOME+4
60-INT((HOME+460)/256)*256:POKE 89,INT
```

```
((HOME+460)/256):RETURN
300 REM PLOT_POINTS
310 GOSUB 210:F=X/4:G=(Y-20)/4:LOCATE
8+F,G+1,A:SOUND 0,20+G-F,10,2:COLOR C*
(A=0):PLOT 8+F,G+1:PLOT 9+F,G+1
320 IF C=1 THEN PLOT 28+F,G+1:COLOR 0:
PLOT 27+F,G+1:A(G,F+1)=INT(2^(6-F)+0.1
)
330 IF C=2 THEN PLOT 27+F,G+1:COLOR 0:
PLOT 28+F,G+1:A(G,F)=INT(2^(7-F)+0.1)
340 IF C=3 THEN PLOT 27+F,G+1:PLOT 28+
F,G+1:A(G,F)=INT(2^(7-F)+0.1):A(G,F+1)
=INT(2^(6-F)+0.1)
350 IF A>0 THEN A(G,F)=0:A(G,F+1)=0
360 A(G,8)=0:FOR D=0 TO 7:A(G,8)=A(G,8
)+A(G,D):NEXT D:POKE CBASE+CHR*B+G,A(
G,8)
370 SOUND 0,0,0,0:GOSUB 220:RETURN
400 REM EDIT
410 GOSUB 180:GOSUB 480
420 POSITION 10,1: ? "- Select characte
r -";
430 GET #3,CHR:GOSUB 500:GOSUB 220:RET
URN
470 FOR A=0 TO 7:POKE CBASE+CHR*B+A,0
:NEXT A
480 CLEAR1$=ZERO$(1,100)
490 FOR A=0 TO 7:FOR B=0 TO 8:A(A,B)=0
:NEXT B:NEXT A:RETURN
500 REM PLOT_CHARACTER
510 POSITION 6,0: ? "Use joystick to mo
ve cursor.":POSITION 8,1: ? "Press FIRE
to plot point."
520 POSITION 14,2: ? "(M for MENU)";
530 GOSUB 240:POSITION 11,1:CHR$(27)
;CHR$(CHR):POSITION 18,1:CHR$(27);CH
R$(CHR+128):POSITION 25,1
540 FOR A=1 TO 5:CHR$(27);CHR$(CHR);
:NEXT A: ? :GOSUB 250
550 POSITION 11,1:CHR$(27);CHR$(CHR)
:POSITION 18,1:CHR$(27);CHR$(CHR+128
):POSITION 25,1
560 FOR A=0 TO 5:CHR$(27);CHR$(CHR);
:NEXT A:GOSUB 210:IF CHR>127 THEN CHR=
CHR-128
570 IF CHR>127 THEN CHR=CHR-128
580 IF CHR>31 AND CHR<96 THEN CHR=CHR-
32:GOTO 600
590 IF CHR<32 THEN CHR=CHR+64
600 R=CBASE+CHR*B:FOR A=0 TO 7:D=PEEK
(R+A):B=A+1
610 F=0:IF D>127 THEN D=D-128:F=F+1:CO
LOR 2:PLOT 27,B:FLOT 8,B:FLOT 9,B:A(A,
0)=128:A(A,8)=A(A,8)+A(A,0)
```

Listing 4 continued on page 179

ENHANCE YOUR COLOR COMPUTER WITH THESE GREAT PRODUCTS!

MACRO-80c DISK BASED EDITOR/ASSEMBLER

This is a powerful macro assembler. screen oriented editor and machine language monitor. It features local labels, conditional assembly, printer formatting and cross reference listings. Assemble multiple files. Program comes on Radio Shack compatible disk with extensive documentation. Price: \$99.95

MICROTEXT COMMUNICATIONS

Make your computer an intelligent printing terminal with off-line storage! Use Microtext for timesharing interactions, printing what is received as it is received and saving text to cassette, and more! Price: \$59.95

PIB8C PARALLEL PRINTER INTERFACE

Use a parallel printer with your Color Computer! Serial-Parallel converter plugs into the serial port and allows use of Centronics-compatible printers. You supply the printer cable. Price: \$69.95

THE MICRO WORKS COLOR FORTH

Color Forth is easier to learn than assembly language, executes in less time than Basic and is faster to program in than Basic. Rompack comes with 112-page manual containing glossary of system-specific words, full standard FIG glossary and complete source. A fascinating language designed for the Color Computer! Price: \$109.95

SDS-80C SOFTWARE DEVELOPMENT SYSTEM

SDS-80C is a Rompack containing a complete editor, assembler and monitor. It allows the user to write, assemble and debug assembly language programs with no reloading, object patching or other hassles. Supports full 6809 instruction set. Price: \$89.95

80C DISASSEMBLER

Runs on the Color Computer and generates your own source listing of the Basic interpreter ROM. Documentation includes useful ROM entry points, complete memory map, I/O hardware details and more. Cassette requires 16K system. Price: \$49.95

GAMES: Star Blaster ★ Pac Attack ★ Berserk ★ Cave Hunter ★ Starfire ★ Astro Blast ★ Starship Chameleon ★
Adventure: Black Sanctum ★ Adventure: Calixto Island ★

THE **MICRO
WORKS**

Also Available: Machine Language Monitor Books Memory Upgrade Kits
Parts and Services Call or write for more information

California Residents add 6% Tax
**Master Charge/Visa and
COD Accepted**

P.O. BOX 1110 DEL MAR, CA 92014 619-942-2400

PKASO™

Printer Interface Family

A
Masterpiece



PKASO Interfaces come complete with Cable, Instructional Diskette and Comprehensive Manual.

The PKASO family makes you and your Apple II or Apple III a master of text and graphics.

PKASO makes it easy to use the features of your printer—select character sizes, vary line spacing, even print in colors. Simple PKASO commands make these features usable from the keyboard or a program.

PKASO also adds features to your system. Press a few keys and get a snapshot "dump" of the image you see on the screen—text or graphics. Add new characters and symbols that you couldn't print before, using our SuperFont™ system. Add our new PipeLine™ printing buffer and your printer can take its time while you and your Apple move on to the next task. The PipeLine is a modular add-on to the standard PKASO board.

The PKASO interface is designed for Apple II and Apple III in all the popular configurations. It prints in full color on the IDS Prism Printer, and in striking black on C. Itoh, Centronics, Epson, IDS, NEC, and Okidata matrix printers.

NEW!

The PKASO PipeLine™ printing buffer keeps your printer from tying up your computer.

- 8K to 64K Bytes of Memory.
- Microprocessor controlled.
- Compression! Increases capacity to millions.
- Clear buffer and select modes easily.



Interactive Structures Inc.
146 Montgomery Avenue
Bala Cynwyd, PA 19004
Telephone: (215) 667-1713

Circle 242 on inquiry card.

A PICTURE'S WORTH A THOUSAND NUMBERS!

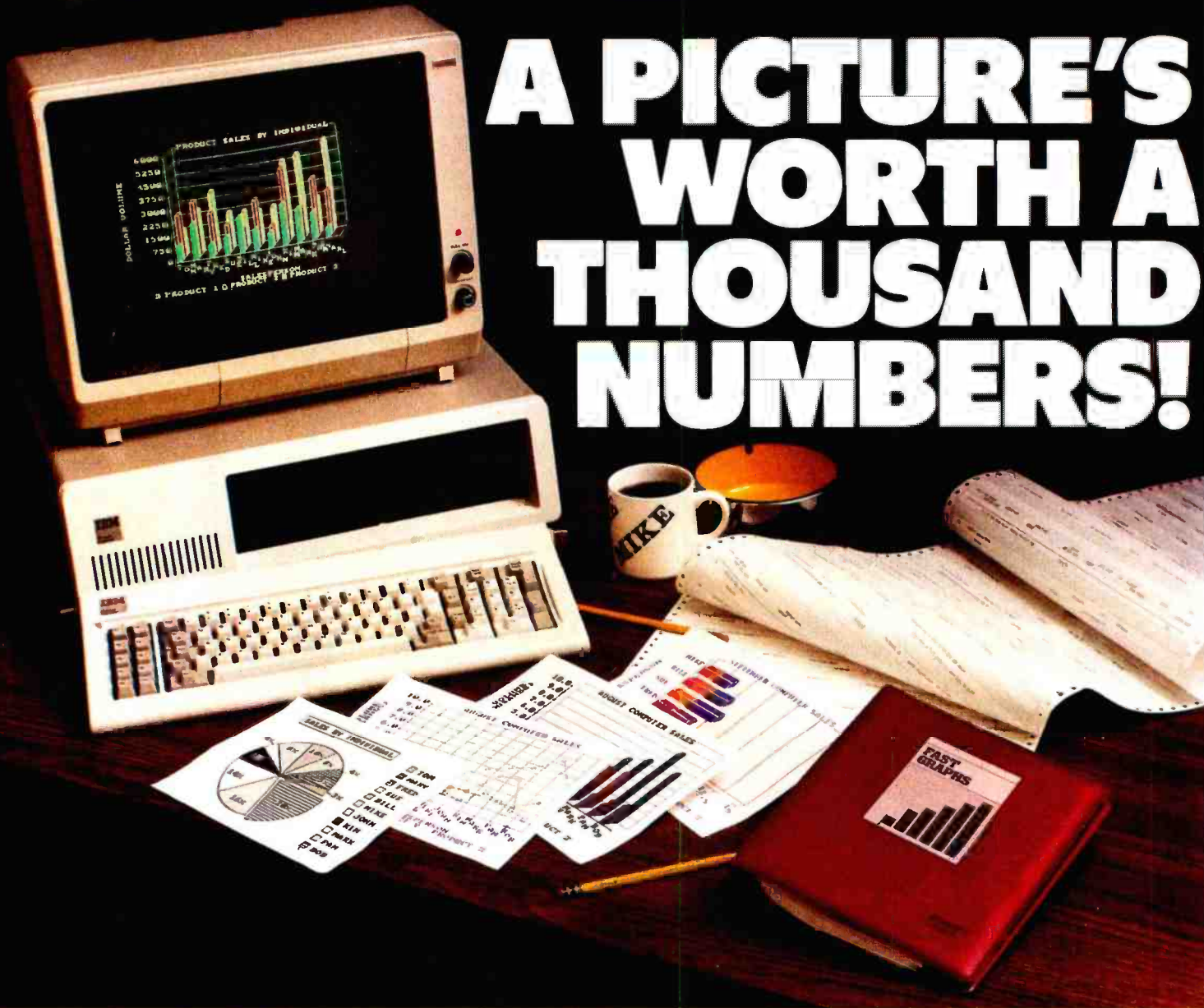

The IBM Personal Computer and Printed Reports

Everyone knows that the IBM Personal Computer™ does a terrific job of storing and manipulating facts and figures. Unfortunately, drawing conclusions from this information requires printed reports often running into the thousands of numbers. Now, however, you can use **FAST GRAPHS™** to replace all those numbers with one simple to understand, pleasing to the eye, graphic report.

FAST GRAPHS™ and the Graphic Report

FAST GRAPHS™ is the most recent addition to Innovative Software's **EXECUTIVE SERIES™**. It converts the numbers from Visicalc® DIF® files, manual entry, or our **EXECUTIVE SERIES™** packages, including **T.I.M.: III** into "graphic reports". Graphic reports may be viewed on your color monitor or sent to any popular graphics printer or plotter. A graphic report can have scatter or line charts, pie charts, and two or three-dimensional bar charts, etc., all of which may be customized by the full graphic editor. This same editor may also be used to paint and draw characters or shapes to be overlaid on a graph.

Your Data Never Looked So Good

If your meetings seem to be "bored meetings" rather than Board Meetings, then **FAST GRAPHS™** is for you. **FAST GRAPHS™** turns dull, boring, printed reports into exciting, colorful "graphic reports". Visit your local IBM dealer today for more information about **FAST GRAPHS™** and our other products. Or give us a call. Either way, you'll be drawing colorful conclusions in no time.

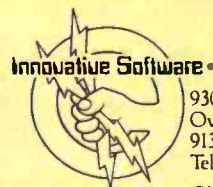

Innovative Software®

9300 W. 110th St., Suite 380
Overland Park, KS 66210
913/383-1089
Telex 209542

Circle 232 on inquiry card.

ATARI GRAPHICS

Listing 4 continued:

```

620 IF D>63 THEN D=D-64:F=F+1:COLOR 1:
PLOT 28,B:PLOT 8,B:PLOT 9,E:A(A,1)=64:
A(A,8)=A(A,8)+A(A,1)
630 IF F>1 THEN COLOR 3:PLOT 27,E:PLOT
28,B:PLOT 8,B:PLOT 9,E
640 F=0:IF D>31 THEN D=D-32:F=F+1:COLO
R 2:PLOT 29,E:PLOT 10,E:PLOT 11,E:A(A,
2)=32:A(A,8)=A(A,8)+A(A,2)
650 IF D>15 THEN D=D-16:F=F+1:COLOR 1:
PLOT 30,B:PLOT 10,E:PLOT 11,E:A(A,3)=1
6:A(A,8)=A(A,8)+A(A,3)
660 IF F>1 THEN COLOR 3:PLOT 29,E:PLOT
30,B:PLOT 10,E:PLOT 11,E
670 F=0:IF D>7 THEN D=D-8:F=F+1:COLOR
2:PLOT 31,B:PLOT 12,E:PLOT 13,E:A(A,4)
=8:A(A,8)=A(A,8)+A(A,4)
680 IF D>3 THEN D=D-4:F=F+1:COLOR 1:PL
OT 32,B:PLOT 12,E:PLOT 13,E:A(A,5)=4:A
(A,8)=A(A,8)+A(A,5)
690 IF F>1 THEN COLOR 3:PLOT 31,E:PLOT
32,B:PLOT 12,E:PLOT 13,E
700 F=0:IF D>1 THEN D=D-2:F=F+1:COLOR
2:PLOT 33,B:PLOT 14,E:PLOT 15,E:A(A,6)
=2:A(A,8)=A(A,8)+A(A,6)
710 IF D>0 THEN F=F+1:COLOR 1:PLOT 34,
B:PLOT 14,E:PLOT 15,E:A(A,7)=1:A(A,8)=
A(A,8)+A(A,7)
720 IF F>1 THEN COLOR 3:PLOT 33,E:PLOT
34,B:PLOT 14,E:PLOT 15,E
730 NEXT A:GOSUB 220:RETURN
800 REM TEST CHARACTERS
810 GOSUB 180:POSITION 5,0:?"Your typ
ed characters":POSITION 7,1:?"will ap
pear below.      NORMAL"
820 POSITION 2,2:?"- Press RETURN f
or menu -":
830 D=1:POKE 764,255:CLEAR4%=ZERO%:GOS
UB 480
840 IF PEEK(764)=255 THEN 840
850 IF PEEK(764)=39 OR PEEK(764)=103 T
HEN 900
860 GET #3,CHR:IF CHR=155 THEN GOSUB 4
80:CLEAR4%=ZERO%:GOSUB 220:POKE 694,0:
RETURN
870 GOSUB 240:POSITION D,1:?" CHR$(27);
CHR$(CHR):GOSUB 250:POSITION D,1:?" CHR
$(27);CHR$(CHR)
880 D=D+1:IF D>38 THEN D=1
890 POKE 764,255:GOTO 840
900 POKE 694,128*(PEEK(694)=0):POKE 53
279,0:GOSUB 220
910 IF PEEK(694)=128 THEN POSITION 29,
1:?" INVERSE "
920 IF PEEK(694)=0 THEN POSITION 29,1:
?" NORMAL "
930 POKE 764,255:GOTO 840
1000 REM LOAD CHARACTER SET
1010 GOSUB 1080:TRAP 1140:OPEN #1,4,0,
FILE$:POKE 850,7:GOSUB 1120:RETURN
1080 POKE 752,0:GOSUB 220:GOSUB 180:PO
SITION 1,0:?"Enter filename. (e.g. D1
:FILENAME.SET)"
1090 POSITION 11,1:INPUT FILE$:POKE 75
2,1:GOSUB 180:RETURN
1100 REM SAVE CHARACTER SET
1110 GOSUB 1080:TRAP 1140:OPEN #1,8,0,
FILE$:POKE 850,11:GOSUB 1120:RETURN
1120 POKE 852,0:POKE 853,CHEASE/256:PO
KE 856,0:POKE 857,4:POKE 756,CHEASE/25
6:A=USR(1555)
1130 CLOSE #1:TRAP 40000:POKE 54286,19
2:POKE 756,224:RETURN
1140 GOSUB 180:POSITION 1,1:?" CHR$(253
);"-Bad connection or improper filename
e-":FOR D=1 TO 600:NEXT D:GOTO 1130
1200 REM JOYSTICK
1210 A=STICK(0):B=STRIG(0)
1220 IF A=7 THEN X=X+B:IF X>24 THEN X=
0
1230 IF A=11 THEN X=X-B:IF X<0 THEN X=
24
1240 IF A=14 THEN Y=Y-4:IF Y<20 THEN Y
=48
1250 IF A=13 THEN Y=Y+4:IF Y>48 THEN Y
=20
1260 POKE 53251,X+56:A%=0%(81-Y,81-Y+1
28)
1270 IF B=1 AND A<>15 THEN GOSUB 80
1280 IF PEEK(764)<>255 THEN GOSUB 1400
1290 IF PEEK(53279)=5 THEN FOR D=0 TO

```

```

3:POKE DL+D+19,4*(PEEK(DL+D+19)=2)+2*(
PEEK(DL+D+19)=4):NEXT D
1300 IF B=0 THEN GOSUB 300
1310 GOTO 1200
1400 REM KEYBOARD CHECK
1410 GOSUB 220:GET #3,KEY:IF KEY=76 TH
EN GOSUB 1000:GOSUB 100
1420 IF KEY=83 THEN GOSUB 1100:GOSUB 1
00
1430 IF KEY=69 THEN GOSUB 400
1440 IF KEY=67 THEN GOSUB 470
1450 IF KEY=84 THEN GOSUB 800:GOSUB 10
0
1460 IF KEY=77 OR KEY=32 THEN GOSUB 10
0
1470 IF KEY=49 THEN C=1
1480 IF KEY=50 THEN C=2
1490 IF KEY=51 THEN C=3
1500 POKE 764,255:RETURN
1600 REM INITIALIZATION
1610 RAMTOP=PEEK(106)-12:POKE 89,RAMTO
P:POKE 88,0:?" CHR$(125):C=1:CHR=65:OPE
N #3,4,0,"K":
1620 POKE 106,RAMTOP:CHEASE=(RAMTOP+8)
*256:PMBASE=(RAMTOP+4)*256:GRAPHICS 0:
POKE 710,176
1630 POKE 203,CHEASE/256:POSITION 9,3:
?" INITIALIZING PROGRAM":GOSUB 490
1640 FOR A=0 TO 24:READ B:POKE 1536+A,
B:NEXT A:POKE 512,0:POKE 513,6
1650 VT=PEEK(134)+256*PEEK(135):AT=FEE
K(140)+256*PEEK(141)
1660 X=CHBASE-AT:Y=57344-AT:GOSUB 1800
1670 POKE VT+2,X2:POKE VT+3,X1:POKE VT
+4,1:POKE VT+5,4:POKE VT+6,1:POKE VT+7
,4
1680 POKE VT+10,Y2:POKE VT+11,Y1:POKE
VT+12,1:POKE VT+13,4:POKE VT+14,1:POKE
VT+15,4:A%=0%
1690 X=FMBASE+896-AT:Y=PMBASE-AT:GOSUB
1800:POKE VT+2,X2:POKE VT+3,X1:POKE V
T+10,Y2:POKE VT+11,Y1
1700 X=PEEK(88)+256*PEEK(89)+100-AT:Y=
RAMTOP*256-AT:GOSUB 1800:POKE VT+18,X2
:POKE VT+19,X1:POKE VT+26,Y2
1710 POKE VT+27,Y1:X=PEEK(88)+256*PEEK
(89)-AT:GOSUB 1800:POKE VT+34,X2:POKE
VT+35,X1
1720 X=FEEK(88)+256*PEEK(89)+380-AT:GO
SUB 1800:POKE VT+42,X2:POKE VT+43,X1
1730 FOR A=4 TO 44 STEP 8:FOR B=0 TO 3
:READ D:POKE VT+A+B,D:NEXT B:NEXT A:GO
TO 2000
1800 X1=INT(X/256):X2=INT(X-(256*X1)):
Y1=INT(Y/256):Y2=INT(Y-(256*Y1)):RETR
N
2000 REM PLAYER/MISSILE GRAPHICS
2010 POKE 54279,PMBASE/256
2020 FOR D=53248 TO 53255:READ X:POKE
D,X:NEXT D:FOR D=53256 TO 53258:POKE D
,1:NEXT D:POKE 53259,3:X=0
2030 FOR A=0 TO 256 STEP 128:FOR D=20
TO 52 STEP 4:POKE FMBASE+512+A+D,21:NE
XT D:NEXT A
2040 FOR D=22 TO 50 STEP 4:POKE FMBASE
+384+D,85:NEXT D:POKE 623,17
2050 Y=20:FOR D=0 TO 3:POKE FMBASE+D+Y
+896,3:NEXT D:FOR D=0 TO 3:POKE FMBASE
+D+80,3:NEXT D
2200 REM ESTABLISH DISPLAY SCREEN
2210 GRAPHICS 0:POKE 752,1:POKE 711,68
:DL=FEEK(560)+256*FEEK(561):HOME=FEEK(
DL+4)+256*PEEK(DL+5):POKE DL+3,72
2220 FOR D=0 TO 8:POKE DL+D+6,8:NEXT D
:POKE DL+18,144:POKE DL+23,4:POKE DL+2
4,4:POKE DL+25,5:POKE DL+26,5
2230 POKE DL+27,65:POKE DL+28,PEEK(560
):POKE DL+29,PEEK(561):POKE 54286,192
2240 GOSUB 230:POSITION 4,0:FOR F=0 TO
3:FOR D=0 TO 31:?" CHR$(27):CHR$(D+32*
F):NEXT D:?" :NEXT F
2250 POKE 559,46:POKE 53277,3:GOSUB 53
0:GOSUB 220:GOSUB 100:FOR D=0 TO 2:POK
E 704+D,6:NEXT D:POKE 707,68:GOTO 1200
2400 DATA 72,138,72,152,72,165,203,141
,10,212,141,9,212,104,168,104,170,104,
64,104,162,16,76,86,228
2410 DATA 128,0,128,0,128,1,128,1,120,
0,120,0,160,0,160,0,100,0,100,0,140,0,
160,0
2420 DATA 149,161,173,56,83,91,99,107

```

DATA PLOTTING SOFTWARE FOR MICROS

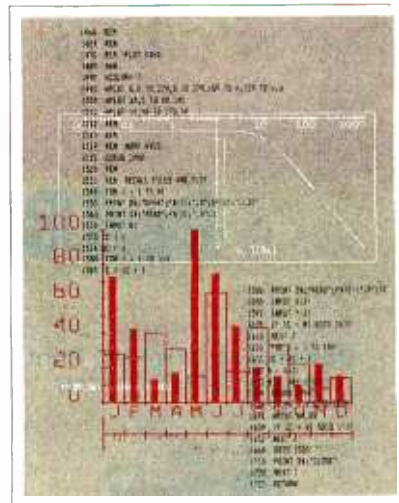

21 Programs
Fully Documented, Copyable
BASIC Listings
Apple II and IBMpc

PIE CHARTS • BAR CHARTS
STOCK MARKET CHARTS
3D SURFACES • HISTOGRAMS
LOG PLOTS • CURVE FITTING
REGRESSION ANALYSIS
DATA MANAGEMENT
STATISTICAL ANALYSIS
TEXT ON GRAPHICS

All programs listed in Applesoft BASIC in a 248 pg book with theory, equations, full explanation of how they work. Modular and menu driven. Use as is, modify and combine for your own applications, or use as building blocks to develop your own programs. Optional 5 1/4" disks of listings available for Apple II+ DOS3.3 48K and IBMpc DOS1.1 48K. This is your best buy in data plotting software!
Book: \$28.50 Disk: \$19.95

ALSO AVAILABLE

Graphic Software for Micros: a self-teaching guide to writing 2D and 3D graphics software-61 programs...*"the best book available on micro graphics.."* Creative Computing 2/82.
Book: \$21.95 Disk: \$19.95

Engineering Software for Micros: 25 programs for CAD, Fourier analysis, optimization, etc.
Book: \$28.50 Disk: \$19.95

Structural Analysis Software for Micros: 14 programs-2D,3D trusses, frames & more.
Book: \$39.95 Disk: \$24.95

KERN PUBLICATIONS

Send check, money order, VISA/MASTERCARD no with exp date to 190 Duck Hill Rd, PO Box 1029, Duxbury, MA 02332. Add \$2 per book postage in US, \$3 UPS, \$4 Canada, \$12 air Europe and Central America, \$18 elsewhere. Specify Apple or IBM with disk orders.

For faster delivery call (617)934-0445

OUR PRICES, SELECTION AND SAME-DAY SHIPPING MAKE US COMPETITIVE.

Red Baron. Home of the Nation's

NEC 8023 Outstanding Graphics, Print Quality & Performance



144 x 160 dots/inch • Proportional Spacing
• Lower case descenders • N x 9 dot matrix
• 8 character sizes • 5 unique alphabets
• Greek character set • Graphic symbols
• 100 CPS print speed • Bi-directional logic-seeking
• Adjustable tractors • Single-sheet friction feed • Vertical & horizontal tabbing

NEC 8023
Dot Matrix List \$795 **\$Call**

IDS Prism 80/132 Affordable Color, Speed



Dot Resolution Graphics • 9-wire staggered printhead • Lowercase descenders
• 200 CPS • Bi-directional, logic-seeking
• 8 character sizes • 80-132 columns
• Proportional spacing • Optional Color
• Text justification

Prism 80 Base List \$1,299 **\$Call**
Prism 132 Base List \$1,499 **\$Call**

NEC Spinwriter 7700 & 3500 Daisy Wheel Quality Leader

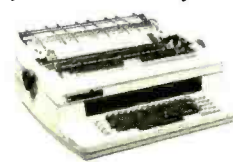

High speed, letter quality • 55/33 CPS
• Typewriter quality • Bi-directional printing
& proportional spacing • Quiet • OCR quality
print • Hi-res plotting/graphing • Quick change
ribbon • Optional cut-sheet feeder, horizontal
or bidirectional tractors • Prints up to 8 copies.

NEC Spinwriter RO
Serial Parallel 7700 List \$3055 **\$2500**
Serial 3510 List \$2290 **\$1700**

Smith Corona TP-1 Daisy Wheel Printer For Under \$900

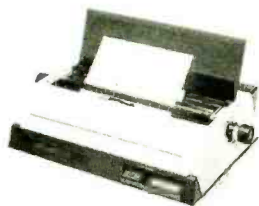

Letter quality • Standard serial or parallel data
interface • Drop-in ribbon • 144 WPM • Various
fonts available • Loads paper like typewriter •
Handles single sheets for forms

Smith Corona TP-1 List \$895 **\$Call**

The Epson Series High-Quality Printers at a Low Price.



**WATCH
FOR NEW
FX
SERIES**

Epson MX80FT List \$745 **\$Call**
Epson MX-100 List \$995 **\$Call**
Full Line of Epson Accessories

Brothers HR-1 Daisy Wheel Perfect for quality, quiet word processing.

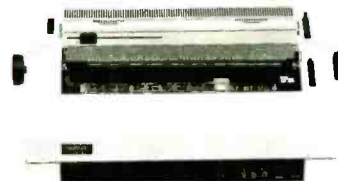

• 16 CPS • Prints up to 6 copies • Bidirectional •
Cloth or carbon quick-change cassette ribbon •
Quiet, efficient operation for word processing •

Brothers HR-1 (Parallel) List \$1,100 **\$Call**
Brothers HR-1 (Serial) . . List \$1,200 **\$Call**

Anadex Silent Scribe The Quiet Serial Matrix Impact Printer



Up to 200 CPS • Dot addressable graphics •
Parallel and serial interfaces standard • Switch
selectable protocol • Cartridge ribbon • Foreign
character sets • Underlining • 1.5K to 3.5K buffer
• Correspondence quality print

Anadex DP-9500A List \$1,725
Anadex DP-9620A List \$1,845
Anadex WP-6000 List \$3,250 **\$Call**

Televideo CRT's Price, Performance & Reliability



910 List \$699 **\$Call**
925 List \$995 **For low**
950 List \$1195 **Prices**

Interface Equipment Complete Stock of Options, Cables and Accessories.

CCS APPLE SERIAL Interface & Cable . . . \$150
ORANGE INTERFACE for Apple II
Parallel Interface Board and Cable . . . \$ 90
NOVATION D-CAT modem \$155
Novation Cat Acoustic Coupler \$150
COMPLETE STOCK OF EPSON
ACCESSORIES \$Call
CUSTOM PRINTER CABLES FOR Apple,
Atari, IBM, TRS-80 (all models) . . . \$Call
HAYES MICROMODEM II \$300
PRINTER STANDS: Large \$ 99
Small \$ 25
PRINTER RIBBONS—Most Types \$Call

OUR PEOPLE MAKE US EXPERTS.

Largest Computer Printer Inventory.

The Grappler+™ Apple® Graphics Interface

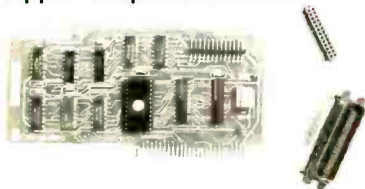

- Graphic and text screen dumps • Dual Hi-Res Graphics • Printer Selector Dip Switch • Apple III compatible • Inverse Graphics • Emphasized Graphics • Double Size Picture • 90° Rotation • Center Graphics • Works with Pascal and CPM® • Optional Bufferboard available

Grappler+ **\$175**

* Requires software driver
Apple is a registered Trademark of Apple, Inc.

The Bufferboard For Apples and Printers

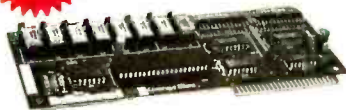

Take your existing printer interface — and buffer it!
• Versions for Grappler+, Apple interface, Epson interface, and others • Comes standard with 16K buffer • Expandable to 32K and 64K • Includes interface docking cable

The Bufferboard **\$185.00**

IDS Microprism 480

Prints like a daisy,
priced like a matrix!

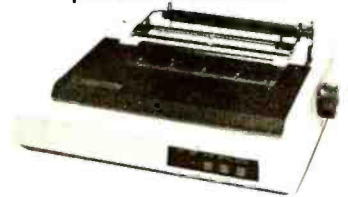

- Correspondence Quality in a Single Pass • Dual Speed 75, 110cps • Proportional Spacing • Bidirectional Logic Seeking Head • Platen pin or pressure feed • 24x9 dot matrix • 10, 12, 16.8 Characters per inch • Double width Characters

IDS Microprism 480... List **\$799** **\$Call**

Our People, Our Product: Both Are Specialized.

Because our salespeople are printer specialists, they know the capabilities of each printer—and how to match one to your exact need. Red Baron's volume stocking assures a low, low price on a wide array of major brands. We're sure you'll like the product and services you get from Red Baron, and we know you'll love our Customer Benefit Package; an exclusive at Red Baron.



Customer Benefit Package

- 1. Free Expert Consultation.** Before you buy, after you buy.
- 2. Technical Staff.** Even your most involved questions get quick, helpful answers from our staff of printer technicians.
- 3. Free Catalog.** Get your informative catalog with printer comparison chart and print samples today!
- 4. Warranty.** The manufacturer's warranty applies where applicable.
- 5. Same-Day Shipping.** Your order is shipped the same day when you call before 11:00 a.m.
- 6. Free MasterCard and Visa.** Call us toll-free and charge your printer to your credit card.
- 7. We Stock What We Sell.** No bait and switch, no hassle. We make every effort to keep a large stock of our advertised products.
- 8. APO/FPO Orders Welcome.**

The Okidata Series Hi-Res or TRS 80 Block Graphics

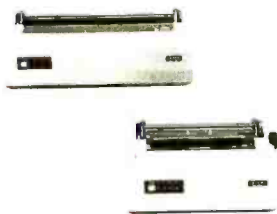

- 120 CPS • 9x9 Matrix • Bidirectional logic seeking printing • Lower case descenders • four print styles • Optional Hi-Res Graphics

Okidata 82A List \$649
Okidata 83A (w/Tractor) .. List \$995
Okidata 84 (Parallel) ... List \$1395 **\$Call**

Here's How To Order:

Phone orders are welcome; same-day shipment on orders placed before 11:00 a.m. Free use of MasterCard and Visa. COD's accepted. Personal checks require 2 weeks clearance. Manufacturer's warranty included on all equipment. Prices subject to revision.

Call Toll Free For Catalog:

(800) 854-8275
CA, AK, HI (714) 630-3322



1100 N. TUSTIN #207, ANAHEIM, CA 92807

Lotus Development Corporation's 1-2-3

A fast, versatile package that combines spreadsheet, graphing, and database functions

Gregg Williams
Senior Editor

When does "evolution" become "revolution"? When I first saw 1-2-3, a spreadsheet/database/graphing system from Lotus Development Corporation, I thought, "Hmm, very well done, but it's just an extension of existing software." True enough. But after using the product for a few hours, I realized it impressed me as more than just an evolutionary product. There may be nothing new under the sun, as they say, but there *are* novel ways to combine old things. In that sense, Lotus's 1-2-3 is modestly revolutionary because it synergetically combines three packages. In this product description, we'll take a look at the system's capabilities.

Spreadsheet Capabilities

1-2-3 is, above all else, a spreadsheet. Like most spreadsheets, it lets you enter either text, numbers, or formulas in a network of "cells" so that, by changing the content of certain cells, you can perform an involved set of calculations automatically. It's safe to say that 1-2-3 has all the features you've ever seen on spreadsheets. You can copy ranges of cells, insert and delete rows and columns, change the output format of a range of cells or the width of a column of cells, and do numerous other functions.

The size of the spreadsheet is 2048 rows of 256 columns. Lotus claims that 1-2-3 will handle up to 640K bytes of memory. You can't fill the entire spreadsheet with that, but it's probably considerably more than enough for most applications.

1-2-3 will soon be available for the IBM Personal Computer (PC) and will eventually be converted to other

microcomputers that use the Intel 8086 or 8088 microprocessor. The initial version of 1-2-3 will need an IBM PC with two disk drives, 128K bytes of memory, and either a monochrome or a color display; if the computer has both, you can view the spreadsheet (on the monochrome monitor) and graphs (on the color monitor) at the same time. If you have only the monochrome video display, you cannot view your graphs; you can only print them out. If you have only the color video display, you can alternate between viewing the spreadsheet and the graph.

Graphing Capabilities

1-2-3's sophisticated graphing commands enable you to create graphs of up to four variables using information already on the spreadsheet. Photo 1a shows a small spreadsheet; photos 1b and 1c show the two graphs of the same data. You can ask for one of five kinds of graphs, including bar and line graphs (of which photo 1b is an example), a pie chart (of one variable only), a stacked bar chart, or an x - y graph (two lists of variables used as x - y coordinate pairs). During my first session, I set up the parameters for a graph in under three minutes; after a few tries, I could do it in less than a minute. The graph is drawn in under two seconds—a far cry from graphing, say, on the Apple II.

Once you've made a graph, three keystrokes will display it in another form; if data in the spreadsheet has been changed, you can display a revised graph with one keystroke. Various options let you change the look of a graph; you can display one in black-and-white if you don't have a color monitor attached to the color video in-

High Resolution RGB Color Monitor Designed for the IBM Personal Computer

FEATURES

- 80 characters x 25 lines
- 690 dots horizontal resolution
- 16 colors
- .31 mm dot pitch tube
- non-glare, black matrix
- plugs directly to IBM PC

\$795.



Princeton Graphic Systems' new HX-12 high resolution color monitor is designed with an NEC.31 mm dot pitch CRT to give you up to 690 dots horizontal resolution. You need not compromise the display quality of your system with monitors rated at less than the 640 horizontal dots generated by your IBM PC. The PGS HX-12 delivers 16 super colors, 80 characters x 25 lines. It is the best price/performance PC direct drive monitor in the market today. Get the PGS HX-12 and discover for yourself how well it complements your IBM Personal Computer.

phic	Systems	High	Resolution	80	character	HX-12	RGB
phic	Systems	High	Resolution	80	character	HX-12	RGB
phic	Systems	High	Resolution	80	character	HX-12	RGB
phic	Systems	High	Resolution	80	character	HX-12	RGB
phic	Systems	High	Resolution	80	character	HX-12	RGB
phic	Systems	High	Resolution	80	character	HX-12	RGB
phic	Systems	High	Resolution	80	character	HX-12	RGB
phic	Systems	High	Resolution	80	character	HX-12	RGB
phic	Systems	High	Resolution	80	character	HX-12	RGB
phic	Systems	High	Resolution	80	character	HX-12	RGB

80 character display

PGS

**Princeton
Graphic Systems**

1a

DATE	Gerrill Illustrated	Popular Day Lady
1/82	248338	10381
2/82	241325	21967
3/82	251861	49278
4/82	272207	283877
5/82	279571	58786
6/82	279571	28198

1b

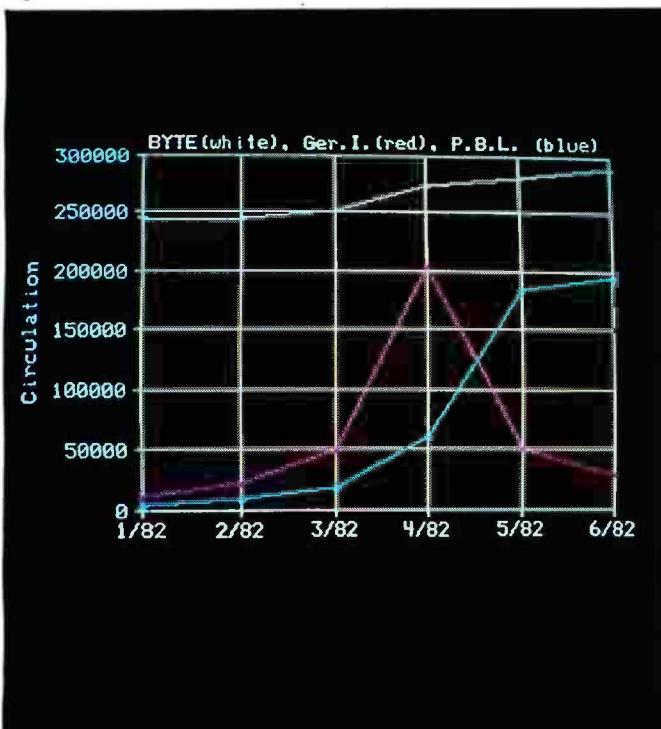

1c

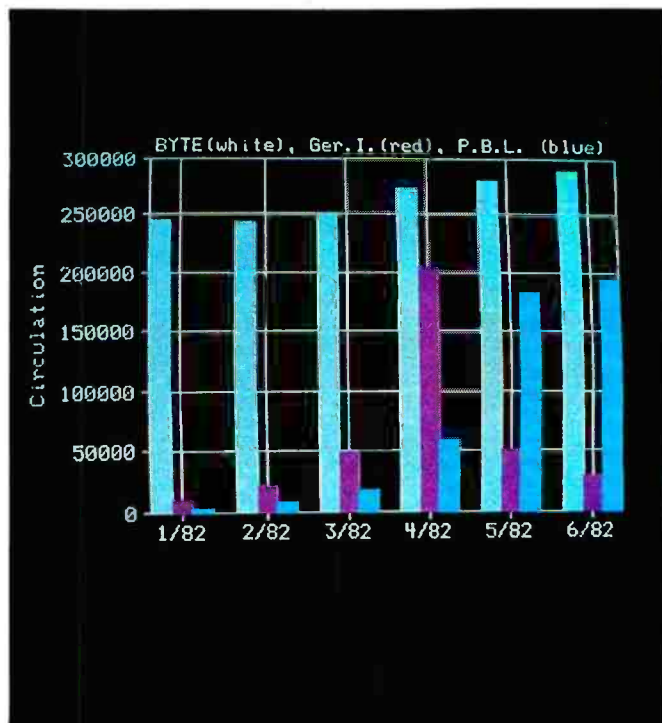

aligned. (The database can be anywhere on the spreadsheet along with nondatabase information.) You can sort a set of records, query it, or use it to retrieve selected records. Records are sorted by a maximum of two keys, each of which specifies a sort operation by either ascending or descending order. The query and retrieve operations are very similar. Both find records that match certain criteria; the former modifies the action of the cursor-up and cursor-down keys so that the cursor will highlight only records that match the criteria, and the latter copies the matching records into a designated area of the spreadsheet.

Photo 2a shows a small collection of records that is being readied for a retrieve operation. 1-2-3 prompts you for the area of the spreadsheet that is considered a collection of records; when you choose that area, 1-2-3 highlights it in reverse video. The top line of the database area contains the values (or, in the case of inequalities, the relationships) you're searching for, the second line is the name for each field, and the lines below that are the actual records. Once the retrieve function is completed, the matching records are deposited in the assigned destination area (see photo 2b).

Granted, 1-2-3's database capabilities don't match those of the expensive databases, so it would be foolish to buy the system in lieu of a full-featured one. But *selection* is a fundamental data-manipulation operation, and any package that can speak to this need is superior to those that don't. I suspect that the database functions in 1-2-3 will be used most often to isolate specific data that will then be graphed (if you had to isolate the data manually, you probably wouldn't bother graphing it). Still, 1-2-3's database can be used in several traditional applications as well as in some less traditional ones—scheduling, for example.

Photo 1: Making graphs from spreadsheet data. Given the small spreadsheet shown in photo 1a, the line graph in photo 1b and the bar graph in photo 1c were both made from the data on the spreadsheet. Once the data to be used has been specified, a different type of graph can be drawn (or a graph with new data can be redrawn) in less than two seconds.

terface. You can also send a graph to the printer; at the moment, only the Epson MX-80 printer is supported, but others will be supported in the final version.

Database Capabilities

You can also use 1-2-3 as a database for storing, sorting, and retrieving records. Although its database capabilities are not comparable to those of, say, dBASE II, they are very useful in conjunction with the other two.

1-2-3 will take an arbitrary area of the spreadsheet to be a database; the entries on a given row are considered to be a *record*, and record fields must be vertically



COMPUTER SYSTEMS

"Quality Throughout"
800-238-3100

Q.T. Products Division
COMPATIBLE COMPUTER CORP.
3330 South Third St. West
Salt Lake City, UT 84115
(801) 974-0999

Q.T. Systems Division
GOLDEN WEST COMPUTERS
60 North 300 West
Provo, UT 84601
(801) 373-1467

NOTICE: CP/M is a trademark of Digital Research, Turbodos of Software 2000 and INFOWARE of Compatible Computer Corporation. The Q.T. products and systems above are produced and sold under license by Compatible Computer Corporation and Golden West Computers, Inc. The Q.T. trademark and product designs remain the property of the licensor, Q.T. Computer Systems, Inc. of Hawthorne, Calif.

NEW IMPROVED 1983 MODELS

The entire Q.T. product line has been redesigned and improved using computer controlled manufacturing techniques to insure the highest quality. Many new features have been added to every item. The Q.T. 1983 models are among the best S-100 products available on the market today. They are fully compatible with the latest 16/32 bit cpu's.

Call (800) 238-3100 today for the location of your nearest dealer and/or to obtain the 1983 Q.T. catalog. Substantial dealer/OEM discount offered.

Stocking dealers with retail showrooms and mail order facilities include:

Priority One, Chatsworth, CA ☎ 800-423-5922

Bison Products, Los Angeles, CA ☎ 213-994-2533

Compatible Computer, New York City ☎ 212-221-7900

TERMS: Cash prepayment @ 2% discount, COO or net 30 days with prior credit approval. Initial dealer/OEM orders must be COO or prepaid (MC/Visa credit card OK). Purchase orders accepted from O&B rated firms. Shipping and handling charges estimated at \$0.50/lb UPS ground and \$1.00/lb UPS Blue Label or airfreight. Minimum \$3.00. Utah residents add sales tax. Export orders welcomed—telex 426382 ITR UI.

Q.T. DISCOUNT MICRO-SYSTEMS PACKAGES

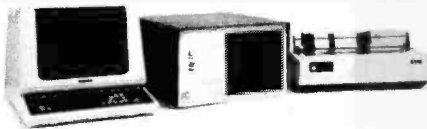

Q.T. MAXI-SYSTEM PACKAGE—Model 800P

\$6,395.00

List \$7,995.00—Save \$1,600.00

Q.T. MINI-SYSTEM PACKAGE—Model 500P

\$3,995.00

List \$4,995.00—Save \$1,000.00

- QT 8" Mainframe with 8 slot Motherboard
- Choice of printer: C. Itoh F-10 daisy wheel or Oki data M84P high speed dot matrix (200 cps.)

—Televideo 925 Full Featured CRT

The Q.T. Maxi-System is an industry standard S-100 expandable microcomputer which is ideal for general business computing, word processing and data base management applications. CP/M operating system is standard. MP/M or Turbodos optional. Unique Infoware[®] utilities simplify operation and user training.

- Electronics on Two Cards
- 4Mz Z80A CPU
- Filtered Fan
- 64K RAM Standard
- Parallel Printer Port
- Two A.C. Outlets
- Universal Disk Controller
- 10-40 MB Hard Disk Option
- Key Lock Switch
- 2 Megabytes on line
- Expandable to 256K RAM
- Two Serial Ports

Package Price Includes Cables, Documentation & Utility Programs. Model 800 alone \$4,995

- Q.T. 5 1/4" MINI-FRAME w/6 slot MB
- Televideo 910 Green CRT
- Dot Matrix printer (M82A)

- CP/M standard. Turbodos optional.
 - Reliable Single Card Electronics
 - Z80 CPU/Universal DMA controller
 - Dual Double Sided/Density Drives
 - Memory: 64K RAM & 320K Disk Drive
 - Cables, manuals, Infoware[®] Utilities
- Model 500 alone \$3,495.00

Q.T. INDUSTRY STANDARD S-100 MAINFRAMES



Q.T. MICRO-FRAME[™]

Q.T. MICRO-FRAME[™]—Series 600

Desk Top—Plain Front Panel

- 6 to 22 slot Motherboard
- Full I/O Cutout Array
- Fused EMI/RFI Filter
- Heavy Duty Power Supply (+8V@16A ±16V@3A)

QTC-MF + 1	No MB	\$499
QTC-MF + 6	6 slot MB	\$599
QTC-MF + 8	8 slot MB	\$649
QTC-MF + 12	12 slot MB	\$699
QTC-MF + 18	18 slot MB	\$799
QTC-MF + 22	22 slot MB	\$899



Q.T. MINI-FRAME[™]

Q.T. MINI-FRAME[™]—Series 500

Desk Top—Dual Mini Drives

- Holds two 5 1/4" Drives
- Full Cutout Array
- 6, 8, or 12 slot MB.
- Fused EMI/RFI Filter
- Hard Disk Power Supply (+8V@16A, ±16V@3A, ±12V@5A, +5V@5A)

QTC-MF + MD	(No MB)	..	\$699
QTC-MF + MD6	6 slot MB	..	\$799
QTC-MF + MD8	8 slot MB	..	\$849
QTC-MF + MD12	12 slot MB	..	\$899



Q.T. MAXI-FRAME[™]

Q.T. MAXI-FRAME[™]—Series 800

Desk Top for Dual 8" Drives

- 6, 8, 12 slot Motherboard
- Universal Drive mounts
- Key lock Power Switch
- Heavy Duty Power supply (+8V@16A, ±16V@3A, +5V@5A, -5V@1A, +24V@5A)

QTC-MF + DD1	No MB	\$799
QTC-MF + DD6	w/6 s. MB	..	\$899
QTC-MF + DD8	w/8 s. MB	..	\$949
QTC-MF + DD12	w/12 s. MB	..	\$999

Q.T. PRO-FRAME[™]—Series 700

Rack Mount—Constant Voltage

QTC-RM + 12	12 slot MB	...	\$799
QTC-RM + 18	18 slot MB	...	\$899
QTC-RM + 22	22 slot MB	...	\$999

Standard features & Options: All QT mainframes are built on a strong steel chassis with sturdy heavy gauge aluminum covers. Heavy duty power supplies have individually fused outputs and are shielded by an EMI/RFI filter & line surge protector. Standard I/O cutouts include provision for 16 DB 25's, 1 DC 37, 2 OA 15's, centronics parallel, 1 34 pin and 2 50 pin IDC ribbon cable connectors. Filtered positive pressure cooling fan. Twin AC outlets provide convenient connection for and control over printer and terminal. Standard colors are charcoal/light grey to match Televideo terminals. Optional colors include brown/tan and federal spec. ivory at extra charge. Constant voltage power available on most models—add \$100.00. EIA rack mount rails available on some units—add \$95.00. Complete OEM customization available on orders of 10 or more units. Contact factory for details and pricing.

Q.T. DISK DRIVE CABINETS AND SUBSYSTEMS



Front—Tandon Panel



Front—no panel



Rear view

Q.T.'s All in One[®]

Universal Disk Drive Cabinet

- Expandable
- Accepts all 8" drives

QT's unique new disk drive cabinet has been designed to accept virtually any 8" drive on the market today from Tandon Thinlines to 40 megabyte Quantums. Features include interchangeable face plates (Qume, Shugart, Tandon, etc.) and "electronics in a drawer" construction to simplify installation and maintenance. Heavy duty power supply will carry any combination of up to four Thinline, two standard, or one hard disk drive with floppy backup. +5V@5A, -5V@1A, +24V@5A.

QTC-DDC8 8V-XX w/one faceplate	\$399.00
Replacement Faceplates (Specify type & number of drives)	\$25.00
Tandon 4-drive power cable	\$15.00
Data Cables available	\$20-50.00



SINGLE 8" VERTICAL CABINET

Size: 11"H 11"W 18"D
Perfect add-on disk drive for any system. Accepts most brands.
QTC-DDC8V \$299



DUAL 8" HORIZONTAL DRIVE CABINET

Dimensions: 5"H 17"W 20"D

Designed to provide basic disk storage capacity for S-100 and other computers. Low profile permits table top stacking.

QTC-DDC + 88H \$349

Q.T. "ALL IN ONE" EXPANDABLE DISK DRIVE SUBSYSTEM SPECIALS

QTC-DDS + 0 with two single sided Siemens Drive (0.5MB)	\$695
QTC-DDS + 1 with one double sided Mitsubishi Drive (1MB)	\$895
QTC-DDS + 2 with two DSDD Mitsubishi Drives (2MB)	\$1,495



SHOP FROM THE CONVENIENCE OF YOUR HOME OR OFFICE WITH THE BIGGEST SELECTION YOU CAN GET YOUR HANDS ON...

CALL OR WRITE FOR OUR SPECIAL CHRISTMAS CATALOG!!
IBM P/C • APPLE • ATARI • NEC • COLUMBIA DATA •
VIC 20 • BASIS 108 • FRANKLIN ACE •
COMBO CATALOG • PRINTERS

Circle 124 on inquiry card.

ORDER TOLL-FREE!! 1-800-854-2833

IBM•IBM•IBM

ACCESSORIES

APPARAT	SEATTLE
Prom Blaster..... 129	64K Ram+*..... 359
Combo Card..... 224	128K Ram+*..... 439
Clock Calendar..... 104	192K Ram+*..... 549
Spool/64 (Parallel)..... 299	256K Ram+*..... 629
AST	
Combo Plus 64K..... 439	*Flash Disk Included
Combo Plus 128K..... 599	AMDEK
Combo Plus 192K..... 769	3" Micro Drives..... 789
Combo Plus 256K..... 939	Color II..... 749
QUALITY COMP.	
Big Blue..... 499	Color III..... 439
MICROTEK	
64K w/Parity..... 249	XEDEX
128K w/Parity..... 359	Baby Blue CP/M..... 489
192K w/Parity..... 539	Baby Blue Ram Plus..... 679
256K w/Parity..... 679	PERSYST
DAVONG	
5 Meg Hard Disk..... 1569	Spectrum Series..... CALL
64K Mem. Expan..... 269	ASYN Comm..... CALL
192K Mem. Expan..... 499	DATAMAC
256K Mem. Expan..... 599	6 Meg Hard Disk..... 2249
QUADRAM	
Quadboard 64K..... 399	12 Meg Hard Disk..... 2495
Quadboard 128K..... 549	18 Meg Hard Disk..... 2989
Quadboard 192K..... 639	DC-1 Disk Cntr..... 1319
Quadboard 256K..... 679	MICROSOFT
Microfazer 16K (Par)..... 209	64K..... 249
Microfazer 64K (Par)..... 209	256K..... 649
Par. Int. Card(8 cable)..... 109	TECMAR

SOFTWARE

Visicalc (256K)..... 185	Logon by Ferox..... 129
Word Star..... 249	Fastscreen by Cu..... 73
Mail Merge..... 88	The Organizer..... 209
Peachtree Pkgs..... CALL	Crosstalk..... 169
Volks Writer..... 139	E.O.Q. by Execuware..... 139
Super Calc..... 217	Fin. Anyl. Pack..... 229
Easy Writer II..... 239	Spell Guard by ISA..... 219
Home Acct. Plus..... 109	Spell Guard (Law)..... 99
CP/M-86 by Cmpview..... 299	Tax Manager 189
Vedit by Cmpview..... 129	Desk Top Plan I..... 239
Vedit-86 by Cmpview..... 199	Visitrend/Visiplot..... 239
The Programmer..... 369	Visidex..... 199
CP/M-86 by Digital..... 279	Joystick by TG..... 49
Basic-80 by MSoff..... 297	Frogger..... 27
Fortran-80 by MSoft..... 419	Lost Colony..... 24
M/Sort by MSoft..... 159	Zork I or II..... 28
Easy by Denver..... 543	Deadline..... 38
Mathemagic by ISM..... 69	Everest Explorer..... 17

Call For Free Catalog

COLUMBIA

DATA PRODUCTS, INC.

THE MULTI-PERSONAL COMPUTER

By Columbia can use Software and Hardware originally intended for the IBM® P/C...

- 8088 Processor
- 128K RAM
- Two RS-232 Serial Ports
- Centronics Parallel Port
- 8 Expansion Slots
- Dual Floppies with 1 Meg Storage

This exciting entrant to the IBM P/C compatibles is lower priced as compared to...

CALL FOR PRICE AND INFORMATION NOW
1-800-854-2833

FREE* SHIPPING
 (with prepaid cash orders)

SALEKEYCOMP II

By Non-Linear Systems

The totally portable, powerful and profitable computer for your home or office.

- Z-80 • 64K Ram • two 5 1/4" floppy-disc drives (double density) • 9" video display (80 col.)
- RS-232C • Parallel Printer • Interface

SOFTWARE INCLUDED!

- CP/M™ 2.2 • SBASIC™ • SELECT™ wordprocessor • PROFITPLAN™ spreadsheet program • UTILITYZE™ menu-driven CP



ATARI

400 16K 264
800 48K 638

410 Recorder..... 77	The Bookkeeper..... 194
810 Disk Drive..... 439	The Entertainer..... 69
825 Printer..... 639	The Educator..... 124
830 Modem..... 159	The Programmer..... 56
850 Interface..... 159	The Communicator..... 334
Full-View 80..... 279	PacMan™..... 33
Joystick (Pair)..... 18	Mouskattack..... 26
48K by Intek..... 189	Chopffiter..... 27
32K by Microtek..... 99	Frogger..... 27
48K by Microtek..... 69	Go!..... 33
Epson Cable..... 34	Microsoft Basic..... 69
Ram Cram..... 109	Word Processor..... 109
Ram Disk..... 429	Visicalc..... 179

Call For Free Catalog

*\$25.00 if Purchased with 400 or 800

Commodore

VIC-20

HARDWARE

Dataset ★..... 64	Super Expander..... 179
Disk Drive..... 319	Programmers Aid Card..... 1
Graphic Printer★..... 319	VicMon..... 3
8K Mem. Expander..... 39	Pro. Ref. Guide..... 1
16K Mem. Expander..... 75	Joystick★..... 9
24K Mem. Expander..... 139	3 Slot Expander..... 1
RS232 Card..... 39	Modem★..... 9
EEE-488 Card..... 69	Centronics Cable..... 1

NEW

6 Slot Expander 1
40 Col. 8K Board 1
Afron Expan. Chassis 1
Video Pak (40/80 col. 16K) 2
Video Pak (40/80 col. 64K)..... 3
Wico Joystick Deluxe 3
Wico Trackball 59
6 Slot (Soft. Select)..... 1
Modem (Auto Ans/Dial)★..... 1

NEW FROM COMPUTER SPECIALTIES

Vic Education Pak..... 1
Vic Small Business Pak..... 1
Vic Home Computer Pak..... 1
Vic Communications Pak..... 1

ON CARTRIDGE

Spiders of Mars..... 36	Outworld..... 36
Robot Blasters..... 30	Adventure Land..... 36
Meteor Run..... 36	Pirate Cove..... 36
Satellites & Meteors..... 36	Mission Impossible..... 36
Amok..... 29	The Count..... 29
Alien Blitz..... 29	Voodoo Castle..... 29
Radar Rat Race..... 23	Astro Blitz..... 23
Sargon II..... 33	Wizard of Wor..... 33
Trashman..... 35	Dogpatch..... 35
Blackhole..... 35	Pinball Spectacular..... 35
Gorf..... 23	Super Alien..... 23
Turtle Graphics..... 36	Vic Fourth..... 36

ON TAPE

Vicalc..... 11	Hsehold Fin. Pack..... 11
Bill Payer..... 14	Vic Journal..... 14
Vic 6 Paks..... 44	Rec/ED Pack I or II..... 44
Vic Trek..... CALL	Un-Word Proc..... CALL

IEEE For 64
 RS232 For 64
 Auto Ans/Dial Modem

★Works with Commodore 64

Call for Vic-20 and CBM-64 Catalog

OKIDATA ML 80
Configured to Vic-20
OR COM-64... \$399.00

RADIO SHACK

COLOR COMPUTER

16K Basic Computer..... 16K
16K Extended Basic Computer..... 16K
Color Printer..... 16K
Complete Selection of Hardware & Software..... 16K



Z-89-81 (48K • 1S 100K Drive)..... 21
Z-90-82 (64K • 1D 160K Drive)..... 23
Z-25-AA Dot Matrix Printer (RS232)..... 12
CP/M 2.2 (5 1/4" Soft)..... 1

NEW

Z-100 CA
13" RGB Color..... 5
ZF-110-22 (Low Profile) 32
ZF-120-22 (All in One) 33

Call For Catalog

NEC

PC - 6001

Features: Color • Sound • 71 Key Keyboard
 • 10 Function Keys
 "The Computer you've been waiting for! Home, Business, Education and Fun."

ACCESSORIES Available include:

- Expansion Unit
- Touch Panel
- Printer

SOFTWARE

- Music Editor
- Graph Generator
- Othello - And More!

PC - 8001

PC-8001..... 719	PC-8031 Dual Drives..... 718
PC-8012 I/O..... 549	CP/M..... 139
The Wedge..... 489	1260 Green Monitor..... 129

Call For Catalog

APPLE COMPATIBLE SOFTWARE

CP/M® SOFTWARE

Basic Interpreter™	CALL	PFS by Soft Pub. Corp.	85
Basic Compiler by MS289		VisiFile by Visicorp.	184
Cobol-80 by Microsoft	539	VisiFld/VisiFile by Visicorp	196
Fortran-80 by Microsoft	146	PPS: Report	69
WordStar*	196	DB Master	164
Mailmerge*	69	PFS: Graph	89
SpellStar*	109	Desktop Plan	184
DataStar*	166	Wall Street by M.L.	219
CalcStar*	109	Graph Magic by ISM	62
SuperCalc	212	Target Planner Calc.	36
d Base II by Ashton-tate	494	Math Magic by ISM	63
G/L by Peachtree	CALL	Home Acct. by Cont.	56
A/R by Peachtree	CALL	UCSD P-System	468
Peachcalc	CALL		
Quickcode	239		
Tax Prepare '82	109		
Real Estate Analyzer	139		
Bag of Tricks	29		
Zoom Graphix	27		
Special Effects	27		

SOFTWARE

Screen Writer II	103	Castle Wolfenstein	19
Magic Window	69	Flight Simulator	26
SuperText II by Muse	118	Sargon II	25
AppleSpeller by Sensible	56	Southern Command	43
Exec Secretary by S.S.	189	Deadline	34
Pro Easy Writer by US129		Time Zone	79
LetterPRTW/mailmerge	109	Kabul Spy	26
Word Handler	147	Zork II	26
General Manager	109	Knight of Diamonds	25
VisiCalc by Visicorp.	183	Wizardry	37
Tax Preparer	CALL	Atlantis	23

*Reg. Trademark of MicroBro. Int'l. Corp.

*CP/M is a Registered Trademark



Apple
SALE

APPLE COMPATIBLE ACCESSORIES

Fourth Drive	299	Sooper Spooler (16K)	299
Fourth Controller	89	Z-80 by Microsoft	214
Rana Elite One	359	VideoTerm (80 col.)	244
Rana Controller	99	Signalman Modem	89
Micro Sci A-2	349	Synergy Card by Spies	169
Micro Sci A-40	349	RGB by Electrohome	159
Micro Sci A-70	489	Parallel Card (8' cable)	69
3" Drives by Amdek	749	Z-Card by ALS	189
Vista Slim Line 8"	CALL	Versa Card	164
8" CNTRL by Vista	499	The Grappler Plus	119
16K Ram (2yr WNTY)	59	Joystick by TG	46
32K by Saturn	186	In Fone	CALL
AIO II	178	The Mill	319
CCS 7710A	129	Lower Case	29
CPS Multi-Func by Mtn	166	Expan Chassis by Mtn	539
Micro Modem II*	278	Winchester Hard Disk	CALL
Smart Modem	219	Apple-Card 4MZ	339
Hayes 1200 Baud	539	Apple-Card 8MZ	429
Enhancer II	124	Strobe Plotter	659
Microbuffer II (16K)	209	System Saver	69
Microbuffer II (32K)	229	Amber Monitor by US1	179
Num. Keypad (23 Key)	115	Function Strip by Videx	59
Disk Emulator (294K)	799	Bubble Mem by MPC	CALL
Sup R Mod	24	App-L-Cache 256K	989
Wico Joystick Delux	37	Wico Apple Trackball	69
Vista Vision 80	266	Smarterm 80 Col.	276
ALF 9 Voice	149	16 Voice by Mtn. Hard	297
Prasso by IS	CALL	8088 Card by ALF	295
Premium Pak by M. S.	528	Synergizer Pack by ALS	579
AD+DAB by Min(nocable)	269	212 Apple-Cat II	619
Apple Cat II	339	The Clock by Mtn Hard	219
Wizard - BPO	149	Voice Box (w/firmware)	149
Wizard - SOB	219	The Dumping-GX	129
Thunder Clock/Cal	119	D-CAT by NOV	144

FRANKLIN ACE 1000



CALL

- Apple II software & hardware compatible
- 64K of RAM memory
- Upper and lower case
- Typewriter-style keyboard
- Twelve key numeric pad
- Alpha lock shift key
- VisiCalc friendly
- 50 watt power supply
- Built-in fan

BASIS 108

THE ALTERNATIVE

- 6502 and Z80 Microprocessors
- 64K RAM, expandable to 128K
- RGB and Composite Video Output
- Selectable 80 or 40 column text display
- High Resolution Graphics: 6 colors, 280 x 192 or 280 x 160 with four lines of text
- 8 bit Parallel I/O • RS-232c Serial I/O
- Detached Keyboard: All standard keyboard functions, Upper/Lower case characters, Numeric keypad, Cursor block, and 15 Programmable special function keys
- Built-in mounting for two 5 1/4 inch floppy disk drives
- Six Apple compatible slots for plug-in peripherals • Game paddle-I/O

DISK DRIVES

ual 35/80 Drive by Fourth	CALL
uper Drive by Fourth	299
ite One by Rana	359
ite Two by Rana	539
2 by Micro-Sci	359
40 by Micro-Sci	349
3 by Micro-Sci	349
Drives by Amdek	749
ew! Datadrive 100% Compatible on sale	269

TERMINALS

Call For Catalog

SPECIALS

Smart Modem* 1200 by Hayes	549
Grappler+	119
5 1/4" Super Drive by Fourth	299
Microprism (80 col) by IDS	595
16K Ram (2 yr. warranty)	59

TELEVIDEO

VI 910	578
VI 910 Plus	589
VI 912	719
VI 925C	789
VI 950C	989

ADDS

ewpoint A-1	479
ewpoint A-2	CALL
ewpoint 160	749

ZENITH

-19-CN	689
T-1-A	559

MONITORS

Call For Catalog

NEC ELECTROHOME

JB1260 12" Green	129	13" RGB (med.res.)	369
JB 1201 12" Color	329	13" RGB (high.res.)	619
12" RGB (Hi-Res)	789	Super Color Board	229

AMDEK

Amber Screen 12" ... 169

Video 300	149		
Color I	309		
Color II	729		
Color III	439		
DVM Board	139		

COMREX

13" Color (composite) 349
13" Color(RGB)/BMP/cj529

DISKETTES

SPECIAL SALE!

Box of 5 1/4" Disks
With 2 Year Warranty (SS/SD)
\$33.99 Including Case

"THE PRINTERS CORNER"

OKIDATA

Microline 80 (Parallel)	315
Microline 82A (Bi-Directional)	429
Microline 83A	719
Microline 84 (Parallel)	1019
Microline 84 (Serial)	1159

NEC

7710	2329
7715	2399
7720	2799
7725	2895
3510 EX	CALL
PC-8023A	479

ANADEX

DP-9500A	1289
DP-9501A	1289

IDS

Microprism (80 column)	629
Prism 132 (incl. sheet feed graphics, sprint, color)	1529

EPSON

MX-80	CALL
MX-80 F/T	CALL
MX-100	CALL

COMREX

CR-1-S (2K Serial)	869
CR-1-C (2K Centronics)	839

DIABLO

Diablo 630	2089
630 KSR	2295

C. ITOH

F-10 Printmaster (Parallel, 55 cps)	1789
F-10 Printmaster (Serial, 55 cps)	1789
Prowriter 8510 AP (Parallel)	439
Prowriter 8510 ACD (Serial)	599
Prowriter II 1550 (15" Parallel)	699
Prowriter II 1550 (15" Serial)	749

BROTHER

HR-1 Parallel	819
HR-1 Serial	889

QUME

Print 9/45 RO	1799
Print 9/55 RO	2289

SMITH-CORONA

TP-1 (Parallel)	589
TP-1 (Serial)	589

COMPUTER SPECIALTIES

TO ORDER: Phone orders invited using Visa, Mastercard, American Express, or bank wire transfers. Visa, MC, and American Express service charge of 2%. Mail orders may send charge card number (include expiration date), cashiers check, money order, or personal check (allow 10 business days for personal or company checks to clear). Please add 3% (\$5.00 minimum) for UPS shipping, handling, and insurance. COD's minimum \$250.00 with \$25.00 deposit. All equipment is in factory cartons with manufacturer warranty. Opened products not returnable. Restocking

fee for returned merchandise. Equipment subject to price change and availability. Retail prices differ from mail order prices. WE SHIP THE SAME DAY ON MOST ORDERS! \$40.00 min. purchase. *With prepaid cash orders *Exclude certain printers & monitors & foreign orders. Calif. residents add 6% State Tax. For APQ and FPO - add 10% (\$25.00 min. for postage, Calif. residents add 6% Sales Tax). Include phone number, credit cards not accepted. Foreign Orders - Include 3% handling, shipped air freight collect credit cards not accepted.

1251 BROADWAY EL CAJON, CA. 92021 (714) 579-0330

The QUAD™

The Effortless Way
To Create Your Data Base
And Related Applications

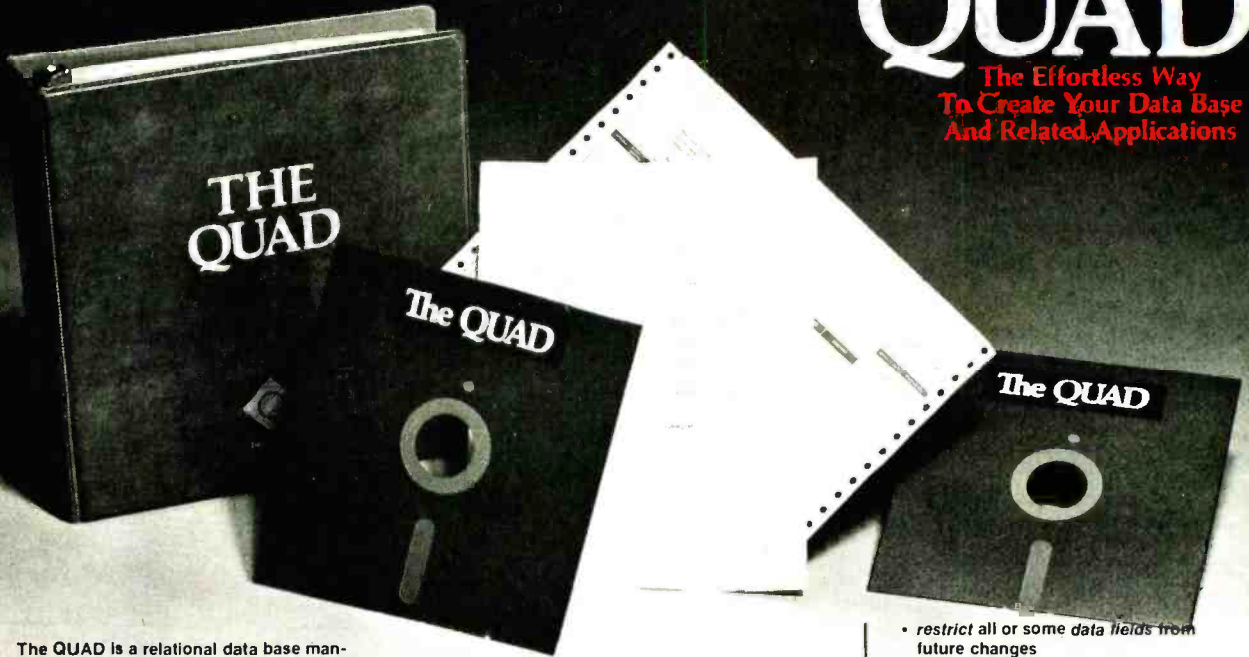

The QUAD is a relational data base management system and applications developer allowing the non-programmer to develop his or her own business and personal applications around a powerful relational data base. Some of the applications you can build with the QUAD are:

BUSINESS

- Accounts Payable
- Agricultural Management
- Construction Management
- General Ledger
- Human Resource Management
- Inventory Control
- Job Costing
- Mail List
- Order Entry
- Payroll
- Personal Scheduling
- Professional Time and Billing
- Property Management
- Sales Analysis

PERSONAL

- Appointment and Gift Register
- Budgeting
- Car Maintenance
- Family Medical Data
- Home Improvement Information
- Income Tax Information
- Insurance Information
- Inventory Information
- Investment Information
- Recipe Information
- Shopping Lists
- Time Management
- Vacation Planning

The QUAD is designed for YOU, the computer user who wants to take full advantage of his computer.

EXTENSIVE REPORTING CAPABILITIES

The QUAD enables you to create an unlimited number of reports in any specific size or form you desire using data from the QUAD database or another database. You may process and/or print data during any report.

PROCESSING DATA

- access information in up to 10 or more files during a report
- perform arithmetic calculations on any data from any file

- update and/or create files based on report processing
- easily compare date information for quick aging analysis
- perform up to 5 levels of subtotaling within each report
- retrieve records in sequential or indexed order
- perform processing based on comparison of data such as nested IF THEN logic

PRINTING DATA

- utilize your printer's capability by printing on any size paper anywhere on the page
- print checks using the English equivalent for dollar and cent values
- specify content of page headings, control headings and footings, detail lines and total lines
- pause between printing of forms

SAMPLE REPORT

CUSTOMER #	CUSTOMER NAME	CURRENCY	# OF DAYS	IN AM DAYS	IN E DYS	TOTAL
1110	ABC COMPANY	1.0000	30	150.00		1.5000
1220	DEF COMPANY	1.0000	45	225.00		2.2500
1330	GHI COMPANY	1.0000	60	300.00		3.0000
1440	JKL COMPANY	1.0000	75	375.00		3.7500
1550	MNO COMPANY	1.0000	90	450.00		4.5000
2007	TOTAL RECEIVABLES	5.0000	210	1050.00		10.5000

POWERFUL UPDATING CAPABILITIES

The QUAD gives you two methods to update data within the data base. One way is directly through the terminal using a data entry process. The other is through batch updating based on existing data within the data base.

- update as many as 10 or more files simultaneously, using the batch update mode
- totally user defined screens
- full screen editing
- record sizes up to 900 characters
- perform calculations based on data entered and data residing in other files
- access three different help screens during the data entry process
- utilize your terminal's video capabilities when creating your terminal update screens

- restrict all or some data fields from future changes
- edit each data field for items such as phone numbers, numeric data, alphanumeric data, date, time, social security number, etc., or your own defined edits
- IF-THEN logic available during both terminal and batch updating

SAMPLE SCREEN

```

05-08-82  ADD Order Entry Information  0 of 75 New Ord.
-----
Order Entry Line Item for CUSTOMER # 1005  Classic Koinz
Customer's P O Number 4325
Salesperson # 15  Martin Smith

Item #  C6507  Qty 100.00
ITEM  Nuts and Bolts  Charge 50
                                             Extended 50.00

Press (ESC) for Help
    
```

OTHER FEATURES

SORT, INDEX, and REORGANIZE data files quickly and easily. Also link to user-written programs directly from the QUAD. Automatically generate menus to access each of your applications.

The QUAD comes complete with an Accounts Receivable application ready for your use and a Checkbook Balancing application for you to build.

The suggested retail price for all this is only \$495.00.

Available for most CP/M compatible hardware.

To order your copy of the QUAD, contact your computer dealer, or call QuanTeckna Research today.



QuanTeckna™
Research Corporation

6902 220th St. S.W. MOUNTLAKE TERRACE, WA.
98043 206/364-6940 or 206/771-2488

CP/M is a trademark of Digital Research, Inc.
QUAD and QuanTeckna are trademarks of
QuanTeckna Research Corporation.



	1	2	3	4	5	6	7	8
1	1.000	500	225	250	200	157	143	125
2	2.000	1.000	500	500	400	313	285	250
3	3.000	1.500	1.000	750	600	470	427	375
4	4.000	2.000	1.500	1.000	800	627	571	500
5	5.000	2.500	2.000	1.250	1.000	684	627	562
6	6.000	3.000	2.500	1.500	1.250	741	684	625
7	7.000	3.500	3.000	1.750	1.500	798	741	687
8	8.000	4.000	3.500	2.000	1.750	855	798	750
9	9.000	4.500	4.000	2.250	2.000	912	855	812

Photo 3: Two-dimensional table creation in 1-2-3. When it's given a spreadsheet, two lists of input values, input cells for both lists, and an output cell, 1-2-3 can automatically create a table that gives the output value for each combination of the two input values. Photos 3a and 3b show the spreadsheet before and after the command is given. The output function shown here is the ratio of the two input values.

Although several features of the spreadsheet module are new to this product, two stand out. First, 1-2-3 allows you to manipulate both spreadsheets and their printed versions (called print files). That means you can save or combine parts of either the spreadsheet itself (including the formulas in each cell) or its printed representation (the letters and numbers in each cell).

The second set of especially noteworthy commands, /DT1 and /DT2, is for creating tables. With them, you can automate the tedious work of charting the behavior of a spreadsheet when one or two input variables vary across a given range of values. You can specify either one or two lists of input arguments, the cell positions in which these values are to be entered, and the cell that will contain the desired output. 1-2-3 will then substitute the input values into the spreadsheet and accumulate the output values in a one- or two-dimensional table. Photo 2a shows the format of the two input ranges (one a column and the other a row) and the corner of the spreadsheet that performs the calculation (for illustrative purposes, the ratio of the two input values). Photo 2b shows the table created by the execution of the /DT2 two-dimensional table-creation command.

Human Engineering

1-2-3 also excels in human engineering factors, those elements of a program that make it easy to use. I cannot overemphasize the importance of human engineering in microcomputer programs. To date, computers have been hard to understand and inconvenient to use, which has discouraged many people from using them. 1-2-3 is one of the few pieces of software that can literally be used by anybody. You can buy 1-2-3 and an IBM Personal Computer and be using the two together the same day.

1-2-3 is one of a new breed of advanced software products that has a disk-based help file. At any time, you

can hit a Help button (the F1 key on the IBM PC) and get one or more screens of information on literally any aspect of the program. The help file, which resides on the A disk of the IBM PC, contains over 250 screens of information. When you hit the F1 key, a menu of topics appears on the screen in under one second (an important consideration if waiting to see disk-based information discourages you from using the Help key). You then use the IBM PC arrow keys to move an inverse-video cursor to the desired topic and press the Return key. Each screen is cross-indexed to related screens and to a main menu, and you can get to any screen in less than 15 seconds. I was able to find the information as quickly as if I had looked it up in the 1-2-3 documentation. Those who are new to computers will be very impressed with this feature and will be much more inclined to use 1-2-3 because of it. (Software Arts' TK Solver also uses a disk-based help file, and I understand future products from Visicorp will include them as well.)

1-2-3 is, to my knowledge, the first spreadsheet program to distribute a comprehensive tutorial package that teaches the beginner how to use it. Software producers have always deliberated over the best way to teach a buyer (regardless of his understanding of the computer) how to use a complicated product. Lotus has incorporated these interactive tutorial programs into 1-2-3. They are reputed to cover, in some depth, the entire program. The segment I saw does its job well; it interactively shows you around the IBM PC keyboard and tells you how to move the cursor around a spreadsheet. This set of programs is, in effect, an indefatigable instructor who is always ready and willing to show you how to use the product and who will never laugh at your mistakes. This is another very strong incentive for the beginner to buy 1-2-3. No matter what your level of expertise, it's a very nice feature.

PLATO WIDENS YOUR CHILD'S WORLD.

In public school systems across the United States, PLATO[®] educational software has proved that it stimulates and speeds learning. Now, for the first time, Control Data has put PLATO lessons on micro-computer disks, so your child can learn at home—and enjoy it.

For information on PLATO educational software, or to order, call toll free 800/233-3784. In California, call 800/233-3785, or write Control Data Publishing Co., P.O. Box 261127, San Diego, CA 92126.

Circle 151 on Inquiry card.

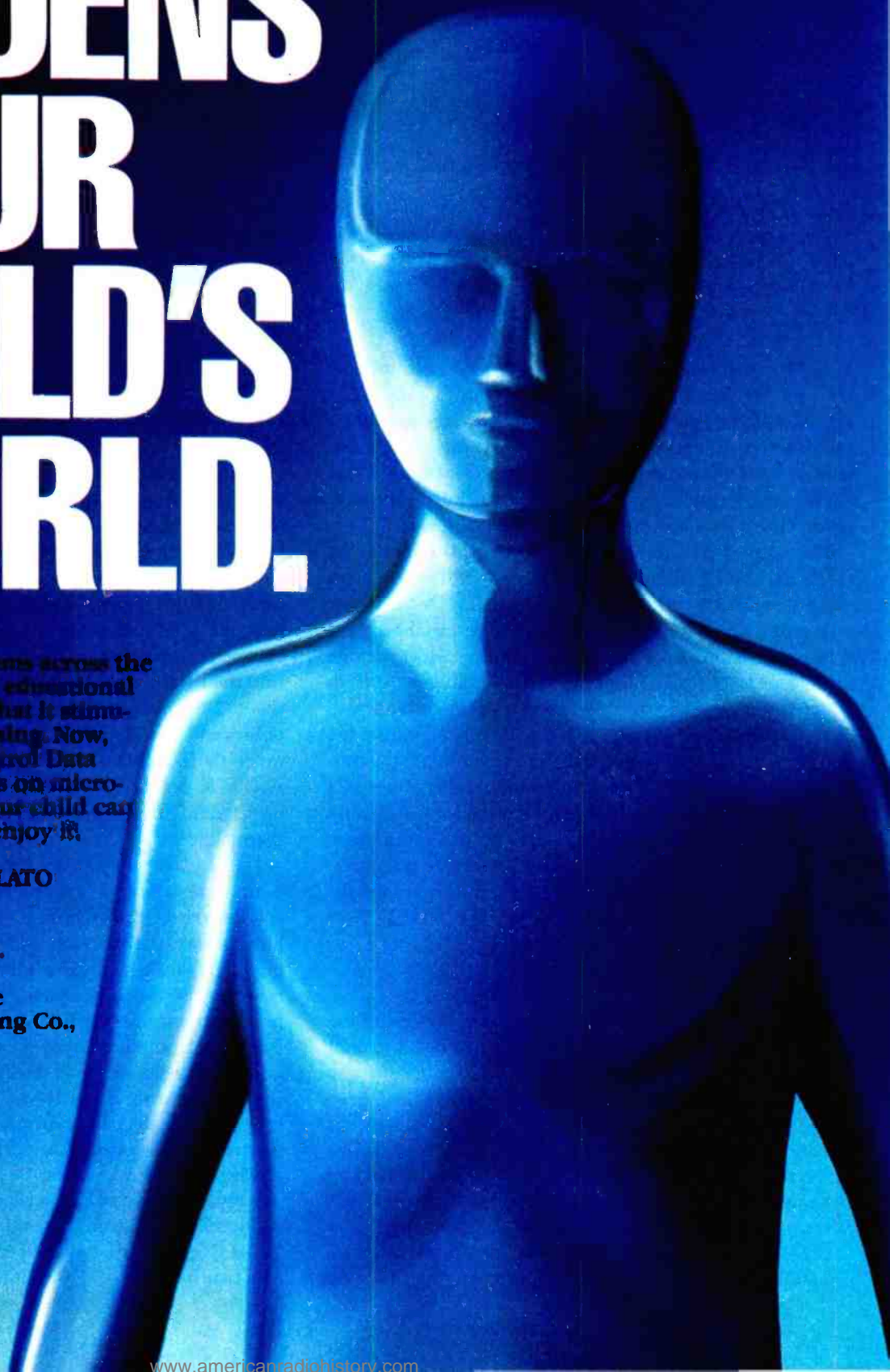

NOW, QUALITY EDUCATIONAL SOFTWARE IS AVAILABLE FOR YOUR HOME COMPUTER.

- PLATO® software now available on disks in Math, Physics, Foreign Languages, Computer Literacy—and more is on the way.
- For use on your Apple II Plus, TI 99/4A or Atari 800.
- Introductory Offering: Single lesson, \$45.00; additional lessons, \$35.00 each. 10-day money-back trial.

CHOOSE THE LESSONS THAT FIT YOUR CHILD'S NEEDS.

- **Basic Number Facts:** lets your child practice basic numbers, including addition with carrying, subtraction without borrowing and multiplication/division with single digits. Kids race against time to build up their speed in these math areas. Designed for elementary school age, or any child who needs practice with basic whole number operations.
- **Whole Numbers:** simulates a pinball game to hold and build interest in whole number operations. Problems include addition, subtraction, multiplication, division and mixed numbers. Designed for elementary and junior high age groups.
- **Decimals:** kids are challenged to break balloons by entering the correct decimal corresponding to the position of the balloon on a vertical line. Numbers are entered on a trial-and-error basis. Software automatically adjusts difficulty to the child's performance. For elementary math students.
- **Fractions:** same format as Decimals, but requires the use of fractions to break the balloons. Numbers are entered on a trial-and-error basis. Balloons may burst in any order until none are left. Difficulty adjusts to your child's performance. For elementary math students.



- **Computer Literacy—Introduction:** this lesson is presented in a friendly, non-intimidating manner with touches of humor and simple, supportive graphics. It presents the history and uses of computers in today's society. Designed for junior or senior high and vocational school students.
- **French Vocabulary Builder.**
- **Spanish Vocabulary Builder.**
- **German Vocabulary Builder:** students are presented with a basic vocabulary of 500 words, including useful verbs, number words or common words for traveling or in the home. Groups of related words give learners context and similarity clues, which help increase foreign language skills. Lessons supplement introductory and/or refresher coursework.
- **Physics—Elementary Mechanics:** provides a problem-solving test in the elementary mechanics of physics. Students are shown a physical problem; then must "purchase" the missing information needed to answer it correctly. The emphasis is on *understanding* the problem, rather than just supplying the correct answers. Designed for senior high age level.

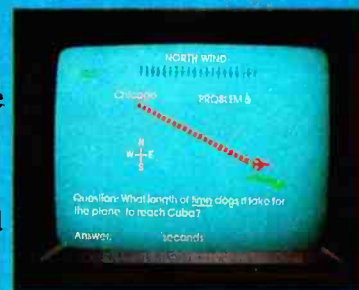

GD
CONTROL
DATA

PLATO
COMPUTER-BASED EDUCATION

Another feature that illustrates 1-2-3's human-engineering design is its jargon-free prompts, explanatory messages, and fail-safe mechanisms. Suppose I want to delete a spreadsheet file. When I type "/F", I get a menu of possible file actions, the first of which is in inverse video. I can execute any action by either moving the inverse video cursor to that action name and hitting the Return key or hitting the key that is the first letter of the action name. If I hit the right-arrow key until the action name "Delete" is in inverse video, I get an explanatory note immediately below the command line that says, "Delete a worksheet, print, or graph file" ("worksheet" is Lotus's name for a spreadsheet). That's what I want to do, so I conveniently hit Return. The inverse video cursor is already positioned on the option I want, "Worksheet", so I hit Return again. 1-2-3 now reads the current disk and gives me a menu of all the spreadsheet files by name. I then move the inverse video cursor to the spreadsheet I want to delete and hit Return again (there's no need to type the file name—just point to it). 1-2-3 displays two options, "No" and "Yes", with the cursor on the "No" option and an explanatory note, "Do not delete the file". By moving the cursor onto the word "Yes" (which includes the note "Delete the file") and pressing Return, I can delete the spreadsheet file. Wouldn't you like a piece of software that does all that for you?

1-2-3 gives you a lot of visual feedback on your choices. The inverse-video cursor and menu system

described above is one such example. (The resemblance to Visicorp's Visiplot package is not accidental; Mitch Kapur, who designed Visiplot, is the president of Lotus.) Another example is 1-2-3's ability to let you specify coordinates by moving the cursor to them instead of listing them by row-column designation. To specify an area of the spreadsheet, you simply move the cursor to a corner of the area with arrow keys, "tack" it in place (usually with the same "." command used in Visicalc), and move the cursor away from that point. A rectangular area that spreads from the current cursor location to the "tacked" location appears in inverse video (see photo 2a).

**Pressing a previously defined
macro key causes the
equivalent string to
be executed as if it had been typed
in from the keyboard—
a feature with great potential.**

Pointing to both spreadsheet locations and menu options makes 1-2-3 very easy to use and reduces errors.

Named ranges are another way of pointing to an area of memory. Any cell or rectangular area of the spreadsheet can be given a name of up to 15 characters. That name can then be used wherever the cell or range coordinates would usually be used. Sometimes, a named range is simply a convenience; in other places (e.g., in the formula for the value of a given cell), it makes the spreadsheet more readable. Microsoft Consumer Products' Multiplan automatically assumes that you can refer to a cell by the text label immediately to its left; 1-2-3 stipulates that you create a named range, but that range is more versatile than a named cell in Microplan. (People at Lotus have told me that the final version of 1-2-3 has an option that lets you refer to a cell automatically by an adjacent label value; you have the choice of positioning the labels below, above, or to the left or right of the cells.)

1-2-3 uses the ten IBM PC function keys (on the left side of the keyboard) in two ways. The unshifted keys are used for ten often used 1-2-3 commands; for example, F1 is the Help key described above, F5 is a Goto key that moves the spreadsheet and cursor to a given location, and F10 is a Redraw command for the most recently drawn chart. The ALT key pressed simultaneously with a letter key gives you 26 user-defined macro keys. You can define each of the 10 available macro keys to be any string of characters you desire, including the unshifted function keys, the arrow keys, and the Return key. When pressed, the macro key causes 1-2-3 to execute the equivalent string as if it had been typed in from the keyboard. This feature has great potential; in certain situations, you may be very glad not to have to retype the same keystrokes repeatedly.

Glad Tidings

To Our Friends
Old And New
We Wish You
The
Season's Best

DATA BASE
SCHEDULING
DENTAL
MEDICAL I

Apple
IBM
TRS-80

CMA

Micro Computer Division
55722 Santa Fe Trail
Yucca Valley, CA 92284
(619) 365-9718

WHY A FORMS PROCESSING DATABASE?

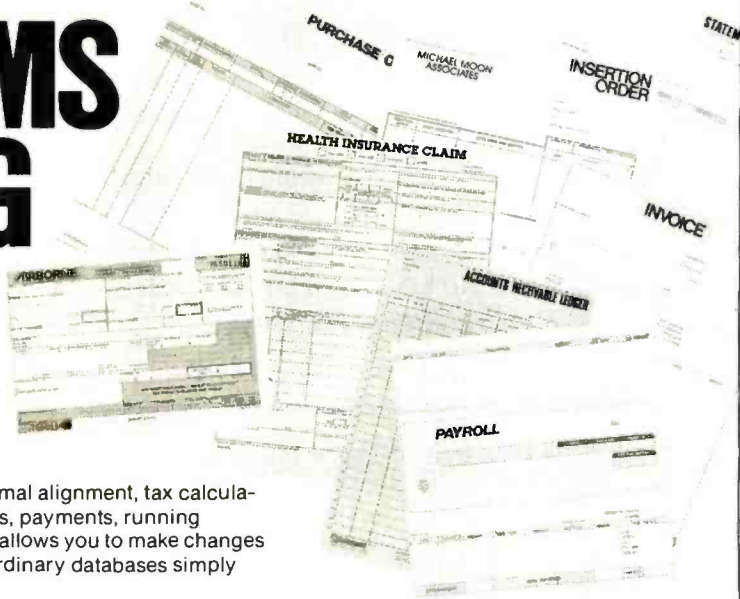

Ever since the introduction of low-cost microcomputers, business professionals have asked for a system that lets office workers use the knowledge they have and the procedures they already understand.

The solution has arrived. VersaForm now provides you and your staff with a natural way to use a computer—a forms processing database system.

THE IDEAL WAY TO USE A COMPUTER

Just about any form in your office can provide a familiar and easily mastered interface to a personal computer. Simply copy a form to the computer screen and you're set.

BUILD YOUR DATABASE WITH ANY OF THESE FORMS

- Bill of Materials
- Client Billing
- Freight Documentation
- Insertion Orders
- Insurance Claims
- Inventory Ledgers
- Invoices
- Job Estimates
- Medical Records
- Personnel Histories
- Project Scheduling
- Purchase Orders

Unlike any other system, VersaForm gets you started on a computer, working the way you're working now . . . you can even use your existing paper forms.

UNIQUELY DESIGNED TO YOUR OFFICE REQUIREMENTS

Most forms have two parts. The form heading contains information that appears only once on each form, like customer name or project number. The transaction region, below, has a variable number of line item entries which might contain quantities, descriptions, unit costs and extensions. These entries require a system

that does decimal alignment, tax calculations, subtotals, payments, running balances, and allows you to make changes at any time. Ordinary databases simply can't do it.

All these features and more are yours with VersaForm. A spectacularly useful print formatting capability enhances professional forms management. The magic of print formatting is the ability to produce from a single form in your database, several completely different printed forms. For example, from a patient record you can produce a history chart, an insurance claim, a statement and standard dunning notice.

In just minutes, a detail or summary report is automatically produced. What's more, you can run the report again and again without having to re-enter the instructions.

APPLE II/III, HARD DISK, IBM PC DATABASE?

VersaForm supports both floppy and hard disk sub-systems. You can swap data files between different systems through a hard disk-based network. From remote locations data disks can be consolidated into company-wide reports.

OPEN-ENDED SYSTEM.

For special requirements, an optional OEM Pascal Interface provides sophisticated users and software developers with powerful VersaForm tools, allowing direct access to the B-tree indexed database. System integrators can add value by creating templates and writing custom interfaces.

Users say VersaForm is the most powerful and easy to use system around. That's because it's more than just a database; it's a true Business Form Processor.

EVERYDAY BUSINESS FORMS DEMAND A TWO-LEVEL RECORD STRUCTURE... ONLY VERSAFORM HAS IT.

HEADING					
NAME MICHAEL, MOON . . . DATE 8-31-87					
FIRM MICHAEL, MOON, ASSOCIATES.					
ADDRESS 770, SOUTH 8, ST SUITE 3.					
CITY SANMATED . . . ST. GA ZIP 34401					
LN	QTY	STK#	DESCRIPTION	UNITS	EXT
01	001	0110	APPLE II	1520.00	1520.00
02	001	0070	DISK II W/CT	895.00	895.00
03	001	0210	DISK II	585.00	585.00
04	001	0030	16K RAM	99.00	99.00
05	001	0050	12 IN MONT	225.00	225.00
06	015	0025	MINI FLOP	5.00	75.00
07	001	0001	VERSAFORM	389.00	389.00
				SUBTOTAL	3818.00
				TAX	217.08
				TOTAL	3835.08

MANAGEMENT REPORTS IN A HURRY

The real power of a forms processing database is evident with VersaForm's reporting facility. You need only point to the data items within a form you want queried, sorted, counted, subtotaled, and totaled. There's no complicated format to enter—VersaForm automatically produces columnar formats, titled, dated and page numbered.

IBM/PC
VERSION NOW AVAILABLE

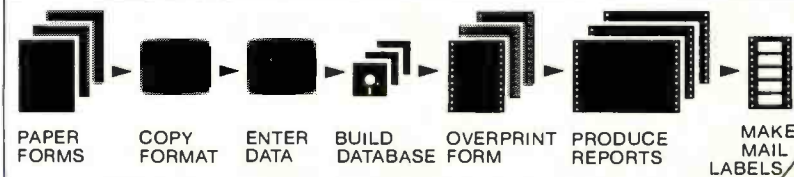

THE ONLY DATABASE THAT COMPLETELY PROCESSES FORMS FROM START TO FINISH.

Dealer and OEM inquiries invited

VersaFormTM
Business Form Processor
Applied Software Technology
14125 Capri Drive
Los Gatos, CA 95030
408/370-2662

1-2-3 has what I call "intelligent" labels, text strings that are not influenced by the current cell width. Say, for example, I want to print a 30-character title across a spreadsheet, and assume that all the cells are 8 characters wide. In many spreadsheet programs, you'd have to split the title manually and enter it in four 8-character chunks—awkward and tedious, right? In 1-2-3, though,

1-2-3's ability to "protect" cells means that data cannot be destroyed unintentionally.

you enter the full title in the first cell you want it to occupy. The string itself stays in that cell as its formula, but in its display it spills over into the space normally used by cells to the right. The effect is the same as with other spreadsheets, but it is achieved much more easily. What if you decide your cells must be 10 characters wide? In other spreadsheet programs, the title is mangled when you change the cell width—each 8-character chunk has two blank characters to its right. But because the value of the string is retained in only one cell, 1-2-3 displays the title correctly despite the change in cell width. Several text-justification commands in 1-2-3 also help format a single string into rectangular spreadsheet areas that occupy one or more rows of cells.

One final human-engineering feature of 1-2-3 is its ability to *protect* cells—that is, to keep you from assigning new values to cells—or ranges of cells. When a spreadsheet is used by anyone but its designer, protected cells allow the person to use it without inadvertently destroying valuable data or formulas. If you try to write a new value into a protected cell, you will get an error message that says the cell is protected. This is a nice feature, but it would be more useful if cells could be "locked" (so you couldn't cancel the protection of a cell) and made invisible, features that are available in Visicorp's Visicalc Advanced Version for the Apple III computer.

Speed and Integration Advantages

In addition to being powerful and easy to use, the various modules of 1-2-3 are fast and well integrated.

Many software developers (Software Arts, Visicorp, and Microsoft Consumer Products, to name a few) are writing their software in high-level languages that are usually compiled to the native code of the machine's microprocessor. They do that in order to move a given program to more than one machine and thus maximize their profits. (Rightly so—good software is very expensive to create.) An interesting side effect of using high-level languages is that the resulting product is slower than if it had been written strictly for the native microprocessor. Depending on the efficiency of the high-level language used, an assembly-language version of a product can be considerably faster and more compact than its high-level counterpart. This is certainly the case with 1-2-3; it is coded in highly optimized 8086 assembly-language code. Granted, I have only Lotus's word that it is "highly optimized," but 1-2-3 is fast—I didn't have to wait when I expected to. [Editor's Note: A demonstration of 1-2-3's capabilities at its recent public unveiling illustrated the program's speed. For example: a spreadsheet was displayed showing a listing of 25 hotels ordered by location. To the right of the hotel listings were 12 or so columns of data showing vital statistics for the hotels. After setting up the appropriate initial conditions, the program was able, within five seconds, to re-sort the hotels by revenue, calculate averages for key pieces of data, reinsert them into the model, add compensating factors for possible future inflation, calculate projected revenue figures for the next few years, and graph the results. . . . C. M.]

Integration is a very important characteristic of 1-2-3. Because the spreadsheet, database, and graphing programs are in the computer simultaneously (1-2-3 does not use overlays to bring in sections of code when called), you are more likely to use them. I for one am always annoyed when I have to wait for UCSD Pascal to load another part of the language system whenever I go, say, from the Filer to the Editor. I would be less apt to experiment with graphing different sets of data with Visicorp's Visicalc and Visiplot, which would involve saving my data to disk, exchanging disks, starting up the Visiplot

NEW SOFTWARE FROM
Single SOURCE Solution™

WSMX80-VERSION 2.1--\$39.95

WSMX80-Version 2.1 is a print processor which extends the capabilities of Word Star™ to optimize the printing features of the MX-80*. The extra commands include creating printing on empty pages, saving line height, chaining different files for continuous printing, changing strikeover character, providing an alternate Greek character set, and redefining control characters. WSMX80 is ideal for complex formulas. Full sub superscripts.

INFOSOFT ACCOUNTING SYSTEM-Version 4.2--\$750.00

The INFOSOFT ACCOUNTING SYSTEM-Version 4.2 is menu-driven. Annual aging of accounts, personalization for different terminal types, includes AP, AR, P, GL, bank account monitoring, point-of sale for sales registers, inventory, special buyers files.

SUPERMAILER-Version 3.7--\$99.50

SUPERMAILER-Version 3.7 is a database management system for assembling, printing mailing lists and making address labels. Sorting is possible by name, zip code, and any other user-defined parameter. SUPERMAILER can strip off sub-lists from the master list and may be configured to one of several disk capacities.

INFOSOFT CHIROPRACTIC BILLING SYSTEM
Version 2.0--\$500.00

The INFOSOFT CHIROPRACTIC BILLING SYSTEM provides a simple menu-driven billing system for Chiropractic offices with multiple practitioners. The INFOSOFT CHIROPRACTIC BILLING SYSTEM allows the user to view all treatments for a patient in a given month, enter daily information, list patients, enter new patients, sort the patient file, change the description of a treatment, age the accounts receivable, merge files, print labels, print statements and audit reports. An inventory of services and products may be kept. A database of 2500 patients may be kept on a single quad diskette.

CYNTHIA--\$149.50

CYNTHIA, a database management system with interactive queries allows a user-definable system for creating order or synthesis out of chaos. All parameters and data-entry requirements may be defined by the user. Each entry item may be merged with other similar files.

EPRIINT--\$29.95

EPRIINT allows the user of the Epson MX80* full command of the printer, including compressed printing, doublestrike, and emphasized printing, with user-selectable vertical and horizontal tabs.

MSIPRIINT--\$29.95

MSIPRIINT allows the user of the MSI full command of the printer, including compressed printing, doublestrike, and emphasized printing, with user-selectable vertical and horizontal tabs.

SBAPREP---Version 4.1---\$500.00

SBAPREP, Version 4.1 is a complete menu-driven package that prepares all of the paperwork for a Small Business Administration loan.

order from:
to Single SOURCE Solution
P.O. Box 578, Concord, CA 94522

IMAGINE IT...

NEW Buffer Options Available Up To 64K

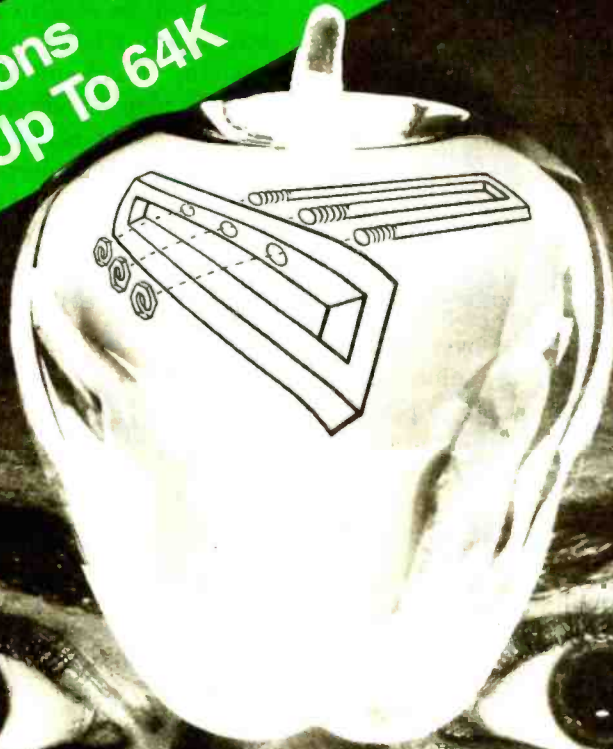

CAPTURE IT

Completely Redesigned. Now, the Grappler+.

The original Grappler was the first graphics interface to give you hi-res screen dumps from your keyboard. The new Grappler+ with *Dual Hi-Res Graphics* adds flexibility with a side-by-side printout of page 1 and page 2 graphics.

Interfacing the Grappler+ to a wide range of printers is easy as changing a dip switch. 4K of exclusive firmware makes the Grappler+ the most intelligent, full-featured Apple® Printer Interface made. And, the Grappler+ is Apple III compatible.*

Up to 64K Buffer Option

An optional Bufferboard can now be added to all existing Grappler and Grappler+ interfaces. See your Apple Dealer for details.

*Requires additional software driver.
**Requires graphics upgrade.

©Orange Micro, Inc. 1982

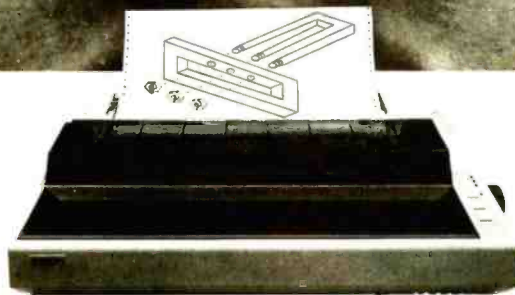

ACTUAL APPLE II PRINTOUT USING GRAPPLER AND EPSON MX100

With The Grappler+™ Printer Interface

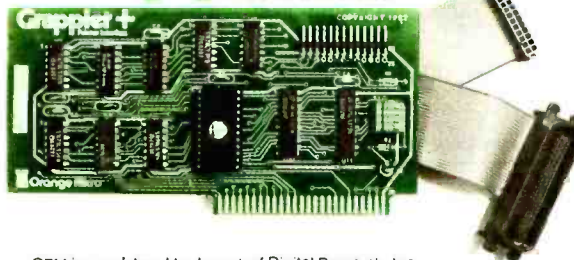

CPM is a registered trademark of Digital Research, Inc.
Apple is a registered trademark of Apple Computer, Inc.

The Grappler+ Features:

- Dual Hi-Res Graphics • Printer Selector Dip Switch • Apple III Compatible* • Graphics Screen Dump • Inverse Graphics • Emphasized Graphics • Double Size Picture • 90° Rotation • Center Graphics • Chart Recorder Mode • Block Graphics • Bell Control • Skip-over-perf • Left and Right Margins • Variable Line Length • Text Screen Dumps.
- The Grappler+ also works with Pascal and CPM.

The Grappler+ interfaces with the following printers:

- Anadex • Centronics • Datasouth • Epson** • NEC • C.Itoh • Okidata**
- The original Grappler is available for IDS 460, 560, Prism, Microprism.



3150 E. La Palma, Suite G
Anaheim, California 92806
U.S.A.

(714) 630-3620
Telex: 183511 CSMA

Foreign Dealer Inquiries Welcome

program, exchanging disks again, reading in the data, and, finally, plotting the data. I would do a similar sequence of disk and program switching to get back to Visicalc and adjust my data. How much experimentation does that rigamarole encourage?

Caveats

This product description is based on more than 20 hours of experimentation with a version of 1-2-3 Lotus loaned to me a month before the design and code were finalized. I experimented with all of the features mentioned in this article and several others. I found 1-2-3 easy to use; it didn't mislead me into doing something I didn't want to do or leave me confused as to my place within the structure of the program. Although I didn't have a copy of the final documentation, I found that a functional specification document I was given and the disk-based help file provided all the information I needed. I did have trouble specifying a new range by pointing in some situations; Lotus told me that this error will be corrected before the product is available commercially.

News from Lotus

1-2-3 will be available for the IBM Personal Computer sometime next month; it will eventually be available for other 8086- and 8088-based microcomputers, although Lotus has announced no definite plans or machines. Lotus has also fixed the price of 1-2-3 at \$495, which makes it a tremendous buy for the money. Staff members point out that 1-2-3 improves on the Visicorp trilogy of Visicalc, Visiplot, and Visidex (which together sell for a total of \$700 in their IBM PC versions) in both price and capabilities.

Mitch Kapor and his team of designers and programmers are incredibly creative: they have come up with

more good ideas than they can possibly implement at one time, but they also implement more of them than I would have thought possible. They have indicated that 1-2-3 will probably be able to read dBASE II files, thus making it possible for 1-2-3 to interchange data with one of the most popular databases around. They also told me that 1-2-3 will be able to make the spreadsheet look like a business form with blanks to be filled in by the user, thus enabling you to enter data into 1-2-3 database areas.

Lotus plans to add several graphics features to the final version. These include visual superimposition of charts, the use of text in user-chosen shapes, sizes, and colors; choice of printed chart size; manual scaling of graph axes; and support of the Hewlett-Packard HP7470A plotter and several popular printers. In addition, Lotus plans to add word-processing capabilities to subsequent releases of 1-2-3.

Conclusions

On the basis of the prerelease version of the software, 1-2-3 promises to be a fast, easy-to-use, integrated package for people who need to manipulate numbers, graphs, and records of data. Its instantly available help file, interactive tutorial programs, and incorporation of tested human-engineering concepts make it particularly impressive. It is one of the first of a new breed of sophisticated applications software that is both powerful and easy to use, even for beginners.

I'm very pleased about 1-2-3's price of \$495. That puts it within the grasp of both the professional who needs a sophisticated spreadsheet program and the individual who wants one for personal use.

In any case, even unfinished, 1-2-3 is a fine piece of software. I look forward to seeing the first and subsequent versions of it. ■

 <p>IBM PERSONAL COMPUTER</p> <p>64K MEMORY, 2 DRIVES (320K EACH), COLOR GRAPHICS ADAPTER CALL</p> <p>64K MEMORY, 2 DRIVES (320K EACH), MONOCHROME DISPLAY & PRINTER ADAPTER 495</p> <p>MONITORS</p> <p>AMDEX LOW-RES 13" COLOR I 365</p> <p>AMDEX RGB 13" COLOR II 775</p> <p>BMC 12" HI-RES GREEN (12EUN) 150</p> <p>NEC JB-1260M 12" GREEN 129</p> <p>NEC JB-1201M 12" GREEN 169</p> <p>TAXAN RGB VISION I 350</p> <p>TAXAN RGB VISION II 525</p> <p>TAXAN RGB VISION III 600</p>	<p>OSBORNE</p>  <p>CALL FOR PRICE & AVAILABILITY</p> <p>CVA-1 MONITOR ADAPTER 35</p> <p>NEC APC</p> <p>H01 ONE DRIVE B&W SYSTEM CALL</p> <p>H02 TWO DRIVES B&W SYSTEM CALL</p> <p>H03 TWO DRIVES COLOR SYSTEM CALL</p> <p>SHARP PC-1500</p> <p>PC-1500 HANDHELD COMPUTER 255</p> <p>CE-150 PRINTER/CASSETTE</p> <p>INTERFACE 215</p> <p>CE-155 8K RAM EXPANSION UNIT 120</p>	<p>brother HR-1</p>  <p>CALL FOR PRICE</p> <table border="0"> <tr> <td>COMREX CR-1-C</td> <td>CALL</td> </tr> <tr> <td>COMREX CR-1-S</td> <td>CALL</td> </tr> <tr> <td>OKIDATA MICROLINE 82A</td> <td>CALL</td> </tr> <tr> <td>OKIDATA MICROLINE 83A</td> <td>CALL</td> </tr> <tr> <td>C.I.TOH STARWRITER F-10-40PU</td> <td>1495</td> </tr> <tr> <td>C.I.TOH PROWRITER 8510AP</td> <td>499</td> </tr> <tr> <td>MICROTEK PARALLEL INTERFACE</td> <td>89</td> </tr> <tr> <td>MICROTEK APPLE DUMPLING-GX</td> <td>129</td> </tr> <tr> <td>*IDS 560G PAPER TIGER</td> <td>1295</td> </tr> <tr> <td>*NEC 3530 SPINWRITER</td> <td>1495</td> </tr> <tr> <td>*OLYMPIA ES100 SERIAL</td> <td>1195</td> </tr> <tr> <td>*SPECIAL OF THE MONTH</td> <td></td> </tr> </table>	COMREX CR-1-C	CALL	COMREX CR-1-S	CALL	OKIDATA MICROLINE 82A	CALL	OKIDATA MICROLINE 83A	CALL	C.I.TOH STARWRITER F-10-40PU	1495	C.I.TOH PROWRITER 8510AP	499	MICROTEK PARALLEL INTERFACE	89	MICROTEK APPLE DUMPLING-GX	129	*IDS 560G PAPER TIGER	1295	*NEC 3530 SPINWRITER	1495	*OLYMPIA ES100 SERIAL	1195	*SPECIAL OF THE MONTH		<p>SCM SMITH-CORONA TP-1</p>  <p>CALL FOR PRICE</p> <p>ATARI 800 & 400</p> <table border="0"> <tr> <td>ATARI 800 (16K)</td> <td>675</td> </tr> <tr> <td>ATARI 400 (16K)</td> <td>250</td> </tr> <tr> <td>410 PROGRAM RECORDER</td> <td>75</td> </tr> <tr> <td>810 DISK DRIVE</td> <td>435</td> </tr> <tr> <td>16K RAM MEMORY MODULE</td> <td>59</td> </tr> <tr> <td>850 INTERFACE MODULE</td> <td>165</td> </tr> <tr> <td>830 ACOUSTIC MODEM</td> <td>159</td> </tr> <tr> <td>ATARI VISICALC</td> <td>199</td> </tr> <tr> <td>ATARI WORD PROCESSOR DISKETTES</td> <td>125</td> </tr> <tr> <td>BASF 5 1/4" SS/DD/HUB RING</td> <td>23</td> </tr> <tr> <td>WABASH 5 1/4" SS/DD/HUB RING</td> <td>22</td> </tr> </table>	ATARI 800 (16K)	675	ATARI 400 (16K)	250	410 PROGRAM RECORDER	75	810 DISK DRIVE	435	16K RAM MEMORY MODULE	59	850 INTERFACE MODULE	165	830 ACOUSTIC MODEM	159	ATARI VISICALC	199	ATARI WORD PROCESSOR DISKETTES	125	BASF 5 1/4" SS/DD/HUB RING	23	WABASH 5 1/4" SS/DD/HUB RING	22
COMREX CR-1-C	CALL																																																
COMREX CR-1-S	CALL																																																
OKIDATA MICROLINE 82A	CALL																																																
OKIDATA MICROLINE 83A	CALL																																																
C.I.TOH STARWRITER F-10-40PU	1495																																																
C.I.TOH PROWRITER 8510AP	499																																																
MICROTEK PARALLEL INTERFACE	89																																																
MICROTEK APPLE DUMPLING-GX	129																																																
*IDS 560G PAPER TIGER	1295																																																
*NEC 3530 SPINWRITER	1495																																																
*OLYMPIA ES100 SERIAL	1195																																																
*SPECIAL OF THE MONTH																																																	
ATARI 800 (16K)	675																																																
ATARI 400 (16K)	250																																																
410 PROGRAM RECORDER	75																																																
810 DISK DRIVE	435																																																
16K RAM MEMORY MODULE	59																																																
850 INTERFACE MODULE	165																																																
830 ACOUSTIC MODEM	159																																																
ATARI VISICALC	199																																																
ATARI WORD PROCESSOR DISKETTES	125																																																
BASF 5 1/4" SS/DD/HUB RING	23																																																
WABASH 5 1/4" SS/DD/HUB RING	22																																																
<p>(800) 854-1941 Outside Ca. Order Deskt</p> <p>computer age</p> <p>4688 CONVOY STREET, SAN DIEGO, CA 92111 CALL OR WRITE FOR COMPLETE PRICE LIST</p>		<p>(619) 565-7092 Technical & California</p> <p>RISK FREE MAIL ORDER</p>	<p>TO ORDER: Please send cashier's check or personal check (allow 10 business days to clear), VISA and Master Card credit card service add 3%. Shipping, handling and insurance in U.S. add 3%. Minimum \$5.00. California residents add 6% sales tax. Foreign orders add 10% for shipping. Equipment is subject to price change and availability. We offer warranty on all equipment. Store prices may differ from mail order prices.</p>																																														

CP/M[®]
IBM[®]
APPLE[®]

PRICE WAR!

WordStar[®] \$249	dBASE II[™] \$489	SuperCalc[™] \$189	Perfect Writer[™] \$249	VisiCalc[®] \$189
WordStar[®] dBASE II[™] \$695	WordStar[®]/ MailMerge[™] \$309	EasyWriter II[™] \$269	Peachtree Software Call	SuperWriter[™] \$249

NOW, PAY LESS, AND GET GREAT SERVICE, TOO!

If you're looking for rock-bottom prices *and* fast, personal service, take a close look at 800-SOFTWARE.

Because we buy in volume, we're able to sell the products you want at prices that finally make some sense. But don't take our word for it. Compare prices and see for yourself!

OUR SERVICE CAN'T BE BEAT.

We take care of you like our business depends on it. Because it does.

When you call 800-SOFTWARE, you get the fastest delivery available anywhere. Which means that every order is filled the day we get it. And that our unique

Order Tracking System[™] is on the job, keeping tabs on your order, every step of the way.

Our giant inventory—one of the largest in the United States—also assures you of the fastest possible service. Everything's in stock so you don't have to wait.

Technical support? Business software expertise? We've got it—and it's the best you'll find *anywhere*.

But, put us to the test. Let us prove what we've proven to satisfied customers around the world.

That our prices *are* lower. That our service *is* better. That there really and truly *is* a difference.

We look forward to your call.

CUSTOMERS TELL OUR STORY BEST!

“I have been very favorably impressed with your prompt and efficient service and excellent prices.”

Peter Sereny, M.D., West Hartford, Connecticut

“Rarely today do I have the opportunity to deal with a firm which shows such a high degree of professional ability. Aloha.”

Joe Neil, Lihue, Hawaii

“It is indeed refreshing to deal with people as personable and professional as you have proven to be.”

Dave Turner, U.S.N., Lubbock, Texas

“Thank you very much for the very prompt service you gave me.”

William Drescher, Lansing, Michigan

All letters on file.

TO ORDER, CALL TOLL-FREE:

800-227-4587

In California, 800-622-0678

or 415-644-3611

CA residents add sales tax.

OR WRITE: 800-SOFTWARE, INC.

185 Berry Street, Suite 6820

San Francisco, CA 94107

- Purchase orders accepted
- Prompt UPS 3 day Blue Label service
- Call for shipping charges and our other low software prices.
- Now open Monday through Saturday.



FREE GIFT!

GET 4 FLOPPY DISKETTES FREE WITH ANY PURCHASE, IF YOU ACT NOW!

- Your choice of 5¼" or 8"
- Brand new



© Copyright 800-Software, Inc. 1982

YOUR PROGRAM HERE



The best software for the IBM Personal Computer. Could it be yours?

Attention, all programmers. Here's a chance to reach the top.

If you've written software that's completed and runs on the IBM Personal Computer, we could be interested in publishing it.

(We also could be interested if it runs on *another* computer. If we select your software, we'll ask you to adapt it to our system.)

But be advised.

Our expectations are great.

Because the software we publish must be good enough to complement IBM Personal Computer hardware. In fact, the more you take advantage of all our hardware capabilities (see the box at right), the more interested in your software we become.

Think about incorporating color graphics into your program, for example.

Use sound. Consider the power of our keyboard and remember to utilize the ten programmable function keys.

In all cases, we're interested in "friendly" software — with emphasis on quality and wide appeal. Programs with the greatest chance of being published must be easy to use, offer a better way to accomplish a task and provide something special to the user.

What kinds of programs? All kinds.

Education. Entertainment. Personal finance. Data management. Self improvement. Games. Communications. And yes, business.

We select programs that will make the IBM Personal Computer an even more useful tool for modern times.

IBM PERSONAL COMPUTER SPECIFICATIONS

User Memory 16K-512K bytes*	Display Screen High-resolution* 80 characters x 25 lines Upper and lower case Green phosphor screen*	Permanent Memory (ROM) 40K bytes*
Microprocessor 16-bit, 8088*	Auxiliary Memory 2 optional internal diskette drives, 5¼", 160K bytes or 320K bytes per diskette	Color/Graphics <i>Text mode:</i> 16 colors* 256 characters and symbols in ROM*
Keyboard 83 keys, 6 ft. cord attaches to system unit*	Operating Systems DOS, UCSD-p System, CP/M-86†	Graphics mode: 4-color resolution: 320h x 200v* Black & white resolution: 640h x 200v*
10 function keys* 10-key numeric pad Tactile feedback*	Languages BASIC, Pascal, FORTRAN, MACRO Assembler, COBOL	Simultaneous graphics & text capability*
Diagnostics Power-on self testing* Parity checking*	Printer Bidirectional* 80 characters/second 12 character styles, up to 132 characters/line*	Communications RS-232-C interface Asynchronous (start/stop) protocol Up to 9600 bits per second
*ADVANCED FEATURES FOR PERSONAL COMPUTERS		

So, if you think your software is the best, consider submitting it. If it's accepted, we'll take care of the publishing, the marketing and the distribution. All you have to do is reap the benefits of our new royalty terms. And you're free to market your program elsewhere *at any time* even if you license it to us.

We're offering the ladder. Think about taking the first step.

For information on how to submit your program, write: IBM Personal Computer,

External Submissions,
Dept. 765 PC, Armonk,
New York 10504.



The IBM Personal Computer A tool for modern times

For an authorized IBM Personal Computer dealer near you (or information from IBM about quantity purchases) call 800-447-4700. In Illinois, 800-322-4400. In Alaska or Hawaii, 800-447-0890. †UCSD p-System is a trademark of the Regents of the University of California. CP/M-86 is a trademark of Digital Research, Inc.

Book Reviews

PET/CBM BASIC

Richard Haskell
Prentice-Hall, 1982
154 pages, softcover
\$12.95

Reviewed by
Joseph Holmes
13049 Broadway Terr.
Oakland, CA 94611

Like other microcomputers, the PET premiered without much published information ready to guide its users. Fortunately, considerably more information is now available. One of the latest and most useful books is *PET/CBM BASIC* by Richard Haskell.

The book is intended to be a course in BASIC programming using a 40-column PET. The modifications for the 80-column CBM microcomputer are listed in one of the book's nine appendixes. The introductory presentation level makes the book useful as both a text and a classroom reference. Haskell stresses structured programming throughout and makes an effort to relate concepts and commands found in other languages or versions of BASIC to PET's BASIC. This approach adds to the value of the book as a programming text.

The inclusion of graphics in many of the program examples, a subject often treated lightly in other PET texts, is a welcome feature. Examples make the book especially well suited to teaching programming to junior high or elementary level students, who respond well to graphics.

The chapters are well organized, and a variety of drawings, diagrams, and photographs make the layout attractive. Because the author photographed most of the listings and all of the screen

outputs directly from the video display, many are just not legible enough to be useful. There should be supplemental printed listings. Several of the photographed listings, however, are readable.

At the beginning of chapter one, Haskell describes his philosophy of learning by doing, and in keeping with that he introduces the reader to the keyboard first. In each successive chapter, he begins with a summary of learning objectives and ends with several practice exercises.

Graphics are introduced in chapter two, where the author discusses the use of the INSERT/DELETE key and RUN and LIST commands in the creation of short graphics programs. By chapter five, he presents programs that manipulate both numbers and graphic symbols to illustrate the INPUT statement.

My wife used the book with students in the upper elementary grades, and they especially enjoyed the Custom Checkerboard Patterns program in which the input of two graphics characters results in the output of a "homemade" checkerboard design. One of the benefits of using graphics in teaching programming is that they motivate the adventurous learner to experiment further.

In chapter seven, the author uses an unusual approach to discuss types of loops. He describes them as Repeat While, Repeat Until, Do While, and Do Until. The For-Next loop is introduced in the following chapter, which culminates in a program that generates an American flag, making liberal use of the loop.

Later in the book, Haskell introduces the use of subroutines as a method of building three-dimensional

block letters. Chapter nine offers another example of the author's use of graphics to teach programming. The use of bar graphs gives the student additional practice in subroutines and serves as an introduction to the READ and DATA statements as well.

In chapter fourteen, Haskell explains how to make sounds on the PET, among them musical notes, clicks, sirens, and a phaser-firing noise. He also includes a schematic for an amplifier to connect to the PET's parallel port because the built-in sound in the latest PET/CBM computers is quite faint. The final chapter concludes with the development of a pro-

gram called PET Organ, which combines graphics and sound. The program displays a labeled organ keyboard which creates sounds that correspond to the appropriate key pressed.

Overall, *PET/CBM BASIC* is both a good text for beginners and a useful reference for old hands. Richard Haskell has filled several gaps in the library of PET materials by including a number of useful graphics applications, an emphasis on structured programming, an explanation of PET sound, and practical examples from his own programming experience. I only wish the book had been published before I learned BASIC programming. ■

BYTE's Bits

Data Resources and Visicorp to Offer Business Information

Data Resources Inc. (DRI), a McGraw-Hill subsidiary, has entered into an agreement with Visicorp that will let personal-computer users access DRI's and McGraw-Hill's business and economic databases, such as Standard & Poor's Compustate, or construction-industry reports from F. W. Dodge. The new service consists of both software and information products. The software will provide users with telephone access to the central data banks and will be distributed through computer stores by Visicorp, maker of Visicalc and other applications software.

Data Resource's information products will be available to users from an on-line catalog and will contain data

and formulas needed for specific applications. When a product is selected, the information will be transferred to the personal computer for ongoing use in Visicalc, Visicorp's popular electronic spreadsheet program.

Full details are available from Data Resources Inc., 29 Hartwell Ave., Lexington, MA 02173, (617) 861-0165.

NACS Relocates

The address and telephone number of NACS (National Association of Computer Stores) given in the *BYTE's Bits* entitled "Computer Stores Listed" is no longer applicable. (See the May 1982 *BYTE*, page 307.) The new address is NACS, POB 1333, Stamford, CT 06904, (203) 323-3143. ■

WESTICO — The Software Express Service that really delivers:

IBM PC SOFTWARE

16 Bit software for IBM PC, Victor 9000, CP/M-86 and MSDOS.

Westico has good news for owners of the new 16 bit microcomputers — a full selection of quality software. Programs for businesses, professionals, and software developers. Westico can provide its CP/M-80 programs for "Baby Blue" and similar 8 bit hardware options. And there's more good news. We deliver more than quality software fast. We deliver Westico. That means you receive Westico's outstanding technical support and expertise when you need it.

MicroGANTI — Sophisticated project planning system which uses Critical Path Method analysis. Visually oriented system makes it easy to interactively define task and project parameters. Budget costs and work hours are also calculated and displayed. Percentage allocation of resources to tasks and partial completion of tasks on the critical path are other features. \$395/\$25.

STATPAK — Statistics software library in Microsoft BASIC designed to give users an effective alternative to time-sharing. Performs probability calculations, independent variable statistics, discrete & continuous distribution functions, regression analysis, means testing, survey data/contingency tables and more. Includes plotting and data management. \$500/\$40.

MINIMODEL — Does big financial planning jobs at micro prices for cash flow projections, financial forecasting, venture analysis, and risk analysis. Model limited to 32,000 by 32,000 cells. Report content and format totally under user control. \$495/\$50.

VERDICT — For law offices with up to 25 attorneys and a total of 35 time-keepers (including paralegals, secretaries, etc.). All time and expenses are distributed to client or other designated overhead accounts. Analysis of billings, aging of receivables, and analysis of each timekeeper's work effort. Produces monthly client review sheets and ready to mail itemized bills. \$750/\$40.

BILLKEEPER — For professional offices — architects, accountants, engineers, consultants, ad agencies — with all of the features of VERDICT. \$750/\$40.

MICRO-TAX — Accepts information, summarizes data, computes tax, and prints returns required by the Internal Revenue Service. LEVEL 1 for individuals produces 14 schedules and forms. \$195. LEVEL 2 for professionals produces 33 schedules and forms. Includes depreciation, state tax interface, integrated data base for year to year data storage. \$1000. LEVEL 3 is a Partnership & Corporate package which produces 19 schedules and forms. \$1000.

POSTMASTER — Mailing list system to maintain name and address files. Produces everything from mailing labels to customized letters. \$150/\$25.

FINALWORD — Full screen interactive word processor with tables of contents, automatic indexes, simultaneous printing and editing. \$300/\$40.

ASCOM — For telecommunications between micros or micro to main frame. Easy to use full menu mode or expert command mode. Built-in commands for auto-dialing modems and tables for character translation, and suppression. Remote mode for controlling other micros. \$175/\$25.

C86 — C language compiler for 8088/8086 machines. \$250/\$25.

CBASIC/86 — Standard microcomputer BASIC language. \$325/\$30.

JANUS/ADA — Compiler for useful subset of ADA language. \$400/\$25.

PASCAL/MT+86 — Compiler generates machine language. \$800/\$30.

SID-86 — Symbolic debugging tool for CP/M-86. \$150/\$15.

EM80/86 — Emulates execution of CP/M-80 programs. \$100/\$10.

UT-86 — Utility programs for PC DOS and MS DOS. \$195/\$25.

The Westico 24-Hour Computer Hotline for 300 baud modems (203) 853-0816 for detailed information and quick access ordering.



● Westico has more than 250 programs that work on a wide variety of microcomputers including ADDS Multivision, Altos, CPT, Cromemco, DEC, Dynabyte, Eagle, Exxon, Facit, Hewlett-Packard, IBM, Intertec, Kaycomp, Monroe, NEC, North Star, Northern Telecom, Ohio Scientific, Otrona Attache, Radio Shack, Sirius, Televideo, Vector Graphic, Victor, Xerox, Zenith. We're working hard to be your software company.

4 Ways to order

- Write Westico, Inc., 25 Van Zant Street, Norwalk, CT 06855.
- Call (203) 853-6880.
- Telex 643-788
- Dial-up our 24-hour computer (300 baud) (203) 853-0816.

COD, MasterCard and VISA accepted.

Prices do not include shipping and are subject to change. In CT add 7½% sales tax. All sales final.

Manual price may be credited toward purchase of software.

Dealer inquiries invited.

WES-57

Copyright © 1982 Westico, Inc.

Call for FREE catalog.

WESTICO
The Software Express Service

25 Van Zant Street • Norwalk, Connecticut 06855
(203) 853-6880 • Telex 643-788

computer mail order west



400
16K..... \$269
32K..... \$349
48K..... \$429

800 — 48K
~~\$369~~ call

410 Recorder.....	\$ 76.00
810 Disk Drive.....	\$449.00
822 Printer.....	\$269.00
825 Printer.....	\$589.00
830 Modem.....	\$159.00
820 Printer.....	\$259.00
850 Interface.....	\$169.00
CX40 Joysticks (Pair).....	\$ 18.00
CX853 Atari 16K Ram.....	\$ 77.95

Microtek 16K Ram.....	\$ 74.95
Axon Ramdisk (128K).....	\$429.95
Intek 48K Board.....	\$159.00
Intek 32K Board.....	\$ 74.00
One Year Extended Warranty.....	\$ 70.00
CX481 Entertainer Package.....	\$ 69.00
CX482 Educator Package.....	\$130.00
CX 483 Programmer Package.....	\$54.00
CX 484 Communicator Package.....	\$344.00
Atari 800 Dust Cover.....	\$6.99
Atari 400 Dust Cover.....	\$6.99
Atari 810 Dust Cover.....	\$6.99

PERCOM

Disk Drives For Atari Computers

S1 Single Drive.....	\$589.00
A1 Add-on Drive.....	\$339.00
S2 Dual Drive.....	\$879.00
Single Side Dual Head.....	\$679.00
Dual Drive Dual Head.....	\$1046.00



μ-SCI

MICRO-SCI Disk Drives For Franklin & Apple



A2.....	\$319.00
A40.....	\$369.00
A70.....	\$499.00
C2 Controller.....	\$79.00
C47 Controller.....	\$89.00

ATARI

Pac Man.....	\$35.00
Centipede.....	\$35.00
Caverns of Mars.....	\$32.00
Asteroids.....	\$29.00
Missile Command.....	\$29.00
Star Raiders.....	\$35.00

DATASOFT

Pacific Coast Highway.....	\$25.00
Canyon Climber.....	\$25.00
Tumble Bugs.....	\$25.00
Shooting Arcade.....	\$25.00
Clowns and Balloons.....	\$25.00
Graphic Master.....	\$30.00
Graphic Generator.....	\$13.00
Micro Painter.....	\$25.00
Text Wizard.....	\$89.00
Spell Wizard.....	\$64.00
Bishop's Square.....	\$25.00

ON-LINE

Jawbreaker.....	\$27.00
Softporn.....	\$27.00
Wizard and the Princess.....	\$29.00
The Next Step.....	\$34.00
Mission Asteroid.....	\$22.00
Mouskattack.....	\$31.00

SYNAPSE

File Manager 800.....	\$79.00
Chicken.....	\$26.00
Dodge Racer.....	\$26.00
Synassembler.....	\$30.00
Page 6.....	\$19.00
Shamus.....	\$26.00
Protector.....	\$26.00
Nautilus.....	\$26.00
Slime.....	\$26.00
Disk Manager.....	\$24.00

K-BYTE

Krazy Shoot Out.....	\$32.00
K-razy Kritters.....	\$32.00
K-razy Antics.....	\$32.00
K-star Patrol.....	\$32.00

STICK STAND
\$6⁹⁹



VISICORP For Apple, IBM, Franklin

Visidex.....	\$189.00
Visifile.....	\$189.00
Visiplot.....	\$159.00
Visiterm.....	\$189.00
Visitrend/Plot.....	\$229.00
VisiSchedule.....	\$229.00
Desktop Plan.....	\$189.00
VISICALC.....	\$179.00

Continental

The Home Accountant (Apple/Franklin).....	\$59.00
The Home Accountant (IBM).....	\$119.00
1st Class Mail.....	\$59.00

FLOPPY DISKS Maxell

MD I (Box of 10).....	\$36.00
MD II (Box of 10).....	\$46.00
MFD I (8").....	\$44.00
MFD II (8" Double Density).....	\$54.00

Verbatim

5 1/4" SS DD.....	\$26.00
5 1/4" DS DD.....	\$36.00

Elephant

5 1/4" SS DD.....	\$19.99
-------------------	---------

TIMEX

TIMEX SINCLAIR 1000

LOWEST PRICE EVER! **\$89.00**

NORTHSTAR ALTOS

Call for price and availability on all models.

MODEMS Hayes

Smart.....	\$239.00
Smart 1200 (1200 baud).....	\$549.00
Chronograph.....	\$199.00
Microdem II.....	\$279.00
Microdem 100.....	\$309.00

Novation

Cat.....	\$144.00
D-Cat.....	\$159.00
Auto Cat.....	\$219.00
212 Auto Cat.....	\$589.00
Apple Cat II.....	\$339.00
212 Apple Cat II.....	\$609.00

Anchor

Mark I (RS-232).....	\$79.00
Mark II (Atari).....	\$79.00
Mark III (TI-99).....	\$109.00
Mark IV (CBM/PET).....	\$125.00
Mark V (OSBORNE).....	\$95.00
Mark VI (IBM-PC).....	\$179.00
Mark VII (Auto Answer/Dial).....	\$119.00
9 Volt Power Supply.....	\$9.00

MONITORS AMDEK

300G.....	\$169.00
Color I.....	\$339.00
Color II.....	\$699.00
Color III.....	\$429.00

BMC

12" Green.....	\$ 85.00
13, Color 1400.....	\$279.00
13" Color 1401 (Mid Res).....	\$369.00

ZENITH

ZVM 121.....	\$ 99.00
--------------	----------

SHARP

Sharp 13" Color TV.....	\$275.00
-------------------------	----------

PANASONIC

TR-120 MIP (High Res. Green).....	\$159.00
CT-160 Dual Mode Color.....	\$299.00

west 800-648-3311 west

Circle 119 on inquiry card.

IN NV. CALL (702) 588-5654
 P.O. BOX 8689 STATELINE, NV. 89449

In-stock items shipped same day you call. No risk, no deposit on C.O.D. orders. Pre-paid orders receive free shipping within the continental United States with no waiting period for certified checks or money orders. Add 3% (minimum \$3.00) shipping and handling on all C.O.D. and Credit Card orders. NV and PA residents add sales tax. All items subject to availability and price change. **NOTE:** We stock manufacturer's and third party software for most all computers on the market! Call today for our new catalogue.

computer mail order east

FRANKLIN ACE1000

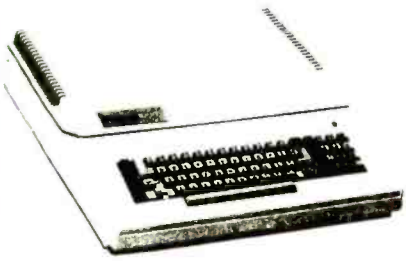

64K Personal Computer Hardware, Software and peripheral compatible with the Apple II and even has some features not found on the Apple.

EAGLE COMPUTER

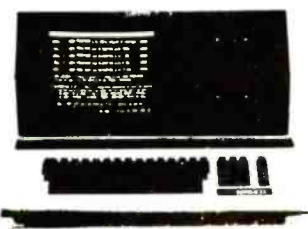

64K RAM
780 KB Disk Storage
Word Processing, Ultracalc CP/M, CBasic Software
Smith Corona TP1 Letter Quality Printer
Our Price \$2995.00
Retail Value \$4895.00

commodore

8032	\$999.00
CBM 64	CALL
4032	\$749.00
8096 Upgrade Kit	\$369.00
Super Pet	\$1599.00
2031	\$369.00
8250 Double Sided Disk Drive	\$1699.00
D9060 5 Megabyte Hard Disk	\$2399.00
D9090 7.5 Megabyte Hard Disk	\$2699.00
8050	\$1299.00
4040	\$969.00
8300 (Letter Quality)	\$1549.00
8023	\$599.00
4022	\$399.00
New Z-Ram. Adds CP/M and 64K Ram	\$549.00
The Manager	\$209.00
Magis	CALL
Word Pro 5 plus	\$319.00
Word Pro 4 plus	\$299.00
Word Pro 3 plus	\$199.00
The Administrator	\$379.00
InfoPro Plus	\$219.00
Power	\$79.00
VIC 20 Dust Cover	\$6.99
CBM 8032 Dust Cover	\$14.99
CBM 8050/4040 Dust Cover	\$10.99

HEWLETT PACKARD



HP-85 \$1969

HP-125	\$1969.00
HP-85 16K Memory Module	\$169.00
5 1/4" Dual Master Disk Drive	\$1799.00
Hard Disk w/ Floppy	\$4349.00
Hard Disk	\$3549.00
"Sweet Lips" Plotter	\$1199.00
80 Column Printer	\$649.00



PC

Call... for price and availability on IBM-PC hardware, software and peripherals.
NEC 3550 Printer (for IBM) \$2099.00

VIC 20 \$179



VIC 1530 Commodore Datassette	\$69.00
BIC 1540 Disk Drive	\$339.00
VIC 1541 (64 Disk Drive)	CALL
VIC 1525 Graphic Printer	\$339.00
VIC 1210 3K Memory Expander	\$32.00
VIC 1110 8K Memory Expander	\$53.00
16K VIC Expansion	\$94.00
VIC 1011 RS232C Terminal Interface	\$43.00
VIC 1112 VIC IEEE-488 Interface	\$86.00
VIC 1211 VIC 20 Super Expander	\$53.00
VIC Mother Board	\$99.00



HEWLETT PACKARD HP 41CV CALCULATOR \$209



HP 41C	\$149.00
HP 10C	\$69.00
HP 11C	\$79.00
HP 12C	\$114.00
NEW 115C	\$109.00
NEW 16C	\$114.00

HPIL PERIPHERALS IN STOCK!

Televideo Terminals

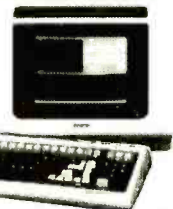

910	\$579.00
912C	\$699.00
920C	\$749.00
925C	\$749.00
950	\$950.00
800A	\$1319.00
802	\$2649.00
802H	\$4695.00
806	\$5795.00
816	\$9495.00

PRINTERS

Smith-Corona

TP-1 \$599



C.ITOH (TEC)

Starwriter (F10-40CPS)	\$1399.00
Printmaster (F10-55CPS)	\$1749.00
Prowriter 80 Col (P)	\$499.00
Prowriter 80 Col (S)	\$629.00
Prowriter 2 (132 Col)	\$799.00

Okidata

82A	\$429.00
83A	\$659.00
84P	\$1079.00
84S	\$1199.00

IDS

132 (fully configured)	\$1599.00
80 (fully configured)	\$1399.00

Call for other configurations

Daisywriter

Letter Quality	\$1049.00
----------------	-----------



PC-1500 POCKET COMPUTER

ALSO AVAILABLE:
Printer w/cassette interface
cassette tape recorder
and 4K and 8K RAM EXTENSIONS

NEC COMPUTERS

8001-A	\$749.00
8031	\$749.00
8012	\$549.00

Printers

8023	\$549.00
7710/7730	\$2399.00
3510/3530	\$1599.00

Monitors

JB-1201	\$159.00
JC-1201	\$329.00
JC-1202	\$899.00

800-233-8950

east

east

IN PA. CALL (717) 327-9575

477 E. THIRD ST., WILLIAMSPORT, PA. 17701

Circle 119 on Inquiry card.

In-stock items shipped same day you call. No risk, no deposit on C.O.D. orders. Pre-paid orders receive free shipping within the continental United States with no waiting period for certified checks or money orders. Add 3% (minimum \$3.00) shipping and handling on all C.O.D. and Credit Card orders. NV and PA residents add sales tax. All items subject to availability and price change. **NOTE:** We stock manufacturer's and third party software for most all computers on the market! Call today for our new catalogue.

Microshell and Unica

Unix-Style Enhancements for CP/M

Christopher Kern
Apartment 839
201 I St., SW
Washington, DC 20024

Unix, the computer operating system developed by Bell Laboratories, has been justly acclaimed for combining a number of powerful features in a simple and uniform package. As a consequence, interest in it has grown rapidly in the last few years.

Unix will run on a variety of large computers and is often used in university, industry, and government computer centers. Many of the new 16-bit microcomputers have Unix or Unix-like operating systems, which is one of the main sources of their appeal. One manufacturer, Cromemco, even makes a Unix-style operating system for an 8-bit computer, using special-purpose hardware.

Now, two new software products, Microshell and Unica, provide conventional 8080-, 8085-, or Z80-based microcomputers using the CP/M operating system with some of the features that have contributed to the popularity of Unix. Though neither one comes close to being a full Unix-like implementation, they are both real improvements over the normal CP/M environment. To appreciate what they do, a brief overview of some Unix features is necessary.

I/O Redirection

One of the most elegant concepts to be popularized by Unix is I/O (input/output) redirection. Many programs

read and write a single I/O stream. Typically, the input is read in from the user's keyboard and the output is displayed on the screen of the video terminal. Sometimes, however, you may want to have the output go into a disk file instead. Unfortunately, with an operating system such as CP/M, there is no easy way to do this. But the Unix command interpreter allows the user to redirect input and output at the time a program is invoked. For example, the Unix command "prog < infile" would run the program "prog" and tell it to take its input from the text file "infile". And the command "prog > outfile" would run the program "prog" and send its output to the text file "outfile".

Suppose, for example, you want to create a file containing the directory of a given disk. If the program to list a directory is called "ls", the command "ls > direct" would write the contents of the disk to the file named "direct", rather than print the listing on the console screen. The file "direct" could then be edited, combined with other files (perhaps to produce a master listing of the contents of a number of disks), or treated just like any other text file.

Or you might need to make the same series of changes in a number of different text files. Under CP/M you would have to edit each of the files in sequence with your

At a Glance

Name

Microshell (Version 1.1)

Type

Unix-style command interpreter for CP/M 2.2

Distributor

New Generation Systems
Inc.
2153 Golf Course Dr.
Reston, VA 22091
(703) 476-9143

Price

\$150 (\$25 for manual only)

Computer

8080-, 8085-, and Z80-based machines running the CP/M 2.2 operating system; 32K bytes of RAM

Documentation

51-page user manual

Audience

CP/M operating system users who want a Unix-style command interpreter

At a Glance

Name

Unica

Type

Unix-style utility programs

Distributor

Knowlogy
POB 283
Wilsonville, OR 97070
(503) 639-3420

Price

\$95 (\$15 for manual only);
\$195 with XM-80 macro
language (\$25 for manuals)

Computer

Z80-based machines running the CP/M 2.2 operating system; 32K bytes of RAM

Documentation

Unica: 48-page user manual;
XM-80: 171-page user and
reference manual

Audience

CP/M operating system users who want Unix-style utility programs

system text editor, repetitively entering the commands for each file. A Unix user, however, would probably make up an editing "script"—a text file containing all the instructions for the editor. Then the input of the editor would be redirected so that it would receive its commands from the script, rather than have them typed in one by one from the keyboard.

Under Unix, by the way, the various physical devices that are connected to the central processor—the console, for example, or the system printer—can be treated just like text files for many purposes, including I/O redirection. Thus, you could get a paper copy of the output of the listing command, "ls", just by directing the output of "ls" to the line printer. If the line printer was known to the system by the name "lp", the command would be "ls > lp".

Pipelines

Another important Unix concept is the *pipeline* or *pipe*. A pipeline is a way of connecting two programs together by sending the output of the first program to the

input of the second program. This is one way that Unix implements the philosophy, which contributes so much to its success, of breaking down big computing jobs into small, manageable pieces. This not only makes writing programs easier (a small, simple program is obviously easier to write than a large, complex one), it also allows the user to rearrange various utility programs into new combinations. In this way, it is possible to perform tasks that were never contemplated when the individual component programs were designed.

For example, you might have one program that took a number of lines of text, arranged them neatly into columns, and displayed them on the console. By using a pipeline, the output of any other program could be fed into this formatting utility to produce multiple-column output. The same approach could be used with other kinds of formatting programs, sorting utilities, and the like. The command "prog1 | prog2", for example, pipes the output of "prog1" to the input of "prog2". The vertical bar (|) is the Unix symbol for a pipeline.

Ideally, "prog1" and "prog2" should be executing simultaneously, with the operating system handling the connection between them and managing any necessary coordination. But the concept of a pipeline can be implemented quite adequately—if somewhat more slowly—with temporary files. A pipeline such as the one above then becomes shorthand for a sequence of I/O redirection. The first half of the command is the equivalent of "prog1 > tempfile"; the second half is the equivalent of "prog2 < tempfile". As we shall see in a moment, this is how both Microshell and Unica handle pipelines.

Single-Function Programs

One practice that flows from the Unix philosophy of keeping programs small and simple is that a program should do only one thing, and that it should do it as well as possible. The result is that Unix (and Unix-style) utility programs exhibit a certain coherence. They tend to be devoid of unrelated features that, however useful they might be, would complicate program design, maintenance, and improvement. This simplicity encourages users to refine their earlier work and that of their predecessors. As a consequence, a given computer system evolves over time, becoming better and better adapted to its users.

The virtue of this approach is best demonstrated by a counterexample. Take the CP/M utility program, STAT. STAT is a very powerful program. It can calculate the amount of free space on a disk. It can provide an alphabetical listing of file names, showing the size and directory attributes (e.g., whether it is read-write or read-only) of each file. It can change the directory attributes of a file or group of files. It can reassign system devices, for example, to make the console a hard-copy terminal rather than a video terminal. It can display the capacity, block and track size, and number of available directory entries on each disk drive. And it can print out the current user number and show which other users have files on the disk drive currently being addressed.



D Base II
Quickcode.
and Dllhil \$749

Franklin Ace 1000.
12" Green Monitor.
\$400 of Software \$1595

Vic 20
with
Disk Drive
\$699

Random House Jkoeurw
with Wordstar \$409

Perfect Filer
and
Perfect Writer \$499

Hayes 1200 Baud
Smartmodem
with
Crosstalk \$679



HOLIDAY PACKAGES



CALL US ABOUT YOUR FREE GIFT WITH PURCHASE

DEVELOPMENT HARDWARE/SOFTWARE

GTEK MODEL 7128 EPROM PROGRAMMER

Compare the features:

- Microprocessor based intelligence for ease of use and interface.
- RS-232 interface and ASCII data formats make the 7128 compatible with virtually any computer with an RS-232 interface port.
- Auto-select baud rate, Xon/Xoff and DTR, CTS are supported.
- Program and read the following: 2508, 2758, 2516, 2716, 27C16, 2532, 2732, 2732A, 27C32, MCM68766, 2564, 2764, 27C64, 27128, (8748, 8749, 8741, 8742, 8751 with socket adapter)
- Automatic use of proper program voltage based on type selected.
- Optional support for EEPROMS
- Menu driven eeprom type selection, no personality modules required.
- Supports Intel and Motorola data formats as well as conversational hex formats. Formatted screen dump and block read commands.
- Interrupt driven type ahead, program and verify real time while sending data.
- Program single byte, block, or whole eeprom.
- Intelligent diagnostics discern between eeprom which is bad and one which merely needs erasing.
- Erasure check command.
- Busy light indicates when power is being applied to program socket.
- Complete with zero insertion force socket and integral 120 VAC power supply. (240 VAC/50HZ available at slight additional charge)
- High Performance/Cost ratio.

Model 7128 PRICE \$389.00

MODEL 7128/24 - budget version of the 7128. Supports 24 pin parts thru 32K only. Upgradable to full 7128 capacity.

Model 7128/24 PRICE \$289.00

Accessories - Erasers, Eproms, Cables



GTEK MODEL 9000 SERIES COMPUTERS

- Two user operating system available.
- 4 MHz Z80 CPU, no wait states
- 128K byte RAM with bank select
- DMA floppy disk operation with track buffering for fast disk I/O.
- 2 serial ports with type ahead, speeds to 76.8K baud.
- Parallel printer port, with 47K interrupt driven spooler.
- Winchester interface port.
- Dual mini-floppies, FORMATTED storage to 1.6 Megabyte.
- Eight inch drives available also.
- One year warranty (90 days on drives)

Highest Performance/Cost ratio
Prices start at \$2390.00 including CP/M*
Contact GTEK direct for quotation on Series 9000 tailored to your specific needs.

CROSS ASSEMBLERS by Avocet Systems, Inc. (For CP/M* based machines)
For the following families:
6805, 6809, 1802, 8048, 8051, 6502, 6800, NEC7500, FB, COP400, Z8

Cross Assembler price \$200.00 each except NEC7500 price \$500.00

* Trademark of Digital Research, Inc.

Post Office Box 289
Waveland, Mississippi 39576
(601) 467-8048

GTEK INC.

With all these capabilities, the STAT command would probably be very hard to modify. Digital Research, which markets CP/M, doesn't supply the source code for the STAT command, and perhaps it is just as well. It would probably be rather difficult to improve one of STAT's many capabilities without bollixing up some other feature.

Another problem is that STAT requires a bewildering variety of optional arguments for all these capabilities; you can't just type in a single mnemonic name and get the information that you want. In fairness, though, STAT provides a command summary—if you can remember how to get it. The default usage, "STAT" with no argument, prints out the bytes remaining on the currently addressed disk.

To be sure, Unix is not completely without problems itself. It has been criticized for its poor choice of mnemonics: "ls" is the directory listing command, "cat" types the contents of a file on the console, and "mv" is used to rename (move) a file. But having a program do only one thing, and having it provide its output in the most commonly used form without the need for optional arguments, is a big step toward simpler computer systems. And it has the important advantage of making it easier for different programs to work together.

Microshell

Microshell is a replacement for the CP/M command interpreter that provides I/O redirection, pipes, and a number of other useful features. The Unix command interpreter is known as the "shell," hence Microshell's name. In addition to the simple redirection commands, "<" for input and ">" for output, Microshell lets you echo output that is being directed to a file on the console ("> +") and to append directed output to an existing file ("> >").

As I mentioned earlier, Microshell provides pipeline capability by using temporary files. As an experiment, I created a pipeline to list the individual words in a text file in alphabetical order, using utility programs that (1) placed each word in the file on a separate line, (2) sorted the lines alphabetically, and (3) filtered out multiple occurrences of the same word. This pipeline didn't break any speed records, but it worked. And if you have an occasional need for a sorted list of the words in a file, connecting existing utilities in a pipeline is certainly an easier way to get it than writing a new program. Programs that read their input, alter it in some way, and then send it to their output are known as *filters*, which fits in with the plumbing analogy of the pipeline. (Incidentally, the source code for the programs I used to construct this word-list pipeline comes from an excellent book, *Software Tools*, by Brian W. Kernighan and P. J. Plauger [Addison-Wesley, 1976]. The programs in the book were written in RATFOR, a FORTRAN preprocessor based on the C language. The book is a good source for explanations of concepts, such as filters, which came from Unix. It is also available in a Pascal version, *Software Tools in Pascal* [Addison-Wesley, 1981].)

IT'S YOUR MOVE MAKE IT NOW

EPSON

CARTRIDGE RIBBONS

MX-80 **MX-100**
\$9.95 Ea. \$12.95 Ea.

MINIMUM ORDER OF 3 RIBBONS
SAVE 10% WITH PURCHASE OF A DOZEN

LABEL SPECIAL

1 ACROSS 3 1/2 x 1 5/16" CONTINUOUS LABELS

NOW 2.99/M (5M Min.)

CHECK-MATE is now a distributor
of Memorex Diskettes

Check-Mate

Toll Free 800-343-7706 Ma 617-963-7694

P.O. Box 103 Randolph, Ma. 02368
WE ACCEPT MASTERCARD AND VISA



LOWER PRICES, COME HELL OR HIGH WATER.

“ I'll match any advertised price on any item you want to buy from us. And if—Heaven forbid!—you find a lower price on what you bought within 30 days, just show me the ad and I'll refund the difference. ”

—Old Nick for
DISCOUNT SOFTWARE

CP/M®

DISK WITH / MANUAL ONLY

ARTIFICIAL INTELLIGENCE*

Medical (PAS-3) \$849/\$40

Dental (PAS-3) \$849/\$40

ASYST DESIGN*/FRONTIER

Prof Time Accounting \$549/\$40

General Subroutine \$269/\$40

Application Utilities \$439/\$40

DIGITAL RESEARCH*

CP/M 2.2

NorihStar \$149/\$25

TRS-80 Model II (P+T) \$159/\$35

Micropolis \$175/\$25

CP/M-Intel MDS \$135

PL/1-80 \$459/\$35

BT-80 \$179/\$30

MAC \$ 85/\$15

RMAC \$179

Sid \$ 65/\$15

Z-Sid \$ 90/\$15

Tex \$ 90/\$15

DeSpool \$ 49/\$10

CB-80 \$459/\$35

CBasic-2 \$ 98/\$20

Lnk-80 \$ 90/\$10

FOX & GELLER

Quickscreen \$135/\$na

Quickcode \$265/\$na

dutil \$ 65/\$na

MICRO-AP*

S-Basic \$269/\$25

Selector IV \$295/\$35

Selector V \$495/\$50

MICRO DATA BASE SYSTEMS*

HDBS \$269/\$35

MDBS \$795/\$40

DRS or QRS or RTL \$269/\$10

MDBS PKG \$1999/\$60

MICROPRO*

WordStar \$289/\$60

Customization Notes \$449/\$na

Mail-Merge \$ 99/\$25

WordStar/Mail-Merge \$369/\$85

DataStar \$249/\$80

WordMaster \$119/\$40

SuperSort I \$199/\$40

SpellStar \$175/\$40

CalcStar \$259/\$na

MICROSOFT*

Basic-80 \$298

Basic Compiler \$329

Fortran-80 \$349

Cobol-80 \$589

M-Sort \$175

Macro-80 \$144

Edit-80 \$ 84

MuSimp/MuMath \$224

MuLisp-80 \$174

FPL: Bus. Planner... \$595

ORGANIC SOFTWARE*

TextWriter III \$111/\$25

DateBook II \$269/\$25

Milestone \$269/\$30

OSBORNE* (McGraw/Hill)

General Ledger \$ 59/\$20

Acc't Rec/Acct Pay \$ 59/\$20

Payroll w/Cost \$ 59/\$20

All 3 \$129/\$60

All 3 + CBASIC-2 \$199/\$75

Enhanced Osborne (vandata) \$269/\$60

(Includes CBasic) \$269/\$60

PEACHTREE*

General Ledger \$399/\$40

Acct Receivable \$399/\$40

Acct Payable \$399/\$40

Payroll \$399/\$40

Inventory \$399/\$40

Surveyor \$399/\$40

Property Mgt \$799/\$40

CPA Client Write-up \$799/\$40

P8 Version Add \$231

MagicCalc \$269/\$25

Peach Pak Series 4 \$1195/\$na

Other less 10%

STAR COMPUTER SYSTEMS

G/L, A/R, A/P, Pay \$ 359

All 4 \$1129

Legal Time Billing \$ 849

Property Mngmt \$ 849

STRUCTURED SYSTEMS

Business Packages, Call for Price

SORCIM*

SuperCalc \$269/\$na

Trans 86 \$115

Act \$157

SUPERSOFT*

Ada \$270/\$na

Diagnostic I \$ 49/\$20

Diagnostic II \$ 84/\$20

Disk Doctor \$ 89/\$20

Forth (8080 or Z80) \$149/\$25

Fortran \$219/\$30

Fortran w/Ratfor \$289/\$35

C Compiler \$225/\$20

Star Edit \$189/\$30

Scratch Pad \$266/\$15

StatGraph \$174/\$15

Analiza II \$ 45/\$na

Dataview \$174/\$15

Disk Edit \$ 89/\$15

Encode/Decode II \$ 84/\$15

Optimizer \$174/\$15

Super M List \$ 68/\$15

Term II \$179/\$15

Zap Z-8000 \$450/\$15

Utilities I \$ 54/\$na

Utilities II \$ 54/\$na

ACCOUNTING PLUS

1 Module \$385/\$na

4 Modules \$1255/\$na

All 8 \$4500/\$na

TCS*

GL or AR or AP or Pay \$ 79/\$25

All 4 \$269/\$99

Inventory \$ 79/\$25

Compiled each \$ 99/\$25

UNICORN*

Mince \$149/\$25

Scribble \$149/\$25

Both \$249/\$50

The Final Word \$270/\$25

WHITESMITHS*

C Compiler \$600/\$30

Pascal (incl "C") \$850/\$45

"PASCAL"

Pascal/MT + Pkg \$449/\$30

Compiler \$315

Sp Prog \$175

Pascal/Z \$349/\$30

Pascal/UCSD 4.0 \$670/\$50

Pascal/M \$355/\$20

Tiny Pascal \$ 76/\$15

"DATA BASE"

FMS-80 \$894/\$45

dBASE II \$595/\$50

Condor II \$535/\$50

FMS-81 \$445/\$na

"WORD PROCESSING"

WordSearch \$179/\$50

SpellGuard \$229/\$25

Peachtext \$289/\$45

Magic Spell \$269/\$25

Spell Binder \$349/\$45

Select \$495/\$na

The Word \$ 65/\$na

The Word Plus \$145/\$na

Palantier-I (WP) \$385/\$na

"COMMUNICATIONS"

Ascrom \$149/\$15

BSTAM \$149/\$na

BSTMS \$149/\$na

Crosstalk \$139/\$na

Move-it \$ 89/\$na

"OTHER GOODIES"

Micro Plan \$419/\$na

Plan 80 \$269/\$30

Target (Interchange) \$125/\$30

Target (Planner) \$189/\$30

Target (Task) \$299/\$30

Plannercalc \$ 50

Tiny C \$ 89/\$50

Tiny C Compiler \$229/\$50

Nevada Cobol \$179/\$25

MicroStat \$224/\$25

Vedit \$130/\$15

MiniModel \$449/\$50

StatPak \$449/\$40

Micro B+ \$229/\$20

Raid \$224/\$35

String/80 \$ 84/\$20

String/80 (source) \$279/\$na

ISIS CP/M Utility \$199/\$50

Lynx \$199/\$20

Supervyz \$ 95/\$na

CP/M Power \$ 75/\$na

Mathe Magic \$ 95/\$na

CIS COBOL \$765/\$na

ZIP MBASIC, CBASIC \$129/\$12

Real Estate Analysis \$116/\$na

APPLE II®

BRODERBUND

G/L (with A/P) \$444

Payroll \$355

INFO UNLIMITED*

EasyWriter (Prof) \$155

Datadex \$129

EasyMailer (Prof) \$134/\$75

Other less 15%

MICROSOFT*

Softcard (Z-80 CP/M) \$298

Fortran \$179

Cobol \$499

Tasc \$139

Premium Package \$699

MICROPRO*

Wordstar \$269/\$60

MailMerge \$ 99/\$25

Wordstar/MailMerge \$349/\$85

SuperSort I \$159/\$40

Spellstar \$129/\$40

CalcStar \$175/\$40

DataStar \$265/\$60

PERSONAL SOFTWARE/VISICORP*

Visicalc 3.3 \$219

Desktop/Plan II \$219

VisiTerm \$ 90

Visidex \$219

Visiplot \$180

Visitrend/Visiplot \$259

Visifile \$219

Visischedule \$259

PEACHTREE*

G/L, A/R, A/P, Pay or Inventory (each) \$224/\$40

Peach Pack P40 \$795

SOFTWARE DIMENSIONS, INC.

Accounting Plus II, G/L, AR, AP, or Inventory (each) (Needs G/L to run) \$385/\$na

"OTHER GOODIES"

Super-Text II \$127

Data Factory \$134

DB Master \$184

Versiform VS1 \$350

VH1 \$445

16-BIT SOFTWARE

WORD PROCESSING

IBM PC

Wordstar \$289

Mailmerge \$109

Easywriter \$314

Easyspeller \$159

Select/Superspell \$535

Write On \$116

Spellguard

also available for 8" 8086 systems) \$229

SP Law (for Spellguard) \$115

Textwriter III \$189

Spellbinder \$349

Final Word \$270

LANGUAGE UTILITIES

IBM PC

Crosstalk \$174

BSTAM \$149

BSTMS \$149

8" 16-BIT SYSTEMS

Pascal MT+ /86, SSP \$765

CBasic 86 \$294

Pascal M/86 \$445

Acti 86 \$157

Trans 86 \$115

XLT 86 \$135

16-BIT 8" AND DISPLAYWRITER

CP/M 86 \$294

MP/M 86 \$585

OTHERS

WE WISH A MERRY CHRISTMAS and HAPPY HANUKKAH TO EVERYONE
TO OUR PATRONS WHO HAVE HELPED MAKE THIS OUR 3rd CHRISTMAS IN BUSINESS — THANK YOU

NEC

ATARI

IBM PC COMPATIBLE HARDWARE

VIC-20

PRINTERS

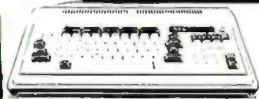

PC-8001 Computer Call for Details
 PC-8001A Microcomputer (32K) 749⁹⁹
 PC-8031A Dual mini-disk drives 749⁹⁹
 PC-8012A IO Unit, 32K, 7 slots 459⁹⁹
 32K Memory Card (for 64K) 169⁹⁹
 RenTec Wedge Expansion w/32K 489⁹⁹

NEC PC-8001 Software

NEC CPM Operating System 125⁹⁹
 WordStar by MicroPro 379⁹⁹
 SuperSort by MicroPro 189⁹⁹

Packages that do not require CPM:
 General Ledger 249⁹⁹
 A/R, A/P, Inventory, Payroll ea. 249⁹⁹
 Report Manager 149⁹⁹
 Select Word Processor 349⁹⁹
 We carry more NEC compatible software



**COMING SOON!
 DEC RAINBOW 100**

Features: 2.80 and 16 bit 8088 processor
 64K shared memory (expandable to 256K)
 24 line x 132 column display, ergonomic
 keyboard, hi-res color graphics 800 x 240
 pixels. CALL FOR MORE DETAILS.

COLUMBIA IBM PC COMPATIBLE
 DATA PRODUCTS, INC. Call For Details

**OVER 1000 ITEMS IN
 OUR WINTER CATALOG
 SEND \$1.00 CREDITED
 TO YOUR NEXT ORDER**



ATARI 800 \$649

Includes 48K Memory

Atari 400 (16K) 299⁹⁹
 410 Program Recorder 79⁹⁹
 810 Disk Drive 439⁹⁹
 850 Interface Module 169⁹⁹
 32K RAM Module 299⁹⁹
 Bit 1 80 column card for 800 299⁹⁹

ATARI SOFTWARE

Word Processor (D) 119⁹⁹
 MicroSoft BASIC (D) 69⁹⁹
 Macro Assembler & Text Editor (d) 69⁹⁹
 Pac-Man (cartridge) 34⁹⁹
 Centipede (cartridge) 34⁹⁹
 Missile Command (cartridge) 29⁹⁹
 Star Raiders (cartridge) 34⁹⁹
 Space Invaders (cartridge) 34⁹⁹
 Caverns of Mars (disk) 29⁹⁹
 Assembler/Editor (cartridge) 49⁹⁹
 We carry much more software for ATARI.

MODEMS

ANCHOR AUTOMATION, INC.

Anchor Automation Signamax I 99⁹⁹
 Anchor Automation Singamax II 119⁹⁹

Hayes

Smartmodem II 300 baud 239⁹⁹
 Smartmodem II 1200 baud 549⁹⁹
 Chronograph 199⁹⁹

Novation

Novation D-Cat direct connect 175⁹⁹
 Cat acoustic modem 149⁹⁹



IBM PC PERSONAL COMPUTER

Please call for price and availability

Apparat, Inc.

Apparat Combo Card w/cable 255⁹⁹
 Apparat Clock/Calendar card 99⁹⁹
 Symtec Hi-Res Lightpen 135⁹⁹

AST

Combo Plus 64K with on-board Serial
 Parallel, and Clock/Calendar 449⁹⁹
 128K 599⁹⁹ 192K 679⁹⁹ 256K 829⁹⁹

MICROSOFT

High Quality Expansion Cards

64K Card 279⁹⁹ 128K 399⁹⁹
 192K Card 519⁹⁹ 256K 639⁹⁹
 64K Upgrade for the IBM RamCard 149⁹⁹

QUADRAM

Quadboards with Serial and Parallel ports,
 clock/calendar, and memory in 64K, 128K,
 192K and 256K configurations. PLEASE
 CALL FOR OUR PRICES.

ADD-ON DISK DRIVES

Tandon TM-100-2 Add-on Drive 299⁹⁹
 Percom Add-on Single Sided Drive 319⁹⁹
 Percom Add-on Double Sided Drive 399⁹⁹

The Friendly Computer



\$189

VIC 1540 Single Disk Drive 339⁹⁹
 Datasette Program Recorder 65⁹⁹
 Joystick Controller 10⁹⁹
 VIC 1520 Graphic Printer 329⁹⁹
 VIC Super Expander 54⁹⁹
 8K RAM Cartridge 49⁹⁹
 16K Ram Cartridge 99⁹⁹
 VIC RS-232C Terminate Interface 39⁹⁹
 VIC Modem 105⁹⁹

Software

ViCheck 19⁹⁹
 VicMon 49⁹⁹
 Spiders of Mars (C) 39⁹⁹
 A100K (Cartridge) 31⁹⁹ Tape 15⁹⁹
 Alien Blitz (C) 32⁹⁹ Tape 19⁹⁹

We have dozens of accessories and programs for the VIC 20. please call

Commodore



PLEASE CALL FOR DETAILS AND PRICES ON COMMODORE 64 EQUIPMENT & ACCESSORIES

Software Available Now:
 Mailing List System 20⁹⁹
 Word (text) Processor 35⁹⁹
 Time Management 25⁹⁹

APPLE, ATARI & TRS-80 Program Loaders for the CBM 64 are Coming Soon!

Anadex 9501A 1349⁹⁹
 Smith Corona (S or P) 639⁹⁹

C. Itoh

F-15 55 CPS (parallel & serial) CALL
 F-10 40 CPS (parallel) 1399⁹⁹
 F-10 40 CPS (serial) 1399⁹⁹
 ProWriter 8510 10" (parallel) 459⁹⁹
 ProWriter 8510 10" (serial) 579⁹⁹
 ProWriter II 1550 15" models CALL

EPSON

MX 80 FT Type II w/graphics CALL
 MX-100 II w/graphics CALL

Integral Data Systems, Inc.

IDS MicroPrism (80 column) 629⁹⁹
 Prism 132 Color (all options) 1589⁹⁹

NEC

8023 Impact Dot Matrix 479⁹⁹
 3510 33 CPS Spinwriters PLEASE CALL

OKIDATA



Okidata 82A 80 col. w/tractor 469⁹⁹
 Okidata 83A 132 col. w/tractor CALL
 Okidata 84A 132 col. PLEASE CALL

NEW!

GEMINI PRINTERS

These printers are similar to the EPSON line and have some additional features:
 Gemini 10 10" 100 CPS Fric/Trac 449⁹⁹
 Gemini 15 15" 100 CPS Fric/Trac 549⁹⁹
 Call for more detail on the Gemini line of Edson compatible printers

DISKETTES

Verbatim 5 1/4" SS/DD 10/29⁹⁹ 100/260⁹⁹
 Scotch 3M 5 1/4" SS/DD 10/39⁹⁹ 100/290⁹⁹
 Gemini 5 1/4" DS/DD 10/44⁹⁹ 100/400⁹⁹
 Scotch 3M 5 1/4" DS/DD 10/43⁹⁹ 100/395⁹⁹

Circle 133 on Inquiry card

One small but nevertheless important feature of Microshell is that it allows lowercase command-line arguments for programs. This is critical for many text-processing applications using filters. A Microshell program to print out each line containing the word "Microshell" will ignore the word "MICROSHELL". I mention this partly because I have been irked by the fact that the CP/M command interpreter turns the entire command line into uppercase, and partly because it illustrates how a seemingly minor improvement in a system function can make the system considerably more flexible. (File names are kept uppercase to guarantee CP/M compatibility.)

Shell Files

It is often useful to execute a batch of commands, one after another, without sitting at the computer console and entering each command individually. CP/M provides such a batch capability with its SUBMIT program. Improved batch processors have been developed by various CP/M users (e.g., Ron Fowler's SUPERSUB in the January 1982 issue of *Lifelines* magazine). But none equals the simplicity of Microshell's shell files. The Microshell command interpreter itself—rather than a separate program—reads a script of commands from a text file and performs them in sequence. Automatic argument substitution is provided, control characters can be included in a shell file, and a shell file can provide input to a program that would normally come from the console (this is similar to CP/M's XSUB program). Shell files can

also be interrupted easily, cutting short a long batch sequence.

Shell files under Microshell are not as flexible as they are under Unix, however. Unix allows shell files to be nested (a command in a shell file can be another shell file). It also provides control structures that can be used to vary the command sequence. But Microshell's shell files are a big improvement over CP/M's SUBMIT. For shorter batch jobs, Microshell provides a nice alternative: multiple commands on a single line, each separated by a semicolon. This is a faster way to execute a simple series of programs than by using a shell file.

Another major Microshell feature is an automatic search routine for commands and files. This makes it possible to ignore which disk drive a particular program or file is on. When Microshell receives a command, it searches first on the disk that is currently being addressed (the logged-in drive, in CP/M parlance). If it can't find it there, it continues the search on other disks according to a user-specified sequence. In a multi-user CP/M system, the automatic command search will also search the User #0 area in addition to the user's own area. This has the effect of making User #0 "public."

Automatic file search comes into play when a running program issues a request for a particular file. If the file can't be found on the current disk, Microshell will search for it along the same search path specified for automatic program searches. Microshell, however, will perform these automatic file searches only for files with certain specified extensions. For example, you can specify

WE'RE STARTING A NEW YEAR WITH A NEW NAME

SOFTWARE	APPLE II and FRANKLIN COMPATIBLE	HARDWARE	FRANKLIN	VIDEO FUN!
APPLE II IBM PC dBASE II DBMS 459** 459** EasyWriter II 199** 259** SORCIM SuperCalc 225** 239** MicroPro WordStar 379** 379** MailMerge 189** 189** SpellStar 189** 189** SuperSol 189** 189** NEW! Thesaurus for use with WordStar: 60,000 words indexed by the 4500 most commonly used words (Apple/IBM) 199** Peachtree Accounting Packages CALL VisiCalc 185** 159** VisiCalc (256K) N/A 199** Extended Version N/A 299** VisiTrend/Plot 225** 239** VisiFile 185** 199** VisiTerm 89** N/A VisiDev 185** 185**	MICROSOFT MICROSOFT SOFTWARE PREMIUM SYSTEM (Includes: Z-80 SoftCard, 16K RamCard, Video, Videoterm, Softswitch, & CP/M User Guide by Osborne), List 755.00 Special Package Pricing — Only 569** Z-80 SoftCard CP/M by Microsoft 259** 16K RamCard by Microsoft & SOURCE 79** Videx Videx VideoTerm 80 Column Card 245** Video Keyboard Enhancer II 119** Utility for 80 Column VisiCalc 39** Hayes Hayes Micronodem II 289** Mountain Computer CPS Multi-Function Card 169** Music Synthesizer System 299** A/D - D/A 16 Ch Interface 279** Romplus - 129** Romwriter 149** Expan Chassis 569** Clock Cal 229** OTHER POPULAR ACCESSORIES ALF 9 Voice Music Card 149** CCS 7710A Async. Serial card 139** Grapple II F. I. Specific printer 139** Laser Lower Case Plus III 39** M&R 80 Column Video cards 299** Novation Apple Cat II 1200 baud 319** Practical Peripheral Buffer cards CALL 119** Thunderware Clock/Calendar 49** TG Joystick 32** VG Paddles 255** Vista Vision 80 Column Card 249** Versawriter Digitizer Pad 249**	APPLE II COMPATIBLE DISK DRIVES Fourth Dimension w/controller 469** Fourth Dimension add on 339** Rana Drive 379** Rana Drive controller card 119** μ-SCI A2 with controller 429** A2 add on 369** A40 with controller 479** A40 add on 389** APPLE and FRANKLIN COMPATIBLE SOFTWARE HowardSoft (1982) Tax Preparer 119** Multi Plan by Microsoft 239** Microsoft TASC 149** Screenwriter II Word Processor 99** PFS Personal Filing System 99** DB Report 85** PB Master by Stowware 165** We stock the Top 100 Selection of software packages for the Apple II and Franklin	FRANKLIN ACE 1000 FEATURES • Apple II Compatible • 64K RAM user memory • Upper/Lower case w/shift lock • Typewriter style keyboard • Twelve key numeric pad • Heavy 50 Watt power supply • Built-in fan The Franklin ACE 1000 is a professional personal computer that is hardware and software compatible with the Apple II and includes many features not found on the Apple II. All programs written for the Apple II will run on the ACE 1000 without modification including those with using high and low resolution color or B&W graphics. The ACE 1000 is plug compatible with the Apple II peripherals that operate in the Apple II will operate in the ACE 1000 without modification.	COLECOVISION  ONLY \$219 State of the Art Video Game Features unsurpassed graphic resolution. Superior arcade-type games, and a remarkable expansion capability allowing the use of existing Atari and Activision cartridges. We carry all of the Coleco Vision add on accessories and cartridges. PLEASE CALL INTELLIVISION ONLY \$249 Includes everything necessary for immediate family enjoyment. List 399** We carry Intellivision accessories too TIMEX Sinclair 1000 \$89 We carry Timex (Sinclair) accessories
MONITORS Amdek Video 300 12" Hi-Res Green 159** Amdek Color 13" Color w/audio 349** Amdek Color II Hi-Res RGB 729** Amdek Color III w/audio w/RGB 449** NEC NEC Hi-Res Green 12" Monitor 169** NEC Composite Color 12" 339** NEC UB 2021 RGB monitor 769** NEC UB 2031 IBM compatible RGB 769** SANYO Sanyo 9" Green monitor 169** Sanyo 12" B&W or Green monitor CALL Sanyo 13" Color or RGB monitor CALL TAXAN Affordable RGB monitors Vision I 12" RGB 380 Lines 389** Vision II 12" RGB 510 Lines 549** Vision III 12" RGB 630 Lines 639** ZENITH Zenith 12" Green monitors 119** USI 12" Amber Monitor 169** USI 12" Green Monitor 179** We carry ELECTROHOME Monitors also. Please call for details and prices.	16K RamBoard FOR APPLE II  \$49 ASSEMBLED & TESTED	Order Toll Free 800-854-6654 Info & California 619 698-8088 MODEM ORDER LINE 619-460-6502 We accept most major credit cards, bank wires, money orders, cashiers or certified checks and personal checks (10 days to clear). For shipping handling and insurance add 3% if pre-paid with a check and 5% if paid by credit card (min. \$5.00). UPS Blue Label service is shipped F.O.B. CA residents add 6% sales tax. Foreign orders are shipped freight collect. All equipment is new and complete with manufacturer's warranty. Send \$1.00 for Catalog/Price List credited to your next purchase. We have a customer satisfaction policy — contact us for details.		

“.OVL” as an automatic file search extension. Then, if a program requests a file such as “TESTFILE.OVL”, Microshell will search all the disks for that file. But if a program requests a file such as “TESTFILE.TXT”, Microshell will search only the current disk for that file.

Replacing the CCP

Microshell is loaded from the normal CP/M environment just like any other command file. When loaded, it automatically locates itself just below the CP/M BDOS (basic disk operating system), which contains the primitive system functions in a form that is identical on all machines. Microshell completely overlays the CCP (console command processor) that is supplied by Digital Research. And it supplies the standard CCP functions—e.g., TYPE, DIR, and USER—as well as its own Unix-style extensions. Because the Microshell command interpreter is much larger than the CCP, it reduces the amount of memory allocated to user programs. In the version of Microshell that I tested, the command interpreter occupied about 9500 bytes.

Because Microshell replaces the CCP, programs that require the CCP to be in place—such as MOVCPM, which is used to change system memory size—obviously will not work under Microshell.

Programs that address CP/M legally—that is, through the designated system calls documented by Digital Research—should run fine. Most commercial software will work under Microshell, but some users-group programs will not. The Microshell manual includes an ap-

pendix on program compatibility. No serious limitations are listed, and I did not find any on my own.

Performance

In some respects, Microshell slows down CP/M's performance. Checking for shell files (batch commands) and automatic command and file searching all require extra disk accesses. It is possible to restrict automatic command searching and to turn off automatic file searching altogether, which will minimize the delay. Restricting automatic command searches to a single disk (i.e., having a “system” disk that contains all executable programs), which most users will probably want to do anyway, will set a maximum of one extra disk access each time a program is invoked.

In one very important respect, however, Microshell speeds up overall system operation; it eliminates the warm boot—the resetting of the system—that occurs after most CP/M programs. (It provides an explicit log-in command for use when changing disks.) On balance, on my system, Microshell makes things happen somewhat faster than they do when the CCP is in place.

Search paths, extension specifications, and other Microshell parameters are supplied by a menu-driven configuration program that comes as part of the Microshell package. The program is easy to use, and Microshell can be reconfigured quickly as the user's needs change. The Microshell manual is difficult to follow in places, but it is quite well organized and appears complete. It even includes a short section entitled “How to

Circle 34 on inquiry card

Listing 1: Three files, FILE1, FILE2, and FILE3, can be concatenated "horizontally" by Unica's HC command. The result of the concatenation is shown in listing 2.

A>TYPE FILE1

MICROPROCESSOR
WORD SIZE
REGISTER SIZE
MAIN MEMORY
MEMORY TYPE
HARD DISK CAPACITY
FLOPPY DISK CAPACITY
SIMULTANEOUS TASKS
OPERATING SYSTEM
SYSTEM LANGUAGE

A>TYPE FILE2

Z80
8 bits
8-16 bits
64 kilobytes
semiconductor
0 bytes
2 megabytes
1
CP/M
PL/M

A>TYPE FILE3

68000
16 bits
16-32 bits
512 kilobytes
magnetic bubble
50 megabytes
0.5 megabytes
5
UNIX
C

Run Microshell without Reading the Manual," which ought to be a statutory requirement for every manual.

Unica

Unica consists of Unix-style utility programs that run under CP/M on a Z80 microprocessor. True to the Unix approach to programming, each of these utilities performs a single function, although most have options that vary the way it performs that function. Some of the functions of the Unica utilities, such as those for directory listing and file concatenation, are available on programs supplied with CP/M by Digital Research. Others, such as file comparison and disk mapping, can be performed by programs that are available from other vendors or the CP/M Users' Group. A few, such as the utility that concatenates programs "horizontally" (see listings 1 and 2) or the one that creates multiple "links" to a single file, do indeed appear to be unique in the CP/M world, as the name "Unica" implies.

The Unica programs all provide input and output redirection, and output from one can be piped to the input of another. Like Microshell, Unica uses temporary files for pipes. Unlike Microshell, however, the I/O redirection and pipe mechanisms are built into each program. When a program is invoked, the first thing it does is scan its command line for these special directives. This allows the normal CP/M command interpreter to be left in place.

This means that while Unica programs allow pipelines, they cannot interact with non-Unica programs. Obviously, this is a less general mechanism than Microshell, which allows any program to participate in a pipeline (assuming the program normally communicates with the console). There is available, however, an optional program called the XM-80 macroprocessor, with which it is possible to write new programs that are compatible with the Unica originals.

Wildcards and Links

Unica programs also respond to Unix-style "wildcards," which are somewhat different than those available under CP/M. A wildcard is a way of specifying

Listing 2: A horizontal concatenation of the three files in listing 1, achieved by using the Unica HC command. The integers in the command line before the last two file names indicate the column where the left margin of that file is to be placed.

A>HC FILE1 31 FILE2 51 FILE3

MICROPROCESSOR	Z80	68000
WORD SIZE	8 bits	16 bits
REGISTER SIZE	8-16 bits	16-32 bits
MAIN MEMORY	64 kilobytes	512 kilobytes
MEMORY TYPE	semiconductor	magnetic bubble
HARD DISK CAPACITY	0 bytes	50 megabytes
FLOPPY DISK CAPACITY	2 megabytes	0.5 megabytes
SIMULTANEOUS TASKS	1	5
OPERATING SYSTEM	CP/M	UNIX
SYSTEM LANGUAGE	PL/M	C

Who says General Ledger is simple?



We do.

BPI System's General Ledger System is one of the most

advanced accounting systems available today for microcomputers.

Ease of use and simplicity of data entry mean that anyone familiar with the basics of bookkeeping can operate the system within minutes, without specialized training. The package includes a demonstration disk for training and a thorough owners manual for quick instruction.

Features programmed into the BPI General Ledger System include six custom journals: Invoice Register, Cash Receipts, Merchandise Purchased, Cash Disbursements, Cash Register Journal, and General Journal. The data entry procedures for these Journals are standardized to make data entry fast and easy. And each of the journals can be listed on your CRT screen or printer.

The BPI General Ledger is probably all the accounting software many businesses will ever need since it also includes important subsidiary ledgers: such as an Accounts Receivable Ledger to record customer activity. An Accounts Payable Ledger to

record vendor activity. And, a Payroll Ledger to maintain monthly, quarterly, and year-to-date information needed for 941 and W-2 reporting.

The BPI General Ledger System can produce up to ten departmental or branch Profit and Loss Statements and a consolidated Profit and Loss Statement.

For quick access to vital information whenever you want it, the following reports can be listed to your CRT screen or printer: Financial Statements, General Ledger, Accounts Receivable Ledger, Accounts Payable Ledger, Monthly, Quarterly, and Year-to-Date Payroll Registers, Merchandise Purchased by Due Date, and alphabetical and numerical sequenced lists of payors/payees, vendors, customers, and employees.

To protect important accounting data, the system even provides for making backup data disks. The process is so simple you can do it as often as you wish. And, the General Ledger interfaces with the entire family of BPI Accounting Systems.

Ask for a demonstration by your computer dealer or write us for more information. You'll see how powerful, yet simple, a General Ledger system can be.



BPI

SYSTEMS™

SIMPLY, THE MOST POWERFUL SOFTWARE IN BUSINESS.

3423 GUADALUPE / AUSTIN, TX 78705 / 512-454-2801

BPI and BPI Systems are trademarks of BPI Systems Inc.

www.americanradiohistory.com

a group of file names with a single reference. For example, the CP/M command "DIR *.EXT" would list all files with the extension ".EXT"; the asterisk would match any file name in the directory. If you wanted to list all the files that began with the letter "A", you would type "DIR A*.*"; the first asterisk would match the remaining letters of the file name and the second asterisk would match the extension. Under Unix and Unica, all files beginning with "A" can be specified by typing "A*"—that is, "A" followed by just a single asterisk. The wildcard will read across the "." specifying the extension.

Two Unica programs—LN, the file link command, and RM, the file removal command—are used to create and eliminate multiple references in the directory to a single file. These references, or links, allow users with different CP/M user numbers to have the same programs or files available to them without cluttering up the disk with extra copies of the files. Although the regular CP/M erase command (ERA) will erase a file link created by the LN command, a warm boot is necessary afterward to make sure that the CP/M disk-allocation routines don't overwrite the file while other links to it remain. The RM program takes care of that automatically.

Unfortunately, the CP/M command interpreter re-

stricts the use of one of the better Unica utilities, SR, which is modeled on the Unix utility GREP. (GREP, as you no doubt have guessed, is an acronym for "globally look for regular expressions and print.") If you use SR to list all the lines in a file containing the word "Unica", it will print all lines that contain "UNICA", "unica", or "unIca" as well because the CCP does not permit lowercase characters in command lines. SR has options to list only the lines that do not contain a given pattern, to count the number of matched lines, and to search more than one file, among others, and it is an extremely useful program to have around despite its command-line limitations.

Another excellent Unica program is the directory listing utility, LS (see listing 3). Although many directory programs are available for CP/M—I think I have collected about half a dozen from the CP/M Users' Group—Unica's LS program is the most flexible. It is also one of the Unica programs for which it is convenient to have directed output, because it is not uncommon to want to put the contents of a disk directory in a file. My only complaint is that LS as supplied insists on printing all the file names in lowercase. While this follows the Unix convention, Unix allows file names to be in lower-

Listing 3: A directory obtained by using Unica's LS command with the optional arguments "-ALM". The "A" argument means show all files, including system files, that would normally not appear in the directory. The "L" option specifies a long format. The "M" argument means provide multicolumn output; otherwise, each file entry would have been printed on a separate line. The first field shows the file attributes. An "r" in the first column means the file is read-only. An "s" in the second column means it is a system file. The next field is the file size in bytes (in CP/M, a multiple of 128 bytes is always allocated). The last field is the file name. While it is printed in lowercase, CP/M file names are actually stored only in uppercase.

A>LS -ALM

```
--      1,408 alloc.crl      --      4,352 dup.com        -s      16,640 mt280.ovl
--      384 alloc.h         --      128 ed.sub           -s      35,840 mt380.ovl
--      3,200 bcdreals.erl  --      6,656 edcpm.com      -s      14,848 mt480.ovl
rs      5,376 bios.sys       --      3,968 float.crl      -s      13,568 mt580.ovl
--      384 byte.h         --      128 fnj.h           --      38,912 mtplus.com
-s      1,152 c.ccc         --      5,760 format.com     --      9,472 mulisp.com
--      5,376 calc.com     --      9,856 fpr.com        --      256 nal.h
--      13,696 cc.com      --      7,680 fpreals.erl   --      128 nfnj.h
-s      15,872 cc2.com     --      2,432 fullheap.erl  --      22,912 paslib.erl
--      5,248 clib.com     --      10,880 hc.com       --      21,760 pencil.com
--      4,608 clink.com    --      18,176 l2.com        --      6,144 pie.com
--      5,120 config.dat   --      9,984 linkmt.com    --      7,424 pip.com
--      13,440 configur.com --      15,232 lisped.sys   --      2,816 randomio.erl
--      22,912 crayon.com  --      16,256 lispexec.sys  --      35,968 sconfig.com
--      1,536 crck.com     --      3,456 lispfuncs.sys --      34,816 scribble.com
--      12,160 customiz.com --      1,792 load.com      --      12,032 sh.com
--      1,792 d.com        --      13,312 ls.com        --      13,952 sr.com
--      512 date.com       --      11,776 mac.com       --      5,248 stat.com
--      4,864 ddt.com      --      6,144 marc.com       --      2,816 sysdef.h
--      9,856 debugger.erl --      18,432 marc.cpm     --      1,792 sysgen.com
--      7,296 deff.crl     --      896 marc.doc       --      17,152 text.com
--      5,760 deff2.crl    --      2,304 marc.rel      --      13,568 unix.txt
--      7,680 diff.com     --      1,408 mh.com        --      7,168 wcount.com
--      2,304 display.com  -s      27,904 mt180.ovl     --      8,960 z80.doc
--      7,296 du.com       -s      23,808 mt185.ovl     --      6,016 z80.lib
```



Franklin's ACE1000 Runs With The Best!

VisiCalc®, DB Master®, Desktop Plan®—they are all running on the Franklin ACE 1000. Cash flow, budgets, word processing or data base management, business or pleasure, the ACE 1000 runs with the best.

The Franklin ACE 1000 is hardware and software compatible with the Apple® II. Franklin users can choose from an enormous selection of programs—programs that run better on the ACE because it includes 64K of RAM, upper and lower case, VisiCalc keys, a numeric pad and an alpha lock key.

Run with the best. Call or write today for the name of your local authorized Franklin dealer.

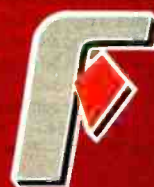
Franklin ACE is a trademark of Franklin Computer Corporation.
Apple is a registered trademark of Apple Computer Inc.
VisiCalc and Desktop Plan are registered trademarks of Visi Corp.
DB Master is a registered trademark of Stoneware.



FRANKLIN
COMPUTER CORPORATION

7030 Colonial Highway
Pennsauken, NJ 08109
609-488-1700



ELECTRONIC/COMPUTER ENGINEERS

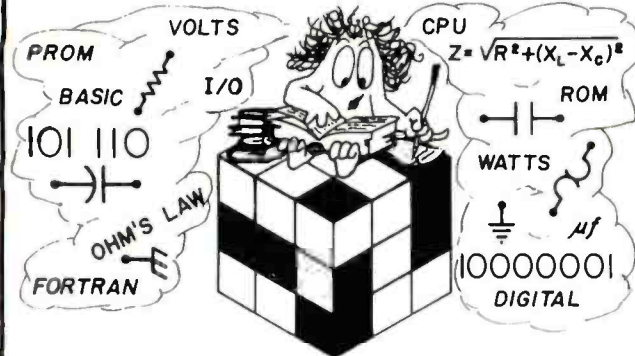

YOU SPENT LONG HOURS STUDYING TO GET YOUR DEGREE, BUT NOW YOU'RE PUZZLED ABOUT WHERE YOU CAN GO TO BEST USE THOSE SKILLS.

WARNER ROBINS AIR LOGISTICS CENTER

offers a civil service career as an engineer with a chance to work with state-of-the-art technology to support the most advanced defense weapons system in the world.

Warner Robins ALC will hire approx. 180 electronic/computer engineers. For more info. call toll free

1-800-841-9193 or 1-800-342-0570 (in Georgia)

or write to: DPCSC—Employment office, Robins A.F.B., Georgia 31098

WARNER ROBINS AIR LOGISTICS CENTER

ROBINS A.F.B., GEORGIA 31098

U.S. CITIZENSHIP REQUIRED - AN EQUAL OPPORTUNITY EMPLOYER



\$595.00

The Last Expansion Unit You Will Ever Have To BUY

The six most commonly required add-on features for your IBM PC

Without Using Any Additional Slots!

- Six additional system slots. (Dynamic Parity Error Correcting Circuitry).*
- Extra heavy duty power supply to power a 5" winchester in your PC.
- Up to 192k of additional memory with our exclusive DPECC (R)
- Two Asynchronous serial ports.*
- Three parallel ports.*
- Real Time Clock.*



The 192k RAM, 2 asynchronous serial ports, 3 parallel ports, and a Real Time Clock are all built on to the motherboard, so you won't have to waste precious slots on them.

The Expansion Unit comes without these options installed. * So you don't have to pay for them if you don't need them. But when you do, all you have to do is plug in the chips and you are ready to go.

***All options are available installed with the Expansion Unit.**



2116 WALSH AVENUE
SANTA CLARA, CA 95050
(408) 727-7548

MARC: An 8-Bit Counterpart to Unix

Microshell and Unica both provide some of the features that have made the Unix operating system so popular. While I was preparing this review, however, I received a prerelease copy of a new 8080-family operating system that goes considerably further toward providing a Unix-like environment. This new system is called MARC, for Machine-Aided Resource Coordinator.

MARC is a complete operating system, not just an enhancement to CP/M. It boots up under CP/M, however, and uses the CP/M BIOS routines (the hardware-dependent section of CP/M) of the host system. That means MARC should work on any machine that can run CP/M. The version I tested was for CP/M 2.2 only. A version of MARC for CP/M 1.4 does exist, but it is unclear at this point whether it will be marketed.

MARC provides a Unix-like command interpreter similar to that of Microshell (MARC, however, accepts Unix-style wildcards). It also provides a file system with a hierarchical directory structure. Devices and file names may be used interchangeably. MARC will run in a CP/M system with a single 64K-byte bank of memory and floppy-disk mass storage.

Because MARC can run only one program at a time, it creates pipelines by using temporary files. Properly speaking, it is a single-user, single-tasking operating system. However, it includes a sophisticated user and group security system, with encrypted password protection, allowing different users to use the system at different times but preventing access to the files of other users.

The MARC package will include a large number of Unix-style utilities; the exact number is still to be determined as of this writing. Chief among them will be the excellent BDS C compiler (see my review in the June 1981 issue of BYTE on page 356). Also, a CP/M emulator will allow most CP/M programs to run under MARC.

The selling price has not been set. It will cost more than CP/M—but not by too much.

I had experimented with an earlier version of MARC in early 1981. At that time, MARC was workable, but very rough, and pretty far away from marketing. Unfortunately, MARC's principal author, Edwin P. Ziembra, died in a swimming accident not long afterward, and responsibility for finishing the project passed to Lauren Weinstein of Vortex Technology (POB 2284, Culver City, CA 90230, [213] 641-7200).

The evaluation copy of MARC that I received in early 1982 was a much more mature product. The only essential piece of software that was missing was the CP/M emulator, and that is expected to be ready by the time this article reaches print. Weinstein was unable to provide a firm release date at the time this was being written. But from what I have seen, it can't be too far away.

case. CP/M does not, and it would make more sense to me to list the CP/M files the way they actually exist in the directory. Incidentally, I have been referring to the Unica programs in uppercase—following the CP/M convention—but in the manual the names are all in lowercase.

A list of the various utility files in Unica is shown in table 1.

NOW ON SALE!

COLOR COMPUTER

16K	LEVEL I	\$279
16K	EXTENDED	\$379
32K	EXTENDED	\$539

COLOR COMPUTER GAMES

★★ NEW RELEASES ★★

COSMIC DOGFIGHT	CASSETTE	14.95
	DISK	19.95
OFFENDER	CASSETTE	29.95
	DISK	34.95

★★ OTHER FAVORITES ★★

PACKETMAN	CASSETTE	24.95
	DISK	29.95
MOONLANDER	CASSETTE	14.95
	DISK	19.95
METEROIDS	CASSETTE	21.95
SPACE INVADERS	CASSETTE	21.95

We Carry The COMPLETE LINE of EPSON Printers!

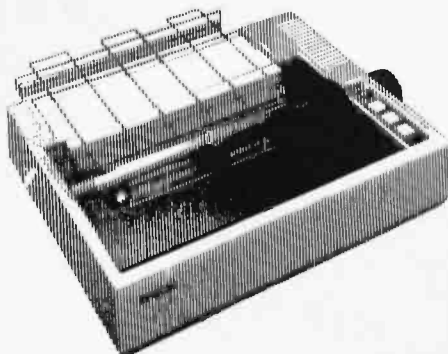

Call NOW for PRICES on the new FX Series Printers!

IBM PERSONAL COMPUTER

I.B.M. P.C. WITH 64K, 2 INTERNAL DUAL SIDED DISK DRIVES AND DRIVE ADAPTOR. 90 DAY WARRANTY.

ONLY \$2699⁹⁵



HARD DRIVES for the TRS-80 MOD III

6*	MEG.	\$1795 ⁰⁰
12*	MEG.	\$1995 ⁰⁰
19*	MEG.	\$2195 ⁰⁰

COMPLETE, READY TO RUN, AVAILABLE!
*unformatted capacity (LDOS Required)

SOFTWARE DISCOUNTS NEWDOS, DOSPLUS

and now LDOS!!

PRICE BREAK! \$129⁰⁰ EACH

FOR TRS-80 MODELS I or III

TRS-80 MOD III

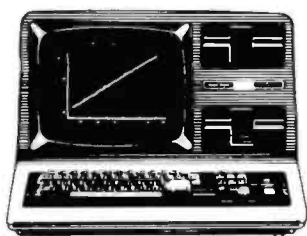

16K	-----	\$825 ⁰⁰
48K	-----	\$849 ⁰⁰
48K, 1 Drive		\$1499 ⁰⁰
48K, 2 Drive		\$1749 ⁰⁰
RS-232 (INSTALLED)		\$92 ⁰⁰

OKIDATA PRINTERS

ML-82A	\$425
ML-83A	\$699
ML-84 (PARALLEL)	\$1049
ML-84 (SERIAL)	\$1299

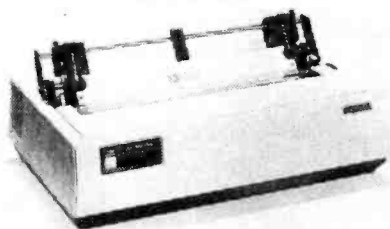

RAM \$15.⁹⁵

MEMORY CHIPS -- for the TRS-80, APPLE, and others

16K SET

17.95 for IBM P.C.

THESE ARE OUR CASH DISCOUNTED PRICES. C.O.D. AND CHARGE ORDERS ARE 3% HIGHER. ALL COMPUTERS ARE SHIPPED FREIGHT COLLECT. PRICES, SPECIFICATIONS AND AVAILABILITY ARE SUBJECT TO CHANGE WITHOUT NOTICE. IBM & IBM PERSONAL COMPUTERS ARE TRADEMARKS OF INTERNATIONAL BUSINESS MACHINES, INC.



918/825-4844

AMERICAN

118 SO. MILL ST
PRYOR, OK 74361

Circle 30 on inquiry card.

Small BUSINESS COMPUTERS

Program	Function
BC	Compares binary files
CAT	Concatenates files or prints them on the terminal
CP	A file copy program
DM	A disk mapper
FID	Determines whether two files are identical
HC	A "horizontal" file concatenator
LN	A link program
LS	A directory listing program
MV	Renames (or moves) a file
RM	Removes files or links to files
SC	Compares source (text) files
SFA	Sets file attributes (e.g., read-only)
SR	A pattern searching program
SRT	Sorts lines alphabetically (in memory)
TEE	Reads one input stream and writes multiple output streams (like a T-shaped pipe fitting)

Table 1: A list of the utility programs in the Unica software package.

All the Unica programs are written in a macro language called XM-80, and all the source code for these programs is included. To write or modify programs in this language, you would need to buy the optional XM-80 macroprocessor (\$100) along with the MACRO-80 assembler from Microsoft (about \$120). XM-80 is designed

to simplify program creation by providing a set of common primitives—such as those for providing I/O redirection and pipes—along with a standardized calling sequence for linking them with other program segments. The point is that if you write a primitive or module in a general enough way, you will have to write it only once. New programs can be put together by combining previously written modules from a library. I did not attempt to do any programming in XM-80, but using macroprocessing to extend an assembly language strikes me as a very good idea.

The Unica manual is extremely comprehensive, with well-designed sections describing each of the utility programs, an explanation of the theory behind XM-80, a detailed section on how to use XM-80, and descriptions of the XM-80 library components. Unfortunately, the prose style at times is turgid, which makes some of the explanations unnecessarily hard to follow.

Conclusion

Both Microshell and Unica provide good introductions to some of the features that have made Unix such a popular operating system. More than that, they are useful enhancements to existing CP/M computer systems in their own right. They increase an existing system's flexibility and make it friendlier to the user. These attributes should be high on the priority list of those who design the next generation of microcomputer operating systems. ■

DEVELOPING SOFTWARE UNDER CP/M? LIFT YOUR OUTPUT WITH MICROSHELL®

When you're into heavyweight software development you need more operating system power than CP/M can offer. MICROSHELL builds up CP/M with UNIX features that really help you put out software. Just for starters: MICROSHELL crunches long CP/M dialogs into one-line commands. Puts muscle and flexibility into SUBMIT commands. Captures CRT output and redirects it to CP/M files without retyping. Pulls programs from another disk drive or user number automatically (makes hard disk handling a snap). And it's ready for more work with no time-consuming warm-start after a program runs. MICROSHELL fits your system—uses just 8K of memory in any CP/M computer from Apple to Zenith. Check out MICROSHELL today and find out what a powerful partner it makes—at only \$150.

*CP/M, Digital Research; UNIX, Bell Laboratories; Apple, Apple Computer, Inc.

Order Toll Free: 800-368-3359
VISA, MasterCard accepted.
Overseas add \$20.00 for air mail.
Manual only: \$25.

**NEW
GENERATION
SYSTEMS, inc.**

2153 Golf Course Drive
Reston, VA 22091
(703) 476-9143

Circle 341 on Inquiry card.

H & E COMPUTRONICS INC.

•• EVERYTHING FOR YOUR TRS-80™ • ATARI™ • APPLE™ • PET™ • CP/M™ • XEROX™ • IBM™ • OSBORNE™ ••

* TRS-80 is a trademark of the Radio Shack Division of Tandy Corp. • ATARI is a trademark of Atari Inc. • APPLE is a trademark of Apple Corp. • PET is a trademark of Commodore
 * CP/M is a trademark of Digital Research • XEROX is a trademark of Xerox Corp • IBM is a trademark of IBM Corp. • OSBORNE is a trademark of Osborne Corp.



BUSINESS PAC 100 100 Ready-To-Run Business Programs

★ All orders processed within 24-Hours
 ★ 30-Day money back guarantee

(ON CASSETTE OR DISKETTE).....Includes 128 Page Users Manual.....
 Inventory Control.....Payroll.....Bookkeeping System.....Stock Calculations.....
 Checkbook Maintenance.....Accounts Receivable.....Accounts Payable.....

BUSINESS 100 PROGRAM LIST

NAME	DESCRIPTION		
1 RULE78	Interest Apportionment by Rule of the 78's	59 WACC	Weighted average cost of capital
2 ANNU1	Annuity computation program	60 COMBPAL	True rate on loan with compensating bal. required
3 DATE	Time between dates	61 DISCBAL	True rate on discounted loan
4 DAYYEAR	Day of year a particular date falls on	62 MERGANAL	Merger analysis computations
5 LEASEINT	Interest rate on lease	63 FINRAT	Financial ratios for a firm
6 BREAKEVN	Breakeven analysis	64 NPV	Net present value of project
7 DEPRSL	Straightline depreciation	65 PRINDLAS	Laspeyres price index
8 DEPRSY	Sum of the digits depreciation	66 PRINDPA	Paasche price index
9 DEPRDB	Declining balance depreciation	67 SEASIND	Constructs seasonal quantity indices for company
10 DEPRDDB	Double declining balance depreciation	68 TIMETR	Time series analysis linear trend
11 TAXDEP	Cash flow vs. depreciation tables	69 TIMEMOV	Time series analysis moving average trend
12 CHECK2	Prints NEBS checks along with daily register	70 FUPRINF	Future price estimation with inflation
13 CHECKBK1	Checkbook maintenance program	71 MAILPAC	Mailing list system
14 MORTGAGE/A	Mortgage amortization table	72 LETWRT	Letter writing system-links with MAILPAC
15 MULTMON	Computes time needed for money to double, triple, etc.	73 SORT3	Sorts list of names
16 SALVAGE	Determines salvage value of an investment	74 LABEL1	Shipping label maker
17 RRVARIN	Rate of return on investment with variable inflows	75 LABEL2	Name label maker
18 RRCONST	Rate of return on investment with constant inflows	76 BUSBJD	DOME business bookkeeping system
19 EFFECT	Effective interest rate of a loan	77 TIMECLK	Computes weeks total hours from timeclock info.
20 FVAL	Future value of an investment (compound interest)	78 ACCTPAY	In memory accounts payable system-storage permitted
21 PVAL	Present value of a future amount	79 INVOICE	Generate invoice on screen and print on printer
22 LOANPAY	Amount of payment on a loan	80 INVENT2	In memory inventory control system
23 REGWITH	Equal withdrawals from investment to leave 0 over	81 TELDIR	Computerized telephone directory
24 SIMPDISK	Simple discount analysis	82 TMUSAN	Time use analysis
25 DATEVAL	Equivalent & nonequivalent dated values for oblig.	83 ASSIGN	Use of assignment algorithm for optimal job assign.
26 ANNUDEF	Present value of deferred annuities	84 ACCTREC	In memory accounts receivable system-storage ok
27 MARKUP	% Markup analysis for items	85 TERMSPAY	Compares 3 methods of repayment of loans
28 SINKFUND	Sinking fund amortization program	86 PAYNET	Computes gross pay required for given net
29 BONDVAL	Value of a bond	87 SELLPR	Computes selling price for given after tax amount
30 DEplete	Depletion analysis	88 ARBCOMP	Arbitrage computations
31 BLACKSH	Black Scholes options analysis	89 DEPRSF	Sinking fund depreciation
32 STOCVAL I	Expected return on stock via discounts dividends	90 UPSZONE	Finds UPS zones from zip code
33 WARVAL	Value of a warrant	91 ENVELOPE	Types envelope including return address
34 BONDVAL2	Value of a bond	92 AUTOEXP	Automobile expense analysis
35 EPSEST	Estimate of future earnings per share for company	93 INSFILE	Insurance policy file
36 BETAALPH	Computes alpha and beta variables for stock	94 PAYROLL2	In memory payroll system
37 SHARPEI	Portfolio selection model-i.e. what stocks to hold	95 DILANAL	Dilution analysis
38 OPTWRITE	Option writing computations	96 LOANAFFD	Loan amount a borrower can afford
39 RTVAL	Value of a right	97 RENTPRCH	Purchase price for rental property
40 EXPVAL	Expected value analysis	98 SALELEAS	Sale-leaseback analysis
41 BAYES	Bayesian decisions	99 RRCONVBD	Investor's rate of return on convertible bond
42 VALPRINF	Value of perfect information	100 PORTVAL9	Stock market portfolio storage-valuation program
43 VALADINF	Value of additional information		
44 UTILITY	Derives utility function		
45 SIMPLEX	Linear programming solution by simplex method		
46 TRANS	Transportation method for linear programming		
47 EOQ	Economic order quantity inventory model		
48 QUEJUE I	Single server queueing (waiting line) model		
49 CVP	Cost-volume-profit analysis		
50 CONDPFROF	Conditional profit tables		
51 OPTLOSS	Opportunity loss tables		
52 FQJQJQ	Fixed quantity economic order quantity model		
53 FQJQJQSH	As above but with shortages permitted		
54 FQJQJQPB	As above but with quantity price breaks		
55 QJUEJQCB	Cost-benefit waiting line analysis		
56 NCFANAL	Net cash-flow analysis for simple investment		
57 PROFIND	Profitability index of a project		
58 CAPI	Cap. Asset Pr. Model analysis of project		

TRS-80 Cassette Version \$99.95
 TRS-80 (Mod-I or III), Pet, Apple or Atari Versions \$99.95
 TRS-80 Mod-II, IBM, Osborne and CP/M Versions \$149.95

ADD \$3.00 FOR SHIPPING IN UPS AREAS
 ADD \$4.00 FOR C.O.D. OR NON-UPS AREAS
 ADD \$5.00 TO CANADA AND MEXICO
 ADD PROPER POSTAGE OUTSIDE OF U.S., CANADA AND MEXICO

COMPUTRONICS INC.
 MATHEMATICAL APPLICATIONS SERVICE

50 N. PASCACK ROAD
 SPRING VALLEY, NEW YORK 10977

ASK FOR OUR 64-PAGE CATALOG
 DEALER INQUIRIES INVITED

NEW TOLL-FREE ORDER LINE
 (OUTSIDE OF N.Y. STATE)
 (800) 431-2818

24 HOUR ORDER LINE
 (914) 425-1535

AMERICAN EXPRESS
 VISA

ALL PRICES & SPECIFICATIONS SUBJECT TO CHANGE
 DELIVERY SUBJECT TO AVAILABILITY

A Slew of Languages, a Slap at Documentation, and a Curse at Keyboards

*Unaccustomed as he is to voicing his opinions,
Jerry drops a few hints.*

Jerry Pournelle
c/o BYTE Publications
POB 372
Hancock, NH 03449

The nature of this column dictates its contents: I have to write about what's been happening here at Chaos Manor. This month we've had two big flaps. One is a frantic effort to clean off my desk so that my wife and I can take a vacation in Europe. She's been planning this trip for a year now. So far I haven't had the heart to tell her that we won't be going alone: I'm taking an Otrona Attache with me.

Anyway, I've been trying to get two books (*Clan and Crown: Janissaries II* and volume one of *Future Men of War*) out the door, dash about to radio and television interview shows to publicize books, answer my mail, and write a couple of chapters of *Footfall*, the next big novel that Larry Niven and I are working on. The usual result of that much activity is that *nothing* gets accomplished, but actually I've done pretty well on everything but the mail.

Meanwhile, flap number two,

which has got downright embarrassing: Alex Pournelle's Introduction to Pascal software package.

Alex's Intro was supposed to be a fairly simple job, requiring a month's work at most. The task was to take some of the teaching programs from Grogono's *Programming in Pascal* and the fundamental required pro-

**If Pascal is a candidate
for the language of the
decade, then we may
have problems.**

grams and input/output primitives in Kernighan and Plauger's *Software Tools in Pascal* and get them running under two popular CP/M Pascal compilers. Then he'd write up notes on problems encountered, add a few pages contrasting the two compilers (Sorcim's Pascal/M and Digital Research's Pascal/MT+), add a few

more pages of tips on using Pascal, and hand it to Barry Workman to publish.

The first draft using Pascal/MT+ was done and looked good, and I could honestly say that the materials saved me a *lot* of time when I tried learning Pascal, so I wrote about it. BYTE's pipeline is, after all, pretty long.

Not long enough. The article came out. Orders came in. The Intro wasn't ready. Now that's not quite accurate: something was ready, but Alex wasn't satisfied with it. He didn't think he was giving people their money's worth. Meanwhile, he'd run into some really colossal problems with the way the compilers handled CP/M files. He could get the teaching programs running, but only through kludges, and he wanted to start over.

Fortunately, the story has a happy ending: the Pascal Intro package has been completely done over, and everyone who bought the old package can get the new one at nominal

Mr. Dow and Mr. Jones introduce Dow Jones Software™



Jones: "Mr. Dow, look what they're selling in that new store down the street: Dow Jones Software. You haven't gotten us into ladies' fashions, have you?"

Dow: "No, Mr. Jones. That's a computer store, and our software products allow investors and business professionals to use a personal computer like this one here to easily manage financial information."

Jones: "But what about our reputation? We've been leaders in serving the business and financial community for over 100 years. Are you sure this new software will be as reliable as The Wall Street Journal and Barron's?"

Dow: "Of course, Jones. Our software is so reliable we back it up with a full-year warranty. People trust Dow Jones Software the same way they trust the Journal. And we have a toll-free Hotline number in case they want expert help."

Jones: "Couldn't that be a lot of phone calls? After all, we've got the Dow Jones Averages to get out every day."

Dow: "Don't worry, Jones. Our software is very easy to use, and we have a fully staffed Customer Service Department to

respond to our dealers and customers."

Jones: "Just what can our software do?"

Dow: "In a nutshell, Jones, with a personal computer, a telephone, a modem and Dow Jones Software, you can easily perform complex analyses on the information available from our information service, Dow Jones News/Retrieval®."

Jones: "People really use our software to make decisions?"

Dow: "Absolutely. Once you've stored the information you want, our software does the rest. For instance, with one Dow Jones Software product you can follow indicators for stocks, sort, rank, screen and set critical points for buying and selling. With another, you can easily construct technical charts. Look at this beautiful graph."

Jones: "You mean all those calculations I've been doing by hand I could do in a fraction of the time with this software? That's great!"

Dow: "It is, Mr. Jones. Just like the Journal, Dow Jones Software is a resource you can bank on!"



Dow Jones Market Analyzer™

A technical analysis product that allows private and professional investors to automatically collect, store and update historical and daily market quotes, and to construct technical analysis charts at the touch of a key.

Dow Jones Market Microscope™

A fundamental analysis product that allows professional money managers to choose and follow indicators for extensive lists of stocks and industry groups, and to sort, rank, screen and set critical points for buying and selling. (Available 4th quarter 1982.)

Dow Jones Market Manager™

A portfolio management product for private or professional investors who desire immediate access to pricing and financial information, and who need an accounting and control system for their portfolios of securities. (Available 4th quarter 1982.)

Dow Jones Connector™

A communications product for the business or professional person who wants instant electronic access to news, facts and vital data at the home or office, via personal computer, simple terminal, communicating word processor or teletypewriter.

For dealer information and a free brochure, call our Customer Service Hotline number:

1-800-257-5114

(in NJ 609-452-1511)

Sold through computer retailers.

DOW JONES SOFTWARE™

...Bank on it.

Call for MTI's late price reductions.

Ask about our "QED" discounts.
VISA & MasterCard orders accepted.

VIDEO TERMINALS	MTI Price
VT 100 DECscope	1595
VT 18X Personal Computing Option	1295
VT 101 DECscope	1195
VT 131 DECscope	1549
VT 132 DECscope	1995
ADM 3A (dumb terminal)	595
ADM 5 (dumb with visual attributes)	645
ADM 31 (two page buffer)	1095
ADM 21 (full editing/visual attributes)	690
ADM 22 (ergonomic/edit/visual att.)	*
ADM 24 (ergonomic/graphics/256 fifo)	*
ADM 32 (ergonomic ADM 31)	*
ADM 36 (DEC system terminal)	*
ADM 42 (eight page buffer available)	*
TI 940 (high performance, 1-page buff.)	1650
Hazeltine Esprit I	585
Hazeltine Esprit II	595
Hazeltine Esprit III	825
Hazeltine Executive 80 Model 20	1495
Hazeltine Executive 80 Model 30	1715

GRAPHICS TERMINALS	
VT 125 (DEC ReGIS firmware)	3280
VT 100 (Tektronix 4010 emulation)	3250
ADM 3A (Tektronix 4010 emulation)	1795
ADM 5 (Tektronix 4010 emulation)	1845
VT 100 w/ TI 810 plot. (Tektronix emu.)	5920

300 BAUD TELEPRINTERS	
LA 34-AA DECwriter IV	1095
Diablo 620 RO spi (letter quality)	1385
Diablo 630 RO spi (non-expandable)	2095
Diablo 630 RO (letter quality)	2295
Diablo 630 KSR (letter quality)	2695
TI 743 (portable thermal printer)	1190
TI 745 (port./built-in coupler)	1485
TI 765 (port./bubble/b-i coupler)	2595

600 BAUD TELEPRINTERS	
Epson MX-80	645
TI 825 KSR impact	1570
TI 825 KSR pkg.	1795

1200 BAUD TELEPRINTERS	
Epson MX-100	895
LA 120 RA (receive only)	2095
LA 120 AA DECwriter III	2295
LA 100 RO Letterprinter	1995
LA 12-A (port./modem/coupler)	2840
TI 783 (Portable thermal teleprinter)	1480
TI 785 (port./built-in coupler)	1750
TI 787 (port./internal modem)	2125
TI 810 RO impact	1475
TI 820 RO pkg.	1850
TI 820 RO pkg.	2025
TI 820 KSR impact	2025
TI 820 KSR pkg.	2195
Lear Siegler 310 ballistic	2025

2400 BAUD	
Dataproducts M 200 (2400 baud)	2910

DATAPRODUCTS LINE PRINTERS	
B-300 (300 lpm Band Printer)	5455
B-600 (600 lpm Band Printer)	6930
B-1000 (1000 lpm Band Printer)	11435
BP-1500 (1500 lpm Band Printer)	18855
(Controllers available for most minis & micros)	

ACOUSTIC COUPLERS	
Omnitec 715 (300 baud orig./full duplex)	170
Omnitec 710 (300 baud orig/half & full)	242
Vadic VA 3413 (300/1200 orig.)	845

MODEMS	
GDC 103A3 (300 baud Bell)	395
GDC 202S/T (1200 baud Bell)	565
VA 3212 (Bell 212-A compatible)	825
VA 3451 (orig./ans. triple modem)	885
VA 3455 (1200 baud orig./ans.)	770
VA 2450 (Bell 201 compatible)	725
VA 103 (300 baud modemphone)	235

*Please call for quotation.



Applications Specialists & Distributors
Computer Terminals, Peripherals & Systems
New York:
516/621-6200, 212/767-0677, 518/449-5959
Outside N.Y.S.: 800/645-6530
New Jersey: 201/227-5552
Ohio: 216/464-6688

cost. Now obviously I'm not a totally disinterested observer; my son wrote this stuff, largely to help me learn—and understand—Pascal. Still, I like to think I can be objective about such things (and do note that I don't own the programs; they belong to Alex). In my judgment, he's done a hell of a job. The package now contains not only the programs, with all the special routines required to get things running smoothly under CP/M, but also a number of essays on typical problems. There's an especially valuable treatment on Pascal errors and what probably causes them.

The Language Debate Goes On

There are at least two reasons I've given Alex's Pascal Introductory Package as much space as I have. One is obvious: as I said at the beginning, I have to write about what we're doing around here, and Lord knows that has been the major activity, not just this month but all summer. There's another and more important reason, namely, that it *did* take all summer.

Pascal is an important language. Nearly every computer publication acts as if it is, and indeed Pascal is a candidate for *the* language of the decade. It is taught to nearly every student at the University of California at San Diego (La Jolla), and UCSD isn't alone in that practice. There are several implementations of Pascal for CP/M, and more are coming.

Alex and his friends are pretty familiar with Pascal—at least with the UCSD implementation of it. Grogono's *Programming in Pascal* and Kernighan and Plauger's *Software Tools in Pascal* are very popular, very highly recommended books, usually thought to be the best introductory works on Pascal.

Yet it has taken *months* of work to get these standard textbook programs running and document the differences between what's printed in the textbook and what actually can run on your CP/M system. Moreover, if there's anyone else who has a package that competes with Alex's, we don't know about it, nor do the professional programmers at several large sys-

tems houses. We know that because we tried to find something, *anything*, that might answer some of the problems Alex encountered. We searched through programming manuals line by line. We called programmers. At one point we considered Ouija boards. None of that was much help. It finally came down to Alex doing just a lot of hard work, finding out what will and will not run, finding compiler bugs and anomalies and glitches, writing them up, and trying another approach, until eventually he had things working properly.

Now of course I'm proud of him; but I'm also appalled. If this is a candidate for *the* language of the decade, we may have problems.

Implementer Blues

You'd be amazed at some of the problems Alex ran into. For example, Kernighan and Plauger assume that the data-type records can contain files, and the ISO (International Standards Organization) standard for Pascal makes the same assumption. Pascal/MT+ follows the standard. Pascal/M, though, like UCSD Pascal, will not allow files in records, which makes file handling complex beyond belief if you want to have several files open at the same time. That situation alone required a number of special procedures and a week's work.

The Pascal/MT+ pattern-finder function POS, which is supposed to find the first instance of a pattern within an array, is not completely reliable. It *usually* works, but that's not good enough; and we didn't have time to map the boundary conditions, which would require more special tests.

Just getting text, when the routines assume that text files consist of 80-character lines terminated by a carriage return and linefeed, can be ridiculously complex.

Some bugs are obscure, but thoroughly deadly. Example: in Pascal/MT+ if you open a comment and forget to close it (that can happen when you erase lines or when you nest comments), Pascal/MT+ goes away into never-never land; you have to reset the whole computer to recover. It doesn't report errors, it

Interested in the IBM Personal Computer?



If you're interested in the IBM Personal Computer then you need PC magazine. PC magazine is the Independent Guide to IBM Personal Computers. Each issue is packed with information for everyone interested in IBM Personal Computers.

PC magazine tells you how to put together the best IBM "PC" system and then how to get the most out of it. Each issue brings you hundreds of colorful pages of evaluations, insights, and straight talk from respected experts—professionals in computer science as well as writers, businessmen, lawyers, educators, and many others.

PC covers software, hardware, applications and most every topic of importance to the thousands of IBM Personal Computer users who read it. To ensure that we give you the information you need, PC includes a special "User-to-User" section, as well as a "PC Wish List", and news about IBM Personal

now. If not fully satisfied when you receive your first copy of PC, simply return your mailing label within 15 days for a full refund.

**This is the
magazine
that tells you
all about it.**

Computer clubs, events and publications.

For a limited time, you can subscribe to PC at NO RISK and still receive a 25% discount off the newsstand price. Enter your subscription

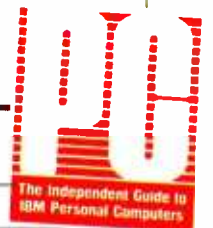

Name _____

Address _____

City _____ State _____ Zip _____

1 year/\$27.00 2 years/\$46.00 3 years/\$54.00

Check enclosed VISA MasterCard Bill me

Card # expires _____

Rates outside the U.S. and Canada are double

Phone Credit Card Orders to:
(Toll Free Number)
California: 800/792-0990, ext. 1136
All Other States: 800/227-3800, ext. 1136

PC Magazine
1528 Irving St.,
S.F., CA 94122

0077

just hangs up. Incidentally, Pascal/MT+ has Error #401, Unexpected End of Input, which is supposed to deal with that situation, but the message doesn't appear.

Neither the Pascal/M nor the Pascal/MT+ manual explains some vital things like forward declarations (stating the complete heading of a procedure before the first procedure or function that refers to it); and alas, neither do the textbooks that I mentioned earlier. The Pascal/M manual does refer the reader to page 82 of Jensen and Wirth's *Pascal User Manual and Report* (Springer-Verlag, 1975), but that doesn't help much. Alex had to add new sections to his teaching aid.

All the implementations—beginning with the UCSD compiler, which everyone has built around—have an annoying defect in string handling. They won't concatenate a single character into a string. They will concatenate "chr" types (example: chr(26) is Control-Z; chr(072) is H) but not single variables of type

CHAR. Someone ought to fix that.

And on, and on, and on. Sigh.

Kernighan's Lament

My August column spoke of Unicorn Systems' implementation of the Kernighan and Plauger *Software Tools* and recommended that those who want to do their own programming learn Pascal rather than RATFOR and FORTRAN (see User's Column, August 1982 BYTE, page 342). Shortly after, I received a letter from Unicorn Systems' Deborah Sherrer.

Unicorn Systems publishes not only the Kernighan and Plauger *Tools* but, more important, what they call a "virtual operating system," that is, a Unix-like "shell" around CP/M. Mrs. Sherrer says, "The choice of language is not critical to the virtual operating system approach. Had the project been designed solely for the microcomputer environment, C or Pascal might have been a more appropriate choice. However, the preprocessor chosen (RATFOR) has proven quite success-

ful in allowing portability between microcomputer and large machine environments. There is no reason why the package could not be available in several languages, though, perhaps with automatic translators between them. We are, in fact, looking into the possibility now and may eventually provide an automatic translator."

I hope Unicorn Systems does that. I like its "virtual operating system," because it lets the operating system do a number of the messy things that at the moment you must do inside your programs. One obvious example is file handling: one of the really horrible problems Alex had with implementing the *Software Tools in Pascal* was the difference in the ways that Pascal/M and Pascal/MT+ handle files; these problems go away if the operating system does this for you, and I am fond of Unicorn Systems' approach to the problem.

Deborah also enclosed a copy of Kernighan's lament.

In July, 1981, Brian Kernighan

- Compatible With Any Personal Computer With 232C Interface (such as: TRS-80, Apple, IBM, DEC, etc.)

- 300 Bits Per Second, Full Duplex (If you need to go faster, ask about the Rixon 1200 bps modems.)

- Front Panel Light Emitting Diodes (LED'S) Monitor: Send Data, Receive Data, Modem Ready, Carrier on

- Front Panel Push Buttons Provide Modem Test Plus Convenient Switching Between Talk and Data Modes

- 14 Regional FREE Dial-In Test Maintenance Centers

TERMS: Send check or money order. (No cash please. If check is not certified shipment will be delayed.) Or, for Visa and Master Charge, include Card Number, Expiration Date and Interbank Number. Sorry, No. COD.

THE LOWEST PRICED FULL FEATURED "PROFESSIONAL" MODEM...

The Rixon R103J

\$159

(Introductory Offer - Retail Price: \$199).

- Compatible With your Standard Home Telephone, Both Rotary and Push Button
- Operates Over All DDD Telephone Lines

- Your Terminal Controls Automatic or Manual Answer

- Automatically Selects Originate or Answer Mode

- Bell 103, 113, and 212 Compatible

Plus...Abort Timer, Quiet Timer, Loss of Carrier Disconnect, Send Space Disconnect and Receive Space Disconnect



TOLL FREE ORDER NUMBER

800-368-2773 Ext. 358

(In Md. 301-622-2121 Ext. 358)

RIXON INC.

ORDERING INFORMATION: Add \$9.00 for sales tax, UPS shipping charge and handling. Include full name address, zip. UPS will not deliver to a Post Office Box Number.

© RIXON INC., 1982 304

Please mail your orders to: Rixon Inc., ATT: R103J Offer, 2120 Industrial Parkway, Silver Springs, Maryland 20904

published Bell Laboratories Computing Science Technical Report #100, entitled "Why Pascal Is Not My Favorite Programming Language." Alex's summary comment is that "he doesn't like Pascal because it isn't C." There's some justice to that. The C programming language was developed at Bell Labs, and Kernighan (with Dennis M. Ritchie) wrote the standard (and just about the only) book on the language (*The C Language*, Prentice-Hall, 1978).

There's also a lot of validity to Kernighan's indictments. The question before the house is, was Kernighan justified in concluding that "Pascal, at least in its standard form, is just plain not suitable for serious programming"; and if he was, then what changes must be made in Pascal to make it a "serious programming language"?

Kernighan divides his objections into four major categories: data types and scope, control flow, environment, and cosmetics.

His first complaint is universal. Pascal was designed as a "strongly typed" language. What that means in practice is that you cannot mindlessly set a variable of one type equal to a variable of another; the compiler will not let you do that. As Kernighan himself notes, this can be a pretty good thing, because it prevents the common FORTRAN mistake of sending a floating-point number off to a subroutine that expects an integer, causing a very hard to find error.

However, in Pascal the size of an array is part of its data type, which is to say that an array dimensioned, say, 10 by 10, is not only a different array from one dimensioned 10 by 15, but a different *kind of animal*, and it's very hard to set one array equal to another. Thus if you want to sort arrays, you have either to set aside a block of memory equal to the very largest array you will ever encounter, then use part of it, or recompile your program every time you have a new array size to worry about. The former method is very wasteful of memory. The latter procedure is at best inconvenient.

His next complaint is against a straw man—that is, there are no

string variables in standard Pascal. In the original language there are only arrays of characters, and because each array size is a different *type*, it is very messy to compare strings or set one string equal to another. Kernighan says, "This botch is the biggest single problem with Pascal. I believe that if it could be fixed, the language would be an order of magnitude more useful." Fortunately, it has been fixed. No actual implementation

of Pascal follows the standard. Nearly all CP/M Pascal implementations use the same device, namely, that a string is an array of characters with the zeroth element containing the string length. This has the inconvenient result that, in most 8-bit machines, strings cannot be longer than 255 characters, but it does give you a mechanism for getting the job done.

His next objection is certainly

QUALITY COMPUTER FORMS AT PRICES YOU CAN AFFORD

WE SUPPORT MORE SYSTEMS WITH FORMS THAN ANYONE!

INVOICES • STATEMENTS • CHECKS • P.O.'S • SHIPPERS • MEDICAL FORMS
INCOME TAX FORMS • W2'S • LETTERHEAD

Accounting Plus • Peachtree • BPI • Open Systems • Structured Systems • Vector Graphics • Howard • Radio Shack • Continental • Designer • Libra • Gold • IMS • Alpha Micro • Cimarron • Van Data • Durrango • Dynabyte • Osborne • Briareus • MCBA • Apple • Great Plains • Emeritus • TCS

We Support 215 Systems Not Listed Here, So If You Don't See Your Software Here Call Toll Free For A Free Sample Packet Of Forms For Your Software.

SHEERCUT WORD PROCESSING LETTERHEAD

SHEER CUT LETTERHEAD FROM CHECKS TO-GO USES A NEW PROCESS TO PRODUCE CONTINUOUS FORM PAPER THAT TRIMS CLEAN WHEN BURST. NORMAL COMPUTER PAPER USES FIVE PERFORATIONS PER INCH, BUT SHEER CUT USES A NEW TECHNOLOGY TO PRODUCE 80 PERFS OR "TIES" PER INCH. THIS PRODUCES A VERY CLEAN AND UNIFORM EDGE WHEN BURST, AND IS ECONOMICAL IN BOTH SMALL AND LARGE QUANTITIES. SHEER CUT IS AVAILABLE ON A STOCK FORM BASIS IN FOUR "CLASSIC LAID" PAPERS, OR IN ANY TYPE PAPER ON A CUSTOM ORDER. EVERY OTHER FORM CAN BE IMPRINTED TO PRODUCE CONTINUOUS FIRST AND SECOND SHEETS. BLANK PRICES ARE \$60 FOR 1,000, \$235 FOR 5,000 AND \$400 FOR 10,000, WITH IMPRINTING, DEALER, AND VOLUME PRICING AVAILABLE.

CONTINUOUS AND SNAP-OUT W2'S

AND OTHER CONTINUOUS
TAX FORMS

Call For Your Free 1982 Continuous Tax Form catalogue.



CALL TOLL FREE NOW: (800) 854-2750 IN CA (800) 552-8817
(714) 460-4975

8384 Hercules St. • P.O. Box 425 • La Mesa, CA 92041



Your Assurance of Value and Service.



valid: there are no *static* variables in Pascal.

A static variable is one that is retained but confined inside a particular function or procedure. An example would be the seed with which you call a random number: there is no necessity for the program as a whole to be able to see that seed, but certainly you must keep it around between calls to the random number function.

Alas, Pascal can't do that. When

you exit a Pascal function or procedure, all its variables go away. To retain the seed, you would have to make it external to the procedure (and probably global), where it can be seen and interfered with by other parts of the program. This can lead to side effects, and bugs thereby generated are among the hardest to find.

And so forth. I'm not going through Kernighan's paper point by

point; those interested should get a copy. However, one of his objections requires some discussion.

Terrorized by GOTO?

One real problem of Pascal is that it has no "break" statement; neither is there a "return" from a function or procedure.

This latter is not a bug, it's a feature: that is, the structured programming approach demands that there be a single entrance and a single exit from any part of a program. In Pascal, you "return" from a function or procedure by running off the end of it.

The problem comes when you want a program that goes

```
(Pseudo-C version)
while (getnext(stuff)) {
  IF (something)
    break
  rest of while loop.
}
```

This is harder to implement in Pascal than it might seem. As Kernighan points out, the approach

```
done := false
while (not done) and
(getnext(stuff)) DO
  if something then
    done := true
  else begin
    rest of loop
  end;
```

doesn't work, because in Pascal you cannot force the "(not done)" to be evaluated before the next call of "getnext". Getting around this leads to an extra level of nesting, for you must put the "getnext" loop inside a "while (not done)" loop.

Pascal enthusiasts would say, "And so what? It's a lot clearer if you make these tests explicitly hierarchical rather than relying on your knowledge of the compiler to see what's done first." They have a point, too. The C programming language (which does guarantee the order of expression evaluations) is popular with computer hackers, but it has a number of fine points that make it hard to use for those who don't work



EXPOTEK

2723 W. Windrose Suite 3
Phoenix, Arizona 85029

1-800-528-8960



All Prices Subject To Change

COMPUTERS	PRINTERS
<p style="text-align: center; font-weight: bold; color: white;">ATARI</p> <p>400K-16K - \$289 800-16K - \$649 410 - \$77 810 - \$429 830 - \$155 850 - \$159</p> <p style="text-align: center; font-weight: bold; color: white;">ALTOS</p> <p>5-15D - \$2249 5-5D - \$4599</p> <p style="text-align: center; font-weight: bold; color: white;">NORTHSTAR</p> <p>Advantage-\$2600 Horizon 64QD-\$2600</p> <p style="text-align: center; font-weight: bold; color: white;">TELEVIDEO</p> <p>802 - \$2649 802H - \$4999 806 - \$5249 800A - \$1400</p> <p style="text-align: center; font-weight: bold; color: white;">FRANKLIN ACE 1000</p> <p style="text-align: center;">\$1099</p>	<p style="text-align: center; font-weight: bold; color: white;">OKIDATA</p> <p>M80 - \$305 M83A - \$649 M82A - \$399 w/Tractor & Grap. \$479 M84P - \$999 M84S - \$1099</p> <p style="text-align: center; font-weight: bold; color: white;">ANADEX</p> <p>9500A - \$1290 9501A - \$1290</p> <p style="text-align: center; font-weight: bold; color: white;">CITOH</p> <p>F-10P - \$1370 F-10S - \$1479 1550P - \$659 Prowriter 1550CD - \$709 8510AP - \$479 8510ACD - \$570</p> <p style="text-align: center; font-weight: bold; color: white;">DATASOUTH</p> <p>DS120 - \$595 DS180 - \$1249</p> <p style="text-align: center; font-weight: bold; color: white;">DIABLO</p> <p>630RO - \$1945 620 - \$1295</p> <p style="text-align: center; font-weight: bold; color: white;">NEC</p> <p>8023 - \$469 7710 - \$2350 3510 - \$1949 7720 - \$2590</p> <p style="text-align: center; font-weight: bold; color: white;">TI</p> <p>810 - \$1240 820 - \$1795</p>
APPLE CARDS	TERMINALS
<p>16K RAM - \$78 Z80 CARD - \$265 Videx Card - \$227 Smart Term - \$279 32K Atari Card - \$99 Clock CARD - \$120</p>	<p style="text-align: center; font-weight: bold; color: white;">ADDS</p> <p>Viewpoint - \$485</p> <p style="text-align: center; font-weight: bold; color: white;">HAZELTINE</p> <p>1500 - \$995 ESPRIT - \$515</p> <p style="text-align: center; font-weight: bold; color: white;">TELEVIDEO</p> <p>910 - \$569 925 - \$718 920 - \$735 950 - \$899</p> <p style="text-align: center; font-weight: bold; color: white;">ZENITH</p> <p>Z19 - \$699 Z89 - \$2129</p>
SOFTWARE	MONITORS
<p style="text-align: center;">All Major Brands - \$CALL</p> <p>Wordstar - \$235 Datastar - \$150 Oakstar - \$100 Spellstar - \$100</p>	<p>Amdek 300 - \$149 Color I - \$315 Amdek Color II - \$689 Color III - \$410 BMC Green - \$88 Sanyo Green - \$220</p>
DISK DRIVE	OTHER MAJOR BRANDS AVAILABLE
<p>Microsci Apple Dr. \$350 Percom Atari Dr. \$390 Percom IBM Dr. \$325 Fourth Dimension Dr. \$350</p>	<p style="text-align: center; font-weight: bold; color: white;">\$CALL</p>
MODEMS	DISKETTES/BOXES
<p>HAYS - MICROMODEM - \$285 HAYS - SMARTMODEM - \$219 HAYS - 1200 Baud - \$530</p>	<p>Elephant - \$20 Scotch - \$25 Dysan - \$35</p>
GUARANTEED LOW PRICES	Customer Service 602-863-0759

TRANSFORM YOUR IBM® TOTALLY GRAPHICS + BUFFERING + TERMINAL

Computer—Printer Output Buffering

- Buffer sizes software selectable 16K, 32K, 48K, 64K
- Uses any standard memory expansion boards
- Buffer size reselection for different sized output jobs, at keyboard level
- Buffers time consuming graphics reproduction as well as text
- Print speed no longer determines processing speed of your PC. Printer virtually functions *independently* of the computer.

Dot Matrix Graphics Hard Copy Reproduction

- Full Color or B/W tones
- Uses any standard memory expansion boards
- All Hires and Medium resolution modes
- 4 dot scale sizes for 4 different blow-up sizes
- Whole graphics screen, or any subsection can be reproduced
- Picture rotation, across or along length of page
- 'Shift'-'PrtSc' feature to make snapshot copies at keyboard level
- Inversion of color/BW for any graphic mode
- Colors on Prism 132/80 can be swapped and mixed as desired
- Compatible with:
EPSON MX-80-80FT-100
NEC 8023
C-ITOH PROWRITER I/II
OKIDATA 82, 83 with graphics
IDS PRISM 132/80, with color and without color options

MICROCOMPUTER

Simultaneous

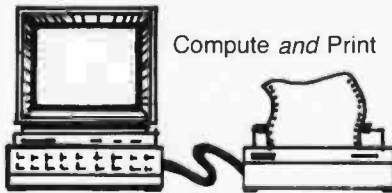

Printer Output Buffering

BUSINESS

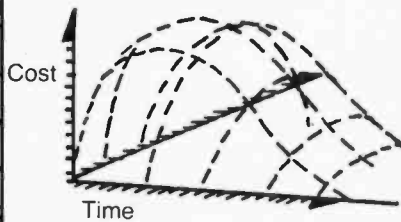

Dot Graphic Reproduction

INDUSTRIES

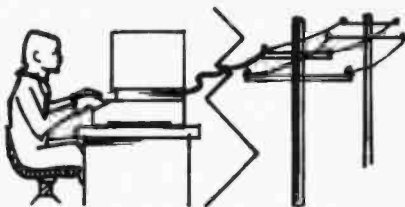

Terminal Emulator

Terminal Emulator Data Acquisition

- RS-232 direct connect or modem connect to remote computer
- Full communications, data logging, printing and viewing
- Software permitting intelligent graphics terminal emulation will be available later.
- Usage of 'INT' call permits specific and easy user adaption of base emulator for any specific terminal function.
- Queuing of incoming and outgoing data allows a user to run a current program and still receive data.
- Modular structure permits easy interfacing to user data bases.

This unique device meets the standard, beats the standard and will be the standard for IBM users of software, worldwide.

The NAME of this *indispensable* device?

I-C-Magic™

PLUG in
and
GO

See local dealer *or* write for technical details.

Attn: ICM Chip
MBI Corp.
1019 8th Street
Golden, CO 80401

Recommended Retail

➡ **\$85⁰⁰** ⬅

Less than \$29 per function!

Circle 369 on inquiry card.

IBM is a registered trademark of International Business Machines, Corp. MBI and I-C-Magic are trademarks of Microcomputer Business Industries, Corp.

**MICROCOMPUTER
BUSINESS
INDUSTRIES
CORPORATION**

MBI

ADMINISTRATIVE OFFICES: 1019 8TH STREET, GOLDEN, COLORADO 80401 (U.S.A.)
TELEPHONE: (303) 279-8438

TWX: 910-934-0191

OUR PRICES WILL GET YOUR ATTENTION. OUR SERVICE WILL KEEP IT.

SOME OF OUR PRODUCTS:



TELEVIDEO COMPUTERS

	LIST	SELL
TS-801 Computer	3295	Call
TS-802 Computer/ Terminal	3495	2663
TS-802H Computer/ Terminal	5995	Call



NORTHSTAR COMPUTERS

	LIST	SELL
ADVANTAGE		
ADV-2Q-64K	3599	Call
HORIZON		
HRZ-2Q-64K	3599	Call
HRZ-1Q-64K-HDS	4999	Call

ZENITH DATA SYSTEMS MONITOR

	LIST	SELL
ZEN-VM-121		
12" Green Screen Monitor	160	110

Ask us about other fine Zenith Products



TELEVIDEO TERMINALS

	LIST	SELL
910 Terminal	699	585
925 Terminal	995	Call
950 Terminal	1195	Call

TELEVIDEO SOFTWARE

	LIST	SELL
TELE SOLUTIONS		
WordStar Plus		
CalcStar		
Packaged For Teletideo	790	Call



PRINTERS

	LIST	SELL
Okidata 82 A	719	494
Star Micronics	449	Call

We also handle NEC, Anadex, Mannesmann Tally and Smith-Corona. Call for prices and availability.



MICROPRO SOFTWARE

	LIST	SELL
WordStar	495	275
Apple WordStar— 16 Sector	375	Call
SpellStar	250	155
MailMerge	250	Call
DataStar	295	205
SuperSort	250	Call
Apple MailMerge— 16 Sector		Call
CalcStar	145	Call

PLUS MANY OTHER FINE PRODUCTS:



UNDER NEW OWNERSHIP

Don't let anyone tell you that service and prices are a trade-off. We're proof you can have both.

Our service begins even before you call. Because we've taken the trouble to select the most reliable equipment and products for sale.

We'll discuss your needs, and help you make the right decision. Then we'll test and configure equipment to be sure it's compatible



with your system. We'll even initialize your software.

Our technical expertise will help you keep your system up, and hold maintenance costs down.

So go ahead and be

CALL TOLL FREE:

800-854-7635

amazed by our low prices, but

remember, the best is yet to come.

Prices change daily—call for current pricing.

In California call 714-562-7571

AUTOMATED EQUIPMENT, INC.

8775 Olive Lane, Suites I & J, Santee, CA 92071

at it a lot; at least I've found that to be true.

Still, the lack of a "break" statement in Pascal can, in more complex situations than the above, lead to some funny-looking code complete with superfluous "bookkeeping" variables. Kernighan goes on to say: "Of course recidivists can use a GOTO and a label (numeric only and it has to be declared) to exit a loop. Otherwise, early exits are a pain, almost always requiring the invention of a Boolean variable [a Boolean variable is one that takes only two values, true and false] and a certain amount of cunning."

Query: why is using GOTO and a label so horrible?

Yes, I know; questions like that can get me thrown out of the lodge. We've all been taught that use of GOTO is *always* improper. But is it? In the early days, the GOTO was much abused, so that it was impossible to follow program logic. The code led you into an opaque tangle of spaghetti.

But because something can be abused doesn't mean it has to be abolished. To return to our example, I see nothing at all wrong with:

```
LABEL 99;
begin
while (getnext(stuff)) DO
  if (something) then GOTO 99
  (* you're done *)
else begin
  rest of loop;
99 :                               (* exit point *)
end;
```

I mean, really, how is this different from the "break" statement? Is it harder to understand? To claim that any use of GOTO is "recidivist" is, in my view, blind prejudice.

There's a New C A'comin' . . .

I have mixed emotions about the C programming language. On the one hand, I open Kernighan and Ritchie and read a chapter or so, and I think I understand what they're saying; then I go try to write some code in C, and the results are an unmitigated disaster. I think I know what a statement like

No Waiting For Software.

Now that the Sage II has sparked the 16-bit super-micro revolution, you might wonder when software will become available.

The answer is now, because the Sage II's p-System operating system accommodates vast libraries of programs already produced for 8-bit machines.

What's more, this exciting micro has fired the imagination of programmers who are busy developing new software to take full advantage of its performance capabilities.

No Wait States.

The Sage II is based on the incredible 68000 processor.

One advantage is the total elimination of memory access wait states so that interaction between the processor, RAM and disk drives is speeded up.

If you've been blaming your floppy for tardiness, consider this: The Sage II loads a 20K program in about a second—from its 5¼" floppy.

The Specs You've Been Waiting For.

8 Mhz 68000 • up to ½ Mb on board RAM • 24-bit bus addresses up to 16 Mb • one or two built-in 5¼" floppy drives—320K to 1.3 Mb • RS-232C ports • Parallel port • IEEE-488 interface • Call or write for full specifications.

No Waiting Until You Can Afford It.

A Sage II with one disk drive and 128K on board RAM is priced at just \$3,600.

It represents more computing power for the money than ever before.



No Waiting For Delivery.

Our assembly, testing, and shipping departments are currently achieving a 4 day turnaround time on incoming orders. Order direct or through your dealer.

A Free P-System For Those Who Don't Wait.

The p-System operating system and Pascal, FORTRAN 77 and BASIC compilers which alone lists for \$1,475, we're now including free with the Sage II.

So see your dealer or give us a call. We'll be waiting to hear from you.

35 North Edison Way, Suite 4, Reno, Nevada 89502. (702) 322-6868.

SAGE

COMPUTER TECHNOLOGY

Circle 413 on Inquiry card.

16 Bits, No Waiting



Europe: TDI Limited, 29 Alma Vale Road, Clifton, Bristol, BS8 2HL UK: (0272) 742796

Pascal & p-System are trademarks of Regents of University of California. 68000 is a trademark of Motorola.

www.americanradiohistory.com

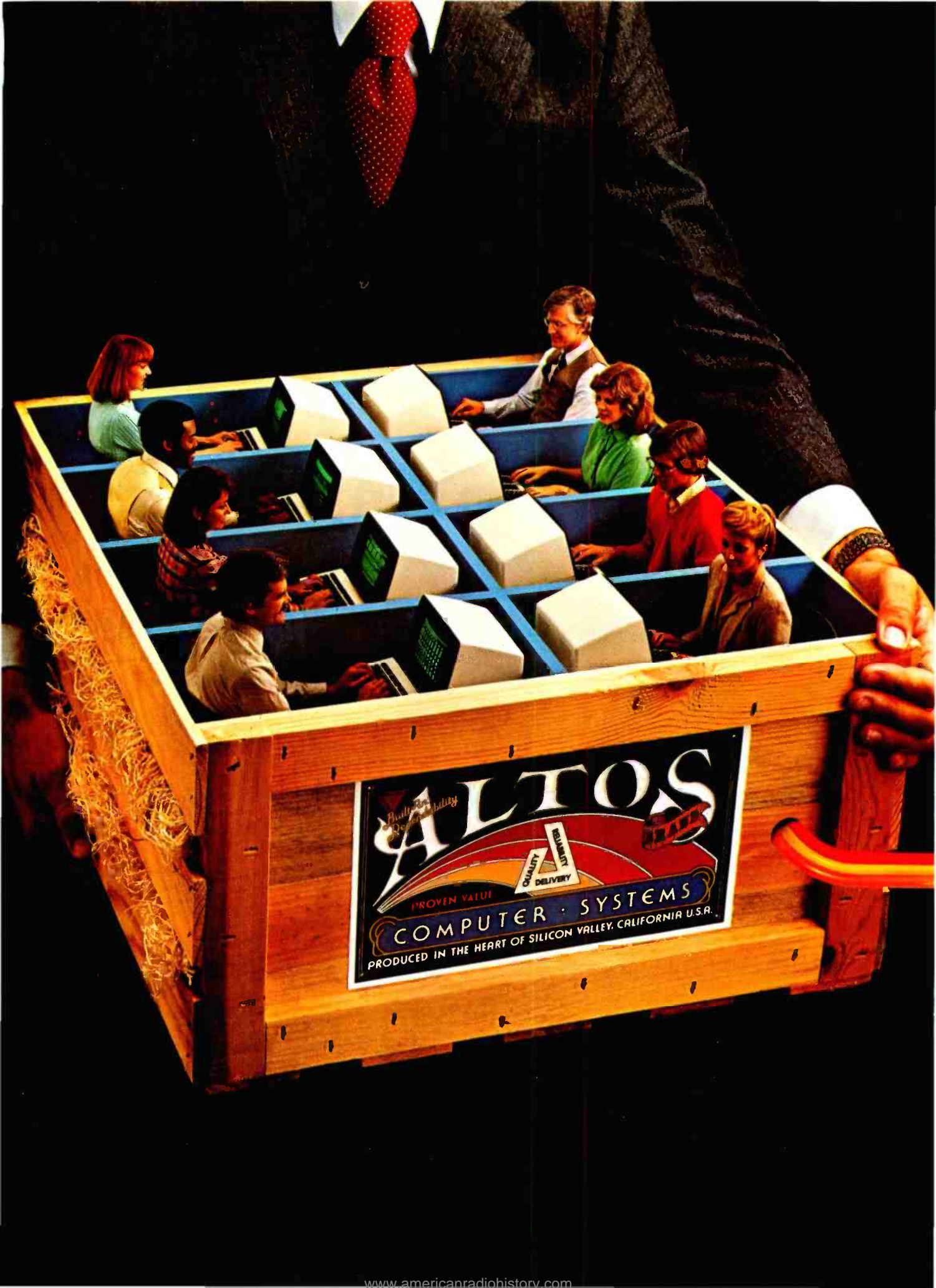

Quality
Delivery

ALTOS

PROVEN VALUE

QUALITY DELIVERY

COMPUTER SYSTEMS

PRODUCED IN THE HEART OF SILICON VALLEY, CALIFORNIA U.S.A.

1 TO 16 USERS TO GO

Altos multi-user 8086 or 68000-based networking computers are chosen by more OEMs and Fortune 1000 companies. Here's why...

ALTOS® 16-bit computer systems do more for more users. They give you more power. More features. And more reliability. For less money.

You get a choice of 8086 or 68000-based family processors, memory management to one MB of RAM, an intelligent Z80™ I/O and disk controller, plus up to 160 megabytes of fast Winchester storage.

A single Altos computer can serve up to 16 users. And every Altos 16-bit computer gives you



Altos also has high-level languages (BASIC, FORTRAN, COBOL and PASCAL), and applications software (ABS/86 and ABS/68 for general accounting, word processing and financial planning).

Since 1977, Altos has delivered more than 30,000 highly reliable, fully socketed, proven single board microcomputers and peripherals built for business.

If you've been looking to go with a more powerful computer that can serve from 1 to 16 users for less money, call or write us today.

INTER-ALTOS LOCAL NETWORK

Series 586, ACS8600 and ACS68000
20-160 MByte Winchester
**1-16 USERS with
ALTOS-NET**

ETHERNET

Series 586, ACS8600 and ACS68000
20-160 MByte Winchester
**1-16 USERS with
ALTOS-NET/UNET™**

REMOTE COMMUNICATIONS

Series 586, ACS8600 and ACS68000
20-160 MByte Winchester
**1-16 USERS with
ALTOS-NET/UNET**

2780/3780
3270
X.25
SNA/SDLC

added features like Multibus™ interfacing, real time clock, power fail detection and comprehensive diagnostics.

But that's just the beginning. Link multiple Altos' together and communicate in the office of the future today. Serve hundreds of users with full Ethernet™ and ALTOS-NET™ hardware and software support. And save money with fewer interconnects.

In addition, Altos supports remote communications protocols such as 2780/3780, 3270, X.25, and SNA/SDLC.

Altos has all the 16-bit software you need, too. With popular operating systems like XENIX™ / UNIX™ (with a user-friendly "business command menu interface"), CP/M-86,™ MP/M-86,™ OASIS-16, MS™ -DOS and PICK for 8086-based systems; plus UNIX System III™ and RM/COS™ for 68000-based systems.

Altos Computer Systems
2360 Bering Drive
San Jose, CA 95131
(408) 946-6700
Telex 171562 ALTOS SNJ
or 470642 ALTO UI

**Packed with
fresh ideas
for business**



**800-538-7872
(In Calif. 800-662-6265)**

Circle 28 on inquiry card.

ALTOS is a registered trademark and ALTOS-NET is a trademark of Altos Computer Systems. Ethernet is a trademark of Xerox Corporation. CP/M-86 and MP/M-86 are trademarks of Digital Research. Inc. MS and XENIX are trademarks of Microsoft Corporation. XENIX is a microcomputer implementation of the UNIX operating system. UNIX is a trademark of Bell Laboratories. UNIX System III is a trademark of Western Electric. RM/COS is a trademark of Ryan-McFarland, Inc. OASIS-16 is a product of Phase One Systems, Inc. PICK is a product of Pick & Associates and Pick Computer Works. Multibus is a trademark and 8086 is a product of Intel Corporation. 68000 is a product of Motorola, Inc. UNET is a trademark of 3Com Corp. Z80 is a trademark and product of Zilog, Inc.
©1982 Altos Computer Systems.

SUPERIOR GRAPHICS HAVE COME DOWN TO EARTH.



"Three Atoms" Courtesy of Greg Abram, University of North Carolina at Chapel Hill

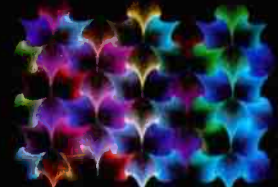

"Aurora" By Richard Katz, Vectrix Corporation

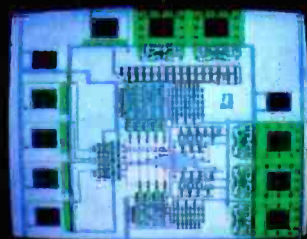

"Integrated Circuit Design" Courtesy of Floyd J. James, University of North Carolina at Chapel Hill



"In The Beginning" By Richard Katz, Vectrix Corporation

\$1995 AND THE FIRST AFFORDABLE HIGH RESOLUTION COLOR GRAPHICS MACHINE IS YOURS

VX128

- **VERY HIGH RESOLUTION** 672 by 480 pixels individually addressable
- **EIGHT COLORS PER PIXEL** 3 bit planes of memory totalling 128K graphics RAM
- **ON-BOARD 16 BIT MICRO-COMPUTER** Intel 8088 microprocessor with additional PROM and RAM and built-in expansion capability
- **3D GRAPHICS SOFTWARE PACKAGE** built-in command set Includes: rotation, scaling, translation, perspective, clipping, viewport, polygon, and filled polygon
- **HARDWARE LINE AND ARC GENERATION** on-board VLSI graphics display controller, 1600 nano-seconds pixel drawing time

- **USER DEFINABLE CHARACTER GENERATION** built-in character set Includes zoom, slant, and variable spacing, or upload your own character definitions



VECTRIX

- **SERIAL AND PARALLEL INTERFACE** 300-19.2K baud and 8 bit parallel port
- **USER FRIENDLY COMMAND FORMAT** supports high level language and hexadecimal transmissions

VX384

- **512 COLORS PER PIXEL** 9bit planes of memory with 384K graphics RAM
- **COLOR LOOKUP TABLE** 8 bit digital-to-analog converters provide a 16 million color palate
- **INCLUDES ALL FEATURES OF VX128** for total of \$3995
- **VXM HIGH RESOLUTION COLOR MONITOR** RGB analog input with 24 kilohertz scan rate, long persistence phosphor \$1295
- **COLOR GRAPHIC PRINTER** with interface cable \$1295



For additional information on VX128, VX384, VXM Monitor or VXP Printer call Toll Free 1-800-334-8181, or 919-272-3479, or write Vectrix Corporation, 700 Battleground Avenue, Greensboro, NC 27401

for (i = 0; i < N; i++)

says, although you don't have to be away from the language long to forget; but then comes

```
int n;
for (n = 0; *s != '\0; s++)
    n++;
return(n);
```

and I have to think some more. Whatever else you say about C, it doesn't much resemble English.

These are not fatal objections; as I said, I often find myself tempted to try using C, especially after I've spent a few minutes talking with Leor Zolman; his enthusiasm is catching. One big problem has been that we don't have a full C for small computers. (True, there's Whitesmiths C; but it wasn't intended for microcomputers; it's a fluke that it works with a Z80 or 8080, getting it running is no easy task, and if you're using it you don't need to read my columns to tell you about languages.)

Then there's Leor's BDS C (BD Software C), available from Lifeboat Associates. I've written about it many times; the main limit to BDS C is that it hasn't any floating-point data types. There are a few other limits, so that you can't—or at least I can't—just copy programs out of Kernighan and Ritchie and expect them to run.

There are a surprising number of other C compilers. Dr. James Van Zandt of Nashua, New Hampshire, has been kind enough to list them all for me:

- **Small-C:** written by Ron Cain, source code published in *Dr. Dobb's Journal*, no. 45, May 1980. Small subset of C, excludes structures, multidimensional arrays, floating point, case statements, and other vital stuff. Source and object code available for \$17 from The Code Works.

- **Small-C Plus:** an extension of Cain's Small-C by Kirk Bailey (adds for and while loops, case statements, and some others). Available for \$25 from Alpha Omega Computer Systems Inc.

- **Q/C:** Another extension of Small-C, by Jim Colvin (includes for loops, case statements, while loops, goto, assignment operators, command line arguments, I/O redirection, etc.) Source (!) and object code available for \$95 from The Code Works.

- **CW/C:** A larger extension of Small-C (includes structures, unions, multidimensional arrays, #ifdef, etc.) Object code only available for \$75 from The Code Works.

- **C/80:** A subset of C based in part on Small-C, with considerable changes by Walt Bilofsky. Excludes floating point, structures, pointers to pointers, etc. Compiles to 8080 assembly language. Object code only available for \$49.95 from The Software Toolworks.

- **Infosoft C:** An extensive rewrite of Small-C by Richard Roth, described in an article in *Dr. Dobb's Journal*, November 1981. (Lacks float, goto, &&, etc.). Complex availability: "A runnable version for \$50 in conjunction with our SAL structured assembler development tool kit listed at \$225. Or source may be licensed for an additional \$250 when the runnable version is licensed." From Infosoft Systems Inc.

- **Supersoft C:** They claim this is "most of version 7 Unix standard C." Object code is \$250. Available from Supersoft Associates.

- **Aztec C II:** "All C language features except bit fields." Advertised in *Dr. Dobb's Journal*, no. 65, March 1982. Object code, assembler, linker available for \$195 from Technical Software Systems. Compiler without floating-point numbers or long integers, \$135.

- **tiny-c One (interpreter) and tiny-c Two (compiler):** A small language similar to C, described in *Dr. Dobb's Journal*, May 1980. Interpreter source and object code (\$100) and compiler object code (\$250) available from tiny-c Associates.

Dr. Van Zandt reports: "I've used Small-C and have started enhancing it. My version compiles at about 220 lines a minute, but it's still slow. I'm looking for a fast compiler that handles floating-point numbers and a matching interpreter for fast debug-

P&T CP/M[®] 2 is GROWING

TRS-80 MODEL II
\$185

Still the best CP/M for the Mod II with features like 596 Kb per diskette, typeahead, full serial port support, and more.

TRS-80 MODEL 16
\$220

Includes full support for thinline drives: gives 1.2 Mb per diskette for the Mod 16 (Z-80 mode) and Mod II's with double sided drives.

RADIO SHACK HARD DISK
\$250

Includes all the features of P&T CP/M 2 plus 8.7 Mb per hard disk drive.

CAMEO HARD DISK

Support for the standard Cameo hard disk system (\$250) or the multiplexer (for multiple computers) system \$400.

CORVUS HARD DISK
\$250

Support for a 5, 10, or 20 Mb Corvus hard disk system.

Start with a Model II floppy system and grow into a hard disk. Since all P&T CP/M 2 systems are fully compatible, you will have no conversion worries.

Special note: P&T hard disk systems allow you the user to configure logical drive assignments to your specifications. Write for more details.

Prepaid VISA, M/C, or COD orders accepted. All prices FOB Goleta and subject to change. CP/M is a registered trademark of Digital Research. TRS-80 is a trademark of Tandy Corp.

PICKLES & TROUT

P.O. BOX 1206
GOLETA, CA 93116
(805) 685-4641



ging. I suspect I'm not alone. Can you help in our search?"

I'm not sure I can help; except for Whitesmiths and BDS, I don't have any of those C compilers, and just at the moment, there aren't any C fanatics among the students and associates working here. Perhaps one day both will materialize. Meanwhile, there is a promising development.

As I began this article, I got a telephone call from the people at MDDBS (Micro Data Base Systems Inc., POB

248, Lafayette, IN 47902). MDDBS is a bunch of Purdue University people with their commercial hats on.

They have arranged to obtain the source code to Leor Zolman's BDS C, which they are enhancing. In particular, they're adding floating-point numbers and long variables.

That might be the answer to Professor Van Zandt's problem. I know that Leor continues to improve his BDS C package, and the MDDBS people have a prodigious reputation for

nearly indestructible software. The combination may be unbeatable.

However, I can't make any promises or guarantees about any of these. I'm not really competent to evaluate C compilers, since I barely know the language. From the amount of mail I get, I know many of my readers are interested in C, and indeed so am I, so I'm happy to report what I can; but alas, I can only report what I know, which isn't much.

MDDBS

The MDDBS program itself is a structured database system that ties into a regular programming language. I'm not certain precisely which languages are supported; I know that versions to match BASIC, FORTRAN, and PL/I are available, because I have them. I do not have them running, and therein lies a tale.

Over a year ago, my mad friend Mac Lean became fascinated with PL/I and, after a couple of months' work, became quite proficient in the language. When MDDBS offered evaluation copies of its database, I asked for versions in BASIC and PL/I. Mac Lean took the PL/I version away; but he soon returned it.

"What's the matter?" I asked.

"I'm not *that* expert," he said. "I'll stick to dBASE II, thanks."

MDDBS went back on the shelf for a while. The other day I dusted it off to see what had discouraged Mac Lean. It didn't take long to find out.

The top document in the MDDBS package was "A Primer on Data Base Management Systems" by Dr. Clyde Holsapple.

I am thinking of giving an award for the most opaque and unreadable document of the year; if I do, Dr. Holsapple is a hands-down winner. I'm sure there's a lot of information in there, but I could read that document until I go blind and I wouldn't understand it. As I sit staring at it, a few glimmers of sense get through to me, but as soon as I put it down, all flees from my head.

Consequently, I have never implemented any MDDBS programs; like Mac Lean, I find either my own "minimum database" or dBASE II more than adequate. I have,

Enter the 8086 Dimension of BRIDGE . . .



BRIDGE Computer Company invites you to enter the 16-bit microcomputer world by investigating our well engineered and fully integrated 8086 system. Specially engineered to satisfy your needs our system includes:

- 8 MHz 8086 CPU with 16-bit bus and 16 MBYTE memory addressing. Available with 8087 math processor chip.
- Two fully implemented serial plus two parallel ports to fully support your peripheral needs.
- With up to 4 single or double-sided 8" double density floppy disk drives.
- 128K Dynamic RAM which fully supports IEEE S-100 bus DMA protocol and 8 or 16 bit pathways. Expandable to several MBYTES.

Based on the 20-slot S-100 InterSystems mainframe, your system is already equipped with an endless array of configuration possibilities. As your needs grow in the future, and as we "BRIDGE" the gap to higher technology, your system can easily be enhanced through this already built-in, add-on capacity.

BRIDGE Computer Company's 8086 system speaks MS-DOS and includes an assembly language development package, systems utilities, MATE (screen-oriented text editor) and an optional FORTRAN-86 compiler from Microsoft. You will also want to inquire about our future CP/M-86 enhancement.

Other available software: BASIC Interpreter, Pascal, BASIC, Aztec C II and COBOL Compilers.

Microsoft's Multiplan Electronic Worksheet

Run your stream of needs under our "BRIDGE" and move to a high performance 8086 computer system. For complete information and prices, call us at (617) 244-8190, circle the reply number or write today.

Dealer inquiries invited.

BRIDGE
Computer Company
DIVISION OF SEA DATA CORPORATION
ONE BRIDGE STREET
NEWTON, MASS. 02158 U.S.A.
PHONE: (617) 244-8190

MS-DOS, BASIC Interpreter, Pascal Compiler, BASIC Compiler, COBOL Compiler are trademarks of Microsoft. CP/M-86 is a trademark of DRI.

Why use other computer media when you could be using MEMOREX high quality error free media?

Free Memorex Mini-Disc Offer - Get free discs!

You'll save money when you buy Memorex, because every carton of 10 Memorex 5 1/4 inch mini-discs sold by Communications Electronics has a coupon good for a free Memorex mini-disc. For every case of 100 Memorex mini-discs you buy from CE, you'll get 10 free Memorex mini-discs, directly from Memorex. The more you order, the more you save. Offer expires December 31, 1982. All Memorex flexible discs sold by CE are of the highest quality, certified 100% error free and backed by a full one year factory warranty.

Flexible Disc Quantity Discounts Available

Memorex Flexible Discs are packed 10 discs to a carton and 10 cartons to a case. Please order only in increments of 100 units for quantity 100 pricing. We are also willing to accommodate your smaller orders. Quantities less than 100 units are available in increments of 10 units at a 10% surcharge. Quantity discounts are also available. Order 500 or more discs at the same time and deduct 1%; 1,000 or more saves you 2%; 2,000 or more saves you 3%; 5,000 or more saves you 4%; 10,000 or more saves you 5%; 25,000 or more saves you 6%; 50,000 or more saves you 7% and 100,000 or more discs earns you an 8% discount off our super low quantity 100 price. Almost all Memorex Flexible Discs are immediately available from CE. Our warehouse facilities are equipped to help us get you the quality product you need, when you need it. If you need further assistance to find the flexible disc that's right for you, call the Memorex flexible disc compatibility hotline. Dial toll-free 800-538-8080 and ask for the flexible disc hotline extension 0997. In California dial 800-672-3525 extension 0997. Outside the U.S.A. dial 408-987-0997 between 9 AM to 4 PM Pacific Time.

SAVE ON MEMOREX FLEXIBLE DISCS

Product Description	Part #	CE quant. 100 price per disc (\$)
8" SSSD IBM Compatible (128 B/S, 26 Sectors)	3062	2.09
8" SSSD Shugart Compatible, 32 Hard Sector	3015	2.09
8" SSSD CPT 8000 Compatible, Soft Sector	3045	2.99
8" SSDD IBM Compatible (128 B/S, 26 Sectors)	3090	2.74
8" DSDD Soft Sector (Unformatted)	3102	3.34
8" DSDD Soft Sector (128 B/S, 26 Sectors)	3115	3.34
8" DSDD Soft Sector (256 B/S, 26 Sectors)	3103	3.34
8" DSDD Soft Sector (512 B/S, 15 Sectors)	3114	3.34
8" DSDD Soft Sector (1024 B/S, 8 Sectors)	3104	3.34
5 1/4" SSDD Soft Sector w/Hub Ring	3481	2.34
5 1/4" SSDD 10 Hard Sector w/Hub Ring	3483	2.34
5 1/4" SSDD 16 Hard Sector w/Hub Ring	3485	2.34
5 1/4" DSDD Soft Sector w/Hub Ring	3491	3.09
5 1/4" DSDD 10 Hard Sector w/Hub Ring	3493	3.09
5 1/4" DSDD 16 Hard Sector w/Hub Ring	3495	3.09
5 1/4" SSQD Soft Sector w/Hub Ring (96 TPI)	3504	2.99
5 1/4" DSQD Soft Sector w/Hub Ring (96 TPI)	3501	3.99

SSSD = Single Sided Single Density; SSDD = Single Sided Double Density; DSDD = Double Sided Double Density; SSQD = Single Sided Quad Density; DSQD = Double Sided Quad Density; TPI = Tracks per inch.

Special offer on Memorex computer tape.

If you mail your order to us and enclose prepayment, deduct \$1.00 per reel from our quantity 100 prices. This means Memorex 25JW can be as low as \$12.99 in 100 quantities. Memorex Computer Tapes are packed 10 tapes to a carton. Please order only in increments of 100 units for quantity 100 pricing. Quantities less than 100 units are available in increments of 10 units at a 10% surcharge. Quantity discounts are also available. Order 500 or more tapes at the same time and deduct 1%; 1,000 or more saves you 2%; 2,000 or more saves you 3%; 3,000 or more saves you 4%; 4,000 or more saves you 5% and 5,000 or more tapes earns you a 6% discount off our super low quantity 100 price. If you need further assistance or information to find the tape that's right for you, call the Memorex Computer Tape Technical Support Group at (408) 987-2937.

SAVE ON MEMOREX COMPUTER TAPE

Product Description	Part #	CE quant. 100 price per reel (\$)
Memorex IV 2400 feet Wrightline Seal	25JW	13.99
Memorex IV 2400 feet Easy Load II Cartridge	25JR	14.99
Memorex IV 1200 feet Wrightline Seal	25FW	10.65
Memorex Quantum 2400 feet Wrightline Seal	27JW	16.20
Memorex Quantum 2400 feet Easy Load II Cart.	27JR	16.99
Memorex Quantum 1200 feet Wrightline Seal	27FW	12.50
Memorex Cubic HD 2400 feet Wrightline Seal	39JW	18.99
Memorex Cubic HD 2400 feet Easy Load II	39JR	19.99
Memorex Cubic HD 1200 feet Wrightline Seal	39FW	13.99

Circle 98 on inquiry card.

New Memorex Lifetime Rigid Disc Pack Product Warranty

All Memorex disc packs sold by CE have a lifetime product warranty. This is your assurance that Memorex disc packs will give you a lifetime of performance and service. Only Memorex can offer you the superior reliability of their exclusive M Formula. In addition, Memorex will assist the original user in isolating and correcting any technical issues that relate to the Memorex product as well as, when appropriate, replace up to one set of read/write heads. If you need further information to find the rigid disc that's right for you, call the Memorex rigid disc compatibility hotline. Dial toll-free 800-538-8080 and ask for the rigid disc hotline extension 1642. In California dial 800-672-3525 extension 1642. Outside the U.S.A. dial 408-987-1642.

SAVE ON MEMOREX RIGID DISC PACKS

Product Description	Part #	CE quant. one price per pack (\$)
Mark III 5 MB. Cartridge Front Load (8 to 32 Sect.)	95-522XX-03	65.00
Top Load (1-to 24 sectors)	94-522XX-03	70.00
CMD-16 "Phoenix Type" CDC Cartridge	98-26600-31	160.00
NCR Cartridge	98-26600-32	160.00
Mark VIII 80 MB. Error Free	72-16600-03	330.00
Flag Free	72-26600-03	320.00
Mark XI 200 MB. Error Free	03-35041	720.00
Flag Free	03-35031-02	560.00
DEC Flag Free	03-35031-03	560.00
Mark XII 200 MB. NCR/CDC Flag Free	03-39001-01	515.00
Honeywell Flag Free	03-39000-01	515.00
Mark XIII 300 MB. Error Free	03-47021	795.00
Flag Free	03-47009	670.00
Mark XIV 80 MB. Unformatted Error Free	74-16600-03	365.00
Flag Free	74-26600-03	300.00
Honeywell Format Flag Free	74-26600-08	315.00
CDC Format Flag Free	74-26600-09	315.00
Mark XV 300 MB. Error Free	03-49011	825.00
Flag Free	03-49001-01	725.00

Smith-Corona TP-1 Letter Quality Printer Special Offer

Buy any Memorex product on this page, and get a Smith-Corona TP-1 letter quality printer for only \$585.00 plus \$20.00 shipping. Specify serial or parallel version.

Buy with Confidence

To get the fastest delivery from CE of your Memorex computer products, send or phone your order directly to our Computer Products Division. Be sure to calculate your price using the CE prices in this ad. Michigan residents please add 4% sales tax. Written purchase orders are accepted from approved government agencies and most well rated firms at a 30% surcharge for net 30 billing. All sales are subject to availability, acceptance and verification. All sales are final. Prices, terms and specifications are subject to change without notice. Out of stock items will be placed on backorder automatically unless CE is instructed differently. Minimum prepaid order \$50.00. Minimum purchase order \$200.00. International orders are invited with a \$20.00 surcharge for special handling in addition to shipping charges. All shipments are F.O.B. Ann Arbor, Michigan. No COD's please. Non-certified and foreign checks require bank clearance.

For shipping charges add \$8.00 per case or partial-case of 100 B-inch flexible discs or \$6.00 per case or partial case of 100 5 1/4-inch mini-discs. For tape shipping, add \$1.00 per reel. For Disc packs add \$10.00 per cartridge (Mark III or CMD-16) or \$15.00 per disc pack for U.P.S. ground shipping and handling in the continental U.S.A.

Mail orders to: Communications Electronics, Box 1002, Ann Arbor, Michigan 48106 U.S.A. If you have a Master Card or Visa card, you may call and place a credit card order. Order toll-free. Dial 800-521-4414. If you are outside the U.S. or in Michigan, dial 313-994-4444. Order your Memorex computer products from CE today.

Copyright ©1982 Communications Electronics™

Ad #090282



Order Toll-Free!
(800) 521-4414

In Michigan (313) 994-4444

MEMOREX
COMPUTER TAPE
DISC CARTRIDGES - RIGID DISCS
FLEXIBLE DISCS

COMMUNICATIONS ELECTRONICS™

Computer Products Division

854 Phoenix □ Box 1002 □ Ann Arbor, Michigan 48106 U.S.A.
Call TOLL-FREE (800) 521-4414 or outside U.S.A. (313) 994-4444

moreover, spoken with a number of MDBS users, including its owners, and they are universally agreed that MDBS is *not* a rival to dBASE II.

MDBS is for "professional programmers only," according to the company. You use MDBS to write highly structured database systems, accounting packages, accounts receivable, inventory management schemes, and highly cross-referenced filing systems. Most of the programming is done in the computer language of your choice; you then hook in the MDBS stuff, which is rigidly structured and said to be easy to work with once you know what you're doing.

Professional programmers I've talked with say they like MDBS. However, they also warn that it is *not* a tool for beginners. Moreover, most agree that MDBS in BASIC is not terribly useful: by the time you know enough about programming to be able to use MDBS, you'll have abandoned BASIC as a language.

My own suspicion is that's true, *ex-*

cept for CB-80, which has sufficiently structured concepts to avoid nearly all of BASIC's quirks, and which is the one BASIC-like language that I think is a serious rival to Pascal and Ada.

As to the PL/I version, Mac Lean wasn't just trying to get out of work. MDBS and dBASE II are quite different in their approach to data management. dBASE II and its rivals are *relational* databases. They store information in what is fundamentally a large two-dimensional array. MDBS and the CODASYL database systems are *hierarchical* in structure. They store information in "trees" and limit the ways that you can climb around in the data tree.

The hierarchical structures are very useful if you know in advance what data you will want to store and have some ideas about how you want the data structured. However, hierarchical structures are not very flexible; if you want to change things around, it's not impossible, but it is quite difficult.

Relational structures, on the other hand, are slower and don't have the fancy record structure of the hierarchical databases; but they're much easier to set up and work with, and, more important, they're a whack of a lot easier to change. It's much easier to add new data categories to a *relational* database than it is to stuff them into a *hierarchical* system.

All of this is—more or less—explained in the MDBS documents, not all of which are quite as opaque as Holsapple's "Primer." Fair warning, though: to get through MDBS, you'll want to be pretty familiar with the computer language of your choice, and you'll want to know a good bit about the structure of the database you're trying to set up. I won't point out that you'll also have to be highly motivated: only the highly motivated will get through the introductory MDBS documents.

The Example Remover?

There's an old proverb, Whom the gods love, they chastise. I hope I may without blasphemy apply that to my relationship with Digital Research (DR).

That is, it should be obvious that I like CP/M, CB-80, Pascal/MT+, and PL/I, all of which are sold by DR; and indeed I'm particularly fond of CB-80, which is certainly the only BASIC that might rival Pascal.

My fondness for DR's products does not, however, extend to its documentation. Now true, I am on public record as saying that I think the old Compiler Systems CBASIC documents among the best in the microcomputer world. Alas, those were written by Gordon Eubanks prior to his company's being bought out by DR. After the sale, Gordon became a vice-president of DR and moved up to Monterey. CBASIC and CB-80 are now published by Digital Research.

The first edition of the CB-80 manual wasn't bad. It has those railroad-track syntax diagrams that I find either trivial or incomprehensible, but like the CBASIC manuals before it, it has plenty of examples.

It wasn't complete (as I learned



IT'S **CRYSTAL CLEAR** RGB Color—the sharpest available today— now for your Apple II, with Ren Tec's **APPLE/RGB** Color Monitor Interface.

Our specially designed unit...

- Interfaces with NEC, Amdek and Electrohome monitors
- Is compatible with 80 column boards
- Fully supports all text and graphic modes
- Plugs easily into I/O slot #7

The APPLE/RGB Color Monitor Interface...\$225.

Our Other Products For Apple

BUFF-ET

Your computer computes while the printer is printing, with this 16K, 32K or 64K buffer. Installs between computers and Centronics-type parallel printers, such as Apple II, IBM-PC, NEC PC-8000 and TRS 80. **from \$199.**

OLYMPIA/REMINGTON **TYPEWRITER INTERFACE**

This RS-232-C serial interface converts Olympia 100, 101, 105 and Remington 210, 220 typewriters to letter-quality printers for your Apple computer. (ES 4010) **\$295.**

See your local computer dealer or contact us.

RENAISSANCE TECHNOLOGY CORPORATION

1070 SHARY CIRCLE, CONCORD, CA 94518 • (415) 676-5757

Dealer Inquiries Welcome

"What if ...



I run out of memory?"

Most people *do* run out of memory with only 18K VisiCalc* workspace. But you can expand your Apple II* to 177K VisiCalc memory! You can also get 80-column display, lower case letters, and hard disk

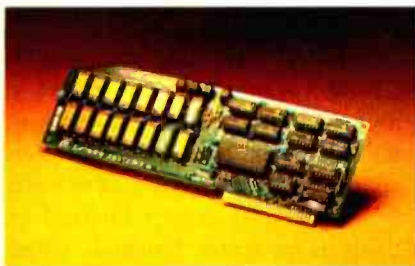

support—all without buying a bigger computer.

The Saturn expansion system for VisiCalc consists of a preboot diskette, one or more plug-in RAM boards, and an optional 80-column display board. You can put the Saturn boards in any slot. And with all that memory, our software lets you save files on more than one diskette.

Each Saturn RAM board includes additional software for other programming applications. So your BASIC, PASCAL, and CP/M programs get an extra bonus.

Ask your computer dealer for more details about the Saturn memory expansion systems. See how much bigger and better your models can become!

*VisiCalc is a registered trademark of VisiCorp. Apple II is a registered trademark of Apple Computers, Inc.

SATURN SYSTEMS INC.

P.O. Box 8050
3990 Varsity Drive
Ann Arbor, MI 48107
1 (313) 973-8422

Fancy Shmancy

Elaborate microprocessor development systems cost a lot of money, and they can close off your engineering options by locking you into just one or two kinds of chips. Sound familiar? Well, read on—we've got a better idea.

Use your desktop computer; anything that will run CP/M* is fine. With our microprocessor cross-assemblers you can produce software for eleven of the most popular chip families, and more are on the way.

In two years on the market, our cross-assemblers have gained a reputation for quality, performance, and reliability. Hundreds of industrial R&D labs and several major semiconductor houses have found these products a fast, cost-effective way to develop their microprocessor software. We invite you to join them.

CP/M CROSS-ASSEMBLERS

Extremely fast absolute assemblers, running under CP/M. Generate object file (Intel hex or Motorola S-record format) and listing from standard assembly language for the target processors listed. Features include comprehensive syntax checking, listing control, nested conditional assembly, and insertion of external source files. All versions listed have been thoroughly field-tested and are available now.

XASM05	6805
XASM09	6809
XASM18	1802
XASM48	8048/41
XASM51	8051
XASM65	6502
XASM68	6800/01
XASM75	NEC 7500
XASMF8	F8/3870
XASMZ8	Z8
XASM400	COP400

Assemblers \$200.00 each
except XASM75 \$500.00

Visa and Mastercard accepted. We ship on 8" single-density and Softcard + 5.25" diskettes. Ask us about other formats. OEM INQUIRIES INVITED.

* Trademark of Digital Research
+ Trademark of Microsoft



**AVOCET
SYSTEMS INC.**

804 S. STATE ST., DOVER, DEL. 19901
302-734-0151
BY82

when I got the obscene-sounding ERROR FU and couldn't find ERROR FU in the error list), and in places it was even wrong, as for example when it told how to make the compiler call attention to any undeclared variables in your program (this is an excellent optional feature of CB-80). So there came out a second edition.

Alas, although it now documents the FU error, the second edition has fewer examples; it's as if someone went through and took out some as superfluous.

If there are any software publishers listening, HEAR AND BELIEVE: there is no such thing as a superfluous example! Even poor documents can be made tolerable if they have plenty of examples, because then you can reason your way by induction; but when there aren't examples, what can you do?

Moreover, the act of testing your examples (and please, please, *never* publish an example unless you yourself have tested it!!) may show you things you didn't know about your program.

Item: one of Gordon Eubanks's assistants told me that the Read Line function in CB-80 reads until it reaches a carriage return.

"Goody!" thought I, for one of my biggest problems is how to deal with text created by editors that mark line ends with a carriage return but no linefeed, since ASCII (American Standard Code for Information Interchange—the character set we all use in CP/M) has no single Newline character.

I proceeded to write a text-mashing program. After all, CB-80 can handle strings up to 32,000 characters long; this ought to make it simple to do things to text. Unfortunately, as I learned to my sorrow, CB-80's Read Line does *not* read until it finds a carriage return. It reads until it finds a linefeed, and of course there aren't any in the files I wanted to work on.

Indeed, the problem gets even more complex: many text editors treat the formfeed character as a Newline as well as a New Page; that is, if you end a line of text with the FF character, the editor believes that you've also ended the line. This isn't an optimum

situation, but lots of editors do it, so if you're trying to get text files into a program, you have to deal with the situation.

Eventually I got the following letter from Gordon Eubanks:

Read Line reads until a linefeed is found. The carriage return is then stripped off the string. The bottom line is that the Read Line works with text files delimited with a carriage return and linefeed pair. The documentation will be updated to clarify this issue. A bigger problem is that many users, I am sure, would like to read text files delimited by a carriage return either followed by a linefeed or not followed by a linefeed.

The reason Read Line is implemented this way is historic. (Historic in the sense that it was perhaps not the best thought out decision.) To change it now would jeopardize many existing programs. I feel a strong obligation to support existing programs and software developers. Any ideas on a solution?

On thinking about it, I have: add a new read statement, say, READ UNTIL (X) where X is something the user can insert for himself. The structure might be a Boolean flag that's false until the (X) character is encountered, then goes true; with that a programmer could handle nearly any file structure. You'd want to be able to do more than one READ UNTIL paired as OR statements: that is, suppose X1 is a carriage return character (ASCII decimal 13) and X2 is a formfeed (ASCII decimal 12); then you READ UNTIL (X1) OR (X2) and you'd have solved the problem of getting text from any editor.

Gordon adds, "The GET function will read a character at a time from a text file and allow you to build strings as you desire. Since CB-80 supports 32,000-byte strings, this is quite practical for many applications."

All true, and one reason I wanted to use CB-80 for my text masher. The problem is that GET is fairly slow. Ah, well.

I found one last problem with CB-80: I wanted to read in text, play about with it, and output it in lines of 80 or fewer characters, broken at spaces between words and terminated by a carriage-return/linefeed pair. (This is program Normal, which is available as part of Alex's Pascal In-

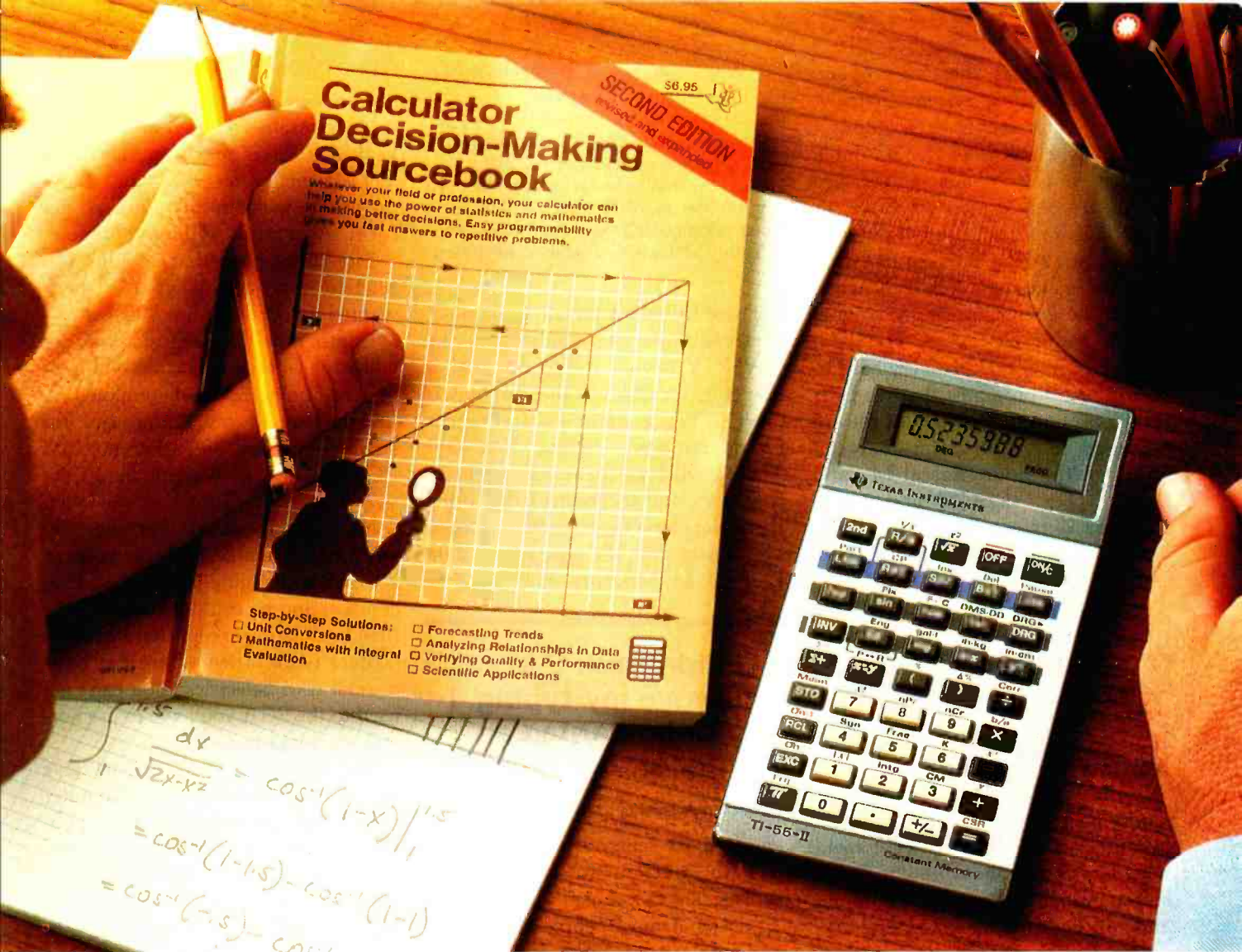

How the TI-55-II makes short work of long problems.

Whenever you can solve complex problems quickly and accurately, you're ahead of the game. And that's exactly what the TI-55-II does for you. By giving you 112 pre-programmed functions (like definite integrals), it allows you to take short cuts without losing accuracy. You'll accomplish a lot more in less time which means increased efficiency.

With our TI-55-II you can tackle problems you thought could only be solved with higher-priced programmables. You're not only getting the standard slide rule functions but also statistical capabilities. This way you can work out linear regressions, permutations and combinations, just to name a few.

The TI-55-II also gives you enough programmability to eliminate a lot of repetitive key punching. Our Constant Memory™ keeps programs and data on tap, even when the calculator is turned off. So once you've entered a formula, you can simply put in the variables to get your solution. The Liquid Crystal Display shows your

answers in standard, scientific or engineering notations — clearly and precisely.

We also help you get the most out of your calculator with the Calculator Decision-Making Sourcebook. It gives you step-by-step examples of the best techniques used for solving mathematical, scientific and statistical problems. And we've included a special section on how to program your TI-55-II.

So next time you're facing another time-consuming problem, cut it down to size with the TI-55-II.



TEXAS INSTRUMENTS

© 1982, Texas Instruments Incorporated.

Circle 463 on inquiry card.

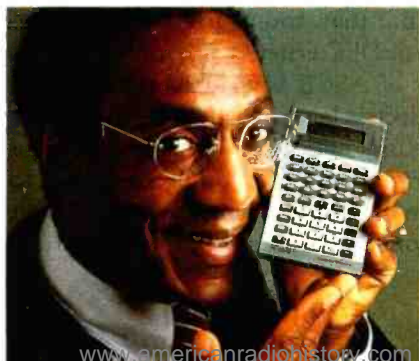

tro package.) Alas, there's a problem in CB-80's output system, namely, that when it is supposed to output a completely blank line, it puts out a linefeed only *without* a carriage return; it's only if there's a space, or *something*, on the line that it puts out the carriage-return/linefeed pair that together make an ASCII Newline (which the documents imply is what CB-80 believes is a Newline character). This makes it very hard to set up Pascal programs that read the text so produced, especially if they're supposed to be programs that can work with both Pascal/M and Pascal/MT+, since M and MT+ look for different line terminators. (Pascal/M ignores linefeed characters entirely.)

Eventually I prevailed, but the result is not as fast as I'd like: Anyway, it works; but the CB-80 manual doesn't mention how CB-80 marks empty lines.

Jiggering Up Your IBM

In the West Coast Computer Faire report ("Computers for Humanity," July 1982 BYTE, page 392), I mentioned an article about how to buy a bare-bones IBM Personal Computer and add your own memory and disk drives. I inadvertently didn't include a reference to the article, which appeared in the first issue of a magazine called *Personal Computer Age*, 10057 Commerce Ave., Tujunga, CA 91042.

That Wrecked Keyboard

Readers will recall that I am no enthusiast of the key layout on the IBM Personal Computer (PC). The company has put extra keys between the normal typewriter-key layout's Z key and the Shift key, and it has reduced the size of the Return key and moved it far, far away from the home keys. It's an understatement to say I'm no enthusiast: indeed, I think it is (1) an insult to American touch-typists and (2) an unmitigated disaster. (I'm reminded of the lawyer who sent a telegram saying, "Sir: F—You. Strong letter follows.")

Davis Foulger of New Canaan, Connecticut, who otherwise likes my column, says:

You're wrong about the keyboard on the IBM Personal Computer. . . . I met the engineer who designed it at a conference in New York. He was obviously pained by the criticism of his baby. . . . He told me that he had a lot of research to support the assertion that the IBM Personal Computer's keyboard was considerably better than a Selectric keyboard.

There follows a certain amount of irrelevant material condemning the QWERTY keyboard. It's not that it isn't true: we all know that not only is QWERTY not optimum for touch-typing, but it was designed that way! That is, when mechanical typewriters first came out, the young ladies using them were able to strike sequences of keys faster than the typewriter could keep up; so the keyboard layout was

**I didn't ask IBM to
improve my typing. I
only wanted a
keyboard, not a career.**

changed to separate key sequences like "th" and "ou" to slow down the typists. The fact remains that QWERTY is what most people learned on, and while it's easy to learn a new board like the Dvorak, it's nearly impossible to go *back* to a QWERTY after you've learned a new keyboard.

Then he points out that the IBM PC keyboard has a lot of keys that normal typewriters don't have. Where should they go?

Now I agree that putting on the full ASCII key set is a *must* for a good keyboard, and one of my major criticisms of the Osborne 1 is that it doesn't have the tilde (~), grave (`), and curly braces { }; indeed, the first thing I look at when I see a new computer is the keyboard, and if it's missing some of the keys my enthusiasm wanes rapidly.

But that, too, is irrelevant. My ancient DECwriter keyboard has the full set of ASCII keys while retaining the Selectric layout including the oversize Return and Shift keys. Mr. Foulger writes that once you become used to the IBM PC keyboard, you find your typing becomes much more accurate.

"Since the Shift key on a Selectric is big, we can be clumsy in reaching for it. As a result, we often are. The PC keyboard forces precision. The Shift key is a small target that won't allow the user to make mistakes in reaching for it. As a result, typing improves."

The problem is that I didn't ask IBM to improve my typing. I only wanted a keyboard, not a career.

Comes now Jim Baen. Jim was my editor at *Galaxy* magazine and later at Ace Books. Somewhere along the line he caught my enthusiasm for small computers, and when the IBM PC came out, he bought one of the very first.

He loves it, except for the silly wrecked keyboard. They say you can get used to hanging if you hang long enough, and he could get used to the IBM keyboard—except that he has to go back to the office, where they have normal IBM Selectrics. You can't get used to the PC if you have to use normal machines too.

Jim Baen, however, doesn't give up. He's interested in computer games—one game he's going to publish will be *Inferno*, by Larry Niven and Jerry Pournelle—for the IBM PC; and now he's found a programmer who thinks he can write software to alter the IBM PC keyboard. The alteration would convert the stupid keys between the Z and the Shift, and the ? and the Shift into Shift keys. It would also convert the ridiculous key that's been put between the home keys and Return into a Return key. To get the characters that these "extra" keys normally make, you hit ALT and the key.

Jim's programmer swears that will work; as of now it's not available but will be Real Soon Now, at which time I may go buy an IBM PC.

Meanwhile, I see from the DEC personal computer documentation that DEC's keyboard also has software reprogrammable keys, and it's probable that some similar trick can be worked with it. It's a pity that you have to kludge things up that way; you'd have thought that IBM and DEC had people smart enough to quit winners. And one day someone will come out with a properly designed keyboard.

CHRISLIN YEARS AHEAD IN MEMORY DESIGN

**COMING SOON!
1 MB DUAL BOARD MEMORY!**

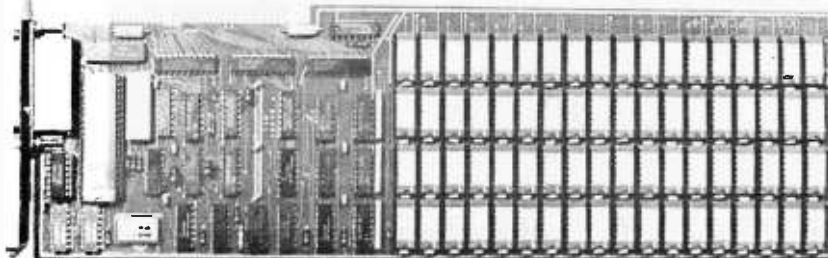

512KB SINGLE BOARD IBM MEMORY W/RS232-C PORT

- Addressable as a contiguous block in 64KB increments thru 1 megabyte.
- On board parity with interrupt on parity error.

SINGLE QTY. PRICE: \$895.00

MEMDISK 1: \$10.00

MEMDISK 1 Allows memory to emulate disks. Increases system performance!!

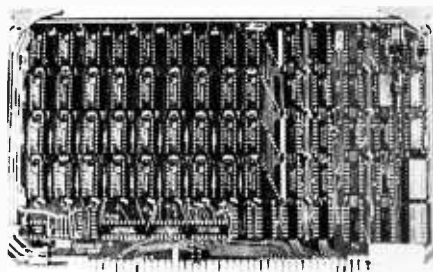

64KB SINGLE BOARD EXORCISOR 1, 11, AND ROCKWELL SYSTEMS 65 MEMORY

- Parity checker on board.
- Addressable as a contiguous block in 4K increments with respect to VXA or VUA.
- Pin to Pin compatibility.

SINGLE QTY. PRICE: \$390.00

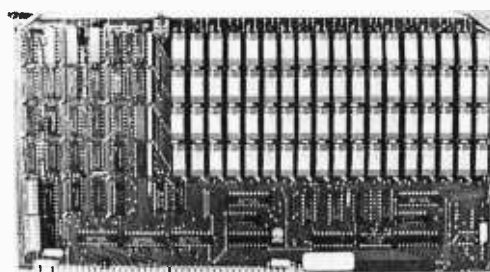

512KB SINGLE BOARD MULTIBUS MEMORY

- Pin to Pin MULTIBUS compatibility for both 8 bit and 16 bit systems.
- On board parity with selectable interrupt on parity ERROR.
- Addressable as a contiguous block in 16K word increments up to 16 megabytes.

SINGLE QTY. PRICE: \$1395.00

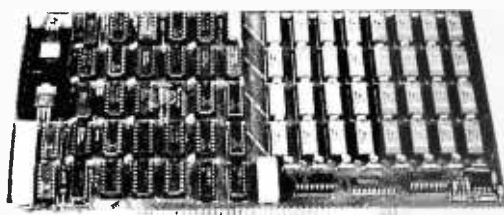

64KB SINGLE BOARD S100 MEMORY

- Addressable as a contiguous block in 4K word increments.
- Battery back-up capability.
- Functions with on-board refresh.

SINGLE QTY. PRICE: \$390.00

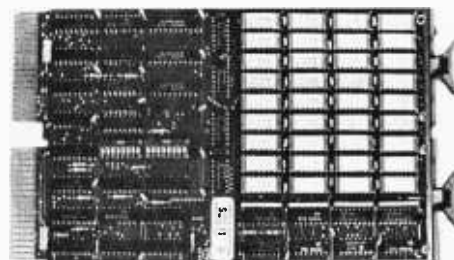

256KB SINGLE BOARD LSI 11 MEMORY

- On board parity generator checker.
- Addressable as a contiguous block in 4K word increments through 4 megabytes.
- Battery back-up mode.

**SINGLE QTY. PRICE: 128K x 18 \$795.00
32K x 18 \$390.00**

DON'T ASK WHY WE CHARGE SO LITTLE, ASK WHY THEY CHARGE SO MUCH.



Chrislin Industries, Inc.

31352 Via Colinas • Westlake Village, CA 91362 • 213-991-2254
TWX 910-494-1253 (CHRISLIN WKVG)

Multibus is a trademark of the Intel Corp.

LSI 11 is a trademark of Digital Equipment Corp.

EXORciser is a trademark of Motorola.

Dire Warnings

Mr. Dale Peters of Oklahoma City is a professional programmer who uses COBOL. He wants me to warn microcomputer users away from COBOL before they become ensnared.

I agree with his sentiments, but I wouldn't have thought the warning necessary. However, Mr. Peters says that applications programming schools are still turning out so-called programmers who know nothing but COBOL, and that data-processing shop managers are beginning to make a serious distinction between COBOL-coders and "real programmers," which they must do "as the cost of program maintenance gets higher and higher compared to hardware costs."

I suppose I have been naive in thinking COBOL a dying language. If my views have any weight, I agree with Edsger Dijkstra: "Teaching COBOL ought to be regarded as a criminal act. . . ." The language is obsolete, limited in power and scope, and not well implemented on small computers. Most COBOL programs I have seen are hard to understand and harder to maintain. There has to be a better language for almost any application you have in mind.

Real Soon Now

Chaos Manor is filled with new stuff. I suppose it's appropriate since it's my birthday today. There's a neat new system that lets you read and write 8-inch CP/M files from an Atari 800. It comes from Vincent Cate, 6708 Landerwood, San Jose, CA 95120, and I've heard good reports about it. It's off with one of my associates who has an Atari; full report next month, but for now I'll just say it works.

We also have sitting on the living room floor the conversion kit to turn my DEC VT100 terminal into a DEC VT180 small computer. Holly Thompson, the DEC marketing lady who brought the system over, says the conversion will take only an hour or so. (Holly, incidentally, is one of the Friends of the English Regency, which Mrs. Marilyn Niven, my partner's wife, is so mad on.) In any event,

full report when I get back from Europe.

I have some intriguing new software, too, such as the Statcom CRTform (Statcom, Suite 202, 5766 Balcones, Austin, TX 78731) programs that say they're programs that write programs. I have versions for CBASIC, PL/I, and PASCAL/MT+. They look similar to the MDDBS pro-

I suppose I have been naive in thinking COBOL a dying language.

grams, but the documents are a whole lot easier for me to understand. Alex will play with the MT+ version while I loll about in Florence and Venice.

Some time ago (see User's Column, January 1982 BYTE, page 132) I reported on the Lobo LX-80, which takes the place of the expansion interface for the TRS-80 Model I. It's more reliable, has many new features including an external data separator, contains part of an operating system in PROM (programmable read-only

memory), and in general is elegant; it kept my TRS-80 viable for at least a year longer than I'd otherwise have used it.

Eliot Lane of Lobo (354 South Fairview, Goleta, CA 93117) tells me Lobo has done it again: a full 64K-byte 5-MHz Z80 computer intended to compete with the TRS-80 Model III, to sell for about \$800. Eliot is bringing one around for Alex to play with while I'm in Europe, so he should be pretty familiar with it by the time I return. If it's as well made as the Lobo LX-80 was, it should be quite a machine. [For a Product Description of the Lobo Max-80, see page 390 of this issue. . . ED]

And of course there's the Otrona Attache, which is a briefcase computer that competes with the Osborne 1 in the same way that a BMW competes with a Volkswagen. I'm taking the Attache rather than the Osborne 1 to Europe because the Attache has a higher tolerance for strange power frequencies and has switch settings to accommodate some of the voltages we're likely to encounter. With any luck there'll be both photographs and a report. ■

Items Reviewed

Aztec C II	object code	\$195
Technical Software Systems	compiler	\$135
POB 55		
Shrewsbury, NJ 07701		
(201) 780-4004		
BDS C		\$150
Lifeboat Associates		
1651 Third Ave.		
New York, NY 10028		
(212) 860-0300		
C compiler for CP/M		\$750
Whitesmiths Ltd.		
Parkway Towers		
485 U. S. Rte. 1 South		
Iselin, NJ 08830		
(201) 750-9000		
C/80, version 2.0		\$49.95
The Software Toolworks		
14478 Glorietta Dr.		
Sherman Oaks, CA 91423		
(213) 986-4885		

Continued on page 246

OF ALL THE THINGS YOU BUY, HOW MANY ARE GOOD ENOUGH TO BE WARRANTED 5 YEARS?

Few disks stand the test of time. Because few are built to the precision standards or certified to the critical levels of Omni's complete line.

Each Omni disk is rated for 12 million passes without disk-related errors or significant wear. Each is certified error-free at a minimum of twice the error-

threshold of your system. And built to exceed all industry specifications including those of ANSI, ECMA, ISO and virtually every drive manufacturer. So you can count on them for the long haul. We guarantee it.

Call toll-free (800 343-7620) for your nearest dealer. In Mass., call 617 799-0197.

Omni Resources, 4 Oak Pond Ave., Millbury, Mass. 01527

Dealers. Software houses.

Check our prices, services and specifications. We offer duplicating, formatting, private labeling, small minimums, fast delivery and copy protection schemes on disks for virtually any system.

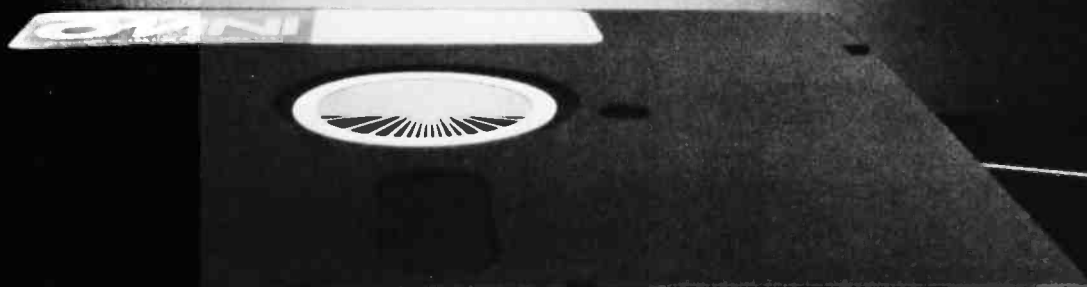

OMNI

**THE DISK GOOD ENOUGH
TO BE WARRANTED 5 YEARS**



SUPERBRAIN II

Model	List	Our Price
SB II 350K byte	\$2495	\$1875
SB II QD 750K	\$2995	\$2250
SB II SD 1.4mb	\$3495	\$2750

NORTHSTAR ADVANTAGE \$2675

ALTOS Call for lowest prices!
Franklin Ace 1000 for education, games, and business. Apple compatible. Call for Lowest Prices!

HARD DISKS Corona

5 MB for IBM	\$1599
10MB FOR IBM	\$1999

PRINTERS

Anadex 200cps, 132 col	\$1359
NEC 8023A	\$479
NEC 3510, 33cps, letter quality	\$1799
NEC 7710, 55cps, letter quality	\$2375
Smith Corona, 12cps, letter quality	\$685
Prowriter, parallel	\$475
F-10 by C. Itoh, 40cps, daisy wheel	\$1400
Okidata 82A, 120cps, serial, parallel	\$474
Okidata 83A, 120cps, serial, parallel	\$724
Epson, all models available	Call for Price
Olivetti DY211, 20cps	\$1368

MODEMS

Hayes Smartmodem	\$219
Hayes 1200 Baud	\$559
Anchor Signalman	\$79
Racal-Vadic 1200 baud	\$728
Ven Tel	Call for Price

MONITORS

NEC Green Screen, hi res.	\$170
NEC Color	\$329
Taxan RGB hi res color	\$315
Amdek Color II	\$722
Amdek 300A Amber monitor	\$164

SOFTWARE

Tons of software available for CP/M and Apple. Our prices are great so call us for pricing before you buy

APPLE ITEMS

Z-80 Softcard w/CP/M & manual	\$285
16K RAM Card	\$136
Videoterm 80 clo. card	\$252
Software	Call for great prices!

To Order Call (206) 362-3398
Call TOLL FREE 1-800-531-3133

PACIFIC COMPUTERS

Division of Mickel Assoc.
11056 Palatine N.
Seattle, WA 98133

Continued from page 244:

CW/C	\$75
Q/C	\$95
Small-C	\$17
The Code Works POB 550 Goleta, CA 93116 (805) 683-1585	

Infsoft C	with SAL structured assembler development tool kit for those who have SAL	\$275
Infsoft Systems Inc. 25 Sylvan Road South Westport, CT 06880 (203) 226-8937	source code (available to those with licensed programs)	\$50 \$250

MDBS	version 1	\$1300
International Software Enterprises (distributor) 85 West Algonquin Arlington Heights, IL 60005 (800) 323-3629	version 3	\$2250

Pascal Introduction Package		\$50
Workman and Associates 112 Marion Ave. Pasadena, CA 91106 (213) 796-4401		

Pascal/M		\$395
Sorcim Corporation 405 Aldo Ave. Santa Clara, CA 95050 (408) 727-7634		

Pascal/MT+	8080, 8085, Z80	\$350
	8086, 8088	\$600
		\$500

CB-80	
Digital Research POB 579 Pacific Grove, CA 93950 (408) 649-3896	

Small-C Plus		\$25
Alpha Omega Computer Systems Inc. POB U Corvallis, OR 97339 (503) 754-1911		

Supersoft C	object code	\$250
Supersoft Associates POB 1628 Champaign, IL 61820 (217) 359-2112		

tiny-c One (interpreter)	(with source on disk and manual)	\$100
---------------------------------	----------------------------------	-------

tiny-c Two (compiler)	(with source on disk and manual)	\$250
tiny-c Associates POB 269 Holmdel, NJ 07733 (201) 671-2296		

Software Tools for CP/M (with virtual operating system)		\$335
Unicorn Systems 30261 Palomares Rd. Castro Valley, CA 94546 (415) 881-4490		



THE SOLUTION IS IN THE VISISERIES.

No matter what kind of problems you're trying to solve with an IBM Personal Computer, there's a program in the ever-expanding IBM VisiSeries™ line that will give you the solution. Faster, better, smarter.

Take our IBM VisiCalc® program. It's #1 in the business. Because it takes the work out of working with business numbers. The IBM VisiCalc program is the powerful "electronic worksheet" that speeds planning and budgeting. You can ask "what if?" and see the answers immediately. So you can analyze the impact of decisions before you make them.

Our IBM VisiTrend/Plot™ program makes it easy to analyze data and see the results in easy-to-understand charts and graphs.

With our IBM VisiFile™ program you can organize, maintain and more effectively use the information your business needs.

Is a lot of your workday taken up with scheduling projects and estimat-

ing costs? Our IBM VisiSchedule™ program will help you do it better, with a lot less work.

And for helping you manage your valuable time, organize your personal information, nothing could be of more value than our IBM VisiDex® program.

Our IBM VisiCalc Business Forecasting Model™ package will give you vital financial information about your business.

And our IBM Desktop/Plan™ program will speed and automate all your financial and business planning.

Put the IBM VisiSeries programs to work on your IBM Personal Computer. Do it by December 31, 1982 and get three

programs for the price of two!

Get all the details from your VisiCorp retail computer dealer. Or write Customer Services, VisiCorp, 2895 Zanker Road, San Jose, CA 95134.

THE IBM
VISISERIES FROM
VISICORP™
PERSONAL SOFTWARE™

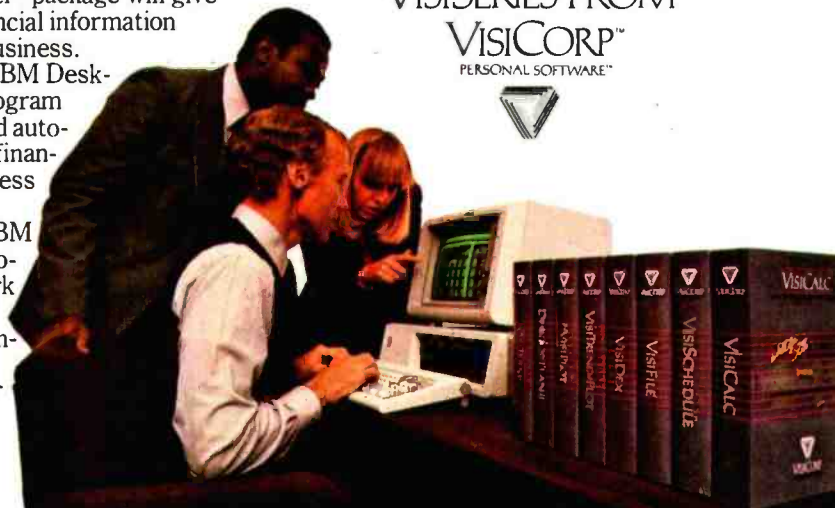

(kə mit·mənt)

Commitment: 1. To pledge or promise to do something.
2. Committal based on trust and confidence.

S.D. Systems commitment to high technology continues:

1. Industry standard S-100 modules.
2. Enhanced modular features to ease system integration.
3. CP/M, MP/M, OASIS and TURBO-DOS compatible SOFTWARE.
4. **ULTRA FAST CP/M "3.0" OPERATING SYSTEM WITH EXTENDED UTILITIES AVAILABLE NOW!**
 - New "XSUB" Features
 - MP/M II File Size Characteristics
 - Supports Multiple Memory Banks

A SYNTECH COMPANY

S D SYSTEMS

Circle 434 on inquiry card.

S-100 Modular Products

All Modular Products
CP/M 3.0 compatible.

SBC-200

The SBC-200, an advanced single board computer using the Z80A, is among the most powerful CPU cards available.

VersaFloppy II

Enhanced Flexible Disk Drive Controller

The Versafloppy II is a state-of-the-art flexible disk drive controller. It can interface with the most widely used drives in the field and handle any four drives simultaneously. Possible combinations are many, including:

- 5¼" single-sided density
- 8" single-sided double density
- 8" double-sided single density

ExpandoRAM II and III

Our ExpandoRAM offers state-of-the-art dynamic Random Access Memory from 16K to 256K and operates on the industry standard S-100 bus. Using the ExpandoRAM, you can operate up to eight

boards on the same bus. True Software bank select and page mode features allow the servicing of multiple users without RAM interference, so you can keep your system speed up. Invisible refresh and synchronization with wait states ensure fast processing.

The ExpandoRAM is compatible with most S-100 Z80A CPUs. Combine the ExpandoRAM with other **SDSYSTEMS** boards and you have a totally integrated system with exceptional capabilities.

VDB-8024

On-Board Z80A Microprocessor SDSYSTEMS

VDB-8024 is a state-of-the-art video display driver board operating on the industry standard S-100 bus and incorporating all the capabilities of a stand-alone terminal. The on-board Z80A microprocessor allows control of all video functions without interfering with the CPU board (The SBC-200). More speed. More efficiency.

The CRT-5037 Video Timer and Controller used with the Z80A provides a glitch free display so it's easier for your operators to read.

Require on-board EPROM supplies all software control.

MPC-4

Multi-port Communicator with Four Serial Ports

The MPC-4 is an S-100 bus, Z80A controlled, intelligent multi-port communications board. Its state-of-the-art design allows up to 15 MPC-4s to be addressed from one

bus. For you, this means that your system can grow as your needs increase.

Four buffered RS-232 serial I/O channels allow for both multi-user and communications applications. And on-board static RAM allows for basic multi-task applications and can be expanded to 2K RAM through two 24 pin sockets.

The on-board Z80A acts as your traffic controller and prevents interference to the host CPU. Faster response times are the result. In addition, you can use the 2K PROM (expandable to 4K) to program the system for variable protocols and terminals.

The MPC-4 offers you flexibility and expandability for system growth as you need it.

**CP/M 3.0
Compatible...
Available NOW!**

Autocontrol's AC-85 A CP/M System on One Board

JoAnne Benedict
RR 1, Box 221B4
Longmont, CO 80501

The Autocontrol single-board computer is one of the best buys on the market. You get a complete computer on a single circuit card; it has been assembled, tested, and burned in for one week. It only needs to be connected to a video terminal and some disk drives in order to run the CP/M disk operating system and attendant software.

Although not quite as flexible as an S-100 system, a single-board computer is a cost-efficient way to get no-frills computing power.

"Maximum function at minimum cost." That was our primary goal as we began our search for *the computer*. Although word processing would be the primary use, we wanted enough versatility for record keeping and engineering problem solving. We wanted a small-business computer at the cost of a personal computer.

After examining and rejecting many popular systems because they were either too expensive or did not provide enough function, we decided to try to put together a system ourselves. Because I am a programmer and my husband is an electronics engineer, we believed we should have more than sufficient expertise to solve whatever problems would arise. We considered several single-board computers and S-100 bus systems, but finally decided on Autocontrol's AC-85 (see photo 1) as providing the best function at the least cost.

The AC-85 board has a fast 8085A-2 central processor and 64K bytes of memory. The floppy-disk controller is an NEC (Nippon Electric Company) μ PD765, which can support up to four 8-inch single- or double-sided floppy-disk drives in either single- or double-density, with any mix of disks running at the same time. The disk controller can handle 5¼-inch disk drives, but the custom CP/M BIOS (basic input/output system) from Autocontrol will not recognize them. Three RS-232C channels with software-selectable settings of 50 to 19,200 bps (bits per second) will support a terminal, a printer, and any auxiliary serial device. The AC-85 board sells for \$750 and is fully assembled, tested, and burned in for one week.

The AC-85 comes with a stand-alone monitor in PROM (programmable read-only memory). If Autocontrol's version of CP/M 2.2 is ordered, a new PROM with a custom BIOS is also shipped. This PROM will automatically load either a regular CP/M distribution disk or a custom CP/M disk from Autocontrol. During a *cold boot*, the custom BIOS and some common disk

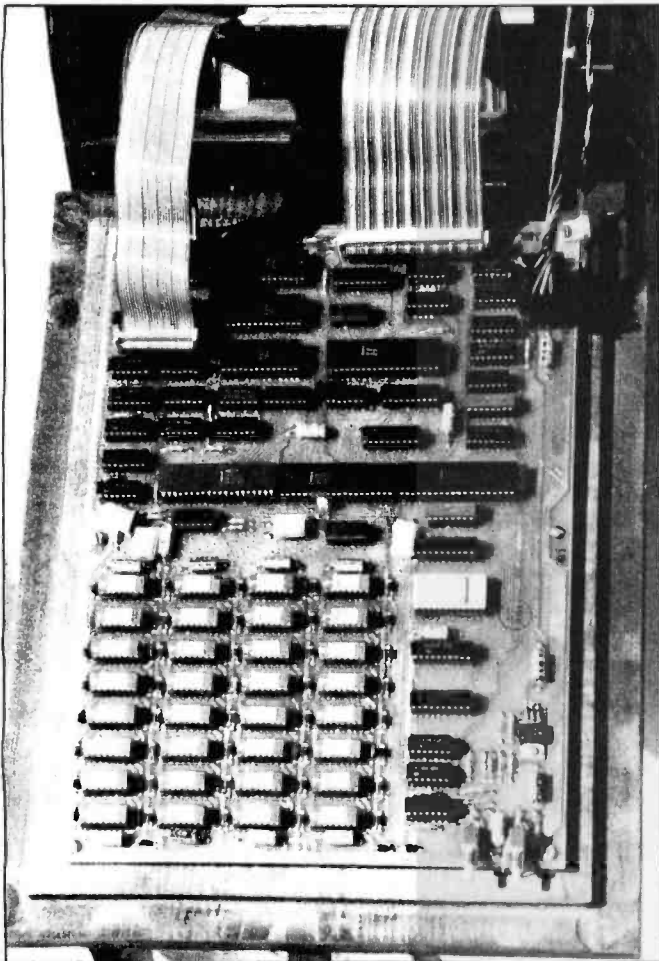

Photo 1: The author's AC-85 mounted in a homemade cabinet.

10 reasons why you should call DataSource® for software...

- 1. Free Systems Analysis** We have developed a variety of self-administered analysis tools to help you identify those products best suited to meet your needs.
- 2. Competitive Prices** Our volume enables us to offer you prices which are consistently competitive. Compare for yourself, then call us toll-free 800-328-2260.
- 3. Express Service: 7 days per week, 24 hours per day** You can place orders any day of the week at any hour of the day or night. Your order will be processed and shipped within 24 hours for all products in stock.
- 4. Discount Structures** We offer significant discounts to any individual, organization or user's group purchasing in quantity.
- 5. Key Account Program** For corporations and institutions, we offer a comprehensive program: volume discounts, complete maintenance packages with an on-site option, specially staffed technical support, tailored training programs and creative financing options.
- 6. Unconditional Money-Back Guarantee** We stand behind everything we sell. If you are not completely satisfied with your purchase, return the item within 60 days and receive a full refund.
- 7. Toll-Free Technical Support** We service what we sell. Our customers have direct access to our technical staff on a toll-free basis. 800-328-2260.
- 8. National Maintenance Network** We offer a variety of maintenance agreements for both software and hardware products. Call for more information.
- 9. Flexible Payment Options** We accept all major credit cards, checks and money orders, as well as purchase orders from corporate accounts.
- 10. State-of-the-Art Software and Hardware** We carry a broad range of what we believe to be the best in software plus carefully selected hardware products and accessories.

Here's a small sampling of products available now from DataSource®
(If you don't see what you need, just call us at the number below.)

DBMS

dBase II - Ashton-Tate	\$495
Condor II - Condor	\$450
Selector V - Micro-AP	\$395
Data Star - MicroPro	\$225
Super Sort I - MicroPro	\$170

Spreadsheets

Super Calc - Sorcim	\$199
Calc Star - MicroPro	\$185
Visicalc - Visi Corp	\$159
Visicalc 256K - Visi Corp	\$195

Languages

Pascal MT+ - Digital Research	\$425
PL-1/80 - Digital Research	\$420
Basic Compiler - Micro Soft	\$310
Basic 80 - Micro Soft	\$275
C Basic - Digital Research	\$125
CB 80 - Digital Research	\$420

Word Processing

Wordstar - MicroPro	\$289
Wordstar/Mailmerge - MicroPro	\$385
Mince - Mark of Unicorn	\$148
The Final Word - Mark of Unicorn	\$250

Spelling

Spellguard - Sorcim	\$225
Spellstar - MicroPro	\$165
The Word - Oasis	\$ 70

Hardware

Smith-Corona TP-1	\$689
C.Itoh F-10 Star Writer - 40 CPS	\$1,475
C.Itoh F-10 Printmaster - 55 CPS	Call for price
C.Itoh Pro Writer	\$515
C.Itoh Pro Writer-Serial	\$650
Hayes Smart Modem 300	\$230
Hayes Smart Modem 300/1200	Call for price
Signalman MK I Modem	\$ 99

NEW! Only from DataSource®

EMULINK for the IBM PC \$995.00
On-Line Binarysynchronous link to the big IBM host. Full 3270 emulation for the IBM Personal Computer. Complete documentation included with diskette and board.

A product of Micro Link Corporation.

Please include 3% for shipping and handling. Minnesota residents, add 5% sales tax. Prices subject to change without notice.

FOR MORE INFORMATION CALL TOLL-FREE

800-328-2260

IN MINNESOTA, CALL 612-544-3615

DATA SOURCE
Systems Corp.

Your source for micro software and hardware

DataSource® Systems Corporation, Dept. BC, 1660 So. Highway 100, Minneapolis, MN 55416

American Express
MasterCard
Visa



At a Glance

Name

AC-85 one-board CP/M computer

Manufacturer

Autocontrol Inc.
11744 Westline Industrial Dr.
St. Louis, MO 63141
(314) 739-0055

Price

\$750 (includes RS-232C and power cables); instruction manual, \$15

Dimensions

8.5 by 12 inches

Processor

Intel 8085A-2

System Clock Frequency

10 MHz

Memory

64K-byte dynamic program-able memory; 8202A RAM controller; PROM memory: 2716, 2K-byte ultraviolet erasable PROM contains a bootstrap loader or a monitor program

Mass Storage

NEC μ PD765 disk controller capable of controlling four 8-inch floppy-disk drives in single- or double-density

RS232-C Channels

Three serial channels of 2651-type with 16 selectable data rates from 50 bps to 19,200 bps

Options

None, but power supplies and extra cables may be purchased

Software

2K-byte monitor EPROM (2716); CP/M 2.2 is available completely configured for an additional \$150; programs to format single- and double-density disks; diagnostics programs for memory, interrupts, and disks; software to reconfigure an existing CP/M 2.2 operating system

Comments

Knowledge of connectors, reading circuit diagrams, and 8085 machine language is needed; board comes fully tested and burned in for one week, so few problems should occur

Audience

Those trying to save money while obtaining an effective computer system

AC-85 POWER CABLE

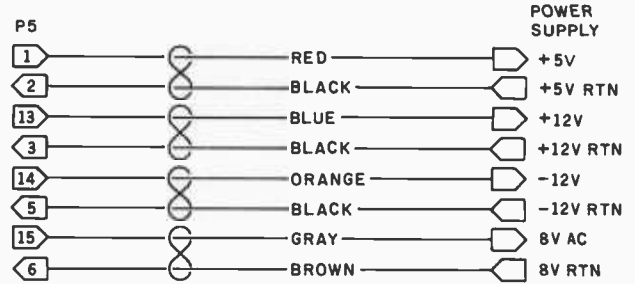

Figure 1: Power-cable connection to the single-board computer.

Cable Connections for the AC-85

The AC-85 single-board computer has four interface connectors and one power-cable connector (see figure 1). The power-cable connector comes prewired and color coded according to the circuit schematic in Autocontrol's documentation. The board includes an op amp that conditions an 8-volt (V) signal developed from the AC power lines that the 8085 can use in a timing or clock program. The signal is routed through the power cable from either a small separate transformer or the transformer that produces the +5-V DC power supply. The power supply must provide +5 V at 1.5 amperes (A), +12 V at 0.3 A, and -12 V at 0.1 A. An on-board voltage regulator converts the -12 V to the -5 V needed for the 4116 memory devices. This power configuration is very easy to accommodate with currently available supplies. We decided to use a larger +5-V supply to power our Siemens floppy-disk drives as well.

Autocontrol provides an RS-232C cable (25 conductors) with the connector to the board already mounted. All we had to do was check the connections needed at the terminal and wire the included connector to match. Autocontrol's instruction manual gives explicit instructions (see figure 2) for wiring all the needed cables to standard peripheral devices, but certain printers or terminals, such as an NEC Spinwriter, may require special configurations (see figure 2b). We found one small error in one of the schematic diagrams; they are correct, however, in the figures here.

The interface cable for the floppy-disk drives uses the standard Shugart pin assignments (see figure 3). We used a standard 50-pin card-edge connector and ribbon cable. Be very careful when attaching the ribbon cable to the pin and card-edge connectors, as a misalignment will result in the disk drives not working.

The instruction manual also gives clear instructions for wiring the options on the Shugart drives; those instructions do not apply to the Siemens drives. To interface to the NEC 765 floppy-disk controller, Siemens drives need two minor wiring changes: when the drives are connected in daisy-chain fashion, only the last drive must have the

routines are moved from the PROM into main memory and the density of each disk is determined. The density of the disks may not be changed without doing another cold boot. The bootstrap loader also moves CP/M from the system disk into memory.

Software is provided in Autocontrol's reconfigured CP/M disk for changing the serial port's data rates or formatting disks. Diagnostic programs for checking the memory, interrupts, and the single- and double-density floppy disks are also included. If you already have CP/M 2.2, a configuration disk is available separately.

Autocontrol's comprehensive manual contains instructions for loading a 20K-byte CP/M distribution disk, loading the AC-85 single-density disk, making 63K-byte CP/M single- or double-density disks, and for making the disk automatically cold boot when the system is first turned on. The manual also explains how to change the data rates for the terminal, printer, and auxiliary devices by modifying a code on the disk. By altering another byte in the same code, you can use either Autocontrol's PROM BIOS or the BIOS residing on the system disk.

FORMULA INTERNATIONAL INC.

12603 CRENSHAW BOULEVARD • HAWTHORNE, CALIFORNIA 90250 • (213) 973-1921

Experience the Pineapple Computer System

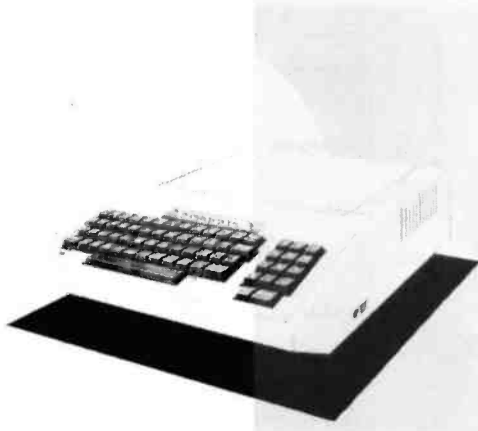

THE Pineapple™

48K Color Computer Kit

Features:

- ★ 6502 MPU
- ★ Color graphics
- ★ Numeric key pad
- ★ Game paddle jacks on both sides
- ★ Speaker volume control on the back
- ★ Expansion slots

\$645⁰⁰
per kit

Easy to assemble! All components are clearly silk screened on the circuit board. Kit includes pre-drilled double sided PC Board, all integrated circuits, sockets, professional high-impact plastic casing, keyboards, connectors and switching power supply. Dealer inquiries invited. No C.O.D. orders

5 1/4" Flexible Disc Sale

Why buy other brands when you can buy WABASH discs for much less and backed by 1 year factory warranty.
All discs come with Hub Rings



PART #	DESCRIPTION	PRICE			
		10-99	100-499	500-999	1 K Up
M13A411X	5 1/4" SSDD Soft Sector	\$2.25	\$2.15	\$2.05	\$1.90
M43A411X	5 1/4" SSDD 10 Hard Sector	\$2.25	\$2.15	\$2.05	\$1.90
M53A411X	5 1/4" SSDD 16 Hard Sector	\$2.25	\$2.15	\$2.05	\$1.90
M14A411X	5 1/4" DSDD Soft Sector	\$3.65	\$3.45	\$3.15	\$2.90
F111111X	8" SSDD IBM compatible	\$2.45	\$2.25	\$2.15	\$2.00
F131211X	8" SSDD 26 sectors 128 bytes	\$3.05	\$2.80	\$2.60	\$2.50

**FOR INFORMATION
CALL (213) 973-1921**

**OUTSIDE CALIFORNIA
PHONE ORDERS ONLY**

**CALL TOLL FREE
1-800-672-8758**

SAVE MORE ON OUR BULK 5 1/4" DISC!

We are not allowed to use the name of the manufacturer. Who cares! Our goal is to save you money! You know who they are if you saw our ad the last few times.

FACTORY PACKED, 100 DISCS PER BOX for just \$1.85 ea. COMES WITH HUB RING AND WRITE PROTECT.

SPECIAL SALE ON LE MONITORS (Sanyo Look Alike)

- 9" Black and White..... \$ 99.50
- 9" Green..... \$120.00
- 12" Black and White..... \$119.50
- 12" Green..... \$139.50



SAVE ON OUR 5 1/4" DISC DRIVE

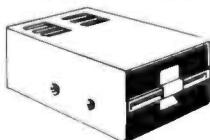

★ 100% Apple® Compatible!
Much more quiet than the Shugart Drives.

\$310.00 Each
\$399.00 Each (with controller)

16K RAM CARD KIT FOR YOUR APPLE® COMPUTER

Kit includes: High Quality P.C. Board • 8 ea. 4116 (200ns) • All the IC's & parts • 16-pin Dip wire • Easy to assemble. You can do it in less than 30 minutes!

\$59.95 per kit
(Limited Quantity)

Inside California
Outside Calif. (Incl. Mexico & Canada)
Overseas

SHIPPING AND HANDLING CHARGES
Under \$50.00 Purchase Over \$50.00 Purchase

10%	5%
15%	10%
25%	20%

Minimum Order \$10.00 / Call. Residents add 6.5% Sales Tax. Phone Orders Accepted on VISA or MC ONLY. NO C.O.D.'s. Prices subject to change without notice.



STORE HOURS
MON-FRI — 10-7
SAT — 10-6

* Apple is a registered trademark of APPLE COMPUTERS, INC.

Circle 204 on inquiry card.

www.americanradiohistory.com

(2a)

CABLING FROM AC-85

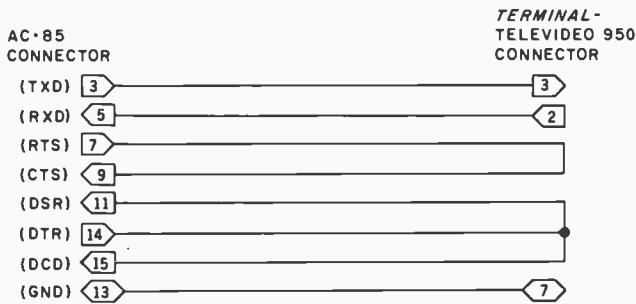

(2b)

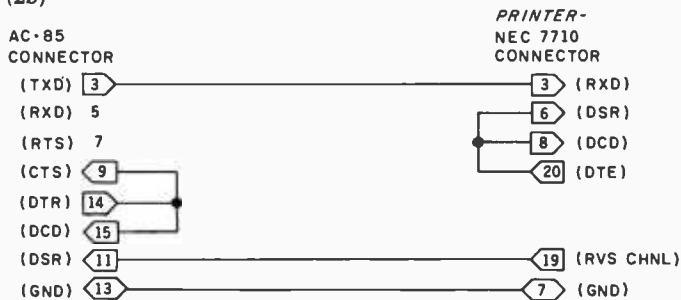
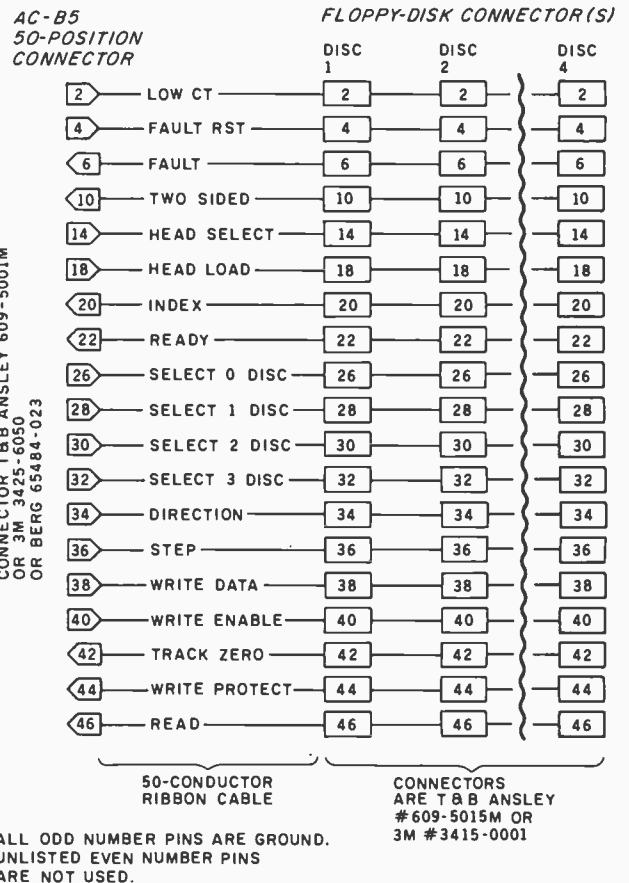

Figure 2: Serial-cable connections for the single-board computer. These connection diagrams (contained in the Autocontrol manual) allow the user to configure RS-232C cables for use with most serial peripheral devices.



CONNECTOR T&B ANSLEY 609-5001M OR 3M 3425-6050 OR BERG 65484-023

ALL ODD NUMBER PINS ARE GROUND. UNLISTED EVEN NUMBER PINS ARE NOT USED.

PION introduces the INTERSTELLAR DRIVE.

A solid state disk emulator for your APPLE*, TRS80, S100, or SS50 computer**

- A FAST mass storage device. Speeds up any program requiring disk access.
- No head seek time, no motor startup time, no moving parts.
- Standard 256K bytes of storage expandable to 1 megabyte.
- Independent regulated power supply.
- Automatic power failure detect and battery backup.
- Hardware error detection and write protect.
- Only 4 bytes-ports of address I/O space used
- Hardware optimized for block transfers and access.
- Drivers, diagnostics, and utilities software provided.

Introductory Price \$1095. plus tax and shipping

MasterCard VISA

SEND FOR FREE BROCHURE Identify your model.

PION, INC. Tel. (617)648-1717
74 Appleton St., Arlington, MA 02174
*Trade Mark Apple **Trade Mark Tandy Corp.

Figure 3: Shugart-compatible disks are accommodated easily. Because the standard pin assignments are used, a cable can be made by attaching connectors directly to a 50-conductor ribbon cable.

terminator network installed. We obtained these changes from the helpful engineering staff at Siemens OEM Division in Anaheim, California.

Because we mounted the AC-85 board in an enclosed cabinet, the Monitor and Boot push-button switches were inaccessible. To solve this problem, we added two normally open, momentary-contact push buttons on the front of the cabinet and wired them in parallel with the original switches. The added wire capacitance to the reset circuitry has not affected operation at all.

Putting It All Together

Using the same criteria for choosing our peripheral devices as we did for choosing the computer itself, we settled on four Siemens FDD 100-8 single-sided, dual-density disk drives; the new Teletideo 950C terminal; and the recently introduced NEC Spinwriter 7710 (obtaining all at lowest discount prices). Our Teletideo 950C terminal arrived first. Because it has a local mode, we were able to check it out quickly and become familiar with it. It had a few problems, but when we called the Teletideo software staff, they were very helpful and sent us two new EPROMs (erasable programmable read-only

The Victor 9000, inside out.

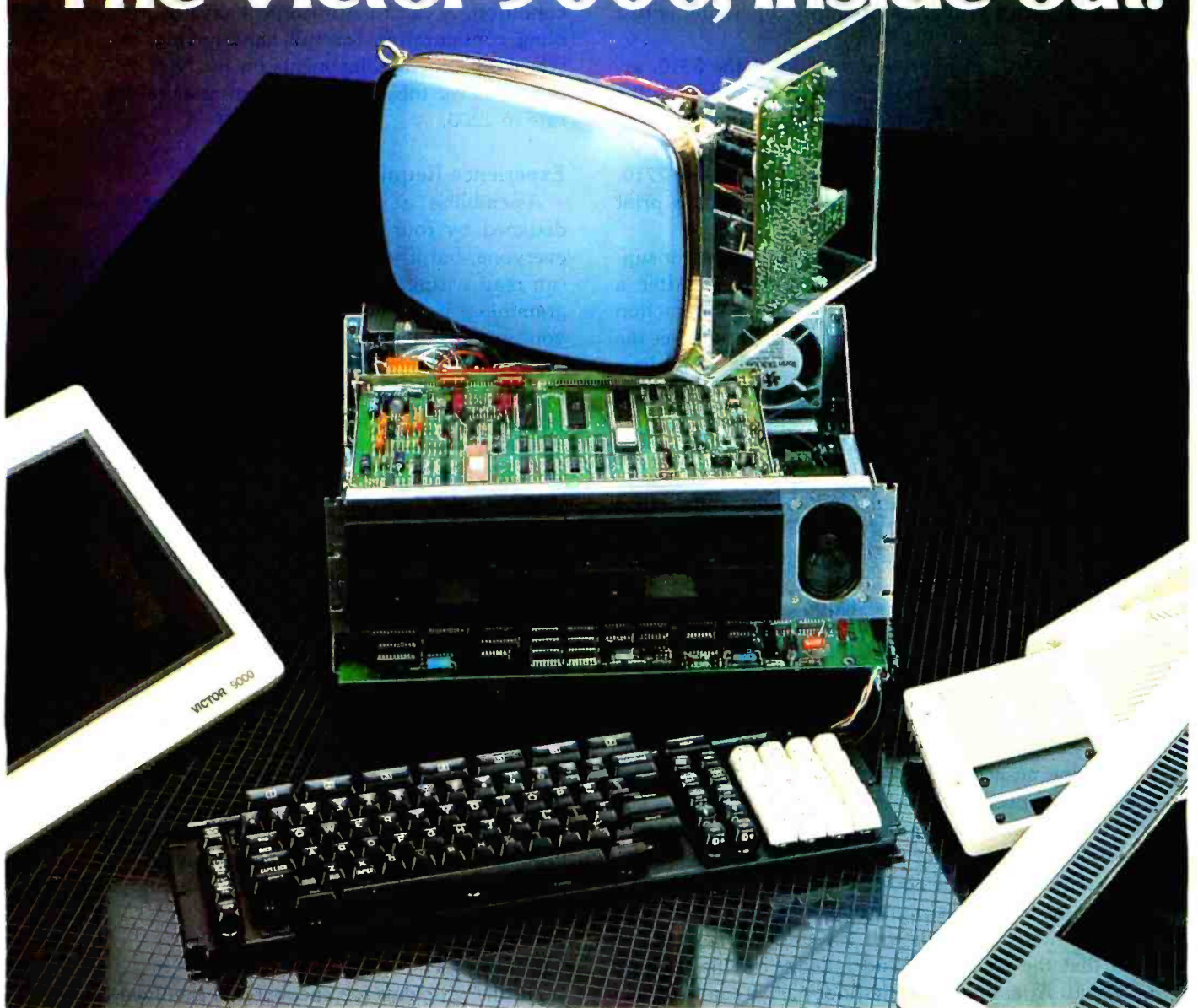

The new standard:

It's what's inside your computer that matters. And just look at what you'll find inside the Victor 9000 desktop computer.

- 128K bytes of memory (or does your application need up to 896 KB... we can deliver it).
- 600K bytes of storage on each diskette (would you prefer 1.2MB — you can have it if you like).
- Two (not one) RS232 ports (ours handle both bisync and SDLC as well as async).
- A parallel port for running printers or IEEE-488 (another inside the box if you supply a connector).
- 16-bit computing... the kind of capacity you need.
- High resolution graphics (is 320,000 individually displayable points enough?).
- A fully programmable keyboard (to go along with the fully programmable screen).
- Tilt and swivel display, plus separate low profile keyboard (in the modern jargon: it's ergonomic).
- First class vocal chords (why settle for clicks and beeps — we speak in plain English with a CODEC).
- CP/M 86* and MS-DOS both support all these solid machine features plus 132 column alphanumeric display — 10 key pad calculator -reloadable keyboard and screen character table — and much more — let your

applications breathe for a change.

- Multilingual programming — tired of BASIC? Try our COBOL, FORTRAN, or PASCAL, or perhaps you have your own favorite — ask us — we might just already have it!

So turn your present computer inside out. If you're not getting all that, then it's time to call Victor for the facts. Just call **1-800-VIC-9000**.

Or write Victor Business Products, P.O. Box 1135, Glenview, IL 60025

VICTOR[®]
Subsidiary of Kidde, Inc.
KIDDE

memories) to replace the original ROMs. It has worked properly ever since. The 950 is an intelligent terminal that can be used with a printer as a memory typewriter with a 96-line capacity.

The NEC 7710, an improved version of the 5510, arrived next. The printer can be connected directly to the Televideo 950C's local printer port. After finally getting the data rate, parity, and word length set properly, we were able to check all the functions on the NEC 7710. We've had no problems with the printer, and its print quality is excellent.

We then connected the AC-85 board to the power supplies and the terminal's RS-232C connector. After a minor cable problem and a session with the instruction manual of the Televideo 950C, we were ecstatic to see the monitor-prompt message appear. With the stand-alone monitor PROM in the AC-85, we could change, display, and execute programs in memory. I wrote a short machine-language program and successfully checked the computer and the terminal.

Other commands available with the stand-alone monitor PROM include filling a block of memory with any hexadecimal value, displaying all the processor's registers, moving a block of data from one address to another, changing any register, reading the contents from a specified input port, writing a given byte to a specified output port, and loading from the PROM or from memory with or without initializing any I/O (input/output).

After an enjoyable session in the woodworking shop constructing an acceptable cabinet for the living room, we finally connected the Siemens floppy-disk drives and replaced the stand-alone monitor PROM with Autocontrol's BIOS PROM. Unfortunately, CP/M did not work. I wrote another machine-code program to issue disk commands to the floppy-disk controller and check the status. Using the monitor to enter and execute the program, we found that the read command failed: "Unable to Read Id," it said. After more troubleshooting, we found an embarrassing connector short in the ribbon cable we built. Now CP/M worked, but we kept getting "BAD SECTOR" messages four out of every five times we issued a CP/M command. One clue was that the problem occurred more often the farther into the disk we read.

It appeared to be a timing problem. I wrote another short machine-language program to tell the NEC 765 controller to change the head-step time from 8 milliseconds (ms) to 6 ms. Using the DDT function of CP/M, we entered and executed the program. The "BAD SECTOR" message no longer occurred, and we immediately changed the appropriate byte in the BIOS on the monitor EPROM. According to the Siemens manual, a step time of 3 ms is the lowest acceptable value. We tried all the values down to 3 ms, but 4 ms seemed to be the fastest reliable head-step time.

Prematurely elated by having three of the four components working, we were not expecting the final frustration when we connected the printer to the AC-85 board.

We kept getting a buffer overflow on the NEC 7710. The AC-85 was not recognizing the printer's buffer 7/8 full condition. A call to Autocontrol gave us the correct cabling configuration for full handshaking. A few more selected protocol adjustments on the NEC 7710 and the printer never missed a byte, even after raising the data rate to 1200.

Experience Required?

Assembling a system from components built and designed by four different companies may not be for everyone, but if you have some electronics background, can read wiring diagrams, and understand a little programming, it should not be very difficult and can save you several thousand dollars.

Autocontrol also sells the AC-85 board assembled in a cabinet with two 8-inch floppy-disk drives. Although you can save some money by assembling it yourself, this may be a viable option for those who need an assembled system ready to go.

If you wish to avoid the interface problems, a call to Autocontrol to find out which peripheral devices they have used and how to connect them would be beneficial.

Another product, which Autocontrol introduced in October 1981, is a similar single-board computer, but with only two serial ports for a printer and auxiliary device. It has a device for controlling a keyboard, and one for controlling a video monitor (with an effective speed of 38,400 bps), so that an external video monitor is not needed. It can be purchased with just a self-contained monitor and keyboard; with the monitor, keyboard, and one floppy disk; or with the monitor, keyboard, one floppy disk, and one hard disk. This could very definitely bring down the cost of a complete system, and may also permit high-speed video graphics. We would not hesitate to buy either board in any case.

Conclusions

All the problems we encountered involved cabling or setting options on the floppy-disk drives, the terminal, and the printer. As of today, all hardware has worked flawlessly. We are very impressed with the lack of problems with the AC-85 board. We are also impressed with the help we received to solve our problems when we called Autocontrol.

I would have been happier if the AC-85 board had Zilog's Z80 instead of Intel's 8085 (mainly because of the additional software available), but the 8085 should be more than sufficient for our needs, because it can run all standard CP/M software.

While a single-board computer is not expandable like an S-100 or standard bus system, the AC-85 is a reliable, reasonably priced alternative. We were able to choose peripheral devices according to our own price/performance criteria, have the joys and frustrations of trying to mesh together four components from four manufacturers, and wind up with a real computer costing \$2000 to \$3000 less than a completely assembled system. ■

IT'S TIME KIDS STARTED USING STRONG LANGUAGE.



We encourage it.

Because now the most powerful educational language is available on the Apple Personal Computer.

Presenting Apple Logo.

It's not just a programming language for computers, but a learning language for people.

Enough so that anyone, working with Apple Logo, can easily learn the programming principles once reserved for college courses.

Apple Logo encourages you to break problems into small steps, and then shows you how to make those steps automatic.



It does all this interactively.

For instance, if you accidentally type "foreword," instead of forward, Apple Logo responds with "I don't know how to foreword."

There is no such thing as a mistake with Apple Logo, only logical statements telling you what needs to be done to make the program work. So the student programs the computer. Not the computer the student.

And as you learn, Apple Logo learns with you. So whether you're a student of 5 or 55, you'll always be challenged — but not overwhelmed.

Apple Logo runs on the Apple II with 64K. And it comes from Apple, the leading personal computer company in education — with the largest library of courseware at all levels.

Apple Logo. It can make getting to know a computer the most positive of learning experiences.

Your kids will swear by it.

The personal computer.



For more information, call (800) 538-9696. In California, call (800) 662-9238. Or write: Apple Computer Inc., 20525 Mariani Avenue, Cupertino, CA 95014. Apple® Logo is a product of Logo Computer Systems, Inc., 222 Brunswick Boulevard, Point-Claire, Quebec, Canada H9R1A6.

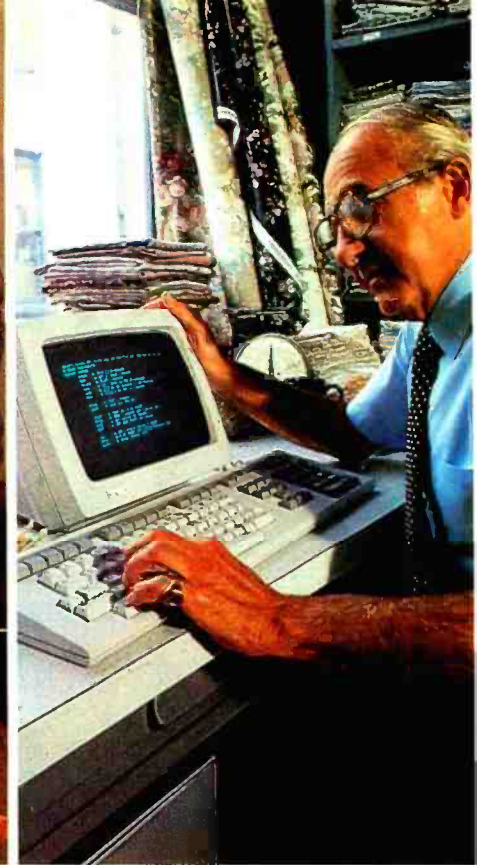

**THE
THREE PERSONAL
COMPUTERS
EXPERTS SAY
"BLOW EVERYTHING
ELSE OUT OF
THE MARKET!"**

Once in a great while, personal computers come along that drive the normally staid computer press to extremes of praise. The personal computers made by Digital Equipment Corporation are such an example. These are the personal computers about which industry analysts such as The Yankee Group have said: "... comparing other currently available personal computers to (Digital's) Professional series is like comparing a sub-compact car to a Porsche."



Pro 300 series

The minicomputer of personal computers.

And further: "The trio of personal computers will blow everything else out of the market."

The Yankee Group was not alone. From the Rosen Electronics Letter: "Digital offers more storage, more memory, more expansion, more columns, and a higher performance central processor." And from The Gartner Group: "...the hardware specifications, design, and future upgrade planning appear superb."



DECmate II

The fully supported small business system.

What could inspire such remarks? Perhaps it was a feature like Digital's bit-map graphics—a graphics capability that makes yesterday's graphics look like yesterday's news. Or maybe it was the overall idea of a personal computer that could do more than one thing at a time. Or storage. Or memory. Or the idea of using two central processors instead of one.

Wouldn't you like to find out a little more about Digital's personal computers? Call 800-DIGITAL and we'll send you our free brochure. Or write: Digital Equipment Corporation, 129 Parker Street, Maynard, MA 01754.

And if our words aren't good enough? Ask anybody else.



Rainbow 100

The low cost high performance machine.

digital
MORE PERSONAL.
MORE COMPUTER.

The Soundchaser Computer Music Systems

Robert A. Moog
Big Briar Inc.
Leicester, NC 28748

The Soundchaser Computer Music Systems are two within a growing class of systems that take advantage of the potent processing, storage, and number-crunching capabilities of personal computers such as the Apple II. Both include a digitally scanned music keyboard to feed musical performance data to an Apple. The Analog system uses one or two of Passport Designs' proprietary, digitally programmable analog tone-producing cards, each of which incorporates three rudimentary synthesizer voices. The Digital system uses the

Mountain Computer Musicsystem, a two-card accessory digital oscillator that produces up to eight two-component musical tones. Each system includes a software package that sets up the tone colors (timbre), ties the tone-producing circuitry to the music keyboard, and provides store and recall (record and playback) functions. Together with the Apple computer, either system is a polyphonic synthesizer with more open-ended versatility than any computerized packaged musical instrument costing less than a basic foreign sports car. The two

systems differ in the types of tone colors they produce, the tone color controls provided, and the musical data-processing capabilities that are available. Photo 1 shows the components of these two systems.

The big difference between computer music systems like the Soundchasers and a conventional polyphonic synthesizer is in the type of "control panel." A conventional synthesizer has a set of hardware controls and switches that are the musician's "handles" to manipulate the sounds. The Soundchaser systems use a "soft" control panel—a graphic video representation of parameters, plus a set of instructions for accessing these controls through alphanumeric commands. For the performing musician, a soft panel is a mixed blessing because its versatility is offset to some degree by the longer time it takes to "set" soft controls. For studio musicians, teachers, and experimenters, however, the software-based system configuration's unprecedented versatility is of great value. It allows the system supplier to increase and improve the system's capabilities through software updates, at modest cost to the user. It also allows users to customize their own systems without danger of wrecking them the way hardware hot-rodders often do.



Photo 1: The hardware of the Soundchaser Computer Music System. The three-voice audio cards of the Analog system are to the left of the instruction manual. The Mountain Computer Musicsystem, used with the Soundchaser Digital system, is to the right of the manual. At the top is the four-octave music keyboard used with both the Digital and the Analog system.

The Music Keyboard

Both the Digital and the Analog Soundchaser systems use a standard-size four-octave organ keyboard.

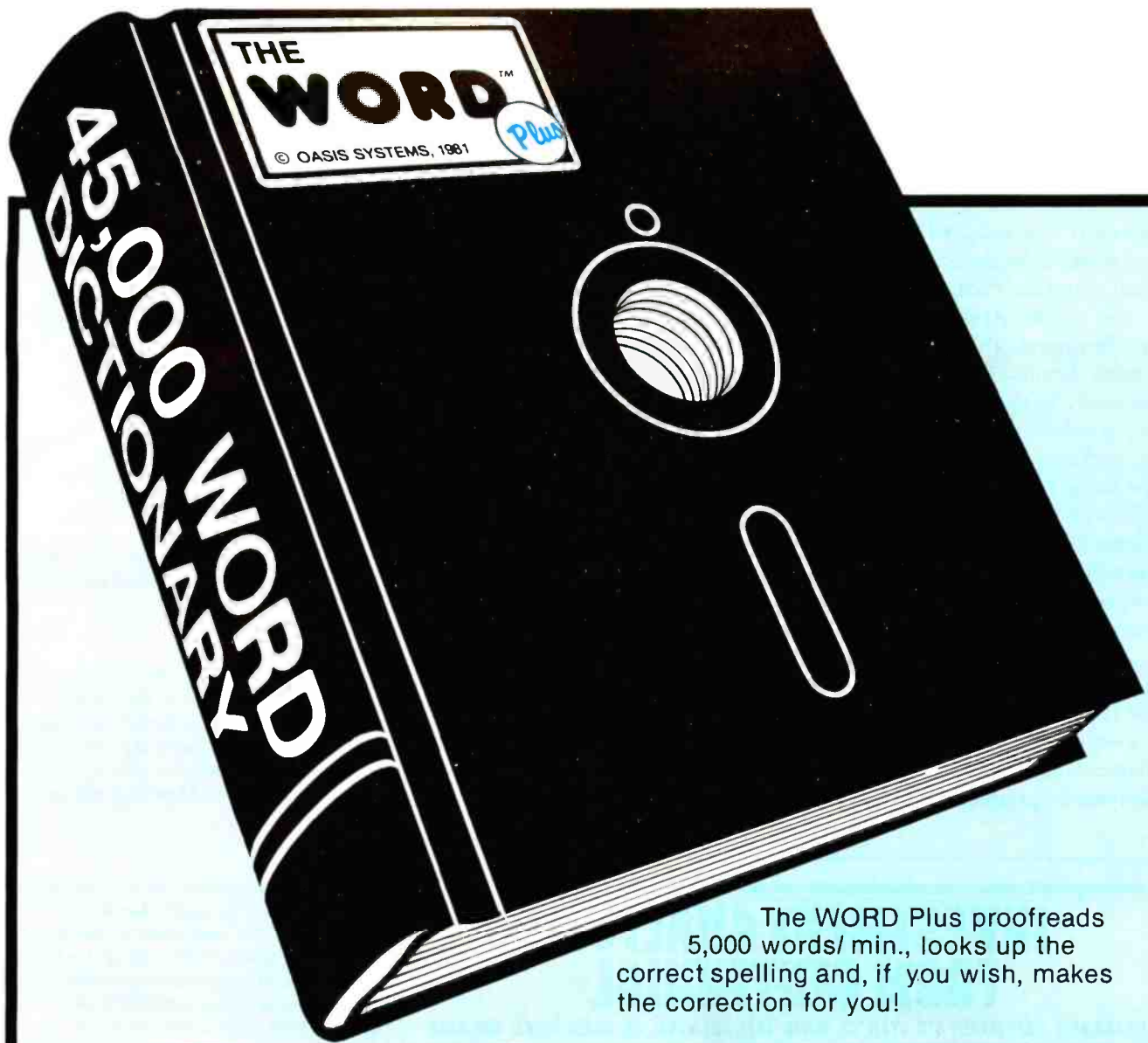

Teach Your Computer to Spell

The WORD Plus proofreads 5,000 words/min., looks up the correct spelling and, if you wish, makes the correction for you!

The WORD Plus can hyphenate files by inserting *soft hyphens* so words break precisely.

The WORD Plus counts words, solves anagrams, crosswords and rhymes!

The WORD Plus works! . . . with WordStar™, Magic Wand™, Mince™, and others.

Available for CP/M™, CP/M-86™, MSDOS (IBM P.C.) and CDOS.

The WORD Plus. \$150.
For more information call: Wayne Holder
Oasis Systems
2765 Reynard Way, San Diego, CA 92103
(714) 291-9489

WordStar is a trademark of Micro Pro, Int'l.
Magic Wand is a trademark of Peachtree Software, Inc.
Mince is a trademark of Mark of the Unicorn.

Distributed by:
SOFTWARE DISTRIBUTORS
1-800-252-4024 (in California)
1-800-421-0814 (outside California)

(Call it a clavier if you want to sound like a real musician.) The keyboard mechanism is housed in an attractive, solid walnut enclosure. No other real-time controls (such as a joystick to perform pitch bending or frequency modulation) are included. A ribbon cable connects the music keyboard to a small interface card, which plugs into one of the Apple's eight card slots. The ribbon cable is so short that the music keyboard must be placed immediately to the right of the Apple unless you have a 16-pin DIP (dual-inline package) extension cable.

The music keyboard tells the Apple which keys are being held down at any time. This information is updated frequently so that the delay between a key depression and the sounding of the tone is not ordinarily perceptible.

The Soundchaser Digital System

The Digital system uses the Mountain Computer Musicsystem digital oscillator as its sole audio source. The Musicsystem produces a tone by

reading a wave table, which is a list of numbers that represent the amplitudes of a succession of closely spaced points on one cycle of a waveform. The wave table is read repeatedly in order to produce a periodic waveform that we hear as a pitched musical tone. The rate at which the wave table is read determines the frequency of repetition of the periodic signal and, therefore, the pitch that we hear. Under control of the Soundchaser Digital software, the Musicsystem covers the frequency range of 33 to 4186 Hz (1 Hz = one vibration per second), which in musical terms is a pitch range of three octaves below middle C on the piano to four octaves above. The Musicsystem frequency resolution is 0.5 Hz, which is adequate for most but not all musical applications.

The wave table for a single Musicsystem tone consists of 256 eight-bit numbers. It occupies one page in the Apple memory. In theory, you can specify any waveshape in the

At a Glance

Name

Soundchaser Computer Music Systems:
Analog system, Digital system

Use

Implements a polyphonic (chord-playing) keyboard-controlled music synthesizer when used with the Apple II microcomputer

Manufacturer

Passport Designs Inc.
116 North Cabrillo Hwy.
Half Moon Bay, CA 94019
(415) 726-0280

Dimensions

Music keyboard is 28 inches by 9½ inches by 3¼ inches; all circuit cards plug into Apple console.

Price

Three-voice Analog system, \$1000; six-voice Analog system, \$1350; Digital system, without Musicsystem card, \$650; Digital system, including Musicsystem card, \$1045; Notewriter software package, \$99; and Musictutor software package \$150

Features

Four-octave keyboard. Analog system uses three-voice or six-voice channels, each consisting of a programmable-counter-type digital oscillator, analog voltage-controlled filter, and analog voltage-controlled amplifier, all under software control. Software generation of tone envelopes and low-frequency modulations, and recording and playing back of keyboard performances. Digital system uses the Mountain Computer Musicsystem to implement an eight-voice polyphonic synthesizer. Optional software implements music-transcribing and instruction programs.

Hardware Needed

48K-byte Apple II computer with video monitor, disk drive, and game paddle; stereo sound system or musical instrument amplifier; Apple language card for some optional software

Documentation

MOS 3.0 manual (to run Analog system), 42 pages; MC1 manual (to run Digital system), 37 pages. Both in 3-ring binder. Musictutor and Notewriter documentation not available at time of writing.

Audience

Musicians, music teachers, sound designers, musical experimenters

INVESTMENT ANALYSIS FROM CENTENNIAL

CENTENNIAL SOFTWARE / 410 17TH ST. SUITE 1375 / DENVER, CO 80202 / (303) 595-9193

STOCK-FOCUS

Find out how low is low and how high is high. Using capital structure and performance data, Stock-focus objectively calculates the underlying value of a stock. The system was first developed by the management science department of a major money center bank, and is now in use by investment advisors, trust companies and brokerage houses. On your screen, Stock-focus will plot an estimate of lowest value, highest value and the current price. You then decide what to buy, sell or hold.

REAL-FOCUS

Exhaustively analyze potential real estate investments using the Wharton School's approach to real estate analysis. In minutes you can project profit, costs, and IRR for any project over a 10 year period. Real-focus accounts for amortization, debt, income, operating expenses, taxes, depreciation, and cash flows for both after-tax holding and the results of sale. With Real-focus you can analyze any potential investment from a single building project to a complex time-phased planned unit development.

THE FOCUS TECHNIQUE

FOCUS is CENTENNIAL SOFTWARE's new approach to Program Architecture, providing a natural interaction between microcomputers and users. It provides worksheet style input screens, free access to all program segments, and the ability to com-



bine individual results files for portfolio analysis. You also receive a usable reference manual, menu helps, a program glossary, multiple report formats and spooling. With our FOCUS technique even the most complex programs are versatile and easy to use.

COMPUTER	MEMORY-K	REAL-FOCUS	STOCK-FOCUS
IBM PC	64	\$179.00	\$189.00
Apple (plus) II	48	149.00	159.00
TRS-80 I	48	149.00	159.00
TRS-80 II	64	179.00	189.00
TRS-80 III	48	149.00	159.00

ALL PROGRAMS IN DISK BASIC

IBM is a trademark of IBM. Apple is a trademark of Apple Computer Corp., TRS-80 is a trademark of Tandy Corporation.

ORDER NOW! FILL IN OR CALL 800-525-2003 (Toll Free)

PROGRAM NAME _____ COMPUTER _____ MEMORY _____
 NAME _____ PHONE # _____
 ADDRESS _____  
 ACCOUNT # _____ EXP. DATE _____

Excellence Acknowledged.



Some people demand the best.

Superior quality at superior value is the key to those few items that rise above the crowd to shine as unique symbols of perfection. We call these the "best" products, and the best in Apple II®-compatible drives is the Micro-Sci line of 5 1/4" floppy disk drives and subsystems.

Business, commercial and professional people needing more storage, greater reliability and faster access than previously available have been impressed with Micro-Sci's A40 system since we introduced it back in 1979. For a lower list price than the Apple Disk II®'s, the A40 offers 20Kb more capacity, faster access time and greater data reliability.

The ideal solution to the Pascal* and CP/M† user's problem of space limitation is a Micro-Sci A70 drive, combining quick access and high reliability with a full 286Kb storage capability.

The newest member of Micro-Sci's Apple II-compatible family is the A2, the perfect alternative drive for entertainment and other

packaged software. A direct replacement for the Disk II, our A2 features total compatibility at a lower cost total. And you can mix, or match, our A2 drive and controller with their drive and controller and vice versa. You have complete freedom of interchangeability.

Micro-Sci even goes one step further with its controllers to include operating features the competition lacks, like jumper-selectable 3.2 and 3.3 DOS.

Give yourself the privilege.

You deserve more for your money, and Micro-Sci delivers the most in quality, reliability and performance.

So when you consider additional drives or a disk subsystem for your Apple II, indulge yourself in the Micro-Sci alternative.

See our complete product line today at a dealer near you.

*(SPECIAL NOTE TO APPLE III® USERS:
Micro-Sci also offers a full range of Apple III-compatible drives. Ask your local dealer for details.)*

μ-SCI

MICRO-SCI

Micro-Sci is a Division of Standun Controls, Inc.

2158 SOUTH HATHAWAY STREET • SANTA ANA, CALIFORNIA 92705 • 714/662-2801 • TELEX: 910-346-6739

International Dealer Inquiries... IMC International Markets Corp. Telephone: 714/730-0963 • Telex: 277782-ROBY UR

® Apple, Apple II, Apple III and Disk II are registered trademarks of Apple Computer, Inc.
*Pascal is a registered trademark of the Regents of the University of California.
†CP/M is a registered trademark of Digital Research, Inc.

Circle 305 on inquiry card.

www.americanradiohistory.com

Main/Frames

Main/Frames

from
\$200

- 30 Models of Enclosures
- Assembled and tested
- Quasi-Coax Motherboards
- Power Supply
- Card cage and guides
- Fan, line, cord, fuse, power & reset switches

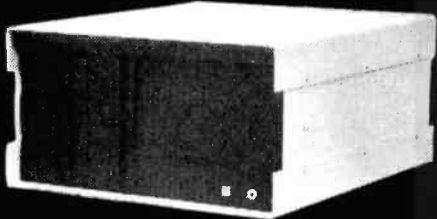

8" Floppy Main/Frame

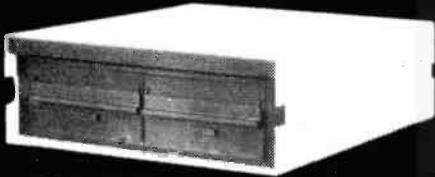

8" Disc Enclosure

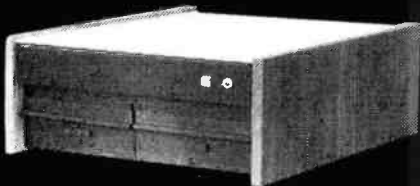

Phase/80 8" Floppy Mainframe

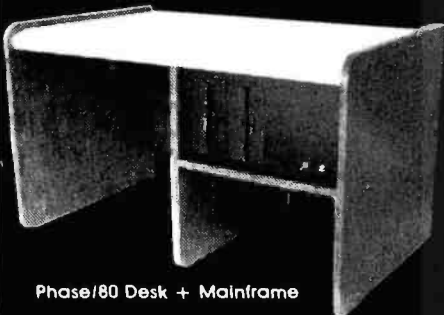

Phase/80 Desk + Mainframe

Write or call for our brochure which includes our application note:
"Building Computers — A Recipe"

INTEGRAND

8620 Roosevelt Ave. • Visalia, CA 93291
209/733-9288

We accept BankAmericard/Visa and MasterCard

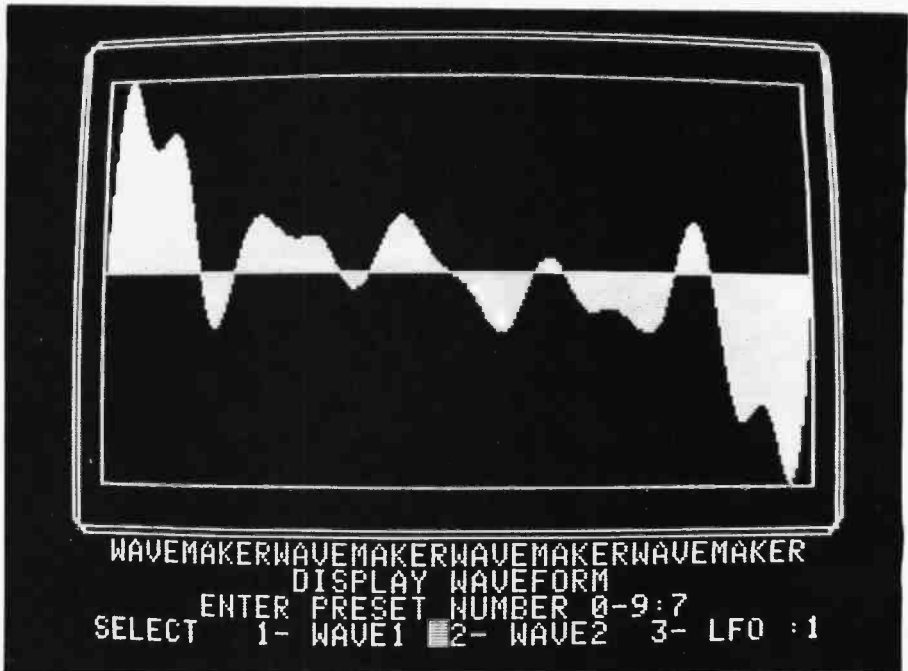

Photo 2: The screen display of the Wavemaker section of the Soundchaser Digital system. The pattern is a graphic representation of one complete wave table.

wave table and produce it with 8-bit resolution by the Musicsystem hardware. The shape of a cycle of a periodic wave determines its overtone content and, therefore, is a factor in determining the tone color that we perceive.

The Wavemaker Section

The Wavemaker section of the Soundchaser software provides the means for loading the wave tables. You specify the amplitudes of the fundamental pitch and the first 15 overtones by typing in the numerical values one at a time. (The sum of all amplitudes must be 100 or less.) The Apple then computes the wave-table entries by summing the sine waves corresponding to the overtones. The wave-table contents can then be displayed graphically as a single cycle. Photo 2 shows a typical display. Once a waveform is displayed, you can continuously redraw it by moving a cursor with a game paddle. Software will be available shortly from Passport Designs to redraw the waveform with straight line segments by first spotting the lines' end points with the paddle, then computing the lines.

In addition to the Create (which computes the waveform from over-

tones), Display (which shows the waveform on the screen), and Edit (which redraws a section of the waveform) functions, the Wavemaker section of the operating software offers Play (which sounds the waveform when a key is depressed) and Smooth (which provides simple filtering to reduce unwanted "alias" noise that often accompanies digitally generated tones). Aside from the Smooth function and the usual anti-aliasing output filters, the Musicsystem provides no filtering; what you put in the wave tables is what you get at the audio output. Because the waveform resolution is only 8 bits in both amplitude and time, the Musicsystem audio output does have steps that are audible as "aliasing" when high-pitched tones are being produced. Even with this limitation, however, the Musicsystem produces many musically useful tone colors (i.e., pleasant, easily blending with other tone colors, and distinctive in character), especially in the low and middle pitch ranges.

The Performance Section

The Performance section of the operating system offers alphanumeric access to pitch range (in octave steps), envelope shaping, low-frequency modulation, and overall volume. The

Chairman of the Boards

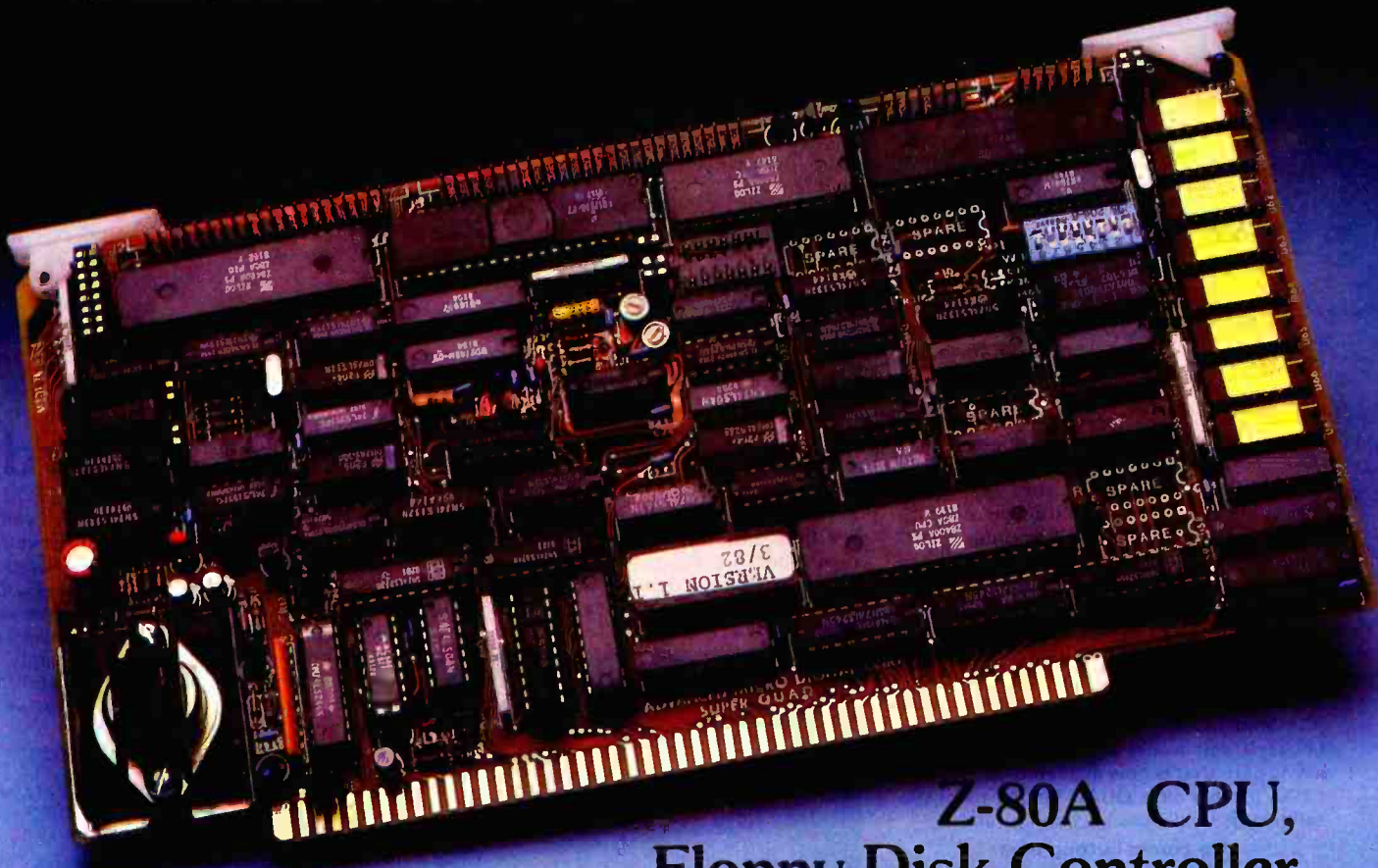

Z-80A CPU, Floppy Disk Controller, 64K of Memory, Serial & Parallel I/O Ports . . . all on a SINGLE S-100 BOARD!

Advanced Digital is the leader in S-100 single board computers. Our attention to quality workmanship, our outstanding performance and proven reliability have made our SUPER QUAD "computer on a board" number one.

Now SUPER QUAD® has been elected "Chairman of the Boards" in the expanding Multi-Processing marketplace. SUPER QUAD functions as the Bus Master and takes charge of many SUPER-SLAVE® processor boards.

SUPER QUAD is so complete, it actually replaces the traditional 4-board S-100 computer and for only \$875.00.

Look at these features:

- IEEE S-100 Standard
- Z-80A CPU
- 64K of Bank Select Memory as well as extended addressing
- Double density floppy disk controller. Both 8" or 5-1/4" Disk Drives
- 2 serial & 2 parallel I/O ports (RS-232 and Intelligent hard disk interface).
- 2K or 4K of monitor EPROM
- Runs with CP/M®, MP/M® and turbo-DOS™

- One year warranty.
- Free copy of bios disk.

Advanced Digital's SUPER-SLAVE processor boards are the ideal directors to work with the Chairman of the Boards and Turbo-DOS® operating system in a multi-user, multi-processor system.

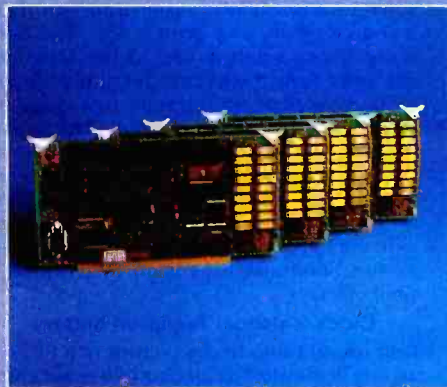

Ask about our new HDC-1001 Hard Disk Controller for both 8" or 5-1/4" hard disk drives, only \$500 retail. For more information, write or call: Sales Dept.

12700-B Knott Street • Garden Grove, California 92641 • (714) 891-4004 TELEX 678401 tab Irin

© Registered Trademark of Digital Research Corp.
™ Registered Trademark of Software 2000 Inc.

© Copyright 1981 Advanced Digital Corp.



SuperDrive & SuperSpooler now included

Why pay hundreds more for a four (as in QUAD) function IBM PC board?

This may be the only board you need to expand your IBM personal computer. Standard with three functions; memory up to 256K in 64K increments, clock/calendar with battery back-up, and asynchronous communication (RS232C serial) port which can be configured as COM1 or COM2. The optional parallel printer port can be added for those of you with the color graphics board, or if you just need an additional printer port (LPT1 or LPT2). If you would like to have a second async port, that is now available for an extra \$100. (In this case QUAD means five.) We sell boards in all possible configurations.

No corner cutting here

You may think that since this board costs so much less there has to be a catch. The catch is you have to put the board in yourself, and set a switch to tell your computer the board is there. It's all done in less than ten minutes. Our clear instructions with illustrations make it a snap. The board is a four layer design with rows of nine memory chips for full parity checking. Each board is solder masked, silk screened, and has gold plated contacts. The memory chip locations are all socketed. All components are premium grade, meet IBM performance specifications, and are burned in and tested prior to shipment. The highly rated design is well proven with several thousand boards in the field providing reliable service.

How much memory?

We offer the board with your choice 64K, 128K, 192K, or 256K. The SuperSpooler software allows you to assign a portion of the add-on memory as a print buffer. The print buffer accepts data as fast as the computer can send it and frees your computer for more productive work. Your printer just keeps on running until the buffer is empty. The SuperDrive software allows you to use memory as you would normally use a disk. This gives you disk access at the speed of RAM memory. Maximum use of SuperDrive is achieved with the new MegaPlus™ board which allows all functions and expansion to 512K in a single slot.

Clock/calendar & clip-on battery

That round thing in the picture is a lithium battery. It may last as long as five years since it is only needed when the computer is turned off. Note the holder it is in. The under \$4.00 battery just slips out and a new one slips in. No soldering required as with some

other clock boards. The clock/calendar sets the time and date when your computer is turned on. This is done with a program which we send you on a diskette. The clock on the board is set using the IBM DOS commands TIME and DATE.

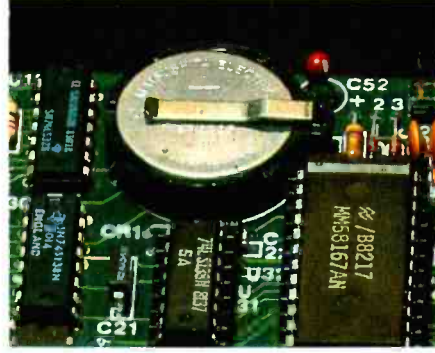

Cheap Software too

What good is great hardware without some good software to use it with? We are now offering some untouchable prices on software that can utilize the features of your board. SUPERCALC, the current cream of the spreadsheet crop, will address 512K and is available with a board for just \$176. Or how about the new DBase II by Ashton-Tate for just \$469?

Why buy from us?

Because we provide the service and support most companies only talk about. We realize how integral the use of this board will be to the everyday use of your computer. What good is a warranty if it takes weeks for repairs to be made? By the time you get your board back from repair you will have forgotten where to put it! We offer 48 hour turnaround or replacement on all warranty repairs. Do you hear anyone else making this promise? Our board comes with little extras like a low cost diagnostics program that let's you do your own testing to be sure you really do have a problem before sending your board for repairs. If you still aren't convinced, and just want to compare prices, remember we don't charge extra for credit cards, shipping, or COD's. If you still want to buy elsewhere ask them if they will face the acid test.

The acid test

Qubie Distributing gives you our 30 day satisfaction guarantee on all board purchases. If you are not completely satisfied we will return the entire cost of your purchase as

well as pay the postage to return it. If you get one of our competitors to give you the same guarantee, buy any other board you think compares and return the one you don't like. We're not worried because we know which one you'll keep. On top of this we give you a one year parts and labor warranty, and a one year extended warranty for \$50. Warranty repairs are done in 48 hours or we will send you a new board.

FREE SOFTWARE

SuperDrive and SuperSpooler Software lets you use your board as fast accessing disk space and as a printer buffer.

TO ORDER BY MAIL SEND:

- your name and shipping address
- memory size. Optional printer port?
- software and cables you need
- daytime phone number
- California residents add 6½% sales tax.
- Company check or credit card number and expiration date. (personal checks take 18 days to clear.)



TO ORDER BY PHONE:

(213) 870-3718 or (805) 482-9829

PRICES:

64K	\$375	192K	\$499
128K	\$439	256K	\$599

(includes async port, memory, clock/calendar, SuperDrive and SuperSpooler software)

OPTIONS:

Parallel Printer port	\$50
Cable for parallel printers	\$35
Cable for Modem or Serial Printer	\$25
Memory Diagnostic Diskette	\$10
SUPERCALC by Sorcim	\$176
DBase II by Ashton-Tate	\$469

SHIPMENT

We pay UPS surface charges. UPS blue label air service \$5 extra. Credit card or bank check orders shipped same day. Personal or company checks take 18 days to clear.

QUBIE' DISTRIBUTING

918 VIA ALONDRA
CAMARILLO, CA 93010

Circle 501 on inquiry card

amplitude (overall loudness) of each tone is shaped by an envelope that builds up, then partially dies away, and levels off as long as a key is held down, finally dying away to silence when the key is released. These envelope segments are called attack, decay, sustain, and release, respectively. Attack, decay, and release times can be set anywhere from 50 milliseconds (ms; 0.050 seconds) to about 6.5 seconds, with 8-bit resolution, while the sustain level can be set from 0 amplitude to the maximum envelope amplitude. Photo 3a shows a typical Soundchaser Digital envelope. When you compare it with a similar envelope from an analog synthesizer (photo 3b), you see that the decay and release segments of the Soundchaser envelope are straight lines rather than exponential curves, a characteristic that results in a somewhat abrupt and "unnatural" sound in some applications.

The MusicSystem has two audio output channels; eight tones are assigned to each channel. By triggering one tone per channel with each key depression and programming different waveforms and envelopes in each channel, you can produce many complex and interesting composite sounds. For instance, you can produce a bell-like sound by putting a sustained tone of low-overtone content in one channel and a rapidly decaying, high-pitched tone in the other channel. The Performance section allows the musician to set up completely separate envelopes for each of the channels, one of the more exciting sonic resources of the system.

Frequency modulation (for producing effects such as vibrato and trills) is implemented by first constructing the modulating waveform in the Wave-maker section and then determining its frequency and amplitude in the Performance section. Modulation speed ranges from one cycle every 6.5 seconds or so (for sirenlike effects) to about 20 cycles per second (for growl effects). When using both audio channels, you can independently control modulation amplitudes for each channel, a feature that has the potential for creating some attractive chorus effects. A negative aspect of

Winston could have sworn a "FIFO Buffer" was a headache remedy.



Until he became an Orange Micro Printer Expert.

Printers Can Be Confusing. Sometimes, even the informed personal computer owner is caught short by the mound of technical differences in printers. In one visit, Winston learned that a *Fifo Buffer* overlaps the computer and printer functions, allowing Mr. Hollingsworth to enter his wine list while his stock report is printing.

We Educate First.

With so many different printers out there with as many different features, we feel a printer education is in order. We take what you already know about computers and explain printers in the same terms. Our current customers seem to like that because of the friends they refer. (Nearly 50% of our business is referral.)

It's Easy To Be An Expert. Orange Micro printer specialists are there to make you feel comfortable with your newfound printer knowledge. And when you decide on the printer right for you, you'll know exactly why you picked it from all the rest. With over 35



popular models to choose from, and a complete selection of cables, options and interface accessories, we have everything you need to get your new printer up and operating in minutes.

We Have The Right Printer For You.

Bring along your toughest printer questions. Our salespeople will answer them honestly and practically. In less time than you'd imagine possible, you'll be a printer expert too!

After all, printers are our only business, so we always do a better job at finding the right one for you.

Orange Micro Printer Stores

850 E. La Palma, Suite J
Anaheim, CA 92806 (714) 630-3622

13604 Ventura Boulevard
Sherman Oaks, CA 91423 (213) 501-3486

3216 Scott Boulevard
Santa Clara, CA 95051 (408) 986-1213

1104 Van Ness
San Francisco, CA 94109 (415) 673-0170

Orange Micro
PRINTER STORE

PERSONAL COMPUTERS PERSONAL COMPUTERS PERSONAL COMPUTERS

OKIDATA MICROLINE 82A

\$499.00

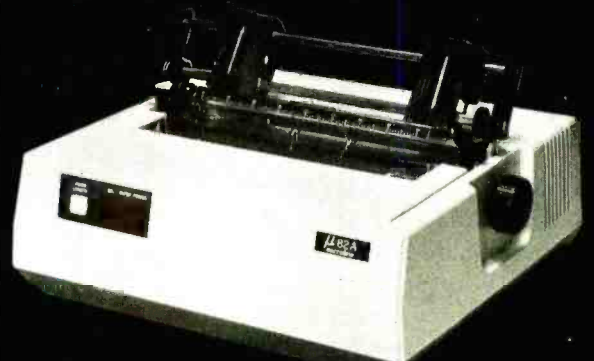

120 CPS, Bi-directional logic seeking 9x9 dot matrix, full 96 ASCII char. Set with true descenders centronics parallel port and RS232 serial port (up to 1200 Baud) standard, 80 col., includes Okigraph dot addressable graphics, friction feed and removable tractor. 22 lbs., 110 volt standard, 220 volt optional.

Altos 5-15D	\$2295.00
Altos 5-5D	4595.00
Amdek Video 300	139.00
Amdek Color I 13" Monitor	315.00
Amdek Color II 13" Hi-Res RGB Monitor	719.00
Amdek Color III 13" RGB Monitor	399.00
Atari 800 Computer w/16K	645.00
Atari 800 Computer w/48K	739.00
Atari 810 Disk Drive	439.00
C-Itoh Prowriter 8510AP (parallel)	459.00
C-Itoh Prowriter 8510ACD (serial)	599.00
C-Itoh Prowriter II	Call for Price
Comrex CR-5500 12" Green Monitor	119.00
Comrex CR-6500 13" Composite Color Monitor	325.00
Comrex Com-Riter w/Serial Interface	879.00
Daisywriter 2000 Letter-Quality Printer	1049.00
Diablo 620 RO Printer	1259.00
Diablo 630 RO Daisywheel Printer	1999.00
Diablo 630 KSR Daisywheel Printer	2349.00
DEC Decwriter IV LA34AA	1095.00
DEC VT100AA Video Terminal	1649.00
DEC Rainbow 100 Personal Computer	2995.00
Epson HX-20 Portable Personal Computer ...	659.00
Epson MX-80FT Type III w/Grafrax Plus	499.00
Epson MX-100FT Type III w/Grafrax Plus ...	699.00
Hayes Micromodem II for Apple II	289.00
Hayes Smartmodem	225.00
Hayes Smartmodem 1200/300 baud	569.00
IDS Microprism	599.00
IDS Prism 80 (w/all options & color)	1379.00
IDS Prism 132 (w/all options & color)	1559.00
M & R Sup-R-Term 80 column card for Apple II	279.00
Microsoft Softcard (Z-80) for Apple II	269.00
Microsoft Premium System for Apple II	579.00
Microsoft 16K Ramcard for Apple II	119.00
Microsoft 64K For IBM	359.00
NEC 3510 Letter Quality Printer w/RS232 ...	1529.00

CALL TOLL FREE!

800-343-0873

NEC 3530 Letter Quality Printer w/Centronics Interface	1659.00
NEC 7710 RO Spinwriter	2195.00
NEC 7730 RO Spinwriter w/Centronics Interface	2195.00
Lear Sigeler ADM3A Dumb Terminal	569.00
NEC PC8023 Dot-Matrix printer	489.00
NEC JB1201M(A) 12" Green Monitor	169.00
NEC JC1201 13" Composite Color Monitor ...	319.00
Okidata Microline 80	329.00
Okidata Microline 82A	419.00
Okidata Microline 83A	695.00
Okidata Microline 84P	979.00
Okidata Microline 84S	1079.00
Rana Elite I Disk For Apple II	359.00
Rana Elite I Disk w/Controller	465.00
Rana Elite II Disk Drive for Apple II	529.00
Smith Corona TP-1 Letter Quality printer	639.00
Televideo 925 Terminal	795.00
Televideo 950 Terminal	995.00
USI Pi-1 9" Green Monitor	159.00
USI Pi-2 12" Green Monitor	159.00
USI Pi-3 12" Amber Monitor	175.00
Videx Videoterm	259.00
Videx Enhancer II	115.00
Xedex Baby Blu CPM Card for IBM	499.00

OMEGA SALES COMPANY

430 PEARL STREET, STOUGHTON, MA 02072

(617) 344-6645 TOLL FREE (800) 343-0873

EPSON MX-80FT

\$499.00



**OMEGA DELIVERS
FOR LESS**

OKIDATA MICROLINE 83A

or

EPSON MX-100 FT

YOUR CHOICE

\$499.00

80 CPS, Bi-directional logic seeking 9x9 dot matrix, full 96 ASCII char. Set with true descenders, centronics-style parallel port (RS232 optional), 80 col. , includes grafrax plus dot addressable graphics, friction feed and removable tractor feed. 19 lbs. , 110 volt only.

SOFTWARE

Omega carries software by the following companies:

- American Business Systems • Ashton Tate • Dakin 5
- Innovative Software • Micropro • Microsoft
- Sorcim • Stoneware • Visicorp

MAGNETIC MEDIA

Omega carries diskettes by the listed companies:

- Dysan • Maxell • Scotch • Verbatim

ACCESSORIES

Omega carries accessories for the Apple II by the following manufacturers:

- D.C. Hyes • Microsoft • Tymac • M & R Enterprises
- Mountain Computer • Kensington Microware
- Practical Peripherals • T. G. Products • Videx

We carry the complete line of Atari Hardware, Software & Peripherals.

We will try to match or beat any price with similar purchase conditions.

**CALL TOLL
FREE!
800-343-0873**

Stock Shipments Same Day or Next
No Surcharge for Credit Cards
All Equipment Factory Fresh w/MFT Warranty
Prices do not Reflect Shipping Charges
Mass. Residents Please Add 5% Sales Tax

**PRICES ARE SUBJECT TO
CHANGE WITHOUT NOTICE**

OMEGA SALES COMPANY

430 PEARL STREET, STOUGHTON, MA 02072

(617) 344-6645 TOLL FREE (800) 343-0873

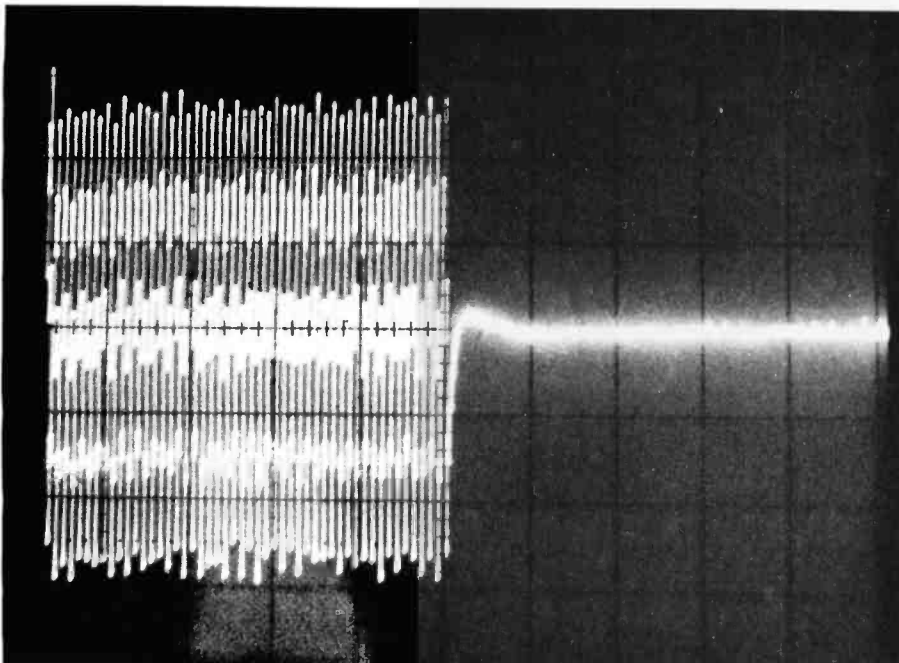

Photo 3a: Screen display of the oscillograph of a Soundchaser digital tone with the fastest possible attack and decay times. The tone is 50 ms long. The overall shape is the tone's "envelope." The individual waveform cycles are not visible because they are so close together.

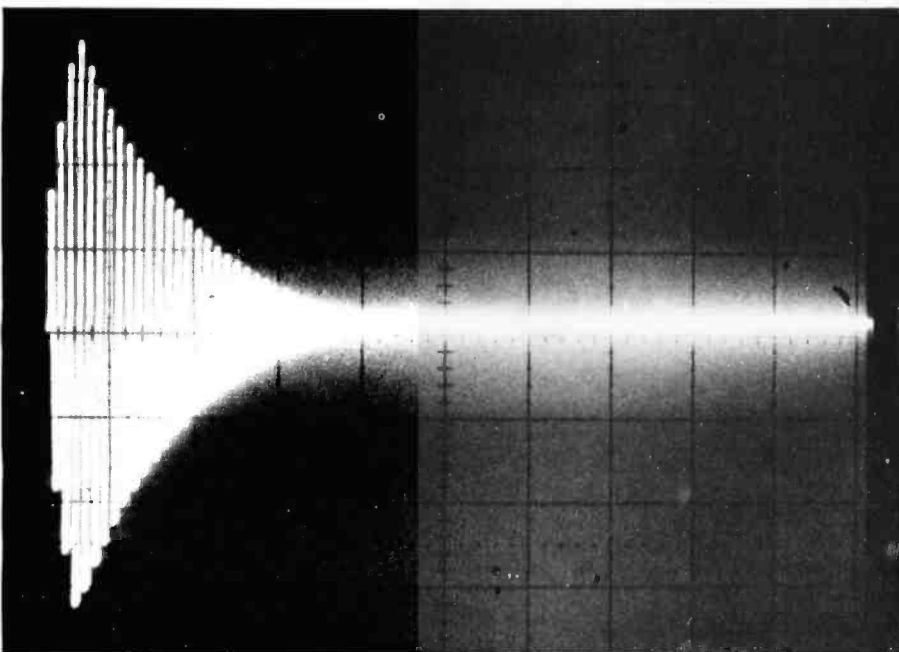

Photo 3b: Screen display of the oscillograph of an analog synthesizer tone with 5-ms attack time and 10-ms decay time. Note that the envelope is shorter but smoother than that shown in photo 3a.

the Performance section is that the modulation amplitude is not the same from note to note: low notes are more widely modulated.

The Sequencer Section

The Sequencer section enables you to record actual keyboard perfor-

mances and assemble them to make multipart (polyphonic) compositions. Two modes are available: Link and 4-Track. In the Link mode, a keyboard performance is recorded as soon as the musician starts to play. At the end of the performance, a single command forms a loop of the

performance, which then begins again when any music key is depressed and repeats until the stop command is issued. Thus, you can use the Link routine to create a repeating background pattern that musicians call an ostinato. The pattern usually serves as an accompaniment, over which a live keyboard performance can be played. The pattern may have as many as eight notes playing simultaneously. However, all notes must have the same tone color.

In the 4-Track mode, the Sequencer behaves somewhat like a four-track recorder. To use this mode, you first record one track by playing the music keyboard. You then play that track back, while simultaneously recording on track two. You repeat the process until four parts are recorded. Any number of keys can be simultaneously depressed when recording any one track, as long as the total number of notes sounding simultaneously on all four tracks does not exceed eight. It is not possible to form a loop in the 4-Track mode.

The Sequencer is easy and fun to use. Just a few alphanumeric commands enable the musician to start recording, switch over to playback, and change channels. You can call up any of the previously created voices (called "preset masters") and assign them to any of the tracks. You can change octave range, modulation amount, envelope parameters, and the preset masters themselves as the sequence is playing back. The playback tempo can be the same speed as the original recording or can be increased in whole numbers up to 8 times the original speed. Some limitations in the Sequencer's operation may, however, frustrate musicians who have used a conventional four-track recorder. Foremost of these is that no facility for editing a track exists. If you make a mistake, you have to record the whole track over. If you want to change one note at a time, you are out of luck. On a multitrack recorder you can generally "punch in" to erase and rerecord small segments of a single track as it is playing back. It would be nice to have that same facility here. It would also be nice to be able to display the actual

897 N.W. Grant Ave. • Corvallis, Oregon 97330 • 503/758-0521

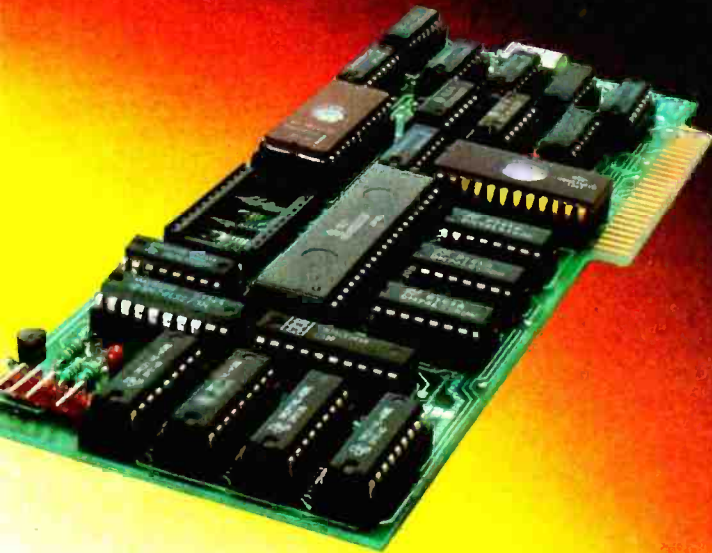

VIDEOTERM

Expanding Horizons in Text Display

Videoterm increases your Apple][[®] display to a full capacity 80 columns. Proofreading text problems are a thing of the past. With Videoterm your text is displayed in upper and lower case characters with true descenders utilizing a 7 by 9 character matrix. The time-tested Videoterm is compatible with most word processors and is available with alternate character fonts. Once you've explored the advantages of Videoterm, you'll discover a whole new world for you and your Apple][.

Suggested retail price: \$345.00

ACCESSORIES

Videoterm Utilities Disc includes:

- Graphics Template System
- Font Editor
- Mid-Res Graphics
- Applesoft Read Screen Utility
- Top & Bottom Scrolling
- Pascal Vidpatch

Suggested price \$37.00



Videoterm Character Set EPROMs

- French
- German
- Inverse
- Katakana [Japanese]
- Math & Greek Symbols
- Norsk



- N. European
- Russian
- Spanish
- Super & Subscript

Suggested price \$29.00 each.

Dvorak EPROM [Enhancer]—\$29.00
Lower Case Chip [Rev 7 & up]—\$29.00

SOFT VIDEO SWITCH

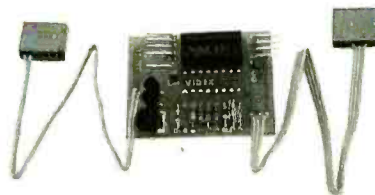

The Soft Video Switch is an automatic version of the popular Switchplate. It knows whether it should display 40 or 80 columns or Apple graphics. It does the tedious work of switching video-out signals so you don't have to. The Soft Video Switch can be controlled by software. May be used with any Videoterm with Firmware 2.0 or greater. The single wire shift mod is also supported. Package price is \$35.00.

ENHANCER][

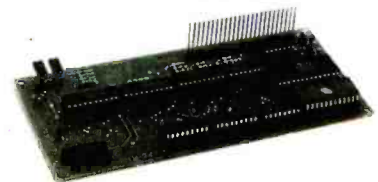

The Enhancer][features a typeahead buffer. Your keyboard has upper and lower case, and will auto repeat any key held down. A single keystroke can become a word or an entire sentence. Controlled by a powerful microprocessor, Enhancer][allows you to re-map your keyboard or add specialized features. Changing a chip creates a totally different keyboard. Enhancer][Utilities Disc included. Suggested retail price \$149.00.

QUADBOARD™

THE FIRST AND ONLY BOARD YOUR IBM PC MAY EVER NEED.

Your IBM personal computer is a very versatile piece of equipment. Perhaps more versatile than you realize. New applications and functions are being developed every day. Now with Quadboard

by Quadram you can keep your options open for tomorrow's technology. Following in the tradition of Quadram Quality, four of Quadram's best selling IBM boards have been combined into one board. Your remaining slots will be left free and available to accommodate future expansion needs and uses which you may not even be able to contemplate today.

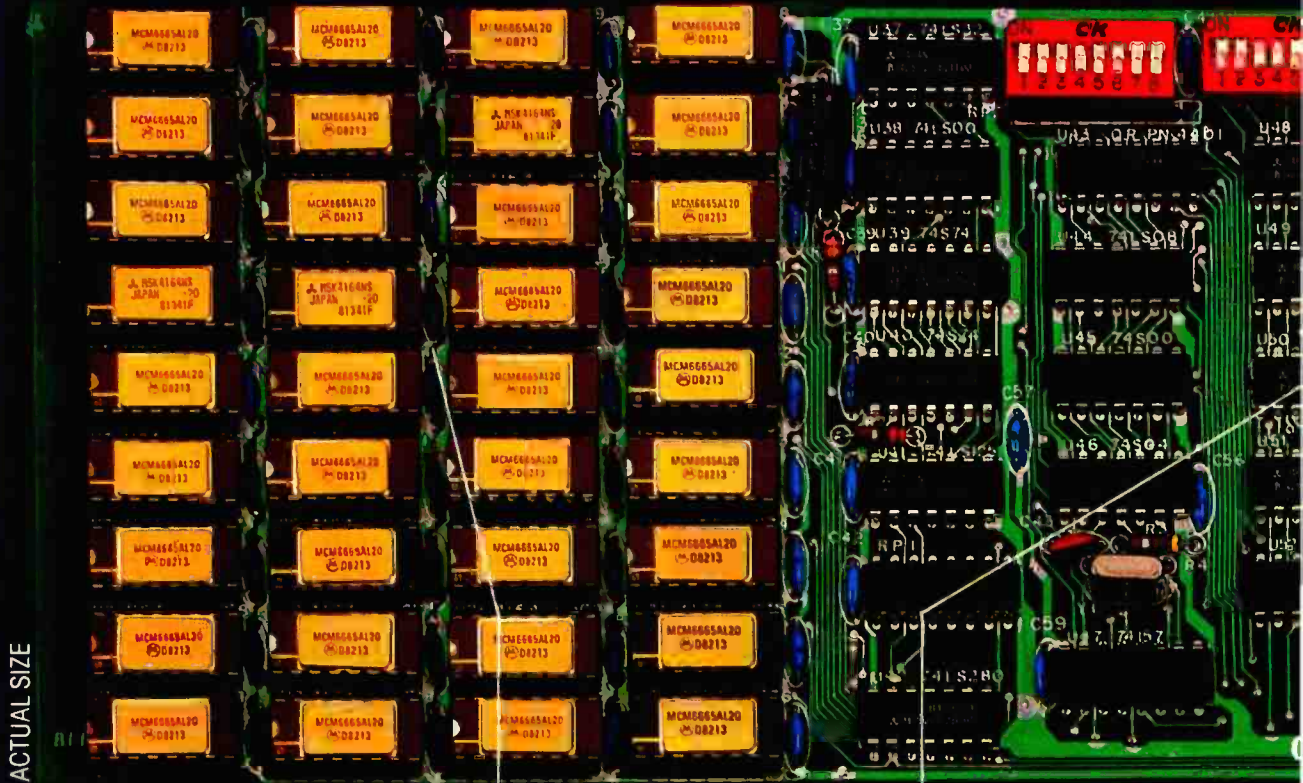

PROVEN DESIGN.

Quadram has been shipping IBM boards with each of the Quadboard functions on separate boards since December, 1981. They are still available as separates (including a Dual Port Async Board) for those who desire a quality board but do not need to keep slots open for future expansion. And they all come with a one year warranty from the leader in technology applications.

256K MEMORY EXPANSION.

Socketed and expandable in 64K increments to 256K, full parity generation and checking are standard. A Quadboard exclusive feature allows parity to be switch disabled to avoid lock-up upon error detection. The dip switches also allow it to be addressed starting on any 64K block so that it takes up only as much as it has memory installed. Memory access and cycle time naturally meet all IBM specifications.

CLOCK/CALENDAR.

Quadboard eliminates the hassle of manually inputting the date on system boot-up by providing for the clock and all software routines necessary for inserting the appropriate programs on your diskettes. The internal computer clock is automatically set for compatibility with most software routines which utilize clock functions. On-board battery keeps the clock running when the computer is off.

SEE OUR AD ON PAGE 282

BY QUADRAM

ALL ON ONE BOARD

Now you can utilize all the PC's capacity with Quadram's extremely flexible configurations. And it's totally compatible with IBM hardware, operating systems, and high level languages. It's a full-size board that can be inserted into any free system slot and it even includes a card edge guide for securely mounting the card in place.

SOFTWARE TOO!

With Quadboard you receive not only hardware but extensive software at no extra cost. Diagnostics, utilities, and Quad-RAM drive software for simulating a floppy drive in memory (a super-fast SOLID STATE DISK!) are all part of the Quadboard package.

\$595

with 64K
Installed

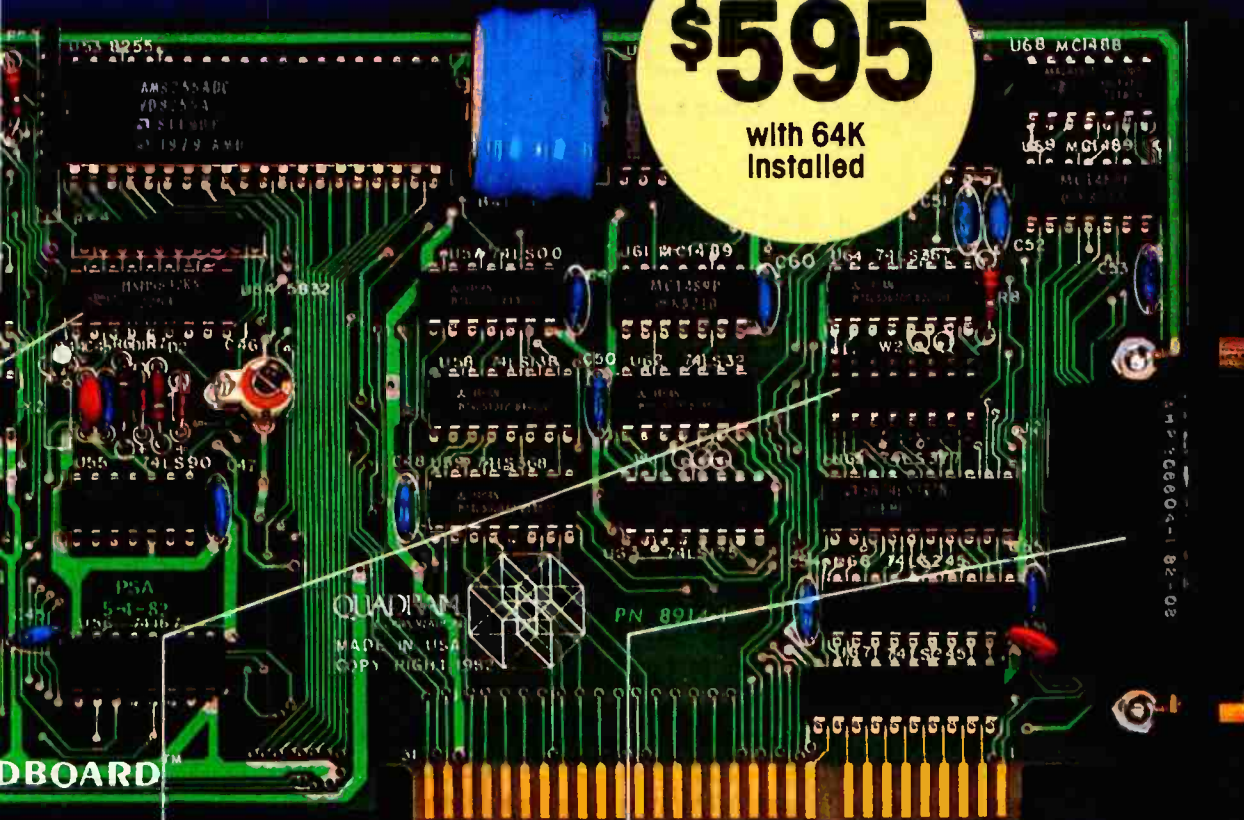

PARALLEL PRINTER I/O.

A 16 pin header on Quadboard is used for inserting a short cable containing a standard DB25 connector. The connector is then mounted in the knock-out hole located in the center of the PC back-plane. The parallel port can be switch disabled or addressed as Printer 1 or 2. No conflict exists with the standard parallel port on the Monochrome board. The internal cable, connector and hardware are all included.

ASYNCHRONOUS (RS232) COMMUNICATION ADAPTER.

Using the same chip as that on the IBM ASYNC board, the device is software programmable for baud rate, character, stop, and parity bits. A male DB25 connector located on the back connector is identical to that on the IBM Async Adapter. The adapter is used for connecting modems, printers (many letter quality printers require RS232), and other serial devices. Switches allow the port to be configured as COM1 or COM2 and the board fully supports IBM Communications Software.

INCREDIBLE PRICE!

Priced at \$595 with 64K installed, \$775 with 128K, \$895 with 192K and \$995 with 256K.

ASK YOUR DEALER.

All products are sold through local personal computer dealers. If yours does not stock Quadram, please ask him to call us at (404) 923-6666.

QUADRAM
CORPORATION



4357 Park Drive / Norcross, Ga. 30093
Circle 388 on Inquiry card.

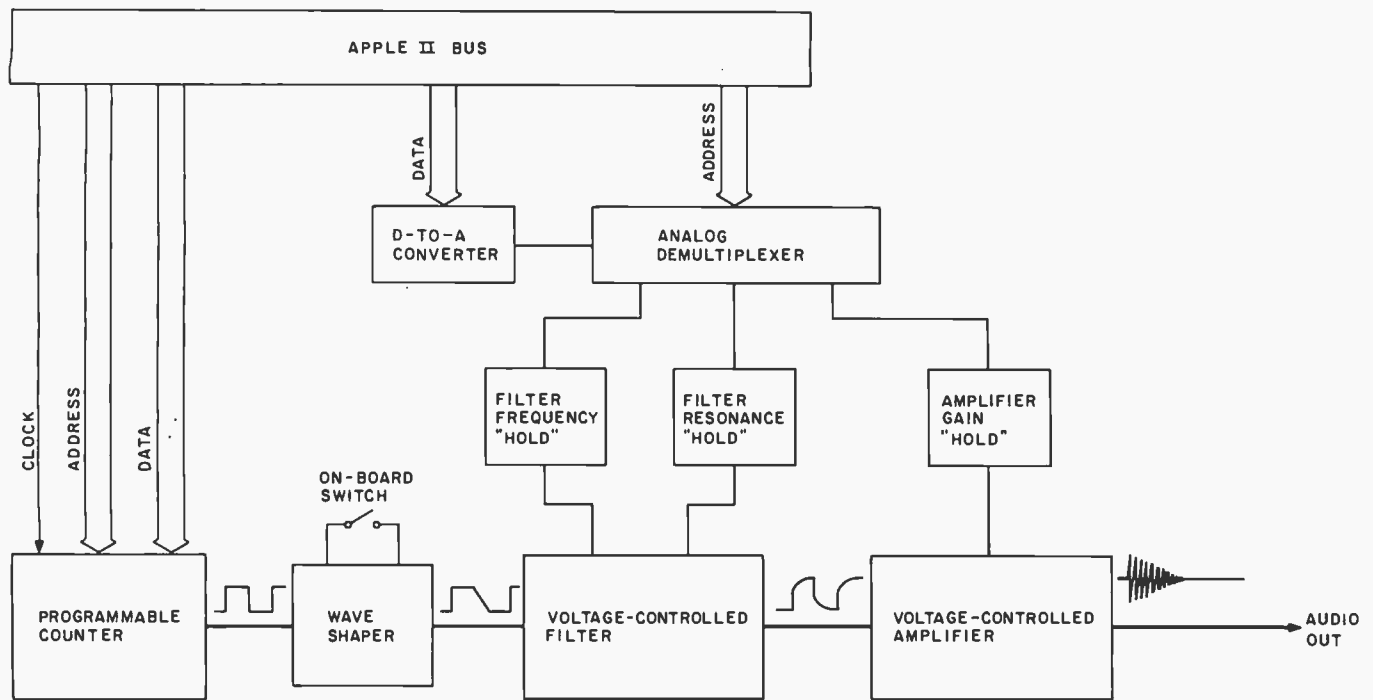

Figure 1: Block diagram of one of the three audio chains of a Soundchaser Analog voice card, along with its associated control circuits.

timings of each note in a track (perhaps as a numerical table) and then edit that table. That would give the musician the option of fine-tuning the timing of individual notes without having to punch in and replay just those notes. For Sunday keyboardists like me, that would be an attractive feature. Since the entire Sequencer resides in the system software, these enhancements could presumably be included in software updates.

In addition to the Wavemaker, Performance, and Sequencer sections, the Soundchaser Digital operating system includes a disk section that contains some basic file-management utilities. The three types of files are called Waveform, Master, and Track and correspond to the data entered in the Wavemaker, Performance, and Sequencer sections. Files can be saved on disk, deleted, and loaded from the disk. The Performance section display provides access to the disk section (as well as to any of the other system sections) through a simple, single-character command.

The Soundchaser Analog System

The Analog system sound-producing hardware and operating software are both radically different from

those of the Digital system. An Analog system audio card contains three very simple analog sound chains, plus a D-to-A (digital-to-analog) converter and demultiplexing circuitry to receive digital control information from the Apple, convert it

When compared with conventional analog synthesizers, the Soundchaser Analog audio chain has limited capabilities.

to analog control voltages, and distribute it to the control inputs of the analog circuit blocks.

Figure 1 shows a single audio chain of the Soundchaser Analog card. The oscillator is a programmable counter that derives the correct frequency by dividing the Apple clock frequency by a software-generated number. The output waveform is a square wave, a shape that produces a hollow, clarinetlike tone. A simple waveshaping circuit changes the overtone content slightly in order to produce a more stringlike quality. This circuit is

activated by one of four small switches on the circuit board itself; it is not under software control. The filter is a standard voltage-controlled "24-dB/oct [decibels per octave] lowpass-resonant" design. (This is the type of filter that most people have in mind when they say, "It sounds like a synthesizer.") The filter's cutoff frequency (the frequency above which the overtones are reduced in strength) and resonance (how strongly the filter emphasizes the overtones whose frequencies are near the cutoff frequency) and the amplifier's gain (amount of amplification) are the three parameters that are under software control through the D-to-A converter.

When compared with conventional analog synthesizers, the Soundchaser Analog audio chain has limited capabilities. With only one waveform per voice, chorus and ensemble effects are not possible. The waveshape choice is meager and inconvenient to implement. The range of filter cutoff frequency and resonance settings seems hardware-limited; you can't produce musically interesting effects, such as very low or very high cutoff frequency and high resonance. Finally, the control signals emerging from

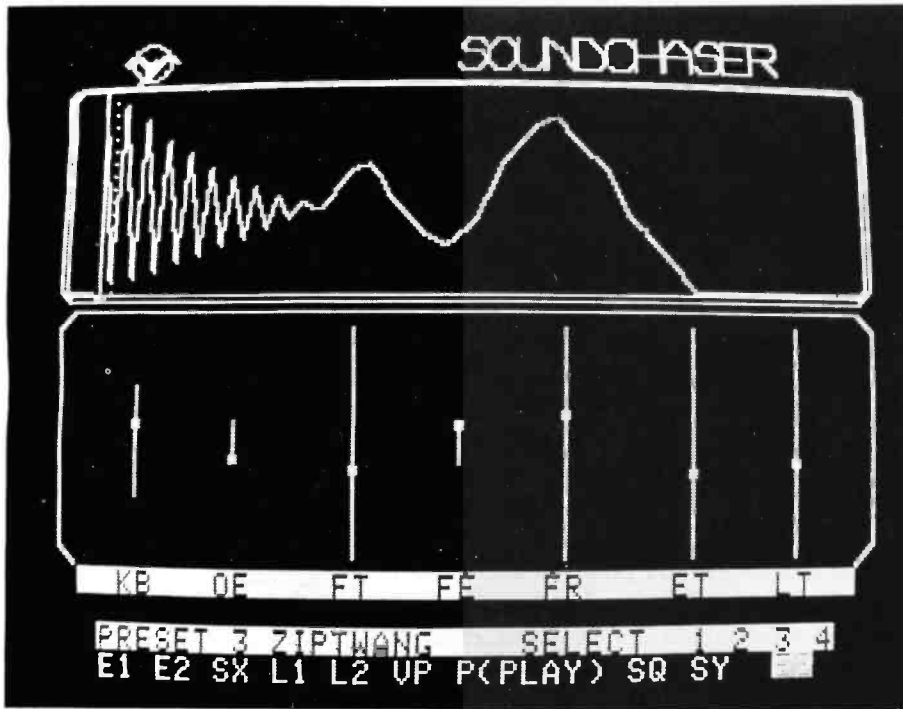

Photo 4: Screen display of a voice panel display of the Soundchaser Analog system. The pattern at the top is a user-defined contour, one of four that is associated with each voice. Below the contour display are the "switches" and "sliders" that are set by use of the game paddle.

the demultiplexer carry rapid fluctuations that affect the overall tone quality.

The Soundchaser Analog "control panel" provides some novel and musically useful control modes. Photo 4 shows the video presentation. The top part of the display provides access to two envelopes (E1 and E2) and single cycles of two repeating modulation patterns (L1 and L2). You can define or edit any of these contours by moving a cursor with a game paddle, a process that takes a steady hand. The latest software version has provision for editing by spotting end points of line segments, then computing the lines themselves. This editing method is more manageable than freehand drawing with the game paddle.

Below the contour display is a series of soft switches and sliders. They control aspects of pitch range: from left to right, whether or not E2 sweeps the oscillator, filter cutoff frequency, whether or not E2 sweeps the filter, filter resonance, overall time scale of E1 and E2, and overall time scale of L1 and L2. You move the software "knobs" with the game pad-

dle, first bringing the cursor to the control, then pressing the game paddle button while turning the game paddle knob to move the software "knob" up and down. The process takes two hands, so you can't do it while you're playing the keyboard. However, it is a fairly natural and easy way to enter data. For people used to hard control panels, one drawback of this display is that you cannot change a control, then immediately hear what that change sounds like. You have to go back and forth from the panel-setting mode to the keyboard-playing mode, a process that requires typing a couple of alphanumeric commands.

The ability to draw control contours of any shape, then stretch or compress them with a few simple commands, is a facility that electronic musicians have long dreamed of. Each envelope and repeating waveform shape has its own sound. Of course, it takes a lot of experience to know what shape contours to draw in order to get the desired effect. However, once you get something you like, you can store it on disk. Soon you'll have a library of effects that

Why pay more for TRS-80

Color Computer
Model II
Model III
Model 16
Printers

EPSON
C. ITOH
FRANKLIN
OKIDATA
APPLE
ATARI

We'll meet or beat any price from an authorized dealer!

Our prices are so low we aren't allowed to print them!

VISA
MasterCard
AMERICAN EXPRESS

Microline 82A \$409
OFFER EXPIRES 12/31/82

We have cables to interface our printers with Commodore, IBM, and Osborne computers. We have the lowest prices, massive inventory, and can deliver for the holidays.

Write or call for FREE Computer Catalog with pictures, specs, accessories and prices.

CALL TOLL FREE: 800-526-5313

Computer Discount of America

COMPUTER DISCOUNT OF AMERICA, INC.
15 Marshall Hill Road, West Milford Mall
West Milford, New Jersey 07480-2198
In New Jersey Call 201-728-8080

you can draw on to add variety and interest to your music.

The Sequencer section of the Soundchaser Analog system allows you to record a short (128 notes or chords) keyboard performance, then play it back while simultaneously playing another tone color on the keyboard. This Sequencer is much more limited than the 4-Track Sequencer of the Soundchaser Digital system, which I described in the first half of the article. However, it has some potential use in providing simple effects during live performance or programmed instructions. Like the Digital system Sequencer, this one doesn't have editing facilities either; you get what you play.

Like the Digital system, the Analog system contains basic file-maintenance functions. File types are Preset (all data to define a tone color), Sequence (a keyboard performance), and Orchestra (a collection of four presets and four sequences). By recording presets and sequences in separate files, you can easily try dif-

ferent tone colors in a given keyboard performance, a facility that is absolutely impossible with audio tape recorders. You can save, delete, and load files for future use or editing.

Optional Software

The Musicutor is a collection of ear-training routines that combine the Soundchasers' (both Analog and Digital systems) accurate-pitch programming and production capabilities with easy-to-read displays in conventional music notation and plain English. The routines, which include interval and melody drill in several degrees of difficulty, plus performance evaluation and grading, seem well thought out. Music students and teachers alike should find Musicutor easy to use. I haven't been subjected to an ear-training class for some 35 years, but I can remember that my fellow students and I squirmed and sweated, one by one, as our bored teacher played intervals and scowled until we came up with the right answer. Contrasted with that less-

than-pleasant memory is my experience with Musicutor. I picked one of the exercises at random and was sucked in. I managed to tear myself away after an hour of drill, during which time I found out where the tarnished edges of my golden ears were.

Notewriter transcribes the keyboard performance of a monophonic musical line into conventional musical notation—of sorts. The problem of transcribing music with all the conventions that musicians expect is difficult. Notewriter sets up the screen with staff lines and key signature, then produces a series of beeps for rhythmic reference. The notes appear as you play them but without refinements such as triplets, accents, and similar standard musical markings. The current version of Notewriter has provisions for editing which allow you to "clean up" the notation. Notewriter also has provision for transposing keys. The software package may find some use in its present form, but for most applications, musicians will find it easier to transcribe single musical lines by hand.

Conclusions

When a musician uses an instrument to make music, the interaction that takes place between the two is as intense and complex as in any man/machine system. When the instrument is a computer music system with some intelligence of its own, the criteria for efficient interaction are especially stringent. Computer music systems must continue to evolve in order for their developers to incorporate all of the refinements that will make them truly efficient and "friendly" tools for musicians. After all, the violin evolved over centuries and the acoustic piano took generations to reach its present musical excellence. We have no reason to believe that the ultimate computer music system, whether it costs \$1000 or \$50,000, is close at hand.

The Soundchasers are evolutionary systems. That is, they have been developed and introduced while computer musical instrument technology is still very young. While some of

ALF COPY SERVICE

FAST • RELIABLE • LOW COST

If you produce software, ALF's disk copying service is the quick, convenient answer to your disk duplication needs. Most orders are shipped in less than a week. Every disk we copy is verified bit by bit and guaranteed 100% flawless. Standard formats include Atari, Apple (including nibble-copy-proof and double-boot formats), IBM, and TRS-80.

Our "no frills" pricing means you don't have to buy extras you don't need—set-up charges from \$10, copying from 30¢ per disk. Of course, we have the frills too—including custom printing and packaging. Call us today for complete details.

BLANK DISKS

Bulk pack boxes of 100:
5¼", 1S DD, unlabeled,
with hub ring. Sleeves
7¢ extra. Add \$2.50
shipping per hundred.

NASHUA (1S SD)	\$1.55
3M	\$1.65
MEMOREX	\$1.65
CDC	\$1.65

ALF (303) 234-0871 1448 ESTES DENVER, CO 80215

their features go far beyond those available from older technologies, other features will, we can assume, seem crude to musicians of the future. Thus, in summarizing the Soundchaser, my listing of shortcomings is intended more as a recommendation for further development than as criticism.

The Soundchaser Digital system, with its Mountain Computer Music-system digital oscillator, constitutes a musically useful polyphonic recording and performance system. The Musicsystem provides a wide variety of pleasing tone colors, while the system software provides adequate routines for specifying envelopes and frequency modulation waveforms. I would like to see more finely defined, faster envelopes and frequency modulation that affected all pitches equally. The Sequencer section is easy to use for four-part music but definitely needs provision for editing.

The Soundchaser Analog system uses voice cards that resemble "bare-bones" analog synthesizers. As audio-tone generators, they are not impressive. The software's strong points are the abilities to draw arbitrary envelopes and modulation waveforms, then use simple commands to stretch or compress these contours in time. The Sequencer section of the Analog system is less useful than that of the Soundchaser Digital system.

The music keyboard (used in both systems) is four octaves long and not touch-sensitive and incorporates no real-time "player" controls. It is adequate for experimental work and teaching but will limit musicians who are used to larger keyboards or who wish to impart expressive nuance to their music.

The Musictutor software package is a well-developed set of computer-aided ear-training routines. Note-writer is a monophonic transcribing routine that, in its present form, has limited usefulness and needs further development.

Written documentation is complete and adequate, if not top-notch. Several appendixes provide welcome background documentation on operating principles and software structure. ■

We Scout Out The Best Buys.

THE PURCHASING AGENT is your computer buying company. We negotiate the purchase of millions of dollars of hardware and software at the best prices each year. Our buying power gives you more hardware and software for your money. Our fee is 25% of what we save you off list price. By participating in the savings, we share a common goal—to save you money.

Call us for your price on any product not listed. All prices shown include our fee.

COMPUTERS

Alpha Micro 1000 VW	\$5,960
Alpha Micro 1030	12.047
Alpha Micro 1051	17.634
Alspa AC1-2/55	2,320
Altos 8000-10	5,850
Altos 8600-10	7,586
Altos Series 5-15D	2,100
Altos Series 5-5D	4,200
Apple 2+ 48K	1,208
Associate	CALL
BMC 20 B	5,422
Burroughs	CALL
California Computer Systems 300-1A	4,414
Columbia Data	CALL
Compupro/Godbout 26% OFF	
Sys. 816/A	4,050
Sys. 816/C	6,630
Cromemco System 1	2,946
Cromemco System 2	3,400
Cromemco 68000 System 1	4,395
DEC VT-180xx	3,344
Dual	12,636
Dynabyte	26% OFF
Eagle II	2,350
Epson Computer	CALL
Fortune	CALL

IBM Personal comp.

CALL	
Baby Blue	CALL
Davong 5 meg. H.D.	1,575
Seattle boards	CALL
IBC Cadet	4,211
Micromation	CALL
Molecular	CALL
Morrow	CALL
NEC 16 bit system	CALL
NEC 8000 64K	
PC System	2,266
NorthStar Advantage	2,625
NorthStar Adv. H.D. 5	4,395
NorthStar Hor. 64K 8-16	CALL
Onyx 5001 MU-6	7,350
Onyx 8000 MU-10	7,900
Osborne	CALL
Sanyo 1000	1,540
Seattle System 2	3,251
Televideo TS-802	2,600
Televideo TS-802H	4,545
Televideo TS-806	5,200
Vector 2600	3,895
Vector 3005	5,495
Vector 4	CALL
Victor	CALL

PRINTERS

Brother, parallel, daisy	853
C. Itoh F-10, daisy	1,350
C. Itoh Prowriter II, dot	699
Diablo 620, daisy,	
25 cps	1,260
Diablo 630, daisy	2,050
IDS Prism 80	7,40
IDS Prism 132 options	1,430
NEC 3510	CALL
NEC 3550	1,995
NEC 7710 R/O	2,325
NEC/Sellum 1, 16K, tractor	2,595
Qume 9/45 full panel	1,865
Qume 9/55 full panel	2,180
Smith Corona TP-1, daisy	681
Tally	CALL
Texas Instr. TI 810	1,240

OTHER PERIPHERALS

Amdek Color II term.	694
Ventel 212 + modem	765
Corvus 10 meg. H.D.	3,825
DEC VT-100 terminal	1,390
Houston Instr. DMP-2	820
Houston Instr. DMP-4	1,195
Houston Instr. DMP-7	1,693
Morrow 20 meg. H.D.	3,650

Mastercard, VISA at 3% handling fee. Prices subject to change without notice. Minimum fee \$150. **EXPORT SERVICES AVAILABLE.** We are agents for overseas computer dealers and distributors. International Telex 470851

On The Frontier of High Technology and Value.



THE PURCHASING AGENT

1635 School Street
Moraga, CA 94556

Call Toll Free
800-227-2288
In California
(415) 376-9020

A Brief Introduction to Electronic Music Synthesizers

Robert A. Moog
Big Briar Inc.
Leicester, NC 28748

Most of today's popular music, as well as a growing amount of jazz, classical, and experimental music, owes its very existence to electronic technology. The electric guitar and bass, those war-horses of rock and roll, are vying with a dazzling array of new keyboard-controlled electronic musical instruments for the attention of today's music makers. Foremost among these new instruments is the electronic music synthesizer, an instrument that allows musicians to build and shape sounds from their component parts.

Synthesists deal with modules and patches (links), with interfaces and processors, with sequences, controls, and data paths. If these terms sound familiar, it is for a good reason: modern-day synthesizers are direct descendents of analog computers, those venerable monsters with vacuum-tube hearts and patch-cord brains that solved algebraic and differential equations with voltages instead of numbers. The analog computer scientist's function generators, adders, and multipliers have become the synthesist's tone oscillators, mix-

ers, and voltage-controlled amplifiers. The vacuum tubes have yielded to complex integrated circuits, and the patch cords (short cables with plugs at both ends for making temporary connections) now live out their lives under stage lights instead of in the cool of the laboratory. Of course, digital computers have completely replaced their analog

In music, the smoothly continuous signals and uniquely versatile hardware of analog computers live on.

ancestors in science and industry. In the arts, however, and especially in music, the smoothly continuous signals and uniquely versatile hardware of analog computers live on.

What Is a Synthesizer?

Analog synthesizers have existed as experimental curiosities for more than half a century and as commercial products since 1964. At present,

hundreds of thousands are in existence, in sizes as small as a candy bar and almost as large as a mission control center. Most of these incorporate a set of basic features, just as most digital computers, from the hand-held to the mainframe, have a processor, memory, clock, and input and output ports. We can divide the innards of a typical analog synthesizer into "ranks" or "voices," each of which produces a single musical tone, like a trumpet or an organ pipe. Small synthesizers have 1 rank; larger instruments have upwards of 16.

The core of a synthesizer rank is the audio chain, a circuit block that generates and processes the tone itself. A typical audio chain, shown in the lower half of figure 1, consists of one to four oscillator-waveshapers, one or two filters, and an amplifier. Each oscillator produces a single repeating waveform, which is generally heard as a musical pitch. Having more than one oscillator per voice enables the musician to produce ensemble sounds, chords, and many other musically interesting effects. The waveform's frequency of repeti-

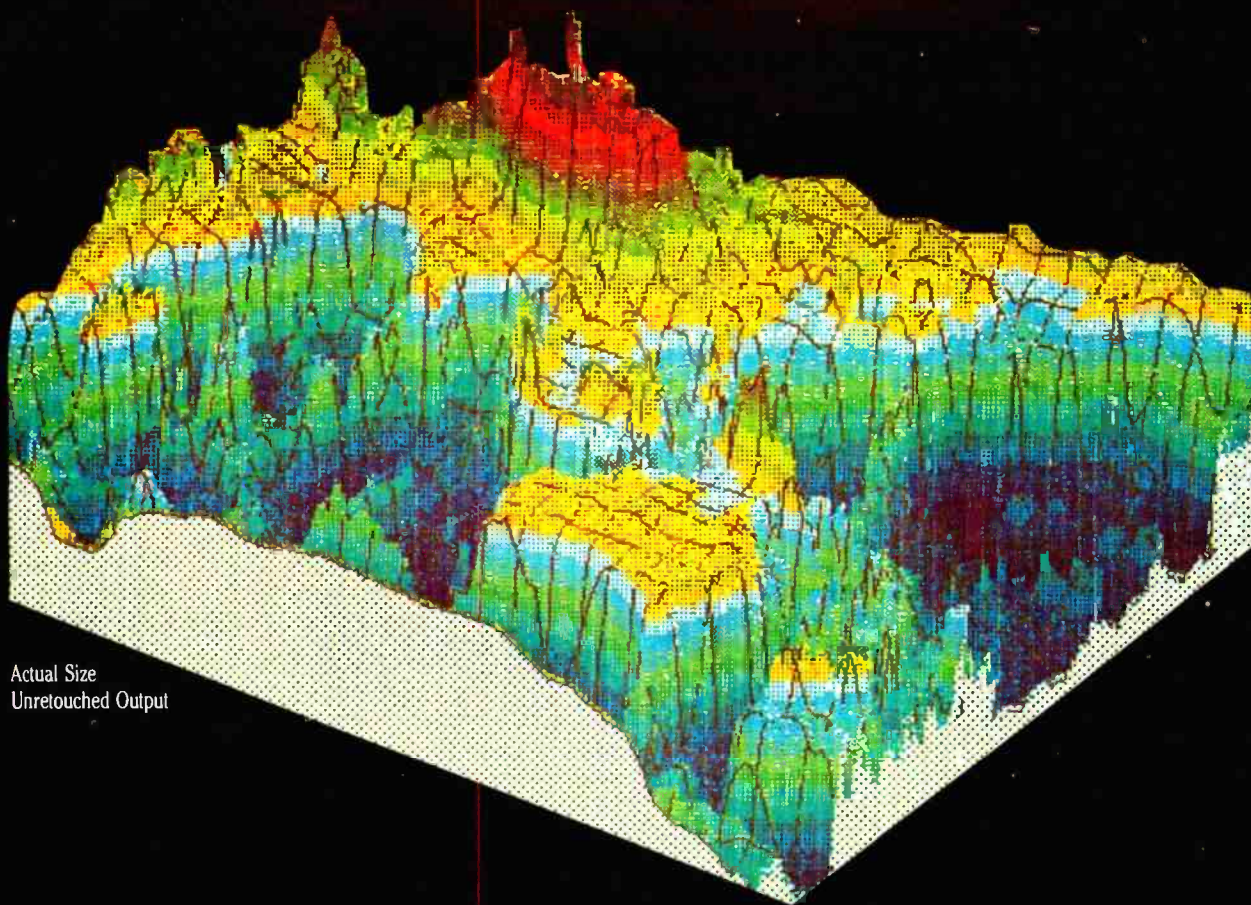

Actual Size
Unretouched Output

COLOR THAT PEAKS FOR ITSELF

EXPLORE THE WORLD OF COLOR OUTPUT WITH THE PRISM PRINTER™. When it comes to color graphics, output quality used to be a function of price. That is, until Integral Data Systems introduced the revolutionary new Prism Printer. The modular design of the Prism Printer now allows you to upgrade by modular components, including the ability to produce brilliant color output at a fraction of the cost of any other color printer/plotter available today.

Prism Printer "paints" in strong, vibrant colors to help display the ups and downs of complex data quickly, point out changes, show trends, and make your point unforgettable, because color communicates. You can produce output quality such as you see in this beautiful graphic representation of the ocean floor made at Woods Hole Oceanographic Institution.

And whether your output requires color or not, that's only one facet of Prism Printer's upgradable flexibility. In addition to Prism Color™, there are other optional modules for virtually any application you can think of—

Dot Plot™ graphics, Auto Sheet Feed for single-sheet and letterhead applications, it's companion Cassette Feeder for high volume word-processing applications, special character sets, and more.

All Prism Printers offer as standard features correspondence-quality output in a single pass with our exclusive overlapping-dot Maisey Mode™, and dual-speed capability for high-speed printing of 200 cps with our Sprint Mode™. In addition, we offer software packages which enable you to print color graphics from Apple II™ and the IBM™ Personal Computer.

If you're looking for a new high in your output quality, at a lower price than you thought possible, check out the Prism Printer now at your local dealer. Color that peaks for itself, from the innovator in imaging technology, Integral Data Systems.

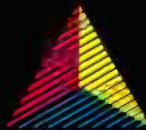

PRISM PRINTER™



Integral Data Systems, Inc.

A Whole New Spectrum of Imaging Ideas

Milford, New Hampshire 03055

Telex: 953032

Toll-free 1 (800) 258-1386

NH, Alaska and Hawaii, (603) 673-9100

Actual

The size, of course, is a dead giveaway. But don't let the size fool you. The HX-20 is not a toy. Or a glorified calculator.

It's a computer.

A real computer, with 16K RAM (optionally expandable to 32K), and 32K ROM (optionally expandable to 64K), RS-232C and serial interfaces, a full-size ASCII keyboard, a built-in printer, a scrollable LCD screen, and sound generation. A micro-cassette and ROM cartridge are available as options.

Viva la différence!

In fact, the only differences between the Epson HX-20 and an ordinary computer are:

- 1) The HX-20 is small enough to fit inside your briefcase;
- 2) It'll run on its own internal power supply for 50-plus hours, and fully recharge in less than eight;
- 3) It gives you up to 10 program functions at the punch of a button;
- 4) It lets you interface with peripherals like the MX Series printers for correspondence quality output, the CX-20 Acoustic Coupler for remote communications, a barcode reader for inventory control, and an audio cassette for loading and saving programs;
- 5) It lets you shut the whole unit off while preserving all programs in RAM; and, last but not least,
- 6) It costs less than \$800. That's right—less.

The perfect traveling companion. With the Epson HX-20 and the optional RAM expansion, you'll be able to compute just about anywhere. Because it's nickel-cadmium batteries and a low-power, all-CMOS memory keep the HX-20 running for over 50 hours. And even if you shut the HX-20 off, a low-voltage system maintains all programs you have in RAM.

Little screen, big picture. The HX-20's unique scrollable LCD screen is the ultimate answer to the question, "How do you get a big screen in a small space?" You just show part of it at a time.



1 size.

Optional Microcassette

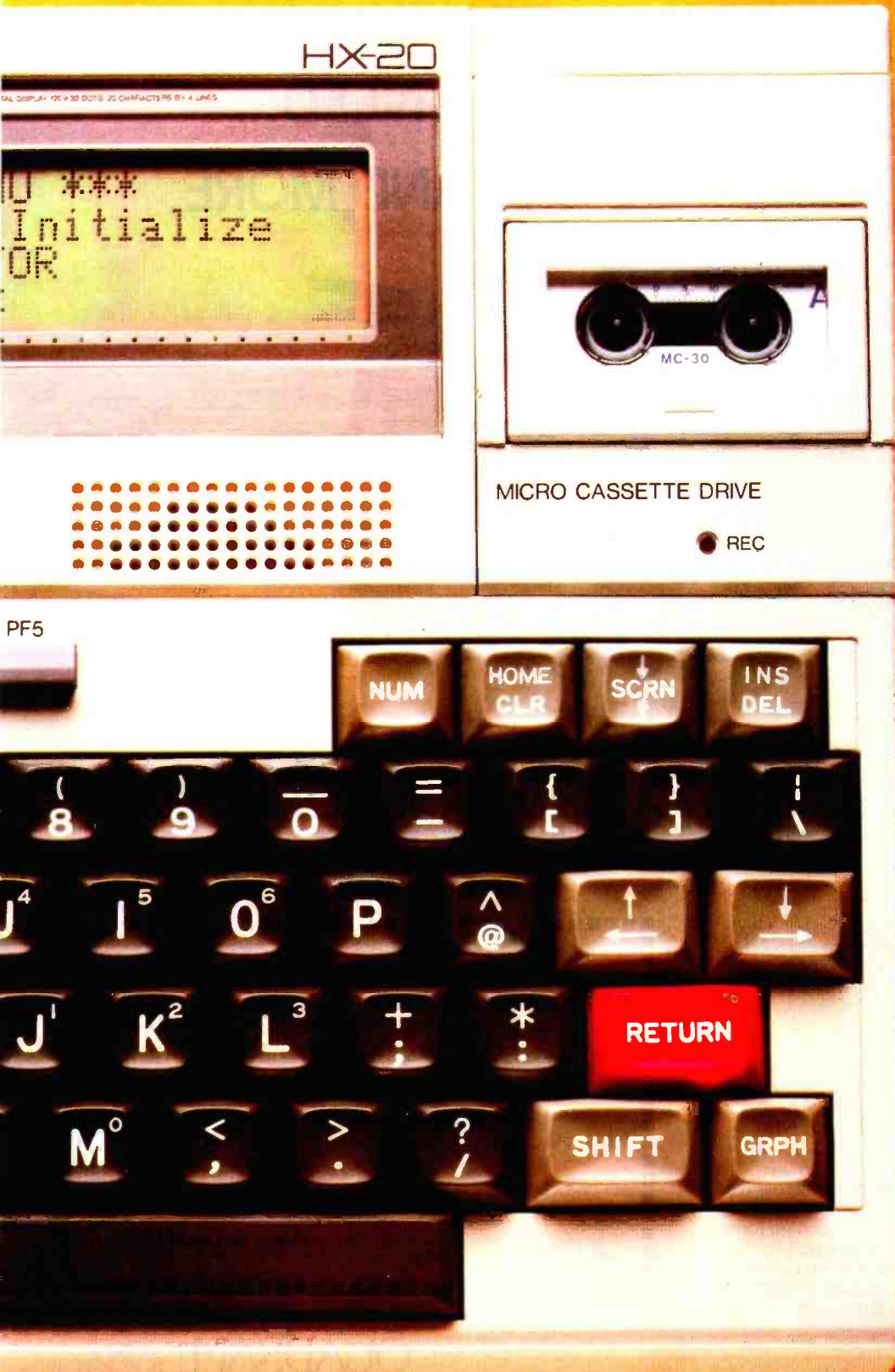

So with the HX-20, you can do programming, word processing and data entry just like you've got a big screen, up to 255 characters wide, with easy-to-read upper and lower case letters, numbers and punctuation and any 20 column by four line part of it visible by user command. **Built in hardcopies.** The HX-20's built-in 24 column dot matrix impact microprinter hands hardcopies to you at 42 LPM, in a crisp, precise 5x7 matrix. It even has bit addressable graphics to give you a pint-sized sales chart, and enough international symbols to print most Western languages.

Epson makes more and better printers than anyone else in the world. Need we say more? **The best is yet to come.** When you hold an HX-20 in your hand, you're not only holding a lot of capacity, you're holding a lot of expansion.

There's a standard cassette interface, a cartridge interface, the RS-232C and serial interfaces, and a system bus that lets you expand RAM and ROM capabilities. There's even a floppy disc drive for maxi capacity in a mini package.

The Epson edge. Surprised that a computer like the HX-20 should come from Epson? You shouldn't be. Because we've been building computers in Japan since 1978. And we've been practicing ultra-high-quality precision manufacturing for a lot longer than that.

We didn't jump right into the American microcomputer market. We could afford to bide our time; to wait for the product that was going to stand America on its ear.

This is it.
The Epson HX-20.

Circle 507 on inquiry card.

EPSON
EPSON AMERICA, INC.
COMPUTER PRODUCTS DIVISION
3415 Kashlwa Street
Torrance, California 90505
(213) 539-9140

FREE MEMORY

THE FIRST AND ONLY
BOARD YOUR IBM
PC MAY EVER
NEED...
AND MORE

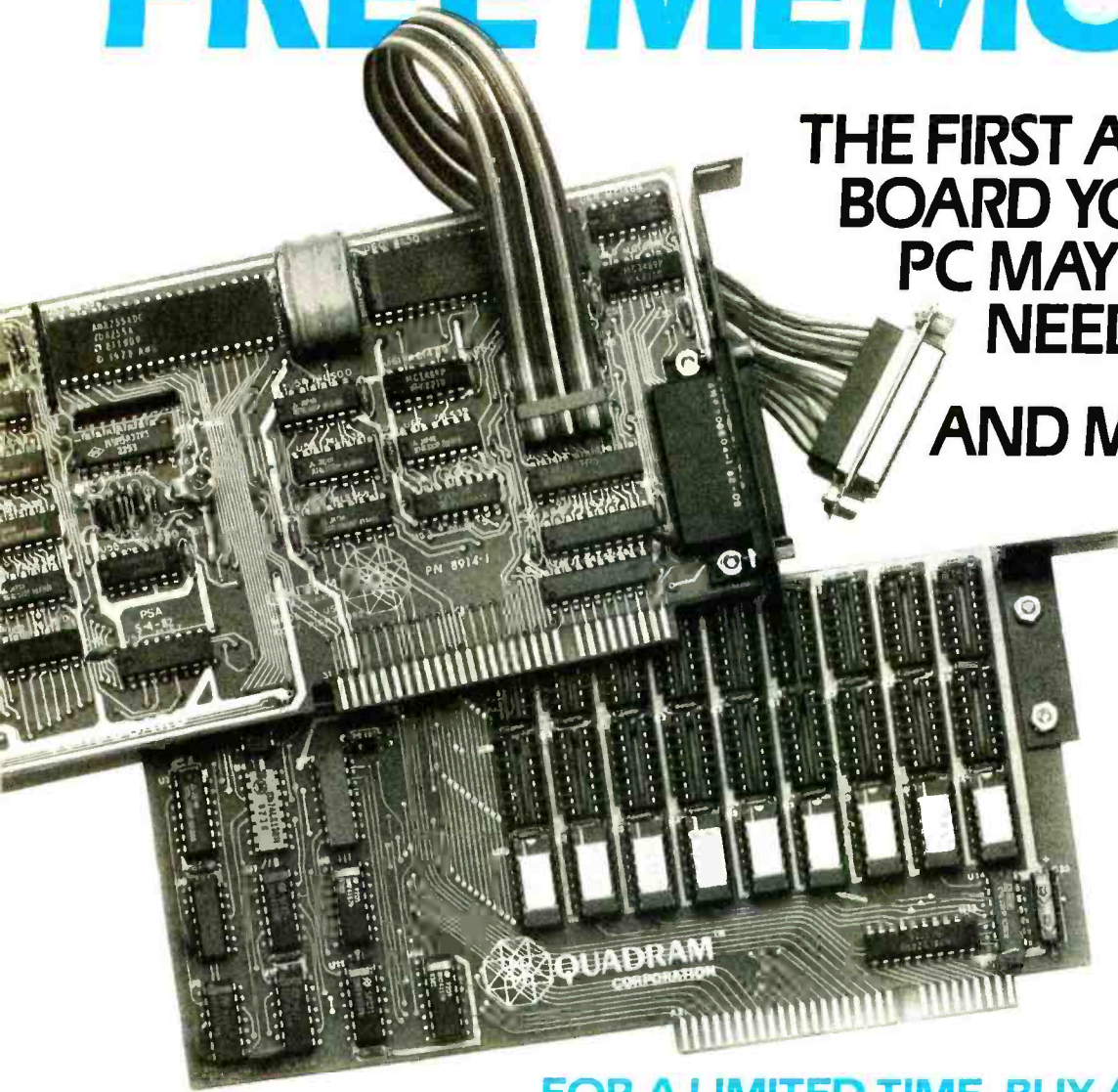

FOR A LIMITED TIME, BUY A 256K
QUADBOARD AND RECEIVE A 64K MEMORY BOARD FREE
OF CHARGE, OR A 192K MEMORY BOARD FOR ONLY \$44.*

In order to receive a free 64K memory board or a 192K memory board for \$44, you must purchase a Quadboard with 256K installed by Quadram from an authorized Quadram dealer between December 1, 1982 and February 15, 1983.

To receive your memory board, send:

- (1) The **original** sales invoice showing dealer name, address, date purchased, and purchase price.
- (2) Coupon from newspaper or magazine (or rebate form available from dealer) completely filled in.
- (3) Proof of purchase (256K label from Quadboard box).
- (4) Warranty card, showing warranty number and all information filled in.
- (5) All receipts, coupons, and proof of purchase forms must be mailed together in order to qualify for a memory board. Must be postmarked no later than March 1, 1983, and received by Quadram by March 15, 1983. Void where prohibited or taxed.

* Quadram suggested retail prices:
256K Quadboard—\$995
64K Memory Board socketed for up to 192K—\$350
192K Memory Board—\$595

Circle 99 on Inquiry card.

Name _____	
Address _____	
City _____ State _____ Zip _____	
Please include shipping and handling charge	\$5.00
<input type="checkbox"/> 64K Memory Board	FREE
<input type="checkbox"/> 192K Memory Board	\$44.00
TOTAL _____	
<input type="checkbox"/> Check Enclosed <input type="checkbox"/> VISA <input type="checkbox"/> MasterCard	
Account # _____ Expiration Date _____	
Offer void where prohibited or taxed by law. Expires February 15, 1983. Allow 8-10 weeks for delivery.	

QUADRAM
CORPORATION

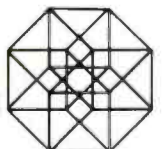

4357 Park Drive/Norcross, Ga. 30093/(404) 923-6666

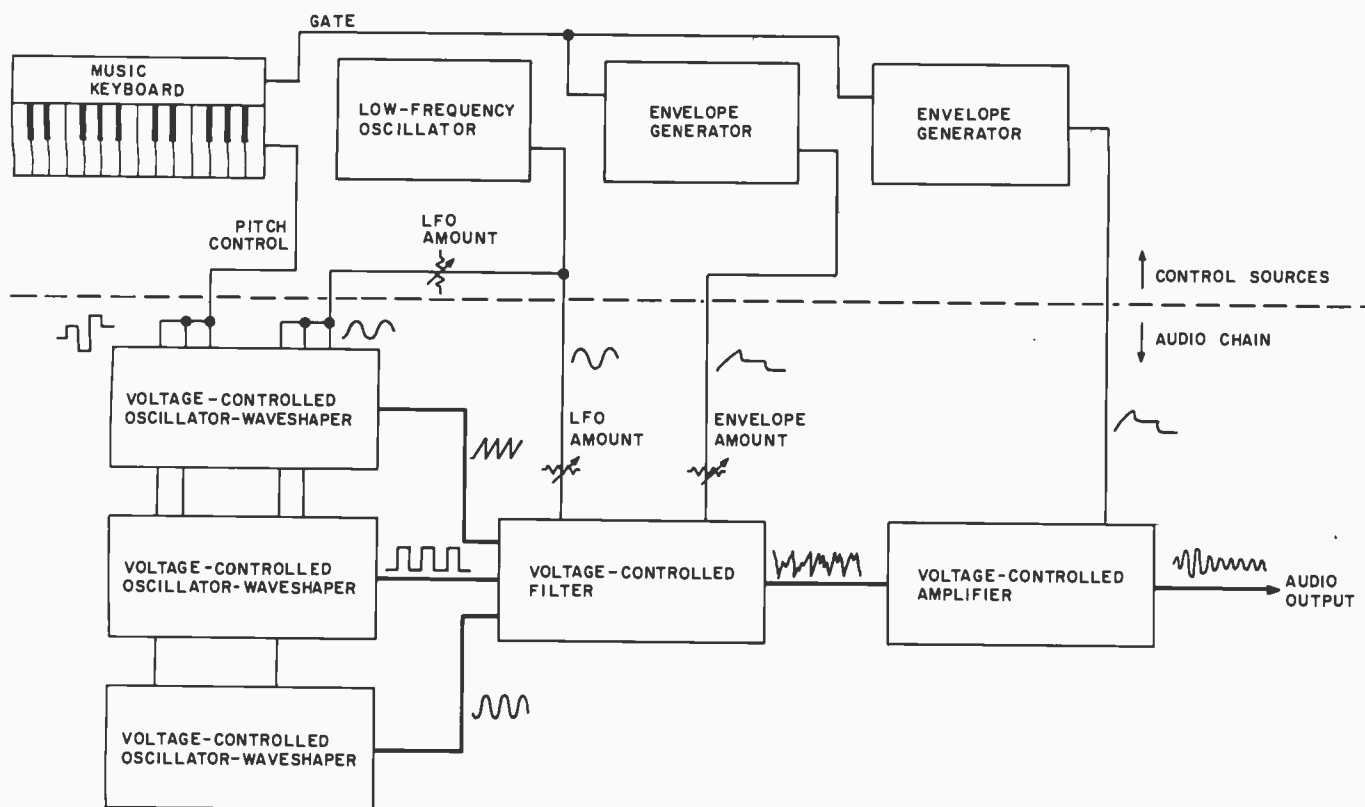

Figure 1: Block diagram of a simple analog music synthesizer. The audio (sound-producing) section lies below the dotted line, while the control (shaping and articulating) section lies above the dotted line.

tion is related to the perceived pitch: when the frequency doubles, the pitch goes up an octave. The shape of the wave determines the overtone content. A signal's overtones are a set of frequencies that are whole-number multiples of the wave's fundamental frequency (the frequency of repetition). We do not hear overtones as distinct pitches but rather as a coloration of the tone's perceived quality. The overtone content, or spectrum, of a signal is related to its waveshape by a mathematical algorithm called the Fourier transform.

The filter alters the oscillator waveform's shape so as to emphasize some overtones and reduce others. A filter is thus a spectrum shaper. Filtering is a powerful way of modifying a sound's tone color. Finally, the amplifier in the audio chain determines the final amplitude, or overall size, of the waveform and thus affects our perception of the sound's loudness.

Voltage Control

Oscillators, filters, and the amplifier in a synthesizer audio chain are generally voltage controlled. This

means that their operating points may be changed by applying varying voltages to the circuits' control inputs. As examples, a series of voltage steps applied to an oscillator's frequency-control input will result in a series of abrupt frequency changes that we hear as a scale; a continuously varying voltage applied to the same control input will give a pitch glide. A control voltage applied to the filter's frequency-control input will move the filter's frequency response back and forth across the audio spectrum, varying the sound's overall brightness, while a control signal applied to the bandwidth input will change the shape of the filter's frequency response, making the sound more or less "vocal" or "nasal." Finally, signals applied to the amplifier's gain-control input will impart dynamic variations to the sound's overall loudness.

Control signals are never heard directly but instead impart motion and texture to the sounds that the audio chain produces. Control signals often influence a sound's tone color (timbre) more than the static properties (initial frequency, initial

waveform, and initial amplitude) of the audio chain. This is because we hear changes in sound much more easily than we hear the average or steady properties of the sound.

Three of the most common sources of control signals are the music keyboard, which produces voltage steps; the generator of low-frequency periodic signals (called an LFO, or low-frequency oscillator), which imparts periodic variations such as vibrato; and the generator of transient signals (called an envelope generator or a contour generator), which provides overall shape to individual notes. The upper half of figure 1 shows a typical complement of control functions. The keyboard changes the oscillator's pitches and may also move the filter's cutoff frequency. The LFO varies either the oscillators or the filter to produce a wide variety of effects that musicians call by names such as vibrato, tremolo, trill, and growl. One of the envelope generators moves the filter frequency response to produce hornlike, plucked-string-like, or vocal ("wah-wah") effects, while the other opens and closes the amplifier

AVAILABLE NOW!

UCSD
p-SYSTEM*
(VERSION IV.1)
FOR THE
VICTOR
9000*

THE MOST PORTABLE, POWERFUL AND POPULAR OPERATING ENVIRONMENT IS NOW AVAILABLE FOR IMMEDIATE SHIPMENT FOR THE VICTOR 9000 / SIRIUS COMPUTER

- Full screen editor
- Comprehensive filer and utilities
- PASCAL, FORTRAN and BASIC compilers
- Object code compatibility with IBM, Osborne, TI, DEC
- Extended memory
- TURTLEGRAPHICS
- Full use of Victor screen
- Native code generator
- Complete trade off between size and speed
- Xenofile
- p-SYSTEM to/from CP/M 86
- Complete documentation 700 pages
- Runtime only systems also available

*Trademarks
Regents of the University of California
Victor Business Products

Combine a great machine with a great operating system

ONLY FROM TDI:

620 HUNGERFORD DRIVE,
SUITE 33,
ROCKVILLE, MD. 20850
(301) 340-8700

29 ALMA VALE ROAD
BRISTOL, U.K. BS8 2HL
0272-742796

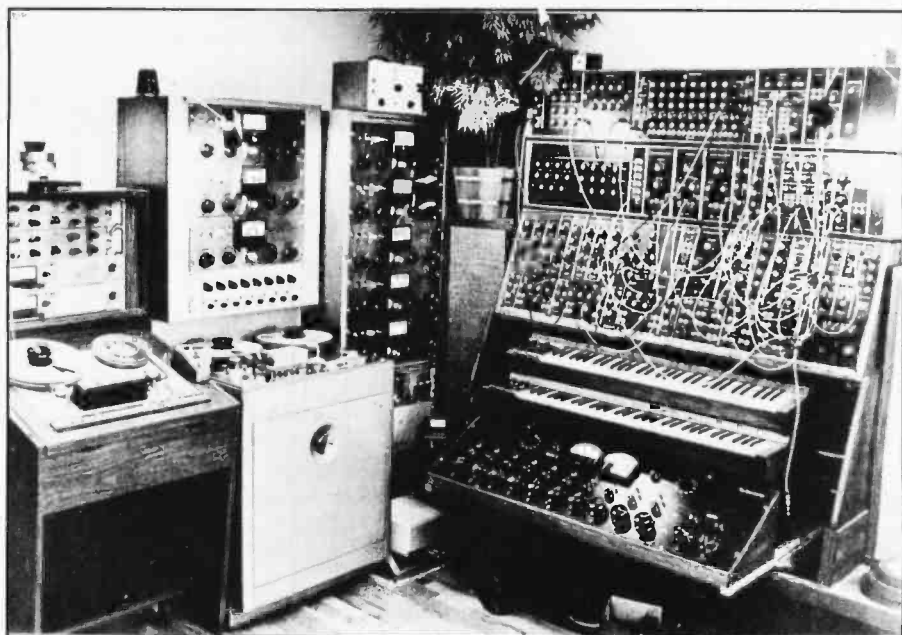

Photo 1: W. Carlos's electronic music production studio in 1968. There Carlos produced the recording "Switched-on Bach." At right is the modular Moog synthesizer. At left is a multitrack recorder, which was used to record the music one line at a time. Below the synthesizer is a 10-input mixer designed and built by Carlos.

to give the sound its overall loudness shape. Generally, the envelope generators are triggered each time a new key is depressed.

Synthesizer Programming

Academic and experimental composers first used synthesizers to explore new ways of making music electronically. In 1968 "Switched-on Bach," a fine recording of the music of J.S. Bach, performed by W. Carlos and B. Folkman, achieved widespread popularity. Carlos and Folkman used a modular Moog synthesizer (see photo 1) to produce all of the recording's sounds and assembled the music on a multitrack tape recorder, one line at a time. Since then, hundreds of synthesizer records have graced the shelves of record stores, and countless television and film scores, commercials, and dramatic presentations have been made by techniques that were pioneered by Carlos and her colleagues.

In Carlos's synthesizer, each circuit function is a separate modular piece of hardware. The musician connects the modules together with audio patch cords and then adjusts the panel controls for the desired operat-

ing points (tone color). Synthesists call this process *programming*. It is differentiated from *performing*, which is actually producing a succession of sounds by playing a music keyboard or similar device. Programming is a problem for many musicians because it takes so long. Worse than that, modular analog synthesizers have no practical way of storing and recalling programs, so a musically interesting, complex tone color or sound pattern may be difficult if not impossible to recreate exactly. Because of these limitations, conventional modular synthesizers are generally not suitable for live performance. Studio musicians who work with tape recorders can afford to spend time getting the right tone colors, but musicians who perform before an audience must have immediate access to their sound palettes.

To meet the needs of live performers, "compact performance synthesizers," featuring quick, accurate access to sound parameters, were introduced in the early 1970s. They were *monophonic* (capable of producing only one or, at most, two notes at a time). Some of the instruments had presets, like vending machines for sounds, while others

MICRO



BUSINESS WORLD INC.
Information Line (213) 996-2252
TOLL FREE MAIL ORDER LINES
(800) 423-5886 Outside Calif.

LE MONITOR

9" GRN PHS MSL 189.00	12" GRN PHS MSL 189.00
OUR PRICE 88.00	OUR PRICE 119.00
Save \$101.00	Save \$70.00



SPECIAL OF THE MONTH GRAPHICS
Add a Genie in Your Computer Intelligent Printer
Interface Card Works With
Integer Basic
Applesoft*
Pascal 1.0 & 1.1
CP/M**
OUR PRICE \$119.00
MSL 159.00
Save \$40.00
*Applesoft is a registered trademark of Apple Computer, Inc.
**CP/M is a registered trademark of Digital Research.



MICRO-SCI APPLE II+ COMPATIBLE DRIVE

W/ CONTROLLER		W/O CONTROLLER	
MSL	OUR PRICE	MSL	OUR PRICE
549.00	429.00	449.00	379.00
Save \$216.00	COMPARE TO APPLE DRIVE	Save \$146.00	COMPARE TO APPLE DRIVE

APPLE IS A REG. TRADE MARK OF APPLE COMPUTER

IBM PERSONAL COMPUTER

INCLUDES:
2 Drives DS/DD
Color Graphic Board
64K Memory
12" BMC GRN PHS

OUR PRICE \$2895.00
MSL 3305.00
Save \$410.00
*Subject to availability

APPLE II PLUS 48K

*Subject to availability

MSL 1530.00
OUR PRICE \$1095.00
Save \$435.00

APPLE IS A REG. TRADEMARK OF APPLE COMPUTER

THE APPLE COMPATIBLE ALTERNATIVE FRANKLIN BUSINESS SYSTEM

Franklin Ace 1000 system • 64K • Disk Drive with controller card • 12" green phs. video monitor.
Color optional \$49.00

OUR PRICE \$1695.00
MSL 2190.00
Save \$495.00
SAVES \$1000 COMPARED TO APPLE SYSTEM

OSBORNE PERSONAL COMPUTER

INCLUDES SOFTWARE

- CPM
- WORDSTAR
- SUPERCALC
- MAIL MERGE
- CB BASIC
- M BASIC

MSL 1795.00
OUR PRICE \$1595.00
Save \$200.00

NEC STUDENT SYSTEM 64K

*NEC PC 80001
*NEC PC 8012
*NEC PC 8031
12" Grn. Phs. Video Monitor

MSL 2839.00
OUR PRICE \$2095.00
Save \$744.00

RADIO SHACK TRS 80 MOD III 48K 2 DRIVE

MSL 2495.00
OUR PRICE \$1733.00
Save \$762.00

Commodore STUDENT SYSTEM

4032 - 32K 40 COL CRT
4940 - DUAL DISK DRIVE

MSL 2590.00
OUR PRICE \$1978.00
Save \$612.00



APPLE ACCESSORIES

	MSL	Our Price
Prometheus Versacard	\$ 295.00	\$ 209.00
CPS Multif. Function Card	235.00	165.00
Video Video Term. 80 Column Card	349.00	239.00
Video Keyboard Enhancer (orig)	99.00	74.00
Video Keyboard Enhancer II	149.00	119.00
2.80 Softcard by Microsoft	395.00	277.00
16K Ramcard by Microsoft	195.00	149.00
Thunderclock/Calendar Card	149.00	109.00
Smartmodem 80 Column Card	349.00	277.00
Corvus Winchester 5MB Disk	3195.00	2900.00
Corvus Winchester 10MB Disk	4995.00	4250.00
Corvus Winchester 20MB Disk	5995.00	5060.00
ALF 3 Voice Music Card	249.00	177.00
ALF 9 Voice Music Card	195.00	145.00
Joysticks By Keyboard Co.	65.00	44.00
2 3 Key Numeric Keypad by Microsoft	149.00	112.00
Music System (16 voices) Mtn	395.00	288.00
AVD+D/A Interface by Mountain	349.00	267.00
Expansion Chassis (8 slots)	449.00	365.00
C Lock/Calendar Card by Mounin	280.00	219.00
Superkiter SD-200 by Mountain	195.00	145.00
Romplus + Card	175.00	119.00
Romwriter Card	195.00	137.00
Ramplus 32K Ram Add Dn(w/16k)	195.00	137.00
Sup R-Fan	65.00	45.00
Sup R-Terminal 80 Column Card	395.00	288.00
Versawriter Digitizer Tablet	349.00	245.00
A Synchronous Serial Card by CCS	175.00	135.00
Centronics Parallel Card by CCS	135.00	109.00
Grappier Printer Interfaces	175.00	135.00
SVA 2+2 Sgl Den 8" Disk Cont		
SVA 2VX4 Megabyte 8" Disk Cont		
Apple Cache 256K By SVA		
IEEE-488 Interface by SSM	495.00	377.00

IBM PERSONAL COMPUTER PERIPHERALS & SOFTWARE

	MSL	Our Price
HARDWARE		
CORVUS Hard Disk 5MB	\$3195.00	\$2795.00
Microsoft		
64K Ram Card	399.00	369.00
128K Ram Card	599.00	475.00
256K Ram Card	995.00	777.00
64K Ram chips	195.00	155.00
Quadram		
Quad Ram 256K, 4function brd	995.00	675.00
TG Products		
Joystick	65.00	47.00
SOFTWARE		
Automated Sim. Temple of Apshe	35.00	28.00
Cavalier Championship Blackjacks	35.00	28.00
Continental Home Accountant Plus	149.00	109.00
Denver EasyExec Accounting Sys.	695.00	535.00
Infocom Deadline	35.00	27.00
Innovative T.I.M. III (a DBMS)	450.00	355.00
ISM Mathmagic	75.00	65.00
Into Unlimited		
Easy writer II	350.00	269.00
Phone Support of Easywriter II	350.00	269.00
Easyspeller (88K words)	150.00	119.00
Easyspeller (aOBMS)	400.00	295.00
Micro Pro Wordstar	495.00	295.00
Scorim Superwriter	395.00	289.00
Super Calc	295.00	210.00
Visicorp Visicalc	200.00	155.00
Visicalc/256K	250.00	189.00
Desktop Plan I	300.00	240.00
VisiTrend/Plot	300.00	240.00
VisiDex	250.00	199.00
VisiFile	250.00	199.00
VersaWriter Graphics Tablet	299.00	255.00
Conquest	29.95	24.00
Frogger	34.95	29.00
The Tax Manager	250.00	199.00
Galaxy	25.00	21.00
Midway Campaign	25.00	17.95
Computer Stocks and Bonds	25.00	21.00
Voyager	25.00	21.00
Draw Poker	21.00	17.95
Lost Colony	21.95	23.95

HP HEWLETT PACKARD

HP-11C Slim-Line Advanced	135.00	119.00
HP-12C Slim-Line Financial	150.00	129.00
HP-41 CV New 2.2		
Bytes Mem	325.00	250.00
HP-41-C Calculator	250.00	185.00
Card Reader For 41CVC	215.00	162.00
Printer For 41CVC	385.00	289.00
Optical Wand For 41 CVC	125.00	97.00
Quad Ram Equals		
4 Mem. Mods	95.00	81.00
Memory Modules For 41C		
HP-97 Programmable Printer	750.00	595.00
HP-67 Programmable Calculator	375.00	295.00
HP-34C Programmable Scientific Calculator	150.00	117.00
HP-38C Programmable Bus. R/E	150.00	117.00
HP-32E Adv. Scientific	55.00	48.00
HP-37E Business Mgmt.	75.00	57.00

MONITORS

NEC		
Nec 12" Hi Res Green Monitor	210.00	165.00
Nec 12" Composite Color Monitor	449.00	345.00
SANYO		
Sanyo 9" B & W	225.00	165.00
Sanyo 9" Green Monitor	225.00	169.00
Sanyo 12" B & W	275.00	185.00
Sanyo 12" Green	320.00	249.00
(New Case Style)		
Sanyo 13" Color Monitor	489.00	359.00
ZENITH		
Zenith 12" Green Monitor	159.00	119.00

PRINTERS

	MSL	Our Price
EPSON		
Epson MX-80 T Type III w/graphics	645.00	429.00
Epson MX-80F/T Type III w/graphics	745.00	525.00
Epson MX-100 Type III w/graphics	995.00	669.00
OKIDATA		
Okidata 824 w/tractor 80 col	649.00	457.00
Okidata 83A W/tractor 132 col	995.00	719.00
Okidata 84A 132 col serial	1495.00	1177.00
Okidata 84A 132 col parallel	1395.00	1019.00
C. ITOH		
C. Itoh F 10 40 cps (parallel)	1795.00	1377.00
C. Itoh F 10 40 cps (serial)		1439.00
C. Itoh Prowriter (parallel)	695.00	519.00
C. Itoh Prowriter (serial)	749.00	565.00

DRIVES

5 1/4" FLOPPY DISK DRIVES		MSL	Our Price
For the IBM Personal Tandem TM 100 1	Single Sided 48TPI	\$295.00	\$239.00
For IBM/AnthraStar/Comemore Tandem TM1002	Dual sided 48TPI	395.00	319.00
5 1/4" WINCHESTER DRIVES			
Seagate ST 506	6.38Mb	1500.00	1179.00
Seagate ST 412	12.76Mb	1750.00	1275.00
Tandon TM 602	6.4Mb	1395.00	1079.00
Tandon TM 603	9.6Mb	1500.00	1179.00

WE RESERVE THE RIGHT TO CORRECT TYPOGRAPHICAL ERRORS. THIS AD SUPERCEDES ALL PREVIOUS ADS.

MICRO 20929 Ventura Blvd. Woodland Hills, Ca. 91364
Telex: 182852 Answer: MICKO TZNA

OUTSIDE CA CALL TOLL FREE 1 (800) 423-5886 IN CA (213) 996-2252

Name (Please print) _____
Address _____
City _____ State _____ Zip _____

Qty	Make	Model	Description	Price	Total

Certified Check or M.O. Bank Wire Transfer Allow 2 weeks clearance for personal check

CREDIT CARD # _____ Exp. Date _____ Signature _____

TOTAL ORDER \$ _____
TAX IF APPLICABLE* _____
SHIPPING & HANDLING** _____
TOTAL ENCLOSED \$ _____

VISA **MasterCard**

reduced the functions of modular instruments to the bare essentials, then replaced patch cords with fast-acting switches.

The biggest programming breakthrough came when microcomputers were built into performance synthesizers. In many late-model synthesizers, microcomputers scan the control panel to store the control setting as digital information for instant, accurate recall, scan the music keyboard to find out what keys the musician is holding down, and assign the pitch values of these keys to the instrument's ranks. In one stroke, the microprocessor-controlled synthesizer thus solved two big equipment problems: (1) rapid access to a wide variety of user-defined tone colors and (2) how to "play" a limited number of voices from a music keyboard with several dozen keys. Today, the microprocessor-controlled *polyphonic* (chord-playing) synthesizers with analog voice circuitry dominate the more expensive end of the electronic keyboard instrument market. They have 4 to 16 analog

voices, 1 or 2 keyboards, and a panel full of committed, "hard" controls and switches. They sell at prices from 2 to 70 "kilobucks." Most musicians agree that they sound very good.

Digital Sound Synthesis

Electronic musical instrument designers are currently embroiled in a debate over whether digital or analog audio circuitry is more "musical." The current widespread popularity of electronic keyboard instruments is due in no small degree to the simple fact that, during the past few decades, we engineers have learned how to make some really fine-sounding analog audio circuitry. Can a digitally generated waveform, consisting of smoothed-out discrete steps, compete for the musician's ears with a continuously generated waveform from an analog circuit? The answer, of course, is yes, if the steps are small enough. We are talking about the steps not only in the audio waveform itself but also in the values of the control parameters that define the musical qualities of the waveform.

For instance, a gliding pitch (called *portamento* by musicians) produced by a conventional analog synthesizer is stepless. One does not hear abrupt steps in pitch because there are none. In a tone produced by a digital oscillator or programmable counter, on the other hand, pitch glides are produced by periodically updating the number that specifies the frequency. If these frequency changes are too great, or if the time interval between them is too long, then we hear steps. If, however, the time between updates is very short, then the glide will sound smooth. In between, we may not actually hear discrete pitch changes, but the sound may have a roughness or muddiness that we barely perceive. Acousticians and musical instrument designers don't really know how rapidly parameters have to change or how fine the change has to be in order for it to be perceived as truly continuous. For this reason, both approaches have their loyal followers. At today's state of the art, both may easily be put under computer control. ■

SuperBrain II™ - CompuStar™ Network Systems

- Excellent dealer & EDM discounts
- CMC's own national on-site service
- Toll-free Ordering & technical assistance
- Module replacement
- Advertising co-op
- After-sale support

CMC ALSO OFFERS

- Six-month warranty
- High resolution graphics
- System support training in our facilities
- Optional green phosphor screen
- Enhanced DOS software with advanced files directory, diagnostics, disk editor, communications software and others

SOFTWARE, PERIPHERALS FOR SUPERBRAIN COMPUSTAR

SOFTWARE		PRINTERS	MODEMS	MISC.
Accounting Plus	Microsoft	Datasouth	Anderson-Jacobson	Line Filters
Wordstar	MBasic	Epson	CAT Novation	Power Supplies
dBase II	Fortran 80	C. Itoh	HARD DISKS	
Microplan	Cobol 80	Okidata	CMC Targa	
Profitplan	M/T Pascal	NEC	Corvus	
Bisynch 80	P/L1 80	Starwriter	MEDIA	
CBasic II	Spellguard	F10	Dysan	
	Spellstar		Verbatim	

**CompuStar
Hard Disk
Systems**
10mb, 32mb & 96mb

Control Data Corp.
Phoenix Drives
9448-96 CMD
9448-32

**LOWEST PRICES
ANYWHERE!**



CMC INTERNATIONAL

A Division of Computer Marketing Corporation
11058 Main Street, Suite 220
Bellevue, Washington 98004
TELEX: 152556 SEATAC

For Information Call (206)453-9777
To Order, Call Toll-free 1-800-426-2963

DEALER INQUIRIES, GSA, GOVERNMENT, EDUCATIONAL BIDS INVITED

SuperBrain and CompuStar are registered trademarks of Intertec Data Systems Corporation

64K STATIC RAM MEMORY

See Us At
Booth 4323
COMDEX

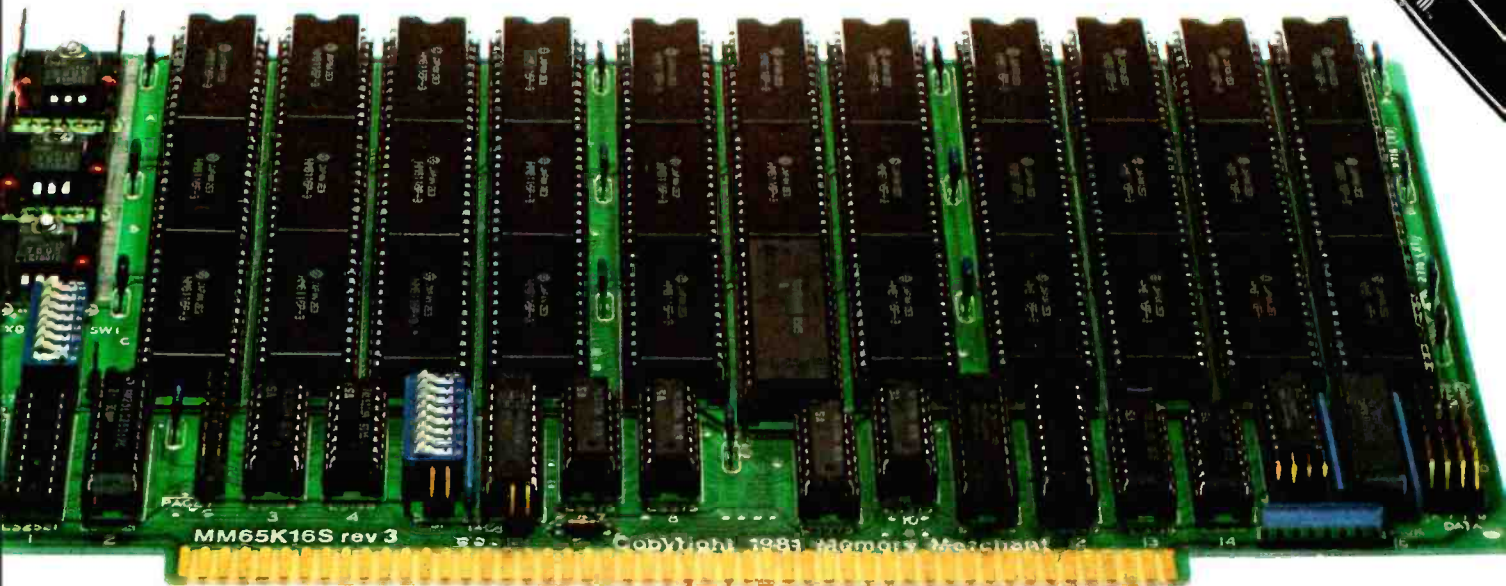

S-100 STATIC MEMORY BREAKTHROUGH

Finally, you can buy state-of-the-art S-100/IEEE 696 static memory for your computer at an unprecedented savings.

Memory Merchant's memory boards provide the advanced features, quality and reliability you need for the kind of operational performance demanded by new high-speed processors.

Completely Assembled.

These memory boards are not kits, nor skeletons — but top-quality, high-performance memories that are shipped to you completely assembled, burned-in, socketed, tested and insured with one of the industry's best warranties.

Superior Design & Quality.

Memory Merchant's boards are created by a designer, well known for his proven ability in advanced, cost-efficient memory design. Innovative circuitry provides you with highly desired features and incredible versatility.

Only first-quality components are used throughout, and each board is rigorously tested to assure perfect and dependable performance.

No Risk Trial.

We are so convinced that you will be absolutely delighted with our boards that we extend a no-risk trial offer. After purchasing one of our boards, you may return it (intact) for any reason within 15 days after shipment and we will refund the purchase price (less shipping).

NEW S-100 PRODUCTS COMING SOON:

- * DUAL 8/16 BIT CPU BOARD
- * 128K 8/16 BIT STATIC RAM
- * 256K 8/16 BIT DYNAMIC RAM

\$629.

48K PARTIALLY POPULATED \$519.
32K PARTIALLY POPULATED \$409.

64K RAM, MODEL MM65K16S

- 64K x 8-bit
- Speed in excess of 6 MHz
- Uses 150ns 16K (2K x 8) static RAMS
- Ultra-low power (435 Ma. max. — loaded with 64K)
- Bank Select **and** Extended Addressing
- A 2K window which can be placed anywhere in the 64K memory map
- Four independently addressable 16K blocks organized as:
 - Two independent 32K banks **or**
 - One 64K Extended Address Page **or**
 - One 48K and one 16K bank for use in MP/M¹ (option)
- Each 32K bank responds independently to phantom
- 2716 (5V) EPROMS may replace any or all of the RAM
- Field-proven operation in CROMEMCO CROMIX* and CDOS*
- Compatible with latest IEEE 696 systems such as Northstar, CompuPro, Morrow, IMS, IMSAI front panel, Altair and many others.

OEM and DEALER inquiries invited.

Memory™
Merchant

14666 Doolittle Drive
San Leandro, CA 94577
(415) 483-1008

Circle 293 on Inquiry card.

FULL TWO-YEAR WARRANTY.

The reliability of our boards, through quality-controlled production and proven performance, has enabled us to extend our warranty to a full two years. That's standard with us, not an option. This includes a 6-month exchange program for defective units.

Shipped direct from stock.

All Memory Merchant's boards are shipped direct from stock, normally within 48 hours of receipt of your order. Call us at (415) 483-1008 and we may be able to ship the same day.

16K RAM, Model MM16K14

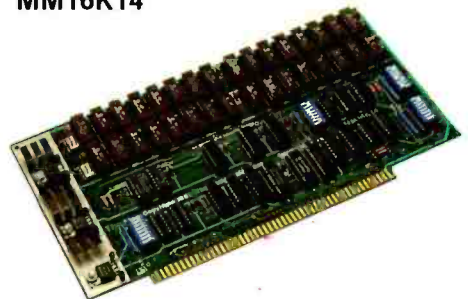

16K STATIC RAM \$169.

16K x 8 Bit
Bank Select & Extended Addressing
Four independently addressable 4K blocks

One 4K segment equipped with 1K windows

Uses field-proven 2114 (1K x 4) RAMS
Low Power (less than 1.2 Amps)
Runs on any S-100 8080, 4 MHz Z-80 or 5 MHz 8085 system.

Prices, terms, specifications subject to change without notice.

*Cromix and CDOS are trademarks of CROMEMCO.

¹ MP/M is a trademark of Digital Research

The 8051 One-Chip Microcomputer

A Most Powerful Microcontroller

*Hardware-intensive applications can show off
the power of software.*

Howard Boyet
Microprocessor Training Inc.
14 East 8th St.
New York, NY 10003

Ron Katz
Bell Telephone Laboratories
Whippany, NJ 07981

The 8051 single-chip microcomputer, and its other versions in the MCS-51 family, is a recent development of the Intel Corporation (see figure 1). It is a complete 8-bit computer fabricated on a single silicon die. Intel claims that the MCS-51 family "is the highest performance microcomputer family in the world and outperforms all microprocessors and microcomputers in control-oriented applications." It achieves a tenfold function/speed improvement over its predecessor, Intel's 8048, by

packing 60,000 transistors onto a silicon die about 230 mils square.

The 8051 is designed for applications in the high end of the single-device computer market. It is intend-

The 8051 packs 60,000 transistors on a single silicon die for enhanced performance.

ed for use in sophisticated real-time instrumentation, industrial controls, and intelligent computer peripheral devices.

Three versions of this microcomputer exist (collectively, this is the MCS-51 family):

- The 8031 has no on-chip program memory. It can address 64K bytes of external program memory, in addi-

tion to 64K bytes of external data memory.

- The 8051 has its lower 4K bytes of program memory filled with on-chip mask-programmable ROM (read-only memory).

- The 8751 has those 4K bytes occupied by EPROM (erasable programmable read-only memory).

Each version can be expanded to 64K bytes of program memory, and/or 64K bytes of data memory, using standard memories and byte-oriented peripheral devices. All three have 128 bytes of internal on-chip data memory and 128 bytes assigned as SFRs (special-function registers), some of which are reserved for future assignment; effectively, there are 256 bytes of internal data memory.

In this article, we shall first broadly describe the unique hardware and software features of the 8051 that make it such a powerful device and

This article is based on the book The 8051: Programming, Interfacing, and Applications. 81 Hands-On Experiments with Intel's SDK-51 by Howard Boyet and Ron Katz, MTI Publications (14 East 8th St., New York, NY 10003, [212] 473-4947), 1982, 396 pages, \$19.95. Mr. Katz's work relative to this article was not sponsored by Bell Telephone Laboratories.

Copyright © 1982 by Howard Boyet and Ron Katz.

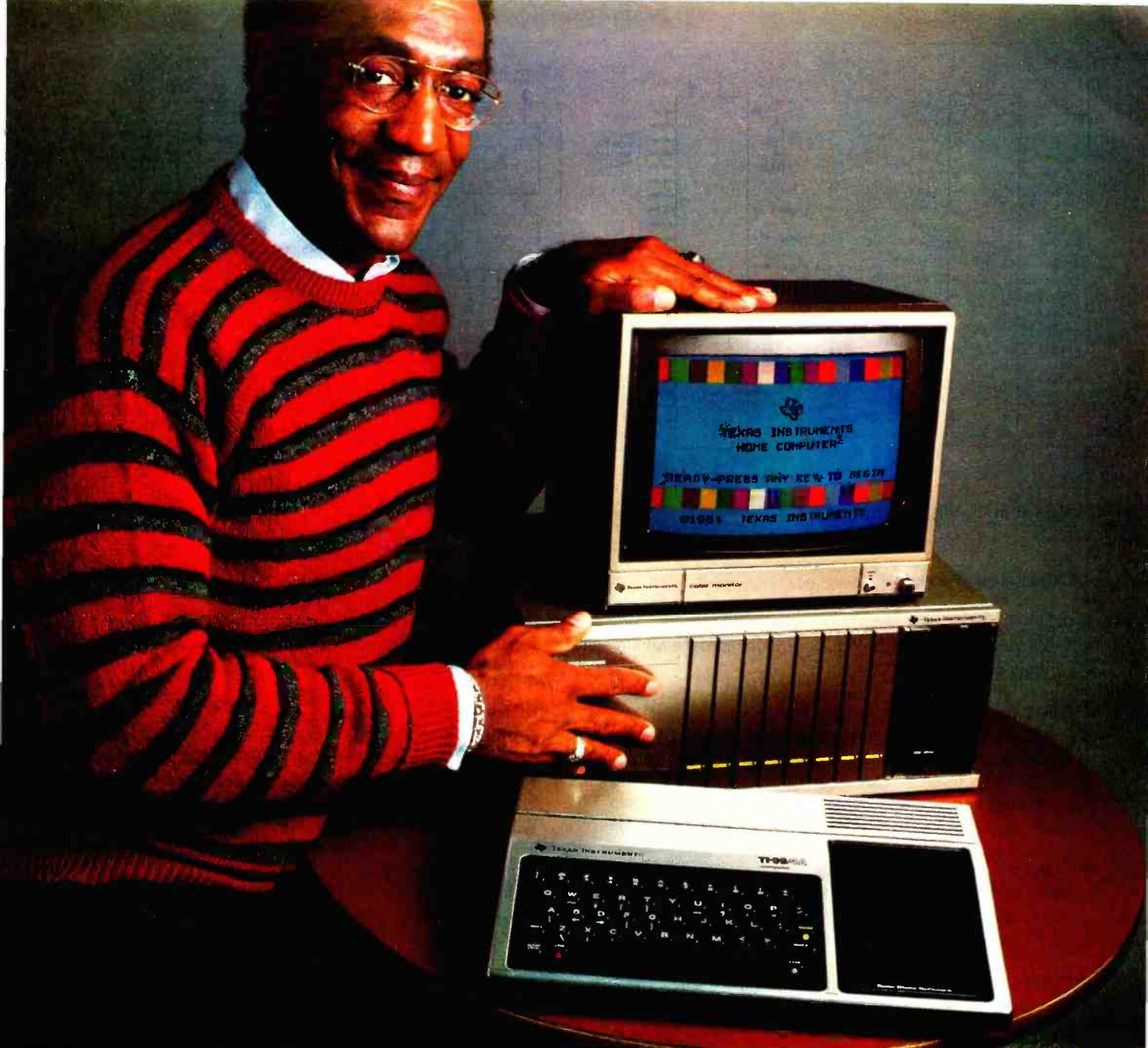

"TI's Home Computer. This is the one."

A lot of computers offer a lot. Only one in its price range offers the most. The TI Home Computer.

Better to begin with. Anyone can start right away with our Solid State Software™ Command Cartridges. Dozens of programs are available in home management, education and entertainment.

Easy to expand. Our Peripheral Expansion System gives you plug-in cards for memory expansion, P-Code capabilities, a disk drive controller and the RS232 Interface. You can also add a modem, speech

synthesizer, disk drive and 80 column dot matrix printer.

Programming flexibility. TI BASIC is built into the Home Computer. But it can also handle TI Extended BASIC, UCSD Pascal* Version IV.0, TI LOGO II, TMS 9900 Assembly Language and TI PILOT. Programs can be stored in the optional Mini Memory Command Cartridge.

High-Tech specs. 16-bit microprocessor, 16K bytes RAM (expandable to 52K). 26K bytes internal ROM, up to 30K bytes external ROM. 3 simultaneous tones from

110 HZ to 40,000 HZ. High resolution video. U. & L.c. Single line overlay for 2nd function. Control & function keys. 16 color graphics with 4 modes & sprites.

Sound impressive? Compare a TI Home Computer with the competition and really be impressed. You won't even need a computer to tell you this is the one.



TEXAS INSTRUMENTS

© 1982 Texas Instruments

*UCSD Pascal is a trademark of the Regents of the University of California
www.americanradiohistory.com

Circle 462 on inquiry card.

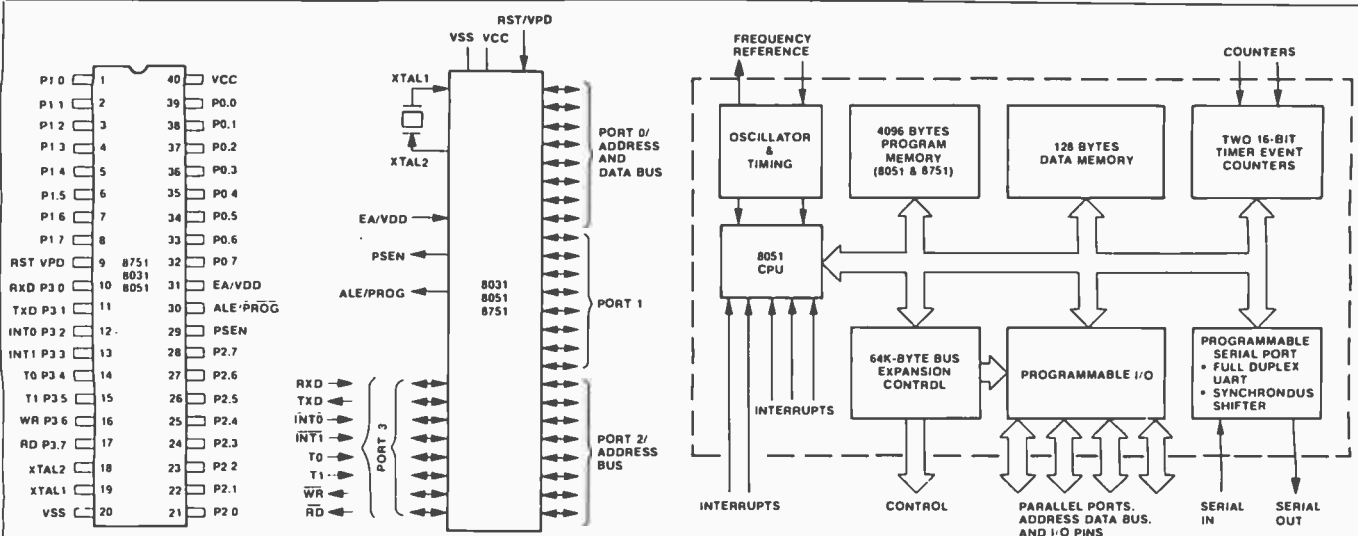

8051 Family Pin Description

V_{SS}
Circuit ground potential.

V_{CC}
+5V power supply during operation, programming and verification.

PORT 0

Port 0 is an 8-bit open drain bidirectional I/O port. It is also the multiplexed low-order address and data bus when using external memory. It is used for data input and output during programming and verification. Port 0 can sink/source two TTL loads.

PORT 1

Port 1 is an 8-bit quasi-bidirectional I/O port. It is used for the low-order address byte during programming and verification. Port 1 can sink/source one TTL load.

PORT 2

Port 2 is an 8-bit quasi-bidirectional I/O port. It also emits the high-order address byte when accessing external memory. It is used for the high-order address and the control signals during programming and verification. Port 2 can sink/source one TTL load.

PORT 3

Port 3 is an 8-bit quasi-bidirectional I/O port. It also contains the interrupt, timer, serial port and \overline{RD} and \overline{WR} pins that are used by various options. The output latch corresponding to a secondary function must be programmed to a one (1) for that function to operate. Port 3 can sink/source one TTL load. The secondary functions are assigned to the pins of Port 3, as follows:

- FXD/data (P3.0). Serial port's receiver data input (asynchronous) or data input/output (synchronous).
- TXD/clock (P3.1). Serial port's transmitter data output (asynchronous) or clock output (synchronous).
- $\overline{INT0}$ (P3.2). Interrupt 0 input or gate control input for counter 0.

- $\overline{INT1}$ (P3.3). Interrupt 1 input or gate control input for counter 1.
- T0 (P3.4). Input to counter 0.
- T1 (P3.5). Input to counter 1.
- \overline{WR} (P3.6). The write control signal latches the data byte from Port 0 into the External Data Memory.
- \overline{RD} (P3.7). The read control signal enables External Data Memory to Port 0.

RST/V_{PD}

A low to high transition on this pin (at approximately 3V) resets the 8051. If V_{PD} is held within its spec (approximately +5V), while V_{CC} drops below spec, V_{PD} will provide standby power to the RAM. When V_{PD} is low, the RAM's current is drawn from V_{CC} . A small internal resistor permits power-on reset using only a capacitor connected to V_{CC} .

ALE/ \overline{PROG}

Provides Address Latch Enable output used for latching the address into external memory during normal operation. Receives the program pulse input during EPROM programming.

PSEN

The Program Store Enable output is a control signal that enables the external Program Memory to the bus during normal fetch operations.

\overline{EA}/VDD

When held at a TTL high level, the 8051 executes instructions from the internal ROM/EPROM when the PC is less than 4096. When held at a TTL low level, the 8051 fetches all instructions from external Program Memory. The pin also receives the 21V EPROM programming supply voltage.

XTAL1

Input to the oscillator's high gain amplifier. A crystal or external source can be used.

XTAL2

Output from the oscillator's amplifier. Required when a crystal is used.

Figure 1: Physical aspects of the Intel 8051. These three drawings show the pin description, the logic symbol, and the block diagram. (This figure is reproduced by permission of Intel Corporation from reference 3.)

Microline 83A

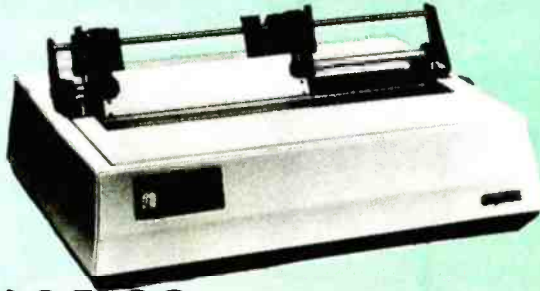

\$694.88 UPS DELIVERED

- 120 characters per second, bi-directional, logic-seeking print action
- Full 136 columns. 10, 16, 5 & 8 cpi, true U/I case (9-pin printhead)
- Both parallel & RS-232C interfacing standard
- Tractor & friction feed with rear & bottom paper paths
- Okigraph ROM for the Microline 83A **\$44.88**



FRANKLIN
COMPUTER CORPORATION

ACE1000



The Franklin Ace 1000 includes 64K RAM, upper & lower case character set, alpha-key lock, numeric keypad, 8 peripheral slots, and a built-in cooling fan. The Franklin Ace 1000 has full hardware/software compatibility with the Apple II®

Our special package price includes a **Franklin Ace 1000**, the **Rana Elite One Drive & Controller**, and a **Pi-4 9" Amber Monitor** and cable.

All for only **\$1764.40**, UPS delivered.

PRINTERS

Anadex DP-9500A	\$1459.88
Anadex DP-9501A	\$1459.88
Anadex DP-9629A	\$1549.88
Centronics 122-1	\$829.88
Centronics 122-3	949.88
Centronics 352	\$1649.88
Centronics 353	\$2324.88
C. Itoh Prowriter	\$499.88
w/RS-232C	\$614.88
C. Itoh Prowriter 2	\$734.88
w/RS-232C	\$794.88
C.Itoh F-10 Starwriter, 40 cps Parallel or RS-232C	\$1499.88
C.Itoh F-10 Printmaster, 55 cps Parallel or RS-232C	\$1799.88
F-10 Tractor	\$289.88
Daisywriter 2000	\$1089.88
Daisywriter Tractor	\$149.88
Daisywriter Cable	\$49.88
Diablo 620	\$1349.88
Diablo 630	\$2264.88
Diablo 630 KSR	\$2794.88
630 Tractor	\$314.88
DMP-85 Printer	\$469.88
IDS Microprism	\$684.88
IDS Prism 80	\$1174.88
Prism 80 w/4-color	\$1539.88
IDS Prism 132	\$1254.88
Prism 132 w/4-color	\$1699.88
Microline 80	\$349.88
Microline 82A	\$439.88
80/82A Tractor	\$59.88
82A Roll Paper Holder	\$49.88
82A Okigraph ROM	\$44.88
Microline 84 w/graphics, tractor Parallel, 200 cps	\$1044.88
RS-232C, 200 cps	\$1164.88
NEC PC-8023A	\$509.88
NEC 3510	\$1929.88
NEC 3530	\$1809.88
NEC 3550	\$2199.88
3500 Tractor	\$239.88
NEC 7710	\$2559.88
NEC 7730	\$2559.88
7700 Tractor	\$359.88

PRINTERS

Qume Sprint 9/45	\$2109.88
Smith Corona TP-1	\$599.88
10 or 12 cpi, parallel or RS-232C	
CALL FOR PRICES on Epson, DIP, MPI, Data south, Qume and other printers.	

MONITORS

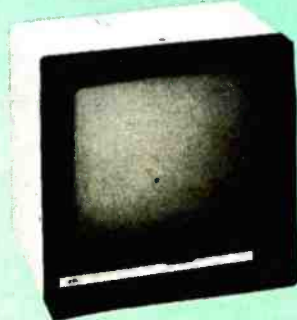

USI Pi-1 (9" green)	\$164.88
USI Pi-2 (12" green)	\$174.88
USI Pi-3 (12" amber)	\$199.88
USI Pi-4 (9" amber)	\$169.88
Amdex 300G (12" green)	\$174.88
Amdex Color I	\$369.88
Amdex Color II (Hi-res RGB)	\$799.88
Amdex Color III (RGB)	\$494.88
Electrohome 1 (RGB)	\$339.88
Electrohome 2 (Hi-res RGB)	\$594.88
Princeton Graphic Systems (Hi-res RGB)	\$699.88
Zenith TVM 121 (12" green)	\$139.88

APPLE PERIPHERALS

PKASO Smart Printer Interfaces	
Centronics card & cable	\$139.88
Epson card & cable	\$139.88
IDS card & cable	\$139.88
IDS Color card & cable	\$159.88
NEC/C. Itoh card & cable	\$139.88
Okidata card & cable	\$139.88

MODEMS



Hayes Smartmodems feature program- ability in any language, auto dial & auto answer, full & half duplex, keyboard con- trol, user-selectable parameters, 7 LED status lights & an audio monitor. Comes complete with power supply and mod- ular telephone cable.	
300 Baud	\$239.88
1200 Baud	\$569.88
Micromodem-II	\$299.88
w/Software	\$329.88
Novation Apple Cat 1200	\$579.88
Novation Apple Cat 300	\$334.88
Novation 1200 Upgrade	\$324.88
Novation Auto Cat 300	\$224.88
Novation Auto-Cat 1200	\$569.88
Novation Cat	\$159.88
Novation D Cat	\$159.88
Signalman Mark 1	\$89.88

APPLE PERIPHERALS

Grappler Plus	\$149.88
Parallel Card w/cable	\$89.88
Rana Systems	
Elite 1 Disk Drive	\$354.88
Elite 2 Disk Drive	\$534.88
Disk Controller	\$109.88
Corona Data Systems	
5mB Hard Disk	\$2049.88
10mB Hard Disk	\$2469.88

MicroSoft	
Premium Package 16K RAMCard, Z80 SoftCard, Videx VideoTerm w/soft video switch, & CP/M Users Guide	
	\$519.88
Z80 SoftCard	\$269.88
16K RAMCard	\$139.88

Mountain Computer	
5mB Hard Disk	\$2549.88
10mB Hard Disk	\$2939.88
Card Reader	\$1399.88
CPS Multifunction	\$174.88
A/D-D/A Converter	\$314.88
RAMplus 16K+ RAMCard	\$164.88
RAMplus 32K+ RAMCard	\$189.88
ROMplus+	\$144.88
ROMwriter Card	\$159.88
SuperTalker	\$179.88

Practical Peripherals	
16K Microbuffer II	\$224.88
32K Microbuffer II	\$254.88
Satum Systems	
32K RAM Board	\$204.88
64K RAM Board	\$359.88
128K RAM Board	\$504.88
SSM AIO Multi- Function Card	\$194.88

Videx	
VideoTerm	\$239.88
w/Soft Video Switch	\$269.88
Enhancer II	\$119.88

Vista	
A-800 Disk Controller for "B" disks	\$499.88
Vision 80 Card	\$249.88

Information & Orders
(603)-673-8857

Orders Only: (800)-343-0726

NO HIDDEN CHARGES

FREE UPS shipping on all orders—No extra charge to use credit cards—All equipment
shipped factory fresh with manufacturer's warranty—COU orders accepted (\$10 fee
added)—No purchase orders accepted—No foreign or APO orders accepted—
Minimum \$50 per order—Prices subject to change.

HIGH TECHNOLOGY AT AFFORDABLE PRICES

THE BOTTOM LINE

MILFORD NH 03055-0423

Circle 71 on Inquiry card.

www.americanradiohistory.com



Two convenience outlets.

Three RS-232 ports and one parallel port.

2.5 megabytes of floppy disk storage.

Space for hard disk option.

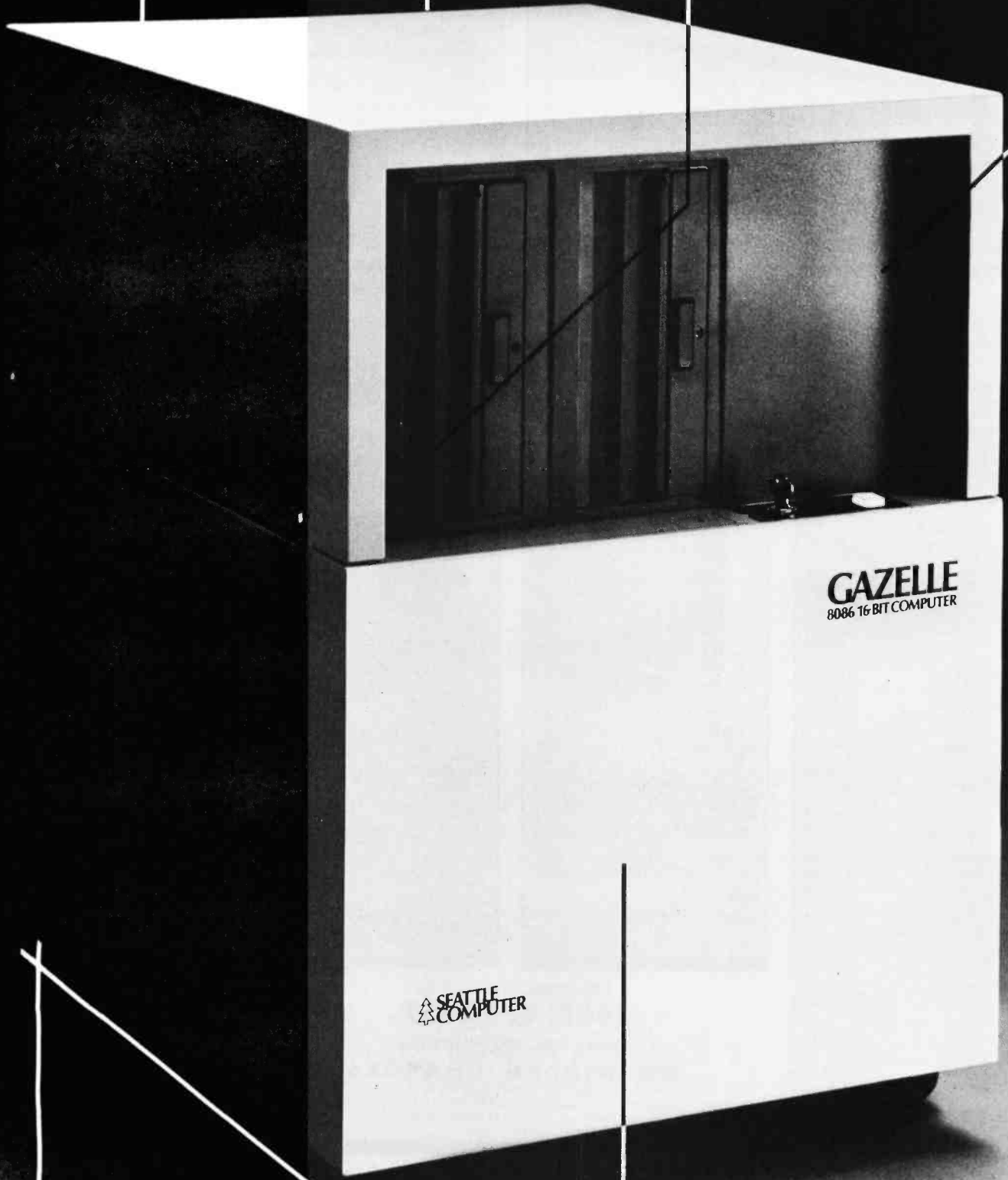

Constant voltage power supply. (provides hard disk power)

Easy roll-about casters.

16-slot S-100 motherboard.

Anatomy of a Gazelle.

When you look inside Seattle Computer's new Gazelle™ 8086 16-Bit microcomputer you'll find its beauty is more than skin deep.

Quite simply the swift, sleek Gazelle is engineered to include the most-wanted features in a micro. And with plenty of room to grow as your needs increase.

8 MHz. 8086 CPU. Fast, reliable with a proven production record.

128K of RAM. Enough memory for most any job. The fast static memory lets our CPU go at full speed.

Three serial, one parallel port. Provides I/O for your terminal, printer, communications, and more at up to 19,200 baud.

Two 8-inch floppy disk drives. Double-sided, double-density for a total of 2.5 megabytes of on-line storage.

The disk controller is capable of handling up to four drives.

Constant-voltage power supply. Provides clean, constant power even under brown-out conditions. And it promotes reliable operation in the noisiest electrical environment.

Expandable. An 18-slot S-100 mother-board allows your system to grow along with your needs. RAM may be increased to 896K or you may choose from a wide variety of options from Seattle Computer or other S-100 manufacturers. There is even a mounting location and power supply for an 8" Winchester disk, which will soon be available as an option.

The Software is Here Now!

MS-DOS operating system. Friendly and easy to use. Includes complete assembly-language development system. Plus it is fully compatible with the

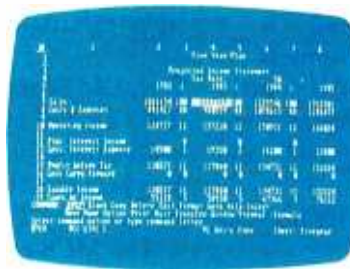

IBM Personal Computer DOS.

Microsoft BASIC interpreter. A fast, 16-bit version of the industry standard. It opens the door to a wide range of existing application programs.

Perfect Writer word processor. The ultimate word processor, that has been rated "excellent" by Infoworld (6-14-82). (Optional spelling checker available.)

Multi-Plan spread sheet. Not just another "Visi-Clone," but a truly superior planning tool. Cross-linking of separate spread sheets provides previously unheard of capability. (Optional.)

Complete language support with Microsoft Pascal, FORTRAN, COBOL, BASIC Compilers available. You can choose the right language for any application. (Optional.)

Best of all, the Gazelle is priced to sell as quickly as it runs. You can buy the fully tested Seattle

Computer Gazelle from your local dealer for \$5995. Add a terminal and printer and you are ready to go.

Call toll free **1-(800)-426-8936** for more information about the world's best, and fastest, micro buy.

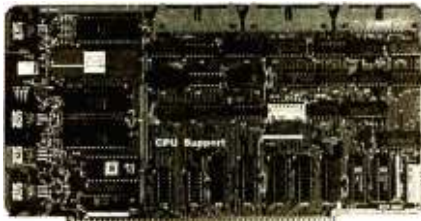

1114 Industry Drive, Seattle, WA 98188
Call for more information about Seattle Computer Products Users Group.

set it apart from other 8-bit byte-oriented microprocessors. We shall then illustrate some of these features with specific examples of 8051 use in which small but concrete programs are given. (Please note that the term 8051 as used here refers to all three members of the MCS-51 family, except where specific differentiation must be made based on memory differences. The instruction sets are identical for all the members.)

Features of the 8051

The 8051 contains:

- 256 bytes of RAM (random-access read/write memory), including the 128 8-bit special-function registers
- 4K bytes of EPROM (8751) or ROM (8051)
- a central processing unit
- four programmable I/O (input/output) ports (32 I/O lines total)
- two 16-bit timer/event counters
- a serial I/O port with serial control (full duplex, UART [universal asynchronous receiver/transmitter], and synchronous shifter)
- internal oscillator and timing circuitry
- five interrupt lines (two from external sources and three from internal ones: the internal interrupts emanate from internal timer 0, timer 1, and the internal serial I/O port), each with a two-level priority capability

- four banks of registers (eight registers per bank)

One of the four I/O ports mentioned above (P3) is comprised of the following eight pins:

- RXD (the serial port's asynchronous receiver-data input or synchronous data input/output)
- TXD (serial port's asynchronous transmitter-data output or synchronous clock output)
- INT0 (interrupt 0 input or gate-control input for timer/counter 0)
- INT1 (interrupt 1 input or gate-control input for timer/counter 1)
- T0 and T1 (test or event counter inputs to timer/counters 0 and 1)
- \overline{WR} (write-control signal that latches a data byte from port 0 into the external data memory)
- \overline{RD} (read-control signal that enables external data memory to port 0)

It should be mentioned that RXD and TXD are not only involved in UART, multiprocessor communications, and bus protocol, but can also be used to implement I/O port expansion.

The MCS-51 instruction set can be divided as follows: 55 percent are 1-byte instructions, 36 percent are 2-byte, and 9 percent are 3-byte; 58 percent of the instructions execute in 1 microsecond (μ s), 40 percent in 2 μ s, and 2 percent in 4 μ s (with a

12-megahertz [MHz] clock). The 4- μ s execution times are associated with the 8051's multiply and divide instructions. Direct memory-to-memory transfer instructions are within the 256 bytes of on-chip memory. Because of the memory-mapped nature of these transfer instructions, a register's contents can be moved directly to one of the four I/O ports or vice versa. This stems from the fact that each of the four ports is itself an SFR with an on-chip address. The bit-addressing feature allows a bit on any 8051 I/O pin to be moved to any other I/O pin via the "Boolean accumulator" (the carry bit). I/O pins have individual addresses; in fact, any addressable bit in on-chip RAM can be moved to an I/O pin or vice versa. Of course, every one of the 210 addressable bits can be tested. Decisions (e.g., conditional jumps) can then be made on the basis of their status. The contents of any of the 256 locations in on-chip memory can be pushed onto the stack and then popped back. The 8051 also features fast (4- μ s) multiply and divide instructions that use 8-bit operands.

One of the unique features of the 8051 is its Boolean (bit) processing capability. It is both a Boolean (bit) and byte processor. As a bit processor, the bit accumulator is the carry bit. Examples of bit-manipulation instructions are: CLR C; CLR bit



Computer Solutions

We sell SemiDisk

for S-100 IBM Personal Computer

TRS-80 Model 2

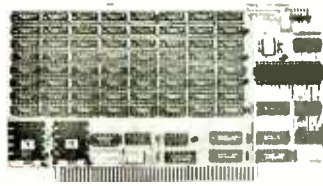

Computing has entered a new era: The SemiDisk era! No longer are you tied down by the speed of floppies or winchesters. Your computer can operate many times faster with a SemiDisk. And with our self installing software it couldn't be easier. Just plug in and hold on! No kidding! Special pricing: \$1595 for 512K Byte and \$2495 for 1 meg Byte.

Specifications:
 TYPE: Semiconductor Disk Emulator
 CAPACITY: 512k or 1Mb
 POWER REQUIREMENTS: 0.6A (512k) 0.9A (1Mb)
 BATTERY BACKUP: 10-12V Unreg. (optional)

For information contact:
 computer Solutions
 Robert Pinkham
 P.O. Box 931
 Hillsboro, OR 97123
 (503) 640-5665
 Circle 123 on inquiry card.

We also offer sales information on S-100, Computer TRS-80.

NEC's crisp, clear, high-performance JC1203 RGB color monitor, an industry standard. Also available, the JC1201 composite video version.

NEC's classic JB1201 green monitor, one of microcomputing's performance legends. Easy on the eye, and the checkbook.



Our impressive new NEC dot matrix printer. Parallel interface, 100 cps, 2K buffer, pin or friction feed. Stunning performance and compatibility in the hottest new peripheral of the year.

Give your IBM system some NEC, and watch its performance soar.

Peripherals from NEC can make almost any computer system better.

Our sparkling new JC1203 color monitor is plug and pin compatible with the 16-color IBM® PC, and delivers the bright, sharp, clear, and stable screen image for which the entire NEC line has long been famous. Similar compatibility is available to owners of Apple II®, Radio

Shack®, and Atari® computers, not to mention our own outstanding NEC PC-8000 series. Also available is a brand new, extremely low cost, NEC green monochrome monitor, the JB1260, perfect companion for an Osborne®, for instance.

Ask your dealer for a demonstration. Or write us at 1401 Estes Avenue, Elk Grove Village, IL 60007.

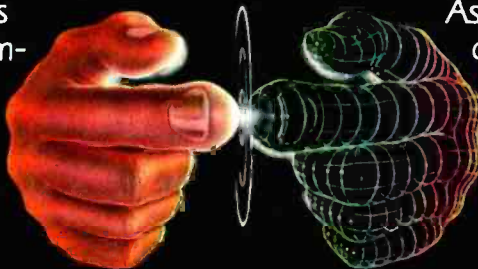

**Productivity
at your fingertips™**

NEC

**NEC Home Electronics (U.S.A.), Inc.
Personal Computer Division**

Nippon Electric Co., Ltd., Tokyo, Japan

PLAYFC

COMPUTER GAMES THAT ARE THE CLOS

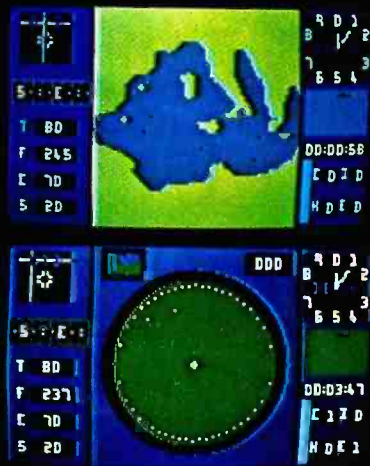

OR REAL

BEST THINGS TO REAL LIFE CHALLENGES.

THORN EMI VIDEO

THORN EMI Video Programming Enterprises, Inc., part of the international entertainment giant, announces 21 computer games that are so real, so challenging, you'll almost forget you're playing a game. You'll be playing for real. No wonder. The graphics are amazingly real-to-life. Action packed. You'll know the moment you start playing one you aren't playing any ordinary computer game. You'll be concentrating too hard.

Take *Submarine Commander*. Your mission? To hunt down and destroy all enemy merchant shipping in Mediterranean waters. How? With your sonar and torpedoes. What if you're attacked? Dive (but not too deep, or you'll crack the hull), dodging the depth charges. Remember to keep checking the instruments for your oxygen level, fuel, battery charge, depth under keel. And keep a sharp lookout for enemy destroyers.

With 21 exciting games to choose from, THORN EMI offers a game for every member of the family. There are super realistic simulator games, like *Submarine Commander* and *Jumbo Jet Pilot*, sports games with lots of fast action, nursery rhyme puzzles, even a financial management game. All have different levels of challenge, so you can make them as challenging as you want, and they can be played on the Atari® 400 and 800 and the VIC® 20. Whatever your favorite pastime—playing pool or darts, soccer or driving a power boat, composing music or doing the *Cube*, THORN EMI has a game just for you.



Atari is a registered trademark of Atari, Inc.
VIC 20 is a registered trademark of Commodore International, Inc.

S-100 Boards from S. C. Digital



FLOPPY DISK CONTROLLER **NEW**

Model FDC1
 ● Single or double density and sided. ● Handles any combination of up to four 8 inch or 5.25 inch floppy disk drives.
 ● Uses powerful NE765A/8272 Controller, Mini dip Data Separator chips. ● DMA data transfer with cross 64K boundaries, 24 bit address lines, DMA arbitration. ● Bank Selectable Monitor/Boot EPROM that will accommodate two different processors. ● CPM Bios Programs. ● Serial port with popular baud rates including 19.2KBAUD.

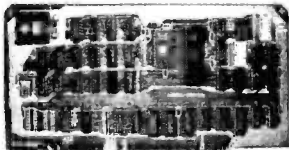

Z80B CPU BOARD

Model Z80 CPU
 ● 2, 4 or 6 Mhz clock, Sw selectable. ● 22 bit addressing using memory mapping in 16K blocks making the addressable range to 4 mega bytes. ● On board bank selectable 2KB or 4KByte of EPROM (not supplied) with Phantom disable.
 ● Jump on reset. ● Provision to run two different CPU's on the same bus, such as forth coming 8086 board.

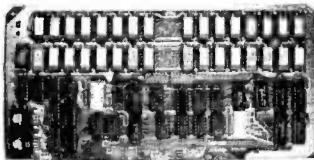

256K DYNAMIC RAM

Model 256KE
 ● 16 or 24 bit address. ● 8/16 bit wide data ● Transparent refresh with unlimited DMA, immune to Wait States, halts, resets. ● Fast access time 180nsec from Smemr or Psync high, will run with Z80, Z8000 to 6mhz, 8080, 8085, 8086 to 8mhz without Wait States. ● Accepts 4116, 4164's.

32K STATIC RAM 'Uniselect: 4'

Model 32KUSM
 ● 8/16 bit data, 16/24 bit address. ● Bank Select by SW selectable port, bit in 32K block. ● Battery backup (battery not supplied) with power-fail detect/automatic Ram disable. ● Complete EPROM (2716) capability with wait states (up to 3), phantom responding or generating.

I/O, MEMORY INTERFACE 'Interface'

Model 3SPC
 ● 3 serials using UART, RS-232C or 20ma current loop.
 ● 1 parallel I/O with hand shakes. ● 4K Ram, 4K EPROM (not supplied). Built in Kansas City Audio Cassette interface.
 ● Baud rates from 19.2K baud to 110 baud. Model 3SPC-N comes with less cassette, current loop, and ram, rom sockets.

All boards conform to IEEE696/S100 specifications, fully socketed, screened legends, masks, Gold contacts. Guaranteed One Full year.

New price effective September 1, 1982

Model	Prices	with
FDC1	\$425	Monitor/Boot EPROM
Z80 CPU	\$349	Memory mapping, 6MHz clock
256KE	\$795	256KB
256KE-128	\$825	128KB
32KUSM	\$389	32KB with CMOS
32KUSM-N	\$189	no ram, no power led
3SPC	\$259	with cassette
3SPC-N	\$229	see above
ZK Monitor	\$55	with source code

All boards come assembled and tested.

Delivery is within 3 to 5 working days. MC, Visa or COD orders accepted. (Add \$6 for COD orders) Illinois residents add 5 1/4 % sales tax.

O.E.M. & DEALER PRICING AVAILABLE

S. C. DIGITAL

P.O. Box 906

1240 N. Highland Ave., Suite #4

Aurora, Illinois 60507

Phone: (312) 897-7749

addr; SETB C; SETB bit addr; CPL C; CPL bit addr; ANL C, bit addr; ANL C, /bit addr; ORL C, bit addr; ORL C, /bit addr; MOV bit addr, C; MOV C, bit addr; JB bit addr, code addr; and JNB bit addr, code addr.

By way of explanation, CLR clears the carry bit or the bit at a bit address; SETB sets those bits; CPL complements those bits; ANL performs the Boolean logic AND on the carry bit and the bit in the designated address (or with the complement of the bit if /bit addr is used) and leaves the resulting bit in the carry bit; ORL does the same with respect to the Boolean logic OR operation; the bit-oriented MOV instructions move the bit in the designated address (it can be an I/O pin) into the carry bit or vice versa; and the JB and JNB instructions are powerful features allowing a conditional jump (decision) to be made based on whether the bit (again, it can be one of 32 I/O pins or any addressable bit in on-chip RAM or SFRs) is a 1 (JB) or a 0 (JNB). The jump is made to the address in the program specified by "code addr" appended in the instruction. These bit-oriented instructions are, in part, responsible for the unique power of the 8051 as a microcontroller.

The number of bit addresses in the 8051 totals 210, including the 32 bit-addressable I/O pins at ports P0, P1, P2, P3, and the bits in 7 other of the 20 SFRs (each 8 bits wide). Sixteen on-chip memory locations, other than the SFRs and the 32 registers in the four banks, are also bit-addressable and thus account for 128 of the 210 bit addresses (the 11 bit-addressable SFRs make up the rest).

You can appreciate that the Boolean-processing capabilities, with the ability to manipulate and control addressable bits, make the 8051 ideal for controlling items such as contacts, indicators, motors, and digital-type on-off I/O devices in all sorts of controller applications, as well as for realization of Boolean output versus input-transfer functions (Boolean combinatorial-logic problems). Thus, contact, relay, switch, TTL (transistor-transistor logic) gate, and other hardware implementations of many combinatorial-logic-type applications

(switching and relay systems, etc.) can now be realized simply and efficiently with the 8051 microcontroller, including all the well-known advantages that a software "black box" can have relative to its hardware-filled counterpart.

It should be noted that the 8051 is also possessed with powerful arithmetic capability, stemming in part from its fast multiply and divide instructions. This is a definite asset and advantage over many other processors in signal-processing and real-time applications (e.g., as a digital filter).

The computational and numerical needs of a controller also require strong arithmetic capabilities to help achieve that control. The 8051, therefore, excels both as a "bit-banger" and as a byte-oriented "number-cruncher."

A word now about the special-function registers (sometimes designated by Intel as the hardware/peripheral registers). Twenty of them are located in on-chip RAM. All of them are byte-addressable; 11 are, in addition, bit-addressable. Those 11 are P0 (port 0), P1 (port 1), P2 (port 2), P3 (port 3) (eight I/O lines per port), TCON (timer-control register), SCON (serial-port control register), IE (interrupt-enable control register), IP (interrupt-priority control register), PSW (program status word), ACC (accumulator with a direct address), and B (B register). Register B is a special register used together with ACC in multiply and divide instructions. The remaining byte-addressable SFRs are SP (stack pointer), DPL and DPH (data pointer—low, high bytes), TMOD (timer mode register), TLO (timer 0 low byte), TL1 (timer 1 low byte), TH0 (timer 0 high byte), TH1 (timer 1 high byte), and SBUF (serial port data buffer).

A working knowledge of the SFRs, in addition to the 8051's instruction set and the structure of its on-chip memory, is essential to mastering the 8051. For a more extensive treatment of the SFRs, refer to our book and the references at the end of this article.

Here are some examples of the SFRs: port 3 is at hexadecimal address

0B0. The eight pins of port 3 on the 8051 are mapped onto the 8 bits of this SFR so that bit 0 of address 0B0 is RXD, bit 1 (address 0B1) is TXD, bit 2 (address 0B2) is INT0, bit 3 (address 0B3) is INT1, bit 4 (address 0B4) is T0 (timer/counter 0 external flag), bit 5 (address 0B5) is T1 (timer/counter 1 external flag), bit 6 (address 0B6) is \overline{WR} (write data to external data memory), and bit 7 (address 0B7) is \overline{RD} (read data from external data memory). These bits are also referred to as P3.0 (bit 0), P3.1 (bit 1), . . . P3.7 (bit 7).

Note that pins T0, T1, INT0, and INT1, having bit addresses, can be treated as four ordinary input pins that can be tested and decisions made accordingly. In the case of INT1 and INT0, the interrupt system must be disabled. The organization of some important SFRs and the definitions of their bits are shown in table 1, reproduced from the Intel 8051 literature by permission of the Intel Corporation. A careful study of that material should give you a good feeling for the role of the SFRs in working with the 8051 and how they can be manipulated for your desired ends. All but one (TMOD) of the seven SFRs detailed in table 1 are bit-addressable, as well as byte-addressable.

Setting or clearing certain individual SFR bits by software will achieve many user requirements (programmable) for the control application:

- setting or clearing RS1 or RS0 (PSW.4 or PSW.3 in the program status word register) will specify one of the four register banks to be worked with
- setting or clearing C/ \overline{T} in TMOD specifies timer or counter mode of operation for the timer/counter
- setting or clearing the M1 or M0 bits in TMOD specifies the type of timer/counter (8-bit, 16-bit, auto reload, 5-bit prescaler, etc.)
- setting or clearing the GATE bit in TMOD serves to determine whether or not gating is used with the timer/counter
- setting or clearing the TR1 or TR0 bits in TCON determines whether

SFR	Description	Hexadecimal Byte Address	Hexadecimal Bit Addresses
PORT 3	Eight I/O lines	0B0	0B0 through 0B7
PSW	Program status word	0D0	0D0 through 0D7 (0D1 reserved)
TCON	Timer/counter control	88	88 through 8F
SCON	Serial-port control	98	98 through 9F
IE	Interrupt-enable control	0A8	0A8 through 0AF (2 bits reserved)
IP	Interrupt-priority control	0B8	0B8 through 0BC (3 bits reserved)
TMOD	Timer/counter mode control	89	---

(MSB)								(LSB)		
RD	WR	T1	T0	INT1	INT0	TXD	RXD			
Symbol	Position	Name and Significance						Symbol	Position	Name and Significance
RD	P3.7	Read data control output. Active low pulse generated by hardware when external data memory is read.						INT1	P3.3	Interrupt 1 input pin. Low-level or falling-edge triggered.
WR	P3.6	Write data control output. Active low pulse generated by hardware when external data memory is written.						INT0	P3.2	Interrupt 0 input pin. Low-level or falling-edge triggered.
T1	P3.5	Timer/counter 1 external input or test pin.						TXD	P3.1	Transmit Data pin for serial port in UART mode. Clock output in shift register mode.
T0	P3.4	Timer/counter 0 external input or test pin.						RXD	P3.0	Receive Data pin for serial port in UART mode. Data I/O pin in shift register mode.

P3—Alternate Special Functions of Port 3

(MSB)								(LSB)		Symbol	Position	Name and Significance
CY	AC	F0	RS1	RS0	OV	—	P					
Symbol	Position	Name and Significance						OV	PSW.2	Overflow flag. Set/cleared by hardware during arithmetic instructions to indicate overflow conditions.		
CY	PSW.7	Carry flag. Set/cleared by hardware or software during certain arithmetic and logical instructions.						—	PSW.1	(reserved)		
AC	PSW.6	Auxiliary Carry flag. Set/cleared by hardware during addition or subtraction instructions to indicate carry or borrow out of bit 3.						P	PSW.0	Parity flag. Set/cleared by hardware each instruction cycle to indicate an odd/even number of "one" bits in the accumulator, i.e., even parity.		
F0	PSW.5	Flag 0. Set, cleared/tested by software as a user-defined status flag.						Note—		the contents of (RS1, RS0) enable the working register banks as follows		
RS1	PSW.4	Register bank Select control bits 1 & 0. Set/cleared by software to determine working register bank (see Note).								(0.0) - Bank 0 (00H-07H)		
RS0	PSW.3									(0.1) - Bank 1 (08H-0FH)		
										(1.0) - Bank 2 (10H-17H)		
										(1.1) - Bank 3 (18H-1FH)		

PSW—Program Status Word Organization

(MSB)								(LSB)		M1	M0	Operating Mode
GATE	C/T	M1	M0	GATE	C/T	M1	M0					
TIMER 1				TIMER 0				0	0			MCS-48 Timer. "TLx" serves as five-bit prescaler.
								0	1			16-bit timer/counter. "THx" and "TLx" are cascaded; there is no prescaler.
								1	0			8-bit auto-reload timer/counter. "THx" holds a value which is to be reloaded into "TLx" each time it overflows.
								1	1			(Timer 0) TLO is an eight-bit timer/counter controlled by the standard Timer 0 control bits TH0 is an eight-bit timer only controlled by Timer 1 control bits.
								1	1			(Timer 1) Timer/counter 1 stopped.

TMOD—Timer/Counter Mode Register

Table 1: Descriptions of some SFRs (special-function registers) in the 8051. (This table is reproduced by permission of Intel Corporation from reference 3.)

Lowest Prices on Personal Computers!

 **Apple II + 48K, Call**
Apple III 126K, Call

Apple II Compatible
Hardware & Software

MICROSOFT

Microsoft Softcard Premium System
(Includes: Softcard, RAM Card, Videz Video-
term 80 Col., Softswitch, Osborne CP/M®
user guide)..... Only \$595
16K RAM Card by Microsoft 145
Z-80 Soft Card by Microsoft 275

Videz

Videz VideoTerm 80 Col. Card... \$245
Videz Keyboard Enhancer I (Orig.)... 75
Videz Keyboard Enhancer II..... 129

Vista COMPUTER
COMPANY, INC.

Vision 80 Video Display Card... \$255
Apple III Clock/Calendar Card... 159
Dbl. Dens. 8" Disc Controller... 299
Dual 8" Disc Drives... Call

Mountain Computer

CPS Multi-Function Card... 169
Music System (16 Voices)... 299
Expansion Chassis (8 Slots)... 569
Clock/Calendar Card... 229
A/D + D/A Interface... 279
Romplus + card... 129
Super Talker SD-200... 149
Keyboard Filter RDM for Romplus... 40
Copy ROM for Romplus... 40
Rom Writer card... 149
Rom Plus 32K RAM add-on (w/16K)... 149

VISICORP

VisiCalc..... \$185
VisiCalc Templates (New)... Call
VisiFile (Data Base Management)... 185
VisiTrend/VisiPlot... 199
VisiSchedule (New)... 239
VisiTerm... 89
VisiDex... 185
Desktop Plan II... 185

Computers for people.
ATARI

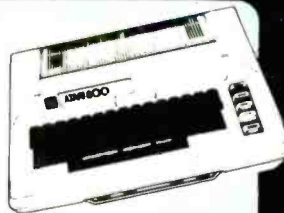

ATARI 400, \$259

ATARI 800, Now w/48K!.. \$659

ATARI 410 Program Recorder..... \$79	ATARI Pac Man..... \$29.95
ATARI 810 Disc Drive..... 419	ATARI Star Raiders..... 29.95
ATARI 850 Interface..... 159	ATARI Missile Command..... 29.95
ATARI 830 Modem..... 145	ATARI Asteroids..... 29.95
ATARI 825 80 Column Printer..... 559	ATARI Centipede..... 29.95
ATARI Joysticks, (Pair)..... 16	ATARI Cavemen of Mars..... 29.95

—WICO—

Arcade Quality
JOYSTICK CONTROLLERS
by WICO..... \$24.95 ea.

—PERCOM—

ATARI SS DD Single Disk Drive... \$679
ATARI SS DD Dual Disk Drive... 999

ALIEN VOICE BOX Voice Synthesizer (for ATARI & Apple), \$99

**hp HEWLETT
PACKARD**

HP-41C... \$149
HP-41CV... \$219

HP-41 Quad Memory Mod...
HP-41 Ext. Func. Mem. Mod... } \$59
HP-41 Ext. Memory Mod...
HP-41 Time Module

HP-41 Card Reader..... \$159
HP-41 Optical Wand..... 99
HP-41 Printer (82143A)... 269
HP-IL Interface Module... 99
HP-IL Printer (82182A)... 379
HP-IL Digital Cassette Drive... 419
HP-IL Video Interface Mod... 229



HP-12C
HP-15C
HP-16C } **115**

Your Choice

HP-11C, \$79 HP-10C, \$59

IBM

QUADBOARD by QUADRAM, Inc.
Memory Expansion, Clock, Parallel
Interface, RS232 Int., ON ONE BOARD!
Quadboard w/84K installed..... \$495
Quadboard w/192K installed..... 719
Quadboard w/256K installed..... 795

—IBM SOFTWARE—

WordStar by MicroPro..... \$299
VisiCalc by Personal Software..... 185



Franklin Ace-1000..... \$1049
Franklin Ace-1000 w/Color..... 1099
Franklin Ace-10 Disc Drive... 429
Franklin Ace-10 Add-On Drive... 379

—MICROSCI—

Apple II + Computable Drive
Disk Drive w/Controller..... \$429
Disk Drive w.o./Controller... 379

—RANA/Apple—

Elite I Disc Drive..... \$349
Elite I Disc Drive w/Controller... 449
Elite II Disc Drive..... 549
Elite Controller Card..... 99

CORVUS SYSTEMS

Corvus Winchester 5 Meg. Disk, \$2959.
Corvus Winchester 10 Meg. Disk, 4295.
Corvus Winchester 20 Meg. Disk, 6195.
Mirror Back-Up..... Call

Advertised prices do not include shipping. Prices are subject to change and offers may be withdrawn without notice.

 **TEXAS INSTRUMENTS
COMPUTERS**

TI-99/4, \$198*

*Net cost after \$100 Factory Rebate.
Peripheral Expansion Sys..... \$195
RS-232 Interface Card... 139
Disk Controller Card... 195
Disc Drive... 299



**TEXAS INSTRUMENTS
SOFTWARE**

PHM-3026 Extended Basic... \$74.95
PHM-3035 Terminal Emulator II... 39.00
PHM-3055 Editor/Assembler... 74.95
PHM-3058 Mini Memory... 74.95
PHM-3013 Prnt. Rec. Keeping... 39.00
PHM-3053 TI Invaders... 32.00
PHM-3057 Munch Man... 32.00
PHM-3054 Car Wars... 32.00
PHM-3112 Persec... 32.00

**TEXAS INSTRUMENTS
CALCULATORS**

TI-88 Calculator... \$260
TI PC-800 Printer/Plotter... 150
TI CA-800 Cassette Interface... 50
TI-59 Calculator... 169
TI-58C
TI-58C Calculator... 79
TI PC-100C Printer/Plotter... 149
TI-55 II Calculator... 40
TI LCD Programmer... 55

AMDEK —MONITORS— **ZENITH**
Color I..... \$339 BMC 12" Gr... \$99
Color II..... 699 Sanyo 9" Gr... 159
Color III..... 429 Sanyo 12" Gr... 209
ZENITH ZYM-121 Green Phos.
only..... \$119

—PRINTERS—
EPSON MX-80... \$429
MX-80FT... 519
MX-100... 715
NEC 802Impact Dot Matrix... \$489
3510 33 CPS Serial... 1749
3530 33 CPS Centronics Par... 1749
Bi-Directional Tractor (3500)... 229
7710 55CPS Serial... 2349
7730 55 CPS Centronics Par... 2349
Tractor for 7700 Series... 229

—MODEMS—
SCM Smith-Corona Daisy Wheel
TP-1.. Now \$629
Novation Novation Cat... \$139
Novation D-Cat... 149
Novation 212... 595
Novation Apple Cat II... 310

—CENTRONICS—
Centronics 730-1 Parallel... \$299
Centronics 737-3 Serial... 299
Hayes Micromodem II... \$279
Smartmodem 300... 219
Smartmodem 1200... 549
Chronograph... 199

Circle 374 on Inquiry card.



Commodore VIC-20..... \$189.95
Commodore Datasette... 87.00
Commodore Super Expander... 59.00
Commodore 8K Memory... 52.00
Commodore VIC Avenger... 24.95
Commodore VIC Super Alien... 24.95
Commodore VIC Jupiter Lander... 24.95

—CABLES—

Parallel Printer Cables
ATARI..... \$35
Apple II... 37
IBM... 40
Osborne... 37

If you are in need of
something you cannot
find in our ad,
PLEASE CALL.

SHARP

PC-1500 Hand Held Computer... \$219
CE-150 Printer/Cass. Interface... 195
CE-152 Cassette Tape Recorder... 75
CE-155 8K RAM Memory Module... 99
CE-151 4K RAM Memory Module... 50



315-478-6800



Table 1 continued:

(MSB)				(LSB)			
TF1	TR1	TF0	TR0	IE1	IT1	IE0	IT0
Symbol	Position	Name and Significance					
TF1	TCON.7	Timer 1 overflow Flag. Set by hardware on timer/counter overflow. Cleared when interrupt processed.					
TR1	TCON.6	Timer 1 Run control bit. Set/cleared by software to turn timer/counter on/off.					
TF0	TCON.5	Timer 0 overflow Flag. Set by hardware on timer counter overflow. Cleared when interrupt processed.					
TR0	TCON.4	Timer 0 Run control bit. Set/cleared by software to turn timer/counter on/off.					
IE1	TCON.3	Interrupt 1 Edge flag. Set by hardware when external interrupt edge detected. Cleared when interrupt processed.					
IT1	TCON.2	Interrupt 1 Type control bit. Set/cleared by software to specify falling edge/low level triggered external interrupts.					
IE0	TCON.1	Interrupt 0 Edge flag. Set by hardware when external interrupt edge detected. Cleared when interrupt processed.					
IT0	TCON.0	Interrupt 0 Type control bit. Set/cleared by software to specify falling edge/low level triggered external interrupts.					

TCON—Timer/Counter Control/Status Register

(MSB)				(LSB)			
SM0	SM1	SM2	REN	TB8	RB8	TI	RI
Symbol	Position	Name and Significance					
SM0	SCON.7	Serial port Mode control bit 0. Set/cleared by software (see note).					
SM1	SCON.6	Serial port Mode control bit 1. Set/cleared by software (see note).					
SM2	SCON.5	Serial port Mode control bit 2. Set by software to disable reception of frames for which bit 8 is zero.					
REN	SCON.4	Receiver Enable control bit. Set/cleared by software to enable/disable serial data reception.					
TB8	SCON.3	Transmit Bit 8 Set/cleared by hardware to determine state of ninth data bit transmitted in 9-bit UART mode.					
RB8	SCON.2	Receive Bit 8. Set/cleared by hardware to indicate state of ninth data bit received.					
TI	SCON.1	Transmit Interrupt flag. Set by hardware when byte transmitted. Cleared by software after servicing.					
RI	SCON.0	Received Interrupt flag. Set by hardware when byte received. Cleared by software after servicing.					
		Note-- the state of (SM0,SM1) selects: (0,0) Shift register I/O expansion. (0,1) 8 bit UART, variable data rate (1,0) 9 bit UART, fixed data rate (1,1) 9 bit UART, variable data rate					

SCON—Serial Port Control/Status Register

(MSB)				(LSB)			
EA	—	—	ES	ET1	ET0	EX1	EX0
Symbol	Position	Name and Significance					
EA	IE.7	Enable All control bit. Cleared by software to disable all interrupts, independent of the state of IE.4-IE.0					
—	IE.6	(reserved)					
—	IE.5	(reserved)					
ES	IE.4	Enable Serial port control bit. Set/cleared by software to enable/disable interrupts from TI or RI flags.					
ET1	IE.3	Enable Timer 1 control bit. Set/cleared by software to enable/disable interrupts from timer/counter 1.					
EX1	IE.2	Enable External interrupt 1 control bit. Set/cleared by software to enable/disable interrupts from INT1.					
ET0	IE.1	Enable Timer 0 control bit. Set/cleared by software to enable/disable interrupts from timer/counter 0					
EX0	IE.0	Enable External interrupt 0 control bit. Set/cleared by software to enable/disable interrupts from INT0.					

IE—Interrupt Enable Register

(MSB)				(LSB)			
—	—	—	PS	PT1	PX1	PT0	PX0
Symbol	Position	Name and Significance					
—	IP.7	(reserved)					
—	IP.6	(reserved)					
—	IP.5	(reserved)					
PS	IP.4	Serial port Priority control bit. Set/cleared by software to specify high/low priority interrupts for Serial port.					
PT1	IP.3	Timer 1 Priority control bit. Set/cleared by software to specify high/low priority interrupts for timer/counter 1.					
PX1	IP.2	External interrupt 1 Priority control bit. Set/cleared by software to specify high/low priority interrupts for INT1.					
PT0	IP.1	Timer 0 Priority control bit. Set/cleared by software to specify high/low priority interrupts for timer/counter 0.					
PX0	IP.0	External interrupt 0 Priority control bit. Set/cleared by software to specify high/low priority interrupts for INT0.					

IP—Interrupt Priority Control Register

Big sale on K's!

16K... \$149.95
32K... \$199.95
48K... \$249.95
64K... \$299.95

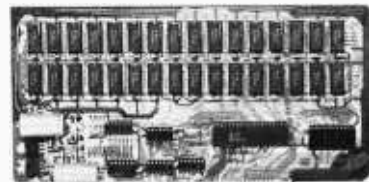

New JAWS-IB

The Ultrabyte Memory Board

Due to the tremendous success of our JAWS I, we were able to make a special purchase of first-quality components at below-cost prices for JAWS-IB. And we are sharing our cost saving with you. But don't be surprised if the next time you see this ad the prices have gone up substantially. Better yet, order now, and get the best memory on the market at the best price on the market.

ONE CHIP DOES IT ALL. Jaws-IB is the Rolls-Royce of all the \$100 dynamic boards. Its heart is Intel's single chip 64K dynamic RAM controller. Eliminates high-current logic parts... delay lines... massive heat sinks... unreliable trick circuits. JAWS-IB solves all these problems.

LOOK WHAT JAWS-IB OFFERS YOU
Hidden refresh... fast performance... low power consumption... latched data outputs... 200 NS 4116 RAM's... on-board crystal... RAM Jumper selectable on 8K boundaries... fully socketed... solder mask on both sides of board... phantom line... designed for 8080, 8085, and Z80 bus signals... works in Explorer, Sol, Horizon, as well as all other well-designed \$100 computers.

10-DAY MONEY-BACK TRIAL: Try a fully wired and tested board for 10 days—then either keep it, return it for full, or simply return it in working condition.

Continental U.S.A. Credit Card Buyers Outside Connecticut:
TO ORDER CALL TOLL FREE 800-243-7428
From Connecticut Or For Assistance:
(203) 354-9375

Please send the items checked below:
JAWS-IB kit:
 16K... \$149.95*
 32K... \$199.95*
 48K... \$249.95*
 64K... \$299.95*

JAWS-IB Fully Assembled, Wired & Tested:
 16K... \$179.95*
 32K... \$239.95*
 48K... \$299.95*
 64K... \$359.95*

EXPANSION KIT, 16K RAM Module, to expand JAWS-IB in 16K blocks up to 64K. \$59.95
*All prices plus \$2 postage and insurance (\$4.00 Canada). Connecticut residents add sales tax.

Total enclosed: \$ _____
 Personal Check Money Order or Cashier's Check
 VISA Master Card (Bank No. _____)
Acct. No. _____ Exp. Date _____
Signature _____
Print Name _____
Address _____
City _____
State _____ Zip _____

NETRONICS R&D Ltd.
333 Litchfield Road, New Milford, CT 06776

timer/counters 1 and 0 are on or off
 ●setting or clearing the IT1 or IT0 bits in TCON specifies whether the external interrupt INT1 or INT0 will be of the falling-edge or low-level-triggered type

●setting or clearing the SM0 or SM1 bits in SCON selects the mode of the serial port (to implement port expansion or choice of 8- or 9-bit UART communication, fixed or variable data rate)

●setting or clearing the EX1 or EX0 bits in the IE register enables or disables interrupts from INT1 or INT0 sources

●setting or clearing the ET1, ET0, or ES bits in IE enables or disables interrupts from timer/counters 1 or 0, or from the serial port (when the latter's buffer has transmitted or received a byte)

●setting or clearing bits 0 through 5 in the IP register specifies high or low priority of interrupts from INTO, timer/counter 0, INT1, timer/counter 1, and serial port

and so on.

Some of the bits in the SFRs are set or cleared by hardware:

●the overflow flag (OV, PSW.2, bit address 0D2) is set or cleared by hardware to indicate the presence or absence of an arithmetic overflow condition

●the P (parity flag) bit 0D0 in PSW (PSW.0) is set or cleared by hardware to indicate an odd or even number of 1 bits in ACC

●TF1 (TCON.7) is set by hardware on timer/counter 1 overflow—it is cleared when that timer 1 interrupt is processed (hence, TF1 is the timer 1 interrupt flag)

●RI (SCON.0) is set by hardware when a byte is received into SBUF at the serial port—it is cleared by software after servicing

●TI (SCON.1) is set by hardware when a byte is transmitted out of SBUF—it is cleared by software after servicing (RI and TI are thus the received and transmit interrupt flags)

As hardware flags, they can be polled easily, as they have bit addresses in most cases, and thereby reveal the status of, for example, SBUF (serial port data buffer—byte received or transmitted), parity, overflow, carry, timer interrupts (made or not), type of interrupt detected (edge or level), etc. All told, you can see that the SFRs and their bit-addressing feature provide a great deal of potential and power to the user.

Working with the 8051

We shall now present several concrete examples that illustrate working with the 8051 and at the same time show just a few of the applications for which it is ideally suited. Naturally, we cannot go very far here in this endeavor. The reader is referred to our book cited at the outset and to the references given at the end of the article. These publications give an in-depth treatment and study of many programming and interfacing applications with the 8051. Because of space, we will choose examples with rather short and succinct programs. (All mnemonics are copyright 1979 and 1981 by the Intel Corporation.)

Using the Boolean Accumulator

We first demonstrate pin-to-pin mapping (bit transfer). Consider port 1 (SFR 90): its eight I/O lines have hexadecimal addresses 90 through 97. Suppose, for example, we wish to have the bit state at pin 97 appear also at pin 90. With the 8051, whenever a pin is to be read, a 1 must first be sent to that pin before reading its state. Thus, we use the following program steps:

```
SETB 97
MOV C, 97
MOV 90, C
```

The first line writes a 1 to bit 97, which can now be read. The second line reads the value into the carry bit, and the third line transfers the value from the carry bit to bit 90 (bit 0 of SFR 90, i.e., bit 0 of port 1).

**If Input Pin Is High,
Put Alarm On, Otherwise Not**
Our hands-on experimentation

You don't know what it is to love a car until you build one.



**The MG Replica
by Fiberfab**

Maybe you've never been in love with a car before. But then, you've probably never built one. That's why the MG Replica is different: it's the car you build yourself. And the doctors, housewives, bankers, and students—among others—who have assembled a Fiberfab MG Replica have learned that this can be one of the most rewarding projects of your life. The MG Replica is a complete kit, that assembles easily over a VW chassis. So you'll love the reliability and great gas mileage it offers, too. And if you're enchanted with the way it looks, wait till you're behind the wheel.

Your relationship starts with a toll-free phone call, for more information:

1-800-328-5671

Fiberfab, Inc., First Western Bank Building, 8800 W. Highway 7, Suite 416, Minneapolis, MN 55426 (612) 933-3047 International TWX: 910-576-3150, FIBERFAB MPS



HARD DISK PACKAGE DEAL: \$980. \$1280.

8 MEGABYTES WITH CONTROLLER

16 MEGABYTES WITH CONTROLLER



THE PACKAGE: THE DEAL:

XCOMP, a worldwide leader in the Hard Disk business for six years is now offering a "Package Deal" to OEMs second to none! Take your choice: The 8MB or the 16MB. Both are Hard Disk specials that indeed offer more.

More **Storage**. More **Value**. More **Support** and More **Speed**.

With the 8MB or the 16MB "Package Deal" you get a formatted drive and controller. Choose from 2 models: 1) The ST/S for S100 Computers and the 2) The ST/R General Purpose Controller with simple 8-bit micro interface for single board computers. There is an optional Z-80 Adapter for the GP Computer that allows you to just "plug 'er in". Nothing to build!

PICK A COMPUTER.

You pick the micro computer and XCOMP will probably be able to provide a "Package Deal", or a Turnkey Subsystem to fulfill your needs.



The 8MB "Package Deal" is \$980. The 16MB "Package Deal" is only \$1280. You get a 2 Board Controller and an 8 or 16MB Mini-scribe Drive. Optional equipment includes Software, Cable set, Adapter and Desk Top Enclosure (pictured).

No sense in shopping around. You won't find a "Package Deal" like this anywhere. Next Step? Call us.

XCOMP's super Hard Disk 8MB or 16MB "Package Deal" both have a complete one-year warranty on parts and workmanship!

"The Deal".

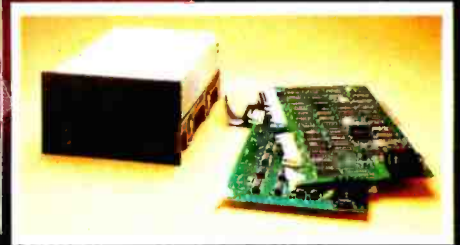

7566 Trade Street/San Diego, CA 92121
Phone (619) 271-8730/TLX 182786

XCOMP
Fast becoming the leader.

YES! I'm interested in your 8MB "Package Deal". Your 16MB "Package Deal".
I have a (type of computer) _____

I am also interested in: "Turnkey" Hard Disk Subsystems. S100 Hard Disk Subsystem.
 General Purpose Subsystem. SG/R Controller for SA1000 Interface. SM/R General Purpose
Controller for Storage Module Drives. AN/R Controller for ANSI Interface Disk and Tape.
 SG/S, SM/S and AN/S same as others for the S100 bus.

Name _____
Company Name _____
Title _____ Phone _____
Address _____
City _____ State _____ Zip _____

CPM is a registered trademark of Digital Research.

WE'RE MAKING LIFE EASIER FOR OEMs. CALL NOW. (619) 271-8730.

VISICALC*

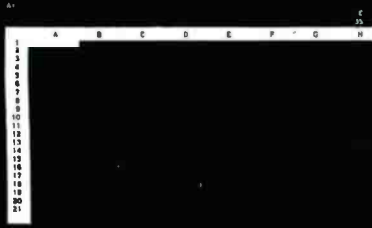

INTERACTIVE ELECTRONIC WORKSHEET

YES

ON-LINE REFERENCE GUIDE

NO

"NAMING" OF CELLS OR AREAS

NO

PLAIN ENGLISH PROMPTS

NO

INDIVIDUAL COLUMN WIDTHS

NO

EXTENSIVE FORMATTING CAPABILITIES

NO

PROTECTED CELLS

NO

MULTIPLE, LINKED WORKSHEETS

NO

SORTING CAPABILITY

NO

VisiCalc[®] was a swell idea for then.

The next generation. First generation electronic worksheets were a good idea. They were early software management tools that could eliminate a lot of hours with a spreadsheet, calculator, pencil and eraser. Enter Multiplan, the next generation electronic worksheet that's as easy to use as it is useful.

Make comparisons. Compare Multiplan to any of the earlier electronic worksheets. We've given you some "prompts" above.

Compare learning time. Multiplan's tutorial book brings you up to speed. Fast. But Multiplan doesn't stop there. Multiplan's On-line Reference Guide gives you instant help if you have questions. It knows where you are in Multiplan and offers information related to your problem, right on the screen.

Compare ease of use. All Multiplan prompts are full length words or phrases. And Multiplan provides "naming," the ability to assign a plain English name to any

cell or area. "Gross Profit = Sales—Cost" rather than "AA44=AZ23—BK154." Which means you can work more intuitively. And faster.

Compare utility. Multiplan lets you link related worksheets so that information is transferred between them automatically. For instance, you can keep regional sales forecasts on separate sheets but link them with your overall company forecast. Then, just change the forecast for any region, and the company forecast sheet is updated automatically. Something you can't do with first generation worksheets.

Compare reports. Not just the work you can do, but the way you can present it. Multiplan's flexible formatting options allow you to produce presentation-quality reports. And its sorting capability lets you sort by either alphabetic or numeric order. So a sales manager who normally lists sales regions alphabetically could sort by amount sold and conveniently rank by sales performance. The

*Based on features in releases VC-20280-AP2 and VC-156Y0-IBM of VisiCalc on the Apple II and IBM-PC respectively.

#1 1 2 3 4 5 6 7

1
2
3
4
5
6
7
8
9
10
11
12
13
14
15
16
17
18
19
20

COMMAND Alpha Blank Copy Delete Edit Format Goto Help Insert Lock Move Name Outline Print Quit Sort Transfer View Worksheet

Select option of type command letter

100% Free Multiplan PROFIT 1

INTERACTIVE ELECTRONIC WORKSHEET **YES**

COMMAND OVERVIEW

The Multiplan worksheet consists of a grid of up to 63 columns in width and 255 rows in height. The screen has one or more windows, with the worksheet and an area showing command messages and status lines. The message line suggests the action to be taken or explains errors when they occur. The status line displays coordinates of the active cell, contents, percentage of storage remaining, and worksheet name. There is a high-contrast active line on the worksheet. The Multiplan file is moved around by pressing the direction keys. The same keys are also used for entering the contents of windows. The Ctrl-Foo keys may be used to go to row 1 (column 1) quickly.

The command menu offers a choice of commands. To get going, you need to:

1. Select an active cell. The direction keys may be used.
2. Select a command. There are two ways to do this. You can move the highlight to a command using the F8 and F10 keys and then press (Enter) or type the first letter.

HELP: Response, Status, Next, Previous, Formulas, Keyboard

Application Commands, Editing, Formulas, Keyboard

Select option or type command letter

100% Free Multiplan PROFIT 2

ON-LINE REFERENCE GUIDE **YES**

#1 1 2 3 4 5 6

1
2
3
4
5
6
7
8
9
10
11
12
13
14
15
16
17
18
19
20

Region 1 Profit Forecast

	Jan	Feb	Mar	Apr	May
Region 1 Sales	2000				
Region 1 Cost	1300				
Region 1 Gross Profit					

Enter a formula

98% Free Multiplan PROFIT 3

"NAMING" OF CELLS OR AREAS **YES**

#1 1 2 3 4 5 6

1
2
3
4
5
6
7
8
9
10
11
12
13
14
15
16
17
18
19
20

Region 1 Profit Forecast

	Jan	Feb	Mar	Apr	May
Region 1 Sales	2000				
Region 1 Cost	1300				
Region 1 Gross Profit	700				

Enter reference to cell or group of cells

98% Free Multiplan PROFIT 4

PLAIN ENGLISH PROMPTS **YES**

#1 1 2 3 4 5

1
2
3
4
5
6
7
8
9
10
11
12
13
14
15
16
17
18
19
20

Region 1 Profit Forecast

	Jan	Feb	Mar	Apr
Region 1 Sales	2000	2000	2420	2662
Region 1 Cost	1300	1430	1573	1730.3
Region 1 Gross Profit	700	770	847	931.7

Enter a number of column

97% Free Multiplan PROFIT 5

INDIVIDUAL COLUMN WIDTHS **YES**

#1 1 2 3 4 5

1
2
3
4
5
6
7
8
9
10
11
12
13
14
15
16
17
18
19
20

Region 1 Profit Forecast

	Jan	Feb	Mar	Apr
Region 1 Sales	\$2,000.00	\$2,000.00	\$2,420.00	\$2,662.00
Region 1 Cost	1,300.00	1,430.00	1,573.00	1,730.30
Region 1 Gross Profit	\$700.00	\$770.00	\$847.00	\$931.70

Enter a formula

97% Free Multiplan PROFIT 6

EXTENSIVE FORMATTING CAPABILITIES **YES**

#1 1 2 3 4 5

1
2
3
4
5
6
7
8
9
10
11
12
13
14
15
16
17
18
19
20

Region 1 Profit Forecast

	Jan	Feb	Mar	Apr
Region 1 Sales	\$2,000.00	\$2,200.00	\$2,420.00	\$2,662.00
Region 1 Cost	1,300.00	1,430.00	1,573.00	1,730.30
Region 1 Gross Profit	\$700.00	\$770.00	\$847.00	\$931.70

Enter # to confirm

97% Free Multiplan PROFIT 7

PROTECTED CELLS **YES**

#1 1 2 3 4 5

1
2
3
4
5
6
7
8
9
10
11
12
13
14
15
16
17
18
19
20

The Company Sales Forecast

	Jan	Feb	Mar	Apr
Region 1 Sales	\$2,000.00	\$2,200.00	\$2,420.00	\$2,662.00
Region 2 Sales	\$1,900.00	\$1,118.50	\$2,362.13	\$2,833.77
Region 3 Sales				
Total Company Sales	\$3,900.00	\$4,318.50	\$4,782.13	\$5,295.77

Enter name on external sheet

97% Free Multiplan SALES

MULTIPLE, LINKED WORKSHEETS **YES**

#1 1 2 3 4 5

1
2
3
4
5
6
7
8
9
10
11
12
13
14
15
16
17
18
19
20

The Company Sales Forecast

	Jan	Feb	Mar	Total
Region 1 Sales	\$1,900.00	\$2,118.50	\$2,362.13	\$4,480.63
Region 2 Sales	\$1,900.00	\$2,017.80	\$2,281.93	\$4,209.73
Region 3 Sales	\$2,000.00	\$2,200.00	\$2,420.00	\$6,720.00
Total Company Sales	\$5,700.00	\$6,336.30	\$7,064.06	\$19,100.36

Enter # to confirm

95% Free Multiplan SALES

SORTING CAPABILITY **YES**

Multiplan™ is a great idea for now.

result is a more meaningful and useful presentation of data. **Compare availability.** With Multiplan, you're not limited to a single range of computers. Multiplan is available for Apple® and for microcomputers that run MS™, DOS, XENIX™ or CP/M-80® operating systems. Multiplan supports both 40- and 80- columns on the Apple II.

Compare the source. Microsoft was the world's first microcomputer software company. Today, Microsoft software is running in well over a million installations, worldwide. Languages. Utilities. Business programs. All, maintained at the state-of-the-art.

Compare for yourself. Drop into your computer store. Compare Multiplan's powerful, user-oriented features to any electronic worksheet on the market. If you've been using VisiCalc, Multiplan's ability to directly utilize your VisiCalc files lets you easily upgrade to Multiplan. And that's just another of the many features designed

to make Multiplan the electronic worksheet for now. And years from now.

BETTER TOOLS FOR MICROCOMPUTERS



Microsoft is a registered trademark, and Multiplan, XENIX, and MS are trademarks of Microsoft Corporation

VisiCalc is a registered trademark of VisiCorp

CP/M-80 is a registered trademark of Digital Research, Inc.

Apple is a registered trademark of Apple Computer, Inc.



IBM memory at realistic prices:

256K WITH AN RS-232C
INTERFACE **\$349**
\$529 WITH SUPERCALC

512K WITH AN RS-232C
INTERFACE **\$579**
\$749 WITH SUPERCALC

Both of these fully-populated memory boards include parity checking and a standard RS-232C interface. They are compatible with all IBM software.

You can expect these boards to meet the highest standards of design and manufacturing quality available — at any price. We are proud to guarantee them fully for a period of two years.

**Alpha
Byte**
**COMPUTER
PRODUCTS**

31245 LA BAYA DRIVE
WESTLAKE VILLAGE, CA 91362

**To order or for
information call**

In New York:

(212) 509-1923

In Los Angeles:

(213) 706-0333

In Dallas:

(214) 744-4251

By Modem:

(213) 883-8976

We guarantee everything we sell for 30 days — no returns after 30 days. Defective software will be replaced free, but all other software returns are subject to 15% restocking fee and must be accompanied by RMA slip. No returns on game software, unless defective.

We accept VISA and MasterCard on all orders. COD orders, up to \$300.

Shipping charges: \$3 for all prepaid orders, actual shipping charges for non-prepays: \$3 for COD orders under 25lbs. (\$6 for over) plus a \$4 surcharge, add 15% for foreign. FPO and APO orders, Calif. add 6% sales tax, L.A. County add 6½%.

Prices quoted are for stock on hand and are subject to change without notice.

with the 8051 was carried out with Intel's SDK-51 (System Design Kit) (see reference 5). Our programs generally began at address 0050 hexadecimal in that system. These are the addresses you will see in this and other programs in these examples. Remember, too, that the SDK-51 has only an in-line assembler. Hence, the appearance of absolute jump addresses below instead of labels. We shall assume input pin to be I/O line 97, and alarm to be output I/O line 90. Both are pins of port 1 (SFR 90). Again, a 1 must be written to pin 97 before reading it. Bits 97 and 90 are the only ones of interest to us here at port 1; the others are not used:

```
0050 MOV 90, #80
0053 JB 97, 58
0056 SJMP 50
0058 SETB 90
005A SJMP 53
```

The first line moves the hexadecimal value 80 to port 1, thus writing a 1 to pin 97 and also turning off pin 90 (the alarm). In the second line, if pin 97 is high, jump to hexadecimal address 0058. The third line causes a jump to address 0050 because pin 97 is low, thus keeping or putting the alarm off. The fourth line puts alarm (bit 90) on because input pin bit 97 was high. The fifth line jumps to address 0053 to poll input pin 97 again.

The SJMP (short jump) instruction, when employed, branches unconditionally to the specified address (here, hexadecimal 0050 in one case, 0053 in the other). It is a 2-byte instruction and can be used whenever the intended destination is either 128 bytes or less preceding the next instruction or 127 bytes or less following the next instruction. The AJMP (absolute jump) instruction is used whenever the destination is within the same 2K-byte block of program memory as the first byte of the instruction following AJMP. If the LJMP (long jump) instruction is used, the destination may be anywhere in the full 64K bytes of program memory.

Do not confuse port 90 (byte) with pin 90 (address bit). The context of the instruction will make the distinction clear. One refers to port 1 (byte), the other to bit 0 of port 1. Thus,

MOV 90, #80 refers to SFR 90 (port 1) and SETB 90 to bit address 90.

Note the use of the JB (jump if bit set) instruction. If the indicated bit address (here, 97) is a 1, a jump is made to the indicated address (hexadecimal 0058). Otherwise, the next instruction is executed. JB inputs the desired bit and tests it before the jump is made based on its value. Since JB is associated with a read of a bit address, a 1 is first written to that address (at hexadecimal 0050 in the program).

Memory-to-Memory Move Instruction

Suppose that on-chip memory address 25 hexadecimal contains a byte that we wish to send to port 1 (at address 90 hexadecimal):

```
0050 MOV 90, 25
0053 SJUMP 53
```

The first line will move the contents of address 25 hexadecimal to port 1. The second line causes a jump to itself (effectively, a halt).

Boolean ANDs, ORs, and External Interrupts

The intent of the program that follows is to demonstrate the employment of both the ORL (Boolean logical OR) and the ANL (Boolean logical AND), as well as the 8051's interrupt facility (in this case, INT1):

```
0050 ORL, 0A8, #84
0053 SETB 8A
0055 MOV 90, #0F
0058 SJMP 58
```

The first line performs a Boolean logical OR on the contents of location 0A8 hexadecimal (the interrupt enable register) with the value 84 hexadecimal. This sets the EA and EX1 bits in the IE register, thus enabling the INT1 line. The SETB instruction sets bit 8A (ITI in the TCON SFR), specifying that INT1 will be triggered by a high-to-low transition. Then, the program moves hexadecimal 0F into port 1, and repeats the instruction at hexadecimal 58, waiting for an interrupt.

When an interrupt occurs, control is transferred to the following routine:

```
0013 ANL 90, #05
0016 RETI
```

Opt for Quality High-Reliability Design

Model HS-2900



Intelligent Buffer

Standard \$348.00
RS-232C Add \$120.00
IEEE-488 Add \$160.00

• 62KB STANDARD • Data compression/copy mode • Self test mode • Centronics I/F standard • RS 232C, IEEE-488 optional • Low price • AC 100/117/220/240V

Model SBC-696

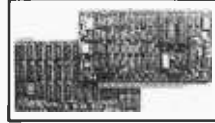

Single Board Computer meeting IEEE-696 (CP/M, SB-80) \$999.00

• 280A • 64K static RAM (ROM replaceable) • RS 232C 2port Centronics Iport • Supports 5. 1/4 floppy by DMA • Meets IEEE S-100 bus • +5V only • 4 layered PCB • Memory card piggy-back on main board • Include CP/M or SB-80

Model SBC-488

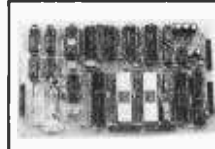

Single Board Computer (IEEE-488 etc)

\$488.00

• Z80 • ROM/RAM total 10KB • IEEE-488 I/F (TMS9914) • RS-232C I/F (8251) • Parallel 6ports (8255) • +5V only

Model GPIB-100



S-100 bus Multifunction Board meeting IEEE-488 \$550.00

• Supports IEEE-488 (TMS9914) • Universal interrupt controller (AM9519) • Programmed interval timer (8253) • Real-time clock, battery backup (MSM5832) • IEEE S-100 I/F • Software handler on 8" diskette (CP/M based)

Model CAP-M20GP



Intelligent Winchester Disk

\$6,200.00

• 8" Winchester disk, maintenance free • IEEE 488, RS-232C (up to 38,400 baud) • Intelligent functions • Supports CP/M based driver • 430(W) x 150(H) x 450(D)mm • AC100/117/220/240V

Model F2P/F2

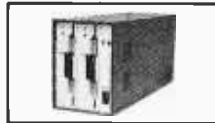

New 8" FD for CROMEMCO and general-purpose system

F2P \$2,580.00
F2 \$1,990.00

• Ultra-slim 8" drive • Signal compatible Persecl299 • No modification of the BIOS of your CROMEMCO is needed (F2P) • Fully compatible with Shugart SA801R and 8501R(F) • Cooling fan, noise filter included • 160(W) x 225(H) x 500(D)mm

ALL PRICES ARE FOB TOKYO AND SUBJECT TO CHANGE WITHOUT NOTICE (Dealer inquiries invited)

International Agent: **RENFUL COMPUTER LTD.**
Rm. 802, Hop Fat Commercial Centre, 490-492, Nathan Road, Kowloon, H.K. Tel: 3-320498(3lines)
Telex: 37546 RENFL HX Cable Address: RENFULCOMP

International Systems & Automation

ISA CO., LTD.

HEIAN BLDG. 2-6-16 OKUBO, SHINJUKU-KU, TOKYO 160 JAPAN
PHONE: 03-232-8570 TELEX: 232445 ISATOK CABLE: ISAHEIAN

CP/M® Users: Access IBM with ReformaTter™

ReformaTter conversion software lets you read and write IBM 3740 diskettes* on your CP/M or MP/M system.

ReformaTter is ideal for CP/M users who want

- Access to large system data bases
- Distributed data processing
- Offline program development
- Database conversion

With ReformaTter, you have the ability to

- Bidirectionally transfer complete files between CP/M and IBM
- Automatically handle ASCII/EBCDIC code conversion
- Display and alter IBM 3740 directory and data

Enjoy the same advantages of mainframe access that other ReformaTter users have. Customers like Upjohn, M&M/Mars, The United Nations, Arthur Young & Co., Sandia Labs, FMC Corp., and Stanford University all use ReformaTter. So can you.

Other versions of ReformaTter conversion software include

CP/M ↔ DEC (RT 11)

TRSDOS Mod. II ↔ CP/M

TRSDOS Mod. II ↔ DEC (RT 11)

Order ReformaTter today for only \$249.

*IBM 3740 basic data exchange format. ReformaTter requires one 8" floppy drive.



(415) 324-9114

TWX: 910-370-7457

467 Hamilton Av., Suite 2, Palo Alto, CA 94301

CP/M is a reg. trademark of Digital Research

Please send complete information on the following versions of ReformaTter _____

Please send ReformaTter CP/M ↔ IBM. My check for \$249 (plus \$5 shipping. Cal. Res. add 6 1/2% sales tax). Charge to my VISA MasterCard.

_____ exp. date _____

Signature _____

Name _____

Company _____

Street _____

City _____

State _____ Zip _____

Mail to MicroTech Exports, Inc.
467 Hamilton Ave., Palo Alto, CA 94301

Listing 1: *Demonstration of the table-jump instruction. The first instruction calls a routine in the monitor to get a character from the keyboard (the ASCII character is stored in the accumulator). Then, the value hexadecimal 100 is moved to DPTR, and control is transferred to the address that is the sum of DPTR with the contents of the accumulator. This listing shows that the possible addresses, 0130, 0134, or 0138, form a table and are loaded with short routines to move a special value to port 1.*

```
0050 LCALL 0E009
0053 MOV DPTR, #100
0056 JMP @ A + DPTR
0130 MOV 90, A
0132 AJMP 0050
0134 MOV 90, A
0136 AJMP 0050
0138 MOV 90, A
013A AJMP 0050
```

Here, the first line performs a Boolean logical AND of the value 05 hexadecimal with the contents of the port at address 90 hexadecimal (the result of the operation, 05, is stored there, too). The second line causes a return of control to the program that was running when the interrupt occurred.

The result of this program is the outputting of hexadecimal 0F to port 1. This is maintained until an interrupt (INT1) occurs when 0F at port 1 changes to 05. The masking of bits 1 and 3 at P1 has been accomplished. If ORL 90, #05 were employed as the first line of the service routine, the result after an interrupt would be 0F at port 1. If in the latter case the byte 0F in the MOV instruction at 0055 were changed to 00, the output at port 1 would first be 00 and the result of an interrupt would again be 05 at that port. Note INT1's vector address: 0013. Vector addresses of RESET, INT0, timer/counter 0, timer/counter 1, and serial I/O port interrupts with the 8051 are, respectively, 0000, 0003, 000B, 001B, and 0023.

Example of Indirect Jumps

The useful table-indexing instruction `JMP @ A + DPTR` (see listing 1) adds the contents of the 16-bit DPTR

(data-pointer register) with that of A (accumulator) and places the sum into the PC (program counter). The program, therefore, next executes the instruction at the address formed by that sum. In the following program, we are using a routine called UCI at address 0E009 hexadecimal in the SDK-51's monitor that, when called (a "long call," LCALL, is needed because UCI resides more than 2K bytes away from our program), waits for the reading of a key and then returns with the ASCII (American Standard Code for Information Interchange) character of the key in the accumulator. We shall press keys 0, 4, or 8 only (key codes 30, 34, or 38).

As a result of the `JMP @ A + DPTR` instruction, the program will then jump to either 0130, 0134, or 0138, where a table of short routines is located. The routine invoked will, naturally, depend on the contents of the accumulator (the key pressed). For simplicity and illustrative purposes only, we shall have the routine at 0130 output 30 (key 0) to port 1, the routine at 0134 will output 34 (key 4) to port 1, and the routine at 0138 will output 38 to port 1.

Depending on the key pressed (either 0, 4, or 8), port 1 will exhibit 30, 34, or 38. There certainly is a shorter and much more direct routine to output the key code in the accumulator to port 1. The program above, as mentioned before, is for illustrative purposes only. Jumps to more involved routines, or to tables, could be implemented at 0130, 0134, and 0138. The `AJMP` is used because the span from 0134 back to 0050 exceeds 128 bytes.

The Multiply and Divide Instructions

The `MUL AB` instruction multiplies the unsigned 8-bit integers in registers A (ACC) and B. The low-order byte of the 16-bit product is left in A and the high-order byte in B. The arithmetic is binary. Thus, if hexadecimal 32 is in B and hexadecimal 53 is in A, `MUL AB` will yield hexadecimal values 76 in A and 16 in B. `DIV AB` divides the unsigned 8-bit integer in register A by the unsigned 8-bit in-

teger in register B. The integer part of the quotient is stored in A and the remainder in B. Dividing by 00 will leave undefined results in A and B. Thus, if hexadecimal 5A is placed in A and hexadecimal 32 in B, the result will then yield 01 in A and hexadecimal 28 in B. Routines employing the MUL and DIV instructions abound in the references cited at the end of the article. It should be noted that with MUL AB, if the product exceeds 255 (OFF hexadecimal), OV (overflow) flag is set; otherwise, it is cleared. The carry flag is always cleared. With DIV AB, the carry flag is always cleared, but OV is set only when division by 00 is attempted, useful in detecting possible contamination of data (noise) and the propagation of same.

Solution to a Combinatorial-Logic Problem

The Boolean processing capability of the 8051 makes it ideal for implementing software solutions to

combinatorial-logic equations. When hardware solutions to such problems result in many gates, relays, switches, contacts, etc., and speed is not a constraint, the advantages of a simple software approach, which eliminates much of the hardware, makes that approach very attractive. For illustrative purposes only, we are going to consider a simple Boolean logic problem and implement its solution using the Boolean bit-processing capabilities of the 8051. We are not suggesting that for such simple problems you should go the microcomputer route. But the problem and its microcomputer solution will illustrate the simplicity and directness of approach, and indicate the great advantages to be reaped in more complicated logic-array implementation situations.

Consider, for example, a truth table involving one digital output (dependent) variable F and three digital input (independent) variables S6, S5, and S4. Here, S6, S5, and S4

will represent the states of digital inputs (here, switches) at bit addresses 96, 95, and 94 of port 1 (SFR 90), and F will drive output bit address 90 (bit 0 of port 1). The latter may drive a relay, machine, alarm, or any other bit-oriented device to be controlled. Assume the truth table is such that after Boolean-algebra realization and minimization, the following combinatorial-logic equation results:

$$F = \overline{S6} \cdot S5 \cdot S4 + S6 \cdot \overline{S4}$$

Listing 2 shows how we can implement this equation with the 8051 and its instruction set.

As the switches S6, S5, and S4 are varied through their eight possible combinations, the F bit at pin 90, driving the device, will take on the proper 1 or 0 (on/off) values in exact accordance with the Boolean-logic equation given above that defined the relationship; this is straightforward and requires no intermediate hardware.

PICK A SYSTEM!

We're offering you our SB-80 system in either 5 1/4" or 8" disk drives, your choice. Either way your system comes with a full size (12" diagonal) non-glare tiltable green screen with 24 lines by 80 character format. Its multi-character set offers blinking cursor, underlining, reverse video, and half and zero intensity. The movable, detachable keyboard has a numeric pad with cursor control and function keys.

- Single Board Technology ■ CP/M® Operating System
- 4 MHz Z80A CPU ■ 64K 200ns Main Memory
- 8-Inch Dual Density Floppy Drives
- 5 1/4-Inch Dual Density Floppy Drives
- 2-Serial Ports ■ 2-Parallel Ports
- 4-Counter/Timers ■ Expandable

For further information about this limited offer call or write:



Nationwide on-site and depot repair service through the professionals at INDESERV.

®CP/M is a registered trademark of Digital Research, Inc.

Colonial Data Services Corp., 105 Sanford Street, Hamden, Conn. 06514 • (203) 288-2524 • Telex: 956014
Circle 93 on inquiry card.

December 1982 © BYTE Publications Inc 309

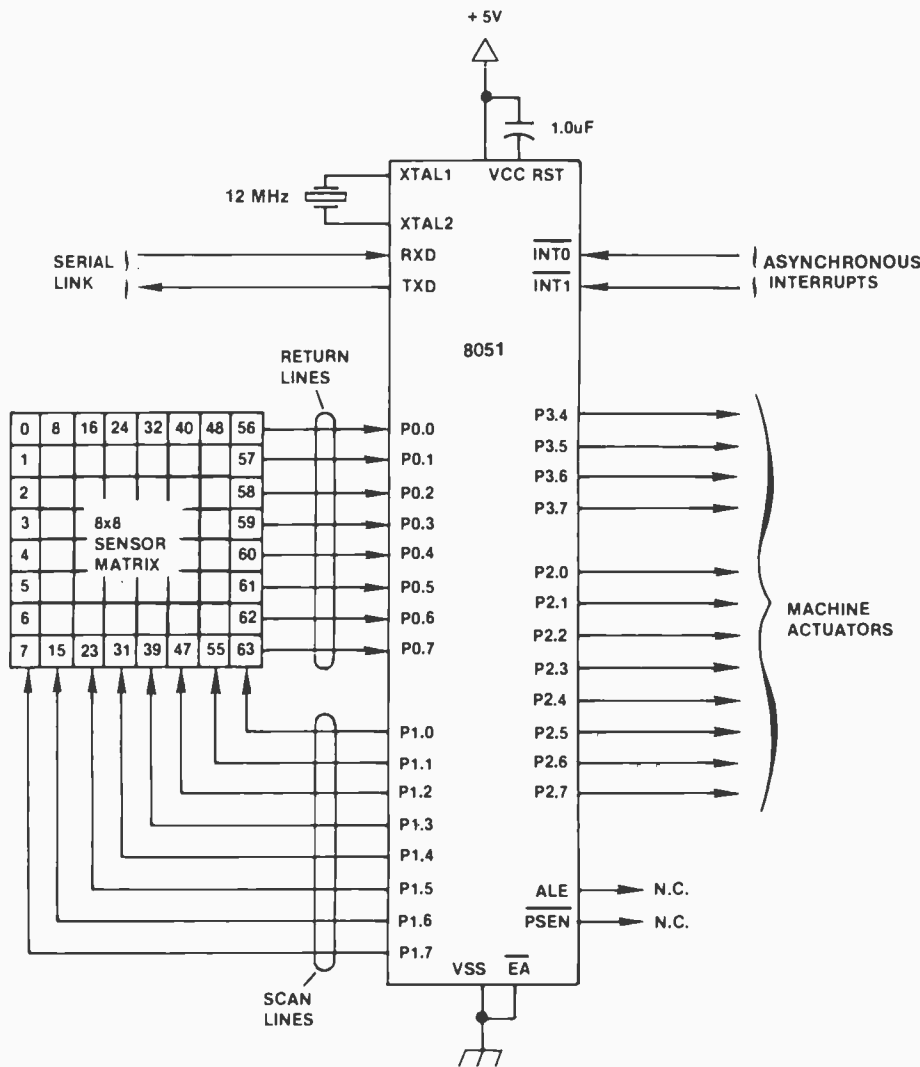

Figure 2: Block diagram for a programmable industrial controller. The system uses 64 input sensors, 12 output signals, remote communications with a host processor (via a high-speed, full-duplex serial link), two prioritized interrupts, and internal real-time and time-of-day clocks. (This figure is reproduced by permission of Intel Corporation from reference 6.)

For control applications, where operating and standby power must be held to a minimum, the 8051 is also available in a CHMOS (high-density complementary metal-oxide semiconductor) version. The Intel high-level language PL/M 51 is available to support development of system software for the MCS-51 series of microcontrollers. Intel is also marketing its iPDS portable 8-bit personal-development system to lend powerful and user-friendly development support for 8051- and 8088-based systems, among others.

Second sources of the 8051 are AMD, Siemens, and Signetics, and of the 80C51, GE-Intersil. ■

References

1. *An Introduction to the Intel MCS-51 Single-Chip Microcomputer Family* by John Wharton. Intel Corporation Applications Note 69, May 1980.
2. *8051 Single-Chip Microcomputer Architectural Specification and Functional Description* by Bob Koehler. Intel Corporation, May 1980.
3. *MCS-51 Family of Single-Chip Microcomputers User's Manual*. Intel Corporation, July 1981.
4. *MCS-51 Macro Assembler User's Guide*. Intel Corporation, 1979.
5. *SDK-51 MCS-51 System Design Kit User's Guide*. Intel Corporation, 1981.
6. *Using the Intel MCS-51 Boolean Processing Capabilities* by John Wharton. Intel Corporation Applications Note 70, May 1980.

TS1000-ZX81 OWNERS

KRAKIT™

WIN \$20,000 or more

KRAKIT™ is an adventure and a treasure hunt for the ZX81 and TS1000 computers. The bank account and prize money actually exist. Be the first to crack the puzzle and the prize is yours. Only one prize will be awarded.

SOLVE 12 CLUES LIKE THIS!

Where it all began. Where the torch was first lit. Where muscles and sinews strain. Where our heroes win acclaim. Where the symbols hold the key.

KRAKIT™ consists of 12 clues on a ready-to-run ZX81 or TS1000 cassette tape (16k RAM). The answer to each clue is the name of a country, a city or town, and a number. If you are the first qualified entrant to solve all 12 clues and declared the winner, you receive two tickets to the city of the secret KRAKIT™ vault location. When you arrive at that location, a check for a minimum amount of \$20,000.00 (U.S.) will be presented to you. The amount of the prize money is augmented weekly.

TS1000-ZX81

RULES

1. The first qualified entrant to be confirmed by the judges to have completed all the clues correctly is the winner.
2. There will be one winner only.
3. No persons connected to International Publishing & Software Inc. or their families are eligible to enter KRAKIT™
4. This offer is not valid where prohibited by law.
5. Due to the confidential nature of KRAKIT™ we regret we are unable to enter into any individual correspondence. All the required information, including how to claim the prize, is on the computer tape.
6. The winner will be required to sign an affidavit of compliance with these rules.



INTERNATIONAL PUBLISHING & SOFTWARE INC.
P.O. BOX 1654, BUFFALO, N.Y. 14216



Mail to:
INTERNATIONAL PUBLISHING & SOFTWARE INC.
P.O. BOX 1654, BUFFALO, N.Y. 14216

Please send _____ copies of KRAKIT™ at \$19.95 plus \$1.50 shipping.

Total _____ enclosed is check money order

Charge to Visa Mastercard

Number _____

Expiry _____ Signature _____
Please Print

Name _____

Address _____

City _____ State _____ Zip _____

Allow 2 weeks for personal checks.

Dealer inquiries welcome.



WC CONSTRUCTION, INC.
San Francisco

Office Memo

Date: November 10, 1982

To: Jack Burns, Division Manager
From: Tom Donohue, President
Subject: Computer recommendations

Your purchase request for six personal computers just reached my desk.

What gives?

I thought you understood our growth plans, Jack, but the computers you've recommended are dead ends. They might do the job today, but what about tomorrow? They don't connect together to form any kind of functional system. The 8-bit models aren't compatible with the 16-bit models. And I doubt the software that runs on the computers you want will be of any use later when we're forced to buy computers that work together.

You saved us a little now, Jack, but your decision will cost us a bundle as we grow into the future. We are growing, Jack, and I'm sure that you want to be part of that growth. See me before you go home tonight.

Tom.

How to avoid this memo.

If you don't want your boss to limit your growth, don't limit the growth of the company.

Consider small business computers that can keep up with your business by giving you options for expansion in the future.

With TeleVideo Systems, Inc. you get what

no other small business computer can offer...

choices for future growth.

Choices that allow the computers you spend good money for today to be part of your growing system tomorrow.

For example, any TeleVideo small business computer can be used as a stand-alone computer.

Then, because you need flexibility for growth, your TeleVideo computer gives you a choice of ways to grow. Because you can add more TeleVideo 8-bit computers. Or TeleVideo 16-bit computers. Or both, to form a single system with up to 16 stations.

Since you need more than computers for a complete system, TeleVideo gives you a choice of peripherals.

Including printers, terminals, disk and tape drives.

And unlike other small business computer systems, TeleVideo has a CPU for every user.

So you can add computers without slowing down the performance of the system as it grows.

Yet no matter what form your TeleVideo system takes as it grows, the CP/M® software you initially invest in for your stand-alone computers can be used on your future multi-user systems. (Thanks to MmmOST™, TeleVideo's unique executive program.)

So you can choose from the largest library of software applications — including graphics — without making a new software investment every time you reconfigure your system.

TeleVideo computers are serviced by TRW's nationwide support network and by TeleVideo's distributors around the world. Easy to understand training packages are also available.

If you're evaluating small business computers, choose the only ones with a future. TeleVideo.

They'll help your future, too.

For more information send in this coupon or call Toll Free: 800-538-1780.

TeleVideo Systems, Inc.
Dept. 610D
1170 Morse Ave.
Sunnyvale, CA 94086

Please send me more information about TeleVideo computers

NAME _____

TITLE _____

COMPANY _____

ADDRESS _____

CITY _____ STATE _____ ZIP _____

PHONE # _____

CP/M is a registered trademark of Digital Research, Inc.
MmmOST is a trademark of TeleVideo Systems, Inc.

Northeast Region 617-369-9370; Eastern Region 212-308-0705; Southeast Region 404-447-1231; Midwest Region 312-969-0112; South Central Region 214-258-6776; Northwest Region 408-745-7760; Southwest Region 714-752-9488; European Sales (Holland) (31) 075-28-7461.



 **TeleVideo Systems, Inc.**

Circle 459 on inquiry card.

Problem Oriented Language

Part 1: A New Method of Input

Data entry can be shortened and simplified by using the POL system.

Mark Finger
2439 Overlook Circle
Lawrence, KS 66044

Are you tired of playing "20 Questions" with your computer every time you want to run your favorite program? Or do you feel like you are in a Chinese restaurant, choosing one from Column A, one from Column B, and one from Column C? Wouldn't you like to be able to change just one parameter in a program without having to answer questions on all the other parameters?

A possible solution to these problems is the Problem Oriented Language (POL) system. POL is useful in both graphics packages and technical programs where many possible parameters are used, but only a few need to be set during any given run. For programs frequently run by experienced users, the POL system is shorter and faster to use. Also, it can more easily match the thought processes of the user because the order of some of the commands may be varied.

What Is POL Input?

POL simplifies the input process, thus reducing some of the tedium involved in using computers. Let's begin by examining the three types of input used.

Most question-and-answer or menu-type inputs require a numeric response, even if it represents a word or phrase choice, because it is easier to use numbers in a program. Question-and-answer sessions are frequently rigid in sequence, and a single error in question 36 can require restarting a 10-minute question-and-answer session.

**POL simplifies the
input process, thus
reducing some of the
tedium involved in
using computers.**

The menu format may be somewhat more forgiving of errors, but it still has to ask many questions, each with a separate answer, leading to a long, boring session. Finally, the thought processes of the person using the program are interrupted by the constant need to read and answer repeated questions.

In contrast, a POL session uses standard terms familiar to the user.

This makes the order of entry for the input more flexible. Finally, POL input is easier to use because it matches more closely the user's thoughts. Fewer interruptions in thinking are required because more information can be put into a single entry.

POL gives a programmer the opportunity to develop a new language that is closely suited to the problem. The words in this new language will preferably be those most often used to describe the problem or topic covered. If the topic is structural engineering, words like "beam," "column," and "load" are used.

Since graphics are often a part of many technical programs, and since graphic images are easily understood, I'll begin by using another graphic example to show how the words of the language are chosen and defined. Consider the following instructions (the results are shown in figure 1):

1. Draw a new graph with all parameters reset to default values.
2. The x axis is linear (default) with values from 0 to 4.
3. The y axis is logarithmic with values from 1 to 100.
4. Draw four major (numbered) divisions with marks (called tics) with

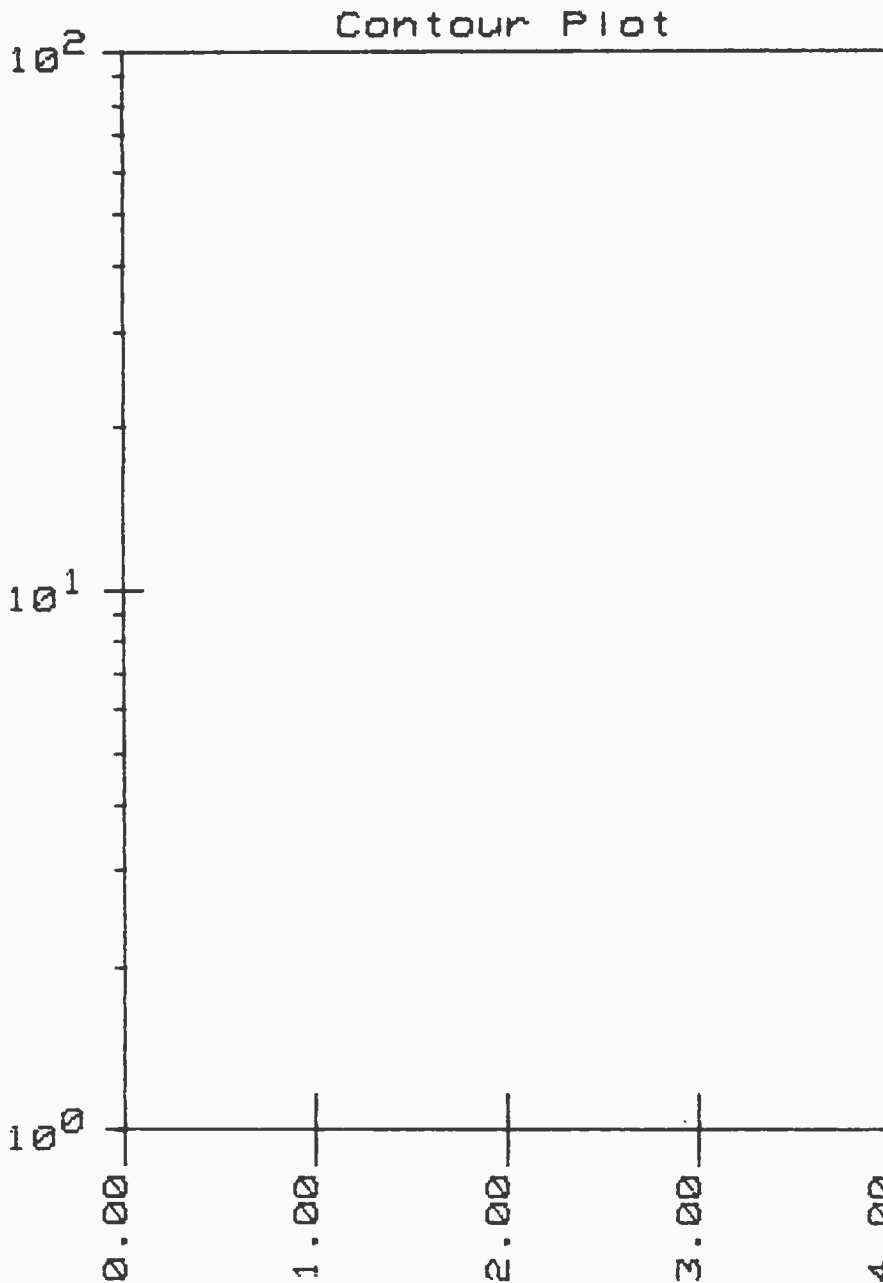

Figure 1: Producing such a graph usually requires an extensive set of instructions and a great deal of user input. The resulting program cannot be easily used for other purposes.

a length of ¼ inch above and below the x axis.

5. Frame the graph (draw lines on the two sides that are not the axes).
6. Title the graph "Contour Plot" and center (default) the title.
7. Draw the graph after the above parameters are set.

Other parameters could be set (e.g., margin, page size, subtitles, x and y axes titles, legends, grid lines, and other characteristics of graphs). Giving the user control over all these characteristics in a question-and-

answer session or by menu can lead to long sessions at the terminal.

The first step in planning a POL system program to draw this graph is to write the input in a logical and readable format:

Draw a graph, with X from 0 to 4, Y axis logarithmic, Y from 1 to 100, X tics major 4 size .25", frame the graph, title "Contour Plot", execute.

This is readable and reasonably similar to the user's thinking. The in-

!!!!FANTASTIC PRICES!!!! FROM DIGITAL DIMENSIONS

OKIDATA

ML-80	\$339
ML-82A	\$435
*ML-83A	\$709
*ML-84(parallel)	\$1,034
*ML-84(serial)	\$1,149
*Includes Tractor Feed	

ANADEX DP8000	\$749
ANADEX DP9500/9501	\$1279
ANADEX 9500A/9501A	\$1359
ANADEX DP9000/9001	\$1209
ANADEX DP9620A	\$1459

SCM-TP 1	\$649
120 word/min Daisy Wheel, 10 or 12 pitch, serial or parallel interface	

DAISYWRITER 2000..... \$1,015
Bidirectional 40cps, 48k buffer, Centronics, 488, RS232, & C. Loop included.

IDS

PRISM 80	\$1,219
Includes sprint mode, dot plot and cut sheet guide	
PRISM 132	\$1,649
Includes all of above and 4-color graphics	

C.ITOH

Prowriter (Parallel)	\$479
Prowriter (Serial)	\$619
Prowriter 2 (Parallel)	\$709
Prowriter 2 (Serial)	\$759
Starwriter F10	\$1,449
Printmaster F-10	\$1,699

FRANKLIN ACE 1000	\$1,849
Includes 64k memory, 5¼" disk, and 12" monitor.	

E-Z COLOR board..... \$230.00
For the Apple II or Apple II Plus. 16-Color, 256 x 192 resolution. Requires 3.3 DOS. Includes demo software and E-Z COLOR Editor.

E-Z COLOR board for S100 Systems

..... **CALL**
E-Z COLOR board for TRS-80..... CALL

INTEX TALKER text-to-speech synthesizer. Serial and parallel interface included
..... **\$280**

AMDEK 13" COLOR-1	\$335
NEC JB1201 GREEN Monitor	\$159

FOR THE IBM P.C.

Quadram Quadboard w/64k	\$429
Quadram Quadboard w/128k	\$519
Quadram Quadboard w/192k	\$609
Quadram Quadboard w/256k	\$699

DIGITAL DIMENSIONS
190 Chapel Rd., Manchester, CT 06040

1-800-243-5222 —Orders Only

Orders & Info Call —203-649-3611

MC/VISA welcome. Allow 2-3 weeks for checks. COD ok. All prices include UPS ground freight in U.S. All orders shipped w/in 24 hrs. CT residents add 7½% sales tax, CPM is T.M. of Digital Research, Prices subject to change without notice.



CS-1,64K Computer w/DD Controller

- Two 5 1/4" DSDD Drives, 8 slots . . . Only \$3349
- CS-1H w/5Meg. Hard Disk Only \$5895
- Multi-User Upgrade Pack. (2 user) . . . \$1895
- 68000 Upgrade Package 3295
- CS-O/D, Z-80 SCC, 64KZ, 16 FDC 4 slots. . . 2545
- DDF, Dual DSDD 5 1/4" Drives. Only 1099
- SP-10, 1 User, (1) 5 1/4" DSDD Drive, 4 packages software, CRT emulates 3102. Only \$1499

COLUMBIA Data Products
16 Bit IBM PC Compatible Systems



Basic model has a 16 Bit 8088 processor, 128K RAM, dual 5 1/4" floppies, DD disk controller, DMA & interrupt controller, 2RS232C serial ports, Centronics parallel printer port, IBM-PC compatible keyboard port, Winchester hard disk interface, programmable tone generator/speaker, eight slots.
Call For Price!



Z89-81
List, \$2895
OUR PRICE
\$2329

- A-87, Two 5 1/4" Drives (48 TPI) \$989
 - Z-89 + A-87 Combination 3279
 - Z-90FA-82 2695
 - Z-37, Two 5 1/4" Drives (96 TPI) 1695
 - Z-90-80 + Z-37 Combination 3985
- Systems come w/CP/M*. Microsoft Basic, and SuperCalc.*

The New SUPERBRAIN II



Now with FREE MicroSoft Basic 80

64K Double or Quad Density units available. Uses two Z-80 CPU's. Commercial-type terminal with 12" monitor. Dual double density minifloppies. Over 350 kilobytes of storage (twice that with quad density drives). Two serial RS232 ports, I/O ports standard. Comes with CP/MTM 2.2 operating system. MiniMicroMart can supply a wide range of CP/M development and application software.

- w/64K Double Density 2099
- w/64K Quad Density 2495
- w/64K Super Density 2995

COMPLETE BUSINESS & WORD PROCESSING IS AVAILABLE FROM US.
Call or Write for details.

TeleVideo Systems



Self contained desk top computers that can be used as stand alone systems or as distributed processing systems with a Winchester hard disk. 64K Quad Density available with or without hard disk. Comes with CP/M® 2.2 or TeleVideo multi-user operating system.

- TVI-802, 64K (2) 5 1/4" DSDD Drives \$2969
- TVI-802H, 64K, (1) 5 1/4" DSDD Drive & 10 Meg. Hard Disk 4995
- TVI-806, 6 user w/9.6Meg. hard disk. . . . 6099
- TVI-816, 16 user system w/23 Meg. hard disk & tape back up. 11045
- TVI-800, Z-80 Work Station 1439

Add 16 work stations to a TeleVideo sixteen user system for an average cost of \$2129/user, 23 Meg. of hard disk storage and a tape back up.

SYSTEMS GROUP

Systems Group, a division of Measurement Systems Controls, long known for high quality memory boards has introduced a line of S100 computer systems. Their implementation of CP/M* is truly unique. MP/M* and OASIS* operating systems are available. In addition to the system we have advertised, System Group offers units with built in Winchester hard disks.

The system comes with 64K of RAM and a DMA floppy disk controller board, as well as, two 8" disk drives. Serial and Parallel ports are provided.



- Model 2812, w/DD, SS 8" Drives \$3999
- Model 2814, w/DD, DS 8" Drives 4699
- Model 2819, w/1DD, DS 8" & 10 Meg. H.D. . . 7420

NorthStar ADVANTAGE

The ADVANTAGE is an integrated desk top computer w/12" bit mapped graphics or character display, 64K, 2 quad drives, also comes with 5 Meg. Winchester hard disk. The ADVANTAGE is upgradable to 16 bits and can be networked.

- ADVANTAGE \$3059
- ADVANTAGE w/5 Meg. Hard Disk 4249
- Graphics CP/M® 125
- Graphics DOS/Basic 125

NorthStar HORIZON

- HORIZON 2Q-64K (S-100) \$3059
- HORIZON 2Q, w/5 Meg. Hard Disk 4249
- HORIZON 1Q, w/18 Meg Hard Disk 6799
- CP/M® 2.2 125

MORROW DECISION ONE

The DECISION ONE is a desk top computer with 64K static RAM, DMA floppy disk controller, 5 1/4" or 8" drives and can be expandable to a multi-user system. Included is CP/M® 2.2, MicroSoft Basic 80 and WordStar.

- DECISION, w/2, 5 1/4" DS, DD drives . . . \$2969
- DECISION, w/1, 5 1/4" DS, DD drive & 5 Meg. hard disk drive. 4499
- (Call for prices on 10 & 16 Meg. hard disks)*
- DECISION, w/2, 8" SS, DD drives \$3735
- DECISION, w/1, 8" SS, DD drive & 10 Meg. hard disk 5859
- (Call for prices on DS, DD 8" & 20 Meg. H.D.)*
- New!** Micro Decision, 5 1/4" SD, DD Drive, Terminal, & Software* Only \$1495
- Micro Decision, (2) 5 1/4" SD, DD Drives, Terminal & Software* Only \$1795
- *Software includes; CP/M®, WordStar, Basic-80, Basic, Spelling Checkers, & Electronic Spreadsheet.*

Systems, Terminals, Printers

put i
ar

TeleVideo



925C

Protected fields, optional 2nd page of memory visual attributes, tilt swivel screen (non-glare P31 green), 25th status/user line, time of day, can emulate 912, 920, RS232C printer port, 50 Baud to 19.2KB., 8x10 character resolution, switchable character sets, function keys self test

910C	\$595
910C +	595
912C	739
920C	789
925C	789
950C	989

HAZELTINE



Esprit I	\$499
Esprit II	Call
1420	595
1500	949
1510	1089
1520	1389
Exec. Basic 20	1065
Exec. Basic 30	1189

SOROC

SOROC IQ-130	\$595
--------------	-------

TI CRT Terminals

940, Basic	\$1599
940, Package	2079

LEAR SIEGLER

ADM 22	\$595
ADM 3A	535
ADM 5A	579

ZENITH data systems

Z-19 Video Terminal

Green Phosphorous Screen.
Now Only

\$729

NEW ZT-1,
(Terminal WITH Auto-Dial Modem) **\$595**



OKIDATA

Microline 80, Parallel	\$359
Microline 82A Serial & Parallel	479
Tractor Option, 80 & 82A	50
Microline 83A, Serial & Parallel	759
Microline 84, Parallel	1149
Microline 84, Serial	1249
Okigraph 82A	85

DIABLO

630 RO	\$2299
630 R155, (All purpose interface)	1998
630 KSR	2825

QUME

Qume 9/45, Full Panel	\$2049
-----------------------	--------

CENTRONICS

737-3, RS232C	<i>New Low!..</i> \$389
730-1, Parallel	<i>New Low!..</i> \$349
704-9, 150 CPS (RS 232C)	1595
704-11, 150 CPS Parallel	1695
122G 120 CPS Parallel	949

NEC Spinwriter



3510 RO, 35 CPS	\$1699
3530 RO, 35 CPS (Centronics Interface)	1859
7710 RO, (RS232C) 55 CPS	2395
7720 KSR (RS232C) 55CPS	2999
7730 RO, 55CPS (Centronics Interface)	2395

IDS INTEGRAL DATA SY



IDS 445G	<i>Special!</i> \$599
MICROPRISM	599
PRISM 80, Basic	Call
PRISM 80, w/o color	1149
PRISM 80, w/color	1499
PRISM 132, Basic	Call
PRISM 132, w/o color	1469
PRISM 132, w/color	1695

Texas Instruments

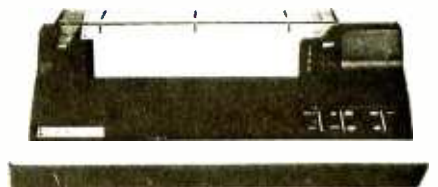

TI 810, Basic	\$1349
TI 810, VCO, ASC II Full	1599
TI 810, Enhanced	1950
TI 810, VCO/Full Enhanced	2099
TI 820, RO w/LC	1645
TI 820, RO w/comp. print, DFC	1795
TI 745, Portable Terminal	1399

EPSON

MX-80	\$489
MX-80FT	589
MX-100FT	789
RS232, w/4K Buffer	135

C.ITOH

ProWriter 8510, Parallel	\$549
ProWriter 8510 ACD, Parallel & Serial	649
ProWriter 1550, Parallel	789
ProWriter 1550, Serial	845
F-10, Parallel or Serial	1599
Daisy Wheel Tractor, For F-10	275

ANADEX

DP-9000A/01A	\$1449
DP-9500A/01A	1449
DP-9620A	1569

MiniMicroMart, Inc.

943 W. Genesee St.
P.O. Box 2991B
Syracuse, New York 13220
Circle 324 on Inquiry card.

(315) 422-4467

TWX 710-542-0431



All prices F.O.B. shipping point, subject to change. All offers subject to withdrawal without notice. Advertised prices reflect a 2% cash discount (orders prepaid prior to shipment). C.O.D.'s & Credit Cards, 2% higher.

...s smaller than the initial list of actions because some choices are assumed to have specific values and other information in the first list was for explanation only. The order of input is relatively unimportant and the sections separated by commas can be reordered; only "draw a graph" and "execute" cannot be moved.

This initial format should be used to determine the keywords in the language and their hierarchy. For example, "size" may apply to the tic size, the axis numerical values, and various labels. The hierarchy is necessary to determine which size is being specified. Keywords should also be selected on the basis of spelling; significant letters will be capitalized. This allows similar words to be distinguished from one another. It also helps eliminate spelling errors in long words. Four letters is my preference, but programming needs may dictate more or less. A space

may be included after the word to distinguish between similar words such as "are" and "area." Significant spaces are shown by an underscore. The previous example of an input may now be written as:

```
DRAW an XY graph with X__
FROM 0 TO__ 4, Y__ axis
LOGarithmic, Y__ FROM 1 TO__
100, X__ TICS MAJOr are 4
SIZE = .25, FRAME the graph,
TITLe 'Contour Plot', EXECute
```

The capitalized portions are significant as keywords. Also, a number of filler words (shown in lowercase) must be allowed for by the programmer.

The programmer developing this new language uses a number of examples like the one given above to construct a tree structure of all the keywords that will be used as a guide in doing the actual programming.

The tree structure for drawing the xy axes is given in listing 1. Later, the programmer will also write a help routine (which contains the words of the language, their definitions, and proper usage) for each major section of the program. This help routine is stored on a disk and can be called from within the program for assistance as it is needed. Since the portion of the program used to draw the axes is a major section, it has its own help routine (shown in listing 2). This is an actual part of a graphics module.

The language used to solve a problem is built up from several sections. For example, a modeling package might be built up using a differential equation section, an integration section, a regression section, and the graphics section given above. In this manner, a "modeling language" would be built up. Similarly, other languages can be developed for other problems, such as structural design in

Listing 1: Tree structure of the keywords used in drawing the graph shown in figure 1. This is used as a guide in developing a particular modeling language.

```
DRAW XY (CONTinue)
NO
X
  LINEs
  LOG
Y
  LINEs
  LOG
GRID
FRAME
LOG
X (flag=1)
Y (flag=2)
LOG
LINEs
TICS
  SIZE ##.#
  SPACe ##.#
  MAJOr ##
  MINOr ##
  VALUes
  SIZE ##.#
  PERPendicular
  PARAllel
  DECImal ##
FROM ##.# TO ##.#
POSITION LEFT ##.# RIGHT ##.#
POSITION TOP ##.# BOTTOm ##.#
MARGIn LEFT ##.# RIGHT ##.#
MARGIn BOTTOm ##.# TOP ##.#
LABEl
  SIZE ##.#
  JUSTify
    LEFT(or TOP)
    CENTER
    RIGHT(or BOTTOm)
  POSITION ##.#
  ORIENTATION
    VERTicAl
    HORTizontAl
  LENGth ##.#
  'string1', 'string2'
PAGEsIZE ##.## ##.##
GRID
FRAMe
LOG
MAXimum (LABEl) (LINEs) ##
CLEAR
EXECute

TITLE (1)
SUBtitle (2)
SIZE ##.#
JUSTify
  LEFT
  CENTER
  RIGHT
POSITION ##.#
LENGth ##.#
'string1', 'string2', ....
LEGEND
POSITION ##.# ##.#
BORDER
BORDERLess
SIZE ##.#
WIDTH ##.#
HRIGHT ##.#
JUSTify
  TOP
  VERTicAl CENTER
  BOTTOm
  LEFT
  HORIZONTAL CENTER
  RIGHT
choice1 'string1', choice2 'string2', ....
CIRCLE
SQUARE
TRIANGLE
STAR
DIAMOND
LINE
DOTTed
DASH
LONG DASH
DOT DASH
DOT DOT DASH
DOT DOT DOT DASH
DOT LONG DASH
DOT DOT LONG DASH
DOT DOT DOT LONG DASH
DASH LONG DASH
DOT DASH LONG DASH
DOT DOT DASH LONG DASH
DOT DOT DOT DASH LONG DASH
```

COMPATIBLE COLOR-I . . .



The popular choice for popular computers . . . at a popular price.

The Color-I Monitor is designed to perform superbly with your Apple II, Atari or VIC Commodore personal computer and others. Highly styled cabinet. It accepts a composite video signal to produce vivid, richly colored graphic and sharp text displays. Very reasonably priced, the Color-I is a giant step above home TV sets and other monitors.

Just write, or call to receive complete specifications on the Amdek Color-I Monitor.

- Quality 260(H) x 300(V) line resolution.
- Built-in speaker and audio amplifier.
- Front mounted controls for easy adjustment.
- Interface cables available for Atari and VIC Commodore computers.
- FCC/UL approved.

2201 Lively Blvd. • Elk Grove Village, IL 60007
(312) 364-1180 TLX: 25-4786

AMDEK CORP.

Amdek . . . your guide to innovative computing!

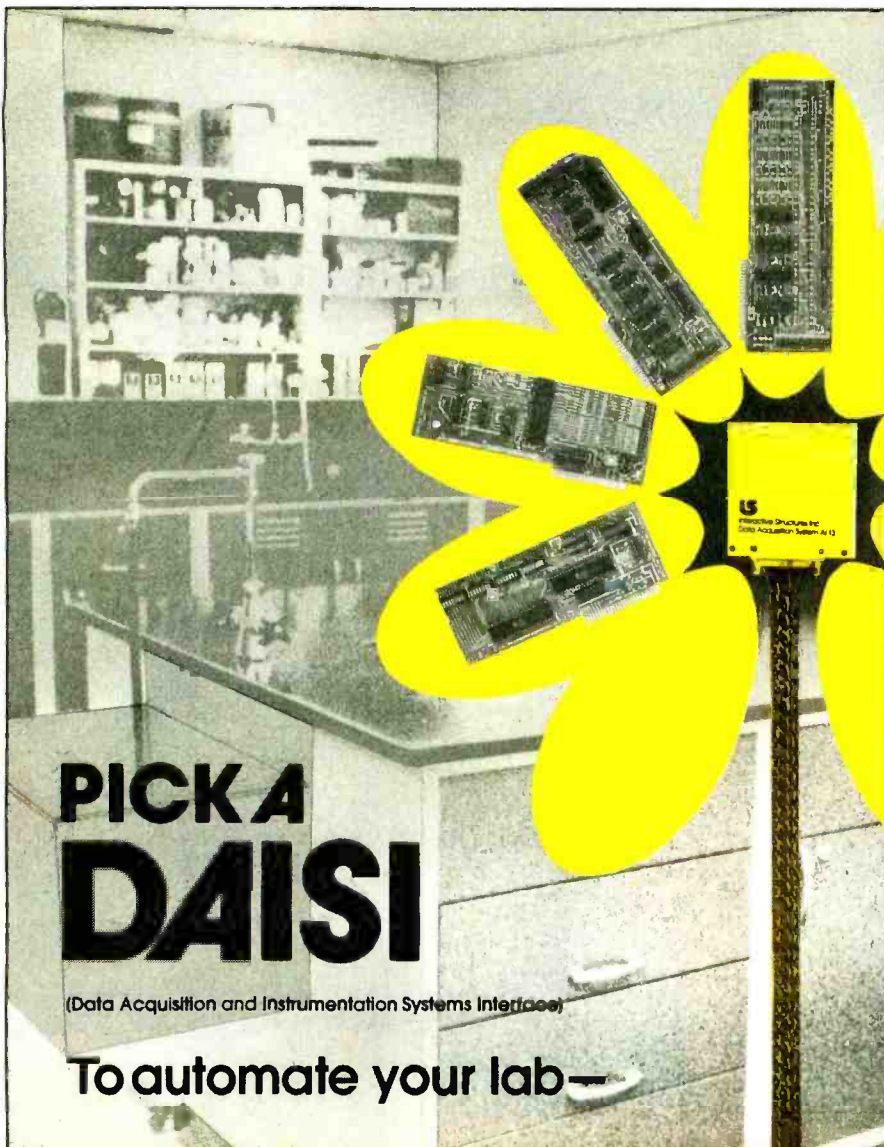

PICK A DAISI

(Data Acquisition and Instrumentation Systems Interface)

To automate your lab—

Exciting new capabilities can blossom in your lab—when you automate it with the DAISI family of data acquisition peripherals for your Apple Computer.

DAISI interfaces, from Interactive Structures, turn your economical Apple into a personal electronic lab assistant. DAISI products are designed to read instruments and sensors, control temperature and pressure . . . with reliability and precision.

Here's a rundown on some DAISI interfaces

AI13, 12-Bit Analog Input System—\$550

- 16 input channels ■ 20 microseconds conversion time.

AI02, 8-Bit Analog Input System—\$299

- 16 input channels ■ 70 microseconds conversion time.

AO03, 8-Bit Analog Output System—\$195-\$437

- up to 8 independent channels ■ range and offset adjustable.

DI09, Digital Interface with Timers—\$330

- timing and interrupt capability ■ direct connection to BCD digits, switches, relays.

Don't settle for garden variety equipment for your laboratory applications. Get the best—at a great price. Pick a DAISI!



Call us for the DAISI dealer near you.

Interactive Structures Inc.
146 Montgomery Ave.
Bala Cynwyd, PA 19004
(215) 667-1713

All DAISI interfaces come complete with cable, instructional diskette and comprehensive manual.

civil engineering, reaction kinetics in chemical engineering, or simple coordinate geometry for high school mathematics.

A POL programming system should:

- be able to break an input line into words, variable names, numbers, special characters, and strings
- be able to match word or variable names
- be able to extract numbers, determine permitted range, and return proper values
- be able to extract strings intact
- allow line continuations for long input sequences
- be able to read stored input sequences from a file
- be as automatic at run-time as possible
- allow changing of special control characters
- allow comments (not processed for keywords)
- allow paging and switching of program sections
- allow for input of numbers or strings at run-time to keyword sequences stored on disk files
- allow for output to the terminal
- allow graphical coordinates or real values to be input from the plotter
- allow automatic skipping of common filler words or characters

These capabilities should be part of any package that claims to have POL input. However, all that has been presented so far is just another—though fancier—way to input data and control information. Problem Oriented Language opens a door to far more than this.

Why Have POL Input?

The use of technical programs with microcomputers is very underdeveloped. Currently, three areas are being developed. First, much work is being done with graphics, especially for the display of equations and data, and for statistical operations on that data. However, it is not easy to take these programs past what they are intended to do, and the input to these programs is either painfully slow or

Text continued on page 328

A day in the life of a Lanier EZ-1™ work processor.



8:30 First, the EZ-1 types the Johnson proposal. *It's sure easier than my old electric.*



9:45 Checks for spelling errors with EZ-Spell.™ *Catches mistake in "miscellaneous."*



10:15 Retrieves current sales trends from the computer. *Then EZ-1 forecasts future trends.**



11:00 Sorts through thousands of records with Data Manager.™ *Selects exactly what I asked for.*

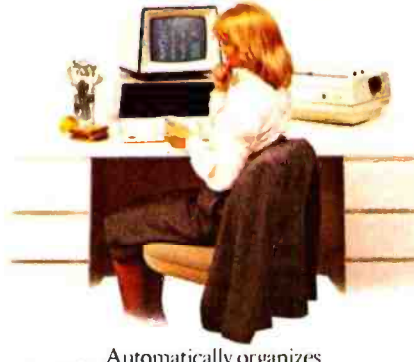

1:30 Automatically organizes report into a special format. *Designed it myself with just a few key strokes.*



2:45 Computes figures easily. *I didn't have to use my calculator once.*



4:00 Updates last month's financial report with EZ-Task.™ *All I do is type in this month's figures.*



4:45 Prints out report in less than 30 seconds a page. *Every one letter-perfect.*



5:00 Stores everything on disc for easy updating. *Good work, EZ-1. See you tomorrow.*

LANIER®

©1982 Lanier Business Products, Inc.

Word processors basically type. Our *work* processor does a whole day's work. From start to finish. It even functions as a small business computer to handle inventory control, receivables and payables.

See what your day could be like with Lanier's EZ-1 work processor.

Send us this coupon or call for an EZ-1 trial in your own office. (800) 241-1706 except in Alaska and Hawaii. In Georgia call collect (404) 321-1244.

*EZ-1's CP/M® compatible operating system provides access to a library of software packages. CP/M® is a registered trademark of Digital Research, Inc.

Mail to: Lanier Business Products, Inc.
1700 Chantilly Drive N.E., Atlanta, GA 30324

Name _____ Title _____

Phone _____ Best time to call _____

Firm _____

Address _____ County _____

City _____ State _____ Zip _____

Dec. '82 Byte 4 76 B K2

COMPUTER WAREHOUSE

CALL TOLL FREE **1-800-528-1054**

ATARI

Special 800 System
800 w/ 48K, recorder, Pac Man or Star Raiders, joysticks..... **Call**

Pac-Man Special
400 w/ 16K, 2 joysticks, Pac-Man **\$333**

800 (48K)..... **\$655**
400..... **\$285**
810 Disk Drive..... **\$440**
850 Interface..... **\$170**
410 Recorder..... **\$75**
830 Modem..... **\$155**
16K Memory..... **\$60**
32K Memory..... **\$90**

COMMODORE

VIC-20..... **\$180**
Datacassette..... **\$60**
Single disk drive..... **\$320**
16K Memory..... **\$95**

TI 99/4A HOME COMPUTER

10" Color monitor..... **\$355**
Disk controller..... **\$220**
Disk drive..... **\$375**
32K Memory..... **\$290**
Expansion box..... **\$185**
Expansion box disk controller..... **\$185**
Expansion box disk drive..... **\$290**
Expansion box 32K memory..... **\$220**

DISK DRIVES

Lobo
Apple 1st Drive..... **\$400**
Apple 2nd Drive..... **\$350**
Percom
Atari D/D Drive..... **\$650**

MONITORS

Zenith
12" Green Screen..... **\$115**
Amdek
Video 300..... **\$145**
Color I..... **\$310**
Color II..... **\$650**
Color III..... **\$390**
BMC..... **Call**
NEC
JB 1201..... **\$155**
JB 1260..... **\$115**

MODEMS

Hayes Smartmodem..... **\$215**
Novation
CAT..... **\$140**
D-CAT..... **\$155**
Signalman
Mark I..... **\$85**

SOFTWARE

	CP/M	IBM		CP/M	IBM
Ashton-Tate	Call	Call	Sorcim Supercalc	\$225	\$225
WordStar	Call	Call	Innovative		
MailMerge	Call	Call	Software T.I.M.	\$425	\$350
SpellStar	Call	Call	CBasic	\$100	NA
Visi-Calc	NA	\$195	Microsoft Basic 80	\$265	NA
Easywriter II	NA	\$275	WordStar, MailMerge,		
Spellguard	\$225	\$225	SpellStar	\$449	\$449

PLEASE ADD \$5 PER SOFTWARE ORDER FOR SHIPPING.

SPECIAL VISICALC SYSTEM

Apple look alike, Lobo 1st Drive,
Zenith Green Screen Monitor, Visicalc..... **\$1595**

PRINTERS

Anadex..... **Call**
Anacom..... **Call**
C. Itoh
F-10—Parallel..... **\$1375**
F-10—Serial..... **\$1375**
55CPS—Series..... **Call**
8510 Parallel..... **\$425**
Comrex
CR-1-S..... **\$800**
CR-1-P..... **\$775**
Datasouth
DS 180..... **\$1175**
Diablo
620 RO wo/ Tractors..... **\$1100**
630 RO wo/ Tractors..... **\$2050**
630KSR wo/ Tractors..... **\$2435**
NEC
PC-8023A..... **\$465**
3510..... **\$1525**
3550..... **\$1935**
7710..... **\$2220**
7720..... **\$2590**

Okidata
Microline 80..... **\$305**
Microline 82-A..... **\$399**
Microline 83-A..... **\$650**
Microline 84..... **Call**

PMC
DMP-85..... **\$410**
Smith-Corona
TP-1..... **\$650**
Star Micronics
DP-8480S..... **\$300**
DP-8480P..... **\$295**

Tally
1805/1802..... **\$1490**
1605/1602..... **\$1325**
MT 160..... **\$625**
MT 180..... **Call**

Texas Instruments
810 Basic..... **Call**

VIDEO TERMINALS

ADDS
Viewpoint..... **\$490**
Televideo
910..... **\$570**
910 Plus..... **\$570**
920..... **\$735**
925..... **\$730**
950..... **\$915**
Zenith
Z-19..... **\$680**
ZT-1..... **\$550**

COMPUTERS

Altos
ACS 8000-15..... **\$3742**
Series 15D..... **\$2125**
Series 5-5D..... **\$4240**
Eagle..... **\$2350**
NEC
8001..... **\$730**
8012..... **\$470**
8031..... **\$730**
Northstar
Advantage..... **\$2800**
Advantage w/ 5MB..... **\$3900**
Horizon II 64K QD..... **\$2625**

Sanyo
MBC-1000 w/ WordStar, CalcStar,
S-Basic, CPM*..... **\$1477**
Above w/ 2 Drives..... **\$2000**
MBC-2000..... **\$2460**
Televideo Systems
TS-802..... **\$2600**
TS-802H..... **\$4450**

HOUSTON INSTRUMENTS

Hi-Plot
DMP-2..... **\$825**
DMP-7/8..... **\$2025**

DISKETTS

Maxell
5 1/4" 0. Sector (100)..... **\$235**



Prices reflect 3% to 5% cash discount. Product shipped in factory cartons with manufacturer's warranty
Please add \$8.00 per order for shipping. Prices & availability subject to change without notice
Send cashier's check or money order all other checks will delay shipping two weeks



2222 E. Indian School Rd. • Phoenix, Arizona 85016
Order Line: 1-800-528-1054 Other Information: 602-954-6109
Order Line Hours: Mon.-Fri. 10-5 MST Saturday 9-1 MST

Listing 2: Output from the HELP routine. These explanations of the various commands can be called by the user as needed.

DRAW plots the axis for the graph. The format is :

```
DRAW XY CONTINUE OPTION,OPTION.....
POLar
CARTesian
```

where XY implies the XY coordinate system
POLar implies a polar coordinate system, and
CARTesian implies a Cartesian coordinate system.

If CONTINUE is not used, all parameters are reset to their default values. Do not use CONTINUE the first time DRAW or REDRAW is used, or an error will result. Use REDRAW if the parameters are to be preserved but the pen position is to be reset for a new graph.

The following words are always skipped over at any place in the line:

```
A
AN
THE
FOR
AND
EQUAL
EQUALS
IS
ARE
OF
GRAPH
```

Commas(,) and equivalence signs(=) are also skipped.

The following options are available for OPTION:

PAGESIZE ###.# ##.#

Enter# the size of the page (in inches) for the plotter. The first number is the width, and the second number is the height. Default for the Diablo printer is 8.5 and 11.

MAXIMUM (LABEL) (LINES) ##

Set# the maximum number of lines (4 is default) for each of TITLE, SUBTITLE, X LABEL, Y LABEL, or LEGEND. This command automatically deletes all labels and resets all label parameters to default values. If it is used, use it before any label values or strings are entered.

```
X LINES draws vertical lines from the major ticks on the X axis
Y LINES draws horizontal lines from the major ticks on the Y axis
GRID draws both horizontal and vertical lines from the major ticks
NO X LINES does not draw the vertical lines
NO Y LINES does not draw the horizontal lines
NO LINES (or NO GRID) does not draw either vertical or horizontal lines
```

Default is NO LINES

```
X LOG makes the X axis logarithmic
Y LOG makes the Y axis logarithmic
LOG makes both axes logarithmic
NO X LOG makes the X axis linear
NO Y LOG makes the Y axis linear
NO LOG makes both axes linear
```

Default is NO LOG

```
FRAME puts a frame (top and right) around the graph
NO FRAME does not put the frame around the graph
```

Default is NO FRAME

```
X TICS PARAMETER
Y TICS PARAMETER
```

where PARAMETER can be:

SIZE ##.#

##.# gives the length of the major ticks in inches (minor ticks are half as long. Default is .125). Each axis is set separately.

SPACE ##.#

##.# gives the length between major ticks in inches
Not implemented on Diablo modules.

MAJOR ##

gives the number of intervals along the given axis for major ticks (Default is 1). MAJOR is automatically set for logarithmic axes.

CHOOSE...

An Apple Desk



A compact Bi-Level desk ideal for the Apple computer system. This 42" x 29½" desk comes with a shelf to hold two Apple disk drives. The top shelf for your TV or monitor and manuals can also have an optional paper slot to accommodate a printer. It is shown here with the optional Corvis shelf which will hold one Corvis disk drive. The Corvis shelf is available on the 52" x 29½" version of the Apple desk.

A Universal Micro Desk



The Universal Micro desk accommodates the S-100 type microcomputers. The desk is available in four sizes: 17.75 inch, 19.06 inch, and 20.75 inch wide openings with 24 inch front-to-rear mounting space. The fourth size is a 20.75 inch wide opening with a 26.50 inch front-to-rear mounting space.

A Mini Rack



Mini racks and mini micro racks have standard venting, cable cut outs and adjustable RETMA rails. Choose a stand alone bay or a 48", 60", or 72" desk model in a variety of colors and wood tones. A custom rack is available for the Cromemco.

A Printer Stand



The Universal printer stand fits the:

Centronics 700's	Diablo 1600's & 2300's
Dec LA 34	T.I. 810 & 820
NEC Spinwriter	Okidata Slimline
Leas Siegler 300's	Anadex 9500's

Delivery in days on most styles in stock. Dealers inquiries invited.

**ELECTRONIC SYSTEMS
FURNITURE
COMPANY**

17129 S. Kingsview Avenue
Carson, California 90746
Telephone: (213)538-9601

December 1982 © BYTE Publications Inc 323

Listing 2 continued on page 324

SUPERBRAIN II

**PRICE
BREAKTHROUGH**

Intertec Data Systems' new SuperBrain II has all the features of the former SuperBrain, plus:

- Below-the-line descenders and reverse video
- Faster, enhanced disk operating system
- Battery operated real-time clock
- Microsoft Basic at no extra charge

NEW SUPERBRAIN II Jr.	\$1,875
350K Disk—64K RAM	
SUPERBRAIN II QD.	\$2,250
700K Disk—64K RAM	
SUPERBRAIN II SD.	\$2,640
1.5 MB Disk—64K RAM	

— Hard Disk Systems —

Intertec 10 MB.	\$2,880
Corvus 5 MB.	2,550
Corvus 10 MB.	3,950
Corvus 20 MB.	4,750

— Printers —

Anadex DP-9501A (150 cps) . . .	\$1,359
Anadex DP-9620A (200 cps) . . .	1,459
Anadex WP-6000 (180/330 cps) . . .	2,759
Comrex CR-1-C (17 cps Daisy) . . .	772
Comrex CR-1-S (17 cps Daisy) . . .	799
Daisywriter-16 (17 cps Daisy) . . .	1,237
Epson MX80 FT x/Graftrax	555
Epson MX100 FT w/Graftrax	725
NEC 8023A Matrix (100 cps)	499
NEC 3510 (RS232) (35 cps)	1,480
NEC 3550 (35 cps) IBM PC	1,949
NEC 7710 (RS232) (55 cps)	2,367
NEC Trimiliner-300 Lpm	4,585
Okidata ML80 (80 cps)	325
Okidata ML82A (120 cps)	475
Okidata ML83A (120 cps)	729
Okidata ML84 (200 cps)	1,175
Smith-Corona TP-1 (12 cps Daisy) . . .	625
Star 8480 TP (80 cps-Parrell)	299
Star 8480 TS (80 cps-Serial)	320
TI 810-Full Package	1,535

Call for Similar Discounts on Other Micro Lines & Printers

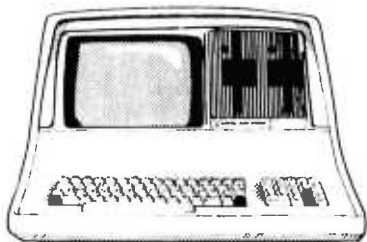

90 Day Money Back Guarantee*
120 Day Extended Warranty**
72 Hour Burn In

Ordering Information: Money Orders, cashier checks or bank wires welcome. Personal or company checks, allow 15 days to clear. Surface freight standard F.O.B. origin. Include your telephone number. No COD's, please. Prices are subject to change without notice. Hours are 9 to 5 CST.

--Free hardware-software catalog--

Call or Write

(214) 931-9069

WEST STAR MICRO

16990 Dallas Parkway • Suite 151
Dallas, Texas 75248

Listing 2 continued:

```

MINOR ##
  ## gives the number of intervals between major ticks(Default is 1)
  MINOR is automatically set for logarithmic axes.

VALUE PARAMETER
  applies to the numbers for the tick marks along each axis
  where PARAMETER can be:

SIZE ##.#
  ##.# is the size of the letters in inches from line to line
  (Default is .25)(sets both axes at the same time)

PERPENDICULAR
  sets the numbers perpendicular to the axis(if the default case)
PARALLEL
  sets the numbers parallel to the axis

DECIMAL ##
  ## sets the number of decimal places in the numbers along
  non-logarithmic axes (sets both axes at the same time--default is 2)

X FROM ##.# TO ##.#
Y FROM ##.# TO ##.#

  determines the minimum and maximum values respectively along the
  stated axis. These will be modified to selected values unless X/TICS
  (or Y/TICS) MAJOR is specified.

X POSITION LEFT ##.# RIGHT ##.#
Y POSITION TOP ##.# BOTTOM ##.#

  sets the distance in inches from the edge of the page to the
  respective side of a framed graphical area. This command can be
  used to position multiple graphs on the same page.

X MARGIN LEFT ##.# RIGHT ##.#
Y MARGIN BOTTOM ##.# TOP ##.#

  sets the amount of clear space(no labels or numbers)in inches around
  the edges of the page(Default is 1 inch on all four sides). This
  command can be used to position multiple graphs on the same page.

X LABEL
Y LABEL

  where the options under each category are:

SIZE ##.#
  determines size in inches from line to line(default is .25 on
  each category). The actual height of the typical capital letter
  is about .7 of the number entered.

JUSTIFY LEFT(or TOP)
      CENTER
      RIGHT(or BOTTOM)

  determines the position indicator relative to the string in the
  category(Default is CENTER for each category)

POSITION ##.#

  ##.# is a fraction from 0.0 to 1.0 indicating the relative
  location of the position indicator along the side from left(or
  top) to right(or bottom). Default is 0.5(which will center the
  label if JUSTIFY is CENTER).

ORIENTATION VERTICAL
      HORIZONTAL

  determines whether letters are vertical or horizontal. Default
  is VERTICAL for XAXIS and HORIZONTAL for YAXIS.

LENGTH ##.#

  ##.# is a number(between 1 and 10)used to expand the
  length of a label(Default is 1.0). 2.0 means the label appears
  twice as long as normal.

"string1","string2",....

  the strings contain the actual labels. The latest set of
  consecutive strings are the ones for that label. Do not insert
  any other command words between the strings for a specific
  label.

CLEAR

  resets all parameters to default values, clears screen, or expects
  a new sheet of paper to be inserted.

EXECUTE

  causes the axes to be drawn using the current parameters.
    
```

Listing 2 continued on page 326

CP/M DATA ENTRY "RADAR"

RADAR is a high speed data entry system that will run on any CP/M system providing a "3741" style key-to-disk environment. RADAR is ideal for replacing KEYPUNCH machines and older, slower key-to-disk systems like the 3741's and 42's.

Features:

- Verify Mode
- Check Digit Processor
- Auto Dup/Manual Dup
- 16 Accumulators
- Parameter Driven (No Programming)
- "Virtual" File Access
- Add or Delete Records
- Record Retrieval By Number Or Content
- Full Editing Capability
- Operator Prompts
- Extremely Fast (Written In Assembly Language)

In addition to "heavy-duty" data entry, RADAR is also the ideal "front-end" for many applications programs, providing aquisition and retrieval of keyed data with a degree of reliability simply not possible with any other technique. RADAR can cut programming time by more than 30%, simply because there is no longer any need to write the "input" portion of a program, just let RADAR handle it!

Write or call for free brochure. The RADAR manual is also available separately for \$25.00.



P.O. Box 3373A
Birmingham, AL 35255
Phone: 205-933-1659

Listing 2 continued:

TITLE option,... (for title at the top of the page)
SUBTITLE option,... (located immediately below the title section)

where the options under each category are:

SIZE ##.#

determines size in inches from line to line (default is .25 on each category). The actual height of the typical capital letter is about .7 of the number entered.

JUSTify LEFT
CENTER
RIGHT

determines the position indicator relative to the string in the category (default is CENTER for each category)

POSITION ##.#

##.# is a fraction from 0.0 to 1.0 indicating the relative location of the position indicator along the top of the graph from left to right. Default is 0.5 (which will center the label if JUSTify is CENTER).

LENGTH ##.#

##.# is a number (between 1 and 10) used to expand the length of a label (Default is 1.0). 2.0 means the label appears twice as long as normal.

'string1', 'string2',

the strings contain the actual labels. The latest set of consecutive strings are the ones for that label. Do not insert any other command words between the strings for a specific label.

LEGEND

the options are:

POSITION ##.# ##.#

gives the position of the legend relative to the X axis and Y axis respectively. Values from 0 to 1 keep the legend with the framed area of the graph. Values greater than 1 for one or both numbers will locate the legend immediately outside the framed area at the right or top respectively. Default is 1.0 1.0, which will place the legend at the upper right corner of the framed graph area.

BORDER
BORDERless

determine whether there will be a frame around the legend. Default is BORDER.

SIZE ##.#

sets the distance between lines in the legend. The actual height of the typical capital letter is about .7 of the number given.

WIDTH ##.#

increases the width of the legend without increasing the letter size. Values are multiples of the normal width.

HEIGHT ##.#

increases the height of the legend by increasing space between lines without increasing letter size. Values are multiples of the normal height.

JUSTify
TOP
VERTICAL CENTER
BOTTOM
LEFT
HORIZONTAL CENTER
RIGHT

sets the location within the legend of the position given by POSITION. Default is VERTICAL CENTER, HORIZONTAL CENTER.

choice1 'string1', choice2 'string2',

where the choices may be line patterns and/or symbols (line patterns must be given first)

LINE
DOT
DASH
DOT DASH
DOT DOT DASH
DOT DOT DOT DASH
LONG DASH

Listing 2 continued on page 328

"The Inflation Fighter is Here"

The "ORANGE+"™ \$995⁰⁰ Suggested List Price



Finally, a dynamic powerful, practical personal computer that is fully Franklin Ace 1000 and Apple® II compatible, yet, lower in price than the competition. Uses existing available software. The "ORANGE+" is the pacesetter of the future, with a **switchable 110-220 volt power supply, upper and lower case with lower case locking key**, enhanced audio and color functions, 8 slot motherboard, game port, fully socketed I.C. board, a 3 ROM operating system, 48K ram, fully expandible.

The "ORANGE+" will interface with peripherals that will work on both the Franklin ACE 1000 or the Apple® II. Thousands of existing software programs, hardware, games, peripherals and accessories will plug right into the New "ORANGE+" COMPUTER.

Best of all is the Price.

The "ORANGE+" could easily be sold for \$1500.00, But no, the inflation fighter retail price is only \$995.00, that's right, Only \$995.00.

Schools, Groups and Companies can now purchase a quality computer at a down to earth price. At these prices, now everyone can afford a powerful personal computer for work or play, add various peripherals and software to build a powerful computer that can do everything the competition can, but for a lot less money.

Ask your favorite dealer for the "ORANGE+" today, if he doesn't have one in stock tell him to write or call his local distributor now.

The "ORANGE+" is fully Apple II and Franklin ACE 1000 compatible.

The "ORANGE+" is fully warranted for 90 days, with a 9 month extended warranty available for an additional \$99.00.

Watch for future exciting products from the manufacturers of the "ORANGE+" COMPUTERS.

Selected Distributorships Available. Dealer Inquiries Invited.

For further information, contact Collins International Trading Corporation, 16311 Ventura Blvd., Suite 500, Encino, California 91436.



ORANGE+™

213-906-3776

Franklin ACE is a trademark of Franklin Computer Corporation
Apple is a registered trademark of Apple Computer Inc.
Orange+ is a trademark of Collins International Trading Corporation

Listing 2 continued:

```
DOT LONG DASH
DOT DOT LONG DASH
DOT DOT DOT LONG DASH
DASH LONG DASH
DOT DASH LONG DASH
DOT DOT DASH LONG DASH
DOT DOT DOT DASH LONG DASH
```

```
CIRClE
SQUARe
TRIAnGLE
DIAMOND
STAR
```

Each time a new set of consecutive option "string" sequences is encountered, the entries are reset to contain only the current entries. All entries must be consecutive and contain no other commands embedded in the sequence.

Text continued from page 320

does not allow complete control of the process. Compare the input of other published programs for graphics to that allowed by listing 3. It is much easier to include graphics in a POL package (as will be demonstrated in part 3 of this series) than to make the traditional subroutine calls with, for example, FORTRAN.

A second area of development is complete packages. Advertisements in microcomputer magazines show a number of technical program packages, especially for statistics and civil engineering. These packages solve a certain type of problem quite well, but using portions of these programs for solving different types of problems is difficult because most packages are not modular (i.e., designed so that parts can easily be rearranged or used in different programs).

A third area is the technical program packages of routines available for mainframe computers (e.g., IBM's Scientific Subroutines package that contains the source listings). However, these packages are usually in FORTRAN, and the programs utilizing these routines frequently strain the capacity of the current generation of microcomputers. The main-line programs written to incorporate these subroutines must also set numerous values required by the subroutines and handle *all* the input and output of the program. This places a heavy burden on the programmer.

The POL system will provide a framework for designing modules that will:

- be easy to combine into large programs

- reduce the load on the programmer writing the main-line program
- be more flexible in use by using Problem Oriented Language input
- provide a large library of modules that can be used in many programs
- make it easy to integrate *plotter-independent* graphics into the program
- be written in BASIC, the language generally used in microcomputers
- not exceed the capacity of current-generation microcomputers, while providing capabilities normally found only in programs run on larger machines

The POL system will make problem solving easier because it will encourage the development of a large library of modules. The modules can then be used to quickly assemble a package to solve specific problems.

What Is Available

A number of program packages on the market have POL input, but many of these packages are not development systems; in other words, they do not allow additional programs or modules to be linked to the current set of programs in order to use the package to solve problems different from those originally envisioned.

At the University of Kansas, two POL development systems are available to me—POLO and GRIP. POLO (Problem Oriented Language Organizer) was developed at the University of Illinois and an application package—called POLO-FINITE—is used in the Department of Civil Engineering on structural-analysis problems. POLO is oriented toward the

CALL YOUR LOCAL DYSAN OFFICE

CA:	Los Angeles (213) 907-1803 Orange County (714) 851-9462 Sacramento (916) 966-8037 San Francisco/Sunnyvale (408) 727-9552
DC:	Washington (703) 356-6441
GA:	Atlanta *(404) 952-0919
IL:	Chicago (312) 882-8176 (800) 323-5609
MA:	Boston (617) 273-5955 *(617) 229-2800
MI:	Detroit (313) 525-8240
MN:	Minneapolis *(612) 814-7199
MO:	St. Louis (314) 434-4011
NY:	New York (212) 687-7122
OH:	Cleveland (216) 333-3725
PA:	Pittsburgh (412) 261-0406 Philadelphia (609) 939-4762
TX:	Dallas/Ft. Worth *(817) 261-5312
WA:	Seattle (206) 455-4725

*Includes OEM Sales

Dysan Diskettes are also available from all ComputerLand Stores, Sears Business Systems Centers, and many independent computer outlets nationwide.

For the location of the Dysan sales outlet nearest you, contact Dysan at: (408) 988-3472

Toll Free: (800) 538-8133
Telex: 171551 DYSAN SNTA
TWX: 910-338-2144

 **Dysan**
CORPORATION

WHAT IS THE TRUE COST OF A DISKETTE?

If you said at least \$186.50*, you're probably close.

Confused? It's simple. The minimum cost of a one-sided, single density 8" diskette equals the purchase price plus the cost of the time to fully load the data onto the disc*. The adjacent diagram tells the story. As you can see, the purchase price of a diskette is a small fraction of the total cost of ownership. So why not pay a few cents more for the best diskette available?

That's where Dysan's quality comes in. Dysan diskettes and mini-diskettes are manufactured to the toughest quality standards in the industry. Every diskette is tested between the tracks as well as on the tracks to insure you 100% error-free recording over the entire disc surface. Dysan quality protects your investment of \$186.50.

You know how costly time and data losses can be should your "bargain" diskette be faulty. Every penny you think you save on the purchase of magnetic media could cost you dearly. Why take the risk when you can have Dysan?



 **Dysan**
CORPORATION

Our Media Is Our Message:

5201 Patrick Henry Drive
Santa Clara, CA 95050

*\$4.00 represents Dysan's suggested retail price for a one-sided, single density 8" diskette, packaged ten to a box. Minimum total cost of ownership = \$186.50

*\$182.50 represents the cost of data loading (approximately 22 hours at 11,106 keystrokes/hour at a labor cost of \$8.23/hour), based on 1981 Data Entry Management Association (DEMA) National Averages.

Fox & Geller's family of programs will double the value of your dBASE II database management system.

dBASE II™ PLUS

Plus 1: QUICKCODE™ The dBASE II Program Generator.

Generate a customer database in 5 minutes with QUICKCODE, the dBASE II program generator. It's that simple.

QUICKCODE writes concise programs to set up and maintain any type of database. Run them as is, or customize them in seconds. You still have all the power of dBASE II, and there is **no programming required**. All you have to do is draw your data entry form on the screen and you're in business.

What about the programs themselves? There are programs to add, edit, delete and print records. And there are programs to print forms (up to 96 lines by 132 columns for wide printers), print mailing labels, or transfer data to WordStar™/MailMerge™. Want **more**? How about programs to do three kinds of data validation, search for records using database keys, and generate customized menus?

On top of **all that**, there are programs to work with portions of your database using your **own** selection criteria and **there are four new data types** which are not found in dBASE II itself.

Absolutely the most powerful program generator you've ever seen. And the easiest to use.

QUICKCODE: \$295.00

Plus 2: dGRAPH™ The dBASE II Graphics System

Now you can combine database and graphics. With dGRAPH, by far the easiest to use graphics package in existence. Just press one key and you've got your graph.

And what graphs! Sales by month. Expense budget by division. This year versus last year. And each one can be a pie chart, bar graph, or line graph. It's up to you.

Advanced features make dGRAPH as powerful as it is easy. Features like autoGRAPH™, which will *automatically* load dBASE II data, compute scales, draw grid lines, and label charts. Then there's automatic shading and overlay graphs. And more.

dGRAPH brings your database to life. dGRAPH draws graphs on Epson, Okidata, and a growing list of other popular printers.

dGRAPH: \$295.00

Plus 3: dUTIL™ The dBASE II Utility Program

dUTIL is Fox & Geller's utility program for dBASE II. dUTIL decreases the running time of dBASE II command files. dUTIL combines your command files automatically to produce a faster running time.

When using dBASE II, you may often find yourself writing the same instructions over and over again. With dUTIL, you can put these instructions into a standard text file using your favorite text editor or word processor, and automatically use them in as many dBASE II command files as you wish.

When debugging a dBASE II command file with dUTIL, you can have all your IF/END IF and DO/ENDDO sequences automatically indented and aligned so that they are readable. dUTIL will also highlight all dBASE II reserved words by setting them to upper case.

dUTIL: \$99.00



Available From Your Local Dealer

dBASE II is a trademark of Ashton-Tate. WordStar and MailMerge is a registered trademark of MicroPro International. QUICKCODE, dGRAPH, dUTIL, dSCAN, autoGRAPH are trademarks for Fox & Geller.

Circle 205 on inquiry card.



FOX & GELLER

Fox & Geller, Inc.
P.O. Box 1053
Teaneck, NJ 07666
201 837-0142

manipulation of large amounts of data (a million items or more) and operates in a batch environment.

GRIP (General Routines for Interactive Processing), developed at the University of Kansas by Rick Hilst and Dr. Kenneth Bishop of the Department of Chemical and Petroleum Engineering, is a set of routines for linking GRIP-compatible modules together and requires a minimum of program writing to do so. In chemical engineering, much work is on a trial-and-error basis that requires the flexibility of POL to reduce the amount of input on the successive attempts. Much of the output is best analyzed in the form of graphs. Therefore, graphic output of data is desirable rather than drawing results by hand.

My own thesis involves the development of a process control simulator for the senior-level class on process control. This package will use GRIP routines for POL input and will assist

students in their work by avoiding much of the tedious transformation of large equations. Much of the output will be in the form of graphs. Some of the input will involve a graphic representation of the system being modeled (a block diagram).

POL for Microcomputers

POL packages or systems are often written in FORTRAN and are designed to run on large mainframe computers. Typical program packages begin at 200,000 bytes when compiled. POLO program packages will have from 50,000 to 250,000 lines of FORTRAN code. This is obviously too large for today's microcomputers based on the Z80 and similar microcomputers. However, my goal is to allow the major portion (80 percent or more) of the capabilities of mainframe POL packages to be available on microcomputers. To do this, I use

a BASIC interpreter and a paging technique.

A BASIC interpreter is required because:

- The program to be interpreted—especially the graphics portion—can be written to occupy less space than a compiled program.
- The paging technique used requires dynamic allocation of memory.
- The paging technique in BASIC is much easier to master than trying to learn how to overlay in FORTRAN.
- Dynamic modification of the program is allowed (introduced in part 2), which simplifies *interactive* processing of equations.

Microsoft BASIC 5.0 was chosen for the following reasons:

- It is written for many machines, making the system transportable.
- Its CHAIN includes MERGE, DELETE, and starting line options.
- Both random and sequential files are supported.
- The sequential records are of variable length and format.
- Multiple logical records may be written in a sector, conserving disk space.
- String variables are dynamically allocated and not preset in length, also conserving memory space.
- It has a LINE INPUT command to treat a single line as a string.

System Required

The minimum computer system recommended to run POL/PS is:

1. CP/M operating system
2. Microsoft BASIC-80
3. At least 20K bytes of program-mable memory above BASIC
4. Dual disks
5. An appropriate plotter if graphics are used

The recommended organization of POL/PS on disk is to place POL-80 and the graphics routines (if used) on the "logged-in" drive (since different plotters require different CP/M configurations). The application modules and their main-line programs should be on the other drive so that applications packages can be changed without starting over. Changing plotters can be done by connecting the new plotter, inserting a different CP/M disk (with a different graphics module), and starting again. All communications between application and graphics modules will be done by means of a disk file whose format is independent of the plotter being used.

This program was developed on a

Vector Graphic System B (Z80) with two 300K-byte minidisks and a Diablo 1650 printer as a plotter. Most Diablo and Diablo-compatible printers are capable of 60 horizontal and 48 vertical spaces per inch in a graphics mode. (Check the specific model for its capability. The Diablo uses an "Escape-3" to turn on graphics and either a "Carriage Return" or "Escape-4" to turn off graphics. I simply use "space", "linefeed", "backspace", ".", and "escape-linefeed" for up.) All the figures in this series were produced using this equipment.

The disks should be of high capacity because there may be more space used by files associated with the module than is used by the actual program. HELP files, error message files, and graphics intermediate files can quickly consume space.

Disk speed is also very important. A page transfer on the Micropolis minidisks takes about 30 seconds by the time all the variables and files are restored. Faster disks—8-inch floppies or Winchester hard disks—can reduce program running time where several pages are involved.

The POL Programming System

I said earlier that the programs customarily run using POL are large. The graphics package is often in itself several times larger than the memory available on a microcomputer unless the size of the program is decreased by making it inflexible. The normal method of handling such large programs is by overlays (on most large machines) or by paging (on virtual memory machines). The POL Programming System (POL/PS) presented here is closer to the paging system because it changes only portions of the program at a time and is relatively easy to implement. Figure 2 shows a diagram of this system.

The block at the top is almost

WICAT 68000

WICAT 68000 based computers are unmatched in price/performance and mature software. A wide variety of options allows you to flexibly configure the system to your needs.

Concurrent's **integral™ database** and **menusystem** relieve you of much of the work in developing applications.

Motorola 68000, 512K memory, IEEE 796 MULTIBUS™, 10MB Winchester, 630KB floppy, terminal, keyboard, system software, choice of Pascal, C, FORTRAN, COBOL, Assembler. Options: UNIX, graphics, IEEE 488

**Six Users
\$12,850**



PERQ features high-resolution graphics, large memory, fast user-microprogrammable stack processor with floating-point, high capacity disk, local Ethernet™ and laser printers for engineers, scientists and researchers.

PERQ

MULTIBUS is a trademark of the Intel Corporation
UNIX is a trademark of Bell Laboratories
Integral is a trademark of Concurrent Corporation
Ethernet is a trademark of Xerox
PERQ is a trademark of Three Rivers Computer Corporation

For details, please write or call
(513)-281-1270

Concurrent™ Corporation
1870 Madison Road Cincinnati, Ohio 45206

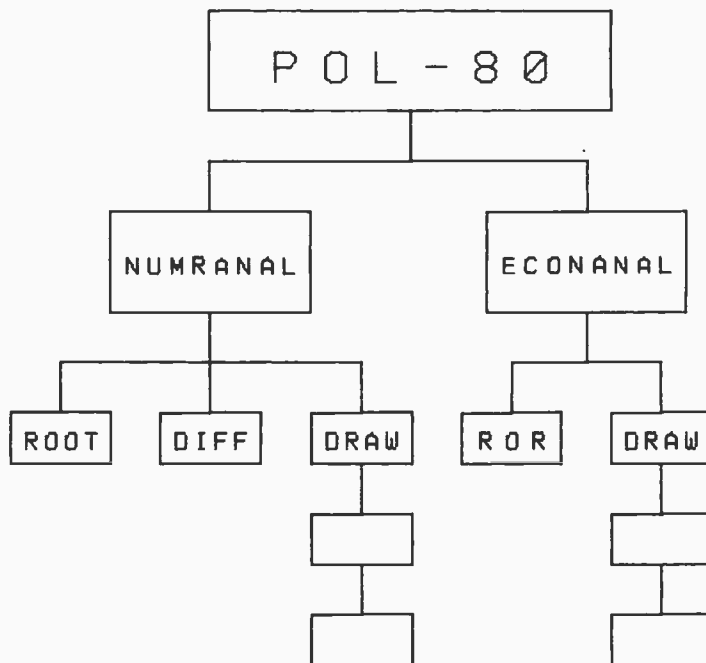

Figure 2: A diagram of the POL system and the interaction between the different modules.

always in the computer's memory and consists of standard subroutines that control the paging of the program and handle the POL input. The next level down represents major application packages. Examples of these are a numerical-analysis package (NUMRANAL) and an economics package (ECONANAL). Each of these consists of a main program. The first four characters of the name form a common prefix for all programs in this application package (e.g., NUMR for numerical analysis, or ECON for economics analysis). At the third level are branches representing the modular subprograms (within each package) that handle the computations and actually make the decisions. Each of these programs may have several pages, which are usually called on sequentially to perform the computations. One example of this is the *xy* axes portion of the graphics package (see listing 1), which has three pages: one to handle the input,

one to compute all the locations on the page (based on the input), and one to actually draw the axes.

To make such a paging scheme work, *one rigid rule must be followed concerning line numbers*. Lines 1 to 2999 are reserved for the input and paging routines and future development. Lines 3000 to 9999 are reserved for user-written programs. Both line 3000 and line 9999 *must* be used in the user-written program, even if only for remarks, because these line numbers are references in CHAINS.

The set of routines to handle POL input—called POL-80—is given in listing 3. The variables are in listing 4. Naming conventions used in POL-80 are given in listing 5. The program listing is well documented and a summary of the capabilities is given below. (Much more detail can be found in the *POL/PS User's Manual*.)

The primary purpose of these routines is input, parsing, and matching. Input is accepted from either the ter-

Text continued on page 362

Listings 3, 4, and 5 are on pages 334-360

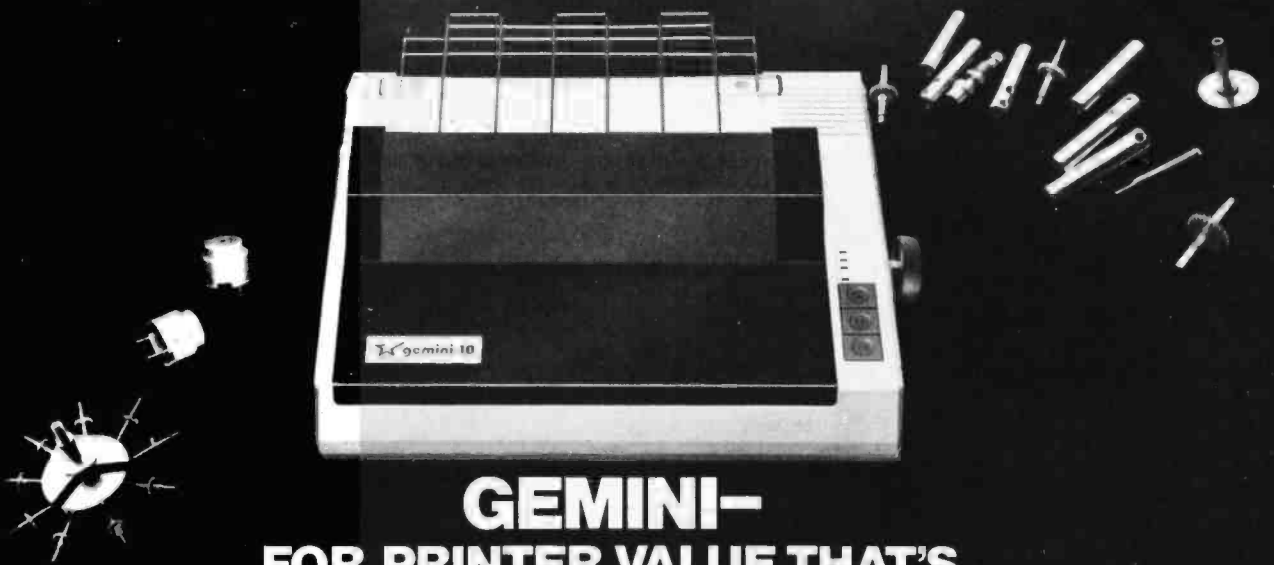

GEMINI— FOR PRINTER VALUE THAT'S OUT OF THIS WORLD

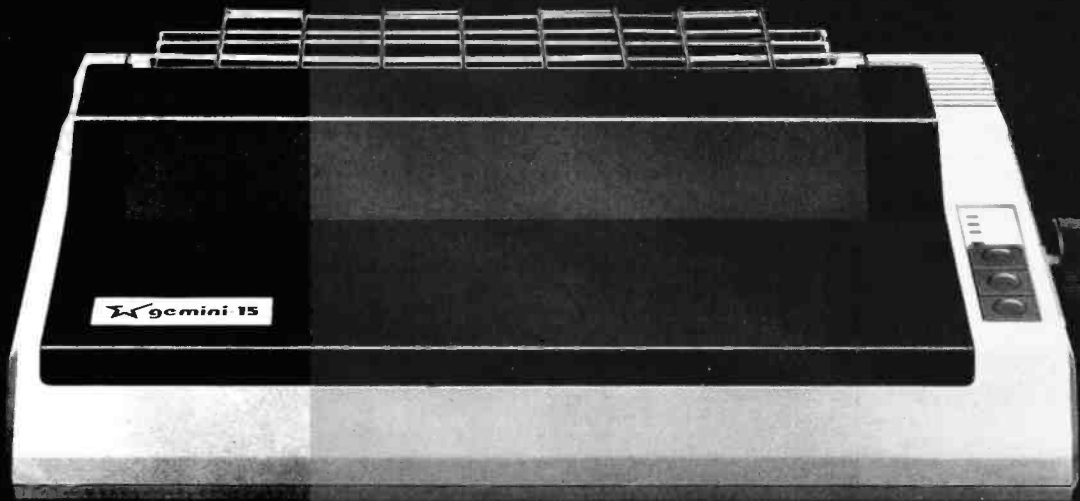

Over thirty years of down-to-earth experience as a precision parts manufacturer has enabled Star to produce the Gemini series of dot matrix printers—a stellar combination of printer quality, flexibility, and reliability. And for a list price of nearly 25% less than the best selling competitor.

The Gemini 10 has a 10" carriage and the Gemini 15 a 15½" carriage. Plus, the Gemini 15 has the added capability of a bottom paper feed. In both models, Gemini quality means a print speed of 100 cps, high-resolution bit image and block graphics, and extra fast forms feed.

Gemini's flexibility is embodied in its diverse specialized printing capabilities such as super/sub script, underlining, back-spacing, double strike mode and emphasized print mode. Another extraordinary standard

feature is a 2.3K buffer. An additional 4K is optional. That's twice the memory of leading, comparable printers. And Gemini is compatible with most software packages that support the leading printers.

Gemini reliability is more than just a promise. It's as concrete as a 180 day warranty (90 days for ribbon and print head), a mean time between failure rate of 5 million lines, a print head life of over 100 million characters, and a 100% duty cycle that allows the Gemini to print continuously. Plus, prompt, nationwide service is readily available.

So if you're looking for an incredibly high-quality, low-cost printer that's out of this world, look to the manufacturer with its feet on the ground—Star and the Gemini 10, Gemini 15 dot matrix printers.

star
MICRONICS • INC

MAKING A NAME FOR OURSELVES

1120 Empire Central Place, Suite 216, Dallas, TX 75247

For more information, please call Bob Hazzard, Vice President, at (214) 631-8560.

Circle 438 on Inquiry card.

C is better than ever.

Whitesmiths, Ltd. is now shipping
Release 2.1 of our highly acclaimed C Compilers for ten different
operating system families on four architectures:

8080, 8085, Z80:

CP/M, CDOS

ISIS-II*

Idris/B80

LSI-11, PDP-11:

RT-11

RSX-11M, RSTS/E, IAS

Idris/R11, UNIX

MC68000:

VERSA dos

Idris/S68k

VAX-11:

VMS

UNIX/32V*

*Available in source form only.

Idris is a trademark of Whitesmiths, Ltd. ■ UNIX is a trademark of Bell Laboratories ■ CP/M is a trademark of Digital Research ■ RSX-11M, RSTS/E, RT-11, LSI-11, PDP-11, IAS, VAX, and VMS are trademarks of Digital Equipment Corporation ■ VERSAdos is a trademark of Motorola Inc.

We've added optimizations, sped up runtime routines, and (ahem) fixed all known bugs. The portable C library is more extensive than ever, with new math functions, pattern matching routines, and support for Ada-style exception handling. And it's easier than ever to interface to new environments.

Native compilers are only \$750, including shipping in the continental U.S. Cross compilers, for most combinations of host system and target machine, are \$1350. A Pascal Compiler may be included for an additional \$200. Old customers may upgrade for just half of the new price. And maintenance is now only 25% of the license fee per year.

Now's the time to write or call.

Distributors: Australia, Fawcay Pty Ltd. P.O.B 224 Hurtsville NSW 2220 570-6100
Japan, Advance Data Controls Corp. Chiyoda-ku, Tokyo 03263-0383
United Kingdom, Real Time Systems, Newcastle upon Tyne 0632 733131

Whitesmiths, Ltd.

Parkway Towers, 'B', 485 US Route 1 So., Iselin, New Jersey 08830 (201) 750-9000 Telex: 645592

**Chances are,
you've already purchased
two-thirds of our digital,
programmable
oscilloscope.**



Apple II, Apple II Plus, Disk II and Silentype are trademarks of Apple Computers, Inc. Epson MX-80 is a trademark of Epson America, Inc.

Now for \$995 you can have the rest.

In a word, the Model 85 aScope™ is a dual channel, DC to 50 MHz, fully programmable, digital memory oscilloscope designed to operate with any Apple II™ or Apple II Plus™ equipped with Disk II™ and display, 48K memory and DOS 3.3.

But don't let aScope's remarkably low price deceive you. Because in about 80 percent of all design or test applications where this sort of instrument would be used, aScope will perform on par with systems in the \$15,000+ category. (Something we feel comfortable saying, having spent a number of years working in research and development for one of the world's leading suppliers of those \$15,000 instruments.)

Still, we recognize it's a somewhat extraordinary promise.



system. But frankly, we suspect you are probably as intrigued as you could be on the basis of one advertisement.

So we'll proceed with a few action recommendations designed to accommodate anyone from the casually curious to the virtually convinced.

First, you should call 800-547-4445. That will provide you with an aScope data sheet and an opportunity to determine whether you'd like to invest \$10 in our comprehensive aScope demonstration disk.

Or simply yield to your initial impulse and order the system, safe in the knowledge that (a) you may use the system for fifteen days, and if not satisfied, return it, and b) NWIS system engineers stand ready to assist you with any questions you may



Single keystroke calls aScope™ operations menu. All sub-menus provide complete prompting.

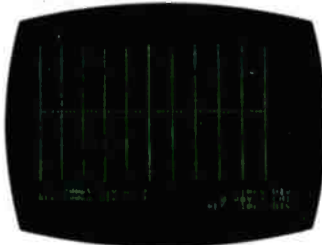

A reference waveform loaded from disk into Channel 2 for comparison with active signal on Channel 1.



Cross-cursor indicates point where aScope™ digital voltmeter (DVM) is calculating waveform voltage for display at bottom of screen.

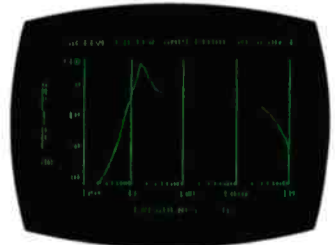

One example of a user-defined co-resident BASIC program; in this case designed to plot an amplitude response curve for an active filter.

So, perhaps before telling you what aScope can do, we ought to tell you how it does it so inexpensively.

Essentially what we've done is depart radically from the existing instrumentation architecture upon which all currently available digital programmable oscilloscope systems are dependent. It simply doesn't make sense to combine a stand-alone

Bandwidth: DC to > 50 MHz equivalent time digitizing (-3dB) DC to > 10 KHz resolvable with real-time digitizing (-3dB)
Resolution: 8 bits (1 part in 256)
Range: 10ns/division to 20s/division
Sensitivity: 5mV/division to 5V/division
Input Impedance: 1MΩ and 20pF

programmable oscilloscope with a controller when to a great extent the micro-computer circuitry and capabilities of one are already available in the other. So we didn't combine, we integrated. Making the aScope a peripheral part of the computer. Supplying only what was necessary to make the computer a high-performance instrument. An instrument capable of things until now assumed impossible for

anywhere near its price.

Things like what, you wonder?

Well naturally, since aScope is fully programmable you may configure a setup, define the analysis of the acquired data you desire and produce an end result display in whatever form is most productive. Many frequently performed routines are already part of aScope's software. However, because no two engineers' needs are exactly the same, the system's architecture was designed to accommodate considerable user modification via co-resident BASIC or assembly language programs.

In addition, aScope will average waveforms. Store a waveform on disk in binary or text form. Store instrument control settings for future automated setup. Or load and display reference waveforms.

aScope is also equipped to deliver waveform voltage readings utilizing a cursor-controlled digital voltmeter. And to generate hard copies via an Epson MX-80™ or Silentype™ printer.

Space permitting, we could go on about the menu-driven commands and other user-sensitive features we've built into this

have regarding aScope capabilities and applications.

The \$995 Model 85 aScope. We admit the performance it delivers for the money is so remarkable, it may initially strike you as unbelievable. However, when you recall all the breakthrough products this industry has seen over the last decade, sounding unbelievable at first is practically a tradition.



NORTHWEST INSTRUMENT SYSTEMS, INC.

P.O. Box 1309
 Beaverton, Oregon
 97075
 800-547-4445
 (503) 297-1434



Circle 304 on inquiry card

Peripherals

Unlimited...

FANTASTIC PRICES!

OUR FAST SERVICE, PRODUCT SELECTION AND OUR CUSTOMERS' SATISFACTION MAKE US #1.

ZENITH

Microsoft Z-80 softcard	\$214
Microsoft RAMCARD	\$129
Z-90-64K DO	\$2588
Z-19 Terminal	\$777
Z-121 Monitor 12"	\$149

ATARI COMPUTERS

Atari 800 16K	\$649
Atari 400	\$318
Atari Interface Module	\$174
Atari 810 Single Disk	\$444
Atari 830 Modem	\$166
Programmer	\$59
Entertainer	\$84
Star Raiders	\$34
16K Mem. Exp. for Atari	\$74
32K Mem. Exp. for Atari	\$114

NEC PRINTERS

7710/30 Spinwriter R/O	\$2295
7720 Spinwriter KSR	\$2649
3510/30 Spinwriter R/O	\$1689

NEC DOT MATRIX

PC-8023	\$474
---------	-------

Call for prices on ribbons, etc.

OKIDATA & MORE

Okidata Microline 82A	\$459
Okidata Microline 83A	\$699
Okidata Microline 84 (P)	\$1069
Okidata Microline 84 (S)	\$1099
Tractor (OKI 80 & 82 only)	\$60
Diablo 620	\$1239
Diablo 630	\$1999
IDS Microprism	\$539

AMDEK & NEC MONITORS

Amdek 12" 300 GRN Phosphor	\$149
Amdek 13" Color I	\$319
Amdek 13" Color II	\$739
Amdek 13" Color III	\$429
NEC JB1201 GRN Phosphor	\$149
NEC JC1201 Color	\$339

EPSON PRINTERS

MX-80 w/Graphtrax Plus	\$469
MX-80FT (Friction & Tractor)	\$529
MX-100 (15" Carriage)	\$699
Grappler Interface	\$129

Call for prices on Ribbons, Cables & Interfaces

NEC-PC 8000 Series Microcomputer

PC-8001A Computer w/32K	\$888
PC-8012A w/32K + Exp. Slots	\$588
PC-8031A Dual Mini Disk	\$888
PC-8032A Add-on Mini Disk	\$777

Call for Software Prices

FOR THE LOWEST PRICE CALL
TOLL FREE
1-800-343-4114

ORDERING INFORMATION

Our order lines are open 9AM to 6PM EST Monday thru Friday. Phone orders are welcome; same day shipment on orders placed before 10AM. Free use of Mastercard and VISA. Personal checks require 2 weeks clearance. Manufacturer's warranty included on all equipment. Prices subject to revision. C.O.D.'s accepted.

For service, quality and delivery call:

PERIPHERALS UNLIMITED
(617) 655-7400

62 N. Main St. • Natick, MA 01760

Listing 3 continued:

```

185 PART=0
   :FCOM:=0
   :MART=2
   :NCOM=0
   :FENT=1
   :GOSUB 1400
190 CHAIN MERGE AB,3000,DELETE 3000-9999
*****

```

MISCELLANEOUS CONTROL HANDLING
(CONTROL CHARACTER CHANGES, INPUT FILE DECLARATIONS, & TRACING)

THE FORMAT IS AS FOLLOWS:

```

!FEC #      0--IMPLIES END OF COMMAND IS END OF LINE OR END-OF-COMMAND
             CHAPACTER(DEFAULT IS :)
             1--IMPLIES END OF COMMAND IS END-OF-COMMAND CHAPACTER ONLY

!PRG C      C--CHARACTER TO INDICATE THE BEGINNING OF PROGRAM OR PLOTTER
             CHANGE COMMANDS(DEFAULT IS @)

!REA C      C--CHARACTER TO INDICATE THE BEGINNING OF A READER OR
             MISCELLANEOUS CONTROL COMMAND(DEFAULT IS !)

!EOC C      C--CHARACTER TO INDICATE THE END OF A COMMAND(DEFAULT IS :)

!EOL C      C--CHARACTER USED TO INDICATE THAT THE REMAINDER OF THE LINE
             IS COMMENTS(DEFAULT IS #)

!INB C      C--CHARACTER USED TO INDICATE THE BEGINNING OF A REQUEST FOR
             GRAPHICAL INPUT(DEFAULT IS {)

!INE C      C--CHARACTER USED TO INDICATE THE END OF A REQUEST FOR
             GRAPHICAL INPUT(DEFAULT IS })

!CON C      C--CHARACTER USED TO INDICATE COMMAND LINE CONTINUATION
             (DEFAULT IS &)

!OUT C      C--CHARACTER USED TO ENCLOSE MESSAGES TO BE OUTPUT TO THE
             TERMINAL(DEFAULT IS $)

!STR C      C--CHARACTER USED TO ENCLOSE INPUT STRINGS ON A COMMAND LINE
             (DEFAULT IS ")

!TER C      C--CHARACTER USED TO REQUEST INPUT FROM THE TERMINAL DURING
             EXECUTION OF THE LINE(DEFAULT IS &)

!FIL "NAME" NAME--NAME OF A SEQUENTIAL FILE CONTAINING A SET OF COMMANDS
             IN THE PROPER FOPMAT TO USE AS INPUT(AN EXAMPLE OF NAME
             IS "B:EXAMPLE")

!TON        TURNS ON THE INTERNAL TRACER IN NLP-80

!TOF        TURNS OFF THE INTERNAL TRACER LIN NLP-80

```

(NOTE--NEVER USE QUOTES (") AS ANY OF THE ABOVE CONTROL CHARACTERS.
THEY WILL GET CHEWED UP DURING CHAINING OF PROGRAMS.)

(NOTE--ONE OF THE EASIEST WAYS TO REDUCE THE PROGRAM SIZE IS TO REMOVE
THIS SECTION (IF DEFAULT PARAMETERS ARE ALWAYS ACCEPTABLE AND
FILE INPUT OR TRACING ARE NOT REQUIRED) --THIS ELIMINATES ABOUT
1K OF PROGRAM (ABOUT 15%)

TO DO THIS:

1. DELETE LINES 200-495
2. IN THE STRING IN LINE 30, CHANGE THE "9" (POSITION 2)
TO A "7"
3. IN LINE 520, ELIMINATE ",200" (THE LAST LINE NUMBER
REFERENCE)

LESSEF AMOUNTS (INDIVIDUAL LINES) MAY BE ELIMINATED IF STEPS 2
AND 3 ARE NOT DONE. FOR EXAMPLE, LINES 210-320 CAN BE ELIMINATED,
AND THE FILE INPUT AND TRACING FUNCTIONS ARE STILL AVAILABLE, BUT
THE PROGRAM IS ABOUT 700 BYTES SHORTER.)

```

*****
200 AB=MTDS (AN,2,3)
   :AN=RIGHT$ (AN,LEN (AN)-4)
210 IF AB="FEC"
   THEN GOSUB 500
   :IF NT=1
       THEN FEOC=IV
       :GOTO 500
   :ELSE NERR=1036
       :GOTO 495
220 IF AB="PRG"
   THEN GOSUB 500
   :IF NT=7
       THEN AP=AB
       :GOTO 500
   :ELSE NERP=1033
       :GOTO 495
230 IF AB="REA"
   THEN GOSUB 500
   :IF NT=7
       THEN MTDS (ADFC,ASC (AR)-31,1)="7"

```

Listing 3 continued on page 340

\$300 Each

50 CP/M[®] UTILITIES IN ONE PACKAGE



POWER

... The first super program that puts YOU in control of CP/M.*

POWER automatically numbers disk files. Just pick file number to Copy, Erase, Reclaim, Rename, Type, etc....Your computer feeds the file names automatically. You do No typing! No typing errors... ever!

**YOU DON'T NEED SYSTEM DISK IN ANY DRIVE!
No more BDO\$ ERRORS!**

YOU Test and Fix bad disks! Reclaim accidentally erased files or programs! Single step thru memory up or down! Search, View, Change memory or disk in a snap! See Status and File Size instantly! Verify Checksums for programs! Load or Save programs at any address.

50 prompted user-friendly functions for housekeeping and a 60 page easy-read users' guide make POWER your most often used software. You'll use it everyday!

POWER will be the last utility you'll ever need or your money back.

POWER works with CP/M & MPM systems (any disk format).

The Professional
Software Programmers Association
has examined, tested and reviewed
and endorses same for purchase.
Certification No. 1583

YOUR MAJOR POWER COMMANDS:

DIR	COPY	REN	ERA
TYPE	TYPEH	TYPEA	TYPEC
RUN	EXIT	SIZE	CHECK
STAT	USER	XUSER	TEST
SETDIR	SETSYS	SETRO	SETWR
RECLAIM	DISK	GROUP	LOG
DS	SPEED	SAVE	LOAD
READ	WRITE	READGR	WRITEGR
DUMP	DUMPX	DUMPH	DUMPA
MOVE	FILL	CM	SEARCH
JP	EX	GO	UBR1
UBR2	UBR3	UBR4	?

ONLY \$149 COD.
FULLY GUARANTEED



FREE If you order POWER now
Year Subscription to
POWER HOT-LETTER

ORDER NOW!

TOLLFREE (800) 227-3800 Ext 28.
IN CA: (800) 792-0990 Ext 28.



COMPUTING!

2519 B Greenwich,
San Francisco, CA 94123.

Micro Power Bench™



- Single Switch Control of CPU and Peripherals
- Built in circuit breaker protects your system
- Four power expansion outlets
- Choice of high quality oak or walnut
- Compatible with IBM, APPLE, TRS-80 and others



Order Direct
800-343-4311

Master Charge and Visa Accepted

CAB-TEK, Inc.

Riverside St., Nashua NH 03062

CIVILIZING COMPUTERS

MX 80

ACOUSTIC ENCLOSURE *99!

DEALER INQUIRIES INVITED

TERMINALS FROM TRANSNET

PURCHASE PLAN • 12-24 MONTH FULL OWNERSHIP PLAN • 36 MONTH LEASE PLAN

DESCRIPTION	PURCHASE PRICE	PER MONTH		
		12 MOS	24 MOS	36 MOS
LA34 DECwriter IV Forms Ctrl.	\$1,095	\$105	\$ 58	\$ 40
LA100 Letter Printer RO	1,995	190	106	72
LA120 DECwriter III KSR	2,295	220	122	83
LA120 DECwriter III RO	2,095	200	112	75
LA12A Portable DECwriter	2,950	280	155	106
VT100 CRT DECscope	1,695	162	90	61
VT101 CRT DECscope	1,195	115	67	43
VT125 CRT Graphics	3,295	315	185	119
VT131 CRT DECscope	1,745	167	93	63
VT132 CRT DECscope	1,995	190	106	72
VT18XAC Personal Computer Option	2,395	230	128	86
T1745 Portable Terminal	1,595	153	85	50
T1765 Bubble Memory Terminal	2,595	249	138	93
T1940 CRT	1,795	173	96	66
T1785 Portable KSR, 120 CPS	1,795	173	96	65
T1787 Portable KSR, 120 CPS	2,195	211	117	80
T1810 RO Printer	1,695	162	90	61
T1820 KSR Printer	2,195	211	117	80
ADM3A CRT Terminal	595	57	34	21
ADM5 CRT Terminal	645	62	36	24
ADM32 CRT Terminal	1,165	112	65	42
CIT-101 CRT	1,525	147	82	55
CIT-161 Color CRT	2,675	257	143	97
CIT-427 Color Graphic CRT	3,095	297	165	112
910 CRT Terminal	650	62	36	24
925 CRT Terminal	850	82	46	31
950 CRT Terminal	1,075	103	57	39
Letter Quality, 7715 RO	2,695	259	144	98
Letter Quality, 7725 KSR	3,195	307	171	115
2030 KSR Printer 30 CPS	1,195	115	67	43
2120 KSR Printer 120 CPS	2,195	211	117	80
MX-80 F/T Printer	745	71	42	27
MX-100 Printer	895	86	48	32
E0400 4 Channel Stat Mux	1,525	147	82	55
E0800 8 Channel Stat Mux	2,050	197	110	74

*DEC is the trademark of Digital Equipment Corporation

FULL OWNERSHIP AFTER 12 OR 24 MONTHS • 10% PURCHASE OPTION AFTER 36 MONTHS

MICROCOMPUTERS
 APPLE • COMMODORE • HP87 • DEC

ACCESSORIES AND PERIPHERAL EQUIPMENT
 ACOUSTIC COUPLERS • MODEMS • THERMAL PAPER • RIBBONS • INTERFACE MODULES • FLOPPY DISK UNITS



TRANSNET CORPORATION
 1945 ROUTE 22 • UNION, N. J. 07083 • (201) 688-7800
 TWX 710-985-5485 800-526-4965 OUTSIDE N. J.

Listing 3 continued:

```

:AR=AR
:MIDS(ADEC,ASC(AR)-31,1)="9"
:GOTO 500
:ELSE NERR=1022
:GOTO 495

240 IF AB="EOC"
THEN GOSUB 500
:IF NT=7
THEN AFOC=AB
:GOTO 500
:ELSE NERR=1023
:GOTO 495

260 IF AB="EOL"
THEN GOSUB 500
:IF NT=7
THEN MIDS(ADEC,ASC(AEOL)-31,1)="7"
:AEOL=AB
:MIDS(ADEC,ASC(AEOL)-31,1)="?"
:GOTO 500
:ELSE NERR=1025
:GOTO 495

270 IF AB="INB"
THEN GOSUB 500
:IF NT=7
THEN AINB=AB
:GOTO 500
:ELSE NERR=1026
:GOTO 495

280 IF AB="INF"
THEN GOSUB 500
:IF NT=7
THEN AINE=AB
:GOTO 500
:ELSE NERR=1027
:GOTO 495

290 IF AB="CON"
THEN GOSUB 500
:IF NT=7
THEN ACON=AB
:GOTO 500
:ELSE NERR=1028
:GOTO 495

300 IF AB="OUT"
THEN GOSUB 500
:IF NT=7
THEN MIDS(ADEC,ASC(AOUT)-31,1)="7"
:AOUT=AB
:MIDS(ADEC,ASC(AOUT)-31,1)="4"
:GOTO 500
:ELSE NERR=1029
:GOTO 495

310 IF AB="STR"
THEN GOSUB 500
:IF NT=7
THEN MIDS(ADEC,ASC(ASSTP)-31,1)="7"
:ASTR=AB
:MIDS(ADEC,ASC(ASSTP)-31,1)="6"
:GOTO 500
:ELSE NERR=1030
:GOTO 495

320 IF AB="TER"
THEN GOSUB 500
:IF NT=7
THEN MIDS(ADEC,ASC(ATER)-31,1)="7"
:ATER=AB
:MIDS(ADEC,ASC(ATER)-31,1)="5"
:GOTO 500
:ELSE NERR=1032
:GOTO 495

330 IF AB="FII,"
THEN GOSUB 500
:IF NT=6
THEN APTI=AR
:FFII=1
:JFII=0
:OPEN "I",#2,APTI
:GOTO 500
:ELSE NERR=1031
:GOTO 495

340 IF AB="TON"
THEN FTP=1
:GOTO 500

350 IF AB="TOP"
THEN FTR=0
:GOTO 500

490 NERR=1035
495 GOSUB 1200
:IEOC=1
:RETURN
    
```

Listing 3 continued on page 342

Christmas

THE PRICE SLASHER!

RANA SYSTEMS
 TELEVIDEO
 FRANKLIN ACE
 OKIDATA NEC
 PRACTICAL
 PERIPHERALS
 NOVIATION
 DIABLO
 SANYO
 ALTOS

C. ITOH QUME
 TEXAS
 INSTRUMENTS
 MICRO SCI
 HAZELTINE
 ANADEX
 AMDEK
 ATARI
 ADDS

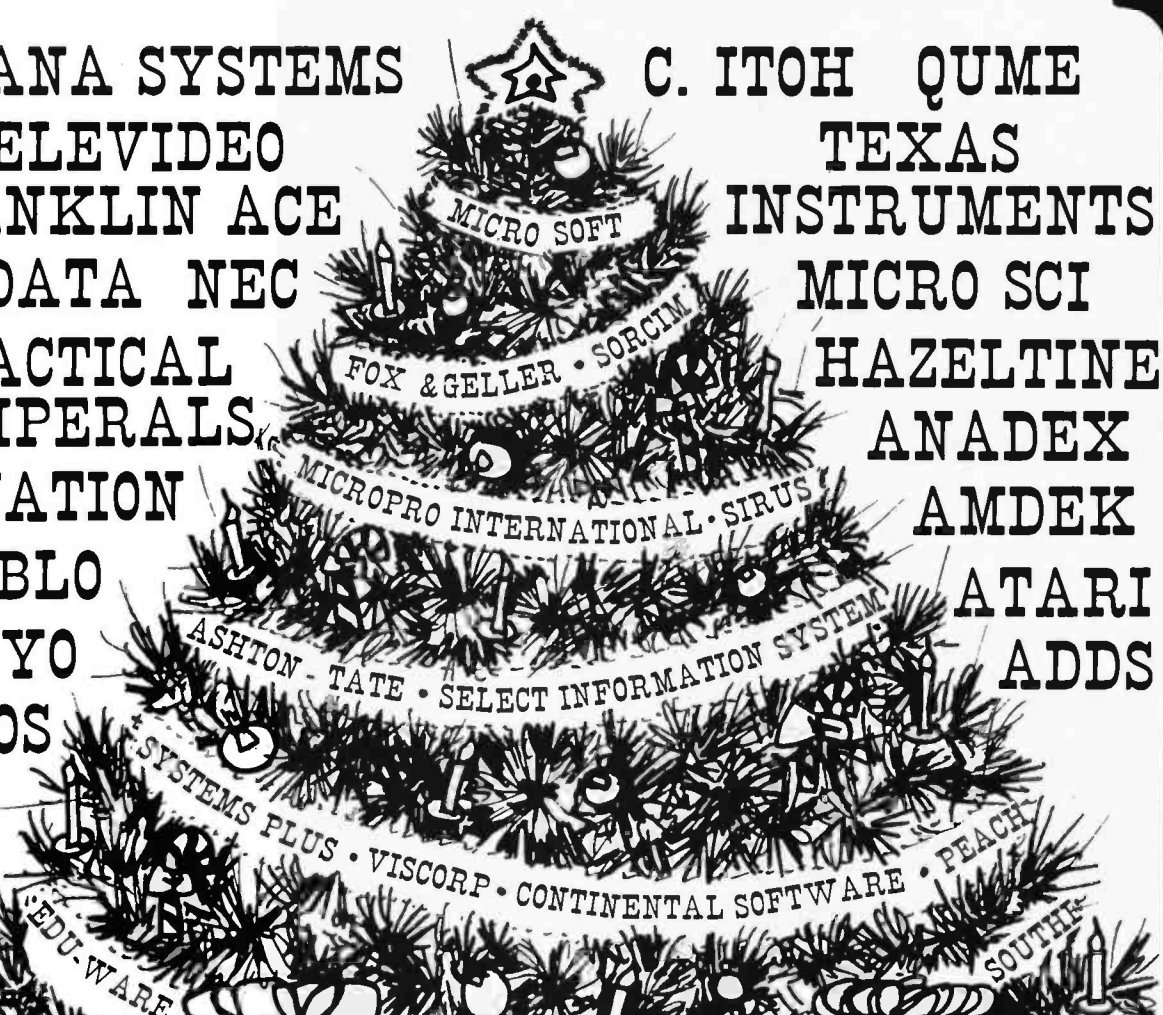

UPPER/LOWER CASE
 CHARACTER
 GENERATOR
 DEC. ONLY
 \$17.95

HOWARD SOFTWARE

FRANKLIN ACE
 HI RES GREEN
 MONITOR
 RANA ELITE 1
 W/CONTROLLER
 DEC. ONLY
 \$1695.00

16 K
 MEMORY BOARD
 FOR APPLE
 DEC. ONLY
 \$62.95

MICROSOFT SOFTCARD
 DEC. ONLY \$239.95

NEC 12" HI RES
 GREEN SCREEN
 MONITOR DEC. ONLY
 \$116.95

Note: Apple is a registered trademark of Apple Computer, Inc
 C/PM is a registered trademark of Digital Research

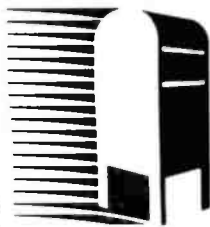

**mail
 comp**

WE ACCEPT • MONEY ORDER • C.O.D. (\$300 MAX.)
 • PERSONAL CHECK (allow 10 days to clear) • CASHIERS or CERTIFIED CHECK
 • VISA • MASTERCARD (add 2%) • BANK WIRE TRANSFERS
 Add 3% for shipping, handling & insurance (\$5 min.) Calif. residents add
 6% tax. All equipment is new, comes with manufacturers guarantees.
 PLUS we guarantee it for 30 days and pay shipping charges on any returns.
 All equipment subject to price change & availability without notice.
 Check quantity discounts

8380 Miramar Road, Suite 200
 San Diego, CA 92126
 TOLL FREE: 800-752-1341
 CALIFORNIA: 619-578-1033
 Circle 282 on inquiry card.

ELCOMP
Dealers welcome!
BOOKS
and SOFTWARE
For ATARI--PET--OSI--APPLE II--6502--VIC-20--Sinclair--Timex

ATARI ATARI ATARI ATARI
ATARI BASIC - Learning by Using
 This new book is an "Action" Book. You do more than read it. Learn the intricacy of ATARI-BASIC through the short programs which are provided. The suggestions challenge you to change and write program routines. Yes, it's exciting - Many of the programs are appropriate for beginners as well as experienced computer users. (Screen Drawings, Special Sounds, Keys, Paddles + Joysticks, Specialized Screen Routines, Graphics and Sound, Peeks and Pokes and special stuff).
 Order-No. 164 \$9.95
ATARI Learning by Using - Book + cassette or disk
 This package includes the book No. 164 plus a cassette or disk (please specify) containing a variety of the programs which are listed in the book.
 Order No.: 7220 \$39.95
 Games for the ATARI-Computer How to program your own games on the ATARI. Complete listings in BASIC and Machine Language of exciting games. Tricks and hints.
 Order-No. 162 \$7.95
GAME PACKAGE for the ATARI
 Book + cassette or disk
 Includes the book No. 162 plus cassette or disk (please specify) containing a variety of the programs listed in the book.
 Order-No. 7221 \$39.95
ATMONA-1
 Machine Language Monitor for the ATARI 400/800.
 This powerful monitor provides you with the firmware support that you need to get the most out of your powerful system. ATMONA-1 comes on a bootable cassette. No cartridges required. Disassemble, Memory Dump HEX + ASCII, (Change Memory Locations, Blocktransfer, fill memory block, save and load machine language programs, start mach. Lang. Progr. (Printer optional).
 Comes with introductory article on how to program the ATARI computer in machine language. (Available also in ROM)
 Order-No. 7022 \$19.95
ATMONA-2 Superstepper
 A very powerful Tracer to explore the ATARI ROM/RAM area. Stop at previously selected address. Opcode or operand (cassette).
 Order-No. 7049 \$49.95
EDITOR/ASSEMBLER for ATARI 800, 32K or 48K RAM
 Extremely fast and powerful Editor/Assembler. (BK Sourcecode in about 5 seconds) Includes ATMONA-1
 Order-No. 7098 \$49.95
MACRO-Assembler for ATARI 800, 32K or 48K RAM
 Please specify your system: RAM, disc or cassette.
 Order-No. 7099 \$89.00
 Add \$39.00 for cartridge version
Gunfight - For ATARI 400/800
 16K RAM, needs two joysticks, animation and sound. (BK machine language)
 Order-No. 7207 \$19.95
Birth control with the ATARI
 (Knaus Ogino) Cass. or disk
 Order No. 7222 \$29.95
Astrology and Biorythm for ATARI (cass. or disk)
 Order No. 7223 \$29.95
EPROM Cartridge KIT for ATARI
 Cartridge (bare board) with instructions (holds two 16K or two 32K EPROMs (2716,2532,2732)
 Order No. 7224 \$19.95
 Order No. 7043 complete \$29.95
Invoice Writing for small business with ATARI 400/800
 16K RAM.
 Order-No. 7022, cass. \$29.85
 Order-No. 7200, disc. \$39.99
Mailing-List No. 7213 \$24.95
Inventory Contr.No.7215 \$24.95
NEW IATEX-1
 This new wordprocessor in machine language (BK) for all ATARI 400/800 computers offers the best price performance ever. 23 editor control commands, 17 formatting commands, dynamic formatting. Vertical and horizontal scrolling (up to 255 char. per line) include command on disk!
 Order No. 7210 cassette \$29.95
 Order No. 7211 disk \$39.95
 Order No. 7212 cartridge \$79.00
Learn FORTH for the ATARI 400/800, cassette or disk
 Order No. 7053 \$19.95
ELCOMP Publishing, Inc., 53 Redrock Lane
 Pomona, CA 91766, Phone: (714) 623 8314
 Payment: Check, Money Order, VISA, MasterCard, Eurocheck. POSTPAID on PREPAID in USA. \$ 5.00 handling fee for C.O.D. All orders outside USA: Add 15% shipping. CA add 8.5% sales tax. ATARI is a registered trademark of ATARI Inc. APPLE is a registered trademark of APPLE Inc. PET+VIC-20 is a trademark of Commodore.

Listing 3 continued:

```

*****
SUBROUTINE PARSER
CALLED WHENEVER ANOTHER ENTITY IS REQUIRED
(USED ONLY BY OTHER SUBROUTINES WITHIN NLP-80)

EXTRACTS THE ENTITY (ENTITY STORED IN "AB") FROM THE CURRENT COMMAND LINE
AND CLASSIFIES IT IN "NT" AS FOLLOWS:

    NT=1--INTEGER NUMBER
    2--REAL NUMBER (CONTAINS A DECIMAL OR A FRACTIONAL PORTION)
    3--WORD CONTAINING LETTERS ONLY
    4--WORD CONTAINING LETTERS AND NUMBERS, BUT BEGINS WITH A LETTER
    5--NOT IMPLEMENTED
    6--STRING
    7--SPECIAL CHARACTER (ANY CHARACTER OTHER THAN A LETTER, NUMBER,
    QUOTE ("), OR BLANK SPACE)

*****
500 AB=""
    :DV=0
    :IV=0
    :AT=""
    :FENT=0
    :IF FERR=1
        THEN RETURN
505 IF IE=1
    THEN RETURN
510 IF LEN(AN)=0
    THEN IF NOT(FOF(1)) OF FEOC=1
        THEN GOSUB 1055
        :ELSE IE=1
        :NT=7
        :RETURN
515 AT=LEFT$(AN,1)
    :NT=VAL(MID$(ADEC,ASC(AT)-31,1))
520 ON NT
    GOTO 640,
    535,
    600,
    540,
    545,
    530,
    550,
    580,
    200
530 IE=INSTR(2,AN,AT)
    :IF IE=0
        THEN NFR=1050
        :GOSUB 1200
        :FERR=1
        :AB=""
        :RETURN
    :ELSE AB=MID$(AN,2,IE-2)
        :AN=RIGHT$(AN,LEN(AN)-IE)
        :RETURN
535 AT=""
    :IE=1
    :RETURN
540 IE=INSTR(2,AN,AT)
    :IF IE=0
        THEN NERR=1051
        :GOSUB 1200
        :FERR=1
        :AB=""
        :RETURN
    :ELSE AB=MID$(AN,2,IE-2)
        :AN=RIGHT$(AN,LEN(AN)-IE)
        :PRINT AB
        :GOTO 510
545 LINE INPUT "?":AT
    :AN=AT+RIGHT$(AN,LEN(AN)-1)
    :GOTO 510
550 AN=RIGHT$(AN,LEN(AN)-1)
    :IF FCOM<>1
        THEN GOTO 560
554 ICOM=0
555 IF AT=ACOM(ICO)
    GOTO 510
556 ICOM=ICOM+1
    :IF ICOM<NCOM
        GOTO 555
560 AB=AT
    :RETURN
580 AN=RIGHT$(AN,LEN(AN)-1)
    :GOTO 510
*****
THIS SECTION OF THE PARSER EXPECTS CATEGORY 3 OR 4 WORDS

*****
500 IF AT="a" AND AM="z"
    THEN AT=CHR$(ASC(AT)-32)
502 AB=AB+AT
505 AN=RIGHT$(AN,LEN(AN)-1)
*****
**INITIALIZE
**CHECK IF AN ERROR
CONDITION EXISTS
**CHECKS IF AT THE END OF
A COMMAND
**CHECKS IF END OF CURRENT
LINE--WILL AUTO FEED IF
CONTINUATION OR IF END OF
LINE IS NOT END OF COMMAND
**EXTRACTS CURRENT CHARACTER
AND CLASSIFIES IT
**DECISION TABLE
PROBABLY NUMBER
COMMENTS
WORDS
TERMINAL OUTPUT STRING
TERMINAL INPUT
STRING
SPECIAL CHARACTER
BLANK
PARAMETER CHANGE PHASE
**STRING INPUT
*COMMENTS(GOTO END OF COMMAND)
**OUTPUT STRING
TO THE TERMINAL
**REQUEST FOR
INPUT FROM THE TERMINAL
**IF THIS POINT IS REACHED,
THE CHARACTER BEING TESTED
IS SOME OTHER
CHARACTER--WE WILL CHECK
IF IT IS A FILLER CHARACTER
AND SKIP OVER ANY SUCH ONES
**SKIP OVER SPACES

```

Listing 3 continued on page 347

The UniFLEX™ Operating System extracts



every last drop

from the 8 bit 6809 microprocessor allowing it to outperform many 16 bit systems

With the UniFLEX™ Operating System, the 8 bit 6809 microprocessor can perform as well as larger CPUs in a multi-user, multi-tasking environment.

Independently developed from the ground up, UniFLEX™ closely models the features found in the UNIX™ Operating System. And in two years of use, UniFLEX™ has proven the abilities of the 6809 to perform large system functions when incorporated into a properly designed mainframe.

Some of the features supported include:

- full multi-user, multi-tasking capabilities
- hierarchical file systems
- device independent I/O
- four Gigabyte disk capacities
- full file protection
- inter-task communication via pipes
- I/O redirection
- task swapping for efficient memory usage
- full random-access files
- comprehensive shell command language
- foreground-background jobs
- electronic mail and printer spooling
- system accounting facilities

The support software currently available for use under UniFLEX™ is extensive.

A sampling of the programs available includes:

- native C compiler (full implementation)
- native Pascal compiler
- FORTRAN 77 ANSI Subset compiler
- COBOL compiler with ISAM files, Report Writer & Sort/Merge
- Extended BASIC interpreter
- Extended BASIC precompiler
- text editing and processing software
- enhanced printer spooler
- variety of absolute and relocatable assemblers
- debug and diagnostic packages

Technical Systems Consultants, Inc. also offers a line of single user FLEX™ software products for 6800 and 6809 processors. For those having an absolute need for a 16 bit processor, UniFLEX™ will be available through OEM licensing arrangements for the 68000 microprocessor. Please call or write for additional information on individual products or OEM licensing arrangements.

UNIX™ is a trademark of Bell Laboratories.
FLEX™ and UniFLEX™ are trademarks of Technical Systems Consultants, Inc.

 technical systems
consultants, inc.

111 Providence Road
Chapel Hill, North Carolina 27514
(919) 493-1451

SONICS DELIVERS:

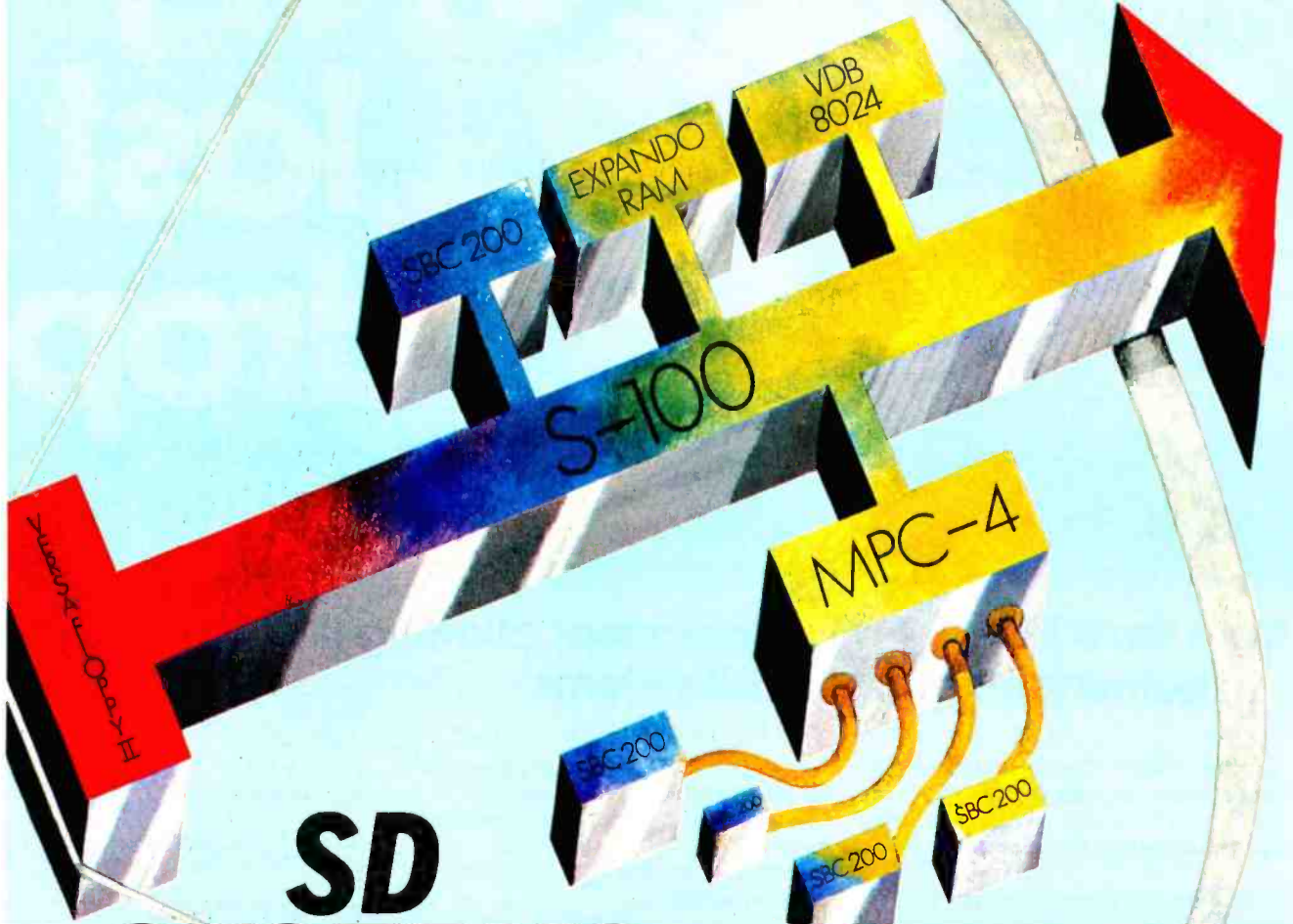

SD SYSTEMS.

SONICS MICRO SYSTEM'S PLEDGE TO THE CUSTOMER IS:

1. PROFESSIONAL TREATMENT
2. FULL TECHNICAL SUPPORT
3. DELIVERIES FROM STOCK
4. BOARD/SYSTEM LEVEL REPAIRS

SINGLE USER SYSTEM _____ \$1080

SBC 200, 64K RAM, VERSA FLOPPY II,

MULTI-USER SYSTEM _____ \$1995

SBC 200, 256K RAM, VERSA FLOPPY II,
MPC-4, COSMOS

SO SYSTEMS COMPATIBLE "TURBOOOS" \$ 350

WITH DOCUMENTATION

SINGLE USER "DISC-LESS" SYSTEM ... \$1770 ...

WITH CP/M 2.2

BOARD LEVEL PRODUCTS

SBC 200	_____	\$ 345
EXPANDORAM II	_____	\$ 443
EXPANDORAM III	_____	\$ 848
VERSA FLOPPY II	_____	\$ 375
VDB 8024	_____	\$ 465
MPC-4	_____	\$ 495
Z-80 STARTER KIT	_____	\$ 299
MODEL 200 64K RAM	_____	
SOFTWARE BANK SELECT	_____	\$ 475
RAM + ROM DISC	_____	
WITH CP/M 2.2	_____	\$1050



SONICS

MICRO SYSTEMS INC.

1500 N.W. 62ND STREET • SUITE 508 • FT. LAUDERDALE, FL 33309 • 1-800-327-5567

In Florida call: 305-776-7177

Clientes Latinoamericanos serán atendidos por nuestro departamento Internacional (en español), bajo la gerencia de la LCDA. Joan Voytes.

DISC-LESS \$1050

Sonics Micro Systems announces the commercial availability of S.D. Systems'...
First "Disc-Less" Micro Computer System. \$1050

1. Replaces Floppy Disc Drives.
2. CP/M,MP/M, Oasis and Turbo-Dos compatible.
3. Transparent to operating system disc commands.
4. No moving parts, no alignment, no media failures.
5. Network ready.
6. FAST!!!!!!!!!!!!!!!

"Ram-Disc" \$630

- Operating under CP/M the "Ram-Disc 128" functions as a fully compatible floppy drive replacement. Maximum single board configuration of 256K Bytes offers the equivalent capacity of 8" floppies. If more local disc image storage is necessary the Ramdisc system may be expanded to a full 40M Bytes.
- Whether operations require the "Ram-Disc 128" to operate as a floppy replacement or as a high speed data acquisition system is

solely dependent on single system configuration.

- In real time data acquisition and subsequent processing applications the "Disc-less" system approach affords mini computer speed and versatility at micro computer prices.

"Rom-Disc" \$289

- The "Rom-Disc-128" is a direct replacement for floppy disc drives used for the purpose of booting the CP/M operating system. Further the "Rom-Disc-128" is a direct replacement for floppy disc drives used to load and store applications programs.
- A total lack of sensitivity to the storage and handling parameters of standard floppy discs make the "Rom-Disc-128's" media virtually "immune" to familiar system failures.
- Under popular CP/M utilities the "Rom-Disc-128" appears as a simple disc drive.
- With CP/M configured in the S.D. Rom format, systems boot in less than 1/10 of a second.
- Equipped with a high speed RS-232 serial port the "Rom-Disc-128" will accommodate

data transfer to and from the host.

- The "Rom-Disc-128" in conjunction with the previously described "Ram-Disc-128" provide true system portability and independence from floppy disc drives.
- Each "Rom-Disc-128" may be attached to a 256K Byte applications "personality module" allowing maximum system flexibility and personality. "Rom-Disc-128" because of its very nature offers "maximum" protection from software piracy.

"Turbo-Dos" \$350

Z-80 CP/M compatible network ready Turbo-Dos in stock, ready for immediate delivery.

Versa Floppy II "With CP/M 3-0" \$475

- Supports dual 5¼", dual 8" or both. "CP/M 3-0" included.



SONICS

MICRO SYSTEMS INC.

1500 N.W. 62 STREET
FORT LAUDERDALE, FL 33309

1-800-327-5567

IN FLORIDA CALL: 305-776-7177

at Sonics "We are Technology"

We're selling Tandon with abandon!

We are overstocked!

Our warehouse runneth over with Tandon Drives.

Help!

Help us clear the decks and help yourself to significant savings on these excellent products.

We've always been high on Tandon. (Even when we're not up to our knees in 'em.) They offer an unsurpassed storage capacity, a very advanced dual-head design, increased throughput — and proven reliability.

So at these prices, you should *definitely* buy a drive. Buy two. Maybe someone you know is having a birthday soon. Buy one for them.

Call immediately. At these prices, they won't last very long. Hopefully.

Tandon's TM100 series of 5-inch mini-floppy disk drives all feature Tandon's patented read/write head design.

Available in four models:

TM100-1 A single-sided, 40 track, 5.25-inch floppy-disk drive with a storage capacity of 250K bytes unformatted and a track-to-track access time of 5-milliseconds 195.00

TM100-2 double-sided, 40 track per side, 5.25-inch floppy-disk drive with a storage capacity of 500K bytes unformatted and a

track-to-track access time of 5-milliseconds 269.00

TM100-3 A single-sided, 80 track, 5.25-inch floppy-disk drive with a storage capacity of 500K bytes unformatted and a track-to-track access time of 3-milliseconds 250.00

TM100-4 A double-sided, 80 track per side, 5.25-inch floppy-disk drive with a storage capacity of 1000K bytes unformatted and a track-to-track access time of 3-milliseconds 369.00

Tandon's TM848 "Thinline" series of 8-inch floppy-disk drives all feature Tandon's patented read/write head design. The unique "Thinline" design allows two drives to be installed in the same space as a single conventional drive.

Available in two models:

TM848-1 A single-sided, 77 track floppy-disk drive with a storage capacity of 600K bytes double density (IBM format), and a 3-millisecond track-to-track access time 379.00

TM848-2 A double-sided, 77 track per side floppy-disk drive with a storage capacity of 1.2 megabytes double density (IBM format), and it has a 3-millisecond track-to-track access time 490.00

MODEL III DISK DRIVE KITS

Controller Kit includes all boards assembled and tested, internal controller, mounting brackets, switching power supply, and installation instructions. Handles 4 drives 360.00

Kit #1: Controller Kit and two TM100-3 single-sided, 80 track drives 875.00

Kit #2: Controller Kit and two TM100-4 double-sided, 80 track drives 1060.00

Kit #3: Controller Kit and two TM100-1 single-sided, 40 track drives 720.00

Kit #4: Controller Kit and two TM100-2 double-sided, 40 track drives 850.00

We built a reputation on our prices and your satisfaction.

We guarantee everything for 30 days. If anything is wrong, return the item and we'll make it right. And we'll pay the shipping charges.

We accept Visa and Master Card on all orders. COD orders, up to \$300.00.

Add \$2.00 for standard UPS shipping and handling on orders under 50 lbs. delivered in continental U.S. Call for shipping charges over 50 lbs. Foreign, FPO and APO orders, add 15% for shipping. Californians, please add 6% sales tax.

Prices quoted are for stock on hand and are subject to change without notice.

CALL OUR MODEM LINE FOR WEEKLY SPECIALS.

To order or for information call

In New York:

(212) 509-1923

In Los Angeles:

(213) 706-0333

In Dallas:

(214) 744-4251

By Modem:

(213) 883-8976

**Alpha
Byte**
**COMPUTER
PRODUCTS**

31245 LA BAYA DRIVE
WESTLAKE VILLAGE, CA 91362

Listing 3 continued:

```

:AT=LEFT$(AN,1)
:IF MIDS(ADEC,ASC(AT)-31,1)="3"
GOTO 600
610 IF AT>="0" AND AT<="9"
THEN IF NT=3
THEN NT=4
:GOTO 600
:ELSE GOTO 600
615 AB=AB+" "
:IART=0
:IF PART=0
THEN RETURN
620 IF AB=AART(IART)
GOTO 500
625 IART=IART+1
:IF IART<NART
GOTO 620
630 RETURN
*****
THIS SECTION OF THE PARSER EXTRACTS CATEGORY 1 OR 2 NUMBERS
*****
640 AN=RIGHT$(AN,LEN(AN)-1)
:IF AT="+" OR AT="-"
THEN IF NOT(((LEFT$(AN,1)=".")AND(MIDS(AN,2,1)>="0" IMMEDIATELY
AND MIDS(AN,2,1)<="9"))OR(LEFT$(AN,1)>="0" FOLLOWED BY A
AND LEFT$(AN,1)<="9")) NUMBER
THEN NT=7
:GOTO 550
645 IF AT="."
THEN IF NOT(LEFT$(AN,1)>="0" AND LEFT$(AN,1)<="9") DECIMAL.
THEN NT=7
:GOTO 550
650 FD=0
:FE=0
:IF AT="+"
GOTO 654
651 IF AB="."
THEN FD=1
:AB="+."
:GOTO 656
654 AB=AT
656 AT=LEFT$(AN,1)
660 IF AT>="0" AND AT<="9"
GOTO 705
665 IF AT="." AND FD=0 AND FE=0
THEN FD=1
:GOTO 705
670 IF (AN="+" OR AT="-")AND(RIGHT$(AB,1)="E" OR RIGHT$(AB,1)="D")
GOTO 705
675 IF NOT(AT="E" OR AT="D")
GOTO 695
678 IF FE=1
GOTO 695
679 IF LEN(AN)<2
GOTO 695
680 IF MIDS(AN,2,1)>="0" AND MIDS(AN,2,1)<="9"
THEN FE=1
:GOTO 705
685 IF NOT(MIDS(AN,2,1)="+" OR MIDS(AN,2,1)="-")
GOTO 695
689 IF LEN(AN)<3
GOTO 695
690 IF MIDS(AN,3,1)>="0" AND MIDS(AN,3,1)<="9"
THEN FE=1
:GOTO 705
695 NT=2
:DV=VAL(AB)
:IF ABS(DV)>32767
THEN IV=SGN(DV)*32767
ELSE IV=DV
696 IF FD=0 AND DV=IV
THEN NT=1
700 RETURN
705 AB=AB+AT
:AN=RIGHT$(AN,LEN(AN)-1)
:IF LEN(AN)=0
GOTO 695
710 AT=LEFT$(AN,1)
:GOTO 660
*****
SUBROUTINE GET WORD
USER-ACCESSIBLE SUBROUTINE (LINE 750) FOR MATCHING ENTITIES
(EXCEPT CATEGORY 6--STRINGS)
FOR NUMBERS, NORMALLY USE SUBROUTINE 850 OR 950
INPUT
AN--THE STRING TO BE MATCHED AGAINST THE CURRENT ENTITY
(FOR CATEGORY 3 OR 4 MATCHES, IT MAY INCLUDE ONE TRAILING BLANK)
NLET--THE NUMBER OF LETTERS BEGINNING AT THE LEFT TO BE MATCHED
(CATEGORY 7 IS ALWAYS "NLET=1")

```

Listing 3 continued on page 348

MODEM

\$129⁹⁵

No other acoustic modem gives you all these features at this low price.



The MFJ-1232 Acoustic Modem gives you a combination of features, quality and performance that others can't match at this price.

0-300 Baud, Bell 103 compatible. Originate/Answer. Half/full duplex. RS-232, TTL, CMOS level compatible. Use any computer. Cassette tape recorder ports save data for reloading or retransmission. 6 pole active filter handles weak signals. Carrier detect LED indicates adequate signal strength for data recognition. Quality "muffs" gives good acoustic coupling, isolates external noise for reliable data transfer. Crystal controlled. "ON" LED. Aluminum cabinet. 110 VAC or 9 volt batteries. 9x1 1/2x4 in.

Apple II, II Plus: software and cable for modem, MFJ-1231, \$39.95. Plugs into game port. No serial board needed.



It's like having an extra port \$79⁹⁵

MFJ-1240 RS-232 TRANSFER SWITCH. Switches computer between 2 peripherals (printer, terminal, modem, etc.). Like having extra port. Push button switches 10 lines (pins 2,3,4,5,6,8,11,15,17,20). Change plug or cable to substitute other lines. Push button reverses transmit-receive lines. LEDs monitor pins 2,3,4,5,6,8,20. PC board eliminates wiring, crosstalk, line interference. 3 RS-232 25 pin connectors. 7x2x6 in.

\$99⁹⁵ MFJ-1108 AC POWER CENTER.

Adds convenience, prevents data loss, head bounce, equipment damage. Relay latches power off during power transients. Multi-filters isolate equipment, eliminate interaction, noise, hash. Varistors suppress spikes. 3 isolated, switched socket pairs. One unswitched for clock, etc. Lighted power, reset switch. Pop-out fuse. 3 wire, 6 ft. cord. 15A, 125V, 1875 watts. Aluminum case. Black. 18x2 1/4x2 in. MFJ-1107, \$79.95. Like 1108 less relay. 8 sockets, 2 unswitched. Other models available, write for free specification sheet.

Order from MFJ and try it. If not delighted, return within 30 days for refund (less shipping).

One year unconditional guarantee. Order yours today. Call toll free 800-647-1800. Charge VISA, MC. Or mail check, money order. Add \$4.00 each for shipping and handling.

CALL TOLL FREE ... 800-647-1800

Call 601-323-5869 in MS, outside continental USA

MFJ ENTERPRISES, INCORPORATED

921 Louisville Road, Starkville, MS 39759



SUPERBRAIN

The super performing, super reliable microcomputer from Intertec Data Systems features twin double-density 5 1/4" drives with 350K or 700K of disk storage - expandable to 10 megabytes. A CP/M* Disk Operating System, 64K of dynamic RAM and more.

\$ SUPER PRICE

Because we're a nationwide distributor of SuperBrain, CompuStar, and the CompuStar 10-Megabyte Disk Storage System, we can offer the absolute lowest prices in the business.

✚ SUPER SERVICE

Better yet, we offer you a great deal of service and support because we want your business tomorrow as well as today.

- We'll burn-in your SuperBrain for 72 hours before we deliver it
- We'll help with installation and configuration
- We'll repair equipment at our service center and replace modules when necessary
- We'll fill your software needs or help you develop your own
- We'll match your SuperBrain with a super printer

For more information call 609-424-4700 or 215-629-1289. To order call toll-free 800-257-5217. In NJ call 609-424-4700.



2 Keystone Avenue
Cherry Hill, NJ 08003

* Registered trademark of Digital Research Inc. SuperBrain and CompuStar are trademarks of Intertec Data Systems.



Listing 3 continued:

```

OUTPUT
  FLAG--INDICATES THE SUCCESS OF THE MATCH
  1--SUCCESSFUL MATCH
  0--UNSUCCESSFUL MATCH
*****
750 IF FENT=1
  THEN GOSUB 500
753 IF FTR=1
  THEN PRINT "MATCHING ENTITY ";AB;" WITH ";AM
755 FLAG=0
  :IF NT<>6
    THEN IF LEFT$(AB,NLEN)=LEFT$(AM,NLEN)
      THEN FLAG=1
      :FENT=1
760 RETURN
*****
SUBROUTINE STRING?
  USER-ACCESSIBLE SUBROUTINE(LINE 800) TO TEST FOR STRINGS (CATEGORY 6)
INPUT--NONE
OUTPUT
  FLAG--INDICATES THE SUCCESS OF THE MATCH
  1--SUCCESSFUL MATCH
  0--UNSUCCESSFUL MATCH
  AB--CONTAINS STRING
*****
800 IF FENT=1
  THEN GOSUB 500
803 IF FTR=1
  THEN PRINT "CHECKING IF ";AB;" IS A STRING"
805 FLAG=0
  :IF NT=6
    THEN FLAG=1
    :FENT=1
810 RETURN
*****
SUBROUTINE INTEGER?
  USER-ACCESSIBLE SUBROUTINE(LINE 850) TO TEST FOR INTEGERS
INPUT
  FT--CODE FOR ACCEPTABLE VALUES
  1--ACCEPT ANY REAL NUMBER OR INTEGER; CONVERT TO INTEGER
  2--ACCEPT ANY REAL NUMBER OR INTEGER; CONVERT TO INTEGER; IF OUTSIDE
  BOUNDS, SET TO NEAREST BOUND
  3--ACCEPT ANY REAL NUMBER OR INTEGER WITHIN THE BOUNDS (REJECT OTHERS);
  CONVERT TO INTEGER
  -1--ACCEPT ONLY INTEGERS (ANY VALUE)
  -2--ACCEPT ONLY INTEGERS; IF OUTSIDE BOUNDS, SET TO NEAREST BOUND
  -3--ACCEPT ONLY INTEGERS WITHIN THE BOUNDS
  BB1--LOWER BOUND
  BB2--UPPER BOUND
  (NOTE--BOTL. BOUNDS MUST BE ENTERED IF CATEGORIES 2,3,-2, OR -3 ARE
  CHOSEN)
OUTPUT
  FLAG--INDICATES THE SUCCESS OF THE TEST
  1--SUCCESSFUL TEST
  0--UNSUCCESSFUL TEST
  IV--CONTAINS THE INTEGER VALUE IF TEST IS SUCCESSFUL
NOTE
  ABSOLUTE VALUES GREATER THAN 32767 WILL BE REDUCED TO 32767 OR -32767
  IF THIS ROUTINE IS USED TO CHECK FOR THE VALUES--USE SUBROUTINE 950
  IF VERY LARGE NUMBERS MAY BE INVOLVED
*****
850 GOSUB 900
852 IF FTR=1
  THEN PRINT "CHECKING IF ";AB;" IS AN INTEGER"
853 IF FLAG=0
  THEN RETURN
855 IF FT>0
  THEN FENT=1
  :RETURN
860 IF NT=1
  THEN FENT=1
  :RETURN
865 FLAG=0
  :RETURN
*****
COMMON SUBROUTINE FOR BOTH INTEGER AND REAL NUMBER TESTING
*****
900 FLAG=0
  :IF FENT=1
    THEN GOSUB 500
905 IF NT=7 AND AT=AINB.
  THEN FENT=1
  :GOSUB 500
  :IF NT<>3
    THEN NERR=1055
*****
**INPUT OF GRAPHICAL VALUES
(REQUIRES GRAPHICS
SUBROUTINE AT LINE 2500)

```

Listing 3 continued on page 350

DATA IMPACT PRODUCTS, INC. PRESENTS THE MOST FLEXIBLE PRINTER ON THE MARKET

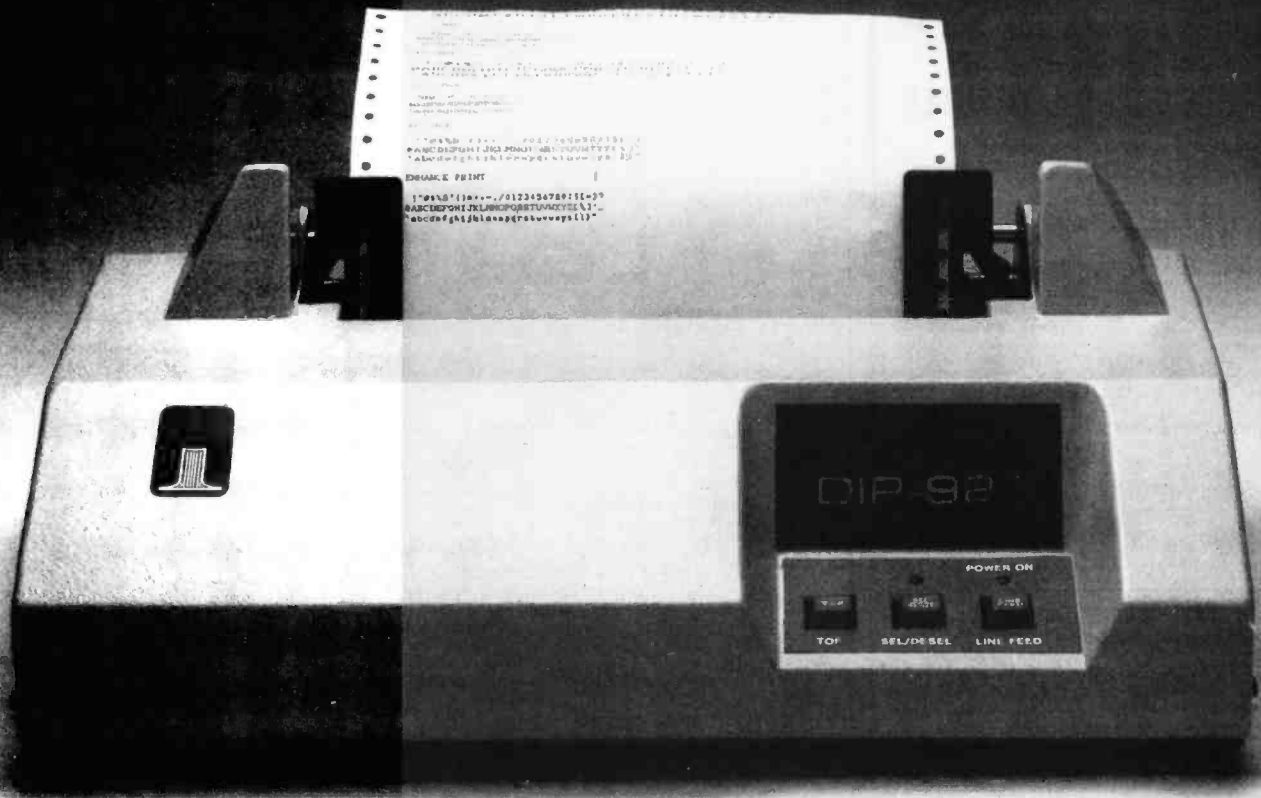

THE NEW D-92 DUAL MODE MODULAR PRINTER

WHY PAY FOR TWO, IF ONE WILL DO?

Why pay for a printer that only does one job, when you can buy one printer that will perform two jobs. *Data Impact Products'* New Dual Mode Printer, the D-92 allows you to print in the data processing mode AND in the correspondence mode for business documents.

WHY PAY MORE IF YOU DON'T HAVE TO?

Finally, there is a printer manufacturer that lets you have it your way. Some manufacturers pass along the extra cost of serial interface to parallel interface users by charging both users the same price. At Data Impact Products we don't think that's fair. If you don't want or need serial we won't charge you for it. However, should you

require serial interface, xon/xoff, 2K buffer, or graphics you can have it. All you have to do is specify your requirements.

QUALITY PRODUCTS AT AFFORDABLE PRICES.

All *Data Impact Products* printers are built with superior materials right here in the United States. Each unit is inspected, tested and burned in at the factory to insure superior quality.

Standard Features on all models includes:

- 800 Character Buffer
- 100 CPS Bidirectional Printing
- Parallel Interface
- Short Line Seeking Logic
- Forms Handling up to Four Parts
- 100% Duty Cycle
- Six Different Character Sizes

INTERFACING FLEXIBILITY AND MORE.

Data Impact Products printers will interface with all popular computers whether it is IBM, Osborne, TRS, Apple, Televideo, Atari, etc.

So, if you want to double your output, lower your costs and increase your flexibility, then call or write us today for more details. You'll be convinced that *Data Impact Products* offers you more products for less money.



DATA IMPACT PRODUCTS, INC.

A Subsidiary of
Advanced Electronics, Inc.

745 Atlantic Avenue
Boston, MA 02110
Telephone: 617-482-4214
Telex: 951047 DIP INC BSN

See us at COMDEX — Booth #2568

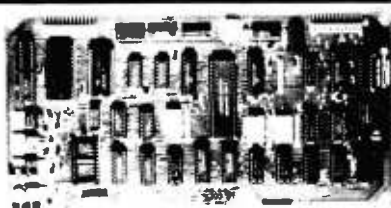

SBC-880 S-100 IEEE STAND ALONE SINGLE BOARD COMPUTER
 USES Z-80A (2 or 4MHz)

FEATURES: RS232 Serial Port and Parallel Printer Port
 • Programmable Baud Rate 110-9600 • Programmable Internal Timers • On Board EPROM • 1K On Board RAM
 • 2.2 CPM Bios for SBC2/4 and FDC-1 **A&T \$295 KR 265**

FDC-1 S-100 IEEE 080 FLOPPY DISC CONTROLLER
 USES WD1795-02

FEATURES: State of the art digital separator • Drives both 5 1/4" or 8" intermixed • Step rates can be intermixed • SD, DD, SS and DS Formats and DS 96TPI (TM100-4) Drives • Digital Prewrite Compensation

Assem and Tested.....\$325 **Assem and Tested.....\$139**
 KR.....295 **KR.....115**
 EPROM to run SBC-880 and FDC-1 with CPM \$40.00

S-100 IEEE REAL TIME CLOCK CALENDAR

GIVE YOUR COMPUTER THE Hour-Min.-Sec.-Day-Month-Year

FEATURES: Software control interrupts • On board Rechargeable Battery maintains clock when computer power is off.

DRIVES ANY PAIR OF STANDARD 5 1/4" DISC DRIVES

NEW APPLE II COMPATIBLE FLOPPY DISC CONTROLLER
 Runs Apple DOS 3.3 • Drives any two standard 5 1/4" drives (Tandon, Shugart, etc.) **Assem & Tested \$195.00**
 Dealer Inquiries Invited

APPLE II COMPATIBLE ASCII FULL KEYBOARD
 OUR PRICE \$99.00

FEATURES: N-Key Rollover Function • Includes [] • High Flexibility for Modification or Expansion • Plug-in Compatible with Apple • Mounts in Apple Case • Upper/Lower Case Outputs • On-Off Indications • Low Power Consumption

SAMWOO MONITORS
 Horizontal resolution of 750 lines at center and 500 lines at corners. Composite video - great with Apple

9" 18MHz BANDWIDTH		12" 12MHz BANDWIDTH	
B and W	\$117	B and W	\$127
Green	121	Green	130
Orange	125	Orange	134

Dealer Inquiries Invited

SUNTRONICS PROTOTYPE BOARDS

APPLE Prototype. Double sided glass with gold plated Apple and General Purpose contacts. Contains matrix of 17 x 63 solder plated donuts on .15" x 1" spacing. **SUN-722 \$13.75**

S-100 Prototype. Double sided glass with gold plated and numbered S-100 contacts. Matrix of 25 x 78 solder plated donuts on .15" x 1" spacing. Locations for headers and regulators. **SUN-721 \$17.85**

SOLDER PLATED w/DOUBLE SIDED TERMINALS .156" CENTERS

15/30 pin, 3 1/2 x 4 1/2 board w/.1" x 2" hole spacing and power strip run every 1.2" **SUN IC-S Holds 21 14 pin ICs \$1.65**

22/44 pin, 4 1/2 x 6 1/2 board w/.1" hole spacing. Contains 4 rows of 67 pins with power strips between rows. **SUN U-75 \$3.25**

22/44 pin, 4 1/2 x 7 board w/.1" x 2" hole spacing and power strips every 1.2". Holds 72 14 pin ICs. **SUN IC-L \$3.95**

Dealer Inquiries Invited

SUNTRONICS XMAS SPECIAL 10% OFF all items listed above this coupon. Offer expires Dec. 31, 1982.

EPROM's, RAM's, CPU, and MISC

1-7	8 up	50 up	1-7	8 up	50 up
2716	\$3.95	\$3.55	CALL	6116P-3 (150nS)	6.10 5.75 CALL
2732	4.75	4.40	CALL	2114L-2 (200nS)	1.62 CALL
2532	7.65	5.95	CALL	4164-2 (200nS)	7.90 7.49 CALL
2784	16.95	14.50	CALL	(150nS available)	CALL

Z-80A CPU 5.29 16K RAM Expansion Kit For TRS-80 Model III \$11.00/8

SUNTRONICS CO., INC.
 12821 Crenshaw Blvd., Hawthorne, CA 90250
 STORE HOURS: MON-FRI 9:00am to 6:30pm SATURDAY 10:00am to 5:00pm
 CALIFORNIA OUTSIDE CALIFORNIA TOLL FREE (213) 644-1149 1-800-421-5775
 (for Tech Info and Cat. orders) (Order Desk Only)
 Mail Order—Minimum Order: \$10. Send Money Order or Check to P.O. BOX 1957—Dept. R, HAWTHORNE, CA 90250. Use your VISA or Mastercard (please include expiration date). Add \$2.00 postage and handling to order. California residents add 6% sales tax.

Listing 3 continued:

```

:GOSUB 1200
:FERR=1
:RETURN
:ELSE IE=INSTR(1,AN,ATNE)
:IF IE=0
    THEN NERR=1056
    :GOSUB 1200
    :FERR=1
    :RETURN
:ELSE AN=RIGHT$(AN,LEN(AN)-IE)
:GOSUB 2500

910 IF NT<>1 AND NT<>2
    THEN RETURN
**NUMBER?

915 IF BB2<BB1 AND ABS(FT)<>1
    THEN NERR=1052
    :GOSUB 1200
    :RETURN
**ARE BOUNDS ACCEPTABLE?

920 IF ABS(FT)=3
    THEN IF DV<=BB2 AND DV>=BB1
        THEN FLAG=1
        :RETURN
    :ELSE RETURN
**WITHIN BOUNDS FOR FT=ABS(3)?

930 FLAG=1
:IF ABS(FT)=1
    THEN RETURN

935 IF FT=2
    THEN IF DV<=BB1
        THEN DV=BB1
        :IV=BB1
        :ELSE IF DV>=BB2
            THEN IV=BB2
            :DV=BB2
    **SET TO NEAREST BOUND?

940 IF FT=-2
    THEN IF DV<BB1
        THEN IF NT=1
            THEN IV=BB1
        ELSE DV=BB1
        ELSE IF DV>BB2
            THEN IF NT=1
                THEN IV=BB2
            ELSE DV=BB2

945 RETURN
*****

```

SUBROUTINE REAL NUMBER?
 USER-ACCESSIBLE SUBROUTINE(LINE 950) TO TEST FOR REAL NUMBERS

INPUT
 FT--CODE FOR ACCEPTABLE VALUES
 1--ACCEPT ANY REAL NUMBER OR INTEGER; CONVERT TO REAL NUMBER
 2--ACCEPT ANY REAL NUMBER OR INTEGER; CONVERT TO REAL NUMBER; IF OUTSIDE BOUNDS, SET TO NEAREST BOUND
 3--ACCEPT ANY REAL NUMBER OR INTEGER WITHIN THE BOUNDS(REJECT OTHERS); CONVERT TO REAL NUMBER
 -1--ACCEPT ONLY REAL NUMBERS(ANY VALUE)
 -2--ACCEPT ONLY REAL NUMBERS; IF OUTSIDE BOUNDS, SET TO NEAREST BOUND
 -3--ACCEPT ONLY REAL NUMBERS WITHIN THE BOUNDS
 BB1--LOWER BOUND
 BB2--UPPER BOUND
 (NOTE--BOTH BOUNDS MUST BE ENTERED IF CATEGORIES 2,3,-2, OR -3 ARE CHOSEN)

OUTPUT
 FLAG--INDICATES THE SUCCESS OF THE TEST
 1--SUCCESSFUL TEST
 0--UNSUCCESSFUL TEST
 DV--CONTAINS THE REAL NUMBER VALUE IF TEST IS SUCCESSFUL.

```

*****
950 GOSUB 900
952 IF FTR=1
    THEN PRINT "CHECKING IF ";AB;" IS A REAL NUMBER"
953 IF FLAG=0
    THEN RETURN
955 IF FT>0
    THEN FENT=1
    :RETURN
960 IF NT=2
    THEN FENT=1
    :RETURN
965 FLAG=0
:RETURN
*****

```

SUBROUTINE NEW COMMAND
 USER-ACCESSIBLE SUBROUTINE(LINE 1050) TO SET UP "AN" SO THAT THE LEFT ENTITY IN A NEW COMMAND IS THE LEFT ENTITY IN "AN"

INPUT--NONE
 OUTPUT--NONE OF CONCERN TO THE USER

```

*****
1050 FERR=0
:IEOC=0
:IE=INSTR(1,AN,AEOC)
:IF IE>0
    THEN AN=RIGHT$(AN,LEN(AN)-IE)
*****

```

Listing 3 continued on page 353



BEST VAN MPG* UNDER THE SUN.

America's Best Selling Van — Now First With 20 MPG!

But Ford Vans aren't best sellers just for setting gasoline mileage milestones. They're all "out front" designed — the engine is moved forward to make loads of room for passengers. And room for loads — up to 4,490 pounds worth.

Plus you get Ford exclusives like tough body-on-frame construction and Twin-I-Beam front suspension. It's no wonder more Ford Vans are on the road than any other make. †

*Diesels excluded.
†Based on R.L. Polk & Co. cumulative registrations as of July, 1981.

Get it together — Buckle up.



BEST VAN MILEAGE

30 EST HWY **(20)** EPA EST MPG

E-100/150 with optional 4-speed overdrive transmission. Use for comparison. Your mileage may differ depending on speed, distance and weather. Actual highway mileage and California ratings lower.

FORD ECONOLINE

FORD DIVISION



AMERICA'S TRUCK **BUILT FORD TOUGH**

GIFFORD COMPUTER SYSTEMS

Multi-user computers that keep pace with business and technology.

Not all computers can lead your business into the future.

Buying a multi-user computer system is a big investment. In time, training, and money. So you'd better choose a system that won't become obsolete.

Circle 211 on Inquiry card.

HARDWARE

8 MHz 16 bit (8088) CPU
6 MHz 8 bit (8085) CPU
Up to 1 megabyte 10 MHz static RAM
2.4 Megabytes of IBM compatible 8 inch floppy disk storage
Up to 80 Megabytes Winchester disk storage
20 slot IEEE 696/S-100 bus
9 RS-232C serial ports

16 bits — Financial planning



16 bits — Accounting



SOFTWARE

MP/M™ 8-16™ including:
CP/M-80™
CP/M-86™
MP/M-86™
dBASE II™ Data Base Management
SuperCalc™ Financial Planning
WordStar™ Word Processing (optional)

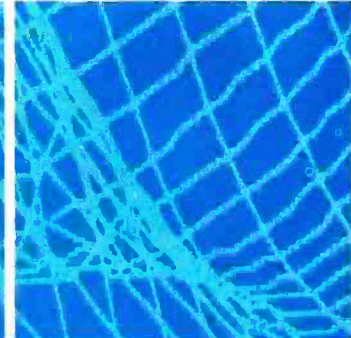
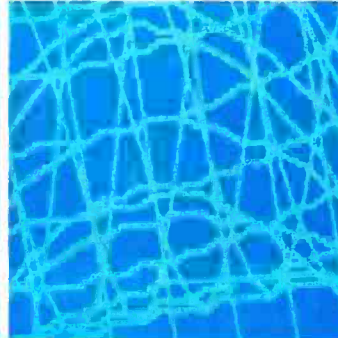
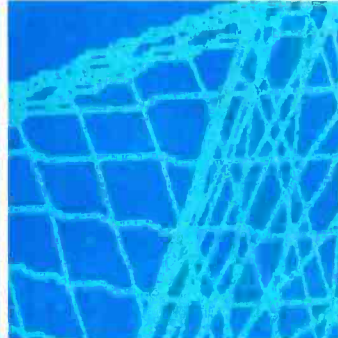

8 bits — Word processing

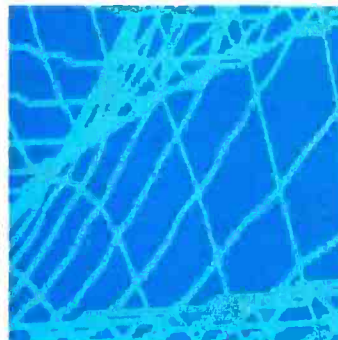

8 bits — Graphics

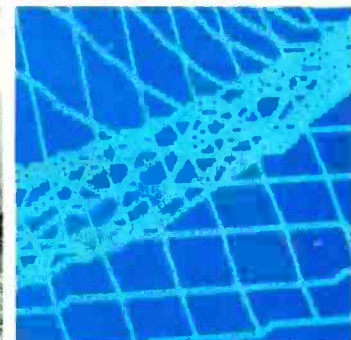

You can begin your investment with a single user installation. Then, you can add up to 6 more terminals as your business grows. And you can add more memory as you need it.

It does the job of two generations of computers at the same time.

With a Gifford Computer System you can use any of the thousands of 8 bit CP/M® programs available. And any of the faster 16 bit CP/M programs, too. If you're using

CP/M already, your investment in training, software and data is protected.

Our systems are designed with your future in mind. With our bus-based system, as new technology becomes available it can be integrated into your computer at an affordable price—protecting your hardware investment.

You get all the support you'll ever need.

We have centers in San Francisco and Los Angeles, with

complete demonstration and support facilities. Call now for a demonstration.

Gifford Computer Systems. We're in business for your future.

MP/M 8-16 is a proprietary implementation of MP/M-86 and was configured for CompuPro by G&G Engineering. CP/M and MP/M are registered trademarks of Digital Research. SuperCalc is a trademark of Sorcim. WordStar is a trademark of MicroPro International Corp. dBASE II is a trademark of Ashton-Tate. CompuPro is a trademark of Godbout Electronics.

Gifford Computer Systems is an authorized CompuPro Systems Center.

GIFFORD
COMPUTER SYSTEMS

A division of

G&G ENGINEERING

1922 Republic Avenue,
San Leandro, CA 94577
(415) 895-0798

My business needs a computer it can grow with.
Please send more information.

Name _____ Title _____ Company _____
Address _____ City _____ State _____ Zip _____
Phone _____ I am currently using CP/M.

Circle 211 on inquiry card.

Listing 3 continued:

```

:FENT=1
:RETURN
:ELSE IF NOT(EOF(1))
      THEN GOSUB 1055
      :GOTO 1050
1051 IF FEOC<1
      THEN GOSUB 1055
      :FENT=1
      :RETURN
1052 GOSUB 1055
      :GOTO 1050
*****
SUBROUTINE FOR READING A CONTINUATION LINE FROM THE CONTINUATION FILE OR A NEW
LINE FROM THE TERMINAL OR INPUT FILE
*****
1055 IF NOT(EOF(1))
      THEN LINE INPUT#1,AN
      :JCON=JCON+1
      :RETURN
1060 CLOSE#1
      :OPEN "O",#1,"READTEMP"
1065 IF FFIL=1
      THEN LINE INPUT#2,AN
      :JFIL=JFIL+1
      :ELSE LINE INPUT "?";AN
1067 IF INSTR(AN,CHRS(34))<>0
      THEN NERR=1053
      :AB=""
      :GOSUB 1200
      :GOTO 1060
1068 IF FTR=1
      THEN PRINT "READING A LINE"
      :PRINT AN
1070 AT=ACON
      :GOSUB 1080
      :IF FLAG=1
      THEN PRINT#1,AN
      :GOTO 1055
      :ELSE IF FFIL=1
      THEN IF EOF(2)
      THEN FFIL=0
      :CLOSE #2
1075 PRINT#1,AN
      :CLOSE#1
      :OPEN "I",#1,"READTEMP"
      :FLAG=0
      :JCON=0
      :GOTO 1055
1080 IF RIGHTS(AN,1)=" "
      THEN AN=LEFT$(AN,LEN(AN)-1)
      :IF LEN(AN)>0
      THEN GOTO 1080
1085 IF RIGHTS(AN,1)=AT
      THEN AN=LEFT$(AN,LEN(AN)-1)
      :FLAG=1
      :RETURN
      :ELSE FLAG=0
      :RETURN
*****
SUBROUTINE SKIP
USER-ACCESSIBLE SUBROUTINE(LINE 1150) TO SKIP OVER CURRENT ENTRY TO THE
NEXT ONE UNLESS IT IS THE END OF A COMMAND

INPUT--NONE

OUTPUT
FLAG--INDICATES SUCCESS OF THE SKIP
1--SUCCESSFUL SKIP--THERE IS MORE TO THE COMMAND
0--UNSUCCESSFUL SKIP--THIS IS THE END OF THE COMMAND
*****
1150 FLAG=0
      :IF IEOC=1
      THEN RETURN
      ELSE IF LEFT$(AB,1)=AEOC AND NT=7
      THEN IEOC=1
      :RETURN
1155 IF AN="" AND FEOC=0
      THEN IEOC=1
      :RETURN
1160 FLAG=1
      :FENT=1
      :RETURN
*****
SUBROUTINE ERRPOP
USER-ACCESSIBLE SUBROUTINE(LINE 1200) TO PRINT ERROR MESSAGE

INPUT
NERR--THE NUMBER OF THE ERROR

```

Listing 3 continued on page 354

DISCOUNT DRIVES

Apple II Disk Drives \$285.00
 Controller \$90.00
 Tandon TM100-2 5 1/4"
 d/s TRS-80 \$249.00
 Tandon TM100-4 5 1/4"
 d/s Zenith \$319.00
 Tandon TM848-1 8" \$355.00
 Tandon TM848-2 8"
 thinline d/s \$417.00
 Tandon TM603 10 MB Wini. . . . \$899.00
 Tandon TM603E 14.2
 MB Wini \$995.00
 SASI Interface \$125.00
 Xebec Controller \$349.00

Elephant floppy disks ss/sd \$17.95 (box of 10)
 "ALL floppies discounted & 100% guaranteed"

WHOLESALE SUPPLIERS

Div. B.O.S.S. Inc.

P.O. Box 22428 Carmel, CA 93922
 Call (408) 373-0320

Circle 56 on inquiry card.

NEW!! The Apple users group software library bonanza at truly affordable prices. For the first time enjoy your Apple to its fullest capacity using specially packed disks with over 80 outstanding programs each. Not available from any other source!

• Applesoft • 3.3 DOS

PROGRAMS \$1-EACH

APPLEWARE INC. offers an extensive variety of interesting, useful and entertaining programs indispensable to the serious computerist including:

Business	Educational	Graphics
Games	Music	Science
Utilities	Data Base	Finance

Library disks 1, 2 & 3 are mixed categories and new disks 4 (Games), 5 (Utilities), 6 (Graphics) & 7 (Integer) at \$59.95 each. Why pay more?

Order direct from this ad and Save up to \$136. Buy disk library package 1, 2 & 3 and get a special bonus disk FREE — over 260 programs for \$179.95 + shipping. For best value, get all 8 disks for \$349, postage prepaid, for over \$30 of our best programs at 65¢ each! Call now toll free: 1-800-327-8664 Florida: 1-305-987-8665 6400 Hayes St Hollywood, FL 33024



Circle 37 on inquiry card.

EPSON

NEW REPLACEMENT
RIBBON CARTRIDGES

MX 70-80 \$ 4.75 ea.
MX 100 10.75 ea.

Please add \$.75 ea. handling/shipping.

LABELS

\$12.00/5000

STOCK #10350—1-15/16" x 3 1/2" x 1 wide.
 White—pressure sensitive—pin feed—
 4 1/4" carrier, packed 5000 per box.
 Add \$2.50 per box handling/shipping.

TERMS: Visa & M.C. (add 4%), check or money order. C.O.D.'s add \$2.00, min. order \$12.00. CA residents add 6% Sales Tax.

StW COMPUTER SUPPLY CO.
 25422 TRABUCO RD. SUITE #200
 EL TORO, CA. 92630 • (714) 768-0370

Circle 410 on inquiry card.

TIM[®] III

The Non-Programming Approach to Data Base Management

Data Base Management

Data management packages were created to save time and money in the development of software solutions to information problems. Many have been designed to accomplish just that, although most have only the programmer in mind. Sure they would save time in the long run, but what of the initial investment in time and effort required to learn the new language? What about the non-programmers in the world who would like an easy yet powerful applications generator? The solution is one of the most highly acclaimed software packages of our time, T.I.M. III.

What is T.I.M.?

T.I.M. is **Total Information Management**. Programmers love it due to its original solutions to classic data management problems. Non-programmers adore it since they can use it to achieve the same results as with other more complicated programming-like packages.

What Makes T.I.M. So Simple to Use?

We at Innovative Software, Inc. designed T.I.M. from day one with the end user in mind. Maybe he is a programmer who doesn't have time to learn a new language. Or perhaps a neophyte who fears coding pads and lines numbered by tens. We felt that a data

management package should be able to be used by anyone from a systems analyst to a secretary. That's why T.I.M. takes a full *menu-driven* approach, uses multiple *HELP* screens, and has a manual that sets a new standard in documentation.

Features of T.I.M.

T.I.M. has all of the features one has come to expect from a data management package, as well as many new ones. For example, a *word processing* interface that allows you to merge information from a T.I.M. file with letters or other documents created by a word processor. Now you can automatically send personalized letters to hundreds or thousands—quickly and easily. T.I.M.'s *Select* command enables you to pull specific information from a file. For example, "All customers who live in a certain ZIP code, whose last name begins with the letter A to L, whose balance due is less than \$50.00." A sophisticated *report generator* and even a *list generator* are also included.

How powerful is T.I.M.? With a maximum record size of 2400 characters and the ability to keep up to forty fields sorted properly at all times, T.I.M. is powerful enough to handle just about any application. T.I.M. can handle over 32,000 records per file, and two files can be linked together for reports if your application requires a many-to-one relationship. T.I.M. also includes all of the same editing commands as your word processor, thus making data entry and

editing a snap. You can also pull selected records from one file to place them into another. Files may be restructured to add or subtract fields and/or change field lengths or types. T.I.M. even has its own utility for backing up hard disks onto floppies.

The Manual

Many people believe that the manual is just as important as the software itself, a view that we at Innovative Software, Inc. tend to share. The manual for T.I.M. is divided into two sections, the Reference section and the Primer. The Reference section describes all of T.I.M.'s commands and subcommands. This is done in English, not in technical terms or in our own language. Even if you have never seen a computer before in your life, you'll be able to read and understand our manual immediately. The second section is a primer which goes through several examples for you, again in plain English. These true-to-life examples take the beginner by the hand and instruct him what to do and when. You will be able to see for yourself that T.I.M.'s only limitation is the imagination of the user.

Where to Find T.I.M.

T.I.M. is available from many fine computer dealers across the country. Or you may purchase from us direct by calling 913/383-1089. Either way you will have the finest data management program available.

Available for CP/M,* and IBM PC DOS.**

CP/M version—\$695. IBM PC version—\$495.

TIM is a Trademark of Innovative Software, Inc.
*CP/M and MP/M are Trademarks of Digital Research
**Trademarks of IBM



Innovative Software, Inc.
9300 W. 110th Street, Suite 380
Overland Park, Kansas 66210 USA
913/383-1089

SUPER I/O™

Interface your TRS80* or Sinclair* with 256 bits of I/O (16 Input ports + 16 Output ports) as a micro development system to your own breadboard project. as a controller (for peripherals, switches, LED's, A/D's, UART's, MODEM's, voice chips, sensors, almost everything electronic), as an easy learning aid, or connect multiple boards for an intercomputer local area network! Simple to program (examples provided in BASIC, FORTRAN & ASSEMBLER)

Soon: Super-I/O™ for Apple II* & IBM PC*

- SUPER - I/O™ BOARD
includes Owners Manual,
cables sold separately \$199**
 - ACCESSORIES
 - TRS-80* Cable (specify model) \$29
 - Sinclair* Cable \$29
 - I/O Port Cable (order as needed 1-16) \$9
 - Owners Manual (manual only) \$29
 - Application & Technical Manual \$49
 - SHIPPING & HANDLING - add \$5
(US only)
- Nevada residents add sales tax
*Check or Money Order
Credit Card orders add 10%
WIN/MILL RESEARCH INC.
453 Crampton Avenue
Reno, Nevada 89502
ORDER PHONE (only) (702) 329-0441
For priority info, send SASE.
*Trade Mark of respective companies

Circle 495 on inquiry card.

DATA COMMUNICATIONS SPECIALISTS FOR IBM PC & SEATTLE COMPUTERS

Teleprocessing software available for above computers to time-sharing host or between two users (send binary files, also).
Version 2 software \$60; Version 3, IBM PC \$95, SEATTLE \$160. Write for details or \$3.00 for manuals.

SEATTLE 8086 computer and MS-DOS*, Pascal, BASIC, FORTRAN, COBOL, Perfect Writer, or Multi-Plan.
SPECIAL PRICE for SEATTLE SYSTEM 2 + 4-port serial board + cables + choice of Microsoft BASIC, Pascal, FORTRAN, or COBOL.

SEATTLE 8086 GAZELLE Computer system.

Write for literature and prices on above systems, or call for quote.

CSCS COMPUTER & STATISTICAL
CONSULTING SERVICES
P.O. BOX 5351
TERRE HAUTE, IN 47805
(812) 466-4111
*Trademark of Microsoft, Inc.

Circle 159 on inquiry card.

MEMOREX Flexible Discs

SAVE 40% Write for your complete list.

5 1/4" Specify soft, 10 or 16 sector Price/10

1 Side, double density	\$24.70
2 Sides, double density	36.40
1 Side, 80 track, double density	32.50
2 Sides, 80 track, double density	44.20

(All 5 1/4" have Hub-rings)

8" Specify soft of 32 sector

1 Side, single density	23.40
1 Side, double density	30.60
2 Sides, double density	35.80

CHECKS -- VISA -- MC -- C.O.D.
(313) 777-7780 ADD \$2 SHIPPING

LYBEN COMPUTER SYSTEMS
27204 Harper Ave.
St. Clair Shores, MI 48081

Circle 274 on inquiry card.

Listing 3 continued:

```

WRITE#7, AN
WRITE#7, DV, FART, FAXES, FCOM, FENT, FEOC, FERF, FFIL, FTR, IEOC, IPRT, IV, JCOM,
      JFIL, NART, NCOM, NERR, NT
1410 FOR IART=0 TO NART
      WRITE#7, AART(IART)
      NEXT IART
1420 FOR ICOM=0 TO NCOM
      WRITE#7, ACOM(ICOM)
      NEXT ICOM
1430 CLOSE
      RETURN

```

SUBROUTINE RESTORE VARIABLES
USER-ACCESSIBLE SUBROUTINE (LINE 1450) TO RESTORE THE VARIABLES AFTER
CHAINING THAT WERE SAVED BY SUBROUTINE 1400

INPUT--NONE

OUTPUT--NONE

```

1450 OPEN "I", #7, "SAVENLP"
      INPUT#7, AB, ACON, ADEC, ADISK, AEOC, AEOL, AFIL, AINB, AINE, AOUT, AP, APRT, APRG,
      AR, ARET, AS*P, AT, ATER
      INPUT#7, AN
      INPUT#7, DV, FART, FAXES, FCOM, FENT, FEOC, FERF, FFIL, FTR, IEOC, IPRT, IV, JCOM,
      JFIL, NART, NCOM, NERR, NT
1460 FOR IART=0 TO NART
      INPUT#7, AART(IART)
      NEXT IART
1470 FOR ICOM=0 TO NCOM
      INPUT#7, ACOM(ICOM)
      NEXT ICOM
1475 CLOSE #7

```

ALTERNATE ENTRY POINT (LINE 1480) TO SUBROUTINE RESTORE VARIABLES
USED IF "ALL" WAS AN OPTION IN "CHAIN"
RESTORES SEQUENTIAL INPUT AND CONTINUATION FILES AND OPENS THE RANDOM
ERROR FILE

INPUT--NONE

OUTPUT--NONE

```

1480 OPEN "I", #1, "READTEMP"
      IF JCOM>0
          THEN FOR IDUM=1 TO JCOM
              LINE INPUT#1, ADUM
              NEXT IDUM
1481 IF FFIL=1
          THEN OPEN "I", #2, APTL
              IF JFIL>0
                  THEN FOR IDUM=1 TO JFIL
                      LINE INPUT#2, ADIM
                      NEXT IDUM
1482 OPEN "R", #3, ADISK+APRG+"ERR", 80
      FIELD #3, 80 AS AERR
      RETURN
1499 REM

```

RESERVED FOR FUTURE DEVELOPMENT (LINES 1500-2499)

```

1500 REM
2499 REM

```

RESERVED FOR PLOTTER-DEPENDENT GRAPHICAL INPUT ROUTINES (LINES 2500-2999)

```

2500 PRINT "YOU HAVE NOT DESIGNATED A PLOTTER TYPE"
      FERR=1
      GOTO 500
2999 REM END GRAPH
3000 REM BEGIN APPLICATION PROGRAM
9999 REM END APPLICATION PROGRAM

```

Listing 4: The variables and their descriptions as used in the POL-80 program.

VARIABLE	DESCRIPTION	EXAMPLE
AART(20)	Array--list of filler words to be skipped	AART(0)="A "
AB	Current entity string	
ACOM(10)	Array--list of characters(not letters or numbers) to be skipped in input	ACOM(0)=","

Listing 4 continued:

ACON	Character for "continuation of input"	Default is "&"
ADEC	Contains the classifications of characters for the decision table	See program line 30
ADISK	Disk unit prefix for current program file	Default is "A:"
AEOC	Character for "end for command"	Default is ":"
AEOL	Character for "end of line" (remainder of line is comments)	Default is "#"
AERR	Error message to be printed on terminal	
AFIL	Filename used for input of commands instead of terminal	
AINB	Character for "graphical input" beginning	Default is "I"
AINE	Character for "graphical input" ending	Default is "I"
AM	Entity for comparison with AB (supplied by user program)	
AN	Remaining portion of input string not yet tested	
AOUT	Character for "output to terminal" from the command line	Default is "\$"
AP	Character for "program exchange"	Default is "@"
APLT	String identifying the plotter being used	"DIA" or "A:DIA" for DIABLO
APRG	Current program name (first 4 letters)	"NUMP"
AR	Character for "input control"	Default is "!"
ARET	Return filename for use in some CHAT! statements	
ASTR	Character for "string delimiter in input"	Default is "'"
AT	Current character or string being tested	
ATER	Character for "input from terminal"	Default is "&"
AVOC	String for command words under VOCABulary	
BB1	Lower boundary in number matching routine (supplied by user program)	
BB2	Upper boundary in number matching routine (supplied by user program)	
DV	Real value of number in input	
FART	Flag--whether to keep or skip over filler words (articles)	0--keep 1--skip
FAXES	Flag--whether axes are drawn	0--no 1--yes
FCOM	Flag--whether to keep or skip over some special characters (like commas)	0--no 1--yes
FD	Flag--decimal found in extracting number	0--no 1--yes
FE	Flag--exponent (D or E) found in extracting number	0--no 1--yes
FENT	Flag--whether to get the next entity (i.e., call the parser)	0--no 1--yes
FEOC	Flag--determines what is the end of a command	0--":" and CR 1--":" only
FERR	Flag--shows error has been made (omit the rest of the current command)	0--no 1--yes
FFIL	Flag--source of input	0--terminal 1--file (APTI)
FLAG	Flag--indicates result from matching routines	0--failed 1--success
FT	Flag--indicates types and range of values acceptable to number matching routines	see remarks at lines 850 & 850
FTR	Flag--trace progress through the input	0--off 1--on
IAPT	Counter used in deleting filler words listed	

Listing 4 continued on page 360

5 1/4" Tandon Drives

• **TM 100-1** **\$195**
(single sided, 40 TRK, single or double density) **Free Shipping**

• **TM 100-2** **\$265**
(double sided, 40 TRK/side single or double density) **Free Shipping**

• **TM 100-4** **\$359**
(double sided, 80 TRK/side 96 TPI, double density) **Free Shipping**

ORDER — TOLL FREE

1-800-531-5475 (If outside of Texas)

(512) 250-1523 (If inside of Texas)

"If we can't ship the next working day, we won't take the order."

Master Card/Visa or check
Texas Residents add 5% sales tax.

CompuAdd Corp.

13010 Research Blvd - #218
Austin, Texas 78750

Circle 101 on inquiry card.

SYSTEM/Z'S BASIC/Z

A New COMPILED Basic for CP/M or MDOS

- No Royalties - No Run-time Charges
- Generates machine code (8080/280)
- Sort Verb - 2000 elements in 2 seconds
- Alpha-numeric Labels
- Chain with Common
- BCD Floating Point Math to 18 Digits
- Editor Tests Syntax As You Type
- Recursive, Multi-line, User Functions
- Dynamically Dimension Arrays
- Selectively Erase Arrays
- Trace and Single-step debugging
- Multi-tiered Error Trapping
- Cursor Addressing, Reverse and Blinking Video

Want to see how it works?
Get DAMAN's Mail-List program for \$30 BASIC/Z run-time packages are included.

Just want further info?
Call or write for free BASIC/Z brochure and mini-manual
BASIC/Z lists for \$345 but from DAMAN it's \$312 Post Paid to North America
VISA and Master Card Accepted. COD available or \$298 with cash discount (cash, check, money order)

Add \$7 for airmail shipment outside N. America
Specify 8", Microp / Vector Graphic, Apple, Osborne
NEC, N. Star
Full BASIC/Z Documentation \$35 (credited to full order)

Suite 14-04
3322 Mem
Parkway, S.W.

daman

(205) 883-8113
Huntsville
Alabama 35801

Circle 162 on inquiry card.

PRINT PERSONAL CHECKS

or letters on your tractor or friction feed, 9 1/2" printer. Print up to 7 checks or 2 letters at one time with the new, tough, re-usable

Paper Caper II

Send \$8.00 check or VISA or MasterCard number and expiration date to

SERVICES SQUARED
Box 2665, Las Cruces, NM
88004-2665

Circle 173 on inquiry card.

CALL "THE COMPUTER-LINE"™ IN COLORADO

We wish all our customers a very happy Christmas and a prosperous New Year.

With most mail-order establishments, low prices are the bottom line. ComputerWorld International believes that it is important to be competitive by offering low prices; however, we regard service as the most important aspect of a mail-order organization. We offer toll free lines so that you, the customer, are able to talk to fully qualified computer specialists trained to answer all your questions pertaining to our line of microcomputers. We are renowned for our excellent after-sales support and our promptness for delivery. Peace of mind and excellence in service is our pledge to all our customers.

IBM Personal Computer Products

QUADRAM CORPORATION

QUADBOARD

The ultimate memory board for the IBM, featuring:

- fully expandable from 64 to 256K
- parallel port
- asynchronous (RS232) serial port
- clock/calendar
- RAM disk drive

INTERFAZER

Used as:

- Peripheral buffer
- Multi-User Printer Controller
- Computer I/O Expander
- Incompatible Device Interface
- Peripheral Multiplexer
- Data Transfer Rate Converter

MICROFAZER

- buffering from 8 to 64K (4 to 32 pages of text)
- printer and computer independent
- parallel/parallel, serial/serial and parallel/serial available
- compute while you print

DAVONG Systems, Inc.

Description:
The Davong Systems Memory Card is a convenient RAM memory expansion card for use in the IBM Personal Computer.
The Memory Card may be placed in any free system slot. It is completely compatible with all IBM Personal Computer software and hardware, and runs at the same speed as IBM memory products.

64K RAM \$225 192K RAM \$499
256K RAM \$599

Hard Disk System for the IBM® Personal Computer. ONLY \$1595.00

Description:
The Davong System's Hard Disk Drive fits conveniently inside the second floppy disk location of the IBM Personal Computer chassis, providing more than 30 times the capacity of a floppy diskette, plus greater speed and reliability.

The DS1-501 System is compatible with IBM software, and supports IBM DOS®. The system includes all necessary components and software for installation.

12 MEGABYTES STORAGE \$2195.00

TANDON DRIVE SPECIAL Double Sided/Double Density 320K BYTES STORAGE TM-100-2

NOW ONLY \$274

SHIPPED ANYWHERE IN THE CONTINENTAL U.S.A.
Call for TM-100-4

RGB Color Monitor SPECIAL!

Princeton Graphic Systems

- 690 Dots Horizontal
- 16 colors
- Non-glare screen
- Sharp looking—matches IBM

IBM SOFTWARE

BUSINESS WORDSTAR	\$289	ENTERTAINMENT GALACTIC ATTACK	\$26
MAILMERGE	\$ 79	ZORK I	\$29
TAX MANAGER	\$199	ZORK II	\$29
256K VISICALC	\$189	DEADLINE	\$39
VISITREND-VISIPLOT	\$239	AT UNBEATABLE PRICES	
VISIDEX	\$189	T and G JOYSTICKS	\$44.95
EASY EFFECTIVE ACCOUNTING SYSTEM	\$389	ADAM AND EVE PADDLES	\$29.95
SUPERCALC	\$219		
SUPERWRITER	\$289		

CALL FOR SOFTWARE NOT LISTED

MAYNARD ELECTRONICS

Floppy Disk Controller/with parallel \$229
Floppy Disk Controller/with serial \$259



BASIS 108 SUMMARIZED

- Single-board computer
- 6502 and Z80 microprocessors built in
- 64K RAM, expandable to 128K (4164 dynamic RAM, 200 ns)
- 2K system Monitor ROM
- 10K address space for ROM or EPROM (type 2716)
- Serial RS-232C interface
- Parallel printer interface
- 6 system expansion slots
- Detachable ANSI standard keyboard with numeric keypad, 15 programmable function keys, and cursor control block
- 2 page text display; 40/80 characters, 24 lines
- Five character sets
- 3 graphics modes with up to 16 colors;
- 40 X 48 blocks, 80 X blocks, and 280 X 192 dots
- Cassette recorder connector (DIN)
- Game control inputs
- 3 TTL inputs and 4 TTL outputs
- B/W video signal, NTSC video signal, and RGB signal

Peripherals For All Computers

PRINTERS

NEC Spinwriter 7710/7730	\$2339
8023A	\$ 489
EPSON (Graftrax Plus)	
MX-80	\$ 429
MX-80FT	\$ 529
MX-100	\$ 699
OKIDATA	
80 no tractor	\$ 339
80 with tractor	\$ 399
82A no tractor	\$ 439
82A with tractor	\$ 479
83A	\$ 689
84A parallel	\$1029
84A serial	\$1139
2K Buffer	\$ 55
Graphics 82A, 83A	\$ 79

C-ITOH

F10 Word Quality Printer
• 40 CPS Printing
• Letter quality excellence
Now Only \$1395

SMITH CORONA TPI
Daisywheel/Letter Quality
NOW ONLY \$589

Prowriter 120cps (Parallel)	\$ 469
Prowriter 120cps (Parallel/Serial)	\$ 619
Prowriter (136 column) Parallel	\$ 699
Prowriter (136 column) Parallel/Serial	\$ 749

All Epson, NEC, C-ITOH and OKIDATA dot matrix printer prices quoted are for immediate delivery inclusive of shipping, insurance and handling charges.

INTEGRAL DATA SYSTEMS

PRISM 132 Color printer with all options
• 200 cps Sprint Mode
• 4-color printing
• Friction/Tractor feed \$1595

MONITORS

Zenith ZVM-121 Phosphor, 15 MHZ	\$ 119
NEC 1201 Phosphor, 20 MHZ	\$ 179
NEC 0112 Composite, Color	\$ 335
NEC 2112 RGB Color	\$ 899
Amdek 300 Phosphor	\$ 179
Amdek Composite, Color	\$ 349
Amdek IBM Compatible Color	\$ 749
BMC Green	\$ 89
BMC Composite, Color	\$ 279

Princeton Graphic RGB Color \$ 599
For IBM
Electrohome RGB \$ 749
Electrohome IBM Cable \$ 49

MODEMS

Hayes Smartmodem, 300 baud	\$219
Hayes Smartmodem, 1200 baud	\$529
Hayes Chronograph	\$189
Novation Cat	\$145
Novation D-Cat	\$165
Novation Auto Cat	\$209
CERMETEK 1200 baud modem	\$CALL

DISKETTES (5 1/4 inch)

SCOTCH WITH PLASTIC LIBRARY CASES (Boxes of 10)
(48 Track single-sided, double density) \$26.50
VERBATIM DATALIFE SS/DD (Boxes of 10) \$24.95
VERBATIM DATALIFE DS/DD (Boxes of 10) \$39.95
ELEPHANT DISKETTES SS/DD (Boxes of 10) \$23.95

TERMINALS

Televideo 910	\$589
Televideo 912	\$695
Televideo 920	\$745
Televideo 925	\$735
Televideo 950	\$925
Adds Viewpoint	\$495

TELEVIDEO COMPUTERS

TS802	\$2695
TS802H	\$4695
TS806 (Multiuser)	\$5195
TS800	\$1295

Circle 127 on inquiry card.

MIND YOUR OWN BUSINESS.

It's time to take a long, hard look at your business.

Chances are, it's not running as productively as it could be.

And the effects—lowered product quality, limited resources, a tighter profit squeeze—can be staggering. Not just for your business, but for our nation as a whole.

There are no instant cures.

Growth in your business—and in this nation—depends on working more productively than ever. And on getting more out of what you're already putting in.

With careful planning and a sustained effort, you can improve the productivity of your operations, the quality of your product, create better job satisfaction within your work force and outperform your competition.

To learn more, send for the American Productivity Center's free brochure, "A Productivity Program... or Productivity Improvement." It will tell you where to start.

Don't put it off.

Minding your own business is the best way to help the business of America.

A public service of this publication, the Ad Council and the American Productivity Center.



AMERICA. WE'VE GOT A JOB TO DO.

Kathleen Sutton, American Productivity Center, 123 N. Post Oak Lane, Houston, Texas 77024

Yes, I would like to improve my company's productivity. Please send me a free copy of "A Productivity Program... or Productivity Improvement."

NAME _____
 ADDRESS _____
 CITY _____ STATE _____ ZIP _____

Listing 4 continued:

	in AAR™	
ICOM	Counter used in deleting characters listed in ACOM	
IDUM	Counter used in resetting the continuation file and AFIL	
IE	Location of a character within a string	
IEOC	Flag--end of command(get new command)	
IH	Flag--used to direct HELP output	0--terminal 1--line printer
IHELP	Counter used in HELP routine	
IK	Counter used in VOCAbulary routine	
IRET	Line number to return to when using a CHAIN statement	
IV	Integer value(rounded)of number in input	
JCON	Number of lines read from the line continuation file(used to reset file after CHAINS)	
JFIL	Number of lines read from file AFIL(used to reset file after CHAINS)	
NART	Subscript of the last filler word(articles)in the current list(array AART)	
NCOM	Subscript of the last character(Jlike commas) in the current list(array ACOM)	
NERR	Number of the error message to be printed	
NLET	Number of letters to be matched in subroutine 750	
NT	Class of current entity	
	1--integer	
	2--real number	
	3--word having letters only	
	4--word having letters and numbers, begins with letter	
	5--word having letters and numbers, begins with number (not currently implemented)	
	6--string	
	7--special character(!@#\$%^&* _-+=[{ }';:/?>.<)	

Listing 5: Filenames and conventions used in the POL-80 program.

Filenames:

POL-80.BAS	The program file for POL-80, stored in ASCII format
READTEMP	The continuation file used by POL-80
POLERR	The random file containing error messages for POL-80
____ERR	The random file containing error messages for a mainline program(for example: NUMRERR for NUMRANAL)
NUMRANAL.BAS	The mainline program stored in ASCII format
NUMR____.BAS	A module called by NUMRANAL, stored in ASCII format
NUMR____	A HELP file for the command given by ____ (4 letters)
VOCANUMR	File used by VOCAbulary, giving the list of main command words for NUMRANAL
SAVEPOL	File used to store POL variables during some CHAINS
____GRIN.BAS	The plotter input routines(Lines 2500-2999) for the plotter given by ____ (3 letters), stored in ASCII format

(Note: Do not store programs in compressed or protected format or they will not work in the CHAINS used in MLP-80)

File Number Assignments:

#1	READTEMP	(the continuation file)	sequential
#2	____	(the input file if using file input)	sequential
#3	____ERR	(the error message file)	random
#4	VOC____	(command word list)	sequential
#5	____	(HELP files)	sequential
#6-?	____	(user files)	(3 required when using graphics)



Oryx software Quality Discount

Check our
Special Priced
Holiday Listings!



GUARANTEED LOWEST PRICES! We will match any advertised price. Just show us the ad.

APPLE

HAYES SMART MODEM	req. 529	NDW
DOW JONES ANALYZER		\$399
Artsci		
Magic Window		\$79
Magic Mailer		56
Magic Words		56
Magic Pack Combo (all above)		176
Beagle Bros.		
Dos Boss	\$22	
Utility City	25	
Apple Mechanic	25	
Broderbund		
Apple Panic	\$25	
Chopfliter	26	
Serpentine	26	
Charles Mann		
Basic Teacher	\$30	
Teacher Plus	32	
Medical II	879	
Denver Software		
EASY (Exec. Acc't'g.)	(Special) \$565	
Financial partner	219	
Pascal Tutor	108	
Pascal Programmer	108	
Ellis Computing		
Nevada Cobol	\$169	
Nevada Pilot	129	
Nevada Edit	99	
Application pkg. ea.	22	
Howard Software		
Real Estate Analyzer	\$145	
Tax preparer '82	127	
Tax preparer state: CA, NY/NJ/IL	60	
Krell Co.		
Logo	\$135	
Logo w/o Frills	89	
Microfocus		
Cis Cobol Std.	\$775	
Forms-2	175	
Micropro		
Wordstar (Reg. CP/M)	\$195	
Mailmerge	85	
Calcstar	145	
Spellstar	145	
Supersort	120	
Word Pak (Special)	329	
Data Pak (Special)	329	
Microsoft		
Basic Compiler	\$315	
Cobol-80	599	
Fortran-80	155	
Time Manager	125	
Omega		
Locksmith	\$79	
Inspector	47	
Watson	44	
Games		
Hayden Sargon II	\$25	
Infocom Zork I or II	32	
Infocom Deadline	42	
L & S Crossword Magic	38	
Sirtech Wizardry	39	
Sirtech Night of Diamonds	29	
Misc.		
ISM Mathmagic	\$80	

ISA Spellguard	199
LJK Edt 6502	82
On-line Screen Writer II	95
Grandon A-Stat 79	140
STC Mailing List	48
Stoneware DB Master	179
Visicorp Visicalc 3.3	185
Visicorp Visischedule	235
Visicorp Adv. Visicalc (Ap. 111)	320
Visicorp Vslpak	499
PFS: Filing Report or Graph	88
Muse Software	
Super Text II	\$125
Address book	43
Form letter	87
Data Plot	52
Peachtree	
Series 40	
G/L, A/R, A/P ea.	\$399
Inventory, Payroll ea.	399
G/L + A/R + A/P (Special)	397
Series 9	
Peachcalc	279
Telecommunications	279

Silicon Valley	
WORDHANDLER	(Special) \$149
Sensible Speller	99

And Many More

CP/M

Mark of Unicorn	
Final Word	\$250

MicroPro

WORDSTAR	(Special) \$250
Mailmerge	95
Calcstar	199
Spellstar	160
Supersort I	170
Data pack (3 in One)	395
Word pack (3 in One)	395

Microsoft

Basic 80	\$285
Basic Compiler	325
Fortran 80	345
Cobol 80	570
Macro 80	140

Peachtree

General Ledger	\$399
Accounts Receivables	399
Accounts Payables	399
Inventory	399
Payroll	399
Property Management	799
CPA Client Write-up	799
Series 8 Module	485
PEACHPAK 4 (G/L, A/R, AP)	(Special) 397
Peachtext	350

Star Computer System

G/L, A/R, A/P or Pay	\$350
Legal Times Billing	845
Property Management	845

Sorcim

Supercalc	\$225
Trans 86	115
Act	155

Supersoft

Diagnostic I	\$48
Diagnostic II	83
Disk Doctor	84
Fortran	215

C Compiler	175
------------	-----

Ashton - Tate

D Base II	\$485
-----------	-------

Byrom Software

BSTAM	\$160
BSTMS	160

CP Aids

Please Call	
-------------	--

Digital Research

Pascal MT +	\$389
MAC	85
SID (8080 Debugger)	65
ZSIO (Z80 Debugger)	90
CP/M 2.2	149
C Basic 2	97
PL/1-80	449

Misc.

Oasis "The Word Plus"	\$120
Micro Ap Selector V	395
Lifboat T/Maker II	225
Epic Superviz	115
The Boss Financial Acctg.	1800
The Boss Payroll System	750
The Boss Time Billing	1090
Fox and Geller Quick Screen	129

Games

Infocom Zork I	\$39
Zork II	39
Deadline	50
Yahoo Catchum	32
Adventure (#1-12)	99
Commodore 64 Software	\$Call

IBM PC

Micropro WORDSTAR	(Special) \$250
Mailmerge	95
IUS Eastwriter	299
IUS Eastspeller	149
Microstuff Crosstalk	129
Alpha Data Base Manager	170
Alpha Mailing List	85
Compuvlew Vedlt	165
Compuvlew CP/M 86	295
Data Most Write-on	110
Word Move It	125
ISA Spellguard	247
Easy (Exec. Acctg. Sys.)	625
Easy Planner	145
Ashlon-Tate D Base II	485
Lifetree Volkswriter	175
Peachtree Accounting Module	399
SPECIAL PEACHPAK (GL, AR & AP)	399
Ecosoft Microstat	257
Supersoft Optimizer	160
Statpak	397
The Final Word	250

Games

Last Colony	\$25
Temple of Apshal	33
Galaxy	22
Midway Campaign	20
Championship Blackjack	34
Frogger	30
The Warp Factor	35

Accessories/ Hardware

Boards	
Co Processors 88 card (Ap. II)	\$795

Softcard (Z80 CP/M Ap. II)	298
CPS MultiFunction	178
Mountain A/D + O/A	289
CCS 12K ROM/PROM	89
CCS A/D Converter	98
CCS Serial Asynch	129
Applescope (your Apple as an Oscilloscope)	595
Videx Enhancer I	149
K & O Enhancer	115
Dan Paymar Lower case	27
ALS Smarterm	379
ALS Z-card	269
Percom Doubler II	167
BH 3 Full View 80 (AT800)	299
BH 3 32K Memory (AT400/800)	159
BYAD DS-1 (54K, Z80, CPM for IBM PC)	599
Datamac 64K (IBM PC)	399
Videx Micromodem Chip	25
Xedex Baby Blue (IBM PC)	495
Quadram Deluxe Board (IBM PC)	445
Quadram 128K Ram (IBM PC)	495
Microfazer 8K Printer Buffer	135
Versacard	160
Bit 3 Dual Comm-plus (Apple II)	209
16K RAM WIZARD - 16 (APPLE II) (Special)	79
Echo II Speech Synthesizer	159
Symtec Light Pen (IBM PC)	140
Symtec Light Pen (AP/II/III)	200

Computers

Commodore/Atari/NEC/Xerox

Call for Price Information

Monitors

Amdex Video 300	\$160
Amdex RGB Color	699
NEC 12" Hires Green	159
Sanyo 12" Hires Green	199
TECO TM - 12 GX Green	147
TECO RGB 13"	525
USI HI-RLS 12" Amber	199
Zenith ZVM 12" Green	115

Modems

Novation Apple-Cat II	\$299
Novation 212 Auto Cat	585
Hayes Smartmodem	225
Hayes Smart Modem 1200	520
Micromodem II	319
Hayes Chronograph	199

Printers

Anadex 9500 Series	\$1,580
Epson	\$Call
C. Itoh Starwriter	1450
C. Itoh Prowriter	499
Diablo 630	2,200
NEC 3530	1,890
NEC 8023A	525
Okidata: Microline 82A	460
Okidata Microline 83A	685
Prism 80 (w/ 4 options) inc. color	1,399
Prism 132 (w/ 4 options)	1,547
Smith-Corona TP-1	675

Disk Drives

RANA ELITE 1 (AP. II)	(Special) \$339
Rana Controller (Ap. II)	110
Micro Sci A35 (Ap. II)	399
Micro Sci A40 (Ap. II)	385
Micro Sci A70	540
Micro Sci Controller (Ap. II)	90
Tandon TM-100-1 (IBM PC)	215
TANDON TM-100-2 (IBM PC)	(Special) 275

ORDER TOLL FREE - Outside WI - 1-800-826-1589

Please: • Wisconsin residents - add 5% sales tax
• Add \$3.50 for shipping per software and small items. Call regarding others.
• Foreign - add 15% handling & shipping for small items & software.

We welcome: • Visa, Mastercharge - (Add 4%)
• Checks (Allow 1-2 weeks for clearing)
• COD (Add \$1.50 per shipment)

For technical information & in Wisconsin: 715-848-2322
Store prices differ from mail order.

Oryx Software • 205 Scott St. • P.O. Box 1961 • Wausau, WI 54401



Text continued from page 332:

terminal or a prepared command file. (Such a file, designated file #2, is opened by the !FIL 'filename' inserted in a previous input command.) The input can consist of more than one physical line—each line containing up to 250 characters—if a continuation character (&) is included at the end of each line. More than one command can exist on a single physical line if the commands are separated by an end-of-command character (:). A call to subroutine 1050 sets the pointer to the beginning of the next command on the line currently in the buffer (AN). If there is no line in the buffer, subroutine 1055 is called to get a line from the continuation buffer (file #1). If the continuation buffer is empty, however, one or more new lines are read from the input source (the terminal or file #2) and placed in the continuation buffer.

When the command line is in the buffer (AN), the user's application

program can attempt to extract information from it by using subroutines 750, 800, 850, and 950. These subroutines allow the program to ask the following questions:

- Is the current entity a specific word or character (e.g., "DRAW" or ":")?
- Is the current entity a string?
- Is the current entity an integer within a certain range of values?
- Is the entity a real number within a certain range of values?

An answer of "yes" to the current question sets FLAG=1 and lets the program go to the next entity in the line.

The actual extracting and categorizing of the current entity is done by subroutine 500 (the parser). It prepares the current entity for matching or examination, while also handling other embedded items within the line.

No process works as smoothly as desired every time. Possible errors in

input can always occur. Therefore, subroutine 1200 is provided to output an error message identifying the source and type of error. The error messages for POL-80 are given in listing 6. An example of an error is found in line 70.

Since there will sometimes be filler words that were not planned for, a "skip" subroutine (line 1150) is provided to get the next entity for further processing. This skip routine should be used sparingly as it may lead to extracting the wrong number, etc., causing invalid or confusing results.

Finally, there is an assistance routine (HELP and VOCABulary—line 1250). If it is invoked and finds a match on the current entity, VOCABulary gives the list of highest-level command words for each main program, and HELP prints the explanation that was stored on the disk for the desired word. The code for this subroutine gives a preview of the theme of the next part of this series.

In addition to the minimum levels of input handling indicated above, some additional capabilities are included. One—reading stored commands from a file—has already been mentioned. This is especially useful where long sets of commands are frequently used—as in drawing standard, but complicated, axes for a graph.

Another capability allows input to the command from the terminal *as the line is being parsed*. This is especially useful for making minor changes in values in input being read from a prepared command file. Such changes are indicated by inserting a percent sign wherever a word, character, phrase, string, or value is to be inserted later:

A third addition allows a message from the command to be output to the terminal by enclosing the message between dollar signs.

These three capabilities—reading from a file of commands, parsing time input from a terminal, and messages to the terminal—can be used to make a POL program appear to have question-and-answer input. Listing 7 shows a set of commands that can be stored in a file that will produce a question-and-answer session. This



**TELEX
FOR CP/M®**

The MicroTLX software with your modem is all you need to connect to the Western Union network. Once online to Western Union, you may send and receive Telex, TWX®, Mailgram®, International Telex, Cable and Telegram messages directly from your CP/M computer. MicroTLX provides automatic dialing, automatic answer, unattended operation and automatic retry of unanswered calls. Included with MicroTLX is an easy to understand manual with examples of all message types, model message files on disk, and an online help facility. MicroTLX is available today with support for the most common modems, more are being added as necessary. Price \$150.00

MicroTLX™

Turn your CP/M® computer into an intelligent Telex/TWX® machine

amt
advanced micro techniques

1291 E. Hillsdale Blvd. Suite 109 Foster City, California 94404 (415) 349-9336
TWX®, Mailgram® are registered trademarks of Western Union, Inc. CP/M® is a registered trademark of Digital Research, Inc.

The COEX

Anatomy of a Printer

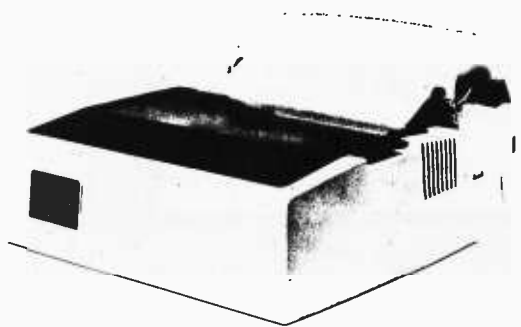
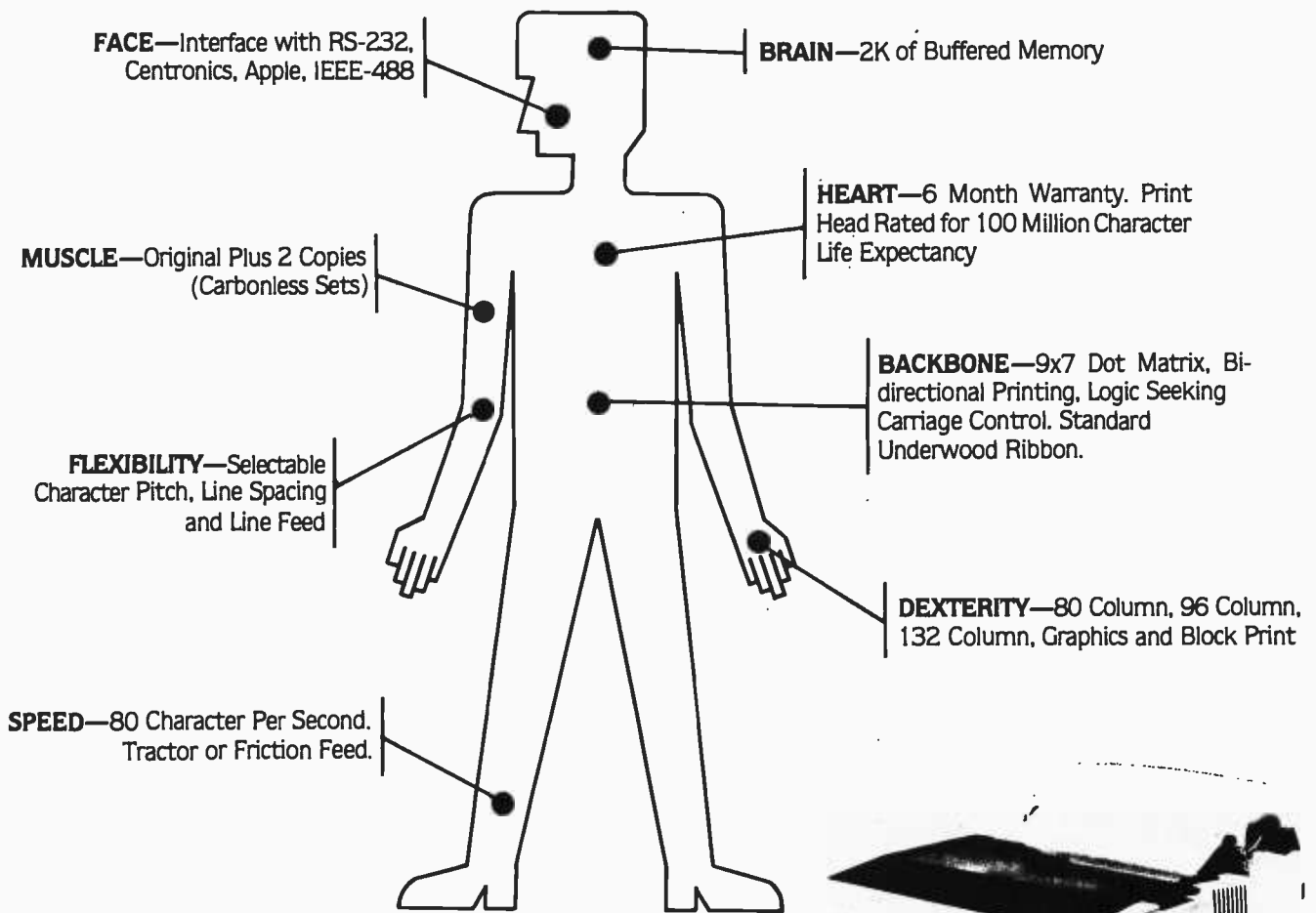

SPECIFICATIONS:

CHARACTER FORMATION PROCESS	Serial, impact dot matrix
STANDARD FONT	9 x 7 (7 needles), 6 x 6 for graphics printing
PRINTING DIRECTION	Bi-directional
NUMBER OF COLUMNS	80, 96 or 132 (40, 48 or 66 for enlarged characters)
CHARACTER SIZE	2.57 mm (.101") x 2.0 mm (.079") for standard 80-column line
CHARACTER DENSITY	5 CPI for 40 column, 10 CPI for 80 column, 12 CPI for 96 column and 16.7 CPI for 132 column
LINE SPACING	1/6", 1/8" and 1/12"
PRINTING SPEED	80 characters per second
NUMBER OF COPIES	2 (original plus 2 copies for carbonless sets)
PAPER WIDTH	8" to 10" for friction-fed paper and 3" to 10" sprocket-fed paper
INKED RIBBON	Standard Underwood spool type 1/2" (13 mm) wide by 11.5 yards (10.5 m) long
DIMENSIONS	387 mm (15.3") wide by 309 mm (12.2") deep by 124 mm (4.9") high. With tractor-feed assy, height is 171 mm (6.7")
POWER CONSUMPTION	90 watts maximum operation 25 watts standby
WEIGHT	8.5 Kg (19 lbs.)

Best of all, the price . . .

\$349⁰⁰

COEX 80-FT

OPTIONS:

COEX Interface Card to Apple **\$49.95**
 Demo Disc for Apple Available to Dealers

Dealer Inquiries Invited

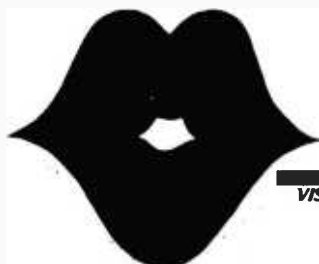

"Have You Kissed Your Computer Lately"
Components Express, Inc.

1380 E. Edinger • Santa Ana, Calif. 92705 • 714/558-3972
 Terms of Sale: Cash, Checks, Credit Cards, M.O., C.O.D. Calif. residents add 6% sales tax.



THE SORT



General Sort and Merge Utility
Created exclusively for the IBM Personal Computer
\$95

THE SORT SORTS:

- BASIC, PASCAL, FORTRAN, COBOL and MailMerge files
- sequential, random files
- records organized by items and lines
- for all common data types (string-text, integer, real, double precision)
- for all common data types (string-text, integer, real, double precision)
- external and internal data representations
- interactive parameter preparation
- record selection

Requires 48 K and one disk drive

Also OMS SOFTWARE DEVELOPMENT SERIES

- A PASCAL SCREEN UNIT Access screen and keyboard from Pascal program - \$40
- B PASCAL DOUBLE PRECISION ARITHMETIC PACKAGE Increase your Pascal integer arithmetic precision to 32 bits! \$40
- C UTILITY PACKAGE - converts video modes, opens communication lines, speeds up I/O, Sets Epson and NEC tabs - \$25

Send order with check/money order to
ORGANIZATIONAL MANAGEMENT SYSTEMS, INC.
3 Chickory Court, Glen Arm. Md. 21057
(301) 668-9011

MD residents include 5% sales tax

Circle 358 on inquiry card.

FREE! FREE! FREE! FREE! FREE!



**SEND FOR OUR NEW
1982/1983
PARTS CATALOG**

THOUSANDS OF
SURPLUS ELECTRONIC
PARTS, SUPPLIES AND
DEVICES.

ALL ELECTRONICS CORP

905 S. Vermont Ave.
P.O. Box 20406
Los Angeles, Cal. 90006

FREE! FREE! FREE! FREE! FREE!

Circle 21 on Inquiry card.

NEW TRS-80® PROGRAM LETS YOU CHART STOCKS LIKE A WALL STREET PRO.

Wall Street TAP is a professional stock market trading tool. It employs the same technical analysis methods used by successful market experts to buy and sell. Time sensitive point & figure, moving average and on volume balance charts are at your fingertips.

User friendly Wall Street TAP spots trends and compares stocks instantly. It is a technical analysis package for the TRS-80 Model I or III 48K, 1 disk drive. *TRS-80, Tandy Corp. Trademark.

Order Your Wall Street TAP Today!

Send check or money order for US \$199.95 along with your name, address, city, state and zip to: Think Software Inc., Dept. B 572 - 810 W. Broadway, Vancouver, B.C. Canada V5Z 4C9. Or use your Visa/MasterCard, include card no., expiry date and signature. Card user phone orders accepted - call (604) 261-7261 24 hrs.

You'll Receive: Wall Street TAP Tape Plus documentation, sample printouts, help desk support. Postage, handling & FREE BOOK - Understanding Wall Street is included in price. Documentation only available. US \$29.95 + \$2 shipping. Dealer inquiries welcomed.

WALL STREET TAP

* Technical Analysis Package.

Now Chart Stocks For More Profits & Bigger Gains.

Circle 464 on Inquiry card.

Listing 6: Error messages that can be used with a POL program. These messages can be incorporated into POL-80.

```
1010,"First commands must be control level until an application program is called"
1021,"No filename (in apostrophes) after PPG"
1022,"No character after REA"
1023,"No character after FOC"
1025,"No character after FOL"
1026,"No character after INB"
1027,"No character after INP"
1028,"No character after CON"
1029,"No character after OUT"
1030,"No character after STR"
1031,"No filename(in apostrophes)after FIL"
1032,"No character after TER"
1033,"No character after PRG"
1034,"Incorrect or no keyword after program exchange level character"
1035,"Incorrect or no keyword after control character level character"
1036,"Missing integer after PEC"
1037,"Missing plotter declaration (in apostrophes) after PL"
1050,"Unbalanced string delimiters"
1051,"Unbalanced delimiters of output to screen"
1052,"Lower boundary for numbers larger than upper boundary"
1053,"Used a quote character (ascii 34) in input"
1054,"Missing option or incorrect command word after HELP"
1055,"Missing X, Y, or Z on graphical input"
1056,"Failed to have closing graphical character"
9999,"*****Last line must always be line 9999 in error list*****"
```

Listing 7: Sample input for a POL program in the question-and-answer format.

```
DRAW XY &
X FROM $Enter lower bound of X axis$ % &
TO $Enter upper bound of X axis$ % &
Y FROM $Enter lower bound of Y axis$ % &
TO $Enter upper bound of Y axis$ % &
TITLE $Enter the lines of the title, each enclosed in apostrophes$ % &
EXECUTE
```

Listing 8: Sample input to produce a contour plot. This input produced figure 3.

```
DRAW XY PAGESIZE 11 11 &
MAXIMUM LABEL LINES 6 &
FRAME &
X FROM -2 TO 3 &
Y FROM -2 TO 3 &
X TICS SIZE .3 &
MINOR 4 &
VALUES SIZE .3 &
Y TICS SIZE .2 &
MINOR 4 &
VALUES SIZE .3 &
TITLE SIZE .5 &
POSITION .4 &
LENGTH 1.5 &
'Contour Plot' &
'of' &
'an Equation' &
SUBTITLE JUSTIFY LEFT &
POSITION .6 &
'by Mark Finger' &
'May, 1981' &
X AXIS LABEL 'X axis' &
Y AXIS LABEL 'Y axis' &
'(units unknown)' &
LEGEND SIZE .25 &
HEADING 'Values' &
POSITION 1.0 0.0 &
DOTTED '1' &
DASH '5' &
LONG DASH '10' &
DOT DASH '20' &
LINE '50' &
EXECUTE
CONTOURS BOUNDARIES -2,-2 3,3 &
INTERVALS BOTH 30 &
ISOPTIONALS 1 DOTTED &
5 DASHED &
10 LONG DASH &
20 DOT DASH &
50 LINE &
EQUATION Z=100*(ABS(Y-X*X))^2+(ABS(1.0-X))^2 &
PLOT
```

Computer Channel

from all our staff "thank you, customers"
LIMITED QUANTITY, HURRY!!!

HOLIDAY
SALE

Printer

MICROPRISM for IBM PC Integral Data System's newest printer 110 cps, 84 x 84 graphics, serial/parallel.....	\$548
PRISM 80 200 cps.....	\$928
PRISM 132 200 cps.....	\$1,088
PRISM 132 all options (color).....	\$1,508
EPSON MX80 FT	\$498
OKIDATA ML84 parallel.....	\$1,078

LNW Computer

LNW I	superb 480 x 192 graphics Z80A, 64K, DOS PLUS BASIC, TRS-80 compatible.....	\$1,238
LNW I	w/RGB interface. Advanced color graphic BASIC.....	\$1,388
LNW I	w/disk drive & Zenith green monitor.....	\$1,598

Zenith 16-Bit

Z-100	dual drives, 128K RAM color board, 225 x 640 graphic.....	\$2,998
ZVM-134	superb color monitor.....	\$528

68000 EXPERT

WICAT	Multibus, up to 1.5 MB RAM, 300 x- 400 graphic option, touch panel, MCG/UNIX, CAD/CAM.....	\$7,000 up
Cromemco	S100, 68000/Z80, CROMIX, up to 4MB RAM	
CS1DZE	256K RAM, two 5 1/4" floppy.....	\$4,068
	S100, up to 3MB RAM, UNIX Basic development system.....	\$3,800
	Full system.....	\$14,500 up

Terminal



HAZELTINE

TELEVIDEO
VISUAL

Z19.....	\$628
ZT-1 w/modem.....	\$548
ESPRIT II.....	\$578
ESPRIT III.....	\$788
950.....	\$948
300.....	\$948

excellent quality, Shugart compatible

MITSUBISHI DISK DRIVE 8" DD, DS, 1.2 MB.....	\$428
DUAL 8" w/CASE & POWER SUPPLY.....	\$1,118

Letter Quality

C.ITOH	F-10 40 cps.....	\$1,378
	F-10 55 cps.....	\$1,688
NEC	3510 35 cps.....	\$1,548
	3550 for IBM PC.....	\$1,918
	7710 55 cps.....	\$2,298
DIABLO	620 20 cps.....	\$1,288

Houston Instrument

HIPAD DIGITIZER	
DT-114 4 control button.....	\$828
DT-11A for APPLE.....	\$678

AMDEK 300 for IBM PC	\$158
COLOR II RGB for IBM PC	\$728
ELECTROHOME RGB	\$588
SANYO RGB	\$828
NOVATION CAT modem	\$158
1200 CAT 212A	\$588
INFONE portable terminal w/modem	\$CALL
NORTHSTAR ADVANTAGE	\$2,888

Prices subject to change. American Express, Visa/Mastercard add 3%. F.O.B. point of shipment. 20% restocking fee for returned merchandise. Personal checks take 3 weeks to clear. COD on certified check only. N.Y. residents add sales tax. Manufacturers' warranty only. International customers, please confirm price before order. Accept P.O. from Fortune 500 & schools.

EXPORT INSTALLATION CUSTOM-PROGRAM

We carry many products & software

Computer Channel

21-55 44th Road
Long Island City, NY 11101

TELEX: 429418 CSTNY

CALL (212) 937-6363 free consultation
& catalogue

Cromemco

CIO IS COMING!

YOU ALWAYS WANT TO OWN A CROMEMCO
BUT CANNOT AFFORD IT, HERE IS YOUR CHANCE

FOR TRS-80 MODEL I OR III IBM PERSONAL COMPUTER

- ★ **MORE SPEED**
10-20 times faster than interpreted BASIC.
- ★ **MORE ROOM**
Very compact compiled code plus VIRTUAL MEMORY makes your RAM act larger. Variable number of block buffers. 31-char.-unique wordnames use only 4 bytes in header!
- ★ **MORE INSTRUCTIONS**
Add YOUR commands to its 79-STANDARD-plus instruction set!
Far more complete than most Forths: single & double precision, arrays, string-handling, clock, graphics (IBM low-res. gives B/W and 16 color or 200 tint color display).
- ★ **MORE EASE**
Excellent full-screen Editor, structured & modular programming
Word search utility
THE NOTEPAD letter writer
Optimized for your TRS-80 or IBM with keyboard repeats, upper/lower case display driver, full ASCII.
- ★ **MORE POWER**
Forth operating system
Concurrent interpreter AND Compiler
VIRTUAL I/O for video and printer, disk and tape (10-Megabyte hard disk available)
Full 8080 or 8088 Assembler aboard
(Z80 Assembler also available for TRS-80)
Intermix 35- to 80-track disk drives
IBM can read, write and run M.3 disks
M.3 can read, write and run M.1 disks

MMS FORTH

THE PROFESSIONAL FORTH SYSTEM FOR TRS-80 & IBM PC

(Thousands of systems in use)

MMSFORTH Disk System (requires 1 disk drive, 32K RAM)
V2.0 for Radio Shack TRS-80 Model I or III \$129.95*
V2.1 for IBM Personal Computer (80-col. screen) \$249.95*

AND MMS GIVES IT PROFESSIONAL SUPPORT

Source code provided
MMSFORTH Newsletter
Many demo programs aboard
MMSFORTH User Groups
Inexpensive upgrades to latest version
Programming staff can provide advice, modifications and custom programs, to fit YOUR needs.

MMSFORTH UTILITIES DISKETTE: includes FLOATING POINT MATH (BASIC ROM routines plus Complex numbers, Rectangular-Polar coordinate conversions, Degrees mode, more); a powerful CROSS-REFERENCER to list Forth words by block and line; plus (TRS-80) a full Forth-style Z80 assembler (requires MMSFORTH V2.0, 1 drive & 32K RAM) \$39.95*

FORTHCOM: communications package provides RS-232 driver, dumb terminal mode, transfer of files or FORTH blocks, and host mode to operate a remote FORTHCOM system (requires MMSFORTH V2.0, 1 drive & 32K RAM) \$39.95*

THE DATAHANDLER: a very fast database management system operable by non-programmers (requires MMSFORTH V2.0, 1 drive & 32K RAM) \$59.95*

FORTHWRITE: fast, powerful word processor w/easy keystrokes, Help screens, manual & demo files. Full proportional w/abs, outdenting. Include other blocks, documents, keyboard inputs, & DATAHANDLER fields—ideal for form letters (requires MMSFORTH V2.0, 2 drives & 48K RAM) \$175.00*

MMSFORTH GAMES DISKETTE: real-time graphics & board games w/source code. Includes BREAKFORTH, CRASH-FORTH, CRYPTOQUOTE, FREEWAY (TRS-80), OTHELLO & TICTACFORTH (requires MMSFORTH V2.0, 1 drive & 32K RAM) \$39.95*

Other MMSFORTH products under development

FORTH BOOKS AVAILABLE

MMSFORTH USERS MANUAL - w/o Appendices \$17.50*
STARTING FORTH - best! \$15.95*
THREADED INTERPRETIVE LANGUAGES - advanced, analysis of FORTH internals \$18.95*
PROGRAM DESIGN & CONSTRUCTION - intro. to structured programming, good for Forth \$18.00*
FORTH-79 STANDARD MANUAL - official reference to 79-STANDARD word set, etc \$13.95*
FORTH SPECIAL ISSUE, BYTE Magazine (Aug. 1980) - A collector's item for Forth users and beginners \$4.00*

* ORDERING INFORMATION: Software prices include manuals and require signing of a single computer license for one-person support. Describe your hardware. Add \$2.00 S/H plus \$3.00 per MMSFORTH and \$1.00 per additional book. Mass. orders add 5% tax. Foreign orders add 20%. UPS COD. VISA and MIC accepted; no unpaid purchase orders or refunds.

Send SASE for free MMSFORTH information
Good dealers sought

Get MMSFORTH products from your
computer dealer or

MILLER MICROCOMPUTER SERVICES
61 Lake Shore Road, Natick, MA 01760
(617) 653-6136

Contour Plot of an Equation

by Mark Finger
May, 1981

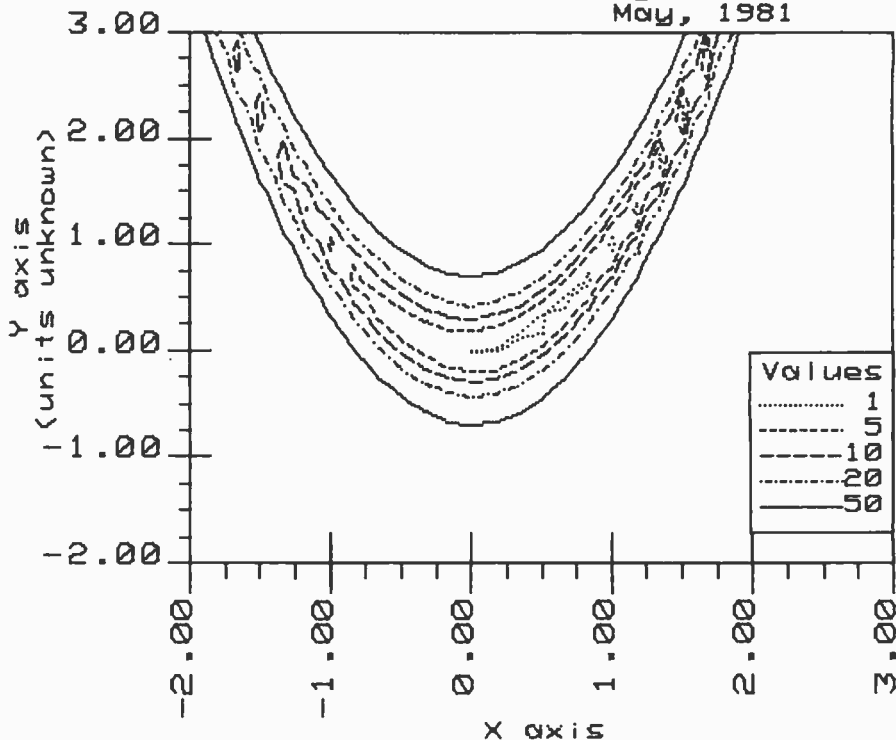

Figure 3: The resulting output from the input of listing 8.

can be an advantage because it allows inexperienced users to be led through a program, while users familiar with POL can use the full range of capabilities.

Another useful function allows remarks, especially in prepared command files. Anything within the current command appearing after a number sign is considered a remark.

Finally, direct graphic coordinate input from a plotter is allowed. Most intelligent plotters have some method of moving the pen to a point on the current graph and passing either virtual or screen coordinates to the program. This feature is explained more fully in the graphics package since the program to implement this capability is not included in this series.

A second major portion of POL-80 concerns program control and paging—lines 1 to 200 and 1400 to 1500. The latter portion will frequently be called from within user programs, as will be demonstrated in parts 2 and 3. Lines 1 to 200 initialize the program

and declare major program or plotter packages to be used. The format for this is more rigid (to conserve program size) than in normal input, and each reference to this section must be the only command on a line. (See listing 3 for further explanations.)

Listing 8 shows most of the capabilities of this input for a sample session that produces a contour plot. The format shown here was chosen for its readability and in a normal session would be input as five or six lines. Figure 3 shows the output for this input. It should be noted that this is but a small portion of an interactive session. An optimizer could be used on this graph to locate the minimum value for Z. A second equation could be plotted for comparison, or a numerical integration could be performed, with that equation plotted on a new graph.

An additional capability, *interactive* entry of equations, is a powerful tool in POL/PS. In listing 8, an equation was entered and stored as a sub-

Add Vision To Your Computer

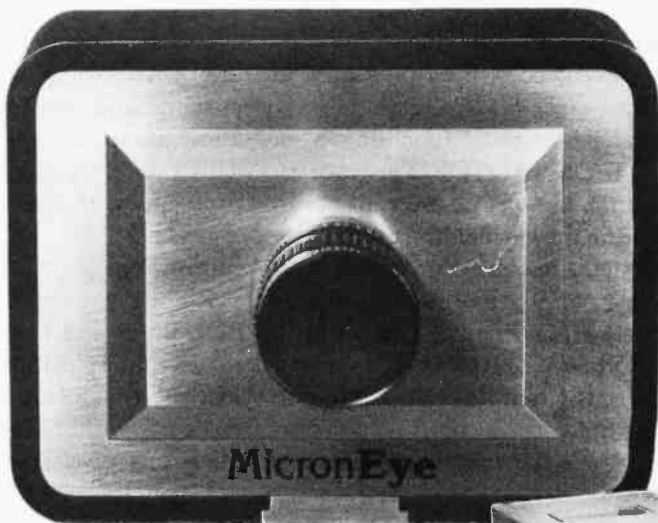

Announcing the MicronEye

Give your computer an eye . . . the new MicronEye, a solid-state image sensing unit using MICRON TECHNOLOGY'S OpticRAM.

The package includes: camera, lens, tripod, 6' telephone cord (camera to computer), floppy disc with camera software routines, instruction manual and serial TTL interface. Please specify Apple II®, IBM-PC®, Radio Shack TRS-80 CC®, Sinclair-Timex®, or Commodore 64®.

PLUG IN AND GO with your personal computer. Most popular baud rates are provided by the MicronEye interface. Options include: spare IS32 OpticRAM, 25' telephone cord, IS32 Bullet with 4' interconnecting cable, zoom or macro lens and RS232 interface. The IS32 Bullet is a 1" diameter by 1½" cylinder housing for the IS32 that con-

nects to the camera by a 4' flat ribbon, useful where a small, remotely-located unit is desired.

The camera has 128 x 256 element resolution capable of transmitting up to 20 frames per second. Software is delivered to you on a floppy disc with self-prompting command modes allowing you to continuously scan, freeze frame, frame store or compare frame to frame. The electronic shutter speed controlling light sensitivity is under software control, either automatic or keyboard entry modes, variable from 0.01 seconds (outdoors) to seconds (darkroom). The MicronEye can be remotely located from the computer by using a longer telephone cord. It is lightweight, and derives power (5V DC at 50ma) from your computer.



MICRON

TECHNOLOGY INCORPORATED

2805 East Columbia Road
Boise, Idaho 83706
(208) 383-4000
TWX 910-970-5973



We're building our reputation . . . on innovation.

I want to give my _____
Apple II®/IBM-PC®/Radio Shack TRS-80 CC®/Commodore 64®/Sinclair-Timex®
personal computer a new look. Please rush _____ standard units of MicronEye
to me at \$475.00 each, plus \$10 for shipping. Apple II® users please specify lan-
guage: _____

Applesoft/Integer Basic/Pascal

Part #	Item	Qty.	Price Each	Total
1	Standard MicronEye Package		\$485.00	
2	IS32 OpticRAM		\$ 34.00	
3	25' Six-Wire Cord		\$ 20.00	
4	IS32 Bullet		\$ 85.00	
5	Instruction Manual		\$ 25.00	
Applicable state sales tax (or exempt # _____)				
TOTAL			\$	

Enclosed is my check or money order for \$ _____ in payment, or,
charge my Mastercard # _____, or Visa # _____
which will expire on _____ (date).

Signature _____

Circle 315 on inquiry card.

PLEASE PRINT ALL INFORMATION -

NAME _____ PHONE # _____

MAILING ADDRESS _____

CITY _____ STATE _____ ZIP _____

SIGNATURE _____

Allow two extra weeks for delivery if not Apple II®

I am very interested but I would like more information before I can make a decision to buy.

My application field of interest is: _____

I recommend Micron offer an option to: _____

I prefer to use _____ computer.

Apple II is a trademark of Apple Computer. IBM is the trademark of International Business Machines. Radio Shack TRS-80 Color Computer is a trademark of Tandy Corporation. Commodore 64 is a trademark of Commodore Corporation. Sinclair-Timex is a trademark of Timex Corporation.



routine within the module. (The procedure involved will be presented in part 2.)

Another helpful function is a trace—!TON and !TOF. The trace indicates the use of POL-80 routines in processing the current line of input by detailing the tests used on each entity. This is especially useful when checking the various input branches in a new module.

The last item is the ability to change the various control characters (see lines 200 to 490). A character

may sometimes be required to assume another meaning within a module or a command line (for example, to allow an apostrophe in a graph title). This capability is allowed to prevent problems with duplicate definitions.

Summary

I have presented the reason for POL input and have shown some of its useful applications. I have also illustrated a framework for the POL/PS within which technical applications programs can be written.

The primary goals of this framework are to encourage the development of a technical program base for microcomputers and to relieve the programmer of some of the difficulties of writing large program packages to solve problems. ■

References

1. Hilst, R.W. "Development and Use of GRIP, the Generalized Routine for Interactive Processing, in the Computer Solution of Chemical Engineering Problems." Master's thesis, University of Kansas, August 1982.
2. Hilst, R.W. and K.A. Bishop. "Recent Advances in the Development and Use of GRIP—A Problem Oriented Language." In *Summer Computer Simulation Conference*, pages 29-35. Seattle, August 1980.
3. Hilst, R.W. and K.A. Bishop. "The Use of GRIP, a Problem Oriented Language, in Chemical Engineering Education." Paper presented at the 87th National AIChE Meeting in Boston during August 1979.
4. Lopez, L.A. "POLO: Problem-Oriented Language Organizer." *Journal of Computers and Structures*, vol. 2, pages 555-572.
5. Lopez, L.A. *POLO II, Programmer's Guide*. Urbana, IL: Engineering Document Center, University of Illinois, February 1973.

MD-10
10 MEGABYTE SUBSYSTEM

\$2695
SUGGESTED RETAIL

MD-20
20 MEGABYTE SUBSYSTEM

\$3595
SUGGESTED RETAIL

10 & 20 MEGABYTE (FORMATTED) 5 1/4" WINCHESTER SUBSYSTEMS

For Z-80 based micros which utilize the CP/M operating system . . .

CCS APPLE (with CP/M) ZENITH/HEATH NORTHSTAR
GODBOUT XEROX 820 ANY Z-80 S-100 SYSTEM
ALSPA TRS-80 MOD II
OSBORNE

All units are delivered completely assembled and tested, with drive, controller, case, power supply, cabling, Z-80 interface and all requisite software. A few features:

THE Z-80 INTERFACE:

- ▶ Supports vectored interrupts
- ▶ Plugs directly into the Z-80 socket on the host CPU (requires no special buss)
- ▶ Allows for DMA operation (if you already have a DMA system)
- ▶ Supports MP/M, OASIS and other operating systems (with additional software)

OUR SOFTWARE:

- ▶ Written in Z-80 assembly language
- ▶ Automatically configures virtually any existing version 2.x CP/M to the hard disk subsystem
- ▶ Includes SOURCE CODE
- ▶ Requires less than 2k of overhead memory
- ▶ Enables the user to read or write a 64k file in less than four seconds

FULL SIX-MONTH WARRANTY!

Deltaer inquiries are more than welcome

CP/M and MP/M are registered trademarks of Digital Research; OASIS is a proprietary product of Phase One Systems, Inc.; Z-80 is a trademark of Zilog.

MEDIA DISTRIBUTING
(408) 438-5454
4444 SCOTTS VALLEY DR.
SCOTTS VALLEY, CA 95066
TERMS: Cashiers Check,
VISA, M/C, COD
Shipping charges
added to all
orders

The following items are available from the author:

1. The POL/PS User's Manual and the ROOTs User's Manual for \$20. These manuals generally supplement but do not duplicate the material presented here. Topics include: detailed rules of input, theory and examples of operation, and programming rules and hints.
2. The two manuals above and a disk containing all the appropriate files for \$30.
3. The items listed above and the graphics package (which includes the contour plotter module) for \$200.

These items will be offered on several disk formats (CP/M 8-inch, Osborne, and others as I can make arrangements). A user's group will be set up, and I will sell software written by others for the POL/PS on a royalty basis. For more information, or to order items, contact:

His Programs
c/o Mark Finger
2439 Overlook Circle
Lawrence, KS 66044



SANYO PLUS

The best deal in a dual drive 64K Z-80 system, now only \$1995. We thoroughly integrate and test each system and warranty each Sanyo Plus for 90 days.

We are so confident of Sanyo's inherent reliability and our pretesting that we will warranty the entire system for a full year for only \$99.

The Sanyo Plus consists of a Sanyo MDC-1000 computer with a built-in 12" high-res. green phosphor 25x80 display. The detached keyboard features 5 special function keys and a 10-key pad. The Sanyo Plus comes complete with a parallel printer port, a serial communications port and room for three additional cards.

Plus we've added a second drive to give you a total formatted disk capacity of 624K.

Plus you get over \$1100 worth of software including CP/M® 2.2, Wordstar 3.0 with training guide, Sanyo Basic-a superset of Microsoft Basic with diagnostics and utilities, CalcStar® - the spreadsheet that works with Wordstar, and a disk with 20 games.

Plus we generate work copies of all your software.

Special Offer: 5 module business software pack: \$99.

No Dealers please. F.O.B. Scottsdale

\$1995

TELEVIDEO



Now backed locally by T.R.W. Built-in CRT, detachable keyboard, dual floppies w/750K formatted capacity, 64K CP/M and more. Special: Telesolutions - Wordstar TM and CalcStar TM w/system \$279.

802 w/CP/M®	\$2669
802H w/CP/M®	\$4539
806 (10 mb.)	\$4995
816 (23 mb.)	\$9195
800A's	\$1299

ALTOS



Our tech's favorite systems. From the lowest priced 3-user systems with either 2 or 6 MG. storage, to 40MG, 8-user 16 bit systems.

Add terminals, printers, and software and we can fully test and configure your system at low prices. Back nationwide by Moore Systems Service.

Series 5-15D	\$2295
Series 5-5D	\$4575
8000-10 w/MP/M R	\$6175
8600-12	\$9525

ZENITH



NEW

IDM-PC Compatible

Introducing the Zenith Z-100. It's the new 8/16 bit system that's CP/M, PC-DOS, and S-100 compatible. Plus it's backed by 300 Zenith service centers nationwide.

Two built-in 320K 5 1/4" drives, 128K RAM, optional color graphics with control of eight colors and 144,000 dots, five 5-100 expansion slots, and a full feature keyboard:

Z120	call
Z110	call
Z-90-82 w/64K	\$2275

NORTHSTAR



New low price on the Incredible Advantage TM. Your choice GDOS and BASIC or GCP/M \$120. Let us burn and test your Advantage TM or Horizon and we'll back it with our own fast warranty service.

Advantage	Call
Horizon II	
64K Quad	\$2665
Advantage	
w/5 mg.	\$3795

TERMINALS



Viewpoint JA Plus: New Viewpoint emulates Lear Siegler, Televideo, or Sorac. We're selling them at a lower price than others charge for older models.

\$489

Zenith ZT-1'	\$559
Televideo 910	\$579
Televideo 925	\$735
Televideo 950	\$927
Zenith Z-19	\$689
Wyse WY-100	\$769
Sorac IQ 130	\$599
Falco TS-1	\$1069
Adds Viewpoint 60	\$724
Hozeltine Espirit	\$499

with built-in modem



Scottsdale Systems Ltd.

617 N. Scottsdale Road, Suite B, Scottsdale, Arizona 85257

 **(602) 941-5856** 

Call 8-5 Mon.-Fri.

CLOSED DECEMBER 18 - JANUARY 2, 1983

Happy Holidays!

SERVICE/ORDERING

INTEGRATION: Prices listed are for new equipment in factory sealed boxes with manufacturer's warranty. We will pretest your equipment, integrate your system, configure your software, provide special cables, etc., for an additional charge. Call for prices.

ORDERING: MAIL ORDER ONLY. Prices listed are for cash. No C.O.D.'s. We sell on a net 20 basis to Fortune 500 companies and Universities Charge cards add 2%. Prices subject to change, product subject to availability. AZ. residents add 5%. Personal checks take 3 weeks to clear. 0-20% restocking fee for returned merchandise. Shipping extra - products are F.O.D. point of shipment. CP/M and MP/M are registered trademarks of Digital Research.

SOFTWARE: We sell all popular CP/M® programs at discount. Software sold only with systems not warranted for suitability.

PRINTERS



NEC8023A	\$469
Okidata 82A	\$409
Okidata 83A	\$645
Okidata 84	\$989
Epson MX80FT	\$484
Epson MX100	\$659
Tally 160 w/trac	\$659
Microprism 80	\$649

HIGH SPEED

Prism 80 "Loaded"	\$1329
Prism 132 "Loaded"	\$1469
Anadex 9501A	\$1369
DaraSouth DS-180	\$1249
T1810's	Call

LETTER QUALITY

NEC 3500*	\$1495
NEC 7700 w/TRAC*	\$2499
Qume 9/45	\$1895

*We offer NEC's with 16K buffers, dual interfaces, and extended warranty - call for prices.

I/O DEVICES

Houston Instrument:

Hi-Pior DMP-2	\$820	Hayes Smartmodem	\$219
Hi-Pior DMP-7/8	\$2019	Hayes 1200 Daud	
Hi Pad DT-11	\$664	Smartmodem	\$524

DAISYWRITER 2000

The best price/throughput in letter quality printers. 40 C.P.S., 48k buffer, 8 protocols, graphics mode, 4 interfaces std., Sub and Superscript, Proportional Spacing, and much more. Uses std. ribbons.

\$1019



BISON PRODUCTS, INC. NOW

**"We've Got More Than Computers"
Software, Video Games, VCR's & More!!**

SOFTWARE

Auto Simulations Armor Assault	\$19.98
Auto Simulations Hellfire Warrior	19.98
Auto Simulations Key of Acheron	10.99
Auto Simulations 3 Pack	25.99
Auto Simulations Morlocs Tower	11.99
Auto Simulations Dragons Eye	16.99
Auto Simulations Alien Garden	21.99
Auto Simulations Plattermania	20.99
Auto Simulations Monster Maze	16.99
Auto Simulations Invasion Orion	14.99
Auto Simulations Jabbertalky	16.99
Auto Simulations New World	16.99
Auto Simulations King Arthurs Heir	16.99
Auto Sim. Esc. from Vulcans Isle	16.99
Auto Sim. Crypt of the Undead	16.99
Auto Simulations Nightmare	16.99
Auto Simulations Oil Barons	59.99
DataSoft Canyon Climber - Apple	15.99
DataSoft Canyon Climber - Atari	15.99
DataSoft Pacific Coast Highway	15.99
Epyx Ric-O-Chet	10.99
Epyx Sorcerer Of Siva	19.99
Epyx Temple of Apshai	19.99
Epyx Star Warrior	19.99
Broderbund Choplifter - Apple	19.99
Broderbund Choplifter - Atari	19.99
Broderbund Arcade Machine	33.99
Broderbund Serpentine - Apple	19.99
Broderbund Serpentine - Atari	19.99
Adv. International Preppie - Apple	18.99
Adv. International Preppie - Atari	18.99
Adv Intl Rear Guard - Apple	18.99
Adv International Rear Guard - Atari	18.99
Adv Intl Sea Dragon - Apple	18.99
Sir-Tech Wizardry	29.99
Sir-Tech Knights of Diamonds	19.99
Sir-Tech Starmaze	19.99
Stomware DB Master	139.00
MicroPro Intl Wordstart - 8"	250.00
MicroPro Intl Wordstart - Apple	200.00
MicroPro Intl Wordstart - IBM PC	250.00
MicroPro Intl Mailmerget	125.00
MicroPro Intl Mailmerget - Apple	125.00
MicroPro Intl Mailmerget - IBM PC	125.00
MicroPro Intl Spellstart	150.00
MicroPro Intl Spellstart - Apple	150.00
MicroPro Intl Datastart - 8"	150.00
MicroPro Intl Datastart - Apple	150.00
MicroPro International Calcstart - 8"	125.00
MicroPro Intl Calcstart - Apple	125.00
MicroPro Intl Supersort - 8"	125.00
MicroPro Intl Supersort - Apple	125.00
MicroPro International Wordstar/Mailmerge Combo-8"	325.00
MicroPro International Wordstar/Mailmerge - Apple	325.00
MicroPro International Wordstar/Mailmerge Combo-IBM PC	325.00
MicroPro International Wordstar/Spellstar Combo - 8"	350.00
MicroPro International Wordstar/Spellstar Combo-Apple	350.00
MicroPro International Wordstar/Spellstar Combo-IBM PC	350.00
MicroPro International Wordstar/Mailmerge/Spelstar-8"	425.00
MicroPro International Wordstar/Mailmerge/Spelstar-Apple	425.00
MicroPro International Wordstar/Mailmerge/Spelstar-IBM	425.00

SOFTWARE

Infocom Deadline	24.99
Infocom Zork I	21.99
Infocom Zork II	21.99
Infocom Zork III	21.99
Infocom Starcross	21.99
Continental Software Home Accountant - Apple	34.99
Continental Software Home Accountant - IBM	80.00
Continental Software First Class Mail - Apple	37.99
Continental Software First Class Mail -IBM PC	69.99
Continental Software 1983 Book of Apple Software	14.99
Continental Software 1983 Book of Atari Software	14.99
Muse Know your Apple	15.99
Muse International Grand Prix	14.99
Muse 3 Mile Island	9.99
Sorcim Supercalc - 8"	169.99
Sorcim Supercalc - IBM PC	169.99
Sorcim Supercalc - Apple	169.99
Sorcim Supercalc - Northstar	169.99
On Line Soft Porn	19.99
On Line Wizard and the Princess	19.99

COMPUTERS - VIDEO GAMES

Atari 800 Computer	649.99
Atari 810 Disk Drive	429.99
Atari 400 Computer	279.99
Atari Star Raiders (400/800)	34.99
Atari Pac Man (400/800)	34.99
Atari Caverns of Mars (400/800)	34.99
Atari Communicator KIts (400/800)	299.99
Atari CX 2600 Video Computer Sys.	138.00
Atari CX 2613 - Adventure	23.99
Atari CX 2613 - Casino	21.99
Atari CX 2638 - Missile Command	21.99
Atari CX 2616 - Peles Soccer	21.99
Atari CX 2631 - Superman	21.99
Atari CX 2648 - Video Pinball	21.99
Atari CX 2610 - Warlords	21.99
Atari CX 2608 - Super Breakout	21.99
Atari CX 2650 - Berzerk	21.99
Atari CX 2655 - Yars Revenge	21.99
Atari CX 2649 - Asteroids	21.99
Atari CX 2646 - Pac Man	23.99
Atari CX 2609 - Defender	23.99
Atari CX 2656 - Adventure I	23.99
Atari CX 2657 - Adventure II	23.99
Atari CX 2660 - Star Raiders	23.99
Franklin ACE 1000 Computer	989.99
Franklin Ace 10 Disk Drive	

COMPUTER PRODUCTS

Maxell MD-1 Diskettes - Box of Ten	24.99
Sanyo DM2112 12" Monitor-Text	89.99
Sanyo DM5109 CX 9" Monitor-Text	114.99
Sanyo DM8112 CX 12" Mn.-Pro. Text	149.99
Sanyo DMC6013 - 13" Data Mon.	279.99
Sayno DMC6113 13" Prof Mon.	549.99
Sayno VMC7013	319.99
Electronic Protection Devices Lemon	34.99
Electronic Protection Devices Lime	44.99
Elec. Protection Devices Orange	69.99
Elec. Protection Devices Peaches	52.99
USI Pi - 1 9" Green Monitor	79.99
USI Pi - 2 12" Green Monitor	99.99
USI Pi - 3 12" Amber Monitor	124.99
USI Pi - 4 9" Amber Monitor	109.99

COMPUTER PRODUCTS

Videx Videoterm 80-Column Card	249.00
Videx Keyboard Enhancer	119.00
Videx Function Strip	59.00
BMC 12" Hi-Res Green CRT	89.00
BMC 13" Color CRT	229.00
NEC 12" Green CRT	169.00
D. C. Hayes Micromodem II	279.00
Microsoft Premium Pack	525.00
Microsoft Z-80 Softcard	279.00

VIDEO PRODUCTS

Hitachi CT 1321 13" Color TV	239.99
Hitachi CT 1322 13" Color TV	229.99
Hitachi CT 1326 13" Color TV Rem	299.99
Hitachi CT 1927 19" Color TV Rem	379.99
Hitachi CT 1928 19" Color TV Rem	425.99
Hitachi CT 1929 19" Color TV Rem	499.99
Hitachi VT 11A Video Tape Recorder	479.99
Hitachi VT 15A Video Tape Recorder	654.99
Hitachi VT 9701 Video Tape Recorder	899.99
Hitachi VT 66P VTR - Port	724.99
Hitachi VT 68P VTR - Port	899.99
RCA AGR054-W B&W 13" TV	114.99
RCA ARG120-W B&W 12" TV	81.99
RCA EGR333-W 13" Color TV	249.99
RCA FGR430 19" Color TV	299.99
RCA FGR460-WR 19" Color TV	379.99
RCA VGT200 Video Cassette Recorder	469.99

CALCULATORS

Hewlett Packard HP 41C Sci. Calc.	169.99
Hewlett Packard HP 12C Sci. Calc.	109.99
Hewlett Packard HP 10C Sci. Calc.	54.99
Royal 4-HPD Palm Size Calculator	24.99
Royal 316-PD Desk Top Calculator	64.99
Olivetti 920 - PD Calculator	119.99

TYPEWRITERS

Olivetti Praxis 30 Typewriter	399.99
Olivetti Praxis 35 Typewriter	449.99
Royal Century 2000 Port. Elec. Type	219.99

PERSONAL ELECTRONICS

Olympus S-904 Pearlcarder	44.99
Olympus S-901 Pearlcarder	74.99
Olympus S-802 Pearlcarder	74.99
Olympus S-902 Pearlcarder	84.99
Olympus S-801 Pearlcarder	129.99
Olympus SR-11 Micro Cass. w/Head	129.99
Olympus X-01 Pearlcarder	149.99
Olympus XR Basic Pearlcarder	189.99
Olympus XR Standard Pearlcarder	229.99
Hitachi TRK 5350H Master Ctrs AM-FM Cass Recorder	31.99
Hitachi TRK 7100H Master Ctrs AM-FM Cass Recorder	61.99
Hitachi TRK 6600H Master Ctrs AM-FM Cass Recorder	131.99
Pioneer SK-100 Stero Radio Cassette	99.99
Pioneer SK-300 Stero Radio Cassette	119.99
Pioneer SK-31 Stero Radio Cassette	169.99
Pioneer G-1 Syscom Hi-Fi	449.99
Electra FF 550 Cordless Phone	99.99
Electra FF3500 Cordless Phone-Pkt	174.99
Electra FF 2500 Cordless Phone-Pkt	184.99

† A Registered Trademark of
MicroPro International

CP/M is a registered Trademark of
Digital Research Corporation

HAS MORE THAN COMPUTERS

COMPUTER SYSTEMS

NEC PC-8001A \$725

Products For Apple Computers

Here are some of the products BISON carries for Apple Computers. If you don't see what you want here, give us a call.

16K RAM Card for Apple II \$ 68
 Microsoft Premium Pack \$ 525
 BISON Add-on Disk Drive
 100% Apple Compatible \$ 279
 Parallel Printer Card with Cable \$ 72
 Apple Compatible Parallel Interface \$ 65
 D. C. Hayes Micromodem II \$ 279
 Graphics Interface for NEC, Epson \$ 129
 Microsoft Z80 Softcard with CP/M® \$ 279
 Videx 80 Column Videoterm \$ 249
 Videx Enhancer \$ 119
 Videx Function Strip \$ 59
 Saturn System Ram Boards 32K \$ 195
 Saturn System Ram Boards 64K \$ 359
 Saturn System Ram Boards 128K \$ 499
 Expand 80 - 80 Column for VisiCalc \$ 99
 Corvus Hard Disk Drives
 5 Megabyte \$2495
 10 Megabyte \$3825
 20 Megabyte \$4575
 For Corvus Mirror ADD \$ 595
 For more Apple information, circle reader service card # 66

PRINTERS

BISON carries all of the major brands of printers. If you need help choosing the proper printer for your needs, call and talk to one of our support technicians.

EPSON MX-80 F/T Type III w/Graftrax \$ 460
 EPSON MX-100 with Graftrax \$ 625
 NEC PC-8023A Fric. & Trac. w/Graph \$ 485
 NEC 7710-1 \$2095
 NEC 7715-1 \$2095
 NEC 7720-1 \$2445
 NEC 7725-1 \$2445
 Okidata Microline 82A w/Trac. - 80 Col. \$ 399
 Okidata Microline 83A w/Trac. - 100 Col. \$ 549
 Okidata Microline 84P - Parallel \$ 925
 Okidata Microline 84PS - 200 cps P/S \$ 999
 C. Itoh Prowriter I - Parallel \$ 485
 C. Itoh Prowriter - I Serial \$ 425
 C. Itoh Prowriter - Parallel/Serial \$ 525
 C. Itoh Prowriter II - Parallel \$ 625
 C. Itoh Prowriter II - Parallel/Serial \$ 675
 C. Itoh F-10 Starwriter - Parallel - 40 cps \$1225
 C. Itoh F-10 Starwriter - Serial - 40 cps \$1225
 Comrex Daisy Wheel Printer - Parallel \$ 735
 Comrex Daisy Wheel Printer - Serial \$ 785
 Comrex Tractor Feed \$ 195
 For more printer information circle reader service card # 67

MONITORS

BMC International
 * 12" Green monitor with P-31 phosphor
 * 15 Mhz * Excellent for 80 column display
 BMC 12" Green Monitor \$ 89
 * 13" Color Monitor * Audio and Video
 * 270 Line resolution
 BMC 13" Color Monitor \$ 229

MONITORS

AMDEK Monitors
 * 12" Green Phosphor
 * Non-Glare
 AMDEK Video 300 Call for Price
 * 13" Color Monitor * RGB Input
 * For IBM/NEC/Apple
 AMDEK Color II Call for Price
 AMDEK Color I Call for Price
 AMDEK Color III Call for Price
NEC
 NEC 12" Green Monitor \$ 169
 NEC 13" Color Monitor \$ 325
 NEC 13" RGB Color Monitor \$ 815
ZENITH
 Zenith 12" Green Monitor \$ 115
 For more information, circle reader service card # 68

TELEVIDEO PRODUCTS

TeleVideo computer terminals and desktop computer systems-high price features at low prices.
TeleVideo TS-802 Computer system
 * 64K, 4 Mhz Z-80A, CP/M®
 * Dual Floppies, 720K Total
 * Same CRT and Keyboard as
 TeleVideo 950 Terminal
 * Network Expansion Capabilities
 TeleVideo TS-802 \$2645
 TeleVideo TS-802H Same as TS-802
 with one floppy and 5-Meg. Hard Disk \$4695
 TeleVideo TVI-925 Terminal \$ 695
 TeleVideo TVI-950 Term. - Top-of-Line \$ 875
 For more information, circle reader service card # 69

SOFTWARE

BISON carries software for all business and personal computer systems. Just select the software you want and call us for our current price. Here are some examples of BISON'S Low Prices:

MicroPro Software
 See Left Hand Page for Prices
Apple Software
 All APPLE Game and Business software. Select the program you want and call for price.
 Save up to 60% off list
Accounting Plus by Systems Plus
 For 8" CP/M®
 General Ledger * Accounts Payable * Accounts Receivable * Payroll * Inventory * Sales Order Entry * Purchase Order Entry and Point of Sale
 G/L \$ 385
 G/L, A/R \$ 745
 G/L, A/R, A/P \$1100
 G/L, A/R, A/P, P/R \$1459
 G/L, A/R, A/P, INV \$1459
 G/L, A/R, A/P, P/R, INV \$1875
 G/L, A/R, A/P, P/R, POS, INV \$2140
 G/L, A/R, A/P, P/R, S/O, INV \$2140
 G/L, A/R, A/P, P/R, P/O, INV \$2140
 G/L, A/R, A/P, P/R, P/O, S/O, INV \$2435
 All 8 Modules \$2695

SOFTWARE

For Apple II
 Pick the Apple Combination you need.
 G/L \$ 276
 G/L, A/R \$ 553
 G/L, INV \$ 553
 G/L, A/R, A/P \$ 649
 G/L, A/R, INV \$ 649
 G/L, A/P, INV \$ 649
 VisiCalc \$ 199
 VisiFile \$ 199
 dBASE II for 8" or Apple ... Call for Lowest Price

S-100 PRODUCTS

Sierra Data Sciences
 S-100 Master/Slave Single Board Computers
 Master - 4 Mhz, Z 80A \$ 690
 Slave - 4 Mhz, Z 80A \$ 625
 Sierra Data CP/M \$ 160
 Sierra Data BIOS \$ 100
 Sierra Manual \$ 25
 Sierra Data - Winchester Adaptor \$ 145
 Sierra Data Turbo DOS \$ 750

QT-Systems Mainframes
 S-100 Mainframe and 8" Drive Enclosures
 * S-100 Power +8V/16A +16V/3A -16V/3A
 * Drive Power +5V/1A -5V/6A +24V/6A
 * Keyed Power Switch
 * EMI Filter * Filtered Fan
 * 2 Switched Power Outlets
 * 15 - DB25 Cutouts
 * DB37 Cutout * IDS 50 Cutout
 * Hard Disk Power Supply
 * Shielded Motherboard * Rugged Card Cage
 * 9 1/2" x 17" x 21" (H x W x D)
 QT 6-Slot, Dual 8" Drives \$ 530
 QT 8-Slot, Dual 8" Drives \$ 560
 QT 12-Slot, Dual 8" Drives \$ 620
 S-100 Mainframe and 5 1/4" Drive Enclosures
 * Similar to 8" Mainframe
 * 7" x 17" x 20" (H x W x D)
 QT 6-Slot, Dual 5 1/4" Drives \$ 455
 QT 8-Slot, Dual 5 1/4" Drives \$ 595
 QT 12-Slot, Dual 5 1/4" Drives \$ 560
 QT All-in-one 8" Disk Drive Cabinet
 Changeable faceplate allows use of all standard 8" floppy and hard disk drives including:
 * Shugart * NEC
 * Qume * Mitsubishi
 * Tandon (Up to 4 Thin-Line)
 Features:
 * Holds 1-4 8" Drives * Modular Power Supply
 * Power +5V/6a -5V/1A +24V/6A
 List Price \$395 **BISON PRICE \$295**

DISK DRIVES

Qume #842 (Replaces Data-Trak 8) \$ 480
 Tandon Thin 8" Sngl.-Side Dbl.-Density \$ 382
 Tandon Double-Density \$ 465

WABASH FLOPPY DISKS

Single-Sided Single Density
 Box of 10 8" or 5 1/4" \$ 19



BISON PRODUCTS INC.
 A CALIFORNIA CORPORATION

"We accept Cash, Certified Checks, VISA and MasterCard"

All merchandise new in factory cartons with manufacturer's warranty
 Corporate and School District P.O.'s accepted subject to credit approval.
 Enclose financial statement with order.

California residents add Sales Tax. Shipping charges added to all orders.

"No refunds without prior approval" - Bison credit only on returned merchandise.

QUANTITIES LIMITED ON SOME ITEMS — PRICES SUBJECT TO CHANGE WITHOUT NOTICE

For Further Information Please Circle Reader Service # 70

Send Mail Orders To: P.O. Box 9078-184 • Van Nuys, California 91409
Orders May Be Picked Up At: 16709 Roscoe Blvd., Sepulveda, California 91406

For Questions or Phone Orders Call:

(213) 994-2533

Practical Dynamic-Memory System Design

A straightforward look at design with dynamic devices.

Rob Belics
9746 Twincrest Dr.
St. Louis, MO 63126

Many a computer experimenter has gotten sweaty palms at the thought of having to tackle the design of a dynamic-memory board. Dynamic memories are notoriously difficult to work with because of the special attention that must be paid to timing relationships. Although using static memory may make small increases in memory size easy, the power consumption of most inexpensive static devices is prohibitive for large systems. With the price of 16K by 1-bit dynamic-memory devices now around two dollars, their price-to-performance ratio is difficult to beat. In this article, I will describe the design of a dynamic-memory system; it's really no harder than any other interfacing job you may have taken on in the past, just more detailed.

The Trade-offs

In addition to their price-to-performance ratio, dynamic memories have an advantage over most static memories because of their simpler structure: one transistor and one capacitor form a basic dynamic bit cell. On the other hand, a static bit is a clocked flip-flop like those in a 7474-type TTL (transistor-transistor logic) device. Each flip-flop is composed of several logic gates that in

turn are composed of several transistors and resistors. Because many transistors and resistors use up a great deal of power, generating a large amount of heat, and because they take up a lot of space, only so many flip-flops can fit on an integrated circuit. This is why static memory rarely approaches the density of dynamic memory.

Of course, you never get something for nothing. The most popular and inexpensive memory device today, the 4116-type 16K by 1-bit dynamic RAM (random-access read/write memory), requires specially developed clocking and timing signals, as well as three separate power-supply voltages that must first be applied in a certain order. Compared to static memories, dynamic memories have slower data-access times (although they are more than fast enough for the average microcomputer). And we've all heard of an insidious problem called *refresh*, haven't we? That dynamic cell's capacitor can't hold a charge forever—it will all leak out if you don't give it a boost every so often. With a little planning, though, these disadvantages are easily overcome and dynamic memories do provide more storage in less space for less money.

What's Inside?

A 4116-type memory contains two identical arrays of cells, each arranged in 128 rows of 64 columns. To access (read or write) one of the cells, an address must be supplied to the memory. It takes a 14-bit address to select 1 bit out of the 16,384 on the chip. The address is multiplexed onto 7 pins to cut down on the size of the DIP (dual-inline package) that houses the chip. This means that we first give the memory 7 row-address bits (A0 through A6), and then we give it the 7 column-address bits (A7 through A13). Thus, the 4116 fits in a 16-pin package instead of a 24-pin package (see figure 1).

To tell the memory which address is which, there is a strobe signal for each part of the address. \overline{RAS} (row-address strobe) is applied when the row address is available to the memory, so that an on-chip decoder can pick one of the 64 rows; \overline{CAS} (column-address strobe) is applied to tell another on-chip decoder to pick one of the 128 columns, as well as selecting which array will be used. A signal called \overline{WRITE} tells the memory whether to read the bit stored at the address or to write a new value there. Making sure that the strobe signals get sent at the right time is the



Merry Christmas from

asap
computer products, inc.

Modems		
Manufacturer	Model #	Price
Novation	CAT	\$159.00
Novation	d-CAT	\$170.00
Novation	Auto-Cat	\$229.00
DC Hayes	Smart Modem	\$215.00
DC Hayes	Micro Modem II (Apple)	\$320.00
DC Hayes	Micro Modem 100	\$320.00
Signalman	Mark I	\$89.00
UDS	UDS 103 LP (300 Bd)	\$185.00
UDS	UDS 202 LP (1200 Bd)	\$245.00
UDS	UDS 212 LP (1200 Bd)	\$495.00
UDS	UDS 212 ALP (1200 Bd)	\$650.00

Monitors		
Manufacturer	Model #	Price
Amdex	100/12" B&W	\$110.00
Amdex	300G/Green	\$165.00
Amdex	Color-1/13"	\$325.00
Sanyo	DM5109CX/9" Grn.	\$175.00
Sanyo	DM 5012/12" B&W	\$215.00
Sanyo	DM 5112ex/12" Grn.	\$225.00
Sanyo	DM C6013/13" Color	\$425.00
Zenith	ZVM-121/12" Grn.	\$115.00
BMC	BM-12EM 12" Grn.	\$145.00
NEC	JB1260 12" Grn.	\$129.00
NEC	JC1201C 13" Color	\$310.00

Terminals		
Manufacturer	Model #	Price
Televideo	TVI 910	\$625.00
Televideo	TVI 912C	\$725.00
Televideo	TVI 925	\$825.00
Televideo	TVI 950C	CALL

CABINET AND SUBSYSTEMS		
CAB5V	Single cabinet only (vertical mounting)	\$ 75.00
CAB5V/10	Single cabinet with 1 Qume DT-5	\$ 375.00
CAB8H	Dual cabinet for 8" (horizontal)	260.00
CAB8V	Cabinet for 8" (vertical)	275.00
CAB8V+1S	Dual cabinet with Shugart 801R (vertical)	\$ 705.00
CAB8H+1S	Dual cabinet with Shugart 801R (horizontal)	\$ 690.00
CAB8V+2S	Dual cabinet with two Shugart 801R (vertical)	\$1,080.00
CAB8H+2S	Dual cabinet with two Shugart 801R (horizontal)	\$1,065.00
CAB8V+1M	Dual cabinet with Mitsubishi 8" (vertical)	\$ 680.00
CAB8H+1M	Dual cabinet with Mitsubishi 8" (horizontal)	\$ 665.00
CAB8V+2M	Dual cabinet with two Mitsubishi 8" (vertical)	\$1,140.00
CAB8H+2M	Dual cabinet with two Mitsubishi 8" (horizontal)	\$1,125.00
CAB8V+1Q	Dual cabinet with Qume DT-8 (vertical)	\$ 750.00
CAB8H+1Q	Dual cabinet with Qume DT-8 (horizontal)	\$ 735.00
CAB8V+2Q	Dual cabinet with two Qume DT-8 (vertical)	\$1,235.00
CAB8H+2Q	Dual cabinet with two Qume DT-8 (horizontal)	\$1,220.00

CABINET DIMENSIONS:
Horizontal — 6 1/2"H x 17 1/2"W x 22"L
Vertical — 9 1/2"H x 11 1/2"W x 21"L

All cabinets come complete with power supply, fan and internal cables.

DISK DRIVES		
Qume DT-5	ANSI 5 1/4" compatibility	\$295.00
Qume DT-8	IBM compatibility	\$465.00
Shugart 801	Standard floppy	\$400.00
Shugart 850	Double-sided floppy	\$600.00
Mitsubishi M2894-63	8" double-sided, double-density	\$435.00
Mitsubishi M4853	5 1/4" 96 TPI, 1MB	\$450.00
Mitsubishi M4854	5 1/4" double-sided, 1.5MB	Call for price.

All drives include manual.

DISKETTES from ASAP

Verbatim 5 1/4" Diskettes			
Part #	Sector		Price
MD525-01	Soft		10/\$27.50
MD525-10	Hard 10		10/\$27.50
MD525-16	Hard 16		10/\$27.50

Memorex 5 1/4" Diskettes			
Part #	Sector		Price
MEM 3481	1/OBL Soft		10/\$27.50
MEM 3483	1/OBL Hard 10		10/\$27.50
MEM 3485	1/OBL Hard 16		10/\$27.50

Memorex 8" Diskettes			
Part #	Sector		Price
MEM 3060	1/Sgl Soft		10/\$35.00
MEM 3090	1/Obl Soft		10/\$40.00
MEM 3102	2/Obl Soft		10/\$45.00

Scotch 3M 5 1/4" Diskettes			
Part #	Side/Dens	Sector	Price
744-0	1/Sgl	Soft	10/\$30.00
744-10	1/Sgl	Hard 10	10/\$30.00
744-16	1/Sgl	Hard 16	10/\$30.00
745-0	2/Obl	Soft	10/\$43.00
745-10	2/Obl	Hard 10	10/\$43.00
745-16	2/Obl	Hard 16	10/\$43.00

Maxell 5 1/4" Diskettes			
Part #	Side/Dens	Sector	Price
MD1	1/Sgl	Soft	10/\$28.00
MD20	2/Obl	Soft	10/\$41.00
MH1	1/Sgl	Hard 16	10/\$35.00
MH20	2/Obl	Hard 16	10/\$48.00

8" Diskettes			
Part #	Side/Dens	Sector	Price
FD1-128	1/Sgl	Soft	10/\$39.00
FH1-32	1/Sgl	Soft 32	10/\$39.00
FD2-XD	2/Obl	Soft	10/\$48.00

Elephant Memory Systems 5 1/4" Diskettes			
Part #	Side/Dens	Sector	Price
EMS 1	1/Sgl	Soft	10/\$25.00
EMS 2	1/Obl	Soft	10/\$27.50
EMS 3	1/Obl	Hard 10	10/\$27.50
EMS 4	1/Obl	Hard 16	10/\$27.50
EMS 5	2/Obl	Soft	10/\$33.00
EMS 6	2/Obl	Hard 10	10/\$33.00
EMS 7	2/Obl	Hard 16	10/\$33.00

SRW Media Storage Cases			
Part #	Size		Price
SRW-5	5 1/4"		\$2.50 ea.
SRW-8	8"		\$3.25 ea.

Connectors			
Part #	Size		Price
DB25P	1-9	10-24	25 up
DB25S	\$2.00	\$1.90	\$1.75
DB25S	\$2.95	\$2.75	\$2.50
DB25C	\$0.95	\$0.85	\$0.75

California Compter System (S-100) Products			
Part #	Description		Price
Model 2065-01	64K Dynamic Ram Bd.		\$349.00
Model 2200-01	Mainframe		\$535.00
Model 2422-01	Floppy Disk Controller with CP/M		\$360.00
Model 2710-01	4-Port Serial I/O Bd.		\$295.00
Model 2720-01	4-Port Parallel I/O Bd.		\$235.00
Model 2719-01	2-Serial/2 Parallel I/O Bd.		\$325.00
Model 2810-01	Z80-CPU Board		\$280.00

(All Boards Assembled & Tested)

ALL PRICES SUBJECT TO CHANGE WITHOUT NOTICE. CALL FOR BEST PRICE.

Ordering information: name, address, phone: ship by: UPS or Mail. Shipping charge: add \$2.90 up to 1 lb. (UPS blue). U.S. Mail add \$1.50 (U.S. only) (\$25.00 minimum order).

Terms: We accept cash, check, money orders, Visa and Master Charge (U.S. funds only). Tax: 6% Calif. res., 6% L.A. County. COD's and terms available on approval (School PO's Accepted).

ATARI® COMPUTER GAMES

ATARI® 800™
(48K) Personal Business Computer Features:

- Computer console
- Atari® 8K basic
- 57 full stroke alpha-numeric keyboard with four function keys
- Operator's manual
- RF modulator
- Power supply

Call for price

Software		Price
Description		
Atari®		
Basketball		\$ 27.00
Super Breakout		\$ 27.00
Chess		\$ 27.00
Video Easel		\$ 26.00
Star Raiders		\$ 32.00
Asteroids		\$ 28.00
Music Composer		\$ 32.00
Assembler/Editor		\$ 45.00
Telelink		\$ 24.00
Space Invaders		\$ 33.00
Missile Command		\$ 28.00
Graph It		\$ 17.95
Touch Typing		\$ 19.95
Stock Charting		\$ 22.95
Stock Analysis		\$ 19.95
Bond Analysis		\$ 22.95
Word Processor		\$110.00
Microsoft BASIC		\$ 75.00
Pac-Man		\$ 33.00
Centipede		\$ 33.00
Caverns of Mars		\$ 29.00

Atari® Optional Accessories		
Model #	Description	Price
410	Program Recorder	\$ 77.00
810	Disk Drive System	\$450.00
822	40-Column Thermal Printer	\$299.00
825	80-Column Dot Matrix Printer	\$645.00
830	Acoustic Modem	\$159.00
850	Interface Module	\$165.00
CX30-D4	Paddle Controls	\$ 17.95
CX40-D4	Joysticks (pair)	\$ 17.95
A32KA	32K RAM Board	\$ 79.95

Printers		
Model #	Description	Price
Anadex 9501A		\$1,425.00
Citoh 8510AP	Prowriter (Parallel)	\$485.00
Citoh 8510ADC	Prowriter (Parallel & Serial)	\$665.00
Citoh F1040PU	Printmaster (Parallel)	CALL
Citoh F1040PU	Printmaster (Serial)	CALL
Citoh 1550	Prowriter II (Parallel)	\$740.00
Citoh 1550	Prowriter II (Parallel & Serial)	\$825.00
Diablo 630 RO		\$1,995.00
Epson MX80	w/Graftrak Plus*	CALL
Epson MX80FT	w/Graftrak Plus*	CALL
Epson MX100		CALL
OKIDATA 82A	(Parallel & Serial)	CALL
OKIDATA 83A	(Parallel & Serial)	CALL
OKIDATA 84AP	(Parallel Only)	CALL
OKIDATA 84AS	(Serial Only)	CALL

*Graftrak Plus Standard on all Models
Printer Interfaces
AEI-1 Parallel Interfaces \$50.00
EPI-1 2K Serial Buffer for Epson \$65.00
OKI-1 2K Serial Buffer for Okidata \$85.00

Printer Cables		
Model #	Description	Price
AEC-1	Parallel Cable to Apple	\$17.95
AEC-2	Parallel Cable to Atari*	\$19.95
RSC-1	RS232C Cable	\$19.95
TRSE-1	Parallel Cable to TRS-80	\$18.95

1198 E. Willow St. Signal Hill, CA 90806 (800) 421-7701 • (213) 595-6431 • (714) 891-2663
ASAP COMPUTER PRODUCTS LTD. 116 Viceroy Road, D-12 Concord, Ontario L4K1A9 Canada (416) 738-0500 (800) 268-1996
computer products, inc.

Pin Assignments

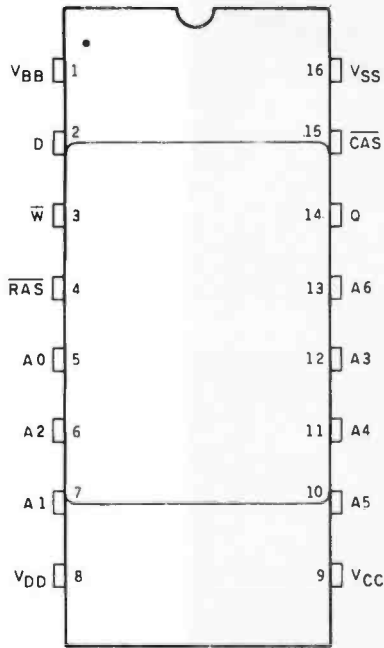

Capacitance	Parameter	Typ	Max	Unit
$C_i(A)$	Input capacitance, address inputs	4	5	pF
$C_i(D)$	Input capacitance, data input	4	5	pF
$C_i(RC)$	Input capacitance, strobe inputs	8	10	pF
$C_i(W)$	Input capacitance, write enable input	8	10	pF
C_o	Output capacitance	5	7	pF

Pin Nomenclature

A0-A6	Address Inputs	\bar{W}	Write Enable
\bar{CAS}	Column address strobe	V_{BB}	- 5-V power supply
D	Data input	V_{CC}	+ 5-V power supply
Q	Data output	V_{DD}	+ 12-V power supply
\bar{RAS}	Row address strobe	V_{SS}	ground

Typical Characteristics

Parameter	TMS 4116-25			Unit	Parameter	TMS 4116-25		
	Min	Max	Unit			Min	Max	Unit
$t_{c(P)}$	Page mode cycle time	275	ns	$t_{h(DWL)}$	Data hold time after \bar{W} low	75	ns	
$t_{c(rd)}$	Read cycle time	410	ns	$t_{h(rd)}$	Read command hold time	0	ns	
$t_{c(W)}$	Write cycle time	410	ns	$t_{h(WCL)}$	Write command hold time after \bar{CAS} low	75	ns	
$t_{c(RW)}$	Read, modify-write cycle time	515	ns	$t_{h(WRL)}$	Write command hold time after \bar{RAS} low	160	ns	
$t_w(CH)$	Pulse width, column address strobe high (precharge time)	100	ns	t_{CHRL}	Delay time, column address strobe high to row address strobe	-20	ns	
$t_w(CL)$	Pulse width, column address strobe low	165	10,000	ns	t_{CLRHL}	Delay time, column address strobe low to row address strobe high	165	ns
$t_w(RH)$	Pulse width, row address strobe high (precharge time)	150	ns	t_{CLWL}	Delay time, column address strobe low to \bar{W} low (read, modify-write cycle only)	125	ns	
$t_w(RL)$	Pulse width, row address strobe low	250	10,000	ns	t_{REF}	Refresh period	2	ms
$t_w(W)$	Write pulse width	75	ns	t_{RLCL}	Delay time, row address strobe low to column address strobe low (maximum value specified only to guarantee access time)	35	85	ns
t_T	Transition times (rise and fall) for \bar{RAS} and \bar{CAS}	3	50	ns	t_{RLWL}	Delay time, row address strobe low to \bar{W} low (read, modify-write cycle only)	200	ns
$t_{su}(AC)$	Column address setup time	-10	ns	t_{WLCL}	Delay time, \bar{W} low to column address strobe low (early write cycle)	-20	ns	
$t_{su}(AR)$	Row address setup time	0	ns	$t_{a(C)}$	Access time from column address strobe	165	ns	
$t_{su}(D)$	Data setup time	0	ns	$t_{a(R)}$	Access time from row address strobe	250	ns	
$t_{su}(rd)$	Read command setup time	0	ns	t_{PXZ}	Output disable time	0	60	ns
$t_{su}(WCH)$	Write command setup time before \bar{CAS} high	100	ns					
$t_{su}(WRH)$	Write command setup time before \bar{RAS} high	100	ns					
$t_h(ACL)$	Column address hold time after \bar{CAS} low	75	ns					
$t_h(AR)$	Row address hold time	35	ns					
$t_h(ARL)$	Column address hold time after \bar{RAS} low	160	ns					
$t_h(CRL)$	\bar{CAS} hold time after \bar{RAS} low	250	ns					
$t_h(DCL)$	Data hold time after \bar{CAS} low	75	ns					
$t_h(DRL)$	Data hold time after \bar{RAS} low	160	ns					

Figure 1: Data sheet for a typical 4116-type dynamic-memory device. The sheet shows pin assignments and gives its characteristics and timing information.

Now your computer can say anything and say it well. Introducing the Votrax Personal Speech System.

Quite articulate.

The unlimited vocabulary Votrax Personal Speech System is the most sophisticated, low cost voice synthesizer available today. Its highly articulate text-to-speech translator lets your computer properly pronounce conversational words at least 95% of the time.

For all those unusual words and proper names, you can define an exception word table and store your own translations. And remember, the entirely self-contained Votrax PS System gets your computer talking without using any valuable computer memory.

Built-in versatility.

Much more than just a voice output device, the Votrax PS System lets you mix either speech and sound effects or speech and music. A programmable master clock and 350 programmable frequencies give you unmatched control of speech and sound effects.

The Votrax PS System offers user expandable ROM for custom applications, user downloadable software and sound effects subroutines for easy user programming. Its programmable speech rate provides more natural rhythm, while 64 programmable amplitude levels give you greater control of word emphasis.

Actual size: 12.2" x 4.5" x 2.6"

Friendly to humans.

Designed to look like a printer to your computer, the Votrax PS System is extremely easy to use. It can be used in tandem with your printer without an additional interface card. Both serial and parallel ports come standard, allowing you to connect the Votrax PS System to virtually any computer. Speech, music and sound effects are only a PRINT statement away.

“Listen here”

What to say after “Hello”.

Businesses will appreciate spoken data transmission, narration of graphic displays and unmanned, oral product demonstrations. Spoken verification of data input will make computers much easier for the blind to use. School children can receive comprehensive

Votrax®

The Votrax Personal Speech System is covered by a limited warranty.

Write Votrax for a free copy.
500 Stephenson Highway, Troy, MI 48084

computer instruction with voice textbooks as well as spoken drills and testing. And then, late at night, you can make those adventure games explode.

A quick list.

- Highly articulate Votrax text-to-speech translator.
- 350 programmable frequencies for speech/sound effects.
- 64 amplitude levels.
- Simultaneous speech and sound effects or speech and music.
- 8 octave, 3 note music synthesis.
- Serial and parallel interface standard.
 - User programmable master clock.
 - User defined exception word table.
 - User programmable speech rate, amplitude and inflection.
 - User expandable ROM for custom applications.
 - User downloadable software.
 - 3,500 character input buffer: sub-divisible for a printer buffer.
- Internal speaker and external speaker jack.
- Real time clock and 8 user defined alarms.
- Oral power up and error prompting.
- X-on/X-off and RTS-CTS handshaking.
- Programmable Baud settings (75-9600).
- Interrupt driven Z-80 microprocessor.
- Parallel/Serial interconnect modes.
- Proper number string translation: the number “154” is pronounced “one hundred fifty four”.

To order, see your local computer retailer or call toll-free

1-800-521-1350

Michigan residents, please call (313) 588-0341. MasterCard, VISA or personal check accepted. The price is \$395 plus \$4 for delivery. Educational discount available. Add sales tax in Michigan and California.

© VOTRAX 1982

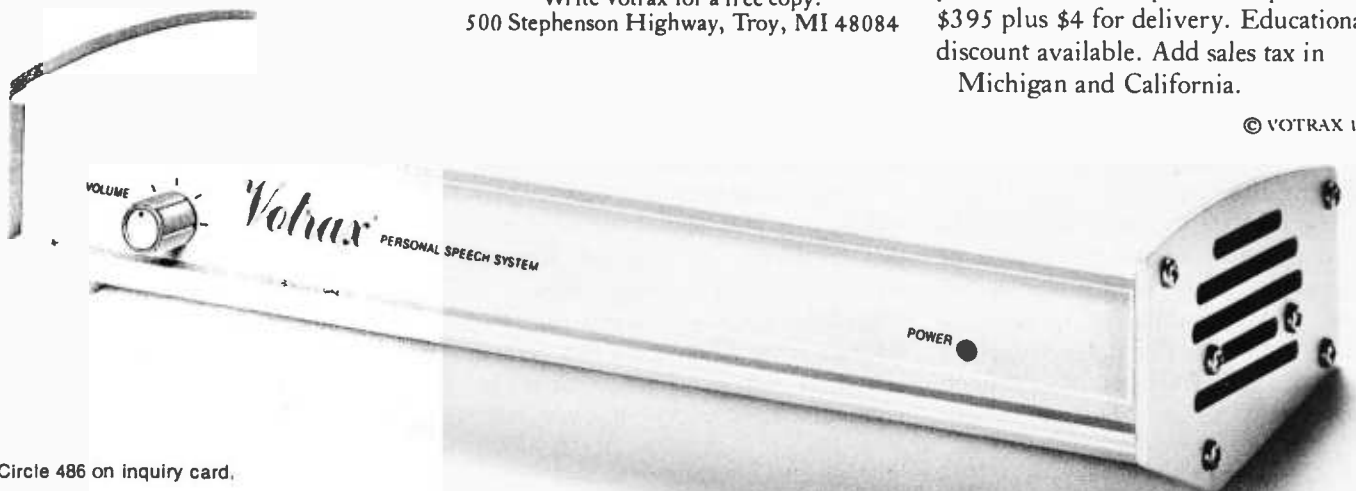

Circle 486 on inquiry card.

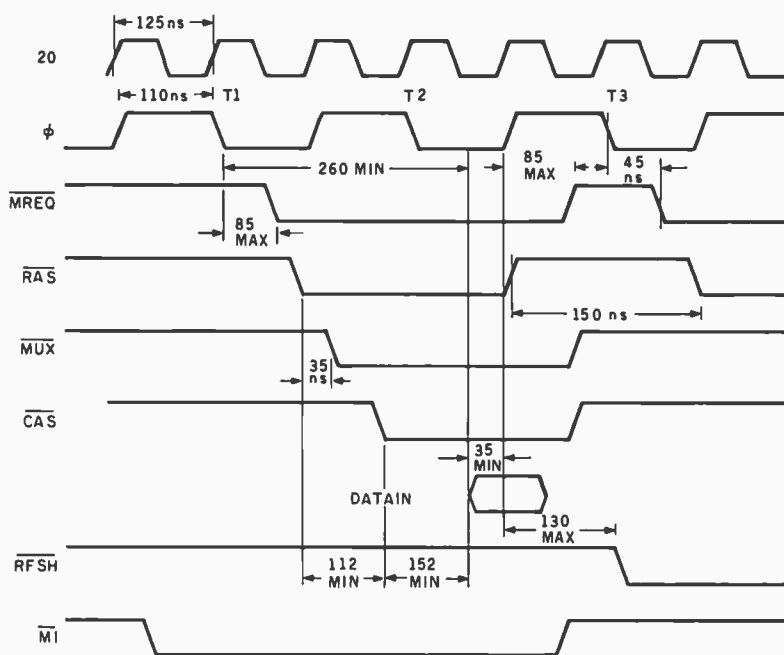

Figure 2: Timing relationships of important memory-control signals. This diagram shows the signals found in a 4-MHz Z80 system; each T-cycle is 250 ns long. Note the delays between RAS, MUX, and CAS, and also their relationship to the time period allowed for data.

name of the game.

When the storage capacitor of a dynamic bit cell is read, its voltage level is compared to a reference charge on a MOS (metal-oxide semiconductor) transistor. Because this charge is drained with each read, it must be replenished before the next operation. This means that RAS and CAS must be held high for a certain length of time to provide precharge.

Refresh is an entirely different headache. Each row of storage capacitors must be recharged to the proper level every 2 milliseconds (ms) because the charge leaks out. The dynamic memory is constructed so that a row of capacitors is refreshed every time it is addressed and RAS goes low. Obviously, every time we read or write to memory, we refresh the row that is accessed.

Getting Started

The first step in any design is to become aware of the limitations of the components used. The 4116s come in many different speeds: the access times usually range from 150 nanoseconds (ns) to 250 ns (although faster and slower versions exist).

Also, although most devices are rated by their access time, this does not tell the whole story. Most dynamic memories require a recovery period after each access. This is usually not a problem, but if it must be taken into consideration in your system, the extra interval is reflected in a memory device's cycle time. It's quite common to pick the slowest or least expensive 4116s available, and then design the rest of the system to the memories' specifications.

Most 8-bit microprocessors can be made to work with 250-ns devices. You'll find that Zilog's Z80 microprocessor is the easiest 8-bit microprocessor to interface to dynamic memory; its signaling is timed just right, and it has its own built-in refresh circuitry. Intel's 8085 has excellent support devices for use with dynamic memory, if you care to pay extra for them.

The Z80 makes refresh easy by providing a refresh signal for us, timed just perfectly. It has an internal refresh counter whose output is placed on the lower seven (or row) address lines while the Z80's refresh signal is active. This counter increments after every op-code fetch

until it has refreshed all 128 rows, then it starts over. This guarantees that all rows will be refreshed; what's more, the refresh occurs while the processor is busy with internal matters (op-code fetches) and is not using the buses. This is called "hidden refresh." (Be careful when using an extended wait state on a Z80, because this may not allow the processor to refresh memory properly.)

You need to decide first how fast your dynamic-memory system must respond. This is determined by the fastest read time that the memory must work with, combined with the delays introduced by other components in the data, address, and control paths. To calculate this read time, get out the data sheet on the microprocessor you're using and look for a signal that indicates the start of a memory access; this is an indication of when the address-bus signals are valid and stable. For Zilog's Z80, the signal to consider is MREQ; Intel's 8085 uses ALE, while the Motorola 6800 uses VMA. This "start" signal will eventually become our RAS.

Make note of the shortest period of time during an op-code fetch from the start signal to the time that valid data must be available (see figure 2). For example, on a Z80 running at 2.5 MHz, each clock cycle (T-cycle) is 400 ns long. MREQ goes low a maximum of 100 ns after clock cycle T1 falls, and data must be available to the Z80 at least 50 ns before the rise of T3. This means that the processor will allow at least 450 ns between providing an address and expecting valid data from the memory. This will not be the access time of the memory devices! Quite a number of delays will be experienced in getting RAS and addresses to the memory, and in getting the data back. In order to find out how much delay is involved, we must look at the circuitry necessary between the processor and the memory.

Developing the Control Signals

The 4116 requires a number of control signals to discover what is expected of it. Each memory device needs to know what portion of the address is being sent, whether the ad-

A LOT OF TERMINAL FOR \$495* OR LESS



Green display with non-glare ergonomic filter

Absolute and relative cursor addressing

Eight data rates from 110 to 19,200 baud

Sharp 7x9 dot matrix characters

50/60 HZ refresh automatic line lock

Lock/unlock keyboard

Clear to "End of Line" and "End of Screen" functions

Transparent mode displays received control codes

24 line x 80 character display

ADM-3A* Compatible

Compact, detached typewriter-style keyboard with 4-foot coiled cord

THE NABU 4503

Introducing the NABU 4503. A truly inexpensive terminal that's packed with more features than you'd expect for such a small price. Dozens of standard features give it a price/performance ratio that's really hard to beat.

The stylish NABU 4503 is

designed for operator comfort, and fits easily on a desk or counter. The compact, detached typewriter-style keyboard has a 4-foot coiled cord, and data is displayed on a 12" easy-on-the-eyes, non-glare green screen.

Check out the NABU 4503. It's the terminal that

gives you a lot of features, without costing you a lot of money.

*Quantity one price—\$495. 25+ price—\$410. Additional generous discounts are available for quantity buyers.

*Registered Trademark of Lear Siegler Inc.



**COMMERCIAL
TERMINALS**

(Formerly Volker-Craig)
Circle 335 on inquiry card.

New York
333 Metro Park,
Rochester, N.Y.
14623
Telephone
(716) 475-1221

California
Telephone
(213) 385-7239

Distributor Headquarters:

California
Allen Edwards Associates
(213) 328-9770

Florida
Amerisoft Business Sys.
(305) 442-8197

Illinois
Bexdata Ltd.
(312) 895-3010

Kentucky
Bolton & Westmeyer
(606) 331-9628

Massachusetts
Marketechs, Inc.
(617) 237-4343

Minnesota
Bexdata Ltd.,
(612) 835-5220
Molenaar, Inc.
(612) 235-3000

New York City
Pro-Comp Systems
(212) 246-0074

Upstate NY
Data-Term
(716) 381-7385

Ohio
Comtel Instruments
(216) 442-8080

Oregon
Data Devices
(503) 641-5500

Utah
Raytel, Inc.
(801) 295-3963

Virginia, Washington DC
Computerware, Inc.
(703) 821-8220

dress is meant for some other device, and whether data is to be stored or retrieved.

Most microprocessors present all 16 bits to the address bus at one time. We must multiplex the 14 least significant of these as two groups of 7 for use by the memory devices. (In a 64K-byte design, the 2 most significant address bits are used to select one of the four banks of memory devices; the other 14 address bits select the particular address on the individual devices.) The most common method is to use several 2-to-1-line multiplexers (74LS157 TTL devices that are the digital equivalent of a four-pole, double-throw switch).

By connecting the 7 least significant bits (the row address) to the "B" inputs of the multiplexer, and the 7 most significant bits (the column address) to the "A" inputs, the row address will be passed to the memory when the multiplexer's Select line is high; the column address will be passed to the memory when the Select line is low. It's easy to see how the

multiplexer's Select signal will be related to the $\overline{\text{RAS}}$ and $\overline{\text{CAS}}$ signals; we'll develop a special signal called $\overline{\text{MUX}}$ to control the multiplexers. (Intel has developed a device, the 3242, that is used solely for controlling dynamic memory. It includes a multiplexer and a refresh counter, which we'll discuss later, on one device; a similar device is also available from Intel. These devices, however, are the more expensive way to go.)

You already know that $\overline{\text{RAS}}$ is nothing more than the low-active start signal ($\overline{\text{MREQ}}$, $\overline{\text{VMA}}$, or $\overline{\text{ALE}}$, depending on the processor used). $\overline{\text{MUX}}$ and $\overline{\text{CAS}}$ are delayed versions of the same signal. The timing of these signals is very important; and it varies according to the speed of the memory devices used.

According to the 4116's data sheet, to read data from the memory we must have the row address on the memory's address pins before $\overline{\text{RAS}}$ goes low (this is specified as the value $t_{r,AR}$). After $\overline{\text{RAS}}$ is activated, the

row address must be stable for at least 35 ns ($t_{h,AR}$). Following this interval, the multiplexer's Select line can be switched so that the column address is available to the memory; another interval of at least 10 ns ($t_{u,AC}$) should be allowed before bringing $\overline{\text{CAS}}$ low. No more than 165 ns later ($t_{c,AC}$), data becomes available from the memory. In order to meet the 250-ns access-time requirement, the $\overline{\text{RAS}}$ -to- $\overline{\text{CAS}}$ time should be no more than 85 ns ($t_{r,CL}$). (One interesting point is that you can wait up to 10 microseconds before bringing $\overline{\text{CAS}}$ low [$t_{w,CL}$].)

Once $\overline{\text{CAS}}$ is low, the output data will remain on the 4116's Dout (data output) pin until $\overline{\text{CAS}}$ goes high. On some dynamic memories, Dout is actually latched, remaining available until $\overline{\text{CAS}}$ is clocked again; but it is safer to assume that Dout signals are not valid unless $\overline{\text{CAS}}$ is low. The 4116-type memories have three-state outputs, so that the output pins of several can be connected together. We will use this feature to simplify the wiring of the memory system: corresponding output bits in each of the four banks will drive their databus line through a single output buffer. Only one of the four banks will be active at one time, however.

You can direct the $\overline{\text{WRITE}}$ output of any of the microprocessors mentioned to the dynamic memory without altering the signal's timing. $\overline{\text{CAS}}$ and $\overline{\text{WRITE}}$ are related: $\overline{\text{WRITE}}$ is active only when $\overline{\text{CAS}}$ is low, and need be held low for only 75 ns after $\overline{\text{CAS}}$ goes low. Of course, data must be present for valid information to be stored.

Design

Knowing what we now know, we can select the most appropriate method for generating the control signals. The approaches open to us are:

- Delay lines. This is the easiest, most reliable, most flexible, and most expensive option. Delay lines come in DIPs and consist of nothing more than a tapped coil with capacitors in series with an input and output. Each output tap represents a delay of the

COMPUTER GEAR—WHOLESALE!

Purchase your Hardware and Software directly from an OEM/Systems Integrator. Take advantage of our buying power! We stock a full line of Board Level Components, Software, and Peripherals for all the Popular Machines in use today. These include S-100, GOBOOUT, MORROW, APPLE, IBM PC, TRS80, OSBORNE, HP, NORTHSTAR, SUPERBRAIN, NEC, Z/H-89, XEROX, and many others. Call for your needs. We'll give you the Lowest Prices, and the Technical Support and Know-How we are quickly becoming well-known for. Satisfied Customers Nationwide! The Nation's Custom Systems House for Business, Education, Science

SOME OF OUR CURRENT SPECIALS:

MICROSOFT MBASIC 80 \$199 • ASHTON-TATE dBASE II \$459 • SYSTEMS PLUS FMS81 \$299
MICROPRO: WORDSTAR \$259, SPELLSTAR \$159, MAILMERGE \$99, PACKAGE-ALL THREE \$489

COMPUPRO

2-80 CPU	\$219	INTERF 2	\$189
8085/88	\$319	INTERF 3	\$445
DISK 1	\$359	INTERF 4	\$299
DISK 2	\$599	ENCLOS 2	\$669
RAM 16	\$439	CP/M 2.2	\$149
RAM 17	\$399	CP/M 86	\$269
INTERF 1	\$189	MP/M 816	\$769
SYS 816A:	\$4495	B:	\$5675
		C:	\$7299

AMD SIN.BD.COMP.	\$675
VID-X2 VIDEO BD	\$319
SD SYS VDB-8024	\$459
IBM PC/2DR/MON	\$3749
SSM V82 VIDEO	\$199
PERTEC 5 1/4" DSDD	\$125
MORROW MULTI/O	\$279

MORROW DESIGNS

NEW MICRODECISION COMPLETE COMPUTER
(INCLUDES CP/M, WOROSTAR, MBASIC, DISK)
1 DRIVE \$945 2 DRIVES \$1219
DJDMA W/CP/M \$439 DJ20 W/CP/M \$349
65K RAM \$429 MULT I/O \$299
NEW 12" GREEN TERMINAL \$499
HARD DISK SUBSYSTEMS, DRIVES—CALL
DECISION 1 MICROCOMPUTER—CALL

SSM VB3A \$399 QUICKCODE \$219 QUICKSCREEN \$129 SUPERCALC \$225
TELEVIDEO TERMINAL SALE: 925 - \$749 SANYO 12" GR(HI RES) \$209 AMDEK 300G \$159
LIMITED SPECIAL: USI 12" AMBER MONITOR-20MHZ (SHARPER THAN SANYO) \$199

WE ARE THE LARGEST IN THE CUSTOM CONFIGURATION OF COMPLETE STATE-OF-THE-ART S-100 SYSTEMS, AT PACKAGE PRICING, WITH INTEGRATION, BURN-IN, & PROGRAMMING

New: CCT Disk Drive Subsystems. Industrial quality 5 1/4", 8", floppy and/or hard disk custom configurations. Strictly the highest quality. ONE 5 1/4" APPLE/IBM: \$299 DUAL 8" SSDD: \$999 DUAL 8" DSDD: \$1399
HD SUPER SPECIAL: 8" DUME/5MEG SHUGART: \$1450—W/DMA CONT&CP/M: \$1999

Announcing the CCT SUPER SUPPLY: +5V@ 8 to 30A; ±16V to 3A+; +24 V to 10A+; +12V@ 2A+; -5V@ 2A+
A well-engineered, compact supply plugable to handle virtually any Mainframe/Floppy/Hard disk combo. Call us

WE HAVE A LARGE STOCK OF IBM PC SOFTWARE. SPECIAL: MICROSOFT IBM PC 64K RAMCARD — \$399!
Micropro—Microsoft—dBase 11—Spellguard—Supercalc Call for any CP/M Software—We stock all formats, at big discount!

WOW!!! SPECIALS \$\$ GOOD THROUGH MONTH END. As supplies last. Rainchecks may be given if possible. Cash Sales Only!

CUSTOM COMPUTER TECHNOLOGY

1 CRAFTSMAN COURT, BOX 4160, SEDONA, ARIZONA, 86340 (602) 282-6299
PRICES & AVAILABILITY SUBJECT TO CHANGE. ALL PRODUCTS NEW, AND CARRY FULL MANUFACTURER'S WARRANTIES
CALL FOR CATALOG. FREE TECHNICAL HELP TO ANYONE. WE CAN CONFIGURE BOARDS & SOFTWARE FOR YOUR SYSTEM
PLUG-IN & GO. AZ RESIDENTS ADD APPLICABLE SALES TAX CP/M TM DIGITAL RESEARCH

TCS Heart of TEXAS COMPUTER SYSTEMS

LEADER in MAIL ORDER DISCOUNTS!

800 433-5184

Texas 817/274-5625

IBM Personal Computer

HARD DISK SYSTEM complete from \$1588
Multi-computer network systems available

INTERNAL DISK DRIVES
80 track (dual 40/320k) \$269

EXTERNAL DISK DRIVES
with matching cabinet & ext. drive cable
80 track (dual 40/320k) \$349
180 track (dual 80/640k) \$489

QUADBOARD 64k-128k-192k-256k
Memory, serial, parallel, clock & calendar
MONITORS
Green - hi resolution \$149
Color I - lo resolution (40 column) \$298
Color II - hi resolution RGB (80 col) \$899

SAVE OVER \$1300 on your IBM SYSTEM
by buying TCS ACCESSORY KIT for IBM
2 80 track 320k Internal Disk Drives
48k additional Memory
Quadboard
MX80FT Printer and Cable
Green hi resolution Monitor
TCS IBM Kit \$1749 complete

DAVONG HARD DISK DRIVES
5 megabyte \$1588
12 megabyte \$2095
10 megabyte \$1995

For IBM peripherals, circle 523

ATARI

ATARI 800 COMPUTER
ATARI 810 DISK DRIVES
Percom Double Density EXT. DRIVES
ATARI 850 Interface and Cable
Compatible PRINTERS and Cables

APPLE

First DISK DRIVE w/controller, DOS 3.3,
cables and manual \$419
Second DISK DRIVE with cable \$319
APPLE to EPSON card and cable
For Apple peripherals, circle 524

TANDON DRIVES

BARE DRIVES ONLY

40 track single sided \$199
80 track (dual sided 40) \$269
160 track (dual sided 80) \$389
5 1/4 inch THINLINE \$Call
8 inch THINLINE \$Call
Winchester Hard Drive \$Call

**WE WILL NOT
BE UNDERSOLD!**

For Tandon products, circle 525

1 DRIVE / Single Cabinet
40 track single sided \$249
80 track (dual sided 40 track) \$329
160 track (dual sided 80 track) \$449

1 DRIVE / Double Cabinet
40 track single sided \$289
80 track (dual sided 40 track) \$369
160 track (dual sided 80 track) \$499

2 DRIVES / Double Cabinet
40 track single sided \$489
80 track (dual sided 40 track) \$839
160 track (dual sided 80 track) \$849

Drives in cabinets come assembled/tested
with power supply. Order cable separately.

CORVUS HARD DISK

CORVUS HARD DISKS complete from \$2695

Add 5, 10 or 20 megabytes of storage to your TRW80, Apple, Atari, Heath, Zenith, IBM, Intertec, S-100 and many others. One or several computers can share a hard disk. Get simultaneous access to data for multiple users. Available now at SUPER SAVINGS.
For Corvus products, circle 526

PRINTERS

TCS has the LOWEST PRICES on IN STOCK PRINTERS!

MATRIX PRINTERS

STAR MICRONICS \$399
NEC 8023A \$495
C.I.TOH 8510 / TEC \$479
ANADEX 9501 w/2k buffer \$1295
LINE PRINTER V (RS) \$Call
LINE PRINTER VI (RS) \$988
LINE PRINTER VII (RS) \$649
CENTRONICS 352 (200 cps) \$1795
CENTRONICS 353 (dual mode) \$2495
OKIDATA 82A \$429
OKIDATA 82A w/tractor \$479
OKIDATA 83A \$685
OKIDATA 84A (serial) \$1169
OKIDATA 84A (parallel) \$1069

HI SPEED BAND PRINTERS

CENTRONICS 8080 (standard) \$CALL
CENTRONICS (quietized) \$CALL

LETTER QUALITY PRINTERS

C.I.TOH F-10 (40 cps) \$1595
DAISY WHEEL II (RS) \$1695
SMITH CORONA TP-1 \$699
BROTHER / COMREX \$629
NEC 7730 \$2375
NEC 3530 \$1785

EPSON PRINTERS

EPSON MX80 \$449
EPSON MX80 FT \$524
EPSON MX100 FT \$685
GRAPHTRAX PLUS comes free in Epson!!

EPSON ACCESSORIES

GRAPHTRAX PLUS (bit image) \$79
MODEL I interface \$29
MODEL I interface/cable to keyboard \$85
MODEL III cable \$29
COLOR Computer Interface/cable \$155
APPLE interface/cable \$89
ATARI cable (must have 850 int) \$38
IBM Personal Computer cable \$45
OSBORNE cable \$38
Serial RS232 2k buffered int.card \$109

EPSON PACK II

Screen oriented bit image graphics generator for the Model III. Create your own characters, symbols, etc. Documentation.
EPSON PACK II bought w/printer \$24.95
EPSON PACK II bought separately \$34.95
Update for EPSON PACK I \$7.50

TRS-80

TCS MODEL III 48k 2 DISK

Systems come with 180 day TCS limited warranty.



\$1695

With standard 40 track
double density drives.
Over 340,000 bytes.
Includes TDOS.

\$1995

With 2 dual headed 40
track dbl.density drives.
Over 730,000 bytes.
Includes TDOS.

For TRS-80 products,
circle 527

Fully assembled and tested systems that are software compatible and functionally identical to Radio Shack units sold at computer stores for \$undreds more.

- CONTROLLER BOARDS are high quality double sided epoxy boards with gold plated contacts.
- POWER SUPPLY is the finest switching type available.
- MOUNTING HARDWARE includes power and data cables.
- DISK DRIVES are Tandon, the same ones used by Radio Shack... 40 track, double density, with a 5 millisecond stepping rate.

TCS MODEL III DISK EXPANSION KITS

- | | |
|--|--------|
| 1 Controller, Power Supply, Mounting Hardware & Instructions | \$379 |
| 2 Controller, Power Supply, Hardware & one 40 track Tandon drive | \$577 |
| 3 Controller, Power Supply, Hardware, two 40 track Tandon drives, 32k memory (everything you need for 2 drive 48k upgrade) | \$799 |
| 3a Kit 3 but with two 80 track drives (dual sided 40s) | \$999 |
| 3b Kit 3 but with two 160 track drives (dual sided 80s) | \$1189 |

MODEL III SYSTEMS

Original 90 day manufacturer's warranty.
MODEL III 4k Level 1 \$599
MODEL III 16k \$818
MODEL III 32k \$998
MODEL III 48k \$968
MODEL III 48k 2Dr/RS232 \$1944
TCS MODEL III Systems use original RS hardware and quality TCS memory.
180 day limited warranty.

TCS MODEL III 16k \$799
TCS MODEL III 32k \$818
TCS MODEL III 48k \$848

COLOR COMPUTER

Original 90 day manufacturer's warranty.
16k Level 1 \$308
16k Extended Basic \$398
32k Extended Basic \$CALL
Color Disk 0 \$479 Disk 1 \$349

TCS COLOR COMPUTERS use original RS hardware & TCS memory.
180 day warranty.

TCS 32k Extended Basic \$499
TCS 32k Memory Upgrade \$79
TCS Color Disk Drive 0 \$449
TCS Color Disk Drive 1/2/3 \$249

Model II .. Model 16 .. Accessories .. \$CALL

TCS is an authorized TRS-80 dealer F701 in Bradv. Texas

WIZARD'S TOUCH Regularly \$199. Introductory Price til 12/31/82 Program Development System \$99

BELIEVE IT OR NOT, YOU CAN DEVELOP YOUR OWN PROGRAM IN 15 MINUTES!!!
The WIZARD'S TOUCH Program Development System is a superior program generator that can provide you with the program you've been looking for. It comes with it's own Disk Operating System, providing unlimited backups.

- With WIZARD'S TOUCH, here's what you can do:
- Custom design your own special form for maximum ease of entering your data. You have total control over defining the number of characters assigned to each field and any other entry restrictions.
 - Fully view and edit all fields at all times. No need to retype an entire field when editing. Just type over the mistakes, or insert or delete them.
 - Create a BTRIEE structured file, allowing you to access your stored data rapidly and without sorting. Duplicate keys are allowed, as well as sub-keys.
 - Enter data at full typing speed.
 - Define your own special self-help or prompt information that will be displayed for any given field, by just touching one key.
 - Expand your program to support up to 8 calculations for each data field. Results can be displayed in any field or in any defined display area. Results can also be saved to disk along with regular data fields. Data such as dates or prices can be formatted as desired.
 - Generate your own reports with the built-in pre-defined or custom defined report generator. Just a few keystrokes can get you a report that can be alphabetized or ordered by any field. And it's all automatic.

The WIZARD'S TOUCH is so fast and easy to use. It makes other development systems of the market look like amateurs. No royalty necessary for resale of programs you develop on WIZARD'S TOUCH. It creates a stand-alone, fully commented, BASIC program, which you can easily modify.
Your purchase includes a free subscription to our WIZARD'S TOUCH newsletter, a quarterly publication with free programs, ideas for applications, updates and more.
Now available for MODEL I/III Coming soon for MODEL II, IBM and APPLE.

TEXAS COMPUTER SYSTEMS

P.O. Box 1327 Arlington, Texas 76004-1327

TECHNICAL ASSISTANCE 817/274-9221

ORDER STATUS 817/277-1913

TELEX/TWX/Easylink ELN 62100790



800 433-5184

No tax out of state. Texans add 5%. Prices subject to change at any time.

input of from 2 ns to 25 ns. Because it's mainly a low-pass filter, the rise and fall times of signals sent through a delay line are terrible; often, delay lines are available with taps that have Schmitt-trigger circuits to "square up" the output signal. Of course, delay lines with this feature cost twice as much as those without it. Both types of delay line are hard to get in single quantity.

•**Gate delays.** It's possible to calculate the delay through TTL gates and use them just as you would use a delay line. For example, where we need a 20-ns delay, we might try using part of a 7408 quad AND gate. It has a maximum high-to-low delay of 19 ns, which would work; but there's the rub: the typical delay value is 12 ns, and the minimum delay value will be about 6 ns. If you use this gate as your delay, you could get anywhere from 6 ns to 19 ns, instead of 20 ns. Although you might be able to handpick a couple of these gates for the desired delay (if you are building one board for yourself), in most cases this wide variation in

delay cannot be tolerated.

•**Clocked systems.** This method gives the most accurate and repeatable results because it uses logic gates arranged to make use of the computer system's clock signals. Obviously, designing a clocked system requires some thought and additional hardware. Trying to come up with a general procedure for solving the problem by this method is not easy. Signals available on one microprocessor are often quite different from those on another. In general, however, the start signal is still developed into \overline{RAS} ; then, it may be fed to a flip-flop so that on the next edge of some clock \overline{MUX} appears. \overline{MUX} is then used as an input for another flip-flop to give \overline{CAS} . The length of time between clock edges must be considered carefully.

•**Combination.** A combination of clocked and gate-delay methods is also possible. An accurate \overline{RAS} , \overline{CAS} , or \overline{MUX} signal could mean we can be "sloppy" with the timing of the other signals. If we talk first about building a delay-line system, most of

what we learn can be used in designing the other systems.

In a Real System

You may never have had to consider this before, but it's critical now: any signal passing through any integrated circuit is delayed some number of nanoseconds before it reaches the output. The amount of delay through a device is listed in most TTL data books as a chart of the device's *switching characteristics*. To find the delay of a signal that is changing from low to high, look at the number listed as t_{pLH} ; for the delay of a high-to-low transition signal, look at t_{pHL} .

The delay times are given assuming that the device is driving a certain capacitive load, usually 15 picofarad (pF) or 50 pF. A standard TTL gate has about 5-pF input capacitance. Because the capacitance takes a small amount of time to charge or discharge (about 0.05 ns per picofarad), the more circuitry we have between the processor and the dynamic memory, the longer the delays are. One thing to remember is that inputs on complex integrated circuits (such as the Select signal on a 74LS157 quad 2-to-1-line multiplexer) often consist of more than one gate. In this case, you must add 1.5 pF for each additional on-chip connection. (The internal connection of these devices is shown on their data sheets.)

Externally, the devices must be connected to the rest of a computer in the fashion shown in the block diagram of figure 3. This shows where items such as address lines, drivers, and multiplexers must go, without getting too specific about the makeup of each one. The control signals are shown being generated by a block that we'll discuss later. Using this block diagram, we can make assumptions about the circuit we'll eventually build. This will allow us to figure out most of the delays involved and will also help us to come up with a final design.

Using TTL to control memory devices made with MOS technology causes an impedance mismatch. The outputs of most TTL devices are low impedance, and they are feeding the high impedance represented by the

HIS CONTRIBUTIONS WERE MADE POSSIBLE BY YOURS.

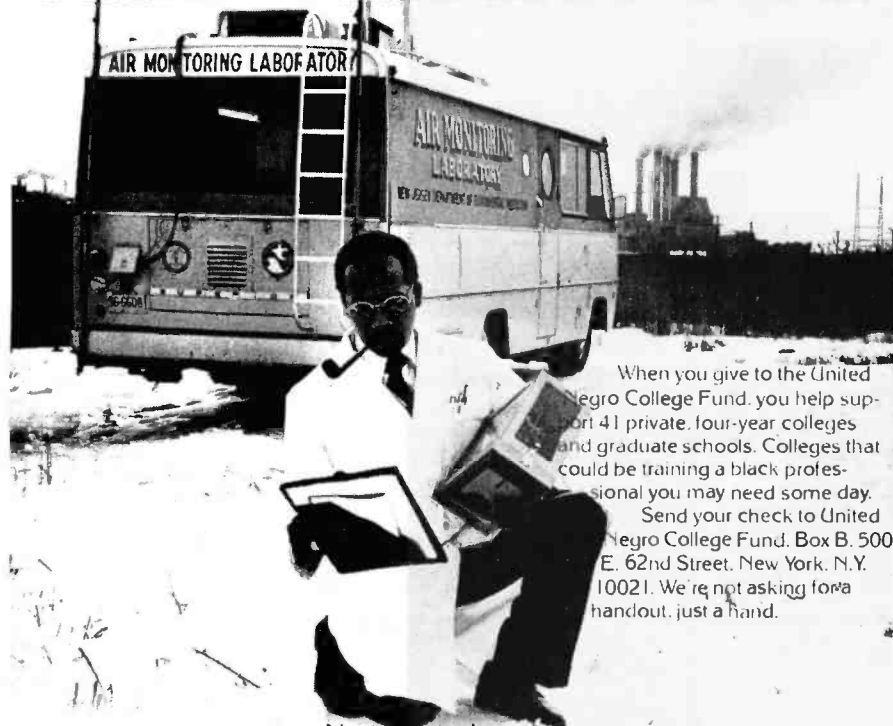

When you give to the United Negro College Fund, you help support 41 private, four-year colleges and graduate schools. Colleges that could be training a black professional you may need some day. Send your check to United Negro College Fund, Box B, 500 E. 62nd Street, New York, N.Y. 10021. We're not asking for a handout, just a hand.

No one can do it alone.

GIVE TO THE UNITED NEGRO COLLEGE FUND.

A mind is a terrible thing to waste.

A public service of this magazine and The Advertising Council.



THE ULTIMATE COMBINATION

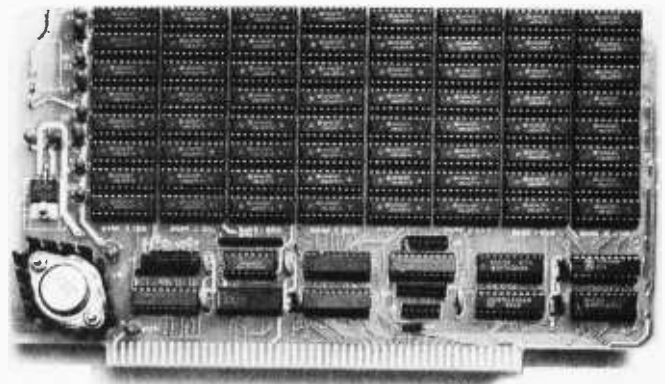
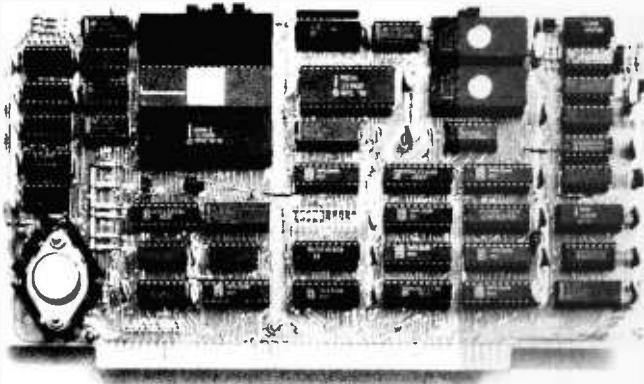

Lightning One* and RAM67

If you have an application problem you can't solve with an eight bit system, try our 16 bit combination. There is no faster combination currently available on the S100 bus and we have benchmarks to prove it.

The *Lightning One** is a state-of-the-art, 8086 S100 bus CPU board. The high speed 8087 floating point processor adds the numeric processing capability of large mini computers and the 8089 I/O processor adds I/O channel capability only found on large mainframes.

RAM67 is our high speed low power CMOS STATIC RAM board. 128K bytes of battery backupable memory are packed on one board. Speedy? Our RAM67 has over 100 ns margin when used with our 10 MHz *Lightning One* CPU Board.

Call or write for more information on The Ultimate Combination: *Lightning One* and RAM67. Lomas Data Products offers a full line of quality S100 bus products . . . systems, software and other "no-nonsense" boards.

LOMAS DATA PRODUCTS,
INC. □ 729 Farm Road, Marlboro,
Massachusetts 01752 □ TELEPHONE: (617) 481-2822

The logo for Lomas Data Products, consisting of the letters "LDP" in a bold, stylized, outlined font.

Dealer and OEM inquiries are invited.

*Trademark of Lomas Data Products, Inc.

memories' MOS inputs. The inputs to 4116-type memories use very little current—on the order of 10 microamperes. To the high current put out by the TTL, it's like running into a brick wall; the current bounces off the MOS device and is reflected back to the TTL driver. It will continue to bounce back and forth at a high frequency until it is dissipated by the resistance in the wire.

This "ringing" could cause the memory devices to falsely perceive triggering on $\overline{\text{RAS}}$ or $\overline{\text{CAS}}$, or make an address look low when it's high. Even worse, the reflected signal may actually make an input go negative, thus destroying the device! For this reason, we should install a series resistor in each of the lines leading to memory-device input pins; the resistors greatly reduce the amount of power reflected. A good starting point is 22 ohms. The actual value might best be chosen experimentally by looking at the signals on an oscilloscope. If your system is using only 16K bytes of 4116-type memory, you might get by without these resistors. With 32K bytes or more, however, the number of reflections increases.

Unfortunately, inserting the series resistor might cause other problems. MOS inputs represent pure capacitance. The added resistance slows down the charging rate of the capacitance, thus affecting the effective speed of the memory. To calculate the effect this has on the device's inherent delay, we need the time-constant formula

$$T = R \times C$$

from which we will derive the relationships

$$t_{p,LH} = 0.92RC \text{ and } t_{p,HL} = 1.6RC$$

In the second and third equations, R will equal the value of the series resistor plus the impedance of the line driver. The impedance of S-series (Schottky) TTL devices is 114 ohms (when you need speed, Schottky is the way to go); for LS-series (low-power Schottky), impedance is about 225 ohms. C equals the total capaci-

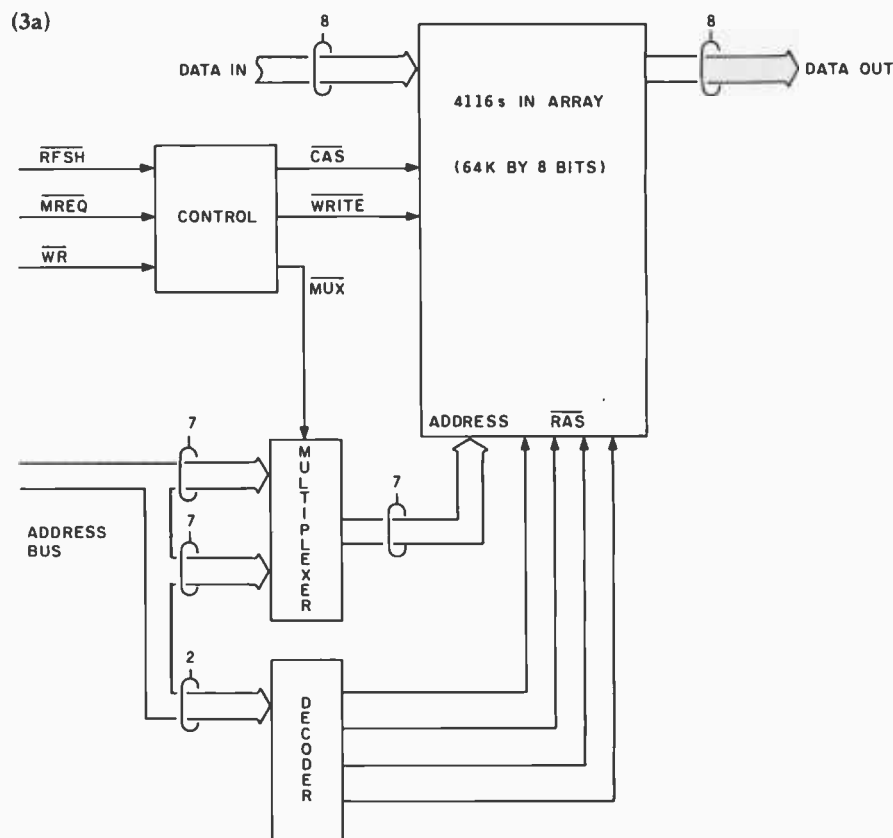

Figure 3: Memory-system diagrams. The block diagram of figure 3a shows generally how the address bus is multiplexed for use by the 4116s, and that the memory-control signals are developed from signals provided by the Z80 processor. In figure 3b, we see a specific diagram of the circuit to accomplish this.

tance on the line plus the capacitance of the circuit board itself.

Let's use the above equations to calculate the rise time of any signal on a bus line for one bank of eight devices—or 16K bytes of memory. Involved are 225 ohms of driver impedance, 22 ohms of series resistance, and 32 pF of capacitance (ignoring board capacitance). Therefore, 247 ohms times 32 pF times 0.92 equals 7.3 ns. The fall time of any signal will be 1.6 times 247 ohms times 32 pF, or 12.7 ns. Remember that address-line capacitance is 4 pF per device, while capacitance on the $\overline{\text{RAS}}$, $\overline{\text{CAS}}$, and $\overline{\text{WRITE}}$ lines will be about 8 pF per device (on these nondata lines, $t_{p,LH}$ equals 1.15RC). The typical input-capacitance value is used because the probability of having nothing but worst-case capacitance on the same line is very, very small.

Timing It Right

Let's explore timing relationships of the control signals by considering the

circuit in figure 3b, developed from the block diagram. How long does it take for an address originated by the microprocessor to reach the dynamic memory? First, we'll calculate the delay the address experiences in getting to the memory; we'll then proceed with the $\overline{\text{RAS}}$ and $\overline{\text{CAS}}$ signals. Several other things must be considered too, not the least of which is what specifications to pay attention to on the data sheet. Typical times are of little value to us because temperature and load changes will vary the delay time. Minimum times are as important as worst-case times, but they are not always specified in data books; however, you can consider them to be half the typical times. We'll use minimum times in a later part of the design.

Assuming that the data, address, and control lines are buffered by a 74LS244-type line driver or similar device, the maximum delay presented is 18 ns with a capacitive load of 45 pF. It's probably best to use the

(3b)

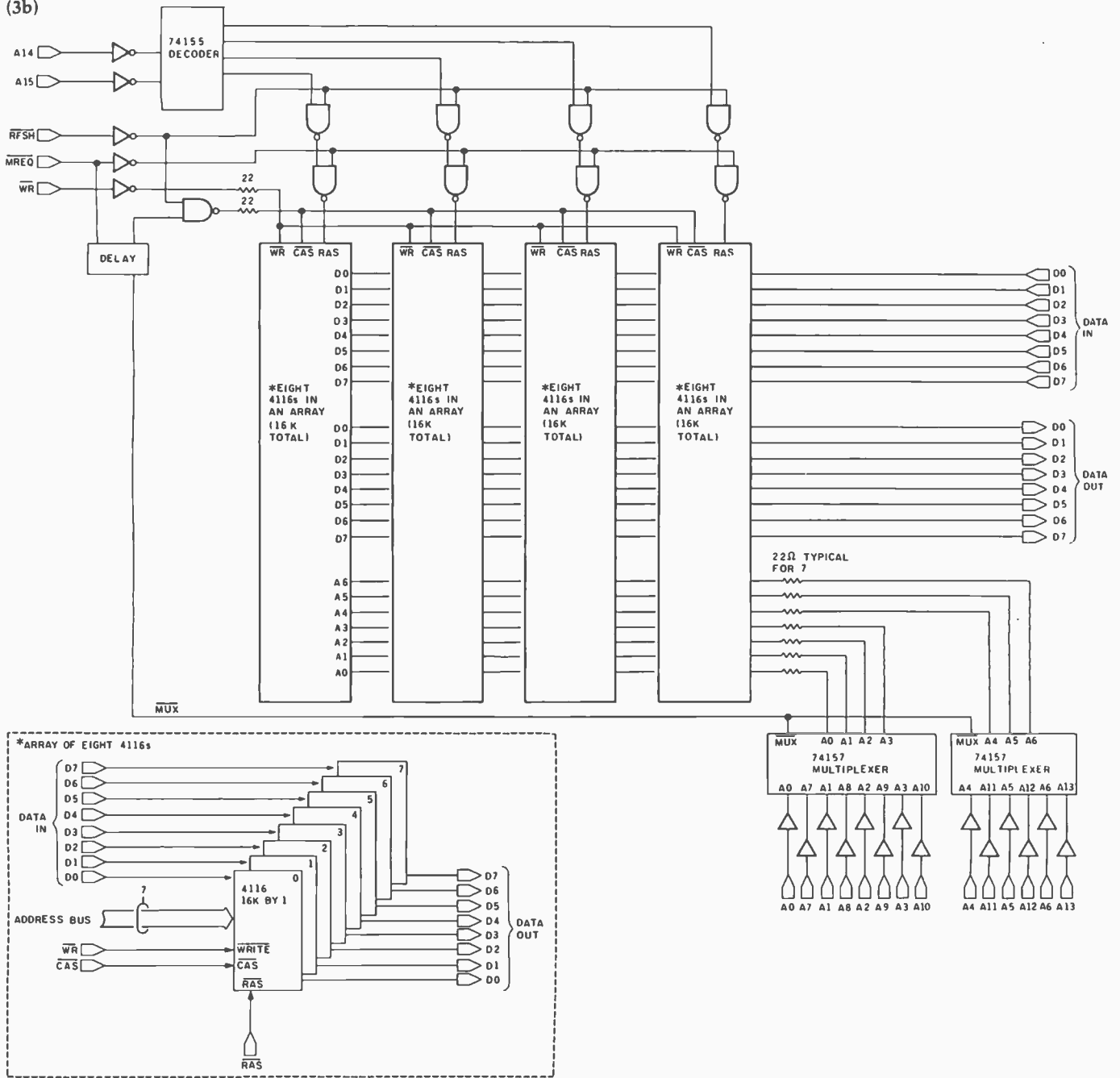

worst-case capacitance because you may later decide to expand the system, adding more gates and increasing the actual capacitance.

Address: The buffered address bus is connected directly to the address multiplexers described earlier. The worst maximum time from the multiplexer's input to its output is 14 ns (the minimum is 5 ns). These times are listed with a capacitive load of 15 pF (CL=15pF), while the input capacitance of a 4116 dynamic-mem-

ory address line is 5 pF. Because each address line feeds eight memory devices, the total capacitance is 40 pF. The delay time changes at the rate of 0.05 ns per picofarad. Therefore, to find the actual delay, we find the difference between 15 pF and 40 pF, multiply this result by 0.05, and discover an additional delay of 12.5 ns, for a total of 26.5 ns. The circuit-board traces (or wire-wrap wire) travel over long paths and can act as a transmission line with induc-

tance and capacitance. To account for this, you must add 1.5 pF per inch—or 2 ns a foot—measured from the driver to the farthest device.

Adding all the delays together (18 ns for the line driver, plus 14 ns for the multiplexer, plus 7.3 ns and 12.7 ns [the rise and fall times]) gives a total of 52 ns (worst case). This is a considerable delay for only eight devices; therefore, removing the series resistor is recommended. For larger systems, switching to

Schottky-type 74LS157 multiplexers will reduce the overall delay, as will using smaller resistors.

RAS: Specifications say that the address from a Z80 microprocessor is stable at least 120 ns before $\overline{\text{MREQ}}$. Since $\overline{\text{MREQ}}$ is our $\overline{\text{RAS}}$ signal, the address will reach the dynamic memory at least 68 ns (120 ns minus the 52-ns delay) before $\overline{\text{MREQ}}$ goes low. $\overline{\text{MREQ}}$ is delayed even more by the 74LS04 inverter and the $\overline{\text{OR}}$ gate shown in the diagram. Its total delay

is 68 ns initially, plus 15 ns for the inverter, plus 16 ns for the $\overline{\text{OR}}$ gate, plus 10 ns for the 192-pF load. Thus, $\overline{\text{RAS}}$ goes low 109 ns after the address. The address setup time required by the 4116s before $\overline{\text{RAS}}$ goes low is zero ($t_{su,AR}$), so no problem exists here.

CAS: After $\overline{\text{RAS}}$, the row address must be stable at least 35 ns ($t_{s,AR}$) before switching to the column address. We can use a delay line to switch the multiplexers by delaying

$\overline{\text{RAS}}$ for 40 ns. For a 48K-byte system, the maximum switch delay will be 8 ns for the device plus 5 ns for the load, or 13 ns. The address will be stable 53 ns after $\overline{\text{RAS}}$ goes low. It must be held 10 ns before $\overline{\text{CAS}}$ ($t_{s,AC}$); therefore, we can create $\overline{\text{CAS}}$ by using the tap on the delay line that delays $\overline{\text{RAS}}$ 60 ns. Because the load on $\overline{\text{CAS}}$ will also be 192 pF, the signal is actually delayed another 10 ns. This is 17 ns after the column address is stable. Data appears at the memories' output 165 ns later, delayed an additional 18 ns by a buffer. The Dout pin goes into high-impedance mode when $\overline{\text{CAS}}$ is high. Thus, output-line driving buffers may not be necessary. Dout by itself will drive two standard TTL loads.

We kept track of the minimum gate delays because if a device is operating at top speed, it may expect signals that are not yet available.

The Total: If you add up all the times from $\overline{\text{RAS}}$, you'll see that data is available in just under the 250-ns maximum time the manufacturer specifies for the memory device. If you include the delay interval from $\overline{\text{MREQ}}$ to $\overline{\text{RAS}}$, the time is under 300 ns. This leaves you plenty of leeway because the Z80 op-code fetch time, as we discovered earlier, is 450 ns (assuming a 2.5-MHz clock).

The reason that we kept track of the minimum gate delays is that, even though the circuit is faster than the maximum delays encountered, if a device is operating at top speed, it may expect signals that are not yet available. You must allow for this situation. If, for example, $\overline{\text{CAS}}$ shows up too soon, the column address may not have had a chance to stabilize. For this reason, you should also go through your circuit to make sure that it meets all the minimum setup and hold times. Again, you can hand-pick the integrated circuits to give you the timing that works in your system.

★ ★ ★ TECHNICAL SALES & SUPPORT STAFF ★ ★ ★

WE OFFER A WIDE RANGE OF CRTs, PRINTERS, GRAPHICS EQUIPMENT, SOFTWARE FOR ALL SYSTEMS. EACH SYSTEM COMPLETELY TESTED, INTEGRATED, READY FOR PLUG-IN OPERATION WHEN YOU RECEIVE IT. WE TAILOR & CONFIGURE SYSTEMS TO MEET YOUR BUDGET AND NEEDS. WE WELCOME YOUR REQUEST FOR TECHNICAL INFO BY PHONE OR LETTER.

COLUMBIA DATA IBM PC LOOK-ALIKE: More features, lower prices. Completely PC hardware & software compatible & interchangeable. Multi-user capability.

GODBOUT: 816A, B & C dual processor. 8085/88. Double sided drives. Up to 384K RAM. Turnkey systems with software.

CAD-GRAPHICS 16: Architects • Designers • Engineers • Create, store and edit drawings. Use arrays, zoom, windows. Completely interactive hardware/software package includes 9900 16 bit microcomputer, high resolution graphics display, digitizer, plotter. Does the work of a \$200,000 system for \$10,200. CP/M® optionally available.

IMS 2 yr. warranty on boards! SX systems w/8" or 5¼" drives, optional 10, 20, or 40 MB Winchester, built-in tape back-up, Z-80 S-100 bus. 5000 system with integrated screen now available. On site service for NY quad-state area.

MULTI-USER IMS: MPU/slave cards give each user CPU, 64K, 2 serial ports.

TURBODOS: Single or multi-user. Spectacularly FAST CP/M® compatible Operating System. Cuts link/edit time in half. Z80 Code interrupt driven. Up to 6X faster than CP/M®; up to 35% increased disk capacity. For IMS, CCS.

FOX & GELLER, the producers of QUICKCODE and D-UTIL, are enthusiastic users of IMS multi-user systems with TurboDOS supplied by John D. Owens Associates.

CROMEMCO: 68000/Z80 dual processor systems. Also, new Z-80 personal computer w/integrated screen, Model C-10.

EPSON QX-10/VALDOCS. Extremely user-friendly computer that can be used with little instruction. Has HELP key. Do Word Processing/Graphics/Calculation in 5 minutes! Read review in September BYTE, page 54.

MASTER MAX: Z80 single card computer, 4 slot, S-100, w/dual 8" drives \$2,540. See details in this issue of BYTE, page 503.

LOMAS DATA 8086 SYSTEM: Complete Lomas card set in 4 or 12 slot mainframe, dual drives, either single or double sided. Options: 8087 & 8089. CP/M® 86, 86-DOS, Winchester interface.

SEATTLE 8086 SYSTEMS Featuring 86-DOS, the IBM PC Operating System. SYSTEM I: 8 MHz CPU, 64K Static RAM System II: with 128K Static RAM.

MAX BOX DISK DRIVE SUBSYSTEM mfg by John D. Owens Assoc. Dual drive cabinet w/regulated power supply, fan, complete internal cabling. Ready to plug in. W/dual Shugart 801s/QUME DT-8s/Tandons/Mitsubishi.

S-100 BOARDS OR BOARD SETS: Godbout, Systems Group, SD Systems, SSM, Tarbell, Morrow, California Computer Systems and others. Discount prices.

Prices subject to change without notice Write or call for product listing

JOHN D. OWENS Associates, Inc.
12 Schubert Street, Staten Island, New York 10305
212 448-6283 212 448-2913 212 448-6298

Circuit Details

You need three voltages to run a dynamic memory: +5 V, +12 V, and -5 V. The +5 V is used only to power the data-output buffers on the memory devices; it can actually be removed by feeding it through a pass transistor and shutting it down when you are not performing a memory read.

Whether you wire-wrap or lay out a printed-circuit board, a good, heavy ground bus is recommended. Be generous with decoupling capacitors! For the +5-V supply, it is necessary to use only one 0.01-microfarad (μF) to 0.1- μF decoupling capacitor for every eight devices. The +12-V supply should be decoupled with a 0.1- μF capacitor at every second device (put a 0.1- μF decoupling capacitor for the -5-V supply on all the ICs in between). A tantalum 22- μF decoupling capacitor should be included for every 16 devices on the +12-V supply, and also where the -5-V supply comes onto the board.

Do not take decoupling lightly! Dynamic RAMs switch a lot of current around at radio frequencies. Therefore, noise is going to be a big problem. Ideally, the bus drivers should be in the center of the memory array if possible; this will keep the length of the leads as short as possible, minimizing the transmission-line effect.

Onward

What do you do if you don't have a Z80? Dynamic-memory interfacing is still possible using the methods just described, but some extra hardware and thinking are involved. Several semiconductor manufacturers are now coming out with dynamic-memory controllers. These devices provide many or all of the needed signals, and some can control up to 128K bytes of memory. Intel's 3242 can be used as the multiplexer and also contains a refresh counter; Intel has a device called the 8202 that also handles most of the necessities for dynamic memory. As you might expect, however, the cost is extremely high compared to what you can do on your own. If you want hidden refresh, you must find or create a

"hole" in your processor's bus accesses (the 6800 and 6502 microprocessors have no such holes).

Fortunately, the 8085 has a good instruction set and even leaves a hole in its op-code fetch just like the Z80: no external operation is being performed during the fourth clock cycle of a fetch. Using a counter, you could watch the status lines for a fetch and count the number of cycles until it's time to start refresh.

The best method for the 6800 and

6502 (it could also work for the 8085) is "burst-mode" refresh: refreshing all the rows one at a time in a short period. Usually, this is done with a counter or timer, such as a 555, that times out about every 1.47 ms, then puts the processor on hold. You then clock the refresh counter and the RAS signal until all 128 rows are recharged. This slows down your system throughput somewhat, but it's easier to do than trying to find a hole in the timing. ■

★ S-100, PERIPHERALS, DATA COMMUNICATIONS, ETC. ★

IBM 3270 USERS - Teletype Model 45
Cluster controllers, terminals, printers. Bisync or SNA/SDLC protocol, local or remote connect. Up to 32 devices on one cluster. Cost effective! Fast delivery!

TTY 40/2 USERS:
New 4420 cost-effective replacement available. Purchase or lease.

MICROANGELO GRAPHICS
SUBSYSTEM W/LIGHT PEN ... \$1,975.
Without light pen 1,615.
Graphics card MA 512 715.
Graphics card MA 520 985.
Color systems from 4 to 256 colors.
Basic color system (4 colors) 2,245.

MICRO-CAD: Interactive graphic software for Z80 C/PM®. For engineers, designers, architects. Create, store and edit drawings. Use arrays, zoom, windows.

HOUSTON INSTRUMENTS
PLOTTERS Standard & intelligent models
DMP-3 ... \$1,195. DMP-4 ... \$1,295.
DMP-6 ... \$1,685. DMP-7 ... \$1,865.
Hi Pad Digitizer \$755.

TELETYPE Model 4320 AAK ... \$1,140.
Model 43ASR, 8 level, 1" tape ... \$2,595.

PARADYNAMICS MAINFRAMES:
High quality S-100 IEEE 696 standard mainframes.

18 slot desk top \$720.
18 slot rack mount \$765.
8 slot with cutouts for 2 5¼" drives, desk top \$810.
As above, rack mount \$855.
220v/50Hz models, same price.

IDS PRINTERS
PRISM 132 color \$1,795.
PRISM 132 black \$1,395.
PRISM 80 color \$1,615.

SEMIDISK for S-100 systems. Allows high speed access to files normally stored on diskette.
512K \$1,795. 1MB \$2,695.

EPSON MX 80 \$515.
MX80 F/T ... \$555. MX 100 ... \$755.

HAYES MICRO MODEM 100 ... \$359.
Smartmodem. \$251. Chronograph. \$224.
PMMI S-100 Modem \$349.
Also NOVATION, RACAL VADIC and U.S. ROBOTICS modems.

PER SCI: Model 299B \$2,300.

★★★ IBM PC USERS ★★★

ADDITIONAL DISCOUNTS FOR GROUP PURCHASES

SEATTLE RAM PLUS w/FLASH DISK
64K RAM + SERIAL I/O \$380.
128K RAM + SERIAL I/O \$500.
192K RAM + SERIAL I/O \$620.
256K RAM + SERIAL I/O \$740.

COLUMBIA DATA BOARDS AND PERIPHERALS
Z80 soft card for CP/M® 80 \$475.
8" floppy disk controller \$228.
Many other boards.

MICROSOFT RAMdrive
64K \$420. 128K \$590.
192K \$760. 256K \$930.

COLORPLUS: Multi-color graphics adapter with parallel port \$949.

8080/8086 EMULATOR runs CP/M® on IBM PC. All I/O runs at operating system speed \$200.

AMDEK COLOR II MONITOR \$810.

PERSYST: Multifunction Board RAM + 2 Serial + 1 parallel \$492.

MICROBYTE IBM-1 Five slot expansion chassis \$805.

CORVUS Hard Disk Systems.
PRINCETON Color Monitor.

I-QUEUE Printer-Buffer.

AST Boards.

Many other IBM PC add-ons and software. Call for up-to-date listing.

WE EXPORT

Overseas Callers: TWX 710 588 2844
Phone 212 448-6298 or Cable: OWENSASSOC

JOHN D. OWENS Associates, Inc.
SEE OUR AD ON FACING PAGE

**TWO MILLION
PEOPLE COULD
USE YOUR
SOFTWARE.
TOO BAD
THEY'VE NEVER
HEARD OF YOU.**

At last count, more than a couple of million Americans owned personal computers. And that number is expected to triple by 1985.

That's a fertile environment for software sales. But a lot of personal computer software organizations are discovering it's not as easy as they might have thought.

The problems boil down to these:

Lack of awareness on the part of personal computer buyers. Lack of understanding on the part of personal computer salespeople. Lack of unlimited dollars to advertise in the myriad magazines that reach this small segment or that small segment of the total market.

If any of this sounds like a familiar frustration to you, we've got good news. *LIST* is here. And its advent heralds a new era in cost-effective software marketing.

LIST isn't another guide. It's not another directory. It's an informative new publication that puts software first. And puts you in touch—directly, inexpensively—with the fastest growing segments of

the personal computer market.

With *LIST*, you'll be able to reach business and professional people at a critical point in the purchase cycle—*before* they've bought their hardware.

At the same time, you'll be able to impact another significant market segment—those people who already own personal computers, and are eager to learn how they can do more with them.

To find out how *LIST* can expand the awareness of your software for less than \$200, send us this coupon. (Hurry! We go to press December 15.)

Or don't. And go on being less well known than you deserve to be.

LIST is published by Redgate Publishing Co., an affiliate of E F Hutton & Co.

1 800 327-1300

In Florida call: 1 305 231-6904

"I WANT TO MAKE MORE PEOPLE AWARE OF MY SOFTWARE."

Please send me literature that explains how *LIST* can help.

I don't want to wait on the mails. Call me right away.

Send to *LIST*, Redgate Publishing Co., 3407 Ocean Drive, Vero Beach, FL 32960. Or phone **1 800 327-1300**.
In Florida call: 1 305 231-6904

NAME _____ TITLE _____

COMPANY _____ TELEPHONE _____

ADDRESS _____

CITY _____ STATE _____ ZIP _____

LIST™

The Software Resource Book
For Personal Computer Users

BY 

Condor database obsoletes compilers!

Condor relational database management system makes your personal/business computer far simpler to use and much more useful to own... for less money... than other software.



Plain English, no computerese.

Condor relational database management is a complete development and operation system. It eliminates BASIC, PL/1, COBOL, FORTRAN, or other compilers in almost every case. It allows you to deal directly with your information without complex code words. In plain English, it lets you manage your business instead of your data.

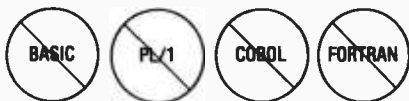

Save 90%. Because no complex programming is needed, Condor saves up to 90% of the cost of program writing and testing! You also eliminate costly and time-consuming programmer "talent searches."

State-of-the-art relational format.

Condor makes traditional programming approaches using compilers *obsolete*. Features such as SORT, DEFINE, ENTER, POST AND REORG permit rapid database creation, access, control, monitoring and manipulation. For instance (by using the JOIN command), you can combine the information contained in two large file cabinets—such as "Purchases" and "Labor Cost"—

into a single file—in one operation. To do the same task, ordinary software usually requires substantial reprogramming.

Easiest to learn and use.

Independent evaluators rate Condor *more "user-friendly" than any other personal/business computer database system*. After a brief study of the manual, you start building a database *within 15 or 20 minutes*.

In fact, Condor has allowed many hundreds of first-time users to produce and process their own management reports.

Only \$295 for entry level.

Condor's multi-level modular design provides full upward compatibility, up to the most powerful software of its kind in the industry. The entry level Condor I features database file development and management; entry, update,

and posting; inquiry and report writing capabilities; and complete operations aids. And as information needs grow, you can easily upgrade to Condor III for writing highly complex reports and fast-query indexing.



Guaranteed to do more work, more easily for greater savings.

Put Condor to the test. Experience its power and versatility firsthand...how it puts you in direct touch with your data, while eliminating complex programming. You must agree that Condor saves you time, work and money...or return it within 30 days for a complete and prompt refund (at participating dealers only).

Questions? See Condor at your local software dealer, write to P.O. Box 8318, Ann Arbor, MI 48107, or call **(313) 769-3988**.

Condor

COMPUTER CORPORATION

P.O. Box 8318, Ann Arbor, MI 48107

The Industry Standard...Selected by Major Dealers, Distributors and Manufacturers.

Book Reviews

8080/Z80 Assembly Language: Techniques for Improved Programming

Alan R. Miller
John Wiley & Sons Inc.
New York, 1981
318 pages, softcover
\$9.95

Reviewed by
Philip E. Bond
27 Sharon Dr.
Spring Valley, NY 10977

If you've ever been faced with customizing the BIOS on your CP/M system, you've participated in what I'd call a "learning experience." And if you want that experience to be successful, a good reference text is crucial. When I started tinkering with the BIOS, Alan Miller's *8080/Z80 Assembly Language* became my guide to assembly-language programming and its relationship to CP/M.

While the author only briefly discusses the fundamentals of assembly language and input and output transfers, he does provide several clear examples of each element of hardware and software. Miller makes specific references to typical 8080/Z80 microprocessors as well as to CP/M. He explains the development

of a CP/M-compatible system monitor in great detail. Beginning with the most basic functions, he shows how to write and debug a useful monitor that uses fewer than 1K bytes and will fit into common PROMs. By the time you finish this section of the book, you should be able to make a custom monitor if the standard one doesn't suit you.

The information in chapter 10 alone is worth the purchase price of the book. Under the heading "Linking Programs to the CP/M Operating System," Miller discusses key elements for customizing the BIOS and explains how to implement IOBYTE. In addition, he provides one routine that gives you access to any memory location and another to list ASCII disk files with date and time.

In keeping with its purpose as a reference text, the book's ten appendixes include the ASCII character set, 8080 and Z80 instructions and a cross-reference, and an explanatory list of abbreviations and acronyms.

8080/Z80 Assembly Language fills in information other reference materials—including Digital's—leave out. The author states that the subject of his book is not the use of CP/M, but anyone thinking of implementing CP/M would do well to look here for methods and answers. ■

BYTE's Bugs

Address Correction

The address given for Aparat, the supplier of NEWDOS/80 Version 2.0 as presented in our review (BYTE June 1982, page 376) is

incorrect. The correct address is Aparat Inc., 4401 South Tamarac Parkway, Denver, CO 80237. ■

NEW from Matco Data Products 64K x 8 bit Static Memory Board for use with RAM or EPROM or any mixture of the two!

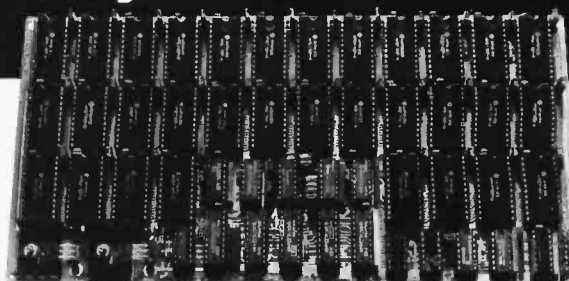

64K Board is only \$475!

Matco Data Products has been supplying California Silicon Valley with superior technology for many years. Our 64K Memory Board is a product we've had many requests for. It is now on the open market.

The 64K Memory Board is a 64K by 8 bit static memory board which may be used with RAM, EPROM, or any mixture of the two. It has been designed to provide the greatest possible flexibility and performance in an S-100 environment, while allowing for growth as the technology continues to change. The primary features are:

- Compatible with Proposed IEEE 696 standard
- Total RAM/EPROM interchange capability (R/W jumpered)
- Extended Address capability (A16-A23)
- Global Addressing possible in 16K groups
- Two Extended pages may be on one card
- Global/Extended allocations are 16K per group
- 0-8 wait states for EPROM with fast CPU's
- Wait states selectable on/off by 16K group
- Responds to PHANTOM* on pin 67 (jumper selected)
- PHANTOM* bottom 48K and/or top 16K
- MWRT generated on-board, or taken from bus
- Automatic deselect of empty sockets via FF detector
- On-board data bus is pulled up for best performance
- Fully socketed, solder mask, and component screen

Contact Matco for delivery details and quantity prices. It's a whole new board in Static Memory Technology.

All boards are assembled, tested, burnt in and supplied with 150 nsec CMOS RAMS plus a 1 year limited warranty, and owner's manual.

PRICES:

64K	\$475.00
48K (Partially loaded)	410.00
32K (Partially loaded)	328.00
A&T Board (Less RAM)	200.00

Distributed by:

MATCO

Manufacturing and Test Company, Inc.

427 Perrymont, San Jose, CA 95125
(408) 998-1655

The Lobo Max-80

Tim Daneliuk
T&R Communications Associates
4927 North Rockwell St.
Chicago, IL 60625

Lobo Drives International has a recipe for a successful microcomputer system: Take a "vanilla" 64K-byte Z80-based CP/M system, add every popular disk interface, throw in a parallel printer port and a couple of serial ports, provide TRS-80 emulation through the powerful LDOS operating system, call the machine the Max-80, then offer to sell the entire package for about \$1000.

I got a prototype of the Max-80, which gave me a chance to use it as a CP/M system and experiment with some of its many features. I was not able to use the TRS-80 emulation, however, because some of the software was still being developed. Still, after spending many hours with this microcomputer system, I am impressed!

Primary Features

The Max-80 is housed in a compact keyboard unit (see photo 1) with a metal baseplate and a Norell plastic top. The concave keyboard has a comfortable feel, 75 keys, and enough space below the keys to rest your palms. A numeric keypad, arrow keys, and individual Control and Escape keys round out the keyboard package. The keyboard can generate the full ASCII (American Standard Code for Information Interchange) character set.

About the Author

Tim Daneliuk is an electrical engineer involved in research and product development for the medical electronics industry. T&R Communications Associates is a company he founded to provide technical writing and consulting services for the electronics industry.

At a Glance

Product

Lobo Max-80

Manufacturer

Lobo Drives International
354 South Fairview
Goleta, CA 93117
(805) 683-1576

Price

Max-80 with CP/M, \$820
high-resolution green-screen monitor, \$175
LDOS option, \$69 with system purchase; \$129 separately
second bank of 64K memory, \$95. All prices include shipping.

Features

5¼- and 8-inch floppy-disk interface, hard-disk interface, two serial ports, TRS-80-type bus, parallel printer port, and 64K memory. Runs with a 5-MHz Z80 processor and comes with battery-backed real-time clock.

Audience

General hobby and business users

Lobo has a reputation for building excellent quality hardware. The Max-80 is clear evidence of that reputation, as well as indicative of the firm's experience in interfacing peripherals. On the back panel, you will find all of the interface card edges and DB-25 connectors for the RS-232C port. The Max-80 is equipped with a DIP (dual-inline package) switch that lets you select which drive is used to boot the system. Standard interfaces for 5¼- and 8-inch floppy-disk drives are provided as well as a SASI



Photo 1: The Max-80 from Lobo Drives International is a 64K-byte computer system offering both CP/M and LDOS. It costs about \$1000.

(Shugart Associates Standard Interface) for a hard disk. Both single- and double-density and single- and double-sided disk operations are supported. In addition, you are provided with two RS-232C ports, a parallel Centronics-compatible printer port, and a buffered TRS-80 Model I-type expansion bus.

The heart of the Max-80 is a 5-MHz Z80 processor. This extra bit of clock speed, as opposed to the usual 4 MHz, ensures reliable data transfer when using fast double-density 8-inch floppy disks and hard-disk systems. If you have been using the TRS-80, the increased speed is clearly evident. The video scrolling on the Max-80 is so rapid that one of the four function keys comes preprogrammed to slow the scroll rate so as to make the display readable. A real-time clock with a battery backup is built into this computer (the battery backup is a long overdue standard feature for microcomputers). You can remove the primary power from the Max-80 for more than 50 days and the clock/calendar will remain accurate.

The I/O (input/output) sections of this machine are similar to the memory-mapped I/O of the TRS-80 Model I. Under software control, the 4K-byte I/O space moves into high memory for CP/M and into low memory for LDOS. This permits the Max-80 to offer both 56K-byte CP/M operation and true TRSDOS (TRS-80) compatibility. Taken together, these two operating systems provide the majority of current 8-bit software. This compatibility may make the Max-80 the best supported 8-bit machine.

This microcomputer outputs a standard composite-video signal, and the display is designed to be used with either CP/M or LDOS. Under CP/M, the display format is 24 lines by 80 columns, while under LDOS it is 16 lines by 64 columns. For each operating system, a low-resolution mode is available, making the display 24 lines by 40 columns with CP/M and 16 lines by 32 columns with LDOS. The video circuitry is synchronized to the clock, and the video twinkling that plagued the TRS-80 is noticeably absent. Each video character is programmable, so you can display a variety of fonts and sizes. Lobo also provides an 18-MHz, high-resolution green-phosphor monochromatic monitor for use with the Max-80. The monitor's dot resolution and clarity are excellent, and a low-reflection nylon-mesh screen cover reduces the glare from ambient light. Because the video display is a separate unit, you can position it for the most comfortable viewing.

Inside the Max-80, you will find two main printed-circuit boards constructed of double-sided fiberglass with plated-through holes. The bottom board is mounted on the metal base and contains the majority of the processor and interface electronics. The top board is mounted on the Norell cover and connects the keyboard, the printer interface, and the hard-disk interface to the rest of the system. The easily accessible electronics should please the hardware enthusiast. Each main piece of electronics can be removed without having to desolder anything.

Perhaps one of the nicest aspects of the Max-80 hardware is that everything is contained in one compact unit. The typical cable tangle is greatly reduced because you simply connect the power, the video display, and the disk-storage system to the back panel of the machine.

Selling Points

Its ability to run both the CP/M and LDOS operating systems gives the Max-80 a degree of software portability that, when combined with its low cost, makes it an excellent system for the novice, the hobbyist, and the small-business user.

Lobo intends to market the Max-80 directly rather than through a dealer network, and the system's low cost is a result of this decision. Having experienced both local dealer support and Lobo's mail-order marketing, I believe that consumers will benefit the most from this approach. The support people at Lobo are knowledgeable, experienced, and consistently more helpful than the dealers I have encountered. The only negative aspect of Lobo's marketing approach is the inevitable delay between ordering and receiving. However, the cost savings are your compensation for the wait.

In my opinion, the Max-80 will be a big seller for Lobo. Although most of the microcomputing press touts the new 16-bit machines, the vast majority of applications software resides in the 8-bit world. Rather than introduce a product based on the newest technology, Lobo gives us a functional, cost-effective product developed from a combination of mature hardware and software. ■

Multidos

A New TRS-80 Disk Operating System

Rowland Archer
Flint Ridge Apartment 59
Hillsborough, NC 27278

Something about the Radio Shack TRS-80 microcomputer seems to inspire people to write disk operating systems for it. A DOS, of course, is a collection of programs responsible for managing other programs and data stored on floppy disks. And judging by the ads I've seen, there seem to be more DOSes for the TRS-80 Models I and III than for any other microcomputer.

Multidos, from Cosmopolitan Electronics Corporation, is the latest candidate to vie for a share of the TRS-80 Model I/III DOS market. It was written by Vernon Hester, the author of an earlier TRS-80 DOS called Ultrados, and is a good value for its price.

Product Overview

Multidos is actually a package of several useful programs, but the most outstanding component of this package is the DOS itself.

The name Multidos refers to the ability of the system to read, write, and copy both single- and double-density disks created by other popular TRS-80 DOSes, a list of which is shown in table 1. It certainly is an impressive programming feat, but the fact that it is needed at all is a sad commentary on the incompatibility of these systems.

I tested the ability of Multidos to read and write disks created by all the Model I/III operating systems listed in table 1 except for DOSPLUS, which I do not own. In all instances it performed as claimed. Unfortunately, the reverse is not necessarily true; other operating systems are not always able to access a Multidos disk.

Also, there is some danger in the careless use of Multidos's ability to read and write disks created by "foreign" disk operating systems. This happens because it is impossible to predict what other DOS authors will do

in the future. The fact that Multidos can read and write disks created by the current version of XYZ DOS is no guarantee that it will be able to handle disks created by the next version. This is not a fault of Multidos; it is just that the new version of a disk operating system may store data differently than the previous version did.

As an illustration of this, my copy of Multidos crashed while attempting to read the directory of a TRSDOS 2.3B disk. (TRSDOS 2.3B is a new version of TRSDOS that Radio Shack is distributing only with its Compiler BASIC, COBOL, and Series I editor/assembler packages.) I asked Hester about this problem, but he indicated that he had not heard of TRSDOS 2.3B.

The bottom line is that you should never use Multidos to read or write a disk created by a DOS that is not specifically mentioned in the Multidos manual as compatible.

For TRS-80 Model I users, a special hardware attachment is still needed in order to use double-density disks. This hardware is usually in the form of an add-on board for the expansion interface unit. Such products are available from:

- Aerocomp (POB 24829, Dallas, TX 75224)
- LNW Research (2630 Walnut, Tustin, CA 92680)
- Percom Data (11220 Pagemill Rd., Dallas, TX 75243)

All these modifications are compatible with Multidos.

[Editor's Note: Recently, Radio Shack released its own version of a Model I double-density add-on board. Vernon Hester informs us that the current version of Multidos has been modified so that it will be compatible with this new enhancement. . . .R. M.]

DBLDOS from Percom Data Company
 DOSPLUS from Micro Systems Software
 (single- and double-density, Model I and III)
 LDOS from Logical Systems Inc.
 (single- and double-density, Model I and III)
 NEWDOS 2.1 from Apparat
 NEWDOS/80 Version 1.0 from Apparat
 (single- and as patched for double-density;
 maximum 2-granule directory)
 NEWDOS/80 Version 2.0 from Apparat
 (read and write single-density, read only double-density)
 TRSDOS from Radio Shack
 (Model I only)
 Ultrados from Level IV Products
 VTOS from Virtual Technology
 (single- and as patched for double-density)

Table 1: Multidos can read, write, and copy disks created by any of these TRS-80 disk operating systems.

Multidos also includes two versions of Disk BASIC (one has some very powerful debugging features—the best I've ever seen), a disk-based editor/assembler for creating assembly-language programs, and several utility programs. Table 2 lists the files that come on a Multidos disk.

Features

Although Cosmopolitan Electronics is stressing the "multi-DOS" read/write ability in its advertising, the system has many other noteworthy capabilities. Table 3 lists some features of Multidos that are not found in TRSDOS 2.3. My favorites include:

- Automatic recognition of disk density (single or double), type, and track count. For example, to copy a file from a double-density LDOS disk in drive 1 to a Multidos disk in drive 0, just load the disks and execute the COPY command—you don't have to indicate in any way that the disk in drive 1 is an LDOS or double-density disk.
- By pressing the : and ; keys simultaneously, you enter the "Mighty Multi" command processor. Mighty Multi lets you view disk directories and kill, list, and copy files. When you are through, you can return to the program that you were previously running with nothing changed. Mighty Multi can be accessed from most programs, as long as they use the standard keyboard routines and leave all the interrupts enabled. Unfortunately, this does not include Radio Shack's Scripsit word processor, which uses its own keyboard driver.
- By typing HELP followed by the name of a Multidos command, you get a brief message telling how to use that command. There is usually enough information to jog your memory—assuming you have read the manual.

Multiple DOS commands can be entered on a single line, and the last DOS command can be repeated by pressing ENTER.

File	Size (grans)	Description
BACKUP/CMD	3	Disk-backup utility
BASIC/CMD	4	SUPERBASIC
BBASIC/CMD	5	SUPERBASIC plus BOSS
COPY/CMD	1	File-copy utility
CREP/SYS	1	BASIC cross-reference utility
DIR/SYS	2	Disk directory
DOS/SYS	3	Multidos kernel
DOS0/SYS through DOS7/SYS	12	Multidos overlays
EA/CMD	7	Disk-based Z80 editor/assembler
EDIT/SYS	1	BASIC program global editor
ERROR/SYS	1	Error messages
FORMAT/CMD	3	Disk formatter
GR/CMD	1	Graphics keyboard driver
HELP/CMD	4	Help command processor
RENUM/SYS	1	BASIC program-renumber utility
RS/CMD	1	RAM Scan memory-search utility
SKIP/CMD	1	Read 40-track disk from 80-track drive
SPOOL/CMD	1	Line-printer spooler utility
VFU/CMD	2	File copy, purge utility

Table 2: A list of the files contained on the Multidos disk. The size of each file is measured in grans, where one gran equals five 256-byte sectors or 1280 bytes. Total size is 54 grans or 69K bytes.

The FORMAT command can format a disk in either single-, double-, or Percom-density. Percom-density, of course, is used by Percom Data's DBLDOS. Although Multidos can create and access disks in any of these formats, the BACKUP command cannot back up a disk in one density to a disk in a different density. However, you can use the Versatile File Utility (VFU, which will be described later) to copy all the files from any density disk to any other density disk, as long as a Multidos disk is in drive 0.

Because of this restriction on the BACKUP command, you cannot create a new Multidos system disk at a different density than the one you bought. You could copy all the files using VFU, but the new disk would not work as a system disk. Multidos expects system files to be in particular places, and VFU doesn't copy the files into these exact places. Cosmopolitan Electronics handles this by letting you purchase additional copies of Multidos, in the density of your choice, for \$15 each.

The Editor/Assembler

Radio Shack's original tape-based editor/assembler program for writing assembly-language programs was modified for disk by Apparat. It has now been modified once more by Hester and is included with Multidos. Most of the commands added by Hester, however, are redundant to features available under the Mighty Multi DOS feature described earlier. One new feature, however, allows you to run the editor/assembler after an accidental exit and to recover whatever was in the text buffer.

Command	Description	Command	Description
JKL	Simultaneous pressing of J, K, and L keys causes contents of screen to be sent to printer. The Break key will terminate JKL. Graphics characters are converted to periods.	DIR	Displays disk directory in alphabetical order. Options to send directory to printer and to list killed files.
HJK	Like JKL, but also sends graphics characters to printer.	DO	Reads a disk file and executes the commands in it as if they were typed at the keyboard.
: ;	Pressing : and ; simultaneously enters Mighty Multi command mode.	FORMS	Sets number of columns per line and number of lines per page for printout.
AUTO	Allows specification of one or more commands to be executed when a disk is booted. TRSDOS allows only one.	FREE	Shows total free space on all disks, as well as individual statistics.
BOOT	Reboots the computer as if the Reset button had been pressed.	HASH	Gives the hash code of a file name. See text for description.
BREAK	Enables or disables the Break key.	KEYBRD	Sets attributes of keyboard: lowercase, blinking cursor, automatically repeating keys, graphics codes, and cursor character. Enables or disables the Clear key.
BUILD	Creates a file of commands to be executed by DO (below).	LINK	Everything sent to the screen is sent to the printer as well, or vice versa.
CLEAR	Sets all bytes in nonprotected RAM from hexadecimal address 5200 to TOPMEM to 0. TOPMEM is the address pointed at by the contents of hexadecimal address 4049.	LOAD	Allows loading files as low as hexadecimal address 5200.
CONFIG	Sets the default disk-drive parameters to be used when the system is booted. Parameters are single- or double-density and track-to-track head-stepping rate. Multidos automatically distinguishes single- and double-density disks, no matter what the setting of CONFIG is.	ROUTE	Sends everything to the screen instead of the printer, or vice versa.
DEAD	Reboots the computer as if power had been turned on.	SKIP	Allows a 40-track disk to be read on an 80-track drive.
		TOPMEM	Sets or displays protected memory pointer.

Table 3: Some significant features of Multidos that are not found in TRSDOS 2.3.

Note that the only parts of the editor/assembler that are mentioned in the documentation are the enhancements that Hester made. The manual states that you will need to purchase Radio Shack's original Model I tape-based editor/assembler to obtain the complete documentation. Unfortunately, this program is becoming increasingly difficult to find, as it has been replaced with Radio Shack's new Series 1 editor/assembler.

By the way, the Multidos manual inadvertently left out the commands to load and save assembler source code using the editor/assembler. I contacted Hester and he supplied them as follows:

```
L D=filespec    Load source file from disk
L T=filespec    Load source file from tape
W D=filespec    Write source file to disk
W T=filespec    Write source file to tape
```

Utilities

The Versatile File Utility lets you copy and purge disk files. First, a menu of files is displayed, containing the disk's directory in alphabetical order. You then move a cursor around, marking files to be copied or deleted. When you have finished, the specified action is performed on all the marked files. VFU's menu orientation makes it easy to use, and it is a good user interface.

VFU lets you execute any machine-language or BASIC program on the disk from the disk-directory display. It will also send a copy of the disk directory to your printer in a format that fits neatly inside (or onto) the disk jacket.

Another utility included with Multidos is called RAM Scan. It allows you to search any portion of RAM (random-access read/write memory) for a byte or word of your choice. What makes RAM Scan unique is that you can tell it to search for the specific Z80 machine-language instructions that reference the word of your choice.

GR is a graphics keyboard driver that lets you enter all the standard TRS-80 graphics characters directly from the keyboard.

A SPOOL utility lets you set aside any amount of memory to be used as a buffer for output to the printer. Hester, by the way, claims that SPOOL stands for "simultaneous peripheral operation on-line." By using the SPOOL command, your relatively fast computer doesn't have to wait for your relatively slow printer. Anything that would normally go to the printer, via an LPRINT or LLIST command from BASIC, will be put into the memory buffer that you set aside with the SPOOL command. SPOOL will "feed" your printer with characters from this buffer at a steady rate while your computer does other work at the same time.

At a Glance

Name
Multidos

Type
Radio Shack TRS-80 Model I and III disk operating system with enhanced Disk BASIC and an editor/assembler

Author
Vernon B. Hester

Distributor
Cosmopolitan Electronics Corporation
POB 234
Plymouth, MI 48170
(313) 397-3126

Price
One 5-inch floppy disk and manual: \$79.95 (plus \$2.50 postage and handling)

Software
Includes disk operating system, Disk BASIC, editor/assembler, and several utilities

Software Format
Available in single-, double-, and Percom-density for Model I, double-density only for Model III

Computer
TRS-80 Model I or III, 16K bytes of RAM (32K for some functions), one to four disk drives; double-density on Model I requires additional hardware

Documentation
66 pages, offset printed in a 3-ring binder; table of contents, but no index; adequate for technically oriented users, but difficult for beginners

Audience
Programmers in need of a disk operating system that can read, write, and copy files from disks created by popular TRS-80 DOSes; also, programmers in need of a superior BASIC program-development environment

Unfortunately, the SPOOL command will not work with a serial printer. It sends its output directly to the parallel printer port instead of calling the standard ROM (read-only memory) routine that is used to access alternate printer drivers.

Disk BASIC

Multidos comes with two versions of Disk BASIC. The production BASIC is called SUPERBASIC and includes all the features of Radio Shack's Disk BASIC plus many extensions. Table 4 lists some of these new features not included in TRS-80 Disk BASIC.

The second version is called BBASIC; it consists of SUPERBASIC plus BOSS, a very nice program-development and debugging tool. BOSS, which is also written by Hester, has been offered for some time as a separate product. Table 5 lists BBASIC's single-stepping and tracing commands. They are by far the most comprehensive and powerful I have seen. I suggest looking over tables 4 and 5 carefully; the features of SUPERBASIC and BBASIC could by themselves justify most of the cost of this package.

I have developed a substantial amount of code under SUPERBASIC and have found the following features very useful:

- A command, P_n , that prints a page of BASIC text on the screen starting at line number n . If P is again typed, the next page after this page is printed.

Command	Description
BASIC !	Enters SUPERBASIC and leaves intact a BASIC program loaded under an alien operating system.
BASIC #	Enters SUPERBASIC and leaves intact a program loaded under Level II BASIC. Level II must have been entered by typing CMD "X."
, (comma)	Edits the current line.
/	Lists the "BREAK in" line.
Shift 1	Lists first,
1	previous,
. (period)	current,
	next, and
Shift	last program lines.
P	Lists a page of BASIC text from current or specified line.
D	Deletes current line.
R	Runs BASIC program.
C	Continues execution of program.
CMD "C"	Deletes unnecessary spaces and linefeeds from BASIC program.
CMD "K"	Zeros out all elements of an array.
CMD "L"	Deletes an array and frees up memory.
CMD "M"	Moves a BASIC program line.
CMD "N"	Duplicates a BASIC program line.
CMD "O"	Allocates a new disk file buffer, in addition to the number specified when BASIC was entered. Defined functions, READ strings, and strings assigned directly in the program, e.g., $A\$ = "XYZ"$, are not retained.
CMD "Q"	Fast sort of a string array.
CMD "V"	Lists all active scalar variables.
CMD "X"	Transfer to Level II BASIC, leaving program in memory intact.
CMD DOS command	Goes to DOS, executes DOS command, then returns to BASIC.
F string	Finds all occurrences of string in a BASIC program.
- (hyphen)	Invokes global editor (see text).
; target	Program cross-reference; target may be a variable, line number, or constant. ";" with no target lists next line containing last target.
: A,B,C,D	Renumbers BASIC program. New first line number is A, increment is B. Starts renumbering at existing line C, ends at existing line D.
NAME file	Chaining function. Loads and runs BASIC program file, keeping current variables intact, except as noted under CMD "O."

Table 4: Some significant features of Multidos SUPERBASIC that are not found in Radio Shack BASIC.

- A fast program-line renumbering command. One drawback is that it cannot move a block of lines.
- A fast program cross-reference command that finds all references to a line number, constant, program variable, or BASIC keyword, and lists them on the screen or the printer.
- Commands to move or duplicate a program line. References to the moved line are not renumbered.

Command	Description
@1	Turns off all trace functions.
@2	Starts writing BASIC line numbers as they are executed in upper right-hand corner of screen. Always displays last four numbers executed.
@3	Sends line-number trace to printer.
@4	Turns off single-step functions.
@5	Single-steps to end of current BASIC line and waits.
@6	Single-steps one BASIC instruction and waits.
@7	Single-steps one BASIC instruction, pauses for specified time, and continues.
@N	Specifies program variables for review by @O command. Nested expressions are allowed, e.g., X(Y,Z).
@O	Shows current values of program variables entered under @N command.

Table 5: A summary of commands in Multidos BOSS BASIC (BBASIC) for tracing BASIC programs, executing programs by single steps, and examining variables at different points during execution. Using POKE commands, you can set breakpoints anywhere in a BASIC program to invoke the @1-@7 commands.

- A FIND command that searches a program for any string of characters—even REM statements are searched.
- A global program editor that lets you split and merge adjacent program lines, selectively change variable names and BASIC keywords, and build packed graphics strings automatically. For example, you could change all occurrences of the variable X to Y, all occurrences of PRINT to LPRINT, etc.

The global program editor is very useful, but it is dif-

ficult to remember the format of the commands. The editor prompts you with a terse "T = " (T stands for Target). You must respond with, for example, "-" to split a line, "/" to merge lines, and so on. I found it necessary to have the manual very close at hand while using the global editor.

A feature that I have not seen anywhere else allows you to go back and forth between Disk BASIC and Level II BASIC without dumping your program to cassette. This is great for testing programs developed under Disk BASIC to see if they will run under Level II.

Another good feature is the fact that SUPERBASIC leaves you with 40,036 bytes of free memory in a 48K-byte machine, more than any other Disk BASIC I have seen. This is especially impressive considering the fact that SUPERBASIC is so feature-packed.

Performance

One of the claims made for Multidos is that it has the fastest COPY and BACKUP commands of any TRS-80 DOS. In practice, these commands do seem quite responsive and at least as fast as those of any other DOS I have used.

While running the BACKUP command, however, I was concerned because the usual "Verifying track . . ." message does not appear as tracks are copied from one disk to another. Was Multidos getting some of its speed by skipping the verification step of disk backup?

Hester confirmed that Multidos does indeed skip this step. He stated that it is an unnecessary step because the disk surface is checked when it is formatted. He said that once the disk is spinning at the correct speed, writing to properly formatted tracks should be error-free. To be sure that the correct speed is attained, Multidos always waits a full second after turning the disk drive motor on before it starts to write.

Hester also said that BACKUP commands in other

Communications Software!

Transfer Files Between Micros & Communicate Over Phone With Large Computers

LYNC is THE choice of professionals for communications between computers. They choose LYNC because of its many powerful features, its ease of use, and it works on many different computers. They use LYNC to transfer program or data files between computers, and to take advantage of the services offered by the Source and other large data-base systems.

LYNC's unique closed-loop error detection and correction protocol gives professionals the assurance that their data is getting across without being lost or garbled because of noisy phone lines.

Computer communications is the wave of the future, and if you are ready for the future, LYNC is here NOW!

E/LYNC: \$45 Special Promotional Offer Ends 2/1/83!

An inexpensive opportunity for you to experience and benefit from computer communications! Send and receive ANY type of files between your computer and another computer using the exclusive LYNC closed-loop protocol. Terminal Emulation mode lets you connect with large database systems or remote bulletin boards. E/LYNC can be upgraded to LYNC for \$80.

LYNC: \$125 Additional Features for Frequent Users!

View local and remote disk directories, re-log local and remote disk drives, fetch files from an operator-less remote computer running LYNC or E/LYNC. Use wildcard filenames or multiple file names when sending or fetching files. Terminal Mode allows sending data files to a remote timeshare system or storing received data to a disk file. (TRS-80 Mod I & III version with most features, \$75)

LICENSING: E/LYNC and LYNC are licensed on a per user basis. If you intend to use either to communicate with another person's computer, they must also purchase E/LYNC or LYNC. Versions for CP/M and TRS-80 are written in Z-80 assembly language. Versions for IBM PC are written in IBM 8088 assembly language and require PC DOS.

DISK FORMATS: 8" Standard, IBM PC, Vector Graphic, Osborne, Cromenco, North Star, SuperBrain, Xerox 820 (8" 5"), NLS KayPro, TRS-80 Mod II with CP/M, and TRS-80 Mod I & III.

TERMS: Money Order, Check, C.O.D., MC or VISA. First Class shipping included. UPS Blue add \$3, C.O.D. add \$5, CA res. add 6%. Overseas Airmail add \$6. Manual Only, \$10 (specify computer).

PHONE ORDERS & TECHNICAL HOT LINE: (805) 966-3077 10am - 4 pm PST Monday - Friday

INTERNATIONAL SOFTWARE ALLIANCE

1835 Mission Ridge Road Santa Barbara, CA 93103

LYNC & E/LYNC are trademarks of Midnight Software CP/M is a trademark of Digital Research

TRS-80 DOSes do not perform a true byte-for-byte comparison of what was read from one disk and what was written to the other; instead, they do only a test for checksum errors. A checksum is a single byte computed by adding all the bytes written to a disk sector. It is written to the disk with the data, and can be compared to the checksum computed when the sector is read back. If the checksums do not match, what is on the disk does not match what is supposed to be written there.

I have never had a problem with disks backed up by Multidos, although most such errors would probably go undetected for a long time anyway. However, I must admit to an uneasy feeling when using the BACKUP command without the verification step. Why would disk controller manufacturers bother to include checksum computation in their hardware if writing to disk was so error-free?

Documentation

The Multidos manual is basically adequate, but it gets sketchy in places. For example, the description of a HASH command contains no discussion of what a hash code is or why you would want to compute one. In case you are wondering, a file's hash code is computed from the characters in its file name, and it is used to speed up the directory search when a file is opened. You would need to compute a hash code only if you were using a disk editor to examine or modify a directory.

In most cases, though, the manual gives you enough information to use the commands if you're willing to do some occasional experimentation. If you have experience with other TRS-80 DOSes, you will find the most frequently used commands familiar enough. But if this is your first DOS and you are not an experienced programmer, you may have some difficulty. The manual uses technical terms quite freely; it reads like it was written by a programmer, not a writer.

A nice touch is the use of different colored paper for the major sections of the manual, an aid in locating the documentation for particular commands. A not-so-nice feature is that although the manual comes in a 3-ring binder, the rings are too small to allow the pages to be easily turned.

Problems

While evaluating Multidos, I ran across several problems that I will now describe. Problems like these, of course, are not uncommon in newly released software products.

I occasionally get a "Drive Not Available" error when I access a disk drive that is in fact available. Hester thinks that this is due to my high-speed clock modification. This may be the case, but I have not noticed this behavior with any other DOS.

In SUPERBASIC, after editing a line that begins with a blank, the next command typed—no matter what it is—results in a "Syntax Error." Hester says that this is due to a ROM error, but this problem is not exhibited by other DOSes.

The TIME and DATE commands accept invalid input; e.g., you can set the time to be 99:99:99 with impunity.

As you can see, these are not major problems, merely annoyances. Fortunately, Hester appears to be interested in fixing the problems and supporting his operating system. He assured me that upgrades will be available at "reasonable prices."

Conclusions

Multidos provides a lot of value for the money. It gives you an opportunity to enjoy a full-featured DOS at a bargain price. Although some aspects of Multidos have the flavor of a "basement enterprise" production, such as occasional misspellings in system messages, the system as a whole seems to stand up well under heavy use.

For those who already own two or more TRS-80 DOSes, Multidos provides a bridge when moving files back and forth between disks created by these systems. Also, if you're planning to buy a disk-based editor/ assembler, you could buy Multidos for the same price and get much more. (But take note of my earlier comment about the editor/ assembler documentation.)

Finally, SUPERBASIC provides an excellent program-development environment. Global editing, cross-referencing, renumbering, single-stepping or variable speed execution with trace, breakpoint setting, and program variable review are great features that make programming in BASIC considerably more productive. ■

★ **INTRO SPECIAL** ★
BASIS 108 Computer
 w/choice of drives
 with controller Call
Micro Sci or Fourth
 w/64K or 128K completely
 assembled, tested and
 configured
 ★ **SPECIAL** ★ **MICROSOFT**
PREMIUM SYSTEM \$599
 ★ **DISKETTE SPECIALS** ★
 Maxell MD-1 (Box of 10) \$ 32
 Maxell 8" (Box of 10) \$ 41
MONITORS
 NEC Hi-Res 12" Green \$129
 NEC RGB 12" Color
 Sanyo Monitors Call
 Amdek Monitors Call
 Electrohome Call
 USI Amber \$169
 Televideo Terminals Call
COMMUNICATIONS
 Hayes Micromodem II \$275
 Hayes Smart Modem \$235
 Hayes Modem 1200 Call
 Microcom

COMMUNI CAL
 INC. TM
 1400 GRANT AVE. / NOVATO, CALIFORNIA 94947
IMMEDIATE DELIVERY
CALL COLLECT 415-892-7139

BUY COMPUTERS FROM PEOPLE WHO KNOW HOW TO USE THEM.
 SERVICES AVAILABLE: SOFTWARE APPLICATIONS • HARDWARE REQUIREMENTS
 COMPUTER SECURITY • TELECOMMUNICATIONS • BUSINESS • SCHOOLS
 CONSULTATION SERVICES.
 Ask about our clients. All equipment tested prior to shipment.
 If you don't see it, please ask us.

APPLE PERIPHERALS		System Saver Fan	\$ 77
Thunderclock	\$125	Saturn Systems	
Mountain Computer Prod.	Call	Axon Products	
Videx Products	for	Fourth Dimension	Call
Microsoft Products	Best	Micro Sci Drives	Call
Corvus Products	Prices	16-Bit Apple Card	Call
TG Joysticks/Paddles	Call	SVA Products	
ABT Keypads	\$ 99	Peachtree Software	

VISA **Master Charge**

Minimum order \$100. Cashiers checks and money orders accepted. Add 3% for VISA or MC. Add 3% for shipping/insurance/handling. UPS. No COD. Prices subject to change. Call to verify. Order hours 9-6 PST, Mon-Fri. Personal checks allow 20 days to clear. All products with full manufacturer's warranty. Factory sealed. Call. Residents add 6% sales tax. Bank wires & P.O.'s accepted. Retail prices may vary.
 Apple is a registered trademark of Apple Computer, Inc. All brand names are registered trademarks.

PRINTERS & INTERFACES
 NEC 8023
 NEC Spinwriter
 Okidata Microline
 IDS & C. Itoh
 Anadex Products
 CCS Interface Cards
 Gume and Diablo
 EPSON w/Graftrax Plus
 Micro Buffer II
 Grappler
 IBM Software and
 Peripherals
 Techmar STB Products
 Atari Software

COMPUTER SYSTEMS
 ALTOS Computers
 ATARI 400 & 800
 Basis 108 Computers
 NEC PC8000 Computers
 Sanyo Computers
 T.I. Home Computer
 Xerox 820-II Computers

APPLE BUSINESS SOFTWARE
 Versaform \$299
 Supercalc CP/M \$210
 DB Master VER 3 \$169

The Last One
 Format II \$275
 Pro Easywriter Combo
 Accounting Plus
 INVOICE PLUS
 FMS-80, 81, 82
 dBASE II
 VISICORP Software

MICRO PRO
 Wordstar
 Supersort
 Mail Merge
 Data Star
 Speñ Star
 Calc Star

Call for Best Prices

GRPRINT: An Apple Utility Program for Dot-Matrix Printers

Douglass R. Arnott
Computers of Woodbury
Valley Creek Mall
Woodbury, MN 55125

With the introduction of numerous dot-matrix printers with graphics capabilities, many Apple II owners have envisioned using such a printer to create the high-resolution graphics screens on paper. For those of you who have gotten bogged down with the Apple's high-resolution screen-addressing technique while attempting to write a program to print the graphics high-resolution screen, or are unfamiliar with assembly-language programming, the GRPRINT program is for you.

One feature of this program is that it is invisible to Applesoft without any use of the LOMEM command. GRPRINT (see listings 1 and 2) fits into the page of memory reserved for machine-language programs, hexadecimal 300 through 3FF. Therefore, Applesoft will not write on top of GRPRINT. Any existing Applesoft graphics program can take advantage of GRPRINT by using a DOS BLOAD command within the program, four POKE statements to set parameters, and a CALL statement. Listing 3 (see page 402) includes a sample GRPRINT program that shows you how GRPRINT can be used under program control. (Also see figure 1.)

GRPRINT was written specifically for an Apple II Plus with disks, interfaced to an IDS (Integral Data Systems) Paper Tiger 445G or Epson MX-80/70. The method employed in GRPRINT is general enough for most dot-matrix printers. However, some modifications may be necessary to the instructions sent to the printer for turning on and off the graphics modes and to the program indexes if the number of needles in the print head used in the graphics mode is different from those employed by the Paper Tiger or Epson.

The Apple II represents each dot on the high-resolution screen as a bit of data organized as 7 bits of a byte oriented along the horizontal axis of the screen. Most printer graphics are represented as 6 bits of a byte arranged along a vertical axis with each bit representing a printed dot. GRPRINT merely reconstructs the Apple's bytes bit by bit so that they are positioned along the vertical axis of the screen and compatible with the printer.

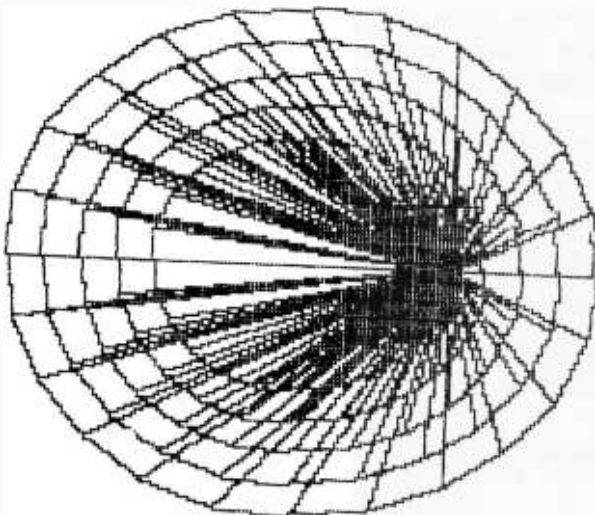

Figure 1: Output from the HOLE program. It was produced with the Paper Tiger 445G printer.

Listing 1: GRPRINT graphics utility program configured for use with an Apple II Plus computer and Integral Data Systems' Paper Tiger 445G printer.

```

----- NEXT OBJECT FILE NAME IS GRPRINT/IDS.OBJO
0305:      2      ORG    $305
0305:      3 *****
0305:      4 * S/R GRPRINT - TO LOAD UNDER PROGRAM CONTROL IN BASIC YOU MUST INCLUDE *
0305:      5 * THESE LINES *
0305:      6 * 10 D%=CHR$(4) *
0305:      7 * 20 PRINT D%;"BLOAD GRPRINT.OBJO" *
0305:      8 * OTHERWISE JUST BLOAD GRPRINT.OBJO *
0305:      9 * THEN DO A CALL 779 TO INITIATE S/R *
0305:     10 *****
0305:     11 * THE FOLLOWING POKES MUST BE SET *
0305:     12 * POKI,768,S S=STARTING LINE # 0-160 FOR SCR1 + 0-192 SCR2 *
0305:     13 * POKI 769,F F=FINISH LINE WHERE VALUES ARE SAME AS ABOVE *
0305:     14 * POKI 771,C C=CHAR/INCH (28=LRG, 29=MED, 30=SMLL) *
0305:     15 * POKI 772,P P=0 FOR SCR1 AND P=1 FOR SCR2 *
0305:     16 *****
0300:     17 STRTL EQU  $300
0301:     18 FINL EQU  $301
0302:     19 LINE EQU  $302
0303:     20 CHAR EQU  $303
0304:     21 SCREEN EQU $304 ;0=SCREEN
001A:     22 PTR EQU  $1A
FDED:     23 COUT EQU  $FDED
C000:     24 KBD EQU  $C000
C010:     25 CKBDS EQU $C010
0305:00 00 00 26 BUFR DFB  $00,$00,$00,$00,$00,$00
0308:00 00 00
0308:A9 80 27 LDA  #$80 ;DISABLE APPLE
030D:BD 7A 04 28 STA  $47A ;VIDEO
0310:A9 11 29 LDA  #$11 ;SELECT PRINTER
0312:20 ED FD 30 JSR  COUT
0315:A9 0D 31 LDA  #$0D ;CLEAR PRINTER BUFFER
0317:20 ED FD 32 JSR  COUT
031A:AD 03 03 33 LDA  CHAR ;SELECT CHAR INCH DENSITY
031D:20 ED FD 34 JSR  COUT
0320:A9 03 35 LDA  #$03 ;SET GRAPHICS
0322:20 ED FD 36 JSR  COUT ;MODE
0325:AD 00 03 37 LDA  STRTL ;GET STARTING LINE #
0328:BD 02 03 38 STA  LINE ;AND STORE
032B:A0 00 39 LDY  #$00 ;INITIALIZE
032D:A2 00 40 LDX  #$00 ;INDEXES
032F:2C 00 C0 41 LOOP1 BIT  KBD ;KEY PRESSED ?
0332:10 07 42 BPL  BYPASS ;NO, BYPASS
0334:A9 84 43 LDA  #$84 ;YES, CHECK FOR CNTRL-D
0336:CD 00 C0 44 CMP  KBD
0339:F0 0F 45 BEQ  RESET ;IF CNTRL-D RETURN TO CALLING PROGRAM
033B:2C 10 C0 46 BYPASS BIT  CKBDS ;CLEAR KEYBD STROBE
033E:AD 02 03 47 LDA  LINE ;START LOOP
0341:CD 01 03 48 CMP  FINL ;LAST LINE ?
0344:90 1C 49 BCC  J1 ;NO,BRANCH AROUND
0346:C0 28 50 CPY  #$28 ;LAST COLUMN ?
0348:90 1E 51 BCC  J2 ;NO BRANCH AROUND
034A:2C 10 C0 52 RESET BIT  CKBDS ;CLEAR KEYBD STROBE
034D:A9 03 53 LDA  #$03 ;RETURN
034F:20 ED FD 54 JSR  COUT ;TO
0352:A9 02 55 LDA  #$02 ;NORMAL
0354:20 ED FD 56 JSR  COUT ;MODE
0357:A9 13 57 LDA  #$13 ;DESELECT PRINTER
0359:20 ED FD 58 JSR  COUT
035C:A9 00 59 LDA  #$00 ;TURN ON APPLE
035E:BD 7A 04 60 STA  $47A ;VIDEO
0361:60 61 RTS ;RETURN TO CALLING PROGRAM
0362:C0 28 62 J1 CPY  #$28 ;TIME TO RESET COLUMN IND?
0364:90 02 63 BCC  J2 ;NO CONTINUE
0366:A0 00 64 LDY  #$00 ;RESET
65 *****
0368:0A 66 J2 ASL  A ;START OF BASE LINE HI-RES
0369:0A 67 ASL  A ;ALGORITHM FROM
036A:29 1C 68 AND  #$1C ;"APPLE-II HI-RES GRAPHICS: RESOLVING THE
036C:85 1E 69 STA  PTR+1 ;RESOLUTION MYTH", BOB BISHOP, THE APPLE ORCHARD,
036E:AD 02 03 70 LDA  LINE ;VOL 1, NO. 2, FALL 1980
0371:6A 71 ROR  A
0372:6A 72 ROR  A
0373:6A 73 ROR  A
0374:6A 74 ROR  A
0375:29 03 75 AND  #$03
0377:05 1B 76 ORA  PTR+1
0379:09 20 77 ORA  #$20
037B:85 1B 78 STA  PTR+1
037D:AD 02 03 79 LDA  LINE
0380:6A 80 ROR  A

```

Listing 1 continued on page 400

Listing 1 continued:

```

0381:29 E0      81      AND  $$E0
0383:85 1A      82      STA  PTR
0385:6A        83      ROR  A
0386:6A        84      ROR  A
0387:29 1B      85      AND  $$1B
0389:05 1A      86      ORA  PTR
038B:85 1A      87      STA  PTR
0388:85 1A      88      *****
038D:AD 04 03   89      LDA  SCREEN      ;WHICH SCREEN?
0390:F0 07     90      BEQ  J3           ;BRANCH IF SCREEN 1
0392:A5 1B     91      LDA  PTR+1       ;GET HIGH BYTE
0394:1B       92      CLC
0395:69 20     93      ADC  $$20        ;ADD FOR SCREEN 2
0397:85 1B     94      STA  PTR+1       ;STR HIGH RESULT
0399:B1 1A     95      J3      LDA  (PTR),Y    ;GET BYTE FROM HI-RES GRAPHICS BUFFER
039B:9D 05 03  96      STA  BUFR,X      ;STR IN PROCESS BUFR
039E:EE 02 03  97      INC  LINE        ;NEXT LINE
03A1:E8       98      INX             ;NEXT BUFR
03A2:E0 06     99      CPX  $$06        ;BUFR FULL ?
03A4:90 89    100     BCC  LOOP1       ;NO GET NEXT BYTE
03A6:C8       101     INY             ;NEXT COLUMN
03A7:C0 28    102     CPY  $$28        ;LAST COLUMN ?
03A9:F0 09    103     BEQ  J4          ;YES JUMP AROUND
03AB:AD 02 03  104     LDA  LINE        ;NO RESET LINE COUNTER
03AE:38       105     SEC
03AF:E9 06    106     SBC  $$06        ;SUBTRACT
03B1:8D 02 03  107     STA  LINE
03B4:98       108     J4      TYA          ;SAVE Y
03B5:48       109     PHA
03B6:A0 07    110     LDY  $$07        ;LOAD INDEX
03B8:A9 00    111     J5      LDA  $$00    ;CLEAR ALL BITS
03BA:A2 00    112     LDX  $$00        ;RESET INDEX
03BC:5E 05 03  113     J6      LSR  BUFR,X  ;PUSH BIT INTO CARRY
03BF:6A       114     ROR  A           ;PUSH CARRY INTO A
03C0:E8       115     INX
03C1:E0 06    116     CPX  $$06        ;ACCUM BYTE FULL ?
03C3:90 F7    117     BCC  J6          ;IF BYTE NOT FULL CONTINUE
03C5:4A       118     LSR  A           ;SHIFT OVER TWO BITS TO
03C6:4A       119     LSR  A           ;GET TO BIT 0
03C7:C9 03    120     CMP  $$03        ;CHECK TO MAKE SURE NO CONTROL CHARACTERS ARE SENT
03C9:D0 03    121     BNE  J8          ;IF NOT BRANCH
03CB:20 ED FD  122     JSR  COUT        ;SEND TWICE TO CLEAR CONTROL CHARACTER
03CE:20 ED FD  123     J8      JSR  COUT        ;SEND BYTE TO PRINTER
03D1:88       124     DEY
03D2:D0 E4    125     BNE  J5          ;GET NEXT BYTE FOR PRINT
03D4:A2 00    126     LDX  $$00        ;RESET BUFR INDEX
03D6:68       127     PLA            ;RETRIEVE COLUMN INDEX
03D7:A8       128     TAY            ;AND PUT IN Y
03D8:C0 28    129     CPY  $$28        ;IF LAST COLUMN, CR
03DA:90 0A    130     BCC  J7          ;
03DC:A9 03    131     LDA  $$03        ;
03DE:20 ED FD  132     JSR  COUT        ;SEND CR TO PRINTER
03E1:A9 0B    133     LDA  $$0B        ;
03E3:20 ED FD  134     JSR  COUT        ;
03E6:4C 2F 03  135     J7      JMP  LOOP1

```

*** SUCCESSFUL ASSEMBLY: NO ERRORS

Listing 2: An alternate version of the GRPRINT graphics utility program configured for the Apple II Plus and the Epson MX-70 or MX-80 printer.

```

----- NEXT OBJECT FILE NAME IS GRPRINT/EPSON.OBJO
0305:      2      ORG  $305
0305:      3      *****
0305:      4      * S/R GRPRINT - TO LOAD UNDER PROGRAM CONTROL IN BASIC YOU MUST INCLUDE *
0305:      5      * THESE LINES *
0305:      6      * 10 D$=CHR$(4) *
0305:      7      * 20 PRINT D$;"BLOAD GRPRINT.OBJO" *
0305:      8      * OTHERWISE JUST BLOAD GRPRINT.OBJO *
0305:      9      * THEN DO A CALL 781 TO INITIATE S/R *
0305:     10     *****
0305:     11     * THE FOLLOWING POKES MUST BE SET *
0305:     12     * POKE 768,S S=STARTING LINE # 0-160 FOR SCR1 + 0-192 *SCR2 *
0305:     13     * POKE 769,F F=FINISH LINE WHERE VALUES ARE SAME AS ABOVE *
0305:     14     * POKE 772,P P=0 FOR SCR1 AND P=1 FOR SCR2 *
0305:     15     *****

```

Listing 2 continued:

```

0300:      16 STRTL   EQU   $300
0301:      17 FINL   EQU   $301
0302:      18 LINE   EQU   $302
0303:      19 SENSE  EQU   $C1C1   ;PRINTER BUSY LINE
0304:      20 SCREEN EQU   $304   ;0=SCREEN
001A:      21 PTR    EQU   $1A
C000:      22 KBD   EQU   $C000
C010:      23 CKBDS  EQU   $C010
0305:00 00 00 24 BUFR   DFB   $00,$00,$00,$00,$00,$00,$00,$00,$00
0308:00 00 00
030B:00 00
030D:A9 1B      25     LDA   ##1B   ;SET LINE SPACING
030F:20 F1 03 26     JSR   COUT  ;ESC A 8
0312:A9 41      27     LDA   ##41
0314:20 F1 03 28     JSR   COUT
0317:A9 08      29     LDA   ##08   ;BINARY 8
0319:20 F1 03 30     JSR   COUT
031C:A9 0D      31     LDA   ##0D   ;CLEAR PRINTER BUFFER
031E:20 F1 03 32     JSR   COUT
0321:A9 0A      33     LDA   ##0A
0323:20 F1 03 34     JSR   COUT
0326:AD 00 03 35     LDA   STRTL  ;GET STARTING LINE #
0329:8D 02 03 36     STA   LINE   ;AND STORE
032C:A2 00      37     LDX   ##00   ;CLEAR X INDEX
032E:4C 63 03 38     JMP   J7    ;JMP TO SET BIT IMAGE MODE
0331:2C 00 C0 39 LOOP1  BIT   KBD    ;KEY PRESSED ?
0334:10 07      40     BPL   BYPASS ;NO, BYPASS
0336:A9 84      41     LDA   ##84   ;YES, CHECK FOR CNTRL-D
0338:CD 00 C0 42     CMP   KBD
033B:F0 0F      43     BEQ   RESET ;IF CNTRL-D RETURN TO CALLING PROGRAM
033D:2C 10 C0 44 BYPASS  BIT   CKBDS  ;CLEAR KEYBD STROBE
0340:AD 02 03 45     LDA   LINE   ;START LOOP
0343:CD 01 03 46     CMP   FINL  ;LAST LINE ?
0346:90 17      47     BCC   J1    ;NO;BRANCH AROUND
0348:C0 28      48     CPY   ##28  ;LAST COLUMN ?
034A:90 2D      49     BCC   J2    ;NO BRANCH AROUND
034C:2C 10 C0 50 RESET  BIT   CKBDS  ;CLEAR KEYBD STROBE
034F:A9 1B      51     LDA   ##1B   ;RESET LINE SPACING
0351:20 F1 03 52     JSR   COUT  ;TO
0354:A9 41      53     LDA   ##41   ;6 LINES PER INCH
0356:20 F1 03 54     JSR   COUT
0359:A9 0C      55     LDA   ##0C   ;
035B:20 F1 03 56     JSR   COUT
035E:60      57     RTS      ;RETURN TO CALLING PROGRAM
035F:C0 28      58 J1     CPY   ##28  ;TIME TO RESET COLUMN IND?
0361:90 16      59     BCC   J2    ;NO CONTINUE
0363:A0 00      60 J7     LDY   ##00   ;RESET
0365:A9 1B      61     LDA   ##1B   ;PUT PRINTER IN BIT IMAGE
0367:20 F1 03 62     JSR   COUT  ;MODE BY SENDING ESC K 280
036A:A9 4B      63     LDA   ##4B   ;WHERE 280 = # OF DOTS ACROSS SCREEN
036C:20 F1 03 64     JSR   COUT
036F:A9 1B      65     LDA   ##1B
0371:20 F1 03 66     JSR   COUT
0374:A9 01      67     LDA   ##01
0376:20 F1 03 68     JSR   COUT
69 *****
0379:0A      70 J2     ASL   A    ;START OF BASE LINE HI-RES
037A:0A      71     ASL   A    ;ALGORITHM FROM
037B:29 1C      72     AND   ##1C   ;"APPLE-II HI-RES GRAPHICS; RESOLVING THE
037D:85 1B      73     STA   PTR+1  ;RESOLUTION MYTH", BOB BISHOP, THE APPLE ORCHARD,
037F:AD 02 03 74     LDA   LINE   ;VOL 1, NO. 2, FALL 1980
0382:6A      75     ROR   A
0383:6A      76     ROR   A
0384:6A      77     ROR   A
0385:6A      78     ROR   A
0386:29 03      79     AND   ##03
0388:05 1B      80     ORA   PTR+1
038A:09 20      81     ORA   ##20
038C:95 1B      82     STA   PTR+1
038E:AD 02 03 83     LDA   LINE
0391:6A      84     ROR   A
0392:29 E0      85     AND   ##E0
0394:85 1A      86     STA   PTR
0396:6A      87     ROR   A
0397:6A      88     ROR   A
0398:29 1B      89     AND   ##1B
039A:05 1A      90     ORA   PTR
039C:85 1A      91     STA   PTR

```

Listing 2 continued:

```

92 *****
039E:AD 04 03 93 LDA SCREEN ;WHICH SCREEN?
03A1:F0 07 94 BEQ J3 ;BRANCH IF SCREEN 1
03A3:A5 1B 95 LDA PTR+1 ;GET HIGH BYTE
03A5:18 96 CLC
03A6:69 20 97 ADC #$20 ;ADD FOR SCREEN 2
03A8:85 1B 98 STA PTR+1 ;STR HIGH RESULT
03AA:B1 1A 99 J3 LDA (PTR),Y ;GET BYTE FROM HI-RES GRAPHICS BUFFER
03AC:9D 05 03 100 STA BUFR,X ;STR IN PROCESS BUFR
03AF:EE 02 03 101 INC LINE ;NEXT LINE
03B2:E8 102 INX ;NEXT BUFR
03B3:E0 08 103 CPX #$08 ;BUFR FULL ?
03B5:90 37 104 BCC J8 ;NO GET NEXT BYTE
03B7:CB 105 INY ;NEXT COLUMN
03B8:C0 28 106 CPY #$28 ;LAST COLUMN ?
03BA:F0 09 107 BEQ J4 ;YES JUMP AROUND
03BC:AD 02 03 108 LDA LINE ;NO RESET LINE COUNTER
03BF:38 109 SEC
03C0:E9 08 110 SBC #$08 ;SUBTRACT
03C2:8D 02 03 111 STA LINE
03C5:98 112 J4 TYA ;SAVE Y
03C6:48 113 PHA
03C7:A0 07 114 LDY #$07 ;LOAD INDEX
03C9:A9 00 115 J5 LDA #$00 ;CLEAR ALL BITS
03CB:A2 00 116 LDX #$00 ;RESET INDEX
03CD:5E 05 03 117 J6 LSR BUFR,X ;PUSH BIT INTO CARRY
03D0:2A 118 ROL A ;PUSH CARRY INTO A
03D1:E8 119 INX
03D2:E0 08 120 CPX #$08 ;ACCUM BYTE FULL ?
03D4:90 F7 121 BCC J6 ;IF BYTE NOT FULL CONTINUE
03D6:20 F1 03 122 JSR COUT ;SEND BYTE TO PRINTER
03D9:88 123 DEY
03DA:D0 ED 124 BNE J5 ;GET NEXT BYTE FOR PRINT
03DC:A2 00 125 LDX #$00 ;RESET BUFR INDEX
03DE:68 126 PLA ;RETRIEVE COLUMN INDEX
03DF:AB 127 TAY ;AND PUT IN Y
03E0:C0 28 128 CPY #$28 ;IF LAST COLUMN, CR
03E2:90 0A 129 BCC J8
03E4:A9 0D 130 LDA #$0D ;SEND CR TO PRINTER
03E6:20 F1 03 131 JSR COUT
03E9:A9 0A 132 LDA #$0A ;SEND LF TO PRINTER
03EB:20 F1 03 133 JSR COUT
03EE:4C 31 03 134 J8 JMP LOOP1
135 *****
03F1: 136 * S/R FOR CHARACTER OUTPUT TO SLOT 1
137 *****
03F1:BD 90 C0 138 COUT STA $C090 ;SEND BYTE TO CARD IN SLOT 1
03F4:AD C1 C1 139 BUSY LDA SENSE ;GET PRINTER STATUS
03F7:C9 FE 140 CMP #$FE ;STILL BUSY
03F9:F0 F9 141 BEQ BUSY ;YES, CHECK AGAIN
03FB:60 142 RTS

```

*** SUCCESSFUL ASSEMBLY; NO ERRORS

Listing 3: HOLE program. An example of how the GRPRINT program works.

```

100 REM HOLE
110 D$ = CHR$(4): REM DOS 3.3 MANUAL PG.29
120 PRINT D$;"BLOAD GRPRINT.DBJO"
130 HGR : HCOLOR= 3
140 DEF FN X(I) = 140 + (Z * COS (I * 6.28 / 360))
150 DEF FN Y(I) = 80 - (Z * SIN (I * 6.28 / 360))
160 FOR Z = 40 TO 80 STEP 10
170 FOR I = 0 TO 360 STEP 15
180 HPLOT 180,80
190 HPLOT TO ( FN X(I)),( FN Y(I))
200 HPLOT ( FN X(I)),( FN Y(I)) TO ( FN X(I - 15)),( FN Y(I - 15))
210 NEXT I
220 NEXT Z
230 POKE 768,0: POKE 769,160
240 POKE 771,30: POKE 772,0
250 CALL 779
260 END

```

To use GRPRINT, you must employ the following commands, which can be entered at the keyboard or under program control (see listing 3, lines 230 through 250):

```
BLOAD GRPRINT.OBJO
POKE 768, STARTLINE
POKE 769, FINISHLINE
POKE 771, HORIZSPACE
POKE 772, HSCREEN
CALL 779
```

The POKE commands control the formatting of the output to the printer, where:

STARTLINE is the vertical line number on the screen where GRPRINT is to start printing
 FINISHLINE is the vertical line number on the screen where GRPRINT is to finish printing
 HORIZSPACE is 28 for a screen printout of 6½ by 2⅞ inches for a 280- by 192-dot screen, equal to 29 for a screen printout of 5½ by 2⅞ inches, or equal to 30 for a screen printout of 4⅞ by 2⅞ inches
 HSCREEN is 0 for high-resolution screen 1 or 1 for high-resolution screen 2

Two Versions

GRPRINT for the IDS printer includes commands that put the printer in graphics mode, return it to the text mode, and refer to the number and orientation of the needles in the print head (see listing 1). Lines 27 to 36 put the IDS 445G into graphics mode, and lines 53 through 60 return the printer to text mode. The IDS 445G has six print needles available for use in the graphics mode, in which bit 0 of any byte accesses the uppermost print needle in the head. As a result, lines 26, 99, 106, 114, and 116 are printer-dependent.

In contrast, Epson MX-80 and MX-70 printers have eight print needles in their graphics mode (bit-image mode), in which bit 0 of any byte accesses the lowermost print needle in the head. Consequently, for the Epson (see listing 2), lines 24, 103, 110, 118, and 120 have indexes of 8, and line 118 is ROL A rather than ROR A. Lines 118 through 122 in listing 1 are specific to the IDS printer; they line up the byte to bit 0 (because of a six-needle head) and ensure that no control characters are sent inadvertently. These lines are not needed for Epson printers. Lines 131, 132, 133, and 134 in listing 1 send a carriage return (VTAB) to the printer and again are specific to the IDS 445G. Lines 130 through 133 in listing 2 are the equivalent codes for a carriage return for the Epson printer. Printer reference manuals will provide you with the information you need to make any necessary changes for other printers.

You may find that the Apple output routine (hexadecimal FDED) will generate some unexpected alterations to your output byte. This appears to be the case with the MX-70. Therefore, a character-output routine was added to the Epson listing to send the output bytes directly to the printer-interface card in slot 1 (see lines 135 through 142).

The HOLE program, shown in listing 3, gives an example of how to use the GRPRINT program. First BSAVE the appropriate version of the GRPRINT program onto your floppy disk, then run the HOLE program. In this example, lines 230 through 240 contain the POKE commands that control the format of the output to the IDS 445G printer. The resulting hard copy from the HOLE program is shown in figure 1. Entering a CTRL-D will stop GRPRINT and return you to the program or monitor.

The GRPRINT program is a fast, simple method for getting graphics output from your Apple II Plus and IDS Paper Tiger 445G or Epson MX-80/70 printer. ■

BYTE's Bugs

Power-Supply Diagram Error

A topological gremlin attacked Steve Ciarcia when he was preparing one of the schematic diagrams for his article "Switching Power Supplies: An Introduction" (November 1981 BYTE, page 36).

In figure 6a on page 43, the connections to the Fairchild 78S40 switching regulator are incorrect as shown, and the diode cathode connection is missing. The corrected diagram is shown here as figure 1. ■

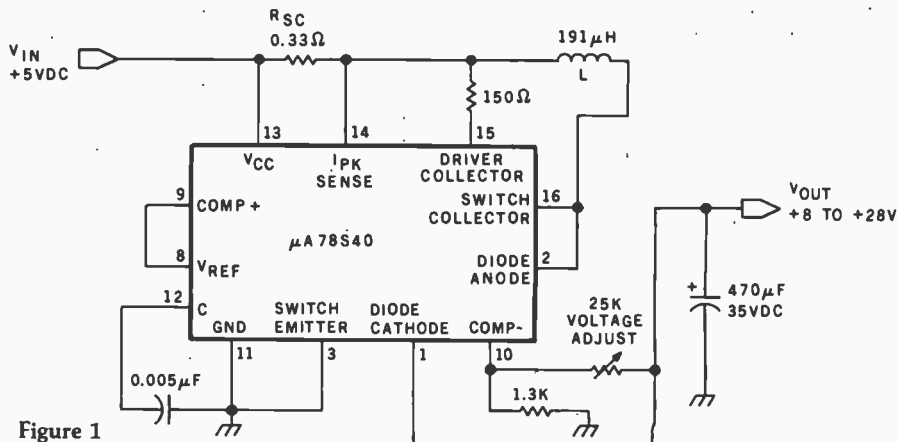

Figure 1

Condor Series 20 DBMS

Jack L. Abbott
8525 North 104th Ave.
Peoria, AZ 85345

At a Glance

Name

Condor Series 20 DBMS, level 3, version 2.09

Type

Database management system

Manufacturer

Condor Corporation
POB 8318
Ann Arbor, MI 48107
(313) 769-3988

Price

\$995

Disk Formats Available

8-inch soft-sector (IBM 3740 format),
almost all 5¼-inch formats

Language

Machine language

Computer Needed

Runs on 8080-family and Z80 microprocessors under the CP/M, CDOS, and MP/M-80 operating systems. Also runs on 8086 and 8088 processors under the MS-DOS and CP/M-86 operating systems. Requires 48K bytes or more of RAM, 80-column by 24-line display with clear-screen capability and addressable cursor, two disk drives with at least 300K-byte total capacity, and printer with formfeed and form-length control, preferably with 132-column print capability

Documentation

Approximately 180 pages, loose-leaf

Audience

Anyone with database needs

A typical business microcomputer user may need special-purpose programs such as inventory management, mailing lists, and appointment calendars. One general-purpose program, a database management system (DBMS), can be used to do the work of these application programs. A DBMS will accept data in the format you establish, process this data as you instruct, and output it in the report format that you designate. The reports can be tables, checks, inventory lists, receipts, etc.

Condor Series 20 DBMS is a relational DBMS developed by Condor Computer Corporation of Ann Arbor, Michigan. (For brevity, I will refer to Condor Series 20 DBMS as Condor DBMS.) It requires a Z80 microcomputer or an 8080-family microprocessor with at least 48K bytes of RAM (random-access read/write memory) under the CP/M-80, CDOS, and MP/M-80 operating systems. The Condor DBMS also runs on 8086 and 8088 microprocessors under the MS-DOS and CP/M-86 operating systems. You need a 24-line by 80-column display terminal with screen-erase, line-wrap, and cursor-addressing capabilities. Two floppy-disk drives with a total capacity of at least 300K bytes of memory are needed. Hard-disk drives can be used if they are supported by the operating system. Condor requires a printer, preferably one with 132-column print capability, form feed, and form-length control.

Condor DBMS is available in three levels. Level 3 is the complete system and includes file management and transaction-processing capabilities (the ability to compare files), as well as the ability to join information from several databases. It includes a report writer and indexing, too. Level 2 offers all the above except for the report writer and the indexing capabilities, and Level 1 includes only the file management and transaction-processing capabilities. A purchaser of Level 1 can upgrade to Level 3

and will receive a credit of \$245 toward the purchase of the Level 3.

The program documentation is in two sections and totals about 180 pages in length. The first section begins with an explanation of how the Condor DBMS interfaces with CP/M or MP/M operating systems and tells how to make a copy of the master disk. You use the copy, of course, for day-to-day operation. The program examples that follow include building a portion of a general ledger, establishing and maintaining an employee file, and developing a mailing-list program. The second section of the manual is an alphabetical listing of each Condor DBMS command. The material is generally well organized and the presentation clear. If you are a newcomer to computing and are going to use Condor DBMS to develop an application program similar to the examples given, you should have no difficulty. It would be helpful if examples of other types of applications were included. The document is not indexed, and it should be.

Condor is preparing new documentation that will be organized somewhat differently. A separate Installation Guide will be provided for each computer and operating system for which the software is available. Thus, a user purchasing the Condor DBMS for an IBM Personal Computer with MS-DOS would receive a manual written specifically for that configuration. This should greatly ease the burden of initial setup for the inexperienced user.

I used two different database files for program familiarization and checkout. The first is a five-record inventory of mobile homes. Each record contains all the information about one mobile home arranged in eight descriptive sections called fields. All the records taken together make up a file. Condor DBMS can have a maximum of 32,767 records per file and as many as 1024 characters (bytes) per record divided among a maximum of 127 fields. No single field can be longer than 127 alphanumeric characters (letters, spaces, and/or numbers) or 10 digits. Because database management systems sometimes perform differently under different loads, my second database file has 2,150 records of five fields each, for a total of 10,750 data items. Later in this article, I will give you the results of my tests with the larger database file.

You adapt Condor DBMS to your system by selecting one of eight commonly used display terminals from a menu. If your terminal is not listed, you can furnish the program with the appropriate ASCII characters for clear-screen and cursor-addressing functions. After you receive the program package, you must sign and return the license agreement. Condor Computer Corporation will then send you a six-digit license number. You must enter the number every time you use Condor DBMS, or the program will handle only 50 records. I don't like this feature; it is one more number that I must remember.

A Typical Application

The first step in developing the representative mobile home inventory program, named MOBINV, is to define the input data format. To load Condor DBMS, you type

in "DBMS". Next you type in the command "DEFINE MOBINV". Condor DBMS then brings up a screen that is blank except for an instruction legend at the bottom. Condor provides full-screen editing; you can move the cursor anywhere on the screen, typing in at the cursor location information like that shown in listing 1. In this example, I aligned each field label on the left margin. Later in this article, you will see an example of a different input data format generated by using this same Define command.

Next you define the attributes of each field. Condor DBMS will display each field label sequentially. You enter whether the field is alphanumeric, alphabetic, numeric, dollar, or Julian (date field). Then you type in field length. Here is an example using the first two lines of the MOBINV input data format:

1. RECORD.NUMBR: N,2, -32767,32767," "
2. STOCK.NUMBR: AN,15,0,15," "

Condor DBMS displays RECORD.NUMBR. You enter "N" for numeric, and "2" for 2 bytes in length. Condor DBMS fills out the rest of the line. The quotation marks hold the default value for each field. Because this program uses hexadecimal (base 16) numeric storage, 2 bytes give the capability of storing up to $\pm 32,767$ decimal (7FFF hexadecimal). One ASCII number requires 1 byte

a message to our subscribers

From time to time we make the BYTE subscriber list available to other companies who wish to send our subscribers promotional material about their products. We take great care to screen these companies, choosing only those who are reputable, and whose products, services or information we feel would be of interest to you. Direct mail is an efficient medium for presenting the latest personal computer goods and services to our subscribers.

Many BYTE subscribers appreciate this controlled use of our mailing list, and look forward to finding information of interest to them in the mail. Used are our subscribers' names and addresses only (no other information we may have is ever given).

While we believe the distribution of this information is of benefit to our subscribers, we firmly respect the wishes of any subscriber who does not want to receive such promotional literature. Should you wish to restrict the use of your name, simply send your request to the following address.

BYTE Publications Inc
Attn: Circulation Department
70 Main St
Peterborough NH
0345B

Listing 1: A representation of the Condor DBMS screen display during definition of an input data format. This example defines the format for a mobile homes inventory. Condor DBMS requires placing field labels in brackets and using underscores to show the number of characters in each field.

```
[RECORD.NUMBR] _ _ _ _ _
[STOCK.NUMBR] _ _ _ _ _
[SUPPLIER] _ _ _ _ _
[MODEL] _ _ _ _ _
[DATE.ORD] _ _ _ _ _
[DATE.RECVD] _ _ _ _ _
[COST]:$ _ _ _ _ _
[SALE.PRICE]:$ _ _ _ _ _
```

Note: This is the first action required to define the input data format. Field labels are typed in brackets. Dashes are the number of characters.

Rep Mode: Ins mode (Ctl A) Abort (Ctl C) End (Ctl E) Refresh Screen (Ctl R)

Listing 2: A representation of the screen display of five records in the MOBINV database of mobile homes. Condor DBMS generated the display in response to the command LIST MOBINV BY RECNR STOCK.NUMBR SUPPLIER MODEL DATE.ORD DATE.REC COST SALE.PRICE.

RECNR	STOCK.NUMBR	SUPPLIER	MODEL	DATE.ORD	DATE.REC	COST	SALE.PRICE
1	1234567XYZ	PALM HARBOR	3BR2BA60F	01/05/81	02/20/81	14375.00	18000.00
2	123456XYZ	NASHUA	1BR15BA40F	03/02/81	04/05/81	12789.00	16000.00
3	23456MNB	LAYTON	2BR1BA40F	01/03/81	02/04/81	14000.00	18585
4	234567ABCDE	AIRSTREAM	1BR1BA32F	01/06/81	03/06/81	21000.00	24000.00
5	1RW14578	SKYLINE	2BR1BA79F	04/03/81	05/08/81	24987.65	31550.00

for storage. Two hexadecimal numbers can be stored in 1 byte. The largest number Condor DBMS will handle is $\pm 2,148,373,647$ decimal. Four bytes are required to store a number of this size. For STOCK.NUMBR, you enter "AN" for alphanumeric and "15" for the maximum number of characters in the field. You define each field in this manner.

After you have defined the input data format, you use the Enter command to get a screen display like the one in listing 1 but without the brackets. You then type in the appropriate data for the five mobile homes in the inventory example. You again have full-screen edit capability available. Condor DBMS stores the entered data in a disk file.

You can display the stored MOBINV records by entering the following command:

```
LIST MOBINV BY RECNR STOCK.NUMBR
SUPPLIER MODEL DATE.ORD DATE.REC
COST SALE.PRICE
```

Listing 2 is a representation of the video display of the five records of the MOBINV database. In this case, I asked Condor DBMS to include all the fields in each record of MOBINV. You can specify which fields you

want displayed. If you want to print this display, Condor DBMS assumes that you have a 132-column printer and will not provide a linefeed until you reach 132 characters. If the printer has only 80 columns, printing any record over 80 characters in length will cause all characters between 80 and 132 to be overprinted at the beginning of the line. Use of the *screen-format* report output described later in this article will solve this problem.

Using English-like commands, you can have Condor DBMS sort the file on any field desired. You can select records by specifying logical comparisons, including less than, greater than, equals, not equal, equal or less than, and equal or more than. For example, you can ask for mobile homes received after May 1981 by entering the command SELECT MOBINV WHERE DATE.RCVD GE 06/01/81 (GE is greater than or equal to). Those units (records) meeting this criterion will be written to a Result file. You can then select all units in the Result file costing less than \$25,000, for example. Again, the mobile homes meeting the selection criterion will be written in a Result file. At any point, you can cause the contents of the Result file to be displayed or printed. An example in the Condor DBMS manual shows how to select wanted names and addresses of customers from a master list. Names of those customers who have not made a purchase

WILD HARE AND DATA GENERAL IN TRIUMPHANT FINISH!



GREAT NEWS FOR DATA GENERAL USERS!

Win in the race for productivity by teaming up with Wild Hare. Our TSS software enhancer makes your system as productive as a rabbit.

Wild Hare's operating system enhancement gives Data General NOVA® and ECLIPSE® users the most from their system. TSS allows you to transform RDOS, ICOS (CS/COBOL) and INFOS® into true multi-lingual, multi-user Time Sharing Systems.

This state-of-the-art system accommodates up to 26 users. Each user can independently edit, compile and execute programs using the

language of his choice, like FORTRAN, ALGOL, BASIC, COBOL, Pascal, Assembler and more.

TSS combines RDOS, INFOS® and ICOS compatibilities with AOS capabilities at a mere fraction of the cost.

In the race for productivity, Wild Hare gives you the edge by multiplying the capabilities of your Data General system. So start things hopping with a 30-day trial run. Remember, slow and steady could eventually win the race. But it takes a Wild Hare in the program for a truly productive finish.



wild hare
COMPUTER SYSTEMS INC.

Listing 3: A sample invoice generated by Condor DBMS from the database MOBINV.

COPPERSTATE MOBILE HOME SALES
1425 N. GRAND AVE.
PEORIA, AZ. 85345
(602) 100-3131

STOCK NUMBER	MANUFACTURER	MODEL	SALE PRICE
123456XYZ	NASHUA	1BR15BA40F	\$ 16000.00

Listing 4: A summary of the attributes of the input data format in the database used to test Condor DBMS. "AN" after each field name stands for alphanumeric. The numbers that follow indicate the length of each field and the minimum and maximum values of the data that the field can hold.

```
REORDER.FLAG: AN,1,0,1  
STOCK.NUMBER: AN,5,0,5  
TYPE: AN,2,0,2  
QUANTITY: AN,4,0,4  
BASE.METAL: AN,3,0,3
```

Record Size (Bytes) = 16

Total Records = 2150

or been contacted within a specified time are placed in a Result file. This data is then used to print mailing labels. Mailing-label printing is limited to one label across; hence, single-label rolls must be used. This is more expensive and slower than using rolls with multiple labels across.

A similar technique can be used to print an invoice when one of the mobile homes is sold. Listing 3 shows an invoice printout example from the MOBINV database. Condor DBMS calls this type of report a *screen format*.

An actual inventory program would include another field in the input data format so that you could flag those units that were sold. (To *flag* a record, you enter a character in a field so that later the record can be selected by testing the field. A "Y" for yes would be entered in a field labeled SOLD.) In our example, I arbitrarily selected the NASHUA as the mobile home that was sold. To extract the record from the database, you type in the command:

```
A>> SELECT MOBINV WHERE SUPPLIER EQ  
NASHUA
```

This action tells Condor DBMS to scan the supplier field of all the records in the MOBINV database and place all records with NASHUA in the supplier field in a Result file. In the MOBINV example, there is only one such record. You can use the screen-format procedure to generate an invoice form called MINVOICE. This form might have the heading "COPPERSTATE MOBILE

HOMES" and labels like "STOCK NUMBER," "MANUFACTURER," etc. To set up a format for this form, you would use procedures similar to those that generated the display represented in listing 1. Instead of putting the field labels down the left margin, you can place them wherever you want them on the screen display, and Condor will remember their placement. You can include any other written information that you want on the form. This procedure produces a formatted-report output for invoices, checks, etc. Most database management systems use much more complex procedures for this function.

Next you might type in the command:

```
B>> PROJECT RESULT BY STOCK.NUMBR  
SUPPLIER MODEL SALE.PRICE
```

This command extracts the field data to print on the MINVOICE form. Then you could type the command PRINT MINVOICE to get a result like that shown in listing 3. In this instance, I changed the input-data-form field label from SUPPLIER to MANUFACTURER on the invoice form header. This report will accept field data from only one file at a time. If you want to include the name and address of the purchaser on the example invoice, then you must add data fields that include this information to the MOBINV input data format. You cannot directly select data from one file that contains the names and addresses of customers and another separate MOBINV file that contains the invoice data and combine this data to print out the invoice form.

This example shows what is possible with this kind of report output. In a real-life situation, stock forms would generally be used with printed title and header (label) information. Because changes in stock forms are often forced by circumstances, Condor's easy methods of making such changes are an important feature.

The screen format is one type of report that the Condor DBMS will generate. There are four others:

1. Columnar format—desired fields selected and printed in columns
2. Columnar format with statistics—field maximum, minimum, average, and totals are included for the selected fields
3. Summary format—includes subtotals and totals for selected fields



AN IMPORTANT ANNOUNCEMENT

by AdaVISIONTM, Inc.

The FIRST COMPLETE INTRODUCTORY VIDEOTAPE COURSE
16 Studio-produced COLOR Videocassettes and complete Study Guide

Ada is the CHALLENGE of the EIGHTIES and NINETIES!

Projections indicate that Ada will be the DOMINANT COMPUTER LANGUAGE DURING the 1980's and BEYOND!

The Ada_Tapes Studio-Produced, Color Videotape Series is the simplest, most economical and effective way to learn the Ada computer language now, for education, industry and government! Train your entire staff on site, at your office!

Ada_Tapes are available right now to teach you all you need to know about Ada.

Unlike seminars and college courses, always expensive and frequently unrewarding, no additional expense need be incurred by having your own personnel attend the Ada Video Course in your own office or home environment! There is no longer any need to disrupt important work schedules of key personnel. Repeat the course as often as you want, and at your own pace! The course is modular: staff members can study different sections of the course at the same time.

As a company, you want to insure your future in our western industrial world. In the 1980's, Ada will become the standard, universal programming language for industry. Your company's ability to respond to critical contract offerings will become increasingly dependent on how much you and your personnel know about Ada!

As an individual programmer or data processing manager, you want to assure yourself of a high salary in the years to come. If that's what you want. You must learn Ada! Knowing Ada is better insurance for the future than an executive Pension Plan! (Better take this ad to your DP Manager!)

No matter what kind of computer hardware you now have or are going to have, there will soon be an Ada compiler for it. Learn the Ada language now, and be ready to fully implement it on your own equipment!

No other computer language that was ever conceived even begins to compare with the power of Ada! Ada is the result of a refining process in which 17 original companies — the best software houses on earth — competed to capture an immense software development contract. Only 4 finalists emerged. Of these four, only one survived! The result was . . . Ada!!

Ada is beautiful!! This new language is destined to play a major role in all future systems. Engineering, mathematics, accounting, embedded systems, machine tool control — no matter what the application! Ada embodies the finest features of all other languages, but with superior modularity, portability and standardization!

The tasking and separate compilation capabilities of Ada in the '80's are what Real Time Programming and Top Down Structure were to the '70's! Ada will be uniformly transportable among all processors! Ada is Ada is Ada — for all processors!

This course has been carefully designed so as to be equally valuable to the programmer well versed in Top-Down Structure concepts, and to the novice wishing to begin his programming career using the latest software technology.

The team that created this course combines a unique blend of massive programming experience and educational visual arts techniques. More than 80 man-years of experience in programming languages and tape based teaching concepts were brought together to produce this outstanding Videotape Course for Ada!

The course lecturer alone brings more than 25 years of experience in developing compiler languages and teaching the computer sciences at both the undergraduate and graduate levels, to this powerful videotape series!

The cost of the entire Ada course is \$4800 for sixteen color videotape cassettes, in any format required — and more than 12 clock hours of intensive Ada instruction!

There are hundreds of example code segments, including many complete programs, each with a thorough explanation. The comprehensive Ada Study Guide accompanying the video cassettes runs parallel with the videotape presentation throughout the entire course.

To order the complete "Comprehensive Course in the ADA Programming Language":

CALL: (313) 567-3650

Send Coupon to:

AdaVISION, Inc.

P.O. Box 43195
Renaissance Center
Detroit, MI 48243

(Note: Extra Study Guides are available at \$30.00 per copy. Quantity discounts are available upon request.)

<input type="checkbox"/> C.O.D.			
<input type="checkbox"/> Check enclosed \$4800.00 (Michigan residents add 4% State Sales Tax)			
Ship () Ada Videotape Courses to:			
Name			
Title			
Address			
City	State	Zip	
Videotape Format:	<input type="checkbox"/> 1/2" VHS	<input type="checkbox"/> 1/2" BetaMax	<input type="checkbox"/> 3/4" U-Matic

*Ada is a trademark of the Department of Defense (Ada Joint Program Office)

4. Statistical format—(see 2 above) no detailed information shown, just summaries of data for groups of records

Listing 4 is an attribute summary of the input data format for my 2150-record test database. This database is a simple vehicle for testing Condor DBMS program functions. The results will vary with different equipment and varying field lengths, record lengths, file sizes, etc. The tests are only intended to determine significant Condor DBMS features and are not extensive enough to be benchmark tests.

ASCII files generated by other programs can be transferred to or from Condor DBMS files. I generated the test file (named TESTDATA) with CBASIC and then transferred the file to Condor DBMS. The STOCK.NUMBER field contains 2150 randomly selected whole numbers (integers) in the range from 0 to 99,999. The QUANTITY field has sequential numbers from 5000 to 7149. The BASE.METAL field contains alphanumeric characters SIL, GOL, or MAG in a random sequence. The other fields contain random numeric data.

In the preceding MOBINV examples, I executed commands one at a time. You could use CP/M's ED (editor) or some word processors to build a command file containing sequenced commands, but knowledge of the Condor DBMS programming language is necessary. The language has an English-like format and is easy to master.

Condor DBMS will run the command file on request. I constructed a command file to select and then print 250 TESTDATA records. I specified logical comparisons on the STOCK.NUMBER field to select the records. Condor DBMS took about 55 seconds to run through the command file, select the records, and start to print.

I entered 50 new records in the TESTDATA file. Condor DBMS accepted them as fast as I could type them in. To re-sort the file by STOCK.NUMBER after entering the new records took about 2 minutes and 30 seconds. It is not strictly necessary to sort the file, but most program operations will be faster if it is sorted.

One record can be located by a logical selection anywhere in the file in an average time of 10 seconds. The record can then be printed, displayed, or edited.

This article presents an overview of the capabilities of Condor DBMS. The inventory examples demonstrate only a limited number of the 41 commands available. Several commands are tailored to handle accounting functions. One of these, the Post command, matches records of the first database file with those of a second, then updates the records of the first with field data from the second for specified fields. At the same time, Post creates a third database file called Result containing all of the fields of the first database that matched those of the second.

The Change command changes the data contents of one or more fields of each record of an entire file to new specified values. Because Change does not include logical selection of records to be changed, you must do this with a separate operation.

The Compute command does mathematical operations (addition, subtraction, multiplication, and division) on field data. In a series of mathematical operations, Condor DBMS gives no priority to operands or parentheses. The operations are carried out from left to right. Care must be exercised in setting up the series so that normal mathematical operation priorities are observed and the desired results obtained.

Condor DBMS lets you run most of the CP/M or MP/M operating system commands without leaving the DBMS and returning to the operating system. Condor DBMS provides equivalent commands for several of the few CP/M commands that do not run on Condor DBMS.

Conclusions

- The Condor DBMS is one of the best. It is fast and will handle almost any application. The Condor DBMS is particularly effective in accounting functions and personnel record processing.

- You must learn a new programming language to use Condor DBMS effectively. The language has an English-language format and is easy to master.

- Examples of different types of applications programs should be included in the documentation.

- Condor DBMS makes no provision for database security.

- Formatted reports (including checks, invoices, inventory lists, etc.) are simple to generate. ■

"FRIENDLY"

Hard Disk Storage Manager Sub-System



Takes confusion and DELAY out of computer operations

- **User Friendly!** Single key commands, auto boot, self-diagnostic
- **Compact!** Convenient, single cabinet, 4½" H x 12" D x 19" W
- **Mega Storage!** 8 volumes = 76 Floppies
- **Fast!** Average access - 80 ms access time, track to track - 3 ms
- **Dependable!** 11,000 MTBS
- **Operates on most Micro Computers**

Single 10 Megabyte Formatted Hard Disk System
(Removable Media Available)

\$3500

Dealer inquiries invited. For immediate response call:
COMPUTER 1-503-640-4200
FUTURES P.O. Box 114, Hillsboro, OR 97123

If you're smart, you'll buy your IBM expansion memory from IDE.

	64KB	128KB	192KB	256KB
IBM	\$475	\$675	\$875	\$1075
COMPUTERLAND*	\$350	\$530	\$710	\$890
SEARS**	\$349	\$524	\$699	\$874
IDE	\$275	\$385	\$485	\$575

Prices based on most recent data available.

*Datamac DM-Series

**Microsoft RAM card

As you can see from the chart above, our memory boards for the IBM Personal Computer cost less than our competitors'. Considerably less.

But if you're smart (and we think you are) you'd never buy a memory product based on price alone. You'd also look for quality, reliability and service.

With IDE, you'll get all that. At a lower price.

Why we cost less.

At IDE, we make only one type of product. Add-ons for the IBM PC.

By concentrating our efforts, we run our company more efficiently. And keep costs down.

We also eliminate things that drive costs up. Like fancy showrooms, high-priced salesmen and the proverbial middleman.

That's how we sell our product for less. Yet still offer you more.

Free installation.

If you live in a selected major metropolitan area, we'll install the IDE memory board right in your home or office. Absolutely free.

If you don't live in one of these cities, we'll send you your board in the mail. And all IDE boards come with the documentation you need to install them within minutes.

One year warranty.

We believe in our memory boards, their advanced design and our quality control facilities.

So we offer you a full one year warranty on all our boards. Not just 90 days.

And we offer an easy way to upgrade.

When you need more memory, just send us \$125 for each additional 64K. We'll send you your new upgraded board and take your old board back. It's that easy.

Order today.

Cut out the coupon and take advantage of our money saving offer. With the discount, ours is the lowest priced board we know of.

But hurry, the offer ends soon.

For more information on our memory boards or our new memory combination board, call us at (617) 272-7360.

And use your head to choose your memory.

If you're quick, you'll save an extra \$50.

IDE Associates

Mail to: IDE Associates, 44 Mall Road, Burlington, MA 01803.

\$50 OFF Send me _____ 64KB _____ 128KB _____ 192KB _____ 256KB
Memory Board(s) Total charge \$ _____
Mass. Residents add 5% Sales Tax.

I have attached CHECK COMPANY P.O.
Please charge my VISA MASTERCARD.

Credit Card #: _____ Expiration Date _____

Name _____

Company _____ Tel. (____) _____

Address _____

City _____ State _____ Zip _____

Offer ends Dec. 31, 1982.

Only one CAD see the world as you do

Introducing the revolutionary Space Tablet™ from MCS.

“Experts” told us that interactive, 3-dimensional graphic design on a microcomputer was still only a future possibility. We couldn't wait. Instead, we developed an affordable, easy-to-use graphics system that can construct and manipulate drawings in 3-dimensional space . . . the Space Tablet.

An added dimension. Like other digitizing systems, the Space Tablet (patent pending) lets you plot and record X and Y coordinates on a two-dimensional plane. But unlike other systems, it also lets you select points off the plane — along the Z axis — for a true 3-dimensional capability.

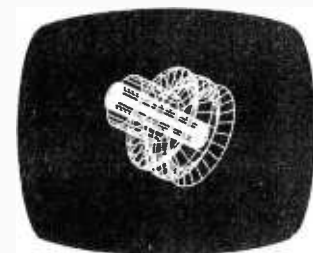

be created by tracing a physical object or an imaginary shape. Here's where the possibilities really begin . . .

Interactive manipulation means total flexibility. The Space Tablet's software packages allow interactive manipulation and editing of points in all three dimensions. *This capability is unique in computer graphics.* Space Graphics™ software for the IBM Personal Computer lets you select a point in space and “pull” it, and all connecting lines, to another location in 3-space. 3-D models can be scaled, rotated and

moved about any axis. New models can be composed by linking together individual components. Three orthogonal views can be called up at once in a split screen format. Software included with the Apple II Space Tablet system gives you similar capabilities. With either system, it's remarkably easy to try all kinds of “what if” possibilities before generating hard copy.

Now, 3-D design is surprisingly affordable. We've priced the Space Tablet systems well within reach of Apple II and IBM PC users. (Software for

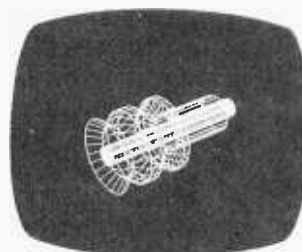
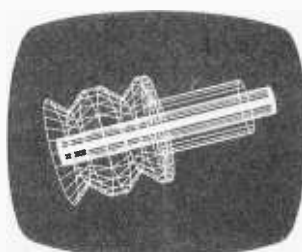

other popular microcomputers will be available soon.) Because it's an entry-level system, the Space Tablet is being used creatively in ways not normally associated with larger, far more costly CAD/CAM systems . . . molecular modeling, physical therapy programming, cell structure analysis, weapons research, medicine, art, architectural planning and, of course, design and engineering. Additional applications are being discovered by OEM purchasers. And, for those needing a 2-dimensional digitizer, the Space Lift arm can be held as a pen, or stylus, to trace slides, X-rays, pictures, graphs, maps and more. We see it as a tool to unleash the imagination.

Our perspective of the world. If the real world were 2-dimensional, conventional design methods would be adequate. Obviously, they're not. Three-dimensional thinking is natural in the development and communication of complex design ideas. That's where MCS comes in. We're committed to the potential of 3-D computer aided design and manufacture. The Space Tablet is the beginning of a revolution in the use of microcomputers to process information and solve problems. And we're just getting started.

A high-resolution 2-D tablet equipped with the Space Lift arm is ready for release. Called Microcad I™,



Circle 299 on inquiry card.

IBM Personal Computer Minimal Configuration: 128K, game paddle adapter, color graphics adapter.

Apple II microcomputer minimal configuration: 64K, DOS 3.3.

system lets your micro ... in 3 dimensions.

MCS SPACE TABLET™ SPECIFICATIONS

The Space Tablet is a 13.5" x 16" clear plastic tablet on which is mounted a precision machined aluminum and delrin arm. It uses precision potentiometers with a linearity of .5%. The resolution of each axis is approximately 1300 distinct states over an angle of 320 degrees. The arms operate in polar coordinates, and the sampling time is approximately .5 sec./pt. (slightly longer for the IBM system).

The Three Axis Model Standard model available only for Apple II.

The Professional Model Available either for the Apple II or the IBM Personal Computer. This model has an additional fourth axis of rotation (a fourth degree of freedom) which provides a much higher degree of flexibility for reaching points in space. Recommended for 3 dimensional work in either a professional or amateur capacity.

it offers improved resolution (to .001") and includes a second generation Space Graphics™ software package with expanded capabilities. To put you in touch with other users, we've developed Space Communications™ to allow transmission of a file — and software for its manipulation — through telephone lines to a receiving station. Architectural and other custom software packages will provide an instantly accessible 3-dimensional vocabulary for designers in any field. We see no limits to the variety of 3-D graphics systems for micro-computers — we have the technology in hand.

For more information about MCS and our products, call (203) 872-0602, or use the coupon below. Micro Control Systems, Inc., 143 Tunnel Road, Vernon, CT 06066.

For orders only call toll-free: 800-243-3587

OK MCS, I see the potential in 3-D computer aided design. Show me more . . .

Name _____ Phone () _____

Company _____

Address _____

City _____ State _____ Zip _____

MCS

We add a 3rd dimension to your computer's potential.

Test Your Memory Using the Barber-Pole Algorithm

Useful diagnostic information is not hard to obtain, as an example coded for the 8080 processor shows.

H. R. Pinnick Jr.
POB 3604
Bartlesville, OK 74005

Although memory-test programs often indicate the presence of a memory error at a given memory location, they often fail to locate the particular memory component that is malfunctioning. We can learn not only the address of the error, but also sufficient information to indicate which memory device (static or dynamic) is causing the problem, by using a convenient algorithm. This algorithm is fast, aids in flagging memory-decoding problems, and helps distinguish between hard and soft memory errors. Since it is analogous to the rotating barber pole found at many barber shops, it is called the "barber-pole" algorithm. First, a brief discussion of other memory tests is appropriate so that they can be compared with the barber-pole memory test.

About the Author

H. R. Pinnick Jr. has a PhD from Indiana University and is a computer engineer at Applied Automation Inc. He has been involved in the field of electronics for the past 20 years, beginning with the repair of airborne radar systems. His current research interests are interfacing microcomputers to existing chemical instrumentation and the development of new instrumentation based upon microcomputers. His hobbies include flying, chemistry, electronics, and reading.

Memory Tests

Many memory-test programs are available, for example, the walking-address memory test. Starting at a user-given even memory address, the algorithm writes the most significant byte of the address in the even mem-

Memory-decoding problems can be probed if the test pattern is appropriately chosen.

ory location and then verifies the byte's contents. Next, the least significant byte of the address is written in the odd or next memory location and is verified. Last, the program goes back to the starting address and verifies all locations. This memory test is rapid, but it can miss hard memory errors (a bit stuck at 1 or 0).

Another test stores the hexadecimal bit pattern 55 (01010101 binary) in the even locations and AA (10101010 binary) in the odd locations, then verifies all locations. The test is repeated, using AA in the even locations and 55 in the odd locations. This rapid test finds both hard and soft errors. (A soft error occurs when the current state of a dynamic-mem-

ory bit is changed by ionizing radiation from the plastic or ceramic integrated-circuit package.) This test has no cross-check specifically for soft errors, except by running the test again.

The most extensive memory-test algorithms are probably the galloping-read test and galloping-write test. The galloping-read test clears memory to all zeros in all locations and stores FF hexadecimal (11111111 binary) in a specified starting address. The test reads all other locations and verifies the presence of 00 hexadecimal, except for the memory byte with FF. Next, the byte with FF is cleared, FF is written in the next memory location, and the reading and verification of all locations are repeated until the last memory location is reached.

The galloping-write test clears memory and stores FF in a specified starting address. The test writes 00 hexadecimal to all other locations and verifies each write. The address of FF's location is verified when found. Next, the byte with FF is cleared and moved to the next memory location. The writing and verification of all locations in this manner are repeated until the last memory location is reached.

The latter two memory tests are ex-

MEMOREX Diskettes



Top-quality Memorex Diskettes from **Tech•Data**, your complete word and data processing supply center. Dealer inquiries invited.

Call Toll Free
1-800-237-8931.
In Florida, call
813-577-2794.

Tech•Data Corporation
3251 Tech Drive North
St. Petersburg, FL 33702

Circle 452 on inquiry card.

REG ALERT! BATTLE STATIONS! MAN THE

EARTH DEFENDER

YOU COMMAND THE EARTH DEFENDER AND PROTECT THE EARTH FROM ATTACKING ALIENS, THREATENING ASTEROIDS AND NUCLEAR MISSILES! HURRY! AIM AND FIRE YOUR LASER!

SAVE YOUR PLANET. PERHAPS FROM ITSELF!
Send \$29.95 to NEW VISION Dept. A1-3
5105 Peachtree Ind. Blvd.
Chamblee Ga. 30341
(404) 455-3688

For Apple II or II+ DOS 3.3 H. Res Graphics and Sounds 15 Day Money Back Guarantee

Copyright 1982 by NEW VISION 1982

Circle 342 on inquiry card.

STOP LOSING MONEY ON TIME-SHARE SERVERS!

LOGICSIM

CP/M based professional logic simulator

- * For engineering work stations.
- * For gate-array, custom and all other IC designers.
- * For digital system engineers.

Logic states, ability to simulate TTL, NMOS, CMOS, PMOS logic, ROM's and RAM's, three-state and transfer gates, wired-or'd nodes, propagation delays, spike and race analysis, expandable pin-number based TTL macro library plus numerous other features make LOGICSIM comparable to industry standard simulators.

It's it now. Send us a \$30 check for LOGICSIM demo copy and User's Manual.

Please specify 8" IBM 3740 5" APPLE II (13/16 sector), CP/M based 56K to 64K systems (APPLE's with CP/M cards). Introductory price \$276.

For more information, call (408) 578-8096. Or write:
E/Z ASSOCIATES, 5889 Starcrest Dr., San Jose, CA 95123

APPLE, CP/M, LOGICSIM are trademarks of Apple Computer, Digital Research and E/Z ASSOCIATES

Circle 186 on inquiry card.

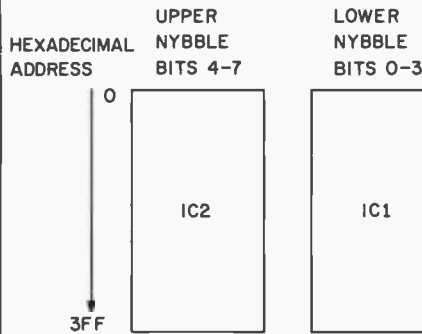

Figure 1: Memory organization of type-2114 static-memory components. These are organized by nybbles in 8-bit words, for a total of 4K bytes.

Binary	Hexadecimal
0000	(00)
0001	(11)
0010	(22)
0100	(44)
1000	(88)
1110	(EE)
1101	(DD)
1011	(BB)
0111	(77)

Table 1a: Barber-pole pattern to test memories organized in 8-bit words by nybbles, such as type-2114 devices, as shown in figure 1. Nine elements are in the table.

Binary	Hexadecimal
0000	(00)
0000	(01)
0000	(02)
0000	(04)
0000	(08)
0001	(10)
0010	(20)
0100	(40)
1000	(80)
1111	(FE)
1111	(FD)
1111	(FB)
1111	(F7)
1110	(EF)
1101	(DF)
1011	(BF)
0111	(7F)

Table 1b: Barber-pole pattern to test memories organized in 8-bit words by bits, such as type-4116 devices, as shown in figure 2. Seventeen elements are in the table.

cellent for the location of memory-overlap problems, but are extremely time-consuming when running a test on previously operational memory. The main limitation of all these tests is their failure to indicate with a high degree of certainty which memory component has a hard error.

Barber-Pole Memory Test

The use of a memory-test program that "barber poles" (rotates by shifting) a binary 1 or 0 across a field of oppositely valued bits in each byte provides for the identification of a defective memory component failing repeatedly as a hard error. Soft errors are not specially flagged, but because of the structure of the error printout, we can surmise that a particular bit error was a soft error. In addition, if the number of elements of the barber pole is appropriately chosen, memory-decoding problems can be probed.

First, let us consider the test of type-2114 static 1024 by 4-bit memories. In a memory configuration using 2114s, one 2114 is the lower nybble of the memory block, and the other is the upper nybble (see figure 1). A pattern that exercises each bit in each chip and provides information about the specific memory chip in error is shown in table 1a. The pattern rotates a binary 1 across a field of four 0s, then rotates a 0 across a field of four 1s.

This is the same approach used for the type-4116 dynamic 16K by 1-bit memories, except that rotation of a 1 or 0 through a field of eight 0s or eight 1s, respectively, is used (see table 1b). The patterns differ because of the different organization of storage in the two memory systems. With this approach, we can determine which memory chip is defective.

Consider the following example. We shall assume that the memory being tested is a group of eight 4116 16K-bit dynamic memories with a storage layout as shown in figure 2, containing an error at address 0000 hexadecimal. The error at 0000 was chosen only to provide the sequence of error messages to be discussed later. The substitution of any other address for address 0000 provides the

THE FORTH SOURCE™

NEW FORTH PRODUCTS

- Personal FORTH** for the IBM-PC by FORTH Inc. Multitasking, full screen editor, floating point support, DOS file handler, color monitor support, turnkey compiler. \$300
- MULTI-TASKING FORTH CP/M**, Northstar & Micropolis. A-FORTH by Shaw Labs, Ltd. can operate your micro like a mainframe. Print, sort, and inter-actively input, all at the same time \$395
- FORTH TUTORIAL** by Laxen & Harris. Two 8" CP/M disks with documentation and a copy of "Starting FORTH" by Brodie. The easy way to learn FORTH. \$95
- "And so FORTH"** by Huang. An indepth how-to book about FORTH with a Z80 implementation. Follows the fig-FORTH model. \$25
- VIC FORTH** by HES. A cartridge for the VIC 20. \$60
- GrafFORTH** by Insoft. A stand alone graphics disk for APPLE II. \$75

MORE FORTH DISKS

FORTH with editor, assembler, and manual. •Source provided. Specify computer!

- | | |
|--|--|
| <input type="checkbox"/> APPLE III/II + by MicroMotion \$100 | <input type="checkbox"/> PET® by FSS \$90 |
| <input type="checkbox"/> APPLE II by Kuntze• \$90 | <input type="checkbox"/> TRS-80/II® by Nautilus Systems• \$90 |
| <input type="checkbox"/> ATARI® by PNS \$90 | <input type="checkbox"/> 6800 by Talbot Microsystems \$100 |
| <input type="checkbox"/> CP/M® by MicroMotion \$100 | <input type="checkbox"/> 6809 by Talbot Microsystems \$100 |
| <input type="checkbox"/> CROMEMCO® by Inner Access \$100 | <input type="checkbox"/> Z80 by Laboratory Microsystems \$50 |
| <input type="checkbox"/> HP-85 by Lange• \$90 | <input type="checkbox"/> 8086/88 by Laboratory Microsystems \$100 |
| <input type="checkbox"/> IBM-PC® by Laboratory Microsystems \$100 | |

Enhanced FORTH with: F-Floating Point, G-Graphics, T-Tutorial, S-Stand Alone, M-Math Chip Support, X-Other Extras, 79-FORTH-79 Specify computer!

- | | |
|---|---|
| <input type="checkbox"/> APPLE III/II + by MicroMotion, F, G, & 79 \$140 | <input type="checkbox"/> TRS-80/II or III by Miller Microcomputer Services, F, X, & 79 \$130 |
| <input type="checkbox"/> CP/M by MicroMotion, F & 79 \$140 | <input type="checkbox"/> 6809 by Talbot Microsystems, T & X \$250 |
| <input type="checkbox"/> H89/Z89 by Haydon, T & S \$250 | <input type="checkbox"/> Z80 by Laboratory Microsystems, F & M Each \$100 |
| <input type="checkbox"/> H89/Z89 by Haydon, T \$175 | <input type="checkbox"/> 8086/88 by Laboratory Microsystems, F & M Each \$100 |
| <input type="checkbox"/> PET by FSS, F & X \$150 | |

CROSS COMPILERS Allow extending, modifying and compiling for speed and memory savings. can also produce ROMable code. •Requires FORTH disk.

- | | |
|---|---|
| <input type="checkbox"/> CP/M \$300 | <input type="checkbox"/> IBM• \$300 |
| <input type="checkbox"/> H89/Z89 \$300 | <input type="checkbox"/> 8086• \$300 |
| <input type="checkbox"/> TRS-80/II \$300 | <input type="checkbox"/> Z80• \$300 |
| <input type="checkbox"/> Northstar® \$300 | <input type="checkbox"/> Apple II \$300 |

- fig-FORTH Programming Aids** for decompiling, callfinding, and translating. Specify computer \$150

fig-FORTH Model and Source, with printed Installation Manual and Source Listing.

- | | | |
|---|----------------|-----------|
| <input type="checkbox"/> APPLE II® .5 1/4 | 8080/Z80* .8 | |
| <input type="checkbox"/> 8086/88, 8 | H89/Z89, 5 1/4 | Each \$65 |

MVP-FORTH - A Public Domain Product

MVP-FORTH contains a kernel for transportability, the FORTH-79 Standard Required Word Set, the vocabulary for the instruction book, STARTING FORTH, by Brodie, editor, assembler, many useful routines, and utilities.

MVP-FORTH PRODUCTS for CP/M® IBM-PC® and Apple®

- MVP-FORTH Programmer's Kit** including disk with documentation, ALL ABOUT FORTH, and STARTING FORTH. Assembly source listing versions. \$100
- MVP-FORTH Disk** with documentation. Assembly source listing version. \$75
- MVP-FORTH Cross Compiler** with MVP-FORTH source in FORTH. \$300
- MVP-FORTH Programming Aids** for decompiling, callfinding, and translating. Specify computer. \$150
- MVP-FORTH Assembly Source** Printed listing. \$20
- ALL ABOUT FORTH** by Haydon. MVP-FORTH reference. \$20

★★★ MVP-FORTH operates under a variety of CPU's, computers, and operating systems. Specify your computer and operating system.★★★

FORTH MANUALS, GUIDES & DOCUMENTS

- | | |
|--|--|
| <input type="checkbox"/> FORTH Encyclopedia by Derick & Baker. A complete programmer's manual to fig-FORTH with FORTH-79 references. Flow charted, 2nd Ed. \$25 | <input type="checkbox"/> TRS-80 User's Manual , MMSFORTH \$19 |
| <input type="checkbox"/> 1980 FORML Proc. \$25 | <input type="checkbox"/> Starting FORTH by Brodie. Best instructional manual available. (soft cover) \$16 |
| <input type="checkbox"/> 1981 FORML Proc. 2 Vol. \$40 | <input type="checkbox"/> Starting FORTH (hard cover) \$20 |
| <input type="checkbox"/> 1982 FORML Proc. \$25 | <input type="checkbox"/> META-FORTH by Cassidy. Cross compiler with 8080 code \$30 |
| <input type="checkbox"/> 1981 Rochester FORTH Proc. \$25 | <input type="checkbox"/> Systems Guide to fig-FORTH \$25 |
| <input type="checkbox"/> 1982 Rochester FORTH Proc. \$25 | <input type="checkbox"/> Caltech FORTH Manual \$12 |
| <input type="checkbox"/> Using FORTH \$25 | <input type="checkbox"/> Invitation to FORTH \$20 |
| <input type="checkbox"/> A FORTH Primer \$25 | <input type="checkbox"/> PDP-11 FORTH User's Manual \$20 |
| <input type="checkbox"/> Threaded Interpretive Languages \$20 | <input type="checkbox"/> CP/M User's Manual , MicroMotion \$20 |
| <input type="checkbox"/> AIM FORTH User's Manual \$12 | <input type="checkbox"/> FORTH-79 Standard \$15 |
| <input type="checkbox"/> APPLE User's Manual MicroMotion \$20 | <input type="checkbox"/> FORTH-79 Standard Conversion \$10 |
| | <input type="checkbox"/> Tiny Pascal in fig-FORTH \$10 |

- Installation Manual for fig-FORTH**, contains FORTH model, glossary, memory map and instructions \$15

Source Listings of fig-FORTH, for specific CPU's and computers. The Installation Manual is required for implementation. Each \$15

- | | | | |
|--------------------------------|----------------------------------|-------------------------------|--|
| <input type="checkbox"/> 1802 | <input type="checkbox"/> 6502 | <input type="checkbox"/> 6800 | <input type="checkbox"/> AlphaMicro |
| <input type="checkbox"/> 8080 | <input type="checkbox"/> 8086/88 | <input type="checkbox"/> 9900 | <input type="checkbox"/> APPLE II |
| <input type="checkbox"/> PACe | <input type="checkbox"/> 6809 | <input type="checkbox"/> NOVA | <input type="checkbox"/> PDP-11/LSI-11 |
| <input type="checkbox"/> 68000 | <input type="checkbox"/> Eclipse | | |

Ordering Information: Check, Money Order (payable to MOUNTAIN VIEW PRESS, INC.), VISA, MasterCard or COD's accepted. No billing or unpaid PO's. California residents add sales tax. Shipping costs in US included in price. Foreign orders, pay in US funds on US bank, include for handling and shipping by Air: \$5 for each item under \$25, \$10 for each item between \$25 and \$99 and \$20 for each item over \$100. Minimum order \$10. All prices and products subject to change or withdrawal without notice. Single system and/or single user license agreement required on some products.

DEALER & AUTHOR INQUIRIES INVITED

MOUNTAIN VIEW PRESS, INC.

PO BOX 4656

MOUNTAIN VIEW, CA 94040

(415) 961-4103

same error messages, but in a different sequence.

If the bit at address 0000 in IC3 (in figure 2) is stuck at 1, an error message can provide us with the information shown in listing 1a. By looking at the bit patterns in the "found value" column of listing 1a, we can tell that bit 2, the third from the right in the binary representation, is always high. If the bit at address 0000 in IC3 in figure 2 is stuck at 0, the error message provides the information shown in listing 1b. The bit pattern of the found value indicates that bit 2 is always low. With the knowledge of the address mapping of the memory components and the found-bit pattern, we can determine exactly which integrated circuit is bad.

Soft memory errors should not give all the error messages in listings 1a and 1b. We would normally expect only one of the nine error messages of listing 1. Memory-decoding errors of the type where two different memory addresses access the same byte or bytes are signified by the odd number

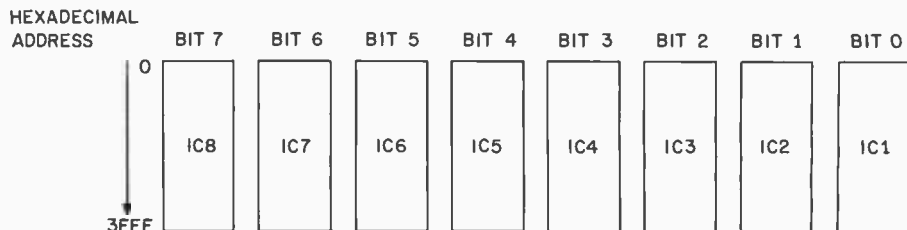

Figure 2: Memory organization of type-4116 dynamic-memory components. These are organized by bits in 8-bit words, for a total of 16K bytes.

of elements (9 or 17), but the exact results of the error-message display are uncertain since I was unable to test this feature specifically.

Memory-Diagnostic Program

The barber-pole test program, shown in listing 2 on pages 422 through 442, is written in assembly language for the Intel 8080 and 8085 microprocessors. It begins with an initialization section to set the stack pointer and zero the error flag. The starting address of the memory test in hexadecimal radix is requested from the user, accepted by the subroutine

GETHX, and stored. Next, the ending address of the memory segment to be tested is requested in the same manner. A test is made to ensure that the starting address is less than or equal to the ending address. If not, an error message is sent to the console, and the program asks for the starting and ending addresses again. When valid addresses have been entered, the number of bytes to be tested is computed and stored.

Upon completion of the above, the pattern length (stored in PATLN) and number of cycles (NCYCL) are initialized, and the memory address of

Text continued on page 444

Listing 1a: Error messages produced by the barber-pole memory-test program when the error being detected is a single bit stuck at the value of 1 in one of the components, IC3 (see figure 2).

Message									Binary Representation of Found Value	
MEMORY ERROR	AT	0000	HEX,	EXPECTED	00,	FOUND	04	0000	0100	
MEMORY ERROR	AT	0000	HEX,	EXPECTED	01,	FOUND	05	0000	0101	
MEMORY ERROR	AT	0000	HEX,	EXPECTED	02,	FOUND	06	0000	0110	
MEMORY ERROR	AT	0000	HEX,	EXPECTED	08,	FOUND	0C	0000	1100	
MEMORY ERROR	AT	0000	HEX,	EXPECTED	10,	FOUND	14	0001	0100	
MEMORY ERROR	AT	0000	HEX,	EXPECTED	20,	FOUND	24	0010	0100	
MEMORY ERROR	AT	0000	HEX,	EXPECTED	40,	FOUND	44	0100	0100	
MEMORY ERROR	AT	0000	HEX,	EXPECTED	80,	FOUND	84	1000	0100	
MEMORY ERROR	AT	0000	HEX,	EXPECTED	FD,	FOUND	FF	1111	1111	

Listing 1b: Error messages produced when the error is a bit stuck at 0 in IC3.

Message									Binary Representation of Found Value	
MEMORY ERROR	AT	0000	HEX,	EXPECTED	04,	FOUND	00	0000	0000	
MEMORY ERROR	AT	0000	HEX,	EXPECTED	FE,	FOUND	FA	1111	1010	
MEMORY ERROR	AT	0000	HEX,	EXPECTED	FD,	FOUND	F9	1111	1001	
MEMORY ERROR	AT	0000	HEX,	EXPECTED	F7,	FOUND	F3	1111	0011	
MEMORY ERROR	AT	0000	HEX,	EXPECTED	EF,	FOUND	EB	1110	1011	
MEMORY ERROR	AT	0000	HEX,	EXPECTED	DF,	FOUND	DB	1101	1011	
MEMORY ERROR	AT	0000	HEX,	EXPECTED	BF,	FOUND	BB	1011	1011	
MEMORY ERROR	AT	0000	HEX,	EXPECTED	7F,	FOUND	7B	0111	1011	

WE'LL GETCHA!

If Esprit II™ didn't, the Esprit III™ will.



Hazeltine's Esprit II™ gave you better cost/performance than any other budget terminal. Better than TVI-910. Better than Viewpoint. Better than ADM-3A. It got a lot of you.

Now we're going to get the rest of you.

The new Hazeltine Esprit III™ emulates TVI-950. The same features. The same keyboard layout. The same command set. Even the same user-PROM capability. The only difference is price. Esprit III costs \$300 less.

In fact, it costs \$100 less than TeleVideo's far less capable TVI-925.

So, now there isn't a terminal left with more performance for the money than a Hazeltine Esprit. Which is why you ought to get one. Or more.

Got it?

Hazeltine Corporation
Computer Terminal Equipment
Commack, NY 11725
(516) 462-5598
or call toll free: 800-645-4508

Hazeltine

The new terminal technology.

	Esprit	ADM 3A*	TVI 910*	Esprit II	View-point*	Esprit III	TVI 925*	TVI 950*
Detached keyboard	No	No	No	Yes	Yes	Yes	Yes	Yes
Buffered mode	Yes	No	No	Yes	No	Yes	Yes	Yes
Tilt screen	No	No	No	Yes	No	Yes	Yes	Yes
Function keys	14	No	10	14	3	22	22	22
Line graphics	No	No	No	No	No	Yes	No	Yes
Page/line transmit	Yes	No	No	Yes	No	Yes	Yes	Yes
Character/line editing	Partial	No	No	Yes	No	Yes	Yes	Yes
Split screen	No	No	No	No	Yes	Yes	Yes	Yes
Smooth scrolling	No	No	No	No	No	Yes	No	Yes
Price (in quantity of one)	\$595	\$595	\$699	\$645	\$645	\$895	\$995	\$1,195

*Trademarks respectively of Lear Siegler, Inc., TeleVideo Systems, Inc. and Applied Digital Data Systems, Inc.

See us at Comdex. Booth 2118.

IT'S A WINNER AT MINI/MICRO '82* THE LCM100 TOP TEN PRODUCT AWARD for "Significant New Product Introduction"

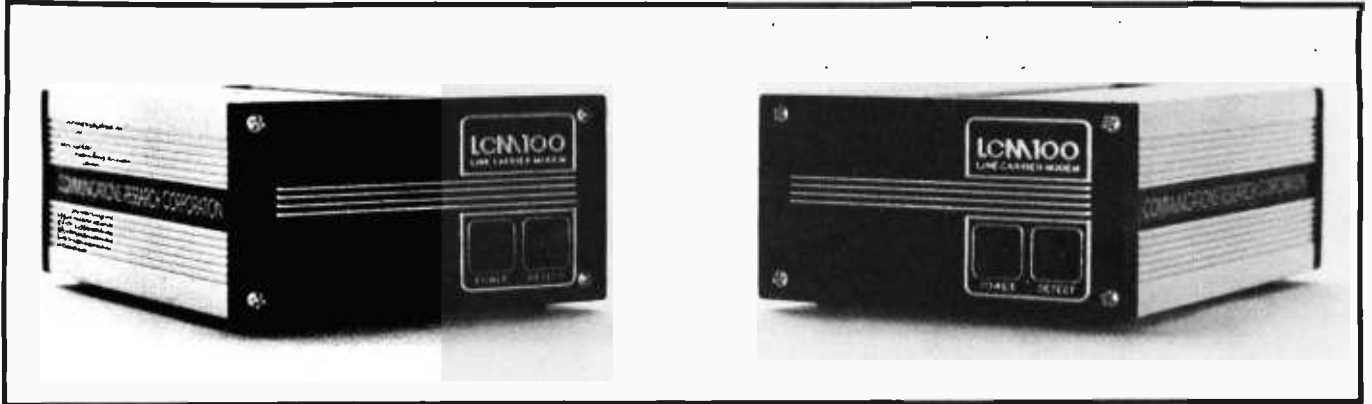

*Award Winning LCM-100/Computer Conference and Exhibition, Anaheim, CA, Sept. 14-16, 1982.

The LCM 100 Line Carrier Modem drew rave reviews from the more than 30,000 attendees at Mini/Micro. The use of AC electrical wiring, in place of RS232 cabling, was an application of line carrier technology that OEM's, dealers

and computer-oriented people in general all found an exciting, practical and inexpensive achievement.

Now, with the LCM, computer data can be transmitted between computer and

terminal, or plotter, or another computer over existing AC lines. It offers an entire new concept of portability for communications systems in offices, business or at home.

Come and see for yourself. VISIT OUR BOOTH NO. 3636 AT COMDEX., and ask about our show special.

Or, call 1-800-426-8075 for complete information about our Dealer Incentive Program. It's one of a kind. Just like our award-winning LCM 100.

CRC

COMMUNICATIONS RESEARCH CORPORATION

1720 130th AVENUE N.E. BELLEVUE, WASH. 98005 (206) 881-9550
A SUBSIDIARY OF ENERGY SCIENCES CORPORATION

Listing 2 continued:

```

CALL          GETHX          ; GET START ADDRESS
INC           MAIN1          ; IF CARRY = 0, INVALID DATA
MOV          H,B             ; MOVE START ADDRESS TO <HL>
MOV          L,C
SHLD        MEMST          ; STORE START ADDRESS
;
;GET END ADDRESS
;
MAIN2:
LXI          H,MESG2        ; POINT TO 'ENTER ADDRESS OF MEMORY END
                                ; IN HEX'
MVI          B,MESL2        ; LENGTH OF MESSAGE 2
CALL        MSGL           ; OUTPUT MESSAGE
CALL        GETHX          ; GET END ADDRESS
INC           MAIN2          ; IF CARRY = 0, INVALID DATA
MOV          H,B             ; MOVE END ADDRESS TO <HL>
MOV          L,C
SHLD        MEMND          ; STORE END ADDRESS
;
;TEST FOR START ADDRESS > END ADDRESS AND COMPUTE
;THE NUMBER OF BYTES TO BE TESTED
;
XCHG        ; MOVE END ADDRESS TO <DE>
LHLD        MEMST          ; MOVE START ADDRESS TO <HL>
MOV          A,H            ; TAKE THE 2'S COMPLEMENT OF THE
CMA          ; START ADDRESS
MOV          H,A
MOV          A,L
CMA
MOV          L,A
INX          H
DAD          D              ; ADD END ADDRESS TO 2'S COMPLEMENT OF
                                ; START ADDRESS
JC           MAIN3          ; IF CARRY = 1, THEN START ADDRESS <= END
                                ; ADDRESS. JUMP OVER NEXT SECTION
LXI          H,MESG3        ; POINT TO 'ERROR: MEMORY START ADDRESS
                                ; > MEMORY END ADDRESS'
MVI          B,MESL3        ; LENGTH OF MESSAGE 3
CALL        MSGL           ; OUTPUT MESSAGE
CALL        CROUT          ; OUTPUT CR AND LF
JMP         MAIN1          ; START OVER
MAIN3:
INX          H              ; COMPUTE NUMBER OF BYTES TO BE TESTED
SHLD        NBYTE          ; STORE NUMBER OF BYTES
;
;SET UP REGISTERS TO ESTABLISH THE BARBER-POLE PATTERN
;
MVI          A,LNPAT        ; SET PATTERN LENGTH
STA          PATLN          ; AND STORE PATTERN LENGTH
STA          NCYCL          ; AND STORE IN NUMBER OF CYCLES
LXI          B,PATRN        ; LOAD <BC> WITH TOP OF PATTERN TABLE
PUSH        B              ; AND SAVE ON STACK
MAIN4:
LHLD        NBYTE          ; MOVE NUMBER OF BYTES TO <HL>
XCHG        ; THEN TO <DE>
LHLD        MEMST          ; LOAD <HL> WITH START ADDRESS
;
;PUT THE BARBER-POLE PATTERN IN R/W MEMORY
;
MAIN5:
LDAX        B              ; MOVE PATTERN ELEMENT TO <A>
MOV          M,A            ; AND STORE IN MEMORY
INX          B              ; POINT TO NEXT PATTERN ELEMENT
INX          H              ; INCREMENT MEMORY POINTER
DCX          D              ; DECREMENT NUMBER OF BYTES
MOV          A,E            ; TEST FOR NUMBER OF BYTES = 0
ORA         D

```

Listing 2 continued on page 426

AMX

Real-Time Multitasking Executive

for
8080, Z80
and 6809

Gives your application a head start

AMX can save you time and money. You can capitalize on our years of multitasking experience. Start your application using a software executive proven with three years of fault-free operation.

Professional software designers use AMX as the starting point for their product and system designs. AMX shields them from the difficulties of managing the micro, freeing them to concentrate on their application.

SIMPLE OPERATION

Complex control programs are divided into a number of separate, more manageable programs, called *tasks*, each designed to do one job. Tasks are written and tested separately and then combined to form a reliable, finished system.

AMX supervises the orderly execution of these tasks, assuring that the most important jobs always get done first. Tasks appear to be executing simultaneously. It's almost like having a separate CPU for each task!

HARDWARE INDEPENDENCE

AMX does not require a particular hardware configuration. *You* control

your environment. *You* pick the I/O method. *You* decide the preferred interrupt service technique for your system. AMX will support your choice.

AMX is fast, compact, and ROMable. Even though the AMX nucleus is less than 1400 bytes in size, it features multiple task priorities, intertask message passing with priority queuing, external event synchronization, and interval timing.

Interface modules are available to allow AMX to be used with C, PASCAL, PL/M, FORTRAN and assembler.

Access to CP/M[®] disk files in real time is possible using the AMX I/O Supervisor.

COMPLETE DOCUMENTATION

AMX can be judged by the quality of our documentation.

We deliver AMX source on diskette to permit AMX to be moved to the software development system of your choice. Our liberal license agreement permits binary (object) distribution without royalties.

HOW TO ORDER

A specification sheet and price list are available, free. Your check or money order for \$75 will purchase the AMX Reference Manual for immediate evaluation (specify 8080, 8085, Z80 or 6809 processor). Add \$25 for postage and handling outside USA and Canada. The standard AMX Multitasking Executive package, including source code, is \$800.

AMX is the choice of professionals the world over. Make it yours, today.

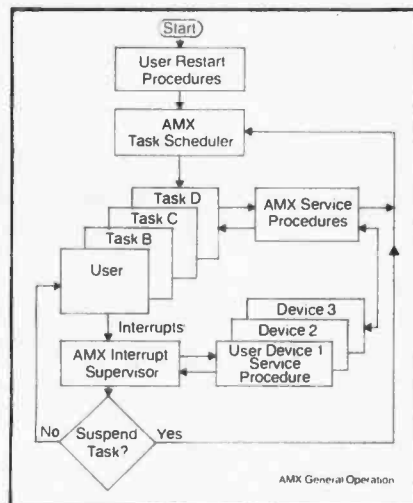

CP/M is a trademark of Digital Research Corp.
Z80 is a trademark of Zilog Corp.



KADAK Products Ltd.



206-1847 W. Broadway Ave., Vancouver, B.C., Canada V6J 1Y5 Phone: (604) 734-2796 Telex: 04-55670

Yes, we're the biggest.

But that isn't what makes us number one.

It's the totality of what we do to make microcomputers more effective for you that makes us number one.

Yes. We have the largest number of packages — simple and complex. Yes. We have the greatest number of formats. Yes. We have the best technical support in the business. Yes. All of our products are immediately available.

But let's take a step back. When the microcomputer world opened up there was little definition and no software. Then came Lifeboat — to meet the need for easy-to-use, fully-tested, reliable software backed by extensive and available service.

Lifeboat developed standards for the industry which led to improved quality, reduced costs, higher levels of technical competence, credibility and reduced user risk.

Today Lifeboat offers personal, professional and corporate end-users, as well as dealers, distributors, authors, OEMs and others, a unique, single-source, full-service Software Support System™.

Everyone looks to us as the source of the most comprehensive, fully-tested line of software. Word processing, financial planning, accounting, graphics, data base management, languages and more. We have it all — for nearly every microcomputer available, including the IBM PC.

Our customer service department provides facilities for mail, telephone, TWX, telex and personal sales. We have a network of offices in the U.S., England, France, Japan, Switzerland and West Germany.

We provide a Software Desk Reference™ which contains up-to-date information about state-of-the-art software books, periodicals and accessories.

We offer subscriptions to *Lifelines*™ The Software Magazine.™ A monthly publication covering new products, tips for microcomputer users, product comparisons and other features to guide the reader before and after a purchase.

As the largest publisher of software, we also print a guide setting standards for software authors.

It takes a lot to become big but it takes even more to become — and remain — number one.

That's our commitment.

Lifeboat Associates, 1651 Third Avenue, New York, New York 10028.
TWX: 710-581-2524 (LBSOFT NYK). TELEX: 640693 (LBSOFT NYK).

Please send me a free Lifeboat Software Desk Reference filled with descriptions of over 200 programs designed for use in professional, business, programming and personal environments.

Please send further information on *Lifelines* and Author's Guide.

Name _____ Title _____

Company _____ Bus. Phone _____

Street _____

City _____ State _____ Zip _____

Lifeboat Associates
World's No. 1 source of micro software CD

Lifelines, The Software Magazine,™ Lifelines Pub. Co.
Software Support System, Software Desk Reference,™ Lifeboat Assoc.
Copyright © 1982, by Lifeboat Associates.

NEW 16-Bit Software Available for the IBM PC, plus...

System Tools:

Emulator/86
EM80/86
PMATE-86
UT86
PANEL-86

Telecommunications:

ASC0M

Languages:

Lattice C Compiler
PL/M

Word Processing Systems And Aids

WordStar
MailMerge
MicroSpell
Spellguard

Data Management Systems:

T.I.M. III

Mailing List Systems

Postmaster

Financial Accounting Packages

General Ledger

Numerical Problem-Solving Tools

Math PC
Plan86
SigmaCalc
Statpak

Professional And Office Aids

Dental Mngmnt Sys. (8000 & 9000)
Insurance Agency
Legal Time Acctng.
Medical Mngmnt Series
(8000 & 9000)

Disk Operating Systems:

MS-DOS (SB-86) — available for OEM license.

8-Bit Software Available

System Tools:

BUG and uBUG
DESPOOL
DISLOG
DISTEL
EDIT
EDIT-80
FILETRAN
IBM/CPM
MAC
MACRO-80
MINCE
PANEL
PASM
PLINK
PLINK II
PMATE
RAID
Reclaim
SID
TRS-80 Model II Cust. Disk
Unlock
WordMaster
XASM: 05, 09, 18, 48, 51, 65, 68, 75,
F8, 400, Z8
ZAP80
ZDT
Z80 Development Package
ZSID

Telecommunications:

ASC0M
BSTAM
BSTMS
eZmail
MicroLink-80
RBTE-80

Languages:

ALGOL-60
APL/V80
BASIC Compiler
BASIC-80
baZc II
BD Software C Compiler
CBASIC-2

CIS COBOL (Standard)

COBOL-80
FORTRAN-80
KBASIC
JRT Pascal
muLISP/muSTAR
Nevada COBOL
Pascal/M
Pascal/MT
Pascal/M +
Pascal/Z
PLA-80
Precision BASIC
STIFF UPPER LISP
S-BASIC
Timin FORTH
Tiny-C
Tiny-C TWO
UCSD Pascal
Whitesmiths' C Compiler
XYBASIC

Language and Applications Tools:

BASIC Utility Disk
DataStar
FABS
FABS II
Forms 2 for CIS COBOL
MAG/sam3,4
MAG/sort
M/SORT for COBOL 80
Programmer's Apprentice
PSORT
QSORT
STRING/80
STRING BIT
SuperSort
ULTRASORT II
VISAM

Word Processing Systems and Aids:

Benchmark
DocuMate/Plus
Letteright
MagicPrint

Magic Wand

Math ★
MicroSpell
SMARTKEY
Spellguard
TEX
Textwriter III
WordIndex
WordStar
WordStar French
WordStar Customization Notes

Data Management Systems:

CONDOR
dBASE II
Formula
HDBS
Hoe
MAG/base1,2,3
MDBS
MicroSEED
T.I.M. III

General Purpose Applications:

CBS
CBS Label Option Pak
Selector III-C2
Selector IV

Mailing List Systems:

Benchmark Mailing List
Mailing Address
MailMerge for WordStar
NAD
Postmaster

Financial Accounting Packages:

BOSS Financial Accounting System
Financial Pkgs. (PTree)
Financial Pkgs. (SSG)
General Ledger Acctng (Univair)
GLector

Numerical Problem-Solving Tools:

Analyst
Ipl
Microstat
muSIMP/muMATH
PLAN80
SigmaCalc
Statpak
T/MAKER II

Professional And Office Aids:

Apartment Mngmnt (Cornwall)
Datebook
Dental Mngmnt (Univair)
Dental Mngmnt-Family (Univair)
GrafTalk
Insurance Agency Mngmnt
Legal Time Acctng (Univair)
Medical Mngmnt (Univair)
Medical Mngmnt-Family (Univair)
PAS 3 Medical
PAS 3 Dental
Professional Time Acctng (PTA)
Property Mngmnt Pkg. (Am. Soft.)
Property Management (PTree)
Sales Pro
Wiremaster

Lifeboat After Hours

Backgammon/Gomoku

Educational Tools

Toricelli Author
Toricelli Studio

Books and Periodicals

APL—An Interactive Approach
Accounts Payable and Accounts
Receivable-CBASIC
CBASIC User Guide
The Computer Glossary
The CP/M Handbook (with MP/M)

The C Programming Language

Crash Course in
Microcomputing
Devil's DP Dictionary
Discover FORTH
DON'T (Or How To Care For
Your Computer)
8080/Z80 Assembly Language
Techniques For Improved
Programming
Executive Computing
Fifty BASIC Exercises
General Ledger-CBASIC
Introduction to Pascal
Lifelines/The Software Magazine
Pascal User Manual and Report
The Pascal Handbook
The Pascal Primer
Payroll with Cost Accounting
—CBASIC
Structured Microprocessor
Programming
A User Guide To The UNIX System
Using CP/M—A Self-Teaching
Guide

Hardware and Accessories

DC Data Cartridges
Diskette Drive Head Cleaning Kits
F floppy Disk Kit
Floppy Saver
Smartmodem
Vari Clean Cleaning Kit

Disk Operating Systems

BRIDOS
CP/M-80
MP/M
SB-80
APPLI-CARD
Softcard

Hard Disk Integration Modules

Media & Formats for 8-AND 16-Bit Microcomputers

This list of available formats is subject to change without notice. If you do not see your computer listed or are uncertain, call to confirm the format code for any particular equipment.

A.B. Dick.....M8
ADD5 Multivision.....RT
AES Super Plus IV.....Q4
ALSPA 8".....A1
Altair 8800.....B1
Altos.....A1
Apple CP/M-80 13 Sector.....RG
Apple CP/M-80 16 Sector.....RR
Archives I.....SG
AVL Eagle I.....RB
AVL Eagle II.....ST
BASF System 7100.....RD
Blackhawk Micropolis Mod II.....Q2
BMC IF-800.....SR
Cado.....A1
California Computer Sys 8".....A1
CDS Versatile 3B.....Q1
CDS Versatile 4.....Q2
Columbia Data Products 8".....A1
Columbia Data Products 5 1/4".....S4
Commodore CBM/PET + SSE
Box + 8050.....C2
Commodore CBM/PET
w/Madison Z-RAM + 8050.....C4
COMPAL-80.....Q2
CompuCorp 655.....Q7
CompuCorp 685.....Q6
Computer Ops N.C. HQ.....S2
Control Data 110.....A1
CPT 8000.....A1
Cromemco System 3.....A1
Cromemco System 2SD/SS.....R6
Cromemco System 2DD/SS.....RX
Cromemco System 2DD/DS.....RY

CSSN Backup.....T1
Datapoint 1550/2150 DD/SS.....AA
Datapoint 1550/2150 DD/DS.....AB
Datavue DU 80-222.....M7
DEC VT 18 X.....SD
Delta Systems.....A1
Digi-Log Microterm II.....RD
Digi-Log Sys. 1000/1500/2000.....RD
Direct OA1000.....M2
DTC Micro 210A.....SC
Durango F-85.....RL
Dynabyte DB8/2.....R1
Dynabyte DB8/4.....A1
Exidy Sorcerer +
LB CP/M-80 5 1/4".....Q2
Exidy Sorcerer +
Exidy CP/M-80 5 1/4".....RW
Exidy Sorcerer +
Exidy CP/M-80 8".....A1
EXO.....A1
Exxon 510/520.....Q5
Findex.....P6
Godbout.....E1
Heath H8 + H47.....A1
Heath H89 + Magnolia CP/M-80.....P7
Heath H89 + Heath CP/M-80.....P7
Helios II.....B2
Heurikon MLZ, SS.....SN
Heurikon MLZ, DS.....SO
Heuristics HCC Spectrum.....A1
Hewlett-Packard-87.....SB
Hewlett-Packard 125, 5 1/4".....SB
Hewlett-Packard 125, 8".....A1
IBEX 7100.....RQ
IBM Personal Computer.....G1
ICL Personal Computer.....RE
iCOM 2411 Micro Floppy.....R3
iCOM 3712.....A1
iCOM 3812.....A1

iCOM 4511 Cartr. CP/M v.1.4.....D1
iCOM 4511 Cartr. CP/M v.2.x.....D2
IMSAI VDP-40/VDP-42.....R4
IMSAI VDP-44.....R5
IMSAI VDP-80.....A1
Industrial Microsystems 5000.....RA
Industrial Microsystems 8000.....A1
Intel iPD5.....M6
Intel MDS SD.....A1
Intel Development Sys.....A1
Inter Systems Ithaca 800.....A1
Intertec Superbrain DOS 0.5-2.x.....RJ
Intertec Superbrain DOS 3.x.....RK
Intertec Superbrain QD.....RS
ISC Intecolor 8063/8360/8963.....A1
Lanier EZ-1.....M3
Lanier Super.....Q4
Lexitron VT 1303 DS/DD.....S8
Lexor Alphasprint Model S1.....S1
Lexor Lexoritron.....S1
Meca Delta-1 5 1/4".....P6
MCOM 2001.....B3
MCOM 2001E.....B4
MCOM 3003.....M1
Micromation.....A1
MicroMega 85.....SC
Micropolis Mod 1.....Q1
Micropolis Mod II.....Q2
MITOS 3200-3202.....SB
Monroe OC 8820, DD/SS.....W1
Morrow Discus.....A1
MosteK.....A1
MSD 5 1/4".....RC
MULTI-TECH-I.....Q2
MULTI-TECH-II.....Q2
Nascom (Gemini drives).....R3
Nascom II with Lucas Drives.....R3
National MSC 6600.....A1
NCR 8140/9010.....A1

NEC PC-8001.....RV
Nicolet Logic Analyzer Model 764.....SX
NNC-80/80W.....A1
North Star SD.....P1
North Star DD.....P2
North Star QD.....P3
Northern Telecom 503.....SM
Nylac Micropolis Mod II.....Q2
Ohio Scientific C3.....A3
OKI IF-800 + MSA CP/M-80.....SP
OKI IF-800 + OKI/LB CP/M-80.....SR
Osborne-1.....SA
Otrona Attache.....MC
Pertec PCC 2000.....A1
PET/CBM + SSE Bx + 8050.....C2
PET/CBM w/Madison Z-RAM +
8050.....C4
Philips P-2000.....MA
Philips MICOM 2001 8".....B3
Philips MICOM 2001E.....B4
Philips MICOM 3003.....M1
Processor Technology Helios II.....B2
Quasar QDP100.....A1
Quay 500.....RQ
Quay 520.....RP
Quay 900.....A1
RAIR DD.....RE
RAIR SD.....R9
Research Machines 5 1/4".....RH
Research Machines 8".....A1
Sanco 7000 5".....RQ
Sanyo MBC 1000.....SY
Sanyo MBC 2000.....SS
Sanyo MBC 3000.....A1
Seattle.....E1
Sony.....U1
SD Systems 5 1/4".....R3
SD Systems 8".....A1
Spacebyte.....A1

Tarbell 8".....A1
TecMar.....E1
TEI 5 1/4".....R3
TEI 8".....A1
Televideo DD/DS.....S5
T.I.P. (Alloy Engineering, Inc.).....T3
Toshiba T200.....SF
Toshiba T250.....A1
Triumph Adler Alphatronic.....SV
T.I.P. (Alloy Engineering, Inc.).....RM
TRS Model 1 + FEC Freedom.....RN
TRS-80 Model 1 + Shuffleboard.....A1
TRS-80 Model II.....A1
Vector MZ.....Q2
Vector System 2800.....A1
Vector System B/VIP.....Q2
Vista V-80 5 1/4" SD.....R8
Vista V2005 DD.....P6
Wangwriter.....SE
WORDPLEX.....S2
XEROX 820, 5 1/4".....S6
XEROX 820, 860 8".....A1
ZEDA 580.....SH
Zenith Z89 + Magnolia CP/M-80.....P7
Zenith Z89 + Zenith CP/M-80.....P7
Zenith DD/SS.....SK
Zenith DD/DS.....SJ
Zilog MK 22-20/25/50.....A1

Program names and computer names are generally trademarks or service marks of the author or manufacturing company.

All Lifeboat (LB) 8-bit software requires SB-80 (or other CP/M-80 compatible disk operating system) unless otherwise stated.

All products are subject to terms and conditions of sale.

Listing 2 continued:

```

JZ          MAIN6          ; IF ZERO, JUMP TO NEXT SECTION
LDA        PATLN          ; LOAD < A > WITH PATTERN LENGTH
DCR        A              ; AND DECREMENT
STA        PATLN          ; STORE DECREMENTED PATTERN LENGTH
JNZ        MAIN5          ; IF PATTERN LENGTH < > 0, THEN LOOP
POP        B              ; RESTORE PATTERN STARTING POINT TO < BC >
PUSH       B              ; AND PUT BACK ON STACK
MVI        A,LNPAT        ; SET PATTERN LENGTH
STA        PATLN          ; AND STORE
JMP        MAIN5          ; LOOP
;
;SET UP REGISTERS TO TEST THE BARBER-POLE PATTERN
;
MAIN6:
POP        B              ; RESTORE PATTERN STARTING POINT TO < BC >
PUSH       B              ; AND PUT BACK ON STACK
MVI        A,LNPAT        ; SET PATTERN LENGTH
STA        PATLN          ; AND STORE
LHLD      NBYTE           ; MOVE NUMBER OF BYTES TO < HL >
XCHG      DE              ; THEN TO < DE >
LHLD      MEMST           ; LOAD < HL > WITH START ADDRESS
;
;TEST THE BARBER-POLE PATTERN
;
MAIN7:
LDAX      B              ; MOVE PATTERN ELEMENT TO < A >
CMP        M              ; AND COMPARE TO MEMORY CONTENTS
CNZ       ERROR          ; IF NOT THE SAME , THEN ERROR
INX       B              ; POINT TO NEXT PATTERN ELEMENT
INX       H              ; INCREMENT MEMORY POINTER
DCX       D              ; DECREMENT NUMBER OF BYTES
MOV       A,E            ; TEST FOR NUMBER OF BYTES = 0
ORA       D
JZ        MAIN8          ; IF ZERO, JUMP TO NEXT SECTION
LDA        PATLN          ; LOAD < A > WITH PATTERN LENGTH
DCR        A              ; AND DECREMENT
STA        PATLN          ; STORE DECREMENTED PATTERN LENGTH
JNZ        MAIN7          ; IF PATTERN LENGTH < > 0, THEN LOOP
POP        B              ; RESTORE PATTERN STARTING POINT TO < BC >
PUSH       B              ; AND PUT BACK ON STACK
MVI        A,LNPAT        ; SET PATTERN LENGTH
STA        PATLN          ; AND STORE
JMP        MAIN7          ; LOOP
;
;SHIFT THE BARBER-POLE PATTERN BY ONE AND TEST FOR
;LAST SHIFT
;
MAIN8:
POP        B              ; RESTORE PATTERN STARTING POINT TO < BC >
INX       B              ; SHIFT BARBER-POLE PATTERN BY ONE
PUSH       B              ; AND PUT BACK ON STACK
MVI        A,LNPAT        ; SET PATTERN LENGTH
STA        PATLN          ; AND STORE PATTERN LENGTH
LDA        NCYCL          ; LOAD < A > WITH NUMBER OF CYCLES
DCR        A              ; AND DECREMENT
STA        NCYCL          ; STORE DECREMENTED NUMBER OF CYCLES
JNZ        MAIN4          ; LOOP FOR THE NEXT BARBER-POLE PATTERN
;
;TEST COMPLETED OUTPUT MESSAGE
;
LDA        ERFLG          ; LOAD < A > WITH ERROR FLAG
ORA        A              ; ESTABLISH FLAGS
JNZ        MAIN9          ; IF NOT ZERO, ERROR CONDITION. JUMP TO
; NEXT SECTION
LXI       H,MESG7         ; POINT TO 'SUCCESSFUL TEST'
MVI       B,MESL7         ; LENGTH OF MESSAGE 7
CALL      MSGL            ; OUTPUT MESSAGE

```

Listing 2 continued on page 428

Micomint will put both a computer development system and an OEM dedicated controller in the palm of your hand for as little as \$127.*

The Z8 Basic Computer/Controller represents a milestone in microcomputer price-performance. The entire computer is 4" by 4½" and includes a tiny BASIC interpreter, 4K bytes of program memory, one RS-232 serial port and two parallel ports plus a variety of other features. The Z8 microcomputer board is completely self-contained and optimized for use as a dedicated controller. Can be battery operated. Comes with over 200 pages of documentation.

Z8 BASIC COMPUTER/CONTROLLER

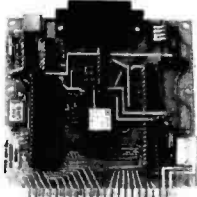

- Uses Zilog Z8671 single chip microcomputer
- On board tiny BASIC interpreter
- 2 parallel ports plus serial I/O port.
- Just connect a CRT terminal and write control programs in BASIC
- 4K bytes of RAM. EPROM pin compatible
- Baud rates 110-9600 BPS
- Data and address buses available for 124K memory and I/O expansion
- Consumes only 1.5 watts at +5, +12 & -12v.

BCC01 Z8 Basic Computer
Assembled & Tested ... \$199.00
BCC02 Z8 Basic Computer
Kit \$169.00*

COMING SOON
A/D Converter 8 Channel 8 Bit
AC I/O Board
• 4 Channel 115Vac inputs
• 4 Channel 115Vac outputs
20 MA ADAPTER

Z8 MEMORY, I/O EXPANSION & CASSETTE INTERFACE

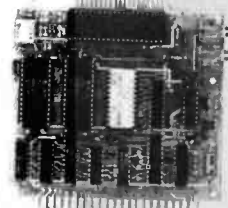

The Z8 Memory, I/O Expansion & Cassette Interface Board (Z8 Expansion Board for short) allows you to add up to 8K of additional memory plus three 8-bit parallel ports to your Z8 Basic Computer/Controller. The memory expansion will support any combination of byte wide RAM memory chips or 2716 or 2732 EPROM. The cassette interface is 300 baud Kansas City Standard (2400Hz/1200Hz).

BCC03 Z8 Expansion Board
w/4K memory \$140.00
BCC04 Z8 Expansion Board
w/8K memory .. \$170.00

Z8 EPROM PROGRAMMER

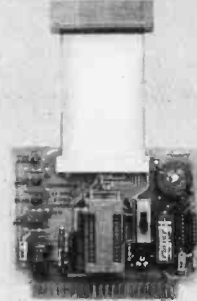

The EPROM Programmer board allows you to transfer application programs in BASIC or Assembly language directly from RAM to either 2716 or 2732 EPROMS. Requires Z8 Basic Expansion Board for operation.
NOTE: We recommend the higher current UPS03 or UPS04 power supply when using the EPROM Programmer.

BCC07 Z8 EPROM Programmer
Assembled & Tested
... \$145.00

Z8 SERIAL EXPANSION BOARD

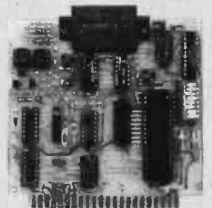

The Serial Expansion Board adds an additional RS-232C serial port to the Z8 system. It runs at 75 to 19,200 baud in all standard protocols. The 20 ma. current loop is opto-isolated for reliability and protection.

BCC08 Z8 Serial Board
Assembled & Tested ... \$180.00

MOTHER-BOARD
MB02 Z8 Mother Board
with 5 connectors (Gold)
Assembled & Tested \$81.00

UNIVERSAL POWER SUPPLY
+5 @ 300 ma. +12 & -12V @ 50 ma.
UPS01 Assembled and
Tested \$ 35.00
UPS02 Kit \$ 27.00
+5 @ 1 amp. +12 & -12V @ 50 ma.
UPS03 Assembled and
Tested \$ 60.00
UPS04 Kit \$ 50.00

Z8 CROSS ASSEMBLERS
FROM ALLEN ASHLEY
XAS01 For TRS-80 Mod I \$ 75.00
XAS02 For TRS-80 Mod III \$ 75.00
XAS03 For CP/M-8" \$150.00
FROM MICRO RESOURCES
MR01 CP/M-8" Diskette . \$ 75.00
MR02 APPLE II CP/M 5¼" \$ 75.00

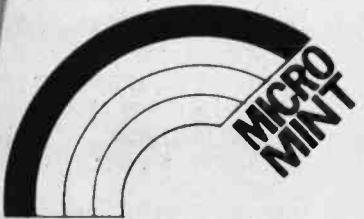
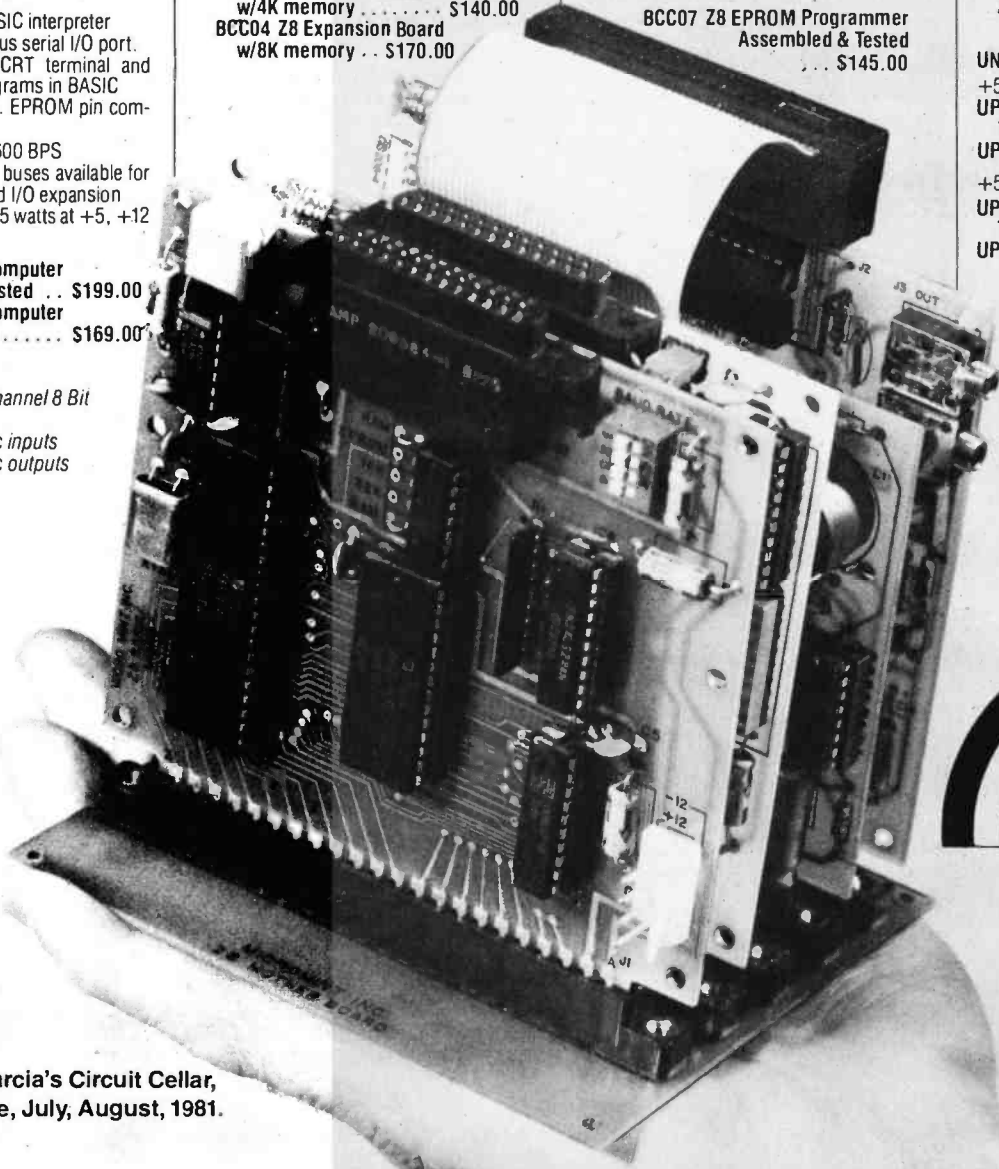

MICROMINT INC.
561 Willow Avenue
Cedarhurst, NY 11516

To Order:
Call Toll Free
1-800-645-3479
For Information Call:
1-516-374-6793

as featured in Ciarcia's Circuit Cellar, Byte Magazine, July, August, 1981.

* is a trademark of Zilog Inc.

CP/M is a trademark of Digital Research

Listing 2 continued:

```

      CALL          CROUT          ; OUTPUT CR AND LF
      RST          1              ; RETURN TO MONITOR
MAIN9:
      LXI          H,MESG8        ; POINT TO 'UNSUCCESSFUL TEST'
      MVI          B,MESL8        ; LENGTH OF MESSAGE 8
      CALL         MSGL           ; OUTPUT MESSAGE
      CALL         CROUT         ; OUTPUT CR AND LF
      RST          1              ; RETURN TO MONITOR
;
; .....
; FUNCTION: CI
; INPUTS: NONE
; OUTPUTS: A—CHARACTER FROM CONSOLE
; CALLS: NOTHING
; DESTROYS: A,F/F'S
; JUMPS: NONE
; DESCRIPTION: CI WAITS UNTIL A CHARACTER HAS BEEN ENTERED AT THE
;              CONSOLE AND THEN RETURNS THE CHARACTER, VIA THE A
;              REGISTER, TO THE CALLING ROUTINE.
;
CI:
      IN           CONST          ; GET STATUS OF CONSOLE = 0EDH
      ANI          RBR            ; CHECK FOR RECEIVER BUFFER READY = 02H
      JZ           CI             ; NOT YET—WAIT
      IN           CHIN           ; READY SO GET CHARACTER = 0ECH
      RET
;
; .....
; FUNCTION: CNVBN
; INPUTS: C—ASCII CHARACTER '0'-'9' OR 'A'-'F'
; OUTPUTS: A—0 TO F HEXADECIMAL
; CALLS: NOTHING
; DESTROYS: A,F/F'S
; JUMPS: NONE
; DESCRIPTION: CNVBN CONVERTS THE ASCII REPRESENTATION OF A HEXADECIMAL
;              CHARACTER INTO ITS CORRESPONDING BINARY VALUE. CNVBN
;              DOES NOT CHECK THE VALIDITY OF ITS INPUT.
;
CNVBN:
      MOV          A,C            ;
      SUI          '0'           ; SUBTRACT CODE FOR '0' FROM ARGUMENT
      CPI          10            ; WANT TO TEST FOR RESULT OF 0 TO 9
      RM          ; IF SO, THEN ALL DONE
      SUI          7             ; ELSE, RESULT BETWEEN 17 AND 23 DECIMAL
      RET                    ; SO RETURN AFTER SUBTRACTING BIAS OF 7
;
; .....
; FUNCTION: CO
; INPUTS: C—CHARACTER TO OUTPUT TO CONSOLE
; OUTPUTS: C—CHARACTER OUTPUT TO CONSOLE
; CALLS: NOTHING
; DESTROYS: A,F/F'S
; JUMPS: NONE
; DESCRIPTION: CO WAITS UNTIL THE CONSOLE IS READY TO ACCEPT A CHARACTER
;              AND THEN SENDS THE INPUT ARGUMENT TO THE CONSOLE.
;
CO:
      IN           CONST          ; GET STATUS OF CONSOLE = 0EDH
      ANI          TRDY          ; SEE IF TRANSMITTER READY = 01H
      JZ           CO            ; NO—WAIT
      MOV          A,C            ; ELSE, MOVE CHARACTER TO A REGISTER FOR
      OUT          CHOUT         ; OUTPUT AND SEND TO CONSOLE = 0ECH
      RET

```

Listing 2 continued on page 430



DATAFLEX™

THE MULTI-USER DATA BASE

SOFTWARE FOR CREATORS

Bring your CP/M* software applications to life with DataFlex. From menus to multi-key ISAM, DataFlex has the features and power you need to create complete turn-key software applications in a RELATIONAL data base environment.

Compare...what else gives you: up to 125 data files with 4 indexes each, fast on-line multi-key ISAM file maintenance, a multi-file report generator, on-line multi-file transaction processing, an easy to use Query, even a "soft" menu to replace the CP/M command mode. All of this using DataFlex's configuration utilities, and NO PROGRAM CODE!

Is it easy to use? You can type in a screen format "image" of a file with your text editor. Then, DataFlex's AUTODEF utility will create the file definition from the screen image...in about five seconds!

DataFlex will handle your multi-user requirements too! It runs under Software 2000's TurboDos Network O/S with data protection to the field level. That means multiple users in the same record at the same time!

If the 16 bit world is your domain, an 8086 version of DataFlex

will be available second quarter '82. And, you can develop now on your 8080/Z-80 system, and transport completed applications to the 8086.

If you need applications now, Data Access has a Library of existing DataFlex applications developed by other creators. They're ready to go at prices that will get you going. The DataFlex Library has Order Entry/Inventory, Accounting, Pharmacy, and Legal Billing, with more being added all the time. For highly specialized requirements, DataFlex's PASCAL Library is available to application developers.

DataFlex can change the way you do business. And, at \$750 it's the best software value in the business. A demo package, which limits file sizes internally, is only \$100 including the manual.

DATAACCESS®

CORPORATION

Get the full system, or get the demo, but get your hands on DataFlex.

4221 Ponce De Leon Blvd.,
Coral Gables, FL 33146

It's software for creators.

(305) 446-0669

"Dealer, Systems House and OEM inquiries invited."

*CP/M is a registered trademark of Digital Research, Pacific Grove, CA.

ALL APPLES® ARE CREATED EQUAL. We Just Make Some Apples More Equal Than Others.

Make your Apple II equal to whatever task you might choose.

You've had your Apple for a while and you're beginning to cast covetous looks at those new, more expensive personal computers with access to more software packages. Or maybe you're getting ready to buy your first computer and you really like the Apple, but you also like some of the features and programs of those more expensive models.

Good. Now's the time for you to know about Advanced Logic Systems. We're the

people who put together all the plug-in function boards and popular software programs that make your Apple perform like the more expensive computers. At a fraction of the cost!

Features that exceed your expectations but not your budget.

All of the products from Advanced Logic have been designed with you in mind. We've made them easy to install—easy to operate. And we make the decision to purchase easy. Because we package the popular software

programs, like WordStar, SuperCalc and Condor Jr. with the necessary hardware to run on your Apple II. These are the total-system packages like ... The Words Set, The Numbers Set, The Files Set and the Synergizer Series. And, we stand behind all of our products with our 1 year limited warranty.

CALL TOLL FREE

Our customer service staff is waiting for you call—800-538-8177. We will be happy to send you our complete catalog of hardware and software packages.

THE DISPATCHER™

An advanced serial RS-232 interface to connect your Apple II to a letter quality printer, modem, external terminal or another computer at any of 7 speeds. \$139.00

Z-CARD™

Adds CP/M® operating system to your Apple II.® Available with WordStar™, SuperCalc™ and Condor™ software programs. \$269.00

PRINTERMATE™

A universal parallel printer interface used to connect your Apple II to any Centronics compatible printer. \$99.00

SMARTERM™

An 80-column video display with 5x7 character set, inverse video, full ASCII keyboard and many more features. An enhanced 7x11 character set is also available. \$345.00

ADD-RAM™

A 16K RAM memory expansion for the 48K Apple II. Required to make the Apple II into a 64K system. \$149.00

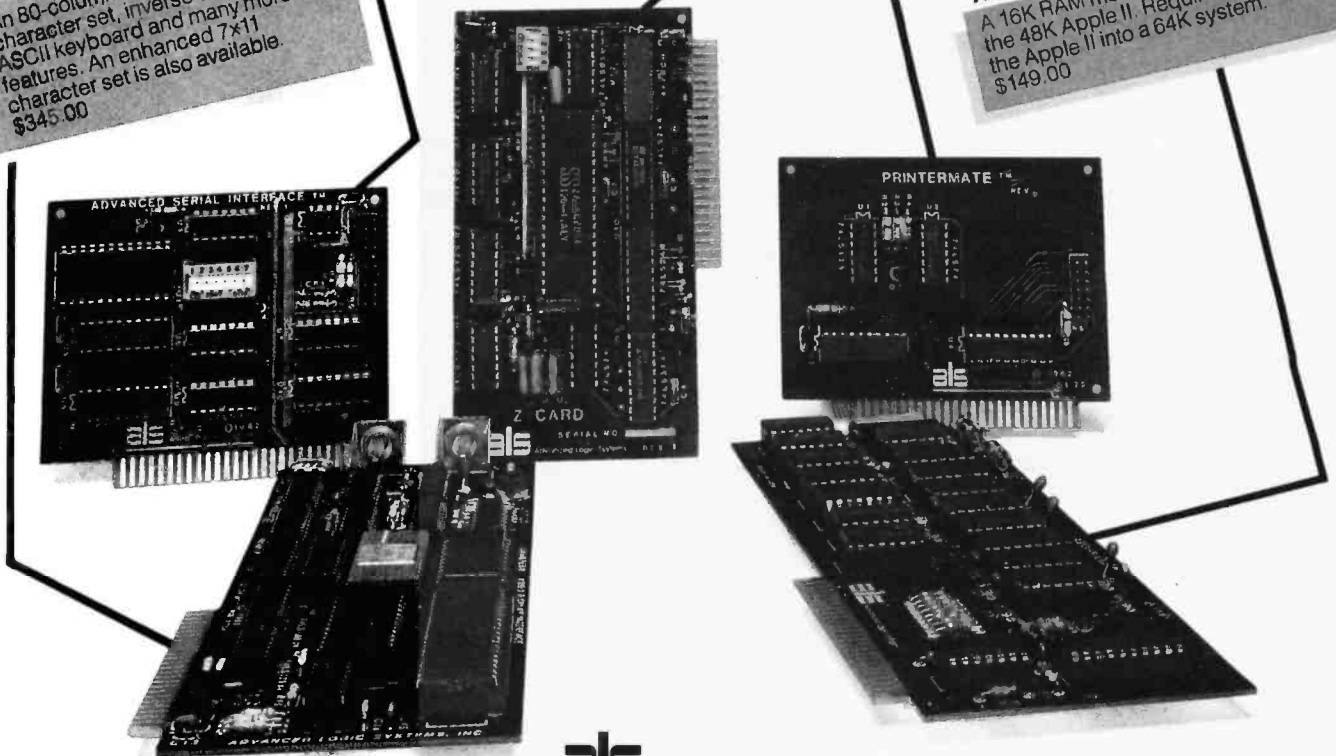

als Advanced Logic Systems

1195 East Arques Avenue, Sunnyvale, CA 94086

Apple, Apple II are registered trademarks of Apple Computer, Inc. CP/M is a registered trademark of Digital Research, Inc. WordStar is a trademark of MicroPro International. SuperCalc is a trademark of Sorcim Corp. Condor is a trademark of Condor Computer Corp. Z-CARD, SMARTERM, ADD-RAM, THE DISPATCHER, PRINTERMATE and SYNERGIZER are all ours!

Circle 544 on inquiry card.
www.americanradiohistory.com

Listing 2 continued:

```

CALL      MSGL      ; OUTPUT MESSAGE
MOV       A,D       ; MOVE UPPER ADDRESS BYTE TO <A> AND
CALL     NMOUT      ; OUTPUT TO THE CONSOLE
MOV       A,E       ; MOVE LOWER ADDRESS BYTE TO <A> AND
CALL     NMOUT      ; OUTPUT TO THE CONSOLE
LXI      H,MESG5    ; POINT TO 'HEX, EXPECTED'
MVI      B,MESL5    ; LENGTH OF MESSAGE 5
CALL     MSGL      ; OUTPUT MESSAGE
POP      B          ; RESTORE CURRENT PATTERN POINTER
PUSH     B          ; AND PUT BACK ON STACK
LDAX    B           ; MOVE EXPECTED PATTERN ELEMENT TO <A>
CALL     NMOUT      ; AND OUTPUT TO THE CONSOLE
LXI      H,MESG6    ; POINT TO 'FOUND'
MVI      B,MESL6    ; LENGTH OF MESSAGE 6
CALL     MSGL      ; OUTPUT MESSAGE
XCHG    ; MOVE MEMORY POINTER TO <HL>
MOV      A,M        ; MOVE FOUND MEMORY VALUE TO <A> AND
CALL     NMOUT      ; OUTPUT TO THE CONSOLE
CALL     CROUT      ; OUTPUT CR AND LF
MVI      A,NZERO    ; MOVE NON-ZERO VALUE TO <A>
STA     ERFLG       ; SET ERROR FLAG TO NON-ZERO VALUE
POP      B          ; RESTORE REGISTERS
POP      H
POP      D
POP      PSW
RET

```

```

.....
; FUNCTION: FRET
; INPUTS: NONE
; OUTPUTS: CARRY—ALWAYS 0
; CALLS: NOTHING
; DESTROYS: CARRY
; JUMPS: NONE
; DESCRIPTION: FRET IS JUMPED TO BY ANY ROUTINE THAT WISHES TO
;              INDICATE FAILURE ON RETURN. FRET SETS THE CARRY
;              FALSE, DENOTING FAILURE, AND THEN RETURNS TO
;              THE CALLER OF THE ROUTINE INVOKING FRET.
;
;

```

```

FRET:
    STC          ; FIRST SET CARRY TRUE
    CMC          ; THEN COMPLEMENT IT TO MAKE IT FALSE
    RET         ; RETURN APPROPRIATELY

```

```

.....
; FUNCTION: GETCH
; INPUTS: NONE
; OUTPUTS: C—NEXT CHARACTER IN INPUT STREAM
; CALLS: CI
; DESTROYS: A,C,F/F'S
; JUMPS: NONE
; DESCRIPTION: GETCH RETURNS THE NEXT CHARACTER IN THE INPUT STREAM
;              TO THE CALLING PROGRAM.
;
;

```

```

GETCH:
    CALL     CI          ; GET CHARACTER FROM TERMINAL
    ANI     PRTO        ; TURN OFF PARITY BIT IN CASE SET BY CONSOLE
                    ; PRTO = 7FH
    MOV     C,A         ; PUT VALUE IN C REGISTER FOR RETURN
    RET

```

```

.....
; FUNCTION: GETHX
; INPUTS: NONE
; OUTPUTS: BC—16-BIT INTEGER

```

Listing 2 continued on page 436

Deciding Which Computer to Buy

Of the 1.9 million people who bought small computers last year, over 20,000 of them bought the wrong computer for their needs. And no wonder. New products are introduced into the market at a breathtaking pace. The language question. The terminology problem -RAMs, ROMs, bits, bytes, bauds, protocols and processors. What's important? What's standard and what's optional? Even the dealers are confused.

To help you tackle this problem, we pulled together many of our sources -including leading experts in the field, manufacturers, marketing analysts, computer dealers and customers. In addition, we utilized computer user groups, clubs and associations throughout the United States, contacts in Japan and numerous industry and business publications. **COMPUTER GUIDE 1983** is the natural result of learning from the knowledge and mistakes of more than one million people.

The following steps will help you with your computer shopping -whether you're buying your first computer, or updating the one you have. **COMPUTER GUIDE 1983** can help you make the right decision.

1. What is the computer to be used for?

You may want to use it for entertainment, financial planning, learning how to speak a foreign language, office work, drawing and many other tasks a computer does well. The possible uses of a computer are as varied as human activities.

2. Which program will do the best job?

There are thousands of application programs on the market to consider. It is the program that gives you the power to control the actions of the computer. You must choose the right application program.

The first section of **COMPUTER GUIDE 1983** surveys each of the application programs available with computers today. Similar programs are grouped together and compared -one against another. **COMPUTER GUIDE 1983** contains over 2,000 application programs, grouped in over 100 categories -including programs for accounting, management, professional uses, word processing, graphics, research, games, learning and special applications. Programs are described using comparison charts -listing for each application program: the program name, computer(s) and system configuration(s) required, the documentation available and the price.

COMPUTER GUIDE 1983 provides you with a quick and efficient way of deciding which application program and which computer and options for that computer can do the right job for you.

3. The language?

You cannot get a computer to do anything useful unless you know how to talk to it. This is no easy task. But, **COMPUTER GUIDE 1983** can help.

The second section of **COMPUTER GUIDE 1983** guides you in selecting the right language. Different dialects of languages are grouped in their generic category. The BASIC language, for example, is a generic name and has many dialects -including Microsoft Basic, Atari Basic, Basic Plus and Basic-80.

Each of these languages have their own machine requirements. **COMPUTER GUIDE 1983** provides the name, machine and machine requirements, documentation and price of over 500 dialects, for over 50 languages. **COMPUTER GUIDE 1983** helps you solve the language problem.

4. What about the machine?

Depending on your needs, there will probably be several computers still in the running. Now the decision is based on the guts of the machines (hardware). **COMPUTER GUIDE 1983** compares machine characteristics in an easy to follow format. You don't have to be an electrical engineer to make an intelligent decision.

The solution is to work top down and not to go any further down than is needed. Your uses for the computer determines which machine characteristics are important. **COMPUTER GUIDE 1983** divides the machine into five areas -the keyboard, video display, printer, other peripherals and I/O, processor and memory and direct access storage. These five areas correspond to your basic machine needs. For example, an accountant needs a keyboard with a numeric keypad; word processing requires a printer; games utilize a video display; a mathematician wants a very fast machine; lots of memory is best when using the LISP language; and so on, as the hardware combines with the application program to develop a complete computer system.

COMPUTER GUIDE 1983 contains machine descriptions for over 250 computer systems, produced by over 150 manufacturers. Information is displayed in spreadsheets -allowing you to get the information you need. You don't have to bother with extraneous details and cumbersome text. **COMPUTER GUIDE 1983** can accommodate millions of people in making the right decision, as varied as those decisions will be.

5. Where to buy the chosen computer system.

COMPUTER GUIDE 1983 lists hundreds of vendors, by geographical location, and by the products they sell. It also provides additional consumer information. The first ship date, the ship rate, the number installed to date, prices and what that includes, purchasing terms and warranties. **COMPUTER GUIDE 1983** contains the names, addresses and phone numbers of hundreds of manufacturers, dealers and stores throughout the United States.

No one wins when you buy the wrong computer or computer product. Make the right decision. Use **COMPUTER GUIDE 1983**.

Send me **COMPUTER GUIDE 1983**
The complete computer buyer's guide.

I'm enclosing my check for \$32.75 plus \$1.50 for shipping.
(Mass. residents add 5% sales tax.)

Mail to: **CESS**
P.O. Box 345, MIT Branch P.O.
Cambridge, MA 02139
(617) 491-8925

Name _____

Address _____

City, State and Zip _____

Please allow six to eight weeks for delivery.

COMPUTER GUIDE and CESS are trademarks of Computer & Electronic Supply Services, P.O. Box 345, MIT Branch P.O., Cambridge, MA 02139.

\$1790



COMPLETE MICRO DECISION COMPUTER SYSTEM INCLUDES:

- COMPUTER:
 - Z80A, 4MHz CPU
 - 64K RAM main memory
 - 200 Kbyte 5 1/4" floppy disk drive
 - Two serial ports
- TERMINAL:
 - 12 Inch 80 x 24 line screen
 - High resolution green phosphor (P-31) display
 - Full size detachable keyboard
 - 14 key numeric keypad
 - Auxiliary RS-232C port
- SOFTWARE:
 - CP/M 2.2 Operating System
 - Microsoft BASIC 80 Ver. 5.2
 - WordStar 3.0 Word Processing
 - 40,000 Word Spelling Checker
 - Powerful Electronic Spreadsheet
 - NorthStar Compatible BASIC Language

Full size smart terminal with detachable keyboard

4MHz, Z80A™ CPU
64K RAM main memory
200 Kbyte 5 1/4" floppy disk
(Osborne, Xerox, IBM formats)
Two serial ports

Complete software package,
including:

CP/M Operating System
WordStar® Word Processing
Microsoft® BASIC 80
NorthStar compatible BAZIC®
Spelling Checker
Electronic Spreadsheet



SEE US AT COMDEX, BOOTH 1674

You can't buy more computer for less.

\$1790 is the total retail price of the complete Micro Decision™ System you see in this ad. And that includes the computer with a disk drive, a full size smart terminal, and over \$1800 worth of software. No other business computer available today offers so much for so little (a comparable Apple system costs almost twice as much).

The Micro Decision is a bargain any way you look at it. The computer alone, with all that software and one disk drive is only \$1195. If you want to add another disk drive, the price is still great: just \$1545. And the smart terminal is only \$595. Retail. As for the microcomputer itself, our Micro Decision

includes a 64K CP/M® 2.2 Operating System. That's the industry standard operating system that gives you access to over 2000 business programs (available right now—right off the shelf).

If you'd like more information, or to find out about our substantial quantity discounts, call us at (415) 430-1970. We'll introduce you to more Morrow. And less price.

LOOK TO MORROW FOR ANSWERS TODAY
MORROW DESIGNS

600 McCormick St.
San Leandro, CA 94577
(415) 430-1970



Circle 328 on inquiry card.

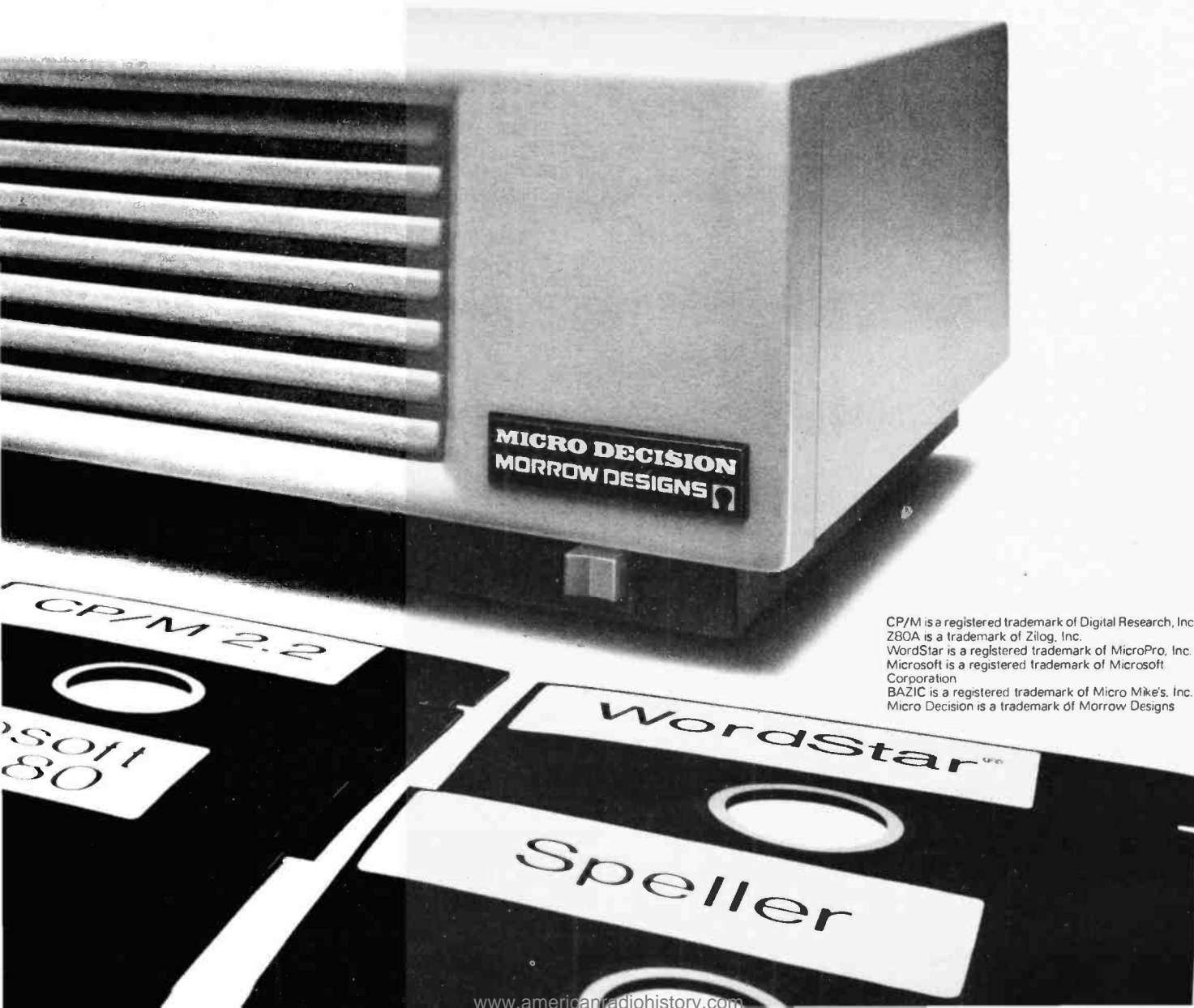

CP/M is a registered trademark of Digital Research, Inc.
Z80A is a trademark of Zilog, Inc.
WordStar is a registered trademark of MicroPro, Inc.
Microsoft is a registered trademark of Microsoft Corporation
BASIC is a registered trademark of Micro Mike's, Inc.
Micro Decision is a trademark of Morrow Designs

Listing 2 continued:

; CARRY—1 IF FIRST CHARACTER NOT DELIMITER
; —0 IF FIRST CHARACTER IS DELIMITER, OR INVALID DIGIT
; CALLS: CNVBN,ECHO,GETCH,VALDG,VALDL
; DESTROYS: A,B,C,D,E,F/F'S
; JUMPS: FRET,SRET
; DESCRIPTION: GETHX ACCEPTS A STRING OF HEX DIGITS FROM THE INPUT
; STREAM AND RETURNS THEIR VALUE AS A 16-BIT BINARY
; INTEGER. IF MORE THAN 4 HEX DIGITS ARE ENTERED,
; ONLY THE LAST 4 ARE USED. THE NUMBER TERMINATES WHEN
; A CARRIAGE RETURN IS ENCOUNTERED. ILLEGAL
; CHARACTERS (NOT HEX DIGITS OR DELIMITER) CAUSE AN
; ERROR INDICATION. IF THE FIRST (VALID) CHARACTER
; ENCOUNTERED IN THE INPUT STREAM IS NOT A DELIMITER,
; GETHX WILL RETURN WITH THE CARRY BIT SET TO 1;
; OTHERWISE, THE CARRY BIT IS SET TO 0 AND THE CONTENTS
; OF BC ARE UNDEFINED.

GETHX:

PUSH H ; SAVE HL
LXI H,0 ; INITIALIZE RESULT
MVI E,0 ; INITIALIZE DIGIT FLAG TO FALSE

GHX05:

CALL GETCH ; GET A CHARACTER
CALL ECHO ; ECHO THE CHARACTER
MOV A,C ; MOVE TO REG. A
CPI CR ; SEE IF CR
JNZ GHX10 ; NO—BRANCH
PUSH H
POP B ; MOVE RESULT TO BC
POP H ; RESTORE HL
MOV A,E ; GET FLAG
ORA A ; SET F/F'S
JNZ SRET ; IF FLAG NON-ZERO, A NUMBER HAS BEEN FOUND
JZ FRET ; ELSE, DELIMITER WAS FIRST CHARACTER

GHX10:

CALL VALDG ; IF NOT DELIMITER, SEE IF DIGIT
JNC GHX15 ; IF NOT A VALID DIGIT, RETURN
CALL CNVBN ; CONVERT DIGIT TO ITS BINARY VALUE
MVI E,OFFH ; SET DIGIT FLAG NON-ZERO
DAD H ; *2
DAD H ; *4
DAD H ; *8
DAD H ; *16
MVI B,0 ; CLEAR UPPER 8 BITS OF BC PAIR
MOV C,A ; BINARY VALUE OF CHARACTER INTO C
DAD B ; ADD THIS VALUE TO PARTIAL RESULT
JMP GHX05 ; GET NEXT CHARACTER

GHX15:

CALL CROUT ; OUTPUT CR AND LF
POP H ; RESTORE RP HL
JMP FRET ; RETURN WITH CARRY = 0

.....
; FUNCTION: MSGL
; INPUTS: B—COUNTER FOR CHARACTERS IN MESSAGE
; HL—ADDRESS OF MESSAGE
; OUTPUTS: NONE
; CALLS: CO
; DESTROYS: A,B,C,H,L,F/F'S
; JUMPS: NONE
; DESCRIPTION: OUTPUTS A MESSAGE AS DETERMINED BY INPUTS.

MSGL:

MOV C,M ; FETCH NEXT CHARACTER TO C REGISTER
CALL CO ; SEND IT TO TERMINAL
INX H ; POINT TO NEXT CHARACTER
DCR B ; DECREMENT BYTE COUNTER

Listing 2 continued on page 438

TRS-80[®] COMPUTERS

PURE RADIO SHACK EQUIPMENT

BUY BY DIRECT-MAIL

1-800-841-0860
CONVENIENT ORDER ENTRY

MICRO MANAGEMENT SYSTEMS INC.

TRS-80 COLOR COMPUTER



DISCOUNT PRICED
FROM

CALL

BUY DIRECT 26-3004

TRS-80 MODEL III COMPUTER



DISCOUNT PRICES
FROM

\$588

BUY DIRECT 26-J061

TRS-80 MODEL 16 COMPUTER



DISCOUNT PRICED
FROM

\$4098

BUY DIRECT 26-6001

FRANKLIN

ACE 1000
COMPUTER
DISCOUNT PRICED
FROM **\$CALL**

SMITH CORONA TP-1
DAISY WHEEL PRINTER

DISCOUNT PRICED
FROM

\$559

BUY DIRECT

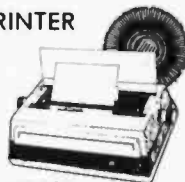

ATARI
HOME COMPUTERS
DISCOUNT
PRICED
FROM **\$629**

TRS-80 MODEL II COMPUTER



DISCOUNT PRICED
FROM

CALL

BUY DIRECT 26-4002

TRS-80 I/III
**HARD
DRIVES** **\$1988**
26-1130

commodore
TEXAS INSTRUMENT
CALL FOR PRICES

TRS-80 PRINTERS MFG BY
RADIO SHACK

DWP-410 \$1287.00
DMP-100 \$339.00
DMP-200 \$679.00
DMP-400 \$1015.00
DMP-500 \$1525.00

PLEASE WRITE US FOR
FREE

•COPY OF OUR CUSTOMER DIS-
COUNT PRICE LIST UPON RE-
QUEST
•COPY OF MANUFACTURERS WARRANTY
UPON REQUEST

**MICRO MANAGEMENT
SYSTEMS INC.**

PARCEL DIVISION
DEPT. NO. 1
2803 THOMASVILLE RD. EAST
CAIRO, GA. 31728

GA. **912-377-7120**
INFO
TM - TANDY CORPORATION

**TRS-80 SOFTWARE
VISICALC, PROFILE,
SCRIPSIT & MORE
\$AVE MONEY**

PRICES AND PRODUCTS SUBJECT TO
CHANGE WITHOUT NOTICE. ORDERS
SUBJECT TO VERIFICATION AND AC-
CEPTANCE.

OKIDATA EPSON

Listing 2 continued:

```

INZ                MSGL                ; RETURN FOR NEXT CHARACTER
RET

.....

; FUNCTION: NMOUT
; INPUTS: A—8-BIT INTEGER
; OUTPUTS: NONE
; CALLS: ECHO, PRVAL
; DESTROYS: A,B,C,F/F'S
; JUMPS: NONE
; DESCRIPTION: NMOUT CONVERTS THE 8-BIT, UNSIGNED INTEGER IN THE
;              A REGISTER INTO 2 ASCII CHARACTERS. THE ASCII CHARACTERS
;              ARE THE ONES REPRESENTING THE 8 BITS. THESE 2
;              CHARACTERS ARE SENT TO THE CONSOLE AT THE CURRENT PRINT
;              POSITION OF THE CONSOLE.
;
NMOUT:
    PUSH            PSW                ; SAVE ARGUMENT
    RRC
    RRC
    RRC
    RRC
    CALL            PRVAL              ; GET UPPER 4 BITS TO LOW 4-BIT POSITIONS
    CALL            PRVAL              ; CONVERT LOWER 4 BITS TO ASCII
    CALL            ECHO               ; SEND TO TERMINAL
    POP             PSW                ; GET BACK ARGUMENT
    CALL            PRVAL
    CALL            ECHO
    RET

.....

; FUNCTION: PRVAL
; INPUTS: A—INTEGER, RANGE 0 TO F
; OUTPUTS: A—ASCII CHARACTER
; CALLS: NOTHING
; DESTROYS: NOTHING
; JUMPS: NONE
; DESCRIPTION: PRVAL CONVERTS A NUMBER IN THE RANGE 0 TO F HEX TO
;              THE CORRESPONDING ASCII CHARACTER, 0-9, A-F. PRVAL
;              DOES NOT CHECK THE VALIDITY OF ITS INPUT ARGUMENT.
;
PRVAL:
    ANI            HCHAR              ; MASK OUT UPPER 4 BITS—WANT 1 HEX CHAR
    ; HCHAR = 0FH
    ADI            90H                ; SET UP A SO THAT A-F CAUSE A CARRY
    DAA            ; ADJUST CONTENTS OF A REGISTER
    ACI            40H                ; ADD IN CARRY AND ADJUST UPPER 4 BITS
    DAA            ; ADJUST CONTENTS OF A REGISTER AGAIN
    MOV            C,A                ; MOVE ASCII CHARACTER TO C
    RET                                ; ALL DONE

.....

; FUNCTION: SRET
; INPUTS: NONE
; OUTPUTS: CARRY = 1
; CALLS: NOTHING
; DESTROYS: CARRY
; JUMPS: NONE
; DESCRIPTION: SRET IS JUMPED TO BY ROUTINES WISHING TO RETURN INDICAT-
;              ING SUCCESS. SRET SETS THE CARRY TRUE AND THEN RE-
;              TURNS TO THE CALLER OF THE ROUTINE INVOKING SRET.
;
SRET:
    STC                ; SET CARRY TRUE
    RET                ; RETURN APPROPRIATELY
```

```

FUNCTION: VALDG
INPUTS: C—ASCII CHARACTER
OUTPUTS: CARRY—1 IF CHARACTER REPRESENTS VALID HEX DIGIT
          —0 OTHERWISE
CALLS: NOTHING
DESTROYS: A,F/F'S
JUMPS: FRET,SRET
DESCRIPTION: VALDG RETURNS INDICATING SUCCESS IF ITS INPUT
            ARGUMENT IS AN ASCII CHARACTER REPRESENTING A VAL-
            ID HEX DIGIT (0-9,A-F), AND FAILURE OTHERWISE.

```

VALDG:

MOV	A,C	
CPI	'0'	; TEST CHARACTER AGAINST '0'
JM	FRET	; IF ASCII CODE LESS, CANNOT BE VALID
		; DIGIT
CPI	'9'	; ELSE, SEE IF IN RANGE '0'-'9'
JM	SRET	; CODE BETWEEN '0' AND '9'
JZ	SRET	; CODE EQUAL '9'
CPI	'A'	; NOT A DIGIT—TRY FOR A LETTER
JM	FRET	; NO—CODE BETWEEN '9' AND 'A'
CPI	'G'	
JP	FRET	; NO—CODE GREATER THAN 'F'
JMP	SRET	; OKAY—CODE IS 'A' TO 'F', INCLUSIVE

Listing 2 continued on page 442

Marymae INDUSTRIES, INC.

**In Texas Orders
Questions & Answers
1-713-392-0747**

**22511 Katy Freeway
Katy (Houston) Texas 77450**

**To Order
1-800-231-3680
800-231-3681**

SAVE BIG DOLLARS ON ALL TRS-80® HARDWARE & SOFTWARE

TRS-80® BY RADIO SHACK. Brand new in cartons delivered. Save state sales tax. Texas residents add only 5% sales tax. Open Mon.-Fri. 9-6, Sat. 9-5. We pay freight and insurance. Come by and see us. Call us for a reference in or near your city. Ref: Farmers State Bank, Brookshire, Texas.

WE OFFER ON REQUEST

Federal Express (Overnight Delivery)

Houston Intercontinental
Airport Delivery (Same Day)

U.P.S. BLUE (Every Day)

References from people who have
bought computers from us probably
in your city

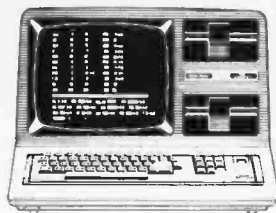

**In stock TRS-80 Model
II and III**

No Tax on Out of Texas Shipments!

**Save
10% 15%**

OR MORE

Reserve Your Model 16 Today

Telex 77-4132 (Fleks Hou)

WE ALWAYS OFFER

NO extra charge for Master Card
or Visa.

We use Direct Freight Lines. No
long waits.

We always pay the freight and
insurance

Toll free order number

Our capability to go to the giant
TRS-80® Computer warehouse 5
hours away, in Ft. Worth, Texas,
to keep you in stock.

JOE McMANUS

* TRS-80 is a Registered Trademark of Tandy Corp

ED McMANUS



The new IBM Instruments Computer System:



Unique combination of features

Unusual flexibility

Attractive price

A new dimension in small computers.

In its price range, the new IBM Instruments Computer System offers higher levels of function and performance than other computers.

For scientific, engineering and general computing applications, including instrument control and data acquisition, data analysis and communications, no other computer is like it.

The IBM Instruments Computer System is based on the highest performance general purpose processor available. Modular design permits you to select a configuration to meet your present needs exactly. Provision for continuing enhancement and upgrading is built in.

The inside story

Basic working memory is exceptionally large. When expanded fully, the IBM Instruments Computer System has up to 5 megabytes of working memory.

You'll find more standard communications ports and more connection modes than on other computers at or near the price. The optional integrated Analog I/O card further enhances connectability.

You'll also find a priority interrupt driven system with 32 levels of interrupt and 4 direct memory access channels.

The outside story

This is a computer that people find simple to understand and easy to use. Up to three interface modes (two programmable keypads and a keyboard) provide a wide range of choices for interacting with the system. Operation is from

menu or by simple direct command.

The system provides integrated high resolution graphics on a CRT. Hard copy is supplied by an optional high resolution 4-color printer/plotter using plain paper. These high levels of resolution are standard from IBM Instruments, extra on others.

Optional diskette and disk drives provide up to 44 megabytes of on-line storage.

A real-time, multitasking operating system and a wide range of programming support enhance the usability of the system.

The value story

The IBM Instruments Computer System can grow easily; you can add options yourself. Your initial investment is protected.

Starting at \$5,695, this system gives you outstanding power, capacity and performance for the money.

SPECIFICATIONS, IBM INSTRUMENTS COMPUTER SYSTEM

Processor <ul style="list-style-type: none">● 68000 8-MHz	Communications <ul style="list-style-type: none">● RS232C—3 ports● IEEE-488 bus● Parallel I/O● VERSAbus* compatible system bus● Analog I/O card	<ul style="list-style-type: none">● 768 x 480 dots● Memory mapped
Working Memory <ul style="list-style-type: none">● Up to 128K bytes of ROM● 128K bytes of RAM expandable in 256K increments up to 5 megabytes	Printer/Plotter <ul style="list-style-type: none">● 4-colors● Up to 200 cps● 200 x 336 dots/inch● Full dot pattern control for graphics plotting	Keyboard and Keypads <ul style="list-style-type: none">● Full alphanumeric keyboard plus 10 programmable keys● Up to 57 programmable soft keys on processor● 10 programmable soft keys on CRT
Disks and Diskettes <ul style="list-style-type: none">● Up to 4 Diskettes, 5¼"-322K bytes or 8"-1 megabyte each● Up to four 5¼" Winchester type disks, 5 or 10 megabytes each	Display Screen <ul style="list-style-type: none">● 12" adjustable● 80 characters x 30 lines	Programming <ul style="list-style-type: none">● BASIC/FORTRAN/PASCAL assemblers● Utilities/Diagnostics● Chromatography, FTIR and other application programs

*Trademark of Motorola, Inc.

We'd like to tell you more about it. Simply call 800-243-7054. In Connecticut, call 800-952-1073. IBM Instruments, Inc., Orchard Park, Box 332, Danbury, CT 06810.

IBM Instruments Inc.

Listing 2 continued:

; BARBER-POLE PATTERN FOR NK x 4 MEMORY COMPONENTS

```
PATRN:      DB          00H,11H,22H,44H,88H,0EEH,0DDH,0BBH,77H
           DB          00H,11H,22H,44H,88H,0EEH,0DDH,0BBH,77H
```

; BARBER-POLE PATTERN FOR NK x 1 MEMORY COMPONENTS

```
PATRN:      DB          00H,01H,02H,04H,08H,10H,20H,40H,80H
           DB          0FEH,0FDH,0FBH,0F7H,0EFH,0DFH,0BFH,7FH
           DB          00H,01H,02H,04H,08H,10H,20H,40H,80H
           DB          0FEH,0FDH,0FBH,0F7H,0EFH,0DFH,0BFH,7FH
```

; MESSAGES

```
MESG1:      DB          'ENTER ADDRESS OF MEMORY START IN HEX '
MESL1:      EQU         $-MESG1
MESG2:      DB          'ENTER ADDRESS OF MEMORY END IN HEX '
MESL2:      EQU         $-MESG2
MESG3:      DB          'ERROR: MEMORY START ADDRESS > MEMORY END ADDRESS'
MESL3:      EQU         $-MESG3
MESG4:      DB          'MEMORY ERROR AT '
MESL4:      EQU         $-MESG4
MESG5:      DB          '  HEX, EXPECTED '
MESL5:      EQU         $-MESG5
MESG6:      DB          ', FOUND '
MESL6:      EQU         $-MESG6
MESG7:      DB          'SUCCESSFUL TEST'
MESL7:      EQU         $-MESG7
MESG8:      DB          'UNSUCCESSFUL TEST'
MESL8:      EQU         $-MESG8
```

; DATA STORAGE

```
ERFLG:      DS          1          ; STORAGE LOCATION FOR ERROR FLAG
           ; ZERO--NO ERROR DURING TEST
           ; NON-ZERO--ERROR DURING TEST
MEMND:      DS          2          ; STORAGE LOCATION FOR END ADDRESS
MEMST:      DS          2          ; STORAGE LOCATION FOR START ADDRESS
NBYTE:      DS          2          ; STORAGE LOCATION FOR NUMBER OF BYTES
NCYCL:      DS          1          ; STORAGE LOCATION FOR NUMBER OF CYCLES
           ; SHIFTS OF THE BARBER POLE
PATLN:      DS          1          ; STORAGE LOCATION FOR PATTERN LENGTH
           END
```

DECEMBER SPECIALS • NEW XEROX 820-II 5 1/4" DS/DD - \$2295*

*PRICE INCLUDES NEW XEROX 820 II DISPLAY/PROCESSOR, KEYBOARD and 2 TANDON DRIVES.



FEATURES: 4MHz, 280A, CPM BASED, 64K RAM, 12" HI RES SCREEN (24 x 80), DD DISK CONTROLLER, THIN LINE GRAPHICS, ENHANCED SCREEN FEATURES (HL INTENSITY, REVERSE VIDEO, FLASHING CHARACTERS), TONE GENERATOR, 2 RS-232 PORTS, ONE PARALLEL PORT, ALSO BOOTS AS INTELLIGENT TERMINAL.

\$199 820/820-II OPTION PKG. Save \$461

- 280C CPU SPEEDUP - Programmable to 8MHz \$149
- DISPLAY RISER - Elevates 4" or 5", Steel Construction \$ 29
- ACRYLIC GREEN SCREEN - Molded to fit CRT \$ 19
- NYLON ANTI-GLARE SCREEN - Stretches over CRT \$ 19
- SYSTEM DUST COVERS - 3 covers \$ 29

\$299 OPTION PACKAGE Save \$691

- INCLUDES ALL THE THE \$199 PACKAGE PLUS--
 - Box of 10 Disettes (\$1/4" SS DD) \$ 25
 - Surge-Protected Multiple Outlet Strip \$ 18
 - Enter Key for Numeric Keypad \$ 18
 - Cooling Fan fits in display/processor, quiet \$ 18
 - Disk Drive Head Cleaning Kit - 5" or 8" \$ 28

820 DD Kit \$299
32K Printer Buffer \$250
Parallel Printer Cable \$ 39

Complete 5MB Hard Drive \$1995
8088 Processor (CP/M 86 and MSDOS Compatible) Call
Anchor Signalman Modem \$ 89

XEROX 820 II SYSTEMS

	LIST	SALE
5 1/4" DS/DD	\$3695	\$2295*
8" SS/DD	\$4095	\$2795*
8" DS/DD	\$4895	\$2995*
10 MB Hard Drive w/Floppy Backup	\$7695	\$4995

microNEST

Box 545, 1700 Front Street
Fort Benton, MT 59442
CALL COLLECT TO ORDER:
(406) 622-5651 9-5 MDT, M-F

VISA, MC, Cash, OK, MD, CDS, Add 3% for VISA or MC.
Add 3% for Ship/Handling fee. Va. 5% Minimum (\$2.50)

XEROX 800-820-II are trademarks of XEROX Corp.
CP/M is trademark of the Digital Research Corp.

Perfect Writer	\$238	Xerox 820 Duty Wheel	\$1195	Okidata M82A	\$ 400
Perfect Speller	\$149	850 Duty Wheel	\$2195	Okidata M83A	\$ 399
Perfect Flor	\$259	Quint Sprint 840	\$1595	Okidata M84P	\$1095
Perfect Calc	\$149	Quint Sprint 3195	\$1395	Okidata M84S	\$1195

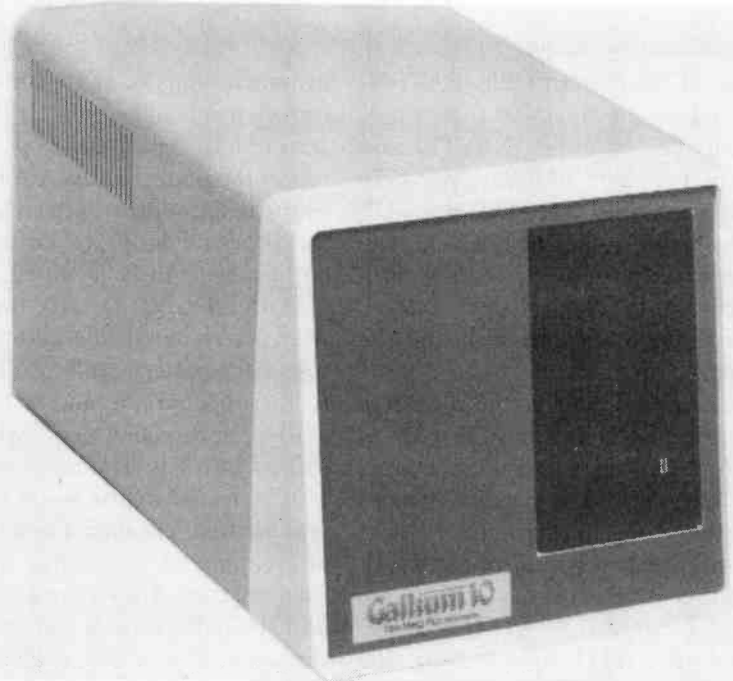

- PRICE:** **2495.00** complete subsystem for Apple II or IBM-PC
- CAPACITY:** **14.4** megabytes unformatted . . . **11.3** megabytes formatted
- EXPANSION:** Total expansion capability to 57.6 megabytes using the same controller and host interface.
- Expansion capability to 18.8 megabytes by adding a second disk drive and using the same cabinet and power supply.
- NETWORK:** For Apple II only, Network capability is available at a cost of \$200 per station

GALLIUM SOFTWARE

For Apple II, the ROM resident software interfaces to DOS 3.3, CPM and PASCAL operating systems. All operating systems remain unmodified so there is no need to make any program changes when using the Gallium. Any system can be booted directly from Gallium.

For IBM-PC, a connect program is provided which brings the Gallium-10 on line and becomes accessible as Drives C and D.

APPLE

UTILITIES

- Format Formats all Surfaces
- Volume Initer Initializes With An "EMPTY" File A Given Number of Volumes in Single, Double or Triple Size DOS 3.3 Volumes
- File Finder Finds All Volumes On Which Any Given File Is Resident
- File Runner Finds & Runs The Given File From the First Volume On Which It Is Resident
- Partition Partitions The Disk For DOS 3.3, CPM & PASCAL Allocating The Required Number Of Sectors For Each Given Operating System
- Connect Connects Gallium To DOS If Booted From Floppy Disk

IBM

UTILITIES

- FDISK Formats All Surfaces, Once Formatted Capacity is 11.5 Megabytes
- DSKLNK Connects Gallium to PC-DOS
- CHKHRD Similar to PC-DOS CHKDSK Utility, Reports Disk Usage

Circle 125 on inquiry card.

XITENSYSTEMS

16815 Hawthorne Blvd.
Lawndale, Ca 90260
(213) 370-3966
(800) 421-1947

Text continued from page 418:

the top of the pattern table (PATRN) is placed on the stack for future use. The number of bytes (NBYTE) and starting memory address (MEMST) are loaded into the DE and HL register pairs, respectively. Next, the barber-pole pattern is loaded into memory.

This is accomplished by using the BC register pair as the pattern-table pointer, the HL pair as the memory-address pointer, and the DE pair as the number of bytes remaining to be loaded. When DE is decremented to zero, the program jumps to the next section, which tests the integrity of the barber-pole pattern.

If DE is not zero, PATLN is decremented. If PATLN is not zero, the

program loops to write another pattern element in memory. If PATLN is zero, the BC pair is set to point to the top of the pattern table, PATLN is set to the length of the pattern table, and the program loops to write another pattern element in memory.

With DE equal to zero, the BC register pair is set to the address of the top of the pattern table, PATLN is set to the appropriate length, NBYTE is loaded into DE, and MEMST is loaded into HL. The barber-pole pattern is tested in the same fashion it was written, except for a comparison and calling of subroutine ERROR if the contents of the memory location and the pattern-table element are not the same. The output of ERROR consists of the messages shown in listings 1a and 1b.

When DE is decremented to zero, the program jumps to the next section, which shifts the barber-pole pattern left by 1 bit and sets PATLN to the appropriate length. The byte NCYCL is decremented by 1 and, if it is not zero, the shifted barber-pole pattern is loaded into memory and verified as discussed above. If NCYCL is zero, the program prints the message "SUCCESSFUL TEST" or "UNSUCCESSFUL TEST", depending upon the value in the data-storage byte, ERFLG (error flag).

Speed of Execution

The speed of this program in performing the memory test is excellent. Using an Intel 8080A-2 processor running at a clock rate of 2.15 MHz, the times to do 4K and 8K bytes are

shown in tables 2a and 2b. The projected time for a successful test of 64K bytes using the pattern in table 1a (9-elements/9-cycle pattern) is approximately 60 seconds; the time for using the pattern in table 1b (17-elements/17-cycle pattern) is approximately 110 seconds.

Summary

The barber-pole memory-test program meets the initial design goals of being rapid, providing sufficient information to indicate which memory component is causing the error, distinguishing between hard and soft memory errors, and aiding in flagging the memory-decoding errors.

A minor problem is that the program requires 9 bytes for data storage and 12 bytes for the stack. Thus, the computer must have part of its memory error-free. ■

Acknowledgments

I would like to thank Leroy A. Noble of the Dickey-John Corporation for an initial discussion of the development of the barber-pole algorithm in PL/M. The assistance of Bob Polack in the coding of the PL/M model is gratefully acknowledged.

The utility routines CI, CNVBN, CO, CROUT, ECHO, FRET, GETCH, GETHX, NMOUT, PRVAL, SRET, and VALDG are reprinted by permission of Intel Corporation, copyright 1977.

Reference

1. Nordin, Floyd L. "Memory Test Program/Keyboard Entry of Start and End Values." *INSITE Users Library*, reference number AA11, page 4-271.

Number of bytes	Time
4K (hexadecimal 1000)	3.8 seconds
8K (hexadecimal 2000)	7.5 seconds

Table 2a: The time required for execution of the barber-pole test of nine-cycle patterns using an Intel 8080A-2 running at a clock frequency of 2.15 MHz.

Number of bytes	Time
4K (hexadecimal 1000)	6.9 seconds
8K (hexadecimal 2000)	13.5 seconds

Table 2b: The time required to run the barber-pole test of 17-cycle patterns on the 2.15-MHz 8080A-2. The crystal frequency of 19.354 MHz is divided by 9.

BTA MODEL 953B EPROM PROGRAMMER - \$359

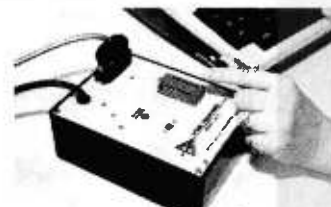



BAY TECHNICAL ASSOCIATES, inc.
 HWY. 603, P.O. BOX 387
 BAY ST. LOUIS, MISSISSIPPI 39520
 (601) 467-8231

- Programs 2508, 2758, 2516, 2716, 27C16, 2532, 2732, 2732A, 27C32, 2564, 2764, 27C64, MCM68766, 27128.
- RS-232, 3 line serial interface, Xon/Xoff format, DB-25 I/O connector.
- No personality modules - software control EPROM selection.
- Extended diagnostics.
- LED warning indicates power applied to EPROM socket.
- Supports Intel, Motorola, and Intel 8086 data formats as well as HEX data dump.
- Automatic baud rate selection.
- Textool zero insertion force socket.
- Available CP/M software.

● Model 953A, programs most 24 pin EPROMS.

Price - \$269.00

EXPLORATIONS IN OFFICE AUTOMATION

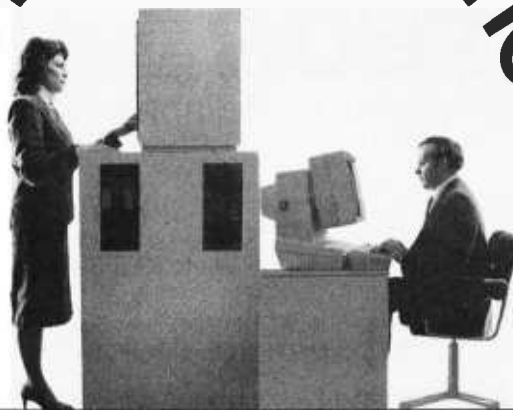

The mind never stops. Your constant search for better, more cost-efficient business methods will lead you to the fourth annual Office Automation Conference, the only one of its kind in the world. Our theme is *Explorations in Office Automation*, and we'll be presenting 50 technical sessions which will examine six areas of interest:

- Advanced Office Technology
- Communications
- Current Office Technology
- Human Factors and Social Issues
- Management and Organizational Issues
- Systems Integration

You'll also discover a panorama of office automation products and services exhibited by more than 150 of the leading manufacturers. There will be four luncheon workshops in which you may choose to participate, and a special presentation by five editors from *Newsweek* who will be conducting a Periscope Panel with lively discussion on events of the day.

We're expecting a sellout crowd at OAC '83, so why don't you fill out and mail this coupon today. Be a part of the office of the future at OAC '83.

THE FOURTH ANNUAL



1983 OFFICE AUTOMATION CONFERENCE



FEBRUARY 21-23, 1983 • CIVIC CENTER • PHILADELPHIA, PA.

SPONSORED BY AMERICAN FEDERATION OF INFORMATION PROCESSING SOCIETIES, INC.

(For more information, cut and mail today.)

NAME _____

TITLE _____

COMPANY _____

ADDRESS _____

CITY _____ STATE _____ ZIP _____

Mail to:



AFIPS
1983 OAC
P.O. Box 9659
Arlington, VA. 22209

9

Marcey Inc.

The METEOR

A System designed for Maximum Reliability, Flexibility and Value

System Specifications:

Processor:

- 4 MHz Z-80A CPU
- 64K Memory - Bank Selected
- 2 Serial & 2 Parallel I/O Ports
- 2K or 4K Shadowed Monitor EPROM
- Double Density Floppy Disk Controller
- Single Board Construction
- Meets IEEE 696 Specifications

Power

Specifications:

- Constant Voltage Power Supply (*Provides Brown-Out Protection*)
- Switchable 110/220V & 50/60 Hz Operation
- +8V/30A +-16V/3A

Chassis

Specifications:

- 1 Slot Shielded Motherboard (*11 Free Slots in Single User System*)
- Dual Double-Sided Double-Density Disk Drives
- 2.2 Megabytes Total Disk Storage
- Black Chassis with Gold Anodized Front Panel

Operating

Systems:

- CP/M Version 2.2 Standard (Included)
- Enhanced Command Control Processor

Available

Options: *(Additional Cost)*

- 4 Thin-Line Floppy Disk Drives (*5 Megabyte Floppy Disk Storage*)
- MP/M Multi-User Operating System
- Turbo-DOS Multi-User Operating System
- Turbo-DOS Multi-Processor Operating System
- Custom Wood Cabinet
- Slave Processors for Multi-Processor Systems

List Price \$4995

Introductory Price \$3495

For Further Information Please Circle Reader Service Card #284

MARCEY Universal S-100 Mainframe

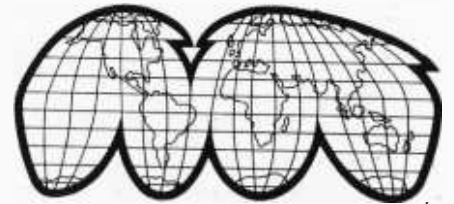

The first S-100 Mainframe that is truly UNIVERSAL.

The power supply is SWITCHABLE between 110/220v and 50/60Hz, and provides BROWN-OUT PROTECTION with its Constant Voltage Transformer.

Available in either 12-slot or 22-slot configurations

Specifications:

- Motherboard — S-100/IEEE-696 — Shielded and Grounded
- Power Supply — +- 8V @ 30A — +- 16V @ 2A
- Constant Voltage Power Transformer
- Switchable 110/220V & 50/60Hz

12 Slot List \$795.00 **Introductory Price \$575.00**

22 Slot List \$995.00 **Introductory Price \$675.00**

For Further Information Please Circle Reader Service Card #285

MARCEY INC.

Distributors of Computers and Computer Products

6700 Valjean Avenue □ Van Nuys, California 91406 □ (213) 994-7734

Dealer Inquiries Invited Quantity Pricing Available

Marcey Inc.

Consumer Products Division

Dealers Shop No More, Marcey Has The Price You're Looking For!!

Computer Software

- Atari
- Automated Simulations
- Budgeco
- Datasoft
- Broderbund
- Adventure International
- MicroPro
- Sir-Tech
- Stoneware
- Software Publishing Co.
- Infocom
- Continental Software
- Muse
- Sorcim

Games

- Atari
- Mattel
- Coleco
- Activision
- Imagic
- Fidelity
- Parker Brothers

Computers Products

- Atari
- Franklin
- Maxell
- Sanyo
- U.S.I.
- BMC
- NEC
- Microsoft
- Mountain Hardware
- Dysan
- Wabash
- Epson
- C. Itoh
- Okidata

Cameras

- Nikon
- Kodak
- Olympus
- Canon

Video Products

- RCA
- Hitachi
- Sanyo
- Panasonic

Calculators

- Hewlett Packard
- Olivetti
- Royal

Typewriters

- Olivetti
- Royal

Radios

- Panasonic
- Hitachi
- Pioneer
- Sanyo

Recorders

- Olympus
- G.E.
- Sanyo
- Panasonic
- Pioneer

Appliances

- Litton
- Whirlpool
- General Electric
- Panasonic

*There's more but we didn't have any more room to put them in,
so please call if you don't see what you want or need!*

The Distribution Company that gives you more!!

MARCEY INC.

Consumer Products Division

6700 Valjean Avenue □ Van Nuys, California 91406 □ (213) 994-7734

Dealer Inquiries Invited Quantity Pricing Available

For Further Information Please Circle Reader Service #286

A Little Apple SOS with Your Pascal

Timothy C. O'Konski
Apple Computer Inc.
10460 Bandley Dr.,
Cupertino, CA 95014

The Apple III is a powerful, versatile personal computer offering the user the Sophisticated Operating System (SOS; pronounced "sauce") and a new expanded version of Pascal. SOS has a flexible and generalized command set to access devices supported by the Apple III, and Pascal offers the advantage of a language designed to teach proper programming practices. The two, therefore, go hand in hand to make applications programming productive and enjoyable. This article presents a particular set of routines to allow direct access to SOS file calls from a Pascal program. (See listing 1, page 450, and listing 2, page 460.)

By making direct system calls to SOS, you can dramatically expand the limited nature of standard Pascal input and output (I/O) constructs, which are a carry-over from the original sequential cassette-tape model. The interpretive Pascal environment on the Apple III allows you to link external (assembly-language) routines to a program or to a separately compilable unit. Thus, you can use the features of SOS for any application program that runs under it.

Although Apple III Pascal allows you to read UCSD Pascal-formatted disks as well as edit, compile, and link source text that was created on the Apple II UCSD Pascal system, the routines described in this article are executable only on the Apple III using SOS-formatted disks.

About the Author

Timothy O'Konski is a senior member of the technical staff at Apple Computer in the Personal Computer Systems Division. He has a bachelor's degree in computer science from the University of California, Berkeley and has been working in the computer industry on systems and applications software for six years.

The Console

The Apple's standard monochrome monitor is supported by the SOS console driver. The greatest advantage of using the console driver rather than Pascal read and write routines is the ability to mix commands and text. With a single call to SOS, you can turn off the cursor, clear the screen, position the cursor at any X,Y position, write a line of data, set a viewport, scroll newly written text up one line, and turn on the cursor. Because the contents of any viewport (an arbitrary rectangular area that you define) can be saved and then restored, error messages can temporarily overlay the current information, which can then be restored in a single control request to the console driver.

The SOS_IO routines that communicate with the console are:

- SOS_Open—opens the console for use by your application
- SOS_Read—reads from the keyboard
- SOS_Write—writes data and issues commands to the display
- SOS_Close—relinquishes use of the console to other programs

Writing to a Printer

With Apple III Pascal, data is passed to the printer on a character-by-character basis. This means that each buffer passed to a printing device via a Pascal write or unitwrite statement is broken down into n SOS calls, where n is the number of bytes given in the write request. This takes $n-1$ times more SOS overhead when compared to a direct request to a SOS printer driver. The performance improvement you get by using a SOS_Open and then

Text continued on page 480

Everybody's making money selling microcomputers. Somebody's going to make money servicing them.

New NRI Home Study Course Shows You How to Make Money Servicing, Repairing, and Programming Personal and Small Business Computers

Seems like every time you turn around, somebody comes along with a new computer for home or business use. And what's made it all possible is the amazing microprocessor, the tiny little chip that's a computer in itself.

Using this new technology, the industry is offering compact, affordable computers that handle things like payrolls, billing, inventory, and other jobs for businesses of every size... perform household functions including budgeting, environmental systems control, indexing recipes. And thousands of hobbyists are already owners, experimenting and developing their own programs.

Growing Demand for Computer Technicians

This is only one of the growth factors influencing the increasing opportunities for qualified computer technicians. The U.S. Department of Labor projects over a 100% increase in job openings for the decade through 1985. Most of them *new* jobs created by the expanding world of the computer.

Learn at Home in Your Spare Time

NRI can train you for this exciting, rewarding field. Train you at home to service not only microcomputers, but word processors and data terminals, too. Train you at your convenience, with clearly written "bite-size" lessons that you do evenings or weekends, without going to classes or quitting your present job.

Your training is built around the latest model of the world's most popular computer. It's the amazing TRS-80™ Model III, with capabilities and features to perform a host of personal and business functions. No other small computer has so much software available for it, no other is used and relied

(TRS-80 is a trademark
of the Radio Shack
division of Tandy Corp.)



on by so many people. And it's yours to keep for personal or business use.

You get plenty of practical experience. Using the NRI Discovery Lab* that also comes as part of your course, you build and study circuits ranging from the simplest to the most advanced. You analyze and troubleshoot using the professional 4-function LCD digital multimeter you keep to use later in your work. Then you use the lab and meter to actually access the interior of your computer... build special circuits and write programs to control them. You "see" your computer at work and demonstrate its power.

Computer Assisted Instruction

Your TRS-80 even helps train you. You receive 4 special lesson tapes in BASIC computer language. Using them in your microcomputer, you "talk" to it as you progress. Errors are explained, graphics and animation drive home key points. Within a matter of minutes, you'll be able to write simple programs yourself.

Become the Complete Computer Person

In addition to training in BASIC and advanced machine language, you gain hands-on experi-

ence in the operation and application of computers to business and personal jobs. You're trained to become the fully rounded, new breed of technician who can interface with the operational, programming and service facets of today's computers. You're ready to take your place in the new electronic age.

Other Opportunities

NRI has been giving ambitious people new electronic skills since 1914. Today's offerings also include TV/Audio/Video Systems servicing with training on our exclusive Healy/Zenith computer-programmable 25" diagonal color TV... Industrial Electronics, Design Technology... and other state-of-the-art courses.

Free Catalog... Mail Card No Salesman Will Call

Send the postage-paid card for our 100-page catalog showing all courses with equipment and complete lesson plans. There's no obligation other than to yourself. See how NRI can help you grow with the most exciting and important new field of the 80's. If card has been removed, please write to us.



NRI Schools
McGraw-Hill Continuing
Education Center
3939 Wisconsin Ave.
Washington, DC 20016

We'll give you tomorrow.



Listing 1: The SOS file-handling routines are represented as an Apple III Pascal intrinsic unit. After compiling this unit and linking it along with the assembled routines, the linked intrinsic unit may be installed in the SYSTEM.LIBRARY file or in a program library file.

```

{$CC Copyright Tim O'Konski 1982}
Unit SOS_IO;

Intrinsic CODE 23;

Interface
  Procedure SOS_Create ( Var Pathname; FileID, AuxID, Storage, EOFBlk : Integer;
    Var RetCode );
  { Creates a file on a block device with the specified pathname. }

  { Input Values :
    Pathname : A Pascal string that is a valid SOS pathname.
    FileID   : The SOS file identification code to associate with the
              created file.
    AuxID    : The SOS auxiliary identification code.
    Storage  : The storage type to create. One is a standard file, thirteen
              is a subdirectory file.
    EOFBlk   : The number of blocks to preallocate for the file on a block
              device. The range is 0 to 32767 blocks.
    Output Values :
    RetCode  : An integer to contain the SOS return code (a zero means no
              errors).
  }

  Procedure SOS_Destroy ( Var Pathname, RetCode );
  { Deletes the file specified by the passed pathname. }

  { Input Values :
    Pathname : The pathname of the file to destroy.
    Output Values :
    RetCode  : An integer to contain the SOS return code (a zero means no
              errors).
  }

  Procedure SOS_Rename ( Var OldPath, NewPath, RetCode );
  { Renames the OldPath to the NewPath-name. }

  { Input Values :
    OldPath  : A Pascal string pathname to change FROM.
    NewPath  : A Pascal string pathname to change TO.
    Output Values :
  }

  RetCode : An integer to contain the SOS return code (a zero means no
  errors).
}

Procedure SOS_Set_Info ( Var Pathname, FileList; ListLeng : Integer;
  Var RetCode );
{ Sets the file information specified by the passed pathname and ListLeng. }

{ Input Values :
  PathName : The pathname to set the file information.
  File List : The up to 15 byte list (the length SOS uses is determined by
  ListLeng;
  Byte 0 - The file attribute bits. Bit 7 set is destroy OK; bit
  6 set is rename OK; bit 1 set is write OK; bit 0 is read OK.
  Byte 1 - The file identification code.
  Bytes 2-3 - The auxiliary identification code.
  Bytes 11 to
  14 - The packed values for the date and time stamp: Year (0..99),
  Month (1..12), Day (1..31), Hour (1..24), Minute (1..60);
  stored in four bytes in the following fashion.

  (high byte) (low byte)
  7 6 5 4 3 2 1 0 | 7 6 5 4 3 2 1 0
  +-----+-----+
  Date | | | | | | | | | | | | | | | |
  +-----+-----+
  Year | | | | | | | | | | | | | | | |
  Month | | | | | | | | | | | | | | | |
  Day | | | | | | | | | | | | | | | |
  +-----+-----+
  (high byte) (low byte)
  7 6 5 4 3 2 1 0 | 7 6 5 4 3 2 1 0
  +-----+-----+
  Time | | | | | | | | | | | | | | | |
  +-----+-----+
  Hour | | | | | | | | | | | | | | | |
  Minute | | | | | | | | | | | | | | | |
  +-----+-----+
  }

  { Use packed array [0..14] of char or 0..255 }

  ListLeng : The file attributes to change. One is only FileAttr, three
  is through FileID, fourteen is through AuxID, and fifteen
  is everything.

  Output Values :
  RetCode : An integer to contain the SOS return code (a zero means no
  errors).
}

Procedure SOS_Get_Info ( Var Pathname, FileList; ListLeng : Integer;
  Var RetCode );
{ Gets the file information specified by the passed pathname. }

{ Input Values :
  PathName : The pathname of the file to get the information from.
  ListLeng : The length of the file information list to be returned
  by SOS (as per the FileList definition).
  Output Values :
}

```

LIFT-OFF FOR NCC '83

MAY 16-19
ANAHEIM, CA.

THE EMERGING
INFORMATION AGE:
COMPUTERS,
COMMUNICATIONS,
AND PEOPLE

Join us next spring for
the most up-to-the-
minute information on
computer technology.
Make plans now to be
part of the 1983 National
Computer Conference —
and of the future!

Sponsored by: American Federation of Information Processing Societies, Inc.;
Association for Computing Machinery; Data Processing Management
Association; IEEE Computer Society; Society for Computer Simulation

For information, fill in and mail to: NCC '83, P.O. Box 9658, Arlington, VA, 22209.

NAME _____
TITLE _____
COMPANY _____
ADDRESS _____
CITY _____
STATE _____
ZIP _____

AFIPS 1



```

FileList : The file information returned on the file with the pathname
passed:
Byte 0 : File attribute
Byte 1 : File identification
Byte 2 & 3 : (Low,High) Auxiliary identification
Byte 4 : Storage type
Bytes 5..8 : (Low,High) EOF in bytes
Bytes 9 & 10 : Blocks currently used
Bytes 11..14 : (Low,High) Modification date and time
(Use packed array [0..14] of char or 0..255)

RetCode : An integer to contain the SOS return code (a zero means no
errors).
}

Procedure SOS_Volume ( Var DevName, VolName, TotalBlks, FreeBlks, RetCode );
{ Gets volume information on the device specified by the passed DevName. }
{ Input Values :
DevName : A Pascal string containing the device name; maximum of
15 characters in length.
Output Values :
VolName : The SOS volume name returned in a Pascal string 15 bytes
long.
TotalBlks : The total number of blocks on the volume, returned
as an UNSIGNED integer value (0 to 65535).
FreeBlks : The number of available blocks on the volume, returned
as an UNSIGNED integer value (0 to 65535).
RetCode : An integer to contain the SOS return code (a zero means no
errors).
}

Procedure SOS_Set_Prefix ( Var Prefix, RetCode );
{ Sets the system prefix (NOT the Pascal prefix!) to the passed prefix
string. }
{ Input Values :
Prefix : A Pascal string up to 255 characters long containing
the system prefix value. Note that a "/" is automatically
added to the end of the system prefix.
Output Values :
RetCode : An integer to contain the SOS return code (a zero means no
errors).
}

Procedure SOS_Get_Prefix ( Var Prefix; Length : Integer; Var RetCode );
{ Gets the current system prefix (NOT the Pascal prefix!). }
{ Input Values :

```

```

Prefix : A Pascal string[n] to receive the current system prefix.
Length : The maximum length of the string, i.e. "n."
Output Values :
RetCode : An integer to contain the SOS return code (a zero means no
errors).
}

Procedure SOS_Open ( Var Path; ReqType, Pages : Integer; Var SysBuf, RefNum,
RetCode );
{ Opens a file with the specified pathname. }
{ Input Values :
Path : A Pascal string containing the pathname of the file to
be opened.
ReqType : The manner in which to open the file, e.g. 0 = file's
attribute, 1 = read only, 2 = write only, 3 = read/write.
Pages : The number of user supplied pages pointed to by the SysBuf
parameter. Note that passing a 0 means that SOS finds its
own buffer. The maximum value is 4; each page is 256 bytes
long. If a 0 is passed, then SOS ignores the SysBuf
parameter, and finds its own buffer.
SysBuf : This must be a 1024 byte buffer for SOS to use for the
duration of the open. CAUTION : You cannot use OR deallocate
this buffer while the file is open. Use a packed array
[0..1023] of char. If the file being opened is not on
a blocked device (e.g. a printer, the console), the SysBuf
pointer is ignored by SOS.
Output Values :
RefNum : This is the SOS file reference number returned as an integer
value, to be used in SOS Read's and SOS Write's to the file.
RetCode : An integer to contain the SOS return code (a zero means no
errors).
}

Procedure SOS_New_Line ( RefNum, Flag : Integer; NewCh : Char; Var RetCode );
{ Enables/disables the "newline" read mode (i.e. stops a read on the specified
NewCh when enabled). }
{ Input Values :
RefNum : The reference number of the file.
Flag : 0..127 is disable; 128..256 is enable the newline mode.
NewCh : the character to be used as a newline character (terminates
the read).
Output Values :
RetCode : An integer to contain the SOS return code (a zero means no
errors).
}

Procedure SOS_Read ( RefNum : Integer; Var InputBuf; BytesReq : Integer;
Var BytesRead, RetCode );

```

FREE SHIPPING

IBM® Personal Computer Products

Davong 5 MB Hard Disk System	\$1525.00
12 MB Hard Disk System	2099.00

Quadram - Quadboard with Parallel

Port, Serial Port, Clock/Calendar,
Expandable to 256 K.

64 K on brd.	\$425.00
128 K on brd.	539.00
192 K on brd.	629.00
256 K on brd.	719.00

Quadram Memory Expansion

192 K Maximum	
64 K on brd.	\$230.00
128 K on brd.	350.00
192 K on brd.	490.00

Amdek Monitors

Mod. 300 Phosphor	\$175.00
Composite Color	345.00
IBM RGB Compatible Color	695.00

IBM/TRS 80 Disk Drives/Cabinets

TM 100-1 Single 40 Track Drive	\$199.00
with Cabinet & P/S	249.00
TM 100-2 Double 40 Track Drive	289.00
TM 100-3 Single 80 Track Drive	289.00
TM 100-4 Double 80 Track Drive	399.00
8" Dual Slim Line Power Supply & Cabinet	249.00
5¼ External Power Supply & Cabinet	49.00

VISA, MASTERCARD (5100 Min. Add 2%)
Or Certified Check

90 Day Warranty (Parts & Labor)
TRS 80 is a Registered Trademark, Tandy Corp.
Prices Subject to Change Without Notice

DATA MAIL

1 - (800) 635-5555

P.O. BOX 818, RESEDA, CA 91335

Apple II® Computer Products

Apple Saver System	\$79.95
Apple Compatible Disk Drive w/Cabinet & Cable	285.00
w/Controller	345.00
16 K Ram Card	60.00
Printer/Graphics Interface	99.95
Davong 5 MB Hard Disk System	1525.00
Davong 12 MB Hard Disk System	2099.00
Apple Compatible Joysticks	35.00

Epson/Smith-Corona Printers



MX80	\$450.00
MX80 F/T	535.00
MX100	685.00
Smith Corona TP-1 Letter Quality Daisy Wheel	575.00
TRS 80 / IBM Parallel Printer Cable	\$29.95
(with purchase of printer)	
TRS / 80 Parallel Printer Cable	39.95
(without printer purchase)	

Our TRS 80® Mod III

48 K; 2 Tandon 5¼ Disk
Drives w/ RS 232.. **\$1725.00**



Memory & Media

IBM 64 K Upgrade Kit (9-4164)	\$79.95
16 K Upgrade Kit (4116)	12.95
Maxell Diskettes	
MD1 - S/S - D/D	\$36.00/Box of 10
MD2 - D/S - D/D	46.00/Box of 10

Commodore VIC-64

\$Call

FREE SHIPPING IN CONTINENTAL U.S.
(TRS 80 MOD III EXCEPTED)

(213) 993-4804
(In Calif.)

Circle 239 on inquiry card.



SA2 ROBOT

\$999

The SA2 is a robot developed for the educational market, and has been designed to meet a requirement for a robot which will emulate, in behaviour and physical attributes, larger industrial robots.

The arm can access 360°, with a reach of 18 inches and a maximum lift of ½lb

Circle 240 on inquiry card.

The Syntheasy

A low cost speech unit complete with
Votrax speech output chip, unlimited
vocabulary, power supply, speaker
and case, all for only -

\$149.95



DEALER INQUIRIES INVITED
For further information contact

INTELLIGENT ARTEFACTS LTD.

19205 Parthenia St., Suite H
Northridge, CA 91324 Tel (213) 993-4803

Circle 239 on inquiry card.

www.americanradiohistory.com

```

    RetCode : An integer to contain the SOS return code (a zero means no
    errors).
}
Procedure SOS_Flush ( RefNum : Integer; Var RetCode );
{ The SOS output buffer associated with the file specified by the passed
reference number is immediately written to the file. }
{ Input Values :
    RefNum : The reference number returned from the SOS_Open request.
Output Values :
    RetCode : An integer to contain the SOS return code (a zero means no
    errors).
}
Procedure SOS_Get_B_Mark ( RefNum : Integer; Var BlockNum, RetCode );
{ Gets the current mark, or position of the file specified by the passed
reference number, rounded up to the nearest 512 byte block. }
{ Input Values :
    RefNum : The SOS file reference number returned by the SOS_Open
    request.
Output Values :
    BlockNum : The mark rounded up to the nearest 512 byte block number.
    Use an integer for the 0..32767 value range.
    RetCode : An integer to contain the SOS return code (a zero means no
    errors).
}
Procedure SOS_Get_B_EOF ( RefNum : Integer; Var BlockNum, RetCode );
{ Gets the current EOF of the file specified by the passed reference number,
rounded up to the nearest 512 byte block. }
{ Input Values :
    RefNum : The SOS file reference number returned by the SOS_Open
    request.
Output Values :
    BlockNum : The EOF rounded up to the nearest 512 byte block number.
    Use an integer for the 0..32767 value range.
    RetCode : An integer to contain the SOS return code (a zero means no
    errors).
}
Procedure SOS_Set_B_Mark ( RefNum, Base, BlockNum : Integer; Var RetCode );
{ Sets the current mark of the specified file to the 512 byte block number
specified. }
{ Input Values :

```

```

    Reads from the file specified by reference number. }
{ Input Values :
    RefNum : The reference number returned from the successful SOS_Open
    request.
    BytesReq : The number of bytes to read as an UNSIGNED integer value
    (0..65535).
Output Values :
    InputBuf : A pointer to the buffer to read into. Use a packed array
    [0..??] of char.
    BytesRead : The actual number of bytes read into InputBuf.
    RetCode : An integer to contain the SOS return code (a zero means no
    errors).
}
Procedure SOS_S_Read ( RefNum : Integer; Var InputBuf; OffSet,
    BytesReq : Integer; Var BytesRead, RetCode );
{ The same as SOS_Read, except that the buffer read into is indexed by OffSet
bytes (e.g. for a read into a string). }
Procedure SOS_Write ( RefNum : Integer; Var BufPtr; NumBytes : Integer;
    Var RetCode );
{ Writes to the file specified by reference number. }
{ Input Values :
    RefNum : The SOS reference number returned from the successful
    SOS_Open request.
    BufPtr : The Pascal buffer to write to the file, a packed array should
    be used.
    NumBytes : The number of bytes to write from BufPtr.
Output Values :
    RetCode : An integer to contain the SOS return code (a zero means no
    errors).
}
Procedure SOS_S_Write ( RefNum : Integer; Var BufPtr; OffSet,
    NumBytes : Integer; Var RetCode );
{ The same as SOS_Write, except that the write buffer pointed to by BufPtr is
indexed by OffSet bytes. }
Procedure SOS_Close ( RefNum : Integer; Var RetCode );
{ Closes the file specified by reference number. }
{ Input Values :
    RefNum : The reference number returned from the SOS_Open request.
Output Values :

```

Need help organizing your data, your office, and your career?

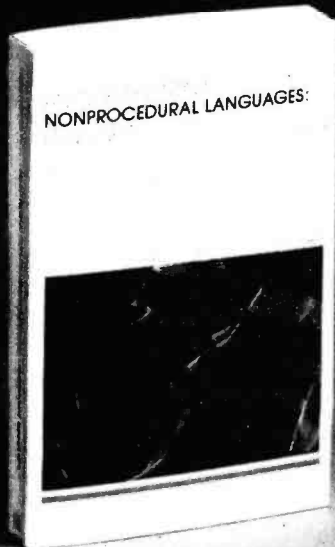

Use this book and one of these disks
to transform your raw data into information for decision making.
Finally, you will have direct access to your databases, your way.

AN INTRODUCTION TO NONPROCEDURAL LANGUAGES from McGraw-Hill Book Company complements a new software product by DeskTop Software Corporation. *AN INTRODUCTION TO NONPROCEDURAL LANGUAGES* presents a new and simplified way to get the most out of your IBM®, Apple®, or DEC® personal computer system. The NPL™ Information Management System is specifically designed to:

- Build new databases quickly
- Search and Sort and Sift through thousands of data items
- Tailor tabular reports to particular needs
- Develop advanced applications without traditional programming

Going into Depth with NPL

This book does more than just describe the NPL System. It covers the basics of these NPL features:

- Interactive report request with flexible selection and screening criteria
- Full mathematical calculations and string manipulations
- Preparation of reports in tabular and letter formats
- Creation of summary and extract files from large files
- Sorting by multiple keys
- Full screen interactive data entry with field validations
- Stored requests for complete applications

The book also discusses actual applications and specific features for the IBM, Apple, and DEC versions of the NPL software. Moreover, NPL language features are compared with five major nonprocedural languages for mainframe computers. Nonprocedural languages have been in use on the large IBM 370 computers since 1968, and are currently in use by over 1500 companies.

The NPL Information Management System

The simple efficiency of the nonprocedural languages used on IBM computers is now available for mini- and microcomputers through NPL. NPL language statements look like plain English...easy to understand, self-documenting. NPL sentences say simply what must be reported; the computer figures out how to produce the desired result.

Sample NPL Sentences

SUM TRANSACTIONS BY CUSTOMER, BY STOCK,
IF ACCNR EXCEEDS 4000, AND IF MONTH IS OCT TO DEC.
PRINT COMPANY, OVER STREET, OVER CITY, STATE, AND ZIPCODE
IF ZIPCODE FROM 07000 TO 10999, AND SKIP 4.

You can order NPL Information Management Systems...

- For the DEC Professional 325/350 computer from Digital Equipment Corporation (order No. QA117-C3 NPL).
- APPLE/NPL from Authorized Apple Computer dealers, for the Apple II and Apple III (available 3/83).
- For the IBM/PC and other computers from DeskTop Software Corporation.

Digital is a registered trademark of Digital Equipment Corporation
Apple is a registered trademark of Apple Computer, Inc.
NPL is a trademark of DeskTop Software Corporation
IBM is a registered trademark of International Business Machines

**Available at your bookseller or computer store.
Or use coupon for a 15-day FREE examination!**

McGraw-Hill Book Company
Attn: D.K. Dennis, 27th Floor
1221 Avenue of the Americas
New York, NY 10020

Please send me the book for 15 days on approval.

- INTRODUCTION TO NONPROCEDURAL LANGUAGES: USING NPL*, \$24.95 (65301-1)
- Bill me. After 15 days I will pay you for the book plus postage, handling and local taxes.
- Enclosed is my check/money order (including tax). McGraw-Hill pays postage and handling. If not satisfied, I may return the book within 15 days for a full refund.
- Please send more information on NPL.

Name _____

Address/Apt. _____

City/State/Zip _____

U411-2144-3

DeskTop
Software Corporation
228 Alexander Street, Princeton, NJ 08540



We Are The Systems Specialist
COMPUSHACK

SPECIAL PRICES ARE ONLY PART OF OUR SERVICE

THE COMPUSHACK LINE OF SPECIALS

APPLE 100% Apple compatible; runs DOS 3.3, PASCAL, CP/M, etc. 15% more storage by using enhancer diskette. 300% faster track-to-track speed.

\$279.00

SUGGESTED RETAIL PRICE \$429.00

Drive with controller card. \$359

Same drive but slim line (no controller). \$399

slim line drive 1 MB capacity + controller \$999

APPLE II+ Complete System:

APPLE II+ Computer, disk drive and controller, 12" monitor, green screen \$1599

APPLE II+ compatible

Winchester drives
 5 MB. . . . \$1795 10 MB. . . . \$1995

Includes controller, cables, software for CP/M, DOS or PASCAL.

8" drive, controller, power supply, cables, cabinet and software . . . \$1595

APPLE II plus 64K, Z80 card, 80 column card, controller hardware diagnostic, DOS 3.3, disk drive 163K, green monitor—runs DOS 3.3, CP/M and PASCAL . . . \$1950

OTHER PRODUCTS FOR APPLE II

VERSACard-multifunction board. . . \$169

BSR Transducer. \$19

Applications/Demo Disk \$25

Parallel Printer Card. \$69

PRT-1 with cable \$75

PRT-1 with EPSON 80/100 screen graphics dump with cable-Graffiti card \$99

PRT-1 with NEC 8023 or C.I.TOH PROWRITER screen Dump Graphics \$99

16K ram card \$89

32K ram card \$175

64K ram card including DOS 3.3 disk emulator. \$279

128K ram card including DOS 3.3 disk emulator \$369

PASCAL disk emulator \$39

DOS 3.3 disk emulator \$39

GRAPPLER INTERFACE CARD . . . \$139.00

- Visicalc Expand Program \$59
- VERSABox Spooler/buffer 16K Centronics Input/Output \$199
- VERSABox Spooler/buffer 16K Centronics and RS232C \$239
- VERSABox Real Time Clock/Display option. \$129
- 16K Memory Modules for VERSABox \$39
- Standard 6' Centronics Parallel Cable for EPSON, C-ITOH, NEC, ANADEx, and others \$22
- Standard 6' Paper Tiger or Prism Printer cable, Parallel Centronics Male DB25. \$26
- Miscellaneous cables for various printers. Please specify for Qume, Diable, Votrax, NEC Spinwriter or other \$26
- 80 Column card \$169
- Z80 card (no CP/M software included) \$149
- Controller for Apple II including hardware diagnostics \$115

FRANKLIN ACE1000 COMPUTER—

Complete System Franklin Ace 1000, Apple compatible, 64K, Upper and Lower case Typewriter style keyboard, 12-Key numeric pad, Alpha lock keys, Visicalc keys, 50 watt power supply and a built in fan. \$1599.00

OSBORNE COMPUTER SYSTEM—

includes CRT, 64K, Dual floppy disks, RS-232 port, IEEE-488 interface, Wordstar, Mailmerge, Supercalc, Mbasic and CP/M. . \$1795.00

ALTOS

Computer 8000-15 \$3999

EAGLE

Computer System
 Eagle II \$2699

Eagle III . . \$3333 Eagle IV . . . \$4999

ADDS VIDEO MONITORS

View Point A1 . \$560 View Point A2 . \$499

TELEVIDEO

910C \$599 912C \$759

CORVUS

5 MB Winchester. \$2999

10 MB. . . . \$4399 20 MB \$5299

PDS Super Software Specials

Word Star. . . \$220 DB Master. . . \$165

Mail Merge. . . \$75 Visicalc \$190

Spell Star . . . \$125 Visiplot \$170

Calc Star . . . \$125 Visiterm \$90

Screenwriter II . \$90 Back It Up. . \$49.95

Bandits . . . \$25.95 Wizardry . . . \$39.95

Inventory Management Synergistic. . \$100



COMPUSHACK
apple®

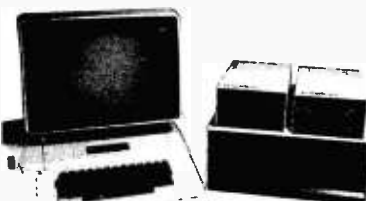

COMPUSHACK
FRANKLIN

DISK DRIVES
TANDON FLOPPY DISK DRIVES
 TM 100-1 SS/DD\$189.00
 TM 100-2 D S/DD\$249.00
 TM 100-4 96 T P I DS/DD\$379.00
HARD DISK SYSTEMS including
 all software and cables.
 DAVONG OR CORONA 5 MB. . \$1795.00
 10 MB. \$1995.00

SHUGART:
 SA 400 \$215 SA 800/801. . . \$379
 SA 450 \$281 SA 850/851. . . \$535
SIEMENS:
 FDD 100-5 . . . \$189 FDD 100-8. . . \$349
 FDD 200-5 . . . \$259 FDD 200-8 . . . \$449
QUME:
 DT-5. \$279 DT-8 \$469
TEAC:
 FD50A \$189 FD55A \$199
 FD50B \$269 FD55B \$279
 FD50E \$269 FD55E \$279
 FD50F \$389 FD55F \$399

MONITORS & PRINTERS
 BMC 12" green \$89
 BMC 12" green (high res.) \$149
 BMC 13" color monitor \$289
 C.I.TOH Prowriter parallel \$499
 C.I.TOH Prowriter serial \$599
 C.I.TOH Prowriter
 15" carriage...Parallel \$699
 FIO Daisywheel letter quality \$1395

MANNESMANN TALLY MT 160
 microcomputer printer. Dot
 Matrix printer, 160 CPS,
 Compact, Cost Effective,
 Built-in graphics. **Save \$200** . . \$799.00

OKIDATA
 82A \$459 83A \$730
 84AP \$999 84AS \$1099
EPSON MX-80 \$469
 MX-80 FT . . . \$525 MX-100 \$699

AMDEK VIDEO MONITORS
 Video-100 . . . \$95 Color II \$675
 Video-300. . . \$169 Color III \$420
 Color I \$345

NEC
 12" green screen \$169
 RGB Color Monitor. \$959
 Spinwriter 3510 \$1799
 NEC Letter quality printer 7715 . . . \$2399
 PC 8001 Call PC 8031A Call
 PC 8012A . . . Call PC 8023A . . . \$479
 PC 8033A . . . Call

CABINETS/POWER SUPPLY
 Dual 8" disk drive cabinet /ps. \$249
 Dual 5 1/4" disk drive cabinet /ps . . . \$99
 Single 5 1/4" disk drive cabinet /ps. . . \$69
 2 single side double density 8" disk drives,
 cabinet/power supply. \$895

SPECIALS OF THE MONTH IBM PC— COMPLETE LINE

IBM PC Complete System: includes 64K
 IBM-PC with 2 Floppy Disk Drives, Floppy
 Drive Controller, 12" monitor, Color
 Graphics card. All for only . . . \$2899.00
AST CARD 512K memory board for IBM-PC—
 512K ram, Clock/Calendar, Serial Port,
 Parallel Port.
 64K . . . \$620.00 512K . . . \$1199.00
AST I/O Interface card with Clock/Calendar
 1 Parallel Port and 2 Serial Ports. \$249.00
AST COMBO CARD 256K ram,
 Parallel Port, Serial Port, Clock
 Calendar and Battery back-up . \$599.00

MAYNARD ELECTRONICS PRODUCTS
 Floppy Disk Controller. \$179.00
 Floppy Disk Controller w/Parallel
 Port. \$229.00
 Floppy Disk Controller w/Serail
 Port. \$239.00
 Memory Card w/256K ram \$499.00

PDS UNIVERSAL MEMORY CARD
 A unique memory card with 256K ram,
 Game Port and Serial Port. . . \$499.00

HERCULES GRAPHICS CARD
 This card gives you 720 x 350
 graphics capabilities and it is
 completely compatible with
 DOS software for only \$489.00

BIG BLUE—Dual I/O ports, dual
 processing, Serial port,
 Parallel port, 5 MHZ Z-80 B,
 64K, Hard disk interface,
 Clock/Calendar, let's you run
 existing CP/M software.
 List \$589.00 **Ours \$479.00**

WE'RE OPENING RETAIL STORES THROUGHOUT THE U.S.A. SOON!

FRANCHISE INQUIRIES WELCOME

Prices subject to change without notice
 ALL FLOPPIES REPAIRED QUICKLY AT LOW COST

Sales and Service:
 (714) 730-7207
 Headquarters
 Telex: 18-3511
 Answer Back CSMA

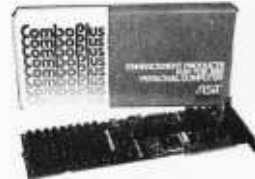
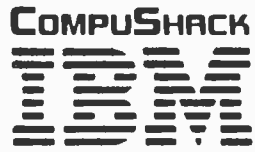

COMPU SHACK
brother
 BROTHER Model HR-1
 16 CPS, Daisywheel,
 letter quality,
 bidirectional printer
 \$769.00

COMPU SHACK
SCM
 SMITH CORONA TP-1
 12 CPS, 10 or 12 CPI,
 Unidirectional
 Letter quality printer
 \$569.00

COMPU SHACK
NEC

COMPU SHACK
 2630-H Walnut Avenue Tustin, CA 92680
 Business Home Computers
 Circle 383 on inquiry card.

```

RefNum      : The SOS file reference number returned by the SOS_Open
              request.
Base        : Where to set the mark relative to : 0 = beginning of the
              file; 1 = end of the file; 2 = positive from the current
              position; 3 = negative from the current position.
BlockNum    : A Integer block number from 0 to 32767 to set the mark to.

Output Values :
RetCode     : An integer to contain the SOS return code (a zero means no
              errors).
}

Procedure SOS_Set_B_EOF ( RefNum, Base, BlockNum : Integer; Var RetCode );
{ Sets the current EOF of the specified file to the 512 byte block number
  specified. }
{ Input Values :
RefNum      : The SOS file reference number returned by the SOS_Open
              request.
Base        : Where to set the mark relative to : 0 = beginning of the
              file; 1 = end of the file; 2 = positive from the current
              position; 3 = negative from the current position.
BlockNum    : A Integer block number from 0 to 32767 to set the EOF to.

Output Values :
RetCode     : An integer to contain the SOS return code (a zero means no
              errors).
}

Procedure SOS_Get_Mark ( RefNum : Integer; Var Low, Hi, RetCode );
{ Gets the mark of the specified file as the byte quantity passed as two
  UNSIGNED 16 bit integers. }
{ Input Values :
RefNum      : The file reference number returned from the SOS_Open request.

Output Values :
Low,Hi      : The mark returned as a 24 bit UNSIGNED quantity.
RetCode     : An integer to contain the SOS return code (a zero means no
              errors).
}

Procedure SOS_Get_EOF ( RefNum : Integer; Var Low, Hi, RetCode );
{ Gets the EOF of the specified file as the byte quantity passed as two
  UNSIGNED 16 bit integers. }
{ Input Values :
RefNum      : The file reference number returned from the SOS_Open request.

Output Values :
Low,Hi      : The file reference number returned from the SOS_Open request.
Base        : Where to set the mark relative to : 0 = beginning of the
              file; 1 = end of the file; 2 = positive from the current
              position; 3 = negative from the current position.
Low,Hi      : The EOF as a 24 bit UNSIGNED quantity. The high byte
              of "HI" MUST BE 0 (i.e. HI = 0..255).

Output Values :
RetCode     : An integer to contain the SOS return code (a zero means no
              errors).
}

Implementation
Procedure SOS_Create; External;
Procedure SOS_Destroy; External;
Procedure SOS_Rename; External;
Procedure SOS_Set_Info; External;
Procedure SOS_Get_Info; External;
Procedure SOS_Volume; External;
Procedure SOS_Set_Prefix; External;
Procedure SOS_Get_Prefix; External;
Procedure SOS_Open; External;
Procedure SOS_New_Line; External;
Procedure SOS_Read; External;
Procedure SOS_Write; External;

```

A Disc Drive Decision Algorithm

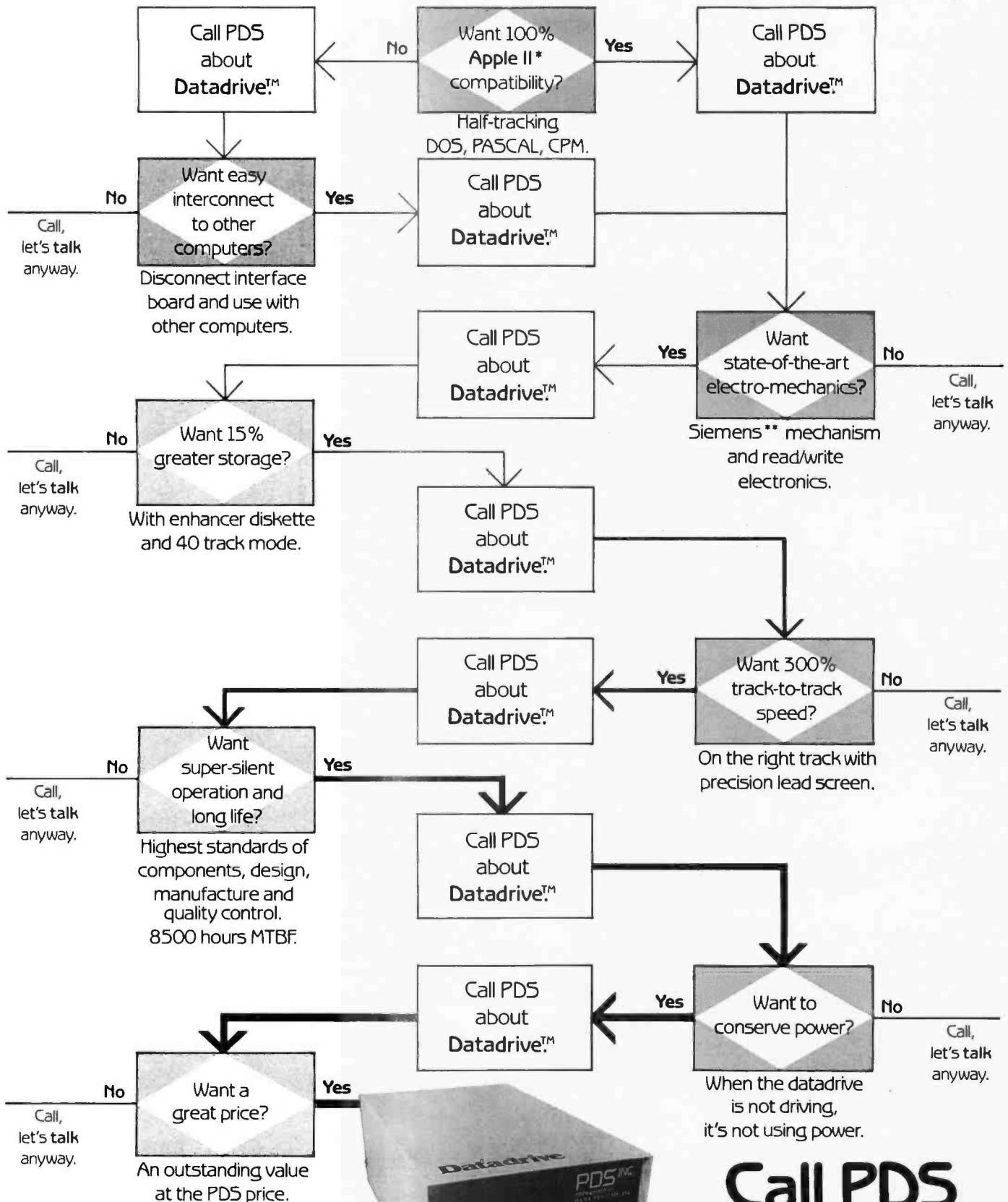

All logical Paths Lead to PDS Datadrive for Your Apple II.

* Apple II is a trademark of Apple Computers Inc.

** Siemens is a trademark of Siemens Corporation.

Call PDS
Universal Inc.
(714) 730-6772
2630 Walnut Ave., Suite G
Tustin, CA 92680

THE WALL STREET JOURNAL

Don't settle for too little, too late.

Subscribe to
The Wall Street Journal
and get all the business news
you need . . . when you need it.



If you're in business and serious about getting ahead, you have to search around to get all the business news you need these days. Even the best daily newspapers give you only a section of business news. And if you have to wait a week to read a business magazine, the news may not be news anymore. You wind up getting too little, too late.

There is one publication that gives you all the business news you need when you need it. The Wall Street Journal. Everyone who is serious about business knows that The Journal is serious business. That's why most successful executives start their day with The Journal. They just open its pages and the world of business is laid out for them—like a map of opportunity. It's where the big business stories break. *It's unmatched in providing valuable information.* It's *the way* the word gets around.

Every business day, The Journal reports anything happening anywhere in the world that can affect business—your business. It tells

you what new products and services are being developed. Where markets are opening up. How companies are coping with inflation and energy problems. Which companies are merging. Whose sales are surging. And along the way you'll probably discover many pointers to help direct your company to bigger profits and boost your own career.

And of course, there's The Journal's famous coverage of investment news designed to help you manage your money more profitably. There are regular feature articles on personal finance with subjects such as tax shelters, mortgages, C.D.'s, stock and bond selection, tax rulings and much, much more.

If you're serious about how you manage your business, your finances, your career, don't settle for "too little, too late." Subscribe to The Wall Street Journal and get all the business news you need . . . when you need it.

You can have The Journal rushed to you every business day for six months (26 weeks) for only \$47—that's about \$1.80 per week. All you have to do is mail the coupon. Do it now!

Call Toll Free
800-345-8540, ext. 14

(in Pennsylvania: 800-662-5180, ext. 14)

THE WALL STREET JOURNAL

Att: Manager of Subscriber Service
Subscriber Service Division
200 Burnett Road
Chicopee, Mass. 01021

Please enter my subscription to The Journal for six months (26 weeks) at \$47.

I prefer one year (52 weeks) at \$89.

Check enclosed Please charge my:

American Express Diners Club MC VISA

Card No. _____ Expires _____

Signature _____

Name _____

Address _____

City _____ State _____ Zip _____

Limited time offer—good in Continental U.S. only.

2AAD

Listing 2 continued:

Return code ptr., List length, File list ptr., Pathname ptr. The COINFO coroutine in SOSGETINFO is used to execute the call.

Global Registers Used:

ZREG0, ZREG1.

Files Used:

The passed pathname is used in the SOS call.

.REF COINFO,SSCINFO
LDA #SETINFO
STA SSGINFO ;Set the SOS call to SETINFO
JHP COINFO ;Go to the coroutine
.PROC SOSGETINFO,4

Name: SOSGETINFO

Stack Usage:

Return code ptr., List length, File list ptr., Pathname ptr.

Global Registers Used:

ZREG0, ZREG1, ZREG2.

Files Used:

The passed pathname is used in the SOS call.

.REF PARAM0,PARAM1,PARAM2,PARAM3,PARAM4
.PARAM5,SOSBLK
.DEF COINFO,SSCINFO

LDA #GETINFO
SSGINFO
RETURN0
ZREG02
PARAM5
ZREG01
ZREG00
#0.
PARAM4
PARAM2
#ZREG01
PARAM3
#ZREG00
PARAM1
#3.
PARAM0

;Set the SOS GETINFO call
;Return code ptr.
;List return length
;File list ptr.
;Pathname ptr.

;File list ZREG
;Pathname ZREG
;Param. count

Name: SOSSETPREFIX

SSCINFO
BRK 0.
.SOSBLK
.WORD (ZREG02),Y
STA TYA
INY
STA (ZREG02),Y ;Post return code
RETURN0
RTS
.PROC SOSVOLUME,5

Name: SOSVOLUME

Stack Usage:

Return code ptr., Free blocks ptr., Total blocks ptr., Volume name ptr., Device name ptr.

Global Registers Used:

ZREG0, ZREG1, ZREG2, ZREG3, ZREG4.

.REF PARAM0,PARAM1,PARAM2,PARAM3,PARAM4
.PARAM5,PARAM6,PARAM7,PARAM8,SOSBLK

Stack Usage:

POP RETURN0 ;Return code ptr.
POP ZREG4 ;Free blocks ptr.
POP ZREG3 ;Total blocks ptr.
POP ZREG2 ;Volume name ptr.
POP ZREG1 ;Device name ptr.
POP ZREG0 #0.
LDY PARAM4
STY PARAM2
STY #ZREG1
LDA PARAM3
STA #ZREG0 ;Volume name ZREG
LDA PARAM1 ;Device name ZREG
STA #4.
LDA PARAM0 ;Param. count
STA VOLUME ;Issue SOS call (assume Y = 0)
SOS (ZREG4),Y ;Post LSB return code
STA PARAM7 ;LSB # free blocks
LDA (ZREG3),Y ;LSB # total blocks
LDA PARAM5 ;MSB return code
(ZREG2),Y ;MSB # free blocks
TYA PARAM6
INY ;MSB # total blocks
STA (ZREG4),Y
LDA PARAM8
STA (ZREG3),Y
LDA PARAM6 ;MSB # free blocks
LDA (ZREG2),Y ;MSB # total blocks
RETURN0

SOSSETPREFIX,2

Name: SOSSETPREFIX

Listing 2 continued on page 466

Dogged attempt to learn a second language.

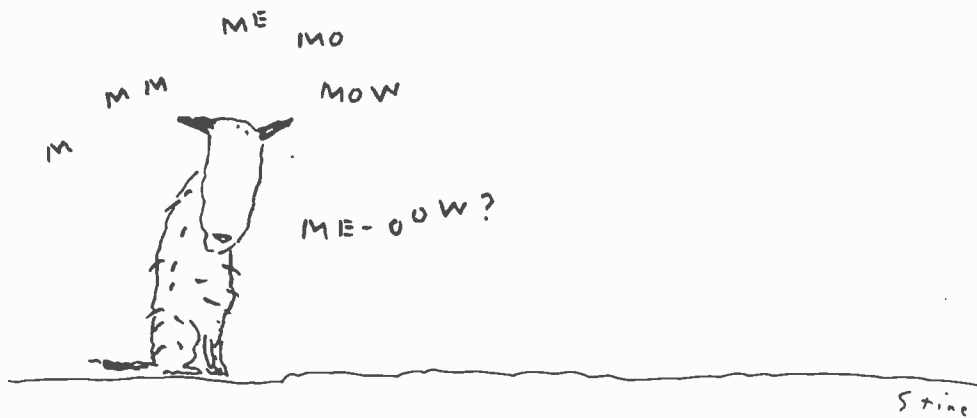

CP M is a registered trademark of Digital Research Corp.

For the name of the dealer nearest you, phone (800) 227-2400, ext. 948; in California, (800) 772-2666, ext. 948. For more information,

And now, InfoStar™

The first DBMS you can use without speaking programmerese.

So put away your GO TOs and DO WHILEs.

InfoStar is one microcomputer data base system that doesn't ask you to write in code. Or learn a programming language. Instead you make selections from an on-screen menu written in one easy language. English.

Which means you don't have to be a programmer or computer jock to use it. But, in case you are, there's something in it for you, too.

With InfoStar, you can generate a custom application four times faster than with other DBMS software.

Reason being it has a lot of the features that made WordStar® the standard in the industry. For instance, select-as-you-go menus prompt you through all procedures. And to format a data entry form or report, you simply draw it on the screen. We've said it before: what you see is what you get.

But, of course, that's not all you get.

Fact is, InfoStar has more informative

(and self-documenting) capabilities than you've come to expect from any microcomputer DBMS.

Starting with report writing. A custom report feature — complete with transactional updating and exception processing abilities — lets you format, manipulate and merge countless different ways. And a quick report feature lets you finish faster than you can count them — usually in 60 seconds or less.

Not that you have to slow down to sort things out either. Because InfoStar can sort five to six times faster than any other DBMS in its class.

And for data entry, there are high-end minicomputer features. Like batch editing. And 200 editing mask combinations, to name a few.

All that's required of you is that you have a CP/M-based computer.

And that you take a trip over to your local computer store to ask about InfoStar.

They don't speak programmerese.

But they're happy to talk business.



MicroPro®
The Microcomputer Software Company

iBEX 7202 FOR \$2,295!

**NEVER BEFORE SO MUCH
FOR SO LITTLE. MERRY CHRISTMAS!**



What a gift from a major Japanese manufacturer! By the end of 1982, we want to move our remaining inventory of 7202's. Due to a special purchase, we are able to offer this product while they last for \$2,295. It's fully documented and comes with a 90-day limited warranty.

This computer features dual 8-inch double-sided, double-density floppy disks, with the format software selectable. Because it supports the IBM 3740 industry-standard format, as well as double-density, data exchange with most other computers is possible.

Look what you get for \$2,295:

- Z80
- CP/M compatible
- 64 kilobyte RAM, expandable to 192 kilobytes
- Dual 8" floppies (1.2 megabytes each) switchable to IBM format
- 12" green phosphor monitor (80 x 24 characters)
- Centronics compatible printer interface
- Serial interface
- Full function keyboard
- Clock timer and calendar (with battery)

Other models also available at special close-out prices.

Access Unlimited

401 North Central Expressway
Richardson, TX 75080

1-800-527-3475 outside Texas
(214) 340-5366 inside Texas

CP/M is a registered trademark
of Digital Research.

Extra savings plus extra backup!

Palomar backs its low, low prices with great extras: (1) Expert technical advice. (2) Fast response on orders. (3) In-house service repairs. (4) Guaranteed satisfaction! That's no-risk mail-order buying!

SPECIAL!

SAVE 31%

Franklin Ace 1000	1,595.00	Taxan 12" Green Screen ...	169.00
TEAC Super 5 Disk Drive ..	495.00	Diskettes	35.00
TEAC Super 5 Controller Card	195.00	Diskette Case	5.00
Gemini 10	499.00		
Genie Graphics Card	99.00		
			\$3,022.00

NOW — \$2,085.

PRINTERS

COMREX

Comriter CR-1C	CALL
Tractor Feed	89.00

EPSON

Comrex 4K Buffer	139.00
Microbuffer - 16K Parallel	159.00
Microbuffer - 8K Serial	159.00

MPI

Apple Ap-Pak	145.00
IEEE Adapter Card	55.00
Hi-Speed RS232 Serial Card	70.00
Apple Parallel Card	110.00
8K Buffer Expansion - 150 G	170.00

NEC

3510 RO Serial	1,515.00
3520 KSR Serial	2,100.00
3530 RO Parallel	1,750.00
3550 RO IBM	1,880.00
7710 RO Serial	2,465.00
7730 RO Parallel	2,465.00
8023-A Dot Matrix	499.00
Bidirectional Tractor (3500)	150.00
Cut Sheet Guide (3500)	90.00
Envelope Handler (3500)	270.00
Horizontal Tractor (7700)	150.00
Bidirectional Tractor (7700)	345.00
Friction Attachment (7700)	35.00

NOVELL

Image 800	999.00
-----------------	--------

OKIDATA

Microline 82-A	519.00
Microline 83-A	745.00
Microline 84-S	1,250.00
Microline 84-P	1,150.00

OLYMPIA

ES 100 KRO	999.00
ES 100	799.00
Ser./Par. Interface	250.00
CCS Apple Serial Card	139.00

SMITH CORONA

TPI	649.00
-----------	--------

STAR MICRONICS

Gemini 10	CALL
Gemini 15	CALL

TEC

PMC 8510 Parallel	475.00
ITOH 8510-A Parallel	499.00
ITOH 8510-A Serial	650.00
ITOH 1550 Parallel	750.00
ITOH 1550 Serial	789.00
ITOH F-10-40	1,535.00
ITOH F-10-55	1,899.00

MONITORS

AMDEK

Video 300 - 12" Green	159.00
Color I - 13" Color Composite ..	379.00
Color II - Hi-Res RGB	799.00
Color III - Lo-Res RGB	469.00
RGB Apple II Card	169.00

COMREX

CR 5500 - 12" Green	155.00
CR 6500 - 13" Composite	315.00
CR 6600 - 13" RGB	429.00

NEC

PC-8041 A- 12" Green	159.00
----------------------------	--------

ZENITH

12" Green	119.00
-----------------	--------

SANYO

9" Hi-Res Green	159.00
12" Green Screen	135.00
12" Hi-Res Green	209.00
13" Color	419.00
13" Hi-Res Color	899.00

TAXAN

KG 12 N - 12" Green	CALL
KA 12 N - 12" Amber	CALL
RGB Vision I	CALL
RGB Vision II	CALL
RGB Apple II Card	129.00

U.S.I.

9" Green Screen	149.00
12" Green Screen	159.00
12" Amber Screen	179.00

SUPPLIES

RIBBONS

Comrex SS, doz	25.00
Comrex MS, doz	57.00
C. Itoh	13.50
Epson MX 80, 80 FT	4.99

PRINTWHEELS

Comrex	18.00
NEC (Thimble)	14.95
Olympia (Whisperdisc)	30.00
Smith Corona	4.95

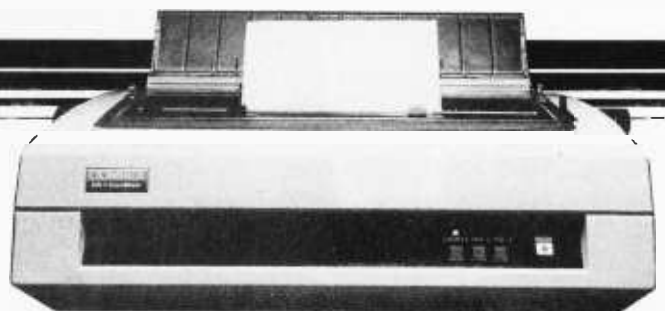

Many products are not listed. Please call our 800 number if you don't see what you are looking for.

APPLE

HARDWARE

Apple II Plus	CALL
CCS IEEE Card	200.00
CCS Analog/Digital Card	120.00
CCS 12K ROM/PRDM Mod.	115.00
Comrex Clock Card	75.00
CPS Multifunction Card	179.00
Microbuffer II 16K	250.00
Microbuffer II 32K	275.00
Microsoft Z80 Softcard	299.00
Microtek 16K Ram Card	99.00
Microtek Parallel Printer Card	89.00

SOFTWARE

BUSINESS	
Financial Partner	191.00
Pascal Tutor	97.00
Pro Easy Writer	137.00
Easy Writer 40 Col	78.00
Super Text II	117.00
The Address Book	38.00
Form Module Letter	78.00
VisiFile	229.00
Desktop Plan III	275.00
Desktop Plan II	229.00
Visiplot	185.00
Visitrend/Visiplot	275.00
VisiFax	229.00
Visiterm	89.00
Visicalc 3.3	729.00
Infotry	198.00
Superspell (Req. Softcard)	435.00
Word Processor (Req. Sctd)	255.00

MISCELLANEOUS

Applesoft Compiler	144.00
Basic Compiler	327.00
Apple-Doc	41.00
D.B. Master	169.00
D.B. Utility Pack	70.00
E-Z Draw 3.3	40.00
Pascal Graph Ed	79.00

IBM

HARDWARE

IBM PC	CALL
Adam & Eve Game Paddles	32.00
Corona 5 MB Winchester	CALL
Corona 10 MB Winchester	CALL
PMC Disk Drive	199.00
516 Printer Interface	239.00
TG Joystick	51.00
64K RAM Card	205.00
128K RAM Card	309.00
192K RAM Card	415.00
256K RAM Card	520.00

MODEMS

HAYES

Micromodem II (Apple II)	299.00
Micromodem II (S-100)	349.00
Smartmodem (RS-232)	225.00
Chronograph (RS-232)	229.00

UDS

103 LP Direct	175.00
103 JLP Auto Answer	209.00
202 LP 1200 BAUD	259.00
212 LP	535.00

S-100 HARDWARE

Tandon TM 100-1 Disk Drive	219.00
Tandon TM 100-2 Disk Drive	259.00
CCS Disk Controller/CPM 2.2	425.00
CCS 16K Static Ram Module	295.00
CCS 32K Static Ram Module	499.00
CCS 2 Serial Port + 2 Parallel	359.00
Comrex Clock Card	119.00
Hayes Micromodem II	349.00

DISK DRIVES

Microtek Graphics Card	105.00
MPC Serial Printer Card	89.00
M&R Super Fan	40.00
Numeric Key Pad	150.00
Paymar Lower Case Adapters	
Old (Rev. 1-8)	31.00
New (Rev. 77)	19.00
TG Game Paddles	30.00
TG Joy Stick	47.00
TG Select-A-Port	47.00
Videx 80 Column Card	299.00
Viewmax 80	249.00
Corona 5MB Winchester	CALL
Corona 10MB Winchester	CALL
Disk II with Controller Card	CALL
Microsci A2 without Controller Card	399.00
Microsci Controller Card	99.00
Rana Disk Drive	359.00
Rana Controller	109.00
TEAC Super 5 Disk Drive	299.00
TEAC Super 5 Controller Card	89.00

PERSONAL/HOME

Typing Tutor	19.00
Elementary Math	31.00
Personal Filing System	98.00
Personal Report System	75.00
Algebra I	31.00
Compu-Math Arith Skill	39.00
Compu-Math Fractions	31.00
Compu-Math Decimals	31.00
Compu-Spells (Req. Data Disk)	23.00

SOFTWARE

BUSINESS	
Write On Word Processor	105.00
Denver Accounting System	589.00
Easy Writer II	275.00
Easy Filer	315.00
Easy Planner	139.00
Easy Speller	139.00

HOME

Home Accountant Plus	119.00
Mathmagic	75.00
Graphmagic	75.00
Tax Manager	209.00

GAMES

Zork I	32.00
Zork II	32.00
Deadline	39.00
Galactic Attack	29.00
Call To Arms	25.00

NOVATION

CAT	140.00
D-CAT	155.00
Auto CAT	209.00
Apple CAT	299.00
Expansion Module	37.00
Handset	29.00

CP/M SOFTWARE

CCS CP/M Control Program 2.2	149.00
CCS CP/M Macro Assembler	89.00
CCS CP/M Symb. Instr. Debug	75.00
CCS CP/M Text Formatter	75.00
CCS CP/M Print Utility	49.00
Hayes Terminal Program (8")	24.00
Microsoft Fortran 80 (8")	499.00
Microsoft Basic Compiler (8")	389.00
Microsoft Basic 80 (8")	349.00



PERSONAL COMPUTERS

ALTOS

ACS 8000-2	3,645.00
ACS 8000-15	4,989.00
ACS 8600-12	12,499.00
ACS 8600-14	14,499.00

APPLE

Apple II Plus	CALL
Disk II	CALL
D.O.S. 3.3	CALL

BASIS

108-0003 (64K)	1,895.00
108-0004 (128K)	1,995.00

KAYCOMP

Kaypro Portable, includes \$250.00 extras	1,795.00
---	----------

FRANKLIN

ACE 1000, 64K	CALL
ACE 10, disk drive	CALL

ACCESSORIES

CABLES

CENTRONICS	
Centronics/Centronics	25.00
Centronics/IBM	30.00
Centronics/Osborne	30.00

RS232

4 wire, male-male, 10 ft	25.00
9 wire, male-male, 10 ft	30.00
4 wire, male-female, 10 ft	25.00
9 wire, male-female, 10 ft	30.00
Switch Box, 2-port	109.00

ORDER TOLL-FREE! Call
800-237-3333

In California call 800-338-5555

TELEX 697120-150

TERMS OF SALE: Cash, check, money order, bank wire transfer, credit card, or purchase orders from qualified firms and institutions. Please include telephone number with order and expiration date on credit card orders. California residents add 6% sales tax. Advertised prices are for prepaid orders F.O.B. shipping point. Add 3% or \$3.00 minimum for shipping in U.S. Pricing and availability subject to change without notice. Address written orders to:

910-105 W. San Marcos Blvd., Dept. B12, San Marcos, CA 92069

PALOMAR

COMPUTER PRODUCTS

```

Stack Usage:
Return code ptr., Newline character, Newline on/off,
Reference number
Global Registers Used:
ZREG00
Files Used:
Sets the newline mode of the file with the passed reference
number.
*****
.PARAM0,PARAM1,PARAM2,PARAM3
SOSBLK
POP RETURN0 ;Return code ptr.
POP ZREG00
PLA PARAM3 ;New line character
STA PARAM2 ;New line on/off
PLA PARAM1 ;Reference number
LDA #3. ;Param. count
SOS PARAM0
NEWLINE
LDY #0.
STA (ZREG00),Y ;LSB return code
TYA (ZREG00),Y
INY ;MSB return code
STA (ZREG00),Y
PUSH RETURN0
RTS
.PROC SOSREAD,5
*****
Name: SOSREAD
Stack Usage:
Return code ptr., Bytes actually read ptr., Bytes requested,
Input buffer ptr., Reference number
Global Registers Used:
ZREG00, ZREG01, ZREG02.
Files Used:
Reads from the file with the passed reference number.
*****
.PARAM0,PARAM1,PARAM2,PARAM3,PARAM4
SOSWRITE,4

```

```

.PARAM6,PARAM7,SOSBLK
CSREAD
RETURN0 ;Return code ptr.
ZREG02 ;Bytes read ptr.
ZREG01 ;# bytes requested
PARAM4 ;Input buffer ptr.
ZREG00 #0.
PARAM3 ;Input buffer ZREG
PARAM2 ;Reference #
PARAM1 #4.
LDA PARAM0 ;Parameter count
STA READ ;Call SOS (assume Y = 0)
SOS (ZREG02),Y
LDA PARAM6
STA (ZREG01),Y
TYA (ZREG01),Y
INY ;Return code
STA (ZREG02),Y
LDA PARAM7 ;Return code
STA (ZREG01),Y ;# bytes actually read
PUSH RETURN0
RTS SOSREAD,6
.PROC
*****
Name: SOSREAD
Stack Usage:
Return code ptr., Bytes actually read ptr., Bytes requested,
Offset, Input buffer ptr., Reference number
Global Registers Used:
ZREG00, ZREG01, ZREG02.
Files Used:
Reads from the file with the passed reference number.
*****
.PARAM0,PARAM1,PARAM2,PARAM3,PARAM4
PARAM6,PARAM7,SOSBLK,CSREAD
RETURN0 ;Return code ptr.
ZREG02 ;Bytes read ptr.
PARAM4 ;# bytes requested
ZREG00 ;Offset
PLA ;IBufPtr + Offset (LSB)
ADC ZREG00
STA ZREG00
PLA ;IBufPtr + Offset (MSB)
ADC ZREG00+1
STA ZREG00+1
JMP CSREAD ;Go to SOSREAD coroutine
.PROC

```

Space Saving Storage

At last, ASAP Computer Products Inc. has created the perfect storage unit for the Apple II. This new data drive slimline out performs any of its competition. This pint-size drive, works 8 times faster than most other drives, saving you space and time. Compare the features of the new ASAP slimline to what you're using now. We're sure you'll agree, this slimline out performs the others.

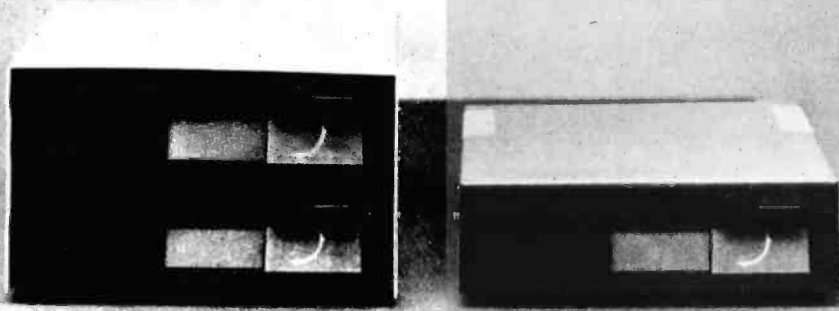

Manufactured by Professional Data Systems, Tustin, California.

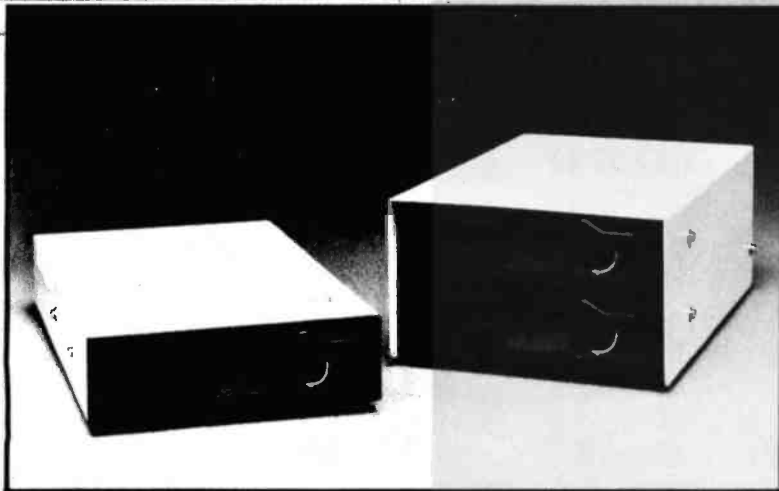

- 8 times faster than APPLE II Drives.
- Direct drive motor of extremely high quality.
- Only 1/2 the size of a regular drive.
- 100% APPLE¹ compatible (including "half track").
- Can be used with IBM PC² and other computers by simply disconnecting Interface Board.
- Mechanism and read - write electronics made by TEAC the world leader in Audio recording machines.
- 1 (one) full year warranty at no extra cost!!!!
- The SLIMLINE is a 35/40 track drive and can take advantage of our ENHANCER Diskette which will give the user 15% more storage capacity & up to 163K Bytes.
- Slimline 1/2 height 163K.
- Dual Slimline drives 1/2 height in one box.
- Slimline 1/2 height (1) Megabyte with controller.

Contact your local dealer for more information. Dealer inquiries invited.

asap
computer
products, inc.

1198 E. Willow St., Signal Hill, CA 90806

Call Toll Free (800) 421-7701

In California (213) 595-6431

or (714) 891-2663

In Canada Call ASAP Computer
Products LTD., 116 Viceroy Rd., D-12 Concord

Toronto, Ontario, Canada L4K 1A9

(416) 738-0500 (800) 268-1996

¹APPLE is TM of APPLE Corporation, Cupertino, California. ²IBM and PC are trademarks of International Business Machines.
Circle 520 on Inquiry card.

MULTI-PROGRAMMER SYSTEM-10

Features:

- Dedicated keys and large display vocabulary for ease of use.
- I/O - 6 baud rates, 13 formats including Intellec, Textronix and Motorola.
- EPROMs, E²PROMs and bipolars.
- Gang option - programs eight at once.
- Remote control option.

\$1,295

**PROGRAMS
OVER 250
DEVICE TYPES**



FUNCTIONS:

- | | | |
|---------------------|-------------------|------------------|
| DISPLAY DEVICE DATA | LOAD DATA | CRC - DEVICE/RAM |
| EDIT RAM DATA | COMPARE FIELDS | CRC - RAM |
| DEVICE PROGRAM | FILL MEMORY FIELD | I/O HOST PROMPT |
| TYPE SELECTION | BLOCK MOVE | DIAGNOSTICS |
| | | and more |



COMPUTER SYSTEMS CORP

100 East Linton Blvd., Delray Beach, Fla. 33444 (305) 272-2051

FREE 56 page catalog

Business Forms and Supplies for MICRO Computers

Standardized, continuous checks, invoices, statements and letterheads work with programs from over 200 software sources . . . or program forms with guides provided. Full color catalog also has stock tab paper, diskettes, other supplies.

- Quality products, low prices
- Small quantities
- No "handling charges"
- Money-Back Guarantee

Fast service by mail or PHONE TOLL FREE
1 + 800-225-9550 (Mass. res. 1 + 800-922-8560)

NAME _____

COMPANY _____

STREET _____

CITY, STATE and ZIP _____

SOFTWARE BRAND (To help us send correct info.) _____ PACKAGE # _____ Do own programming

COMPUTER MAKE _____ MODEL _____ Not Purchased

LINE OF BUSINESS _____ Number of Employees _____

Neb Computer Forms

CODE 11003

78 Hollis Street, Groton, Massachusetts 01471
A division of New England Business Service, Inc.

NOW YOU CAN GET A \$30.00 FACTORY REBATE WHEN YOU PURCHASE A QUANTUM DATA VIDEO CARTRIDGE OR VIDEO COMBO CARTRIDGE.

The ODI 40/80 Video Cartridge and Video Combo Cartridge is the means to upgrade the VIC-20 computer to a 40 x 24 or an 80 x 24 character display, providing a wealth of new uses for the VIC-20. With the appropriate software, you can now accomplish quality word processing and various business functions that previously were very difficult with only the VIC's standard 22 character video display.

- Features a high quality 8 x 8 dot matrix.
- Character-by-character reverse video attributes allowing adjacent characters to have different attributes.
- All features are accessible through BASIC using POKE commands.
- Black & White composite video. 6545 controller does not support color. The black and white composite video output has the same connector as the VIC video output. 5 pin DIN jack.
- Includes two character sets: The ANSI standard 7-bit character set and the Commodore character set.



The ASCII character set features all of the standard lowercase and uppercase letters, symbols and numbers.

- Operates in VIC-20 block graphics mode.
- Plugs directly into the VIC-20 memory expansion port or the ODI Mini-Mother or Maxi-Mother boards.
- Contains 2K of CMOS internal video RAM; no system RAM is used by the Video Cartridge.
- 40 columns can be viewed using your home T.V. while 80 columns require using a video monitor.

40/80 VIDEO CARTRIDGE
O-K memory:
\$219.95

40/80 VIDEO COMBO CARTRIDGE
w/16-K RAM:
\$319.95

QUANTUM DATA, INC.



3001 Redhill Ave., Building 4,
Suite 105, Costa Mesa, CA 92626
(714) 966-6553 Catalogs
(714) 754-1945 Dealer Hot Line

PUT THE BYTE ON YOUR COMPUTER WITH 10 OR 20 Mbyte STORAGE

EVOLUTIONARY ELECTRONICS INC. OFFERS 10 OR 20 Mbyte STORAGE FOR APPLE II PLUS & FRANKLIN ACE MICRO COMPUTERS

EEI HAS FULL BIT AND BIG BYTE HARD DISK SYSTEMS

COMPLETE WITH CONTROLLERS, ADAPTERS, AND SOFTWARE FOR APPLE AND FRANKLIN COMPUTERS

PRICES START AT

\$ 2295 - 10 Mbyte
\$ 2895 - 20 Mbyte

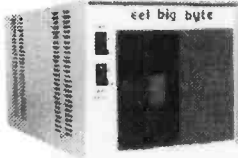

ALSO AVAILABLE: 64K DUAL DRIVE 6809 MICRO PROCESSING SYSTEMS WITH FULL BUSINESS SOFTWARE

Eei's MONTHLY SPECIAL SHUGART SA 450's—\$275

WE HAVE THE FULL LINE OF SHUGART HARD AND FLOPPY DISK DRIVES CALL WEEKDAYS FROM 9AM-6PM. 1-503-289-3988

EVOLUTIONARY ELECTRONICS, INC. 433 N.E. LOMBARD PORTLAND, ORE. 97211

© 82 S. A

THEY SAY IT ALL... WE DO IT ALL!



ANNOUNCING THE C86™ C COMPILER — THE COMPILER THAT SPEAKS THE LANGUAGE OF THE FUTURE!

Kernighan and Ritchie's book, *The C Programming Language*, is the key source for C. Just as fundamental is the C86™ C Compiler.

The C86™ C Compiler is especially designed for the IBM® Personal, IBM® Display Writer, CP/M-86® and MS-DOS®

For further information on the C programming language and the C86™ C Compiler, please contact:



Computer Innovations, Inc.
75 Pine Street
Lincroft, New Jersey 07738
Telephone: (201) 530-0995

C86 is a trademark of Computer Innovations, Inc. CP/M-86 is a trademark of Digital Research. IBM and MS-DOS are registered trademarks of International Business Machines, Inc.

Veytec, inc.

AUTHORIZED DIABLO DISTRIBUTOR

305-859-7340
US Wats 800-327-9744
FL Wats 800-432-9205

942 E. FAIRLANE AVENUE
P.O. BOX 13947
ORLANDO, FLORIDA 32809

CALL OUR ORDER ENTRY DEPT.
FOR PRINTER PRICES

DIABLO 630 API PRINTERS-RECEIVE ONLY

- TRS 80 Mod 1 & Mod 3
- Centronics Interface
- IEEE Interface
- IBM Interface
- Apple Interface
- Standard RS-232C

DIABLO KSR PRINTERS

Standard K104 Serial KSR

FORMS TRACTORS

- Uni-Directional \$215.00
- Bi-Directional \$230.00

DIABLO PRINTWHEELS

- Plastic \$ 5.90 ea.
- US 88 Character Metal \$42.00 ea.
- US 96 Character Metal \$48.00 ea.

"NEW" DIABLO 620 SPI PRINTERS — RECEIVE ONLY

Standard RS-232C
(Pictured Below)



DIABLO RIBBONS

		(1-12 doz)	(13-36 doz)
301980-04	HyType II	\$4.00 ea.	\$3.75 ea.
40980	HyType II	4.00 ea.	3.75 ea.
38000	HyType I	3.50 ea.	3.10 ea.
38002	HyType I M/S	3.50 ea.	3.10 ea.
8R1077	Universal	6.30 ea.	5.50 ea.
24650-02	Matrix	7.75 ea.	7.00 ea.

FOR THE BEST PRICES — CALL US TODAY!

START YOUR OWN COMPUTER CO.

HOW TO START YOUR OWN SYSTEMS HOUSE \$36.
7th edition, November 1981

Written by the founder of a successful systems house, this fact-filled 220-page manual covers virtually all aspects of starting and operating a small systems company. It is abundant with useful, real-life samples: contracts, proposals, agreements and a complete business plan are included in full, and may be used immediately by the reader. Proven, field-tested solutions to the many problems facing small turnkey vendors are presented.

HOW TO BECOME A SUCCESSFUL COMPUTER CONSULTANT \$28.
by Leslie Nelson, 4th revised edition, December 1981

Independent consultants are becoming a vitally important factor in the micro-computer field, filling the gap between the computer vendors and commercial/industrial users. The rewards of the consultant can be high: freedom, more satisfying work and doubled or tripled income. This manual provides comprehensive background information and step-by-step directions for those interested to explore this lucrative field.

HOW TO SELL YOUR MICRO SOFTWARE \$19.95
by B. J. Korites, Ph.D. May 1982

The best practical guide for those with software to sell. Detailed discussion of the eight best marketing strategies. How to sell through distributors, brokers, computer manufacturers. Advertising techniques. Pricing strategies. Software security.

HOW TO START YOUR OWN WORD PROCESSING SERVICE \$48.
by Leslie Nelson, 2nd edition, October 1982

Turn a small investment into a steady money making business that adds \$10,000, \$50,000 or \$100,000 to your income. Detailed start-up, marketing and operations plans are included.

Send check, money order, VISA, Master Charge or American Express # and exp. date. Publisher pays 4th class shipping. Add \$1.00 per book for UPS shipping (USA) only. NJ residents add 5% sales tax. For faster shipment on credit card orders call (201) 783-6940.

ESSEX PUBLISHING CO. Dept. 2
285 Bloomfield Avenue • Caldwell, N.J. 07006

CUSTOM-PRINTED

BOOKS & MANUALS

for the computer industry

For over 20 years, D. Armstrong has specialized in printing quality books and manuals.

We're professionals who know and understand the computer industry's needs.

Our in-plant facilities include type-setting, art, printing and binding.

- Perfect Binding
- Saddle Stitch
- Ring Binders
- Wire-O-Binding
- Spiral Binding
- Hardback

For Quotations Call: 1-800-231-6441
Texas: 1-800-392-4311

D. Armstrong
Company, Inc. BOOK PRINTERS

5806 Antoine • Houston, Texas 77091 • Phone: (713) 957-4818

Now, you can balance your checking account...
even if you never could before, with

THE SMART CHECKBOOK™

Your personal financial manager

Its unique checkbook reconciliation mode finds the mistakes in your checkbook for you and makes corrections easily.

For example it:

- Shows items returned by your bank which you forgot to enter.
- Locates duplicate entries.
- Finds differences in amounts entered in your checkbook, and those charged by your bank.
- Even catches mistakes the bank made.

In short, it enables you to BALANCE YOUR CHECKBOOK with ease and confidence. Or, an unlimited number of checking and credit card accounts, for that matter.

AND THERE'S MUCH MORE...

A powerful data base manager, checkwriter, budget information, automatic and customized reports and tables.

SMALL BUSINESSES...

Keeps track of Schedule C revenues and expenses and displays them in monthly income statement form for a whole year.

AT TAX TIME...

List and total your tax deductions with pushbutton ease for any of 16 Form 1040 tax categories.

ORDER THE SMART CHECKBOOK NOW...

ONLY \$149. Available for most CP/M and CP/M-86 formats (requires 56K) and the IBM PC-DOS (requires 64K). Dealer inquiries welcome.

Phone: (703) 281-1621 OR WRITE: Box 3456
McLean, VA
22103



SOFTQUEST

CP/M is a registered trademark of Digital Research. The Smart Checkbook is a trademark of Softquest.

SLUDER

SEATTLE GAZELLE 128K ONLY \$4695.

BUDGET SYSTEMS READY TO BOOT & RUN

- TTSBC-1 4MHZ 280.64K.(2)5"Q DRS.10 SLOT.CP/M SB \$1895
 - TTSBC-2 4MHZ 280.64K.(2)8" DRS.10 SLOT.CP/M SB 2295
 - LDP86-2 10MHZ 8086.64K.(2)8"DRS.10 SLOT.CP/M SB 3195
 - LDPHD-1 10MHZ 8086.128K.1FD.1HD.40MB.10/S.CPM SB 6595
 - LDPMPM2 5MHZ 8086/8089.256K.(1)8"FD.(1)10MBHD.SB 6895
 - GB85801 6MHZ 8085/8088.64K.(2)8"DRS.10 SLOT SB 2895
 - GBCPUZ1 6MHZ CPU Z.64K.(2)8"DRS.10 SLOT.CP/M SB 2795
 - GB80862 10MHZ 8086.64K.(2)8"DRS.10SLOT.CP/M86 SB 3195
 - GB68K-2 10MHZ 68000.64K.(2)8"DRS.10SLOT.CP/M68 3195
 - GB808D-1 6MHZ 85/88.64K.(1)8"FD.(1)40MBHD.CP/M SB 6195
 - 10.20. & 40 MEGABYTE HARD DISK SYSTEMS AVAIL GB & LDP
 - SCP86-1 8MHZ 8086.SCPFDC.64K.2 8"drs.MSDOS. SB 3095
- TT=Teletek. LDP=Lomas Data Products. GB=Godbout and SCP=Seattle Computer Products. All SLUDER integrated Double Sided 8" Qumes only \$200 more in above Systems

LUXURY SYSTEMS READY TO BOOT & RUN

- LGBZ-1 6MHZ CPU Z ALL CSC w/C.V.T. PS.Qumes w/SB 3995
 - LGBB-1 7/8MHZ 8085/8088 CSC C.V.T. PS.Qumes w/SB 4095
 - LGB86-1 10MHZ 8086 CSC C.V.T. PS.Qumes.CP/M86 SB 4450
 - LLDP-1 LOMAS 10MHZ 8086.C.V.T. PS.Qumes.CPM86 SB 4195
- SPELLBINDER WORDPROCESSING INCLUDED WITH OUR SYSTEMS

CP/M & MP/M are TM of Digital Research

- Godbout Disk 2/CP/M86 & Fujitsu 40MB HD Bare DR \$3695
 - Godbout Disk 1 & CPM \$445. Disk 1 & CP/M86 550
 - GB RAM 21 A&T 128K 985. LOMAS RAM 67 128K 875
 - LOMAS LIGHTNING 1 8086 420. LOMAS 10MHZ 8086 520
 - LOMAS LDP72 DISK CONTR 220. CP/M86 FOR LOMAS 195
 - RAM 67 128K & BAT B/U 950. LOMAS HAZITALL 260
 - EPSON MX80 FT & GRAF 499. TELEVIDEO 950 899
- P.O. BOX 951 WESTMINSTER. CA 92683-0951 (714)895-1746

MASTER ELECTRONICS, INC.

*TRS-80 is a trademark of Tandy

CAN SET YOU UP IN A

TRS-80

STATE-OF-THE-ART-COMPUTER

STARTING AT 15% DISCOUNT!

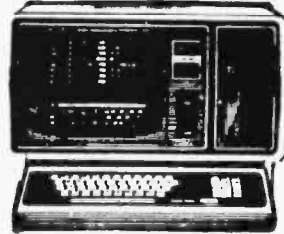

FULLY STOCKED

IN: Model II's

Model III's

ALL-PRINTERS

AND — MORE!!

* PLUS *

THE ALL NEW:

Model 16 and the 8.5 meg. Hard Drive!

CALL US NOW!!!

Toll FREE: 1-800-531-7323

TEXAS CALL COLLECT: 512/689-5536

FREE
DELIVERY

MASTER ELECTRONICS, INC.
154 NORTH 5th
RAYMONDVILLE, TX 78580

NO
OUT-OF-STATE
SALES TAX

STOP! CHECK OUT OUR UNBEATABLE PRICES

Dual Disk Sub-Systems (while supplies last)

- 2, FDD-100-8 • Dual Power Supply • Fan • Fuse Holder
- Power Switch • Power Cable
- Horizontal Cabinet
- Assembled and Tested

Only \$799.00

Rana For Apple

- 40 Tracks • Write Protect Switch • 300% Faster • Fully Compatible 3.2 or 3.3 dos
- Controller Controls 4 Drives

Rana Elite Controller \$340.00
99.00

Franklin ACE 1000

- 64K Memory • Fan Cooled
- Upper & Lower Case
- Numeric Pad

\$1,099.00

TANDON (Give Away)

- * TM-100-1 \$189.00
- * TM-100-2 259.00
- TM-100-3 269.00
- TM-100-4 369.00
- * IBM Compatible

Siemens 8" Drives

Same as FDD-100-8 NEW
801R Only \$219.00
10 for \$200.00 each
90 Day Warranty

Disk Drives — 8"

- Shugart 801R \$379.00
- Shugart 851R 459.00
- Mitsubishi dbi/dbi 419.00
- Qume DT-8 469.00

Printers (Over Stock)

- Microline 82A \$ 439.00
- Microline 83A 685.00
- Microline 84P 989.00
- Microline 84S 1098.00
- C.Itoh Prowriter, Par. 441.00
- C.Itoh Prowriter, Ser. 585.00
- NEC 8023A 469.00

Monitors

Green Screens

- Zenith (ZVM121) \$110.00
- BMC-12A 87.00
- BMC-12EU, 18MHZ 99.00

Color Screens

- BMC-1400CL \$269.00
- Amdek Color I 339.00
- Amdek Color II 689.00

Computer Components Unlimited

P.O. Box 1936, Hawthorne, CA 90250
Sales Office: 12308 Burl Avenue
Hawthorne, CA 90250

Order Desk:
(213) 219-0808
Customer Service:
(213) 219-0811

All merchandise new. We accept MC, Visa, Check & P.O.'s from qualified firms. CA Res. add 6 1/2% Sales Tax. Please add shipping: \$3.50 first 5 lbs., 60¢ ea. add. lb.

We will do anything
to find what you
need at the Best Prices

SOS_Write calls to write to a printer is readily discernible. For applications programs that print more than one page of data, the SOS interface is the method of choice.

SOS File Management

By using SOS file calls for reading and writing to block devices (i.e., floppy and hard disks), your applications program does not have to take into account the specific attributes of each hardware device. This allows you to write general-purpose programs that communicate to all block devices supported by SOS, including any devices to be supported in the future. Because only the SOS file structure is required to store and retrieve information, it's not necessary to write specialized software into an applications program to handle a floppy disk and another set of routines to control larger-capacity devices. This is managed by SOS at a level that is transparent to your Pascal program. The file-management calls available are described in table 1 and file-system error codes are listed in table 2 (page 482).

Helpful Hints

Because Apple III Pascal allows assembly-language reference parameters to bypass type-checking, you can use this feature to allow greater flexibility in defining output-parameter data types. For example, any Pascal data type can be passed as the argument to any reference parameter in these assembly-language routines. This lets the assembly-language routine overwrite whatever variable has been passed as a call by a reference parameter. A possible outcome is that you can easily pass the wrong variable to any reference parameter and have the assembly-language routine post the returned value in whatever data type you've just passed it.

In the Apple III Pascal system, a segment that contains external (i.e., assembly-language) routines is not allowed to cross any 32K-byte bank boundary. Therefore, the Pascal system may leave unusable holes in memory when loading units that contain assembly-language routines. The way to avoid this problem is to use the intrinsic unit SOS_IO in listing 1.

When compiling your main program, use the "{\$NOLOAD+}" compile-time option as the first statement. Then, add a "{\$R SOS_IO}" compile-time command after the main line's Begin statement. The Pascal interpreter will load the SOS_IO unit first, which allows your P-code-only Pascal program to cross any bank boundary that is encountered further along in the loading process.

Apple III Pascal consumes 1100 bytes of buffer space in the data space for each file that is opened, including any character device such as a printer or console. SOS, however, does not use the buffer passed on an open request (i.e., the SysBuf parameter in listing 1), unless the device is a block device. This means you can save considerable stack and heap space by using SOS to output to a printer or a console. Any variable (the integer I, for example) can be used as the SysBuf parameter when using the SOS_Open routine for a printer or the console. Note

Call	Description
SOS_Create	Creates a file on a blocked device (i.e., disk) and preallocates blocks for a new file, if desired.
SOS_Destroy	Removes a file from a blocked device, if possible.
SOS_Rename	Changes the name of a file.
SOS_Set_Info	Defines the directory information to be associated with a specified file.
SOS_Get_Info	Returns the directory information associated with a specified file.
SOS_Volume	Returns the volume name, total blocks in use, and total number of free blocks for any block device.
SOS_Set_Prefix	Sets the system prefix path name. This is <i>not</i> the Pascal prefix.
SOS_Get_Prefix	Returns the current system prefix path name.
SOS_Open	Opens any SOS file configured into the system, including the console or any printer.
SOS_New_Line	Disables or enables and sets the "read until" character for the specified SOS file.
SOS_Read	Reads from a specified file.
SOS_S_Read	Reads from a specified file into an indexed buffer. Useful for reading in a Pascal-string variable after turning off range checking (i.e., {\$R-}).
SOS_Write	Writes to a specified file.
SOS_S_Write	Writes to a specified file from an indexed buffer. Useful for writing string variables.
SOS_Close	Closes the specified file. If the passed reference number is 0, all user files are closed.
SOS_Flush	Writes out any information currently buffered by SOS to the specified file. Works in a similar fashion to SOS_Close with a 0 reference number passed to it. This gives the applications programmer the ability on demand to write out to disk all SOS file buffers.
SOS_Get_B_Mark	Gets the current file mark rounded up to the closest block number.
SOS_Set_B_Mark	Sets the current file position to the passed block number.
SOS_Get_B_EOF	Gets the current EOF rounded up to the closest block number.
SOS_Set_B_EOF	Sets the EOF to the passed block number. SOS 1.1 does not deallocate blocks if the EOF is reduced.
SOS_Get_Mark	Gets the current file mark and returns the low 16 bits in "Low" and the high-order 8 bits (of the 24-bit mark) in "Hi."
SOS_Set_Mark	Sets the mark to the 24-bit quantity passed.
SOS_Get_EOF	Gets the current EOF and returns the 24-bit quantity in "Low" and "Hi."
SOS_Set_EOF	Sets the EOF to the 24-bit quantity passed.

Table 1: SOS file-management calls. When you use SOS file calls for reading or writing to your floppy disk, your applications programs do not have to take into account each drive's attributes.

In Less Than 3 Minutes

Your IBM Model 50, 60, or 75
Electronic Typewriter
can be an RS232C PRINTER or TERMINAL



CALIFORNIA MICRO COMPUTER Models 5060 and 5061 can be installed easily and require NO modifications to the typewriter.

For additional information contact:

CALIFORNIA MICRO COMPUTER
9323 Warbler Ave., Fountain Valley, CA.
92708 (714) 968-0890

Kill Surges Like Lightning!

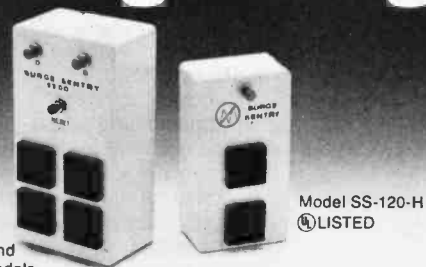

Surge/Dropout and U.S. Standard models.

Model SS-120-H
UL LISTED

Now, with Surge Sentry™, you can protect your personal computer, or entire home computer/entertainment center from destructive power surges, drops, and electrical noise . . . starting at less than \$90!

Simply plug Surge Sentry in for fast, *permanent* protection. Surge Sentry will not degrade . . . no matter how many surges it kills. The indicator light tells you it's working perfectly, and we back every unit with a one year "no questions asked" warranty.

To learn more about surges and the entire Surge Sentry line, call or write:

**RKS
INDUSTRIES**

Toll-free (800) 892-1342, from California (408) 438-5760
4865 Scotts Valley Drive, Scotts Valley, CA 95066

WHAT'S ECC?

ECC (Error Correction Code) is a polynomial derivative which is used to detect and correct errors. In simpler terms, this means that the computer will detect and automatically correct data errors sometimes generated spuriously in the equipment.

VR Data's HARD DISK III has this feature. If your system will abend or die during a data error or if you must always have the correct data for your functions, ECC is a necessity. This feature has filtered down from the larger computer systems and is now used by manufacturers of superior micro computer products.

Imagine a 5 meg Winchester Hard Disk with the following features:

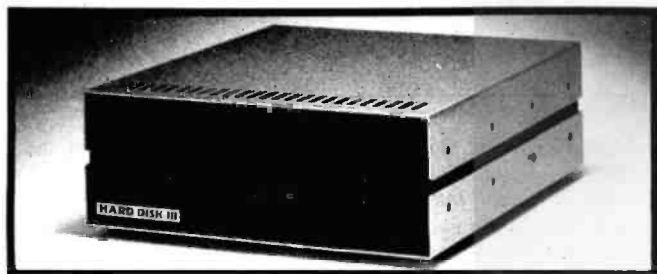

ALL FOR \$1899. Complete

- ECC—onboard buffer
- FCC approval—Heavy Duty Power Supply
- Automatic power on with system
- Heavy duty linear power supply
- Gold plated contact on all connectors
- Heavy gauge aluminum chassis
- 115/230 VAC 60/50 HZ Standard
- State-of-the-art controller
- 2 pass forced air cooling system

ONLY FROM **VRdata**

777 Henderson Boulevard N-6 Folcroft, PA 19032
(215) 461-5300 (800) 345-8102

Interfaces to: Radio Shack TRS 80 Model I • Radio Shack TRS 80 Model III • IBM Personal Computer • Others to be announced

Error Number	Error Message
32	Invalid request code
34	Invalid control parameter list
35	Character device not open
36	Device not available
37	Resource not available
44	Invalid byte count
45	Invalid block number
64	Invalid path-name syntax
65	Too many character files open
66	Too many block files open
67	Invalid file reference number
68	Cannot find the specified path name
69	Volume not found
70	File not found
71	Duplicate file name
72	Overrun error due to lack of disk space
73	Directory full
74	Incompatible file format
75	Unsupported storage type
76	Attempted read past end-of-file
77	File position out of range
78	Illegal access attempted
79	User's buffer too small
80	File busy
82	Not a SOS volume
83	Invalid value in list parameter
84	Out of memory for SOS system buffer
85	Buffer table full
86	Invalid system buffer parameter
87	Duplicate volume error
88	Not a block device. Only Open, Newline, Read, Write, and Close calls can reference a character file.
89	File level error
90	Invalid bit-map address found on volume

Table 2: SOS file system errors.

that a blocked-device SysBuf must be untouched and always available to SOS while the file is open. Because of that requirement, the usual scope rules for a Pascal file must be rigorously followed to keep Pascal from deallocating a SOS SysBuf before closing the file.

Although the file-handler routines in listing 1 are represented as an Apple III Pascal intrinsic unit, the declarations can alternatively be used piecemeal by suffixing an "External;" after each procedure declaration and compiling them along with any Pascal main program. However, a SOS_Data must always be included because all of the routines use it as the SOS parameter block-data area. Additionally, the following routines must be used in pairs, as they share code:

SOS_Set_Info and SOS_Get_Info
 SOS_Read and SOS_S_Read
 SOS_Write and SOS_S_Write
 SOS_Get_B_Mark and SOS_Get_B_EOF
 SOS_Set_B_Mark and SOS_Set_B_EOF
 SOS_Get_Mark and SOS_Get_EOF
 SOS_Set_Mark and SOS_Set_EOF

Linking the Pascal program with the assembled external routines would allow it to be run without having a SYSTEM.LIBRARY or program library on-line.

Conclusion

By using SOS_IO for file operations in your Apple III Pascal programs, you gain flexibility and power in addition to a considerable performance improvement. With a Pascal file, you always run the risk of crashing the program with "IO err: Volume not found" whenever an in-

General-purpose applications programs are possible by using Pascal and SOS in combination.

valid device is specified in a Reset or Rewrite call. A SOS_Open request will not crash the program, but will instead return the appropriate error code if the path name cannot be located. The file type, modification date and time, as well as other attributes can be modified for every SOS file by means of a SOS_Set_Info call. Since the SOS_IO call communicates directly with SOS, no additional Pascal preprocessing takes place. Because of this, control characters are not expanded or translated into other characters. This feature not only reduces the amount of preprocessing, but reduces any potential anomalous effects generated whenever nondata characters are written out.

The use of SOS_IO can also result in significant memory savings. The complete set of SOS_IO file-processing routines is slightly larger than 1K bytes of code. For each Pascal file opened by calling Reset or Rewrite, a mandatory 1K-byte buffer is reserved. Therefore, the entire SOS_IO package fits into the space saved using the SOS_IO to write to just one nonblocked device. Any Pascal application that deals with the Apple III only should consider using SOS_IO as a means to enhance performance and potentially realize some memory savings. ■

References

1. *Apple III Owners Guide*. Cupertino, CA: Apple Computer Inc., 1981.
 2. *Apple III Pascal: Introduction, Filer, and Editor*. Cupertino, CA: Apple Computer Inc., 1981.
 3. *Apple III Pascal Program Preparation Tools*. Cupertino, CA: Apple Computer Inc., 1981.
 4. *Apple III Pascal Programmer's Manual*, volumes 1 and 2. Cupertino, CA: Apple Computer Inc., 1981.
 5. *Apple III Standard Device Drivers*. Cupertino, CA: Apple Computer Inc., 1981.
 6. Scanlon, Leo J. *6502 Software Design*. Indianapolis, IN: Howard W. Sams & Co. Inc., 1980.
 7. Zaks, Rodnay. *Programming the 6502*. Berkeley, CA: Sybex, 1978.
-

YOU CAN MAKE A FORTUNE IN MICROS!

THE MICRO COMPUTER BUSINESS WILL GROW FROM \$10 TO \$100 BILLION IN THE NEXT EIGHT YEARS! ARE YOU READY TO CASH IN?

The micro computer business is predicted to grow from its present \$10 billion to \$100 billion before 1990! Imagine the possibilities this opens for you! No matter where you live, if you're starting up or presently in business, no other industry offers you more opportunities!

Now, finally, all the inside information you need to secure a prosperous future in this dynamic industry is available in one place - **THE COMPUTER ENTREPRENEUR MANUAL!** - An immense information source, compiled by our inquisitive research team, aided by a panel of experts and business people from all areas of the computer industry!

We present the inside story of more than 100 lucrative computer businesses you can enter, where you'll find the real opportunities for the eighties: from one man operations like Programming Author, Word Processing Center or Consulting, to Systems House, Service Bureau, Computer Store etc! Many at little or no investment! All the invaluable facts and figures: How to start, Capital needs, Profit estimates and Margins, How to Sell and Market, How missing technical or business experience need not stand in your way, Source of Suppliers, etc! Details that could take years to find out on your own!

We'll show you inside tricks, like how to never again pay retail for computer products and consumer electronics, even for one item - right now, while you're starting your business! How to get free merchandise and trade show invitations, etc. This alone will more than pay for the manual! You'll read actual case histories of other computer entrepreneurs, so you can learn from their mistakes, and profit from their success stories! Where you'll be one year from now depends on your actions today! Let us show you how to take the first crucial steps!

Order now and take advantage of our limited introduction special, **THE COMPUTER ENTREPRENEUR MANUAL**, and a six month subscription to **THE COMPUTER ENTREPRENEUR REPORT/NEWSLETTER** (so you're always up-to-date with the industry), both for only \$29.95! You must be convinced on how easy you can strike it rich in the micro computer business - or you may return the manual for a full refund within thirty days! **USE OUR TOLL FREE NUMBER TO ORDER!**

EVERYTHING YOU NEED TO KNOW TO SUCCEED IN THE COMPUTER BUSINESS IS ALL IN THIS MANUAL!

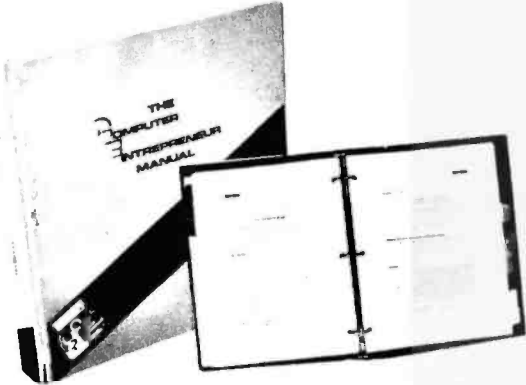

THE COMPUTER ENTREPRENEUR MANUAL has the answers to all your questions about selecting, starting and successfully running a computer business! There has never been such a comprehensive collection of know-how and information about this business in one place! All the facts you need to plan and achieve your goals in easy-to-follow, step-by-step instructions!

These are some of the 100-plus businesses covered in **PART ONE** of the manual, with the facts on how to start and run. Start-up Cost (Even how to operate on a shoestring), What profits to expect, Wholesale prices, Mark-ups, Suppliers, future outlook, case histories for each, etc:

Systems House, Software Author (who to sell to and who to avoid), Service Bureau, Software Publisher (How to find programs that sell, Word Processing Service, Consulting and Consultant Broker (use your skills or those of others, make \$150 - \$1000 a day!), The Incredible Games Business, Computer Store (Franchises, Pro and Contra, or a low inventory store in your home!), OEM, Hardware Mfg. Data base and Teletext Service (big prospects!), Used Computers, Repairs, Rent-A-Computer, Promote Fests and Trade Shows, Turnkey Systems,

Bartering, Mail Order, Compile and rent mailing lists, Specialized Data Headhunting and Temp Help Service, Tech Writer Shop, Custom Engineering, The highly profitable Seminars and Training Business, and many more!

Many new ideas and ground floor opportunities! Interviews and success stories on companies of all sizes! Privy info on the profits made: How some computer store operators net \$100 - \$250,000! Little known outfits that made their owners millionaires, one of these low-key companies, making simple boards, went from nil to \$20,000,000 and 100 employees in four years! Programmers that make \$300,000, Thousands of micro millionaires in the making, etc!

Whatever your goal is - Silicon Valley Tycoon, or just a business at home - we guarantee you'll find a business to suit you - or your money back!

PART TWO of the manual is loaded with the know-how and "streetfighting" savvy you need, both as a novice or business veteran, to get started, to stay and to prosper in the micro computer business! A goldmine of information in clear and easy-to-use instructions: How to prepare your Business Plan, Outside financing, The mistakes you must avoid, How to hire and manage employees, incorporation (when, and how to do it cheaply), Surviving bad times, Record Keeping, how to estimate your market before you start, Use multiple locations to maximize profits, how to promote and stay steps ahead of the competition! How to get free advertising, free merchandise, free advice, Power negotiating with suppliers to double your profit margins, etc! Even how to keep a present job while starting a business part time!

Don't miss this opportunity to be part of this great industry - the next success story could be your own! Order the manual today! Part one and two, bound in a deluxe ring binder, where you can also collect our newsletter (free for six months with the manual - a \$32.50 value!) - all for only \$29.95!



THE COMPUTER ENTREPRENEUR NEWSLETTER - ALL THE LATEST INSIDE BUSINESS NEWS! NOW! SIX MONTHS FREE WITH YOUR MANUAL!

You're always attuned to the industry, and your manual kept up-to-date, with our newsletter! Each issue has the latest business news, ideas, new suppliers, our indispensable "watchdog" column on profits, discounts (don't miss mfg's promos, like recently, when top video monitor sold at \$80 - that's half wholesale, one third of the retail price!), the competition, the big deals, etc! Feature stories with start-up info and case histories on new micro businesses!

You'll get invitations to trade shows and conventions, the usage of our advisory service and our discount buying service for your purchases!

You'll find many items in our newsletter that will save you the cost of your manual many times over!



CALL TOLL FREE! CHARGE IT!
Credit Card Orders (MC, VISA only)
accepted 24 hours/day
1-800-227-3800
Ask for extension 1135
In California call
1-800-792-0990



Order by phone (Credit cards only), or use the coupon:

Mail to **THE COMPUTER ENTREPRENEUR PUBLISHING CO.**
PO BOX 456, Grand Central Station, New York, N.Y. 10163

Please send me **THE COMPUTER ENTREPRENEUR MANUAL**, and the six month free subscription to **THE COMPUTER ENTREPRENEUR REPORT/NEWSLETTER**. All for only \$29.95, plus \$3 for postage/handling (NY residents: add \$2.64 for sales tax). If I decide not to keep the manual, I may return it within 30 days for a full refund.

NAME: _____

ADDRESS: _____

CITY, STATE, ZIP: _____

Check or M.O. enclosed Charge to VISA MC

CARD #: _____

Exp. Date: _____

SIGNATURE: _____

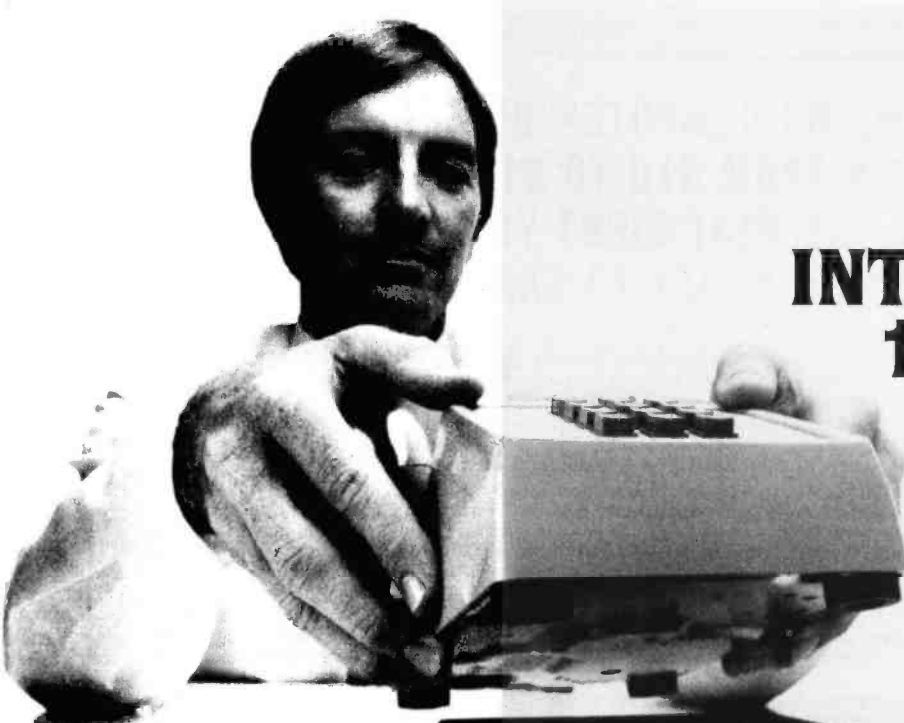

INTRODUCING THE 103 and 103/212 SMART-CAT™ MODEMS.

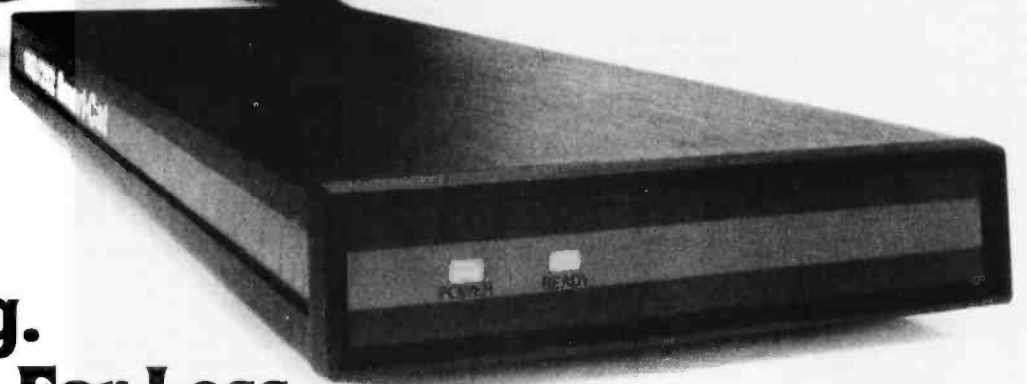

They Do Everything. With Less. For Less.

Take your pick. With either one, you'll get two very important advantages.

First, each is the best modem in its class. They do more, do it easier and do it in less space. The reason: our LSI technology is state-of-the-art. Our Smart-Cats run better and cooler—and will for years.

Second, you can get your hands on either one of them right now. No waiting. Your local dealer has a shelf full.

The price is something else, too. Suggested retail:
The 103/212 Smart-Cat \$595.
The 103 Smart-Cat \$249.

See your dealer today and get yours. He does have a bunch, but it's not unlimited.

SMART-CAT MODEM FEATURES:

- Built-in Dialer (Touch-Tone or Rotary) • Auto Answer
- Direct Connect
- Analog & Digital Loopback Test
- Extensive Software Command Set
- Busy Detect (Allows Modem To Be Programmed To Redial)
- 103 Smart-Cat Modem: 300 Baud, Full Duplex
- 103/212 Smart-Cat Modem: 300 or 1200 Baud, Full Duplex



New Smart-Cat 103 and 103/212 modems.



18664 Oxnard Street, Tarzana, CA 91356

(800) 423-5419

In California: (213) 996-5060

Circle 528 on inquiry card.

Look at what the best modem has been reduced to.

Our engineers have come up with some state-of-the-art LSI technology and a whole new modem.

It's smaller. J-Cat is about 1/5th the size of an ordinary modem. Easy to stick-on, tuck-in, put anywhere you want.

It's better. J-Cat does the things you need for professional performance. No fussing to get it into the right answer or originate mode; it does it automatically. LED's show you status; and audio "beeps" tell you when you reach a busy signal, detect a carrier, get a dial tone, etc.

And you can hook it into any modular RJ11C phone jack.

It costs less. If you've shopped around, you know a modem with close to these features costs \$250 or more. Our LSI technology has let us do the right thing with the price, too. Suggested retail—\$149.

Smaller is definitely better.

See your dealer. He has them right now.

Introducing the Novation **J-CAT**TM



J-CAT FEATURES:

- Direct Connect, FCC Part 68 Registered
- Auto Answer
- Auto Search (Originate or Answer Mode)
- Disconnect/Test Key
- Connect/Break Key
- Self-Test
- Audio Line Status Indicator
- Dialtone/Busy Status at Serial I/O Connector
- Off Hook Control at Serial I/O Connector
- Compatible With EIA-RS232C or TTL Interfaces
- Low Power
- And it's from Novation, the world's leader in personal communications.



(800) 423-5419

In California:

(213) 996-5060

Circle 529 on inquiry card.

18664 Oxnard Street, Tarzana, CA 91356

A Versatile Low-Cost Microprocessor Controller Module

Add intelligence to your latest project at minimal expense.

David L. Craig
134 Victor St.
Holland Park 4121
Queensland, Australia

One of the original aims of the microprocessor was to replace complex, discrete, and small-scale integrated circuits (ICs) with a general-purpose programmable device flexible enough to meet the needs of a variety of applications. The microprocessor can shrink the size and complexity of the digital logic circuitry necessary to perform a particular task and can also make practical circuits that would otherwise be too complex to consider. Extra niceties of performance and user convenience can often be added at no extra cost. The problem for experimental and "one-off," or single-quantity, projects has been to find a method of building a microprocessor controller that is inexpensive enough and small enough to be competitive with more conventional logic designs in "low-end," or unsophisticated, applications.

Many single-board computers and microprocessor-evaluation kits are available that can serve as controller modules, but these are too large, overly powerful, and far too expensive for low-end controller applications. Also available now are a number of single-IC microcomputers

(e.g., Intel 8048, Zilog Z8, Motorola 6805), but most of these are impractical for small-quantity designs because they incorporate on-chip mask-programmed ROM (read-only memory), thus the minimum order is several thousand units.

The few single-IC microcomputers with either on-chip EPROM (erasable programmable read-only memory) (e.g., Intel 8748, Motorola 68705) or with a "piggyback" socket (e.g., Zilog Z8-03) for a standard EPROM would be ideal as controllers for small-quantity applications because they contain a processor, RAM (random-access read/write memory), EPROM, I/O (input/output) lines, and a timer, all of which are essential for a general-purpose controller. Unfortunately these are still very difficult to obtain and not inexpensive enough to produce one-off controllers.

The aim of the design described in this article was to produce a very small, low-cost microcomputer module that would be suitable for a large number of controller applications, using only the most readily available components. The total cost of the module presented here is ap-

proximately \$30.

The module consists of a 100- by 60-millimeter (mm) single-sided printed-circuit board with a 24-pin edge connector. The board accommodates a Motorola 6802 microprocessor, a 2716-type (+5-volt-only) EPROM, a 6820 (or 6821) PIA (peripheral interface adapter), a crystal-controlled clock circuit with a 60-Hz interrupt generator, and a +5-volt (V) power-supply regulator. Thus, the user has available 128 bytes of programmable memory, 2048 bytes of EPROM, 19 programmable I/O lines, and a source of real-time interrupts. All communication with external circuitry is through the 19 I/O lines. You can produce a powerful controller with this configuration. The complete circuit schematic of the module is shown in figure 1.

Circuit Description

The microprocessor used in the module is the Motorola MC6802. The MC6802 was chosen because it is readily available at a low cost (less than \$10 in single quantities). Also it contains 128 bytes of on-chip memory, so no additional memory ICs are

Reliable Business Software

DATASMITH software requires no previous computer experience, so it can be used effectively by your present office staff. The menu-driven systems feature extensive error detection and correction facilities, so they are "friendly" to the user.

- **GENERAL LEDGER.** Everything you need to keep the books. Features easy-to-use data entry and error correction, trial balance, fast post, and a variety of comprehensive reports. Automatic error detection keeps the books in balance. Writes checks and makes journal entries in one operation.
- **PAYROLL.** A very flexible system that adapts to a wide variety of needs. Features Federal, state, and local tax calculations, EI credit, and special pay and deduction amounts. Prints all necessary reports, paychecks, and W-2 forms.
- **DATA MANAGER.** A powerful generalized data management system that lets you define, enter, update, sort, select, and print reports from a database of your own design. Applicable to almost any job where records must be kept, this system can replace literally hundreds of programs.

Put your computer to work with these sophisticated systems now. Programs are available for 48K or larger two-disk systems in your choice of code for Microsoft BASIC-80[™] under CP/M[™], IBM[®] Personal Computer BASIC, or Micropolis[®] BASIC.

DATASMITH

Box 8036, Shawnee Mission, KS 66208. (913) 381-9118



RADIO SHACK TRS-80's[™] Full Line

WE PAY SHIPPING in the 48 continental states on prepaid orders of \$100.00 or more.

NO TAXES are collected on out-of-state shipments.

WE ACCEPT Visa, MasterCard and American Express, or you can save additional money by paying cash.

TOLL FREE ORDER NUMBER 800/531-7466

Pan American Electronics

1117 Conway • Department B
Mission, Texas 78572
Phone: 512/581-2766
Telex Number 767339

TM — Trademark of Tandy Corporation

General Software

Mailing Address:
1454 S. 25th St.
Terre Haute, IN 47803
WE HONOR
VISA and MASTERCHARGE

TOLL FREE - Outside Indiana
1-800-457-0517
ORDER DESKS
(812) 234-9421

Best Selection Best Service

Write for our famous CATALOG. Contains many items not in ad. Still only \$1.00 (refund with purchase) Outside US add \$10 plus Air Parcel Postage. Add \$3.50 postage and handling per each item. Indiana residents add 4% sales tax. Allow 2 weeks on checks. COD add \$3.00 per item. Prices subject to change without notice. All items subject to availability.

	Disk with Manual	Manual Only
ARTIFICIAL INTELLIGENCE		
Dental (PAS-3)		\$849/40
Medical (PAS-3)		\$849/40
ASHTON-TATE		
*dBASEIII		\$525/50
BALCONES		
The Boss Fin. Acc. System		\$1750
BYROM SOFTWARE		
*BSTAM		\$149
*BSTMS		\$149

COMPUTER CONTROL	
*Fabs(B-Tree)	\$159/35
Ultrasoft	\$159/35
CONDOR COMPUTER	
Condor II	\$515/55
Condor II	\$795/55
DIGITAL RESEARCH	
CP/M	
2.2 Intel MDS-800	\$149/35
Northstar (Horizon)	\$149/35
Micropolis	\$169/35
TRS Model II	\$159/45
CB-80	\$429/45
PL1-80	\$429/50
CBasic2	\$ 98/30
EPIC COMPUTER	
*Super vyz	\$ 89/25
FAIRCOM	
*Micro B+	\$229/30
(Specify language)	
FINANCIAL PLANNING	
*Mini Model	\$429/50
FRIENDS	
ACCESS 80 I	\$249/50
ACCESS 80 II	\$429/50
FRONTIER SOFTWARE	
Professional	
Time Accounting	\$549/50
General Subroutine	\$269/50
Application Utilities	\$439/50
ISA	
Spellguard	\$229/30
SP/Law	\$109
PASCAL LANGUAGE	
Pascal Z	\$349/40
Pascal MT + V5.5	\$429/40
Compiler	\$316/25
SPP Only	\$165/15
KEY BITS	
Wordsearch	\$179/50
String 80	\$ 84/25
String 80 (Source)	\$279
UNICORN	
Final Word	\$255
LEXISOFT	
*Spellbinder	\$349/55
MICRO AP	
Selector IV	\$249/40
Selector V	\$449/50
SBasic	\$269/40
MICRO TAX	
*Level I	\$249
*Level II	\$995

*Level III	\$749
*Combo II + III	\$1495
Microsoft 5.3	49
Run time module	
MICRO PRO[®]	
Wordstar	\$295/60
Call for NEW LOW PRICES	
MICROSOFT	
Basic-80	\$298
Basic Compiler	\$329
Fortran-80	\$349
Cobol-80	\$629
M-Scr	\$124
Macro-80	\$144
Edit-80	\$ 84
MuSimp/muMath	\$224
MuLisp-80	\$174
NORTHWEST ANALYTICAL	
*Statpak	\$409/45
OASIS	
***The Word**	\$ 75
ORGANIC SOFTWARE	
*Textwriter III	\$111/25
*Datebook	\$269/25
*Milestone	\$269/30
PEACHTREE[®] SOFTWARE	
General Ledger	\$399/60
Accounts Receivable	\$399/60
Accounts Payable	\$399/60
Payroll	\$399/60
Inventory	\$399/60
Mailing Address for PB Version	add \$119
Series 6-Peachtree	
CPA	\$799/60
Property Mgt	\$799/60
Passive Payroll	\$449/60
Series 7-Peachtree	
Sales Tracker	\$3049/60
AR-Sales Analysis	\$1299/60
Inventory	\$799/40
Order Entry	\$699/40
REDDING GROUP	
*Lynx	\$199/25
SORCIM	
*Pascal/M 280	\$349/40
Pascal/M 86/88	\$449/40
*Act 65	\$149/20
*Act 68	
*Act 69	
*Act 86/88	\$149/25

*Trans 86	\$119/25
*Supercalc	\$269
SOUTHERN COMPUTERS	
Call for our unbeatable low prices.	
STRUCTURED SYSTEMS GROUP	
GL, AR, AP, PR, OE	\$849/50
Call for others	
SUPERSOFT	
*Diagnostic II	\$ 84/20
*Forth	\$149/30
*SSS Fortran	\$219/30
*Fortran w/RATFOR	\$289/35
*C Compiler	\$175/20
*Tiny Pascal	\$ 80/25
*Disk Doctor	\$ 84/20
*Term I	\$129/25
Term II	\$169/25
Z8000 Xassembler	\$449/35
Games & Others less 10%	
WHITESMITHS	
C Compiler	\$700/40
Pascal (incl C)	\$900/45
IBM PERSONAL COMPUTER	
Wordstar 3.2	\$309/60
Mailmerge	\$109/25
Supercalc	\$269/NA
Visicalc (256K)	\$229/NA
Optimizer	\$200/NA
Supersoft C - CP/M86	\$500/NA
Peachtree	
3 Pak GL, AP, AR	\$595
Final Word	\$265
Condor I, II, III	CALL
Statpak	\$439
BSTAM	\$149
Move-It	\$129
Easy Writer II	\$315
Easy Speller	\$155
Easy Filer (dBase mgr.)	\$335
Spellbinder	\$355/49
APPLE II DOS	
Word Handler II	\$155/49
Broderbund Software	
General Ledger (w/ A/P)	\$435
Payroll	\$325
Professional Easywriter	\$155
Mfg. Inventory and Control Program	
T1900, 300 Meg. storage required	
Distributed in Cobol object code	
Call for Info	\$20000/NA
Write for catalog (\$1.00) and other listings	

* Available for Apple with Softcard

7

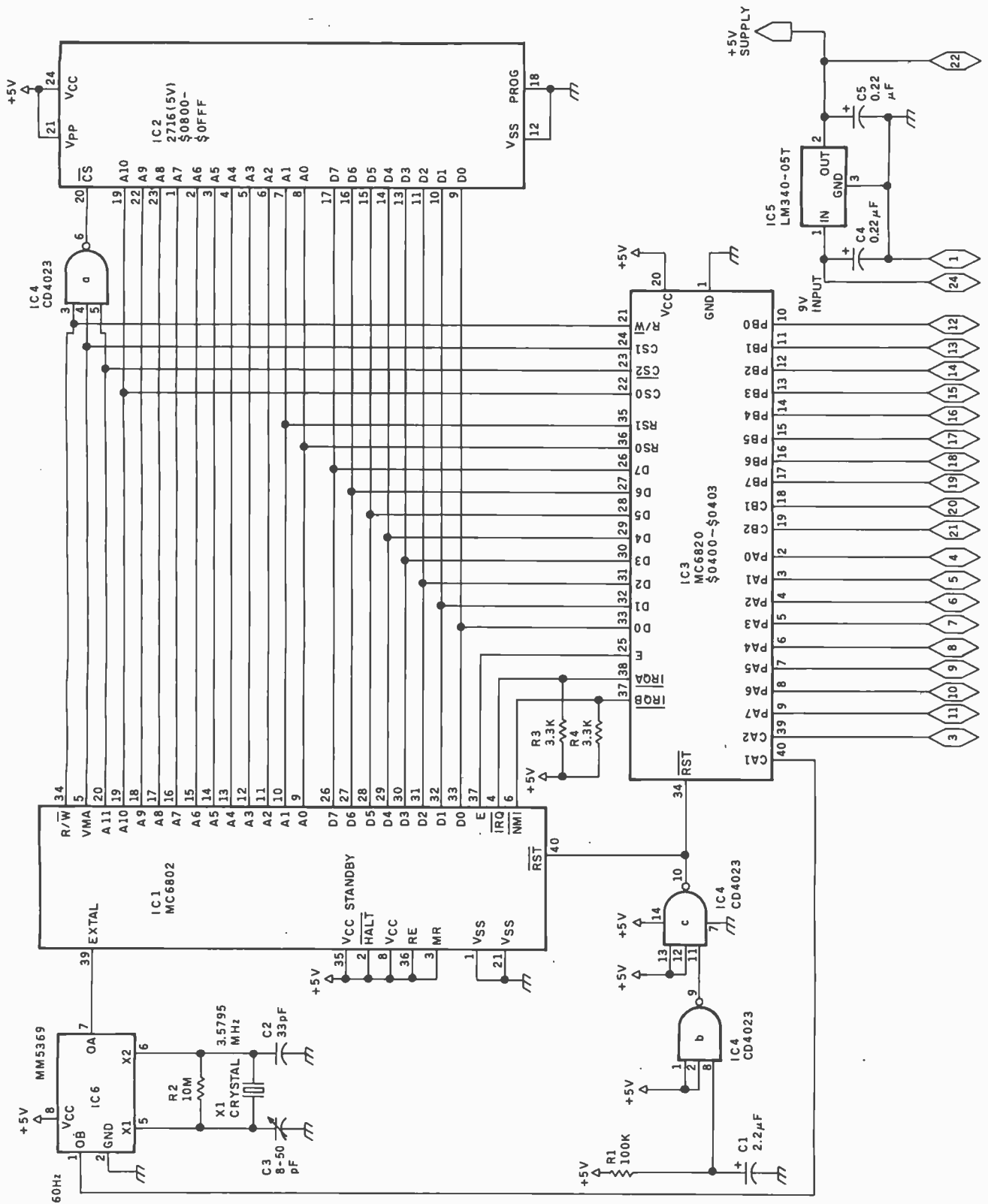

Figure 1: Circuit diagram of the complete microcomputer module. The printed-circuit board is single-sided, and the main integrated circuits provide programmable memory, EPROM, I/O, and a counter. Other circuitry provides the system clock, a 60-Hz interrupt, and +5-V power regulation.

OSI SOFTWARE

Challenger 1P / Superboard II

HEXDOS is a remarkable disk operating system which surpasses the capabilities of OS65D. But because HEXDOS uses subroutines in OSI's ROM BASIC, it is very compact (only 2K). HEXDOS provides you with easy-to-use commands and saves 10K of memory and disk space!

- Load or save BASIC programs, machine language, and data files by name. Chain BASIC programs from disk.
- Up to 22 data files may be open simultaneously.
- Full trace of BASIC programs with optional single-stepping.
- Includes a disassembler and demonstration programs: CHECKBOOK and ADDRESSBOOK (personal data base management), LIFE, SURROUND, REVERSI, BACKGAMMON, and BSR CONTROLLER (home control).

Price: \$49.50 (5¼-inch diskette and 40-page manual)

HEXASM is a powerful macro-assembler plus utilities. Requires HEXDOS and 20K RAM. Price: \$38.50

TEC65 is a versatile text editor/editing language. Requires HEXDOS. Price: \$38.50

Your satisfaction guaranteed, or your money promptly and completely refunded. For more information, send \$1.00 for our catalog of OSI, Apple, AIM, KIM, and SYM software.

The 6502 Program Exchange

2920 West Moana
Reno, NV 89509
(702) 825-8413

VISA



TELEPHONE VOICE RESPONSE

The V100 interactive voice synthesizer

with telephone interface is an Apple II® or IBM Personal Computer® compatible, low-cost, solution to remote data base access arrangements.

\$395⁰⁰

V100-A

- Direct telephone connection, auto-dial/answer
- Touch-tone® generation and detection
- Includes 300 word, LPC vocabulary
- Software for sentence/library construction
- Expandable with 1300 (\$495) high quality LPC words

For a demonstration call toll free (800) 538-7002
In California call (408) 942-1595

VYNET CORPORATION

2405 Qume Dr., San Jose, CA 95131 (408) 942-1037

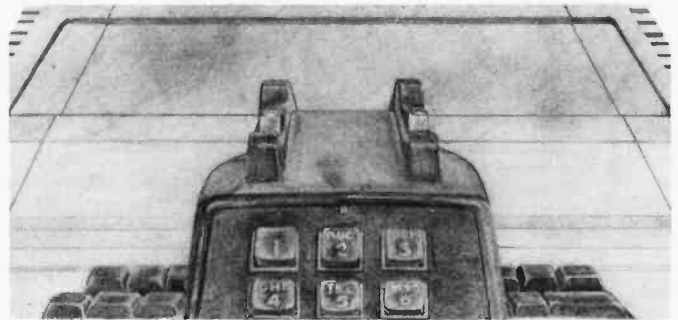

12" B&W MONITOR

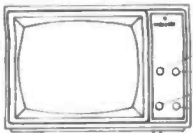

Contrast
Power/Bright
V-Hold
H-Hold

VIDEO 100 by AMDEK

FULL
FACTORY
WARRANTY

\$79⁹⁵

for APPLE

16K RAM CARD

Language Transparent
COEX FACTORY
WARRANTY

\$69⁹⁵

5¼" Floppy DISKETTES

All Certified-100% Guaranteed

BOX of 100 ... **\$149⁰⁰**
Above with
Hub Rings **\$169.00**

FLOPPY DISK DRIVE

From Fourth Dimension Systems
with • Track Zero Micro Switch
• DOS 3.2.1 & DOS 3.3
• CP/M and PASCAL

DESIGNED
FOR YOUR
APPLE™ **\$287⁹⁵**

Controller Card
for above **\$99.00**

COEX 80-FT DOT MATRIX PRINTER

- Interface with Apple™, Centronics RS-232, IEEE-488
- 9x7 Dot Matrix, 80 CPS, Bi-Directional Printing
- 2K Buffered Memory
- 80, 96, 132 Columns, Graphics and Block Printing
- Selectable Char Pitch, Line Spacing and Feed

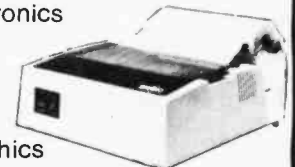

COEX Interface Card to APPLE **\$49.95**

\$349⁰⁰

VISION-80® \$249⁰⁰

80x24 Video Display Card
Vista Computer Company's new Vision-80 board is a sophisticated yet easy to use video display card for the Apple™ computer.

EXTENDER CARDS

for APPLE **\$16.95**
for I.B.M. **\$19.95**

PROTOTYPING CARDS

for APPLE **\$19.95**
for I.B.M. **\$49.95**

PARALLEL INTERFACE EPSON TO APPLE

New From **\$49⁹⁵** CABLE INCLUDED

"Have You Kissed Your Computer Lately?"

Components Express, Inc.

1380 E. Edinger • Santa Ana, Calif. 92705 • 714/558-3972

Terms of Sale: Cash, Checks, Credit Cards, M.O., C.O.D. Calif. residents add 6% sales tax.

VISA



THE [^]Quality ALTERNATIVE BASIS 108



System Highlights

- Dual Processors
- 64K or 128K RAM
- Selectable 40 or 80 column text
- Color Graphics Resolution
 - 280h x 192v High
 - 80h x 48v Medium
 - 40h x 48v Low
- Built-In Parallel & Serial Interface
- Three video output modes
- Detached Keyboard with:
 - Normal typewriter functions
 - Numeric keypad
 - Function keys
 - Cursor block

The BASIS 108 upholds the fine tradition of quality and craftsmanship inherent in German technology.

This German-made micro-computer system features Z-80* and 6502 processors, making the system compatible with more computer languages, operating systems, and software than any other off-the-shelf microcomputer available in its price category. Additionally, the 108's large memory capacity, built-in interfaces, and full-feature detached keyboard combine to make the 108 the most capable microcomputer at any price. And, the BASIS 108's price makes it the most cost effective micro-computer for any computing application.

**BASIS 108 —
A HERITAGE
OF EXCELLENCE!**

5435 Scotts Valley Drive
Scotts Valley, CA 95066
(408) 438-5804
TWX: 910-598-4512

BASIS
INCORPORATED 

*Z-80 is a trademark of Zilog, Inc.

required for "scratch pad" (memory for storage of temporary values).

For the controller to do useful work it must follow instructions stored in its memory. For program memory, the controller uses a 2716-type EPROM that can store 2048 bytes. The 2716 was chosen because it is readily available, currently costs approximately \$6 in single quantities, and is easy to program and erase. The capacity of the 2716 allows storage of quite a lengthy machine-language program.

The module is designed to operate from an unregulated 9-V-DC power supply—easily obtained from a calculator-type AC adapter. Regulated +5 V DC for use by the module is obtained from IC5, a 7805 (or LM 340-T-5) three-terminal regulator. The +5-V supply is made available at the module's edge connector for use with associated interface circuitry. The module's current drain is approximately 250 milliamperes (mA), with the regulator being capable of supplying approximately 400 mA safely without a heat sink. (Care must be taken not to overload the regulator with too much extra circuitry.)

Although the MC6802 microprocessor itself has a built-in oscillator circuit requiring only an external crystal for operation, an external oscillator circuit is used. IC6 is a crystal oscillator with buffered output at the crystal frequency and incorporating a 17-stage frequency divider. With the 3.579545-MHz crystal used, which is an NTSC (National Television System Committee) television color subcarrier crystal, the frequency divider output is 60 Hz. This is connected to the CA1 input of the MC6820 PIA to provide a source of interrupts. This is very useful in controller applications to allow timing of operations without tying up the processor in software timing loops. The MC6802 divides the clock frequency by 4 internally, and so runs at 894,886 Hz—10 percent below the microprocessor's 1-MHz maximum allowable clock frequency.

The only reset facility provided for the module is a power-on reset. The combination of R1 and C1 buffered through two gates (b and c) of IC4

Circle 196 on inquiry card.

Edix™ + Wordix™ has word processing features that our competitors are still dreaming about . . .



\$390 buys the whole dream.

Edix Editing Features

- Up to 4 screen windows
- Up to 12 file buffers
- Top-to-bottom and side-to-side scrolling
- Regular expression searching and translating
- Intra- and inter-buffer moving and copying
- Online help
- Online tutorial

Call or write for our brochure.

Wordix Formatting Features

- Auto footnotes
- Auto table of contents
- Auto hyphenation
- Multi-line headers and footers
- Multi-column layout
- Powerful macros
- Data file access

Requires 128K IBM PC Edix alone: \$195



Box 154 Louisville, Colorado 80027 303 447-9495

™ Trademark of Emerging Technology Consultants, Inc.

SPECIALS ON IBM PERSONAL COMPUTER

- A. 64K system unit & keyboard, two 320K drives & controller, color graphic card 12" BMC green monitor . . . ~~\$2,615~~ \$2,850
- B. 64K system unit & keyboard, two 320K drives & controller, IBM monitor, monitor/printer adapter . . . ~~\$3,795~~ \$3,255

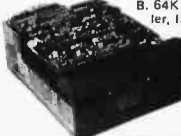

5 1/4" TANDON DRIVES

Brand new IBM compatible internal drives. Fully supported by the new PC DOS 1.10. Our exclusive step-by-step instruction makes installation easy.

- Single sided (160 KB) . . . \$450 \$207.99
- Double sided (320 KB) . . . \$660 \$289.99



MEMORY BOARDS by AST

User expandable to 256K. IBM compatible and supported by PC DOS. Assembled, burned-in & tested. 1-year warranty.

	64K	128K	192K	256K
Memory board without port	\$295	\$407	\$518	\$629
with Serial OR Parallel Port	\$325	\$447	\$558	\$669
with BOTH Serial & Parallel Ports	\$375	\$487	\$598	\$709
with Serial, Parallel Ports & Clock	\$405	\$517	\$628	\$739



RAM EXPANSION PACK
16K (9 chips) for system board
250 ns . . . \$25.00
150 ns . . . \$35.00

***** PRINTERS SALE *****

Epson MX80FT w/Graphtrax-Plus, 80 CPS	\$695	\$499
NEC Spinwriter 3550 New/ 203 col., Serial	\$2,950	\$2,099
C. Itoh Prowriter 8510 AP 120 CPS, Parallel	\$795	\$459
C. Itoh F-10 Daisywheel, 40 CPS, Parallel	\$1,995	\$1,375
C. Itoh F-10 Daisywheel, 55 CPS, Parallel	\$2,295	\$1,699
Brother HR-1 Daisywheel, 15 CPS, Parallel	\$1,260	\$829



Kaise AUTORANGING DIGITAL MULTIMETERS

The state-of-the-art autoranging DMMs -- from Japan's foremost meter mfr.

Model SK-6440:-

- 3.5-digit LCD with auto unit and sign indications
- Full autoranging on Volt and Ohm with 10A AC/DC range
- Input value can be put into memory to make difference measurements like a galvanometer
- Autoranging Voltage Test: 200mV-1000V DC, 2V-600VAC
- AC/DC Current Tests: 200mA-10A
- Resistance Tests: 20Ω-200KΩ
- Autoranging Low Power Ohm Tests: 2KΩ-200KΩ
- DC Volt Accuracy: ±0.8% reading, ±0.2% full scale
- Low Battery Consumption: 300 hrs. on two AA batteries (Included)
- Test leads with protective rim prevents fingers from touching probe
- Compact size: 5" x 3 1/4" x 1 1/4"
- Submerged connectors for added safety
- Folding tilt stand for easy viewing
- Dual fuse for safety protection



- Model SK-6330:- All the above plus these additional features:
- DC Volt Accuracy: ±0.5% reading, ±0.2% full scale
- Built-in Beeper (switchable) for continuity tests, overload warning
- Extended AC/DC current range: 20mA-10A
- Manually overrides the autoranging function so that the desired range can be selected for voltage and resistance measurements
- Zero Adjust function cancels the resistance value of test leads for the easiest and most accurate measurements

HARD CASE for above two models . . . \$10.00

To order, please send money order or cashier's check. Personal checks may cause delay up to 4 weeks. Visa/Mastercard welcome. Add 1% (Min. \$3) of total order value for shipping & Handling by UPS truck. California residents add sales tax. COD's requires 20% deposits. Prices & availability subject to change without notice.



EASTERN ENTERPRISES, INC.

2937 S. VAIL, COMMERCE, CA 90040 • (213)725-3080



Executive Peripheral Systems unveils their new EPS keyboard: the key to a more professional Apple II



At last, a detachable, full-function keyboard to plug into your Apple II

- * 12 special function keys enhance the value of any software package
- * Function keys are pre-programmed using EPS-PROMWARE modules, available for all popular software packages.
- * Helps you learn software quickly
- * Faster data entry and editing
- * Detachability means less fatigue
- * Less need to look up commands in manuals

Features:

- * 10 key numeric pad
- * 6 dedicated edit keys
- * 6 cursor control keys
- * working shift key
- * 12 special function keys, programmed using EPS-PROMWARE modules
- * includes a EPS-PROMWARE module for BASIC

\$350.
Suggested
Retail

EPS

Executive Peripheral Systems, Inc. 800 San Antonio Road, Palo Alto, CA 94303, (415) 856-2822

Visit our booth (2468) at the Comdex Show

Data-Vu™

So Powerful, So Friendly,
It's for the Professional It's for Personal Use

Everyone has heard that the cost of computing is going down, but by the time you're finished with a Database Management System you can rely on you've spent hundreds and maybe thousands of dollars. At Thinkers Soft Inc., the price of computing is more reasonable than you think. Data-Vu™ by Thinkers Soft Inc. has three features which makes it one of the most powerful data management facilities available.

A COMPLETE DATA MANAGEMENT FACILITY

1. Automatic Form Generator
Allow you to generate forms on the screen and use them as a personalized tool

2. Relational Database Manager
Designed for the small firm or professional who would like a convenient but inexpensive data base management system.

3. The Report Generator Program
Specifically designed to retrieve information from the data base with simple statements, perform arithmetic operations, and much more.

ALL THIS FOR
\$129 (Disk & Manual)
\$35.00 for manual only.

Minimum system requirement: 48K CP/M-80* (check manufacturer's user's manual)
Specify Diskette Format.
\$2 additional shipping costs per diskette.
Prices subject to change without notice.
Available Soon: CP/M 86 version.

*Registered trademark of Digital Research, Inc.

Thinkers Soft, Inc.

P.O. Box 221, 221 Clinton Rd., Garden City, NY 11530

Dealer Inquiries Invited **Call Today (516) 294-8104**
We Accept Master Charge

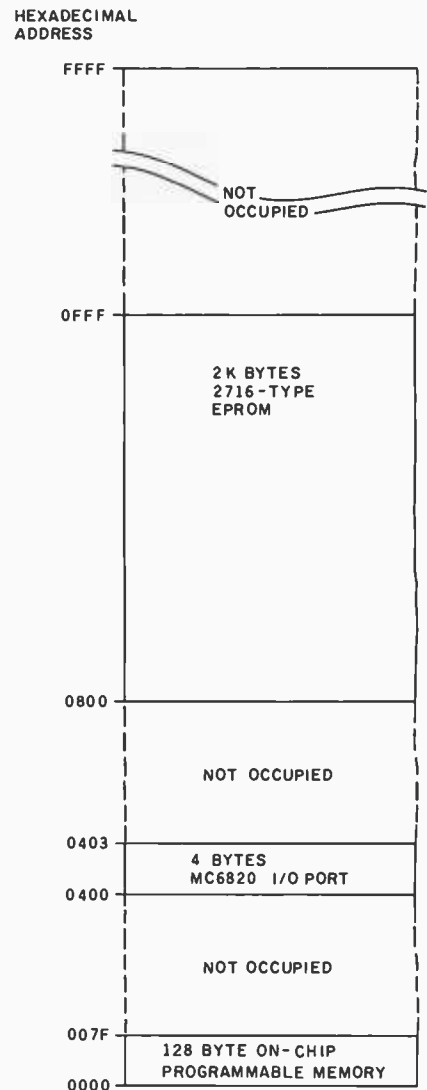

Figure 2: Memory map of the module's address space. Unoccupied gaps are due to the simple decoding method that uses some address lines to directly enable the peripheral integrated circuits.

provides a reset pulse to the MC6802 processor and the MC6820 PIA when power is applied. This forces the processor to begin execution of an initialization routine in the EPROM.

The eight data-bus lines of the MC6802 processor are connected to the data-bus lines of the 2716 EPROM and the MC6820 PIA. These lines are not buffered and are not available for connection off the module.

Exhaustive address decoding is not used; only enough of the 16 address lines of the MC6802 are used to sepa-

TeleVideo® Users!

Single Key Access to 46 WordStar® Commands

The TV1000 is Designed for the 925,950, Intelligent I and 800 Through 816 Computers

Features:

- 46 single key stroke commands
- Faster cursor and keyboarding
- User-oriented command selection & location
- Soft switch activates the enhancement with no loss of TeleVideo attributes.

Includes:
46 replacement key caps
Replacement ROM



Introductory Price: \$150
(Good until 12/15/82 reg. list \$220)
40 Pin Inserter/Extractor set \$15.
California Res. add 6½% Tax

WordTechSystems

953 Mountain View Dr. Suite 114
Lafayette, California 94549
(415) 254-7747

DEALER INQUIRIES INVITED

TRADEMARK WORDSTAR MICROPRO VISA/MC/COD

DECEMBER SPECIALS

Advanced Micro Digital Single board computer A&T	699.00
Godbout "Compupro" Systems A, B, & C	Call
Morrow Designs Multi I/D 3S, 1P, RTC, A&T	269.00
IBM P.C. boards by Tecmar & Seattle Computer	Call
S-100's own 8" dual drive box w/P/S, fan, & internal cables A&T	349.00
California Computer Systems - floppy disk controller w/CP/M 2.2 A&T	340.00
SSM I/O-4 2P + 2S ports A&T	203.00
Ithaca Intersystems Main frame w/a front panel A&T	1299.00
Paradynamics "Pronto" main frame, 18 slot w/room for 2 floppy drives	999.00

VISIT OUR SHOWROOM - Hrs. - 9:00 A.M. - 5:30 P.M. M-F

Subject to Available Quantities • Prices Quoted Include Cash Discounts. Shipping & Insurance Extra.

We carry products from all Major Manufacturers



UV EPROM ERASER

- * Erases over 15 EPROMS - 15 minutes erase time
- * Element life 7700 hours
- * Intensity: 12Ws 1/2cm² at 1"
- * Erases all UV EPROMS (2716, 2732, 2516, 2532, etc.)

\$49.95*

*HOBBY MODEL

INDUSTRIAL MODEL
QUV-T8/2N
\$68.95

WITH TIMER & SAFETY SWITCH
QUV-T8/2T
\$97.50

ABOVE 220VAC 50HZ
QUV-T8/2TE
\$109.50

PRICE INCLUDES PERSONALITY MODULES



STAND ALONE RS-232 INTELLIGENT PROGRAMMER \$489.00

PROGRAMS: 2508, 2516, 2532, 2716, 2732, 2732A, 2758, 8748, 8749
OPTIONAL MODULES: 2564, 2764, 8755A, 8741

- * STAND ALONE, CRT, OR COMPUTER CONTROL
- * UPLOAD/DOWNLOAD IN MOTOROLA OR INTEL HEX FORMAT
- * MICROPROCESSOR BASED * 4 K INTERNAL RAM
- * 90 DAY PARTS & LABOR WARRANTY ON ALL PRODUCTS

★ **GANG PROGRAMMER**
Soon to be released

PHONE ORDERS (305) 776-5870

TWX: 510-955-9496 • WE ACCEPT VISA, MC, CHECKS, C.O.D., MONEY ORDER

LOGICAL DEVICES INC.

781 W. OAKLAND PARK BLVD. • FT. LAUDERDALE, FL 33311

ADD: \$4.00 SHIPPING \$2.00 C.O.D. CHARGES

Get your computer talking and save \$126.

The Type-'N-Talk™ speech synthesizer is now available for only \$249.

The Type-'N-Talk™ text-to-speech synthesizer automatically translates your text into electronic speech and allows your computer to speak with an unlimited vocabulary. Standard with an RS-232C interface, Type-'N-Talk has an internal microprocessor and 750 character buffer. And remember, it doesn't use your computer's memory to make your text speak.

Here's what you get.

- Unlimited vocabulary SC-01 speech synthesizer chip.
- Text-to-speech algorithm for translation.
- RS-232C interface.
- Selectable Baud (75-9600).

“talk is cheaper”

Votrax

Type-'N-Talk is covered by a limited warranty. Write *Votrax* for a free copy.
500 Stephenson Highway,
Troy, MI 48084.

- Spelling and phoneme access modes.
 - 750 character buffer.
 - Data echo of ASCII characters.
 - Complete installation and programming instructions.
- Great new software is available for Type-'N-Talk equipped computer systems. To order, see your local computer retailer or call toll-free

1-800-521-1350

Michigan residents, call (313) 588-0341. MasterCard, VISA or personal check accepted. The price is \$249 plus \$4 for delivery. Educational discount available. Add sales tax in Michigan and California.

© VOTRAX 1982





THE SBC80A designed for multiprocessor /slave or I/O processor, has on board Z80A-CPU; DMA; 128K dual ported RAM, no wait state, byte/word accessible; Eprom sockets up to 32K; 2 RS232; 2 parallel ports; Memory Map Prom; 3 counter/timer; floppy controller; hard disk interface; math chip AM9511; 20 bit Intel Multibus 21 vectored interrupts; auxiliary power input for stand alone. From \$895 (qty.1)

INNOVATIVE RESEARCH, INC.
17071 Kampen Ln, Huntington Bch, CA92647
714-842-0492. Multibus Intel trademark.

Circle 231 on inquiry card.

MEMOREX FLEXIBLE DISCS

WE WILL NOT BE UNDER-
SOLD!! Call Free (800)235-4137
for prices and information. Dealer
inquiries invited and C.O.D.'s
accepted.

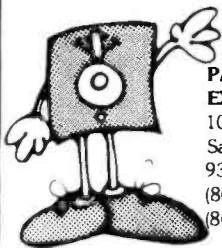

**PACIFIC
EXCHANGES**
100 Foothill Blvd.
San Luis Obispo, CA
93401. In Cal. call
(800)592-5935 or
(805)543-1037

Circle 361 on Inquiry card.

VOICE SYNTHESIZER VOCABULARY DEVELOPMENT SYSTEM

CREATE YOUR OWN CUSTOM VOCABULARIES
For TI 5220 or GI SP-250 Speech Synthesizers
Using Your S-100 or INTELLEC™ Micro

INCLUDES HARDWARE AND SOFTWARE FOR:
DMA Voice Digitizing and Playback (8 bit mu-law codec)
• Parameter Extraction and Coding • Screen Oriented
Parameter Editor • Voice Synthesis

MODEL VPP-696 for S-100 (IEEE-696 Compatible) - CP/M80
MODEL VPP-796 for INTELLEC™ MDS - ISIS II

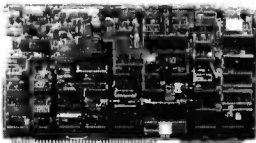

\$3900

(Includes Hardware and Software)

adisa corporation
APPLIED DIGITAL SIGNAL ANALYSIS
P.O. Box 1364 Palo Alto, CA 94301 (415) 326-7303
Intellec is a trademark of Intel Corp.

Circle 11 on Inquiry card.

(3a)

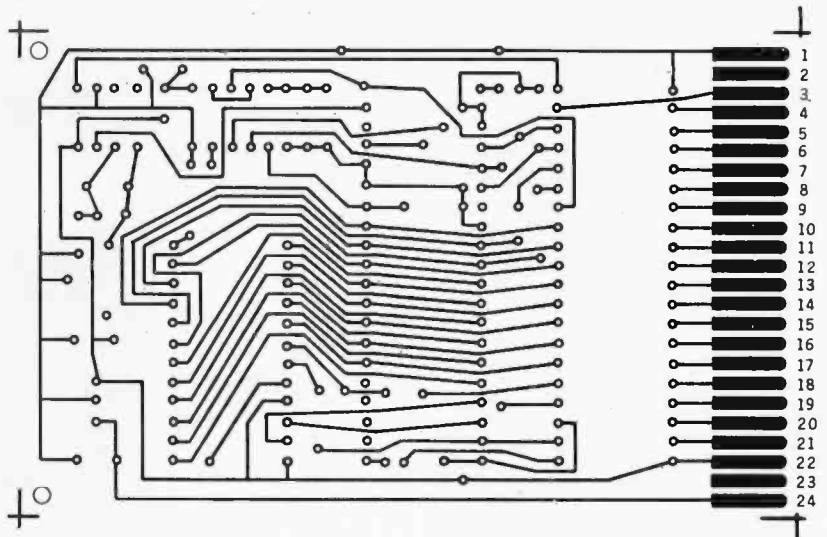

(3b)

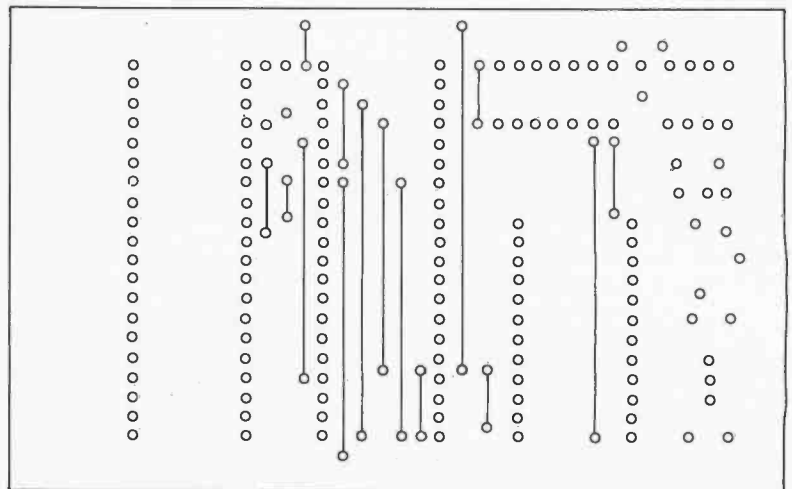

(3c)

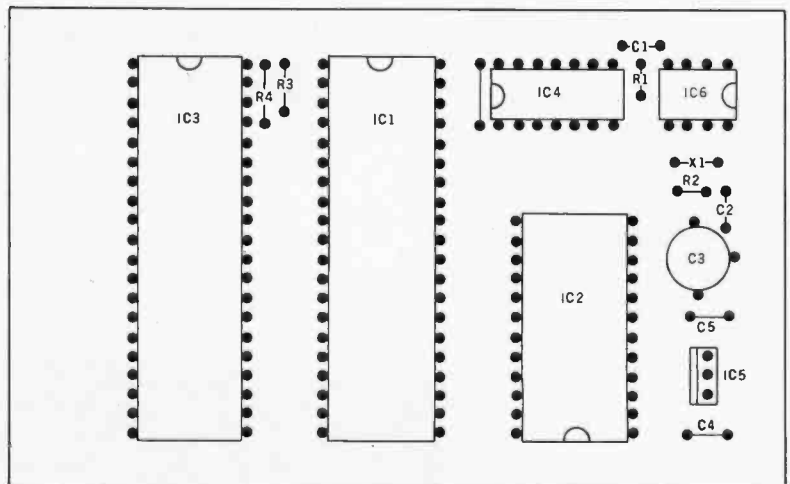

Figure 3: Artwork for creating the printed-circuit board. Figure 3a shows the full-sized etching pattern for the single-sided board; figure 3b shows where to install wire jumpers on the component side of the board. Component placement is shown in figure 3c.

New update from Tarbell . . .

CP/M DATABASE for only \$100!

IMPROVED FEATURES

- 3 times faster than previous version
- CB80 language source and COM files included
- improved query language
- up to 19 files open at once
- command file processor
- no limit on record length or number of records

OTHER ADVANTAGES

- variable-length fields
- field names of any length
- field names may include spaces
- sequential or random files
- optional index files
- also runs under CBASIC

INTERACTIVE PROGRAMS

Tarbell Database also includes these interactive programs: DBSORT, sorts random files; DBSETUP, creates a file; DBENTRY for entering data; DBUPDATE for changing files; DBQUERY for accessing data; DBLABEL for printing labels; DBLETTER for printing letters; DBCOPY to change structure of a file.

TARBELL VALUE

Dollar for dollar, you can't get a better value than Tarbell's updated Database System. Ask your nearest Tarbell dealer for a demo.



950 Dovlen Place, Suite B
Carson, CA 90746
(213) 538-4251

CP/M, CB80 and CBASIC are trademarks of Digital Research.

Send for your **FREE** catalog today!

COMPUTER SUPPLIES



Introducing the largest computer and word processing supply catalog ever published. Visible's 164-page direct order catalog features more than 3500 supply and accessory products. Thousands of data processing managers nationwide buy their supplies direct from this catalog because they like the large selection, the ease of ordering, the fast delivery and the quality products. Plus, we've just introduced 150 new products this fall to meet the demands of an ever-changing computer environment.

To receive your **FREE** 1982 catalog, simply call Toll-Free 800-323-0628 (in Illinois, call 312-377-0990) or circle the Reader Service Card number below.

The complete source for all your computer supplies and accessories!

VISIBLE COMPUTER SUPPLY CORPORATION

A Subsidiary of Wallace Computer Services, Inc.
3626 Stern Drive, St. Charles, IL 60174
1615 S. Stockton St., Lodi, CA 95241

Lyc0 Computer Marketing & Consultants

TO ORDER CALL US **TOLL FREE 800-233-8760**
In PA 1-717-398-4079

November ATARI SPECIALS

810 Disk Drive	\$429.00
32K RAM	\$ 79.00
400 32K RAM	\$349.00
800 48K RAM	\$609.00

410 RECORDER	\$ 75.00
825 PRINTER	\$575.00
830 MODEM	\$159.00
850 INTERFACE	\$164.00
CX494 COMMUNICATOR	\$325.00
CX483 PROGRAMMER	\$ 49.00
CX481 ENTERTAINER	\$ 69.00
PACMAN	\$ 32.75
CENTIPEDE	\$ 32.75
STAR RAIDERS	\$ 35.00
ASTEROIDS	\$ 28.75
BASKETBALL	\$ 26.75
MISSILE COMMAND	\$ 28.75
KRAZY SHOOT	\$ 35.00
EASTERN FRONT 1941	\$ 25.50
CX404 WORD PRO	\$109.00
PILOT HOME	\$ 65.00
PILOT EDUCATOR	\$ 99.00
MONKEY WRENCH	\$ 42.00
MACRO ASSEMBLER	\$ 69.00
MICROSOFT BASIC	\$ 65.00

commodore

PACKAGES

CX481 Entertainer	\$69.00
CX482 Educator	\$125.00
CX483 Programmer	\$49.00
CX494 Communicator	\$325.00
PRINTERS - IN STOCK	
EPSON	\$ CALL
OKIDATA	\$ CALL
PROWRITER	\$ CALL
PERCOM DISK DRIVES	\$ CALL
VIC 20	\$189.00
VIC DATASETTE	\$ 67.00
VIC DISK DRIVE	\$329.00
VIC 1515 PRINTER	\$355.00
16K RAM/ROM	\$ 99.00
PROGRAMMER AID	\$ 45.00
VICMON	\$ 45.00
ADVENTURE SERIES (ea.)	\$ 35.00
OMEGA RACE	\$ 35.00
GORF	\$ 35.00
SARGON II CHESS	\$ 35.00



TO ORDER CALL TOLL FREE 800-233-8760
In PA 1-717-398-4079
or send order to
Lyc0 Computer
P.O. Box 5088
Jersey Shore, PA 17740

IBM USERS

SAVE 25% ON YOUR PC UPGRADES

ANATRON MULTIFUNCTION RAM BOARD 64 KB Standard **\$450**

Socketed for easy memory expansion • Each port individually disabled
Parallel Printer Port may be configured as LPT1 or LPT2 or LPT3
Two RS 232 ports configured as COM1 and COM2 • Base address
selectable on any 64 KB boundary • All features fully compatible with IBM PC

EVERYTHING FOR THE PC

HARDWARE	SOFTWARE
<ul style="list-style-type: none"> • Disk Drives: <ul style="list-style-type: none"> Single Sided [160 kb] \$239.00 Double Sided [320 kb] \$300.00 • RAM Expansion Packages for <ul style="list-style-type: none"> Mother Board [16 kb] \$25.00 Memory Expansion Board [64 kb] \$130.00 • Printers [NEC, EPSON, OKIDATA] \$CALL • Monitors [NEC, TEKO, AMDEK] \$CALL • Diskettes [3M <small>single-sided</small> / <small>double-sided</small>] \$CALL • Extension Cables for: <ul style="list-style-type: none"> Printer \$CALL Monitor [two cable set] \$CALL Keyboard \$CALL 	<ul style="list-style-type: none"> • Condor DBMS • Ed-Word® Screen Editor/Word Processor • NECPRINT [NEC 8023AC print utility] • GRAPHDUMP <p style="text-align: center; font-size: small;"><i>Prices reflect 3% Cash Discount</i></p> <p style="text-align: center;">More hardware and software coming. Call for details.</p>

AEGIS SYSTEMS

P.O. Box 401
Terms FOB Saline
202 West Bennett Street, Saline, Michigan 48176
Hours 9 a.m. — 5 p.m. E.S.T.
1-800 521-0521
Michigan [313] 429-2678

rate the RAM, EPROM, and I/O ports in the address space. There are a number of "don't care" address bits. (See figure 2 for a simple map of the address space.) The address-bus lines are not buffered and are not available for connection off the module.

The MC6820 PIA provides 16 I/O lines that are independently programmable as inputs or outputs. In addition, the MC6820 has 4 programmable control lines. One of these control lines, CA1, is used as the 60-Hz interrupt input. The other 3 control lines and the 16 I/O lines are available at the module's edge connector for interfacing the controller to external circuitry. All communication between the controller module and external circuitry is through these 19 I/O lines.

The Printed-Circuit Board

The printed-circuit board for the controller module measures 100 by 60 mm with a 24-pin edge connection (2.54-mm spacing). The board is single-sided to reduce costs. This necessitates a number of wire links on the component side of the board. The printed-circuit board, wiring link positions, and component overlay diagrams are shown in figure 3.

Prototype matrix boards of the same size, also with a 24-pin edge connection, are available from a number of suppliers. These matching boards are ideal for building interface modules for use with the controller module.

Software and Interface Hardware

The MC6802 processor uses an instruction set identical to the MC6800 processor. Any of the Motorola MC6800 development systems or evaluation kits are suitable for software generation. A Motorola D2 kit with 4K bytes of memory is very suitable because its address space covers the RAM and EPROM address space of the controller module. The user PIA of the D2 kit can be used to simulate the PIA on the controller module. The interface circuitry simply plugs into the user PIA, and all hardware and software debugging can be performed using the D2 kit.

apple

Dist. by Bell & Howell

800 368-3417

Turning Prices Upside Down for Christmas

\$999

<p>IBM PARTS</p> <ul style="list-style-type: none"> DeVong 5Meg \$Call Xedex Baby Blue \$Call Seattle 64K \$1739 Visicalc 256K \$750 Visifile \$1149 Wordstar \$1775 Condor \$679 Micro Tax I \$199 Comrex RGB Color \$599 Math ★ for Word ★ \$87 	<p>PRINTERS</p> <ul style="list-style-type: none"> NECS \$325 IDS Prisms \$618 Diablo 630 \$91 Strobe Plotter \$795 Strobe Plotter \$289 <p>SYSTEMS</p> <ul style="list-style-type: none"> Micro Decision \$199 Kay Pro II \$188 Atari 800 48K \$179 Commodore VIC 20 \$199 TIMEX Computer \$38 <p>1500 Programs In Stock</p>	<p>SOFTWARE</p> <ul style="list-style-type: none"> Wizardsry \$28 Master Type \$28 DB Master \$179 Wordstar \$199 Visicalc \$188 Pascal \$199 Hays Apple Modem \$289 Amdex RGB Color II \$795 BMC Monitor \$91 Premium Pack \$618 Quentin Drives \$325 Disk II & Controller \$495 	<p>SOFTWARE</p> <ul style="list-style-type: none"> Wizardsry \$28 Master Type \$28 DB Master \$179 Wordstar \$199 Visicalc \$188 Pascal \$199 Hays Apple Modem \$289 Amdex RGB Color II \$795 BMC Monitor \$91 Premium Pack \$618 Quentin Drives \$325 Disk II & Controller \$495
--	---	--	--

THE Computer Learning Tree

Government Sales

Call 703-750-2632

7023 Little River Tnpk.
Annandale, VA 22003

Expand your IBM PC

Special Factory Rebate Worth \$100.00!

Order a 5¼" Winchester hard disk from (PC)² and return your 5¼" floppy Tandon, TM100-2 to us and we will send you a check for \$100.00. This offer expires soon - so ACT NOW!

Add-In Winchester Disk System

\$1895⁰⁰
For
6M Bytes

(PC)²'s Add-In Winchester Disk System is housed within the IBM chassis and is easy to install directly into the floppy slot, reducing desktop space. Also available in 12 and 18 M Bytes capacity.

Memory Expansion Board

\$249⁰⁰

(PC)²'s Expansion Board offers 4 TIMES the amount of memory offered by IBM. P.C. Configurations can be set at 64K, 128K, 192K and 256K Bytes. Board can be easily upgraded in 64K capacities. Upgradability is the key!

Asynchronous Communications Controller

As
little as
\$85⁰⁰

1 or 2 line capability on one card.
Totally compatible with IBM software and diagnostics.

Combination Memory/Asynchronous Controller Board

\$319⁰⁰

(PC)² high capacity memories are combined on one board with single or double ported asynchronous communications controllers to create the (PC)² Combination Memory Expansion/Asynchronous Controller Board. (PC)² Combo Boards are fully upgradeable in 64K increments up to the 256K byte board capacity and are configured with support for one or two RS-232C Ports.

Larger quantity pricing is available. For further details call (PC)² Today.

Phone or Write Now! **(408) 749-9313**

(PC)², 510 Lawrence Expressway No. 678 Sunnyvale, CA 94086

Postage and Handling included within continental U.S.A.

One year warranty on all board products.

MasterCard, Visa, Checks and C.O.D. accepted.

PLUG COMPATIBLES FOR PERSONAL COMPUTERS



When the system is operating satisfactorily, the program can be transferred to EPROM and the controller module can replace the D2 kit.

Program alterations to allow software developed on a D2 kit to run on the controller module are minimal. The main program change required is to change the PIA address from hexadecimal 8004 through 8007 (for the D2 kit) to hexadecimal 0400 through 0403 for the controller module. This requires the change of only two bytes if all program references to the PIA use indexed addressing with the index register being loaded from a double-byte constant in memory each time it is used.

One other possible program change would be to use software loops to perform timing functions. The controller runs at an internal clock frequency of 894.886 kHz, compared with a D2 kit, for example, which runs at a clock frequency of 614.4 kHz. Adjustment of timing-loop execution times is simple if the loop counter is loaded from a constant in memory each time it is used. Then only a single memory constant need be altered, irrespective of the number of times it is used.

A number of standard interface modules can also be produced to cope with the most common interface requirements. From an \$8 calculator I have designed and built an interface module for use with a 24-key keypad and an 8-digit, 7-segment LED (light-emitting diode) display. I have also built a module (costing approximately \$4) that can be configured as a 7-bit A/D (analog-to-digital) or D/A (digital-to-analog) converter. As a D/A converter, the module uses only two PIA lines, and as an A/D converter, only three PIA lines. Relay drivers, lamp drivers, and switch inputs are easily implemented.

Standard software routines can be used to drive the standard interface modules and provide other commonly used software functions, e.g., a real-time clock driven by the 60-Hz interrupt source. This allows a wide range of different controllers to be produced with relatively little effort by mixing and matching standard hardware and software modules. ■

READ AMERICA'S NUMBER 1 NON-SELLER.

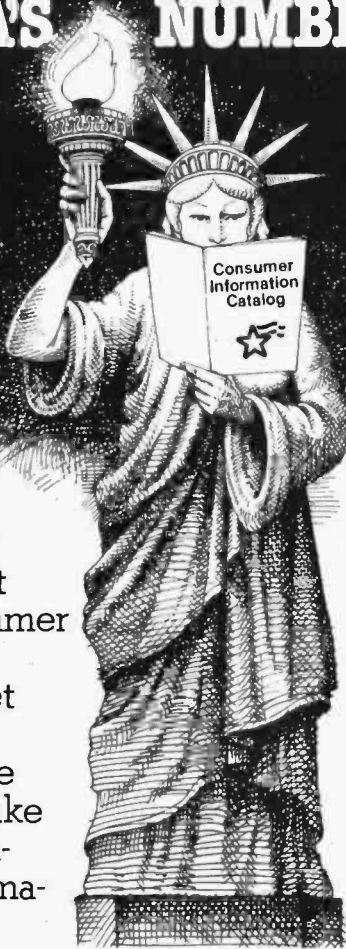

Not for sale in any bookstore! Not available at any price! The new Consumer Information Catalog!

It's the free booklet that lists over 200 helpful Federal publications; more than half, free. On topics like home repairs. Money management. Nutrition. Informa-

tion that could help you to a better way of life.

To get your free copy, just write:

**CONSUMER INFORMATION
CENTER,
DEPT. E
PUEBLO, COLORADO
81009**

 General Services Administration

29.95

FOR TWO CP/M* PROGRAMS:
TRANSFER (XFER) & DISASSEMBLER (DASM)
WITH COMPREHENSIVE USER MANUALS

WST — SOFTWARE THAT PERFORMS!

*CP/M is a Digital Research TM.

CP/M 8080/8085/Z80 DISASSEMBLER (DASM)

Debugging machine code? Need a source listing? Use the W.S.T. DASM. DASM quickly diasassembles .COM files into .ASM files. DASM automatically detects CODE/DATA segments and allows manual override of this detection. A symbol table is produced upon request at any time during disassembly. Don't be stuck with just a Z80 disassembler, try the W.S.T. DASM.

CP/M FILE TRANSFER PROGRAM (XFER)

Have two computers and only one program? Use the W.S.T. XFER to transfer it. XFER transfers all types of CP/M files quickly and is simple to use. Send a 12K program in just 13 seconds running at 9600 baud. Some simple I/O patching is required and serial hardware is not included. Don't retype that program—XFER it!

SEND ME ONE 8" SSSD DISKETTE WITH BOTH PROGRAMS AND USER MANUALS FOR \$29.95

Name _____

Address _____

City _____ State _____ Zip _____

Check C.O.D. MasterCard VISA

(CA Residents add sales tax. Add \$6.00 for shipping outside North America.)

Card No. _____ Exp. _____

Authorized Signature _____

WST INC.

5701 Atlantic Blvd.
Maywood, CA 90270

(213) 582-0701

News and Speculation about Personal Computing

Conducted by Sol Libes

Random Rumors:

Casio Computer is rumored readying a personal computer that costs \$63. It will be introduced in Japan. . . . Expect a price cut on the Sinclair ZX81 if sales begin to falter as they did in England when the new Sinclair color Spectrum computer was introduced. . . . Look for Panasonic to introduce a \$300 personal computer in February. . . . IBM may soon begin production of the PC outside the U. S. with a goal of producing over 1 million units next year. . . . Apple is expected to introduce an Ethernet interface for the Apple III. It has reached an agreement with 3Com Corporation to purchase \$3.6 million worth of network interfaces. . . . Both Teletype and Applied Digital Data Systems will come out with low-cost color display terminals shortly. . . . Honeywell is presumed to be ready to market a personal computer using the Victor 9000 machine. . . .

Predictions for 1983:

In past years, it has been my practice to make some predictions for the coming year in my December column. In looking back at my predictions made last year and in prior years, I am surprised at how many have come true . . . typically over 85 percent. So, let me stick my neck out once again and make some predictions for 1983.

First, I predict that 1983 will be the year of the true portable computer. Osborne having shown the way, you can expect Radio Shack, Apple, and IBM to introduce portable

personal computer systems. I assume that they will fit into a briefcase, have flat-panel displays, microflop drives, and built-in direct-connect modems. They will also use CMOS (complementary metal-oxide semiconductor) circuits operable from small, low-cost batteries; hence, they will be true portable systems. Expect them to have CMOS RAM (random-access read/write memory) with battery backup rather than bubble memory. Watch for the Japanese to attack this market next year.

Second, I predict that the personal computer market will divide into several separate and distinct markets with three or four suppliers dominant in each. Thus, we will see diverse markets ranging from consumer computers selling for \$60 to \$70, to home word-processing computers going for \$1000-\$2000, to small-business computers in the \$3000-\$5000 price range, workstations in local networks selling for \$5000-\$8000, and multiuser systems ranging from \$7000 to \$10,000. No one supplier will dominate more than one market, so we can plan on several dozen successful manufacturers and probably well over a hundred different personal computer system makers.

Third, following from that prediction, is the prospect that the number of new personal computer systems coming to market will probably be at the staggering rate of almost one per working day. Look for one-third of them to come from Japan.

Fourth, systems with separate, cableless, radio-linked keyboards will flourish—no more connecting cables getting in the way. And, I hope,

manufacturers will make a concerted effort to standardize keyboard layouts. Also, I predict that several manufacturers will add voice input/output that acts as an aid to, rather than a replacement for, keyboards. Voice output should be the next big feature added to low-cost personal computers.

Fifth, don't be surprised to see IC modem chips capable of operating at 9600 bps (bits per second) and possibly as high as 19,200 bps.

Sixth, I await the introduction of erasable optical memory systems for microcomputers capable of storing up to 100 megabytes on a single disk.

Seventh, the microflop and micro Winchester drives will start replacing miniflop and mini Winchester drives in personal computers. Within two or three years, microflops and micro Winchesters should be the dominant storage systems on personal computers.

Eight, expect arcade video games where the player actually gets into the game. For example, a flight simulator that actually gives the player a feeling of movement, acceleration, and of really flying a spaceship, with voice recognition that will respond to such commands as "Fire one!" and "Blast off!"

Apple Doings: Looks as if Apple has decided to introduce the Apple II-E this January. Unless, of course, the company decides to make changes again. Rumor has it that Apple planned to introduce the new Apple II replacement in September and initiated a special sale price to

clear out inventory. But sales increased to the point where Apple decided to continue producing the Apple II for another few months and do some further design work on the II-E. Over the summer, several software houses received prototypes of the II-E so that they could get a head start on applications software development. It is rumored that the II-E will not be completely software-compatible with its predecessor.

Apple's 68000-based workstation, called Lisa, is reportedly out on beta test with several potential corporate customers. Rumor has it that units are being used in a local network configuration.

Apple disclosed that it has won injunctions against four more Hong Kong-based makers of alleged imitation Apple II computers. Also, the U. S. Customs Service has reportedly begun confiscating and destroying imitation Apples arriving at ports in the U. S. It has been estimated that as many as 20 companies are making about 5000 Apples a month with retail prices as low as \$200. Compare that to the U. S. price of \$1200 to \$1400.

Continuing to tighten up its sales/distribution organization, Apple has cancelled central purchasing agreements with two more independent retail chains, Compushop in Richardson, Texas, and The Computer Store (TCS) in Sudbury, Massachusetts. Compushop and TCS outlets will now have to buy equipment directly from Apple at standard dealer prices. The reason given was the same as in the previous cases of Computerland and Xerox: the sales organizations refused to let

Apple dictate where new stores could be opened.

Former Mail-Order Dealer Sues HP: Computer Place Inc., Carmel, California, has filed an antitrust suit against HP (Hewlett-Packard) alleging that the company is stopping mail-order distribution of personal computer and calculator products. Computerland was named as a codefendant. Computer Place alleges that HP stopped supporting dealer national advertising and refused to make available its new HP-86 personal computer to dealers who would not support local customers. It also claims that this action forced it out of business. It is interesting to note that a similar action filed against Apple Computer by three of its former mail-order dealers was dismissed.

Price War Develops: Atari and Commodore have accelerated the low-end personal computer price war with discounts on software, peripherals, and even basic units. This is in response to Texas Instruments' \$100 rebate program. Atari is offering coupons good toward the purchase of software, while Commodore has reduced the base price of its VIC-20. The result is that both the VIC-20 and TI-99/4A can now be purchased for well under \$200. I have seen both units being offered by stores in my area for under \$180. It is likely that Tandy will soon reduce the price of its Color Computer.

At these prices, personal computers are close to the selling prices of computer games and are beginning to affect game sales. (Speculation is that this is why Atari is offering games coupons instead of a price reduction.) The dealer cost for a computer is now down around \$150; however, dealers rely

on sales of software and peripherals to make a profit. Commodore is boasting that it is now producing 70,000 VIC-20s a month and, even with the \$150 dealer price, is still making a healthy profit on each unit shipped. The question is how this will affect sales of Commodore's soon to be released Max game machine, which will carry a \$179 price tag.

In the meantime, the Timex/Sinclair 1000 (aka the Sinclair ZX81 with 2K-byte RAM), selling at just under \$100 and already being discounted, is taking sales away from Texas Instruments, Atari, and Commodore in nationwide chains such as K-Mart.

This price war is upsetting to several Japanese companies who were planning to offer low-end computers. NEC, which planned to introduce its PC-6000 with a \$450 price, is now going through a redesign to eliminate features and reduce the price. Also, NEC is rumored to be designing a very low cost machine to compete with the VIC-20. Matsushita's Panasonic subsidiary, which had already disclosed that it planned to retail two computers, the JR-100 and JR-200, in early 1983 with prices in the \$300 range, has postponed introduction until summer as these products go through redesign. Sanyo, however, expects to begin selling a machine next August that will compete with the Timex/Sinclair.

The price war is undeniably making it difficult for new companies to enter the low-end marketplace. And those that do plan to enter are being thrown off balance as to pricing and timing of their entries.

Software Marketing Changing: Did you know that more than 150 new programs are marketed each month? It's getting like the record and book publishing

Do You Use a Printer or Modem?

The average microcomputer "moves" data at 120,000 characters a second. A typical disk drive transfers it at 27,000 CPS. Most printers however plod along at 100 CPS and many modems squeak out 30 CPS. That's quite a drop in efficiency not to mention a waste of computing power!

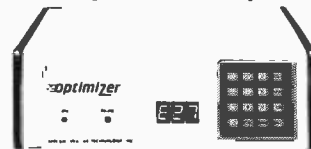

We've broken this bottleneck with a smart little "white" box called the PRINTER OPTIMIZER[®] that features a 64,000 to 256,000 character memory buffer. Now you can "print" your inventory in 2 seconds instead of 10 minutes, and no longer will your computer be tied up transmitting or receiving modem transmissions. The OPTIMIZER is smart too. You'll notice a keypad and display in our picture. You can tell the OPTIMIZER to convert data, send control sequences, pause on cue, and more. For example: access all of your printer's capabilities (graphics, font size, forms control, special symbols) with the ease of selecting a station on a pushbutton car radio. Use it to adapt an XYZ printer to your ABC computer running a PDQ word processing program. Run a serial printer or modem from a parallel port. If you can afford and justify a disk drive, then you certainly need our OPTIMIZER to bring your printer, plotter or modem "up to speed" with the rest of your system.

If You Need A Letter Quality Printer

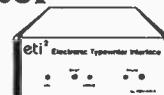

...then consider our affordable yet high quality alternative. Our MEDIAMIX ETI²[®] converts an IBM Electronic Typewriter (and some other brands) into a computer printer. Every office needs a typewriter. So for example, you can buy an IBM Model 50 ET that costs about \$1200 and have a superior typewriter, and then with our ETI² have a printer that produces probably the highest quality printed image available. You can even do typesetting like this ad! And for financial printing you can't beat a wide carriage IBM ET. It's a truly cost effective investment. There are a number of arguments in favor of choosing this route over a single use computer printer, and we have an article on this subject you should read.

We apply technology creatively, with insight and with respect for the non-technical end user. Feel welcome to write or call our toll free number for more information.

APPLIED CREATIVE TECHNOLOGY, INC.

2723 Avenue E East, Suite 717
Arlington, Texas 76011
(817)-261-6905
(800)-433-5373

COPYRIGHT 1982

industries. Word-processing programs, for example, already number more than one hundred, and the competition is becoming intense.

Software suppliers trying to establish brand names are providing slick packages for their products. The plain plastic sandwich bags will soon be a thing of the past, as software packages look more and more like record packages. In addition, suppliers are upping ad budgets and increasing promotional efforts, all of which serves to jack up the retail price.

But purchasers often have had trouble getting programs to work properly. Suppliers are finally beginning to face the problem by offering service with the product. For example, Peachtree Software now provides 30 days of free consultation with its software.

Currently, about half of all software is purchased via mail order. However, some experts are betting that this will shift to stores that will sell software much as record shops sell records: customers can walk in and see a demonstration of the software packages before they buy.

Unix On 8-Bit Systems:

We see an awful lot of promotion for Unix-like systems on 16-bit computers, particularly 68000-based machines. However, it is worth noting that Unix-like systems are also available on 8-bit machines. For example, several suppliers of 6809-based systems are furnishing the Uniflex operating system from Technical Systems Consultants (Chapel Hill, North Carolina). Also, Morrow Designs, located in Richmond, California, offers its Micronix operating system for the Z80-based Decision I.

Both of these systems offer multiuser, multitasking capability with file management nearly identical to that of Unix. They use a shell that in-

cludes I/O redirection, pipes, and many other Unix-like features.

Motorola Announces 68000 Enhancements:

Motorola has announced that next year it plans to make available several new versions of its 16-bit 68000 microprocessor. Prototypes of some of these new parts are already being tested by potential customers.

First, Motorola will market a reduced-bus version called the 68008. It will have an external 8-bit data bus and reduced address space (1 megabyte), come in a 48-pin package, and operate with 6800 peripheral chips.

Next will be the 68010, a virtual-machine version of the 68000. It will be able to recover control of the machine after memory faults, so it can be used in a demand-paged environment. Virtual-memory support improves the 68000's ability to handle multiuser systems.

Last will be the 68020, a full 32-bit version of the 68000. It will have a 32-bit-wide data bus and an instruction cache memory. Consequently, it will run programs two to four times faster than the 68000.

IBM Aims To Fit A 370 Into A 68000:

According to a technical paper that appeared in a recent issue of IBM's *Journal of Research and Development*, researchers at IBM's Endicott, New York, facility are attempting to recode Motorola 68000 microprocessors to implement the functions of an IBM System/370. The 16-bit 68000 microprocessor was selected because it is microcoded and has seventeen 32-bit general-purpose registers. The full 370 would require about four times the microcode capability of the current 68000; however, the hope is that within a

few years a 370 will be encoded into one 68000. In the meantime, the research group intends to partition the 370 architecture among a number of 68000s, which will communicate over a local bus and share common local storage.

Japanese Adopt U.S. Software:

More and more Japanese personal computer systems are being introduced in the U. S., but the surprising thing is that they are using American software rather than Japanese-made software. For example, Hitachi, NEC, and Panasonic will soon introduce systems using Microsoft's MS-DOS operating system, while Sony, Mitsubishi, Sanyo, and Hitachi are using the CP/M operating system from Digital Research. Hitachi will use both the MS-DOS and CP/M disk operating systems.

Not only are Japanese companies contracting with U. S. firms to supply operating systems, they are also looking to them for languages and applications programs. Structured Systems Group, for example, has signed contracts to provide its accounting software for several Japanese computers.

Atari And Lucasfilms Enter Joint Venture:

Atari has announced the formation of a new company with Lucasfilms (creator of *Star Wars*, *The Empire Strikes Back*, and *Raiders of the Lost Ark*). Each firm has an equal share of the new venture. The first product will be a video game based on *Raiders of the Lost Ark*.

Getting Robots To Walk:

Currently, mobile robots get around on wheels or tank-like tracks. But research is under way at Carnegie-Mellon and Ohio State universities to develop walking robots. Although

humans take walking for granted, it is a highly complex task fraught with such problems as balance and coordination of many sequences of joint and leg movements.

It is hoped that computers can be taught to cope with this problem. The walking robot being developed at Carnegie-Mellon will have six legs. This work is being funded by the Defense Department. Work on walking robots is also being done in Japan and the Soviet Union.

Artificial Intelligence News:

The introduction of the Motorola 68010 upgraded 16-bit microprocessor and the recent use of the LISP language for writing applications programs may lead to the use of AI (artificial intelligence) techniques in applications programming. LISP has long been the language of the AI community. Although there have been a few implementations of LISP on 8-bit machines, they have had very limited performance, and anyone doing serious AI work was forced to use large mini-computers. This, however, appears to be changing.

For example, the University of Pittsburgh has developed "Internist 1," which, in a test at Massachusetts General Hospital in Boston, proved almost as capable at diagnosing some diseases as physicians. Although currently running on a very large computer, this program is now being transported to run on several 68000-based microcomputers. Also, Cognitive Systems Inc., an offshoot of the Yale artificial-intelligence lab, has developed programs for stockbrokers, paralegals, accountants, and tax advisors that are already running on the 68000-based Apollo computer (Apollo Computer Inc., North Billerica, Massachusetts).

Current 68000-based systems that are large enough to support these LISP programs, such as the Apollo, cost in the \$40,000 range. However, the introduction of the Motorola 68010 and the National Semiconductor 16032 is expected to soon reduce these costs to the \$20,000 to \$30,000 range. Xerox has already announced a LISP machine, called Dandelion, which it expects will sell for under \$30,000.

Japanese Attack Disk-Drive Market: Apple Computer recently switched from Shugart to Alps Electric Ltd. drives, and DEC (Digital Equipment Corporation) and Tandy have awarded Teac the contract for supplying 5¼-inch drives for their new personal computers. These signs indicate that the Japanese have become much more aggressive in pursuit of OEM (original equipment manufacturer) floppy-disk drive contracts.

The greatest Japanese penetration of the floppy-disk market is anticipated in the half-height and microfloppy arenas. NEC and Mitsubishi have already entered the half-height market, which is currently dominated by Tandon. OEM prices of half-height double-sided 8-inch drives are already down in the \$370 area. The greatest competition should be in the half-height 5¼-inch drive area, where Alps, Qume, and Teac are expected to start shipping drives to compete against Tandon and Shugart. Competition in the microfloppy arena should develop in late 1983 when more companies start shipping these drives. Presently, Sony appears to be the leader in the microfloppy area. For example, Sony has already signed a contract to supply Hewlett-Packard with 3½-inch microfloppy drives that can store 437.5K bytes.

Sony is rumored to be ready to announce a double-sided version of its drive.

The Japanese are also expected to make major inroads into the Winchester-drive marketplace. Currently, some 75 percent of this market is in the hands of Seagate and Tandon with Shugart, Control Data, Quantum, Priam, and Mircopolis sharing the remainder.

Computer Store Franchises: I have a friend who owns two computer stores, plans to soon open a third, and employs more than two dozen people. Six years ago when he started his little retail operation in his basement, it was open only nights and weekends. Those days are gone.

Today, opening a computer store usually means buying a franchise. Generally, this requires an initial fee ranging from \$15,000 to \$45,000, depending on location, and that's followed by a monthly royalty fee that may be 5 to 6 percent of gross sales. In addition, you may be hit with a cooperative advertising fee, which is typically 1 to 3 percent of gross sales. Nonpayment of these fees, failure to comply with the franchisor's rules and regulations for running the store, or unauthorized transfer of the franchise to another person can result in loss of the franchise.

The franchisor usually provides plans and specifications for store construction as well as training, supervision, and education of the franchisee's employees. The franchisor will provide advertising and purchasing of products and supplies at advantageous prices.

Franchising experts today estimate that opening a franchised computer store requires a minimum of \$200,000 capital to be successful.

IEEE For Software Engineering Standards:

The Institute of Electrical and Electronics Engineers (IEEE) has organized a Software Engineering Standards Committee with several working groups. The purpose is to create standards, guides, and recommended practices for software engineering. The working groups are concerned with areas ranging from software quality assurance to a recommended practice for the Ada programming language. For more information on these groups, contact Fletcher J. Buckley, RCA, Moorestown, NJ 08057, (609) 778-3606.

Graphics Standards

Emerging: Digital Equipment Corporation, Intel Corporation, and Tektronix have

announced that they will adopt and support the North American Presentation Level Protocol Syntax (NAPLPS) and Virtual Device Interface (VDI) standards for creating and transmitting computer-graphics images. NAPLPS and VDI are currently being evaluated by the American National Standards Institute X3L2 and X3H3 committees, respectively.

IBM To Conduct Education Test:

IBM is lending 300 personal computers with voice output, color graphics, and a programmed series of exercises designed to teach reading and writing to selected schools as part of a test. For example, to teach writing, the computer will show a child a picture of a cat and then will ask the child to

MASTER MAX

\$2540.

Z-80 S-100 SYSTEM W/DUAL 8" DRIVES

FEATURING:

S-100, IEEE 696 4 SLOT MOTHERBOARD
 Z80 AT 4MHZ SINGLE CARD COMPUTER including:
 64K RAM (64KX1 chips) / 2 serial ports (ZSIO) / 2 eight bit parallel ports, one usable as intelligent Winchester interface (ZPIO) / On-board EPROM (2732) / NEC floppy disk controller / all devices interrupt driven / real time clock
 CP / M 2.2^o
 DUAL TANDON 8" DRIVES, single sided, double density, 1.2 MB.
 Quality, regulated power supply. Three empty slots for expansion. Compact, light weight, modular construction.
 Dimensions: 17½" wide, 5½" high, 23" deep.

OPTIONS:

220 volt, 50HZ operation at no extra charge
 Double sided, double density 8" drives, 2.4 MB: Add. . . . \$335.
 Turbodos single user with spooler: Add. \$100.
 Turbodos multi user with spooler: Add. \$550.

All high quality, high performance components from reliable established manufacturers.

We can also provide you with terminal, printer, other peripherals and software from our extensive catalogue.
 CALL OR WRITE FOR FURTHER DETAILS OR FOR DEMONSTRATION
 Prices subject to change without notice.

WE EXPORT JOHN D. OWENS WE EXPORT
 Associates, Inc.

12 Schubert Street, Staten Island, New York 10305
 (212) 448 6283 (212) 448 6298 (212) 448 2913
 TWX: 710 588 2844 CABLE: OWENSASSOC.
 Please See Our Other Ads in This Issue on Pages 384-385

spell "cat" while helping him find the right letters by lighting areas in both phonic and regular alphabets.

Taxi Dispatching Going Digital: The dispatching of taxis via voice radio may soon be a thing of the past. Several Canadian taxi companies have switched from voice-radio dispatching to computerized radio dispatching. The taxis are equipped with a video display and keyboard.

Here's how it works: a driver enters information as to which zone he is in or headed for, whether the cab is empty, etc. The central computer then sends a message as to where to pick up the next ride. No other driver gets the call, so no one can try to beat the cabbie to the fare, which sometimes happens with voice dispatching. With computerized dispatching, companies are claiming that they can now handle as many as 500 cabs per channel whereas before the limit was about 150. Who knows, maybe they will let the passengers play Pac-Man on the system between pick-up and destination.

Computers Being Sold Door-to-Door: Two companies are already selling personal computers door-to-door, via phone, or through small Tupperware-party-like gatherings. Tronics Marketing Corporation, Houston, Texas, claims to have nearly 10,000 door-to-door salesmen in 50 states selling Texas Instruments personal computers. The Dallas-based Dynasty Computer Corporation claims that it has 2300 "distributors" selling a private-label system. Both companies have set up pyramid-type sales organizations in which distributors enlist sales agents to do the actual selling.

On The Business Side: Tandy reported that for the fiscal year that ended June 30, 1982 revenues were up 21% to more than \$2 billion. Earnings increased over 32% to more than \$224 million. Most of this gain was due to a 72% increase at Tandy's computer operations. Tandy estimates that its computer business now accounts for about 31% of its total revenues, or approximately \$640 million. This makes Tandy far and

away the largest manufacturer of personal-computer systems.

Vector Graphic posted a \$252,000 loss for the last quarter of the year on a 10% decline in sales. Sales for the year, however, were up almost 45% to over \$36 million compared with 1981 sales of \$25 million. The decrease in the fourth quarter was blamed on dealers holding off ordering in anticipation of the introduction of a new computer system and an inventory theft of \$600,000 worth of merchandise.

Random News Bits: Intel has reduced the price of its 8087 mathematics processor integrated circuit from \$320 (1000-unit quantity) to \$150, and prices are expected to drop further next year. Intel has been shipping the 8087 since December 1981. . . . Scopex Instruments Ltd. (Pixmore Ave., Letchworth, Hertfordshire, England) has introduced an oscilloscope with a flat liquid-crystal display screen. . . . Siemens A.G. (Munich, West Germany) has announced an experimental 14-inch, flat, high-resolution color screen CRT (cathode-ray

tube) that can display 28 lines of 80 characters. . . . Human Computing Resources Corporation in Toronto, Canada, has begun work on transporting Unix System III to National Semiconductor's 16032 microprocessor. . . . Phosphor Products Ltd., Poole, Dorset, England, is reportedly developing a compact flat-panel videotex terminal. . . .

Quotation Of The Month: "Because of the nonproprietary software and limited distribution [of the PC], IBM has not only invited in Japanese competition, but has handed over a large portion of the market to the Japanese on a silver platter." John Roach, President, Radio Shack, *Computer Update Magazine*, July/August 1982

MAIL: I receive a large number of letters each month as a result of this column. If you write to me and wish a response, please include a self-addressed, stamped envelope.

Sol Libes
POB 1192
Mountainside, NJ 07092 ■

POWER PROTECTION FOR YOUR SYSTEM

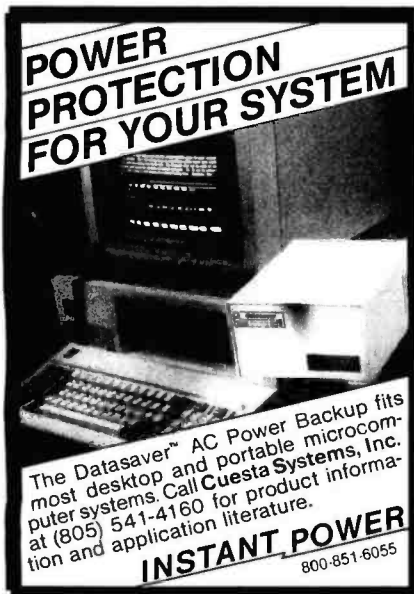

The Datasaver™ AC Power Backup fits most desktop and portable microcomputer systems. Call **Cuesta Systems, Inc.** at (805) 541-4160 for product information and application literature.

INSTANT POWER
800-851-6055

Circle 541 on Inquiry card.

GAME DESIGNER

HAVE YOU HEARD ABOUT THE FROB™

The Game Development System for the Atari® VCS

It allows just about anyone the opportunity to design home video game cartridges for the Atari VCS game console.

The Miracle of Creation Can Be Yours™

Call: 408-429-1552
or write: Frobco P.O. Box 2780
Santa Cruz, CA 95063



Circle 542 on Inquiry card.

SE BUSCAN PROGRAMAS EN ESPAÑOL

International Micro Systems está solicitando para distribuir en Estados Unidos y en Latinoamérica excelente software en español, si usted tiene un buen programa, bien documentado en algunas de las siguientes aplicaciones: Educación, Entrenamiento o Negocio nos gustaría establecer contacto con usted.

Envíenos una breve descripción del mismo incluyendo los requerimientos de equipos.

International Micro Systems, Inc.
9380 Sunset Drive, Suite B-210
Miami, Florida 33173 U.S.A.
Ph: (305) 279-0186 - 279-0194

Circle 543 on Inquiry card.

Clubs and Newsletters

Attention: Doctors

The *Medical Computer Journal* has reviews of medical hardware and software, news of the latest developments in the medical field, and features on the uses of computers in laboratories and offices. It is published six times a year. The annual cost is \$25 for individuals and \$35 for libraries, institutions, and overseas mailings. For further information, write to the Medical Computer Journal, 42 East High St., East Hampton, CT 06424, or call (203) 267-2934.

Count on ABACUS

The Atari Bay Area Computer Users Society (ABACUS) welcomes anyone in the San Francisco area who wishes to attend monthly meetings and subscribe to its newsletter. The newsletter is accepting informative articles and short programs. ABACUS is also willing to trade newsletter subscriptions with other user groups. Contact ABACUS through Dave Mentley, POB 325, El Cerrito, CA 94530.

Listen to This

VoiceneWS is published 10 times a year to report the latest news concerning speech-synthesis and speech-recognition technology. The annual subscription rate is \$95 in the U. S. and \$120 overseas. Write the editor at POB 1891, Rockville, MD 20850, or call (301) 424-0114.

Attention: Lawyers

The *Lawyer's Microcomputer* is a monthly newsletter written specifically about practical applications of the

Last Call for Clubs and Newsletters Directory

To be included in the fifth edition of the *BYTE Clubs and Newsletters Directory*, your club or publication must supply the following information.

1. name of organization or publication
2. mailing address
3. contact person and telephone number
4. name of newsletter or publication
5. special interests

Send your information to *Clubs and Newsletters Directory*, BYTE/McGraw-Hill, POB 372, Hancock, NH 03449.

TRS-80 in the law office. Research on printer quality, choosing software, and how to finance a computer are all included in the first issue. Yearly subscriptions are \$28 (U. S.), \$37 (Canada), and \$43 (foreign). For more information, write Rose T. Wilkins, R. P. W. Publishing Corp., POB 1046, Lexington, SC 29072, or call (803) 359-2077.

Sorcim's Newsletter

Sorcim Corporation's newsletter *Supernews* is designed to provide user-friendly information for new users of Sorcim products. Published quarterly, *Supernews* includes articles on template-building and computer shows. New products, update policies, and customer support columns are featured. Suggestions for articles are welcome. For further information, contact *Supernews*, Sorcim Corp., 405 Aldo Ave., Santa Clara, CA 95050, or call (408) 727-7634.

Atari Group in the Berkshires

The Berkshire Users Group (Atari) of Berkshire County, Massachusetts, is a support

group for owners of Atari 400 and 800 personal computers. BUG(A) meets on the second Saturday of each month. Members would like to exchange newsletters and information with other user groups. For more information write BUG(A), POB 593, Great Barrington, MA 01230, or call (413) 528-1438 or 528-0744.

Active Club in Finland

The 1800 Users Club of Finland meets monthly in Helsinki. Members engage in hardware and software competitions and produce a newsletter. Group members also receive a free subscription to a Finnish electronics magazine. We seek contact with other clubs. Send a self-addressed envelope to Richard Eller, 1800 Users Club, POB 559, 00101 Helsinki 10, Finland.

Newsletter Swapping

The Central Florida Computer Society (CFCS) publishes a newsletter, *Bussline*, containing information on various users groups, hard-

ware and software reviews, and buy-sell-swap ads. CFCS members would like to swap monthly newsletters with other like-minded clubs. Send your newsletter to CFCS Inc., 2821 Sunset Dr., Apopka, FL 32703.

TRS-80 Users Meet in LA

The TRS-80 Model I Users Group of West Los Angeles meets on the last Tuesday of each month. All users are invited to attend and exchange ideas and public-domain software. For more information, write Mike Miller, 10210 Woodbine St. -1, Los Angeles, CA 90034, or call (213) 836-4103.

Welcome in Wichita

In Wichita, Kansas, a Commodore VIC-20 Users Club meets monthly to exchange the latest news and public-domain programs. Anyone is welcome. For the current meeting time and a copy of the newsletter write to Walter Lounsbury, 739 Litchfield, Wichita, KS 67203, or call (316) 262-4861.

Stay Up to Date with Eagle News

Eagle Computer, manufacturer of desktop computers for small businesses, produces *Eagle News*, a monthly newsletter. *Eagle News* contains the latest information about Eagle computers, trade shows, software news, and new products. For your copy, contact Eagle Computer Inc., Building C, 983 University Ave., Los Gatos, CA 95030, (408) 395-5005. ■

Ask BYTE

Conducted by Steve Clarcia

Magnetic-Tape Standard

Dear Steve,

I built an FSK (frequency-shift keyed) cassette interface for my homebrewed 8080-based microcomputer. Do you know of a standard or frequently used format for recording data on magnetic tape? I want my system to be compatible with commercial software.

Michael D. Zahorik
New Berlin, WI

One of the problems with the personal computer industry is its lack of standards. A format known as the Kansas City Standard is used on many 8080-type systems. This standard, named after the location of the conference that established it, uses 1200 Hz to indicate a 0 and 2400 Hz to indicate a 1. These frequencies were chosen to be compatible with the bandwidth and frequency response of typical cassette recorders. With the homebrew FSK system for your computer and this information, you should have no trouble with compatibility.
... Steve

Increasing Line Counts

Dear Steve,

In the March 1982 BYTE, you responded to a letter about high-speed printers (see "High-Speed Printers," page 442). You stated that the IBM laser printer is capable of 1800 lpm (lines per minute); however, IBM claims 1000 pages in 6 minutes, or approximately 11,000 lpm (almost 6 times as fast as 1800 lpm).

Charles Gawthrop
Wilmington, DE

Thank you very much for your letter. I have received many responses to the decimal point error that crept into that Ask BYTE answer. The correct number should have been 18,000 lines per minute, and even that is not its maximum speed.

From IBM's literature, the following calculations can be made: "allows printing at either 6, 8, or 12 lines per inch. . . ." . . . "can process, for example, 1000 11-inch-long pages in approximately 6 minutes of continuous printing, regardless of the number of lines per page."

Now, 11 inches/page \times 12 lines/inch = 132 lines/page
1000 pages/6 minutes = 166.67 pages/minute
166.67 pages/minute \times 132 lines/page = 22,000 lines/minute

In reality, with 6 or 8 lines per inch and 66 lines per page, the effective number of lines per minute will be less. . . .
Steve

No Joy In Stickville

Dear Steve,

I own an Atari 800, and I have been disappointed in the performance of Atari's joysticks. They are not accurate and don't always make a good electrical connection.

I have been trying to build my own using momentary switches to make the five connections needed for motion and firing. Do you know where I can buy the appropriate female plug needed for the Atari? Also, do you have any suggestions for building a joystick, or do you know any companies making better-quality Atari-compatible joysticks?

Thanks for your help. Your articles are great.

Louis Yelgin
Malden, MA

The connector used on the rear of the Atari for the joysticks is a 9-pin Type D subminiature. It's available from many of the mail-order houses that advertise in BYTE; look for Priority One Electronics and California Digital ads in any issue.

Wico, a company that manufactures parts for arcade games, makes a deluxe version of the Atari joystick. It is large, solidly built, and has a trigger button on top of the stick, as well as one in the normal position. Order the Command Controller Joystick (part number: 15-9714) from Wico, 6400 West Grosse Point Rd., Niles, IL 60648, (312) 647-7500. . . .Steve

Shielding TV from Interference

Dear Steve,

I recently purchased the disk drive for the TRS-80 Color Computer. Since adding this device, I have experienced an annoying amount of interference on my television set. The drive's manual came with a flier warning that this problem might be present in some of the earlier machines and, if that was the case, you should return the computer to a service center for additional shielding.

I would prefer to make the modifications that might be necessary myself. Could you please give me an idea of what could correct this problem.

Thanks for whatever help you can give.

Richard D. Fothergill
Pittsfield, MA

The interference that you are experiencing with the TRS-80 Color Computer disk drive is probably caused by radiation from the cable that connects the drive to the computer. The cable is acting as an antenna, and to eliminate the radiation, it must be shielded. My article in the January 1981 BYTE, "Electromagnetic Interference" (page 48), describes the sources of electromagnetic interference and how to cure them.

Wrapping the disk-drive cable in several layers of aluminum foil and grounding the foil to the computer should be beneficial. But frankly, if Radio Shack has a free fix, I would let the service center do it. It will be neater and may help the resale value of the computer at some later date. . . . Steve

Chess Program for Home Brewers

Dear Steve,

I'd like to buy a chess-playing program for my computer. My problem is that I don't have a standard personal computer but two home-built systems. One is 6809-based, with keyboard and video display. The other is Z80-based, with 32K bytes of memory and plenty of space for 2716-type EPROMs (erasable programmable read-only memories).

I'd like to know how to change an existing chess program so that it could be run on my Z80-based computer and so that the input and output can be done through the 6809 computer, allowing it to process all communication with a human opponent.

I'm planning to use dot graphics to display the chessboard and a light pen to make moves. This means I must know the hexadecimal locations of the chess program's I/O routines and how the parameters are passed. Further, I need to know the cassette format used for storing the program. I think any cassette format can be read by a little hardware and software. A Z80 PIO (parallel input/output integrated circuit) is provided in the Z80 system.

Matti Kassi
Vantaa, Finland

The easiest way to get a chess program on your Z80 computer is to get a copy of the book Sargon—A Computer Chess Program, by Dan and Kathe Spracklen, and start typing. It is published by Hayden Publishing Company and is available from TSE Hardside (6 South St., Milford, NH 03055) for \$15.95 plus shipping. It contains complete documentation for all of Sargon's algorithms and a program listing in Z80 assembly language. With the information provided, you can tailor the program to fit any Z80 machine with 8K bytes of memory. Block diagrams and an index to subroutines are also included. All you need is the patience to type it in.

... Steve

Sorting Out Computer Languages

Dear Steve,

I've learned a great deal from reading your answers in Ask BYTE. Now, I would like to have an answer to a question that deals with a comparison of programming languages.

Obviously, no one lan-

guage is best. I assume they vary in a number of ways, such as ease or difficulty in learning, ease in debugging, efficiency in run time and in memory space, etc. And, of considerable importance, some languages lend themselves better for certain types of applications. I would very much like to find something—a book perhaps—that sets forth a comparison of all the major languages—giving their characteristics and especially the facility with which they lend themselves to various uses. Can you tell me where I can find such a comparison?

Donald W. Kearney
Martinsburg, WV

An informative and timely article on the comparison of computer languages appeared in the December 1981 Popular Electronics magazine, beginning on page 40. "Computer Language Confusion... Sorting It Out," by Stanley S. Veit, discusses computer languages so as to provide an understanding of what is available and to help you choose the most appropriate one for a particular application.

... Steve

Full ASCII Codes Transmittable

Dear Steve,

I own an Apple II Plus system and a Hayes Microcomputer Products Micromodem II. For some time now, I have been searching for software or hardware that will permit me to transmit both uppercase and lowercase ASCII (American Standard Code for Information Interchange) codes to another computer system (namely, a PDP VAX-11/70 with a Unix operating system). I have been unable to find anything of moderate price (say, \$100 to \$200) that

will allow me to do this. If you can give me any advice, I sure would appreciate it.

Thanks.
Michael T. Conley
Albuquerque, NM

The best program for you to use is Visicorp's Visiterm. With Visiterm, your Apple II Plus becomes an on-line terminal with the ability to define keyboard macro instructions, define your own character set, and transfer Apple-soft or Integer BASIC listings

or text or binary files over a standard phone line. It is designed to work with the Micromodem and it automatically displays uppercase and lowercase on the screen.

Visiterm has a suggested retail price of \$100 and is available from local dealers and Visicorp, 2895 Zanker Rd., San Jose, CA 95134, (408) 942-6000. My answer sure sounds like a commercial, but I've seen this program and can highly recommend it.

... Steve

In "Ask BYTE," Steve Ciarcia answers questions on any area of microcomputing. The most representative questions received each month will be answered and published. Do you have a nagging problem? Send your inquiry to:

Ask BYTE
c/o Steve Ciarcia
POB 582
Glastonbury CT 06033

If you are a subscriber to The Source, chat with Steve (TCE317) directly. Due to the high volume of inquiries, personal replies cannot be given. Be sure to include "Ask BYTE" in the address.

MICROSTAT® - Release 3.0

MICROSTAT® + baZic® = PERFORMANCE

The best just got better! MICROSTAT has been the leader in the statistics field for microcomputers since 1979, and the new release 3.0 outperforms and is noticeably faster than previous versions. Just a few of the features include:

- GREATER ACCURACY**
BCD with up to 14 digit precision;
- PROGRAM ENHANCEMENTS**
Missing data capabilities and many more;
- FASTER EXECUTION**
Calculation time greatly reduced;
- DYNAMIC FILE ALLOCATION**
Data can be inserted, added, or deleted;
- SPECIAL PRICE:**

For a limited time get MICROSTAT plus baZic complete with program disk and documentation for each for \$395.00, save \$50.00!

The MICROSTAT - baZic version requires: a Z80 CPU, CP/M™ and 48K of memory. Available formats: 8" SD disk or 5¼" North Star only. Check with your dealer for other formats. Also available for: Microsoft's Basic-80™, North Star DOS and IBM. For more information, call or write:



ECOSOFT INC.

P.O. Box 68602
Indianapolis, IN 46268-0602
(317) 255-6476



MICROSTAT is a registered trademark of ECOSOFT, INC.
baZic is a registered trademark of MICROMIKES, INC.
CP/M is a registered trademark of DIGITAL RESEARCH
Basic-80 is a registered trademark of MICROSOFT

Software Received

Apple

Advanced System Editor, a screen-oriented text editor for the UCSD Pascal system. The editor provides all common word-processing features, including copy, delete, find, search, and replace. For the Apple II; floppy disk, \$175. Volition Systems, POB 1236, Del Mar, CA 92014.

The Big Math Attack, a tutorial game covering basic mathematics problems. The object is to solve a simple equation before it reaches the bottom of the screen. The more equations you solve, the faster they drop. For the Apple II; floppy disk and cassette, \$25 and \$20, respectively. Thesis, POB 147, Garden City, MI 48135.

Bipolar Psychological Inventory, a multidimensional personality test. This program administers, scores, and interprets test results and prints a report with norm, profile, and significant items. For the Apple II; floppy disk, \$250. Diagnostic Specialists Inc., 1170 North 660 W, Orem, UT 84057.

Corral I.O.1, a cost-return analysis program for beef producers and related industries. Provides a complete breakdown and report of all costs and expenses. For the Apple II; floppy disk, \$150. Applied Micro Systems, RR 3, Box 309-B, Leavenworth, KS 66048.

Crazy Mazey, an arcade-type game. Within the intricate maze are secret hordes of cash. Find the cash and run for your life. Killer cars will try to stop you in the 19 levels of the maze. For the Apple II; floppy disk, \$29.95. Datamost, 9748 Cozycroft Ave., Chatsworth, CA 91311.

Crush, Crumble, and Chomp, a simulation game that lets you become the monster you always longed to be. This game allows you to

design your own monster and let it loose on a city where it feeds on human tidbits. For the Apple II; floppy disk, \$29.95. Epyx/Automated Simulations, POB 4247, Mountain View, CA 94040.

The Curse of Crowley Manor, an adventure-type game. What starts out as a simple homicide investigation changes into a descent into the world of the occult. Solve the mystery or face the gates of Hades. For the Apple II; floppy disk, \$29.95. Adventure International, POB 3435, Longwood, FL 32750.

Death Race 82, an arcade-type game. You must escape from the killer robots in the Death Squad Cars by piloting your turbocar through the 10 levels of the maze. Destroy robots and increase your score. For the Apple II; floppy disk, \$29.95. Avant-Garde Creations, POB 30160, Eugene, OR 97403.

Diskcovery, a disk-utility package. Examine, edit, and store information on any track or sector of a disk. Recover, alphabetize, and purge any files on a disk. Other utilities included. For the Apple II; floppy disk, \$59.95. Micro Mantic Computer, 541 Northeast McWilliams Rd., Bremerton, WA 98310.

Double Check, a check-book balancer and money-management program. Establish up to 100 expense categories, and this program will sort all expenses and provide you with a total for tax deductions. For the Apple II; floppy disk, \$49.95. Computer Tax Service, POB 7915, Incline Village, NV 89450.

Eliminator, an arcade-type game. You must protect your energizers on the planet surface from the 15 waves of attacking alien spacecraft. Destroy the aliens to increase your score. For the Apple II;

floppy disk, \$29.95. Adventure International (see address above).

Federation, an arcade-type game. You must wipe out the merciless invading Dron Drones. Develop the correct strategy to skillfully deploy your Federation spacecraft. For the Apple II; floppy disk, \$29.95. Avant-Garde Creations (see address above).

Graphic Writer, a program that lets you print your own character sets. Features provided include underline, bold-face, large and small letters, and the ability to use inverse print with most word-processing programs and printers. For the Apple II; floppy disk, \$54.95. Computer Station Software, 11610 Page Service Dr., St. Louis, MO 63141.

Laf Pak, four arcade-type games: Creepy Corridors, Apple Zap, Space Race, and Mine Sweep. Each game requires a different tactic to win. For the Apple II or II Plus; floppy disk, \$34.95. Sierra On-line Inc., 36575 Mudge Ranch Rd., Coarsegold, CA 93614.

Lazermaze, an arcade-type game. To resolve interstellar conflicts, a single combat game has been developed. Accurately fire your laser at the alien and your planet could win the war. For the Apple II Plus; floppy disk, \$29.95. Avant-Garde Creations (see address above).

Marauder, a two-level arcade-type game. You must descend to the alien planet's surface through a rain of laser fire and torpedoes. Once on the ground, you must destroy the central computer, which is guarded by robots. For the Apple II or II Plus; floppy disk, \$34.95. Sierra On-line Inc. (see address above).

Mars Cars, an arcade-type game. There are tales of a great treasure on Mars, but it's guarded by an ancient defense

system. If you can destroy the dreaded Mars Cars, the treasure is yours. For the Apple II; floppy disk, \$29.95. Datamost (see address above).

The Mask of the Sun, an adventure-type game. You are an archaeologist and treasure-hunter seeking the fabulous Mask of the Sun, a gold artifact. But there's this curse. For the Apple II; floppy disk, \$39.95. Ultrasoft Inc., 24001 Southeast 103rd St., Issaquah, WA 98027.

Mission Impossible, a graphics adventure game. You must save the world from nuclear disaster by deactivating the world's first automated nuclear reactor. The game has full-color graphics. For the Apple II; floppy disk, \$29.95. Adventure International (see address above).

Oil Rig, a simulation where you try to become a tycoon by buying, selling, and drilling for oil. Manipulate the price of oil with purchases and trades, while ruthlessly acquiring wealth. For the Apple II; floppy disk, \$29.95. Computer Programs Unlimited, 9710 24th Ave. SE, Everett, WA 98204.

The Printographer, a high-resolution printing utility that allows you to dump a picture from the disk to any dot-matrix or daisy-wheel printer. The utility comes configured for most printers. For the Apple II; floppy disk, \$49.95. Southwestern Data Systems, 10761-E Woodside Ave., Santee, CA 92071.

Serpentine, an arcade-type game. You control one serpent in your quest to destroy all the evil serpents. You must outwit, outmaneuver, and eat the evil serpents to win the game. For the Apple II; floppy disk, \$34.95. Broderbund Software, 1938 Fourth St., San Rafael, CA 94901.

Succession, a maze-type

game. Your creature, the Masher, must get all the creatures with numbers on their bodies into the correct order within the specified time limit. Four levels of difficulty. For the Apple II or II Plus; floppy disk, \$29.95. Piccadilly Software Inc., 89 Summit Ave., Summit, NJ 07901.

Test Writer, a program that produces multiple-choice tests of any length from a pool of questions developed by the user. Its automated index card system is useful for almost any subject. For the Apple II Plus; floppy disk, \$35. Persimmon Software, 502 C. Savannah St., Greensboro, NC 27406.

Tic Tac Show, a multi-player question-and-answer game program. You can enter your own questions and answers to develop a computer-assisted instruction game. Several different subjects can be stored on disk. For the Apple II; floppy disk, \$19.95. Computer Advanced Ideas, Suite 341M, 1442 A Walnut St., Berkeley, CA 94709.

The Tool, a business-applications program generator. This package handles all screen editing, field formatting, and entry validation. Includes a database manager and a report generator. Configured for use with BASIC. For the Apple II; floppy disk, \$395. High Technology Software, 2201 Northeast 63rd St., POB 14665, Oklahoma City, OK 73113.

Tunnel Terror, an arcade-type game. You are given three ships, and you must shoot down the center of the tunnel to prevent the enemy from destroying you. This game has 61 levels for up to four players. For the Apple II; floppy disk, \$29.95. Adventure International (see address above.)

The Wreck of the B. S. M. Pandora, a simulation game. You assume the role of a crewman trying to save your ship-

mates, a cargo of dangerous alien creatures, and your ship from a fatal accident. For the Apple II; floppy disk, \$50. Apple Computer Inc., 10260 Bandley Dr., Cupertino, CA 95014.

Atari

Airstrike, an arcade-type game. Fight your way through the alien cavern as you shoot or dodge missiles and bombs. Destroy the alien fighters as you traverse through the levels of the fortress. For the Atari 400 and 800; cassette, \$39.95. English Software Co., POB 3185, Redondo Beach, CA 90277.

Legionnaire, a real-time simulation game. Control the forces of the Roman Legions as you battle the Gaulish barbarians. The game features high-resolution graphics and sound. For the Atari 400 and 800; cassette, \$35. Avalon Hill Game Co., 4517 Harford Rd., Baltimore, MD 21214.

Pirate Adventure, a high-resolution adventure-type game. In this game, you attempt to go from your London flat to Treasure Island as you search for the long-lost treasure of Long John Silver. For the Atari 400 and 800; floppy disk, \$39.95. Adventure International, POB 3435, Longwood, FL 32750.

Preppie, an arcade-type game. You must retrieve golf balls from the world's toughest golf course, the Nasty Nine, or cease to be a preppie. For the Atari 400 and 800; floppy disk, \$29.95. Adventure International (see address above).

Sentinel, an arcade-type game. Your mission is to destroy the enemy's missile silos while protecting your cities from the incoming missiles. You must also destroy the strategic bombers and alien intruders. For the Atari 400 and 800; floppy disk, \$29.95. Med Systems

Software, POB 3558, Chapel Hill, NC 27514.

Soccer, an arcade-type game. This game uses high-resolution graphics to produce a real-time simulation of the game of soccer. Two, three, or four players can control opposing teams. For the Atari 400 and 800; floppy disk, \$29.95. Gamma Software, POB 25625, Los Angeles, CA 90025.

Text Editor, a line-oriented text editor. This simplified editor can be used as a word processor or as an editor for BASIC programs. Character line length is limited to 128 characters. For the Atari 400 and 800; floppy disk, \$25. Softcenter Industries, 26 Country Ridge Rd., Pomona, CA 91766.

Atari VCS

Barnstorming, an arcade-type game. Pilot your biplane through barns, over windmills, and around flocks of geese. The object is to get the quickest time for flying over the course. For the Atari VCS (video computer system); cartridge, \$31.95. Activision, Drawer 7286, Mountain View, CA 94042.

Berzerk, an arcade-type game. You are trapped in a series of electric mazes. If you touch the walls, you will be destroyed. To get out, you must dodge or shoot the robot guards. For one player. For the Atari VCS; cartridge, \$31.95. Atari Inc., 1196 Borregas Ave., POB 427, Sunnyvale, CA 94086.

Chopper Command, an arcade-type game. You control a chopper that's guarding a convoy of trucks delivering medical supplies. You must destroy the attacking enemy aircraft with your missiles. For the Atari VCS; cartridge, \$31.95. Activision (see address above).

Defender, an arcade-type

game. You must defend the Earth from attack by alien ships. Destroy the bombers, swarms, landers, and mutants. For the Atari VCS; cartridge, \$37.95. Atari Inc. (see address above).

Dragster, an arcade-type game. Race your dragster against another car and the clock. Your joystick becomes the clutch, gearshift, and gas pedal. For the Atari VCS; cartridge, \$22.95. Activision (see address above).

Frogger, an arcade-type game. The object is to get your frog across the road, over the river, and home. For the Atari VCS; floppy disk, \$30. Parker Brothers, POB 1012, Beverly, MA 01915.

Grand Prix, an arcade-type game. Control a Grand Prix race car and maneuver your vehicle around the course. The game features high-resolution graphics and sound. For one player. For the Atari VCS; cartridge, \$31.95. Activision (see address above).

Ice Hockey, an arcade-type game. You control your forward player to shoot the puck into the opposition's goal or defend your own goal. Game has automatic scorekeeping and timing. For one or two players. For the Atari VCS; cartridge, \$31.95. Activision (see address above).

Kaboom, an arcade-type game. The mad bomber is dropping bombs from a high wall. You must catch the bombs in buckets of water. For one player. For the Atari VCS; cartridge, \$22.95. Activision (see address above).

Laser Blast, an arcade-type game. You must destroy the invading aliens by blasting them with your laser. The longer you play, the more difficult the game becomes. For one player. For the Atari VCS; cartridge, \$22.95. Activision (see address above).

Megamania, an arcade-type game. You must shoot down

Software Received

the alien objects, which include celestial dice, spinning bow ties, flying widgets, and hostile hamburgers. For one player. For the Atari VCS; cartridge, \$31.95. Activision (see address above).

Pitfall, an arcade-type game. Hidden in the jungle are several treasures. You must swing through trees, jump over bottomless pits, and journey through underground passages. For one player. For the Atari VCS; cartridge, \$31.95. Activision (see address above).

Skiing, an arcade-type game. Step onto the slopes for a skiing experience that ranges all the way from the beginner's slope to an Olympic downhill run. Beat your best time. For one player. For the Atari VCS; cartridge, \$22.95. Activision (see address above).

Starmaster, an arcade-type game. You are in the cockpit of a starfighter. Your mission is to defend your starbase from attacks and to search out and destroy the enemy's fighters. For one player. For the Atari VCS; cartridge, \$31.95. Activision (see address above).

Star Wars: The Empire Strikes Back, an arcade-type game. Based on the popular film, this game pits the Rebel Snowspeeders, controlled by the player, against the Imperial Walkers on the ice planet Hoth. For one or two players. For the Atari VCS and the Sears Video Arcade; cartridge, \$30. Parker Brothers (see address above).

Tennis, a graphics simulation game. You can rush the net, play the baseline, or roam the court in this version of tennis. The game provides automatic scorekeeping. For one or two players. For the Atari VCS; cartridge, \$22.95. Activision (see address above).

Volleyball, an arcade-type game. This simulation of volleyball follows standard

rules. The game uses setups and spiking. For one or two players. For the Atari VCS; cartridge, \$26.95. Atari Inc. (see address above).

CP/M

CP+, a user-friendly program that replaces CP/M commands with English-language "menus," messages, and directions. It provides you with a software print spooler, help option, and other functions. For CP/M-based systems; floppy disk, \$150. Taurus Software, Suite 815, 870 Market St., San Francisco, CA 94102.

Compare for CP/M-80, a utility program that locates and documents the differences between two text files. The files may be text or source-code files for programs in assembler, BASIC, PL/I, or other languages. For CP/M-based systems; floppy disk, \$105. Solution Technology Inc., Suite 218, 1499 West Palmetto Park Rd., Boca Raton, FL 33432.

MAG/base3, a database applications-development system. You can design a database to your own specifications for any application. This system includes password protection and entry and edit functions. For CP/M-based systems; floppy disk, \$795. Micro Applications Group, Suite 205, 20201 Sherman Way, Canoga Park, CA 91306.

Micro-WYL, a line-oriented text editor. This program performs all the standard text-editing functions, including moving and copy text within a document, global search and replace, and copying external files. For CP/M-based systems; floppy disk, \$25. Realworld Software Inc., Suite 103, 913 South Fourth St., DeKalb, IL 60115.

PROMUtil, a utility for programming, reading, verifying, and editing EPROMs (erasable programmable read-only memories). Designed for use

with the SD Systems' PROM 100 S-100 programmer board, the program can work with 2708, 2716 and 2732 EPROMs. For CP/M-based systems; floppy disk, \$70. Concise Datacom Systems Inc., 1503 Pear Tree Lane, Bensalem, PA 19020.

UAPLink, a telecomputing file-transfer program. Designed specifically for Digital Equipment Corporation's VT18X computer, this program features data compression, file protection, and global transfer commands. For VT18X computers running CP/M; floppy disk, \$250. Unique Automation Products, Suite L, 17922 Sky Park Circle, Irvine, CA 92714.

Heath

Exterminator, an arcade-type game. As the Exterminator, your job is to wipe out the anthropod eggs before they hatch into deadly carnivorous creatures. For one player. For the H89, Z-90, and H8/H19; floppy disk, \$19.50. Evryware, POB 60802, Sunnyvale, CA 94088.

Key-Wiz, a multikeyword database-management program. This program operates as a file of "index cards" and will search a file for a particular keyword. Save up to 300 entries of 60 lines each. For the H89; floppy disk, \$19.95. Interactive Micro Systems, POB 21007, Columbus, OH 43221.

IBM Personal Computer

Friendlyware PC Introductory Set, a set of programs for novices. Includes games, utilities, and business applications. The user's manual explains the workings of the computer. For the IBM Personal Computer; floppy disk, \$49.95. Friendlysoft Inc., 213 Pebblebrook, Arlington, TX 76014.

Highcalc, a highway design and construction utility package. It calculates the cut and

fill amounts required for highway construction. For use by contractors and engineers. For the IBM Personal Computer; floppy disk, \$195. Softov Consultants, Suite R102, 360 Bloor St. E, Toronto, Ontario, M4W 3M3, Canada.

Pairstat, a statistics program used to evaluate and present paired data. Statistical results can include R square, standard deviation, beta, plot of residuals, and mean. For the IBM Personal Computer; floppy disk, \$150. Davell Custom Software, POB 4162, Cleveland, TN 37311.

Supercref, a BASIC language cross-referencing program. This program will display a list of all variables or commands used in a program and the line-number references. It can output information to printer or disk. For the IBM Personal Computer; floppy disk, \$25. The Write Ring, 5050 Garford #160, Long Beach, CA 90815.

Intellivision

Las Vegas Poker & Blackjack, a set of graphics simulation games. You can play four different card games: five or seven card stud, draw poker, or blackjack. The program keeps track of all bets and winnings. For one player. For the Intellivision Master Component; cartridge, \$29.97. Mattel Electronics, 5150 Rosecrans Ave., Hawthorne, CA 90250.

Space Spartans, an arcade-type game featuring voice output. The game pits you against an invading alien fleet. You must protect your starbases from attack. The game requires the Intellivoice voice-synthesis module. For the Intellivision Master Component; cartridge, \$45. Mattel Electronics (see address above).

Star Strike, an arcade-type game. You must defend the Earth from attack by an alien

space station. Shoot the alien fighters and bomb the targets to win the game. For one player. For the Intellivision Master Component; cartridge, \$34.97. Mattel Electronics (see address above).

TRS-80

Crush, Crumble, and Chomp, a simulation-type game (see description under Apple). For the TRS-80 Models I and III; floppy disk, \$29.95. Epyx/Automated Simulations, POB 4247, Mountain View, CA 94040.

Dunzin, an adventure, fantasy role-playing game. You start the game as a novice warrior. Your quest is to enter the dungeon and obtain various treasures. For one player. For the TRS-80 Models I and III; floppy disk, \$29.95. Med Systems Software, POB 3558, Chapel Hill, NC 27514.

Halls of Time, an arcade-type game. Your ship is trapped in a giant maze. There is only one exit, and you must find it before you run out of energy. The game features three-dimensional graphics. For the TRS-80 Model III; floppy disk and cassette, \$27.95 and \$23.95, respectively. Mops Computer Systems Inc., POB 26416, Austin, TX 78755.

The Institute, an adventure-type game. The game scenario has you trapped in a mysterious asylum. You are apparently sane, but your fellow inmates are not. You must try to escape by solving various problems. For the TRS-80 Models I and III; floppy disk, \$19.95. Med Systems Software (see address above).

Laser Defense, an arcade-type game. You are in control of the United States' strategic laser defense satellites. You must intercept the incoming missiles with the laser beams. For one player. For the TRS-80 Models I and III; floppy disk, \$18.95. Med

Systems Software (see address above).

Sea Dragon, an arcade-type game. You are the commander of a nuclear submarine. Your mission is to destroy an undersea nuclear reactor. But watch out for the depth charges, mines, and other dangers. For the TRS-80 Models I and III; floppy disk, \$24.95. Adventure International, POB 3435, Longwood, FL 32750.

Star Trap, an arcade-type game. The object of this game is to destroy all the bouncing stars in the time allotted. Stars are captured by opening the grid beneath them. For one or two players. For the TRS-80 Models I and III; floppy disk, \$17.95. Med Systems Software (see address above).

Subterranean Encounter, a graphics adventure-type game. You must solve both strategic and word puzzles. There are alligators in the moat, a sorcerer, and a knight. For one player. For the TRS-80 Models I and III; floppy disk, \$29.95. Toucan Software, 4024 Canonero Court, Fair Oaks, CA 95628.

ZX81

Artist, a graphics development program. You can create your own graphics using the 30 commands in this program. Draw, erase, move, copy, and save your graphics. You can also define commands. For the Timex Sinclair 1000 and ZX81 (16K RAM); cassette, \$10. Ksoft, 845 Wellner Rd., Naperville, IL 60540.

Krakit, an adventure and treasure hunt game. The game gives you 12 clues. If you discover the answer to all the clues, you'll learn how to claim the \$20,000 in prize money from the publishers. For the Timex Sinclair 1000 and ZX81; cassette, \$19.95. International Publishing & Software, POB 1654, Buffalo, NY 14216.

Meteorites, an arcade-type game. Your ships must shoot the meteorites or be destroyed. You have the full mobility of your ship and can fire in any direction. For one player. For the Timex Sinclair 1000 and ZX81; cassette, \$14.95. Softsync Inc., POB 480, Murray Hill Station, New York, NY 10156.

Red Alert, an arcade-type game. You must attack the alien fuel dumps that are located in a mountainous region and protected by enemy fighters. For one player. For the Timex Sinclair 1000 and ZX81; cassette, \$14.95. Softsync Inc. (see address above). ■

This is a list of software packages that have been received by BYTE Publications during the past month. The list is correct to the best of our knowledge, but it is not meant to be a full description of the product or the forms in which the product is available. In particular, some packages may be sold for several machines or in both cassette and floppy-disk format; the product listed here is the version received by BYTE Publications.

This is an all-inclusive list that makes no comment on the quality or usefulness of the software listed. We regret that we cannot review every software package we receive. Instead, this list is meant to be a monthly acknowledgment of these packages and the companies that sent them. All software received is considered to be on loan to BYTE and is returned to the manufacturer after a set period of time. Companies sending software packages should be sure to include the list price of the packages and (where appropriate) the alternate forms in which they are available.

YOU'VE JUST FOUND THE MISSING LINK!



Computer Shopper is your link to individuals who buy, sell and trade computer equipment and software among themselves nationwide. No other magazine fills this void in the marketplace chain.

Thousands of cost-conscious computer enthusiasts save by shopping in Computer Shopper every month through hundreds of classified ads. And new equipment advertisers offer some of the lowest prices in the nation.

Computer Shopper's unbiased articles make for some unique reading among magazines and there's a "help" column to answer difficult problems you may have with interfacing, etc.

For a limited time you can subscribe to Computer Shopper with a 6 month trial for only \$6 or 12 months for only \$10. MasterCard & VISA accepted.

6 month trial, \$6 or 12 months for only \$10

COMPUTER SHOPPER
P.O. Box F 305 • Titusville, FL 32780

305-269-3211

Books Received

Apple Pascal: A Programming Guide, Allen B. Tucker, Jr. New York: Holt, Rinehart & Winston, 1982; 247 pages, 18.5 by 23.2 cm, softcover, ISBN 0-03-059547-9, \$17.95.

Apple Pascal Games, Douglas Hergert and Joseph T. Kalash. Berkeley, CA: Sybex, 1981; 371 pages, 17.2 by 22.3 cm, softcover, ISBN 0-89588-074-1, \$14.95.

Applying Computers in Social Service and Mental Health Agencies, Simon Slavin, ed. New York: The Haworth Press, 1982; 195 pages, 16.4 by 23.4 cm, hardcover, ISBN 0-86656-102-1, \$30.

BASIC for Business, Douglas Hergert. Berkeley, CA: Sybex, 1982; 223 pages, 17.5 by 22.6 cm, softcover, ISBN 0-89588-080-6, \$12.95.

BASIC for Business, For the TRS-80 Model II & III, Alan J. Parker. Reston, VA: Reston

Publishing, 1982; 277 pages, 17.4 by 23.3 cm, softcover, ISBN 0-8359-0352-4, \$14.95.

COBOL, George Jackson. Blue Ridge Summit, PA: Tab Books, 1982; 290 pages, 12.6 by 20.7 cm, softcover, ISBN 0-8306-1398-6, \$9.95.

Comparative Studies in Software Acquisition, Steven Glaseman. Lexington, MA: Lexington Books, 1982; 131 pages, 16.4 by 23.3 cm, hardcover, ISBN 0-669-05422-4, \$18.95.

Computer Architecture and Organization, Theodore H. Meyer. Beaverton, OR: Dilithium Press, 1982; 333 pages, 13.8 by 21.8 cm, softcover, ISBN 0-918389-55-X, \$16.95.

Computers and Man, 3rd edition, Richard C. Doft. San Francisco, CA: Boyd & Fraser Publishing, 1982; 500 pages, 16.4 by 23.4 cm, softcover, ISBN 0-87835-121-3, \$16.95.

Data Communications for Microcomputers, Elizabeth A. Nichols, Joseph C. Nichols, and Keith R. Musson. New York: McGraw-Hill, 1982; 264 pages, 15 by 22.5 cm, softcover, ISBN 0-07-04680-4, \$16.95.

80 Practical Time-Saving Programs for the TRS-80, Charles J. Carroll. Blue Ridge Summit, PA: Tab Books, 1982; 252 pages, 12.6 by 20.7 cm, softcover, ISBN 0-8306-1293-9, \$9.95.

FORTRAN Programs for Scientists and Engineers, Alan R. Miller. Berkeley, CA: Sybex, 1982; 320 pages, 17.4 by 23.2 cm, softcover, ISBN 0-89588-082-2, \$15.95.

Fundamentals of Interactive Computer Graphics, J. D. Foley and A. Van Dam. Reading, MA: Addison-Wesley, 1982; 664 pages, 16.5 by 24 cm, hardcover, ISBN 0-201-14468-9, \$34.95.

The Guide to DP Training Courses: Descriptions of Over 300 Programs and Workshops, Roger Sullivan, ed. Amherst, MA: Human Resource Development Press (22 Amherst Rd.), 1982; 358 pages, 29 by 26 cm, spiral binder, ISBN 0-914234-61-7, \$95.

The HP-IL System: An Introductory Guide to the Hewlett-Packard Interface Loop, Gerry Kane, Steve Harper, and David Ushijima. Berkeley, CA: Osborne/McGraw-Hill, 1982; 106 pages, 18.5 by 23.3 cm, softcover, ISBN 0-931988-77-2, \$16.99.

Illustrated Computer Science Dictionary for Young People, Donald D. Spencer. Ormand Beach, FL: Camelot Publishing, 1982; 128 pages, 15.2 by 22.7 cm, softcover, ISBN 0-89218-053-6, \$8.95.

Implementing BASICs, How BASICs Work, William Payne and Patricia Payne. Reston, VA: Reston Publishing, 1982; 210 pages, 16.4 by 23.4 cm, hardcover, ISBN 0-8359-3045-9, \$21.

An Introduction to Process Control and Digital Minicomputers, Peter L. Ginn. Houston, TX: Gulf Publishing Co., 1982; 291 pages, 16.4 by 23.4 cm, hardcover, ISBN 0-87201-180-1, \$26.95.

Literary Machines, Ted Nelson. Swarthmore, PA: Theodore Holm Nelson Publisher, 1982; 125 pages, 21.6 by 22.8 cm, softcover, ISBN-none, \$15.

Microprocessor Operating Systems, volume 1, John Zarella, ed. Suisun City, CA: Microcomputer Applications (POB E), 1981; 155 pages, 14.9 by 22.7 cm, softcover, ISBN 0-935230-03-3, \$12.95.

Microcomputer Systems, Ivan Flores and Christopher Terry. New York: Van Nostrand Reinhold, 1982; 288 pages, 15.6 by 23.5 cm, hardcover, ISBN 0-442-26141-1, \$22.50.

A Micro-PROLOG Primer, 2nd edition, K. L. Clark, J. R. Ennals, and F. G. McCabe. London, England: Logic Programming Associates Ltd., (36 Gorst Rd.) 1982; 130 pages, 14.7 by 20.8 cm, softcover, ISBN-none, \$17.

Modeling and Simulation on Microcomputers, Lance A. Leventhal, ed. La Jolla, CA: Simulation Councils Inc. (POB 2228), 1982; 120 pages, 21.6 by 27.9 cm, softcover, ISBN-none, \$20.

101 Microprocessor Software and Hardware Projects, Frank P. Tedeschi and Gary Kueck. Blue Ridge Summit, PA: Tab Books, 1982; 294 pages, 12.6 by 20.7 cm, softcover, ISBN 0-8306-1333-1, \$8.95.

119 Practical Programs for the TRS-80 Pocket Computer, John Clark Craig. Blue Ridge Summit, PA: Tab Books, 1982; 298 pages, 12.6 by 20.7 cm, softcover, ISBN 0-8306-1350-1, \$9.95.

Pascal Implementation, Compiler and Assembler/Interpreter, S. Pemberton and M. C. Daniels. New York:

CHIPS & DALE

THE INFLATION FIGHTERS!

*** SPECIAL ***

- 4116 250ns 8/\$15.00 100+ \$1.05 ea.
- 4116 200ns 8/\$11.00 100+ \$1.18 ea.
- 4116 150ns 8/\$14.50 100+ \$1.50 ea.
- 4116 120ns 8/\$16.50 100+ \$1.80 ea.
- 2114L 300ns 8/\$13.00
- 2114L 200ns 8/\$14.75
- *4164 200ns \$5.85
- *4164 150ns \$6.85 ea.
- *6116 150ns \$6.75
- *6116 200ns \$4.75
- *1791 Disk Controller \$20.00
- Z80A CPU \$3.00 ea.
- 8251A \$4.00 ea.
- 2716-1 (5V)350ns 8/\$5.50 ea. \$6.25 ea.
- *2716 (5V)450ns \$3.35 ea.
- *2732 (5V)450ns \$4.75 ea.
- *2532 (5V)450ns \$4.75 ea.
- *2764 5V 300ns 28 pin \$16.50 ea.

COMPUTERS

NEC P.C.-8000	sugg. lists	C & D
8001 Comp 32K	\$995.00	\$715.00
8012 I/O unit	\$649.00	\$475.00
8031 Dual Minidisk unit	\$995.00	\$715.00
Other NEC Products	CALL	-
Altos Computers	CALL	-
Eagle II	\$2995.00	CALL
Eagle III	\$3995.00	CALL
Sage II (16 bit)	CALL	CALL
IBM P.C. complete sys (with or w/out hard disk)	CALL	CALL

PRINTERS

Epson MX80 Graphtrax Plus	-	CALL
Epson MX80 F/T Graphtrax Plus	-	CALL
Epson MX100 Graphtrax Plus	-	\$645.00
NEC Printer P.C. 8023	\$695.00	\$465.00
Other NEC Printers	-	CALL
Okidata Printers		
B2A	\$748.00	\$397.00
B3A	\$995.00	\$645.00
B4A	\$1395.00	CALL
PACFMARK 2350	\$2800.00	\$2200.00
Smith-Corona Printers TP-1	\$895.00	CALL
Diablo Printers 630 (R102)	\$2710.00	\$1989.00
ProWriters Starwriter Printmaster	-	CALL
C. Itoh Printers	-	CALL

SOFTWARE CP/M, IBM, Apple, TRS-80, Atari

Package 1 includes Wordstar, Mail Merge, Spellstar (CP/M)	CALL
Package 2 includes Data Star, Calcstar, Supersort (CP/M)	CALL
dBase II (CP/M) IBM	\$425.00
FNS 80 (CP/M)	\$597.00
CALL for other mfg., comp., prnts, modems, terminals, chips, & software	
Hayes Smart Modem 300 Baud	\$240.00

Allow up to 3 wks. for personal checks to clear. Please include phone number. Prices subject to change without notice. Shipping & Handling for Chips \$3.50. FOB Bellevue, WA. for all else. Wash. residents add 6.5% Sales Tax.

CHIPS & DALE
10655 N.E. 4th St., Suite 400
Bellevue, WA 98004
1-206-451-9770

Halsted Press, 1982; 82 pages, 16.4 by 23.4 cm, hardcover, ISBN 0-470-27325-9, \$64.95

Pascal Implementation, The P4 Compiler, S. Pemberton and M. C. Daniels. New York: Halsted Press, 1982; 172 pages, 16.4 by 23.4 cm, hardcover, ISBN 0-470-27325-9, \$64.95.

Pascal Programming Structures for Motorola Microprocessors, George W. Cherry. Reston, VA: Reston Publishing, 1982; 359 pages, 17.4 by 23.2 cm, softcover, ISBN 0-8359-5471-4, \$15.95.

PL/I Programming Problems and Applications, David T. Barnard and Robert G. Crawford. Reston, VA: Reston Publishing, 1982; 216 pages, 17.4 by 23.2 cm, softcover, ISBN 0-8359-5554-0, \$10.95.

A Practical Guide to Word Processing and Office Management Systems. Merrimack, NH: Digital Equipment Corp., 1982; 117 pages, 13.6 by 21.4 cm, softcover, ISBN-none, \$5.

Problem Solving and Comprehension, 3rd edition. Arthur Whimbey and Jack Lockhead. Philadelphia, PA: The Franklin Institute Press, 1982; 343 pages, 15.2 by 22.6 cm, softcover, ISBN 0-89168-048-9, \$10.95.

Problem Solving and Structured Programming in WAT-FIV, Frank L. Friedman and Elliot B. Koffman. Reading, MA: Addison-Wesley, 1982; 527 pages, 16.4 by 23.4 cm, softcover, ISBN 0-201-10482-2, \$16.95.

Software Reflected, Robert

L. Baber. New York: Elsevier Science Publishing Co., 1982; 210 pages, 16.4 by 23.4 cm, hardcover, ISBN 0-444-86372-9, \$29.95.

Teletext and Videotex in the United States, J. Tydeman, H. Lipinski, R. Adler, M. Nyhan, and L. Zwimpfer. New York: McGraw-Hill, 1982; 314 pages, 19.5 by 24.1 cm, softcover, ISBN 0-07-000427-7, \$30.

The Third Book of Ohio Scientific, S. Roberts. Pomona, CA: Elcomp Publishing (POB 1194), 1982; 127 pages, 13.6 by 20.8 cm, softcover, ISBN 3-921682-77-0, \$7.95.

TRS-80 Data Communications Systems, Frank J. Derfler Jr. Englewood Cliffs, NJ: Prentice-Hall, 1982; 159 pages, 17.4 by 23.2 cm, softcover, ISBN 0-13-931220-X, \$12.95.

UCSD Pascal: A Beginner's Guide to Programming Microcomputers, J. N. P. Hume and R. C. Holt. Reston, VA: Reston Publishing, 1982; 346 pages, 17.4 by 23.2 cm, softcover, ISBN 0-8359-7913-X, \$12.95.

User-Designed Computing, Louis Schlueter Jr. Lexington, MA: Lexington Books, 1982; 145 pages, 16.4 by 23.3 cm, hardcover, ISBN 0-669-05377-5, \$17.95.

Your Atari Computer: A Guide to Atari 400/800 Personal Computers, Lon Poole, Martin McNiff, and Steven Cook. Berkeley, CA: Osborne/McGraw-Hill, 1982; 458 pages, 16.4 by 23.4 cm, softcover, ISBN 0-931988-65-9, \$16.95. ■

This is a list of books received at BYTE Publications during this past month. Although the list is not meant to be exhaustive, its purpose is to acquaint BYTE readers with recently published titles in computer science and related fields. We regret that we cannot review or comment on all the books we receive; instead, this list is meant to be a monthly acknowledgment of these books and the publishers who sent them.

COMMUNICATIONS SOFTWARE

Give your personal computers error free communications with your corporate computer or with each other - mix and match.

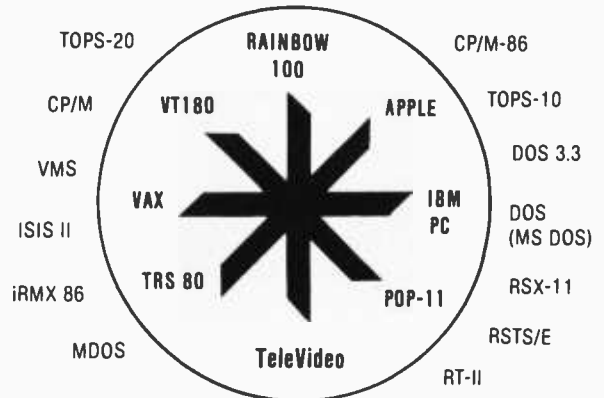

Communicate with us.

polygon associates, inc.

9 American Industrial Drive, St. Louis, Missouri 63043
314/576-7709 TWX 910/764-0876

Micromint will put both a computer development system and an OEM dedicated controller in the palm of your hand for only \$195

- Z8 MICROCOMPUTER
- On board tiny BASIC interpreter.
- Parallel and serial I/O ports.
- 6 interrupts.

- RS-232 CONNECTOR
- Just attach a CRT terminal and immediately write control programs in BASIC.

- 4K BYTES OF RAM
- Z6132 4K X 8 low power quasi-static RAM. EPROM pin compatible.

- SWITCH SELECTABLE BAUD RATES
- 110-9600 BPS.

- FULLY EXPANDABLE
- Data and address buses available for 124K memory and I/O expansion.
- 2 onboard parallel ports.

- 7.3728MHZ crystal for fast control operations.
- JUMPER SELECTABLE MEMORY OPTIONS
- 4K RAM, 2716 or 2732 EPROM operation.

- LOW POWER
- Consumes only 1 1/2 WATTS at +5, +12 and -12V

Optional power supply (+5, +12 and -12V) \$35.
Please include \$4 for shipping and handling.

To Order:
Call Toll Free: 1-800-645-3479
(In N.Y. State Call: 1-516-374-6793)
For Information Call: 1-516-374-6793

MICROMINT INC.
917 Midway
Woodmere, N.Y. 11598

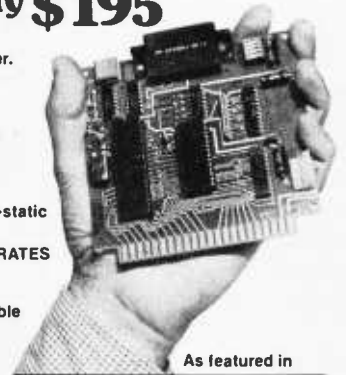

As featured in

Ciarcia's Circuit Cellar,
Byte Magazine,
July and August 1981.

Z8 is a trademark of Zilog Inc.



Event Queue

December 1982

December

Information Management and Technology Seminars, various sites throughout the U.S. Among the wide variety of seminars offered by Datamation Institute are "Financial Management's Use of Computer Graphics" and "Database Management Systems." Registration fees range from \$595 to \$795, depending upon duration and the topic covered. For details, contact Ms. Joan Merrick, Datamation Institute Seminar Coordination Office, Suite 415, 850 Boylston St., Chestnut Hill, MA 02167, (617) 738-5020. For information on in-house presentations, contact Art Gutmann, Datamation Institute for Information Management and Technology, Seminar Coordination Office, Suite 803, 331 Madison Ave., New York, NY 10017, (212) 697-2361.

December-January 1983

Intensive Seminars for Professional Development, Worcester Polytechnic Institute campus and various sites in the New York City and Boston metropolitan areas. Some of the topics to be presented are "Project Management," "Leadership Skills and Management Tools for High-Technology Professionals," and "Management Skills for First-Line Supervisors." Fees range from \$495 to \$990. Complete details are available from Ms. Ginny Bazarian, Office of Continuing Education, Higgins House, Worcester Polytechnic Institute, Worcester, MA 01609, (617) 793-5517. For information on in-house seminars, call Robert J. Hall at (617) 793-5574.

December-January 1983

Courses from Q.E.D. Information Sciences, various sites throughout the U.S. Among the courses offered are "Screen Design," "Designing Systems Controls," and "Teleprocessing Network Design." Complete course outlines are available from Priscilla Goudreault, Q.E.D. Information Sciences Inc., Q.E.D. Plaza, POB 181, Wellesley, MA 02181, (800) 343-4848; in Massachusetts, (617) 237-5656.

December-February 1983

Seminars of Interest to Women Professionals, various sites around Boston, MA. This series of one- and two-day seminars is presented by Boston University Metropolitan College. Among the topics on the agenda are "Managing Word Processing to Increase Productivity and Profitability," "Advanced Management for Women: Beyond the Basics," and "Data Processing Fundamentals for Accounting and Financial Managers." The seminar fees are \$325 and \$495, depending on duration. For registration information, contact Ms. Joan Merrick, University Seminar Center, Suite 415, 850 Boylston St., Chestnut Hill, MA 02167, (617) 738-5020.

December-March 1983

Courses for Developers and Users of Computer Systems, various sites throughout the U. S. Among the courses offered by the AMA (American Management Associations) are "Fundamentals of Data Processing for the Nondata Processing Executive," "BASIC: A Computer Language for Managers," and "Database Concepts and Designs." For complete registration and course information, contact the AMA, 135 West

50th St., New York, NY 10020, (212) 586-8100.

December 9-11

The 1982 California Educational Exposition, Anaheim Convention Center, Anaheim, CA. This exposition's theme is "Public Education: Our Purpose—Our Future." Exhibits and an all-day computer-literacy workshop highlight this event. Address inquiries to Alice Lytle, California School Boards Association, 916 23rd St., Sacramento, CA 95816, (916) 443-4691.

December 9-12

Southeast Computer Show and Office Equipment Exposition, Civic Center, Atlanta, GA. For details, contact Computer Expositions Inc., POB 3315, Annapolis, MD 21403, (800) 368-2066; in Maryland, (301) 263-8044.

December 10

The 1982 Computer Networking Symposium, Gaithersburg, MD. "Planning for the Near Term: The Next Three Years" is the theme for this symposium, which is sponsored by the IEEE Computer Society Technical Committee on Computer Communication and the Institute for Computer Sciences and Technology of the National Bureau of Standards. Papers related to the design, selection, and implementation of network systems within the next three years will be delivered. Areas of particular interest include long-haul networks, local-area networks, and satellite systems. Full details are available from Computer Networking Symposium, IEEE Computer Society, POB 639, Silver Spring, MD 20901, (301) 589-3386.

December 12-17

Small Computers in Biomedical Research, Woods Hole, MA. This course is sponsored by the Marine Biological Laboratory. It emphasizes hands-on exercises using several fully equipped microprocessor systems. The concentration is on basic machine operation and assembly language. Other topics include number systems, machine logic and architecture, operating systems, and flowcharting and interrupts. Contact the Marine Biological Laboratory, Woods Hole, MA 02543, (617) 548-3705.

December 13-15

Microcomputers in Education, Boulder, CO. This workshop is designed for educators at all levels. Topics to be covered include BASIC and Graphics, Logo, administrative uses of microcomputers, and microcomputers as laboratory instruments. Hands-on experience with a variety of computers will be provided. Information is available from Ms. Sharon Woodruff, Technical Education Research Centers, 8 Elliot St., Cambridge, MA 02138, (617) 547-3890.

December 13-15

Office Automation for Management Productivity, Shoreham Hotel, Washington, DC. Conference sections will focus on better methods to evaluate productivity, to select equipment or procedures, to integrate equipment or procedures into an organization, and to get people to work effectively in a changing environment. For further details, contact the Information Exchange, Suite 334, 4500 South Four Mile Run Dr., Arlington, VA 22204, (703) 820-5720.

December 13-16

Database: A Builder's Guide, San Francisco, CA. This seminar, led by Robert Holland, focuses on identifying subject databases and defining data architecture. For complete information, contact the Technology Transfer Institute, 741 10th St., Santa Monica, CA 90402, (213) 394-8305.

December 13-16

F8 & F3870 Microcomputer Systems, Santa Clara, CA. This is one of several courses offered by the Microprocessor Division of Fairchild Camera and Instrument Corporation. For more information, contact Fairchild Camera and Instrument Corp., Education Center, 3420 Central Expressway, Santa Clara, CA 95051, (408) 773-2161.

December 13-17

C Programming Workshop, Boston, MA. This workshop is designed for programmers or engineers able to program in another language. Areas to be explored include C operands and operators, C preprocessors, pointers and arrays, and structures and unions. The fee is \$1000. A full course outline is available from Joan Hall, Plum Hall Inc., RD 2 Box 235P, Pleasantville, NJ 08232, (609) 927-3770.

December 13-17

Digital Continuous-System Simulation, University of Maryland University College, College Park, MD. The fee for this course is \$975. For details, contact Marc Rosenberg, UCLA Extension, Continuing Education in Engineering and Mathematics, 6266 Boelter Hall, Los Angeles, CA 90024, (213) 825-1047.

December 14-15

Plenary Technology, Palo Alto, CA. Details are avail-

able from the Yankee Group, POB 43, Harvard Square, Cambridge, MA 02138, (617) 542-0100.

December 14-15

World Update '83, New York, NY. This industry briefing is designed for key management personnel. The focus is on what happened in the communications industry this year and what will happen in the future. Contact the DMW Group Inc., Publishing & Seminar Division, 2020 Hogback Rd., Ann Arbor, MI 48104, (800) 521-7802; in Michigan, (313) 971-5234.

December 14-16

A Business Approach to Systems Controls, Chicago, IL. The fee for this seminar is \$600. Contact the Registrar, Arthur Andersen & Co., Center for Professional Education, 1405 North Fifth Ave., St. Charles, IL 60174, (800) 323-0815; in Illinois, (800) 942-0851.

December 14-17

Systems Project Management, Chicago, IL. The fee for this seminar is \$900. For full details, contact the Registrar, Arthur Andersen & Co., Center for Professional Education, 1405 North Fifth Ave., St. Charles, IL 60174, (800) 323-0815; in Illinois, (800) 942-0851.

December 15-16

Local Area Networks: Architecture, Technology, and Products, Marriott Inn North, Dallas, TX. Topics to be covered at this workshop include network concepts and architectures, local-network characterization, internetworking, and standards. The registration fee is \$570. Contact Technology Concepts

Inc., 730 Boston Post Rd., Sudbury, MA 01776, (617) 443-4637.

December 20-21

Using Microcomputers in the Business Environment, Chicago, IL. This course is designed for managers and executives with little or no experience in microcomputing, but who want to understand its potential in the business environment. The course offers hands-on experience by providing one microcomputer for every two participants. The tuition is \$500. Contact the Registrar, Arthur Andersen & Co., Center for Professional Education, 1405 North Fifth Ave., St. Charles, IL 60174, (800) 323-0815; in Illinois, (800) 942-0851.

December 28-29

Using Microcomputers in the Business Environment, Washington, DC. For details, see December 20-21.

January 1983

January 5-7

The Sixteenth Hawaii International Conference on System Sciences, Honolulu, HI. This conference will focus on recent developments in the theory and practice of computer software, hardware, and advanced computer systems applications as related to information and systems science. Special emphasis will be placed on medical information processing, decision support systems, and office systems and technology. Further information is available from Emily M. Yano Jorgensen, Office of Management Programs, College of Business Administration, University of Hawaii, 2404 Maile Way

C-202, Honolulu, HI 96822, (808) 948-7396.

January 11-12

Local Area Networks: Architecture, Technology, and Products, Sheraton-Tara Hotel, Framingham, MA. See December 15-16 for details.

January 13

Network Optimization and Tariff Impact Strategies, San Francisco, CA. This seminar will provide a concise overview of maximizing network potential and how to plan corporate strategies to minimize the impact of tariff increases. Contact the DMW Group Inc., Publishing and Seminar Division, 2020 Hogback Rd., Ann Arbor, MI 48104, (800) 521-7802; in Michigan, (313) 971-5234.

January 18-19

Local Area Networks: Architecture, Technology, and Products, Berkeley Marina Marriott Inn, Berkeley, CA. See December 15-16 for details.

January 18-20

Microcomputers in Education, Tallahassee, FL. For details, see December 13-15.

January 18-20

Southcon/83, High-Technology Electronics Exhibition and Convention, Georgia World Congress Center, Atlanta, GA. Contact Electronic Conventions Inc., 999 North Sepulveda Blvd., El Segundo, CA 90245, (800) 421-6816; in California, (213) 772-2965.

January 18-21

Defining Software Requirements, Specifications, and Tests, San Diego, CA.

Participants in this short course will learn how to analyze and document end-user requirements, generate software requirements that include test plans, and plan the sequencing of test and integration procedures. The fee is \$845. Further details are available from Ruth Dordick, Integrated Computer Systems, 3304 Pico Blvd., POB 5339, Santa Monica, CA 90405, (213) 450-2060.

January 20-21

The Twelfth Annual National Measurement Science Conference and Exhibition, Hyatt Ricketts Hotel, Palo Alto, CA. This conference is intended for managers, scientists, engineers, and operating personnel. Its theme is "Accuracy and Automation." Seminar sessions will stress practical applications of new equipment and techniques to solve measurement problems. By format and objective, this conference will promote professional and state-of-the-art approaches and emerging technologies in the fields of measurement science. For registration information, contact Bob Weber, Lockheed Missile & Space Corp., Sunnyvale, CA 94046, (408) 742-2957.

January 21-23

CP/M '83, Moscone Center, San Francisco, CA. This international exposition and conference is designed for CP/M manufacturers, software developers, distributors, and users. The exposition will be the largest presentation of CP/M-based hardware and software ever assembled. Seminars and conferences will explore CP/M applications, technical information, development aids, venture-capital programs, and software distribution. Separate end-user conferences will be held. Adam Osborne, Chris Morgan, Tony Gold, Sol Libes,

and Gary Kildall have assisted in organizing this show for Digital Research Inc. Contact National Computer Shows, 824 Boylston St., Chestnut Hill, MA 02167, (800) 343-2222; in Massachusetts, (617) 739-2000.

January 24-25

Computers in Agriculture Conference and Trade Fair, Red Lion Inn, Sacramento, CA. This conference and exposition is designed to address the needs of farmers and ranchers. More than 20 speakers and 60 hardware and software exhibitors will attend. The conference seeks to answer basic questions confronting farmers and ranchers considering the purchase of a computer. For details, write to Kim Schnoor, Western Agricultural Chemicals Association, Suite 209, 6650 Belleau Wood Lane, Sacramento, CA 95831.

January 25-27

The First Annual Automated Office Expo, Moscone Center, San Francisco, CA. This show will feature computer and telecommunications systems, graphics, peripherals, and word-processing systems. This show is sponsored by *Infosystems* magazine. Contact Automated Office Expo, Suite 400, 222 West Adams St., Chicago, IL 60606, (800) 621-2134; in Illinois, (312) 263-3131.

January 25-28

Designing Real-Time Hardware for Digital Signal and Image Processing, Los Angeles, CA. Participants in this short course will learn how to implement digital filters, fast Fourier transforms, correlation, modulation, and other real-time processes by designing with general-purpose 16-bit microproces-

sors. Case histories and lectures will be featured. The fee is \$845. Contact Ruth Dordick, Integrated Computer Systems, 3304 Pico Blvd., POB 5339, Santa Monica, CA 90405, (213) 450-2060.

January 31-February 2

Communication Networks '83, the Rivergate, New Orleans, LA. This fifth annual conference and exposition will encompass the voice, data, and telecommunications industry with sessions and demonstrations. The theme is "Communications Cost Control Via High Technology." Topics on the agenda include electronic mail and office communications, local-area networks and internetting, and modems and multiplexers. Optional in-depth skill seminars will be held. These seminars, led by industry leaders, include lectures, class activities, and a workbook. General registration fees are \$395; skill seminars cost \$295. Contact Louise Myerow, Conference Management Group, CW Communications Inc., POB 880, Framingham, MA 01701, (800) 225-4698; in Massachusetts, (617) 879-0700 collect.

February 1983

February 1-4

Advanced Microprocessor Programming and Applications Techniques, Los Angeles, CA. This short course is designed to teach participants how to use real-time operating systems, design customized modules to implement real-time functions, apply 16-bit microprocessor families, and how to structure multiprocessor and multicomputer architectures. The fee is \$845. Contact Ruth Dordick, Integrated Com-

puter Systems, 3304 Pico Blvd., POB 5339, Santa Monica, CA 90405, (213) 450-2060.

February 1-4

Defining Software Requirements, Specifications, and Tests, Washington, DC. For details, see January 18-21.

February 7-9

Microcomputers in Education, Washington, DC. For details, see December 13-15.

February 8-9

Local Area Networks: Architecture, Technology, and Products, Hyatt Regency Hotel, Atlanta, GA. For details, see December 15-16.

February 15-18

Peripheral Array Processors for Signal Processing and Simulation, University of California, Los Angeles. The fee for this course is \$845. Contact Marc Rosenberg at the UCLA Extension, Continuing Education in Engineering and Mathematics, 6266 Boelter Hall, Los Angeles, CA 90024, (213) 825-1047.

February 15-18

Designing Real-Time Hardware for Digital Signal and Image Processing, Washington, DC. For details, see January 25-28.

February 16-18

Talmis, Ambassador West, Chicago, IL. Information is available from Talmis Inc., 115 North Oak Park Ave., Oak Park, IL 60301, (312) 848-4000.

February 16-19

Data and Telecommunications/Japan Exposition '83,

Tokyo Ryutsu Centre, Tokyo, Japan. Contact Cahners Exposition Group, Cahners Plaza, 1350 East Touhy Ave., POB 5060, Des Plaines, IL 60018, (312) 299-9311. In Japan, contact Cahners Exposition Group S.A., Hino Building 3F, 3-4-11 Uchikanda, Chiyoda-ku, Tokyo 101, Japan; tel: 03-254-6041.

February 17-19

Microcomputers in Education, New York, NY. For details, see December 13-15.

February 21-23

Office Automation Conference, Civic Center, Philadelphia, PA. More than 200 exhibitors are expected to participate in this conference. Fifty technical sessions will explore such topics as ad-

vanced office technology, current office technology and systems, and human factors and social issues. Details are available from the American Federation of Information Processing Societies Inc., 1815 North Lynn St., Arlington, VA 22209, (703) 558-3624.

February 22-26

The Eighteenth Annual Bias-Microelettronica '83, Milan, Italy. This international exposition is expected to attract more than 80,000 visitors. Areas of interest include active and passive components, instrumentation and equipment for component manufacturing, laboratory instrumentation, microcomputers, peripherals, and telecommunications systems. For information, contact Ente Italiano

Organizzazione Mostre, Bias-Microelettronica '83, Viale Premuda 2, 20129 Milan, Italy; tel: 796.096; Telex: CONSEL 334022.

February 25-27

The Second Annual Computer Expo '83, Tupperware Convention Center, Orlan-

do, FL. This exposition features mini- and microcomputers. The focus is on hardware, software, word processing, graphics, peripherals, supplies, services, and computer furnishings. Seminars will be held. Contact Tom Blayney, POB 1185, Longwood, FL 32750, (305) 339-1731.■

In order to gain optimal coverage of your organization's computer conferences, seminars, workshops, courses, etc, notice should reach our office at least three months in advance of the date of the event. Entries should be sent to: Event Queue, BYTE Publications, POB 372, Hancock NH 03449. Each month we publish the current contents of the queue for the month of the cover date and the two following calendar months. Thus a given event may appear as many as three times in this section if it is sent to us far enough in advance.

NEW!

IT'S A ROM CARD!

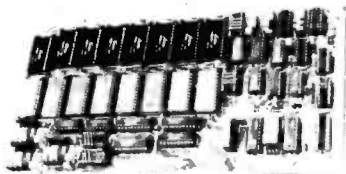

S-100

up to

512K ROM

Featuring two independent banks of 8 sites (28 pin sockets) the ADS Memorizer_™ allows you **mix RAM with ROM** or dedicate to either. Independent wait states (0-5) per bank supports fast RAMS with slow Eproms! Allows system to run at max speed! **Uses any 1K x 8 to *32K x 8 part RAM or ROM! Extended memory address or bank select.**

*Single supply

NEW!

IT'S A RAM CARD!

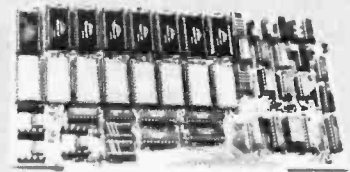

S-100

up to

128K STATIC RAM

Ackerman Digital Systems, Inc.

110 N. York Road
Elmhurst, IL 60126
(312) 530-8992

ads

COPYRIGHT 1982

BYTE INDEX UPDATE

January 1982 — December 1982

"When did you run that review of the six personal computers from Japan? I think it was in the spring, but I'm not sure of the exact issue."

"In what issue of BYTE did Steve Ciarcia write about interactive-videodisc controllers?"

"When was it that Gregg Williams reviewed the IBM Personal Computer?"

Ours is the age of information. Name any topic and there'll be an article on it *somewhere*. But *somewhere* doesn't help much if you're the one looking for specific information. The real question in the end is "How can I find what I want quickly and easily?"

In this issue of BYTE we present the first annual BYTE Index Update. In December 1981, as a service to our readers, we included a comprehensive, cumulative index covering every issue of the magazine between September 1975 and December 1981, inclusive. Among the information represented is every article and product review that has appeared in the pages of BYTE.

All entries in the index are arranged by subject descriptors, and an article may be listed under several descriptors. Any article for which a correction was published has an asterisk after its title. The correction can be found under the heading "BYTE Corrections." The figure below shows a typical index entry and describes what the different parts mean.

For those who require information beyond what is presented here, Microcomputer Information Services (which prepared the BYTE Index and the 1982 Update) publishes *Microcomputer Index*, which covers 20 microcomputer-oriented magazines and includes abstracts for each entry. For more information on *Microcomputer Index*, you can reach MIS by calling (408) 984-1097.

Index Entry:

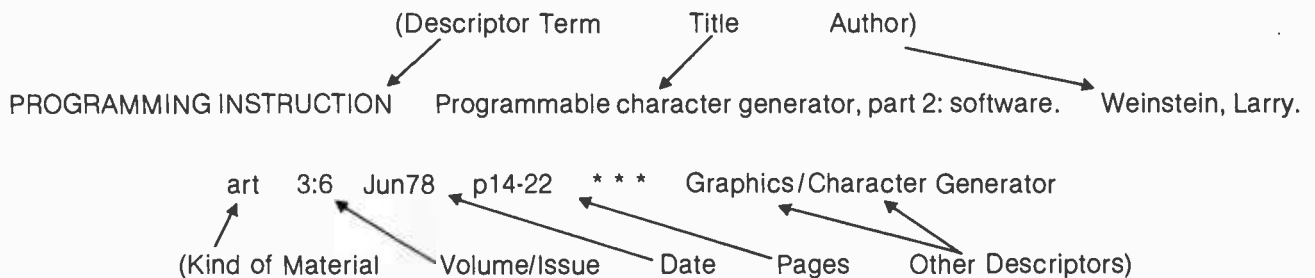

Key to Abbreviations

- | | | | |
|---------------|-------------------------------------|--------------|---|
| art | article | L1 | program listing in BASIC |
| br | book review | L2 | program listing in machine language |
| col | column | L3 | program listing in assembly language |
| hr | hardware review | L4 | program listing in FORTRAN |
| let | letter | L5 | program listing in COBOL |
| sr | software review | L6 | program listing in Pascal |
| * | see BYTE Corrections | L7 | program listing in FORTH |
| *** | marker symbol for other descriptors | L8 | program listing in C programming language |
| | | L9 | other programming language |

- 1802
Clocked interrupts for the COSMAC Elf. Price, Gary. art L3 7:1 Jan82 p304-322 ***
Clock / Elf / Multi-tasking
Tuning up the 1802: a simple music composition trainer. Makosinski, Art. col L2 7:7 Jul82 p442-447 *** Music / VIP
- 4004
Microprocessor's tenth birthday. Morgan, Chris. col 7:3 Mar82 pb-10 *** Microprocessor / History
- 6502
Build an EPROM emulator. Kehne, Eric. art 7:2 Feb82 p194-203 *** Hardware Construction / EPROM / Emulator
- 6802
Versatile low-cost microprocessor controller module. Craig, David. art 7:12 Dec82 p486-498 *** Hardware Construction / Control
- 6809
6809 machine-code disassembler. Dubner, Joseph. art L3 7:2 Feb82 p340-364 *** Disassembler
- 68701
Let the MC68701 program itself. Morales/Ruhberg, col L3 7:8 Aug82 p380-394 *** EPROM / Hardware Construction / EPROM Programmer
- 8051
8051 one-chip microcomputer: a most powerful microcontroller. Doyet/Katz, art 7:12 Dec82 p288-311 *** Control / Microprocessor
- 8080
8080-based remote appliance controller. Staehlin, David. art L3 7:1 Jan82 p239-292 *** Control / Home / Heath HB
Test your memory using the Barber-Pole algorithm. Pinnick, H.R.. art L3 7:12 Dec82 p414-444 *** Memory / Test / 8085
- 8085
Test your memory using the Barber-Pole algorithm. Pinnick, H.R. art L3 7:12 Dec82 p414-444 *** Memory / Test / 8080
- 8086
Upward migration, part I: translators (CP/M-86 translators). Taylor/Lemons, art L3 7:6 Jun82 p21-344 *** Translators / CP/M / CP/M-86
- 8088
Build the Circuit Cellar MPX-16 computer system, part I. Ciarcia, Steve. col 7:11 Nov82 p78-114 *** Hardware Construction / Microcomputer System
Build the Circuit Cellar MPX-16 computer system, part 2. Ciarcia, Steve. col 7:12 Dec82 p42-78 *** Hardware Construction / Microcomputer System
- A/D CONVERTER
Apple variable errors / Strain-Gage data collection. Ciarcia, Steve. col 7:4 Apr82 p431 *** Apple II / BASIC
Inexpensive transducers for the TRS-80, part II (real-world monitoring). Barden, William. art 7:11 Nov82 p416-446 *** Interface / TRS-80 Model I / TRS-80 Color
Model III A to D revisited. Barden, William. art L1 7:9 Sep82 p398-418 *** Analog/Digital Circuit / Hardware Construction / TRS-80 Model III
- AC-85
Autocontrol's AC-85: a CP/M system on one board. Benedict, JoAnne. hr 7:12 Dec82 p250-256 *** Hardware Review / Microcomputer System / CP/M
- APL
Microcomputers in cultural anthropology: APL programs for qualitative... Werner, Oswald. art L9 7:7 Jul82 p290-280 *** Social Science / Research / Anthropology
- ASCII
Input/output primer, part 5: character codes. Leibson, Steve. art 7:6 Jun82 p242-258 *** Input/Output / Baudot Code
- ACCOUNTING
Supercalc, spelling programs, BASIC compilers, and home-grown accounting. Pournelle, Jerry. col 7:5 May82 p226-243 *** Spelling / Compiler
- ADA
Ada, MINCE, CP/M utilities, overpriced documentation and Analiza II. Pournelle, Jerry. col 7:7 Jul82 p290-310 *** Word Processing / Documentation / CP/M
- AGRICULTURE
Computer-controlled irrigation / ZX81 home control / Current overloads. Ciarcia, Steve. col 7:7 Jul82 p420 *** Ask BYTE / Control / TRS-80 Color
Cows and catalogs / TV jitter bugs / Downloading to CP/M / Speedometer. Ciarcia, Steve. col 7:5 May82 p398-400 *** Ask BYTE / TRS-80 Color / CP/M
- ANALOG/DIGITAL CIRCUIT
Analog interfacing in the real world. Ciarcia, Steve. col 7:1 Jan82 p72-98 *** Hardware Construction / Digital/Analog Circuit / Interface
Build a joystick A-to-D converter for the TRS-80 Model I or III. darden, William. art L1 7:1 Jan82 p100-104 *** Joystick / TRS-80 Model I / TRS-80 Model III
Model III A to D revisited. Barden, William. art L1 7:9 Sep82 p398-418 *** Hardware Construction / TRS-80 Model III / A/D Converter
- ANIMATION
Computer animation with color registers: fast animation in BASIC (Atari) Fox/Waite. art L1 7:11 Nov82 p194-214 *** Programming Instruction / BASIC / Atari
- ANIMATION (CONTINUED)
Graphics Magician: easy animation for the Apple II. Callamaras, Peter. sr 7:11 Nov82 p138-144 *** Software Review / Apple II / Utility Program
Tronic imagery. Sorensen, Peter. art 7:11 Nov82 p48-74 *** Motion Pictures / High Resolution Graphics
- ANTHROPOLOGY
Microcomputers in cultural anthropology: APL programs for qualitative... Werner, Oswald. art L9 7:7 Jul82 p290-280 *** Social Science / Research / APL
- APPLE DOS
Converting Apple DOS and Pascal text files. Matthews, John. art L6 7:4 Apr82 p447-463 *** Conversions / Apple II / Pascal
- APPLE II
Accidental reset protection for the Apple II. DeWilde, Greg. col 7:1 Jan82 p234-238 *** Hardware Modification
Adaptive-firmware card for the Apple II (alternative input techniques). Schwedja/etal. art 7:9 Sep82 p276-314 *** Handicapped / Input/Output / Hardware Construction
Add a peripheral interface adapter to your Apple II. Ciszewski, Kenneth. col L3 7:1 Jan82 p324-330 *** Interface / Hardware Construction / Parallel Input/Output
Apple talks with the deaf. Rhodus, Ned. art L3 7:1 Jan82 p366-386 *** Handicapped / Interface / Telecommunications
Apple variable errors / Strain-Gage data collection. Ciarcia, Steve. col 7:4 Apr82 p431 *** BASIC / A/D Converter
Converting Apple DOS and Pascal text files. Matthews, John. art L6 7:4 Apr82 p447-463 *** Conversions / Apple DOS / Pascal
Give your Apple a voice (Radio Shack Speech Synthesizer). Blankenship, John. art L1 7:5 May82 p446-456 *** Voice Synthesis / Interface / Hardware Construction
Interpretive language used to program the CPR system. Laumer, Mike. art L9 7:6 Jun82 p126-130 *** Languages / Videodisc
Logo music. Bamberger, Jeanne. art 7:8 Aug82 p325-328 *** Logo / Music
Personal computer as an interface to a corporate...information system. McBurney, N.R. art L6 7:10 Oct82 p315-358 *** Terminal / Pascal / Management
Stock market / Basic questions / Portable terminals / Measuring devices. Ciarcia, Steve. col 7:9 Sep82 p499-500 *** Ask BYTE / Stock Market / Terminal
TAF: terminal Apple with file transfer. Gabriele, Tom. art L1 7:6 Jun82 p410-432 *** Terminal / Data Transmission / Telecommunications
TRS-80 assembly language / Apple 16-bit / Construction tips / Selectric. Ciarcia, Steve. col 7:2 Feb82 p369-371 *** Ask BYTE / Assembly Language / Printer
Turn your Apple II into a storage oscilloscope. Korba, Larry. art L3 7:9 Sep82 p520-530 *** Test Equipment / Hardware Construction
VIA experiment board / Totem poles and TTL / Bus standard stops here. Ciarcia, Steve. col 7:4 Apr82 p429 *** Input/Output / S-100 Bus / Standards
- EDUCATION
Assisted instructional development system. Wolfe, George. hr 7:8 Aug82 p408-414 *** Hardware Review / Computer Assisted Instruction / Education
Leading fish to water: early observations on the use of Logo. Higginson, William. art 7:8 Aug82 p328-329 *** Logo / Education
- GAMES
Alien typhoon (Apple II game). Latocha, Walt. sr 7:5 May82 p224 *** Software Review / Arcade / Games
Apple Panic. Williams, Gregg. sr 7:3 Mar82 p68-69 *** Software Review / Games / Arcade
Beer Run (Apple II arcade game). Little, Arthur. sr 7:9 Sep82 p375-379 *** Software Review / Games / Arcade
Charge! (game contest winner #2). Ray, C. Anthony. art L1 7:12 Dec82 p112-120 *** Games / Contests / Arcade
Cosmic conquest (game contest winner #1). Sartori-Angus, Alan. art L7 7:12 Dec82 p124-138 *** Games / Contests / Arcade
Deadline: the butler did it...this time. Morgan, Chris. sr 7:12 Dec82 p160-161 *** Software Review / Games / Strategy
Game of rat and dragon (Apple II). Smith, Talbot. art L3 7:11 Nov82 p336-374 *** Games / Arcade / Contests
Quinti-maze (Apple II game). Tsuk, Robert. art L1 7:9 Sep82 p24-30 *** Games / Puzzles / Strategy
Ricochet. Williams, Gregg. sr 7:12 Dec82 p142-146 *** Software Review / Games / Arcade
Ringquest (Apple II adventure game). Mills, Gordon. art L1 7:10 Oct82 p176-206 *** Games / Strategy / Contests
Swashbuckler (Apple II arcade game). Spangenberg, Scott. sr 7:9 Sep82 p362-367 *** Software Review / Games / Arcade
Tawala's last redoubt (Apple II and TRS-80 adventure game). Lesser, Hartley. sr 7:6 Jun82 p235-236 *** Software Review / Strategy / Games
- APPLE II (CONTINUED)
Zero Gravity Pinball (Apple II arcade game). Friedman, Mark. sr 7:9 Sep82 p370-372 *** Software Review / Games / Arcade
- GRAPHICS
CHEOIT: a graphics-character editor (Apple Pascal). Sweet, Jerry. art L6 7:5 May82 p426-444 *** Utility Program / Pascal / Graphics
Double-width Silentepe graphics for your Apple. Putney, Charles. col L3 7:2 Feb82 p413-423 *** High Resolution Graphics / Printer / Utility Program
Executive briefing system: a color graphics development for the Apple II. Callamaras, Peter. sr 7:11 Nov82 p164-170 *** Software Review / Utility Program / High Resolution Graphics
GRPRINT: an Apple utility program for dot-matrix printers. Arnott, Douglas. art L3 7:12 Dec82 p398-403 *** Utility Program / Printer / High Resolution Graphics
High-resolution sprite-oriented color graphics. Ciarcia, Steve. col L3 7:8 Aug82 p57-80 *** Color Graphics / Interface / Logo
Interactive 3-D graphics for the Apple II. Pichholtz, Andrew. art L1 7:11 Nov82 p474-505 *** Three-Dimensional Graphics / Pascal
Problem solving with Logo: using turtle graphics to redraw a design. Weinreb, William. art L9 7:11 Nov82 p118-134 *** Turtle Graphics / Logo / Problem-Solving
- HARDWARE REVIEW
Apple II 80-column video boards: five popular units. Howland, John. hr 7:5 May82 p252-266 *** Hardware Review / Video Display
Applescope stores dual traces. MacNicol, Gregory. hr 7:6 Jun82 p364-372 *** Hardware Review / Test Equipment
Assisted instructional development system. Wolfe, George. hr 7:8 Aug82 p408-414 *** Hardware Review / Computer Assisted Instruction / Education
Cognivox V10-1003: voice recognition and output for the Apple II. Murray, William. hr 7:9 Sep82 p231-238 *** Hardware Review / Speech Recognition
Dithertizer II (video-digitizer interface for the Apple II). Tomas, Joe. hr 7:2 Feb82 p219-224 *** Hardware Review / Digital Video / Interface
John Bell Engineering's Apple II Parallel Interface Board. Rhodes, Ned. hr L3 7:3 Mar82 p414-430 *** Hardware Review / Parallel Input/Output / Clock
More Apple 80-column boards. Williams, Gregg. hr 7:5 May82 p266-271 *** Hardware Review / Video Display
Soundchaser Computer Music Systems. Moog, Robert. hr 7:12 Dec82 p260-277 *** Hardware Review / Music / Musical Instrument
Strawberry Tree's Dual Thermometer Card for the Apple. Murray, William. hr 7:4 Apr82 p96-100 *** Hardware Review
- PROGRAMMING INSTRUCTION
Guided tour of Apple Pascal units and libraries. Tonkens, Ross. art L6 7:2 Feb82 p225-244 *** Programming Instruction / Pascal
- SOFTWARE REVIEW
Alien typhoon (Apple II game). Latocha, Walt. sr 7:5 May82 p224 *** Software Review / Arcade / Games
App-L-ISP (Apple II LISP). Bonar/Levitan. sr L9 7:6 Jun82 p220-230 *** Software Review / LISP
Apple Panic. Williams, Gregg. sr 7:3 Mar82 p68-69 *** Software Review / Games / Arcade
Beer Run (Apple II arcade game). Little, Arthur. sr 7:9 Sep82 p375-379 *** Software Review / Games / Arcade
Comparison of five compilers for Apple BASIC. Taylor/Taylor. sr L1 7:9 Sep82 p440-464 *** Software Review / Benchmark Testing / Compiler
Deadline: the butler did it...this time. Morgan, Chris. sr 7:12 Dec82 p160-161 *** Software Review / Games / Strategy
EduWare's Statistics 3.0. Elliott, Brownlee. sr 7:10 Oct82 p400-404 *** Software Review / Statistics
Executive briefing system: a color graphics development for the Apple II. Callamaras, Peter. sr 7:11 Nov82 p164-170 *** Software Review / Utility Program
Flexibility of VisiPlot (Apple II). Ramsdell, Robert. sr 7:2 Feb82 p32-36 *** Software Review / Plotting / Utility Program
Graphics Magician: easy animation for the Apple II. Callamaras, Peter. sr 7:11 Nov82 p138-144 *** Software Review / Animation / Utility Program
Logo for the Apple II, the TI-99/4A and the TRS-80 Color Computer. Williams, Gregg. sr L9 7:8 Aug82 p230-290 *** Software Review / Logo / TI-99/4A
Micro-Decision Support System/Finance (DSS/F). Moskowitz, Robert. sr 7:6 Jun82 p488-492 *** Software Review / Finances / Financial Modeling
Ricochet. Williams, Gregg. sr 7:12 Dec82 p142-146 *** Software Review / Games / Arcade
Super FORTH isn't. Williams, Gregg. sr 7:5 May82 p296-298 *** Software Review / FORTH

APPLE II (CONTINUED)

Swa.hbuckler (Apple II arcade game).
Spangenberg, Scott. sr 7:9 Sep82 p362-367
*** Software Review / Games / Arcade
Tawala's last redoubt (Apple II and TRS-80
adventure game). Lesser, Hartley. sr 7:6
Jun82 p235-236 *** Software Review /
Strategy / Games
Two tax aids (Individual Tax Plan and Tax
Preparer). Kvam, Mary Jo. sr 7:2 Feb82
p204-212 *** Software Review / Taxes /
Federal Government
Zero Gravity Pinball (Apple II arcade game).
Friedman, Mark. sr 7:9 Sep82 p370-372 ***
Software Review / Games / Arcade

TRS-80 MODEL I

Apple Sweet Talker / Low-cost monitor / TRS-80
vector graphics. Ciarcia, Steve. col 7:1
Jan82 p408-409 *** Ask BYTE / Video Display
/ TRS-80 Model I

UTILITY PROGRAM

CHEDIT: a graphics-character editor (Apple
Pascal). Sweet, Jerry. art L6 7:5 May82
p426-444 *** Utility Program / Pascal /
Graphics
Double-width Silentyte graphics for your Apple.
Putney, Charles. col L3 7:2 Feb82 p413-423
*** High Resolution Graphics / Printer /
Utility Program
Epson MX-80 print-control program for the Apple
II. Starbuck, Bill. col L1 7:3 Mar82
p166-170 *** Utility Program / Printer
Executive briefing system: a color graphics
development for the Apple II Callamaras,
Peter. sr 7:11 Nov82 p164-170 ***
Software Review / Utility Program
Finding words that sound alike: the Soundex
algorithm. Jacobs, Jacob. col L1 7:3 Mar82
p473-474 *** Utility Program / BASIC
Flexibility of VisiPlot (Apple II). Ramsdell,
Robert. sr 7:2 Feb82 p32-36 *** Software
Review / Plotting / Utility Program
GEOSAT program (calculates the position of
communications satellites). Emmett, Steve.
art L1 7:1 Jan82 p420-432 *** Utility
Program / Broadcasting / Data Transmission
GRPRINT: an Apple utility program for dot-matrix
printers. Arnott, Douglas. art L3 7:12
Dec82 p398-403 *** Utility Program / Printer
/ High Resolution Graphics
Graphics Magician: easy animation for the Apple
II. Callamaras, Peter. sr 7:11 Nov82
p138-144 *** Software Review / Animation /
Utility Program
Lowercase descenders for the Epson MX-70 (Apple
II). Piggott, Bruce. art L3 7:3 Mar82
p248-254 *** Utility Program / Lowercase
Modification / Printer
Shape-drawing program for Diablo printers (Apple
II). Brock, Thomas. col L1 7:3 Mar82
p310-314 *** Utility Program / Printer

APPLE III

Apple III and its new profile. Moore, Robin. hr
L1 7:9 Sep82 p92-132 *** Hardware Review
/ Hard Disk Drive / Benchmark Testing
Little Apple SOS with your Pascal. O'Koniski,
Tim. art L3 7:12 Dec82 p448-482 ***
Pascal / Input/Output / Documentation

ARCADE

Action games for the VIC-20. Kavanagh, Russell.
sr 7:12 Dec82 p150-156 *** Software Review
/ Games / VIC-20
Advanced Star Raider tactics and strategies.
Harris, C. Donald. col 7:9 Sep82 p383-396
*** Games / Atari
Alien typhoon (Apple II game). Latocha, Walt.
sr 7:5 May82 p224 *** Software Review /
Games / Apple II
Apple Panic. Williams, Gregg. sr 7:3 Mar82
p68-69 *** Software Review / Games / Apple II
Armored Patrol. Callamaras, Pete. sr 7:6
Jun82 p162-166 *** Software Review / Games /
TRS-80 Model I
Beer Run (Apple II arcade game). Little, Arthur.
sr 7:9 Sep82 p375-379 *** Software Review
/ Games / Apple II
Charge! (game contest winner #2). Ray, C.
Anthony. art L1 7:12 Dec82 p112-120 ***
Games / Contests / Apple II
Coinless arcade (Dec82). Clark/Williams.
7:12 Dec82 p84-91 *** Games
Cosmic conquest (game contest winner #1).
Sartori-Angus, Alan. art L7 7:12 Dec82
p124-138 *** Games / Contests / Apple II
Dino Wars. Stewart, George. sr 7:3 Mar82
p74-76 *** Software Review / Games / TRS-80
Color
Galactic Chase. Wszola, Stan. sr 7:6 Jun82
p176-180 *** Software Review / Games / Atari
Game of rat and dragon (Apple II). Smith,
Talbot. art L3 7:11 Nov82 p336-374 ***
Games / Apple II / Contests
Missile Command. Wszola, Stanley. sr 7:3
Mar82 p70-74 *** Software Review / Games /
Atari
Penetrator. Wszola, Stan. sr 7:12 Dec82
p162-164 *** Software Review / Games / TRS-80
Model III
Play's the thing. Clark, Pamela. col 7:12
Dec82 p8-10 *** Games
Ricochet. Williams, Gregg. sr 7:12 Dec82
p142-146 *** Software Review / Games / Apple
II
Swashbuckler (Apple II arcade game).
Spangenberg, Scott. sr 7:9 Sep82 p362-367
*** Software Review / Games / Apple II

ARCADE (CONTINUED)

The Eliminator: mayhem in space, TRS-80 style.
Pike, Silas. sr 7:6 Jun82 p170-174 ***
Software Review / Games / TRS-80 Model I
Vectrex Arcade System. Clark, Pamela. hr 7:12
Dec82 p92-93 *** Hardware Review / Video
Game System / Games
Videosyncrasies (Atari Star Raider tactics).
Feigel, Curtis. col 7:9 Sep82 p386-390 ***
Games / Atari
Zero Gravity Pinball (Apple II arcade game).
Friedman, Mark. sr 7:9 Sep82 p370-372 ***
Software Review / Games / Apple II

ARCHAEOLOGY
Breaking the jargon barrier: designing programs
for humanists. Heite/Heite. art L1 7:7
Jul82 p76-104 *** Statistics / PET / Social
Science

ART
Homebrew graphics digitizer. Atkins/Castro-Cid.
art L1 7:2 Feb82 p72-86 *** Graphics /
Hardware Construction / Graphics Tablet
Weaving stimulator. Heiser, Paul. art L1 7:9
Sep82 p513-519 *** North Star

ASK BYTE
8-bit vs. 16-bit / Sensing motions / EPROM
programmer note. Ciarcia, Steve. col 7:6
Jun82 p436-438 *** Microprocessor / Security
Apple Sweet Talker / Low-cost monitor / TRS-80
vector graphics. Ciarcia, Steve. col 7:1
Jan82 p408-409 *** Apple II / Video Display
/ TRS-80 Model I
Battery power / PC info / Burnout / Lifelines /
Tape cassette / EPROM. Ciarcia, Steve. col
7:12 Dec82 p532-533 ***
Composite PET video / Z80-based voice-recognition
system. Ciarcia, Steve. col 7:8 Aug82 p420
*** Video Display / PET / Speech Recognition
Computer-controlled irrigation / ZX81 home
control / Current overloads. Ciarcia, Steve.
col 7:7 Jul82 p420 *** Agriculture /
Control / TRS-80 Color
Control sources / Apple/North Star compiler /
S-100 systems. Ciarcia, Steve. col 7:2
Feb82 p367-369 *** Control / Compiler /
S-100 Bus
Cows and catalogs / TV jitter bugs / Downloading
to CP/M / Speedometer. Ciarcia, Steve. col
7:5 May82 p398-400 *** Agriculture / TRS-80
Color / CP/M
Data in, garbage out / RS-232C-to-IEEE-488
interface. Ciarcia, Steve. col 7:5 May82
p400-404 *** Power Supply / RS-232 / IEEE-488
Bus
Disk drives / ADM-3 lowercase / VIC cassette /
S-100 & TRS-80 / ZX81. Ciarcia, Steve. col
7:10 Oct82 p452-454 *** Floppy Disk Drive /
VIC-20 / TRS-80 Model I
High speed printers / Level I tape format /
Computer lab essentials. Ciarcia, Steve. col
7:3 Mar82 p442-443 *** Printer / TRS-80
Model I / Test Equipment
Letter-quality electrics / Bank selecting memory
/ 50 Hz power. Ciarcia, Steve. col 7:10
Oct82 p452 *** Typewriter / Memory / Power
Supply
Mail order / TRS-80 merge / Z80 monitor /
Color-monitor bandwidths. Ciarcia, Steve. col
7:1 Jan82 p404-406 *** Retailing / TRS-80
Model I / Monitor
Plotting with the TRS-80 / Matter of environment
/ Feasibility study. Ciarcia, Steve. col 7:3
Mar82 p445-446 *** Plotting / Operating
Systems / Consumer Information
Programming the RS-232 serial port / Build your
own / RF1. Ciarcia, Steve. col 7:3 Mar82
p444-445 *** RS-232 / Radio-frequency
Interference / Design
Redefining Atari characters / Keyboard connection
/ Battery Apple. Ciarcia, Steve. col 7:7
Jul82 p420-421 *** Atari / Keyboard / Power
Supply
Soroc IQ-120 slave monitor / OSI shift-lock
problem / Audible alarms. Ciarcia, Steve. col
7:6 Jun82 p434-435 *** Video Display / OSI
/ Keyboard
Speech synthesizer application / Problems with
EPROM / Modem interface. Ciarcia, Steve. col
7:3 Mar82 p442 *** Voice Synthesis / EPROM
/ Modem
Stock market / Basic questions / Portable
terminals / Measuring devices. Ciarcia, Steve.
col 7:9 Sep82 p499-500 *** Stock Market /
Terminal / Apple II
TRS-80 EPROMs / TI-58C printer interface /
ROM-based BASIC / Power backup. Ciarcia,
Steve. col 7:2 Feb82 p365-366 *** TRS-80
Model I / Printer / Calculator
TRS-80 assembly language / Apple 16-bit /
Construction tips / Selectric. Ciarcia, Steve.
col 7:2 Feb82 p369-371 *** Assembly
Language / Apple II / Printer
TRS-80 clock / Low-cost computers. Ciarcia,
Steve. col 7:9 Sep82 p500-501 *** TRS-80
Model I / Microcomputer System
Tape standard / Line counts / Joystick / RF1 /
Chess / Languages. Ciarcia, Steve. col 7:12
Dec82 p506-507 ***
Tips on homebrewing / BASIC in ROM / Line
disturbances / Clock. Ciarcia, Steve. col
7:8 Aug82 p418-420 *** Homebrew / Power
Supply / Clock

ASSEMBLER

TRS-80 disk editor/assemblers. Daneliuk, T.A..
sr 7:9 Sep82 p537-539 *** Software Review
/ TRS-80 Model I / TRS-80 Model III

ASSEMBLY LANGUAGE

TRS-80 assembly language / Apple 16-bit /
Construction tips / Selectric. Ciarcia, Steve.
col 7:2 Feb82 p369-371 *** Ask BYTE /
Apple II / Printer

ASSOCIATIONS

Young People's Logo Association. Muller, James.
art 7:8 Aug82 p333-334 *** Clubs / Logo

ATARI
Advanced Star Raider tactics and strategies.
Harris, C. Donald. col 7:9 Sep82 p383-396
*** Games / Arcade
Atari tutorial, part 10: human engineering.
Crawford, Chris. art 7:6 Jun82 p302-318
*** User Interface
Atari tutorial, part 5: scrolling. Crawford,
Chris. art 7:1 Jan82 p26-34 ***
Programming Instruction / Graphics / BASIC
Atari tutorial, part 6: Atari BASIC. Winner,
Lane. art L1 7:2 Feb82 p91-118 ***
Programming Instruction / BASIC
Atari tutorial, part 7: sound. Fraser, Bob. art
L1 7:3 Mar82 p80-98 *** Programming
Instruction / BASIC / Sound Effects
Atari tutorial, part 8: generating sound with
software. Fraser, Bob. art L3 7:4 Apr82
p134-150 *** Sound Effects / Programming
Instruction / BASIC
Atari tutorial, part 9: even more colors!
Pitta/Winner. art L1 7:5 May82 p148-160
*** Color Graphics / Programming Instruction /
BASIC
Character editor for the Atari. Kilby, Tim. art
L1 7:12 Dec82 p167-179 *** Graphics /
Utility Program / Programming Instruction
Computer animation with color registers: fast
animation in BASIC (Atari). Fox/Waite. art
L1 7:11 Nov82 p194-214 *** Programming
Instruction / BASIC / Animation
Galactic Chase. Wszola, Stan. sr 7:6 Jun82
p176-180 *** Software Review / Arcade / Games
Missile Command. Wszola, Stanley. sr 7:3
Mar82 p70-74 *** Software Review / Games /
Arcade
Redefining Atari characters / Keyboard connection
/ Battery Apple. Ciarcia, Steve. col 7:7
Jul82 p420-421 *** Ask BYTE / Keyboard /
Power Supply
Videosyncrasies (Atari Star Raider tactics).
Feigel, Curtis. col 7:9 Sep82 p386-390 ***
Games / Arcade

BASIC
Anatomy and development of a batch-processing
system. Walters, Gene. art L1 7:5 May82
p334-386 *** Programming Instruction /
Programming Design / North Star
Apple variable errors / Strain-Gage data
collection. Ciarcia, Steve. col 7:4 Apr82
p431 *** Apple II / A/D Converter
Atari tutorial, part 5: scrolling. Crawford,
Chris. art 7:1 Jan82 p26-34 ***
Programming Instruction / Atari / Graphics
Atari tutorial, part 6: Atari BASIC. Winner,
Lane. art L1 7:2 Feb82 p91-118 ***
Programming Instruction / Atari
Atari tutorial, part 7: sound. Fraser, Bob. art
L1 7:3 Mar82 p80-98 *** Programming
Instruction / Sound Effects / Atari
Atari tutorial, part 8: generating sound with
software. Fraser, Bob. art L3 7:4 Apr82
p134-150 *** Atari / Sound Effects /
Programming Instruction
Atari tutorial, part 9: even more colors!
Pitta/Winner. art L1 7:5 May82 p148-160
*** Atari / Color Graphics / Programming
Instruction
BASIC and Pascal benchmark, elegance, apologies
and FORTH. Pournelle, Jerry. col L1 7:10
Oct82 p254-288 *** Benchmark Testing /
Languages / FORTH
BASIC formatted printing (TI BASIC). Subbaiah,
Malladi. col L1 7:3 Mar82 p162-164 ***
Utility Program
BASIC plotting subroutine: sophisticated plotting
with your MX-80. Bregoli, Lawrence. art L1
7:3 Mar82 p142-156 *** Plotting / Utility
Program / Printer
Computer animation with color registers: fast
animation in BASIC (Atari). Fox/Waite. art
L1 7:11 Nov82 p194-214 *** Programming
Instruction / Animation / Atari
Finding words that sound alike: the Soundex
algorithm. Jacobs, Jacob. col L1 7:3 Mar82
p473-474 *** Utility Program / Apple II
Microsoft's BASIC compiler for the TRS-80.
Kelly, Mahlon. sr L1 7:3 Mar82 p358-370
*** Software Review / Compiler / TRS-80 Model
I
On the way to standard BASIC. Kurtz, Thomas.
art 7:6 Jun82 p182-218 *** Standards
Radio Shack Compiler BASIC. Archer, Rowland. sr
L1 7:10 Oct82 p224-250 *** Software
Review / Compiler / TRS-80 Model I
Skip sequential: a new file structure for
microcomputers. Purdum, Jack. art L1 7:3
Mar82 p466-472 *** Data Structures /
Programming Instruction / North Star
Structured programming in BASIC. Sobell, Mark.
art L1 7:1 Jan82 p410-415 *** Structured
Programming / Programming Instruction /
Cromemco
Structured strings in BASIC. Stockburger, David.
col L1 7:5 May82 p308-316 ***
Programming Instruction / Poly-88 / Structured
Programming
TRS-80 BASIC program hang-ups: the reasons and
some solutions. Tesler, Glenn. art L3 7:5
May82 p318-330 *** Programming Instruction /
TRS-80 Model I / TRS-80 Model III

BASIC (CONTINUED)

Text-handling routines in extended BASIC. Greenalgh, Roger. col L1 7:0 Jun82 p460-467 *** Utility Program

BMC 1F800
BMC 1F800. Kocher/Keith. hr 7:5 May82 p62-6b *** Hardware Review / Microcomputer System

BYTE CORRECTIONS
Computing inflation / A closer look at the IBM Personal Computer. col L1 7:3 Mar82 p434-441 ***
Life after death / 6809 machine-code disassembler. col 7:10 Oct82 p390 ***
Mystery coil turns up in Circuit Cellar. col 7:5 May82 p300 ***
PDQ: a data manager for beginners. col L1 7:2 Feb82 p376 ***
Switched assignments ("dUBO-Based Remote Appliance Controller"). col 7:1 Jul82 p32 ***
Switching power supplies / Atari tutorial, part 3. col 7:2 Feb82 p327 ***
Tree searching yields bugs. Steiner, Michael. col 7:0 Jun82 p400 ***

BAUDOT CODE
Input/output primer, part 3: character codes. Leibson, Steve. art 7:6 Jun82 p424-258 ***
Input/Output / ASCII

BENCHMARK TESTING
Apple III and its new Profile. Moore, Robin. hr L1 7:9 Sep82 p92-132 *** Hardware Review / Apple III / Hard Disk Drive
BASIC and Pascal benchmark, elegance, apologies and FORTH. Pournelle, Jerry. col L1 7:10 Oct82 p254-288 *** Languages / FORTH / BASIC
Comparison of five compilers for Apple BASIC. Taylor/Taylor. sr L1 7:9 Sep82 p440-464 *** Software Review / Apple II / Compiler
Four implementations of Pascal. Woteki/Sand. sr L6 7:3 Mar82 p316-356 *** Software Review / Pascal / CP/M
Six personal computers from Japan. Kocher/Keith. art 7:5 May82 p61-102 *** Hardware Review / Microcomputer System
Upward migration, part 2: a comparison of CP/M-86 and MS-DOS. Taylor/Lemmons. art 7:7 Jul82 p330-356 *** CP/M-86 / Operating Systems / MS-DOS

BINARY
Base conversion on the TRS-80 Pocket Computer. Dolan, David. col L1 7:4 Apr82 p436-438 *** Conversions / TRS-80 Pocket Computer / Hexadecimal

BINARY CODED DECIMAL
Input/output primer, part 4: the BCD and serial interfaces. Leibson, Steve. art 7:5 May82 p202-220 *** Serial Input/Output / Interface / RS-232

BINARY-CODED TEXT
Binary-coded text: a text compression method. Tropper, Richard. art 7:4 Apr82 p398-413 *** Information Storage

BOOK REVIEW
Semidisk, Software Tools, the BDOS blues, Power, and LISPs. Pournelle, Jerry. col 7:8 Aug82 p342-363 *** CP/M / LISP / Utility Program
Terminals, keyboards, and...software piracy. Pournelle, Jerry. col 7:11 Nov82 p394-415 *** Terminal / Keyboard / Software Piracy

BROADCASTING
GEOSAT program (calculates the position of communications satellites). Emmett, Steve. art L1 7:1 Jan82 p420-432 *** Utility Program / Data Transmission / Apple II

BUBBLE MEMORY
Bubcom80. Kocher/Keith. hr 7:5 May82 p92-100 *** Hardware Review / Microcomputer System / Bubcom80

BUBCOM80
Bubcom80. Kocher/Keith. hr 7:5 May82 p92-100 *** Hardware Review / Microcomputer System / Bubble Memory

BUSINESS
Adapting microcomputers to Wall Street. Franz, Robert. art 7:10 Oct82 p80-94 *** Stock Market / Management / Investment
Beyond the peaks of Visicalc (Desktop Plan II, Microfinesse, PlanDu). Bishop, Jack. sr 7:10 Oct82 p29-39 *** Software Review / Financial Modeling / Planning
Commodore 8032 business system. Dickerman, Harold. hr 7:3 Aug82 p366-376 *** Hardware Review / Microcomputer System / CBM 8032
Custom and standardized forms for the microcomputer user. Lemmons, Philip. art 7:3 Mar82 p198-205 *** Forms
Designing the Star user interface. Smith/et al. art 7:4 Apr82 p242-282 *** Xerox Star / User Interface
Fill forms system: CP/M programs to cut down on paperwork. Roch, Bill. art L1 7:3 Mar82 p218-238 *** Utility Program / Printer / OSborne I, Danmke, Mark. nr 7:6 Jun82 p348-362 *** Hardware Review / OSborne I / Microcomputer System
Programming PERT in BASIC. Zimmerman/Conrad. art L1 7:5 May82 p405-473 *** Planning / Management / TRS-80 Model I
Programming critical-path method in BASIC. Zimmerman/Conrad. art L1 7:7 Jul82 p378-390 *** Management / TRS-80 Model I
Tax tips for computer owners. Feuerman/Molier. art 7:2 Feb82 p212-214 *** Taxes / Federal Government
What makes business programming hard?. Woodward, James. art 7:10 Oct82 p68-76 *** Programming Design

C PROGRAMMING LANGUAGE

Slew of languages, a slap at documentation, and a curse at keyboards. Pournelle, Jerry. col 7:12 Dec82 p222-246 *** Languages / Pascal / Keyboard
Underline filter for matrix printers. Reed, Adam. col L8 7:3 Mar82 p300-306 *** Printer / Utility Program

CBM
Commodore 4022 printer. Holmes, Joseph. hr 7:3 Mar82 p26-36 *** Hardware Review / Printer / PET
Controlling heat surges / VIC-20 video display / Sweet Talker interface. Ciarcia, Steve. col 7:4 Apr82 p430-431 *** TRS-80 Model I / VIC-20 / Voice Synthesis

CBM 8032
Commodore 8032 business system. Dickerman, Harold. hr 7:8 Aug82 p366-376 *** Hardware Review / Business / Microcomputer System

COBOL
COBOL for the TRS-80 Models I and III. Archer, Rowland. sr L5 7:3 Mar82 p384-412 *** Software Review / TRS-80 Model I / TRS-80 Model III

COSMAC
COSMAC EPROM programmer. Rubis, Dan. art L3 7:1 Jan82 p344-364 *** EPROM / Hardware Construction

CP/M
Ada, MINCE, CP/M utilities, overpriced documentation and Analiza II. Pournelle, Jerry. col 7:7 Jul82 p290-310 *** Ada / Word Processing / Documentation
Autocontrol's AC-85: a CP/M system on one board. Benedict, JoAnne. hr 7:12 Dec82 p250-256 *** Hardware Review / Microcomputer System / AC-85
CP/M, your time has come (real-time clock). Calaway/Hill. art L3 7:5 May82 p479-493 *** Clock / Hardware Construction
Condor Series 20/rOBMS. Abbott, Jack. sr 7:12 Dec82 p404-410 *** Software Review / Data Base Management
Cows and catalogs / TV jitter bugs / Downloading to CP/M / Speedometer. Ciarcia, Steve. col 7:5 May82 p398-400 *** Ask BYTE / Agriculture / TRS-80 Color
Database management with Ashton-Tate's dBase II. Abbott, Jack. sr 7:7 Jul82 p412-416 *** Software Review / Data Base Management
Fill forms system: CP/M programs to cut down on paperwork. Roch, Bill. art L1 7:3 Mar82 p218-238 *** Utility Program / Business / Printer
Four implementations of Pascal. Woteki/Sand. sr L6 7:3 Mar82 p316-356 *** Software Review / Pascal / Benchmark Testing
Listing the disk directory in CP/M-based Pascal. Hunt, Daniel. col L6 7:6 Jun82 p497-501 *** Pascal / Utility Program
Microshell and Unica: Unix-style enhancements for CP/M. Kern, Christopher. sr 7:12 Dec82 p206-220 *** Software Review / Utility Program / UNIX
PL/I for microcomputers (CP/M). Lehman, John. sr L9 7:5 May82 p246-250 *** Software Review / PL/I
Pickles & Trout CP/M for the TRS-80 Model II. Smith, Hal. sr 7:9 Sep82 p531-536 *** Software Review / TRS-80 Model II / Operating Systems
Program generators (The Last One and Quic-N-Easi). Stewart, George. sr L1 7:8 Aug82 p38-56 *** Software Review / Program Generator / TRS-80 Model III
Selector IV by Micro-Ap: an information-management program. Abbott, Jack. sr L1 7:4 Apr82 p371-376 *** Software Review / Data Base Management
Semidisk, Software Tools, the BDOS blues, Power, and LISPs. Pournelle, Jerry. col 7:8 Aug82 p342-363 *** LISP / Book Review / Utility Program
Systems Plus: FMS-80. Abbott, Jack. sr 7:10 Oct82 p447-450 *** Software Review / Data Base Management
Text editing with Compuvision's VEDIT. Thompson, H.B.. sr 7:3 Mar82 p262-270 *** Software Review / Text Editor
Upward migration, part 1: translators (CP/M-86 translators). Taylor/Lemmons. art L3 7:6 Jun82 p321-344 *** Translators / CP/M-86 / 8086

CP/M-86
MS-DOS and CP/M-86 on the IBM Personal Computer: not my dream.... Tinsdale, Mark. col 7:7 Jul82 p354-355 *** Operating Systems / IBM Personal Computer / MS-DOS
MS-DOS and CP/M-86: a system manufacturer's view. Lomas, Richard. col 7:7 Jul82 p352 *** Operating Systems / MS-DOS
Strengths and gaps in MS-DOS and CP/M-86. Fortson/Cook. col 7:7 Jul82 p342-344 *** Operating Systems / MS-DOS
Systems integrator's view of MS-DOS and CP/M-86. Houston, Jerry. col 7:7 Jul82 p338-339 *** Operating Systems / MS-DOS
Upward migration, part 1: translators (CP/M-86 translators). Taylor/Lemmons. art L3 7:6 Jun82 p321-344 *** Translators / M-86 / 8086
Upward migration, part 2: a comparison of CP/M-86 and MS-DOS. Taylor/Lemmons. art 7:7 Jul82 p330-356 *** Operating Systems / Benchmark Testing / MS-DOS

CP/M-86 (CONTINUED)

Vote for MS-DOS. Colvin, Neil. col 7:7 Jul82 p356 *** Operating Systems / MS-DOS

CALCULATOR
Draw poker for the TI-59. Boyle, Lee. col L9 7:7 Jul82 p434-440 *** Games
Getting the most from your TI programmer. Patton, Robert. col L9 7:9 Sep82 p540-541 *** Conversions / Decimal / Hexadecimal
Hewlett-Packard interface loop - HPIL: unique two-wire system.... Katz, Robert. nr 7:4 Apr82 p76-93 *** Hardware Review / Interface
TRS-80 EPROMs / TI-SBC printer interface / ROM-based BASIC / Power backup. Ciarcia, Steve. col 7:2 Feb82 p365-366 *** Ask BYTE / TRS-80 Model I / Printer

CANON CX-1
Canon CX-1. Kocher/Keith. hr 7:5 May82 p66-69 *** Hardware Review / Microcomputer System

CAREER OPPORTUNITIES
Career opportunities in computing. Johnston, Jacqueline. art 7:4 Apr82 p439-446 *** Job Opportunities / Information Sources

CHARACTER GENERATOR
Japanese character sets. col 7:5 May82 p63 *** Foreign Language

CHILDREN
Group of the turtle (group theory in Logo). Lerou, Uri. art 7:8 Aug82 p330-331 *** Logo / Mathematics / Research
Introducing Logo to children. Solomon, Cynthia. art L9 7:8 Aug82 p196-208 *** Programming Instruction / Logo
Logo research at Bank Street College. Jewson/Pea. art 7:8 Aug82 p332-333 *** Logo / Research / Problem-Solving
Logo: an approach to educating disabled children. Weir/et al. art 7:9 Sep82 p422-360 *** Logo / Handicapped / Special Education

CLOCK
Build a half-year clock for the Color Computer: fourth in a series. Barden, William. art L3 7:3 Mar82 p100-122 *** Hardware Construction / TRS-80 Color / Wire Wrap
CP/M, your time has come (real-time clock). Calaway/Hill. art L3 7:5 May82 p479-493 *** CP/M / Hardware Construction
Clocked interrupts for the COSMAC Elf. Price, Gary. art L3 7:1 Jan82 p304-322 *** 1802 / Elf / Multi-tasking
Everyone can know the real time (real-time clocks). Ciarcia, Steve. col L1 7:5 May82 p34-58 *** Hardware Construction / 28 John Bell Engineering's Apple II Parallel Interface Board. Rhodes, Ned. hr L3 7:3 Mar82 p414-430 *** Hardware Review / Parallel Input/Output / Apple II
SOFTIM: a software timer. Terpr3r, Dan. col L3 7:1 Jan82 p436-439 *** 2-80 / Programming Instruction
Tips on homebrewing / BASIC in ROM / Line disturbances & Clock. Ciarcia, Steve. col 7:8 Aug82 p418-420 *** Ask BYTE / Homebrew / Power Supply

CLUBS
Young People's Logo Association. Muller, James. art 7:8 Aug82 p333-334 *** Associations / Logo

COLOR DISPLAY
How to use color displays effectively. Durrett/Trezona. art 7:4 Apr82 p50-53 *** Color Graphics / Video Display / User Interface

COLOR GRAPHICS
Atari tutorial, part 9: even more colors! Pitka/Winner. art L1 7:5 May82 p148-160 *** Atari / Programming Instruction / BASIC
High-resolution sprite-oriented color graphics. Ciarcia, Steve. col L3 7:8 Aug82 p57-80 *** Interface / Apple II / Logo
How to use color displays effectively. Durrett/Trezona. art 7:4 Apr82 p50-53 *** Color Display / Video Display / User Interface
Scion Color System. Danmke, Mark. hr 7:7 Jul82 p54-59 *** Hardware Review / S-100 Bus / High Resolution Graphics

COLOR PRINTER
Integral Data Systems' Prism Printer. Umloer, Ed. hr 7:3 Mar82 p44-49 *** Hardware Review / Printer

COMPILER
Comparison of five compilers for Apple BASIC. Taylor/Taylor. sr L1 7:9 Sep82 p440-464 *** Software Review / Benchmark Testing / Apple II
Control sources / Apple/North Star compiler / S-100 systems. Ciarcia, Steve. col 7:2 Feb82 p367-369 *** Ask BYTE / Control / S-100 Bus
Letters, Pascal, CB/80, and Cardfile. Pournelle, Jerry. col 7:9 Sep82 p318-341 *** Pascal / Word Processing
Microsoft's BASIC compiler for the TRS-80. Kelly, Mahlon. sr L1 7:3 Mar82 p358-370 *** Software Review / BASIC / TRS-80 Model I
Radio Shack Compiler BASIC. Archer, Rowland. sr L1 7:10 Oct82 p224-250 *** Software Review / BASIC / TRS-80 Model I
Supercalc, spelling programs, BASIC compilers, and home-grown accounting. Pournelle, Jerry. col 7:5 May82 p226-243 *** Spelling / Accounting

COMPUTER ASSISTED INSTRUCTION
Assisted instructional development system. Wolfe, George. hr 7:8 Aug82 p408-414 *** Hardware Review / Apple II / Education

- COMPUTER ASSISTED INSTRUCTION (CONTINUED)**
 Thirty more days to faster input. Roberts, Edward. col L1 7:1 Jan82 p106 ***
 Keyboard / TRS-80 Model I / Education
 Videodiscs in education: integrating the computer and... Béjar, Isaac. art L6 7:6 Jun82 p78-104 *** Videodisc / Education
- COMPUTER INSTRUCTION**
 Input/Output primer, part 1: what is I/O? Leibson, Steve. art 7:2 Feb82 p122-146 ***
 Input/Output / Definitions
 Input/Output primer, part 2: interrupts and direct memory access. Leibson, Steve. art 7:3 Mar82 p126-140 *** Input/Output
 Input/Output primer, part 3: the parallel and HP-IB (IEEE-488 interfaces). Leibson, Steve. art 7:4 Apr82 p146-204 *** Parallel
 Input/Output / IEEE-488 Bus / Interface
 Microcomputer graphics primer. Williams, Gregg. art 7:11 Nov82 p448-470 *** Graphics / Video Display / Vendor Guide
- CONFERENCE**
 Third NCGA and the future of computer graphics. Pournelle, Alexander. art 7:11 Nov82 p30-44 *** Graphics / Future
- CONSUMER ELECTRONICS**
 Machines behind the machines (Japanese Manufacturers). Lemmons, Phil. art 7:5 May82 p115-138 *** Manufacturing / Foreign Competition
- CONSUMER INFORMATION**
 Designing a text editor? The user comes first. Jong, Steven. art 7:4 Apr82 p284-300 ***
 Text Editor / Programming Design / Word Processing
 Maintenance alternatives for personal computers. Whitaker, Lewis. art 7:6 Jun82 p452-459 *** Maintenance
 Plotting with the TRS-80 / Matter of environment / Feasibility study. Ciarcia, Steve. col 7:3 Mar82 p445-446 *** Ask BYTE / Plotting / Operating Systems
 Some answers to frequently asked questions. Morgan, Chris. col 7:10 Oct82 p6-14 *** Videotex
- CONTESTS**
 And the winners are... (game contest). col 7:8 Aug82 p84-85 *** Games
 BYTE game contest #2. col 7:8 Aug82 p86-87 *** Games
 Charge! (game contest winner #2). Ray, C. Anthony. art L1 7:12 Dec82 p112-120 *** Games / Arcade / Apple II
 Cosmic conquest (game contest winner #1). Sartori-Angus, Alan. art L7 7:12 Dec82 p124-138 *** Games / Apple II / Arcade
 Game of rat and dragon (Apple II). Smith, Talbot. art L3 7:11 Nov82 p336-374 *** Games / Arcade / Apple II
 Ringquest (Apple II adventure game). Mills, Gordon. art L1 7:10 Oct82 p176-206 *** Games / Strategy / Apple II
- CONTROL**
 8051 one-chip microcomputer: a most powerful microcontroller. doyet/katz. art 7:12 Dec82 p288-311 *** Microprocessor / 8051
 8080-based remote appliance controller. Staehlin, David. art L3 7:1 Jan82 p239-292 *** Home / 8080 / Heath HB
 AC motor control: simple algorithms and hardware. Nyberg, Jostein. col 7:1 Jan82 p118-121 *** Interface / Hardware Construction
 Build an interactive-videodisc controller (Pioneer VP-100W). Ciarcia, Steve. col 7:6 Jun82 p60-74 *** Videodisc / Interface / Hardware Construction
 Computer-controlled irrigation / ZX81 home control / Current overloads. Ciarcia, Steve. col 7:7 Jul82 p420 *** Ask BYTE / Agriculture / TRS-80 Color
 Control sources / Apple/Worth Star compiler / S-100 systems. Ciarcia, Steve. col 7:2 Feb82 p367-369 *** Ask BYTE / Compiler / S-100 Bus
 Putting real-world interfaces to work, part 1 (TRS-80 monitoring). Barden, William. art 7:10 Oct82 p96-123 *** Hardware Construction / TRS-80 Model I / Interface
 Use infrared communication for remote control. Ciarcia, Steve. col 7:4 Apr82 p40-49 *** Hardware Construction / Home
 Versatile low-cost microprocessor controller module. Craig, David. art 7:12 Dec82 p486-498 *** Hardware Construction / 8082
- CONVERSIONS**
 Adapting "Harvesting the Sun's Energy" for the Commodore PET. Berry, Jerry. col L1 7:6 Jun82 p404-408 *** Solar Energy / PET / Home
 Base conversion on the TRS-80 Pocket Computer. Dolan, David. col L1 7:4 Apr82 p430-438 *** Binary / TRS-80 Pocket Computer / Hexadecimal
 Converting Apple DOS and Pascal text files. Matthews, John. art L6 7:4 Apr82 p447-463 *** Apple II / Apple DOS / Pascal
 Getting the most from your TI programmer. Patton, Robert. col L9 7:9 Sep82 p540-541 *** Calculator / Decimal / Hexadecimal
- COPYRIGHT**
 Case of the purloined object code: can it be solved (part 1)? Stern, Richard. art 7:9 Sep82 p420-438 *** Law / Software Publishing / Patent
 Case of the purloined object code: can it be solved?, part 2 (protection). Stern, Richard. art 7:10 Oct82 p210-222 *** Law / Software Publishing
- COPYRIGHT (CONTINUED)**
 Copyrights, computers and the Betamax case. Klasson, Walter. art 7:5 May82 p22-30 *** Law / Software Publishing / Software Piracy
- CORPORATE INFORMATION**
 Microcomputer profits. Libes, Sol. col 7:5 May82 p394 ***
- CROMEMCO**
 Structured programming in BASIC. Sobell, Mark. art L1 7:1 Jan82 p410-415 *** Structured Programming / BASIC / Programming Instruction
 Word-counting utility for writers. Roberts, Steven. col L3 7:6 Jun82 p237-240 *** Writing / Utility Program
- CRYPTOLOGY**
 BASIC program for home cryptography. Roberts, Ralph. col L1 7:4 Apr82 p432-434 ***
 Smoke Signal Broadcasting
- DATA BASE MANAGEMENT**
 Condor Series 20r/DBMS. Abbott, Jack. sr 7:12 Dec82 p404-410 *** Software Review / CP/M
 Database management with Ashton-Tate's dBase II. Abbott, Jack. sr 7:7 Jul82 p412-416 *** Software Review / CP/M
 Selector IV by Micro-Ap: an information-management program. Abbott, Jack. sr L1 7:4 Apr82 p371-376 *** Software Review / CP/M
 Systems Plus: FMS-80. Abbott, Jack. sr 7:10 Oct82 p447-450 *** Software Review / CP/M
- DATA STRUCTURES**
 Effective text-compression algorithm. Cortesi, David. art L9 7:1 Jan82 p397-403 *** Programming Design / Word Processing / Information Storage
 Skip sequential: a new file structure for microcomputers. Purdum, Jack. art L1 7:3 Mar82 p466-472 *** Programming Instruction / BASIC / North Star
- DATA TRANSMISSION**
 GEOSAT program (calculates the position of communications satellites). Emmett, Steve. art L1 7:1 Jan82 p420-432 *** Utility Program / Broadcasting / Apple II
 TAFT: terminal Apple with file transfer. Gabriele, Tom. art L1 7:6 Jun82 p410-432 *** Terminal / Apple II / Telecommunications
- DECIMAL**
 Getting the most from your TI programmer. Patton, Robert. col L9 7:9 Sep82 p540-541 *** Calculator / Conversions / Hexadecimal
- DECISION MAKING**
 Conditionals in LISP (decision-making function). Howard, M.S. col L9 7:6 Jun82 p493-496 *** LISP / Programming Instruction
- DEFINITIONS**
 Input/Output primer, part 1: what is I/O? Leibson, Steve. art 7:2 Feb82 p122-146 ***
 Input/Output / Computer Instruction
 Logo - a cultural glossary. Goldenberg, E. Paul. art 7:8 Aug82 p210-228 *** Logo
 Videodisc interfacing primer. Daynes, Rod. art 7:6 Jun82 p48-59 *** Videodisc / Interface
- DESIGN**
 Board to death. Swanson, Jon. art 7:12 Dec82 p94-95 *** Puzzles
 Brief introduction to electronic music synthesizers. Moog, Robert. art 7:12 Dec82 p278-286 *** Music / Musical Instrument
 Chuck Peddle: an interview with the chief designer of the Victor 9000. Lemmons, Phil. art 7:11 Nov82 p256-271 *** Interview / People / Victor 9000
 FDA regulation of computerized medical devices. Jorgens/et al. art 7:9 Sep82 p204-214 *** Medicine / Handicapped / Government Regulation
 Floppy-disk performance. Yaltrakis, N. col 7:1 Jan82 p114-116 *** Floppy Disk Drive / Test
 Hierarchical interrupts. Foster, Caxton. col 7:5 May82 p457-459 *** Microprocessor
 Introduction to the human applications standard computer interface, pt 1. Rutkowski, Chris. art 7:10 Oct82 p291-310 *** User Interface / Standards
 Practical dynamic-memory system design. Belics, Rob. art 7:12 Dec82 p372-385 *** Memory / Interface
 Programming the RS-232 serial port / Build your own / RF1. Ciarcia, Steve. col 7:3 Mar82 p444-445 *** Ask BYTE / RS-232 / Radio-frequency Interference
- DIGITAL AUDIO**
 Analyze audio by visualizing. Phillips, Thomas. col L3 7:1 Jan82 p206-214 *** Voice Synthesis / /
- DIGITAL VIDEO**
 Build a video digitizer (image processing). Keryan, Michael. art 7:11 Nov82 p174-192 *** Hardware Construction / Image Processing
 Dithertizer II (video-digitizer interface for the Apple II). Tomas, Joe. hr 7:2 Feb82 p219-224 *** Hardware Review / Interface / Apple II
- DIGITAL/ANALOG CIRCUIT**
 Analog interfacing in the real world. Ciarcia, Steve. col 7:1 Jan82 p72-98 *** Hardware Construction / Analog/Digital Circuit / Interface
- DIRECTORIES**
 BYTE printer directory. Feigel, Curtis. art 7:3 Mar82 p278-296 *** Printer
- DISASSEMBLER**
 6809 machine-code disassembler. Dubner, Joseph. art L3 7:2 Feb82 p340-364 *** 6809
- DISKETTES**
 Find that disk (storing disks). Bruninga, R.E. col 7:6 Jun82 p232 ***
- DOCUMENTATION**
 Ada, MINCE, CP/M utilities, overpriced documentation and Analiza II. Pournelle, Jerry. col 7:7 Jul82 p290-310 *** Ada / Word Processing / CP/M
 INS8070 series instruction set summary. Chiang, James. col 7:7 Jul82 p406-407 *** INS8070
 Little Apple SOS with your Pascal. O'Konski, Tim. art L3 7:12 Dec82 p448-482 *** Apple III / Pascal / Input/Output
- EPROM**
 Build an EPROM emulator. Rehneke, Eric. art 7:2 Feb82 p194-203 *** Hardware Construction / Emulator / 6502
 COSMAC EPROM programmer. Rubis, Dan. art L3 7:1 Jan82 p344-364 *** COSMAC / Hardware Construction
 Let the MC68701 program itself. Morales/Ruhberg. col L3 7:8 Aug82 p380-394 *** Hardware Construction / 68701 / EPROM Programmer
 Speech synthesizer application / Problems with EPROM / Modem interface. Ciarcia, Steve. col 7:3 Mar82 p442 *** Ask BYTE / Voice Synthesis / Modem
- EPROM PROGRAMMER**
 Let the MC68701 program itself. Morales/Ruhberg. col L3 7:8 Aug82 p380-394 *** Instruction / 68701 / EPROM Programmer
- EDUCATION**
 Assisted instructional development system. Wolfe, George. hr 7:8 Aug82 p408-414 *** Hardware Review / Computer Assisted Instruction / Apple II
 Designing computer-based microworlds (Logo). Lawler, R.W. art L9 7:8 Aug82 p138-160 *** Logo / Programming Design
 Leading fish to water: early observations on the use of Logo. Higginson, William. art 7:8 Aug82 p328-329 *** Logo / Apple II
 Thirty more days to faster input. Roberts, Edward. col L1 7:1 Jan82 p186 ***
 Keyboard / Computer Assisted Instruction / TRS-80 Model I
 Videodiscs in education: integrating the computer and... Béjar, Isaac. art L6 7:6 Jun82 p78-104 *** Videodisc / Computer Assisted Instruction
 Why Logo? (problem-solving skills). Harvey, Brian. art L9 7:8 Aug82 p163-193 *** Logo / Problem-Solving
- ELEMENTARY EDUCATION**
 Lamplighter project (Logo). Gorman, Henry. art 7:8 Aug82 p331-332 *** Logo
 Logo in the schools. Watt, Daniel. art 7:8 Aug82 p116-134 *** Logo / Research / Information Sources
 Logo update. Lemmons, Phil. art 7:8 Aug82 p334-340 *** Logo / Secondary Education / Higher Education
- ELF**
 Clocked interrupts for the COSMAC Elf. Price, Gary. art L3 7:1 Jan82 p304-322 *** 1802 / Clock / Multi-tasking
- EMULATOR**
 Build an EPROM emulator. Rehneke, Eric. art 7:2 Feb82 p194-203 *** Hardware Construction / EPROM / 6502
- EPSON HX-20**
 Epson HX-20: the first BYTE-sized computer. Williams, Gregg. art 7:4 Apr82 p104-106 *** Microcomputer System
- EPSON QX-10**
 Epson QX-10 Valdocs System. Williams, Gregg. art 7:9 Sep82 p54-57 *** Microcomputer System
- FORTH**
 BASIC and Pascal benchmark, elegance, apologies and FORTH. Pournelle, Jerry. col L1 7:10 Oct82 p254-288 *** Benchmark Testing / Languages / BASIC
 Computer toolbox (microcomputer as a lab assistant). Bernstein, Mark. art 7:3 Mar82 p456-465 *** Higher Education / Research / Science
 Disk operating system for FORTH: an in-depth look at how a DOS operates. Reece, Peter. art L7 7:4 Apr82 p322-358 *** Operating Systems / Programming Design / TRS-80 Model I
 Super FORTH isn't. Williams, Gregg. sr 7:5 May82 p296-298 *** Software Review / Apple II
- FEDERAL GOVERNMENT**
 FIT - a federal income tax program in UCSD Pascal. Heyman, Edward. art L6 7:2 Feb82 p148-190+ *** Taxes / Pascal
 Keeping our technological edge. Morgan, Chris. col 7:8 Aug82 p6-18 *** Research / Foreign Competition
 Tax tips for computer owners. Feuerman/Moller. art 7:2 Feb82 p212-214 *** Taxes / Business
 Two tax aids (Individual Tax Plan and Tax Preparer). Kvam, Mary Jo. sr 7:2 Feb82 p204-212 *** Software Review / Taxes / Apple II
- FICTION**
 Computers, fiction and poetry (stories and poems written by computers). McKean, Kevin. art 7:7 Jul82 p50-53 *** Poetry / Writing
- FINANCES**
 Micro-Decision Support System/Finance (DSS/F). Moskowitz, Robert. sr 7:6 Jun82 p488-492 *** Software Review / Financial Modeling / Apple II
 Pascal NOW: let Pascal balance your NOW account. Doyle, Thomas. art L6 7:2 Feb82 p290-322 *** Pascal / Money

FINANCIAL MODELING

Beyond the peaks of Visicalc (Desktop Plan II, Microfinesse, Plan80). Bishop, Jack. sr 7:10 Oct82 p29-39 *** Software Review / Planning / Business
Micro-Decision Support System/Finance (DSS/F). Moskowitz, Robert. sr 7:6 Jun82 p48d-492 *** Software Review / Finances / Apple II

FLOPPY DISK DRIVE

Disk drives / ADM-3 lowercase / VIC cassette / S-100 & TRS-80 / ZX81. Ciarcia, Steve. col 7:10 Oct82 p452-454 *** Ask BYTE / VIC-zu / TRS-80 Model I
Floppy-disk performance. Yalirakis, N. col 7:1 Jan82 p114-116 *** Test / Design
Heath/Zenith Model 47 dual floppy-disk system. Kern, Christopher. hr 7:8 Aug82 p39d-406 *** Hardware Review / Heath H89 / Zenith Z89

FLYING

Jetset (TRS-80 Model II flying simulation). Szymanski, Eugene. art L1 7:11 Nov82 p272-322 *** Games / TRS-80 Model II / Simulation
Omni aviation navigation system. Campbell, Richard. art L1 7:6 Jun82 p46d-47d *** Navigation / Simulation / Mathematics

FOREIGN COMPETITION

Japan and the "64K" Question. Morgan, Chris. col 7:5 May82 p6-10 *** Future
Japan maps computer domination. Manuel, Tom. art 7:5 May82 p140-144 *** Research / Future
Japanese manufacturers - how successful will they be?. Zipnick, Ted. col 7:5 May82 p11d *** Marketing
Keeping our technological edge. Morgan, Chris. col 7:8 Aug82 p6-1d *** Research / Federal Government
Machines behind the machines (Japanese Manufacturers). Lemmons, Phil. art 7:5 May82 p115-138 *** Manufacturing / Consumer Electronics

FOREIGN LANGUAGE

Japanese character sets. col 7:5 May82 p63 *** Character Generator

FORMS

Custom and standardized forms for the microcomputer user. Lemmons, Philip. art 7:3 Mar82 p198-205 *** Business

FOURIER TRANSFORMS

Fast approximation for fast Fourier. Polczynski, Mark. col 7:2 Feb82 p248-250 *** Mathematics

FUJITSU FM-8

Fujitsu FM-8. Kocher/Keith. hr 7:5 May82 p86-92 *** Hardware Review / Microcomputer System

FUTURE

Japan and the "64K" Question. Morgan, Chris. col 7:5 May82 p6-10 *** Foreign Competition
Japan maps computer domination. Manuel, Tom. art 7:5 May82 p140-144 *** Research / Foreign Competition
Third NCGA and the future of computer graphics. Pournelle, Alexander. art 7:11 Nov82 p37-44 *** Conference / Graphics

GAMES

Action games for the VIC-20. Kavanagh, Russell. sr 7:12 Dec82 p150-156 *** Software Review / Arcade / VIC-20
Advanced Star Raider tactics and strategies. Harris, C. Donald. col 7:9 Sep82 p383-396 *** Atari / Arcade
Alien typhoon (Apple II game). Latocha, Walt. sr 7:5 May82 p224 *** Software Review / Arcade / Apple II
And the winners are... (game contest). col 7:8 Aug82 p84-85 *** Contests
Apple Panic. Williams, Gregg. sr 7:3 Mar82 p68-69 *** Software Review / Arcade / Apple II
Armored Patrol. Callamaras, Pete. sr 7:6 Jun82 p162-166 *** Software Review / Arcade / TRS-80 Model I
BYTE game contest #2. col 7:8 Aug82 p86-87 *** Contests
Beer Run (Apple II arcade game). Little, Arthur. sr 7:9 Sep82 p375-379 *** Software Review / Arcade / Apple II
Charge! (game contest winner #2). Ray, C. Anthony. art L1 7:12 Dec82 p112-120 *** Contests / Arcade / Apple II
Coinless arcade (Dec82). Clark/Williams. art 7:12 Dec82 p84-91 *** Arcade
Cosmic conquest (game contest winner #1). Sartori-Angus, Alan. art L7 7:12 Dec82 p124-138 *** Contests / Apple II / Arcade
Deadline: the butler did it...this time. Morgan, Chris. sr 7:12 Dec82 p160-161 *** Software Review / Strategy / Apple II
Design techniques and ideals for computer games. Crawford, Chris. art 7:12 Dec82 p96-108 *** Programming Design
Dino Wars. Stewart, George. sr 7:3 Mar82 p74-76 *** Software Review / Arcade / TRS-80 Color
Draw poker for the TI-59. Boyle, Lee. col L9 7:7 Jul82 p34-44 *** Calculator
Galactic Chase. Wszola, Stan. sr 7:6 Jun82 p176-180 *** Software Review / Arcade / Atari
Game of rat and dragon (Apple II). Smith, Talbot. art L3 7:11 Nov82 p336-374 *** Arcade / Apple II / Contests
Jetset (TRS-80 Model II flying simulation). Szymanski, Eugene. art L1 7:11 Nov82 p272-322 *** TRS-80 Model II / Simulation / Flying

GAMES (CONTINUED)

Marketplace (TRS-80 Model III telecommunication game). Dickinson, Robert. art L1 7:10 Oct82 p146-174 *** Telecommunications / Strategy / TRS-80 Model III
Missile Command. Wszola, Stanley. sr 7:3 Mar82 p70-74 *** Software Review / Arcade / Atari
Penetrator. Wszola, Stan. sr 7:12 Dec82 p162-164 *** Software Review / Arcade / TRS-80 Model III
Play's the thing. Clark, Pamela. col 7:12 Dec82 p6-10 *** Arcade
Quinti-maze (Apple II game). Tsuk, Robert. art L1 7:9 Sep82 p24-30 *** Puzzles / Apple II / Strategy
Ricochet. Williams, Gregg. sr 7:12 Dec82 p142-146 *** Software Review / Arcade / Apple II
Ringquest (Apple II adventure game). Mills, Gordon. art L1 7:10 Oct82 p176-206 *** Strategy / Apple II / Contests
Swashbuckler (Apple II arcade game). Spangenberg, Scott. sr 7:9 Sep82 p362-367 *** Software Review / Arcade / Apple II
Tawala's last redoubt (Apple II and TRS-80 adventure game). Lesser, Hartley. sr 7:6 Jun82 p235-236 *** Software Review / Strategy / Apple II
The Eliminator: mayhem in space, TRS-80 style. Pike, Silas. sr 7:6 Jun82 p170-174 *** Software Review / Arcade / TRS-80 Model I
Three Dee Tee (TRS-80 Color Computer game). Stuart, John. art L1 7:9 Sep82 p34-50 *** Puzzles / Strategy / TRS-80 Color
Vectrex Arcade System. Clark, Pamela. hr 7:12 Dec82 p92-93 *** Hardware Review / Video Game System / Arcade
Videosyncrasies (Atari Star Raider tactics). Feigel, Curtis. col 7:9 Sep82 p386-390 *** Arcade / Atari
Zero Gravity Pinball (Apple II arcade game). Friedman, Mark. sr 7:9 Sep82 p370-372 *** Software Review / Arcade / Apple II

GOVERNMENT REGULATION

FDA regulation of computerized medical devices. Jorgens/et al. art 7:9 Sep82 p204-214 *** Medicine / Design / Handicapped

GRAPHICS

Atari tutorial, part 5: scrolling. Crawford, Chris. art 7:1 Jan82 p26-34 *** Programming Instruction / Atari / BASIC
Beginner's guide to Logo. Abelson, Harold. art L9 7:8 Aug82 p88-112 *** Programming Instruction / Logo
CHEDIT: a graphics-character editor (Apple Pascal). Sweet, Jerry. art L6 7:5 May82 p426-444 *** Utility Program / Apple II / Pascal
Character editor for the Atari. Kilby, Tim. art L1 7:12 Dec82 p167-179 *** Utility Program / Atari / Programming Instruction
Double your TRS-80's graphics resolution. Haddad, George. col L1 7:7 Jul82 p448-451 *** TRS-80 Model I / Hardware Modification
Homebrew graphics digitizer. Atkins/Castro-Cid. art L1 7:2 Feb82 p72-86 *** Art / Hardware Construction / Graphics Tablet
Microcomputer graphics primer. Williams, Gregg. art 7:11 Nov82 p448-470 *** Video Display / Computer Instruction / Vendor Guide
Third NCGA and the future of computer graphics. Pournelle, Alexander. art 7:11 Nov82 p30-44 *** Conference / Future

GRAPHICS TABLET

Homebrew graphics digitizer. Atkins/Castro-Cid. art L1 7:2 Feb82 p72-86 *** Hardware Construction / Graphics Tablet

HP-75C

Deus ex Machina of the technological age. Morgan, Chris. col 7:12 Dec82 p6-10 *** Portable Computer

HAND-HELD COMPUTER

New horizon for nonvocal communication devices. Demasco/Foulds. art L1 7:9 Sep82 p166-182 *** Handicapped

HANDICAPPED

Abilityphone (message system for handicapped people). Rush, William. hr 7:9 Sep82 p240-246 *** Hardware Review / Telecommunications / Telephone
Adaptive-firmware card for the Apple II (alternative input techniques). Schwajda/et al. art 7:9 Sep82 p276-314 *** Input/Output / Hardware Construction / Apple II
Apple talks with the deaf. Rhodes, Ned. art L3 7:1 Jan82 p366-386 *** Interface / Apple II / Telecommunications
Braille writing in Pascal. Fant, Alfred. art L6 7:9 Sep82 p250-268 *** Printer
Computers can play a dual role for disabled individuals. Vanderheiden, Gregg. art 7:9 Sep82 p136-162 *** Information Sources
FDA regulation of computerized medical devices. Jorgens/et al. art 7:9 Sep82 p204-214 *** Medicine / Design / Government Regulation
Let there be talking people too. Dahmke, Mark. col 7:9 Sep82 p6-8 *** Voice Synthesis
Logo: an approach to educating disabled children. Weir/et al. art 7:9 Sep82 p342-360 *** Logo / Special Education / Children
Minspeak (semantic compaction system for disabled individuals). Baker, Bruce. art 7:9 Sep82 p186-202 *** Voice Synthesis
New horizon for nonvocal communication devices. Demasco/Foulds. art L1 7:9 Sep82 p166-182 *** Hand-held Computer

HANDICAPPED (CONTINUED)

Talking terminals (text-to-speech translation). Stoffel, David. art 7:9 Sep82 p218-227 *** Terminal / Voice Synthesis / Vendor Guide

HARD DISK DRIVE

Apple III and its new Profile. Moore, Robin. hr L1 7:9 Sep82 p92-132 *** Hardware Review / Apple III / Benchmark Testing
Four new products from Radio Shack (TRS-80 Model 16, hard disk, terminal). Morgan, Chris. art 7:3 Mar82 p40-43 *** TRS-80 Pocket Computer / High Resolution Graphics / TRS-80 Model 16

HARDWARE CONSTRUCTION

AC motor control: simple algorithms and hardware. Hyberg, Jostein. col 7:1 Jan82 p118-121 *** Control / Interface
Adaptive-firmware card for the Apple II (alternative input techniques). Schwajda/et al. art 7:9 Sep82 p276-314 *** Handicapped / Input/Output / Apple II
Add a cassette interface to your VIC-20. Hale, William. col 7:3 Mar82 p272-274 *** Tape Cassette / Interface / VIC-20
Add a peripheral interface adapter to your Apple II. Ciszewski, Kenneth. col L3 7:1 Jan82 p324-330 *** Interface / Parallel Input/Output / Apple II
Add programmable sound effects to your computer. Ciarcia, Steve. col L1 7:7 Jul82 p60-72 *** Sound Effects / Interface
Analog interfacing in the real world. Ciarcia, Steve. col 7:1 Jan82 p72-98 *** Analog/Digital Circuit / Digital/Analog Circuit / Interface
Build a computerized weather station. Ciarcia, Steve. col L3 7:2 Feb82 p38-68 *** Weather / Kit Building / Voice Synthesis
Build a half-year clock for the Color Computer: fourth in a series. Barden, William. art L3 7:3 Mar82 p100-122 *** Clock / TRS-80 Color / Wire Wrap
Build a video digitizer (image processing). Keryan, Michael. art 7:11 Nov82 p174-192 *** Digital Video / Image Processing
Build an EPROM emulator. Rehne, Eric. art 7:2 Feb82 p194-203 *** EPROM / Emulator / 6502
Build an interactive-videoedisc controller (Pioneer VP-1000). Ciarcia, Steve. col 7:6 Jun82 p60-74 *** Videodisc / Interface / Control
Build the Circuit Cellar MPX-16 computer system, part 1. Ciarcia, Steve. col 7:11 Nov82 p78-114 *** Microcomputer System / 8088
Build the Circuit Cellar MPX-16 computer system, part 2. Ciarcia, Steve. col 7:12 Dec82 p42-78 *** Microcomputer System / 8088
Build the Microvox text-to-speech synthesizer, part 1: hardware. Ciarcia, Steve. col 7:9 Sep82 p64-88 *** Voice Synthesis
Build the Microvox text-to-speech synthesizer, part 2: software. Ciarcia, Steve. col L9 7:10 Oct82 p40-64 *** Voice Synthesis / Programming Instruction
COSMAC EPROM programmer. Rubis, Dan. art L3 7:1 Jan82 p344-364 *** COSMAC / EPROM CP/M, your time has come (real-time clock). Calaway/Hill. art L3 7:5 May82 p479-493 *** Clock / CP/M
Everyone can know the real time (real-time clocks). Ciarcia, Steve. col L1 7:5 May82 p34-58 *** Clock / Z8
General-purpose I/O board for the Color Computer. Barden, William. art L1 7:6 Jun82 p260-282 *** Interface / TRS-80 Color / Input/Output
General-purpose I/O board for the TRS-80 Models I and II. Barden, William. art L1 7:8 Aug82 p291-321 *** Input/Output / TRS-80 Model I / TRS-80 Model III
Give your Apple a voice (Radio Shack Speech Synthesizer). Blankenship, John. art L1 7:5 May82 p446-456 *** Voice Synthesis / Interface / Apple II
Homebrew graphics digitizer. Atkins/Castro-Cid. art L3 7:2 Feb82 p72-86 *** Graphics / Art / Graphics Tablet
Let the MC68701 program itself. Morales/Ruhberg. col L3 7:8 Aug82 p380-394 *** EPROM / 68701 / EPROM Programmer
Memory expansion for the ZX80. Ernde, Hilton. art L3 7:1 Jan82 p216-232 *** Memory / Kit Building / Sinclair ZX80
Microvex: the other type of video display. Garrett, Billy. art L1 7:11 Nov82 p508-528 *** Video Display / High Resolution Graphics / TRS-80 Model I
Model III A to D revisited. Barden, William. art L1 7:9 Sep82 p398-418 *** Analog/Digital Circuit / TRS-80 Model III / A/D Converter
Po(r)tpourri of ideas (TRS-80 tone generator, telephone dialer, RS-232). Barden, William. art L3 7:4 Apr82 p158-182 *** TRS-80 Model I / TRS-80 Model III / Input/Output
Putting real-world interfaces to work, part 1 (TRS-80 monitoring). Barden, William. art 7:10 Oct82 p96-123 *** Control / TRS-80 Model I / Interface
Turn your Apple II into a storage oscilloscope. Korba, Larry. art L3 7:9 Sep82 p520-530 *** Test Equipment / Apple II
Use infrared communication for remote control. Ciarcia, Steve. col 7:4 Apr82 p40-49 *** Control / Home
Use voiceprints to analyze speech. Ciarcia, Steve. col 7:3 Mar82 p50-64 *** Speech Recognition

HARDWARE CONSTRUCTION (CONTINUED)

Versatile low-cost microprocessor controller module. Craig, David. art 7:12 Dec82 p486-498 *** Control / 6802
Voice synthesis for the Color Computer: third in a series. Barden, William. art L3 7:2 Feb82 p258-286 *** TRS-80 Color / Voice Synthesis
HARDWARE MODIFICATION
Accidental reset protection for the Apple II. Dewilde, Greg. col 7:1 Jan82 p234-236 *** Apple II
Add a full-sized keyboard to Sinclair's ZX80. Cosshall, Wayne. art 7:3 Mar82 p256-261 *** Sinclair ZX80 / Keyboard
Double your TRS-80's graphics resolution. Haddad, George. col L1 7:7 Jul82 p448-451 *** TRS-80 Model I / Graphics
Modify your Paper Tiger for different paper thicknesses. Sarna, R.P.. art 7:3 Mar82 p158-160 *** Printer
Z80 starting address: one jump further. Lemmen, Steven. col 7:1 Jan82 p433-435 *** Z-80

HARDWARE REVIEW

Abilityphone (message system for handicapped people). Rush, William. hr 7:9 Sep82 p240-246 *** Handicapped / Telecommunications / Telephone
Autocontrol's AC-85: a CP/M system on one board. Benedict, JoAnne. hr 7:12 Dec82 p250-256 *** Microcomputer System / CP/M / AC-85
BMC 1f800. Kocher/Keith. hr 7:5 May82 p62-66 *** Microcomputer System / BMC 1f800
Base 2 printer. Jeffries, Walter. hr 7:3 Mar82 p200-216 *** Printer
Bubcom80. Kocher/Keith. hr 7:5 May82 p92-100 *** Microcomputer System / Bubble Memory / Bubcom80
CMOS: memory with a future, ideas behind CompuPro's RAM 17. Anderson, Craig. hr 7:1 Jan82 p418-419 *** Memory / S-100 Bus
Canon CX-1. Kocher/Keith. hr 7:5 May82 p66-69 *** Microcomputer System / Canon CX-1
Closer look at the IBM Personal Computer. Williams, Gregg. hr L1 7:1 Jan82 p36-68 *** IBM Personal Computer / Microcomputer System
Coln Robotics Armadroid: the small-systems robot. Leininger, Steve. hr 7:5 May82 p286-294 *** Robots / Kit Building
Colonial SB-80. Little, Arthur. hr 7:11 Nov82 p324-334 *** Microcomputer System / SB-80
Color Computer disk system. Stearns, Colin. hr 7:7 Jul82 p312-328 *** Minidisk Drive / TRS-80 Color / Operating Systems
Commodore 4022 printer. Holmes, Joseph. hr 7:3 Mar82 p26-36 *** Printer / PET / CBM
Fujitsu FM-8. Kocher/Keith. hr 7:5 May82 p86-92 *** Microcomputer System / Fujitsu FM-8
Heath/Zenith Model 47 dual floppy-disk system. Kern, Christopher. hr 7:8 Aug82 p398-406 *** Floppy Disk Drive / Heath H89 / Zenith 289
Hewlett-Packard interface loop - HPIL: unique two-wire system.... Katz, Robert. hr 7:4 Apr82 p76-93 *** Calculator / Interface
Hitachi MB-6890. Kocher/Keith. hr 7:5 May82 p74-84 *** Microcomputer System / Hitachi MB-6890
Integral Data Systems' Prism Printer. Umor, Ed. hr 7:3 Mar82 p44-49 *** Color Printer / Printer
It all depends on your viewpoint (ADDS Viewpoint video terminal). Moore, Allen. hr 7:7 Jul82 p408-411 *** Terminal
Lobo Max-80. Daneiliuk, Tim. hr 7:12 Dec82 p390-391 *** Microcomputer System / Lobo Max-80
Mediamix's ETI. Welborn, Robert. hr 7:7 Jul82 p284-288 *** Printer / Interface / Typewriter
NEC PC-8001 A. Kocher/Keith. hr 7:5 May82 p69-74 *** PC-8001 / Microcomputer System
RCA VP-3301 data terminal. Daneiliuk, Tim. hr 7:1 Jan82 p123-128 *** Terminal
SD Systems' Z80 Starter Kit. Angevine, Wayne. hr 7:1 Jan82 p332-342 *** Z-80 / Microcomputer System / Kit Building
Six personal computers from Japan. Kocher/Keith. art 7:5 May82 p81-102 *** Microcomputer System / Benchmark Testing
Tele-VIC: Commodore breaks the \$100 price barrier for modems. Lebow, Max. hr L1 7:3 Mar82 p240-246 *** VIC-20 / Modem / Terminal
Victor victorious: the Victor 9000 computer. Lemmons, Phil. hr 7:11 Nov82 p216-254 *** Microcomputer System / Victor 9000
Wise Technology's WY-100 terminal. Haas, Mark. hr 7:10 Oct82 p392-396 *** Terminal

APPLE II

Apple II 80-column video boards: five popular units. Howland, John. hr 7:5 May82 p252-266 *** Video Display / Apple II
Apple III and its new Profile. Moore, Robin. hr L1 7:9 Sep82 p92-132 *** Apple III / Hard Disk Drive / Benchmark Testing
Applescope stores dual traces. MacNicol, Gregory. hr 7:6 Jun82 p364-372 *** Test Equipment / Apple II
Assisted instructional development system. Wolfe, George. hr 7:8 Aug82 p408-414 *** Computer Assisted Instruction / Apple II / Education
Cognivox V10-1003: voice recognition and output for the Apple II. Murray, William. hr 7:9 Sep82 p231-238 *** Speech Recognition / Apple II

HARDWARE REVIEW (CONTINUED)

Dithertizer II (video-digizer interface for the Apple II). Tomas, Joe. hr 7:2 Feb82 p219-224 *** Digital Video / Interface / Apple II
John Bell Engineering's Apple II Parallel Interface Board. Rhodes, Ned. hr L1 7:3 Mar82 p414-430 *** Parallel Input/Output / Apple II / Clock
More Apple 80-column boards. Williams, Gregg. hr 7:5 May82 p266-271 *** Video Display / Apple II
Soundchaser Computer Music Systems. Moog, Robert. hr 7:12 Dec82 p260-277 *** Music / Apple II / Musical Instrument
Strawberry Tree's Dual Thermometer Card for the Apple. Murray, William. hr 7:4 Apr82 p96-100 *** Apple II

BUSINESS

Commodore 8032 business system. Dickerman, Harold. hr 7:8 Aug82 p366-376 *** Business / Microcomputer System / CBM 8032
Osborne I. Dahmke, Mark. hr 7:6 Jun82 p348-362 *** Osborne I / Microcomputer System / Business

EDUCATION

Assisted instructional development system. Wolfe, George. hr 7:8 Aug82 p408-414 *** Computer Assisted Instruction / Apple II / Education

GAMES

Vectrex Arcade System. Clark, Pamela. hr 7:12 Dec82 p92-93 *** Video Game System / Games / Arcade

GRAPHICS

Cambridge Development Lab's High-Resolution Video Graphics System. DeKock, James. hr 7:11 Nov82 p148-160 *** Interface / High Resolution Graphics / S-100 Bus
Graphics II by Selanar: high-resolution hard copy from a DECwriter. Macero/et al. hr L1 7:3 Mar82 p172-196 *** High Resolution Graphics / Printer
Scion Color System. Dahmke, Mark. hr 7:7 Jul82 p54-59 *** Color Graphics / S-100 Bus / High Resolution Graphics

HEATH H89

8080-based remote appliance controller. Staehlin, David. art L3 7:1 Jan82 p239-292 *** Control / Home / 8080

HEATH H89

Heath/Zenith Model 47 dual floppy-disk system. Kern, Christopher. hr 7:8 Aug82 p398-406 *** Hardware Review / Floppy Disk Drive / Zenith 289

HEXADECIMAL

Dolan conversion on the TRS-80 Pocket Computer. Bolan, David. col L1 7:4 Apr82 p436-438 *** Conversions / Binary / TRS-80 Pocket Computer
Getting the most from your TI programmer. Patton, Robert. col L9 7:9 Sep82 p540-541 *** Calculator / Conversions / Decimal

HIGH RESOLUTION GRAPHICS

Cambridge Development Lab's High-Resolution Video Graphics System. DeKock, James. hr 7:11 Nov82 p148-160 *** Hardware Review / Interface / S-100 Bus
Double-width Silentyte graphics for your Apple. Putney, Charles. col L3 7:2 Feb82 p413-423 *** Apple II / Printer / Utility Program

Executive briefing system: a color graphics development for the Apple II. Gallamaras, Peter. sr 7:11 Nov82 p164-170 *** Software Review / Utility Program / Apple II
Four new products from Radio Shack (TRS-80 Model 16, hard disk, terminal). Morgan, Chris. art 7:3 Mar82 p40-43 *** Hard Disk Drive / TRS-80 Pocket Computer / TRS-80 Model 16

GRPRINT: an Apple utility program for dot-matrix printers. Arnott, Douglas. art L3 7:12 Dec82 p398-403 *** Utility Program / Printer / Apple II
Graphics II by Selanar: high-resolution hard copy from a DECwriter. Macero/et al. hr L1 7:3 Mar82 p172-196 *** Hardware Review / Printer
Microvec: the other type of video display. Garrett, Billy. art L1 7:11 Nov82 p508-528 *** Video Display / Hardware Construction / TRS-80 Model I

Scion Color System. Dahmke, Mark. hr 7:7 Jul82 p54-59 *** Hardware Review / Color Graphics / S-100 Bus
Tronic imagery. Sorensen, Peter. art 7:11 Nov82 p48-74 *** Motion Pictures / Animation

HIGHER EDUCATION

Computer toolbox (microcomputer as a lab assistant). Bernstein, Mark. art 7:3 Mar82 p456-465 *** Research / Science / FORTH
Logo update. Lemmons, Phil. art 7:8 Aug82 p334-340 *** Logo / Secondary Education / Elementary Education

HISTORY

Historian and the microcomputer. Rowney, Don. art 7:7 Jul82 p166-176 *** Social Science / Statistics
Microprocessor's tenth birthday. Morgan, Chris. col 7:3 Mar82 p6-10 *** Microprocessor / 4004

HITACHI MB-6890

Hitachi MB-6890. Kocher/Keith. hr 7:5 May82 p74-84 *** Hardware Review / Microcomputer System

HOME

8080-based remote appliance controller. Staehlin, David. art L3 7:1 Jan82 p239-292 *** Control / 8080 / Heath H89
Adapting "Harvesting the Sun's Energy" for the Commodore PET. Berry, Jerry. col L1 7:6 Jun82 p404-408 *** Solar Energy / PET / Conversions
Use infrared communication for remote control. Ciarcia, Steve. col 7:4 Apr82 p40-49 *** Control / Hardware Construction

HOME BREW

Tips on homebrewing / BASIC in ROM / Line disturbances / Clock. Ciarcia, Steve. col 7:8 Aug82 p418-420 *** Ask BYTE / Power Supply / Clock

HUMOR

Generic word processor: a word-processing system for all your needs. Schrodt, Philip. art 7:4 Apr82 p32-36 ***
MicroShakespeare - 3. Kalnik, Andrew. col 7:4 Apr82 p362-366 ***

IBM PERSONAL COMPUTER

Closer look at the IBM Personal Computer. Williams, Gregg. hr L1 7:1 Jan82 p36-68 *** Hardware Review / Microcomputer System
Human-factors case study based on the IBM Personal Computer. Cooper/et al. art 7:4 Apr82 p56-72 *** User Interface / Keyboard / Video Display
Lotus Development Corporation's 1-2-3. Williams, Gregg. sr 7:12 Dec82 p182-198 *** Software Review / Spreadsheet
MS-DOS and CP/M-86 on the IBM Personal Computer: not my dream.... Tinsdale, Mark. col 7:7 Jul82 p354-355 *** Operating Systems / CP/M-86 / MS-DOS
Of IBM, operating systems and Rosetta Stones. Morgan, Chris. col 7:1 Jan82 p6-10 *** Operating Systems / Standards

IEEE-488 BUS

Data in, garbage out / RS-232C-to-IEEE-488 interface. Ciarcia, Steve. col 7:5 May82 p400-404 *** Ask BYTE / Power Supply / RS-232
Input/Output primer, part 3: the parallel and HP1B (IEEE-488 interfaces). Leibson, Steve. art 7:4 Apr82 p186-208 *** Parallel Input/Output / Computer Instruction / Interface

INS8070

INS8070 series instruction set summary. Chiang, James. col 7:7 Jul82 p406-407 *** Documentation

IMAGE PROCESSING

Build a video digitizer (image processing). Keryan, Michael. art 7:11 Nov82 p174-192 *** Hardware Construction / Digital Video

INDEXING

1982 BYTE index. Microcomputer Index. col 7:12 Dec82 p518- *** Information Sources

INFORMATION SOURCES

1982 BYTE index. Microcomputer Index. col 7:12 Dec82 p518- *** Indexing
Career opportunities in computing. Johnston, Jacqueline. art 7:4 Apr82 p439-446 ***
Job Opportunities / Career Opportunities
Computers can play a dual role for disabled individuals. Vanderheiden, Gregg. art 7:9 Sep82 p136-162 *** Handicapped
Logo in the schools. Watt, Daniel. art 7:8 Aug82 p116-134 *** Logo / Elementary Education / Research

INFORMATION STORAGE

Binary-coded text: a text compression method. Tropper, Richard. art 7:4 Apr82 p398-413 *** Binary-Coded Text
Effective text-compression algorithm. Cortesi, David. art L9 7:1 Jan82 p397-403 *** Programming Design / Word Processing / Data Structures
Generate Huffman codes. Sellers, Jeff. col L1 7:7 Jul82 p441 ***

Video discs and optical data storage. Moberg/Laefsky. art 7:6 Jun82 p142-160 *** Videodisc / Research / Office Automation

INPUT/OUTPUT

Adaptive-firmware card for the Apple II (alternative input techniques). Schwajda/et al. art 7:9 Sep82 p276-314 ***
Handicapped / Hardware Construction / Apple II
General-purpose I/O board for the Color Computer. Barden, William. art L1 7:6 Jun82 p260-282 *** Hardware Construction / Interface / TRS-80 Color
General-purpose I/O board for the TRS-80 Models I and III. Barden, William. art L1 7:8 Aug82 p291-321 *** Hardware Construction / TRS-80 Model I / TRS-80 Model III
Input/Output primer, part 1: what is I/O?. Leibson, Steve. art 7:2 Feb82 p122-146 ***
Computer Instruction / Definitions
Input/Output primer, part 2: interrupts and direct memory access. Leibson, Steve. art 7:3 Mar82 p126-140 *** Computer Instruction
Input/Output primer, part 6: interrupts, buffers, grounds and.... Leibson, Steve. art 7:7 Jul82 p34-46 *** Interface
Input/output primer, part 5: character codes. Leibson, Steve. art 7:6 Jun82 p242-258 ***
Baudot Code / ASCII
Little Apple SOS with your Pascal. O'Konski, Tim. art L3 7:12 Dec82 p448-482 ***
Apple III / Pascal / Documentation
Po(r)tpourri of ideas (TRS-80 tone generator, telephone dialer, RS-232). Barden, William. art L3 7:4 Apr82 p158-182 *** TRS-80 Model I / TRS-80 Model III / Hardware Construction

INPUT/OUTPUT (CONTINUED)

Ports of entry and soft breezes for the Color computer and Model III. Barden, William. col L3 7:5 May82 p162-198 *** TRS-d0 Color / TRS-80 Model III / Tape Cassette
VIA experiment board / Totem poles and TTL / Bus standard stops here. Ciarcia, Steve. col 7:4 Apr82 p429 *** Apple II / S-100 Bus / Standards

INTEGRATED CIRCUITS

VIP expansion / TTL data books. Ciarcia, Steve. col 7:3 Mar82 p446-447 *** VIP

INTERFACE

AC motor control: simple algorithms and hardware. Nyberg, Jostein. col 7:1 Jan82 p118-121 *** Control / Hardware Construction
Add a cassette interface to your VIC-20. Hale, William. col 7:3 Mar82 p272-274 *** Hardware Construction / Tape Cassette / VIC-20
Add a peripheral interface adapter to your Apple II. Ciszewski, Kenneth. col L3 7:1 Jan82 p324-330 *** Hardware Construction / Parallel Input/Output / Apple II

Build programmable sound effects to your computer. Ciarcia, Steve. col L1 7:7 Jul82 p60-72 *** Sound Effects / Hardware Construction

Analog interfacing in the real world. Ciarcia, Steve. col 7:1 Jan82 p72-98 *** Hardware Construction / Analog/Digital Circuit / Digital/Analog Circuit

Apple talks with the deaf. Rhodes, Ned. art L3 7:1 Jan82 p360-366 *** Handicapped / Apple II / Telecommunications

Build an interactive videodisc controller (Pioneer VP-1000). Ciarcia, Steve. col 7:6 Jun82 p60-74 *** Videodisc / Control / Hardware Construction

Cambridge Development Lab's High-Resolution Video Graphics System. Dekock, James. hr 7:11 Nov82 p148-160 *** Hardware Review / High Resolution Graphics / S-100 Bus

Dithertizer II (video-digitalizer interface for the Apple II). Tomas, Joe. hr 7:2 Feb82 p219-224 *** Hardware Review / Digital Video / Apple II

General-purpose I/O board for the Color Computer. Barden, William. col L1 7:6 Jun82 p260-282 *** Hardware Construction / TRS-80 Color / Input/Output

Give your Apple a voice (Radio Shack Speech Synthesizer). Blankenship, Jonn. art L1 7:5 May82 p446-456 *** Voice Synthesis / Hardware Construction / Apple II

Hewlett-Packard interface loop - HPIL: unique two-wire system... Katz, Robert. hr 7:4 Apr82 p76-93 *** Hardware Review / Calculator

High-resolution sprite-oriented color graphics. Ciarcia, Steve. col L3 7:8 Aug82 p57-80 *** Color Graphics / Apple II / Logo

Inexpensive transducers for the TRS-80, part II (real-world monitoring). Barden, William. art 7:11 Nov82 p416-444 *** TRS-80 Model I / TRS-80 Color / A/D Converter

Input/Output primer, part 3: the parallel and HP1B (IEEE-488 interfaces) Leibson, Steve. art 7:4 Apr82 p166-208 *** Parallel

Input/Output primer, part 4: the BCD and serial interfaces. Leibson, Steve. art 7:5 May82 p202-220 *** Serial Input/Output / Binary Coded Decimal / RS-232

Input/Output primer, part 6: interrupts, buffers, grounds and... Leibson, Steve. art 7:7 Jul82 p34-46 *** Input/Output

Mediamix's ETI. Welborn, Robert. hr 7:7 Jul82 p284-288 *** Hardware Review / Printer / Typewriter

Practical dynamic-memory system design. Belics, Rob. art 7:12 Dec82 p372-385 *** Memory / Design

Putting real-world interfaces to work, part 1 (TRS-80 monitoring). Barden, William. art 7:10 Oct82 p96-123 *** Hardware Construction / Control / TRS-80 Model I

Videodisc interfacing primer. Daynes, Rod. art 7:6 Jun82 p40-59 *** Videodisc / Definitions

INTERVIEW
Chuck Peddle: an interview with the chief designer of the Victor 9000. Lemmons, Phil. art 7:11 Nov82 p260-271 *** People / Design / Victor 9000

INVESTMENT
Adapting microcomputers to wall Street. Franz, Robert. art 7:10 Oct82 p80-92 *** Stock Market / Management / Business

JOB OPPORTUNITIES
Career opportunities in computing. Johnston, Jacqueline. art 7:4 Apr82 p439-446 *** Career Opportunities / Information Sources

JOYSTICK
Build a joystick A-to-D converter for the TRS-80 Model I or III. Barden, William. art L1 7:1 Jan82 p100-104 *** Analog/Digital Circuit / TRS-80 Model I / TRS-80 Model III

KEYBOARD
Add a full-sized keyboard to Sinclair's ZX80. Cosshall, Wayne. art 7:3 Mar82 p260-261 *** Hardware Modification / Sinclair ZX80

Human-factors case study based on the IBM Personal Computer. Cooper et al. art 7:4 Apr82 p50-72 *** User Interface / IBM Personal Computer / Video Display

MOD III: TRS-80 Model III features for your Model I. Rocke, Joe. art L1 7:4 Apr82 p380-396 *** TRS-80 Model I / Utility Program / Video Display

KEYBOARD (CONTINUED)

Redefining Atari characters / Keyboard connection / Battery Apple. Ciarcia, Steve. col 7:7 Jul82 p420-421 *** Ask BYTE / Atari / Power Supply

Slew of languages, a slap at documentation, and a curse at keyboards. Pournelle, Jerry. col 7:12 Dec82 p222-246 *** Languages / Pascal / C Programming Language

Soroc IQ-120 slave monitor / OSI shift-lock problem / Audible alarms. Ciarcia, Steve. col 7:6 Jun82 p434-435 *** Ask BYTE / Video Display / OSI

Terminal madness, The Word, Grammatik, and then some. Pournelle, Jerry. col 7:6 Jun82 p286-300 *** Terminal / Spelling / Pascal

Terminals, keyboards, and... software piracy. Pournelle, Jerry. col 7:11 Nov82 p394-415 *** Terminal / Software Piracy / Book Review

Thirty more days to faster input. Roberts, Edward. col L1 7:1 Jan82 p186 *** Computer Assisted Instruction / TRS-80 Model I / Education

KIT BUILDING
Build a computerized weather station. Ciarcia, Steve. col L3 7:2 Feb82 p38-68 *** Weather / Hardware Construction / Voice Synthesis

Coln Robotics Armroid: the small-systems robot. Leininger, Steve. hr 7:5 May82 p286-294 *** Hardware Review / Robots

Memory expansion for the ZX80. Ernde, Hilton. art L3 7:1 Jan82 p216-232 *** Memory / Hardware Construction / Sinclair ZX80

SD Systems' Z80 Starter Kit. Angevine, Wayne. hr 7:1 Jan82 p332-342 *** Hardware Review / Z-80 / Microcomputer System

LISP
App-L-ISP (Apple II LISP). Bonar/Levitan. sr L9 7:6 Jun82 p220-230 *** Software Review / Apple II

Conditionals in LISP (decision-making function). Howard, M.S. col L9 7:6 Jun82 p493-496 *** Decision Making / Programming Instruction

Semidisk, Software Tools, the BOOS blues, Power, and LISPs. Pournelle, Jerry. col 7:8 Aug82 p342-363 *** CP/M / Book Review / Utility Program

LANGUAGES
BASIC and Pascal benchmark, elegance, apologies and FORTH. Pournelle, Jerry. col L1 7:10 Oct82 p254-288 *** Benchmark Testing / FORTH / BASIC

Interpretive language used to program the CPR system. Laumer, Mike. art L9 7:6 Jun82 p126-130 *** Videodisc / Apple II

Operating systems, languages, statistics, pirates and the lone wolf. Pournelle, Jerry. col 7:1 Jan82 p132-158 *** Operating Systems / Statistics / Software Piracy

Problem oriented language, part 1: a new method of input. Finger, Mark. art L1 7:12 Dec82 p314-368 *** Programming Design

Slew of languages, a slap at documentation, and a curse at keyboards. Pournelle, Jerry. col 7:12 Dec82 p222-246 *** Pascal / C Programming Language / Keyboard

LAW
Case of the purloined object code: can it be solved (part 1)? Stern, Richard. art 7:9 Sep82 p420-438 *** Copyright / Software Publishing / Patent

Case of the purloined object code: can it be solved?, part 2 (protection). Stern, Richard. art 7:10 Oct82 p210-222 *** Copyright / Software Publishing

Copyrights, computers and the Betamax case. Klasson, Walter. art 7:5 May82 p22-30 *** Copyright / Software Publishing / Software Piracy

Naming your software: considerations under the trademark laws. Becker, Stephen. art 7:10 Oct82 p380-384 *** Software Publishing

LOAD MAX-80. Daneliuk, Tim. hr 7:12 Dec82 p390-391 *** Hardware Review / Microcomputer System

LOGO
Beginners' guide to Logo. Abelson, Harold. art L9 7:8 Aug82 p88-112 *** Programming Instruction / Graphics

Designing computer-based microworlds (Logo). Lawler, R.W. art L9 7:8 Aug82 p138-160 *** Education / Programming Design

Group of the turtle (group theory in Logo). Leron, Uri. art 7:8 Aug82 p330-331 *** Mathematics / Children / Research

High-resolution sprite-oriented color graphics. Ciarcia, Steve. col L3 7:8 Aug82 p57-80 *** Color Graphics / Interface / Apple II

Introducing Logo to children. Solomon, Cynthia. art L9 7:8 Aug82 p196-208 *** Programming Instruction / Children

Lamplighter project (Logo). Gorman, Henry. art 7:8 Aug82 p331-332 *** Elementary Education

Leading fish to water: early observations on the use of Logo. Higginson, William. art 7:8 Aug82 p328-329 *** Apple II / Education

Learning physics from a dynaturtle. diSessa/White. art 7:8 Aug82 p324 *** Physics / Secondary Education

Logo - a cultural glossary. Goldenberg, E. Paul. art 7:8 Aug82 p210-228 *** Definitions

Logo for the Apple II, the TI-99/4A and the TRS-80 Color Computer. Williams, Gregg. sr L9 7:8 Aug82 p230-290 *** Software Review / Apple II / TI-99/4A

LOGO (CONTINUED)

Logo in the schools. Watt, Daniel. art 7:8 Aug82 p116-134 *** Elementary Education / Research / Information Sources

Logo music. Bamberger, Jeanne. art 7:8 Aug82 p325-328 *** Music / Apple II

Logo project PROKOP. Boecker/Fischer. art 7:4 Aug82 p329-330 *** Secondary Education / Research / Problem-Solving

Logo research at Bank Street College. Jewson/Pea. art 7:8 Aug82 p332-333 *** Research / Children / Problem-Solving

Logo update. Lemmons, Phil. art 7:8 Aug82 p334-340 *** Secondary Education / Elementary Education / Higher Education

Logo: an approach to educating disabled children. Weir et al. art 7:9 Sep82 p342-360 *** Handicapped / Special Education / Children

Problem solving with Logo: using turtle graphics to redraw a design. Wehrnre, William. art L9 7:11 Nov82 p118-134 *** Turtle Graphics / Apple II / Problem-Solving

Why Logo? (problem-solving skills). Harvey, Brian. art L9 7:8 Aug82 p163-193 *** Education / Problem-Solving

Young People's Logo Association. Muller, James. art 7:8 Aug82 p333-334 *** Associations / Clubs

LOWERCASE MODIFICATION
Lowercase descenders for the Epson MX-70 (Apple II). Piggott, Bruce. art L3 7:3 Mar82 p248-254 *** Utility Program / Apple II / Printer

MIKBUG
MIKBUG and the TRS-80, part 2: A file transfer and debugging package. Labenski, Robert. art L3 7:1 Jan82 p100-110 *** Utility Program / TRS-80 Model I / Terminal

MS-DOS
Limited high-level languages: caveats for MS-DOS software developers. Wilson, Camilo. col 7:7 Jul82 p334 *** Operating Systems

MS-DOS and CP/M-86 on the IBM Personal Computer: not my dream... Tinsdale, Mark. col 7:7 Jul82 p354-355 *** Operating Systems / CP/M-86 / IBM Personal Computer

MS-DOS and CP/M-86: a system manufacturer's view. Lomas, Richard. col 7:7 Jul82 p352 *** Operating Systems / CP/M-86

Strengths and gaps in MS-DOS and CP/M-86. Fortson/Lock. col 7:7 Jul82 p342-344 *** Operating Systems / CP/M-86

Systems integrator's view of MS-DOS and CP/M-86. Houston, Jerry. col 7:7 Jul82 p338-339 *** Operating Systems / CP/M-86

Upward migration, part 2: a comparison of CP/M-86 and MS-DOS. Taylor/Lemmons. art 7:7 Jul82 p330-356 *** CP/M-86 / Operating Systems / Benchmark Testing

Vote for MS-DOS. Colvin, Neil. col 7:7 Jul82 p356 *** Operating Systems / CP/M-86

MACHINE LANGUAGE
Easy entry program for Radio Shack's Color Computer. Field, Tim. col L1 7:4 Apr82 p482-487 *** TRS-80 Color / Utility Program

MAINTENANCE
Maintenance alternatives for personal computers. Whitaker, Lewis. art 7:6 Jun82 p452-459 *** Consumer Information

Troubleshooting with electronic signatures. Piggott, Kenneth. art 7:1 Jan82 p190-204 *** Troubleshooting / Signature Analysis

MANAGEMENT
Adapting microcomputers to Wall Street. Franz, Robert. art 7:10 Oct82 p80-92 *** Stock Market / Investment / Business

Personal computer as an interface to a corporate... information system. McBurney, N.R. art L6 7:10 Oct82 p315-358 *** Terminal / Apple II / Pascal

Programming PERT in BASIC. Zimmerman/Conrad. art L1 7:5 May82 p465-478 *** Planning / Business / TRS-80 Model I

Programming critical-path method in BASIC. Zimmerman/Conrad. art L1 7:7 Jul82 p378-390 *** TRS-80 Model I / Business

MANUFACTURING
Machines behind the machines (Japanese Manufacturers). Lemmons, Phil. art 7:5 May82 p115-138 *** Consumer Electronics / Foreign Competition

State of industrial robotics. Callahan, J. Michael. art 7:10 Oct82 p128-142 *** Robots / Vendor Guide

MARKETING
Japanese manufacturers - how successful will they be?. Zipnick, Ted. col 7:5 May82 p118 *** Foreign Competition

MATHEMATICS
Fast approximation for fast Fourier. Polczynski, Mark. col 7:2 Feb82 p248-250 *** Fourier Transforms

Generating Mohr's circle (TRS-80 Model I). Fink, Robert. col L1 7:10 Oct82 p312-313 *** Physics / TRS-80 Model I

Group of the turtle (group theory in Logo). Leron, Uri. art 7:8 Aug82 p330-331 *** Logo / Children / Research

Dmni aviation navigation system. Campbell, Richard. art L1 7:6 Jun82 p468-478 *** Navigation / Simulation / Flying

Osborne I, Zeke's new friends, and spelling revisited. Pournelle, Jerry. col 7:4 Apr82 p212-236 *** Osborne I / Spelling / Word Processing

Software Arts' TK Solver. Williams, Gregg. sr 7:10 Oct82 p360-376 *** Software Review / Utility Program

- MEDICINE**
 FDA regulation of computerized medical devices. Jorgens/et al. art 7:9 Sep82 p204-214 *** Design / Handicapped / Government Regulation
 Interactive training in cardiopulmonary resuscitation. Hon, David. art L9 7:6 Jun82 p108-138 *** Training / Videodisc / Simulation
- MEMORY**
 CMOS: memory with a future, ideas behind CompuPro's RAM 17. Anderson, Craig. hr 7:1 Jan82 p416-419 *** Hardware Review / S-100 Bus
 Letter-quality electrics / Bank selecting memory / 50 Hz power. Ciarcia, Steve. col 7:10 Oct82 p452 *** Ask BYTE / Typewriter / Power Supply
 Memory expansion for the Z80. Ernde, Hilton. art L3 7:1 Jan82 p216-232 *** Kit Building / Hardware Construction / Sinclair Z80
 Practical dynamic-memory system design. Belics, Rob. art 7:12 Dec82 p372-385 *** Design / Interface
 Test your memory using the Barber-Pole algorithm. Pinnick, H.R. art L3 7:12 Dec82 p414-444 *** Test / 8080 / 8085
- MICROCOMPUTER SYSTEM**
 Autocontrol's AC-85: a CP/M system on one board. Benedict, JoAnne. hr 7:12 Dec82 p250-256 *** Hardware Review / CP/M / AC-85
 BMC iF800. Kocher/Keith. hr 7:5 May82 p62-66 *** Hardware Review / BMC iF800
 Briefcase computer market heats up. Morgan, Chris. col 7:7 Jul82 pb-10 *** Portable Computer / Terminal
 Bubcom80. Kocher/Keith. hr 7:5 May82 p92-100 *** Hardware Review / Bubble Memory / Bubcom80
 Build the Circuit Cellar MPX-16 computer system, part 1. Ciarcia, Steve. col 7:11 Nov82 p78-114 *** Hardware Construction / 8088
 Build the Circuit Cellar MPX-16 computer system, part 2. Ciarcia, Steve. col 7:12 Dec82 p42-78 *** Hardware Construction / 8088
 Canon CX-1. Kocher/Keith. hr 7:5 May82 p66-69 *** Hardware Review / Canon CX-1
 Closer look at the IBM Personal Computer. Williams, Gregg. hr L7 7:1 Jan82 p36-68 *** Hardware Review / IBM Personal Computer
 Colonial SB-80. Little, Arthur. hr 7:11 Nov82 p324-334 *** Hardware Review / SB-80
 Commodore BU32 business system. Dickerman, Harold. hr 7:8 Aug82 p366-376 *** Hardware Review / Business / CBM 8032
 Epson HX-20: the first BYTE-sized computer. Williams, Gregg. art 7:4 Apr82 p104-106 *** Epson HX-20
 Epson QX-10 Valdco system. Williams, Gregg. art 7:9 Sep82 p4-57 *** Epson QX-10
 Fujitsu FM-8. Kocher/Keith. hr 7:5 May82 p86-92 *** Hardware Review / Fujitsu FM-8
 Hitachi MB-6890. Kocher/Keith. hr 7:5 May82 p74-84 *** Hardware Review / Hitachi MB-6890
 Japan update (Consumer Electronics Show). Haas, Mark. art 7:5 May82 p106-110 *** Shows
 Lobo Max-80. Daneliuk, Tim. hr 7:12 Dec82 p390-391 *** Hardware Review / Lobo Max-80
 NEC PC-8001 A. Kocher/Keith. hr 7:5 May82 p69-74 *** Hardware Review / PC-8001
 Osborne 1. Dahmke, Mark. hr 7:6 Jun82 p348-362 *** Hardware Review / Osborne 1 / Business
 SD Systems' Z80 Starter Kit. Angevine, Wayne. hr 7:1 Jan82 p332-342 *** Hardware Review / Z-80 / Kit Building
 Six personal computers from Japan. Kocher/Keith. art 7:5 May82 p61-102 *** Hardware Review / Benchmark Testing
 TRS-80 clock / Low-cost computers. Ciarcia, Steve. col 7:9 Sep82 p500-501 *** Ask BYTE / TRS-80 Model I
 Victor victorious: the Victor 9000 computer. Lemmons, Phil. hr 7:11 Nov82 p216-254 *** Hardware Review / Victor 9000
- MICROPROCESSOR**
 8-bit vs. 16-bit / Sensing motions / EPROM programmer note. Ciarcia, Steve. col 7:6 Jun82 p436-438 *** Ask BYTE / Security
 8051 one-chip microcomputer: a most powerful microcontroller. Boyet/Katz. art 7:12 Dec82 p288-311 *** Control / 8051
 Hierarchical interrupts. Foster, Caxton. col 7:5 May82 p457-459 *** Design
 Microprocessor's tenth birthday. Morgan, Chris. col 7:3 Mar82 pb-10 *** History / 4004
- MINDISK DRIVE**
 Color Computer disk system. Stearman, Colin. hr 7:7 Jul82 p312-328 *** Hardware Review / TRS-80 Color / Operating Systems
- MODEM**
 Speech synthesizer application / Problems with EPROM / Modem interface. Ciarcia, Steve. col 7:3 Mar82 p442 *** Ask BYTE / Voice Synthesis / EPROM
 Tele-VIC: Commodore breaks the \$100 price barrier for modems. Lebow, Max. hr L1 7:3 Mar82 p240-246 *** Hardware Review / VIC-20 / Terminal
- MONEY**
 Pascal NOW: let Pascal balance your NOW account. Doyle, Thomas. art L6 7:2 Feb82 p290-322 *** Pascal / Finances
- MONITOR**
 Mail order / TRS-80 merge / Z80 monitor / Color-monitor bandwidths. Ciarcia, Steve. col 7:1 Jan82 p404-406 *** Ask BYTE / Retailing / TRS-80 Model I
- MOTION PICTURES**
 Tronic imagery. Sorensen, Peter. art 7:11 Nov82 p48-74 *** Animation / High Resolution Graphics
- MULTI-PROCESSING**
 Simple multiprocessor implementation. Harrington, John. art L3 7:4 Apr82 p464-471 *** SWTPC / SWTPC 6809
- MULTI-TASKING**
 Clocked interrupts for the COSMAC Elf. Price, Gary. art L3 7:1 Jan82 p304-322 *** 1802 / Clock / Elf
- MUSIC**
 Brief introduction to electronic music synthesizers. Moog, Robert. art 7:12 Dec82 p278-286 *** Design / Musical Instrument
 Logo music. Bamberger, Jeanne. art 7:8 Aug82 p325-328 *** Logo / Apple II
 Soundchaser Computer Music Systems. Moog, Robert. hr 7:12 Dec82 p260-277 *** Hardware Review / Apple II / Musical Instrument
 Tuning up the 1802: a simple music composition trainer. Makosinski, Art. col L2 7:7 Jul82 p442-447 *** 1802 / VIP
- MUSICAL INSTRUMENT**
 Brief introduction to electronic music synthesizers. Moog, Robert. art 7:12 Dec82 p278-286 *** cal Instrument
 Soundchaser Computer Music Systems. Moog, Robert. hr 7:12 Dec82 p260-277 *** Hardware Review / sical Instrument
- NAVIGATION**
 Omni aviation navigation system. Campbell, Richard. art L1 7:6 Jun82 p468-478 *** Simulation / Mathematics / Flying
- NORTH STAR**
 Anatomy and development of a batch-processing system. Walters, Gene. art L1 7:5 May82 p334-386 *** Programming Instruction / Programming Design / BASIC
 Skip sequential: a new file structure for microcomputers. Purdum, Jack. art L1 7:3 Mar82 p466-472 *** Data Structures / Programming Instruction / BASIC
 Two word processors for North Star. Coudal, Edgar. sr 7:4 Apr82 p312-320 *** Software Review / Word Processing
 Weaving simulator. Meiser, Paul. art L1 7:9 Sep82 p513-519 *** Art
- OSI**
 Soroc IQ-120 slave monitor / OSI shift-lock problem / Audible alarms. Ciarcia, Steve. col 7:6 Jun82 p434-435 *** Ask BYTE / Video Display / Keyboard
- OFFICE AUTOMATION**
 Videodiscs and optical data storage. Moberg/Laefsky. art 7:6 Jun82 p142-160 *** Information Storage / Videodisc / Research
- OPERATING SYSTEMS**
 Color Computer disk system. Stearman, Colin. hr 7:7 Jul82 p312-328 *** Hardware Review / Minidisk Drive / TRS-80 Color
 Disk operating system for FORTH: an in-depth look at how a DOS operates. Reece, Peter. art L7 7:4 Apr82 p322-358 *** FORTH / Programming Design / TRS-80 Model I
 LDOS - disk operating system for the TRS-80. Daneliuk, Tim. sr L1 7:3 Mar82 p372-382 *** Software Review / TRS-80 Model I / TRS-80 Model III
 Limited high-level languages: caveats for MS-DOS software developers. Wilson, Camilo. col 7:7 Jul82 p334 *** MS-DOS
 MS-DOS and CP/M-86 on the IBM Personal Computer: not my dream... Tinsdale, Mark. col 7:7 Jul82 p354-355 *** CP/M-86 / IBM Personal Computer / MS-DOS
 MS-DOS and CP/M-86: a system manufacturer's view. Lomas, Richard. col 7:7 Jul82 p352 *** CP/M-86 / MS-DOS
 Multidos: a new TRS-80 disk operating system. Archer, Rowland. sr 7:12 Dec82 p392-397 *** Software Review / TRS-80 Model I / TRS-80 Model III
 NEWDOS/80 Version 2.0 (TRS-80 Model I/III). Kelly, Mahlon. sr 7:6 Jun82 p376-400 *** Software Review / TRS-80 Model I / TRS-80 Model III
 Of IBM, operating systems and Rosetta Stones. Morgan, Chris. col 7:1 Jan82 pb-10 *** IBM Personal Computer / Standards
 Operating systems, languages, statistics, pirates and the lone wolf. Pournelle, Jerry. col 7:1 Jan82 p132-158 *** Languages / Statistics / Software Piracy
 Pickles & Trout CP/M for the TRS-80 Model II. Smith, Hal. sr 7:9 Sep82 p531-536 *** Software Review / CP/M / TRS-80 Model II
 Plotting with the TRS-80 / Matter of environment / Feasibility study. Ciarcia, Steve. col 7:3 Mar82 p445-446 *** Ask BYTE / Plotting / Consumer Information
 Strengths and gaps in MS-DOS and CP/M-86. Fortson/Lock. col 7:7 Jul82 p342-344 *** CP/M-86 / MS-DOS
 Systems integrator's view of MS-DOS and CP/M-86. Houston, Jerry. col 7:7 Jul82 p338-339 *** CP/M-86 / MS-DOS
 Upward migration, part 2: a comparison of CP/M-86 and MS-DOS. Taylor/Lemmons. art 7:7 Jul82 p330-356 *** CP/M-86 / Benchmark Testing / MS-DOS
 Vote for MS-DOS. Colvin, Neil. col 7:7 Jul82 p36 *** CP/M-86 / MS-DOS
- OSBORNE 1**
 Osborne 1, Zeke's new friends, and spelling revisited. Pournelle, Jerry. col 7:4 Apr82 p212-238 *** Spelling / Word Processing / Mathematics
- OSBORNE 1 (CONTINUED)**
 Osborne 1. Dahmke, Mark. hr 7:6 Jun82 p348-362 *** Hardware Review / Microcomputer System / Business
 PC-8001
 NEC PC-8001 A. Kocher/Keith. hr 7:5 May82 p69-74 *** Hardware Review / Microcomputer System
 PET
 Adapting "Harvesting the Sun's Energy" for the Commodore PET. Berry, Jerry. col L1 7:6 Jun82 p404-408 *** Solar Energy / Home / Conversions
 Breaking the jargon barrier: designing programs for humanists. Heite/Heite. art L1 7:7 Jul82 p76-104 *** Statistics / Social Science / Archaeology
 Commodore 4022 printer. Holmes, Joseph. hr 7:3 Mar82 p26-36 *** Hardware Review / Printer / CBM
 Composite PET video / 28-based voice-recognition system. Ciarcia, Steve. col 7:8 Aug82 p420 *** Ask BYTE / Video Display / Speech Recognition
 Measuring attitudes with a PET. Heise, David. art L1 7:7 Jul82 p208-246 *** Social Science / Psychology / Survey
- PL/I**
 PL/I for microcomputers (CP/M). Lehman, John. sr L9 7:5 May82 p246-250 *** Software Review / CP/M
- PARALLEL INPUT/OUTPUT**
 Add a peripheral interface adapter to your Apple II. Ciszewski, Kenneth. col L3 7:1 Jan82 p324-330 *** Interface / Hardware Construction / Apple II
 Input/output primer, part 3: the parallel and HP18 (IEEE-488 interfaces). Leibson, Steve. art 7:4 Apr82 p186-208 *** IEEE-488 Bus / Computer Instruction / Interface
 John Bell Engineering's Apple II Parallel Interface Board. Rhodes, Med. hr L3 7:3 Mar82 p414-430 *** Hardware Review / Apple II / Clock
- PASCAL**
 CHEDIT: a graphics-character editor (Apple Pascal). Sweet, Jerry. art L6 7:5 May82 p426-444 *** Utility Program / Apple II / Graphics
 Converting Apple DOS and Pascal text files. Matthews, John. art L6 7:4 Apr82 p447-463 *** Conversions / Apple II / Apple DOS
 FIT - a federal income tax program in UCSD Pascal. Heyman, Edward. art L6 7:2 Feb82 p148-190 *** Taxes / Federal Government
 Four implementations of Pascal. Woteki/Sand. sr L6 7:3 Mar82 p316-356 *** Software Review / CP/M / Benchmark Testing
 Guided tour of Apple Pascal units and libraries. Tonkens, Ross. art L6 7:2 Feb82 p225-244 *** Programming Instruction / Apple II
 Idiot-proof input in Pascal. Booch, Grady. col L6 7:7 Jul82 p452-453 *** Programming Instruction
 Interactive 3-D graphics for the Apple II. Pickholtz, Andrew. art L1 7:11 Nov82 p474-505 *** Three-Dimensional Graphics / Apple II
 Letters, Pascal, CB/80, and Cardfile. Pournelle, Jerry. col 7:9 Sep82 p318-341 *** Compiler / Word Processing
 Listing the disk directory in CP/M-based Pascal. Hunt, Daniel. col L6 7:6 Jun82 p497-501 *** Utility Program / CP/M
 Little Apple SOS with your Pascal. O'Konksi, Tim. art L3 7:12 Dec82 p448-482 *** Apple III / Input/Output / Documentation
 More maze building. Meldner, Thomas. art L6 7:5 May82 p274-284 *** Puzzles
 Pascal NOW: let Pascal balance your NOW account. Doyle, Thomas. art L6 7:2 Feb82 p290-322 *** Money / Finances
 Pascal standards. Doyle, Thomas. col 7:2 Feb82 p322 *** Standards
 Personal computer as an interface to a corporate...information system. McBurney, M.R. art L6 7:10 Oct82 p315-358 *** Terminal / Apple II / Management
 Slew of languages, a slap at documentation, and a curse at keyboards. Pournelle, Jerry. col 7:12 Dec82 p222-246 *** Languages / C Programming Language / Keyboard
 Terminal madness, The Word, Grammatik, and then some. Pournelle, Jerry. col 7:6 Jun82 p286-300 *** Terminal / Keyboard / Spelling
- PATENT**
 Case of the purloined object code: can it be solved (part1)? Stern, Richard. art 7:9 Sep82 p420-438 *** Copyright / Law / Software Publishing
- PEOPLE**
 Chuck Peddle: an interview with the chief designer of the Victor 9000. Lemmons, Phil. art 7:11 Nov82 p256-271 *** Interview / Design / Victor 9000
- PHYSICS**
 Generating Mohr's circle (TRS-80 Model I). Fink, Robert. col L1 7:10 Oct82 p312-313 *** Mathematics / TRS-80 Model I
 Learning physics from a dynaturtle. diSessa/White. art 7:8 Aug82 p324 *** Logo / Secondary Education
- PLANNING**
 Beyond the peaks of Visicalc (Desktop Plan II, Microfinese, Plan80). Bishop, Jack. sr 7:10 Oct82 p29-39 *** Software Review / Financial Modeling / Business

PLANNING (CONTINUED)

Programming PERT in BASIC. Zimmerman/Conrad. ar: L1 7:5 May82 p465-478 *** Management / Business / TRS-80 Model I

PLOTTING

BASIC plotting subroutine: sophisticated plotting with your MX-80. Bregoli, Lawrence. art L1 7:3 Mar82 p142-156 *** Utility Program / Printer / BASIC

Flexibility of VisiPlot (Apple II). Ramsdell, Robert. sr 7:2 Feb82 p32-36 *** Software Review / Utility Program / Apple II

Plotting with the TRS-80 / Matter of environment / Feasibility study. Ciarcia, Steve. col 7:3 Mar82 p445-446 *** Ask BYTE / Operating Systems / Consumer Information

POETRY

Computers, fiction and poetry (stories and poems written by computers). McKean, Kevin. art 7:7 Jul82 p50-53 *** Fiction / Writing

POLITICS

Microcomputers in the study of politics: predicting wars.... Schrodt, Philip. art L6 7:7 Jul82 p108-134 *** Social Science / Simulation / Predictions

POLY-88

Structured strings in BASIC. Stockburger, David. col L1 7:5 May82 p308-316 *** Programming Instruction / BASIC / Structured Programming

PORTABLE COMPUTER

Briefcase computer market heats up. Morgan, Chris. col 7:7 Jul82 p6-10 *** Terminal / Microcomputer System

Deus ex Machina of the technological age. Morgan, Chris. col 7:12 Dec82 p0-10 *** HP-75C

POWER SUPPLY

Data in, garbage out / RS-232C-to-IEEE-488 interface. Ciarcia, Steve. col 7:5 May82 p400-404 *** Ask BYTE / RS-232 / IEEE-488 Bus Letter-quality selectrics / Bank selecting memory / 50 Hz power. Ciarcia, Steve. col 7:10 Oct82 p452 *** Ask BYTE / Typewriter / Memory

Redefining Atari characters / Keyboard connection / Battery Apple. Ciarcia, Steve. col 7:7 Jul82 p420-421 *** Ask BYTE / Atari / Keyboard

Tips on homebrewing / BASIC in ROM / Line disturbances / Clock. Ciarcia, Steve. col 7:8 Aug82 p418-420 *** Ask BYTE / Homebrew / Clock

PREDICTIONS

Microcomputers in the study of politics: predicting wars.... Schrodt, Philip. art L6 7:7 Jul82 p108-134 *** Social Science / Politics / Simulation

PRINTER

BASIC plotting subroutine: sophisticated plotting with your MX-80. Bregoli, Lawrence. art L1 7:3 Mar82 p142-156 *** Plotting / Utility Program / BASIC

BYTE printer directory. Feigel, Curtis. art 7:3 Mar82 p278-296 *** Directories

Base 2 printer. Jeffries, Walter. hr 7:3 Mar82 p206-216 *** Hardware Review

Braille writing in Pascal. Fant, Alfred. art L6 7:9 Sep82 p250-268 *** Handicapped

Commodore 4022 printer. Holmes, Joseph. hr 7:3 Mar82 p26-36 *** Hardware Review / PET / CBM

Double-width Silentyper graphics for your Apple. Putney, Charles. col L3 7:2 Feb82 p413-423 *** High Resolution Graphics / Apple II / Utility Program

Epson MX-80 print-control program for the Apple II. Starbuck, Bill. col L1 7:3 Mar82 p166-170 *** Utility Program / Apple II

Fill forms system: CP/M programs to cut down on paperwork. Roch, Bill. art L1 7:3 Mar82 p218-236 *** Utility Program / Business / CP/M

GRAPRINT: an Apple utility program for dot-matrix printers. Arndt, Douglas. art L3 7:12 Dec82 p398-403 *** Utility Program / High Resolution Graphics / Apple II

Ghost of Epsosn past (Epson MX-80 printer problem). Fehrenbach, Paul. col L1 7:7 Jul82 p432-433 ***

Graphics II by Selanar: high-resolution hard copy from a OECwriter. Macero/et al. hr L1 7:3 Mar82 p172-196 *** Hardware Review / High Resolution Graphics

High speed printers / Level I tape format / Computer lab essentials. Ciarcia, Steve. col 7:3 Mar82 p442-444 *** Ask BYTE / TRS-80 Model I / Test Equipment

Integral Data Systems' Prism Printer. Umior, Ed. hr 7:3 Mar82 p44-49 *** Hardware Review / Color Printer

Lowercase descenders for the Epson MX-70 (Apple II). Piggott, Bruce. art L3 7:3 Mar82 p248-254 *** Utility Program / Lowercase Modification / Apple II

Mediamix's ETL. Welborn, Robert. hr 7:7 Jul82 p284-288 *** Hardware Review / Interface / Typewriter

Modify your Paper Tiger for different paper thicknesses. Sarna, R.P. art 7:3 Mar82 p158-160 *** Hardware Modification

Shape-drawing program for Diablo printers (Apple II). Brock, Thomas. col L1 7:3 Mar82 p110-114 *** Utility Program / Apple II

PRINTER (CONTINUED)

TRS-80 assembly language / Apple 16-bit / Construction tips / Selectric. Ciarcia, Steve. col 7:2 Feb82 p369-371 *** Ask BYTE / Assembly Language / Apple II

Underline filter for matrix printers. Reed, Adam. col L8 7:3 Mar82 p300-306 *** Utility Program / C Programming Language

PROBLEM-SOLVING

Logo project PROKOP. Boecker/Fischer. art 7:8 Aug82 p329-330 *** Secondary Education / Logo / Research

Logo research at Bank Street College. Jewson/Pea. art 7:8 Aug82 p332-333 *** Logo / Research / Children

Problem solving with Logo: using turtle graphics to redraw a design. Weinreb, William. art L9 7:11 Nov82 p118-134 *** Turtle Graphics / Logo / Apple II

Why Logo? (problem-solving skills). Harvey, Brian. art L9 7:8 Aug82 p163-193 *** Logo / Education

PROGRAM GENERATOR

Program generators (The Last One and Quic-N-Easi). Stewart, George. sr L1 7:8 Aug82 p38-56 *** Software Review / CP/M / TRS-80 Model III

PROGRAMMING DESIGN

Anatomy and development of a batch-processing system. Walters, Gene. art L1 7:5 May82 p334-386 *** Programming Instruction / BASIC / North Star

Design techniques and ideals for computer games. Crawford, Chris. art 7:12 Dec82 p96-108 *** Games

Designing a text editor? The user comes first. Jong, Steven. art 7:4 Apr82 p284-300 *** Text Editor / Word Processing / Consumer Information

Designing computer-based microworlds (Logo). Lawler, R.W. art L9 7:8 Aug82 p138-160 *** Logo / Education

Disk operating system for FORTH: an in-depth look at how a DOS operates. Reece, Peter. art L7 7:4 Apr82 p322-358 *** Operating Systems / FORTH / TRS-80 Model I

Effective text-compression algorithm. Cortesi, David. art L9 7:1 Jan82 p397-403 *** Word Processing / Information Storage / Data Structures

Human-factors style guide for program design. Simpson, Henry. art 7:4 Apr82 p108-132 *** User Interface

Managing words: what capabilities should you have with a text editor?. Finseth, Craig. art 7:4 Apr82 p302-310 *** Text Editor / Word Processing

Problem oriented language, part 1: a new method of input. Finger, Mark. art L1 7:12 Dec82 p314-368 *** Languages

Program your own text editor, part 1: avoid complex commands.... Fobes, Richard. art 7:9 Sep82 p476-489 *** Text Editor

Program your own text editor, part 2 (video-display-oriented text editor). Fobes, Richard. art L3 7:10 Oct82 p406-446 *** Text Editor

Software tools for writers. Holder, Wayne. art L3 7:7 Jul82 p138-163 *** Writing / Spelling / Word Processing

What makes business programming hard?. Woodward, James. art 7:10 Oct82 p68-76 *** Business

PROGRAMMING INSTRUCTION

Anatomy and development of a batch-processing system. Walters, Gene. art L1 7:5 May82 p334-386 *** Programming Design / BASIC / North Star

Atari tutorial, part 5: scrolling. Crawford, Chris. art 7:1 Jan82 p26-34 *** Atari / Graphics / BASIC

Atari tutorial, part 6: Atari BASIC. Winner, Lane. art L1 7:2 Feb82 p91-118 *** BASIC / Atari

Atari tutorial, part 7: sound. Fraser, Bob. art L1 7:3 Mar82 p80-98 *** BASIC / Sound Effects / Atari

Atari tutorial, part 8: generating sound with software. Fraser, Bob. art L3 7:4 Apr82 p134-150 *** Atari / Sound Effects / BASIC

Atari tutorial, part 9: even more colors!. Pitta/Winner. art L1 7:5 May82 p148-160 *** Atari / Color Graphics / BASIC

Beginners' guide to Logo. Abelson, Harold. art L9 7:8 Aug82 p88-112 *** Logo / Graphics

Build the Microvox text-to-speech synthesizer, part 2: software. Ciarcia, Steve. col L9 7:10 Oct82 p40-64 *** Hardware Construction / Voice Synthesis

Character editor for the Atari. Kilyb, Tim. art L1 7:12 Dec82 p167-179 *** Graphics / Utility Program / Atari

Computer animation with color registers: fast animation in BASIC (Atari). Fox/Waite. art L1 7:11 Nov82 p194-214 *** BASIC / Animation / Atari

Conditionals in LISP (decision-making function). Howard, M.S. col L9 7:6 Jun82 p493-496 *** LISP / Decision Making

Guided tour of Apple Pascal units and libraries. Tonkens, Ross. art L6 7:2 Feb82 p225-244 *** Pascal / Apple II

Idiot-proof input in Pascal. Booch, Grady. col L6 7:7 Jul82 p452-453 *** Pascal

Introducing Logo to children. Solomon, Cynthia. art L9 7:8 Aug82 p196-208 *** Logo / Children

PROGRAMMING INSTRUCTION (CONTINUED)

SOFTIM: a software timer. Terpstra, Dan. col L3 7:1 Jan82 p436-439 *** Z-80 / Clock

Skip sequential: a new file structure for microcomputers. Purdum, Jack. art L1 7:3 Mar82 p466-472 *** Data Structures / BASIC / North Star

Structured programming in BASIC. Sobell, Mark. art L1 7:1 Jan82 p410-415 *** Structured Programming / BASIC / Cromemco

Structured strings in BASIC. Stockburger, David. col L1 7:5 May82 p308-316 *** BASIC / Poly-88 / Structured Programming

TRS-80 BASIC program hang-ups: the reasons and some solutions. Tesler, Glenn. art L3 7:5 May82 p318-330 *** BASIC / TRS-80 Model I / TRS-80 Model III

Using the LOOKUP function in VisiCalc. Ramsdell, Robert. col 7:8 Aug82 p443-445 *** VisiCalc / Taxes

PSYCHOLOGY

Measuring attitudes with a PET. Heise, David. art L1 7:7 Jul82 p208-246 *** Social Science / PET / Survey

PUZZLES

Board to death. Swanson, Jon. art 7:12 Dec82 p94-95 *** Design

More maze building. Neldner, Thomas. art L6 7:5 May82 p274-284 *** Pascal

Quinti-maze (Apple II game). Tsuk, Robert. art L1 7:9 Sep82 p24-30 *** Games / Apple II / Strategy

Three Dee Tee (TRS-80 Color Computer game). Stuart, John. art L1 7:9 Sep82 p34-50 *** Games / Strategy / TRS-80 Color

RS-232

Data in, garbage out / RS-232C-to-IEEE-488 interface. Ciarcia, Steve. col 7:5 May82 p400-404 *** Ask BYTE / Power Supply / IEEE-488 Bus

Input/Output primer, part 4: the BCD and serial interfaces. Leibson, Steve. art 7:5 May82 p202-220 *** Serial Input/Output / Interface / Binary Coded Decimal

Programming the RS-232 serial port / Build your own / RFL. Ciarcia, Steve. col 7:3 Mar82 p444-445 *** Ask BYTE / Radio-Frequency Interference / Design

Using the Model I/III RS-232C port. Barden, William. art L1 7:7 Jul82 p360-376 *** TRS-80 Model I / TRS-80 Model III / Serial Input/Output

RADIO-FREQUENCY INTERFERENCE

Programming the RS-232 serial port / Build your own / RFL. Ciarcia, Steve. col 7:3 Mar82 p444-445 *** Ask BYTE / RS-232 / Design

RESEARCH

Computer toolbox (microcomputer as a lab assistant). Bernstein, Mark. art 7:3 Mar82 p456-465 *** Higher Education / Science / FORTH

Group of the turtle (group theory in Logo). Leron, Uri. art 7:8 Aug82 p330-331 *** Logo / Mathematics / Children

Japan maps computer domination. Manuel, Tom. art 7:5 May82 p140-144 *** Foreign Competition / Future

Keeping our technological edge. Morgan, Chris. col 7:8 Aug82 p6-18 *** Federal Government / Foreign Competition

Logo in the schools. Watt, Daniel. art 7:8 Aug82 p116-134 *** Logo / Elementary Education / Information Sources

Logo project PROKOP. Boecker/Fischer. art 7:8 Aug82 p329-330 *** Secondary Education / Logo / Problem-Solving

Logo research at Bank Street College. Jewson/Pea. art 7:8 Aug82 p332-333 *** Logo / Children / Problem-Solving

Microcomputers in cultural anthropology: APL programs for qualitative... Werner, Oswald. art L9 7:7 Jul82 p250-280 *** Social Science / APL / Anthropology

Videodiscs and optical data storage. Moberg/Laefsky. art 7:6 Jun82 p142-160 *** Information Storage / Videodisc / Office Automation

RETAILING

Mail order / TRS-80 merge / Z80 monitor / Color-monitor bandwidths. Ciarcia, Steve. col 7:1 Jan82 p404-406 *** Ask BYTE / TRS-80 Model I / Monitor

ROBOTS

Colne Robotics Armroid: the small-systems robot. Leininger, Steve. hr 7:5 May82 p286-294 *** Hardware Review / Kit Building

State of industrial robotics. Callahan, J. Michael. art 7:10 Oct82 p128-142 *** Manufacturing / Vendor Guide

S-100 BUS

CMOS: memory with a future, ideas behind CompuPro's RAM 17. Anderson, Craig. hr 7:1 Jan82 p416-419 *** Hardware Review / Memory

Cambridge Development Lab's High-Resolution Video Graphics System. DeKock, James. hr 7:11 Nov82 p148-160 *** Hardware Review / Interface / High Resolution Graphics

Control sources / Apple/North Star compiler / S-100 systems. Ciarcia, Steve. col 7:2 Feb82 p367-369 *** Ask BYTE / Control / Compiler

Scion Color System. Dahmke, Mark. hr 7:7 Jul82 p54-59 *** Hardware Review / Color Graphics / High Resolution Graphics

VIA experiment board / Totem poles and TTL / Bus standard stops here. Ciarcia, Steve. col 7:4 Apr82 p429 *** Input/Output / Apple II / Standards

Colonial SB-80. Little, Arthur. hr 7:11 Nov82
p324-334 *** Hardware Review / Microcomputer
System

SWTPC

Simple multiprocessor implementation.

Harrington, John. art L3 7:4 Apr82
p464-471 *** SWTPC 6809 / Multi-Processing

SWTPC 6809

Simple multiprocessor implementation.
Harrington, John. art L3 7:4 Apr82
p464-471 *** 6809 / Multi-Processing

SCIENCE

Computer toolbox (microcomputer as a lab
assistant). Bernstein, Mark. art 7:3 Mar82
p456-465 *** Higher Education / Research /
FORTH

SECONDARY EDUCATION

Learning physics from a dynaturtle.
diSessa/White. art 7:8 Aug82 p324 ***
Logo / Physics

Logo project PROKOP. Boecker/Fischer. art 7:8
Aug82 p329-330 *** Logo / Research /
Problem-Solving

Logo update. Lemmons, Phil. art 7:8 Aug82
p334-340 *** Logo / Elementary Education /
Higher Education

SECURITY

8-bit vs. 16-bit / Sensing motions / EPROM
programmer note. Ciarcia, Steve. col 7:6
Jun82 p436-438 *** Ask BYTE / Microprocessor

SERIAL INPUT/OUTPUT

Input/Output primer, part 4: the BCD and serial
interfaces. Leibson, Steve. art 7:5 May82
p202-220 *** Interface / Binary Coded Decimal
/ RS-232

Using the Model I/III RS-232C port. Barden,
William. art L1 7:7 Jul82 p360-376 ***
RS-232 / TRS-80 Model I / TRS-80 Model III

SHOWS

Computers for humanity (West Coast Computer Faire
#7). Pournelle, Jerry. art 7:7 Jul82
p392-400 ***

Hanover fair. Ramsdell, Robert. art 7:9 Sep82
p62-63 ***

Japan update (Consumer Electronics Show). Haas,
Mark. art 7:5 May82 p106-110 ***
Microcomputer System

NCC report (1982). Morgan, Chris. art 7:9
Sep82 p58-61 ***

Report from COMDEX. Morgan, Chris. col 7:2
Feb82 p6-16 ***

West Coast Computer Faire Report. Morgan, Chris.
col 7:6 Jun82 p6-22 ***

SIGNATURE ANALYSIS

Digital troubleshooting with signature analysis
(HP-5004A). Piubeni, Steven. art 7:9 Sep82
p466-474 *** Troubleshooting

Troubleshooting with electronic signatures.
Piggott, Kenneth. art 7:1 Jan82 p190-204
*** Troubleshooting / Maintenance

SIMULATION

Interactive training in cardiopulmonary
resuscitation. Hon, David. art L9 7:6
Jun82 p108-138 *** Medicine / Training /
Videodisc

Jetset (TRS-80 Model II flying simulation).
Szymanski, Eugene. art L1 7:11 Nov82
p272-322 *** Games / TRS-80 Model II / Flying

Microcomputers in the study of politics:
predicting wars.... Schrodt, Philip. art L6
7:7 Jul82 p108-134 *** Social Science /
Politics / Predictions

Omni aviation navigation system. Campbell,
Richard. art L1 7:6 Jun82 p468-478 ***
Navigation / Mathematics / Flying

Simulating neighborhood segregation.
Dethlefsen/Moody. art L1 7:7 Jul82
p178-206 *** Social Science / TRS-80 Model I

SINCLAIR ZX80

Add a full-sized keyboard to Sinclair's ZX80.
Cosshall, Wayne. art 7:3 Mar82 p256-261
*** Hardware Modification / Keyboard

Memory expansion for the ZX80. Ernde, Hilton.
art L3 7:1 Jan82 p216-232 *** Memory /
Kit Building / Hardware Construction

SMOKE SIGNAL BROADCASTING

BASIC program for home cryptography. Roberts,
Ralph. col L1 7:4 Apr82 p432-434 ***
Cryptography

SOCIAL SCIENCE

Breaking the jargon barrier: designing programs
for humanists. Heite/Heite. art L1 7:7
Jul82 p76-104 *** Statistics / PET /
Archaeology

Historian and the microcomputer. Rowney, Don.
art 7:7 Jul82 p166-176 *** History /
Statistics

Measuring attitudes with a PET. Heise, David.
art L1 7:7 Jul82 p208-246 *** Psychology
/ PET / Survey

Microcomputers in cultural anthropology: APL
programs for qualitative.... Werner, Oswald.
art L9 7:7 Jul82 p250-280 *** Research /
APL / Anthropology

Microcomputers in the study of politics:
predicting wars.... Schrodt, Philip. art L6
7:7 Jul82 p108-134 *** Politics /
Simulation / Predictions

Simulating neighborhood segregation.
Dethlefsen/Moody. art L1 7:7 Jul82
p178-206 *** Simulation / TRS-80 Model I

SOFTWARE PIRACY

Copyrights, computers and the Betamax case.
Klason, Walter. art 7:5 May82 p22-30 ***
Copyright / Law / Software Publishing

SOFTWARE PIRACY (CONTINUED)

Operating systems, languages, statistics, pirates
and the lone wolf. Pournelle, Jerry. col 7:1
Jan82 p132-158 *** Operating Systems /
Languages / Statistics

Terminals, keyboards, and...software piracy.
Pournelle, Jerry. col 7:11 Nov82 p394-415
*** Terminal / Keyboard / Book Review

SOFTWARE PUBLISHING

Case of the purloined object code: can it be
solved (part1)? Stern, Richard. art 7:9
Sep82 p420-438 *** Copyright / Law / Patent

Case of the purloined object code: can it be
solved?, part 2 (protection). Stern, Richard.
art 7:10 Oct82 p210-222 *** Law /
Copyright

Computers and the special education classroom.
Sicoli, Thomas. col 7:9 Sep82 p270-274 ***
Special Education / Vendor Guide

Copyrights, computers and the Betamax case.
Klason, Walter. art 7:5 May82 p22-30 ***
Copyright / Law / Software Piracy

Naming your software: considerations under the
trademark laws. Becker, Stephen. art 7:10
Oct82 p380-384 *** Law

SOFTWARE REVIEW

Condor Series 20/rDBMS. Abbott, Jack. sr 7:12
Dec82 p404-410 *** Data Base Management /
CP/M

Database management with Ashton-Tate's dBase II.
Abbott, Jack. sr 7:7 Jul82 p412-416 ***
Data Base Management / CP/M

Four implementations of Pascal. Woteki/Sand. sr
L6 7:3 Mar82 p316-356 *** Pascal / CP/M /
Benchmark Testing

Lotus Development Corporation's 1-2-3. Williams,
Gregg. sr 7:12 Dec82 p182-198 *** IBM
Personal Computer / Spreadsheet

PL/I for microcomputers (CP/M). Lehman, John.
sr L9 7:5 May82 p246-250 *** PL/I / CP/M

Selector IV by Micro-App: an
information-management program. Abbott, Jack.
sr L1 7:4 Apr82 p371-376 *** Data Base
Management / CP/M

Systems Plus: FMS-80. Abbott, Jack. sr 7:10
Oct82 p447-450 *** Data Base Management /
CP/M

Text editing with Compuviv's VEDIT. Thompson,
H.B. sr 7:3 Mar82 p262-270 *** Text
Editor / CP/M

APPLE II

Alien typhoon (Apple II game). Latocha, Walt.
sr 7:5 May82 p224 *** Arcade / Games /
Apple II

App-L-ISP (Apple II LISP). Bonar/Levitan. sr
L9 7:6 Jun82 p220-230 *** LISP / Apple II

Apple Panic. Williams, Gregg. sr 7:3 Mar82
p68-69 *** Games / Arcade / Apple II

Beer Run (Apple II arcade game). Little, Arthur.
sr 7:9 Sep82 p375-379 *** Games / Arcade
/ Apple II

Comparison of five compilers for Apple BASIC.
Taylor/Taylor. sr L1 7:9 Sep82 p440-464
*** Benchmark Testing / Apple II / Compiler

Deadline: the butler did it...this time. Morgan,
Chris. sr 7:12 Dec82 p160-161 *** Games /
Strategy / Apple II

Edu-Ware's Statistics 3.0. Elliott, Brownlee.
sr 7:10 Oct82 p400-404 *** Statistics /
Apple II

Executive briefing system: a color graphics
development for the Apple II. Callamaras,
Peter. sr 7:11 Nov82 p164-170 *** Utility
Program / High Resolution Graphics / Apple II

Flexibility of VisiPlot (Apple II). Ramsdell,
Robert. sr 7:2 Feb82 p32-36 *** Plotting
/ Utility Program / Apple II

Graphics Magician: easy animation for the Apple
II. Callamaras, Peter. sr 7:11 Nov82
p138-144 *** Animation / Apple II / Utility
Program

Logo for the Apple II, the TI-99/4A and the
TRS-80 Color Computer. Williams, Gregg. sr
L9 7:8 Aug82 p230-290 *** Logo / Apple II
/ TI-99/4A

Micro-Decision Support System/Finance (DSS/F).
Moskowitz, Robert. sr 7:6 Jun82 p488-492
*** Finances / Financial Modeling / Apple II

Ricochet. Williams, Gregg. sr 7:12 Dec82
p142-146 *** Games / Arcade / Apple II

Super FORTH isn't. Williams, Gregg. sr 7:5
May82 p296-298 *** FORTH / Apple II

Swashbuckler (Apple II arcade game).
Spangenberg, Scott. sr 7:9 Sep82 p362-367
*** Games / Arcade / Apple II

Tawala's last redoubt (Apple II and TRS-80
adventure game). Lesser, Hartley. sr 7:6
Jun82 p235-236 *** Strategy / Games / Apple
II

Two tax aids (Individual Tax Plan and Tax
Preparer). Kvam, Mary Jo. sr 7:2 Feb82
p204-212 *** Taxes / Apple II / Federal
Government

Zero Gravity Pinball (Apple II arcade game).
Friedman, Mark. sr 7:9 Sep82 p370-372 ***
Games / Arcade / Apple II

ATARI

Galactic Chase. Wszola, Stan. sr 7:6 Jun82
p176-180 *** Arcade / Games / Atari

Missile Command. Wszola, Stanley. sr 7:3
Mar82 p70-74 *** Games / Arcade / Atari

BUSINESS

Beyond the peaks of Visicalc (Desktop Plan II,
Microfinesse, Plan80). Bishop, Jack. sr 7:10
Oct82 p29-39 *** Financial Modeling /
Planning / Business

SOFTWARE REVIEW (CONTINUED)

GAMES

Alien typhoon (Apple II game). Latocha, Walt.
sr 7:5 May82 p224 *** Arcade / Games /
Apple II

Apple Panic. Williams, Gregg. sr 7:3 Mar82
p68-69 *** Games / Arcade / Apple II

Armored Patrol. Callamaras, Pete. sr 7:6
Jun82 p162-166 *** Arcade / Games / TRS-80
Model I

Beer Run (Apple II arcade game). Little, Arthur.
sr 7:9 Sep82 p375-379 *** Games / Arcade
/ Apple II

Deadline: the butler did it...this time. Morgan,
Chris. sr 7:12 Dec82 p160-161 *** Games /
Strategy / Apple II

Dino Wars. Stewart, George. sr 7:3 Mar82
p74-76 *** Arcade / Games / TRS-80 Color

Galactic Chase. Wszola, Stan. sr 7:6 Jun82
p176-180 *** Arcade / Games / Atari

Missile Command. Wszola, Stanley. sr 7:3
Mar82 p70-74 *** Games / Arcade / Atari

Penetrator. Wszola, Stan. sr 7:12 Dec82
p162-164 *** Games / Arcade / TRS-80 Model III

Ricochet. Williams, Gregg. sr 7:12 Dec82
p142-146 *** Games / Arcade / Apple II

Swashbuckler (Apple II arcade game).
Spangenberg, Scott. sr 7:9 Sep82 p362-367
*** Games / Arcade / Apple II

Tawala's last redoubt (Apple II and TRS-80
adventure game). Lesser, Hartley. sr 7:6
Jun82 p235-236 *** Strategy / Games / Apple
II

The Eliminator: mayhem in space, TRS-80 style.
Pike, Silas. sr 7:6 Jun82 p170-174 ***
Arcade / Games / TRS-80 Model I

Zero Gravity Pinball (Apple II arcade game).
Friedman, Mark. sr 7:9 Sep82 p370-372 ***
Games / Arcade / Apple II

GRAPHICS

Executive briefing system: a color graphics
development for the Apple II. Callamaras,
Peter. sr 7:11 Nov82 p164-170 *** Utility
Program / High Resolution Graphics / Apple II

MATHEMATICS

Software Arts' TK Solver. Williams, Gregg. sr
7:10 Oct82 p360-376 *** Mathematics /
Utility Program

TRS-80 MODEL I

Armored Patrol. Callamaras, Pete. sr 7:6
Jun82 p162-166 *** Arcade / Games / TRS-80
Model I

COBOL for the TRS-80 Models I and III. Archer,
Rowland. sr L5 7:3 Mar82 p384-412 ***
COBOL / TRS-80 Model I / TRS-80 Model III

LDOS - disk operating system for the TRS-80.
Daneliuk, Tim. sr L1 7:3 Mar82 p372-382
*** Operating Systems / TRS-80 Model I /
TRS-80 Model III

Microsoft's BASIC compiler for the TRS-80.
Kelly, Mahlon. sr L1 7:3 Mar82 p358-370
*** Compiler / BASIC / TRS-80 Model I

Multidos: a new TRS-80 disk operating system.
Archer, Rowland. sr 7:12 Dec82 p392-397
*** Operating Systems / TRS-80 Model I /
TRS-80 Model III

NEWDOS/80 Version 2.0 (TRS-80 Model I/III).
Kelly, Mahlon. sr 7:6 Jun82 p376-400 ***
Operating Systems / TRS-80 Model I / TRS-80
Model III

Omniterm: smart terminal program for the TRS-80.
Liddil, Bob. sr 7:2 Feb82 p252-256 ***
Terminal / TRS-80 Model I / TRS-80 Model III

Penetrator. Wszola, Stan. sr 7:12 Dec82
p162-164 *** Games / Arcade / TRS-80 Model III

Pickles & Trout CP/M for the TRS-80 Model II.
Smith, Hal. sr 7:9 Sep82 p531-536 ***
CP/M / TRS-80 Model II / Operating Systems

Program generators (The Last One and
Quic-N-East). Stewart, George. sr L1 7:8
Aug82 p38-56 *** Program Generator / CP/M /
TRS-80 Model I

Radio Shack Compiler BASIC. Archer, Rowland. sr
L1 7:10 Oct82 p224-250 *** Compiler /
BASIC / TRS-80 Model I

TRS-80 disk editor/assembler. Daneliuk, T.A.
sr 7:9 Sep82 p537-539 *** Assembler /
TRS-80 Model I / TRS-80 Model III

The Eliminator: mayhem in space, TRS-80 style.
Pike, Silas. sr 7:6 Jun82 p170-174 ***
Arcade / Games / TRS-80 Model I

UTILITY PROGRAM

Executive briefing system: a color graphics
development for the Apple II. Callamaras,
Peter. sr 7:11 Nov82 p164-170 *** Utility
Program / High Resolution Graphics / Apple II

Flexibility of VisiPlot (Apple II). Ramsdell,
Robert. sr 7:2 Feb82 p32-36 *** Plotting
/ Utility Program / Apple II

Graphics Magician: easy animation for the Apple
II. Callamaras, Peter. sr 7:11 Nov82
p138-144 *** Animation / Apple II / Utility
Program

Microshell and Unica: Unix-style enhancements for
CP/M. Kern, Christopher. sr 7:12 Dec82
p206-220 *** Utility Program / UNIX / CP/M

Software Arts' TK Solver. Williams, Gregg. sr
7:10 Oct82 p360-376 *** Mathematics /
Utility Program

WORD PROCESSING

Two word processors for North Star. Coudal,
Edgar. sr 7:6 Apr82 p312-320 *** Word
Processing / North Star

SOLAR ENERGY

Adapting "Harvesting the Sun's Energy" for the Commodore PET. Berry, Jerry. col L1 7:6 Jun82 p404-408 *** PET / Home / Conversions

SOUND EFFECTS

Add programmable sound effects to your computer. Ciarcia, Steve. col L1 7:7 Jul82 p60-72 *** Hardware Construction / Interface
Atari tutorial, part 7: sound. Fraser, Bob. art L1 7:3 Mar82 p80-9d *** Programming Instruction / BASIC / Atari
Atari tutorial, part 8: generating sound with software. Fraser, Bob. art L3 7:4 Apr82 p134-150 *** Atari / Programming Instruction / BASIC

SPECIAL EDUCATION

Computers and the special education classroom. Sicoli, Thomas. col 7:9 Sep82 p270-274 *** Software Publishing / Vendor Guide
Logo: an approach to educating disabled children. Weir/et al. art 7:9 Sep82 p442-460 *** Logo / Handicapped / Children

SPEECH RECOGNITION

Cognivox V10-1003: voice recognition and output for the Apple II. Murray, William. hr 7:9 Sep82 p231-238 *** Hardware Review / Apple II
Composite PET video / Z8-based voice-recognition system. Ciarcia, Steve. col 7:8 Aug82 p420 *** Ask BYTE / Video Display / PET
Use voiceprints to analyze speech. Ciarcia, Steve. col 7:3 Mar82 p50-64 *** Hardware Construction

SPELLING

Osborne I, Zeke's new friends, and spelling revisited. Pournelle, Jerry. col 7:4 Apr82 p212-238 *** Osborne I / Word Processing / Mathematics
Software tools for writers. Holder, Wayne. art L3 7:7 Jul82 p138-163 *** Writing / Word Processing / Programming Design
Supercalc, spelling programs, BASIC compilers, and home-grown accounting. Pournelle, Jerry. col 7:5 May82 p226-243 *** Compiler / Accounting
Terminal madness, The Word, Grammatik, and then some. Pournelle, Jerry. col 7:6 Jun82 p286-300 *** Terminal / Keyboard / Pascal

SPREADSHEET

Lotus Development Corporation's 1-2-3. Williams, Gregg. sr 7:12 Dec82 p182-198 *** Software Review / IBM Personal Computer

STANDARDS

Introduction to the human applications standard computer interface, pt 1. Rutkowski, Chris. art 7:10 Oct82 p291-310 *** User Interface / Design
Introduction to the human applications standard computer interface, pt 2. Rutkowski, Chris. art 7:11 Nov82 p379-390 *** User Interface
Of IBM, operating systems and Rosetta Stones. Morgan, Chris. col 7:1 Jan82 p6-10 *** IBM Personal Computer / Operating Systems
On the way to standard BASIC. Kurtz, Thomas. art 7:6 Jun82 p182-218 *** BASIC
Pascal standards. Doyle, Thomas. col 7:2 Feb82 p322 *** Pascal
VIA experiment board / Totem poles and TTL / Bus standard stops here. Ciarcia, Steve. col 7:4 Apr82 p429 *** Input/Output / Apple II / S-100 Bus

STATISTICS

Breaking the jargon barrier: designing programs for humanists. Heite/Heite. art L1 7:7 Jul82 p76-104 *** PET / Social Science / Archaeology
Edu-Ware's Statistics 3.0. Elliott, Brownlee. sr 7:10 Oct82 p400-404 *** Software Review / Apple II
Historian and the microcomputer. Rowney, Don. art 7:7 Jul82 p166-176 *** History / Social Science
Operating systems, languages, statistics, pirates and the lone wolf. Pournelle, Jerry. col 7:1 Jan82 p132-158 *** Operating Systems / Languages / Software Piracy

STOCK MARKET

Adapting microcomputers to Wall Street. Franz, Robert. art 7:10 Oct82 p80-92 *** Management / Investment / Business
Stock market / Basic questions / Portable terminals / Measuring devices. Ciarcia, Steve. col 7:9 Sep82 p499-500 *** Ask BYTE / Terminal / Apple II

STRATEGY

Deadline: the butler did it...this time. Morgan, Chris. sr 7:12 Dec82 p160-161 *** Software Review / Games / Apple II
Marketplace (TRS-80 Model III telecomputing game). Dickinson, Robert. art L1 7:10 Oct82 p146-174 *** Games / Telecommunications / TRS-80 Model III
Quinti-maze (Apple II game). Tsuk, Robert. art L1 7:9 Sep82 p24-30 *** Games / Puzzles / Apple II
Ringquest (Apple II adventure game). Mills, Gordon. art L1 7:10 Oct82 p176-206 *** Games / Apple II / Contests
Tawala's last redoubt (Apple II and TRS-80 adventure game). Lesser, Hartley. sr 7:6 Jun82 p235-236 *** Software Review / Games / Apple II
Three Dee Tee (TRS-80 Color Computer game). Stuart, John. art L1 7:9 Sep82 p34-50 *** Games / Puzzles / TRS-80 Color

STRUCTURED PROGRAMMING

Structured programming in BASIC. Sobell, Mark. art L1 7:1 Jan82 p410-415 *** BASIC / Programming Instruction / Cromenco
Structured strings in BASIC. Stockburger, David. col L1 7:5 May82 p308-316 *** Programming Instruction / BASIC / Poly-88
SURVEY
Measuring attitudes with a PET. Heise, David. art L1 7:7 Jul82 p20d-246 *** Social Science / Psychology / PET

TI-99/4A

Logo for the Apple II, the TI-99/4A and the TRS-80 Color Computer. Williams, Gregg. sr L9 7:8 Aug82 p230-290 *** Software Review / Logo / Apple II

TRS-80 COLOR

Build a half-year clock for the Color Computer: fourth in a series. Barden, William. art L3 7:3 Mar82 p100-122 *** Clock / Hardware Construction / Wire Wrap
Color Computer disk system. Stearns, Colin. hr 7:7 Jul82 p312-328 *** Hardware Review / Mindisk Drive / Operating Systems
Computer-controlled irrigation / ZX81 home control / Current overloads. Ciarcia, Steve. col 7:7 Jul82 p420 *** Ask BYTE / Agriculture / Control
Cows and catalogs / TV jitter bugs / Downloading to CP/M / Speedometer. Ciarcia, Steve. col 7:5 May82 p398-400 *** Ask BYTE / Agriculture / CP/M
Dino Wars. Stewart, George. sr 7:3 Mar82 p74-76 *** Software Review / Arcade / Games
Easy entry program for Radio Shack's Color Computer. Field, Tim. col L1 7:4 Apr82 p482-487 *** Utility Program / Machine Language
General-purpose I/O board for the Color Computer. Barden, William. art L1 7:6 Jun82 p260-282 *** Hardware Construction / Interface / Input/Output
Inexpensive transducers for the TRS-80, part II (real-world monitoring). Barden, William. art 7:11 Nov82 p416-444 *** Interface / TRS-80 Model I / A/D Converter
Ports of entry and soft breezes for the Color computer and Model III. Barden, William. art L3 7:5 May82 p162-198 *** TRS-80 Model III / Tape Cassette / Input/Output
Three Dee Tee (TRS-80 Color Computer game). Stuart, John. art L1 7:9 Sep82 p34-50 *** Games / Puzzles / Strategy
Voice synthesis for the Color Computer: third in a series. Barden, William. art L3 7:2 Feb82 p258-286 *** Voice Synthesis / Hardware Construction

TRS-80 MODEL 16

Four new products from Radio Shack (TRS-80 Model 16, hard disk, terminal). Morgan, Chris. art 7:3 Mar82 p40-43 *** Hard Disk Drive / TRS-80 Pocket Computer / High Resolution Graphics

TRS-80 MODEL I

Apple Sweet Talker / Low-cost monitor / TRS-80 vector graphics. Ciarcia, Steve. col 7:1 Jan82 p408-409 *** Ask BYTE / Apple II / Video Display
Armored Patrol. Callamaras, Pete. sr 7:6 Jun82 p162-166 *** Software Review / Arcade / Games
Build a Joystick A-to-D converter for the TRS-80 Model I or III. Barden, William. art L1 7:1 Jan82 p160-184 *** Joystick / Analog/Digital Circuit / TRS-80 Model III
COBOL for the TRS-80 Models I and III. Archer, Rowland. sr L5 7:3 Mar82 p384-412 *** Software Review / COBOL / TRS-80 Model III
Controlling heat surges / VIC-20 video display / Sweet Talker interface. Ciarcia, Steve. col 7:4 Apr82 p430-431 *** VIC-20 / Voice Synthesis / CBM
Disk drives / ADM-3 lowercase / VIC cassette / S-100 & TRS-80 / ZX81. Ciarcia, Steve. col 7:10 Oct82 p452-454 *** Ask BYTE / Floppy Disk Drive / VIC-20
Disk operating system for FORTH: an in-depth look at how a DOS operates. Reece, Peter. art L7 7:4 Apr82 p322-358 *** Operating Systems / FORTH / Programming Design
Double your TRS-80's graphics resolution. Haddad, George. col L1 7:7 Jul82 p448-451 *** Graphics / Hardware Modification
General-purpose I/O board for the TRS-80 Models I and III. Barden, William. art L1 7:8 Aug82 p291-321 *** Input/Output / Hardware Construction / TRS-80 Model III
Generating Mohr's circle (TRS-80 Model I). Fink, Robert. col L1 7:10 Oct82 p312-313 *** Physics / Mathematics
High speed printers / Level I tape format / Computer lab essentials. Ciarcia, Steve. col 7:3 Mar82 p442-443 *** Ask BYTE / Printer / Test Equipment
Inexpensive transducers for the TRS-80, part II (real-world monitoring). Barden, William. art 7:11 Nov82 p416-444 *** Interface / TRS-80 Color / A/D Converter
LDOS - disk operating system for the TRS-80. Daneliuk, Tim. sr L1 7:3 Mar82 p372-382 *** Software Review / Operating Systems / TRS-80 Model III
MIKBUG and the TRS-80, part 2: A file transfer and debugging package. Labenski, Robert. art L3 7:1 Jan82 p100-110 *** Utility Program / MIKBUG / Terminal

TRS-80 MODEL I (CONTINUED)

MOD III: TRS-80 Model III features for your Model I. Locke, Joe. art L1 7:4 Apr82 p380-396 *** Utility Program / Keyboard / Video Display
Mail order / TRS-80 merge / Z80 monitor / Color-monitor bandwidths. Ciarcia, Steve. col 7:1 Jan82 p404-406 *** Ask BYTE / Retailing / Monitor
Microsoft's BASIC compiler for the TRS-80. Kelly, Mahlon. sr L1 7:3 Mar82 p358-370 *** Software Review / Compiler / BASIC
Microvex: the other type of video display. Garrett, Billy. art L1 7:11 Nov82 p508-528 *** Video Display / Hardware Construction / High Resolution Graphics
Multidos: a new TRS-80 disk operating system. Archer, Rowland. sr 7:12 Dec82 p392-397 *** Software Review / Operating Systems / TRS-80 Model III
NEWDOS/80 Version 2.0 (TRS-80 Model I/III). Kelly, Mahlon. sr 7:6 Jun82 p376-400 *** Software Review / Operating Systems / TRS-80 Model III
OmniTerm: smart terminal program for the TRS-80. Liddil, Bob. sr 7:2 Feb82 p252-256 *** Software Review / Terminal / TRS-80 Model III
Po(r)tpourri of ideas (TRS-80 tone generator, telephone dialer, RS-232). Barden, William. art L3 7:4 Apr82 p158-182 *** TRS-80 Model III / Input/Output / Hardware Construction
Programming PERT in BASIC. Zimmerman/Conrad. art L1 7:5 May82 p465-478 *** Planning / Management / Business
Programming critical-path method in BASIC. Zimmerman/Conrad. art L1 7:7 Jul82 p378-390 *** Management / Business
Putting real-world interfaces to work, part I (TRS-80 monitoring). Barden, William. art 7:10 Oct82 p96-123 *** Hardware Construction / Control / Interface
Radio Shack Compiler BASIC. Archer, Rowland. sr L1 7:10 Oct82 p224-250 *** Software Review / Compiler / BASIC
Simulating neighborhood segregation. Dethlefsen/Moody. art L1 7:7 Jul82 p178-206 *** Social Science / Simulation
TRS-80 BASIC program hang-ups: the reasons and some solutions. Tesler, Glenn. art L3 7:5 May82 p318-330 *** Programming Instruction / BASIC / TRS-80 Model III
TRS-80 EPROMS / TI-58C printer interface / ROM-based BASIC / Power backup. Ciarcia, Steve. col 7:2 Feb82 p365-366 *** Ask BYTE / Printer / Calculator
TRS-80 clock / Low-cost computers. Ciarcia, Steve. col 7:9 Sep82 p500-501 *** Ask BYTE / Microcomputer System
TRS-80 disk editor/assemblers. Daneliuk, T.A. sr 7:9 Sep82 p537-539 *** Software Review / Assembler / TRS-80 Model III
The Eliminator: mayhem in space, TRS-80 style. Pike, Silas. sr 7:6 Jun82 p170-174 *** Software Review / Arcade / Games
Thirty more days to faster input. Roberts, Edward. col L1 7:1 Jan82 p186 *** Keyboard / Computer Assisted Instruction / Education
Using the Model I/III RS-232C port. Barden, William. art L1 7:7 Jul82 p360-376 *** RS-232 / TRS-80 Model III / Serial Input/Output
TRS-80 MODEL II
Jetset (TRS-80 Model II flying simulation). Szymanski, Eugene. art L1 7:11 Nov82 p272-322 *** Games / Simulation / Flying Pickles & Trout CP/M for the TRS-80 Model II. Smith, Hal. sr 7:9 Sep82 p531-536 *** Software Review / CP/M / Operating Systems
TRS-80 MODEL III
Build a Joystick A-to-D converter for the TRS-80 Model I or III. Barden, William. art L1 7:1 Jan82 p160-184 *** Joystick / Analog/Digital Circuit / S-80 Model III
COBOL for the TRS-80 Models I and III. Archer, Rowland. sr L5 7:3 Mar82 p384-412 *** Software Review / COBOL / S-80 Model III
General-purpose I/O board for the TRS-80 Models I and III. Barden, William. art L1 7:8 Aug82 p291-321 *** Input/Output / Hardware Construction / S-80 Model III
LDOS - disk operating system for the TRS-80. Daneliuk, Tim. sr L1 7:3 Mar82 p372-382 *** Software Review / Operating Systems / S-80 Model III
Marketplace (TRS-80 Model III telecomputing game). Dickinson, Robert. art L1 7:10 Oct82 p146-174 *** Games / Telecommunications / Strategy
Model III A to D revisited. Barden, William. art L1 7:9 Sep82 p398-418 *** Analog/Digital Circuit / Hardware Construction / A/D Converter
Multidos: a new TRS-80 disk operating system. Archer, Rowland. sr 7:12 Dec82 p392-397 *** Software Review / Operating Systems / S-80 Model III
NEWDOS/80 Version 2.0 (TRS-80 Model I/III). Kelly, Mahlon. sr 7:6 Jun82 p376-400 *** Software Review / Operating Systems / S-80 Model III
OmniTerm: smart terminal program for the TRS-80. Liddil, Bob. sr 7:2 Feb82 p252-256 *** Software Review / Terminal / S-80 Model III
Penetrator. Wszola, Stan. sr 7:12 Dec82 p162-164 *** Software Review / Games / Arcade
Po(r)tpourri of ideas (TRS-80 tone generator, telephone dialer, RS-232). Barden, William. art L3 7:4 Apr82 p158-182 *** S-80 Model III / Input/Output / Hardware Construction

TRS-80 MODEL III (CONTINUED)

Ports of entry and soft breezes for the Color computer and Model III. Barden, William. art L3 7:5 May82 p162-198 *** TRS-80 Color / Tape Cassette / Input/Output

Program generators (The Last One and Quic-N-Easi). Stewart, George. sr L1 7:8 Aug82 p38-56 *** Software Review / Program Generator / CP/M

TRS-80 BASIC program hang-ups: the reasons and some solutions. Tesler, Glenn. art L3 7:5 May82 p31d-330 *** Programming Instruction / BASIC / S-80 Model III

TRS-80 disk editor/assemblers. Daneliuk, T.A. sr 7:9 Sep82 p537-539 *** Software Review / Assembler / S-80 Model III

Using the Model I/III RS-232C port. Barden, William. art L1 7:7 Jul82 p360-376 *** RS-232 / S-80 Model III / Serial Input/Output

TRS-80 POCKET COMPUTER

Base conversion on the TRS-80 Pocket Computer. Dolan, David. col L1 7:4 Apr82 p436-43d *** Conversions / Binary / Hexadecimal

Four new products from Radio Shack (TRS-80 Model 1b, hard disk, terminal). Morgan, Chris. art 7:3 Mar82 p40-43 *** Hard Disk Drive / High Resolution Graphics / TRS-80 Model 1b

TAPE CASSETTE

Add a cassette interface to your VIC-20. Hale, William. col 7:3 Mar82 p272-274 *** Hardware Construction / Interface / VIC-20

Ports of entry and soft breezes for the Color computer and Model III. Barden, William. art L3 7:5 May82 p162-198 *** TRS-80 Color / TRS-80 Model III / Input/Output

TAXES

FIT - a federal income tax program in UCSD Pascal. Heyman, Edward. art L6 7:2 Feb82 p148-190 *** Federal Government / Pascal

Tax tips for computer owners. Feuerman/Moller. art 7:2 Feb82 p212-214 *** Business / Federal Government

Two tax aids (Individual Tax Plan and Tax Preparer). Kvan, Mary Jo. sr 7:2 Feb82 p204-212 *** Software Review / Apple II / Federal Government

Using the LOOKUP function in VisiCalc. Ramsdell, Robert. col 7:8 Aug82 p443-445 *** VisiCalc / Programming Instruction

TELECOMMUNICATIONS

Abilityphone (message system for handicapped people). Rush, William. hr 7:9 Sep82 p240-246 *** Hardware Review / Handicapped / Telephone

Apple talks with the deaf. Rhodes, Ned. art L3 7:1 Jan82 p366-386 *** Handicapped / Interface / Apple II

Marketplace (TRS-80 Model III telecomputing game). Dickinson, Robert. art L1 7:10 Oct82 p146-174 *** Games / Strategy / TRS-80 Model III

TAF: terminal Apple with file transfer. Gabriele, Tom. art L1 7:6 Jun82 p410-432 *** Terminal / Apple II / Data Transmission

TELEPHONE

Abilityphone (message system for handicapped people). Rush, William. hr 7:9 Sep82 p240-246 *** Hardware Review / Handicapped / Telecommunications

TERMINAL

Briefcase computer market heats up. Morgan, Chris. col 7:7 Jul82 p6-10 *** Portable Computer / Microcomputer System

It all depends on your viewpoint (AODS Viewpoint video terminal). Moore, Allen. hr 7:7 Jul82 p408-411 *** Hardware Review

MIKBUG and the TRS-80, part 2: A file transfer and debugging package. Labenski, Robert. art L3 7:1 Jan82 p100-110 *** Utility Program / TRS-80 Model I / MIKBUG

Omiterm: smart terminal program for the TRS-80. Liddil, Bob. sr 7:2 Feb82 p252-256 *** Software Review / TRS-80 Model I / TRS-80 Model III

Personal computer as an interface to a corporate...information system. McBurney, N.R. art L6 7:10 Oct82 p315-358 *** Apple II / Pascal / Management

RCA VP-3301 data terminal. Daneliuk, Tim. hr 7:1 Jan82 p124-128 *** Hardware Review

Revolution in your pocket (IXO Telecomputing System). Morgan, Chris. col 7:4 Apr82 p6-18 ***

Stock market / Basic questions / Portable terminals / Measuring devices. Ciarcia, Steve. col 7:9 Sep82 p499-500 *** Ask BYTE / Stock Market / Apple II

TAF: terminal Apple with file transfer. Gabriele, Tom. art L1 7:6 Jun82 p410-432 *** Apple II / Data Transmission / Telecommunications

Talking terminals (text-to-speech translation). Stoffel, David. art 7:9 Sep82 p218-227 *** Voice Synthesis / Handicapped / Vendor Guide

Tele-VIC: Commodore breaks the \$100 price barrier for modems. Lebow, Max. hr L1 7:3 Mar82 p240-246 *** Hardware Review / Modem / Terminal

Terminal madness, The Word, Grammatik, and then some. Pournelle, Jerry. col 7:6 Jun82 p286-300 *** Keyboard / Spelling / Pascal

Terminals, keyboards, and...software piracy. Pournelle, Jerry. col 7:11 Nov82 p394-415 *** Keyboard / Software Piracy / Book Review

Wise Technology's WY-100 terminal. Haas, Mark. hr 7:10 Oct82 p392-396 *** Hardware Review

TEST

Floppy-disk performance. Yalirakis, N. col 7:1 Jan82 p114-116 *** Floppy Disk Drive / Design

TEST (CONTINUED)

Test your memory using the Barber-Pole algorithm. Pinnick, H.R. art L3 7:12 Dec82 p414-444 *** Memory / 8080 / 8085

TEST EQUIPMENT

Applescope stores dual traces. MacNicol, Gregory. hr 7:6 Jun82 p364-372 *** Hardware Review / Apple II

High speed printers / Level I tape format / Computer lab essentials. Ciarcia, Steve. col 7:3 Mar82 p442-443 *** Ask BYTE / Printer / TRS-80 Model I

Turn your Apple II into a storage oscilloscope. Korba, Larry. art L3 7:9 Sep82 p520-530 *** Hardware Construction / Apple II

TEXT EDITOR

Designing a text editor? The user comes first. Jong, Steven. art 7:4 Apr82 p284-300 *** Programming Design / Word Processing / Consumer Information

Managing words: what capabilities should you have with a text editor?. Finseth, Craig. art 7:4 Apr82 p302-310 *** Word Processing / Programming Design

Program your own text editor, part 1: avoid complex commands.... Fobes, Richard. art 7:9 Sep82 p476-489 *** Programming Design

Program your own text editor, part 2 (video-display-oriented text editor). Fobes, Richard. art L3 7:10 Oct82 p406-446 *** Programming Design

Text editing with Compuser's VEDIT. Thompson, H.B. sr 7:3 Mar82 p262-270 *** Software Review / CP/M

THREE-DIMENSIONAL GRAPHICS

Interactive 3-D graphics for the Apple II. Pichholtz, Andrew. art L1 7:11 Nov82 p474-505 *** Apple II / Pascal

TINY BASIC

Introduction to NSC Tiny BASIC: the language of the IMS8073. Handy, Jim. art L1 7:4 Apr82 p472-481 ***

TRAINING

Interactive training in cardiopulmonary resuscitation. Hon, David. art L9 7:6 Jun82 p108-138 *** Medicine / Videodisc / Simulation

TRANSLATORS

Upward migration, part 1: translators (CP/M-86 translators). Taylor/Lemons. art L3 7:6 Jun82 p321-344 *** CP/M / CP/M-86 / 8086

TROUBLESHOOTING

Digital troubleshooting with signature analysis (HP-5004A). Plubeni, Steven. art 7:9 Sep82 p466-474 *** Signature Analysis

Troubleshooting with electronic signatures. Piggott, Kenneth. art 7:1 Jan82 p190-204 *** Maintenance / Signature Analysis

TURTLE GRAPHICS

Problem solving with Logo: using turtle graphics to redraw a design. Weinreb, William. art L9 7:11 Nov82 p118-134 *** Logo / Apple II / Problem-Solving

TYPEWRITER

Letter-quality selectrics / Bank selecting memory / 50 Hz power. Ciarcia, Steve. col 7:10 Oct82 p452 *** Ask BYTE / Memory / Power Supply

Mediamix's ETI. Welborn, Robert. hr 7:7 Jul82 p284-288 *** Hardware Review / Printer / Interface

UNIX

Microshell and Unica: Unix-style enhancements for CP/M. Kern, Christopher. sr 7:12 Dec82 p206-220 *** Software Review / Utility Program / CP/M

USER INTERFACE

Atari tutorial, part 10: human engineering. Crawford, Chris. art 7:6 Jun82 p302-318 *** Atari

Designing the Star user interface. Smith/et al. art 7:4 Apr82 p242-282 *** Xerox Star / Business

How to use color displays effectively. Durrett/Trezona. art 7:4 Apr82 p50-53 *** Color Display / Color Graphics / Video Display

Human-factors case study based on the IBM Personal Computer. Cooper/et al. art 7:4 Apr82 p56-72 *** IBM Personal Computer / Keyboard / Video Display

Human-factors style guide for program design. Simpson, Henry. art 7:4 Apr82 p108-132 *** Programming Design

Introduction to the human applications standard computer interface, pt 1. Rutkowski, Chris. art 7:10 Oct82 p291-310 *** Standards / Design

Introduction to the human applications standard computer interface, pt 2. Rutkowski, Chris. art 7:11 Nov82 p379-390 *** Standards

UTILITY PROGRAM

BASIC formatted printing (TI BASIC). Subbaih, Malladi. col L1 7:3 Mar82 p162-164 *** BASIC

BASIC plotting subroutine: sophisticated plotting with your MX-80. Bregoli, Lawrence. art L1 7:3 Mar82 p142-156 *** Plotting / Printer / BASIC

CHEEDIT: a graphics-character editor (Apple Pascal). Sweet, Jerry. art L6 7:5 May82 p426-444 *** Apple II / Pascal / Graphics

Character editor for the Atari. Kilby, Tim. art L1 7:12 Dec82 p167-179 *** Graphics / Atari / Programming Instruction

Double-width Silentyper graphics for your Apple. Putney, Charles. col L3 7:2 Feb82 p413-423 *** High Resolution Graphics / Apple II / Printer

UTILITY PROGRAM (CONTINUED)

Easy entry program for Radio Shack's Color Computer. Field, Tim. col L1 7:4 Apr82 p482-487 *** TRS-80 Color / Machine Language

Epson MX-80 print-control program for the Apple II. Starbuck, Bill. col L1 7:3 Mar82 p166-170 *** Printer / Apple II

Executive briefing system: a color graphics development for the Apple II. Callamaras, Peter. sr 7:11 Nov82 p164-170 *** Software Review / High Resolution Graphics / Apple II

Fill forms system: CP/M programs to cut down on paperwork. Roch, Bill. art L1 7:3 Mar82 p218-238 *** Business / Printer / CP/M

Finding words that sound alike: the Soundex algorithm. Jacobs, Jacob. col L1 7:3 Mar82 p473-474 *** BASIC / Apple II

Flexibility of VisiPlot (Apple II). Ramsdell, Robert. sr 7:2 Feb82 p32-36 *** Software Review / Plotting / Apple II

GEOSAT program (calculates the position of communications satellites). Emmett, Steve. art L1 7:1 Jan82 p420-432 *** Broadcasting / Data Transmission / Apple II

GRPRINT: an Apple utility program for dot-matrix printers. Arnott, Douglas. art L3 7:12 Dec82 p398-403 *** Printer / High Resolution Graphics / Apple II

Graphics Magician: easy animation for the Apple II. Callamaras, Peter. sr 7:11 Nov82 p138-144 *** Software Review / Animation / Apple II

Listing the disk directory in CP/M-based Pascal. Hunt, Daniel. col L6 7:6 Jun82 p497-501 *** Pascal / CP/M

Lowercase descenders for the Epson MX-70 (Apple II). Piggott, Bruce. art L3 7:3 Mar82 p248-254 *** Lowercase Modification / Apple II / Printer

MIKBUG and the TRS-80, part 2: A file transfer and debugging package. Labenski, Robert. art L3 7:1 Jan82 p100-110 *** TRS-80 Model I / MIKBUG / Terminal

MOD III: TRS-80 Model III features for your Model I. Roche, Joe. art L1 7:4 Apr82 p380-396 *** TRS-80 Model I / Keyboard / Video Display

Microshell and Unica: Unix-style enhancements for CP/M. Kern, Christopher. sr 7:12 Dec82 p206-220 *** Software Review / UNIX / CP/M

Semidisk, Software Tools, the 8005 blues, Power, and LISPs. Pournelle, Jerry. col 7:8 Aug82 p342-363 *** CP/M / LISP / Book Review

Shape-drawing program for Diablo printers (Apple II). Brock, Thomas. col L1 7:3 Mar82 p310-314 *** Printer / Apple II

Software Arts' TK Solver. Williams, Gregg. sr 7:10 Oct82 p360-376 *** Software Review / Mathematics

Text-handling routines in extended BASIC. Greenhalgh, Roger. col L1 7:6 Jun82 p460-467 *** BASIC

Underline filter for matrix printers. Reed, Adam. col L8 7:3 Mar82 p300-306 *** Printer / C Programming Language

Word-counting utility for writers. Roberts, Steven. col L3 7:6 Jun82 p237-240 *** Writing / Cromemco

VIC-20

Action games for the VIC-20. Kavanagh, Russell. sr 7:12 Dec82 p150-156 *** Software Review / Games / Arcade

Add a cassette interface to your VIC-20. Hale, William. col 7:3 Mar82 p272-274 *** Hardware Construction / Tape Cassette / Interface

Controlling heat surges / VIC-20 video display / Sweet Talker interface. Ciarcia, Steve. col 7:4 Apr82 p430-431 *** TRS-80 Model I / Voice Synthesis / IBM

Disk drives / ADM-3 lowercase / VIC cassette / S-100 & TRS-80 / ZX81. Ciarcia, Steve. col 7:10 Oct82 p452-454 *** Ask BYTE / Floppy Disk Drive / TRS-80 Model I

Tele-VIC: Commodore breaks the \$100 price barrier for modems. Lebow, Max. hr L1 7:3 Mar82 p240-246 *** Hardware Review / Modem / Terminal

VIP

Tuning up the 1802: a simple music composition trainer. Makosinski, Art. col L2 7:7 Jul82 p442-447 *** Music / 1802

VIP expansion / TTL data books. Ciarcia, Steve. col 7:3 Mar82 p446-447 *** Integrated Circuits

VENDOR GUIDE

Computers and the special education classroom. Sicoli, Thomas. col 7:9 Sep82 p270-274 *** Special Education / Software Publishing

Microcomputer graphics primer. Williams, Gregg. art 7:11 Nov82 p448-470 *** Graphics / Video Display / Computer Instruction

State of industrial robotics. Callahan, J. Michael. art 7:10 Oct82 p128-142 *** Robots / Manufacturing

Talking terminals (text-to-speech translation). Stoffel, David. art 7:9 Sep82 p218-227 *** Terminal / Voice Synthesis / Handicapped

VICTOR 9000

Chuck Peddle: an interview with the chief designer of the Victor 9000. Lemmons, Phil. art 7:11 Nov82 p256-271 *** Interview / People / Design

Victor victorious: the Victor 9000 computer. Lemmons, Phil. hr 7:11 Nov82 p216-254 *** Hardware Review / Microcomputer System

VIDEO DISPLAY

Apple II 80-column video boards: five popular units. Howland, John. hr 7:5 May82 p252-266 *** Hardware Review / Apple II

VIDEO DISPLAY (CONTINUED)

Apple Sweet Talker / Low-cost monitor / TRS-8U vector graphics. Ciarcia, Steve. col 7:1 Jan82 p408-409 *** Ask BYTE / Apple II / TRS-80 Model I
 Composite PET video / Z8-based voice-recognition system. Ciarcia, Steve. col 7:8 Aug82 p420 *** Ask BYTE / PET / Speech Recognition
 How to use color displays effectively. Durrett/Trezona. art 7:4 Apr82 p50-53 *** Color Display / Color Graphics / User Interface
 Human-factors case study based on the IBM Personal Computer. Cooper/et al. art 7:4 Apr82 p56-72 *** User Interface / IBM Personal Computer / Keyboard
 MOD III: TRS-80 Model III features for your Model I. Rocke, Joe. art L1 7:4 Apr82 p380-396 *** TRS-80 Model I / Utility Program / Keyboard
 Microcomputer graphics primer. Williams, Gregg. art 7:11 Nov82 p448-470 *** Graphics / Computer Instruction / Vendor Guide
 Microvex: the other type of video display. Garrett, Billy. art L1 7:11 Nov82 p508-528 *** Hardware Construction / High Resolution Graphics / TRS-80 Model I
 More Apple 80-column boards. Williams, Gregg. hr 7:5 May82 p266-271 *** Hardware Review / Apple II
 Soroc 1Q-120 slave monitor / OSI shift-lock problem / Audible alarms. Ciarcia, Steve. col 7:6 Jun82 p434-435 *** Ask BYTE / OSI / Keyboard

VIDEO GAME SYSTEM

Vectrex Arcade System. Clark, Pamela. hr 7:12 Dec82 p92-93 *** Hardware Review / Games / Arcade

VIDEO DISC

Build an interactive-videodisc controller (Pioneer VP-1000). Ciarcia, Steve. col 7:6 Jun82 p60-74 *** Interface / Control / Hardware Construction
 Interactive training in cardiopulmonary resuscitation. Hon, David. art L9 7:6 Jun82 p108-138 *** Medicine / Training / Simulation
 Interpretive language used to program the CPR system. Laumer, Mike. art L9 7:6 Jun82 p126-130 *** Languages / Apple II
 Videodisc interfacing primer. Daynes, Rod. art 7:6 Jun82 p48-59 *** Definitions / Interface
 Videodiscs and optical data storage. Moberg/Laefsky. art 7:6 Jun82 p142-160 *** Information Storage / Research / Office Automation
 Videodiscs in education: integrating the computer and... Bejar, Isaac. art L6 7:6 Jun82 p78-104 *** Education / Computer Assisted Instruction

VIDEOTEX

Some answers to frequently asked questions. Morgan, Chris. col 7:10 Oct82 p6-14 *** Consumer Information

VISICALC

Using the LOOKUP function in VisiCalc. Ramsdell, Robert. col 7:8 Aug82 p443-445 *** Programming Instruction / Taxes

VOICE SYNTHESIS

Analyze audio by visualizing. Phillips, Thomas. col L3 7:1 Jan82 p206-214 *** Digital Audio / /
 Build a computerized weather station. Ciarcia, Steve. col L3 7:2 Feb82 p38-68 *** Weather / Hardware Construction / Kit Building
 Build the Microvox text-to-speech synthesizer, part 1: hardware. Ciarcia, Steve. col 7:9 Sep82 p64-88 *** Hardware Construction
 Build the Microvox text-to-speech synthesizer, part 2: software. Ciarcia, Steve. col L9 7:10 Oct82 p40-64 *** Hardware Construction / Programming Instruction
 Controlling heat surges / VIC-20 video display / Sweet Talker interface. Ciarcia, Steve. col 7:4 Apr82 p430-431 *** TRS-80 Model I / VIC-20 / CBM
 Give your Apple a voice (Radio Shack Speech Synthesizer). Blankenship, John. art L1 7:5 May82 p446-456 *** Interface / Hardware Construction / Apple II
 Let there be talking people too. Danke, Mark. col 7:9 Sep82 p6-8 *** Handicapped
 Minspeak (semantic compaction system for disabled individuals). Baker, Bruce. art 7:9 Sep82 p186-202 *** Handicapped
 Speech synthesizer application / Problems with EPROM / Modem interface. Ciarcia, Steve. col 7:3 Mar82 p442 *** Ask BYTE / EPROM / Modem
 Talking terminals (text-to-speech translation). Stoffel, David. art 7:9 Sep82 p218-227 *** Terminal / Handicapped / Vendor Guide
 Voice synthesis for the Color Computer: third in a series. Barden, William. art L3 7:2 Feb82 p258-286 *** TRS-80 Color / Hardware Construction

WEATHER

Build a computerized weather station. Ciarcia, Steve. col L3 7:2 Feb82 p38-68 *** Hardware Construction / Kit Building / Voice Synthesis

WIRE WRAP

Build a half-year clock for the Color Computer: fourth in a series. Barden, William. art L3 7:3 Mar82 p100-122 *** Clock / Hardware Construction / TRS-80 Color

WORD PROCESSING

Ada, MINCE. CP/M utilities, overpriced documentation and Analiza II. Pournelle, Jerry. col 7:7 Jul82 p290-310 *** Ada / Documentation / CP/M

WORD PROCESSING (CONTINUED)

Designing a text editor? The user comes first. Jong, Steven. art 7:4 Apr82 p284-300 *** Text Editor / Programming Design / Consumer Information
 Effective text-compression algorithm. Cortesi, David. art L9 7:1 Jan82 p397-403 *** Programming Design / Information Storage / Data Structures
 Letters, Pascal, CB/80, and Cardfile. Pournelle, Jerry. col 7:9 Sep82 p318-341 *** Pascal / Compiler
 Managing words: what capabilities should you have with a text editor?. Finseth, Craig. art 7:4 Apr82 p302-310 *** Text Editor / Programming Design /
 Osborne 1, Zeke's new friends, and spelling revisited. Pournelle, Jerry. col 7:4 Apr82 p212-238 *** Osborne 1 / Spelling / Mathematics
 Software tools for writers. Holder, Wayne. art L3 7:7 Jul82 p138-163 *** Writing / Spelling / Programming Design
 Two word processors for North Star. Coudal, Edgar. sr 7:4 Apr82 p312-320 *** Software Review / North Star

WRITING

Computers, fiction and poetry (stories and poems written by computers). McKean, Kevin. art 7:7 Jul82 p50-53 *** Fiction / Poetry

Software tools for writers. Holder, Wayne. art L3 7:7 Jul82 p138-163 *** Spelling / Word Processing / Programming Design
 Word-counting utility for writers. Roberts, Steven. col L3 7:6 Jun82 p237-240 *** Utility Program / Cromemco

XEROX STAR

Designing the Star user interface. Smith/et al. art 7:4 Apr82 p242-282 *** User Interface / Business

Z-80

SO Systems' Z80 Starter Kit. Angevine, Wayne. hr 7:1 Jan82 p332-342 *** Hardware Review / Microcomputer System / Kit Building
 SOFTIM: a software timer. Terpstra, Dan. col L3 7:1 Jan82 p436-439 *** Programming Instruction / Clock
 Z80 starting address: one jump further. Lemmen, Steven. col 7:1 Jan82 p433-435 *** Hardware Modification

Z8

Everyone can know the real time (real-time clocks). Ciarcia, Steve. col L1 7:5 May82 p34-58 *** Clock / Hardware Construction

ZENITH Z89

Heath/Zenith Model 47 dual floppy-disk system. Kern, Christopher. hr 7:8 Aug82 p398-406 *** Hardware Review / Floppy Disk Drive / Heath 89

Collector Edition BYTE COVERS

The Byte covers shown below are available as beautiful Collector Edition Prints. Each full color print is 11 in. x 14 in., including a 1/2 in. border, and is part of an edition strictly limited to 500 prints. Each print is faithfully reproduced from the original painting on museum quality acid-free paper, and is personally inspected, signed and numbered by the artist, Robert Tinney. A Certificate of Authenticity accompanies each print attesting to its quality and limited number.

Collector Edition Prints are carefully packaged flat to avoid bending, and are shipped first class. The price of each print is \$25, plus \$3 per shipment for postage and handling (\$8 overseas). The prints are also available as 4-print sets: Set 9-12, Set 13-16, and Set 17-20. Each set costs \$80, plus postage and handling. To order your own favorite Byte cover as a beautiful Collector Edition Print, use the convenient coupon below. Visa or MasterCard orders may call 1-504-272-7266.

			
#17 Winter Computing \$25	#18 Seventeen Seventy-Six \$25	#19 Crystal Ball \$25	#20 Digital Arts \$25
			
#13 Future Computers? \$25	#14 Smalltalk \$25	#15 Software \$25	#16 Chip Building \$25
			
#9 Software Piracy \$25	#10 Programming Route \$25	#11 Forth \$25	#12 Future Past \$25

Please send me the following Prints (\$25), or Sets (\$80). I have enclosed check or money order.

QTY. TITLE & PRINT NO. AMOUNT Visa MasterCard

_____ \$ _____ Card No. _____

_____ \$ _____ Exp. Date: _____

_____ \$ _____ SHIP MY PRINTS TO:

_____ \$ _____ Name: _____

_____ \$ _____ Address: _____

_____ \$ _____ City: _____

_____ \$ _____ State: _____ Zip: _____

postage & handling \$3.00 (Overseas \$8.00) TOTAL \$ _____

Mail this coupon to:
robert tinney graphics
 1864 N. Pamela Drive
 Baton Rouge, LA
 70815

FOR VISA OR MASTERCARD ORDERS
 or for more information
CALL 1-504-272-7266
 Daytime or Evenings

What's New?

Games

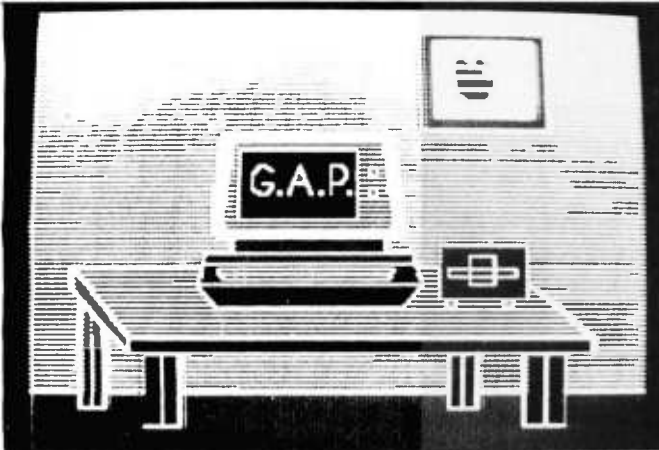

Game Animation Package

The Game Animation Package from Synergistic Software lets Applesoft programmers design full-color, high-resolution graphics. For arcade-type games, the package provides bit-mapped graphics, and its vector-graphics capabilities make full-screen pictures available for use in logos, maps, and gameboards for adventure games. Other features include two-dimensional im-

ages with lines, circles, and ellipses.

The Game Animation Package runs on 48K-byte Apple IIs with DOS 3.3 and Applesoft BASIC. It costs \$49.95. Complete details are available from Synergistic Software, Suite 201, 830 North Riverside Dr., Renton, WA 98055, (800) 426-6505; in Washington, (206) 226-3216. Circle 600 on inquiry card.

Stock-Market Simulation

Fifteen different stocks are yours to manipulate with Blue Chip Software's stock-market simulation game, Millionaire. You can buy and sell stocks, put options, buy on margin, and borrow against your net worth. Players can summon corporate histories and week-by-week industry trends and graphs.

Millionaire runs on the Apple II Plus and Apple III computers. It costs \$79.95. Versions are available for the IBM Personal Computer, Osborne 1, and CP/M-based systems for \$99.95. Contact Blue Chip Software, Suite 215, 18653 Ventura Blvd., Tarzana, CA 91356, (213) 881-8288. Circle 602 on inquiry card.

Invaders Runs on Osborne

Invaders is a full-color, high-resolution arcade-type game from The Software Toolworks. In Invaders, waves of attacking aliens attempt to land, and you, sheltered behind ever-shrinking barricades, must beat them back with your space cannon. Game parameters can be modified to increase the challenge, and you can redesign the graphics display.

Designed for the Osborne 1, Invaders costs \$19.95. It's available at Computerland stores, Osborne dealers, or factory-direct from The Software Toolworks, 14478 Gloriet-

ta Dr., Sherman Oaks, CA 91423, (213) 986-4885. When ordering from the manufacturer, enclose \$2 for postage and handling. Circle 603 on inquiry card.

Professional Blackjack Strategies

Intelligent Statements has released Ken Uston's Professional Blackjack—The Ultimate Game, The Winningest System. This program teaches computer-developed Blackjack strategies and simulates the playing environments of 50 different casinos.

Ken Uston's Professional Blackjack requires 48K bytes of RAM (random-access read/write memory), a disk drive, and a color or monochrome display. It costs \$89.95, plus \$2 shipping and handling. Versions for the Apple II, Atari, IBM Personal Computer, TRS-80, and CP/M-based systems are available. Contact Intelligent Statements Inc., POB 600, Holmes, PA 19043, (800) 345-8112; in Pennsylvania, (800) 662-2444. Circle 604 on inquiry card.

Foreign Products

Report Generator

The Mistress Report Writer from Rhodnius Inc. is a report generator designed to be used in conjunction with the Mistress database-management



Stick Stand Has Easy-Grip Control Knob

K-Byte's Stick Stand joystick has a ball-shaped easy-grip control knob. The Stick Stand is designed to reduce hand and wrist fatigue, and it frees one hand for operating a fire button. Assembly is simple: you snap the control knob

onto the joystick and then place the joystick into the Stick Stand.

The Stick Stand fits the Atari VCS and Sears Video Arcade and Atari 400/800 joysticks. It costs \$6.99 and is available from K-Byte, 1705 Austin, POB 456, Troy, MI 48099, (313) 524-9878. Circle 601 on inquiry card.

What's New?

system. This system allows formatting and pagination of complex reports with values from Mistress databases and Unix commands. Retrieved values can be printed in a variety of formats, and arithmetic operations can be performed on them. Other features include grouping of data at any number of levels and such functions as sorting and subtotaling at any level. The suggested retail price is \$2000. Complete details are available from Rhodnius Inc., POB 1, Station D, Scarborough, Ontario, M1R 4Y7, Canada, (416) 922-1743. Circle 605 on inquiry card.

tants, Veungsdalsveien 1, 3600 Kongsberg, Norway; tel: (03) 73 49 60. Circle 606 on inquiry card.

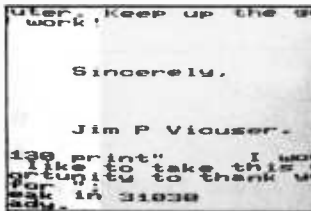
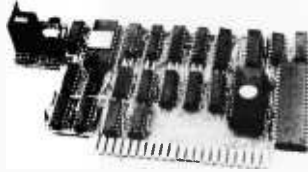

Display-Mode Expansion for VIC

Computer World's video cartridge for the Commodore VIC-20 gives you selectable 25-line by 40- or 80-character display formats, which let you use programs written for the 2000, 3000, 4000, and 8000 CBM computers. Standard features include true uppercase and lowercase descenders, full cursor control, and VIC and PET/CBM graphics capabilities. The cartridge expands the VIC's RAM (random-access read/write memory) to 32K bytes. It does not require an external power supply.

The cartridge requires an Arfon or Commodore expansion box equipped with 3K-, 8K-, or 16K-byte RAM cartridges. It costs \$249. Contact Computer World, Hilvertsweg 99, 1214 JB Hilversum, Holland; tel: 035-12633; Telex: 43776 INCO NL. Circle 607 on inquiry card.

M68000 Disassembler

Norsoft Consultants is marketing an M68000 disassembler program that can interpret all 68000 instructions and produce readable source files. The disassembler's input file is a Motorola S-format ASCII (American Standard Code for Information Interchange) file, and the output file contains standard Motorola 68000 instruction mnemonics and addressing syntax. The disassembler can produce a cross-reference list to all absolute addresses found in the input file.

Written in Pascal, this disassembler will run on a variety of 68000-based systems under different operating systems. The price is \$200. Full details are available from Norsoft Consul-

Robot Programming Language

Biomatik will soon introduce a programming language for microcomputer-controlled robots and manipulators called PASRO (PASCAL for ROBots). PASRO features elements that control robots and claws, elements for addressing process periphery and sensors, predefined special data types for robot-control programming, and arithmetic operators for flexible manipulation of new data types.

PASRO requires an ISO (International Standards Organization) Pascal compiler and will run on machines such as the Osborne 1. The price is 1.800 DM (approximately \$750). Contact Biomatik GmbH, Carl-Mez-Str. 81-83, D-7800 Freiburg i. Br., West Germany; tel: 0761-43045; Telex: 7721508 bios.

Circle 608 on inquiry card.

The ADA1450 comes completely assembled and tested with a case, cable, and power supply for \$149. Phone or write to Connecticut Microcomputer, 36 Del Mar Dr., Brookfield, CT 06804, (203) 775-4595. Circle 609 on inquiry card.

Removable-Cartridge Winchester-Disk Drive

The SQ306 is a 3 $\frac{1}{16}$ -inch (100 mm) removable-cartridge Winchester disk drive from Syquest Technology. Fully compatible with Seagate Technology's 5 $\frac{1}{4}$ -inch fixed-disk Winchester drive (the model ST506/406), the SQ306 can store 6.38 megabytes of data and use controller interfaces designed for the ST506, such as the DTC 510A, Xebec SA1410, and Western Digital's WD 1000. The drive is said to be fully operational within 15 seconds of cartridge insertion.

The SQ306 uses disk packs marketed under the name of Q-Pak. They feature thin metallic-alloy platters that are impervious to dust, smoke, and humidity. The cartridges cost \$35 each. The SQ306 has a suggested retail price of approximately \$800. Contact Syquest Technology, 44160 Warm Springs Blvd., Fremont, CA 94538, (415) 490-7511.

Circle 610 on inquiry card.

PERIPHERALS

PET/CBM Serial Printer Adapter

The ADA1450 printer adapter from Connecticut Microcomputer allows Commodore PET and CBM computers to use standard serial printers. The adapter features switch-selectable uppercase and lowercase, uppercase and lowercase reverse, and uppercase only. It works with Commodore disks and with Wordpro, BASIC, and other software.

What's New?



10-Megabyte Winchester Back-up System

The Companion series of digital tape-cassette backup units for 5¼-inch Winchester disk-drive systems are marketed by MFE Corporation. According to the manufacturer, this backup system is capable of storing up to 10 megabytes of data on a single tape cassette in 4 minutes. Companion's cassette tapes, known as Back-Paks, resemble ANSI (American National Standards Institute) and ECMA (European Computer Manufacturers Association) standard 0.150-inch high-density digital cassettes.

The series comes in two versions: the Model 505, which holds 5 megabytes of data, and the Model 510 for twice that amount. The evaluation price of the Companion 505 is \$995. The Model 510 is \$1175. Full details are available from MFE

Corp. Keewaydin Dr., Salem, NH 03079, (603) 893-1921.

Circle 611 on inquiry card.

Visual 50 Terminal

The Visual 50 can emulate Hazeltine Esprit, ADDS Viewpoint, Lear Siegler ADM-3A, and DEC VT-52 terminals. Produced by Visual Technology, the Visual 50 features menu-driven set-up modes in nonvolatile memory that permit easy selection of terminal parameters. A detached keyboard, smooth scroll, 7 by 9 dot-matrix characters, an 80-character by 24-line display, and a nonglare screen are standard. Other features include tilt and swivel abilities, n-key rollover, status line, a line-drawing character set, and line insertion and deletion.

The Visual 50 costs \$695 and can be purchased through Visual Technology dealers. Service is available in major cities through Sorbus Service, a division of Management Associates Inc. Full specifications can be obtained from Visual Technology Inc., 540 Main St., Tewksbury, MA 01876, (617) 851-5000.

Circle 612 on inquiry card.

Two Terminals from Hazeltine

Hazeltine Corporation has added two more members to its line of computer terminals: the Executive 10 and the Esprit II. The Executive 10 has eight programmable-function keys, a programmable twenty-fifth status line, a full set of editing features, a 7 by 10 dot-matrix display, a split-screen display, and a business graphics-character set. Standard features include a detached keyboard and a tilt-and-swivel, nonglare green display. The Executive 10 costs \$1195.

A nonglare display, green characters, and the ability to project the complete 128-character ASCII (American Standard Code for Information Interchange) set are among the Esprit II's standard features. Its editing capabilities include character insert and delete, line insert and delete, and local print. The detachable Esprit II keyboard has two-key rollover and a 14-key numeric

pad. Compatible with the Hazeltine 1500, the Esprit also emulates Applied Digital Data Systems' Regent 25 or Lear Siegler's ADM-3. The suggested price is \$645. For purchasing information, contact Hazeltine Corp., Computer Terminal Equipment, Greenlawn, NY 11740, (800) 645-5300; in New York, (516) 549-4532.

Circle 613 on inquiry card.

Solid-State Disk Emulators for the Apple

Synetix Micro Products Inc. has announced the availability of single-board SSDs (solid-state disk emulators) for the Apple II or Apple II Plus. Software compatible with Apple DOS 3.3, Apple Pascal, and the CP/M operating system, the SSD cards plug directly into any Apple I/O slot except 0 and do not require external power. Up to seven SSD cards can be installed in the Apple.

The cards are offered in a 147K-byte single-disk version and in a 294K-byte dual-disk version. The suggested prices are \$450 and \$850, respectively. Dealer prices are available. A kit that upgrades the 147K-byte SSD to 256K bytes costs \$350. Contact Synetix Micro Products Inc., 15120 Northeast 95th St., Redmond, WA 98052, (800) 426-7412; in Washington, (206) 881-8440. Circle 614 on inquiry card.

What's New?

SOFTWARE

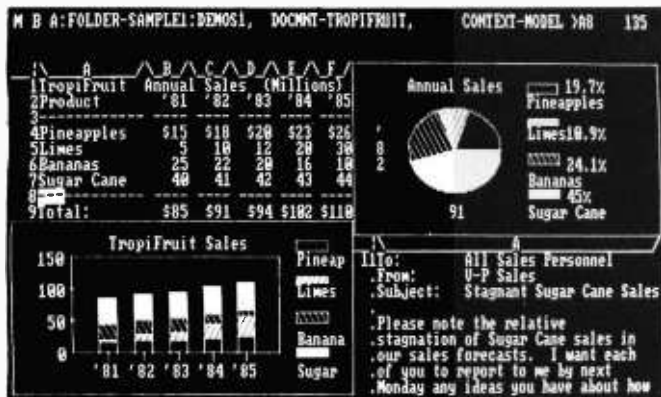

Five Business Functions in One Program

The Context MBA incorporates electronic spreadsheet, telecommunications, word processing, graphics, and database functions in a single program. Developed by Context Management Systems, MBA's electronic spreadsheet gives business managers "what if" financial models that can be shown as one of nine different graphs. Information from the spreadsheet can be used in reports generated with MBA's word-processing function. The

relational-like database has near instant recall, and it searches and retrieves or sorts only the information requested.

MBA requires a 256K-byte IBM Personal Computer outfitted with dual-disk drives and the IBM color graphics card. The suggested retail price is \$695. Contact Context Management Systems, Suite 100, 23864 Hawthorne Blvd., Torrance, CA 91604.

Circle 615 on inquiry card.

CP+ for Friendlier Microcomputers

CP+ replaces CP/M commands with English-language menus and directions. According to Taurus Software Corporation, operating a microcomputer with CP+ is a simple matter of following the steps outlined on the screen. In addition to menus and directions, CP+ offers operator messages and Help commands.

CP+ is compatible with

any CP/M-based system, including those with optional add-on circuit boards for CP/M. CP+ installs on top of CP/M versions 1.4 and 2.2. It costs \$150 per copy, complete with documentation. For details, contact Taurus Software Corp., Suite 817, 870 Market St., San Francisco, CA 94102, (415) 788-0888. Circle 616 on inquiry card.

Cross-Assembler for Z8

System-Z8 is a CP/M-compatible cross-assembler for Zilog's Z8 micro-processor. It features a macro assembler, an interactive editor and assembler, a text editor, and a cross-reference generator. Its macro assembler has full macro and conditional assembly features and the ability to chain a series of source files together during a single assembly.

System-Z8 is available on soft-sectored 8-inch CP/M disks (3740 format) and 5¼-inch North Star and Micropolis Mod II (Lifeboat adaptation) formatted disks. It costs \$150, including documentation and full user support by telephone or mail. Current System-Z8 owners are eligible for a free update procedure. Contact Allen Ashley, 395 Sierra Madre Villa, Pasadena, CA 91107, (213) 793-5748. Circle 617 on inquiry card.

BASIC subroutine. Standard features include dynamic disk-space management, record buffering, searching by full key or partial key, forward and backward sequential retrieval, and the ability to access up to seven ISAM files simultaneously. Among the commands provided are open and close a file; add, delete, and update records; get next and previous record; get first and last record; and show file statistics.

The ISAM Database runs on 48K-byte IBM Personal Computers with one disk drive, PC-DOS, and disk BASIC. It's available for \$69.95 from Ensign Software, Suite E, 2312 North Cole Rd., Boise, ID 83704, (208) 378-8086. Circle 618 on inquiry card.

Interact with Your Apple

Savvy Marketing International's Savvy Personal Language System allows personal-language interaction between your Apple II and you. Using its Adaptive Recognition Processing system, which "trains" an internal Robot Programmer that actually writes your programs in machine language, Savvy lets you work with your own words, phrases, and expressions. The ability to redefine system commands is provided, so all programs can be modified at any time. Standard features include decimal arithmetic, a virtual-resource manager, and

Database Sorts 5000 Records in 12 Seconds

The ISAM Database from Ensign Software is said to be able to sort 5000 records in 12 seconds. ISAM (indexed sequential-access method) provides keyed access to data files for reading, writing, updating, and deleting records within the file. It interfaces directly to BASIC programs through a few variables, and it's accessed by executing a call to a

What's New?

ISAM (indexed sequential-access method) file structures.

Savvy comes with general ledger, accounts receivable, accounts payable, payroll, mailing list, document writer, and inventory control applications programs. Complete with Z80 processor card, firmware, instruction manual, and the applications packages, the Savvy Personal Language System for the Apple II costs \$950. It's available from Savvy Marketing International, 9th Floor, 100 South Ellsworth St., San Mateo, CA 94401, (415) 340-0335. Circle 619 on inquiry card.

C Compiler for 6809 Systems

Introl Corporation's Introl-C/6809 version 2.0 C language compiler system is designed for 6809-based computers running under Flex-09, Uniflex, OS-9, or CP/M DOSes. Introl-C generates position-independent and re-entrant 6809 assembly-language code that's easily assembled with a supplied assembler. All standard C language functions are supported, except bit-fields, initializers, and the #line and #if preprocessor directives. Written entirely in the C language, this package includes a C compiler, a 6809 assembler, linking loader, and library manager. Source code for the runtime library is provided.

The price for Introl-

C/6809 ranges between \$375 and \$425, depending upon operating system. Your purchase includes unlimited rights to distribute the object code produced with the compiler. It comes in both 5¼- and 8-inch floppy-disk formats. Source code for the 6809 assembler, written in C, is available as an option. For further details, contact Introl Corp., 647 West Virginia St., Milwaukee, WI 53204, (414) 276-2937.

Circle 620 on inquiry card.

Subscription-Management Program

Publiphile is a software and hardware subscription-management system for the small publisher. Designed by WPL Associates, this system can handle from several hundred to approximately 20,000 subscribers, and it can generate mailing labels in a variety of formats. Some of the subscriber information provided by Publiphile includes separate billing addresses, purchase and credit-card orders, bad credit names, special offers, and advanced and multiple renewals. On-screen verification of individual subscriber data is permitted, and Publiphile provides hard copy for circulation summaries, expiration counts, renewal analysis, cash receipts, bank deposits, accounts receivable, earned income, and subscriber liability reports.

Publiphile operates on

the Apple II, NEC APC, IBM Personal Computer, Radio Shack TRS-80 Model II, Victor 9000, and many CP/M-based systems. A Publiphile system ranges in price from \$5000 to \$20,000, which includes hardware and software for full-function word processing and connection to electronic publishing services such as Newsnet. Publiphile software can be purchased separately. For further information, contact WPL Associates Inc., Department 01, 1105-F Spring St., Silver Spring, MD 20910, (301) 589-8588.

Circle 621 on inquiry card.

PUBLICATIONS

Directory Lists People with Similar Interests

The Personal Computer Owners Directory can help you locate people with the same interests or computer as you and who are willing to trade information. Interests covered range from adventure-type games to word processing.

For a free, permanent listing in the Personal Computer Owners Directory send your name, address, computer type, interests, and trade information (optional) to Personal Computer Owners, Department 1B, POB 426, Feeding Hills, MA 01030. To receive the current issue of the directory and the next issue containing your listing, enclose \$9.95.



Bell 201-Compatible Modems Described

An 8-page brochure describing Racal-Vadic's line of Bell 201-compatible modems for remote terminals and computer sites is available free of charge from the company. Included are technical aspects, applications, ordering information, and complete product specifications for the firm's family of 2400-bps (bit-per-second) half-duplex modems. Future brochures from Racal-Vadic will detail its 300-, 1200-, and 2400-bps full-duplex modems, as well as its 1200- and 4800-bps half-duplex modems. For your copy, contact Racal-Vadic, Sales Department, 222 Caspian Dr., Sunnyvale, CA 94086, (408) 744-0810.

Circle 622 on inquiry card.

CIME Focuses on Computers in Design

CIME (Computers in Mechanical Engineering) is a quarterly publication of the American Society of Mechanical Engineers (ASME), a nonprofit organization. CIME probes how computers are used and how computers can be used in the design, manufacture, measure-

What's New?

ment, and control of machines and industrial processes. It features case histories, work-measurement guidelines, summaries of available software, computer-aided design and modeling programs, robotics design and applications,

and cost analysis. Annual subscriptions cost \$20. Contact CIME, American Society of Mechanical Engineers, 345 East 47th St., New York, NY 10017, (212) 705-7750. Circle 623 on inquiry card.

SYSTEMS



CIE Systems Markets Line of Business Computers

CIE Systems' 680 family of single- and multiuser business computers is based on Motorola's M68000 microprocessor and Intel's Multibus. The basic 680, the Model 680/10, is a single-user integrated workstation that comes with a built-in display, comprehensive video electronics, a detachable keyboard, and Data Technical Analysts PRO-IV applications processor. The operating speed is 8 MHz, and the 680/10 carries 128K bytes of high-speed RAM (random-access read/write memory), three RS-232C serial ports, a parallel printer port, a 10-megabyte hard disk for mass storage, and a 500K-byte 5¼-inch floppy-disk drive for backup. For expansion, an extra slot in the Multibus chassis is provided. Software supported includes the Unix III and Regulus operating systems. Standard features on multiuser 680s include 256K bytes of expandable RAM and the ability to sup-

port from 3 to 16 workstations.

In OEM (original equipment manufacturer) quantities, the 680/10 costs \$5200. Multiuser 680s range in price from \$6000 to about \$12,000. Full product specifications can be obtained from CIE Systems, 2515 McCabe Way, POB 16579, Irvine, CA 92713, (714) 957-1112. Circle 625 on inquiry card.



Husky Outdoor Computer

Husky is a hand-held portable computer designed for outdoor use. Produced by Sarasota Automation, Husky features 144K bytes of memory and an LCD (liquid-crystal display) that can display 128 characters in 4 lines. It includes a BASIC interpreter, the Z80 instruc-

ACCOUNTS RECEIVABLE

ORDER PROCESSING

FIXED ASSETS

GENERAL LEDGER

ACCOUNTS PAYABLE

PAYROLL

PURCHASE ORDERS

FORTUNE SYSTEMS

SYSTEMS

SYSTEMS

FORTUNE SYSTEMS

SYSTEMS

SYSTEMS

SYSTEMS

Fortune Business Software Explained

Fortune Systems Corporation has produced a series of brochures describing the Business Accounting System, a comprehensive software package designed for the Fortune 32:16 microcomputer. The Business Accounting System comprises order processing, accounts receivable, purchase orders, accounts payable, payroll, fixed assets, and general-ledger programs. The brochures detail individual features of these menu-

driven programs, which can function as stand-alone packages or interface with other Fortune software.

The Business Accounting System is part of Fortune Systems' single- and multiuser business systems, which include word processing, financial modeling, and business graphics programs. Contact Fortune Systems Corp., 1501 Industrial Rd., San Carlos, CA 94070, (415) 595-5014. Circle 624 on inquiry card.

What's New?

tion set, and an RS-232C/V4 port. The CP/M-compatible Husky is battery-powered and housed in a sealed aluminum case with a membrane-protected keyboard. Its dimensions are 9½ by 8 by 1¾ inches. Husky weighs 4½

pounds and has been successfully operated in 15 feet of water. For further information, contact Sarasota Automation Inc., 1500 North Washington Blvd., Sarasota, FL 33577, (813) 366-8770. Circle 626 on inquiry card.

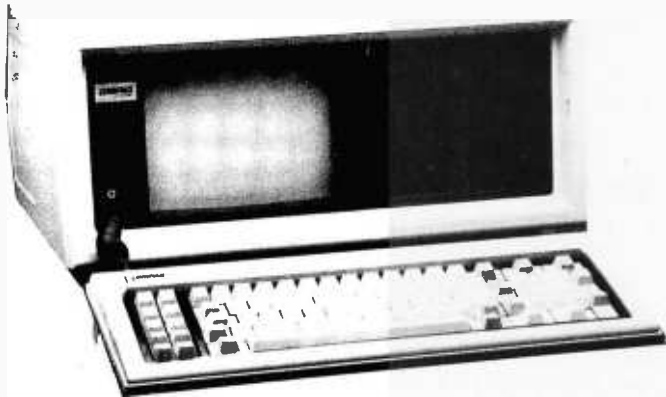

IBM-Compatible Portable from Compaq

Compaq Computer Corporation's Compaq portable computer is IBM PC-compatible. According to the manufacturer, it is able to run all the major business and applications programs written for the PC. The unit is housed in a 20-by 8½-by 15¾-inch plastic enclosure and weighs in at 28 pounds. Its 9-inch (diagonal) high-resolution screen displays 25 lines by 80 characters. Characters are formed by a 7 by 9 dot matrix in a 9 by 14 cell. The monitor is also capable of displaying IBM PC-compatible high-resolution graphics, and provision is made for driving an external red/green/blue monitor for full-color graphics. The display also has adjustable viewing angles. Compaq's

keyboard is detachable from the main unit and is connected by a 6-foot retractable coiled cable. The keyboard layout is identical to that of the IBM PC, with a 10-key numeric pad and 10 function keys, as well as cursor-control keys and an adjustable typing angle.

Compaq uses the Intel 8088 microprocessor, and a socket is provided for the addition of an 8087 mathematics coprocessor in the future. Microsoft MS-DOS version 1.1 and GWBASIC are included. The system comes with 128K bytes of 9-bit parity RAM (random-access read/write memory), expandable to 256K bytes on the main-system board, and 16K bytes of video-display RAM. The main-system board also

contains three IBM PC-compatible expansion slots, a parallel printer port, and outputs for a color monitor, composite video, and connection to a standard television set through an RF (radio frequency) modulator.

The basic Compaq system includes one 320K-byte double-sided double-density 5¼-inch floppy-disk drive, 128K bytes of RAM, and a parallel printer interface. The suggested price is \$2995. Available options include a second floppy-disk drive, an asynchronous-communications interface, and a serial printer interface. Compaq will be available at computer-specialty retail stores in January. For further information, contact Compaq Computer Corp., 12337 Jones Rd., Houston, TX 77070, (713) 890-7390. Circle 627 on inquiry card.

sity floppy disks are supported, and the CP/M-based 128-I is supplied with CTC (counter/timer circuit), DMA (direct memory access), PIO (parallel input/output), and other support chips. Standard equipment includes two software-programmable RS-232C serial ports, a Centronics-type parallel printer interface, an expansion bus, and a smart Winchester disk controller interface that can handle Western Digital, IMI, and Corvus intelligent disk controllers.

The 128-I costs \$600 and can be ordered from Insight Enterprises Corp., Suite 12, 373 North Western, Los Angeles, CA 90004, (213) 461-3262. Circle 628 on inquiry card.

STD Bus-based Systems

Xitex Corporation's XM850S STD bus-based microcomputers have dual 8-inch slimline drives and two RS-232C ports. Optional capabilities include 5¼-inch Winchester- and floppy-disk drives.

A typical XM850S system features 2.4 megabytes of 8-inch floppy-disk storage, 64K bytes of dynamic RAM (random-access read/write memory), a 4-MHz Z80 processor, and the CP/M 2.2 operating system. In single units, this system costs \$4799. A version with 2.4 megabytes of floppy-disk storage and 12.7 megabytes of 5¼-inch Winchester-disk storage is available for \$8049.

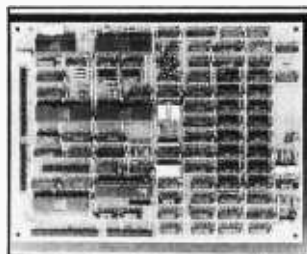

Versatile Single-Board Computer

The 128-I single-board computer from Insight Enterprises features 128K bytes of RAM (random-access read/write memory) and a Zilog Z80A processor. Both 5¼- and 8-inch double-sided double-den-

What's New?

For full details, contact Xitex Corp., 9861 Chartwell Dr., Dallas, TX 75243, (214) 349-2491.
Circle 629 on inquiry card.



Middi-Cadet

Integrated Business Computers has introduced a smaller version of its Super-Cadet microcomputer, called Middi-Cadet. Middi-Cadet measures 12 inches wide by 6 inches tall by 17 inches, so it can fit comfortably on most desktops. Standard features include 256K bytes of RAM (random-access read/write memory), a 20-megabyte 5¼-inch hard disk, a 1-megabyte floppy-disk drive, 10 serial ports, and one Centronics port. Middi-Cadet's memory can be bank-switched within any 4K-byte block, and its bank sizes are switch-selectable. Middi-Cadet also features switch-selectable MP/M-to-Oasis-to-Famos operating systems.

Optional equipment for Middi-Cadet includes a cache memory, a cartridge-tape controller, and a bisynchronous port for communications capabilities. Middi-Cadet has a suggested retail price of \$7500. For full details, contact Integrated Business Computers, 21592 Marilla St., Chatsworth, CA 91311, (213) 882-9007.

Circle 630 on inquiry card.

MISCELLANEOUS

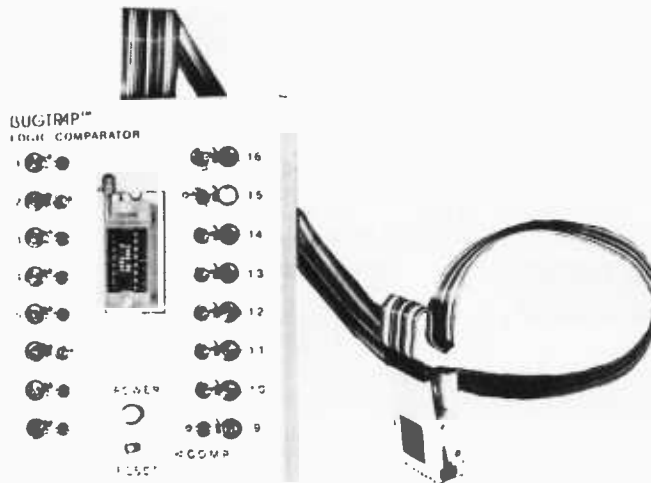

Logic Comparator

The Bugtrap Logic Comparator from Bugtrap Instrumentation is a troubleshooting tool that compares TTL (transistor-transistor logic) devices in circuit. It compares the output activity of the circuit being tested to that of a known good circuit. The circuits share a system input, but their outputs are separated and continuously compared. Any miscomparisons cause an error signal to be generated and a cor-

responding LED (light-emitting diode) to light.

The Bugtrap Logic Comparator comes with a reference manual that documents more than 100 of the most commonly used and testable TTL chips. It costs \$265 and comes with a 14-day money-back trial period. For further details, contact Bugtrap Instrumentation, 1173 Tasman Dr., Sunnyvale, CA 94086, (408) 734-1118.

Circle 631 on inquiry card.

RS-232C Line Tester

B & B Electronics is offering an RS-232C tester that monitors and displays the status of seven RS-232C lines. The tester has LEDs (light-emitting diodes) that display the status of the following lines: transmit data, receive data, request-to-send, clear-to-send, data set ready, carrier detect, and data terminal ready. The unit has one 25-pin

male and one female connector for insertion into any RS-232C interface.

The tester does not require power and is designed to remain in-line permanently. It does not affect data-transfer ability. It costs \$39.95, postage paid, and is available from B & B Electronics, POB 475, Mendota, IL 61342, (815) 539-5827.

Circle 632 on inquiry card.

Winchester Controller with DMA

Compupro is marketing a high-performance Winchester disk controller that can directly access a 16-megabyte address space. The Disk 2 controller board has high-speed DMA (direct memory access) protocols that allow processor-independent data transfer between system memory and Winchester-type 8- and 14-inch drives. It can handle four drives, with up to 16 heads per drive. The Disk 2 is compatible with IEEE 696/S-100 bus standards and with MP/M, Oasis, CP/M-80, and CP/M-86 operating systems.

Disk 2 will work with the Shugart SA4000 series, Fujitsu 2300 series, and Memorex 101 series drives. The suggested retail price is \$795; OEM (original equipment manufacturer) prices on request. Contact Compupro Systems, Oakland Airport, Oakland, CA 94614, (415) 562-0638.
Circle 633 on inquiry card.

Apple II Data-Protection System

Datalok from Atlantis Computers makes the DES (Data Encryption Standard) Algorithm for data protection available to Apple II or CP/M users. By storing data in encrypted form, Datalok prevents unauthorized individuals from tampering with your information. It uses a WD2001 DES chip on a board configured for the Apple bus and is supplied with in-



BISON PRODUCTS, INC.

A CALIFORNIA CORPORATION



Winter Sale! 20% Off on New 1983 Q.T. Models.

Bison sells and supports the full line of Q.T. S-100 microcomputer and disk storage products. Choose a preconfigured, ready-to-run package, or assemble your own system from the wide range of Q.T. and other compatible S-100 components available. One of our support technicians will be glad to help you select the proper configuration to meet your needs. Bison carries everything you need from terminals and printers through software to blank floppy disks. (For more S-100 information, circle Reader Service Card #69)

We also have some older S models at bigger discounts. Check out our other ad or call for details. Request your 1983 Q.T. Catalog today!

Q.T. DISCOUNT MICRO-SYSTEMS PACKAGES



Q.T. MAXI-SYSTEM PACKAGE—Model 800P

\$6,395.00

List \$7,995.00—Save \$1,600.00

Q.T. MINI-SYSTEM PACKAGE—Model 500P

\$3,995.00

List \$4,995.00—Save \$1,000.00

—QT 8" Mainframe with 8 slot Motherboard —Teletideo 925 Full Featured CRT
—Choice of printer: C. Itoh F-10 daisy wheel or Oki data M84P high speed dot matrix (200 cps.)

The Q.T. Maxi-System is an industry standard S-100 expandable microcomputer which is ideal for general business computing, word processing and data base management applications. CP/M operating system is standard. MP/M or Turbos optional. Unique Infoware™ utilities simplify operation and user training.

- Electronics on Two Cards
 - 4MZ Z80A CPU
 - Filtered Fan
 - 64K RAM Standard
 - Parallel Printer Port
 - Two A.C. Outlets
 - Universal Disk Controller
 - 10-40 MB Hard Disk Option
 - Key Lock Switch
 - 2 Megabytes on line
 - Expandable to 256K RAM
 - Two Serial Ports
- Package Price Includes Cables, Documentation & Utility Programs. Model 800 alone \$4,995

- CP/M standard. Turbos optional.
- Reliable Single Card Electronics
- Z80 CPU/Universal DMA controller
- Dual Double Sided/Density Drives
- Memory: 64K RAM & 320K Disk Drive
- Cables, manuals, Infoware™ Utilities

Q.T. INDUSTRY STANDARD S-100 MAINFRAMES

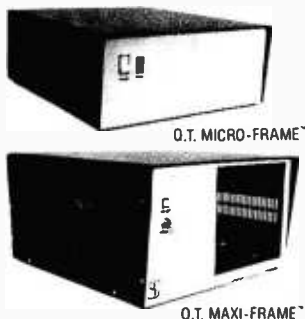

Q.T. MICRO-FRAME™—Series 600

Desk Top—Plain Front Panel

- 6 to 22 slot Motherboard
- Full I/O Cutout Array
- Fused EMI/RFI Filter
- Heavy Duty Power Supply (+8V@16A ±16V@3A)

6 slot MB ... List \$599 ... Bison \$479
8 slot MB ... List \$649 ... Bison \$519
12 slot MB ... List \$699 ... Bison \$559
18 slot MB ... List \$799 ... Bison \$639
22 slot MB ... List \$899 ... Bison \$719

Q.T. MINI-FRAME™—Series 500

Desk Top—Dual Mini Drives

- Holds two 5 1/4" Drives
- Full Cutout Array
- 6, 8, or 12 slot MB.
- Fused EMI/RFI Filter
- Hard Disk Power Supply (+8V@16A, ±16V@3A, ±12V@5A, +5V@5A)

6 slot MB ... List \$799 ... Bison \$639
8 slot MB ... List \$849 ... Bison \$679
12 slot MB ... List \$899 ... Bison \$719

Q.T. MAXI-FRAME™ Series 800

Desk Top for Dual 8" Drives

- 6, 8, 12 slot Motherboard
- Universal Drive mounts
- Key lock Power Switch
- Heavy Duty Power supply (+8V@16A, ±16V@3A, +5V@5A, -5V@1A, +24V@5A)

6 slot MB ... List \$899 ... Bison \$719
8 slot MB ... List \$949 ... Bison \$759
12 slot MB ... List \$999 ... Bison \$799

Q.T. DISK DRIVE CABINETS AND SUBSYSTEMS



Front—Tandon Panel



Rear view

Q.T.'s All in One™

- Universal Disk Drive Cabinet
- Expandable
- Accepts all 8" drives

QT's unique new disk drive cabinet has been designed to accept virtually any 8" drive on the market today from Tandon Thinlines to 40 megabyte Quantums. Features include interchangeable face plates (Qume, Shugart, Tandon, etc.) and "electronics in a drawer" construction to simplify installation and maintenance. Heavy duty power supply will carry any combination of up to four Thinline, two standard, or one hard disk drive with floppy backup. +5V@5A, -5V@1A, +24V@5A.

DDC8 8V-XX w/one faceplate ... List \$399 ... Bison \$319.00
Replacement Faceplates (Specify type) \$25.00



SINGLE 8" VERTICAL CABINET

Size: 11"H 11"W 18"D
Perfect add-on disk drive for any system. Accepts most brands.
DDC8V ... List \$299 ... Bison \$239



DUAL 8" HORIZONTAL DRIVE CABINET

Dimensions: 5"H 17"W 20"D
Designed to provide basic disk storage capacity for S-100 and other computers. Low profile permits table top stacking.
QTC-DDC + 88H ... List \$349 ... Bison \$279

SEND MAIL ORDERS TO:
P.O. Box 9078-184
Van Nuys, CA 91409

ORDERS MAY BE PICKED UP AT:
6700 Van Nuys Ave.
Van Nuys, CA 91409

FOR PHONE ORDERS OR
TECHNICAL INFO CALL:
(213) 994-2533

"We accept Cash, Certified Checks, VISA, and MasterCard." All merchandise new in factory cartons with manufacturer's warranty. Corporate and School District P.O.'s accepted subject to credit approval. Enclose financial statement with order. California residents add Sales Tax. Shipping charges added to all orders. No refunds without prior approval. Bison credit only on returned merchandise. Quantities limited on some items—prices subject to change without notice.

What's New?

teractive software that lets you encrypt and encode data by responding to a few questions. No programming is required.

Two software utilities are supplied with Datalok. The first is the ability to encrypt and decrypt any file created under Apple DOS, such as text, integer, binary, or Applesoft. The second lets you lock and unlock an entire disk, thereby rendering it inaccessible and unbootable to unwelcome users.

Datalok requires 48K bytes of RAM (random-access read/write memory), one disk drive, DOS 3.2 or 3.3, and Applesoft BASIC. The price is \$349. The CP/M software costs \$69. Order Model ACS-1A from Atlantis Computers, 31-14 Broadway, Astoria, NY 11106, (212) 728-6700. Circle 634 on inquiry card.

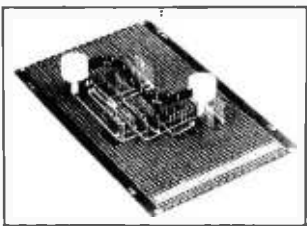

Tool for Wire-Wrapping

OK Industries' WA-1 Wrap-Aid wire-measuring tape ruler is designed for wire-wrapping applications. This tool eliminates wasted wire, helps prevent errors by identifying both posts to be wrapped, and can help you determine the best wire path. Special post extensions are provided for wire routing.

Here's how it works: one end of Wrap-Aid is placed over the first post to be wrapped. The other end is then pulled through the wiring path and placed over the second post. The length of wire required is then read directly from the tape.

The WA-1 Wrap-Aid costs \$4.95. It's available from many electronics distributors or from OK Industries Inc., 3455 Conner St., Bronx, NY 10475, (212) 994-6600.

Circle 635 on inquiry card.



Impact Detector

Shockwatch is a small glass capsule that attaches to hard-disk units and detects and flags mechanical shocks that may indicate possible damage to the unit. Manufactured by Media Recovery, Shockwatch is designed to be an integral part of any of six configurations of hard-disk packs. It uses a combination of liquid surface tension and capillary action to detect trouble. Indicators that turn from white to red alert you to an impact of a degree that could cause misalignment of the disk, which can result in a head crash. Contact Media Recovery Inc., 1435 Round Table Dr., Dallas, TX 75247, (800) 527-9497; in Texas, (214) 630-9625. Circle 636 on inquiry card.



Ethernet for IBM

A series of products that link IBM Personal Computers together in an Ethernet local-network environment has been introduced by 3Com Corporation. All the Etherseries products are plug- and software-compatible with the PC and provide users with peripheral and information sharing and personal communications capabilities. Among the items in the series is Etherlink, which includes a plug-in controller/transceiver board, software, and manual. It costs \$950.

Also available is Ethershare, a 16-bit microcomputer-based file server with a 10-megabyte Winchester-disk drive. It supports as many as 20 workstations (dependent only on disk capacity) and allows each user access to the Winchester drive as if it were a part of his system. The disk-sharing software makes storage appear as "virtual floppy disks." Most disks have a file backup system whereby files are periodi-

cally copied so as to protect against system failures. A hard-disk backup system on floppy disk or an optional tape-cartridge system is available. Passwords can be assigned so that access to data can be limited. Ethershare costs \$11,500.

When equipped with a printer and Etherprint software, Ethershare can support spooled printer sharing. Another product, Ethermail, provides Ethershare with electronic-mail collection and distribution capabilities. Ethermail permits messages to be automatically amended with attachments from any PC DOS file.

The Etherseries will be expanded to allow other personal computers to communicate with each other. In addition, more software is being developed. Complete details are available from 3Com Corp., 1390 Shorebird Way, Mountain View, CA 94043, (415) 961-9602. Circle 637 on inquiry card.

WE STOCK
EAGLE COMPUTERS

EAGLE
COMPUTER

USI Video Monitors—Green or AMBER
20 MHz hi-res. Dealer and OEM inquiries
invited



SPECIALS on INTEGRATED CIRCUITS

6502	7.45	10/ 6.95	50/ 6.55	100/ 6.15
6502A/6512A	8.40	10/ 7.95	50/ 7.35	100/ 6.90
6520 PIA	5.15	10/ 4.90	50/ 4.45	100/ 4.15
6522 VIA	6.45	10/ 6.10	50/ 5.75	100/ 5.45
6532	7.90	10/ 7.40	50/ 7.00	100/ 6.60
2114-L200		2.45	25/ 2.30	100/ 2.15
2716 EPROM	4.90	5/ 4.50	10/ 4.00	
2532 EPROM	8.90	5/ 8.45	10/ 7.90	
6116 2Kx8				
CMOS RAM	8.90	5/ 8.45	10/ 7.90	
4116 RAM		8 for 14		
Zero Insertion Force 24 pin Socket (Scanbe)	2.00			



Anchor Automation Signalman Modems
FREE SOURCE MEMBERSHIP WITH SIGNALMAN

All Signalman Modems are Direct Connect, and include cables to connect to your computer and to the telephone. Signalman Modems provide the best price-performance values, and start at less than \$100. **Dealer and OEM Inquiries Invited**

- Mark I RS232
- Mark II for Atari 850
- Mark IV for CBM/PET with software
- Mark V for Osborne (software available)
- Mark VI for IBM Personal Computer
- Mark VII Auto Dial/Auto Answer
- Mark VIII Bell 212 Auto Dial/Answer

DC HAYES Smartmodem	229
RS232 MODEM — Acoustic	119
RS232 MODEM — CCITT frequencies	175

We carry Apple II+ from Bell & Howell

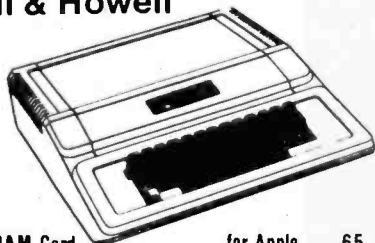

16K RAM Card	for Apple	65
Apple LOGO		150
Video Recorder Interface		545
Super Serial Card		149
Thunderclock Plus		119
Z80 Softcard and CP/M		295
Parallel Printer Interface/Cable		85
Grappler Interface		139
TG Products Joystick for Apple		48
TG Paddles		32
DC Hayes Micromodem II		299
Videx 80 Column Card		259
fullFORTH+ for Apple (fig-Forth)		85
Silentype Printer and Card		310
Graphics Tablet and Card		645
Apple PASCAL Language		195
Apple FORTAN		160
We stock EDUWARE Software		
GENIS I Courseware Development System		185
Unicom Grade Reporting or School Inventory		250
Executive Briefing System with fonts		225
Apple Dumping (Microtek) Printer Interface		115
Apple Dumping with 16K Buffer		160

commodore

See us for Personal, Business,
and Educational requirements.
Educational Discounts available.

PETSCAN \$245 base price

Allows you to connect up to 35 CBM/PET Computers to shared disk drives and printers. Completely transparent to the user. Perfect for schools or multiple word processing configurations. Base configuration supports 2 computers. Additional computer hookups \$100 each.

Commodore COMMUNICATES!

COMPACT \$129

Intelligent Terminal Package includes:
ACIA hardware based interface, DB25 Cable and STCP Software with remote telemetry, transfer to/from disk, printer output, XON-XOFF control, user program control, and status line.

VE-2 IEEE to Parallel Interface 119

Includes case, power supply, full 8-bit transmission, and switch selectable character conversion to ASCII.

VIC 20	189	VIC Sargon II Chess	32
VIC Printer	335	VIC GORF	32
VIC 3K RAM	32	Meteor Run (UMI)	39
VIC 8K RAM	53	VIC Radar Rattrace	24
VIC 16K RAM	99	Amok (UMI)	20
VIC Disk Drive	395	Snakman	15
VIC Pinball	32	Rubik's Cube	13
VIC Omega Race	32	Programmers Reference	15
Spiders of Mars (UMI)	39	Renaissance (UMI)	39
VIC Draw Poker	24	VIC Superslot	23

VICTORY Software for VIC

Street Sweepers	12	Maze in 3-D	12
Night Rider	11	Cosmic Debris	12
Treasures of Bat Cave	12	Grave Robbers Advent.	11
Games Pack I	12	Games Pack II	12
Victory Casino	8	Adventure Park I	12
Adventure Pack II	12	Trek	11

TNW 486/103 with DAA	450
Computer's First Book of PET/CBM	11
POWER ROM Utilities for PET/CBM	78
WordPro 3+ - 32K CBM, disk, printer	195
WordPro 4+ - 8032, disk, printer	300
SPELLMASTER spelling checker for WordPro	170
COPY-WRITER Professional Word Processor	159
VISICALC for PET, ATARI, or Apple	190
PE-TRAX PET to Epson Graphics Software	35
SM-KIT enhanced PET/CBM ROM Utilities	40
Programmers Toolkit - PET ROM Utilities	35
PET Spacermaker II ROM Switch	36
2 Meter PET to IEEE or IEEE to IEEE Cable	40
Dust Cover for PET, CBM, 4040, or 8050	8
VIC or C64 Parallel Printer Interface	85
CmC IEEE-RS232 Printer Interface — PET	120
SADI Intelligent IEEE-RS232 or parallel	235
Library of PET Subroutines	12
Programming the PET/CBM (Computer) — R. West	20
Computer's First Book of VIC	11
Whole PET Catalog (Midnight Gazette)	8
Color Chart Video Board for PET	125
PET Fun and Games (Cursor)	11

FlexFile for PET/CBM \$110

Database, Report Writer with Calculations, Mailing Lists

FORTH for PET full FIG model — Cargill/Riley \$50

Metacompiler for FORTH for independent object code 30

KMMM PASCAL for PET/CAM 85

EARL for PET/CBM Disk-based ASSEMBLER 65

Super Graphics — BASIC Language Exercises 45

Fast machine language graphics routines for PET/CBM

RAM/ROM for PET/CBM 4K \$75 8K \$90

DISK SPECIALS



SCOTCH (3M) 5"	10/ 2.30	50/ 2.35	100/ 2.10
SCOTCH (3M) 8"	10/ 2.45	50/ 2.25	100/ 2.20

We stock VERBATIM DISKS

Write for Dealer and OEM prices.

BASF 5" or 8"	10/ 2.00	20/ 1.95	100/ 1.85
Wabash 5"	10/ 1.80	50/ 1.75	100/ 1.70
Wabash 8"	10/ 2.25	50/ 2.20	100/ 2.10

We stock MAXELL DISKS

Write for dealer and OEM prices.

Disk Storage Pages	10 for \$4	Hub Rings 50 for \$6
Disk Library Cases	8"—3.00	5"—2.25
Head Cleaning Kits	11	

CASSETTES—AGFA PE-611 PREMIUM

High output, low noise, 5 screw housings.

C-10	10/56	50/50	100/48
C-30	10/73	50/68	100/66

SPECIALS

Timex/Sinclair Computer	95
Zenith ZVM-121 Green Phosphor Monitor	109
INTEX Talker Text to Speech System	265
Epson, Okidata, Prowriter printers available	
Brother Daisy Wheel Printer	880
STARWRITER Daisy Wheel Printer F10	1445
We Stock AMDEK Monitors	
Watanabe Intelligent Plotter 1095	6-pen 1395
Staticide anti-static spray	6
dBASE II	445

ALL BOOK and SOFTWARE PRICES DISCOUNTED
A P Products 15% OFF

Synertek SYM-1 Microcomputer	SALE 189
KTM-2/80 Synertek Video and Keyboard	349
KTM-3/80 Synertek Tubeless Terminal	385

Alspa Computer, Inc.

The price-performance leader. Includes Z80A, 1 or 2 full 8" drives (double density, double sided), 3 serial and 1 parallel port, and winchester port. Prices start at less than \$2000. DEALER and OEM inquiries invited.

ZENITH data systems

Z90-80 64K	1995
Z90-82 64K 1 double dens. drive	2245
Z37 1.3 Megabyte Dual Drive	1355
Z19 Video Terminal (VT-52 compatible)	695
ZT-1 Intelligent Communications Terminal	550
Z100 16-bit/8-bit System	CALL



800 Computer	649	Microsoft BASIC	72
400—16K	269	MISSILE COMMAND	29
810 Disk Drive	440	ASTEROIDS	29
825 Printer	625	STAR RAIDERS	34
850 Interface	170	Space Invaders	29
Inside Atari DOS	18	Music Composer	35
Joysticks or Paddles	19	Caverns of Mars	33
16K RAM (Microtek)	69	PAC-MAN	36
32K RAM (Microtek)	99	CENTIPEDE	36
Pilot	65	First Book of Atari	11
Super Breakout	29	Anchor Modem—Atari	85
APX Software	Call	Other Atari products	Call

WRITE FOR CATALOG

Add \$1.25 per order for shipping. We pay balance of UPS surface charges on all prepaid orders. Prices listed are on cash discount basis. Regular prices slightly higher. Prices subject to change.

252 Bethlehem Pike
Colmar, PA 18915

215-822-7727

A B Computers

Circle 5 on inquiry card.

What's New?



Computer Is on the Dot

Dot is a portable computer that's fully compatible with the IBM Personal Computer. Dot, engineered and marketed by Computer Devices Inc., features Intel's 16-bit 8088 microprocessor and the MS-DOS operating system from Microsoft. Standard equipment includes 64K bytes of memory and a 5-by 9-inch monochrome display with bit-mapped graphics. The display has 32K bytes of dedicated RAM (random-access read/write memory) and

variable character modes of 40, 80, or 132 columns by 16 or 25 lines. Dot comes with two Sony 3½-inch disk drives that provide 287K bytes of storage (formatted) per disk.

Options include an embedded printer with 5 by 10 dot-matrix uppercase and lowercase characters, two RS-232C ports, a Zilog Z80 to run CP/M version 2.2, and a built-in 300- or 300/1200-bit-per-second modem. User applications software includes an electronic spreadsheet, a word processor, a time and proj-

ect scheduler, business graphics, and accounting software. Prices for the Dot ranges from \$2995 to \$3997, depending upon options. For complete details, contact Computer Devices Inc., 25 North Ave., Burlington, MA 01803, (800) 343-5104; in Massachusetts, (617) 273-1550. In Canada, call Datamex Ltd. at (416) 781-9135.

Circle 638 on inquiry card.

Relational Database Management System

ABW Corporation's RL-1 Relational Database Management system is designed for the IBM Personal Computer and CP/M-based systems. This database is fully relational and comes with such operators as selection, projection, and join. Standard features include a query language,

relational editor, and program interface.

A variety of applications packages are available for use with the RL-1 system, including a report generator, a graphics processor, inventory and production control, and general ledger and other accounting packages. The suggested retail price for the RL-1 Database Management system is \$495. For full details, contact ABW Corp., POB M1047, Ann Arbor, MI 48106, (313) 971-9364.

Circle 639 on inquiry card.

Cube Aids Program Instruction

Metacommet Software's Programmable Cube can help teach programming because it corresponds to the popular cube game. This program simulates all six sides of the cube in six colors (or special shades for black-and-white displays) as well as each move's motion. A solver provides a step-by-step guide through the solution of any scrambled cube. The Programmable Cube is supplied with a programming language designed especially for cubes, pattern-matching and control constructs, and an editor and debugger.

The Programmable Cube runs on Apple II computers and is available in both 48K- and 64K-byte versions. It costs \$34.95. Contact Metacommet Software, POB 31337, Hartford, CT 06103.

Circle 640 on inquiry card.

Where Do New Products Items Come From?

The information printed in the new products pages of BYTE is obtained from "new product" or "press release" copy sent by the promoters of new products. If in our judgment the information might be of interest to the personal computing experimenters and homebrewers who read BYTE, we print it in some form. We openly solicit releases and photos from manufacturers and suppliers to this marketplace. The information is printed more or less as a first-in first-out queue, subject to occasional priority modifications. While we would not knowingly print untrue or inaccurate data, or data from unreliable companies, our capacity to evaluate the products and companies appearing in the "What's New?" feature is necessarily limited. We therefore cannot be responsible for product quality or company performance.

Beautiful Plots with PLOTPAK™

PLOTPAK is a complete plotting library that runs under FORTRAN-80 and includes drivers for the following screens and plotters:

- MicroAngelo MA 512
- ADM + Retrographics
- TEK 4010 compatible terminals
- Houston Instruments DMP-4
- HP plotters 7225B and 7470
- Radio Shack Printer/Plotter

PLOTPAK (.REL file):\$275.

PLOTPAK source code plus two drivers:\$365.

BRIDGE

Computer Company
DIVISION OF Sea Data Corporation
One Bridge Street, Newton, MA 02158
TEL. (617) 244-8190 TLX: 951107

Circle 74 on Inquiry card.

IPEX **NEW!**

"ELF" Interface
Converts Your
Typewriter Into Printer



- Finest print quality
- Easy Installation
- Fits IBM Electric® and Electronic Typewriters
- Models for all popular computers
- Call or write for more information, today!
- Low cost
- Quick delivery

- We export to all countries -

IPEX INTERNATIONAL INC.
5115 Douglas Fir Rd.
Calabasas, CA 91302 U.S.A.
Tel: (213) 710-1444 TLX/TWX: 910 494 2100

Circle 250 on Inquiry card.

GRAPHIC SOFTWARE ON CP/M FOR ENGINEERING & BUSINESS SYSTEMS

ON PLOTTERS, CNT'S, DOT MATRIX, AND M.P. PRINTERS
SHEETS, PLOTS, AND PRINTS

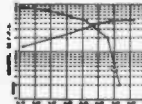
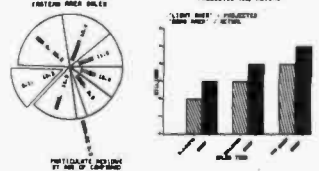

PLOTWARE - Z
TRY IT OUT AND BUY
FROM YOUR DEALER. OR CALL
THE ENERCORP COMPANY

P.O. BOX 28014
LAKEWOOD, CO. 80229
(303) 988-1648

PLOTWARE-Z GIVES YOU MAXIMUM RESOLUTION GRAPHICS. NOT A "BLOCKY" MEMORY MAPPED DRAWING WITH BOXES INTERACTIVE, MENU DRIVEN, *DOT MATRIX:EPSON, IDS, ETC. *FOR ASCII DISK FILES, OR *PLOTTER:HPGLII, OTHERS. *COMPILER (.REL FILES) *ARC:TEXTADRIX, SCION, ETC. *KEYS: USER INTERFACE *M.P. PRINTERS:GEM, DIGITAL *SOFTWARE UPWARDS COMPATIBLE (CALCOMP, DISPLA, PLOTIO) *HARDWARE UPWARDS COMPATIBLE (EPP, PERITH ELNER, IBM) *DRAWING QUALITY CHARACTER SET (SHOW HERE) OR COMPLEX SCRIPT, ITALICS, GOTHIC, ARABIC, OR "HARC-YOUR-OWN" !! \$399 COMPLETE. \$35 (ANNUAL DAILY), VISA, M.C. THIS AD CANNOT TOTALLY BE PLOTWARE-Z OR HPLOT DMP-4

Circle 197 on Inquiry card.

ONE BOARD CP/M SYSTEM!

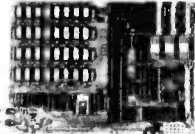

only \$750
Assm., Tested
& Burned-In
for one week

Features:

- 8 1/2 by 12 inches
- 10 MHz 8085 CPU
- 64K RAM
- 3 RS-232 channels
- 8272 Floppy Disk Controller
- Handles Single/Double Density
- One to Four Drives. 801R or 850R.

Documentation \$15.
CP/M Floppy Disk Operating System \$150
Check or Money Order

autocontrol
INCORPORATED

11400 Dorsett Rd.
St. Louis, MO 63043
(314) 739-0055

Circle 49 on Inquiry card.

FALL CLEARANCE SPECIAL

PERTEC TAPE DRIVES

T6860-9-25

New \$1595
Used \$795

T6848-9-25

New \$1495
Used \$695

WANGCO TAPE DRIVES MODEL 812

New \$995
Used \$495

(714) 973-4773

SOUTH COAST COMPUTER SYSTEMS, INC.
1415 E. McFadden
Santa Ana, CA 92705

Circle 436 on Inquiry card.

S-100 Single Board WINCHESTER "EASY DISK CONTROLLER"

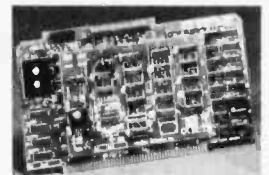

- Works with any S-100 CPU + IEE 696
- Supports 5 1/4", 8" and 14" Drives
- ST-506, SA-1000, SA-4000 Interfaces
- Record Accessible 1-K sector buffer frees host memory, matches DMA speed
- On-board microprocessor - auto seeks, simple, very small software driver
- Dealers and Distributors invited

Assembled and tested with formatter/test program and operating system drivers.
VISA, MasterCard - specify drive - \$545.
Monitor Dynamics, Inc.
1121 West Ninth St. • Upland, CA 91786
(714) 985-7214

Circle 327 on Inquiry card.

AUTOMATE YOUR OFFICE WITH ASCII SOFTWARE CONTROLLABLE SWITCHES



- User selectable software controllable
- Switches computers and peripherals
- User determined control words
- Supports 150 to 19200 baud
- Totally portable with AC option
- Features manual override operation

Advanced Systems Concepts, Inc.
P.O. Box 0
Altadena, California 91001
(213) 684-5461 or 794-2308

Circle 17 on Inquiry card.

8087 SUPPORT For the IBM PC and CP/M-86.

8087 CHIP.....\$223
APPLICATIONS

FFTs.....\$75
MATRIXPAK.....\$75

18 DIGIT TRIGONOMETRICS.....\$75

LANGUAGE SUPPORT

87MACRO™.....\$150

87BASIC™.....\$125

87PASCAL™.....\$125

87FORTRAN™.....\$125

IBM Personal Computer is a registered trademark of IBM Corp. CP/M-86 is a trademark of Digital Research, Inc. 8087 is a trademark of Intel Corp. 87/88GUIDE, 87MACRO, 87BASIC, 87PASCAL, 87FORTRAN and MicroWare are trademarks of MicroWare, Inc.

MicroWare

P.O. Box 79
Kingston, MA
02364
(617) 746-7341

Circle 321 on Inquiry card.

DISKETTES 3M Scotch BRAND

AT SUPER LOW PRICES
WE WILL SHIP YOUR
ORDER WITHIN 24 HOURS
AND WE PAY THE
SHIPPING CHARGES

VISA COD ACCEPTED

DEALER INQUIRIES INVITED

CALL TOLL FREE 800 922-8193

IN CALIFORNIA
800 468-1068



Tayco Business Forms
Computer Supplies
Post Office Box 605
Newbury Park, CA 91320

Circle 451 on Inquiry card.

**SUNNY LOW LOW COST
POWER SUPPLIES
(LINEAR & SWITCHING)
FOR S-100, DISK DRIVES**

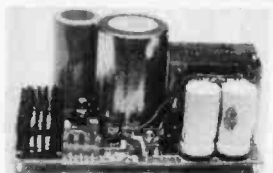
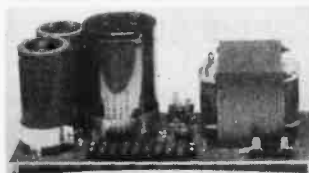

KIT 1, 2 & 3 For S-100

R3 For 3 x 8" (or 5 1/4") Disks

S3 For S-100 & Two Disks

S-100 & DISK POWER SUPPLY "S3" OPEN FRAME, ASSY. & TESTED, 6 OUTPUTS. SIZE: 10" (W) x 6" (D) x 5" (H) 102.95

REGUL. OUTPUTS FOR DISKS: +5V @ 5A OVP, -5V @ 1A, +24V (OR +12V) @ 5A-7A PEAK. ADJUSTABLE AND UNREGUL. OUTPUTS FOR S-100: +8V @ 14A, ± 16V @ 3A. FUSES PROTECT ALL REGUL. OUTPUTS. IDEAL FOR THE MAINFRAME WITH 12 SLOTS & 2 x 8" or 5 1/4" FLOPPY (OR 1x FLOPPY & 1x HARD DISK).

DISK POWER SUPPLIES: OPEN FRAME, ASSY. & TESTED, REGULATED, ADJUSTABLE & FUSES PROTECT.

ITEM	IDEAL FOR	+5V OVP	-5V (or -12V)	+24V (or +12V)	+8V Unreg.	SIZE W x D x H	PRICE
R0	2 x 8" SLIMLINE	2.5A		2.5A - 5A Peak		5" x 4" x 4"	49.95
R1	2 x 8" or 2 x 5 1/4" DISK	3A	1A	3A - 5A Peak	2A	8" x 4" x 3 3/4"	54.95
R2	3 x 8" (or 5 1/4") FLOPPY	6A	1A (or 2.5A)	6A - 8A Peak		1. 8 1/2" x 5" x 4 3/8" or 2. 10" x 4 7/8" x 3 3/4"	69.95
R3	or 1x Floppy & 1x Hard	6A	1A	6A - 8A Peak		1. 9" x 6 1/4" x 4 3/8" or 2. 9" x 5 1/4" x 5 1/4"	69.95

OPTION: ± 12V @ 1A CAN BE ADDED TO ITEM "R3" SIZE 1. ONLY, COSTS \$12.00 MORE.

S-100 POWER SUPPLY KITS (OPEN FRAME WITH BASE PLATE, 3 HRS. ASSY. TIME)

ITEM	(IDEAL FOR)	+8V	-8V	+16V	-16V	+28V	SIZE: WxDxH	PRICE
KIT 1	15 CARDS	15A	---	2.5A	2.5A	---	12" x 5" x 4 7/8"	54.95
KIT 2	20 CARDS	25A	---	3A	3A	---	12" x 5" x 4 7/8"	61.95
KIT 3	DISK SYSTEM	15A	1A	3A	3A	5A	13 1/2" x 5" x 4 7/8"	69.95

SHIPPING FOR EA. PWR SUPPLY: \$5.50 IN CALIF; \$8.00 IN OTHER STATES; \$18.00 IN CANADA. FOR EA. TRANSFORMER: \$5.00 IN ALL STATES; \$12.00 IN CANADA. CALIF. RESIDENTS ADD 6.5% SALES TAX.

POWER TRANSFORMERS (WITH MOUNTING BRACKETS)

ITEM	PRIMARY	SECONDARY #1	SECONDARY #2	SECONDARY #3	SIZE WxDxH	PRICE
T1	110/120	2x8 Vac, 15A	28 Vac, CT, 2.5A	----	3 3/4" x 3 3/8" x 3 1/8"	22.95
T2	110/120	2 x 8 Vac, 25A	28 Vac, CT, 3.5A	----	3 3/4" x 4 3/8" x 3 1/8"	28.95
T3	110/120	2 x 8 Vac, 15A	28 Vac, CT, 3A	48 Vac, CT, 2.5A	3 3/4" x 4 3/8" x 3 1/8"	30.95
T4	110/120	2 x 8 Vac, 6A	28 Vac, CT, 1.5A	48 Vac, CT, 3A	3 3/4" x 3 3/8" x 3 1/8"	23.95
T5	110/120	16 Vac, CT, 3A	28 Vac, CT, 2A	(48 Vac, if specified)	3" x 3" x 2 1/2"	15.95

**ATTENTION O.E.M.'S
YOUR SPECIAL NEEDS OR
DESIGNS OF TRANSFORMER,
LINEAR & SWITCHING PWR
SUPPLY WILL BE MADE TO
ORDER AT SUNNY LOW LOW
COST & FASTEST DELIVERY.**



MAILING ADDRESS:
P.O. BOX 4296
TORRANCE, CA 90510
TELE: 182558

**SUNNY INTERNATIONAL
(TRANSFORMERS MANUFACTURER)
(213) 328-2425 MON-SAT 9-6**

SHIPPING ADDRESS:
22129 1/2 S. VERMONT AVE
TORRANCE, CA 90502



Super Sale!

40% Off On Ohio Scientific Superboard II A Complete Computer System On A Board

Includes full-size 53-key keyboard, video and audio cassette interfaces; SWAP, Modem, sampler cassettes; manual; 8K BASIC-in-ROM, with 8K RAM. Requires 5-V/3 amp regulated DC power supply. 30-day limited warranty. Supply is limited. ONLY \$200.00

Plus Sensational Limited-Time Savings On Ohio Scientific C1P Series personal computers, Superboard and C1P accessories, spare replacement parts, printers, monitors, integrated circuits, and other computer-related components.

To Order

Call us directly or return order coupon with your check, money order, or Mastercard or Visa Account Number. Orders will normally be shipped within 48 hours after receipt. \$100.00 minimum order.

FREE

Sampler Cassettes with each Superboard II and C1P series order!

Taxi (Game), Electronic Equations, Loan Finance, Straight and Constant Depreciation. Uneven Cash Flows

Tiger Tank, Flip Flop, (Logic Game), Hectic, Black Jack, Master Mind



Cleveland Consumer Computers & Components
1333 S. Chillicothe Road, Aurora, OH 44202
TO ORDER: CALL 1-800-321-5805 TOLL FREE
(Ohio Residents Call 216-562-4136)

- SUPERBOARD II, \$200.00
- Send Detailed Catalog/Order Form

Name _____

Address _____

City _____ State _____ Zip _____

Payment by enclosed check or money order or charge to:

MasterCard VISA

Account # _____ Expiration Date _____

Total Amount Charged or Enclosed \$ _____

Ohio Residents Add 5.5% Sales Tax. All Orders Will Be Shipped Insured By UPS Unless Requested Otherwise.



DUAL DRIVE SUBSYSTEMS



HORIZONTAL OR VERTICAL
Fully Assembled and tested units

w/two Shugart 801R SS/DD	\$ 975.00
w/two Shugart 851R DS/DD	1225.00
w/two Qume DT-8 DS/DD	1250.00
w/two Tandon 848-1 SS/DD	995.00
w/two Tandon 848-2 DS/DD	1195.00
Cabinet A & T w/Power Supply and Accs.	235.00
Cabinet Top and Bottom	69.50



CCS SYSTEM 2410 . . \$1995.00

- Includes CP/M® 2.2
- 2-Serial/1-Parallel Port
- DMA Disk Controller
- Hardware Vectored Interrupts
- 2-Real Time Clocks
- Supports CP/M®, MP/M®, OASIS

CCS 2200 System, A & T.. 1625.00

- 2810 CPU
 - 2422 Disk Controller
 - 2065C 64K
 - 2200A Mainframe
 - CCS Apple Boards . . .
- Only—255.00
Only—330.00
Only—320.00
Only—475.00
Call Toll Free For Prices

DECEMBER SPECIAL

S-100-4 MINI'S

Choose the System that fits your needs
A complete computer system ready to add on a terminal and printer. All systems include CP/M 2.2® software and system manual set. Full six-month parts and labor warranty excluding drives which carry the full O.E.M. manufacturers warranty. All S-100-4 systems advertised are in stock assembled and tested available for immediate delivery.

MINI FLOPPY

Only \$1395.00
COMPLETE*



- ★ with 48 TPI single sided double density 5¼" . \$1395.00
- ★ with 48 TPI double sided double density 5¼" . \$1495.00
- ★ with 96 TPI double sided double density 5¼" . \$1650.00

An inexpensive but powerful system featuring a 4 slot S-100 bus chassis with the XOR S-100 board set: 4-MHZ Z-80 CPU • 64K dynamic memory • multi-sector mixed density disk controller • 2-RS232 output ports in the rear for your terminal and printer • 3 eight-bit parallel ports on the CPU ready to add a cable and interface to your printer • All above systems are in stock • Includes CP/M® 2.2. CP/M is a trademark of Digital Research Corp.

HARD DISK

Only \$2995.00
COMPLETE



These S-100-4 systems may be very small in size (9"H x 9½" W x 18½" L) but look at the size of the ATASI® 5¼" Winchester hard disks we offer!

4 models to choose from

- ★ Seagate 5 Megabyte System
- ★ #3020 15.6 Megabyte* System
- ★ #3033 26 Megabyte* System
- ★ #3046 36 Megabyte* System

The above systems include a 96 TPI double sided double density 5¼" floppy as standard. The hard-disk is controlled via Western Digital's controller for hard disks. Other features are the same as system at left.

*Actual storage space after formatting.

TAPE BACKUP

ONLY \$4250.00
COMPLETE



Now available through U.S. Micro Sales the XOR IRWIN 510 S-100-4 tape backup system with 10 megabytes of hard disk storage. Back up your hard disk on a

mini-tape (we're talking 10 meg.) in less than 3½ minutes! The above system includes a 96 TPI DS/DD floppy drive and this system's modular design allows you to add a second floppy for only \$395.00.

CALL FOR QUANTITY PRICES!



SHARE THE COST OF LIVING.

GIVE TO THE AMERICAN CANCER SOCIETY.

And then there were none.

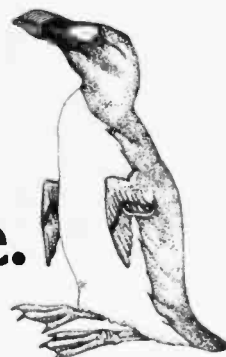

The list of already extinct animals grows . . . the great auk, the Texas gray wolf, the Badlands bighorn, the sea mink, the passenger pigeon . . .

What happens if civilization continues to slowly choke out wildlife species by species?

Man cannot live on a planet unfit for animals.

Join an organization that's doing something about preserving our endangered species. Get involved. Write the National Wildlife Federation, Department 105, 1412 16th Street, NW, Washington, DC 20036.

It's not too late.



TWO Locations to Serve You

★ **EAST Coast Call (815) 485-4002**

★ **WEST Coast Call (714) 891-2677**

OUT OF ORDER TOLL FREE!

STATE 1 - 800 - 435-9357



MICRO SALES

TERMS: 4We accept VISA/MC, prepay, check or money order. Please allow personal check two weeks to clear before shipment. \$5.00 handling charge on all orders under \$50.00. 15% Restocking Fee. All orders shipped via U.P.S. unless otherwise specified. ★Our products carry a full 6 months parts and labor warranty excluding drives, printers and terminals which carry the full O.E.M. factory warranty. **PRICES SUBJECT TO CHANGE WITHOUT NOTICE.**

★ **EAST 11 Edison Drive, New Lenox, Illinois 60451**
 ★ **WEST 15381 Chemical Lane, Huntington Beach, CA 92649**

UNIVERSAL POWER SUPPLY



For Big Board, Apple or Aim 65

- +5VDC @ 3 Amps
- +12VDC @ .750 Amps
- 12VDC @ .750 Amps
- 5VDC @ .500 Amps

Dimensions: 4" x 4" x 11"

\$69.95

DISK DRIVE POWER SUPPLY

For 2 - 8" or 5" Drives

- + 5 VDC @ 4 Amps
- + 24 VDC @ 3 Amps
- 5 VDC @ 1 Amp

AC Cables for 2 Drives \$7.50



Dimensions: 4" x 4" x 11"

\$59.95

S-100 POWER SUPPLY



- +8VDC @ 30 Amps
- +16VDC @ 6 Amps
- 16VDC @ 6 Amps
- PC Board Design

Dimensions: 5" x 6" x 11"

\$89.50

TERMINALS

Telivideo 910+ with green screen **\$575**

T.V. 925 **\$739** T.V. 950 **\$945**

Adds viewpoint with green screen **\$519**

Zenith Z-19. **\$740**

PRINTERS

Epson MX-80FT **\$549.00**

Epson MX-100FT **\$699.00**

Okidata 82A 80 column **\$465.00**

Okidata 83A 132 column. **\$745.00**

C-ITOH Prowriter I **\$525.00**

I.D.S. Microprism Model 480 . **\$565.00**

8" DISK DRIVES

SA801R **388.00 ea.** Two for **379.00 ea.**

SA851R **535.00 ea.** Two for **529.00 ea.**

QUME DT-8 . **540.00 ea.** Two for **529.00 ea.**

Tandon 848-1 **395.00 ea.** Two for **388.00 ea.**

Tandon 848-2 **525.00 ea.** Two for **519.00 ea.**

Mitsubishi Model 2896 DS/DD **475.00 ea.**

S-100 MOD KIT
by XOR

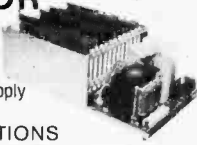

For test or systems applications. Complete S-100 12 Slot Main-frame with Disk Drive Power Supply for 4 Drives.

SPECIFICATIONS

Unregulated	Regulated
+8V @ 30A	+5V @ 5A
±16V @ 6A	+24V @ 3A
	-5V @ 1A

\$225.00 Kit with 12 S-100 Bus Connectors
 \$255.00 Assem. and Tested with 12 Bus Connectors
 \$15.00 AC/DC Drive Cable Set for 2 Drives
 Dimensions 6" x 10" x 18" — Shipping Weight 25 lbs.

Cooling Power

4 1/8"

Low Velocity Whisper® Fans
 Only \$18.00 ea.
 Finger Guards \$2.50 each.



XOR
S-100 MOD

CALL FOR QUANTITY PRICES!

S-100-4



\$1695.00

- ★ 4 Slot S-100 Bus
- ★ Two Separate Power Supplies
- ★ XOR S-100 Board set
- ★ Includes CP/M® 2.2 and Man1
- ★ All Cables Provided
- ★ Dimensions only 9" x 9" x 18 1/2"

S-100-4 System Complete with:

2-Tandon Thinline 8" (Model TM-848-1 SS/DD)
 Part #S-1000-40 **\$1695.00**

2-Tandon Thinline 8" (Model TM-848-2 DS/DD)
 Part #S-1000-39 **\$1950.00**

Now we are able to offer Mitsubishi thinline drives DSDD model 2896 for full 2.4 megabytes of formatted storage. All S-100-4 systems with these drives will include a full 6 months parts and labor warranty including the drives! Part #S-1000-34

S-100-8



\$1795.00

TERMINAL

- ★ Feather Touch Capacitance Kybrd.
- ★ SOROC Type Screen Attribute Set
- ★ Half Intensity
- ★ 60 Key Standard ASCII
- ★ 8 Special Function Keys
- ★ 20 Screen Editing Keys

COMPUTER

- ★ XOR S-100 Board set
- ★ Programmable Keyboard Set
- ★ Includes CP/M® 2.2
- ★ 8 Slot S-100 Bus

S-100-8 System Complete With:

Shugart 801R Subsystem* (#S-1000-22) . . . **\$2675.00**

Shugart 851R Subsystem* (#S-1000-23) . . . **2925.00**

Qume DT-8 Subsystem* (#S-1000-24) **2950.00**

Shugart SA 400 Minis (#S-1000-25) **2350.00**

Complete System, No Drives (#S-1000-21) . **1795.00**

**Available in Horizontal or Vertical Cabinet*

S-100-12



\$1350.00

- ★ With the XOR S-100 MOD
- ★ 12 Slot Motherboard and Card Cage
- ★ +8V @ 30A ★ +16V @ 6A
- ★ DC Power to Run up to 4 Drives
- ★ XOR S-100 Board set*
- ★ Includes CP/M® 2.2 Software and Manual
- ★ All Cables Provided
- ★ Complete Manual Set

S-100-12 System Complete With:

2-Shugart 801R (#S-1000-30) **\$ 2125.00**

2-Shugart 851R (#S-1000-31) **2425.00**

2-Qume DT-8 (#S-1000-32) **2450.00**

Complete System, no drives **1350.00**

Cabinet only - Includes Switches, Fan & AC/DC Wiring (#S-1000-28) **250.00**

Dimensions 11" x 21" x 22"
 CP/M® is a trademark of Digital Research

SOFTWARE

CALCSTAR	150.00
C BASIC	118.00
DATA STAR	265.00
DISK DOCTOR	85.00
MACRO ASSEMBLER	90.00
MAILMERGE	115.00
SPELLSTAR	190.00
WORDSTAR	275.00

CALL FOR SOFTWARE NOT LISTED

ZENITH DATA SYSTEMS

CALL TOLL FREE FOR PRICES
 1 - 800 - 435-9357

Controller Board for 8" and 5" Drives for the Z-89, Z-90 or H-89 Computers... Comes w/CP/M® 2.2 on 8" and 5" media

Only \$550.00

Apple 8" Disk Controller Card **\$395.00**

ZVX4 Dual Density, Single & Double Sided - Auto Boot Disk 2 + 2 Single Density Single or Dual Sided **300.00**



Complete line of add on drives for Apple
CALL TOLL FREE FOR PRICES

64 K

DYNAMIC RAMS and EPROMS
TOSHIBA
HITACHI
FUJITSU
NEC
OKI
MITSUBISHI

WHOLESALE AND RETAIL

Monarchy Engineering Inc.
380 Swift Avenue, Unit 21
So. San Francisco, CA 94080
Phone (415) 873-3055

WRITE OR CALL FOR OUR
LATEST INVENTORY LIST.

Circle 326 on Inquiry card.



Solve your disc problems. Buy 100% surface tested Dysan diskettes. All orders shipped from stock, within 24 hours. Call toll FREE (800) 235-4137 for prices and information. Visa and Master Card accepted.

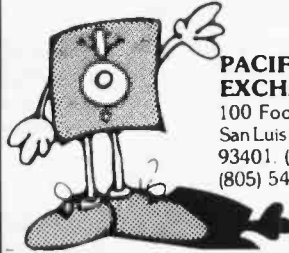

PACIFIC EXCHANGES
100 Foothill Blvd.
San Luis Obispo, CA
93401. (In Cal. call
(805) 543-1037.)

Circle 361 on Inquiry card.

PC/FORTH™

Complete FORTH program development systems for the IBM® Personal Computer. Packages include interpreter/compiler with virtual memory management, line editor, custom screen editor, assembler, decompiler, utilities, file and record access modules, and many demonstration programs. 150 page user manual. \$100.00

Software floating point, Intel 8087 support, color graphics extensions, and target compiler available at additional cost.

Specify PC-DOS or CP/M-86®. One disk drive and 48 kbytes RAM required. Software supplied on 5 1/4 inch single sided soft .sectored double density diskettes.

Laboratory Microsystems
4147 Beethoven Street
Los Angeles, CA 90066
(213) 306-7412

IBM is a registered trademark of International Business Machines Corp.
CP/M is a registered trademark of Digital Research, Inc.

Circle 261 on Inquiry card.

HOW TO REPAIR THE APPLE*

NOVEMBER 15th RELEASE DATE.

A comprehensive guide to repair your Apple II* or Apple II plus* computer.

With repair rates soaring and outrageous repair bills being charged for even simple repairs, THIS GUIDE CAN SAVE YOU MONEY!

ONLY \$39.95

Note: If ordered prior to release date, pay only

\$34.95.

DATA-LINE (602) 820-0082
2961 S. LAS PALMAS
MESA, ARIZONA 85202

*Trademark of
APPLE COMPUTER INC.

Circle 168 on Inquiry card.

ANALOG ↔ DIGITAL DIGITAL ↔ ANALOG

CONVERSION MODULES

SOFTWARE GAIN CONTROL

high accuracy — programmable gain instrumentation amplifier — custom board test — \$100 — 2 to 15 khz conversion time — mixable high and low inputs — gain from 1 to 1024 — 12-bit — sample and hold amplifier
8-channel differential — 16-channel — analog to digital high accuracy — programmable gain instrumentation amplifier — custom board test — \$100 — 2 to 15 khz conversion time — mixable high and low inputs — gain from 1 to 1024 — 12-bit — sample and hold amplifier
8-channel differential — 16-channel — analog to digital high accuracy — programmable gain instrumentation amplifier — custom board test — \$100 — 2 to 15 khz

For additional details about the AD-100-4 and other fine California Data Corporation 100% individually tested, high reliability products, circle the reader service card number below or for faster response write or call us.

CALIFORNIA DATA CORPORATION
3475 Old Conejo Road, Suite C-10
Newbury Park, CA 91320
(805) 498-3651

Circle 80 on Inquiry card.

if you use CP/M® then you need DISK FIX!

DISK FIX is a disk editor which can display, edit or copy any sector of a CP/M floppy and/or hard disk. The DISK FIX utility can be used to recover files from disks with damaged directories, to reconstruct files with bad sectors, to restore erased files and to do general disk editing.

DISK FIX automatically configures to floppy and hard disks, just insert the program disk and it is ready to run. A single CPU license is available for \$150. Call software HOT LINE 906/228-7622.

The Software Store
706 Chippewa Square • Marquette MI 49855

Circle 431 on inquiry card.

EDGE-86 AN INDUSTRIAL QUALITY 8086 OEM SYSTEM

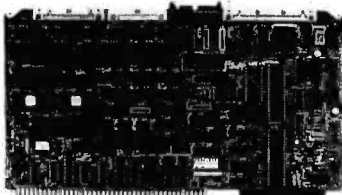

• HARDWARE

— A Multibus® COMPATIBLE 8086 CPU BOARD WITH DMA FLOPPY CONTROLLER, INTERRUPT CONTROLLER, PROGRAMMABLE TIMERS, 3 SERIAL PORTS, TWO PARALLEL I/O PORTS, AND 8K BYTES OF PROM WITH BOOT STRAP LOADER FOR CP/M®.
— 128K BYTES DYNAMIC RAM BOARD.
— 4-SLOT MULTIBUS CARD CAGE, WITH COMPLETE DOCUMENTATION AND SCHEMATICS, ALL FOR \$1250.

• SOFTWARE

— CP/M® O.S. WITH COMPLETE UTILITIES . . . \$250.
— OFF THE SHELF DELIVERY—

EDGE MICRO SYSTEMS
195 W. EL CAMINO REAL, SUNNYVALE, CA 94086
TELEPHONE: 408-738-4729

* Multibus TM of Intel. †CP/M® TM of Digital Research.

Circle 189 on Inquiry card.

BASF FlexyDisks®

5 1/4"

Specify soft,
10 or 16 sector

	Price/10	Price/100
1 sided/double density	\$20.00	\$185.00
2 sided/double density	34.50	325.00

8"

Specify soft
or 32 sector

	Price/10	Price/100
1 sided/single density	\$21.00	\$195.00
1 sided/double density	29.50	275.00
2 sided/double density	34.50	325.00

Certified Check - Money Order - Personal Check
Allow up to 2 weeks for personal checks to clear.
Add \$1.50 to each order for U.P.S. shipping charges.

NJ Residents add 6% NJ Sales Tax

DATA
EXCHANGE, INC.

280 Dukes Parkway, P.O. Box 85
Somerville, N.J. 08876 • (201) 725-6680

Dealer Inquiries Invited

Circle 165 on Inquiry card.

Now... You Can Monitor 7 Most Important RS-232 Interface Lines

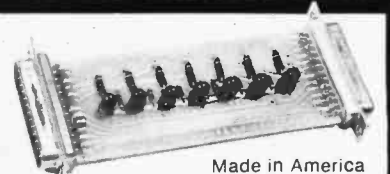

Made in America

RS-232-INTERFACE TESTER

connects in series with any RS-232 interface. LED's clearly display status of 7 functions: transmit data, receive data, request to send, clear to send, data set ready, carrier detect, data terminal ready. Requires no power, may be left in permanently. Satisfaction guaranteed. ORDER NOW! Only \$39.95 ppd (IL res. add 5% sales tax). we accept MC, Visa. FREE: Illustrated catalog of problem detecting equipment. Phone 815/539-5827. Make checks payable to:

B&B electronics
Box 475-B; MENDDA, IL 61342

Circle 53 on inquiry card.

EPSON

MX 80 F/T III
 MX 100 III - 100 CPS
 BOTH WITH GRAFTRAX
 HX-20 COMPUTER

Cards and cables for all computers
 Please Call For Best Prices

OKIDATA

82 A \$399⁰⁰
 83 A \$649⁰⁰

BASIS 108

APPLE COMPATIBLE
 COMPUTER
 CALL FOR LOWEST PRICE

16K RAM CARD

For Apple® II/II+
 Compatible with:
 Dos 3.3® CP/M®
 Visicalc®, Pascal®

2 Year
 Warranty **\$59⁰⁰**
 Fully tested
 and assembled

SOFTWARE

WE HAVE IT ALL!
 OVER 500 TITLES

- APPLE • CP/M
- IBM • ATARI

PARTIAL LISTING

Applewriter II	\$99 ⁰⁰
Arcade Machine	35 ⁰⁰
Bag of Tricks	SCALL
BPI GL	299 ⁰⁰
Choplifter	27 ⁰⁰
Data Factory	249 ⁰⁰
dBase II	489 ⁰⁰
DB Master	169 ⁰⁰
Executive Secretary	SCALL
Frogger	27 ⁰⁰
Home Accountant	59 ⁰⁰
Peachtree	SCALL
PFS	89 ⁰⁰
S.A.M.	SCALL
Screenwriter II	89 ⁰⁰
Supercalc	199 ⁰⁰
Versaform	285 ⁰⁰
Visicalc	179 ⁰⁰
Visifile	179 ⁰⁰
Wizardry	39 ⁰⁰
Word Handler	159 ⁰⁰
Wordstar	SCALL

SMITH-CORONA

LETTER QUALITY
 DAISY
 WHEEL
 PRINTER



\$575

HARDWARE

Disk Library Case	\$2.50
Hayes Modems	SCALL
Lobo Drives	SCALL
Microsoft Softcard	259 ⁰⁰
Novation Modems	SCALL
Paymar Lower Case	23 ⁰⁰
Vista Products	SCALL
Wizard BPO	159 ⁰⁰
16K Ram 4116(8)	11 ⁰⁰
64K Ram 4164(8)	88 ⁰⁰
3-Ring Disk Sheets (10)	5 ⁰⁰

Videx

80 Column	\$239 ⁰⁰
Enhancer II	119 ⁰⁰
Softswitch	25 ⁰⁰
Function Strip	59 ⁰⁰
Inverse Video	19 ⁰⁰

SATURN SYSTEMS

64K	\$319 ⁰⁰
128K	459 ⁰⁰
V-C Expand 80	75 ⁰⁰

ATARI

Atari 800 (48K)	SCALL
Atari 400 (16K)	299 ⁰⁰
Visicalc	179 ⁰⁰
LJK Letter Perfect	119 ⁰⁰
32K memory	79 ⁰⁰
Software & acces.	SCALL

Mountain Computer

CPS Card	\$149 ⁰⁰
CPS Cable	SCALL
Ramplus+ 32K	139 ⁰⁰
Rom Writer	139 ⁰⁰
Clock	195 ⁰⁰
Music System	299 ⁰⁰
Super Talker	149 ⁰⁰
Expansion Chassis	559 ⁰⁰
Card Reader	SCALL
A/D-D/A	269 ⁰⁰
V-C Expand	SCALL

Verbatim

5 1/4" (100)	\$239 ⁰⁰
5 1/4" (10)	25 ⁹⁵
8" (10)	39 ⁹⁵
Head Cleaning kit	7 ⁵⁰

μ-SCI

APPLE II

A2 DISK II Replacement	\$299 ⁰⁰
A40 40 TRACK	359 ⁰⁰
A70 70 TRACK	479 ⁰⁰

APPLE III

A3 DISK III Replacement	\$339 ⁰⁰
A73 70 TRACK	529 ⁰⁰
A143 140 TRACK	669 ⁰⁰

KENSINGTON MICROWARE

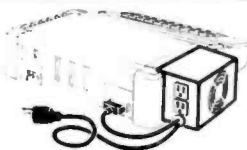

SYSTEM SAVER

- UL Listed
- Surge
- Suppression
- Dual outlet

\$65

TG Products

Paddles	\$29 ⁰⁰
Joystick II	40 ⁰⁰
Select-A-Port	47 ⁰⁰
All of Above	109 ⁰⁰
Joystick III	SCALL
Joystick IBM	45 ⁰⁰

BMC

12" Green AU	\$88 ⁰⁰
12" Green EU	129 ⁰⁰
Amber	SCALL
RGB (IBM)	SCALL
13" Color Composite	\$269

EPSON RIBBONS

MX 80 \$10⁰⁰ ea or 3 for 25⁰⁰
 MX 100 15⁰⁰ ea or 3 for 39⁰⁰

DEALER
 INQUIRIES
 INVITED



COMPUTER
 DISCOUNT
 PRODUCTS
 (408) 985-0400

MAIL ORDERS & RETAIL STORE

860 S. Winchester Blvd.
 San Jose, CA 95128
 MON-FRI 8-5 SAT 10-4

Mail and phone orders welcome. CA residents add 6 1/2% TAX. Prices subject to change. All items FOB San Jose VISA, MC, AMEX, MO, CASHIERS CHECK, COD OK. Personal checks allow 2 weeks for processing. Schools PO's accepted.

CHRISTMAS HOURS: MON-FRI 8AM - 7PM - SAT & SUN 10AM - 4PM

T.H.E. SMART TERMINAL™



Software that turns your Atari 400 or 800 into a real smart terminal. Send and receive data from all popular data services. Works with cassette or disk for upload/download. 16K min. Available at Atari Dealers Worldwide or directly from Binary. VISA/MC/AMEX/COD/CHECK. Cassette \$49.95 Disk \$49.95 add \$2.50 P & H U.S. \$5.00 overseas.

BINARY™

Computer Software
3237 Woodward Ave.
Berkley, MI 48072
(313) 548-0533

BINARY CORPORATION

Circle 65 on inquiry card.

SIGMA TEK INTERNATIONAL CORPORATION

327 Clarkin Ct., Walnut Creek, CA 94598

(415) 938-5097

MICROPROCESSOR CRYSTALS (MHz)

1 000	1 2288	1 6896	1 8432	4.00 each
2 000	2 097152	2 4576		3.00 each
3 2768	3 579545	4 000	4 194304	4 433619
4 9152	5 000	5 0688	5 185	5 7143
6 000	6 144	6 400	6 5636	7 000
7 3728	8 000	10 000	11 000	12 000
14 31818	15 575	18 000	18 432	2.00 each
19 6608	20 000	22 1184	32 000	48 000

TUNING FORK CRYSTALS (3 x 8 Minature)

32 768 KHz	1.50 each
30 KHz to 50 KHz	Inquire

EPROMS

2532 (5V 450 ns)	4.75 each
2732 (5V 450 ns)	4.50 each
2764 (5V 450 ns)	10.00 each

DYNAMIC RAMS

4164 (150 ns)	7.00 each
---------------	-----------

N.A.S.H.U.A.

5 1/4" mini floppy diskette
SS/SD Soft Sector 20.00 box/10 pc..

Minimum order \$10.00 For shipping include \$2.00 for UPS ground. \$3.00 for UPS Blue Label Air. California residents add sales tax.

Circle 420 on inquiry card.

YOU'VE JUST FOUND



THE MISSING LINK!

Computer Shopper is your link to individuals who buy, sell and trade computer equipment and software among themselves nationwide. No other magazine fills this void in the marketplace chain.

Thousands of cost-conscious computer enthusiasts use Computer Shopper every month through hundreds of classified ads. And new equipment advertisers offer some of the lowest prices in the nation.

Subscribe to Computer Shopper with a 6 month trial for \$6 or 12 months for only \$10. MasterCard & VISA accepted.

COMPUTER SHOPPER

P.O. Box F311 • Titusville, FL 32780
305-269-3211

Circle 122 on inquiry card.

LOOK TO THE FUTURE... EPROM-32

The only EPROM programmer you need!

- IEEE-696 (S-100) EPROM programmer for single supply (+5V) EPROMs
- Programs current 1K through 16K (byte) EPROMs plus future 32K EPROMs.
- EPROM can be verified through a port or located in memory space for verification and use.
- Personality Modules adapt board to different EPROM types: PM-1—2508, 2758 PM-3—2732, 2732A PM-6—68764 2516, 2716 PM-4—2564 PM-7—2528 PM-2—2532 PM-5—2764 PM-8—27128
- Single zero-insertion-pressure socket accommodates both 24-pin and 28-pin EPROM packages.
- On-board DC-to-DC converter with adjustable regulator for programming voltage.
- Double-sided PC board with solder masks, silkscreen and gold-plated contact fingers.
- 8080/280 control software includes commands for programming, verification, disk I/O and editing.
- Comprehensive user's manual contains source listing of control software.

MicroDynamics

\$269.95

(assembled & tested)

Corporation
P.O. Box 17577
Memphis, TN 38117
(901)-765-0619

Price includes EPROM-32, documentation and two Personality Modules (specify). Additional Modules—\$7.95. Control software on 8 inch single density CP/M-compatible diskette—\$9.95.

MasterCard & Visa

TN residents add 6% sales tax.

Circle 312 on inquiry card.



Scotch®
DISKETTES

Call Toll-Free

1-800-328-DISC for prices and information. Dealer inquiries invited. C.O.D. and charge cards accepted. All orders shipped from stock, within 24 hours. Call toll FREE



North Hills Corporation

3564 Rolling View Dr.

White Bear Lake, MN 55110

1-800-328-DISC

MN Call Collect 1-612-770-0485

Circle 345 on inquiry card.

EPICS® COMPUTER SOFTWARE for EXECUTIVES and MANAGERS

- Name/Address/Key Information
- Personal Schedule
- Corporate Schedule
- Document Tracking
- File Indexing Schema
- Tickler File

Functional, well engineered software in the Pascal programming language for Apple II and TRS-80 Model II Computers. Plus seminars to help your computer understand you.

SOFTWARE CONSULTING SERVICES

901 Whittier Drive, Allentown, Pa. 18103

(215) 797-9690

ATT. Martha Cichelli

*TM) Apple Computer Co., **TM) Tandy Corp.

Circle 427 on inquiry card.

STATISTICAL SOFTWARE

ELF—Stepwise regression, factor analysis, correlation coefficients, cross-tabs, simple statistics, t-tests, ANOVA, stepwise discriminant analysis, all BASIC transformations and more. \$200.00.

TWG/ARIMA—Box-Jenkins for seasonal and non-seasonal models. \$300.00.

EASI/ARIMA—Automatic Box-Jenkins program for stock and commodity traders. \$300.00

All are for the Apple II* with 48K of memory, Applesoft* and DOS 3.3.

Visa and MasterCard accepted.
Call or write:

The Winchendon Group
3907 Lakota Road
P.O. Box 10114
Alexandria, VA 22310
(703) 960-2587

*Trademarks of Apple Computer, Inc.

Circle 496 on inquiry card.

OMEGA

The Last Disassembler
You Will Ever Need!

Mnemonics Externally Defined

Zilog, Intel, PASM Supplied

ASCII/HEX Preconditioner

Can Externally Def. Equates

Optional Address Listing

ASM/PASM/M80 Compatible

DB statements forcible over user specified range

\$150. complete/\$25. manual only for further information contact

COMPUTER TOOLBOX, INC.

1325 East Main St.

Waterbury, Ct. 06705

Phone (203) 754-4197

CONTROL DATA DISKETTES

5 1/4" SPECIFY SOFT. 10 or 16 SECTORS

	PRICE/10	PRICE/50	PRICE/100
SSSD	\$23.00	\$112.00	\$215.00
SSDD	26.00	126.00	235.00
DSDD	32.00	156.00	295.00

8" SPECIFY SOFT or 32 SECTORS

	PRICE/10	PRICE/50	PRICE/100
SSSD	\$25.00	\$122.00	\$223.00
SSDD	30.00	145.00	263.00
OSDD	34.80	165.00	303.00

CALL TOLL FREE - ORDERS ONLY

800-824-7888

800-852-7777

ASK FOR OPERATOR #906

CHECKS, M.D. VISA, M.C. - ADD \$2.00 SHIPPING
CA RESIDENTS ADD 6% SALES TAX

Creativity Unlimited

P.O. Box 3304, Saratoga, CA 95070-1304

Circle 155 on inquiry card.

BEFORE YOU GET TOO EXCITED ABOUT LOBO'S NEW COMPUTER, THERE'S SOMETHING YOU SHOULD KNOW.

There's plenty to be excited about in Lobo's new MAX-80,™ as you'll see in just a minute.

But first we want to warn you: you can't get one right away. Already, orders are coming in faster than we can build systems. However, if you can appreciate an incredible price/performance bargain, you'll agree the MAX-80 is well worth waiting for.

WHAT'S ALL THE EXCITEMENT ABOUT?

We're glad you asked. And the answer is pretty simple. Just look at this list of standard features:

- **5 MHz Z-80B processor.** That's 2½ times the speed of a TRS-80 Model III or Soft-Card/Apple!
- **64k RAM.** 128k is a low-cost option.
- **CP/M included.** A few more dollars get you LDOS, an incredibly powerful operating system that lets you run standard Radio Shack software.
- **Software-selectable 25 x 80, 16 x 64, and 16 x 32 screen formats.** For full compatibility with CP/M and TRS-80 applications.
- **All disk interfaces built in.** Plug in any combination of 5¼" floppies, 8" floppies, and Winchester disk.
- **Two RS-232 serial ports.** Ready to plug in modems, printers, or what-have-you.
- **Centronics-type parallel port.** For any printer using this standard interface.
- **Plus:** numeric keypad with 4 function keys, software definable text and graphics characters, built-in clock/calendar with battery backup, and buffered I/O expander port.

Now for the best part: *the factory-direct price for all this power is just \$820—including shipping and Lobo's standard 1-year hardware warranty!*

WHAT TO DO NOW.

Call Lobo toll-free. Tell us what hardware and software configuration you're interested in (see below), and we'll give you an approximate shipping date. A \$100 deposit will hold your place on the waiting list.

Then get a good book to help you pass the time.

MAX-80

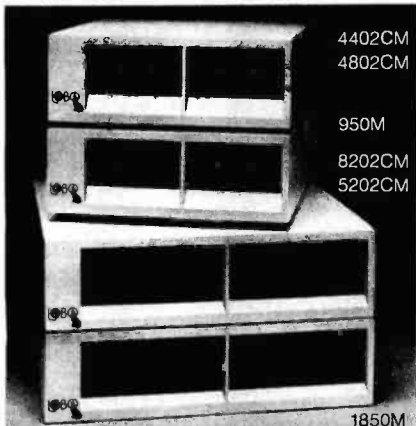
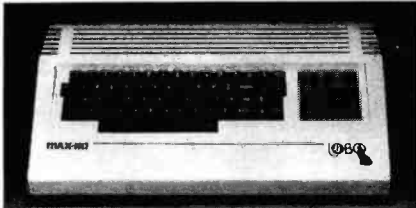

CPU and Accessories

MAX-80 computer with 64k RAM and CP/M	\$ 820.00
64k expansion RAM (installed)	\$ 95.00
12" (diag.) high-resolution anti-glare green phosphor monitor	\$ 175.00
LDOS operating system instead of CP/M	\$ 39.00
LDOS operating system in addition to CP/M	\$ 69.00

Dual 5¼" Floppy Disk Systems

4402CM single-sided, 40 track; 180 kB per diskette	\$ 690.00
4802CM double-sided, 80 track; 720 kB per diskette	\$1,175.00

Dual 8" Floppy Disk Systems

NOTE: Lobo CP/M permits reading and writing standard single-sided, single density CP/M disks with either of these systems.

8202CM single-sided, double density; 577 kB per diskette	\$1,185.00
5202CM double-sided, double density; 1155 kB per diskette	\$1,485.00
Winchester Disk Systems	
950M 5¼" system: 4.8 MB hard disk plus 720 kB floppy	\$2,405.00

950MX same as 950M above but no floppy drive	\$2,100.00
1850M 8" system: 8.0 MB hard disk plus 1155 kB floppy	\$3,085.00

The Lobo Warranty

All Lobo hardware products carry a limited 1-year parts and labor warranty. Call or write for complete warranty statement.

© 1982 Lobo Drives International, Goleta, CA
 CP/M trademark of Digital Research Corp.
 TRS-80 trademark of Tandy Corporation.
 SoftCard trademark of Microsoft Corporation.
 Apple trademark of Apple Computer.
 LDOS trademark of Logical Systems Incorporated.

ALL PRICES INCLUDE SHIPPING WITHIN THE U.S.A.
 California residents add 6% sales tax.
 Payable by credit card, check, or money order.

TOLL-FREE ORDER NUMBERS:

U.S. (except California): **800-235-1245**
In California: 800-322-6103 or 800-322-6104 Hours: 7AM—5PM Pacific Time.



Lobo Drives International
 Dept. BY 12
 358 S. Fairview Ave.
 Goleta, CA 93117

Prices subject to change without notice.

THE COMPUTER SPECIALISTS

Apple II plus 48K, Apple Disk Drive II with Interface DOS 3.3, Apple III, 12" Monitor and the Apple Monitor Stand

All for Only **\$1799⁰⁰**
FREE! Apple Writer II with purchase of this fabulous package

BUSINESSMAN'S SPECIAL

Apple II plus 48K, Apple Disk Drive w/interface DOS 3.3, 12" Hi Res Green Monitor, Visicalc 3.3, Planning & Financial Forecasting Software

Only **\$1979⁰⁰**
 16K RAM Card \$74⁹⁵
 w/purchase of above package



WORD PROCESSOR SYSTEM

Apple II plus 48K, Apple Disk Dr. w/interface DOS 3.3, 12" Hi Res Green Monitor, OKIDATA Microline 80 Printer, Printer Interface Card & Cable, Screenwriter II

Only **\$2325⁰⁰**



HP-83A **\$1149⁹⁵**

HP-85A **\$2099⁹⁵**

*700 Free Software! direct from manufl.

Call or write for details!

HP-87 XM **\$2495⁹⁵**

HP-125 **\$2099⁹⁵**

— Accessories —

82901M 5 1/4" Dual

Disc Drive **\$1694⁹⁵**

82905A Serial Pmt. **\$619⁹⁵**

HP-7470A Graphics plotter also available in Serial for use with the Apple² and Franklin² Computers
 Now Only **\$1269⁹⁵**

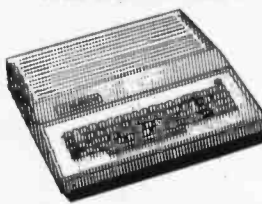

DATA BASE MANAGER

Franklin ACE 1000 64K, Micro-Sci Disk Drive w/interface, 12" Hi Res Green Monitor, Stoneware DB-Master Data Base Manager

Call or Write

NEW! ACE 1000

THE PERSONAL PROFESSIONAL COMPUTER THAT'S HARDWARE AND SOFTWARE COMPATIBLE w/APPLE II PLUSTM

64K RAM, Upper & Lower Case, 12 Key Numeric Keypad, Built-in Fan, Typewriter Style Keyboard

Call or Write

BUSINESSMAN'S SPECIAL

ACE 1000 64K, Micro-Sci Disk Drive w/controller, 12" Hi Res Green Monitor, Visicalc 3.3

Call or Write

SOFTWARE & ACCESSORIES FOR APPLE[®] and FRANKLIN[®]

RANA

Elite 1 Disc Drive, with 15% more storage capacity than Apples' drive Only **\$369⁵⁰**
 Controller Card Only **109.95**

MICRO SCI

A-2 Disc Drive, the cost effective alternative to the Disc II, with controller Only **\$409⁹⁵**
 without controller Only **329.95**

KENSINGTON

System Saver Fan, with built-in surge protector for Apple[®] II Only **\$74⁹⁵**

MICRO PRO Special Offer!

Word Pack Includes WordStar, MailMerge, and SpellStar All 3 for Only **\$329⁰⁰**

NOVATION

Apple Cat II, direct line modem Only **\$299⁹⁵**
 Apple Cat II, 212 Upgrade Only **\$329⁹⁵**
 Apple is a registered trademark of Apple Computer, Inc.

VISICORP PROGRAMS

Visicalc **\$184⁹⁵** Visifile **\$184⁹⁵**
 Visiplot **\$239⁹⁸** Visiterm **\$79⁹⁵**
 Visidex **\$184⁹⁵** Visischedule **\$239⁹⁵**
 Desktop Plan II **\$194⁹⁵**

ADDITIONAL "ADD-ONS"

DC HAYES Micromodem II **\$289⁹⁵**
 VIDEK Keyboard Enhancer II **\$119⁹⁵**
 VIDEK Videoterm 80 Col. Board **\$259⁹⁵**
 VIDEK Function Strip (Use w/Enhancer II) **\$62⁹⁵**
 TKC Numeric Keypad (Apple only) **\$134⁹⁵**
 ABT Numeric Keypad (Apple only) **\$99⁹⁵**
THUNDERCLOCK PLUS **\$119⁹⁵**
 PKASO Parallel interface **\$134⁹⁵**
 MICROSOFT Z-80 CPM Card **\$259⁹⁵**
 MICROSOFT 16K RAM Card **\$99⁹⁵**
 TG Joystick **\$47⁵⁰** TKC Joystick **\$44⁹⁵**

VOTRAX TYPE-N-TALK

Lets your computer talk to you Only **\$199⁹⁵**
 Available for Apple/Franklin/Atari/VIC-20

NEW! APPLI CARD

Z-80 Card with 64K RAM Only **\$369⁹⁵**

FORMAT II WORD PROCESSOR

with mail list, user friendly Only **\$199⁹⁵**

MICROSOFT PREMIUM PACK

Z-80 CPM Card, VIDEK Videoterm 80 Col. board, CPM user's guide & MICROSOFT RAM Card

All for only **\$549⁹⁵**

Plus you receive a FREE Videx Soft Switch (a \$30 Value!)

MICROBUFFER II by Practical Peripherals
 32K Only **\$249⁹⁵** 16K Only **\$214⁹⁵**

MICROBUFFER for EPSON

16K Parallel **\$134⁹⁵** 8K Serial **\$134⁹⁵**
 Franklin ACE is a trademark of Franklin Computer Co.

COMPUTER SPECIALS! TEXAS INSTRUMENTS

TI 99 4/A with RF Modulator **\$199⁹⁵**
 After Mig's Cash Rebate, Plus 2 FREE offers from TI Call or Write for details!

COMMODORE

VIC-20 with RF Modulator **\$184⁹⁵**
 RCA VP-3501 built-in modem **\$339⁹⁵**
 ATARI 400 **\$269⁹⁵**
 ATARI 800 **\$99⁹⁵**
 TIMEX Sinclair 1000 48K Memory 49.95 32K Memory 99.95

SHARP (Handheld)

PC-1500 **\$214⁹⁵** CE-150 Printer **\$174⁹⁵**
 PC-1211 with CE-122 Printer **\$124⁹⁵**

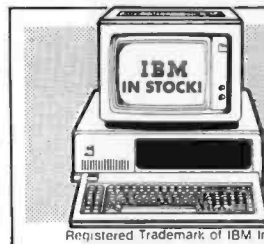

Registered Trademark of IBM Inc

SOFTWARE & ACCESSORIES

IBM Orig. 5 1/4" Disk SS/DD pk of 10 **34.95**
 IBM Orig. 5 1/4" Disk DS/DD pk. of 10 **49.95**
 TANDON DS/DD Disk Drive 320K **279.95**
 IBM is a registered trademark of IBM, Inc.
 BIG BLUE **469.95**
 Quadram Parallel printer card w/cable **129.00**
 QUADRAM Serial card with cable **110.00**
 QUAD Board 64K/449.00 QUAD Board 256K/749.00
 VISICALC/256K 185.00 SUPERCALC 209.95
 PC Pedestal for Monochrome Display **69.95**
 MICROSOFT RAM Card
 64K **279.95** 256K **629.95**
 POWER TEXT Word Processor **299.95**
 PECH TREE Accounting GL, AP&AR 3-pk. **489.00**
 VISITREND/VISIPLOT **239.00**
 VISIDEX 185.00 VISIFILE **239.00**

DISKETTE SPECIALS!

(10 pk except where indicated)

MAXELL MD-1 SS 5 1/4" **34.95**
 MAXELL MD-2 DS/DD 5 1/4" **49.95**
 MAXELL FD-2 DS/DD 8" (Soft Sector) **69.95**
 VERBATIM SS/DD 5 1/4" **31.95**
 VERBATIM DS/DD 5 1/4" **46.50**
 MEMOREX SS/DD 5 1/4" **23.95**
 CONTROL DATA SS/DD 5 1/4" (12 pk) **25.95**
 NEW! IBM SS/DD 5 1/4" **34.95**
 NEW! IBM DS/DD 5 1/4" **49.95**

For quantity discount prices please call or write!

ATARI



BUSINESSMAN'S SPECIAL

Atari 800 48K, Atari 810 Disk Drive and Visicalc 3.3
 Now Only **\$1399⁹⁵**

WORD PROCESSOR

Atari 800 48K, Atari 810 Disk Drive, Atari Word Processor, 850 Interface, Okidata Microline 82A Printer with Connecting Cable
 Now Only **\$1999⁰⁰**

EPSON
 MX-80 III F/T 80-136 Column Dot Matrix, Tractor or Friction Feed, Bidirectional, 80 CPS, Graftrax Plus Call
 MX-100III F/T 136-233 Column, Tractor or Friction Feed, Bidirectional, 80 CPS, Graftrax Plus Call

OKIDATA

MICROLINE 82A 120 CPS, Bidirectional, Parallel-Serial, 80/132 Columns, Friction & Pin Feed **449.95**
 MICROLINE 83A FT 120 CPS, Bidirectional, 136 Columns, Serial/Parallel, Friction and Tractor **699.00**
 New! MICROLINE 84A FT 200 CPS, Bidirectional, 136 Column, Parallel, Friction and Tractor **1099.00**
 Serial w/2K Buffer **1199.00**
 New! C.I.TOH 1550 120 CPS, 136/232 Column, FT Graph Parallel **769.00**
 Parallel and Serial **809.00**

C.I.TOH F-10 Daisy Wheel, Letter Quality Printer, 40 CPS, Parallel **1499.00**
SMITH CORONA TP-1 Letter quality Daisy wheel printer, Microprocessor electronics, Serial or Parallel interface, 120 words per minute **639.00**

MONITORS

USI PI-2 12" High Res. Green **159.00**
 USI PI-3 12" High Res. Amber **189.00**
 SANYO 13" Color **389.95**
 AMDEK 300 12" Green **149.95**
 AMDEK 13" Color I **329.00**
 AMDEK Color II RGB High Res. **699.95**
 AMDEK Color Interface Board (RGB) **159.00**
 NEC JB 12" Green **179.95**
 NEC JC 12" Color **349.95**
 BMC-1200 12" Green **149.00**
ELECTROHOME
 ECM-1302-1 13" RGB Monitor Hi-Res. with NTSC Interface **399.95**
 1302-2 High Res. RGB **599.95**
 COLOR BOARD for APPLE II **199.95**

OSBORNE

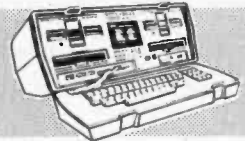

Complete w/the following software: Wordstar, Mailmerge, Supercalc, CBasic and MBasic.

Now In Stock!

Software & Accessories

X-MON monitor adapter **39.95**
 CENTRONIX printer cable **59.95**
 Keyboard extender cable 4 ft. **49.95**
 RS232 Serial cable **39.95**

Games for Osborne

Vetor 20.00 Star Trek **15.00**
 Trapper 15.00 Catacomb **18.00**

CORPORATE ACCOUNTS WELCOME

(212) 260-4410

TOLL FREE OUT-OF-STATE

800-221-7774
800-221-5858

67 West 47th Street, New York, N.Y. 10036
 115 West 45th Street, New York, N.Y. 10036
 MAIL ORDER ADDRESS: 36 E. 19th St. New York, N.Y. 10003

47st. Computer
 Computers and Business Equipment

A Division of **47st. Photo Inc.**

Items on sale for limited time only, and are subject to limited availability. Not responsible for typographical errors. This ad supersedes all other ads prior to Dec. 1982. Prices effective as of Oct. 28, 1982 and are subject to change without notice. All orders subject to verification and acceptance. Minimum shipping and handling \$4.95

5 1/4" Floppy Disk Drives

(Direct IBM® Plug-in)

TANDON Model TM 100-1 . \$189* ea.
TANDON Model TM 100-2 . \$269* ea.
12" Green Phosphor Zenith Monitor \$109* ea.

IBM EXPANSION BOARDS

64K Memory \$275* ea.
128K Memory \$375* ea.
192K Memory \$450* ea.
256K Memory \$510* ea.
Floppy Controller \$180* ea.
16K System BD Memory . \$ 25* ea.

MC / VISA or C.O.D. with certified check or money order. Arkansas residents add sales tax.

For information or orders, call
501-777-9859

G-H Computer Systems, Inc.
P.O. Box 871 • Hope, AR 71801
* Plus Shipping.

Circle 207 on Inquiry card.

digital group computers

by AEON inc.



Z 80 84K 1 FLOPPY DOUBLE DENSITY (11MGI) 5meg HARD DISK
BASIS OPERATING SYSTEM 80 CHARACTER TERMINAL w/4
RS232 CHANNELS \$5395
5MEG HARD DISK w/cab. and controller \$1800
10MEG HARD DISK w/cab. and controller \$2300
POWER SUPPLY for hard disk \$ 188
BATTERY CLOCK CARD 1 milisecond tick for multi user \$ 150
32K STATIC msec 4k increments of bank select \$ 375
SPEECH SYNTHESIZER 384k of speech rom \$ 285
CPU w/rom board, no wait states at 4MHZ \$ 200
4 channel RS 232 COMMUNICATIONS CARD \$ 180
DOUBLE DENSITY DISK CONTROLLER \$ 275
HAYES SMART MODEM \$ 220

AEON Electronics

1855 S. Pearl, Suite MSB
Denver, CO 80210
303-777-AEON



Circle 19 on Inquiry card.

TeleVideo USERS!

COGITATE Fast Dump/Restore System for TS 802H, 806.

- Back-up files twice as fast as PIP.
- Double the storage, up to 700K/diskette, with multiple diskette capability \$90.00

COGITATE Type Ahead With Print Screen

- Print key prints screen.
- 64 character type ahead buffer \$90.00

COGITATE 2780/3780 Communications System.

- Communicates with most IBM systems.
- Many features for remote job entry \$400.00

TurboDOS

- MULTI-USER \$750.00
- SEMINARS \$250.00

CP/M® is registered trademark of Digital Research, Inc.
TurboDOS is a registered trademark of Software 2000, Inc.

PLUS OTHER GOOD TELEVIDEO STUFF!

COGITATE, Inc.

SPECIALISTS IN UNIQUE TELEVIDEO SOFTWARE
24000 Telegraph Road, Southfield, MI 48034
(313) 352-2345

VISA/MASTER CARD Accepted

Circle 91 on inquiry card.

NOW MAKE SOLID CONNECTIONS.... Male or Female

RS 232 GENDER REVERSERS



\$19.95 each
postpaid
American Made

Order either two male or two female connectors with all 25 pins interconnected. Both Gender Reversers just \$34.95 post-paid. Purchase Orders from rated firms accepted. Get free illustrated catalog of interface and monitoring equipment.



B&B electronics

P.O. Box 475-B • Mendota, IL 61342
Phone (815) 539-5827

Circle 54 on inquiry card.

maxell Floppy Disks



BEST PRICES IN THE U.S.

Call for our special dealer program. C.O.D.'s accepted.
TOLL FREE (800) 652-8162
In California (213) 901-8881



U.S. EXCHANGE
14831 Bessmer St.
Van Nuys, CA 91411-2773



Circle 476 on Inquiry card.

THE SBC 8671

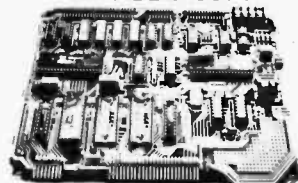

FEATURES: Zilog Z8671 Microprocessor with on chip 2K basic interpreter: Full RS-232 and Opto Isolated 20 MA current loop serial communications with baud rates from 110 9600 baud: Three 28 pin JEDEC standard byte wide universal memory sockets for up to 48K of on board user memory. Prom memory map decoder for selection of any ROM/RAM mix between standard EPROMS and byte wide static RAMS including the new 8K x 8 static RAMS: 48 parallel I/O lines on board. 32 of which are pin compatible with industry standard power opto I/O modules and have sockets for universal 7400 style line drivers or R-Pack line terminators. Module bus for full expansion: All chips socketed: Industrial grade construction.

Price \$325 each Custom and OEM versions also available



LEHMANN & ASSOCIATES
P.O. Box 566, Maumee, Ohio 43537
(419) 891-0687

Circle 266 on inquiry card.

UNIFORTH

Check with us before you order FORTH from any other distributor. UNIFORTH is available for most Z-80, 8086/8088, LSI/PDP-11, 68000 or 16032 computers, either stand-alone or as a task under an operating system. UNIFORTH adheres to the FORTH-79 standard, and includes a video editor, floating point routines, and an assembler. We offer a solid, professional system with extensive documentation and option packages. Prices: \$60 (basic) to \$300 (multi-user).

Requires 8" floppies.

Unified Software Systems
P.O. Box 2644
New Carrollton, Md 20784
(301) 552-1295

Circle 479 on Inquiry card.



CONVERT YOUR SERIAL PORT TO PARALLEL

- * RS232 Type Input
- * Handshake Signals
- * 8 Baud Rate Selections
- * Centronics Type Output
- * 8 Latched Outputs
- * Compact 3 1/4" x 4 3/4" x 1 1/2"

Now you can operate parallel printers and other devices from a standard RS232 serial port. Ideally suited for operation of popular printers such as the NEC 8023A and others. Latched output lines can be used to control eight external circuits from a single serial control line. Great for ROBOT CONTROL! Available with optional Centronics type connector on output.

only \$79.95

Companion Parallel/Serial Unit Available Soon

Engineering Specialties

Conn. Opt. Add \$12.00
Cal. Res. Add 8% Tax
13% UPS Shipping



1501-B Pine Street
P.O. Box 2233
Oxnard, CA 93030



CALL (805) 487-1665 or 487-1666
For FAST Delivery

Circle 198 on Inquiry card.

TAXMAN-83

An Interactive TAX MANAGEMENT Program for VisiCalc™ & SuperCalc™ Users

TAXMAN-83 provides the user with the capability to easily calculate his 1982 taxes by using the already proven VisiCalc™ and SuperCalc™ software.

TAXMAN-83 includes the following features: Federal 1040 pages 1 & 2, Schedules A, B, C, D, E, F, G, R, RP, SE, ES, U; Forms 1116, 2106, 2119, 2210, 2440, 2441, 3903, 4136, 4137, 4255, 4562, 4625, 4684, 4726, 4797, 4868, 4874, 4952, 4970, 4972, 5329, 5405, 5544, 5695, 5884, 6251, 6252, Tax Schedules X, Y, Z, Tax Tables. Sales tax tables for all states, plus local multiplier.

TAXMAN-83 produces all final calculations and results that need only be transcribed to the proper form, as detailed in the TAXMAN-83 documentation manual.

TAXMAN-83 is now available for most microcomputers utilizing VisiCalc™ or SuperCalc™.

VisiCalc is trademark of Personal Software Incorporated. SuperCalc is trademark of Sorcim Corporation.



PRICED AT ONLY \$95.00



Phone Orders Call: 1-205-533-7590

MasterCard & Visa (Shipment 1/31/83)

ATSUKO COMPUTING INTERNATIONAL
303 Williams Avenue, Huntsville, AL 35801

Circle 48 on inquiry card.

FOR ONLY \$129.95 Learn Computing From The Ground Up

Build a Computer kit that grows with you, and can expand to 64k RAM, Microsoft BASIC, Text Editor/Assembler, Word Processor, Floppy Disks and more.

EXPLORER/85

Here's the low cost way to learn the fundamentals of computing, the all-important basics you'll need more and more as you advance in computer skills. For just \$129.95 you get the advanced design Explorer/85 motherboard, with all the features you need to learn how to write and use programs. And it can grow into a system that is a match for any personal computer on the market. Look at these features: 8085 Central Processing Unit, the microprocessor "heart" of the Explorer/85. (Join the millions who will buy and use the 8080/8085 this year alone!) Four 8-bit plus one-half input/output ports from which you can input and output your programs, as well as control exterior switches, relays, lights, etc. a cassette interface that lets you store and reload programs you've learned to write. deluxe 2,000 byte operating system/monitor makes it easy to learn computing in several important areas: simple, fast writing and entering of programs. It permits access by you to all parts of the system so you can check on the status of any point in the program. It allows tracing each program step by step, with provision for displaying all the contents of the CPU (registers, flags, etc.) and it does much more!

You get all this in the starting level (Level A) of the Explorer/85 for only \$129.95. Incredible! To use, just plug in your 8VDC power supply and terminal or keyboard/display unit — if you don't have them, see our special offers below.

Level A computer kit (Terminal Version) ... \$129.95 plus \$3 P&I.*
 Level A kit (Hex Keypad/Display Version) ... \$129.95 plus \$3 P&I.*
 Level B — This "building block" converts the motherboard into a two-slot S100 bus (industry standard) computer. Now you can plug in any of the hundreds of S100 cards available.

Level B kit ... \$49.95 plus \$2 P&I.*
 S100 bus connectors (two required) ... \$4.85 each, postpaid.
 Level C — Add still more computing power. This "building block" mounts directly on the motherboard and expands the S100 bus to six slots.

Level C kit ... \$39.95 plus \$2 P&I.*
 S100 bus connectors (five required) ... \$4.85 each, postpaid.
 Level D — When you reach the point in learning that requires more memory, you have two choices: either add 4k of a memory directly on the motherboard, or add 16k to 64k of memory by means of a single S100 card, our famous "JAWS".

Level D kit (CHECK ONE) ... \$49.95 plus \$3 P&I.*
 S100 "JAWS" ... \$149.95 plus \$2 P&I.*
 S100 "JAWS" ... \$199.95 plus \$2 P&I.*
 S100 "JAWS" ... \$249.95 plus \$2 P&I.*
 S100 "JAWS" ... \$299.95 plus \$2 P&I.*

Level E — An important "building block," it activates the 8k ROM/PROM space on the motherboard. Now just plug in our 8k Microsoft BASIC or your own custom programs.
 Level E kit ... \$5.95 plus \$0.6 P&I.*
 Microsoft BASIC — It's the language that allows you to talk English to your computer! It is available three ways: 8k cassette version of Microsoft BASIC (requires Level B and 12k of RAM minimum, we suggest a 16k S100 "JAWS" — see above) ... \$64.95 postpaid.
 8k ROM version of Microsoft BASIC (requires Level B and Level E and 4k RAM, just plug into your Level E sockets. We suggest either the Level D RAM expansion or a 16k S100 "JAWS") ... \$99.95 plus \$2 P&I.*
 Disk version of Microsoft BASIC (requires Level B and 12k of RAM, floppy disk controller, 8" floppy disk drive) ... \$225 postpaid.

TEXT EDITOR/ASSEMBLER — The editor/assembler is a software tool (a program) designed to simplify the task of writing programs. As your programs become longer and more complex, the assembler can save you many hours of programming time. This software includes an editor program that enters the programs you write, makes changes, and saves the programs on cassettes. The assembler performs the clerical task of translating symbolic code into the computer-readable object code. The editor/assembler program is available either in cassette or a ROM version.

Editor/Assembler (Cassette version, requires Level B and 4k RAM in RAM, we suggest 16k "JAWS" — see above) ... \$59.95 plus \$2 P&I.*
 Editor/Assembler (ROM version, supplied on an S100 card, requires Level B and 4k RAM in RAM — we suggest either Level D or 16k "JAWS") ... \$99.95 plus \$2 P&I.*

FLOPPY DISK — A remarkable "building block" Add our 8" floppy disk when you need faster operation, more convenient program storage, perhaps a business application, and access to the literally thousands of programs and program languages available today. You simply plug them into your Explorer/85 disk system — it accepts all IBM formatted CP/M programs.
 8" Floppy Disk Drive ... \$49.95 plus \$12 P&I.*
 Floppy Controller Card ... \$199.95 plus \$2 P&I.*
 Disk Drive Cabinet & Power Supply ... \$69.95 plus \$3 P&I.*

Driver Cables (set up for two drives) ... \$25.00 plus \$1.50 P&I.*
 CP/M 2.2 Disk Operating System: Includes Text Editor/Assembler, dynamic debugger, and other features that give your Explorer/85 access to thousands of existing CP/M-based programs ... \$150.00 postpaid.

NEED A POWER SUPPLY? Consider our AP-1. It can supply all the power you need for a fully expanded Explorer/85 (note: disk drives have their own power supply) Plus the AP-1 fits neatly into the attractive Explorer steel cabinet (see below).
 AP-1 Power Supply kit (8V @ 5 amps) in deluxe steel cabinet ... \$39.95 plus \$2 P&I.*

NEED A TERMINAL? We offer you choices: the least expensive one is our Hex Keypad/Display kit that displays the information on a calculator-type screen. The other choice is our ASCII Keyboard/Computer Terminal kit that can be used with either



1. Plug in Netronic's Hex Keypad/Display
2. Add Level B to convert to S100
3. Add 4k RAM
4. Plug in Level E that interprets Microsoft BASIC or Editor/Assembler in ROM
5. Add two S100 boards
6. Add your own custom circuits (prototyping board)
7. Connect terminal

- CRT monitor or a TV set (if you have an RF modulator).
- Hex Keypad/Display kit ... \$69.95 plus \$2 P&I.*
- FASTERM - 64 TERMINAL KIT — Featuring a 56 key ASCII Keyboard, 128 character set upper and lower case, 75 ohm output, 8 baud rates: 150 to 19,200 (switch selectable), RS232C or 20 MA output, 32 or 64 character by 16 line formats, complete with Deluxee Steel Cabinet and Power Supply ... \$199.95 plus \$3 P&I.*
- RF Modulator kit (allows you to use your TV set as a monitor) ... \$2.95 postpaid.
- 12" Video Monitor (10MHz bandwidth) ... \$139.95 plus \$5 P&I.*
- Deluxee Steel Cabinet for the Explorer/85 ... \$48.95 plus \$3 P&I.*
- Fan for cabinet ... \$15.00 plus \$1.50 P&I.*



ORDER A SPECIAL-PRICE EXPLORER/85 PAK — THERE'S ONE FOR EVERY NEED.

- Beginner Pak (Save \$28.00) — You get Level A (Terminal Version) with Monitor Source Listing (\$25 value) AP-1, 5-amp. power supply, Intel 8085 Users Manual ... (Reg. \$199.95) SPECIAL \$169.95 plus \$4 P&I.*
- Experimenter Pak (Save \$53.40) — You get Level A (Hex Keypad/Display Version) with Hex Keypad/Display, Intel 8085 User Manual, Level A Hex Monitor Source Listing, and AP-1 5-amp. power supply ... (Reg. \$279.95) SPECIAL \$229.95 plus \$6 P&I.*
- Special Microsoft BASIC Pak (Save \$103.00) — You get Levels A (Terminal Version), B (4k RAM), E (8k Microsoft in ROM), Intel 8085 User Manual, Level A Monitor Source Listing, and AP-1 5-amp. power supply ... (Reg. \$439.70) SPECIAL \$329.95 plus \$7 P&I.*
- Add A Rom-Version Text Editor/Assembler (Requires Levels B and D or S100 Memory) ... \$99.95 plus \$2 P&I.*

Starter B" Disk System — Includes Level A, B floppy disk controller, one CDC B" disk-drive, two-drive cable, two S100 connectors, just add your own power supplies, cabinets and hardware ... (Reg. \$1065.00) SPECIAL \$999.95 plus \$13 P&I.*
 32k Starter System, \$1045.95 plus \$13 P&I.*
 48k Starter System, \$1145.95 plus \$13 P&I.*
 Add to any of above Explorer steel cabinet, AP-1 5-amp. power supply, Level C with two S100 connectors, disk drive cabinet and power supply, two sub-D connectors for connecting your printer and terminal ... (Reg. \$225.95) SPECIAL \$199.95 plus \$3 P&I.*
 Complete 64k System, Wired & Tested ... \$1650.00 plus \$26 P&I.*

Special! Complete Business Software Pak (Save \$625.00) — Includes CP/M 2.2 Microsoft BASIC, General Ledger, Accounts Receivable, Accounts Payable, Payroll Package ... (Reg. \$1325) SPECIAL \$699.95 postpaid.

*P&I stands for "postage & insurance." For Canadian orders, double this amount.

Continental Credit Card Buyers Outside Connecticut:
TO ORDER
 Call Toll Free:
800-243-7428

To Order From Connecticut, or For Technical Assistance, Call (203) 354-9375

CP/M is a reg. trademark of Digital Research

★ (Clip and mail entire ad) ★

SEND ME THE ITEMS CHECKED ABOVE

Total Enclosed (Conn. Residents add sales tax).
 Paid by:
 Personal Check Cashier's Check/Money Order
 VISA MASTER CARD (Bank No. _____)

Acct. No. _____ Exp. Date _____

Signature _____

Print Name _____

Address _____

City _____

State _____ Zip _____

ANNOUNCING TWO NEW TERMINALS

Smart • Fast • Graphics • Matching Modem and \$295 Printer

Netronics announces a state of the art breakthrough in terminals. Now at prices you can afford, you can go on-line with data-bank and computer phone-line services. It's all yours: "electronic newspapers," educational services, Dow-Jones stock reports, games, recipes, personal computing with any level language, program exchanges, electronic bulletin boards ... and more every day!!!



Netronics offers two new terminals, both feature a full 56 key/128 character typewriter-style keyboard, baud rates to 19.2 kilobaud, a rugged steel cabinet and power supply. The simplest one, FASTERM-64, is a 16 line x 64 or 32 character per line unit, with a serial printer port for making hard copy of all incoming data, and optional provisions for block and special character graphics. The "smart" version, SMARTERM-80, features either 24 line by 80 characters per line or 16 by 40 characters per line. It offers on-screen editing with page-at-a-time printing, 12,000 pixel graphics, line graphics, absolute cursor addressing, underlining, reverse video, one-half intensity and much more ... simply plug them into your computer or our phone modem and be on-line instantly. Use your TV set (RF modulator required) or our deluxe green-phosphor monitor pictured above. For hard copy just add our matched printer.

Prices breakthrough!!! Own the FASTERM-64, a complete terminal kit, ready to plug in for just \$199.95 or order the SMARTERM-80 kit for just \$299.95, (both available wired and tested). Be on-line with the million-dollar computers and data services today ... we even supply the necessary subscription forms.

More good news: All the components in our terminals are available separately (see coupon), so you buy only what you need!!!

Price breakthrough!!! Own the SMARTERM-80, a complete terminal kit, ready to plug in for just \$299.95 or order the FASTERM-64 kit for just \$199.95, (both available wired and tested). Be on-line with the million-dollar computers and data services today ... we even supply the necessary subscription forms.

More good news: All the components in our terminals are available separately (see coupon), so you buy only what you need!!!

More good news: All the components in our terminals are available separately (see coupon), so you buy only what you need!!!

FASTERM-64 ... DISPLAY FORMAT: 64 or 32 characters/line by 16 lines ... 96 displayable ASCII characters (upper & lower case) ... 8 baud rates: 150, 300, 600, 1200, 2400, 4800, 9600, 19,200 (switch sel.) ... LINE OUTPUT: RS232C or 20 ma current loop ... VIDEO OUTPUT: 1V P/P (EIA RS-170) ... CURSOR MODES: home & clear screen, erase to end of line, erase cursor line, cursor up & down, auto carriage return/line feed at end of line & auto scrolling ... REVERSE VIDEO ... BLINKING CURSOR ... PARITY: off, even or odd ... STOP BITS: 1, 1.5, 2 ... DATA BITS PER CHARACTER: 5, 6, 7 or 8 ... CHARACTER OUTPUT: 5 by 7 dot matrix in a 7 by 12 cell ... PRINTER OUTPUT: prints all incoming data ... 1K ON BOARD RAM ... 2K ON BOARD ROM ... LINE OR PASTAL CONTROLLED ... COMPLETE WITH POWER SUPPLY ... OPTIONAL GRAPHICS MODE: Includes 34 Greek & math characters plus 30 special graphics characters ... ASCII ENCODED KEYBOARD: 56 key/128 characters.

SMARTERM-80 ... DISPLAY FORMAT: 80 characters by 24 lines or 40 characters by 16 lines 128 displayable ASCII characters (upper & lower case) 8 baud rates: 110, 300, 600, 1200, 2400, 4800, 9600, 19,200 ... LINE OUTPUT: RS232C or 20 ma current loop ... VIDEO OUTPUT: 1V P/P (EIA RS-170) ... EDITING FEATURES: insert/delete line, insert/delete character, forward/back tab ... LINE OR PASTAL CONTROLLED ... PAGE PRINT FUNCTION ... CURSOR POSITIONING: up, down, right, left, plus absolute cursor positioning with read back ... VISUAL ATTRIBUTES: underline, blink, reverse video, half intensity, & blank ... GRAPHICS: 12,000 pixel resolution block plus line graphics ... ON-SCREEN PARITY INDICATOR ... PARITY: off, even or odd ... STOP BITS: 110 baud 2, all others 1 ... CHAR. OUTPUT: 7 by 11 character in a 9 by 12 block ... PRINTER OUTPUT ... 60 OR 50 HZ VERTICAL REFRESH ... BLINKING BLOCK CURSOR ... CRYSTAL CONTROLLED ... 2K ON BOARD RAM ... ASCII ENCODED KEYBOARD: 56 key/128 character ... 4K ON BOARD ROM ... COMPLETE WITH POWER SUPPLY.

TELEPHONE MODEM 103 O/A ... FULL DUPLEX, FCC APPROVED ... DATA RATE: 300 baud ... INTERFACE: RS232C and TTY ... CONTROLS: talk/data switch (no need to connect and disconnect phone), original/answer switch on rear panel ... NO POWER SUPPLY REQUIRED.

ASCII KEYBOARD ASCII-3 ... 56 KEY/128 CHARACTER ASCII ENCODED ... UPPER & LOWER CASE ... FULLY DEBOUNCED ... 2 KEY ROLLOVER ... POS OR NEG LOGIC WITH POS STROBE ... REQUIRES +5 & -12V DC (SUPPLIED FROM VIDEO BOARDS) ... PRINTER COMET I ... SERIAL IO TO 9600 BAUD ... 80 CHARACTER COLUMN (132 COMPRESSED) ... 10" TRACTOR FEED ... UPPER/LOWER CASE ... INDUSTRY STANDARD RIBBONS ... 4 CHARACTER SIZES ... 9 BY 7 DOT MATRIX ... BI-DIRECTIONAL PRINTING



Continental U.S.A. Credit Card Buyers Outside Connecticut
CALL TOLL FREE 800-243-7428

To Order From Connecticut Or For Tech. Assist. Call (203) 354-9375

NETRONICS R&D LTD. Dept.
 333 Litchfield Road, New Milford, CT 06776

Please send the items checked below:

- COMPLETE FASTERM-64 TERMINAL (Includes FASTVID-64 video board ASCII-3 keyboard, steel cabinet and power supply) ... kit \$199.95 plus \$3 P&I ... wired & tested \$249.95 plus \$3 P&I ... graphics option: add \$19.95 to each of above
- COMPLETE SMARTERM-80 TERMINAL (Includes SMARTVID-80 video board, ASCII-3 keyboard, steel cabinet and power supply) ... kit \$299.95 plus \$3 P&I ... wired and tested \$369.95 plus \$3 P&I
- FASTVID-64 VIDEO BOARD (requires +5 & -12V DC) ... kit \$99.95 plus \$3 P&I ... graphics option add \$19.95 ... wired & tested \$129.95 plus \$3 P&I ... graphics option add \$19.95
- SMARTVID-80 VIDEO BOARD (requires +5 & +/-12V DC) ... kit \$199.95 plus \$3 P&I ... wired & tested \$249.95 plus \$3 P&I
- DELUXE STEEL TERMINAL CABINET ... \$199.95 plus \$3 P&I
- ASCII-3 KEYBOARD (requires +5 & -12VDC) ... kit \$69.95 plus \$3 P&I ... wired and tested \$89.95 plus \$3 P&I
- POWER SUPPLY (powers ASCII-3 keyboard & video boards) ... kit only \$19.95 plus \$2 P&I
- ZENITH VIDEO MONITOR (high resolution green phosphor) ... wired & tested \$149.95 plus \$6 P&I
- TELEPHONE MODEM MODEL 103 O/A ... wired & tested \$189.95 plus \$3 P&I
- DOT MATRIX PRINTER Comet I ... wired & tested \$299.95 plus \$10 P&I
- RF MODULATOR MOD RF-1 ... kit only \$8.95 plus \$1 P&I
- 3FT-25 LEAD MODEM/TERMINAL OR PRINTER/TERMINAL CONNECTOR CABLE ... \$14.95 ea plus \$2 P&I

For Canadian orders, double the postage. Conn. res. add sales tax.

Total Enclosed \$

Personal Check Cashier's Check/Money Order
 VISA MasterCard (Bank No. _____)

Acct. No. _____ Exp. Date _____

Signature _____

Print Name _____

Address _____

City _____ State _____ Zip _____

NETRONICS Research & Development Ltd.
 333 Litchfield Road, New Milford, CT 06776

MicroScript™

Are you wasting valuable time trying to format complex documents with a word processor or obsolete text formatter?

MicroScript™ is a state of the art text formatter specifically designed for the production of technical manuals, specifications, and other complex documents. This powerful tool pays for itself the first time you use it. Featuring:

- generalized markup
- left alignment
- center alignment
- right alignment
- justification
- left indentation
- right indentation
- bold text
- underscored text
- proportional spacing
- fully definable page
- multiple columns
- headers and footers
- floating text blocks
- footnotes
- variable line spacing
- widow suppression
- section numbering
- imbedded documents
- automatic lists
- macro processing
- symbol processing
- table of contents
- direct printer control
- Initialization profile
- page numbering

\$99 postpaid within U.S., outside U.S. add \$10. CA residents add 6%. Specify CP/M-80*, CP/M-86*, MS-DOS*, or PC-DOS* printer type, disk format.

Software Technique™

6531 Crown Blvd., Suite 3A • San Jose, CA 95120
(408) 997-5026

* CP/M-80, CP/M-86 trademarks of Digital Research. MS-DOS trademark of Microsoft. PC-DOS trademark of IBM Corporation.

Circle 432 on Inquiry card.

wabash®

When it comes to
Flexible Disks, nobody
does it better than
Wabash.

MasterCard. Visa Accepted.
Call Free: (800) 235-4137



PACIFIC
EXCHANGES
100 Foothill Blvd.
San Luis Obispo, CA
93401 (In Cal. call
(805) 543-1037.)

Circle 361 on Inquiry card.

MICROPRINTER

ACOUSTIC ENCLOSURE

\$99 to \$199

Model	Printer	Sug. Ret.
MPC I	Epson MX80	\$99
MPC II	OKI 824	\$129
MPC III	MX 100, OKI 831,	\$179
	Others	
MPC IV	IDS, Many Others	\$249

- Reduces Printer Noise Up To 90%
- Walnut or Oak Veneer
- Heavy Duty Acrylic Cover
- Add UPS Shipping and Handling

CAB - TEK

CIVILIZING PRINTERS

ORDER NOW

800-343-4311

MasterCharge & Visa Accepted

DEALER INQUIRIES INVITED

CAB-TEK, Inc. Riverside St. Nashua, NH 03062

Circle 78 on Inquiry card.

COMPUTER DISKETTES COMPUTER CASSETTES, CASSETTE DUPLICATING SERVICE

APPLE-IBM(P.C.)-ATARI-HEATH-OSBORN
COMMODORE-TRS-80-SINCLAIR-NORTH STAR

Diskettes 100% Certified	Unit Price	10 Pack
5-1/4" SSDD Soft Sector		
W/Hub Ring	\$2.75	\$25.00
5-1/4" SSDD 10 Hard Sector	2.75	25.00
5-1/4" DSDD Soft Sector	3.75	35.00
8" SSDD IBM Compatible	3.50	32.50

Computer Cassettes with MAXELL Computer
Cassette Tape 100% Certified - Instant Play/
Record - Sliding Lock Out Doors

C- 5 (25 Feet)	2.00	17.50
C-10 (50 Feet)	2.25	20.00
C-20 (100 Feet)	2.65	22.00
C-30 (150 Feet)	2.75	24.00
C-60 (300 Feet)	2.90	26.00
C-90 (450 Feet)	3.10	30.00

Cassette Duplicating - Add \$2.00 per unit.

Check Master Charge Visa
Card # _____ Expiration Date _____

Send to: Magnetic Information Systems
P.O. Box 806, 415 Howe Ave., Shelton, CT 06484
(203) 735-6477 • Dealers Inquiry Welcomed
Minimum Credit Card Order \$10.00

Circle 281 on Inquiry card.

Get Smart!



Get Your Computer An
Automatic Port Selector
(ASU-3)

Our ASU-3 will connect your CPU or CRT to any one of 3 peripherals. Just enter a command from your keyboard and the desired peripheral is automatically connected. Also available for 5 and for 7 peripherals. The baud rate is set automatically. Many options are available. The only low cost, smart switch on the market.

SWITCH TO GILTRONIX.



970 San Antonio Rd., Palo Alto, CA 94306. Call (415) 493-1300

Circle 213 on Inquiry card.

CALL 800-343-1078 FOR THE BEST PRICE.

Call P.R.I.C.E. for big savings on home computers, software, video cassette recorders, car stereo, home stereo, portable radios and tape recorders, cordless telephones, and answering machines, video games, tapes, and movies.

P.R.I.C.E. will beat any legitimate offer on in-stock items. Call our toll-free number now! 800-343-1078. In Mass. 617-961-2400.

PRICE™

67 Teed Dr., B1282, Randolph, MA 02368

Circle 359 on Inquiry card.

APPLE ATARI

FOURTH DRIVE	\$294.95	LOWEST PRICED 800 (48K) - CALL!	
FOURTH (W/Controller)	\$384.95	800 (48K)	\$619.00
FOURTH DUAL DRV.	\$984.95	PERFORM D/D DISK DRV	\$559.00
APPLE DUMPLING-GX	\$75.95	810 DISK DRIVE	\$429.00
Chiquiter (D)	\$24.95	410 RECORDER	\$14.00
Sargon II (D)	\$24.95	850 INTERFACE	\$164.00
Software Automatic Mouth	\$86.95	480 COMP (16K)	\$265.00
Snack Attack	\$20.95	ENTERTAINER	\$66.95
Way Out (D)	\$28.95	COMMUNICATOR	\$289.00
Flight Simulator (D)	\$28.95	BOOKKEEPER KIT	\$179.95
Zork I or II (D)	\$28.95	32K RAM (Module)	\$95.95
Deadline (D)	\$35.95	32K RAM (Inter)	\$174.95
The Home Accountant	\$52.95	48K RAM (Inter/40)	\$139.95
Yat Class Mail (D)	\$52.95	RAMDISK	\$425.00
Ultima (D)	\$28.95	SIENL MAN MK II	\$78.95
Gorgon (D)	\$28.95	WIC JOYSTICK	\$24.95
Bandits (D)	\$24.95	WIC TRACKBALL	\$54.95
Wizard (D)	\$35.95	Eastarm From 128K (CID)	\$22.95
Microwave (D)	\$24.95	Macro Assm. & Editor (D)	\$65.95
Master Type (D)	\$28.95	Assembler Editor (R)	\$44.95
Pinball (D)	\$21.95	Centipede (R)	\$32.95
Screenwriter II (D)	\$89.95	Pac Man (R)	\$32.95
Super Text (40/96/70) (D)	\$86.95	Chopfruit (R)	\$24.95
Viscacalc 3.3 (D)	\$174.95	Frogger (CID)	\$24.95

PRINTERS

NEC 8023A-C	\$469.00
SMITH CORONA TM	\$589.00
AXIOM GP-100	\$269.00
VIC-64	CALL!
VIC-20	\$182.95
1530 RECORDER	\$63.95
1525 PRINTER	\$314.95
1540 DISK DRIVE	\$314.95

FREE PRICE LIST

COSMIC COMPUTERS

ORDER LINES OPEN
MON-SAT 9 am - 9 pm
228 N. PROSPECTORS RD.
DIAMOND BAR, CA. 91765

THE ABOVE PRICES ARE FOR PREPAID ORDERS
Add \$2.00 shipping per software order. Shipments in
U.S. Non-U.S. software orders, add \$5.00. Hardware
Shipping, call for cost. CASH, residents add 6% sales
tax. Cash, Checks or Money Orders billed same day.
Personal checks require a weeks to clear. Mailer
Card area (fill in for software only, add 3% surcharge).
Include card no. expiration date and signature. Prices
subject to change.

(714) 861-1265

APPLE AND ATARI ARE REGISTERED TRADEMARKS

Circle 152 on Inquiry card.

IBM PC Software

When you want the
very best...

SSI Delivers.

P-Edit: The professional program editor. Full screen context editing with dynamic file handling. \$145.00.

FORTH: FIG compatible system with all of the standard features plus many extras. \$95.00.

For information, call toll free:
1-800-321-5906.

Satellite Software Int'
288 W. Center, Orem, UT 84057

Circle 412 on Inquiry card.

SuperCalc

(and other CP/M spread sheet)

USERS

CON-CALC

- ★ Consolidates up to 256 worksheets
 - ★ Adds a third dimension to your electronic spread sheet programs
 - ★ Includes logic for Rate of Return
 - ★ 8" disk—CP/M & MBASIC required
- Test disk and manual in plastic mailer—\$15

\$125.00 VISA/MC accepted

SUNWEST SOFTWARE

2000 S. Logan

Denver, Co. 80210

(303) 777-9400

(dealer inquiries invited)

- ★ CON-CALC™ Sunwest Software
- ★ SuperCalc™ of Sorcim
- ★ CP/M™ TM Digital Research
- ★ MBASIC™ Microsoft

Circle 445 on Inquiry card.

DECADES OF SERVICE

Washington Computer Services

97 Spring Street
New York, New York 10012

an affiliate of **WASHINGTON ELECTRIC COMPANY** est. 1912
CUSTOM COMPUTER ROOM WIRING SINCE 1960

TO ORDER: CALL OUR TOLL-FREE NUMBER: (800)221-5416

In N.Y. State and for technical information: (212) 226-2121

HOURS: 9 AM-5:30 PM (EST) Monday-Friday

TELEX: 12-5606

CABLE: WASHCOMP NYK

FULLY CONFIGURED BUSINESS SYSTEMS

The following are some examples of the fully assembled and tested business and scientific computer systems which we offer:

IMS INTERNATIONAL The Premier Multi-User Computer System **CALL**
8000 SX. multi-user, multi-processor, turbo DOS **FOR**
CPM 2.2. FULL 2 YEAR WARRANTY! **CONFIGURATION**
5000IS. S-100 desk top mainframe
On-Site Service Contracts Available

MORROW DESIGNS MICRODECISION from below \$1200
ZENITH 8088/8055—Runs both 8 & 16 bit software. Green or high res.
NEC color. CP/M, MS-DOS
APC-8086, 16 bit, 128K, 8" DRIVES, 1024x1024 Color Graphic.
32 bit F.P. Proc., MS DOS, CP/M 86 from \$3295

PC-8800 Personal Computer

The Professional's Work Station
NEC on N.Y.S. Contract #P-07220

IBM 68000 16 bit multi-user, S-100. UNIX V. 7 **SCALL**

SEATTLE COMPUTER 8086 16 bit, 128K RAM, S-100. Syst. #2 **\$3499**

Systems Group XEROX. **MORROW DESIGNS**
California Computer Systems GODBOUNT **ALTOS**
NorthStar 8 & 16 BIT BOARDS & SYSTEMS

SCION MicroAngelo Hi Res Graphics Systems **SCALL**
Similar savings on SSM, DELTA, DYNABYTE, TELEVIDEO, OIGIAC, ADDS, DEC.
DATA GEN., ATARI, TECMAR AND MANY OTHERS

PRINTERS

Teletype 40. 300 LPM-typewriter quality, RS-232 interface. This quality printer is available in many configurations including forms access, quietized case, etc. **from Only \$3200**

Teletype 43 from \$995

ANADIX	DIABLO	MANNESMANN TALLY
CENTRONICS	EPSON	NEC AMERICA
C. ITOH	FACIT	QUME
DATA PRODUCTS	OKIDATA	SMITH CORONA
DIGITAL EQUIP. CORP.	OLIVETTI	TELETYPE
INTERGRAL DATA SYS.	QANTEX	TEXAS INSTRUMENTS

8" DISK DRIVE SALE

NOW!

8" SHUGART SA801R \$385 8" SHUGART SA 851R \$540 2 for \$1025
QUME DATATRACK 8 or MITSUBISHI \$550 2 for \$1050
Enclosure, power supply for 2 8" drives A & T \$350
MORROW DISCUS 2D + CP/M® MICROSOFT BASIC, CONT. \$950
VISTA **SCALL**

HARD DISK SPECIALS

CORVUS **MORROW DESIGNS** **AMF** **RDES** & **XCOMP** **KONAN**
TERMINALS PMMI MODEM \$359
TELETYPE ADDS IBM 1301
TELEVIDEO ANN ARBOR DIGITAL EQUIP. CORP.
LEAR SIEGLER VISUAL HAZELTINE

AMPEX Dialogue 81™ Interactive Terminal

• Full cursor control
• Full editing keys
• Full visual attributes
• 2 pages (4 page optional)
• Printer port
• Black & White, Green, or Amber screen **\$795**

BACK TO SCHOOL SPECIAL! ZENITH ZT-1

Built-in Auto Dial Modem Terminal
DEC VT-52 Compatible;
96 ASCII + 33 graphics cursor control keys. Editing functions. Many other functions. **\$669**

SOFTWARE

DBASE II	\$525	WORDSTAR	\$300
F & G QUICKCODE	SCALL	MAILMERGE	\$110
MBASIC-80	\$275	DATASAR	\$230
MBASIC COMPILER	\$316	CONDOR III	\$716
FORTRAN-80	\$349	MILESTONE	\$235
COBOL-80	\$574	SUPERCALC	\$221
PL/1-80	\$425	FMS-80	\$649
PASCAL MT + V5.5	\$398	SELECTOR V	\$396
WHITESMITH'S C	\$660	SPELLGUARD	\$236
CB-80	\$420	CHANG-MICROPLAN	SCALL
RM COBOL	\$699	PEARL (LEVEL 3)	\$549
LIFEBOAT SOFTWARE	SCALL	AMERICAN BUS. SYST.	SCALL
SUPERSOFT	SCALL	ACCOUNTING PLUS	SCALL
BSTAM, BSTMS	\$200	VANDATA/OSBORNE	\$500
PASCAL Z	SCALL	STRUCTURED SYST.	SCALL
PEACHTREE	SCALL	GRAHAM-DORIAN	SCALL

8" SDSS; Call For Other Formats

PLEASE! Do not confuse us with mail order dealers. We are a full service distributor serving the data processing & installation needs of business & industry from micros to mainframes. System houses, Educational institutions & governmental agencies given special consideration. Leasing available.

N. Y. State agencies, municipalities, and schools — call us for information on our O.G.S. term contracts on hardware & software.

DEALER and INTERNATIONAL INQUIRIES WELCOME

For fast delivery, send certified check, money order or call to arrange direct bank wire transfer. Personal or company checks require two to three weeks to clear. Prices subject to change without notice; call for latest prices. Prices include 3% cash discount. N.Y. residents add sales tax. Qantex is a trademark of North Atlantic Industries, Inc. Accounting Plus is a trademark of Software Dimensions. Wordstar, Mailmerge and Datastar are trademarks of Micropro. CP/M® is a trademark of Digital Research. All sales subject to our standard sale conditions (available on request). Call for shipping charges. Above prices do not include customization or installation.

Shielded RS 232 Cables w/DB-25 connectors up to 7 conductors, specify male/female ends, length & pin interconnects \$11.00 + .40/ft.

Hazeltine ESPRIT I green screen emulator \$575.00
 ESPRIT II detachable keyboard \$625.00
 Other Hazeltine models available

Televideo 910+ full featured terminal \$589.00
 925 terminal w/detachable keyboard \$759.00
 950 graphics terminal w/det. keyboard \$985.00
 970 Call for price

second page memory for 925/950 \$80.00

Novation CAT 0-300 baud Acoustic coupled modem \$149.00
 D-CAT 0-300 baud Direct connect modem \$159.00
 AUTOCAT 0-300 baud auto answer modem \$199.00
 APPLE CAT 0-300 baud modem \$319.00
 212AUTOCAT 0-300 baud/1200 baud 212A Auto Answer modem \$595.00
 212APPLE CAT II 300/1200 baud modem \$650.00
 212APPLE CAT II 1200 baud upgrade for Apple Cat II modem \$350.00

UOS 212LP ilne powered 1200 baud only modem \$439.00

OKI-DATA uL82A 9 1/2" carriage 120 cps printer \$459.00
 uL83A 15" carriage 120 cps printer \$725.00
 uL84 15" carriage 200 cps serial or parallel printer \$1199.00
 High speed interface w/2KByte buffer \$139.00

Certified check, money order or C.O.D. VISA and MasterCard add 3%. Personal or company checks require 2 to 3 weeks to clear. All prices in U.S. dollars. Michigan residents add 4% tax. F.O.B. MI. Clemens, Michigan 48024.

ELECTROSONICS
 P.O. Box 1141, Mt. Clemens, MI 48044
 (313) 286-6969

Circle 194 on Inquiry card.

PAL*
Development System



- Programs MMI, National and TI 20-pin and 24-pin PALs
- PALASM assembles Boolean equations
- SIMULATE verifies Boolean equations
- Continuity Test verifies socket connection
- Function Test PALs to your truth table
- 4K byte RAM with space compressions allows large PAL Design Specification
- Continuous Loop Magnetic Tape stores PAL Design Specification
- Use with ASCII Terminal or Host computer
- IMMEDIATE delivery, \$1,800

Structured Design, Inc.
 1700 Wyatt Drive, Santa Clara, CA 95054
 408 / 988-0725 • Telex 172931
 *PAL is a registered trademark of Monolithic Memories

Circle 442 on Inquiry card.

6-12 hour turnaround!
 \$5.00 minimum • 190 timesteps
 300 baud • 1200 baud

Typesetting
 from your
Personal Computer

Personal Publishingsm
 service and software turns your personal computer into an editorial/production system just like those used by the major book and magazine publishers. Call or write for more information.

800-368-3342
703-683-9414 in Virginia
 Intergraphics, Inc., 106-A S. Columbus St.
 Alexandria, Virginia 22314

Visa MasterCard American Express

Circle 245 on inquiry card.

EPROM PROGRAMMER
 for the Apple II

PROGRAMS
 2716 27128
 2732 27C16
 2732A 27C32
 2764 27C64

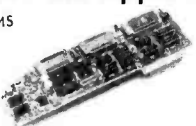

Completely self-contained single board fits in any Apple II I/O slot. Programs present and future EPROMs. Complete software supplied is 100% menu-driven, friendly, easy to use, flexible and powerful. Has EPROM POWER ON/OFF switch. Conservatively designed, well built, well burned in, well tested, reliable, guaranteed, all common parts, all ICs in gold-plated sockets, three ZIF sockets gold-plated. No jumpers or plugs. Uses standard ODS binary files. Turn your Apple into powerful software development system for only \$395. Excellent customer references available. Data sheet and catalog of other Apple II products free. Manual \$3.00.

HMS Hollister MicroSystems, Inc.
 1455 Airport Boulevard
 San Jose, California 95110
 (408) 293-3900

Contact your local dealer

Circle 223 on inquiry card.

FIRST QUALITY
RIBBONS
EPSON

MX70/80 3/\$22.00
 MX100 3/\$40.00

3 12
Centronics Zippack \$9 \$30
Diablo Film \$14 \$42
Qume Film \$9 \$30

Write for free catalogue!

\$2 ship. Checks (2 wks to clear)
Visa & MC: Name/No./Exp. Date

oread tech 8609 College Blvd.
 Overland Park, KS
 66210
 1-913-341-0588

Circle 57 on Inquiry card.

WIREMASTER



Whip your wire wrap and PC layout problems with **WIREMASTER**

WIREMASTER is a software tool for design, layout, and assembly of hardware. Your schematic is fed to **WIREMASTER**, which produces network maps, cross-references, wire and parts lists, and debug checklists. **CHANGEMASTER** keeps track of fixes and updates. **PLOTBOARD** and **PRINTBOARD** give pictures of the layout. Post-processors for wirewrap machines available. Runs on 8 and 16 bit CP/M, CDOS, and MSDOS. \$200.

AFTERTHOUGHT ENGINEERING 7266 Courtney Dr., San Diego, CA 92111, (714) 279-2868.

Circle 20 on inquiry card.

PConnection
 modem card for IBM PC

Plug your PC into the exciting world of telecommunications with the PConnection, Microperipheral's new Bell 103/113 compatible modem card. This quality direct connect modem card fits inside the PC leaving your work area uncluttered by stacks of hardware. Features include autodialing (Touch Tone or pulse), autoanswer, built-in speaker for line monitoring, and an additional RS-232 port. Software selectable protocol and modes \$350. Dealer inquiries welcome.

the microperipheral corporation
 2643 151st PINE, Redmond, WA 98052
 (206) 881-7544

IBM is a Registered Trademark of International Business Machine Corp.

Circle 316 on Inquiry card.

REAL TIME CALENDAR CLOCK
\$49.50



- Hr/Min/Sec Date/Year Day of Week Leap Yr Capability
- 2 programmable clock outputs: 2 Hz-32 KHz, 24-hr programmable alarm interrupt
- 12 or 24 hour format
- 50 bytes battery backed RAM. Automatically recharged battery runs clock for at least 3 months when computer is off.

Model No. CL 104 IBM PC

MODELS AVAILABLE FOR ALL MAJOR PERSONAL COMPUTERS. 1-800-228-6505

VISA/MasterCard accepted

Tic-Tock Systems
 P.O. Box 50813
 Palo Alto, CA
 94303

Circle 467 on inquiry card.

maxell.
Floppy Disks



SAVE 40% Write for your complete list.

5 1/4" Specify soft, 10 or 16 sector Price/10

MD1 or MH1 SS/DD \$33
 MD2 or MH2 DS/DD 47
 MD1-DDM SS/QD/96 TP1 43
 MD2-DDM DS/QD/96 TP1 53

8" Specify soft or 32 sector

FD1 or FH1 SS/DD 43
 FD2 or FH2 DS/DD 53

CHECKS — VISA — MC — C.O.D.
 (313) 777-7780 ADD \$2 SHIPPING

LYBEN COMPUTER SYSTEMS
 27204 Harper Ave.
 St. Clair Shores, MI 48081

Circle 276 on inquiry card.

WE WILL NOT BE UNDERSOLD

SOFTWARE

MICROPRO	
Wordstar	\$239.00
Mailmerge	\$ 89.00
Customization Notes	\$359.00
Spellstar	\$239.00
Datatar	\$199.00
Calcstar	\$199.00
MICROSOFT	
Basic Interpreter	\$349.00
Basic Compiler	\$389.00
Fortran 80	\$499.00
Cobol 80	\$695.00
DATA BASE	
dBase II	\$599.00

IBM PC SOFTWARE

INFORMATION UNLIMITED	
Easy Writer	\$289.00
Easy Speller	\$149.00
Easy Filer	\$319.00
VISICORP	
VisiCalc 256K	\$199.00
VisiDex	\$209.00
VisiFile	\$219.00
VisiTrend/VisiPlot	\$259.00
VisiTerm	\$99.00
MICROPRO	
Mailmerge	\$119.00
Wordstar	\$239.00
MISCELLANEOUS	
Supercalc by Sorcim	\$229.00
Superwriter by Sorcim	\$289.00
Home Accountant Plus	\$139.00
ENTERTAINMENT	
Deadline	\$39.00
Temple of Apshai	\$29.00
Curse of Ra	\$15.99
Call For More IBM Software And Accessories	

DISK DRIVES

CCI 100 for the TRS-80 Model 1	
5 1/4 40 track	\$299.00
CCI 189 for the Zenith Z-89	
5 1/4 40 track	\$379.00
CORVUS 5M with Mirror	\$3089.00
CORVUS 10M with Mirror	\$4489.00
CORVUS 20M with Mirror	\$5389.00
CORVUS interfaces	CALL
RANA SYSTEMS add-on Disc Drive for the Apple II	CALL
Elite Two 80 Track	CALL
Elite One 40 Track	CALL
Elite Controller	CALL
Elite Two 80 Track	CALL
Elite Three 80 Track double-sided	CALL

DISKETTES

Maxell 5 1/4 single side	\$39.00
Maxell 8 single side	\$49.00
Maxell 5 1/4 double side	\$45.00
Maxell 8 double side	\$55.00
BASF 5 1/4	\$26.95
BASF 8	\$36.00
Verbatim 5 1/4	\$26.95
Verbatim 8	\$36.00
Wabash 5 1/4	\$21.95

IBM PC ACCESSORIES

64K Card by Microsoft	\$435.00
Joystick by T & G	\$49.00
128K Card	\$579.00
192K Card	\$629.00
256K Card	\$699.00
Combo Card by Apparat	\$249.00
Call for more IBM PC add-ons	

For fast delivery, send certified checks, money orders, or call to arrange direct bank wire transfers. Personal or company checks require one to three weeks to clear. All prices are mail order only and are subject to change without notice. Call for shipping charges.

APPLE SOFTWARE

MICROPRO	
Wordstar	\$199.00
Mailmerge	\$ 89.00
Spellstar	\$149.00
DataStar	\$199.00
CalcStar	\$189.00
VISICORP	
VisiCalc	\$199.00
VisiTerm	\$79.00
VisiDex	\$199.00
VisiPlot	\$169.00
VisiFile	\$199.00
VisiSchedule	\$259.00
VisiTrend/Plot	\$239.00
MISCELLANEOUS	
Micro Courier	\$219.00
Screen Director	\$129.00
Executive Briefing System	\$169.00
Supercalc	\$199.00
Personal Filing System	\$115.00
PFS Report Writer	\$75.00
Word Handler	\$169.00
ENTERTAINMENT	
Beer Run	\$28.00
Zork I, II	\$26.95
Deadline	\$39.00
Chop Lifter	\$24.95
Cannonball Blitz	\$29.95
Knights of Diamonds	\$29.95
Midnight Magic	\$32.00
Wizardry	\$45.00
Tuesday Morning Quarterback	\$24.95
Crush, Crumble & Chomp	\$24.95
Datestones of Ryn	\$15.99
Morloc's Tower	\$15.99
Snack Attack	\$23.95
Star Blazer	\$24.95

APPLE ACCESSORIES

ADVANCED LOGIC	
Add-Ram 16K Card	\$99.00
Z-Card CP/M for the Apple II	\$225.00
Smarterm 80 Column Board w/Softswitch	\$249.00
Z-80 Card by Microsoft	\$319.00
16K Card by Microsoft	\$159.00
32K Card by Saturn	\$199.00
Keyboard Enhancer II by Videx	\$125.00
Videoterm by Videx	\$259.00
Game Paddles by TG	\$49.00
Joystick by TG	\$49.00
Numeric Keypad by Keyboard Co.	\$139.00
ALF 9 Voice Board	\$159.00
ALF 3 Voice Board	\$229.00
System Saver by Kensington	\$75.00
Microbuffer II 16K w/graphics	\$259.00
Microbuffer II 32K w/graphics	\$299.00
APPLE INTERFACE CARDS BY CCS	
Serial Asynch. #7710	\$139.00
Centronics #7729	\$149.00
Call for other CCS cards	

RAM

16K Ram Kit for Apple II; TRS80	
200 nano seconds, 4116 chips	\$17.50

DEALER INQUIRIES

PLEASE CALL

1-800-343-7036

COMPUTERS

CALIFORNIA COMPUTER SYSTEM	
Mainframe 2200a	\$485.00
Z-80 CPU 2810a	\$265.00
64K RAM 2065	\$569.00
Floppy Controller 2422a	\$359.00
ZENITH	
Z-89 48K	CALL
Z-90 64K	CALL
Z-100	CALL
Call For Prices On The Complete Zenith Line	
CASIO FX702P Pocket Computer	\$179.00
Sanyo MBC 1000 64K	CALL
Call For Prices On Complete Sanyo Computer Line	

PRINTERS

NEC 3550 for the IBM PC	\$2195.00
NEC 7710 Serial	\$2395.00
NEC 7720 KSR	\$2749.00
NEC 7730 Parallel	\$2395.00
NEC 3510 Serial	\$1850.00
NEC 3520	\$2099.00
NEC 3530 Parallel	\$1850.00
Antex "Generic Model of the Prowriter"	\$479.00
Epson MX-80	CALL
Epson MX-80FT	CALL
Epson MX-100	CALL
IDS Micro Prism	CALL
IDS Prism 80	CALL
IDS Prism 132	CALL
Okidata Microline 80	CALL
Okidata Microline 82A	CALL
Okidata Microline 83A	CALL
Okidata Microline 84	CALL
Datasouth 180 cps	CALL

MONITORS

SMD 13" Color	\$329.00
Sanyo 9" B & W	\$135.00
Sanyo 9" Green	\$140.00
Sanyo 12" B & W	\$179.00
Sanyo 12" Green	\$189.00
Sanyo 13" Color	\$359.00
Zenith 12" Green	\$95.00
Zenith 13" Color	\$339.00
Electrohome 13" HI-RES	
Color Monitor	\$829.00
Electrohome 13" Color	\$349.00
Electrohome 12" B&W	\$179.00
Electrohome 12" Green	\$189.00
Electrohome 9" B&W	\$149.00
Electrohome 9" Green	\$159.00

SPECIAL OF THE MONTH

SMD 13"
COLOR MONITOR
\$329.00

TERMINALS

ADDS Viewpoint	\$495.00
Zenith Z-19	\$679.00
Televideo 910	\$595.00
Televideo 925	\$779.00
Televideo 950	\$989.00
Zenith ZT-100	\$595.00

TELECOMMUNICATIONS

Novation Cat Modem	\$139.00
Novation D-CAT	\$149.00
Novation AUTO-CAT	\$199.00
Novation APPLE CAT	\$299.00
Hayes Smart Modem	\$249.00
Smart Modem 1200	CALL
Hayes Micro-Modem	\$295.00
Hayes Chronograph	\$225.00
Signalman Mark I	\$85.00

The CPU Shop

TO ORDER CALL TOLL FREE 1-800-343-6522

420-438 Rutherford Ave., Dept. BY12, Charlestown, Massachusetts 02129



Hours 9 AM - 9 PM (EST) Mon.-Fri. (Sat. till 6)
Technical information call 617/242-3361

TWX- 710-348-1796

Massachusetts Residents call 617/242-3361
Massachusetts Residents add 5% Sales Tax

Circle 154 on inquiry card.

BYTE December 1982 559

U.K. AND EUROPE: CONTACT VINCELOD LTD. 47 GOLDHURST TERRACE LONDON NW6

"THE BIG BOARD"
 OEM - INDUSTRIAL - BUSINESS - SCIENTIFIC
SINGLE BOARD COMPUTER KIT!
Z-80 CPU! 64K RAM!

NEW!

NEW LOWER PRICES

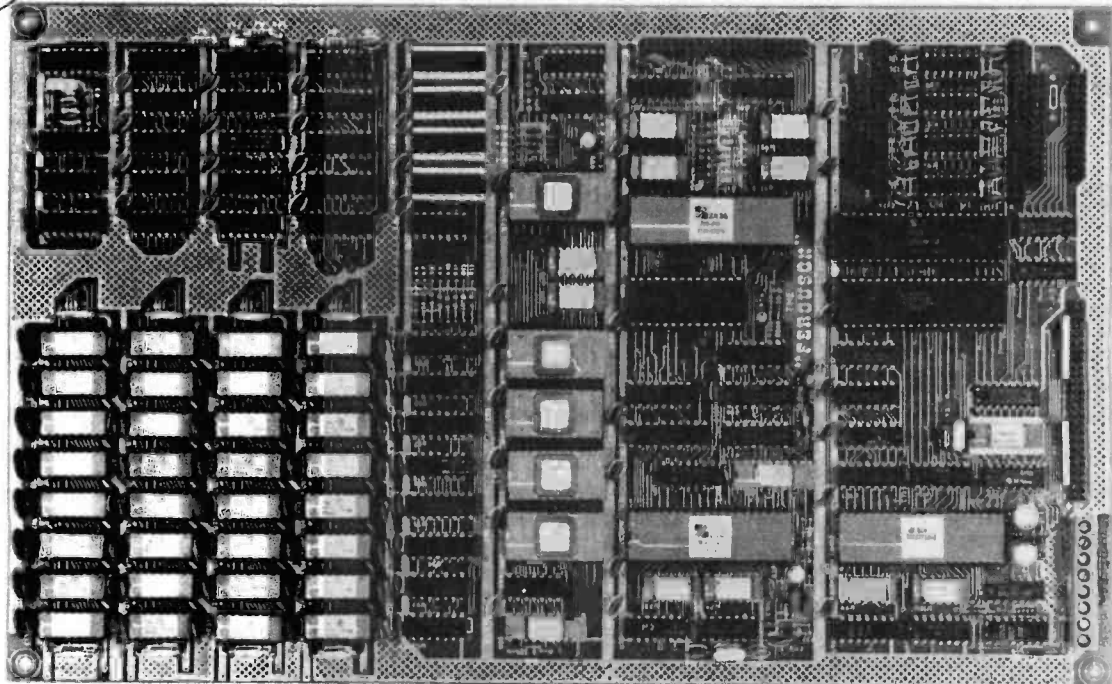

PARTIALLY ASSEMBLED KITS
 For All Sockets Installed
 And Soldered Add \$50.

WANT MORE INFO?
 Full Documentation and
 Schematics — \$5.

THE BIG BOARD PROJECT: Three years in the works, and maybe too good to be true. A tribute to hard headed, no compromise, high performance, American engineering! The Big Board gives you all the most needed computing features on one board at a very reasonable cost. The Big Board was designed from scratch to run the latest version of CP/M*. Just imagine all the off-the-shelf software that can be run on the Big Board without any modifications needed! Take a Big Board, add a couple of 8 inch disc drives, power supply, an enclosure, C.R.T., and you have a total Business System for about 1/3 the cost you might expect to pay.

\$399.00 ** (64K KIT BASIC I/O)

SIZE: 8 1/2 x 13 1/4 IN.
 SAME AS AN 8 IN. DRIVE.
 REQUIRES: -5V @ 3 AMPS
 - 12V @ .5 AMPS.

FULLY SOCKETED! FEATURES: (Remember, all this on one board!)

64K RAM

Uses industry standard 4116 RAM'S. All 64K is available to the user, our VIDEO and EPROM sections do not make holes in system RAM. Also, very special care was taken in the RAM array PC layout to eliminate potential noise and glitches.

Z-80 CPU

Running at 2.5 MHZ. Handles all 4116 RAM refresh and supports Mode 2 INTERRUPTS. Fully buffered and runs 8080 software.

SERIAL I/O (OPTIONAL)

Full 2 channels using the Z80 SIO and the SMC 8116 Baud Rate Generator. FULL RS232! For synchronous or asynchronous communication. In synchronous mode, the clocks can be transmitted or received by a modem. Both channels can be set up for either data-communication or data-terminals. Supports mode 2 Int. Price for all parts and connectors: \$49

BASIC I/O

Consists of a separate parallel port (Z80 PIO) for use with an ASCII encoded keyboard for input. Output would be on the 80 x 24 Video Display.

BLANK PC BOARD — \$149

The blank Big Board PC Board comes complete with full documentation (including schematics), the character ROM, the PFM 3.3 MONITOR ROM, and a diskette with the source of our BIOS, BOOT, and PFM 3.3 MONITOR.

CP/M* 2.2 FOR BIG BOARD

The popular CP/M* D.O.S. to run on Big Board is available for \$159.00.

PRICE CUT!

PFM 3.3 2K SYSTEM MONITOR

The real power of the Big Board lies in its PFM 3.3 on board monitor. PFM commands include: Dump Memory, Boot CP/M*, Copy, Examine, Fill Memory, Test Memory, Go To, Read and Write I/O Ports, Disc Read (Drive, Track, Sector), and Search. PFM occupies one of the four 2716 EPROM locations provided. Z-80 is a Trademark of Zilog.

FLOPPY DISC CONTROLLER

Uses WD1771 controller chip with a TTL Data Separator for enhanced reliability. IBM 3740 compatible. Supports up to four 8 inch disc drives. Directly compatible with standard Shugart drives such as the SA800 or SA801. Drives can be configured for remote AC off-on. Runs CP/M* 2.2.

TWO PORT PARALLEL I/O (OPTIONAL)

Uses Z-80 PIO. Full 16 bits, fully buffered, bi-directional. User selectable hand shake polarity. Set of all parts and connectors for parallel I/O: \$19.95

REAL TIME CLOCK (OPTIONAL)

Uses Z-80 CTC. Can be configured as a Counter on Real Time Clock. Set of all parts: \$9.95

24 x 80 CHARACTER VIDEO

With a crisp, flicker-free display that looks extremely sharp even on small monitors. Hardware scroll and full cursor control. Composite video or split video and sync. Character set is supplied on a 2716 style ROM, making customized fonts easy. Sync pulses can be any desired length or polarity. Video may be inverted or true. 5 x 7 Matrix - Upper & Lower Case

Digital Research Computers
 (OF TEXAS)
 P.O. BOX 401565 • GARLAND, TEXAS 75040 • (214) 271-3538

TERMS: Shipments will be made approximately 3 to 6 weeks after we receive your order. VISA, MC, cash accepted. We will accept COD's (for the Big Board only) with a \$75 deposit. Balance UPS COD. Add \$4.00 shipping.
 USA AND CANADA ONLY

*TRADEMARK OF DIGITAL RESEARCH. NOT ASSOCIATED WITH DIGITAL RESEARCH OF CALIFORNIA, THE ORIGINATORS OF CPM SOFTWARE
 **1 TO 4 PIECE DOMESTIC USA PRICE.

NEW! **REDUCED PRICE**

MEGARAM
IBM COMPATIBLE MEMORY BOARD

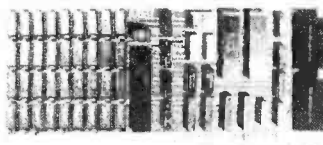

*Registered Trademark of IBM

FEATURES:

- On Board Memory Expansion from 64K to 1M Byte
- Memory Write Protect Command
- Program Controlled Banking Capability in 128K or 512K Blocks
- Memory Error Detection
- Flexible Memory Boundary Selection
- On Board Two MDRAM Supported Asynchronous RS-232-C Ports
- Price Starts at ~~\$396.00~~ \$395.00

MEI Microcomputer
Business
International

P.O. BOX 16115, IRVINE, CA 92713
(714) 553-0133 (714) 727-0202

Circle 191 on Inquiry card.

Maxell Floppy Disks

The Mini-Disks
with maximum quality.



Dealer inquiries
invited. C.O.D.'s
accepted. Call
FREE (800) 235-4137.



PACIFIC EXCHANGES
100 Foothill Blvd., San Luis
San Luis Obispo, CA 93401.
In Cal. call (800) 592-5935 or
(805) 543-1037.

Circle 361 on Inquiry card.

CP/M COMPATIBLE—CP/M EFFICIENT

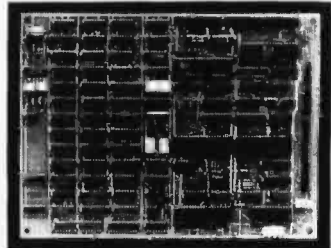

- 4 MHz Z-80A CPU
- Two banks of 64K RAM
- Two RS-232 serial ports
- Full centronics printer port
- True hard disk interface
- External DMA I/O
- Compatible with 5 inch and 8 inch drives, single/double density
- Real time clock
- 5 volts only at 1.5 amps
- Compact size

**Special introductory offer
Only 600.00**

IET
INSIGHT ENTERPRISES, CORPORATION
373 N. Western Ave., Suite 12,
Los Angeles, CA 90004, (213) 461-3262
Dealer, OEM, International Inquiries Welcome

Circle 234 on Inquiry card.

**Garden Of Eden
Computers**
"The Apple Paradise"

	LIST	SALE	All 3
DC Hayes Micromodem	\$379	\$269	Pieces
Source Subscription			
Fee	\$100	\$79	\$399
ASCII Express II	\$79.95	\$64	

Don't Miss The Great RANA Disk Drive Sale

RANA Disk Drive Controller [Controls up to 4 Drives]	\$99
*Completely Apple compatible. Mix up to 4 Apple and RANA drives on the same RANA controller:	
RANA Drives:	
1 Drive w/o controller	\$323
1 Drive w/controller	\$422
2 Drives w/o controller	\$630
2 Drives w/controller	\$725

NEC 12" Green Monitor Econo (JB 1260)	\$113.00
RH Electronics Super Fan II	\$62.50
Microsoft 16K Ramcard	Now Just \$99
T.S. Joystick	\$39.95
NEC BD23A Desk Top Graphics Printer	\$479
The Grappler + Graphic Printer Interface	\$129

PHONE: 714-894-9528
"Ask for our newest price list"

Garden Of Eden
Computers
9909 Gladia Drive
Fountain Valley, CA 92708
Mail order only

We discount all lines of hardware and software.
We accept Visa, Mastercard, Cash, M.O. Same day shipments, 2% ser. chg. on cards
All orders shipped via UPS

Circle 208 on Inquiry card.

**ATR8000: THE DOUBLE DENSITY
DISK INTERFACE FOR
ATARI®
800/400**



- 16K RAM upgradable to 64K.
- With OSA+

Version 4 is double density.

- Runs standard 5 1/4" or 8" drives.
- A Z80 4 MHz controller.
- A serial and a parallel port.
- Software compatible with existing ATARI software.
- Is CP/M compatible (with 64K).

ATR8000	\$499.95
OSA+ Version 4	\$ 49.95
5 1/4" drive	\$399.95
64K Upgrade	—Call—

SOFTWARE PUBLISHERS, INC.
2500 E. Randol Mill Rd., Suite 125
Arlington, TX 76011 (817) 469-1181

Circle 430 on Inquiry card.

OVER-VOLTAGE
PROTECT YOUR SYSTEM
(Computer/Disk/Printer)
FROM OVERVOLTAGE
(GUARANTEED)

Make Your Own:
SCHEMATIC/INSTRUCTIONS
Only (easy assembly) \$ 995

KIT (with parts) \$1595

COMPLETE KIT \$3995
(Allow 3 Weeks for Delivery)

Send Check/Money Order to:

SAFETEK
P.O. Box 283
DeSoto, Texas 75115

Circle 222 on Inquiry card.

IBM® PC SOFTWARE

FORTH-32™ allows access to all of the PC memory using intermixed 16/32 bit addressing. Screen editor, assembler, decompiler, debug, graphics, CASE, and DOS interface. Package Builder Utility produces compact marketable software. \$150. Floating Point Library I Software or 80871. \$50.

QUESTalk™ Asynchronous Communications connects your PC to other computers. Menu driven with help feature, terminal or local mode. UPLOAD/DOWNLOAD file transfers. Multiple BAUD rates. \$45.

PrintPak™ allows customized printouts via menu driven selection of page headers, line numbers, character type, time, date and more. \$45.

DiskPak™ recovers erased files, prints, views and modifies sectors and more. \$35.

Edlin Recovery Utility reclaims the file you thought you lost when the disk was full. \$35.

Quest
QUEST RESEARCH, INC.

PO Box 2553 ■ Huntsville, AL 35804 ■ 205-533-9405
Toll Free 800-558-8088

Circle 395 on inquiry card.

CENTERLINE™



COMPUTERCENTER™ \$199 Sug Ret
PRINTERCENTER™ \$299 Sug Ret

CAB-TEK
CIVILIZING COMPUTERS
800-343-4311
MASTERCARD & VISA ACCEPTED
DEALER INQUIRIES INVITED
CAB-TEK, Inc.
Riverside St. Nashua, NH 03062

Circle 79 on inquiry card.

**MEMOREX
Flexible Discs**



**BEST PRICES
IN THE U.S.**

Call for our special dealer program. C.O.D.'s accepted
TOLL FREE (800) 652-8162
In California (213) 901-8881

U.S. EXCHANGE
U.S. EXCHANGE
14831 Bessemer St.
Van Nuys, CA 91411-2773

Circle 477 on Inquiry card.

INDUSTRIAL CONTROL MICROCOMPUTERS

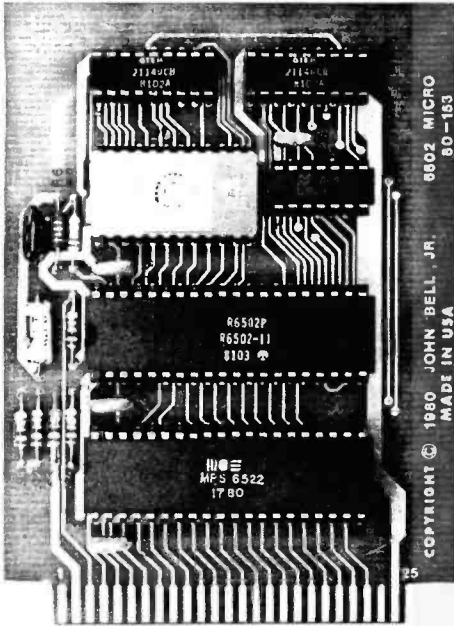

6502 AND Z80 MICROCOMPUTERS ARE DEDICATED COMPUTERS DESIGNED FOR CONTROL FUNCTIONS.

THESE BOARDS FEATURE:

- 4096 BYTES EPROM
- 1024 BYTES RAM
- ALL BOARDS INCLUDE COMPLETE DOCUMENTATION
- 50 PIN CONNECTOR INCLUDED
- EPROM AVAILABLE SEPARATELY

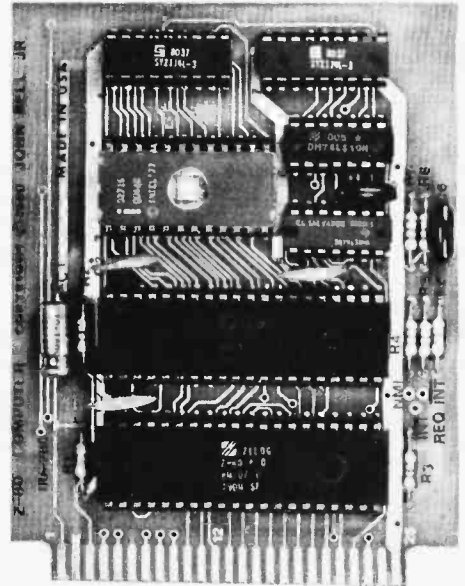

JOHN BELL ENGINEERING'S 6502 MICROCOMPUTER FEATURES:

- 1024 BYTES RAM
- 4096 BYTES EPROM
- USES ONE 6522 VIA (DOC. INCL.)
- 2 8 BIT BIDIRECTIONAL I/O PORTS
- 2 16 BIT PROGRAMMABLE TIMER/COUNTERS
- SERIAL DATA PORT
- LATCHED I/O WITH HANDSHAKING LOGIC
- TTL AND CMOS COMPATIBLE

80-153A LIST 100-499
EPROM NOT INCLUDED \$110.95 \$66.57

JOHN BELL ENGINEERING'S NEW Z80 MICROCOMPUTER FEATURES:

- Z80 CPU-SOFTWARE COMPATIBLE WITH Z80, 8080 AND 8085 MICROPROCESSORS
- 4096 BYTES EPROM
- 1024 BYTES RAM
- SINGLE 5V POWER SUPPLY AT 300MA
- CLOCK FREQUENCY IS 2MHZ, RC CONTROLLED
- Z80 PIO (DOC. INCL.)
- 2 8-BIT BIDIRECTIONAL I/O PORTS
- LATCHED I/O WITH HANDSHAKING LOGIC
- TTL AND CMOS COMPATIBLE

80-280A LIST 100-499
EPROM NOT INCLUDED \$129.95 \$77.97

USE YOUR 6502 OR Z80 MICROCOMPUTER TO CONTROL EVERYTHING!

- YOUR HOME SECURITY SYSTEM
- HEAT CONTROL
- LIGHT CONTROL
- SOLAR HEATING AND POWER SYSTEMS
- AUTOMATIC CONTROL OF TAPE RECORDERS
- TRAFFIC LIGHT CONTROL
- IRRIGATION SYSTEMS
- AUTOMATIC CONTROL OF VIDEO RECORDERS
- ROBOT CONTROL
- AUTOMATIC DIALER
- AUTOMATED SLIDE SHOW CONTROL
- COMMUNICATION SYSTEMS FOR THE DISABLED
- THE WORLD



JOHN BELL ENGINEERING, INC.

ALL PRODUCTS ARE AVAILABLE FROM JOHN BELL ENGINEERING, INC. • 1014 CENTER ST., SAN CARLOS, CA 94070
 ADD SALES TAX IN CALIFORNIA • ADD 5% SHIPPING & HANDLING 3% FOR ORDERS OVER \$100



SEND \$1.00 FOR CATALOG

(415) 592-8411
 WILL CALL HOURS: 9am-4pm

10% OUTSIDE U.S.A.
 ADD \$1.50 FOR C.O.D.



#300

Now, Interconnect Any Two RS232 Devices

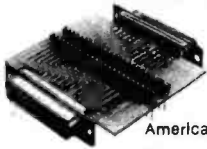

WIRING ADAPTER
\$24.95 postpaid

American Made

Connects any two RS232 devices in any pattern. Temporary or permanent. Comes complete with ten plug-in jumper wires. Wiring Adapter just \$24.95 postpaid. Purchase Orders accepted from rated firms. Get FREE illustrated catalog of interface and monitoring equipment.



B&B electronics
P.O. Box 475-B • Mendota, IL 61342
Phone: (815) 539-5827

Circle 55 on Inquiry card.

8086/8087/8088 CROSS SOFTWARE PACKAGES

1 C cross compiler for the 8086. All facilities of the complete C language, including floating point for the 8087, are supported. Optionally, memory can be allocated for use with the 8088. Output is symbolic assembly language. The compiler is suitable for use in porting UNIX to the 8086.

2 Cross assembler/linker/librarian/downline loader for the 8086. Assembler input is an extension to that used by Intel. Loader output is a file in standard Intel hex format.

3 Simulator/debugger for the 8086. Capabilities include display, breakpoints, interpretive execution, as well as many others.

Host System: PDP-11 running RT-11, RSX-11M, UNIX/V6, UNIX/V7; or VAX-11 running VMS, UNIX/32V.

For additional information:

Advanced Digital Products, Inc.

1701 21st Ave. S., Suite 222 • Nashville, TN 37212
Phone (615) 383-7520

Intel is a trademark of Intel Corporation; UNIX and UNIX/32V are trademarks of Bell Laboratories; RT-11, RSX-11M, PDP-11, VMS, and VAX-11 are trademarks of Digital Equipment Corporation.

Circle 14 on Inquiry card.

MICRO DISCOUNTS Low Sensible Prices

*SYSTEMS

IBM Personal Computer • Franklin • Basis 108
NEC • Kaycomp • Apple II, III
Osborne..... \$1595.00

*PRINTERS

C - Ithos • NEC 8023 • Epson • Micraline
As low as \$299.00
F-10 • Brother HR-1 • Smith Corona \$574.00

*MONITORS

BMC...18M2..... \$89.00
BMC...Color..... \$259.00

Apple & IBM Compatible Hardware, Software Accessories

MICRO DISCOUNTS

714/673-0233

4625 W. Pacific Coast Hwy.
Newport Beach, CA 92660

ASK ABOUT OUR DISCOUNT CATALOG
Dealer Inquiries Invited

Circle 32 on Inquiry card.

TANDON UPGRADES

100-2 = \$225.00
100-1* = \$ 95.00

*That's right, a new 100-2 for \$225.00 and your old 100-1 working or not.

100-1 to 100-2 Upgrade

Upgrade your 100-1 you now have, to a 100-2 for only \$189.00.

*100-1 = \$95.00

Complete factory reconditioning with full guarantee.

ANGEL's

Computer Products

(213) 891-5546

Circle 34 on inquiry card.

ZENITH/Heath Users

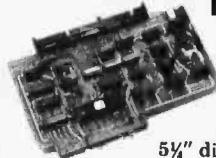

Double Your
5 1/4" disk storage
capacity without adding a drive.

Get twice as much from your H88 or H89 microcomputer. Our FDC-880H floppy disk controller, in conjunction with your 5 1/4" drives, for example, expands memory capacity from 256 bytes to 512 bytes per sector.

And it handles single and double-sided, single and double-density, 8" and 5 1/4" drives — simultaneously.



C.D.R. Systems Inc.

Controlled Data Recording Systems Inc.
7210 Clairmont Mesa Blvd., San Diego, CA 92111
(714) 560-1272

Circle 82 on Inquiry card.

IBM P.C. DISK DRIVES

TANDON TM100-2 \$259
5 1/4" Double-sided, 48TPI, 360KB
TRS-80*, Vector, North Star, Cromemco...Compatible Disk Drives
TANDON TM100-1 \$199
5 1/4" Single-Sided, 48TPI
TM100-4 \$365
5 1/4" Double-Sided, 96TPI
TM848-1 \$395
8" Single-Sided, 48TPI
TM848-2 \$495
8" Double-Sided, 48TPI
ZENITH *COMPATIBLE 5 1/4" & 8" Disk Drives and SUBSYSTEMS Including:
I-47 Single or Dual 8" \$1995/
Intelligent Flex Disk Subsystem \$2795
Immed. Delivery-Full Pre-Ship Testing & Support.
• 24 Hour Ordering Service •

INTEK

(714) 630-6600

2730 Regal Park Dr.
Anaheim, CA 92806



Circle 184 on Inquiry card.

DEMO INVENTORY SALE

** Limited Quantities **

REG. NOW

Datavue		
Displaymaster	\$1,997	\$1,200
Televideo 950	1,195	850
Centronics 353	2,495	1,975
Datamedia		
Excel 42	995	775

NEW ADDS VIEWPOINTS
FROM \$495.00

ECONOMY PERIPHERALS
(404) 952-0231

SPECIAL SPECIAL

SPECIAL	MCP 64KS STATIC RAM MEMORY	\$325.00	SPECIAL	MCP COMPUTER PRODUCTS	\$4995.00
SPECIAL	MCP/SCC-6MHz Z80 S-100 CPU	\$350.00	SPECIAL	AND TWO 8" DS, DD FLOPPY DISKS AND ONE 10M 5.25" WINCHESTER DISK	\$3195.00
SPECIAL	MCP/FDC-DD FLOPPY DISK CONTROLLER	\$280.00	SPECIAL	Suite 104-444 6992 El Camino Real	
SPECIAL	MCP/VDB-80X24 VIDEO CONTROLLER	\$249.00	SPECIAL	Carlsbad, CA 92008 (714) 438-3270	
SPECIAL	MCP 80/100B 6 MHz Z80 MAINFRAME		SPECIAL	FREE CPM 2.2 WITH MAINFRAME	

Circle 291 on Inquiry card.

New! INTRCEPT™

INTRCEPT™ executes CP/M™, CDOS™ and/or YOUR OWN system calls in CP/M 2.2 programs.

Comes configured for CDOS: design your own system calls using the optionally available source code.

Transparent: no program changes.
Compact & fast: 1K Z80 code.
Portable: no CP/M patches.

From \$89.95.
Write for details:

PRO microSystems

6609 Sagewood Lane
Poway, California 92064
(714) 578-1240

Circle 382 on Inquiry card.

PRIVACY in your micro

MICROCRYPT scrambles data and programs in your computer - unscrambles them with a password you select. A must for multi-user systems - Perfect with dBase II.[™] Easy to use - Fast - For CP/M,[™] MP/M[™] - Only \$125.

Order today: 800-368-3359

VISA, Master Card accepted

NEW GENERATION SYSTEMS

2153 Golf Course Drive,
Reston, VA 22091 703/476-9143

[™]CP/M, MP/M: Digital Research;
dBase II: Ashton-Tate

Circle 536 on inquiry card.

Verbatim[®] Diskettes



Top-quality Verbatim[®] Diskettes from Tech•Data, your complete word and data processing supply center. Dealer inquiries invited.

Call Toll Free
1-800-237-8931.

In Florida, call
813-577-2794.



Tech•Data Corporation
3251 Tech Drive North
St. Petersburg, FL 33702

Circle 453 on inquiry card.

NEW! M-68000 SINGLE BOARD COMPUTER

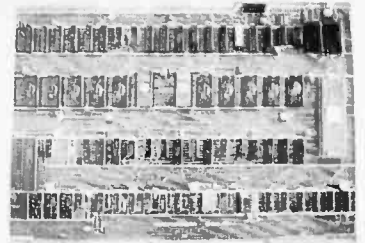

FEATURES:

16 M Motorola 68000 CPU operating @ 10MHz, 20k bytes of on-board fast static RAM, 16k bytes of on-board EPROM space, 7 levels of prioritized auto-vectorized interrupts, 2 memory expansion buses (up to 256K), 2 serial communication ports (RS-232C), 16-bit bidirectional parallel port, 4800 peripheral accommodation bus, 5x16-bit counter/timers with vectored interrupts, on-board real time clock, software compatible with Motorola MEX88K3DM board.

PRICE:

Bare board with documentation	\$99.95
MEX88K3DM compatible monitor in 2764 EPROM's	\$120.00
M68000 CPU & memory map PROM	\$115.00
Shipping and handling (Domestic)	\$3.00
(Foreign)	\$15.00

EMS Educational Microcomputer Systems
P.O. Box 3415 Irvine, CA 92713-0315

714-553-0133

Circle 190 on inquiry card.

cc6502

C cross compiler for the 6502. With the exception of three minor features, all facilities of the complete C language are supported. Output is symbolic assembly language and is easily customized to existing assemblers. This cross compiler has been in use for over one year.

Host System: PDP-11 running RT-11, RSX-11M, UNIX/V6, UNIX/V7; or VAX-11 running VMS, UNIX/32V.

For additional information, contact



Advanced Digital Products, Inc.

1701 21st Ave. S., Suite 222 • Nashville, TN 37212
Phone (615) 383-7520

UNIX and UNIX/32V are trademarks of Bell Laboratories; RT-11, RSX-11M, PDP-11, VMS, and VAX-11 are trademarks of Digital Equipment Corporation.

Circle 15 on inquiry card.

SMITH-CORONA TP-1 Letter Quality•Daisy Wheel Printers



\$565

- BROTHER HR-1 (2k Buffer, 16 cps) \$775
- DAISY WRITER (48k Buffer) \$999
- BYTEWRITER (Typewriter/Printer) .. \$699
- C-ITOH F-10 (40 cps) \$1295

STAR ★ MICRONICS \$299

- OKIDATA 82 A \$420
- OKIDATA 83 A \$825
- Please see other AD page 560

MICRO TECHNOLOGY

7817 Ivanhoe Ave., La Jolla, CA 92037
(619) 457-2149

Circle 307 on inquiry card.

S-100 ULTRA-RES GRAPHICS

- N. E. C. UPD 7220 GRAPHICS PROCESSOR
- 1024 x 1024 PIXEL MEMORY PLANE
- 1 to 8 VIDEO PLANES, RGB 8 COLOR
- HARDWARE ZOOM 1 to 16 TIMES
- PROGRAMMABLE DISPLAY RESOLUTION FROM 1024 h by 1024 v
- Software Drivers
- GRAPHICS PROCESSOR, 1 MEG. PIXEL PLANE

STARTING at \$995.00

COMING SOON:

- MULTI-BUS
- Q-BUS COMPATIBLE

CSD INC.

P. O. Box 253
Sudbury, MA 01776
(617) 443-2750

Circle 539 on inquiry card.

D/Punch?

D/Punch Conversion Kits will help you SAVE MONEY, SAVE STORAGE SPACE, SAVE TIME. D/Punch Kits are engineered so you can quickly, accurately, & safely make alterations necessary to let you use both sides of your M or S sectorized SINGLE-SIDED Diskettes. Converting 1 box of diskettes will more than pay for each D/Punch Kit. • Hub-Reinforcer Kit accurately positions Hub-Reinf. Ring to hub opening. • Disk Sleeve lets you replace your lost or damaged sleeves. Indicate your system config. with order.

- | | |
|--|---------|
| a. D/Punch Kit A — (5 1/4" drives & eq.) for ex. [Apple, Atari, CBM 4040, Franklin] | \$ 6.95 |
| b. D/Punch Kit B — (5 1/4" drives & eq.) for ex. [TRS 80 (Mod. I, II), IBM, Osborne, Zenith] | 14.95 |
| c. D/Punch Kit C — (8" drives & eq.) for ex. [Atrox, Zenith, TRS 80 Mod II] | 16.95 |
| d. Labels — [100 pcs] | 3.00 |
| e. Write-Protect Stickers — [100 pcs] | 2.65 |
| f. Hub-Reinforcer Kit (5 1/4") | 10.99 |
| g. Hub-Reinforcer Kit (8") | 12.99 |
| h. Hub-Reinforcer Rings (5 1/4") — [50 pcs] | 5.85 |
| i. Hub-Reinforcer Rings (8") — [50 pcs] | 6.20 |
| j. Disk Sleeves (5 1/4") — [10 pcs] | 2.35 |
| k. Disk Sleeves (8") — [10 pcs] | 3.85 |

Add \$2 shipping & handling for each \$15 order increment. AK, HI, & overseas cust. write for S&H charges. MA res. add 5% tax. Send check or money order to:

D/Punch Co. (BB-12)

P.O. Box 201, Newton Hlds, MA 02161

Tel: (617) 964-2126 Telex: 4991009 CHTRI

© 1982, D/Punch Corp., Pat. Pend

Circle 537 on inquiry card.

printer/terminal KIT



INSTALL IT YOURSELF AND SAVE!

INTERFACES WITH OLIVETTI PRAXIS
MODELS 30 AND 35

THE KIT INCLUDES:

- FULLY ASSEMBLED BOARD
- COMPLETE MOUNTING HARDWARE
- WIRING AND INSTRUCTIONS

CENTRONICS PARALLEL - \$200.00

SERIAL/PARALLEL COMBO. - \$280.00

ALSO AVAILABLE...

BRAND NEW PRAXIS 30'S AND 35'S

SYSTEMED CORPORATION

P.O. Box 18, Shingletown Rd. Mt. City, TN 37683
(615) 727-6000

Circle 540 on inquiry card.

IBM PC Software

SOFTSPOOL^(tm) — printer spooler
*Creates true foreground/background operation
*Buffer sizes user modifiable (1-128K)
*Program execution no longer linked to printer speed.
\$49.95 (includes disk & doc)

KEYSWAP^(tm) — typing utility
*Transforms the PC's keyboard into a standard typewriter keyboard
*Poorly positioned keys are relocated and replaced
*Optional audible feedback on "toggle" keys
*Increases "touch typist" efficiency
*\$69.95 (includes disk, stick-on labels & doc)

BOTH PROGRAMS

*Work with any program that runs under DOS (EASYWRITER^(tm), VISICALC^(tm), WORDSTAR^(tm), etc.)

*Ideal for Business or Software development

PROCRYP^(tm) — software protection program
*Encrypts, serializes, and copy protects your programs — Now for price!

Now 'til 2/1/83 SOFTSPOOL & KEYSWAP for \$99.95
FOR ORDERS OR INFO CALL — (617) 662-0856

OR SEND CHECK TO:
Rickerdata
P.O. Box 288
Burlington, MA 01803

MC & VISA
accepted
Add \$2.50 S&H

terms & conditions may change w/o notice

Circle 538 on inquiry card.

- Quality Components • Over 650 Items Available From Our 700
- Competitive Prices Authorized JIM-PAK Distributors
- Send Self-Addressed Stamped Envelope for 1983 Catalog and Distributor List

BUG TRAY

New!

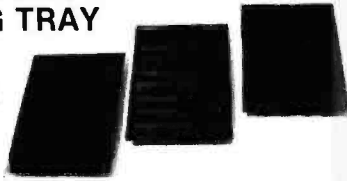

BUG TRAY™ — Stores in Bug Cage • Molded plastic • Three styles: Open (1 compartment); Vertical (5 compartments); and Horizontal (8 compartments) • Ideal for tools, hardware, components, etc. • Color: Black • Size: 3.55" x 5.05" x .6".

Part No.	Description	Price
BTH-002	Horizontal Tray (2)	\$3.89
BTV-002	Vertical Tray (2)	3.89
BTO-002	Open Tray (2)	3.89

DATA BOOKS

Part No.	Description	Price
30001	National CMOS	\$ 7.95
30003	National Linear	12.95
30005	National TTL Logic	10.95
30008	National Memory	7.95
30009	Intersil Data	10.95
30013	Zilog Micro	8.95
10400	Intel Data	15.95

CONNECTORS



Part No.	Description	Price
DE9P	9 Pin Plug	\$1.95
DE9S	9 Pin Socket	2.49
DA15P	15 Pin Plug	2.49
DA15S	15 Pin Socket	3.29
DB25P	25 Pin Plug (Meets RS232)	3.79
DB25S	25 Pin Socket (Meets RS232)	4.49
DC37P	37 Pin Plug	5.49
DC37S	37 Pin Socket	6.49
DD50P	50 Pin Plug	6.49
DD50S	50 Pin Socket	7.49
Accessories		
DE-9H	Hood for DE-9 Series Connectors	\$1.39
DE-15H	Hood for DA-15 Series Connectors	1.49
DB25H	Hood for DB25 Series Connectors	1.79
DC37H	Hood for DC37 Series Connectors	1.59
DD50H	Hood for DD50 Series Connectors	1.79

BUG CAGE

New!

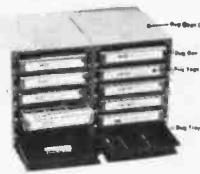

BUG CAGE™ — 6 locations store Bug Boxes, Big Bug Boxes or Bug Trays • Modular & Interlocking • Cage size: 5-1/8" x 5" x 3-7/8" • Color: Blue

Part No. BGC-001B Price \$5.95

LSI BIG BUG BOXTM — Designed to store large IC's, Resistors, Capacitors and Diodes • Three vertical and three horizontal dividers included • Color: Blue • Size: 4.9" x 3.3" x .6".

Part No. BLX-002B (2 Boxes) Price \$6.55

ANTI-STATIC

BLX-002BAS (2 Boxes) \$8.49

JE224 Adjustable Switching Power Supply Kit

4-24VDC REGULATED, UP TO 5AMP

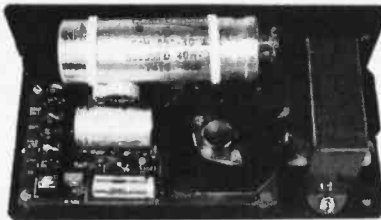

The JE224 is a high-efficiency power supply utilizing a LH1605 5 amp switching regulator. The LH1605 provides high current output while maintaining a small physical configuration. Open frame type to allow mounting into restricted areas.

FEATURES: Adjustable 4-24VDC: 5VDC @ 5A, 6VDC @ 4.8A, 9VDC @ 4.1A, 12VDC @ 3.3A, 18VDC @ 1.9A, 24VDC @ .5A. Overvoltage protection. Input: 115VAC 50/60Hz. Output variations within 20mV. Size: 8.24" L x 4.25" W x 2.25" H. Weight: 3.25 lbs.

JE224 KIT \$79.95 each

BUG BOX

New!

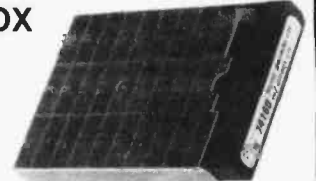

BUG BOXTM — 30 Individual compartments • Stores 60 8-pin or 30 14- or 16-pin DIPs • Heavy duty injection molded plastic • Clear plastic cover slides & locks • Cover marked w/numbers 1-30 • Compartment size: 1" x 3.75" x .5" deep • Box size: 4.9" x 3.3" x .6" • Weight: 1.75 oz. • Color: Blue

Part No. BGX-002B (2 Boxes) Price \$4.59

ANTI-STATIC

BGX-002BAS (2 Boxes) \$6.55

JOYSTICKS

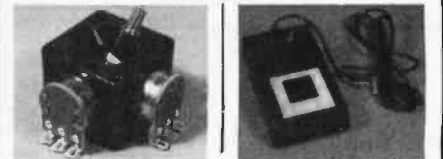

JS-5K	5K Linear Taper Pots	\$5.95
JS-100K	100K Linear Taper Pots	\$5.25
JS-150K	150K Linear Taper Pots	\$4.95
JVC-40	40K (2) Video Controller in case	\$3.95

Muffin-Style Fan



- 105cfm free air delivery
- 4.68" sq. x 1.50" depth
- 10 years continuous duty at 20°C
- Impedance protected, ambients to 70°C
- 115V 50/60Hz 14W
- Weight: 17 oz.

MU2A1 \$15.95

Sprite-Style Fan



- 36cfm free air delivery
- 3.125" sq. x 1.665" depth
- 10 years continuous duty at 20°C
- 115V 50/60Hz

PWS2107 \$15.95

Anti-Theft Auto Alarm System

• Audible horn is activated when door or trunk is opened • Alarm sounds for 3 min. — unless turned off by secret 3-digit code. • Wire cutting will not deactivate alarm. • Code set by owner. • Uses only 0.01mA power. • System complete w/one black-box control unit; one personal coded keyboard; 2 sets of sensors; one audible horn; & wiring (incl. one 10A fuse).

CA-06 Auto Alarm \$59.95

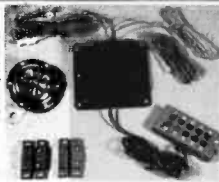

Stereo Cassette Player

with FM Stereo Tuner Pack

- Lightweight Headphones
- CrO2/Metal/Normal Tape Selector
- Anti-Rolling Mechanism

FEATURES: • Blue carrying case, shoulder strap, belt strap, lightweight headphones, FM stereo tuner pack & instruction manual • Talkline • Tone selector • CrO2/Metal/Normal tape selector • LED operation indicator • Built-in microphone • Stop/eject, play, rewind/review, fast forward/cue, tape/radio selector functions • Vol. control • Ext. power input jack • Headphone jack • Auto-stop mechanism (shuts off player when tape ends) • Anti-rolling mechanism (prevents sound from quivering when walking, jogging, etc.) • Weight: 13 oz. • Requires 4 AA batteries (not included) • Size: 6"L x 4"W x 1-1/8"H

Model TWF-802 \$69.95

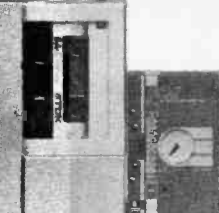

Jim-pak
DIODES
CRYSTALS
TRANSISTORS
SOCKETS
KITS
SWITCHES
RESISTORS
LEDS
HEAT SINKS
KEYBOARDS
WIRE
SPEAKERS
TOOLS
CORDS
SOLDER
IC'S
BOOKS
CAPACITORS
and more...

Door Security System

- Coded door alarm. • Instant or 7-second delay system. • Alarm activated as door is opened. • Can be de-activated by pressing personal code. • Power: One 9V battery (not incl.). • System includes one personal coded keyboard and one magnetic sensor.

ES-07 Door Alarm \$29.95

Home Alarm System

- Self-installation • Presettable w/individual 3-digit code — no key nec. • Instant or 10-sec. delayed warning system • Alarm system incl. window & door contacts • One 9V battery required (not incl.) • Low power consumption (0.01mA) • Loud audible alarm (90db) • Delayed exit feature • System complete w/one control station with built-in siren and test button; 4 magnetic contact sets & connecting wires for entire system

ST-05 Home Alarm System \$59.95

Mini Stereo AM/FM Receiver

WITH HEADPHONES For Joggers, Cyclists, Skaters & Sports Events



FEATURES: Lightweight headphones. Left/right balance control. Full fidelity stereo sound. Additional black soft carrying case & shoulder strap. Belt-clip (hands-free). Uses 3 AA cell batteries (not included). Compact size: 3-1/8" H x 4-7/8" L x 1"D. Wt. 6 oz.

MODEL 2830 \$29.95

2708, 2716, 2732 & 2764 EPROM Programmer

J664 EPROM PROGRAMMER

8K TO 64K EPROMS — 24 AND 28 PIN PACKAGES
Self-Contained — Requires No Additional Systems for Operation

NEW!



• Programs, validates, and checks for properly erased EPROMs • Emulates PROMs via EPROM • RS232C Computer Interface for editing/programming • Loads data into RAM by keyboard • Changes data in RAM by keyboard • Loads RAM from an EPROM • Compares EPROMs for content differences • Copies EPROMs • Power Input: 115VAC, 50Hz, 10W power consumption • Enclosure: Color-coded, light tan plastic w/wooded mchra. front and plates • Size: 5-5/8" x 5-1/2" x 3-1/8" • Wt.: 8-1/2 lbs.

J664-A EPROM Programmer \$995.00
Assembled & Tested (Includes JM16A Module)

J665 — RS232C INTERFACE OPTION — The J665 RS232C Interface Option implements computer access to the J664's RAM. Sample software written in BASIC provided for TRS-80 Model I. Level II Computer. Base rate: 5000 baud. Light: 8 bits • odd parity. Stop bits: 2. Option may be adapted to other computers.

J664-ARS EPROM Prog. w/J665 Option \$1195.00
Assembled and Tested (Includes JM16A Module)

EPROM JUMPER MODULES — The J664's JUMPER MODULE (Personal Module) is a plug-in module that pre-tests J664 for proper programming pulses to the EPROM & configures EPROM socket connections for that particular EPROM.

Part No.	EPROM	EPROM MANUFACTURER	PRICE
JM08A	2708	AMD, Motorola, National, Intel, TI	\$14.95
JM16A	2716, 1MS2516	Intel, Motorola, National, NEC, TI	\$14.95
JM16B	1MS2716	Motorola, TI, (1+5-17, 2, 12)	\$14.95
JM32A	1MS2532	Motorola, TI	\$14.95
JM32B	2732	AMD, Fujitsu, NEC, Hitachi, Intel	\$14.95
JM64A	2M648764	Motorola	\$14.95
JM64B	2764	Intel	\$14.95
JM64C	1MS2564	TI	\$14.95

CONSUMER PRODUCTS

SECURITY ALARM SYSTEMS

Home Alarm System

- Self-installation • Prerequisite w/independent 3-digit code — no key, no. • Instant or 10 sec. delayed warning system • Alarm system incl. window & door contacts • One 9V battery required (not incl.) • Low power consumption (100mA) • Loud audible alarm (90db) • Delayed exit feature • System complete w/out central station with built-in siren and test button, 4 magnetic contact sets & connecting wires for inside system

ST-05 Home Alarm System \$59.95

Door Security System

- Coded door alarm, • Instant or 7-second delay system • Alarm activated as door is opened • Can be de-activated by pressing personal code • Power: One 9V battery (not incl.) • System includes one personal code keypad and one magnetic sensor

ES-07 Door Alarm \$29.95

Anti-Theft Auto Alarm System

- Audible horn is activated when door/trunk is opened • Alarm sounds for 3 min. — unless turned off by secret 3-digit code • Wire cutting will not deactivate alarm • Code set by owner • Uses only 0.01mA power • System complete w/out black-box control unit, one personal code keypad, 2 sets of sensors, one audible horn, & wiring (incl. one 10A fuse)

CA-06 Auto Alarm \$59.95

DIGITAL QUARTZ TIME PEN

- 5-Function: Hours, Minutes, Seconds, Month, Day • Liquid Crystal Display 1 1/8" digits • Battery included • Uses standard Postnet Ink refills • Ultra-quiet design (5% 1/4")

7717L	Black/Gold Trim	\$9.95 each
7717G	Stainless Steel/Gold Trim	\$9.95 each
7717R	Red/Gold Trim	\$9.95 each

STICK-ON CLOCK

5-Function LCD Quartz Digital

- Hours • Minutes • Seconds • Month • Day • Flashing Color • Ideal for car, kitchen, bathroom, office, etc. • 1 1/4" digits • Runs 2 years on 1 battery (incl.) • Size: 1-3/8" Round. Specify color: Red/ST-001R; White/ST-001W; Black/ST-001B

ST-001 (Specify letter) \$4.95 each or 2/78.95

Stereo Cassette Player with FM Stereo Tuner Pack

- Lightweight Headphones
- 80/2Metal/Normal Tape Selector
- Anti-Rolling Mechanism

FEATURES: Blue carrying case, shoulder strap, bell strap, lightweight headphones, FM stereo tuner pack & instruction manual • Talkline • Tone selector • 80/2Metal/Normal tape selector • LED operation indicator • Built-in microphone • Stop/Eject, play, rewind/advance, fast forward/cue, tape/record selector functions • Volume control • Ext. power input jack • Headphone jack • Auto-stop mechanism (shuts off player when tape ends) • Anti-rolling mechanism (prevents sound from quivering when walking, jogging, etc.) • Weight: 13 oz. • Requires 4 AA batteries (not included). Size: 6" L x 4" W x 1-1/8" H.

Model TWf-802 \$69.95
AM3-4 AA Alkaline Batteries \$43.95

Mini Stereo AM/FM Receiver

WITH HEADPHONES For Jugglers, Cyclists, Skaters & Sports Events

FEATURES: Lightweight headphones, Left/right balance control, Full fidelity stereo sound, Additional black soft carrying case and shoulder strap, Belt clip (hands free), Operates on 3 AA cell batteries (not incl. - see below), Compact size: 3-1/8" H x 4-7/8" L x 1-7/8" W, 6.2 oz.

Model 2830 \$29.95
AM3-3 AA Alkaline Batteries \$32.95

KEYBOARDS — POWER SUPPLIES

MICRO SWITCH 69-KEY KEYBOARD
Data Entry Keyboard, Encoded Output, 4-bit Parallel EBC DIC, Switching: Half Effect, 24-pin Edge Card Connection, Complete w/Pin Connections. Can easily be modified to ASCII code.
Part No. **KB69SD12-2** (Fits into DTE-20 Enclosure) \$19.95 each

MICRO SWITCH 85-KEY KEYBOARD
Word Processing Keyboard, 25 Pin Edge Card Connection, Supply Voltage +5VDC, Main keyboard is QWERTY. Additional Key Pads for Cursor and word processing functions.
Part No. **85SD18-1** \$29.95 each

MICRO SWITCH 88-KEY KEYBOARD (PARALLEL)
Data Entry Keyboard with a Diablo 160 Terminal, Supply Voltage, +6V, -12V, Switching: Half Effect — 18-pin Edge Card Connection, Schematic Included, Data 8048 Card Only.
Part No. **88SD22** (Fits into DTE-20 Enclosure) \$69.95 each

POWER SUPPLY +5VDC @ 1 AMP REGULATED Transaction Tech
Output +5VDC @ 1A (at +30VDC) req. Input 115VAC 50/60Hz, 2-line (black/white) self-enclosed case, 5 n. 3 cond. black power cord, 8 1/2" W x 7" D x 2 1/4" H, Wt. 3 lbs. Data sheet incl.
Part No. **PS51194** \$19.95 each

POWER SUPPLY +5VDC @ 1 AMP REGULATED B Industries
Output +5VDC @ 1 amp, +36-240V ac, 400mA or less, 30VAC (max. 1) @ 1.5 amp. Input 115VAC 50/60 Hz, 2-line (black/white) self-enclosed case, 5 n. 3 cond. black power cord, 8 1/2" W x 7" D x 2 1/4" H, Wt. 3 lbs. Data sheet incl.
Part No. **PS4070** \$24.95 each

POWER SUPPLY +5VDC @ 3 AMP REGULATED Deitron
Input: 115VAC, 47-442Hz, Output: 5VDC Adjustable @ 3 amp, 6VDC @ 2.5 amp. Adjustable current limit, Ripple & Noise: 18V rms, 50Hz P-P — 2 mounting surfaces, UL recognized. Size: 4 1/2" L x 4 1/2" W x 2 1/2" H, Wt. 2 lbs. Data sheet included.
Part No. **OPS-1** \$29.95 each

MULTI-VOLTAGE POWER SUPPLY +5, +12, -12VDC REGULATED
Input: 105-125VAC, 47-63Hz 208-250VAC, 47-63Hz, Output: +5VDC @ 2 amp Adj., 5VDC @ 1.5 amp, +12VDC @ 1 amp Adj., -12V @ 2 amp Adj., Overvoltage protection. Size: 1 1/2" L x 4 7/8" W x 3 3/4" H, Data sheet included.
Part No. **RA0250** \$39.95 each

POWER SUPPLY +5VDC @ 7.5 AMP, 12VDC @ 1.5 AMP SWITCHING
Input: 115VAC, 50-60Hz @ 3 amp/230VAC, 50Hz @ 1.5 amp. Fan volt./power supply select switch (115/230VAC), Output: 5VDC @ 7.5 amp, 12VDC @ 1.5 amp, 8 n. blk. pow. cord, 1 1/4" W x 1 3/4" L x 3 1/2" H, Wt. 6 lbs.

POWER SUPPLY 4-Channel Switching Power Supply
Microprocessor, mini-computer, terminal, medical equipment and process control applications. Input: 90-130VAC, 47-442Hz, Output: +5VDC @ 5A, -5VDC @ 1A, +12VDC @ 1A, -12VDC @ 1A, Line reg. ±0.2%, Ripple: 30mV p-p, Load reg. ±1%, Overcurrent protection, Adj.: 5V main output ±10%, 5-30V, 3.17V, 5 & 4.15/16V, Wt. 1 1/2 lbs.

POWER SUPPLY Adjustable Switching 4-24VDC to 5 Amps
Adj. 4-24VDC; 5VDC @ 5A, 6VDC @ 4.8A, 9VDC @ 4.1A, 12VDC @ 3.3A, 18VDC @ 1.9A, 24VDC @ 1.5A, Overvoltage Protection. Input: 115VAC 50/60Hz, Output variations within 20mV, 8.25" L x 4 1/2" W x 2 3/4" H, Wt. 3.25 lbs.

JEZ24 KH \$79.95 each
JEZ24A Assembled & Tested \$99.95 each

SORENSEN Regulated Power Supplies

Sorensen's open construction (SOC) power supplies are series-regulated solid-state systems, designed to provide reg. DC voltages at 6 levels (2-28 vrange). These units are open-framed on sturdy black anodized aluminum for excellent mounting.

FEATURES: 115/208/230VAC input @ 50/60Hz, Low Ripple, 1.5mVrms, 5mV P-P maximum. Adjustable current limit. Voltage adjustment control. All schematics and specifications supplied with unit. Series A, B, C, E have in-line mounting surfaces (Series F, bottom mounting only).

Part No.	Series	Output Voltage	Adjustment Range	Output Current	Reg. @ 100% Load	Line Reg.	Size (H x W x D)	Weight	Price
SOC 2-8	A	2-8	2-8	1.0	0.05	0.05	8.50 x 4.00 x 2.50	4.3 lbs.	\$18.00
SOC 2-16	F	1-9	2-16	2.0	0.10	0.10	10.50 x 4.00 x 2.50	10 lbs.	\$20.00
SOC 2-28	E	4-28	5-28	18.0	15.0	19.0	14.00 x 4.00 x 2.75	12 lbs.	28.00
SOC 2-30	F	4-28	5-28	28.0	21.0	21.0	16.00 x 4.00 x 2.75	18 lbs.	48.00
SOC 12-11	E	11-14	12-6	11.0	8.2	8.6	14.00 x 4.00 x 1.22	12 lbs.	44.00
SOC18-8	C	14-16	18-7.5	8.0	6.2	3.8	7.00 x 4.00 x 3.37	8.8 lbs.	28.00
SOC 18-8	E	14-16	18-7.5	18.0	7.8	7.8	9.00 x 4.00 x 1.62	12 lbs.	38.00
SOC 18-13	A	14-16	18-7.5	13.0	10.8	9.0	10.00 x 4.00 x 1.62	10 lbs.	48.00
SOC 28-8	A	28.0	28.0	4.0	4.8	4.8	4.00 x 4.00 x 1.27	2 lbs.	24.00

BUG BOX™ STORAGE SYSTEMS

BUG CAGE™ (BGC-001) with Bug Boxes

LSI BUG BOX BGC™ — Designed to store ICs, Resistors, Capacitors and Diodes • Divided into three compartments measuring 1" x 4 1/2" x 3 1/2" deep • Three vertical and three horizontal dividers included • Heavy duty injection molded plastic • Box size: 4 9/16" x 3 3/8" x 6" • Weight: 1.75 oz.

LSI BIG BUG BOX™
Please specify color code: (B) Blue, (R) Red, (W) White, (Y) Yellow
Part No./Color Code QTY PRICE
BGC-001-1 1 \$ 3.29
BGC-001-4 10 19.99

ANTI-STATIC
BGC-001-1 JAS 1 \$ 5.29
BGC-001-4 JAS 10 28.89

BUG CAGE™ — 12 locations store Bug Boxes. Big Bug Boxes or Bug Trays • Modular and interlocking • Heavy duty injection molded plastic • Each cage has 8 alignment notches, 4 pins, 4 covers, 4 slides & locks • Cover marked number 1-30 • Compartment size: 3.75" x 5" deep • Box size: 4 9/16" x 3 3/8" x 6" • Weight: 1.75 oz.

Part No./Color Code QTY PRICE
BGC-001-1 2 Cages (6 loc. ea.) \$11.95/pkg

BUG TRAY™

Stores In Bug Cage • Molded plastic • Three styles: Open (1 compartment 3.05" x 4.5" x 6") Vertical (5 compartments 4.6" x 6") and Horizontal (8 compartments 4" x 3.95" x 6") • Ideal for tools, hardware, components, etc. • Tray size: 6.5" x 5.05" x 1.5" • Black color only

Part No.	Description	Price
BTH-001	Horizontal Bug Tray	\$1.95
BTV-001	Vertical Bug Tray	1.95
BTO-001	Open Bug Tray	1.95
BTX-003	1 of each Bug Tray (3)	4.88

JUMPER AND CABLE ASSEMBLIES

STANDARD DIP JUMPERS

All jumpers use low profile dip plug with heavy duty pins for repeated disconnect applications.

Part No.	Color	Value	Length	Price
J21-1	White	10K	1/2"	0.70
D14-2	White	10K	2 1/2"	2.05
D14-3	White	10K	3 1/2"	2.35
D14-4	White	10K	4 1/2"	2.65
D14-5	White	10K	5 1/2"	3.19
D14-314	White	10K	3 1/2"	3.49
D14-1	White	10K	1 1/2"	1.89
D14-2	White	10K	2 1/2"	2.19
D14-3	White	10K	3 1/2"	2.59
D14-4	White	10K	4 1/2"	2.99
D14-5	White	10K	5 1/2"	3.29
D14-314	White	10K	3 1/2"	3.59
D24-1	White	10K	1 1/2"	2.89
D24-2	White	10K	2 1/2"	3.19
D24-3	White	10K	3 1/2"	3.59
D24-4	White	10K	4 1/2"	3.89
D24-5	White	10K	5 1/2"	4.39

STANDARD DB25 SERIES CABLES

Now you can order DB25 P or S connectors with the cable necessary to fit your application. Choose from our standard full color in stock lengths. Call today.

Part No.	Description	Price
BPT-012	TTL	\$7.95
BPC-012	CMOS	8.95
BPM-012	Combo	14.95
BPU-012	Microprocessor	9.95

STANDARD CABLES

Part No.	Cable Length	Connectors	Price
BD25P-4	4 feet	1-DB25P	\$7.95
BD25S-4	4 feet	1-DB25S	8.49
BD25P-4-P	4 feet	2-DB25P	13.49
BD25S-4-S	4 feet	1-DB25P/1-DB25S	13.75
BD25S-4-E	4 feet	2-DB25S	13.95

\$10.00 Minimum Order — U.S. Funds Only
California Residents Add 6% Sales Tax
Postage — Add \$3.00 plus \$1.50 Insurance
Send S.A.S.E. for Monthly Sales Flyer!

Spec Sheets 30¢ each
California Postage for your
FREE 1983 JAMECO CATALOG
Prices Subject to Change

Mail Order: Electronics • Worldwide

ameco ELECTRONICS

NEW! Telex Number 178043

1355 SHOREWAY ROAD, BELMONT, CA 94002
PHONE ORDERS WELCOME — (415) 592-8097

5 1/4" Mini-Floppy Disk Drive

FOR TRS-80 MODEL I (Industry Standard)
Features single or double density. Recording mode: FM single, FM double density. Power: +12VDC (±0.6V) 1.8 amps max. 5VDC (±0.25V) 0.8 amps max. Unit as pictured at left (does not incl. case, power supply or cables). 30-page data book included. Weighs 3 1/2 pounds. Size: 5 1/4" W x 8 1/4" x 3 1/4" H Limited Quantity!

Part No. **FD200** \$179.95
Single-sided, 40 tracks, 250K bytes capacity

Part No. **FD250** \$199.95
Double-sided, 35 tracks, 438K bytes capacity

EXPAND YOUR TRS-80

Model 1 = From 4K to 16K Requires (1) One Kit
Model 3 = From 4K to 48K Requires (3) Three Kits
Color = From 4K to 16K Requires (1) One Kit

Model 1 equipped with Expansion board up to 48K Two Kits Required — One Kit Required for each 16K of Expansion —

TRS-80 16K Conversion Kit

Kit comes complete with 8 ecm M5250 (UPD416/4116) 16K Dynamic RAM (7ns) and documentation for conversion.

TRS-16K2 1200ns \$14.95
TRS-16K3 200ns \$12.95
TRS-16K4 250ns \$10.95

TRS-80 Color 32K or 64K Conversion Kit

Kit comes complete with 8 ea. 4164-2 (200ns), 84K Dyn. RAMs & conversion documentation. Converts TRS-80 color computers from 4K-32K Memory or 16K-64K Memory.

TRS-64K2 (200ns) \$54.95

Universal Computer Keyboard Enclosure

DTE Blank Disc Top Enclosures are designed for easy modification. High strength epoxy molded end pieces in mchra. brown finish. Sliding top/bottom panel for sensor compartment access. Top/bottom panels, 600° clamp arm, acrylic type 1200 finish (top) or clear for best paint adhesion after modification. Ventilated top/bottom panels for cooling efficiency.

Part No. **DTE-20** Panel width 20" \$34.95

Sprite-style Fan

- 36cm free air delivery
- 3.125" sq. x 1.665" depth
- 10 yrs. cont. duty at 20°C
- 115V 50/60Hz
- For Apple users

PWS2107U Cleaned & tested (used) \$ 9.95 ea.
PWS2107F New \$14.95 ea.

Muffin-style Fan

- 105cm free air delivery
- 4.68" sq. x 1.50" depth
- 10 yrs. cont. duty at 20°C
- Impedance protected, ambients to 70°C
- 115V 50/60Hz 14W 17.0z.

MU2A-1U Cleaned & tested (used) \$9.95 ea.
MU2A-1N New \$14.95 ea.

JOYSTICKS

JS-5K	5K Linear Taper Pots	\$5.25
JS-100K	100K Linear Taper Pots	\$4.95
JS-150K	150K Linear Taper Pots	\$4.75
JVC-40	40K (2) Video Controller In Case	\$3.95

UV-EPROM Eraser

8 Chips — 51 Minutes

1 Chip — 37 Minutes

UVS-11EL Replacement Bulb

..... \$16.95

DE-4 UV-EPROM Eraser

..... \$79.95

Wall Transformers AC and DC Types

Part No.	Input	Output	Price
AC 250 (Picture)	117V/60Hz	12VAC 250mA	\$3.95
AC 500	117V/60Hz	12VAC 500mA	\$4.95
AC1000	117V/60Hz	12VAC 1 amp	\$5.95
AC3004	117V/60Hz	9.2VAC 2.5 amp	\$3.95
DC 800	120V/60Hz	8VDC 400mA	\$1.95
DC812	120V/60Hz	8.3VDC 300mA	\$6.95
DC840	117V/60Hz	8.5VDC 275mA	\$2.95
DC900	120V/60Hz	9VDC 500mA	\$3.95
DC1200	120V/60Hz	12VDC 300mA	\$2.95
DV5200	117V/60Hz	9VAC 200mA	\$3.25

Siemens 8" Floppy Disk Drive

- Single-Sided
- 77 Tracks
- 400/800K Bytes Capacity
- Industry Standard

The FDD100-8" Floppy Disk Drive (Industry Standard) features single or double density. Recording mode: FM single, FM double density. Transfer rate: 250K bits/sec. Single density: 500K bits/sec. double density. The FDD100-8" is designed to work with the single-sided soft sector IBM Diskette I, or, any standard cartridge. Hard sector option available. Power: 115/230VAC @ 50/60Hz, +24VDC @ 1.7 amps max., +5VDC @ 1.2 amps max. Unit as pictured above (does not include case, power supply or cables). Size: 8 1/4" W x 14 1/4" x 4 5/8" H. Weighs 12 lbs. Incl. 95pg manual.

Part No. **FDD100-8** Buy 1 for \$289.95 each
FDD100-8 Buy 10 for \$259.95 each
FDD100-8 Buy 20 for \$249.95 each

We Have It! . . . At the best prices.

**Call For Super Value
On S-100 System With
Dbl. Dens. 8" Drives!**

INTERTEC SUPERBRAIN II Free! MicroSoft Basic 80

Self-contained computer with dual disks and two RS232C ports. Complete with CP/M 2.2.

64K Jr. \$2099
64K QD \$2495
64K SD \$2949
10 Meg. DDS Hard Disk \$2995

VIDEO TERMINALS

SOROC IQ 130	595
SOROC IQ 135	749
SOROC IQ 135G	799
SOROC IQ 140	1149
HAZELTINE ESPRIT	CALL
ESPRIT-II	CALL
1420	CALL
1500	CALL
1510	CALL
1520	CALL
TELEVIDEO 910C	CALL
912C	CALL
920C	CALL
925C	CALL
950C	CALL
TEXAS INST. 940 BASIC	1599
940 Package	2079
745 Portable Terminal	1399
745 Portable Terminal w/ U/L/Case	1495
INTERTEC INTERTUBE III	749
ZENITH Z-19	729

PRINTERS

ANADEX DP-9000 A/01A	\$1449
DP-9501A	1449
PAPER TIGER IDS 445G	Special! 599
PRISM PRINTER IDS-80, w/ color	Call
IDS-80, w/ color	Call
IDS-132, w/ color	1695
NEC 3510, RO RS232C 35 CPS	New Low, \$1699
NEC 3530, RO Centr. Inter. 35CPS	Special, 1859
NEC 7710, RO RS232C 55CPS	2395
NEC 7720, KSR, RS232C 55CPS	2999
NEC 7730, RO, Centr. Inter. 55CPS	2395
QUME Sprint 9/45	
Lid or Full, 45 CPS, RS232C	Only 2049
C.I.TOH Pro Writer, Parallel	549
Serial and Parallel	649
DIABLO 630 RO RS232C 55CPS	2299
CENTRONICS 730-1, Parallel	349
737-3, RS232C	389
704-11, Parallel	1693
704-9, RS232C	1595
122G, Parallel, 120 CPS	949
EPSON	
MX80	489
MX80FT	589
MX100FT	789
RS232 Serial Interface	65
RS232/2K BufferInterface	125
Grafrax II	90
Apple Printer Interface	75
TI810 Basic, RS232C	1349
810 Basic, RS232C & Parallel	1395
810 w/full ASCII, vertical forms control compressed print	1599
820 RO, Basic	1645
820 KSR, Basic	1839

OKIDATA Microline 80	359
Tractor-feed option	50
Microline 82A	479
Microline 83A	759
Microline 84 PARALLEL	1149
Microline 84 SERIAL	1249

MONITORS

ZENITH-ZYM-121, 12" Green Phos.	\$125
AMDEK 100, 12" NEW LOW	99
100G, 12" Green Phosphor	149
300, 12" Green Phos., Hi. Res.	199
Color-1, 13"	359
Color II, 13", R.G.B. Hi Res.	799
Apple adapt. for R.G.B.	159
BMC-12A, 12" Gr. Phos.	New Low 99

**NorthStar
Call For Prices**

FLOPPY DISK SYSTEMS

MORROW DESIGNS	
Discus 2D, single drive DD	\$898*
Dual Discus 2D, dual drive DD	1549*
Discus 2 + 2, double sided DD	1239*
Dual Discus 2 + 2	2139
Dual DMA Discus 2D	1619*

HARD DISK SUBSYSTEMS

MORROW DESIGNS	
Discus M-5 5 Meg.	New Low \$1559*
Discus M-10 10 Meg.	3095*
Discus M-26 26 Meg.	3795*
CORVUS 5 Meg.	2699
10 Meg.	4245
20 Meg.	5095
KONAN David 5 Meg.	2499
10 Meg.	3049
15 Meg.	3295
INTERTEC 10 Meg.	SPECIAL \$2995

*Includes CP/M 2.2 and Microsoft Basic.

FLOPPY DISK CONTROLLER BOARDS

CROMEMCO 16FDC DD	\$499
NORTH STAR DD	479
MORROW Disk Jockey 2D, A&T	329
INTERSYSTEMS, FDC-2, A&T	439
TARBELL DD, A&T	445
SYSTEMS GROUP DD DMA	439

ESCON CONVERSION FOR IBM SELECTRIC

Complete with microprocessor controller and power supply. Factory built. User installs solenoid assembly or it can be done at ESCON Factory.

RS232 Serial & Parallel \$534
 Cable for above 25

PROM PROGRAMMERS

SSM PB1 Kit	\$152
SSM PB1, A&T	225

MODEMS

NOVATION CAT Acoustic Modem	\$149
D-Cat Direct Connect (300 Baud)	155
AUTO CAT Auto Answer	219
APPLE CAT	329
D-CAT (1200) Baud	599
103 JLP Auto Answer	219
DC HAYES MICROMODEM II (Apple)	339
Smart Modem (300 Baud)	239
Smart Modem (1200 Baud)	595
Potomac Micro Magic (S 100)	339

CALIFORNIA COMPUTER SYSTEMS

Z80 CPU Board	\$ \$269
Disk Controller 2422, w/CP/M	359
16K Static, A&T	259
32K Static, A&T	399
64K Dynamic RAM	335
System 2210 w/64K, CP/M 2.2	1745

CPU BOARDS

(assembled unless noted)	
NORTHSTAR Z-80A (ZPB-A/A)	\$269
INTERSYSTEMS (MPU-80)	349
SSM CB1 8080, A&T	214
CB2, Z-80, A&T	289
CB2, Z-80, Kit	219
SYSTEMSGROUP Z 80 with I/O	419

MEMORY BOARDS

NORTHSTAR 16K RAM	\$299
HRAM 64K	589
HRAM 32K	419
CROMEMCO 16KZ	419
CROMEMCO 64KZ	595
MEMORY MERCHANT	
16K Static, 4MHz	159
64K Static, 4MHz	549
SYSTEMS GROUP	
Measurement Systems & Controls	
DM4800 48K Board	499
DM6400 64K Board	529
DMB6400 64K Board	595

GODBOUT (A&T)

CPU Z	\$ \$249
CPU 8085 88	359
RAM 20 32	359
RAM 17 64	675
RAM 21	1439
Interfacer 1	209
Interfacer 2	209
Disk 1	419
System Support 1	335
Enclosure 2 (Desk)	699
Enclosure 2 (Rack)	759

VIDEO BOARDS I/O Mapped

SD SYSTEMS	
VDB-8024, A&T	\$469
SSM VB2 I/O, Kit	169
VB2 I/O, A&T	229
MEMORY MAPPED	
VB1C, 16x64, Kit	152
VB1C, 16x64, A&T	206
VB3, 80 Char. 4MHz, Kit	359
VB3, 80 Char. 4MHz, A&T	419

APPLE BOARDS

CALIFORNIA COMPUTER	
7710A Asynchronous Ser Interface	\$129
7712A Synchronous Ser. Interface	149
7424A Calendar Clock	105
7728A Centronics Printer Interface	99

**MicroPro WordStar,
SpellStar, MailMerge.**

List, \$895 **-Special, \$399-**

(popular formats only)

-Limited Supply, Limited Time-

**MicroPro DataStar, CalcStar,
SuperSort.** List, \$895 **Only \$399**

(popular formats only)

SuperCalc, . . \$179

(popular formats only)

-Limited Supply, Limited Time-

MiniMicroMart, Inc.

943 W. Genesee St.
P.O. Box 2991B
Syracuse, New York 13220

(315) 422-4467

TWX 710-542-0431



All prices F.O.B. shipping point, subject to change. All offers subject to withdrawal without notice. Advertised prices reflect a 2% cash discount (orders prepaid prior to shipment). C.O.D.'s & Credit Cards, 2% higher.

CENTRONICS®

730-1* (parallel)

Dot Matrix Printer

**Same as TRS-80 Line Printer II formerly sold by Radio Shack for \$995*

730-1 \$349

List #860 CEN-27301-0

STANDARD FEATURES

- 100 characters/second @ 10 CPI; 132 CPL @ 16.7 CPI
- 80 characters/line
- 30 lpm with 80 columns printed
- 75 lpm with 20 columns printed
- microprocessor electronics
- 7x7 dot matrix
- 10 characters/inch and 16.7 characters/inch
- 6 lpi vertical
- unidirectional print and return approximately 10 ips
- 3-way paper handling system
- 96 character ASCII
- 1 Line Buffer, Parallel 256 Char. Buffer, Serial

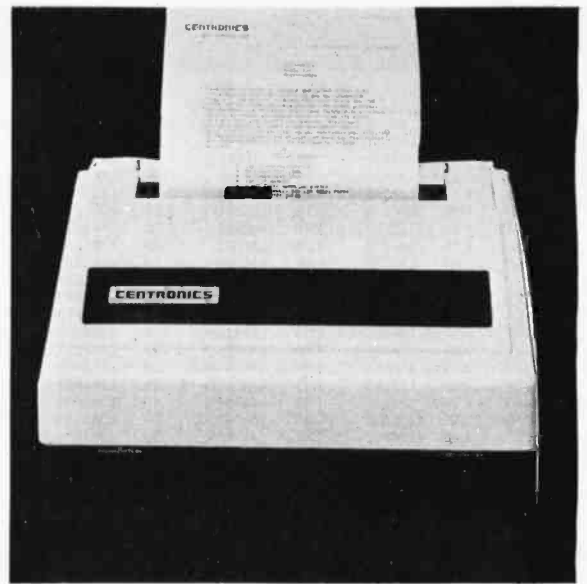

Other Outstanding Printer Values...

ANADEx DP-9500.....	\$1349	CENTRONICS 730-1, Parallel.....	349	T1810 Basic, RS232C.....	1349
DP-9501.....	1349	737-3, RS232C.....	389	810 Basic, RS232C & Parallel.....	1395
PAPER TIGER IDS 445G.....	<i>Special!</i> 599	739-1 w/ Graphics, Parallel.....	525	810 w/full ASCII, vertical forms control compressed print.....	1599
PRISM PRINTER IDS-80, w/o color....	Call	739-3B w/ Graphics, RS232C.....	639	820 RO, Basic.....	1645
IDS-80, w/color.....	Call	704-11, Parallel.....	1695	820 KSR, Basic.....	1839
IDS-132, w/color.....	1695	704-9, RS232C.....	1595	OKIDATA Microline 80.....	359
C.I.TOH Pro Writer, Parallel.....	549	122G, Parallel, 120 CPS.....	949	Tractor-feed option.....	50
Serial and Parallel.....	689	EPSON		Microline 82A.....	479
DIABLO 630 RO RS232C. 55CPS.....	2299	MX80.....	489	Microline 83A.....	759
NEC 3510, RO RS232C 35 CPS.....	1945	MX80FT.....	589	Microline 84 PARALLEL.....	1149
NEC 3530, RO, Centr. Inter. 35CPS.....	1945	MX100FT.....	789	Microline 84 SERIAL.....	1249
NEC 7710, RO RS232C 55 CPS.....	2395	RS232 Serial Interface.....	65		
NEC 7720, KSR, RS232C 55CPS.....	2999	RS232/2K BufferInterface.....	125		
NEC 7730, RO, Centr. Inter. 55 CPS.....	2395	Graftrax II.....	90		
QUME Sprint 9/45		Apple Printer Interface.....	75		
Ltd or Full, 45 CPS, RS232C.....	<i>NEW LOW!</i>				

All prices F.O.B. shipping point, subject to change. All offers are subject to change without notice. Advertised prices reflect a 2% cash discount (order prepaid prior to shipment). C.O.D.'s and credit card orders are 2% higher.

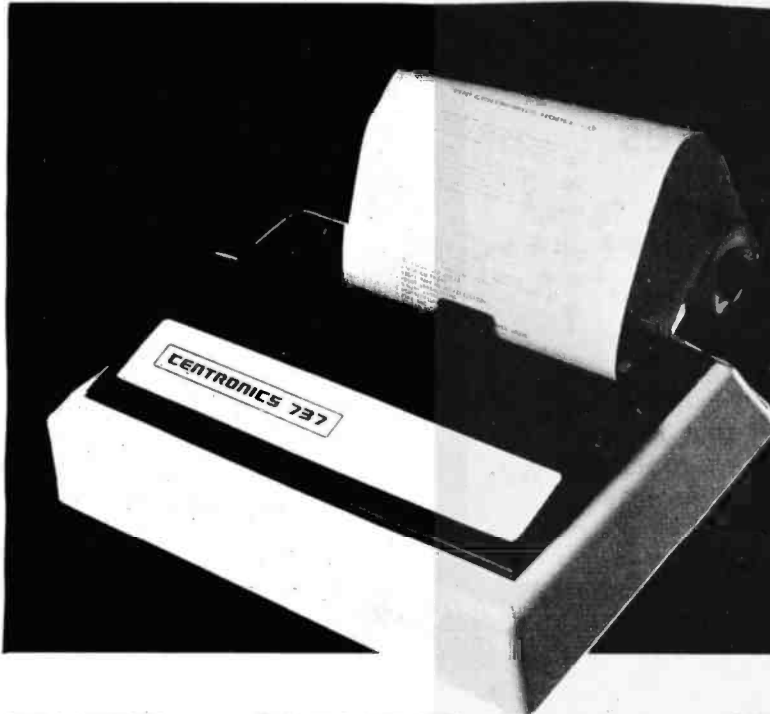

737-3 Dot Matrix Printer \$389

(RS232 Serial) CEN-27373-0

STANDARD FEATURES

- 80 CPS — Proportional Spaced Mode
- 50 CPS — Monospaced Mode
- Proportional Spacing, Plus 10 CPI and 16.7 CPI
- Nx9 (Proportional) or 7x8 (Monospaced) Dot Matrix
- 3 Way Paper Handling System
- 96 Character ASCII
- Microprocessor Electronics
- Expanded Print
- Right Margin Justification
- Print Underlining
- 9-Wire Free Flight Print Head
- Bidirectional Stepper Motor Paper Drive
- Full One Line Buffer
- 21 LPM With 80 Columns Printed
- 58 LPM With 20 Columns Printed
- 6 Lines Per Inch Vertical Spacing
- Paper Tear Bar

PAPER HANDLING

Roll Paper: 8 1/2"
Fan Fold: 9"
Cut Sheet: 8 1/2"

MiniMicroMart, Inc.

943 W. Genesee St. P.O. Box 2991B Syracuse, N.Y. 13220 (315) 422-4467 TWX 710-542-0431

LINEAR

LM301	.34	LM339	.99	NE564	2.95	LM1496	.85
LM301H	.79	LM340 (see 7800)		LM565	.99	LM1558H	3.10
LM307	.45	LM348	.99	LM566	1.49	LM1800	2.37
LM308	.69	LM350K	4.95	LM567	.89	LM1812	8.25
LM308H	1.15	LM350T	4.60	NE570	3.95	LM1830	3.50
LM309H	1.95	LM358	.69	NE571	2.95	LM1871	5.49
LM309K	1.25	LM359	1.79	NE592	2.75	LM1872	5.49
LM310	1.75	LM376	3.75	LM703	.89	LM1877	3.25
LM311	.64	LM377	1.95	LM709	.59	LM1889	1.95
LM311H	.89	LM378	2.50	LM710	.75	LM1896	1.75
LM312H	1.75	LM379	4.50	LM711	.79	LM2877	2.05
LM317K	3.95	LM380	.89	LM723	.49	LM2878	2.25
LM317T	1.19	LM380N-8	1.10	LM723H	.55	LM2900	.85
LM318	1.49	LM381	1.60	LM733	.98	LM2901	1.00
LM318H	1.59	LM382	1.60	LM741N-8	.35	LM3900	.59
LM319H	1.25	LM383	1.95	LM741N-14	.35	LM3905	1.25
LM319	1.25	LM384	1.95	LM741H	.40	LM3909	.98
LM320 (see 7900)		LM386	.89	LM747	.69	LM3911	2.25
LM322	1.65	LM387	1.40	LM748	.59	LM3914	3.95
LM323K	4.95	LM389	1.35	LM1014	1.19	LM3915	3.95
LM324	.59	LM390	1.95	LM1303	1.95	LM3916	3.95
LM329	.65	LM392	.69	LM1310	1.49	MC4024	3.95
LM331	3.95	LM394H	4.60	MC1330	1.69	MC4044	4.50
LM334	1.19	LM399H	5.00	MC1349	1.89	RC4136	1.25
LM335	1.40	NE531	2.95	MC1350	1.19	RC4151	3.95
LM336	1.75	NE536	6.00	MC1358	1.69	LM4250	1.75
LM337K	3.95	NE555	.34	LM1414	1.59	LM4500	3.25
LM337T	1.95	NE556	.65	LM1458	.59	LM13080	1.29
LM338K	6.95	NE558	1.50	LM1488	.69	LM13600	1.49
		NE561	19.95	LM1489	.69	LM13700	1.49

H = TO-5 CAN

T = TO-220

K = TO-3

RCA

CA 3023	2.75	CA 3082	1.65
CA 3039	1.29	CA 3083	1.55
CA 3046	1.25	CA 3086	.80
CA 3059	2.90	CA 3089	2.99
CA 3060	2.90	CA 3096	3.49
CA 3065	1.75	CA 3130	1.30
CA 3080	1.10	CA 3140	1.15
CA 3081	1.65	CA 3146	1.85
		CA 3160	1.19

TI

TL494	4.20	75365	1.95
TL496	1.65	75450	.59
TL497	3.25	75451	.39
75107	1.49	75452	.39
75110	1.95	75453	.39
75150	1.95	75454	.39
75154	1.95	75491	.79
75188	1.25	75492	.79
75189	1.25	75493	.89
		75494	.89

BI FET

TL071	.79	TL084	2.19
TL072	1.19	LF347	2.19
TL074	2.19	LF351	.60
TL081	.79	LF353	1.00
TL082	1.19	LF355	1.10
TL083	1.19	LF356	1.10
		LF357	1.40

VOLTAGE REGULATORS

7805T	.89	7905T	.99
7808T	.89	7908T	.99
7812T	.89	7912T	.99
7815T	.89	7915T	.99
7824T	.89	7924T	.99
7805K	1.39	7905K	1.49
7812K	1.39	7912K	1.49
7815K	1.39	7915K	1.49
7824K	1.39	7924K	1.49
78L05	.69	79L05	.79
78L12	.69	79L12	.79
78L15	.69	79L15	.79
78H05K	9.95	LM323K	4.95
78H12K	9.95	UA78S40	1.95

T = TO-220

K = TO-3

L = TO-92

5 1/4" DISK DRIVES

TANDON

TM100-1 (FOR IBM)	229.00
TM100-2 (FOR IBM)	295.00

SHUGART

SA 400L (40 TRACK)	199.95
SA 400 (35 TRACK)	189.95

CABINET FOR 5 1/4" DISK DRIVE

- ★ COLOR MATCHES APPLE
- ★ FITS SHUGART

SPECIAL — \$29.95

MICROCOMPUTER HARDWARE HANDBOOK

FROM ELCOMP — \$14.95

Over 800 pages of manufacturers data sheets on most commonly used IC's.

Includes:

- ★ TTL — 74/74LS and 74F
- ★ CMOS
- ★ Voltage Regulators
- ★ Memory — RAM, ROM, EPROM
- ★ CPU's — 6800, 6500, Z80, 8080, 8085, 8086/8
- ★ MPU support & interface — 6800, 6500, Z80, 8200, etc.

WE NOW STOCK A COMPLETE LINE OF DISC, ELECTROLYTIC, MONOLITHIC AND TANTALUM CAPACITORS

RESISTORS

1/4 WATT 5% CARBON FILM ALL STANDARD VALUES	
FROM 1 OHM TO 10 MEG OHM	
50 PCS. SAME VALUE	.025 EA.
100 PCS. SAME VALUE	.02 EA.
1000 PCS. SAME VALUE	.015 EA.

VISIT OUR RETAIL STORE — NEW HOURS —
M-W-F, 9-5
T-Th., 9-9 Sat. 11-3

PLEASE USE YOUR CUSTOMER NUMBER WHEN ORDERING

TERMS: For shipping include \$2 for UPS Ground or \$3 for UPS Blue Label Air. Items over 5 pounds require additional shipping charges. Foreign orders include sufficient amount for shipping. There is a \$10 minimum order. Bay Area and Los Angeles Counties add 6% Sales Tax. Other California residents add 6% Sales Tax. We reserve the right to substitute manufacturer. Not responsible for typographical errors. Prices are subject to change without notice. We will match or beat any competitor's price provided it is not below our cost.

BEST SELLING BOOKS

OSBORNE/MC GRAW-HILL

Apple II User's Guide	14.95
CRT Controller's Handbook	9.95
68000 Assembly Language Programming	16.99
CBASIC User Guide	15.00

SYBEX

Your Your First Computer	8.95
The CP/M Handbook	14.95
The PASCAL Handbook	18.95
Microprocessor Interfacing Techniques	17.95

VISIT OUR RETAIL STORE

★ NEW HOURS ★

NOW OPEN

TUESDAY & THURSDAY EVENINGS TILL 9:00 P.M.

CHRISTMAS SPECIALS

NASHUA 5 1/4" Diskettes

TOP QUALITY — LOW PRICE!

Single Sided, Single Density
Soft Sektored with Hub Ring

\$19⁹⁵ BOX OF 10

NEWPORT PROSTICK

- ★ Professional Quality Atari-Type Joystick
- ★ Improve your scores — A must for maze games

\$31⁰⁰ EACH

- ★ Extremely Rugged — Actual Arcade game Joystick
- ★ All parts are replaceable
- ★ 36 Month Warranty

\$59⁹⁵ PAIR

JDR MICRODEVICES, INC.

1224 S. Bascom Avenue
San Jose, CA 95128

800-538-5000 • 800-662-6279 (CA)
(408) 995-5430 • Telex 171-110

©1982 JDR MICRODEVICES, INC.

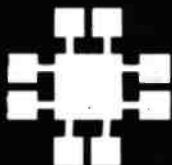

THE ULTIMATE APPLE*

COOLING FAN \$69⁹⁵

- ★ Easy Installation
- ★ No modification of Apple required.
- ★ Color matches Apple.
- ★ Switch on front controls fan, computer and monitor.
- ★ Ultra-quiet, reliable fan.
- ★ Completely eliminates problems caused by overheating

16K RAM CARD

- ★ Upgrade your 48K Apple II to full 64K of RAM.
- ★ Fully software and hardware compatible with the Apple language card and microsoft Z80 card.
- ★ Eliminates the need for the Applesoft or Integer Basic ROM card when used in conjunction with DOS 3.3.
- ★ Allows you to run Apple Fortran or Pascal with no difficulty.
- ★ Available as bare board, kit, or assembled and tested board.

PRICE REDUCED

ASSEMBLED & TESTED \$49.95
 BARE CARD \$14.95 KIT \$44.95

DISK DRIVE \$299⁹⁵

- ★ Includes metal cabinet
- ★ Color matches Apple
- ★ 35 Tracks/single side
- ★ Includes cable
- ★ Use with Apple II Controller

ORDER TOLL FREE

800-538-5000

800-662-6279

(CALIFORNIA RESIDENTS)

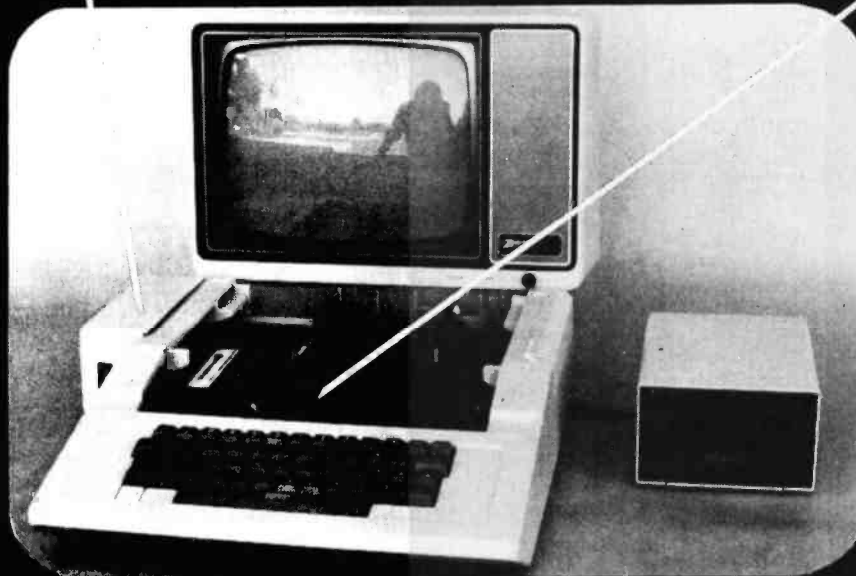

MONITORS

NEC JB1201M \$169⁰⁰
 ZENITH ZUM-121 \$119⁰⁰
 COLOR
 AMDEK COLOR I \$335⁰⁰
 NEC JC 1201M \$329⁰⁰

PRINTERS

MX-80
 MX-80FT
 MX-100

CALL FOR PRICE

WE HAVE APPLE AND TRS-80
 INTERFACE CARDS AND CABLES

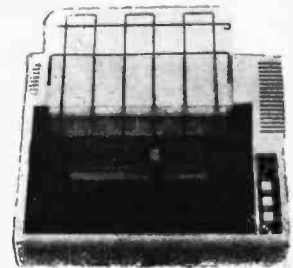

SA400 35 TRACK DISK DRIVE CLEARANCE

- ★ VERY LIMITED SUPPLY
- ★ MODIFY FOR USE IN APPLE
- ★ PRE-REVISION "L" MODEL
- ★ THEY WON'T LAST LONG

\$189⁹⁵

5 1/4" DISKETTES

ATHANA SS SD SOFT 24.95
 MEMOREX SS SD SOFT 26.95
 VERBATIM SS SD SOFT 29.95
 VERBATIM 10 SECTION HARD 29.95

©1982 JDM MICRODEVICES, INC.

4164 64K DYNAMIC \$625

200 NS

TMM2016 2KX8 STATIC \$415

200 NS

ALL MERCHANDISE 100% GUARANTEED!

CALL US FOR VOLUME QUOTES

STATIC RAMS

2101	256 x 4 (450ns)	1.95
5101	256 x 4 (450ns) (cmos)	3.95
2102-1	1024 x 1 (450ns)	.89
2102L-4	1024 x 1 (450ns) (LP)	1.29
2102L-2	1024 x 1 (250ns) (LP)	1.69
2111	256 x 4 (450ns)	2.99
2112	256 x 4 (450ns)	2.99
2114	1024 x 4 (450ns)	8/14.95
2114L-4	1024 x 4 (450ns) (LP)	8/15.25
2114L-3	1024 x 4 (300ns) (LP)	8/15.45
2114L-2	1024 x 4 (200ns) (LP)	8/15.95
2147	4096 x 1 (55ns)	4.95
TMS4044-4	4096 x 1 (450ns)	3.49
TMS4044-3	4096 x 1 (300ns)	3.99
TMS4044-2	4096 x 1 (200ns)	4.49
MK4118	1024 x 8 (250ns)	9.95
TMM2016-200	2048 x 8 (200ns)	4.15
TMM2016-150	2048 x 8 (150ns)	4.95
TMM2016-100	2048 x 8 (100ns)	6.15
HM6116-4	2048 x 8 (200ns) (cmos)	4.95
HM6116-3	2048 x 8 (150ns) (cmos)	5.95
HM6116-2	2048 x 8 (120ns) (cmos)	8.95
HM6116LP-4	2048 x 8 (200ns) (cmos) (LP)	6.95
HM6116LP-3	2048 x 8 (150ns) (cmos) (LP)	8.95
HM6116LP-2	2048 x 8 (120ns) (cmos) (LP)	10.95
Z-6132	4096 x 8 (300ns) (Qstat)	34.95

LP = Low Power Qstat = Quasi-Static

DYNAMIC RAMS

TMS4027	4096 x 1 (250ns)	1.99
MK4108	8192 x 1 (200ns)	1.95
MM5298	8192 x 1 (250ns)	1.85
4116-300	16384 x 1 (300ns)	8/11.75
4116-250	16384 x 1 (250ns)	8/11.95
4116-200	16384 x 1 (200ns)	8/13.95
4116-150	16384 x 1 (150ns)	8/15.95
4116-120	16384 x 1 (120ns)	8/29.95
2118	16384 x 1 (150ns) (5v)	4.95
MK4816	2048 x 8 (300ns) (5v)	24.95
4164-200	65536 x 1 (200ns) (5v)	6.25
4164-150	65536 x 1 (150ns) (5v)	7.25

5V = single 5 volt supply

EPROMS

1702	256 x 8 (1us)	4.50
2708	1024 x 8 (450ns)	3.95
2758	1024 x 8 (450ns) (5v)	5.95
2716	2048 x 8 (450ns) (5v)	3.95
2716-1	2048 x 8 (350ns) (5v)	6.25
TMS2716	2048 x 8 (450ns)	7.95
TMS2532	4096 x 8 (450ns) (5v)	7.95
2732	4096 x 8 (450ns) (5v)	4.95
2732-250	4096 x 8 (250ns) (5v)	12.95
2732-200	4096 x 8 (200ns) (5v)	16.95
2764	8192 x 8 (450ns) (5v)	16.95
2764-250	8192 x 8 (250ns) (5v)	18.95
2764-200	8192 x 8 (200ns) (5v)	19.95
TMS2564	8192 x 8 (450ns) (5v)	24.95
MC68764	8192 x 8 (450ns) (5v) (24 pin)	call

5v = Single 5 Volt Supply

EPROM ERASERS

	Timer	Capacity Chip	Intensity (uW/Cm ²)	
PE-14		6	5,200	83.00
PE-14T	X	6	5,200	119.00
PE-24T	X	9	6,700	175.00
PL-265T	X	20	6,700	255.00
PR-125T	X	16	15,000	349.00
PR-320	X	32	15,000	595.00

DISC CONTROLLERS

1771	16.95
1791	29.95
1793	38.95
1795	54.95
1797	54.95
6843	34.95
8272	39.95
UPD765	39.95
1691	18.95
2143	18.95

INTERFACE

8T26	1.69
8T28	2.49
8T95	.99
8T96	.99
8T97	.99
8T98	.99
DM8131	2.95
DP8304	2.29
DS8835	1.99
DS8836	.99

MISC.

3242	7.95
3341	4.95
MC3470	4.95
MC3480	9.00
11C90	13.95
95H90	7.95
2513-001 UP	9.95
2513-002 LOW	9.95

SOUND CHIPS

76477	3.95
76489	8.95
AY3-8910	12.95
MC3340	1.49

CRT CONTROLLERS

6845	14.95
68B45	35.95
HD46505SP	15.95
6847	12.25
68047	24.95
8275	29.95
7220	99.95
CRT5027	39.95
CRT5037	49.95
TMS9918A	39.95

BIT-RATE GENERATORS

MC14411	11.95
BR1941	11.95
4702	12.95
COM5016	16.95
COM8116	10.95
MM5307	10.95

UARTS

AY3-1014	6.95
AY5-1013	3.95
PT1472	9.95
TR1602	3.95
2350	9.95
2651	8.95
TMS6011	5.95
IM6402	7.95
IM6403	8.95
INS8250	14.95

KEYBOARD CHIPS

AYS-2376	11.95
AYS-3600	11.95
74C922	See 74C00
74C923	Series Prices

CLOCK CIRCUITS

MM5314	4.95
MM5369	3.95
MM5375	4.95
MM58167	8.95
MM58174	11.95
MSM5832	6.95

Z-80 2.5 Mhz

Z80-CPU	3.95
Z80-CTC	5.95
Z80-DART	15.25
Z80-DMA	17.50
Z80-PIO	5.75
Z80-SIO/0	18.50
Z80-SIO/1	18.50
Z80-SIO/2	18.50
Z80-SIO/9	16.95

4.0 Mhz

Z80A-CPU	6.00
Z80A-CTC	8.65
Z80A-DART	18.75
Z80A-DMA	27.50
Z80A-PIO	6.00
Z80A-SIO/0	22.50
Z80A-SIO/1	22.50
Z80A-SIO/2	22.50
Z80A-SIO/9	19.95

6.0 Mhz

Z80B-CPU	17.95
Z80B-CTC	15.50
Z80B-PIO	15.50

ZILOG

Z6132	34.95
Z8671	39.95

CRYSTALS

32.768 khz	1.95
1.0 mhz	4.95
1.8432	4.95
2.0	3.95
2.097152	3.95
2.4576	3.95
3.2768	3.95
3.579535	3.95
4.0	3.95
5.0	3.95
5.0688	3.95
5.185	3.95
5.7143	3.95
6.0	3.95
6.144	3.95
6.5536	3.95
8.0	3.95
10.7836	3.95
14.31818	3.95
15.0	3.95
16.0	3.95
18.0	3.95
18.432	3.95
20.0	3.95
22.1184	3.95
32.0	3.95

DATA ACQUISITION

ADC0800	15.55
ADC0804	3.49
ADC0809	4.49
ADC0817	9.95
DAC0800	4.95
DAC0806	1.95
DAC0808	2.95
DAC1020	8.25
DAC1022	5.95
MC1408L6	1.95
MC1408L8	2.95

8000

8035	5.95
8039	6.95
INS-8060	17.95
INS-8073	24.95
8080	3.95
8085	5.95
8085A-2	11.95
8086	29.95
8087	CALL
8088	39.95
8089	89.95
8155	7.95
8156	8.95
8185	29.95
8185-2	39.95
8741	39.95
8748	29.95
8755	32.00

8200

8202	29.95
8203	39.95
8205	3.50
8212	1.80
8214	3.85
8216	1.75
8224	2.25
8226	1.80
8228	3.49
8237	19.95
8238	4.49
8243	4.45
8250	10.95
8251	4.49
8253	6.95
8253-5	7.95
8255	4.49
8255-5	5.25
8257	7.95
8257-5	8.95
8259	6.90
8259-5	7.50
8271	39.95
8272	39.95
8275	29.95
8279	8.95
8279-5	10.00
8282	6.50
8283	6.50
8284	5.50
8286	6.50
8287	6.50
8288	25.00
8289	49.95

6800

68000	99.95
6800	4.95
6802	7.95
6808	13.90
6809E	19.95
6809	12.95
6810	2.95
6820	4.95
6821	3.25
6828	14.95
6840	12.95
6843	34.95
6844	25.95
6845	14.95
6847	12.25
6850	3.45
6852	5.75
6860	9.95
6862	11.95
6875	6.95
6880	2.25
6883	24.95
68047	24.95
68488	19.95

6800 = 1MHZ

68B00	10.95
68B02	22.25
68B09E	29.95
68B09	29.95
68B10	7.95
68B21	12.95
68B45	35.95
68B50	12.95

6800 = 2 MHZ

6502	5.95
6504	6.95
6505	8.95
6507	9.95
6520	4.35
6522	8.75
6532	11.25
6545	22.50
6551	11.85

2 MHZ

6502A	9.95
6522A	11.70
6532A	12.40
6545A	28.50
6551A	12.95

3 MHZ

6502B	14.95
-------	-------

FUNCTION GENERATORS

MC4024	3.95
LM566	1.49
XR2206	3.75
8038	3.95

EXAR

XR 2206	3.75
XR 2207	3.85
XR 2208	3.90
XR 2211	5.25
XR 2240	3.25

INTERSIL

ICL7103	9.50
ICL7106	9.95
ICL7107	12.95
ICL8038	3.95
ICM7207A	5.59
ICM7208	15.95

9000 SERIES

9316	1.00
9334	2.50
9368	3.95
9401	9.95
9601	.75
9602	1.50
96S02	1.95

JDR MICRODEVICES, INC.

1224 S. Bascom Avenue
San Jose, CA 95128

800-538-5000 • 800-662-6279 (CA)
(408) 995-5430 • Telex 171-110

© 1982 JDR MICRODEVICES, INC.

— NEW HOURS —
M-W-F, 9-5
RETAIL STORE T-Th, 9-9 Sat. 11-3

PLEASE USE YOUR CUSTOMER NUMBER WHEN ORDERING

TERMS: For shipping include \$2 for UPS Ground or \$3 for UPS Blue Label Air. Items over 5 pounds require additional shipping charges. Foreign orders, include sufficient amount for shipping. There is a \$10 minimum order. Bay Area and Los Angeles Counties add 6 1/2% Sales Tax. Other California residents add 6% Sales Tax. We reserve the right to substitute manufacturer. Not responsible for typographical errors. Prices are subject to change without notice. We will match or beat any competitor's price provided it is not below our cost.

2716 16K EPROMS **\$3.95** EACH
 ALL MERCHANDISE 100% GUARANTEED!

2732 32K EPROMS **\$4.95** EACH
 CALL US FOR VOLUME QUOTES

74LS00			
74LS00	.24	74LS86	.39
74LS01	.25	74LS90	.55
74LS02	.25	74LS91	.89
74LS03	.25	74LS92	.55
74LS04	.24	74LS93	.55
74LS05	.25	74LS95	.75
74LS08	.28	74LS96	.89
74LS09	.29	74LS107	.39
74LS10	.25	74LS109	.39
74LS11	.35	74LS112	.39
74LS12	.35	74LS113	.39
74LS13	.45	74LS114	.39
74LS14	.59	74LS122	.45
74LS15	.35	74LS123	.79
74LS20	.25	74LS124	2.90
74LS21	.29	74LS125	.49
74LS22	.25	74LS126	.49
74LS26	.29	74LS132	.59
74LS27	.29	74LS133	.59
74LS28	.35	74LS136	.39
74LS30	.25	74LS137	.99
74LS32	.29	74LS138	.55
74LS33	.55	74LS139	.55
74LS37	.35	74LS145	1.20
74LS38	.35	74LS147	2.49
74LS40	.25	74LS148	1.35
74LS42	.49	74LS151	.55
74LS47	.75	74LS153	.55
74LS48	.75	74LS154	1.90
74LS49	.75	74LS155	.69
74LS51	.25	74LS156	.69
74LS54	.29	74LS157	.65
74LS55	.29	74LS158	.59
74LS63	1.25	74LS160	.69
74LS73	.39	74LS161	.65
74LS74	.35	74LS162	.69
74LS75	.39	74LS163	.65
74LS76	.39	74LS164	.69
74LS78	.49	74LS165	.95
74LS83	.60	74LS166	1.95
74LS85	.69	74LS168	1.75
74LS169	1.75	74LS323	2.75
74LS170	1.49	74LS324	1.75
74LS173	.69	74LS352	1.29
74LS174	.55	74LS353	1.29
74LS175	.55	74LS363	1.35
74LS181	2.15	74LS364	1.95
74LS189	8.95	74LS365	.49
74LS190	.89	74LS366	.49
74LS191	.89	74LS367	.45
74LS192	.79	74LS368	.45
74LS193	.79	74LS373	.99
74LS194	.69	74LS374	.99
74LS195	.69	74LS377	1.39
74LS196	.79	74LS378	1.18
74LS197	.79	74LS379	1.35
74LS221	.89	74LS385	1.90
74LS240	.95	74LS386	.45
74LS241	.99	74LS390	1.19
74LS242	.99	74LS393	1.19
74LS243	.99	74LS395	1.19
74LS244	.99	74LS399	1.49
74LS245	1.49	74LS424	2.95
74LS247	.75	74LS447	.37
74LS248	.99	74LS490	1.95
74LS249	.99	74LS624	3.99
74LS251	.59	74LS668	1.69
74LS253	.59	74LS669	1.89
74LS257	.59	74LS670	1.49
74LS258	.59	74LS674	9.65
74LS259	2.75	74LS682	3.20
74LS260	.59	74LS683	3.20
74LS266	.55	74LS684	3.20
74LS273	1.49	74LS685	3.20
74LS275	3.35	74LS688	2.40
74LS279	.49	74LS689	3.20
74LS280	1.98	74LS783	24.95
74LS283	.69	81LS95	1.49
74LS290	.89	81LS96	1.49
74LS293	.89	81LS97	1.49
74LS295	.99	81LS98	1.49
74LS298	.89	25LS2521	2.80
		25LS2569	4.25

IC SOCKETS

1-99	100
8 pin ST	.13 .11
14 pin ST	.15 .12
16 pin ST	.17 .13
18 pin ST	.20 .18
20 pin ST	.29 .27
22 pin ST	.30 .27
24 pin ST	.30 .27
28 pin ST	.40 .32
40 pin ST	.49 .39
ST = SOLDER TAIL	
8 pin WW	.59 .49
14 pin WW	.69 .52
16 pin WW	.69 .58
18 pin WW	.99 .90
20 pin WW	1.09 .98
22 pin WW	1.39 1.28
24 pin WW	1.49 1.35
28 pin WW	1.69 1.49
40 pin WW	1.99 1.80
WW = WIREWRAP	
16 pin ZIF	6.75 call
24 pin ZIF	9.95 call
ZIF = TEXTPOOL (Zero Insertion Force)	

CONNECTORS

RS232 MALE	2.95
RS232 FEMALE	3.50
RS232 FEMALE	
RIGHT ANGLE	5.25
RS232 HOOD	1.25
S-100 ST	3.95
S-100 WW	4.95

DIP SWITCHES

4 POSITION	.85
5 POSITION	.90
6 POSITION	.90
7 POSITION	.95
8 POSITION	.95

7400

7400	.19	74132	.45
7401	.19	74136	.50
7402	.19	74141	.65
7403	.19	74142	2.95
7404	.19	74143	2.95
7405	.25	74145	.60
7406	.29	74147	1.75
7407	.29	74148	1.20
7408	.24	74150	1.35
7409	.19	74151	.55
7410	.19	74152	.65
7411	.25	74153	.55
7412	.30	74154	1.25
7413	.35	74155	.75
7414	.49	74156	.65
7416	.25	74157	.55
7417	.25	74159	1.65
7420	.19	74160	.85
7421	.35	74161	.69
7422	.35	74162	.85
7423	.29	74163	.69
7425	.29	74164	.85
7426	.29	74165	.85
7427	.29	74166	1.00
7428	.45	74167	2.95
7430	.19	74170	1.65
7432	.29	74172	5.95
7433	.45	74173	.75
7437	.29	74174	.89
7438	.29	74175	.89
7440	.19	74176	.89
7442	.49	74177	.75
7443	.65	74178	1.15
7444	.69	74179	1.75
7445	.69	74180	.75
7446	.69	74181	2.25
7447	.69	74182	.75
7448	.69	74184	2.00
7450	.19	74185	2.00
7451	.23	74186	18.50
7453	.23	74190	1.15
7454	.23	74191	1.15
7460	.23	74192	.79
7470	.35	74193	.79
7472	.29	74194	.85
7473	.34	74195	.85
7474	.33	74196	.79
7475	.45	74197	.75
7476	.35	74198	1.35
7480	.59	74199	1.35
7481	1.10	74221	1.35
7482	.95	74246	1.35
7483	.50	74247	1.25
7485	.59	74248	1.85
7486	.35	74249	1.95
7489	2.15	74251	.75
7490	.35	74259	2.25
7491	.40	74265	1.35
7492	.50	74273	1.95
7493	.35	74276	1.25
7494	.65	74279	.75
7495	.55	74283	2.00
7496	.70	74284	3.75
7497	2.75	74285	3.75
74100	1.75	74290	.95
74107	.30	74293	.75
74109	.45	74298	.85
74110	.45	74351	2.25
74111	.55	74365	.65
74116	1.55	74366	.65
74120	1.20	74367	.65
74121	.29	74368	.65
74122	.45	74376	2.20
74123	.49	74390	1.75
74125	.45	74393	1.35
74126	.45	74425	3.15
74128	.55	74426	.85
		74490	2.55

CMOS

4000	.29	4528	1.19
4001	.25	4531	.95
4002	.25	4532	1.95
4006	.89	4538	1.95
4007	.29	4539	1.95
4008	.95	4543	1.19
4009	.39	4555	.95
4010	.45	4556	.95
4011	.25	4581	1.95
4012	.25	4582	1.95
4013	.38	4584	.75
4014	.79	4585	.75
4015	.39	4702	12.95
4016	.39	74C00	.35
4017	.69	74C02	.35
4018	.79	74C04	.35
4019	.39	74C08	.35
4020	.75	74C10	.35
4021	.79	74C14	.59
4022	.79	74C20	.35
4023	.29	74C30	.35
4024	.65	74C32	.39
4025	.29	74C42	1.29
4026	1.65	74C48	1.99
4027	.45	74C73	.65
4028	.69	74C74	.65
4029	.79	74C76	.80
4030	.39	74C83	1.95
4034	1.95	74C85	1.95
4035	.85	74C86	.39
4040	.75	74C89	4.50
4041	.75	74C90	1.19
4042	.69	74C93	1.75
4043	.85	74C95	.99
4044	.79	74C107	.89
4046	.85	74C150	5.75
4047	.95	74C151	2.25
4049	.35	74C154	3.25
4050	.35	74C157	1.75
4051	.79	74C160	1.19
4053	.79	74C161	1.19
4060	.89	74C162	1.19
4066	.39	74C163	1.19
4068	.39	74C164	1.39
4069	.29	74C165	2.00
4070	.35	74C173	.79
4071	.29	74C174	1.19
4072	.29	74C175	1.19
4073	.29	74C192	1.49
4075	.29	74C193	1.49
4076	.79	74C185	1.39
4078	.29	74C200	5.75
4081	.29	74C221	1.75
4082	.29	74C373	2.45
4085	.95	74C374	2.45
4086	.95	74C901	.39
4093	.49	74C902	.85
4098	2.49	74C903	.85
4099	1.95	74C905	10.95
14409	12.95	74C906	.95
14410	12.95	74C907	1.00
14411	11.95	74C908	2.00
14412	12.95	74C909	2.75
14419	7.95	74C910	9.95
4502	.95	74C911	8.95
4503	.65	74C912	8.95
4508	1.95	74C914	1.95
4510	.85	74C915	1.19
4511	.85	74C918	2.75
4512	.85	74C920	17.95
4514	1.25	74C921	15.95
4515	1.79	74C922	4.49
4516	1.55	74C923	4.95
4518	.89	74C925	5.95
4519	.39	74C926	7.95
4520	.79	74C927	7.95
4522	1.25	74C928	7.95
4526	1.25	74C929	19.95
4527	1.95	74C930	19.95

Prices Slashed!
74S00

74S00	.32	74S163	1.95
74S02	.35	74S168	3.95
74S03	.35	74S169	3.95
74S04	.35	74S174	.95
74S05	.35	74S175	.95
74S08	.35	74S181	3.95
74S09	.40	74S182	2.95
74S10	.35	74S188	1.95
74S11	.35	74S189	6.95
74S15	.35	74S194	1.49
74S20	.35	74S195	1.49
74S22	.35	74S196	1.49
74S30	.35	74S197	1.49
74S32	.40	74S201	6.95
74S37	.88	74S225	7.95
74S38	.85	74S240	2.20
74S40	.35	74S241	2.20
74S51	.35	74S244	2.20
74S64	.40	74S251	.95
74S65	.40	74S253	.95
74S74	.50	74S257	.95
74S85	1.99	74S258	.95
74S86	.50	74S260	.79
74S112	.50	74S274	19.95
74S113	.50	74S275	19.95
74S11			

THERE ARE NO BETTER BOARDS —
THERE ARE NO BETTER PRICES!

CompuPro FROM SYSTEMS PRIORITY ONE ELECTRONICS

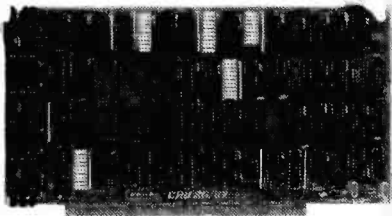

CPU BOARDS
CO-PROCESSOR 8086/8087
16 bit 8 or 10 MHz 8086 CPU with sockets
for 8087 and 80130

Part No.	Description	List Price	Our Price
BLGBT180A	A&T 8MHz 8086 only	\$695.00	\$825.00
BLGBT180C	CSC 10MHz 8086 only	\$850.00	\$785.00
BLGBT186A87	A&T with 8087 option	\$995.00	\$925.00
BLGBT180C87	CSC with 8087 option*	\$1150.00	\$1085.00

*8087 Limits clock speed to 5MHz

DUAL PROCESSOR 8085-8088

6 or 8 MHz Provides true 16 Bit Power with a standard
8 bit S-100 bus

BLGBT1612A	A&T 6MHz	\$425.00	\$399.00
BLGBT1612C	CSC 6/8 MHz	\$525.00	\$498.00

CPUZ - Z80 CPU NOW 6MHz!

3/6 MHz Z80 CPU with 24 Bit Addressing.

FASTEST Z80 CPU AVAILABLE!

BLGBT160A	3/6 MHz A&T	\$295.00	\$280.00
BLGBT160C	3/6 MHz CSC	\$395.00	\$375.00



DISK CONTROLLERS
DISK 1 FLOPPY CONTROLLER

Fast DMA, Soft Sector, Controls 8" or 5 1/4" Single or
Double Densitiv. OLIR BEST!

* With the purchase of GBT171-A or -C

BLPDB171ACPM	A&T w/CP/M2.2 & BJOS	\$670.00	\$495.00
B' PDB171CCPM	CSC w/CP/M2.2 & BJOS	\$770.00	\$600.00
BLIBTCPMA0*	CP/M 2.2 for Z80/8085 with manuals & BIOS 8" S/D disk		\$175.00
BLGBTCPM88	CP/M for 8086 with manuals & BJOS 8" S/D disk		\$300.00
BLGBT171A	Assembled & Tested	\$495.00	\$450.00
BLGBT171C	CSC 200 hr burn-in	\$595.00	\$555.00

DISK 2/SELECTOR CHANNEL
HARD DISK CONTROLLER

Fast DMA 2 board set. Controls 4 Shugart 4000 series
or Fujitsu 2300 type drives. Includes CP/M 2.2*

BLGBT177A	Assembled & Tested	\$795.00	\$750.00
BLGBT177C	CSC	\$895.00	\$850.00

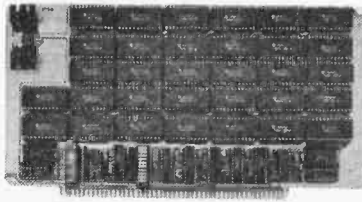

CMOS RAM SALE!

RAM 17 - 64K CMOS STATIC RAM

RAM 17, 12 MHz, 2 Watt, DMA Compatible 24 Bit Addressing

Part No.	Description	List Price	Our Price
BLGBT175A64	64K A&T	\$599.00	\$550.00
BLGBT175C64	64K CSC	\$699.00	\$650.00

RAM 16 - 32K x 16 BIT CMOS STATIC RAM

8 and/or 16 Bit

816 RAM 16 12 MHz, 32K x 16 or 64K x 8

IEEE/696 16 Bit 2 Watt, 24 Bit Addressing

BLGBT160A	64K A&T	\$650.00	\$599.00
BLGBT160C	64K CSC	\$750.00	\$699.00

NEW! RAM 21 - 128K STATIC RAM

816 RAM 21 12MHz, 128K x 8 or 64K x 16

IEEE/696 8 or 16 Bit 1.2 Amps, 24 Bit Addressing

BLGBT190A	128K A&T	\$1350.00	\$1225.00
BLGBT190C	128K CSC	\$1450.00	\$1375.00

M-DRIVE SOLID STATE DISK DRIVE,
3500% FASTER!

Not Really, But the Next Best Thing for CompuPro 8085/88 Users. Call for
Detail on M-Drive.

M-Drive requires a 6MHz CPU 8085/88 dual processor, Disk 1 DMA disk
controller and System Support 1 Multifunction Board

BLGBTM0128KA	128K of A&T memory & M-Drive Software	\$1198.00
BLGBTM0128KC	128K of CSC memory & M-Drive Software	\$1398.00
BLGBTM0256KA	256K of A&T memory & M-Drive Software	\$2395.00
BLGBTM0256KC	256K of CSC memory & M-Drive Software	\$2795.00

STATIC MEMORY BOARDS

RAM 20 - 32K STATIC RAM

RAM 20 10 MHz, 4K byte block disable, bank select
or 24 bit addressing available 8, 16, 24 or 32K

BLGBT184AA8	8K A&T	\$210.00	\$180.00
BLGBT184AC8	8K CSC	\$280.00	\$280.00
BLGBT184AA16	16K A&T	\$285.00	\$280.00
BLGBT184AC16	16K CSC	\$355.00	\$325.00
BLGBT184AA24	24K A&T	\$355.00	\$325.00
BLGBT184AC24	24K CSC	\$425.00	\$385.00
BLGBT184AA32	32K A&T	\$425.00	\$385.00
BLGBT184AC32	32K CSC	\$495.00	\$450.00



S-100 MAINFRAME

110V 60Hz CVT Mainframe uses famous 20 slot

COMPUPRO Motherboard. (55 lbs.)

BLGBTENC20R	20 Slot Rackmount	\$895.00	\$825.00
BLGBTENC20K	20 Slot Desk Top	\$825.00	\$760.00

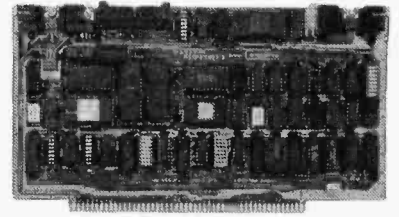

I/O BOARDS

SYSTEM SUPPORT 1 MULTIFUNCTION BOARD

Serial port (software prog. baud), 4K EPROM or RAM
provision, 15 levels of interrupt, real time clock,
optional math processor

Part No.	Description	List Price	Our Price
BLGBT182A	Assembled & Tested	\$395.00	\$380.00
BLGBT182C	CSC	\$495.00	\$460.00
BLGBT8231	Math Chip		\$195.00
BLGBT8232	Math Chip		\$195.00
BLGBT182AM1	A&T with 8231 Math Chip		\$490.00
BLGBT182CM1	CSC w/8231 Math Chip		\$685.00
BLGBT182AM2	A&T w/8232 Math Chip		\$490.00
BLGBT182CM2	CSC w/8232 Math Chip		\$685.00

MPX CHANNEL BOARD

I/O Multiplexer, using 8085A-2 CPU on board with 4K RAM

BLGBT186A4	Assembled & Tested	\$495.00	\$445.00
BLGBT186C4	CSC	\$595.00	\$535.00
	With 16K RAM		
BLGBT186A16	Assembled & Tested	\$649.00	\$585.00
BLGBT186C16	CSC	\$749.00	\$675.00

INTERFACER 1

Two Serial I/O

BLGBT133A	Assembled & Tested	\$249.00	\$219.00
BLGBT133C	CSC	\$324.00	\$298.00

INTERFACER 2

Three parallel, one serial I/O board

BLGBT150A	Assembled & Tested	\$249.00	\$219.00
BLGBT150C	CSC	\$324.00	\$288.00

INTERFACER 3

Eight channel multi-use serial I/O board

BLGBT148A	Assembled & Tested	\$699.00	\$629.00
BLGBT1748C	CSC 200 hr. 8 Port	\$849.00	\$775.00
BLGBT1745A	Assembled & Tested	\$599.00	\$559.00
BLGBT1745C	CSC 200hr. 5 port	\$699.00	\$629.00

INTERFACER 4

Three Serial, 1 Parallel, 1 Centronics Parallel

BLGBT167A	Assembled & Tested	\$395.00	\$350.00
BLGBT167C	CSC	\$495.00	\$450.00

SPECTRUM COLOR GRAPHICS

Color Graphics board with Parallel I/O

BLGBT144A	Assembled & Tested	\$299.00	\$285.00
BLGBT144C	CSC	\$395.00	\$375.00

S-100 MOTHERBOARDS

Active termination, 6-12-20 Slot

BLGBT153A	A&T 6 slot, 2 lbs.	\$140.00	\$125.00
BLGBT153C	CSC 6 slot, 2 lbs.	\$190.00	\$155.00
BLGBT154A	A&T 12 slot, 3 lbs.	\$175.00	\$155.00
BLGBT154C	CSC 12 slot, 3 lbs.	\$240.00	\$220.00
BLGBT155A	A&T 20 slot, 4 lbs.	\$265.00	\$235.00
BLGBT155C	CSC 20 slot, 4 lbs.	\$340.00	\$310.00

PRIORITY ONE ELECTRONICS

5" DISKETTES



SOFT SECTOR
40 TRACK SINGLE SIDED
DOUBLE DENSITY WITH
HUB REINFORCING RINGS
PACKAGE OF 10 **\$19.95**

BONUS!



FREE!! KASSETTE 10
LIBRARY CASE WITH
PACKAGE OF 10 DISKETTES

A \$4.25 VALUE!! BLPRI5SD0 (Shipping Weight 2 lbs.)

BLPRI500 package of 80 less Library Case **\$120.00**

EIA/RS232 WALL PLATES

(Does not include connectors)

BLIIWP08251 Single punched

4/\$10.00

BLIIWP08252 Dual Punched

4/\$12.00

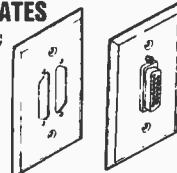

RS232 "D" SUB-MINIATURE CONNECTORS

	1-9	10-24	25-99
BLCNDDA25P 25 Pin Male	\$3.00	\$2.75	\$2.25
BLCNDDA25S 25 Pin Female	\$4.00	\$3.75	\$3.00
BLCNDD051212 1 Pc. Grey Hood	\$1.80	\$1.45	\$1.30
BLCNDD025H 2 c. Grey Hood	\$1.50	\$1.25	\$1.10
BLCNDD05122B 2 Pc. Black Hood	\$1.80	\$1.65	\$1.45



TWX YOUR LIST TO
SANTA AT 1200 BAUD
FOR ONLY \$495.00!!

AUTO DIAL 212A MODEM

The AUTO DIAL 212A Modem is a direct connect 0-300 or 1200 baud modem capable of dialing and calling for you. The AUTO DIAL 212A is compatible in function to the DC Hayes SMARTMODEM™.

Part No.	Description	List Price	SALE Price
BLUSRADIAL212A	0-300, 1200 baud dialing modem	\$599.00	\$495.00

ACCOUSTIC MODEM



The PHONE LINK Modem is a 300 baud RS232 compatible acoustic modem capable of operating as either an answer or originate modem. It is BELL 103/113 compatible and will accept most standard phone handsets.

BLUSRPLNK	0-300 Baud acoustic modem	\$149.00	\$129.00
-----------	---------------------------	----------	-----------------

MICRO LINK DIRECT CONNECT MODEMS



The MICRO LINK Modems are available in either 0-300 or 1200 baud transmission rates and both are RS232 compatible. Operation can be answer or originate.

BLUSRMLNK300	0-300 baud direct connect	\$179.00	\$159.00
BLUSRMLNK1200	1200 baud direct connect	\$449.00	\$399.00

AUTO LINK

DIRECT CONNECT AUTO ANSWER MODEMS



The AUTO LINK Modems are auto answer modems capable of operating at 0-300 baud or 1200 baud transmission rates. The AUTO LINK Modems can be operated in either answer or originate modes.

BLUSRALNK300	0-300 baud auto/direct connect	\$219.00	\$195.00
BLUSRALNK1200	1200 baud auto/direct connect	\$499.00	\$449.00
BLUSRALNK212A	0-300, 1200 baud auto/direct	\$549.00	\$495.00

Specs	USRADIAL212A	USRMLNK300	USRMLNK1200	USRALNK300	USRALNK1200	USRPLNK
1200 Baud	X	X	X	X		
0-300 Baud	X	X	X		X	X
Auto Dial	X					
(Hayes Smartmodem compatible)						
Auto Answer	X	X	X	X		
Auto Mode Select	X	X	X	X	X	X
DTR Override	X	X	X	X	X	X
RS232 pins 2&3 reversible	X	X	X	X	X	X
LED Indicators:	X	X	X	X	X	X
Carrier Detect	X	X	X	X	X	X
Analog Loopback/Self Test	X	X	X	X	X	X
Send Data	X	X	X	X	X	X
Receive Data	X	X	X	X	X	X
Terminal Ready	X	X	X	X	X	X
Off Hook	X	X	X	X	X	X
Answer Mode	X	X	X	X	X	X
Ring Indicate	X	X	X	X	X	X
High Speed	X	X				

SEND \$1.00 TODAY
FOR THE NEW, FULL COLOR
FALL 1982 ENGINEERING
SELECTION GUIDE!



S-100 STARTER SYSTEM

We've bundled our most popular 3 board combination to form a complete S-100 System,

just add mainframe, peripherals and cables! **BLPBCCSSP1**

CCS2810 4MHz Z80 CPU

- 2/4 MHz CPU
- On board RS-232 Serial port
- On board Monitor

\$695.00*

LIST PRICE: \$1125.00

CCS2422 DISK CONTROLLER

- Controls 4, 8" or 5 1/4" drives
- IBM 3740 Standard
- Supports single or double density
- Supports single or double sided
- Plug compatible with Shugart, Mitsubishi, MPI, Qume, Tandon, and Siemens

2080*With the purchase of two disk drives
\$750.00 if purchased separately

CCS2065 64K 4MHz RAM

- 4116 Low power dynamic RAMs
- Supports DMA
- Bank Select up to 512K
- Fail Safe refresh circuitry

ALL BOARDS ASSEMBLED & TESTED - PLUG & RUN!!

Para Dynamics

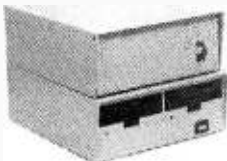

18 SLOT S-100 MAINFRAME

CVT Power Supply, forced air cooling; security lock
120 or 220V AC @ 50 or 60Hz +8V @ 30A +16V @ 5A +16V @ 2A
Part No. Description List Price Our Price

BLPDN20180	Desk Top (43 lbs.)	\$880.00	\$780.00
BLPDN2018R	Rack Mount (43 lbs.)	\$925.00	\$835.00

8 SLOT S-100 MAINFRAME WITH CUTOUTS FOR 2 4 1/4" DISK DRIVES

+5 @ 6A +8 @ 20A +12 @ 5A +16 @ 2, -16 @ 2

BLPDN25080	Desk Top (43 lbs.)	\$890.00	\$800.00
BLPDN2508R	Rack Mount (43 lbs.)	\$950.00	\$855.00

DISK DRIVE FACILITY

Accommodates two 8" floppy drives, of Shugart, Qume, or similar design and dimensions. 110 or 220V AC at 50 or 60Hz CVT power.

BLPDN22000	Desk Top (32 lbs.)	\$650.00	\$595.00
BLPDN2200R	Rack Mount (34 lbs.)	\$675.00	\$605.00

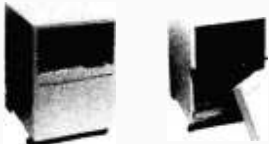

Free standing cabinet. Will accept 2, 8" floppy disks and 1, 8" rigid disk. 18 slot card cage will accept the double height 10" x 10" S-100 cards (Alpha Micro and others). CVT Power Supply ±12V @ 3A
+24 @ 8A +16 @ 5A +16 @ 2A +8 @ 30A +5 @ 7A +5V @ 3A
PRONTO COMPLETE WITH POWER SUPPLY POWER-UP SEQUENCER
BLPDN20182 PRONTO with sequencer \$1595.00 \$1435.00
Shipping motor freight collect

DATA GARD™ SGL WABER LINE MONITOR POWER CONDITIONERS



Before you plug in your computer, you'd better consider how you are going to insure or protect your investment from unwanted electrical pollution.

DG115 SERIES

SINGLE STAGE SPIKE PROTECTION

Part No.	Description	WL	List	1-9	10-24
BLWBROG115P	Wall unit plug in	2 lbs	\$49.95	\$39.95	\$34.95
BLWBROG115S	6 outlet strip w/SW<	3 lbs	\$61.95	\$49.95	\$42.00

DG315

3 STAGE SPIKE FILTER AND FOUR STAGE NOISE FILTER

BLWBROG315P	Wall unit plug in	2 lbs	\$153.95	\$119.95	\$99.95
BLWBROG315S	6 outlet strip w/SW<	3 lbs	\$193.95	\$149.95	\$119.95
BLWBROG315R	6 outlet rack w/SW<	8 lb	\$193.95	\$149.95	\$119.95

SMITH-CORONA TP-1

LETTER QUALITY - ELECTRONIC TEXT PRINTER

\$599.00



- BLSCMTP1210 (Serial)
- BLSCMTP1P10 (Parallel)
- 12 CPS • 10 CPI • 6 LPI • SERIAL OR PARALLEL INTERFACE
- 50-192K Baud • Friction Feed • 88 Character
- BLSCM12625 TPI Black Milar Ribbon **\$3.50**
- BLSCM12650 TPI Black Fabric Ribbon **\$7.50**

PRIORITY ONE ELECTRONICS

9161 DEERING AVE • CHATSWORTH, CA: 91311

ORDER TOLL FREE (800) 423-5922 - CA, AK, HI CALL (213) 709-5464

Terms: U.S. VISA, MC, BAC, Check, Money Order, U.S. Funds Only. CA residents add 6 1/2% Sales Tax. MINIMUM PREPAID ORDER \$15.00. Include MINIMUM SHIPPING & HANDLING of \$3.00 for the first 3 lbs plus 40¢ for each additional pound. Orders over 50 lbs. sent freight collect. Just in case, please include your phone number. PRICES subject to change without notice. We will do our best to maintain prices through December, 1982. Credit Card orders will be charged appropriate freight. If you haven't received your Fall '82 Engineering Selection Guide, send \$1.00 for your copy today! Sale prices are for prepaid orders only.

SIEMENS FDD100-8 TRUCKLOAD PURCHASE!

WE'VE CAPTURED THE 8" FLOPPY DRIVE MARKET
WITH A HUGE FACTORY DIRECT PURCHASE!!



**FDD100-8
8" FLOPPY**

WOW!!

See Previous Pages
For More Great Deals!!

**SINGLE-SIDED
DOUBLE DENSITY
90 DAY WARRANTY
SHUGART 801R COMPATIBLE**

DUAL 8" SUBSYSTEM

BLCCS2422A Controller w/CP/M 2.2 1 \$395.00
 BLSIEFDD1008 8" Drive 2 \$550.00
**IN A DUAL HORIZONTAL CABINET
 WITH POWER SUPPLY \$395.00**

AND DATA CABLE
SAVE \$380.00

\$995.00

Same as above, with CCS2810 Z80
 4MHz CPU and CCS 2065 64K Dynamic RAM:

\$1390.00

BLP0BSIESUB2

1 \$ 35.00
 \$1375.00
 BLP0BSIESUB1



\$275.00 1
\$259.00 2-9
\$225.00 10+

BLSIEFDD1008
 DEM INQUIRIES INVITED
 (Include \$7.00 per drive for shipping)

DON'T MISS OUT!



International
 Instrumentation
 Incorporated



- Positive Pressure Filter Cooling
- Power Supply: 4A@+5V, 3A@+24V 1A@-5V
- Each output is individually fused
- Hinged top for easy access
- Heavy non-flex. 090 aluminum base
- Modular power connectors

BUY DRIVES AND CABINET TOGETHER AND SAVE!!

**DUAL 8" SIEMENS FDD1008,
 DUAL 8" CABINET POWER SUPPLY
 AND INTERNAL POWER CABLES**
 IF BOUGHT SEPARATELY: \$910.00

PRICED AT: **\$695.00**

ENVIRONMENT MONITOR PANEL
 Temperature and voltage monitor with visual and audible alarm for overtemp condition. Direct Digital Readout of internal temperature in C° on standard DVM

BLIIF0E002 CABINET ONLY 1Sh. Wt. 38 lbs.; \$295.00
 BLP0BSIESUB1 2-Drives, Cabinet, & disk environment monitor \$775.00
 BLIIF0E002EM Cabinet only, with disk environment monitor \$375.00



WORLD'S BEST SELLING TERMINAL!

Extra Memory Pages
FREE!

- BLP0BTLV9252P* \$749.00
 *TeleVideo 925 w/free 2nd page memory kit: a \$95.00 value!
- BLP0BTLV9504P* \$949.00
 *TeleVideo 950 w/free 2nd, 3rd & 4th page memory kit \$285.00 value
- BLTLV910 \$609.00
 With emulations & foreign languages
- BLTLV910BLK \$609.00
 Black mode version of above
 *Shipping Weight 37 lbs.;



BEST BUYS!

MITSUBISHI ELECTRIC



**Better Than
 QUME!
 Better Than
 SHUGART!**

8" Double-sided, double-density, interchangeable with QUME & Shugart
 BLMITM289483 Shipping Weight 16 lbs. \$450.00
 BLMITM289463M Manual \$ 10.00

2 or More \$435.00 each



INTERNATIONAL INSTRUMENTATION, INC.



DUAL 8" FLOPPY DRIVE CABINET

FEATURES:

- Positive pressure forced air cooling for reliable disk drive operation
- AC input via 3 wire 7 foot International cord/socket set
- AC input EMI filtered to six amps to help prevent disk crashes due to power spikes and line noise
- 14 gauge main chassis
- Integral power supply with 5V@6A/5V@1A/24V@6A
- Double-sided custom PC power board and supply
- Each DC supply and AC separately fused

BLIIF0E002 Shipping Weight 38 lbs. \$295.00

TWO MITSUBISHI 8" DRIVES AND CABINET TOGETHER!!

DRIVES AND
 CABINET SHIPPED
 SEPARATELY
 BLP0BMITFDE

\$1150.00

Tandon

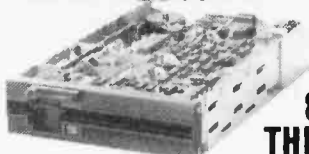

**8-INCH
 THIN LINE**

Exactly one-half the height of any other model
 Proprietary, high-resolution, read-write heads patented
 by Tandon

D.C. nly operation - no AC required
 Industry standard interface
 Three millisecond track-to-track access time (9 lbs.)
 BLTNDTM8481 Single Sided \$380.00 2 or more: \$370.00 ea
 BLTNDTM8482 Double Sided \$495.00 2 or more: \$485.00 ea

TANDON 5 1/4" DRIVES

- BLTNDTM1001 Single Sided, 250KB (5 lbs.) \$220.00 ea
2 or More \$200.00 ea.
- BLTNDTM1002 Double Sided, 500KB \$295.00 ea.
2 or More \$270.00 ea.
- BLTNDTM1003 Single Sided, 500KB \$295.00 ea.
2 or More \$270.00 ea.
- BLTNDTM1004 Double Sided, 1000KB \$395.00 ea.
2 or More \$375.00 ea.

DUAL THIN LINE CABINET by

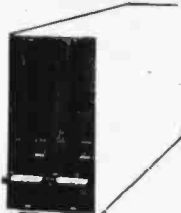

JMR

- Fan Cooled
- 24V @ 4A/5A Surge
- 5V @ 2A
- Scratch Resistant Baked Enamel Finish

BLJMR1LC Cabinet & Power Supply List \$200.00 \$180.00
 Shipping Weight 12 lbs.

BUY THE CABINET AND DRIVES TOGETHER:

BLP0BJMRTD01 w/two TNDTM8481s (30 lbs.) \$920.00
 BLP0BJMRTD02 w/two TNDTM8482s (30 lbs.) \$1150.00
 Includes Power Cables

VISUAL 50

- Low profile detached keyboard features sculptured keys with matte finish
- Screen tilts and swivels
- 80 x 24 display with 25th status line
- 7 x 9 dot matrix with full decoders
- RS-232 Serial interface w/auxiliary RS-232 port
- 128 Character ASCII set and 31 character line drawing set



INTRODUCTORY OFFER!!

BLVLS50BW Non glare Black & White \$695.00 \$650.00
 BLVLS506R P31 green display \$750.00 \$685.00
 (Shipping Weight 37 lbs.)

5 1/4" DISK CABINET FOR SINGLE OR DOUBLE DRIVES

JMR



SINGLE 5V@1A 12V@1.5A Shipping weight 5 lbs.
 DOUBLE 5V@2A 12V@3A Shipping weight 9 lbs.

BLJMR1C5 Single 5 1/4" Drive Cabinet \$79.00
 BLJMR2C5 Dual 5 1/4" Drive Cabinet \$99.00
 DUAL 5 1/4" CABINET WITH INTERNAL DATA CABLES
 BLJMR2C5C With Internal Data Cable \$115.00

REPEAT OF A SELLOUT!!

WOW!

BK PRECISION

**MODEL 1500
QUAD INPUT,
EIGHT-TRACE DESIGN
\$1495.00**

LIST PRICE \$2250.00

This new generation scope utilizes a combination of techniques never before applied to oscilloscope design, resulting in an efficient, light weight and reliable unit.

- 100 MHz response
- Maximum sweep rate of 2 nSec/division
- 1 mV/division vertical sensitivity (CH 1 & 2)
- Eight-trace, four-channel operation provides 2 trigger views or four separate vertical inputs
- Calibrated Delayed Sweep operation
- Alternate Sweep to view main timebase and delayed timebase simultaneously

- Vertical Mode trigger selection to display four input signals in sync — even if they are unrelated in frequency
- Bright 16KV, 8 cm x 10 cm CRT display with internal graticule
- Compact overall size; only 5.4 x 11.2 x 15.75 inches and 16.5 pounds. Small enough to fit under any airline seat

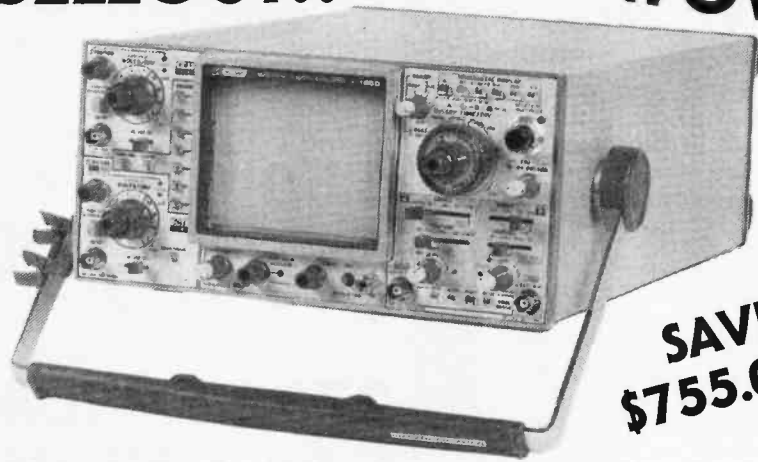

**SAVE
\$755.00!!**

The B&K Model 1500 offers all the capabilities you might demand from a lab grade oscilloscope, and at a price that will fit your budget. The cost? Remarkably reasonable especially when you compare it to the other leading 60MHz and 100MHz dual trace scopes that are currently available. This price breakthrough is made possible by **PRIORITY ONE ELECTRONICS** unequalled purchasing power. As the largest distributor of high performance oscilloscopes, we were able to place a humongous order with B&K and then pass the savings along to you!

Two x10 100MHz probes are included with each Model 1500. Optional accessories that you may wish to include on your order:

- | | | |
|---|----------------|---|
| BLBKPLC100 Snap-on front cover | \$26.00 | B&K-Precision backs the 1500 with a one year warranty and has service centers |
| BLBKPLC150 Vinyl carrying case for probes and cables | \$32.00 | located nationwide. |

BK PRECISION DMM
3 1/2-Digit 5 Function



- 200 mV AC/DC voltage ranges
- 200 μ A to 10A AC/DC current ranges
- Auto zeroing; auto polarity
- 10 megohm input impedance
- Completely overload protected
- Overrange indication of all ranges
- High-energy fuse for added safety
- Complete with test leads and carrying case

BLP2805 List: \$100.00

SALE: \$88.00

BK PRECISION DMM
3 1/2-Digit Portable



- High-contrast liquid-crystal display
- Auto zeroing; auto polarity
- 10 megohm input impedance
- DC accuracy 1% typical
- Fully overload protected
- High-energy fuse for added safety
- Complete with test leads and carrying case

BLP2801 List: \$65.00

SALE: \$58.00

FLUKE PORTABLE DMMs

- | | |
|--|-----------------|
| BLFLU8060A 4 1/2 Digits w/Freq Meter | \$349.00 |
| BLFLU8062A 4 1/2 Digit - Tru RMS | \$279.00 |
| BLFLU8024B 3 1/2 Digit "Investigator" | \$249.00 |
| BLFLU8020B 3 1/2 Digit "Analyst" | \$194.00 |
| BLFLU8021B 3 1/2 Digit "Troubleshooter" | \$159.00 |

HITACHI DUAL TRACE OSCILLOSCOPES



V-353F

**35 MHz
DELAYED SWEEP**

- Single time base delay sweep
- rectangular CRT with internal graticule
- High sensitivity 1mV/div (7MHz)
- Large dynamic range of 8 div to full bandwidth
- CH1 output
- Built-in signal delay line

BLHITV353F List: \$949.00

SALE: \$799.00



V-203F

**20 MHz
DELAYED SWEEP**

- Single time base delay sweep
- High sensitivity 1mV/div (5MHz)
- Full TV triggering
- X-Y operation
- CH1 Output
- High reliability, MTBF 20,000 hours

BLHITV203F List: \$749.00

SALE: \$625.00



V-302F

30 MHz

- High sensitivity 1mV/div (5 MHz)
- Full TV Triggering
- X-Y operation
- CH1 Output
- Built-in signal delay line
- High reliability, MTBF 20,000 hours

BLHITV302F List: \$799.00

SALE: \$699.00



V-152F

15 MHz

- High Sensitivity 1mV/div (5MHz)
- Full TV Triggering
- X-Y operation
- X10 sweep time magnification
- High reliability, MTBF 20,000 hours

BLHITV152F List: \$595.00

SALE: \$495.00



V-352F

**35 MHz
DUAL TRACE**

BLHITV352F
List: \$895.00

**SALE:
\$749.00**

Same as V353F, except without delayed sweep



V202F

**20 MHz
DUAL TRACE**

BLHITV202F
List: \$695.00

**SALE:
\$575.00**

Same as V203F, except without delayed sweep

PRIORITY ONE ELECTRONICS
9161 DEERING AVE • CHATSWORTH, CA 91311

ORDER TOLL FREE (800) 423-5922 - CA, AK, HI CALL (213) 709-5464

Terms: U.S. VISA, MC, BAC, Check, Money Order, U.S. Funds Only. CA residents add 6 1/2% Sales Tax. MINIMUM PREPAID ORDER \$15.00. Include MINIMUM SHIPPING & HANDLING of \$3.00 for the first 3 lbs. plus 40¢ for each additional pound. Orders over 50 lbs. sent freight collect. Just in case, please include your phone number. Prices subject to change without notice. We will do our best to maintain prices through December, 1982. Credit Card orders will be charged appropriate freight. If you haven't received your Fall '82 Engineering Selection Guide, send \$1.00 for your copy today! Sale prices are for prepaid orders only.

California Digital

Post Office Box 3097 B • Torrance, California 90503

★ **FREE** ★
Plastic library case supplied with all diskettes purchased from California Digital
\$24.95

Private labeled for California Digital by one of the most respected producers of magnetic media. Each diskette is certified double density at 40 tracks. To insure extended media life all diskette are manufactured with a reinforced hub. Each box of diskettes is supplied with a free plastic library case.
Soft sector CAL-501, Ten sector CAL-510
Ten boxes \$22.75 One hundred boxes \$21.50

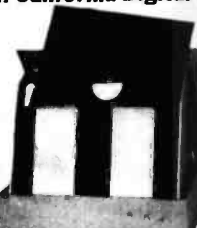

5 1/4" DISKETTES WITH LIBRARY CASE
\$26.50

Your Choice
SCOTCH MEMOREX VERBATIM

	Single Side Double Density	Soft Sector 10 Sector	16 Sector	
SCOTCH	744D-0	744D-10	744D-16	26.50
MEMOREX	3481	3483	3485	26.50
VERBATIM	525-01	525-10	NA	26.50
MAXELL	MD1	MH1-10	MH1-16	29.85
DYSAN	104/1D	107/1D	NA	45.00

	Double Side Double Density			
SCOTCH	745-0	745-10	745-16	42.50
VERBATIM	550-01	550-10	NA	42.50
MAXELL	MD2-D	MH2-10D	MH2-16D	45.00
DYSAN	104/2D	107/2D	NA	49.50
DYSAN 96	204/2D	NA	NA	59.50

EIGHT INCH DISKETTES						
Single Side Single Density		Single Side Double Density				
SCOTCH	740-0	29.50	SCOTCH	741-0	39.00	
MEMOREX	3060	29.50	MEMOREX	3090	35.00	
DYSAN	3740/1	39.50	DYSAN	3740/D	57.50	
Thirty Two Sector		Double side Double Density				
SCOTCH	740-32	29.50	SCOTCH	743-0	47.50	
Search Head Changing Size 8" Plastic Library Cases Size 8" Double Floppy Tapes 1 1/2 diskettes Size 8" Double Floppy Tapes 1 1/2 diskettes Size 8"		24.85	2.95	MEMOREX	3114	39.50
			DYSAN	3740/2D	65.00	

Microwitch ASCII KEYBOARD \$79
Each keyboard contains 81 high reliability Hall Effect keys. Outputs seven bit parallel ASCII MIC-81SD5 3 Lbs.

Flip & File \$18.95
Plastic storage file allows immediate access to over 50 diskettes.
3 1/4" INC-525 \$18.95 4 lbs.
8" INC-800 \$19.95 6 lbs.

MEMORY

2716 EPROM 4.50 450ns	64K DYNAMIC 6.95 4164 200ns
16K STATIC 7.00 6116 200ns	16K DYNAMIC 1.95 4116 200ns



2732 EPROM SALE \$6.95

	DYNAMIC MEMORY		
4116-150ns 16k	1.31	32-	100-
4116-200ns 16k	1.95	1.85	1.75
4164-150ns 64k Japan 128 refresh	1.75	1.85	1.50
4164-150ns 64k Texas Inst. 256 refresh	8.95	8.25	7.90
4164-200ns 64k Japan 128 refresh	7.00		
41256-200ns 4k	8.50	7.75	7.50
41256-200ns 4k			call for pricing

	STATIC MEMORY		
21L02-200ns 1k	1.49	1.29	1.1b
21L02-450ns 1k	1.29	1.15	.99
21L2-450ns 2k	3.95	3.50	3.25

	EPROMS		
2708-450ns 8k	3.50	2.95	2.75
2716-450ns 16k	4.50	4.15	3.75
2716TMS-450ns 16k tri-voltage	7.95	7.65	7.25
2516-450ns 16k	6.95	5.95	5.45
2732-350ns 16k	8.50	8.00	7.60
2732-450ns 16k	8.95	8.65	8.25
2532-450ns 16k	10.95	10.65	10.35
2764-450ns 64k	14.95	13.75	12.50
27128-450ns 128k			call for pricing

\$49.95
ASTECH SWITCHING POWER SUPPLY
Output: +5v .3A; +12v .9A; -12v .075A.
Suitable for Apple look-a-like. ATC-1298

SWITCHES

	DIP SWITCHES		TOGGLE		ea. 100+
3	.88	.75	.69	7101 on/on	1.19 .98
4	.89	.73	.79	7103 on/off/on	1.39 1.19
8	1.05	.91	.87	7107 mm. on	1.35 1.19
12	1.19	.99	.91	7108 mm. on	1.39 1.19
				7205 dip/mt	1.85 1.65

CONNECTORS

GOLD EDGE CONNECTORS		"D" Type	
S-100 .125" centers	each 100	10-24	25+
Imzal solder .250" row	\$2.89 \$2.50	DE8P male	1.80 \$1.40 \$1.30
Imzal wire wrap (T)	3.95 3.50	DE8S female	2.25 2.00 1.90
Sullins III-Hel. .250"	4.50 4.00	DE hood	1.50 1.35 1.20
Sullins III-Hel. W/W	8.25 4.90	DA15P male	2.35 2.15 2.00
Sullins /Alair .140"	4.95 4.50	DA15S female	3.25 3.10 2.90
.150" Centers (standard)		Da hood 2/P	1.60 1.35 1.30
22/44 Kim Eyelet	2.50 2.15	DB 25P male	2.50 2.35 2.25
36/72 Digital Group S/T	3.95 3.50	DB 25S female	3.35 3.15 3.05
36/72 Digital Group W/W	6.00 6.15	DB hood 2/P	1.35 1.15 1.05
43/86 Motorola 6800 S/T	7.00 6.15	DC31P male	4.20 4.00 3.70
43/86 Note. 6800 W/W	6.00 5.85	DC37S female	6.00 3.75 3.50
		DC hood 2/P	2.25 2.00 1.75
		DD50P male	3.50 3.10 4.75
		DD50S female	8.10 8.90 8.00
		DD80 hood 2/P	2.60 2.40 2.10

INTEGRATED CIRCUIT SOCKETS		CENTRONICS	
Low Profile	Wire Wrap	57-30260	7.95 6.75 5.75
each 100	each 100		
8 pin \$1.0 \$0.9	\$4.8 \$4.1		
14 pin .10 .09	.48 .41		
16 pin .12 .11	.50 .45		
18 pin .15 .13	.68 .61		
24 pin .20 .18	.94 .87		
40 pin .32 .30	1.60 1.47		

RIBBON CABLE CONNECTORS	
1724 3" disk	4.8 4.15 3.95
20/40 TRS-80	5.65 6.05 4.70
23/30 8" disk	5.90 5.13 4.90



	Eight Inch Single Sided		
	One	Two	Ten
SHUGART SA801R	\$395	385	375
SIEMENS FDD100-8	259	259	225
TANDON 848-1 SLIMLINE	379	369	359

	Eight Inch Double Sided		
SHUGART SA851R	525	495	475
QUME DATA TRACK 8	525	495	475
MITSUBISHI M2894-63	485	475	469
OLIVETTI 802/851	369	359	349
TANDON 848-2 SLIMLINE	495	485	475
SHUGART 860 THINLINE	569	549	539

	Five Inch Single Sided		
SHUGART SA400	215	209	199
TANDON TM 100-1	209	199	195

	Five Inch Double Sided		
SHUGART SA450	349	329	315
TANDON TM 100-2	295	269	259
TANDON 96TPI TM100-4	369	355	350
OLIVETTI 502 3/4 height	239	225	215

Three Inch Rigid Floppy
HITACHI-AMDEK call for pricing

	Five Inch Winchester		
SEAGATE 506 6 Megabyte	759	725	695
SEAGATE 512 12 Megabyte	995	960	960
TANDON 603SE 14 Megabyte	995	960	895
WESTERN DYNAX removable	995	960	950

Upon request, all drives are supplied with power connectors and manual



\$750 Eight Inch Subsystem
Two Siemens FDD100-8 disk drives with power supply, 4" exhaust fan complete with all necessary power cables.
Same as above but with:
Shugart 801R MSD2801 \$1195 Olivetti 802 CAL2802 \$1250
Shugart 851R MSD2851 1450 Qume DT8 MSD80T 1450

ECLIPSE 100 \$695
INDUSTRIAL S-100 MAINFRAME

Suitable for hospital and industrial applications. Constructed from 304 brushed stainless steel. Modular 500 watt toroid power supply provides ±8 volts at 30 Amps and ±16 volts at 4 Amps. Supplied with standard 18 slot Faraday mother board. Auxiliary switched AC receptacles. The Eclipse 100 can be either table or rack mounted. Provisions for internally mounting a ten megabyte Winchester disk drive.
The Eclipse 100 is the perfect mainframe to fill the void left by the now defunct TCI Corporation. EPS-100 50 lbs.



All merchandise sold by California Digital is premium grade. Shipping: First five pounds \$3.00. Each additional \$.50. Foreign orders: 10% shipping. Excess will be refunded. California residents add 6% sales tax. COD's discouraged. Open accounts extended to state supported educational institutions and companies with a "strong" Dun & Bradstreet. Warehouse: 15006 Inglewood Blvd. Van Nuys, CA 91411

TOLL FREE ORDER LINE (800) 421-5041
TECHNICAL & CALIFORNIA (213) 679-9001

California Digital

Post Office Box 3097 B • Torrance, California 90503

Super Buy \$259

SIEMENS

FDD100-8

8" DISK DRIVE

10 Drives \$225 • 100 Drives \$209

California Digital has recently participated in the purchase of several thousand Siemens FDD 100-8 floppy disk drives. These units are electronically and physically similar to that of the Shugart 801R disk drive. Any application that will accept an 801R will work with the Siemens FDD 100-8 drive. All units are new and shipped in factory sealed boxes. Because of the extremely low price we expect a quick sell out. Please reserve your units early. SEA-F1008 17 lbs. Manual and connectors supplied free upon request. Also available: Two drive subsystem supplied in steel enclosure with power supply and fan. \$750.00 CAL-2F1008

Scotch Diskettes

FREE \$10.95

FLIP & FILE

With purchase of five boxes of Scotch diskettes.

We have recently purchased the entire excess inventory of 5 1/4" Scotch brand diskettes from Digital Equipment Corporation. The diskettes are all single sided double density available in soft, ten and sixteen sector. Buy one box and we supply a free plastic library storage case, buy five boxes and we supply a free flip and file storage tub. Take advantage of this one time offer and stock up for the winter. Prime Scotch brand diskettes priced below dealer cost. Soft sector for Apple & IBM MMM-SD7440; Ten sector MMM-SD7441; Sixteen sector MMM-SD7441 2lbs.

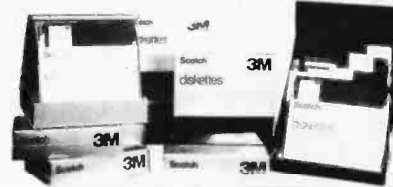

PRINTERS

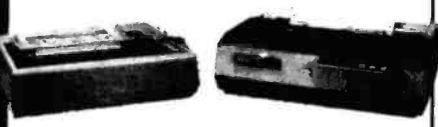

MATRIX PRINTERS

Okidata 824 serial & parallel 9.5" paper OKI-824	459.00
Okidata 834 serial 5 parallel 15" paper OKI-834	695.00
Okidata 844 parallel only 15" paper OKI-844P	1,079.00
Okidata 844 serial & parallel 15" paper OKI-844S	1,219.00
Edson 14860 with graphics and tractor feed EPS-14860	
Edson MK80T7 with graphics, friction & tractor feed EPS-MK80T7	539.00
Edson MK100 with graphics, 15" paper EPS-MK100	695.00
NEC 8023A parallel 9.5" paper graphics NEC-8023A	489.00
Anadex 9500A high speed dot matrix printer 15" ADX-9500A	1,279.00
Anadex 9501A 15" paper with graphics ADX-9501A	1,279.00
Telex Instruments 810 serial 15" upper & lower case TEX-810	1,299.00
Datascouth DS180 high speed 180 char/sec 15" DSI-180	1,295.00
Prowriter 8510 parallel 9.5" PRO-8510P	495.00
Prowriter 8510 serial 9.5" PRO-8510S	639.00
Prowriter II 15" paper PRO-2P	750.00
Purintonix P300 high speed printer 300 lines/min P1X-P300	4,500.00
Purintonix P500 high speed printer 600 lines/min P1X-P500	6,150.00
IDS prism 80 column graphics, non-color IDS-PR80	1,150.00
IDS prism 132 COLOR with graphics 15" paper IDS-PR132C	1,650.00
Minnesota 1805 200 cps serial MATN-1805	1,650.00

WORD PROCESSING PRINTERS

NEC7710 55 char/sec thinbile serial only NEC-7710	2,379.00
NEC7730 same as above parallel only NEC-7730	2,379.00
NEC3510 serial 15" NEC-3510	1,715.00
Diablo G20R01 25 cps serial DBL-620	1,201.00
Diablo G30 40 cps serial DBL-630	2,250.00
Smith Corona TP-1 daisy wheel parallel SCMT-PP1	659.00
Smith Corona TP-1 daisy wheel serial SCMT-TP1S	659.00
Brotter HR11 daisy wheel printer parallel BTH-HR1P	855.00
Brotter HR11 serial interface BTH-HR1S	895.00
Diablo G30 DBL-430	2,095.00
Starwriter F10 serial PRO-F10S	1,475.00
Starwriter F10 parallel PRO-F10P	1,475.00

MONITORS

Zenith Z121 green phosphor 12" 40/60 column switch ZTH-Z121	115.00
BMC 12A green phosphor 15 MHz composite video BMC-12A	88.00
BMC 12EA green phosphor 20 MHz high resolution BMC-12EA	139.00
NEC JB1071 green phosphor 18 MHz composite video NEC-JB1071	169.00
NEC JB1260 green phosphor commercial grade composite NEC-1260	129.00
Motorola 22" open frame blk/white composite video M01-BW23	159.00
Motorola 12" open frame blk/white requires horiz sync, 5 pow M01-BW12	69.00
Conarc 9" open frame requires horiz sync & power supply COH-BW9	59.00
NEC JC1201 composite color NEC-JC1201	325.00
NEC RGB monitor NEC-1202RM	475.00
BMC 13 Composite video BMC-1400CL	139.00
BMC 13 RGB color monitor BMC-1401RGB	349.00
BMC interface card for Apple II for above RGB BMC-81RGB	129.00
Comtec HiHatch 13" RGB high res. monitor COM-6500	539.00
Comtec HiHatch 13" Composite color monitor COM-6500	395.00
Amdek color #1 composite video AMD-100	349.00
Amdek color #2 high res. RGB color monitor AMD-200	739.00
Amdek color #3 commercial grade color RGB AMD-300	475.00

Direct Connect MODEMS

Hayes Microcommod 100 S-100 modem HYS-100	319.00
Hayes Smart Modem RS232C HYS-232	229.00
Hayes Microcommod II Apple direct connect HYS-MM2	199.00
Hayes Chronograph time & date HYS-CHR232	199.00
Novation Cat acoustic connect NOV-CAT	149.00
Novation Cat direct connect via handset NOV-DCAT	169.00
Novation 212 Autoconn Bell 212A NOV-212A	595.00
Novation Auto Cat 103 NOV-AUTO	219.00
Universal 103LP direct connect, time powered UDS-103LP	169.00
Universal 103PJ direct connect, auto answer UDS-103PJ	209.00
Universal 202 direct connect 1200 baud, half duplex UDS-202LP	189.00
Universal 212LP direct connect 1200 baud, full duplex UDS-212LP	450.00
Signatman Mark I direct connect with terminal cable SGL-MK1	89.00

TERMINALS



Amplex Dialogue 80 green screen, two page, function keys APX-080C	795.00
Amplex Dialogue 80 amber screen, two page, function keys APX-080A	795.00
Amplex Dialogue 80 green screen, Selectric keyboard APX-081G	895.00
Amplex Dialogue 81 amber screen, Selectric keyboard APX-081A	895.00
Amplex Touch Term screen command for data entry APX-081A	895.00
Wysely horz & vert split screen, metal case, detach keyboard, WYS-100	825.00
Teletideo 910C emulator TVI-910C	595.00
Teletideo 910 Plus block mode TVI-910P	595.00
Teletideo 925C detachable keyboard, 22 function keys TVI-925	795.00
Teletideo 950 graphic char. split screen, 22 functions TVI-950	985.00
IBM 3101-10 detachable keyboard, green IBM-3101	1,195.00
Zenith Z-19 keyboard ZTH-Z19	765.00
Adas Viewpoint A1 detachable keyboard ADD-VP1	498.00
Adas Viewpoint A2 w/ cursor, green screen ADD-VP2	595.00
Adas Viewpoint A3 emulator, ADD-VP3	575.00

APPLE 48K Plus \$1089



APPLE BRAND PRODUCTS

APL-48P Apple Plus 48K RAM	
APL-OSK1 Apple disk with controller card	560.00
APL-OSK2 Apple disk without controller card	495.00

XITEN

XTN-G10 Xiten 10 Megabyte Gallium hard disk	1,995.00
XTN-16K 16K RAM card for Apple II	69.00

RANA SYSTEMS

RAN-APL1 Apple add on disk drive with controller	525.00
RAN-APL2 Apple add on drive without controller	395.00

CALIFORNIA COMPUTER SYSTEMS

CCS-7710 Asynchronous Serial Interface	125.00
CCS-7728 Centronics Parallel Interface	95.00
CCS-7720 Apple Parallel Interface	95.00
CCS-7114 12K Rom/Prom Module	115.00
CCS-7424 Calendar/Clock Module	95.00
CCS-7440 Programmable Timer	95.00
CCS-7811B Arithmetic Processor for Apple II plus	319.00

MOUNTAIN COMPUTERS, INC.

MNT-CPS CPS Multifunction Card	169.00
MNT-TCLK Clock/Calendar	149.00
MNT-STLK SuperTalker S2020	149.00
MNT-ROMF Rom Plus with Keyboard later	169.00
MNT-ROMRTR Rom Writer with Eeprom socket	145.00
MNT-ADDA A-to-D/A Converter	289.00
MNT-BSR X-10 Control Card for BSR system	149.00

MICRO SOFT

MSF-SFTCRD Microsoft Z-80 CPU card	249.00
MSF-16KRAM Microsoft 16K RAM card	125.00

VISTA

VSA-A800 Vista 8" controller card	489.00
VSA-VIS80 Vista Vision 8"	289.00
MCI-CTRL Micro Soft disk drive controller	89.00

FOURTH DIMENSION

FDN-SPDRDV Super Drive-35 track Apple add on	329.00
--	--------

SORRENTO VALLEY ASSOC

SV4-221 Single sided, single density controller	360.00
SV4-222 Double sided, single density controller	360.00
SV4-223 Single or double sided, double density	475.00

ADVANCED BUSINESS TECH

ABT-13KEYW 13-Key pad for new Apple	95.00
-------------------------------------	-------

S-100 BOARDS



16 BIT MICROPROCESSORS

GBT-8687 Godbout 8086/8087 Microprocessor board	495.00
GBT-8687 Godbout 8086/8087 dual 8 bit microprocessor	359.00
SEA-8086 Seagate Computer 16 bit micro two board set	689.00
TEC-8086 Tecmar Computer 16 bit microprocessor	595.00
LOM-8086 Lomas Data Systems Lighting One call	
WAV-BL11 WaveMate Bullet I with floppy, 256K inst 5-100	795.00
AMD-780 Advanced Micro Digital, Hecoy & Gak	750.00
TEL-FC01 Telextek FDC1 Single board NEC785 controller	675.00

SINGLE BOARD COMPUTERS

GBT-2810 Godbout Z80 & CPU 12 bit extended address	275.00
CCS-2810 California Computer Z-80 microprocessor	275.00
SD-39020 SD Systems 595-200 Z-80 microprocessor	275.00
MSM-280 Measurement System Z-80 280 microprocessor	425.00
TAR-280 Tarbell Electronics Z-80 with two RS232 ports	395.00

8 BIT MICROPROCESSORS

GBT-2810 Godbout Z80 & CPU 12 bit extended address	275.00
CCS-2810 California Computer Z-80 microprocessor	275.00
SD-39020 SD Systems 595-200 Z-80 microprocessor	275.00
MSM-280 Measurement System Z-80 280 microprocessor	425.00
TAR-280 Tarbell Electronics Z-80 with two RS232 ports	395.00

FLOPPY DISK CONTROLLERS

GBT-05K1 Godbout Disk One double density NEC-765	375.00
MDS-032 Morrow Designs Disk Jockey II with CPM	300.00
MDS-031 Morrow Designs Disk Jockey I single density	225.00
CCS-2422 California Computer 2422 with CPM	339.00
TAR-03C Tarbell Electronics double density controller	419.00
TAR-03C Tarbell Electronics single density controller	279.00

CPM OPERATING SYSTEM

GBT-CPM22 Godbout CPM 2.2 for Disk One 8 bit operation	150.00
GBT-CPM460 Godbout CPM 86 for Disk One for use with 6566	265.00
GBT-CPM86 Godbout CPM 86 for operation with 8086 board	495.00

HARD DISK CONTROLLER

GBT-05K2 Godbout Disk II hard disk controller	695.00
GBT-05K3 Godbout Disk III hard disk controller	695.00
MDS-W506 Morrow Designs Winchester for Single 5 1/4"	495.00
WD-1000 Western Digital WD-1000 (not S-100)	495.00

EPROM BOARDS

ADS-PB100 Ackerman Digital Prom Blaster 100	275.00
SDS-#100 SD Systems Prom-100 programmer	260.00
SSM-#100 SSM Prom programmer up to 2716	195.00
DGR-F32 Digital Research 32K Eprom read only board	195.00

STATIC MEMORY BOARDS

CAL-564 California Digital Static 64 K 816 bit (512K)	595.00
GBT-R16 Godbout Ram 16 64K memory 816 bit	760.00
GBT-R17 Godbout Ram 17 64K memory 8 bit 24 bit add	350.00
GBT-R20 Godbout Ram 20 32K static memory 4K bound	375.00
GBT-R21 Godbout Ram 21 128K 816 bit static memory	995.00
CCS-2116 California Computer 2116 16K static memory	335.00

DYNAMIC MEMORY BOARDS

CAL-0266 California Digital 256K dynamic memory 8 bit	495.00
SOS-EX3 SD Systems Expanoram II 256K dynamic memory	795.00
CCS-2065 California Computers 2065 64K dynamic memory	395.00
MSM-DM364 Measurement Systems DM364/4 Alpha Micro	595.00

INTERFACE BOARDS

MDS-SB1 Morrow Designs Switchboard 2 serial 4 parallel	739.00
MDS-AT11 Morrow Designs Multiboard 3 serial 2 parallel	375.00
GBT-1334 Godbout Interface I 2 serial ports	199.00
GBT-150A Godbout Interface II 1 serial/2 parallel	199.00
GBT-135A Godbout Interface III with 5 serial ports	495.00
GBT-135A Godbout Interface III with 8 serial ports	545.00
GBT-187A Godbout Interface IV 3 serial/2 parallel	289.00
CCS-2710 California Computer 2710 serial interface	295.00
CCS-2702 California Computer 2702 serial I 2 serial	295.00
CCS-2710 California Computer 2710 parallel	219.00

SPECIAL FUNCTION BOARDS

HYS-#100 D.C. Hayes Microcommod S-100 FCC approved	329.00
ADS-N100 Ackerman Digital Rosemaker with 1/4" vertical module	119.00
OTC-CE100 OT Computer clock/calendar board	159.00
SDS-M300 Silicon Microsystems clocks, chips, implemnetors	965.00
TEC-AD212 Tecmar A/D 12 bit Accuracy 16 channel	345.00
GBT-SV53 Godbout System Support board	595.00
S99911 Godbout System Support with 8231/ 9511 math chip	539.00
MCI-1B1 Mullen's encoder board with test probe	79.00
MCI-1C10 Mullen's Opto Isolator controls & channels	179.00
ADS-4C100 Ackerman Digital Kluge prototype board	149.00
IFD-T300 IFO Technology area array prototype board	149.00
ART-048100 Arter Electronics 4810 area proto board	25.00
ART-6P100 Arter Electronics 6P100 proto board	75.00
CAL-1815 California Digital General purpose solder	35.00

OCR READER

OPTICAL RECOGNITION EQUIPMENT

\$295

DISPLAYED ASCII OUTPUT

WAND TEST DOCUMENT 4013016-001 REV. A

This optical recognition reader is the same unit currently used at the check out register at your local Sears, Roebuck or J.C. Penney retail outlets. These units can be used for inputting data for inventory control, point of sale, or any application where accuracy and speed are essential. See OCR font above. Interfaces eight bit ASCII parallel with "handshaking". Documentation and application notes included. Each reader is a brand new in factory sealed boxes. Original acquisition is approximately \$2,500. OCR-720 15 lbs.

ADVANCED COMPUTER PRODUCTS

SEND \$2.99 for 104 PAGE CATALOG

LINEAR

78H05K	\$5.95	LM1414N	\$1.90
78M06	1.49	LM1488N/N	49
78M12	1.49	MC1488N	99
LM1084H	2.95	MC1489N	99
LM300H	.99	LM1496N	.89
LM301CN	.35	LM1558N	1.50
LM304H	1.98	LM1820N	.95
LM305H	1.98	LM1850N	.95
LM306H	3.25	LM1889N	3.10
LM307CN	2.25	LM2111N	1.75
LM308CN	1.98	LM2900N	.99
LM309K	.49	LM2901N	2.50
LM310CN	1.25	LM2917N	2.95
LM311D/CN	.69	CA3018T	2.19
LM312H	1.25	CA3018T	1.74
LM317T	1.70	CA3021T	3.49
LM318CN	1.49	CA3023T	2.99
LM319N/H	1.25	CA3035T	2.75
LM320K-XX*	1.35	CA3039T	1.29
LM320T-XX*	1.39	CA3048N	1.29
LM321H-XX*	1.99	CA3051N	1.49
LM323K	4.95	CA3059N	3.19
LM324N	.95	CA3060N	3.19
LM327K	5.95	CA3062N	4.95
LM338K	6.95	LM3065N	4.19
LM339N	9.95	CA3080T	1.29
LM340H-XX*	7.15	CA3081N	1.69
LM340T-XX*	1.25	CA3082N	1.69
LM340H-XX*	1.25	CA3083N	1.55
LM344H	1.95	CA3086N	80
LM348N	1.20	CA3089N	2.99
LM350K	5.60	CA3096N	3.49
LM358CN	1.99	CA3097N	1.99
LM360N	1.49	CA3130T	3.90
LM372N	1.95	CA3140T	1.19
LM376N	3.75	CA3148N	2.49
LM377N	2.75	CA3160T	1.19
LM380CN/N	2.25	CA3190N	1.95
LM381N	1.19	CA3410N	7.49
LM383T	1.99	MC3423N	1.49
LM386N	1.25	MC3460N	3.95
LM387N	1.40	SG3524N	3.95
LM390N	1.95	CA3600N	3.39
NE531V/T	3.75	LM3900N	5.95
NE555V	3.95	LM3905N	1.19
NE558N	4.95	LM3920N	1.99
NE561T	19.95	LM3941N	3.75
NE565N/H	1.25	LM3915N	3.95
NE568N/V	1.75	LM3918N	3.75
NE567V/H	1.50	RC4131N	2.95
NE592N	2.75	RC4135N	1.10
LM702H	1.99	LM702H	1.99
LM709N/H	.75	RC4194TK	4.95
LM710N/H	.75	RC4195TK	5.40
LM711N/H	.39	ULN2001	1.25
LM715N	1.95	ULN2003	1.50
LM720N	.65	SN75450N	.59
LM733H	.95	SN75451N	.35
LM739N	1.15	SN75452N	.49
LM741CN/H	.33	SN75453N	.49
LM741CN-14	.19	SN75454N	.89
LM747N/H	.75	SN75491N	.89
LM748N/H	.39	SN75492N	.89
LM760CN	2.95	SN75493N	.89
LM7310N	1.99	SN75494N	.89
MC1330	1.95	TL494CN	4.20
MC1350	1.95	TL496CP	1.65
MC1358	1.75		

7400

7400 \$	19	7475 \$	3.98	74161 \$	8.88
7401	22	7476 \$	3.94	74162	8.97
7402	22	7479 \$	6.00	74163	8.7
7403	22	7480	.49	74164	8.7
7404	22	7482	.95	74165	8.7
7405	23	7483	.55	74166	1.20
7406	35	7485	.65	74167	1.95
7407	35	7486	.35	74170	1.89
7408	26	7489	1.75	74172	4.75
7409	23	7490	.39	74173	7.9
7410	22	7491	.57	74174	8.9
7411	29	7492	.45	74175	8.5
7412	29	7493	.45	74176	7.5
7413	39	7494	.69	74177	7.5
7414	59	7495	.55	74179	1.34
7415	29	7496	.69	74180	7.5
7416	29	7497	2.90	74181	1.75
7417	22	74100	2.90	74182	7.5
7418	32	74107	3.2	74184	2.25
7419	37	74109	.37	74185	2.25
7420	39	74116	.35	74186	9.95
7421	29	74121	2.9	74188	9.90
7422	39	74122	3.9	74190	1.15
7423	25	74123	5.9	74191	1.15
7424	45	74125	3.9	74192	8.5
7425	43	74126	.44	74193	8.5
7426	49	74128	.69	74194	8.5
7427	35	74132	.69	74195	8.5
7428	35	74136	.75	74196	8.5
7429	35	74139	.95	74197	8.5
7430	39	74141	.79	74198	1.39
7431	25	74142	2.95	74199	1.39
7432	35	74144	.95	74201	1.19
7433	35	74145	.82	74202	1.19
7434	34	74147	1.95	74203	1.85
7435	34	74148	1.20	74204	1.85
7436	34	74150	1.09	74205	1.40
7437	34	74151	.87	74206	3.90
7438	34	74152	.67	74207	1.25
7439	34	74153	.67	74208	1.25
7440	34	74154	1.19	74209	1.25
7441	34	74155	.78	74210	1.25
7442	34	74156	.78	74211	1.25
7443	34	74157	.69	74212	1.25
7444	34	74158	.69	74213	1.25
7445	34	74159	.69	74214	1.25
7446	34	74160	.88	74215	1.25
7447	34	74161	.88	74216	1.25
7448	34	74162	.88	74217	1.25
7449	34	74163	.88	74218	1.25
7450	34	74164	.88	74219	1.25

16K Apple™ Ramcard

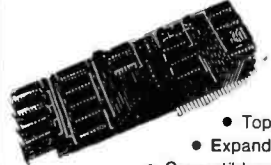

LIST 195
ACP
\$69.95

- Full 1 year warranty
- Top quality - gold fingers
- Expand Apple II 48K to 64K
- Compatible with Z-80 Softcard™
- Allows system to run with CP/M™, PASCAL, DOS 3.3, COBOL, Visicalc, etc.
- Supplied with extra 16K RAM & has (2) LED's

32K STATIC RAM

2 or 4 MHz
Expandable
Uses
2114L's

16K 4 MHz Kit	\$159.95
16K 4 MHz AST	217.95
32K 4 MHz Kit	199.95
32K 4 MHz AST	299.95
BARE BOARD	39.95
Bare Bd/w/all parts less mem.	99.95

BARE BOARDS

S-100 Sound Board	\$34.95
8080A CPU	34.95
32K Static RAM (2114)	34.95
6K EPROM (2708)	34.95
2708/2716 EPROM	34.95
ACP Proto Board	22.95
Vector 8800 Proto	22.20
Vector 8803 11 slot MB	29.95
ACP Extender with connector	18.95
13 Slot Mother Board (WMC)	32.95
9 Slot Mother Board (WMC)	29.95
8 Slot Mother Bd (Expandable)	34.95
Floppy PCB (8" SHUGART)	39.95
S100(AYS-8010) Sound Board	34.95
Apple Sound Board	24.95

64K CMOS RAM

S100 (200nS)
Uses 2716's \$349.00
or 6116's
Assembled & Tested \$399.00

MOSTEK 4K RAMS

29¢ ea.
200,000 pieces in stock - priced to move. Same as MK4027 except 1MS refresh. MK4015 4Kx1 RAM.

STEPPER MOTOR

Operates by applying 12VDC in one direction and then reversing polarity for square wave. Uses 12VDC. Clock Wise Rotation. Rated 3 RPM at 4 P.P.S. with a 5 degree stepping angle.

ACP PRICE \$4.95 ea. 10 for \$39.95

UV "EPROM" ERASER

Model UVs-11E \$79.95
Holds 4 EPROM's at a time \$325.00

4K STATIC RAM

SELL-OFF 10/\$9.90
Same as TMS4044 but designed specifically for Z-80 based systems. This is a full-spec 4Kx1 RAM, 450nS. Order: P/N Zilog 6104-4 while supply lasts.

16K Memory Expansion Kits for Apple/TRS-80

8 pcs 4116 16K
200/250nS
Specify computer \$12.95
CALL FOR VOLUME PRICING

Zilog Z8 CPU with TINY BASIC

Debug prog. \$49.95
Plus 6132 companion quasi-static RAM 29.95

Stepper Motor

USED IN DATA PRODUCTS PRINTER \$19.95 ea.

CONNECTORS

DB25P (RS232)	\$3.25
DB25S Female	3.75
Hood	1.25
Sei with Hood, Sat	7.50
22/44 S/T, KIM	2.95
43/86 S/T, MOT	6.50
50/100 S-100 Connector W/W	4.95
50/100 S-100 Connector S/T	3.95

Astec RF Modulator

for COLOR & B/W
P/N 1082 Channel 3 or 4 \$6.95

1200 BAUD MODEM IC

Features:
• 1200 Baud
• 40 Pin
• 5 Volts Only
SL1200.....\$129.00

PARALLEL ALPHA NUMERIC PRINTER

19 Column Printer prints 16 numerical columns plus 3 columns which have math, alpha and other notations. Each wheel has 12 positions with position 12 blank. Position 11 on numerical columns have decimal point or *. Utilizes 2.75" wide adding machine tape and a dual color ink ribbon. Input data parallel with four bit BCD comparator circuit (schematic provided). Print rate, 3lines per second. Operating voltage 22-28VDC with typical cycle time of 340mS. Size 6 1/2" W x 3 1/8" H x 5 1/2" Dp. New. \$17.50 ea. 3/\$45

MICROPROCESSORS

Z8001	\$99.00	80081	\$14.95	6802P	14.95
Z8002	69.00	2001	9.90	8005	14.95
Z80	9.95	9901A	1.99	8031	12.95
Z80A	11.95	9900JL	49.95	8073N	34.95
F-8 (3850)	16.95	6502	9.95	8755	49.95
2650	16.95	6502A	16.95	8748	49.95
1802	8.75	06E100	29.95	6809	30.00
8080A	4.75	6800	11.75	8086	49.95
8085	14.95	6800B	19.95	6800C	129.95

RAMS

6116/2016	\$7.95	2147	\$5.99	6290	\$1.99
8264-64K	8.50	411	5.99	5298	1.49
4116-2	1.99	414	4.69	6508	4.50
4116-2	8/12.95	1101	.99	6518	6.79
2101	3.99	1103	.99	8581	3.79
2102	2.99	4027	4.89	6604	3.99
2102-2	1.49	4044	3.99	6605	7.99
2102-4	1.29	4050	4.69	9130	8.99
2111	3.49	4060	4.69	9140	8.99
2112	3.49	4096	3.99	93415	6.99
2114	1.99	4115	1.49	93425	6.99
2114L-2	3.25	4200	7.95		
2114L-4	1.25	4201	1.29		
2125	6.99	5280	4.60		

SUPPORT

8155	\$9.95	8259	\$8.95	68047	\$22.95
8158	9.95	8275	19.95	68488	19.95
8202	29.95	8279	5.02	13505	22.95
8205	2.89	6810	4.75	6520	6.95
8212	2.75	6820	6.50	8522	9.95
8214	4.95	6821	8.50	6530-X	24.95
8218	2.75	6828	10.50	6532	17.95
8224	2.95	8834	16.95	6551	19.95
8226	2.95	8845	22.95	Z80-PIO	9.50
8228	8.95	8847	27.95	Z80-PIO	9.50
8243	9.50	6850	5.25	Z80-CTC	6.50
8250	14.95	6852	5.25	Z80A-CTC	9.50
8251	6.50	6860	10.95	Z80-DMA	19.95
8253	11.95	6862	10.95	Z80A-DMA	27.95
8255	9.50	6875	5.95	Z80-SIO	24.95
8257	9.50	6880	2.49	Z80A-SIO	29.95

MOS PROMS

2764 (8Kx8) TS	56.95	2708 (450nS)	\$5.75
2713 (4096) TS	12.95	2708 (650nS)	5.25
2716/2516 5V	7.95	1702A	5.75
(20Kx8) TS	7.95	MM5203AC	14.50
TMS2716 5V 12V	17.95	MM5204W	8.95
2758 5V (450nS)	3.50		

HI-TECH

2513-051 (5V) User	\$9.50	DAC08	59.95
2513-051 (5V) User	19.95	DAC10	9.95
2513-AD015 (5V) User	14.95	8018 Function Generator	5.50
MC68670 ASCII Shifted 1295	MC4024 VCO	2.95	
MC68670 Man Symbol 1395	LM566 VCO	1.95	
MC68670 Alpha Control			

ADVANCED COMPUTER PRODUCTS

SEND \$2.00 for 104 PAGE CATALOG

Vista COMPUTER

Vision 80
as reviewed in
May BYTE pg. 266

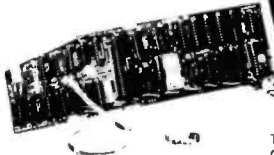

This is the widely discussed Cadillac 80 column card for the Apple II. The Vision 80 responds to more Apple text screen commands than any other board. It supports PASCAL, Microsofts Z80 Softcard and can be used as an Intelligent Terminal.
List Price... \$395.00 Special Low Price... \$269.00
The Vision 80 can also be used in conjunction with the Vision 40 (allows enhanced character sets) and the Vision 20 for lower case.

IBM COMPARE UNBEATABLE ADD-ON PRICES!

- MEMORY VISTA 576K Expandable In 64K Increments
 - w/256K populated only \$999
 - w/512K populated only 1599
 - w/576K populated only 1799
- VISTA/SUPERCALC/SUPERCACHE*
 - 192K with IBM SUPERCALC 799
- MICROSOFT RAMCARD
 - 64K w/RAMDRIVE (expandable) 419
 - 256K w/RAMDRIVE 899
- AST MEMORY CARD
 - 64K EXPANDABLE 499
 - 256K w/PARITY 899
- AST "COMBO CARD"
 - MEMORY, ASYNCH COMM. PARALLEL
 - E4K SP 525
 - 256K SP 1049
- INTERFACE CARDS
 - AST ADVANCED COMMUNICATIONS
 - 2 RS232 PORTS 269
 - BABY BLUE Z80 CARD 559
 - PROTOTYPE CARD 69
 - EXTENDER CARD 29
 - DISK DRIVES - ADD-IN (Compatible) 239
 - EPSON ADD-ON PRINTER 429
 - SUPR'MOD V RF MODULATOR 49
 - EPSON TO IBM CABLE 49

EPSON

OLYMPIA

MX80... \$429.00
MX80FT... 529.00
MX100FT... 725.00
Apple I/O w/cable... 54.95
Serial I/O w/cable... 95.00
Serial I/O w/2k & cable... 129.00
Graph Tax... 89.00
Printer Pat (P80)... 29.95
Printer Pat (P100)... 39.95

Letter quality Daisy Wheel Typewriter interfaces to Apple, Atari, NEC, TRS80 and RS232 Serial ports.

ES1000 Comp. Print	\$1690	\$1385
ES100 Typewriter Print	1195	1050
GO10 Apple I/O card	349	169
GO11 Other I/O's	349	299
I/O Cable	49	29

C. Itoh

STARWRITER F-10
40 CPS Daisy Wheel... \$1475
PRO-WRITER 8510A
120 CPS Dot Matrix Parallel... 599

OKIDATA

- 120 cps
- Logic seeking
- Double width & condensed print
- Font selection, character pitch & line spacing program controllable
- Bi-directional printing

82A 120 cps w/tractor	\$499.00
83A 120 cps 136 columns	740.00
84A-P 200 cps 136 col	999.00
84A-S Serial w/2K Buffer	1199.00
Apple Card	49.95
Apple Cable	19.95
Serial Card w/2K	129.95
Graphics ROM (82A/83A)	75.00

DIABLO 630

Diablo 630RO \$2095

NEC 8023

● 144 x 160 dots/inch ● Proportional spacing ● Lower case descenders ● No 9 dot matrix ● 8 char. sizes ● 5 unique alphabets ● Greek character set ● Graphic symbols ● 100 cps ● Bi-directional logic seeking ● Adjustable tractor ● Single sheet tractor feed ● Vertical & horizontal tabbing

LIST ACP
Prism 80 \$899 \$ 699
IDS Paper Tiger 560G 1365 1099
Prism 132 (color) 1985 1875

NEC 8023... List \$795 ACP \$549

IDS PAPER TIGER

- Dot Resolution Graphics ● 9-wire stag. printhead
- Lower case descenders
- Over 150 cps
- Bi-directional, logic seeking ● 8 character sizes ● 80-132 col. ● Hi-res dot graphics ● Proportional spacing
- Text justification

LIST ACP
Prism 80 \$899 \$ 699
IDS Paper Tiger 560G 1365 1099
Prism 132 (color) 1985 1875

OTRONA ATTACHE

- Truly Portable 18 lbs.
- Includes: CP/M*, Wordstar-plus™ Basic 80, Valet & Charton
- Includes: (2) Double Density, Double Sided thin drives. ● 380K Bytes each

ACP PRICE... \$3595.00

KAYCOMP II

- Full 9" Green Screen
- CP/M Based
- Portable Business Computer

● Complete w/CP/M 2.2 M BASIC, Magic Worksheet, Selec Word Processing, and Teach

ACP Price... only \$1795

ATARI

MODEL	LIST	ACP
800 with 16K	\$1080.00	\$689.95
800 with 48K	1280.00	789.95
800 with 32K + 128K		1295.00
810 Disk Drive	600.00	469.95
825 Printer	993.00	699.95
830 Acoustic Modem	199.00	159.95
850 Interface Module	219.95	189.95
Atari Viscalc	200.00	169.00
Atari PAC-MAN		CALL
Microtek 16K RAM	99.00	75.00
Microtek 32K RAM	199.00	149.00
Axaich 128K RAM		CALL
400 with 16K	399.95	329.95

5 1/4" DISK DRIVES

MODEL	SSDD	LIST	ACP
TM100-1	SSDD	\$219.95	
SA400	SSDD	249.95	
TM100-2	DSDD	298.95	
TM100-3	SSDD	298.95	
TM100-4	DSDD	419.95	
B-51	SSDD	224.95	
B-52	DSDD	334.95	
B-51	SSDD	399.95	
B-92	DSDD	459.95	

5 1/4" Cabinets with Power Supply
Single cabinet w/power supply... \$69.95
Dual cabinet w/power supply... 94.95

8" DISK DRIVES

MODEL	SSDD	LIST	ACP
SA801R	SSDD	\$395.00	
SA851R	DSDD	549.00	
TM848-1	SSDD	425.00	
TM848-2	DSDD	575.00	
DT-8	DSDD	525.00	
FDD100-B	SSDD	299.00	
FDD200-B	DSDD	399.00	
V1000	Case/Power Supply	375.00	
Dual 8" Power Supply		599.00	

APPLE System Saver FAN

Surge Suppressor Fan Double Outlet Receptacle... \$79.95

SANYO

FCC CLASS 2 APPROVED

MODEL	LIST	ACP
4509 9" B/W	\$210	\$169
5109CX 9" Green	220	179
8012X 12" B/W	250	219
8012X 12" Green	260	229
8013 13" Color	470	422
6113 12" RGB	995	899

NEW Down & Dirty
2012 12" B/W 145 139
2112 12" Green 169 155

USI Computer Products

SANYO EQUIVALENT

MODEL	LIST	ACP
P.I. 8" Green	\$199	\$159
P.II 12" Green	199	149
P.III 12" Orange	249	199

TERMINALS

MODEL	LIST	ACP
910C	\$599	
920C	769	
925C	749	
950	969	

● 144 x 160 dots/inch ● Proportional spacing ● Lower case descenders ● No 9 dot matrix ● 8 char. sizes ● 5 unique alphabets ● Greek character set ● Graphic symbols ● 100 cps ● Bi-directional logic seeking ● Adjustable tractor ● Single sheet tractor feed ● Vertical & horizontal tabbing

TOLL FREE 800-854-8230 TWX 910-595-1565

APPLE II DIMENSION SYSTEMS

Apple II Compatible Disk Drive
Totally compatible to Apple Drives.

\$299.00 only

Controller... \$99.00
Just plug in and run.

Vista Computer Company

Add 8" Disk Drives To Your Apple II Up To 2.4 Megabyte!

- Now "TRIMLINE V1100" with Tandon Thinline DS DD Drives.
- | | |
|-------------------|-----------|
| Tandon Dual DS DD | \$1995.00 |
| Qume Dual DS DD | 1895.00 |
| Shugart Dual 801R | 1495.00 |

APPLE COMPUTER Authorized Dealer

ON DISK FOR APPLE SAVE UP TO 40% OFF

MODEL	ACP
Viscalc 3.3	\$189
Supercalc	189
Visi Trend/Visi Plot	235
Visi Dex	199
Visi File	169
Visi Plot	159
Desk top Plan II/III	199
Visi Schedule	239
Visi Term	69
Zork	34
Versa Form	287
dBase II Ashton-Tate	489
Wordstar	235
Mail Merge	82
Soft Star	159
Data Star	169
Calc Star	189
Super Sort	132
Spellguard	219
DB Master (new)	178
DB Utility	72
PFS II/III	69
Report II/III	69
Locksmith 4.0	74
Accounting Plus	1195
Microcourier	229
Microtelegraph	229

HP HEWLETT PACKARD

HP85A Computer... \$1985
HP87 Computer... 1945
● 82907A 32K Model 239
● 82908A 64K Model 349
● 82909A 128K Model 599
● 82900A CP/M with 64K 425

HP125 Computer... 1985
7470 Low Cost Plotter... 1265
9895A 8" Dual Floppy... 5135

HP HEWLETT PACKARD CALCULATORS

MODEL	LIST	ACP
HP41C Prog. Scientific	\$189	
HP41CV w/2.2K Memory	256	
HP41 Memory Module	26	
HP41 Quad RAM	83	
HP41 Card Reader	169	
HP41 Printer	292	
HP41 Optical Wand	99	
HP-IL Interface Loop	119	
HP12C Advanced Scientific	119	
HP12C Financial	129	
HP34C Prog. Scientific	112	
HP38C Prog. Business	116	

Apple Computer Authorized Dealer

MODEL	LIST	ACP
Apple II Plus w/48K	\$1530.00	\$1099.00
Apple II Plus w/64K	1729.00	1199.00
Apple II System Special w/64K		
Z80 Card, Vision 80	2519.00	1775.00
Apple III w/128K	3495.00	2895.00
Apple III w/256K	4295.00	3495.00
ProFile Hard Disk Drive	3499.00	2899.00
Vista Apple III Timecard	135.00	169.00

Apple Products Available In-store Only

APPLE HARDWARE

MODEL	LIST	ACP
Apple II Disk II w/Controller	\$645.00	\$529.00
Apple II Disk II w/o	525.00	449.00
Apple Family System	2495.00	1995.00
Prototype Card	24.00	21.95
IEEE-488 Interface	450.00	375.00
Extended Warranty - 1 yr	225.00	199.00
Super Serial Card	195.00	174.95
Language Card	195.00	169.95
Graphic Tablet w/I/O	795.00	695.00

Available In-store Only

MORE HARDWARE

MODEL	LIST	ACP
MICROSOFT Z80 Softcard	\$395.00	\$269.00
16K Ramcard	195.00	129.00
The Premium Package	899.00	579.00
SSM AIO-II 4 Function Serial/Parallel	225.00	179.00
AIO Serial/Parallel	195.00	165.00

KEYBOARD COMPANY

Numeric Keypad	149.95	124.95
Apple II Joystick	49.95	44.50
Apple II Handcontrollers	29.95	25.85

PROMETHEUS

VERSABox Spool/Buf/r	249.00	199.00
VERSAcard Four-in-1	199.00	168.00
AUTO-DGC diagnostics	127.00	117.00

VISTA COMPUTER CO.

Vision 80 80x24 Card	395.00	269.00
Vision 40 40 col enhance	199.00	149.00
Vision 20 Lo case ROM	29.95	25.00
A800 8" DS, DD Controller	595.00	499.00
PROM Development Bd	595.00	399.00
GB75 IBM typewriter I/O	195.00	169.00
40 Char Type-ahead Buffer	49.95	35.00

VIDEX

Videoterm 80x24 Card	345.00	279.00
Keyboard Enhancer II	149.00	129.00
Soft Switch	35.00	30.00
Function Strip Keys	79.00	69.00

PRACTICAL PERIPHERALS

16K Microbuffer	259.00	220.00
32K Microbuffer	299.00	253.00
Snapshot Option	69.00	59.00

VOTRAX

Type 'n' Talk Speech	375.00	339.00
----------------------	--------	--------

SCOTT INSTRUMENTS

Voice Recogn'n VET80	799.00	675.00
----------------------	--------	--------

CORVUS

5 Mb Hard Disk	3750.00	2995.00
10 Mb Hard Disk	5350.00	4325.00
20 Mb Hard Disk	6450.00	5240.00

ORANGE MICRO

The Mapper I/O	195.00	135.00
----------------	--------	--------

SATURON SYSTEMS

32K RAM Card	239.00	189.00
64K RAM Card	425.00	355.00
128K RAM Card	599.00	505.00

NOVATION

Apple-Cal II	389.00	329.00
--------------	--------	--------

HAYES MICROCOMPUTER

Hayes Chronograph	249.00	229.00
Micromodem II	349.00	289.00
Smartmodem	299.00	229.00

MOUNTAIN COMPUTER

CPS Multifunction	239.00	169.00
RAM Plus	189.00	139.00
Expansion Chassis	750.00	699.00
Music System	395.00	335.00
100,000 Day Clock	375.00	325.00
The Clock	280.00	249.00
A/D plus D/A	350.00	299.00
Supertalker	199.00	169.00
Introl X-10 Controller	200.00	175.00
ROM Plus	155.00	129.00
Keyboard Filter ROM	55.00	44.00
Copy ROM	55.00	44.00
ROM Wrt	175.00	159.00

M&R ENTERPRISES

Sup'term 80x24 Card	299.00	279.00
PowerSwitcher 6 Amp Supply	295.00	239.00
Sup'Mod II RF Modulator	35.00	28.00
Apple Fan	55.00	43.00

ALS

The "Z" Card Z80 card	295.00	219.00
Smarterm 80x24 Card	349.00	279.00
The Synergizer Package	699.00	549.00

16K RAM CARD

Apple II 16K Compatible with Z80 Softcard™ ... PASCAL CP/M™ Full 1 year Warranty. Top Quality by COEX

NEW LOW PRICE \$699.95

Also from COEX NEW EPSON Parallel Interface for Apple.

With cable... \$54.95

Do Kay Computer Products, Inc.

VISIT OUR RETAIL STORE
AND RECEIVE A 5% DISCOUNT!

3250 KELLER STREET, #9 • SANTA CLARA, CA 95050

16 K APPLE* II RAM CARD

BARE BOARD 14.00
KIT 39.90
ASSEMBLED 45.00

*Apple is a trademark of Apple Computer, Inc.

INTERFACE

8T26	1.65
8T28	1.95
8T95	.95
8T96	.95
8T97	.95
8T98	.95
DM8131	2.90
DP8304	2.25
DS8836	1.25

1702	1ns	3.00
2708	450ns	2.99
2758	5V 450ns	9.75
TMS 2516	5V 450ns	5.75
2716	5V 450ns	3.49
2716-1	5V 350ns	7.85
TMS 2716	450ns	8.75
2532	5V 450ns	7.85
2732	5V 450ns	6.49
2764	5V 450ns	Call
MC 68764	(5V 450ns) (24 pin)	Call

DYNAMIC RAMS

TMS 4027	250ns	2.00
MK 4108	200ns	1.75
MM 5298	250ns	1.75
4116-1	150ns	1.75
4116-2	200ns	1.25
4116-3	250ns	1.15
2118	5V 150ns	Call
MK 4816	5V 300ns	Call
4164-200	5V 200ns	Call
4164-150	5V 150ns	Call

STATIC RAMS

2101	450ns	1
2102-1	450ns	1
2102L-2	250ns LP	2
2111	450ns	1
2112	450ns	2
2114	450ns	1
2114 L-3	300ns LP	1
2114 L-2	200ns LP	1
2147	55ns	8
TMS 4044-4	450ns	3
TMS 4044-3	300ns	3
TMS 4044-2	200ns	3
MK 4118	250ns	9
TMM 2016	200ns	5
TMM2016	150ns	6
TMM 2016	100ns	7
HM6116-4	200ns	1
HM6116-3	150ns	1
HM6116-2	120ns	1
Z-6132	300ns	1

LP = Low Power

RESISTORS

1/4 WATT 5% CARBON FILM
ALL STANDARD VALUES
FROM 1 OHM TO 10 MEG OHM
50 PCS. SAME VALUE .0200
100 PCS. SAME VALUE .0150
1000 PCS. SAME VALUE .0125

6500

1 MHZ	
6502	5.4
6504	6.9
6505	7.6
6507	9.9
6520	4.3
6522	7.9
6532	9.9
6545	19.9
6551	11.7
2 MHZ	
6502A	9.4
6522A	10.9
6532A	11.9
6545A	27.9
6551A	11.9
3 MHZ	
6502B	11.9

**We Will Beat
Any Competitors'
Prices!**

74LS00 SERIES

74LS00	.24	74LS123	.95	74LS253	.80
74LS01	.24	74LS124	2.90	74LS257	.80
74LS02	.24	74LS125	.95	74LS258	.80
74LS03	.24	74LS126	.79	74LS259	2.80
74LS04	.24	74LS132	.75	74LS260	.60
74LS05	.24	74LS135	.49	74LS266	.49
74LS08	.24	74LS137	.95	74LS273	1.60
74LS10	.24	74LS138	.75	74LS275	3.25
74LS11	.30	74LS139	.75	74LS279	.49
74LS12	.30	74LS145	1.10	74LS280	1.95
74LS13	.40	74LS147	2.20	74LS283	.95
74LS14	.89	74LS148	1.20	74LS290	1.20
74LS15	.30	74LS151	.75	74LS293	1.79
74LS20	.24	74LS153	.75	74LS295	.99
74LS21	.30	74LS154	1.75	74LS298	.99
74LS22	.24	74LS155	.89	74LS324	1.75
74LS26	.30	74LS156	.89	74LS352	1.49
74LS27	.24	74LS157	.75	74LS353	1.49
74LS28	.30	74LS158	.75	74LS363	1.49
74LS30	.24	74LS160	.95	74LS364	1.95
74LS32	.36	74LS161	.95	74LS365	.89
74LS33	.55	74LS162	.95	74LS366	.89
74LS37	.55	74LS163	.95	74LS367	.69
74LS38	.35	74LS164	.95	74LS368	.69
74LS40	.30	74LS165	.95	74LS373	.99
74LS42	.49	74LS166	1.95	74LS374	1.69
74LS47	.75	74LS168	1.69	74LS377	1.40
74LS48	.75	74LS169	1.69	74LS378	1.15
74LS49	.75	74LS170	1.69	74LS379	1.35
74LS51	.30	74LS173	.75	74LS385	1.89
74LS54	.35	74LS174	.89	74LS386	.59
74LS55	.35	74LS175	.89	74LS390	1.79
74LS63	1.20	74LS181	1.99	74LS393	1.70
74LS73	.39	74LS189	9.50	74LS395	1.50
74LS74	.44	74LS190	.89	74LS399	1.59
74LS75	.49	74LS191	.89	74LS424	2.89
74LS76	.39	74LS192	.89	74LS447	.75
74LS78	.49	74LS193	.89	74LS490	1.89
74LS83	.75	74LS194	.89	74LS668	1.65
74LS85	.95	74LS195	.89	74LS669	1.85
74LS86	.39	74LS196	.79	74LS670	2.10
74LS90	.65	74LS197	.79	74LS674	9.50
74LS91	.79	74LS221	1.10	74LS682	2.99
74LS92	.65	74LS240	.95	74LS683	2.39
74LS93	.59	74LS241	.95	74LS684	2.39
74LS95	.79	74LS242	1.79	74LS685	2.39
74LS96	.79	74LS243	1.79	74LS688	2.39
74LS107	.39	74LS244	.95	74LS689	2.39
74LS109	.39	74LS245	1.89		
74LS112	.39	74LS247	.79	81LS95	1.65
74LS113	.39	74LS248	1.20	81LS96	1.65
74LS114	.49	74LS249	.89	81LS97	1.65
74LS122	.45	74LS251	1.25	81LS98	1.65

UARTS

AY5 1014	5.85
AY5 1013	3.90
AY5 2376	10.95
TR 1602	3.90
1M 6402	7.85
1M 6403	8.85

LEDS

Jumbo Red	10/1.00
Jumbo Green	6/1.00
Jumbo Yellow	6/1.00

DIP SWITCHES

4 Position	.85
5 Position	.90
6 Position	.90
7 Position	.90
8 Position	.95

EXAR

XR 2206	3.75
XR 2207	3.75
XR 2208	3.90
XR 2211	5.25
XR 2240	3.25

RCA

CA 3010	.95
CA 3013	1.99
CA 3023	2.75
CA 3035	2.49
CA 3039	1.25
CA 3046	1.25
CA 3053	1.45
CA 3059	2.90
CA 3060	2.90
CA 3065	1.75
CA 3080	1.10
CA 3081	1.65
CA 3082	1.65
CA 3083	1.65
CA 3086	8.00
CA 3089	2.90
CA 3130	1.25
CA 3140	1.15
CA 3146	1.75
CA 3160	1.15
CA 3401	3.59
CA 3600	3.45

CMOS

4000	.25	4086	.90	74C89	4.5
4001	.30	4093	.90	74C90	1.7
4002	.30	4098	2.49	74C93	1.7
4006	.90	4099	1.90	74C95	1.7
4007	.25	4502	.90	74C107	1.0
4008	.90	4503	.60	74C150	5.7
4009	.45	4508	1.90	74C151	2.2
4010	.45	4510	.90	74C154	3.2
4011	.30	4511	.90	74C157	1.7
4012	.30	4512	.90	74C160	2.0
4013	.45	4514	1.20	74C161	2.0
4014	.90	4515	2.20	74C162	2.0
4015	.90	4516	1.50	74C163	2.0
4016	.45	4518	1.20	74C164	2.0
4017	1.15	4519	1.20	74C165	2.0
4018	.90	4520	1.20	74C173	2.0
4019	.45	4522	1.20	74C174	2.2
4020	.90	4526	1.20	74C175	2.2
4021	.90	4527	1.90	74C192	2.2
4022	1.10	4528	1.20	74C193	2.2
4023	.35	4531	.90	74C195	2.2
4024	.75	4532	1.90	74C200	5.7
4025	.35	4538	1.90	74C221	2.2
4026	1.60	4539	1.90	74C373	2.7
4027	.60	4543	2.70	74C374	2.7
4028	.75	4555	.90	74C901	.8
4029	.90	4556	.90	74C902	.8
4030	.45	4581	1.90	74C903	.8
4034	2.90	4582	1.90	74C905	10.9
4035	.85	4584	.90	74C906	.9
4040	.90	4585	.90	74C907	1.00
4041	1.20			74C908	2.00
4042	.75	80C07	.90	74C909	2.7
4043	.75	80C95	.90	74C910	9.9
4044	.75	80C96	.90	74C911	10.00
4046	.90	80C97	.90	74C912	10.00
4047	.90	80C98	1.15	74C914	1.9
4049	.50			74C915	2.00
4050	.50	74C00	.35	74C918	2.7
4051	.90	74C02	.35	74C920	17.9
4053	.90	74C04	.35	74C921	15.9
4060	1.39	74C08	.35	74C922	5.5
4066	.75	74C10	.35	74C923	5.9
4068	.39	74C14	1.50	74C925	6.7
4069	.30	74C20	.35	74C926	7.9
4070	.35	74C30	.35	74C927	7.9
4071	.30	74C32	.50	74C928	7.9
4072	.30	74C42	1.75	74C929	19.9
4073	.30	74C48	1.20	74C930	19.9
4075	.30	74C73	.65		
4076	.90	74C74	.85	14409	12.9
4078	.30	74C76	.80	14410	12.9
4081	.30	74C83	1.95	14411	11.9
4082	.30	74C85	1.95	14412	12.9
4085	.90	74C86	.95	14419	4.9

Do Kay Computer Products, Inc.

3250 Keller Street, #9
Santa Clara, CA 95050

(800) 538-8800

Calif. Residents
(800) 848 8008

Local Phone
(408) 988-0697

STORE HOURS:
MON-FRI 8:30 A.M.-6:00 P.M.
SAT 10:00 A.M.-3:00 P.M.



TERMS: For shipping include \$2.00 for UPS Ground. \$3.00 for UPS Blue Label Air. \$10.00 minimum order. Bay Area residents add 6% Sales Tax. California residents add 6% Sales Tax. We reserve the right to limit quantities and substitute manufacturer. Prices subject to change without notice. Send SASE for complete list.

APPLE II USERS DISK DRIVE!

- Includes metal cabinet
- Color matches Apple
- 35 Tracks/single side
- Includes cable
- Use with Apple II Controller

279.00

WITH CONTROLLER CARD - 359.95

APPLE **UPGRADE** **TRS-80**

4116 - 200_{ns} 8/10.00

2.5 MHZ		Z80A-DMA	25.95
Z80-CPU	3.75	Z80A-DART	17.95
Z80-PIO	4.95	Z80A-S(O)0	21.95
Z80-CTC	4.95	Z80A-SIO/1	21.95
Z80-DMA	16.95	Z80A-SIO/2	21.95
Z80-DART	14.95	Z80A-SIO/9	18.95
Z80-SIO/0	17.95	6.0 MHZ	
Z80-SIO/1	17.95	Z80B-CPU	16.95
Z80-SIO/2	17.95	Z80B-PIO	14.95
Z80-SIO/9	16.95	Z80B-CTC	14.95
4.0 MHZ		ZILOG	
Z80A-CPU	4.95	Z6132	Call
Z80A-PIO	4.95	Z8671	Call
Z80A-CTC	6.95		

Z80 SERIES

DoKay Computer Products, Inc.

VISIT OUR RETAIL STORE
AND RECEIVE A 5% DISCOUNT!

3250 KELLER STREET, #9 • SANTA CLARA, CA 95050

Diskettes

5 1/4"

ATHANA SS SD SOFT	23.95
ATHANA SS DD SOFT	24.95
ATHANA DS DD SOFT	31.95

BULK
SS DD SOFT

\$1.85 ea.

LINEAR

LM301	.32	LM741	.29
LM308	.75	LM747	.75
LM309K	1.25	LM748	.49
LM311	.64	LM1310	2.45
LM317T	1.65	MC1330	1.69
LM317K	1.70	MC1350	1.25
LM318	1.49	MC1358	1.69
LM323K	3.75	LM1411	1.49
LM324	.59	LM1458	.55
LM337K	3.90	LM1488	.95
LM339	.79	LM1489	.95
LM377	2.25	LM1600	2.45
LM380	1.25	LM1889	2.45
LM386	1.00	LM3900	.59
LM555	.38	LM3909	.95
LM556	.65	LM3914	3.70
LM565	.95	LM3915	3.70
LM566	1.45	LM3916	3.70
LM567	.99	75451	.35
LM723	.49	75452	.35
LM733	.95	75453	.35

ORDER TOLL FREE
(800) 538-8800
(800) 848-8008
(CALIFORNIA RESIDENTS)
ALL MERCHANDISE IS 100% GUARANTEED

CLOCK CIRCUITS

MM 5314	4.90
MM 5369	3.90
MM 5375	4.90
MM 58167	8.90
MM 58174	10.95
MSM 5832	6.90

9000 SERIES

9316	.95
9334	2.39
9368	3.69
9401	8.95
9601	.69
9602	1.39
96502	1.79

MISC.

11 C 90	12.95
3242	6.95
MC 3470	7.95
MC 3480	8.95
ULN 2003	5.95
CA 3146	1.75
2513-001 up	9.69
2513-002 low	9.69

VOLTAGE REGULATORS

7805T	.75	7908T	.85
7808T	.75	7912T	.85
7812T	.75	7915T	.85
7815T	.75	7924T	.95
7824T	.85		
7805K	1.29	7905K	1.39
7812K	1.29	7912K	1.39
7815K	1.29	7915K	1.39
7824K	1.29	7924K	1.39
7905T	.85		

T = TO-220
K = TO-3

CONNECTORS

RS232 Male	3.00
RS232 Female	3.50
RS232 Female Right Angle	4.95
RS232 Hood	1.20
30 pin Edge	2.49
44 pin Edge	2.49
50 pin Edge	2.69
86 pin Edge	3.90
100 pin ST	3.90
100 pin W/W	4.90

CRYSTALS

32.768 KHZ	1.90	5.185	3.90
10 MHZ	4.50	5.7143	3.90
1.8432	4.50	6.5536	3.90
2.0	3.90	8.0	3.00
2.097152	3.90	10.0	3.00
2.4576	3.90	14.31818	3.90
3.2768	3.90	18.0	3.00
3.579545	3.00	18.432	3.00
4.0	3.00	20.0	3.00
5.0	3.00	22.1184	3.00
5.0688	3.90	32.0	3.90

8000

8035	6.95	8239	4.75
8039	7.59	8243	4.75
8080A	3.90	8250	14.90
8085A	7.95	8251	4.50
8088	34.95	8253	8.75
8155	7.75	8253-5	9.75
8156	8.75	8255	4.50
8185	29.00	8255-5	5.20
8741	39.00	8257	8.50
8748	14.95	8259	6.85
8755	29.95	8272	39.00
8202	27.95	8275	29.00
8205	3.45	8279	9.25
8212	1.80	8279-5	9.95
8214	3.75	8282	6.50
8216	1.75	8283	6.50
8224	2.45	8284	5.50
8226	1.80	8286	6.50
8228	4.50	8287	6.50
8237	19.00	8288	25.00
8238	4.75	8289	49.00

Disc Controllers

1771	16.00
1791	27.95
1793	29.95
1795	49.95
1797	49.95
1691	17.95
UPD 765	34.95

6800
1 MHz

6800	4.75
6802	8.65
6808	8.45
6809	11.95
6809 E	17.95
6810	2.90
6820	3.50
6821	3.50
6828	14.90
6840	7.95
6843	32.95
6844	32.95
6845	16.90
6847	11.95
6850	3.20
6852	3.50
6860	10.90
6862	11.90
6875	6.90
6880	1.80
6883	22.95

IC Sockets

	ST	W/W
8 PIN	.10	.49
14 PIN	.12	.50
16 PIN	.15	.57
18 PIN	.20	.85
20 PIN	.25	.99
22 PIN	.25	1.30
24 PIN	.25	1.40
28 PIN	.35	1.50
40 PIN	.40	1.80

ST = Soldertail
W/W = Wirewrap

2 MHz

68B00	10.00
68B02	21.95
68B09	28.95
68B09 E	29.90
68B10	7.90
68B21	12.00
68B45	34.00
68B50	12.00

8 MHz

68000	95.95
-------	-------

Power Supplies

MOUNTED ON PC BOARD
MANUFACTURED BY CONVER
+5 VOLT 4 AMP
±12 VOLT 1 AMP

34.95



DoKay Computer Products, Inc.
3250 Keller Street, #9
Santa Clara, CA 95050
(800) 538-8800
Local Phone (408) 988-0697
Calif. Residents (800) 848-8008

STORE HOURS:
MON-FRI 8:30 A.M.-6:00 P.M.
SAT 10:00 A.M.-3:00 P.M.



TERMS: For shipping include \$2.00 for UPS Ground. \$3.00 for UPS Blue Label Air. \$10.00 minimum order. Bay Area residents add 6% Sales Tax. California residents add 6% Sales Tax. We reserve the right to limit quantities and substitute manufacturer. Prices subject to change without notice. Send SASE for complete list.

Disk Drive for Apple \$289.95

Modems

SIGNALMAN - Anchor

Direct-connect automatic answer/originate selection, 300 Baud full duplex, Bell 103, includes RS-232 cable
IOM-5600A Signalman \$89.95

SMARTMODEM - Hayes

Sophisticated direct-connect auto-answer/auto-dial modem, touch-tone or pulse dialing, RS-232C interface, programmable
IOM-5400A Smartmodem \$224.95
IOK-1500A Hayes Chronograph \$218.95
IOM-2010A Micromodem II \$328.95
IOM-2012A Terminal program for MMII \$89.95
IOM-1100A Micromodem 100 \$366.95

APPLE-CAT - Novation

Software selectable 1200 or 300 Baud, direct connect, auto-answer/auto-dial, touch & pulse dialing, auxiliary 3-wire RS-232C serial port for printer
IOM-5232A Save \$50.00 \$324.95

1200 BAUD SMARTMODEM - Hayes

1200 and 300 baud, all the features of the standard Smartmodem plus 1200 baud, 212 compatible, full or half duplex.
IOM-5500A Smartmodem 1200 \$599.95

1200 BAUD AUTO CAT - Novation

212 Auto Cat, 1200 & 300 baud, auto dial/answer/disconnect, LED readout displays mode, analog/digital loop-back self tests, usable with multi-line phones.
IOM-5231A 212 Auto Cat \$649.95

Video Monitors

HI-RES 12" GREEN - Zenith

15 MHz bandwidth 700 lines/inch, P31 green phosphor, switchable 40 or 80 columns, small, light-weight & portable.
VDM-201201 List price \$189.95 \$129.95

12" GREEN SCREEN - NEC

20 MHz bandwidth, P31 phosphor ultra-high resolution video monitor with audio.
VDM-651200 Deluxe model \$199.95
VDM-651260 Economy model \$149.95

12" COLOR MONITOR - NEC

High resolution color monitor with audio.
VDC-651212 Color monitor \$389.95
NEC-1202D RGB color monitor \$999.95

13" COLOR MONITORS - BMC

18 MHz RGB & composite video color monitors.
VDC-421320 13" RGB Color \$369.95
VDC-421310 13" Composite video \$329.95
VDX-420090 RGB card for Apple \$149.95

COLOR MONITORS - Amdek

Reasonably priced color video monitors.
VDC-80130 13" Color I \$379.95
VDC-801320 13" Color II \$894.95
IOV-2300A DVM board for Apple \$199.95

AMBER or GREEN MONITORS - Jade

High resolution 18 MHz compact video monitors.
VDM-751210 12" Amber phosphor \$149.95
VDM-751220 12" Green phosphor \$139.95
VDM-750910 9" Amber phosphor \$149.95
VDM-750920 9" Green phosphor \$139.95

EPROM Erasers

ULTRA-VIOLET EPROM ERASERS

Inexpensive erasers for industry or home.
XME-3100A Spectronics w/o timer \$69.50
XME-3101A Spectronics with timer \$94.50
XME-3200A Economy model \$39.95

CP/M 3.0 Upgrade

NEW CP/M 3.0 - Digital Research

CP/M 3.0 is Digital Research's latest version of the industry standard disk operating system. It features many performance improvements such as intelligent record buffering, improved directory handling, "HELP" facility, time/date stamping of files and many more improvements. **AND A TREMENDOUS INCREASE IN SPEED !!!**, it is fully CP/M 2.2 compatible and requires no changes to your existing application software. Available only to VersaT floppy II owners with SBC-200 CPU's

SFC-55009057F CP/M 3.0 8" with manuals \$200.00
SFC-55009057D CP/M 3.0 manual set \$30.00

Apple II Accessories

APPLE DISK DRIVE - Fourth Dimension

Totally Apple compatible, 143,360 bytes per drive on DOS 3.3, half-track capability - reads all Apple software, plugs right in to Apple controller as second drive, DOS 3.3, 3.2.1, Pascal, & CP/M compatible.

MSM-123200 40 Track add on Apple drive \$289.95
MSM-123200 Controller with free DOS 3.3 \$99.95

16K RAM CARD - for Apple II

Expand your Apple II to 64K, use as language card, full 1 year warranty. Why spend \$175.00 ?
MEX-16700A Save over \$100.00 \$69.95

Z-80 CPU CARD - for Apple II

Two computers in one, Z-80 & 6502, more than doubles the power and potential of your Apple, includes Z-80 CPU card CP/M and complete manual set.
CPX-62800A A & T with software \$249.95

APPLE-CAT - Novation

Software selectable 1200 or 300 baud, direct connect, auto-answer/auto-dial, auxiliary 3-wire RS232C serial port for printer.
IOM-5232A Save \$50.00!!! \$325.95

8" DISK CONTROLLER - Vista

New from Vista Computer, single or double sided, single or double density, compatible with DOS 3.2/3.3, Pascal, & CP/M 2.2, Shugart & Qume compatible
IOD-2700A A & T \$499.95

2 MEGABYTES for Apple II

Complete package includes: Two 8" double-density disk drives, Vista double-density 8" disk controller, cabinet, power supply, & cables. DOS 3.2/3.3, CP/M 2.2, & Pascal compatible.

1 MegaByte Package Kit \$1495.00
1 MegaByte Package A & T \$1695.00
2 MegaByte Package Kit \$1795.00
2 MegaByte Package A & T \$1995.95

VISION 80 - Vista Computer

80 column x 24 line video card for Apple II, 128 ASCII characters, upper and lower case, 9 x 10 dot matrix with 3 dot descenders, standard data media terminal control codes, CP/M Pascal & Fortran compatible. 50/60 Hz
IOV-2400A Vista Vision 80 \$299.95

CPS MULTICARD - Mtn. Computer

Three cards in one! Real time clock/calendar, serial interface, & parallel interface - all on one card.
IOX-2300A A & T \$179.95

Power Strips

ISOBAR - GSC

Isolates & protects your valuable equipment from high voltage spikes & AC line noise. inductive isolated ground, 15 amp circuit breaker. U.L. listed

EME-115103 3 socket \$39.50
EME-115105 4 socket \$49.50
EME-115100 8 socket \$54.50
EME-115110 9 socket rackmount \$74.50

Single Board Computer

SUPERQUAD - Adv. Micro Digital

Single board, standard size S-100 computer system, 4 MHz Z-80A, single or double density disk controller for 5 1/4" or 8" drives, 64K RAM, extended addressing, up to 4K of EPROM, 2 serial & 2 parallel I/O ports, real time interrupt clock, CP/M compatible.

CPC-30800A A & T \$724.95
IOX-4232A Serial I/O adapter \$29.95

Z-80 STARTER KIT - SD Systems

Complete Z-80 microcomputer with RAM, ROM, I/O, keyboard, display, kludge area, manual, & workbook.
CPS-30100K Kit with workbook \$299.95
CPS-30100A A & T with workbook \$469.95

AIM-65 - Rockwell International

Complete 6502 microcomputer with alphanumeric display, printer, keyboard, & instruction manual.

CPK-50165A 1K AIM-65 \$424.95
CPK-50465A 4K AIM-65 \$474.95
SFK-74600008E 8K Basic ROM \$64.95
SFK-64600004E 4K assembler ROM \$43.95
SFK-74600020E PL/65 ROM \$84.95
SFK-74600010E Forth ROM \$64.95
SFK-74600030E Instant Pascal \$99.95
PSX-030A Power supply \$64.95
ENX-00002 Enclosure \$54.95

SPECIAL PACKAGE

4K AIM-65, 8K Basic, power supply, & enclosure
Special Package Price \$649.95

S-100 EPROM Boards

PROM-100 - SD Systems

2708, 2716, 2732 EPROM programmer with software.
MEM-99520K Kit with software \$189.95
MEM-99520A A & T with software \$249.95

PB-1 - SSM Microcomputer

2708, 2716 EPROM board with on-board programmer.
MEM-99510K Kit with manual \$154.95
MEM-99510A A & T with manual \$219.95

EPROM BOARD - Jade

16K or 32K uses 2708 or 2716 EPROMs, 1K boundary.
MEM-16230K Kit w/o EPROMs \$79.95
MEM-16230A A & T w/o EPROMs \$119.95

S-100 Video Boards

SPECTRUM COLOR - CompuPro

Full-function color graphics board, up to 8 colors, 256 x 192 graphics, parallel I/O port, 8K RAM.
IOV-1870A A & T \$348.95
IOV-1870C CSC \$398.95

MICROANGELO - Scion

Ultra-high-resolution 512 x 480, 256 color or black & white S-100 video board
IOV-1500A A & T \$799.95

S-100 MotherBoards

ISO-BUS - Jade

Silent, simple, and on sale - a better motherboard
6 Slot (5 1/4" x 8 1/2")
MBS-061B Bare board \$22.95
MBS-061K Kit \$39.95
MBS-061A A & T \$69.95
12 Slot (9 1/4" x 8 1/2")
MBS-121B Bare board \$34.95
MBS-121K Kit \$69.95
MBS-121A A & T \$109.95
18 Slot (14 1/2" x 8 1/2")
MBS-181B Bare board \$54.95
MBS-181K Kit \$99.95
MBS-181A A & T \$149.95

ACTIVE TERMINATOR - CompuPro

A true mother's helper.
TSX-100A A & T \$59.45

Circle 253 on inquiry card.

Prices may be slightly higher at our retail locations. Please call the store nearest you for local price and availability.

64K Static RAM \$299.95

S-100 CPU Boards

8086/8087 - CompuPro

16 bit, 8 or 10 MHz 8086 CPU with provisions for 8087 & 80130
 CPU-70520A 8 MHz 8086 A & T \$624.95
 CPU-70520C 8 MHz 8086 CSC \$764.95
 CPU-70530A with 8087 A & T \$1224.95
 CPU-70530C with 8087 CSC \$1455.95

8085/8088 - CompuPro

Both 8 & 16 bit CPUs, standard 8 bit S-100 bus, up to 8 MHz, accesses 16 Megabytes of memory
 CPU-20510A 6 MHz A & T \$398.95
 CPU-20510C 6 8 MHz CSC \$497.95

CPU-Z - CompuPro

2 4 MHz Z80A CPU, 24 bit addressing
 CPU-30500A 2 4 MHz A & T \$279.95
 CPU-30500C 3 6 MHz CSC \$374.95

SBC-200 - SD Systems

4 MHz Z-80 CPU with serial & parallel I/O, 1K RAM, 8K ROM space, monitor PROM included
 CPC-30200A A & T \$399.95

THE BIG Z - Jade

2 or 4 MHz switchable Z-80 CPU board with serial I/O, accommodates 2708, 2716, or 2732 EPROM, baud rates from 75 to 9600
 CPU-30201B Bare board w manual \$35.00
 CPU-30201K Kit with manual \$149.95
 CPU-30210A A & T with manual \$199.95

CB-2 - SSM Microcomputer

2 or 4 MHz Z-80 CPU board with provision for up to 8K of ROM or 4K of RAM on board, extended addressing, IEEE S-100, front panel compatible
 CPU-30300K Kit with manual \$229.95
 CPU-30300A A & T with manual \$274.95

2810 Z-80 CPU - C.C.S.

2 or 4 MHz Z-80 CPU with serial I/O port & on-board monitor PROM, front panel compatible
 CPU-30400A A & T with PROM \$289.95

2820 Z-80 DMA CPU - C.C.S.

4 MHz Z-80 CPU board with 2 serial I/O ports & Centronics parallel I/O port, separate data & status ports, DMA daisy chain compatible
 CPU-30420A A & T with manual \$569.95

S-100 Disk Controllers

DISK 1 - CompuPro

8" or 5 1/4" DMA disk controller, single or double density, single or double sided, 10 MHz.
 IOD-1810A A & T \$449.95
 IOD-1810C CSC \$554.95
 SFC-52506580F 8" CP/M 2.2 for Z-80 \$174.95
 SFC-52506586F 8" CP/M 2.2 for 8086 \$299.95
 SFO-54158000F Oasis single user \$499.95
 SFO-54158002F Oasis multi-user \$849.95

VERSAFLOPPY II - SD Systems

Double density disk controller for any combination of 5 1/4" and 8" single or double sided, analog phase-locked loop data separator, vectored interrupts, CP/M 2.2 & Oasis compatible, control/diagnostic software PROM included.
 IOD-1160A A & T with PROM \$359.95
 SFC-55009047F CP/M 2.2 with VF II \$99.95

2242 DISK CONTROLLER - C.C.S.

5 1/4" or 8" double density disk controller with on-board boot loader ROM, free CP/M 2.2 & manual set.
 IOD-1300A A & T with CP/M 2.2 \$399.95

DOUBLE D - Jade

High reliability double density disk controller with on-board Z-80A, auxiliary printer port, IEEE S-100, can function in multi-user interrupt driven bus.
 IOD-1200B Bare board & h/wr man \$59.95
 IOD-1200K Kit w/h/wr & slt/wr man \$299.95
 IOD-1200A A & T w/h/wr & slt/wr man \$325.95
 SFC-59002001F CP/M 2.2 with Double D \$99.95

Circle 253 on inquiry card.

S-100 Memory Boards

256K RAMDISK - SD Systems

ExpandoRAM III expandable from 64K to 256K using 64K x 1 RAM chips, compatible with CP/M, MP/M, Oasis, Cromemco, & most other Z-80 based systems, functions as ultra-high speed disk drive when used with optional RAMDISK software.
 MEM-65064A 64K A & T \$474.95
 MEM-65128A 128K A & T \$574.95
 MEM-65192A 192K A & T \$674.95
 MEM-65256A 256K A & T \$774.95
 SFC-55009000F RAMDISK slt/wr CP/M 2.2 \$44.95
 SFC-55009000F RAMDISK with EXRAM III \$24.95

128K RAM 21 - CompuPro

128K x 8 bit or 64K x 16 bit static RAM board, 12 MHz, 24 bit addressing.
 MEM-12810A A & T \$1609.95
 MEM-12810C CSC \$1794.95

64K RAM 17 - CompuPro

64K CMOS static RAM board, 10 MHz, low power less than 4 watts, DMA compatible, 24 bit addressing.
 MEM-64180A 64K A & T \$549.95
 MEM-64180C 64K CSC \$698.95

64K RAM 16 - CompuPro

32K x 16 bit or 64K x 8 bit low power static RAM board, 10 MHz, 24 bit addressing.
 MEM-32180A RAM 16 A & T \$598.95
 MEM-32180C RAM 16 CSC \$698.95

64K STATIC RAM - SSM

IEEE 696 S-100 standard, up to 6MHz 8 Bit, 12MHz 16 Bit, 24 Bit extended addressing, disable-able in 2K increments
 MEM-64300A A & T \$499.95

64K STATIC RAM - Mem Merchant

64K static S-100 RAM card, 4 to 16K banks up to 8 MHz.
 MEM-64400A 64K A & T \$499.95

64K STATIC RAM - Jade

Uses new 2K x 8 static RAMs, fully supports IEEE 696 24 bit extended addressing, 200ns RAMs, lower 32K or entire board phantomable, 2716 EPROMs may be subbed for RAMs, any 2K segment of upper 8K may be disabled, low power typically less than 500ma.
 MEM-99152B Bare board \$49.95
 MEM-99152K Kit less RAM \$99.95
 MEM-32152K 32K kit \$199.95
 MEM-56152K 56K kit \$289.95
 MEM-64152K 64K kit \$299.95
 Assembled & Tested add \$50.00

2066 64K RAM - C.C.S.

64K RAM board with bank and block select switching functions for Cromemco Cromix & Alpha Micro.
 MEM-64566A 64K A & T \$424.95

64K EXPANDORAM II - SD Systems

Expandable RAM board from 16K to 64K using 4116 RAM chips.
 MEM-16630A 16K A & T \$344.95
 MEM-32631A 32K A & T \$364.95
 MEM-48632A 48K A & T \$384.95
 MEM-64633A 64K A & T \$399.95

MEMORY BANK - Jade

4 MHz S-100 bank selectable expandable to 64K.
 MEM-99730B Bare board w manual \$49.95
 MEM-99730K Kit with no RAM \$179.95
 MEM-32731K 32K kit \$199.95
 MEM-64733K 64K kit \$249.95
 Assembled & Tested add \$50.00

16K STATIC RAM - Mem Merchant

4MHz low-power static RAM board, IEEE S-100, bank selectable, addressable in 4K blocks, disable-able in 1K segments extended addressing.
 MEM-16171A 16K A & T \$149.95

S-100 I/O Boards

SYSTEM SUPPORT 1 - CompuPro

Real time clock, three 16 bit interval timers, dual interrupt controllers (15 levels), up to 4K EPROM/RAM, RS-232C serial channel, provision for 9511A 9512 math chip.
 IOX-1850A SS1 A & T \$359.95
 IOX-1850C SS1 CSC \$459.95
 IOX-1855A with 9511 A & T \$554.95
 IOX-1855C with 9511 CSC \$654.95
 IOX-1860A with 9512 A & T \$554.95
 IOX-1860C with 9512 CSC \$654.95

INTERFACER 1 - CompuPro

2 serial I/O ports 50-19.2K baud.
 IOI-1810A A & T \$218.95
 IOI-1810C CSC \$288.95

INTERFACER 2 - CompuPro

3 parallel, 1 serial, & interrupt timer.
 IOI-1820A A & T \$218.95
 IOI-1820C CSC \$288.95

INTERFACER 3 - CompuPro

5 or 8 channel serial I/O board for interrupt driven multi-user systems up to 250K baud.
 IOI-1835A 5 port A & T \$558.95
 IOI-1835C 5 port CSC \$628.95
 IOI-1838A 8 port A & T \$628.95
 IOI-1838C 8 port CSC \$749.95

INTERFACER 4 - CompuPro

3 serial, 1 parallel, 1 Centronics parallel.
 IOI-1840A A & T \$314.95
 IOI-1840C CSC \$414.95

MPX - CompuPro

Multi-user I/O multiplexer & interrupt controller with on-board 8085A-2 CPU & 4K or 16K of RAM.
 IOI-1875A 4K MPX A & T \$444.95
 IOI-1875C 4K MPX CSC \$534.95
 IOI-1880A 16K MPX A & T \$584.95
 IOI-1880C 16K MPX CSC \$674.95

I/O-8 - SSM Microcomputer

Eight software programmable serial I/O ports, 110-19.2K Baud, ideal for multi-user systems
 IOI-1018A A & T \$469.95

I/O-5 - SSM Microcomputer

Two serial & 3 parallel I/O ports, 110-19.2K Baud
 IOI-1015A A & T \$289.95

MPC-4 - SD Systems

Intelligent 4-port serial I/O card, on-board Z-80A, 2K RAM, 4K PROM area, on-board firmware, fully buffered, vectored interrupts, four CTC channels, add to SD Board set for powerful multi-user system
 IOI-1504A A & T w/software \$495.00

I/O-4 - SSM Microcomputer

2 serial I/O ports plus 2 parallel I/O ports.
 IOI-1010B Bare board w/manual \$35.00
 IOI-1010K Kit with manual \$179.95
 IOI-1010A A & T with manual \$249.95

2830 6 PORT SERIAL - C.C.S.

Six asynchronous RS-232C serial I/O ports with programmable baud rates.
 IOI-1040A A & T with manual \$529.95

2710 4 PORT SERIAL - C.C.S.

Four RS-232C serial I/O ports with full handshaking.
 IOI-1060A A & T with manual \$319.95

2719 2 SER & 2 PAR - C.C.S.

Two RS-232C serial I/O ports plus two 8 bit parallel I/O ports.
 IOI-1080A A & T with manual \$349.95

See page 588 for Ordering Information

8" Double-Density Disk Drive \$249

Save \$500.00 Dual 8" Disk Drive Sub-System Kit - \$695.00 Assembled & Tested - \$795.00

Printers on Sale

NEW EPSONS with GRAFTRAX-plus



MX-80 MX-80FT MX-100

Available only from your local Jade Retail Store

**Dallas, Woodland Hills,
Santa Ana, San Diego,
Sunnyvale, Los Angeles**

Call the store near you for price or information.

INDUSTRIAL QUALITY PRINTERS - Okidata We Can Beat Any Price... Call Us !!!

Microline 82A 80/132 column, 120 CPS, 9 x 9 dot matrix, friction feed, pin feed, adjustable tractor feed (optional), handles 4 part forms up to 9.5" wide, rear & bottom feed, paper tear bar, 100% duty cycle/200,000,000 character print head, bi-directional/logic seeking, both serial & parallel interfaces included, front panel switch & program control of 10 different form lengths, uses inexpensive spool type ribbons, double width & condensed characters, true lower case descenders & graphics
PRM-43082 Friction & pin feed Call

Microline 83A 132/232 column, 120 CPS, forms up to 15" wide, removable tractor, plus all the features of the 82A.
PRM-43083 with FREE tractor Call

Microline 84 132/232 column, Hi-speed 200 CPS, full dot graphics built in, plus all the features of the 83A.
PRM-43084 Centronics parallel Call
PRM-43085 Serial with 2K buffer Call

PRA-27081 Apple card \$39.95
PRA-27082 Apple cable \$19.95
PRA-27087 TRS-80 cable \$24.95
PRA-43081 2K hi speed serial card \$99.95
PRA-43082 Hi-res graphics ROMs 82A \$49.95
PRA-43083 Hi-graphics ROMs 83A \$49.95
PRA-43088 Tractor option for 82A \$49.95
PRA-43080 Extra ribbons pkg. of 2 \$9.95

8023 DOT MATRIX - NEC

100 CPS, proportional spacing, hi-resolution graphics, correspondence quality printing, bi-directional tractor & friction feed.

NEC-8023A 8023 parallel \$499.95
NEC-8023-01 8023 ribbon \$11.95

TP-1 LETTER QUALITY - SCM

12 CPS daisy wheel printer from Smith Corona.

PRD-45101 Centronics parallel \$648.95
PRD-45102 RS-232C serial \$648.95

LETTER QUALITY PRINTER - Jade

Uses standard daisy wheels and ribbon cartridges, 16 CPS bi-directional printing, semi-automatic paper loader (single sheet or fan fold), 10/12/15 pitch, up to 16" paper, built-in noise suppression cover.

PRD-11001 Centronics parallel \$899.95
PRD-11002 RS-232C serial model \$969.95
PRA-11000 Tractor Option \$169.95

KSR DAISY WHEEL - Anderson-Jacobson

Letter quality communications terminal/printer with full typewriter keyboard, 30 CPS Diablo print mechanism, RS-232 interface, includes free printer stand with deluxe casters, print wheel, ribbon, friction feed standard (tractor feed optional), factory refurbished with 30 day warranty, shipped freight collect.

PRD-99100 AJ KSR printer \$995.00
PRA-99200 Tractor option \$150.00

PRINTER PALS - F.M.J. Inc.

Desk top printer stand and continuous form paper holder.

PRA-99080 for MX-80, MX-80FT, Oki 82A, NEC .. \$29.95
PRA-99100 for MX-100, Oki 83A & 84 \$34.95
PRA-99700 for letter quality printers \$49.95

Circle 254 on inquiry card.

5 1/4" Disk Drives

Tandon TM100-1 single-sided double-density 48 TPI
MSM-551001 \$219.95 ea 2 for \$199.95 ea

Shugart SA400L single-sided double-density 40 track
MSM-104000 \$234.95 ea 2 for \$224.95 ea

Shugart SA455 half-size double-sided 48 TPI
MSM-104550 \$349.95 ea 2 for \$329.95 ea

Shugart SA465 half-size double-sided 96 TPI
MSM-104650 \$399.95 ea 2 for \$379.95 ea

Tandon TM100-2 double-sided double-density 48 TPI
MSM-551002 \$294.95 ea 2 for \$269.95 ea

Shugart SA450 double-sided double-density 35 track
MSM-104500 \$349.95 ea 2 for \$329.95 ea

Tandon TM100-3 single-sided double-density 96 TPI
MSM-551003 \$294.95 ea 2 for \$269.95 ea

Tandon TM100-4 double-sided double-density 96 TPI
MSM-551004 \$394.95 ea 2 for \$374.95 ea

MPI B-51 single-sided double-density 40 track
MSM-155100 \$234.95 ea 2 for \$224.95 ea

MPI B-52 double-sided double-density 40 track
MSM-155200 \$344.95 ea 2 for \$334.95 ea

MPI B-91 single-sided double-density 77 track
MSM-155300 \$369.95 ea 2 for \$359.95 ea

MPI B-92 double-sided double-density 77 track
MSM-155400 \$469.95 ea 2 for \$459.95 ea

5 1/4" Cabinets with Power Supply

END-000216 Single cab w/power supply \$69.95
END-000226 Dual cab w/power supply \$94.95

8" Disk Drives

Shugart SA810 half-size single-sided double-density
MSF-108100 \$424.95 ea 2 for \$394.95 ea

Shugart SA860 half-size double-sided double-density
MSF-108600 \$574.95 ea 2 for \$549.95 ea

Shugart SA801R single-sided double-density
MSF-10801R \$394.95 ea 2 for \$389.95 ea

Shugart SA851R double-sided double-density
MSF-10851R \$554.95 ea 2 for \$529.95 ea

Tandon TM848-1 single-sided double-den thin-line
MSF-558481 \$379.95 ea 2 for \$369.95 ea

Tandon TM848-2 double-sided double-den thin-line
MSF-558482 \$494.95 ea 2 for \$484.95 ea

Qume DT-8 double-sided double-density
MSF-750080 \$524.95 ea 2 for \$498.95 ea

Mitsubishi M2894-63 double-sided double-density
MSF-289463 \$494.95 ea 2 for \$474.95 ea

Siemens FDD 100-8 single-sided double-density
MSF-201120 \$274.95 ea 2 for \$249.00 ea

Dual Disk Sub-Systems

Disk Sub-Systems - Jade

Handsome metal cabinet with proportionally balanced air flow system, rugged dual drive power supply, power cable kit, power switch, line cord, fuse holder, cooling fan, neoprene rubber feet, all necessary hardware to mount 2-8" disk drives, power supply, and fan, does not include signal cable.

Dual 8" Sub-Assembly Cabinet

END-000420 Bare cabinet \$59.95
END-000421 Cabinet kit \$225.00
END-000431 A & T \$359.95

8" Sub-Systems - Single Sided, Double Density

END-000423 Kit w/2 FD100-8Ds \$695.00
END-000424 A & T w/2 FD100-8Ds \$795.00
END-000433 Kit w/2 SA-801Rs \$999.95
END-000434 A & T w/2 SA-801Rs \$1195.00

8" Sub-Systems - Double Sided, Double Density

END-000426 Kit w/2 DT-8s \$1224.95
END-000427 A & T w/2 DT-8s \$1424.95
END-000436 Kit w/2 SA-851Rs \$1274.95
END-000437 A & T w/2 SA-851Rs \$1474.95

Prices may be slightly higher at our retail locations. Please contact the store in your area for exact pricing.

IBM PC Accessories

512K PC/RAM STACK - Hammond

A high quality, high density memory expansion board for your PC, cool-quiet-reliable operation, full parity checking, unique stacking sockets, expandable from 256K to 512K, MDRIVE high speed RAMDISK software only \$25.00 with 256K or 512K board purchase.

MEX-25600A 256K assembled & tested \$795.00
MEX-51200A 512K assembled & tested \$999.95
MEX-25600S MDRIVE disk emulator \$25.00

256K PC/RAM - Hammond Engineering

* User expandable from 64K to 256K, same high quality standards as the RAM Stack above, designed for medium memory expansion requirements.

* MEX-64000A 64K assembled & tested \$299.95
MEX-128000A 128K assembled & tested \$399.95
MEX-192000A 192K assembled & tested \$499.95
MEX-256000A 256K assembled & tested \$569.95

PC/SASI RAM - Hammond Engineering

Three boards in one, 256K of RAM, RS-232 asynchronous serial interface, and a SASI (Shugart Assoc Standard Interface) hard disk interface.

IOX-6000A PC/SASI RAM \$1095.00

PC EXTENDER CARD - Computel

High quality extender card with free connectors for IBM PC bus.

TSX-300A A & T with connectors \$42.95

WIRE WRAP BOARD - Computel

Highest quality, extremely versatile proto typing board with gold plated card edge for IBM PC.

TSX-310A Proto board \$59.95

Jade Bus Probe

THE BUS PROBE - Jade

Inexpensive S-100 Diagnostic Analyzer

So your computer is down. And you don't have an oscilloscope. And you don't have a front panel... You're not alone - most computers have their occasional bad days. But without diagnostic equipment such as an oscilloscope (expensive!) or a front panel (expensive!), it can be very difficult to pinpoint the problem. Even if you have an extender board with a superfast logic probe, you can't see more than one signal at a time. You're stuck, right?

Not anymore. Jade is proud to offer our cost-effective solution to the problems mentioned above: **THE BUS PROBE.**

Whether you're a hobbyist with a cantankerous kludge or a field technician with an anxious computer owner breathing down your neck, you'll find **THE BUS PROBE** speeds your repair time remarkably. Just plug in **THE BUS PROBE** and you'll be able to see all the IEEE S-100 signals in action. **THE BUS PROBE** allows you to see inputs, outputs, memory reads and writes, instruction fetches, DMA channels, vectored interrupts, 8 or 16 bit wide data transfers, plus the three bus supply voltages.

An on-board pulse generator can provide repetitive resets, interrupts, or wait states, for trouble shooting.

TSX-200B Bare board \$59.95
TSX-200A Kit \$119.95
TSX-200A A&T \$149.95

Place Orders Toll Free

Continental U.S. Inside California

800-421-5500 800-262-1710

For Technical Inquiries or Customer Service call:

213-973-7707

JADE
Computer Products

4901 W. Rosecrans, Hawthorne, CA 90250

We accept cash, checks, credit cards, or Purchase Orders from qualified firms & institutions. Minimum prepaid order \$15 California residents add 6 1/2% tax. Export customers outside the US or Canada please add 10% to all prices. Prices and availability subject to change without notice. Shipping & handling charges via UPS Ground 50¢/lb, UPS Air \$1.00/lb minimum charge \$3.00

Unclassified Ads

FOR SALE: Seven 100-megabyte Calcomp Trident hard-disk drives: asking \$10 per megabyte. Also, two 1600 BPI 125 IPS tape drives with auto load. All IBM-compatible. Includes cables and manuals. Excellent for the industrious hobbyist. Call Alex at (305) 392-4128 or 940-3338.

FOR SALE: IMSAI 8080 22-slot, S-100 bus system, including front panel, processor board, disk drive with controller, 32K static RAM, video board, full ASCII keyboard with interface, portable black-and-white TV as display, Mullen extender board with logic probe, BASIC, DOS, and monitor; \$2150. Also, Equipment rack with 19- by 72-inch panel area, including rear door, outlet strip, and cooling fan. Make an offer. Ronald Roybal, 856-105 Minnesota Ave., San Jose, CA 95125. (408) 297-7096 evenings.

WANTED: CDC Hawk 10-megabyte hard-disk drive or Shugart SA-1004 Winchester drive. Must be reasonable. Steve Waechter, POB 3597, Fullerton, CA 92634. (714) 674-3071 evenings. 871-2863 days.

FOR SALE: BYTE from issue #1 through June 1980. Mint condition with shelf box holders. Best written offer within 30 days of this ad. Include name, address, and phone number. C. A. Reece, 1915 White Rose, Carrollton, TX 75007.

FOR SALE: Burroughs L4000 computer complete with tape punch and punched tape reader in working condition. You must provide shipping. Will fit in the back of a one-half ton pickup truck. Best offer. Russell Tiffany, R.R. 1, Box 28, Hallstead, PA 18822.

FOR SALE: OSI C3-S1 computer with 48K static RAM, dual 8-inch disk drives, 6502/6800/280 processor, all manuals, two operating systems, BASIC, and much software. New: \$4400; sell: \$3100. A. Babudro, POB 5758, San Diego, CA 92105. (714) 284-9646.

FOR SALE: Heath H-8 complete system with 48K RAM, 4-port serial I/O, CP/M-capable with H-17 dual floppy disk, CP/M and miscellaneous software included, plus more than 40 minidisks with light use. System carefully assembled, in excellent condition, with all manuals. \$2675 value in last catalog, will sell all for \$1750 including shipping. Or, will sell separately. Also, old H-9 terminal, video needs work, keyboard and video display okay, make an offer. Gary Hammond, POB 54, Weirs Beach, NH 03246. (603) 497-3521 evenings.

FOR SALE: First-class system. Godbout Big 16 plus drives, analog I/O, smart terminal, cables, CP/M-80, CP/M-86, Pascal-MT+, Pascal/M-86, VEDIT, and more. Excellent condition. Hard to beat at \$3995. Karl Siple, 3400 Lloyds Lane E-5, Mobile, AL 36609. (205) 343-2820 evenings.

NOTICE: Inmate working with Burroughs 1800 series in FORTRAN, COBOL and BASIC. Also, TRS-80 Model I Level II. Would like to correspond and exchange ideas, programs, and advanced concepts with computer enthusiasts. Will execute individual's programs, as long as they are contributing to educational benefits. Also, would like hard copies of TRS-80 software: games and educational. David Bensingler, #R106-475, POB 56, Lebanon, OH 45036.

FOR SALE: CompuColor II with 16K RAM, 32K ROM, disk, 15 MHz color display, 71-key keyboard, RS-232C port, 24-hour clock, graphics and DOS in ROM, all manuals, and documentation for hardware and software included. Also, software includes Statistics, word processing, Data Base Management, assembler, editor, chess, Star Trek and eight other game disks. Cost \$2280, will sell for \$1100. C. Lovejoy, 49 South St., Natick, MA 01760. (617) 655-8851 7-9 p.m.

FOR SALE: Strictly Commodore back issues: almost one-half of each issue consists of practical, useful, and entertaining programs for PET, VIC-20, CBM, and Super PET computers; \$2 each. Also have several exciting arcade-type games: \$15 each. R. Olanson, 47 Coachwood Pl. N.W., Calgary, Alberta, T3H 1E1 Canada.

FOR SALE: Apple II Plus computer with 16K RAM and Leedex Video 100 black-and-white 12-inch monitor; both 1 year old. Total price \$1100. Certified check, 1 pay shipping. Dr. Alan J. Grant, 530 44th St., Brooklyn, NY 11220. (212) 436-1714.

FOR SALE: TRS-80 16K Level II with Scott Adams' Adventure 1 through 3 and Starfighter; Big Five's Galaxy Invasion; Radio Shack's Dancing Demon, Raaka-Tu, Space Warp, and Dumb Terminal with cable; Soft Sector Marketing's Alien Defense; Med System's Labyrinth. I upgraded to an Osborne I. Also, I want information on converting the POKE statements in Avalon Hill's Tanktics into something I can use on the Osborne I. Robert Bauer, 4059-L Donald, Eugene, OR 97405. (503) 344-4592.

FOR SALE: Apple II system including 48K memory, Applesoft in ROM, disk drive, Z80 Softcard, RS-232C interface card, plus a library of over 100 programs; \$2200. R. S. Steele, 103 West Melbourne, Oak Ridge, TN 37830. (615) 482-5633.

FOR SALE: TI 99/4A computer that has been barely used. \$300 with video modulator and one command module. T. N. Gautier, 475B South Appletree Ave., Tucson, AZ 85730. (602) 790-4533.

WANTED: Apple computer programs to swap, including Mountain Computer Music System disks. Jerry Bolin, 831 Poplar St., Missoula, MT 59802.

WANTED: Information on software with medical applications for a reference source on medical computing. I am interested in programs related to medical diagnosis, decision making, record keeping, office management, clinical research, or medical education. A listing of available programs and their sources will be included in the final publication. Jeffrey D. Horbar, M.D., Computer Section, Pediatrics, University of Vermont, College of Medicine, Given Building, Burlington, VT 05405.

FOR SALE: Microfiche retrieval and reading system, automated, computer-controlled. Also, used Image Systems Model 201 with computer interface, holds 720 fiche. Asking \$9500. R. Klein, 2929 East 6th St., Tucson, AZ 85716. (602) 327-2636 or 626-4119.

FOR SALE: IBM Correcting Selectric typewriter/printer; \$1000. Conversion was done by Micro Computer Devices of California. The unit includes a black box and accepts RS-232C serial interface from terminal or microcomputer. Extra features include sound reduction, dead-key disconnect (for foreign-language work), and a set of 24 typing elements. Also HP-82143A thermal printer for HP-41C programmable calculator at one-half of the list price. M. Barret, 2 Tudor City, I-C North, New York, NY 10017. (212) 949-0009.

FOR SALE: BYTE #1 through 12/79 in excellent condition. \$150 or best offer. Also have Interface Age, Keyboard Microcomputing, 80-US, TRS-80 Monthly, and Creative Computing Gary S. Fix, 5505 Diablo Dr., Sacramento, CA 95842.

FOR SALE: Processor Technology SOL-20 terminal computer has 16K memory plug-in with several program-cassettes, BASIC, Electric Pencil by Shryer, etc. Electrohome 14-inch black-and-white TV monitor. Anderson-Jacobson (IBM) AJ841 Electronic terminal printer that gives letter-copy printout in uppercase and lowercase. Complete setup for \$1600. Also, Tektronix Model 5403 mainframe dual-trace oscilloscope with display readout. In excellent condition; \$1600. Bob Goodman, POB 452, Alexandria, LA 71301. (318) 445-0262 or 640-1466 after 6 p.m.

FOR SALE: LA-36 DECwriter, including RS-232C interface, shelf, casters, cover, manual, etc. Perfect condition; \$900 (plus shipping) or trade for video terminal. Also selling Tally Model 420 high-speed paper-tape punch and Model 424 reader; \$50 each. Printec 100 cps printer; \$100. Paper tape; \$25/case (28 rolls). Peter Smart, POB 150, Silver Lake, NH 03875. (603) 367-8004.

LEGAL NOTICE

U.S. POSTAL SERVICE
STATEMENT OF OWNERSHIP,
MANAGEMENT
AND CIRCULATION
(Required by 39 U.S.C. 3685)

- Title of publication: *BYTE*.
- Date of filing: *September 24, 1982*.
- Frequency of issue: *monthly*.
- Number of issues published annually: *12*.
- Annual Subscription Price: *\$19.00*.
- Complete mailing address of known office of publication: *70 Main Street, Peterborough, NH 03458*.
- Complete mailing address of the headquarters or general business offices of the publishers: *1221 Avenue of the Americas, New York, NY 10020*.
- Full names and complete mailing address of publisher, editor, and managing editor: *Publisher, Virginia Londoner, 70 Main Street, Peterborough, NH 03458; Editor, Christopher P. Morgan, 70 Main Street, Peterborough, NH 03458; Managing Editor, Mark Haas, 70 Main Street, Peterborough, NH 03458*.
- Owner: *The owner is McGraw-Hill, Inc., 1221 Avenue of the Americas, New York, NY 10020. Stockholders holding 1 percent or more of stock are: Donald C. McGraw, Jr.; Harold W. McGraw, Jr.; John L. McGraw; William H. McGraw; June M. McBroom; Elizabeth McGraw Webster; all of 1221 Avenue of the Americas, New York, NY 10020; Public Retirement Board of Ohio, 277 East Town Street, Columbus, OH 43215; College Retirement Equities Fund, 730 Third Avenue, New York, NY 10017; E. I. du Pont de Nemours & Company, Inc. c/o Wilmington Trust Company, Box 146, 1 Rodney Square, Wilmington, DE 19899; Cede & Co. c/o Chase Manhattan Bank, N.A., 1211 Avenue of the Americas, New York, NY 10036*.
- Known bondholders, mortgagees, and other security holders owning or holding 1 percent or more of total amount of bonds, mortgages or other securities: *None*.
- Not applicable.
- Extent and nature of circulation:

	Average No. Copies Each Issue During Preceding 12 Months	Actual No. Copies of Single Issue Published Nearest to Filing Date
A. Total No. Copies B. Paid Circulation	302,000	330,000
1. Sales through dealers and carriers, street vendors and counter sales	70,476	94,430
2. Mail Subscription	211,421	228,085
C. Total Paid Circulation	281,897	322,515
D. Free distribution by mail, carrier or other means samples, complimentary, and other free copies	3,089	2,173
E. Total distribution	284,986	324,688
F. Copies not distributed		
1. Office use, left over, unaccounted, spoiled after printing	6,945	5,312
2. Return from news agents	10,069	None to date
G. Total	302,000	330,000

11. I certify that the statements made by me above are correct and complete.
BY
Virginia Londoner, Publisher

UNCLASSIFIED POLICY: Readers who have computer equipment to buy, sell, or trade or who are requesting or giving advice may send a notice to *BYTE* for inclusion in the *Unclassified Ads* section. To be considered for publication, an advertisement must be non-commercial (individuals or bona fide computer clubs only), typed double-spaced on plain white paper, contain 75 words or fewer, and include complete name and address. This service is free of charge; notices are printed once only as space permits. Your confirmation of placement is appearance in an issue of *BYTE* as we engage in no correspondence. Please allow at least three months for your ad to appear. Send your notices to *Unclassified Ads*, *BYTE/McGraw-Hill*, POB 372, Hancock, NH 03449.

Unclassified Ads

FOR SALE: Motorola Exorset 30 computer: 48K expandable to 56K, with supplied board. With MEX6850 ACIA card, MEX6816 16K RAM card, and MEX68PPP EPROM programmer. Software includes: XDOS, MBASIC compiler, 6800.05.09 macro assemblers, editor, Exorbug monitor, and more. All for \$3000. Bob, (312) 547-0611 evenings.

FOR SALE OR TRADE: Vogue 400C Line Printer. Heavy (500 lbs.) duty, large, fast (600 ipm) printer, available in exchange for STD or Multibus cards, cash, and/or antique, classic, or best-seller computer literature (pre-79 BYTE, Knuth, Scott Kim, etc.). Bill Hall, 3 Scott Rd., West Townsend, MA 01474. (617) 597-6247 or 658-5125.

FOR SALE: SYM-1 single-board computer and 32K memory board. Both for \$250 or best offer. Charles Hembree, POB 942, El Cerrito, CA 94530. (415) 527-6677.

FOR SALE: Back issues of computer magazines: 9 titles, 124 issues, 1977 to 1982. Send SASE for list. David H. Simmons, POB 7000-140, Redondo Beach, CA 90277.

WANTED: Back issues of the following magazines: Compute, Creative Computing, Personal Computing, 80 Microcomputing, Keyboard Microcomputing, and BYTE. If you have any of these magazines in excellent condition for sale, send magazine titles, years, volumes, numbers, and your asking price. Anthony Ayiomamitis, POB 512, Station P, Toronto, Ontario, M5S 2T1 Canada.

FOR SALE: Used Apple II Plus with 48K, modem, and Integer card for \$1100. In excellent working condition. David Albert, 330 East 71st St., New York, NY 10021. (212) 988-7436.

WANTED: OSI C2 OEM: advise on age, condition, and price. M. Hirsch, POB 209, Old Westbury, NY 11568. (516) 626-1265.

FOR SALE: Various back issues of Keyboard Microcomputing, \$3 includes postage. 101 BASIC Computer Games by Ahi, \$4. Programs For Beginners by Blechmann, \$5 includes postage. Problem Solving Principles by Lewis, \$5 includes postage. Musical Applications of Microprocessors by Chamberlain, \$12 includes postage. Excess postage will be refunded. Douglas Stewart, 15 Mountain View Rd., Cape Elizabeth, ME 04107. (207) 767-2351.

FOR SALE: 48 issues of BYTE from November 1977 to June 1982. Also, 12 recent issues of Creative Computing and various copies of onComputing Computer, Best of Byte, volume 1, and IEEE Microprocessors & Microcomputers, second edition. Subjects range from computer art to voice synthesis. Many articles on hardware construction. Magazines include hundreds of super games for TRS-80, Apple, PET, and IBM. All for \$80. David Luneau, RFD 9 Box HBA, Concord, NH 03301. (603) 225-4743.

WANTED: Computer terminal with modem. I am just beginning to use a computer and have access to a DEC-10 system. I am looking for a quality terminal with modem in good working condition at a very reasonable price. B. Lieberman, 627 Beverly Rd., Pittsburgh, PA 15243. (412) 343-2508 or 624-3763.

WANTED: IMSAI VDP-80 64K RAM with 8-inch disk drives, in good condition. A. M. Agapos, 147 Bradley Dr., Slidell, LA 70458. (504) 286-6896 or 643-0791.

WANTED: Help for Mexican computer hackers. They need spare parts, modules, diagrams, software, etc. for a TI-960A computer. Also would experiment with other computers. If you give away any hardware, software, documentation, etc., please send to James Moran, 9873 Lily St., El Paso, TX 79927.

FOR SALE: Commodore VIC-20 in good condition. Includes radio frequency modulator, cassette player, joystick, game paddles, several issues of VIC users magazine, and software including VIXEL #1 and #2, \$400 or best offer. Brian Hibbert, Apt. 804, 1501 East Gardner Lane, Peoria Heights, IL 61614. (309) 686-3689 evenings.

Answers to "Board to Death" quiz on pages 94-95.

Photo 1: Panasonic Link (hand-held computer)

Photo 2: Commodore VIC-20

Photo 3: Colonial Data Systems SB-80

Photo 4: California Computer Systems 2200A

Photo 5: Corvus Concept

Photo 6: Apple II Plus, revision D

Photo 7: 16K-byte TRS-80 Color Computer

Photo 8: Western Digital Pascal Microengine

Photo 9: Atari 400

Photo 10: Sinclair ZX80

Photo 11: Autocontrol AC-85

Photo 12: IBM Personal Computer

Speech Synthesizer Speaks Up for Number One

BYTE readers again have put Steve Ciarcia in the top spot. His article "Build the Microvox Text-to-Speech Synthesizer, Part 1: Hardware" has earned him first place in the September BOMB contest. He'll receive the \$100 prize. Second place goes to Senior Technical Editor Gregg Williams for his product description of "The Epson QX-10 Valdocs System." As a staff member he is not eligible for the \$50 second-place award. And Robin Moore earned third place for his review, "The Apple III and Its New Profile."

BOMB

BYTE's Ongoing Monitor Box

Article #	Page	Article	Author(s)
1	42	Build the Circuit Cellar MPX-16 Computer System, Part 2	Ciarcia
2	84	The Coinless Arcade—Rediscovered	Clark, Williams
3	92	The Vectrex Arcade System	Clark
4	94	Board to Death	Swanson
5	96	Design Techniques and Ideals for Computer Games	Crawford
6	112	Charge!	Ray
7	124	Cosmic Conquest	Sartori-Angus
8	142	Ricochet	Williams
9	150	Action Games for the VIC-20	Kavanagh
10	160	Deadline	Morgan
11	162	Penetrator	Wszola
12	167	Character Editor for the Atari	Kilby
13	206	Microshell and Unica, Unix-Style Enhancements for CP/M	Kern
14	222	User's Column: A Slew of Languages, a Slap at Documentation, and a Curse at Keyboards	Pournelle
15	250	Autocontrol's AC-85, a CP/M System on One Board	Benedict
16	260	The Soundchaser Computer Music Systems	Moog
17	278	A Brief Introduction to Electronic Music Synthesizers	Moog
18	288	The 8051 One-Chip Microcomputer: A Most Powerful Microcontroller	Boyet, Katz
19	314	Problem-Oriented Language, Part 1: A New Method of Input	Finger
20	372	Practical Dynamic-Memory System Design	Belics
21	392	Múltidos—A New TRS-80 Disk Operating System	Archer
22	404	Condor Series 20 DBMS	Abbott
23	414	Test Your Memory Using the Barber-Pole Algorithm	Pinnick
24	486	A Versatile Low-Cost Microprocessor Controller Module	Craig

Reader Service

Inquiry No.	Page No.	Inquiry No.	Page No.	Inquiry No.	Page No.	Inquiry No.	Page No.
1	47th STREET COMPUTER 553	84	CHECK-MATE 210	182	DUAL SYS.CONTROL CORP. 66	275	LYBEN COMP.SYS. 552
2	6502 PROGRAM EXCHANGE 489	85	CHECKS-TO-GO 227	183	DUAL SYS.CONTROL CORP. 70	276	LYBEN COMP.SYS. 558
3	800 SOFTWARE 199	86	CHIPS & DALE 512	184	DYSAN CORP. 328, 329	277	LYBEN COMP.SYS. 560
4	A SYSTEMS CORP. 174	88	CHRISLIN INDUSTRIES 243	186	E/Z ASSOC. 416	278	LYCO COMPUTER 495
5	A.S.T.RESEARCH 45	279	CLEVELAND CONS.COMP.& COMPONENTS 545	264	EASTERN ENTERPRISES 491	280	MACROTECH INT'L. 38
6	AB COMPUTERS 542	283	CMA 194	187	ECONOMY PERIPHERALS 564	281	MAGNETIC INFORMATION 556
5	ABACUS DATA INC. 80, 81	90	CMC,INT'L. 286	188	ECOSOFT 507	282	MAILCOMP INC. 341
7	ABC DATA PRODUCTS 156	91	COGITATE 554	189	EDGE MICROSYSTEMS 548	284	MARCEY,INC. 446
545	ACCESS UNLIMITED 467	92	COLLINS INT'L. TRADING CO. 327	190	EDUCATIONAL MICROCOMP. 566	285	MARCEY,INC. 446
8	ACKERMAN DIGITAL SYS. 517	93	COLONIAL DATA SERV. 309	192	ELCOMP PUBLISHING INC. 342	286	MARCEY,INC. 447
9	ADA-VISION 409	94	COLUMBIA DATA PROD. 37	193	ELECTRONIC SYS.FURN. 323	287	MARYMAC INDUSTRIES 439
10	ADDMASTER CORP. 552	95	COMMODORE BUSN.MACH. 79	194	ELECTROSONICS 558	288	MASTER ELECTR. INC. 479
11	ADISA CORP. 494	96	COMMUNICAL, INC. 397	195	ELLIS COMPUTING 10	515	MATCO DATA PROD. 389
12	ADV. MICRO TECHNIQUES 362	97	COMMUNICATION RESEARCH 421	196	EMERGING TECH.CONSLT. 491	191	MBI 562
13	ADV.COMP.PROD. 582, 583	98	COMMUNICATIONS ELECTR. 237	*	EMPIRICAL RESRCH. GRP. 34	289	MCGRAW-HILL COLL.DIV. 455
*	ADV.DIGITAL CORP. 265	99	COMP.ELECTR. SUPPLY SVC. 433	197	ENERCOMP 544	290	MCP COMP.PROD. 564
14	ADV.DIGITAL PROD. 564	41	COMPONENTS EXPRESS 363	548	ENGINEERING SPECIALTIES 554	292	MEDIA DISTRIBUTING 368
15	ADV.DIGITAL PROD. 566	505	COMPONENTS EXPRESS 489	507	ENGINEERING SPECIALTIES 334	293	MEMORY MERCHANT 287
544	ADV.LOGIC SYSTEMS 431	101	COMPUADD 357	199	ESSEX PUBLISHING 477	294	METAVAN INC. 164
17	ADV.SYS. CONCEPTS 544	550	COMPUART 107	200	EVOLUTIONARY ELECTR. INC. 475	295	MFJ ENTERPRISES INC. 347
18	AEGIS SYSTEMS 496	102	COMPULINK CORP. 22	201	EXECUTIVE PERIPHERAL SYS. 491	296	MICRO BUSINESS WORLD 285
19	AEON ELECTRONICS 554	103	COMPUPRO/GODBOU 117	202	EXPOTEK 228	298	MICRO COMP. CO. INC. 552
20	AFTERTHOUGHT ENG. 558	104	COMPUPRO/GODBOU 158, 159	203	FIBERFAB, INC. 302	299	MICRO CONTROL SYS. 412, 413
*	ALF PRODUCTS, INC. 276	383	COMPUSHACK 456, 457	*	FORD MOTOR CO. 351	32	MICRO DISCOUNTS 564
21	ALL ELECTRONICS CORP. 364	106	COMPUTER AGE 198	204	FORMULA INT'L. 253	300	MICRO MAGAZINE 552
23	ALPHA BYTE COMP.PROD. 58, 59	107	COMPUTER APPARATUS 497	205	FOX & GELLER INC. 330	301	MICRO MANAGEMENT SYS. 437
24	ALPHA BYTE COMP.PROD. 306	108	COMPUTER CHANNEL 365	206	FRANKLIN COMP.CORP. 217	302	MICRO MINT 427
25	ALPHA BYTE COMP.PROD. 346	109	COMPUTER COMPONENTS UNLTD. 479	542	FROBCO 504	532	MICRO MINT 513
26	ALPHA SOFTWARE 21	110	COMPUTER DISC. OF AM. 275	207	G-H COMPUTER SYS. 554	535	MICRO PRO INT'L. 464, 465
27	ALSPA COMP.SYS. 75	111	COMPUTER DISCOUNT PROD. 549	208	GARDEN OF EDEN COMP. 562	305	MICRO SCI 263
28	ALTOS COMP.SYS. 232, 233	517	COMPENTREPRENEUR PUB.CO. 483	209	GENERAL SOFTWARE 487	306	MICRO TECHNOLOGY 560
29	AMDEK CORP. 319	112	COMPUTER EXCHANGE 110, 111	534	GENIE COMPUTER CORP. 147	307	MICRO TECHNOLOGY 566
30	AMER.SMALL. BUSN. COMP. 219	113	COMPUTER EXCHANGE 110, 111	210	GENIE COMPUTER CORP. 148, 149	308	MICRO WEST 442
31	AMER.SQUARE COMP. 173	114	COMPUTER EXCHANGE 110, 111	211	GIFFORD COMP. SYS. 352	309	MICRO WORKS, THE 176
33	ANACAPA RESEARCH ASSOC. 552	516	COMPUTER FUTURES 410	212	GILTRONIX, INC. 164	310	MICROCOMP.BUSN.IND. 127
34	ANGELS COMP.PROD. 564	117	COMPUTER INNOVATIONS 475	213	GILTRONIX, INC. 556	309	MICROCOMP. BUSN. IND. 229
35	APPARAT INC. 27	118	COMP. LEARNING TREE 496	214	GLOUCESTER COMP. 354	312	MICRODYNAMICS 550
36	APPLE COMPUTER 140, 141	119	COMP. MAIL ORDER 204, 205	215	GTEK INC. 210	314	MICROHOUSE 208, 209
514	APPLE COMPUTER 257	120	COMPUTER PLUS 144	216	H&E COMPUTRONICS 221	315	MICRON TECHNOLOGY 367
37	APPLEWARE, INC. 353	121	COMPUTER SHOPPER 511	218	HAYES MICROCOMP.PROD. 103	316	MICROPERIPH.CORP. THE 558
38	APPLIED BUSN.CONCEPTS 164	122	COMPUTER SHOPPER 550	219	HAZELTINE CORP. 419	317	MICROPROCESSORS UNLTD. 560
*	APPLIED CREATIVE TECH. 501	123	COMPUTER SOLUTIONS 294	220	HEALTH COMPANY 129	318	MICROSOFT 304, 305
39	APPLIED SOFTWARE TECH. 195	124	COMPUTER SPCLTIES. 188, 189	223	HOLLISTER MICROSYSTEMS 558	319	MICROSTUFF, INC. 119
40	ARBA 136	125	COMPUTER STOP, THE 443	224	HONOR SYS.SOFTWARE 552	320	MICROTECH EXPORTS 308
389	ARCHIVE 325	*	COMPUTER TOOLBOX, INC. 550	225	I.B.C. 19	321	MICROWARE 544
547	ARK MICROSYSTEMS 334	126	COMPUTER WRHSE. 322	226	IBM 200, 201	322	MIKOS 60
43	ARTIFICIAL INT'L.RESRCH. 164	127	COMPUTERS WHOLESAL 166	509	IBM INSTRUMENTS INC. 440, 441	323	MILLER MICROCOMP.SERV. 366
169	ASAP 373	128	COMPUTERWORLD INT'L. 358, 359	227	IDE CORPORATION 411	324	MIND SYSTEMS CORP. 170
520	ASAP 471	128	COMPUTING 339	228	IMS INTERNATIONAL 125	324	MINI MICRO MART 316, 317
44	ASC ASSOCIATES 354	130	COMPUVIEW PROD. INC. 67	16	INDIGO DATA SYS. INC. 113	325	MINI MICRO MART 570, 571
45	ASHTON-TATE 72, 73	131	CONCURRENT CORP. 332	231	INNOVATIVE RESEARCH 494	326	MONARCHY ENG. INC. 548
*	ASPEN SFTW.CO. 32	132	CONDOR COMP.CORP. 388	232	INNOVATIVE SOFTWARE 178	327	MONITOR DYNAMICS 544
46	ATARI 121	133	CONSUMER COMP. 212	233	INNOVATIVE SOFTWARE 355	328	MORROW DESIGNS 434, 435
47	ATHENA COMP & ELECTR. SYS. 9	134	CONSUMER COMP. 213	234	INSIGHT ENTERPRISES 562	329	MOUNTAIN VIEW PRESS 417
48	ATSUKO COMPUTING INT'L. 554	135	CONTROL CORP. 552	543	INT'L. MICRO SYS. INC. 504	330	MPC PERIPHERALS 69
49	AUTOCONTROL INC. 544	151	CONTROL DATA 192, 193	235	INT'L. PUBLISHING & SFTW. 311	331	MPI 15
50	AUTOMATED EQUIPMNT. 230	152	COSMIC COMP.UNLTD. 556	236	INT'L. TRADE CONSULTANTS 560	332	MTI SYSTEMS CORP. 224
51	AVOCET 240	153	COST PLUS COMP. 560	*	INT'L SFTW. ALLIANCE 396	333	MUSYS 152
52	A.V.T. ELECTRONICS 33	154	CPU SHOP, THE 559	237	INTEGRAL DATA SYS. 279	334	N.W.S. INC. 560
53	B&B ELECTR. 548	155	CREATIVITY UNLTD. 550	238	INTEGRAND 264	335	NABU COMMERCIAL TERMINALS 377
54	B&B ELECTR. 554	156	CROMEMCO CII, 1	164	INTEK 564	*	NCAIAFIPS 451
55	B & B ELECTR. 564	157	CROMEMCO 2	240	INTELLIGENT ARTEFACTS 453	337	NEBS 473
58	BASF 17	159	CSCS 356	241	INTERACTIVE MICROWARE 154	338	NEC HOME ELECTR.USA 295
59	BASIS, INC. 490	539	CSX 566	242	INTERACTIVE STRUCT. 177	339	NEC INFORMATION SYS. 115
60	BAUSCH & LOMB INSTR.SYS. 35	160	CUSTOM COMP.TECH. 378	245	INTERGRAPHICS 558	519	NEC INFORMATION SYS. 185
61	BAUSCH & LOMB INSTR.SYS. 35	541	CUESTA SYS. 504	246	INTERTEC DATA SYS. 29	*	NETRONICS 301, 555
62	BAY TECHNICAL ASSOC. 444	42	CYBERNETICS INC. 71	248	INTEX SYSTEMS 146	340	NETWORK CONSULTING CORP. 18
63	BELL JOHN ENGR. 563	537	D. ARMSTRONG CO. INC. 477	249	IOTC 552	341	NEW GENERATION SYS. 220
64	BHRT 165	162	D/PUNCH 566	250	IPEX INT'L. 544	536	NEW GENERATION SYS. 566
65	BIBLIOGRAPHIC RETRIEVAL 57	*	DAMAN 357	251	ISA CO.LTD. 307	342	NEW VISION 416
66	BINARY CORP. 550	163	DATA ACCESS CORP. 429	252	J.C.SYSTEMS 20	343	NORSOFT CONSULT. 164
67	BISON PROD INC. 370, 371	165	DATA BASE SOLUTIONS 172	254	JADE COMP.PROD. 588	344	NORTH HILLS CORP. 164
68	BISON PROD INC. 370, 371	239	DATA EXCHANGE 548	255	JAMECO ELECTR. 568, 569	345	NORTH HILLS CORP. 550
69	BISON PROD INC. 370, 371	166	DATA MAIL 453	256	JDR MICRODEVICES 572, 573	304	NORTHWEST INST.SYS.INC. 336, 337
70	BISON PROD INC. 370, 371	168	DATA SOURCE SYS.CORP. 251	257	JDR MICRODEVICES 574, 575	528	NOVATION 484
554	BISON PROD INC. 540	170	DATA-LINE 548	518	JIM-PAK 567	529	NOVATION 485
71	BOTTOM LINE, THE 291	171	DATASMITH 487	258	JRT SYSTEMS 11	*	NRI SCHOOLS ELECTR. DIV. 449
72	BPI SYSTEMS 215	172	DATASOUTH COMP.CORP. 68	259	KADAK PRODUCTS 423	348	OASIS SYSTEMS 261
73	BRIDGE COMPUTER 236	174	DATASOUTH COMP.CORP. 155	260	KERN PUBLISHING 179	551	ODESTA 99
74	BRIDGE COMPUTER 544	175	DECISION RESOURCES 145	261	LABORATORY MICROSYS. 548	349	OFFICE AUTOMATION CONF. 445.
*	BYTE BACK ISSUES 108	176	DENISON KYBE CORP. 43	262	LANIER BUSN.PROD. 321	350	OMEGA SALES 268, 269
*	BYTE PUBL. INC. 405	177	DESIGNWARE INC. 560	263	LEADING EDGE PROD. CIII	351	OMNI RESOURCES 245
75	BYTEK COMP. SYS. 473	177	DIGITAL DIMENSIONS 315	266	LEHMANN & ASSOC. 554	352	ORANGE MICRO 267
76	BYTEWRITER 28	178	DIGITAL EQUIPMNT.CORP. 258, 259	268	LIFEBOAT ASSOC. 424, 425	353	ORANGE MICRO 267
77	CAB-TEK, INC. 340	*	DIGITAL MARKETING 6	269	LNW RESEARCH 101	354	ORANGE MICRO 171
78	CAB-TEK, INC. 556	179	DIGITAL RESRCH. COMP. 561	270	LOBO DRIVES INT'L. 551	355	ORANGE MICRO 197
79	CAB-TEK, INC. 562	180	DIP INC. 349	271	LOGICAL DEVICES 493	57	OREAD TECH 558
80	CALIF. DATA CORP. 548	181	DISCOUNT SOFTWARE 211	272	LOMAS DATA PRODUCTS 381	356	ORGANIZTL. MGMT. SYS. 364
*	CALIF. DIGITAL 580, 581	*	DISK SUPPLY CO. 36	273	LOW COST PERIPHERALS 560	357	ORGANIZTL. MGMT. SYS. 560
*	CALIF.MICRO.COMP. 481	181	DOKAY COMP.PROD. INC. 584, 585	274	LYBEN COMP.SYS. 356	358	ORYX SOFTWARE 361
82	CDR SYSTEMS 564	*	DOW JONES SOFTWARE 223			*	OWENS ASSOC. 384, 385, 503
83	CENTENNIAL SOFTWARE 262						P.R.I.C.E. 556

To get further information on the products advertised in BYTE, fill out the reader service card with your name and address. Then circle the appropriate numbers for the advertisers you select from the list. Add a 20-cent stamp to the card, then drop it in the mail. Not only do you gain information, but our advertisers are encouraged to use the marketplace provided by BYTE. This helps us bring you a bigger BYTE. The index is provided as an additional service by the publisher, who assumes no liability for errors or omissions. *Correspond directly with company.

Reader Service

Inquiry No.	Page No.	Inquiry No.	Page No.	Inquiry No.	Page No.	Inquiry No.	Page No.
373	PERIPHERALS UNLTD. 338	410	S&W COMPUTER SUPPLY 353	444	SUNTRONICS 350	475	U.S. ROBOTICS 138
374	PERSONAL COMP.SYS. 300	411	S-100 INC. 493	445	SUNWEST SOFTWARE 556	476	U.S. EXCHANGE 554
375	PERSONAL SYS.TECHN. 63	434	S.D.SYSTEMS 248, 249	446	SUPERSOFT 131	477	U.S. EXCHANGE 562
376	PICKLES & TROUT 235	412	S.S.I. 556	447	SUPERSOFT 133	478	ULTRA MAGNETICS TECHN. 139
116	PION INC. 254	222	SAFETEK 562	448	SUPERSOFT 135	479	UNIFIED SOFTWARE SYS. 554
377	POLYGON ASSOCIATES 513	413	SAGE COMP. TECH. 231	449	SYNCOM SYSTEMS 26	480	VERBATIM CORP. 175
378	PRACTICAL PERIPH. 24, 25	414	SATURN SYSTEMS INC. 239	540	SYSTEMED CORP. 566	508	VECTRIX 234
379	PRINCETON GRAPHIC SYS. 183	415	SAVVY MARKTG.INT'L. 47	450	TARBELL ELECTR. 495	481	VEYTEC INC. 475
380	PRIORITY ONE 576, 577	510	SCION CORP 5	546	TATUM LABS 334	533	VICTOR BUSN.MACH. 255
381	PRIORITY ONE 578, 579	511	SCION CORP 5	451	TAYCO BUSINESS FORMS 544	482	VIDEX 271
382	PRO MICRO SYS. 564	512	SCION CORP 5	468	T.D.I. 284	483	VISIBLE COMP.SUPPLY 495
384	PROFESSIONAL DATA SYS. 459	*	SCOTTSDALE SYSTEMS 369	452	TECH-DATA CORP. 416	*	VISICORP INC. 247
385	PROGRAMMERS SOFT. EX. 154	417	SEATTLE COMP. PRODS. 292, 293	453	TECH-DATA CORP. 566	485	VISTA COMPUTER CO. 65
386	PROTOSYS 64	418	SEIKOSHA CORP. 105	*	TECHNICAL SYS.CONSLTNS. 343	486	VOTRAX 375
387	PURCHASING AGENT,THE 277	173	SERVICES SQUARED 357	455	TECMAR INC. 61	487	VOTRAX 493
552	QT/GOLDEN WEST 187	419	SIERRA DATA SCIENCES 39	*	TEKTRONIX INC. 137	*	VR DATA 481
388	QUADRAM CORP. 272, 273	420	SIGMATEK 550	457	TELECON SYSTEMS 161	488	VYNET CORP. 489
89	QUADRAM CORP. 282	421	SINGLE SOURCE SOLUTIONS 196	458	TELETEK 55	489	WALL STREET JOURNAL 461
390	QUANTECKNA 190	422	SLUDER 479	459	TELEVIDEO INC. 312, 313	*	WARNER ROBINS AFB 218
391	QUANTUM DATA 473	423	SOFT IMAGES 109	460	TERMINALS TERRIFIC 8	490	WASHINGTON COMP.SERV. 144
392	QUARK ENGINEERING 157	424	SOFTTECH MICROSYS. 77	523	TEXAS COMP.SYS. 379	491	WASHINGTON COMP.SERV. 557
393	QUASAR DATA PROD.INC. 153	425	SOFTQUEST 477	524	TEXAS COMP.SYS. 379	493	WEST STAR MICRO 324
501	QUBIE DISTRIBUTORS 266	426	SOFTWARE BANC 51	525	TEXAS COMP.SYS. 379	*	WESTICO INC. 203
394	QUEST ELECTR. 565	427	SOFTWARE CONSLTG.SERV. 550	526	TEXAS COMP.SYS. 379	*	WHITESMITHS LTD. 335
395	QUEST RESEARCH INC. 562	428	SOFTWARE DISTR. 82	527	TEXAS COMP.SYS. 379	56	WHOLESALE SUPPLIERS 353
396	QUICK TAX 56	429	SOFTWARE MODELS 172	462	TEXAS INSTRUMENTS 289	494	WILD HARE COMP.SYS. 407
399	RACET COMPUTES 186	430	SOFTWARE PUBLISHERS 562	463	TEXAS INSTRUMENTS 241	495	WIN/MILL RESEARCH INC. 356
400	RADIO SHACK CIV	431	SOFTWARE STORE 548	464	THINK SOFTWARE 364	496	WINCHENDON GRP.,THE 550
401	RANA SYSTEMS 30, 31	432	SOFTWARE TECHNIQUE 556	465	THINKER'S SOFT INC. 492	497	WINTEK CORP. 552
402	RCE 415	*	SOLID STATE SALES 310	*	THORN EMI 296, 297	498	WINTERHALTER & ASSOC. 497
403	RCS INC. 218	435	SONICS MICRO SYS. 344, 345	467	TIC-TOC SYSTEM SYS. 379	500	WORDTECH SYSTEMS 492
404	RED BARON COMPPROD. 180, 181	436	SOUTHCOAST COMP.SYS. 544	*	TINNEY ROBT. GRAPHICS 531	492	W.S.T. 499
405	RED GATE PUBL.CO. 386, 387	437	SOUTHERN COMP.SYS. 326	506	TMP/UNITED SOFT. CO. 151	502	X COMP 303
406	RENAISSANCE TECHN. 238	438	STAR MICRONICS 333	469	TRANSNET CORP. 340		
538	RICKERDATA 566	439	STREET ELECTR. CORP. 126	470	TRISTAR DATA SYS. 348		
407	RIXON 226	440	STROBE 23	471	TSK ELECTR.CORP. 169		
408	RKS INDUSTRIES, INC. 481	442	STRUCTURED DESIGN 558	473	U.S. MICRO SALES 546		
409	S C DIGITAL 298	443	SUNNY INT'L. 545	474	U.S. MICRO SALES 547		

*Correspond directly with company.

National Advertising Sales Representatives:

Northeast (617) 444-3946
ME, NH, VT, MA, CT, RI, DE, MD,
VA, WV, OK, TX, Upstate NY,
Eastern Canada

Hajar Associates
280 Hillside Ave.
Needham Heights, MA 02194

Mid Atlantic (201) 741-7744
NY, NYC, NJ, PA

Hajar Associates
321 Broad St.
Red Bank, NJ 07701

Southeast (305) 628-3525
NC, SC, GA, FL, AL, MS, TN,
KY, LA

Hajar Associates
Diplomat Bldg.
5400 Diplomat Circle
Suite 205
Orlando, FL 32810

Midwest (312) 966-0160
MN, WI, MI, IA, IL, IN, OH,
MO, NE, KS, ND, SD, AR

Hajar Associates
5225 Old Orchard Rd.
Suite 50
Skokie, IL 60076

Northwest (415) 964-0706
AK, HI, WA, OR, ID, MT, WY,
Northern California, Nevada Except
Las Vegas, Western Canada

Hajar Associates
1000 Elwell Ct.
Suite 124
Palo Alto, CA 94303

Southwest (714) 540-3554
UT, CO, AZ, NM, Las Vegas,
Southern California

Hajar Associates
3303 Harbor Blvd.
Suite H-4A
Costa Mesa, CA 92626

European Advertising Sales Representatives:

Mrs. Marla Sarmento
Pedro Teixeira 8, Off. 320
Iberia Mart 1
Madrid 4, Spain
45 52 891

Mr. Andrew Karnig
Andrew Karnig & Associates
Kungsholmsgatan 10
112 27 Stockholm, Sweden
08 51 68 70

Mr. Hans Csokor
Publmedia
Relsnerstrasse 61
A-1037 Vienna, Austria

Mrs. Gurit Gepner
McGraw-Hill Publishing Co.
115 Yosephthal St.
Bat Yam, Israel
866 561 321 39

Mr. Fritz Krusebecker
McGraw-Hill Publishing Co.
Liebigstrasse 27C
D-6000 Frankfurt/Main 1
West Germany
72 01 81

Mr. Michael Sales
McGraw-Hill Publishing Co.
17 rue Georges Bizet
F 75116 Paris
France
720 33 42

Mr. Simon Smith
McGraw-Hill Publishing Co.
34 Dover St.
London W1X 3RA
England
01 493 1451

Mr. Elio Gonzaga
McGraw-Hill Publishing Co.
Via Baracchini 1
20123 Milan, Italy
86 90 617

Far East/Pacific
Seavex Ltd.
05-49/50 Tanglin Shopping Center
19 Tanglin Rd. Singapore 1024
Republic of Singapore

Seavex, Ltd.
Room 102, Yu Yuet Lai Bldg.
43-55 Wyndham St. Central
Hong Kong

THE LEADING EDGE IN PRINTERS

ONE GREAT LINE. ONE GREAT WARRANTY.

Finally, there's one full family of printers that covers every business or word processing application—all from C. Itoh, a company known for packing more product into less price, and all distributed exclusively by Leading Edge, a company known for searching out and providing that very thing. Which means that one call to one source can get you any printer, any time you need it, for any purpose. All backed by a full years' warranty from Leading Edge. (Try *that* on any other line of printers.)

THE PRO'S.

The Prowriters: business printers—and more. The "more" is a dot-matrix process with more dots. It gives you denser, correspondence quality copy (as opposed to business quality copy, which looks like a bad job of spray-painting).

Prowriter: 120 cps. 80 columns dot matrix compressable to 136. 10" carriage. Parallel or serial interface.

Prowriter 2: Same as Prowriter, except 15" carriage allows full 136 columns in normal print mode. Parallel or serial interface.

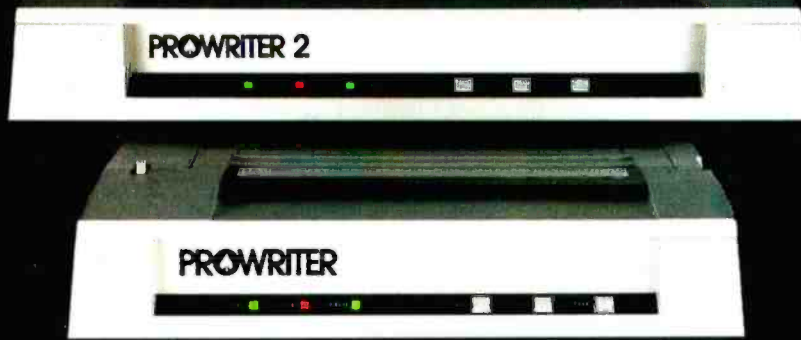

THE STAR.

The Starwriter F-10. In short (or more precisely, in a sleek 6" high, 30-pound unit), it gives you more of just about everything—except bulk and noise—than any other printer in its price range. It's a 40 cps letter-quality daisy-wheel with a bunch of built-in functions to simplify and speed up word processing. It plugs into almost any micro on the market, serial or parallel.



THE MASTER.

The Printmaster F-10. Does all the same good stuff as the Starwriter except, at 55 cps, the Master does it faster.



Distributed Exclusively by Leading Edge Products, Inc., 225 Turnpike Street, Canton, Massachusetts 02021.
Call: toll-free 1-800-343-6833; or in Massachusetts call collect (617) 828-8150. Telex 951-624.

Circle 263 on Inquiry card.

All Radio Shack TRS-80® Color Computers Cut \$100

Take Your Pick And Save Big!

Low As **299⁹⁵**
Less
TV



A Smart Investment. Radio Shack's popular TRS-80 Color Computer is now on sale. You can get this complete, versatile system with a 16K-byte memory and Standard Color BASIC language for only \$299.95 (Cat. No. 26-3004, reg. \$399.95). It's the affordable way for the entire family to start computing!

A Programmer's Dream. If you want to create high-resolution color graphics, then select a sale-priced TRS-80 Color Computer with Extended BASIC. Get 16K memory for \$399.95 (26-3002, reg. \$499.95) or 32K memory for \$549.95 (26-3003, reg. \$649.95).

Sophisticated. Extended BASIC offers a 256 x 192 screen resolution, 9-digit accuracy, arrays, editing, tracing, error messages, PEEK, POKE and many other features a serious programmer demands.

Easy to Use. Simple, one-line commands let you produce incredible drawings, designs, business and engineering charts, even animation with color, music and sound effects. Our excellent tutorial manuals (included) quickly show you how. And we offer the advanced programmer an Editor/Assembler in a Program Pak™ cartridge for special applications.

Expandable. There's a built-in RS-232C serial interface, a 1500-baud cassette port and a ROM port. That means you can add disk drives, a printer, our new color plotter or graphics tablet, a digitizer, modem and other peripherals to meet future needs.

The Perfect Gift to Give . . . or Get! Save \$100 on the TRS-80 Color Computer of your choice at a Radio Shack Computer Center, store or participating dealer today.

Radio Shack®

The biggest name in little computers™

A DIVISION OF TANDY CORPORATION

Retail prices may vary at individual stores and dealers.

Circle 400 on inquiry card.

www.americanradiohistory.com