

THE BROADCAST ENGINEERS' JOURNAL  
Ed. Stolzenberger, Editor  
116-03 91st Avenue Richmond Hill 18, N. Y.

Postmaster: If undelivered for any reason,  
notify sender, stating reason, on form 3547,  
postage for which is guaranteed.

F A GEHRES WQBF-TV  
2232 E POWELL  
EVANSVILLE 14 IND  
5151

Sec. 34.66 P. L. & R.  
U. S. POSTAGE  
**PAID**  
New York, N. Y.  
Permit No. 2961

OFFICIAL PUBLICATION OF THE NATIONAL ASSOCIATION OF BROADCAST ENGINEERS AND TECHNICIANS

# THE BROADCAST ENGINEERS' JOURNAL

*F. A. Gehres*

MAY, 1950

VOL. 17

No. 5

Serving Radio-TV Men Since 1934

**N. A. B. E. T.**

NAT'L ASS'N of BROADCAST ENGINEERS and TECHNICIANS

FROM NORTH TO SOUTH \* FROM EAST TO WEST

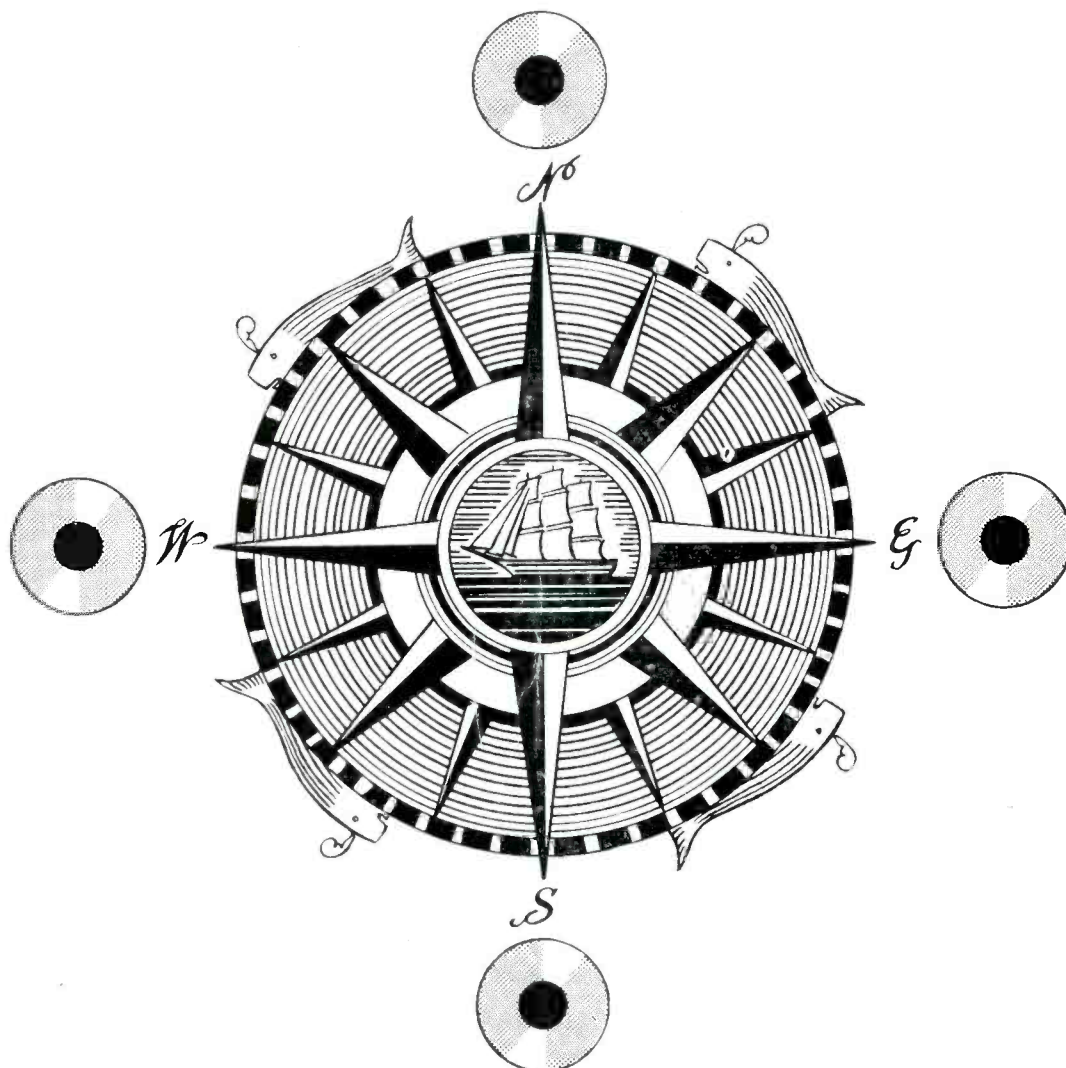

ADVANCE BLANKS STILL LEAD THE REST....!

For transcriptions of superior quality, try  
ADVANCE RECORDING BLANKS now.

**Advance**

**Recording Products Company**

36-12 34th STREET • Stillwell 4-7837 • LONG ISLAND CITY, N. Y.

# THE BROADCAST ENGINEERS' JOURNAL

ED. STOLZENBERGER, EDITOR AND BUSINESS MGR.

Editorial, Advertising and Circulation Offices:  
116-03 91st Avenue, Richmond Hill 18, N. Y.  
Telephone: Virginia 9-5553

VOLUME 17, No. 5



MAY, 1950

Contents copyright, 1950, by NABET Publications

## TABLE OF CONTENTS

	PAGE
NABET President McDonnell's Message .....	2
Graphical General Solutions .....	3
RMA Re-establishes the National Television System Committee .....	6
The National Television System Committee .....	6
Is Color Television Ready for the Home? .....	9
UHF Telecasting Progress .....	11
Engineers Foresee Use of TV in War .....	12
Labor-Management News .....	14
Chicago News .....	16
Washington News .....	17
Mohawk News .....	17
Omaha News .....	18

## THE BROADCAST ENGINEERS' JOURNAL

OFFICIAL PUBLICATION OF THE N. A. B. E. T.

Trustees: Chairman of the Board, H. L. Byers; NABET Pres. J. R. McDonnell, DeWitt C. Shultis, R. W. Bauer, Fred Smith.

Secretary-Treasurer ..... GEORGE MAHER

### ASSOCIATE EDITORS

Chicago .....	C. K. BRIGHT, and DICK DAVIS
Cleveland .....	EARL HOLL
Detroit .....	WALT BAKER
Dixie .....	SAM LILES
Hollywood .....	JOHN T. BAXTER
Mohawk .....	JOHN F. McMAHON
Metropolitan New York .....	TED KRUSE
Omaha .....	GEORGE S. JELINEK
Philadelphia .....	R. J. WILKE
Pittsburgh .....	FRANK E. HENRY
Rochester, N. Y. ....	B. HOLLY
Rocky Mountain .....	GEORGE SOLLENBERGER
San Francisco .....	M. A. DWYER
St. Lawrence, N. Y. ....	ALEN A. CORBIN
Syracuse, N. Y. ....	PAUL K. NORTH
Washington .....	W. D. DEEM

The Broadcast Engineers' Journal is a privately printed monthly publication issued by NABET Publications. Address all communications to Publication office: E. Stolzenberger, 116-03 91st Avenue, Richmond Hill 18, L. I., N. Y. Telephone Virginia 9-5553.

Advertising rates and information supplied on request. Subscription, \$2.50 per year; \$4.00 for two years. Single copies, except Christmas Yearbook, 35c; Christmas Yearbook, \$1.00. All remittances in advance. Foreign: add postage. Back copies 50c, back Yearbooks, \$2.00.

Nothing appearing in The Broadcast Engineers' Journal shall be construed to be an expression of The Broadcast Engineers' Journal or the National Association of Broadcast Engineers and Technicians, but must be construed as an individual expression of the author or authors.

#### NABET NATIONAL OFFICE

Room 543, 80 E. Jackson Blvd., Chicago 4, Ill. Tel. Wabash 2-2462  
George Maher, Executive Secretary

# National Association Broadcast Engineers and Technicians

OF, BY, and FOR  
THE  
BROADCAST  
ENGINEER

Contact any of the following officers for further information:

**J. R. McDonnell, Pres.**  
375 O'Farrell St., Room 101  
San Francisco 2, Calif.  
Ordway 3-8484

**Geo. Maher, Executive Secy.**  
80 E. Jackson Blvd., Rm. 543  
Chicago 4, Illinois  
Wabash 2-2462

**C. L. Gorsuch, Nat'l Rep.**  
421 7th Ave., Room 1002  
New York 1, N. Y.  
Wisconsin 7-0327

**James H. Brown, Nat'l Rep.**  
6223 Selma Ave., Rm. 109  
Hollywood 28, Calif.  
Hillside 9311

#### Chapter Chairmen

**Chicago:**  
George W. Smith  
6434 S. Francisco Ave.  
Chicago, Ill.

**Cleveland:**  
Harold V. Brandt  
R. D. No. 2  
Brunswick, Ohio

**Detroit:**  
David B. Stewart  
1160 Seward St.  
Detroit 2, Mich.

**Dixie:**  
J. Willard Dean  
22 Shepherd St.  
Raleigh, N. Car.

**Hollywood:**  
Ben M. Doty  
3330 Charleston Way  
Hollywood 28, Calif.

**Metropolitan New York:**  
Ed. Stolzenberger  
116-03 - 91 Avenue  
Richmond Hill 18, N. Y.

**D. C. Shultis**  
75 Kenwood Road  
Riveredge, N. J.

**R. W. Bauer**  
1436 Lexington Ave.,  
New York 28, N. Y.

**Mohawk:**  
Donald P. Morey  
12 Morningside Dr. RFD 6  
Schenectady 6, N. Y.

**Omaha:**  
D. Roy Glanton  
5500 Kansas Ave. Rt. 2  
Omaha 12, Nebraska

**Philadelphia:**  
R. J. Wilke  
4718 Chestnut  
Philadelphia, Pa.

**Pittsburgh:**  
W. C. Stuchell  
247 Cornell Ave.  
Pittsburgh 29, Pa.

**Rochester:**  
Edward Lynch, Vice-Pres.  
109 Wolcott Ave.  
Rochester 11, N. Y.

**Rocky Mountain:**  
Aubrey F. Blake  
2901 Eaton Street  
Denver 14, Colorado  
Wabash 2-2462

**San Francisco:**  
Richard T. Parks  
10 Leroy Place  
San Francisco, Calif.

**St. Lawrence:**  
David H. Lane  
119 Maple St.  
Black River, N. Y.

**Syracuse:**  
Robert M. Dykeman  
203 Kinne Street  
E. Syracuse, N. Y.

**Washington:**  
P. E. Anderson  
3108 Wellington Rd.  
Alexandria, Va.

#### Section Chairmen

**Atlanta:**  
Broughton W. Benning  
2883 Stewart Avenue  
Hapeville, Ga.

**Binghamton:**  
P. Sarantopoulos  
27 Exchange St.  
Binghamton, N. Y.

**Connecticut Valley:**  
A. T. Sagan  
52 Orchard St.  
Chicopee, Mass.

**Elmira:**  
L. C. Hartman  
422 Fulton St.  
Elmira, N. Y.

**Fairmont:**  
O. C. Swisher  
632 Orr St.  
Fairmont, W. Va.

**Kingston:**  
J. G. McNelis  
304 Greenkill Ave.  
Kingston, N. Y.

**Louisville:**  
W. H. Morrison  
725 S. 41 St.  
Louisville, Ky.

**Mid-Hudson:**  
Robert Masterson  
6 Bush Avenue  
Newburgh, N. Y.

**Richmond:**  
Elmore Taggart  
2010 Seddon Rd.,  
Richmond 22, Va.

**San Diego:**  
J. A. Kemp  
1576 Acheson  
San Diego 11, Calif.





## A Message to the Members of NABET

from

**JOHN R. McDONNELL**  
President, NABET

Upon the completion of the balloting on affiliation, and the membership's decision to remain independent, we find NABET activities continuing at an accelerated pace. Network negotiations, independent negotiations, organizational work, and all phases of union activity are being prosecuted vigorously—in all ways—the large part of the load being carried by NABET's full time Officers. These men are well qualified for the tasks at hand, but, if their work is to be effective, it must be supplemented by the concentrated endeavors of the membership who have their own and NABET's best interests at heart. Our union has been built, to a large degree, upon the work which has been done by union-minded members and our progress in the future will be in direct ratio to the activity and determination of the individuals who comprise NABET. While this is true of any union, it is most particularly true of one such as ours, which is relatively small in numbers, but spread across 3,000 miles in jurisdiction.

May is the month for Chapter elections in NABET. I urge the membership to survey their ranks (and officers) with a view to electing strong, intelligent leadership for the next term. Your future welfare, and the welfare of the union, depends greatly upon the calibre of the men selected as Chapter Chairman, and, it is the membership's responsibility to vote carefully and wisely in choosing local officers, who, in turn, become national officers of the union. NABET is a democratic organization, but, like any democracy, it is only as strong as the will and determination of its citizens.

Make your will felt, your voice heard and your vote count. NABET is your union and it needs you.

J. R. McDONNELL, *President.*

## Union Can't Be Bypassed During Strike, NLRB Rules

The National Labor Relations Board ruled that an employer violated the Taft-Hartley Act by offering employees a higher starting wage than he had offered the union representing employees on strike.

The Board held that the company had failed to fulfill its obligation to bargain under the act "by bypassing the union and individually offering old and new employees a higher wage rate than it had offered the union, as the exclusive statutory representative."

The Board's decision—made by a three-member panel composed of Chairman Paul M. Herzog and Board Members John M. Houston and James J. Reynolds, Jr.—was unanimous.

The company involved is the Pacific Gamble-Robinson Co., of Seattle, Wash., a wholesale grocery concern. The unfair



## George Maher

NABET

Executive

Secretary

EDITOR'S NOTE: NABET Executive Secretary Maher's comments on the Network negotiations, in progress at this writing, will appear in the next issue of this journal.

practices occurred at the company's Sault Ste. Marie, Mich., plant. The charges were brought by Local 328 of the Teamsters' Union (AFL).

The Board ordered the company to cease "unilaterally offering and granting higher rates of pay or other improved terms or conditions of employment, without first bargaining in respect thereto" with the teamsters' local as the exclusive bargaining representative of its employees. The Board also ordered the company to reinstate nine striking employees with back pay dating from February 28, 1949, when the strikers offered unconditionally to return to work. The Board ordered the company, if necessary, to dismiss all replacements hired on and after August 30, 1948, except those who were employees at the time of the strike.

The union called the strike August 27, 1948, after rejecting a company offer of an increase of 10 cents per hour. At the time of the strike, the pay rates in the plant were: 77 cents an hour for the first six months of employment, 82½ cents an hour for the next six months, and 88 cents an hour thereafter.

Three days after the strike was called, the company began offering strike replacements a starting rate of 98 cents an hour, 11 cents more than the 87 cents an hour previously offered to the union. On September 8, 1948, the company again met with the union but declined to increase its offer above 87 cents.

## Compulsory Profit-Sharing

The United Press reports under March 3 dateline from Santiago, Chile, as follows:

"A law making it compulsory for employers to distribute among their white collar workers from 20 to 25% of their annual profits, became effective today.

"Its provisions, retroactive to Jan. 1, 1949, are variously estimated to cost employers between \$70,000,000 and \$150,000,000.

"Employers have until March 31 to pay the bonuses for last year."

**DEADLINE is 2nd OF EVERY MONTH. EXAMPLE: COPY RECEIVED MARCH 2nd APPEARS IN THE APRIL ISSUE, IN THE MAIL APRIL 1st.**

# GRAPHICAL GENERAL SOLUTIONS

By

N. E. Sprecher, Maintenance Supervisor, NBC New York Television

J. R. De Baun, Technical Supervisor, NBC New York Uptown TV Studios

The use of vectors as an aid to solving or understanding electrical circuits can be of great value. Oftentimes an overall picture can be graphically presented with much greater clarity by the use of vectors than by the use of mathematical solutions. The following discussion points out a little-known fact regarding the shunt peaked or compensated plate load of video amplifiers, namely that there is a frequency where the magnitude of the impedance of the plate load remains constant for all values of the plate load resistor. What is more to the point, it illustrates the use of vectors for a non-mathematical general solution as well as affording a review of circuit fundamentals.

What is the impedance (amplitude and phase angle) for the following circuit as  $R$  is varied from  $\infty$  to  $0$ ? Note that reactance values are given, hence the following discussion is for one frequency.

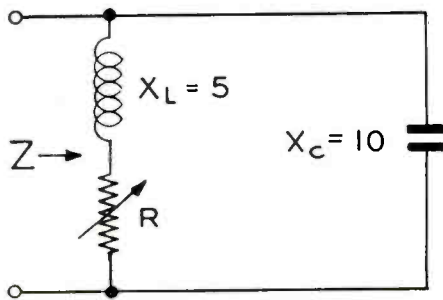

FIG. 1

From inspection if  $R = \infty$  i.e., is open, the circuit  $Z$  is 10 ohms of capacitive reactance.

For a second value of  $Z$ , if  $R = 0$ , i.e., is shorted, the circuit becomes

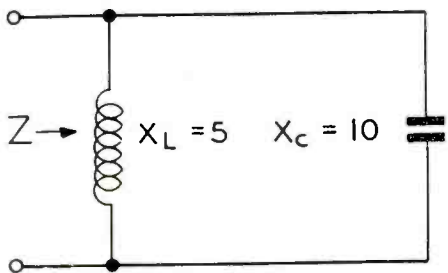

FIG. 2

But the 5 ohms of inductive reactance is replaceable by two inductances in parallel of 10 ohms reactance each and the circuit becomes.

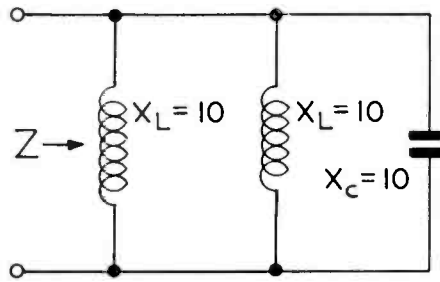

FIG. 3

This circuit is seen to be composed of 10 ohms of inductive reactance in parallel with a parallel resonant circuit. Thus, the impedance of the circuit is 10 ohms of inductive reactance.

For a third point, assume  $R = 5$  ohms

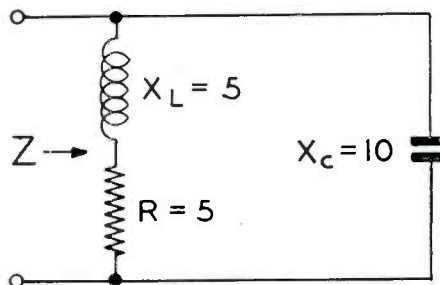

FIG. 4

This circuit is replaceable with

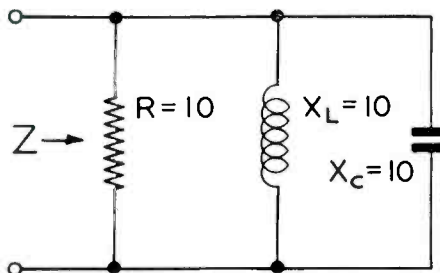

FIG. 5

because, as may have been observed, the equivalent parallel circuit for

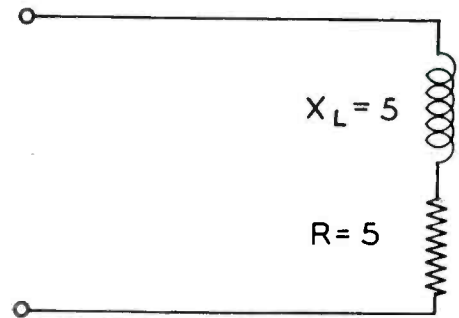

FIG. 6

is

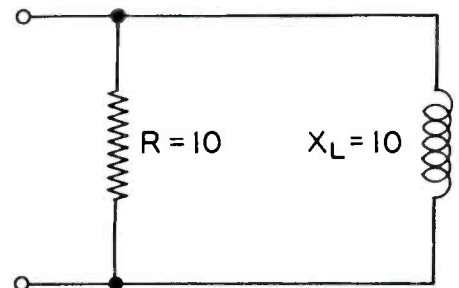

FIG. 7

(a few calculations in converting series circuits to parallel equivalents will reveal that two components of equal value in series are always replaceable by twice their value in a parallel circuit—as indicated above)

But

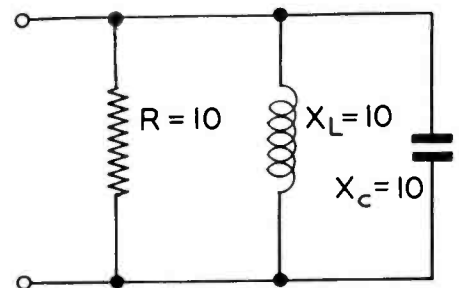

FIG. 8

is a 10 ohm resistor in parallel with a parallel resonant circuit and  $\therefore Z=10$  ohms of resistance.

We have determined the circuit  $Z$  (amplitude and phase) for three values of  $R$ . They are

$R=\infty$	$Z=10 \angle -90^\circ$
$R=0$	$Z=10 \angle 90^\circ$
$R=5$	$Z=10 \angle 0^\circ$

If three values of  $R$  are assumed to give enough of an indication it can be said that the magnitude of the impedance remains constant and the phase angle goes from  $-90^\circ$  through 0 to  $+90^\circ$  as  $R$  varies from  $\infty$  to 0.

For a graphical proof on the same problem the following is offered:

If a voltage  $E$  is applied to the circuit

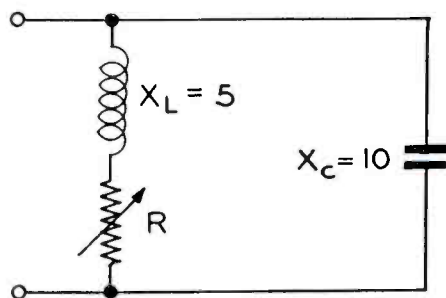

FIG. 9

we can set down the following facts from inspection:

- The total current which flows due to  $E$  will be inversely proportional to the magnitude of the total  $Z$  and will vary inversely in phase with the angle of the total  $Z$ .
- The current through  $C$  will remain constant and will lead  $E$  by  $90^\circ$ .
- The current through  $LR$  will vary as  $R$  is varied in the following manner:
  - It will be a maximum and will lag  $E$  by  $90^\circ$  when  $R=0$ .
  - It will approach a minimum (0) and will approach an in-phase relationship with  $E$  when  $R$  approaches  $\infty$ .
  - It will vary in amplitude directly as the value of  $IX_L$ .
  - It will vary in phase relationship with  $E$  directly as  $IR$  varies in phase relationship with  $E$ .
- The total voltage drop across  $LR$  is always  $E$ , i.e.,  $IX_L + IR = E$ .
- $IX_L$  is always at right angles to  $IR$ .

From these established relationships (d and e) we can start our graphical presentation by drawing the vector diagram.

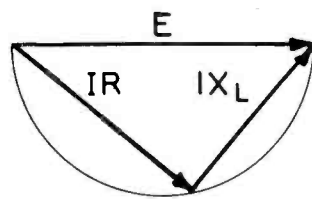

FIG. 10

You may recall a proposition in plane geometry which stated that an inscribed angle is measured by one-half its intercepted arc. A corollary of this proposition is an angle inscribed in a semi-circle is a right angle. The converse of this leads to the proposition that the locus of the vertices of right triangles having a given hypotenuse as a base is a circle drawn on the hypotenuse as a diameter.

Also, from previously stated facts (b) we can add to our vector diagram

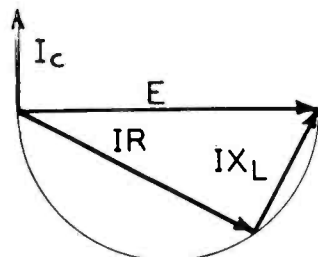

FIG. 11

$I_C$  which remains constant and at  $90^\circ$  to  $E$ . We next can add  $I_{LR}$  for its known value when  $R=0$ . Note that  $I_{LR}$  under this condition is twice the amplitude of  $I_C$ .

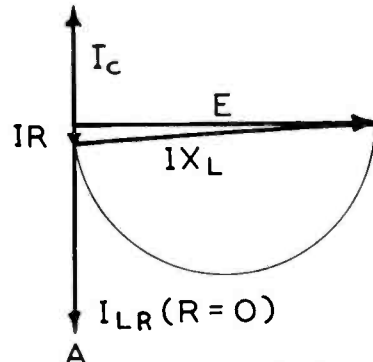

FIG. 12

But, if as has been stated,  $I_{LR}$  varies in phase with respect to  $E$  as  $IR$ , and in magnitude as  $IX_L$ , then the point  $A$  of the

vector  $OA$  will describe a semi-circle as  $R$  is varied. This gives us the value in phase and magnitude of  $I_{LR}$  for all values of  $R$ . Graphically, this is most readily realized if arbitrarily by construction we make  $E$  the same magnitude as  $I_{LR}$  (for  $R=0$ ). Utilizing this arbitrary relationship between  $E$  and the currents that flow, we can directly transpose magnitude and angles for  $I_{LR}$  from magnitudes of  $IX_L$  and angles of  $IR$ .

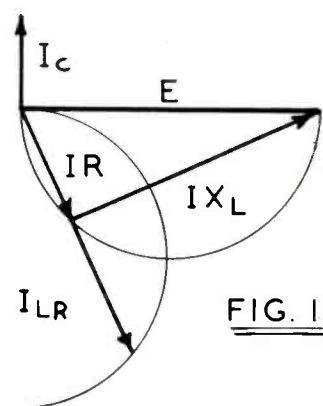
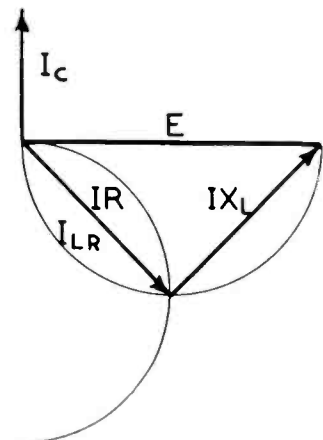
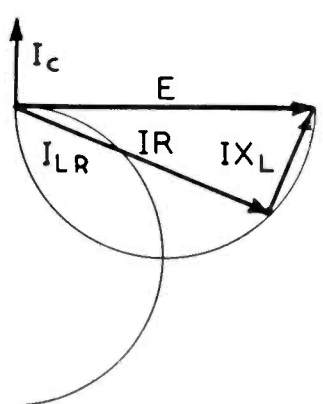

FIG. 13



But the total current is the vector sum of  $I_{LR} + I_C$ . Therefore, if we add  $I_C$  to

# Book Review

## Elements of Sound Recording

By John G. Frayne and Halley Wolfe, both Ph.Ds, of Electrical Research Products Division of Western Electric Company, Inc. Published by John Wiley & Sons, Inc., New York, 1949. 686 pages, approx. 6x9 inches, \$8.50.

This text covers in detail those subjects which belong peculiarly to the restricted field of sound recording and reproducing, and which are not discussed in books

devoted to the allied fields of electronics, radio engineering, etc.

Mathematical treatment is limited to those subjects in which it is desirable for a basic understanding of the point under discussion.

The text covers topics from the nature of sound to stereophonic recording, and contains almost 500 illustrations. Chapter headings are:

1. Nature of Sound, Sound Waves, and Their Perception—15 pages.
2. Electrical, Acoustical, and Mechanical Circuits—18 pages.

3. Microphones and Their Uses—32 pages.
  4. Vacuum Tubes—18 pages.
  5. Audio Amplifiers—21 pages.
  6. Network Theory—9 pages.
  7. Attenuators—19 pages.
  8. Filters—26 pages.
  9. Equalizers—14 pages.
  10. Compressing and Limiting — 11 pages.
  11. Recording Systems—21 pages.
  12. Electrical Measurements—20 pages.
  13. Principles of Disc Recording—38 pages.
  14. Disk Records and Their Processing —10 pages.
  15. Fundamental Principles of Variable-Density Recording—17 pages.
  16. Variable-Density Recording with the Light Valve—27 pages.
  17. Variable-Intensity Modulators — 17 pages.
  18. Principles of Variable-Area Recording—26 pages.
  19. Variable-Area Modulators—22 pages.
  20. Noise-Reduction Methods—23 pages.
  21. Intermodulation Test Methods—16 pages.
  22. Flutter and Its Measurement—17 pages.
  23. Film and Disc Drive Mechanisms—20 pages.
  24. Motor Drive Systems—23 pages.
  25. Film Laboratory Processes—24 pages.
  26. Rerecording—24 pages.
  27. 35-mm Motion-Picture Reproducing Systems—26 pages.
  28. 16-mm Sound Film Systems—21 pages.
  29. Magnetic Recording—29 pages.
  30. Loudspeaker Systems—26 pages.
  31. Acoustics of Stages and Theatres—29 pages.
  32. Stereophonic Recording—15 pages.
- Index—12 pages.

It is a pleasure to bring this text to the attention of our readers.

### GRAPHICAL SOLUTIONS—from Page 4

all values of  $I_{LR}$  we will have a graph of  $I_{TOTAL}$ .

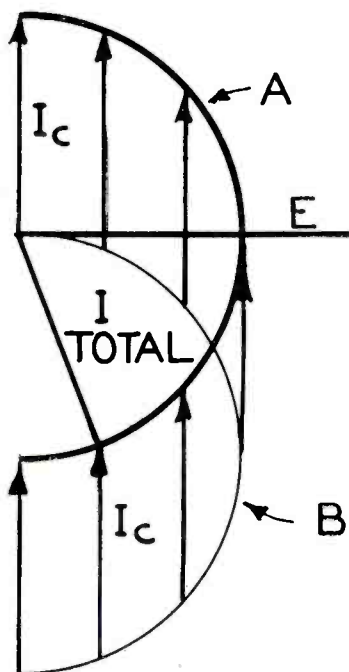

**FIG. 14**

From which it is seen that the earlier assumption that  $I_{TOTAL}$  remains constant in amplitude but varies  $180^\circ$  in phase as  $R$  varies from 0 to  $\infty$  is correct. And, since the  $Z$  of the circuit will vary inversely in amplitude and inversely in phase with  $I_{TOTAL}$ , the  $Z$  of the circuit can be said to be constant in amplitude but variable in phase as  $R$  is varied.

It may be of interest to point out that this condition exists in shunt peaked video amplifiers. That is, at the frequency that

$X_L$  of the peaking coil equals  $X_C/2$  of the distributed capacity the magnitude of the  $Z$  of the circuit is independent of the value of the load resistor but the phase angle of the  $Z$  can vary through  $180^\circ$  with varying values of  $R$ .

Of possible further interest is the fact that this arrangement lends itself to application as a variable phase shifter at fixed frequencies. If we drive

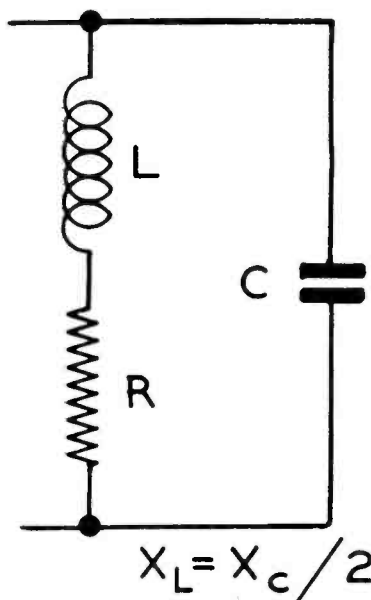

**FIG. 15**

$$X_L = X_C / 2$$

from a constant current source (pentode) the voltage developed across the circuit will vary as the  $Z$ . As seen from the foregoing examples, the voltage will remain constant in amplitude but shift  $180^\circ$  in phase as  $R$  is varied from 0 to  $\infty$ .



**is the only union of broadcast engineers whose sole concern is the welfare of the broadcast engineer.**



# RMA Again Establishes NTSC

Creation of a National Television System Committee to attain industry-wide agreement on technical developments needed for the expansion of television to all sections of the country and for the establishment of basic standards which will bring color television to reality, has been announced by the Radio Manufacturers Association.

Dr. W. R. G. Baker, vice president of the Electronics Department of General Electric Company and director of RMA's Engineering Department, will serve as chairman of the group. Donald G. Fink, editor of "Electronics," and David B. Smith, vice president in charge of engineering and research of Philco Corporation, are vice chairmen. Leading authorities from qualified technical societies, from broadcasting companies, and from member and non-member firms in the manufacturing industry will be invited to participate.

The committee proposes to cooperate closely with the Federal Communications Commission on color television and, later, upon the extension of television service to new sections of the country and to areas that are inadequately covered at present. The committee will make regular reports to the Commission and will be available for the study of special problems.

Appointment of the group followed a meeting in New York of the RMA's Television Committee, of which Max F. Balcom, vice president of Sylvania Electric Products, Inc, is chairman, at which the industry's progress in the development of color television was reviewed. The NTSC, it was agreed, would be charged with assembling technical data on (1) the allocation of channels in the unused ultra-high-frequencies, (2) procedures which will enable FCC to lift its present "freeze" on very-high-frequency allocations, and (3) basic standards for the future development of a commercially practicable color television system.

Dr. Baker was chairman of a similar television system committee which, in 1941, drafted and recommended to the FCC standards upon which black and white television has been built.

The Radio Manufacturers Association, comprising a majority of television set and component manufacturers, will initiate and finance the new engineering

# NATIONAL TELEVISION SYSTEM COMMITTEE

Chairman—W. R. G. Baker.....  
Radio Manufacturers Association  
General Electric Company  
Electronics Park  
Syracuse, New York

Vice Chairman—D. G. Fink .....  
Editor of Electronics  
McGraw-Hill Publishing Company  
330 West 42nd Street  
New York, New York

Vice Chairman—D. B. Smith .....  
Vice President, Philco Corporation  
Tioga & C Streets, Philadelphia, Pa.

Secretary .....  
Mrs. Martha Kinzie  
General Electric Company  
Syracuse, New York

Organization	Representative	Alternate
Admiral Corporation 3800 Cortland Street Chicago 47, Illinois	Mr. R. M. Jones	Mr. Joe Marty, Jr.
Color Television, Inc. 24 California Street San Francisco, California	Mr. Samuel Smith	Mr. Arthur S. Matthews 30 Sterling Street San Francisco, Calif.
Crosley Division AVCO Mfg. Corp. 1329 Arlington Street Cincinnati 25, Ohio	Mr. Lewis M. Clement	Mr. P. F. G. Holst
Allen B. DuMont Laboratories, Inc. 750 Bloomfield Avenue Clifton, New Jersey	Dr. Allen B. DuMont President	Dr. T. T. Goldsmith, Jr.
Electronics McGraw-Hill Publishing Company 330 West 42nd Street New York, New York	Mr. D. G. Fink, Editor	
Federal Telecommunications Laboratories, Inc. 500 Washington Ave. Nutley 10, New Jersey	Mr. Emile Labin Technical Director	Mr. N. H. Young
General Electric Company Electronics Park Syracuse, New York	Mr. I. J. Kaar Mgr. of Engineering	Mr. J. E. Keister
Dr. Alfred N. Goldsmith 597 Fifth Avenue New York, New York	Dr. A. N. Goldsmith	
Hazeltine Electronics Corporation 58-25 Little Neck Parkway Little Neck, L. I., New York	Mr. A. V. Loughren Vice President	Mr. Knox McIlwain
Hogan Laboratories, Inc. 155 Perry Street New York, New York	Mr. John V. L. Hogan President	Mr. Frank A. Hester Chief Engineer
Motorola, Inc. 4545 Augusta Boulevard Chicago 51, Illinois	Mr. E. B. Passow Product. Manager Television Department	Dr. Kurt Schlesinger
National Association of Broadcasters 1771 N. Street, N. W. Washington 6, D. C.	Mr. E. K. Jett Station WNAR-TV	Mr. Neal McNaughton Director of Engineering
Philco Corporation Tioga and C Streets Philadelphia 34, Pa.	Mr. D. B. Smith Vice President	Mr. F. J. Bingley
Radio Corporation of America RCA Laboratories Princeton, New Jersey	Dr. Elmer Engstrom Vice President	Mr. G. L. Beers
Television Broadcasters Association 500 5th Avenue, Room 1038 New York 18, New York	Mr. Raymond F. Guy	



## NTSC—Cont'd

study, but the committee will have full jurisdiction with respect to its technical findings.

In creating the committee, Raymond C. Cosgrove, president of RMA, said: "While color television is not yet ready for commercial application, laboratory development has progressed to a point where pooling of information and concerted action from all sources is essential to creation of standards which will eventually bring it out of the laboratory and controlled broadcast stage and into the home.

"Television manufacturers are eager to present color to the public just as soon as research and field testing have made it practical for broadcasting and home use—but not before.

"In the meantime, it is believed that the National Television System Committee will be able to assemble the data necessary to letting all sections of the country enjoy the benefits of television, and not just selected areas."

### Purpose

This organization has been charged by the Board of Directors of the Radio Manufacturers Association to assemble technical data on:

1. The allocation of channels in the ultra-high-frequency band.
2. Procedures which will enable the Federal Communications Commission to lift the "freeze" on very-high-frequency allocations.
3. Basic standards for the development of a commercially practicable system of color television and to undertake such additional work as may be in the interest of providing more adequate television service to the American public.

### Committee and Membership

The Chairman of the National Television System Committee will be appointed by the Board of Directors of the Radio Manufacturers Association.

The Chairman of the National Television System Committee shall appoint one or more Vice Chairmen and such other officers as may be necessary.

Members of the National Television System Committee will consist of representatives of those organizations broadly interested and experienced in the television field. In addition, there will be included representatives of such national technical organizations as are vitally interested in the research and development of television as well as individuals not

Westinghouse Electric Corporation Baltimore 3, Maryland	Mr. Ralph Harmon	Mr. Maynard R. Briggs
Zenith Radio Corporation 6001 Dickens Avenue Chicago 39, Illinois	Mr. J. E. Brown	Mr. John Bell
Observers for Bell Telephone Laboratories	Mr. A. G. Jensen	Mr. P. Mertz

## PANELS

### Panel 1 COLOR SYSTEM ANALYSIS

Mr. D. G. Fink—Chairman Editor of Electronics McGraw-Publishing Company 333 West 42nd Street New York 18, New York	Mr. A. G. Jensen, Vice Chairman Bell Telephone Laboratories Murray Hill, New Jersey
--------------------------------------------------------------------------------------------------------------------------------	-------------------------------------------------------------------------------------------

Scope: The determination of the essential characteristics of 6 mc frame, line and dot sequential color systems, the formulation of the types of standards required for each and the influence of such standards on system performance.

### Panel 2 SUBJECTIVE ANALYSIS OF COLOR SYSTEMS

Dr. Alfred N. Goldsmith—Chairman 597 Fifth Avenue New York, New York	Vice Chairman to be appointed
----------------------------------------------------------------------------	-------------------------------

Scope: The determination and evaluation of the psychological and physiological factors influencing the performance of color systems as they affect the viewer.

### Panel 3 ALLOCATIONS

Mr. John V. L. Hogan—Chairman Hogan Laboratories, Inc. 155 Perry Street New York, New York	Vice Chairman to be appointed
-----------------------------------------------------------------------------------------------------	-------------------------------

Scope: The study of the principles of UHF and VHF allocations including means of reducing interstation and inter-receiver interference and the effects of various allocation schemes on coverage and interference.

### Panel 4 TRANSMITTERS

Mr. P. J. Herbst—Chairman RCA—Victor Division Camden, New Jersey	Mr. C. D. Kentner—Vice Chairman RCA—Victor Division Camden, New Jersey
------------------------------------------------------------------------	------------------------------------------------------------------------------

Scope: The determination of the requirements of the UHF and VHF transmitters, transmitter tubes and transmitting antennas for monochrome and color transmitters, and the present and future means of meeting these requirements.

### Panel 5 RECEIVERS

Mr. David B. Smith—Chairman Philco Corporation Tioga and C Streets Philadelphia, Pennsylvania	Vice Chairman to be appointed
--------------------------------------------------------------------------------------------------------	-------------------------------

Scope: The determination of the requirements of the VHF and UHF receivers, tubes and receiving antennas for monochrome and color services and the present and future means of meeting these requirements.

### Panel 6 TRANSMITTER-RECEIVER COORDINATION

Mr. I. J. Kaar—Chairman General Electric Company Electronics Park Syracuse, New York	Vice Chairman to be appointed
-----------------------------------------------------------------------------------------------	-------------------------------

## NTSC—Cont'd

associated with any organization, association or company.

The Chairman of the National Television System Committee with the concurrence of the Vice Chairman shall appoint the members of the Committee and their alternates.

A quorum for the National Television System Committee will comprise 75 per cent of its membership and a majority vote of those present will be required for the approval of any proposal. Every effort will be made to obtain a unanimous approval of all proposals.

The Chairman of the National Television System Committee may vote only in case of a tie.

The Vice Chairmen of the National Television System Committee may vote. No other officers of the organization may vote.

An alternate member of the National Television System Committee shall vote only when the duly appointed representative is absent.

### **Panel Purpose and Functions**

The various projects may be assigned to individual members of the National Television System Committee or to panels appointed by the Chairman of the National Television System Committee with the concurrence of the Vice Chairmen.

The Panel Chairmen shall be appointed by the Chairman of the National Television System Committee with the concurrence of the Vice Chairmen.

Panel Chairmen shall appoint a Vice Chairman, Panel Secretary, the members of the panel and if necessary alternate members.

In the operations of the panels, a quorum for any working meeting will comprise 50 per cent of the membership of the panel and a majority vote of those present will be required for the approval of any proposal. The Chairman of a panel may vote only in case of a tie.

In the event of the lack of a quorum present at any announced meeting of either the National Television System Committee or any of its panels, action may be taken by a majority vote of those present, but such action will not be valid unless, and until, three quarters of the total membership of the National Television System Committee or panel, as the case may be, approves such action by correspondence.

The members of the panels will be drawn from any company, association or organization regardless of affiliation and may also include individuals not associated with any organization. The only

Scope: The investigation of the "lock-and-key" aspects of system design including synchronization, scanning geometry and rates, pre-emphasis and de-emphasis, etc.

### **Panel 7 COLOR RENDITION**

Mr. A. V. Loughren—Chairman  
Hazeltine Electronics Corporation  
58-25 Little Neck Parkway  
Little Neck, Long Island, New York

Mr. W. T. Wintringham—Vice Chairman  
Bell Telephone Laboratories  
Murray Hill, New Jersey

Scope: The investigation and evaluation as related to overall system performance of such factors as choice of color filters and phosphors, the relative importance of the area covered on the chromaticity diagram, the displacement of color coordinates from object to image, and the flicker-luminosity relationship.

### **Panel 8 TERMINAL APPARATUS**

Dr. T. T. Goldsmith, Jr., Chairman  
Allen B. DuMont Laboratories, Inc.  
Bloomfield Avenue and Shafto Street  
Clifton, New Jersey

Vice Chairman to be appointed

Scope: The performance requirements of cameras and viewing devices for three color systems. The evaluation of the performance of existing and proposed devices in terms of these requirements.

requirement for membership on any panel is recognized skill, interest, and ability in the assigned project.

As the work of the National Television System Committee proceeds it may be desirable to add panels, modify the scopes or to discharge a panel upon the completion of its assigned task.

### **Panel Reports**

Upon the completion and approval of the assigned project by a panel a final report stating both the majority and minority opinions together with a complete record of all meetings will be submitted to the National Television System Committee for its approval.

### **Meetings and Records**

Meetings of the National Television System Committee and its panels shall be called at the discretion of the respective chairman.

Detailed minutes will be kept of all meetings and will record the names and votes of all voting, together with a clear statement of any minority opinion.

The minutes of all meetings shall be circulated to those attending the meeting and when approved shall constitute "official minutes."

Official minutes will then be distributed to all members of the National Television System Committee and its component panels, and such others as may be approved by the Chairman subject to the concurrence of the Vice Chairmen.

## **BOOK REVIEW**

### **How To Service Radios With An Oscilloscope**

Author and publisher: Sylvania Electric Products Inc., 500 Fifth Ave., New York. 72 pages, 8½x11 inches, paper cover.

This instruction booklet has been designed as a practical reference for radio, television, and amplifier servicemen, and technicians in general.

Included are over 90 diagrams, tables, and circuit diagrams, well illustrated with waveform patterns as they appear on the face of an oscilloscope in actual service application. The Chapter headings are:

1. Oscilloscope Fundamentals—5 pages.
2. The Linear Time Base—3 pages.
3. The Complete Oscilloscope—12 pages.
4. Voltage Measurements with the Oscilloscope—6 pages.
5. Use of the Oscilloscope in Radio Receiver Servicing—13 pages.
6. Use of the Oscilloscope in Audio Amplifier Testing—8 pages.
7. Use of the Oscilloscope in Transmitter Testing—4 pages.
8. Miscellaneous Applications—11 pages.

The booklet is nominally priced at \$1, and of course is well worth it. Especially helpful for the pre-television technician, and for those engaged in general electronic maintenance and transmission work.

## **NABET—Of, By, and For Radio-TV Men.**

# Is Color Television Ready For the Home?

By the Radio Manufacturers Association

The Federal Communications Commission's extensive hearings on color television have led many to ask, "When will color television be available?"

This pamphlet seeks to present the latest information on that question, as indicated by testimony presented to the FCC.

*Q. Can television broadcast be made in color?*

A. Yes. Color pictures have been transmitted experimentally, in laboratories, as far back as 1928.

*Q. What are the principal issues which the FCC must decide?*

A. (1) Is research in color television sufficiently advanced to offer commercial color broadcasts to the public?

(2) Shall color, when approved by the FCC and offered to the public, be broadcast on a fully "compatible" basis—that is, will owners of sets in use at the time still be able to get black-and-white pictures from color broadcasts without any change in their existing receivers and without any reduction in the quality of the picture?

*Q. How many color system are under discussion at the hearings?*

A. Three. The Columbia Broadcasting System has proposed a "mechanical" system similar to one offered at prior FCC hearings in 1946, but with certain refinements. The Radio Corporation of America has proposed a newer, all-electronic system, based on scientific principles not fully developed in 1946. Color Television, Inc., of San Francisco, also has presented data on still another all-electronic system.

*Q. Are other color systems possible?*

A. Yes, numerous other systems are theoretically possible. Interesting developments have been described by Dr. Charles Willard Geer of the University of Southern California and by a group of scientists at the Rensselaer Polytechnic Institute. Additional research is going on in laboratories all over the country.

Some of the systems which are still on the drawing-board may have features substantially superior to any so far announced.

*Q. What are the important characteristics of the systems currently under consideration?*

A. The RCA system is all-electronic,

and uses broadcasting standards that are basically "compatible" with those used for black-and-white transmission.

On the basis of engineering principles the color pictures broadcast by the RCA system should be equal in quality to those now broadcast in black-and-white. The system is still so new that RCA engineers state that further laboratory experimentation is necessary to bring the system up to its commercial potentialities.

The CTI (Color Television, Inc.) system, like RCA's, is all-electronic and is basically compatible with existing broadcasting standards. In other engineering particulars, however, it is substantially different from the RCA proposal. It, too, is subject to further laboratory development.

The CBS system is based on revolving color-filter disks, both in the camera and in the receiver. Essentially it is a mechanical, rather than an electronic, system. Its signals must be transmitted on standards which conflict with existing standards for black-and-white. It is, therefore, "non-compatible."

While numerous changes have been made, the current CBS system is basically the same as the system demonstrated to the FCC during the 1946 hearings and rejected. Since it was begun earlier, there has been more opportunity to develop broadcasting and receiving apparatus than with the RCA and CTI systems.

Objections to the CBS system voiced at the hearings encompassed, in general, the following points:

1. The non-compatibility of the system would mean that every existing television set (estimated at nearly 8,000,000 by the end of 1950) would have to be "adapted" before it could receive any picture, even in black-and-white, from a color broadcast. This would require present set-owners to invest additional money simply to maintain the same television service they now have. This seems manifestly unfair.

If any large percentage of the 8,000,000 owners should not adapt their sets, the audience for color broadcasts would be so limited at the outset that few broadcasters or advertisers could afford to put color programs on the air. Thus the growth of color television would be substantially handicapped by the adoption of any non-compatible system.

2. Pictures broadcast over the proposed CBS system would have a "definition" of only 405 lines, as compared with 525 on existing broadcasts. CBS officials have conceded there would be a 45% reduction in the ability to portray detail—a step backward as far as picture quality is concerned.

3. The CBS system is inherently limited in the size of direct-view picture tube that can be used.

Cabinets must be large enough to contain a spinning color disk more than twice the diameter of the picture tube, plus a motor to turn it. For that reason, table models could use nothing larger than 7-inch tubes, and even console models would be limited to 12-inch tubes. (CBS proposes the use of a magnifying lens to make the picture seem larger, but such artificially blown-up pictures have not been popular on black-and-white sets, and no manufacturer now uses or recommends magnifiers.)

This limitation on size would be another step backward, for in black-and-white television the trend is strongly toward 16-inch and even larger tubes.

*Q. Why shouldn't we go ahead with some one of the systems now, trusting the scientists to overcome any existing weaknesses as we go along?*

A. The majority of the television set manufacturers, expressing their opinion through the Radio Manufacturers Association, have urged that no color broadcasting "standards" be approved by the FCC until the proposed systems have been thoroughly field-tested. This is the only way to determine whether color reception is basically satisfactory under everyday conditions, as contrasted with the carefully controlled demonstration set-ups which have been used so far by all the sponsors.

The FCC has asked that such tests be made on each proposed system, but it will be some time before these can be completed.

*Q. If color television were introduced now and the initial standards proved unsatisfactory, would it not be possible to change them later on?*

A. No. Once basic standards are set, they cannot be changed without involving obsolescence of every piece of transmitting equipment and every receiving set then in existence.



An analogy may help to clarify this. All railroad cars in the United States have wheels that are "standard" gauge—i.e., 4 ft. 8½ ins. apart. An engineer might find that a better car could be built if the wheels could be placed 5 ft. 6 ins. apart. But nothing could—or would—be done about it. The new type of car could not run on existing tracks. And if the tracks were moved farther apart, then all existing railway cars would become obsolete overnight.

Thus, when standards are set, all future improvements must be within the framework of those standards. That is why it is so important that the original framework be a sound one, suitable for use for years to come.

Color television will need not one, but a dozen or more such standards. Inasmuch as the whole future development of the art must fit into the pattern thus established, the harm that could be done by over-hasty action is apparent.

*Q. After color television becomes available, will all broadcasts be made in color?*

A. No, for reasons parallel to those in the motion picture industry, where at least 85 per cent of all feature pictures are still produced in black-and-white even though Technicolor was developed years ago. There will be many programs for which the extra cost of color simply will not be justified.

*Q. After color is authorized, with all new receiving sets be equipped to receive it?*

A. Again, the answer is "no."

Color receivers always will cost more, since they must contain everything needed in a black-and-white receiver, plus something extra to give the color. Inevitably there will be large numbers of people to whom the extra pleasure provided by color will just not be worth the extra money involved.

*Q. What procedure is recommended for developing commercial color television as quickly as possible?*

A. The Radio Manufacturers Association's basic policies with respect to color television are printed on the inside back cover of this pamphlet.

Applying them to the situations we find today, a procedure somewhat as follows seems desirable:

1. The FCC should encourage continued development of all color systems which are or which can be made compatible, and which can produce pictures of a quality at least equal to today's black-and-white.

2. On the initiative of the Radio Manufacturers Association, a group of the

nation's leading television experts—including representatives of set and equipment manufacturers, broadcasters, and qualified technical organizations—has been organized as a National Television System Committee. This committee is analyzing various color proposals and will conduct tests on each system. When testing is completed, the NTSC will prepare and submit to FCC a set of proposed standards for color broadcasting.

3. Public hearings then would be required, after which the Commission could promulgate final standards with confidence that they provide the best framework that engineers can devise for a satisfying and permanent color service in the public interest.

The above procedure parallels that which was used a decade ago for the development of standards for black-and-white television. The proposed standards developed then by the first National Television System Committee, also sponsored by the Radio Manufacturers Association, still form the keystone of today's extensive and satisfying black-and-white broadcasting service.

The establishment of color standards would give the "go ahead" signal to the manufacturers of transmission equipment and receiving sets. They could then develop the designs they plan to put on the commercial market, test them in the field; plan their assembly lines and production techniques; inform their suppliers of the component parts that will be needed; and finally, after the pipelines from their suppliers (and their suppliers' suppliers) fill up, get into commercial production.

*Q. What does this all add up to in terms of when color television will become available?*

A. No one can say with any certainty, but obviously not for considerable time.

All groups—consumers, manufacturers, broadcasters, advertisers—would like to have color television just as soon as it is technically and economically feasible.

Scientists know enough about color to be sure that it can be developed. There is no question about that. But putting a timetable on research is impossible. We are equally sure, for example, that atomic energy some day will become available for commercial purposes. But not even the Atomic Energy Commission can say just when. No doctor will set a definite date for discovering a cure for cancer, or even for the common cold. Obviously, it is anyone's guess. But you can recognize why some experts are reluctant to fix a date and others talk about "years" rather than "months" when they do their guess-

timating about a timetable for color television.

*Q. Pending a final decision on color, what other action on television should be taken by the FCC?*

A. As soon as possible, the FCC should lift the existing "freeze" on authorizations for the construction of additional television broadcasting facilities utilizing the existing very high frequency (VHF) channels, and also should establish additional broadcasting channels in the ultra high frequency (UHF) range of the radio spectrum.

Until this action is taken, many sections of the country will have no television service whatsoever, and set-owners in still other sections will have an inadequate number of stations from which to select a program that they like.

The National Television System Committee, in addition to its work with color television, is fully qualified to develop any additional technical information which FCC may require before taking this next major step in the development of a truly nation-wide television service.

## Color Television Recommendations of the Radio Manufacturers Association

1. RMA recommends that color television be made available at the earliest practicable date consistent with the establishment of sound standards.

2. RMA urges the Federal Communications Commission not to approve final standards until adequate field and practical home tests—which have not yet been made—establish their soundness so that the public may buy with the assurance that the system is permanent and that further experimentation will not be done at their expense. Pending adequate testing, RMA does not recommend any particular system.

3. RMA urges that such color television be based on the compatible principle by which programs transmitted in color may be received in black-and-white on the millions of receivers now in public use without modification cost or inconvenience to the public and without degrading the quality below that of present pictures. RMA is confident that the combined knowledge and ability of the industry as a whole can produce a set of standards for a compatible color system of equal quality to present black-and-white.

4. RMA recommends the immediate lifting of the freeze on commercial television applications. It believes that, while the initial freezing was proper, technical progress and information presently avail-

To Page 12

# UHF Telecasting Progress

## New 1000-Watt UHF Transmitter and High-Gain Antenna Seen Facilitating Early Establishment of Service in Upper TV Frequency Bands.

Details of new transmitting equipment designed for use in the ultra-high frequency channels proposed by the FCC for commercial telecasting were described in papers presented by two RCA engineers before the annual convention of the Institute of Radio Engineers.

Delegates from all parts of the nation attending the IRE symposium on UHF and color television at the Hotel Commodore heard Thomas M. Gluyas, of the RCA Engineering Products Department, describe the new RCA Type TTU-1A UHF transmitter and the design features and techniques worked out in RCA's Camden, N. J., transmitter laboratories. Owen O. Fiet, in a second paper, described the RCA Type TFU-20A high-gain, slot-type antenna and radiating system for UHF transmission.

The papers revealed for the first time detailed information on new commercial ultra-high frequency equipment now available from RCA. Considerable interest was aroused by the talks, since the new RCA equipment, which operates in the higher frequency channels proposed by the FCC, is expected to help in the utilization of UHF frequencies for TV and thus relieve the limited channel situation in the present UHF television band.

Mr. Gluyas outlined the development of tubes, circuits, and components of the radiating system designed to provide a useful power output at UHF frequencies.

Equipments of the type described in the IRE papers are being operated by NBC under an experimental authorization in the UHF installation at Bridgeport, Conn. Operating in the band from 529 to 535 megacycles, this installation employs in both the transmitter and the radiating system the new technique described by Mr. Gluyas and Mr. Fiet. The transmitter develops approximately one kilowatt of RF power at the peaks of the synchronizing signal. The use of a high-gain antenna and improved types of transmission line is expected to produce an effective radiated power of about 15 to 17 KW.

The Type TTU-1A transmitter is housed in six racks, each measuring approximately 25 inches square by 84 inches high. The styling is similar to the RCA Type TT-500B, 500-watt VHF television transmitter, which is a basic part of the new UHF transmitter. The VHF portion of the unit provides RF power at

176.75 mc and 178.25 mc for the visual and aural channels, respectively. This part of the unit is located in the two central bays. The two right hand bays house the tripler, power amplifier, and power supplies for the visual channel, while the corresponding apparatus for the aural channel is housed in the two bays to the left.

The tripler stages of the visual and aural transmitters each consist of eight Type RCA 4X150A tetrode tubes operating in parallel in a single cavity. These stages drive the grids of the final stages, each of which also employs eight Type RCA 4X150A tubes in a single-cavity arrangement. Modulation of the visual transmitter is accomplished by means of

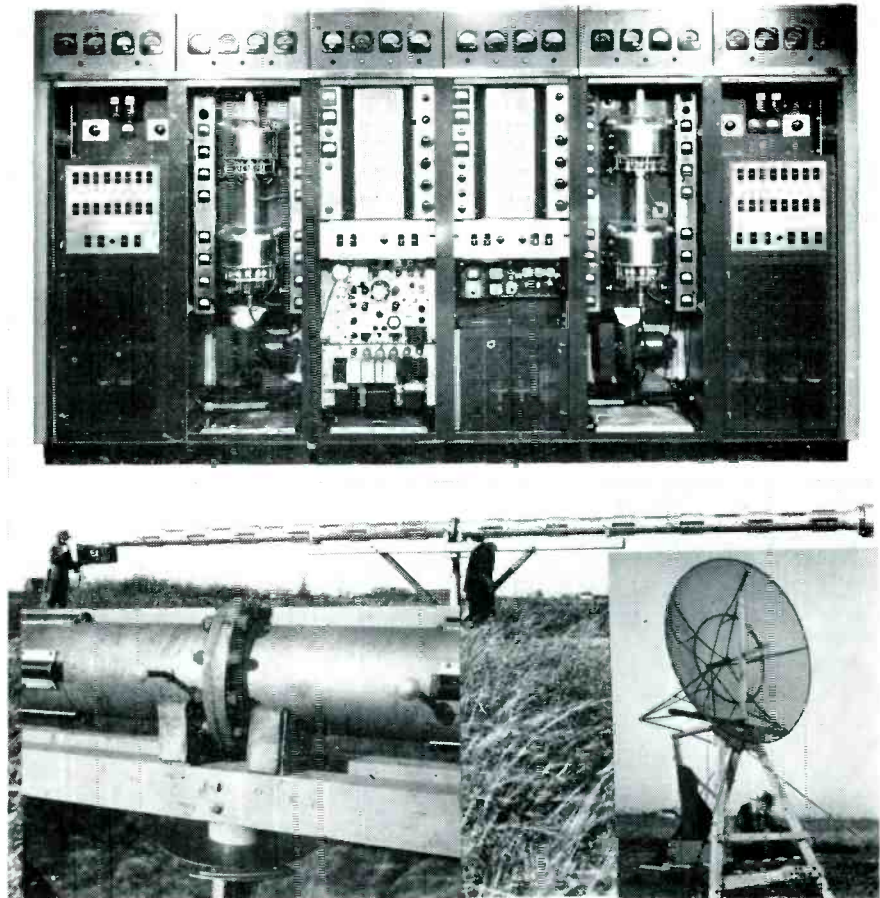

Top—FIRST COMMERCIAL UHF TELEVISION TRANSMITTER

First commercial TV equipment for the ultra-high frequency bands announced by RCA is this 1000-watt RCA Type TTU-1A television transmitter. The front of the transmitter is shown with all doors open disclosing the various units. The VHF portion of the unit, which provides RF power at 176.75mc and 178.25mc for the visual and aural channels, respectively, is housed in the two center cabinets. The two right-hand bays house the tripler, power amplifier, and power supplies for the visual channel, while the corresponding equipment for the aural channel is housed in the two bays to the left.

Bottom—RCA's NEW UHF TELEVISION ANTENNA

The high-gain, slot-type antenna, RCA Type TFU-20A, which is the heart of the new ultra-high frequency television radiating system developed by the Radio Corporation of America, is shown undergoing recent field tests at the company's Camden, N. J. plant. The new antennas can provide a power gain of approximately 20.



## UHF Telecasting

a cathode follower consisting of eight Type 616 tubes connected in parallel. This stage modulates the grids of the final stage. Separate excitation and bias adjustments are provided for the power amplifier tubes, as well as separate meters and overload relays. Thus, the PA tubes can be adjusted to share the load equally. Modulation of the aural channel is accomplished in the conventional manner.

Mr. Gluyas described how the VHF transmission circuits were modified to triple the frequency and double the power, while still maintaining a low circuit loss. The task of finding tubes small enough to accommodate the short-wave lengths, yet powerful enough for the equipment, presented another major engineering problem. All modifications were premised on the use of standard components wherever possible, and only tube types in full commercial production were considered in the circuit design, the speaker said.

Noise reduction on the sound transmitter and maintenance of carrier frequency stability, with sufficient separation between the video and aural signals for operation of certain television receivers, also posed unusual problems for the RCA engineers, Mr. Gluyas stated.

The new transmitter meets all UHF demands in performance. The frequency stability of the visual transmitter is 0.002 per cent. This is obtained by crystal control of the master oscillator. A special circuit design maintains the 4.5 mc frequency difference between the visual and aural carriers with an accuracy of 450 cycles. The transmitter is capable of developing 1.4 kilowatts at the peak of the synchronizing signal. Under normal conditions, the peak power output will be maintained at 1 kilowatt to increase tube life. Picture quality is comparable to that obtained from RCA VHF transmitters.

The new Type TFU-20A antenna designed for UHF operation has the narrowest beam and highest gain of any antenna to be built for broadcasting purposes, Mr. Fiet revealed. The radiating system consists of a high-gain slot-type antenna fed by a single coaxial line. A "notch" type diplexer is employed to isolate the visual and aural transmitters. The visual channel is equipped with a vestigial sideband filter providing attenuation characteristics in accordance with the requirements of a six-megacycle television channel.

The TFU-20A consists of a ten-inch

diameter conductor in which twenty-two groups of slots have been cut. These slots are one-half wavelength long and are separated vertically by a distance equivalent to one-half wavelength. The overall length of the antenna is approximately 40 feet. The slots are energized from a coaxial feed arranged to provide a balance in both power and phase between the upper and lower halves of the array. By this means, a circular horizontal pattern is obtained. The vertical pattern has a beam width of approximately two degrees between the halfpower points. Antenna gain measurements indicate that the present power gain is of the order of 17.3.

The transmission line to the antenna is standard  $3\frac{1}{8}$  inch diameter coaxial line. This has a measured attenuation of 0.222 db per 100 feet. The approximate line length is 250 feet.

The diplexing unit consists of sharply resonant circuits arranged to provide high attenuation between the two transmitters and the antenna at the carrier frequency of the other transmitter. The unit is constructed from elements employing coaxial lines as resonant circuits.

Among auxiliary equipment for UHF broadcasting, RCA has developed input and monitoring racks for monitoring frequency stability and quality of the sound signal, dummy load to calibrate power output, and a picture and waveform demodulator for testing video picture signal and viewing the waveform.

---

## Is Color TV Ready?

From Page 10

able have eliminated the need for any longer withholding television service from the remainder of our country. The allocations in the ultra high frequencies (UHF) should proceed with all practicable expedition, and very high frequency (VHF) allocations should be made promptly.

---

## Engineers Foresee Use of TV in War

Television is exerting and will continue to have a tremendous impact on employment, education, war and politics, it was predicted during a symposium on television sponsored by the American Institute of Electrical Engineers in connection with the 116th annual meeting of the American Association for the Advancement of Science.

Ricardo Muniz, general manager of the Receiver Division of the Allen B. DuMont laboratories, said that the impact of television on society "can hardly be exaggerated."

Other speakers on the symposium were Sterling W. Fisher, manager of public affairs and education department, National Broadcasting Company, and E. Finley Carter, vice-president in charge of engineering, Sylvania Electric Products, Inc., W. L. Laurence, New York Times science reporter, was the moderator.

"It is not unfair to state that, until recently, the scientist and engineer have been too prone to concentrate their active effort upon discovery of new physical principles and the creation of new devices while ignoring completely their impact upon society," Mr. Carter said. "We have been apt to beget our brainchildren with reckless abandon and then cast them upon a society not fully able to cope with them, much less than to direct their use into worth-while channels. We would certainly be considered disreputable parents should we follow the same practice in regard to our biological progeny."

Speaking of the future of television, Mr. Muniz said: "I think it would not take very much to convince you of the potentialities of television as a stable industry, with a long term of years ahead of it."

Citing the fact that advertising revenue this year is expected to reach \$30,000,000, Mr. Muniz asserted that "only the surface has been scratched," and television will create "greater business volume," and "there will be more sales opportunities for all media."

He said there are an estimated 180,000 persons now engaged in television manufacture and telecasting, with television only in its third full year. The industry will produce 2,000,000 receivers this year and a yearly rate of 5,000,000 is likely in 1953. Television payrolls will amount to \$300,000,000 this year, he said.

Mr. Muniz predicted widespread use of television in education, and said that the politicians of the future must have "powerful television" personalities if they are to succeed.

Should war again face us, he asserted, "television would be an invaluable mass instruction medium in disseminating among the people precautionary measures, protective and defensive action such as measures to be taken against fire bombs, buzz bombs, poison gases, atomic radiation, etc., and many lesser emergencies."



## NUCLEAR RESEARCH

Important advances in nuclear research, astronomy, photoelectric spectrometry, and other fields involving work with light at extremely low levels are foreseen with the announcement of a greatly improved 1P21 multiplier phototube by the RCA Tube Department.

Multiplier phototubes are extraordinary photoelectric "eyes" capable of picking up the feeblest illumination, converting it into electrical current, and "multiplying" or amplifying the current as much as several million times.

The 1P21, already an outstanding tube of the multiplier type, has now been made more useful as the result of an intensive development program at the RCA Tube Department's Lancaster, Pa., plant. The "equivalent noise input" of the improved 1P21 has been reduced to  $5 \times 10^{-13}$  lumen (0.000,000,000,000 51 lumen) at room temperature. This value represents a six-fold reduction in operational noise and permits a corresponding reduction in the lower limit of measurable light intensities. This extension in the range of the improved 1P21 makes it an even more valuable aid for astronomers studying light from distant stars, for nuclear scientists studying atomic radiation, and for other laboratory research work requiring measurement of light of extremely low intensity.

Typical application of the new tube in atomic research involves the use of a "light-piping" technique to measure radiation generated by a cyclotron. To overcome the problem of introducing a test instrument into the cyclotron itself, this technique utilizes a long light-conductive rod of quartz or clear plastic with a phosphor on the end of it. Flashes of light or "scintillations" produced when radioactive particle radiation strikes the phosphor are conducted down the rod to the phototube, which is housed in a light-tight box outside the cyclotron. In this way, radioactivity caused by the cyclotron beam can be conveniently and accurately measured.

The 1P21 is particularly useful where light is to be picked up from a small area. For use in measurement applications in which the radiation is available from a relatively large area, such as a phosphor coating, the larger end-on cathode surface of the recently announced RCA-5819 multiplier phototube offers advantages.

The 1P21 and the 5819 utilize the phenomenon of "secondary emission" to achieve their enormous amplification. Feeble illumination striking the photocathode of the multiplier tubes releases a number of electrons. These electrons are swept electrically through a series of "dynodes" or amplifying stages within the tube, snowballing into an avalanche as additional electrons are released at each stage, and emerging as an electrical current which provides a highly useful signal for research work.

The newly improved 1P21 and its companion multiplier phototube, the 5819, represent notable advances in phototube design and have considerably extended the usefulness of the scintillation counter, an instrument that is fast replacing the Geiger counter for the detection and measurement of nuclear radiation in many applications.

---

*Heading Cuts* for Chapter news columns. Chapters without regular heading cuts and desiring same, should send in photo, cartoon, or drawing of subject matter that they wish used to identify and distinguish their column.

**Climaxing 15 years experience in training PRACTICAL ENGINEERS . . . we announce completely NEW and MODERN AM - FM - TV STUDIO, TRANSMITTERS, and IMAGE ORTHICON CAMERA CHAIN . . . specially designed and planned to give the student the practical experience needed to be a real asset to an engineering staff.**

**Request our descriptive catalog describing at length the specialized training and equipment offered here.**

**Our Placement Department will furnish data on graduates upon request.**

*Phone or Wire Collect*  
**Telephone TEmple 3-4620**

## **RADIO ELECTRONIC TELEVISION SCHOOLS**

**3730 Woodward Avenue, Detroit 1, Michigan**

## **CAPPS\***

SAPPHIRE is, and has always been, the only material for making cutting styli for high class recordings.

C A P P S\* Patented Sapphire Styli (2187512) are the original and accepted standard for high class professional acetate recordings.

*Imitated but not equalled*

**FRANK L. CAPPS & CO., Inc.**

244 W. 49th STREET NEW YORK CITY  
Telephone CIRCLE 6-5285

\*Reg. U. S. Pat. Off.

# LABOR - MANAGEMENT NEWS

## The Secretary Says:

The President of the United States and the members of his administration believe in free enterprise.

For the purpose of buttressing private enterprise, President Truman and his administration insist on using certain collective insurance policies. We are for unemployment compensation. We are for a reasonable pension system which will adequately protect people in their old age. We are for extending the minimum-wage law to cover as many workers as possible. We are for making sure that workers shall have the right to band together and that management shall be under an obligation to bargain collectively with their representatives.

We are for all these things and for other measures of social and economic justice, not because we are against business, but because we are for business and for all other components of our economy and society. All we wish to do is to serve the general welfare and to make private enterprise the full-fledged helper of the common good.

Enlightened private enterprise protects the rich *and* the poor, and it does so by being vigilant in the defense of the rights of the toilers as it is vigilant in its defense of the rights of the property-owner and the stockholder. Thus the capitalist system must be used for the building up of our economy so that the masses of our people will profit at the same time that industry and business are profiting. This is economic fair play. This is spreading the benefits of prosperity as far as possible.

---

## McComb Issues Revised Rules Under Amended Wage-Hour Law

First of a series of new and revised interpretative bulletins and regulations were issued by the Department of Labor's Wage and Hour and Public Contracts Divisions, acting upon advice of William S. Tyson, Solicitor of Labor, as the new 75-cent minimum wage and other amendments of the Fair Labor Standards Act—wage-hour law—became effective on January 25.

Issued in the material issued as the changed law became operative was Administrator Wm. R. McComb's new interpretative bulletin on overtime compensation. This bulletin, which discusses in detail the revised overtime compensation provisions of the wage-hour law, was awaited by both employers and employees seeking the Administrator's interpretations of how the amended law will apply to overtime compensation problems which Congress sought to clarify through the changes.

Issued as "a practical guide to employers and employees as to how the office representing the public interest in the enforcement of the law will seek to apply it," the bulletin cites the fundamental requirement of the wage-hour law's overtime provisions. This is that overtime pay "at a rate not less than one and one-half times the regular rate at which the employee is actually employed" must be paid to all employees who are covered by the law and not exempt from the overtime requirement.

The new bulletin emphasizes that the "regular rate" is a rate per hour, regardless of how an employee is paid. The

bulletin then provides examples of how to compute the "regular rate" for employees, whether employed by the hour, by the job, by the piece, or otherwise.

Detailed discussion is offered concerning the seven types of payments made by employers under varying circumstances. The amended wage-hour law for the first time enumerates and classifies these types as excluded from an employee's "regular rate" for overtime-pay computation purposes.

Of particular interest to employers and employees in the forestry and logging and small sawmill industries is the Administrator's interpretative bulletin on the new exemption provided in the amended wage-hour law for certain "forestry or logging operations." It emphasizes that sawmilling operations are not within the exemption, except in the case of an employer who has 12 or fewer persons employed in the operations.

The bulletin points out that the new exemption is a complete one—from both the minimum-wage and overtime provisions of the wage-hour law, but that it is limited. The operations named are expressed in "terms of ordinary speech" whose meaning is clear, the bulletin states, adding that incidental activities normally performed by employees in such operations are included within the exemption.

Considerable action was taken by the Administrator with respect to the section of the wage-hour law under which he is directed to specify the conditions for the employment of certain workers at subminimum rates. Principal activity here was with respect to the regulations governing the employment of learners. The Administrator revoked some regulations issued a number of years ago, revised others, and issued new ones for certain industries.

More than 3,000 learner and student-learner applications were received in January alone. Those granted by the Administrator permitted employment of limited numbers of learners for specific periods, and at rates ranging from 55 cents upwards, in situations where necessary, as the law provides, "to prevent curtailment of opportunities for employment."

Two new regulations were issued by the Administrator under the revised overtime provisions of the law. One defines "bona fide profit-sharing plan or trust," as referred to in the amended law, under which payments to employees will not affect their "regular rate" in computing overtime pay. The other regulation defines the term "talent fees," as used in the radio and television industries, which the amended law also provides shall be excluded from an employee's "regular rate."

Next to be issued will be the Administrator's new interpretative bulletins on the general application, or coverage, of the wage-hour law as amended, and on his interpretation of the revised exemption for "retail or service establishments."

---

## Jobs For Engineers May Increase 100,000 In Next 10 Years

Employment in engineering—the third largest profession, and one of the fastest-growing—may increase by as much as 100,000 in the next 10 years, or to a total of roughly 450,000. However, many members of the very large graduating classes coming out of engineering schools may be unable to find engineering jobs in the next few years, although their training

may help them get administrative, sales, or other technical positions.

These are the main conclusions of a 120-page bulletin, "Employment Outlook for Engineers," issued recently by the Department of Labor's Bureau of Labor Statistics. In addition to describing the employment outlook for the engineering profession and its major branches, the bulletin gives information on earnings and occupational mobility.

The number of engineers in the United States increased nearly tenfold between 1890 and 1940, rising from 27,000 to about 260,000; in the spring of 1948, the profession is estimated to have numbered 350,000. Furthermore, employment in this occupation is expected to continue to expand in the future, although the rate of increase may become less. The expansion in employment between 1948 and 1960 may average about 8,000 jobs per year, although the yearly increase will vary.

Engineers will also be needed to replace those who leave the profession because of death, retirement, or transfer to other occupations. Those losses are estimated at 10,000 currently. Toward the end of the 1950's, they may rise to about 13,000 per year.

These estimates suggest that the total demand for engineering graduates in the United States, including both the expected expansion in employment and replacement needs, will approximate 17,000 or 18,000 annually for the next few years. Toward the end of the 1950-60 decade, the demand may well rise to about 21,000 or 22,000 a year.

Over the past few decades, engineering schools have trained increasing numbers of students; the number of persons receiving engineering degrees rose from an average of 7,000 a year in the 1920's to about 10,000 a year in the 1930's. Since the war, graduations have soared higher than ever before. During 1947-48, about 32,000 engineering students were graduated; in 1948-49, the number rose to about 44,000. Enrollments in the fall of 1949 indicate that more than 36,000 in 1951, and nearly 29,000 in 1952. Actually, the number of graduates in these years may be higher, owing to student transfers from junior colleges and the possibility of lower drop-out rates. Following the decline in the early part of the decade, the number of graduates is expected to increase gradually into the 1960's.

A comparison of the estimated supply of and demand for engineering graduates leads to several conclusions. The number of graduates will greatly exceed the number of engineering job openings in the next few years. Although in the next few years, the total number of new graduates will probably exceed the number of openings in engineering positions, the employment situation will vary among the different branches of the profession. There is also likely to be a continuing demand for men with special abilities or training in such work as research and design. In the past, even in times of depressed industrial activity, the engineer who was at or near the top in ability had little trouble in obtaining or keeping a job.

The outlook for students who will be graduated from college in 1955 or later is difficult to evaluate. The profession will probably expand considerably during this decade but new graduates may continue to face competition for employment.

The study has been issued as BLS Bulletin No. 968 and is available at 50 cents from the Superintendent of Documents. A wall chart, illustrating the trends of engineer supply and demand, and a brief summary issued in 1949 may be obtained free from the Bureau of Labor Statistics, Department of Labor, Washington 25, D. C.

## SPRING — SEASON OF HOPE

By CHESTER M. WRIGHT

Time was when this month was a month of hope, of the promise of good things to come; a time of renewed life, with rains and sproutings and leafings, with the blessings and fruitings to lie just beyond, beckoning.

Time was, too, when this month was for many a month of expected returning employment and wages, after a lean winter.

And also time was when our nation's war fleets were painted the white of peace and expected peace, visiting strange ports on missions of friendship.

Such turmoil as there was, we looked upon as perhaps the normal turmoil of a steady growing nation. There were the outbursts of violence, as bitter employers, short-sighted and narrow, laid the foundations for violence by the use of private detective and strike-breaking thugs. And a militant young labor movement knew jolly well how to fight back and now and then to win a step ahead.

The calendar will not bring back its faded leaves—and again, "it is later than you think."

\* \* \*

Today there are labor struggles, but there are no mobs of strike-breakers and provocateurs. Conflicts are largely fought by statisticians, economists and lawyers. There are too many lawyers in the picture, but that was forecast when our country adopted laws for the governing of the ways of labor disputes.

Today perhaps the greatest concern in the mind of man is: "When will the new bombs start exploding and how many millions can one of them kill."

A bright columnist friend of mine writes that he craves to know how great a circle of destruction will be wrought by an H-bomb. He wants to know so that he may know how far from his city he should find a home. It is symptomatic, this concern of his.

On the other hand, one of our great scientists tells us we should let up a bit on secrecy, so that atomic energy may be more quickly developed for peace.

\* \* \*

When civilized nations swung from feudalism into capitalism, the wrench was great and its spread over more than a couple of decades. It inflicted great misery upon many. But so did feudalism.

Much of humanity escapes misery. And there is plenty of it today.

However, except for the worry as to how much future lies ahead for our race, we have more and more and better and better for more and more people.

"How wonderful is our world," might be the theme of a great tome, could we but learn among us how to live in peace—how to end the horror of dread that flows to us out of the threat of the atom bomb and the hydrogen bomb.

But not one among us in America knows whether tomorrow may bring the first terrible blast. The decision does not lie with us and there's the rub—the awful, aching rub that must come to all but the most stupid and dullard minds.

Have we made progress in the bright field of science to the point where our own progress may breed its very destruction? It could be so, unless nations learn!

\* \* \*

If nations are to learn, they must learn quickly.

For, mark this down, men in labor temples, in counting houses and in homes—forces in motion must move toward a climax. There is no other way.





## CHICAGO —By DICK DAVIS

Having missed a month getting a column in the Journal for Chicago, I've been living in constant fear of getting one of those very nasty letters which Stolzy sends out ever so often. So far none has been forthcoming so I suppose I'm forgiven.

Now that spring has officially arrived, everyone around here has begun to get that well-known itch, fishing and golfing, that is. I'm not too much of a fisherman but I do like to get out and gouge up the fairways once in awhile. This time of the year is notorious for house cleaning also. Besides helping out the little woman at home, By Spears and Al King have their hands full putting the recording equipment in condition for Daylight Saving Time delayed broadcast operations.

Of course every spring starts a flock of rumors floating around and Chicago has its share of them. Leading the current list is the story that ABC-TV Chicago may soon have that bona fide Master Control which has been coming since opening night. Along with that, one executive foresees as many as thirteen TV studios here in the not too distant future.

Now that the vacation season is in full swing we have both some old and new faces with us. Mr. Joseph Kuhn, formerly of Universal Recording, has joined ABC. Back from last year we have Mr. Clifford H. Braun and Mr. Robert M. Popke. Cliff has been instructing in Television Studio Techniques at American Television Institute here in Chicago, and Bob has been with television station KMTV in Omaha, Nebraska. I was especially glad to see Bob come back.

Noble Moore, who was with us last year, was invited to come back, but I understand that he now holds a very nice supervisory position with Hallicrafters Corporation. By the way, he just became a proud papa again. So did Joe Kresnicka of the Penthouse studio. He recently passed out cigars in honor of a new daughter, Susan Ann.

George Hillas, of Telecine, is spending his vacation in the Phillipines this year. He and Chuck Leslie, one of the announcers, are to be the guests of Leopoldo Ruitz, Consul of the Phillipines.

John Ducker of the Civic studio, is going to Mexico for his three weeks on an alleged treasure hunt. I think someone sold John an old map or something.

Charlie De Janovich of the Penthouse studio, will undoubtedly spend his vacation looking for a place to live. He has a nice apartment now but he's been requested, or rather ordered, to vacate by some time in May. It seems that there is a maximum allowable income out there and since Charlie received the promotion to TD, as the saying goes, "He's had it." Things surely get tough when you get in the upper bracket.

Jim Lato has finally got back to field work after so long a

time. He's replacing Roger Parker on the Lawrence Welk show. Roger has been transferred to KECA Hollywood. For the benefit of the Hams, Roger's call is W9KDI.

Joe Alusic, besides performing his regular duties as TD of the Penthouse studio, is also the big cheese treasurer of the coffee pot up there. I had a tour there the other day and Joe was very perturbed at the time. Some unscrupulous character has stooped so low as to pay for his coffee with beer chips from the Argyle Tavern. Joe says he's found the neighborhood and expects to make an arrest any day now.

The Maintenance engineers have built a new stabilizing amplifier which is supposed to do everything but make coffee. Right now they're working on a distribution amplifier which will incorporate that feature.

Jimmy Valentine, Engineering Operations Supervisor here in Chicago, recently announced his engagement to Miss Carol Howard, Program Operations Manager for KECA Hollywood. They plan to be married in April and spend their honeymoon in South America and Cuba.

We really had our share of the accidents last month. Elmer Kubitz tells me that his wife slipped on the ice and broke her leg.

Dolores Martin, our pretty NABET secretary, was making French fries the other night and splashed hot grease all over herself. She wasn't seriously burned but she ruined a good suit.

Up to Studio A the other night they were doing a show called Little Revue. One of the cameramen passed out right on the air. He was on the Fearless dolly camera and had it cranked way up high shooting down. As he fell the stage manager grabbed him with one hand and the camera with the other. Roy Hayward, the TD, rushed out of the control room and took over. I was watching the show at the time, but you'd never have known that anything unusual happened.

The remote unit was setting up cameras the other night for the wrestling show out at Rainbo Arena when a little mishap occurred. Steve Gabocy had a camera on his back carrying it up a ladder to the platform and the ladder fell over. He held on to it all the way down and they both landed on the view finder of another camera. The result was some banged up equipment and a shaken up engineer. Steve says the camera worked better that night than it ever had before. The drop test will be routine maintenance in the field from now on, I suppose.

A couple of months ago I was assigned to the field crew for one day. You might know that that was the day they picked to reroute what seemed to me about 10,000 feet of camera cable. I spent the evening climbing around the rafters of the Arena with cables on my back. Last Monday night the whole Civic crew had a wee taste of field life. We did a show in the studio and then immediately picked up all of our equipment and rushed like madmen out to the Chicago Colosseum and did the Roller Derby. After those two experiences I really hand it to the field engineers. Believe me, lugging those cameras and cables around is no fun. Even with all the free beer that was served after we went off the air I'll still take studio work if you don't mind.

Boy I'm hungry!!      So long.

DICK DAVIS.

# NABET

## A RADIOMAN'S UNION



## WASHINGTON

By W. D. DEEM

During one of the Saturday telecasts of the TV Shoppers Review at one of the local theatres here in the district, several autograph seekers were on hand and the heroes of those kids were not the artists on the show, but the illustrious cameramen. Obliging, Wally Bush, Joe Kriss, and Al Argentieri, all of WNBW, responded to the wishes of the awe stricken boys and gave them the autographs.

About the most important thing that could happen over at WOIC would be the okaying by the District Zoning Commission of the reclassification of the area that WOIC occupies. At present it is classified Class A residential. It is just a stone's throw away from a large Sears, Roebuck store which is in a commercial classification zone. If WOIC were classed commercial they could expand their studio space with very little trouble!

Three fellows at WOIC are awaiting the stork's decision on whether it will be a boy or a girl and in one case whether or not in will be!!! They are Norm Bailey, Tom Fanning, and Harry Reimers.

In the last issue I stated that the final hearings of the FCC on color were being conducted. I was in error. During the week of April 6th there were more hearings. The main issue at this time seems to be the single tube issue. RCA has been demonstrating two kinds of single tube receivers and at this time of writing hadn't decided which of the two they would finally make. One was a single electron gun which shoots beams at the color screen from different angles as it rotates and the other has three stationary guns, each of which takes care of a sep-

arate color. Both shoot through masks containing 117,000 holes, (per single color of screen), and there is no danger of any gun activating the wrong color. Both kinds can be made in any size, the bigger the easier, and both kinds can be watched at any angle. Even if and when the FCC does finally set standards on a system it will take several months for the manufacturers to tool up and start mass production. Color TV is like a big juicy apple that isn't quite ripe yet.

The following incident actually happened during one of the color demonstrations last February. Jim Spear, magician, was performing in front of one of the color cameras, presenting a trick using colored silks. One trick had to do with the taking of three colored silks, red, white and blue and stuffing them into a small box at one end and drawing from the other end an American flag. Part of the trick was to purposely drop the blue silk for effect, but the color engineers in the control room did not realize that it was on purpose and didn't even notice that it wasn't there until the American flag was pulled from the other end minus the blue field. They started looking for trouble in the system exclaiming, "Where is the blue channel? The blue is missing from the picture." By this time the trick had been completed. Jim Spear had done the trick again, this time inserting the blue silk and pulled a completed flag from the box. A sigh of relief was heard from inside the control room.

Soft ball is again in the air. Dodd Boyd has been chosen to manage the NBC team in the Radio League in the district this season. Johnny Batchelder has taken over the League management and Jim Simpson is to manage the WOIC team.

Dean Luce will manage the WMAL team this year!

The games are played every Saturday morning on the diamonds at the Monument Grounds.—73, W. D. Deem.

## MOHAWK

By JOHN F. McMAHON

Well here it is the merry month of May and the flowers are blooming, etc. Even the Helderberg Mountains have lost their covering of snow and the golf season is in full swing. It is about the time of year to plan the vacation trips, etc.

Congratulations are in order for the Carl Youngs, who greeted the Spring with an addition to the household, someone to fill up the new house, Carl.

The affiliation results are in and I hope

everyone is as satisfied as I, with the results. These outfits just didn't have anything to offer us, so there was no use getting tied up, under the circumstances.

The fellows at WRGB Transmitter have a little peanut whistle ten meter rig on the air now and will be looking over the band, after television program time in the future. It only runs ten or fifteen watts and we had no TVI, which surprised me in a way. I thought there was a possibility that it would overload microwave receiver or so, anyway.

Jack Hahn should have his car back in gear by now, the boy did a lot of work on it, that most guys wouldn't even attempt and the only bad effects were a couple of stiff muscles.

We hear tell that pert Betty Kelly finds it lonely getting up for the early trick at WSNY control room and also that the song "Cry of The Wild Goose" is one of her favorites. How 'bout that?

Frank Froman is in the market for a replacement to take over his 1240 DJ job. This night work sure does wreck a guy's social life.

I'd like to pass along the sincere condolences to Ed Robinson also of WSNY, who lost his mother in March.

Jack Winters is knocking himself out with work on his new house and also in study, on a CREI course.

Steve Fitz, another WSNY lad has just moved into a new apartment and is busy getting the wife and family established.

Dave Dangler tells me that the WSNY Xmtr is well nigh flooded, what with the thawing snow and a bit of rain plus the low level location. Better keep a row boat ready Dave.

His sojourn at WGY Studio has given Charlie Lewis a chance to get down to brass tacks on a PP 813 rig. Chuck is going to give the Hi power boys a run for the D-X.

Gus Coopersmith had a rough run-in with a soldering iron and we hope there are no ill effects from it.

Don Morey is one of the ten Meter stalwarts in this region and he checked our ten meter rig recently. It was quite a QSO, as the rig was in one room and the receiver in another about forty feet away. I about ran myself bowlegged traipsing back and forth!

Hort Mosher and I had occasion to cuss our Jeep truck the other day, when the contrary old bus refused to start and stranded us on the hill for the night.

Just had a look at Pres. McDonnell's report and I LIKE THAT NEW WOIC CONTRACT!

Glad to hear that Dale Applegate down at WRC is staying on the ball. Just like



in K.C. Dale?

Hope the F.C.C. gets the frequency allocations straightened out soon so NABET can embrace some new TV stations.

Big Nick Nickels is gathering gear for a 4-250A rig. That ain't no bad Xmtr.

Due to a misprint, a recent issue of the BEJ had Hort Mosher's call as W2DE that should have been W2DEL. Sorry.

Red Wilson has gotten the local Ford dealer on the ball, so now I get pretty fair service.

Newt Barnes has been beating his research lab buddies out of components for the rest of the gang on the hill.

Joe Decker, of WGY is also looking for W7's on Forty.

Has anyone tried working some of the fone DX on Forty, huh?

Guess that is about all for this time, so I'll be CNU.—Mac.



## OMAHA NEWS

By BOB RUDD

WOW-TV has been going strong for some time now and the routine of things have been pretty well established. Bill Dunbar is now TV Studio Supervisor. Larry Sibia is TV Transmitter Supervisor. They have a fine crew of fellows, many whom you already know or whose names you have seen in this column many times before. They are: Cy Hagrman, Louie Deboer, Dick Peck, Al Maller, Johnny Brunken and the very latest addition "WEN" Murray from Kansas City, Mo. Part time TV men are: Percy Ziegler, Roy Ekberg, and Bob Engdale. The last three named combine AM and TV.

G. Flynn, a WOW old timer, was made Operations Supervisor last fall and has been doing a fine job directing overall operations of the AM-Studios and TV-

Studios and Transmitter. AM Transmitter operations are under the direction of Roy Glanton, Omaha Chapter Chairman.

There has been a lot of ham activity going on out here. The gang has established a 10 meter mobile net and the frequency of 29468 KC has been chosen for working and calling. Coincidental with that has been the choosing of 29640KC as the National 10 meter distress frequency by the league. Present calls operating on 29648KC are: WØVNA (Dunbar), WØAPX (Sibia), WØDCQ (Maller), and WØLIQ (Ekberg). All stations are using vertical whips and have found that a length of 93 or 94 inches does the best job. A number of tests from all over the city indicates that whips of this length put out a better ground wave and a more consistent signal. If any of the gang hear the boys give them a shout as they will be listening.

A recent high wind has somewhat crimped the activities of a couple of the gang here. WØMHV (Flynn) lost his beam in a recent high wind that reached a velocity of 75 mph. At the same time WØGTC (Glanton) discovered that his beam was being torn from its moorings so a quick approach with a ladder and rope saved the situation from becoming drastic but did not prevent the supporting mast from being weakened. Well such are the problems of being a "ham." Speaking of hams, hope that Hiller gets on from his place in up-State New York so we can work him. Try 40 meter cw, Harry, and we will be looking for you.

There have been a flock of new babies here in recent weeks. First Bob Rudd was passing out (cigars I mean) and then Ray Clark (WOW news caster), then Percy Ziegler, then Ralph Laska. Now soon, or by the time this is in print, there will be new arrivals at the homes of Dick Peck (TV) and Bill Kotera (WOW chief engineer). I hastily add that we are not like the lady, who, when being questioned by the census taker, said that she had 21 children but her husband DID DO plumbing on the side! We have steady jobs here (we think).

Well enough of that. G. Flynn, recently returned from a trip to the South on the WOW Farm Tour, got off the train to learn that his wife and two little boys had been hurt only five minutes earlier, in a car crash. Mrs. Flynn had been on her way to the station to meet Glenn. The morning sun blinded her, resulting in an intersection crash that upset the car. She received a broken arm and a crushed hand. The children were bruised but not seriously injured.

Mark McGowan (AM Transmitter)

has moved into his new home in Benson and is quite happy. He has enough ground now to put up antennas and is heard on 75 meter phone regularly under his call of WØNZ.

I should mention that Bob Engdale (AM and TV) is running the Johnny Carson Show four days a week. How he manages to get in those fast switches and fades is beyond me. I guess that's why he is running it. Perc Ziegler handles the show the other two week days.

Here are a few gleanings from KODY, KMTV, and KMA. Bill Cowdery attended the April meeting of the Omaha Chapter at the invitation of the Chapter. Bill is the KODY Councilman at KODY, North Platte, Nebr. Harley Pratt is the other NABET member at KODY. Harley will complete two years at KODY April 21st. KMTV has been on the air since July of 1949 and doing a bang up job. A fine bunch of fellows all the way around. The writer has not met all of the gang yet but their enthusiasm at union meetings is refreshing and encouraging. It is hoped that we will have more news of the WMTV and KMA in future issues of the Journal.

## BOOK REVIEW

### Theory and Design of Electron Beams

Authored by J. R. Pierce, member of the Technical Staff of the Bell Telephone Laboratories, published in 1949 by D. Van Nostrand Company, Inc., New York. 197 pages approx. 6x9 inches, price: \$3.50.

A mathematical treatment of the general subject of electron beams, without specific consideration of application. Differing from most other texts which discuss the subject in relation to the electron microscope or image tubes, the author's prime interest has been in the field of amplifiers and oscillators.

The several Chapters are titled:

1. Properties of Electric and Magnetic Fields.
2. Forces and Equations of Motion.
3. Simple Electron Motions.
4. Some General Relations.
5. Some Typical Special Problems.
6. The Paraxial Ray Problem.
7. Magnetic and Electric Lenses—Analytical and Numerical Solutions.
8. The Effect of Thermal Velocities.
9. Space Charge in Electron Beams.
10. Electron Guns.
11. About Designing Electron Beam Devices.

Appendix and Index.



## New Tubes Triple Portable Radio Battery Life

**New types of radio receiving tubes developed by Sylvania Electric permit use of lighter, more compact batteries and represent first major advance in tubes for portable radios since 1938.**

A new line of miniature radio tubes for portable radio receivers which triple useful battery life and provide performance comparable to similar tube types has been announced by the Radio Tube Division of Sylvania Electric Products, Inc.

"The new line of tubes," Shaw said, "are the first to be announced in this country in more than ten years in which filament current has been reduced below 40 milliamperes per tube. The new tubes require only 25 milliamperes per tube or a fraction of the current required for a flashlight bulb. This means that "A" batteries used in portable receivers will last approximately three times as long with the new tubes as with other available types, since by halving battery drain, useful battery life is tripled."

Shaw also said that the new tubes will provide radio set performance comparable to that of other available battery types for portable broadcast receivers. The low current requirements of the new type tubes should also make possible radio receivers that are more compact and lighter in weight while requiring less frequent replacement of filament batteries.

Since the cost of maintenance of portable receivers is largely a matter of battery replacement, the new tubes should also make possible much more economical set operation.

"Exhaustive tests in stock model portable radio receivers," Shaw stated, "have been conducted with both standard battery type tubes and the new types to determine set performance with respect to sensitivity and selectivity throughout the broadcast bands. Standard 67½ and 90 volt portable "B" batteries were used. In this way we were able to observe and measure actual performance of the new miniature tubes compared with that of older types in a range of conditions typical of actual set operation."

The new Sylvania low-drain battery tubes include type 1U6, a heptode converter with oscillator anode as a separate element; type 1AF5, a diode pentode; type 1AF4, a sharp cutoff r-f pentode; and type 3E5, a beam power output tube. All tubes have 25 milliamperes filaments and

are supplied with 7-pin miniature button bases.

Power required for a complement of the new tubes in a typical battery-operated superheterodyne is only 2.1 watts or one-half the average required for other available types. The new tubes will also operate satisfactorily over a range of 1.4 volts to 1.1 volts, or about ten per cent greater than the rating of comparable types.

## Fox and RCA Continue Large Screen TV Work

The signing of a new contract for cooperative research looking toward further advancement of the applications of large-screen television in the motion picture industry was announced by the Twentieth Century-Fox Film Corporation and the Radio Corporation of America.

Representing expansion as well as continuation of the cooperative program carried on by these two organizations for the past two years, the new agreement calls for delivery of several new RCA equipments, including one of RCA's first commercial-type instantaneous theatre TV systems (Model PT-100) and the first production model of RCA's new intermediate-film TV system.

Incorporated in equipments furnished under the new contract, it was disclosed by Mr. S. P. Skouras, President of Twentieth Century-Fox, and Mr. Frank M. Folsom, President of the Radio Corporation of America, will be numerous improvements in circuits, electron tubes, and other components.

The two corporations whose cooperative research to date has contributed heavily to the development of the first commercial theatre television equipment, will each continue development work. Earl I. Sponable, Technical Director of the film corporation and a pioneer in theatre television development, will continue to direct his company's research in this field under the new contract. The contract is the outgrowth of negotiations between Mr. Sponable and Barton Kreuzer, Manager of Theatre and Film Recording Activities of the RCA Engineering Products Department.

Commenting on the enthusiasm expressed by various exhibitors and theatre circuit representatives who have witnessed demonstrations of instantaneous theatre television in the past few months, W. W. Watts, Vice President in charge of the RCA Engineering Products Department,

predicted that 1950 will be marked by significant growth in commercial applications of this new medium of mass communication and mass entertainment.

"Various groups are drafting plans for commercial installations, as well as far special programming for the theatre and methods of program distribution," he said, "and I am confident that theatre television history will be made in the year ahead."

## Coax To Memphis

Memphis, Tenn., was joined to the Bell System's expanding television networks March 1, according to the Long Lines Department of the American Telephone and Telegraph Company.

This addition, the first in 1950, brings to 26 the number of cities receiving network telecasts by means of Bell System facilities, which now extend about 9,000 channel miles in length.

Inclusion of Memphis makes it the southernmost point reached by network television at the present time. The new television network link was made possible by adding special equipment to an existing section of coaxial cable which runs south from St. Louis, Mo.

Programs from New York reach St. Louis via Chicago. En route to Memphis the cable crosses the Mississippi from east to west at St. Louis and again, this time from west to east, at the Tennessee metropolis. This cable has for many months been providing hundreds of long distance telephone circuits to help carry the heavy telephone traffic along the route between the midwestern and southwestern areas of the nation.

The cable was a joint undertaking of the Southwestern Bell Telephone Company, Southern Bell, and A. T. & T.'s Long Lines Department. Construction of the cable was begun in November, 1947.

By the end of 1950, it is planned to have network service available in over 40 cities—as far north as Minneapolis, Minn., as far south as Jacksonville, Fla., and as far west as Omaha, Neb. The network will then comprise some 15,000 channel miles.

Other southern cities scheduled to be added in the 1950 program include Norfolk, Va., which will be linked by a radio relay hookup with Richmond in April. In September, Greensboro and Charlotte, N. C.; Atlanta, Ga.; Birmingham, Ala.; and Jacksonville will, according to present plans, begin receiving network video programs by means of coaxial cable running south from New York via Philadelphia, Washington, and Richmond.

## Record TV Output Continued In January, RMA Reports

Running counter to the traditional post-holiday pattern, television set production by RMA member-companies continued at a record level in January, the Radio Manufacturers Association reported. RMA member-companies reported the manufacture of 335,588 television receivers in four working weeks in January, 1950.

The January output exceeded December and all 1949 months except November which covered a five-week period. Average weekly production of TV sets during the month reached 83,897—an increase of 16 per cent over the December average and eight per cent above the average for the record-breaking last quarter of 1949. An all-time peak was reached during the last week when 97,986 sets were produced.

Radio production also remained at about the fourth quarter level with 660,195 sets reported. FM and FM-AM receivers reported by RMA member-companies totalled 89,136 with an additional 34,087 TV sets reported as equipped for FM reception.

Total radio and television set production in January amounted to 995,783 receivers, RMA said.

## Tube Sales for New Sets Up, Replacements Down In 1949

Sales of radio receiving tubes in 1949 to manufacturers for new television and radio sets rose in 1949 over 1948, but replacement business declined sufficiently to bring total industry sales 5.9 million units under the previous year, the Radio Manufacturers' Association reported today.

December sales for all uses, however, were 4.5 million above the corresponding month in 1948 and only slightly under sales in November 1949.

Sales for new sets in 1949 totalled 147,298,436 units as against 146,162,214 in 1948. Total tube sales were 198,753,295 in 1949 and 204,720,378 in 1948. December sales totalled 23,807,281 tubes.

Tubes sold for replacement in 1949 declined from 47,056,521 in 1948 to 39,696,297 last year. Exports of 10,072,845 in 1949 were only slightly under those of 1948 and sales of 1,685,717 tubes to government agencies were almost double those of 1948.

## TV and Radio Set Sales in 1949 Established New Industry Record

Manufacturers sales of television and radio sets in 1949 established a new dollar

volume record for the industry, rising about 13 per cent above the previous peak reached in 1948, Raymond C. Cosgrove, president of the Radio Manufacturers Association, said.

Preliminary estimates indicate that total set sales at the manufacturer level aggregated more than \$850 million as compared with \$750 million in 1948, Mr. Cosgrove said, and the increase was due entirely to the sharp rise in television receiver production as radio set sales declined substantially.

"Thanks to the high rate of TV set sales, especially during the last quarter, the industry in 1949 did the greatest volume of business in its history," Mr. Cosgrove said. "Television receiver sales, because of their greater value, accounted for more than 65 per cent of the set industry's gross income or close to \$560 million.

"Converted to retail values, the industry's record production of well over 2,800,000 television receivers represented more than \$875 million with radios bringing the combined retail value of television and radio sets to better than \$1.3 billion for the past year, not counting installing and servicing charges."

Mr. Cosgrove pointed out that the value of television receivers manufactured in 1949 was twice that of all TV sets produced between World War II and the end of 1948.

"This means that the nearly 4,000,000 television receivers produced since the war, figured at retail value, represent a public investment of more than \$1,250,000,000," he added. Mr. Cosgrove pointed out, however, that the 4,000,000 figure constituted total TV receiver production through 1949 rather than sets in use.

"The industry's 1949 record sales were accompanied by substantial reductions in prices of television receivers during the year as economies achieved through increasing production volume were passed on by the manufacturer to the consumer," Mr. Cosgrove said.

## Improved Quality Components Topic of Technical Conference

Under the sponsorship of three industry organizations, radio and electrical engineers will meet with military and other government representatives for a "Conference on Improved Quality Electronic Components" in Washington, May 9-11, it was announced by the committee in charge of the program.

The three-day conference will be sponsored by the Institute of Radio Engineers,

the American Institute of Electrical Engineers, and the Radio Manufacturers Association with the assistance of the military services, the Research and Development Board of the Department of Defense, and the National Bureau of Standards.

New techniques for producing longer-life components, especially for military, aircraft and industrial electronic equipment, will be discussed at the symposium to be held in the new Department of Interior auditorium. A program is now in preparation.

"The symposium will pose the problem of achieving the same high degree of dependability and service life in electronic equipment as is now possible in electrical equipment of other types," J. G. Reid, Jr., of the National Bureau of Standards, who is chairman of the Program Committee, explained. The symposium will give emphasis to the following topics, the chairman said:

- (1) Improved quality of circuit elements for greater dependability of electronic equipments.
- (2) Unitized packaging as a means for greater dependability through simplified maintenance.
- (3) Miniaturization, particularly as applied to the unit package.
- (4) Circuit elements compatible with design requirements of the unit package.

Mr. Reid added that "progress of research and development and the problems encountered in these fields will be reported by representatives of industry, the military services, and government laboratories. Trends in the design and manufacture of electronic equipment will be discussed. Pertinent standards and specifications will be reviewed."

Sponsor representatives of the organizations supporting the conference are: Dr. W. R. G. Baker and M. R. Briggs, of the RMA Engineering Department; J. G. Brainerd, of IRE; and W. R. Clark and W. G. Dow, of the American Institute of Electrical Engineers.

F. J. Given, of Bell Telephone Laboratories, is chairman of the Steering Committee, and L. G. Cumming, of IRE, is vice chairman. Virgil Graham, ofsylvania Electric Products, Inc., and associate director of the RMA Engineering Department, is chairman of the Publicity Committee.

Other committee chairmen, in addition to Mr. Reid, are: A. F. Murray, Tele-Tech magazine, Proceedings Publications Committee; Dr. Baker, Finance; and J. C. P. Long, Bureau of Aeronautics, Navy Department, Local Arrangements.



# How electronic "paintbrushes" create pictures in our newest art form

There's not a single moving part in a Kinescope —but it gives you pictures in motion

No. 4 in a series outlining high points in television history

*Photos from the historical collection of RCA*

● Ever watch an artist at work—seen how his brush moves over the canvas to place a dot here, a shadow, a line, a mass, or highlight there, until a picture is formed?

Next time you're asked how television pictures are made, remember the paintbrush comparison. But the "brush" is a stationary electron gun, and the "paint" is a highly refined coating of fluorescent material made light or dark in orderly pattern by electrons.

Developed by Dr. V. K. Zworykin, now of RCA Laboratories, the kinescope picture tube is one of the scientific advances which gave us *all-electronic* television . . . instead of the crude, and now outmoded, mechanical techniques.

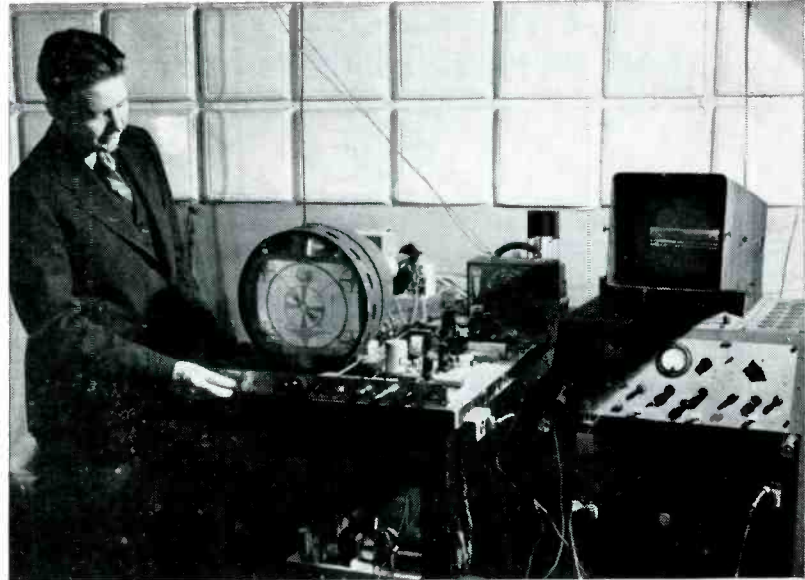

An experimental model of the kinescope—developed by Dr. V. K. Zworykin of RCA Laboratories—is seen undergoing laboratory tests.

Today, through research at RCA Laboratories, these complex kinescope picture tubes are mass-produced at RCA's tube plants in Lancaster, Pa., and Marion, Indiana. Industrial authorities call this operation one of the most breath-taking applications of mass production methods to the job of making a precision instrument.

Thousands of kinescope faceplates must be precisely and evenly coated with a film of absolutely pure fluorescent material . . . the electron gun is perfectly synchronized with the electron beam in the image orthicon tube of RCA television cameras . . . the vacuum produced in each tube must be *10 times more perfect* than that in a standard radio tube—or in an electric light bulb!

Once it has been completely assembled, your RCA kinescope picture tube is ready to operate in a home television receiver. In action, an electrically heated surface emits a stream of electrons, and the stream is compressed by finely machined cylinders and pin-holed disks into a pencil-thin beam. Moving back and forth in obedience to a radio signal—faster than the eye can perceive—the beam paints a picture on the face of the kinescope. For each picture, the electron beam must race across the "screen" *525 times*. To create the illusion of motion, 30 such pictures are "painted" in every single second.

Yet despite these terrific speeds, there are no moving mechanical parts in an RCA kinescope. You enjoy the newest of our arts because electrons can be made to be obedient.

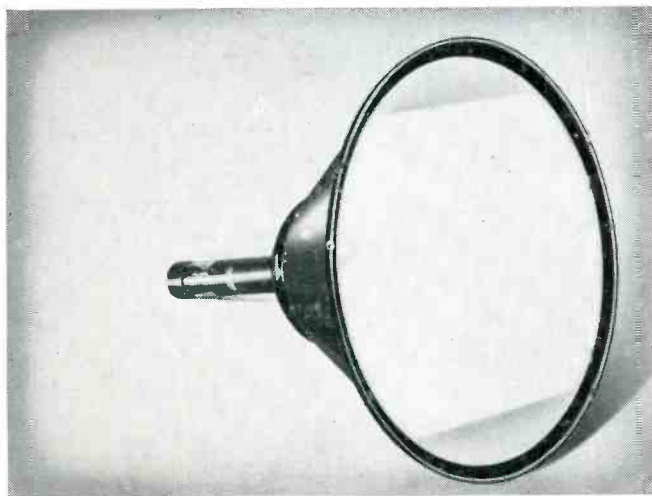

New 16-inch RCA glass-and-metal kinescope picture tube, almost 5 inches shorter than previous types, incorporates a new type of glare-free glass in its faceplate—Filterglass.





# CHOOSE...

## from DAVEN'S complete line of VOLUME LEVEL INDICATORS

Daven Volume Level Indicators are designed to indicate audio levels in broadcasting, sound recording and allied fields where visual indication of volume is desired. Extremely sensitive, they are sturdily constructed and correctly damped for precise monitoring. Preferred by leading sound and electronic engineers throughout the world, these units incorporate all the latest DAVEN mechanical and electrical features.

### GENERAL SPECIFICATIONS:

<b>Input Impedance</b>	Type 910 and 911—7500 ohms. Type 915—7500 ohms bridging and 600 ohms terminating. Type 920—12,500 ohms.
<b>Frequency Range</b>	Less than 0.2db variation from 30 to 17,000 cycles.
<b>Meter Scale</b>	—20VU to +3 VU and 0 to 100%. Type A has VU reading on upper scale. Type B has percentage reading on upper scale. Scale is large, clearly marked and carefully designed to minimize eye fatigue.
<b>Indicating Meter</b>	NAB Standard; 4 inch square, rectifier type possessing ideal characteristics for monitoring purposes.
<b>Mounting</b>	Rack models 19" long for standard relay rack; portable models available in walnut cabinets.
<b>Finish</b>	Standard, black aluminite panel. Other colors available upon request.



**Type 920**  
Rack model, low-level bridging type. Meter multiplier range: —20 VU to +20 VU. Power supply, 100—130 V, 60 cycle AC, with voltage regulator for normal variations. Reference level: 1 mv into 600 ohms. Special ranges on request.



**Type 915**  
Rack model, terminating and bridging type. Meter multiplier ranges: Terminating, —6 VU to +32 VU; bridging +4 VU to +2 VU; or terminating, —6 VU to +16 VU; bridging, +4 VU to +2 VU. 2 VU steps. Reference level: 1 mv into 600 ohms.



**Type 910**  
Rack model has same characteristics as Type 911. Available with illuminated scale, if desired.



**Type 911**  
Portable model, bridging type. Meter multiplier is a constant impedance "T" network which extends the range of the instrument in steps of 2 VU from +4 VU to +22 VU or +4 VU to +26 VU. Reference level: 1 mv into 600 ohms.

Write to Dept. BE-5 for additional information.

The Best Equipment  
Deserves The Finest Attenuators  
... Always Specify DAVEN

# THE DAVEN CO.

191 CENTRAL AVENUE NEWARK 4, NEW JERSEY