

NABET

Presents

Vol. 16 No. 12

DECEMBER

F. Gehres

1949

THE BROADCAST
ENGINEERS' JOURNAL
1950 YEAR BOOK



S-M-O-O-T-H

N-A-T-U-R-A-L

L-A-S-T-I-N-G

Specified by

major recording engineers

for major recording performance

...a trial on the turntable

will convince you, too!

ADVANCE RECORDING BLANKS

Advance

Recording Products Company

36-12 34th STREET • STILLWELL 4-7837 • LONG ISLAND CITY, N. Y.



Once again, it is the pleasure of the
BROADCAST ENGINEERS and TECHNICIANS
individually and collectively to wish their Associates
among the

ACTORS

ARTISTS

DIRECTORS

EXECUTIVES

PRODUCERS

MUSICIANS, and the

DEALERS • DISTRIBUTORS • MANUFACTURERS

from Coast - to - Coast —



And

BEST WISHES FOR SUCCESS IN 1950

THE BROADCAST ENGINEERS' JOURNAL

ED. STOLZENBERGER, EDITOR AND BUSINESS MGR.

Editorial, Advertising and Circulation Offices:
116-03 91st Avenue, Richmond Hill 18, N. Y.
Telephone: Virginia 9-5553

VOLUME 16, No. 12



DECEMBER, 1949

Contents copyright, 1949, by NABET Publications

TABLE OF CONTENTS

	PAGE
NABET Greetings to the Radio Industry	1
NABET President McDonnell's Message	3
Important Message from Retiring Executive Secretary C. Westover	4
NABET's National Officers	5
Color Television Technical Data	7
Summaries of I.R.E. Technical Papers	8
Review of Current Technical Literature	10
Sixteenth Annual Meeting of the NABET National Council	12
Radio & Television Engineers Seek "One Union"	18
RCA Color Television System	43
Hollywood News	58
St. Lawrence News	68
Washington News	73
New York News	78

THE BROADCAST ENGINEERS' JOURNAL

OFFICIAL PUBLICATION OF THE N. A. B. E. T.

Trustees: NABET Pres. J. R. McDonnell, D. C. Shultis, R. W. Bauer,
Fred Smith, H. L. Byers.

Secretary-Treasurer H. E. HILLER

ASSOCIATE EDITORS

Chicago	FRANK GENEREUX
Cleveland	EARL HOLL
Detroit	WALT BAKER
Dixie	SAM LILES
Engineering Chapter	D. C. SHULTIS
Hollywood	JOHN T. BAXTER
Hudson Chapter	GENE CLARK
Mohawk	JOHN F. McMAHON
New York	BOB ZWECK and GEO. HALVONIK
Omaha	LOUIS DE BOER
Philadelphia	R. J. WILKE
Pittsburgh	FRANK E. HENRY
Rochester, N. Y.	B. HOLLY
Rocky Mountain	GEORGE SOLLENBERGER
San Francisco	C. T. STEVENS
St. Lawrence, N. Y.	ALEEN A. CORBIN
Syracuse, N. Y.	PAUL K. NORTH
Washington	W. D. DEEM

The Broadcast Engineers' Journal is a privately printed monthly publication issued by NABET Publications. Address all communications to Publication office: E. Stolzenberger, 116-03 91st Avenue, Richmond Hill 18, L. I., N. Y. Telephone Virginia 9-5553.

Advertising rates and information supplied on request. Subscription, \$2.50 per year; \$4.00 for two years. Single copies, except Christmas Yearbook, 35c; Christmas Yearbook, \$1.00. All remittances in advance. Foreign: add postage. Back copies 50c, back Yearbooks, \$2.00.

Nothing appearing in The Broadcast Engineers' Journal shall be construed to be an expression of The Broadcast Engineers' Journal or the National Association of Broadcast Engineers and Technicians, but must be construed as an individual expression of the author or authors.

NATIONAL N.A.B.E.T. OFFICE

Room 1002, 421 Seventh Ave., New York 1, N. Y.
Mr. C. Westover, Executive Secretary Wisconsin 7-0327

National Association Broadcast Engineers and Technicians

OF, BY, and FOR
THE
BROADCAST
ENGINEER

Contact any of the following officers for further information:

J. R. McDonnell, Pres.
375 O'Farrell St., Room 101
San Francisco 2, Calif.
Ordway 3-8484

C. Westover, Exec. Sec'y.

H. E. Hiller, Nat'l Sec.-Treas.
C. L. Gorsuch, Nat'l Rep.
421 7th Ave., Room 1002
New York 1, N. Y.
Wisconsin 7-0327

Geo. Maher, National Rep.
80E. Jackson Blvd. Rm. 543
Chicago 4, Ill.
Wabash 2462

James H. Brown, Nat'l Rep.
6223 Selma Ave., Rm. 109
Hollywood 28, Calif.
Hillside 9311

Chapter Chairmen

Chicago:
George Maher
80 E. Jackson Blvd. Rm. 543
Chicago 4, Ill.

Cleveland:
Harold V. Brandt
R. D. No. 2
Brunswick, Ohio

Detroit:
David B. Stewart
1160 Seward St.
Detroit 2, Mich.

Dixie:
J. Willard Dean
22 Shepherd St.
Raleigh, N. Car.

Engineering:
D. C. Shultis
75 Kenwood Road
Riveredge, N. J.

Hollywood:
Ben M. Doty
3330 Charleston Way
Hollywood 28, Calif. •

Mohawk:
Donald P. Morey
12 Morningside Dr. RFD 6
Schenectady 6, N. Y.

New York:
Ed Stolzenberger
116-03, 91 Avenue
Richmond Hill 18, N. Y.

Omaha:
D. Roy Glanton
5500 Kansas Ave. Rt. 2
Omaha 12, Nebraska

Philadelphia:
R. J. Wilke
4718 Chestnut
Philadelphia, Pa.

Pittsburgh:
W. C. Stuchell
247 Cornell Ave.
Pittsburgh 29, Pa.

Rochester:
Edward Lynch, Vice-Pres.
109 Wolcott Ave.
Rochester 11, N. Y.

Rocky Mountain:
Aubrey F. Blake
2901 Eaton Street
Denver 14, Colorado

San Francisco:
Richard T. Parks
10 Leroy Place
San Francisco, Calif.

St. Lawrence:
David H. Lane
119 Maple St.
Black River, N. Y.

Syracuse:
Robert M. Dykeman
203 Kinne Street
E. Syracuse, N. Y.

Washington:
P. E. Anderson
3108 Wellington Rd.
Alexandria, Va.

Section Chairmen

Atlanta:
Broughton W. Benning
2883 Stewart Avenue
Hapeville, Ga.

Binghamton:
P. Sarantapoulas
27 Exchange St.
Binghamton, N. Y.

Connecticut Valley:
A. T. Sagan
52 Orchard St.
Chicopee, Mass.

Elmira:
L. C. Hartman
422 Fulton St.
Elmira, N. Y.

Fairmont:
O. C. Swisher
632 Orr St.
Fairmont, W. Va.

Kingston:
J. G. McNelis
304 Greenkill Ave.
Kingston, N. Y.

Louisville:
W. H. Morrison
725 S. 41 St.
Louisville, Ky.

Mid-Hudson:
Robert Masterson
6 Bush Avenue
Newburgh, N. Y.

Richmond:
Elmore Taggart
2010 Seddon Rd.,
Richmond 22, Va.

San Diego:
J. A. Kemp
1576 Acheson
San Diego 11, Calif.



A Message

— from —

John R. McDonnell

President, N. A. B. E. T.



JOHN R. McDONNELL
President, NABET

IN LOOKING forward to a new year we can anticipate many problems—many heartaches—some success—some failures. Our successes will depend upon our ability to meet the problems in a true cooperative union spirit. . . . Our failures will be in direct ratio to our inability to achieve that union spirit. It is the member's responsibility to develop an understanding of union affairs that will enable him to participate fully and to make a solid contribution toward the betterment of himself and his fellow workers.

It is a pleasure to again extend my best wishes to the members of NABET and in their behalf wish a most prosperous 1950 to our friends and associates in the Radio-Television Industry.

Sincerely,

JOHN R. McDONNELL,
President—NABET





C. WESTOVER
Executive Secretary

AN IMPORTANT MESSAGE

from

CLARENCE WESTOVER

Retiring

NABET Executive Secretary

LACKING the services of a paid publicity man, this article will be homespun.

An advertisement in a New York paper recently hit me in the eye. It was a plea to the public to pressure the members of Congress to pass legislation to break down (even further) labor unions.

Abolish the labor monopoly was the theme. Without going into the entire labor picture, let us see how much more can be done in breaking down labor in broadcasting and television.

Presently in existence there are three unions, NABET, IBEW and ACA, who, between them, practically represent all organized radio. The IATSE also is in the picture, but at this moment to a minor degree. If we look at the large unorganized group of radio men, there is a fifth division of monopoly. How much more disorganization would the industry want among radio engineers and technicians?

It is high time that radiomen take positive action to create unity in the industry, for themselves and their families. Too long now have we radiomen been divided. Too long have radiomen played into the

hands of the industry by standing apart from one another.

The time is now for Labor to forget rivalries, ideologies, that separate Labor into many camps. Witness the CIO-AF of L, the many independent unions.

For those of us in the radio and television industries, it is high time that we seek a formula that will unite us and effectively repudiate the plea that we be even further divided. Let radiomen as a unit collectively, and individually, start to pressure OUR congressional lawmakers to recognize the American Right to organize in unions of our own choosing. Let us also do some searching for replacements for those lawmakers who prefer to listen to the siren song of the NAM and the NAB.

Further disunity is horrible to contemplate in radio unless we are to go back to those days before the NRA.

Radiomen,—let us show the publisher of that advertisement that its appeal to us in the industry was lost.

One union for radiomen is the only answer to such management propaganda. *Let's have it soon!*



George Maher
Executive Secretary
And Mid-West NABET
National Representative

**NABET
NATIONAL
OFFICERS**



J. R. McDonnell
President, NABET

Harry E. Hiller
National
Secretary-Treasurer
NABET



Cliff Gorsuch
Eastern
National
Representative
NABBT



James H. Brown
West Coast
National
Representative
NABET



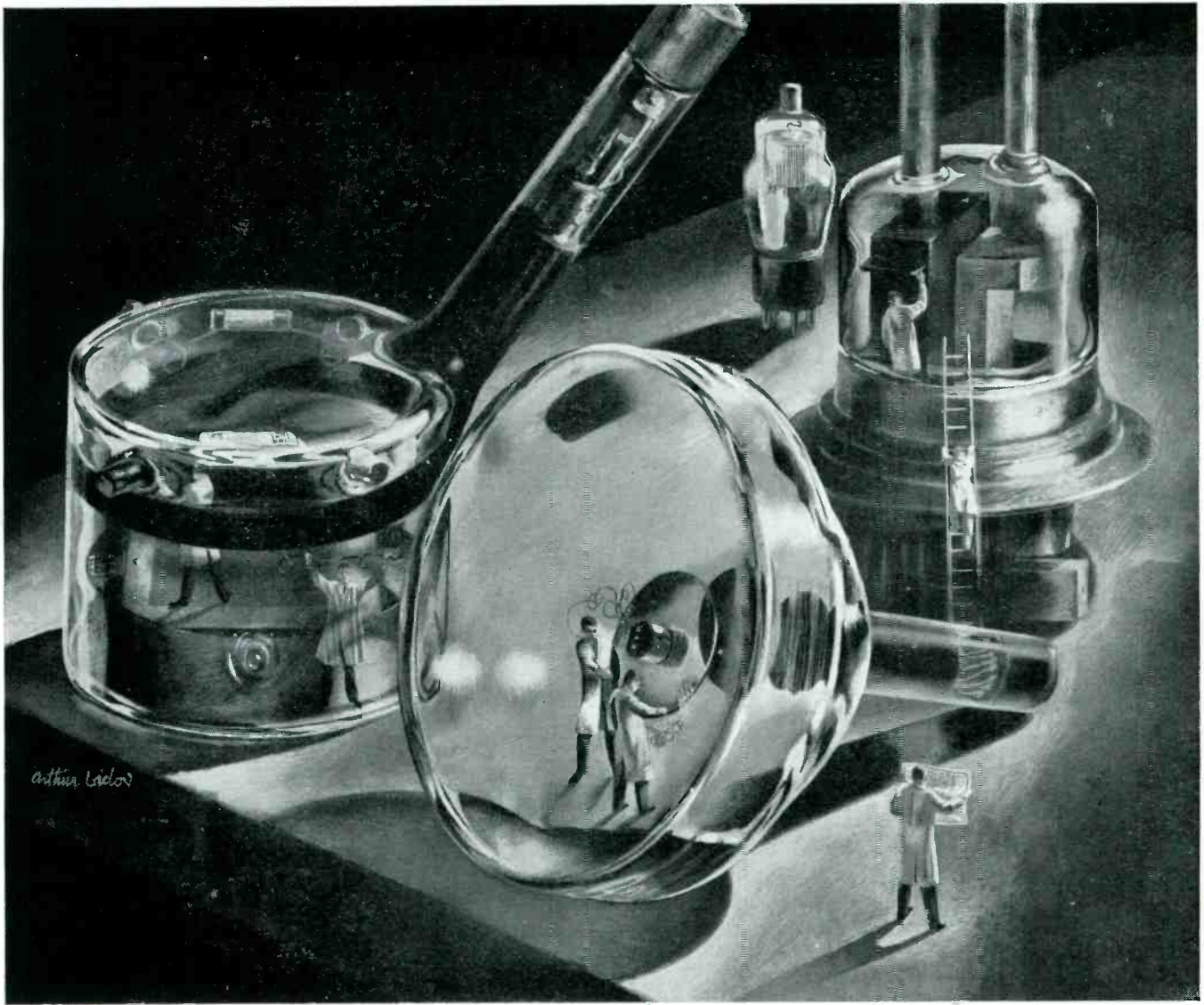

Scientists at RCA Laboratories solve exacting problems within the "nothingness" of vacuum tubes.

Inside story of Better Television

Now television is flashing *visual* entertainment, news, and educational material to millions of people. The "inside story" of its rapid growth is the history of some remarkable tubes. Inside these tubes, electrons are put to work—to perform, for your benefit, the miracle of long-distance vision.

The screen of your direct-view television receiver is actually the face of a tube—the kinescope developed by Dr. V. K. Zworykin and his colleagues of RCA Laboratories—on which electrons in motion "paint" pic-

tures. A tube, too, is the "eye" of RCA's supersensitive Image Orthicon television camera, which can "see" clearly by the light of a match.

And since you asked for big-picture television, they developed projection receivers—also a way to "weld" glass and metal, thus speeding the production of 16-inch direct-viewing tubes . . . at lower cost.

To these basic "firsts," RCA scientists have added advance after advance, which are daily bringing television into the lives of more and more people.

How you profit

Advanced research in television tubes is just one way in which RCA Laboratories work in your interest. Their leadership in science and engineering adds *value beyond price* to any product or service of RCA and RCA Victor.

Examples of the newest advances in radio, television, and electronics—in action—may be seen at RCA Exhibition Hall, 36 West 49th Street, New York. Admission is free. Radio Corporation of America, Radio City, New York 20.



RADIO CORPORATION of AMERICA

World Leader in Radio — First in Television

COLOR TV TECHNICAL DATA

As Supplied to the F.C.C. by Radio Corporation of America.

Mr. Paul A. Walker, Acting Chairman
Federal Communications Commission
Washington 25, D. C.

Re: Docket Nos. 8736, 8975
9175 and 8976

Dear Sir:

This letter constitutes the supplemental engineering statement requested in your letter of August 29, 1949. It relates to the RCA color television system described in the comments filed by RCA on August 25, 1949, in the above proceedings.

The color system which we will describe and demonstrate at the hearings in these proceedings has its roots in the simultaneous method first disclosed by RCA on October 30, 1946. This method was described in detail at the hearing in Docket No. 7896. The new system includes, however, later developments which accomplish transmission of a high definition color picture in a 6-megacycle channel.

There is no degradation of the quality of the received picture. The system is completely compatible so that present receiving sets need no modification or converter in order to receive color transmission in monochrome.

The RCA letter dated August 25, 1949, pointed out that this new color system has the following characteristics:

- (1) 6 megacycle channel
- (2) Fully compatible

- (3) 525 lines
- (4) 60 fields per second
- (5) Field interlaced
- (6) Picture dot interlaced
- (7) 15 color pictures per second
- (8) Time multiplex transmission
- (9) All electronic

The transmitted signal is entirely consistent with the "Standards of Good Engineering Practice Concerning Television Broadcast Stations." This is the fundamental basis for compatibility and means that a current monochrome receiver will respond in the same way as it would if a standard black-and-white camera originated the picture signal.

A block diagram of the broadcasting station for this RCA color system is shown in Figure 1. The color camera, related equipment and synchronizing generator are the same as for the wide-band simultaneous system. These were described by RCA in Dockets No. 7896 and No. 8976. (See also: *RCA Review*, Vol. VII, No. 4, pp. 459-468, December, 1946; *Proc. I.R.E.*, Vol. 35, No. 9, pp. 861-875, September, 1947.)

This studio apparatus provides three signals, one for each of the primary colors (green, red and blue). Each of these signals may contain frequency components out to a maximum of four megacycles, and in addition an average or dc component. For one signal routing of Figure 1, each color signal

To Page 23

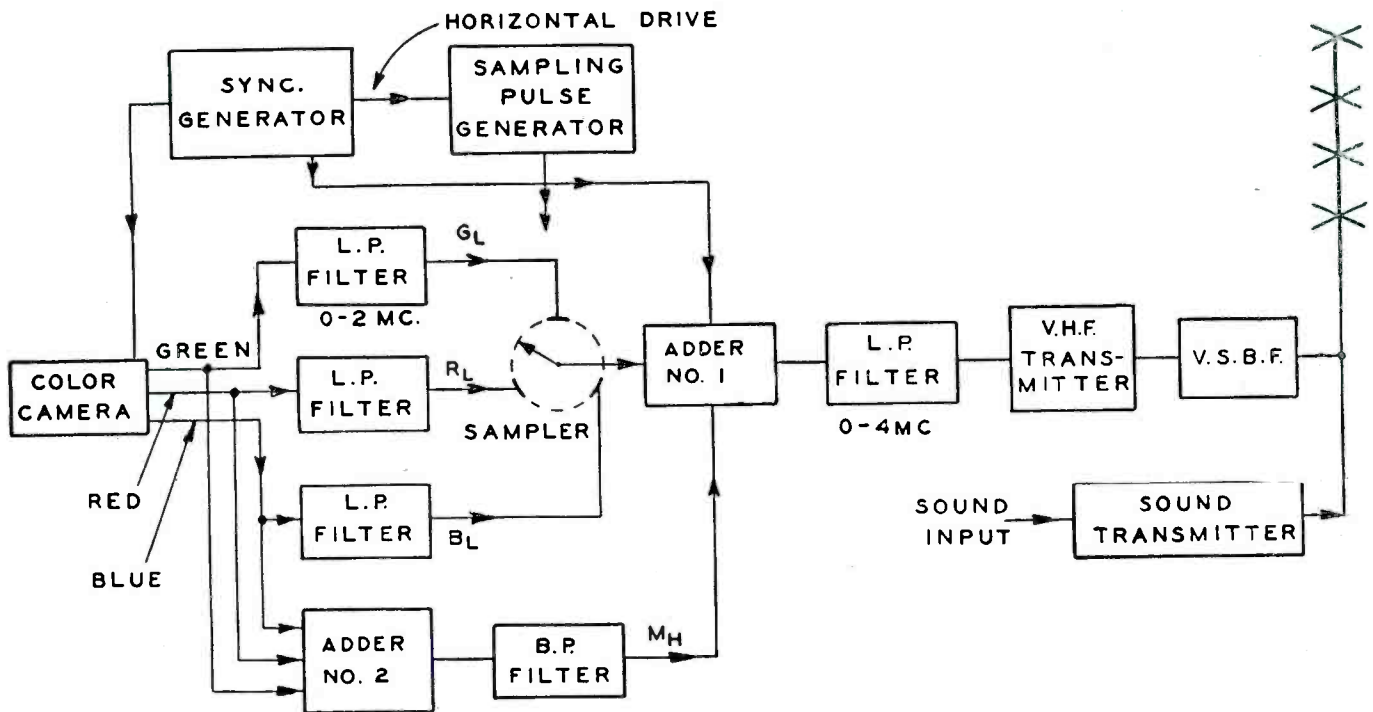

COLOR TELEVISION TRANSMITTER

FIG. 1

Official I.R.E. Summaries of Technical Papers

Presented at the 1949 IRE Convention—continued from last month

NAVIGATION AIDS I

Chairman, W. L. EVERITT

(University of Illinois, Urbana, Ill.)

115. The Determination of Ground Speed of Aircraft Using Pulse-Doppler Radar.

IRVING WOLFF, S. W. SEELEY, EARL ANDERSON, AND W. D. HERSCHBERGER, RCA Laboratories Division, Radio Corporation of America, Princeton, N. J.

Apparatus is described for determining the ground speed of aircraft over both water and land, using airborne pulse-doppler radar. In this equipment pulse signals are transmitted both forward and rearward, the phases of the returning signals are compared, and the rate of phase shift is determined. Directional antennas are not required since the angle can be determined by time-gating circuits. This has the additional advantage of making the determination independent of the pitch of the aircraft. Experimental tests indicate that ground-speed determination can be made with reasonable accuracy using such equipment.

116. The DIMEAL, Aircraft Approach and Landing System.

LUDLOW B. HALLMAN, JR., Wright-Patterson Air Force Base, Dayton, Ohio.

The paper suggests and briefly describes an aircraft approach and landing system which makes use of the standard radar-type distance-measuring equipment to establish the "localizer" or runway alignment patterns. The "descent" or "glide" path is established by means of altimeters of the pressure and radio types contained entirely within the aircraft. The suggested name DIMEAL is derived from the words *DI*stance *ME*asuring *E*quipment and *AL*timeters.

117. Theoretical Aspects of Nonsynchronous Multiplex Systems.

WARREN D. WHITE, Airborne Instruments Laboratories, Inc., Mineola, L. I., N. Y.

In the past, considerable attention has been given to various forms of frequency-division and time-division multiplex systems in which information from a number of sources is transmitted over a common channel. Most of these systems, however, require that the information from the various sources be assembled at a common location where a systematic multiplex operation can be performed. With the advent of recent advances in the theory of communication by Shannon and others, it is now possible to examine the case where a multiplicity of geographically separated transmitters share a common channel without the benefit of various

synchronizing techniques. Such nonsynchronous multiplex systems are important in the case of air navigation and other applications where the bandwidth of a channel is for some reason not consistent with the amount of intelligence to be transmitted. The theoretical information capacity of some simpler forms of nonsynchronous systems is considered.

118. Band-Pass Circuit Design for Very-Narrow Band, Very-Long-Range Direction-Finder Receivers to Minimize Bearing Error Due to Receiver Mistuning.

MILTON DISHAL AND HOMER MORROW, Federal Telecommunication Laboratories, Inc., Nutley, N. J.

In very-long-range navigational systems, it is desirable to use the narrowest possible receiver bandwidth to obtain maximum receiver sensitivity.

When the receiver pass band is just wide enough to accommodate the sidebands passing through the receiver, the nonlinear phase shift near the edges of the pass band produces a bearing error when the receiver is not correctly tuned. This paper presents the analysis and design values for band-pass circuits to obtain minimum direction-finding bearing error with receiver mistuning, and points out the fact that the bandwidth of the phase-response curve of a network may be more useful than the bandwidth of the amplitude-response shape when complex waveform reproduction is of importance.

119. Crystal Control at 1,000 Mc for Aerial Navigation.

S. H. DODDINGTON, Federal Telecommunication Laboratories, Inc., Nutley, N. J.

The problems faced in the design of a crystal-controlled channelling system are described, together with the solution adopted for an airborne pulse-type distance-measuring equipment, operating on 51 channels in the 960- to 1,215-Mc band, each channel permitting simultaneous service to 50 aircraft at distances up to 100 miles with better than 1 per cent accuracy.

SYMPOSIUM: MARKETING

Chairman, E. H. VOGEL

(General Electric Company, Syracuse, N. Y.)

1. **Market Research.**
E. H. VOGEL, General Electric Company, Syracuse, N. Y.
2. **The Application of Market and Field Research in Product Planning and Design.**
O. H. L. JENSEN, Philco Corporation, Philadelphia, Pa.
3. **Sales Planning and Distribution.**
LEE McCANNE, Stromberg-Carlson Company, Rochester, N. Y.

4. National Advertising.

M. F. MAHONY, Maxon, Inc., New York, N. Y.

5. Sales Training and Sales Promotion.

W. E. MACKIE, Zenith Radio Corporation, Chicago, Ill.

Marketing television equipment is a process as significant as its manufacture, and the growing postwar trend is toward a broader use of market and product research in order to enable manufacturers to understand the buying public and forecast its needs. Estimated industry sales are based on the compilation and use of national economic data, such as extent of employment, general income, cost of living, trends of cost and prices, estimated spendable income, and dollars available for purchase other than basic necessities. Manufacturers also must consider seasonal variations in the sale of the different categories and the estimated strength of their competitors, as well as surveying their own products and customers' preferences, and tabulating such reports for use in product planning. This work will be described by Mr. Vogel.

Developing a new model in the radio or television field involves a number of factors. The manufacturer, as Mr. Jensen will point out, must first determine as far as possible the type or model of radio receiver the public wants, both with respect to performance and appearance. Cabinets and technical components must be developed simultaneously and according to definite schedules, so that over-all competition will be on time. The balance between the cost of manufacture and the selling price required in order to assure reasonable profit for the manufacturer must be reached.

Introducing a new model to the trade and to the public involves co-ordination of the various sales factors. Literature is released to all field representatives, distributors, and dealers, and eventually to the public under the classification of advertising. Timing, Mr. McCanne will state in his paper on sales planning and distribution, must be accurate, so that adequate merchandise can be provided to meet initial demands. Radio sets are generally distributed from the manufacturer to the wholesaler to the dealer. They are also, however, sold directly to the dealer and through mail-order houses, both of which methods have signal advantages.

Mr. Mahony will describe the vital part

advertising plays in merchandising radio and television sets. Advertisements must be prepared according to the medium for which they are destined: national magazines for broad registration and impression, newspapers for local point-of-sale advertising and possible dealer identification. Not only are there differences in copy appeal between newspapers and magazines, but among the various types of magazines themselves. Aside from graphic advertising, there is also tremendous value in using radio itself as an advertising medium, and indications show that television may eventually surpass even radio as an advertising power.

Sales promotion methods directly follow advertising, as Mr. Macke will show. Store backgrounds, window displays, signs, literature, broadsides—all tie in with national advertising in exploiting the advertiser's products. Salesmen and retailers themselves must be trained in the new product, and many wholesale distributors use numerous methods—charts, slides, films, and so on—in order to indoctrinate their own personnel and the dealers whom they serve.

The final decision, however, rests with the public; and, no matter how much preparation the manufacturer has made, if the public does not like a model, everything he has done is valueless.

ELECTRONICS III— ELECTRON-TUBE THEORY

Chairman, W. G. Dow

(Department of Electrical Engineering, University of Michigan, Ann Arbor, Mich.)

120. General Solution of the Two-Beam Electron-Wave-Tube Equation.

A. V. HAEFF, H. D. ARNETT, AND W. STEIN, Naval Research Laboratory, Washington, D. C.

The analysis of the new mechanism of microwave energy amplification based on space-charge wave amplification effects occurring as a result of interaction between streams of charged particles, is extended to the case of two beams of arbitrary space-charge density and velocity distribution. It is shown that, for any current distribution, amplification of space-charge waves will take place over a limited frequency range determined by the distribution. The real component of the propagation constant defining the amplifying properties of such streams is computed in terms of the "inhomogeneity factor" and the "distribution index," which are dimensionless parameters relating to velocity difference and current division between the two streams. As the ratio of currents or velocities is increased, the frequency range over which energy amplification takes place increases, but the maximum gain per unit length of such streams and the effective bandwidth decrease.

CANNON PLUGS

TYPE "XL" SERIES

ZINC PLUGS



XL-3-12 Cord Plug
\$1.20 List



XL-3-11 Cord Plug
\$1.25 List

STEEL XL PLUGS



XL-3-11SC (steel)
\$2.80 List



XL-3-12SC
\$2.75 List

RECEPTACLES



XL-3-14 Recept.
\$1.00 List



XL-3-13N Recept.
\$1.25 List



XL-3-14N Recept.
\$1.15 List



XL-3-13 Recept.
\$1.25 List

ADAPTER RECEPTACLES

Made in three types to fit most popular microphones. Standard Pin Inserts.

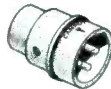

XL-3-50T
\$1.15 List



XL-3-50
\$1.05 List

\$1.30 List
XL-3-50N



ALSO AVAILABLE IN FOUR

CONTACT INSERTS

(4 10-amp. contacts)



The firm of Leroy W. Beier took over the representation on December 1st, 1948 of Cannon Electric Products in the following counties of three states:

IN INDIANA: Lake, Porter, La Porte.

IN ILLINOIS: Hancock, McDonough, Schuyler, Fulton, Mason, Tazewell, Peoria, Woodford, McLean, Ford, Iroquois, Livingston, Kankakee, Grundy, Will, LaSalle, Kendall, Putnam, Marshall, Stark, Knox, Warren, Henderson, Mercer, Rock Island, Henry, Bureau, Whiteside, Lee, DeKalb, Kane, DuPage, Cook, Lake, McHenry, Boone, Winnebago, Stephenson, Jo Daviess, Carroll, and Ogle.

IN IOWA: Delaware, Linn, Jones, Jackson, Cedar, Washington, Dubuque, Clinton, Scott, Louisa, Muscatine, Henry, and Des Moines.

KNOW OUR REPRESENTATIVES



LEROY W. BEIER



A. H. PETERSON

W. F. MARSH

Mr. Beier's office is located at 600 South Michigan Avenue, Chicago 5. Telephone: HARRISON 7-4240.

SINCE 1915

CANNON ELECTRIC

Development Company 3209 HUMBOLDT ST., LOS ANGELES 31, CALIF.

IN CANADA: Cannon Electric Ltd., Toronto • World Export: Frazer & Hansen, San Francisco, California
DIVISION OF CANNON MANUFACTURING CORPORATION



Review of Current Technical Literature

By Lawrence W. Lockwood

Audio Engineering—Sept. 1949

New Developments in Logarithmic Amplifiers—C. LeBel.

A description of a novel method of converting an audio signal to an output voltage which is proportional to sound level.

Lateral Feedback Disc Recorder—G. Yenzer

How proper use of feedback improves lateral type recorders.

Audio Engineering—Oct. 1949

Audio Frequency Measurements—W. Black, H. Scott

Pt. I: Design, development, and maintenance all depend on the measuring procedures employed. The authors discuss these methods thoroughly and present reasons for every step.

Communication News—June 1949

Modulators for High Power Transmitters—H. Teunissen

General considerations and a more detailed design of a modulator for a 100 kw transmitter.

Communications—August 1949

The WDTV Field Coverage Study—R. Lewis

Survey of signal strength of Pittsburgh station by research division of Allen B. DuMont labs and personnel of broadcaster reveals many vital TV service factors which may serve as a basis of approach in future proof of performance probes.

Triangular High Band TV Loop Antenna System—A. Kandoian, R. Felsenheld

Broadcast horizontal type loop design with all instantaneous currents in phase, achieved by three coaxially fed folded dipoles arranged symmetrically around a supporting structure at 120° spacing.

Communications—Sept. 1949

Mid-Level Modulation for TV Transmitters—N. Young

Design, featuring modulation applied to the grid of a penultimate RF amplifier and vestigial sideband characteristic supplied by filter between transmitter and antenna, found to reduce size of modulator system.

Broadcast Transmitter HV Metallic Rectifier Systems—N. Tharp, C. Hooper

Metallic rectifier banks, designed for 50kw AM and FM transmitters, provide 5 amperes at 11,500 volts DC and 4

amperes at 12,500 volts DC in modulator and power amplifier supplies.

A Cathode Ray Tube Video Scanner—R. Thompson

Device developed as a test and program source, includes a focus stabilizer, provision for twenty-five 2x2 slides, automatic fade to black, gamma corrector and polarity inverter.

FM-TV—August 1949

Local TV Commercials—C. Snow

A versatile optical system, carrying four slides, provides continuous animation and attention-compelling effects.

FM-TV—Sept. 1949

Adding FM to an AM Array—M. Jones, I. Mager

WCAO Baltimore replaced one of its towers in eight days, restored the original AM pattern within an hour.

Proceedings of the IRE—Oct. 1949

A Video Frequency Noise Spectrum Analyzer—P. Jastram, G. McCouch

A frequency range of 50 kc to 10 mc is covered without band switching. Width of analyzing pass band, 33 kc. remains constant over the measuring range. Lowest spectral level measurable is 7 microvolts per root kc.

Proceedings of the IRE—Nov. 1949

A Variable Phase Shift Frequency Modulated Oscillator—O. DeLange

Theory of operation of a phase shift type of oscillator is discussed briefly.

RCA Review—Sept. 1949

Direction Microphone—H. Olson, J. Preston

Smooth frequency characteristic over the frequency range of 50 to 15,000 cycles. Directional efficiency, i.e., energy response to random sounds is one-tenth.

The Image Isocon—An experimental Television Pickup Tube Based on the Scattering of Low Velocity Electrons—P. Weimer

New experimental pickup tube similar in performance and physical appearance to the image orthicon.

Tele Tech—Sept. 1949

Measuring Modulation Depths of TV Signals—R. Burr

Description of methods employed and equipment required by manufacturers and industrial laboratories in maintaining correct test signal modulation levels for accurate receiver adjustments.

Illumination for Television Studios—H. Gurin

Discussion of problems and experience gained in using various light sources. Studios incorporating most recent combination of illuminants and structural elements for easy manipulation described.

Increased Contrast With New Picture Tubes

Use of teleglas, new Pittsburgh Plate Glass Co. product in metal CR tubes reported by C. Szegho of Rauland. Zenith is first major manufacturer to market receivers that have picture tubes with the filter type face plates.

Tele Tech—Oct. 1949

Two Second AM Proof of Performance—A. Schoen-fuss

Unique monitoring system permits a continuous check on critical direction radiation of the antenna.

Illumination for Television Studios—H. Gurin

Third in series described above.

Philco's New Built-in TV Aerial

A description of the constructional and operational features of the system now used in all receiver models.

TV Set Shipments by Areas

TV Service Area	Half Year (1949)	Accumulative (Since Jan. 1, 1947)
Albany, N. Y.	9,801	22,580
Albuquerque, N. M.	71	317
Atlanta, Ga.	3,184	8,015
Baltimore, Md.	21,158	49,259
Birmingham, Ala.	2,199	2,222
Boston, Mass.	49,286	88,233
Buffalo, N. Y.	12,092	21,196
Charlotte, N. C.	1,718	1,949
Chicago, Ill.	77,278	156,694
Cincinnati, O.	19,196	33,283
Cleveland, O.	31,406	52,714
Dallas, Texas	2,016	8,303
Davenport, Iowa	473	921
Detroit, Mich.	36,535	62,871
Erie, Pa.	690	993
Greensboro, N. C.	562	562
Houston, Texas	2,106	4,365
Huntington, W. Va.	30	30
Indianapolis, Ind.	5,704	6,276
Jacksonville, Fla.	95	95
Kansas City, Mo.	4,549	5,098
Los Angeles, Calif.	60,407	137,332
Louisville, Ky.	2,042	5,161
Memphis, Tenn.	1,970	5,072
Miami, Fla.	2,800	3,643
Milwaukee, Wisc.	10,439	23,378
Minneapolis, Minn.	4,711	10,947
Nashville, Tenn.	58	113
Newark, N. J.	59,978	163,504
New Haven, Conn.	10,733	27,805
New Orleans, La.	1,691	5,674
New York City	152,619	425,648
Oklahoma City, Okla.	2,810	2,838
Omaha, Nebr.	1,109	1,146
Philadelphia, Pa.	75,222	204,461
Phoenix, Ariz.	22	22
Pittsburgh, Pa.	15,185	21,323
Portland, Ore.	425	559
Richmond, Va.	2,879	6,100
St. Louis, Mo.	12,944	29,196
St. Petersburg, Fla.	51	95
Salt Lake City, Utah	861	1,862
San Antonio, Texas	87	87
San Francisco, Calif.	7,897	20,194
Seattle, Wash.	2,591	7,160
Syracuse, N. Y.	2,196	4,599
Toledo, O.	7,378	13,008
Tulsa, Okla.	203	203
Washington, D. C.	22,709	53,305
Miscellaneous		5,961
Total	742,166	1,706,372

Climaxing 15 years experience in training **PRACTICAL ENGINEERS** . . . we announce completely **NEW** and **MODERN AM - FM - TV STUDIO, TRANSMITTERS, and IMAGE ORTHICON CAMERA CHAIN** . . . specially designed and planned to give the student the practical experience needed to be a real asset to an engineering staff.

Request our descriptive catalog describing at length the specialized training and equipment offered here.

Our Placement Department will furnish data on graduates upon request.

Phone or Wire Collect
Telephone TEmple 3-4620

RADIO ELECTRONIC TELEVISION SCHOOLS

3730 Woodward Avenue, Detroit 1, Michigan

CAPPS*

SAPPHIRE is, and has always been, the only material for making cutting styli for high class recordings.

CAPPS* Patented Sapphire Styli (2187512) are the original and accepted standard for high class professional acetate recordings.

Imitated but not equalled

FRANK L. CAPPS & CO., Inc.

244 W. 49th STREET NEW YORK CITY
Telephone CIRCLE 6-5285

*Reg. U. S. Pat. Off.

SIXTEENTH ANNUAL MEETING OF THE NABET NATIONAL COUNCIL, NEW YORK, OCT. 1949

HARRY E. HILLER
Honored in Plaque Presentation



NABET NATIONAL EXECUTIVE BOARD

Seated: President John R. McDonnell, and Vice-President Edward Lynch.
Standing: Paul E. Anderson of Washington, Richard T. Parks of San Francisco, and Ed. Stolzenberger of New York.

The sixteenth annual meeting of the NABET National Council met in New York, October 9 thru 15th.

The subject of possible NABET affiliation was high among the important subject matter that came before the Council. An official Affiliation Committee was elected to fact-find and report, and the affiliation ballot machinery was set up. Else-

where in this NABET Yearbook you will find whatever additional information was available at press time.

Reports of the prior year's operation were presented by the Officers and standing Committees, and the internal operation has been geared to better serve and protect the interests of radio and television technicians and associated crafts and skills.



Don Morey, Chairman Mohawk Chapter; Harold V. Brandt, Chairman Cleveland Chapter; Paul E. Anderson, Chairman Washington; Jack Paine, Sec'y New York Chapter; Chairman Stuchell of Pittsburgh; H. L. Byers, New York Councilman and Member of the Journal Board of Trustees.



ENGINEERING AND NEW YORK CHAPTER OFFIAL DINNER TO THE 1949 NATIONAL COUNCIL.



COUNCILMEN AND MEMBERS OF THE ENGINEERING AND NEW YORK CHAPTERS APPROVE THE DINNER!



R. T. Parks, Chairman San Francisco; C. L. Gorsuch, Eastern Nat'l Representative; R. M. Dykeman, Chairman Syracuse; C. Westover, retiring Executive Sec'y.; Vice Pres. Edward Lynch and Chairman Rochester; President John R. McDonnell; Ed. Stolzenberger and DeWitt C. Shultis, Chairmen of the New York and Engineering Chapters, hosts to the Nat'l Council.

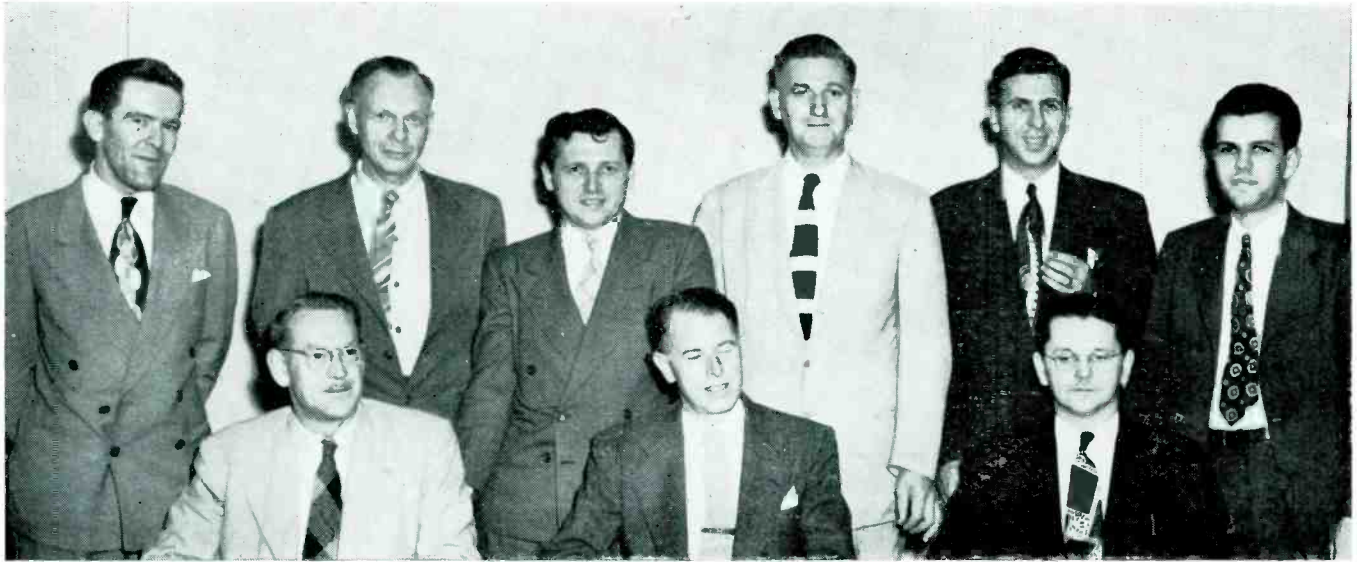

ENGINEERING CHAPTER

Seated, left to right: E. Nolen, Councilman Audio-Video Facilities; Chairman D. C. Shultis, Secretary-Treasurer A. Rokosz. Standing, Engineering members Frank Connolly, Elmer Dustin, Charles Taris, Eric Berglund, Ed Borgos, and Ulrich Caro.

The official dinner to the National Council was jointly sponsored by the Engineering and the New York Chapters, and was held at Schraft's, Fifty-first Street, Radio City.

The National Council had been in session since noon, Sunday, October 9th, and recessed at 6 p.m. Thursday, October 13th for the official dinner.

After a very satisfactory roast beef dinner, Stolzenberger addressed the gathering and outlined the scope of the business before the National Council.

Harry E. Hiller had announced to the National Council his

plans to retire from 28 years of radio broadcasting and union work, and he was asked to address the dinner gathering on the state of the union, and the various trends as he saw them facing all broadcast engineers and technicians.

The photos on these pages were then taken, and the National Council took leave to return to their work.

Unavoidably absent, were Budget Committee members George Maher, Chicago Chairman and Mid-West National Representative, and J. Willard Dean, Chairman of the Dixie Chapter NABET.

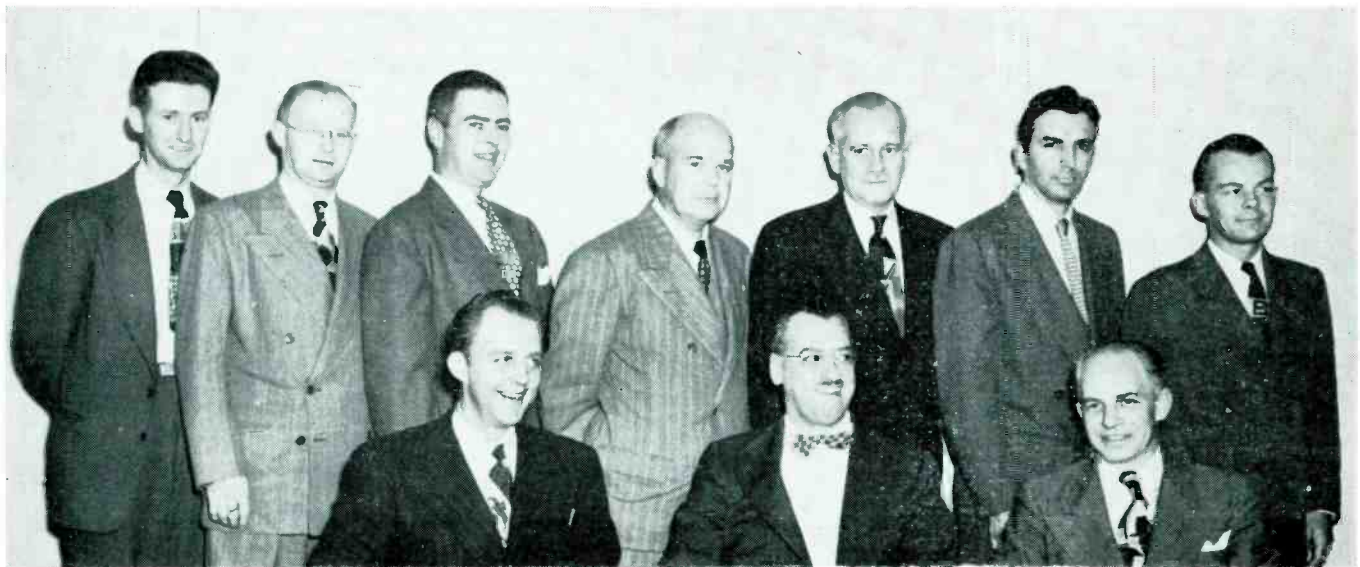

NEW YORK CHAPTER

Seated, left to right: Jack Paine, Secretary; Ed Stolzenberger, Chairman; Rudy Bauer, Secretary-Treasurer. Standing: G. V. Schneyer, Councilmen H. L. Byers, Jim Connor, Gordon Windham, Dan Murphy, J. Rynack, and Gil McDonald.

NABET PRESIDENT
JOHN R. McDONNELL
CHECKS WITH THE
HOST CHAIRMEN
STOLZENBERGER AND
SHULTIS

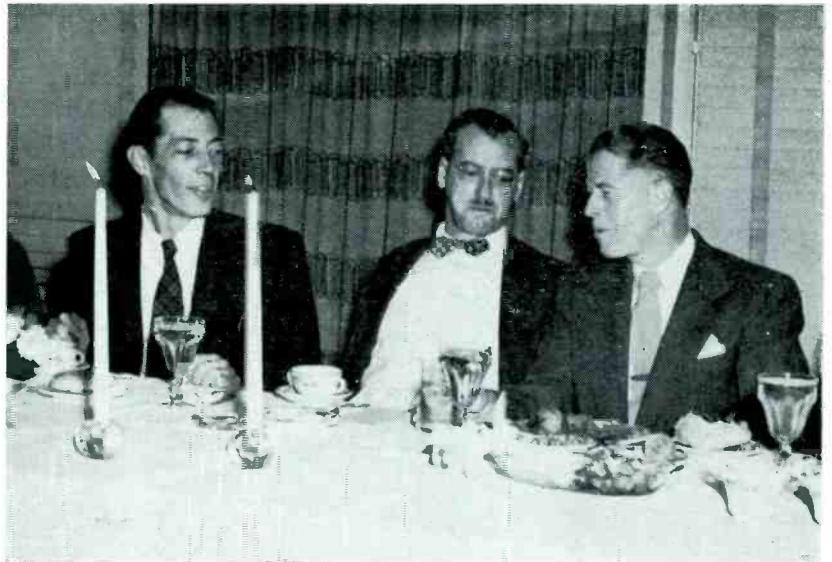

National Secretary-Treasurer
Harry E. Hiller (Center)
covers a point in discussion
with Engineering Chairman Shultis
(left)
and D. Roy Glanton,
Chairman of Omaha Chapter (right)

Left to right, Detroit Chapter
Chairman Dave Stewart,
Hollywood Chapter Chairman
Ben M. Doty,
Philadelphia Chairman
R. J. Wilke, and
NABET's West Coast National
Representative and former
NABET President
J. Harvey Brown





Every Sunday On CBS

With

MARY LIVINGSTON • PHIL HARRIS
ROCHESTER • DENNIS DAY
DON WILSON

Writers

SAM PERRIN • MILT JOSEFBERG • GEORGE BALZER
JOHN TACKABERRY

Producer

HILLIARD MARKS

Agency

Batten, Barton, Durstine & Osborne, Inc.

Sponsor

LUCKY STRIKE CIGARETTES

Jack Benny

Holiday Greetings

From the Staff of

The Broadcast Engineers' Journal



ED. STOLZENBERGER
Editor and Business Manager



R. W. BAUER
Member of the Board



D. C. SHULTIS
Chairman, Engineering Chapter
Member of the Board



H. L. BYERS
Member of the Board



FRED SMITH
Member of the Board



HARRY E. HILLER
Treasurer



JOHN R. McDONNELL
President, NABET
Member of the Board

Radio and TV Engineers Seek "One Union"

Of, By, and For Radio & Television Engineers and Technicians

NABET COMMITTEE Meets With IBEW Radio Advisory Committee. Agreement Reached On Type of Organizational Structure Needed To Serve and Protect the Interests of ALL Radio-TV Men.

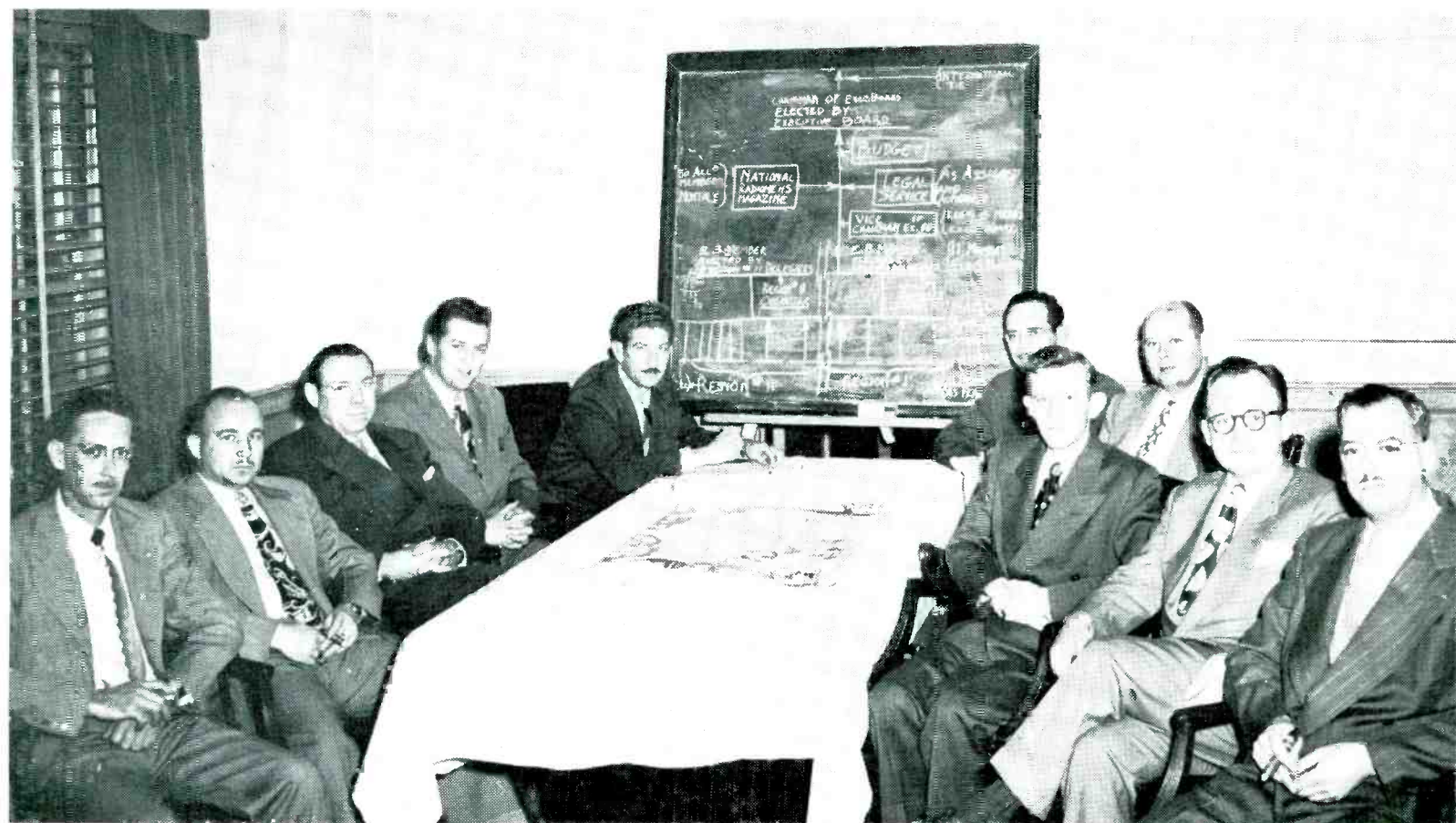

Nabet Committee Meets With I.B.E.W. Radio Advisory Committee in Washington, D. C., Nov. 1949.

Wide areas of agreement were reached during these meetings, confirming the important natural community of interest of all radio and television technicians, regardless of their employer or union affiliation. On the blackboard, is the organizational chart of an autonomous radio and television union, complete with administration, budget, and close coordination between the widely scattered membership. The geographical division of the country is shown on the map reposing between the Committee Members. The map is reproduced on the opposite page.

Left side of table, IBEW Committee members Frederick J. Fabre, New Orleans; Robert W. Robbins, Indianapolis; Charles Calame, New York; Tyler Byrne, Boston; and Roy Tindall, Hollywood. Right side of table, NABET Commit-

tee Members James H. Brown, Hollywood; J. Willard Dean, Raleigh; Edward Lynch, Rochester, N. Y.; George Maher, Chicago; Ed. Stolzenberger, New York.

NABET President John R. McDonnell issued the following statement following the week-long meetings of the NABET Affiliation Committee with the CWA, IBEW, and the IATSE:

As directed by the NABET National Council, the NABET Affiliation Committee met during the week of November 7, 1949 with representatives of the Communication Workers of America (CIO), International Brotherhood of Electrical Workers (AFL) and International Alliance of Theatrical Stage Employees (AFL) relative to possible NABET affiliation. A preliminary NABET Affiliation Committee report is being

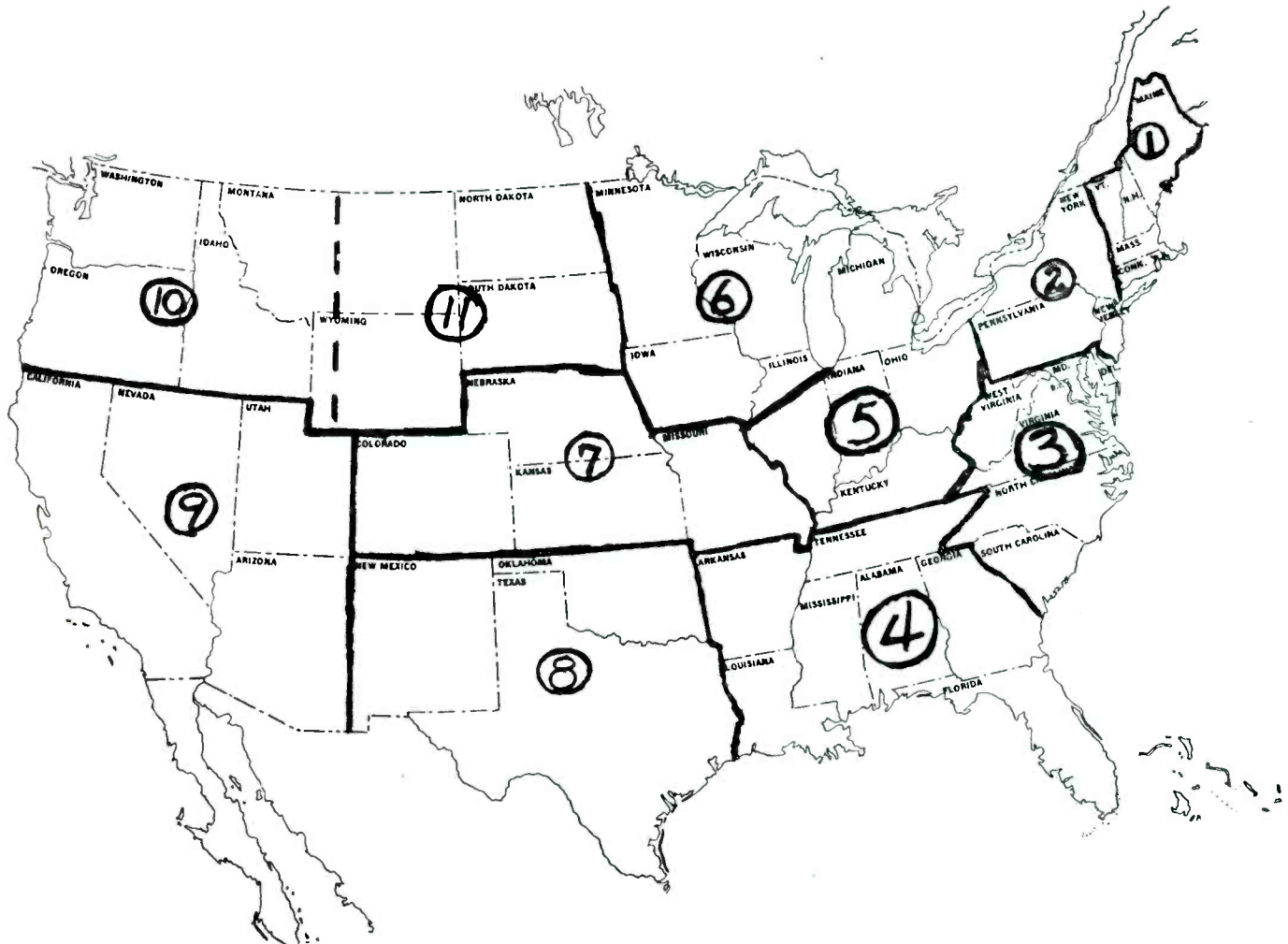

prepared, and will very shortly be in your hands.

You will find that the reactions of the IBEW and IATSE have not yet been received and that a final committee report in complete detail will be issued to the entire NABET membership at the earliest possible moment.

Following the preliminary report and prior to the issuance of the final Affiliation Committee report, in order to keep you fully informed, you will receive brief progress reports from

the President's office from time to time as additional information is received. This will counteract any honest though misguided misinformation or rumors that may be detrimental to the best interests of ALL radio and television personnel.

JOHN R. McDONNELL, *President*
National Association of Broadcast
Engineers and Technicians.

The Sec'y. of Labor Says:-

The American people regard the maintenance of full production, employment, and incomes as a major responsibility of government. In other words the Employment Act of 1946 actually reflects the desire and hope of the American people. When indications of growing unemployment appeared recently, the people turned to their government with the question, "What are you doing about the economic situation?"

We have seen that defense built in advance against depression and unemployment are highly effective. It can now be said that a recession like that of 1921-22, or a major depression like that of 1932-33, was not in the cards. Why? Because of unemployment insurance and social security pro-

grams, because of minimum wage legislation, agricultural price supports, bank deposit and mortgage guarantees, and all the other devices set up to protect the country from the economic havoc of earlier days.

But our national economic policy ought not to consist merely of a defensive strategy against recession. It must be affirmative, positive, creative. We must exert energy to make our free economy as productive as possible.

Full employment depends on a high level of investment and expenditure throughout our economy. When private investment and expenditure falls off, public investment and expenditure must take its place in an amount sufficient to maintain full employment. And full employment in our country is vital to world peace.



Season's Greetings



Bob Hope

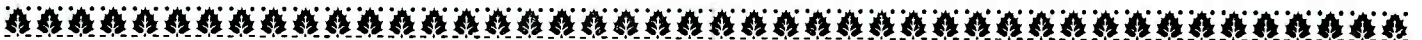



AUDIO ENGINEERING SUPPLIES • KEYS

PANELS • PLUGS • POWER SUPPLIES

GAIN SETS • TRANSFORMERS

EQUALIZERS • KNOBS • DIALS

• VU METERS

DB METERS

TRANSMISSION LINE • TERMINAL BLOCKS

AMPLIFIERS • PATCH CORDS • FILTERS



CINEMA
ENGINEERING
COMPANY
1510 West Verdugo
Burbank, California

**WRITE FOR
FREE
1950 CATALOG**

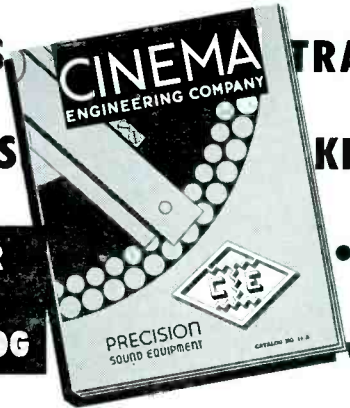

CINEMA
ENGINEERING
COMPANY
1510 West Verdugo
Burbank, California



Fibber McGee and Molly

(MARIAN and JIM JORDAN)





Best Wishes

from

ABC Sports Director

Harry Wismer



GREETINGS

FROM

The Voices of **NBC** New York

Tex Antoine
Kenneth Banghart
Ray Barrett
Mel Brandt
Bill Cochrane
Fred Collins
Jack Costello

Robert Denton
Dick Dudley
Arthur Gary
Ben Grauer
Rad Hall
Bill Hanrahan
Ed Herlihy

Wayne Howell
Clyde Kittell
Bill Malcolm
Charles F. McCarthy
Don Pardo
Lionel Ricau
Peter Roberts

Roger Tuttle

Robert Warren

Known informlly as **THE FEEDBACK CLUB**

COLOR TV TECHNICAL DATA

From Page 7

passes through a low-pass filter which eliminates frequency components above two megacycles. The green-channel signal coming out of its particular low-pass filter is designated as GL on Figure 1, indicating that at this point the signal contains the dc component and ac components with frequencies of two megacycles or less. The three low-frequency signals, GL, RL, and BL, are then sent into an electronic commutator or sampler.

The manner in which this sampler functions will be discussed in detail later. In essence, however, at this point in the circuit each color signal is sampled for a very short time, 3.8×10^6 times per second for each color. Current investigations are aimed at determining whether this rate is optimum or whether a slight deviation from this value is desirable.

The sampling pulse generator is an integral part of the electronic commutator and makes use of the trailing edge of the horizontal synchronizing pulse to time the sampling of each of the color signals.

From the sampler the signals pass to an electronic combining device called Adder No. 1 in Figure 1. Standard synchronizing signals from the synchronizing generator are also applied at this point.

The principle of "mixed highs," described by RCA in Docket Nos. 7896 and 8976, is also utilized. For the second signal routing of Figure 1, the three color signals from the camera are combined in electronic Adder No. 2 and then are passed through a band-pass filter. The output of this filter contains frequencies between two and four megacycles, with contributions from each of the three color channels. The signal at the output of the band-pass filter is designated as MH, the mixed-highs signal. The mixed-high frequencies

are fed to Adder No. 1 which is already receiving the signals from the sampler and from the synchronizing generator.

The signal resulting from the addition of these three signals, namely, the sampler output, the mixed highs and the synchronizing pulses, then goes to a low-pass filter which cuts off at four megacycles. The signal from this filter is applied to the modulator of a conventional VHF or UHF television transmitter. No change in the normal transmitter equipment is required. The transmitter is used just as existing VHF transmitters are used, with the same vestigial sideband filter, sound transmitter, diplexer, and transmitting antenna.

The functioning of the electronic sampler will now be considered in more detail. Figure 2 illustrates the action of the system in large uniform polychromatic areas, with the three primary colors represented by three different signal strengths. Figure 2 (a) shows the output of the sampler due to the green signal only. The green channel signal is sampled every 0.263 microsecond ($0.263 = 1/3.8$). At a time 0.0877 microsecond after a green sample, a sample is taken of the red signal. This time delay is one-third of the time between successive green samples. The red samples continue to be taken 0.263 microsecond apart as shown in Figure 2 (c). The blue samples are taken at the same rate and follow the red samples by a time of 0.0877 microsecond, as indicated in Figure 2(e). The composite output of the sampler consists of a superposition of the green, red, and blue trains of pulses or samples. Figure 2(g) shows the state of affairs in the circuit between the sampler and Adder No. 1, and, except for the synchronizing pulses and the mixed highs, represents the signal feeding into the low-pass filter. Since only large area color is under consideration for the moment, the mixed-highs signal need not be included. The narrow green pulses of Figure 2(a), occurring at a rate of 3.8×10^6 pulses per second, are smoothed by the low-pass filter to give the result shown in Figure 2(b). This wave consists of a dc component, which is the average of the pulse sample, plus a sine wave which has a frequency of 3.8 megacycles (the filter having removed the higher order harmonics). The 3.8-megacycle sine wave and the dc component change together, as the green signal changes in strength, in such a way that the signal of Figure 2(b) always passes through zero at the same interval of time after the peak regardless of the strength of the green signal. The smoothed sample of the

$$\text{green signal may be expressed as: } \frac{G(t)}{3} \left\{ 1 + 2\cos(2\pi ft) \right\}$$

where $G(t)$ is the green signal as a function of time, and f is the sampling frequency, namely 3.8 megacycles. A study of this expression reveals that the smoothed green sample goes through zero 120 and 240 electrical degrees after the signal has reached its maximum value.

The red samples of Figure 2(c) are smoothed by the filter to yield the result shown in Figure 2(d). This again is made up of a dc component and a sine wave with a frequency of 3.8 megacycles.

Smoothing of the blue sampling pulses results in the contribution shown in Figure 2(f). It should be noted in Figures 2(b), 2(d), and 2(f) that when any one color signal out of the filter reaches its maximum value, the other two responses are crossing the zero axis.

While the curves of Figures 2(b), 2(d), and 2(f) have been shown separately for illustrative purposes, it should be remembered that the pulse train of Figure 2(g) goes into the low-

To Page 28

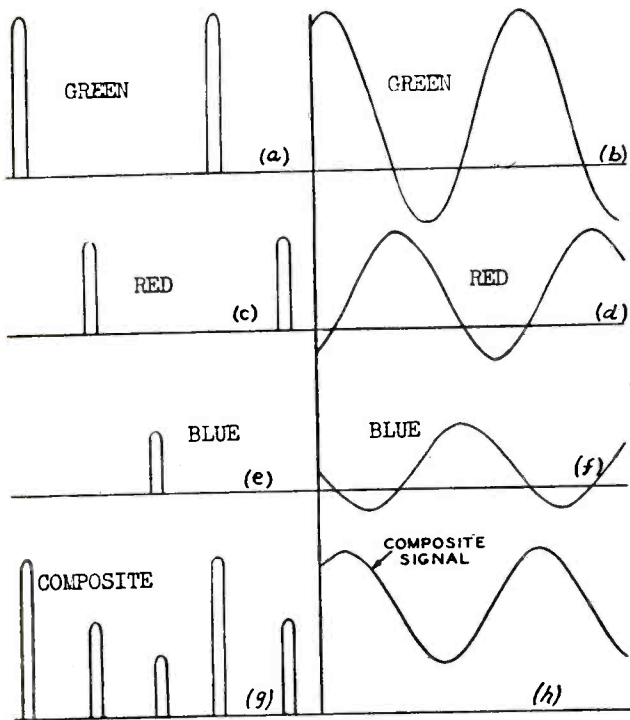

FIG 2



Season's Greetings

FROM THE ENGINEERS

HOLLYWOOD CHAPTER

N. A. B. E. T.

NBC
Hollywood

KNBH
Hollywood

ABC
Hollywood

KFI
KFI - FM
KFI - TV
Los Angeles

KFSD
San Diego

KECA
KECA - FM
KECA - TV
Los Angeles



Season's Greetings

John Scott Trotter



HERE'S TO YOU ENGINEERS—
We couldn't do without you!

Ralph Edwards

"This Is Your Life"
Wednesdays

"Truth or Consequences"
Saturdays



Greetings
and
Best Wishes
to
N A B E T



AXEL GRUENBERG

"TODAY'S CHILDREN"
"THIS IS YOUR LIFE"

SOUTHERN CALIFORNIA DISTRIBUTORS

GENERAL  ELECTRIC

AIR CONDITIONING AND HEATING EQUIPMENT

C. G. Hokanson Company, Inc.

AIR CONDITIONING

AND HEATING

E N G I N E E R S

C O N T R A C T O R S

A R I Z O N A 7 - 4 2 3 1

B R A D S H A W 2 - 3 2 6 8

OLYMPIC and SEPULVEDA

2140 PONTIUS AVENUE

LOS ANGELES 25, CALIF.

Best Wishes to Ray Ferguson and all of the great N.A.B.E.T. gang
from

the "GREAT GILDERSLEEVE" gang

Harold Peary — Walter Tetley — Ken Christy — Mary Lee Robb — Kathy
Lewis — Lillian Randolph — Gloria Holliday — Earle Ross — Richard Le
Grand — Arthur Q. Bryan — Paul West — Andy White — John Elliotte —
Jack Meakin — Monte Frazer — Frank Pittman — Fran Van Hartesveldt.

on N. B. C. Every Wednesday Night

for the

KRAFT FOODS CO.

COLOR TV TECHNICAL DATA

From Page 23

pass filter. Thus the composite signal of Figure 2(h) comes out of the smoothing filter. In this figure, the dc component is the sum of the dc components of the green, red, and blue signals, while the 3.8-megacycle sine wave is the sum of three sine waves, resulting in a 3.8-megacycle sine wave with a new amplitude and phase position superimposed on the composite dc component.

The signal of Figure 2(h) is applied to the modulator of the transmitter. As has been explained, the signal at this point for large and small picture areas contains frequency components up to the limit of the low-pass filter or up to four megacycles.

The action of the system in the presence of a varying color may be illustrated by means of Figure 3. In Figure 3(a), the three color signals are shown as they enter the sampler, with the appropriate sampling pulses as they come out of the sampler indicated by vertical lines. These same pulses are shown in Figure 3(b), with the envelope indicating the result of smoothing in the filter. This envelope may also be regarded as the envelope of the transmitted radio-frequency signal, neglecting the contribution of the mixed-highs signal.

A few words of explanation regarding mixed-highs is appropriate. First, we have demonstrated that the mixed-highs procedure is successful and satisfactory in a wide-band simultaneous system. In the RCA color television system the sampling process by itself is sufficient to carry high frequency components of each color signal so that when combined the resulting band width is below four megacycles (the sampling determines the highest frequency which will be passed). However, the choice has been made to sample for the lower half of the video band (up to two megacycles) and to use the mixed-highs principle for the upper half of the video band because this has technical advantages.

Figure 4 is a block diagram of one type of color television receiver. The radio-frequency circuits, the picture intermediate-frequency amplifiers, the second detector, the sound intermediate-frequency amplifiers, the discriminator, and the audio circuits are identical with those of a conventional black-and-white receiver. The composite video and synchronizing signals from the second detector enter an electronic device called the "sync separator," which removes the video and sends the synchronizing pulses to the deflection circuits and to the sampling pulse generator. The sampling pulse generator utilizes the trailing edge of the horizontal synchronizing pulse to actuate the receiver sampler in synchronism with the transmitter sampler.

The signal from the second detector also enters the sampler. It has the same form as the composite signal of Figure 2(h), or as the solid envelope of Figure 3(b). For ease of reference, Figure 2(h) has been reproduced on Figure 5(a). The electronic commutator samples the composite signal every 0.0877 microsecond, producing the short pulses shown on Figure 5(a). The amplitude of each of these pulses is determined by the amplitude of the composite wave at that particular instant.

The commutator feeds these pulses into three separate video amplifiers which in turn control three cathode-ray tubes or kinescopes having appropriate color-producing phosphors. This method for portraying the single color picture with three kinescopes in a projection system is similar to that demonstrated

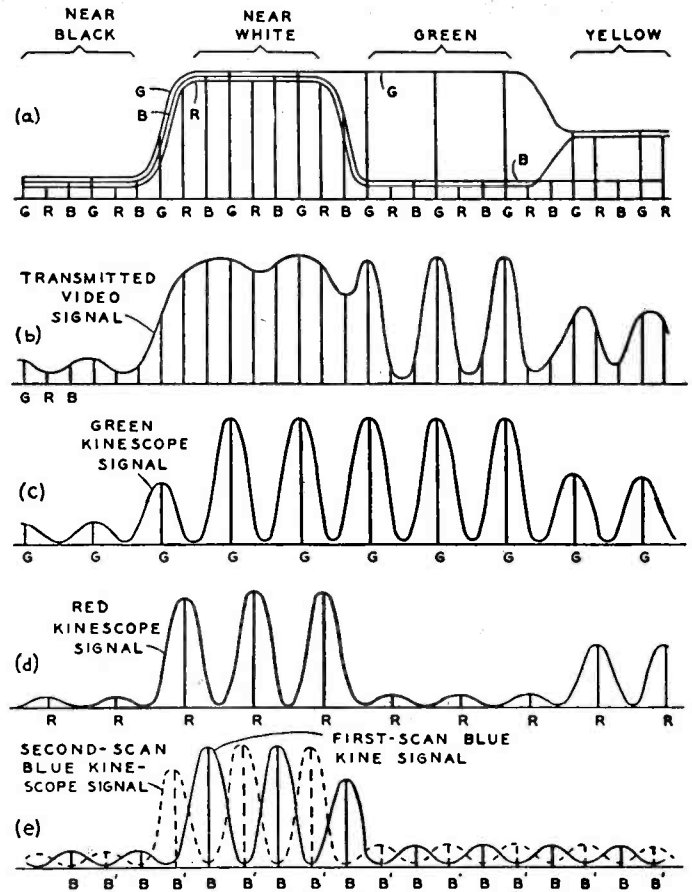

FIG. 3

to the Commission during the hearing on Docket No. 7896. (See also: *RCA Review*, Vol. VII, No. 4, pp. 459-468, December, 1946; *Proc. I.R.E.*, Vol. 35, No. 9, pp. 861-875, September, 1947.)

The video amplifiers have a flat response to four megacycles gradually drop off in response from that frequency to seven megacycles, and have great attenuation above seven megacycles. (We are discussing here the frequency response of the video amplifiers only and not channel requirements.)

The sampler sends the pulses to each of the video amplifiers and its attendant kinescope in succession. For instance, in Figure 5(a), the first pulse shown in green goes to the green kinescope, the next pulse goes to the red kinescope, while the third pulse is sent to the blue kinescope. The green kinescope receives the fourth, seventh, tenth, and so on. Thus while the individual pulses coming out of the sampler are 0.0877 microsecond apart, the green pulses going to the video amplifier for the green kinescope repeat every 0.263 microsecond. The green channel pulses of Figure 5(a), passing through the video amplifier, lose all frequency components except the fundamental frequency of 3.8 megacycles and the dc component. The resultant smoothed signals are shown in Figure 5(b). The green, red, and blue signals are shown in superposition on this figure for illustration. It should be remembered that at this point the green signal shown is that fed to the green kinescope, while the red and blue signals are applied to their individual kinescopes.

Examination of Figures 2(b), 2(d), 2(f), and 2(h), has

To Page 33

Season's Greetings



E. Broox Randall & Sons, Inc.

INSURANCE

For Every Purpose

HOLLYWOOD

BEVERLY HILLS

SANTA MONICA

SAN FERNANDO VALLEY

AIR CONDITIONING

REFRIGERATION

**AUTHORIZED WESTINGHOUSE
DISTRIBUTORS**

WESTERN AID

&

REFRIGERATION, Inc.

1819 GLENDALE BOULEVARD
LOS ANGELES 26, CALIFORNIA
PHONE OL. 1117

Engineers - Contractors

SERVING THE AIR CONDITIONING NEEDS
OF THE
TELEVISION AND RADIO INDUSTRY
ALONG THE PACIFIC COAST

P L E A S E

Stay Well, Ed. Conture

We're all pulling

for you—

All of us with

ART LINKLETTER'S

"PILLSBURY HOUSE PARTY"

AND

John Guedel Radio Productions

*P.S.—If you happen to be ill again by the time this goes
to press, change above to "Get Well."

(2226)

Almost Two Decades of Service

to the

BROADCASTING INDUSTRY

As another year rolls around we take
this opportunity to extend to our many
friends in the Broadcasting Industry our
deep appreciation and our sincere wishes
for a successful year to come.

Radio Specialties Company

1956 South Figueroa Street
Los Angeles 7, California



BING

[Faint, illegible text, possibly bleed-through from the reverse side of the page]



Season's Greetings

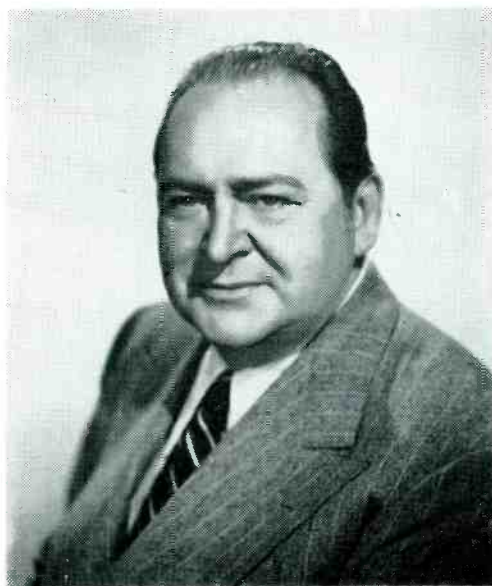

EDWARD ARNOLD

"MR. PRESIDENT"
A B C



Thanks to you all and
Season's Greetings

from

FREDDY MARTIN



LEO J. MEYBERG COMPANY, Inc.

- . . . Complete stock of all major lines of electronic equipment
- . . . RCA Distributors
- . . . For your convenience, branches in San Francisco and Los Angeles.

For prompt, courteous and specialized service

"CALL MEYBERG FIRST"

Leo J. Meyberg Company, Inc.

2027 So. Figueroa St.
Los Angeles 7, RI - 7-4451

70 Tenth Street
San Francisco 1, Market 1-3400



Alice Faye

And

Phil Harris



REXALL PROGRAM



SUNDAY AFTERNOONS

7:30 P.M., E.S.T.

N. B. C

4:30 P.M., P.S.T.

COLOR TV TECHNICAL DATA

From Page 28

already revealed that, when the green signal is maximum, the red and blue signals are passing through zero. Hence, since the composite signal is sampled for green by a narrow pulse at the receiver at this exact instant, the receiver sampling pulse is a true measure of the green signal and includes no dilution from the red or blue signals. Likewise, the red and blue samples are each taken at points on the composite signal where no cross-talk is contributed from the other two color signals.

Assuming that the kinescope actually cuts off with negative applied signal, and neglecting the non-linearity of the input control-voltage vs. light-output characteristic of the kinescope, the solid lines of Figure 5(c) may be regarded as the effective light intensity along one line scan on the screen of the green kinescope. Figures 3(c), 3(d), and 3(e) show the effective signals on the green, red, and blue kinescopes, again for a single line scan.

Returning now to Figure 5(c), it may be seen that a single line scan on the green channel lays down a series of green dots on the screen as shown by the solid lines. As was indicated above, these dots occur at a 3.8-megacycle rate. If fine detail were involved to such an extent that two adjacent pulses in the green channel in a single line scan were of different amplitude, it is basic that the highest frequency component of use in establishing picture detail would be a sine wave which went from a crest to a trough in the time between the two adjacent green pulses. This sine wave would then have a frequency of 1.9 megacycles. The fact that each pulse has a

rise equivalent to twice this frequency allows the use of picture-dot interlacing to secure full detail up to 3.8 megacycles. This is accomplished by shifting the sampling pulses the next time that the same line is scanned so that the dots are then laid down between the dots that were laid down in the first scan. This second series of green dots is shown by the broken curves in Figure 5(c). In this figure, the dots shown by broken curves are the same amplitude as the dots shown by the solid curves. For resolution of very fine detail the dots laid down in the first scan would differ in amplitude from the dots laid down in the second scan of this same line. Figure 3(e) shows the signal at the blue kinescope for the first scanning of the line, with the dotted line showing the kinescope voltage for the second scanning of the same line.

Inspection of Figure 5(b) reveals that while a single line scan lays down a series of green dots on the screen with space between dots, this space is completely filled at the same time by red and blue dots, with great overlapping of the dots.

The scanning sequence used in the RCA color television system is illustrated in Figure 6. Here each square represents a dot on the screen. Because of the overlapping of dots, each square should be approximately fifty per cent longer than shown.

During the first scanning field, illustrated by the upper diagram in this figure, the odd numbered lines are scanned in order. That is, the three colored dots are laid down in order along line 1 as shown. Next, line 3 is scanned with a displacement of one and one-half squares for each color. The remaining odd lines are scanned in order with the color dot pattern shown. This scanning of the first field takes place in one-sixtieth of a second. During the second field, the even

To Page 38

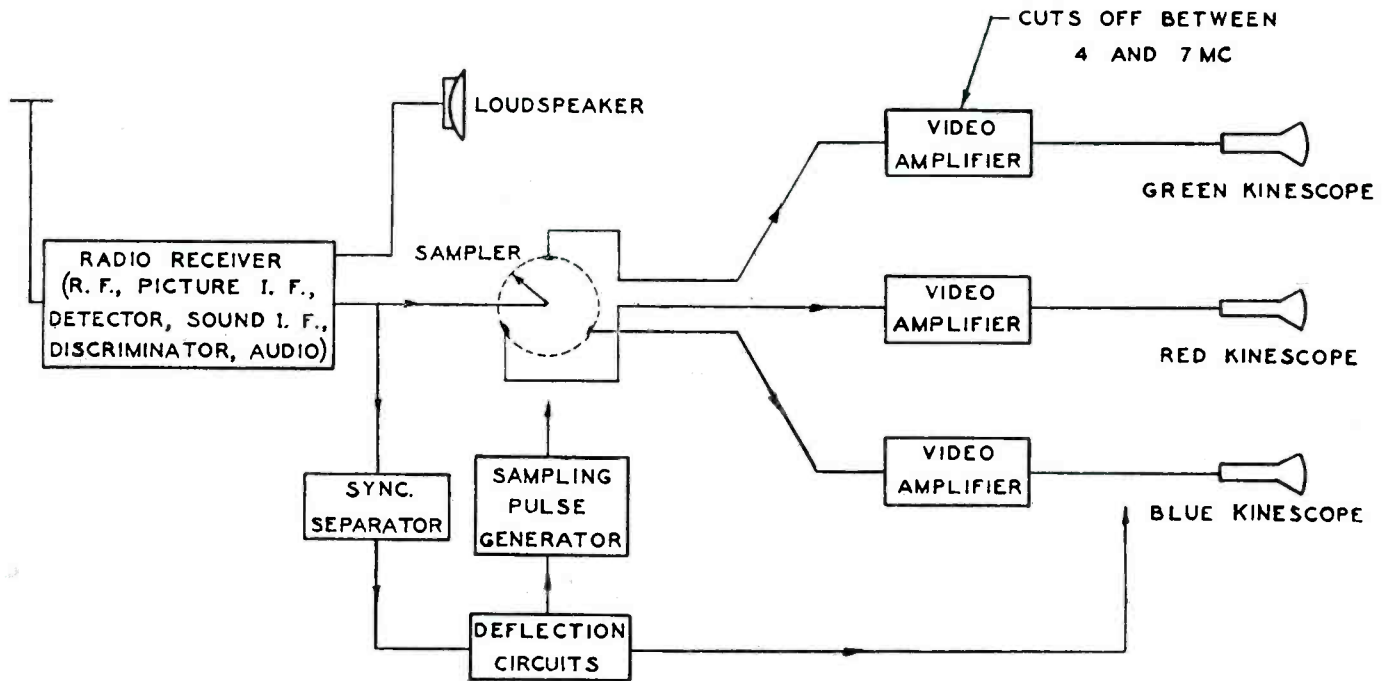

COLOR TELEVISION RECEIVER

FIG. 4

*Holiday Greetings to the Engineers of
Southern California and Arizona*
W. BERT KNIGHT CO., Inc.
908 Venice Boulevard Los Angeles 15

Representing
SHURE BROTHERS—MICROPHONES
CORNELL-DUBILIER ELECTRIC CORP.—CAPACITORS
WARD-LEONARD ELECTRIC COMPANY—RESISTORS
STANDARD TRANSFORMER CORP.—TRANSFORMERS
HYTRON RADIO & ELECTRONICS—TUBES
JAMES MILLEN MFG. CO.—PARTS

Season's Greetings

FROM

RADIO TELEVISION SUPPLY CO.

Your Electronic Supplier

341 W. 18th STREET
(Between Hope and Grand—near
Olympic Auditorium)

Los Angeles 15, Calif.

Merry Christmas

AND

a Happy New Year

TO THE

Broadcast Engineers



for your Electronic Supplies

DOW RADIO, Inc.

1759 E. Colorado, Pasadena 4, California

Dial — Ryan 1-6683

Merry Christmas



from



Red Skelton

SEASONS

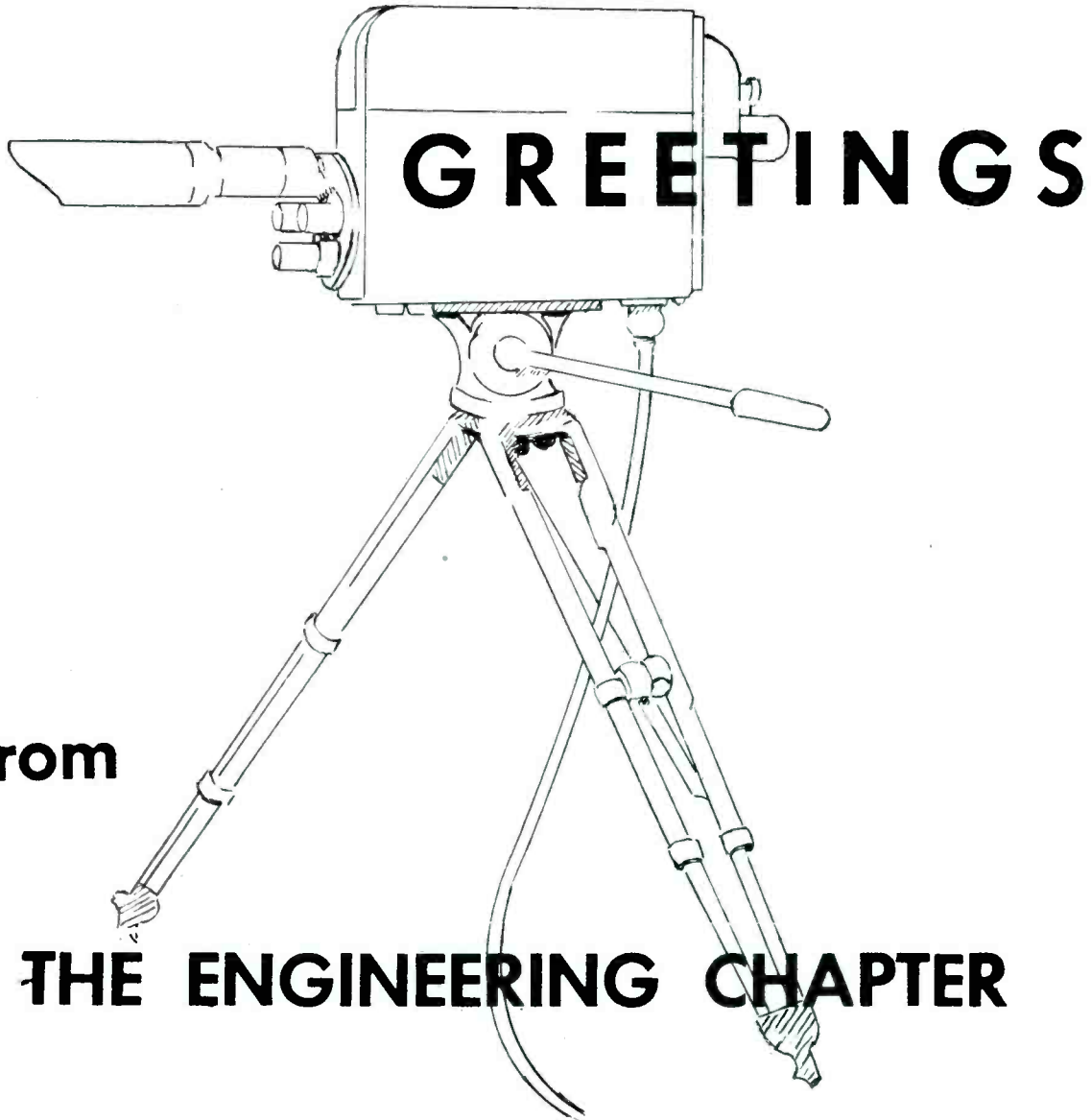

from

THE ENGINEERING CHAPTER

**NATIONAL ASSOCIATION OF
BROADCAST ENGINEERS & TECHNICIANS**

DeWITT C. SHULTIS, Chairman



Season's Greetings

TEX & JINX



BEST WISHES FROM
BRANDY
AND HIS ARRANGER—JOHN GART

bill meeder



ALLEN PRESCOTT

I've been sitting here a whole year.
Is Television ready?



"We love yez all dearly"

ED and PEGEEN FITZGERALD

W J Z

COLOR TV TECHNICAL DATA

From Page 33

lines are scanned, first line 2 with the colors laid down in over lapping dots as shown, then line 4 and so on. The dot pattern laid down during the third field is shown by the lower diagram, where the odd lines are scanned in succession. During the fourth field, the even lines are again scanned in succession with the color dot pattern shown.

Thus, in the RCA color television system, the odd lines are scanned during the first field, but dots of the same primary color are separated by spaces. The even lines are scanned during the second field, again with spaces between like color dots. During the third field, the odd lines are again scanned but with the color dots displaced so that the spaces are filled. The even lines are scanned during the fourth field, with the color dots displaced to fill in the spaces left during the second field scanning. Four scanning fields are required to completely cover the picture area, with all spaces filled, with say, green dots. Simultaneously, the area is being covered with red dots and with blue dots. Since there are 60 fields per second, it may be said that there are 15 complete color pictures per second. It should be remembered that the effective field rate for large-area flicker is 60 per second, the same as for current black-and-white receivers. At viewing distances such that the picture line structure is not resolved, the effect of small-area flicker due to line interlace and picture-dot interlace is not visible.

When the radio signal from the RCA color television system is received on a current black-and-white receiver, in good adjustment, the output of the second detector is represented by Figure 2(h), or, when the picture is of varying color, by the envelope of Figure 3(b). With mixed highs also transmitted as shown in Figure 1, the black-and-white receiver then develops on its kinescope a black-and-white picture with

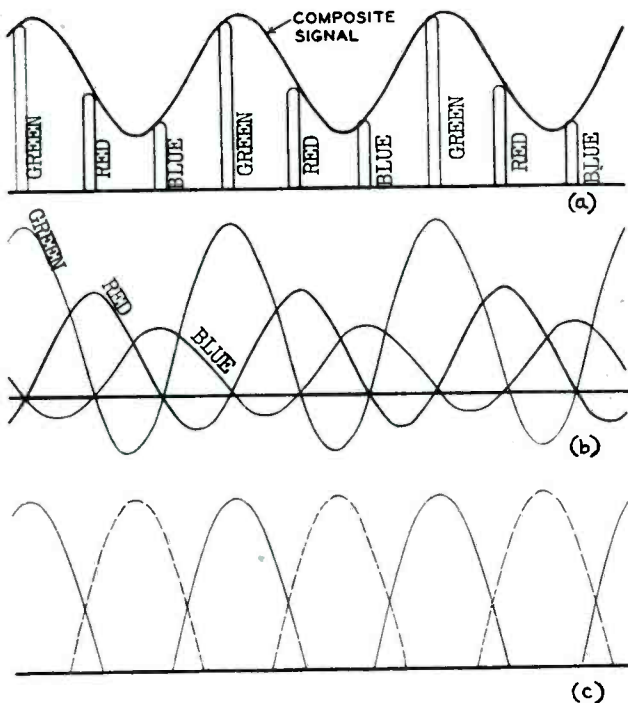

FIG. 5

G	R	B	G	R	B	G	R	B	G	R	B	1
	B	G	R	B	G	R	B	G	R	B	G	2
	B	G	R	B	G	R	B	G	R	B	G	3
G	R	B	G	R	B	G	R	B	G	R	B	4
G	R	B	G	R	B	G	R	B	G	R	B	5
	B	G	R	B	G	R	B	G	R	B	G	6

FIRST AND SECOND FIELDS

	B	G	R	B	G	R	B	G	R	B	G	1
G	R	B	G	R	B	G	R	B	G	R	B	2
G	R	B	G	R	B	G	R	B	G	R	B	3
	B	G	R	B	G	R	B	G	R	B	G	4
	B	G	R	B	G	R	B	G	R	B	G	5
G	R	B	G	R	B	G	R	B	G	R	B	6

THIRD AND FOURTH FIELDS

FIG. 6

full resolution. The 3.8-megacycle sine wave superimposed on the picture signal produces a dot pattern on the kinescope, but due to interlace and line structure the dots are not visible at normal viewing distance.

In our laboratory setup, using the standard wedge pattern to test horizontal resolution, we have obtained the same resolution figure when reproducing the color transmission on an unchanged current model black-and-white receiver as one may obtain with the same receiver on a well-designed, well-adjusted black-and-white system using present broadcast standards. We have also obtained the same resolution figure when reproducing the color transmission on a color receiver.

For color transmissions received on a color receiver, band saving is accomplished for the radio channel, first, by the sampling process wherein the color signals are transmitted in time-multiplex fashion. The second aspect of the band saving process is through picture-dot interlacing. At the receiver the effect of the greater band width is restored by the inverse sampling and by circuit arrangements to scan so as to picture-dot interlace.

For color transmissions received in monochrome on a current black-and-white receiver no band saving is involved, but because the transmitted signal contains all the resolution which a black-and-white signal of the same scene would have, the resulting monochrome picture will have the full resolution of the current standards.

To adapt a current black-and-white receiver to receive color transmissions in color will require the addition of circuits to accomplish the inverse sampling, a picture-tube viewing arrangement or combination and associated power supplies. For the demonstrations at the time of the hearing we will have

To Page 63

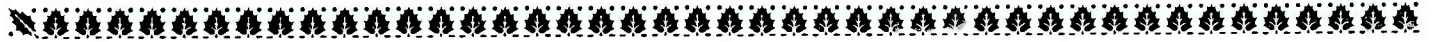

GREETINGS

From

THE
VILLAGE
BARN



Greenwich Village

New York, U. S. A.



The Home of Square Dances,

Country Games, and

Fine Entertainment



WNBC

WOR





“A radio engineer can either MAKE you or break you”

this saying still holds true!!

thanks, boys.

Rosa Rio

THE RADIO WRITERS GUILD

of the

AUTHORS LEAGUE OF AMERICA, Inc.



EASTERN REGION



Season's Greetings

from—

RADIO CITY BAR & GRILL

HURLEY BROS. & DALY

Where Stage, Screen and Radio Stars Meet

Finest Wines and Liquors

N. E. Corner of 49th St. & Avenue of the Americas

FEATURING GOOD FOOD AND DRINKS

Served in a Friendly Atmosphere

Under Management of
CONN HURLEY

BEST WISHES

from

DON

MacLAUGHLIN





PEACHY PATCH CORDS

To

N A B E T

From

Walter Kiernan



Season's Greetings Boys

Here's Looking Atcha

JOHNNY OLSEN

Best Wishes from

STAATS COTSWORTH



GOOD LUCK

from

ALICE CLEMENTS,

Producer

Horn & Hardart Children's Hour



Greetings

JOE HASEL

ABC Sportcaster

THE STORE FOR Savings

- Refrigerators
- Television
- Radios
- Vacuum Cleaners
- Washing Machines
- Ranges
- Air Conditioners
- Electrical Appliances
- Sporting Goods
- Cameras
- Luggage
- Diamonds
- Jewelry
- Bicycles
- Giftware

We're mighty proud of the hundreds of friends we've made among the readers of Broadcast Engineers. Here in our handsome new building we display a tremendous amount of merchandise . . . the finest products of America's largest makers — all offered at the lowest possible prices. Come in and let us show you the "special values" . . . (which we always have in reserve for readers of Broadcast Engineers). You'll appreciate the advantages of shopping . . . and saving . . . at Monarch-Saphin.

New Type Department Store
MONARCH SAPHIN

Open Thurs. Eve's.

56 WEST 45th ST., N. Y. Phone MU 2-1470

Hempstead, L. I., Branch—120 Main St.

Hempstead 2-9182

Open daily and Saturday 10 a.m.-10 p.m.

Wednesday 10 a.m.-6 p.m.

Season's Greetings to the Engineers

From Guy and the Boys

Guy Lombardo And His Royal Canadians

Currently appearing at Hotel
Roosevelt Grill
New York

Greetings



CHARLES F. McCARTHY

Unofficial McCarthy Reaction:
A Top Notch Holiday to You All.

Karl Swenson



Lora Lawton
Road of Life
Crime Photographer
Radio City Playhouse
Break the Bank
"Lights Out"—NBC-TV

JAN MINER

PARKER & BATTERSBY

Camera, Gift and Specialty Shops

Shop 5, Mezzanine, 30 Rockefeller Plaza

Shop 46 West 50th St., Rockefeller Center

New York 20, N. Y.

The World Famous RADIO CITY PHARMACY

R.C.A. Building, New York, N. Y.

**FOR ALL YOUR DRUG STORE AND
FOUNTAIN NEEDS**

Phone, Circle 7-3476—7

KAUFMAN & BEDRICK PHARMACY, INC.

43 West 49th Street, Rockefeller Center, New York, N. Y.

D. LOWENSTEIN

H. DEMAS

RCA COLOR TELEVISION SYSTEM

First Public Demonstration of Field Test Broadcast Shows All-Electronic, High-Definition and Completely Compatible Color System Which Can Supplement Black-and-White Service Without Disturbing Present Sets

The first scheduled program of color television broadcasts—a part of the Radio Corporation of America's field tests—was presented recently by RCA to demonstrate to the Federal Communications Commission and to the public the new RCA all-electronic, high-definition and completely compatible color television system.

The initial demonstration was presented for the official record of the FCC in its current hearings relating to the adoption of technical standards for color television service. This demonstration and subsequent color transmissions, originating at the National Broadcasting Company's WNBW studios at the Wardman Park Hotel, will provide an opportunity for representatives of the Government, the press, science, industry and the public to observe the color system which RCA believes to be the best foundation for satisfactory standards.

Continuing demonstrations are planned to show how this system can be the basis for the establishment of a color television service without obsoleting present black-and-white sets.

The program featured variety artists, radio and television stars, color motion pictures and color slides, all scanned by color cameras to demonstrate the effectiveness of the new RCA system in transmitting and receiving scenes and action in natural colors for the added enjoyment of the public.

A special entertainment program presented some of America's favorite entertainers, seen for the first time in color television. NBC television favorites Kukla, Fran and Ollie of television's top puppet show introduced other stars including Gladys Swarthout of the Metropolitan Opera who sang the

"Habanera" from Carmen, juggler Rudy Cardenas and the dance team of Fred and Susan Barry. Dickinson Eastham, understudy to the "South Pacific" star Ezio Pinza sang "Some Enchanted Evening" with Miss Swarthout. The commercial possibilities of color television were demonstrated by Sid Stone, the popular "Pitch man" of Milton Berle's Texas Star Theatre. A 19-piece NBC orchestra under Norman Cloutier provided accompaniment for the talented stars as they appeared in brightly colored costumes characteristic of their roles.

Objective of RCA

Speaking for the record, Dr. Elmer W. Engstrom, Vice President in Charge of Research, RCA Laboratories, declared: "RCA has believed from the beginning that television should

To Page 48



RCA color television cameras operating in the studio of WNBW, Washington, D. C.



RCA's new color television camera with cover removed. In the center foreground are two dichronic mirrors which allow green rays to pass through to the lens of the center image orthicon tube, while reflecting red rays via a silvered mirror to the right-hand tube, and the blue rays by another mirror to the tube on the left. In the rear are some of the camera's electronic control elements. Richard C. Webb, research engineer of RCA Laboratories, is shown with the camera.

Season's Greetings

From Your Favorite

*Radio, TV, Sound Equipment and Electronic
Distributor*

SEND FOR OUR NEW 1950 CATALOG.

NEW YORK

Offices and Warehouse
242 W. 55th St., N. Y. 19



CHICAGO

323 W. Madison Street
Chicago 6, Ill.

New York City Stores: 115-17 W. 45th Street and 212 Fulton Street

Circle 7-0051

Founded 1888

TREPEL
Rockefeller Center

Flowers

Personal Management
JACK TREPEL

RCA Building
52 West 50th Street
New York 20, N. Y.

Greetings

TO THE BROADCAST ENGINEERS

WEBER and WEBER

Haberdashers - Hatters

ROCKEFELLER CENTER 20, N. Y.

In New York . . .

MASTERS, Inc.

66 West 48th Street

New York 19, N. Y.



In Hollywood . . .

MASTERS MART

1261 N. Vine Street

Hollywood, Calif.



AIR
FEATURES
Inc.



247 PARK AVENUE
NEW YORK, N. Y.



Greetings

Paul Lavalle



EVERY GOOD WISH

from

SEASON'S GREETINGS

The Collyers

Hugh James



Marian Shockley

Bud Collyer



R
T
D
G



Bags, Trunks, Airway Luggage & Leather Novelties

DEXTOR & CO.

53 West 49th Street, N. Y. 20

ROCKEFELLER CENTER

Circle 5-7460



May your Audio be high-
And your Video bright
With Great Frequency—
this coming year.



Ed Herlihy



The Season's Best To Everyone

from Walter, and Bob Hoops

Economy Blue Print Co., Inc.

9 Rockefeller Plaza, New York 20, N. Y.



COLOR TV SYSTEM

From Page 43

progress from black-and-white to color just as soon as this was practical. Believing this, RCA has aggressively worked upon all promising systems of color television and has earnestly directed its efforts to this end.

"RCA has believed that color television, when established, should be based upon a lasting foundation of proper standards, excellent performance, and should be developed in an orderly manner with regard to the black-and-white television service.

"RCA is pleased that its experimental work and engineering analysis provide the basis, and this we may now state with conviction, for high-definition color television within six-megacycle VHF and UHF channels and compatible with the present black-and-white service.

"This system for the first time enables color television in 6-mc to proceed upon a lasting foundation of proper standards, excellent performance and complete compatibility with existing receivers."

Importance of Compatibility

Dr. Engstrom pointed out that the RCA color television system is a compatible system. This means, he explained, that present television receivers can receive color programs in black-and-white without any modification. Also, when a broadcaster shifts from black-and-white transmission to color transmission, the viewer of an existing black-and-white receiver is unaware of the shift. On the other hand, a viewer of a new color set, receiving programs in color, will, when the broadcaster changes from color to black-and-white transmission, see black-and-white pictures without making any changes in his receiver.

"The question of compatibility is of great importance not only to the present owner of a black-and-white receiver, but

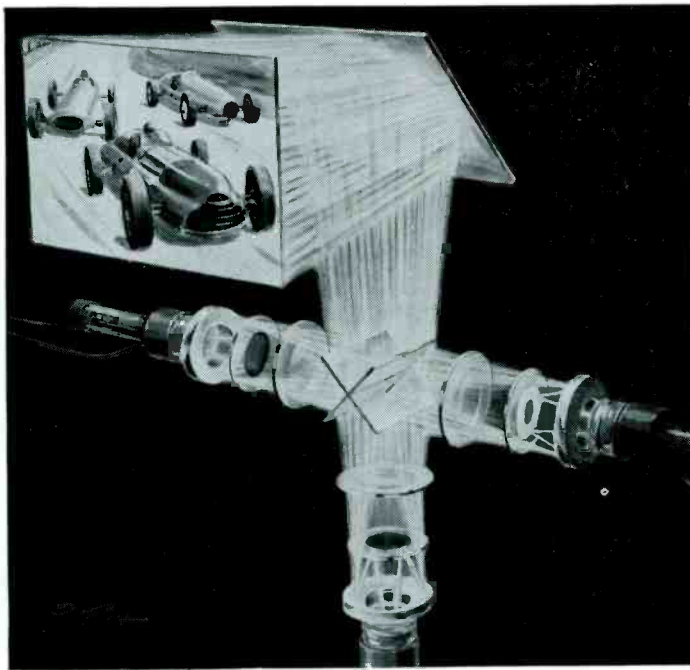

RCA color television projection picture-reproducing system, using three projection kinescopes, reflective optics and a pair of dichroic mirrors.



Studio control panel of the RCA color television system.

may very well be fundamental to the economics of a color television broadcasting service," said Dr. Engstrom. "In considering the public interest, it is necessary to take into account these economic factors, because the public cannot be served unless the broadcasters are able to render a commercial service.

"With a compatible system a broadcaster first starting color schedules is automatically assured that he will retain his full potential audience on all the receivers in his service area, both black-and-white receivers and new color receivers. The economics of the television broadcasting industry appear to be such that regular color broadcasting service might be seriously delayed if the broadcasting must sacrifice circulation, and therefore revenue, in order to provide color transmissions.

"With a fully compatible system, however, the broadcaster can change at will, either from color to black-and-white or the reverse, without disturbing the viewers of either the existing receivers or color receivers, and without requiring adjustments to either type of receiver. This means no loss of audience at the start or later, which will no doubt be an important factor for some time, because it is probable that many programs will be transmitted in black-and-white even when color becomes an established service."

With appropriate production design, Dr. Engstrom declared, RCA believes that new color receivers of reasonable cost, practical to install, and simple to operate can be made available by the radio industry. He pointed out that economies and price reductions have been achieved in black-and-white sets and similarly it may be expected that economies and price reductions will be experienced in color receivers as demand and quantity production develop.

Adapting Sets to Receive Color

Existing black-and-white television receivers may be converted to receive color pictures by various methods in the RCA color system, Dr. Engstrom said. He described these methods as follows:

1. By using a separate converter unit containing appropriate electronic gear and picture tube viewing arrangement of a ten-inch diameter size.
2. By substituting a new projection unit for the cathode ray tube in the black-and-white set.
3. By adding one tube to the cathode ray tube in the black-and-white set and changing the three-color signal to a two-color signal to be viewed on the two-cathode-ray-tube combination.

Scope For Future Improvement

"In a medium of such tremendous social and economic im-

To Page 53

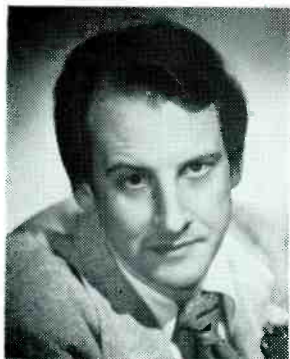

Many Thanks

for adding a

HANS CONREID

and mixing well

Season's Greetings

and Thanks to all the Boys

ROMELLE FAY

Organist and Composer

MUSICAL DIRECTOR OF
NATION'S LEADING DAYTIME
SHOW

"Today's Children"



AS EVER—

Friendly greetings from all of us behind the
mike to you at the controls. Sincere thanks
and kind regards to each and all of YOU.

"Merry Xmas and a Happy New Year"

WALTER ARNOLD
REED BROWNING
LOU COOK
BILL CRAGO
BOB CUMMINGS
DRESSER DAHLSTEAD
BILL DAVIDSON
IRVING HOWARD

MEL HUNT
OWEN JAMES
JACK LATHAM
BURLEIGH SMITH
BILL SPARGROVE
DICK TUFELD
HARRY WALSTRUM

ABC

HOLLYWOOD ANNOUNCERS

and our best gal

MARGOT DUBA

KECA, AM-FM

KECA—TV



TO THE ENGINEERS!

The Guys Who Make Us Or Break Us

BEST WISHES AND HEARTFELT THANKS

Ozzie and Harriet



William Morris Agency, Inc.

EST.  1898

NEW YORK • BEVERLY HILLS • CHICAGO • LONDON

Greetings

DAVE KLEIN

With best wishes to all our friends of
N.A.B.E.T.

CASTLE'S, Inc.

Photographic Supplies and Equipment

1529 Vine Street

Opposite N.B.C.

HOLLYWOOD 28, CALIF.

**A JIM LANSING
"SIGNATURE"
SPEAKER**

A quarter of a century of research and development have built a foundation of continued leadership and excellence of performance that has not been equalled.

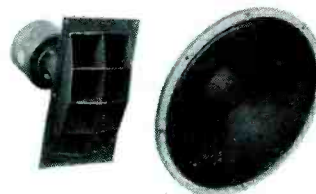

DI175H High Frequency Driver and Horn	DI30A Low Frequency Speaker
Power Input—25 Watts.	Power Input—25 Watts
Impedance—16 Ohms	Impedance—16 Ohms
Oper. Range 800-16,000 cycles.	Resonant Freq. 25 cycles.

JAMES B. LANSING SOUND, Inc.
2439 FLETCHER DRIVE
Los Angeles 26, Calif.

Where would we be if it weren't for the Engineers?

So Happy New Year to you "Mixer-Masters"

"THE LIFE OF RILEY"

NBC—TV and RADIO

Sincerely,

IRVING BRECHER

Season's Greetings

from

LUM and ABNER



Best Wishes

from

TEX WILLIAMS
SMOKEY ROGER
DEUCE SPRIGGENS
and
THE WESTERN CARAVAN

Thanks for Everything



HENRY RUSSELL

Director of Music * Western Division * N. B. C.

HOWDY!

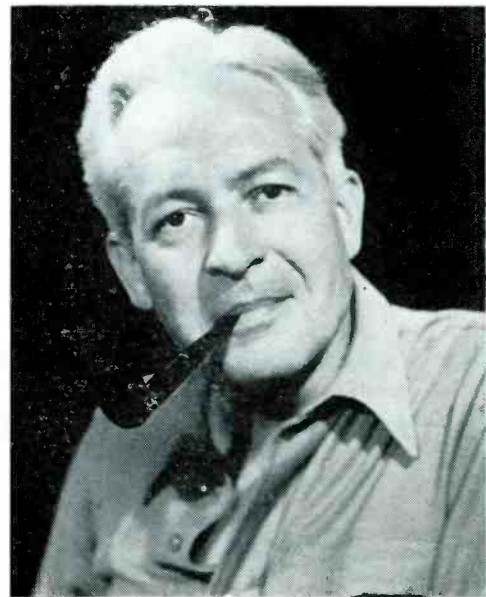

ART BAKER
and his
NOTEBOOK

Have you seen the
PORTATAPE?
The First *Complete* Portable
Tape Recorder
STANCIL-HOFFMAN
CORPORATION
Hollywood, California

LIGHTS, 13 Jobs for
CAMERA, 13 Performers in
13 Weeks!
ACTION!

Highest Television Mail Pull on NBC—Hollywood
AN ARMER-GRAUMAN-KING PRODUCTION

COLOR TV SYSTEM

From Page 48

pact as color television," continued Dr. Engstrom, "RCA believes that it is vitally important that the system adopted be based upon such principles that its future improvement is unhampered. The RCA color television system provides this scope and flexibility.

"It is the belief of RCA that this new system provides for the first time a sound basis for bringing color television service to the public, as well as full scope for the continuing development of color as the art progresses, without involving obsolescence of present-day black-and-white receivers. RCA color is a complete departure from mechanical color and the rotating color discs and moving parts which have characterized all the mechanical color systems invented since 1925."

Equipment Used In Demonstrations

Dr. Engstrom said that the RCA color television equipment used in the demonstrations before the FCC and others was developed at RCA Laboratories, Princeton, New Jersey. It consists of two cameras for live subjects in the studio, one camera for color motion picture film, and one camera for color slides. There are two color monitors and a control-room console. Color pick-ups also are viewed in the studio on a specially-built receiving unit, designed with 16-inch tubes.

This studio equipment not only provides ample flexibility for current operations, but has the necessary elements for conducting the continuing color broadcasts planned by RCA at the conclusion of these demonstrations.

The WNBW transmitter used in the demonstrations operates on Channel 4 of the assigned standard black-and-white television band.

Color receivers and black-and-white receivers for the demon-

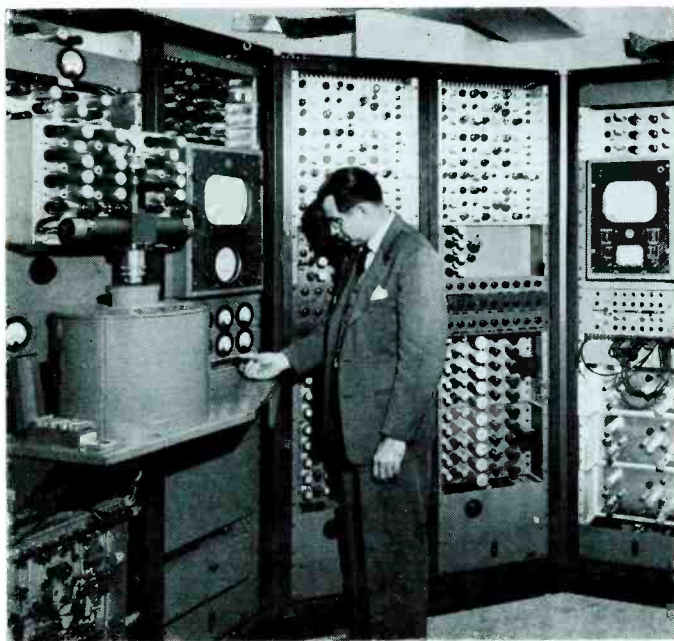

Partial view of equipment which includes studio control units of the new RCA all-electronic, high-definition, compatible color television system as installed at the NBC station WNBW, Washington, D. C. Ray D. Kell, head of the Television Section, RCA Laboratories, is seen operating the monochrome monitor.

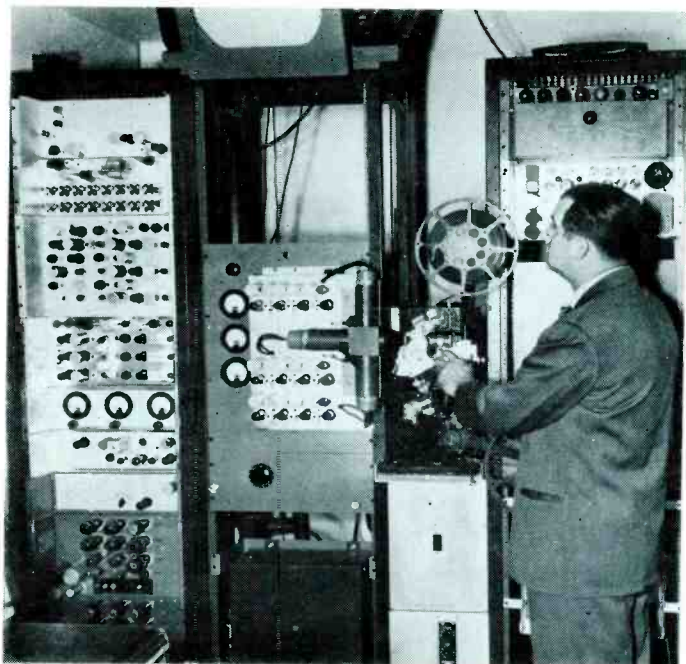

The 16-mm. color motion picture projector which is one of the units of the RCA color television system. At the left is the electronic sampler which takes 3,800,000 samples of each color a second.

strations are installed at the Washington Hotel, two miles from the transmitter. Since the RCA color system is compatible, RCA engineers pointed out that the transmissions in color do not interfere in any way with the regular black-and-white service of WNBW. In fact, any owner of a standard television receiver in Washington and surrounding areas can view the current demonstrations and subsequent field tests in black-and-white with full detail.

New Color Camera Being Developed

An increasing number of color receivers is to be made available by RCA for field testing to obtain technical data, service experience and user comment and reaction, Dr. Engstrom reported that RCA has started development of a field type color camera and associated apparatus. This is expected to be ready next spring and will then be added to the field test set-up. This field camera will use a new camera tube which will greatly reduce the size of the camera itself. A mock-up of this camera and an operating sample of the camera tube were displayed during the demonstration.

How the RCA Color System Works

Briefly, as Dr. Engstrom explained, this is what happens when the RCA color television system goes into action:

The color camera in the studio is equipped with three separate tubes. Each of these pick-up tubes, equipped with an appropriate color filter, receives one—and only one—of the primary colors, which in Television are *red*, *blue* and *green*. In transmitting a color picture, these colors are electronically "sampled" in rapid sequence and combined. The combination is then transmitted as a unit over a standard television transmitter.

At the receiving end, the single television signal is fed to an electronic arrangement which is the inverse of the sampler at the pick-up. The combination is separated and a signal

To Page 68

Greetings from the

CLEVELAND CHAPTER

WTAM Studios

C. E. Ames
A. Caliguire
T. C. Cox
J. J. Francis
J. W. Hyatt
W. Kost
A. C. Krohn
E. P. Kukis
A. M. McMahan
G. Molnar
B. C. Pruitt
G. E. Ward
G. Makinson
W. C. Pruitt

WNBK Studios

J. Azman, Jr.
C. S. Bidlack
H. B. Caskey
A. Chandler
S. E. Dombrady
J. Elliott
W. Gieseke
W. A. Howard
G. W. Iski
H. R. Jagoda
P. Kirrkamm
M. W. Kitchen

L. S. Moore
R. T. Monroe
J. F. Myers
E. C. Phillippi
C. W. Smith
H. Sombor
H. A. Spiller
D. Turley
B. W. Vinton
F. E. Whittam
J. Wilhelm

WTAM - WNBK

Transmitter

F. H. Anthony
M. M. Bracic
H. V. Brandt
G. Buchanan
A. H. Butler
J. A. Cheeks
E. Holl
W. R. Jerome
P. A. Newell
R. Plaisted
J. K. Sanderson
A. B. Stewart

Studios

F. L. Barrett
F. Y. Best
C. Carment
J. M. Carment
J. F. Eagan
D. Irwin
R. Krejny

W H K

R. Maczka
A. J. Pekkola
P. Quay
A. Rajnicek
P. C. Tuttle
E. Austin

Transmitter

M. T. Bennett
C. A. Draper
H. B. Okeson
J. Sturtevant
J. F. Ulrich
P. S. Van Deusen

WHKK

W. E. Batchelder

C. Lustic

B. V. Berg

A. Smith

P. Hromish



BEST WISHES
from
TOM FIELD
WTAM - WNBK



HAPPY HOLIDAY
FROM
OFF THE RECORD (The greatest show in radio)
TO
THE ENGINEERS (The greatest guys in radio)
TOM HALEY

Best Wishes

BRYON WADE

"Personalities in the News"

WTAM



BRYON WADE at HOME

WNBK-NBC Channel 4

"Every Friday Afternoon at Five"

Merry Christmas and the Best of Everything
To the Best in the Business
The Engineers

JOE MULVIHILL

THE 1100 CLUB

Monday thru Friday

on WTAM, NBC, Cleveland

SUPPORT

NABUG

The National Association of
Broadcast Unions and Guilds

Season's Greetings

from

DETROIT
CHAPTER
NABET

WWJ WJLB WTAC
WWJ-TV WBBC WKMH



"IT'S JIMMY BLADE
AND HIS MUSIC"

CHICAGO MOTOR CLUB
WMAQ—NBC Chicago

Best Wishes

From

THE DETROIT LOCAL

of

A. F. R. A.

Greetings from

RICHARD PAIGE

and

ADELE SCOTT PAIGE

NBC — Chicago



Best Wishes

For A LONG LIFE

DON GALLAGHER



Season's Greetings

"FROM OUR HOUSE TO YOURS"

Neighborly Music by the

Hometowners

NBC-CHICAGO



Duane Swalley Betty Bennett Larry Wellington
Kenny Carbonel Earl Randall

Greetings

ART VAN DAMME and his Quintette



The Season's Best Wishes

to the Engineers JOE GALLICCHIO Director of Music NBC-Chicago



Best Wishes

DAVID LE WINTER and his Orchestra Pump Room Ambassador East Hotel Chicago



The Warmest Sort of Greeting from Chicago HARRY ELDERS "Curtain Time"





HOLLYWOOD

By JOHN T. BAXTER

Well, in the first place, I'm not Norm Dewes. No, I don't even lay any claim to being a writer. It's just that Ben Doty, our Hollywood Chapter Chairman, happened to find out I owned a typewriter. Anyway, when Norm Dewes found himself no longer able to conduct this little—uh—thing, I wound up with it.

Before I go any farther, I'd better explain to the reading public just where the inimitable Mr. Dewes has gone. It seems ABC used to have a show starring one Bing Crosby. It went to another network and so did its engineer, our Norman. ABC engineering will never be the same. For one thing, it's going to be a lot more sedate. No more pertinent penciled post-scripts on the bottom of vital memos—no more cigar butts getting ground into commercial, etc.—no more—h-m-m-m-mm. I'd better not go on. Someone at CBS might read this.

— At any rate, the ABC boys are going to miss him, as I know readers of the journal will. Norm was one of the real characters on the staff, along with being a good guy and a swell engineer. He is a rare combination of an excellent mixer and a thoroughly competent technician. Norm is one of those fellows who, somehow, *always* has the right answer for everything. To Norm, in all sincerity, we wish the very best. To CBS, someone *should* have warned you.

On Saturday, October first, ABC lost another valued member of the engineering department. Gaylord "Gene" Durham passed away at his home. He had been suffering for some time from a heart condition. For the past several months Gene had been assigned to the KECA-TV transmitter at Mt. Wilson, and had been living on the premises. Gene was for many years with KFSD in San Diego, then came to NBC Hollywood. Several years ago he joined the Studio-Field group at ABC where he was until his transfer to the TV transmitter. It was a profound and unexpected shock to those of us who knew Gene and had worked with him. He was

one of the "good guys" in the world, and the loss cannot help but be considered a personal one by all who knew him.

The hallowed halls of NBC are again ringing with the familiar sounds of the fall shows. The tape-bug has bitten many of the current big names in radio and NBC has developed its own Ampex-artists to take care of them. I'm told the overtime checks flow like water.

Received a note from Bob Finch in NBC recording which we'll pass on to you as is:

"Jake O'Kelley, well known ex-NBC NY and Hollywood engineer, and I latched on to a good fifteen day job this summer during my vacation period. We did a public address job at the California State Fair in Sacramento for the night shows. It was a very elaborate type show that was played on seven stages. We had twenty-two mikes out with the two of us mixing on a twenty-five position mixer. It was a lot of fun while it lasted, but after four days work we ran into an unhappy union situation with some of the stage hands. The Fair committee decided, to save any embarrassment, to pay us off with full pay for the fifteen days after only four days of work. Needless to say, it was fine and dandy with us. Jake went back to his mountain cabin in Camino, and I took the other two weeks of my vacation back to Colorado to go fishing with Russ Thompson of KOA transmitter. Jake is looking 'in the pink' and says that although he misses the radio game, the life of a 'normal' man has agreed with him. He is now considering a deal in managing a group of theatres up and down the coast.

"Incidentally, I visited some of the boys at KOA while I was in Denver, and they are all certainly TV conscious and have done a great job in building up a camera chain, etc. With such abundant interest now, when Denver doesn't even have a TV station on the air, shows what enthusiasm they will have when and if the mile high city starts shootin' ether pictures."

To Page 63



This is your toastmaster, Don McNeill and our fine Breakfast Club Sponsors saying "THANKS" to all the ABC Station Engineers for catching our cues. 'Be Good to Yourself' during the coming year.

DON McNEILL BREAKFAST CLUB

Morton Downey

CARMEN MASTREN



MUSICAL DIRECTOR

Songs by Morton Downey

COCA COLA—Tues., Thurs., Sat., NBC Network
11-11:15 P. M.

Roberta Quinlan



MOHAWK SHOWROOM

MON. - WED. - FRI.



Best Wishes

Bob Stanton

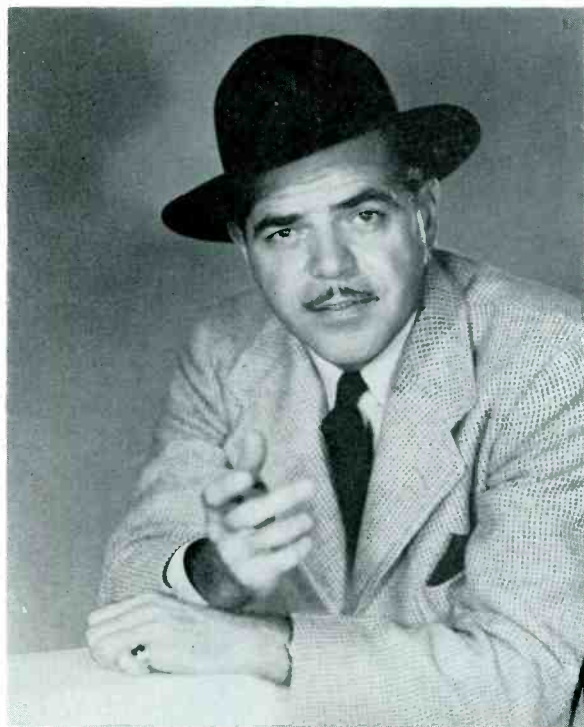

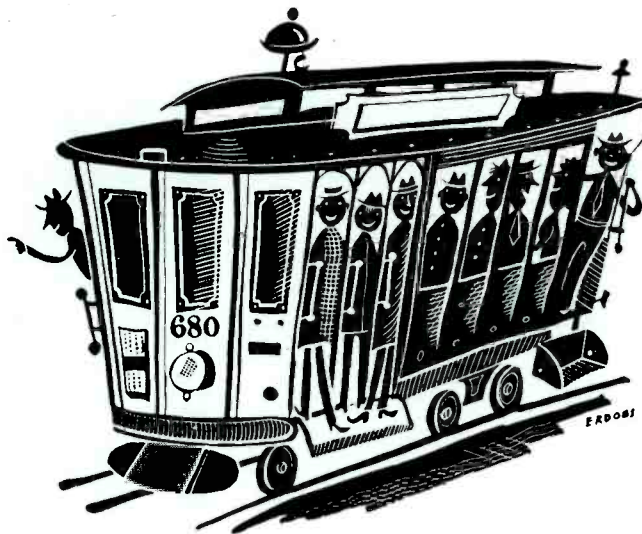

Season's Greetings
to Our
Broadcast Engineers
and
Technicians
KNBC

The Station of Northern California



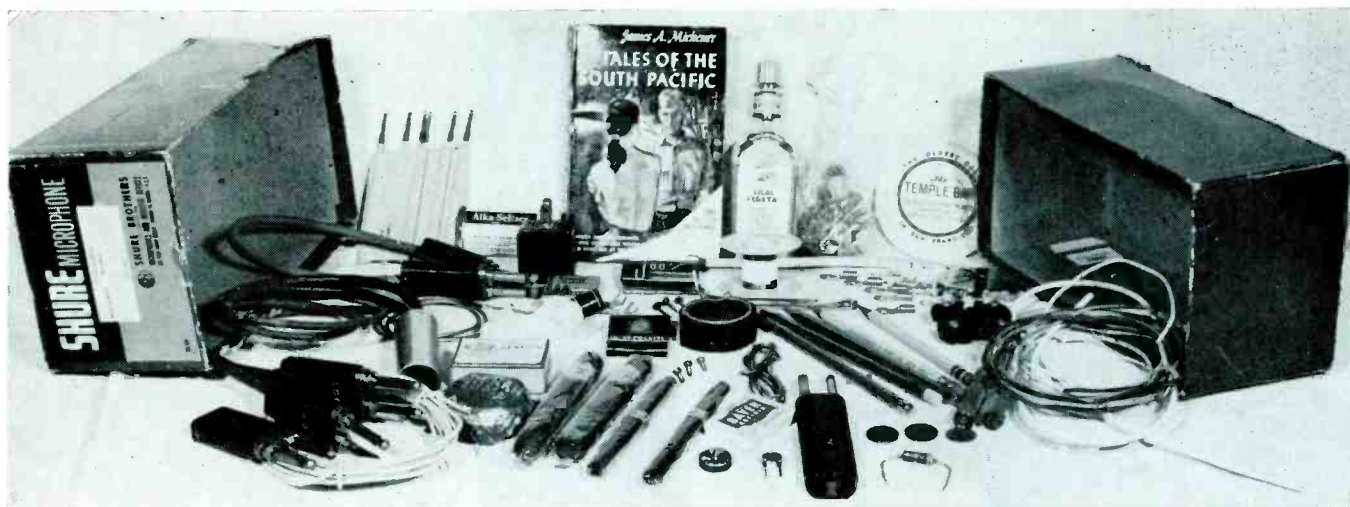

"REMOTE KIT" — SALUTE TO NORMAN DEWES

Seems good to hear about Jake, second hand though it is. Why don't you come down and see us some time, Jake?

Biggest news from NABET on the west coast is, of course, the opening of ABC's huge new TV Center. Of the seven TV stations on the air in Los Angeles, KECA-TV has easily the largest, finest, and best equipped studios and location. Their opening night show on September sixteenth was one of the real highlights of the TV year in Los Angeles, and the NABET boys behind the scenes contributed not a little to its all 'round excellence.

The engineering department at TV Center has started its existence with a pretty good sized staff. Some are old faces, transferred from the AM departments, but the majority are new men. The roster of TV men now stands as follows:

Studios—new

John DeMos	Richard Loeb	Charles Colman
Arch Griffin	Irwin Stanton	James Morris
Alan Hess	Alex Quiroga	Dave Atkins
Harold Huntzman	A. T. Hurley	Robert King
Alfred Kallman	Ernest Thornton	Charles Turner
Frank Kennedy	A. M. Jarvis	Richard Stevens

Studios—old

Tom Ashton
Marvin Headrick
Al Hayward
Donald McCroskey
Bill Williams

Transmitter—new

Earl Faris

Transmitter—old

Bob McGaughey
Guy Glenn
Paul Miller
Kent Young

Twenty-eight men. That's not bad for such a youngster.

That seems to wind up column No. One for yours truly. Christmas Carols will soon be ringing clear and Auld Lang Syne will not be too far away. Sooooo, Hollywood sends "Merry Christmas and Happy New Year" to NABET members from Coast to Coast. As Norm used to say, BCNU.

COLOR TV TECHNICAL DATA

From Page 38

several setups available to illustrate and to demonstrate what may be done.

We have described an embodiment of this RCA color television system which we will demonstrate in Washington at the time of the hearing. The studio equipment will be installed in the NBC station (WNBW) at the Wardman Park Hotel. The system operates within the framework of the present standards and is consistent with the "Standards of Good Engineering Practice. Concerning Television Broadcast Stations." The transmitted signal contains sufficient information within the six-megacycle channel to enable a color receiver of the type shown in Figure 4 to display a color picture of high definition. At the transmitter, time multiplex sampling has been used together with bypassed mixed highs. In the receiver shown in Figure 4, the total signal consisting of the sampled signal plus the mixed highs has been inserted in the receiver sampler and picture-dot interlacing has been used to achieve high definition. Other arrangements of the receiver are possible, one of which is currently under investigation at RCA Laboratories. The result of this investigation will be presented at the time of the hearing. In this alternate receiver, the entire signal is fed into the sampler as before. However, in this case, low-pass filters with cut-off frequencies of approximately two megacycles are inserted between the sampler and the kinescopes. The low-frequency filters smooth out the pulses of Figure 5(c) so that the adjacent light spots of a single color in one line scan now almost completely overlap. Because the pulses have been broadened by the 2-megacycle filters in this receiver, horizontal resolution will not be increased by picture-dot interlacing at the receiver. Full resolution, however, is restored by obtaining mixed highs from the signal ahead of the receiver sampler and bypassing the mixed highs through a bandpass filter to the green, red, and blue kinescopes.

The color television receiver of Figure 4 and the alternate

To Page 68



RAY HENLE
FELIX MORLEY
NED BROOKS
FRED MORRISON
FRANK HANIGHEN

Best Wishes to a Fine Bunch of Fellows
the Editors of

SUNOCO 3-STAR EXTRA

HI MEN!

Thanks Again

JIM GIBBONS

ABC—WMAL
Washington
(3469)



Compliments of

General Electric Supply Corporation

Distributors of

Nationally Known Electric Supplies

Amateur Equipment

Laboratory Equipment

705 EDGEWOOD STREET, N. E.

Hudson 6800

Greetings from

E. H. RIETZKE and the C. R. E. I. STAFF

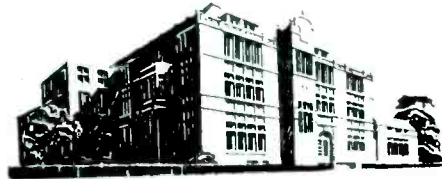

Capitol Radio Engineering Institute

an accredited Technical Institute

16th STREET and PARK ROAD, N. W.

Washington 10, D. C.

New York (7)

170 Broadway

San Francisco (2)

760 Market Street

*Season's
Greetings*

To a Bunch of Good
Sports

**STEVE
DOUGLAS**

NBC SPORTS
AM - FM - TV



WARDMAN PARK

hotel

CONNECTICUT AVENUE AT WOODLEY
ROAD, WASHINGTON, D. C.

*One of America's
Great Hotels*

AND HOME OF TV STATION

WNBW

NBC TELEVISION



*"That's all from
Washington at
this time."*

EARL GODWIN

THANKS TO THE BOYS

From

Morgan Beatty



"NEWS OF THE WORLD"

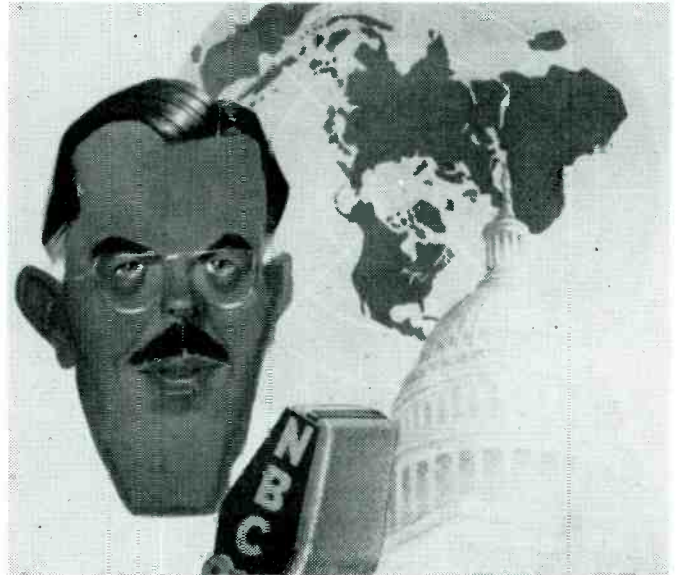

Thanks very much

— From —

BAUKAGE



Greetings and Best Wishes to The Engineers

ARTHUR J. "DUTCH" BERGMAN



ROBERT McCORMICK "that's all from Washington"

CAPITOL RADIO WHOLESALERS

2120-22 14th St., N. W.
Washington 9, D. C.
Hobart 0800

the Capital's oldest Parts Distributer.



In behalf of students and graduates of the National Radio Institute, and the N. R. I. Staff, I extend most cordial Season's Greetings to the N. A. B. E. T.

J. E. Smith
President

NATIONAL RADIO INSTITUTE, WASHINGTON, D. C.

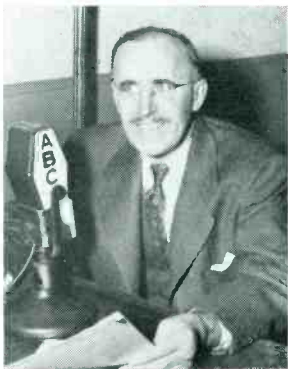

*Best Wishes to
All the Boys*

**ALBERT L.
WARNER**

WMAL - WASHINGTON

Thanks, Aggain . . .



RICHARD HARKNESS

NBC — WASHINGTON

KENYON RADIO SUPPLY CO.

Distributors

Electronic and Television Components

2020 14th STREET, N. W.

Washington 9, D. C.

Columbia 3161



ST. LAWRENCE

By ALEN A. CORBIN

Despite the fact that two whole big months have gone by in which silence has prevailed, *The Broadcast Engineers' Journal*-ly speaking, from this corner, there still seems to be a great big dearth of "news."

There are a few vital statistics, however, as follows: The George Gebhards welcomed their third child, a seven and one-half pound boy, named *David* George. This makes two boys to one girl for the Gebhards. I asked George prior to the event if, since he already had as much of a variety as is possible, he had any preference. To which question George immediately responded that he wanted a boy as he and Johnnie were no match for Helen and Gail. They needed another male to even hold their own in any dispute. Be it duly recorded that the Gebhard males have a new sparring partner.

A week later our production manager's population quote was two-thirds filled when the Mrs. gave birth to their second child, first boy. The stork beat the schedule by six weeks, but despite the fact that the boy was a lightweight of four pounds, he is doing nicely. Our production manager is a nice young man named *David* Graves. Being Dave's first-born son, it follows that the young Mr. Graves was subsequently named *Jeremy* Thoma.

The Mike Yonkovigs were breathlessly happy to report that they have purchased a home of their own here in town. These glad tidings were followed by some not so nice ones when Mike took off for his home town of Shamokin, Pennsylvania, to see his Dad who is ailing.

Bee Jay (B. J.) Gillespie and her husband, lousy capitalists, last month purchased a 1947 Buick roadmaster convertible. Betty had a week's vacation in October, but she stayed home and rested. Working in radio fifty weeks a year is enough to force anyone to take a rest. The need was augmented by the caperings of three year old Tommy G.

Dave Lane, our chapter chairman, took his wife, Frances, along on his trip to the National Convention in New York, and they stayed a few days extra in the Big City to see the sights. They came home only so Dave could take his two weeks' vacation, which is still in process. Like most land-owners, though, at least half of his time is spent repairing the house, etc.

Gail Pfister's husband moved up to Canton and St. Lawrence U. this fall and took Gail with him. And thus another female member of our engineering staff has left us for good. Stan Ivill has come down from Massena. Incidentally, Stan tells me that the reason he went to WMSA in the first place was that he wanted to get into NABET. He could have

gone to several other stations that were offering more wages. That's the kind of members we need.

I understand Caroline Ryan McDonald is living a mad social life in Syracuse. She and Jim have bought new furniture and completely furnished their own apartment. What with the new people they have met at the University, besides Caroline's old cronies, and the wives of the other members of the staff of WSYR, they are not at all lonely. That has turned into a good deal for Jim. He has a couple of talent shows, and he even feeds network at least once a week.

John Wicks will have some relief from just running the FM control board now. John took a try for his license a few weeks back, and the boy MADE THE GRADE.

Pappy Davis has been home to Auburn the past week and just got home. He did some light hunting and got ten squirrels (sob!). He saw a fox and a deer, but he didn't have the right gun with him (a fine excuse, eh?).

The Glenn Halls are now on one of their frequent trips to Penn Yan to see Glenn's people. They also took a short trip to New York City earlier this year for a wedding in the family of Mrs. Hall.

In a couple of weeks I shall be off to New York myself to see some plays. One I don't have to worry about is "South Pacific," since I saw this in April after it first opened, (I knew I could think of something to make you drool with envy).

I hear Willie Walck is thinking of buying a television set this winter. In order to receive in this town, or in Black River, where Bill lives (I use the term loosely), he'll have to have an aerial that will make the Empire State look like a one-story shanty.

—Alen A. Corbin.

COLOR TV TECHNICAL DATA

From Page 63

receiver just described are but two examples of many possible designs and indicate the flexibility afforded a receiver designer. For the color transmitter the same flexibility of circuit arrangement is possible. For both receivers and transmitters this flexibility exists within the framework of the current television standards.

Very truly yours,
 RADIO CORPORATION OF AMERICA
 /s/ E. W. ENGSTROM
 Vice President in Charge of Research
 RCA Laboratories Division.

COLOR TV SYSTEM

From Page 53

representing each color goes to a tube in the receiver which reproduces a picture in that particular color. The three separate colors are then viewed simultaneously as a single, complete color picture.

The RCA all-electronic color television system retains all of the black-and-white picture characteristics, such as the number of lines and fields per second, and to these adds color. The picture detail, smoothness of motion and other characteristics are the same as for black-and-white. It is as high in definition as black-and-white. This is fundamental, Dr. Engstrom said, for to accomplish less would be to reduce color television to something secondary to the present black-and-white television system, and hence of uncertain lasting utility.



WASHINGTON CHAPTER NABET

WOIC
WMAL - AM - FM - TV
WOL - AM - FM
WNBW
WRC - FM - AM

"Everything In Electronics"

Electronic wholesalers, inc.

2010 - 14th STREET, N. W.

WASHINGTON 9, D. C.

Hudson 5200



Greetings from

"E I D

In Washington"

Training films
Outstanding commercials
Production facilities
Sound and script.

Immediate Service
News coverage
in 16mm film

WASHINGTON
VIDEO
PRODUCTIONS,
INC.

900 19th Street N. W.
Washington 6, D. C.

SEASON'S

**C
H
A
R
L
I
E**

WMAL
ABC



GREETINGS

**E
D
W
A
R
D
S**

WMAL - TV
WASHINGTON

To the Engineers:

We appreciate your whole-hearted acceptance of the world's finest tape recorder - the **AMPEX**

New York

**CHARLES E. RYND
RUSSELL O. HUDSON
W. O. SUMMERLIN**

Hollywood

**JACK MULLIN
MURDO MacKENZIE
FRANK HEALY**

AUDIO & VIDEO PRODUCTS CORP.

1650 BROADWAY
New York 9, New York

8324 FONTAIN AVE.
Los Angeles 46, Calif.

WITH EVERY GOOD WISH

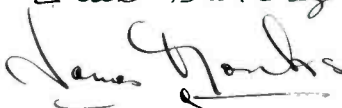
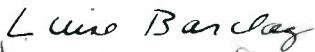
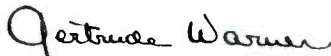
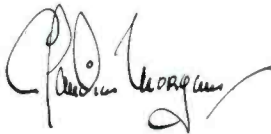

THE RIGHT TO HAPPINESS



... WINS, In the U. N. ...

Greetings YESTERDAY (Oct. 27, 1949) ...

KENNETH BANGHART ...

NBC NEWSROOM ...



Greetings

THANKS BOYS

Perry Como



Greetings



MITCHELL AYRES

Merry Christmas Fellows



The Fontaine Sisters

MARGIE - BEA - GERI

Vertical text on the right side of the Mitchell Ayres portrait, likely a photo credit or name, which is difficult to read due to its small size and orientation.





—Specializing in—

ELECTRONIC SUPPLIES

for the

BROADCASTERS

INDUSTRIALS

AMATEURS

Complete Stock of All Major Lines

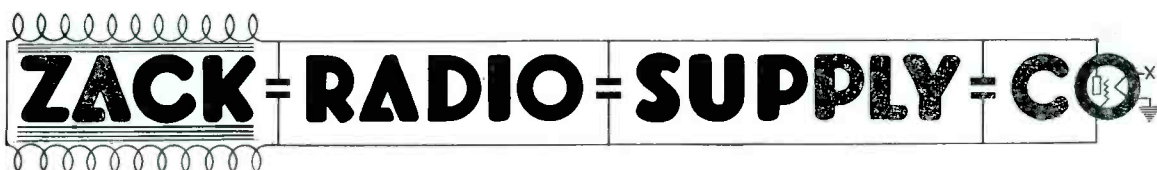

1426 Market St., San Francisco

225 Hamilton Ave., Palo Alto

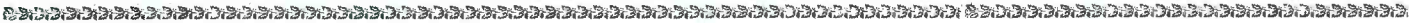

MARINA CLUB

GUY CASSIDY

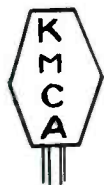

JACK KING

"and, you all know Cassidy"

Greetings

Ruth Andersen

News

"Barbabra Lee"

Disc Jockette

Bob Letts

NBC - KNBC

"California

Commentary"



SIX SALVOS FROM THE KGO-TV

PROGRAM DEPARTMENT

San Francisco

Bill Hollenbeck

Jeanne Le Feure

Allan Shaw

Dave Crandell

Nancy MacDuff

Ed. Smith

Season's Greetings

To The Engineers

from

"Jolly Bill"

Steinke

KNBC - S.F.





WASHINGTON

By W. D. DEEM

The Washington Chapter was honored with the presence of our National Executive Secretary, *Mr. Westover* and President of the CWA, *Mr. J. A. Beirne*. Mr. Westover was introduced by the local chapter chairman, Paul Anderson, and spoke on the subject of affiliation. He started out by explaining the reason for "all this literature on affiliation." He explained that other unions wanted to affiliate and work beside us and to help us operate some of our equipment, while CWA, if we affiliated with them would let us run our own show. At this point he introduced Mr. Beirne, an excellent speaker, and a master in the art of holding the audience's attention. Mr. Beirne told CWA's side of the merger. He told us that he was aware of the fact that we were a small union and that financial gain was a minor issue. CWA would gain in prestige as a major factor and this was taken as a compliment to NABET.

CWA is willing to help us establish and International Charter at any time we feel that we are strong enough numerically and financially, he explained. At the conclusion of his address Mr. Beirne was ready to answer any questions in the minds of the NABET members present.

The attitude of the NABET members was cautious. They held back on the issue until they had obtained all the facts available—seems to be a natural tendency born into a radio engineer not to take anything for granted, but first to test things and fully acquaint himself with all the facts. So it was with the members of NABET and it showed up in the questions that were asked.

Sam Newman, WNBW Xmtr. Asst. Station Engineer, led in the questioning. Sam first asked what would be the fate of NABET if we should remain independent. Mr. Beirne replied that the pressure of stronger unions would increase with each added station and that the way it is now we are fighting a losing battle.

Dave Zarin of WOIC asked some well put questions as did several other engineers present.

Mr. Beirne concluded by summarizing the benefits he believes both NABET and CWA would get out of the merger. He said that NABET would have stronger bargaining power, assistance for expanding, plus the organizing, publicity, educational and research facilities of CWA. CWA would get, besides the meager 50c per member in NABET as Nat'l Dues, prestige in having as part of their union highly trained men. This concluded the regular meeting which left nothing to do except to get underway on the sandwiches and beer which we proceeded to do.

* * *

The Zoomar boys from Chicago, *John Casagrande*, Camera-man, and *Bob Rahnert*, Video Engineer, were in Washington the second week in October. They were here to do the *Kukla, Fran and Ollie* show while the RCA color demonstrations were going on. On Monday night, October 10, *Bob* and *Cass* were setting up the show in the Wardman Park Studios. *Bob* had the tape measure out measuring off the distance from the stage setting to the zoomar camera and *Cass* had his light meter and was busy adjusting lights, everything was in order. The color tests had concluded and *Kukla, Fran and Ollie* was ready to go on the air. About five minutes before air time something happened, don't know exactly what, but when the show actually got under way the color cameras were in the exact positions that six minutes before the Chicago black and white cameras had been. *Cass* and *Bob* just stood by and watched that show. They did a wonderful job on the remaining four shows out of Washington and went back to Chicago having shown the Washington crew some good camera and video work.

* * *

On the RCA color demonstrations *Dodd Boyd* did some double duty. Capsule skits were being done over and over and all were being carried on one color camera. This method of demonstration was due to the small number of people that were able to crowd into the control room and studios at one time and it was felt that the jam could be handled by using only one camera. *Dodd* really earned his overtime as did all the WNBW crew on that assignment.

Johnny Rogers and *Mac McClelland* also had some new experiences with the color demonstrations. All of the equipment was new, but they didn't let that faze them and handled the new color control units and monitors like they had been operating them for years.

Leon Chromak collected and assembled material for a preliminary instruction book for the new equipment. Leon has a flare for this type of work and presented a very nice set of explanations and alignment instructions for the book.

Jim Deaver and Co. up in Master Control had some weird patches to make in order to distribute the various color and black and white shows that cropped up that week.

* * *

During one of the capsule shows for color, I was operating the color camera, and *Smokey Stover* was handling the lights and cables. During a lull in the show while we were on slide, *Smokey* motioned to one of the visiting spectators and mumbled to me that he was the President of the radio school in Kansas from which *Smokey* graduated prior to coming to WNBW. I said "Well, why don't you say 'hello' to him." He replied, "Gee, I don't want him to think that I went all through his school just to learn how to carry camera cable."

Changes in Personnel in Washington—Dorson Ullman,

To Page 78



WATCH YOUR
LEVELS!
also
Season's Greetings
ZEKE
MANNERS

SAM HAYES

Wishes you a

*Merry
Decibel*



TERRY
O'SULLIVAN

Wishes you a

HAPPY
NEMO

Greetings from

Wishbone Hollow, Calif.

CYCLONE MALONE,
Sheriff

Sponsored on KNBH Hollywood

BY
CURRIES

Ice Cream - Candy - Bakery



"HERE'S THAT BAND AGAIN"

with

OUR SINCEREST THANKS

DICK JURGENS





ABC

NBC

WAIT

UNIVERSAL RECORDING

C.H.I.C.A.G.O
CHAPTER NABET

George Maher, *Chairman*

George W. Smith, *Secretary-Treasurer*

Fred C. Shidel, *Treasurer*

RCA RECORDING

WGRC

WOWO

WROK

Holiday Greetings



MARCH
OF
DIMES
APPEAL

Fellow Members:—

The annual March of Dimes campaign to raise funds to fight Infantile Paralysis is now under way. The period from Dec. 15, 1949, to January 31, 1950, has been designated as the time for the drive.

The National Association of Broadcast Engineers and Technicians would like to inform its members that the National Foundation for Infantile Paralysis has a Labor Division that sees to it that union members and their families are given the best medical care and financial assistance whenever and wherever needed. Regardless of race, creed or color, this service is available without any embarrassment to all members of organized labor.

Although unions have reason to be proud of last year's contributions from organized labor, they must double and treble their efforts this year. Individually and collectively, as union members, we have a responsibility to our communities in this fight.

After all contributions have been collected by the Chairman or his appointee, please send to NABET, 421 Seventh Ave., Room 1002, New York 1, N. Y., your check or money order made payable to the National Foundation for Infantile Paralysis. Please do not issue the checks in the name of our organization. Remember that 50% of all money collected goes to the Foundation's Chapter in your community, while the remaining 50% is returned to the National Foundation for Infantile Paralysis to be used for research. Please indicate in each return, that the checks or money orders are for the March of Dimes.

A successful campaign in our union will enable the Foundation to continue to bring help to the helpless, hope to the hopeless, and dignity to the crushed in spirit. Again, thank you for your kind cooperation.

Sincerely,

C. WESTOVER.

NANCY CRAIG

ABC — New York

YORK BAR & RESTAURANT, Inc.

Sixth Ave. Opp. Radio City

New York



Christmas Greetings

Martin Block



HERB SHELDON

Merry Yuletide

from

JACK COSTELLO

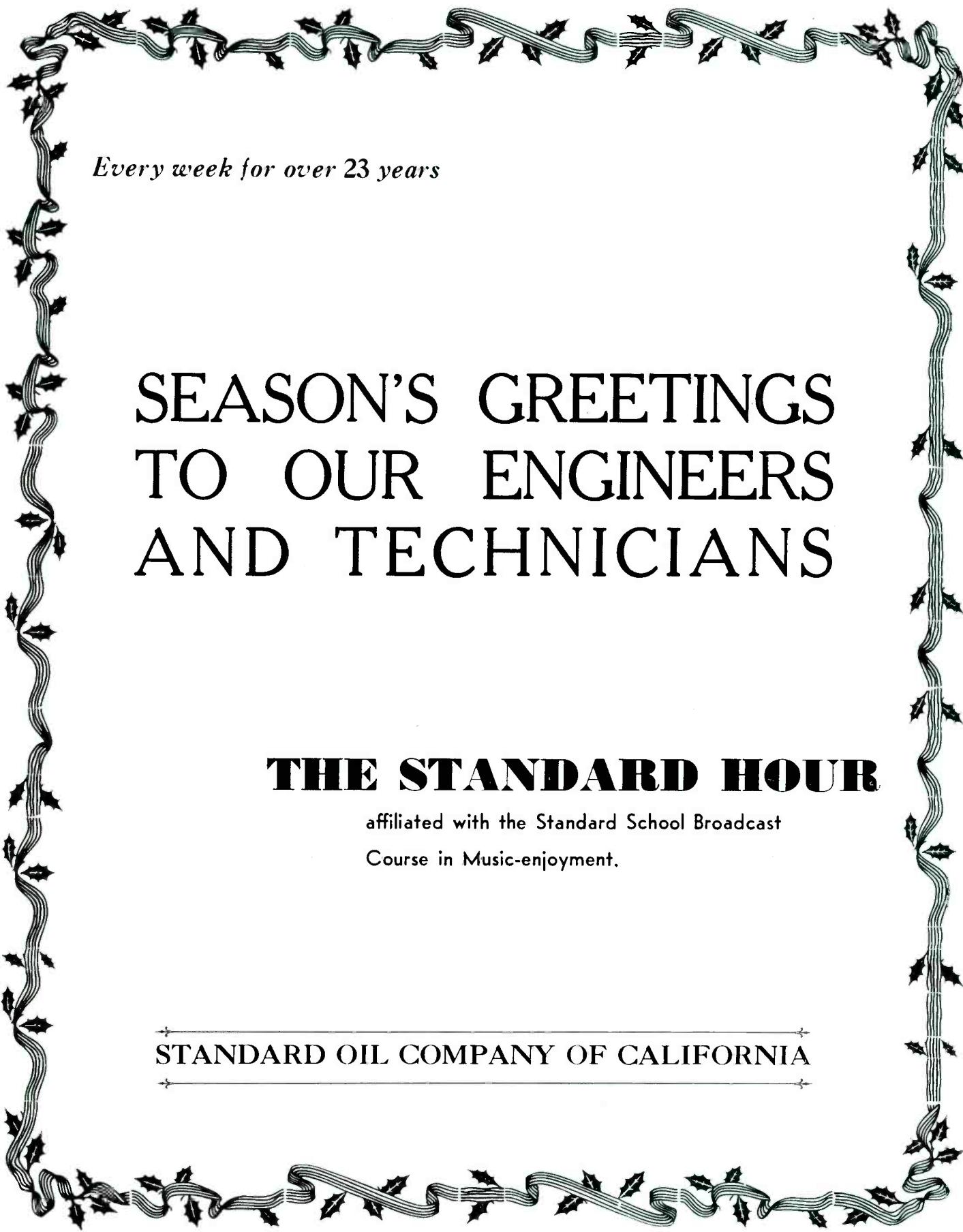

Every week for over 23 years

SEASON'S GREETINGS TO OUR ENGINEERS AND TECHNICIANS

THE STANDARD HOUR

affiliated with the Standard School Broadcast
Course in Music-enjoyment.

—→
STANDARD OIL COMPANY OF CALIFORNIA
←—



NEW YORK—By Bob Zweck

There's a saying to the effect that "Self praise smacks of conceit." There's another one reminding that: "You've got to blow your own horn once in awhile." Considering these, and other, advices from the "masters," I say that now is as good a time as any to sing out the praises of the Engineers. . . . Be he (and she) in studio operations, recording, or master control; be he in Radio City or out in the middle of "God's country" working a 250 watter; be he an old supervisor or just the new green apprentice, he deserves a vote of thanks from the industry and from the radio-listening, and TV viewing, public he serves so well. . . . True, indeed, that not every man has been a Marconi or an Armstrong, nor has each one of us had the opportunity to hold two leads together in an oil filled barrel so that "the show might go on," but I'll bet there are a helluva lot of you who can remember getting up at 3:15 A.M. to get the station on at 5:30. And, particularly at the smaller stations, I'll bet we can roundup a few who, in addition to their other CHORES, have had a broom shoved in their HANDS. These things we take as part of the job. We like our work. Most of us take pride in the part we play in turning out a good show. BUT—a slap on the back, a smile or word of appreciation for our efforts certainly would not cost too much—and not to mistake us for part of "the equipment" would certainly be rich in dividends.

Radio-TV is big, and growing every year. The part the engineer-technician plays will keep pace. The demands put to engineering will, as in the past, be met; and be met with room to spare.

In keeping with the holiday season, may I, together with the Journal staff, wish our readers, advertisers, and the whole doggone industry a very Merry Xmas and a Happy, Prosperous New Year.

DO WE HAVE YOUR ZONE NUMBER?

WASHINGTON—From Page 73

Video Engineer of WNBW has left NBC for a position elsewhere—sorry to see you leave Dorson. *Bill Wells* has transferred from film and master control to field and studio at WNBW. *Mr. Haines* has transferred from the Chicago TV studios to WNBW. *Joe Donahoe* has changed over from the programing to the engineering department here at NBC, and *Joe Kriss* has transferred from WRC to WNBW. I understand that *Mac McCollom* and *Joe Williams* both of WRC are coming out to WNBW in the near future, and *Bill Cornell* formerly of WOL is now at WRC.

In closing I and the Washington Chapter want to wish all of you in the Nat'l. Office and in the Chapters all over the U. S. a Merry Christmas and a prosperous New Year.

DEADLINE is 2nd OF EVERY MONTH. EXAMPLE: COPY RECEIVED MARCH 2nd APPEARS IN THE APRIL ISSUE, IN THE MAIL APRIL 1st.

SUBSCRIPTION BLANK

THE BROADCAST ENGINEERS' JOURNAL
116-03 91st Avenue, Richmond Hill 18, N. Y.

Gentlemen: Please enter my subscription to The Broadcast Engineers' Journal to start with the next issue.

Name..... (Station.....)

Address

City, P. O. Zone, State.....

Check attached for \$2.50, 1 year; \$4.00, 2 years.

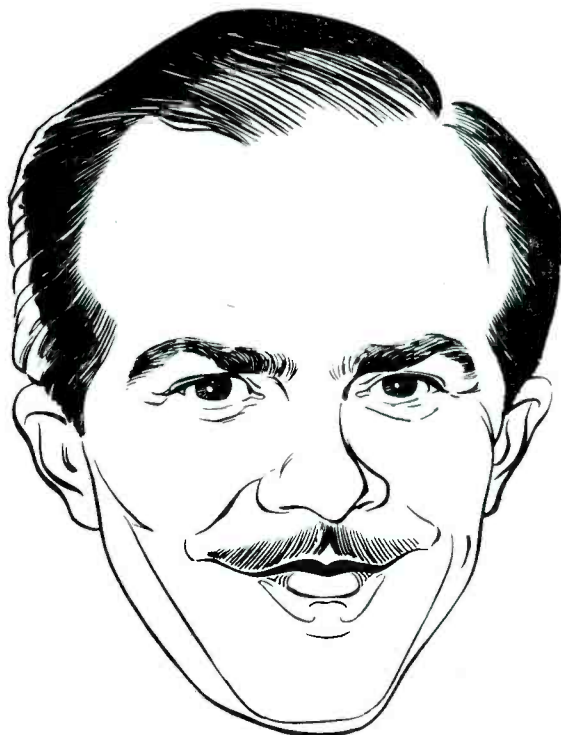

Holiday Greetings

from

BILL HERSON

to the

WASHINGTON NABET GANG

with a special nod to "HORTON THE HORRIFIC!!"

LABOR - MANAGEMENT NEWS

Probably a great many persons over the country smiled when they saw a wired AP photo of an old woman holding a sheaf of currency and saying, "I don't trust no banks." She had pinned all her money to her clothing for safe keeping.

There is something worth noting about that picture. It is the fact that it takes a long, long time for all of the people to get to understand any one thing, no matter how simple.

The old woman had a little over \$2,000 in bills. It has been a long time now since the New Deal enacted the program of Bank Deposit Insurance, covering deposits up to \$5,000.

No matter what might have happened to the bank, the old woman's money would have been guarded for her and paid to her by Uncle Sam.

The money had been put in one of the most dangerous of all places, while the safest of all places was ignored.

* * *

Today the post office is a completely safe place for any amount deposited therein. Banks are safe for any amount up to the limit of insurance.

There are some things that government does for us—some things that had not been done and would not be done by private business or industry.

It is good that we strive to keep in private hands all that can be done in that way. But government, taking a new look at the country when FDR came into office, found that a great many things could be done by the government and should be so done.

The letters FDIC now stare us in the face at the tellers' windows in almost all our banks. They mean Federal Deposit Insurance Corporation—which means Uncle Sam.

Similarly, the Home Owners Loan Corporation saved many a home during the dark months of the great depression—and it liquidated at a profit. Farms were saved in like manner.

The good of people became the goal of the government and wonderful days came to many who were looking doom in the face.

* * *

Today there is widespread effort to condemn some proposals under the general term, "welfare state," or "statism," on the general theory that you can kill an idea with an adjective if you use it often enough and with sneer enough in the voice.

The Truman compulsory health insurance bill comes under that heading.

Now I think it remains to be seen, after much more study, whether the bill as it stands, is the right proposal.

But I do know that somehow the sick and the injured must be cared for—and too many of them are simply unable to care for themselves.

The American Medical Association has used the term "socialized medicine" as a condemning adjective phrase. But, of course, the bill does not propose socialized medicine at all. Gradually doctors, getting wise to themselves, are dropping the phrase as a means of fighting what a great many of them do not want to fight at all.

Wouldn't it be much better and wiser to deal with the matter on its merits?

* * *

Going back to the beginning and repeating, it takes a long time for all of the people to grasp and understand even a simple idea.

A lot of people do not yet know why the union ship is a sound idea and one that works better than any other.

It takes a long, long time.

So little do so many understand that some of our states have laws against the closed union shop. As a general rule we go forward, but in some things we go backward.

So, let's not laugh too much at the simple old soul who pinned her money to her clothing.

Some otherwise very bright minds are pinning their economic ideas to their clothing.

Here's an example: An American will discuss and argue about democracy. But a communist will not argue about communism. It's a matter of take it and like it. He will berate democracy, but he will admit nothing wrong about communism, the most despotic proposal ever offered seriously to humankind.

It is a very interesting and often confusing world.—CMW.

SUPREME COURT RULES ON VETERANS

A recent decision of the United States Supreme Court on seniority rights of veterans is of paramount importance to all former servicemen who returned to their former jobs in civil life, according to William S. Tyson, Solicitor of the United States Department of Labor.

In commenting on the decision (*Aeronautical Industrial Lodge v. Campbell*, June 20, 1949), Tyson said that:

During the past 2 or 3 years increasing importance has attached to the problem: To what extent are veterans re-employed in accordance with the Selective Training and Service Act of 1940 and related statutes subject to nondiscriminatory changes in collective bargaining agreements? One parallel question—To what extent are veterans protected by the statute against discrimination?—becomes increasingly significant if and when unemployment mounts rapidly.

The Supreme Court's decision in the above case sheds a good deal of light on these and similar issues. The Court decided that the statutes do not necessarily invalidate a provision of a collective bargaining agreement adopted during a veteran's absence in military service because it reduces the veteran's seniority. The new provision accorded top seniority to union chairmen in layoffs. The veteran sued for loss of wages due to a layoff within the year following his reinstatement, while union chairmen with less length of service were continued at work because of their top seniority. The Supreme Court ruled that the reemployment statutes do restrict readjustments of seniority rights to the disadvantage of the veteran during his absence. However, the change here was held not to violate the statutes because the new provision was reasonable and customary, it did not discriminate in effect against veterans as such, and it was not adopted as a "skilled device of hostility to veterans."

Position Changes

The decision indicates that the veteran's position, including seniority, status, pay, and other features, may be changed for the worse during military service if the change results from action both nondiscriminatory and in good faith. An

agreement is nondiscriminatory if it does not by language or effect single out veterans for adverse treatment because of their absence in military service. Discrimination may exist where veterans are the only, or the vast majority of, persons hurt by a change in rules, or where the harmful effects are far greater for veterans than for others.

Benefits Strengthened

The Campbell decision also strengthens the veteran's right to count military service toward tenure of employment to obtain any benefits (such as vacation pay or pensions) dependent on length of employment. If, as the Court said, the statutory clause "considered on furlough or leave of absence" guarantees the veteran participation in advantages created during his absence and protects him against discrimination because of his absence, it seems clear that the clause goes beyond merely guaranteeing the veteran the same treatment as other employees on furlough. That is, he is to accrue advantages during his absence, regardless of the fact that contract or custom might prevent other employees on leave from accumulating seniority or vacation benefits.

Not Favored

By its remark that the veteran "is not favored as a furloughed employee as against his fellows," the Court pointed out that the veteran is not insulated against a downward movement of the economic escalator, and that he cannot pass his fellow passengers who remain on the escalator and on the job. Accumulation of vacation rights during the veteran's absence is not affected by these last two limitations. These views are further supported by the Court's later observation that the veteran's "rights, including seniority, as an employee on furlough (were) defined by the agreement of 1945 inasmuch as that agreement in no wise disadvantaged his position because he was in the military service."

On the question of lawfulness of changes in seniority, the Supreme Court said that Congress, in requiring the veteran to be reinstated in his position "without loss of seniority," neither defined seniority nor created a seniority system, but recognized existing seniority systems. The Court recognized that seniority, in principle, reflects the relative dates of employment by the employer.

Sickness, Disability Laws Passed In Two More States

The problem of providing for loss of income because of non-work-connected sickness or injury has received considerable attention in the States meeting in legislative session this year. Fifteen of the States and Alaska considered bills to provide benefits for such disability, and in two, New York and Washington, the bills became law. This makes a total of five States providing such benefits—Rhode Island enacting its law in 1942, California in 1946, and New Jersey in 1948.

New York provides weekly benefits, based on wages received, ranging from \$10 to \$26 for a maximum of 13 weeks in any one year. The Washington act provides benefits of \$10 to \$25 for a maximum of 26 weeks. The Washington plan will be financed by a tax of 1 percent on an employee's wages up to \$3,000 a year. In New York distinction is made between persons who are disabled while working and those disabled during a period of unemployment. For the former the fund is financed by employee contributions of one-half of 1 percent of wages received, but not more than 30 cents a week. The employer pays the additional cost.

To provide benefits for workers disabled while unemployed, a special contribution of one-tenth of 1 percent of wages re-

ceived, with a limit of 6 cents a week, is required of employees up to June 30, 1950. An equal amount is paid by employers. After June 30, 1950, however, such benefits will be financed by an annual assessment on all insurance carriers in the amount required to maintain adequate reserves.

Both State laws provide for a waiting period of 1 week for each disability, and both provide for payment of benefits for part weeks of disability.

Private plans for such sickness and disability insurance are permitted in both States, subject to approval of the administrator of the act, if such plans provide for the payment of benefits at least as favorable as the disability benefits under the State plans, and, in Washington, if they meet certain other specified standards.

Washington is coordinating the program with the unemployment insurance administration while New York has put the law's administration under the workmen's compensation board.

Union and Employer Liable To Worker Illegally Fired

The National Labor Relations Board unanimously ruled that an employer and a union each may be liable for the full amount of wages lost by an employee who is laid off illegally by the employer at the insistence of the union. However, the Board made it clear that it will collect for the employee only the total amount of wages actually lost.

Following somewhat the pattern long followed by the courts in cases where two or more individuals are found to be jointly liable for damages in tort cases, the Board holds the union and the employer "jointly and severally" liable for the employee's loss of wages. This enables the Board—in case either the employer or the union is unable to pay—to collect the entire amount from the party which is able to pay.

It was the first decision by the Board in a contested case on the provision of the Taft-Hartley Act which makes a union, as well as an employer, liable for back pay in certain cases of illegal discrimination against employees. The National Labor Relations Act, which the present law amended, made only employers liable to back-pay orders.

Ordered Reimbursement

In its decision the Board ordered a New York truck operator and a local of the AFL Teamsters Union "jointly and severally" to reimburse an employee for the loss of wages he suffered when he was laid off because he was in arrears on his union dues. The employer laid off the employee after two other employees, who were union members in good standing, struck at direction of the union. The Board held the lay-off constituted illegal discrimination in violation of the act because the employer and the union had no valid union-shop agreement.

The Board in making its first interpretation of the amended section 10 (c), which authorizes it to require repayment of back wages from both unions and employers, made two other significant rulings:

1. "When it finds both an employer and a union guilty of discrimination against an employee and orders back pay, the Board will not attempt to apportion the amount that each owes.

2. "The act makes no distinction between primary and secondary responsibility for discriminatory treatment of an employee."

GREETINGS FROM--

Lee Dayton	Jackson Weaver
Hal Stepler	Ted Dunlap
Charlie Edwards	Baxter Ward
Dean Luce	Frank Harden
Jack Henry	Paul Riviere

ANNOUNCING STAFF

WMAL - AM - FM - TV

ABC WASHINGTON

A Successful Year

ROCKY MOUNTAIN CHAPTER NABET

KOA

Denver

KFKA

Greeley



HOLIDAY GREETINGS
To All NABET Members

including

R. E. T. S. Graduates Who
Are Members Employed
In the Field

RADIO ELECTRONIC TELEVISION SCHOOLS

3730 Woodward Ave., Detroit 1, Michigan
"Training Electronic Specialists Since 1935"

DING HO



105 W. 49 St., New York

Circle 7-6250

Commission establishes grace period and makes other changes in commercial operator and amateur station and operator license renewal requirements.

The Commission, on August 18, 1949, adopted an Order amending Parts 12 and 13 of its Rules Governing Amateur Radio Service and Commercial Radio Operators respectively. These amendments became effective September 1, 1949, except that during the period ending with September 30, 1949, the presently existing three months service requirement instead of the newly adopted one year service requirement will continue to apply to certain unexpired commercial operator licenses.

Under the amendments, the Commission established a grace period of one year so that a license which has expired may be renewed on an application filed during the grace period in the same way that it would have been renewed on an application filed before the license expired. The newly adopted rule provides that grace period will be for one year after date of expiration of license. A special additional provision, however, is made in the case of commercial operator licenses which may have expired between July 1, 1948, and September 1, 1949. For these licenses, a special grace period of one year is provided commencing with September 1, 1949, and ending with August 31, 1950.

The amendments also change the service requirements for renewal of commercial operator licenses. Hereafter, a showing of only two instead of three years satisfactory service during the five year license term will be required for renewal without examination, and there will be no requirement that there be one year of continuous service immediately prior to filing the renewal application. Also, the service requirement for renewal upon the basis of a renewal type examination has been changed from three months to one year satisfactory service during the last three years of the license term. In this connection, a special temporary provision is made so that applications for renewal by renewal type examination will be considered under the former three months service requirement instead of under the newly adopted one year service requirement if such applications are filed with the Commission or postmarked on or before September 30, 1949, and during the last year of the term of the license concerned.

The Commission pointed out that the grace period was established to eliminate cases of hardship in which an applicant, through forgetfulness or for some other reason which did not justify a waiver of the rules, failed to file his renewal application before his license expired and consequently was forced to qualify in the usual way for a new license. It was particularly emphasized by the Commission, however, that a license which has expired is no longer valid and that any operation during the grace period under an expired license is just as illegal as similar operation without any license whatever.

The Commission also emphasized that holders of commercial operator licenses which have expired at any time on or since July 1, 1948 may be in a position to obtain license renewals upon the basis of these new rules by filing applications on or after September 1, 1949. Such applications may be filed whether or not previous applications have been filed, and whether or not applications previously filed have been denied because they were filed after expiration of licenses or because of failure by the applicant to comply with the renewal service requirements then in force.

FEDERAL COMMUNICATIONS COMMISSION,
T. J. Slowie, Secretary



GREETINGS

from

MOHAWK CHAPTER



N. A. B. E. T.



Fort Orange Radio Distributing Co.

642-44 Broadway

Albany, N. Y.

Electronic Specialists Since 1921



Schwartz's Radio & Electronic Distributor

Serviceman - Amateur - Engineer

710-712 BROADWAY

SCHENECTADY, N. Y.

Phone: 6-4717



SUPPORT

NABET

ADVERTISERS!





ED. STOLZENBERGER
Chairman

Season's Greetings

from the

New York Chapter NABET



R. W. BAUER
Secretary-Treasurer

The New York Chapter Council



J. Kinsel
ABC
Television

S. Monroe
NBC
Sound. Eff.

C. T. Ross
ABC
Sound. Eff.

H. Conway
MUZAK
Recording

G. Windham
NBC
Maintenance

D. Murphy
WNBC
Transmitter

A. Ballentine
RCA-Victor
Recording

J. Rynack
ABC
Traffic



N. Youngster
Treasurer

T. Clements
ABC-NBC
Master Control

L. Zangaro
NBC
Commun.

J. Connor
NBC
Traffic

C. Beardsley
NBC
Recording

M. K. Moon
Short Wave
Transmitters

L. Tyrrell
ABC
Television

J. Paine
NBC
Studio



R. Ward
ABC
Studio

A. Perry
ABC
Commun.

G. Peters
NBC
Studio

J. O'Neill
ABC
Studio

J. Hackett
ABC-NBC
Field

G. McDonald
ABC
Television

W. Chambers
Asst. Secy.

H. L. Byers
ABC
Transmitter

HARVEY TWO GREAT NAMES MAGNECORD

Combine these units to suit your needs and your purse. For portable or studio use. Conforms to all N.A.B. specifications. Precision capstan and drive assures perfect lip-synch for 16mm sound recording.

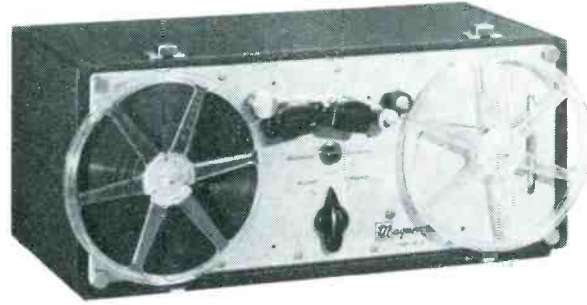

PT-6A . . . \$278 and PT-6AH . . . \$294

The PT-6A Tape Recorders are now in use in hundreds of broadcast stations and recording studios. Two tape speeds: 7½ and 15 inches plus high speed forward on the PT-6AH for cueing purposes.

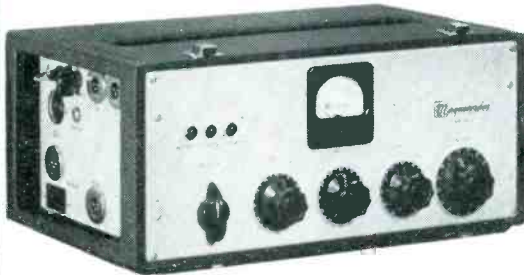

PT-6P . . . \$462

BROADCAST QUALITY RECORDING AND REPRODUCTION

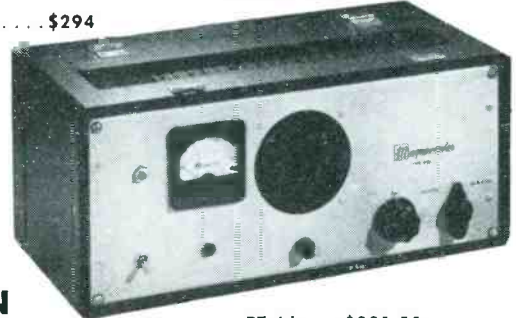

PT-6J . . . \$221.50

Designed for professional use, these units provide the highest quality. Frequency response ± 2 db from 40 to 15000 cycles, less than 2% harmonic distortion at full modulation. The recorder has high speed rewind (45 seconds) and high speed forward is available on the PT-6AH at slightly higher cost. The PT-6P amplifier is a fully portable record-playback-remote unit with 3 mike inputs and monitor speaker. The PT-6J has single mike input monitor speaker, jack for external speaker, can be used for public address. Full details of these remarkable units require pages. Come in for a demonstration or write us for full details.

PT-6A	Basic Recorder mechanism, includes 7½ and 15 inch capstans, interconnecting cords and portable carrying case . . .	\$278.00
PT-6AH	Basic recorder, same as above, with high speed forward	294.00
PT-6P	Portable Mixer Amplifier, in portable case	462.00
PT-6J	Amplifier	221.50
PT-6R	Rack mount amplifier	383.00
PT-6H	Rack Panel, for mounting PT-6A	6.85
PT-6M	Auxiliary spooling mechanism	135.00
PT-6T	Throwover Switch for using 2 PT-6A units with 1 PT-6P amplifier	19.60

...and the MAGNECORD PT-6R RACK AMPLIFIER

For studio use, or for interchangeable studio and remote, the PT-6R provides the studio half of the combination. Designed to take the PT-6A or PT-6AH recording mechanism (as shown in illustration), the recording unit may be lifted out in a few seconds and placed in its case for portable use.

This amplifier combines stable, broadcast-quality operation with solid construction. It has a single input channel and gain control providing either 600 ohms zero level, or high impedance bridging input. Pre- and post-emphasis equalization is built-in, compensating for tape magnetic characteristics. Program is fed to the PT-6R flat, and the playback is fed to the line flat. 600-ohm line output; signal develops approximately 1 ma in the PT-6A recording head. Response is flat, ± 2 db, 40 cps to 15 kc at 15" tape speed; 40 cps to 7 kc at 7½" tape speed. Three-position switch selects "record" or "listen", proper equalization being inserted for either operation, third switch position removes all equalization.

Volume level meter is supplemented by headphone jack on front panel. Uses 1-12AX7, 2-12AU7, 1-6X4, and supplies operating power for the bias oscillator unit in the PT-6A recording mechanism. 117 volts, 60 cycle, 1 phase, 60 watts. Standard 19" relay rack panel, 14" high, 12½" deep. **Complete, including tubes \$383.00**

All in stock for immediate delivery.

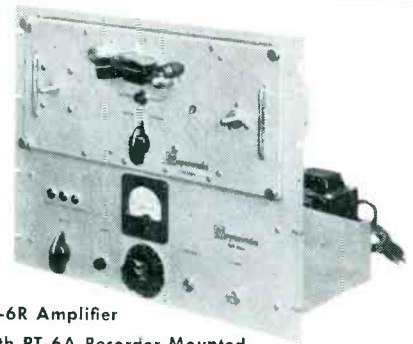

PT-6R Amplifier with PT-6A Recorder Mounted

All prices Net, F.O.B. New York and subject to change without notice.

Telephone: **3hr** Luxembourg 2-1500

HARVEY
RADIO COMPANY INC.
103 West 43rd St., New York 18, N. Y.

A "Brand New" SOLUTION

TO YOUR

AUDIO MEASUREMENT PROBLEMS

Daven's Moderate Priced Transmission Measuring Set

This is the instrument for which you have been waiting! For accuracy and efficiency, the Daven Type 11 A gain set, will fill your bill. Incorporating many of the features employed in more expensive models, this unit may be used to make all the precise measurements required by the FCC. This is a direct reading instrument, entirely eliminating time-consuming computations.

A new design feature, permits the servicing and inspection of all components from the front of the panel, with a maximum of ease and in a minimum of time.

It is no longer necessary to use makeshift equipment for determining the transmission characteristics of audio systems. The Type 11 A gain set has been priced low enough to place it within the reach of the most limited budget.

FEATURES

FREQUENCY RANGE:
20 cycles to 20 KC.

ACCURACY:
Accuracy is ± 0.1 db, from 20 cps to 20 KC.

OUTPUT LEVELS:
Ranges of output levels: +4 to -110 db and -10 to -124 db in steps of 0.1 db.

ACCESSIBILITY:
All components accessible from front of rack panel— for ease of servicing.

IMPEDANCE RANGES:
(a) *Source Section*— 600-150 ohms internally terminated.
600-250-150-30 ohms terminated.
(b) *Load Section*— 600-250-150-16-8-4 ohms.

APPLICATIONS

- AUDIO GAIN MEASUREMENTS.
- AUDIO LOSS MEASUREMENTS.
- MEASUREMENTS OF MATCHING AND BRIDGING DEVICES.
- COMPLEX CIRCUIT MEASUREMENTS.
- MEASURING MISMATCH LOSS.
- FREQUENCY RESPONSE MEASUREMENTS.
- CHECKING CABLE LOSS.
- TELEPHONE REPEATER DATA.

WRITE TO DEPT. BE-5 FOR ADDITIONAL INFORMATION.

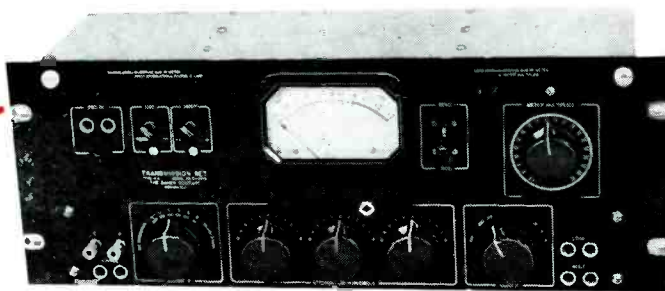

ALWAYS SPECIFY DAVEN FOR PRECISION EQUIPMENT

THE **DAVEN** CO

191 CENTRAL AVENUE
NEWARK 4, NEW JERSEY