

THE BROADCAST ENGINEERS' JOURNAL
ED. STOLZENBERGER, EDITOR
116-03 91ST AVENUE, RICHMOND HILL 18, N. Y.

POSTMASTER: IF UNDELIVERABLE FOR ANY
REASON, NOTIFY SENDER, STATING REASON.
ON FORM 3547, POSTAGE FOR WHICH IS
GUARANTEED

F A GEHRES WGBF-WEOA
2232 E POWELL
EVANSVILLE 14 IND
S148

Sec. 562, P. L. and R

U. S. POSTAGE
PAID

New York, N. Y.
Permit No. 2961

OFFICIAL PUBLICATION OF THE NATIONAL ASSOCIATION OF BROADCAST ENGINEERS AND TECHNICIANS



The Broadcast Engineers' Journal

In this Issue --

- Determining Range and Performance of Micro-Wave Radar
- Use of a Program Peak Limiter in FM Broadcasting
- Commercial Radar
- Instantaneous 'Scope Positioning
- IRE 1947 Convention Technical Papers
- NEWS—FM—Television—Industry

VOL. 14 No. 5

MAY 1947

SINCE 1934 . . . OF, BY AND FOR

THE BROADCAST ENGINEER

A Major Advancement in the Recording Blank Field . . .

10 Year Guarantee

**GOULD-MOODY PROFESSIONAL QUALITY "BLACK SEAL"
ALUMINUM INSTANTANEOUS RECORDING BLANKS
AT NO INCREASE IN PRICES!**

After prolonged research and experimentation, we have introduced technological improvements into "Black Seal" blanks that not only increase the life span, but materially enhance the other fine characteristics of these blanks. And so positive are we of the performance of these perfected "Black Seals" that we've placed an unconditional guarantee of ten years on each one of them.

What Does This Guarantee Mean to You?

It means that Gould-Moody "Black Seal" blanks will not rip up, disintegrate or powder after the first playing if kept in storage for any long period of time. It means that atmospheric conditions and changes, moisture and dampness, and old age will have no effect on blanks bearing "Black Seal" labels. It means that you'll be in no danger of losing valuable recordings in what, up until now, you have considered your safe library of recordings. And it means that you can expect the finest reproduction from the finest blank you have ever had on your turntable.

You Can't Afford To Be A Recording Isolationist

Whether you're a recording engineer in New York, Burbank or Wichita . . . no matter how well satisfied you are with your present blanks—you can't afford to be a recording isolationist now. Try these new Gould-Moody "Black Seal" blanks. Cut a few. If, for any reason whatsoever, you do not like them, you can return them at our expense.



**GOULD-MOODY'S PREFERRED RESHARPENING SERVICE
restores the point on your precious recording needle
SAPPHIRE! STELLITE!**

Exact workmanship assures lower surface noise and longer wear. In fact, needles and styli refinished by Gould-Moody are frequently reported to last longer than the original points. And the extreme accuracy with which that last 3/1000ths of an inch is shaped enables the needle to fit with microscopic perfection into the groove, thereby reducing record wear to minimum. This saving, in many cases, exceeds the cost of Gould-Moody resharpening.

THE GOULD-MOODY COMPANY

RECORDING BLANK DIVISION

395 BROADWAY, NEW-YORK 13, N. Y.

Burned up— but still "alive"!

SHURE

The "556" Broadcast Dynamic shown here un-retouched was badly burned in a fire Jan. 7 that gutted the Rita Theatre in Longview, Texas, where it was being used in a remote show for Radio Station KFRO. Surprising part of the story is that the Microphone worked perfectly when tested in Service Department shown in insert below.



This blown up section of the microphone case graphically shows extent of damage caused by fire.



Harley Westphal, Service Mgr., and Mel Krumrey, Jobber Sales, testing the "Burned Up—But Still Alive" Shure "556" Broadcast Dynamic.



SHURE BROTHERS, Inc.

Microphones and Acoustic Devices

225 West Huron Street

Chicago 10, Illinois



25th ANNIVERSARY!

The world's finest
precision disc
recording machine —
used and recommended
wherever the finest
recordings are made

Today — Write, Phone, or Wire
your order for
SCULLY MASTER RECORDERS

SCULLY Machine Company

62 Walter Street

Bridgeport 8, Conn.

Telephone BRidgeport 4-5300

THE BROADCAST ENGINEERS' JOURNAL

Ed. Stolzenberger Editor and Business Mgr.

Editorial, Advertising and Circulation Offices:
116-03 91st Avenue, Richmond Hill 18, N. Y.
Telephone: Virginia 9-5553

Volume 14, No. 5



May, 1947

Contents Copyright, 1947, by NABET Publications

TABLE OF CONTENTS

	Page
NABET Activity	3
NABET-IBEW Cooperation	17
NABET Group Councilmen—Attention ..	17
Determining Range and Performance of Micro-Wave Radar	4
Use of a Program Peak Limiter in FM Broadcasting	8
Commercial Radar	13
Cleveland Digs Out	14
Letter from San Francisco	14
Television Activity	16
Instantaneous 'Scope Positioning	18
IRC Technical Papers	20
New York News	22
FM News	23
Television News	24

THE BROADCAST ENGINEERS' JOURNAL

OFFICIAL PUBLICATION OF THE N.A.B.E.T.

Trustees: A. T. POWLEY, Chairman; C. L. BENNIS, R. R. DAVIS,
M. JACOBSON, W. L. PAYNE, G. RILEY

Treasurer..... H. E. HILLER

ASSOCIATE EDITORS

Baltimore.....	ALEC BEAUCHAMP
Boston.....	JAMES W. HUGHES
Chicago.....	D. R. FITCH
Cleveland.....	EARL HOLL
Denver.....	GEORGE POGUE
Detroit.....	DAVE STEWART
Dixie.....	D. GORDON MCCRARY
Engineering Chapter.....	E. B. BERLUND, JACK IRVING
Hollywood.....	NORMAN DEWES
Hudson Chapter.....	PAT MILLER
Mohawk.....	J. W. GAGNE
New York.....	GIL McDONALD
Omaha.....	CY HAGRMAN
Philadelphia.....	
Pittsburgh.....	FRANK E. HENRY
Rochester, N. Y.....	GEORGE WILSON, DONALD ANDERSON
San Francisco.....	KEN MARTIN, JACK VAN WART
St. Lawrence, N. Y.....	MISS ALEEN CORBIN
Washington.....	L. A. MCCLELLAND

The Broadcast Engineers' Journal is a privately printed monthly publication issued by NABET Publications. Address all communications to Publication office: E. Stolzenberger, 116-03 91st Avenue, Richmond Hill 18, L. I., N. Y. Telephone Virginia 9-5553.

Advertising rates and information supplied on request. Subscription, \$2.50 per year; \$4.00 for two years. Single copies, except Christmas Yearbook, 35c; Christmas Yearbook, \$1.00. All remittances in advance. Foreign: add postage. Back copies 50c, back Yearbooks, \$2.00.

Nothing appearing in The Broadcast Engineers' Journal shall be construed to be an expression of The Broadcast Engineers' Journal or the National Association of Broadcast Engineers and Technicians, but must be construed as an individual expression of the author or authors.

NATIONAL N.A.B.E.T. OFFICE
Room 501, 60 Court Street, Brooklyn 2, N. Y.
A. T. Powley, President

NABET ACTIVITY

* The National Association of Broadcast Engineers and Technicians, through its president, A. T. Powley, announced today that it had issued instructions to its members to carry out its agreement with the American Union of Telephone Workers (NFTW) and to extend this agreement to all legitimate telephone unions during any strike period that may result with the collapse of negotiations in the telephone industry.



A. T. Powley

Powley expressed complete agreement with the telephone workers in the justice of their case. Stated the NABET president:

"Members of NABET are in deepest sympathy with the telephone workers. In the control rooms and in the maintenance of the long distance telephone systems, the telephone workers do work very similar to our own, yet their scale of wages at top levels is much lower than ours. We feel that an increase in their wage is essential and justifiable. We shall do everything possible, within our contract rights, to aid them".

* * *

* RWG—Radio Writers' Guild, has voted to strike to obtain recognition for free lance radio writers, and the elimination of undesirable practices; will affect the Guild's 1500 members nationally.

* It was good to hear from R. B. Rennaker, Broadcast Sales Manager of the Collins Radio Co., who was former president of the Associated Broadcast Technicians, and a former CBS engineer. He says in part, "... I wish to take this opportunity to commend you on the fine job the Journal has done and which I am sure you are planning to continue... please remember me to all the NABET engineers, including President Powley."

* Radio jobs at MacArthur headquarters in Tokyo. Those interested should file Civil Service form 57 available at major Post Offices; contact War Dep't, Washington.

* CBS-Hollywood white-collarites recently obtained average 26½% wage increases; variation, 20% minimum to 60% maximum.

* AFM-Hollywood insisting on 33 1/3% increase, with networks counter-proposal of 25% for commercials and 15% for staff.

* Reported that ASCAP took in six million dollars from the networks during 1946.

* AFRA-Chicago has obtained 30% increase for actors, singers, announcers, at half-dozen "B" stations. \$20./week raise increased former \$63.50/week to present \$83.50.

* Drop-off in theatre and nite club attendance has hyped radio Hooper-ratings, contradicting fears of drop-off of listener habits.

(Continued on Page Twenty-four)

National Association of Broadcast Engineers and Technicians

The only Union that is 100% Of, By and For the
BROADCAST ENGINEER



Attention Broadcast Engineers!

- NABET is a dignified union *worthy* of your support.
- NABET is an *effective* union, Of, By, and For the Broadcast Engineer *exclusively*, operated upon and dedicated to the principle that every member has a right to know what is going on in the union's "front office."
- NABET is controlled by its members; they have the right to vote on all matters of union policy. As a NABET member, you would have the right to *Okay* any actions which your President might take.

Contact any of the following officers for further information

- | | |
|---|--|
| A. T. Powley, President | John H. Hogan
9312 Sudbury Road
Silver Springs, Md. |
| Harry C. Hiller
Nat'l Sec'y-Treasurer
66 Court Street
Brooklyn 2, N. Y. | William Justin Flanders
2 Holly Street
Hingham, Mass. |
| James H. Brown
Vice President
6000 Sunset Boulevard
Hollywood 28, Calif. | Wm. H. Johnson
100 E. Manda Road
Havertown, Pa. |
| Cliff Gorsuch
National Representative
66 Court Street
Brooklyn 2, N. Y. | C. Edward Jung
1405 Carswell Street
Baltimore 18, Md. |
| Charles L. Bennis
Apt. DA-2
117-14 Union Turnpike
Kew Gardens 15, N. Y. | John R. McDonnell
252 Oakdale Avenue
Mill Valley, Calif. |
| Harold V. Brandt
19 Elm Street
Brecksville, O. | Mark L. McGowan
2703 Spalding Street
Omaha, Neb. |
| Reid R. Davis
18 Squirrel Hill Road
Roslyn Heights, N. Y. | Don Morey
Apt. 26-A, 3 Circle Lane
Albany 3, N. Y. |
| J. Willard Dean
217 E. North Street
Raleigh, N. C. | Donald A. Muir
1200 W. Colvin Street
Syracuse 7, N. Y. |
| Garland S. Dutton
1225 Clarkson Street
Denver, Col. | Walter L. Payne
68-07 Colonial Avenue
Forest Hills, N. Y. |
| Roger C. Ellis
820 University Place
Grosse Pointe, Mich. | Clyde M. Reed
363 Olancha Avenue
Brentwood, Pgh., Pa. |
| George Gebhard
134 William Street
Watertown, N. Y. | Frank C. Schnepfer
3508 West 97th Street
Evergreen Park, Ill. |
| | Charles Synder
106 Pembroke Street
Rochester 7, N. Y. |

Determining Range and Performance of Micro-Wave Radar

By Jordan McQuay

RANGE and performance of micro-wave radar equipment can be predicted mathematically with considerable accuracy and *without* the usual long and tedious processes of measuring antenna current, field strength, receiver sensitivity, and other factors.

Prediction is possible by use of a group of important radar equations which involve: power relations, power density, antenna gain, the scattering characteristics of air targets, attenuation of pulsed u-h-f signals in space, signal/noise level at the receiver, and receiver bandwidth.

All of these influence the maximum effective working range of radar equipment. And through a knowledge of their individual magnitudes and related effects, the technical performance of the equipment may be calculated with a high degree of accuracy.

Power and Gain Relations

Omnidirectional antennas radiate energy uniformly in all directions with a total power output of P_T watts.

Assuming a perfect case: where the antenna is a point source of energy, at a range or distance of r meters a surface around the antenna would have $4\pi r^2$ meters (i.e., a sphere).

Thus, the density of the power *per square meter* can be stated as

$$P_U = \frac{P_T}{4\pi r^2} \text{ watts per sq. meter} \quad [1]$$

To concentrate power in a given direction, however, a u-h-f radar antenna is required to transmit a highly directional (i.e., very narrow) beam of radiation. In other words, the radar transmitting antenna must have an extremely high value of G gain.

A half-wave dipole has only a slight power gain in its direction of maximum radiation, expressed by

$$G_{\text{Dipole}} \cong \frac{3}{2} \quad [2]$$

A parabolic reflector energized by a point source of energy at its focus, introduces a high degree of power gain when the area A of the parabola aperture is considerably larger than the operating wave length. This power gain

is expressed by

$$G_{\text{parab}} = \frac{8\pi A}{3\lambda^2} \quad [3]$$

When the half-wave dipole [equation 2] is mounted at the focus of the parabolic reflector [equation 3], the gain of the combined arrangement is given by

$$G = \frac{4\pi A}{\lambda^2} C \quad [4]$$

A correction factor C of 0.93 or 93% is necessary, since the half-wave dipole radiator can not satisfy the requirement of a point source of radiation for the parabolic reflector.

The intensity of a parabola-controlled energy beam falls to zero at an angle of about $1.22 \lambda/2R$,—where R is the radius of the aperture of the parabolic reflector.

Use of electromagnetic horn radiators will usually result in much higher values of gain G than are normally possible with dipoles and parabolic reflectors. However, such increased values of gain G will depend upon (1) the type or physical shape of the horn, (2) its beam angle, and (3) its flare angle.

Since the parabolic reflector is most widely used in radar equipment, this type of u-h-f antenna alone will be discussed in this article.

Referring to previous equations and to figure 1, for any value of gain G , the power density S_T at a distance r in the direction of maximum radiation is determined by

$$S_T = \frac{P_T G}{4\pi r^2} \text{ watts per sq. meter} \quad [5]$$

By inspection, equations [1] and [5] may be combined as follows:

$$S_T = P_U G \text{ watts per sq. meter} \quad [6]$$

As shown by the geometrical configuration of figure 1, microwaves emanating from any type of antenna have a spherical wave front travelling outward from a source which can be considered the center of the sphere. When the u-h-f energy is concentrated

in a given direction, the wave fronts within the narrow beam are also spherical with reference to the point source of radiation.

When the spherical wave front strikes an aircraft at a distance r and at some elevation above ground, the target instantly absorbs and reradiates a portion of the impinging power S_T .

Although for many practical purposes an aircraft is usually considered to be a perfect reflector of radar impulses, this is not true because of an energy loss determined by the scattering factor of the aircraft.

Scattering Factor

The amount of power reradiation toward the radar set only is governed by the scattering factor F of the airborne target. Value of this factor F is extremely difficult to determine—since it varies disproportionately according to the size and type of aircraft, and the direction of flight with respect to the radar set.

The factor F has the dimensions of a length, not an area. But in radar equations the factor is usually squared, representing approximately—but only approximately—the cross-sectional area of the plane exposed to the radar beam of pulsed energy.

Value of the scattering factor F is influenced by the following quantities and conditions:

1. Angle of arrival of incident u-h-f waves.
2. Polarization of incident u-h-f waves.
3. Cross-sectional area of the target directly exposed to the u-h-f waves.
4. Position and direction of flight of the target in space, with respect to the radar set.

Because of these several factors, the value of the factor F must be determined by empirical means.

However, in practice this factor is approximately one meter for small types of planes—such as fighter and reconnaissance aircraft.

Every aircraft—regardless of type—has its "own" scattering factor. Considerable development still remains to be done in this field of radar research. But a number of observations and gen-

eral conclusions can be stated concerning the factor F :

1. It is roughly proportional to the square root of the projected or exposed area of the aircraft.

2. It is greater for a large plane than for a small plane.

3. It is greater for a metal plane than for a non-metal or part-metal aircraft.

4. It is greater when the aircraft is headed directly toward the radar set than when in any other position.

5. It is generally fixed in value for all operating microwave-lengths of 10 centimeters or less.

6. It is greater for vertically polarized waves than for horizontally polarized waves.

7. It is independent of wave length in the centimeter operating region.

As stated earlier, microwave energy impinging upon the target is reradiated toward the radar set according to the scattering factor F . The amount of power reradiated by the target toward the radar set is determined by

$$P_s = S_T F^2 \text{ watts} \quad [7]$$

This energy is not radiated uniformly or consistently, because of the physical shape and construction of modern aircraft—presenting assorted convex and concave surfaces as well as flat surfaces set at a variety of angles with respect to the ground radar station.

Thus, radiation is omnidirectional only in the general sense, since it fluctuates almost constantly. Field strength patterns around the aircraft are continuously transient.

This explains, in part, the more-or-less continuous fluctuations of target echoes appearing on the radar receiving oscilloscope.

The field pattern of the plane's reradiation may be likened, however, to a very distorted sphere which is constantly changing in shape.

Largest percentage of the reradiated energy is dissipated in space or in directions other than toward the radar receiving set. However, a portion of the reradiated energy does reach the radar set. And for purposes of this discussion, the target aircraft may be considered a point source of power radiation.

And that portion of the reradiated energy travelling toward the radar set spreads through a sphere having a radius r equal to the distance from aircraft to radar set.

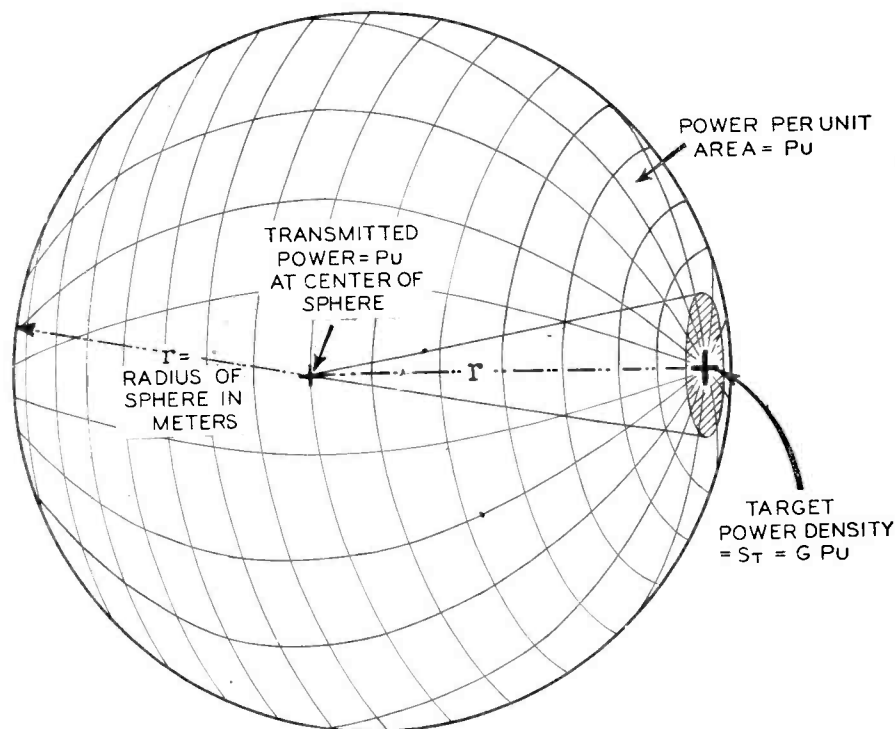

Fig. 1. Transmission of Radar Pulses — at the point source of a Sphere.

Wave Reception

On arrival at the radar receiver, the energy has a power density determined by

$$S_R = \frac{P_T F^2}{4\pi r^2} \text{ watts per sq. meter} \quad [8]$$

Gain of the receiving antenna must be considered at this point. However, since most radar sets use identical antennas for both reception and transmission, the receiving antenna has the same gain and directional characteristics as the transmitting antenna. [See equations 2, 3, 4.]

Combining equation [5] with equation [8], the power density at the receiver can be expressed in terms of antenna gain and original transmitted power, as follows:

$$S_R = \frac{P_T F^2 G}{(4\pi)^2 r^4} \text{ watts per sq. meter} \quad [9]$$

The actual amount of power present at the receiver input (when a parabolic reflector is employed) is expressed by the equation:

$$P_R = A S_R \text{ watts} \quad [10]$$

By combining equations [9] and [10], the actual power at the input

terminals of the receiver can also be stated:

$$P_R = \frac{A P_T F^2 G}{(4\pi)^2 r^4} \text{ watts} \quad [11]$$

Equation [11] establishes several important radar relations, and is of considerable use in predicting radar performance—particularly the maximum operating range of the equipment. When restated in terms of range or distance r to the target, a new equation results.

$$r = \sqrt[4]{\frac{A P_T F^2 G}{P_R (4\pi)^2}} \text{ meters} \quad [12]$$

By inspection of the above equation it can be seen that for a given value of transmitter power, antenna constants, and a fixed scattering factor F for the aircraft target,—the maximum range of the equipment will be dependent upon only one factor: the minimum discernible power at the input to the receiver, or the minimum value of P_R .

An equation for the maximum range of a type of radar equipment under a given set of operating conditions, can be derived from equation [12] and will appear as follows:

$$r_{\text{Max}} = \sqrt[4]{\frac{A P_T F^2 G}{P_{R(\text{Min})} (4\pi)^2}} \text{ meters} \quad [13]$$

A study of the above equation reveals that the maximum range of a radar set is dependent upon the fourth root of:

1. The transmitter power.
2. The gain of the antenna.
3. The scattering factor F , and
4. The reciprocal of the minimum received power which is discernible.

The range of a radar set can, therefore, be increased by decreasing the factor P_R (P_{min}). This decrease of minimum discernible received power has the same effect as a like increase in the transmitter power P_T .

Equation [13] also shows that the range of the radar set is greater when the antenna gain is high, or when the scattering factor F is large.

Further study of equation [13] reveals some interesting information relative to the factors under the radical, and their influence on the maximum operating range of the radar set.

The fourth root of the transmitter power P_T indicates that there is only a relatively small increase in range for a large increase in the transmitter power output. For example, if the power P_T is doubled, the range is increased by only about 20 percent.

Likewise, a large increase in either antenna gain or in the area of the parabolic reflector will result in a similar (relatively small) increase in operating range.

Reducing the minimum discernible received power increases the range in a similar but reciprocal relation. For example, if the minimum discernible received power is reduced by one-half, the range is extended about 20 percent. And this reduction, as previously mentioned, has the same effect on the maximum range as increasing the transmitter power output P_T .

However, a high peak power is not used merely for the sake of extending the range of the radar equipment. Later it will be shown that the maximum output power P_T is used to obtain a sufficient average power for a given maximum range, after the pulse requirements of the radar system have been established.

Another factor in radar reception, is the problem of thermal noise.

Noise Factors

As can be expected, the usefulness of received echoes is limited by the thermal or circuit noise present within the radar receiver. Thus, the minimum discernible power signal is determined by the signal-to-noise ratio of the receiver.

Thermal noise in a perfect receiver is known to be $KT B$ watts,—where K is

Boltzman's constant (1.38×10^{-23} watts per degree per cycle), T is absolute temperature (in degrees Kelvin), and B is the bandwidth of the receiver (in cycles per second). The quantity $KT B$ is the available external noise power, or one-quarter of the noise power generated by random motion of charges in space and developed in the antenna's radiation resistance.

Every receiver introduces some noise due to thermal agitation. And this added noise is known as the noise figure N of the receiver.

Thus, the total noise present in a receiving circuit can be expressed by:

$$P_{noise} = N (KT B) \quad [14]$$

Since the signal power has been obtained by equation [11], the signal-to-noise ratio S/N can be determined by the ratio of equation [11] to equation [14], which can be stated:

$$\frac{S}{N} = \frac{P_R}{P_{noise}} = \frac{A P_T F^2 G}{(4\pi)^2 r^4 N (KT B)} \quad [15]$$

This relationship can be expressed in terms of maximum range, similar to equation [13], by the following:

$$r_{Max} = \frac{\sqrt[4]{A P_T F^2 G}}{\sqrt{N (KT B) (4\pi)^2}} \text{ meters} \quad [16]$$

Substituting equation [4] for the value of gain G in equation [16], the latter equation becomes:

$$r_{Max} = \frac{\sqrt[4]{A^2 P_T F^2 C}}{\sqrt{N (KT B) \lambda^2 4\pi}} \text{ meters} \quad [17]$$

From a study of equation [17] it can be seen that the maximum range is reached when the minimum discernible receiver power P_R (P_{min}) is equal to the noise power P_{noise} .

Thermal noise power generated in the circuits of the radar receiver depends upon the bandwidth B in cycles. And there is an increase in thermal noise directly proportional to increases in the bandwidth B . As the noise factor increases, the maximum range of the radar equipment is reduced.

Thus, if the bandwidth is too wide, the noise factor will be so great as to limit radar operations. On the other hand, if the bandwidth is too narrow, the amplitude of the pulses will be diminished.

Between these two limits there is an optimum value of bandwidth offering the highest value of signal-to-noise ratio.

This optimum bandwidth is inversely proportional to the width or duration D of the radar pulse, and can be stated by:

$$B_{optimum} = \frac{2}{D} \quad [18]$$

Signal-to-noise ratio of a receiver, operating with an optimum bandwidth, is not dependent upon the peak power transmitted—but the average power. The average power is compressed into narrow-duration high-amplitude pulses not merely for the sake of radiating high power, but to allow the radar receiver to distinguish between transmitted pulses and reflected echoes.

For this reason, high (peak) output power is a necessity for pulse-modulated radar transmitters. And some receiver noise must be tolerated.

From the foregoing it can be seen that the maximum range of a radar detection system depends primarily upon the average power of the transmitter, and is independent of the pulse width or duration. Pulse width is determined by the requirements of minimum detection range.

In terms of the echo signal, the received power is more-or-less proportional to the transmitted power. And the received power is also proportional to the square of the area of the parabolic reflector, when such an antenna is used for detection purposes.

The received power diminishes inversely as the square of the operating wave length, and inversely as the fourth power of the range of the target aircraft.

The received power is somewhat proportional to the area and scattering factor of the target aircraft, and to the aspect of the target with respect to the radar detection site. In general, larger planes reradiate stronger echoes than smaller planes. And planes flying toward the radar station reradiate stronger echoes than those signals reradiated in other aspects.

Table of Symbols

- A = Aperture area of parabolic reflector in sq. meters.
- B = Bandwidth of radar receiver in cycles per second.

(Continued on Page Twelve)

No time...

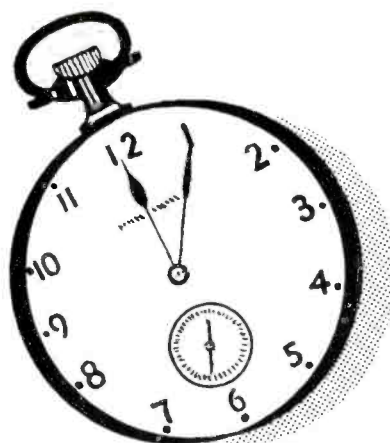

like the present...

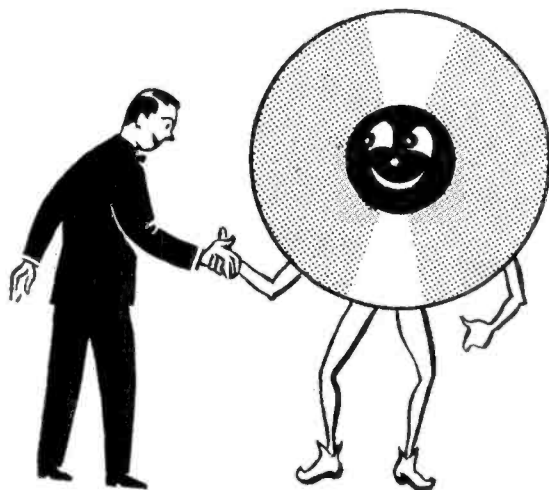

...TO GET TO KNOW
ADVANCE
RECORDING BLANKS

“They talk—they sing—they play—NATURALLY”

Advance
Recording Products
Company

36-12 34th STREET • Stillwell 4-7837 • LONG ISLAND CITY, N. Y.

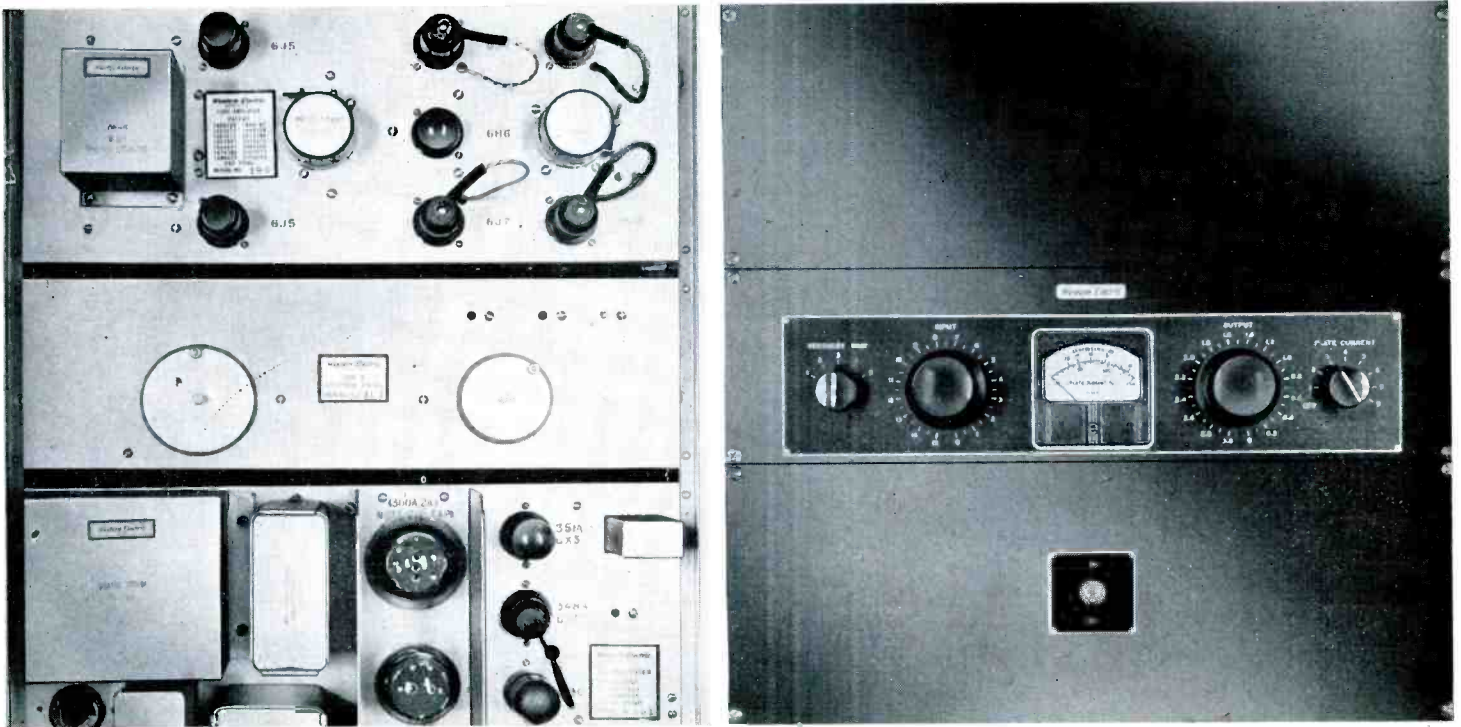

The W. E. Co. 1126 type Program-Operated Level-Governing Amplifier — rear view at left, front view at right: over-modulation is avoided without introducing distortion.

Use of a Program Peak Limiter in FM Broadcasting

By W. L. Black

Bell Telephone Laboratories

Reprinted by permission from the *Western Electric Oscillator*

IN any practical amplification system which is intended to have the maximum naturalness and dynamic range, the limitations of noise for low level, and overmodulation for high level, portions of a program are sufficient to seriously degrade the overall performance. The requirements for manually controlling programs of wide dynamic range to minimize these limitations are beyond average human capabilities.

It is generally possible to keep the low level portions above noise as these are rarely sudden in occurrence. Furthermore, no particularly harmful effects occur if the manual monitoring is not sufficiently rapid to prevent the program level instantaneously dropping below threshold noise. High level portions however cannot be accurately or instantaneously anticipated and consequently the limitation of overmodulation becomes serious and imposes a terrific burden upon the monitor operator.

In order to avoid overmodulation numerous devices have been used which may be classified briefly in the following categories:*

1. Compressor in which the output is held within a fixed dynamic range over a relatively wide portion of the input range.

2. Peak Chopper which merely cuts off the peaks of individual audio frequency waves when the instantaneous peak exceeds a predetermined value.

3. Peak Limiter which quickly reduces gain and slowly restores it when the instantaneous peak exceeds a predetermined value.

The compressor and peak chopper obviously cannot be used in any high quality system as the first excessively reduces the dynamic range and the second is a serious source of high harmonic distortion. A properly designed limiter which is for all practical purposes an instantaneously acting volume control operated by program peaks will cause no distortion, and when used only to avoid overmodulation and not as a compressor will not obviously detract from the naturalness or realism of the program material. Such a device must, of course, not only accomplish the desired objective of avoiding overmodulation but must do so without

introducing distortion or other spurious components.

The Western Electric 1126 Type Program-Operated Level-Governing Amplifier¹ has been designed to fulfill these requirements. The speed of operation is sufficiently rapid to reduce the gain to the proper value to avoid overmodulation in the first half cycle of an average program peak signal and succeeding portions of the peak are undistorted. Harmonic distortion has been held to less than 1 per cent over the operating range, including limiting, and spurious components have been minimized so as to be unobservable under the critical listening conditions.

The need for a program operated limiter in frequency modulated transmitters has been misunderstood and a difference of opinion regarding the

* "Devices for Controlling Amplitude Characteristics of Telephonic Signals" by A. C. Norwine, *Bell System Technical Journal*, October, 1938.

¹ "Program-Operated Level-Governing Amplifier" by W. L. Black and N. C. Norman, *Proceedings IRE*, Vol. 29, pp. 573-578, November, 1941.

desirability of a limiter has arisen. This discussion is intended to resolve existing misconceptions.

Assume a frequency modulated radio transmitter is adjusted for 100 per cent modulation (75 kilocycle carrier swing by definition) using a single frequency audio input. Then if the audio frequency input voltage is reduced by one half or 6 db, the modulation is reduced to 50 per cent or to 37½ kilocycle swing. A further 6 db voltage decrease reduces modulation to 25 per cent or 18¾ kilocycle swing. Or if the input voltage is doubled (increased 6 db), the modulation becomes 200 per cent or a 150 kilocycle swing. A further 6 db voltage increase results in 400 per cent modulation or 300 kilocycle carrier swing.

Under single frequency test conditions, input variations of 12 db, if modulation capabilities are being checked, are obviously absurd. However, consider the program transmission problem. Laboratory listening tests, using the standard volume indicator² in a system capable of transmitting frequencies only to 11000 cycles and including a sharply overloading amplifier, have indicated that for tolerable distortion the margin of system transmission capability required indicated by the volume indicator ranges, for the most critical listener, all the way from 3 db for dance music to approximately 14 db for male speech. This is due to the differences between volume indicator readings which give the r.m.s. voltage integrated over a finite interval and the peak voltages actually present in complex program material. Thus, it may be seen that the transmitter operator is faced with a difficult decision. If the level as shown by the volume indicator is chosen to coincide with the 100 per cent modulation level for a single frequency, the peaks, some of which are as much as 12 to 14 db above volume indicator level, correspondingly overmodulate the transmitter instantaneously several hundred per cent. If, however, the peaks are allowed for, and the level as shown by the volume indicator is correspondingly reduced some 10 db or more, then overmodulation is ex-

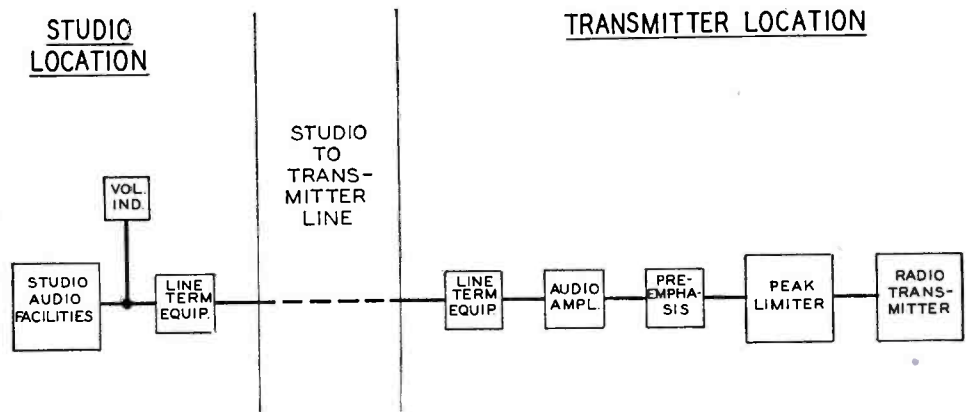

Figure 1. Peak Limiter shown in relation to transmitter — is located after the preemphasis network.

perienced infrequently, if at all, on instantaneous peaks, but the average modulation is then extremely low, having a maximum value in the order of 30 per cent.

Early Peak Limiter

In the past, in amplitude modulation broadcasting systems this dilemma has been resolved by a compromise determined by two considerations. First, the station operator's desire is to maintain as high an average percentage of modulation as possible. This objective is spurred on further by regulatory rules requiring the operation of such transmitters at not less than 85 per cent modulation on peaks of frequent recurrence in so far as possible. The second consideration, where relatively high average modulation level is achieved, is the use of the peak limiter. The first commercial device of this type, the Western Electric 110A Program Amplifier, was described in 1938³. However, even this compromise was not entirely adequate in some instances. In particular, at least one instance is known where the frequency of occurrence of overmodulation was such that interference was experienced in adjacent transmission channels. This was identified, when the disturbing transmitter was transmitting the music of dance orchestras, by the rhythm which was characterized by brass instruments such as trombones having relatively high ratio of instantaneous peak power to integrated average power. This difficulty led to the development of an improved peak limiter, the Western Electric 1126 Type Program-Operated Level-Governing Amplifier⁴. This device has had continued satisfactory field service both in installations where the avoidance of overmodulation has been stressed and in systems where the maximum obtainable increased modulation level con-

sistent with no disturbing overmodulation has been the principal criterion.

In a frequency modulated system the frequency band transmitted is wider, the listener's observation tends to be more critical and finally an equalizer to preemphasize the higher frequencies is incorporated in the transmitter system. Discounting for a moment the use of a preemphasis network, let us consider the practical effects of overmodulation in an FM broadcasting system. In such a system the carrier frequency swing which can be accommodated by the receiver, using intolerable aural distortion in the output as a criterion, is ordinarily the practical limitation in determining the satisfactory percentage of modulation which can be achieved. The entire frequency modulation broadcasting system is organized on the basis that a 75 kilocycle carrier swing is 100 per cent modulation.

Receivers Tested

It is, therefore, fair to assume that receivers will not ordinarily be made capable of handling much greater swing than this amount. Indeed, several years ago observations made in conjunction with transmission from the then experimental frequency modulation station W2XOR indicated that, of three different commercial receivers, two were able to accommodate peak carrier swings up to 80 kilocycles and the third only up to 50 kilocycles, although all were ostensibly designed for the standard swing of 75 kilocycles. In such receivers, the effect of swing beyond the circuit capabilities is essentially similar to exceeding the overload point of a sharply overloaded amplifier as previously described. Indeed, using the receivers mentioned, this effect existed to an exaggerated extent probably due to the abrupt and considerable departure from linearity

² "A New Standard Volume Indicator and Reference Level" by H. A. Chinn, D. K. Gannett and R. M. Morris. *Proceedings IRE*, Vol. 28, pp. 1-17, January 1940; *Bell System Technical Journal*, Vol. XIX, pp. 94-137, January 1940.

³ "Volume Limiting Amplifier" by O. M. Hovgaard, *Bell Laboratories Record*, Vol. XVI, No. 5, January 1938.

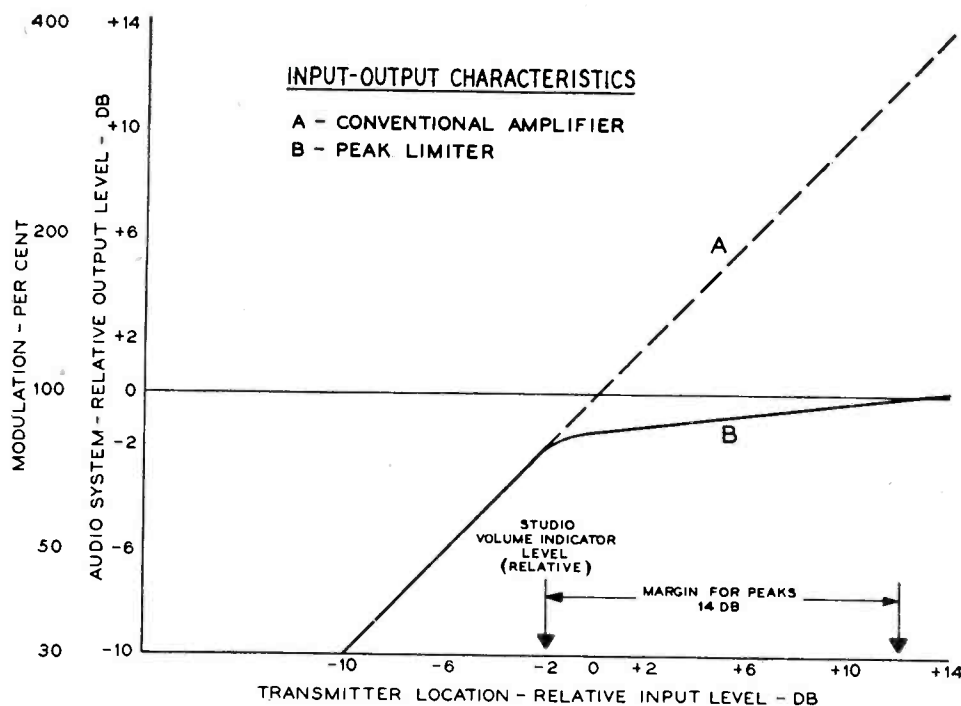

Figure 2. Characteristic curve designated "B" is representative of performance of 1126 Type Amplifier.

which occurred when the carrier swing for which the circuit was designed was exceeded. Therefore, the indications are, particularly with the tendency to more critical listening, that overmodulation must be as nearly minimized as possible, if not completely avoided. While it continues to be true that it is desirable to maintain a high average modulation, the burden on the system due to overmodulation is much more acute than in amplitude modulation systems. This is important from a practical point of view since a monitor under the control of the transmitter operator may be so designed that it will accept a wider over-swing than the listener's receiver. In such a case, there would be no indication, excepting complaints from listeners, that poor quality due to disturbing overmodulation was occurring.

Let us now return to the preemphasis incorporated in the frequency modulation system for noise reduction. The presence of this preemphasis further tends to complicate the frequency modulation control problem in three ways.

1. The disparity between peak modulation levels and volume indicator readings (remembering that the indicator is normally connected at the output of the studio equipment and ahead of the preemphasis) is further increased by increasing the higher frequency energy peaks of transient complex waves.

2. The modulation level obtained for a given volume reading even on sustained tones is increased whenever the program material contains substantial energy at frequencies above 1000 cycles.

3. The spread of relative values of peak voltages obtained from different program materials of apparent equal loudness but of different character is increased; or conversely, the spread of apparent loudness for different types of program material when their peak voltages are maintained equal is increased.

The first factor applies principally to speech where peak voltage increases, due to preemphasis, ranging from 0 to 3 db, depending upon the individual voice, have been observed. The second factor applies principally to certain solo instruments such as strings and brasses and especially to the trumpet and trombone when muted. The latter are commonly used in dance orchestras, and under such conditions peak voltage increases as high as 12 db due to preemphasis have been observed.

The third factor applies to programs generally where musical numbers of various types may be interspersed with announcements, dialogue, sound effects and applause. If the operating aim is to maintain normal loudness relations among the various program parts, the operator must keep modulation very low most of the time to allow for the

high frequencies occurring in the few passages whose peak voltage will be substantially increased by preemphasis. If, on the other hand, the operating objective is to obtain the maximum allowable modulation for all parts, the operator must "ride gain" constantly and use widely different volume indicator references for different types of program material while the apparent loudness will vary radically with the energy versus frequency distribution of the material. It is to be noted, moreover, that this requires additional controlling of gain over and above the type normally done at the program originating point, thus requiring more or less constant attention at the transmitter.

Function of a Peak Limiter

In practice the final control of peak modulation is obviously most desirably the function of a peak limiter such as the 1126 Type Amplifier to which reference has been made.¹ In this connection, several additional factors warrant observation. If the peak limiter is located in the system before the preemphasis network and is adjusted to limit the maximum carrier swing for single low frequencies to approximately 75 kilocycles, it is found that the preemphasis following tends to nullify the peak limiter's usefulness on certain types of programs by increasing the peak voltage at higher frequencies beyond the maximum established by the limiter for single low frequencies. If, on the other hand, the limiter is adjusted to operate so that approximately 75 kilocycle swing is obtained with a single high frequency input, then a large portion of the transmission is at an extremely low average modulation level. It is thus obvious that the limiter must be located after the preemphasis network as shown in Figure 1. This, however, introduces a new operating problem: namely, the difficulty of keeping the amount of limiting under control with varying types of program material. This, however, may be overcome satisfactorily by a compromise between the extremes of the third factor encountered by the use of preemphasis, as already described. It should further be noted that limiting seems much more objectionable when preemphasis is used. Whereas in a flat system the compression is confined to loud passages, with preemphasis its occurrence bears no obvious relation to program loudness. The effect is particularly disturbing on brass bands where the cymbal crash normally accompanying a

(Continued on Page Twelve)

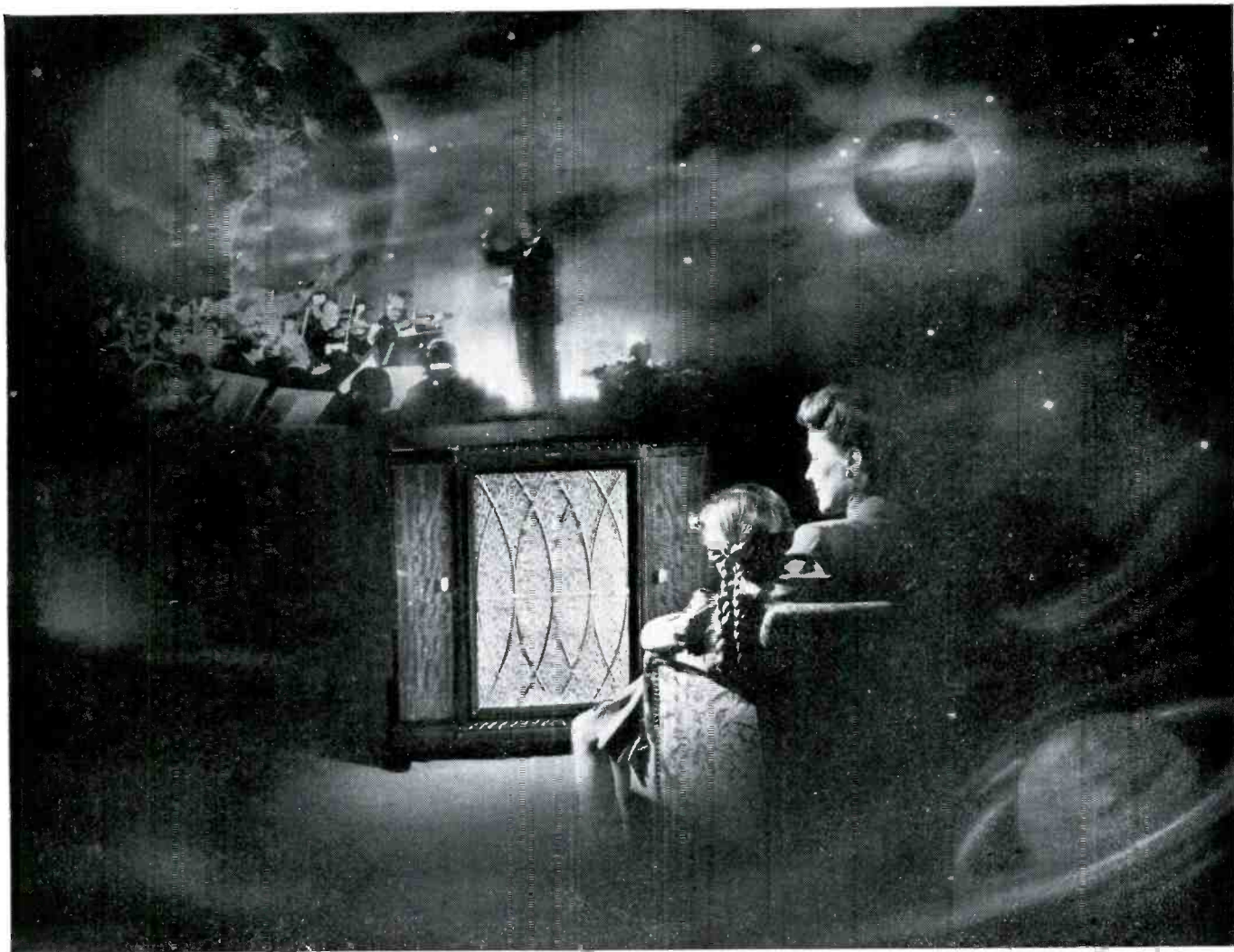

Frequency-Modulation radio reception is virtually free from natural static—even thunderstorms do not interrupt.

FM Radio—another world in listening pleasure!

It's as though the orchestra were right in the room with you—and the room suspended in the silence of space. When you listen to music over RCA Victor FM, you hear FM at its finest.

Natural static interference ordinarily caused by thunderstorms does not mar FM radio reception. You are in a different, new world of utter quiet where you hear only the lifelike music. Moreover, you enjoy the same perfect reception day or night.

The vast experience, research and skills at RCA Laboratories, such as aided in the development of RCA Victor

FM, are constantly applied to all RCA products, so that each one is always at the top of its field.

And when you buy anything bearing the RCA or RCA Victor name—whether it's a radio (standard, or FM, or both), a television receiver, Victrola radio-phonograph, a phonograph record or a radio tube, you know you are getting one of the finest of its kind that science has yet achieved. "Victrola" T.M. Reg. U. S. Pat. Off.

Radio Corporation of America, RCA Building, Radio City, New York 20. Listen to The RCA Victor Show, Sundays, 2:00 P.M., Eastern Daylight Time, over the NBC network.



With the new RCA Victor AM-FM sets you'll hear FM radio—and standard AM radio too, at their finest. Ask your RCA Victor dealer for a demonstration of the fine new Crestwood series of Victrola AM-FM radio-phonographs.



RADIO CORPORATION of AMERICA

Peak Limiter

(Continued from Page Ten)

crescendo controls the limiting and the resulting compression causes the loudness to drop just when the ear expects it to increase. Of course, the obvious solution is to align the system that compression is minimized.

In the alignment of the system, account must be taken of the characteristic of the peak limiter beyond the point on its input-output characteristic where limiting starts. Refer to Figure 2 in which the curve designated "B" is representative of the performance of the 1126 Type Amplifier. It will be noted that when the volume indicator input level is -2 db (relative) there is a 14 db margin for peaks from that point to the corresponding output level where 100 per cent modulation occurs. It should be further noted that if a conventional amplifier following the input-output characteristic designated "A" is used, it would be necessary to reduce the volume indicator input level to -14 db (relative) to insure that 14 db peaks did not exceed 100 per cent modulation.

In conclusion and summary:

1. "Cracking" or "breaking" on modulation peaks in frequency modulation systems is attributable to operation with peak carrier swings greater than some receivers will accommodate and is difficult to avoid when no peak limiter is used or when preemphasis is used after the peak limiter in the system.

2. "Fading away" of received volume on instrumental passages, when the limiter is used after the preemphasis, is inevitable, unless maximum limiting is kept very low. This requires maintenance of levels far below the limiting thresholds on passages whose energy is mainly below 1000 cycles. While the preemphasis theoretically affords a substantial gain in over-all signal-to-noise ratio, in practice this gain tends to be nullified by the necessity for general reduction in modulation levels if various types of program material, including some with substantial high frequency energy, are to be transmitted at uniform loudness. This is true whether a peak limiter is incorporated in the system or not.

3. The problem of maintaining high average modulation without observable distortion on peaks is more acute in present FM systems because of the wider frequency and volume ranges transmitted and the generally higher performance standards expected. The use of preemphasis, however, appears

to contribute materially toward the complication of this basic problem.

4. As for a limiting amplifier, it appears that its use to permit a substantial increase in average modulation as is done in amplitude systems is not warranted, as such use involves a sacrifice of realism in reproduction which cannot be tolerated in any really high quality system, much less in one using preemphasis. However, as a "safety valve" to minimize the possibility of overmodulation, its value is beyond question.

Consequently, it is recommended that a peak limiter having a stable point at which limiting occurs, adequate frequency response, low harmonic distortion and low output noise level and incorporating a visual indicator of compression be used, provided it is installed in the system beyond the preemphasis network (see Figure 1). The system should be so aligned that the indicated compression is of very infrequent occurrence. Further, at least initially, observations should be made with representative radio receivers and, if any audible signs of overload due to over-swing are observed, additional operating margin should be allowed by reducing the level at the radio transmitter input.

This discussion has been predicated upon distortion which largely occurs in the radio frequency portion of a receiver which may not have been observable in the past because of limitations imposed by audio frequency amplifiers and restricted range loudspeakers. With the use of higher quality amplifiers and loudspeakers which are essential for full realization of the inherent high quality of frequency modulation broadcasting it becomes of paramount importance to avoid distortion caused by over-swing of frequency modulated carriers beyond the capabilities of the receiver.

Radar Range

(Continued from Page Six)

C = Correction Factor:

(a) 0.93 for dipole-parabola antenna.

(b) 1.00 for electromagnetic horn radiator.

D = Duration of radar pulse, in microseconds.

F = Scattering Factor of aircraft in meters.

F² = Cross-sectional area of aircraft in sq. meters.

K = Boltzman's Constant:
 1.38×10^{-23} watts
per degree per cycle.

KTB = Available external noise power in watts.

N = Noise figure: additional internal noise generated by a receiver.

P_{noise} = N (KTB) = Total noise in a radar receiver in watts.

P_R = Power reradiated by target, appearing at radar receiver input, in watts.

P_{R (Min)} = Minimum discernible (usable) power reradiated by target and appearing at input of radar receiver, in watts.

P_S = Power reradiated by target at the target, in watts.

P_T = Peak power output of radar transmitter in watts.

P_U = Power density per unit area at a distance *r* from transmitter, in watts.

r = Range or distance from radar to target; radius of sphere; in meters.

R = Radius of aperture of parabolic reflector in meters.

s/N = Signal-to-noise ratio. [See P_{noise}]

S_T = Power density at radar transmitter in direction of maximum gain, in watts per sq. meter.

S_R = Power density at radar receiver after reradiation of wave by target, in watts per sq. meter.

T = Absolute temperature in degrees Kelvin.

~~~~~  
If it concerns the broadcast engineer  
—he will read it in the

**BROADCAST**

**ENGINEERS'**

**JOURNAL**

Since 1934, Of, By, and For  
The Broadcast Engineer

~~~~~

Commercial Radar

By Jordan McQuay

FIRST entry in the new field of marine navigational radar has just recently been announced by Radiomarine Corporation of America. Using typical microwave radar equipment, the set uses a magnetron which operates with a wave length of 3.2 centimeters. A plan-position-indicator 12-inch oscilloscope produces a luminous map-like image of surrounding land, water obstacles, and other ships up to distances of 50 miles and regardless of weather conditions. The set is capable of detecting buoys and small obstacles at ranges as short as 80 yards.

Announcement of the new marine radar equipment was made after exhaustive test-operation aboard a Great Lakes steamer: the modern ore carrier *A. H. Ferbert*. Tests were carried on during the vessel's regularly scheduled 6-day round-trip voyages between Conneaut, Ohio, and Two Harbors, Michigan.

Operated daily by the ship's personnel, results obtained are described as being extremely satisfactory. The radar picture is so distinct (Fig. 1) that the ship's captain—Frank Davenport—has been able to determine whether an approaching vessel is a passenger ship, a

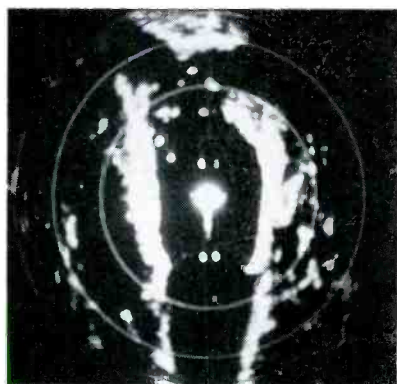

Figure 1. Typical oscilloscope image caught by the new Radiomarine radar aboard the steamer "A. H. Ferbert," as the ore ship was proceeding northward through St. Mary's River which connects Lakes Huron and Superior. Brilliant center spot represents ship, and distances are measured outwardly from this point. All large white blotches indicate land formations; at the top is the outline of Harwood point, toward which the vessel is heading. Two pairs of buoys, one pair directly ahead of the ship and the other aft, are both clearly visible. Width of the river at this point is approximately one mile.

self-loader, or a conventional bulk carrier at distances up to 25 miles, during fog or heavy rainstorms.

Vessel personnel were able to locate and plot positions of rain squalls with the radar—and also detect ship and



Figure 2. Aboard the Great Lakes steamer "A. H. Ferbert," Capt. Frank Davenport (left) listens while C. E. Moore of Radiomarine Corp. explains operation of new marine radar gear. Indicator unit in foreground has a "daytime" hood over the 12-inch oscilloscope on the face of which the radar image appears.

buoy targets both in and beyond the squalls. When navigating through extremely narrow channels, it was consistently possible to distinguish on the oscilloscope the contours of shorelines on both sides—even when the vessel was only 250 feet from the shore.

Installation of the oscilloscope or indicator unit in the pilot house (Fig. 2) permits instantaneous use of the radar equipment by the skipper—when the information's needed most: in heavy weather, storms, fog, mist, and darkness.

The radar antenna is mounted on a 12 foot platform (Fig. 3) above the pilot house. The antenna rotates in the horizontal plane and transmits a beam only 1.6 degrees in width. An open-ended truncated parabolic reflector is fed by a short length of wave guide; the wave guide literally "sprays" u-h-f waves against the reflector which, in turn, directs the radiation out into space. The field pattern of such radiation is extremely narrow in the horizontal plane, providing the desired

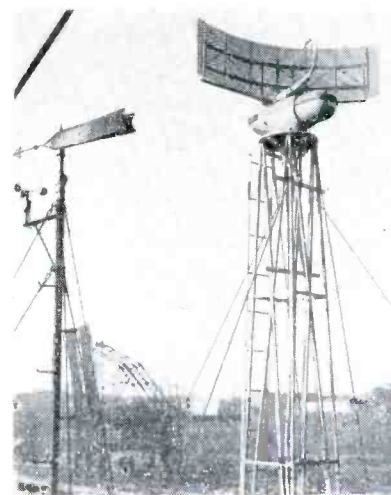

Figure 3. Wave guide antenna and semi-parabolic reflector of the Radiomarine marine radar. Antenna unit is mounted on a 12-foot steel top atop pilot house of steamer "A. H. Ferbert."

degree of accuracy. The narrow u-h-f beam hugs the surface of the water and picks up buoys, small objects, and other ships not only at short ranges—but at distances twice as great as those afforded by low-frequency wartime marine radar equipment. Land masses up to 50 miles distant can be clearly identified on the scope.

One unique feature of this Radiomarine radar is the provision for instantaneous switching from *relative bearing* to *true bearing* presentation on the oscilloscope. In the *relative bearing* presentation, the scope picture is oriented with respect to the ship's bow, so that the area ahead of the vessel appears at the top of the image, the area to starboard appears at the right, and so forth. This form of scope presentation is especially useful in navigating rivers and narrow channels.

The installation aboard the *A. H. Ferbert* is the first step in a general program now in progress aboard a large number of Great Lakes vessels.

NABET

100% Of, By, and For
the Broadcast Engineer

Inquiries should be addressed directly to:

A. T. Powley, President
N.A.B.C.T.
66 Court St.,
Brooklyn 2, N. Y.

or to any of the NABET National Officers listed on page three.

From Cleveland

March 28, 1947

Dear Stolzie:

Ohio is now digging out from under one of the bigger and better blizzards of the past twenty years. Buchanan, Anthony, and the writer were marooned at WTAM transmitter for several days. The roads were blocked so, that even snow plows couldn't move. Soooo—we did what they would have done in Texas—standby and keep the program and emergency bulletins going out.

Luckily, there was chow enough in the galley for two or three days (with careful planning). We had plenty of coffee, and that helped. The whole thing struck me so funny that I punched out the enclosed sketch. (Course, I never expect to be able to write like Pruitt—or spin yarns like Burrell, but by Gar, I can drink coffee like Stan Peck.)

Well, I just want to say that I miss the New York gang, every one. Please give my best to all. 73.

R. J. Ross "Bateese" Plaisted
W8KJI

ONE BEEG BLOW
March 25, 1947

This is day
Of the beeg blow
No can come
No can go

Much snow fall
Then wind mak drift
We drink much coffee
Work two shift

The power line
She stay oke
The voltage jump
But we sell soap

Weatherguy say
Spreeng she is har
We frostbite the ear
Yell No, By Gar

The second day
Is good for dam
More snow come
And drift all tam

We shovel much
But more snow blow
We work more watch
No come, no go

Sun show bees face
Once in a while
But all the tam
The snow she pile

We stretch the chow
Pull belt more tight
And dream of steak
We no can bite

But four o'clock
Relief man is har
Much chow he breeng
We eat, By Gar

More snow come
But now is joke
For we can sleep
And all is oke

So now is end
Dees lettle fable
We go home in morning
If we are able

—R.J.P.

Another Letter From San Francisco

DEAR ED:

Ed, I hope you don't have as much trouble prying stuff out of your gang as I do out of the dumbies (vocally, that is,) out here. Honestly, SOMETHING must happen to or about SOME of them, but howinell do you find out WHAT and WHEN?

Anyhow, here's the picture of the Parks' spinach crop you asked for. Some crop, eh?

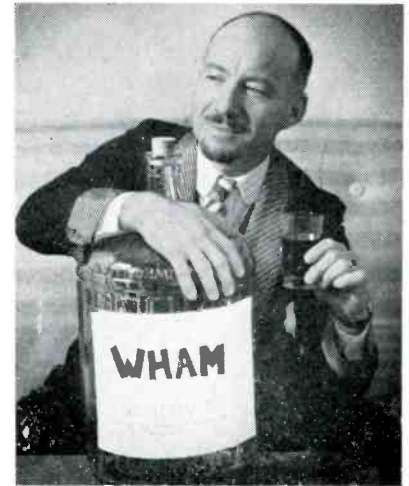

Photo by T. Morse
ABC—San Francisco
ENGINEER DICK PARKS

We all tried to prevail upon Dick to let it grow, but he complained that it tickled! I tried to get some "cheese-cake" to go with the spinach, (making a souffle, perhaps?), but no go. And while on the subject of Dick, this happened. Dick wanted to buy a seven-eighths wood bit, and the neighborhood hardware man, bless him, after diligent search, came up with this gem—"Sorry, sir, I have 13/16, 14/16, and 15/16, but no 7/8s." Well, Dick told it so that I thought it was funny.

George Dewing had a nice mid-winter vacation at Sun Valley, thanks to Lowell Thomas. George admits that he is strictly a "fire-side skier," but did admit to riding the lifts on occasions. From mid-winter in Idaho, to warm spring in California may not be so far, at that—witness Bud Maxwell and Jack

AVAILABLE NOW — From
NEW YORK'S LEADING DISTRIBUTOR!
of RADIO & ELECTRONIC EQUIPMENT!

The BROOK AMPLIFIER



Designed by Lincoln Walsh High Quality Negligible Distortion

Frequency response 20 to 20,000 cycles ± 0.2 db. Patented automatic bias control. Triode output — 30 watts.

Model 10C Basic Amplifier **17640** net
Model 10C2 with preamp. **22050** net

Available with wide selection input and output impedances. Ask us for Brook data.

The PICKERING PICKUP

For lateral-cut 10", 12" and 16" recordings



For "Clean" phono reproduction

Model 161 Magnetic reproducer for lateral-cut phonograph records and transcriptions. Virtually no intermodulation or harmonic distortion, nor frequency discrimination from 30 to 15,000 cps. Specify 500/600 or 10,000 ohms. Net. **8400**

Model 163A — Five-position Equalizer for standard and N.A.B. record characteristic compensation. **4200**

Model 164 — Equalizer-Preamplifier for model 161 pickup. Specify high or low output impedance. Complete Pickering data on request. **9600**

ALTEC LANSING



Model 600 — 12" PM Dia-Cone Speaker with high frequency metal diaphragm and mechanical dividing network. Rated 20 watts. 10 ohm voice coil. **4760**
Net price

Model 603 — 15" PM Multicell Dia-Cone Speaker, superb quality. **8400**
Price

Also Altec Lansing Duplex, cabinets, matching transformers, etc. Ask us for Altec Lansing literature.



VISIT OUR SOUND STUDIO

See and hear this equipment on demonstration. If you wish, bring your own test records.

TERMINAL RADIO CORP.

85 Cortlandt Street
New York 7, N. Y.

van Wart remember him?) spending their joint days off refurbishing "bee furniture," which, they tell me, is shop slang for bee hives and the related equipment. Jack says the warm weather almost caught 'em short, as the bees decided "spring was here," before the paint was dry, or something.

The recent adjustment of staff numbers has resulted in Earl Sorensen, the "Derrible Dane," being moved to a daylight watch instead of the midnight-to-eight tour that he held down for lo these many months. Among his first assignments was a maintenance one in an ABC office, and he spent a couple of hours looking for said office! Earl says it certainly is nice to see how the other half lives, and to get acquainted with Marge and the twins again!

The work on the new KGO 50-kwer has bogged down somewhere, but not the plans of the KGO gang to be ready for the move southward, when and if. Leader of the movement so far seems to be Don Bernard, who has purchased a plot of ground, and is spending spare moments building a 2-car garage that he and his family can occupy until house-building becomes more practical.

Tommy Watson was sent out to make a wire recording of a helicopter test flight, but do you think they could get Tom off of the ground? Oh no, not Tommy, he compromised by staying on the ground with the recorder, and sending the microphone up in the ship. The ship went off of the ground all of ten feet, but that was nine feet six inches too far for Tom.

A spattering of new cars is making its appearance around these parts. Lucky engineers include Guy Cassidy with a Ford and Russ Butler with a Hydramatic convertible, with all the fittings. Russ reports that he hasn't got HIS fingers caught in the mechanisms as yet, but that his Boxer pup formed an early opinion of the contraption when Russ decided to lower (or raise) the top while the pup was enjoying the scenery from the rear seat. The dog's almost as big as Russ, and the resulting exchange of verbage was probably quite worth hearing, if not printable. In the market for anything with four wheels and an engine is Norm Tapper, whose vacation plans are built around transportation of some sort, somewhere. Also expecting are "Duke" Fuhrman and numerous announcers.

Speaking of vacations, the coming of that enjoyable part of the year finds us welcoming back to the fold, Dale Gordon to Recording, Milt Cooper and Bob Wood to the studio, and probably Joe Jobbins at KPO and Petty at KGO, for vacation reliefs.

Somebody made Lee Kolm a present of one of those new-fangled electric dish-washers and garbage disposers, but by the time Lee ran the gamut of plumbers, electricians, linoleum experts, etc., he almost gave it back! These San Francisco building restrictions, etc., certainly don't make it any easier for would-be users of those labor-saving devices. On the other hand, Bob Salle, faced with eviction last Fall, solved the prob-

(Continued on Page Sixteen)

Broadcast Engineers' Journal for May, 1947 **15**

NEW
TECH-LAB
DEVELOPMENT

For **RAPID**
MEASUREMENT
OF
AUDIO FREQUENCY
GAIN or LOSS

TYPE 1A
TRANSMISSION
MEASURING SET



Completely Self-Contained
PORTABLE • AC OPERATED

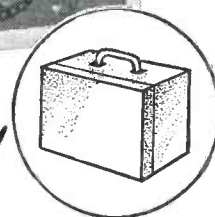

With this instrument it is possible to quickly and accurately analyze and service equipment in different locations without fuss in time consuming demounting and transportation of apparatus. It will thus pay for itself in a short time and no modern radio station can afford to be without it. It can also be used to good advantage in factory checking and inspection of audio equipment.

The set combines in a modern efficient manner an accurate vacuum tube voltmeter, an audio oscillator with four fixed frequencies and a precision attenuator all mounted in a handy cabinet easily carried by the operator.

SPECIFICATIONS

- GAIN: Up to 80 db.
- LOSS: 60 db. maximum.
- VACUUM TUBE VOLTMETER:
Range—40 to +40 db.
(1 mv. ref. level)
- AUDIO OSCILLATOR:
Freq. Range; 100 to
10,000.
- PRECISION ATTENUATOR:
Flat to 20 KC; 93 db.
in 1 db. steps.
- DIMENSIONS:
10 1/4" x 16 1/4" x 8 3/4"
- WEIGHT: 30 lbs.
- INPUT: 115 Volts.
60 cycles, 70 watts.

TECH
LABORATORIES, INC.

Manufacturers of Precision Electrical Resistance Instruments
337 CENTRAL AVE. • JERSEY CITY 7, N. J.

San Francisco

(Continued from Page Fifteen)

lem by buying the house he was renting, in Marin County, and proceeding to completely remodel same, outside and in, with no trouble at all, except that caused by material shortages, etc., Bob had to take a course in forestry so that he could remove a couple of redwood trees in the way of the prospective enlarging projects.

Nothing very startling to tell about the Hams and their activities. Parks still awaiting delivery of his promised Collins 30-K, and his new RCA CR-88 receiver. I acquired Dick's original AR-88, and after having rebuilt my own shack to accommodate it, I find it is really QUITE a receiver, inspite of its massiveness! I would certainly like to hook up with some of you fellows back there. Hows about a call sometime? Cramer of KGO continues to work world-wide on 10, and Andresen still experimenting with power supplies, for what I don't know. Also hear McAulay of KPO on occasions.

Geo. McElwain has been conducting a reception survey on the few FM stations in operation in the San Francisco area. He comes up with some rather startling results, that tend to disprove the altitude requirements for transmitting antennae. More of

that later, when a thorough investigation is completed.

Sam Melnicoe, part owner and chief engineer of KEEN, San Jose, keeps busy plus, trying to beat a May 1st deadline air-time for the new station. Latest reports are that the two towers have been erected, and that most of the equipment has been delivered and is only awaiting housing and hook-up to get on the air!

I just heard that a couple of Ken Martin's dogs made reserve winners at the recent Oakland Dog Show. Congrats, Ken, and hope you go clear thru to winners and get some championship points next time. Gosh, I thought Sid Blank was the only "doggie" one among us!

Enough of this for now, Ed. 73 and see you next month.

Ed Parkhurst

* * * *

* Pausing for a chat at the recent I.R.E. Show are David Hall, right, author of "Record Book" and leading authority on recorded music and F. Sumner Hall (no relation to David Hall), well-known recording expert. To make things interesting, F. Sumner Hall was 'til recently chief recording engineer

of Carnegie Hall (no relation to the Messrs. Hall!) The Terminal Radio Corporation, distributors of radio and electronic equipment, 85 Cortlandt Street, New York City, recently was



appointed distributor of the Pickering Pickup and Brook High Fidelity Amplifier. F. Sumner Hall, national sales engineer for these two firms, reports keen interest in both products at Terminal's exhibit at the Radio Show sponsored by the Institute of Radio Engineers.

Television Activity

Continental Broadcasting Corp. Boston. Granted CP for experimental television station.

Conestoga Television Ass'n, Lancaster, Pa. Granted CP for experimental television station to intercept signals from Philco-Philadelphia and rebroadcast them in the Lancaster area.

KRLD Radio Corp., Dallas. Granted CP for new commercial television station, Channel 4, 66 to 72 Mc., 46 kw.

Courier-Journal & Louisville Times Co., Louisville. Granted CP for new commercial television station, channel 9, 186 to 192 Mc., 9.6 kw.

Iowa State College, Ames, Iowa. Granted CP for non-commercial television station, channel 4, 66 to 72 Mc., 13 kw.

Milwaukee Journal, Milwaukee, Wisc. CP for a new commercial television station, Channel No. 3, 60-66 mc.

E. F. Peffer, Stockton, Calif. CP for a new commercial television station, Channel No. 8, 180-186 mc.

American Broadcasting Co., San Francisco. CP for a new commercial television station, Channel No. 7, 174-180 mc.

Fort Industry Co., Detroit. CP for new commercial television station, Channel No. 2, 54-60 mc.

Maison Blanche Co., New Orleans. Granted CP for new commercial television station, Channel No. 4, 66-72 mc.

* USSR said to have given NBC television rights to newsreels, etc.; WNBT Network expected to scoop newsreels in reaching audiences.

* Sarkes Tarzian, Bloomington, Indiana, granted CP for commercial tele on Channel 10, 192 to 198 mc., 1 kw., unlimited hours.

* Daily News Television Co., Philadelphia, granted CP for commercial television on Channel 12, 204 to 210 mc., 2 kw.

* Southern Radio & Television Eqpt. Co., Miami, Fla., granted CP for commercial tele, Channel 4, 66 to 72 mc., 1.5 kw.

* Washington, D. C. television got its big push week of April 14th, with the opening of major league baseball; RCA-Victor, U. S. Television, etc., providing the demonstration tele receivers.

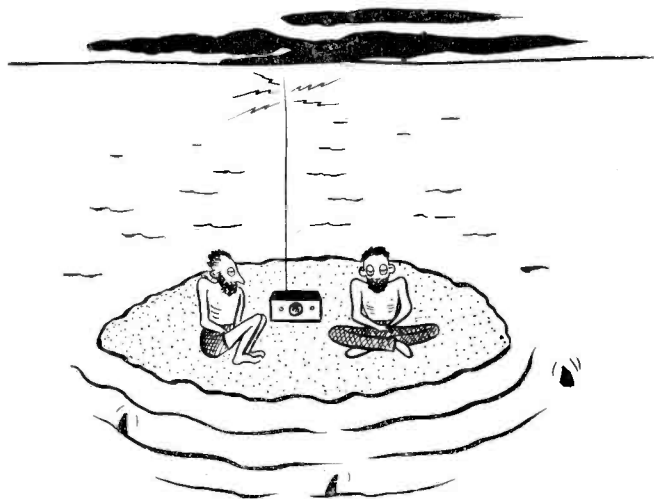

"... Now, you mix that special sauce with your lamb stew
... and then ..."

NABET — IBEW Cooperation

WHAT happened to the IBEW Negotiating Committee?

What happened to IBEW's word that they would cooperate with NABET in the negotiation of the 4-Network contracts?

Prior to the expiration of the ABC, CBS, MBS, and NBC network contracts, NABET President A. T. Powley met with IBEW V. P. Dan Tracy in Washington, D. C. They discussed the common problems of their respective broadcast engineering memberships. There was full agreement on the urgent need for NABET-IBEW "top-level" as well as rank-and-file membership cooperation, in the face of a reported NAM-NAB seventy-million dollar budget to bust, break, and buy-off labor unions and intimidate their leaders, and to obtain disgraceful anti-labor legislation that in effect would give every worker the choice of:

Laboring for as long a work-week and for as low a salary as the NAM-NAB might dictate, or

The alien alternative of conscription into the Army or a jail sentence for violation of forced-labor laws.

At key broadcast centers around the country, similar meetings were held between local NABET and IBEW officials and rank-and-file members.

These national-officer and local-officer inter-union meetings led to agreement that the National Negotiation Committees of NABET and IBEW would meet in New York prior to their respective negotiations; that they would cooperate fully before, during, and after their negotiations in an effort to minimize as much as possible, the restrictive labor aims sought by the NAM-NAB.

A preliminary meeting between the two national negotiating committees took place at the Hotel Roosevelt, in New York. The IBEW national negotiators have not been seen since!

NABET learned that IBEW-CBS negotiations were going on, but all NABET negotiating committee attempts to reach the IBEW negotiators failed. During this period, the NABET-ABC-WOR-NBC negotiations were under way.

NABET next learned that Messrs Calame and King of the New York local IBEW, had made a secret deal with CBS V. P. Frank White. As a result of this IBEW-CBS deal, the IBEW negotiations were summarily suspended, and Mr. Calame is reported to have told the IBEW National Negotiating Committee to "go home", and that they would receive an "explanation" later! A typical IBEW "deal".

There are approximately 6,500 employed broadcast and television engineers in the country, at an average \$5,000. annual salary. The salary budget for the nation's broadcast engineers exceeds \$30,000,000.—a sizable sum. It is not beyond the realm of possibility that a good part of the NAM-NAB \$70,000,000. union-busting budget has been ear-marked to divide and whittle-down the broadcast engineers. The hide-and-seek tactics of the IBEW negotiators have played directly into such a plan—and against the best interests of the broadcast engineers. We regret to say that this has been and appears still to be the policy of the IBEW.

The present IBEW-CBS negotiations are following the pattern of the infamous 1945 negotiations, when IBEW—as usual—went into hiding and waited while NABET fought for the present \$475./month (\$109.60/week) industry standard. Then, after IBEW learned of NABET's new contract at \$109.60/week, IBEW had the gall to sign its only network contract (with CBS) at a penny an hour (40c per week) over the NABET network contracts. IBEW then claimed that NABET held them down—that if NABET had gotten a larger increase, IBEW could then have gotten a larger increase too!

All of this is "old hat" to the old hands at broadcast engineering. Standard IBEW operation. However, assured by the present IBEW leadership that things had changed, NABET went along in good faith on the current NABET-IBEW cooperative contract negotiations.

As anticipated, NABET was taken for the standard IBEW ride. NABET has recovered from this double-cross, rallied, and is stronger than ever as the outstanding representative of the nation's broadcast engineers.

Once again, IBEW has collapsed under the impact of negotiation resistance; once again, IBEW is standing by, waiting for NABET to further raise the standards of the broadcast engineer, so that IBEW can bring its head out of shameful hiding and proclaim, "me too, plus a penny an hour!"

What happened to the IBEW Negotiating Committee?

What happened to IBEW's word that they would cooperate with NABET in the negotiation of the 4-Network contracts?

Group Councilmen — Attention

On page 23 of our Jan. 1947 Journal, we published a membership-inquiry coupon; from the overwhelming lack of response, we presume that all are saving their copies and didn't want to tear out the coupon. Therefor this note to all Group Councilmen of all Chapters and Sections.

About two years ago, our then NABET VP Thor LaCroix made a sincere effort to obtain the ham-calls of all our members for publication in our Journal; the individual Chapters failed to supply the information—but strangely, the individual members still ask us when we are going to publish the list of ham calls! The second item of concern is the Postal Zone numbers of our individual members; the individual need only ask his mail carrier, rural delivery agent, or local postmaster for his PO Zone number or Rural Route number. Councilmen are requested to:—

Post on bulletin board, a sheet of paper ruled in columns, headed as follows:

Name Zone No. RR No. Ham Call Ph/CW Freq. Power

—When all the members of your group have filled in the requested data, either pass on to your Chapter Sec'y for forwarding, or put in mail directly to the Editor. At the upper-right-hand corner, indicate name of Chapter, and name of group, and date—EdS. May/47.

Instantaneous 'Scope Positioning

By J. H. Platz

IN COMMON with many other hams the author purchased one of the BC412 radar oscilloscope units with the idea of revamping it into a general purpose oscilloscope.

With the adequate space and power available it was decided to make the unit as useful as possible by installing wide band amplifiers. This purpose would have been partially defeated however, by using ordinary capacity coupling from the final deflection amplifiers to the CR tube deflection plates.

Attempts to increase low frequency response by increasing the coupling capacity resulted in negligible improvement and also yielded an undesirable by-product in the excessive time required for variation of the positioning controls to take effect. Users of 'scopes will concur in the statement that excessive lag in the positioning action can be very annoying.

It was decided to attempt to overcome both difficulties without undue

complications. The circuit of Figure 1 was the ultimate result. In it there are no coupling capacities to the deflection plates and the action of the positioning control is instantaneous. Low frequency response is best attested by its ability to reproduce a fifty cycle square wave to near perfection.

In the circuit, T_1 and T_2 are push-pull 6L6 deflection amplifiers, the plates of which are directly connected to DP_1 and DP_2 , the deflection plates of the 'scope tube. R_9 and R_{10} serve as plate load resistors for T_1 and T_2 and they also—as will be seen—play a part in operation of the positioning action. Cathode-coupled phase inversion is used to get push-pull operation of the deflection amplifiers. The resistance R_k (shown in dotted lines) is the effective resistance from cathodes to ground and is actually composed of the series-parallel combination of R_1 , R_2 , R_3 , and R_4 . This resistance R_k is somewhat greater than the ordinary value of cathode resistance normally used for push-pull 6L6 tubes. The

voltage drop across R_k will be designated as E_k and appears across the series combination $R_3 \cdot R_4$ which serves as a voltage divider to apply a portion of E_k to the grid of T_2 . E_k also appears across $R_1 \cdot R_2$ and again a voltage divider is used to apply a portion of E_k to the grid circuit of T_1 . In this case however, the voltage tapped off for bias is variable.

It will be seen that if R_1 is set to provide a value of bias to the grid of T_1 , exactly equal to that supplied to the grid of T_2 the two tubes will draw equal plate currents and the DC voltages developed at the plates of T_1 and T_2 will be equal. These equal voltages are applied to DP_1 and DP_2 and cause the electron stream to pass midway between the deflection plates. If the tap on R_1 is moved toward ground, the negative bias on T_1 is increased, which decreases its plate current, and increases the voltage at its plate and consequently the voltage applied to DP_1 . With DP_1 driven positive the electron stream will be deflected toward it. At the same time, phase inversion action of R_k will drive the grid of T_2 in a positive direction, increasing the plate current of T_2 and decreasing the positive voltage at DP_2 which will decrease its attraction of the electron stream, and the electron stream will be further deflected toward DP_1 .

There will be essentially no lag between movement of the positioning control R_1 and positioning of the spot itself. Strictly speaking, there will be a slight delay since the voltage across C_1 must change with each change of the setting of R_1 but this delay is so brief that the spot appears to move as rapidly as it is possible to manually vary R_2 .

In applying this arrangement, it should be noted that the deflection plates are about 300 volts positive with respect to ground and their voltage with respect to the other elements of the tube is increased accordingly. It may be necessary to adjust the first and second anode voltages applied to the tube in order to retain sharp focussing. In particular it should be necessary to raise the second anode voltage to a value corresponding to the average deflection plate voltage but experience with this has been inconclusive. It should also be noted that the screens of T_1 and T_2 are not bypassed in order to permit the voltage drop across R_k to reinforce the phase inversion action of R_k .

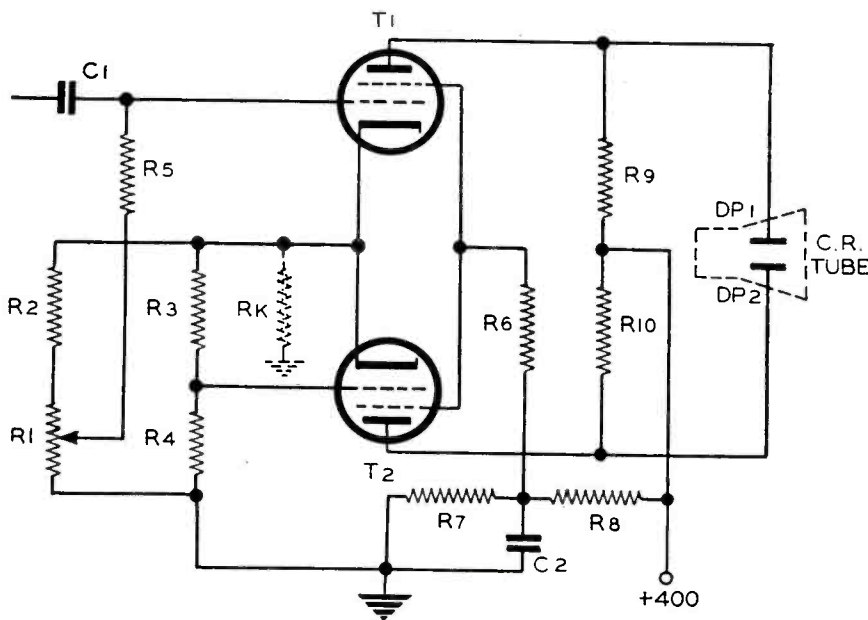

Figure 1

- | | |
|----------------------------|------------------------------|
| R_1 1000 ohm wire-wound. | R_7 10,000 ohm, 5 watt. |
| R_2 500 ohm wire-wound. | R_8 25,000 ohm, 5 watt. |
| R_3 1000 ohm, 1 watt. | R_9 30,000 ohm, 5 watt. |
| R_4 500 ohm, 1 watt. | R_{10} 30,000 ohm, 5 watt. |
| R_5 ½ megohm, 1 watt. | C_1 0.5 mfd. |
| R_6 50,000 ohm, 1 watt. | C_2 8 mfd. electrolytic. |

Crystal Ball Dep't

The Journals addressed to the following are undeliverable by the United States Post Office, for the reasons stated by the Post Office on P. O. Form No. 3547, as follows:

R. P. Bord (Dixie)—moved.
 D. I. Conley (Fairmont)—moved.
 F. Anthony (Cleveland)—moved.
 M. Rhodes (Engineering)—moved, left no address.
 J. C. MacDonald (New York)—moved.
 V. L. Harvey (San Francisco)—moved.
 W. B. Joyner (San Francisco)—moved.
 R. L. Gartner (Hollywood)—moved, left no address.
 H. C. Gray (Hollywood)—moved.
 M. B. Jacobs (Hollywood)—moved.
 J. C. Marino (Hollywood)—moved.
 F. H. Ragsdale (Hollywood)—moved.
 M. F. Turner (Albuquerque)—moved.
 J. R. O'Kelly (Hollywood)—moved.
 J. P. Moses (Boston)—moved.
 R. T. Keowen (Engineering)—moved.
 C. McElroy (Denver)—moved.
 C. H. Cassidy (San Francisco)—moved.
 M. Knodel (Chicago)—not there.
 J. D. McLeod (Hollywood)—unknown.
 R. Study (New York)—unknown.
 V. G. Klein (Richmond)—moved, left no address.
 R. McNally, Jr. (Baltimore)—moved.
 E. L. Tolleson (Chicago)—moved.
 G. McCrary (Raleigh)—moved.
 M. D. Holland (New York)—moved.
 F. C. Shidel (Chicago)—moved.
 T. K. Abernathy (Richmond)—moved.
 W. S. Carson (Engineering)—moved.
 H. B. Okeson (Cleveland)—moved.
 P. R. Quay (Cleveland)—moved.
 H. I. Powell (Hollywood)—moved.
 S. Lowell (Albuquerque)—moved.
 S. A. Blank (San Francisco)—moved.
 H. C. Root (Albuquerque)—moved.
 W. T. Holl (Louisville)—moved.
 F. A. Oliver (San Francisco)—moved, left no address.
 C. W. Ross (Pittsburgh)—moved.
 A. Nilson (Hudson)—moved.
 A. P. Davis, Jr. (Boston)—moved.
 W. Wright (New York)—moved.

How Gray Can My Hair Get Department

We become amazed at different times about different things. This time the subject seems to be, "What is a proper and complete address as recognized by the Post Office Dep't.?"

For example, if we received a complaint of non-receipt of the Journal, and the note was signed,

Ed Dold, Dixon, California

We would be as perplexed as a broadcaster without a microphone! Now, of course, the Post Office couldn't properly deliver our note to Mr. Dold, in which we would have asked him for his complete and proper address, so that we could add his name to the Journal's mailing list. Could this have really happened? Yeah, man!

A

A



ALLIED

*The Name to Remember for
Quality in Recording Discs*

ORDERS SHIPPED PROMPTLY

ALLIED RECORDING PRODUCTS COMPANY

21-09 43rd Ave., Long Island City, N. Y.

Phone STillwell 4-2318 Cable: Allrecord, New York

The 1947 Winter I. R. E. Meeting

Summaries of Technical Papers — Continued From Last Issue

By Ed Stolzenberger

No papers are available in preprint or reprint form nor is there any assurance that any of them will be published in the "proceedings of the I.R.E." although it is hoped that many of them will appear in the subsequent issues.

AIDS TO NAVIGATION

Chairman, W. L. BARROW

(Sperry Gyroscope Company, Inc.,
Great Neck, L. I. New York)

21. Relations Between Band-Width, Speed of Indication, and Signal-to-Noise Ratio in Radio Navigation and Direction-Finding.

H. Busignies and M. Dishal

(Federal Telecommunication Laboratories,
New York, N. Y.)

Theoretical and experimental results obtained in the last few years in direction finders and radio aids to navigation are considered. The relation between speed of position determination, bandwidth, noise and radio-frequency stability indicates that bandwidths 100 times too large are commonly used. The naviglobe system and loran are also discussed.

22. Targets for Microwave Radar Navigation.

S. D. Robertson

(Bell Telephone Laboratories, Inc.,
New York, N. Y.)

The effective echoing areas of certain radar targets can be calculated, while other more complicated structures have been investigated experimentally. This paper considers a number of practical targets with emphasis on trihedral and biconical corner reflectors. Especially designed targets of high efficiency may be of aid to radar navigation.

23. A Comparison of Interrogation By Search Radars and By Separate Interrogators in Pulse Transponder Systems.

F. A. Darwin

(Hazeltine Electronics Corporation,
Little Neck, L. I., New York.)

Marked similarity between transponder-interrogators and search radars is pointed out, as well as the differences desirable in their characteristics. Features of a single equipment performing both functions are outlined, concluding that, for adequate traffic-handling capacity with minimum complexity, radars are best used as radars, with separate, servile, interrogators in cooperation.

24. Low-Frequency Loran.

V. S. Carson, S. Seaton, M. Rothman,
and M. Pomerantz

(Watson Laboratories, Red Bank,
New Jersey.)

The theory and operation of low-frequency loran is described. A comparison of its operation with standard loran and an evaluation of the relative merits of each system is presented. Part II of this paper summarizes operational results achieved with this system and discusses many problems and effects which have been observed in Arctic operations.

25. Elimination of Precipitation Static.

W. H. Bennett

(National Bureau of Standards,
Washington, D. C.)

Space-charge limitation of current generally prevents existing devices from eliminating severe static, and the polyethylene-inserted antenna wire which has been proposed is open to serious objection. A more nearly ideal solution will be presented and its physical characteristics analyzed.

NUCLEONICS INSTRUMENTATION

Chairman, W. C. WHITE

(General Electric Company,
Schenectady, N. Y.)

26. Nucleonics Instrumentation.

V. C. Wilson

(General Electric Company,
Schenectady, New York.)

Emphasis will be placed upon the problem and requirements of electronic instruments in the fields of nuclear research and engineering, pile and other process control, and health protection. Brief descriptions of some of the new instruments will be given for purposes of illustration.

27. Proportional Counters and Geiger Counters.

S. A. Korff

(New York University, Washington Square,
New York, N. Y.)

Proportional counters are built for the purpose of distinguishing between neutrons, alpha particles, electrons, protons or gamma rays, and for counting the numbers of each. Geiger counters, and coincidence combinations, and anti-counters will be described and discussed. Operations and applications will be stressed.

28. Cloud Chambers.

G. C. Baldwin

(General Electric Company,
Schenectady, New York.)

The cloud chamber employs preferential

condensation of supersaturated vapor about ions produced by energetic charged particles to reveal the individual history of each particle's passage through a gas. Techniques of cloud chamber operation and methods by which a particle's nature is determined from its track in a cloud chamber will be discussed with illustrative photographs taken in experiments with the 100-million-electron-volt betatron at Schenectady.

29. Applications of the Vibrating-Reed Electrometer.

W. P. Jesse

(Argonne National Laboratories,
Chicago, Illinois.)

This instrument, developed by Palevsky, Swank and Grenchik, is of the dynamic condenser type, suitable for measuring small currents or charges. An A.C. component is generated by a magnetically driven vibrating reed which constitutes the lower plate of the condenser. This A.C. component is amplified, rectified, and degeneratively fed back to the oscillating system. The background current of the instrument is about 10 to 17 amperes. Applications of this instrument to nuclear work will be discussed.

30. Pulse Amplifiers for Ionization Detection.

M. Sands

(Massachusetts Institute of Technology,
Cambridge, Massachusetts.)

The equivalent circuits of ionization detectors and the pertinent characteristics of electrical pulse counters are discussed. A pulse amplifier is considered as a coupling device between the two. Desirable properties and possible methods of achieving them are described. Gain, stability, pulse shaping (band width), and signal-to-noise ratio are covered.

MICROWAVE COMPONENTS AND TEST EQUIPMENT

Chairman, W. H. DOHERTY

(Bell Telephone Laboratories, Inc.,
Whippany, N. J.)

31. Experimental Determination of Helical-Wave Properties.

C. C. Cutler

(Bell Telephone Laboratories, Inc.,
New York, N. Y.)

The properties of the wave propagated along a helix used in the traveling-wave amplifier are discussed. A description is given of measurements of field strength on the axis, field distributions around the helix, and the velocity of propagation. It is concluded that the actual field in the helix described is about

10 per cent stronger than would be predicted from the relations developed by J. R. Pierce for a hypothetical helical surface.

32. A Stabilized Magnetron for Beacon Service.

C. P. Vogel and B. B. Brown

(RCA Victor Division, Radio Corporation of America, Lancaster Pennsylvania.)

J. S. Donal, C. L. Cuccia and W. J. Dodds

(RCA Laboratories Division, Radio Corporation of America, Princeton, New Jersey.)

The 2J41 is a stabilized, tunable, pulsed magnetron, designed for 9310-megacycle portable beacon equipment. The power output is 300 watts peak at 0.3 per cent duty. The tube is of header construction with the magnetic inserts at cathode potential. Frequency stabilization is obtained by use of an external permanently coupled to the output circuit of the tube.

33. Coupled-Circuits Used as Tunable Band-Pass Filters in the Ultra-High-Frequency and Microwave Regions.

R. O. Petrich

(Airborne Instruments Laboratory, Inc., Mineola, New York.)

Tunable over-coupled circuits suitable for use as preselectors in the ultra-high-frequency and microwave regions are described. Electrical and mechanical design characteristics are given, and techniques employed in tuning and matching over a 2-to-1 frequency range are discussed. Ganged coaxial resonators are employed, with aperture-type inter-circuit coupling.

34. Broad-Band Very-High-Frequency Amplifiers.

A. M. Levine and M. G. Hollobaugh

(Federal Telecommunication Laboratories, Inc., New York, N. Y.)

Problems encountered in the design of wide-band intermediate-frequency amplifiers, are described. These amplifiers are novel in that the center frequencies are somewhat higher than those usually encountered, being located in the region above 100 megacycles. Considerations of choice of tube types, comparisons between various coupling means including the use of inverse feedback, and performance are covered.

35. The Measurement of Delay Distortion in Microwave Repeaters.

D. H. Ring

(Bell Telephone Laboratories, Inc., New York, N. Y.)

The delay distortion which is present in wide-band amplifiers with flat amplitude response is examined to determine the precision required for significant measurements. It is found that a precision of better than 0.001 micro-second in relative delay measurements is desirable.

Measuring equipment operating in the intermediate-frequency range from 50 to 80

megacycles with the required precision is described.

TELEVISION A

Chairman, D. B. SINCLAIR

(General Radio Company, Cambridge, Mass.)

36. Synchro-Lite for Television Film Projectors.

L. C. Downes and J. F. Wiggin

(General Electric Company, Schenectady, New York.)

It has been customary in motion-picture projectors for television to make use of a continuous source of light interrupted by a mechanical shutter. The pulsed light source discussed in this paper accomplishes the desired result electronically without the use of mechanical shutters. A gas-discharge flash lamp is used. Its timing is accurately controlled by a television synchronizing signal.

37. Video-Frequency Negative-Feedback Amplifiers.

M. G. Hollobaugh, J. A. Rado and A. M. Levine

(Federal Telecommunication Laboratories, Inc., New York, N. Y.)

The use of negative feedback in lieu of complex coupling networks to obtain wide-band high-gain amplification is applied to amplifiers for video frequencies. A general theory is developed, giving figures of merit which permits comparison with other types of video-frequency-amplifier circuits. Experimental results for several types of actual amplifiers using the principles stated are described.

38. Radio-Frequency Performance of Some Receiving Tubes for Television.

R. M. Cohen

(RCA Victor Division, Radio Corporation of America, Harrison, New Jersey.)

Several receiving-type tubes may be used to advantage in television receivers designed to tune all 13 channels. This paper discusses the performance of these tube types in radio-frequency amplifiers, mixers, and local-oscillator applications. Both push-pull "balanced" circuits and single-ended "unbalanced" circuits are discussed. Data are presented for over-all gain, noise, image rejection, and oscillator frequency stability. These data are taken at two respective points in the band: 60 and 200 megacycles.

39. A Theory of Multistage Wide-Band Amplifier Design.

W. E. Bradley

(Philco Corporation, Philadelphia, Pennsylvania.)

A technique of great flexibility and power in the design of multistage wide-band amplifiers, developed in the course of television research between 1938 and 1941 in the laboratories of the Philco Corporation, is described. The method is especially applicable to amplifiers in which the individual stages

are sufficiently simple so that the algebraic expression for stage gain is easily calculable.

40. Recent Advances in the Design of Intermediate-Frequency Amplifiers for Television Receivers.

C. Marsh

(Allen B. DuMont Laboratories, Passaic, New Jersey.)

A survey is made of the factors to be considered in the design of a video intermediate-frequency system. New factors and problems introduced by the use of the higher intermediate frequencies are discussed. Some practical systems are described and compared from the standpoint of performance and manufacture. No attempt is made to recommend any particular amplifier system.

(CONTINUED NEXT MONTH)

Trade News

* Harry Adelman, Scenic Radio, N. Y., became the proud father of a daughter, Barbara Ruth. Cigars at 53 Park Place!

* Turkish government has ordered a 150 kw RCA transmitter capable of operation between 540 and 1600 kc, and complete broadcast studio and plant facilities. "Radio Istanbul" will become one of the most powerful radio voices in the world.

* The General Radio "Experimenter" for March contains an interesting item on the development of its search (intelligence) radar receiver, having a frequency range of 40 to 4000 mc!

* Chicago Radio Parts Show—week of May 11, 1947. A four-day national electronics equipment show, which is expected to excel prior shows, will be held in Chicago from May 11 thru May 16th, at 111 W. Washington St. The radio show is operated on a non-profit basis, and is jointly sponsored by the National Electronic Distributors Ass'n, Assoc. of Electronic Parts & Equipment Mfgs, Sales Managers Club Eastern Division, and the Radio Manufacturers Ass'n.



If it concerns the Broadcast Engineer, he will read it in The Broadcast Engineers' Journal.

— FOR SALE —

LEAD COVERED CABLE

200,000 FEET

NEW ON REELS, Single conductor lead-covered flexible cable. No. 14 gauge stranded. 1/64" lead wall. Insulation is Cambric wrap, cotton braid on Cambric. 41 strands of No. 33 tinned wire. 7 Cambric wraps. One cotton weave (paraffin). Price 10c per foot f.o.b. Indianapolis.

H. KAUFMAN COMPANY

1415 So. Senate Ave.

Indianapolis, Ind.

COPIES

**BY DIRECT CUTTING
OF YOUR RECORDINGS**

33 $\frac{1}{3}$ RPM transcriptions
for broadcast or audition
use.

24 HOUR SERVICE
—packaged and shipped
from Chicago.

Aluminum based material
available for broadcast use.

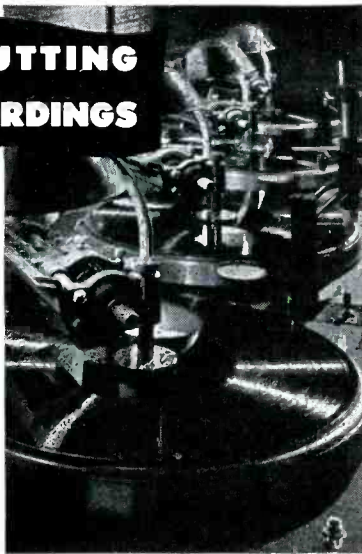

Write for
complete
details and
prices.

L. S. TOOGOOD

RECORDING COMPANY

221 N. LA SALLE ST. CHICAGO 1

New York Calling

By Gil McDonald

WE HAD planned to devote this column entirely to a description of the New York NBC Recording setup complete with pictures but we failed to reckon with a serious shortage of flash bulbs. They are as scarce in New York as soap in the Collyer mansion.

Congrats to Al Bradley of ABC Studio who married Peggy Lloyd on March 21st. Lots of luck and a very happy married life to both of you. Peggy is mistress of ceremonies on an early morning show over WOV, one of the New York independent stations.

Sal Salanitro of maintenance has been hibernating in the equipment room for the past few weeks. His current job is to bring the studio prints up to date due to the many changes going on in the studio section.

His many friends at Both NBC and ABC join in congratulating Ray Guy of engineering on his selection as treasurer of the Institute of Radio Engineers.

Pete Narkon's wife thinks she married a blue-beard. Just about the time Pete put his 400 watt CW rig on the air, the XYL bought a beautiful new silk bed spread. Every time she makes the bed, she gets a terrific static discharge, and now refuses to have anything to do with the aforementioned spread unless she wears rubber gloves. She is quoted to have told Pete, "Everything was so nice around here until you built that fool wireless. Now I think you're trying to do me in."

ABC lost two of its best liked studio engineers this month. Al Hayward left to work for ABC in Hollywood and Jim Taylor left to work for a new electronic advertising project at better pay, better hours, better future . . . hey bub, do you need a hepler (Helper that is!). Lots of luck to two nice guys.

Mel Lewis and Al Neu of maintenance busy making extensive changes in the equipment room.

There is a real knock 'em down and drag 'em out DX contest going on among Gil McDonald, Merle Worster, Bill Tague, and John O'Neil on 20 meter phone. The scores resemble Johnny Pawlek's famed Hollywood golf scores. We don't eat candy or tell lies during Lent, so we'll report the results next month. 73—Gil.

New York News

By Ted Kruse

After an absence of a few years, I am once again committing my I.Q. to public perusal. Nothing much has happened outside of a major war, world wide economic changes and the liquidation of some long standing friends. Nothing much at least has changed in New York. It is still the most coldblooded and unfriendly city in the U. S. This may be denied, but it is a fact. A fellow worker may drop dead on Sunday and it would be Friday before ten percent of the New York Chapter membership would know about it. Every member leads his own important life (in a small way) and the dickens with everyone else. Chicago, while almost as large, seems to keep that small town interest in his fellowman. Perhaps due to its size, N. Y. just does not give a hang about the other fellow. Proof of this is the fact that the engineers in Chicago, Washington, etc., manage to get together at least once a year. They meet, talk, get to know each other, and enjoy themselves in a spirit of friendship. In New York, you would have to club the membership with an assessment before anyone would attend an affair. This spirit is reflected in our union relations. We in New York are the most uninformed and misinformed group in the country. We gripe more and do less than anybody. The strange part of this, is the fact that the average New York Chapter member is not a native New Yorker, so it must be the "hugeness" of the Big City.

Art Poppele, Telev. Mtee., will be out for a few weeks due to a collapsed lung. This happened when Art stretched and took a deep breath at the same time. Caution! If you feel like taking a deep breath, play it safe and take two small ones.

Dave Moloney, the Engineering Dept. Master of Ceremonies, has finally returned to the fold. Dave has been in Hollywood about a year building new studios for NBC.

John O'Neill, SE ABCO, has just reported for duty after a siege of pneumonia and a relapse. Johnny looks a little "peaked" but otherwise feels fine.

Einar Johnson transferred from Empire State television and FM transmitter to Audio Maintenance where his varied talents will come in handy.

Hollywood's gain is our loss with the transfer of Al Hayward to the coast. Al is a great person and a good worker. We know he leaves with best wishes from everyone.

Willard "Red" DuBois, SE, will be out of circulation for a few weeks due to a work-connected hernia operation. In his absence, George (I Hate People) Mathes will handle the Fred Waring Show.

FM News

* G.E. proposes a 2½ watt FM installation for educational institutions, to permit low-budget schools to utilize the channels assigned to educational services (non-commercial). The range is expected to cover the average campus, and signal would be received on regular FM receiver.

* RMA-member companies report 1946 transmitter sales as follows:

AM — \$10½ million;

FM — \$4¾ million;

Television — \$4¾ million.

* Those reports of excessive FM frequency drift have backfired. FCC sets transmitter frequency tolerances; these tolerances are always exceeded by reputable manufacturers. Receiver stability tolerances and standard tests are a simple matter for the RMA and the FMA to handle. No serious problem exists.

* RMA survey of FM receiver production estimates 2.6 million sets with FM facilities will be manufactured during 1947; majority will be AM-FM consoles due to higher FM manufacturing costs.

* FM transmitter manufacturers estimate they will deliver more than 700 FM transmitters during 1947.

* A recent survey by the Radio Manufacturers Association indicates that radio set manufacturers are planning to produce approximately 2,600,000 receivers with FM facilities in 1947. The majority of them will be AM-FM consoles due to higher FM manufacturing costs.

A special RMA committee on FM, appointed by RMA President R. C. Cosgrove, to make a "realistic" report on the outlook for FM set and transmitter production this year, however, took a more cautious view, after a thorough analysis of all factors, and estimated that the 1947 output of FM sets possibly will be between 1.8 and 2.1 million because of anticipated production difficulties.

The RMA committee, which presented its report at a meeting with a committee of the FM Association at the Statler Hotel on April 8, said it is "most encouraged" by the 1947 outlook for FM set and transmitter production but warned that the growth of this new broadcasting service will be gradual and would be hampered rather than aided at this time by the manufacturing of "cheap FM sets" which would not realize the full advantages of FM broadcasting.

The special RMA Committee on Liaison with the FMA is headed by L. F. Hardy, vice-president of the Philco Corp., Philadelphia. Other members are: Ben Abrams, president of the Emerson Radio & Phonograph Corp., New York; E. A. Nicholas, president of the Farnsworth Television and Radio

(Continued on Page Twenty-four)

CAPPS*

SAPPHIRE is, and has always been, the only material for making cutting styli for high class recordings.

CAPPS* Patented Sapphire Styli (2187512) are the original and accepted standard for high class professional acetate recordings.

Imitated but not equalled

FRANK L. CAPPS & CO., Inc.

244 W. 49th STREET NEW YORK CITY

Telephone Circle 6-5285

Reg. U. S. Pat. Off.

for your work or hobby

NEWARK OFFERS YOU

Source of supply for all radio and electronic equipment and parts. Products of leading manufacturers in the industrial as well as home equipment fields. Complete stocks.

Through its Bargain Bulletins, the latest news about the latest developments in radio and electronic equipment. Get on the list to receive these valuable bulletins regularly.

Prompt, speedy delivery on orders. Expert and courteous advice on equipment and parts problems.

Complete stocks of all leading public address systems, plus able advice on setting up special installations.

Visit any one of our three large stores. You will find complete stocks of industrial equipment and parts as well as home, appliance and radio equipment. Send us your name and address and ask for Bargain Bulletins

• Mail Orders Filled From Either New York City or Chicago
• Write 212 U W. 55th St., N. Y. C. or 323 U W. Madison St., Chicago

NEW YORK
Offices & Warehouse
242 W. 55th St., N.Y. 19

NEWARK
ELECTRIC COMPANY, INC.

CHICAGO
323 W. Madison St.
Chicago 6, Ill.

New York City Stores: 115-17 W. 45th St. & 212 Fulton St.

NABET Activity

(Continued from
Page Three)

* Excerpts from talk *Relation of the Engineering Profession to Industry* before IRE National Convention, by Dr. C. B. Jolliffe, Executive V.P., RCA Laboratories:

"... We should break out of our professional shell and become better citizens. In fact, I think a broadening of interest would make us better engineers."

"... You can exert a profound influence on community life, business, and government. But first, you must convince others of your availability for expert counsel and leadership. You must abandon the 'ivory tower'."

"... The requirements of leadership are simple, yet exacting. In the engineering field, they call for a broadening of interest, and an exercise of duty over and beyond the technical limits of our profession. We must acquire a greater knowledge of human behavior, business operations, and social institutions. Only by so doing can we be prepared to accept greater responsibilities."

"... As competition grows, engineers will be subjected more and more to commercial and political pressures for the sake of expediency. These pressures must be resisted with all of our power..."

"... As professional men, zealous of our position in society, we must be prepared to deal summarily with those who would lower our standards".

FM News

(Continued from
Page Twenty-three)

Corp., Fort Wayne, Ind.; H. C. Bonfig, vice-president of the Zenith Radio Corp., Chicago; and S. P. Taylor of the Western Electric Co., New York, and chairman of the RMA Transmitter Division. RMA President Cosgrove, general manager of the Crosley Division, Cincinnati, is an ex-officio member of the committee.

Radio manufacturers, as well as their distributors and dealers, are just as anxious to sell FM sets as are the FM broadcasters to build up listening audiences, the committee declared. But manufacturers also must serve the needs of standard or AM broadcasters and their millions of listeners, many of whom do not have FM services, it added. Publicity by some FM broadcasters advising listeners not to buy a radio set "unless it has an FM band," the manufacturers said, "is not constructive but destructive to FM."

"It is true that under the right conditions, FM supplies certain advantages to the consumer. As far as the public is concerned, these advantages will be realized when stations of sufficient power are broadcasting, and their radio set is of such a character as to allow them to receive the transmission with the lack of noise and the added fidelity that are inherent in FM.

SUBSCRIPTION BLANK

THE BROADCAST ENGINEERS' JOURNAL
116-03 91st Avenue, Richmond Hill 18, N. Y.

Gentlemen: Please enter my subscription to The Broadcast Engineers' Journal to start with the next issue.

Name..... (Station.....)

Address

City, P. O. Zone, State.....

Check attached for \$2.50, 1 year; \$4.00, 2 years.

"In addition to this, however, the program material must be of such a nature as to attract the listener and make him want to make the necessary additional investment in the radio product which is required by the added FM service."

Pointing out that it has taken approximately 25 years to make possible the present AM radio program service and to provide the public with sixty million receiving sets, the committee commented: "It is obvious that the creation of such an audience for FM, even at enormous production levels, will take some time."

The radio manufacturing industry, the committee said, has produced approximately as many FM radio sets during the first quarter of 1947 as it did during the entire year 1946, and the production rate is expected to continue climbing each month. March's output of 67,364 brings the quarter's total to 172,276.

"It is very natural and realistic that an added service of the nature of FM should be first presented and applied to sets of the more expensive class, inasmuch as this class of merchandise can most readily absorb the increased cost without greatly affecting the retail price," the report stated.

Television News

* Chicago will have an NBC television station in operation some time in 1948.

* Crystal-ballers expect million-dollar sports gates to be dwarfed with the advent of commercial theatre television.

* Considerable personnel changes at WABD-DuMont NY tele; streamlining in the executive setup, with Sam Cuff out and Leonard Cramer in as general manager; program activities not to be curtailed.

* WCBS-TV going right ahead with its black and white programming, and has sold several new accounts.

* DuMont offers a low-cost tele installation at \$90,000, considerably under nearest competitive figure.

* WDDT Detroit's first tele station, on the air, and demonstrating the feasibility of this new Ad medium to the agencies and sponsors.

* FCC has extended effective date of its mandatory minimum 28-hour tele programming week to July 31st.

* RCA announces increased brightness for its 15 x 20 inch projection tele receiver, comparing with brightness of direct-view kinescopes.

* "Zoomar" lens developed by Dr. Bach; features variable angle of view. In use, the Zoomar lens is mounted on tele camera, and set at long focal length for large close-up of face. The lens is focused, and no further change of focus is required unless the relative distance between subject and lens is changed. Now, by operation of the focal length control, the focal length of the lens system is continuously and smoothly shortened, and the subject appears to move away from the camera to a full length shot. In this case, the diameter variation was approximately 8 to 1. Early reports in the lay press erroneously suggested the Zoomar would replace, or make unnecessary, the present cameramen or camera dolly manipulators. We believe time will indicate that this will not be the case, and instead, the novel lens system will find its prime use as a special effect device. In its present form, the lens system is quite large and bulky, and resolution is inferior to the capability of the television system. Thirty years of movie making and ten years of television hasn't uncovered a substitute for a skilled cameraman. Amen.

More Broadcasting Stations ...



1947

1946
1945
1944
1943
1942
1941
1940
1939
1938
1937
1936
1935
1934
1933
1932
1931
1930
1929
1928
1927
1926
1925
1924
1923
1922
1921
1920
1919
1918
1917
1916
1915
1914
1913
1912
1911
1910
1909
1908
1907
1906
1905
1904
1903
1902
1901
1900

... for more years ...

... have used more

Presto 6 N's than any

other recorder

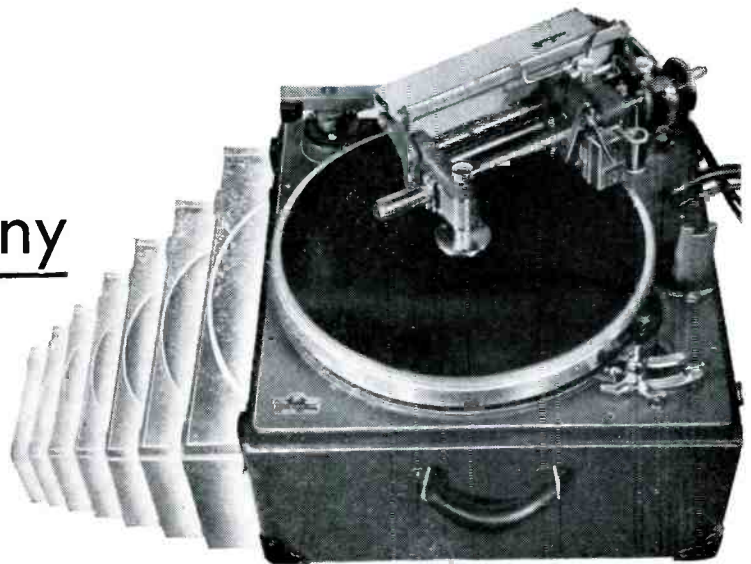

RECORDING CORPORATION • 242 WEST 55TH STREET • NEW YORK 19, N. Y.

Walter P. Downs, Ltd., in Canada

World's largest manufacturer of instantaneous sound recording equipment and discs

DAVEN ENGINEERING

AGAIN BRINGS YOU A NEW AND *Better* ATTENUATOR

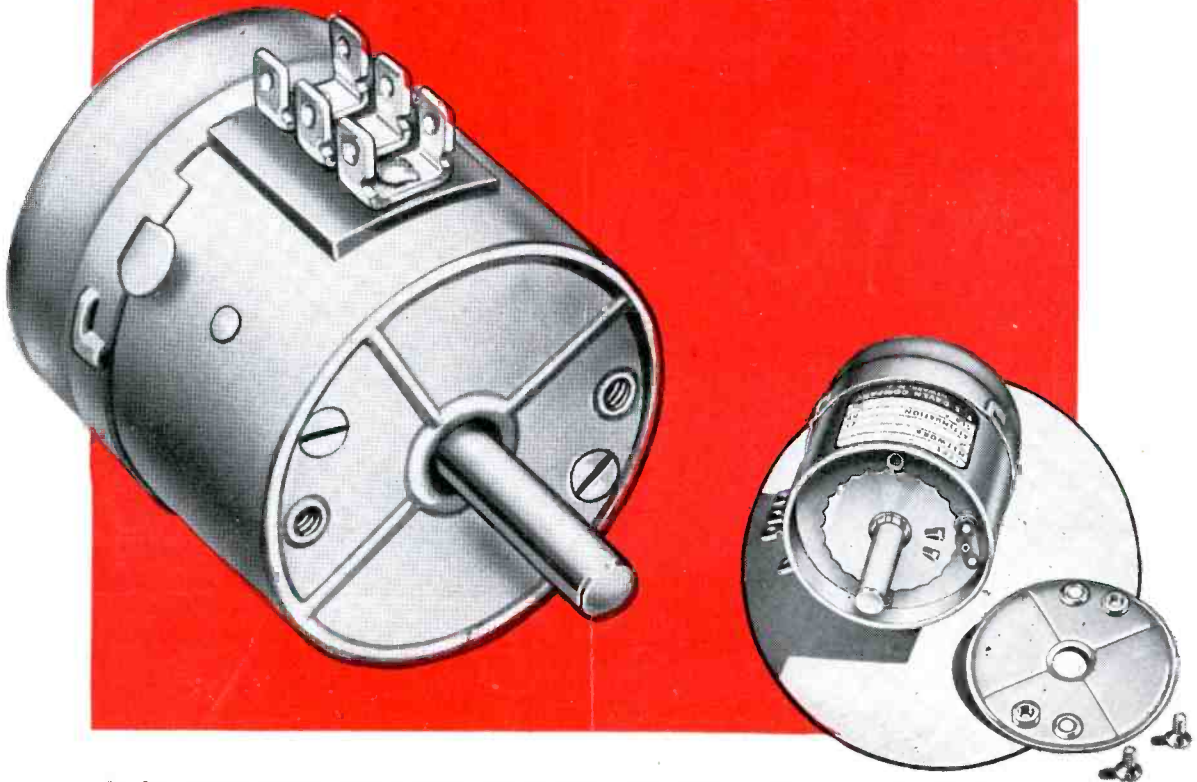

In keeping with our policy of continually improving our products, we have developed a new and better design for the mechanical construction* of our attenuators. In addition to improved standard features, the latest Daven units offer a choice of mountings and an optional ground lug. Dimensions of the new type attenuators make them interchangeable with preceding models.

*Patent Pending.

IMPROVED FEATURES

- ▶ A non-ferrous can with an attractive finish.
- ▶ A dust-proof housing which provides total shielding.
- ▶ A two piece can with a positive lock, which is constructed so that the dust cover can readily be removed with one hand. No more screws or knurled nuts to strip, misplace or drop.
- ▶ 50% less space is required than heretofore to remove the new shallow dust cover, thus permitting the unit to be mounted in a smaller space than formerly.
- ▶ Good electrical contact is assured between the front of the unit and the back cover.
- ▶ All fibre and other moisture absorbing parts have been eliminated.
- ▶ A ground lug on the shield may be supplied, if required.
- ▶ Two hole mounting is standard on the new type units, however single hole mounting may be secured.
- ▶ A roller type detent, as shown above, replaces the former ball and spring mechanism. Advantages of the roller detent are longer life and more positive action.

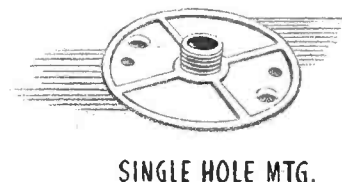
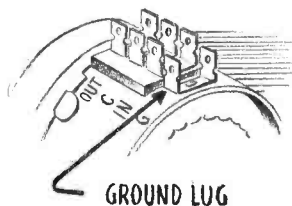
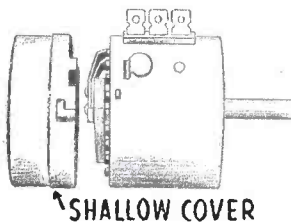

May we suggest, when purchasing speech input equipment, that you specify DAVEN CONTROLS.

THE **DAVEN** CO.

191 CENTRAL AVENUE
NEWARK 4, NEW JERSEY

www.americanradiohistory.com