

# BMTE

THE MAGAZINE OF BROADCAST MANAGEMENT/ENGINEERING

## KLPR-TV SPOTLIGHTS COUNTRY PROGRAMS

BM-4-81-15-1  
J D BROOKBANK-CHF ENG  
WMNI  
289 AVERY RD  
HILLIARD OHIO

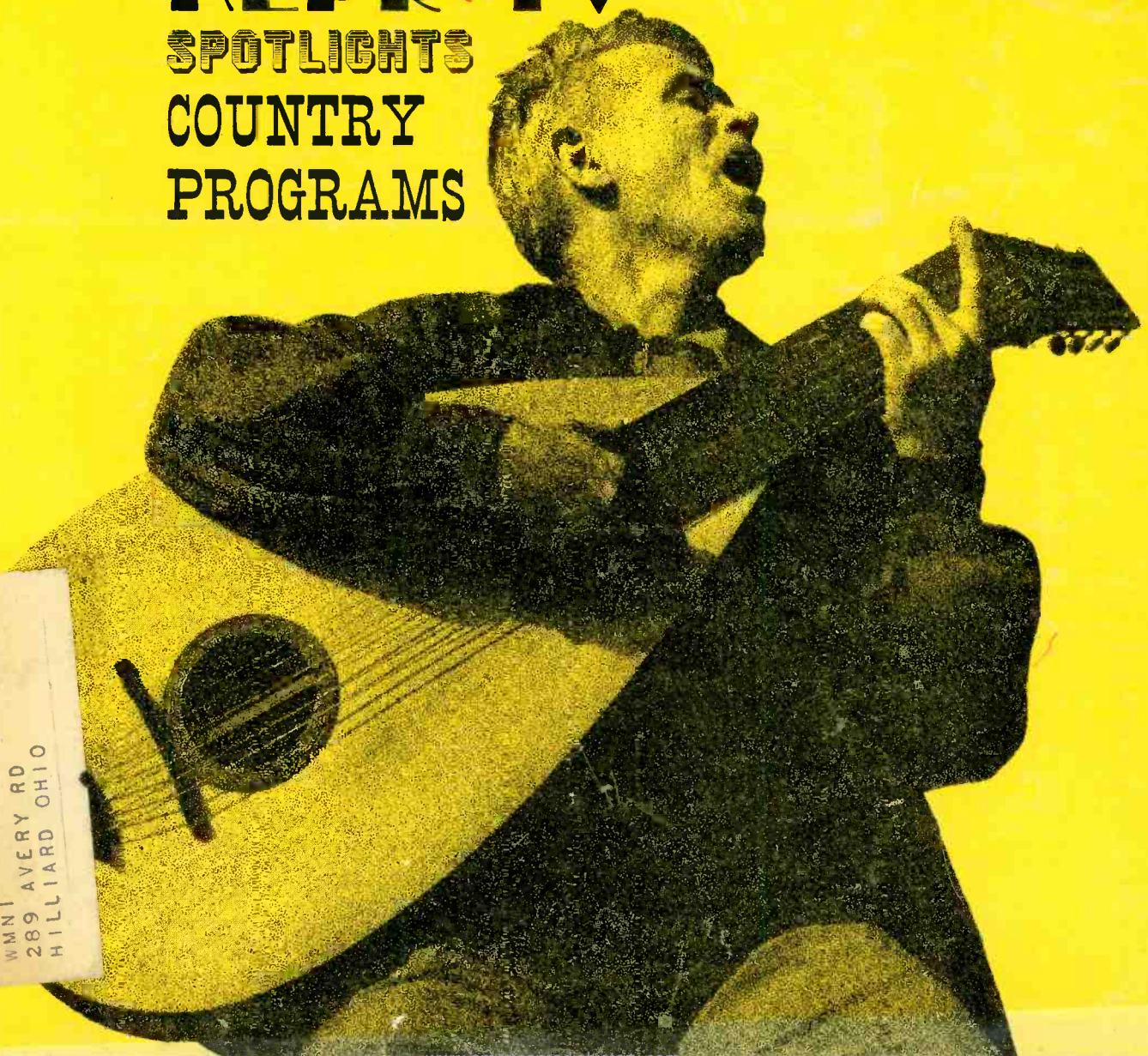



## what does it take to be first in CATV (and how do you stay there) ?

Jerrold's answer is: "Customer satisfaction!" Our systems satisfy the CATV owner/operator because they're engineered for subscriber satisfaction. When you buy Jerrold, you get . . .

**Reputation**—15 years and 1,700 systems after we equipped the first commercially successful CATV system, more CATV operators depend upon Jerrold for subscriber satisfaction than upon any other single source. *Jerrold is Number One* in the CATV industry.

**Know-how**—Jerrold has consistently maintained the industry's largest

staff of development engineers. A staff which has provided such "firsts" as the Channel Commander which made 12-Channel systems a



**STARLINE MAIN-TRUNK STATION**  
All active equipment for any specific location fits into a similar compact housing.

reality. A staff which is justifiably proud of its latest "first": Starline—the new standard for solid-state CATV distribution system quality and performance.

**Services**—Jerrold has built more systems on a "turnkey" basis than any other manufacturer/contractor in CATV. Our nationwide organization can help you in any and every stage of providing a profitable CATV system—from marketing and engineering-surveys, through system engineering and construction, to turning over to you a complete, operating system.

Whatever your CATV requirement—consult Jerrold first. Call 215-925-9870 or write: CATV Systems Division, **JERROLD ELECTRONICS CORPORATION**, 401 Walnut Street, Philadelphia, Pa. 19106

**JERROLD**

**FIRST IN CATV** The nation's largest, most experienced manufacturer/supplier of CATV equipment and services.

Circle 2 on Reader Service Card

Every TV Station  
Doesn't Use Belden  
Wire and Cable...

but most of them do!



## like **WBAL-TV**

### BALTIMORE

In their new \$2,000,000 studio building, Belden Audio, Camera, and Control Cables were used exclusively.

## **WGN-TV**

### CHICAGO

In this mammoth new Mid-America TV and radio broadcasting center, 90% of all Camera, Microphone, and Audio Cables are Belden.

## **KTRK-TV**

### HOUSTON

The exclusive use of Belden Camera, Audio, and Control Cables by this ABC affiliate helps them to maintain their continuous, highly efficient programming.

power supply cords • cord sets and portable cordage • magnet wire • lead wire • automotive wire and cable • aircraft wires • welding cable

**Belden**

The extensive use of Belden wire and cable by radio and television stations reflects the engineered quality of all Belden wire and cable. It offers lighter weight, lower coefficient of friction, greater flexibility, easier termination, and exclusive Beldfoil\* insulations for elimination of crosstalk.

Belden manufactures a complete line of wire and cable for all TV and radio broadcasting, recording studios, remote control circuits, and similar applications. Call your Belden electronic distributor, or write for catalog.

\*Belden Trademark—Reg. U.S. Pat. Off. 8-6-3

**BELDEN MANUFACTURING COMPANY** • 415 South Kilpatrick • Chicago, Illinois 60644

May, 1966 — BM/E

# BM/E

## THE MAGAZINE OF BROADCAST MANAGEMENT/ ENGINEERING

**Publisher:**  
MAL PARKS, JR.

**Editor:**  
VERNE M. RAY

**Corporate Editorial Director:**  
JAMES A. LIPPKE

**Art Director:**  
GUS SAUTER

**Associate Editor:**  
CHARLES BUFFINGTON

**Production Manager:**  
HELEN HORAN

**Editorial Production:**  
INEZ ATHEY

**Circulation Director:**  
H. C. GAINER

**Circulation Fulfillment:**  
N. VARTABEDIAN

**Reader Service:**  
R. R. BELL

**Promotion Manager:**  
E. L. GRAY

**Classified Advertising Manager:**  
EILEEN HESSON

Often improperly indentified with folk, mountain, hillbilly, or western styles, modern "country music" has a popular flavor all its own. This month's cover, intended to dramatize the present popularity of country music, represents a unique combination of old and new. Orange portion at top is opaque view of TV studio lighting system. Singer is John Jacob Niles, "Dean of American Folk Singers," who wrote "I Wonder as I Wander" and "Black is the Color of My True Love's Hair." Also several books, including "Songs My Mother Never Taught Me." (Photo courtesy The Bettman Archives.)

- 6 **Broadcast Industry News**  
Timely reports on events, people, and companies.
- 13 **Interpreting the FCC Rules & Regulations**  
First of two parts concerning the Commission's policies on "duopoly" and "control of mass media."
- 18 **Selecting a Color Camera**  
Place your order for the units which best suit your needs—but don't expect delivery before next year.
- 29 **Design & Operation of Directional AM Antennas**  
Part 5—How to compute the effects of mutual impedance for a two-tower system.
- 32 **KLPR-TV, Pioneer Country Music UHF**  
A new "U" plans to make it with country programming, syndication, and extension of daytime AM service.
- 36 **FM Overmodulation: Cause & Cure**  
How pre-emphasis and de-emphasis affect modulation, and steps you can take to insure proper operation.
- 40 **Promoting & Selling Cable Service**  
Guidelines on how to select and use media to best advantage for your system.

---

- 46 **NAB Convention Review**  
A recap of the greatest show in broadcasting. It was a "really big shew."
- 48 **Convention Exhibit Roundup**  
Details on new equipment at the NAB Convention.

---

- 68 **Broadcast Equipment**  
Reports on newly introduced products and components.
- 75 **Names in the News**
- 76 **Broadcasters' Speak**
- 78 **Literature of Interest**
- 79 **Advertisers' Index**
- 80 **Engineering Casebook**  
How one station uses automatic telephone equipment to provide a weather and news reporting service.
- 81 **Reader Service Card**

MACTIER PUBLISHING CORP., BRYCE GRAY, JR., President  
820 Second Ave., New York, N.Y. 10017, 212 MO 1-0450  
BM/E Editorial & Production Offices: 18 Frederick Rd., Thurmont, Md. 21788—phone 301 271-7151

*Publishers also of:*  
EEE—the magazine of Circuit Design Engineering  
ELECTRONIC PROCUREMENT  
VOLT/AGE—the magazine of Electrical Apparatus Maintenance

BM/E, the magazine of Broadcast Management/Engineering, is published monthly by Mactier Publishing Corp. All notices pertaining to undeliverable mail or subscriptions should be addressed to 820 Second Ave., New York, N.Y. 10017.

BM/E is circulated without charge to those responsible for station operation and for specifying and authorizing the purchase of equipment used in broadcast facilities. These facilities include AM, FM, and TV broadcast stations; CATV systems; ETV stations, networks and studios; audio and video recording studios; consultants, etc. Others please write for subscription prices.

Copyright © 1966 by Mactier Publishing Corp., New York City. Controlled Circulation postage paid at Orange, Conn.

**This is the new FM Volumax.  
It prevents FM overmodulation without distortion.  
It eliminates SCA crosstalk.  
It solves your pre-emphasis problem.**

**It is yours absolutely free.**  
(for 30 days)



Overmodulation. An FM station engineer's headache. Use a clipper and you get distortion. Use a common limiter and you get pumping. You could reduce modulation levels. But that's not the answer.

So CBS Laboratories developed something new. A solid state FM limiting device that replaces common limiters and clippers. And it is unconditionally guaranteed to pre-

vent FM overmodulation and SCA crosstalk *without distortion*.

Hard to believe it does everything we say? Just send this page and your station letterhead. We'll send you the FM Volumax free. (For MPX stations we'll send the stereo model.)

Use it 30 days. After that, send it back if you can part with it. We'll even pay the freight. Or keep it for

only \$695. Double that if you want the stereo model.

AM broadcasters were quick to respond to our free 30-day Audimax and Volumax offer. Now with the new FM Volumax we can make you the same offer. Be the first on *your band*.

**CBS LABORATORIES**  
Stamford, Connecticut, A Division of  
Columbia Broadcasting System, Inc.

Circle 6 on Reader Service Card

# BROADCAST INDUSTRY NEWS

## Church-Owned "U" Orders Color Gear

KITR, San Bernardino, Cal., a church-owned UHF station scheduled to begin colorcasting July 1, has ordered some \$250,000 worth of studio and transmitting equipment from RCA. C. Stephen McDaniel, KITR General Manager, said the contract covered color film and monitoring systems for studios in San Bernardino and Glendale, and a transmitting facility to be erected at Sunset Ridge, a 5,400' point near Mt. Baldy. A 30-kw transmitter, coupled to a pylon DA will enable the new station to serve a viewer potential of 10,000,000 persons in the area between San Diego and Santa Barbara. Mr. McDaniel estimated the UHF receivers in the area at 2,750,000. The new Channel-30 station is owned by Faith Center, an interdenominational church, which also owns KHOF-FM, a 100-kw station in Los Angeles.

## Low-Cost VTR System

Two electronics engineers, in a paper presented at the IEEE Convention, described a system known as the Sonic Vee for producing video playbacks for under \$400 and instant home movie playbacks for under \$650. The authors, George Doundoulakis



New Sparta Electronic facilities in Sacramento, Cal., include a dust-free filtered air system and a new design lab. The building, at 5851 Florin-Perkins Rd., has a special lighting system. This is Sparta's 3rd move to larger quarters in the last five years.

TV cameraman Richard Hance tests the new Fairchild 900 single system sound camera. Considered a revolutionary step forward in 8mm sound photography, the Model 900 has a 200-ft magazine for a running time of 11 minutes on each side of the film. It has through-the-lens focusing and viewing, and sound recording level can be checked with a viewfinder monitoring system. The self-threading camera operates at 18 and 24 fps and is said to be compatible with any standard 8mm projector. Kodachrome II magnetically pre-stripped double 8mm and Du Pont 931A black and white pre-stripped film can be used. Cameraman Hance plans to furnish the WFLD, Chicago, staff with the cameras for candid news specials.



and Ira Kamen, said "the use of standard, low-cost 1/4" tapes, operating at 15 ips, is the breakthrough we have all been waiting for to make home TV playbacks practical and low-cost TV tape libraries available."

The new system uses a novel method whereby fast scan TV pictures can be instantly processed, using extremely narrow bandwidths. The equipment demonstrated produced test pictures with a bandwidth of only 30 kc. Plans are under way for a facsimile test over FM.

## Texas CATV's Meet

More than 600 CATV system owners and operators from Texas and surrounding states convened for the 6th Annual Convention of the Texas CATV Association during the first week-end of April. Highlights of the convention included addresses by Governor John Connolly and Congressman Walter Rogers (D-Tex.). The Congressman is a strong advocate of a "hands-off" policy for federal regulation of CATV, and is the sponsor of the bill placed before the House Commerce Committee to bar FCC regulation of most CATV systems. He has been quoted as doubting that the FCC has authority to issue regulations over CATV.

Other federal and state officials on the convention program

included Congressman Omar Bureson (D-Tex.), Lt. Gov. Preston Smith, House Speaker Ben Barnes, Sen. Tom Creighton, Rep. Ben Atwell, and Mr. Robert Johnson, Exec. Dir. of the Texas Legislative Council. These officials participated in a panel discussion on public affairs.

## NAB Radio Program Clinics

Six radio program clinics will be conducted by the NAB during May and June. Designed to include virtually every phase of radio programming, the clinics will cover country and modern music, "beautiful" music, sports, news, public service, and FM programming. The clinics will be held May 9-10 in Portland, Ore.; May 12-13 in Houston, Tex.; May 23-24 St. Louis, Mo.; May

## Henry Ends Reign

Shortly after his return from Chicago NAB Convention, E. William Henry officially resigned his post as FCC Chairman, effective May 1. There is no news from the Capitol regarding who the President might choose to fill the vacancy. While it could go to one of three Democrats now in office (Robert Bartley, Kenneth Cox, or Lee Loevinger), speculation is that Mr. Johnson will look elsewhere.

**JAMPRO**

# Directionalized Dual Polarized FM Antennas are **PATTERN TESTED** prior to shipment

The new Jampro testing range allows our design engineers to erect, test and adjust every antenna to conform to your specific vertical and horizontal pattern requirements before shipment is made.

Since the mounting pole and tower affect the radiated pattern, our engineers can actually duplicate your mounting specifications when adjusting your new directional antenna. We'll even adjust for phasing and spacing of the dual bays, which is often required in tight or multiple null patterns.

Contact Jampro for newly developed technical information regarding Dual Polarized FM Directional Antenna measurements and performance.

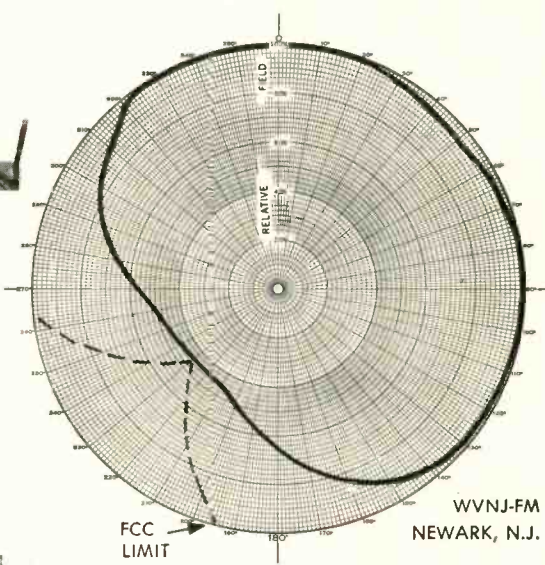

### ADVANTAGES OF JAMPRO'S NEW DIRECTIONALIZED DUAL POLARIZED FM ANTENNA

Effective radiated power can be increased and still protect neighboring short spaced stations. The VSWR Bandwidth is not affected and the antenna peak gain is nearly always increased.

**JAMPRO**

**ANTENNA  
6939 POWER INN ROAD**

**COMPANY  
SACRAMENTO, CALIFORNIA**

PHONE:  
AREA CODE 916  
**442-1177**

Circle 7 on Reader Service Card

## MICROFLECT

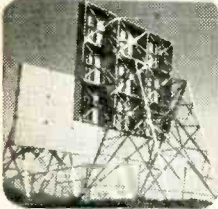

### REPEATERS

Ground mounted, flat, billboard type passive repeaters. 30 standard models up to 30' x 48'.

## MICROFLECT

### REFLECTORS

Tower mounted elliptical reflectors. 5 models up to 12' x 17'. Exclusive Omni-Mount.

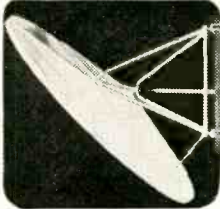

## MICROFLECT

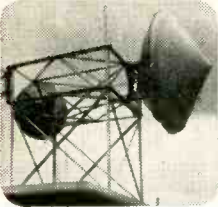

### ANTENNA MOUNTS

Rigid swing pipe, pylon, tripod, tower & frame antenna mounts.

## MICROFLECT

### SELF-SUPPORTING TOWERS

Quality self-supporting towers. 3 and 4 legged. Heights to 300'.

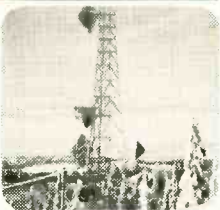

## MICROFLECT



### FIELD ERECTION

Experienced personnel. Dependable construction and erection . . . on schedule.

## MICROFLECT

QUALITY MICROWAVE PRODUCTS . . . 13 Gc RIGIDITY

FLAT, BILLBOARD TYPE PASSIVE REPEATERS  
TOWER MOUNTED REFLECTORS  
SELF-SUPPORTING TOWERS  
STUB TOWERS & ROOF MOUNTS

Write for literature

**MICROFLECT CO., INC.**

3575 25th SE · Salem, Ore. 97302  
AC 503 PHONE 363-9267

Circle 8 on Reader Service Card

26-27 in Minneapolis, Minn.; June 6-7 Tarrytown, N.Y.; and June 9-10 in Ft. Lauderdale, Fla. Limited to employees of member stations, the fee for the 1½-day sessions is \$20, which includes a luncheon and reception.

## ETV Conference

The U.S. Office of Education has asked the Georgia Department of Education to conduct the first national conference on educational TV. Chief state school officers and the administrator in charge of ETV from each of the 50 states and Puerto Rico will exchange information on the status of ETV. The conference, to be held May 10-12 in Atlanta, will assist those states without ETV and acquaint the nation's top educators with ETV trends.

## Jerrold Expands

Jerrold sales and administrative offices have been moved to new facilities at 401 Walnut St., Philadelphia, Pa., where 7 floors, totaling 63,000 sq. ft., have been leased. The plant at 15th and Lehigh, which housed offices and production facilities, is being devoted entirely to manufacturing.

## Superior Cable Plans Expansion

Production facilities for solid aluminum sheath cable will be constructed on a 44-acre industrial site purchased by Superior Cable Corp., Hickory, N.C. The plant will be in eastern Catawba County north of the Sherrills Ford Section on the Southern Railway spur line serving Plant Marshall. J. L. Robb, Superior's president, advises that production equipment has already been received and is ready for installation at the new site.

## CATV Ordered to Show Cause

The FCC has directed Buckeye Cablevision, Inc., to show cause why it should not be ordered to cease and desist from further operation of its CATV System in Toledo, O., which commenced operation March 16, carrying signals of WKBD-TV Detroit and WJIM-TV Lansing beyond their Grade B contours in violation of Section 74.1107 of the rules. In a separate and sub-



sequent action, Mission Cable TV, Inc. (owner) and Trans-Video Corp. (operator) of system in Poyay, Cal. were directed to show cause for extending Los Angeles TV signals into predicted Grade A contours of San Diego stations KGBM-TV and KOGO-TV.

## 750-kw Transmitters for Kuwait

The Kuwait Ministry of Guidance and Information has signed a contract with the Marconi Co. for

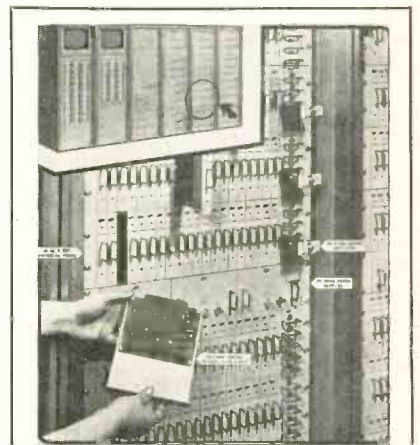

Dynair Electronics, San Diego, Cal., has received a contract to supply video distribution equipment for installation at the Apollo launch complex at the Kennedy Space Flight Center. The equipment will be part of a multi-million dollar closed-circuit TV system to monitor pre-flight and launch activities. Shown is a typical Dynair solid-state video switching system which provides 113 monitor locations with push-button access to 49 camera signals.



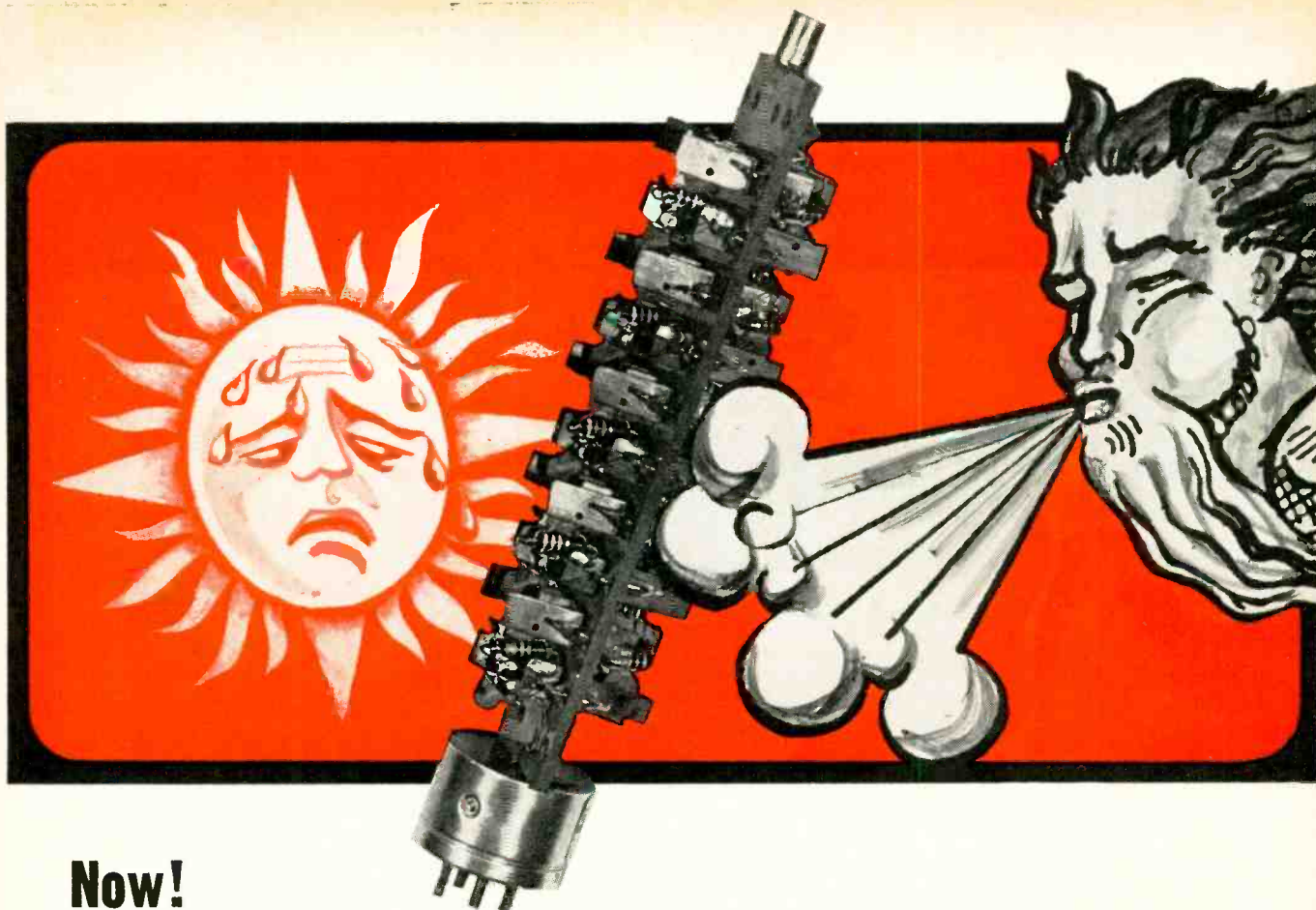

**Now!**  
**End "Off-Air" Panic and Eliminate**  
**Temperature Worries Forever, with... WILKINSON**  
**SILICON RECTIFIERS**

No more finicky temperature sensitive mercury vapor rectifiers . . . Go on cold mornings! Forget heating and air conditioning! . . . Wilkinson Silicon Replacement Rectifiers produce no filament heat and function below  $-60^{\circ}\text{C}$ .

No longer high priced! Wilkinson Silicon Rectifiers cost less than others and can be repaired in seconds with low-cost replacement diodes. No encapsulation used! No more guesswork or costly test time! You know at a glance the exact status of your complete power supply because a "GO, NO GO" indicator warns when the reverse leakage of any diode is in excess of 50 microamps. Wilkinson Rectifiers virtually last forever!

Now it's easy and economical to solid state the power supplies in high power equipment. With Wilkinson Rectifiers no rewiring is necessary. Just plug them into your present mercury vapor tube socket. Filament transformers as well as other components are left in place.

Modernize your equipment today! Consult the Tube Replacement Chart shown here and order now!

**FEATURES:** Light Indicator on each diode warns of any difficulty or high voltage ON. • Easily replaceable low-cost diodes. • Reduces heat — power cost — hash. • Operates from  $-65^{\circ}\text{C}$  to  $+70^{\circ}\text{C}$  Free Convection. • Eliminates warm-up time.

TUBE REPLACEMENT CHART					
WE TYPE	REPLACES TUBE TYPE		P.R.V. AMPS		UNIT PRICE
SR-3-1	866A	816	3KV	1	10.95
SR-10-6	872	8008	10KV	6	50.00
SR-10-12	872	8008 575	10KV	12	60.00
SR-14-6	872	8008 575	14KV	6	72.00
SR-14-12	872	8008 575	14KV	12	84.00
SR-20-6	6894	6895 673	20KV	6	100.00
SR-20-12	6894	6895 673	20KV	12	120.00
SR-24-15	869B		24KV	15	225.00
SR-32-25	857B		32KV	25	475.00

FOR COMPLETE DETAILS WRITE:

**WILKINSON ELECTRONICS, INC.**

1937 MACDADE BLVD. • WOODLYN, PA. 19094  
 TELEPHONE (AREA CODE 215) 874-5236 874-5237

Circle 9 on Reader Service Card

# NOW! GIVE YOUR FM STATION 100% MODULATION CAPABILITY



## WITH THE FAIRCHILD CONAX!

■ Now! The FAIRCHILD CONAX enables FM radio stations to increase their signal strength and apparent loudness potential by the effective control of high frequencies which cause trouble when pre-emphasized. High frequencies add sparkle and "bite" to program material and pre-emphasis improves signal-to-noise ratios. When the two are combined, however, it often becomes necessary to decrease the station's power to eliminate over-modulation possibilities.

■ How can high frequencies, which normally contain less energy than mid or low frequencies, cause trouble when pre-emphasis is applied? Simple! High frequency information, such as the jingling of keys, the sharp "s", the muted trumpet, cymbals, or other high frequency sounds, often become high frequency "spikes" when pre-emphasized thereby exceeding the FCC 100% modulation limitation. By making high frequency information "spike-free" (through the use of inaudible super fast attack and release times) the FAIRCHILD CONAX now allows the use of the full high frequency pre-emphasis curve.

### HERE'S A STEP-BY-STEP GRAPHIC ANALYSIS OF THE FAIRCHILD CONAX IN ACTION...

**FIG A** - Normal program material with program information distributed in mid range—500 to 5000 cycles.

**FIG B** - Same program material pre-emphasized. Still trouble-free.

**FIG C** - Program material with a high percentage of high frequency material in its content—such as found on today's records.

**FIG D** - Same high frequency program material (hot) after pre-emphasis. Note high frequency "spikes" now exceed 100% of modulation.

**FIG E** - Same program material now controlled by the FAIRCHILD CONAX action.

\* Note even with pre-emphasis the lack of troublesome high frequency "spikes" that normally would cause over-modulation.

■ The FAIRCHILD CONAX has an exclusive patented pre-emphasis circuit which applies a standard pre-emphasis curve to any entering signal. The patented FAIRCHILD CONAX frequency dividing and controlling network allows accurate and inaudible control only of the troublesome high frequency "spikes". This means you can transmit a signal with high average modulation level up to 3 db higher, utilizing the full apparent loudness possibilities of your rated power. In FM stereo and SCA transmission, the FAIRCHILD CONAX prevents splatter between the SCA channel and the stereo channel, allowing you to use both of these dollar producing signals to their fullest. Now full modulation capabilities can be realized without the danger of FCC citation or any change in the transmitted sound of your signal. Now FAIRCHILD CONAX gives your station that brighter and louder sound... the sound that sells. **AVAILABLE IN MONO OR STEREO COMPACT SIZE!**

Write to FAIRCHILD — the pacemaker in professional audio products — for complete details.

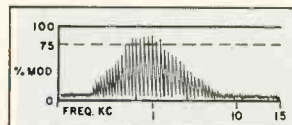

FIG A

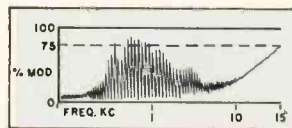

FIG B

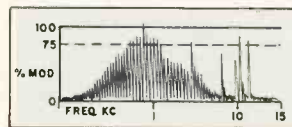

FIG C

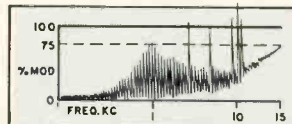

FIG D

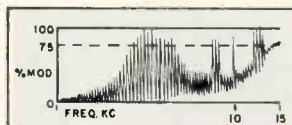

FIG E

the installation of three 750-kw medium wave transmitters. Under terms of the pact, 6 Kuwaiti engineers will be trained to operate and maintain the equipment, due for 1967 delivery.

### VR-660B Price Cut

A \$3500 price cut on the VR-660B CCTV master VTR has been announced by Ampex. The new price, \$8,000, includes the Edicon system, slow motion capability, and other accessories normally included with the VR-660B. Also included is the instructional closed-circuit TV workshop held at the Ampex training center, Redwood City, Cal.

### 16th Broadcast Symposium

Date for this year's IEEE Broadcast Symposium is September 23-24. As in the past, the assembly will be held in Washington, D.C.

### Entron Opens 5th CATV System

Robert J. McGeehan, Pres., Entron, Inc., announced the opening of a new CATV system (its 5th) in Sharon, Pa. The system, which will offer service to 15,000 homes, was engineered and constructed by Entron and will ultimately represent \$1 million investment. Known as Shenango Cable TV, Inc., the company is carrying 11 TV signals and a 24-hour time-weather channel to subscribers in Sharon, Sharpsville, and Hickory, Pa. Coverage is scheduled to spread to Brookfield and Masurey, O., and West Middlesex and Wheatland, Pa.

*Continued on page 75*



Preformed Line Products Co., Cleveland, O., has completed construction of a new 24,000 sq. ft. addition to its manufacturing facility in Palo Alto, Cal. The new structure will be used for warehousing materials and inventory, freeing other areas for production expansion. The addition represents a 60% increase in floor space for the manufacture of pole-line hardware.

# FAIRCHILD

RECORDING EQUIPMENT CORPORATION  
10-40 45th Ave., Long Island City 1, N. Y.

Circle 10 on Reader Service Card

# HOW TO SUCCEED IN RADIO and TV PAPER WORK WITHOUT HARDLY TRYING

**PLASTA LUCENT**™

## PLASTIC TRANSLUCENT MASTERS

completely eliminates RE-TYPING and RE-WRITING OF ...

- PROGRAM LOGS
- SCHEDULE SHEETS
- STATUS REPORTS
- TIME AND MEDIA REPORTS

+ plus +

... *Accounting and Statistical Reports* ... *Audit Control Reports*  
... *Reporting Schedules* ... *Internal Systems and Procedures*

### WHY is **PLASTA LUCENT**™ so UNIQUE?

- ELIMINATES the need of repetitive copying month after month of All identifications, captions and descriptive headings.
- ELIMINATES time consuming and messy erasures.
- ELIMINATES intermediate copying.
- ELIMINATES transcription of Repetitive information as well as all transcription errors.
- ELIMINATES costly proof-reading time.
- ELIMINATES outside purchases of pre-printed work schedules for internal and field applications.
- ELIMINATES hazy and illegible reports.
- Affords you any number Sharp, Clear and Accurate copies.

**PLASTA LUCENT**™ masters are PERMANENT, DURABLE, LONG LASTING and can be repeatedly used. THE COST OF WRITING comes down to practically nothing and is actually absorbed by the continuous use of PLASTIC TRANSLUCENT MASTERS.

**PLASTA LUCENT**™ has been PROVEN to be the one step "SHORT-CUT" to office efficiency in PROGRAMMING, ACCOUNTING and OFFICE procedural work.

**PLASTA LUCENT**™ Plastic Translucent Masters can be reproduced on Xerox, Bruning, Ozalid as well as other types of existing reproduction equipment.

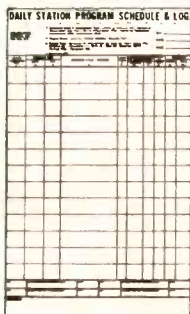

*Samples and  
Catalog  
Available  
upon Request*

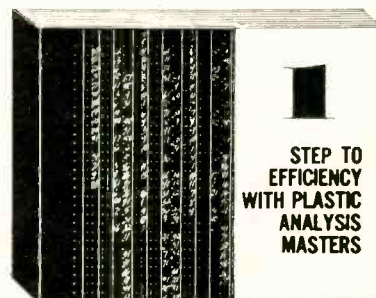

Another TIME SAVER brought to you by the nation's largest producer of translucent forms.

**TRANS FACE** PROCESS COMPANY

480 Canal Street, New York, N. Y. 10013 · Tel.: (212) 966-2650

THE NATION'S LARGEST MANUFACTURING PRINTERS OF TRANSLUCENT FORMS

*Distributors and dealers from coast to coast*

Circle 11 on Reader Service Card

# Only complete test equipment line designed especially for 75 ohm cable distribution

*finest all solid-state all-channel sweep generator on the market*

## U/V sweep generator, model 4122

Solid-state. Has two switch-selected electronically swept ranges: entire UHF TV spectrum (470 to 890 mc); entire VHF TV spectrum including subchannels (20 to 240 mc).

Sweep widths are continuously variable from 5 mc to the entire VHF or UHF range in one sweep. Center frequency can be tuned across the complete band on each range regardless of the sweep width setting. An output level attenuator is adjustable over a 60 db range. Automatic Level Control (ALC) on both ranges assures constant output. Fully regulated power supply for stable operation.

The sweep oscillator is varacter tuned (no moving parts) for silent operation and long life. For VHF output the UHF sweep is mixed with a fixed oscillator signal at 900 mc and the resultant difference signal is amplified and level controlled to cover the complete VHF TV spectrum.

The horizontal sweep rate of 60 cps, derived from the power line, is available as a sine wave at the front panel for connection to the oscilloscope. Use of the sine-wave horizontal permits oscilloscopes to be fed by available local line voltage for summation sweeps of large distribution systems.

## UHF sweep generator, model 4114

Same quality features as the Blonder-Tongue 4122 UHF/VHF Sweep Generator but covers range of 470 to 890 mc only.

*only all-channel field strength meter in a single unit*

## UHF/VHF field strength meter, FSM-2

Solid-state superheterodyne circuitry. Accurate enough for the lab. Portable enough for field work. Instantly convertible from VHF to UHF with the flip of a switch. Measures RF signals at 75 ohm impedance (VHF/UHF balun supplied for 300 ohm measurements) in two ranges: VHF (52 to 216 mc) and UHF (470 to 890 mc). Sensitivity variable from 100 microvolts to 3v. for full scale meter deflection. Reads both average and peak level. AC line or integral battery operation. Fully regulated power supply. Indispensable for field strength surveys, MATV/CATV system maintenance, loss and gain measurements and percent modulation tests. Precise amplifier gain and attenuation measurements.

## RF switcher (dc to 900 mc) 4102

Electronically-actuated, high-speed switch, solid-state, permits two signal tracings to be simultaneously displayed on an oscilloscope, either superimposed or alternately, at the rate of 30 cps. Either tracing can be seen independently for making direct, immediate comparisons between input and output voltages of any circuit under test for precisely measuring VSWR, amplifier gain, or attenuation and other applications involving equipment performance evaluation against given standards. Provision for 360 degree phase adjustments.

## Delay line (dc to 900 mc) 4107

Compact and portable, fully shielded, precision 75 ohm coax delay line for use as a match cable for impedance measurements and other laboratory applications where a standard cable of superior quality is required. Designed primarily for use in conjunction with the Blonder-Tongue 4102 RF switcher, this delay line provides an accurate impedance standard to make fast and precise VSWR measurements over a very wide bandwidth. Designed to be one half wave length at 5 mc, the line allows convenient measurement of bandwidth, sweep width and sweep linearity.

*Blonder-Tongue offers a complete line of color-approved products for CATV:*

*Amplifiers (trunk line distributed, high output, single-channel and broad band); converters (crystal-controlled); accessories (Tap-offs, splitters, mixers, matching transformers) and the famous "Stinger" pressure taps. For details write.*



# BLONDER-TONGUE

9 Alling Street, Newark, New Jersey 07102

Circle 12 on Reader Service Card

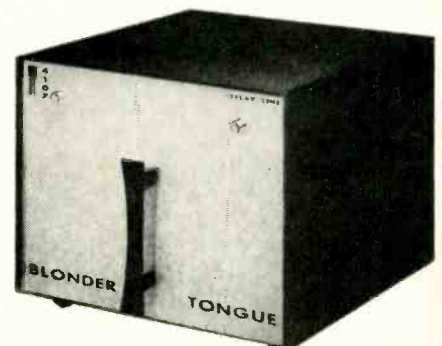

# INTERPRETING THE **FCC** RULES & REGULATIONS

## The Drive for Diversified Ownership

**D**URING RECENT years, many broadcasters, and those hoping to become broadcasters, have found themselves confronted with an insurmountable barrier—the so-called “multiple ownership” or “concentration of control” rules. Frequently, these rules have precluded broadcasters from (1) selling their stations to specific parties and (2) purchasing desirable nearby broadcast facilities.

### FCC's Goals in General

Specifically, the FCC has concerned itself with: (1) Multiple ownership—the ownership of too many broadcast stations (more than 7 AM's, 7 FM's, 5 VHF TV's, and 2 UHF TV's) by one individual or organization; (2) duopoly—the ownership by one individual or organization of two stations in the same area, resulting in an overlap of their signals; and, most importantly, (3) concentration of control of mass media—common ownership of the local broadcast property, newspapers, and the like. The multiple ownership and duopoly rules are commonly referred to as the “concentration of control” rules and may be found in Sections 73.35, 73.240, and 73.636 of the Rules and Regulations of the Federal Communications Commission. The concentration of control of *mass media* is not precluded by a specific rule but is rather impeded by Commission *policy*.

These provisions are designed to further maximum competition among broadcasters and, more significantly, *the greatest possible diversity of programming sources and viewpoints*. The Commission has dedicated itself to the prevention of undue concentration of control of mass media and to the development of the greatest diversity and variety in the presentation of information, opinion, and broadcast material. Its actions in this area have been guided by the Congressional policy against monopoly in the Communications Act, and the concept, as recognized by the courts, that the communications business is and should be one of free competition. (See FCC 64-1171, December 18, 1964.)

### The Duopoly Rules

As adopted initially Sections 3.35(a), 3.240(a), and 3.636(a) of the Commission's Rules provided limitations on the common ownership or control of multiple AM, FM, and TV stations which served substantially the same area. These provisions of the rules, commonly referred to as the “duopoly” or “overlap” rules, were intended to preserve and augment the op-

portunities for effective competition in the broadcast industry and to implement the Commission's policy in favor of maximizing diversification of program and service viewpoints. The latter policy has assumed a very special importance in a democratic society. As stated in the following case, it is well established that “. . . the widest possible dissemination of information from diverse and antagonistic sources is essential to the welfare of the public . . .” (*Associated Press v. United States*, 326 U.S. 1,20; *Scripps-Howard Radio, Inc. v. F.C.C.*, 89 U.S. App. D.C. 13, 19, 189 F. 2d 677 cert. den., 342 U.S. 830).

### Basic Duopoly — Rules of the '40s

The rules prohibiting substantial overlap of commonly owned stations were adopted in the early 1940's. The rules do not read the same. For example, the *AM rule* prohibited overlap where “a substantial portion of the applicant's existing station's primary service would receive primary service from the station in question, except upon a showing that the public interest . . . would be served through such multiple ownership situation.” The *TV and FM rules* were stated in terms of the licensee not owning or operating “. . . another FM or TV station which serves substantially the same area.”

In a statement of policy back in April 1944 the Commission explained that in administering the rule it would grant waivers after giving consideration to “. . . such factors as the location of centers of population and distribution and populations to which services of stations are directed as indicated by commercial business of stations, news broadcast, sources of programs and talent, coverage claims and listening audience.”

The first decision of any importance involving the application of the new provisions concerned *Fetzer Broadcast Corp.*, 3 R.R. 884. John Fetzer, WKZO Kalamazoo, Mich., applied for a permit to construct a new station in Grand Rapids, although 76% of the area included in the proposed 2 mv/m contour would be overlapped by the 2 mv/m contour of WKZO, and the same contour of the proposed station would overlap 5.5% of the similar contour of WKZO. However, the Commission granted the application, finding that the two cities were separate and distinct and that, based on listener surveys, WKZO programs had little or no sales value in Grand Rapids. And, the overlap was insufficient to outweigh the advantages which would

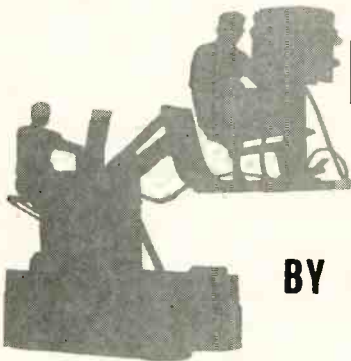
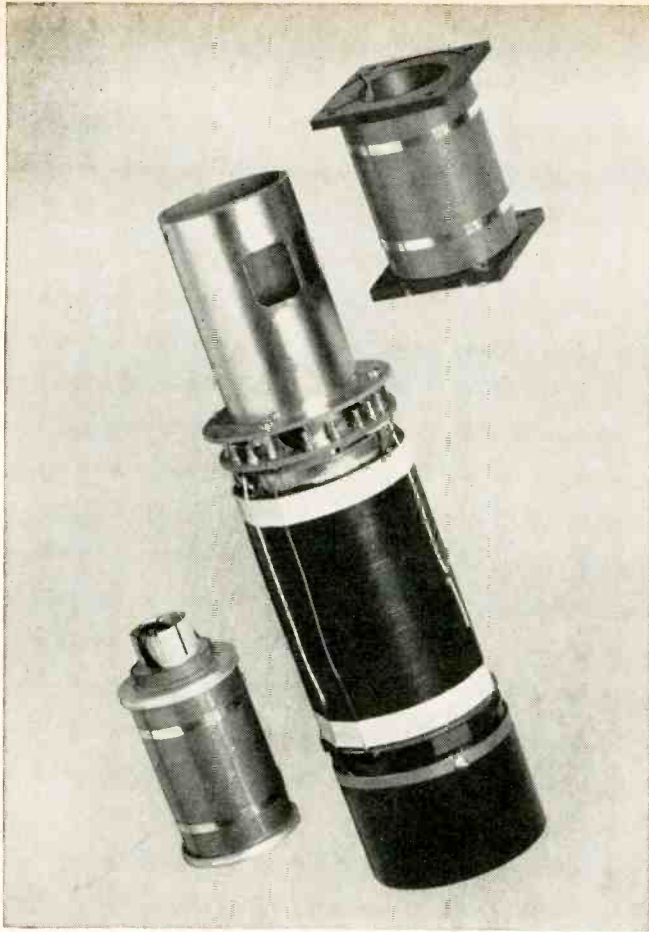

## FOCUS ON QUALITY

BY



**CLETRON**, manufacturer of Orthicon and Vidicon Deflection Components for Commercial and Military applications offers you quality-engineered products and services that have been incorporated as standards in the country's leading manufacturing companies of Television Camera Equipment.

Write today for additional technical literature, drawings and engineering specifications on the complete line of Cletron Deflection Components.



*Quality products by Cletron . . .  
Manufacturers of Deflection Components, Custom  
Transformers and Sound Reproducing Devices . . .*

**Cletron** CLEVELAND ELECTRONICS, INC.

1974 East 61st Street, Cleveland, Ohio 44103, U.S.A.  
Circle 13 on Reader Service Card

be gained by granting the application and thereby providing an additional outlet to Grand Rapids with a population of 164,000.

Probably the next most significant case was that involving the application of *Stanislaus County Broadcasters Inc.* for consent to the assignment of license for KBOX Modesto, Cal., to *McClatchy Broadcasting Company*. The Initial Decision, 13 R.R. 1077, proposing a grant of the application, was affirmed by the Commission (13 R.R. 1100a). At the time the application was filed, McClatchy was already the licensee of several AM and FM stations, including KFBK, 50 kw, Sacramento; KMJ, 5 kw, Fresno; KERN, Bakersfield; and KOH, Reno. McClatchy was also the permittee of KMJ-TV Fresno, and the licensee of KBBE-FM Modesto. Modesto, Sacramento, and Fresno are all in the San Joaquin Valley, Sacramento being 68 miles northwest of Modesto, and Fresno 90 miles to the southeast. The 0.5 mv/m contour of the Fresno station included all of the same contour of the Modesto station (KBOX), and the 0.5 mv/m contour of KPBK overlapped 90.4% thereof. Of the approximately 800,000 persons within the 0.5 mv/m contour of KBOX, more than 50% actually received primary service from KBOX and KMJ, while more than 675,000 received such service from KFBK. Approximately 400,000 persons received primary service from both KBOX and KMJ, while about an equal number received such service from both KBOX and KFBK. Furthermore, McClatchy published one of the two newspapers in Sacramento and the only paper in Modesto and in Fresno.

In connection with its proposal to acquire the Modesto station, McClatchy conducted an expensive survey of listener preferences, mailing over 1,000 questionnaires. It also made a study of the current programming of the three Modesto AM stations. It was shown that McClatchy's policy was to confine its selling of radio time on that particular station to its individual trade area and not to solicit business in the overlapping service area in competition with another McClatchy station or any other station in another city. Furthermore, it appeared that the programs of KFBK and KMJ enjoyed a very small audience in Modesto. McClatchy represented that if it acquired a Modesto station, the sale of commercial time to retailers would be limited to the Modesto trading zone.

In concluding that a grant of the application would not violate the spirit of Rule 3.35, the Commission found that McClatchy had met its burden of proof, that the record was clear that the McClatchy stations in Sacramento and Fresno will not serve Modesto either with respect to programming or to advertising and commercial solicitation, that KFBK and KMJ have no audience in Modesto, that a grant of the application would result in a program service which the then licensee, without McClatchy's resources, was unable to render, including programming in categories which had received little or no attention.

### Diversification Rules Replace Policy in 1964

After approximately 20 years of application of the above rules and policy, the Commission

# GET MORE CATV SYSTEM FOR THE



From one basic, solid-state design a full range of 8 trunkline and bridging amplifiers can be developed. Plug-in interchangeability permits custom design at mass-production prices.

## ALL THESE MODULES ARE INTERCHANGEABLE!

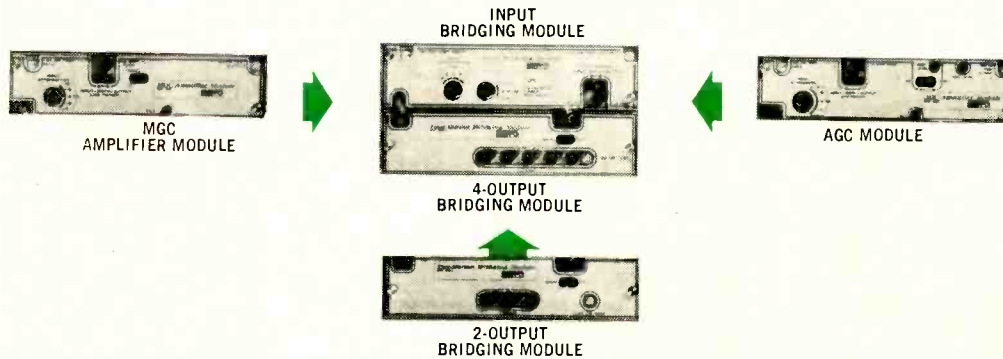

## SPECIFICATIONS

	TRUNK AMPLIFIERS	TRUNK/BRIDGING AMPLIFIERS	BRIDGING AMPLIFIERS
TRUNKLINE FULL GAIN @ Ch. 13	30 db, min.	30 db, min.	—
FEEDER LINE FULL GAIN @ Ch. 13 — 2-outputs	—	33 db, min.	31 db, min.
— 4-outputs	—	30 db, min.	28 db, min.
TRUNKLINE OPERATIONAL GAIN — Spacing @ Ch. 13	25 db	25 db	—
MAX. OUTPUT CAPABILITY @ 1/2 TILT† —			
Trunkline	35 dbmv @ Ch. 13	35 dbmv @ Ch. 13	—
Feeder Line — 2-outputs	—	43 dbmv @ Ch. 13	43 dbmv @ Ch. 13
Feeder Line — 4-outputs	—	40 dbmv @ Ch. 13	40 dbmv @ Ch. 13
NOISE FIGURE @ Operational Gain	12 db, nom.	12 db, nom.	—
TRUNKLINE INSERTION LOSS	0	0	1 db
BANDWIDTH	50-220 Mc	50-220 Mc	50-220 Mc
RESPONSE FLATNESS — Trunkline	±0.25 db	±0.25 db	—
— Feeder Line	—	±0.5 db	±0.5 db
AGC RANGE (Automatic GAIN & TILT) — Automatic Gain Units Only	±1 db output change with up to 6 db (cable equivalent) input change		
TRUNKLINE CONTROLS —			
INPUT ATTENUATOR (Switchable Pad)	Range: 0, 3, 6, 9, 12 db (steps)		
GAIN (Variable) — MGC Units Only	Range: 0-5	Range: 0-3	—
TILT (Variable) — AGC Units	Range: ±3 db (cable equivalent)		
— MGC Units	Range: 22 to 28 db (cable equivalent)		
LINE POWER (Switch)	Function: AC power source selection — IN, OUT, BOTH		
EQUALIZER (Switchable)	—	—	Range: 0.3, 4.9, 10-15 cb (steps)
AGC LEVEL (Variable) — AGC Units Only	Function: set automatic control output level		
MGC LEVEL (Variable) — AGC Units Only	Function: set manual control output level		
AGC/MGC (Switch) — AGC Units Only	Function: AGC-MGC operation selection		
FEEDER LINE CONTROLS —			
GAIN (Variable)	—	Range: 0 to 3 db (continuous)	
TILT (Variable)	—	Range: 0 to 3 db (continuous)	
INPUT ATTENUATOR (Switchable Pad)	—	Range: 0, 3, 6, 9, 12 db (steps)	
ISOLATION (between feeder outputs)	—	17 db	17 db
IMPEDANCE MATCH — Trunkline Input	21 db Return Loss (VSWR 1.2:1)		
— Trunkline Output	15 db Return Loss (VSWR 1.4:1)	21 db Return Loss (VSWR 1.2:1)	
— Feeder Line Output	—	18 db Return Loss (VSWR 1.3:1)	
TEST POINTS — Trunkline Input	-20 db (RF)	-20 db (RF)	-20 db (RF)
— Trunkline Output	-20 db (RF)	-20 db (RF)	-20 db (RF)
— Feeder Line Output	—	-20 db (RF)	-20 db (RF)
AMBIENT TEMPERATURE RANGE	-40° to +140°F	-40° to +140°F	-40° to +140°F
POWER REQUIREMENT	18 to 30 volts RMS, 0.6 ampere, max.	18 to 30 volts RMS, 1.2 ampere, max.	18 to 30 volts RMS, 0.8 ampere, max.
HOUSING DIMENSIONS	4" x 9 1/4" x 14 1/2"	4" x 9 1/4" x 14 1/2"	4" x 9 1/4" x 14 1/2"
SHIPPING WEIGHT	10 Lbs. MGC Unit 10 1/2 Lbs. AGC Unit	13 Lbs. 2-outputs 14 Lbs. 4-outputs	12 3/4 Lbs. 2-outputs 13 3/4 Lbs. 4-outputs

† For -57 db cross-modulation and 32 amplifiers in cascade, 12 channels

\* See footnote on inside back page.

MAKE US PROVE IT! Write, phone collect or visit KAISER-COX CATV for details:



KAISER-COX CORPORATION / P. O. Box 9728, Phoenix, Ariz. 85020, Phone (602) 944-4411

DEPEND ON KAISER-COX FOR CATV LEADERSHIP TODAY AND TOMORROW

Circle 14 on Reader Service Card

# 16 HOURS Of Background Music REEL-TO-REEL REEL-TO-REEL REEL-TO-REEL REEL-TO-REEL

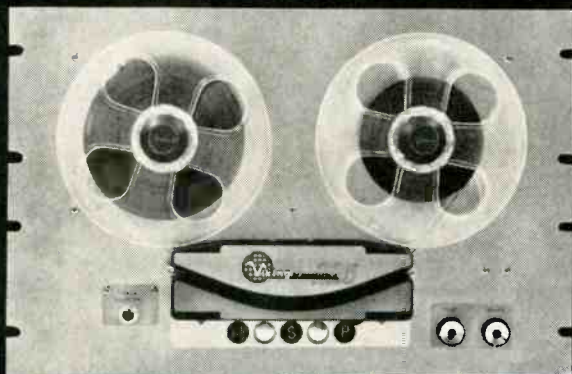

## SOLID STATE MODEL 225

Automatic, two-directional playback of quarter track monaural tapes provides 16 hours of background music for AIRPORTS, AMUSEMENT PARKS, BOWLING ALLEYS, CLUBS, DEPARTMENT STORES, DEPOTS, FACTORIES, HOTELS, OFFICE BUILDINGS, RESORTS, SHOPPING CENTERS, STADIUMS.

Model 225 operates at 1-7/8 ips and is an electrically controlled tape transport with hysteresis synchronous capstan drive. Includes push-button choice of program track and solid state tape playback preamplifier - connects readily to existing sound systems.

Model 225 \$500.00

Optional model 225-T contains output transformer to match 600 ohm balanced or unbalanced lines with taps for 6, 150 and 1500 ohm output.

Model 225-T \$510.00

Background music tapes available from Viking for your own sales or leasing plan.

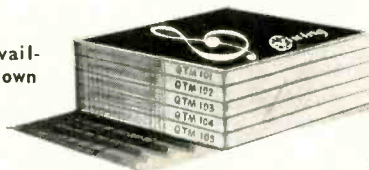

**Viking** OF MINNEAPOLIS®

9600 Aldrich Ave. S. Minneapolis, Minnesota, 55420

CANADA: Alex L. Clark, Ltd., 3751 Bloor St. W., Islington, Ontario  
Electro Tec Marketers, Ltd., 1624 W. Third Av., Vancouver, British Columbia  
CENTRAL & SOUTH AMERICA: ManRep Corp., P.O. Box 429 N. Miami Beach, Florida, U.S.A.  
OVERSEAS EXPORT: International Division Viking of Minneapolis, Inc., 9600 Aldrich Av. S.  
Minneapolis, Minn., U.S.A.

Circle 15 on Reader Service Card

decided that the general prohibitions contained therein should be replaced by more definite standards. This decision was prompted by the overwhelming evidence that, with the passage of time, broadcasting had become an extremely strong force as a media of mass communication. The available frequencies were shrinking quickly, and there were too many applications for available broadcast facilities. Therefore, in order to further its long established policy of maximizing diversification of program and service viewpoints, the Commission adopted a "Notice Of Proposed Rule Making" (See FCC 62-747, 22304, Docket No. 14711, adopted July 13, 1962). The rules as proposed would (1) prohibit overlap of Grade A service contours of commonly owned TV stations, (2) prohibit overlap of the 1 mv/m service contours for commonly owned AM and FM stations, (3) apply to applicants for new stations, major changes in existing stations, and assignments and transfers of control, and (4) the AM rules would not apply to Class IV (local) stations desiring to increase power to a maximum of 1 kw, nor to noncommercial educational FM and TV stations.

*The Rules, [73.25 (a), 73.240(a), and 73.636(a)] as finally adopted on May 20, 1964, contained the same provisions as stated above; however, the TV Rule (Section 73.636) was changed from Grade A to Grade B! The Commission decided that because TV had become such a great force in swaying public opinion than either of the aural services, a more restrictive overlap rule than that proposed was necessary. The Commission stated that, "the more restrictive standard we have chosen for television will have the effect of limiting future ownership to a maximum of two stations in most states and, thus, will act indirectly to curb regional concentrations of ownership as well as overlap itself."*

In the case of "satellite" TV stations, the Commission eased its stringent overlap requirements. Because these operations generally exist at locations where operation of an independent station is economically not feasible, and, since prohibiting the establishment of these stations through duopoly rules would tend to destroy TV service in the area involved, *the Commission exempted TV "satellites" from the fixed overlap prohibitions.* Each application affecting them would be considered on a case-by-case basis, whereby the Commission will apply the same criteria that it originally followed in granting waivers to the overlap rules established in the 1940's.

### Cases Broaden the 1964 Duopoly Rules

On September 30, 1964, the Commission adopted a Memorandum Opinion and Order in the above-styled proceeding. It issued the Order after considering numerous Petitions For Reconsideration. Many of the comments stated that the nature of the overlap problem is such that it needed to be treated on the same basis as the past—on a case-by-case basis; the fixed rule was too inflexible. The Commission stated that the adoption of the fixed rule did not mean that all flexibility is lost, and the Com-



mission has the duty to make the "ultimate judgment whether the grant of a license would serve the public interest, convenience, or necessity." *NBC v. U.S.*, 319 U.S. 290, 225 (1943). Also, in *U.S. v. Storer Broadcasting Co.*, 351 U.S. 192 (1956), the Commission stated that a request for waiver of the new rule, which showed on its face that application of the new rule would be inappropriate, would be entitled to a hearing. This statement should not be interpreted to mean that all requests for a waiver must be granted a hearing. Only those requests which set forth sufficient reasons to justify a waiver need be granted a hearing.

*The Commission seems to be saying that it will adhere to the new overlap rules as closely as possible; however, if a party makes a sufficiently cogent showing, under the criteria discussed for waiver under the initial overlap rules, the Commission will grant a hearing.*

Two recent cases concerning the duopoly problem may shed some light on the subject. On May 19, 1965, the Commission denied the Application For Transfer Of Control of Bay Video, Inc., permittee of Station WBVI-TV, Channel 13, Panama City, Florida (BTC-4497). Approximately 65% of the Grade B contour area of Station WBVI-TV would be overlapped by the Grade B contour of the transferee's other TV station. This large amount of overlap was predicated upon a reduction of power and tower height of station WBVI-TV as requested in the application for modification of its facilities. Briefly, a grant of both applications (for Transfer of Control and Modification of CP) would result in a significant shrinkage of the proposed service area of Station WBVI-TV in an attempt to justify a waiver of the Grade B overlap prohibition. The population covered by WBVI-TV's Grade B contour would have been reduced from 377,326 to 137,333. In denying the above application, the Commission stated, "To grant the pending applications would mean not only the acceptance of a substantial overlap, prohibited by our new rules, but also the deprivation of substantial areas of potential service as now authorized by the contours of Station WBVI-TV."

The second case concerns an application by WCSH-TV Portland, Me. for modification of a CP to change its transmitter site and increase the station's coverage. A grant of the application would cause increased coverage of Grade B contours between WCSH-TV and a commonly owned station, WLBZ-TV Bangor, Me. The request for waiver of Section 73.636(a)(1) basically stated that the new site and facilities would provide a better signal in its coverage area. No other reasons such as inability to deliver usable signals in its coverage area, adverse economic conditions requiring expansion of contours, were given. It stated that a grant of the application would bring it closer to parity with two competitors in the Portland market. The Commission granted the application, and, it there waived Section 73.636(a)(1). Whether the Commission will maintain as lenient a policy in the future seems highly doubtful.

Next month we will pursue the Commission's rules and policies on multiple ownership and concentration of control of mass media. ●

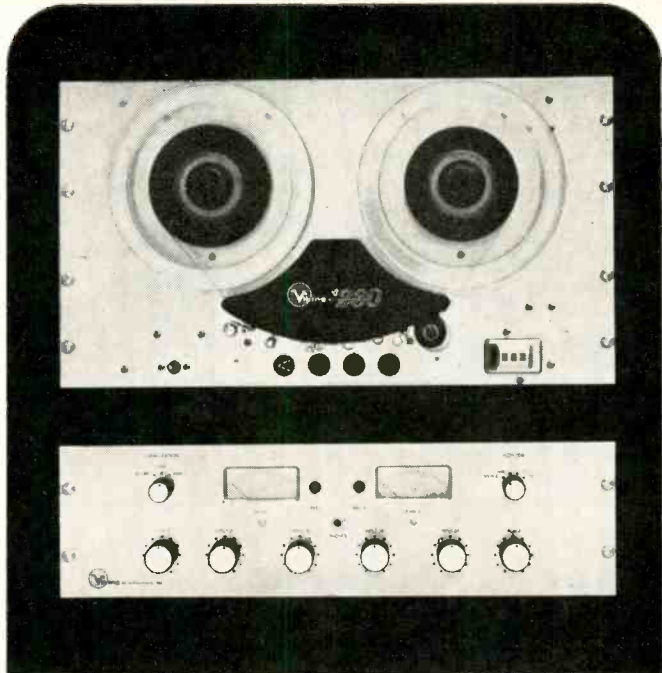

## MODEL 230

**VERSATILE, INDUSTRIAL TAPE TRANSPORT  
AND MATCHING SOLID STATE ELECTRONICS -  
IDEAL FOR REMOTE AND AUTOMATIC  
APPLICATIONS.**

### MODEL 230

Reliable, heavy duty three motor tape transport designed for advanced technology in industry, business, research and education. Electrical momentary push-button controls, complete interchangeable head block assemblies plus a variety of optional features distinguish the model 230 as one of the most versatile tape transports available.

Model 230 tape transports from \$322.00

### AMPLIFIERS

Solid state, record and playback amplifiers of modular design with interchangeable plug-in options, mixing controls, A-B monitoring, 600 OHM line output, illuminated VU meters, exceed NAB standards.

Rack Mount Monaural RPI10 \$299.00  
Stereo RPI20 \$399.00

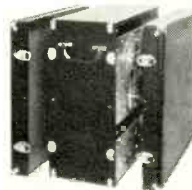

Portable Case "100"  
with detachable front and back,  
accepts model 230 and either RPI10  
or RPI20 amplifier.

"100" case only \$59.50

**FOR COMPLETE INFORMATION  
PLEASE WRITE FOR CATALOG ...**



**Viking OF MINNEAPOLIS®**  
9600 Aldrich Ave. S. Minneapolis, Minnesota, 55420

CANADA: Alex L. Clark, Ltd., 3751 Bloor St. W., Islington, Ontario  
Electro Tec Markets, Ltd., 1624 W. Third Av., Vancouver, British Columbia  
CENTRAL & SOUTH AMERICA: Man Rep Corp., P.O. Box 429 N. Miami Beach, Florida, U.S.A.  
OVERSEAS EXPORT: International Division Viking of Minneapolis, Inc.,  
9600 Aldrich Av. S. Minneapolis, Minn., U.S.A.

Circle 16 on Reader Service Card

# Selecting a Color Camera

By Charlie Buffington,  
Associate Editor

With the head-long rush into color, and particularly with live production, prospective buyers should become intimately acquainted with the competitive characteristics of currently available equipment.

LAST YEAR, the choice in new color TV studio cameras lay between the 3-Plumbicon Norelco model and RCA's 4-tube I.O./vidicon design. Then, as now, those in a hurry to install live color facilities were faced with the problem of availability. Pressed with a desire for anything that would do the job, many stations bought used equipment. RCA even renewed production of TK-41 models to try and fill the gap. Some stations who were hoping to have live color facilities last fall are *still* waiting for de-

livery of equipment.

This year, availability is still a major problem. However, there are now five major color studio camera suppliers. Broadcasters touring this year's NAB exhibits were treated to a dazzling array of color camera systems. Norelco and RCA staged return engagements, with units that incorporated a year's worth of refinements. G-E, Marconi, and Sarkes-Tarzian unveiled their brand-new models, all tipping the scales in favor of the 4-tube design. Shihaden Corp. made a play for in-



RCA TK-42 with built-in zoom lens, or TK-43 with external Varotal V lens, uses 4 pickup tubes. A 4½" I.O. serves the luminance channel and three 1" vidicons are used in the chrominance channels. Solid-state components, except for high voltage rectifiers and tubes in picture and waveform monitors, are mounted in plug-in modules which may be removed and operated for servicing by extender cords. Camera zoom and focus are controlled by "D" handles located at lower left and right corners of the rear of the camera; the handles also serve to pan, tilt, and dolly the camera. As a separate unit, the viewfinder is mounted on a sliding track which allows it to be pulled out for service. A cooling and heating system maintains optimum operating temperatures of the chrominance pickup tubes. Feedback stabilization circuitry is used to compensate for component aging and for ambient temperature changes. Reference devices are used to maintain critical control voltages and currents at optimum values.

Built-in calibration and alignment pulses are provided for alignment and setup. Automatic black level control and self-adjusting cable timing are provided, and colorplexing circuitry may be adjusted by using the normal waveform and picture monitors. Alignment and setup may be made by one man at the camera location, using the camera viewfinder and built-in facilities. A color bar generator is built into the auxiliary equipment for colorplexing circuitry adjustment.

The control panel is in two sections: a remote control panel and a color control panel. Maximum cable lengths are 1000' for studio and 2000' for field use. Camera and viewfinder weigh 280 lbs. Price is approximately \$79,000.

If you think  
all video tapes are alike,  
feel this one\*

\* You're feeling the smoothest, longest wearing video tape you can find today

or better yet, try using it

**MEMOREX**  
PRECISION MAGNETIC TAPE



TO MEMOREX CORPORATION:

I have not tried Memorex precision video tape. Please see that I get a free sample reel of  1"  2" tape.

My Tape Recorder is a: \_\_\_\_\_

Serial Number \_\_\_\_\_

NAME \_\_\_\_\_

ORGANIZATION \_\_\_\_\_

ADDRESS \_\_\_\_\_

CITY & STATE \_\_\_\_\_ ZIP \_\_\_\_\_



When you put a reel of Memorex precision video tape on your recorder, you can expect a number of performance benefits from its superior surface smoothness. Low initial dropout and slow rate of dropout build-up give you freedom from streaking over a significantly greater number of re-plays; reduced head-wear and low head-clogging give you greater reliability and longer life from your recorder. Behind this reel of smooth-surfaced tape is the industry's most advanced tape-making technology — a depth of technical know-how and experience which has long since made Memorex the number one supplier of precision broadband tapes for instrumentation recording and premium digital tapes for computer data processing.

# MEMOREX

## PRECISION MAGNETIC TAPE

Memorex Branch Offices in Boston, New York, Philadelphia, Washington, Atlanta, Orlando, Dayton, Chicago, Detroit, Dallas, Los Angeles, San Francisco; Offices and Affiliates in London, Cologne, and Paris.

**BUSINESS REPLY MAIL**

No Postage Stamp Necessary if Mailed in the United States

Postage Will Be Paid By

**MEMOREX CORPORATION**

Memorex Park

Santa Clara, California 95052

FIRST CLASS  
PERMIT  
No. 250  
SANTA CLARA  
CALIFORNIA



terest in their 2-tube design, using one I.O. in the luminance channel and another for chrominance. The latter channel produces sequential RGB signals through a sampling process. Shiba also has a 3-tube design, which was not shown. Neither model is slated for delivery in the U.S. at present.

BM/E's editors learned that still another manufacturer has completed development of a live color camera chain. EMI Electronics, Ltd., reportedly has its 4-Plumbicon model ready. The

reason given for not showing it at the NAB Convention is the current shortage of Plumbicon tubes. However, this problem is expected to ease, and EMI is likely to make its camera available later this year

### Which One to Buy?

The debates over color registration, purity, noise levels, setup time, light levels, etc., are still ever-present. Many strides have been taken during the past year to improve and simplify setup procedures. One-man setup and

"hands-off" operation are now common terminology.

However, the old bug-a-boo—the question of delivery—is still the big problem. Even with the big increase in number of suppliers, most camera chains ordered now won't be delivered before early next year. Thus, the decision facing anyone wanting to obtain a color camera chain today is based on two major questions: (1) Which one best suits the particular need? (2) When will it be delivered, ready to operate?

The answer to the first question, in view of the second, may be purely academic in many cases. However, since most suppliers are fairly competitive insofar as delivery dates are concerned, prospective buyers seem to be basing their choice on the basis of performance, ease-of-operation, portability, price, etc. Unquestionably, however, many chief engineers have been instructed to "get us a color camera that works. We can worry about engineering details next year!"

The broadcaster or producer faced with the decision of which color camera to buy may find himself torn between conflicting philosophies and a multitude of rather complicated specifications. Of course, he can always wait awhile, wait for technological advances to help him make up his mind. However, the push to get into live color operation, in many cases, won't permit a delayed decision and, unless he gets his name in somebody's hat, the prospective color camera purchaser may have to wait a long time for delivery. It will be a long time before anything like off-the-shelf delivery conditions exist.

How, then, can you decide which type camera to buy? There are differences in the type and number of pickup tubes, optical and lens system, size and weight, and operational characteristics. Only an in-depth analysis of the features of each system, as they relate to your studio facilities and operational requirements, can provide you with sufficient knowledge to make a wise choice.

### Pickup Tube Types

Presently, there are only three pick-up tube types used—the image orthicon, vidicon, and Plumbicon; the latter two (and

**Norelco PC-70**, like the first-generation PC-60, uses 3 Plumbicons for both chrominance and monochrome pickup. Distributed in the U.S. by Visual Electronics, the camera unit consists of two major separable units, the camera proper and the zoom lens unit. Pickup functions (beam-split, Plumbicons, yokes, preamps, etc.) occupy one side of the camera, while the other side houses viewfinder circuitry, servo amplifiers, and low-voltage power supplies. The optical system includes a prism color-separating block; the zoom lens features servo control of zoom and focus at either the camera position or the control point (the iris may be controlled only at the control point).

The 6½" viewfinder has 3 push buttons which enable the operator to view any channel separately or any combination of signal superimposition. This feature is designed to help in setting up camera registration. A 4th push button enables the cameraman to overpeak the



video signal for critical focus adjustment. A zoom angle indicator is located directly below the viewfinder tube, and a viewing hood may be adjusted in any vertical position over an angle of 30°. The camera control unit includes separate operating and registration panels. Waveform and voltage test points and setup controls are located on the front plate of individual modules. The camera head, including 42 lb. lens, weighs 162 lbs. Price is about \$70,000.

the *selenicon*, which still may be introduced this year) are similar in operating principle. The I.O. produces a video signal by photo-emission and secondary emission, while the vidicon and Plumbicon (and *selenicon*) employ the photoconduction principle. The Plumbicon, however, uses a different photoconductive layer. In physical size, I.O.s are larger than either vidicons or Plumbicons, and, therefore, require more space inside a camera (Plumbicons are slightly larger than vidicons).

Tube sensitivity is determined primarily by the light transfer characteristic. Normally, the I.O.

produces a greater signal current than the Plumbicon or vidicon, a result of the I.O.'s secondary emission characteristic. This higher current does not, however, necessarily indicate higher sensitivity; the real sensitivity criterion is based on the electrical operating point and existing illumination.

An important factor in determining the operating point of any tube is the signal-to-noise ratio in the video signal—the ratio (expressed in db) between the useful signal and the effective value of noises. With the I.O. the noise level is a function of signal level,

and even more so with Plumbicons and vidicons because of the use of non-linear amplification for gamma correction. The noise frequency also has a bearing on the signal-to-noise ratio—high frequency noise is less detrimental than low frequency noise. The I.O. output is so large that the noise component of the signal comes entirely from the tube itself and is almost independent of frequency. Therefore, the I.O. noise spectrum is essentially a horizontal line.

Vidicons and Plumbicons produce smaller signal currents, and the noise element originates almost entirely from sensitive sig-

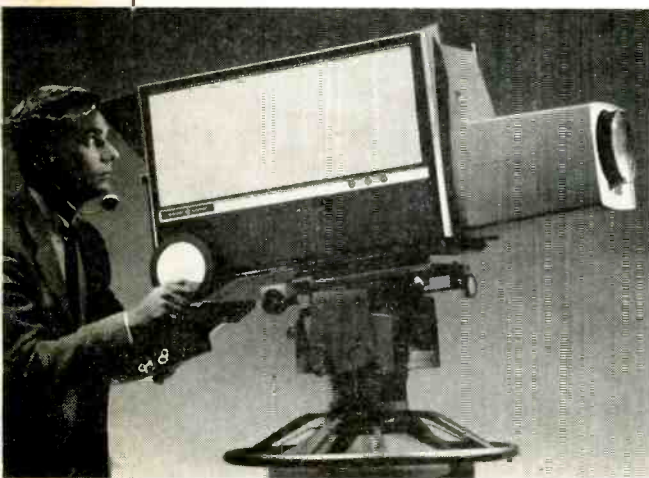

G.E. PE 250 uses 4 Plumbicons, three in chrominance channels and one in the luminance channel. A precision-type optical bench and relay optics (mounted in a dust-proof enclosure) diverts 30% of the available light to the luminance channel with the remainder directed through dichroic mirrors to the chrominance pickups. Circuitry is of solid-state modular construction. Plumbicons can be removed without disturbing yoke assemblies by unplugging the socket on the base of the tube and sliding the tubes out through an access panel on the rear of the camera. With the side cover of the head dropped down, an adjustment panel swings out so that it is accessible from the rear of the camera. Adjustments are simplified by a meter which indicates a go/no-go condition for each measurement function. Viewfinder display is selected by push buttons. Gear-driven zoom and focus controls have been designed to eliminate backlash. Including a built-in 10-to-1 zoom lens (extenders may be inserted through a port in the lens assembly), the PE 250 weighs less than 150 lbs. Price is about \$70,000.

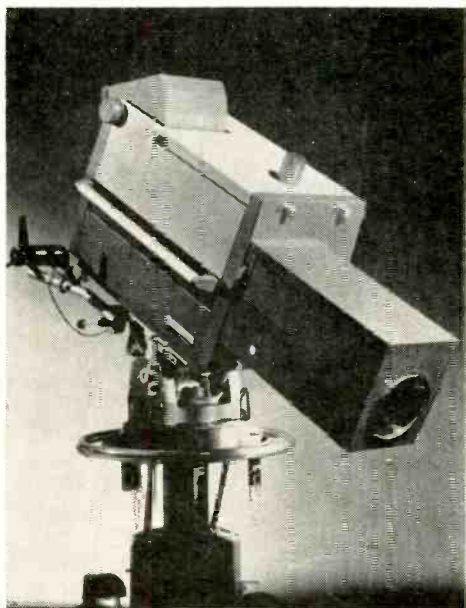

Marconi Mark VII (distributed in the U.S. by Ampex) uses 4 Plumbicons, three for chrominance and one for luminance pickup. With the exception of a nuvistor in the first stage of each head amplifier and tube-type rectifiers in the viewfinder, the camera is of solid-state plug-in construction. Designed to accept any standard zoom lens, it can also be adapted to take a single fixed-focus lens. The optical system is mounted on a fixed plate enclosed by a dust-proof cover. An optical switch is said to provide full camera sensitivity for black-and-white operation. Two filter wheels are incorporated in the lens assembly, each with an open position; one offers 3 neutral density filters, the other a choice of 3 color filters. Zoom, focus, and iris may be servo controlled, or zoom and focus may be controlled manually with servo control of the iris only. The servo control is located on the operation control panel.

A 7" viewfinder is mounted on 2 quick-release clamps which permit it to be tilted and locked over a wide angle. The viewfinder may also be detached and operated up to 30' away from the camera. A 3-position switch selects the signal to be displayed on the viewfinder: either the luminance channel signal, elected by the monitor switch on the control unit, or, a signal from an external source. Normally, the luminance signal is displayed and the monitor signal used for setup. The external signal, fed in at the camera control unit, is intended to help the camera-man align his picture with the picture from another camera. Excluding lens, the camera weighs 115 lbs. Price is about \$85,000.

**Sarkes Tarzian Series 88** color camera optical system is designed to use a small I.O. or Plumbicon in the luminance channel and Plumbicons, vidicons, or any similar size tube in the chrominance channels. According to the manufacturer, tubes are interchangeable in the field. All camera optics are enclosed in a dust and light-proof housing, and camera and processing circuitry is solid-state and mounted on plug-in modules.

Camera setup is accomplished with controls located on a single panel on the left side. All channels are said to require no further attention until component changes are made. The viewfinder is mounted on a sliding track and the entire assembly can be removed. Viewfinder input may be selected by a rotary switch on the viewfinder panel; choices include internal video, external video, mix (superimposition of internal and external video), and the fourth input is for test and registration purposes.

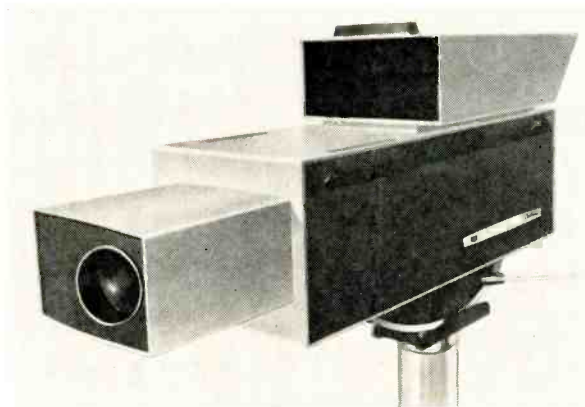

The remote control panel includes push-button selection of operating mode from fully manual to fully automatic. Individual control or combinations of automatic and manual features can be used. A built-in servo-powered 10-to-1 zoom lens is detachable; zoom and focus are controlled by electrical controls at the lower left and right control arms of the camera. Iris opening is controlled from the remote panel. Including viewfinder and lens, the camera weighs 129 lbs. Price is approximately \$75,000.

nal amplifier inputs. As a result, noise increases with frequency on a fairly linear scale.

I.O. signal current is proportional to illumination over a certain range; above a certain value, commonly called the "knee," the I.O. becomes saturated. If, however, beam current is properly set, illumination above the knee can still be handled. The knee acts as an automatic current limiter, which is an important advantage where scene lighting may have unusually bright spots. The optimum I.O. operating point is at or just over the knee. Development of a 4½" I.O. with a higher knee has provided a better signal-to-noise ratio, better resolution, and the

ability to pick up a greater range of scene lighting. Only under poor lighting conditions, where the operating point is considerably below the knee, does discharge lag become noticeable.

The vidicon will not handle as wide a range of scene lighting at a given set of operating parameters. If a tube is set to operate at too high an illumination level, white areas may be "washed-out" and there will be a tendency toward "blooming." After-images and trailing effects are likely to occur under these conditions. Then, too, when optimum operating parameters are exceeded, dark current (signal current when no light is falling on the

tube) increases at a greater than proportional rate, resulting in picture quality deterioration. The vidicon has characteristically slow response at low scene illumination due to its photoconductive lag. (This condition is reported to be lessened in some later designs.)

Plumbicons, while similar to vidicons in most respects, have been shown to have lower dark currents. Also, the photoconductive lag is smaller and independent of illumination. Plumbicons do require gamma correction (uneven amplification for each color) while vidicons and I.O.s may be used without such correction. Usually, though, most cameras have provision for gamma correction.

### Number of Tubes

The choice between a 3- and 4-tube camera does not seem as important as it once was. If the camera is to be used for on-location remote pickups, portability is the dominant factor. In the past, Norelco's 3-tube unit was the answer, but now it is rivaled in a size and weight by the new 4-Plumbicon models introduced by G-E, Marconi, and Sarkes-Tarzian. If the camera is to be used solely for studio work, size and weight are less important.

The difference in setup time required for 3- and 4-tube cameras has narrowed due to advanced circuitry and built-in test equipment. Registration of the 3-tube camera has been improved by new circuitry which allows greater tolerance for registration errors. The 4-tube camera derives its black and white signal from the luminance channel, while the 3-tube unit "manufactures" the monochrome signal from the 3 chrominance outputs. In this respect, it seems that the 4-tube camera may be more stable. However, the day is fast approaching when the presence of a compatible luminance signal will greatly diminish in importance.

### Sensitivity

Signal-to-noise ratio largely determines camera sensitivity. There are actually two noise values which must be considered—luminance noise, which relates to the sum of the luminances of the 3 colors, and chrominance noise, which relates to the fluctuations in each color. The most important is luminance noise, and this value is determined in part by pickup

tube characteristics and associated circuitry. Some manufacturers claim a signal-to-noise ratio as high as 38 db. It appears from available information that a 40 db signal-to-noise ratio is about the highest attainable with present day tubes.

As far as scene lighting is concerned, most cameras will operate at 150 to 250 ft. candles of illumination (some with considerably less with minor adjustment). Another factor which must be considered is operational capability under conditions where lighting may vary widely. In these instances, 4-tube cameras, and particular I.O. designs, appear to be more adaptable than others.

### What About Film Cameras?

Delivery schedules for film cameras are not quite as far behind as for studio cameras, but by the same token, color film cameras are not expected to be in off-the-shelf supply, at least in the near future. Prices are competitive, \$50 to \$60 thousand, depending on accessories and control panel options. At present, there are only three U.S. suppliers of film camera chains.

*G-E's PE 240 A/B* uses 4 vidicons for monochrome or color operation. The transistorized equipment consists of two main parts—the PC-16-B camera and a remotely located monitoring and control position. Light for the vidicons is focused at the center of a field lens, then split by selective optical filters into 4 paths and re-imaged by individual lenses onto the vidicon faces. The resulting signal is amplified and sent to the video processing modules mounted in drawers in the camera pedestal. The registration control panel provides controls to register the system and the monitor selector panel allows switching between video signals for various displays needed during registration. Gamma is adjustable on all 4 channels; automatic contrast control also compensates for variable film density. The unit is 22" wide, 58" high, and the optical center is 48" from the floor. Weight is 250 lbs.

*RCA's TK-27* uses 4 vidicons and is transistorized with plug-in circuit modules for color or b&w. Many circuit functions in the 4 channels are identical, resulting in duplicate and interchangeable

modules. Automatic circuits provide means for film density variation. Prisms are used to separate and direct the light image to each channel. Dichroic surfaces are sealed within the optical block. Setup pulses, built-in and switch operable, may be inserted for checking system sta-

For Manufacturer's Data

#### **Ampex Corp.**

Marconi Resident Engineer  
401 Broadway  
Redwood City, Cal. 94063

#### **Cohu Electronics, Inc.**

P.O. Box 623  
San Diego, Cal. 92112

#### **General Electric**

Visual Communications Products  
Electronics Park, Bldg. 7-315  
Syracuse, N.Y. 13201

#### **Radio Corp. of America**

Broadcast of Communications  
Products  
Front & Cooper Sts. Bldg. 15-5  
Camden, N.J. 08102

#### **Sarkes Tarzian**

Broadcast Equipment Div.  
East Hillside Drive  
Bloomington, Ind.

#### **Visual Electronics (U. S. Distributor for North American Philips Co.)**

356 W. 40th St.  
New York, N.Y. 10018

#### **EMI Electronics Ltd.**

Broadcast Equipment Div.  
Hayes, Middlesex, England

#### **Shibaden Corp. of America**

58-25 Brooklyn-Queens Expressway  
Woodside, N.Y. 11377

bility. The equipment also includes a built-in color bar generator. Remote controls are included in 3 panels designed for side-by-side mounting. The unit is 24" wide, 58" high, and the optical centerline is 48" above floor level. Weight is 250 lbs.

*Sarkes Tarzian Series 77*, designed to use any type film pickup tube, presently employs 4 vidicons for color or b&w. Optics, includ-

ing field lens, are self-contained in the camera pedestal, which also has provision for mounting picture monitors and camera processing equipment. Automatic circuits provide control of white level, black level and peak-to-peak video on all 4 channels to compensate for variation in film density. Any portion of the automatic control system may be disabled by push-button control. The remote control panel includes push-button selection of operating modes. Input monitoring facilities are included for setup; video and waveform monitoring is independently selectable. The camera weighs 600 lbs. measures 35 $\frac{3}{4}$ " wide and 54" high.

### Operation

As the state of the art advances the time required to train personnel for color camera setup and operation decreases. Most new cameras have built-in calibration generators which enable one man to set up a camera in less than an hour's time. With some camera chains the video operator can control setup adjustments from a remote panel. Longer periods of "hands off" operation are possible as a result of advanced design and greater stability. Fewer operating controls on the camera head contribute to increased remote control capability.

Some units are said to be capable of producing a usable picture with a 15-minute warmup period, but this, of course, based on an interpretation of what is considered "usable." In most cases, "matched" sets of chrominance channel tubes are no longer required, although any three tubes selected at random may not provide optimum performance. The point is that most cameras will tolerate more dissimilarities in pickup tubes than would former units.

At this stage of the game, camera similarities and dissimilarities may be less of a factor in deciding which camera to buy. For those who feel they must begin live color programming at the earliest possible date, merely getting a camera may be more important than *which* camera. In the final analysis, camera selection must be guided by the individual features of each unit as they lend themselves to the needs of the station. The biggest problem is: Can you wait until that particular model is available or will you have to accept an interim choice? ●





**3M show you new way  
to get rid of paleface!**

 **How?** 

# color tape plus!

New "Scotch"<sup>BRAND</sup> Video Tape No. 399  
opens a new dimension in video quality



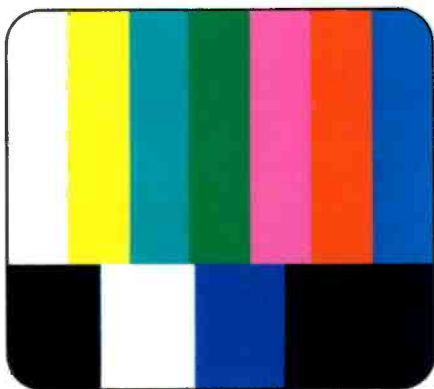

**Livelier, truer colors:** Colors appear brighter, clearer, life-like. Up to 5db better signal-to-noise ratio for multiple generation copies. New oxide, new binder, new coating technique make this possible.

**Stronger black and whites:** Compatible high fidelity resolution with startling presence. Minimal background interference or blur. It's a picture that's truly *alive!*



**Longer life:** Capable of 2,000 passes with no oxide rub-off or increase in dropouts; no visible indication of head to tape contact. Almost impossible to wear out. Virtually unlimited shelf life.

**Cleaner running:** Will not shed, block or rub-off. Leaves no oxide deposit on heads or guides. Assures better results—averages less than 15 dropouts per minute.



**Perfect copies:** Create up to 4th generation duplicates that only the most experienced eye can distinguish from the master tape.

**Improved sound:** Dynamic range is substantially improved across the sound spectrum. Tape background noise is significantly reduced. New No. 399 gives you living sound to match the picture!

**Total versatility:** Can be used for both high-band and low-band recording. Recorders need no special adjustments or set-ups.

**Field proven:** Thoroughly tested and proven in actual broadcasting use by networks, local television stations and production studios.



**“Scotch”<sup>BRAND</sup> Video Tape No. 399**

**color  
tape  
plus!** adds a new  
dimension to  
your programming.

Fig. 1. Mutual impedance and current ratios for two towers of equal height (based on measurements and calculations).

Fig. 2. Pattern of two-tower array computations (1.05  $\angle 0^\circ$  and 1.00  $\angle 130^\circ$  are the same as 1.05  $\angle -65^\circ$  and 1.00  $\angle 65^\circ$ ).

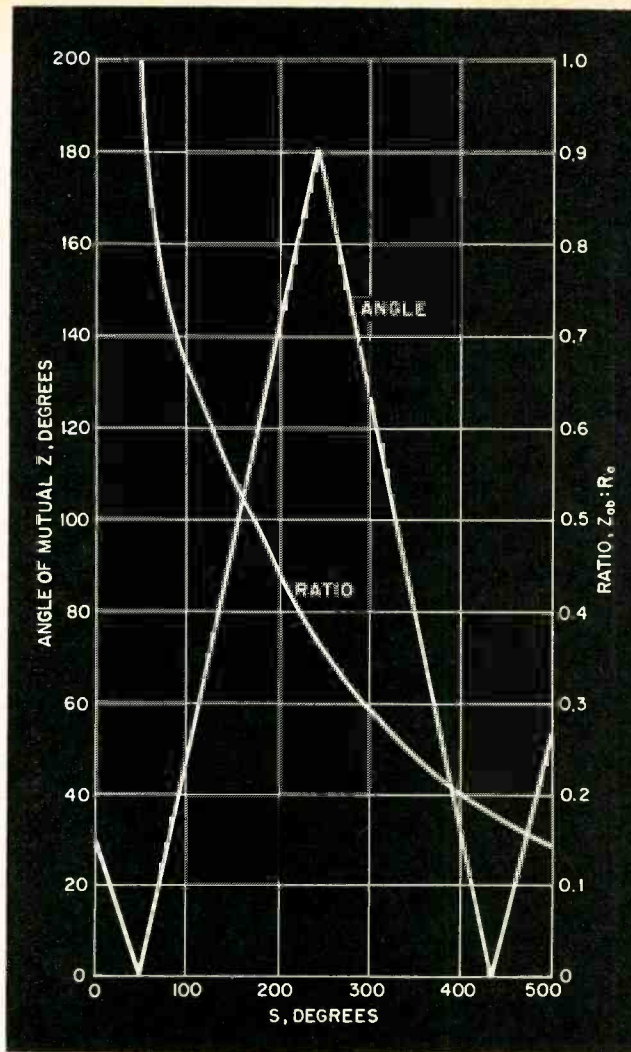

Next, the current ratios must be computed. Note that in every case the same value is repeated for the reverse relationship of the towers. Because one tower is the reference tower, we enter  $1 \angle 0^\circ$  for this tower. The first set of boxes now shows self and mutual impedances.

The coupled impedances are computed by multiplying each number in the current ratio box by the corresponding self and mutual impedances from the first box. The coupled impedances are now converted to rectangular form and entered in the rectangular form boxes. To obtain the actual base operating impedances and reactances, we merely add all the real numbers in the last set of boxes (rectangular form) and enter on the last line; then, add all the imaginary numbers in that box. Now we have the actual computed base operating resistance and reactance, and from these parameters we can calculate the required power and coupling components. (See page 50, Jan. BM/E. for additional data on measuring mutual impedance.)

### Designing a System

Let us design a two-tower array applying some of the principles covered in this series. The rather heavy earlier concentration on vectors, and similar (somewhat theoretical) material was presented to illustrate the principles on which the directional pattern is built. The actual application is merely a continuation of these principles with the addition of applied math. This example could be a part of an FCC application, although it is not generally necessary to be so comprehensive. However, it is always essential to go through these computations even though they are not shown in the application. A seasoned consulting engineer will often know the electrical characteristics of a proposed array and will not find it necessary to go through the whole process every time. But, in order to compute the phasing and feeder system, he has to know all the parameters presented here.

Let us assume that we are designing a two-tower array to provide minimum radiation on one side and maximum on the other; in other words, a form of cardioid or heart shaped pattern. Due to high costs, only a small piece of ground is available. This will require short tower spacing (re-

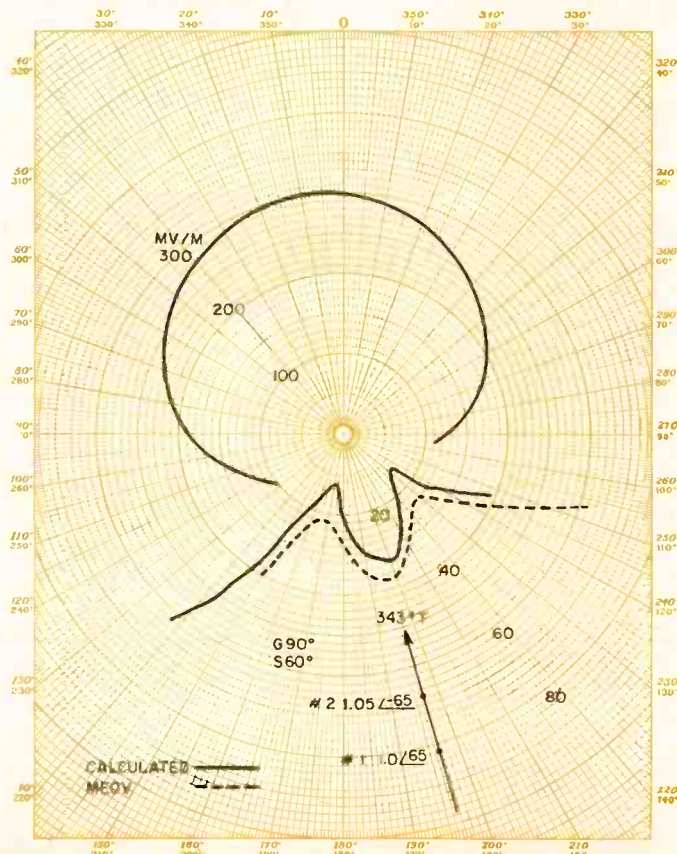

member, it is necessary to have sufficient land for the radials which must equal the tower height). We have decided to use quarter-wave towers to provide reasonable radiation, and help toward ease of adjustment. We do not specify any special frequency for this application; the example is intended to show what is needed for any frequency. Therefore, we use only electrical degrees which can be translated into wavelength

by using the ratio  $\frac{300,000}{F_{kc}}$

This gives the wavelength in meters (multiply by 3.3 for approximate length in feet).

We assume that the array is to be built on perfectly conducting earth. This is not the case, of course, but a good ground system helps, and, in any case, some standard of comparison has to be made. Assuming the best means that any errors will be on the side of poorer coverage, rather than better coverage. Therefore, interference problems will be generally slightly less than the theoretical.

The formula for computing a two-tower array is (taking every parameter into account):

$$E = K f (\theta) \frac{[E_1 |B/2 + (S/2) \cos_c \phi \cos \theta + E_2 |-B/2 - (S/2) \cos_c \phi \cos \theta]}{E = 2K f (\theta) E_1 E_2 \cos^2 [B/2 (S/2) \cos_c \phi \cos \theta] + (E_1 - E_2)^{2/4} \}^{1/2} \quad (1)$$

Where:

E = attenuated field in mv/m (at one mile)

E<sub>1</sub> = relative field from tower #1 (1.0 for this example)

E<sub>2</sub> = relative field from tower #2 (1.05 for this example)

B = electrical phasing (130°)

S = tower spacing (60°)

G = tower height (90°)

φ = horizontal angle

θ = vertical angle (not needed in this case because we are not concerned with vertical radiation in a daytime station). Elimination of the vertical angle reduces θ to zero.

The results of the computation have to be converted to mv/m by the factor 2K, which equals:

$$2 E_{rms} \frac{[E_1^2 + E_2^2 + 2 E_1 E_2 \cos B \text{ Jo } (S)]^{1/2}}{E_{rms} = \text{array RMS} = E_t \text{ VG} \times \text{LF} \quad (3)$$

The expression, Jo (S) = Jo, is a Bessel function. It is found in the NAB Engineering Handbook (or similar engineering tables).

$$E_{rms} = \text{array RMS} = E_t \text{ VG} \times \text{LF} \quad (3)$$

E<sub>t</sub> = theoretical radiation from one tower 90° high with no losses.

Table I—Mutual Impedance Matrix

Practical	
Self & Mutual Z	
Z <sub>11</sub>	Z <sub>12</sub>
Z <sub>21</sub>	Z <sub>22</sub>
Current Ratios	
I <sub>1</sub> /I <sub>2</sub>	I <sub>1</sub> /I <sub>2</sub>
I <sub>2</sub> /I <sub>1</sub>	I <sub>2</sub> /I <sub>1</sub>
Coupled Z	
Z <sub>11</sub> I <sub>1</sub> /I <sub>1</sub>	Z <sub>12</sub> I <sub>1</sub> /I <sub>2</sub>
Z <sub>21</sub> I <sub>2</sub> /I <sub>1</sub>	Z <sub>22</sub> I <sub>2</sub> /I <sub>2</sub>
Rectangular Form	
R + jx	R + jx
R + jx	R × jx
Operating Base Z	
R <sub>1</sub> + jx <sub>1</sub>	R <sub>2</sub> + jx <sub>2</sub>

Theoretical	
Self & Mutual Z	
45 + j40	31 /-36
31 /-36	45 + j40
Current Ratios	
1/0°	0.8/130
1.25/-130	1/0°
Coupled Z	
45 + j40	25/-94
50/-90	45 + j40
Rectangular Form	
45 + j40	-1.75 + j24.95
0 - j56	45 + j40
Operating Base Z	
45 - j16	43.25 + j65

For our example, 500 watts input power equals 139 mv/v. Vertical gain is:

$$\text{VG} = \frac{[E_1^2 + E_2^2 + 2 E_1 E_2 \cos B \text{ Jo } (S)]^{1/2}}{[E_1^2 + E_2^2 + 2 E_1 E_2 \cos B (R_m/R_s)]^{1/2}} \quad (4)$$

R<sub>m</sub> = mutual resistance between #1 and #2 = 29 ohms

R<sub>s</sub> = self resistance of each tower (36.6 ohms)

Substituting in equation (4), VG equals 1.034.

Loss factor (LF) equals:

$$\frac{[I_1^2 R_1 + I_2^2 R_2]^{1/2}}{[I_1^2 R_1 + I_1^2 R^2 + (I_1^2 + I_2^2) R_L]^{1/2}}$$

Where:

I<sub>1</sub> = relative current in tower No. 1 (1.0)

I<sub>2</sub> = relative current in tower No. 2 (1.05)

R<sub>t</sub> is the assumed loss in each tower (2.5 is an acceptable figure)

R<sub>1</sub> = operating base resistance of No. 1  
= R<sub>s</sub> + (I<sub>2</sub>/I<sub>1</sub>)/Z/Cos (B + p) (6)

Where:

Z = mutual impedance between towers (29.6)

P = phase angle of Z (-11)

That completes the basic preparation of the data sheet. Many engineers print up similar pages with blanks for the variables and merely enter these values for each different antenna array. This saves a great deal of time, because the completed sheet can be included as part of the engineering exhibit if desired.

Next, we insert these values in equation (6): R<sub>1</sub> = 12.5 ohms; R<sub>2</sub> = 22.9 ohms. In equation (5) Loss Factor (LF), we use 0.94; in equation (3) E<sub>rms</sub> = 135 mv/m; 2K (the conversion factor) (Z) = 257.

Now putting all these items together in equation (1) we can compute the actual radiation for any azimuth (horizontal angle). It is simplest to reduce the equation to:

$$E = 257 [1.05 \cos^2 (65 + 30 \cos \phi) + .0006]^{1/2}$$

To prepare the required information for the FCC, we can take any desired angle and substitute it for φ. By doing this equation (1) becomes:

$$E = 23.7 \text{ mv/m radiation at } 0^\circ \text{ or } (360^\circ)$$

The remainder of the pattern is computed by setting up a matrix as was shown in Part 2 of this series. Different headings are used and the radiation is computed for every 10° from 0° through 180°. Beyond 180° the values begin to decrease with the horizontal angle so that, in drawing the antenna pattern, the corresponding value is plotted for each corresponding angle on the other side of the 180° line. The computed pattern is shown in Fig. 2.

This series will conclude with the next installment. ●

# **KLPR-TV, Pioneer Country Music UHF**

Many of tomorrow's UHF outlets will offer specialized programming. Here's what an AM daytime operator is doing with Channel 14 in Oklahoma City, in the face of three VHF competitors.

By Tony Christopher

A unique TV broadcast operation was inaugurated in Oklahoma City last month — a UHF facility went on the air with a full schedule of country and western programming. Country music and TV are no strangers—more than a few stations program locally originated and produced shows. And then there are occasional network productions, such as the Danny Thomas Special aired by NBC on March 13. But never before has one station devoted its entire schedule to a country and western format. KLPR-TV's only deviation from the all-country format is a live teen show with contemporary pop music and dancing, a type of program previously non-existent in Oklahoma City.

Big Chief Broadcasting began planning for a TV station in 1962 after successfully operating daytime KLPR for four years (acquired in 1958). They applied for the Channel 19 assigned to Oklahoma City, and ended up with 14 as a result of the reallocation of assignments. (Anyone prone to such beliefs might conclude that the Guardian Angel assigned watch over UHF stations was pulling the right strings.)

## **Why Country Music?**

Public demand for more diversified TV programming is at an all-time high. But just being different is still not enough. Successful programming of any independent station requires an in-

imate knowledge of the market. Some method or means must be used to measure the potential audience for any type of programming, and then a suitable program format, designed to fill the need, must be devised. In this age of specialization, there is probably some need for some specialty in every market, and it's up to the broadcaster to figure out what that need is.

In Oklahoma City, the three existing TV stations carry the networks. However, they carry little or no country and western programs. In recent years, *contemporary* country music—a matured version of “hillbilly” or “mountain” music—has experienced a national resurgence of rather notable proportions. In fact, American country music has gone international in a big way. Some country records are even making the so-called pop hit lists.

The belief in the need for country music in Oklahoma City is not based on suppositions or pipe dreams, or on any national averages. It is based on actual experience. KLPR is the city's only country music station, and its success is an adequate indication of the audience demand for such programming, or at least indication enough to foster a half million dollar investment. However, to further support this belief, KLPR radio listeners were asked if they would like to have a country music TV station, and the salesmen made a point of

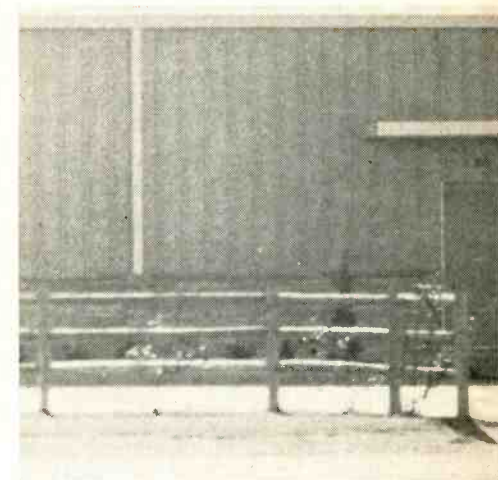

impression-testing potential advertisers. The results were encouraging. Long before the scheduled sign-on date, KLPR-TV management felt quite certain they were on the right track.

## **Program Sources**

It's one thing to talk about a country music TV format, but something else to develop it. There's a vast difference between radio and TV. In radio, records provide the bulk of the programming, but records are hardly the answer for TV, or at least not the total answer. Viewers would most certainly become bored just watching a disc jockey spin records hour after hour. TV must provide *visual* entertainment; viewers want to *see* the performance!

Live shows need live talent, and this can be costly. In the beginning, Big Chief Broadcasting publicized the need for local talent, by radio and by word-of-mouth. Response was encouraging, to say the least. Today, it seems the source of local talent is almost endless, and much of it is very good. KLPR-TV encourages local talent and provides a “showcase” for performers. Each individual or group is carefully auditioned and chosen on the basis of their professionalism. Local groups, anxious for exposure, are willing to work for talent fees which are tacked onto the time charge. Local shows produced with national stars are handled basically the



Studio and transmitter building is modest, but serves the purpose.

same way. KLPR-TV has received commitments from such nationally-known personalities as Faron Young, Wanda Jackson, and Red Sovine. Other stars are expected to sign on.

Complementary to the TV operation, the Big Chief Production Co. is devoted to producing and taping programs and commercials. The facility is in operation from 7 AM to 5 PM and is available to any advertiser or to tape any program. Shows featuring both local and national talent are used locally, then syndicated through a national agency to provide similar stations with relatively low-cost programming, based on the size of the market and its potential. Talent remuneration is based on residuals after the production cost (about \$80 per hour) has been recovered.

### Program Structure

Initially, KLPR-TV is operating on a part-time basis, from 4:55 PM to midnight. The news schedule, a departure from the standard TV program format, is composed of 5-minute newscasts before the hour. A 15-minute newscast is aired at 10 PM. Manager Omer Thompson feels that this approach is better than the less frequent and longer newscasts simply because viewers are given more up-to-the-minute concise reports and are more quickly apprised of what is happening. The hourly news summary makes good sense since; in effect, the

TV coverage takes up where the daytime AM leaves off. (And, of course, the TV schedule does not have to fit network timing.)

News facilities of the sister AM are used, including the news wire and mobile news vehicles. The news service charges an additional fee for permission to use the AM news wire; however, the cost is less than for two news services. Also, since the AM studios are right next door to the TV building, it is not too inconvenient. KLPR operates two mobile news cruisers equipped with direct on-the-air gear. In addition, each of 4 salesmen has a two-way radio car from which he can call in news stories. The salesmen are instructed not to go looking for news, but to report when they come across or are near the scene of an incident. (Salesmen cannot go on the air from their cars).

The teen bandstand-type show runs from 5 to 5:55. Called "Hop-A-Long," it features local talent and recorded contemporary music for dancing.

"Tonight in Oklahoma," 10:30 to midnight, is a talk-type show with live and taped single musical numbers interspersed. Show host, station President Jack Beasley (an area show business personality in his own right) interviews anyone who has anything to say of interest to Oklahomans. Guests include city and state officials, successful businessmen who have gone the rags-

### Equipment Costs

<b>Cameras:</b>	
2 Mark X cameras	
2 M.T.I. cameras	\$80,000
<b>VTRs:</b>	
2 Allenized units	120,000
1 Sony (portable)	32,000
<b>Transmitter:</b>	
Townsend 30-kw	127,000
<b>Antenna System:</b>	
Tower, 500'	20,000
Jampro, 40-gain zig-zag	60,000
<b>Building</b>	75,000
<b>Cost of Operation (Monthly)</b>	
TV Studio	\$21,500
Mobile Van	4,000
<b>Billing (Monthly)</b>	
Air time	30,000
Mobile	8,000

to-riches route, individuals with a "cause" or who represent an organization with a "cause," etc. While not intended to be a call-in show, some calls are taken when they pertain to querying a guest on some facet of his experience or knowledge.

The Sunday schedule is longer—8 AM to midnight—and is devoted largely to religious programming. Some programming is sustaining; some groups and churches purchase time and it is expected that more will do so.

### Operating Staff

Part-time operation requires fewer part-time personnel, which helps to hold down operating

### Rates

**Time classification:** Class AA—7-10 PM; Class A—6-7 PM, 10-11 PM; Class B—5-6 PM, 11-12 M

Programs	Rates		Spots	
Class AA	13X	260X	13X	312X
55 min	\$210	157.50	60 sec 42.00	29.40
30 min	126	94.50	20-30 35.70	25.00
15 min	84	63.00	8-10 20.15	14.10
Class A				
55 min	168	126	60 sec 33.60	23.50
30 min	100.30	75.60	20-30 28.55	20.00
15 min	67.20	50.40	8-10 16.15	11.30
15 min	67.20	50.40	8-10 16.15	11.30
5 min	50.40	37.80		
Class B				
55 min	126.00	94.50	60 sec 25.20	17.65
30 min	75.60	56.70	20-30 21.40	15.00
15 min	50.40	37.80	8-10 12.10	8.60
5 min	37.80	28.35		

**Newscasts:** Top rate, 5 min. prime time, 13x—\$78.00; 312x—\$54.60; 15 min—\$82.20 (13x), \$62.05 (312x).

**Special Spot Rates:** Fixed position—3, 5, 10 per week—Class AA 60 sec. rates from \$37.80 to \$30.20; Class A 60 sec. rates from \$30.25 to \$24.25; Class B 60 sec. rates from \$22.70 to \$18.20. Shorter announcements proportionately lower.

**Best time available:** 6, 9, 15, 21 per week; 60 sec rates from \$126.00 to \$315 (4 weeks \$456 to \$1092).

#### Production charges

**Programs:** 60 min—\$120; 30 min—\$60; 15 min—\$40; 10 min—\$30; other than 5 min—\$25. (Includes two cameras, director, video man or sports caster, audio man, use of equipment).

**Spots:** 60 or 20 sec—from \$20 for one spot to \$65 for 5 spots; 10 or 8 sec—from \$12 for one spot to \$40 for 5 spots (limit of 45 min. per spot for 60 or 20 sec.; limit of 30 min. per spot for 8-10 sec.

Where applicable, talent charges must be added.)

**Reserved tape sessions:** \$20 per ¼ hr., ½ hr. min.

**Dubbing charges:** \$20 per ¼ hr. min. (not including reel or tape).

costs. The staff consists of two cameramen, a technical director, a floor manager, and an announcer who tapes all station breaks and is available for other duties. The equipment is maintained by a full-time engineer. Newscasts are handled by the AM news staff; other AM staff members fill-in where and when needed.

KLPR-TV management hired an experienced TV staff; this is not, they feel, the place to cut corners. This way, supporting AM staffers can be trained to spell TV personnel during sick leaves and vacations without upsetting the operation. Then, too, trained AM staff people will be available for possible expansion in the TV operating day.

#### Equipment & Plant

KLPR-TV operates with one large studio (60' x 60') and two Visual Mark X camera chains. Two Allenized VTRs, located in the master control room, are used for program and commercial recording and playback.

A mobile unit houses two M.T.I. low light-level Vidicon cameras and a Sony portable VTR, making it possible to pick up and record on-the-scene news reports and on-location commercials and programs. When needed, the portable cameras can be moved into the studio for live or taped video pickups. The mobile van is proving to be a good in-



Country format has attracted talented local and nationally known performers. Ray Frushay is on camera, backed up by Billy K. Mar and The Country Gentlemen.

Station invested in two Allenized VTR's, vital to production of syndicated shows. A backlog of taped programs, produced last fall and winter, minimized initial programming problems.

Country and western music is enlivened with action provided by such talent as The Ben Smathers Dancers.

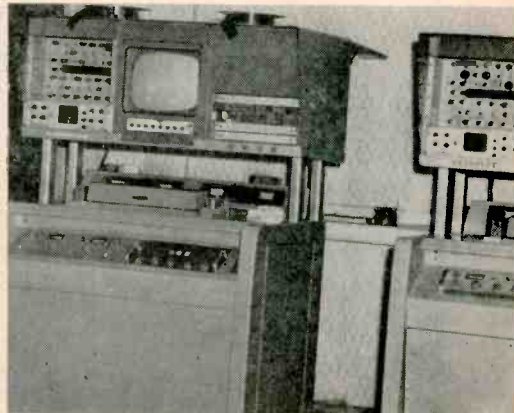



vestment, too, as an added inducement for advertisers to buy spots.

To get all the signal coverage possible, KLPR-TV operates with maximum power. A 40-gain 100' Jampro antenna mounted atop a 500' tower is fed by a 30-kw Townsend transmitter. The 1000-kw ERP signal provides primary coverage within a 48-mile radius and fringe signals reach points some 75 to 80 miles away.

Initial cost of the KLPR-TV plant was modest, at least when compared to the huge sums many VHF's have invested.

Cost of the building, including lighting circuits, air-conditioning, etc., was \$75,000. Total expenditure prior to air time was something just over \$500,000.

### Station Promotion

Naturally, the sister AM was used to talk-up the country music format beginning way back in 1962. After the CP was granted earlier this year, the pace of promotionals was, of course, increased. The TV operation is closely tied in with the AM—in fact, they are wholly compatible and complementary.

In addition to radio, newspaper ads were and are used to build the image of the station. Six station-owned cars are painted with both radio and TV call letters; their circulation in the area has helped call attention to the new TV station. Some \$8,000 has been spent on promotion thus far, primarily on newspaper space.

### What About Sales?

The highly experimental nature of this bold new venture would

tax the ingenuity of the most skilled salesmen. Attracting advertisers, even before the station went on the air, imposed a dual hardship. As an inducement the initial rate structure was set at about one-third that of the other stations in the market. Prior to the air date, commitments were received from 90 per cent of KLPR's radio advertisers. Bread and beer companies, food manufacturers, banks, and savings and loan institutions have extended a portion of their radio budget into TV. Management feels that the low-rate structure is certain to attract car dealers, furniture dealers, and others who are advertising on other stations.

With the inception of the TV idea, KLPR salesmen began talking TV with every potential advertiser who would listen. The results have been encouraging—long-time radio users (and some who had never used country radio) indicated an almost immediate interest in TV. Before the on-air date, at least 12 contracts had been signed, and since then several have joined the ranks (even some who were skeptical at first).

Although some advertisers are devoting part of their KLPR radio budget to TV, there are indications that some previous non-radio users will be convinced of the value of country radio as a result of TV advertising response. Some advertisers have indicated that a portion of their budget will be diverted from other stations in an effort to reach a broader audience.

Without a concrete circulation figure, KLPR-TV had to base its rate structure on the actual cost

of operation plus a cushion to cover unsold and sustaining time. Presently, the monthly operation of KLPR-TV costs between \$20 and \$25 thousand. The rate card was designed to cover this, plus a reasonable margin. After several months of operation, more accurate cost-per-thousand figures will be developed.

KLPR-TV was able to accomplish what many TV's would like to do—or even radio stations, for that matter—begin operation at the break-even point. This situation was due, at least in part, to a pretty hot local primary political campaign. Other TV stations were sold out; thus, a rather hefty chunk of business came to KLPR during the first month of operation. Without the political business, KLPR-TV management expected to turn the financial corner after two or three months of operation.

### What About Color?

There is color in KLPR's future, but at present, only 7% of Oklahoma City homes are capable of receiving color. In view of the higher initial investment (at least another \$250,000), management decided to delay color programming until the color set penetration increases. They feel that, due to the comparatively small number of color sets in their area, they are not too strongly obliged to offer color programming immediately, but within a year, they expect to begin color operation, especially if the operation proves successful enough to support the added investment. In the meantime, the TV operation will have a chance to get off the ground under a little lighter financial load and with fewer technical problems.

### Will They Succeed?

KLPR-TV seems to have a foot in the door—it's off to a good start. Now only time will tell. UHF-TV operators in some locations are facing a night-marish situation. As each market is different, so must the type and scope of operation be different. There is no easy out in any case, but it appears that if a would-be operator is armed with an intimate knowledge of his market, works unrelentingly to succeed, and has a good share of old-fashioned guts, he stands a pretty fair chance of making a success in UHF-TV. ●

Master control room is simple, with direct view of single 60' x 60' studio.



# FM Overmodulation: Cause & Cure

By Harry A. Etkin

Overmodulation is a problem every FM broadcaster faces.  
Here's how to eliminate it.

WITH THE continued improvement in recording and FM broadcasting equipment, the increased use of special equalization effects by recording artists and studios, the differences in micro-

Mr. Etkin is a staff engineer, WQAL-FM Philadelphia, Pa.

phone equalization and response, and the use of close microphone techniques, the high frequencies fed into FM broadcast transmitters are often of sufficient amplitude (after pre-emphasis) to cause serious overmodulation problems. The increasing number of incidents of FM overmodulation, and the resultant FCC cita-

tions, indicate a real need for corrective actions.

## Why Does the Problem Exist?

Normally the lower frequency component of an audio signal is amplified more than the higher frequencies. This occurs at every step between the input equipment and the transmitter, unavoidably adding a high frequency noise to the desired audio signal. As a result, the signal-to-noise ratio is low at the high frequencies. Where the audio spectrum from 50 to 15,000 cps is utilized, a situation such as this cannot be tolerated.

To improve signal-to-noise ratios, various methods of equalization and pre-emphasis are employed. Pre-emphasis—increasing the amplitude of high frequency audio signals before they are fed to the transmitter—reduces the unfavorable relationship between high frequency audio and high frequency noise. High frequency program signal is increased, while the high frequency noise level remains the same, improving the high frequency signal-to-noise ratio.

However, as signal-to-noise ratios increase, equalization or pre-emphasis can actually result in signal degradation due to distortion brought about by the excessive high frequency signal levels that are forced through the various amplifiers. The main reason for the equalization and pre-emphasis network is to make sure that high frequencies are not blocked out by the inherent noise characteristics.

Since there is less energy in the upper section of the 50 to 15,000 cps region than there is in the portion below 1,000 cps, a 75-microsecond pre-emphasis curve was adopted by the FCC to take advantage of this distribution. Fig. 1 illustrates the standard pre-emphasis characteristic curve. The solid curve shows a flat response below 200 cps; at 1,000 cps the gain rises to +0.9 db, to +8.3 db at 5,000 cps, to +13.8 db at 10,000 cps, and at 15,000 cps the gain increases to +17 db. In general, a 75-microsecond pre-emphasis curve means that amplifiers all along the audio line will be handling a 15,000 cycle signal 17 db higher than the 1,000 cps signal. If the transmission at 1,000 cycles is to be maintained at an adequate level, there is a definite probability of overloading the amplifiers at 15,000 cycles when us-

Fig. 1. Standard pre-emphasis curve. Frequency response limits are shown by solid and dashed lines.

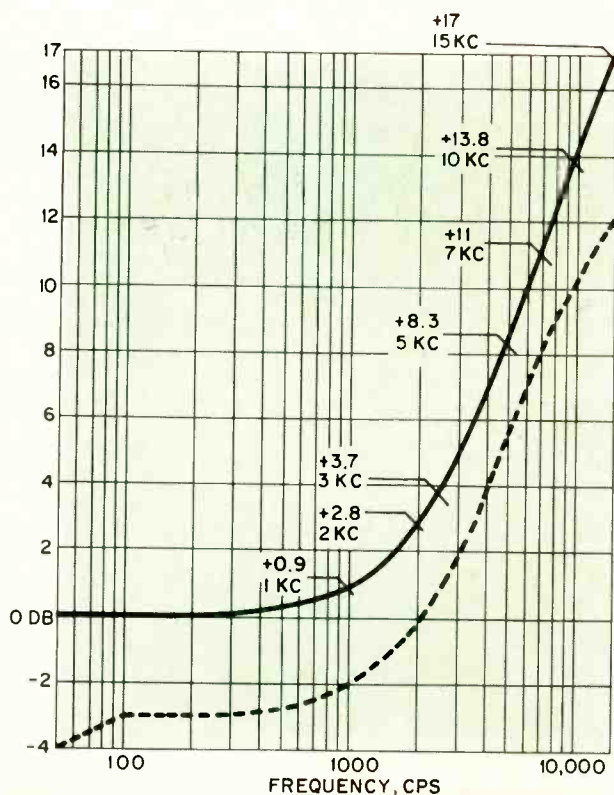

ing the 75-microsecond pre-emphasis.

### What are the Causes?

The FCC standard pre-emphasis curve is quite severe. When this curve was adopted, FM programming was not too competitive and the FM broadcaster usually operated the transmitter with low values of modulation to allow the transmission of the full dynamic range of recordings. The standard practice for FM broadcasters was to operate at a low modulation level without the use of peak limiting amplifiers. Although limiters are being used today, more FM stations are still being given citations for overmodulation. This has led many engineers to the conclusion that limiters were not operating correctly. However, tests showed that they were operating on a flat response curve, and the high frequency signal fell below the threshold of limiting. Overmodulation is caused by pre-emphasis of the audio signal *after* it passes through the limiter.

A limiter cannot always handle the complete job of loudness and level control. High-amplitude, high-frequency signals can trigger the limiter and cause a drop in overall program level, balance, and loudness. Where the limiter is inserted *after* pre-emphasis, it will be particularly susceptible to this triggering with a reduction instead of an increase in signal strength. This method of operation can limit the high frequencies as well as the mid-range and low frequencies. If the program level is maintained well below the threshold of limiting, acceptable program levels will be produced. However, some programs will cause unnatural effects, as shown in Fig. 2. The results shown are for a limiter with an attack time of approximately one millisecond and a 90% recovery time of about two seconds. When the pre-emphasized high-frequency peaks exceed the threshold of limiting, gain at mid-frequencies is reduced. Thus, the de-emphasized signal sounds like the limiter is undergoing a blocking-type of oscillation; the gain suddenly drops, then recovers on the normal RC slope. This type of programming will produce a large group of complaining listeners. The right side of Fig. 2 shows the same signal without pre-emphasis.

If the limiter is placed before pre-emphasis, and if it is not trig-

gered by high frequency peaks, the pre-emphasis can cause transmitter overmodulation with all its distortion and problems. Live studio programs, music, and other recorded sounds containing applause, percussion noises, finger-snapping, clinking and tinkling of glasses and keys, tap dancing, and other peaked high frequency sounds (when combined with program music or speech) will cause transients that will trigger the limiter and actually cause an attendant gain reduction. If the

emphasize the signal to restore the original frequency response. It can be seen that overmodulation will result if the high frequencies exceed the limits of the curve shown by the shaded area in Fig. 3.

FM transmitters are designed to tolerate extensive overmodulation with a minimum of distortion. However, considerable overloads can swing the carrier beyond the maximum  $\pm 75$  kc limit. A 6 db program peak with low percentages of modulation will produce

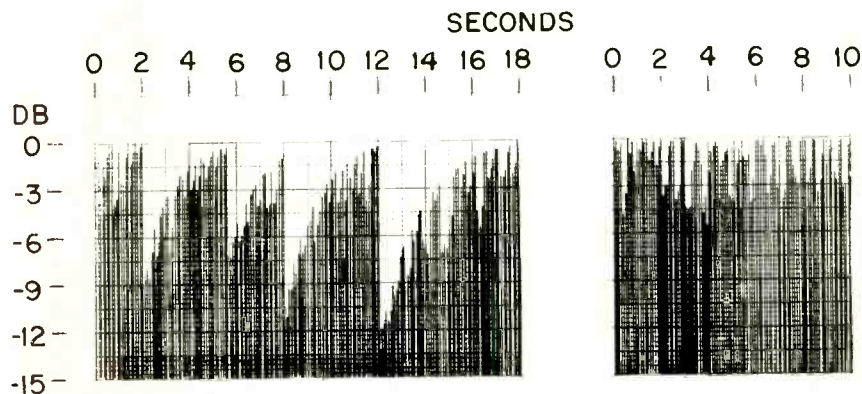

Fig. 2. Typical limiter operation with pre-emphasis ahead of the limiter. The same signal without pre-emphasis is on the right.

### FCC Pre-emphasis Regulations

Paragraph 73.317 of Vol. III of the Rules states:

1. The transmitter shall operate satisfactorily in the operating power range with a frequency swing of  $\pm 75$  kc at 100% modulation.
2. The system shall be capable of transmitting a band of frequencies from 50 to 15,000 cps. Pre-emphasis shall be employed in accordance with the impedance-frequency characteristic of a series inductance resistance network having a time constant of 75 microseconds. The deviation of the system response from the standard pre-emphasis curve shall lie between the two limits as shown in Fig. 1. The upper of these limits shall be uniform (no deviation) from 50 to 15,000 cps. The lower limits shall be uniform from 100 to 7500 cps, 3 db below the upper limit; from 100 to 50 cps the lower limit shall fall from the 3 db limit at a uniform rate of 1 db per octave (4 db at 50 cps); from 7,500 to 15,000 cps, the lower limit shall fall from the 3 db limit at a uniform rate of 2 db per octave (5 db at 15,000 cps).

high-frequency content of music and other recorded sounds never exceeded the curve in Fig. 3, the limiter signal could be fed into the FM transmitter pre-emphasis network without causing overmodulation. However, present day microphone techniques and orchestration, combined with RIAA treble pre-emphasis, often create quite impossible levels at the highest audio frequencies. Fig 3 is complementary to the standard pre-emphasis curve and can be used in the FM receiver to de-

a carrier swing to  $\pm 150$  kc, which is well beyond the allowable limit. Numerous measurement studies, using spectrum and wave analyzers, have been made.\* The data provides a typical peak power distribution curve, as shown in Fig. 4. This is a composite curve of the peak power measured from many types of programs broadcast from a typical FM station. During

\*Study measurement data developed and compiled by Gates Radio Co., Advanced Development Engineering Dept., Quincy, Illinois.

these measurements, the limiter was set up for a constant mid-range level. The very high and very low frequency peaks occurred much less frequently than the intermediate high and low frequency peaks. Yet, these peaks show why broadcast stations are being given citations for overmodulation. From this study the broadcaster can assume that every FM broadcast station, without preventive overmodulation systems, will pro-

duce a peak power distribution curve that will equal or exceed Fig. 4.

To reduce the excessive accelerations which occur at high frequencies, many FM stations simply reduce the modulation level to an average of 50%. This practice reduces the average program power output to one-quarter of the maximum allowed (Fig. 5.) The curve indicates that no overmodulation occurs below 5,000

cycles, but it is possible to overmodulate the transmitter as high as 70% at 15 kc. The 10-kc portion of the curve shows that overmodulation can exist up to 150%. Thus, even though the mid-frequencies are controlled by the limiter, the transmitter should be operated at a lower level of mid-frequency modulation to prevent high frequency overmodulation.

Even with 30% modulation, signals containing sharp transients could still cause more than 100% modulation at high frequencies. With 30% average modulation, the program power output of the FM station is approximately one-tenth of the maximum power allowed. In general, operation with very low modulation levels is not very practical because many of the peaks which cause the reduction in modulation are so great that many FM receivers will not pass the signal and listeners are usually incapable of hearing it.

### What Are the Cures?

The most logical approach would be to eliminate the necessity of pre-emphasizing FM signals in the transmitter. The great hardship in achieving this objective is to have the set manufacturers modify receiver circuitry.

Since this isn't immediately practical, corrective measures must be employed. One method is to install a low pass filter which will cut off all signals that fall on the slope of the filter curve (Fig. 6). This actually results in signal degradation just to protect the station from a relatively few overmodulation peaks. Thus, the low pass filter is not the cure for the overload problems.

Another method of controlling the high frequency peaks, developed primarily for the disc recording industry, pre-emphasizes the program material, acts upon the troublesome high frequency signals, and de-emphasizes in a complementary manner to give an overall flat output. Although this type of operation can eliminate overmodulation in most cases, it can cause gain reduction at all frequencies above 600 to 900 cycles with some resultant signal degradation.

When a limiter is installed in the system ahead of this unit (with low frequencies controlled to approximately 90% modulation), the resultant signal will contain a small amount of overmodulation in the 1100 to 1200 cycle area. There will also be

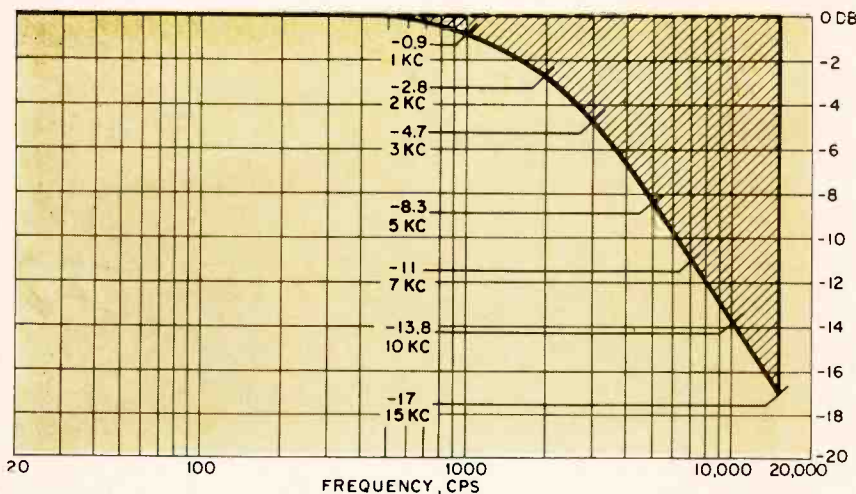

Fig. 3. Standard FM receiver de-emphasis curve.

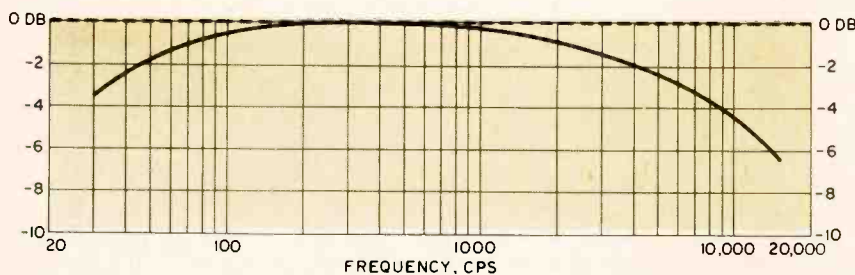

Fig. 4. Typical peak power distribution curve at limiter output.

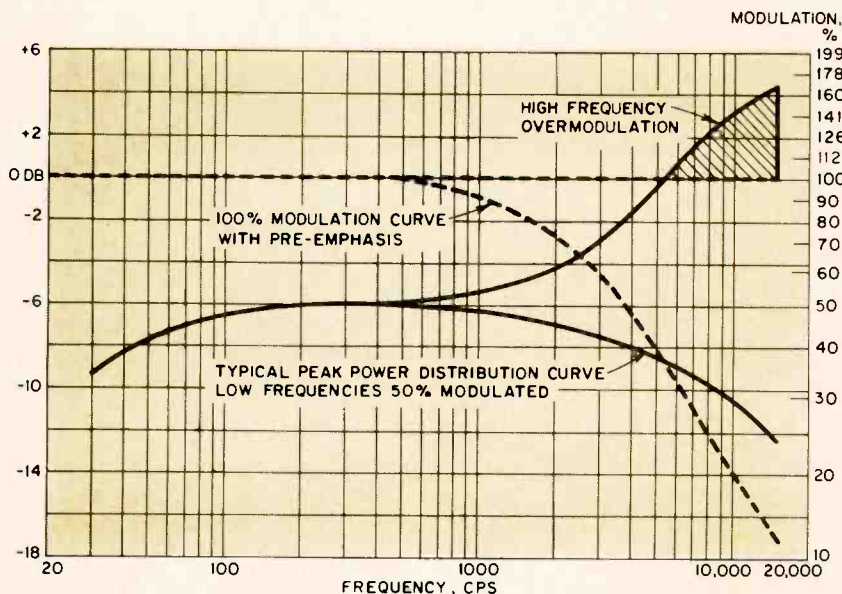

Fig. 5. Typical peak power distribution curve at 50% modulation.

overmodulation peaks above 6500 cycles which may rise to 130% at 15 kc. Peaks are also produced in the 2 to 5 kc region (Fig. 7).

The most economical approach is to use a device that is most advantageous from a coverage standpoint—a unit which automatically controls the audio levels. The automatic level control is intended for use between the limiter and the FM transmitter. It is designed for both stereo and monaural service and can maintain a relatively constant output, much in the same manner that an operator might, by carefully and constantly riding gain on the program. The automatic level control unit and the limiter supplement one another ideally, permitting a higher average level of program material and preventing overmodulation on sudden program peaks (Fig. 8).

The program material fed from the limiter into the automatic level control unit is pre-emphasized with a standard 75-microsecond curve; the sudden program peaks that exceed this curve are clipped off. The signal is then fed through a standard 75-microsecond de-emphasis curve to give an overall flat response. The overall response, shown in Fig. 8, is +0.2 db at 10 kc, -0.2 db at 15 kc, and essentially flat below these frequencies. Average modulation as high as 98% can be obtained without overmodulation. In operation, only those peaks which would cause overmodulation are affected, and they are generally the higher audio frequencies. The attack and release time is instantaneous for immediate and continuous protection, and there is no deterioration of the dynamic range in program material.

### Costs

Since stereo is becoming a standard practice with FM broadcasters, limiter and automatic level control units should serve both purposes. A dual peak limiting amplifier costs from \$900 to \$1,000 and the automatic level control unit runs between \$500 and \$600 (not including installation costs). The combined use of these units will improve program and commercial production, cut costs, and boost power output at least eight times. More importantly, better control of program quality is maintained. By expanding effective range and improv-

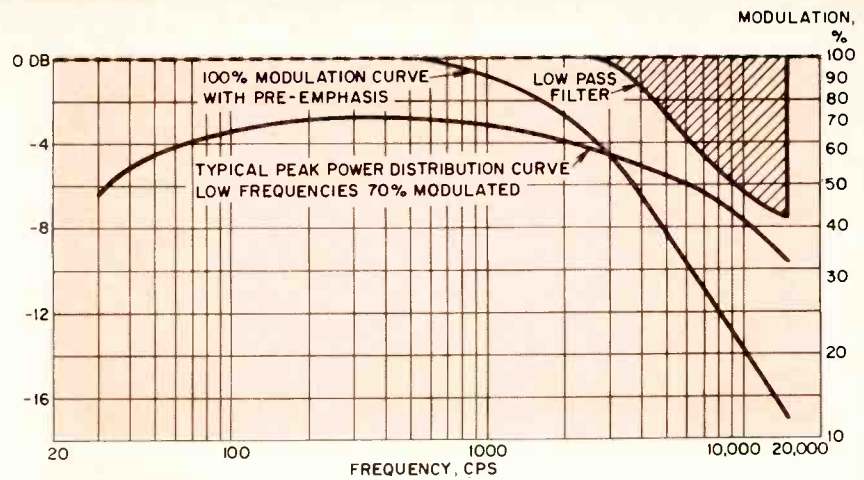

Fig. 6. Performance of low-pass filter.

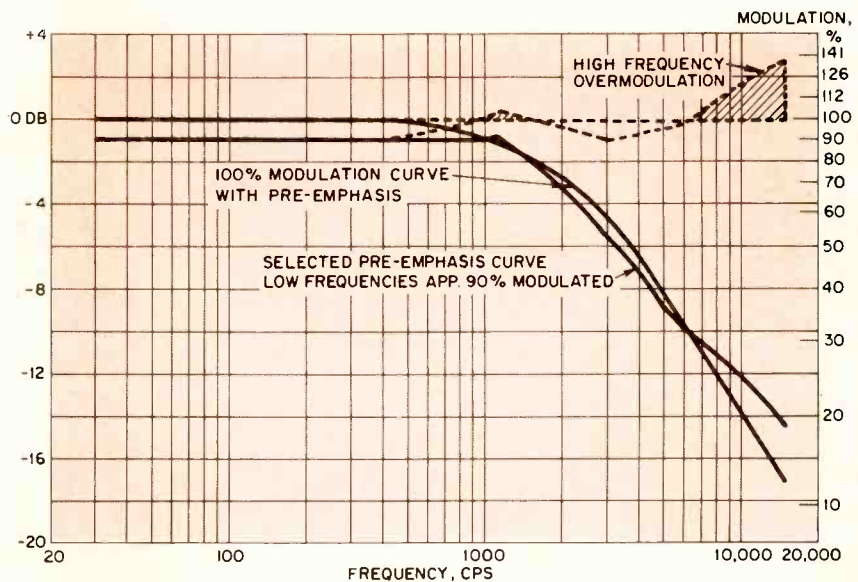

Fig. 7. Results of a typical selected pre-emphasis curve.

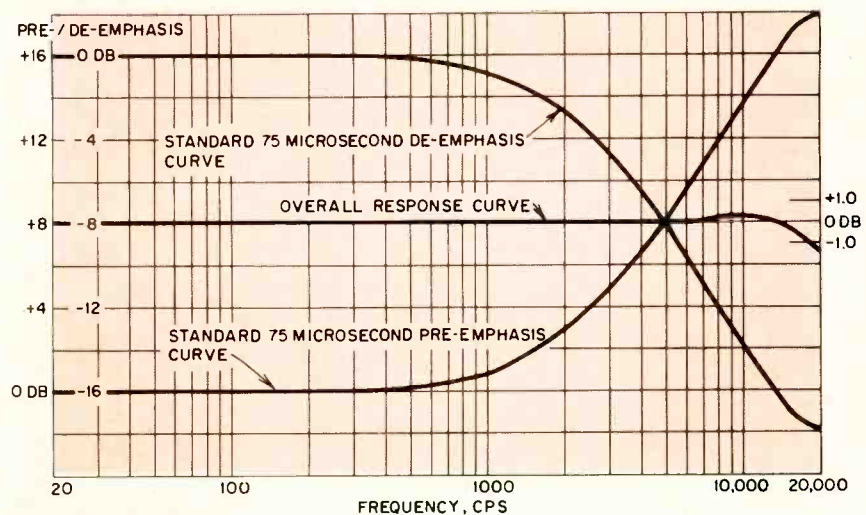

Fig. 8. Test data curves from an automatic level control unit.

ing reception, it should bring in extra advertising revenue.

The use of a peak limiting amplifier and automatic level control unit inserted between the audio system and the FM trans-

mitter is the ideal approach for putting a ceiling on the high frequency peaks. Whether used for stereo or monaural, FM listeners will enjoy full range reproduction at a pleasant level. ●

# Promoting & Selling Cable Service

By Samuel S. Street

**How should advertising be used to promote CATV?  
Here are some guidelines.**

**T**HE CHIEF function of cable system advertising is to increase demands for hookups, secure more subscribers. It also reminds present subscribers of the value of your service and discourages disconnects. But while an advertising campaign can be resoundingly successful, it can also fail miserably. Everything depends on the right combination of factors—involving the amount of advertising, media used, and the effectiveness of the presentations. If your publicity and advertising are handled with care, it will offer a subtle psychological bonus. Repeated favorable impressions establish your service in the mind of the public. In addition, you gain stature as a welcome and respected asset to the business community. If you “bungle” the job, on the other hand, an ad campaign can actually work against you.

A CATV operator can effectively use newspapers, radio, billboards, transit cards, direct mail, and, of course, his old friend, TV. Quite often it is wise to use a combination of several mediums in a well integrated campaign.

## Publicity—“Free advertising”

There are several ways to gain valuable free publicity. One is to send news releases to local papers, radio stations, and, perhaps even service club bulletins, etc. Every time something important happens in your operation—new employees, additions, etc. — a news release should be sent to local news media. If you are personally acquainted with an editor or broadcaster, follow the release

Mr. Street is Director of Marketing, Viking Industries, Hoboken, N.J.

with a phone call. However, if you don't know him, don't try to pressure or influence him in any way. Remember, he swings a big red pencil.

In order to reach the public, you also need the help of other people. The newspaper editor, the local radio station manager, the town printer—these are the people you will be working with to reach your customer. If you don't know them well, you have a great big hole in your promotional program that no amount of money will fill. Get to know these people. Attend a few civic club meetings — Lions, Kiwanis, Rotary, JC's, etc. Show an interest in the local school board; actively help with a local project. Publicity of this sort is sometimes more effective than paid advertising because it demonstrates the uses of cable TV in public service and your interest in the community. By participating in such activities, you are better able to keep abreast of local developments. You gain publicity for your system by participating in civic activities. Most important, you know, on a more personal, friendly basis, the people who make and disseminate news.

## Media Selection

Since advertising is a business investment, the decision of where and when to place it must be well guided. The decision to use any medium, or combination of media, should be based on tangible facts, not on what you or your friends might like. All too often advertising is determined by the tastes or whims of the advertiser when it should be determined by the tastes and whims of the listener or reader. To be economically effective, advertising must



This billboard sells cable TV to over 3,700 subscribers each day. Cost is \$100 a month.

reach the greatest number of people at the lowest possible cost.

To reach people—your prospective subscribers—you must learn their likes and dislikes — what they listen to or watch, their traveling habits as they go to and from work, shopping, etc. A native or long time resident of a community has an edge here, but a stranger can learn. The radio and TV stations, the newspapers, and outdoor advertising companies can contribute to your knowledge, but watching and listening to people—getting to know them and their habits is the best way to learn what makes them tick. When you know or begin to learn these things, you have only to apply unbiased reason to reach them through the advertising media available.

# This is CATV Show Biz

...or how to make your system a box-office hit

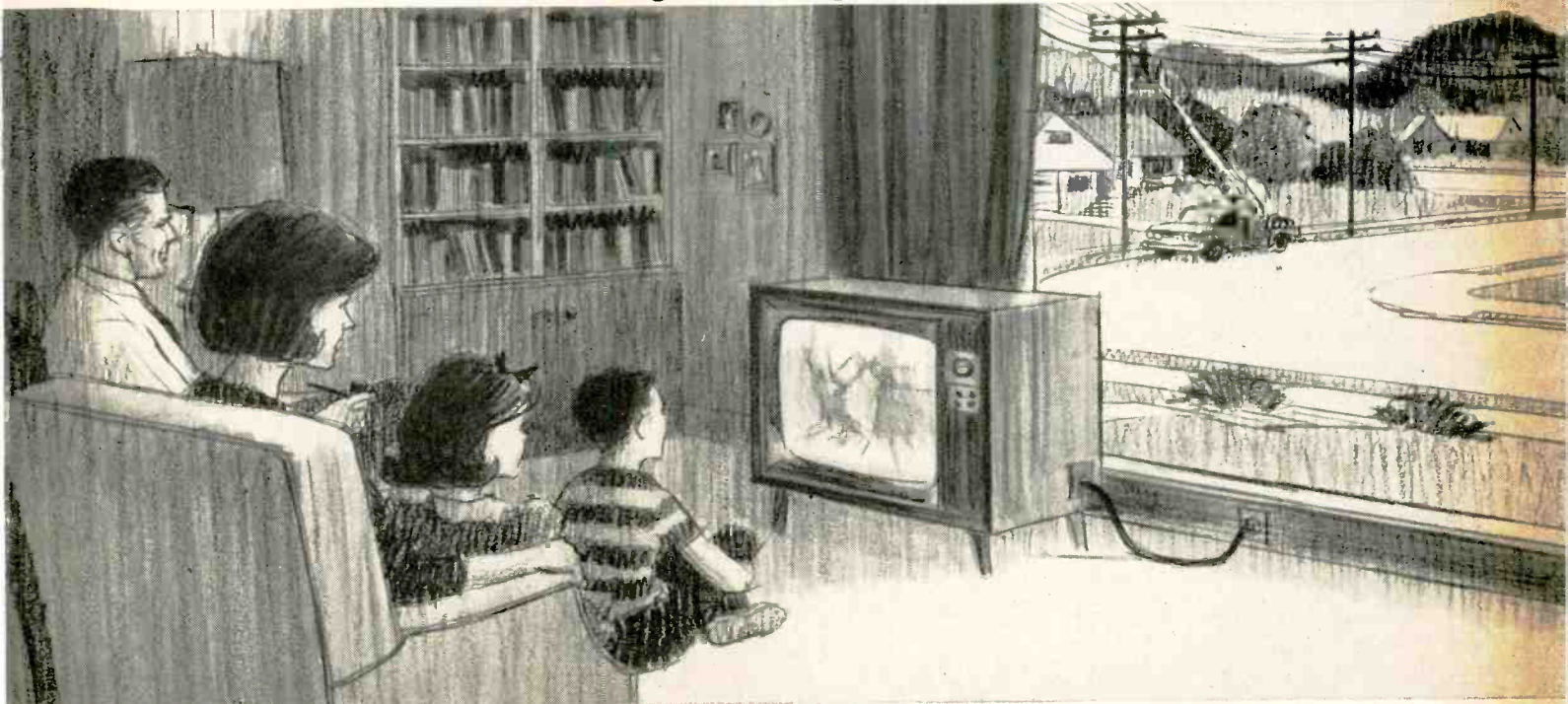

Cable: Available in seamless lengths up to 1/2 mile

Timatch<sup>®</sup> perfect match connectors

Putting a good show on the home screens of your subscribers is one part of CATV show business. Having the equipment to back up your programming—with clear, dependable pictures that don't ghost, fade or give up altogether—is another.

Times 30db CATV cable—and instantly-installed matching connectors—delivers award-winning performance to your subscribers' homes year after year. It's the surest way to keep them happy and put profits in your system's picture.

Times cable is trouble-free because of the way it's made:

in continuous seamless lengths up to 1/2 mile. This means fewer splices, fewer trouble points, less maintenance . . . and less labor cost. And because it's seamless, it's water and vaporproof . . . won't stop the signal short of target. All in all, you get improved electrical performance from Times cable and matching Timatch connectors. Long after so-called economy cable has been replaced, Times cable will still be a top performer, even while you're upgrading your system.

To take advantage of this direct way to assure your system's pay-out, contact Times for information on its CATV cable.

TIMES WIRE AND CABLE/A Div. of The International Silver Co./Wallingford, Conn. /Transmission System Design & Engineering/Standard & Special Purpose Coaxial Cable/Multiconductor Cable/Complete Cable Assemblies

Circle 19 on Reader Service Card

There is no best medium; they all must reach somebody or they wouldn't be in business. It usually boils down to those which appear to be capable of reaching the biggest chunk of prospects consistent with the amount of money you have to spend. Often more than one medium is involved; a combination of several mediums in usually most effective. Whatever your appropriation, it must go into the best available advertising vehicles if the investment is to be justified.

Some CATV companies spend 5% of their monthly subscriber fees on advertising; apparently this works well. Of course, in a new system, an advertising appropriation based on 5% of subscriber income could be too small to effectively do the job. Another method of setting an advertising budget is to base it on the number of subscribers you realistically might expect to sign up in a month. By using this latter method in a new system, or one just getting off the ground, the advertising budget is tied directly to the potential of the system, rather than being left to some imaginary figure.

### Newspaper Advertising

Thousands may read your ad, but they read it as individuals. Therefore "You" is the most important word in your advertisement. A potential customer is not interested in facts about your system unless he can see what's in it for him. So, tell him—tell your story simply, stressing the benefits to him, including the price. Indicate clearly the company name, address, and phone number. The benefits of your products and services should be stressed: Better reception, substantiated by testimonials; greater channel selection (list channels); no unsightly antennas; picture *this* not *that*. The CATV tower, or a picture of a family watching TV, are always good general illustrations for your ad. Special or regularly scheduled TV programs can be successfully tied in with your ad—especially if some popular shows happen to be on poorly received channels. For example, your ad may suggest that cable subscribers can watch "Bonanza" without the snowstorm.

Use a minimum of type faces, but do vary your type size to offset monotony. When considering ads, give them careful thought.

Don't throw them together in 15 minutes just to get something in. The importance of ad content can't be stressed too much. Acknowledged experts have concluded that the best ad is 9 times more effective than the poorest ad of the same size.

### Radio Advertising

Radio incorporates an element lacking in printed ads—*sound*. Your message is more believable and colorful when you are able to utilize radio. You may want to sponsor a program, such as the local news spots, perhaps on an alternating basis with another firm; or, you can stagger spot announcements in prime time, especially during a special promotion. Surveys indicate that there are three radios for every person in the U.S. Radio is heard in the car, often at work, and at home. Most people listen for news, music, and special events. The hours of 7-8 AM, the noon hour, and 5-6 PM are considered prime time. During these hours an advertiser really has a captive audience. Again, your announcement may be tied in with TV programming, or prepared to stress the same theme as a concurrent newspaper ad.

In some cases, the cost of radio time is high, compared to newspaper costs. In some cases, the cost per impression may actually be lower. Nevertheless, there are many times, such as during a grand opening, when radio will give you the kind of response you can get in no other way.

### Point of Purchase

Supermarkets make good use of point-of-purchase displays. All of us at one time or another have been handed a tasty sausage by a "pretty miss" who spiels out a message about the "Zesty Sausages on sale today." Suddenly we are reminded that it has been a long time since we had some really good sausage! Point-of-purchase displays motivate people to buy on the spot, whether it be sausages or Cable TV.

Banks, television and appliance stores, your own cable office—all can be used effectively for point-of-purchase displays. The display illustrated costs approximately \$1.00. The card tells the "cable television story" and includes a postage-paid return as part of the motivation. It is a good idea to use such displays in conjunction

with special promotions to improve effectiveness. Emphasizing the customer's benefits with plenty of "action" copy is a must for this type of advertising. You must convince the customer to buy *NOW*.

### Billboard Advertising

The billboard type of display is probably the purest form of advertising—at least it's the oldest. A billboard's only purpose is selling; it is not used in conjunction with music, news, or any other device, but stands alone. The message should be clearly and simply stated. Utilize color and translate your message into a few bold words. Used as part of your advertising program, billboards are tremendously effective if the sign is located where it can be easily seen, and seen often, by your prospective subscribers.

### Transit Advertising

Trucks, busses, taxicabs, etc., are excellent vehicles for repeating your message. All your service trucks should carry your name and slogan. For about \$3.00 you can buy an aluminum frame for your trucks. Cardboard inserts can be displayed in the frame and changed with ease as necessary for new promotions. Advertise Cable TV in general, with a message that is easy to read, colorful, and sports your company name. In most cases, a cable system does not have competition in its own locality, so the emphasis should be on *cable* TV.

### Direct Mail

Like direct sales, direct mail effectively pinpoints the market. You should have the addresses of all non-subscribers. These can be obtained by comparing telephone listings with your subscriber list. If you can gain the cooperation of TV set sales and service dealers, they can supply you with names of their customers and non-subscribers. Frequently, brochures or folders telling the cable TV story should be sent to non-subscribers. Again, *action* copy should be utilized, urging the reader to do something—namely, to subscribe to Cable TV—*now*. Clinch the sales talk with an offer too good to resist.

Direct mail is a good way to test copy and special offers. If keyed properly, results of any mailing can be tested against an-



## Do's and Don'ts of Good Advertising

- DO** plan your budget carefully and realistically—too little will be ineffective, too much will waste money.
- DO** determine who you are trying to sell and use the proper media to reach them.
- DO** aim your ad copy to the individual and give him the reasons why he shouldn't deprive himself of your service.
- DO** research the results of a campaign—find out why it worked or didn't work, then apply these facts to future campaigns.
- DON'T** just toss a few hundred dollars into an advertising "kitty" and "see what happens."
- DON'T** buy an advertising schedule because you like it—make sure it's what your prospective subscriber likes.
- DON'T** aim your ad copy at "the masses"—you miss the individuals who pay the bills.
- DON'T** just say "better luck next time" or "the heck with advertising" if it fails—find out why. The same applies to successful campaigns.

other to determine offers which will work best for you. Remember, when testing, to keep all factors, such as the size of mailings, equal for effective comparison.

The time of arrival of your direct mail pieces should be tested. Prospects who receive advertising on Monday are said to be least impressed while those who get direct mail advertising on Tuesday are more favorably impressed. Mailings received just before or just after holidays don't seem to fare too well.

## Television Advertising

When TV spots can be purchased at reasonable cost, and can adequately cover your market, it is a helpful and natural advertising medium. However, due to the expense, it must be used with careful consideration. As of this writing, I do not know of a cable system that runs a heavy TV schedule.

## Direct Sales

Extensive use of direct sales is a must. There is no substitute for direct contact with a prospective customer. Many techniques and gimmicks are available for direct sales. Some systems use premiums, flipbooks, audio visual aids, free trials, and combination offers. The best offer for you is the one that gets results in your community. The heart of a direct sales program is the salesman (or woman). No matter what gimmick you use, the enthusiastic, well-mannered salesman can make or break the sale.

He or she is your company image. Salesmen's reports should be filed daily, and salesmen should find out *why* the prospect did or didn't buy. This information is invaluable in planning your marketing and advertising programs.

There are many methods of compensating direct salespeople. Some companies pay straight commission—usually \$5 to \$7.50 per hookup. Others use a \$40 to \$50 a week base plus \$1 to \$3 commission per hookup. Several outside companies offer packaged direct sales programs for which the cable system pays between \$20 to \$30 per connection, plus collateral, literature, and expenses.

No matter what form you choose for your direct sales program, in-house or out-of-house,

*Continued on page 77*



Transit advertising is effective and inexpensive. Silk screened posters cost 50¢ to \$1 each; frames cost about \$3 a set.



Color point-of-purchase displays, distributed on a commission basis in local stores and public buildings, can produce startling results. The folder in this display, explaining cable TV's advantages, increased subscribers by 22%. Banks, TV and appliance stores, and your own office, can be used effectively for such point-of-purchase displays.



This battery-operated film strip projector provides an audio-visual direct sales aid. Using local sales people, the film trip delivers a prepared sales pitch.

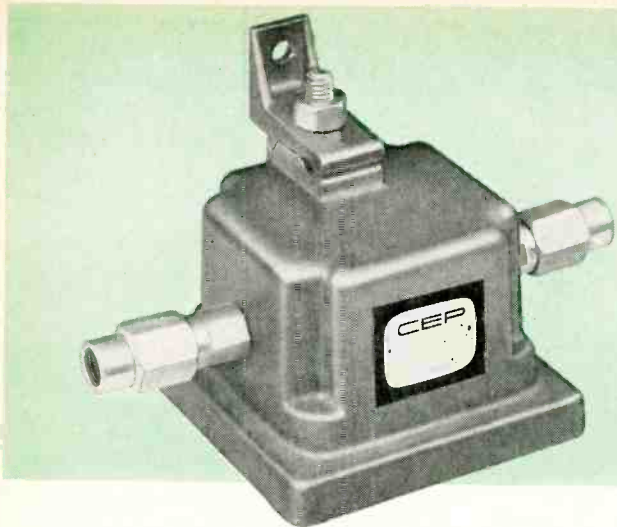

# THE NEW CRAFTSMAN MODULAR DIRECTIONAL TAP

Here's one way to keep your labor costs down, profits up. Craftsman's new Modular Directional Tap, shown above, is one proven way to easily, surely, service

subscriber line changes using labor that can change connections from one to four subscribers in less than five minutes, tops. Here's all there is to it.

## Don't Disconnect ... **INTERCHANGE!**

The four plates shown here are the outlet connecting plates for use with our new Modular Directional Tap. They are easily interchangeable in the bottom of the housing, a simple matter of unscrewing four permanently held screws, removing one plate and replacing it with another. Each bottom plate has a cut-off corner which allows it to be connected in only one way—the right way. They provide a perfect connection every time, even when the subscriber is not home. Each unit has a radiation-proof gasket to prevent signal leakage. And these new Craftsman Modular Directional Taps provide extremely low through loss (only .25 db for 18 db tap attenuation), and high return loss. Try a few of these Modular Directional Taps on for size in your system. We believe you'll find they are among the most significant advances ever made in CATV. We'll be glad to send you more technical information. Just write to us at the address below or call us collect.



Bottom view of housing with module plate removed.



Four way module plate



Three way module plate



Two way module plate



One way module plate

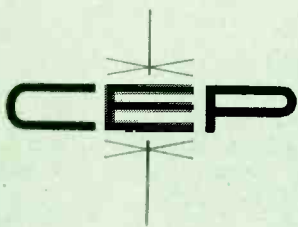

**CRAFTSMAN ELECTRONIC PRODUCTS, INC.**

133 WEST SENECA ST., MANLIUS, N.Y. 13104 AREA CODE 315—OVERbrook 2-9105

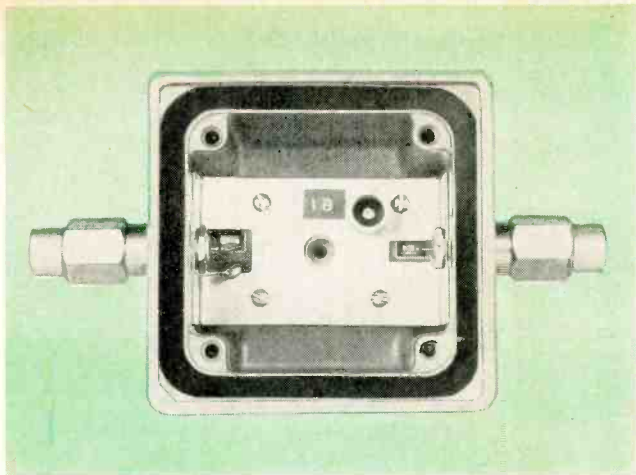

Bottom view of housing with module plate removed illustrating RFI gasket.

# THE CRAFTSMAN QUALITY STORY...

Aside from the prospects of faster service, lower labor costs, and resulting higher profit margins for subscriber service changes, perhaps the most intriguing features of the new Craftsman Modular Directional Taps are the extremely low through loss (only .25 db for 18 db tap attenuation), and high return loss. We feel the easiest and most believable way to show this to you is to show you a TDR test simulating actual field conditions, terminated and unterminated at the tap.

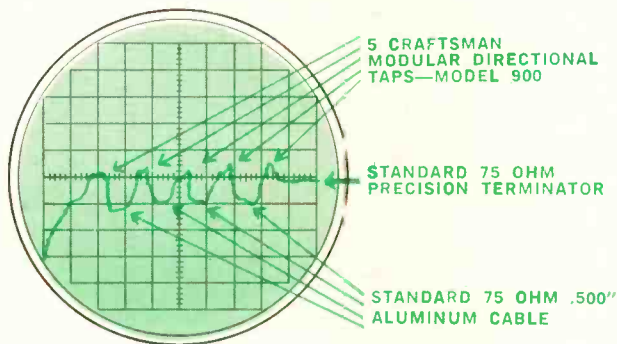

In the top scope trace, 5 Craftsman Modular Directional Taps (14, 18, 22, 26, and 30 db tap units) are connected to a section of standard 75 ohm .500" aluminum cable. They are unterminated at the tap port. Notice how the peaks representing the Modular Tap Units are closer to the ideal 75 ohm reference line than the .500" aluminum cable. Thus we may reasonably state the Craftsman Taps are more ideally matched than the cable itself.

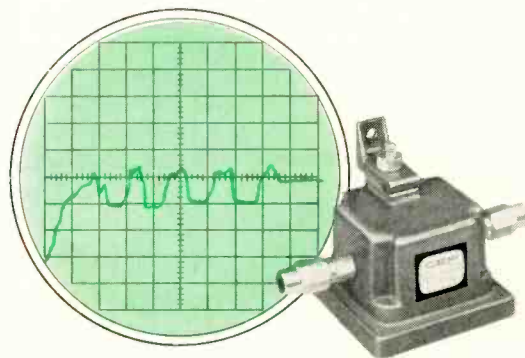

In the bottom scope trace the only difference is the tap off ports of the five units are terminated. As you can see, the difference between the two scope traces is negligible. No appreciable impedance mismatch is introduced to the feeder line in either case.

Now add this to the lower labor costs, and faster changeover from 1 to 4 units (less than five minutes), and you'll begin to see why we believe this Craftsman Modular Directional Tap is a uniquely significant advance in CATV. We'll be glad to send you more technical information. Just write to us at the address below or call us collect.



**CRAFTSMAN ELECTRONIC PRODUCTS, INC.**

133 WEST SENECA ST., MANLIUS, N. Y. 13104 AREA CODE 315—OVERbrook 2-9105

Circle 20 on Reader Service Card

# NAB CONVENTION

## in REVIEW

### FCC Regulation . . . Modern Radio . . . FM & UHF . . . Color TV

If anyone needed an indicator to measure the status of today's broadcast industry, he might well choose the 44th Annual NAB Convention. Not only was it the biggest ever, in terms of attendance and space requirements, but it was extremely well planned, orderly, and sophisticated. Also, this year's broadcasters spent at least 50% more than ever before for new equipment. And while a good share of the expenditure went for big-ticket items such as color studio and film cameras, high-band VTRs, and automated programming and switching systems, smaller off-the shelf equipments were also sold in greater quantities than ever before.

Topics discussed at the management and engineering sessions also provide an excellent yardstick of broadcasting's current status. Attendance at the radio and TV assemblies was greater than ever—most sessions were crowded, several drew SRO audiences. The opening General Assembly brought more than 2,000 delegates together in the Grand Ballroom.

#### Keep FCC Out of Programming

Following presentation of NAB's Distinguished Service Award to editor and publisher Sol Taishoff, NAB President Vincent Wasilewski outlined the need for a program to thwart the growing inroads of FCC interference in radio and TV programming. He emphasized the necessity for congressional action to prevent the FCC from shaping station programming policies.

#### Urge for Self-Regulation

In a strong urge for increased attention to self-regulation, NAB Code Authority Director Howard Bell stated that progress during the past year was a "record characterized by the pursuit of a strengthened Code." His talk, "The Challenges of Self-Regulation," emphasized that monitoring, continuity acceptance, and public information activities of the past year "have added important dimensions to the concept of industry self-regulation."

Lee Fondren (KLZ Denver), outgoing Chairman of the Radio Code Board, called for more widespread support of the Code, citing that

broadcasters who maintain high standards have more listeners and bring in more dollars.

Radio's growth and maturity was highlighted by Jack W. Lee, WSAZ Huntington, W.Va. He stated that the number of radio stations is now at an all-time high and profits have never been better.

#### Henry Talks of Programming and Cigarette Commercials

FCC Chairman E. William Henry, speaking at the March 29th management luncheon, emphasized the need for more TV programming at the local level. He pointed out that satellite relays could eliminate the need for many of today's stations unless they served as outlets for local expression. While Mr. Henry made no comment concerning FCC policy and regulation which might affect programming, he commented that more creativity is expended in producing commercials than in preparing programs.

Henry praised broadcasters' efforts toward setting up and following the Code, but then picked it apart by saying "it had no teeth" insofar as cigarette advertising is

A week after his return from the Chicago Convention, Henry formally submitted his resignation to President Johnson. Effective date: May 1. While Chicago speech hinted at "tougher" FCC policies on programming and commercialism, it looks like Mr. Henry may have been taking advantage of this last opportunity to leave his imprimatur on broadcasting.



concerned. "Viewers are led to believe cigarette smoking is the key to fun and games with the opposite sex, social success, and virility," he said, in spite of the present controversies concerning its harmful effects.

Following Henry's speech, Code Director Howard Bell rebutted with a statement outlining the self-regulatory efforts taken by his office, which he said are in accordance with the provisions and intent of cigarette labeling legislation.

#### Sounds of '66

The opening radio management assembly was a real treat, entertaining as well as instructional. The sounds of modern, professional radio were highlighted with live and recorded examples which set the pace for today's successful broadcasting. Country music, popular music, modern music, talk and information, news, small market, and middle-of-the-road formats were discussed by experts who had used them with a great deal of success. Increased creativity and better quality in programming, de-

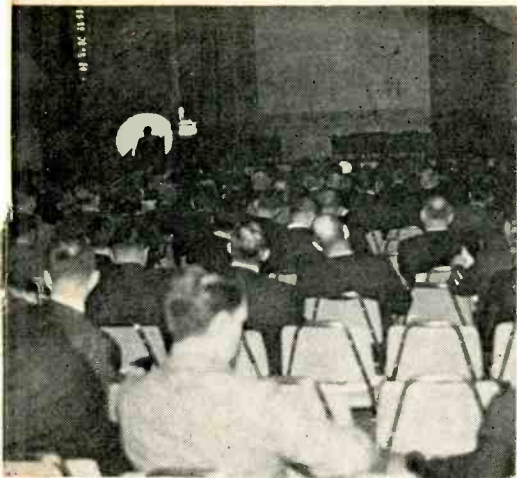

signed to capture and serve the needs of a specific audience, seemed to be the underlying theme supported by each of the speakers.

### Bright Future for FM

FM Day speakers were definitely bullish about the future of FM radio. An ad agency executive and the owner of a large appliance store chain both gave outstanding evidence of their individual successes with FM radio commercials. Each told how they used FM in a different market as the major medium for highly successful advertising campaigns.

Dave Polinger, WTFM New York, Harold Tanner, WLDM Detroit, and David Bennett, Triangle Stations, Philadelphia, all gave evidence that FM stations, in many cases, were as good as, and sometimes better than, their AM counterparts. Methods used to achieve success were described by these panelists, who cited their own operations as examples. The audience was informed, in no uncertain terms, that FM radio is no longer a sleeping giant; industry forecasts indicate that some 10 million FM radios will be purchased this year, over 12% of them for automobiles. According to Mr. Tanner, "FM radio is being examined by aggressive and alert business firms, and they are amazed at what they are discovering."

Everett Dillard, WASH Washington, pointed out that FM broadcasters now have a saleable product, that prospective time buyers no longer have a negative attitude toward FM. Sherril Taylor, NAB v.p. for radio, reported that FM revenues have been increasing steadily, and should reach \$100 million for this year.

### And as for Television . . .

The emphasis — naturally — was on color. The management Color Conference, attended by an estimated crowd of nearly 1,000 broadcasters, concentrated on techniques for programming, promoting, and selling

color. An interesting panel session — How to Buy Color Equipment — was also conducted. Harry E. Smith of General Electric, John Auld from North American Philips, RCA's Charles H. Colledge, and Larry Wieland of Ampex were questioned with regard to what to buy. John Wilner, Hearst Stations, Baltimore, and Robert Flanders, Time-Life Stations, Indianapolis, addressed the panel with written questions from the audience (and some they concocted on their own). The panelists readily conceded that production of some equipment — particularly studio cameras — was far behind the demand, and that deliveries were being scheduled 12 months and more in the future. As if to indicate that the shortage of color equipment is not the fault of the manufacturers, the panel emphasized the necessity for broadcasters to keep suppliers more closely ad-

vised of their present and future needs. TV broadcasters were also advised to consider reputation, experience, and service when choosing an equipment supplier.

### UHF Hopes Spurred

Like FM, another of broadcasting's underdogs was given increased hope by a panel of leading independent broadcasters who outlined successful formulas for operating an unaffiliated TV station. NAB's Bill Carlisle said it was coincidental that the panelists were all UHF broadcasters, but few would deny that UHF is just another name for "unaffiliated station." All the panelists supported program formats with local and special audience appeal. On the expense side of the ledger, "U" operators were given examples of how to curtail costs in "frills and extras."

## ENGINEERING CONFERENCE

Automation, remote control, new operating and measurement techniques and equipments — and, of course, color — were all given in-depth treatment during the radio and TV engineering sessions. Of special interest were several papers dealing with studio and film color camera experiences, minimizing color errors in multiple video tape recordings, and the color camera panel session, a repeat from last year's program.

One of the more spectacular new equipment developments, discussed in a paper delivered by William Butler of Westel Corp., is a portable magnetic-tape camera for re-

ording tapes suitable for direct over-the-air TV playback.

Other important papers dealt with researches in loudness measurement, remote control and automatic logging for radio and TV operations, and test and measurement techniques. Panel sessions on automated tape-programming systems and the Emergency Broadcasting System were other timely and worthwhile contributions to modern broadcast engineering operations. (A synopsis of these and all other papers delivered during the conference was included in the April BM/E Convention Guide booklet.)

## TOURING THE EXHIBITS

### Color . . . Automation . . . Big Sales

Exhibitors talked themselves hoarse, and gladly. They wrote more business this year, by far, than at any previous NAB Convention. Products from more than 125 suppliers were displayed in the 116-booth exhibit areas. TFE dominated the entire 5th floor, radio program distributors filled dozens of suites, and it all spilled over into several neighboring hotels. Exhibitors contributed an additional 2500 people to the overflow crowd of over 5,000 broadcasters. Prospective customers looked, listened, asked questions, then bought. And how they bought! In fact, few of the thousands of items on display are now in a back-order delivery situation, ranging up to 14-16 months.

Color equipment, as expected, pretty well dominated the display areas. Ampex, G-E, RCA, Sarks Tarzian, Conrac, North American Philips, and Visual deserve the honors for elaborate and sophisticated color TV exhibits. These firms alone are conservatively estimated to have written orders worth in excess of \$20 million.

But color was not totally dominant. Automated tape systems displayed by several firms carried placards indicating they had already been sold to specific stations. Sales of transmitters were brisk, too. Continental, Gates, Townsend Associates, OCA Electronics, Standard, and Bauer reported excellent sales — some units right off the floor.



Celebrating Visual's 10th Anniversary —Jim Tharpe, George Wagner, and Conrac's Bill Moreland.



Ray McMartin (r) is pleased with response to his firm's latest FM broadcast equipment.

Interest in automated TV master control systems was also high. New



Dynair Pres. E. G. Gramman gave away Skyrafters transmitter. Carol Day holds winner's card.

systems demonstrated by American Famcor and Hancock Telecontrol drew constant attention, but didn't seem to detract in the least from 2nd generation equipment demonstrations conducted by Riker, Sarkes Tarzian, and Ward Electronics.

#### How about CATV?

Ameco, Entron, Jerrold, and Viking were back again this year. New exhibitors included Kaiser-Cox and Spencer - Kennedy. Though none of these manufacturers were located in the more heavily trafficked East

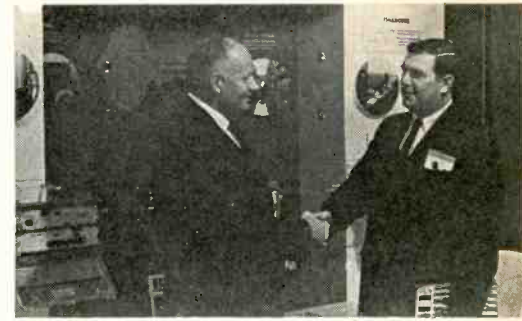

Duane Crist (l), new Exec. v.p. for Kaiser-Cox Corp., meets BM/E's Mal Parks, Jr.

and West exhibit halls, they seemed pleased with broadcasters' response to their sophisticated cable distribution gear. Compared with this year's broadcast equipment sales, the amount of CATV business written may not seem significant, yet the fact that some turnkey contracts were signed, and several plant estimates were requested, is a strong indication of broadcast interests in CATV. Last year they were only thinking about it, this year they're buying—FCC rules notwithstanding.

## EXHIBIT ROUNDUP

While an advance report on products to be displayed was included in BM/E's March issue, details on many units were withheld by manufacturers until show time. The following roundup report contains data supplementary to the March Preview. For more information on products mentioned, circle the appropriate number on this month's Reader Service Card.

**Advance Industries:** Aluminum buildings for housing microwave or other tower-site equipment, pre-assembled with standard wiring, heating, and ventilating (where specified).

Circle 52 on Reader Service Card

**Albion Optical Co:** integrated zoom and focus demand system offering 7 preset zoom positions, 11 zoom speeds, focus preselection, and zoom indicator. Also focus preselector, panel-mounted zoom and focus demand unit, zoom lens servo controls, Varotal 10 zoom lens, Varotal IXSP zoom, focus and iris servo package, and gyro-stabilized "Dyna-lens" designed to eliminate picture jumping caused by camera vibration.

Circle 58 on Reader Service Card

**Alford Mfg. Co:** VHF and UHF antennas for transmitter powers up

to 50 kw. Omnidirectional antenna gains up to 20 for VHF and up to 50 for UHF are available; directional antennas gains of 36 and 80 can be designed. Also vertically and horizontally polarized FM antennas, diplexing filters, vestigial sideband filters, coaxial switches, power dividers, and RF measuring instruments.

Circle 59 on Reader Service Card

**Altec Lansing:** 9704 Gain Set, designed to measure gain, loss, frequency response and signal level of audio devices. Monitor amplifiers, condenser mic systems, lavalier mics, and rotary switches for consoles.

Circle 60 on Reader Service Card

**Ameco** exhibit emphasized total CATV service. Manufacturing sys-

tem and equipment financing, turnkey and rebuild construction services were depicted, along with representative units from the line of solid-state distribution equipment.

Circle 61 on Reader Service Card

**American Electronics Labs:** prototypes of new Colorvue Series CATV amplifiers. In-line basic trunk amplifier will accommodate variety of plug - in modules including trunk amplifier, bridging amplifier, AGC, and line feeder. Display also included AM-1KA 1-kw AM transmitter and FM-1KA 1-kw FM transmitter.

Circle 62 on Reader Service Card

**Ampex Corp.** demonstrated its new VR-1200 high-band color VTR for the first time. The unit, priced at \$46,500 to \$70,000 depending on accessories, is economy version of top-of-the-line VR-2000. VR-1100E mobile VTR, modernization kit to equip VR-1000 and VR-1100 for high-band operation, new video head assembly with interchangeable plug-in head preamplifiers designed for any Ampex transverse scan VTR, and three new products for VR-2000: automatic velocity compensator, low-band switchable standards unit, and head alignment kit. The

# NEW

## FOR THE BROADCASTER WHO CARES ABOUT LOOKS!

### A COMPLETE "SHOWCASE" AUDIO CONTROL CENTER

FOR LESS THAN \$4000.



SPARTA now makes it possible to buy top quality studio equipment, as well as high style "Showcase" cabinets — at a price that fits every budget conscious broadcaster.

- A SPARTA transistorized Studio Console with microphone and digital clock.
- SPARTA dual Turntable System.
- Complete SPARTA-MATIC Tape Cartridge System and cartridge library.

This entire audio center, including SPARTA "Showcase" cabinetry comes to you ready to install in your studio — OR the mix and match "Showcase" cabinetry may be purchased separately to meet customized studio requirements.

#### CABINERY CONSTRUCTION AND FINISH

SPARTA Showcase Cabinets are constructed with top grade wood veneers laminated under heat and pressure to a beautiful platinum toned walnut wood grain finish. Table and desk tops are finished with an extremely hard Formica laminate, in a soft Dove Grey to blend with the rich wood grain. The design thoughtfully provides easy access to all wiring, yet keeps it out of sight for a truly customized appearance.

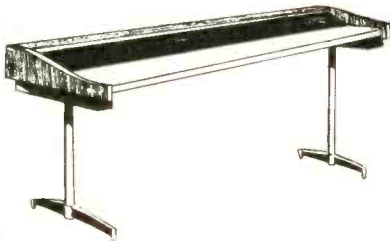

#### STUDIO CONSOLE DESK

Sleek, modern styling accents the spacious console desk that is designed for ideal operator convenience. Stainless steel pedestal legs provide plenty of knee room, and just the right height for the console. Plenty of counter depth, too. Fits most any console arrangement.



#### SINGLE OR DUAL TURNTABLE CABINET RETURNS

To mix and match with the studio control desk, the turntable top is identical to the console desk level. Available for one or two SPARTA TC-12 turntable installations. Sliding doors concealing the record storage area can be removed for standard rack mount.

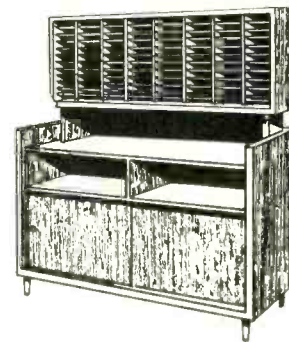

#### UTILITY TABLE RETURN CABINET WITH HUTCH ACCESSORY

Standard 19" wide shelves are located immediately beneath table top area so both rack mounted and table top cartridge equipment can be utilized. There is still plenty of storage area below. The separate CARTRIDGE HUTCH fits neatly over the utility table cabinet to store cartridges at finger-tip convenience. Height is low enough so operator need not move from his chair to reach the top row.

# SPARTA

## ELECTRONIC CORPORATION

5851 FLORIN-PERKINS RD. SACRAMENTO, CALIF. 95828

PHONE: (916) 452-5353

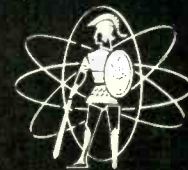

Circle 22 on Reader Service Card



Ampex VR1200 is designed for color operation in small stations.

AG-300 audio recorder, an advanced generation of 300 Series, was also shown.

Circle 86 on Reader Service Card

**Andrew Corp:** Heliac flexible air and foam dielectric cable for AM, FM, TV, and CATV use. Coax transfer switches, STL antenna positioners and microwave antennas.

Circle 69 on Reader Service Card

**Automatic Tape Control** demonstrated Model STCD-9 Simplex Programmer, designed to control as many as 9 tape sources in any combination of cartridge or reel-to-reel units, with thumbwheel switches to provide sequential control of up to 24 events. Price is \$1660. Display included several complete operating program automation systems, plus unit with elapsed time indicator which provides remote control of recording functions on any equipment having momentary closed-contact switching. Priced at \$120, Model RC-T will register over 200 hours of recording time before timer recycles.

Circle 71 on Reader Service Card

**Ball Bros.** introduced an AGC video amplifier designed to automatically compensate for variety of studio signal deficiencies. Two versions of Mark VIII are available, one for use where local drives are supplied and B unit for remote operation. Both models are capable of handling color and provide continuous monitoring of signals from variety of equipment. Also shown was new line of Mark IX video and pulse distribution amplifiers designed for color studio applications.

Circle 72 on Reader Service Card

**Bauer Electronics:** New 7500/5000-watt FM transmitter capable of stereo and multiplex operation, with wide-band response within 1/2 db from 30 cps to 300 kc; monaural response is within 1/2 db from 40 to 15,000 cps. FM noise below 100% modulation is -65% db and AM noise below 100% modulation is -50% db.

Circle 73 on Reader Service Card

**Beckman & Whitley:** CM16 portable 16mm sound camera with single

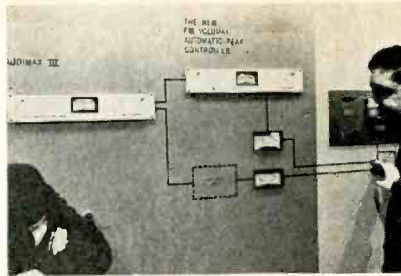

CBS Labs conducted live demonstration of FM Volumax unit.

sound system, plus double-system sound capability. Weighs 14 lbs with loaded 400' magazine and 12 to 120mm zoom lens.

Circle 168 on Reader Service Card

**Boston Insulated Wire and Cable:** camera cable for Marconi Mark VII; cables and connectors for I.O. and Plumbicon cameras. Molded rubber attachable studio lighting connectors for 20-, 45-, and 60-amp applications, and custom designed pre-wired studio video distribution boxes for monochrome and color installation and conversion.

Circle 74 on Reader Service Card

**Broadcast Electronics:** Improved versions of Spotmaster Super B and Series 400A tape cartridge systems. Ten Spot multicartridge equipment. New solid-state audio distribution amplifier, RA-4CA remote amplifier, 500A-DL push-button program delay unit, TT20A equalized turntable pre-amp, and various tape system accessories.

Circle 76 on Reader Service Card

**CBS Laboratories:** FM Volumax designed to prevent FM over-modulation and SCA crosstalk using time-varying functions to separately control low and high frequencies and instantaneous final limiting. Also Model 600 wide-range program monitor for measurement of program audio, noise, and crosstalk on single 60 db scale.

Circle 77 on Reader Service Card

**CCA Electronics** displayed "dual reliable" transmitter Model AM-5000DX. Tubes are operated at 50% of rated capacity; maximum anticipated off-air time is 5 sec. Also exhibited were several FM transmitters and frequency and modulation monitors.

Circle 103 on Reader Service Card

**Century Lighting:** 1313 and 1314 500-1000w quartz-iodine floodlights designed for base and fill lighting with 14" reflectors. 1313 has pipe-mount C-clamp and color frame holder. 1314 has same features plus screw-feed focusing mechanism to adjust range from flood to spot

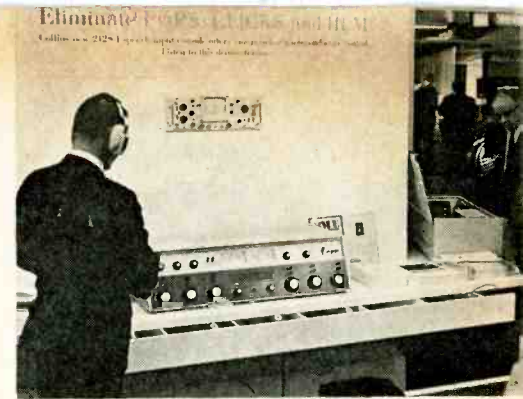

Listening test proves Collins 212S stereo console is noiseless.

lighting. Also several fresnel units and low profile border lights.

Circle 78 on Reader Service Card

**Cleveland Electronics:** Plumbicon focus and alignment coil assembly, covered with Mu Metal shield to reduce normal external ambient electrical interferences, priced at \$189.20. Complete line of vidicon and I.O. deflection components. Also design facsimile of a 50-kw AM plate transformer, part of magnetic transmitter component line.

Circle 79 on Reader Service Card

**Cohu Electronics** exhibited 3-vidicon color camera system with optional 9" viewfinder. 1000 Series color system features built-in registration reference, f/1.9 optical system, and provision for any C-mount vidicon lens. Black level control is maintained on color channels by keyed clamps, and adjustable gamma correction is provided for all three channels. Remote control up to 1000' is possible. Also solid-state RGB or RGBM color encoder with built-in EIA color-bar and burst-flag generators, 3100 Series CCTV camera with special controls for use as monochrome film reproducer, and, video distribution and switching systems.

Circle 80 on Reader Service Card

**Collins Radio Co.** featured live demonstration of 212S-1 stereo console, using stereo headsets and oscilloscope display, noiseless switching feature of the console was emphasized. Also shown was MW-408D 1w microwave system designed for STL applications. Equipment features "unitized" powering concept and solid-state receiver. Also on display were 900C-1 FM modulation monitor, 820E/F AM transmitter with extended control panel, 20V-3 AM transmitter, 830D-1A 1-kw FM transmitter, 830F-1A 10-kw FM transmitter, and the 212M-1 monaural console.

Circle 81 on Reader Service Card

**ColorTran:** electronic dimmers and quartz-iodine units: LQBM Series Broads available in variable-beam



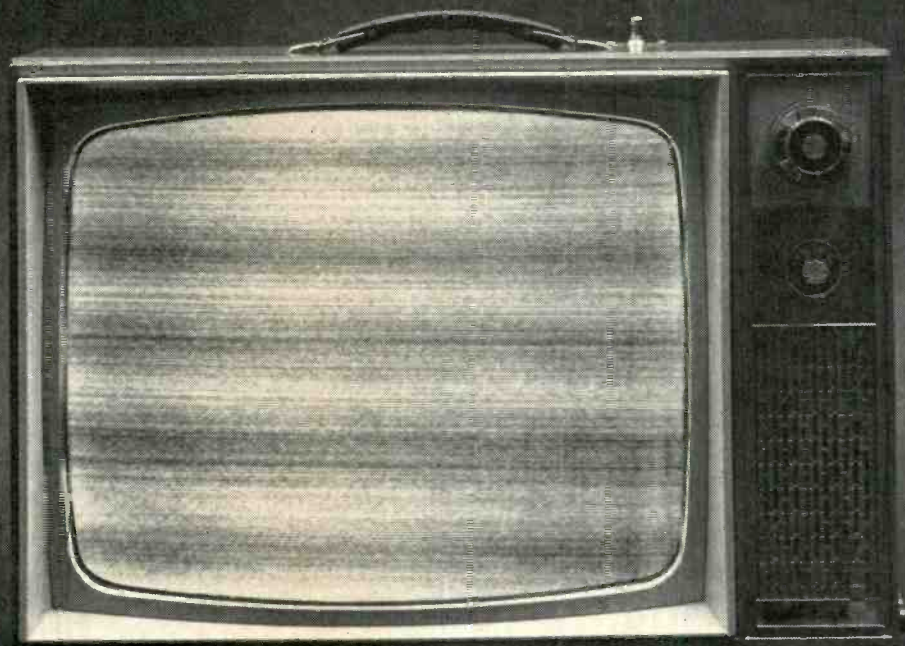

## This kind of programming costs you money

You're in business for one reason: to make a profit.

Anything that takes away from your profit-making is your enemy. That's why you're way ahead when you choose Lenkurt microwave transmission equipment for your CATV or ETV system.

For instance, there's our 76 TV microwave relay system that has become the standard of the industry, due to its outstanding performance, ease-of-maintenance, and economical operation. 76 TV is designed to handle monochrome or color transmission and lets you insert and drop programs with ease at intermediate locations.

There is also Lenkurt's 75A, the ideal backbone microwave relay system. Because of its non-demodulating heterodyne repeaters, 75A delivers clear, sharp monochrome and color TV pictures regardless of distance, terrain, or weather.

Lenkurt microwave systems have proved themselves in virtually every situation. From high on Freel Peak in Nevada where 76 TV brings in a sharp high-resolution picture (even

when snow levels reach 20 feet), to an ETV closed-circuit system at the University of Kansas Medical Center. And our 75A has been transmitting high quality pictures for a number of CATV networks in New York and Pennsylvania.

And remember, when you buy Lenkurt equipment, you are buying more than hardware; you are purchasing Lenkurt's heritage and reputation for quality and continuity.

It all comes down to this: when you're thinking about microwave transmission equipment, for any application, think of Lenkurt. We'll show you how to improve your picture — both TV and profit. Write or call Lenkurt Electric Co., Inc., San Carlos, California. Other offices in Atlanta, Chicago, Dallas, and New York City.

**LENKURT ELECTRIC**  
SUBSIDIARY OF  
GENERAL TELEPHONE & ELECTRONICS **GTE**

Circle 23 on Reader Service Card

single model and fixed-beam single and double models. LQS Series Soft-Lite fill-light designed to replace cone-type lights for overall base and fill lighting.

Circle 82 on Reader Service Card

**Conrac:** New RBB9 solid-state TV monitor, fits in 8 3/4" rack space; two monitors, or waveform scope and monitor combination, may be mounted side by side. Video response is 10 cps to 10 mc. Also complete line of color and black-and-white monitors.

Circle 83 on Reader Service Card

**Continental Electronics:** PROLOG automatic programming system will assemble program elements from more than 250 sources. System can operate, complete with automatic logging, for 24 hours or more, mono or stereo, and can also be used during periods of manual-live operation to improve operator efficiency. Also shown was Type 317C 50-kw AM transmitter.

Circle 84 on Reader Service Card

**Cummins Engine Co.** displayed 25-kw power generator. Brushless 4-pole generator is self-excited, has revolving field and solid-state regulator. Built-in system provides adjustable battery-charging capacity. A "see-through" demonstration 125-kw unit showed how the equipment operates.

Circle 88 on Reader Service Card

**Dage-Bell** displayed Model 520 TV studio camera offering choice of vidicon or Plumbicon pickup tube. Weighing less than 80 lbs, unit provides 600-line corner resolution, variable gamma and aperture correction, and 3-position viewfinder video selection. Also Type 585 sync generator, and automatic switching accessory which insures against outages by instantly shifting sync generators in event of failure.

Circle 89 on Reader Service Card

**Dresser-Ideco:** guyed towers from 50 to 2000 ft; self-supporting towers from 50 to 2000 ft; candelabra TV towers for any height and combination of antennas.

Circle 90 on Reader Service Card

**Eimac/Varian Associates** featured UHF klystrons and power tubes.



**Dynair Electronics** introduced solid-state sideband analyzer for use in alignment of TV transmitters or CATV modulators. Model TS-100A is tunable through all 12 VHF channels, provide facilities for video modulation of unit under test and analysis of RF output. Also Series SS sequential switcher for automatic sequencing of up to 50 camera inputs to single CCTV monitor; RX-4A VHF-TV tuner designed for color and monochrome operation. Dynair also exhibited SKY-515 VHF communications gear produced by newly acquired subsidiary, Skycrafters, Inc., manufacturers of aircraft radio equipment.

Circle 91 on Reader Service Card

**Eastman Kodak:** High-speed 16 and 35mm color film for color TV news. Ektachrome EF film (Type B) is suitable for use with tungsten light indoors, without filters, or outdoors with 85 or 85N filter. Outdoor daylight color film, Ektachrome EF, offers exposure indices from 80 to 1280, with a normal of 160.

Circle 93 on Reader Service Card

**Eimac Div. of Varian Assoc.** introduced new line of low-power UHF klystrons designed for 1- to 5-kw service. Also new replacement tube developed for 1-kw AM transmitters. Two tubes develop 1200w in existing 1-kw equipment. Extra 200w margin is intended to contribute to longer life and full input at antenna base.

Circle 94 on Reader Service Card

**Electronics, Missiles and Communications** showed 1-kw TV translator. Both self-contained translator and 1-kw amplifier are available. Also exhibited were UHF-TV to VHF-TV translators and 2500-mc ETV transmitter and receiver-converter.

Circle 95 on Reader Service Card

**Entron** exhibited new in-a-line CATV distribution amplifier equipment and Model M-1 solid-state field-strength meter for checking VHF and UHF signal reception. Firm offers complete CATV services, including on-site signal surveys, system planning and construction, turnkey, financing, and technical and management training.

Circle 97 on Reader Service Card

**Fairchild Recording** introduced an audio control device designed to provide audio level balance between live and recorded program sources. Model 656 Balance/Gard is power-sensing control device that screens program material and reduces loudness as necessary. Balance/Gard acts on continued sound intensity, is designed to work with conventional limiters rather than as replacement. Display also included new 830 stereo console with "lumiten" attenuators, various console

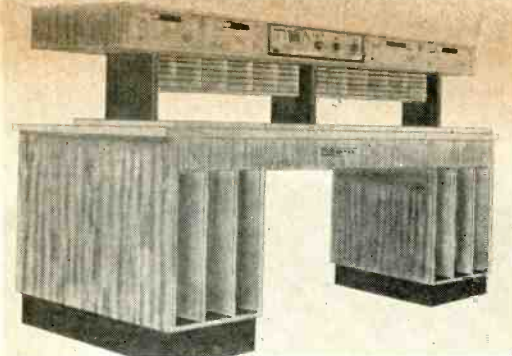

Gates 202 Programmer combines cartridge, disc, and live audio.

components, turntables, and reverb units.

Circle 98 on Reader Service Card

**Filmline Corp:** FE-50 and FE-30 16mm Ektachrome film processors, designed for daylight operation, will process perforated or unperforated film at variable speeds up to 50 and 30 fpm. Overdrive system sensitivity allows film to be held manually while machine is in operation.

Circle 99 on Reader Service Card

**Fort Worth Tower Co.** introduced tropo scatter antenna system designed for high gain in narrow or broad beam, utilizing space diversity to eliminate fades and interference. 150' x 80' single array model is designed for signal reception under 90 miles; 270' x 80' double array offers reliable reception from 130 to 150 miles.

Circle 100 on Reader Service Card

**Gates Radio** introduced several new products, including VP-50 50-kw AM transmitter with only 4 tubes and BC-5H 5-kw AM transmitter; Vanguard II 1-kw AM transmitter with a single tube; 202 automatic programming system, combining cart tape, disc, and live sources. Consoles shown included 5-channel stereo Statesman, 8-channel Gateway II, and 3-output channel Dualux II.

Circle 101 on Reader Service Card



**General Electric** exhibit featured new PE-250 studio color camera and PE-240 color film camera. PE-250 uses 4 Plumbicons; PE-240 uses 4 vidicons. Also demonstrated were two new solid-state modular audio consoles, BC-31-B and BC-35-A/B. The complete line of audio processing gear was available, along with other TV studio and film camera

New G-E BC-35 audio console, available in monaural or stereo.

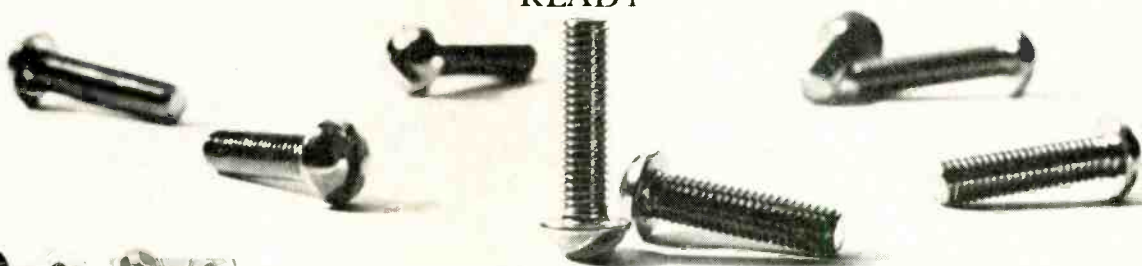

YOU  
NEED  
EXACTLY  
EIGHT  
ACCESSORIES  
TO  
MAKE A  
MAGNECORD  
MODEL  
1021  
OR  
MODEL  
1022  
BROADCAST  
READY



Magnecord's monaural Model 1021 and stereophonic Model 1022 are the most complete tape recorder/reproducers for professional use. Every Magnecord is engineered to mount in standard relay racks and ready to operate! Input impedances and input sensitivity levels are exactly matched to standard broadcast equipment. Ease of operation is built right in, too, insuring gentle tape handling and immediate response through the most difficult production techniques.  Both models are available in relay versions (Models 1021R or 1022R) that provide operation in all modes from one or more remote stations without the use of jumper plugs.  Now Magnecord 8-plus reels increase program capacity over 50% for lengthy network and remote programming without interruption...even operas! At 7.5 ips, 8-plus reels have a capacity for 1.25 hours of recording...at 3.75 you get 2.50 hours recording in each direction.  FREE OFFER! Write for eight standard screws and new brochure on Magnecord Models 1021 and 1022. See your authorized Magnecord dealer for your recorder.

 **Magnecord**  
DIVISION OF THE  
TELEX CORPORATION  
P. O. Box 1526 / Tulsa, Oklahoma 74101

Circle 24 on Reader Service Card

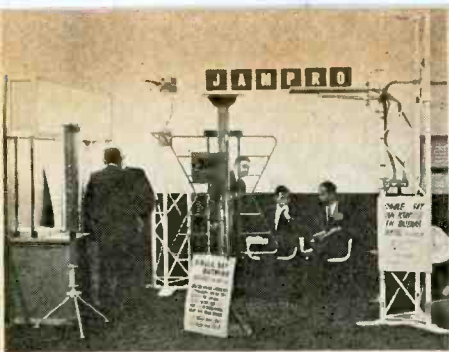

Jampro displayed models of directional and polarized antennas.

gear, VHF and UHF transmitters, helical and zig-zag TV antennas, and remote control equipment.

Circle 102 on Reader Service Card

Hancock Telecontrol demonstrated stored program, digital-control machine with magnetic core memory capable of controlling 100 video sources. Unicon is designed to coordinate video signals with proper mixture of audio to output line of the station. All functions related to control of both audio and video, including transition speed variation and mixing or supering events, are performed without manual intervention.

Circle 104 on Reader Service Card

Hewlett-Packard: Model 191A TV waveform scope. Featuring solid-state design, discrete selection of lines 16 through 21, 20-kv CRT for viewing sine-squared T/2 pulse, positive field selection, and 5 sweep modes. Design includes special response filters for accurate reproduction and measurement of differential gain for complex pulse waveforms such as vertical interval test signals.

Circle 105 on Reader Service Card

Houston Fearless Corp: 60 fpm color Labmaster and 30 fpm Colormaster, designed to process Ektachrome and Anscochrome high-speed reversal films. Both systems incorporate all accessories required for high-speed processing of rapid access news film. 30 fpm unit can be converted to color at comparatively low cost.

Circle 106 on Reader Service Card

International Good Music: Model 510-4 control unit with standard and "Actan" switch units, stereo transports for music, 24-cartridge carousel, time announcer, program logger, and network switcher.

Jerrold featured cable-powered Starline CATV system equipment.



"Actan" memory drum, a plug-in optional control feature, increases normal capacity of Series 500 system to 8 music channels, with sequential control of up to 60 steps.

Circle 107 on Reader Service Card

Jampro Antenna Co: Batwing antenna designed for highband VHF-TV channels. Also zig-zag UHF-TV antenna, horizontally-polarized and dual-polarized FM antennas, and 2.5-kmc ETV microwave antenna with power gain ratio of 20.

Circle 108 on Reader Service Card

Jerrold Electronics Corp: exhibited 440 Series microwave equipment designed for relaying color and b&w TV signals in broadcast, CATV, and other operations. Transmitter uses vapor-phase-stabilized klystron, which provides 2w output, and a completely solid-state receiver. Transmitter is frequency stabilized by both an AFC circuit and a vapor-phase temperature stabilizer. Both units are designed to FCC, CCIR EIA, and AAR standards. Also shown was 1w CARS band microwave gear with 8-mc baseband, flat to .25 db, and cable-powered Starline CATV distribution equipment which provides cascadeability up to 50 amplifiers with cross-modulation down 57 db and s/n ratio of 40 db.

Circle 109 on Reader Service Card

Kaiser - Cox Corp: Phoenician CATV equipment, featuring die-cast aluminum cases with universal-type fittings to accommodate all popular sizes and types of cable. New series is designed for easier installation, field testing, service, and convertability, with the added advantage of low parts inventory and minimum investment for major components. Modular units for KCAH housing include various manual or automatic gain trunk and bridging amplifier combinations for up to four outputs and necessary gain requirements.

Circle 110 on Reader Service Card

Kalart Co: 16mm sound projector which feeds directly into vidicon camera. Similar to Model STV-18, new model will handle color or monochrome film with magnetic or optical sound. Price is under \$1,000. Also Tele-Beam projector Model A912-A, priced at \$2,630.

Circle 111 on Reader Service Card

KRS Instruments introduced 6-deck cartridge-tape machine designed for remote control. Priced at \$1985, unit is identical to the SB6 Series, priced at \$2385, with exception that local start-stop controls have been eliminated. Also shown were automation units, including a programmer, sequencer, tone sensor, and SB1 Series single-deck cartridge machine.

Circle 112 on Reader Service Card

Lenkurt Electric: microwave equipment for inter-city, STL, and remote TV pickup. 76TV offers both de-



Visitors in McMartin booth check TBM-4500 FM/stereo monitor.

modulating and heterodyne repeaters for black-and-white or color operation. TV program audio can be carried along with video by means of an optional program channel operating at baseband of 7.5 mc.

Circle 113 on Reader Service Card

MaCarTa dual cartridge time announcer designed to provide automatic correct time announcements for program automation systems. Model 581 self-contained in slide-out rack mount, is \$1195. Two time announcement cartridges are priced at \$125. Also record and playback cartridge tape decks, Mark II Carousel, and Model RS-10 random selector.

Circle 115 on Reader Service Card

Magnecord Div. of Telex Corp. demonstrated Model 1028 stereo tape recorder with anti-magnetic stainless-steel capstan and optically aligned heads and tape gate. Also shown were several stereo and monaural Telex headsets and boom microphone headsets.

Circle 116 on Reader Service Card

Marconi exhibit, in Ampex booth, featured Mark VII 4-Plumbicon color camera. Unit is transistorized, weighs 142 lbs, sells for \$85,000. Also shown was Mark V picture monitor and semi-automatic switching equipment, plus B3740 Series special-effects equipment for color and monochrome operation.

Circle 117 on Reader Service Card

Marti Electronics: Hybrid ring combiner designed for 942-952 mc band. Unit combines outputs of two 950-mc transmitters or receivers, into common transmission line and antenna. Ring combiner can save from \$800 and up on antenna systems; two units are priced at \$175. Also shown was line of STL equipment.

Circle 118 on Reader Service Card

McMartin Industries TBM-4500 FM/stereo monitor. Unit allows simultaneous readings of both left and right channels and direct measurement of separation and crosstalk down to -50 db. Other units included TBM-3500A main channel monitor and TBM-4000 main channel and SCA multiplex monitor. All three are transistorized and incorporate increased meter speed, two major improvements over earlier "A" designation tube models.

Circle 119 on Reader Service Card

# SUPERIOR COAXIAL CABLES

BEST  
for any  
CATV  
system

For aerial plant  
**SUPERIOR**  
Cell-O-Air®  
COAXIAL CABLE

Expanded polyethylene  
dielectric

For buried plant  
**SUPERIOR**  
"Solid-D"  
COAXIAL CABLE

Solid polyethylene  
dielectric

Guaranteed Maximum Attenuation db/100' at 68° F					
Cell-O-Air	Ch. 2	Ch. 6	108 mc.	Ch. 7	Ch. 13
4920	0.75	0.93	1.09	1.41	1.57
4930	0.58	0.68	0.80	1.07	1.20
"Solid-D"					
6020	0.74	0.91	1.05	1.38	1.55
6030	0.56	0.67	0.79	1.05	1.19

Every reel sweep-tested over its full length

## GUARANTEED FOR FIVE YEARS

Superior 75 ohm coaxial cable with "Coppergard" shield is guaranteed to be 100% sweep-tested prior to shipment, with no attenuation discontinuity greater than 1% at all frequencies up to 220 megacycles, and with high frequency impedance guaranteed to be 75 ohms plus or minus 3 ohms; and can be expected to show no excessive attenuation increase, provided jacket and/or outer conductor are not damaged during installation and remain free from damage caused by external sources.

The specific coaxial cable product manufactured in accordance with the requirements of the factory order number listed below, is guaranteed to be of first quality in material and workmanship. In the event of failure under normal service conditions, when such failure is proved to be caused by faulty material or manufacturing defects, Superior Cable Corporation will:

- (1.) Replace material and pay for labor costs incurred for replacement, if such failure occurs within one year after date of installation.
- (2.) Replace material only, if such failure occurs during the next four years after date of installation.

This five-year guarantee pertains to Superior "Cell-O-Air" expanded polyethylene coaxial cable only when utilized in aerial installation; and pertains to Superior "Solid-D" solid polyethylene coaxial cable when utilized in aerial or direct burial installations; and is applicable only when proper installation procedures and techniques are followed.

- Full spectrum capability
- Long-term transmission stability
- Outside plant reliability

SUPERIOR Coaxial Cables — with Coppergard — are manufactured under Superior's system of step-by-step supervision and quality controls. From basic materials to final cable — sharp attention to every critical detail assures performance worthy of SUPERIOR's name . . . and five year guarantee.

For detailed information and prices, write



## SUPERIOR CABLE

Superior Cable Corporation • Hickory, North Carolina 28601

10139

Circle 25 on Reader Service Card

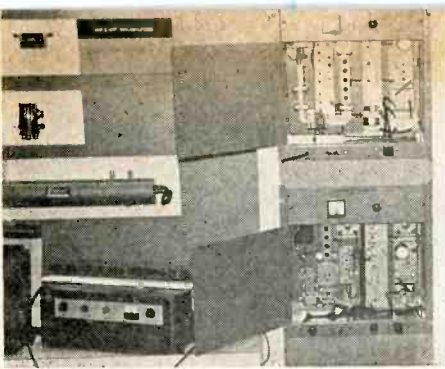

7-gc TV relay equipment was shown by Microwave Associates.

**Melcor Electronics:** Solid-state audio equipment for broadcast and recording applications. Featured units were C-20 compressor amp and A-47 50w monitor amp. Also shown were preamp/program amp and program equalizer units.

Circle 120 on Reader Service Card

**Memorex Corp:** Type 77V video tape, said to have an inordinately low drop-out rate, offers greater freedom from head clogging and reduced head wear. Magnetically and electrically compatible, may be intermixed with other tape without recorder readjustment or realignment. Includes extra length to allow recording of color bar and calibration signals.

Circle 121 on Reader Service Card

**Microwave Associates** introduced a new 7-gc TV link. FRV 7001 equipment is entirely solid-state with 250-mw transmitter output. High level mixer makes demodulation unnecessary at each repeater station. Where bi-directional operation is required, rack-mounted transmitter and receiver can be multiplexed to common antenna. Display also included operating MA-2 and MA-7 microwave equipment. Firm is offering tunnel diode amplifiers in 2-, 3-, 6-, and 7-gc bands at about half former prices as a result of production lot manufacturing.

Circle 122 on Reader Service Card

**D. B. Milliken Co.:** 16mm kinescope recording camera which can be installed on any existing TVR system. DBM-64A operates in synchronization with vertical blanking, thus eliminating usual midfield splice. Entirely rotary, film transport design eliminates camera vibration common to reciprocating units.

Circle 123 on Reader Service Card

3M's Professional Recorder features "Isoloop" transport.

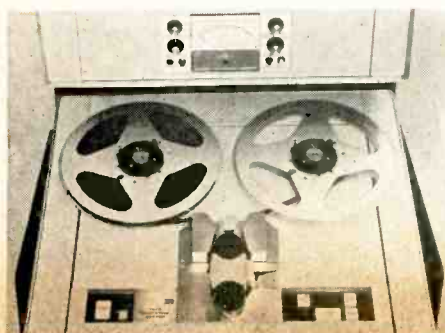

MVR Videodisc recorder provides stop-action and instant replay.

**3M Company** introduced new video tape for improved multiple generation copies. Compatible with any quadraplex VTR, Scotch Brand #399 "color tape plus" is said to represent breakthroughs in signal-to-noise, dropout, and wear characteristics, and capable of up to 2,000 passes without visible picture degradation or tape wear. Other products include #151 lubricated audio tape and improved model audio recorders.

Circle 124 on Reader Service Card

**Miratel:** High-line-rate, high-resolution TV monitors operating at 30-mc video bandwidth. HLB Series operates within 525 to 1203 line-scan rate change, available in 14", 17", and 21" sizes.

Circle 125 on Reader Service Card

**Moseley Associates:** RFA-1 solid-state RF amplifier designed to drive remotely-located frequency and modulation monitors. Wide band-pass is achieved with ceramic filter making it suitable for operation in conjunction with the firm's line of remote control equipment. Also complete line of FM multiplex terminal gear.

Circle 126 on Reader Service Card

**MVR Corp.** demonstrated video disc recorders designed for instant-replay and stop-action operations. 40-lb Model VDR-210CF records 20-second segments which can be stopped, reversed, or shown in slow motion in either direction. Price is \$10,200. Several VTR models with stop-action features are available.

Circle 127 on Reader Service Card

**North American Philips** introduced PC-70 3-Plumbicon color camera. PC-70 features zoom optics, prism beam split, and solid-state circuitry. Improvements over PC-60 include smaller console and additional lens options. Also shown were AKG/Norelco microphones, including new D202 woofer-tweeter which divides audio between two capsules, one for bass, the other for treble.

Circle 128 on Reader Service Card

**Northern Electric** demonstrated broadcast video switching system incorporating several new features.



Nortronics offered broad line of magnetic tape-head replacements.

Using planar-junction silicon transistors, telephone-type wire spring relays and ferreed memory elements, the 8' x 5' video control matrix, with preset automatic mixing system, 13-event memory and Richmond Hill special-effects generator, were assembled to demonstrate the switcher's capability. Also exhibited were PCA-1 program controlled amplifier with limiting and automatic gain control features, and a portable audio production center.

Circle 129 on Reader Service Card

**Nortronics** exhibited tape recorder heads for almost any application. On display was Stencil-Hoffman 1/3 to 1/6 ips recorder using Nortronic heads. Tape-head replacement guide for all type reel-to-reel and cartridge machines, including manufacturer's part number and Nortronic's replacement number, is available.

Circle 130 on Reader Service Card

**Perfection Music Inc.** introduced good music program automation equipment. Taped music program library consists of 80% instrumental and 20% choral vocal groups, available in both monaural or stereo. PMI automation gear can be combined with existing systems; new systems, from a basic setup costing under \$1,000 to full-time sophisticated systems, are available.

Circle 131 on Reader Service Card

**Raytheon CADPO** showed KTR III microwave equipment for 6-gc band. Solid-state, with 10w output, uses heterodyne design which eliminates repeater demodulation and remodulation circuits. Employing modular design, with removable front and side panels, all gear for single repeater mounts in single rack.

Circle 132 on Reader Service Card

**RCA Broadcast Div.** used three TV studio settings to demonstrate its

Raytheon offered 5-year warranty on microwave link equipment.



*We can custom make your switcher.* If you have special switcher requirements that demand custom manufacture, then International Nuclear can be of service to you. An International Nuclear audio and video crossbar

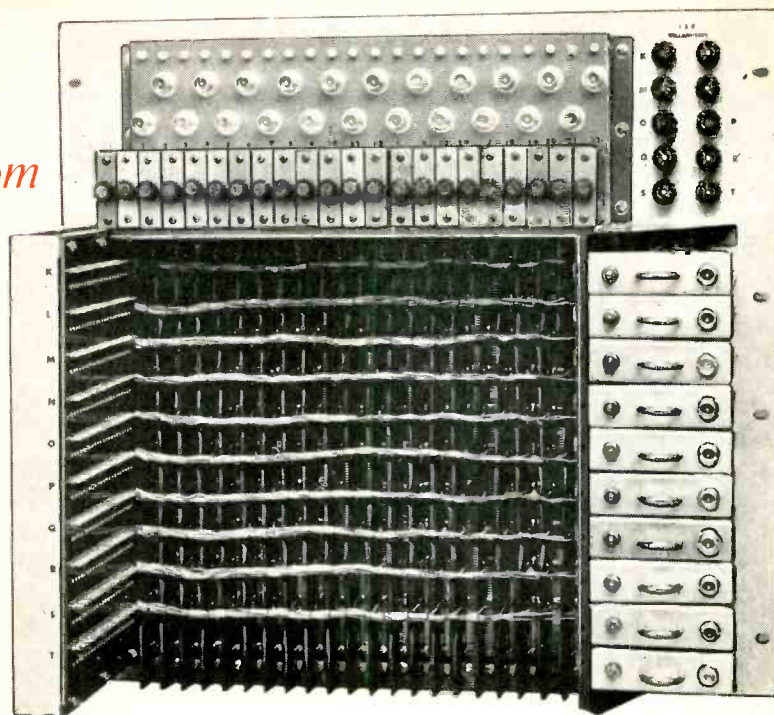

switcher can be assembled to house any number of inputs or outputs. Each input line is a printed circuit. All amplifiers and power supplies are completely solid state. A single standard type transistor is used throughout the circuitry.

All components are readily accessible and operate well within their rating. Custom switchers handle double re-entry switching as well as composite or noncomposite switching.

*We can custom make your switcher.* The new reed-type relays which we use are metal contacts operating in a glass sealed atmosphere. Control of these relays is accomplished by an external push-button and tally light console.

Telephone companies and space programs have proven that this type of relay is the only reliable method of switching video.

*Yes sir, we can custom make your switcher.*

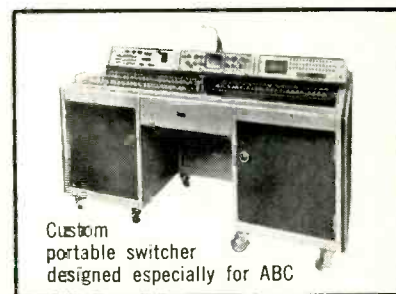

Custom portable switcher designed especially for ABC

*We invite your inquiry, write or phone collect, today*

**INTERNATIONAL NUCLEAR CORPORATION**

608 NORRIS AVENUE • NASHVILLE, TENNESSEE • PHONE 254-3366

Circle 26 on Reader Service Card



# Why tailor your needs to a standard console when you can tailor a console to your needs with Altec Audio Controls?

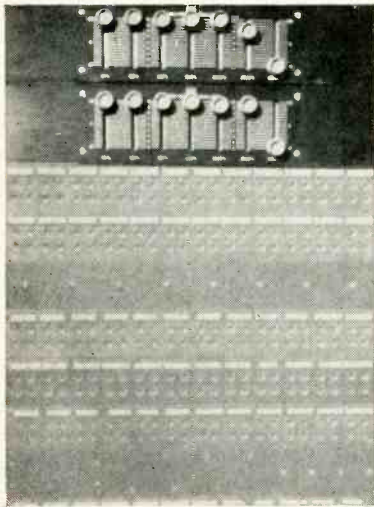

Like the clean, functional console above, which Ancha Electronics of Chicago built for the University of Illinois. There was simply *nothing* available in standard console that would fit into a narrow space, provide complete graphic equalizers plus variable high-low-pass filters for *each* channel, and have all-silicon preamplifiers.

Using Altec audio components, Ancha Electronics, an authorized Altec Sound Contractor, custom-designed this beautifully flexible console, whose performance would be tough to match. The University of Illinois is using its new console both for stereo recording and as a master for rerecording.

A good representation of Altec audio control components can be found in the installation, including straight-line mixers, rotary attenuators, stereo pan pots, mixing networks, and fixed-loss pads.

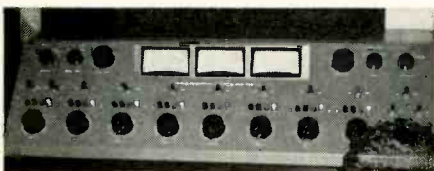

## 45-STEP MIXERS IN THIS CUSTOM CONSOLE FOR WEFM, CHICAGO!

After scrutinizing all the standard equipment available, WEFM decided that only a custom Altec console could meet their needs. After all, where else could they get a standard console with 45-step, 1db-per-step, mixers?

Now WEFM not only has mixers capable of very fine level control, but also *all-silicon* preamplifiers and various other Altec audio control components that add up to flat response, low noise, and rugged reliability for day-in, day-out operation.

## LET ALTEC PROVIDE THE COMPONENTS FOR YOUR DREAM CONSOLE

Your console's going to be around for a long time. Why not make sure it's *exactly* what you want? Send on your letterhead today for special professional discounts (available to bona fide broadcast and recording studios *only*). We'll send you the name of your nearest Professional Altec Distributor and our new studio-equipment catalog. Write Dept. BME5



**ALTEC LANSING**  
A Division of *GE* Ling Altec, Inc.  
ANAHEIM, CALIFORNIA  
© 1966 AL

Circle 27 on Reader Service Card



Attractive Rust booth and new equipment drew constant traffic.

TK-42 and TK-43 color cameras. One camera fed live monitor and another fed color VTR for later playback. TR-70 tape system and TK-27 color film camera were demonstrated. Also shown was 55-kw UHF-TV transmitter and 6-gc TV relay system designed for rack-mounting or portable use. High-band conversion kits for 7 VTR models were announced.

Circle 133 on Reader Service Card

RCA Electronic Components displayed replacement vidicons and I.O.s, power tubes, retrofit silicon rectifier units, and several popular broadcast units.

Circle 134 on Reader Service Card

Riker Industries showed new video switcher and automated master control switcher using Chrono-Log STEP system. Also shown were Newline sync generator, Model 6620, priced at \$1990; encoded color bar generator, Model 5618, priced at \$1500; Colorizer which allows color to be added to monochrome camera output, at \$1400; and Newline video test set, Model 6601, priced at \$1990.

Circle 135 on Reader Service Card

Rohde & Schwarz Sales Co. introduced complete video transmission assembly, including video noise meter, Videoscope, oscilloscope, sideband adapter, and video test signal generator. Also shown were TV channel signal generator (Type SBTf), TV demodulator (Type AMF), group delay test set (Type LFM), stereo coder (Type MSC), stereo decoder (Type MSDC), and field strength indicators (Types HUZ and HUZ).

Circle 136 on Reader Service Card

Rohn Systems: towers for all broadcast, microwave, and CATV applications.

Circle 137 on Reader Service Card

Rust Corp. introduced remote control video and audio switching system designed for rapid selection of audio and video inputs. Dial-operated RMS-106 accepts 10 composite video/audio signals and is connected to master switching unit by 5-conductor cable. Priced at \$350, it can be used for TV studio mon-



# How to climb aboard the **color** bandwagon easily, economically, with RCA-4415/S, -4416/S image orthicons...

Color TV is really rolling in high gear... And now, you may be facing the question of creating a color facility—with new studios, lighting, air conditioning and other equipment.

Being old-timers at color, we anticipated some of these facility problems and developed the RCA-4415/S, -4416/S, a matched-set of three image orthicons. They perform well in cameras for color at lighting levels usually available in black-and-white studios and eliminate the need for extra air conditioning equipment as well.

Another good feature of these tubes is that they behave more like the old faithful 5820A or 7293A's that you have been using in black and white during the past years. In the color camera, they can stand more over-exposure and are a little less finicky on the operating controls. For example, when you have a suntanned actress working in a gleaming white kitchen, you can operate with the highlights fairly far above the image orthicon knee without having the color picture going to pot.

We make up carefully matched sets consisting of two 4415/S Image Orthicons for the red and green channels, and one 4416/S Image Orthicon for the blue channel where a lot of "umph" in blue sensitivity is needed. The three mates of the set are matched to track very well and produce a nice uniform color picture. In addition, the sensitivities are balanced so that each tube is just about working at its maximum sensitivity and you are not throwing away extra light in the optical system to favor one low sensitivity channel. The result is good color pick-up at black-and-white studio lighting levels.

For further information about RCA Image Orthicons contact your RCA Broadcast Tube Distributor.

RCA ELECTRONIC COMPONENTS AND DEVICES, HARRISON, N.J.

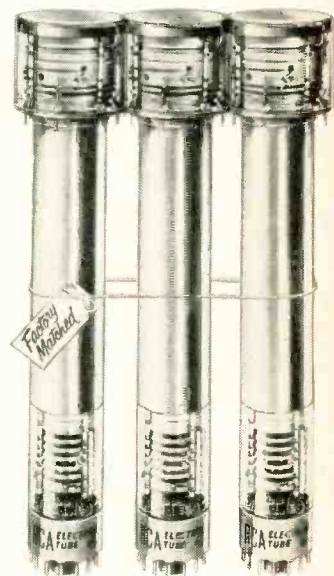

**Available From Your  
RCA Broadcast Tube Distributor**



**The Most Trusted Name in Electronics**

Circle 21 on Reader Service Card

# CINEMA PRECISION AUDIO EQUIPMENT



## AUDIO ATTENUATORS

Cinema's new compact rotary slide-wire attenuator is now available for your mixing consoles as single or ganged units. A must where smooth control is desired. Other standard types are also available for applications demanding precision noiseless attenuation, reliability and long term stability.

## GRAPHIC EQUALIZER

The Cinema Graphic Equalizer offers a compact system of extreme flexibility. Each of the six controls permit the operator to equalize or attenuate that portion of the spectrum 8 db. This is an active unit having zero insertion loss and up to 35 db additional gain.

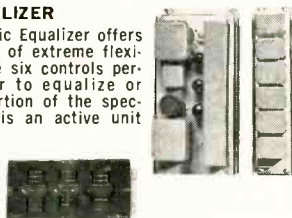

## DIP FILTER

Features a notch depth of 50 db minimum and which is continuously variable from 30 to 9,000 cps. Extremely useful for removing single frequency noise and for harmonic distortion measurements.



## PROGRAM EQUALIZER

Provides for accurate frequency response corrections in audio equipment. Easy operation of the two control knobs allow over 395 curve combinations. Detented action of the controls permits reference dial settings for future duplication of desired characteristics.

## DEGAUSSERS

Cinema bulk degaussers are a favorite with sound men throughout the world. Provides erasure of program material and residual noise from magnetic tapes on reels up to 17 inches in diameter and 2 inches wide. Also, "Pencil" type degaussers are available for erasing small areas thus avoiding splicing.



Hi-Q's Cinema precision audio equipment is backed by an enviable reputation generated by over 25 years of outstanding service in critical sound recording, broadcast and laboratory applications. Many other custom audio products are available. Put the benefit of our experience to work for you. Write for Hi-Q's Cinema precision audio equipment literature today.

**HI-Q<sup>®</sup> AEROVOX  
DIVISION CORPORATION  
CINEMA PLANT**

1100 CHESTNUT STREET, BURBANK, CALIFORNIA 91503  
PHONE: 213-849-5511 • TWX: 213-846-3578

Circle 29 on Reader Service Card



Shure Bros. displayed full line of broadcast microphones.

itoring and control, CCTV camera selection, and CATV program source selection. Also shown was telephone line converter which converts Rust remote control equipment from 2-metallic pair to single pair system, and Autolog AP-12 alarm panel which provides alarm output when either of two monitored parameters deviate above or below predetermined limits.

Circle 138 on Reader Service Card

Sarkes Tarzian exhibit highlighted Series 88 color studio camera and Series 77 color film chain cameras. Series 88 uses Plumbicon or I.O. in luminance channel, and vidicons, Plumbicons, or other similar tube in three chrominance channels. Also shown was a 6000L monochrome studio and 3500F monochrome film chain camera, VIS-88 vertical interval switcher and VIS-75 video switching system, CA-1000-B audio console system, and APT-1000B computer for programming.

Circle 139 on Reader Service Card

Sony Corp. new electronic editor for BV-120 VTR. Also BV-120, which offers variable slow-motion and stop-motion capability. Portable equipment included waveform monitor and signal stabilizer.

Circle 169 on Reader Service Card

Shure Bros: SM50 omnidirectional dynamic microphone with built-in windscreen intended for remote interviews, news, sports, and a variety of studio and field applications. Exhibit included several studio microphones and audio products.

Circle 143 on Reader Service Card

Sennheiser Corp. showed directional condenser mic. MKH 805 has output impedance of 10 ohms, designed to be connected to circuitry with input  $Z$  of 150 ohms min. Power is duplexed into audio cable, eliminating need for another conductor. Frequency response is 50 to 20,000 cps, EIA rating is -115.4 db; weight is 13 oz., price is \$351.

Circle 141 on Reader Service Card

Shibaden Corp. demonstrated new color TV camera using two image orthicons, one for luminance and one for chrominance. Camera, weighing under 200 lbs. and priced at \$50,000, will not be available in the U.S. until domestic Japanese



Sparta's Jack Lawson demonstrates Vega wireless microphone.

production goals are nearer fulfillment.

Circle 142 on Reader Service Card

Sparta Electronic Corp. exhibited new Vega 20 capacitor mic, said to offer linear response throughout the audio spectrum. Price, including power supply is \$185. Also demonstrated was Vega-Mike wireless microphone. New Sparta equipment included 2-channel, 3-input battery-powered remote amplifier, Model RA-5; Model A-20 8-channel console; Model AS-30 stereo console with 8 inputs; Model A-15 console with 12 inputs; and 600 Series stereo cartridge tape equipment. New line of turntable cabinets and console desks designed to provide custom installation with mix and match versatility were also shown.

Circle 151 on Reader Service Card

Schafer Electronics introduced program logger which will record 24 hours per track on 1200" reel. 330 Series logger operates at 1/3 or 1/6 ips, is available in up to 4-track standard and up to 8-track on special order. Two models are offered: 331 records one program source, 332 records two (AM and FM) program sources simultaneously. Price of 331 is \$1495. Also shown was ANP 800 automatic network switching system designed to operate in conjunction with CU-8 or CU-8S control units of 800 programming system. ANP-800 includes digital clock, Ampex PB-355 playback, and switching panel providing up to 14 combinations of time to operate any of 10 functions. Price is \$4990.

Circle 140 on Reader Service Card

Spencer-Kennedy Labs exhibited Model 262 wideband solid-state high-level distribution amplifier. Unit



SKL displayed CATV amplifiers and components, system design.

# This is not a whispering campaign...

but you might think so. The way word has gotten round from one audio engineer to another, one station exec or record mogul to another . . . about the blessed quietness of the new 3M Professional Tape Recorder. How it has increased signal-to-noise ratio 15 db. How our younger generations are the equal of anyone else's master. How it makes a 10 or more decibel difference in noise on your finest LP pressings. And you needn't plug in the oscilloscope — this difference you can *hear!*

An ingenious two-track system — "Dynatrack" mastering—extends the weighted dynamic range of audio tape systems to at least 80 db below third harmonic distortion. This means, of course, that *our third generation dub equals anybody else's master.*

The "Dynatrack" system keeps you on a clear track, virtually distortion-free. Here's how: a single signal is recorded simultaneously on a high or "H" track at normal NAB-standard level for higher level signals; and on a low or "L" track with a pre-emphasized response — high frequencies as

much as 15 db — the better to record lower sound level signals.

On very soft sounds usually lost when recording at NAB levels, the low track puts out a clean, undistorted signal. However, when the low or "L" track approaches distortion, an automatic circuit anticipates and switches to the high or "H" track — noiselessly and in milliseconds. The reserve volume capability of the "H" track thereby provides an extension of the dynamic range.

"Isoloop" foils flutter. The unique 3M "Isoloop" — virtually an isolated loop of tape in the most critical part of the recorder — is controlled by a differential drive capstan that also keeps tape loop tension constant. The loop hugs the tape heads snugly, and isolates the tape from the rest of the transport. The tape path in the loop is very short. Unsupported tape is reduced to 3½ inches. Less tape free to shimmy, shake over the heads! Unprecedented tape support like this considerably lessens flutter rate from that in ordinary professional recorders.

NAB tapes? Si! Yes, your present pre-recorded tapes *will* play, and with new brilliance, on the 3M Recorder. And you can record standard tapes, to be played on NAB-standard machines.

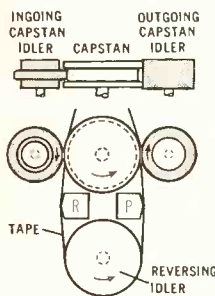
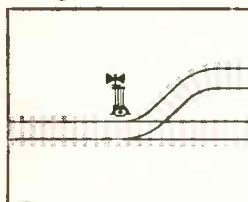

Plug in 2 new circuit boards to convert from the expanded range of the 3M Recorder to conventional recording.

Merely everything is here. Amplitude linearization for lower distortion. Phase correction for cleaner sound. Silicon solid-state circuitry. Overdub sync is available. Modular electronics. Epoxy glass circuit boards. Photoelectric tape position sensing. Interlock tape safety—go directly from "fast forward" or "rewind" to "play." Vernier precision editing location and marking. Etc. All made-in-America.

Now offering: Complete console. Portable units, complete in two shock-mounted carrying cases. You may also purchase the "Dynatrack" electronics system, or the "Isoloop" tape transport separately. The coupon will bring you a descriptive brochure.

## (NAB Compatibility, too!)

3M Company, Revere-Mincom Division  
Attention: Norman G. Lyall, Sales Manager  
2501 Hudson Road, St. Paul, Minn. 55119

Tell me more about the new 3M Professional Tape Recorder. Especially as it relates to

My name \_\_\_\_\_  
Company \_\_\_\_\_  
Title or job \_\_\_\_\_  
Address \_\_\_\_\_  
City \_\_\_\_\_  
State \_\_\_\_\_ Zip \_\_\_\_\_

Revere-Mincom **3M** COMPANY

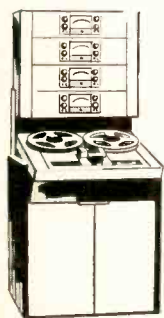



Tape-Athon's new system for pre-set audio program automation.

provides 50 db gain at 216 mc, 10 db manual gain control range, 6 db manual tilt range, and internal regulated power supply; also furnishes unregulated low-voltage AC for cable-powering number of line extension amplifiers. Price is \$450.  
*Circle 154 on Reader Service Card*

Standard Electronics displayed first production model of solid-state TV transmitter, also new single cabinet TV transmitter / driver. Presently available for Channels 7 through 13, design provides 5-kw visual and 500w aural outputs; amplifiers may be added for higher outputs and



Viking's motto heads complete CATV equipment and services display.

multiple visual/aural ratios.  
*Circle 158 on Reader Service Card*

Sylvania Electric Products: Mobile TV production van including two SC-9A vidicon cameras, mobile VTR, 14" monitor, two 8" monitors, waveform monitor, 2-channel audio mixer/amp, camera intercom headsets, video switcher, power control and metering panel, sync generator, digital clock, and remote camera controls. Price is \$5900.

*Circle 160 on Reader Service Card*

Syscom Div. of AMP, Inc. (American Pamcor, Inc.) introduced new

video/audio switching system. AMP MAD (multi-aperture devices) magnetic arrays are used as control element for binary logic bit for audio/video cross-point control. Modular plug-in design allows for any required number of inputs and outputs. Programmer automatically initiates fades, pre-rolls, stops, changes, pre-selects, audio amplifier controls, and selection of proper crosspoint of switcher. Up to 30 events may be pre-loaded manually or by tab cards or tape.

*Circle 178 on Reader Service Card*

Tape-Athon exhibited automatic programming system which sells for \$5,000. Basic system holds two music transports and one 24-cartridge message unit. Control console may be removed up to 200'. System operates with silence sensing or tone circuitry. Also introduced was "Maestro" tape transport with two capstans; measured starting time is said to be .01 sec. over a 30-minute span of tape, initial and second run will coincide within 2-sec.

*Circle 163 on Reader Service Card*

Tapecaster Electronics: Series 700 tape cartridge machines designed for

# SINGLE-SYSTEM EDITING NOW AVAILABLE!

## NEW!

Model DR-1 Displacement Recorder

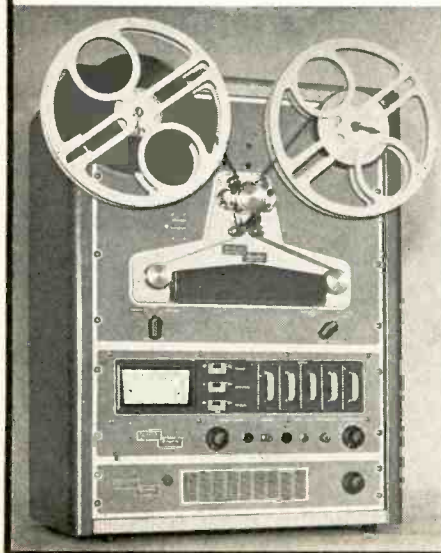

The Magnasync Model DR-1 Displacement Recorder automatically re-positions the sound track of a processed 16mm single-system release print film to "editor's sync" . . . sound and corresponding picture "in line" . . . for rapid, accurate editing, and then automatically re-positions sound track to "printer's sync" or "projection sync" for immediate projection, most often required by TV and Documentary producers.

The DR-1 eliminates equipment associated with conventional, cumbersome, inaccurate double-system transfer of 100 mil original magnetic sound track to a second 16mm magnetic sound track. One Displacement Recorder, and viewer equipped with magnetic head are the only equipments required. "In line" editing eliminates "flip-flap" . . . unwanted, unassociated picture sound.

Unit may be interlocked with other magnetic film recording equipment and projectors including conventional TV chain projectors. An audio input permits addition of sound to unrecorded release print film, and playback audio output is provided for projection tracks.

Circuitry is modular plug-in solid state. Monitor speaker, headphone output and automatic switching provided. Available for 115 V, 50-60 cycle.

Price: \$1785.00 Send for literature.

*Dealer inquiries invited.*

**MAGNASYNC**  
 CORPORATION  
 Subsidiary of Monogram Industries, Inc.



5547 Satsuma Avenue, North Hollywood, California 91601  
 Phone: (213) 877-1591

Cable: "MAGNASYNC"



*Circle 30 on Reader Service Card*

# Cummins: the power that didn't fail at...WHDH, Boston

© 1966 Cummins Engine Company, Inc., Columbus, Indiana



Seconds after Boston was hit by the massive Northeast power failure, WHDH-FM and TV had power. Cummins Diesel Generator power.

Power to broadcast continuous radio blackout reports during the critical first hours. Power to relay special network reports. Power to help prevent a general panic in the Boston area.

Their Cummins generator went to work instantly. Automatically. And it stayed on the job until WHDH was certain of normal power—a total of seven hours without a falter. This is the kind of reliability you buy when you specify Cummins. And we have units that match your precise needs, from 1½ to 400 KW. They may cost you far less than one more power failure. Call or send the coupon. We'll prove our point.

For complete information on Cummins emergency power, send this coupon.

James J. Strathmann, Manager  
Emergency Power Section  
Cummins Engine Company, Inc.  
1000 Fifth Street,  
Columbus, Indiana 47201

Name \_\_\_\_\_

Firm \_\_\_\_\_

Address \_\_\_\_\_

City \_\_\_\_\_

State \_\_\_\_\_ Zip \_\_\_\_\_

Phone No. \_\_\_\_\_

4-894

Look for Cummins  
in the Yellow Pages  
under "Engines—Diesel"



# EIMAC

offers new 1 kW PEP  
tetrode for SSB with  
highest linearity—at least  
-40 db in typical operation

EIMAC's new 4CX1500B power tetrode is the most linear tube on the market; intermodulation distortion characteristics under typical operating conditions are at least -40db at all drive power levels from zero to maximum. The new tube is ideal for advanced single sideband transmitters demanding high linearity to avoid channel-to-channel interference. The 4CX1500B is the product of a four-year development study which included optimization of internal tube geometry by computer techniques. Rated maximum plate dissipation of this radial beam tetrode is 1500 watts, and control grid dissipation rating is 1 watt maximum. Because the 4CX1500B has very low grid interception (typically less than 1.5 mA grid current), it is possible to drive the grid positive without adverse effects upon the distortion level; the tube is therefore recommended for Class AB<sub>2</sub> linear amplifier service. For further information, write Product Manager, Power Grid Tubes, or contact your nearest EIMAC distributor.

#### TYPICAL OPERATION (Frequencies Below 30 MHz)

DC Plate Voltage	2500	2750	2900 volts
DC Screen Voltage	225	225	225 volts
DC Grid Voltage	-34	-34	-34 volts
Zero-Signal DC Plate Current	300	300	300 mA
Single-Tone DC Plate Current	720	755	710 mA
Two-Tone DC Plate Current	530	555	542 mA
Driving Power	1.5	1.5	1.5 watts
Useful Output Power	900	1100	1100 watts
Intermodulation Distortion Products			
3rd Order	-38	-40	-40 db
5th Order	-47	-48	-48 db

**EIMAC**  
Division of Varian  
San Carlos, California 94070



**Eimac** 4CX 1500B

5  
10  
20  
30  
40  
db

We have a new brochure  
entitled "Single Sideband."  
Write for your copy.

Circle 33 on Reader Service Card



# BROADCAST EQUIPMENT

"reliable profit makers"

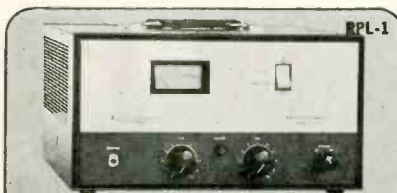

## REMOTE PICK-UP SYSTEM

- Unequaled 160 mc/s performance for quality broadcasting
- $\pm 1.5$  db 50-10,000 cps.
  - 1.6% max. distortion

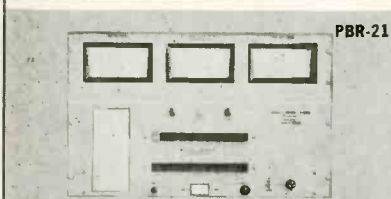

## REMOTE CONTROL SYSTEMS

- For AM-TV-FM via single AC phone line or STL
- Push-Button
  - Silicon Solid-State
  - 21 Channels



## 950 mc/s AURAL STL

- For AM, FM, Stereo and TV
- $\pm 0.5$  db 50-15,000 cps
  - Less than 1% distortion
  - Provision for SCA Multiplex, Remote Control and Order Circuits

# MOSELEY ASSOCIATES, INC.

135 NOGAL DRIVE  
SANTA BARBARA, CALIFORNIA  
(805) 967-0424

Circle 34 on Reader Service Card



FM equipment and silicon rectifiers were offered by Wilkinson.

50G. Other products included matched Elcon I.O.s for color, vertical interval and fast-lap video switching, production switching with special effects, master control switcher, VAT preselect switcher. Circle 180 on Reader Service Card

Vital Industries display included Model VI-10A video distribution amplifier, designed for color or monochrome. Unit rack-mounts 16 outputs in 1 1/4" space; gain is adjustable from -6 db to +6 db. VI-41 is designed to add composite sync and blanking pulses to as many as 12 video sources. Circle 181 on Reader Service Card

Vitro Electronics: Nems-Clarke FIM-135 solid-state filed intensity meter for AM broadcasters; new line of stainless steel jacks and plugs; phase monitors for DA systems; HF and VHF field intensity meters. Circle 182 on Reader Service Card

Ward Electronics Industries demonstrated VHF and UHF demodulators designed to provide precise check on transmitter linearity and performance; audio program amplifier which provides 80 db of gain; audio tone generator with both continuous and pip outputs; audio switching unit which can be used as routing switcher, audio portion of an audio-follow-video switcher, or as switching unit in an audio console; and custom audio consoles with video switcher type control panels. Circle 187 on Reader Service Card

Westel Co. demonstrated newly developed portable recording TV camera—hand-carried and battery-powered for shooting 1/2-hour TV tapes with sound. Camera unit, complete with TV pickup tube, viewfinder, and mic, weighs 7 lbs. Shoulder-worn recording mechanism weighs 23 lbs. Circle 189 on Reader Service Card

Wilkinson Electronics: TM-1A solid-state field intensity meter designed for reliability and ease of operation. Also offered were direct replacement silicon rectifier stacks, and LA-1B limiting amp, SG-1D stereo gen, AMM-1A modulation monitor, AMF-1A freq. monitor, Circle 193 on Reader Service Card

NEW by B&S



(ACTUAL SIZE)

Catalog 2620

6X MAGNIFICATION

Birns & Sawyer

# AuriBell

FOCUSIGHT™



Slip into film gate ... look into viewer



Write TV Division:

fast, exact lens  
check for sharpness,  
focus and parallax

Designed for Auricon Cine-Voice, Bell & Howell 70 series and most other 16mm cameras with removable or retractable film gate, to save time, money and film. \$4950

SEND FOR 1966 RENTAL CATALOG



**BIRNS & SAWYER**  
Cine Equipment

6424 SANTA MONICA BLVD. • HOLLYWOOD 30, CALIF. • HD 4-5166

Circle 36 on Reader Service Card

## Helpful Books on 10-Day FREE Trial!

- NAB ENGINEERING HANDBOOK**  
1728 pages of invaluable data!  
Order TAB-35 ..... only \$29.50
- ANTENNA ENGINEERING HANDBOOK**  
Fully covers the antenna art in 1013 pp.  
Order TAB-40 ..... only \$25.00
- CATV SYSTEM ENGINEERING**  
First book on technical phases of CATV.  
208 pp.  
Order No. 98 ..... only \$12.95
- PLANNING THE LOCAL UHF-TV STATION**  
Brand-new guide on how to set up a "U."  
Order TAB-43 ..... only \$10.00
- CATV SOURCEBOOK**  
Indispensable reference for all in CATV.  
Order TAB-99 ..... only \$9.95
- RADIO STATION MANAGEMENT**  
A wealth of stimulating ideas!  
Order TAB-61 ..... only \$5.75
- RADIO OPERATING Q. & A.**  
All the data needed to pass FCC exams.  
Order TAB-37 ..... only \$8.25
- TELEVISION BROADCASTING**  
A storehouse of practical technical data!  
Order No. 84 ..... only \$15.00
- TELEVISION STATION MANAGEMENT**  
Discusses practical day-to-day problems.  
Order TAB-57 ..... only \$6.95

### NO RISK COUPON—MAIL TODAY

TAB Books, Drawer D, Thurmont, Md. 21788  
Please send me book(s) listed below.  
I enclose \$ \_\_\_\_\_ B566  
 Please invoice on 10-day FREE trial.

Name \_\_\_\_\_  
Station or Co. \_\_\_\_\_  
Address \_\_\_\_\_  
City \_\_\_\_\_ State \_\_\_\_\_

Circle 35 on Reader Service Card





# Tektronix spectrum analyzers cover the spectrum

(1 MHz to 10.5 GHz)

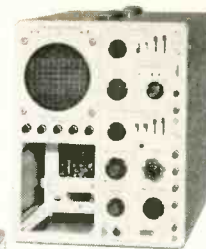

1 MHz to 36 MHz  
TYPE 1L10



10 MHz to 4.2 GHz  
TYPE 1L20

925 MHz to 10.5 GHz  
TYPE 1L30

They're all designed by Tektronix specifically for use in Tektronix oscilloscopes

## Features of Tektronix Spectrum Analyzers

(Types 1L20 and 1L30)

- Internal phase lock
- 100 MHz calibrated dispersion
- 1 kHz resolution
- $\pm 1.5$  dB display flatness

With any Tektronix oscilloscope that accepts letter and 1-series plug-ins, plus one of these spectrum analyzer plug-ins, you can extend the measurement capability of your laboratory to include spectrum analysis in the frequency range between 1 MHz and 10.5 GHz.

The Tektronix combination of spectrum analyzer and oscilloscope lets you make simple and accurate frequency measurements directly from the CRT display. The availability of many other plug-ins makes the oscilloscope an even more versatile laboratory measurement instrument.

Tektronix offers an outstanding measurement value in an oscilloscope-spectrum analyzer package, particularly when its cost is compared with a typical single-purpose spectrum analyzer.

### TEKTRONIX SPECTRUM ANALYZER CHARACTERISTICS

	TYPE 1L10 <i>(for use in Tektronix oscilloscopes accepting letter and 1-series plug-in units)</i>	TYPE 1L20	TYPE 1L30	TYPE 3L10 <i>(for use in Type 561A, 564 and 565 oscilloscopes)</i>
Frequency Range	1 MHz to 36 MHz	10 MHz to 4.2 GHz	925 MHz to 10.5 GHz	1 MHz to 36 MHz
Sensitivity	-100 dBm	-110 dBm to -90 dBm	-105 dBm to -75 dBm	-100 dBm
Calibrated Dispersion	2 kHz/cm to 10 Hz/cm	10 MHz/cm to 1 kHz/cm		2 kHz/div to 10 Hz/div
Resolution	1 kHz to 10 Hz	100 kHz to 1 kHz		1 kHz to 10 Hz
Incidental FM	IF: 5 Hz LO: 25 Hz + 1 Hz/MHz dial frequency	With internal phase lock, less than 300 Hz		IF: 5 Hz LO: 25 Hz + 1 Hz/MHz dial frequency
Display	Log, linear, linear X10 and video	Log, linear, square law and video		Log, linear and video
Price	\$1100	\$1825	\$1825	\$1200

For a demonstration, call your nearby Tektronix field engineer, or write: Tektronix, Inc., P. O. Box 500, Beaverton, Oregon 97005.

U.S. Sales Prices, f.o.b. Beaverton, Oregon

**Tektronix, Inc.**

*If you are interested in helping advance the state-of-the-art in oscilloscope design, write D. A. Thompson, professional placement manager.*

Circle 37 on Reader Service Card

**Stainless  
SS**

**TOWER-**

“space saver  
for TV, CATV  
and microwave”

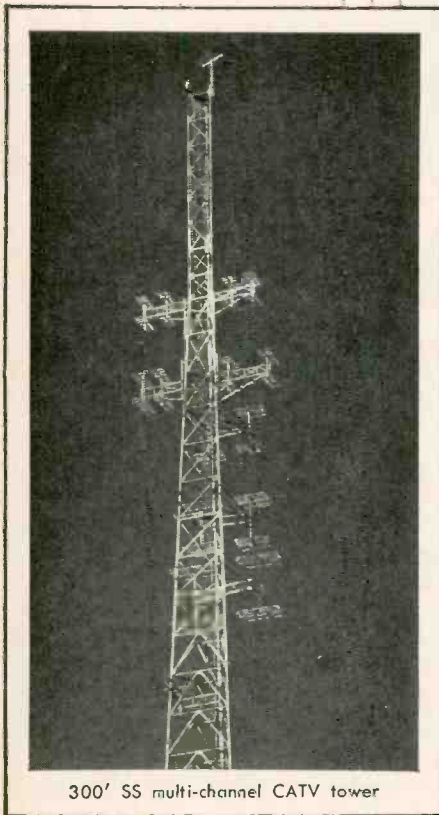

300' SS multi-channel CATV tower

- Self supporting—no guys
- Ideal on mountain peaks, buildings and city lots
- Heavy loading capability
- Minimum maintenance



Get your  
free book  
describing  
**STAINLESS'**  
installations.

**Stainless, inc.**

NORTH WALES • PENNA. 19154  
IN CANADA: Walscan, Limited, Toronto, Ontario

Circle 38 on Reader Service Card

# BROADCAST EQUIPMENT

## CATV Head End Tuner

A head-end unit designed for any VHF channel is being marketed by Jerrold Electronics, Philadelphia, Pa. The Channel Commander offers plug-in modular construction comprising 6 units (tuner, IF-AGC, AFC-ASC, crystal-con-



trolled converter/amplifier, standby carrier oscillator, and power supply). The tuner will receive any VHF channel, according to the position of the selector. The output channel may be changed by replacing the output module. Said to be compatible with existing equipment, the Model COM is rack-mounted in a 7" panel.

Circle 86 on Reader Service Card

## Reversing Tape Recorder

An automatic tape reversing system activated by silence has been introduced by Superscope, Inc., Sun Valley, Cal., U.S. Distributor of Sony tape recorders. The Electronic Sensory Perception system uses an electronic decoder which scans and automatically senses

sound modulations on the tape; when the modulations cease, the ESP decoder reverses the tape within 10 seconds. Old, new, or pre-recorded tapes will operate the system, which is incorporated in the new Model 660 recorder. The stereo 660 also includes XL-4 4-speaker quadraxial sound, 7½ and 3¾ ips speeds with a 50 db signal-to-noise ratio, and 30-18,000 cps frequency response. Price, including two F-96 mics, is \$575.

Circle 64 on Reader Service Card

## Coax Stripper

A hand tool developed to prepare coax cable for connectors in a single operation is being manu-



factured by Western Electronic Products Co., San Clemente, Cal. Three blades cut insulation and conducting braid to required

## Sound Track Recorder

The Magnasync Corp., N. Hollywood, Cal., is offering a displacement recorder designed to automatically re-position the sound track of a processed 16mm single-system release print film to editor's sync (sound and corresponding picture in-line). After editing, the sound track is automatically re-positioned to printer or projection sync. The Model DR-1 is said to eliminate equipment associated with conventional double-system transfer of 100 mil original magnetic sound track to a second 16mm magnetic sound track. The unit may be interlocked with other magnetic film recording equipment and projectors. An audio input permits sound to be added to unrecorded release print film. Price is \$1785.

Circle 53 on Reader Service Card

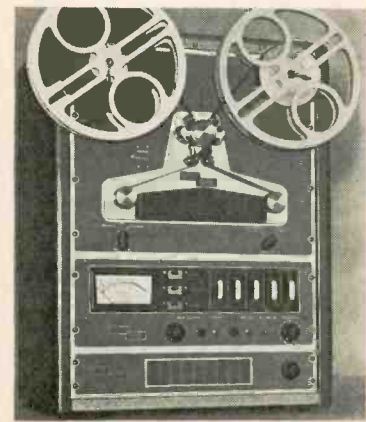

even on  
the windiest  
corner  
of the  
windy  
city

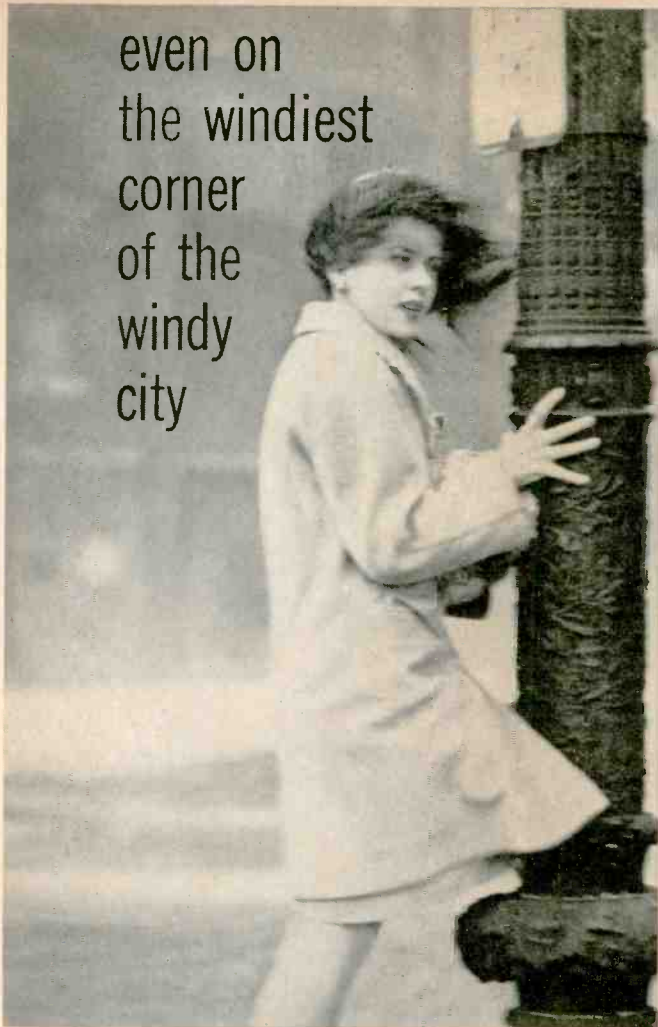

...this  
microphone  
needs no  
external  
windscreen

Shure's remarkable new SM50 omnidirectional dynamic microphone is SELF-WINDSCREENED! It is strikingly immune to wind noises and explosive breath sounds—making it ideal as a dependable "workhorse" microphone for remote interviews, news, sports pick-ups and a variety of field and studio applications. The five-element built-in windscreen makes it virtually pop-proof in close talking situations. And unlike other "built-in" windscreens, this one is "unitized" and self-contained with no bits or pieces to re-assemble after cleaning. In fact, you can actually rinse dirt, saliva, lipstick and other screen-clogging foreign matter out of the windscreen assembly under running water as often as needed—or replace the "unitized" assembly if necessary in a matter of seconds.

Additionally, the SM50 is the cleanest sounding professional microphone at anywhere near its price class. It delivers highly intelligible, natural and pleasing speech and vocal music that is especially full-bodied and rich in the critical mid-range.

It is extremely rugged and will require little or no down time as the years go by. Too, when comparing it to other moderately priced omnidirectionals, it is lighter in weight, supremely well-balanced for "handability," has a detachable cable, and a rubber mounted cartridge for minimizing handling noises. The SM50 is worthy of your most serious consideration.

For additional information, write directly to Mr. Robert Carr, Manager of Professional Products Division, Shure Brothers, Inc., 222 Hartrey Avenue, Evanston, Illinois.

## SHURE SM50

OMNIDIRECTIONAL DYNAMIC MICROPHONE

SHURE PROFESSIONAL MICROPHONES... FOR BETTER AUDIO



**MODEL SM56**  
CARDIOID  
DYNAMIC

Extremely versatile in studio, control room, and remote use. Also widely acclaimed for rhythm recording. Bright, clean sound. Exceptionally uniform cardioid pattern gives optimum control of environment.



**MODEL SM33**  
UNIDIRECTIONAL  
RIBBON

Warm, smooth sound for studio, control room, and scoring stage. Super-cardioid directional pattern. Compact, yet rugged.

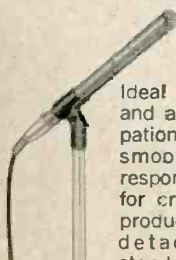

**MODEL SM76**  
3/4" OMNIDIRECTIONAL  
DYNAMIC

Ideal for interviews and audience participation, yet unusually smooth wide range response (40-20 KC) for critical music reproduction. Instantly detachable from stand. Steel case with Cannon connector.



**MODEL SM50**  
OMNIDIRECTIONAL  
DYNAMIC

Self-windscreened and pop-free for news, sports, remotes, and interviews. Also ideal for many studio and control room applications. Comfortably balanced for hand or stand use. Natural response.

Circle 39 on Reader Service Card



# TULLITO® SAFETY CLAMP

patented, other patents pending

A Lifesaver for workmen  
on . . . POLES/TOWERS/  
TANKS/STACKS/DERRICKS

Locks instantly —  
absolute safety assured.  
Fully approved by  
industrial commissioners  
and safety engineers.

Write for complete information—

**MEYER MACHINE, INC.**

P.O. Box 114 • Red Wing, Minn.

Circle 40 on Reader Service Card

Automatic  
Broadcasting  
tailormade to your  
needs through the  
building block  
concept from

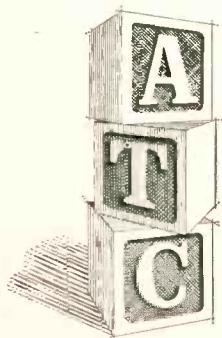

Send for FREE 35-pg. booklet "Plan-  
ning for Automated Broadcasting."  
Or call collect today 309-829-7006.

**AUTOMATIC**  **TAPECONTROL**  
1107 E. Croxton Ave. Bloomington, Ill.

Circle 41 on Reader Service Card

45's 45's 45's 45's 45's

**MR. STATION OWNER:**



Where  
to put  
**45's**

Model GS0736  
shown

Model GS0724 24" wide \$69.50  
Model GS0736 36" wide \$84.50  
Model GS0748 48" wide \$99.50

Prices include crating.

5% discount if check  
accompanies order

**GRINNAN FIXTURE CO.**  
**MINERVA, OHIO**

Circle 42 on Reader Service Card

lengths and depths for any stand-  
ard coax connector. The tool will  
accept cables from .075 to .435  
diameter, with inserts for various  
cable sizes. The Model CX-1  
weighs less than 12 oz. Cutting  
blades may be replaced without  
disassembly and a complete set of  
spacers for all standard connector  
configurations is included with  
one cable insert. Additional in-  
serts are available for a complete  
range of cable sizes. Price is  
\$39.50.

Circle 65 on Reader Service Card

## Sound-Slide Synchronizer

A unit designed to synchronize  
stereo tape recorders and Kodak  
Carousel projectors has been an-  
nounced by Eastman Kodak Co.,  
Rochester, N.Y. Said to provide

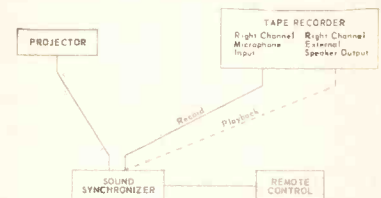

automatic slide-sound programs  
without audible slide-changing  
signals, the synchronizer is con-  
nected by plug to the projector's  
remote control receptacle and the  
projector's remote control switch  
is plugged into the synchronizer's  
receptacle. Voice and musical  
background are recorded on one  
track and a change-slide signal is  
recorded on the second track. As  
the tape plays, it automatically  
switches slides to coincide with  
commentary and background.  
Price is less than \$30.

Circle 66 on Reader Service Card

## Variable Attenuator

Viking Industries, Hoboken, N.J.,  
has developed an inline variable  
attenuator containing a 3 db and

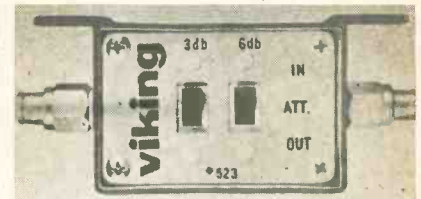

a 6 db pad. Each may be used  
individually or combined for a  
total of 9 db. The Model 523 has  
a switchable pad which passes 8  
amps AC or DC. Bandpass is  
said to be within ¼ db from 0  
to 220 mc; input and output  
VSWR is 1.25:1 max. Viking has  
also introduced multiple trunkline  
couplers designed to split a single

# When the viewers are home enjoying the show ...you will be too!

(Thanks to Raytheon's  
Dual Link II)

With Raytheon's new Dual Link II, getting home on time is as automatic as your STL protection. The Dual Link II, a *solid-state* hot-standby television microwave equipment, provides completely automated transmitter switching and duplicated receiver STL protection. Since equipment can be serviced during normal programming hours, after-hours



maintenance and revenue losses from STL outages are gone forever. The equipment can handle up to four audio channels for AM, FM, stereo, or TV, and will transmit NTSC color with 1.0+ watt output. If your station is considering improving color performance and the replacement of overworked tube-type equipment, check the Dual Link II, first. It's warranted for 5 full years and "guaranteed" to get you home on time, everytime. Mail this coupon for complete information.

**RAYTHEON**

Sales Manager  
Raytheon Co., CADPO  
1415 Providence Tpk.  
Norwood, Mass. 02062

Please send me the  
full story on Dual Link II.

Name \_\_\_\_\_

Title \_\_\_\_\_ Station \_\_\_\_\_

Address \_\_\_\_\_

City & State \_\_\_\_\_ Zip Code \_\_\_\_\_

Circle 43 on Reader Service Card

## DROP MAN'S DELIGHT

# SKL

## MULTITAPS

True Directional Couplers

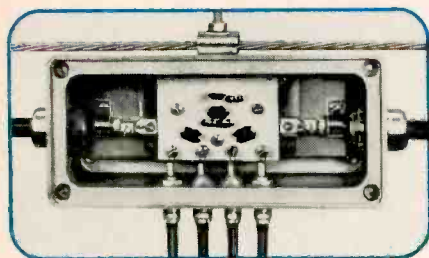

- Economical
- Easy-to-Install
- Undistorted Color Transmission
- A Must For Wide-Band Systems

Retaining the electrically superior directional coupler principle in a compact printed circuit tap and tap adder combination, SKL Multitaps can be used with various feeder cables. They are packed complete with no mating parts to buy.

Available in values of 10, 16 or 22 db tap loss, they fit aluminum, copper, corrugated or braided feeder cables,  $\frac{3}{8}$ " to  $\frac{1}{2}$ " o.d. without coaxial connectors.

SKL tap adder inserts serve up to four subscribers from one location with one low through loss. Purchases in lots of 100 or more reduce cost per subscriber tap to as low as \$3.59.

Try some in your system. Once you do, we think you'll want more. Call 617-254-5400, write today or plan to see the complete SKL line at the NCTA Show in Miami in June.

# SKL

**SPENCER-KENNEDY LABORATORIES, INC.**

1320 SOLDIERS FIELD ROAD  
BOSTON, MASS. 02135  
Circle 44 on Reader Service Card

### "Standby" Microwave

"Outage insurance" for TV broadcasters is offered in the form of automatic parallel microwave equipment introduced by Raytheon. The solid-state (except klystron) KTR-II Dual Link provides automatic transmitter switching and duplicated receiver protection for TV STLs. It will handle monochrome or color TV program with audio at a minimum of 1w output in the 6875 to 7125 mc range.

Circle 54 on Reader Service Card

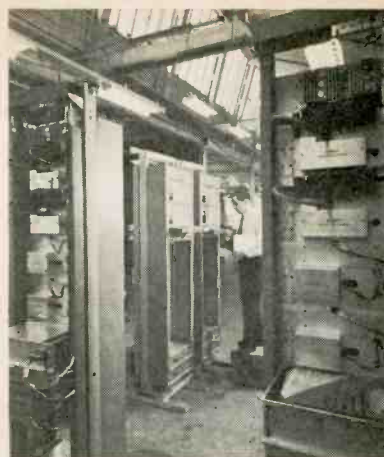

trunk into 2 or 4 trunklines or to combine 2 or 4 trunklines into a single trunk. Both units allow AC or DC through power.

Circle 67 on Reader Service Card

### Audio Compressor

A solid-state compressor with a 10:1 compression ratio and plug-in circuitry, designed to provide automatic control of system gain,

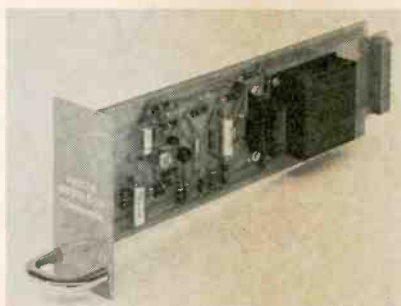

is available from Melcor Electronics, Farmingdale, N.Y. The Model C-20 is composed of two separate units, a CA-20 plug-in unit and the CC-20 control portion for panel mounting. The latter includes a compression meter and variable controls for threshold level and release time adjustment. Price is \$136.

Circle 70 on Reader Service Card

### Portable Preamp

A portable transistorized preamp, designed for recording, re-



notes, and for use with portable tape recorders, has been developed by Bogen Communica-

tions Div. of Lear Siegler, Inc., Paramus, N.J. The Model RTP-1 may be powered from batteries or AC line; inputs include 2 high or low impedance mics, 2 auxiliary inputs on fader control, and one bridging input. Two units may be paralleled to mix 6 inputs. Output is 100 mw into a 600-ohm line. Battery drain is 30 ma and frequency response is 20-20,000 cps.

Circle 114 on Reader Service Card

### Stereo Cartridge

Stanton Magnetics, Plainview, L.I., N.Y., has introduced its Calibration Standard Series 581 pickup cartridges, designed for use as a primary standard in recording studio and broadcast systems checkout. Frequency response is flat within  $1\frac{1}{2}$  to 2 db from 20 cps to 20 kc (within 1 db to 10 kc). Minimum output is 0.8 mv/cm, cartridge weight is 5 grams, and mounting centers are 7/16 to



$\frac{1}{2}$ ". The self-supporting longhair brush removes loose lint, dust, and fuzz from playing surfaces. Model 500A for on-air use is \$30.00; Model 581A for recording studio is \$49.50.

Circle 96 on Reader Service Card

### Video Pulse Amplifier

A pulse amplifier for video distribution and switching systems has been announced by Cohu Electronics, Inc., San Diego, Cal. The 9800 Series plug-in unit is a re-

generative amplifier which processes and distributes sync from one input to 4 outputs; input may be horizontal or vertical drive, blanking, or sync. Isolation between outputs is said to be greater than 40 db to 1 mc. Input level may be from 1.5 to 5v; output level is adjustable from 3.5 to 4.5 v, 75-ohm source-terminated. 10 units will fit into a 5¼" standard rack frame with provision for looping through 75-ohm lines (permits paralleling inputs of a number of amplifiers). Prices: amplifier, \$190; frame, \$200.

Circle 92 on Reader Service Card

### CATV Pole Brackets

The Pruzan Co., Seattle, Wash., has designed a pole clearance extension bracket which provides the 15" pole clearance required in many areas. The bracket requires 9" of pole mounting space and enables existing pole use without

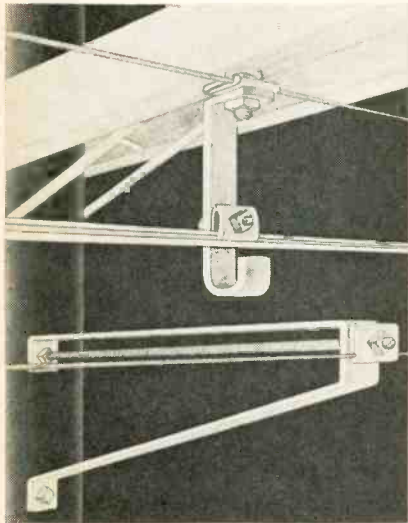

adding another crossarm. Double arming bolt provides added reinforcement.

Also available is a figure-8 crossarm bracket which allows one or more cables to be mounted on an existing crossarm. Cable can be rested on the bracket while being strung.

Circle 57 on Reader Service Card

### Antenna Switching Matrix

A U.S. Patent for a high-power antenna switching matrix has been granted to Charles S. Wright and Kenneth Owen, vp's of Delta Electronics, Inc., Alexandria, Va. Model SLS-1 uses a strip-line technique to provide flexibility in connecting any number of transmitters to any number of loads. The compact unit uses a plunger-type switching mechanism which removes residual stubs from ac-

# NEW

FROM

**EMCEE**

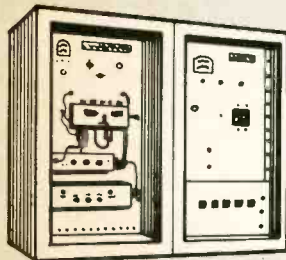

**1KW  
TRANSLATOR**  
UHF

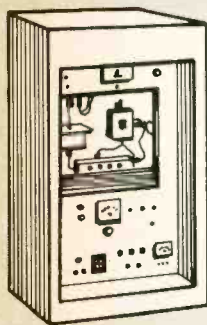

**1KW  
TRANSMITTER**  
UHF

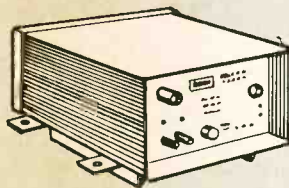

**1 WATT  
TRANSISTORIZED  
TRANSLATOR**  
VHF ONLY

Send for full details . . . now.

**EMCEE**

**Electronics Missiles & Communications Inc.**

160 EAST THIRD STREET, MT. VERNON, NEW YORK 10550

TELEPHONE: (914) 668-3012

Circle 45 on Reader Service Card

# The Commentator:

"I needed a headset that eliminates noise, provides a noise-canceling broadcast quality microphone, leaves both hands free, is comfortable over long stretches, and really takes punishment. My **Roanwell** does the whole job! Do you read me, Cameraman?"



11 Roanwell TV Specials to choose from — a model for every studio/field use. Users include ABC, CBS, NBC (all nationwide). Write for free brochure.



**ROANWELL CORPORATION** Roanwell Building  
180 Varick Street, New York, N. Y. 10014 (212) YUkon 9-1090 • TWX: (212) 640-4791

Circle 46 on Reader Service Card

tive circuits and provides mechanical and electrical interlock. A remote status panel may be connected to the switch for either manual or remote operation. The SLS-1 has a power rating of 50 kw average from DC to 30 mc; characteristic impedance is 50 ohms with a VSWR of 1.15 or less and a cross-channel isolation said to exceed 65 db.

Circle 75 on Reader Service Card

## TV Viewfinder Added

The addition of a 5" Sony TV monitor to the Cohu 3100 4-lens turret TV camera is said to ex-



tend its usefulness as a viewfinder camera for general studio applications. The monitor, available from Gordon Enterprises, N. Hollywood, Cal., can be easily re-

moved and replaced. All power connections are made through the camera.

Circle 55 on Reader Service Card

## "Ditch Witch" Trenchers

Underground CATV systems installations can be handled speedily with the Model C-4 Ditch Witch trenchers, according to Charles Machine Works, Perry,



Okla. The self-propelled machine is 32" wide and weighs 400 lbs. The hardened steel roller chain uses bolt-on replaceable teeth and digs trenches 3", 4", or 6" wide

and up to 2' deep at speeds up to 6 fpm.

Circle 63 on Readers Service Card

## Obstruction/Warning Light Controls

Precision Multiple Controls, Inc., Ridgewood, N.J., has developed a twist-in control, conforming to FAA specifications, which auto-

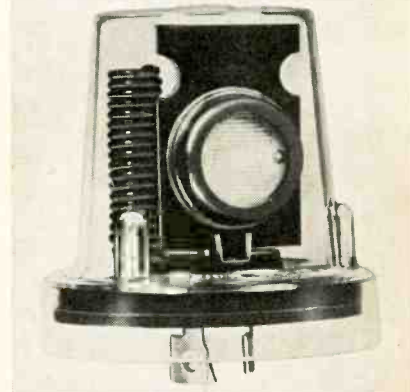

matically energizes a circuit at 35 ft. candles and de-energizes at 58 ft. candles. Model 102FAA (rated at 1800 va), uses a standard twist-in base (EEI-NEMA), and Model 452FAA (rated at 3000 va) uses a standard 4-blade watt-hour meter base. The 102FAA is priced at \$28, the 452FAA at \$44.50.

Circle 87 on Reader Service Card

## CATV Automatic Level Control

Spencer - Kennedy Labs, Boston, Mass., has introduced a wide-band automatic level control designed to maintain a constant pre-set trunk amplifier output. A directional coupler provides input and output connections. The Model 275 will operate in response to either a TV signal or a pilot carrier signal; a tunable filter allows selection of any TV carrier or pilot in the 165 to 190 mc range. The unit is solid-state and power-regulated.

Circle 85 on Reader Service Card

## Video Tape Book

"Video Tape Recording" is a comprehensive documented report written in layman's language but including enough valuable technical data to be of interest to engineers. Beginning with a detailed history, the authors describe the recording method, with a discussion of the advantages and disadvantages of each. Some of the problems involved in video signal recording and comparative costs of equipment are discussed. Price is \$12.

Circle 56 on Reader Service Card



## NAMES IN THE NEWS

**Edward H. Denyer** has been appointed communications products sales manager for Raytheon's international sales force. **Robert E. Slater** has been named manager of marketing for Raytheon's Sorenson Operation, succeeding **James D. Bowen** who was promoted to operation manager.

**L. Kenneth Powley**, southeastern field representative for Superior Cable Corp., has been promoted to district sales manager.



L. K. Powley

H. L. Cook

**Harvey L. Cook** has been appointed marketing manager of Kalart Co.

**Clarence L. Boice** has been named development engineering manager at Allen Electronics. **George Hurst** was appointed operations manager.

**Charles L. (Bill) Dietderich** has been named international sales manager of Cascade Electronics, according to **Donn G. Nelson**, vp and gen-



C. L. Dietderich

Robert Ashby

eral manager. **Robert D. Ashby** was appointed director of advertising and **Joseph L. Derocher** named director of systems engineering and construction.

Spencer-Kennedy Labs has appointed pres. **Charles H. Wright** chief executive officer. **Donald Spencer** will devote his time to man-



C. H. Wright

Don Spencer

agement of company-owned systems. **George Green** was named vp finance and marketing. **Hy Triller** has been named marketing manager.

**Thomas W. Harleman** has been

named Ampex national sales manager, succeeding **Robert R. Owen**, who has been promoted to general manager of marketing. Mr. Harleman was midwestern regional manager.

**S. S. Street** has joined Viking Industries as director of marketing and will be responsible for marketing and promotion of the company's products.



S. S. Street

George Kanen

**George C. Kanen** has been named to fill the newly created post of director of sales administration at Entron.

**Mrs. Marianne B. Campbell**, general manager of WJEH, Gallipolis, O., was elected the the NAB Board of Directors to fill the vacancy created by the death of Gene Trace.

**Leonard Tow** has been named to fill the new position of director of administration and planning at Tele-

Prompter. Dr. Tow joined the company last September.

**Robert H. Huston** has been named executive v.p. of American Cable Television, affiliate of Ameco, Inc., by **Bruce Merrill**, chairman of the board. Mr. Huston was director of corporate relations for Cox Broadcasting Corp.

**Charles E. Prampf**, formerly v.p. and general manager of Aerovox Hi-Q Div., has been named to the newly-created position of executive v.p., Aerovox Corp.

**Duane W. Crist**, recently named v.p. in charge of finance and general administration, Kaiser-Cox Corp., has been appointed executive v.p. and general manager. He will have complete charge of Phoenix operations.



Duane Crist

John Russell

**John G. Russell** has joined Tele-Mation as national CATV sales manager.

## The Cameraman:

"I've got the whole picture. I needed a headset that's just as comfortable and noise-eliminating as yours but also monitors both program and the director. The **Roanwell** I've got has a noise-canceling mike to boot."



11 Roanwell TV Specials to choose from — a model for every studio/field use. Users include ABC, CBS, NBC (all nationwide). Write for free brochure.



**ROANWELL CORPORATION** Roanwell Building  
180 Varick Street, New York, N. Y. 10014 (212) YUkon 9-1090 • TWX: (212) 640-4791

Circle 47 on Reader Service Card

# BROADCASTERS SPEAK

After receiving the February edition of BM/E I just couldn't resist writing you this letter. I think your magazine is the most informative publication available. Your continuing series, Building an FM Station, is most interesting. I would like a copy of the material in its entirety if and when available.

I wish you could have an article on preventive maintenance for AM-FM combination stations in the near future. Thanks again for the great magazine.

Kerry Bramham, C.E.  
WCHK-AM-FM  
Canton, Ga.

Our company maintains radio stations K-BUB Sparks and KCBN Reno, and we serve as engineering consultants to other stations in our area.

Our Engineering Department feels that BM/E is of great value in keeping pace with the current rules, regulations, and tools of the trade. We have found special articles, such as Building an FM Station, of great interest.

Keep up the good work!  
Larry E. Oakley, Gen. Mgr.  
Sierra Electronics and Engineering  
Reno, Nev.

I have enjoyed your articles on building an FM Station. Would it be possible to get reprints?

Louis Mitzlaff, Sales Mgr.  
WITV Danville, Ill.

Preparation of a complete book, including the 6-part series on Building an FM Station and several other FM articles, is now underway. Watch for announcement regarding availability.

We are grateful for our copy of BM/E each month. The articles it carries are very instructive and the advertisements are of much use to people like us, who are specialized in the import and distribution of communications and broadcasting equipment, electronic products, instruments and components.

G. V. Desai, Manager  
Communications Div.  
Forbes, Forbes Campbell & Co. Ltd.  
Bombay, India

I think BM/E is the greatest thing yet to be published for small stations where managers are also engineers, copywriters, salesmen, etc. May I offer some suggestions for future articles?

1. Collection plans which have worked.
2. Ways to save money using the U.S. mail.
3. Emergency Action Notification System.
4. Questions for quiz programs, including sources.

These are just a few ideas I would like to see in your magazine; again,

my congratulations on your fine publication.

William J. Kiewel  
Manager, KROX  
Crookston, Minn.

How about a little help on a new project? Underwater television! Underwater Photographic Service is looking into some fascinating underwater TV possibilities, and we need some sources of inexpensive TV cameras. Do you have names and addresses for manufacturers of closed circuit TV units—cameras, monitors, etc.—perhaps such as those used for cable TV information channels, or similar units for industrial TV?

Don't worry about the underwater end of it; that we're equipped to handle, but we do need to know of a source for a small camera, preferably with a one-inch tube, at a reasonable price, for our first experiments.

E. Mitchell Shulman  
Underwater Photographic Service, Inc.  
Marathon, Fla.

Information sent as requested.

We refer you to our letter of 28th May, 1965, requesting that you place the Board's name on your mailing list. We advise that BM/E is being received regularly and we find it so useful that we would be glad if copies could be made available to the three Senior Engineers in our interstate offices.

J. A. McNamara, Secretary  
Australian Broadcasting  
Control Board, Melbourne

## CRAFTSMAN

Craftsman's new back-matched epoxy filled hybrid splitter-mixer's battleship construction insures high AC/DC isolation and rugged dependability.

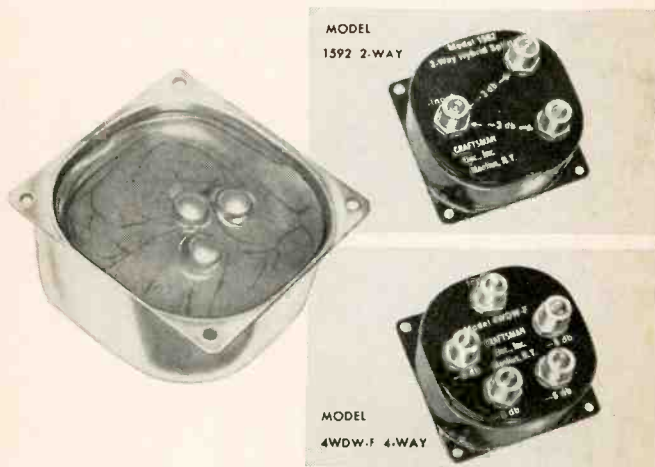

No need to buy expensive outdoor splitters — Craftsman now has available the Astro-Cast type of Epoxy — guaranteed not to crack or melt in extreme temperatures.

**CRAFTSMAN**  
ELECTRONIC PRODUCTS, INC.

133 WEST SENECA ST.  
Area Code 315

MANLIUS, N. Y. 13104  
Phone OVerbrook 2-9105

CEP

THE PIONEER CATV ACCESSORY MANUFACTURER

Circle 48 on Reader Service Card

## Command Towers

towers for  
every communication need

- MICROWAVE
- RADIO
- TELEVISION
- C.A.T.V.

Command quality! Order Command Products and Services, reflectors, special engineering and fabrication, erection and installation.

Protect your equipment with steel!

Perma-Porta Buildings



- PERMANENT
- PORTABLE
- PREASSEMBLED
- PREPARED



**COMMAND COMMUNICATIONS**

636 BADGEROW BLDG. • SIOUX CITY, IOWA 51101  
(712) 252-4017

Microwave  Radio  Television  C.A.T.V.  Buildings  
Name .....  
Address .....  
City ..... State .....

Circle 49 on Reader Service Card

## CATV Advertising

(continued from page 43)

make it a pivot point in your advertising plans and budget.

### Other Methods

The use of premiums can certainly be a motivating force in all forms of advertising, and at the same time create an immense amount of good will. However, when you advertise premiums, use adjectives sparingly — exaggerations don't pay. Small appliances, jewelry, gift certificates, and any number of items can be used successfully to induce non-subscribers to sign up, if the premiums are genuine and are truthfully represented.

A word of caution—Federal lottery laws prohibit premium gifts where there is an element of chance. The word "free" must be used carefully. Some states and municipalities also have regulations (and taxes) to control the use of premiums. Where there is any doubt, an attorney can see that you are safe instead of sorry. Remembrance advertising, book matches, calendars, etc., keeps your name in front of your customers and may lead them to feel a bit better when they receive your monthly statements.

Renting display space at community home or builders' shows can pay off rather well. You can present your case to a new home builder in several ways: no unsightly antenna to mar the appearance of a new home, concealed set connections, etc.

### Outlook

As we go into the larger and more complex metropolitan areas, cable television advertising will become much more complicated. All media will have to be screened carefully to pinpoint desired markets. Today's methods of determining media combinations are relatively simple, as far as CATV advertising is concerned. But today's methods will only scatter like buckshot in the more complicated metropolitan areas.

Advertising will also be more expensive. But it will also become more and more important to add and retain subscribers as competition increases. Advertising is a selling tool. It's your job to see that it pays off. Study your market, study the available media, then plan your advertising. Good advertising will pay for itself, many times.

**SAVE \$3.00 ON THIS SPECIAL PREPUB OFFER!**

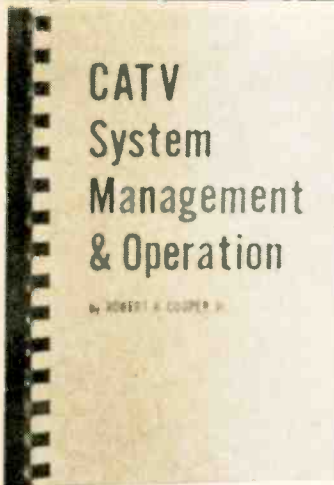

**280 PAGES OF  
INVALUABLE DATA!**

# CATV SYSTEM MANAGEMENT & OPERATION

by Robert B. Cooper, Jr., Vice-President, Valley-Vision, Inc.

Here is the first book on the subject and it's written by a recognized expert in the field—Bob Cooper, Jr., holder of a dozen CATV franchises. This brand-new volume, due off the presses on May 25th, 1966, is a complete guidebook to CATV—from locating new

CATV situations, through acquiring a franchise, obtaining financing, opening, and operating a system, budgeting, and buying and selling systems.

Reading as easy as a novel, seldom has a book been so destined to become the "bible" of the industry. There is little, if anything, about CATV not covered. While primarily non-technical in nature, *CATV System Management & Operation* covers the technical aspects the owner-manager should be aware of. It also discusses literally scores of helpful points on designing, installing and constructing a cable system. And, most importantly, it includes cost data throughout.

But the real strength of this unique volume lies in the practical tips it provides—guideposts learned the hard way by the author in his years of CATV experience. Everything you need to know about CATV is included—from the legal ins and outs of acquiring a franchise, through negotiating a pole-line contract, to acquiring capital, selecting equipment, etc. Five Appendices offer invaluable data in the form of a Model Ordinance, Joint Pole Agreement, Construction Specs for CATV on Pole Lines, CATV Cash Flow Charts, and Subscriber Contract.

The Special Prepublication price of \$9.95 prevails through June 30th; thereafter the price is \$12.95. Order now at our risk for a FREE 10-day examination. *Send no money!* Simply fill in and mail the NO-RISK coupon below to obtain this invaluable guide.

### PARTIAL LIST OF CONTENTS

- Introduction: A Capsule History; Public Utility Status; The FCC; CATV vs Broadcasters; Copyright Status.
- Types of Systems: Low Band and FM; Low Band and High Band Add-on; All Band Systems; Super Systems.
- Locating New CATV Situations: Off-Air Reception; Surveying the Town; Local Investors.
- Franchise Acquisition: Processes; Local Appeal; Appearing in Force; Mechanics; Checklist for Franchise Applications; Rates.
- Planning the Cable Plant: Plant Capacity; Expansion Capacity; Construction Techniques; Underground Systems; Municipal-Owned Poles; Setting Your Own Poles; Joint Pole Agreements.
- Site Surveys and Antenna Site Designs: Pitfalls in Mountain Sites; Over-Water Paths; Towers and Concrete Work; What Grade of Signal?; UHF Channels; Adjacent-Channel VHF Problems.
- Plant Construction Techniques: Do It Yourself or Have It Built?; Turnkey Installations; Installing It Yourself; Construction Notes; Electronic Construction Notes; Synopsis of Plant Construction; Building on the Telephone Plant.
- Choosing CATV Equipment: Towers; Preamplifiers; Transmission Lines; Head-End Amplifier Equipment; Plant Amplifier Equipment; Passive Plant Equipment; Taps and Transformers; The Cable.
- Lending Sources and Financing: Invested Capital; Leased-Plant Systems; Types of Loans; Security; Evaluating Existing Systems for Purchase; Checklist for System Purchase; Funding Sources.
- Opening and Promoting the New System; Promoting During Construction; Using Local Media; Free Trial Service; Opening Day; Selling Through Local TV Dealers; Continuing Sales Program; Non-Paid Advertising With A Purpose; Regular TV News Columns; Door-to-Door Sales.
- Typical System Expenses: The Work Force; Typical System Budget.
- Public Relations: Starting and Maintaining It; Evaluating and Adding New Channels and Services: Auxiliary Services; FM Music Channel; FM Signal Carriage; Weather Channel; Live and Film Public Service.
- Trends and the Future: Franchise Trends; TELCO Trends; Buy-Sell Trends; Operational Trends; Legislative Trends; Maximum Service Trends.
- Appendices.

### PUBLISHER'S GUARANTEE

Put the information in this book to work for you for 10 days. If it doesn't prove to be worth several times its cost, return it and we'll cancel invoice.

### NO RISK COUPON—MAIL TODAY

BC566

TAB Books, Drawer D, Thurmont, Md. 21788  
Please send me \_\_\_\_\_ copies of "CATV SYSTEM MANAGEMENT & OPERATION" at the special prepublication price of only \$9.95 (regular price \$12.95)

I enclose \$ \_\_\_\_\_  
 Please invoice on 10-day FREE trial

Name \_\_\_\_\_

Company \_\_\_\_\_

Address \_\_\_\_\_

City \_\_\_\_\_ State \_\_\_\_\_ Zip \_\_\_\_\_

Circle 50 on Reader Service Card

# LITERATURE of INTEREST

For additional data, circle No. shown on Reader Service Card.

**Audio equipment** catalog from Aero-vox Hi-Q Div. lists sound recording and broadcast units. Includes attenuators, filters, equalizers, degaussers, etc. **149**

**Headsets** with 20-, 150-, and 300-ohm impedances listed in 4-page brochure from Roanwell. Includes description of 8 available mics, transistorized amplifiers, matching transformers. **152**

## THE LEADER IN CATV TOWERS

"Quality—Service  
and Price!"



Yes, quality, service and price on CATV systems are the reasons for Fort Worth Tower's position as the industry's leading supplier. Experience gained as a pioneer supplier of CATV enables Fort Worth Tower to provide you with a quality product at a price that is reasonable and attractive.

Take advantage of our experience. For assistance in systems planning, engineering and complete systems quotations . . .

CALL OR WRITE TODAY

### Fort Worth Tower

COMPANY, INCORPORATED

P.O. Box 8597, Fort Worth, Texas  
(817) JE 6-5676

— Associated Companies —

Tommy Moore, Inc.—Big State Engineering, Inc.  
Tower Construction Finance, Inc.

Circle 51 on Reader Service Card

**FM high frequency modulation control unit** described in brochure from Fairchild. Lists operational characteristics and specifications for Conax unit. **148**

**Video tape specification data** and bibliography of technical information from Memorex library of reprints. **184**

**Field intensity meter**, Model 4N-1, also serves as null detector, signal generator, AM monitor receiver. Described in technical data from Wilkinson. **185**

**Camera tube catalog** from RCA Electronic Components lists image orthicons and vidicons. Includes complete technical information. **188**

**CATV directional tap pedestal mount** for underground systems. Catalog sheet from Viking Industries includes specifications and prices. **159**

**TV STL equipment** described in detailed specification data from Microwave Associates. Doubles as portable TV pickup relay. **190**

**Audio consoles** using photoconductive cell design described in brochure from Collins. Includes monaural and stereo units. **191**

**Video preamp**, solid-state design for replacing tube-type amplifiers in TK-41 color camera, described in data sheets from International Nuclear Corp. **192**

**CATV distribution equipment** listed in catalog from Benco TV Corp. Includes MATV units, test equipment, antennas, and price sheets. **157**



**Taped music service**, complete with equipment specification data, fully described in 4-color, 12-page brochure from IGM. **145**

**TV S wire grip** illustrated in fact sheet from the Pruzan Co. Available in aluminum or stainless steel. **161**

**Cartridge tape equipment** described in technical bulletin from KRS. Includes details on SB6A Series Stact Broadcasters and all-cartridge audio automation. **170**

**Sync generator** designed for monochromatic operation described in brochure from Northern Electric. **195**

**CATV test equipment** listed in catalog sheets from Blonder-Tongue. Also fact sheets on line and distribution equipment. **155**

"**Impedance Discontinuities in CATV Cables**" discusses input impedance deviations, coax jumper cables, and cable periodicities. Available from Superior Cable, includes graphic illustrations and tables. **156**

**Books** on all phases of radio-TV-CATV, many unavailable from other sources, fully described and illustrated in 8-page catalog from TAB Books. **186**

**Dynamic microphone** with omnidirectional pickup pattern described in bulletin from Shure Bros. **150**



**UHF transmitters**, klystron designs from 15 to 55 kw, fully described in 4-color, 12-page specification guide from Townsend Associates. **147**

**Wire and cable** for radio and TV, recording studio, remote control circuitry listed in catalog from Belden. **197**

**Directional tap** for CATV applications described in technical information from Craftsman Electronic Products. **198**

**Test & measurement data** in Hewlett-Packard Journal, technical information of interest and value to broadcast and CATV engineers. **146**

**Antenna system equipment** listed in 104-page catalog from Andrew. Includes UHF, VHF, microwave antennas, coax cables, waveguides, RF switching devices, pressurization equipment, etc. **165**

**Sync generators and accessories**, genlock, color standard, dot-bar generators, automatic changeover switch described in 4-page tech data sheet from Cohu Electronics. **166**

**CATV equipment catalog** from CAS Manufacturing Co. includes specifications on amplifiers, directional line taps, indoor accessories, connectors and fittings, stereo FM and tape head end units, Weather/View system. **173**

**Modulation meter**, wide-range solid-state unit for AM or FM signal measurement, described in short-form catalog from Marconi Instruments. **183**

**CATV cable brochure** from Alpha Wire discusses weather damage and illustrates weather-resistant cable. **153**

**Test accessories**, molded patch cords, cable assemblies, banana plugs, test leads, socket adaptors, etc. 32-page general catalog II 66 from Pomona Electronics. **144**

**CATV bridging amplifier data sheets** from C-Cor Electronics describe features of new Novacor line which includes 12 amplifier models. **175**

**Report form masters** of translucent plastic for use in making up program logs, schedules, etc., described in catalog from Trans-Face Process Co. **196**

**Slide-sound presentations** using Kodak Carousel projection system described in brochure "How to Succeed in the Business of Showing." Discusses use of multiple projectors with synchronized sound. **176**

**Cable support wire clamp** described in data from Ansonia Wire & Cable. The Ankogrip clamp is designed for figure-8 distribution wire. **171**

"**Experimenter**," monthly General Radio publication carries articles of interest to broadcasters, CATV operators. Includes much test equipment application data. **162**

# BM/E

## ADVERTISERS INDEX

Aerovox Corp., Hi-Q Div. ....	60
Altec Lansing Corp. ....	58
Automatic Tape Control ....	70
Belden Mfg. Co. ....	3
Birns and Sawyer Cine Eqmt. ....	66
Blonder Tongue Labs., Inc. ....	12
CBS Laboratories ....	5
Cleveland Electronics, Inc. ....	14
Command Communications ....	76
Craftsman Electronic Products, Inc. ....	44-45, 76
Cummins Engine Co., Inc. ....	63
EIMAC Div. of Varian Assoc. ....	65
Electronics, Missiles, and Com- munications (EMCEE) ....	73
Fairchild Recording Equipment Co. ....	10
Ft. Worth Tower Co. ....	78
Grinnan Fixture Co. ....	70
International Nuclear Corp. ....	57
Jampro Antenna Co. ....	7
Jerrold Electronics Corp. ....	Cover 2
Kaiser-Cox Corp. ....	15
Lenkurt Electric Co., Inc. ....	51
Magnasync Corp. ....	62
Magnecord Sales Dept., Midwestern Instruments, Inc. ....	53
Memorex Corp. ....	19, 20
Microflex Co., Inc. ....	8
Meyer Machine, Inc. ....	70
3M Company Revere Mincom Div. ....	61
Magnetic Products Div. ....	25-28
Moseley Assoc., Inc. ....	66
Raytheon Company, CADPO Div. ....	71
RCA Electronic Components & Devices ....	59
Riker Industries, Inc. ....	Cover 3
Roanwell Corp. ....	74, 75
Sarkes Tarzian, Inc. ....	Cover 4
Shure Bros. Inc. ....	69
Sparta Electronic Corp. ....	49
Spencer-Kennedy Labs., Inc. ....	72
Stainless, Inc. ....	68
Superior Cable Corp. ....	55
Tektronix Inc. ....	67
Times Wire and Cable Corp. ....	41
Transface Process Co. ....	11
Triking of Minneapolis ....	16, 17
Vitro Electronics ....	64
Wilkinson Electronics, Inc. ....	9

### STANCIL-HOFFMAN CORP.

- BROADCAST REFERENCE & LOGGING RECORDER
- 24 Hours Continuous—7" Tape Reel
- From 1 to 4 Separate Channels
- Also 7.5 IPS STEREO & MONO
- For Automated Stations
- 921 N. Highland Ave.,  
Hollywood, Calif. 90038

### GEORGE P. ADAIR ENGINEERING COMPANY

Consulting Telecommunications Engineers  
AM-FM-TV Broadcast CATV Microwave  
Mobile and Fixed Communications Systems  
901-20th St., N.W., Washington, D.C. 20006  
(202) 333-1116 AFCCE Cable: Gaengco



### MALARKEY, TAYLOR & ASSOCIATES

CATV  
Brokers-Consultants-Engineering  
WASHINGTON, D.C.  
1101 17th St., N.W. Area Code 202 223-2345

## CLASSIFIED

Cost of regular Classified Advg. in BM/E is only 15¢ per word, with a minimum charge of \$2.00. Display classified advg. rates are \$17.50 per inch on a one-time basis; \$12.50 on a 12-time schedule. No extra charge for box number. Send all replies to Box No., BM/E, 18 Frederick Rd., Thurmont, Md. 21788.

### POSITIONS WANTED

College student needs \$1,000 for continuation of studies. Engineering experience w/NBC owned and operated; announcing with Cleveland FMer. Available June 13 Third ticket. Write Henry Navin, 9325 Beacon, Cleveland, Ohio.

### HELP WANTED

#### WANTED

Field Engineers to install and test high-power UHF television transmitters. Excellent opportunity with growing organization. Telephone 413-733-2284 or write Townsend Associates, P.O. Box 215, Feeding Hills, Mass.

Michigan daytimer has immediate opening for first phone, engineer announcer. Good salary, paid employee hospital and life insurance, plus many benefits. Reply immediately, giving a complete resume of experience, past employment and past earnings to Robert D. Dittmer, Dittmer Broadcasting, P. O. Box 276, St. Johns, Michigan 48879.

Immediate openings with radio and TV stations in all parts of the country for chief engineers and both transmitter and studio engineers. Send resume today to: Nationwide Radio & TV Employment Agency, 645 North Michigan Avenue, Chicago, Illinois, or call Area Code: 312-337-7075.

Grow with midwest group serving non-metropolitan markets. Openings for Chief-Engineer-Announcer; News Director; and salesman who can merit the client's confidence. Box 5661, c/o BME.

### EQUIPMENT FOR SALE

New and Reconditioned Remote Pickup and 2-way radio equip., Fire and Police Receivers. All brands and models. Sales Manager, Box 738, Phone 817-594-5171, Weatherford, Texas.

Broadcast equipment bought, sold and traded. Ampex, McIntosh, Crown, Gates, etc. Leasing and financing available. F.T.C. Brewer Company, 2400 West Hayes Street, Pensacola, Florida.

5 KW Standard Electronic FM used 3 1/2 years. Also matching stereo generator, both for \$6650.00. WKLS, Atlanta.

Need 5,000 watt AM transmitter . . . good condition only . . . KHIL . . . Willcox, Arizona.

For Sale: 10 kw Westinghouse FM transmitter. A-1 condition—new 7 years ago. \$3,000.00 F.O.B. WSOM, Salem, Ohio.

### INSTRUCTION

"It's REI and Here's Why!" First phone license in (5) weeks—and we guarantee it. Tuition only \$295. Rooms \$6-12 per week. Classes begin every 5 weeks in beautiful Sarasota by the sea, on May 23-June 27—August 1. Call or write Radio Engineering Institute, 1336 Main St., Sarasota, Fla.

F.C.C. First Phone in 6 weeks plus 300 hours theory and practical application. License guaranteed. Free placement service. Florida Institute of Electronics, 3160 Main St., Weirton, W.Va.

## CASEBOOK

(Continued from page 80)

high-school games, the scores are included as soon as they are phoned in, and the part-time student operator also records and dubs to cartridge a beeper report of the progress of the game as well as the final score for use on morning sportscasts. We pay one dollar for each such sports story phoned in, and have one or two students at each local school assigned to this sports reporter's task. They enjoy it. We even accept collect calls when they are on away-from-home games.

Our part-time student staff has enough free time during the evening to do homework and take care of other station chores as well—



Close-up of the message counter (Directory Department Keyed Ad Meter). Husky right angle strap-iron shelf brackets from a local hardware store were used to mount them so the counters were clearly visible.

card files, typing, dubbing spots from tape to cart, etc.

With the message counters showing several thousand calls each week, we were able to sell the service to a large local firm. The message on the automatic phone now includes a 15-second commercial as well as our "KRCB Weatherphone" identification, and the project is more than self-supporting. The sponsor also includes a card advertisement about the service in all his billing, which of course is valuable additional exposure for the station. And it is indeed a real, honest service to the community. ●

Announcing, programming, first phone, all phases electronics. Thorough, intensive practical training. Methods and results proved many times. Free placement service. Allied Technical Schools, 207 Madison, Memphis, Tennessee.

Professional School of Radio and Television broadcasting. Classes taught by working professionals from major stations. Write E.I.T., 2457 Woodward Avenue, Detroit, Michigan 48201.

## 'Round-the-Clock "Weather-Phone"

by E. Mitchell Shulman

A community service  
that can be profitable

THE door to financial success for any radio station, small or large, major market or isolated town, is community acceptance. A station which makes a sincere effort to serve the community will soon become one of the necessities of life and business.

One of the keys to this door is offering services of real benefit to the individual people of the community, services obtainable only from their own local radio station.

At KRCB it occurred to us that, even though we broadcast a complete weather summary every 20 minutes, there were still many persons who were not getting weather information when they

wanted it. Further, as a daytimer, we had no service to offer after sunset to keep ourselves fixed in our listeners' minds. We finally hit upon the idea of using automatic answering telephones. Since our plan would also require additional help, we decided to hire a couple of local college students willing to work evenings.

We learned that Bell Telephone made available an automatic telephone answering set (Western Electric KS 16765,LI), on which the subscriber can record any message up to two minutes in length, and can change the message as often as he wishes. Also available on special order is a counting device (Directory De-

partment Keyed Ad Meter), which will show the total number of calls received and answered by the automatic answering set.

The installation as pictured was installed in a corridor leading into our newsroom. Every hour during the day from sign-on to sign-off, the announcer or newsmen on duty records the weather forecast, the latest temperature, and a news headline on both phones. After sign-off, one of the student staff continues the same service until midnight, seven days a week. From midnight to dawn, the 12 o'clock recording is of course still available to the public. In bad weather we include road conditions, obtained from the State Highway Patrol. The local police force supports this service ardently—it has cut telephone calls requesting road conditions from a flood to a trickle.

On evenings when there are local sporting events, including

*Continued on page 79*

Close-up of the operating position of the "weather-phone." The left and right push-button boxes control the recording or automatic answering function of their respective sets. The center push buttons connect the wall telephone to either answering set. The key switch to the right of the phone is used to "busy out" an answering set while recording a new message. When one set is busy, calls are automatically transferred to the other set. Without this "busy key," a caller will hear the ring but get no answer while a message is being recorded.

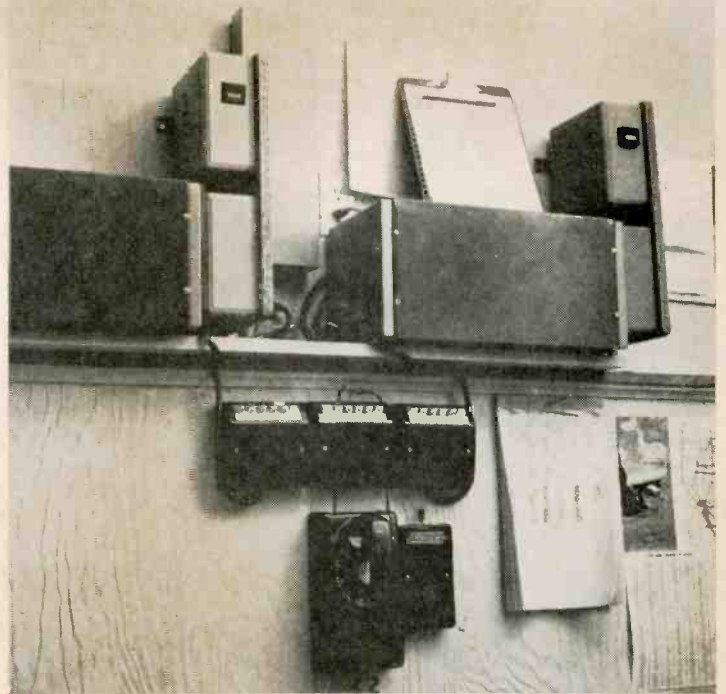

The complete KRCB 'weather-phone' installation. Two automatic answering sets, two message counters, one wall phone with a push button to connect it to either answering set for recording, and a key switch to "busy out" the line while recordings are made.

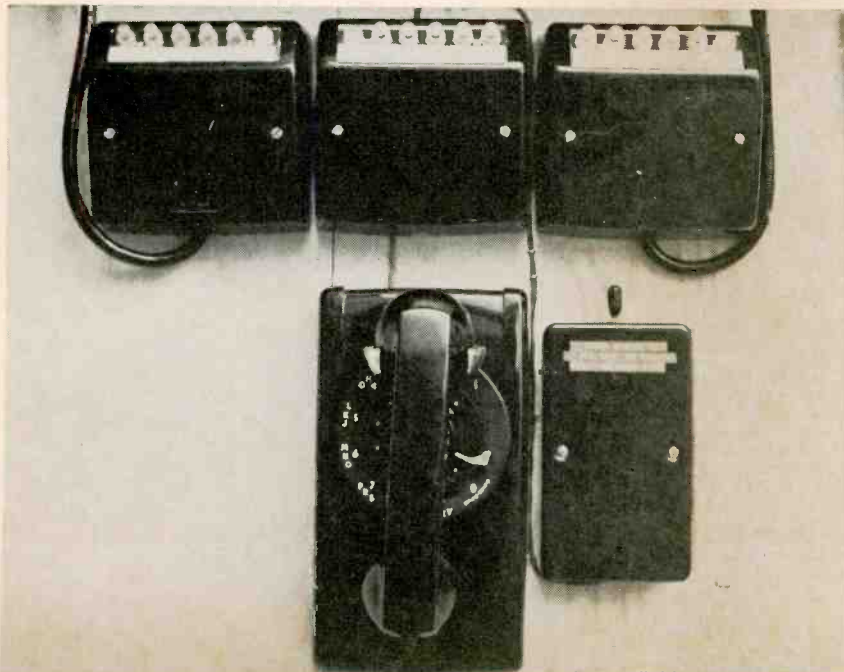

# INTRODUCING THE RIKER "NEWLINE" SYNC GENERATOR

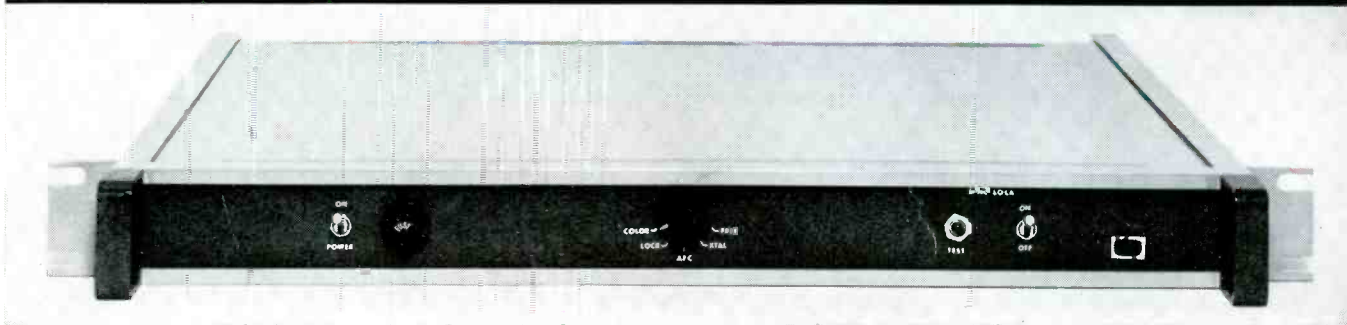

## ...THE START OF THE REVOLUTION

4 years ago Riker Industries started a revolution in Sync Generators. Today, Riker Sync Generators—the acknowledged leader—are in use by all major networks, prominent TV stations and leading television centers. Riker is first again with the "NEWLINE" series... ideally suited for all television facilities with the same high quality of all Riker Sync Generators.

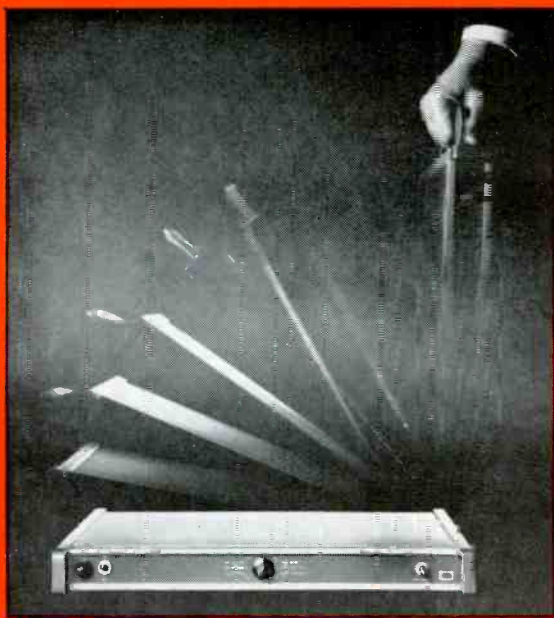

### ...ALSO IN THE "NEWLINE" PACKAGE THE "NEWLINE" VIDEO TEST SET

**FEATURES:** multiburst • sin<sup>2</sup> window (T and 2T) • stair-step or modulated or modulated, internally or externally • front panel comp/nor comp switch • internally or externally driven • rack mounting or instantly portable • highest quality silicon transistor circuits.

Model # **6601** Video Test Set: **\$1990**

### MODEL 6620 "NEWLINE" SYNC GENERATOR

#### FEATURES

All Transistor • Built-In Sync Lock  
Compact 1 3/4" Rack Space • Ultimate Stability  
Built-In Power Supply • EIA Sync  
Self-Contained Power Supply

#### DESCRIPTION

The 6620 "NEWLINE" Sync Generator is housed in a 1 3/4" enclosed dust-proof frame suitable for rack mounting or portable use. All circuitry is mounted on a 1/8" glass epoxy printed circuit board. A front panel mode switch offers selection of: Crystal, Free Running, AFC, or Sync Lock. The master oscillator circuitry is designed for ultimate timing accuracy. Sync Lock circuitry will lock the master oscillator in phase to an external composite video signal. Multivibrators generate all required pulses. Each pulse is regenerated for accurate control of rise times.

#### SPECIFICATIONS

Pulse Widths ..... All Set to EIA Specifications  
Rise Times ..... .10 to .15 Microseconds  
Overshoot or Tilt ..... Less than 1% All Pulses  
Sync Lock Input ..... .5 to 2V Video or 2 to 8V Sync

Send for information

Model # **6620**

Price: **\$1,990**

RIKER VIDEO INDUSTRIES, INC.



...thinking always of tomorrow

Order Lane, Huntington Station, New York Phone 516 HA 1-3444 Atlanta Los Angeles, Detroit, Washington, D.C.

Circle 3 on Reader Service Card

"Hear me out. I'm the New Uher 4000-S.  
the greatest little professional tape recorder in the whole wide  
world. There is no end to my versatility. I have traveled  
everywhere...from the top of Mt. Everest to the bottomless pits  
of Africa (take me anywhere, I weigh less than 9 lbs.).  
Here is just a resume of my most important features:  
(I hope I'm not going too fast for you).

**RANGERTONE:** exclusive accessory for lip synchronization for  
professional and home movies. **AKUSTOMAT:** (a tape saver)  
You simply speak and I record. You stop speaking I stop.  
(quite intelligent.) **DIA-PILOT:** Impulse transmitter  
for fully automatic control of slide projectors and  
animated displays. Fully transistorized, four speeds (15/16, 1 7/8,  
3 3/4, 7 1/2) Records up to 8 1/2 hours on 5" reel. Piano keyboard  
for rewind, start/playback, pause stop, record and fast forward.  
Built-in battery "pak" or AC powered. Large illuminated VU meter.  
My references: Well ask any professional radio or TV commentator,  
reporter, engineer or anthropologist. Thank you for your time.  
Additional information furnished upon request or see your  
dealer for a full demonstration.  
Sound begins and ends with a Uher\* Tape Recorder."

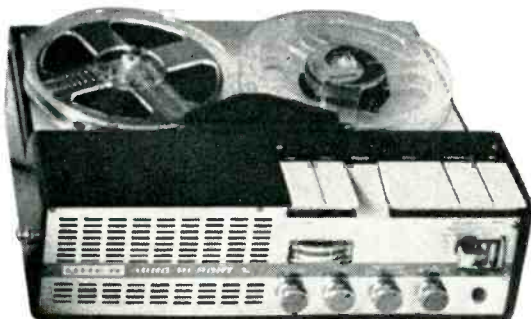

**101, martel**  
MARTEL ELECTRONICS

(\*PRONOUNCED U-ER)

LOS ANGELES: 2356 SOUTH COTNER, NEW YORK CITY: 1199 BROADWAY, CHICAGO: 5445 NORTH LINCOLN AVENUE

Circle Item 19 on Tech Data Card

## RUSSCO BROADCAST Turntables

**Separate Tone Arm  
mounting plate for  
easy installation**

- Single lever controls  
33, 45, 78 speeds
- Plays 45 RPM's  
without adapter
- Illuminated speed  
indicators
- Sold with or without  
arm (GREY or REK-O-KUT)
- Instant acceleration
- Heavy duty—  
professional quality
- Competitive low price
- Call or write for folder

**Unconditionally  
Guaranteed**  
—against defects in  
material or work-  
manship when given  
normal maintenance

**SOLD DIRECT  
—OR TO  
DEALERS**

**RUSSCO Electronics Mfg.**  
6879 N. SUNNYSIDE, CLOVIS, CALIF.  
PH. 299-4692

Circle Item 20 on Tech Data Card

## CUSTOM SPECIALISTS TO BROADCASTERS

Broadcasting is your  
business . . .

Serving you is our  
business . . .

- Equipment Sales
- Custom Fabrication
- Installation Supervision
- 24-hour Parts Service
- Complete Test Facilities

Think first of WE for com-  
plete, reliable broadcasting  
equipment and service.

**Wilkinson Electronics, Inc.**  
1937 W. MacDade Blvd.  
Woodlyn, Pa. 19094  
Telephone: 215-874-5237

Circle Item 21 on Tech Data Card

zontal-blanking and driving multi-  
vibrators is obtained directly from  
the 15,750-cps signal, but the trig-  
ger for the horizontal-synchronizing  
multivibrator is delayed .025H by  
a second delay line.

The vertical-drive multivibrator  
is triggered directly from the 60-cps  
input signal, and the vertical-  
blanking and the 9H triggers are  
obtained from the output of the  
vertical-drive multivibrator. The  
10,500-cps input triggers a chain  
of two bistable multivibrators (de-  
signed No. 1 and No. 2 in Fig.  
2), which reduces the repetition rate  
to 2625 cps. The output of the sec-  
ond bistable multivibrator is a sym-  
metrical square wave occurring  
2625 times per second with both  
signal polarities present. The 9H  
signal and the 2625-cps symmetri-  
cal square waves are used to gen-  
erate the composite synchronizing  
signal.

Since 2625 cps is not divisible  
by 60 cps, each bistable multivi-  
brator must be reset by one of the  
60-cps signals. The trailing edge of  
the vertical-drive pulse is used to  
accomplish this triggering.

### Pulse Shaper and Outputs

The pulse-shaper unit combines  
the pulses formed in the pulse-  
former unit to obtain the four out-  
put waveforms required. Horizont-  
al- and vertical-drive waveforms  
are acceptable directly from their  
respective multivibrators, so direct  
connection between the pulse-  
former unit and the output circuits  
is used. The synchronizing and  
blanking signals are composite  
waveforms which require the addi-  
tion of several previously formed  
pulse trains. Fig. 3 shows how the  
signals present at the input of each  
OR circuit in the pulse-shaper are  
added to obtain the two composite  
signals.

Identical output circuits are used  
to amplify the four output wave-  
forms for application to 75-ohm  
loads. Each output stage consists of  
two inverter amplifiers and an  
emitter-follower output circuit.

The overall electrical design and  
operation of the synchronizing gen-  
erator have been described. Next  
month, the specific circuits used  
will be described, and construction  
considerations will be discussed. ▲



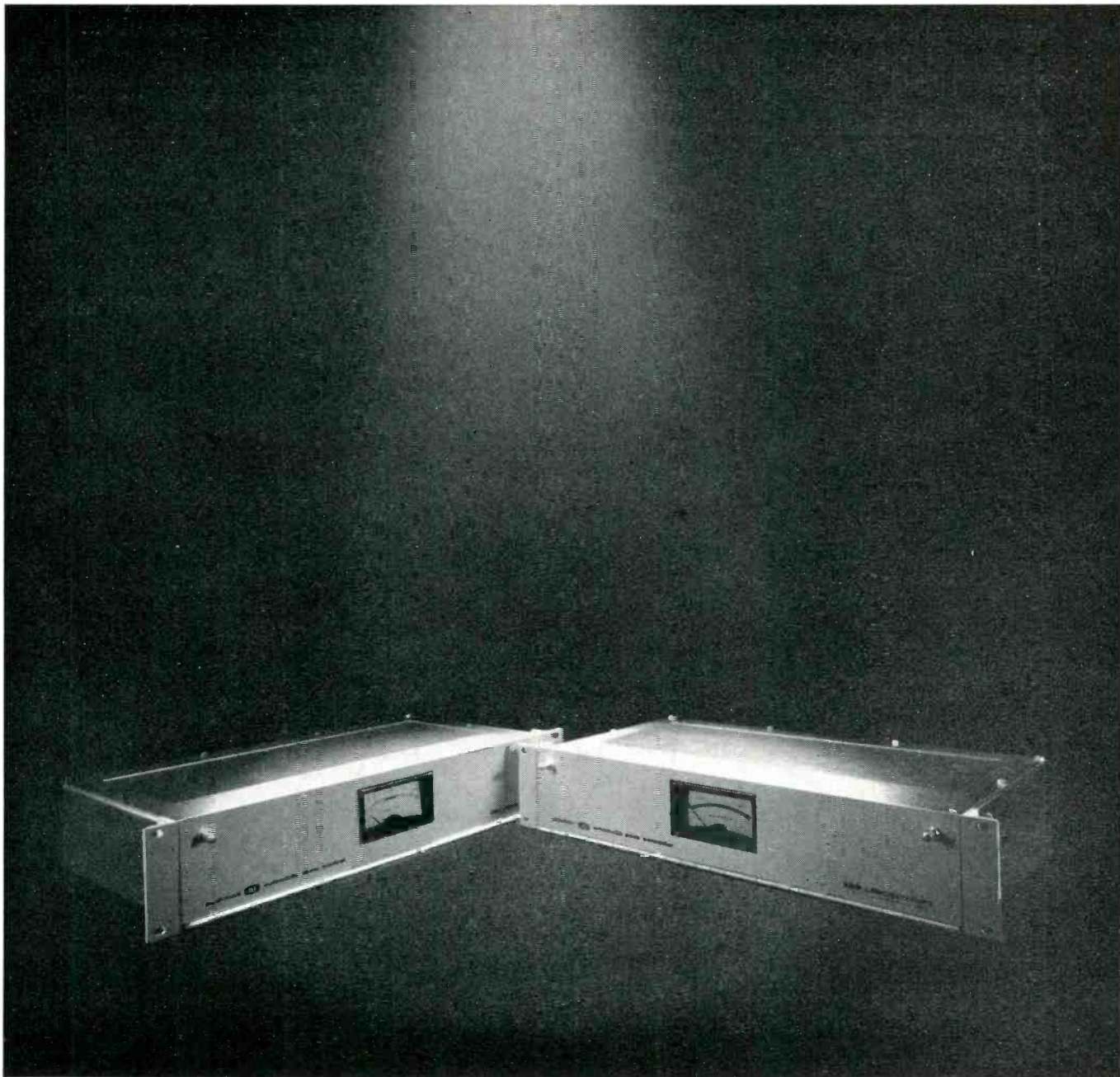

**See the Max Brothers increase your program power up to 8-fold!**  
 (That's the new solid state Audimax on the left... and the Volumax on the right)

Hear this unique combo perform free in your studio for 30 days! Now CBS Laboratories gives you the famous Max Brothers (Audimax and Volumax) both solid state for the first time. They'll perform free in your studio for 30 days. Then, if you're not convinced that solid state Audimax can "ride" gain to increase program power up to 4-1, and solid state Volumax can control modulation peaks for as much as an additional 2-1 increase, you can cancel the Max Brothers, with no obligation.

See why the Max Brothers are broadcasting's new money-making stars! Audimax is an automatic level controller that outmodes the ordinary AGC. A brilliant studio technician without human shortcomings. By automatically controlling audio levels, it frees engineers, cuts costs and boosts your signal. Volumax has a few specialties of its own. It outmodes conventional peak limiters by controlling peaks automatically without side effects. By expanding effective range and im-

proving reception in fringe areas, it brings in extra advertising revenues. Call or write CBS Laboratories for a bulletin with complete details on Audimax and Volumax. REMEMBER! Together, the Max Brothers can increase your program power up to 8-fold. Decrease operating costs. Bring in more advertising. For just \$665 each. Can you afford *not* to ask for a FREE 30-day trial?

**CBS LABORATORIES**  
 Stamford, Connecticut. A Division of  
 Columbia Broadcasting System, Inc.

Circle Item 22 on Tech Data Card

# TELEVISION IN AMERICAN SAMOA

by **H. Eugene Larson**, Consulting Author, Engineer, KVZK, Pago Pago, American Samoa — Television forms the basis of the modern educational system in this American territory.

American Samoa is an unincorporated territory of the United States administered by the Department of the Interior. It is comprised of the eastern islands of the Samoan group, which is located in the Pacific Ocean approximately 2,000 miles southwest of Hawaii and 1,600 miles northeast of the northern tip of New Zealand. There are seven islands in the American Samoan group. The administrative offices are near Pago Pago Harbor on the island of Tutuila.

The present Governor, H. Rex Lee, decided to improve an archaic Samoan educational system by making extensive use of instructional television. The U. S. Congress approved funds for this TV system in 1963. The project included the construction of a TV center which houses the studios, control areas, offices, a library for the lesson

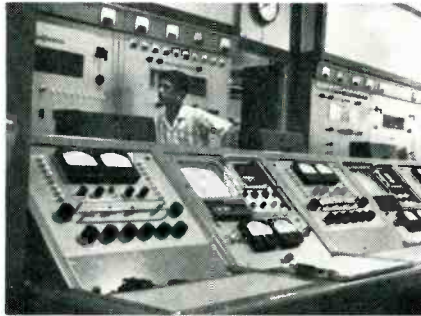

Fig. 1. View of transmitter control room.

preparation, a shop for set construction, graphics areas, and photographic dark rooms. Also included are a mountaintop transmitter and new consolidated school buildings designed for television teaching.

As the system now operates, three levels of instruction are prepared in the studio building. The lessons are either recorded on TV tape for later release or are relayed by microwave to the transmitter on

Mount Alava. Three transmitters (see Fig. 1), operating on channels 2, 4, and 5, broadcast the material to consolidated school sites on the American Samoan islands of Tutuila, Aunu'u, Ta'u, Olosega, and Of'u. Islands in the Western Samoa group also receive the signals.

## TV Studio Building

The TV building in the village of Utulei contains four studios located around a ground-floor central control area (Fig. 2). Each studio has a control room (Fig. 3) equipped with video monitors, a video switcher, remote controls for film and slide projectors (Fig. 4), and an audio console. Located in master control are synchronizing generators, control units, channel amplifiers and power supplies for six image-orthicon cameras, and four vidicon film and slide cameras. A 16-mm film projector and a dual-drum slide projector are multiplexed into each vidicon film camera. Three microwave transmitters are used to relay the pictures and sound to the transmitter site on Mount Alava. Four television tape machines are used to record and play back the TV lessons. All switchers are rack-mounted relay types with vertical-interval switching used in the output lines. Tally-light con-

• Please turn to page 45

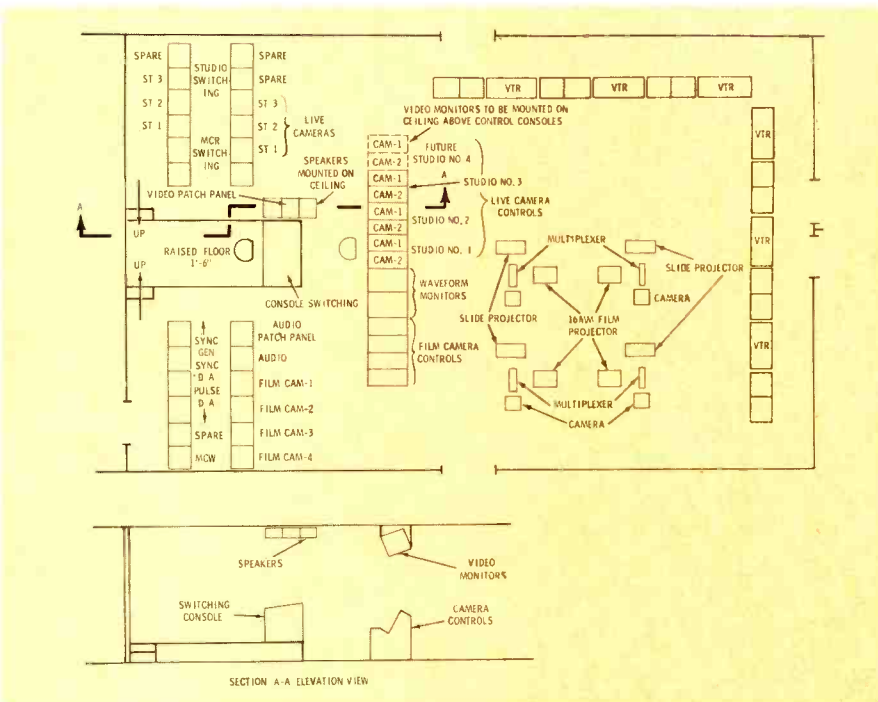

Fig. 2. The station studios are arranged around this ground-floor central control area.



Fig. 3. Video and audio master control.

# WHEN KOSS & REK-O-KUT PLEDGE THEMSELVES TO QUALITY, HERE'S WHAT THEY MEAN

When John C. Koss purchased control of Rek-O-Kut, he discussed "quality" with Sid Simonson (Rek-O-Kut Manufacturing Vice-President) and Hal Dennis (Rek-O-Kut Sales Vice President). "There's a reason why everyone thinks of Rek-O-Kut as the very finest in single-play turntables. There's a reason why every audio engineer in the business knows and respects Rek-O-Kut equipment," said Koss.

"The reason," Simonson explained, "is that for over 25 years, we paid particular attention to purchase of parts and raw materials. Then we tooled for absolute precision in machining and assembly. If something wasn't perfect, we scrapped it!"

"Good," said Koss, "that's what I do with our headphones and that's what I want continued with our turntables." And that's what is now being done at the Milwaukee plant.



**KOSS PRO-4 STEREOPHONES**

**\$45.00**

Truly a professional instrument. Frequency response: 30-20,000 cps. Impedance: 50 ohms to be used with 4, 8, or 16 ohm outputs. Fluid-filled ear cushions for positive seal and comfort over long listening periods. Highest quality drivers mounted in acoustically designed chambers provide unusually smooth frequency response. Equipped for boom mike attachment.



**REK-O-KUT B-12H TURNTABLE**

**\$165.00**

Three speed. Noise level: -59 db below average recording level. Wow and flutter: 0.085% RMS. Custom-built, heavy duty Hysteresis Synchronous motor for constant speed and "hush" performance. On-off signal indicator.

Write for complete details and specifications on all Koss and Rek-O-Kut products.

**KOSS**

**REK-O-KUT**

2227 N. 31ST STREET • MILWAUKEE 8, WIS.

Circle Item 23 on Tech Data Card

JAMPRO

DUAL POLARIZED FM ANTENNA WILL

# INCREASE YOUR SIGNAL!

Now you can achieve RF radiation the EASY, PRACTICAL WAY! The new JAMPRO dual polarized FM antenna will increase your signal many times to establish new listeners in hilly areas, give you more signal to home radios using built-in antennas and car FM sets. Contact JAMPRO today for a dual polarized system especially suited to your ERP requirements.

## CONVERT YOUR EXISTING ANTENNA

A new, low cost Dual Polarized Conversion Kit is now available from JAMPRO. Complete with power divider, vertical elements, and instructions for field installation, you can convert your present FM antenna into a dual polarized system. Contact JAMPRO for details.

Contact JAMPRO for newly developed technical information regarding Dual Polarized antenna measurements and performances.

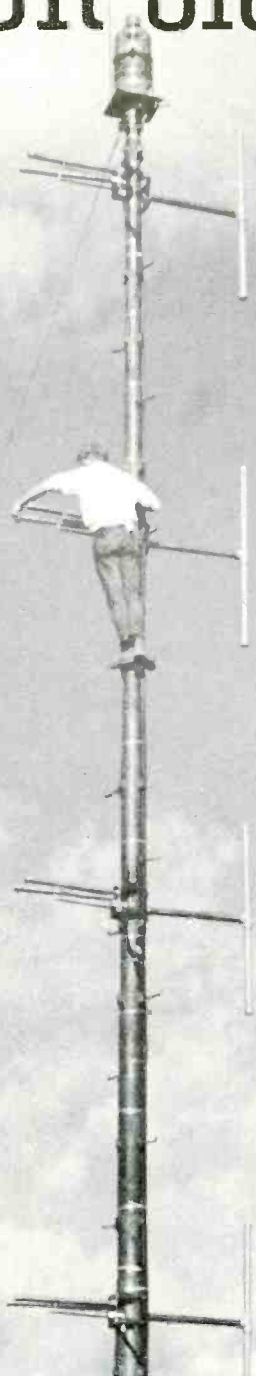

JAMPRO

ANTENNA  
6939 POWER INN ROAD

COMPANY  
SACRAMENTO, CALIFORNIA

PHONE:  
AREA CODE 916  
442-1177

## TV In Samoa

(Continued from page 42)

tacts in the output-line switcher control an audio-follows-video switcher, which is located in the audio rack along with audio output line AGC amplifiers. AC wiring travels through trenches in the floor. DC-control, video, and audio cables are located in overhead cable trays.

### Transmitter

Before the transmitter building was completed, construction was started on a mile-long aerial cable tramway running between a lower terminal on Mauga'o'ali'i Ridge near the studio building and the transmitter site on Mount Alava. This tramway system was used to carry the transmitters and the antenna to the mountain site. It now provides the transmitter operators with a scenic commuting ride across Pago Pago Harbor. Tourists also make the aerial tramway trip a part of their island sight-seeing.

Space is provided in the transmitter building for six transmitters; three are installed and in use. The

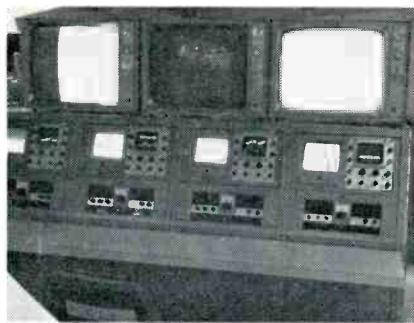

Fig. 4. Camera control units and monitors.

building contains living quarters, storage and shop space. Culinary water for use in the building is collected on the roof and stored in a redwood tank. The antenna system consists of a 4-bay batwing for channels 4 and 5 above a 4-bay channel-2 antenna. The antennas are mounted on the top of a 100' self-supporting tower. The diplexer for combining channels 4 and 5 is located in the bay behind the transmitters.

### Schools

Classroom buildings were constructed in the manner of the traditional Samoan fale (an oval perimeter of posts with a thatched roof). However, concrete posts and redwood shingles were used instead of log posts and thatch. When the project is completed, there will be 26 consolidated elementary schools in operation. Students in levels one and two sit on mats on the floor while viewing their lessons on 21" TV receivers. Students in higher levels use conventional desks. External audio amplifiers and speakers are used to overcome the high ambient noise levels found in some locations. Conduits are provided for the RF distribution cables, and some schools are equipped with an RF distribution amplifier to overcome splitter and tap-off losses. De-snowers are used at difficult receiving locations.

### Conclusion

The Samoan TV system is attracting considerable attention from all over the world. The system is unique because all of the elementary school instruction is done through television; most mainland systems use television for enrichment or partial teaching. This installation will probably be the model for many other instructional television systems. ▲

## Automatic Broadcasting as easy as

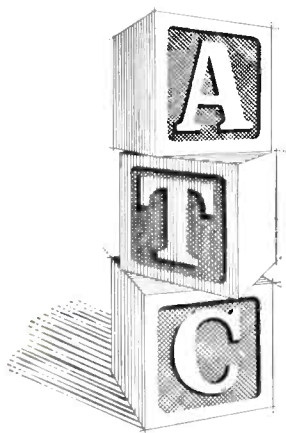

Send for FREE 35-pg. booklet "Planning for Automated Broadcasting." Or call collect today 309-829-1228.

**AUTOMATIC**  **TAPE CONTROL**

1107 E. Croxton Ave. Bloomington, Ill.

Circle Item 26 on Tech Data Card

April, 1965

## NORTRONICS DOES IT AGAIN!

Ever since cartridge machines were first introduced into broadcasting, the process of replacing worn, rear-mount heads has been both expensive and time consuming. **NO LONGER!**

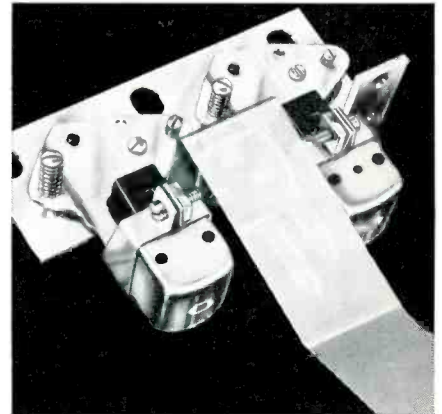

Nortronics, as part of their constant effort to increase quality and ease of operation through advanced research and development, have pioneered a revolutionary, new method... a Quik-Kit assembly which accommodates no-mount heads in your cartridge equipment. What's more, now you can replace worn heads with genuine Nortronics laminated core, hyperbolic, all-metal face no-mount heads!

These unique Quik-Kits are semi-aligned and completely assembled; micrometer adjustments for height, azimuth and face alignment as well as a special lock screw to "freeze" adjustments, are provided.

Write for Form No. 7208 today! It gives complete information about converting your cartridge machines to no-mount heads, and which Nortronics heads to use.

  
**Nortronics**

8143 Tenth Ave. N., Minneapolis, Minn. 55427

Circle Item 25 on Tech Data Card



## Improve your image the proven way

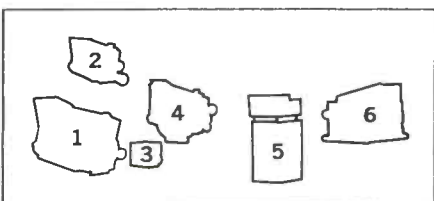

From G.E.'s complete line you will find the camera that will add just the right snap to both your station image and your viewers' reception. G-E camera

systems are the finest...the result of pioneering research in solid-state circuitry that has led to increased reliability, optimum performance and greater economy. G-E camera systems are user proven...in station after station where G-E equipment is now building better images...creating better pictures.

**1. PE-23—First Professional Transistorized Studio Vidicon Camera.** Proven by more than two years of network

use. Ideally suited for news, panel and quiz shows, as well as educational programming. Soon to be available with advanced lead-oxide pickup tubes.

**2. PE-26—Television's Newest, Portable, All Transistorized 3" I.O. Studio System.** Best 3" I.O. picture you ever saw—in a smaller, lighter package. Completely transistorized. Perfect for remote applications.



Studio location courtesy WSYR-TV, Syracuse, N. Y.

## with General Electric 1965 Cameras.

**3. PE-27—Advanced Transistorized Version of Television's Most Widely Accepted Film Camera.** Best response, lowest noise, least lag from a 1" separate mesh vidicon tube. Transistorized. Designed for hands-off operation.

**4. PE-29—The Aristocrat Of All Monochrome Cameras.** Designed to give finest picture quality for exacting studio productions and video tapings. Owners agree. Side by side comparisons prove it.

**5. PE-24—First 4-Vidicon Universal Film Camera.** Now programming finest quality color and monochrome film for 26 local stations and the ABC-TV Network.

**6. PE-25—Television's Most Advanced 3-I.O. Studio Color Camera.** Unmatched stability and excellent color registration. Extensively transistorized. Consistently sharp, true and clear pictures.

For all your camera requirements, contact your G-E Broadcast Equipment Representative, or, General Electric Company, Visual Communications Products, Building 7-315, Electronics Park, Syracuse, N. Y. 13201. GE-12

Visual Communications Products,  
**GENERAL ELECTRIC**  
 Electronics Park, Syracuse, N. Y.

# DIRECTIONAL ANTENNA STABILITY

by **J. Gordon Elder**, Consulting Author, Consulting Engineer, King City, Ontario, Canada — A review of some of the causes of array instability and some of the possible remedies.

Many aspects of AM array design, installation, and adjustment have already been considered in recent issues of this magazine. The discussion that follows concerns array stability and design methods for its improvement. This subject has become quite important in recent years, especially since satisfactory stability is a prerequisite for remote-control authorization. In addition, due to the increased occupancy of the band, the suppression of radiation toward other stations often requires a highly directional pattern and a multi-tower array.

## Stability Factors

Assume that the preliminary design has yielded a theoretical pattern that meets all protection requirements. Whether or not these can be achieved and maintained in practice depends on several factors, including tower height and spacing; site and surroundings; ground sys-

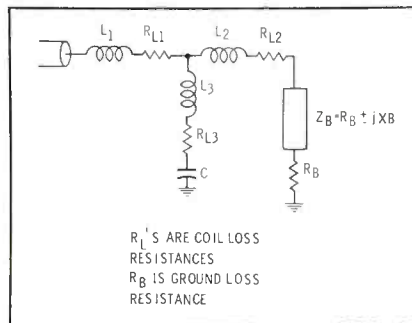

**Fig. 1. Equivalent circuit of a tower and its tuning unit shows loss resistances.**

tem; tuning, phasing, and power-division system; and monitoring system.

## Array Design

First consider the tower itself. An antenna may correctly be regarded as an impedance transformer which matches its own driving-point impedance to the characteristic impedance ( $Z_0$ ) of free space. In broadcast arrays, the base operating impedance may be a few ohms to a few hundred ohms. The value depends on tower height and spacing and the driving currents (Table 1). The impedance of free space is a constant 340 ohms.

Based on the preliminary pattern calculations, both a tentative site and tower height may be selected. Driving-point impedances can be calculated for use in estimating the efficiency and stability of the array. There are various ways of assessing array stability. One method assumes small phase shifts and current changes on each tower, for example,  $\pm 2^\circ$  and  $\pm 2\%$ . Alternatively, if there is a critical (low-resistance) tower in the array, the maximum permissible variations in the magnitude and phase of its current may be calculated.

If protection requirements require a front-to-back or front-to-side ratio of more than 20:1 (26 db), it is usually found that the permissible current variations are quite small; they may be less than  $\pm 1\%$  and  $\pm 1^\circ$  per tower in a critical array. Small errors such as these can easily occur due to seasonal temperature changes, variations in moisture content of the ground, and gradual changes in the system. Therefore, considerable care is required during design, construction, and routine maintenance to ensure that adequate stability is achieved and maintained. Based on protection requirements, the stability analysis, planned precautions and experience, the consulting engineer assigns a maximum expected operating value (MEOV) of radiated field in protected directions.

## Resistance Variations

A principal source of instability is changes in the loss resistance of the ground system (Fig. 1). For design calculations, the loss is often assumed to be two ohms per tower, but the actual value may average from less than one ohm to several ohms, depending on the type of soil and the size and condition of the ground system. Losses can be reduced by: (1) use of a large ground system (at least 120 radials of .4 wavelength average per tower), (2) a large sheet of copper mesh laid at each tower base with little or no soil over it (to reduce dielectric losses) and all radials soldered to it, (3) wire fences and other conductors kept well clear of the towers, and (4) a site that is free from vegetation.

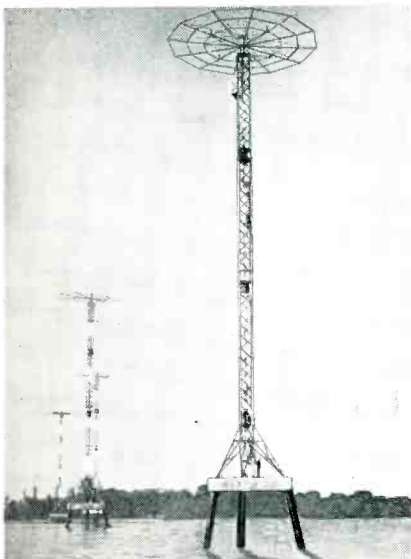

**Array of 150' top-loaded self-supporting towers in Lake Ontario for station CKEY.**



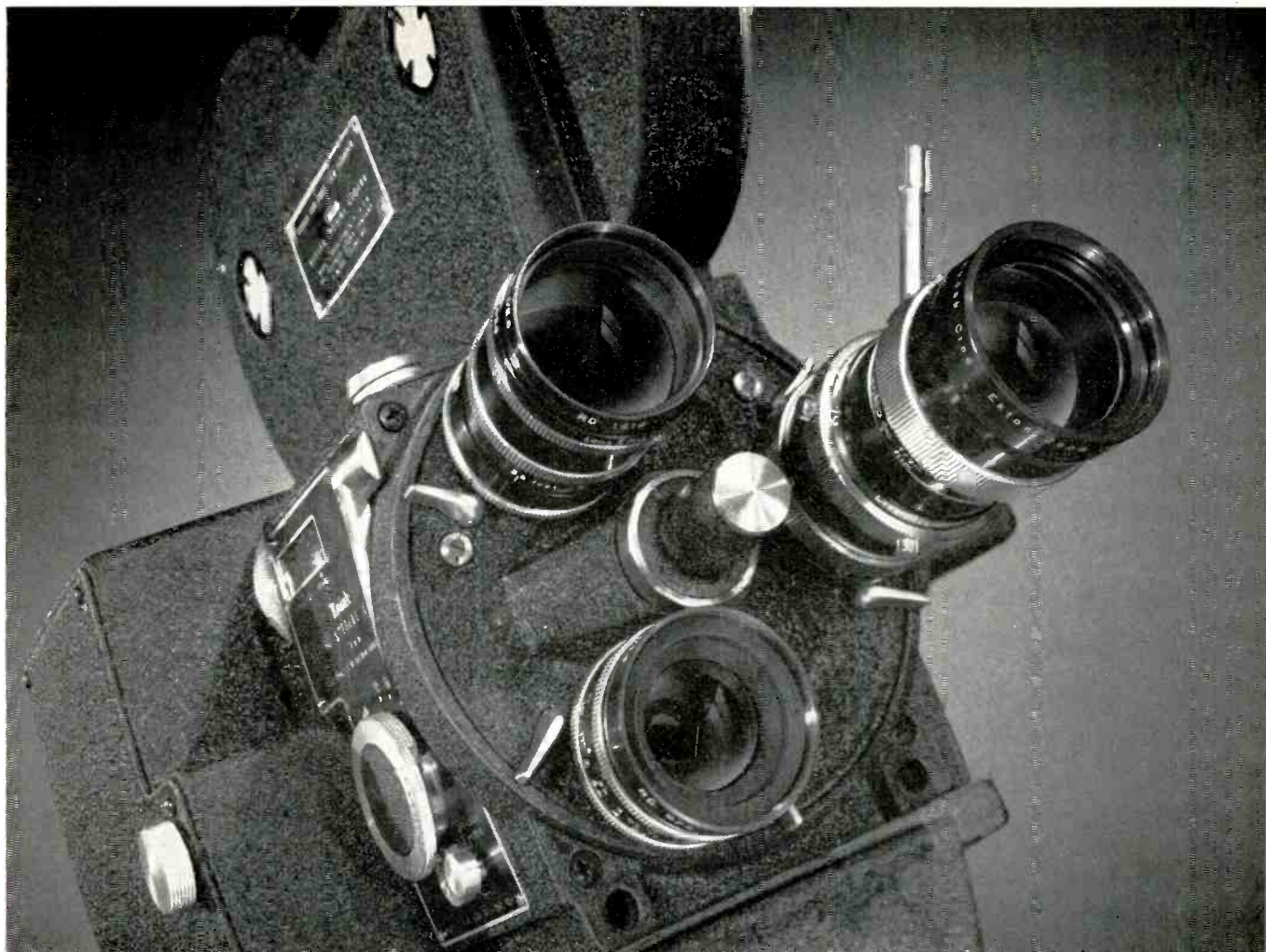

Looking for the camera that's versatile and trouble-free, the one designed to meet all your station's needs? Meet the

## KODAK Reflex Special Camera

With the KODAK Reflex Special Camera and its accessories you have a complete 16mm motion picture system, both sound and silent. The camera provides the most accurate reflex viewing and is ruggedly engineered for continuous day-to-day performance in the field and in the studio. But most important, the camera's optical and film-transport systems assure recorded images unmatched in sharp-

ness and steadiness. Here are some of the quality features contributing to its versatility:

1. Variable shutter permits exposure and depth-of-field control in addition to that provided by lens diaphragm. This feature is particularly valuable when shooting news events in low-light conditions.
2. Ground-glass reticule shows exact scene which reaches film, provides accuracy as

great as any camera-rackover system but with the speed and convenience of reflex viewing.

3. Adjustable eyepiece can be locked into position. Normal 10X magnification can be increased to 20X for precision focusing—assuring extreme sharpness in the projected image.

4. Three-lens turret provides flexibility to meet any situation. Type R lens mounts and positive-action turret afford great accuracy and speed of lens change.

5. Nine KODAK EKTON Lenses have been developed for this camera, ranging in focal length from 10mm to 150mm, including a new *f*/2.2

zoom lens with variable focus from 17.5 to 70mm. These superb optics yield images of extraordinary resolution.

6. Single-system sound-recording accessory provides the portability and dependability necessary for news reporting and features maintenance-free transistorized amplifier.

**The KODAK Reflex Special Camera is part of a rapid-access 16mm TV film system that takes you from "on the spot" to "on the screen" in minutes. It includes camera, pre-stripped films, processor and projector. For a brochure with complete details, write to:**

**Motion Picture and Education Markets Division EASTMAN KODAK COMPANY** Rochester, N. Y. 14650

or the regional sales offices: New York, Chicago, Hollywood

Circle Item 28 on Tech Data Card

# THIS IS SOLID-STATE. THIS IS NOT...



Everyone knows that solid-state is as *modern as tomorrow* . . . and vacuum tubes are as *dated as the horse and buggy era*. The day a tube-type CATV system is fired up, it is obsolete, antiquated, out-moded. ■ And everyone also knows that Ameco is the CATV manufacturer who *pioneered and originated* the solid-state concept in cable television equipment. While competition scoffed and said it couldn't be done . . . Ameco's Research and Development Department went ahead and did it! ■ Now the others are attempting to go solid-state in a desperate effort to catch up with Ameco's three year lead. ■ So if your company is considering CATV . . . solid-state Ameco is the one to consider. Might just as well go with the *recognized leader* in the cable television field . . . Ameco. You'll be glad you did.



P. O. Box 11326  
PHOENIX, ARIZONA 85017  
TELE: 602-252-6041

**AMECO QUALITY...  
THE ENVY OF CATV**

Circle Item 29 on Tech Data Card

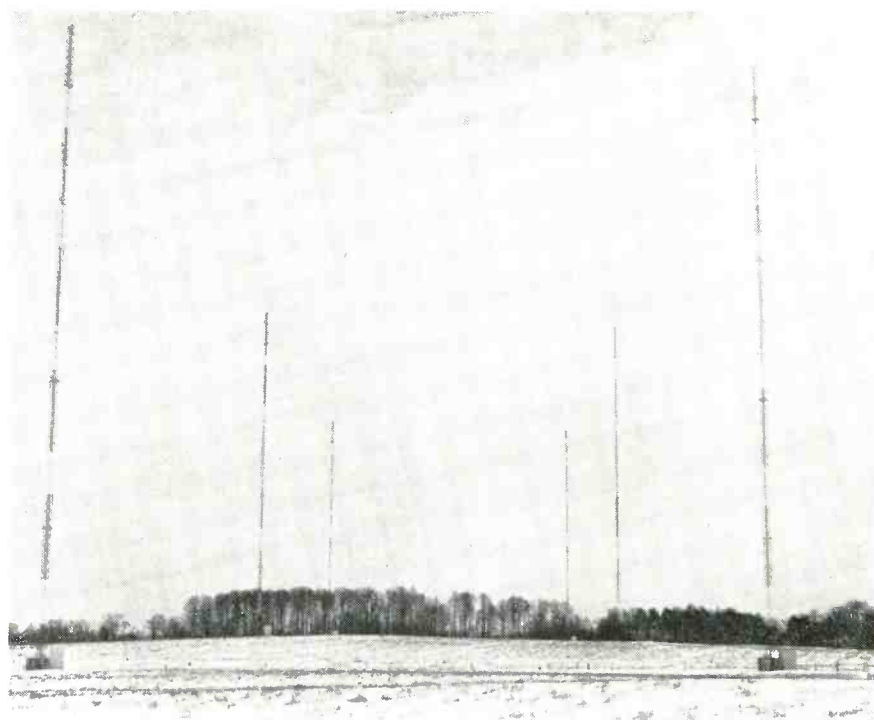

This wide-spaced six-tower parallelogram directional array is used at station CHIC.

The effect of variations in ground losses can be reduced by using tall towers and wide-spaced arrays to raise the driving point or operating resistances. For example, assume that the loss resistance increases by .25 ohm. If the tower involved has an operating resistance of 50 ohms—which is about equal to that of a single 90° tower—the increase is only .5%. If a —90° section is used for matching, the tower current would fall by about 1% and its phase would lead by .3°. On the other hand, if the tower is almost parasitic and has an operating resistance of only 1 ohm, the increase is 25%. This would probably cause excessive changes in the phase-monitor readings for that tower and excessive pattern distortion.

A slight change in tower reactance may be caused by guy wire icing, or broken or dirty insulators.

The effect is similar to that of a resistance change, inversely proportional to the operating resistance.

For these reasons (among others) parasitic towers are disfavored. If the use of such a tower is unavoidable, a fixed resistor may be built into the matching section to increase and stabilize losses. Similarly, short towers and close-spaced arrays should be avoided whenever possible.

The above example illustrates the improved stability resulting from higher operating resistance and taller towers. In addition, increased tower height helps to raise the horizontal radiation efficiency of the array. Otherwise, this may be less than the minimum required for the station. Large highly directive arrays can also be adjusted more quickly during the initial proof if driving-point impedances are mainly resistive and approximately equal to

Table 1. Factors Determining Base Impedance

PARAMETERS	DERIVED FROM	DETERMINE
Self impedance $Z_S$	tower height & diameter	Base operating impedance $Z_B$ $(R_B \pm j X_B)$
Mutual impedance $Z_M$	$Z_S$ and spacing	
Base current ratio & phase	pattern shape	

# How does this 7 FOOT MONSTER help solve your sound problems?

 The giant microphone shown here is the biggest microphone in captivity! The Model 643 is also the most directional microphone sold today. It helped E-V win the first Academy Award for microphone design in 22 years.

But beyond this, the 643 has been one of our most effective field research tools, offering a far-reaching insight into the nature of directional microphones, and their applications.

An obvious result of 643 research is our unique Model 642. Same E-V Cardiline™ principle\*, but only 18 inches long. It reaches up to twice as far as any other broadcast unidirectional microphone to give you better long distance pickups than were dreamed possible a few years ago.

And this same basic research stimulated the development of our new Model 668 cardioid microphone. It uses the Continuously Variable-D® cardioid principle (a creative development from our exclusive Variable-D patent\*) to provide smoother cardioid action—plus more versatility—than any other boom microphone you can use.

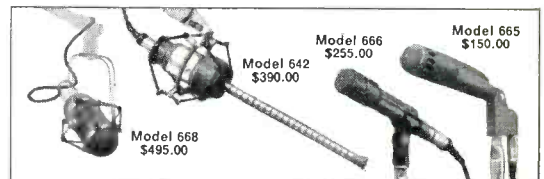

But let's not ignore the most popular professional cardioid microphone of all, the Model 666. Here's where the Variable-D principle got its start. And since the introduction of our seven foot laboratory, the 666—and its companion, the 665—has been further refined to offer better performance and value than ever before.

From such startling microphones as the 643, come continuing basic improvements—and the tools you need to solve your most difficult sound problems. Only E-V provides this kind of design leadership. E-V microphones in your studio will give you a big head start toward better sound. After all, we're at least seven feet ahead of everybody!

**ELECTRO-VOICE, INC.**

Dept. 451V, Buchanan, Michigan 49107

**Electro-Voice®**  
SETTING NEW STANDARDS IN SOUND

Circle Item 30 on Tech Data Card

# UP-DATE

YOUR OLD 3"

R.C.A. / IMAGE  
G.E. / ORTHICON  
DUMONT / T.V. CAMERA  
MARCONI /  
& OTHERS

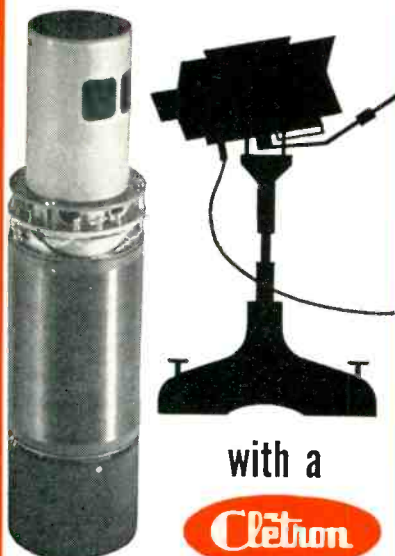

with a

**Cletron**

## 3" IMAGE ORTHICON DEFLECTION YOKE

(Part No. OY-64)

- Flatter Field
- Sharper Corners
- Improved Resolution
- Quieter Image Section
- Better Cooling for Longer Tube Life

## and 3" IMAGE ORTHICON ALIGNMENT COIL

(Part No. OA-3)

**Cletron**

Write today to:

**CLEVELAND ELECTRONICS, INC.**  
1975 East 61st St. • Cleveland, Ohio 44103

Another quality product by  
Cletron... Manufacturers of Deflection  
Components, Custom Transformers  
and Sound Reproducing Devices

Circle Item 31 on Tech Data Card

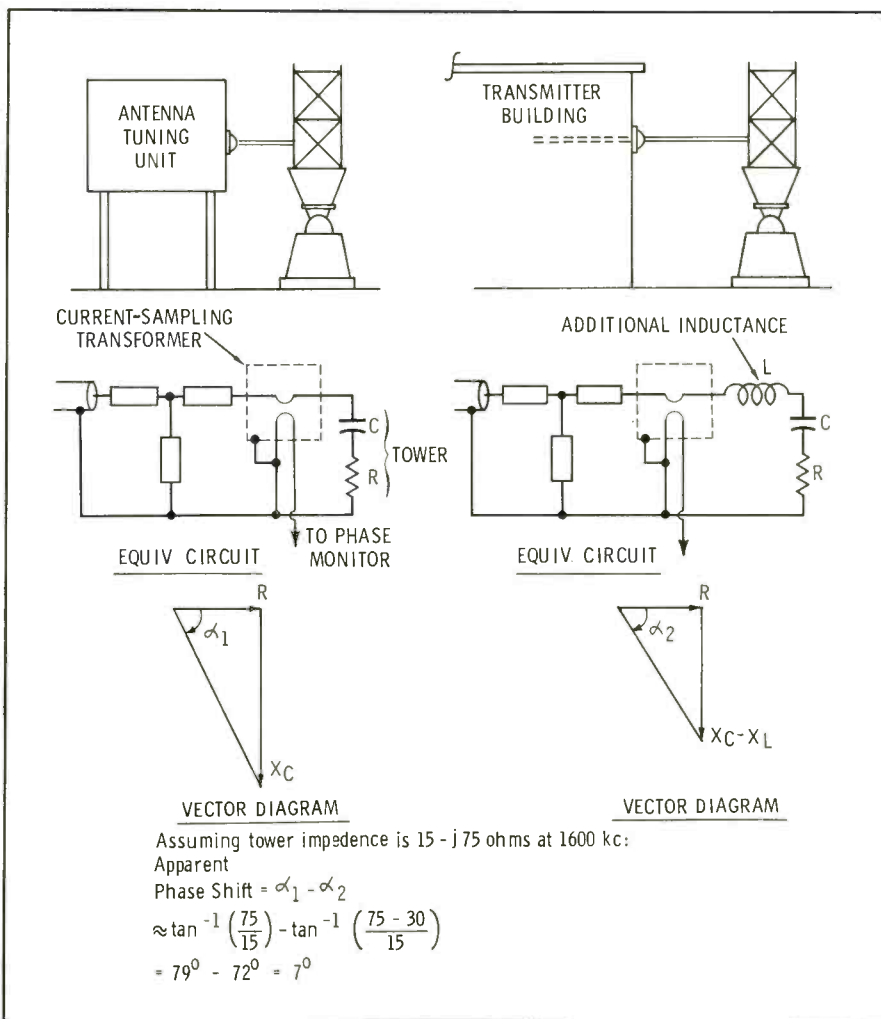

the line impedance. In some cases, inversion of tower currents during the design provides the identical pattern with improved driving-point impedances.

### Construction Considerations

To achieve good stability, all power and coaxial cables on the site should be buried. All RF grounds must be properly made using heavy copper strap. All tuning components must be conservatively rated. Coils must be mounted at right angles and adequately spaced to avoid mutual coupling. Low values of capacitive reactance should be obtained by using a large capacitor—not a small one in series with a large coil (the combination operating near resonance), since this would cause instability and reduce the circuit bandwidth.

Suitable design of the RF power distribution system may provide inherent compensation for changes in tower operating impedances and

thus improved stability.

If there are high-voltage transmission towers or tall chimneys near the site, it is probable that these will reradiate some of the transmitted power. From their electrical height and the induced voltage, their influence may be assessed approximately. Measurements taken during the proof of performance will determine which obstructions, if any, must be detuned to avoid excessive null fill. Unfortunately, reradiators are really loosely coupled parasitic radiators and subject to the stability problems mentioned earlier.

### Monitoring Considerations

Thermocouple ammeters are usually calibrated by the manufacturer at room temperature. On a hot summer day, readings will be low by 5% or more, and in mid-winter they will be high. Temperature variations slightly alter tuning component values and the electrical length of coaxial cable. For these

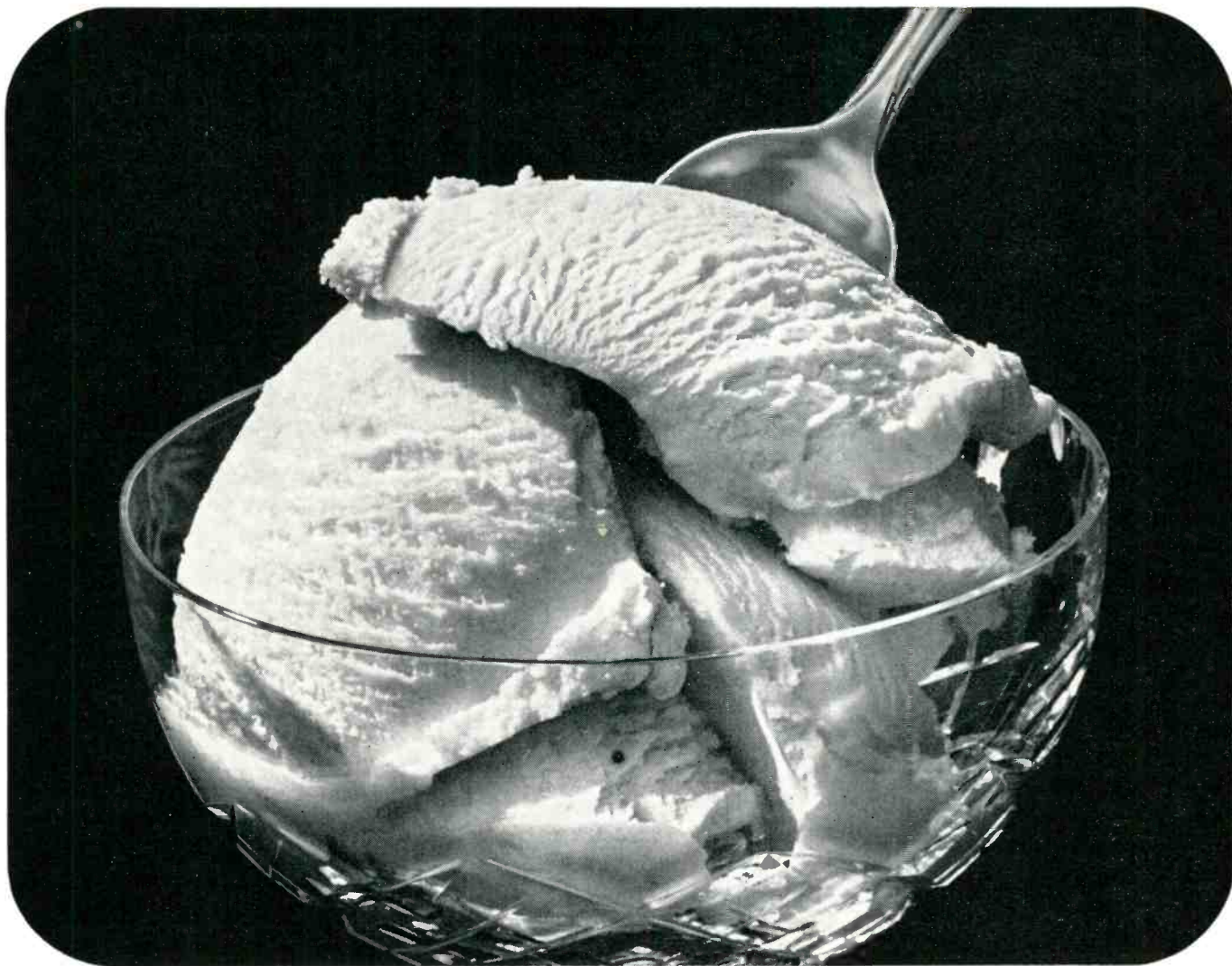

## Live couldn't. Scotch® Brand Video Tape did.

### Kept ice cream from melting for KAKE-TV!

Video tape makes sure the ice cream always looks its most appealing on tv. Pleases the sponsor, Steffen's Dairy. Brings in the customers. And makes the commercials less expensive to produce.

Used to be at KAKE, Wichita, the ice cream dishes were set up under the lights prior to the 10 p.m. news. But began to melt before the mid-program commercial. Adding an extra man to put the ice cream in place at the last second was considered. But going to video tape proved both more convenient and less expensive.

KAKE now tapes virtually all evening commercials by local clients in advance. Less crew is needed during the evenings. The advertiser enjoys greater control over his commercials. And the commercials themselves have *live* picture quality without danger of an on-the-air goof.

*KAKE is among more than 200 stations throughout the country that are utilizing 3M's video tape program to show advertisers that taped commercials best show their merchandise. Stations near you are now offering a variety of helpful reference materials as well as production service. Give them a call. Or write 3M Magnetic Products, Dept. MDV-45, St. Paul, Minn. 55119.*

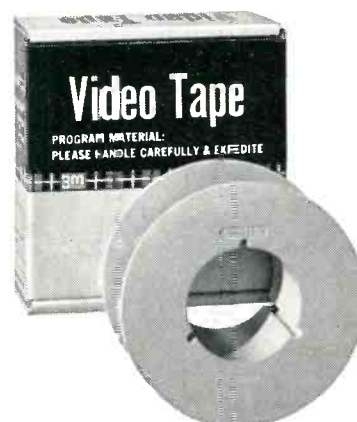

Magnetic Products Division **3M**  
COMPANY

"SCOTCH" AND THE PLAID DESIGN ARE REG. TMS OF 3M CO. © 1965, 3M CO.

Circle Item 32 on Tech Data Card

# Oxide shed after one hour use

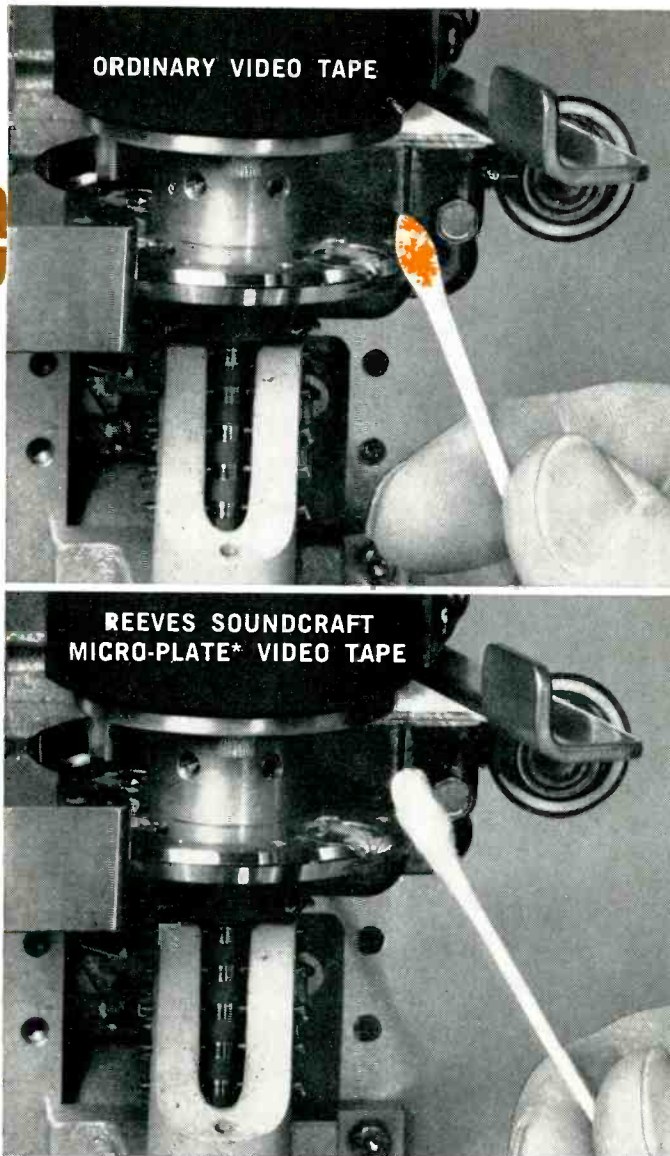

What happens too frequently *during* one hour use can't be illustrated. The picture is *gone*—the inevitable result of oxide shedding from your ordinary video tape.

One of the major causes of lost or poor quality video images is oxide shedding which takes place when ordinary video tape passes over your recording heads! Deposited there as a powdery substance, it can melt under heat (friction). It can foul the head or be redeposited on the tape. This progressive buildup ultimately prevents intimate tape-to-head contact resulting in loss of video picture.

But here's *proof* that Soundcraft MICRO-PLATE\* Video Tape eliminates undesirable oxide shedding.

Run any ordinary video tape for one hour. Clean your heads with a cotton swab. Note the large residues of oxide on the swab. Now repeat the process with Reeves Soundcraft. By comparison, the swab is spotless. *Even after 500 hours with Reeves Soundcraft, your head wheel panel is as clean and free of oxide discoloration as when it was installed in the machine.*

A unique oxide/binder system combined with the MICRO-PLATE\* process makes the difference. The result is the smoothest surface of any tape made today. Prove it—by making your own oxide shed test. Order a reel of Soundcraft MICRO-PLATE\* Video Tape today—or write for complete specifications. \*T.M.



**REEVES SOUNDRAFT**  
DIVISION OF REEVES INDUSTRIES INC.  
GREAT PASTURE ROAD, DANBURY, CONN.

New York • Chicago • Los Angeles • Export: C.B.S. Int'l., 46 E. 52 St., N.Y.C. • Toronto: Applied Electronics.

Circle Item 33 on Tech Data Card

reasons, the tuning huts of critical arrays are occasionally heated to a constant ambient temperature. In this case the huts may also be shielded and heat insulated.

In many recent AM installations the transmitter building is located beside one of the towers. The open line feeding that tower may be 10' longer than those from the other antenna tuning units. This would involve an additional self inductance of about three microhenries and a reactance of nine ohms at 540 kc or thirty ohms at 1600 kc. If base-current sampling transformers are used for phase monitoring, this difference in line inductance would result in phase readings different from the theoretical values in order to develop the correct pattern (Fig. 2). The shift will often be less than 7° if the frequency and/or operating resistance is lower than shown, but it will be greater if the tower's electrical height is about 90° and the array produces operating impedances that are almost resistive. However, it is helpful to consider this source of error when adjusting an array. Measurements to equalize the physical or electrical lengths of the sampling lines will not avoid it, though pairing towers and adjusting for a null on their axis will. The discrepancy could be avoided by including a two- or three-turn surge-limiting coil in the short feed lines only or by using sampling loops. It is evident that other sources of error will frequently be more important than this one, especially in the case of a close-spaced array.

Precision phase monitors are available that have a resolution of  $\pm 0.1\%$  for magnitude and  $\pm 0.1^\circ$  for phase. They are necessary for the successful operation of a highly critical array.

## Conclusion

Some of the problems associated with critical arrays have been outlined. It will be apparent that arrays of this type can be very expensive if properly engineered. The advantages of this approach may not be apparent to management; it is up to the engineer to convince them that a marginal design installed at minimum cost is false economy. ▲

# What's the big deal about Times' new 2000 ft. seamless sheath CATV cable?



**Plenty!** It not only saves you money in installation and maintenance. It performs better throughout the life of your CATV system . . . and actually increases system profits.

1. **Easily saves you 10% on installation and shipping costs.** 2,000 ft. lengths mean fewer splices. This saves you 8% in the cost of labor and splice connectors. Only 1 reel needed for 2,000 ft. of cable instead of 1 reel for each 1,000 ft. saves you an additional 2% in handling and shipping.

2. **Increases profit.** The fewer the splices, the less maintenance needed. Every splice is a potential trouble-expense point. Less maintenance means less labor cost and more profit over the life of the system.

3. **Improved electrical performance.** Times JT-1000 cable, in 2,000 ft. lengths, is manufactured with a guaranteed 26db minimum return loss—a must for minimum ghosting. Seamless tube sheath gives you the radiation protection you need when high power level amplifiers are used. And because it's seamless, Times JT-1000 cable won't let in moisture vapor that stops your signal short of target.

And don't forget . . . long after so-called economy cable has been replaced, Times JT-1000 cable will still be a top performer.

It's a fact: Re-installing a cable system costs more than the original installation. With a so-called economy system, your system starts deteriorating the day you put it in. But Times' JT-1000 cable keeps pace while you're upgrading your system and lives up to your system's planned potential. Why not take advantage of this direct way to improve your system's profits?



**TIMES**  
WIRE AND CABLE

Division of the International Silver Co.

Transmission System Design and Engineering/Standard & Special Coaxial Cable/Multiconductor Cable/Complete Cable Assemblies/Teflon\* Hook-Up Wire  
COPYRIGHT 1965

\*A DU PONT TRADEMARK

# Next Month In Broadcast Engineering



## COMPLETE COVERAGE OF THE NAB SHOW

●  
**Automate to Make, Not Save, Money**

●  
**Phase Monitor Sensitivity**

●  
**The Versatile Cathode Follower**

●  
**Solid-State Microwave Relay**

**Plus: Engineer's Exchange, Book Reviews, Washington Bulletin, Letters, Products, News, and Other Interesting Features.**

Reserve your copies now! Simply fill in and send us the convenient subscription card bound into this issue — you'll receive the Broadcast Engineer's Maintenance Guide free of charge.

## Two BE Consulting Authors Promoted

Two long-time members of the BROADCAST ENGINEERING Consulting Author staff, Elton B. Chick of the Rounsaville stations and Melvon G. Hart of the Balaban stations, have been promoted to positions of increased responsibility in their respective organizations. Readers will recall articles by both of these men which give ample evidence of their capabilities and interest in all phases of broadcast engineering.



Having served as director of engineering off the Rounsaville stations for several years, Mr. Chick has recently been elected a vice-president of that group and appointed general manager of the Louisville station, WLOU. Prior to this most recent appointment, Mr. Chick headquartered at WCIN, Cincinnati, where he directed the engineering activities of the six-station group.



Engineering direction of the two-station Balaban group is now the responsibility of Melvon G. Hart, recently appointed technical director of WIL, St. Louis, Missouri and KBOX, Dallas, Texas. Mr. Hart was previously technical director for the St. Louis station and has been a member of the Balaban engineering staff since 1956. ▲



# You asked for it — Now here it is!

## An All New Solid State Video Clamper / Stabilizer Amplifier

The Vital Video Clamper/Stabilizer Amplifier was designed to answer the need for a video processing unit which provides highest performance on color and monochrome television signals. It also has very high stability of all functions, achieved through the use of complete and accurate temperature compensation and excellent power supply regulation.



MODEL VI-500 VIDEO CLAMPER/STABILIZER AMPLIFIER

*Here are a few of the functions performed by this unit:*

- Maintains constant video and sync. levels at the output, measured in reference to blanking, despite large variations in video and/or sync. levels at the input. The peak to peak input level can vary from 0.5 volt to 4 volts while white peaks are held constant, within 2% of the present level at the output, measured in reference to blanking. May be used with non-composite signals.
- Provides a clean video signal at the output even if the input signal is mixed with as much as 10 volts of hum or other low frequency disturbances. More than 50 db. reduction of extraneous 60 cycle hum in the video signal is achieved by means of driven sync. tip clamps. There is less than 1% tilt on a 60 cycle square wave.
- Reformed, noise free sync. is combined with the composite output signal and maintained at a constant preset amplitude in reference to blanking regardless of input level variations. This sync. portion of the output signal is independently adjustable from less than 0.1 volt to more than 0.75 volt, peak to peak. An auxiliary sync. output is also provided which delivers a constant 4 volts, peak to peak of clean, reformed sync.
- Equalization for up to 1000 feet of Belden 8281 cable is provided which is accurate within 0.25 db. to 10 mcs. and is continuously adjustable for any length of Belden 8281 cable from zero up to 1000 feet. Negligible envelope delay is introduced at any setting. This equalization is also suitable for other cable types.
- A white stretch circuit (which may be completely switched out) has great flexibility of adjustment to more accurately match the compression characteristics of transmitters.
- Four identical video outputs are provided with 40 db. isolation at 3.58 mcs. between outputs.

### *Applications include:*

- At the outputs of cameras, switchers, video tape recorders, microwave systems, long lines and off-air pickups.
- At the inputs of video tape recorders, microwave systems and transmitters.

Price for the VI-500 complete with remote controls . . . . \$1390.00

*Write for complete information and specifications*

## VITAL INDUSTRIES

3614 SOUTHWEST ARCHER ROAD  
GAINESVILLE, FLORIDA—PHONE 372-7254

Circle Item 35 on Tech Data Card



**Let FAIRCHILD  
put teeth  
into your  
sound!**

### FAIRCHILD DYNALIZER

The newest approach for the creation of "apparent loudness"—the Dynalizer is an automatic audio spectrum equalizer which redistributes frequency response of the channel to compensate for listening response curves as developed by Fletcher-Munson. Adds fullness and body to program material. Completely automatic with flexible controls. Easily integrated into existing equipment. Two models available: Model 673—Dynalizer only (17 db insertion loss.) Model 683—Complete no loss Dynalizer system (as illustrated.)



### FAIRCHILD CONAX



The world-acknowledged device that eliminates distortion problems caused by pre-emphasis curves. Allows higher average program levels through inaudible control of high frequencies. Invaluable in FM broadcast and disc recording. Eliminates stereo splatter problems in multiplex channels. Mono or stereo.

### FAIRCHILD LIMITER

Fast attack stereo limiter with low distortion and absence of thumps. Sum and difference limiting position eliminates floating stereo image, despite amount of limiting used in one of the two channels. Also includes regular channel A and B limiting. Dual controls and dual meters provided. Now used throughout the world in recording and broadcast studios. (Mono model available.)

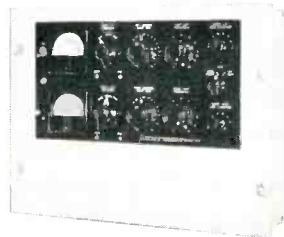

### Introducing the New FAIRCHILD REVERBERTRON

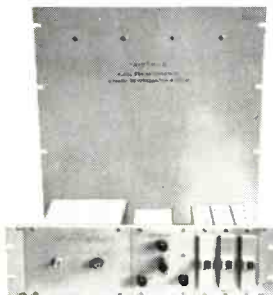

Reverberation now comes in a compact, portable, attractive and rack mountable package 24½" high by 19" wide with the FAIRCHILD REVERBERTRON. The REVERBERTRON, Model 658A, comes complete with mixing system for reverberated to regular signal mixing and contains a unique electronic control of reverberant time. Three time periods available at the flick of a switch—fast (staccato); a moderate time period; and a prolonged time decay for unusual effects.

The compact size of the FAIRCHILD REVERBERTRON and its relatively low cost now allows every studio and broadcaster to have the production-plus of controlled flexible reverberation with the FAIRCHILD REVERBERTRON.

Write to Fairchild—the pacemaker in professional audio products—for complete details.

# FAIRCHILD

FAIRCHILD RECORDING EQUIPMENT CORP., 10-40 45TH AVE., LONG ISLAND CITY 1, N. Y.

Circle Item 36 on Tech Data Card

## BOOK REVIEW

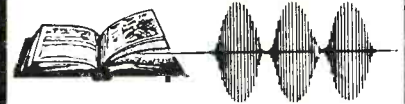

**Understanding Lasers and Masers;** Stanley Leinwoll; John F. Rider Publishers, Inc., New York, New York; 96 pages, 6" x 9", paperbound. Over the last decade or so the acronyms "laser" and "maser" and related words have appeared increasingly often in both technical and non-technical writing. It is the purpose of this book to provide the reader with an understanding of what these devices are, how they work, and how they are used.

The book is divided into seven chapters. The first describes the underlying principles of laser and maser amplification. The next three chapters describe, in general terms, various types of gas and solid-state lasers and masers. As a part of the descriptions, the history of the development of these devices is traced.

The fifth chapter discusses past, present, and future applications of masers and lasers. As in the earlier chapters, the history of development forms an integral part of the discussion. Scientific experiments and uses in military, industrial, and medical applications receive mention. Descriptions of some "do-it-yourself laser kits" conclude the chapter.

A chapter on communications applications describes qualitatively the methods used to modulate and demodulate the coherent light beam produced by the laser. Methods of internal and external modulation are included. The final chapter lists some of the laser products currently on the market.

The book is illustrated with drawings and photographs. The language is simple, and only a little of the simplest algebra is used in a few of the explanations. The book is written for the beginner, the reader who knows little or nothing about masers and lasers and wishes to get a general idea of what they're all about.

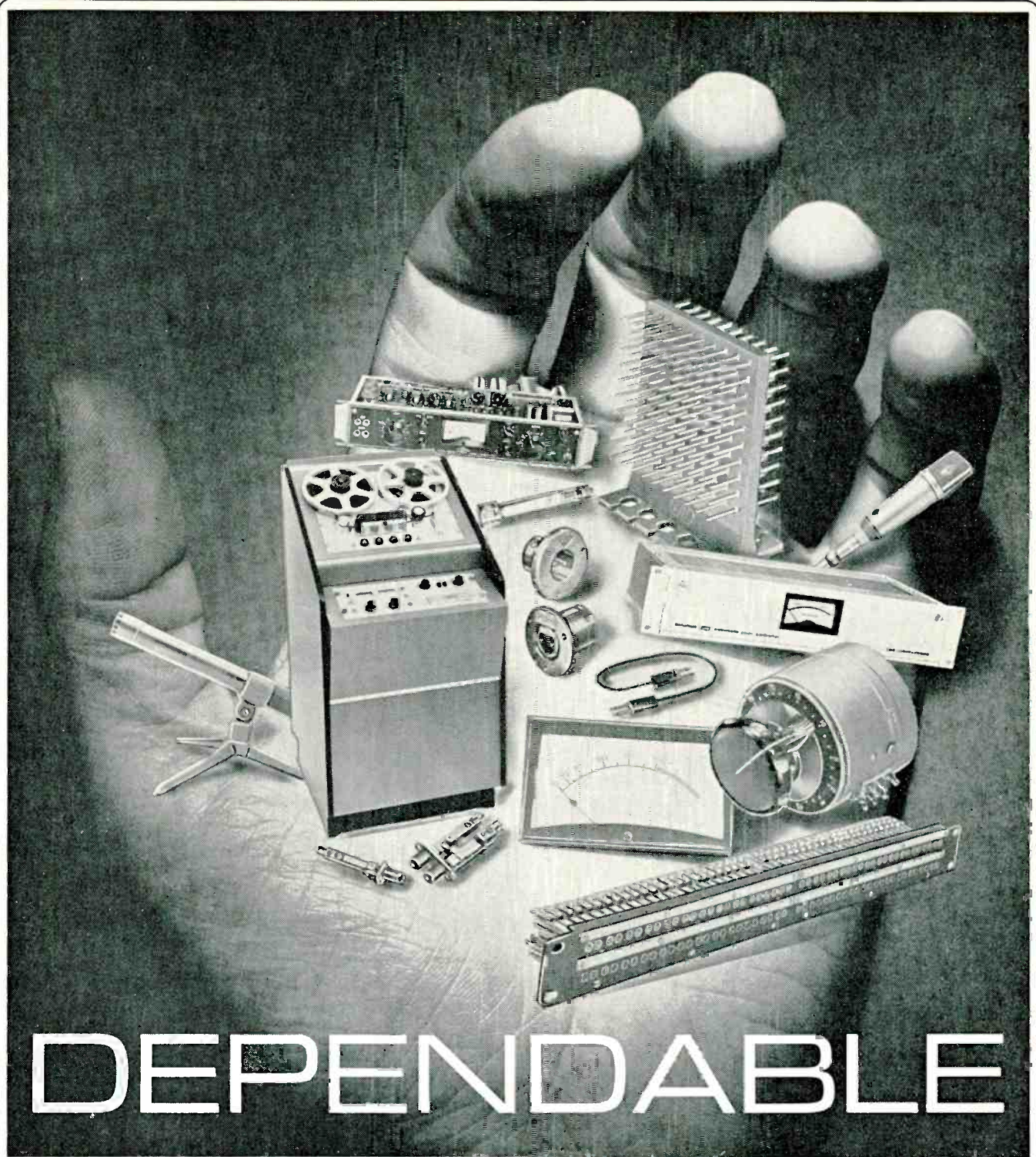

# DEPENDABLE



**HARVEY RADIO CO., INC.**

103 West 43rd Street / New York, N.Y. 10036 / (212) JUdson 2-1500  
 Federal Electronics, Inc. (Subsidiary) / Vestal Parkway, Vestal, N.Y. / (607) PIONEER 8-8211

"Anything, anywhere, anytime, always" is Harvey's other name. From the most sophisticated tape decks to the smallest replacement parts for professional broadcast and studio recording equipment. All from the greatest names in the business. No need to hunt when you can call *Harvey-collect* — from anywhere in the U.S. Your first order will demonstrate the dependability of America's oldest distributor of professional equipment. Phone or write today.

Always on hand: A.D.C. • ALTEC • AMPEX • A.P.I. • CANNON • CBS LABORATORIES • DAVEN • ELECTRO-VOICE • LANGEVIN • MCINTOSH • NEUMANN • PULTEC • R.C.A. • SENNHEISER • UNIVERSAL AUDIO

Circle Item 37 on Tech Data Card

# AN RF PATCHING SYSTEM FOR TV

by **Bill Kessel**, Consulting Author,  
Chief Engineer KTVT, Ft. Worth, Texas—  
An interesting and versatile system to  
simplify maintenance, testing, and  
emergency operations.

There are many configurations which can be used to tie the output of a television transmitter and its associated equipment to the transmission lines which feed the antenna. These range from fixed lines, which must be disassembled in order to do any checking, to motorized switches that will change connections at the push of a button.

In designing a transmitter installation at KTVT, we decided against either of these extremes. The first is too static and leaves no leeway for quick checks at various points in the system or for fast switching of components in an emergency. The motorized system that would satisfy our needs would be prohibitively expensive. Our design, therefore, falls between the two extremes.

There were two main considerations in the design of the system. Since there was to be no standby antenna or transmitter at the new

location, we needed a quick and easy way to bypass any piece of gear which might go bad. We also needed a fast means of connecting any component of the system into the dummy load for testing.

This was accomplished as shown in Fig. 1. Panels A and B use 1½" coax patches and have 3 poles. Panel C uses 3½" coax patches and has 7 poles. The patches for panels D and E use 6" coax and have 7 poles.

The question may arise here as to whether the patches used on panels D and E are not too cumbersome to handle easily. It was necessary to use the 6" patches at this point because of the power involved. The 6" patch is somewhat large and heavy but can nevertheless be handled by one man.

The A and B panels are mounted at the top of the driver transmitters—one on the aural and one on the

visual. They are mounted close to the output spigot of the transmitter to keep the plumbing as short as possible. Panels C, D, and E are grouped behind the transmitter, adjacent to the filterplexer and power divider (see Fig. 2).

Our solution to the problem of making the antenna and transmission line redundant was to install a General Electric TY-53 helical antenna with a two-line feed. This antenna is a three-bay device which is normally fed with one line. By using power division at the bottom, we are feeding two bays with one line and one bay with the other. Thus, in case of failure in either one of the lines or in a section of the antenna, we are able, by patching, to continue operation on the undamaged portion. Operation on fewer than the full three bays of the antenna results in reduced power but does not affect the cir-

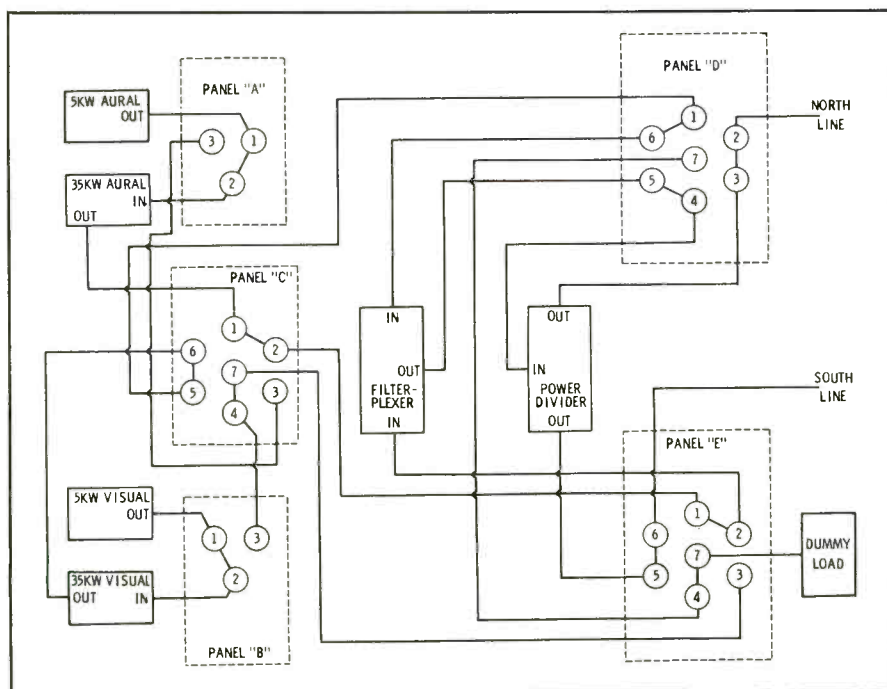

Fig. 1. Interconnection diagram of the RF-patching system shows panel layouts.

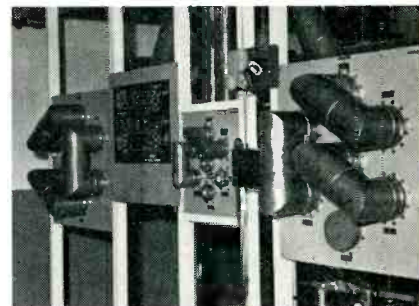

Fig. 2. Relative size of patches seen in view of panels "C", "D", and "E."

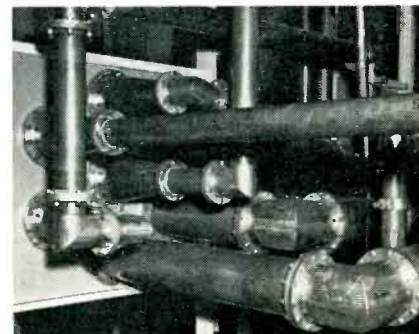
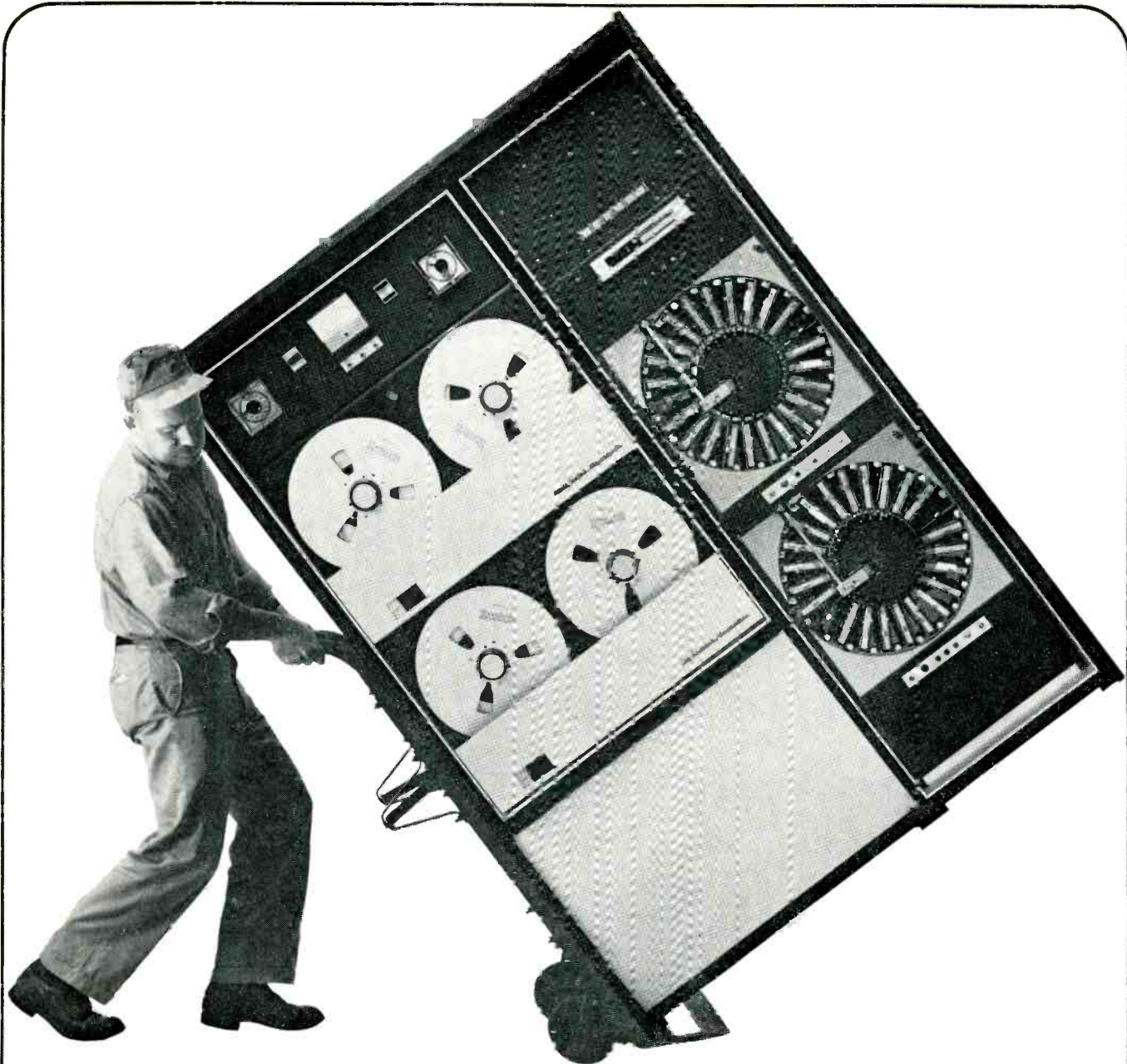

Fig. 3. Rear view, panels "C", "D", "E."



## HERE'S PROLOG I...

it separates you from AM and puts you in FM automatically!

two tape transports provide 12 hours of music without repeating any selection, and you can alternate from tape to tape at any time interval desired  single cartridge and up to 48 rotating cartridge units can be scheduled to play at any time interval desired  can be expanded into major Prolog System for unattended programming and logging

for brochure on Prolog Type 100-2 System, write Commercial Sales, Continental Electronics Mfg. Co., Box 17040, Dallas, Texas 75217 and request Prolog I

**LTV** *Continental Electronics*  
A DIVISION OF LING-TEMCO-VOUGHT, INC.

Circle Item 38 on Tech Data Card



# take me out to the ballpark...



(and leave me there)

The Blonder-Tongue Observer 2 is a broadcast quality vidicon viewfinder camera. It's extremely light and portable, making it ideal for remotes. Also, picture quality is so close to that of an image orthicon, you can use it for up to 80% of your studio work.

You can buy the Observer 2 for a fraction of the cost of an image orthicon—\$4160. But, the biggest saving is in operating costs. For example, you can buy seven vidicon tubes for the price of a single image orthicon—and each vidicon lasts twice as long.

The B-T Observer 2 has an 8" viewfinder screen, a 4 lens turret, and reliable solid-state circuitry. To arrange for a demonstration by your local Blonder-Tongue representative, write:

**BLONDER-TONGUE**  
9 Alling Street, Newark, New Jersey 07102  
home TV accessories • closed circuit TV •  
community TV • UHF converters • master TV

Circle Item 39 on Tech Data Card

cularity of the pattern.

The patches as shown in Fig. 1 are set for normal operation. Changing the patches on panels A and B from 1-2 to 1-3 lifts the respective driver from its associated amplifier. The driver output then appears on panel C where it can be routed directly on the air through the filterplexer or, by way of panel E, to the dummy load. An overall rear view of panel E is shown in Fig. 3.

Further inspection of Fig. 1 will show that the dummy load can very quickly be connected to the output of any of the transmitters. It can just as quickly be connected to the output of the filterplexer or to either output of the power divider. Thus, in case it becomes necessary to go to one-line operation, the dummy load is readily available to connect to the unloaded spigot on the power divider.

It will also be noted that by pulling the patches between 5-6 on panel E and 2-3 on panel D it is possible to look directly into the transmission lines going up the tower for DC pulse measurements, etc.

While a system such as this will add to the cost of an installation, we feel that it will pay for itself through time saved in maintenance procedures and during emergencies.

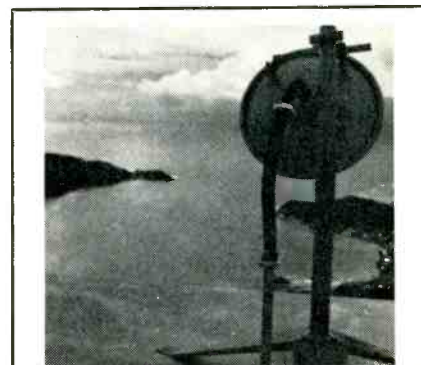

## About the Cover

Our cover this month shows the view of Pago Pago Harbor from the television transmitting site atop Mount Alava. Television is being used to bring the advantages of modern education to the Islands. For the story, turn to Page 42.

1. **STOP** you lost your turn by missing our ad in the March issue. Go back and look at page 86.

**BIONIC INSTRUMENTS, INC.**

# Just What Does a TV Computer Programmer Do?

First thing it does is go to work saving money—if it's Tarzian's new Automatic Programmer for Television (APT). APT starts paying its own way immediately by eliminating make goods caused by operator error. It can't get flustered—can't panic. Prime time, or any time.

With a Tarzian computer programmer, productions run smoother . . . faster. At APT's command, intricate combinations of switches, fades, dissolves, supers, pre-rolls, previews, etc. are executed precisely as required by your programming. With NO mistakes. And all automatically, free-

ing station personnel for more productive effort. APT speaks your language, too. All this solid state workhorse needs to go into action is the information right off your program log. No confusing translation into computer lingo. And anyone who can read the log can load it into the computer. It's really that simple.

APT is a true computer—not just an automation switcher. It was designed solely for television—not modified from some other use. It's all solid state. It interfaces readily with existing equipment. And, it costs less than a VTR.

*First computer programmer designed specifically for television by a major television manufacturer.*



*A call or letter brings our brochure with all the details.*

**S A R K E S**  
BROADCAST EQUIPMENT DIVISION



**T A R Z I A N**  
BLOOMINGTON, INDIANA

Circle Item 41 on Tech Data Card

# SYNCHRONIZED TAPE SYSTEMS FOR FILMS

by Allen B. Smith, SMPTE—A simple and concise explanation of portable double-system sound-recording techniques using control-signal synchronization.

For many years, American television news cameramen have used magnetic and optical sound-recording cameras both for on-the-spot action news coverage and for longer documentary film productions. Sound, synchronized with the visual image, contributes tremendously to the impact of these specialized television programs; it is, as a matter of fact, essential. As a necessary and inseparable element of the medium, however, synchronized sound has suffered from the widespread use of single-system techniques by which sound is recorded directly on the film (either optically or magnetically).

The limitations of the single system are primarily twofold. Because the sound track is physically a part of the film which carries the visual images, independent editing of visual and aural content (for smoothness, cut-action shots, fades, dissolves, multiple images, and many other special effects) is impossible. Secondly, optical sound quality is only marginal—the upper frequency limit seldom exceeds 3500 cps in practice—and magnetic-stripe response, though better, still falls short of the capability of the FM sound channel used in television broadcasting. The first shortcoming fairly well precludes imaginative

film production, while the second is wasteful for its failure to provide maximum utilization of the sound quality inherent in FM systems. Even aside from limited frequency response, both single-system techniques (magnetic and optical) introduce serious distortion products using average equipment under most field conditions. There are at least three relatively new and excellent single-system cameras, but even these are restricted in their adaptability for serious film production (except in double-system use, of which some are capable) and will likely be limited to large-station and network news coverage where immediacy is more important than visual excitement. High initial cost (in the \$5,000 to \$15,000 range) discourages their use by most smaller stations.

## Double-System Sound

The picture is not completely dark for the station wishing to obtain the maximum advantage from film, however, because there is a second possible approach. Double-system sound recording provides separate film and sound tracks which can be cut independently, timed, and combined in a composite print for a result limited only by the imagination and technical competence of the producer and his staff. Since editing and makeup of the separate picture and sound reels require rather lengthy preparation, double-system techniques are not generally applied to day-to-day newfilm production. They are admirably suited, however, for most other film applications (particularly so to commercial spots) because of their versatility and adaptability to special effects.

With separate picture and sound tracks, a method of positive synchronization must provide a means for assuring the correct relative position of the picture and sound information (26-frame separation for optical sound, 28 frame for magnetic—see Fig. 1) as each scene is edited. If all shooting were done in the studio, the problem could be resolved easily by using synchronous motors to power both camera and recorder. If sprocketed 16-mm, acetate-base magnetic film were used on the recorder (a common commercial film practice) to eliminate mechanical slippage and stretching, the 60-cps line frequency would ensure precise synchronization of picture and sound, and a clap-stick would give visual and aural start marks for reference during editing. Since studio and sound stage are seldom available during the production of documentary films, however, film producers have had to use a different synchronizing method to avoid carrying massive gasoline-powered AC generators into the field (although high-budget Hollywood film companies still use this approach).

The requirements for a portable synchronous sound/film system are rather demanding. The recorder, first of all, must be small and light;

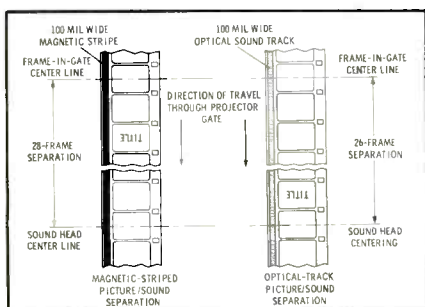

Fig. 1. Relative positions of both picture and sound tracks on final 16mm print film.

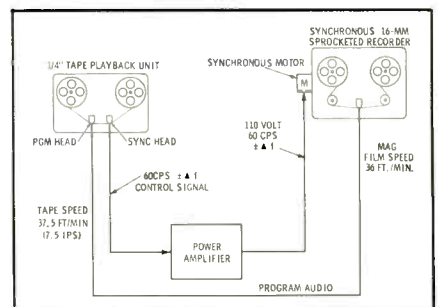
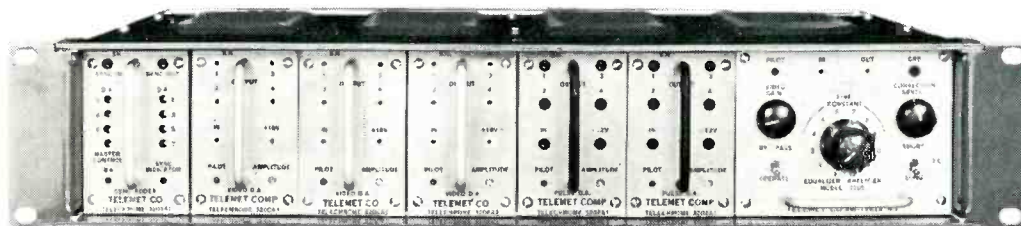

Fig. 2. Power-amplifier resolving method is most direct of the three basic techniques.



# SATISFY ALL DISTRIBUTION REQUIREMENTS

*with these transistorized and completely self-contained modules*



**MODEL 4000** Rack Mounting Frame provides common mounting facility for any combination of modules.

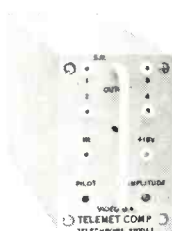

**MODEL 3200**

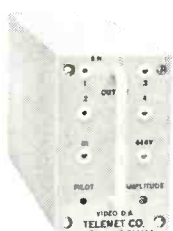

**MODEL 3206**

**MODELS 3200 and 3206** Video Distribution Amplifiers feature high impedance bridging inputs and 4 identical isolated outputs, source terminated in 75 ohms.

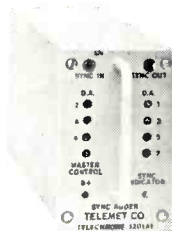

**MODEL 3201**

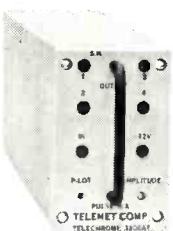

**MODEL 3202**

**MODEL 3201** Sync Adder provides a means of mixing sync into any or all video amplifiers in the frame.

**MODEL 3202** Pulse Distribution Amplifier regenerates sync, blanking or drive pulses, providing 4 identical isolated outputs.



**MODEL 3205**

**MODEL 3205** Equalizer Amplifier now contains frequency boost circuits providing up to 10 db at 4.5 Mc. Slope adjustable to match cable. Also provides adjustable time constant correction. Ideal for Frequency Phone Correction of long coaxial lines.

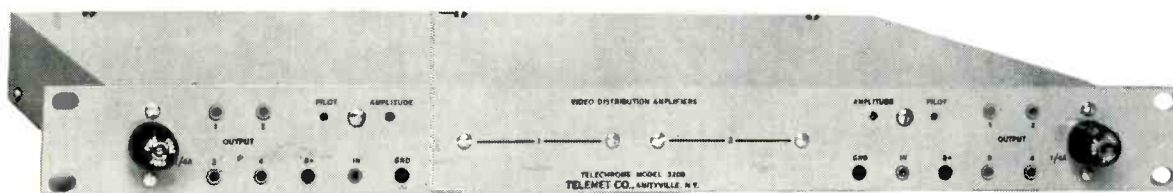

**NEW MODEL 3208** Dual Video Distribution Amplifier actually contains 2 separate and completely independent amplifiers and power supplies of the Model 3206 type in a space-saving configuration.



**TELEMET COMPANY**  
a division of  
**GIANNINI SCIENTIFIC CORPORATION**  
185 DIXON AVENUE, AMITYVILLE, N.Y. • PHONE (516) 541-3600

Circle Item 42 on Tech Data Card

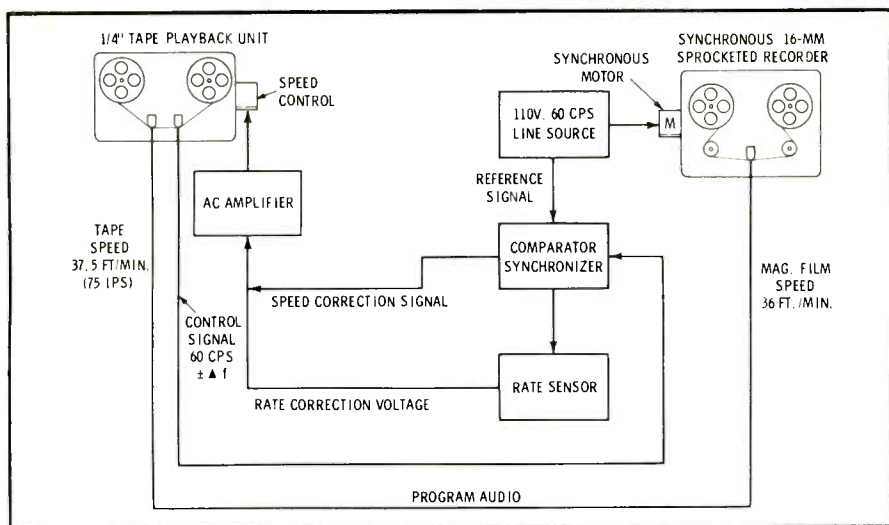

Fig. 3. This system compensates for errors in relative speed, smooths correction rate.

yet it must have a broad and flat frequency response—a tough requirement even for most studio recorders. There must also be a means for assuring a constant relative speed for the camera- and recorder-drive motors or a means for correcting speed differences at a later stage. Early (relatively unsuccessful) attempts used a camera-mounted sprocketed-film recorder which had a flexible-shaft coupling between the camera and recorder; this approach is now seldom seen in broadcast use.

### Control-Signal Sync

Electrical control-signal synchronization of compact recorders using standard 1/4" magnetic tape has proved an ideal answer. A new generation of high-quality recorders (primarily of European origin) was described in an earlier article\*, and these recorders provide the basis for the portable system.

The control-signal concept of syn-

chronization is relatively simple, once the basic problems of double-system film work are understood. The difficulties stem, as already indicated, from the need for precise speed control of both film and tape. This requirement is complicated by the fact that 1/4" magnetic tape sometimes stretches significantly during long runs and slips as it is pulled through the recorder by the capstan/idler drive system. The net result of speed variations and stretch/slippage errors is a loss of synchronization between picture and sound. It must also be understood that for editing purposes, the final sound track must be on sprocketed magnetic or optical film (the trend—primarily for reasons of quality—is to magnetic). Control-signal synchronization using the portable recorders, therefore, is only an intermediate step between filming on location with practically unlimited physical freedom and the transfer of the sound track to sprocketed film for easier and more imaginative editing.

The control-signal system compensates for speed variations and

mechanically induced errors by using a camera-generated 60-cps signal as a time-based reference at a standard level of 1.2 to 1.8 volts. The reference signal is applied to the 1/4" tape through a separate recorder head which erases a narrow segment of the program audio and records the 60-cps control signal in its place; the control track and the program-audio track exist side-by-side on the same tape.

### Resolving the Sound

The program audio is resolved (transferred to sprocketed film) by one of three basic methods. Using the power amplifier method (Fig. 2), the 60-cps reference signal is taken from the tape during playback, amplified, and used as the power source for the synchronous drive motor in the sprocketed-film recorder. The frequency variation of the control signal determines the speed of the sprocketed-film unit. Any change in the 60-cps time-based reference signal (whether caused by camera or recorder speed variations) will result in a corrective effect on the sprocketed 16-mm film recorder.

The second system (Fig. 3) has two basic elements: the synchronous sprocketed recorder which is driven directly from the 60-cps line, and the playback unit which uses a closed-loop feedback system. Output of the feedback loop is regulated by the control signal which is compared in the comparator/synchronizer to a reference voltage derived from the 60-cps line source. A rate-sensor circuit then smooths the action of the correction voltage to eliminate rate-change effects which distort the program audio, particularly on slow, sustained musical passages. This system uses a rotary-shaft resolver which receives a reference voltage into its rotor windings and the 60-cps error-correction voltage into its stator windings. When the phase of the two signals is identical, there is no rotary motion of the resolver shaft; a phase error causes the shaft to rotate through an arc proportional to the magnitude of the error. This rotary-shaft motion is linked to a potentiometer which applies a correction voltage to the speed-control unit in the recorder. Rate correction is provided by an additional voltage derived from the motion of the po-

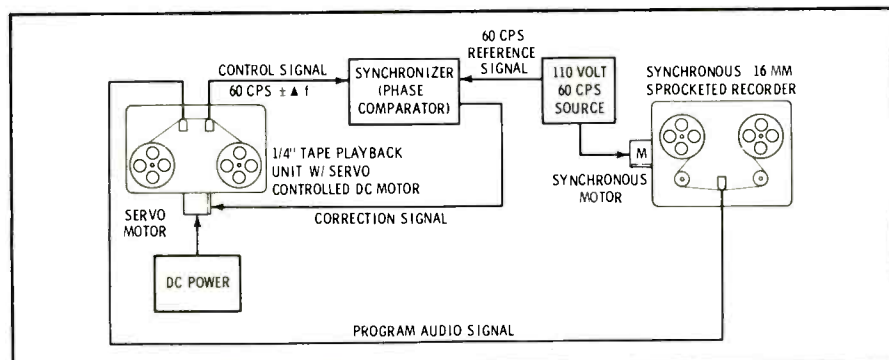
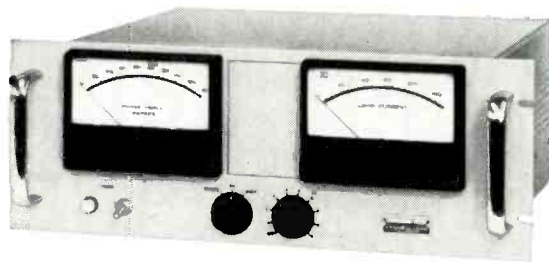

Fig. 4. In servo-motor method, the frequency differential generates the correction signal.

*New  
solid state phase monitor*

*can be remoted  
replaces Type 108E  
simple to operate*



Nems-Clarke offers a completely new phase monitor to broadcasters who are planning new facilities or modernizing old ones. □ The type 112 Phase Monitor is a replacement for the type 108E. It is much simpler to operate, easier to read accurately, and incorporates all circuitry necessary to permit future adaptation to remote control. Silicon transistors are used throughout for high reliability, long life and excellent temperature stability. □ Phase angle is read out on a panel meter having a continuous 0 to 180° scale. Readings are not affected by modulation and they are presented instantly as each tower is selected, with no adjustments required. Loop current is read out on a single meter, as a percentage of the reference tower. Automatic day-night switching of reference levels is incorporated. □ For both phase angle and loop current, a proportional, linear D.C. voltage is generated, so that these functions may be read out on a chart recorder, digital voltmeter, or fed over lines for remote metering. □ Panel meters are of the taut-band type, to eliminate pointer binding, and have mirror scales to improve reading accuracy. Vitro Electronics, 919 Jesup-Blair Drive, Silver Spring, Md.

SPECIFICATIONS: Absolute Accuracy:  $\pm 1.0$  degree • Resolution: 0.5 degree • Input Impedance: 51 or 75 ohms • Number of Inputs: Up to 9 • Input Level: 1.5 to 20 volts, rms • Size: 19" wide x 7" high x 14" deep behind panel • Power Input: 115/230 v., 50-60 cps, 15 watts •

**Vitro ELECTRONICS**

**NEMS-CLARKE—RECOGNIZED STANDARD IN BROADCAST EQUIPMENT**

Circle Item 43 on Tech Data Card

# AT LAST

CARTRIDGE SERVICE  
YOU CAN COUNT ON



## DID YOU KNOW . . . . .

- You can have your old cartridges reconditioned by experts
- no charge for minor parts
- ALL** cartridges **PRETESTED** under actual broadcast conditions
- no minimum
- no service charge for small orders
- return shipment in 48 hours
- factory trained personnel
- new cartridge warranty
- You can have any size Fidelipac tape cartridge shipped immediately from stock
- You can have all cartridge parts for do it yourself cartridge maintenance.
- JOA incorporates all of these as a part of their service to the broadcaster.

phone or write:



Cartridge Service  
P. O. Box 3087,  
Philadelphia, Pa. 19150  
Area Code 215, TUrner 6-7993

Circle Item 44 on Tech Data Card

## New! Lang Solid State AMPLIFIER/SPEAKER

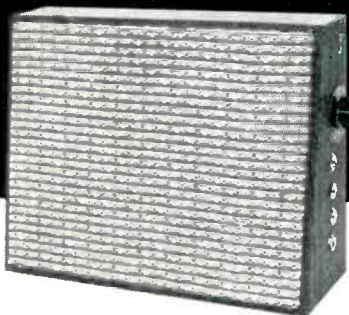

... for superb broadcast monitoring!

Primarily intended for use in broadcast offices where good quality monitoring is required, the LANG AMPLIFIER/SPEAKER contains its own solid state amplifier, power supply, and volume control. Stands vertical (as pictured) or horizontal if desired and can readily be hung on your wall.

**Price: \$78.**

Also available with input selector switch for use where monitoring of several lines is required.

For complete details and new Lang Catalog write.

**LANG ELECTRONICS INC.**  
507 FIFTH AVE., N.Y. 17  
For all your audio needs — Look to Lang!

Circle Item 45 on Tech Data Card

tentiometer. Speed correction is accomplished by a variable-capstan system or by a variable-speed servo motor. This system, which is used on equipment manufactured or modified by Rangertone, Inc., provides smooth and constant speed correction.

The third basic system of resolving the field-recorded sound track is shown in Fig. 4. This system takes advantage of the servo-motor capstan drive used in the Nagra portable recorder. The sprocketed recorder is driven synchronously from the 110-volt, 60-cps line, thus maintaining a constant speed. The synchronizer also receives an input from the line for comparison with the control signal which is fed from the recorder on playback. In the synchronizer, a difference voltage appears when the frequency of the two signals is not identical, and it is this voltage which is used to control the speed of the servo motor to correct for the variation. This system provides a very high degree of stability, but it has a narrow margin (about  $\pm 1.5\%$ ) of speed correction and can introduce wow if the rate of correction becomes excessive.

### Detailed Operation Of A Hypothetical System

As mentioned previously, portable synchronous recording using  $\frac{1}{4}$ " magnetic tape is simply an intermediate step between live sound and the sprocketed 16-mm magnetic film required for double-system editing. The purpose of the control signal is to provide a time-based reference against which the actual physical length of the final picture and sound films can be compared. The end result must be a one-to-one footage correspondence between picture and sound for each separate scene shot on location (see Fig. 5). With the three basic systems

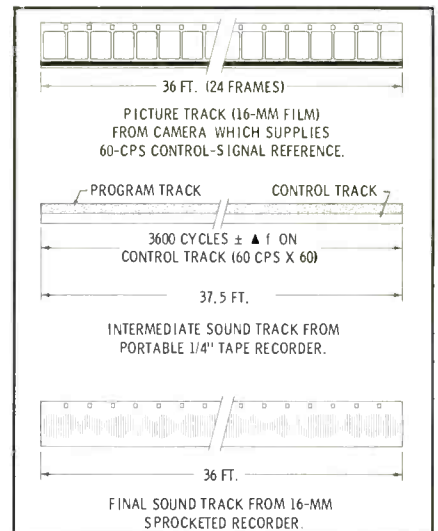

Fig. 5. Relative physical dimensions of elements comprising synchronizing system.

fairly well outlined, a better understanding of the entire control-signal concept can be obtained by reference to Fig. 6, which illustrates a hypothetical system reduced to simple terms for clarity.

A common approach to portable double-system recording (illustrated in Fig. 6A) employs a camera equipped with an electromechanically governed DC drive motor powered by a battery pack. The synchronizing signal is supplied by a small rotary generator mounted in the camera. (It is also practical to use a 110-volt 60-cps synchronous drive motor powered by a transistorized DC-AC inverter. The sync pulse is then derived from a small transformer which is mounted in the camera and connected across the power source in parallel with the drive motor.) The sync pulse is cable-connected through the recorder to a separate recording head which has its own high-frequency bias circuit. A narrow segment of the  $\frac{1}{4}$ " tape receives the control signal. Program audio is applied to the tape, through a separate head, by means of standard audio prac-

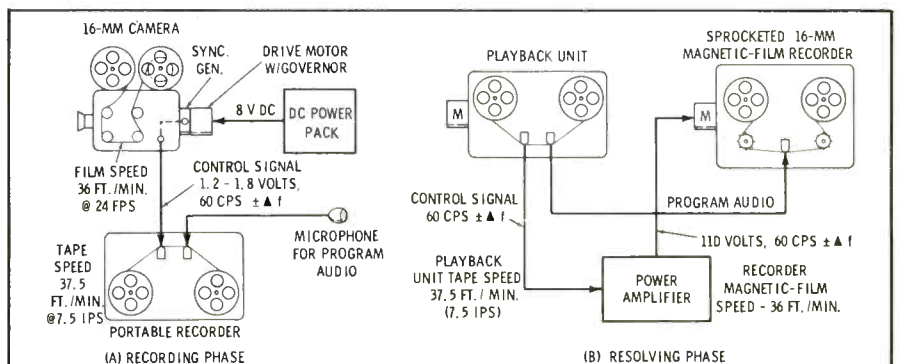
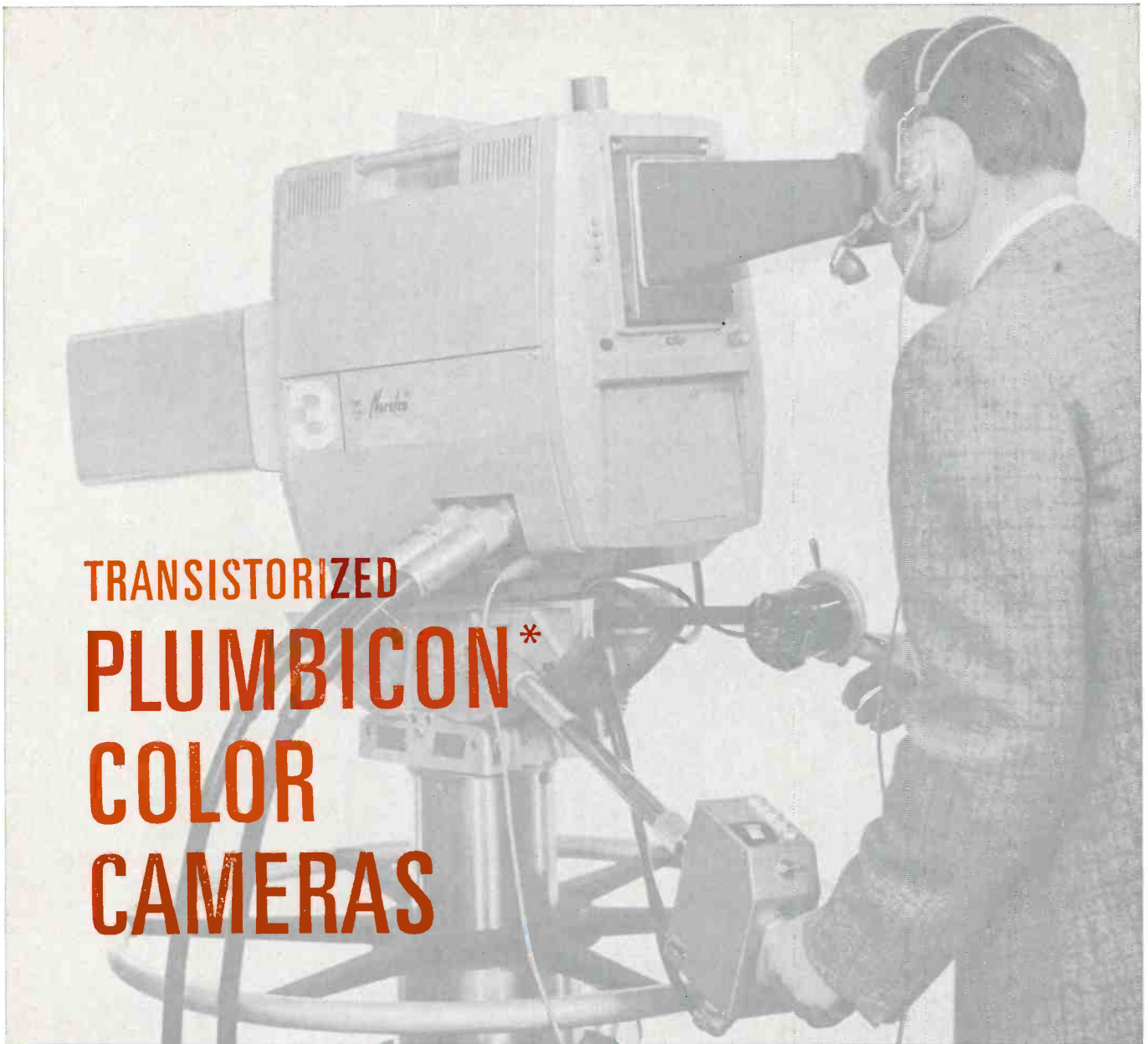

Fig. 6. Hypothetical setup shows function of portable double-system sync equipment.



# TRANSISTORIZED PLUMBICON\* COLOR CAMERAS

*Size and weight* of these new cameras are comparable to current black-and-white cameras. The ultimate in compact design and low power consumption permit their use in difficult areas.

The heart of these new cameras is the PLUMBICON TV Camera Tube. Its ideal characteristics eliminate many of the problems common to other types of pickup tubes. The long linear light transfer properties and extremely low dark current, provide unexcelled "genuine" color over an extended tonal range and enable operation under less scene illumination . . . resulting in less heat on the set. (*Typical operation 125 foot candles*).

The PLUMBICON, developed by Philips, is used in a wide range of Norelco color and black-and-white cameras manufactured in Mount Vernon, N. Y.

*\*PLUMBICON is a registered trademark.*

*Norelco Studio Equipment . . .  
represented nationally by*  
**VISUAL ELECTRONICS CORPORATION**  
356 West 40th Street • New York, N. Y. 10018

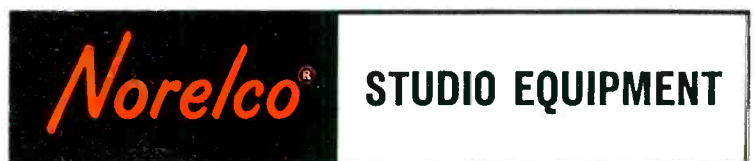

**NORTH AMERICAN PHILIPS COMPANY, INC.**  
900 South Columbus Avenue, Mount Vernon, New York 10550  
Circle Item 46 on Tech Data Card



# 12th SPRING CONVENTION AND EXHIBITS

## OF THE AUDIO ENGINEERING SOCIETY

HOLLYWOOD ROOSEVELT HOTEL  
7000 Hollywood Boulevard

Showing Professional Audio Equipment for Studio and Laboratory

## APRIL 27 - 30 TECHNICAL SESSIONS ON

- Magnetic Tape Recording and Applications
- The Solid State of Audio
- Microphones and Loudspeakers
- Audio Applications I
- Disc Recording
- Audio Applications II
- Recording and Broadcast Studio Applications

plus sessions at  
**POLICE FACILITIES AUDITORIUM**  
130 N. Spring Street, Los Angeles and

**THE MUSIC CENTER**  
135 N. Grand Avenue, Los Angeles

**SESSIONS:** Tuesday through Thursday, 9:30 a.m., 1:30 and 7:30 p.m. Friday, 9:30 a.m., Police Facilities Auditorium, noon, Music Center. Annual Award Banquet, Thursday, 7:30 p.m.

**EXHIBITION:** Tuesday and Wednesday, noon to 8:00 p.m.; Thursday, noon to 5:30 p.m.

For Program, write or telephone:

William L. Robinson,  
Convention Chairman

**Capitol Records, Inc.**

1750 N. Vine Street  
Hollywood 28, California  
(213 HO 2-6252)

The Audio Engineering Society

Circle Item 47 on Tech Data Card

tices through a single microphone or a multiple-microphone/mixer arrangement.

In operation, the camera and recorder maintain rather unchanging speeds because of their high degree of speed regulation. The linear speeds are quite different—36 ft/min (24 frames per second) for the film in the camera and 37.5 ft/min (7.5 inches per second) for the 1/4" tape—their relative speed varies only a small amount. It is the small relative speed error that must be corrected using the control-signal reference; their absolute linear speeds are incidental to the system.

The relative speed difference is seen by the tape's control-signal track as a frequency difference. This is true because there are but two conditions of relative speed variation: (1) The relative speed of the film is faster than that of the tape (whether caused by an increase in camera speed or by a decrease in recorder speed); (2) the relative speed of the film is slower than that of the tape (whether caused by a decrease in camera speed or by an increase in recorder speed). Since the control-signal frequency is pro-

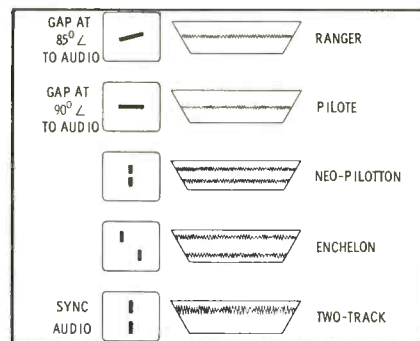

Fig. 7. Record-head arrangement of the four control-signal synchronizing methods.

portional to the relative film speed, under condition (1) above, the control-signal track sees an increased frequency (more complete cycles per linear measure); under condition (2), it sees a decreased frequency (fewer complete cycles).

During transfer to sprocketed film (Fig. 6B), the control signal is recovered from the tape by a standard playback head, amplified by the power amplifier to a 110-volt level, and used to power the sprocketed recorder. If we assume, initially, that the playback unit has a synchronous motor and will thus maintain a constant speed, the action of the control-signal voltage is more easily apparent. When the frequency of the control-signal voltage is higher than its normal 60-cps rate, the frequency-dependent synchronous motor in the sprocketed recorder increases speed, and the 16-mm magnetic film moves at a rate which corresponds exactly to the relative speed increase of the film in the camera (during the filming of the scene) which put the increased-frequency control signal on the tape. Similarly, when the control-signal frequency is lower than its normal 60-cps rate, the sprocketed recorder slows to a rate which corresponds to the original decrease in relative film/tape speed. The result is a sound track on 16-mm sprocketed magnetic film recorded at 36 ft/min in exact synchronism, scene for scene, with the picture film.

Visual and aural start-cue marks are obtained during filming using the time-honored clap stick or by using a separate unit on the camera which simultaneously flashes a light to "bloop" one picture frame and operates a relay which feeds the 60-cps sync pulse to the recorder. The "flash frame" on the picture film corresponds in synchronous time to the start of the control sig-

Assure 100% COMPLETE ERASURE of Recorded Tape ON THE REEL

Use the

## Magneraser®

— the Original and still the best!

Quickly erases a reel of magnetic tape or sound film of any size or type. Erasure is 100% complete even on severely overloaded tape. Lowers background noise level of unused tape 3 to 6 db. Also demagnetizes record-playback and erase heads. Only \$24.00. Two-year Guarantee. Available at your dealer's or write us.

## New ULTRA-SENSITIVE FLUTTER METER



With built-in Three-Range Filter, 3 kc Test Oscillator, High Gain Pre-amplifier and Limiter. Filter Ranges: 0.5 to 6 cps; 0.5 to 250 cps; 5 to 250 cps.

Designed for rapid visual indication of flutter and wow. Meets standards set by the IEEE... Condensed Specs.: Input Voltage, 0.001 to 300 Volts; Ranges, 0.01 to 3%; Limiter Range, 20 db.; Oscillator (built-in), 3000 cycles; Net Price, \$495.00... Write for complete specifications and free 12-page booklet on Flutter.

**AMPLIFIER CORP. of AMERICA**  
398 Broadway, New York 13, N. Y. • WO 6-2929

Circle Item 48 on Tech Data Card

# EIMAC

## announces broad new line of reliable vacuum capacitors

Need a really reliable fixed or variable vacuum capacitor? Bothered because you can't find a capacitor conservatively rated to meet increased power and current ratings of today's advanced transmitters? Relax. Try a VacCap. New Eimac VacCaps feature a unique patented design which results in higher rf rms current ratings. All-copper-and-ceramic construction permits manufacture at higher bakeout temperatures, with improved vacuum and longer life. And

prices are competitive! VacCaps, fixed and variable, can deliver any value of capacitance up to 1500 picofarads at any voltage from 5 to 50 kV, and at current ratings up to 225 amperes. No special cooling is required. For details and technical data contact Applications Engineering, Power Grid Tube Division.

EITEL-McCULLOUGH, INC., San Carlos, Calif.

In Europe, contact Eitel-McCullough, S.A.,  
15 rue du Jeu-de-l'Arc, Geneva, Switzerland



Circle Item 49 on Tech Data Card

**More changes in FM rules**  
 FCC adopts plan allowing short-spaced stations to improve their coverage

....and Bauer has the packages to help you increase your effective power economically and quickly. The Bauer 1 KW FM Transmitter, for instance, with a



four bay antenna will give you maximum power with watts to spare. AMPLIFIER ONLY AVAILABLE IF YOU WANT TO USE YOUR EXISTING EXCITER. Features include:

- Automatic Power Control—Lowest Tube Investment in the Industry
- Automatic Voltage Control
- Solid State Rectifiers
- Stable Grounded Grid Operation—Remote Control Provisions. Both packages available in "Kit" form or factory assembled. High Power Amplifiers available for special Vertical Power Combinations.

Increase your power and coverage by calling Bauer today for all the facts.

**Bauer**  
**ELECTRONICS CORPORATION**

1663 Industrial Road, San Carlos, California  
 Area Code 415 591-9466

Circle Item 50 on Tech Data Card

nal, thus providing visible and audible cue marks for the editor.

### System Variations

The manner of recording the all-important control signal varies considerably from system to system, but the concept is identical for all. Fig. 7 shows the track configurations for the four methods in common usage. A fifth method using two separate half tracks is also illustrated, but this approach is seldom taken by professionals, primarily because of the lack of suitable portable equipment. The previously mentioned article in the January 1965 issue gives a description of these various methods and discusses the equipment with which each system is used.

An interesting variation of the control-signal system of synchronization is used by several professionals in conjunction with the Eclair 16-mm camera and Perfectone recorder. The Eclair is particularly suited for highly mobile film assignments because of its unique physical design and quiet operation. Synchronism in this system is obtained as shown in Fig. 8 and depends on two matched-frequency 10.6-kc crystals. One crystal is divided down to 60 cps and used to stabilize a transistorized, battery-powered AC inverter which powers a standard 110-volt, 60-cps synchronous camera motor. The cameraman, therefore, has a completely independent 60-cps synchronous unit. The second of the two matched crystals is divided down for use in the recorder to provide a 60-cps control signal, just as if it were being received from the camera unit. The 1/4" tape is resolved in the normal manner, using the control signal as a synchronous reference.

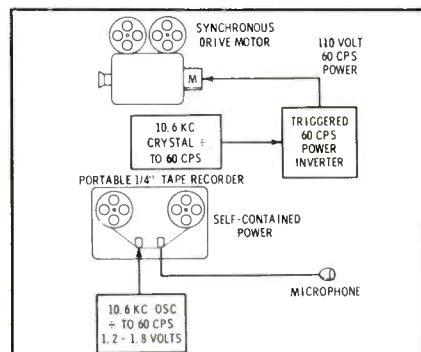

Fig. 8. Camera and recorder use matched crystals to provide the synchronization.

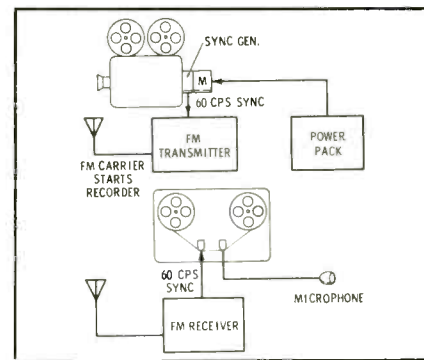

Fig. 9. Wireless synchronization is provided by transistorized transmitter and receiver.

The crystals used in this system are vacuum sealed and exhibit stability on the order of  $10^{-5}$ . This tolerance permits a loss in synchronization of no more than  $\pm .14$  frame at 24 fps for a continuous, 10-minute 16-mm film run which represents 14,400 frames. For all practical purposes, this degree of accuracy constitutes complete synchronization. Using a three-man crew and a wireless microphone, absolute physical independence of cameraman, sound man, and reporter/interviewer is attainable.

Yet another control-signal system is shown in Fig. 9. In this system a small, transistorized unit at the camera transmits the synchronizing signal to a receiver used in conjunction with the recorder. When the camera is started, the transmitter's carrier signal starts the recorder. Then, when the camera and recorder are up to speed and the take begins, the camera is "blooped," and the 60-cps control signal is transmitted simultaneously to the recorder. The cameraman, therefore, controls operation of the recorder and retains complete freedom from interconnecting cables.

### Conclusion

The advantages to be obtained from double-system filming more than outweigh the disadvantages of the system, particularly since portability is so necessary to modern film practice. Double-system work requires more time and planning, but for professional results in visual effects and sound quality, no other approach will deliver nearly as much. New equipment and new techniques promise greater enjoyment for viewers across the nation and increased freedom of expression for the film-unit director, the cameraman, and the editor. ▲





## Sony targets the sound you want

### Telemike Exclusive: Built-in Monitor Facility\*

Now, with *three* readily interchangeable sound tele-probes, similar in principle to changeable telephoto lenses, you can 'zoom' in from varying distances for the precise sound you're after. The 18-inch probe may be used for 'close-ups,' as far back as 75 feet from the sound source; the 34-inch probe from 150 feet. A 7-foot probe is optional for distances beyond 150 feet.

\*The most unique feature, a Sony exclusive, is the built-in, battery powered, solid state monitoring amplifier in the pistol grip handle, which assures the operator that he is transmitting the source with pin-point accuracy.

**OTHER FEATURES, OTHER USES:** The new Sony F-75 Dynamic Tele-Microphone is highly directional at the point of probe, with exceptional rejection of side and back noises (35 to 40 db sensitivity differential). Recessed switching allows quick selection of impedances (150, 250 and 10K). The uniform frequency response, controlled polar pattern, and unprecedented rejection of background noise eliminates feedback interference in P. A. systems.

The complete Sony F-75 Tele-Microphone includes two sound probes, 18 and 34 inch lengths, monitoring pistol grip handle and the Sony dynamic headset, all in a velvet-lined compartmentalized carrying case, for less than **\$395**. For specifications and a catalog of the complete line of Sony microphones, visit your nearest Sony/Superscope franchised dealer, or write: Superscope, Inc. Dept. 52, Sun Valley, Calif. *The best sound is Sony.*

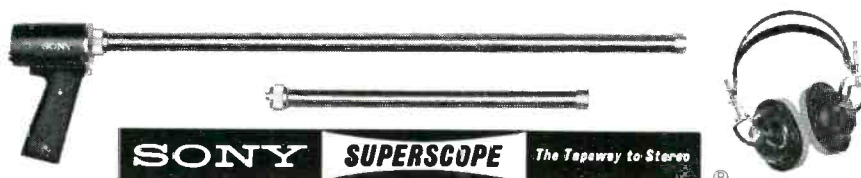

Circle Item 51 on Tech Data Card

# CHECKING BROADCAST SPURIOUS EMISSIONS

by **Elton B. Chick**, Consulting Author,  
 Director of Engineering, Rounsaville radio  
 stations — A practical discussion of an  
 important part of a station's annual  
 performance measurements.

The expansion of facilities in the communications and broadcast fields has been enormous during the past decade, and the problem of control of harmonic and other spurious emissions from the many transmitters has become a serious one. For standard broadcast stations, new limits on spurious emissions were imposed during this period; FCC Rule 73.40 gives the requirements for transmitters. It goes without saying that every broadcast station should regularly check for such emissions; in fact, Rule 73.47 requires "measurements or evidence showing that spurious radiations, including radio-frequency harmonics, are suppressed or are not present to a degree capable of causing objectionable interference to other radio services." This requirement is a part of the annually required Equipment Performance Measurements. The intent of this article is to offer suggestions which will aid in compliance with these rules.

## Requirements

A close look at Rule 73.40 re-

veals that the suppression of spurious emissions is to be considered in band segments related to the carrier frequency. These are emissions removed from the carrier frequency by: (1) 15 to 30 kc, (2) 30 to 75 kc, (3) more than 75 kc. Fig. 1 shows the positions of these bands in relation to the carrier frequency. It also shows the amount of reduction, specified in decibels related to the unmodulated carrier level, required within each band.

## Measurements

How does one go about checking such emissions? The ideal way would be to use a field-intensity meter which has a wide tuning range so that it could be used to check not only the adjacent channels but the harmonic frequencies as well. Unfortunately, such an instrument is not widely available. However, many stations do possess or have access to field-intensity meters which measure within the broadcast band. These instruments are most helpful in checking in the adjacent channels, and for stations having carrier frequencies below

800 kc they can be used for checking the strength of the second harmonic.

When a standard field-intensity meter is available, the measurements necessary to check adjacent channels (except for stations at or near either end of the broadcast band) can be made easily. One procedure for conducting these tests is to set up the field-strength meter a short distance from the station—a mile or more, depending on the station's power—and listen within the bands shown in Fig. 1. The strength of any emission from the station outside the assigned channel should be recorded. Also, the strength of the station's carrier at this point should be measured and logged. The relative strength of the spurious emission is computed as follows:

$$N = 20 \log_{10} \frac{E_1}{E_2}$$

Where:

- N is the number of decibels below carrier level,
- E<sub>1</sub> is the strength of the carrier

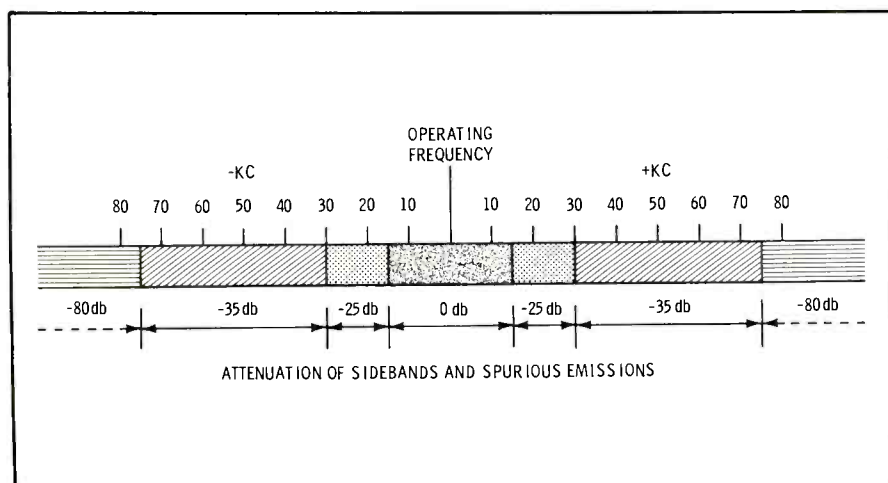

Fig. 1. Diagram shows required levels of signal suppression in various frequency bands.

BANDS	ATTENUATION	SIGNAL
±15 kc	0 db	100 mv/m
±15-30 kc	25 db	5.62 mv/m
±30-75 kc	35 db	1.75 mv/m
±75+ kc	80 db	.01 mv/m

in mv/m, and  
 $E_2$  is the strength of the spurious  
emission in mv/m.

As an example, consider a point  
where the carrier has a strength of  
100 mv/m and a spurious emission  
which has a strength of 2.5 mv/m  
is observed 25 kc from the carrier.  
The magnitude of the spurious  
emission is then:

$$N = 20 \log_{10} \frac{100}{2.5} = 32 \text{ db}$$

This emission is thus more than 25  
db below the carrier level and may  
be considered to be in compliance  
with the FCC rules unless the signal  
is causing harmful interference.

Consider now the case of a 10  
mv/m signal at the same point. Its  
level would be only 20 db down,  
and correction would be required.  
Table 1 shows the signal levels cor-  
responding to the required amounts  
of attenuation and a 100 mv/m  
carrier level.

Observations such as those de-  
scribed above should be made at  
several points and in several direc-  
tions. This is especially true of sta-  
tions using directional antennas,  
since the radiation pattern of spu-  
rious emissions is likely to be dif-  
ferent from the pattern at the  
carrier frequency.

In checking for harmonics and  
other undesirable radiations outside  
the broadcast band, unless a suit-  
able field meter is available the best  
bet is to use a high-quality com-  
munications receiver. This type of  
receiver, especially one having mul-  
tiple-conversion circuitry, is quite  
selective and is less likely to gen-  
erate spurious signals within itself  
than are other types.

A communications receiver used  
to check for harmonics should be  
in good working order, accurately  
calibrated or have a built-in crystal  
calibrator, and equipped with a  
good outdoor wire antenna that is  
25 or 50' long and in the clear. In  
using the communications receiver,  
the observations will have to be  
evaluated subjectively. One point  
to keep in mind is the importance  
of learning whether any harmonics  
or other spurious radiations present  
cause interference. This is difficult  
to evaluate accurately, since a har-  
monic can cause interference several

# 25 Pounds of Versatility.

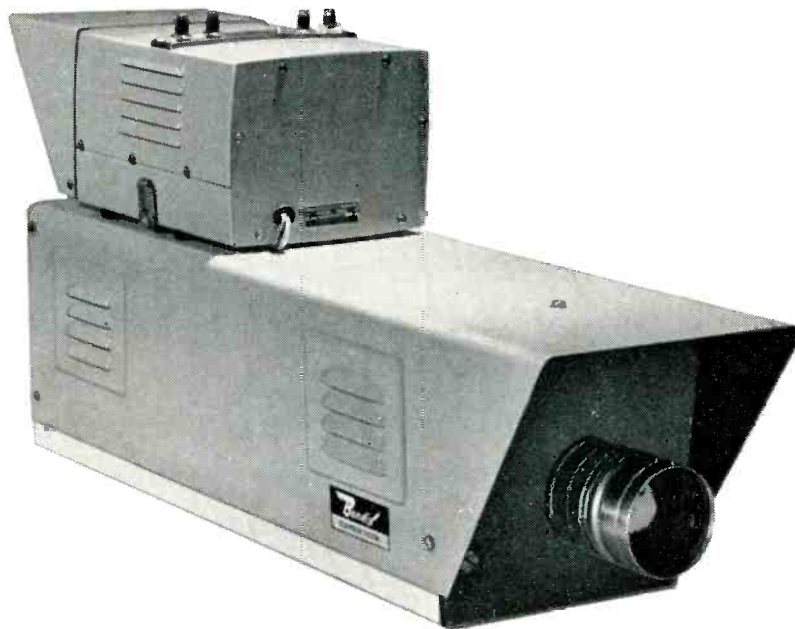

## The Bendix BX-8A Image Orthicon.

The Bendix BX-8A Image Orthicon Camera System is a remarkable develop-  
ment for the television industry.

There's nothing like it for portability and performance. It's rugged, reliable  
and stable. It provides studio quality pictures under field conditions. It  
makes remote pickup possibilities as varied as the imagination, and is  
unexcelled for many studio jobs.

The American Broadcasting Company selected the BX-8A camera and  
proved its value during the Winter Olympics, the political conventions, the  
Summer Olympic tryouts, and other special events.

### Here are some of the features that attracted ABC:

- Small size, light weight (camera unit 25 lbs.)
- Excellent resolution under varying light conditions
- Remote control of all camera functions (control unit separable from camera by more than 1000 feet)
- Detachable viewfinder, intercom options
- Stability in outdoor environments
- Adaptability to a variety of lens systems
- Very low power consumption
- Meets all EIA standards for broadcast television
- Compatible with normal broadcast facilities

We can't tell you all of the other features of the camera here. But we would like to give you the complete story. To get the picture first hand, contact us for details at Baltimore, Maryland.

**Bendix Radio Division**



Circle Item 32 on Tech Data Card

hundred miles away while causing no local problem. Observations made at several points and in different directions are most helpful in gaining a true picture of harmonic radiation.

In addition to listening on the harmonic frequencies, checks should be made at other frequencies both above and below the carrier frequency. Although such an occurrence is unusual, a transmitter can produce spurious emissions below its fundamental frequency, often as a result of some internal oscillation

within the transmitter or as the result of a heterodyne process involving signals from other stations.

In investigating this condition, it is helpful to consider the heterodyne or image frequencies that may be developed with other local stations. The frequencies of these emissions can be predicted accurately so that a check of them is simplified. As an example of the possibilities, consider two stations in close proximity whose frequencies are 630 kc (station A) and 1240 kc (station B). The following frequencies could be

produced by mixing of signals from the two stations:

- 1870 kc, the sum of the carrier frequencies between the carrier frequencies
- 610 kc, the difference between the carrier frequencies
- 20 kc, the difference between the 2nd harmonic of A and the fundamental of B
- 650 kc, the difference between the 3rd harmonic of A and the fundamental of B
- 590 kc, the difference between the 2nd harmonic of B and the 3rd harmonic of A

These are only five of the many possible combinations. When three or four stations are located nearby, the possibilities are rather disconcerting. Fortunately, most of the combinations do not develop, and the FCC rules regarding distance and frequency separation help to minimize the problem.

#### Summary

To summarize, in searching for spurious emissions these five steps are helpful:

1. Check the exact harmonic frequencies, and where possible measure the strength of the spurious signals and compute their value in relation to the carrier.
2. Check for undesirable sidebands within the range of 15 to 75 kc from the carrier. The levels of these emissions are most easily measured with a standard field-intensity meter.
3. Check for heterodyne frequencies by evaluating the possible combinations up through the 3rd harmonics of the station under observation and nearby stations.
4. Check as much of the remaining spectrum as is practical.
5. Keep notes on all observations for later reference.

Numerous manuals and some recent articles give information on the cure of spurious emissions. Generally, such emissions are eliminated either by transmitter repair and adjustment or by RF traps and filters at the output of the transmitter. (See "Cross Modulation—Cause and Cure," by Robert A. Jones, BROADCAST ENGINEERING, July 1964, p. 24.) Good luck and good hunting! ▲



## INNOVATION

... ANOTHER KEY TO

## SPARTA SUCCESS

### SPARTA A-20 AUDIO CONSOLE



The new transistorized Sparta A-20 is designed for continuous usage for AM, FM, and TV audio control rooms, recording studios. It employs eight faders that can mix from a selection of sixteen audio inputs. With added features like individual amplifier modules, both program and audition channels, exceptional input switching versatility, self contained power supply, monitor amplifier with speaker — the A-20 really is — an "Innovation".

Contact your Spartaman today for complete catalog information.

LOOK  
TO  
SPARTA  
FOR THE  
KEY  
TO  
BETTER  
BROADCASTING

# SPARTA ELECTRONIC CORPORATION

6450 FREEPORT BLVD. • SACRAMENTO, CALIF. 95822

Circle Item 53 on Tech Data Card

# ENGINEERS' EXCHANGE

## Speeding Routine Line Checks

by M. Barlow, Montreal, Quebec

At any station faced with 24-hour programming, overworked technicians, and operators who have limited technical knowledge, anything that reduces the routine maintenance load is a help. At our station we have three audio lines to the FM transmitter, one each to the AM and SW transmitters, and an emergency feed to AM from an FM receiver. Routine frequency and distortion runs on all these lines occupy considerable time and require operators at the studio and both transmitter sites. The natural tendency was to forget the routine tests and work on something else instead.

To give a "go-no-go" indication, we have adopted a modification of a routine TV transmitter test in which a pulse-and-bar video signal is originated by master control and the off-the-air waveform is compared with a photo taken after a complete system check. For our audio test, we have recorded a one-minute tape of seven test tones ranging from 100 cps to 15 kc (with appropriate voice announcements in between). After program hours, the operator plays this tape (always from the same machine) through his console (always switched the same way) and logs the VU-meter readings. He then repeats the tape, feeding the tone signals in turn to each transmitter through its associated line and logging the modulation-meter reading for each tone. A separate record sheet for each audio line is provided so that each week's readings are under each other. By adjusting levels so that the 400-cps reading is the same each week, it is easy to see whether any change in response has occurred since the previous check.

The actual readings may indicate a rather poor response, since they are the sum of the individual frequency responses of everything from tape machine to transmitter monitor. However, it is only **changes** that are important if the system is

initially within the required response limits. Changes of more than 1 db are brought to the attention of the maintenance crew, who can then check out each part in turn in the normal way. In this manner the operators can check the performance of the system and leave the maintenance men free until unsatisfactory performance develops. This method does not, of course, provide a check for distortion or noise, so these should still be checked from time to time.

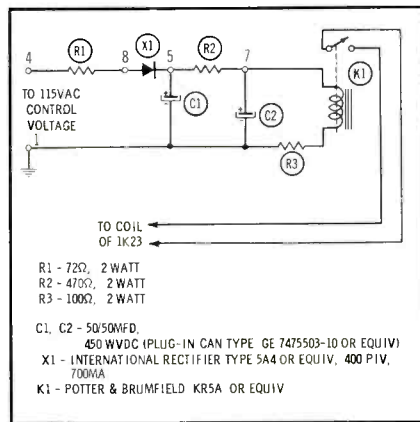

## Substitute Time Delay

by Bruce L. Mackey, Chief Engineer  
WKRT, Cortland, New York

Recently, the power-interruption reclosure relay, 1K24, in our GE XT-1-A AM transmitter failed. The purpose of this relay is to prevent reapplication of plate power to the transmitter after the occurrence of a line-voltage interruption of greater duration than three seconds. The original time-delay relay uses a mechanical assembly to introduce a delay of about three seconds before its normally closed contacts are opened. As long as the contacts remain closed, full plate voltage is reapplied to the transmitter as soon as primary power is restored. When the contacts open after three seconds, it is necessary to wait for the normal time delay (45 seconds) before plate voltage can be applied.

To avoid the expense of a duplicate relay, we decided on the accompanying circuit, which directly replaces 1K24. The circuit connections are made to the pins of an octal socket (the pin numbers are

shown on the diagram) which is mounted in a hole punched in the transmitter panel on which the original relay was installed. The electrolytic capacitor employed is a plug-in type for ease of replacement. The unenclosed relay is mounted on the rear of the panel, since in this location only filtered air reaches the relay during normal operation of the transmitter. The time delay obtained with the circuit shown is identical to that of the mechanical unit being replaced.

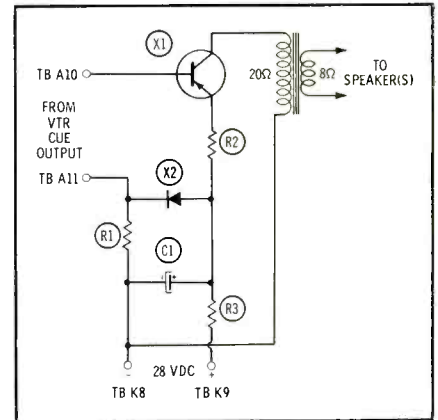

## Cue Amplifier for Video Tape Machine

by Norman E. Hall, Studio Supervisor,  
KERO-TV, Bakersfield, Calif.

When we first received our VR-1000B video tape machines, we simply hooked the 8-dbm cut-track output to a 500-ohm-to-voice-coil transformer and then to a speaker to allow us to use a sequence of tones for cue purposes. After several complaints from the operators that the cue audio level was too low, we decided to increase this level as simply as possible.

We built a single-transistor amplifier that operates from the tape-machine 28 VDC supply. The amplifier uses a single 2N301A power transistor and draws .5 amp from the supply. The unit uses 14 watts of power, of which 9 watts is dissipated in R3.

The 20-ohm-to-8-ohm output transformer was a homemade unit, but several commercial units are available, such as the Chicago Stancor TA-12, the Triad TV-29X or TY-64X, and the UTC CAT-15. Another possible source of a suitable transformer is a car radio having a transistor output stage. Or if the builder isn't squeamish about

running DC through the speaker voice coil, the transformer could be eliminated.

The silicon diode used for X2 was a "bargain-counter" 750-ma, 400-PIV top hat unit, but almost any small silicon diode would work as well. The transistor was mounted on a heat sink, but if the unit were mounted in a small metal chassis-box, the transistor could be mounted to the chassis with an insulated mounting kit, and the heat sink would not be needed. The unit was constructed on a 3½" by 5¼" piece of prepunched terminal board; matching push-in terminals were used. The completed unit was mounted on the rack No. 2 terminal assembly in the space left for terminal board G, which was not included in either of our machines.

The 500-ohm cue output of the machines is available at terminals 10 and 11 of terminal board A; the input terminals of the amplifier are connected there. The amplifier output may feed one or more speakers. The 28 VDC is available at terminals 8 (+) and 9 (—) of terminal board K.

In testing the unit before connecting it to the machines, we used a 12-volt lantern battery with good results. If we were to start this project again, we would probably use an integral 8 VDC supply. This would eliminate R3 and the needless dissipation of heat from this resistor.

## Turntable Inputs For Remotes

by Roy Gallagher, Ft. Lauderdale, Fla.

The need for a lightweight remote amplifier with two phono inputs (and one or more microphone inputs) for remote DJ shows and "record-hops" led us to modify a standard remote-line amplifier for such use. For the sake of economy, we took the direct approach to por-

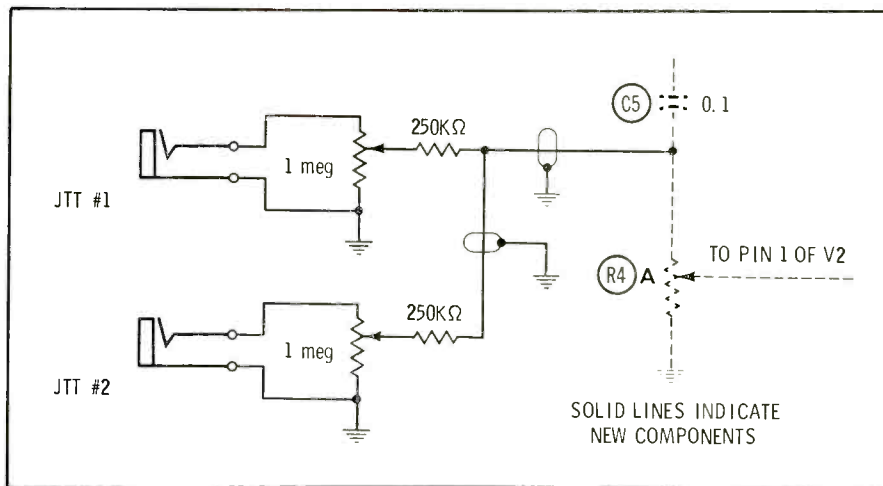

tability, using a Gates Dynamote as our starting point. The Dynamote has a four-channel, low-level mixer which feeds a program amplifier having a dual volume control that governs the input level to the grids of the second and third stages of the amplifier. The output of this amplifier feeds a VU meter, a line pad, and an elaborate switching system. One switch selects one or the other of two program lines or an order line to feed the program out. The other switch places the operator's headphones across the amplifier or across either program line. Since very few stations today will use two lines, these switches may be removed. In their place, a couple of one-megohm volume controls, one for each turntable, can be mounted (see photo). The microphone-input panel on the rear of the unit has plenty of space for mounting two standard phone jacks.

Since most ceramic cartridges give bood bass response with a one-megohm load, and since the output level is just right to feed into the grid of the second tube (5879) in the program amplifier (see diagram), we chose ceramics. The resistors in series with the center contact of each volume control prevent interaction between the controls and prevent the shorting to ground of the input from the microphone preamplifier stage. Note that the combined output of the turntables is fed to the high side of only one of the pots in the dual master control. This requires no alteration of the amplifier's printed-circuit board, since the master control is mounted on the front panel where it's very easy to reach.

The selector switches on the

front panel can be treated in a number of ways. We removed them completely, soldering and taping the necessary leads to keep the unit functional; unused leads were clipped from the switches and their ends taped. The headphone switch was wired so that it was across the amplifier output at all times; this corresponds to the center position of the original switch. The line-selector switch was removed, and its leads were soldered and connected so the output of the amplifier normally feeds line No. 1. Two 2000-ohm resistors, connected from each line terminal directly to its corresponding headphone jack on the rear of the unit, allow a quick check of the output. It will also be possible to listen to the cue signal from the line, if necessary.

We built a portable console using two turntables and the altered remote amplifier and have found it useful for broadcasting "real-live" DJ programs. Total cost for parts used in adding two turntable inputs to the remote amplifier was around \$6. ▲

**STANCIL-HOFFMAN CORP.**

- MINITAPE PROFESSIONAL BATTERY Operated Portable Recorder, Mono Stereo, Synchronous.
- MAGNETIC FILM RECORDERS, Single and Multi-Channel, 16, 17½, 35 MM.
- BROADCAST LOGGING Recorders, Slow Speed Single Channel to 32 Channels.
- HIGH SPEED TAPE DUPLICATORS for Full, Half and Two Track Stereo Duplication.

921 N. Highland Ave., Hollywood 38, Calif.

**SALES ENGINEER  
BROADCAST EQUIPMENT**

Profitable, growth-minded company, leader in broadcast equipment field, has immediate opening for sales engineer to travel and sell technical equipment primarily to AM, FM and TV stations in exclusive territory. Requires good knowledge of broadcast equipment. Must be sales minded. Self-starter. BSEE or equivalent and minimum three years in field of radio broadcasting. Excellent salary plus commission. Travel expense paid. Complete company benefits. An equal opportunity employer.

Send resume to Broadcast Engineering, Dept. 124.



# Alright... Cut it out



Yes... cut out those slow starts, annoying maintenance and bothersome adjustments with a QRK Professional Turntable. Simplified, patented design provides "blast-off" acceleration for instant "queing." Exclusive Platter-dapter plays 45's, 10's or 12's without pop-up gadgets. All this PLUS sustained performance backed by a full year warranty AND prompt service.

- Only 3 moving parts
- PLATTER-PROTECTOR Rim
- Oilite Bearings
- Positive fingertip control



Now...

# Cut this out

...and get **FREE** an accurate full range STROBOSCOPE test disc with our detailed illustrated brochure on QRK turntables.



NAME \_\_\_\_\_

ADDRESS \_\_\_\_\_

CITY \_\_\_\_\_

STATE \_\_\_\_\_



Send this coupon or write to



**ELECTRONIC PRODUCTS**

2125 N. Barton • Fresno, California

## What to Do

(Continued from page 15)

tially destroyed tower can only be guessed, the operator who has some towers of his directional system remaining knows more of the problem he is facing. The antenna-resistance report of a nondirectional station or the proof-of-performance report of a directional station provide information describing the base impedance of at least one tower. In most directional antenna systems, the towers are all similar, so a good estimate is that the base impedances of all towers in the system are similar.

Fig. 3 shows an L network best for use where the short-antenna resistance is less than the characteristic impedance of the transmission line. At least for the stub antenna, a larger inductance will be needed in the output arm than the operator may be accustomed to seeing. This is because an unusual type of antenna is being matched.

Using the estimated value of antenna impedance and the transmission-line impedance, first calculate and come as close as possible to constructing a network similar to the one shown in Fig. 3. In the circuit of Fig. 3, when  $I_A^2 = I_2^2 + I_L^2$ , the circuit presents a resistive termination to the transmission line. It is then necessary to adjust the network for the proper resistance of the termination while maintaining the required current relationship. The

optimum termination can be determined by adjustment of the network while keeping in mind you desire maximum antenna current; normal values of transmitter current and voltage; and, of dubious value, equal current at both ends of the transmission line. Remember that in a line one-half wavelength long, it is possible to have equal currents at both ends even though the line is improperly terminated, so evaluate such an indication carefully.

To tune the circuit of Fig. 3, the current-squared relation should first be obtained. It is helpful when making these adjustments to attempt to maintain a constant value of transmission-line current,  $I_L$ , approximately equal to  $\sqrt{W/Z_s}$ , where  $W$  is the anticipated power output of the transmitter. Should the transmitter require overloading to obtain the desired line current, the input resistance of the coupling network is too great, and shunt reactance  $X_2$  must be changed to a more positive value. Conversely, if the transmitter is under-loaded when the desired value of  $I_L$  is obtained, it follows that the input resistance of the network is too small and a more negative value of  $X_2$  is required. The value of  $X_1$  also affects the input resistance substantially, and since the antenna reactance is not known, it is impossible to predict the effect on input resistance of an increase or decrease of  $X_1$ . Trial and error adjustment of the com-

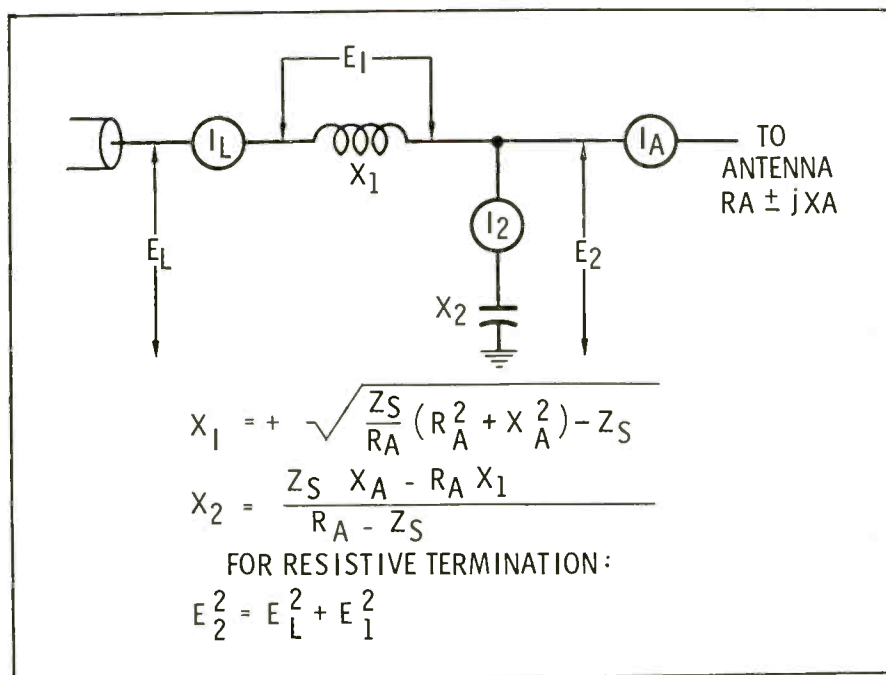

Fig. 4. Network for use when the antenna resistance exceeds the line impedance.



ponents—in a systematic manner and with orderly notes—is necessary.

The circuit of Fig. 4 is used where the antenna resistance is greater than the characteristic impedance of the transmission line. Adjustment of this circuit requires a vacuum-tube voltmeter. When  $E_2^2 = E_L^2 + E_1^2$ , the network presents a resistive termination to the transmission line. In this circuit,  $X_1$  controls input reactance and has negligible effect upon input resistance, whereas with the circuit of Fig. 3 there is substantial interaction on input resistance and reactance. The adjustment is made by setting  $X_2$  to give the desired input resistance and then removing with  $X_1$  whatever reactance is present.

More practically, this means adjusting the components until the voltage-squared relationship is obtained and then checking to see if the line has the same current at both ends. If the line current at the transmitter is greater than the line current at the coupling unit, it follows

that the resistance looking into the coupling unit is greater than the line impedance. To increase the input resistance, decrease the capacitance at  $X_2$ . To decrease the input resistance, increase the capacitance at  $X_2$ .

Calculation of the reactance of a capacitor is straightforward. Estimation of reactance of a coil is a little more difficult. Experience shows that when a coil is mounted among all the other components in a network and on a metal panel, the reactance can be expected to vary linearly with the number of turns. A typical coil that is likely to be encountered would have an inductance of 17  $\mu$ h, 16 turns, and a 15-amp rating. Unless you have more definite information, begin by calculating the reactance of a 17- $\mu$ h coil at your frequency, and assume the reactance to be distributed linearly along the turns of the coil. Also remember that large values of reactance can be produced by a parallel circuit tuned to either side of resonance.

Do not overlook the importance of knowing where your transmitter

normally tunes, either by knowing the dial numbers or the position of the variable inductor or capacitor. You will be better able to estimate the load you are working into and the power output of the transmitter when you have achieved resonance at the normal settings.

### Conclusion

It would be wise to anticipate these problems well before an emergency actually occurs. Consult a good standard text for additional discussion on wire antennas and matching circuits. It may be advisable to erect a horizontal wire antenna temporarily and assemble and adjust a network such as described here during the experimental period. Even if the antenna and network are not assembled, the calculations may be made without the pressure of an emergency. Then if an antenna emergency does arise, you will be at least partly prepared, and your preparation will help you handle the situation calmly and efficiently. ▲

**PREPARE  
TO BE!!!!  
AMAZED**

see and hear the famous

**SINGING CLOCK**  
Just push a button...and it sings the exact time...in rhyme!

**GRC**

**COMMERCIAL RECORDING CORPORATION**

2425 CARLISLE / DALLAS, TEXAS 75201  
Call us collect! PHONE: 214-748-8004

creators of the "money maker"



Circle Item 55 on Tech Data Card

# WANTED

## OLDEST MAGNECORD MODEL PT6

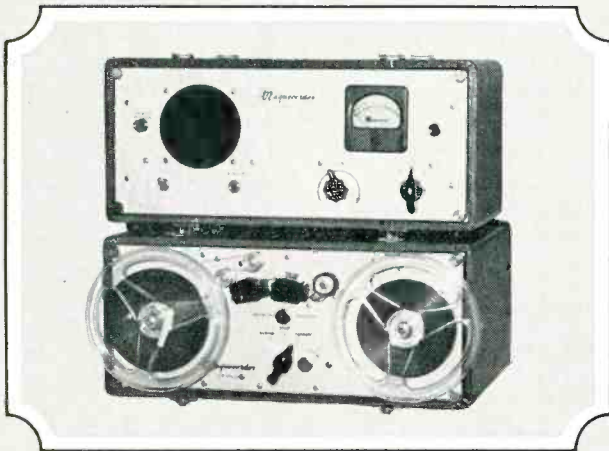

Thousands of Magnecords are delivered . . . never to be seen by our service department. This is marvelous testimony to Magnecord reliability and long life. But even we don't know just how long a Magnecord keeps performing. That's why Magnecord, America's first magnetic tape recorder manufacturer, is offering a reward for the oldest operating PT6. We're giving a new Magnecord just to satisfy our curiosity!

## REWARD

In exchange for the oldest operating Model PT6, Magnecord will give a choice of any new model in the magnificent 1000 series.

### MAGNECORD ANNOUNCES NEW ONE YEAR WARRANTY

In the belief that users of quality tape equipment buy performance rather than paper promises, Magnecord has always issued a 90 day warranty. While others concentrated on promises we concentrated on performance. Magnecord acceptance has

proven the wisdom of this policy. But from now on, each Magnecord gets a one year warranty. However, you can expect the same reliability and lasting quality that has kept Magnecord first choice of discriminating tape equipment users.

Get contest rules and entry blank at your Magnecord dealer or write:



**Magnecord Sales Div.**  
MIDWESTERN INSTRUMENTS

Subsidiary of the TELEX Corporation  
P. O. Box 7509 / Tulsa, Oklahoma 74105

Circle Item 56 on Tech Data Card

## RF Techniques

(Continued from page 22)

method of power measurement, these power losses must be considered. For example: The licensed aural power is 2 kw at the input to the transmission line. If the diplexer has a 10% loss, the transmitter must deliver 2.22 kw to make up the loss.

When the direct method is used, a dummy load and wattmeter are connected in place of the transmission line immediately following the diplexer. The transmitter is adjusted to provide the power required at this point (as indicated on the wattmeter), and the reflectometer on the transmitter is adjusted to 100%. This automatically compensates for the diplexer loss. No modulation is applied to the aural transmitter during these measurements, and the visual carrier should not be on. It is a good idea to check the tracking of the reflectometer with the wattmeter at the 80%, 100%, and 110% power points.

Although the indirect method is permitted, it is seldom used. Since the load and wattmeter are required for power measurements of the visual transmitter, it is a simple matter to check the aural power at the same time.

### Visual Transmitter

Measurement of the visual-transmitter power is even more complicated. Only the direct method of measuring power output is permitted, and the power level must be constantly monitored with a peak-reading device during operation.

The sideband filters, diplexers, etc., are considered a part of the visual transmitter, and the output power is measured immediately following these units. Losses from these units are incorporated into the visual transmitter design. (Filters, diplexers, etc., are not considered part of the aural transmitter.)

Loads and wattmeters differ according to the carrier frequency and power they are required to measure. Low-power loads are usually air cooled (Fig. 3A), while high-power units are water cooled (Fig. 3B). Old-style loads for VHF transmitters were water cooled, and the temperature rise of the water was used to determine power from a nomograph or by calculation. Pres-

ent-day VHF loads are used with a separate wattmeter. UHF loads are water cooled and use a separate wattmeter. A typical small wattmeter is shown in Fig. 4. The high-power model uses no resistor. Instead, a section of special transmission line, matched to the main transmission line and shorted at the end, is used as a load. Whatever type of load and wattmeter is used, only the average power while the transmitter is modulated with a standard black picture is read (Fig. 5).

Since the operating power must be monitored with a peak-reading reflectometer, it is necessary to calculate the peak power after the average power has been determined. The FCC specifies that the average power must be multiplied by a factor of 1.68 when calculating the peak power. This factor is based on the waveform content of the black-picture signal.

After the load and wattmeter have been connected in place of the regular transmission line (Fig. 6), the cooling (if used) should be turned on, the aural transmitter turned off, and the visual transmitter turned on. It is at about this time that the engineer may wish he had more hands and could be in more than one place at the same time. It is best to have one man watch the CRO, keep the chopper going, and make sync-level adjustments while the second man makes adjustments to the black level and drive controls, keeps the transmitter accurately tuned, and observes the wattmeter. It is amazing how much change in the average power reading results from small changes in sync, black level, and stage tuning. All adjustments should be made in small increments until the required conditions of modulation, stage tuning, final-stage plate current and voltage, and average power output are met. The calibrating control should then be adjusted so the reflectometer reads 100%, and the control should then be locked in place. The required average power level is equal to the peak power divided by 1.68. Stage tuning and coupling devices can affect sync levels and, therefore, the power measurements. Hence, the best time to make power measurements is after the transmitter has been ad-

justed for best bandpass and all coupling and tuning adjustments have been completed.

The FCC requires that reflectometers or other direct power-measurement devices used to monitor output power, whether for FM or TV, be calibrated at intervals no greater than 6 months apart. Appropriate data describing these calibrations must be entered in the maintenance log.

Disconnecting a coaxial line to install a dummy load, or for any other reason, always introduces the possibility of something going wrong when the line is returned to its normal connection. A good precautionary technique is to compare the VSWR reading obtained before opening the line with the one obtained after the line has been reconnected. Any increase in VSWR value is sufficient reason to look for something wrong.

And most important of all—remember to disconnect the dummy load and connect the transmitter back to the antenna! ▲

## ELIMINATE DOWN TIME

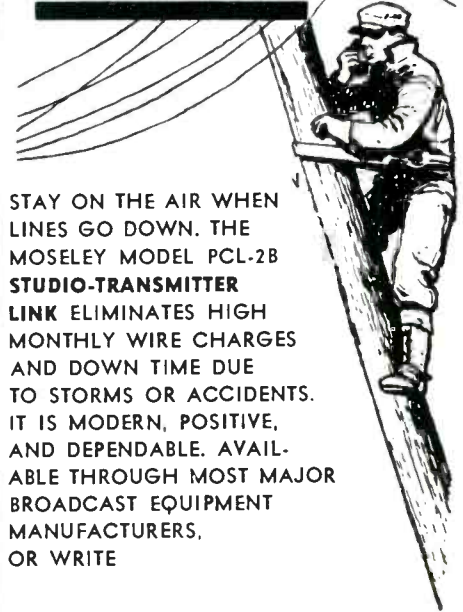

STAY ON THE AIR WHEN LINES GO DOWN. THE MOSELEY MODEL PCL-2B STUDIO-TRANSMITTER LINK ELIMINATES HIGH MONTHLY WIRE CHARGES AND DOWN TIME DUE TO STORMS OR ACCIDENTS. IT IS MODERN, POSITIVE, AND DEPENDABLE. AVAILABLE THROUGH MOST MAJOR BROADCAST EQUIPMENT MANUFACTURERS, OR WRITE



MOSELEY ASSOCIATES INC.

Circle Item 58 on Tech Data Card

## Scala Precision Antennas

- \* OFF-THE-AIR PICKUP — FM or TV
- \* LOW POWER UHF, VHF TV TRANSMITTING
- \* STL AND TELEMETERING ANTENNAS

Engineered to meet rigid FM and TV station specifications, and to endure the tests of weather and time.

Built to your specifications by

**SCALA RADIO CORP.**

2814 19th STREET  
SAN FRANCISCO 10  
VA 6-2898

Circle Item 57 on Tech Data Card

Ask for Catalog No. GC-65



**BIRD**

## Remote Control Pair

(Continued from page 19)

### Switching Circuit

A variety of combinations of functions can be controlled with this unit. The arrangement used at KWHK is shown in Fig. 3. Relay K9 is energized through terminals 1 and 2, and K10 is energized through terminals 3 and 4. These relays correspond, respectively, to relays CR1 and CR2 in Fig. 2 on page 10 of the June 1964 issue of BROADCAST ENGINEERING.

Terminals 5 and 6 energize relay K11, which latches through one set of its own contacts and NC terminals 13 and 14. This relay switches spare line No. 1 into program line No. 1, which normally carries program material to the transmitter. Terminals 7 and 8 control K12 which also is connected as a latching relay. Action of this relay switches the network source into program line No. 1. Either or both of these relays can be released by an open circuit between terminals 13 and 14.

Control - circuit action between

terminals 9 and 10 closes latching relay K13, which switches spare line No. 2 onto program line No. 2, normally used for network transmission. Similarly, K14 operates to switch the program source onto network program line No. 2. Either or both relays can be released when the control-circuit path between terminals 15 and 16 is opened.

For KWHK, this system is better than a dial stepper setup because almost instantly we can start or stop our automatic programmer, switch two-way mobile units on the air, or, if necessary, change from local program to network or to either of two

remote broadcast points via the spare line inputs. At the transmitter, in addition to our regular telephone, we have an extension on our first line at the studio. This gives us a better answering service when the studio is unattended. By leaving line No. 1 set into the beeper amplifier, which in turn is patched into one of the spare line inputs, we can put our newsmen on the air via telephone when the use of a car radio is impossible.

All this helps in our constant effort to bring about efficiency and improved quality in the programs that we present to our listeners. ▲

## SPOTMASTER Tape Cartridge Winder

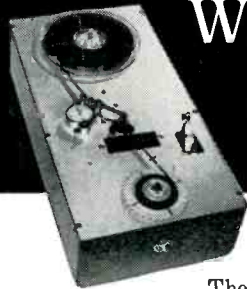

The new Model TP-1A is a rugged, dependable and field tested unit. It is easy to operate and fills a need in every station using cartridge equipment. Will handle all reel sizes. High speed winding at 22½" per second. Worn tape in old cartridges is easy to replace. New or old cartridges may be wound to any length. Tape Timer with minute and second calibration optional and extra. Installed on winder or available as accessory. TP-1A is \$94.50, with Tape Timer \$119.50.

Write or wire for complete details.

*Spotmaster*

**BROADCAST ELECTRONICS, INC.**  
8800 Brookville Road  
Silver Spring, Maryland

Circle Item 59 on Tech Data Card

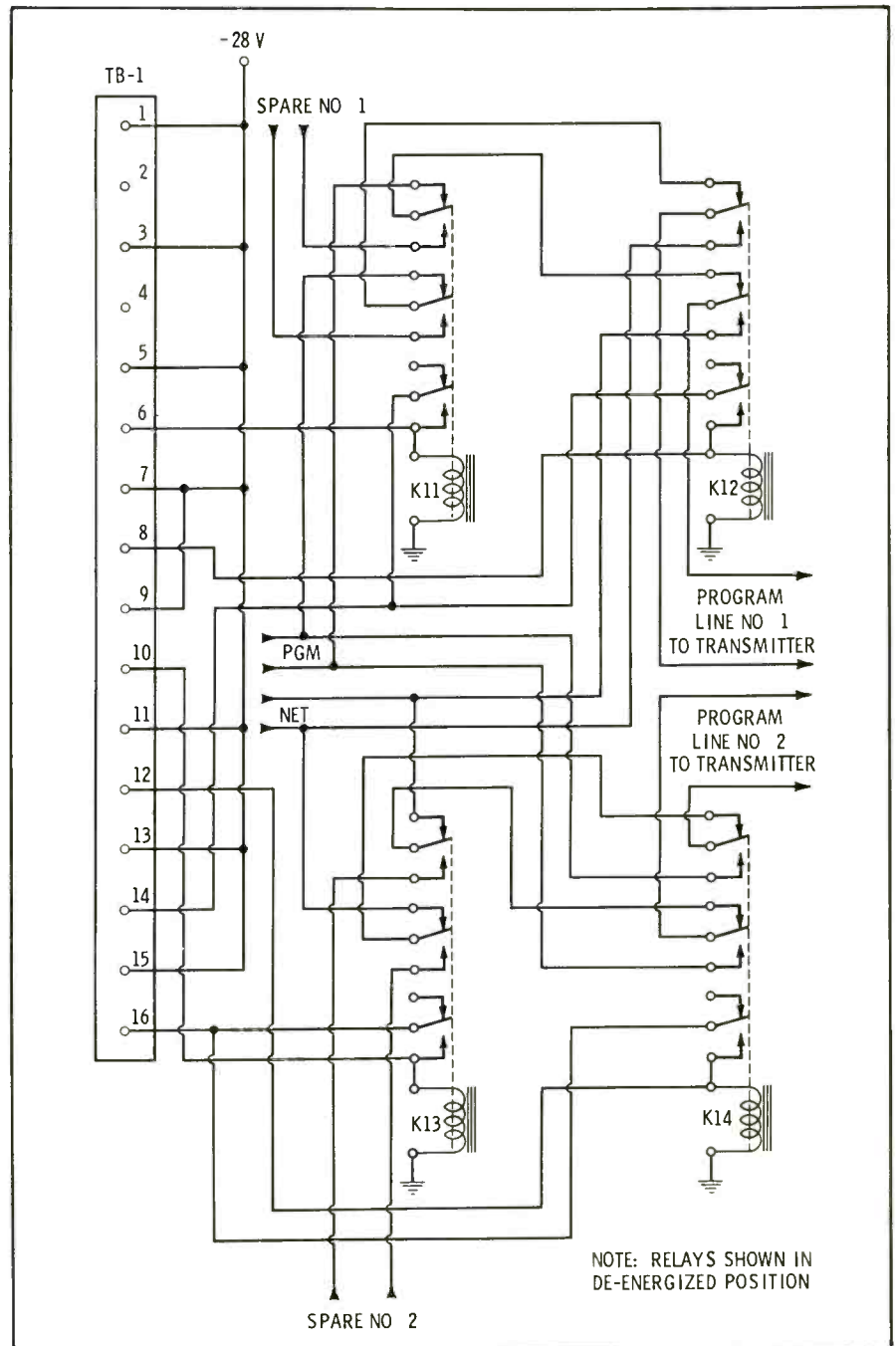

Fig. 3. A circuit-switching arrangement used in conjunction with remote control.

# NEWS OF THE INDUSTRY

## NATIONAL

### Salary Survey

Results of recent surveys by the **National Associates of Broadcasters** show that radio and TV-station employee's salaries have increased 6% and 7%, respectively, over the past two years. As reported by **TELEVISION DIGEST**, the salary ranges were as follows:

Television			
	Low	High	Ave
Announcers	\$105	\$237	\$153
Chief Engineers	158	279	207
Cameramen	73	160	96
Floormen	51	118	77
Technicians	95	180	129
Sales Managers	189	454	...

Radio			
	Low	High	Ave
Announcers	\$ 78	\$245	\$104
Technicians	80	192	101
Chief Engineers	98	257	125
Traffic Managers	62	120	72
Sales Managers	136	464	187

Pay rates varied widely according to the size of station and to a lesser degree according to geographic location (North or South).

### Towers Being Built

Three TV towers ranging to 1529' in height are to be built by **Dresser-Ideco**. Station **KHMA-TV**, a commercial television station at Houma, Louisiana, will be the owner of the 1529' tower. This will be a guyed tower designed to survive winds of hurricane strength. At Joplin, Missouri, Station **KODE-TV** has ordered a 999' guyed tower, which will also incorporate a 200' AM radiator. The third tower is for the University of Washington, Seattle, which has contracted for a 590' self-supporting tower for that university's educational TV project.

### Stereo by Satellite

In a recent test, a stereo signal transmitted from the earth was received by a satellite orbiting at an altitude of 5000 miles and retransmitted back to earth. The test, involving **Collins Mfg. Co.** stereo equipment, took place at NASA's Goddard Space Flight Center communication ground station at Goldstone Dry Lake, California. Engineers described the test as a success.

The purpose of the test was to gather further proof that the American method of stereo broadcasting (known to radio engineers as the "Pilot-Tone" method) should be adopted as a world standard. Results of the test will be presented to a meeting in Vienna, Austria, March 25-April 7, of Study Group X of the Commission Consultatif International de Radio (CCIR). At the Vienna meeting, Study Group X is slated to consider making a recommendation for interna-

tional standardization of stereo broadcasting. This recommendation would be presented to a plenary session of the CCIR in 1966 for adoption.

During the test, a stereo recording of voice, music, and tones for measurement was fed into a stereo generator. The generator provided a single, composite signal for modulating a NASA transmitter, which beamed the signal to the orbiting Relay II satellite. After receiving the signal, Relay II retransmitted it back to earth. On the ground, the signal was received by NASA equipment and fed into a stereo modulation monitor to unscramble the composite signal into left- and right-channel outputs, which were tape recorded. Both recordings—before and after—will be played at the meeting in Vienna to illustrate that with use of the "Pilot-Tone" method stereo quality can be maintained through a satellite relay.

### VOA Modernization

The New York headquarters of the Voice of America is undergoing a complete modernization. Prime contractor for the job is **Fairchild Recording Corporation**, of Long Island City. The planned improvement at VOA includes installation of completely new studios and a master-control room. The equipment employs only solid-state circuitry.

### CATV School

**Entron's** first three-day course in CATV-system maintenance was conducted by Heinz Blum, Vice-President, Engineering. Students from New York, New Jersey, Illinois, Minnesota, Tennessee, Alabama, Mississippi, North Carolina, New Mexico, and Pennsylvania participated in the course, which included instruction in all phases of installation, operation, and maintenance of Entron CATV systems.

The welcoming address to the group was given by Ed Whitney, Entron's Vice-President. Irving Kuzminsky, the company's Director of Advanced Engineering, discussed head-end equipment and alignment. Other topics covered included

theory; maintenance of various units; and systems layout, extensions, and practices. Each school day consisted of eight hours of instruction and alignment practice. Similar classes are planned for the near future.

### Large-Scale CATV Modernization

One of the nation's largest operators of CATV systems, **H & B American Corp.**, has announced a major modernization program. Five systems will be completely rebuilt, one will be partially rebuilt, and one new system will be installed. All systems will use solid-state equipment.

According to Leon Papernow, Vice-President of Operations, this modernization is being undertaken to provide subscribers with more program variety and improved picture quality. Once the changeover is completed, all seven systems will be capable of carrying up to 12 TV channels and 20 FM stations.

To implement the program, H & B has purchased from Jerrold Electronics, in the largest single equipment-purchase contract in the history of CATV, enough solid-state equipment to send signals through more than 500 miles of cables.

## INTERNATIONAL

### Training Plans for Foreign Broadcasters

The Committee on International Broadcasting of the **National Association of Broadcasters** has arranged to train three foreign broadcasters in United States television stations. Kim Kyu, program manager, Dongyang Telecasting Network Company, Ltd., Seoul, Korea, will be assigned to the American Broadcasting Company through ABC International. He will work at the network and in ABC - owned - and - operated stations. Jacques Cogniaux, program director for Belgian National Radio and TV, will train at **WBAL-TV**, Baltimore. Anton Kjaedegaard, chief of programming in the cultural department, Danish State TV, will be assigned to **WTOP-TV**, Washington. Each broadcaster will spend two months in practical training assignments at his host television station. The placement program is being carried out in cooperation with the State Department. ▲

Ask for Catalog No. GC-65



QUALITY INSTRUMENTS

RF POWER

**BIRD**

# NEW PRODUCTS

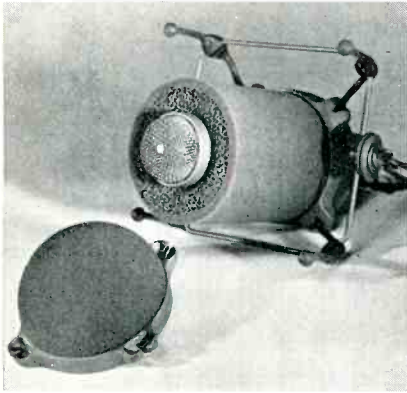

## Foam Windscreen

A special windscreen made from an "open-pore" polyurethane foam is an integral part of a number of professional-model microphones manufactured by **Electro-Voice, Inc.** The windscreen reduces the velocity of air entering the microphone from wind or fast movement and prevents distortion of sound. Called Acoustifoam (TM), the porous material is manufactured by the Foam Division, **Scott Paper Company**. The material does not affect frequency response or the polar pattern of microphones.

Acoustifoam is a porous ester-type polyurethane foam which has no exterior surface membranes to block pas-

sage of sound. With 97% of its volume consisting of air space, the foam is made of thousands of interconnecting strands which break up the air stream and substantially reduce its velocity. Windscreens made of Acoustifoam have operated effectively in outdoor wind velocities up to 40 mph. The polyurethane windscreens also protect sensitive microphones against airborne dust particles. Dust that collects on the interior strands of the material may be removed by washing the windscreen under running water. If severely soiled, the foam may be washed in a mild soap. Excess water is squeezed out.

Circle Item 106 on Tech Data Card

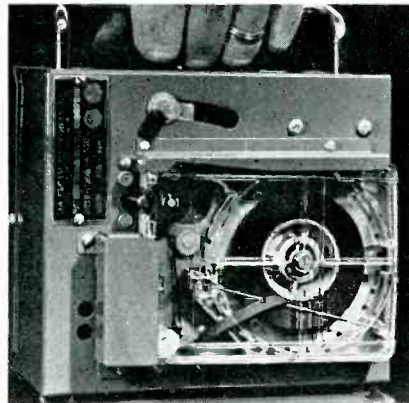

## Cartridge Tape Playback

This new portable tape-playback is a cartridge type for radio stations. It is the Model 200B "Audio-Magic" introduced by **LaCrosse Electronics, Inc.** The unit employs a four-stage transistor amplifier with 5" speaker and operates on 115 volts AC with a 1-watt output at less than 3% distortion. Tape speed is 7½ ips. Price is \$49.95.

Circle Item 107 on Tech Data Card

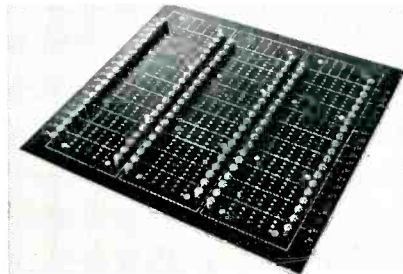

## Program Boards

Cordless program boards for timecasting TV and radio broadcasting operations are now available from **Seaelectro Corp.**, Mamaroneck, N. Y. The new "Seaelectro-board" provides the advantages of matrix design, with either bussed or individual outputs, operations indicator lights, RF patch areas, and appropriate front-panel markings. The unit provides instant visual readout of the program plan, plus elapsed-time and real-time identification. The electrical contacts are rated at 5 amps. Shorting pins, diode holders, component holders, and illuminated monitoring pins are available as plug-in accessories.

Circle Item 108 on Tech Data Card



## Multipurpose Wideband Oscilloscope

A new wideband oscilloscope, the Type 546 by **Tektronix, Inc.**, accepts the new 1-A Series Plug-In Units for general-purpose DC-to-50-mc dual-trace applications and also the "letter-series" plug-ins for strain gage, multichannel, differential, and operational amplifier applications in the DC-up-to-30-mc area. Dual-trace sensitivity with a Type 1A1 Plug-In Unit is to 50 mv/cm from DC to 50 mc and to 5 mv/cm from DC to 28 mc. For applications demanding greater sensitivity, the two input channels can be cascaded to provide single-trace displays at approximately 500 uv/cm sensitivity from 2 cps to 15 mc. Sweep range of the Type 546 is from 0.1 usec/cm to 5 sec/cm, with sweep magnification extending the fastest sweep to 10 nsec/cm. Triggering facilities, including automatic and single-sweep operation, provide for triggering beyond 50 mc. Continuously variable calibrated sweep delay, with trace brightening to indicate the exact portion of signal that appears on the magnified display, enables precise time measurements. Signal delay is through a delay line that requires no tuning and has uniform transient response. A 6-cm by 10-cm internal graticule, with controllable illumination, allows parallax-free measurements and waveform photography with sharp delineation of the graticule markings. The price is \$1750.

Circle Item 109 on Tech Data Card



## Adjustable Tape Cartridge

An adjustable tape cartridge designed to NAB standards is available from the

## KILL THE HEAT!



Replace hot tube rectifiers NOW with life-time, indestructible, no-heat silicons.

2400 PIV-1 amp  
replaces 5R4 ... \$3.95

1800 PIV-1 amp  
replaces 5U4 ... \$1.95

Replacements available for most tubes. Order 10 or more for Special Quantity prices.



**Wilkinson Electronics, Inc.**  
1937 W. MacDade Blvd.  
Woodlyn, Pa. 19094  
Telephone: 215-874-5237

Circle Item 60 on Tech Data Card

**Amerline Corp.** Polyurethane pressure pads can be adjusted with a screw driver without taking the cartridge apart, and the patented hyperbolic take-off hub assures excellent fidelity. A Delrin-tonylon center bearing provides smooth tape motion and each loaded cartridge is tested for minimum wow and flutter with a 3 kc test tone. No bearing lubrication is required. Tape lock and guide features prevent tape loosening. Stock sizes range from 40 seconds to 5½ minutes. Empty cartridges are also available from stock.

Circle Item 110 on Tech Data Card

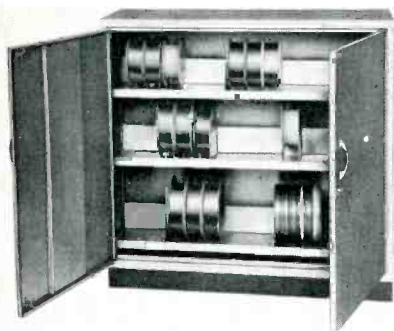

### Tape and Film Storage

To meet the growing need for film and video-tape storage facilities, the **Jack C. Coffey Co., Inc.**, North Chicago, Ill., is producing add-on filing and storage units with capacities ranging from eight 14" video-tape reels to 45 6", 6½", and 8" reels. The equipment may also be used for storage of 16 mm motion-picture films in reels or cans. These LUXOR units can be used with present film or tape cabinets having lock-stacking or add-on features to provide added storage space under lock and key. Four basic units form many combinations to suit various video-tape library requirements. Mobile or stationary bases for permanent locations or movable storage and an adjustable-height, big-wheel utility table for general studio and library use are also available.

Circle Item 111 on Tech Data Card



### Dynamic Cardioid Microphone

**AKG of America** is now offering the D-119CS, a new member of the AKG D-19 group of dynamic cardioid microphones. The D-119CS has a frequency range of 40 to 16,000 cps with a deviation of only ±3 db. The cardioid characteristics of this microphone give an effective front-to-back discrimination of approximately 15 db. Sensitivity is listed

sa -75 db. The unit is provided with bass-attenuation switch (-10 db at 50 cps) and noiseless on-off switch. It is delivered with matching connector, stand adapter, 15' cable and wind-protection cover. Impedance is 200 ohms; a high-impedance transformer (AKG U-212) is available.

Circle Item 112 on Tech Data Card

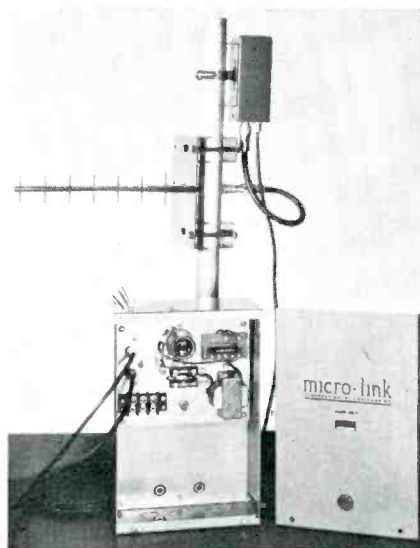

### ETV Converter

Reception of up to five program channels in the 2500-mc Instructional Television band is possible with **Micro-Link Corporation's** Model CE-5 receiving converter. The equipment consists of a mast-mounted converter and an associated indoor-mounted power supply. The converter is completely weather-proof, weighs three lbs, and is provided with necessary mounting hardware. A single coaxial cable supplies power to and carries signals from the converter.

The equipment employs all-solid-state circuitry. Technical specifications include an input frequency range of 2500 to 2686 mc, an output frequency of 168 to 222 mc, a passband ripple of less than ±1 db, and noise figure of less than 13 db. Input impedance is 50 ohms; output impedance is 75 ohms. Frequency stability of ±.005% or better is obtained through crystal control. Maximum input level is -30 dbm (7 millivolts)

for 1% intermodulation (5 channels). The operating temperature range is -40 to +140°F. Price of the CE-5 is \$800.

Circle Item 113 on Tech Data Card



### New Microphone Accessory

This new microphone accessory makes possible instantaneous microphone removal as well as safe attachment to any stand or support—both without threading on or off. The Model LO-2 is made by **Atlas Sound**, Div. of American Trading and Production Corp. The quick-disconnect feature of the accessory is achieved by a special two-piece interlocking design. One half stays with the microphone, and the other half remains on the stand. A positive lock holds the microphone securely and safely in place until a pushbutton is deliberately released. Price is \$3.50 list. ▲

Circle Item 114 on Tech Data Card

**STOP** you lost your turn by missing our ad in the March issue. Go back and look at page 86 for **NEW REMOTE CONTROL** from **BIONIC INSTRUMENTS, INC.**

Circle Item 91 on Tech Data Card

Get NEW CATALOG of wattmeters, loads, filters, switches

QUALITY INSTRUMENTS

FOR RF POWER MEASUREMENT



**BIRD ELECTRONIC CORPORATION**

30303 AURORA RD. • CLEVELAND (SOLON) OHIO 44139

Circle Item 61 on Tech Data Card

## THE CHIEF ENGINEER

... Helps Solve Your Technical Problems

Readers are invited to send their questions to the "Chief Engineer"; those of most general interest will be published.

I am the Chief Engineer of an AM broadcast station. We have just completed the construction of our station in accordance with our construction permit, and during this time, I ran into a problem which was solvable in our case, but might have been difficult to solve in other cases.

Our construction began during the

month of November under rather mild weather conditions. After the tower was erected, the weather turned quite cold, and the ground became frozen. Fortunately, the freeze line did not extend more than a few inches into the ground, and we were able to bury the ground system, as required by the construction permit. I am curious, however, what would have happened if the ground had frozen to a significant depth, such as occurred in the following few weeks, thus not permitting us to bury our ground system.

This is a practical problem that confronts many broadcast stations, particularly in the northern portions of the

country. If you had not been able to bury the ground system due to the ground being frozen, the proper procedure would have been to install the ground system above the ground. You would then file the required material with the Commission in connection with your license application, which would include impedance measurements as required by FCC Form 302. You would indicate in Paragraph 13 of FCC Form 302 that the ground system had been laid on the ground, and that further information would be supplied when the ground system was buried. After the spring thaw, you then would be able to bury the ground radial wires in accordance with the specifications outlined in the original application.

After the burial of the ground system, you would be required to file a separate Form 302, together with the new measured impedance resulting from the burial of the ground system. A few ohms difference in the measured resistance would be expected.

**We propose to install a studio/transmitter link (STL) for broadcast of the aural program material between our studio and our transmitter. Do we need a licensed operator on duty if remote control is contemplated, or is unattended operation permitted?**

Section 74.533(a) of the Commission's Rules indicates that such an aural broadcast STL may be operated by remote control providing a licensed operator of the proper grade is stationed at the control point at all times. Part (b) of this Section, however, permits the operation of intermediate relay stations without a licensed operator on duty provided certain safeguards, which are outlined, are complied with. This means that for a single-hop transmission, a licensed operator is required to be on duty at the control point at all times. However, in cases of multi-hop transmission, unattended operation is permitted for the intermediate relay stations.

**What are the Commission's rules relative to permissible variations in phase readings of a directional antenna? I note specifically that the ratio of our currents may not vary more than  $\pm 5\%$ , but nothing is said about phase.**

The Commission has no rules regarding permissible variations in phase for a standard-broadcast directional antenna. In cases such as this, unwritten Commission policy usually applies.

One rule of thumb used by the Commission's engineers is that a variation in relative phase of any of the towers in a directional antenna system should not vary more than  $\pm 2^\circ$  from the licensed value. However, this does not mean that occasional excursions beyond this limit will not be allowed, since such variations can occur from time to time because of climatic or other changes. It does mean that phase variations which are greater than this amount for extended periods of time may make the station vulnerable to citation. ▲

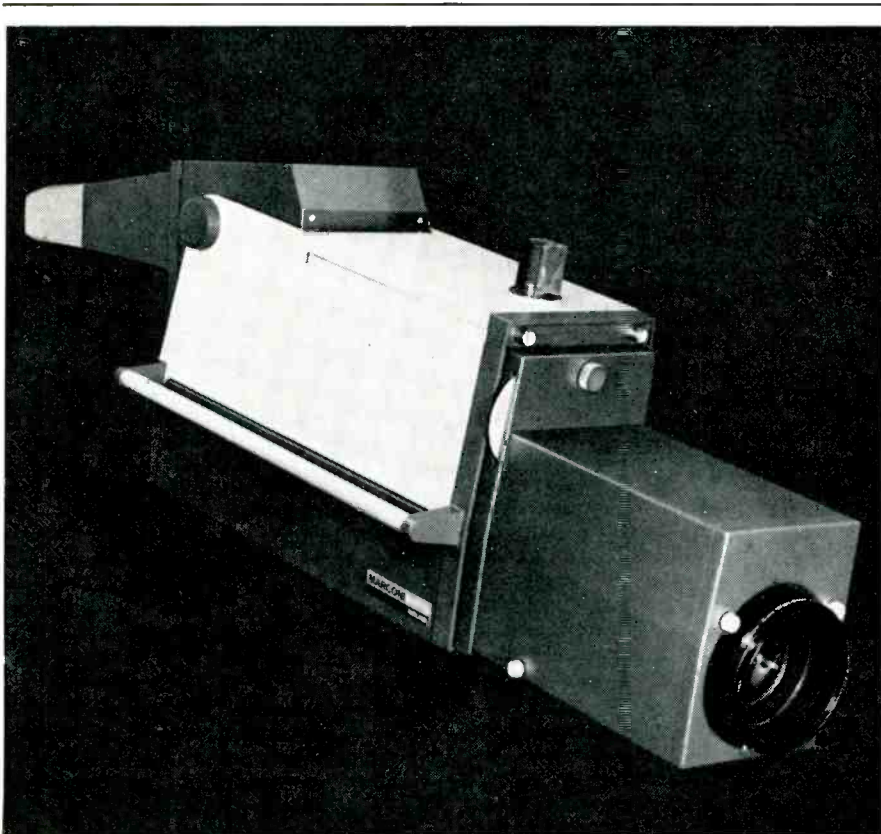

WORLD'S FIRST FULLY TRANSISTORIZED TILTING VIEWFINDER  
4½" IMAGE ORTHICON ZOOM CAMERA

The new Marconi Mark V. Here's the broadcasting and teleproduction camera that's as advanced as the Mark IV when it was introduced 5 years ago. And everybody's still trying to catch up with that one. Here are some of the things they'll have to shoot for to equal the new Mark V: integrated 10 to 1 zoom lens; a unique tilting viewfinder; near perfect linearity and geometry; precision mechanics; superbly stable circuitry. You can have as little or as much remote control as you

desire. Two new types of joy-stick remote control panels make the Mark V extraordinarily easy to operate. The lens may be manually or servo controlled. And it's from Marconi, makers of the world's standard television camera. The new Marconi Mark V and the whole line of Marconi equipment is distributed by Ampex. Term leasing and financing are available. For complete information call your Ampex representative or write to: Ampex Corp., Redwood City, California.



© AMPEX CORP. 1965

Circle Item 62 on Tech Data Card

# AMPEX



# ENGINEERS' TECH DATA

## AUDIO & RECORDING EQUIPMENT

64. ATLAS SOUND—Catalog 564 describes line of public-address speakers and microphone stands for commercial and industrial sound-distribution systems.
65. ATC—Specification sheet on solid-state multiple-cartridge unit suggests monophonic and stereophonic applications for automated systems.
66. BROADCAST ELECTRONICS—Packet contains specifications and prices for Spotmaster tape-cartridge systems and new Portapak 1 portable playback unit for use by salesmen.
67. CINE SONIC SOUND—Data sheet describes rental service which supplies background music on 7", 10½", and 14" reels, stereo or mono.
68. CONCORD ELECTRONICS—Brochures on Model WX-8010 wireless microphone, R-series automatic tape recorders for broadcast use.
69. EASTMAN KODAK—Brochure S1-6 gives useful and interesting information about sound recording tape.
70. EDLEMAN & ASSOCIATES—Data on Model 520 broadcast equipment and Model DV-300 portable video recorder.
71. GIBBS—Brochures describe principles of sound reverberation and give locations of dealers.
72. GOTHAM—Descriptive material and application notes on Neumann U-64 cardioid microphone.
73. HARVEY—Engineering bulletin on Langevin 4000-series solid-state sound reinforcing modules.
74. MAGNASYNC—Brochures and booklets describe magnetic-film sound equipment for motion-picture work.
75. MILES—Sound reproducing and indexing system providing six hours recording time on continuous belt in covered in brochures.
76. QUAM-NICHOLS—1965 catalog lists speakers for background music, high-fidelity systems, autos, and general replacement.
77. SENNHEISER—Instructions for the connection of dynamic and condenser microphones.
78. SPARTA—Illustrated product brochure gives complete specifications and prices of Sparta-Matic tape units, Sparta audio consoles, turntables, preamplifiers, and other studio equipment.
79. VIKING—RP-120 professional-type tape amplifier is described in booklet.
80. WALLACH ASSOCIATES—Series of brochures describes line of cabinets for storing tapes, records, filmstrip, slides, etc.

## COMPONENTS & MATERIALS

81. AMPEREX—Newly revised edition of semiconductor catalog lists items for many applications.
82. CORNELL DUBILIER—Write for descriptive material on TV, FM components, rotor systems, and a cross reference guide for vibrators.
83. SPRAGUE—Twelve-page folder shows line of transistors and Unicircuit® networks.
84. SWITCHCRAFT—New product bulletin 150 gives information on complete line of "Lo-Cap" lever switches with phosphor-bronze actuator and contact springs.

## MICROWAVE DEVICES

85. MICRO-LINK—Brochures on Model 520A portable microwave relay link, and Model 600 fixed-station relay link with planning tips.
86. MOSLEY—Literature describes Citizens-band antennas.

## MOBILE RADIO & COMMUNICATIONS

87. G-E—Bulletin ECR-1174 describes lease arrangements for Porta-Mobile two-way radio equipment for on-the-spot news remotes.

## POWER DEVICES

88. HEVI-DUTY—Bulletin 7-12 provides data on line-voltage regulator which uses saturable-core reactor.
89. TERADO—Booklet gives information on Galaxy 50-20 power inverter.

## RADIO & CONTROL ROOM EQUIPMENT

90. ALTEC LANSING—Folder shows line of audio equipment for broadcasting uses.
91. BIONIC—Brochure on small two-line remote control amplifier having individual controls for each transmitter circuit.
92. GATES—Four solid-state remote amplifiers described in application sheets.
93. KARG—Data sheets provide information of crystal-controlled FM broadcast monitor Model XT-3.
94. RUST—New Autolog AL-100R data sheet for remote-control of broadcast stations.

## REFERENCE MATERIAL & SCHOOLS

95. BLONDER-TONGUE—Booklet entitled "How to Set the Stage for Educational TV" briefly describes the requirements and benefits of ETV broadcasting.
96. CLEVELAND INSTITUTE—Booklet describes courses in electronics, including those for broadcast engineering and FCC license preparation.

## STUDIO & CAMERA EQUIPMENT

97. CLEVELAND ELECTRONICS—Data concerns modifications using new deflection yoke and alignment coil to update 3" image orthicon cameras.
98. DU MONT—Brochure and technical data on the Du Mont TC-175 transistorized, closed-circuit television camera with 700-line resolution.
99. ROANWELL—Brochure gives technical specifications of broad line of headsets for camera and control-room use.
100. ZOOMAR—Information in brochures gives particulars on Angenieux zoom lenses for IO and vidicon cameras, describes remote-controlled pan and tilt head.

## TELEVISION EQUIPMENT

101. MOSELEY—Solid-state, 21-channel remote-control system for AM, FM, TV described in brochure.
102. TELEMET—Literature describes new solid-state color-processing amplifier, color-bar generator, clamper amplifier, and cable terminal equipment for 124-ohm balanced PEVL cable.
103. VITAL—Data sheets provide information on Models VI-10A video-distribution amplifier, Model VI-20 pulse-distribution amplifier, and Model VI-500 video clamper/stabilizer amplifier.

## TEST EQUIPMENT & INSTRUMENTS

104. DELTA—Application bulletin No. 2 describes installation and use of common-point impedance bridges.

## TRANSMITTER & ANTENNA DEVICES

105. CCA—Catalog sheets on full line of AM and FM transmitters and other broadcast equipment.

## Professional Services

### VIR JAMES

CONSULTING RADIO ENGINEERS  
Applications and Field Engineering  
345 Colorado Blvd.  
Phone: (Area Code 303) 333-5562  
**DENVER, COLORADO 80206**  
Member AFCCE

### JAMES C. McNARY

Consulting Engineer  
National Press Bldg.  
Washington 4, D. C.  
Telephone District 7-1205  
Member AFCCE

### LAWRENCE BEHR ASSOCIATES, Inc.

RADIO ENGINEERING CONSULTANTS  
FM Applications and Field Engineering  
also  
AM — Communications — CATV  
LAWRENCE BEHR, PRESIDENT  
2501 East Fourth Street  
**Greenville, North Carolina**  
919-PL 8-3966

### OSCAR LEON CUELLAR

Consulting Radio Engineer  
AM-FM-TV  
411 Phoenix Title Building 623-1121  
Directional Antennas Design  
Applications and Field Engineering  
Tucson, Arizona 85701  
Member IEEE

### CARL E. SMITH

CONSULTING RADIO ENGINEERS  
AM, FM, TV and CATV  
8200 Snowville Road  
Cleveland, Ohio 44141  
Phone: 216-526-4386  
Member AFCCE

### CAMBRIDGE CRYSTALS

#### PRECISION FREQUENCY MEASURING SERVICE

SPECIALISTS FOR AM-FM-TV  
445 Concord Ave. Phone 876-2810  
Cambridge, Mass. 02138

## Classified

Advertising rates in the Classified Section are ten cents per word. Minimum charge is \$2.00. Blind box number is 50 cents extra. Check or money order must be enclosed with ad.

The classified columns are not open to the advertising of any broadcast equipment or supplies regularly produced by manufacturers unless the equipment is used and no longer owned by the manufacturer. Display advertising must be purchased in such cases.

## EQUIPMENT FOR SALE

Everything in used broadcast equipment. Write for complete listings. Broadcast Equipment and Supply Co., Box 3141, Bristol, Tennessee. 11-64 6t

Ampex Head Assemblies for 300 and 400 series recorders reconditioned. Service includes lapping and polishing all three head stacks, cleaning entire assembly, readjusting and replacement of guides, and alignment of stacks as to azimuth and zenith. Full track assemblies—\$60.00. Taber Manufacturing & Engineering Co., 2619 Lincoln Ave., Alameda, California. 5-64 tf

G.E. FM FREQUENCY AND MODULATION MONITOR 4BM1A1. Best offer over \$700 takes it. Write: Roy Trumbull, P.O. Box 247, Corte Madera, Calif. 4-65 1t

Television/Radio/communications gear of any type available. From a tower to a tube. Microwave, transmitters, cameras, studio equipment, mikes, etc. Advise your needs—offers. Electrofind Co., 440 Columbus Ave., NYC. 212-EN-25680. 8-64 tf

COMMERCIAL CRYSTALS and new or replacement crystals for RCA, Gates, W. E. Bliley, and J-K holders; regrounding, repair, etc. BC-604 crystals; also service on AM monitors and H-P 335B FM monitors. Nationwide unsolicited testimonials praise our products and fast service. Eidson Electronic Company, Box 96, Temple, Texas. 5-64 tf

Parabolic antennas, six foot dia., new, solid surface with hardware, dipole, etc. \$125.00 each. S-W Electric Cable Company, Willow & Twenty-Fourth Streets, Oakland, California. 832-3527. 10-64 tf

Will buy or trade used tape and disc recording equipment—Ampex, Concertone, Magnecord, Presto, etc. Audio equipment for sale. Boynton Studio, 295 Main St., Tuckahoe, N. Y. 1-64 tf

Laboratory Test Equipment, microwave components, all frequency and makes at real low prices. Write or call for information. Jericho Electronic Supplies, Sid Gordon Electronics, 80 West Jericho Turnpike, Syosset, Long Island, N. Y. (516) WA 1-7580. 12-64 6t

AMPEX 350 SERIES reconditioned capstan idlers for \$7.50 exchange. Send us your old ones, or order them for \$10.00 and get \$2.50 back after sending the old ones in. Ours have new bearings, the rubber softened and surface precision ground. TABER MANUFACTURING & ENGINEERING CO., 2619 Lincoln Ave., Alameda, California. 1-65 12t

AMPEX 350 SERIES reconditioned capstan drive motors (BODINE NCH-33 only) \$85.00 exchange. Send us your old one, or order for \$100.00 and get \$15.00 back after sending old one in. Ours have new bearings and rewound stator. Package motor well. TABER MANUFACTURING & ENGINEERING CO., 2619 Lincoln Ave., Alameda California. 1-65 12t

Two Pultec PC 10 R1AA equalized phono amplifiers, 18 months old, \$195.00 each. Neuman DST62 stereo phono cartridge 10 hours use, \$45.00. Shipped prepaid with check or money order. W. R. Fletcher, 604 Thornhill Drive, Lafayette Hill, Pa. 3-65 2t

Parabolic antenna, 4-ft. diameter. New solid surface aluminum with hardware and diapole. \$85 each. Empire Device heads for NF 105, half price. Jericho Electronics Supplies, Sid Gordon Electronics, 80 West Jericho Turnpike, Syosset, Long Island, N.Y. (516) WA. 1-7580. 3-65 3t

ELECTRONIC TUBES—Top Brands SOLD at substantial savings; (Minimum Order \$15.00). Authorized GE Amperex, Dumont and Eimac Distributor. Send for FREE Buyers' Guide for all your Tube Requirements. TOP CASH PAID for your excess inventory. (New Only—Commercial Quantities). Metropolitan Supply Corp., 443 Park Avenue South, New York, N.Y. 100161 (212) MU 6-2834. 3-65 5t

McJONES 612A 6KW watercooled load 44-1000MC. Save half. In new condition at \$375.00 F.O.B. Wilkinson Electronics, 1937 W. MacDade Blvd., Woodlyn, Pa. 19094. 21-5-874-5236. 4-65 1t

New RCA 50KW watercooled load AM with pump and flow indicator. \$1,200.00 value for \$550.00 F.O.B. Wilkinson Electronics, 1937 W. MacDade Blvd., Woodlyn, Pa. 19094. 215-874-5236. 4-65 1t

Audio Equipment bought, sold, traded. Ampex, Fairchild, Crown, McIntosh, Viking, F. T. C. Brewer Company, 2400 West Hayes Street, Pensacola, Florida. 3-64 tf

Surplus recording equipment for sale. Scully, RCA, Magnecord, Concertone. Send for list. Boyd Recording Service, 2924 Lemmon Ave. East, Dallas, Texas. 4-65 1t

REL Stereo FM Microwave links, 944 mcs. Currently in operation. New receivers (alone worth \$2,000.00) plus many spare tubes and parts. \$2,800 complete. KPEN, 1001 California Street, San Francisco 8, California. TUXedo 5-4311. 4-65 1t

## EQUIPMENT WANTED

A 469-B condenser manufactured by Western Electric Company for their 504 B2, 3 kw FM transmitter. Contact Bill Bratton, Chief engineer, WLAP, Lexington, Ky. 606-255-6300. 11-64-6t

## Personnel

Engineering Supervisor—First phone, 14 years T.V. experience; network T.V. remote supervisory, design, construction, maintenance, operations, administration. Desires responsible position. Write Broadcast Engineering, Dept. 127.

## Advertisers' Index

Altec Lansing Corp.....	12
AMECO .....	50
Ampex Corp.....	88
Amplifier Corp. of America.....	70
Audio Engineering Society, Inc.....	70
Automatic Tape Control, Inc.....	45
Bauer Electronics Corp.....	72
Belden Mfg. Co.....	31
Bendix Corp.....	75
Bionic Instruments, Inc.....	62, 87
Bird Electronics.....	83, 85, 87
Blonder-Tongue Labs.....	62
Broadcast Electronics.....	30, 38, 84
CBS Labs, Inc.....	41
Cleveland Electronics.....	52
Cleveland Institute of Electronics.....	32
Collins Radio.....	8, 9
Commercial Recording Corp.....	81
Continental Electronics.....	61
Dage TV Co.....	29
Eastman Kodak Co.....	49
Eitel-McCullough, Inc.....	71
Electro-Voice, Inc.....	51
Fairchild Recording Co.....	4, 58
Gates Radio Co.....	27
General Electric Co.....	46, 47
Harvey Radio.....	59
International Nuclear Corp.....	Cover 3
JOA Cartridge Service.....	68
Jampro Antenna Co.....	44
Lang Electronics, Inc.....	30, 68
Magnecord, Midwestern Instruments	82
Martel Electronics.....	40
Minnesota Mining & Mfg. Co.....	53
Moseley Associates.....	83
Moviola Mfg. Co.....	30
Norelco Audio Video Products.....	69
Northern Electric Co., Ltd.....	10, 11
Nortronics.....	45
QRK Electronics.....	80
RCA Electronic Components and Devices.....	Cover 4
Reeves Industries.....	54
Rek-O-Kut.....	43
Riker Industries.....	Cover 2
Russco Electronics Mfg.....	40
Rust Corp. of America.....	3
Sarkes Tarzian, Inc.....	63
Scala Radio Co.....	83
Sony Superscope.....	73
Sparta Electronics Corp.....	76
Stancil-Hoffman Corp.....	78
Superior Cable Corp.....	39
Sylvania Electric Products.....	37
Tektronix, Inc.....	35
Telemet Co.....	65
Times Wire & Cable Co.....	55
Video Medical Electronics Corp.....	5
Visual Electronics Corp.....	6
Vital Electronics.....	57
Vitro Electronics.....	67
Ward Electronic Industries, Inc.....	7
Wilkinson Electronics.....	40, 86

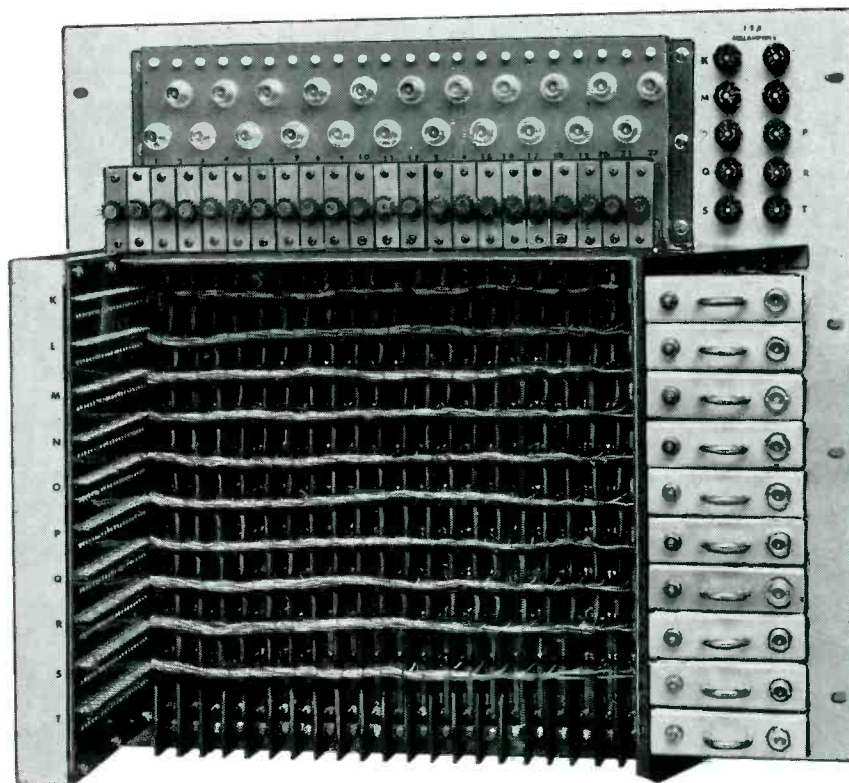

# WE CAN CUSTOM MAKE YOUR SWITCHER

ANY NUMBER INPUTS OR OUTPUTS TO SUIT YOUR NEEDS

If you have special switcher requirements that demand custom manufacture, then International Nuclear can be of service to you. An International Nuclear audio and video crossbar switcher can be assembled to house any number of inputs or outputs. Each input line is a printed circuit. All amplifiers and power supplies are completely solid state. A single standard type transistor is used throughout the circuitry. All components are readily accessible and operate well within their rating. Custom switchers handle double re-entry switching as well as composite or noncomposite switching. The new reed-type relays which we use are metal contacts operating in a glass sealed atmosphere. Control of these relays is accomplished by an external push-button and tally light console. Telephone companies and space programs have proven that this type of relay is the only reliable method of switching video.

We invite your inquiry, write or phone collect today.

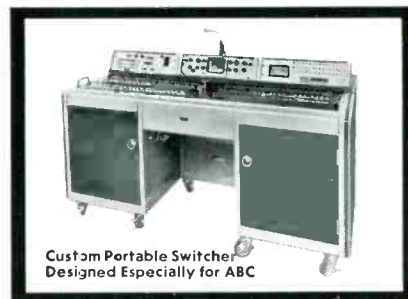

Custom Portable Switcher  
Designed Especially for ABC



**INTERNATIONAL NUCLEAR CORPORATION**  
608 NORRIS AVENUE • NASHVILLE, TENN. • PHONE 254-3366

Circle Item 63 on Tech Data Card

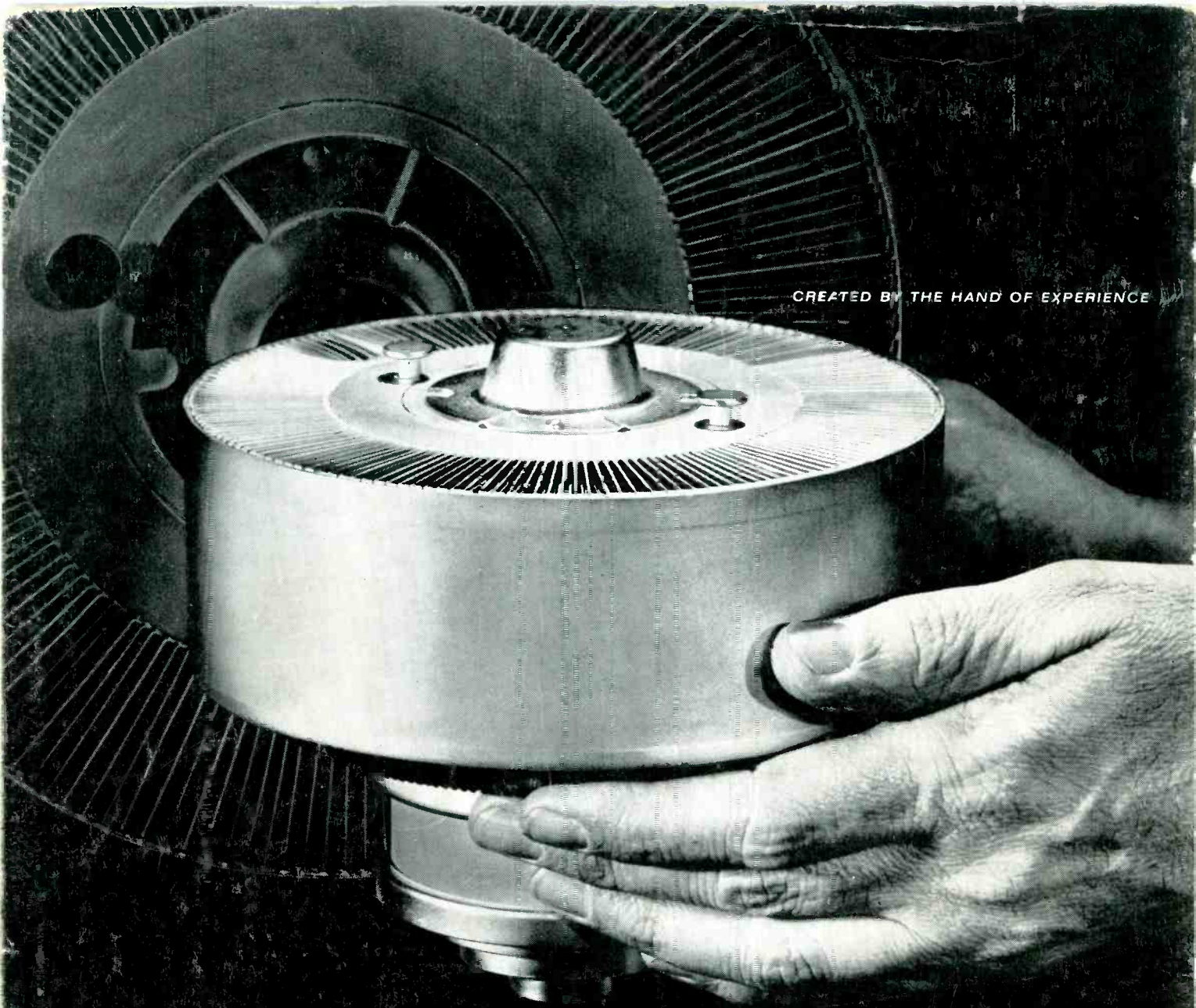

CREATED BY THE HAND OF EXPERIENCE

## AND NOW... THE RCA-8501 FOR 10 KW UHF-TV

Designed for operation in the 1- to 10-KW range the RCA-8501, forced-air-cooled tetrode, allows greater economies in RF amplifier design and operation. Featuring Cermolox<sup>®</sup> design, this new tube offers the advantages of its military prototypes—high perveance, high gain, low voltage operation, forced-air cooling... plus a rugged long-life thoriated tungsten filament. A single tube delivers 5.5 KW peak sync at 890 Mc.

To keep up-to-date on RCA innovations, keep in touch with your local RCA Broadcast Tube Distributor. He is ready to provide current information on new and improved RCA types. Ask for a copy of Product Guide for RCA Power Tubes, PWR-506A.

RCA ELECTRONIC COMPONENTS AND DEVICES, HARRISON, N. J.

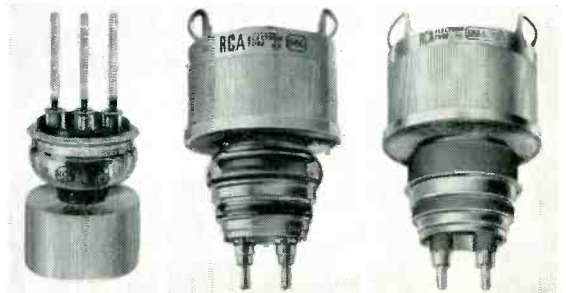

Familiar names—RCA-5762/7C24, -6166, -6166A/7007,—yet today's improved RCA versions are still the best buys a broadcaster can make—kept in the forefront of broadcast technology through continual improvement by experienced RCA design and production engineering.



The Most Trusted Name in Electronics