

BROADCAST[®] ENGINEERING

AN INTERTEC PUBLICATION

November 1989/\$4.50

Managing the changing workbench

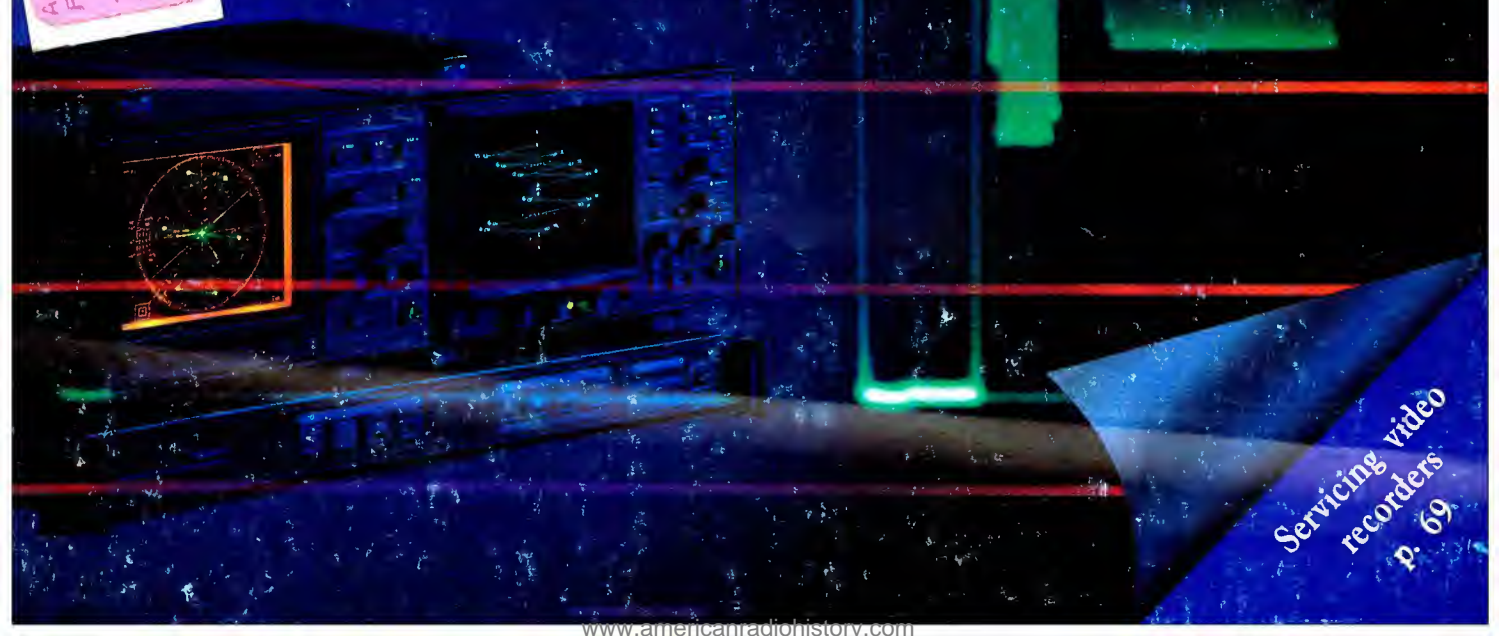
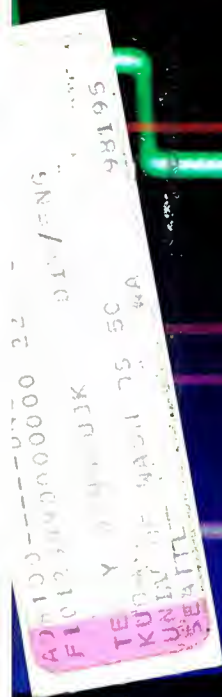

Servicing video
recorders
p. 69

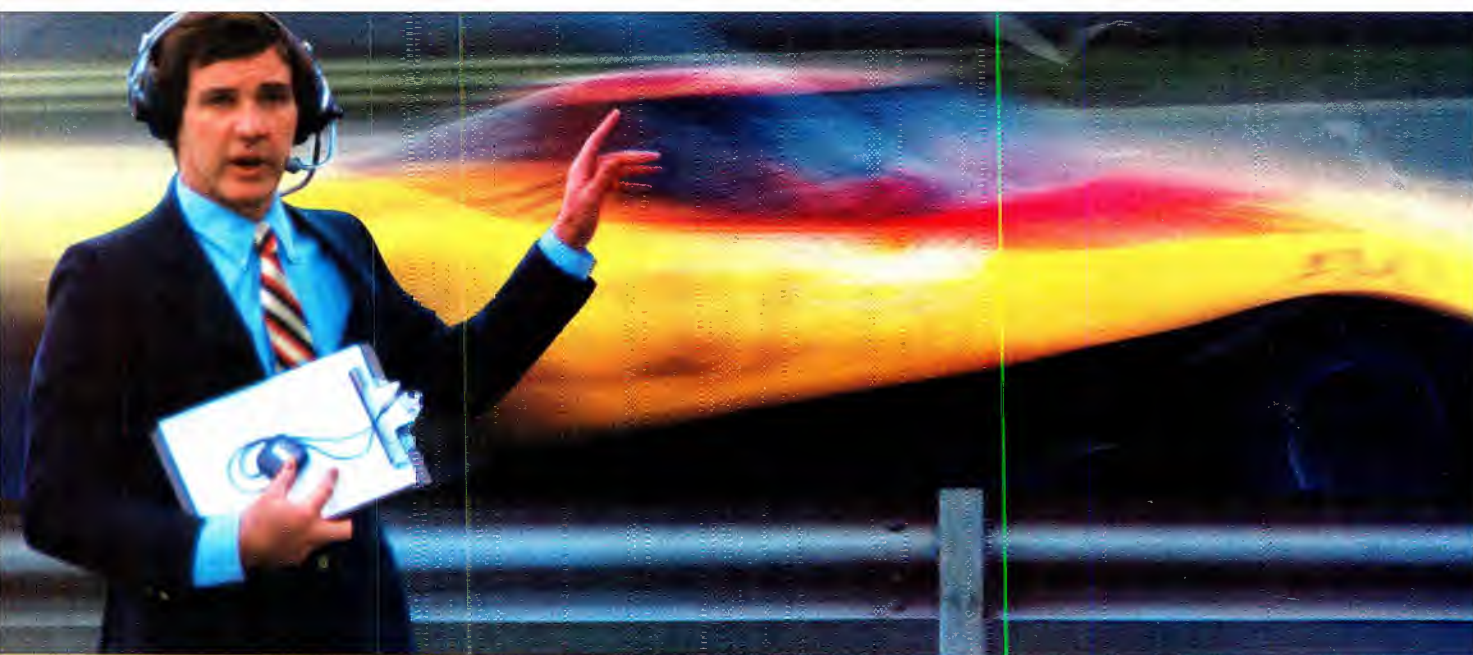

Rev into stereo— With the remarkable new FP32 ENG Mixer.

Introducing the stereo version of our legendary FP31.

Stereo adds incredible dimension and realism to sports and news coverage. And Shure's new compact FP32 Stereo Mixer makes ENG and EFP applications easy and economical.

Consider these advantages:

- Three transformer-coupled XLR isolated inputs and stereo outputs, all switchable to low-impedance mic or line level.
- Dual mini and 1/4" stereo headphone jacks.
- Built-in slate mic and slate tone.
- Battery, phantom, and A/B power (no special power supplies needed).

Plus new stereo advantages:

- Full stereo capability with separate, detented stereo pan pots and monitoring capability.

- Full 48 volt phantom capability.

Size? Only 2⁵/₁₆" x 7¹/₄" x 6", comparable to our FP31. Weight? Just 2¹/₂ pounds. Price? Hundreds less than you would expect. Stereo is here to stay. So is the FP32. For complete information about our full line of field production gear, write or call: Shure Brothers Inc., 222 Hartrey Avenue, Evanston, IL 60202-3696. (312) 866-2553



The new FP42 Stereo Production Mixer — the stereo counterpart to our M267. Four channels with independent center detented pan pots and cuing. Headphone amplifier. Adjustable limiters.

Circle (1) on Reply Card



SHURE

Breaking Sound Barriers™

ADD-ONS



DIGITAL
PROCESSING SYSTEMS INC.

ON
POWER

DPS-275
COMPONENT TBC/FRAMESTORE

Without ADD-UP.

How much would you pay for a true component, infinite-window TBC/Framestore?

Now add multi-format input capability, transcoding between NTSC, Y/C 688, Y/C 3.58, MII and Betacam. So you maintain superior quality in interformat dubs and you can handle all your VTR's with one TBC.

Add full-time multi-format output availability, regardless of input. To let you simultaneously distribute composite, Y/C and component video.

Add four field memory, freeze-field frame, variable strobe, A.T.R. chroma noise reduction and chrominance edge enhancement for improved playback quality.

Add a digitally programmable proc amp with ten non-volatile memories for saving information between scenes.

Add a built-in test signal generator, so you don't need separate and expensive test equipment.

Add RS-232 serial remote control.

The grand total?

To get all that – and more – for just \$6,450, move your fingers from your calculator to your phone. And call your nearby Midwest sales representative.



MIDWEST
Communications Corp.

One Sperti Dr. • Edgewood, KY 41017
(606) 331-8990

Circle (3) on Reply Card

Contents

November 1989 • Volume 31 • Number 11



Page 32

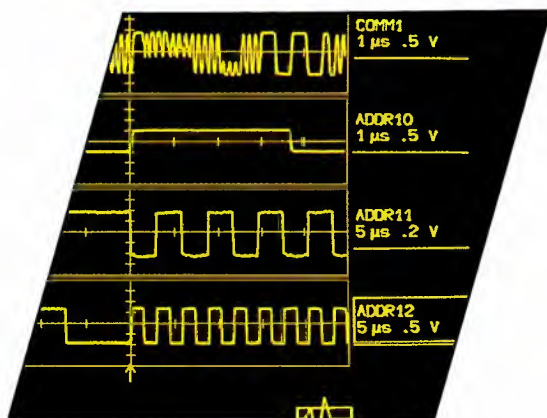

Page 42



Page 78

BROADCAST engineering

SIXTH ANNUAL STATION MAINTENANCE SPECIAL REPORT:

As the equipment used by broadcasters becomes more complex, the requirements for highly skilled maintenance technicians also increase. Maintenance personnel today require advanced test equipment and must think in a "systems mode" to troubleshoot much of the hardware in the field. This month, in our sixth annual Maintenance Special Report, we will examine how to maintain the latest broadcast hardware. The report consists of the following articles:

26 Servicing Local Area Networks

By Michael W. Dahlgren, Novell

Getting machines to work is only half the battle; getting them to talk is just as important.

32 The New Breed of Test Instruments

By Conrad Persson, editor of Electronic Servicing & Technology

Help is on the way for your worst troubleshooting problems

42 Advances in Digital Oscilloscopes

By Steve Montgomery, LeCroy Corporation

Tough testing problems are now easier to solve thanks to new digital oscilloscopes.

48 Automated Test Instruments

By Gregory D. Carey, Sencore

Personal computers can function as powerful troubleshooting tools.

69 Maintaining Small-Format Video Recorder:

By Brent Robinson, KSL-TV

Preventive maintenance and cleanliness will boost the performance and extend the life of your VTR.

OTHER FEATURES:

78 Tape Recording Technology

By Jerry Whitaker, editorial director

Audio and video magnetic recording has had a great impact on broadcasting than any other single development since the invention of radio/TV transmission itself.

ON THE COVER

As new technologies are introduced to broadcasters, new approaches also are required in equipment maintenance and repair. This month, we examine station maintenance in the era of computers. Our cover illustrates the sophisticated test signals and equipment necessary to maintain electronic hardware today. (Photo courtesy of Tektronix.)

DEPARTMENTS

4 News	18 Troubleshooting
6 Editorial	20 Management for Engineers
8 FCC Update	112 Station-to-Station
10 Strictly TV	118 SBE Update
12 re: Radio	122 People
14 Satellite Technology	124 Business
16 Circuits	126 New Products

Hitachi makes it easy.



NOW, THE RIGHT CHOICE IN ADVANCED CCD CAMERAS IS CLEARER THAN EVER. THE NEW SK-F3 AND SK-F700.

Hitachi presents two new 3-chip CCD broadcast cameras that give you higher resolution and better image quality than you have ever seen before in a broadcast camera.

The SK-F3 dockable and the SK-F700 studio cameras include the newest Frame Interline Transfer (FIT) CCD technology. Smear is virtually eliminated. Sensitivity is dramatically improved.

A 6-speed electronic shutter and contrast function are both built-in. And as for high resolution, the SK-F3 and SK-F700 hit a crystal clear 700 lines.

Your choice for a high performance camera system has never been easier. Learn more about the new SK-F3 and SK-F700. In the studio or in the field, they are clearly superior.

Contact Hitachi, 175 Crossways Park West, Woodbury, NY 11797, (516) 921-7200.

 **Hitachi Denshi America, Ltd.**
NEW YORK • LOS ANGELES • CHICAGO • DALLAS • ATLANTA

By Paula Janicke,
staff editor

Comark to install 240kW transmitter

Comark Communications, Colmar, PA, has received an order from WDRB-TV, channel 41, in Louisville, KY, for a 240kW Klystrode transmitter. The station, operated by Independence Television, a subsidiary of Blade Communications, Toledo, OH, is scheduled to go on air with the new transmitter early next year.

The design of the CTTU-240SKT involves five Eimac 60kW, water-cooled Klystrodes configured in a "Magic Tee" RF system. This will be the ninth Klystrode-equipped transmitter installed by Comark since its first one was put into service in Wrens, GA, in June 1988.

U.S. companies back Faroudja's SuperNTSC

Nine U.S. companies will provide fund-

ing to Faroudja Research Enterprises (FRE), Sunnyvale, CA, to enable the company to complete the product development and field testing of its SuperNTSC advanced TV transmission system. The companies, all of which are in the areas of cable, broadcast or TV equipment manufacturing, are: Capital Cities/ABC, Comcast Cable Communications, Continental Cablevision, General Instrument Corporation, Newhouse Broadcasting, Scientific Atlanta, Tele-Communications, Viacom International and Westinghouse Broadcasting.

The SuperNTSC system combines preprocessing at the transmitter and post-processing at the TV receiver. The preprocessing, even on existing TV sets, eliminates NTSC transmission artifacts. Maintaining full compatibility with the current NTSC format, the system operates within a single 6MHz channel. It requires no additional subcarrier and no extra bandwidth for broadcast, cable and satellite transmission and is designed to be compatible with cable feeder and distribution plants. SuperNTSC receivers with noise

reduction, image enhancement and line doubling (525 to 1,050) are said to deliver subjective image quality approaching that of 35mm film.

A major element in the product development will be the selection of twelve cable sites across the country at which end-to-end testing of regularly scheduled cable and broadcast programming can be performed. Through this testing, FRE hopes to demonstrate the quality reception of advanced television, provide valuable information to broadcasters and cable operators as to the implementation of the system, and obtain market research about consumer demand.

Sony to offer serial digital interfaces

Sony, Teaneck, NJ, has announced that it will provide serial digital input/output capability to all its future digital video products complying with the 4:2:2 digital component signal format and 4fsc NTSC and PAL composite digital formats. The

Continued on page 110

BROADCAST engineering

Editorial and advertising correspondence should be addressed to: P.O. Box 12901, Overland Park, KS 66212-9981 (a suburb of Kansas City, MO); (913) 888-4664. Telex: 42-4156 Intertec OLPK. Circulation correspondence should be sent to the above address, under P.O. Box 12937. RAPIDFAX: (913) 541-6697.

EDITORIAL

Jerry Whitaker, *Editorial Director*
Brad Dick, *Radio Technical Editor*
Carl Bentz, *Technical and Special Projects Editor*
Rick Lehtinen, *TV Technical Editor*
Tom Cook, *Senior Managing Editor*
Paula Janicke, *Staff Editor*
Dawn Hightower, *Associate Editor*
Suzanne Oliver, *Editorial Assistant*
Jennifer Hinkle, *Editorial Assistant*
Pat Blanton, *Directory Editor*

ART

Stephanie Swail, *Graphic Designer*

EDITORIAL CONSULTANTS

Fred Ampel, *Audio*
Nils Conrad Persson, *Electronics*
Ned Soseman, *Video*
Michael Heiss, *Consulting Editor*
Don McCroskey, *Consulting Editor*

BUSINESS

Cameron Bishop, *Group Vice President*
Duane Heifer, *Group Publisher*
Stephanie Hanaway, *Marketing Director*
Evelyn Hornaday, *Promotions Manager*
Darren Sextro, *Promotions Coordinator*
Dee Unger, *Advertising Business Manager*
Mary Birnbaum, *Advertising Production Supervisor*
Sally Nickoley, *Advertising Coordinator*

ADMINISTRATION

R.J. Hancock, *President*
Chuck Rash, *Corporate Circulation Director*
Sandra Stewart, *Circulation Director*
Doug Wilding, *Circulation Manager*
Customer Service: 913-541-6628
Kevin Callahan, *Creative Director*

TECHNICAL CONSULTANTS

Eric Neil Angevine, *Broadcast Acoustics*
John H. Battison, *Antennas/Radiation*
Blair Benson, *TV Technology*
Dennis Ciapura, *Radio Technology*
Dane E. Erickson, *Systems Design*
Howard T. Head, *European Correspondent*
Wallace Johnson, *FCC/Bdct. Engineering*
John Kean, *Subcarrier Technology*
Donald L. Markley, *Transmission Facilities*
Harry C. Martin, *Legal*
Robert J. Nissen, *Studio/Communications*
Hugh R. Paul, *International Engineering*
Art Schneider, *A.C.E., Post-production*
Elmer Smalling III, *Cable/Satellite Systems*
Vincent Wasilewski, *Communications Law*

MEMBER ORGANIZATIONS

SUSTAINING MEMBERS OF:

- Acoustical Society of America
- Society of Broadcast Engineers
- Society of Motion Picture and TV Engineers

Member,
Association of Business Publishers

ABP

Member,
Business Publications
Audit of Circulation

BPA

BROADCAST ENGINEERING is edited for corporate management, engineers/technicians and other station management personnel at commercial and educational radio and TV stations, teleproduction studios, recording studios, CATV and CCTV facilities and government agencies. Qualified persons include consulting engineers and dealer/distributors of broadcast equipment.

BROADCAST ENGINEERING (ISSN 0007-1794) is published monthly (except in the fall, when two issues are published) and mailed free to qualified persons within the United States and Canada in occupations described here by Intertec Publishing Corporation, 9221 Quivira Road, Overland Park, KS 66215. Second-class postage paid at Shawnee Mission, KS, and additional mailing offices. POSTMASTER: Send address changes to **Broadcast Engineering**, P.O. Box 12960, Overland Park, KS 66212.

SUBSCRIPTIONS: **Broadcast Engineering** is mailed free to qualified persons in occupations described above. Others may subscribe at the following rates: United States, one year, \$50; all other countries (surface mail), one year \$60. Rates include postage. Foreign air mail and Canadian first class options are available at the annual subscription rate of \$115. Single copy price \$4.50, except for the annual Buyers' Guide/Spec Book, which is \$20. Back issues, when available, \$5; Buyers' Guide/Spec Book back issues \$23. Adjustments necessitated by subscription termination at single copy rate. Allow six to eight weeks delivery for change of address or new subscription.

Photocopy rights: Permission to photocopy for internal or personal use is granted by Intertec Publishing Corporation for libraries and others registered with Copyright Clearance Center (CCC), provided the base fee of \$2.00 per copy of article is paid directly to CCC, 21 Congress St., Salem, MA 01970. Special requests should be addressed to Cameron Bishop, group vice president. ISSN 0007-1794 \$2.00 + \$0.00.

©1989 by Intertec Publishing.
All rights reserved.

Advertising offices listed on page 143.

INTERTEC
PUBLISHING CORPORATION

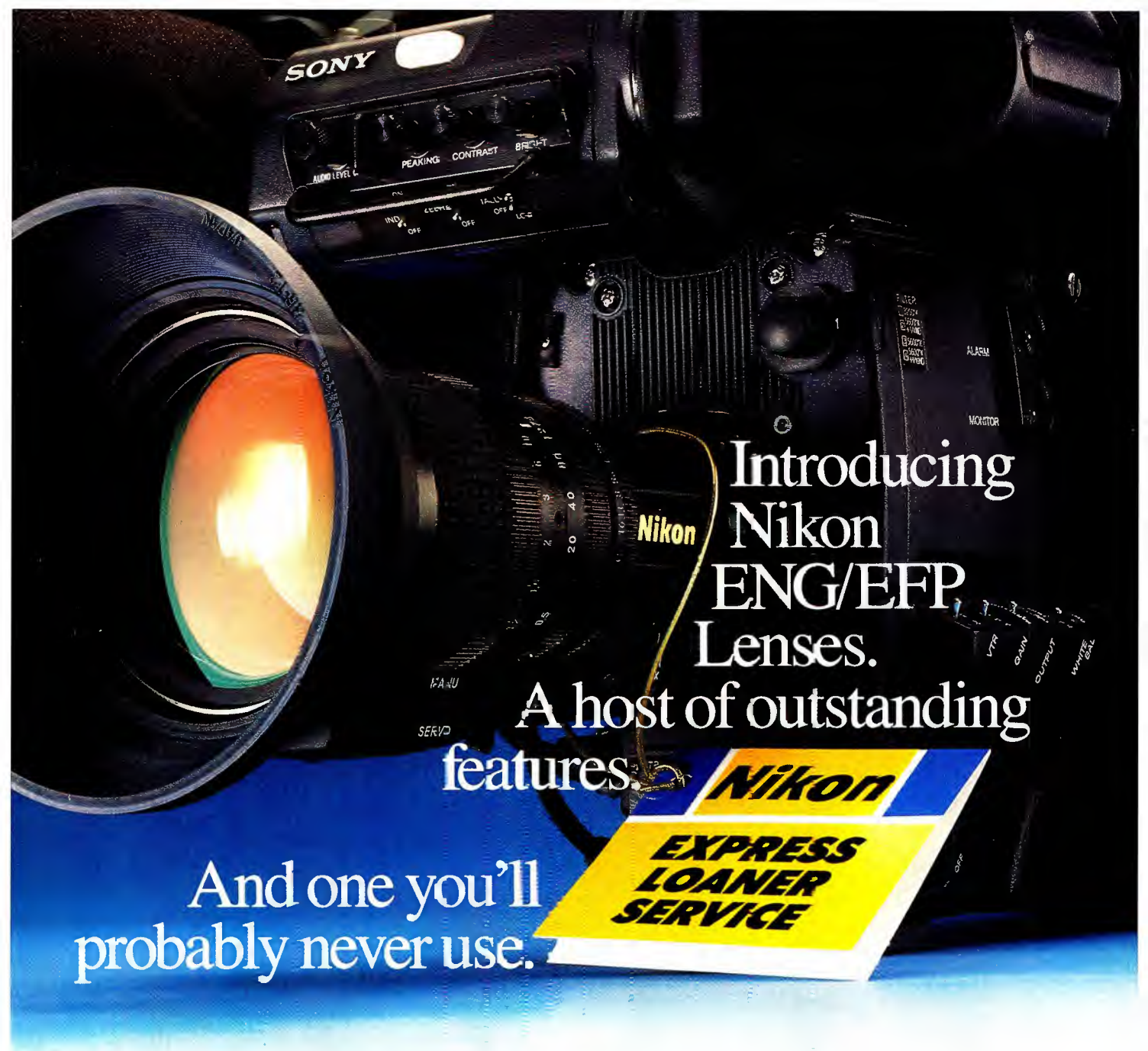

Introducing Nikon ENG/EFP Lenses.

A host of outstanding
features.

And one you'll
probably never use.

Selecting an ENG/EFP lens for your $\frac{2}{3}$ " CCD camera is a creative decision. It should be lightweight, responsive and zoom smooth as silk at any speed. Its design should utilize Extra-low Dispersion Glass to minimize chromatic aberration. It should include an anti-reflection coating for improved spectrum transmission ratio. And it should have an advanced design that improves corner resolution and produces a high, flat MTF curve. In short, it should be a Nikon.

But selecting an ENG/EFP lens is also a business decision. And on that score we provide something almost as compelling as Nikon quality – our unique Express Loaner Service. Simply register the Warranty, then in the unlikely event your lens needs service we'll get you a loaner lens overnight. All your investment in equipment

and crews is more secure than ever before.

A service like this is remarkable in itself. But not quite as remarkable as our lenses.

As with all Nikon products, our new ENG/EFP lenses have all our renowned quality, tradition and technology built right in. Our growing line is also fully accessorized, including adapters that allow the use of your entire arsenal of Nikkor 35mm SLR camera lenses for special effects.

To find out more, call Nikon Electronic Imaging at (516) 222-0200 or write for our complete brochure: Nikon Electronic Imaging, Dept. D1 101 Cleveland Avenue, Bayshore, NY 11706.

Nikon
ELECTRONIC IMAGING

© 1989 Nikon Inc.

Circle (4) on Reply Card



Agenda set by new chairman

By Harry Martin

In an appearance before the House Subcommittee on Telecommunications and Finance, incoming FCC Chairman Alfred C. Sikes outlined five policy goals he hopes the commission will achieve over the coming years. Following are the objectives he foresees in these areas:

- **Infrastructure:** To pursue an electronic infrastructure that is not simply adequate, but fully meets the broad range of commercial, governmental, social and personal needs of the American people.
- **Adaptive regulation:** To stress effective, but adaptive, communications regulation, while continuing to remove outmoded or unnecessary rules.
- **Spectrum efficiency:** To promote greater efficiency and innovation in the use of the spectrum and further the interests of the United States in international regulatory forums.
- **Competitiveness:** To increase awareness of the international competitiveness implications of FCC actions.
- **Excellence in public service:** To re-emphasize the provision of timely, efficient service to the public.

Difficult issues

Regarding common carriers, Sikes told Congress that the commission faces difficult choices. He said the challenge is that, as the agency seeks to "peel back" outmoded regulations that needlessly curtail price and service competition, it also must maintain the regulatory safeguards that are essential to full and fair competition. Implementing the commission's "Price Caps" decision regarding long-distance services, as well as continuing to pursue the goal of open network architecture, also will require close attention.

In the mass media field, Sikes said the commission is pursuing a comprehensive review of the competitiveness of the cable TV industry, as directed by the 1984 Cable Communications Policy Act. The agency also is seeking to strengthen its "AM Improvement" program. High-definition television (HDTV) is another area that will pose difficult issues in the coming year, each of which will have ma-

ior repercussions in terms of future competition and public service.

Enforcing rules and regulations to ensure quality service to the public while minimizing interference is another area Sikes plans to emphasize. He also hopes to improve the commission's technical and research capabilities.

Radio goals set

In a speech delivered at the NAB's radio convention in New Orleans in late September, Sikes outlined specific goals in the area of radio regulation. He stressed the changing competitive and demographic environment in which radio stations currently operate and highlighted three areas in which the commission will promote significant improvement.

First, the commission will focus on ways to strengthen the ability of radio stations to compete, as well as on facilitating new entry. In this connection, Sikes pointed to the comprehensive AM improvement program, in which modernization of FCC rules governing power increases, measurement of interference and the like will be considered. The agency has announced plans for an en banc hearing to consider specific industry proposals for improving AM broadcasting.

The second initiative mentioned by Sikes is a plan to speed up FCC procedures. Given the radio industry's need to adjust rapidly to meet changing market conditions, Sikes said processing time for applications will be improved. The new chairman is concerned particularly about the excessive legal and other costs that unnecessary regulatory delays can impose. To help improve the situation, he appointed Roy Stewart, a highly respected veteran FCC manager, as mass media bureau chief.

Sikes' third goal is to move the radio industry to place a higher priority on the "pursuit of excellence" in programming. He indicated his concern about material that falls below the decency standards previously embodied in the NAB Code. He also emphasized the public responsibility of broadcasters to act with intelligence and care in selecting programming to ensure that the public is well-informed.

The chairman also promised that he

would work with the industry to help ensure that broadcasters have the freedom to develop sound, voluntary program standards consistent with the antitrust laws. The proliferation of "shock" radio and the resulting flood of public complaints have kindled congressional interest in government-imposed standards.

Recent EEO actions

In recent decisions in the area of equal employment opportunity (EEO) regulations, the commission has imposed reporting requirements, heavy fines and/or short-term renewals on stations found to have violated the agency's EEO rules, particularly in the area of recruitment.

In a case decided in July, reporting conditions and a \$15,000 fine were imposed where none of a licensee's 35 full-time hires between 1986 and 1988 were members of minorities, and the station had no minority employees even though the labor force in the MSA was 10.4% minority. Reporting conditions require a licensee, on an annual basis, to demonstrate its efforts to recruit and hire a member of a minority group each time a new employee is hired.

Two licensees in violation of EEO regulations were fined, one \$18,000 and the other \$20,000, in a September decision. The station receiving the \$18,000 fine also was made subject to the reporting conditions. The commission found the station had not made meaningful efforts to recruit minority employees and did not maintain race and gender records of the pool of applicants for its vacant positions.

In the case of the licensee with the \$20,000 fine, a short-term license renewal also was imposed. This sanction not only requires periodic reporting on EEO efforts, but also requires the filing of another renewal application within three years.

These more severe sanctions were imposed because the licensee failed to consult any recruitment sources in filling 25 of 39 full-time vacancies that occurred during the period from 1985 to 1988. Instead, the positions were filled by non-minority applicants who, in turn, were referred by the station's non-minority employees. [:-=)]

Martin is a partner with the legal firm of Reddy, Begley & Martin, Washington, DC.

Introducing the Power to Perform...

Model

200-1

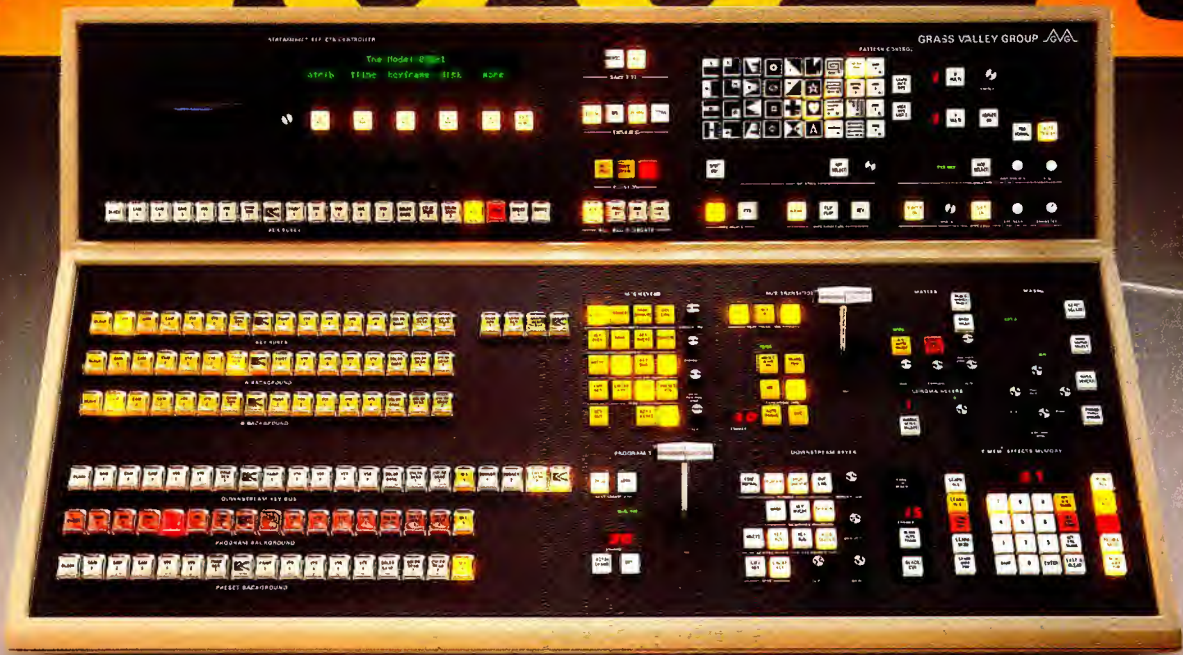

...at an irresistible price.

You're looking for a one mix effects switcher. Yet you don't want to sacrifice big switcher power and performance.

We've got the perfect solution. The new Model 200-1 has the power to create many effects associated with larger, more expensive switchers. Power unmatched by any other one mix effects switcher:

- 20 inputs
- E MEM® Effects Memory System
- Three powerful keyers
- True linear keying in each keyer
- Most powerful key masking available
- Program/preset flip-flop mixer
- Powerful options including:
 - Borderline® key edger with transparent shadow, Streamline™ effects controller with disk storage and timeline sequencing,

safe title generator, 4 fully timed AUX busses, analog and matrix pattern expansion, and more.

Big switcher power at a small switcher price. The Model 200-1 is the perfect solution.

UNDER \$26,000

For complete details on the Model 200-1 production switcher, contact the GVG office nearest you.

Grass Valley Group®

A TEKTRONIX COMPANY

THE GRASS VALLEY GROUP INC.

P.O. Box 1114, Grass Valley, CA 95945 USA
Telephone (916) 478-3000
TRT: 160432

OFFICES: New York (201) 845-7988; District of Columbia (301) 622-6313; Atlanta (404) 493-1255; Chicago (219) 264-0931; Minneapolis (612) 483-2594; Dallas/Fort Worth (817) 483-7447; Los Angeles (818) 999-2303; San Francisco (415) 968-6680; GVG International Ltd. (U.K.) +44-962-843939; Grass Valley Group Asia (HK) +852-3-7396632

Circle (6) on Reply Card

Gateways open up the world

By Dave Webb

Two terms of increasing importance to broadcasters are *audiotext* and *videotext*. Audiotext is a dial-up information system that resembles an overgrown voice-mail system. Videotext is a method of distributing text or graphic information, similar to having a remote terminal connected to a mainframe computer in your house.

Services such as these, whereby an individual can access information from the outside world from a terminal located in the home or office, are called "gateways." The relationship these gateway services will play in the fight for viewer attention is unclear at present. It is certain, however, that if viewers are watching a videotext monitor or listening to an audiotext service, they are not watching your station. In these terms, these services can be a threat to TV broadcasters. Nothing can keep broadcasters from providing gateway-type services of their own, however, to resist market encroachment from these new services.

Audiotext

Audiotext services are presently the most highly developed of the gateway offerings. Presumably, this is because the technology to deliver the gateway signal is the standard dial-up telephone network already in place. Also, any customer who accesses the audiotext system already has the necessary receive terminal, which is a telephone.

Because current statutes prevent the phone company from putting any programming on the gateway, it offers only the hardware, billing and collection. These services include a trunk into the telephone network, memory for message playback and record memory so that callers can leave their names and numbers for callback.

The telcos sell bulk time and memory space on the audiotext mainframe to "system operators," companies expert in the gateway's programming and operation. Clients who wish to use the gateway are called "information providers." The information providers contract with the system operators, who resell them system time and other services. The system operators



are given a list of those who used their portion of the gateway, and the operators calculate charges. They generate computer tapes containing billing data, which they return to the telco for inclusion in the customers' bills.

One Texas audiotext service already has had a positive impact on broadcasting. The city is served by numerous cable TV systems, some with overlapping coverage areas. One company, which had high name recognition, found that its switchboard constantly was clogged with calls meant for competing cable systems. The solution? Callers now hear a message that prompts them to enter in their ZIP codes. Gateway software sorts the incoming calls and automatically outdials to the correct system.

TV's reply

Several broadcasters have jumped on the audiotext bandwagon. Usually this is achieved by combining a catchy custom phone number with some informational item the station is well-situated to provide.

For example, KSL-TV, Salt Lake City, gets a tremendous number of calls requesting high school football scores. Prep games usually are played on Friday nights, and are sometimes still in progress during the station's 10 p.m. newscast.

KSL provides an audiotext service that reads the scores to about 1,900 callers every game night. The station found a catchy custom phone number (KSL-GAME), added a short commercial message before the scores, and came up with a service that meets a real need and more than pays for itself.

Videotext slow to arrive

Video versions of gateways are under development, but they have gotten off to a slower start. The reasons for this are twofold. First, the public-switched telephone network cannot currently support more than basic "video," usually just text or static graphics that can be transmitted over a modem. Second, the terminal expense is high compared with telephones. Some orders have been placed for tens of thousands of special videotext receivers, which might lead to increased standardization

and lowered per-terminal costs. Of course, if one includes modem-equipped personal computers that check into bulletin boards, the videotext gateways can be considered much more advanced.

TV fights back

Broadcasting's answer to videotext gateways probably lies in the vertical blanking interval (VBI). Data services, such as teletext, can pack significant chunks of information into otherwise unused lines. As with wire-based services, some terminal equipment at the user premises still is required. This cost is fairly small (about \$300), however, and many decoders have features that increase their utility, such as remote-control channel changers and volume controls. The display and recording devices for the teletext signals are common televisions and VCRs. Fan-out from one decoder to many displays is achieved easily.

The data throughput capabilities on latest-generation VBI systems are said to be phenomenal. Allegedly, one system is capable of passing the entire contents of eight different newswires simultaneously.

Old ways die hard

The broadcasting mindset is one factor that may be renewing the growth of teletext, because broadcasters frequently concentrate on information for the masses. Often, such information consists of lists of school closures, weather and sports updates and news briefs. Because these services are available from many other sources, however, the public has little incentive to purchase decoders.

Narrowcasting may be a more profitable opportunity. For instance, an agreement could be struck to transmit metro bus route delay information to kiosks in bus stops, or convention information pages to kiosks in hotels and civic centers. Such uses have little mass appeal, but they allow transport agencies and facility operators to improve their services while achieving great savings. Several sales contracts in the low-thousand-dollar range still add up to significant station revenue, especially when hundreds of such narrowcasting opportunities exist in each station's vertical interval. [:-:~)]))]

Webb is senior editor, Teletext 5, KSL-TV, Salt Lake City.



**GET A GREAT DEAL ON A DYAXIS WORKSTATION
WHEN YOU CHOOSE STUDER REVOX C270 SERIES RECORDERS.**

DIGITAL INSURANCE A C270 Series reel-to-reel with a hard disk option? Yes, Studer has just acquired Dyaxis, the most price competitive and capable digital audio workstation available. Now when you buy a Revox C270 (or a Studer A807) Series reel-to-reel, we'll give you a discount certificate worth up to \$2,500 on your future Dyaxis purchase. That's your hard disk option!

THE C270 SERIES This exciting new line of recorders provides you with all the traditional Studer Revox benefits—mechanical precision, electronic sophistication, supreme sound quality and superior support—adding up to state-of-the-art analog recording technology. The C270 is available in 2, 4, and 8-track versions with or without remote/autolocator.

BEST BUY Compare the "street" price and performance of any C270 Series machine with the competition, and you'll find there *is* no competition. The die-cast deck plate and head block, the precision mechanics and a host of powerful features tell you any C270 Series machine will last as long as you need a reel-to-reel in this emerging era of digital workstations. And in the digital future, you'll need analog recorders that will sound good—for a long time. That's why your last reel-to-reel should be a Studer Revox.

TIME CODE...OR NOT The C270 2-track version offers optional center track time code for effortless synchronization to picture or sound. The C274 4-track and C278 8-track are both equally adaptable to production or post. The optional remote/autolocator stores 18 start/stop addresses and provides full transport and channel remote control to fit into any professional studio environment.

LOGGING TOO For station logging applications, special super low speed versions of the C274 and C278 are available with built-in time/date code generator and reader with search capabilities, providing up to 25 hours of continuous audio on one reel of tape.

STUDER DYAXIS With over 200 Dyaxis systems delivered worldwide, Studer has become *the* leading supplier of Digital Audio Hard Disk Systems, and the *only* major reel-to-reel supplier currently delivering such digital workstations. Buy either, and you choose a leader. Studer Revox.

Call your Studer Revox Professional Products Dealer—your Digital Insurance Agent—or Studer Revox direct to receive all the details. And remember, your purchase of any C270 insures that your future will be digital—with Dyaxis.



STUDER REVOX

Studer Revox America, Inc.
1125 Elm Hill Pike • Nashville, TN 37210 • (615) 251-5651
New York (212) 255-1162 • Los Angeles (818) 780-1234
Studer Revox Canada Ltd., Toronto (416) 425-2831

Circle (7) on Reply Card

Pre-winter maintenance checklist

By John Battison, P.E.

Preparing your transmitter site for winter should be a priority task this time of year. A little time spent doing repair work in the mild autumn weather may save you from the cold, unpleasant experience of outside work in the middle of a January blizzard.

Antenna component inspection

It's a good idea to open all jacks and clean shorting bars and the contacts across the meter switch. If you use toroidal transformers for base current measurement, make sure the coils are secured in place and all connections still are sound. Some older ATUs use copper straps that run from component to component to form the ground connection. Make sure that connections to this strap still are good.

The RF connection from the ATU output to the tower base always should be double-checked. There should be at least a single turn in the copper-tubing connection. If not, form a new loop from a new piece of tubing. The loop should be at least 12 inches in diameter and installed between the tower base and the ATU feed-through insulator. This is one of the better lightning protectors, and it's quite economical.

Base insulators can freeze and crack in cold weather because of plugged weep holes. Be sure yours are clear and all fittings are tight.

Lightning protection

Spark or lightning gaps can open and close. When was the last time you checked the spacing? If in doubt, check the gaps by closing them until they just flash with 125% modulation. Then open them up an additional 1/8-inch to 1/4-inch, depending on power.

The wires to the horns should be horizontal so when an arc strikes, it runs "up" the horns and extinguishes. Similarly, ball gaps should be set so an arc will run up the balls and extinguish.

The ground system should be in top condition. Check all soldered joints for both



mechanical and electrical integrity. If any of the connections appear weak or corroded, resolder them with hard solder or brazing.

Summer's vegetation growth around the tower base must be cleared out. (It should be done at regular intervals all year.) Not only does the Federal Communications Commission frown on high weeds around the base, but the weeds also can cause instability to DA systems with changing weather conditions.

Now is the time to look at the tower fences, gates and locks. Any weaknesses will show up during the winter, and nothing is more annoying than standing in the snow struggling with a stuck padlock to make base readings.

Spare parts and records

A highly visible transmitter is more likely to be in good condition than one stuck in a remote building and out of mind until something goes wrong. In either case, be sure spare tubes and transistors and cards are available. Double-check remote-control units as well as their inputs — wire or radio. Check remote meter-calibration circuits for stability, and replace any questionable elements.

The FCC still requires a quarterly tower light inspection, and now is a good time to do one. Complete the inspection and log the results after the tower crew has relamped and inspected the tower. Also, regardless of whether you are DA or non-DA, make and record some monitor point readings.

If you are DA, check your usual points and log. If you are non-DA, go out and make some field-strength readings at some arbitrary points that can be reached easily in winter and are meaningful to your station coverage. Log these readings. If at some time during the winter the PD complains of low signals, you can check whether everything is all right, or you can crank up the compression if it's needed!

Be sure that you enter everything you have done into your maintenance log. Not only does it form a record for next year's work, but also it provides you with a key to troublesome items that require watching during the coming months. Another bonus for recording all maintenance work

is that if you are inspected, or any questions of proper operation arise, you can refer to this log and avoid possible citations. Good records indicate your desire and efforts to maintain your installation in top condition.

There may be other items, either forgotten or peculiar to some situations, that probably would make interesting reading. If you have some personal suggestions, please let me know.

Rules update

In a recent column, I stated that the FCC requires frequency measurements be made at intervals of not more than 40 days apart. Several readers rushed to correct my error. The commission has removed the 40-day requirement, but I still advise my clients to continue making this measurement, because it demonstrates adherence to standards and ensures that your transmitter is on frequency. I recommend this practice because many of my clients have older AM transmitters that are more susceptible to frequency wandering. Some readers correctly pointed out that modern solid-state transmitters with phase-locked loops, or the equivalent, rarely wander far off frequency.

Ira Wilner, contract engineer, wrote from Vermont to say he thought my discussion of required emission tests in the same column could be misleading. Perish the thought. To reconfirm my own interpretation of the rules, I called my guru at the commission who offered this further explanation: AM stations must have installed NRSC-1 by June 30, 1990. If they have NRSC-1 in use they are considered to be in compliance with RF mask rules, unless our nemesis, the FCC spectrum analyzer, shows otherwise. If the station does not use NRSC-1, emission measurements must be made.

This practice is in effect until 1994 when NRSC-2 becomes effective. As I read it, and the commission confirmed, when NRSC-1 is used, emission measurements need not be made.

Battison, BE's consultant on antennas and radiation, owns John H. Battison and Associates, a consulting engineering company in Loudonville, near Columbus, OH.

Dolby SR improves the medium for your message.

TAPE RECORDERS

Dolby SR provides the performance attributed to digital systems while maintaining such analog virtues as economy, editing ease, and tape interchange.

CARTS

Along with their familiar ruggedness and all-around utility, carts with Dolby SR capture the full dynamics of all your source material, digital or analog.

1-INCH VTR'S

With Dolby SR, video can sound as good as it looks. Signal purity is maintained through the multiple tape generations necessary in today's post-production techniques.



DISCRETE STL'S AND RPU'S

Dolby SR improves headroom and lowers noise, while suppressing the effects of interference and fade.

TV STL AUDIO SUB-CARRIERS

With Dolby SR, there's no need to re-allocate subcarrier frequencies or replace existing equipment in order to deliver high quality audio to the transmitter.

SATELLITE AUDIO

Dolby SR improves analog channels without audible side effects yielding performance rivaling digital systems.

Listeners today expect better sound wherever they go — at home, at the movies, in the car. To keep up with their expectations, you need Dolby SR. Two channels, with the compact, easy-to-operate Dolby Model 363 (shown). Or up to 24 channels, with Dolby Laboratories' multitrack products.

Dolby SR dramatically reduces noise, increases headroom, and lowers distortion from initial production to final transmission. That means you can deliver your message today with the clarity you've been expecting from the technology of tomorrow.

First bird launched 25 years ago

By Elmer Smalling III

It hardly seems possible that satellite communications is approaching its 25th birthday! In 1965, the International Satellite Organization (INTELSAT) launched its first bird, Intelsat I, in geosynchronous orbit over the Atlantic Ocean. This satellite, also known as Early Bird, was limited to transceiving about 240 telephone voice circuits or one TV circuit. It was a small, cylindrical satellite with a single, monopole-type antenna on top and four antennas radiating from the bottom of the spacecraft, around its apogee motor. It was spin-stabilized (spun on its axis at a fixed rate to gain orbital stability through gyroscopic action).

The satellites that followed Early Bird still were spin-stabilized with omnidirectional, monopole-type antennas, but they allowed for worldwide communications because they were spaced equally around the globe, an approach that had been discussed previously by science-fiction writer Arthur C. Clarke.

In 1965, the Soviets launched their own satellite system called Lightning (Molniya in Russian). These were not deployed in geosynchronous orbits, but in long, elliptical orbits, with their apogee over the Soviet Union.

By 1969, the Intelsat-deployed birds had a capacity of 1,500 telephone circuits and one TV channel. These later birds also had directional antennas, so that the 60% previously lost to outer space was directed to Earth. Putting directional dish antennas on these satellites required that the antenna platforms be de-spun by an electric motor that rotated at the same speed as the main spacecraft, only in the opposite direction. By the early 1970s, Intelsat was deploying satellites with capacities of more than 2,500 telephone circuits and two TV signals.

The first American communications satellite was a spin-stabilized device launched by Western Union (Westar). It carried 12 transponders, each with TV transmission capability or multiple telephone circuits.

In 1975, RCA developed its Satcom series of satellites with 3-axis stabilization, achieved using internal wheels that resem-



bled a gyroscope. This innovation eliminated the need to spin and de-spin parts of the satellite and resulted in a smaller, more reliable vehicle. The 3-axis system now is used by many satellite builders. The Satcom satellites provided 24 transponders capable of video or telephony transmission.

TV moves skyward

In 1975, a cable-programming distributor began using the first Satcom for nationwide distribution to cable headends. Each headend needed some expensive (at that time) equipment, such as a dish, low-noise

The first American communications satellite was a spin-stabilized device launched by Western Union (Westar).

amplifier and receiver. An early cable-TV TVRO could cost as much as \$50,000 — a lot of money for the majority of cable operators, who were Mom-and-Pop businesses. As more programming providers jumped on the satellite bandwagon, more birds were launched to accommodate this new interest in single point-to-multipoint communications.

Eventually, TV networks began using this new tool to replace the coaxial and microwave networks that had been in place for years, costing millions of dollars a month to operate. The new satellite transponders cost about \$1 million a year to lease. With \$50,000 to \$200,000 per earth station (broadcasters usually required higher-quality TVROs than cable operators), and an average network of 250 stations, it wasn't long before satellite distribution paid big dividends.

Enter satellite news

In the early 1980s, remote satellite

transmit-and-receive vehicles were designed for news and sports pickups. The size of the dish needed to transmit an FCC-quality transmission at C-band made for a unwieldy vehicle that resulted in a great road weight and required extra setup time for unfolding the dish. The natural alternative was to select a higher frequency available to broadcasters: the Ku-band. At first, many experts predicted poor operation at this high frequency, especially during inclement weather. But the Ku-band proved reliable, and equipment blossomed from almost every major manufacturer. Broadcasters could buy fly-away Ku-band packs that could be taken on board a commercial airliner as luggage, or they could build a compact yet powerful remote satellite receive/transmit vehicle. The situation has not changed much over the past few years. Broadcasters and cable programming suppliers are using C- and Ku-band with confidence for their most important programming.

Scrambling

Many of the services have been scrambled to keep the millions of home satellite dish owners from seeing backfeeds or prefeeds. Cable programming has been scrambled to prevent unauthorized viewing, although the process has introduced additional noise to the service and has proved to be flawed.

What's in the future?

It is hard to predict what the future holds for satellite TV distribution. Fiber-optic networks, which provide for more bandwidth and a much greater signal-to-noise ratio, gradually are connecting every city in the nation, and enough fibers exist to provide any number of networks with secure, clean TV transmission.

Although it is in vogue to plan for HDTV, viewing an HDTV program on a link that has the S/N ratio of current satellite or RF over-the-air TV station transmission media would be self-defeating. If satellite broadcasting does not change from the present, somewhat antiquated modulation schemes to wider-band digital video/audio transmission, a good choice for the long haul would be 100% fiber distribution. **I-[-(=))))**

Smalling, BE's consultant on cable/satellite systems, is president of Jenel Systems and Design, Dallas.

FOR NEWS EDITING, ON-AIR, AND PRODUCTION



RADIO'S TOP TEN!

For news editing, on-air, or in the production studio, Otari has exactly the equipment and features to fit any application, or budget.

When you are ready for a multitrack recorder, you can choose from our BQII, MKIII/4, MKIII/8, MTR-10, or the MX-70 with 8 or 16 tracks. Need a 2-track? Choose our famous "workhorse" MX5050 BII, MKIII/2, or the brand new MX-55! Looking for top-end performance? The MTR-10 has all the features you need to stay ahead in the competitive world of broadcast. We also offer three models of our CTM-10 cart machine, and if yours is an automated radio station, our ARS-1000 reproducer is the most popular in the world.

So you see, whatever you need for today, or for the future, Otari can provide it from a complete line of high quality, ultra-reliable tape recorders. Call your nearest Otari dealer today, or contact Otari at (415) 341-5900 for "Technology You Can Trust".

OTARI

Circle (9) on Reply Card

www.americanradiohistory.com

Use Smith charts for RF design

By Gerry Kaufhold II

Since the FCC changed the requirements for licensing of broadcast engineers, the available pool of experienced radio frequency engineers has shrunk dramatically, creating a need for engineers familiar with RF design techniques.

RF design roadblocks

Because radio frequency has an inherently alternating current, all RF signals are sensitive not only to pure resistance, but also to frequency-dependent factors, such as inductance and capacitance. As the frequency of an RF signal increases, the phenomenon of "skin effect" is encountered, which causes currents to propagate along the outer surface of wires rather than within the core. These factors complicate any calculations regarding circuit parameters. Special care is needed in any project designed to work in the RF range.

Math headaches

In the 1860s, James Clerk Maxwell and Karl Friedrich Gauss developed the mathematical equations that described electromagnetic radiation, now known as radio frequency energy. RF can be represented by complicated mathematics, such as hyperbolic or quadratic functions, or by polynomial functions and differential equations. These equations involve complex numbers and must be solved for each specific frequency at each characteristic impedance, a time-consuming and error-prone process.

Researchers soon determined that it would simplify matters greatly if there existed a single, unified way to solve all RF problems, but there were several complications. The first was the variation caused by frequency. As mentioned, each frequency reacts differently to a given impedance. The second complication was the wide range of possible fundamental impedances. For example, no two broadcast antennas have exactly the same characteristic impedance, but most fall into the range of 30Ω - 120Ω . The uncertainty caused by poking ranges of numbers into mathematics better suited for discrete values undoubtedly helped lead to

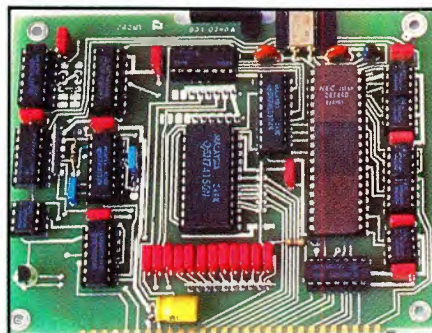

the common engineering notion of the "guesstimate."

Engineering pioneers began to consider other methods of obtaining solutions. The Astrolabe, used by seagoing navigators for centuries, is a tool that solves complicated spherical-geometry math functions using a circular graphics card and straightforward rules and procedures. In 1931, Phillip H. Smith took the graphical solution introduced by the Astrolabe and applied it to the problem of determining the standing wave ratios of coaxial cables. Smith's first chart was quite complicated, but after several years of refining, it has become the most universal tool for RF design work.

Two quantities must be determined before using a Smith chart: normalized impedance and propagation constant.

Characteristic impedance

Two quantities must be determined before using a Smith chart: normalized impedance and propagation constant. In addition, the expected or measured characteristic impedance of at least one part of the RF circuit must be defined.

Whenever an RF signal goes into a transmission line (or RF amplifier circuit) there is a brief time during which energy flows only forward into the line (or circuit). When the RF wave has traveled to the end or termination of the transmission line, the smallest mismatch will cause some energy to be reflected. During the brief time when only RF energy is flowing forward, the signal "sees" the characteristic impedance (or ideal impedance) of the transmission line or circuit. For transmission lines, this number is specified by the manufacturer over a range of frequencies.

Propagation constant

The propagation constant of a transmis-

sion line is the natural logarithm of the ratio between the input current vs. the output current for only the forward-traveling portion of the wave. It assumes that the length of the transmission line is exactly one wavelength of the frequency of interest.

The propagation constant is a complex number, with the *real* portion representing the resistive attenuation of the transmission line, and the *complex* portion representing the phase constant. The phase constant includes both the wavelength within the transmission line and the velocity of propagation.

Normalized and characteristic impedance

When the characteristic impedance and propagation are constant, the ideal performance of forward-traveling waves in a unit length of transmission line can be defined. The normalized characteristic impedance provides the actual results of using the transmission line in a given application.

If a generator (source) of RF is connected to one end of a transmission line and a receiver (load) to the other, several circuit mismatches will be introduced. As long as its output impedance is close to the characteristic impedance of the transmission line, the generator will not have much impact. The receiver, or load, and the length of the transmission line exert a much greater influence. For example, if the receiver is an open circuit, by Kirchoff's laws almost 100% of the energy injected into the transmission line will be reflected.

The Smith chart becomes most valuable in determining how to provide maximum energy transfer from the transmission line into the load. Using the chart, the values of circuit elements can be found that will provide maximum transfer of energy among a predefined RF generator, a variable-length piece of transmission line and the load. In addition to transmission-line problems, Smith chart techniques apply to RF amplifiers, attenuators, directional couplers, antennas, antenna-matching networks and signal-distribution networks.

||:~(-))|||)

Kaufhold is a market development engineer for SGS-Thomson Microelectronics, Phoenix.



First Class Sound. Affordable Price.

Orban's popular XT2 Six-Band Limiter Accessory for OPTIMOD-FM® 8100A has been chosen by many major-market stations seeking a "highly processed" sound that's also clean, natural, and easy to listen to. What's particularly significant is how many have chosen the XT2 after comparing it to "another unit" — which costs twice as much! (The XT2 costs only US\$2,075!)*

How does Orban provide superior performance at a modest price? Simple — the XT2 uses your host OPTIMOD-FM's power supply and much of its circuitry to achieve efficiency, economy, and performance so high that the XT2 would be the processor of choice even if cost were no object.

The XT2 provides bass, presence, and brilliance equalization, plus density and clipping controls, to let you precisely tailor the sound to your station's format and target audience.

Ask your Orban Dealer for information about Orban's powerful First Class winner — the XT2. Or write, call, or FAX us directly.

orban

a division of AKG Acoustics, Inc.
645 Bryant St., San Francisco, California 94107 USA
Telex 17-1480 FAX (415) 957-1070
Telephone (415) 957-1067 or (800) 227-4498

Circle (10) on Reply Card

CD troubleshooting

By Brad Dick,
radio technical editor

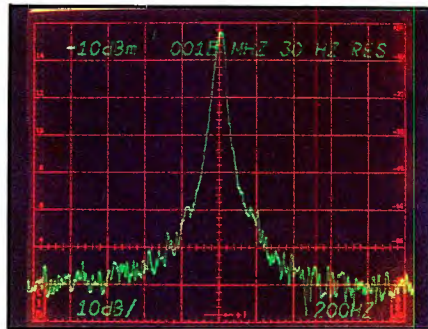

Most of the errors that happen during the playback of a CD result from scratches, dust and dirt. Each time these occur on a disc, data can be lost. Even minor damage to time-contiguous recorded data can be catastrophic to the audio recovery process.

Rearranged data

One key to accurate data recovery is adopting a spread recording scheme. In this manner, the blocks of data are recorded in a fixed pattern along with code words in a process called *interleaving*.

Even minor damage to time-contiguous recorded data can be catastrophic to the audio recovery process.

In Figure 1(a), the original data blocks are shown recorded in a time-sequenced manner. Each block of data is related to the next block by a specific time reference. In Figure 1(b), the original blocks of data have been rearranged (interleaved). In this case, each adjacent block of data is no

longer related to the next block of data by the same time + N factor, with N being constant.

With interleaving, the missing pieces of data are spread throughout the analog signal.

Although the interleaved signal appears to be recorded in a random fashion in Figure 1(b), that is not the case. The actual recording sequence is quite precise and is determined in the encoding process.

Missing data

Once the CD is produced, many opportunities for damage occur. Dirt, scratches and manufacturing defects all can cause the loss of data, as shown in Figure 1(c).

Figure 1(d) shows how the player might recover the data. Note that seven damaged blocks now are spread throughout the message. Although every word is missing a character, most of each word is intact. It now becomes a matter of error correction to develop the missing pieces of data. If the data cannot be corrected exactly, then an approximation can be developed. In an extreme case of damage,

the CD player will mute the output when the data is missing or corrupted. In most cases, the muting is inaudible.

Error correction

Figure 2 shows how the sequence of audio recording and reproduction from a CD might occur. In Figure 2(a), the original

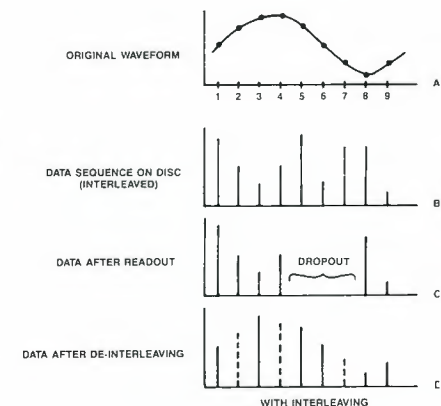

Figure 2. The recording process band-limits the audio. Therefore, you can assume there will be no abrupt changes between adjacent samples. This makes interpolation (the dashed lines shown here) fairly easy. Study the Nyquist theorem for more detailed explanation of why this is possible.

analog waveform is sampled at regular intervals. The data is rearranged (interleaved) and recorded on the disc as shown in Figure 2(b). The scratch or dropout is shown as missing data in Figure 2(c). With interleaving, the missing pieces of data are spread throughout the analog signal. Once the data is reassembled in the correct order by the decoders, the errors are spread throughout the signal.

It now becomes a process of correction or interpolation to replace the missing samples, as shown in Figure 2(d). The interleaving system allows the compact disc system to correct for up to seven frames (32 bytes each) of data.

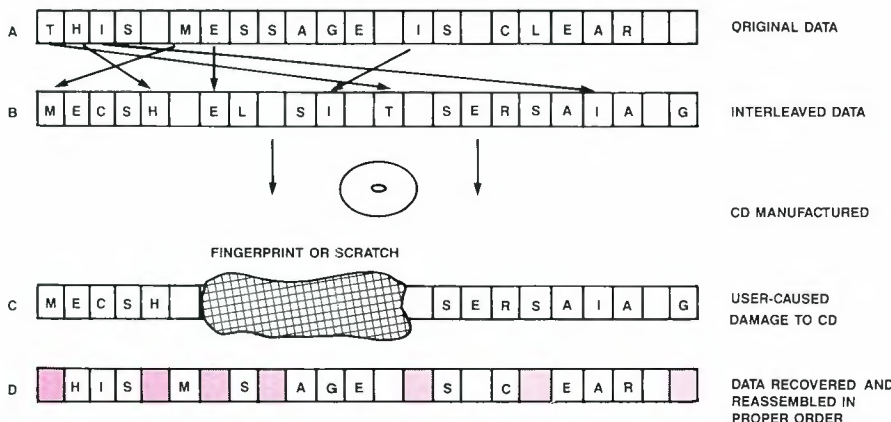

Figure 1. Interleaving records the data in a sequence that does not represent an increasing time scale. Any dropout, therefore, will be less likely to affect any time-contiguous databytes. In this example, no more than one contiguous frame is affected, and complete correction is likely.

Acknowledgment: Appreciation is expressed to Laura Tyson, sales engineer, Denon America; Martin Ledford, quality control manager, Denon Digital Industries; and Dave C. Bowman, director of professional products, Studer Revox for their help with this column. | :-(-) |

“We’ve always known JVC makes great cameras...”



...so we were especially interested to hear about their new KY-25U three chip camera. We've been looking for a camera that offers at least 700 lines of resolution, can dock with our component VTR's, and won't eat up our limited budget."

JVC's engineers specifically designed the KY-25U to be a versatile camera, with multiple signal outputs for docking to any component VTR, satisfying all the rigorous demands of field acquisition. Plus, it's well balanced, comfortable and feels great to use.

It's an outstanding camera that will give you over 700 lines of resolution to take advantage of today's superior recording formats like S-VHS, MII and Betacam. Three $\frac{2}{3}$ " high density CCDs, each with 360,000 effective pixels and a

signal-to-noise ratio of 60dB, ensure exceptional picture quality.

Compare the KY-25U's compact size and advanced features including high speed shutter, stereo audio, advanced circuitry and much more. You'll agree...for price and performance there is just no better camera available today.

For further information call 1-800-JVC-5825 or write JVC PROFESSIONAL PRODUCTS COMPANY, 41 Slater Drive, Elmwood Park, NJ 07407.



JVC[®]

PROFESSIONAL



Circle (11) on Reply Card

www.americanradiohistory.com



On being a leader

By Brad Dick,
radio technical editor

The type of message you use to communicate your desires affects greatly how it is perceived. Messages that include "you" often carry the penalty of arousing defensiveness in the other person.

You-messages not only fail to elicit the desired behavior, but also can damage relationships. People don't like being told what to do. It's human nature for people to dig in their heels and resist doing what they're being told to do. In fact, *you-messages* frequently force others to become even more firmly entrenched in their unacceptable behavior. What should you do?

Don't point fingers

If you want the behavior of others to change, you must make the process as painless as possible for them and encourage them to choose more appropriate behavior.

If you say, "You are at fault for causing me a problem," "You should have known better," or "You don't care much about this job, do you?" are you going to receive a positive response? Not likely. Instead, the other person will become defensive and resist the type of change you want.

Using an *I-message* allows the other person to identify with your needs and keeps you from pointing the incriminating finger of blame. Blame often is misplaced and usually misunderstood, especially by the receiver.

Also, people seldom are aware that their behavior is unacceptable, because they act out of a desire to meet their own needs. If their needs do not match yours, it's time for change. This is where the *I-message* can be effective.

I-messages

There are three major components to the *I-message*:

1. A brief description of the behavior you think is inappropriate.
2. Your honest feelings about the behavior.
3. The tangible effect of the behavior on you.

Would you be likely to respond positively and decide to change your behavior if your supervisor directed one of the following messages to you?

- "When I find the bench in a mess, I waste time looking for the tools I need."
- "I'm concerned about your department's personnel costs. They are higher than budget, and I've been asked to justify them to corporate."
- "When you come to work late, someone else has to cover for you. Yesterday, we were late into network because Gus had to cover for you while also trying to load tapes. I'm upset because now I have to justify the mistake to the GM."

Each of these messages communicates the three components of the *I-message*. They do not rely on *you-messages*, which easily can result in defensiveness. The problem is clearly stated, and the effect of the behavior on you is made plain. With such non-threatening language, you stand a better chance of getting the other person to change behavior to meet your standards.

Who's in control

Remember that when you confront another person about a behavioral problem, you are not in control of the outcome. You have the problem, but it is the other person who must ultimately decide whether to change.

Behavior is not always changed easily. Giving up an entrenched, habitual way of doing things is difficult at best. You can provide support by helping the person work through the six steps of problem-solving discussed in previous columns. The process takes effort, but it may lessen the stresses you feel from that "problem person."

Even if you use the proper *I-messages*, defensive behavior may result. If so, you have to shift gears and use some of the techniques learned earlier.

Shift gears

If the other person becomes defensive or hostile, shift to the active listening mode. This gives the person an opportunity to vent feelings and may allow you to discover an underlying problem. The worst thing you can do in this situation, however, is to cut off comments by saying something like this:

- You: (interrupting) "Now just a minute, Mary, I told you that..."

Such a response is guaranteed to intensify entrenchment and enforce unacceptable behavior. Let the other person talk. What harm can it do for you to listen?

It's also important that you not let the other person keep you off track. The intent of the communication is to cause the person to willingly change behavior. Try using a combination of *I-messages* and active listening:

- "I see what you're saying, but I really need to have this report completed on time."
- "You're saying that the camera is too old to hold alignment?"

In each case, you're telling the other person that you understand and accept what was said, which is not the same as agreeing with it. By this action, you show your willingness to listen. Once that's established, the person is more likely to be receptive to your position.

Active listening also may offer you the opportunity to gather more information and to view the situation more clearly. It may be that you've missed something in your original appraisal, and the process could change your attitude. You might discover that the person's report was late because the computer was down, for example.

Once you have additional data, the behavior you've found to be unacceptable may be acceptable *under the circumstances*. If so, you'll probably choose to respond differently than you had planned. In any case, active listening is non-threatening for both parties.

The planned response

Next time you're faced with problem behavior, put these three steps into practice:

1. Understand who owns the problem.
2. Use 3-part *I-messages*.
3. Shift to active listening as soon as defensiveness occurs.

These techniques form a powerful tool in establishing effective and productive communication with your staff.

NEW FROM ARRAKIS SYSTEMS

10,000 SERIES

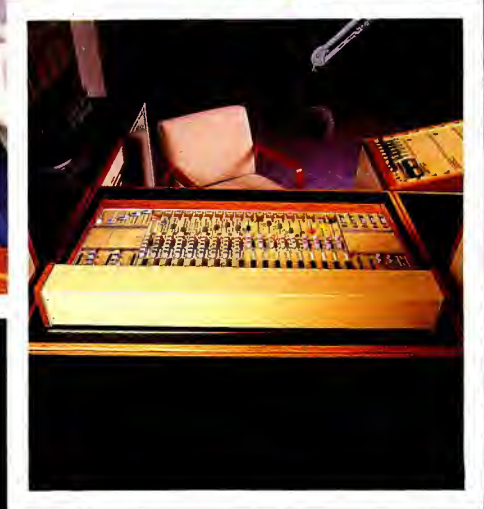
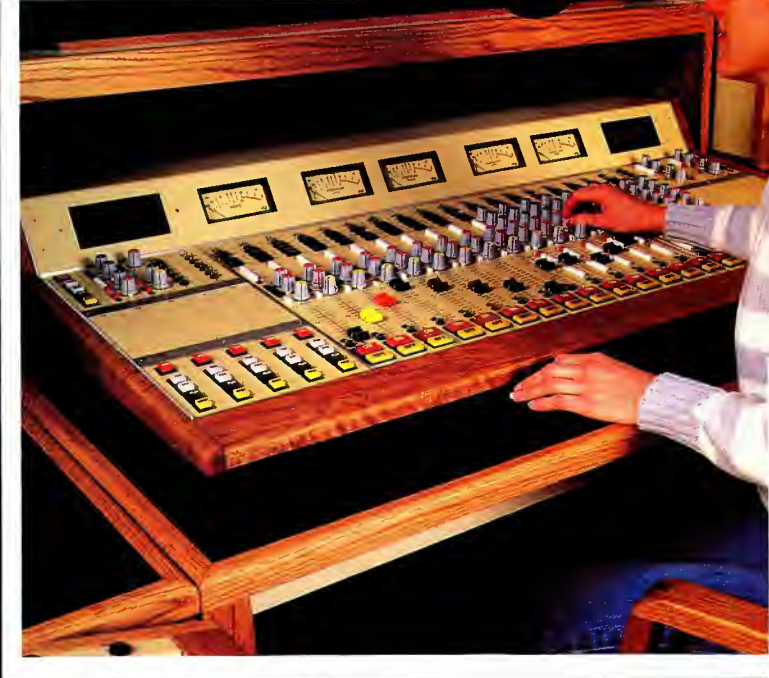
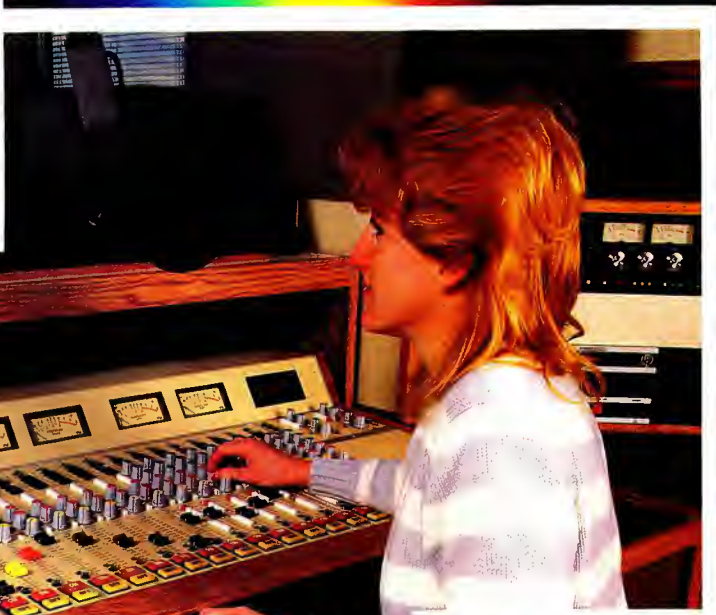

**For features, performance, price and reliability,
NOBODY BUILDS CONSOLES LIKE ARRAKIS.
Call (303) 224-2248**

Circle (13) on Reply Card

ARRAKIS SYSTEMS INC. 2619 MIDPOINT DRIVE FORT COLLINS, CO 80525



Station maintenance special report

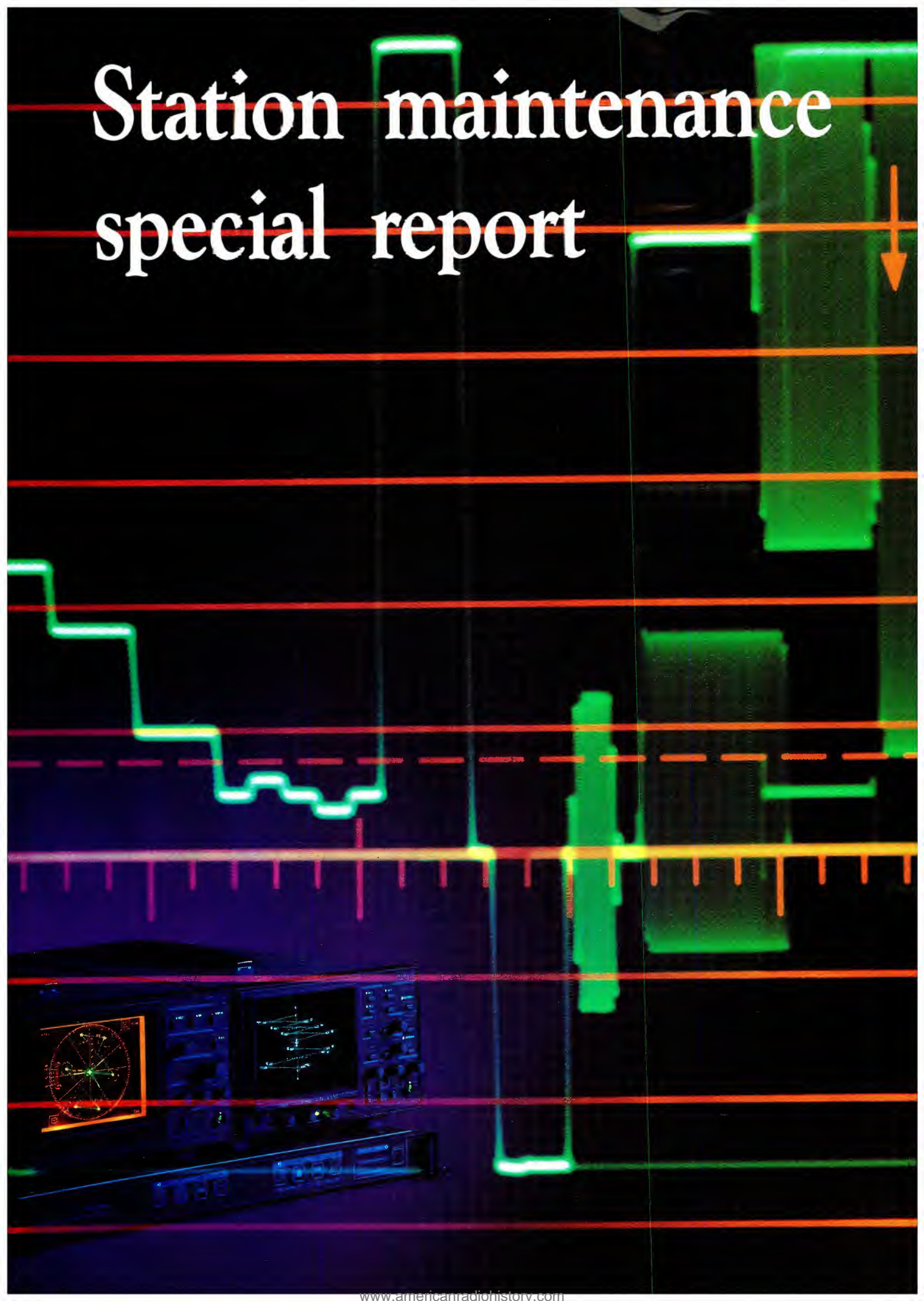

Equipment maintenance has become a whole new ballgame.

As the equipment used by broadcasters becomes more complex, the requirements for highly skilled maintenance technicians also increase. Maintenance personnel today require advanced test equipment and must think in a "systems mode" to troubleshoot much of the hardware in the field. This month, in our sixth annual Maintenance Special Report, we will examine how to maintain the latest broadcast hardware.

New technologies and changing economic conditions have reshaped the way the professional audio-video industry views maintenance. As technology drives equipment design forward, the maintenance difficulties will continue to increase. Such problems can be met only through improved test equipment and increased technician training. Equipment maintenance today is a new ballgame. The stakes are high to get into the game. But the stakes are higher to stay out.

Our Maintenance Special Report includes the following elements:

1. "Servicing Local Area Networks" 26
2. "The New Breed of Test Instruments" 32
3. "Advances in Digital Oscilloscopes" 42
4. "Automated Test Instruments" 48
5. "Maintaining Small-Format Video Recorders" 69

Equipment maintenance can be an exciting, rewarding profession. The key is to stay abreast of the technology.



Jerry Whitaker,
editorial director

Equipment maintenance today isn't what it used to be. And that's probably a good thing. New test instruments provide engineers with greatly expanded troubleshooting information. (Photo courtesy of Tektronix.)



YOUR



SHIP JUST CAME IN.

Watching the horizon for more of Type IX?

That's Sony's value line of U-Matic SP™ 3/4-inch video equipment.

Well, the goods are here. And they're not just good. They're great.

There are three new pieces: the VO-9850 Editing Recorder, VO-9800 Recorder/Player, and the VO-8800 Portable Recorder. They will dazzle you with advanced capabilities. And affordable prices.

One innovation is software control. A menu on the screen lets you preset an optional time code and access other machine functions, such as diagnostics, by means of front panel software switches.

The RS-422 serial interface for remote control is bi-directional, so that the edit controller is continually updated on machine status.

Plus longitudinal SMPTE time code, for ± 0 frame accuracy. Not to mention the Dolby® C audio noise reduction, with balanced audio XLR connectors.

But see these wonderful new arrivals for yourself. Just call Sony at 1-800-523-SONY.

Sony Communications Products Company, 1600 Queen Anne Road, Teaneck, NJ 07666. © 1989 Sony Corporation of America. Sony and U-Matic SP are trademarks of Sony. Dolby C is a registered trademark of Dolby Laboratories, Inc.

SONY®

PROFESSIONAL VIDEO

Servicing local area networks

By Michael W. Dahlgren

Getting machines to work is only half the battle; getting them to talk is just as important.

In today's business environment, communication is the vital link to success, especially in the broadcast industry. For many stations, the use of local area networks (LANs) has provided an efficient way to communicate internally. LANs offer the answer to many business problems by providing the technology for more efficient communication between systems. With all the advantages LANs offer, the LAN market is now one of the fastest-growing segments in the computer industry.

For the maintenance department, the introduction of LANs has brought the need for a different approach to service. Because one of the major assets of a LAN is the ability for machine-to-machine communication, or for type A machine to talk to type B machine, LAN service can become a complex task. The service technician must have an understanding of the machines in the network, as well as the interaction between the machines. Regardless of your exposure to the LAN environment, educating yourself about the concepts of the system will contribute to the success of your department.

Inside the LAN

Although few would argue that personal computers have become the computation-

Dahlgren is product manager for Novell Service Division, Provo, UT.

al darling of the business world, one sore spot still blemishes an otherwise pristine relationship — finding people who really know how to get them to work. That is especially true when those PCs are running on a local area network.

Not many stations have personnel with the proper training to adequately handle some of the bewildering connectivity situations that can arise when piecing together LANs. The technical issues involved in creating symmetry and synergy between multiple environments (getting your DEC to talk to the 3270 host without knocking any Macintoshes off the vines) can get pretty staggering.

These challenges have made LAN services one of the most lucrative fields in the information systems (IS) industry. The PC network marketplace is the fastest-growing segment of the IS industry. LANs are being used in hundreds of different situations, from simple accounting and data-processing systems to complex integration systems tying together all conceivable protocols and environments within a multimedia corporation.

The OSI

For all its limitations, and there are many, the Open Interconnections Standards (OSI) model is the most broadly accepted explanation of LAN transmissions in an open system. By stepping through

the model with an imaginary transmission, we will be able to demonstrate the areas where problems are likely to happen and where the maintenance department should concentrate its efforts.

LANs primarily are involved in the business of making data transmission possible. The OSI model breaks the process of data transmission into seven steps:

• Physical layer

The physical layer is responsible for carrying an electrical current through the computer hardware that eventually translates into something meaningful for the computer operators. The most fundamental components on the physical layer are the central processing units, disks, drives and I/O channels — those components that handle the initial data binary datastream.

This layer can be affected by overuse. For instance, if a file server is burdened with requests from workstations, the results may show up in error statistics that reflect the server's inability to handle all incoming requests or an overabundance of *response time outs* — a message sent back to the workstation that the waiting period allotted for a response from the file server has passed without action from the file server.

Error messages of this sort, which can be gathered by any number of commer-

“The beacons were blown out of their sockets, but our transmitter barely blinked.”

Robert LaFore knows all about lightning. As Chief Engineer for WQPW-FM “Power 96” in Valdosta, Georgia, he’d better: His 600 foot tower

“Still is, in fact—it’s our back-up now. Basically, we shopped around enough to be sure Harris could match or top the competition in both price and features: Things like Automatic Power Control for simple remote operation. Then we ordered a 20 kW HT 20FM transmitter.”

About 45 days later WQPW’s transmitter arrived (meanwhile, Robert supervised construction of a new transmitter building, tower and antenna). “We just took it out of the box and put it right on the air,” he says. “Even the tuning movements were small. The installation went so smoothly, I told the factory ‘You’ve got to do something—this transmitter’s boring.’”

After a number of months of service, WQPW’s HT 20FM remains just as “boring.” Robert has only shut it down for routine monthly maintenance. “Even that is minimal,” he told us. “I vacuum the cabinet out, check tube cooling, make sure nothing’s overheating, and that’s about it. Two or three times a week I do a meter check and log the readings. They hardly ever

change. In fact, we’re still using almost the same tuning numbers we got from the factory. And we’re getting a very noticeable improvement in audio quality from our new Harris THE-1 exciter.”

As you can tell, WQPW is very proud of their new transmitter. We’re just as proud that



Direct strike!

WQPW'S 600 FT. TOWER TAKES THEM WHENEVER THERE'S LIGHTNING.

is the tallest object for miles around. “We’ve been hit so hard the tower beacons were blown out of their sockets,” he told us recently, “and so often that the lightning rod looks like someone’s been beating chunks out of it with a sledgehammer. But so far our new Harris HT 20FM transmitter barely blinks at lightning. Occasionally we get a PA Plate Overload message, but that’s it.”

Robert also knows something about Harris reliability: Until they received a power increase to 50,000 Watts last year, WQPW had been on the air with a 3.5 kW Harris transmitter for thirteen years. “That transmitter was very good to us,” Robert reports.

Chief Engineer Robert LaFore

WITH HIS NEW HARRIS HT 20FM 20 KW FM TRANSMITTER.



Look south

FROM WQPW'S TOWER, AND YOU CAN SEE ALL THE WAY TO FLORIDA.

our HT 20FM is living up to their confidence in Harris engineering. But then, we expected it do exactly that from the moment it took shape on the drawing board.

For more information on HT family FM transmitters from 1 to 35 kW, call toll-free (800) 4-HARRIS. Ext. 3022. Outside the continental US, fax us at (217) 224-2764. And for the widest selection of studio products, call Allied Broadcast Equipment toll-free at (800) 622-0022.



HARRIS BROADCAST DIVISION
MARKETING DEPARTMENT
P.O. BOX 4290 • QUINCY, IL USA 62035-4290

Circle (115) on Reply Card

cially available software diagnostic utilities, can indicate an overburdened file server or a hardware flaw within the system. Intermittent response time-out errors can be caused by a corrupted *network interface card* (NIC) in the server. A steady flow of time-out errors throughout all nodes on the network may indicate the need for another server or bridge. Hardware problems are among the easiest to locate. In simple configurations where something has suddenly gone wrong, the physical layer and the datalink layer should be the first suspects.

- *Datalink layer*

Level 2 of the OSI model, the datalink layer, describes hardware that enables data transmission, NICs and cabling systems. This layer integrates datapackets into messages or transmission, checks them, and then sends them on their merry way. Sometimes this layer also will send out an "arrived safely" or "did not arrive correctly" message back to the transport layer (layer 4), which monitors this communication layer.

Because most functions of the datalink layer (in PC-based systems) take place in integrated circuits on NIC cards, not much software analysis is needed. As mentioned previously, when something happens on the network, the datalink layer is among the first to suspect. This is one of the areas where complications engendered by multivendor environments can show up.

Because of the complexities of linking multiple topologies, cabling systems and operating systems, any of these problems can creep up:

1. RF disturbance: Transmitters, ac power controllers and other computers can all transmit energy that may interfere with data transmitted on the cable. This often is the single biggest problem in broadband networks. It can manifest itself through excessive checksum errors and/or garbled data.

2. Sloppy installations: Problems related to the datalink layer commonly result from shoddy cable installation. Stringing out too much cable without boosting the signal causes cable loss and the possibility of noise pickup. Ethernet runs can stretch up to 1,000 feet, depending on the cable; a token ring system will go 600 feet with the same qualification. The need for additional distance can be remedied in several ways. Either place a bridge, gateway, active hub, equalizer or amplifier on the line, or use less cable.

The datalink layer also includes routing hardware, such as active and passive hubs, multiple-access units (for token ring, StarLAN and ARCnet networks) and other routing devices. If a router goes out, there will be no mistaking the problem — the segment of the network it supports will go down.

- *Network layer*

Layer 3 of the OSI model guarantees the delivery of transmissions as requested by the upper layer of the OSI model. By making sure signals get to their designated targets, then translating logical addresses into physical addresses (determining where the incoming transmission should be stored), the network layer guarantees a level of transmission reliability. Errors of this type (lost data or misplaced data) can be traced back to the network layer, in most cases eventually incriminating the network operating system.



Computers have reshaped the way broadcasters do business. The next big step for many stations is to tie all of the individual systems together. (Photo courtesy of John Brewer, Shawnee Mission, KS.)

The network layer also is responsible for statistical tracking and communications with other environments, such as gateways. Level 3 also decides which route is the best to take, given the needs of the transmission. If router tables are being corrupted or it's taking an excessive amount of time to route from one network to another, an operating system error on the network layer may be involved.

- *Transport layer*

Layer 4, the transport layer, acts as an interface between the bottom three and the upper three layers, ensuring that the proper connections are maintained. It does the same work as the network layer, only on a local level. The network-operating system driver (ie: the *shell driver* under NetWare) does transport layer tasks, so flaws in connections between PCs on an internet can sometimes be attributed to the shell driver. Also, these error statistics may indicate whether levels 2 and 3

do their jobs correctly. If they do, the transport layer doesn't have much to do. Network-operating system drivers do not generally cause many problems so this should not be an area of much concern.

The transport layer also may have the ability to save transmissions that were enroute in the case of a system crash, or re-route that transmission to its destination in case of primary route failure.

The transport layer also monitors transmission, checking to make sure the packets that arrive at the destination node are consistent with the build specifications given to the sending node in layer 2. In other words, the datalink layer in the sending node builds a series of packets according to specifications sent down from higher levels, then sends these packets off to a destination node (node B). The transport layer monitors these packets to ensure they arrive according to specifications indicated in the original build order. If they don't, the transport layer calls for a retransmission.

Some operating systems refer to this as a *sequenced packet exchange* (SPX) transmission, meaning the operating system guarantees delivery of the packet. If the operating system itself depends upon SPX transmissions, errors such as (*****) indicate a transport layer failure. *Event control block* (ECB) and malformed packet problems often refer to an application that is not compatible with the operating system, although in some cases, those problems have been caused by faulty interface cards. Error statistics that would be encountered here are the checksum errors and malformed packets.

- *Session layer*

Level 5 is responsible for turning communications on and off between communicating parties. Unlike other levels, the session layer can receive instructions from the application layer through NetBIOS, skipping the layer directly above it, which is, in this case, DOS.

NetBIOS and APPC are the protocol biggies here. These protocols allow applications to talk across the network. Multivendor problems often can crop up in this layer. Problems with gateway access usually fall into level 5 for the OSI model, and are often related to APPC or NetBIOS compatibility issues.

- *Presentation layer*

The presentation layer sees that application layer commands are translated into syntax understood throughout the network. It also translates incoming transmissions for layer 7, acting like a butler who tells the French cook to prepare lambchops for dinner, then tells the master that they are out of celery.

The presentation layer masks other devices and software functions, allowing

Here's another reason we sell more cart machines than anyone else.



The Delta series. The world's most popular cart machine over the last five years.

And here are three more.

Our Authorized 3M Dealers

Allied Broadcast
Equipment
800/622-0022

Broadcast
Services Company
919/934-6869

Broadcast
Supply West
800/426-8434

3M International Tapetronics — The World Leader In Cart Machines.

FLUSH MOUNT 75 OHM BNC CONNECTORS

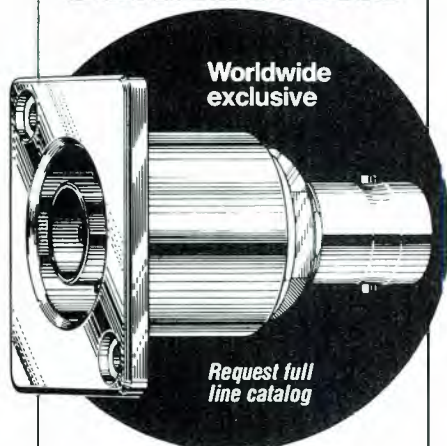

- Recessed panelmount less prone to damage.
- Fully isolated. Compatible with all other manufacturers BNC connectors.
- Beryllium copper external contact with gold coated center contact pin.
- VSWR characteristic (<1.1) up to 2 GHz.

CANARE™

CANARE CABLE INC.

511 5th St., UNIT G, SAN FERNANDO, CA 91340
(818) 365-2446 • FAX (818) 365-0479

Circle (19) on Reply Card

a workstation to emulate a 3270 terminal through an emulation card and software.

Reverse video, blinking cursors and graphics also fall into the domain of the presentation layer. Its software controls printers and plotters, and may handle encryption and special file formatting. Problems in this area are often the result of products that are either not compatible with the operating system, an interface card, a resident protocol or another application (especially TSR programs).

• Application layer

This is where the application and network OS functions reside. Print spooling, file sharing and E-mail all reside here. The application layer translates application requests into network application requests. It allows a stand-alone process to take place on the network by interfacing from the application to the network, thereby providing the first layer of communications into other open systems on the network.

In cases where an application is at fault, software diagnostics often will show a high number of ECB errors, malformed packets, packets that are too small or too large and severe time-out errors. If an application is not compatible with the operating

system, little can be done outside of re-writing the application.

Network installation

Fiber optics is the medium of the future. The only thing currently holding it back is the cost of interface hardware, which should drop considerably once the applicable standard (FDDI) is in place. But fiber installation poses distinct challenges: It is difficult to splice, requiring the use of special equipment that aligns the glass filament and ensures that the ends of the fiber meet perfectly so there is no deflection. A drop cable just can't be tapped in, as with coax.

And there is the issue of a lack of standards. Although everyone has announced support for FDDI, multiple would-be standards are vying for their market share. Someone has to sort out which cable works with which card and connector, and also make sure that the system installed today correctly anticipates emerging products.

||:~:~)))))

NEW! Wireless Clear-Com

6 Beltpacks— No Wires!

FCC Approved

<p>▲ Clear-Com quality audio</p> <p>▼ Extends range of wired system with up to six wireless transceivers</p> <p>▲ Exceptional RF performance — virtually transparent from the wired system</p>	<p>▲ Full-duplex, high band operation</p> <p>▼ Developed for the professional user</p>
--	--

CONTACT YOUR CLEAR-COM DEALER, OR CALL/WRITE:

945 Camelia
Berkeley, CA 94710
415-527-6666
FAX 415-527-6699

Circle (18) on Reply Card

Looking for a job?
Have something to sell?
Have a professional service to offer?
Put *Broadcast Engineering's* Classifieds to work for you!

- BE's total readership of over 74,000 . . .
- low, low rates of only \$1.50/word . . .

and

- magazine retention of over 1 year for longer exposure of your ad message
- means you get *results* for a very small investment!—

Call Renée Hambleton at
 913-888-4664 to place your
 classified ad in the very next
 available issue.

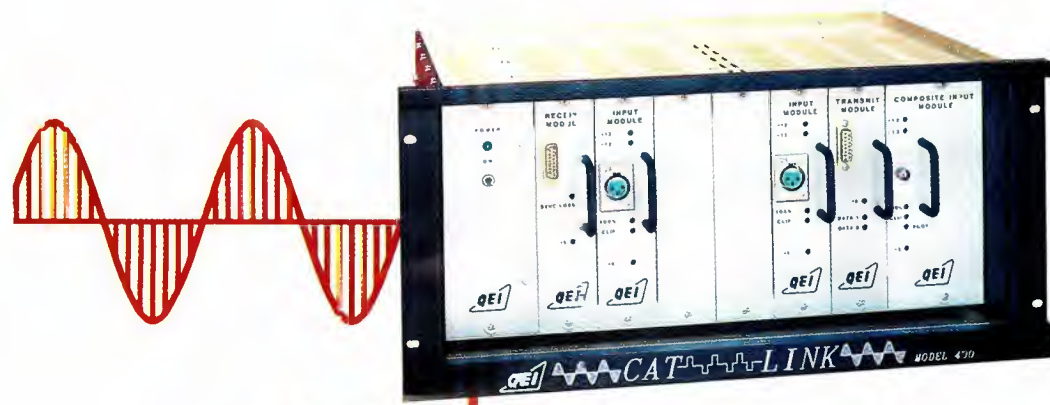

The STL/TSL for the 90s is here now. And not a moment too soon.

- Two Way Multi-Channel Communications
- Transparent Digital Audio
- Multiple Signal Path Options



It's time for a new kind of STL. Drastic cost increases are just one sign that the phone company is tired of balanced equalized lines and is ready to pull the Class A plug. Meanwhile, microwave spectrum is scarce—in some areas, channels are unavailable.

QEI's new CATLink Composite Audio Transmission Link is the *digital* STL alternative. It transmits composite and other signals over a single telco T1 data line*. T1 service costs less than Class A, and it's so reliable that the big banks use it for their vital financial data.

CATLink encodes the fully processed *composite* signal and decodes it at your transmitter, so you can run the stereo generator and processing at the studio. At the same time, CATLink configurations can send and receive SCAs, control channels, voice communications, RS232 data, AM audio, transmitter readings, and satellite or remote programs.

With CATLink, you always get full stereo separation: There are none of the phase or amplitude fluctuations that plague dual-channel STLs. Dynamic range is up to 84 dB, and your processed composite signal can use virtually all of it. So the only thing you'll hear is clear, clean, undistorted audio.

Worried about replacing Class A lines, getting a microwave channel, or sight-line infringement? Call QEI toll-free at 800-334-9154 for full info on CATLink, the bidirectional, digital, *easy-wired* STL. And turn the weak link in your signal chain into one of the strongest.

* CATLink will also drive over a mile of twisted pair wire, nearly two miles of fiber optic cable, or a 23 GHz STL.

Quality • Engineering • Innovation
 P.O. Box D • One Airport Drive
 Williamstown, New Jersey 08094
 24 Hr. Service Hotline 609-728-2020 • Fax 609-629-1751



Circle (15) on Reply Card

The new breed of test instruments

By Conrad Persson

Help is on the way for your worst troubleshooting problems.

Servicing computer-based professional equipment typically has involved locating the problem at the PC-board level and then replacing the defective board. Taken on a case-by-case basis, this approach seems quick and efficient. The inefficiency in the approach, which is readily apparent, is the investment required to keep a stock of spare boards on hand. Another problem is that a board that appears to be faulty may actually turn out to be perfect.

The ideal solution is to troubleshoot down to the component level and replace faulty components instead of board swapping. In some cases, this approach can require sophisticated and expensive test equipment. In other cases, however, simple test instruments will do the job. Two of the most basic pieces of test gear are the digital multimeter and logic probe.

Multimeters come of age

$E = IR$. That more or less sums up the idea of electricity and electronics. Of course, there's a lot more to it than that, but that relationship covers the first several chapters in most texts. It seems appropriate, then, that the most basic electrical/electronics tester, the multimeter, will test for E, I and R.

Of course, the multimeter is by no
Continued on page 36

Persson is editor of *Electronic Servicing & Technology* magazine, an Intertec publication.



Multimeters have come a long way from the analog VOM. New meters offer users better accuracy and more features than ever before.

ABEKAS

SIX YEAR OLD JUGGLER BECOMES TV HIT.

Juggling over 1,000 images is tough. But the Abekas A42 Digital Still Store makes it easy. In fact, for six years running, leading TV stations have made the A42 their chosen method of image storage. It's a big hit. And for good reason. The A42's on-line hard disk provides safe, cost effective storage of up to 1050 frames/2100 fields. For off-line storage there's a digital streaming tape drive. You get excellent multi-generation capability. Single or dual output. A powerful optional library system. Digital video processing that assures clean, crisp high-quality images and D-2 composite digital compatibility. You want to juggle over a thousand images with ease? The Abekas A42 is the standard. For details: (415) 369-5111



Abekas

A Carlton Company

Leading in Digital Innovation

Atlanta (404) 451-0637 Chicago (708) 699-9400
Dallas (214) 385-4544 Los Angeles (818) 954-8700
New York (516) 829-0820 San Francisco (415) 369-6791

Circle (16) on Reply Card

More and more people are lining up for the Panasonic SVHS Pro Series.

One look is all it takes. And you'll see why more and more people are lining up for the Panasonic® SVHS Pro Series. Because anyone in the market for a high-quality professional video production system, simply can't afford not to look at what the Pro Series can do for them.

Take Cost-Performance. The Panasonic SVHS Pro Series delivers both. By combining the efficiency and systems flexibility of half-inch technology with the exceptional performance of Y/C component signal processing.

The result. A comprehensive video production system that provides two hours of operation on a single cassette. With over 400 lines of horizontal resolution. And signal integrity through five generations.

By now it should be obvious. The closer you look and the more you compare the Pro Series to historical video formats, the sooner you'll line up for the Pro Series.

As a Panasonic SVHS Pro Series user, you'll have direct access to Panasonic's nationwide network of engineering, service and technical support specialists. And with over 300 professionally trained dealers, many of whom are self servicing, you'll always get the most out of your Pro Series equipment.

Finally, a professional video format more and more people are lining up for. The Panasonic SVHS Pro Series.

For more information and your local dealer, call your nearest regional office.

Eastern Zone: (201) 348-7620 • Central Zone: (312) 981-4826

Southern Zone:

Dallas Region: (817) 685-1122 • Atlanta Region: (404) 925-6837

Western Zone:

Seattle Region: (206) 285-8883 • Los Angeles Region: (714) 373-7275





To assure excellent quality, support, service and professionalism, the Panasonic Pro Series is available through authorized dealers.

Panasonic

Professional/Industrial Video

Circle (17) on Reply Card

THE LEADER IS AT IT AGAIN!

WE'VE ALREADY BUILT AND INSTALLED AN OPERATIONAL HDTV SYSTEM!

Just ask KBLR-TV39 in Las Vegas, Nevada. JAMPRO provided their antenna which permits the transmission of an HDTV signal.

State-of-the art technology and JAMPRO continue to grow together . . . we were on the leading edge when we developed the first circular polarized television antenna . . . and that tradition continues today.

OUR SYSTEM PROVIDES

- Pattern stability
- Non-scanning characteristics
- A band width wide enough to provide the superior broadcasting of a high definition signal.

FOR DETAILS

(916) 383-1177 • Telex: 377321
FAX (916) 383-1182



6939 Power Inn Road
Sacramento, CA 95828

Circle (79) on Reply Card

Continued from page 32

means the only piece of test equipment a technician needs to troubleshoot a defective piece of professional electronics equipment. This is evidenced by the shelves full of test equipment used every day by competent technicians: oscilloscopes, frequency counters, signal generators and more. But used correctly, a multimeter, especially one of today's sophisticated units, can isolate many faults in electronic circuitry.

The most basic multimeter in today's arsenal of electronic test meters is the volt-ohm-milliammeter (VOM). These units cost less than \$100, yet they let you check ac and dc voltages, resistances and currents in the milliampere range. To some degree, you also can check for semiconductor junctions, and VOMs make dandy circuit-continuity checkers, especially when they have audible output.

You have to be sure to learn the capabilities and limitations of one of these basic instruments. For example, unless the meter is otherwise specified, its frequency response is probably limited. If you're trying to measure the value of a signal at several kilohertz, the signal will be attenuated by the input circuitry of the meter, and your measurement will not be accurate.

Another limitation of the typical low-cost multimeter is that most do not give a true rms indication of an ac waveform. So if the signal you're measuring is not a pure sinusoid, the measured value will not be the true rms value. True rms meters exist, but they are generally considerably more expensive than other multimeters.

A bell here, a whistle there

Beyond the basic VOM functions, one of today's sophisticated digital multimeters (DMMs) may contain a number of functions that have evolved over the years. Some units offer an array of measurement functions that technicians a few years ago would never have dreamed of.

Figure 1 is a generalized block diagram of a DMM. One of today's popular multimeter capabilities is a diode test. Not only does this function test diodes, but it

also tests other semiconductor junctions, and so acts as a quick test of whether a diode or transistor junction is OK, open or leaky.

When a meter is used in the resistance testing mode, it places a low voltage with a constant-current characteristic across the test leads. Once the leads are connected, the voltage across the test leads is determined by the product of the resistance being read and the known-constant current. The meter then measures that voltage and converts it into resistance.

The diode test is accomplished by placing a higher voltage across the meter's test leads than is available for most resistance ranges. But it limits the current to a smaller value than is allowed for the resistance measurements. This combination ensures that the semiconductor junction will be turned on when the meter is connected in the forward direction, but the current is limited to a safe amount that will not damage the junction.

Converting voltages

One of the more popular methods of converting a voltage into a digital signal is the *dual-slope conversion* method or the *double integration* method. (See Figure 2.) V_{in} is the input voltage — the voltage to be measured. V_{REF} is a reference voltage of polarity opposite that of the measured voltage supplied by the meter. Capacitor C and operational amplifier A constitute an integrator circuit. Switch S_1 is an electronic switch that is initially in the position shown.

When the meter probes are first connected to the voltage of interest, that voltage is applied to the input of the integrator for a period of time (called the *integration period*) that was determined by the designers of the meter. (Integration periods are ordinarily selected to be related to the 60Hz line frequency, so integration periods of 1/60th of a second and 1/10th of a second are common.) The output of the integrator is a voltage that is determined by the RC time constant of R and C. Because of the nature of the integrator, the maximum voltage (the voltage at the end of the integration period)

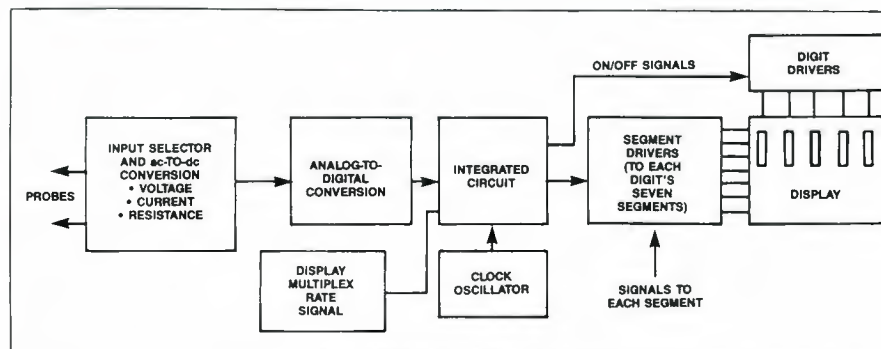
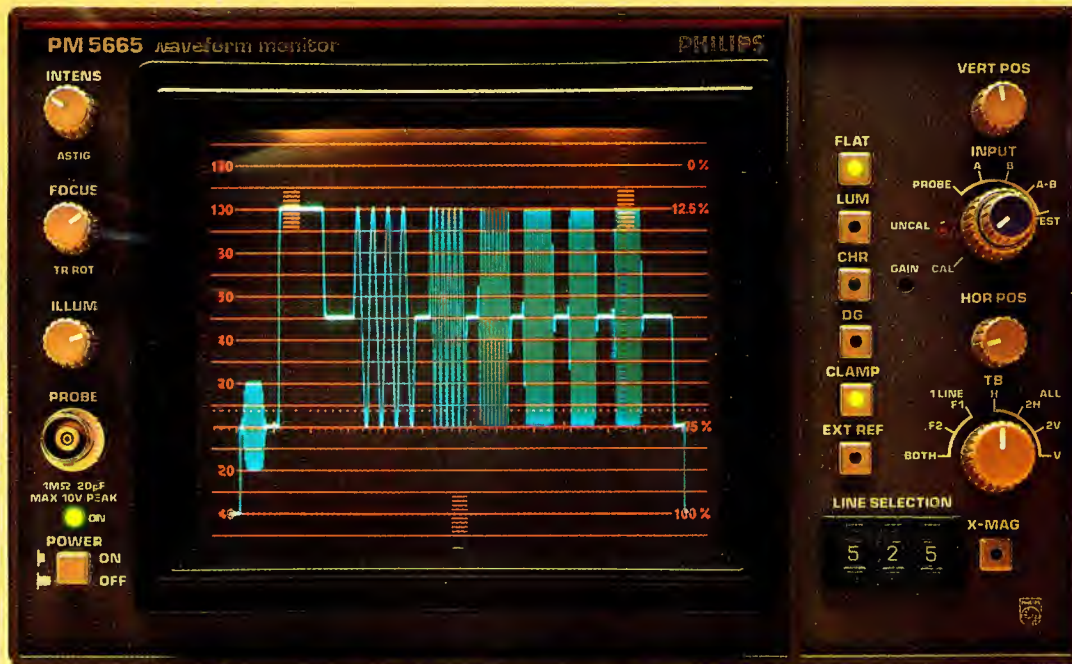

Figure 1. Block diagram of a basic DMM. LSI chip technology has reduced most of the individual elements shown in this diagram to a single IC.

Our special introductory



price ends December 31...



...so call now for your 14-day free trial!

For a limited time only, you can evaluate your choice of Philips waveform monitors and vectorscopes in your facility for two full weeks at no cost or obligation. Compare the accuracy, versatility and ease-of-use of our instruments against the established brand, or whatever you've been using.

Then, compare our introductory price against what you'd pay for theirs. We think you'll find ours the justifiable choice on both price and performance. To find out whether we're as good as we say, call BTC now at 704-547-TEST to arrange for your free evaluation.

BTC



PHILIPS

BTC Test & Measurement, Inc., 8927 J. M. Keynes Drive, Charlotte, North Carolina 28213

Circle (20) on Reply Card

www.americanradiohistory.com

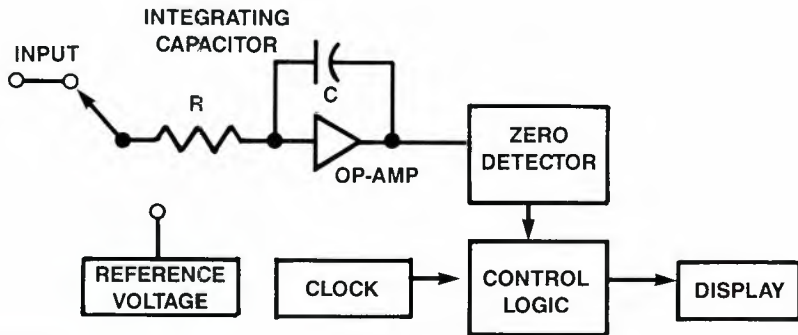

FIGURE 2A

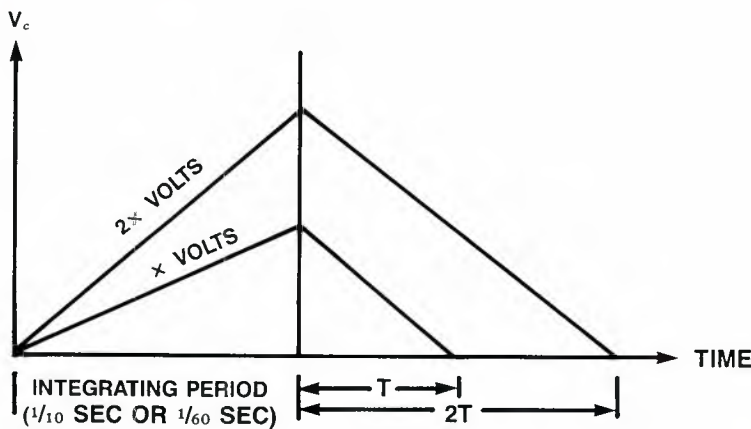

FIGURE 2B

Figure 2. The analog-to-digital conversion process. (a) illustrates the basic circuitry involved; (b) shows a graph of V_c vs. time. Because the slope of the discharge curve is identical regardless of the ultimate voltage reached by the integrator, the discharge period and, therefore, the number of counts recorded by the logic circuitry, are proportional to that voltage.



A test unit such as this can apply test signals and interpret results by exercising a computer system through its I/O connections. The system then outputs a message to guide the technician to the suspect pins of the suspect components. (Photo courtesy of Vu-Data Corporation.)

is proportional to the voltage being measured.

At the end of the integration period, switch S_1 is moved to the other position and a voltage of polarity opposite to the polarity of the measured voltage is applied. In this configuration, the capacitor is discharged until its voltage reaches zero.

As shown in Figure 2(b), the discharge interval will be directly proportional to the maximum voltage, which is proportional to the applied voltage. As a specific case, if the input voltage is doubled, the discharge interval will double.

At the same time that the integration interval ends and the discharge interval be-

gins, a counter that is part of the meter circuitry begins counting pulses generated by a clock circuit. When the voltage reaches zero, the counter stops counting. The number of pulses counted is, therefore, proportional to the discharge period. This count is converted to a digital number and displayed as the measured voltage. Although this method works well, it is somewhat slow, so many microcomputer-based meters use a variation called *multislope integration*.

New meters to come

Multimeters offer more possibilities today than ever before. Large-scale integration (LSI) is making it possible to pack more functions into the limited space inside a DMM, without significantly increasing the cost of the device. Also, because of competition among manufacturers, the functionality of DMMs is improving. The result: increasingly sophisticated products.

The logic probe

The logic probe tells the technician whether the logic state of the point being tested is at a logic high or low. A sophisticated probe will have indicators to show whether the test point is high or low or is exhibiting pulses. Some will even have a memory or pulse stretcher that will show the presence of a 1-shot pulse. The indicators are usually LEDs. In some cases, a single LED is used to indicate any of the conditions (high, low or pulsing). In other cases, individual LEDs are used for each indication.

Let's say you're troubleshooting using a logic probe that is capable of testing a number of different types of logic circuits: TTL, DTL, CMOS. You would connect the probe's power input to the power supply from which the circuitry being tested derives its power. Connecting the probe in this manner will indicate the approximate value of signal voltage that constitutes a logic low or high. For example, the power-supply voltage for a CMOS logic circuit is 18V. A logic low in this circuit would be about 30% of that value or 5.4V. A logic high would be about 70% of 18V, or approximately 12.6V.

If you suspect a specific IC, it would make sense to go directly to that IC once you have the logic probe connected into the circuit's power supply. Otherwise, use the time-tested method of starting approximately in the middle of the circuit and let the results at the point guide you upstream or downstream a half-circuit at a time.

Servicing computer-based systems can be done on just about any level. You can swap boards (where the product is modular) or troubleshoot to the component level. If you choose the latter, a wide variety of test instruments, from simple to complex, is available.

[:-:)]]]]



What should you expect from the company that designed the first color video noise meter?

Clearly, everything.

Fifteen years ago, when we introduced the first color video noise meter there was a lot to make noise about. Today, with the advent of super tapes, super formats and CCD technology, measuring noise accurately has become an exacting science. Shibasoku's VN30A Series Color Video Noise Meters rise to the occasion with some improvements of significant note.

Little Windows.

New user defined measurement windows, easily constructed from the front panel, can be located anywhere on the screen. Create a spot window as small as a $4\mu\text{s}$ line segment and infinitely expand it up to full field. You can even place it in the vertical blanking interval.

Free Buss Rides.

Whether you've already automated testing, or plan to in the future, you get a GP-IB as standard equipment. That's right, standard. Not an expensive add-on afterthought.

And All The Extras.

The new VN30A Series gives you all the little extras like automatic sag compensation, auto level control and automatic memory for noise mode measurement. This means you can initiate a test quickly, in fact, at the touch of a single button. To help you isolate noise more precisely, the VN30A Series will let you measure even field, odd field or full field. And, the VN31AX will automatically select between NTSC and PAL.

To find out why, for price and performance, the VN30A Series is clearly the leading color video noise meter, contact us today.



Asaca/Shibasoku Corporation of America
12509 Beatrice Street, Los Angeles, CA 90066
(213) 827-7144 FAX (213) 306-1382

Circle (21) on Reply Card

MASTERPIECE BY RENOIR.



Genius is the secret of this great painting—and of the great images from two remarkable Sony CCD cameras. The BVP-7 and BVP-70.

The heart of both cameras is a CCD sen-

sor that only Sony could design and make: the 768 HAD (Hole Accumulated Diode).

The 768 HAD is from the industry leader in CCD technology. So it produces an astonishing, true-to-life image that you won't believe

until you see it.

The BVP-70 uses the FIT version of the 768 HAD sensor, making it the premier camera for critical EFP applications. With a full 700 lines of resolution and an extremely low

MASTERPIECE BY SONY.



signal-to-noise ratio. And almost no fixed-pattern noise.

Sony's workhorse camera is the BVP-7, which delivers masterpieces in an enormous range of EFP situations. It's virtually identical

to the BVP-70, incorporating the IT version of the 768 HAD sensor.

To see these masterpieces, don't go to a museum. Just contact your Sony Broadcast Sales Engineer. Or call (800) 635-SONY.

Sony Communications Products Company, 1600 Queen Anne Road, Teaneck, NJ 07666.
© 1989 Sony Corporation of America. Sony is a registered trademark of Sony.

SONY®

BROADCAST PRODUCTS

Advances in digital oscilloscopes

By Steve Montgomery

Tough testing problems are now easier to solve thanks to new digital oscilloscopes.

Recent developments have enabled digital oscilloscopes to be used as effective troubleshooting tools for computer maintenance and repair. Digital scopes can capture and analyze transient signals such as race conditions, clock jitter, glitches, dropouts and intermittent faults. Automated features reduce testing and troubleshooting costs via recallable instrument setups, direct readout of answer and unattended monitoring.

Digital oscilloscopes have some inherent benefits not available on most analog oscilloscopes. These include increased resolution (A/D dependent), memory storage of digitized waveforms, automatic setups for repetitive signals, instant hard-copy output on printers and plotters and complete remote programmability via GPIB for automated test applications. Single-shot digitizing oscilloscopes capture transient signals and allow the user to view the waveform that preceded the trigger point.

Digital memory storage, rather than CRT storage, produces a number of benefits:

- Simple data transfers to host computer for analysis or archive.
- Local data analysis and direct readout of answers via a local processor inside the

oscilloscope.

- Cursors to read out delta and absolute voltage and time.
- No CRT blooming for display of fast transients.

Digital memory allows for full-bandwidth capture of long-duration wave-

forms, thus storing all the signal details. The waveform can then be expanded to expose the details on a particular section.

Until recently, digital oscilloscope bandwidth was limited to about 100MHz. For higher-frequency TTL, ECL and GaAs circuit measurements, an analog scope was

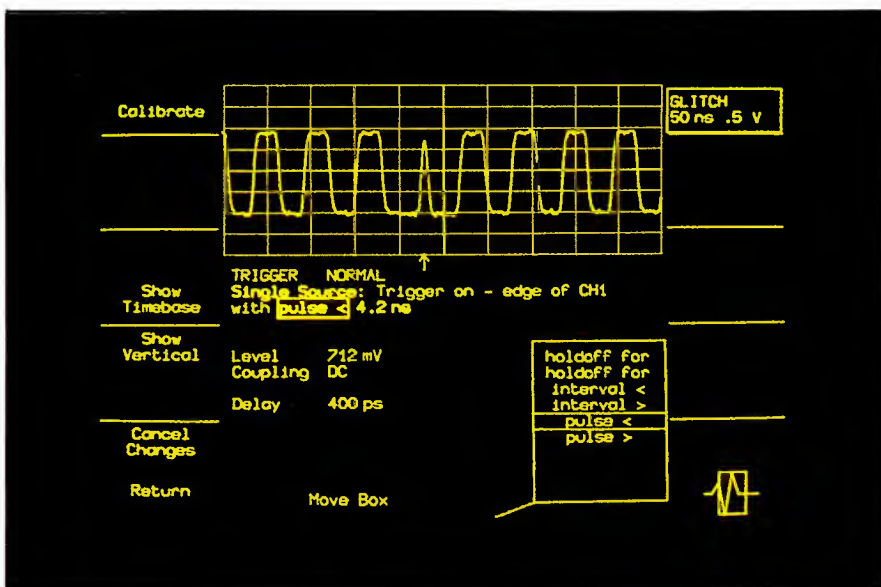

Advanced single-source triggering functions let the technician find a "needle in the haystack." The oscilloscope can lock in on elusive signals such as glitches, dropouts, missing bits or intermittent bad data, thereby saving hours of troubleshooting time.

Montgomery is P.E. at the LeCroy Corporation, Chestnut Ridge, NY.

THE LONG WAIT FOR DEPENDABLE WIRELESS INTERCOM IS OVER.

Telex

RADIOCOM

**is here and headset
intercoms will never
be the same.**

Rad ocom is new! It's a complete wireless intercommunication system from Telex, a company famous for its headsets, intercoms and wireless microphones. Even though it's a professional high band (150 to 216 MHz) system the cost is so low it will amaze you. Four beltback transceivers can operate from the BTR-200 base station, and when two base

stations are daisy-chained together, up to 8 headset stations can be tied into a full duplex communication network. Just think of the problem-solving possibilities.

The stylish new beltback transceivers are compatible with Telex Audiocom headsets or other headsets with four pin XLR connectors. By using Telex Radiocom you can incorporate wireless headset stations into most existing wired intercom systems for exciting new mobility and freedom.

Yes the long wait for depend-

able wireless intercom is over but it was worth it. Each Telex system is completely tested as a system before it's shipped and carries the exclusive Telex THREE YEAR limited warranty. For complete details write to: Telex Communications, Inc., 9600 Aldrich Av. So., Minneapolis, MN 55420.

© 1989 Telex Communications, Inc.

TELEX®

Circle (22) on Reply Card

necessary. But now digital scope bandwidth rivals that of its analog counterpart. Several feature-packed 300MHz+ scopes are available for use with passive probes. Most passive probes are limited to the 300-400MHz bandwidth, and thus limit overall system measurement bandwidth. (Fifty probes and active probes offer extended bandwidth.)

Digital scopes have the potential for superior accuracy. For a high-frequency digital oscilloscope, 3% total system accuracy is considered good. Furthermore, digital scopes can read out amplitudes and times directly from data stored in memory. Measurement accuracy is not degraded by the operator interpolating trace positions with respect to a CRT grid, as when using an analog scope.

Single-shot digitizing allows capture of transient and intermittent signals associated with the most difficult troubleshooting problems such as signal glitches, dropouts, logic race conditions, intermittent faults, clock jitter and power-up sequences. With single-shot digitizing, the waveform is captured the first time it occurs, on the first trigger. It is then immediately displayed. Thus, single-shot digital oscilloscopes operate in similar fashion to analog oscilloscopes.

Advanced triggering

Basic single-source triggering modes usually let the user select the desired source, its coupling, level and slope. The more advanced transient digitizing oscilloscopes also contain triggering circuitry similar to that found in logic analyzers. These powerful features let the user trigger on elusive conditions, such as pulse widths less than or greater than expected, intervals less than or greater than expected and logic conditions. The logic triggering can include digital pattern, state-qualified and time/event-qualified conditions. Many of these trigger modes are further enhanced by allowing the user to hold off the trigger by a selectable time or number of events. Holdoff is especially useful when the signal contains bursts or patterns.

Pulse-width triggering lets the operator quickly check for pulses narrower or wider than expected. The pulse-width trigger circuitry checks the time from the trigger-source transition of a given slope (the rising edge) to the next transition of opposite slope (the falling edge). The operator can interactively dial in the pulse-width threshold for a trigger.

For example, in digital-circuit testing, where the circuit under test normally uses

an internal clock, a glitch could be considered any signal narrower than one-half a clock period. Pre-trigger information could be displayed to show what events led up to the glitch.

Interval triggering lets the operator quickly check for intervals narrower or wider than expected. Interval-trigger circuitry checks from the trigger-source transition of a given slope (rising edge) to the next transition of the same slope (rising edge). Typical applications include monitoring for transmission phase changes in the output of a modem or for signal dropouts, such as missing bits on a computer hard disk.

Pattern triggering lets the user trigger on the logic state (high, low or don't care) of several inputs. The inputs can come from either external trigger inputs or the input channels themselves. The trigger can be generated either upon entering or exiting the pattern. Applications include triggering on a particular address select or databus condition in a microprocessor-based system. Once the pattern trigger is set up, the operator can probe throughout the circuit, taking measurements synchronous with the trigger.

State-qualified triggering enables the oscilloscope to trigger on one source, such

LARCAN

"The design allows us to operate without a backup."

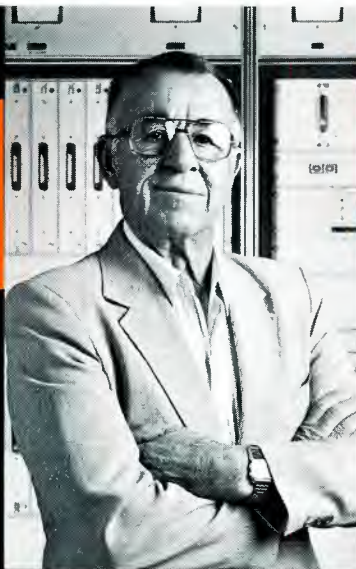

"The redundant design of the LARCAN transmitter allows us to operate without a backup unit. Failure of one or two modules would not take the transmitter off the air—in fact, they can be replaced while the transmitter is running."

**Tom L. Bracanovich, VP Eng.
Malrite Communications**

What gives so many engineers this much confidence in their 100% solid state M Series VHF transmitters? Why are more stations choosing LARCAN's proven third generation engineering every month? Find out—and put *your* station on the pathway to LARCAN M Series performance. Just call the RF experts of LDL Communications at (301) 498-2200. We'll send you full information on the many reasons why LARCAN M Series 100% solid state VHF transmitters from 3 to 60 kW are "your best choice for the long run."

LDL Communications Inc.

14440 Cherry Lane Court, Ste. 201, Laurel MD 20707

Tel: (301) 498-2200 Fax: (301) 498-7952 Tlx: 821569

Where digital and analogue meet (to give you the best of both worlds.)

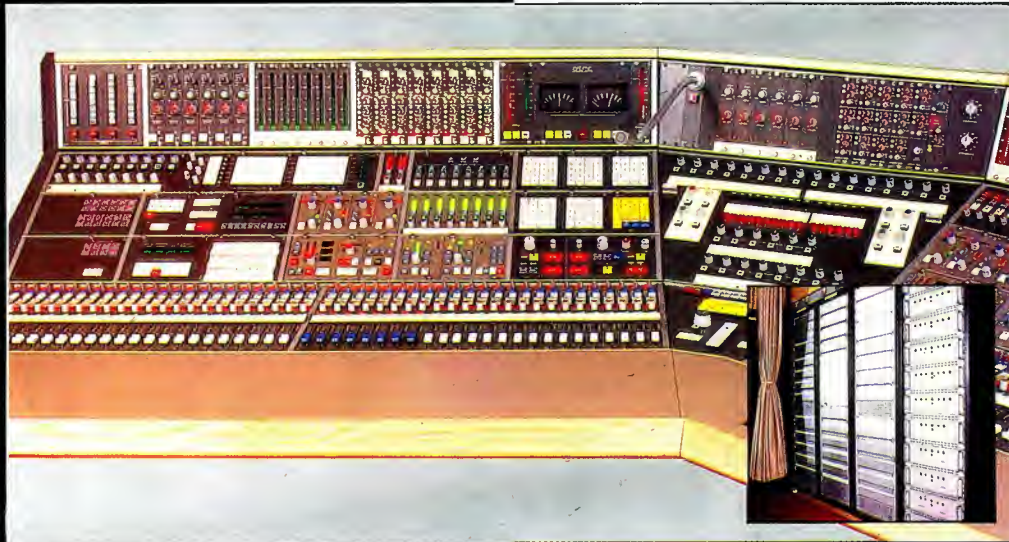

96 channel VCS at BBC TV Centre Studio 4

The AMS Virtual Console System

ams
AMS Industries plc

AMS, Billington Road, Burnley, Lancs. BB11 5ES.
Tel (0282) 57011. Telex 63108 AMS-G. Fax (0282) 39542.
AMS Inc., 3827 Stone Way North, Seattle, WA 98103 USA.
Tel (206) 633 1956 Fax (206) 547 6890



The Queen's Award for Export Achievement to Edendeck Ltd 1985 and
AMS Industries plc 1986. In July 1985 Edendeck Ltd became AMS Industries plc.

If your day starts with a wish that you had up to 128 different audio channels, instantly reconfigurable to provide different groups and outputs – each selectable for mono/stereo, microphone, line or tape input with a memory that can reset every function to what you were doing yesterday, or even last week; look no further.

Our comprehensive brochure explains the benefits of a digitally controlled analogue audio desk and details how to plan the layout of your own Virtual Console System. The VCS isn't just something on paper though – it is already offering reliable service to Thames Television (2 consoles) and the BBC (4 consoles), including a 112 channel desk working as the BBC Master Sound Control OB vehicle.

- Free assignment of faders for maximum flexibility.
- Ergonomic layout with high resolution displays/controls.
- Three RAM and multiple disc based memories.
- Instantaneous memory reset of all functions.
- 1 inch fader modules permit a large console to live in a small space.
- High performance, proven audio circuitry.
- Diagnostic self test for ease of servicing.
- Orders now being accepted for the Post Production version of the VCS with moving fader automation.

STOP PRESS... Systems currently under production for Channel 4 TV, NRK Oslo and BBC Colour Mobile Central Control Room... STOP PRESS



4000 Series
Consoles



Hard Disc
Editor



Digitally
Assignable
Consoles



DMX/RMX
Digital Audio
Processors



Stereo and
Surround
Microphones



Digital Mixing
Consoles

www.americanradiohistory.com

Circle (24) on Reply Card

as the input signal itself, only after a logic pattern occurs. The pattern acts as an enable or disable for the single source.

Advanced features

Some digital oscilloscopes provide enhanced digital-triggering modes by letting the user select the level and slope for each input. This flexibility makes it easy to look for odd pulse shapes in the pulse-width trigger mode and for subtle dropouts in the interval trigger mode. It also simplifies testing different logic types (TTL, CMOS, ECL), and testing analog/digital

combinational circuits with dual-logic triggering.

Multiple-channel scopes compound this flexibility. Once a trigger has been generated, multiple simultaneously sampled inputs let the user monitor conditions at several places in the circuit under test, with each channel synchronized to the trigger.

A useful feature for monitoring signal jitter or drift on a repetitive signal is called "enveloping," "extrema," "waveform delta" or "roof/floor." As the waveshape changes with respect to the trigger, the

scope generates upper and lower (roof/floor) traces. For every "nth" sample point with respect to the trigger, the maximum and minimum values are saved. Thus, any jitter or drift is displayed in the envelope. The operator can test for temperature-dependent problems by heating or cooling the circuit and watching the envelope.

Look before you buy

Not all digital oscilloscopes provide all these benefits. The advanced triggering features provide most of their benefit in conjunction with single-shot sampling. Repetitive-sampling scopes can only capture and display signals that repeat precisely from cycle to cycle. Several cycles of the waveform are used to create a digitally reconstructed representation of the waveform. If the signal varies from cycle to cycle, digital oscilloscopes that only use sampling heads or interleaved sampling can be less effective than a standard analog oscilloscope for accurately viewing the waveform. Most of the inexpensive digital oscilloscopes either only sample repetitively or have repetitive sampling for high-frequency signals and very slow single-shot sampling.

Beware of the wide bandwidth digital oscilloscopes that offer exceptional resolution (greater than 8 bits), especially if it comes at a low competitive price. This combination often indicates use of repetitive signal-acquisition scope architectures. Signal averaging is used to enhance resolution. It is a valid technique, but requires repetitive signals with a stable trigger point from cycle to cycle.

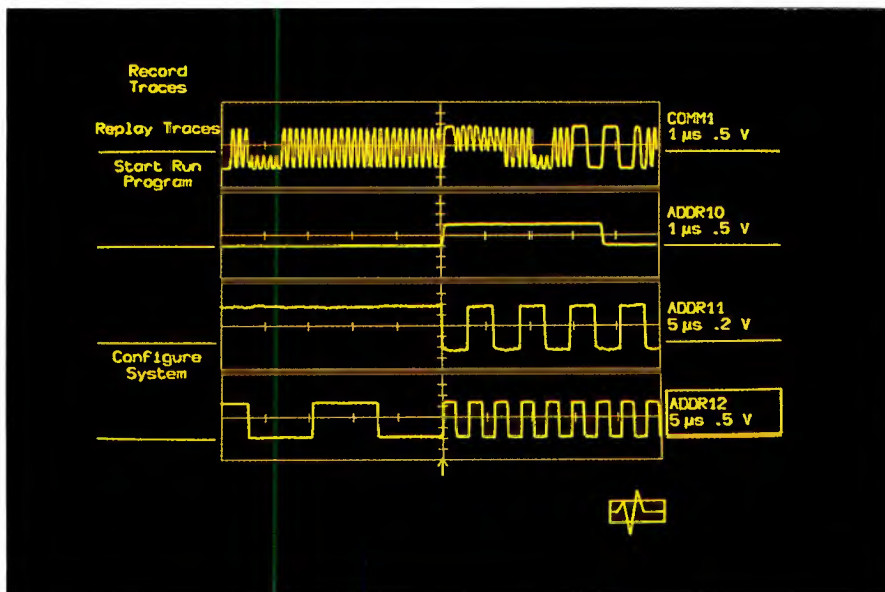

Pattern- or state-qualified triggering synchronizes the displayed waveforms with a particular logic pattern. The pattern can be selected to match a particular address or databus value. Other portions of the unit under test can then be probed to show activity synchronous with this pattern occurrence.

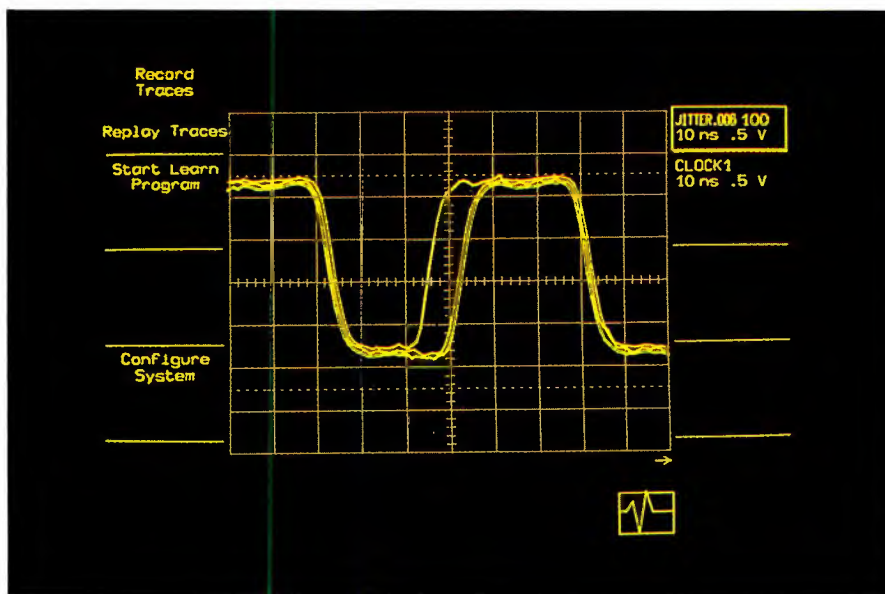

Roof and floor traces expose signal jitter or drift. As the signal changes, the envelope expands to indicate the maximum and minimum signal positions.

⌋ [= (=))]]]]

Rigid Coaxial Transmission Lines Deliver Low Losses...High Gains.



Cablewave Systems delivers everything you need and expect from Rigid Coaxial Transmission Line performance...superior quality, plus optimum mechanical and electrical specifications.

To achieve this, Cablewave Systems fabricates high conductivity, hard-drawn copper tubing with precision machined, pin-type Teflon dielectric insulators. Standard 50 ohm transmission line is offered in sizes from $\frac{7}{8}$ " thru $9\frac{3}{16}$ "; 75 ohm in $6\frac{1}{8}$ " and $9\frac{3}{16}$ ". All utilize EIA bolt type flanges and inner connectors compatible with EIA

standards, MIL specs and international IEC recommendations. Aluminum outer conductor 50 and 75 ohm transmission lines are available on special order.

To complement our full line of Rigid Coaxial Transmission Lines and accessories, Cablewave Systems also manufactures a complete line of semi-flexible air and foam dielectric coaxial cables and connectors.

For a copy of our 48 page Rigid Coaxial Transmission Line catalog and information on other broadcast and RF communication products, contact Cablewave Systems.

Cablewave Systems

DIVISION OF RADIO FREQUENCY SYSTEMS, INC.
60 Dodge Ave., North Haven, CT 06473 • (203) 239-3311

Circle (27) on Reply Card

www.americanradiohistory.com

Automated test instruments

By Gregory D. Carey

Personal computers can function as powerful troubleshooting tools.

Did you know that if you have a personal computer (PC) and test equipment with the appropriate interface hardware, you can hook it up to a broadcast product that has an intermittent failure, go away, and have the computer store test values? With this setup, if the problem occurs while you're away, you can interrogate the computer and determine the nature of the problem.

The PC has more capability in electronic testing and servicing than most people realize. It can be connected to many test instruments to make some testing automatic.

The computer interface

Two types of computer interface systems are used to connect test instruments and computers: IEEE-488 and RS-232. The IEEE-488 format also is called the *general-purpose interface bus* (GPIB) or the *Hewlett-Packard interface bus* (HPIB). RS-232 is the standard serial interface used on many computers. The two interface systems have advantages for different uses.

Both approaches to computer interfacing let you connect a computer to external devices. Both are bidirectional, which allows the computer to either send information out or to receive it back from the

outside world. A few very expensive test instruments have both built-in, but most test instruments with computer interfaces have either one or the other, based on how the instrument will be used.

Test instruments with GPIB greatly outnumber those with RS-232. Several thousand test instruments are available with GPIB interfacing as an option. A few plotters and printers also use GPIB, but they usually are intended for use in a system that already uses the GPIB format for test instruments.

By comparison, RS-232 is more common than GPIB in computers. Printers, plotters, scanners and modems often use the *standard serial interface*, which is another name for RS-232. Some printers use a third protocol known as the *Centronics parallel* standard. This parallel format is used when data flows in only one direction, from the computer to the printer. The only test instruments that have RS-232 typically are those used for remote sensing, such as RF signal-strength meters.

Neither RS-232 or GPIB is ideal for every instrument application. Each protocol works well in some uses, marginally in others and poorly in still others. Table 1 shows the relative advantages and disadvantages of the two protocols. Notice that the only advantage common to both is the ability to move data in both directions. After that, the two look quite different. The decision of which system is to be used for

a particular application must be based on what the system needs to do. Because RS-232 is already built into personal computers, many users want to use it for automation. Yet GPIB is the preferred protocol for most test-equipment applications.

Primary differences

Although RS-232 has several secondary advantages, its single biggest advantage being that it can easily send signals over longer distances. It can directly send signals about 1,000 feet in one run of cable. A *line extender* lets the run go even further. For example, many mainframe computers use RS-232 to send data to printers located in different parts of a business. Inexpensive twisted-pair cables interconnect the computer and printer.

If data must be sent over longer distances, a modem can be used to convert RS-232 signals into a form that can be fed over a standard telephone line. GPIB signals must first be converted to RS-232 if a modem is needed.

By contrast, GPIB's single biggest advantage is that it can work with several instruments simultaneously. This capability is essential when an automated test requires more than one item to be under computer control. For example, a manufacturer might use GPIB to automate several pieces of test equipment at the end of a production line. Up to 15 different units can be

Continued on page 52

Carey is an application engineer with Sencore, Sioux Falls, SD.



Fortunately, there is one tape company that's as demanding as you are.



In this business, people are always striving for perfection. Always raising their standards and expectations. At 3M, we share that commitment. Because we realize that you can't afford a tape problem. And neither can we. So when it comes to products and service, we have one primary goal: We won't be satisfied until you are.



Circle (28) on Reply Card





Take a closer look . . .

Betacam built by Ampex!

You already know that Betacam SP is the world's most popular acquisition video format. But did you know that Ampex has been in the Betacam business for over three years? What's more, we build and test Betacam SP portable and studio video recorders, cameras, camcorders and accessories in our own factory.

Ampex Betacam SP products meet the demands of broadcast professionals everywhere. The CVR-300 integrated camcorder shown here performs under the most demanding conditions, with 670 line resolution and an electronic shutter.

Better yet, Ampex offers not only Betacam SP products, but also a full line of production and post-production equipment for both component and composite systems. And if you ever need help, highly qualified Ampex service people will respond, fast!

Call us at 1-800-25AMPEX for information about Betacam SP products from Ampex.



AMPEX

connected simultaneously when GPIB is used.

The reason for these differences is the way the signals are fed to and from the computer. RS-232 is a bidirectional serial system. GPIB is a parallel format. Eight

separate wires carry the GPIB data into or out of the computer, allowing an entire byte to move at one time. If all things were equal, this would make GPIB eight times faster than RS-232. (GPIB can actually transfer data about 260 times faster

than the fastest RS-232 data rate because of other electrical differences in GPIB.)

One additional feature of the eight data-lines is that they provide a standard way to address any of the external units, either one at a time or in groups, allowing connection of several units. RS-232 needs complicated mechanical or electrical signal switching to work with multiple instruments.

Availability of interfaces

RS-232 interface ports are either included as part of a PC or easily added with a low-cost accessory board. RS-232 will interface with many printers.

Third-party manufacturers make accessories to add GPIB to IBM and Apple Macintosh computers. Similar accessories were available for Apple II, Commodore and Radio Shack TRS-80 computers earlier, but most manufacturers have discontinued making these cards. Some specialized computers, such as those from Hewlett-Packard and Fluke, are designed as instrument controllers and use GPIB as their main input/output port.

Because RS-232 is common on computers but GPIB often is needed for test-equipment automation, several manufacturers make protocol converters that trans-

ADVANTAGES:	RS-232	GPIB
Bidirectional data transfer	X	X
Works with long cables	X	
Sends data by phone	X	
Included in most computers	X	
Inexpensive cables and connectors	X	
Controls one to 15 units		X
Fast data transfer		X
Standard to most test equipment		X
Automatically adjusts speed		X
Plug-together compatibility		X
One standard connector		X
Advanced software available		X
DISADVANTAGES:		
Controls only one unit	X	
Speed of computer must match controlled unit	X	
Many data formats	X	
Many wiring variations	X	
Several connector styles	X	
Higher cost to add		X
Short cable runs only		X
Expensive multiconductor cable		X

Table 1. Comparison of the RS-232 and GPIB standards.



**Cellular Remote
QUALITY BROADCAST
PROFIT CENTER**

The clear choice for quality. The Cellcast Remote Broadcast Studio is perfect for retail promotions, news, sports and special events. Cellcast combines the best features of a professional mixing console and a cellular telephone into one convenient package. Now remotes are fast and easy. If Cellcast sounds like a profit center to you, give us a call today!

Cellcast™
REMOTE BROADCAST STUDIO

CALL TOLL FREE 1-800-852-1333. Tri-Tech, Inc., 2415 East Skelly Drive, Tulsa, Oklahoma 74105

Circle (25) on Reply Card

A2

Ask for our
FREE CATALOG
OF PROFESSIONAL
Sound RECORDING
& DUPLICATING SUPPLIES



**Blank-Loaded
AUDIO CASSETTES**

now from
STOCK
in
**CHICAGO
and
L.A.**



**CASSETTE BOXES
LABELS • ALBUMS**

**AGFA AMPEX
3M Scotch
TDK maxell
TAPE**

**ACCESSORIES
from
3M • EDITALL**





**Polyline™ Empty
REELS & BOXES**

Polyline Corp.
1233 Rand Rd. • Des Plaines, IL 60016
(708) 298-5300

Circle (26) on Reply Card

Solid-state TV transmitters for the 21st century.

© 1989 NEC America, Inc.



Solid-state transmitters are destined to dominate in UHF and VHF broadcasting. With NEC's new series of fully solid-state TV transmitters, you can move into 21st century technology today.

Our new PCU-900SSW JHF transmitters feature the latest semiconductor and RF circuit technologies. The 800W PA modules use 110W power transistors specially developed by NEC. All adjustments are handled automatically by a high performance synthesized exciter. The closer you look at these trend-setting systems, the more innovations and refinements you discover.

There are five models in the PCU-900SSW series—5/10/20/30

and 40kW. All models represent a radical improvement over tube transmitter performance.

Check these features:

- Higher reliability: redundancy enhanced by parallel use of power transistors and PA modules.
- Higher stability: voltage fluctuations of $\pm 10\%$ handled without AVR.
- Less maintenance: Jet Air Cooling for power transistors.
- Lower power consumption: class AB operation.
- Greater safety: operate on 28V DC power; PA and power supply modules replaceable

without interruption of broadcasting.

- VHF TV transmitters: NEC also offers 5 models of fully solid-state VHF transmitters—5/10/15/20/30kW.

For performance ahead of current tube-technology, look into NEC's fully solid-state TV transmitters.

For further information, please contact:

NEC America, Inc.
Broadcast Equipment Division
383 Omni Drive
Richardson, Texas 75080-3545
Tel : 214-907-4710
Fax: 214-907-4711



late the RS-232 signals to GPIB. These converters let you take advantage of the benefits of both communications protocols for even more versatility.

Both RS-232 and GPIB are based on industrywide standards, but only GPIB is a *true standard*. RS-232 has hundreds of variations to make direct connection more difficult.

Various RS-232 schemes

The RS-232 standard specifies voltage levels and polarity so that one RS-232

feeds another directly. However, the many variations in RS-232 make it notoriously difficult to work with when you are connecting two devices for the first time. The difficulty comes from variations in data transfer rates, data formats and electrical connectors. Once you get it running, it generally works well from then on unless you add or change some part of the system.

First, RS-232 encompasses 15 different data transfer rates. The rate of data transfer is measured in *baud*. One baud is the

transfer of one databit per second. A 300-baud device transfers data at 300 bits per second. It takes about 10 bits (seven or eight databits plus two or three control bits) to form one character (byte), so the data transfers at one-tenth the baud rate. A baud rate of 300 yields about 30 characters per second, and the fastest RS-232 baud rate of 19,200 sends data at about 1,900 characters per second.

The computer and the external device must use the same baud rate to communicate. If the two rates are different, each character is garbled, and all data is lost. Most RS-232 devices have configuration switches that let you set the baud rate to match the computer system.

Aside from speed variations, there are nearly a dozen data-format variations. Databytes can be either seven or eight bits long. RS-232 then adds stop bits and parity bits, which help ensure accurate data transfer. There can be one or two stop bits, and parity can be none, even, odd, mark

Full Compression. No Depression.



If you're really depressed by the fact that broadcast quality full video compression systems *start* at \$17,000, ALTA Pictoris offers you a fresh start that will really impress you.

\$10,900. For broadcast quality infinite video compression, and so much more. Variable cropping and positioning over live background video. Colored borders. Auto zoom in and out. Dissolve. Programmable presets. GPI trigger. Digital effects that include negative video, vertical and horizontal inversion, posterization, mosaic and freeze. And spectacular 5.5 MHz, 450-line resolution video, with full 8-bit Y/C component processing.

ALTA Pictoris. Another example of ALTA's "Technology of Value" that designs a whole lot more into packages that cost a whole lot less. Call us for the dealer nearest you.



535 Race Street, San Jose, CA 95126
TEL 408/297-2582 FAX 408/297-1206



Circle (30) on Reply Card

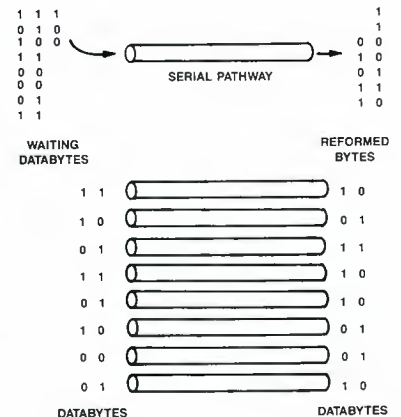

Figure 1. The serial RS-232 protocol must send data one bit at a time down the serial line; the parallel GPIB sends eight parallel bits at once. Additional technical differences allow the GPIB to be 260 times faster in some uses.

or space for even more variations. The number of stop and parity bits also must match in order for data to move from one device to the other. Again, switches on the unit let the user match an instrument to the computer system.

Also, RS-232 uses at least four different physical connectors with five, eight, nine and 25 pins. The 25-pin version has been the most common, but it has dozens of different wiring variations. Luckily, the main data and ground pins are always the same. Table 2 shows the four pins that are always the same.

The data-out and the data-in pins interchange, depending on whether you're considering the computer end or the oth-

DISCOUNT VIDEO WAREHOUSE

TERMS:
Payment In Advance Or COD
Cashiers Or Certified Check Only
FOB: Mt. Prospect, IL

- Quantities Limited
- All Prices subject to change
- All Sales Final

Discount Video Warehouse is a wholly owned subsidiary of Roscor Corporation

An Incredible Sony Camera at an Incredible DVW Price!

Lowest Price Anywhere!

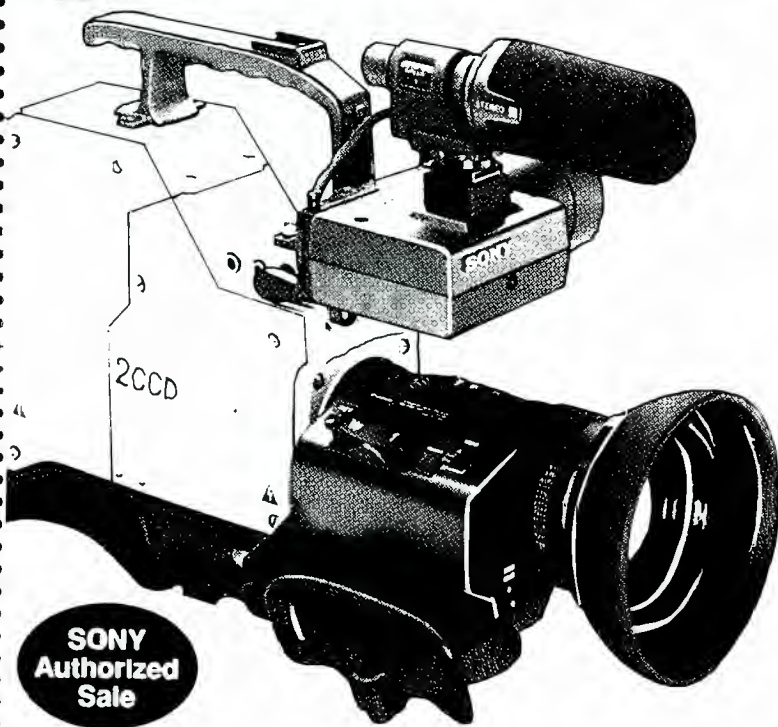

SONY[®] 2 CCD Color Camera

EDP-10F with Fujinon 13X Lens

- High Resolution - 550 Lines
- High Quality CCD's "768 HAD" Interline Transfer Features Sony's Innovative "Double P-Well" Design Assuring Reduced Noise, Reduced Smear and Excellent Performance Even in Extreme Lighting Conditions
- 25 Lux Minimum Illumination
- High Speed Electronic Shutter - 6 Positions Up To 1/2000th Second Gives You Blur-free Images of Even Fast Moving Objects. The Perfect Camera for Sports, Manufacturing, Research or any Action Analysis Application.
- Interfaces With Most VCR's-4 Position VCR Selection Switch Handles, 3/4", S-VHS and Industrial and Consumer Half-Inch Portables.
- Y/C Out

System includes:

Camera Head, Camera Adaptor, 1/5" Viewfinder, Stereo Mic, and Fujinon A13X10 Servo Zoom Lens

Manufacturer's Suggested
List Price
\$5280.

Dealer Inquiries
Welcome

Incredible DVW Special Price

\$1995.

*while quantities last!

P.O. Box 36
Mount Prospect, IL 60056

PHONE TOLL FREE

1-800-323-8148

In Illinois Phone
(312) 299-525

Circle (31) on Reply Card

er end of the cable. The "out" of the computer must feed the "in" of the external device and vice versa. There is a 50-50 chance that an RS-232 cable will connect the inputs and the outputs correctly. Some devices have switches or jumpers to let the user exchange the wiring of the "in" and "out" pins when the output of the computer connects to the output of the other device.

If there is no way to internally switch the pins, there are two solutions: custom-wired cables or an adapter plug that

reverses the connectors (a null-modem adapter, modem eliminator, cable switcher or line reverser). The null-modem has a female connector on one side and a male connector on the other with the wires exchanged between them (pin 2 on one side connects to pin 3 on the other and vice versa). The null-modem also exchanges the pins used for the handshaking functions that will be explained.

GIPIB standard connections

All GIPIB connections and signals are the

FUNCTION:	PIN
Safety ground	1
Data out	2 or 3
Data in	3 or 2
Data ground	7

Table 2. Four standard pins of the RS-232 connector.

same. You can connect any GPIB device to any GPIB computer, and be confident the signals electrically match each other. If the two devices don't work together, the problem is in the software or in the device setup because there are no variations in the electrical performance.

GPIB does not need settings for baud rate, stop bits and parity bits because of its standard data format. The format uses the same pins for all data going to or coming from the computer. Also, the system automatically adjusts its data transfer speed. GPIB can transfer data at any speed from less than one character per second to 500,000 characters per second, making it up to 260 times faster than an RS-232 system operating at 19,200 baud. Few instruments supply data that fast, but the system is capable of this speed without modification.



All four of these connectors are used for RS-232, depending on the brand and model of computer. The 25-pin connector (far right) is used most often.

Now there's an easier, more efficient way to locate your video tapes...

I NEED THAT TAPE NOW!



...with NSI's PC based Video Tape Library System.

This new video tape archival and locating system was used by NBC Sports for their coverage of the 1988 Summer Olympics in Seoul, and now it's available for stations.

Consider this partial list of features:

- Runs on a single IBM (or compatible) PC in standalone mode or on a PC network for many users.
- Scans bar code labels on the tape to update the tape's location.
- Provides 11 search criteria with which you can specify a tape; use one or any combination of them.



(We will customize these criteria for FREE for your installation.)

- Provides a **KEYWORD** search facility which can be used in any of the 11 categories.
- It's **FAST** — on a PC we can search through 15,000 tapes and find 20 in 3 seconds.

Why spend large amounts of money for a system which is an add on to traffic or a newsroom system?

This system is cost effective NOW, and is compatible with most cart machines.

For more information call or write:
Nesbit Systems, Inc.



5 Vaughn Drive • Princeton, N.J. 08540 • 609-799-1482

Circle (32) on Reply Card



DISCOVER A HOT NEW TALENT. GIVE LEADER'S SYNC/TEST GENERATORS A FREE SCREEN TEST.

Notice the sleek, high-tech profiles. Now move in for a close-up look at Leader's impressive line of video sync/test generators. Then call us and we'll outfit your production, post-production, or service facility with one of our state-of-the-art sync/test generators for a free 2-week trial period—with no obligation.

You'll find Leader's affordable, full-line coverage includes a model ideally suited for your needs. The model 411 is a sync and test signal source, perfect for use in production and post-production facilities. It features digital gen lock and its own internal clock and can be driven by either. The 411 generates sync timing with test patterns having the tight tolerances only possible with digitally synthesized signals. And a 10-bit DA ensures excellent accuracy for all test signals.

The sophisticated and versatile

LCG-420 modular sync/test generator is right on the mark for video analysis and evaluation of broadcast cameras and VCRs. The new 408, incorporating the latest in CPU technology, is your best choice for service and repair. And for portable applications, try our compact, battery-powered LCG-409 pattern generator. But whichever you choose, you'll discover the quality and reliability that are built into every Leader product.

So call and ask about our free "Screen Test"—it could make *you* the hot new talent! For our full-line catalog, in NY call 516 231-6900. Or call toll-free:

1 800 645-5104

LEADER
FOR PROFESSIONALS WHO KNOW
THE DIFFERENCE



Leader Instruments Corporation, 380 Oser Avenue, Hauppauge, New York 11788
Regional Offices: Chicago, Dallas, Los Angeles, Boston, Atlanta. In Canada call Omnitronix Ltd., 416 828-6221.

Circle (33) on Reply Card for product information.
Circle (34) on Reply Card for product demonstration.

connection, however, which limits GPIB to short runs. Longer runs cause capacitive loading, which may cause distortion of high-speed data.

Handshaking

There must be some method for the external device to tell the computer to temporarily halt its data transfer if the device

is busy doing something else. Similarly, the computer must halt incoming data if it cannot immediately process the information.
Continued on page 62

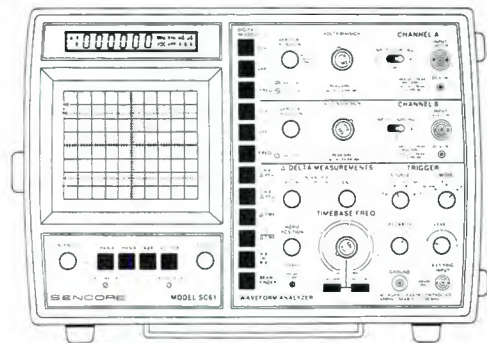
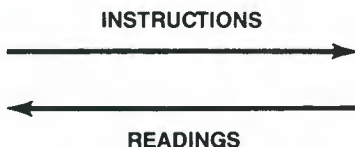
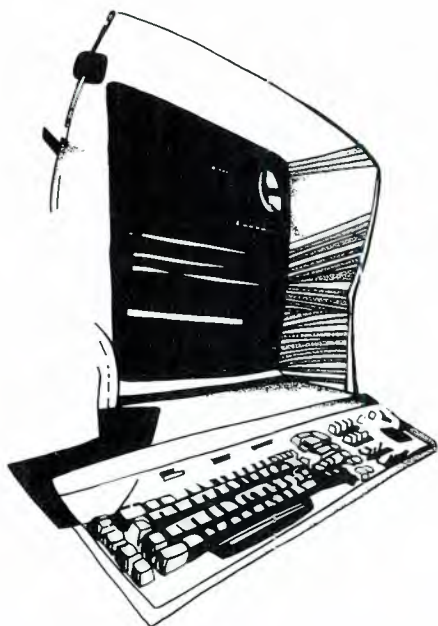

Automation calls for bidirectional communications. The computer must set the instrument to the correct function, and the results must feed from the instrument back to the computer.

PUT YOUR PC ON LINE WITH THE NEW PC ACCESSIBLE MRC 1620 REMOTE CONTROL SYSTEM

As a broadcast engineer, you want to utilize the newest PC technology that will work intelligently and make your job as easy as possible. The Moseley MRC 1620 is the first intelligent, PC-accessible, integrated package that will do just that. This cost-effective system consists of a stand alone Remote Terminal that allows an optional Control Terminal or IBM PC with TaskMaster20 software to monitor and control remote facilities from dedicated and/or dial-up control points.

The MRC 1620

- Operates as a stand alone dial-up Remote Terminal or with standard studio Control Terminal.
- Dual communication ports at Control and Remote Terminal allow direct and dial-up access at either terminal.
- Comes standard with 32 relay isolated commands, 16 telemetry and 16 status channels with filtered terminal blocks.
- Front panel LEDs provide visual indicators of input channel and system status. Digital meter displays telemetry, channel value, calibration and limits.



Make the Intelligent Choice!
The MRC 1620 Remote Control System



The TaskMaster20 Software

- The easy to use software automatically adjusts out of parameter conditions according to user defined control strategy.
- Current alarm conditions are displayed on an "alarm" page. Up to 20 of the latest alarms and hourly log data from the last 30 hours (stored in battery backed RAM of the MRC 1620) can be reviewed at your convenience.
- Monitors up to 63 sites.
- Remote set-up attributes and calibration may be downloaded from the remote terminal and stored to disk for editing and future uploading.

For your free TaskMaster20 software demo disk, contact Moseley Marketing at 805-968-9621.



Moseley Associates Incorporated
111 Castilian Drive
Santa Barbara, CA
93117-3093

Phone 805 968 9621
Telex 658448
FAX: 805 685 9638

Circle (35) on Reply Card

HEADSETS AHEAD OF THE GAME— IN MORE WAYS THAN ONE

For coaches and broadcasters alike— the pros pick Telex.

On the football field and in the broadcast booth high atop the stadium you'll find Telex Headsets are the choice of the pros. National Football league stadiums and major television networks use a variety of Telex Professional Headset models day-in and day-out.

Furthermore, thousands of colleges, high schools and local radio/television stations who have recognized the value

of clean, clear, dependable communications are also using Telex. If you're not already using a Telex, we urge you to take a closer look next time you have a requirement.

A model for every purpose.

Whether your need is communication, camera, sportscaster, studio announcing or inconspicuous on-camera listening, Telex has a model that will fit your requirements perfectly. No other headset manufacturer has the tremendous model variety Telex offers.



Lightweight, full cushion, single sided or dual, boom mic or monitor headsets are all fully described in the latest Telex Headset Catalog. Full specifications are included and the catalog is free. Call or write today: Telex Communications, Inc., 9600 Aldrich Avenue South, Minneapolis, Minnesota 55420

© 1989 Telex Communications, Inc.

TELEX®

Circle (36) on Reply Card

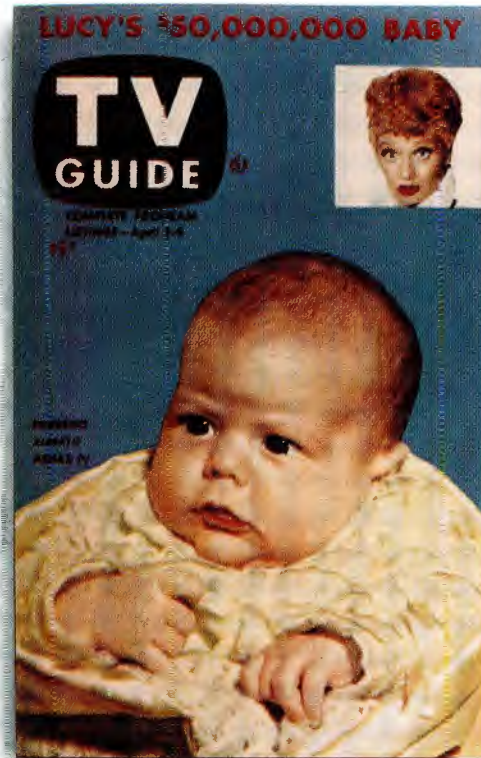

TV Program Scanner

One of these revolutionary ideas the world looks at TV v

BTS did not invent *TV GUIDE*.® Walter Annenberg of Triangle Publications did.

But you'd be surprised at how many of the most revolutionary ideas in the history of video did come from BTS. In fact, because we look at things differently, the whole world looks at things differently.

We introduced the first 3-D computer animation system. The first software-based character generator. The Plumbicon camera tube. The B format for videotape recording. The modular routing switcher. And of course, the first CCD film scanner, for which we won one of our three Emmies.

BTS has been a technological innovator in the video industry for six decades. Our cameras,

©TV GUIDE Copyright 1953 by Triangle Publications, Inc. Radnor, PA



CCD Film Scanner

Many changes in the way is not invented by BTS.

switchers, videotape recorders and graphics equipment are among the best-engineered, highest quality and most reliable in the world. Our work in High Definition and CCD products is pacing an industry which faces the most sweeping technological advances since its beginning.

And we're as dedicated to better product service and support as we are to better products.

So although BTS may not yet be a household word, here's a word to the wise. In the years ahead, BTS will continue to be more forward thinking, more responsive and more innovative in our approach to video technology than anyone else.

Including Walter Annenberg.

BTS
The name behind
what's ahead.

BTS is Broadcast Television Systems, a joint company of Bosch and Philips. For more information, please call 1-800-562-1136 or write BTS, P.O. Box 30816, Salt Lake City, UT 84130-0816.

Circle (37) on Reply Card

www.americanradiohistory.com

Continued from page 58

tion. Handshaking provides a means to properly control data transfer. If handshaking is not used (or is not timed correctly), individual characters of data will be lost. In extreme cases of poor handshaking, hundreds or thousands of characters may disappear.

GPIB takes care of handshaking with a single, standard method so there is really nothing to consider in the design of a unit. It either meets GPIB standards and works, or it doesn't. RS-232 uses two methods of handshaking, with variations on each.

Transferring data by telephone requires a method of handshaking that can be encoded on a standard phone line. The only method that works here is software handshaking. In this mode, the indicators to start and stop data transfer are sent as special characters with the other data. The most commonly used software handshake is called the X-ON/X-OFF (also called the DC1/DC3) system. Sending a special character (Control-S) to the device sending data causes it to stop. Sending another special character (Control-Q) causes it to start again.

A second, less common system, is called the ETX/ACK protocol. This is a complex system that eliminates the need for the

sending device to constantly monitor the returning line for a busy signal. It often is used when data is sent between mainframe computers. The data is grouped into blocks with the same number of characters. Control characters embedded with the other data mark the end of blocks. The receiving device must be able to store entire blocks of data until it can be processed.

RS-232 systems that don't involve modems might use software handshaking or a hardware handshaking system. With hardware handshaking, two more wires connect between the computer and the external device. One signals the computer to stop sending characters if the external device is busy; the other serves the same function in the opposite direction.

Several pins are used for hardware handshaking. The most common are pins 6 and 20. Others, however, might use pins 11 or 19; still others use pins 4 and 5 for different handshaking purposes.

A breakout box is a special tester with lights that show which pins are active when an RS-232 system is connected. This tester often saves time when a device is first connected to a computer. After the connections have been determined, the breakout box is removed and a cable is

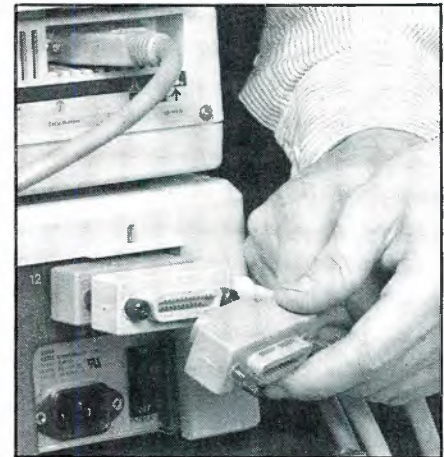

There is only one type of GPIB connector used. Most have a male and a female connector on each cable end, allowing the connectors to be stacked on top of each other.

connected in its place.

Software considerations

Before you can automate a system, you must have a computer program that will do the necessary job. This specification once required someone to write a different computer program for each task. Because every application is different from every other one, this program was custom-written for each specific job. The program can be written in BASIC, FORTRAN, PASCAL or machine language. Complex tasks often need involved programs.

This problem now is being overcome by several companies that are selling software which, in effect, writes software. The user enters the codes needed by each automatic instrument. The purchased program then puts the final software together after the user answers several questions on the computer screen. The purchased software then looks up the specific codes

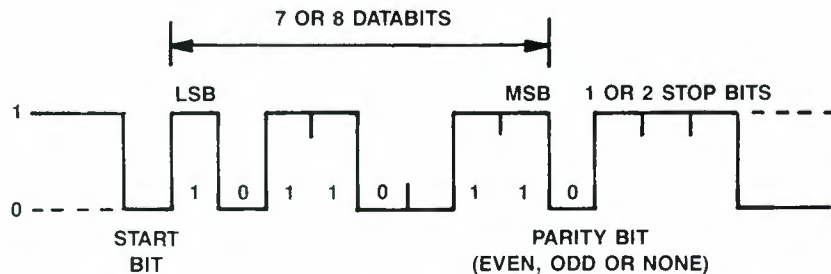

Figure 2. The computer and the external device must have identical data formats for them to communicate with RS-232.

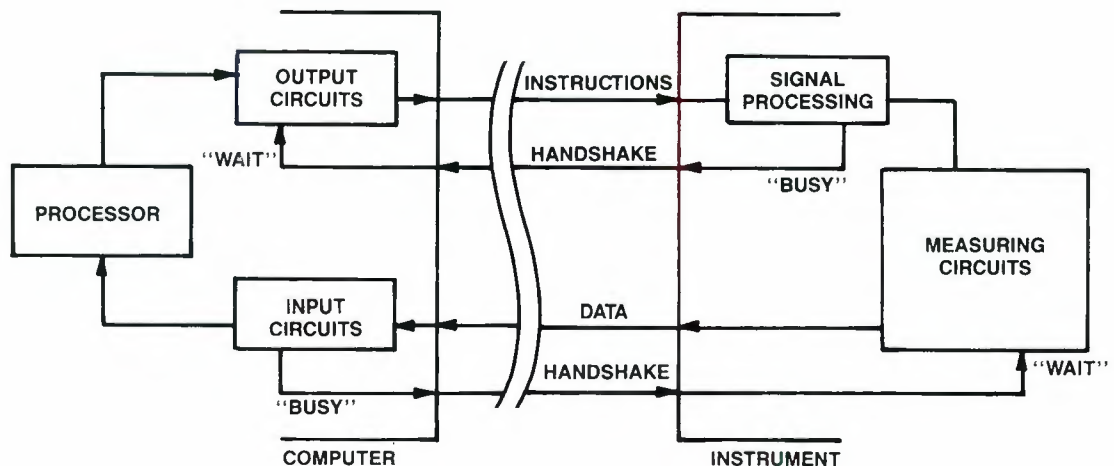

Figure 3. The handshaking signals halt the data flow if the device at either end of the cable is busy. Both RS-232 and IEEE-488 use handshaking.

In broadcasting, Image and Power are everything.

BURLE is committed to providing a full range of camera and power broadcast tubes.

As television celebrates its Golden Anniversary, BURLE continues a 50 year tradition of broadcast technology leadership. We've supplied you with Vistacon, Saticon and Vidicon camera tubes since their introduction. And our power tubes are the industry standard for VHF TV.



BURLE supplies a wide variety of camera and power tubes for the broadcast industry.

It takes a domestic source like BURLE to maintain a half century commitment to producing and supplying a full line of broadcast electron tubes. From camera to transmitter, BURLE provides the tubes that keep the broadcasting industry on the air. Count on us to keep you supplied with the full range of broadcast camera and power tubes you need. Today and tomorrow. Contact your local BURLE broadcast tube distributor, or call us at 1-800-827-TUBE.

Experience counts.

BURLE Electron
Tubes

Circle (38) on Reply Card

www.americanradiohistory.com

needed for each instrument and prepares software that performs the needed tests.

Automatic generation of computer programming greatly reduces the need to have experienced programmers on staff. Once installed in the computer, the programming becomes as simple as fitting graphic symbols together on the screen. This may be the breakthrough needed to bring automation out of the factory and design lab and into the station.

What automation can do

What can you do with test equipment after connecting it to a computer? Three general uses of computer-controlled instruments are data gathering, automatic testing and guided-probe testing. All depend on the correct software to control the instruments. The first two applications are available and require moderate computer-programming skills. The third is used by some large corporations and government agencies and may find its way into other areas as PCs gain in power. Descriptions of these applications follow:

- *Data gathering*

Acquiring data can often be accomplished with a computer and a single instrument. The computer collects dozens or hundreds of readings until some event

happens. This event may be a preset length of time or the occurrence of some condition at a test point, such as exceeding a preset voltage or dropping below a preset voltage. For example, intermittent faults may be tested this way. Every reading from a variety of test points may be stored in the computer.

- *Automatic testing*

The computer performs a number of tests that are difficult to perform manually. The computer may control several test instruments such as power supplies, generators, meters and frequency counters to perform the test. For example, an audio amplifier can be automatically tested for power output, frequency response and separation. The data can then be printed upon demand to document that the unit meets original specifications.

- *Guided-probe testing*

Fully automated diagnostic testing is still a dream for many people. The computer directs the operator to connect to a test point. Based on that reading, it determines which test point needs to be tested next. After several tests, the computer determines which stage or component is defective.

This method is currently used by a few government agencies and large manufac-

turers that service thousands of identical units or circuit boards. The limitation is the complicated computer programs needed to do the job correctly.

1-2-)))

PACO

Ni-Cad Batteries

World-wide Use



WITH EXTRA LONG LIFE

Quick 'Dememorizer' Charger

Paco's 'Dememorizer' charger (KD-120A II) has a built-in discharger that automatically corrects "memory" or fading. Simplifies recharging of all Ni-Cad batteries.

Tel: 213-719-9065
FAX: 213-516-8181
ELEC. U.S.A., INC.
 1842-B West 169th St., Gardena, CA 90247

Circle (40) on Reply Card

Time Code Is Not Black or White.

It's Gray.

Gray Engineering Laboratories

Gray can solve even your most difficult time code engineering problems quickly and easily. Not only do we have the right product for every application, but engineers know they can rely on the quality and precision of our instruments.

Turn to the source for Time Code Receivers, Generators and Transmitters, Vertical Interval Decoders and Encoders, Code Phase Correctors and Indicators, Video Reticle Generators, Film Counter/User Bit Multiplexers, and other products.



All Gray Engineering equipment is covered by a Five-Year Warranty, including parts and labor.

GRAY ENGINEERING LABORATORIES
 504-P W. Chapman Avenue
 Orange, CA 92668 714-997-4151

© 1988 Gray Engineering Laboratories

Circle (41) on Reply Card

**Sometimes
when you
want to
impress people,
you have to drop
a few names.**

So w

~~Amperex[®]~~



In the past, you bought our passive components from Mepco/Centralab. Our discrete semiconductors and professional components from Amperex. And our ferrite materials from Ferroxcube.

What you received were superior components. Professional service. Prompt delivery. Competitive prices. From companies whose products and relationships you value.

What you didn't get was a single source able to fulfill your discrete product needs. And now, you do.

Now we're Philips Components Discrete Products Division

One company representing millions of passive components, discrete semiconductors and component materials. A newly consolidated sales organization providing better service and stronger technical support. Backed by one of the largest electronic component manufacturers in the world: Philips.

For our customers, that means quality products. Leadership in surface-mount technology. All from a single vendor dedicated to the North American marketplace. And the benefit

Philips Components

e did.

~~MEPCO CENTRALAB~~

~~INCUBE~~

thousands of millions of dollars spent annually in electronic component research. Research that keeps Philips—and you—head of the competition.

The new Philips Components Discrete Products Division. Or a look at our product groups, just turn the page. Or call us for a line card and product literature. We think you'll be quite impressed with how much we can offer. Even if it took dropping a few names.

Philips Components

Discrete Products Division

2001 W. Blue Heron Blvd.

P.O. Box 10330

Riviera Beach, FL 33404

Tel: **1-800-447-3762**

407-881-3200 (locally)

Fax: 407-881-3300



PHILIPS

Philips Components Discrete Products Division

PASSIVE COMPONENTS GROUP (Capacitors)

4561 Colorado Blvd.
Los Angeles, CA 90039
Tel: 818/240-4880
Fax: 818/500-9174

- Monolithic Ceramic Chip Capacitors

7158 Merchant Ave.
El Paso, TX 79915
Tel: 915-775-4242
Fax: 915/775-4249

- Disc Ceramic Capacitors
- Leaded Monolithic Ceramic Capacitors

5900 Australian Ave.
West Palm Beach, FL 33407
Tel: 407/863-2000
Fax: 407/863-1811

- Tantalum Capacitors (SMD,* Solid, Wet Slug)

6071 St. Andrews Rd.
Columbia, SC 29212
Tel: 803/772-2500
Fax: 803/772-2445

- Film Capacitors
- AC Dry Metalized Film Capacitors
- Film Trimmer Capacitors
- Tantalum Capacitors (Foil)
- AC Motor Start Capacitors
- DC Aluminum Electrolytic Capacitors

PASSIVE COMPONENTS GROUP (Resistors)

Airport Road, P.O. Box 760
Mineral Wells, TX 76067
Tel: 817/325-7871
Fax: 817-326-2215

- Metal Film Resistors
- Carbon Film Resistors
- Precision MELF SMD* Resistors
- Thick Film SMD* Resistors
- High-Voltage Resistors
- Power Film Resistors
- Non-Linear Resistors
- Relative Humidity Sensors
- Standard Resistor Networks

Mecpocal Company
11468 Sorrento Valley Road
San Diego, CA 92121
Tel: 619/453-0332
Fax: 619/481-1123

- Variable Resistors/Trimming Potentiometers
- Rotary Switches
- Hi Rel Fuses

DISCRETE SEMICONDUCTOR GROUP

George Washington Highway
Smithfield, RI 02917
Tel: 401/232-0500
Fax: 401/232-1047

- Discrete Semiconductors:
Power Devices
Surface Mount Devices
Small Signal Products
Microwave Transistors
CATV and RF Power Modules

- Optoelectronics:
LCD's
Infrared Detectors
Sensors

Semiconductor Lasers
Optocouplers
IR and Visible LED's

MATERIALS GROUP

5083 Kings Highway
Saugerties, NY 12477
Tel: 914/246-2811
Fax: 914/246-2811 ext. 427

- Linear Ferrites
- Advanced Ceramic Technologies
- Permanent Magnets

PROFESSIONAL COMPONENTS GROUP

George Washington Highway
Smithfield, RI 02917
Tel: 401/232-0500
Fax: 401/232-1047

- Klystrons
- Circulators
- Rectifier Stacks
- Photomultiplier Tubes
- Geiger Mueller Tubes
- Microchannel Plates
- Electron Multipliers
- Reed Switches
- CRTs

100 Providence Pike
Slatersville, RI 02876
Tel: 401/762-3800
Fax: 401/762-3805 Ext. 324

- Solid State Image Sensors
- Intensified CCD
- Image Intensifiers
- Vidicon & Newvicon* Camera Tubes
- Plumbicon* Camera Tubes
- Military Camera Tubes

1-800-447-3762

Philips Components



PHILIPS

Circle (39) on Reply Card

www.americanradiohistory.com

Maintaining small-format video recorders

By Brent Robinson

Preventive maintenance and cleanliness will boost the performance and extend the life of your VTR.

Microsurgery or maintenance? Today's small-format videotape recorders may leave you wondering which one you're performing. Once you've been exposed to these mini-marvels, however, you'll find maintenance easier than it seems. Although frightening to some, preventive maintenance is the key to keeping these machines running — a vital step in ensuring the reliability, tape interchangeability and signal quality of small-format machines. Preventive maintenance also provides a practical means of training and gaining familiarity with this new breed of VTR.

The maintenance procedures described in this article can be performed, for the most part, with either component analog video (CAV) or conventional test equipment. Also, the signal system described here will be for the Betacam format. Mechanical suggestions should be valid for both machines.

Preventive medicine

Ideally, preventive maintenance would be performed according to a schedule based on the number of hours the machine has been in service and the environmental conditions in which the machine has been operated. Although this is a nice thought, it is not a practical one. With to-

Robinson is studio maintenance supervisor, KSL-TV, Salt Lake City.

day's tight budgets, it may not be possible to schedule downtime with such frequency. Once or twice per year may be the maximum number of times that a particular machine will receive any kind of attention. This is a problem. The solution is to be methodical and to be able to recognize, and give special attention to, the weak points in the machine.

A thorough cleaning is the first thing to do. This includes all tape contact surfaces, threading rings, gears and rollers. Cleaning also affords you the opportunity to do a complete mechanical inspection of pinchrollers, threading systems, scanner surfaces, tape guides, cassette carriage assemblies, head-cleaning rollers and any other moving parts. As a general rule, pinchrollers and drive belts should be replaced every six months. Keep a good stock of mechanical parts on hand.

Tape guides in small-format VTRs play a critical role in maintaining high performance and interchangeability, because of the narrow track widths and extremely thin tape. Any slight variations in the tape path could cause poor tracking or instability, such as vertical jitter. Worn tape guides also can cause tape damage. To avoid these problems, replace all tape guides at 1-year intervals for machines that are in constant use. If usage is light, once every two years would be sufficient.

A word of warning: When replacing

tape guides, replace only one at a time. Monitor the off-tape RF signal as each guide is replaced, then adjust that guide for a flat envelope. This will help maintain the original tape path alignment, perhaps saving you hours of adjustment.

The stationary audio head stack is susceptible to wear. This is simply because videotape is abrasive, and it runs continuously across the audio head in all modes of operation. The audio head also acts as a tape guide. If you notice excessive head wear, replace the head stack to maintain the original tape path. If there is excessive head wear, the audio specs probably will not be achievable.

The lower scanner guide is another critical area, but it is easy to forget. A sharp, but relatively soft, object (such as a bamboo skewer) can be dipped in xylene and rubbed over the scanner groove following normal cleaning. This procedure will remove any tape oxide residue in the scanner groove, improving off-tape RF stability and tape interchangeability.

While you are cleaning the machine, inspect all mechanical levers for cracks and bends. Examine plastic or metal cams for excessive wear. Make sure there is no dust build-up on photo-interrupters. Also, because these small-format VTRs are so tightly packed and run so hot, proper air circulation is a must. It is always a good idea to inspect the cooling fans for bad

bearings. To do this, gently twirl the blade with your fingers, comparing the amount of play and the smoothness of rotation to that of a new one.

Also, check out the power supply. This is especially important if the device has been subject to overheating because of a faulty cooling fan. Measure the voltages, and look for any abnormalities such as hum or unfiltered switching noise. These types of problems become quite evident in the video presentation.

About tensions

Tape tension also can play a major role in interchangeability, and it always should be checked during preventive maintenance. You can measure holdback tension using a Tentelometer-type instrument. One of the new, modified probe assemblies, which has a lower profile, is greatly preferable because of the limited space between the videotape and the scanner surface. Alternatively, a dummy reel and a spring gauge, set up as recommended by the manufacturer, could be used to make this measurement. This is less convenient, but it reduces the possibility of scratching the scanner or damaging the video heads, and it is likely to be more accurate.

Generally, only a check of tape tensions is needed. If tension cannot be adjusted to within specifications, the problem may lie in the supply or take-up motor.

Signal system checks

Signal-processing checks should be performed at least yearly to maintain a high level of audio and video quality. These performance checks would include playback and record, audio-level and frequency-response calibration. Video performance checks would include playback luminance and chroma-level checks, luminance-to-chrominance timing, TBC output levels and encoder quadrature. Signal-processing measurements for the record side would include decoder comb filter, decoder luminance and chrominance levels, and luminance-to-chrominance timing.

• Audio check:

Audio playback and record performance should be checked at least once a year. The playback level, frequency response and head phase should be tested using a manufacturer-recommended alignment tape. The typical specification for audio on this type of VTR is 50Hz to 15kHz ± 3 dB. If the results of testing are outside the specification window and cannot be brought back into specification using the VTR's adjustments, replace the head stack at this time.

The performance check on the audio record function should be made with the most commonly used videotape in the facility. These measurements include record equalization and self-recorded playback

level calibration. Again, if these measurements cannot be brought into specifications, the head is probably at fault.

• Video check:

Video performance verification should start with the playback heads. If the off-tape RF level is low during use of the alignment tape, and the tracking is peaked, the video heads probably are worn and should be replaced. Also, tearing or bearding during playback of video with sharp dark-to-white transitions would indicate a worn head. If the machine is properly cared for, expected head life is approximately three to four years.

Video-processing system adjustments

Once the video heads have been verified, the video-processing checks can be performed. Check the playback portion of the machine first, because it will be used as a reference during record verification. (See Figure 1.)

Component timing

To properly adjust the video-processing circuits, use a manufacturer-recommended reference tape. The most critical adjustment with the most pronounced effect on the video is the luminance-to-chrominance (Y-C) timing. A Y-C timing error would present itself as a soft picture. Re-

Continued on page 74

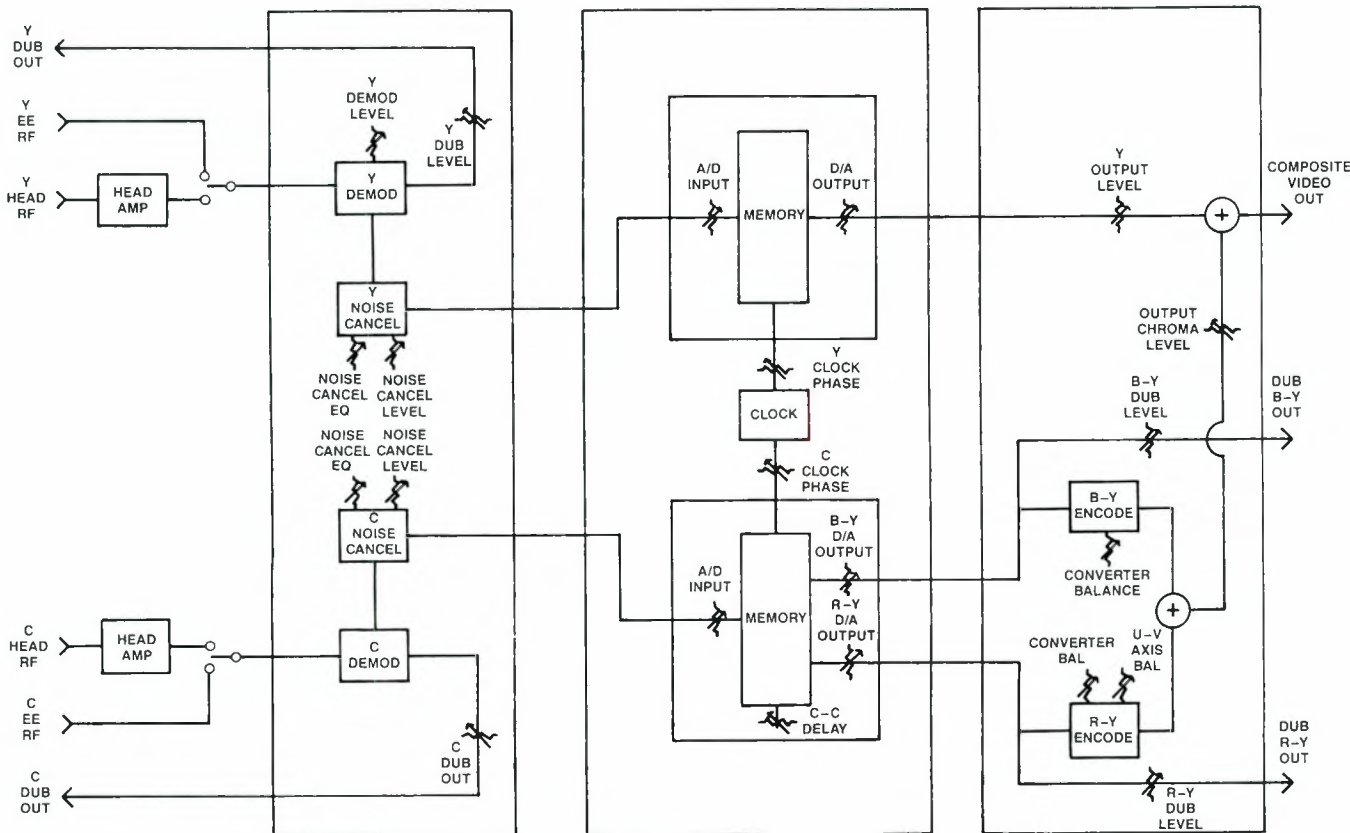

Figure 1. Typical block diagram of the playback signal flow.

Hello world. We can put you on a pedestal.

Sachtler has uniquely combined a pneumatic center column with a double-wheeled, steerable combi-dolly that utilizes modular construction and lightweight materials. The dial-in steps of drag and built-in counterbalancing let you pan and tilt smoothly and precisely, fast or slow, in any direction. It's as close as you can get to taking your studio with you on location. Anywhere. Anytime.

Sachtler is so confident of the performance of the Combi-Ped system that it has extended its normal usage warranty from 1 to 3 years and guarantees its leak-proof fluid modules for 5 years. It's the best warranty in the business and comes only with the best camera support systems in the world.

Call or write today for more information and the location of your nearest Sachtler dealer for a hands-on demonstration.

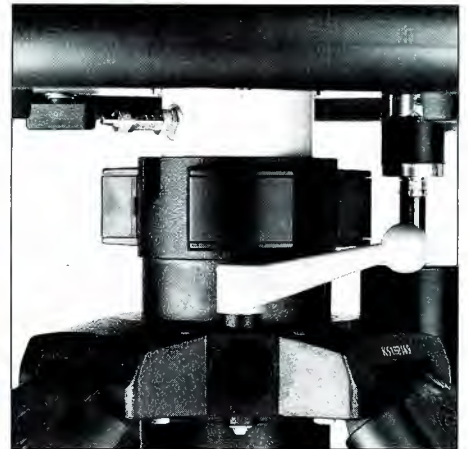

sachtler[®]
corporation of america



55 North Main Street
Freeport, NY 11520
Phone: (516) 867-4900

West coast:

3316 West Victory Blvd.
Burbank, CA 91595
Phone: (818) 845-4446

Circle (42) on Reply Card



SONY'S NEW UHF WIRELESS SYSTEM GIVES YOU EVERYTHING

A wireless system you can count on to do its job when your job is on the line. The new Sony WRT-28 UHF transmitter and WRR-28 UHF receiver utilize state-of-the-art surface mount technol-



ogy for the ultimate in reliability and miniaturization.

Sony advances wireless technology to a new plateau with transparent sound quality and superior interference rejection. Plus the

YOU'D WANT FROM A WIRED MICROPHONE SYSTEM WITHOUT THE WIRE.



versatility of a switchable linear or compander mode.

Amazingly light and compact, the 28 Series UHF system goes anywhere, performing over a wide operational range. Powered by "AA"

batteries, available worldwide.
The Sony UHF Wireless System.

SONY®

PROFESSIONAL AUDIO

It performs like a wired microphone. With no strings attached.

To find out more, call us at
1-800-635-SONY.

Sony Communications Products Company, 1600 Queen Anne Rd., Teaneck, NJ 07666. © 1989 Sony Corporation of America. Sony is a registered trademark of Sony.

Continued from page 70

member, however, that three separate signals are present in component video. The timing relationship between the two color-difference channels, C-C (color-to-color) delay, must be adjusted before the Y-C delay.

Several methods may be used to check the C-C delay. The first is simply to view the playback of the color-bar portion of the alignment tape, using the machine's composite output connected to a composite vectorscope while making this adjustment. The idea here is to adjust the C-C delay to place the scope trace between the green dot and the magenta dot so that it passes through the origin of the vectorscope. (See Figure 2.) This procedure works well, but is not as accurate as the second method.



Figure 2. The C-C alignment check using a composite vectorscope. The goal is to adjust the C-C delay so as to place the scope trace between the green dot and the magenta dot so that it passes through the origin.

The second method requires the use of CAV test equipment and a special alignment tape that has the Bowtie timing signal recorded on it. In this procedure, the component video outputs of the VTR are connected to a component waveform monitor. The interconnect cables from the VTR to the CAV waveform monitor must be exactly the same length to maintain timing calibration.

Set the waveform monitor to the Bowtie mode, at a sweep rate of 10 seconds per division, to view two horizontal lines. While viewing the Bowtie signal from the VTR, adjust the C-C timing and the Y-C timing simultaneously. Using the 20ns markers provided on the Bowtie signal, adjust the Y-C timing to place the null at 0ns or at the center of the display. (See Figure 3.) An incomplete null would indicate that a chroma-level adjustment is required. If the two waveforms displayed on the waveform monitor both were nulled in the center, it would be an indication of proper C-C timing. If one of the two nulls in the waveforms were not in the center, then its C-C timing could be adjusted at this time. (See Figure 4.)

An alternate method to perform C-C and

Y-C timing requires only an ordinary oscilloscope and a video reference tape with a 12.5T pulse. The luminance-channel output of the machine is connected to channel 1 of the oscilloscope, and one of the color-difference channels is connected to channel 2. Invert the channel 2 input, and add it to channel 1. The objective is to achieve a null between luminance and chrominance. If a null cannot be achieved, adjust the scope's variable vertical sensitivity calibration control to expand the display upwards. If a Y-C timing error exists, it will present itself as an "S" curve on the oscilloscope, and you then should adjust the color-difference channel's timing.

The same procedure should be followed for the remaining color-difference channel. In some machines, however, only one color-difference channel has adjustable timing. In this case, adjust for the non-variable channel first, using the overall Y-C timing control. Then adjust the remaining channel.

Playback video levels

Once proper timing has been established, the video levels can be checked and adjusted as necessary. The levels of the luminance and time-compressed chrominance signals should be verified at the outputs of the demodulators. The component analog video output levels, which are time-base-corrected, also should be checked, because these outputs feed the encoder circuitry. Again, all verifications should be made with a manufacturer-recommended alignment tape.

The encoder adjustments require the use of only an NTSC waveform monitor, a vectorscope and a reference tape. While playing the color-bar portion of the alignment tape, minimize the subcarrier on the sync tip and on the white bar, as viewed on the waveform monitor, using the converter balance controls. To achieve proper quadrature, adjust the U-V axis balance control so that all vectors are in the refer-

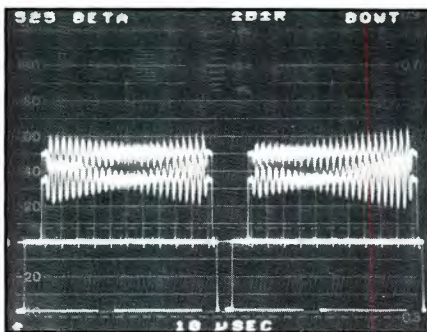

Figure 3. A more accurate C-C alignment uses CAV test equipment and an alignment tape recorded with the Bowtie timing signal. The Y-C timing is adjusted to place the null at the display's center. An incomplete null indicates need for chroma adjustment.



Figure 4. A C-C error will be displayed on a CAV waveform by showing one of the two nulls being off-center.

ence boxes on the vectorscope.

If you note any luminance- or chrominance-level discrepancies, adjust the encoder at this point. The playback portion of the machine now can be used as a reference for the record portion.

Record section

The areas that should be checked are the luminance and chrominance separation, chrominance decoding, chrominance time compression and modulation of the luminance and chrominance signals. Component analog video test equipment is the fastest and easiest way to set up the record section, but alignment still is possible through the use of standard NTSC equipment. (See Figure 5.)

Comb filter

The most critical adjustments in this section involve maintaining Y-C timing after separation has taken place. Let's first turn our attention, however, to the comb filter that achieves this separation. This filter is extremely selective, and if misadjusted, it will cause the video to be soft and contain unwanted artifacts.

The function of the comb filter is to remove unwanted high-frequency luminance information from the chrominance signal. This is accomplished by using a vertical correlator. (See Figure 6.) The circuit uses delay lines to create 0H, 1H and 2H delayed video signals. The 1H delayed signal is inverted so that the 1H delayed luminance information is out of phase with the other two signals. This means that the chrominance information on the 1H delayed signal is now in-phase with the other two. (This occurs because of the 4-field sequence of subcarrier phase to H phase in the video color frame.) The three signals are fed into a matrix where the Y component is eliminated.

The vertically correlated signal then is fed into the horizontal correlator. This circuit eliminates cross-color effects by again using delay lines. Instead of being delayed 1H and 2H, however, the signal is delayed by one-half cycle of subcarrier (140ns), and one full cycle of subcarrier (280ns). The

Our "small revolution" is making big waves in shotgun microphone design!

Model 4071

Line + Gradient Condenser Microphone
(shown with AT8415 Shock Mount)



The Model AT4071 is just 15½" long, while the AT4073 is a mere 9". Yet, both 40-Series shotguns perform far "longer" than their actual size. Because inside these two new Audio-Technica studio condenser microphones is a revolutionary approach to shotgun design.

New Coaxial Tube Design

In effect, the ingenious coaxial interference tubes perform as though the microphones were half again as long. Our unique tube design goes far beyond the normal phase cancellation that occurs in a simple resistance-damped tube. There is actually a tube-within-a-tube, creating a separate, acoustically longer path for the lowest frequencies. Low frequency directivity (normally a simple function of tube length) is maintained, yet the microphone size is reduced to a far more practical length.

The Result: A Better Working Tool

This shorter length for a given acceptance angle has practical benefits in the studio and the field. It's easier to avoid shadows and to stay well out of the frame. Cancellation from the back is also impressive, making exact mike

placement less critical. And the very light weight (far less than the others) will be appreciated by every user. As a bonus, the nested internal construction makes the 40-Series shotguns unusually resistant to accidental damage.

Clean Transformerless Output

Listen carefully to the 40-Series sound. The transformerless output insures fast, distortion-free response to transients. You'll hear crisp, natural dynamics over an extended frequency range, even under high SPL conditions. Output of 40-Series models is extremely high, for a very favorable signal-to-noise ratio. A built-in high-pass filter is included, of course.

Quiet in Every Way

The low noise of these new microphones is impressive. Self-noise is almost immeasurable. Equally important, the rejection of wind and handling noise is outstanding. Coupled with excellent sensitivity, the 40-Series design allows you to take

full advantage of the finest digital and analog studio electronics.

Compatible and Competitively Priced

Finally, both can be powered from any 12-48V phantom power supply. They come complete with foam windscreen, stand clamp, and case. Yet, with all their advances and performance superiorities, the new A-T 40-Series microphones are priced competitively with the best known shotguns.

The significant performance advances of these new 40-Series microphones demand a trial in your most difficult environment. Heft them. Hear them. Compare them in every way. This bold new technology will change your expectations about shotgun performance!

Circle (43) on Reply Card

www.americanradiohistory.com



half-cycle delayed signal is inverted so that all real chrominance information will be in phase. Any unwanted Y information will be out of phase at this point. The signals then are fed into a matrix where the Y

component is canceled out.

The chroma-canceller circuit works by inverting the chrominance, which has been bandpass-filtered and correlated. The inverted chrominance then is added to the

composite signal, removing the chrominance by cancellation.

The comb filter typically is adjusted by feeding it a multiburst signal, which is a luminance signal. Then, the 3.58MHz component is minimized while viewing the filter's chrominance output. Next, view the luminance output, and minimize the chrominance component with the chroma-canceller control.

Following Y-C separation, the chrominance signal is decoded into its components, R-Y and B-Y, the two color-difference signals. After decoding, any residual subcarrier must be removed, and the component signal levels must be set.

Y/C timing

Now that you are at the video signal component level, consider Y-C timing errors. Input a composite 12.5T pulse, and monitor the luminance on channel 1 of the oscilloscope. On channel 2, monitor one of the color-difference channels. Invert and add channel 2, and adjust the scope variable gain to achieve a null. If an "S" curve exists, the VTR's phase-equalization control must be adjusted for that channel. Repeat this operation for

Continued on page 138

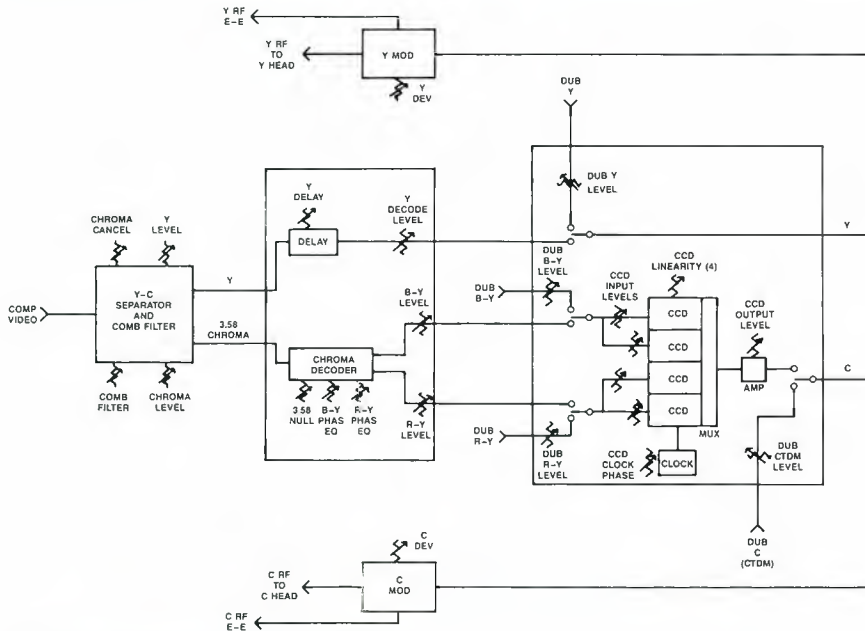

Figure 5. Block diagram of record signal flow.

How to Protect Your Studio Equipment



And Make It Last Longer

FREE money-making literature. What you need to know about UPS — uninterruptible power systems. How to get complete protection from power line problems. 350 VA to 15 KVA models from the world's largest manufacturer of single-phase UPS.

Best Power Technology, Inc.
P.O. Box 280, Necedah, WI 54646

Toll-Free
(800) 356-5794, ext. 3802
(608) 565-7200, ext. 3802

Circle (56) on Reply Card

The art of shaping sound.

SONEX is a high-performance acoustical foam that upgrades your studio inexpensively. Ideal for a temporary isolation booth, it can also eliminate slap echo and harsh resonances in the main room or silence noisy tape equipment in the control booth.

Write for our color brochure today.



Alpha Audio Acoustics
2049 West Broad Street
Richmond, Virginia 23220 USA
(804) 358-3852 FAX: (804) 358-9496
Acoustic Products for the Audio Industry

Circle (55) on Reply Card



The standards converter with the smoothest moving image of any system.

OKI's Digital Television Standards Converter Model LT2000 achieves *True Motion Continuity*. Next Generation Technology has produced the "Motion Vector System" (MVS™), making possible the first portable standards converter to eliminate motion discontinuity, or jerkiness, that occurs with high-speed camera panning and fast-action video program material. Other standards converters, using the now antiquated 2-and 4-field interpolation systems, fail to reduce motion discontinuity, and as a result are unacceptable for the professional market.

MVS™ divides each field of video into pixel sections for motion vector detection and measurement, using the Interactive Gradient Method (IGM). IGM, the most advanced method ever

developed for precise and finite motion detection, allows the LT 2000 to produce the smoothest moving image of any system available. MVS™ accomplishes this without the resolution loss common on other high-end standards

converters. The displayed video picture is not only free from conversion artifacts, but also without interpolation resolution loss. The end result...a clean, sharp picture with *True Motion Continuity!*

With the LT2000, your only problem is telling the output from the input!

* IGM is a development of Kokusai Den Shin Denwa Co., Ltd.



TV STANDARDS CONVERTER

LT2000TSC

Circle (45) on Reply Card

Head Office:
Overseas Marketing & Sales
10-3, Shibaura 4-chome,
Minato-ku, Tokyo 108, Japan
Tel: (03) 454-2111
Fax: (03) 452-5214
Telex: J22627
Cable: OKIDENKI TOKYO

London Office
Ground Floor North 3,
Shortlands, Hammersmith
International Centre,
London W6, U.K.
Tel: (01) 741-2324
Fax: (01) 741-4122
Telex: 927029 OKIDEN G

Local OKI Distributor

SAECO INTERNATIONAL
1122 East Chevy Chase Drive,
Glendale, CA 91205,
U.S.A.
Tel: (213) 245-7708
Fax: (818) 241-2691

ALEX L. CLARK LTD.
30 Dorchester Avenue
Toronto, Ontario M8Z 4W6,
Canada
Tel: (416) 255-8594
Fax: (416) 255-9260

OKI

Ok Electric Industry Co., Ltd.
Tokyo, Japan

Tape recording technology

By Jerry Whitaker, editorial director

Audio and video magnetic recording has had a greater impact on broadcasting than any other single development since the invention of radio/TV transmission itself.

The date: April 14, 1956

The place: Normandy Lounge, Chicago

The event: Annual CBS-TV affiliates meeting

As the impact of what was happening before them sank in, the silence was broken by an equally sudden roar of applause, cheers, whistles and stamping of feet. The curtain behind the podium opened to reveal a large, gray console that looked like a gargantuan audiotape recorder with overgrown reels of tape on its horizontal top plate. Hovering over this whirring magnetic monster, with looks of obvious relief, were a few of the engineers responsible for developing it.

The race to develop television in the 1920s and '30s by Baird, Zworykin, Farnsworth and many others was re-enacted in the 1950s by Bing Crosby Enterprises, Ampex, RCA and companies in Germany, France and Japan. All were struggling to develop a means of storing complex video signals on magnetic tape.

The concept of magnetic storage was developed by Vladimir Poulsen (Denmark) in 1899, but the technology remained a laboratory concept until the Germans developed their *Magnetophone* tape recorder. Starting in 1931, AEG engineers in Berlin began working on the Magneto-

phone (a dc-bias machine) while BASF chemists produced the first modern iron-oxide tape formula. The discovery of ac-bias recording (in the United States) in 1939-40 led to regular on-air use of the Magnetophone on German radio by 1941.

John T. (Jack) Mullin is credited for bringing the Magnetophone to the United States after the war. He served in the U.S. Army Signal Corps and was assigned to the RAF as a liaison officer concerned with the interchange of technical information. After the invasion of France, Mullin and his group set up shop in Paris with the objective of ferreting out developments in which the Germans may have been active during the war and at the time of their retreat.

Mullin's discovery

Approximately six Magnetophone machines had been captured and tested as the war drew to a close, but Mullin found them to have poor dynamic range. The background noise, in fact, was worse than a 78rpm shellac record. The distortion was high as well. A British army officer, however, told Mullin about a machine being used at the studios of Radio Frankfurt that provided remarkable dynamic range and low distortion. Mullin, although skeptical, ventured to the station. He later wrote the following account of his visit:

Radio Frankfurt had vacated the city during heavy bombing raids and had relo-

cated to a large house at a resort spa north of the city in a small town called Bra Nauheim. The station was being directed by the U.S. Armed Forces Radio Service, but the German staff was still operating and maintaining the equipment.

I asked if I might hear one of the tape machines they were using. An order was directed to one of the technicians and I was taken into a room in which there was a large loudspeaker and two of the Magnetophones. The mechanism appeared to be the same as the ones we had in Paris, but there was an obvious difference in the electronics.

The technician placed a roll of tape on one of the machines and started it. Suddenly, out of complete silence, an orchestra bloomed into being with fidelity such as I have never heard in my life. From deep resonant bass to the shimmering of the flute, it was all there. It was clean! It was free from any noticeable distortion. And if that were not enough, the dynamic range was fantastic compared with anything I had ever experienced.

Mullin's assistant photographed all the schematic diagrams and instruction manuals (which were in German) and talked the officer in charge of the Frankfurt station out of a few rolls of tape. Mullin later brought two of the Magnetophones back with him to the United States. After making some modifications and tests, he was ready to demonstrate the capabilities of



PESA SWAT

Saves Time - Saves Money - Maintains Quality

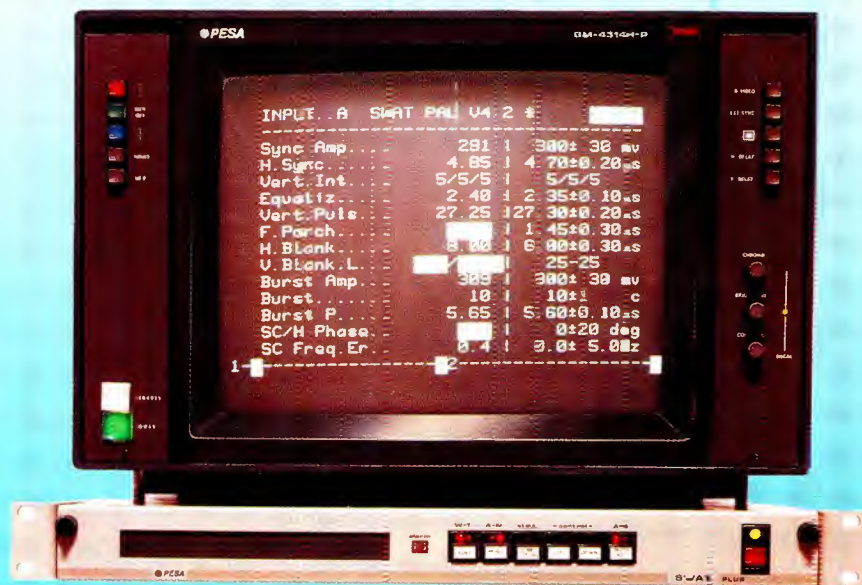

Automatic Monitoring of Sync and Blanking Parameters

Auto Measurement Mode

- Sync Amplitude
- Horizontal Sync Width
- Number of Vertical Sync Pulses
- Equalizer Width
- Vertical Pulse Width
- Front Porch Width
- Horizontal Blanking Width
- Vertical Blanking Width
- Burst Amplitude
- Number of Cycles in Burst
- Burst Position (PAL)/Breezeway (NTSC)
- SC/H Phase
- SC Frequency Error
- Line Detection of Vertical Interval information

Auto Timing Mode

Between 2 video inputs:-

- Measures - SC Phase Horizontal delay
- Confirms - SC Lock Horizontal Lock H. Lock (PAL) Vertical Lock Pal Lock

Auto Failure Indication

- Video fail
- SC/H unlock
- No interlace
- Unbalanced burst
- No burst
- Inv. R-Y phase (PAL)
- Burst blanking
- Vertical Blanking
- No V. Sync
- Number of Lines
- Field Period

'Out of Tolerance' Alarms

- Any measurement out of 'User-Programmed or RS170A Tolerance' and the SWAT gives 3 visual Alarms plus 'relay closure'
- RS 232 port to printer or P.C. interface
- Manual Mode for parameter changes
- Self test

 PESA

• Grupo INISEL

Circle (46) on Reply Card

Pesa America Inc., 6073 N.W. 167 Street, Suite C-4, Miami, Florida 33015
Telephone (305) 556-9638 Fax (305) 556 5536

Corporate Headquarters: Pesa Electrónica S.A., Albalá 12, 28037 Madrid, Spain. Telephone 754 00 78. Telex 48449 PESAE E

the machines. Through a stroke of good fortune, Mullin was asked to demonstrate the capabilities of his Magnetophones to singer Bing Crosby.

The demonstration was a huge success, and it led to the development of the Ampex model 200, the first audio recorder produced in the United States. The machine first was used by ABC in 1948. The rugged design of the model 200, and the financial and political support of Crosby, turned industry skepticism about magnetic recording into widespread confidence — almost overnight. Crosby later founded Bing Crosby Enterprises to conduct a variety of broadcasting and recording research.

Recording pictures

The early days of television were solidly intertwined with film, film processing and live programming. By the late 1940s, TV engineers already had developed a whole new field within broadcasting and teleproduction: TV recording. Today, there are thousands of video recording specialists in the world, but in the late '40s, only a few could lay claim to that remarkable title. To understand the impact of the revolution of the videotape recorder on

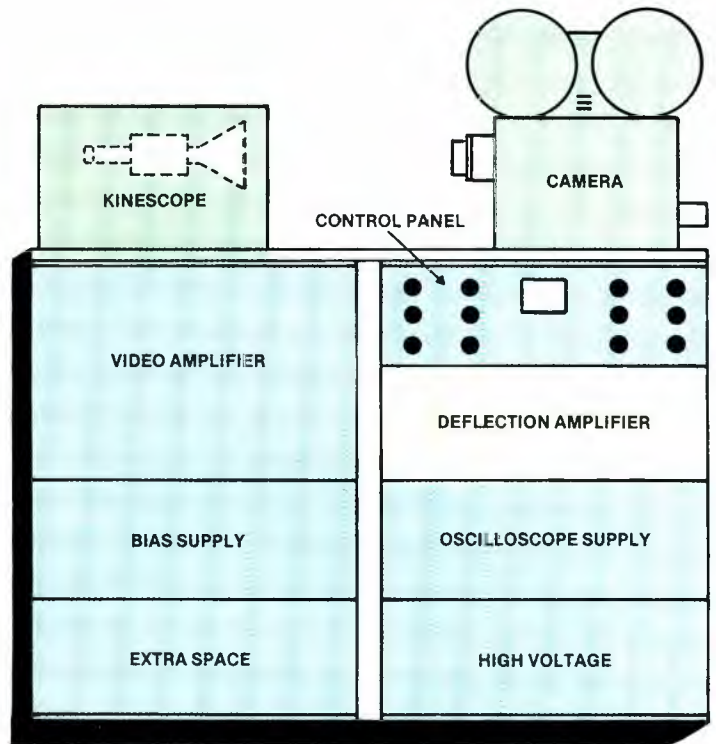
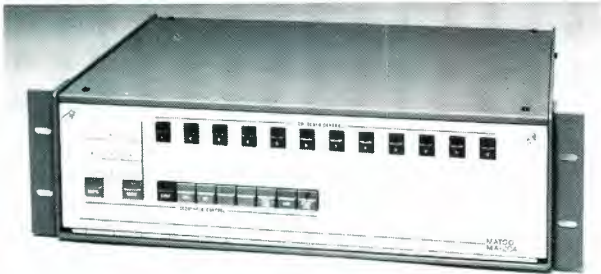

Figure 1. The layout of an RCA kinescope recorder showing placement of the various electronic subsystems.

THE AFFORDABLE PLAYBACK SYSTEM MA-204



STANDARD FEATURES:

- Simple, dedicated control panel
- 700 Event capability
- Battery backed real time clock and event memory
- 12 X 1 Stereo AFV switcher

OPTIONS INCLUDE:

- SVHS Switching
- SYNC Distribution
- 2 or 3 Channel configuration
- PC Enhancement to allow downloading of events list

MATCO

427 Perrymont Avenue
San Jose, California 95125
(408) 998-1655 • FAX (408) 998-8020

Circle (47) on Reply Card

New High Power Lightning Protection

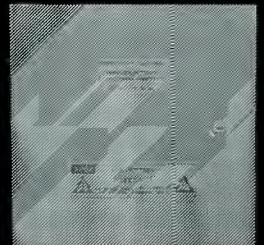
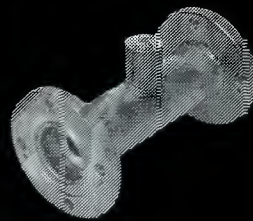

7/8" to 3-1/8" EIA
Hard line
100 KA surge

240, 377, 480V
3ø
Power Mains

For these and any of our other
450 protectors and grounding systems contact

PolyPhaser Corporation

OUR 10TH
YEAR

P.O. Box 1237, Gardnerville, NV 89410-1237
(800) 325-7170 or
(702) 782-2511 FAX: (702) 782-4476

Circle (48) on Reply Card

HE'S USING IT TO MAKE IT BIG.

KEITH NEALY, PRESIDENT, CREATIVE DIR., THE NEALY GROUP

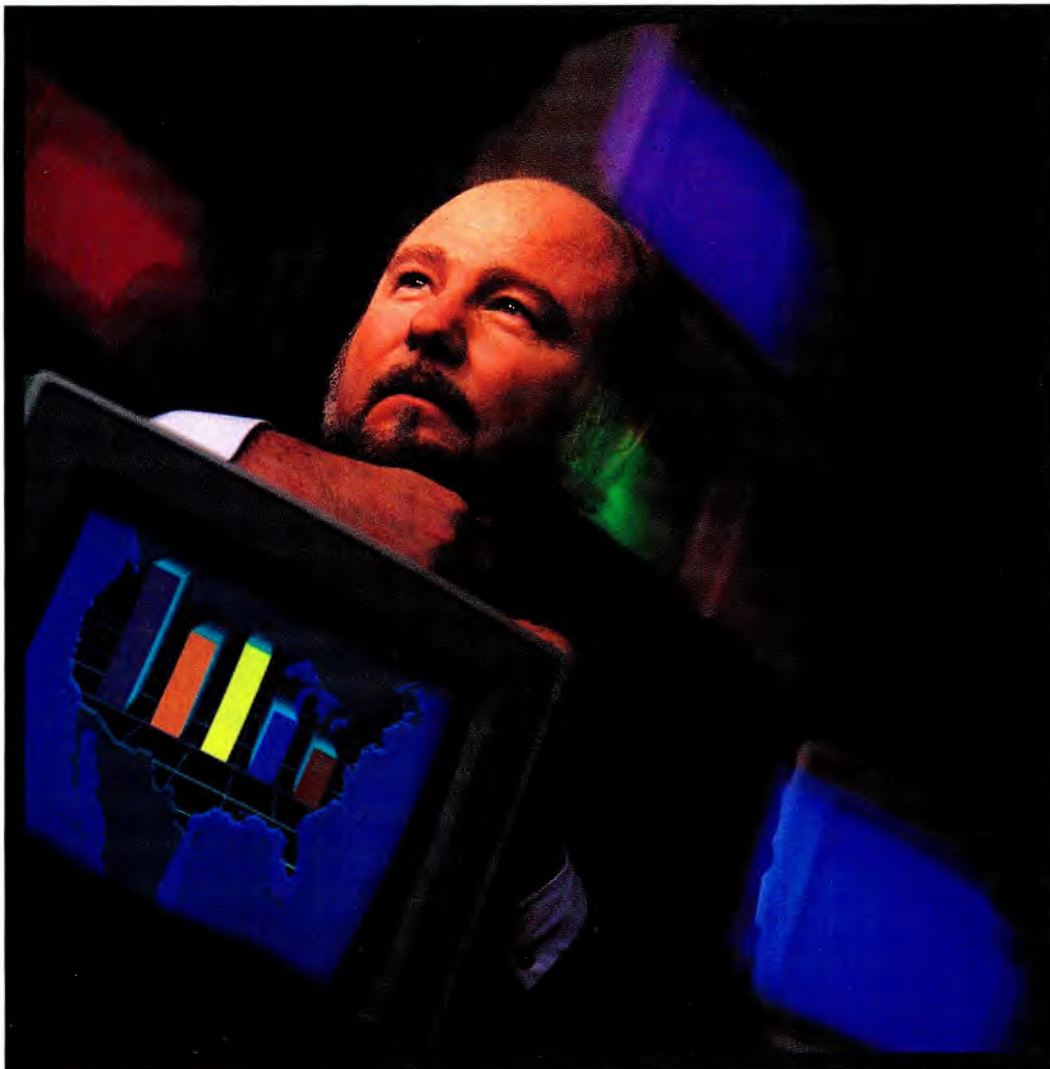

Keith Nealy stages events. Big ones. Imagine 8 or 9 computers (he uses Amigas) creating images that are projected then onto screens (or played on large monitors); imagine superimposing graphics (generated on the Amigas, of course) onto video (also handled by the Amigas); imagine doing these kinds of multi-media events for clients such as:

AT&T
Exxon Chemical
G.D. Searle
Pharmaceuticals
Pfizer
Lancôme
Sony

Does Keith Nealy ever get nervous? Apparently not. In

fact, increased pressure causes him to go from calm to calmer. That's one reason he's so good.

The Nealy Group also creates corporate image pieces, produces national sales meetings (often to introduce new products), stages awards ceremonies, and consults on marketing communications strategies.

They handle everything with Amigas. Why? Because the Amigas handle *everything*: video production, titling, 35 mm slides, special effects, animation, and desktop publishing. Even post-production editing.

"The Amiga runs our entire business. Correspondence. Spreadsheets. Everything you need to run the back end. And, of course, our multi-media events.

"The Amiga fills a niche for any Corporate/Industrial Production Studio: as a character generator, Digital Video Effects (DVE) source; as a paintbox; everything from word processing to budgeting to video production, all with one computer."

AMIGA. THE COMPUTER FOR THE CREATIVE MIND.™

The Amiga allows you to fly. Faster than you thought you could. Without spending a lot of money. Without waiting around another 50 years. Amiga from Commodore. Why not give us a call at 800-627-9595.

Commodore®

CASE NO. 115

© 1989 Commodore Electronics, Ltd. Commodore and the Commodore logo are registered trademarks of Commodore Electronics, Ltd. Amiga is a registered trademark of Commodore-Amiga, Inc.

Circle (49) on Reply Card

www.americanradiohistory.com

the TV industry, we must look at life before the VTR, when video recording meant kinescope.

The kinescope dominated TV recording for time delay in the early 1950s. A kinescope recorder basically was a special

16mm or 35mm film camera mounted in a large box aimed at a high-quality monochrome video monitor (a kinescope). Figure 1 illustrates the layout of a kinescope. Figure 2 shows a basic block diagram. All things considered, the kinescope made respectable and reliable TV recordings. Most engineers called the process "kine" (pronounced "kinney") for short.

The kinescope was a clever device. Its film camera ran at a speed of 24fps (frames per second). Because the TV image repeated at 60 fields (or 30 frames) per second, the film had to move intermittently between video frames, and then be rock-steady during exposure. Theoretically, the pulldown period for the film frame should be during the video vertical interval of less than 2ms, something no mechanical contraction could do.

Several kine makers, such as RCA, Acme, General Precision, Eastman Kodak and Palmer Films found various ways around the problem. They developed novel shutter mechanisms that used the extra six frames of the 30-frame video signal to move the film. This action integrated the video half-images into what seemed like smooth 24fps film pictures. Of course, the kines were played back on the

Continued on page 86

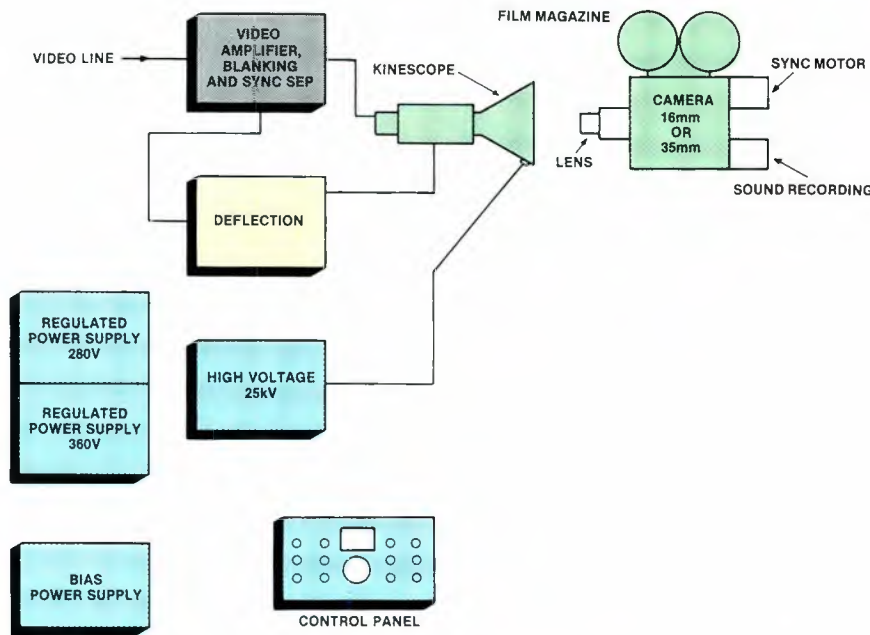
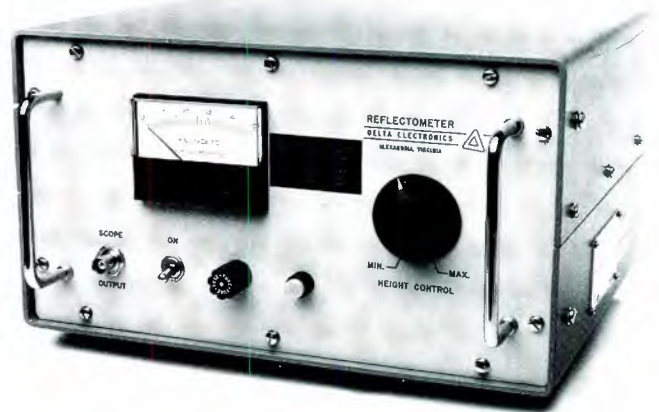

Figure 2. The kinescope consisted basically of a projector and a special 16mm or 35mm camera. Special timing circuits were needed to synchronize the TV field rate (30Hz) with the film rate (24fps).

Heart Monitor.



No matter how you look at it, the heartbeat of your TV station depends on a healthy transmission line. If a problem develops, how would you ever know until it's too late?

Now there's a way to check your line thoroughly and accurately before a simple problem becomes a major malfunction. It's the PRH-1 High Power Pulse Reflectometer from Delta Electronics.

The rugged PRH-1 puts out a low current, 5,000 volt variable pulse that overcomes the obstacles of long transmission lines, with no risk of damage. What you end up with is a series of echoes from the pulse displayed on your oscilloscope screen which represent your transmission line. The shape of the echoes determines the nature of any problem.

The PRH-1 operates like a champ in high RF fields, withstanding interference without any visible degradation of

pulse echoes. This makes the PRH-1 ideally suited for crowded antenna farms and community antennas, unlike traditional time domain reflectometers. Its ability to measure AM and FM lines as well make the PRH-1 a sound investment.

What you don't know about your transmission line can hurt you. Considering the consequences you'll suffer being knocked off the air, shouldn't you consider buying the PRH-1 as your top priority?

To see actual PRH-1 test results, call or write today. Delta Electronics, Inc., 5730 General Washington Drive, P.O. Box 11268, Alexandria, VA 22312. Telephone: (703) 354-3350, FAX: (703) 354-0216, Telex: 90-1963.

The Above Standard
Industry Standard.

DELTA ELECTRONICS



©1989 Delta Electronics, Inc.

Circle (50) on Reply Card

**COMARK, THE TECHNOLOGY LEADER,
PROVIDING POWERFUL SIGNALS
TO POWERFUL PEOPLE — *EFFICIENTLY***



**A Comark field proven* Klystrode[®]
powered transmitter is now in service
at WETA-TV, the home of PBS
in Washington, D.C.**

Comark financing or leasing available to
qualified buyers.

*Six transmitters in service as of October 31st.
A total of ten scheduled by the end of 1989.

*For further information on Comark's complete line of water
or air cooled Klystrode equipped transmitters call or write:*



COMARK

COMARK COMMUNICATIONS, INC. 1989[®]

A Thomson-CSF Company

Route 309 & Advance Lane, Colmar, PA 18915

(215) 822-0777 • FAX: (215) 822-9129 • TELEX: 846075

Klystrode[®] is a registered trademark of Varian Associates, Inc.

www.americanradiohistory.com

In business, as in life, you get what you pay for. True, there are values to be had, but when selecting a studio camera one word speaks louder than any other: technology.

Consider Ikegami's HK-323 field/studio camera. Performance and technology-wise, no other studio camera comes close. Which is why some of our competitors are attempting to convince you that their inferior, and often old technology, is worth buying at a reduced price. Fact is when it comes to quality versus price, the HK-323 is the best value in the industry!

It's small, lightweight design, combined with the most sophisticated engineering available, eliminates what was once the need for separate studio and field cameras, and goes one better by offering a hand held version, the HK-323P, which operates from the same base station.



The HK-323P hand-held companion camera.

Other unique and state-of-the-art features include: a Master Control Panel (MCP) that can control up to 40 cameras with triax, multicore, or fiber-optic cable (a triax repeater option triples cable length from one to three miles), fully automatic setup including green registration (all automatic or manual adjustments are stored

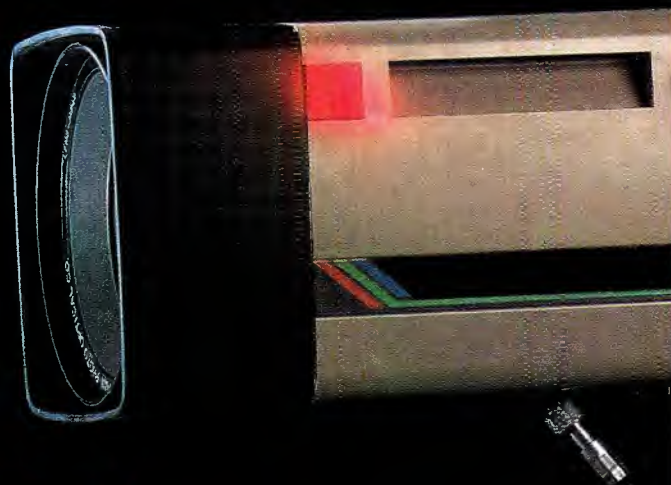

THE HK-323 FIELD/STUDIO CAMERA:

**CONSIDER ANY
OTHER STUDIO CAMERA,
YOU'LL PAY THE PRICE!**

Ikegami

in memory, powered by a lithium battery, whose 5-year life is backed up by a permanent, redundant E²-PROM, 1" or 3/4" Diode Gun Plumbicons® (upon request), high performance prism optics, a broad contrast range knee circuit that handles 1600% normal level, built-in color corrector, comet tail suppression, scene file memory with up to four presets, and the sharpest picture quality regardless of scene color content or special color lighting.

Ikegami's commitment to quality goes right down to our all fiberglass board construction, component selection, and body construction.

Some day our competitors would like to manufacture a camera this good. Until then, don't be taken in by what seems like a great deal. You'll pay the price.

For more information, contact your Ikegami Office.

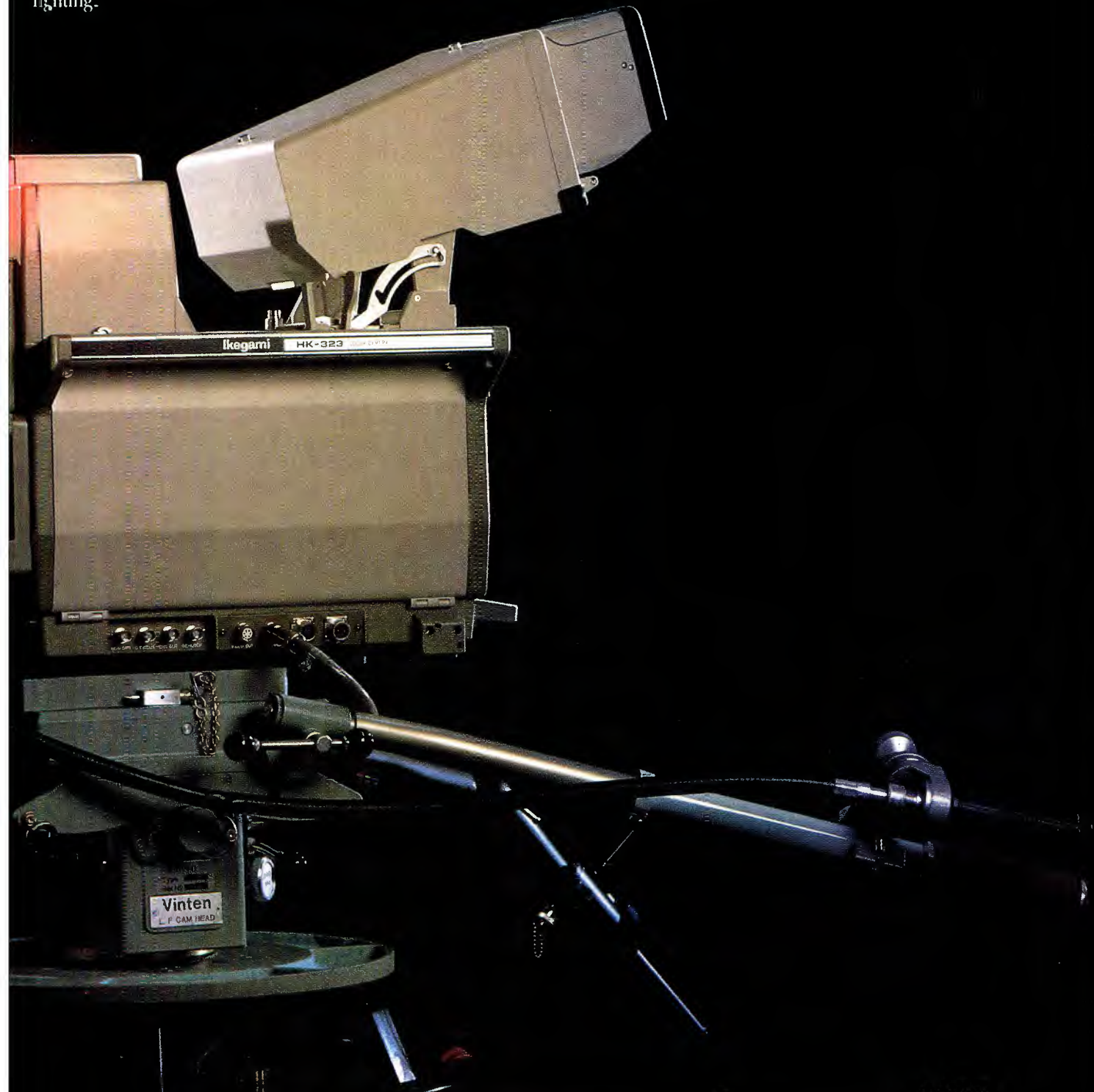

Ikegami Electronics (USA), Inc 37 Brook Avenue, Maywood, NJ 07607
East Coast: (201) 568-9171 West Coast: (213) 534-0050 Southeast: (305) 735-2203
Southwest: (214) 859-2363 Midwest: (312) 834-9774 Hawaii: (808) 946-5955

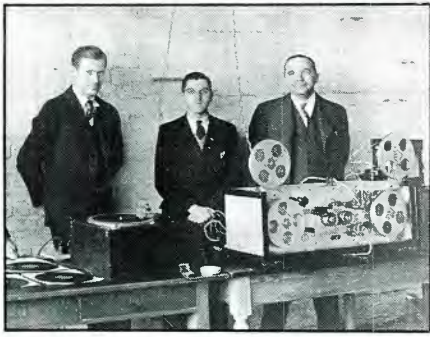

The invention of the annular sound head by Eduard Schueller, an AEG engineer, cleared the way for the first tape recorder, unveiled at the 1935 Berlin Radio Exhibition. Schueller (left) and two members of his AEG development team pose behind their invention. (Courtesy of AEG.)

Continued from page 82

air using regular 24fps film chains, so the conversion to film was complete.

The toughest operational problem with kines was the *shutter bar*. Although recording engineers tried to get precise synchronization between the camera shutter and the video image, problems often surfaced. The various sources of sync usually were locked to their own primary power references, causing a dark line or shutter bar to drift through the filmed image. One solution involved driving the kine film camera from signals locked to the sync that was coming in with the video source, then stripping the sync a moment later.

Another problem with kine quality was the gray scale. It was difficult to match the non-linear gray-scale characteristics of the video system. Many times when engineers were able to get a good film look on a kine recording, the image just didn't reproduce well on the iconoscope cameras used in film chains. Engineers continually were fighting problems with kinescope phosphors, blooming on white objects, gamma transfer characteristics, variable film sensitivity and chemical processing.

The kine image and optical audio quality often left something to be desired, but the broadcast industry had no choice. All three networks were using kines for time delay to the West Coast.

By 1954, the cost of kinescoping for time delay had gone sky-high. American TV operations used more raw film for kines than all of the Hollywood film studios combined. It was estimated that NBC used more than one million feet of film a month in its New York facility to time-shift programs. The networks would have gladly paid a king's ransom for an alternative TV recording method. Enter magnetic recording.

Video magnetic recording

The earliest known proposal for the use

of magnetic recording to store pictures dates back to the late 1920s and a British patent office grant to Boris Ritcheouluff of London. Ritcheouluff designed a picture recorder of considerable ingenuity based on the Poulsen machine, developed in Denmark many years before.

A 1932 German technical publication described a series of schemes for picture telegraphy proposed by Dr. Fritz Schroeter, professor at the Berlin Technischen Hochschule and a director of Telefunken. The illustrations in the book clearly resemble present-day transverse and helical-scanning formats.

In 1938, Luigi Marzocci, an Italian inventor, filed a patent application for a variety of rotary head recorders that were intended for sound recording, and so labeled in the patent. Nevertheless, the drawings are amazingly similar to the arcuate and transverse video recording concepts that came later with the first Ampex VTR. In fact, the company that held the rights to Marzocci's invention was prompted to consider legal action against Ampex after it commercialized its VTR.

Even as the Ampex group was developing the transverse recorder, German engineer Eduard Schueller, working in Hamburg for Telefunken, filed for a patent covering a 2-head helical recorder that is almost identical in concept to some of the machines later produced in the United States, Japan and Germany.

The race begins

As early as 1950, Jack Mullin, Bing Crosby's recordist and chief engineer, began working at the newly established electronics division of Crosby Enterprises to develop a magnetic TV recorder. Mullin and

colleague Wayne Johnson developed some interesting prototype recorders that used fixed heads and high tape speeds to achieve the high head-to-tape velocities needed for TV recording.

The Mullin-Crosby machine started out with 12 tracks at 120ips on 1-inch tape. Ten tracks carried the monochrome video information, a clock track provided control synchronization and an FM audio track completed the format. The basic theory was to use frequency-division multiplexing with the 10 channels covering the desired video range. A bandwidth of 17kHz per channel produced a cumulative spectrum of 1.7MHz, adequate for monochrome reproduction. Sync was recorded on a separate track to avoid the distortion effects of the band-separation filters.

By 1952, Crosby Enterprises was inviting broadcasters in to look at credible results of off-air black-and-white recordings. There were, however, some severe picture impairments that would require much improvement before the recorder could be considered acceptable to broadcasters.

Three years later, Mullin had the machine recording color video using a total of five tracks: three for recording RGB information, one for vertical and horizontal sync and one for the FM audio track. The 1/2-inch-wide tape ran at 240ips. People who saw the Crosby video prototype say the picture quality was pretty good, except for a fuzzy, screen-door look over the image.

After transverse video recording was introduced, the Crosby project was acquired by 3M Company as its Mincom Division, and was put to other recording tasks in the instrumentation field.

Meanwhile, David Sarnoff, head of RCA,

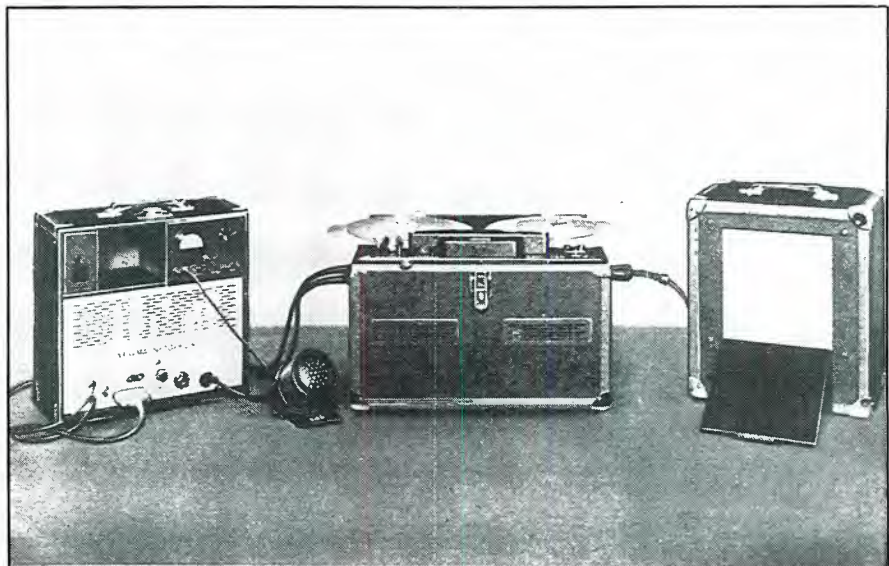

This Magnetophone "model K-4" tape deck is similar to the two machines brought back to San Francisco by Jack Mullin in 1946. Mullin's machines inspired Ampex to produce the first successful U.S. professional audiotape recorder in 1948. (Courtesy of AEG and Ampex.)



POPULAR PRODUCERS

Betacam is rapidly becoming one of the most popular production formats in both field and studio applications. And Ampex 198 Betacam and 298 Betacam SP video-cassettes are popular professional choices for a full range of needs. When

you need high reliability in an ENG/EFP tape, the choice is Ampex 198. Or, when you need the ultimate in performance, the choice is Ampex 298, with its high-coercivity metal-particle formulation. Both offer you high-impact ABS plastic cassettes for rugged dependability and the unique Ampex labeling system for easy access and

storage. And all backed by the industry's most acclaimed service and support organization. No wonder they're so popular. They're from Ampex.

AMPEX
THE PROFESSIONAL CHOICE

*Ampex Recording Media Corporation
401 Broadway, Redwood City,
CA 94063, (415) 367-3809*

Circle (52) on Reply Card

expected his engineers to come up with a magnetic TV recorder. Sarnoff reportedly wanted the machine and a few other innovations from RCA as a present to mark the upcoming anniversary of his 50th year in the radio business. The development team was headed by Dr. Harold Olson. The effort resulted in a longitudinal, high-speed VTR that made monochrome and color pictures.

The first laboratory prototype was

shown publicly in 1953. It used 1/2-inch-wide tape and ran at 30 feet per second (ft/s). The tape featured five tracks. A 7,000-foot reel ran for just four minutes. Subsequently, the tape speed was lowered to 20ft/s, and the playing time was increased to 15 minutes.

RCA felt confident enough with this advanced color machine to make some program demonstrations at NBC in late 1955. It was even used for about two minutes

on the air. The RCA system reduced the incoming color video signal into its RGB elements, each of which went on a separate track, as did the synchronizing information. The fifth track carried FM audio information. The stationary magnetic heads of one micron gap width could handle frequencies up to 1.5MHz.

The RCA machine introduced many innovations that became fairly standard on subsequent VTRs. Tape-tension servos, eddy current brakes, luminance/chrominance separation and sync reinsertion all are familiar techniques today, and they all came about in those early recorders.

The BBC also saw the potential advantages of a vision magnetic recorder, and in 1952, assigned Dr. Peter Axon to lead a long-term effort in that direction. The machine was called VERA (Vision Electronic Recording Apparatus) and was quite different from its contemporaries. Many of the developments achieved in this recorder served as departure points for subsequent helical VTRs.

The 1/2-inch tape moved at 16ft/s; a 21-inch-diameter reel gave 15 minutes of playing time. VERA was capable of 3MHz bandwidth, a significant achievement for its era in longitudinal recording. The fundamental approach involved the separa-



A staggering amount of progress has resulted from the development of magnetic tape technology over the past five decades. Shown is a 48-track digital audio recorder. Contrast it with the Magnetophone photo. (Courtesy of Sony).



Videotek's new, compact VSG-21 sync generator provides four test signals, balanced audio tone and continuous blackburst.

Videotek's done it again—packed more features for less money into a single product—our new VSG-21. It's equipped with four selectable NTSC test signals, SMPTE color bars, Multiburst and 10-step modulated stairstep or 10-step unmodulated stairstep.

That's just one example. Look at our full line of feature-rich sync generators, all engineered for zero defects. The VSG-201 has 6 blackburst outputs, audio test tone and "textbook" accurate SMPTE color bars and can be genlocked with guaranteed SC/H Phase regardless of input phase. With our Times Six Plus, at the touch of a button, you can synchronize and automatically time six devices regardless of various cable lengths or equipment drift. And our Times Six allows manual centralized control of six devices.

Get them all at a price that's in sync with your budget.

VIDEOTEK INC.
American made technology.
And value.

243 Shoemaker Road • Pottstown, Pennsylvania 19464
(215)327-2292 • TWX: 710-653-0125 • FAX: (215)327-9295

Circle (53) on Reply Card

Introducing the Canon J20x7.5B IE SUPER.



Without a doubt, the new Canon J20x SUPER is the finest of the new generation of CCD lenses designed specifically for CCD cameras. Offering the kind of versatility to make it a star performer in any size studio.

The J20x SUPER boasts an incredibly high and flat M.T.F. to provide greater contrast and excellent resolution, especially at the corners.

And as in all Canon CCD lenses, we've reduced both lateral and longitudinal chromatic aberration to virtually zero for each color channel. Bright and sharp, even at the longest focal lengths.

Plus, the J20x SUPER's internal focusing

design reduces chromatic aberration during focusing, provides a higher M.T.F. at each channel (even at M.O.D.) and results in less distortion at wide angle settings.

This incredible lens even focuses as close as 3¾ inches in macro!

Simply stated, the new Canon J20x7.5B IE will perform flawlessly in a wide range of studio and field applications. But then again, you wouldn't expect anything less from a Canon broadcast lens.



Focal length: 7.5-150mm
(1.5-300mm w/2x extender)
Max. Relative Aperture:
1:1.5 through 118mm
1:1.9 at 150mm

Canon

PERFORMANCE WITHOUT COMPROMISE.

Canon USA, Inc., New York Office: One Jencho Plaza, Jericho, NY 11753 (516) 933-6300. Dallas Office: 3200 Regent Blvd., Irving, TX 75063 (214) 830-9600. Chicago Office: 100 Park Blvd., Itasca, IL 60143 (312) 250-6200. West Coast Office: 123 Paulmarino Avenue East, Costa Mesa, CA 92626 (714) 979-6000. Canon Canada, Inc., 6390 Dixie Road, Mississauga, Ontario L5T1P7, Canada (416) 795-2012.

Circle (54) on Reply Card



GLOBAL SUPPORT FOR GLOBAL COMMUNICATIONS

Microprocessor Controlled Klystron High Power Amplifiers

Field-proven and recognized for wide spectrum coverage and consistent, reliable output, MCL's Microprocessor Controlled (and Standard Logic) Klystron High Power Amplifiers (SATCOM C-Band and Ku-Band) are accepted and proven by communications experts worldwide. MCL Series 10000 Klystron Amplifiers are designed to withstand variable environmental and mechanical conditions and are engineered for minimum maintenance and repair.

MCL's SATCOM Series 10000 Amplifier Systems feature a host of standard equipment and options, including:

- full microprocessor (or CMOS Logic) system control panel
- modular assembly for rapid sub-assembly access
- Motorized Channel Selectors available
- RS232, RS422, IEEE488, or Contact Remote Interfaces
- electrical/mechanical "no-step" or SCR AC line regulator drawer
- Beam Supply on casters; all other assemblies on slides
- ruggedization for transportable applications
- and more!

MCL is the leader in the field of amplifiers and allied equipment for the field of satellite communications. MCL offers a complete line of products, at competitive prices, quality-tested and proven to provide *unexcelled performance*.

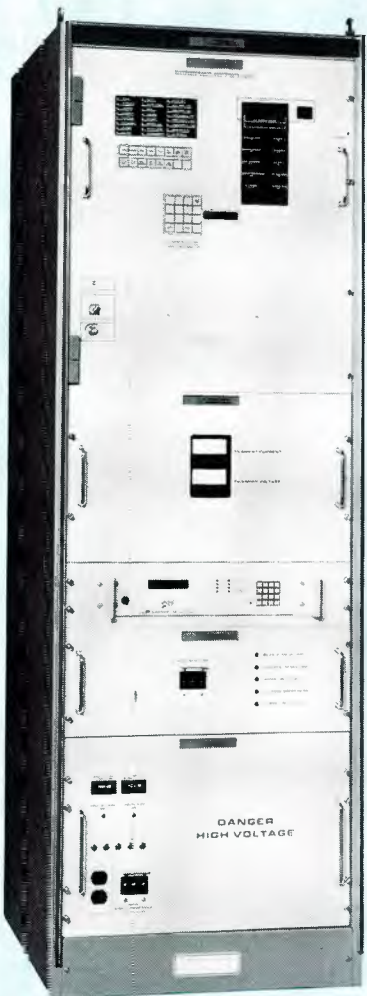

Microprocessor amplifier shown

Write or call MCL today and request your FREE copy of Brochure #1001 (Microprocessor Logic) or Brochure #9009 (Standard CMOS Logic) for details and technical specifications.



MCL

MCL, INC.
501 S. Woodcreek Road
Bolingbrook, IL 60439
312-759-9500 TWX 910-683-1899

Manufacturers of TWT and Klystron Amplifiers for Satellite Communications.
24-Hour Sales and Technical Support for Immediate Service Worldwide.

• Shelby Henderson, the model-maker.
In retrospect, all members of the small team that developed the Ampex VTR credit one individual for its eventual emergence. This person was not known so much for his technical skills, which were considerable, but for his tenacity and purposeful single-mindedness in the face of every possible adversity that lack of time, money and technical precedent can impose. That man was Charles Ginsburg, a young, obscure engineer who joined Ampex in late 1951 specifically to make pictures on tape. He did so to the utter amazement of his industry peers.

At the beginning of the effort in 1951, the concept of the video recorder system involved the use of three tape heads mounted on the surface of a drum, scanning in an arcuate fashion the surface of a 2-inch-wide tape. The tape-to-head speed was about 2,500ips (with the tape moving at 30ips). This speed proved to be impractical, however, and eventually was set at 1,500ips. Designers hoped the system would give dependable recording frequencies as high as 2.5MHz. Progress was slow in the early months of the project, but in October 1952, engineers were able to demonstrate an almost unrecognizable picture that still was promising enough to maintain management's enthusiasm in the video recording project.

By March 1953, a second machine had been built using four heads mounted on the plane face of the drum (instead of three). An amplitude-modulation system was used in the recorder, and a switching arrangement selected the proper heads during rotation of the drum. The capstan motor was driven directly from the 60Hz line frequency and the high-speed drum motor was driven by a power amplifier whose input was the fifth harmonic of that signal (300Hz). A reference drum-motor speed signal was recorded on the tape along with the video information and used during playback to provide control for the drum-motor power amplifier.

In September 1954, after several periods of inactivity, the VTR project was recommenced in earnest, with several significant technical changes. Instead of the arcuate sweep configuration, engineers changed to a geometry that became standard in the late 1950s in which the tape wrapped transversely around the rotating head drum. Consequently, the video information was written across the moving tape in straight lines. An automatic gain control also was developed to compensate for amplitude fluctuations of the rotating-head recording system.

Creating the head assembly was a monumental task. Engineers had to develop a head unit that met stringent mechanical and electrical specifications. Complicating the process were the high centrifugal forces that the head assembly

Circle (58) on Reply Card



The best wireless performance at any price.

Pro Plus microphone systems from Vega.

They're the wireless choice of major broadcast networks, video producers, and television/film studios the world over.

Why?

Because Pro Plus provides superior rejection of interference . . . high signal-to-noise performance through the exclusive Dynex II® processing system . . . and the extended operating range you demand.

It's also the best-sounding, most reliable wireless mic available, bar none.

So remember—

Other high-end wireless microphones may cost more than a Vega, but that doesn't guarantee they'll deliver the performance you paid for.

Of course, you don't have to buy a Vega wireless. You can always pay more for less.

 **Vega**

a MARK IV company

faced during operation.

In December 1954, the first picture was demonstrated using the new geometry and modified electronics. In the words of

Charles Ginsburg, leader of the Ampex research team, "It took a great deal of faith and understanding to be optimistic in the face of some rather gross shortcomings in

the reproduced picture." The decision then was made to attack the video-recording process from a different perspective.

A recording system using vestigial-sideband frequency modulation was proposed to replace the amplitude-modulation technique. In January 1955, the first pictures were seen using the FM video-recording system. A few months later, the engineering team gave a convincing demonstration to the Ampex board of directors. Although the resolution was extremely low (the system bandwidth was somewhat less than 1.5MHz), and the video monitor had to be modified to compensate for horizontal instabilities generated by the system, the images produced by the recorder were good enough to persuade management that work should continue.

Development progressed with a number of changes and improvements in the recording system. Vacuum-controlled tape tension was introduced to the unit, and a radical redesign of the tape heads (going to a sandwich-type of construction) was made.

The final push

In early February 1956, the engineering team put on a demonstration for what was supposed to be a small Ampex management group. About 30 company people showed up, however, for the historic event. Ginsburg remembers the demonstration:

For all of us on the engineering project, this was the most dramatic demonstration we were to make. The guests arrived, were seated, a few words were spoken to the effect that we would show them what we had produced, and the machine was put in the playback mode to reproduce a program we had recorded an hour earlier.

We then announced that we would record a sequence and immediately play it back. We recorded for about two minutes, rewound the tape and pushed the playback button. Completely silent up to this point, the entire group rose to its feet and shook the building with hand-clapping and shouting.

A crash program followed the demonstration, with the introduction of the machine to the industry scheduled for the National Association of Radio and Television Broadcasters (later shortened to, and now referred to, as NAB) Convention in Chicago, just six weeks away. In the weeks that followed the demonstration to Ampex management, a number of visitors were shown the video recorder. Engineering executives from CBS, ABC, NBC and the BBC were sworn to absolute secrecy and ushered in and out separately so they would not see each other.

As a result of a visit by Bill Lodge, CBS, arrangements were made to use a demonstration model, the Mark IV machine,

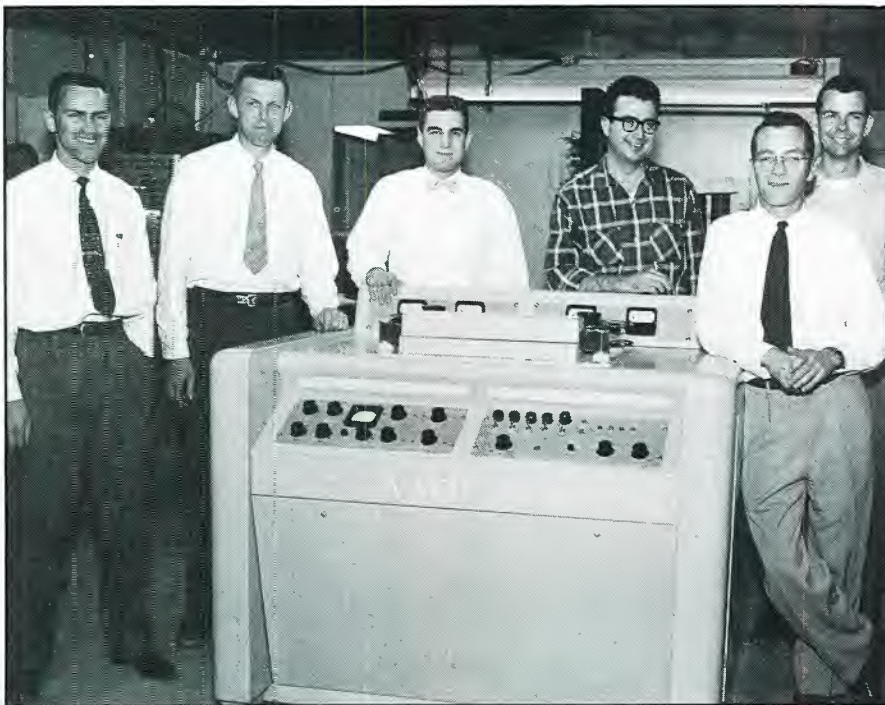

Members of the Ampex videotape recorder R&D team pose around the prototype Mark IV VTR that changed TV broadcasting. Shown (from left) are Fred Pfost, Shelby Henderson, Ray Dolby, Alex Maxey, Charles Ginsburg (team leader) and Charles Anderson. (Courtesy of Ampex.)



The world's first practical videotape recorder, the Ampex-Mark IV prototype VTR, was unveiled in April 1956 at the National Association of Radio and Television Broadcasters (NAB) convention. (Courtesy of Ampex.)

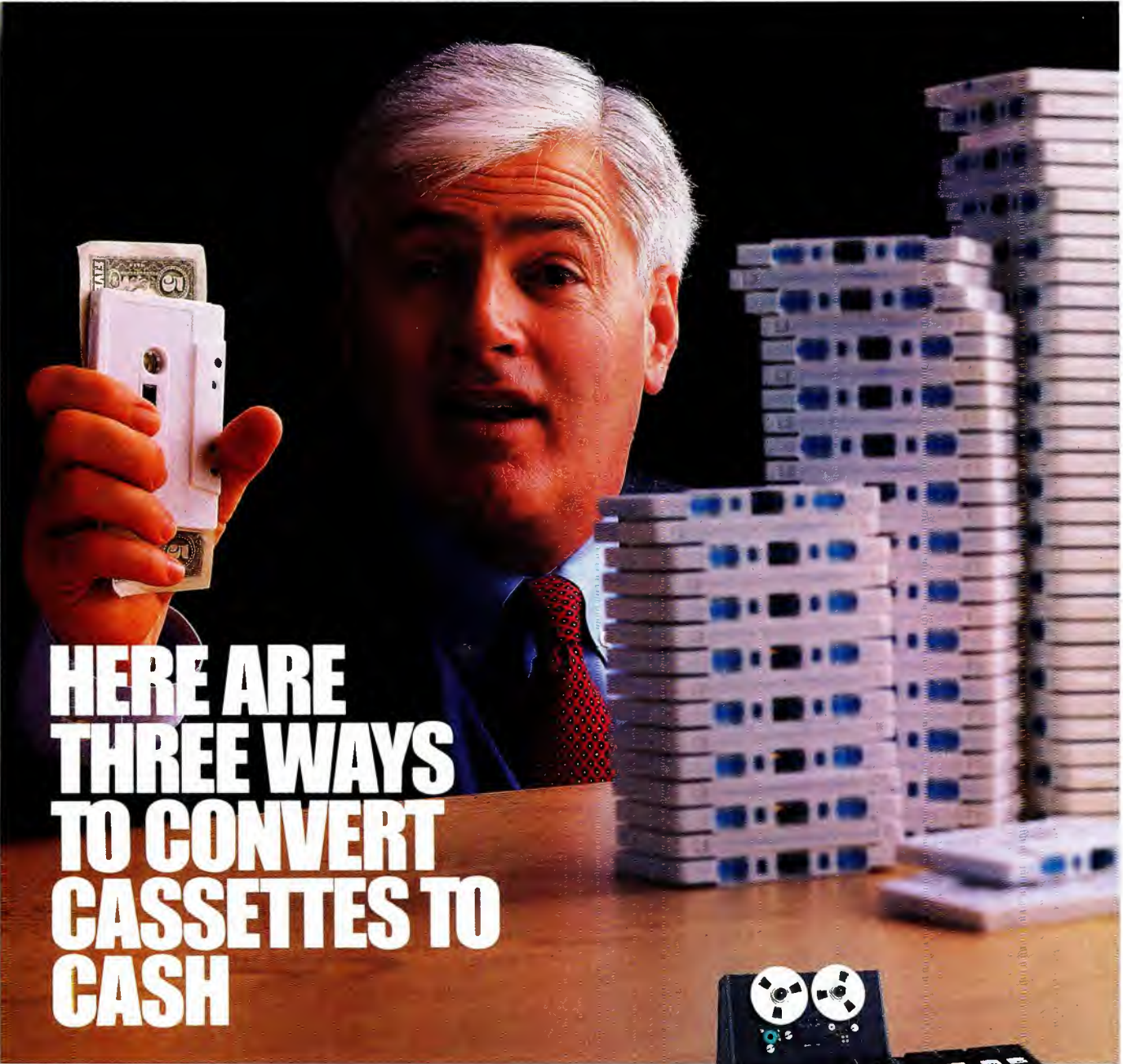

HERE ARE THREE WAYS TO CONVERT CASSETTES TO CASH

- ✓ **Add new profit opportunities** by starting your own high speed tape duplication department.
- ✓ **Increase production** of your current tape duplication department by adding modules as you grow.
- ✓ **Save the money** you're spending on cassettes now. Produce them yourself for only the cost of the tapes.

Telex is the leader in high speed audio tape duplication equipment with products ranging from the compact, economical

Copyette® series to the professional 6120XLP shown here. The Telex 6120 series provides outstanding audio quality, unlimited expandability and profitable production capabilities. It's available in high production 16X speed or 8X speed for highly critical audio needs.

Hearing is believing
For full details including specifications and a free demo tape, call or write today.



6120 High Speed Duplicator

Call toll free: 800-828-6107

Telex Communications, Inc.
9600 Aldrich Av. So.
Minneapolis, MN 55420 **BE 11/89**

Name _____
 Company _____
 Address _____
 City _____ State _____ Zip _____
 Telephone _____

© 1989 Telex Communications, Inc.



Circle (60) on Reply Card

which had not yet been assembled, for a surprise showing to the annual CBS affiliates meeting that was to occur the day before the formal opening of the NAB.

With just six weeks to go before the show, working hours were extended considerably to complete construction of the Mark IV unit. At the same time, development work was continued so that the picture to be demonstrated in Chicago would be as good as CBS was expecting it to be. The activity became furious. The administrative engineer for the considerably enlarged group shed his business suit in favor of work shirt and jeans. He spent most of his regular time plus nights and weekends modifying mounting brackets for the new Mark IV console, making cable assemblies and building redesigned electronic assemblies.

A 3-year-old idea of placing the switching transients in the horizontal-blanking interval was rushed into hardware form as the *blanking switcher* and integrated into the basic system as a toggle-switch option. An automatic rotary-head degaussing system came into being to eliminate the necessity of manually demagnetizing the video heads after a recording operation and before playback.

Meanwhile, it had been decided that the

Mark III machine used for the Ampex management demonstration should be used for a press demo on the same day that NAB was to begin. Therefore, while Mark III was being used for development work, it also had to be prepared for the press appearance. The true orphan of the project, the audio, which had been sadly neglected up to this point, was made to



The first broadcast via videotape took place on Nov. 30, 1956. CBS Television City in Hollywood, shown here, replayed the "Douglas Edwards and the News" program three hours after it was received on the West Coast. CBS engineer John Radis stands at the controls of the Ampex VRX-1000. Note the racks of support electronics (on the left) for the tape transport. (Courtesy of Ampex.)

at least approach professional standards.

Ampex management also suggested that a piece of equipment that was to cost upwards of \$50,000 should look substantially more polished than the engineering models used for demonstration purposes to date. The prototype machines were housed in crude-looking consoles and partially filled racks. A more compact console and rack-mounting system were developed to accommodate the wishes of the Ampex brass and the expectations of potential customers.

The long days and weeks paid off. The Mark IV was complete and broken down into a number of pieces for shipment to Chicago. Three days before the press demonstration, however, the Redwood City machine was having severe mechanical trouble. Some of the team left for Chicago, and the rest stayed in Redwood City to patch the Mark III back together.

The demonstrations were scheduled for Saturday. By Thursday afternoon, the Mark IV was assembled in Chicago and was making the best pictures the team had yet seen on tape. A predictable situation then occurred. The CBS engineering staff said the pictures were not good enough. The signal-to-noise ratio was too low, and the noise banding was intolerable.

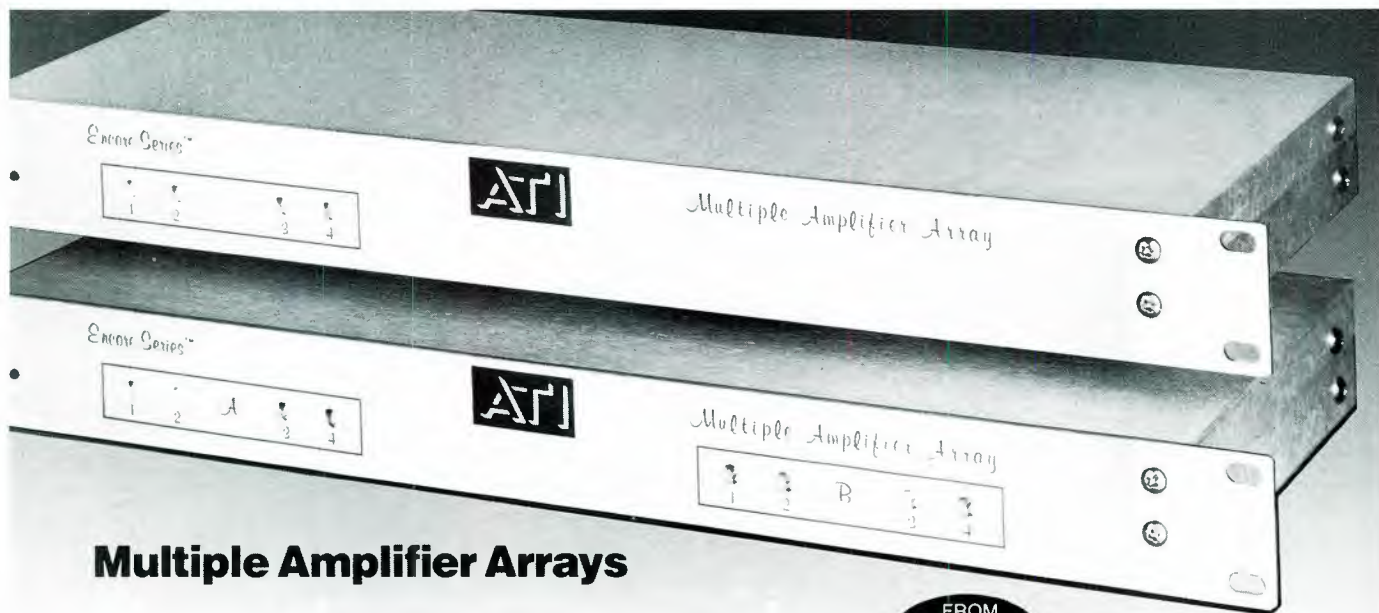

Multiple Amplifier Arrays

FROM
\$349

Four or eight channels for **YOU** to easily configure as Microphone, Line Buffer, Distribution and Level Matching Amplifiers. Form sum and difference networks, Interface phone lines, Drive headphones, Make a

simple Mixer or Press Box . . . just by changing jumpers. Gains to 82dB, Low noise balanced inputs. Clean +24dBm active or transformer balanced outputs.

Configurable circuitry. . . to fit **your** needs.

Call or write for free detailed brochure.

AUDIO TECHNOLOGIES, INC.
328 W. Maple Ave., Horsham, PA 19044
(215) 443-0330 • FAX (215) 443-0394



Circle (61) on Reply Card



MAGNI's been your answer for flexible, multi-format test and measurement since 1984. Now you've honored our products with the Emmy® award for Outstanding Achievement in Engineering Development in Television Test and Measurement.

Thank you.

MAGNI®
MAGNI SYSTEMS, INC.
9500 SW Gemini Drive
Beaverton, OR 97005 USA
(503) 626-8400
(800) 237-5964
FAX (503) 626-6225
TLX 650-2769743MCI

Magni is a registered trademark of Magni Systems, Inc. Magni Systems is a trademark of Magni Systems, Inc. Emmy © NATAS.

Circle (62) on Reply Card

Between Thursday night and Friday night, the team trimmed and adjusted the machine, aided by the last-minute delivery of new tape samples that greatly exceeded the performance of anything they had used before. Meanwhile, the crew in Redwood City had solved its mechanical problems and was ready for the press demonstration.

The big day

On April 14, there was an air of conviviality among the 200 or so station owners and managers attending the CBS TV affiliates meeting that preceded the opening of the 1956 NAB convention. As the guests filed into the Normandy Lounge to listen to their headquarters manager, William Lodge, deliver the annual report, they had no inkling that this meeting would reveal to the world a technical development that would change television forever.

At such gatherings, it was not unexpected to have a camera pointed at the podium and a few monitors set up in the room to convey an aura of television. If any attendees in the room noticed an unfamiliar, high-pitched whine, they probably assumed that it was due to a faulty fluorescent lamp or some external machinery.



Early VTR engineers constantly had to cope with venetian blinding (shown at left), caused either by inadequate tip penetration or incorrect head spacing (quadrature error). (Courtesy of Ampex.)

At the end of Lodge's prepared presentation, there was a pregnant pause. Suddenly, the monitors in the room were showing what must have seemed to the audience to be an impossibility. The attendees found they were looking at an instant playback of the Lodge speech, with an image clarity indistinguishable from the original they had seen a few minutes earlier. A hushed silence filled the room as they tried to relate this assault on their senses, which told them that TV images could not be immediately repeated by any known device. Then, cheers and applause

broke out.

Because there was no available monitor, the Ampex team behind the curtain could not check the playback before punching it up on the TV screens in other parts of the room. They had to operate on the blind faith that everything was working well. That short silence at the beginning of the playback seemed like an eternity to Ginsburg, Dolby, Anderson and Pfost.

The station executives crowded around the VTR, trapping the operating personnel against the machine while they pushed, elbowed and stood on chairs to get a glimpse of this latest video marvel. The members of the VTR crew, who just a few minutes earlier were holding their breaths in the hope that this hastily assembled contraption would perform on cue, were now busily answering questions from excited interrogators who were curious about performance, price and availability.

After news of the breakthrough spread throughout the convention, pandemonium broke loose, and Ampex was flooded with orders. The era of videotape recording had arrived. Engineers who witnessed the event still remark about its historical significance. The demonstration machines were far from finished products, however.



The choice of the professionals...



310B PROFESSIONAL PHONO PREAMP/EQUALIZER
... Interfaces magnetic phono cartridges for optimum calibration of audio systems. Available with balanced or unbalanced output.



PBR ANNOUNCER'S EARPHONE ...
Ideal for on camera studio work and remote coverage.



The **Dynaphase 30M/SR** is a shoulder rest single cup headphone that provides the ultimate in convenience, comfort and superb sound quality. Made to rest on either your left or right shoulder, or shoulder rest can be detached and used as a single cup hand-held monitor.



680EL ... Delivers sound excellence and stands up to backcueing, vibrations and mishandling.

Stanton is the company with a total commitment to quality and reliability—producing products for the Recording Industry, the Broadcast Industry and the Professionals in Audio.



101 Sunnyside Blvd., Plainview, NY 11803



500AL ... For heavy duty on-the-air use with wide tracking force range.

Circle (63) on Reply Card

STILL FAR ABOVE THE REST

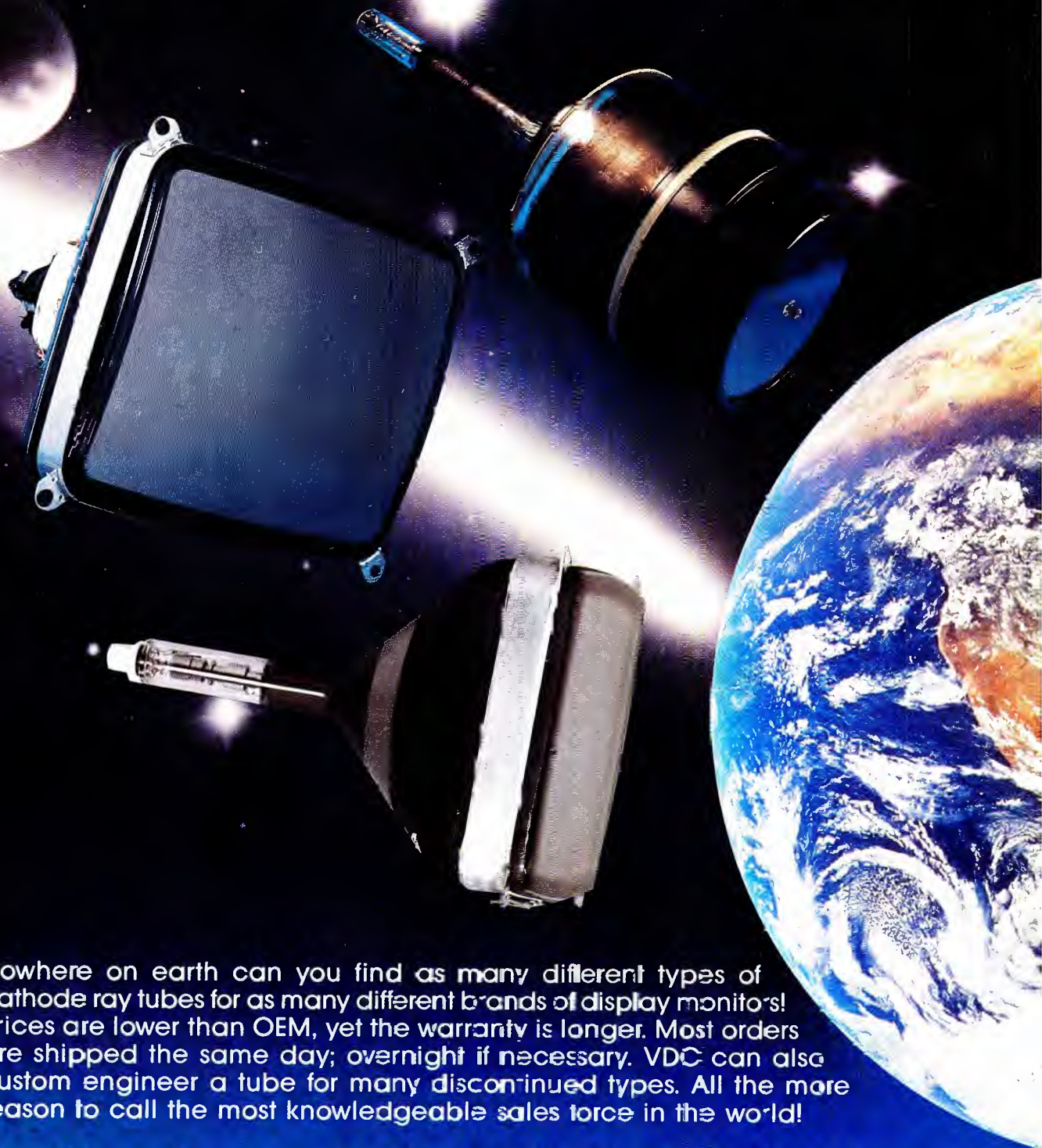

Nowhere on earth can you find as many different types of cathode ray tubes for as many different brands of display monitors! Prices are lower than OEM, yet the warranty is longer. Most orders are shipped the same day; overnight if necessary. VDC can also custom engineer a tube for many discontinued types. All the more reason to call the most knowledgeable sales force in the world!

Call: 800-241-5005, 404-938-2080, Fax 404-493-3903
OR SEE YOUR LOCAL AUTHORIZED VDC DISTRIBUTOR.

VIDEO DISPLAY CORPORATION
1868 Tucker Industrial Drive • Tucker, Georgia 30084



Circle (64) on Reply Card



The progress of the videotape recording from 1953 to 1956. Clockwise from top left: Shirley Temple, recorded in late 1953 using AM signal processing; the Bob Crosby show, 1954, using FM signal processing; an FM videotape picture of a kinescope broadcast, mid-1954; and FM recording, early 1956. (Courtesy of Ampex.)

The "real work" begins

The next several months were hard work for the entire engineering team. Ampex had originally expected to deliver five prototype machines by late summer or early fall to customers in government agencies for evaluation, along with a gradual program leading to delivery of machines for TV use starting in 1957. Now, however, the engineers were faced with the pressure of producing 16 hand-built machines, most of them going to broadcasters for immediate on-air use. All the same, they had to gear up for full-scale production of VTRs for an eager industry.

Despite the subjectively good pictures demonstrated in April 1956, much needed to be accomplished. A review of the tasks that faced the team before it could release the first machine for air use revealed how shaky the technical ground really was. Some of the key tasks involved:

- *Tape evaluation.* Until then, none of the personnel, machine facilities or technical advances had been sufficient to properly evaluate magnetic tape for video recording. The tape program consumed many hundreds of work hours and was the cause of severe headaches to the tape manufacturer, Ampex engineering staff and early network customers.

The engineers who know RF best already know us very well.



If you're looking for superior rigid coaxial transmission line and RF components, your transmitter or tower might be a good place to start. Take a look around — you'll probably find the bright blue Myat logo. TV and radio RF engineers at Harris, Acrodyne, QEI, Micro Communications, and Broadcast Electronics all routinely specify our products. And so do the antenna experts at Jampro and the engineers for the Navy's top airborne radar system.

All of these manufacturers demand long life and superior efficiency. They expect the highest quality materials, the toughest construction techniques, plus the most effective expansion compensation designs. And, like you, they have budgets and schedules to meet. All of them demand Myat, because they know Myat delivers.

Next time you need rigid transmission line or RF components, call your favorite RF equipment distributor or phone us direct at (201) 767-5380. For quality, durability, value and service, Myat is the name to know.

MYAT, INC. • 380 CHESTNUT ST. • P.O. BOX 425 • NORWOOD, NJ 07648
TELEPHONE: (201) 767-5380 • FAX: (201) 767-4147



Circle (65) on Reply Card

MORE THAN CABINETS, WE OFFER SOLUTIONS.

Everything in consoles and racks for the video professional.

We've been designing and building high quality video consoles and racks for over 35 years. So we know the ropes. This experience can save you considerable time and money.

Preassembled, modular units make it easy.

You can choose from hundreds of video consoles, cabinets, racks, desks, EMI/RFI enclosures, and accessories in a wide range of hi-tech colors and styles.

Our consoles and racks are modular for future expansion and everything is preassembled for quick, easy set up.



Modular design provides flexibility.

Free design assistance.

If you like, our team of professional designers can help you design your own custom system.

They'll work with you so you'll get maximum aesthetics, ergonomics, efficiency, durability, and economy.

Quality you can count on.

When you choose Stantron video consoles and racks you're choosing the highest quality.

Our years of experience assures you the very best solution whether it's simply a VTR/VCR rack or an entire room of custom consoles.



A full range of power panels and strips.

Get all the facts.

Fill out the coupon or Reader Reply Card. Or, just give us a call. We'll rush you our new Preplanner and Video Catalog.



Professional design assistance.



Direct your inquiries to:

Stantron

Marketing Manager
6900-6918 Beck Ave.
No. Hollywood, CA 91605
Phone: (818) 841-1825 Fax: (818) 841-8892

FREE

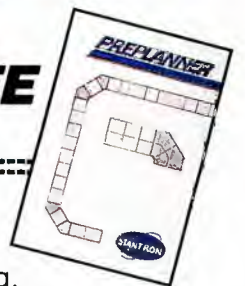

Console and Rack Preplanner and Video Catalog!

Please rush me your Preplanner and Catalog.

Name _____
Title _____
Company _____
Address _____
City _____ State _____ Zip _____
Phone _____

BE/11-89

Call me, I'm interested. Circle (66) on Reply card.
Send literature. Circle (67) on Reply card.

- *Tape head life.* The predicted head life for the early machines was just 100 hours. Worse yet, the heads were made in a tedious, one-at-a-time fashion. The many parameters in head construction, several of which had been varied madly in cut-and-try fashion to squeeze out a few precious decibels of signal-to-noise ratio for the April demonstration, had to be frozen to establish some standard before delivery of the first machines to customers. At the same time, head construction had to evolve into a semi-production process, rather than remain a one-at-a-time hand-crafting technique.

- *Processing hardware.* A processing unit had to be designed and built that was capable of providing blanking and sync in the reproduced signal. It also had to be sufficiently free of noise to allow the video to be handled without difficulty by conventional stabilization amplifiers and clamps anywhere along the transmission line.

- *Picture improvements.* The picture reproduced from tape had to be greatly improved with respect to noise, resolution, overshoot, ringing and horizontal stability.

- *Mechanical considerations.* The entire machine and all individual chassis had to be repackaged and tested. The mechanical design details were endless. The top-plate components had to be not only reliable, but also completely interchangeable.

On the air!

The historic first broadcast via videotape was the CBS airing of the "Douglas Edwards and the News" program on Nov. 30, 1956, from New York. CBS Television City

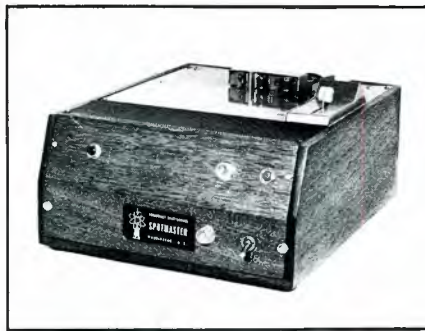

There is some dispute over which company built the first audio cartridge machine. This Spotmaster deck is at least one of the world's first cart machines, built in 1959. (Courtesy of Broadcast Electronics.)

in Hollywood replayed the broadcast three hours after it was received on the West Coast. CBS' confidence in the new machines was not all that high, and for a month, the network ran a backup kinescope just in case of a breakdown.

"Headhunting," as it was known at the time, was a major problem in the early machines. Headhunting caused picture jitter for home viewers with receivers that had horizontal AFC circuits designed for fringe-area reception. Viewer complaints instigated a crash program to alleviate the defect before CBS could make good on its threat to take the machines off the air. Ampex engineers literally slept in the VTR room to have access to the Mark IV machines during non-broadcast hours, between 1 a.m. and 5 a.m. A lot of midnight oil was burned to solve the problem.

In the ensuing months, NBC and ABC

followed the CBS lead. Ampex built 16 Mark IV production prototypes in 1956-57, calling them the VRX-1000, before beginning production of the VR-1000 in 1957.

RCA unveiled its version of the VTR, the TRT-1A, in 1957. The machine used the same head and video systems as the Ampex VR-1000. RCA began marketing the VTR process as *quadruplex* recording, based on the fact that the machine had four video heads. The industry soon adopted the shortened version of the name, terming it *quad*.

Audio cartridge machine

Video products usually capture the attention of most attendees at the annual NAB conventions. However, in 1959, the main attraction at the convention was the first audio cartridge recorder. Until then, the playback of program material was handled by disks and reel-to-reel tape decks.

The late '50s was a time of dynamic change in radio as the industry moved from a medium offering long, discrete programs to one offering a single, continuous program made of many short pieces. The rapid-fire, music-and-news format came to be known as Top 40 radio.

Acetate discs could handle the pace of a Top 40 format, but offered poor fidelity. The lead-in grooves sounded scratchy after several cuttings and, after many plays, the stylus often would jump grooves. Reel-to-reel, on the other hand, offered excellent fidelity but suffered from loading, cuing and tape-breakage problems. A playback system was needed that offered the fidelity of reel-to-reel decks combined with the handling ease, rapid cuing and instant start of acetate discs.

The audio cartridge machine as we know it was developed by two stations working in the late 1950s toward the common goal of devising a better method for playing back commercial announcements. The stations were WJBC-AM, Bloomington, IL, and WWDC-AM, Washington, DC. The WJBC project began as an idea cooked up by Vern Nolte, general manager of the station; Ted Bailey, chief engineer; and Jack Jenkins, Bailey's assistant. They had come up with the idea of using short-length cartridges for commercial announcements and having them recue automatically. Design of the electronics to accomplish the scheme belonged to Bailey and Jenkins.

On Jan. 13, 1959, Nolte wrote to Parker Gates, president of the Gates division of Harris Intertype, proposing that the company manufacture and market their cartridge machine. Three days later, Gates wrote back to Nolte to thank him for the offer, and explained that his company was already working on a spot playback device of its own. He was, therefore, not interested in developing a product

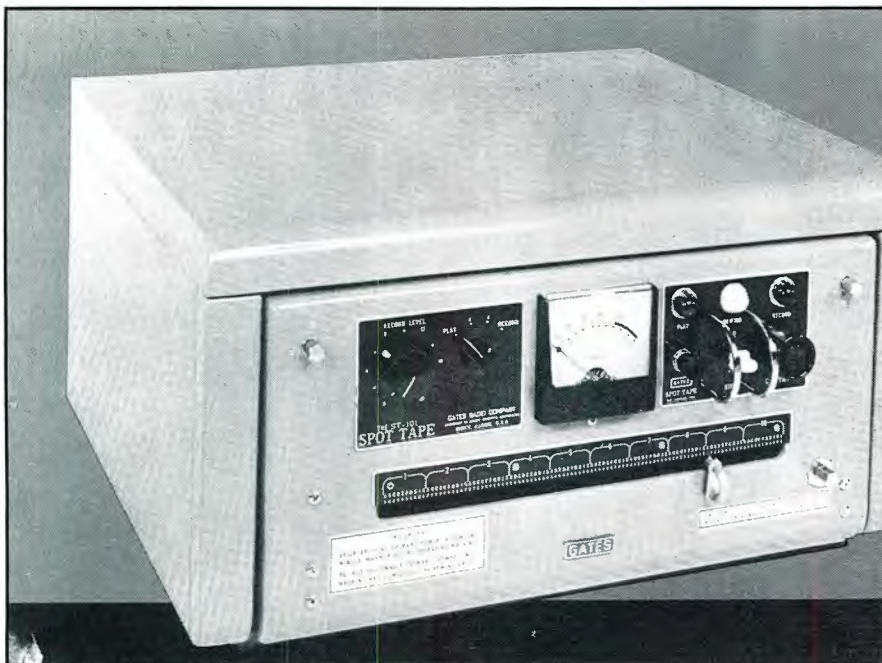

The Gates ST-101 spot tape recorder. The selector bar on the front panel determined which prerecorded announcement was played. The spot playback system was introduced at the 1959 NAB convention. (Courtesy of Harris.)

Everything you always wanted in a tube camera. Except tubes.

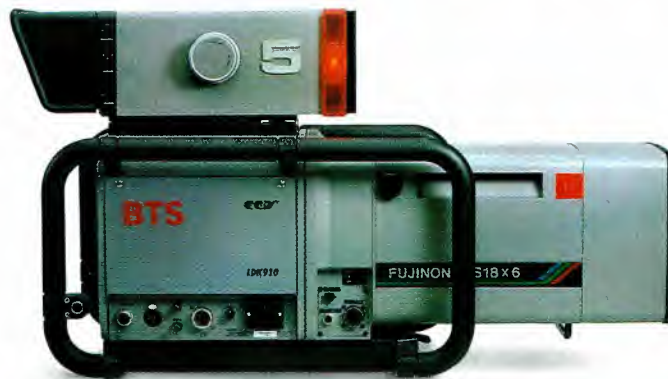

LDK 910 CCD Studio Camera

What you've always wanted in a tube camera is the best picture possible. But now you get the best picture in a CCD Camera — the new BTS LDK 910. And you'll never miss the tubes. Because the LDK 910 meets or beats the picture quality of tube cameras with a new

CCD sensor that employs over 800 pixels per line, and over 406,000 total picture elements.

In addition to excellent resolution, the LDK 910 has a high signal-to-noise ratio, high sensitivity and accurate colorimetry. Along with a few other things you don't get with tubes. Such as BTS's frame-transfer technology, which eliminates smear. A high dynamic contrast range without blooming or burn-in. And excellent dynamic resolution enhanced



LDK 91 CCD Portable Camera

by advanced electronic shutter control. It's also ready to shoot when you are — no waiting for warm up.

And here's another reason you won't miss the missing tubes. Not only is the LDK 910 priced competitively with tube cameras, but it costs less than you'd probably spend replacing worn out tubes over the life of a studio camera.

But of course, big ideas also come in small packages. The LDK 91, a lightweight, easy-to-handle ENG/EPF camera, is the LDK 910's portable companion. Singled out by *Broadcast Engineering* magazine as one of the ten "Pick Hits" of NAB '89, it has the same CCD sensor and the same top picture quality as the LDK 910.

Together, these fully compatible CCD cameras

will make your old ideas about picture quality go right down the tubes. For complete information and technical specifications on the new LDK 910 and LDK 91, call BTS at **1 800-562-1136, ext. 11.**

BTS
The name behind
what's ahead.

that would duplicate something they already had.

The product Gates was referring to was the ST-101, better known as the *101 Spotter*. Unlike cartridge designs that used an endless loop of 1/4-inch tape, the 101 Spotter employed a 13-inch-wide band of tape on which spots were recorded side by side. An indexed, sliding-head arrangement allowed the user to select any one of 101 spots. Rights to the machine had been purchased earlier by Gates from Nelson Rupard, manager of KIND-AM, Independence, KS.

After having been turned down by Gates, Nolte pitched the idea to Collins Radio. Gene Randolph, a sales representative for Collins, paid a visit to WJBC early in 1959. Bailey and Jenkins told him about their cartridge tape system, which was being used on the air to play commercials. As a former control board operator who had handled countless small reels of tape for commercial announcements, Randolph saw what a boon such a machine would be to radio broadcasting.

Randolph returned to the Collins factory in Cedar Rapids, IA, and told his boss about the cartridge system. Within 24 hours, John Haerle, product line manager at Collins, and a company attorney

were in Bloomington to work out a marketing agreement with Nolte.

In a crash program, Collins arranged with Nolte's newly formed Automatic Tape Company (ATC) to produce enough car-

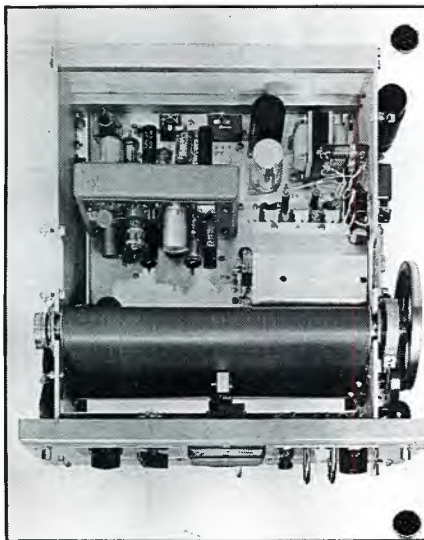

Internal view of the ST-101 showing the magnetic tape cylinder. The roll could be replaced in the field in about 15 minutes, if necessary. (Courtesy of Harris.)

tridge decks to show at the NAB convention some six weeks away. The original models were designated P-150 (for those having a 15-inch mounting panel for desk-top use) and the P-190 (for 19-inch rack-mounting). The record amplifier, with a single cue tone, was a separate assembly. More than a thousand units were sold from the convention floor that year. The purchase price of a record/play system was \$945.

Meanwhile, a parallel development effort was under way in Washington, DC, at station WWDC, to develop an endless loop, automatic recuing tape-cartridge system. Principals in the effort were Ross Beville, chief engineer of the station, and Austin Knox, who had built a crude endless-loop machine for background music applications. The two men joined forces and formed Broadcast Electronics on June 18, 1959. The company's product was the *Spotmaster* cartridge machine. Ben Strauss, who owned WWDC, provided most of the financial support for the company in the early days.

Although Broadcast Electronics was not incorporated until after the Collins/ATC machine was introduced at the 1959 NAB convention, company records show that the first Spotmaster system had been shipped months earlier. So, who was first?

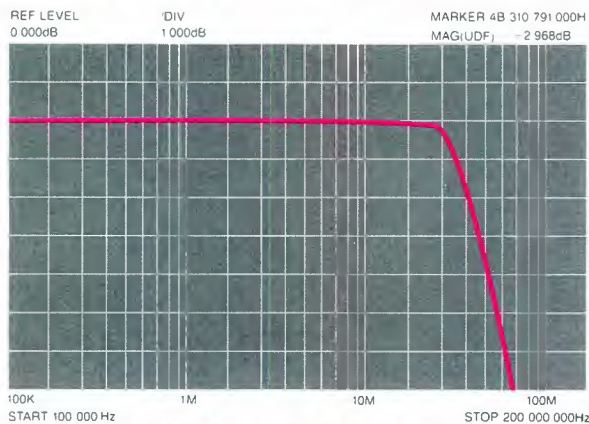

AVITEL. THE BEST LINE IN THE BUSINESS.

Avitel introduces a new high performance, modular line of equalizing Video Distribution Amplifiers. Utilizing extensive hybrid-SMD technology, Avitel is setting the standard for VDAs with an impressive list of features which include: ■ integral 3dB cable equalization, ■ 7 matched 75ohm outputs per DA, ■ differential looping input, ■ 13 modules per frame, ■ front panel controls for gain and equalization. In addition, the Avitel DA has the following plug in, user installed module options: ■ variable clamp, ■ user adjustable video delay, ■ extended cable equalizer, ■ DARTbus sync signal monitoring, ■ dual power supplies, ■ 30 MHz HDTV bandwidth. But that's not all. Avitel, with over 10 years of worldwide product leadership, has put a highly competitive price tag on each of their new DA's. Now that's a line too good to resist.



AVITEL ELECTRONICS CORPORATION 3678 W. 2100 S., SALT LAKE CITY, UTAH 84120, (801) 977-9553

Circle (69) on Reply Card

HIGH ENERGY DEGAUSSER Model TD-5



Erases all formats including:

- Beta SP, D1 & D2
- MII
- Reels up to 2" x 16"

Features:

- High Gauss Field
- Gauss Field Orientation
- Continuous Duty Capability
- Built-in Timer
- Thermal Overheat Protection

Call to arrange your Free Demo Tape

Manufactured by:

AUDIOLAB ELECTRONICS, INC.

5831 Rosebud Ln., Bldg. C
Sacramento, CA 95841
Phone (916) 348-0200
FAX (916) 348-1512

Circle (70) on Reply Card

STEREO

FM

87.0 → 108.0 MHz

TUNED

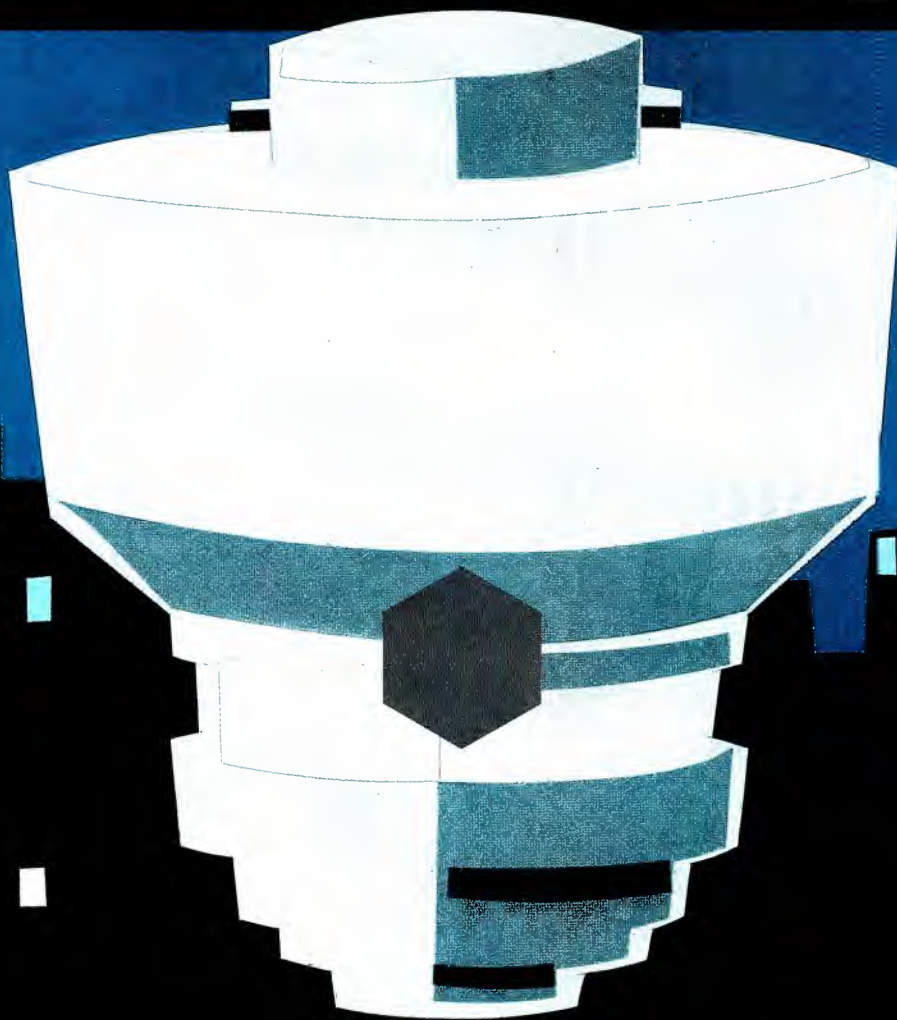

WHO'S AT THE HEART OF DEPENDABLE FM POWER?

Thomson Tubes Electroniques!

Guarantee the technical and price performance of your FM station with proven and innovative Thomson FM tetrodes. There's a complete range ready to meet your current and future needs.

Models range from 10kW up to an impressive 100kW. To optimize performance under all conditions, our tetrodes benefit from advanced Thomson technologies such as Pyrobloc[®] pyrolytic grids and Hypervapotron[®] vapor phase cooling.

Each tetrode is available with matched FM circuit (grounded grid or grounded cathode) easily tunable from 87 to 108 MHz.

Make the right investment in dependable FM power with FM Tetrodes from Thomson. It's the best way to fine-tune your station's performance!

 **THOMSON TUBES
ELECTRONIQUES**

Circle (71) on Reply Card

France : BOULOGNE-BILLANCOURT
Tel. : (33-1) 49 09 28 28
Fax : (33-1) 46 04 52 09

Brasil : SAO-PAULO
Tel. : (55-11) 542 47 22
Fax : (55-11) 61 50 18

Canada : MONTREAL
Tel. : (1-514) 874 00 88
Fax : (1-514) 874 40 76

Deutschland : MÜNCHEN
Tel. : (49-89) 78 79 - 0
Fax : (49-89) 78 79 - 145

España : MADRID
Tel. : (34-1) 519 45 20
Fax : (34-1) 519 44 77

Hong-Kong : WANCHAI
Tel. : (852-5) 865 32 33
Fax : (852-5) 865 31 25

Inde : NEW DELHI
Tel. : (91-11) 644 7883
Fax : (91-11) 644 7883

Italia : ROMA
Tel. : (39-6) 639 02 48
Fax : (39-6) 639 02 07

Japan : TOKYO
Tel. : (81-3) 264 63 46
Fax : (81-3) 264 66 96

Sverige : TYRESO
Tel. : (46-8) 742 02 10
Fax : (46-8) 742 80 20

United Kingdom : BASINGSTOKE
Tel. : (44-256) 84 33 23
Fax : (44-256) 84 29 71

U.S.A. : TOTOWA, NJ
Tel. : (1-201) 812-9000
Fax : (1-201) 812-9050

www.americanradiohistory.com

It depends upon whom you ask.

The two cart machines were similar in design, and certainly, similar in function. The primary difference was the automatic-release mechanism used on the Collins/ATC system vs. the manual-release mechanism used on the Spotmaster.

Tape takes over

After tape-cartridge equipment was shown at NAB in 1959, it became obvious to Gates/Harris Intertype that the ST-101

was not going to make any significant marketing inroads. The system had several limitations: Announcements could not exceed 90 seconds and, before the next spot could be selected and played, the tape had to be rewound, similar to a player piano roll.

The machine was set to automatically recue when the 90-second limit of tape travel had been reached. Alternately, the user could initiate a rewind by pressing a front-panel switch. Full rewind of the tape

could be accomplished in 22 seconds. A spot tape index scale was placed on the front panel to allow selection of the desired announcement. A tape speed of 5 1/2 ips was used. If needed, tape cylinders could be replaced in about 15 minutes. Routine exchange of tapes was not recommended, however.

Faced with the competition of the tape cartridge, Gates began to look for a way to enter the cartridge business. Between the first showing of the Collins/ATC machine in 1959 and 1966, the partnership of the two companies had been dissolved. ATC was manufacturing cart machines on its own in Bloomington. Gates struck a deal with the owners of the company to buy ATC in 1967, and three years later moved the operations to Quincy, IL. At that point, Jenkins and several other former ATC employees founded International Tapetronics Corporation (ITC) in Bloomington. The Gates/Harris Intertype cart machines were marketed as the *Criterion* line.

The majority of endless-loop tape designs used the Fidelipac cartridge whose inventor-patents covered the movable pinchroller, which eliminated the need to have a roller mounted inside each cartridge. The Fidelipac drive arrangement

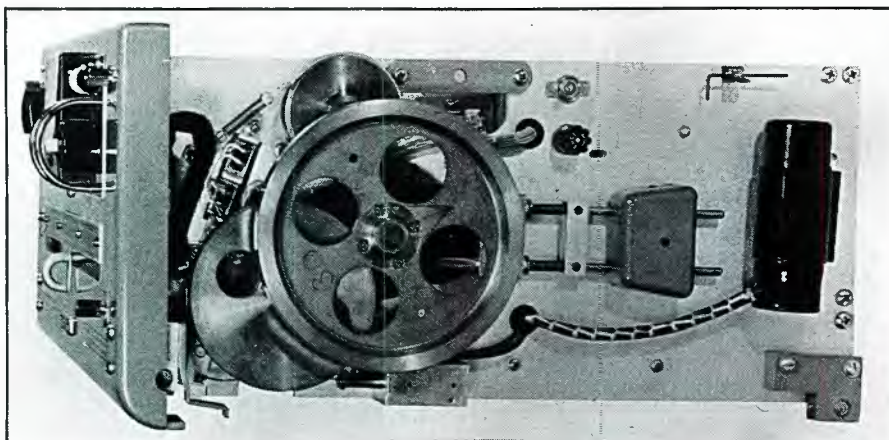

Side view of the magnetic tape cylinder of the Gates ST-101 spot recorder/player. (Courtesy of Harris.)

Winsted® Preferred by Professionals Worldwide

MODEL V8501
MODEL V8506
MODEL V8532
MODEL V8503

ELECTRONIC EQUIPMENT CABINETS

Versatile equipment cabinets for audio or video equipment. Available from 10 1/2"-78 3/4" of usable rack space. Removable side panels for easy installation, servicing. Optional front and rear doors. Shadow gray and putty enamel finish.

For our free full-color FULL-LINE CATALOG, call toll-free: **(800) 447-2257**

THE WINSTED CORPORATION
10901 Hampshire Avenue So. • Minneapolis, MN 55438
612-944-8556

FAX: 612-944-1546
Circle (72) on Reply Card

CANDYBOX SOLUTION SERIES

A total solution to the nasty ground-loop hum

A MUST for remote trucks.

CB 100-HK HumKiller

Isolates up to 1,000V AC of hum. • Compensates up to 1,000 ft. cable. • Clamps video with variable speed. • DG: < 0.25%, DP < 0.25 deg. • 6 isolated outputs.

SHINTRON

80 TAYLOR ST., LITTLETON, MA 01460-2426
TEL: 508-486-3900 FAX: 508-486-0782

Circle (73) on Reply Card



The Faroudja

NTSC ENCODER

Ahead of its time

The Faroudja CTE-2 NTSC Encoder delivers to your viewers the best picture quality on screen. This is why so many broadcasters use it.

By pioneering the use of comb filters and detail processors within their encoders, Faroudja Laboratories has changed the nature of NTSC.

No more rainbow patterns

No dot crawl—no softness

No blurry reds (with DP option)

The Faroudja Encoder is one of the building blocks of the fully compatible SuperNTSC™ ATV System.

FAROUDJALABORATORIES

Faroudja Laboratories Inc.
946 Benicia Avenue
Sunnyvale, California 94086
Telephone 408/245-1492
Telex 278559 MUHA UR
Fax 408/245-3363



Circle (74) on Reply Card

www.americanradiohistory.com

was used in some Viking tape-cartridge audio players designed for point-of-purchase displays.

Despite widespread enthusiasm for the new cartridge system, there were growing pains. One of the major problems was pressure-pad adjustment. If not properly

set, the tape audio could sound muffled or the cue tone could be missed.

A testimony to the classic design of the cartridge machine pioneered by WJBC's Nolte, Bailey and Jenkins and WWDC's Beville, Knox and Strauss is the long life it has enjoyed. Cartridge use continues to

increase at radio and TV stations each year, despite new digital-storage systems that promise greater flexibility and better audio performance. Industry experts have, in fact, been predicting the demise of the cart machine for most of this decade. The old master, however, keeps on running.



Cartridge machines have become a key component in both on-air and production work. Despite the progress made by digital storage systems, the cart machine remains the primary source of commercial and music playback.

Bibliography

- Anderson, Charles. "The Progression of Videotape Recording." **Broadcast Engineering**, May 1979.
- Ginsberg, Charles. "The Birth of Videotape Recording." Ampex Corporation.
- _____. "The First VTR: A Historical Perspective." **Broadcast Engineering**, May 1981.
- Graubart, Lawrence. "Magnetic Tape Trends." Ampex, Magnetic Tape Division.
- Hammar, Peter. "The Birth of the VTR." **Broadcast Engineering**, June 1986.
- Mullin, Jack. "Discovering Magnetic Tape." **Broadcast Engineering**, May 1979.
- Randolph, Gene. "The History of the Cart Machine." **Broadcast Engineering**, August 1984.
- Roizen, Joseph. "Video Tape Recorders: A Never Ending Revolution." **Broadcast Engineering**, April and May 1976.
- Schneider, Arthur. "The Growth of Videotape Editing." **Broadcast Engineering**, May 1981.
- Schow, Edison. "A Review of Television Systems and the Systems for Recording Television." *Sound and Video Contractor*, May 1989.
- Schubin, Mark. "From Tiny Tubes to Giant Screens." *Video Review*, April 1989.
- Ziff, Richard. "The 25th Anniversary of the Videotape." **Broadcast Engineering**, April 1981.
- "Retrospective: The History of Video Developments." *Video Systems*, March 1985.

Professional Time Code

P-1
Portable Generator/Reader

F-21
SMPTE Time Code Generator/Reader/
Character Inserter

Fast Forward Video

Call your local dealer or contact us at (714) 852-8404

Fast Forward Video

Circle (75) on Reply Card

T1 Digital Audio

A Clear Difference
Across Town or
Around the World

Digital audio over T1 circuits consistently provides higher quality than conventional methods. Use T1 digital audio for:

- Local program circuits.
- Long-distance program circuits.
- Studio-to-transmitter links.

And you can easily configure multiple program circuits with voice and even data.

Call us to discuss how Intrplex T1 digital audio can benefit you.

Intrplex

Intrplex, Incorporated, 59 Porter Rd., P.O. Box 2427, Littleton, MA 01460-3427
TEL: (508) 486-3722 / FAX: (508) 486-0709

Circle (76) on Reply Card

MISSING



The evolution of remote broadcasting has long been plagued with a missing link, the link between site and studio. Trying to get high fidelity audio over a standard telephone line has been a little like nailing jello to a tree. But now the missing link is history.

Digital Frequency Extension, the New Generation.

Relying on the predictable quality of advanced signal processing technology, our EFT-3000 3-Line Digital Frequency Extender will give you the great remote sound you want. In fact, frequency response of 50Hz to 7.5kHz over three standard (dial-up) telephone lines.

A Giant Leap for Broadcasting.

In addition to giving you and your

LINK

listeners the audio quality you deserve, the EFT-3000 can be set-up quickly by just one person. Once you've plugged-in and established the lines, all you do is punch a single button. In about ten seconds the EFT-3000 takes care of line equalization, group time delay and line level adjustments.

With auto-dialing, automatic answer and automatic encode/

decode, set-up and operation are...you guessed it—automatic. And built-in microphone and headset amplifiers and front panel Touch-Tone® pad eliminate the need to drag extra gear to the remote site.

Survival of the Fittest.

To survive the rigors of field production and get high fidelity sound back to the studio, you need the EFT-3000. But, hearing is believing, so we have a demo tape you've got to hear. To get your copy and find out more about the EFT-3000 and our entire line of frequency extenders, just contact your local Gentner distributor or give us

a call. Remember, we're the ones who made the missing link a shadow of the past.



Circle (77) on Reply Card

GENTNER
TELEPHONE PRODUCTS

1825 Research Way • Salt Lake City, UT 84119 • (801) 975-7200 • FAX (801) 977-0087

©1989-Gentner Electronics Corporation

www.americanradiohistory.com

News

Continued from page 4

company's current digital VTRs provide for digital parallel inputs and outputs. The new interface is capable of handling signals with up to 10 bits of resolution for video and 20 bits of resolution for the audio signal (four channels).

The interface is being offered as a practical way to provide digital I/O capabilities to facilities that plan to integrate D-1 component and D-2 composite in the same environment. So that existing digital equipment can be adapted, Sony is offering conversion kits and adapter boxes for its own equipment as well as digital video equipment manufactured by other companies.

To obtain adapter boxes, write: Sony Communications Products Company, 1600 Queen Anne Road, Teaneck, NJ 07666.

Companies lauded for technical achievement

At its annual engineering Emmy awards ceremony, the National Academy of Television Arts and Sciences presented its prestigious Outstanding Achievement in Engineering Development Award to the following companies:

- Ampex (Redwood City, CA), for development of the D-2 composite digital video recording format.
- CBS (New York), for development of an intelligent master control system for TV stations and networks.
- Magni Systems (Beaverton, OR), for development of the Magni 2000 series of programmable test signal generators.
- RTS Systems (Burbank, CA), for development of professional 2-wire intercommunication systems for use in TV production and broadcast operations.

• Sony (New York), for development of the D-2 composite digital video recording format.

The academy bestows the technical achievement Emmy awards to individuals or companies for engineering developments that are either extensive improvements or so innovative that they materially affect the transmission, recording or reception of television.

NAB, EIA to promote high-quality AM

The National Association of Broadcasters and the Electronic Industries Association Consumer Electronics Group (EIA/CEG) have agreed to work jointly to advocate the improvement of AM sound by promoting the use of National Radio Systems Committee (NRSC) standards in AM receivers. Their goal is to create a certification mark or logo that could be used by receiver manufacturers to designate that their designs comply with NRSC standards. The logo on the faceplate of a receiver would signal the consumer that the receiver is not only of high quality, but also meets NRSC standards.

to give further details, analysts estimate that the company would have to pay about \$100 million to take over Reeves.

This purchase would fall in line with Thames' strategy of diversifying in its core TV business. The company's goal is to be in a good competitive position for allocation of U.K. franchises in 1991. Thames, which already sells programs to the United States (its "Jack The Ripper" mini-series achieved sales of \$11.3 million), is particularly anxious to gain access to the CBS, NBC and ABC networks.

Home viewers prefer native tongue

Europeans accustomed to hearing their own language on television show little interest in foreign-language programs. According to a poll commissioned by the European Community, only 25% of the British, 33% of the Irish and 37% of Germans say they would watch foreign-language television. But in countries where programs already can be seen in several languages, viewers express more interest in foreign-language programming.

Satellite TV sales boom in U.K.

Sales of satellite TV receiving equipment in the United Kingdom have soared, according to the "FT Satellite Monitor." It is estimated that 160,000 British homes now can receive satellite channels directly. The latest monthly research carried out for the "Financial Times" does, however, suggest that the potential market for satellite television (those who say they will definitely or probably install equipment) is declining as some of the "probables" decide against it. [:(=)]

News From Europe

By John Blau,
European correspondent

Thames TV negotiates with Reeves

Thames Television, the largest ITV contractor, has been holding talks concerning the possible acquisition of Reeves Communications. Although Thames has declined

RUNNING OUT OF RACK SPACE?

1 3/4" PANEL HEIGHT — SERIAL CODE OUTPUT, FOR DRIVING SLAVES

CLOCKS



TIMERS

ES362 AP — UP/DOWN TIMER \$463
ES192AP/194AP — 12/24 HOUR CLOCK \$278 • ES520 60 MINUTE TIMER \$169



PRACTICAL SOLUTIONS FOR 17 YEARS 142 SIERRA STREET • EL SEGUNDO, CA 90245 • (213) 322-2136

Circle (80) on Reply Card

THE
SOURCE

**Just what
gives us
the nerve
to say
no other
transmitters
are in our league?**

The simple fact that no other transmitters back up the claim like the Toshiba 2000 Series VHF Transmitters.

Because while others are busy introducing their first generation solid state design, Toshiba is years ahead with the introduction of their second generation. The most transparent available.

Because no other transmitters come with Toshiba's 35 years of proven experience and unsurpassed reliability.

Or Toshiba's remarkable high tech design features. Like our exclusive new RF Power MOSFET Progressive Air Cooling System. One-to-one power supply-amplifier redundancy. And superb MTBF ratings.

Or Toshiba's in-house production of all key components. For cost-efficiency you can take to the bank. From the front access, lightweight plug-in modules to the last rivet and weld, the 2000 Series concept focuses on both the obvious efficiencies of purchase price and the more subtle efficiencies of designed-in high stability to minimize adjustments and training.

Wrap it up with outputs that range from 5KW to 64KW – as well as technical support, service and parts from Midwest's centrally-located headquarters – and we think you'll agree, it doesn't take nerve to say we're in a league all our own... it just takes a firm grasp of reality.



MIDWEST
Communications Corp.

One Sperti Drive
Edgewood, KY 41017
(606) 331-8990

For complete information on the Toshiba 2000 Series, call the sales representative in a league all his own. Call Midwest.



32KW 2000 Series VHF TRANSMITTER

TOSHIBA

Circle (113) on Reply Card

www.americanradiohistory.com

ACTS sets computer time and much more

By Donald Sullivan

On March 9, 1988, the National Institute of Standards and Technology (NIST), formerly the National Bureau of Standards, initiated the Automated Computer Time Service (ACTS). It is a telephone time service designed to provide computers with telephone access to NIST time at accuracies approaching one 1ms (0.001s). Features include automated compensation for telephone-line delay, advanced alert for changes to and from daylight-saving time and advanced notice of insertion of leap seconds. The ASCII-character time code operates with most standard modems and computer systems. Although the system can be used to set computer clocks, simple hardware also can be developed to set non-computer clock systems. The service can be accessed by calling 303-494-4774.

Computer-access procedure

With the correct user software, NIST-ACTS provides three modes for checking and/or setting computer time-of-day clocks. In the simplest form of the 1,200-baud service, the user receives the time code and an on-time marker/character. The marker/character is advanced a fixed period to approximately account for modem and telephone-line delays. Accuracy in this mode should be no worse than 0.1s, unless the connection is routed through a satellite.

If the user's 1,200-baud system echoes all characters back to NIST, the round-trip line delay will be measured and the on-time marker advanced to compensate for that delay. The accuracy in this mode should be better than 10ms. Our experience so far indicates that the asymmetry in conventional 1,200-baud modems limits the accuracy at this level. Repeatability is about 1ms.

Access at 300 baud provides the same service, but there generally is less problem with modem asymmetry. The accuracy is approximately 1ms.

Predicted accuracy is based upon the assumption that the telephone connection is reciprocal, that is, both directions of communication follow the same path with the same delay. Discussions with tele-

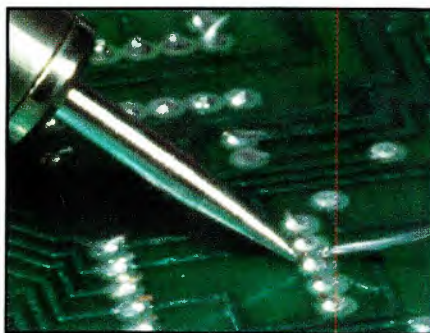

phone carriers indicate that this is the general mode of operation and our tests support that position.

Displayed time

Table 1 shows what your computer screen will display upon accessing the NIST time service. The current time is valid at the *on-time marker* (OTM), with either an (*) or a (#). The on-time marker (*) will be transmitted 45ms early to account for the 8ms required to send one

the same internal delay as that used by NIST, then the (#) OTM should arrive at the user within ± 2 ms of the correct time. However, NIST has studied different brands of 1,200-baud modems and found internal delays from 24ms to 40ms and offsets of the (#) OTM of ± 10 ms.

Because many computer internal clocks can be set only with granularity of 20ms to 50ms, the ± 10 ms accuracy should be more than adequate. In any case, the repeatability of the offset for the (#) OTM

? = HELP

National Institute of Standards and Technology
Telephone Time Service

(1 second pause here)

MJD	YR	MO	DA	H	M	S	ST	S	UT1	MSADV	OTM	L	D
47222	88	- 03	- 02	21:39:15	83	0	+3	045.0	UTC(NIST)	*			
47222	88	- 03	- 02	21:39:16	83	0	+3	045.0	UTC(NIST)	*			
47222	88	- 03	- 02	21:39:17	83	0	+3	045.0	UTC(NIST)	*			
47222	88	- 03	- 02	21:39:18	83	0	+3	045.0	UTC(NIST)	*			
47222	88	- 03	- 02	21:39:19	83	0	+3	037.6	UTC(NIST)	#			
47222	88	- 03	- 02	21:39:20	83	0	+3	037.6	UTC(NIST)	#			
etc...etc.....													

Table 1. Typical screen display of connection sequence and time when accessing the ACTS system at 1,200 baud.

character at 1,200 baud, plus an additional 7ms for delay from NIST to the user, and approximately 30ms *scrambler* delay inherent in 1,200-baud modems.

If the caller echoes all characters, NIST will measure the round-trip delay and advance the on-time marker so that the midpoint of the stop bit arrives at the user on time. The amount of MSADV will reflect the actual required advance in milliseconds and the OTM will be a (#). The NIST system requires four consecutive and consistent delay measurements before switching from (*) to (#).

Highly accurate

If the user has a 1,200-baud modem with

should be within ± 2 ms, if the dial-up path is reciprocal and the user doesn't change the brand or model of modem used.

This should be true even if the dial-up path on one day is a land line of less than 40ms (one way) and on the next day is a satellite link of 260ms to 300ms. In the rare event that the path is one way by satellite and the other way by land line with a round-trip measurement in the range of 90ms to 260ms, the OTM will remain an (*), indicating 45ms advance. In other words, the NIST system is designed to reject a delay that probably arises from a connection involving satellite transmission in one direction and land line in the other.

If you want the best possible accuracy

Sullivan is chief, Time and Frequency Division, National Institute of Standards and Technology, Boulder, CO.

This switcher handles standard bandwidth like it's going out of style.



TVS/TAS-3000 Distribution Switcher

The new TVS/TAS-3000 video/audio distribution switcher from BTS handles standard bandwidth switching in stride. But the fact is, standard bandwidth may not be the standard much longer. And that's why the TVS/TAS-3000 is not your standard switcher.

With the advent of wide bandwidth video, you'll need a switcher that can handle the new higher bandwidth signals. The 3000 will. It provides a video bandwidth of more than 50 MHz, measured with a full-amplitude sine wave or video signal. Which makes it upwardly compatible with HDTV or computer graphics—no matter what the standard.

The TVS/TAS-3000 also delivers the cleanest signal and expands to accommodate any matrix size to meet your specific needs.

And if high bandwidth capacity isn't a require-

ment, BTS still has you covered with our best-selling switcher, the TVS/TAS-2000. The 2000 represents the same advanced technology and quality as the 3000 in a standard bandwidth switcher. BTS also offers a full-range of control panels and distribution amplifiers for a complete system designed, tested and guaranteed by one supplier.

All BTS switchers undergo 100% computerized factory testing and are protected with a 5-year warranty. In the unlikely event you do have a problem, simply return the board for a free replacement.

Dependable, performing switchers from BTS. Anything else is substandard. Call for information and technical specifications today: **1-800-562-1136, ext. 21.**

BTS

The name behind what's ahead.

BTS is Broadcast Television Systems, a joint company of Bosch and Philips, P.O. Box 30816, Salt Lake City, UT 84130-0816.

Circle (78) on Reply Card



Some new faces and free tuition

By Bob Van Buhler

Some new faces have appeared at the national SBE office. One of them belongs to Elberta Clayton, who has joined the staff as membership secretary. She handles member and board correspondence, the job bank and accounts receivable and acts as chapter liaison. Another new staff member, Florence Romer, processes new member applications, sends out scholarship information and handles other administrative tasks in the national office.

Under the direction of executive secretary Helen Pfeifer, the national office also is staffed by Mary Brush, long-time certification committee assistant. An additional position in the national office has yet to be filled.

Free tuition

The Ennes Foundation has awarded free tuition to the NAB's 5-day satellite uplink operators' training seminar. The course, which was held Sept. 25-29 in Vienna, VA, a Washington, DC, suburb, is approved by the foundation. Successful students of the course who are SBE-certified are awarded a satellite uplink operator's endorsement. Richard E. Goldy, a member of Chapter 105 in Houston and an SENG operator at KPRC-TV in that city, received free tuition to attend the course.

In light of the sensitive nature of the technology involved in satellite transmission, the course fills a vital industry need. Because different uplink services can share the same spectrum on each transponder of a given satellite, interference is highly possible. Untrained uplink operators or those using improper procedures can interrupt or interfere with other transmissions. Uplink operators also can cause undesired intermodulation products or rob power from other services by operating their units at excessive power levels. It is in the broadcast industry's interest to ensure access to training for satellite uplink operators.

In cooperation with the NAB's Office of Science and Technology, the Ennes Foundation also will be offering free tuitions to NAB's management development seminar at Notre Dame University, the direc-

tional antenna seminar, the digital radio station seminar and the next satellite uplink training seminar. Application procedures will be detailed in future "SBE Update" columns. If you're interested in participating through paid enrollment, contact the NAB for more information.

Ennes grants

A member located in the Philippines has been awarded a \$1,500 educational grant by the Ennes Foundation. R. Basilio Apolinario, Zamboanga City, Mindanao, used the funds to obtain stateside training at the Harris MW-50 school in Quincy, IL. The grant was made possible through the cooperation of the United States Telephone and Telecommunications Institute (USTTI) and the Ennes Foundation, which also covered the transportation costs. Apolinario is SBE-certified.

This type of activity is in line with the goals and purposes of both the SBE and the Ennes Foundation, the educational arm of the society. Founded in 1986 to implement the organization's goals and priorities for member training, education and administration of scholarships, the foundation provides assistance to worthy students seeking help in pursuing a career in broadcast engineering.

Certification exams

SBE certification examinations are being held this month within local chapters in the United States as well as abroad. Most testing will occur Nov. 10-20.

The next chance to take certification exams will be at the 1990 NAB convention in Atlanta, on March 31. The deadline to apply for testing at NAB is Feb. 9. After the convention, the next test cycle will be June 8-18 at local chapters and abroad. Application deadline for the June test cycle is April 11.

Study guides for all certification examinations are available from the national office. Call Mary Brush at 317-842-0836 for additional information.

Computer-based testing

The Ennes Foundation also is testing Version 1.11 of a computerized study guide developed in a cooperative arrangement with Chariot Software Group. The study

guide provides a 50-question sample test for Broadcast Technologist, Broadcast Engineer TV, Broadcast Engineer AM-FM, Senior Broadcast Engineer TV and Senior Broadcast Engineer AM-FM examinations. The program is complete with automatic scoring. The training program retests the student on missed questions and provides other interactive features.

Apple, Macintosh and IBM-compatible versions will be available. Many engineers at the SBE convention assisted in software development by taking the test and completing a questionnaire. For more information on the new study guide, contact Ennes Foundation executive director Jim Wulliman at 602-648-1250.

Insurance

SBE still offers open enrollment for both life and health insurance coverage through the New York Life Insurance Company. The plans draw their membership base from a large group of U.S. engineering societies and organizations. As the membership base increases, rates are affected favorably; credits often are applied to the policies, reducing the overall insurance premium costs to the SBE member. For brochures, rates and other information, contact administrator Steve Lovell, of Smith-Sternum Associates, at 202-296-8030.

Check your status

Are you eligible for a higher membership category? If you've been a member for more than 15 years, you are eligible for senior membership in the society. If you're a retiring member, look into arranging a lifetime membership so that you can retain your membership benefits. If you have any questions about your status, contact Helen Pfeifer or Elberta Clayton at the national office.

Van Buhler is manager of engineering at KNIX-AM/FM, Phoenix.

Editor's note: For additional information about SBE activities, !GO BPFORUM on CompuServe. ☺☺☺☺☺☺☺☺☺☺

Let's compare automated audio test equipment performance:

KEY PERFORMANCE SPECS	AUDIO PRECISION SYSTEM ONE	H-P 8903B	S-T 3100/3200	TEK AA5001/SC5010
Flatness 20-20kHz, gen/analyzer	0.03/0.03 dB	0.06/0.2 dB ¹	0.1/0.1 dB	0.05/0.1 dB
Amplitude accuracy, gen/analyzer	0.1/0.1 dB	0.2/0.2 dB	0.2 dB/no spec	0.2/0.3 dB
Generator amplitude range	+30 to -90 dBm	+17 to -68 dBm	+30.6 to -90 dEm	+28 to -72 dBm
System THD + N 20-20kHz, 80 k BW	0.0015%	0.01%	0.0018% ²	0.0032%
Min. amplitude for THD + N function	25 microvolts	50 millivolts	30 millivolts	60 millivolts
Residual noise (80 kHz BW)	3.0 μV	15 μV	4.0 μV	3.0 μV
Analyzer stereo separation @ 20 kHz	140 dB	function not avail.	100 dB	function not avail.
Common mode rejection ratio	70 dB, 50-20kHz	60 dB, 20-1kHz	100 dB @ 60 Hz	50 dB, @ 5C/60 Hz
Speed, THD function (autorange)	10 sec 16-pt sweep	1.5 sec to 1st rdng	2.5 sec to 1st rdng	2.5 sec to 1st rdng
Speed, amplitude function (autorange)	10 sec 30-pt sweep (2 chan simultaneous)	1.5 sec to 1st rdng (1 channel)	1.3 sec to 1st rdng (per channel)	2.0 sec to 1st rdng (1 channel)
PRICE (U.S. DOMESTIC)				
Computer-interfaceable instrument	\$6950	\$5800	\$9985	total
Software package	included	none available	\$575-\$1220	system
Typical controller	\$600-\$3000 ³	\$5750 ⁴	\$1000-\$3400 ⁵	\$16490 ⁶

¹ Analyzer flatness not specified separately; analyzer accuracy 0.2 dB 20 Hz-20 kHz

² Total system THD + N not specified; generator THD plus analyzer distortion specs added together equal 0.0018%

³ Personal computer. Interface card included in instrument price.

⁴ H-P Model 310M IEEE-488 compatible

⁵ Personal computer plus IEEE-488 interface card

⁶ Total of instruments, software, Tek 4041/4205 IEEE-488 controller

Competitive data compiled from H-P 1988 catalog, S-T data sheet 3000A 1987, Tektronix 1988 catalog.

For a much more complete comparison of these and other audio test systems, call or write Audio Precision.

System One

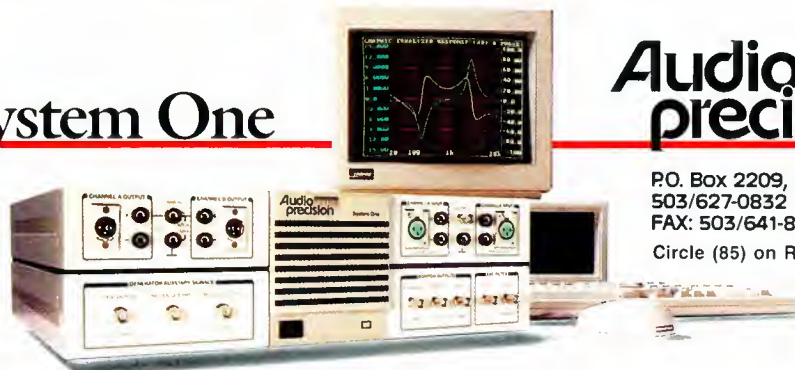

Audio precision

P.O. Box 2209, Beaverton, OR 97075
 503/627-0832 1-800/231-7350
 FAX: 503/641-8906, TELEX: 283957 AUDIO UR
 Circle (85) on Reply Card

**When it Comes
to PiRod Quality,
Service and Support,
the Sky's the Limit.**



Avoid the pitfalls of tower purchase. Let us send you a copy of Tower Specification. Write or call today.



PIROD INC.

P.O. Box 128
Plymouth, IN 46563-0128
Telephone (219) 936-4222

Circle (86) on Reply Card

STATEMENT OF OWNERSHIP

Statement of Ownership, Management and Circulation (Act of August 12, 1970; Section 3685, Title 39, United States Code).

1. Title of publication: Broadcast Engineering.
- 1A. 00071794.
2. Date of filing: Sept. 27, 1989.
3. Frequency of issue: Monthly, except in Fall when two issues are published.
- 3A. Number of issues published annually: 13.
- 3B. Annual subscription price: FREE TO QUALIFIED.
4. Location of known office of publication (street, city, county, state, zip code): 9221 Quivira Road, Overland Park, Johnson County, Kansas 66215.
5. Location of the headquarters or general business offices of the publishers (not printers): 9221 Quivira Road, Overland Park, Johnson County, Kansas 66215.
6. Names and addresses of publisher, editor, and managing editor. Publisher: Duane Hefner, 9221 Quivira Road, Overland Park, Kansas 66215. Editor: Jerry Whitaker, 9221 Quivira Road, Overland Park, Kansas 66215. Managing Editor: Tom Cook, 9221 Quivira Road, Overland Park, Kansas 66215.
7. Owner (If owned by a corporation, its name and address must be stated and also immediately thereunder the names and addresses of stockholders owning or holding 1 percent or more of total amount of stock. If not owned by a corporation, the names and addresses of the individual owners must be given. If owned by a partnership or other unincorporated firm, its name and address, as well as that of each individual must be given. If the publication is published by a nonprofit organization, its name and address must be stated.) Intertec Group, Inc., 599 Lexington Ave., 36th Floor, New York, NY 10022.
8. Known bondholders, mortgagees, and other security holders owning or holding 1 percent or more of total amount of bonds, mortgages or other securities (if there are none, so state): None.
9. For completion by nonprofit organizations authorized to mail at special rates: Not Applicable.
10. This item must be completed for all publications except those that do not carry advertising other than the publisher's own and are named in sections 132.231, 132.232 and 132.233, postal manual (Sections 4355a, 4354b, and 4356 of Title 39, United States Code).

	Average No. Copies Each Issue During Preceding 12 Months	Single Issue Nearest To Filing Date
A. Total No. Copies Printed (Net Press Run)	39,500	39,300
B. Paid and/or Requested Circulation		
1. Sales through dealers and carriers, street vendors and counter sales	—	—
2. Mail subscriptions	516	422
C. Total Paid and/or Requested Circulation	516	422
D. Free Distribution (including samples) by mail, carrier delivery or other means	37,417	37,416
E. Total Distribution (Sum of C and D)	37,933	37,838
F. Office use, left over, unaccounted, spoiled after printing	1,567	1,462
G. Total (Sum of E and F should equal net press run shown in A)	39,500	39,300

I certify that the statements made by me above are correct. (Signature of editor, publisher, business manager, or owner.)

Sandra Stewart,
Circulation Director



GO AHEAD! MAKE YOUR DAY.

Show Panasonic Broadcast Systems your busiest log, your toughest break. We'll make your day, and we'll make it easier.

Over 25 stations nationwide rely on Panasonic's M.A.R.C. to handle every scheduled playback from I.D.'s, spots and promos to programs and network. M.A.R.C. works elegantly with traffic systems from Bias, JDS, Columbine or Enterprise, and finds trouble long before it hits air. As-Run logs document what ran, when, and if not, why not.

The M.A.R.C. is one tough customer. Its superior 1/2-inch MII image quality, its street-smart software and its advanced Matsushita robotics make the M.A.R.C. unbeatable.

Panasonic's M.A.R.C. stays ahead technologically. Its VTR interface controls outboard 1 inch VTR's; a new optional Off-Line Cassette Dub System enables dubbing material onto MII cassettes with minimal operator entry.

So, go ahead. Sit down at M.A.R.C.'s keyboard, and let M.A.R.C. make your day.

Panasonic Broadcast Systems Company Field Offices (Northeast) Washington, DC (703) 759-6900
(Southeast) Norcross, GA (404) 925-6721 (Midwest) Arlington Heights, IL (312) 981-7325/(317) 852-3715
(Southwest) Fort Worth, TX (817) 685-1132 (Western) Cypress, CA (714) 373-7200 (Northwest) (408) 846-7974
Bias, JDS, Columbine and Enterprise are trademarks of their respective owners.

Panasonic Broadcast Systems Company, One Panasonic Way, Secaucus, NJ 07094 (201) 348-7671

Panasonic
Broadcast Systems

Circle (104) on Reply Card

www.americanradiohistory.com

Raymond D. Lucas has been appointed senior vice president, strategic operations and chief strategic officer, for Scientific Atlanta, Atlanta. He is responsible for directing and coordinating business planning and new business development activities.

Mark C. Gray and **John McPherson** have been appointed to positions with Sony, Park Ridge, NJ. Gray is president of the newly formed Sony Peripheral Systems Company. McPherson is vice president, marketing services. He is responsible for overseeing a variety of marketing-related functions for each independent operating

unit under the Sony Business and Professional Products Group. These responsibilities include advertising, direct marketing, literature and collateral support, meetings and trade shows.

Chuck Heffner and **James Hudmon** have been appointed to positions with Quanta, San Jose, CA. Heffner is product specialist at Quanta Editing Products. He is responsible for marketing and sales for the Western United States. Hudmon is national sales manager. He also assumes responsibility for the Midwest and Northeast territories. **Stephen DiFranco** has been promoted to product specialist for

Quanta Editing Products.

James Baudin has been appointed international marketing manager for 3M Professional Audio/Video and Specialty Products Division, St. Paul, MN. He is responsible for providing marketing assistance and support to the Asia-Pacific, Canadian and Latin American markets.

Michael C. Lang and **Mary Frost** have been named to positions with ABC Television Network Group. Lang is vice president and assistant to the president of broadcast operations and engineering. Frost is director, telecommunications operations, in the broadcasting operations and engineering department.

Bernard Backaert has been named European sales manager for The Alta Group, San Jose, CA. He is based in Belgium and operates within the corporate framework of Dynatech Broadcast Group. He is responsible for Alta activities within the European Community.

Brian Scott has been appointed district sales manager for Altec Lansing, Oklahoma City. He serves the company's contractors and consultants in the western portions of New York and Pennsylvania, and Ohio, West Virginia, Kentucky and Indiana.

Fred Layn, Frank Foster and **Joseph Grega** have been appointed to positions with Ampex Recording Media, Redwood City, CA. Layn is product manager, professional audiotape. He is responsible for the development and implementation of sales and marketing programs to support the professional analog and digital audiotape and accessory products. Foster is product manager, videotape. He is responsible for implementation of product development and support programs for the line of 1-inch and 3/4-inch U-matic format videotape products. Grega is product manager, digital videotape. He is responsible for the development and implementation of product and marketing support programs for the 319 D-2 and 219 D-1 digital videotape product line.

Gilbert Kuang, Robert Stevens and **Michael Teeling** have been appointed to positions with IDB Communications Group, Los Angeles. Kuang is vice president of corporate planning. He will oversee the planning and implementation of projects meeting the company's long-range goals. He also will identify and develop new services for customers, and work to maximize the capabilities of all the company's divisions, including the newly acquired Hughes Television Net-

DIGITAL POST.

Sony's PCM-3402 two-channel digital audio recorder is the natural choice for digital video post production work. It's fully compatible with Sony's BVE-9000 video editor. It also features a built-in chase synchronizer with the ability to convert SMPTE, EBU and film timecode.

To find out more, contact the Sony Professional Audio Office nearest you:
East: (201) 368-5185
West: (818) 841-8711
South: (615) 883-8140
Central: (312) 773-6001



PCM-3402

- TWIN-DASH 1/4" two-channel digital format
- 9-pin serial port for control by Sony BVE-9000 editor
- Built-in machine-to-machine editing capability
- Digital fader and balance control

SONY
PROFESSIONAL AUDIO

Sony Communications Products Company,
1600 Queen Anne Rd., Teaneck, N.J. 07666
© 1989 Sony Corporation of America.
Sony is a registered trademark of Sony

work and CICI. Stevens has joined the audio sales team. He is responsible for the sales and marketing of the Sports Satellite Interconnect. He also will be working on increasing the company's international sports presence and targeting the college sports market domestically. Teeling is public relations coordinator. He will oversee daily media relations, distributing information in all company activities. His duties also will include editing a bi-monthly newsletter and coordinating promotional events.

Chuck Evans has been appointed Midwest regional sales manager at JVC Professional Products Company, Elmwood Park, NJ. He will coordinate the sales, administration and marketing efforts of the district sales representatives in the Midwest.

Rupert L. Stow has been named director of information at Captain of America/Eleven Twenty Five Productions, New York. In this new position, he is responsible for overseeing The High-Definition Training Workshops, a new educational service. The job also encompasses marketing, research, strategic planning and education.

W. Tom Beams, president of Aurora Systems, Redwood City, CA, a subsidiary of Chyron, has assumed the additional duties of president of CMX, a division of Chyron, Santa Clara, CA. Beams is responsible for the day-to-day managing and long-term planning of CMX.

Bob McNabb has been appointed U.S. regional manager for Digital Audio Research, Hollywood, CA. He is based at the Los Angeles office.

Jeffrey B. Gouch has been appointed central regional sales manager for For-A Corporation of America, Newton, MA. He works with the company's factory representatives, dealers and end-users throughout a 17-state territory across the Midwest.

Jack Dawson has been appointed chief executive officer for Vinten Broadcast, Suffolk, England. He is responsible for general management, marketing and sales for the United States, Central and South America.

Bishop Ellison has been appointed TV-RF sales manager for the Western United States for Harris Broadcast Division, Quincy, IL. He represents transmission equipment, service and training programs to broadcasters in Alaska, Arizona, California, Hawaii, Idaho, Nevada, New Mexico,

Oregon, Utah and Washington.

Barry Goldsmith has been appointed director of subsidiary operations for Basys, Yonkers, NY. He is responsible for subsidiary operations, which include Connelly Systems and Jemani Ltd. He also is responsible for overseeing all sales and marketing activities, which covers North and South America, the Pacific Rim and Australia.

M. Michael D'Amore and **Tom Garofalo** have been appointed to positions with BTS Broadcast Television Systems, Salt Lake City. D'Amore is director

of business development. He is responsible for developing marketing programs. He also will participate in the evaluation of new business opportunities and serve as chairman of the company's soon-to-be-established U.S. Customer Advisory Board. Garofalo has assumed sales management responsibilities as the Western zone manager. He oversees the direction of seven sales representatives.

||:~:~)))))

ANALOG POST.

Sony's APR-5003V two-channel analog recorder with centertrack timecode provides maximum flexibility for video post production applications. It communicates serially with both Sony BVE-9000 and BVE-900 video editors and features a built-in timecode reader/generator.

To find out more, contact the Sony Professional Audio Office nearest you:

East: (201) 368-5185

West: (818) 841-8711

South: (615) 883-8140

Central: (312) 773-6001



APR-5003V

- Analog two-channel recorder with IEC centertrack timecode
- 9-pin serial port for communicating with Sony BVE-900/9000 video editors • Video-style preview, edit, and review editing
- Built-in timecode reader/generator with a video reference input
- Built-in chase synchronizer which accepts LTC or VITC
- Microprocessor-assisted audio alignment

SONY

PROFESSIONAL AUDIO

Sony Communications Products Company,
1600 Queen Anne Rd., Teaneck, N.J. 07666
© 1989 Sony Corporation of America.
Sony is a registered trademark of Sony

NEMAL ELECTRONICS

Precision Broadcast Cables — NEC CL2

VIDEO

P/N 1570

- Same size as RG 59
- Low Loss .7 db at 10 MHZ
- Double Shielded

AUDIO

P/N 2201A

- One Pair 22 ga reduced diameter
- Available in 7 colors
- Foil-bonded to jacket for one-step stripping

Call for your copy of our new, 44-page
Cable and Connector Selection Guide

1-800-327-5999

FAX 1-305-895-8178

INT'L 1-305-899-0900

AVAILABLE FROM STOCK together with 1,500 different types of Broadcast Cables, Connectors, Patching Equipment and Crimping Tools.

NEMAL ELECTRONICS INTERNATIONAL, INC.

12240 NE 14 Ave.

North Miami, FL 33161 • **TELEX 6975377**

Offices in New York and Florida

Circle (92) on Reply Card

Wide Band

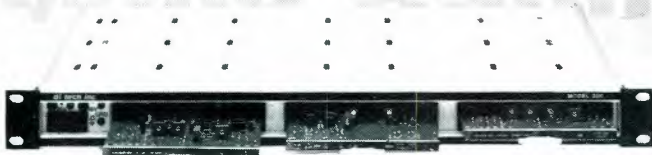

Video Distribution

+/- 0.75 dB @ 60 MHz!

Model 220

- 1 input, 6 output
- high performance spec.
- +/- 3 dB gain

Model 222

- Switchable Clamper
- Eq. to 1000' 8281 cable
- Slew rate > 250 V/μsec.

**Moderately Priced. Ideal for
HDTV, RGB and all general uses**



di-tech

48 Jefryn Boulevard, Deer Park, NY 11729

Tel: (516) 667-6300 • Fax: (516) 595-1012

Circle (93) on Reply Card

Accom establishes U.S. regional offices

Accom, Menlo Park, CA, has established a U.S. sales organization, with offices in Los Angeles, Chicago and New York.

CEI to design and build labs for ATTC

Communications Engineering (CEI), Alexandria, VA, has been retained by the Advanced Television Test Center (ATTC) to design and build a state-of-the-art facility to conduct comprehensive tests of the many different TV transmission systems that are being proposed. CEI will provide consulting, engineering, turnkey design and installation of a complete laboratory to be used in evaluating systems for future transmission of HDTV. This includes all laboratory and technical-area acoustical design, space planning, electrical and HVAC specifications, as well as HDTV support-systems design for audio and video throughout the facility.

The test center's plant uses digital high-definition videotape recorders, composite digital tape machines and specialty computer-driven HDTV picture-generation equipment. Space includes two system proponent test equipment rooms, terminal equipment/VTR room, computer-processing room, RF and CATV test-bed rooms, acoustically correct viewing/conference/demo area, lab workshops, equipment storage area and technical offices.

Digital F/X opens New York facility

Digital F/X, Mountain View, CA, has opened a sales and service facility in New York City for the DF/X 200 integrated digital production system and Compositum digital production suite.

The facility is located at Lexington Avenue and 44th Street. It will serve as the East Coast sales, training and service headquarters. The facility includes a full Compositum digital production suite.

In addition to providing sales and service, the facility will allow the company to train its customers in the operation of the DF/X 200 and Compositum systems.

Harris training center adds program

Harris Broadcast Division, Quincy, IL, will add a 5-day training program, structured to give broadcast engineers a comprehensive overview of digital control logic, to the roster of regularly scheduled Broadcast Technology Training Center classes in 1990.

The digital control logic class will offer extensive hands-on practice in addition to theory. It is open to all broadcast engineers, but enrollment will be limited. Tuition for the class, which includes all take-home instructional materials, is \$649.

Specific topics will include (but not be limited to) Triacs and SCR semiconductors; testing of semiconductors; troubleshooting techniques; TTL and CMOS control logic families; and correct procedures for handling static-sensitive components. Engineers enrolling in the program will receive a short home-study packet covering some of the basic digital information prior to the course.

For more information about the program, call the Broadcast Technology Training Center weekdays at 217-222-8200, ext. 3508, or write: Harris Broadcast Technology Training Center, P.O. Box 4290, Quincy, IL 62305-4290.

Studer acquires IMS

Studer International A.G., Regensdorf, Switzerland, has completed the acquisition of Integrated Media Systems (IMS), Menlo Park, CA, through a U.S. holding company in Nashville, TN.

The move brings the IMS hard disk workstation, Dyaxis, into the Studer product line. It will be available through Studer's

Continued on page 140

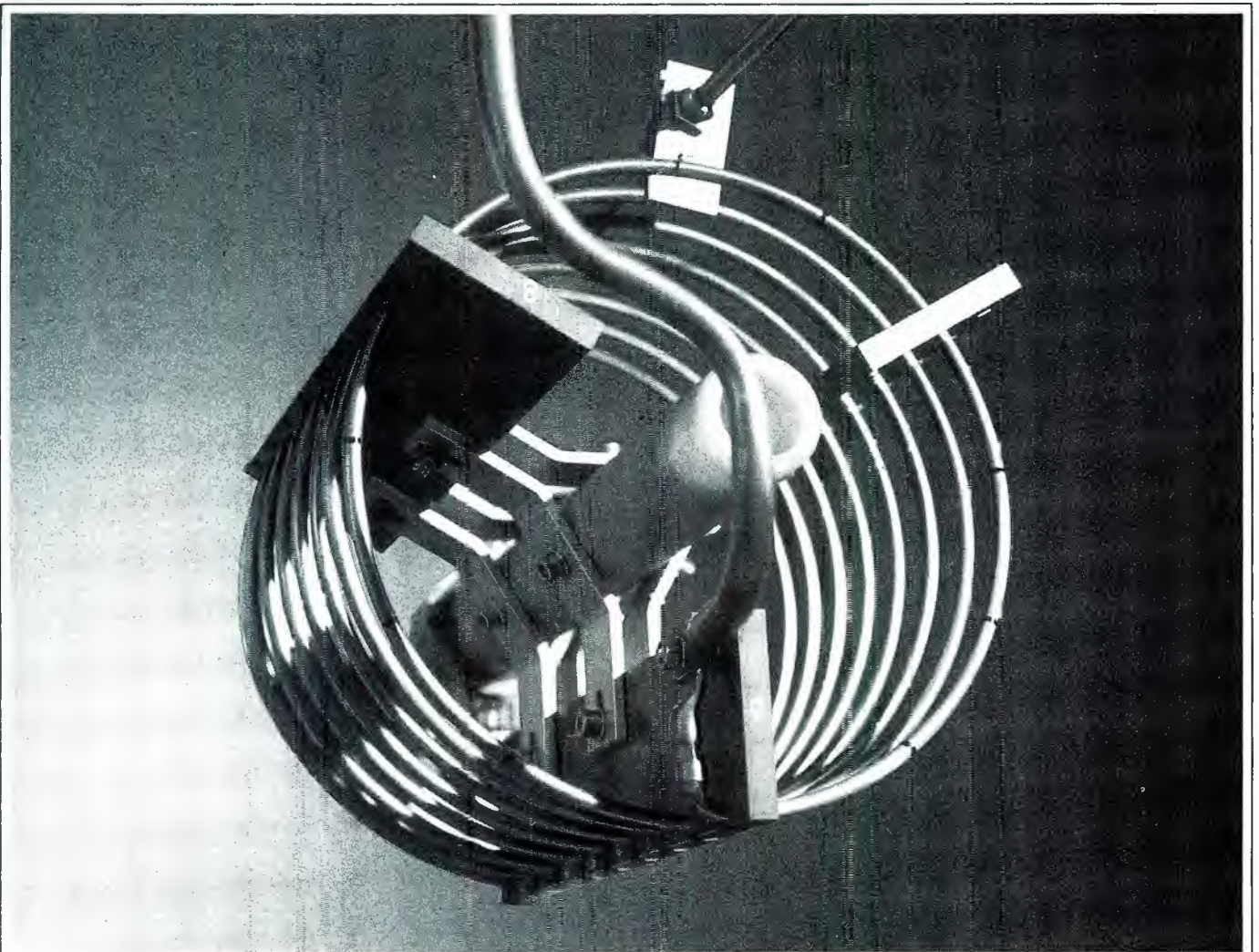

On the Air with AEG.

First-class technological achievements are a tradition at AEG. These successes are based on wellfounded experience, since AEG can look back on 80 years of proven transmitter design experience.

Moreover, AEG has been building broadcasting transmitters since 1923, and today it is one of the leading manufacturers offering innovative expertise in broadcasting.

Modern high-power transmitters with ratings from 100 to 600 kW, a program of long, medium and short wave broadcasting transmitters and more than 80 Pantel transmitters throughout the globe represent ultramodern engineering perfection.

Pantel is a PDM method of modulation having high overall efficiency. Significant savings of energy are achieved by using DAM (volume dependent amplitude modulation) conveniently applicable to Pantel transmitters. All short wave transmitters are offered with SSB, the operation mode of the future.

AEG supplies on a turnkey basis complete broadcast transmitting stations that guarantee high operational reliability, economic operation and long life. Further advantages are full remote-control facilities suitable for unattended operation, and compact mechanical design.

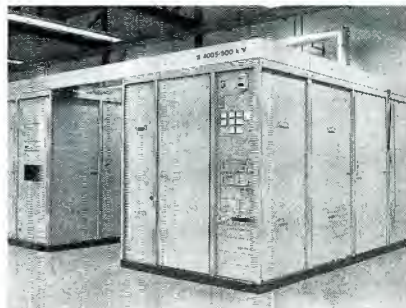

In addition to the high-power transmitters, AEG also supplies complete broadcast transmitting stations for VHF FM and Band IV/V television including suitable antenna systems satisfying all directivity and gain requirements. Of course, maintenance and thorough technical training by experts are

considered natural elements of the total AEG service.

TELEFUNKEN Sendertechnik GmbH
Sickingenstrasse 20-28 · D-1000 Berlin 21
Federal Republic of Germany · Telephone:
(30) 34 63-0 · Telex 181 819 · Telefax: (30)
34 63 24 19

Coupon

Please send me further information on high-power transmitters:

Name: _____

Company: _____

Address: _____

AO WAK 765 E

AEG

Circle (87) on Reply Card

Safe area generators

Broadcast Video Systems has introduced two safe area generators:

- The SA103 safe area generator provides four independent channels controlled from a 16-button keypad. Each channel may be programmed individually with the user's choice of safe action; safe title; center cross; blanking markers; two programmable rectangles; 10-second countdown clock; and a 6-row, 28-character slate generator.
- The SA102 portable safe area generator is housed in a 3" x 3" x 7/8" box and is switchable between safe action/title and crosshatch.

Circle (350) on Reply Card

FM transmitters

Continental Electronics, a division of Varian Associates, has introduced the solid-state FM transmitter group. It is designed to address the requirements of the Class A broadcaster. The group is available in two power levels: 1,000W and 500W.

The transmitter is totally contained in a 42-inch-tall cabinet, and uses the Ultimate 802A 50W exciter. The driver section and exciter are installed on slide mounts for easy access. Wideband output of the 50W exciter can be connected directly to the input of the transmission line for emergency operation.

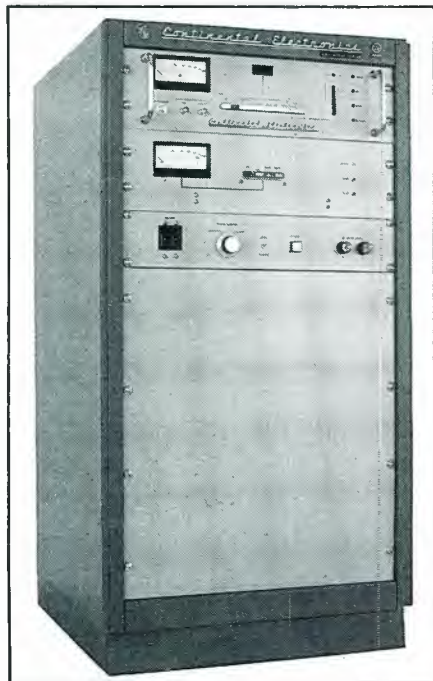

Circle (351) on Reply Card

Remote-control system

Moseley Associates has announced the MRC 1620 remote-control system, which replaces the current MRC 1600 remote-

control model.

The system consists of a stand-alone remote terminal with an optional control terminal. Both the remote and control terminals have dual communications ports for either direct or dial-up access. The unit comes standard with 32 relay isolated commands, 16 telemetry and 16 status channels.

The system also features the TaskMaster20, a PC software program that talks to the remote site from secondary control points. It automatically adjusts out-of-parameter conditions according to user-defined strategy.

Circle (352) on Reply Card

VHF TV transmitter and FM transmitters



Harris has introduced the following products:

- The HT 15LS is a 15kW VHF lowband solid-state TV transmitter. It features built-in parallel redundancy for continuous on-air operation and a user-friendly design for reduced technical labor costs. The transmitter features a control cabinet, an aural PA cabinet and a visual PA cabinet. The control cabinet provides push-button operation for on/off, remote/local and power raise/lower functions and a display screen with bar graph and digital readouts of power, VSWR, voltage and current parameters. The aural PA and visual PA cabinets feature 1,050W FET power amplifier modules.

- The HT 7FM is a 3kW-8kW FM transmitter. It features a compact, single-cabinet design. It is available for standard single-phase or 3-phase installation, and uses a single high-efficiency 4CX7500A tetrode in a 1/4-wave cavity. A low-velocity direct-drive air system cools the PA tubes and RF driver while maintaining low ambient noise levels. Other standard features include automatic RF power control, proportional VSWR foldback, automatic restart, soft start, adjustable/metered filament voltage control and a discrete logic solid-state controller.

- The HT 500FM is a 500W transmitter. The 100% solid-state design replaces tubes

with long-life FET RF amplifiers. Each integrated RF amplifier module is self-protected against ac and dc overloads and open or shorted RF loads. Amplifiers require no tuning or adjustment to produce full-rated power from 87.5MHz to 108MHz. Each amplifier block, with its own power supply and cooling, can operate independently outside the transmitter. Test bench maintenance can be performed on any RF block while the rest of the transmitter remains on the air.

Circle (353) on Reply Card

Amiga weather graphics

Accu-Weather has announced enhancements to the Amiga graphics weather system. Software changes include fast frame loops from satellite imagery, scripted graphic downloading, full-screen graphics displays, 9,600-baud communications and improved communications when using the Accu-Weather Front Door unit. The package includes Version 1.2 software with the use of the Director and the Director toolkit software.

Circle (354) on Reply Card

Synchronizer software

Adams-Smith has released level K software for the model 2600 SY synchronizer module. The software includes job and shuttle of VCRs, VTRs and biphas-type transports with push-button or motion-control knobs.

Circle (355) on Reply Card

Dub center and monitor

Allied Broadcast Equipment has introduced SqueezePlay, an AM/FM radio/cassette unit with an integrated skimming system for recording on-air programming. The unit can be set to record for 2-minute segments or 30 seconds per cycle with pause times of two seconds to 3.5 minutes. The unit includes record and play functions.



Circle (356) on Reply Card

Fiber-optic assemblies

AMP has introduced cable assemblies for a variety of single-mode and multi-

THE GRASS ISN'T ALWAYS GREENER.



DYNAIR introduces the DYNA MITE small routing switcher. And suddenly the competition's switchers are looking a little wilted.

Perhaps that's because DYNA MITE is available in 10 X 10, 20 X 10. And 30 X 10. In video or audio. As

well as in a 10 X 10 single-unit A/V package. No doubt it has something to do with DYNA MITE's modular design, too. Which lets you expand all the way to 30 X 10 video or audio.

And as your needs grow, DYNA MITE continues to protect your routing switcher investment. By allowing you to stack units. And make the move to component video or stereo audio. You can even use DYNA MITE modules within our

larger Dynasty frame for almost unlimited expansion. Even beyond 30 X 10. And with a full

40 MHz bandwidth, DYNA MITE delivers high-performance output now. While covering your future HDTV needs. Plus DYNA MITE's 2 RU frame

gives you a full-function X-Y control. Standard. And it can also be controlled by any DYNAIR remote control panel. Or by computer.

Our prices? Let's just say they're competitive. Very competitive. Even when compared to narrow-band switchers.

All of which no doubt has the competition's switchers feeling a little green. With envy.

For a more in-depth look, call 800-854-2831.

	10, 20 or 30 Inputs	Fully Expandable	40 MHz HDTV Ready	Built-In Control Panel
Grass Valley	NO	NO	NO	NO
DYNAIR DYNA MITE	YES	YES	YES	YES

Graphic evidence that the DYNA MITE routing switcher outperforms the competition.



DYNAIR
Call today, 800-854-2831

Circle (89) on Reply Card

mode optical fiber configurations and cable types. Light-duty single and dual types are available for both modes, as well as DUALAN and DUALAN plenum cable. Two-fiber breakout cable is available in the single mode. FSMA I, biconic plug, mini-BNC plug and ST-type bayonet connector and fixed-shroud duplex-connector types are available for multimode use.

Circle (357) on Reply Card

Digital microphone

Ariel has introduced the DM-N digital microphone, based on the Motorola 56ADC A/D devices, for use with NeXT computers. The stereo analog pickup digitally encodes voice and music signals for analysis, modification or storage on computer disk. Controlled from a NeXT computer to adjust bandwidth and sample rate and reduce high-frequency noise, the mi-

crophone provides outputs directly to an SCSI interface. Input jacks allow connection of CD players as well as various metering devices through the microphone to the computer.



Circle (358) on Reply Card

EDL translations

AMS Industries has released EDL Translator software for the AudioFile digital audio system. The package enables CMX and Sony EDL data to be prepared and transferred to AudioFile through an IBM-compatible PC, which is equipped with dual disk drives, one of which must be 3 1/2 inches. User knowledge of DOS is recommended.

Circle (359) on Reply Card

Machine interfaces

Audio Kinetics has announced additional machine-control interfaces for the ES1.11 EBus and Q.Lock synchronizers. ES1.11/DR1200 allows the AKAI DR1200 digital 12-track recorder to be locked to other audio and video equipment. A modification to the AKAI unit significantly reduces lockup time. An interface is available for the Q.Lock synchronizer, for the Fostex D-20 SMPTE/RDAT master recorder.

Circle (360) on Reply Card

Video production mixer

BTS has introduced the "diamond" video production switcher for composite and component video signals. Inputs to a preselection matrix provide for 30 external sources with six component signals. Two M/E levels each provide three key stages with independent masking with an additional universal key and fade-to-black stage in the program path. A reduced number of controls offer quick access to a wide range of operating facilities. Multiple menus and status displays are provided.

Circle (361) on Reply Card

NON-OPTIONED

INTERCOM.
WHEN YOU WANT
IT SIMPLE.
WITHOUT THE FRILLS.

INTRODUCING THE BP325 PORTABLE USER STATION:
USER PROGRAMMABLE.
MICROPROCESSOR ASSISTED.
DISTINCTIVE DESIGN.

RTS SYSTEMS
INCORPORATED
1100 WEST CHESTNUT STREET BURBANK, CALIFORNIA 91506
PHONE 818 566-6700 FAX 818 343-7953

Circle (90) on Reply Card

Sound-control material

AZONIC has introduced a series of acoustical and sound-absorption material. Different forms are available and include the AZP AZONIC Pyramid in patterns of various sizes; AZ2000, AZ3000 and AZ4000 acoustical convolute patterns; and AZMAX-6 and AZMAX-8 wedge designs with more surface area.

Circle (362) on Reply Card

Mini audio cable

Belden Wire & Cable has introduced the 1266A miniature, twisted-pair audio cable. Available in multiples with red, green, blue, black and yellow jackets for identification, the 0.145-inch OD cable can be pulled through cramped quarters easily. The polypropylene-insulated cable includes Beldfoil shielding and retains a high flexibility with 22AWG 7×30 copper conductors. The cable is NEC CM-rated and passes the UL 1581 vertical tray flame test.

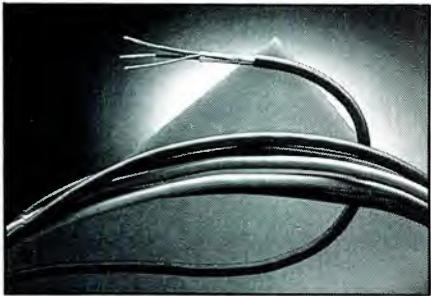

Circle (363) on Reply Card

Water-column loads

Bird Electronics has introduced three water-column loads for UHF television. Each model is factory-tuned for an optimum VSWR over the 6MHz channel. The three models serve 50kW, 80kW and 100kW power levels. A mixture of water and ethylene glycol is used, and a heat exchanger is required.

Circle (364) on Reply Card

Airplay data tracking

Broadcast Data Systems has introduced RadioTrack, an airplay system that monitors what songs are played by each station in a market on a day-by-day and hour-by-hour basis. Leader Watch reveals airplay data from top stations in a format. Competitor Watch provides airplay information and demographic data per market.

Circle (365) on Reply Card

Replacement batteries

Energex Systems has introduced the XP90 battery, a direct replacement for BP90 units with a 12.5% increase in capacity to 4.5Ah. One-hour fast-charge cells are used in the assemblies. High-

temperature sensors and replaceable plug-in fuses are incorporated into the product.

Circle (366) on Reply Card

Digital telephone hybrid

Gentner Electronics has released the Digital Hybrid II telephone interface unit, based on a 16-bit Motorola signal processor. The system avoids the hollow sound

effect as well as system feedback. Switching selects mix-minus and mic pre-amp outputs, while a record button starts the tape recorder and routes a mix output of caller plus send to the recorder. The hybrid also may be used instead of a speakerphone for simultaneous 2-way conversations in conference-room applications.

Circle (367) on Reply Card

FULLY-OPTIONED

INTERCOM.
WHEN YOU NEED
IT SPECIAL.
WITH LOTS OF CHANGES.

INTRODUCING THE BP325 PORTABLE USER STATION:
USER PROGRAMMABLE.
MICROPROCESSOR ASSISTED.
DISTINCTIVE DESIGN.

RTS SYSTEMS
INCORPORATED
1100 WEST CHESTNUT STREET BURBANK, CALIFORNIA 91506
PHONE 818 566-6700 FAX 818 843-7953

© 1988 by Donkey, Inc.

Circle (91) on Reply Card

America's Full-Time Broadcast Supplier



6:00-6:00
Pacific



7:00-7:00
Mountain



8:00-8:00
Central



9:00-9:00
Eastern

When BSW was founded in 1973, our goal was to establish a single source supply house to serve the needs of America's broadcast professionals. Regional offices solved the problem of time zone but only served to delay delivery of equipment critical to a station's operation.

So we decided to work overtime every day of the week. 12 hours a day, there is a qualified sales engineer on duty who knows your business and your needs. And there's only one number you need to know — toll free across America. BSW's commitment to service is why we're America's full-time broadcast supplier.

BSW

BROADCAST SUPPLY WEST

1-800-426-8434

ORDERS • INFORMATION • SPECIFICATIONS
BSW • 7012 27th Street W • Tacoma, WA 98466 • FAX 206-565-8114

Circle (88) on Reply Card

Prompting on LAN

Computer Prompting has introduced the following products:

- The CPC-1000N and CPC-2000N SmartPrompter+ systems feature a LAN interface, which allows operation with any electronic newsroom system. Simultaneous script-scroll and script-loading are possible through a multitasking capability.
- The CPC-1000D prompter with SmartDisplay+ is based on gas plasma-discharge technology and uses a 9.5-inch diagonal display. The prompter weighs approximately nine pounds.

Circle (368) on Reply Card

Effects unit

Crosspoint Latch has introduced the 6063 Picture Mover. The device, installed with one of the company's production switchers, allows the operator to create pull off/on and push off/on effects in conjunction with any TBC. Control of the additional transition effects is accomplished with the switcher fader levers or may be assigned to the auto-transition mode. Four preset transition rates include 1/4 seconds, 1/2 seconds, one second and two seconds. A variable setting extends the range to five seconds. A 3-input switcher allows three individual sources to feed the switcher external key input.

Circle (369) on Reply Card

Protective headwear

David Clark Company has introduced the K-10 helmet kit. It is suited for ENG or EFP camera operators working on high-risk assignments. The shell meets MIL-H-85047A specifications for impact protection. A washable helmet liner adjusts to fit and allows the helmet to be worn with any over-the-head noise-attenuating headset.



Circle (370) on Reply Card

Audio automation

Drake-Chenault has introduced DigiTotal, a computer music-management system, which offers partial or total program automation. A total of 255 different sources are available. A 60-hour library of 1,100 songs on VHS tape offers a wide selection of music or other information.

Circle (371) on Reply Card

Light-control consoles

Electronics Diversified, Light Control Specialists has introduced three control consoles, each providing manual or memory-controlled operation. The Minstrel offers 48 control channels for up to 512 dimmers. The Omega is a 72-channel system for 960 dimmers. The Troubadour III includes 120 control channels for 512 dimmers. All allow cross-fade and an independent master with timers. Special effects are optional for the Minstrel. All consoles support DMX-512 digital control protocol. Omega and Troubadour III also provide AMX-192, CMX-512 and Fiber-Link control.

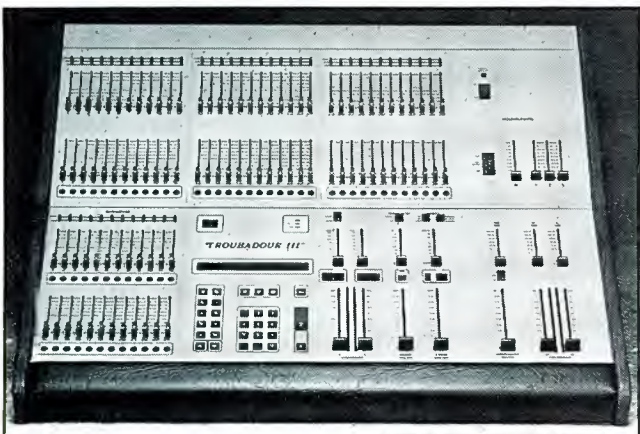

Circle (372) on Reply Card

Abrasive tape

The E. C. Mitchell Company has introduced a series of flat abrasive tapes for cleaning electrical contacts and terminals. The tapes, available in widths from 1/16 inches to 1/4 inches, have abrasive material on both surfaces, allowing mating contacts to be cleaned at the same time. Aluminum oxide, silicon carbide and crocus materials are available.

Circle (373) on Reply Card

Video multiplexer

Gennum has released the GX-214 4x video multiplexer device. The bipolar crosspoint IC is available in 14-pin DIL or SMD packages to provide differential gain and phase of 0.05% and 0.05°. The target market is CATV switching and signal-routing systems.

Circle (374) on Reply Card

Music-format automation

MacroMedia has introduced the AUDISK/ts, a hard disk software/hardware system that can replace up to five cart decks, commercial playback equipment, an audio switcher, production cart recorder and automation system. The unit is expandable to six additional drives; approximately 190 minutes of stereo may be stored for immediate random recall. The unit also may be used with a PC as the central controller for a satellite-relayed, music-automation system.

Circle (375) on Reply Card

WHEN IT'S TIME TO WORK, WE PLAY.

ON AIR

Few things can make you look worse than equipment that doesn't work or *c.e.* What you need is a CD deck that's at home in the studio, not at home in the home.

Tascam's CD-401 and CD-501 were especially designed for the broadcast environment. Their extra-rugged chassis design insures consistent, reliable performance even through demanding non-stop use.

Disc after disc, day after day, year after year.

Of course, they include all the features you'd expect. Independent D/A converters for the left and right channels, balanced +4 outputs and sub code cut for system automation.

Plus a 3-beam laser pick-up that provides perfect alignment and instantaneous error correction.

Don't let a consumer deck turn your programming into the original amateur hour. Contact us or visit your Tascam dealer for more information about the CD-401 & CD-501. No matter how hard you play them, they're guaranteed to work.

TASCAM®



© 1989 TASC America, Inc., 7733 Telegraph Road, Montebello, CA 90640, 213/726-0303.

Circle (94) on Reply Card

TIMECODE EDITING... LIVING DANGEROUSLY?



Not if you have the new ADx-02 Timecode Analyzer. This is a sophisticated test instrument, as well as a fully functional reader-generator with video Key and L.E.D. displays. It can save you time and money. Finding timecode errors on tape before an edit is attempted, or matching color frames and Sch phase, or tracking on a Betacam is easy. For the engineer, it can be the quickest way to set tape speed, realign video play-back heads or check an audio synchronizer for wow. Each timecode bit is displayed graphically.

The ADx-02 is being used around the world in a variety of environments and applications. But the diagnostics function is not the end of the story, the ADx-02 is a very versatile timecode reader-generator-inserter, with multiple screen displays, selectable fonts, three jam-sync modes, stable code generation, full speed range read and much more. So why buy just a timecode reader-generator?

The ADx-02.

The only timecode unit that can safely save you money.
Call us for our new 1990 audio products brochure

ADx Systems Inc.
274 Madison Avenue, New York, NY 10016
The World Leader in Timecode.

For more information contact your local dealer or call us at 1-800-444-4-A-D-X.

Circle (95) on Reply Card

AUDIO LINE MONITOR / BRIDGING SWITCHER

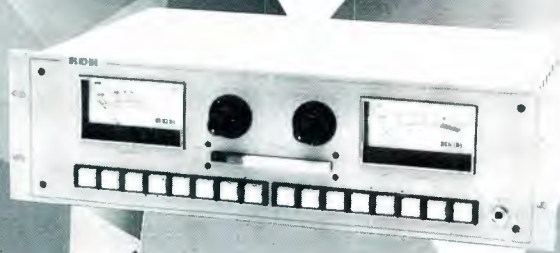

- Accurately measures the signal levels and quality of multiple audio sources, mono or stereo.
- Both standard VU ballistic and fast acting peak response metering of individual or multiple inputs or outputs.
- High quality Power Amp for headphone or external loudspeakers.
- 8 and 16 channel mono units have built-in speaker.
- Independent balanced line amplifier output with level control.
- Silent electronic switching, interlocked standard, non-interlock optional.
- Remote control and unlimited input expansion available.

913 West 223rd Street; Torrance, CA 90502
Phone: (213) 533-1498 / FAX: 213-533-6050

ROH

Circle (96) on Reply Card

Digital cart system

Gotham Audio and Ferrograph have introduced the series 9 digital broadcast cart machines. The model 9500 is a recorder/reproducer system. It is based on 16-bit sampling at 44.1kHz, and uses a hard-shell 5.25-inch cartridge that provides 3.3 minutes of stereo. At 32kHz, 36 minutes of monophonic sound may be recorded. VU meters with peak LEDs are standard. Titling and assembly or cut-and-paste editing is possible with an optional computer terminal connected via a serial control port. The front panel is designed to emulate audio cart machine operation.



Circle (376) on Reply Card

Audio deviation, level devices

FM Systems has introduced an audio-deviation meter and audio-level control unit. The ADM-1 deviation meter provides peak deviation of monaural or stereo modulation in any cable channel without removing the channel from service. Primarily targeted at CATV applications, the unit can be used on any RF modulation signal. The ALM673 audio-level master includes a switch to select between dual-mono or single-stereo audio channels. LED indicators are included to show the amount of gain control (a range of 30dB) to hold the output level within 0.5dB.

Circle (377) on Reply Card

Re-recording console

Harrison by GLW has introduced the SR-490 audio console for film scoring and re-recording applications. The 24-track on-line recording unit includes mixing-bus pairs for left, right, center and surround features.

Circle (378) on Reply Card

Enhanced toolkit

Jensen Tools has introduced an enhanced version of the JTK-87 field engineer's toolkit. Deep cases with two removable pallets provide a gate-swing feature for quick access to equipment housed in the bottom of the case.

Circle (379) on Reply Card

Fiber-optic connectors

OFTI has introduced the STC series 2.5mm bayonet fiber-optic connectors. A stainless steel-tip ferrule provides support and consistent contact between the optical conductors in two connectors and is available for fiber sizes ranging from 125 to 1,000 microns.

Circle (380) on Reply Card

Steel clamp tool

Panduit has introduced the PPTMT pneumatic tie/clamp tool for installation of stainless steel ties and clamps on pipes and cable bundles. The tool operates from 85psi non-lubricated air, and uses replaceable tension grippers and cutter blades.

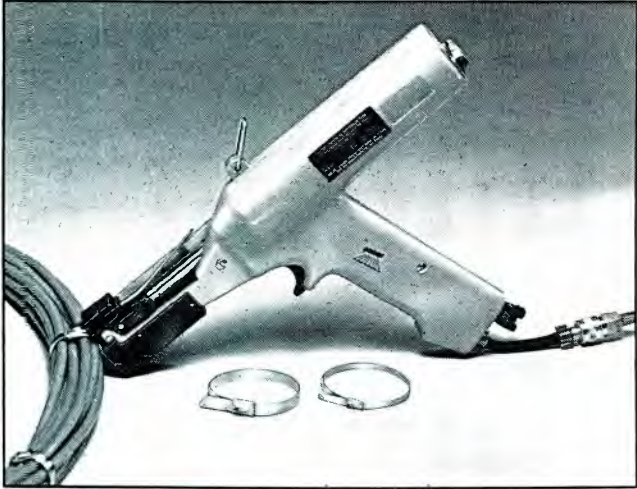

Circle (381) on Reply Card

Audio-editing accessory

Soundtracs has introduced the AFV controller, an audio-follow-video system. Available for eight channels of audio from an FMX console, this accessory unit is controlled from a video editor with BVE or GPI interfacing.

Circle (382) on Reply Card

Production slate

Nalpak Video Sales has announced the VID-SLATE, a production slate in 4"×5" and 7"×9" sizes. Both slates are constructed of 0.06-inch styrene with permanent black silk-screened markings.

Circle (400) on Reply Card

Interface and mic DA

BSS Audio and *Klark Teknik* have introduced the AR-416 4-channel active direct-input device interfacing low-level, high-impedance signals to low-impedance inputs of mixing, processing and other audio equipment. The unit requires one rack space.

The companies also have introduced the MSR-604 microphone DA, which supplies multiple destinations with the output from a microphone without the undue signal degradation that results from other signal-splitting methods. A companion power supply, model 602, supports up to 10 of the 4-channel splitter units.

Circle (383) on Reply Card

Animation software

Thomson Digital Image has released Version 2.1 of the Explore animation system. Operated by a point-and-click user interface with pulldown menus and multiple windows, the software introduces Contour to deal with visible and hidden lines for HPGL and PostScript devices; Preview for real-time animation preview playbacks; Transform for non-linear transformations of objects in real time; a 4:2:2 support interface and beveled 2-D and 3-D typefaces from 14 standard fonts as well as an extensive library of bitstream fonts.

Circle (384) on Reply Card

THIS PRODUCTION ASSISTANT WILL NEVER ASK FOR TIME OFF.

Twenty-four hours a day, seven days a week. That's the kind of dedicated service you can expect from the new 3030 quarter inch recorder from Tascam.

The 3030 is a real studio workaholic, designed to do a little of everything, and do it well. At only \$2,299* one of the things it does best is save your budget.

From its proprietary heads, offering extended headroom and quieter recording, to its built-in dbx type I professional noise reduction, the 3030 delivers sound you can count on, time after time.

Whether you're fine-tuning for a particular kind of tape, or just matching previous recordings, you'll appreciate the 3030's choice of on-air or production-quality tape speeds, and the switchable print levels.

Split second cueing decisions are no problem, thanks to micro-touch pushbuttons, while Auto Cue Mark, Duplesync, and Tape-Run-Time counter simplify your spot production. Mic inputs make direct voice-overs a breeze.

And with balanced and unbalanced inputs/outputs, the rack-mountable 3030 slips easily into any existing system.

Contact us or visit your Tascam dealer for more information about the 3030. It turns out, good help isn't hard to find after all.

TASCAM



© 1989 TEAC America, Inc., 7733 Telegraph Road, Montebello, CA 90640, 213/726-0303
*Manufacturer's Suggested Retail Price

Circle (97) on Reply Card

Solve your intercom interface problems forever.

CLEAR-COM

TW-12B

System Interface



** Interfaces: Clear-Com to RTS
RTS to Clear-Com
Clear-Com to Clear-Com
even RTS to RTS*

** Easy, fast, accurate nulling -
up to 40dB!*

** Matches system levels³ - even between
incorrect or multiple terminations!*

** Transformer isolated/opto-coupled
to eliminate ground loop hum,
buzz and noise!*

Call Clear-Com or your
local dealer for details



Clear-Com
Intercom Systems

945 Camelia St.
Berkeley, CA 94710
415/527-6666

Circle (109) on Reply Card

Countdown generator

Sigmacon Industries has released the Videscribe 700, a countdown and slate generator, which also may be used for studio prompting and some character-generator functions. The unit counts from nine to three, then switches to an external video source. A backup battery is included, as well as gen-lock capability.

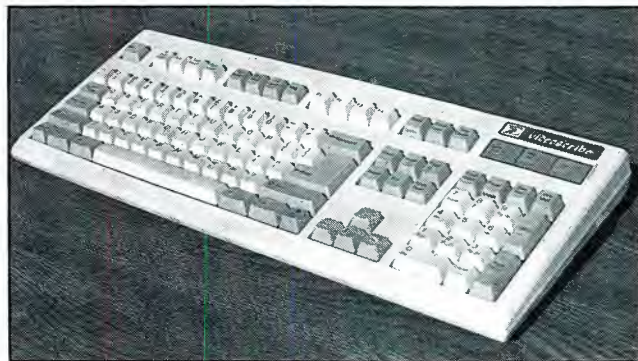

Circle (385) on Reply Card

HMI PAR fixture

LTM Corporation of America has introduced the CINEPAR 2500 lighting instrument. Based on an HMI 2.5kW single-ended lamp, a parabolic reflector produces an intense, narrow beam of light four times brighter than 1.2kW fixtures. A set of lenses varies beam focus from narrow to extra wide. The unit operates with an Mk-III Alimarc compact ballast.

Circle (386) on Reply Card

ID source, TC translator

Queue Systems has introduced the VID video ID generator for NTSC and PAL video. For use in duplication, transponder ID and remote pickup, the unit supersedes an ID or message up to 20 characters over video. A 32-message PROM allows switch-selection of IDs, black-and-white characters with or without contrasting box, two character sizes and position control. The time code translator reads longitudinal time code at $1/20$ - $50\times$ play speeds, converting the information to RS-232 or RS-422 data. Data rates from 150 baud to 19.2k-baud may be selected for the serial signal. In drop-frame or non-drop-frame modes, the unit allows two points to be memorized with time-duration calculation between the points.

Circle (387) on Reply Card

Management software

Xymox Systems has released Myriad Facility Manager, a software package for production and post-production project management. Modules of the package include sales bits, job costing, job/work order generation, schedules, invoicing, library management, accounting and word processing.

Circle (388) on Reply Card

Standards converter

OKI Electric has introduced the LT2000TSC standards converter with MVS motion-vector system processing for true motion continuity and highly transparent imaging. The system supports NTSC-3.58, PAL, PAL-M and SECAM with NTSC-4.43 input only, as well as Y/C (S-VHS), RGB and Y/R-Y/B-Y inputs and outputs. In addition to a full-featured proc-amp, the unit includes noise reduction, automatic input selection and H/V image enhancement.

Circle (389) on Reply Card

SHOOT FROM THE HIP

STUDIO NEWSROOM LECTURE HALL O.R. CEILING CONFERENCE ROOM STADIUM COURTROOM

Only Vectorcam™ by Vicon offers all these pan/tilt possibilities and more.

Vicon Vectorcam™ camera positioning systems put professional-quality camera control at your fingertips—whether the camera is in your corporate conference room or positioned out of reach on the ceiling of a sports arena.

There's a Vectorcam™ system for your application from under \$4,000 for a basic system to under \$40,000 for a 4-camera programmable system with memory, 99 presets per camera station and RS232 compatibility.

And you can depend on the quality of Vectorcam™ systems because they're built to last—by Vicon, a company devoted to innovative accessories that enhance television camera operation. Vectorcam's rugged construction, close-tolerance gearing and high quality components ensure accurate positioning with precise stops, pans, tilts, zooms and focus.

The Vectorcam™ remote control unit is available in desktop or rack-mount configurations and can be tailored to your application. So, when it's time to shoot from the hip—or anywhere else—contact the professionals at Vicon or at your local Vicon dealer.

Professional
Products
Division



VICON

Vicon Industries Inc.
525 Broad Hollow Road
Melville, New York 11747-3703
516-293-2200
Fax: 516-293-2627

Circle (81) on Reply Card



V6035PT



V6033PT



V7000C



V7100C

V6100PT/V6000PT



***It takes teamwork to
produce the industry's
best-performing router.
It takes confidence to
guarantee it for ten
years.***

At Utah Scientific, people know how to work together to bring you the best in product design, product performance, and product support. Products like the AVS-2, the new generation of Utah Scientific routers.

With the best operating specs in the business, the AVS-2 offers these exclusive features:

- surface mount component technology—increased packaging density for maximum size reduction with no sacrifice in signal integrity
- up to 525 crosspoints per rack unit including power supplies
- 1280 x 1280 matrix sizes with 8 separately addressable levels
- HDTV compatible—video frequency response flat to 30 MHz



- matrix cards automatically assigned to location—change card positions without reprogramming
- full matrix salvo capability—reconfigure in one vertical interval
- only multi-sourced components are used—no hybrid circuitry.

And even though the AVS-2 is a revolutionary new design, we have the confidence to guarantee it for ten full years—parts and labor.

That means you can have confidence every time you buy a Utah Scientific product. Confidence that you are buying the best. Confidence that our team of experts is available to help you whenever you need it. Confidence that your Utah Scientific switcher will keep working for you year-after-year with the best reliability record in the industry.

Call us today for more information about the AVS-2 or any other Utah Scientific product.



Confidence in Quality.

Utah Scientific, Inc. • 4750 Wiley Post Way
Salt Lake City, Utah 84116-2878
(801) 575-8801 Toll Free: (800) 453-8782

Dynatech Broadcast Group

Circle (114) on Reply Card

Continued from page 76

remaining color-difference channel.

The decoded color-difference channels next feed into the time-compression circuitry, where the two color signals, which take up two horizontal lines of time, will be compressed into one horizontal line time period. Most machines use four CCD devices to accomplish this. Because all CCDs are not created equal, we must adjust the input level to each of the CCD

devices to achieve identical output levels from each.

The CCDs also have biasing adjustments. This biasing determines the linearity of the CCD; therefore, the symmetry of each device can be made identical. Incorrect alignments would result in double vectors and incorrect quadrature. In some of the new machines, this time compression is handled by digital processing, eliminating the need for most of these ad-

justments.

In this time compression of the color-difference signals, the chance for Y-C timing errors is reintroduced. The Y-C timing can be modified through control of the CCD clocking phase. Because the playback portion of the machine has been set previously, the Y-C delay now can be viewed at the VTR's composite video output using a waveform monitor.

Use a 12.5T pulse as an input signal, and record about 30 seconds on a blank cassette. When playing back this recording, verify the CCD clocking phase by confirming that the waveform monitor shows no "S" curve at the base of the 12.5T pulse.

The luminance and chrominance output levels of the time-compression module should be adjusted to the machine's specifications at the point these signals are fed into the modulator circuitry. Adjust these modulators by viewing a SMPTE standard color-bar signal at the composite output on a waveform monitor. Adjust the luminance deviation to achieve 100% video level, and adjust the chrominance deviation to achieve 90IRE units peak to peak on the waveform monitor.

This concludes the setup using standard NTSC test equipment.

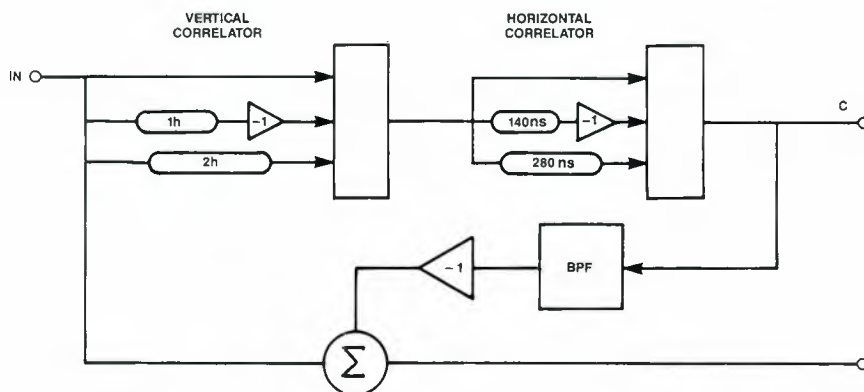

Figure 6. Comb filter block diagram.

GCR-201E 25A, 17KV	GCR-701 80 A, 40KV
GELECO, Toronto, CAN (416)421-5631	

Circle (112) on Reply Card

TIMECODE TRANSLATOR
 CONVERT TIMECODE INTO RS232/RS422 DATA FOR PROCESSING BY YOUR COMPUTER!
 A timecode translator made by QUEUE SYSTEMS will convert longitudinal timecode into serial data in either RS232 or RS422 format at selectable data rates from 150 to 19.2 Kbaud which can be read and acted upon by your personal computer! Completely frame accurate. Our software can be customized to respond with timecode data in response to a query from your computer or continuously! Many extras! Call or write for details! \$849
 QUEUE SYSTEMS 7985 Santa Monica Bl. Ste. 109-295, W. Hollywood CA 90046 (213) 855-0258

Circle (106) on Reply Card

VIDEO SUPPLIES
 CABLES • CONNECTORS • CANARE • BELDEN • SWITCHCRAFT • D.A.'s • TIES • BATTERIES • NEUTRIK • 60 INTERFACE BOXES • TAPE • 500 DPF. TAPE LABELS • GAFFERS TAPE • CASES • PATCH BAYS • LIGHTS • ACOUSTIC FOAM • FORMS • MICROPHONES • SONEC • STANDS • MOUNTS • WIND SCREENS • ZEPPELINS • FIBRE OPTICS • RACKS • DUCT • REELS • TESTERS • FILTERS • CHEMICALS • TOOLS • ON-AIR LIGHTS • DEGAUSSERS • INTERFACE DEVICES • HEADPHONES • CLIPS • SWITCHES • CAM & S-VHS CABLE

FREE!
 America's most unique catalog for audio and video!

MARKERTEK VIDEO SUPPLY
 145 Ulster Ave., Saugerties, NY 12477 U.S.A.
 TOLL FREE 1-800-522-2025
 In NY: 914-246-3036

Circle (102) on Reply Card

PRECISION MAGNETIC TEST TAPES

STL

Standard Tape Laboratory, Inc.
 26120 Eden Landing Road #5, Hayward, CA 94545
 (415) 786-3546

Circle (108) on Reply Card

AS-101 AUDIO SWITCHER

- Illuminated and legendable control buttons
- Instant or overlap switching
- Front panel accessible level controls
- Optional RS-232 interface
- Optional relay follow switch outputs
- Plug-in screw-clamp terminals

CONEX ELECTRO SYSTEMS

P.O. Box 1342 Bellingham, WA 98227 (206) 734-4323

Circle (105) on Reply Card

FACTORY DIRECT

Custom Cases	Acoustic Foam	Custom Stands	Studio Furniture

Request Catalogue 800-343-1433, 516-563-0633
 Island Cases, 1121-20 Lincoln Ave., Holbrook NY 11741

Circle (116) on Reply Card

Free Catalog & Audio/Video Applications
 Mic, EQ, Line, Tape, Phono, Osc, Trans., Video, ACN, Pwr. Supp.

Routing Switchers (ST-A/V) (24, 16, 12, 8, 4, 2 stations)

Press Boxes 1-in/15-out Video/Audio 2-in/24-out Audio

Video & Audio Dist. Amps. RGB-Sync Dist. Amps.

OPAMP LABS INC (213) 934-3566
 1033 N Sycamore Av LOS ANGELES CA, 90038

Circle (107) on Reply Card

CAV setup

Making these adjustments using CAV test gear is the same as using NTSC gear, except that the adjustments are easier to perform and more accurate. With CAV, the modulators would be adjusted first, after the playback system has been checked, using a Y-C signal (luminance and time-compressed chroma) from the test generator to the dub input.

You could adjust the time-compression circuitry by connecting the Y, R-Y and B-Y outputs of the generator to the component input of the machine. The CCD linearity and levels then could be corrected, and you could check the Y-C delay at this time, while viewing the composite or the component outputs of the machine.

Observations

Following are some of the author's observations about this type of machine:

First, all adjustments must be made at the normal operating temperature of the circuitry. Do not leave a PC board on an extender more than a few minutes, because this may affect the accuracy of the adjustments. Also, the operating temperature inside these machines is high, and if strange things are happening, perhaps they are being caused by a dried-up electrolytic capacitor somewhere in the circuitry. Obviously, the best way to prevent this is ventilation, so check the cooling fans often.

Second, because of the small size of the PC boards, problems may develop in which traces open completely or partially. Also, plate-through holes that really are not plated through have been observed. Some of these problems may be solved simply by resoldering the landing or the plated-through hole. Others can be solved only by installing a jumper wire.

A note about the surface-mounted integrated circuits (ICs) used in this equipment. Beware that some of these ICs are glued onto the PC board before being soldered into place. This is particularly the case with portable decks. A chemical debonder may be applied to the area being worked on after the solder has been removed.

The benefits of CAV

The video and audio that these machines produce is of high quality, but to maintain that quality, check the specifications yearly. As demonstrated, these tests can be accomplished without the use of special test equipment, but for speed, accuracy and efficiency, the use of component analog video test gear is recommended.

Editor's note: "Bowtie" is a 3-channel, CAV test signal used to determine whether timing differences exist between the channels of component analog video equipment. The signal was developed by Tektronix, Beaverton, OR, and has since been released for general use.

[:T-:))]]]]

Sometimes We're Judged



lexicon



RAMSA

Eventide

REVOX

Symetrix



crown

MARTI



beyerdynamic))))))



By The Companies We Keep

Over 200 manufacturers put their trust and confidence in BSW to represent their products. We have earned their respect by servicing the needs of thousands of broadcasters for over 17 years.

How about you? If you're fed up with the "song and dance", the hassles, and proverbial runaround from your present audio equipment supplier, please give us a try. At BSW, we work 12 hours daily, to give you the best possible service and competitive pricing. We invite you to be the judge. Call us toll free and allow us an opportunity to earn your trust and confidence for all your audio equipment needs.

BSW[®]

BROADCAST SUPPLY WEST

1-800-426-8434

ORDERS • INFORMATION • SPECIFICATIONS

BSW • 7012 27th Street W • Tacoma, WA 98466 • FAX 206-565-8114

Circle (110) on Reply Card

November 1989 *Broadcast Engineering* 139

Continued from page 124

existing worldwide sales network. Future product development at the IMS Silicon Valley facilities will be carried out and expanded in close cooperation with the Studer organization in Switzerland.

The IMS organization has changed its name to Studer Editech Corporation (SEC) and operates as a wholly owned subsidiary.

Quanta reorganizes customer service departments

Quanta, Salt Lake City, has reorganized its customer service and marketing departments.

Also, the Delta 1 character generator will be sold in the United States through two different distribution channels in order to more closely match the needs of the specific post-production marketplaces.

Serving video production and post-production facilities will be the Dynatech Graphics Products direct-sales force, which also offers the Colorgraphics line of high-quality video paint systems and the Colorgraphics Da Vinci color-correction system.

Servicing the industrial/corporate post-production marketplace will be Quanta's regional sales representative managers and their chosen sales reps. Marketing of the Delta 1, as well as manufacturing and service, will be handled by Quanta.

North American Philips' divisions change name

Philips Components Discrete Products Division, Riviera Beach, FL, is the result of a merger of Mepco/Centralab, Amperex and Ferroxcube, all North American Philips Corporation divisions. The name change is part of the worldwide policy to position Philips' components activities in the global electronic industry.

Under its new name, the company will be able to supply an even broader range of electrical components. In order to provide continuity and to avoid any confusion, the company will continue to use the Mepco/Centralab, Amperex and Ferroxcube names as brand names through a transition period.

Also, Philips Components Discrete Products Division has announced it will consolidate its Plumbicon camera-tube production at Slatersville, RI. The consolidation combines the two manufacturing sites of Slatersville and Eindhoven, the Netherlands, into one main production center. The Eindhoven facility will remain as a source for additional stock and will provide measuring facilities, application support and product expertise.

||:~:~))|||

REDUCE ON-AIR ERRORS!

TV Cart Automatic Sequencer System

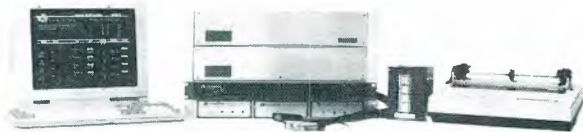

MicroCart 50

Replace your TCR/ACR For Less than \$50,000, Complete with Eight SP Transports, Wired and Tested in a Beautiful Custom Cabinet

(800) 950-2223

American
BROADCAST SYSTEMS, INC.

\$14,900 For eight transports

- * CRT Display of Run Sched.
- * 2-Second Preroll
- * Stereo Audio * Recue Button
- * Quick Last Minute Changes
- * Self Programming
- * Plays Programs and Spots
- * Upgradable, expandable
- * Easy, nontechnical operation
- * Computer, cables, switcher, CRTs, DAs, Printer, and R/C Panel supplied
- * Reliable--

Just ask our customers!

Circle (98) on Reply Card

VIDEO IDENTIFIER

Low cost insertion of ID or any message up to 20 characters.

- Stores 32 ID's in EPROM
- Fully positionable
- Variable size
- White or black characters
- With Box background or without
- RTSC or PAL
- One rack unit
- Power off relay bypass
- Remote controllable

Great for source identification, "spoofing", serializing work tapes, preventing piracy, etc. Keeps your CG available for more important tasks. \$849

For more information call or write

QUEUE SYSTEMS

7985 Santa Monica Bl. Ste. 109-295, W. Hollywood, CA 90046 (213) 656-0258

Circle (100) on Reply Card

FINALLY, A RACKMOUNT SLIDE KIT THAT WORKS!

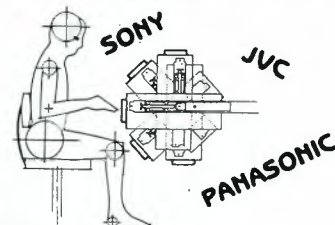

FOR MORE INFORMATION... CALL 800-635-9297

ERGO INDUSTRIES

Circle (101) on Reply Card



For AM, FM, SCA and TV modulation monitors.

WHEN ACCURACY COUNTS...COUNT ON...

Call (215) 687-5550 or write for more information on Belar AM, FM, Stereo, SCA and TV monitors.

BELAR
ELECTRONICS LABORATORY, INC.
LANCASTER AVE. AT DORSET, DEVON, PA 19333

Circle (99) on Reply Card

Fix It by FAX. Faster Free Service!

FAX us your circuit, we'll FAX you our recommended modifications at no charge. Same day transformer shipping from stock.

jensen transformers
INCORPORATED

10735 Burbank Blvd. • North Hollywood, CA 91601
FAX (818) 763-4574 Phone (213) 876-0059
TELEX 6502919207 MCI UW

(Mon-Thurs, 9am-5pm Pacific time)

Circle (103) on Reply Card

Professional services

VIR JAMES P.C.
CONSULTING ENGINEERS
Applications and Field Engineering
Computerized Frequency Surveys
3137 W. Kentucky Ave. — 80219
(303) 937-1900
DENVER, COLORADO
Member AFCCE & NAB

USED EQUIPMENT
THE LARGEST DEALER IN THE WORLD
PRO VIDEO & FILM EQUIPMENT GROUP
PHONE 214-869-0011 FAX 214-869-0145

EVANS ASSOCIATES
CONSULTING TELECOMMUNICATIONS ENGINEERS
AM-FM-TV-CATV-ITFS-LPTV SATELLITE
216 N. Green Bay Road
Thiensville, Wisconsin 53092
Phone: (414) 242-6000 Member AFCCE

dataworld MAPS
• TERRAIN SHADOWING
• POPULATION DENSITY
• CONTOUR COVERAGE
• SPECIALS
(301) 652-8822 (800) 368-5754

D. L. MARKLEY
& Associates, Inc.
CONSULTING ENGINEERS
2401 West Moss Ave.
Peoria, Illinois 61604
(309) 673-7511
Member AFCCE

K. BLAIR BENSON
Consultant
Television Technology
23 Park Lane
Norwalk, CT 06854
203-838-9049

TEKNIMAX
TELECOMMUNICATIONS
DENNIS R. CIAPURA
PRESIDENT
11385 FORESTVIEW LN.
SAN DIEGO CA 92131 (619) 695-2429

SMITH and POWSTENKO
Broadcasting and Telecommunications
Consultants
2033 M Street N.W., Suite 600
Washington, D. C. 20036
(202) 293-7742

Robert J. Nissen
THE NISSEN GROUP, INC.
Communications Technology Consultants
32 Ridge Drive • Port Washington, New York 11050
(516) 944-5477

DSI
COMMUNICATIONS INC.
• Radio and Television System Design
• Transmitter and Studio Installation
• Microwave and Satellite Engineering
and Installation
627 Boulevard
Kenilworth, NJ 07033
201-245-4833

CHUCK JONES
ANTENNA SYSTEMS SPECIALIST
618-564-2481
SOUTHERN ILLINOIS ANTENNAS
ROUTE 3, BOX 114
METROPOLIS, IL 62960

ERIC NEIL ANGEVINE, P.E.
consultant in acoustics
specializing in broadcast studio acoustics
910 Lakeridge Drive Stillwater, OK 74075
405-744-6444 405-372-3949

PROMOTE YOUR SERVICES
and increase business
for as low as \$55 per insertion.
Call 913/888-4664.

UNUSED CALL LETTERS
MAILING LABELS
AM • FM • TV
dataworld[®]
301-652-8822 800-368-5754

PATCHPRINTS[®] VIDEO TIE LINES
In 1 2 3 4 Aux
Custom Patch Bay Labeling
By
PATCH BAY DESIGNATION COMPANY
Div. of Glendale Rubber Stamp & Printing Co., Inc.
P.O. Box 6278, Glendale, CA 91205 Telephone (818) 241-5585
4742 San Fernando Road Glendale, CA 91204 FAX (818) 507-5050

East Coast Video Systems
ON LINE IN TIME
A full service company providing...
• Consultation
• Engineering & Design
• Installations
• Training
Serving...
• Cable Systems
• Corporate Facilities
• Broadcast Facilities
• Teleproduction Facilities
178 Casterline Road • Danville, NJ 07834 • (201) 751-5655

Consultation Services

Lightning - Power Conditioning - Grounding
Over 40 years experience, work guaranteed

Roy Carpenter
President

Lightning Eliminators and Consultants
13007 Lakeland Rd., Santa Fe Springs, CA 90670
(714) 946-6886 TWX 910-586-1381

Franklyn R. Beemish & Co.
Engineering for the Video, Motion Picture & Recording Industries
VIDEO POST, BROADCASTING, CONFERENCE CTRS, THEATERS, RECORDING
FACILITIES AND SYSTEMS DESIGN & IMPLEMENTATION
ANALOG & DIGITAL VIDEO, AUDIO, HDTV
ARCHITECTURAL ENGINEERING
ELECTRICAL, HVAC, ACOUSTICAL
574 Sunrise Highway, Baldwin, NY 11510 516/867-8510

JOHN H. BATTISON PE.
CONSULTING BROADCAST ENGINEER,
FCC APPLICATIONS AM, FM, TV, LPTV
Antenna Design, Proofs, Fieldwork
2684 State Route 60 RD#1
Londonville, OH 44842
419-994-3849

Stainless, inc.
New Towers, Antenna Structures
Engineering Studies, Modifications
Inspections, Erection, Appraisals
North Wales, PA 19454
215-699-4871 FAX 699-9597

BROADCAST DATABASE
dataworld[®]
MAPS
Coverage/Terrain Shadowing
Allocation Studies • Directories
P.O. Box 30730 301-652-8822
Bethesda, MD 20814 800-368-5754

Consulting Communications Engineers
• FCC Data Bases
• FCC Applications and Field Engineering
• Frequency Searches and Coordination
• AM-FM-CATV-ITFS-LPTV

OWL ENGINEERING, INC.
Consulting Communications Engineers
1306 W. County Road F, St. Paul, MN 55112
(612) 631-1338 "Member AFCCE"

NETCOM (201)837-8424
NETWORK COMMUNICATIONS CONSULTANTS
931 TEANECK RD. TEANECK, N.J. 07666
STATE-OF-THE-ART ENGINEERING FOR AUDIO & VIDEO
• FACILITY PLANNING
• SYSTEM DESIGN
• CAD SERVICES
JAMES TRONOLONE
ENGINEER

CALL US For New and Rebuilt
Radio Broadcast Equipment
HE HALL
Electronics
(804)-977-1100
1712 Allied Street Charlottesville, Va. 22901

Advertising rates in Classified Section are \$1.50 per word, each insertion, and must be accompanied by payment to insure publication.

Each initial or abbreviation counts a full word. Minimum classified charge, \$35.00.

For ads on which replies are sent to us for forwarding (blind ads), there is an additional charge of \$40.00 per insertion, to cover department number, processing of replies, and mailing costs.

SERVICES

TRANSMITTER TUBE REBUILDING SINCE 1941: 3CX2500, 4CX5000, 4CX15000 and many others. Write for details. FREELAND PRODUCTS INC., 75412 Highway 25, Covington, LA 70433. (504) 893-1243 or (800) 642-7626. 6-79-tfn

FCC GENERAL CLASS LICENSE. Cassette recorded lessons with seminars in Washington, Newark, Philadelphia. Bob Johnson Telecommunications. Phone (213) 379-4461. 11-89-11

TRAINING

YOU SPEND A FORTUNE on equipment and put your best into your programs. Why shouldn't they look and sound as good as they possibly can? Reviewers in magazines everywhere recommend the techniques found in "The Complete Camera Clinic", "Shaping Your Sound" and "Creative Video Techniques" with Harry Mathias, as great ways to improve the quality of your productions. CALL FREE: (800) 777-1576. First Light Video Publishing, 374 N. Ridgewood, L.A., CA 90004. 10-89-31

EQUIPMENT WANTED

WE ARE LOOKING FOR PARTS for our RCA TT10AH/TT25BH as well as 5762 and 6166A tubes. If you have any of these items available, please call 603-641-9060 and ask for Joe Paciorowski. 11-89-11

FOR SALE

HIGHEST PRICES for 112 Phase Monitors, vacuum capacitors and clean, one kw or greater powered AM and FM Transmitters. All duty and transportation paid. Surplus Equipment Sales, 2 Thorncliffe Park Dr., Unit 28, Toronto, Canada M4H 1H2, 416-421-5631. 6-89-tfn

1200 FEET of 6/8 inch, 50 OHM, Coaxial Transmission Line, 20 foot sections. Contact John Gordon, KTBO-TV, 3705 N.W. 63rd St., Oklahoma City, OK 73116. 405/848-1414. 09-89-31

FOR SALE: Tubes 3CX1500A7, 4CX250B, 4CX5000A, 4CX3000A, and more. We carry lg. inventory, all major brands (EIMAC, AMPEREX, RCA) Call Stew 1-800-842-1489. 09-89-41

2 IKEGAMI 730A&H/CANON LENS' CCU, 33 ft. Camera Cable, AC Power, Shipping Cases, Low Hours. O'Connor 30 Head/Tripod. Ultimate News Matte II. Call Pat (703) 558-1818. 10-89-21

PROF. VIDEO EDITING AND ENG EQUIPMENT: Sony 4-5800, 6-5850, 2-IVES II, 2-RM440 edit controllers, 2-Chyron VP2 CG, Tex Victor, Wave Form, Sync Color Bar. 2-TBC's, Cross Point 5112.6109. Alta PYXIS switcher. Tascam M30 mixer, Sony 1220, 1271, 19100 monitors, Sony 2-M3K cameras 14X FUJ. lenses, Sony BVU 50, BVU110 recorders. JVC VHS editing 2-8600 & RM86 Editor. Many other pieces lights, battery belts, microphones, cases, etc. List available on request. 301-840-0296. 10-89-31

RCA TP-66 FILM PROJ "NEW" \$5K, used fully overhauled TP-66 \$4500, all access., any part or assembly. Refurbishing services for TP-66 and TP-7..PARTS available. SIMBER BROADCAST SERVICES, INC., (609) 435-1091. 11-89-11

SONY BVH-500A, HT-500A, BC-210, BP-90's, \$10K; BVH-2800, Edit 3, DT, PCM, TC, \$35K; Sony CCU-360T (4), \$16.5K each; CA-31 (4), \$5.5K each. All in EXCELLENT condition. MVS (206) 622-9995. 11-89-21

2 IKEGAMI 79EAL CAMERAS, low hours, excellent condition, Canon lenses, complete kits, \$16,000 each. David Marlin, 7 Minola Road, Lexington, MA 02173 617/861-1346. 11-89-11

SITUATION WANTED

TECHNICAL EIC/VIDEO ENGINEER. 16 years experience including major television network and nationwide mobile production facilities. FCC licensed/SBE Senior Television certified. For resume and information: (412) 264-4756. 11-89-11

HELP WANTED

PRODUCT MANAGER: Excellent opportunity now available for an experienced Product Manager who will be responsible for market research and product definition. Will manage new product development from concept through engineering design, pricing and market introduction. A background in broadcast, industrial or government video/audio engineering plus 5 to 10 years product marketing management experience in an electronics manufacturing company is desired. We offer a competitive compensation package. Please send resume, including earnings expectations to: DYNAIR ELECTRONICS, INC., 5275 Market Street, San Diego, CA 92114. Equal Opportunity Employer. 11-89-11

MAINTENANCE ENGINEER with three to five years experience wanted for VHF-TV station. RF experience required. Full benefits. Send resume and salary requirements to: Richard Hielt, WHSV-TV, P.O. Box TV3, Harrisonburg, VA 22801. 11-89-21

WANTED: RF engineers and satellite earth station operators. Military experience OK. Please send resume to: STARS, 16250 Filbert St., Sylmar, CA 91342 ATTN, Diane Streett. 11-89-11

HELP WANTED

MAINTENANCE ENGINEERS needed for Christian teleproduction facility. Experience in maintenance and component level repair required. Ampex AVC, ADO, VPR-3, Beta. Scientific Atlanta/MCL satellite. Resume to Chief Engineer, P.O. Box 819099-9099, Dallas, TX 75381. 8-89-61

BROADCAST ENGINEER SHADOW TRAFFIC NETWORK'S New York network center needs a second engineer. Duties include repair and maintenance of audio, RF, computer and telecommunications equipment. Applicant must be familiar with needs of a broadcast operation. Reply to: Shadow Traffic Network, 201 Route 17, Rutherford, New Jersey 07070, Attn: Jim Walling. 10-89-31

"REMOTE TRUCK MAINTENANCE engineers for Multimedia Video Productions in Cincinnati, Ohio. Must have leadership qualities and be willing to travel. Excellent pay and benefits. Send resume to Director of Mobile Engineering, 250 Production Plaza, Cincinnati, Ohio 45219." 10-89-21

COMMUNICATIONS SYSTEMS ENGINEER: PBS is seeking an experienced electrical engineer to develop and evaluate new technologies to determine the feasibility and cost effectiveness of implementation. Responsibilities include providing in-depth technical analyses, participating in ongoing development projects, and monitoring industry standards committees. Successful applicant will have a BS degree in electrical engineering with a minimum of 5-7 years experience in broadcast systems engineering, satellite, or data communications. PBS offers a salary commensurate with experience and an excellent benefits package. Interested candidates should send letter of interest, resume, and salary requirements to: PBS, Attn.: Carla A. Gibson, 1320 Braddock Place, Alexandria, VA 22314. PBS is an equal opportunity employer. 11-89-11

WE'RE BUYING

West Coast Broadcast group seeks information on quality used UHF broadcast equipment including the following:

**60 kw transmitter
(Klystrone or Klystrode)
10 kw transmitter
5 kw transmitter
Microwave Dishes
Portable Microwave Equipment
Tower Structures
Building Enclosures
Test Equipment
(I.E. Wave Form/Vectorscope)**

Send information and pricing by **FAX** to Roger Terneuzen, (805) 485-6057.

Classified

HELP WANTED

ENGINEERING MANAGER—Ideal candidates will have 5-10 years experience in television broadcast and/or production engineering with an additional 2-5 years supervisory or management experience a must. This position requires excellent communication skills, a working knowledge of sophisticated post production techniques and high technical standards. This position provides engineering support to a multiple station facility including a fine arts radio station. Please send resume and salary history to QED Communications Inc., Human Resources Department, 4802 Fifth Avenue, Pittsburgh, PA 15213, EOE M/F/H/V. 11-89-11

CHIEF TRANSMISSION ENGINEER—Arkansas ETV Network seeks an RF Supervisor for 5 transmitter network with 10 hop microwave distribution system. Applicants need 10 years experience with VHF, UHF, MW & 430 and supervisory assignments. Send resume with names and phone numbers of 3 professional references to: AETN-Personnel, P.O. Box 1250, Conwa7, AR 72032. AETN is an AA/EEO. 11-89-11

TECHNICAL PERSONNEL: New York City based industry leader in corporate television programming is seeking freelance professionals with broadcast experience in the areas of maintenance, editing and technical operations including video shading, video tape operations, TD, Chyron and audio operations. Experience in live television broadcast ing a plus. Send resume and salary history to BROADCAST ENGINEERING, P.O. Box 12901, Dept. 708, Overland Park, KS 66212. 11-82-11

MAINTENANCE ENGINEER trained on Sony BVU-800 and general ENG equipment. We are looking for someone who wants to join a hardworking staff with two years of broadcast experience. Equal Opportunity Employer, women and minorities are encouraged to apply. Allan Burbach, KSNT-TV, P.O. Box 2700, Topeka, Kansas 66601. 11-89-11

HELP WANTED (CONT.)

ENGINEERING MANAGER—KXOA AM/FM, Sacramento, seeking an individual with a good mix of technical, business, and people skills to lead a winning engineering department. Must have good communication, computer, and troubleshooting skills; also experience with AM DA, high power FM, and automation systems. SBE certification is highly desirable and necessary in lieu of any formal training. Send resumes & letters of interest to: John Geary, General Manager, KXOA, 280 Commerce Cir., Sacramento, CA 95815. Equal Opportunity Employer M/F. 11-89-11

MAINTENANCE ENGINEER for UHF TV station. Need technician with experience repairing studio equipment. Send resume to: Gary King, WXON-TV, 27777 Franklin Rd., Suite 708, Southfield, Michigan 48034. Equal Opportunity Employer. 11-89-31

DIRECTOR OF ENGINEERING—BSU RADIO NETWORK. **Responsibilities**: designing, installing, & maintaining broadcast facilities including transmission, studio & remote; ensure that FCC requirements and EBS standards are met; and teach 1 course per year. **Qualifications**: BA degree in electronic engineering or related field plus 4 years experience in radio broadcast engineering or 8 years of experience, and the ability to function independently with a high level of productivity. **Salary**: mid-thirties plus benefits. **To apply**: Send letter of application, resume, the names of 3 references, and supporting documentation to Dr. Richard Bullington, Chair, Director of Engineering Search Committee, Boise State University, 1910 University Drive, Boise, ID 83725. (208) 385-3648. **Closing date**: Position will remain open until filled. EEO/AA INSTITUTION. 11-89-11

SENIOR MAINTENANCE TECHNICIAN. An evangelical, non-profit Christian organization needs maintenance tech. for major radio production facility. Candidate must have experience with radio production, recording and cassette duplication systems, and thorough knowledge of radio supervision, at times under deadline pressure. Must have A.S. degree or 3-5 years related work experience. Multitrack experience and familiarity with computers and television systems certification desirable. Send resume to: Focus on the Family, 801 Corporate Center Drive, Pomona, CA 91768. 11-89-11

Director of Video Engineering

Leading nat'l cable TV programming company seeks individual w/strong background in video engineering to oversee & be responsible for major facility on LI. Must be well versed in all tape formats & have ability to supervise staff of maintenance engineers. Excellent communications skills & the ability to work under pressure essential. B.S. in Engineering required. Company offers competitive salary & benefits package. Send resume & salary requirement to:

Human Resources Manager
RAINBOW PROGRAM ENTERPRISES
PO Box 999-GB
Woodbury, New York 11797

TELEVISION TRANSMITTER MAINTENANCE ENGINEER: Experience on low-band Harris TV-30L and RCA TT-25L necessary. Send resume and salary requirements to: PERSONNEL, WATE-TV 6, P.O. Box 2349, Knoxville, TN 37901. No phone calls and NO BEGINNERS. WATE-TV/Nationwide Communications Inc., is an Equal Opportunity Employer. Women and minorities are encouraged to apply. 11-89-11

Advertising sales offices

NEW YORK, NEW YORK

Diane Gottlieb-Klusner
Telephone: (212) 702-3404
Telefax: (212) 702-7802
Mike Trerotoli
Telephone: (212) 702-3405
Telefax: (212) 702-7802
866 Third Ave.
New York, NY 10022

CHICAGO, ILLINOIS

Vytas Urbanas
Telephone: (312) 435-2361
Telefax: (312) 922-1408
55 East Jackson
Suite 1100
Chicago, IL 60604

TOKYO, JAPAN

Mashy Yoshikawa
Orient Echo, Inc.
1101 Grand Maison
Shimomiyabi-Cho 2-18
Shinjuku-ku, Tokyo 162, Japan
Telephone: (03) 235-5961
Telex: J-33376 MYORIENT

CLASSIFIED ADVERTISING OVERLAND PARK, KANSAS

Renée Hambleton
P.O. Box 12901
Overland Park, KS 66212
913-888-4664

SANTA MONICA, CALIFORNIA

Herbert A. Schiff
Telephone: (213) 393-9285
Telefax: (213) 393-2381
Jason Perlman
Telephone: (213) 458-9987
Telefax: (213) 393-2381
Schiff & Associates
501 Santa Monica Blvd, Ste. 504.
Santa Monica, CA 90401

OXFORD, ENGLAND

Nicholas McGeachin
Intertec Publishing Corp.
Roseleigh House
New Street
Deddington
Oxford OX5 4SP
England
Telephone: (0869) 38794
Telefax: (0869) 38040
Telex: 837469 BES G

FREWVILLE, SOUTH AUSTRALIA

John Williamson
Hastwell, Williamson, Rep. Pty. Ltd.
109 Conyngham Street
Frewville 5063
South Australia
Phone: 799-522
FAX: 08 79 9522
Telex: AA87113 HANDM

TECHNICAL SUPPORT

Midwest Communications Corporation, the nation's largest professional video equipment distributor, has several openings throughout the United States for service personnel. Positions range from entry level technician through branch service manager. Basic skills required: excellent analog and digital theory and component level repair of television program origination/distribution equipment. Knowledge of RF theory and television transmitter experience is a plus.

Career tracks for technicians can lead to service center management, field engineering or sales engineering positions. Midwest offers an excellent compensation and benefits package and a unique opportunity to grow with a dynamic organization.

For confidential consideration, please send your resume to:

John Loughmiller
Midwest Communications Corporation
One Sperti Drive
Edgewood, KY 41017

Midwest Communications is an equal opportunity employer.



Ad index

	Page Number	Reader Service Number	Advertiser Hotline		Page Number	Reader Service Number	Advertiser Hotline
A/V Broadcast China	91	57		LDL Communications	44	23	301/498-2200
Abekas Video Systems	33	16	415/369-5111	Leader Instruments Corp.	57	33,34	800/645-5104
ADX Systems— USA	132	95	800/444-4239	Leitch Video Of America, Inc.	IBC	2	804/424-7290
AEG Olympia Ag	125	87		3M Broadcast & Related Products	29	14	800/328-1684
Alpha Audio	76	55	804/358-3852	3M Magnetic Media Div.	49	28	800/328-1684
Alta Group Inc.	54	30	408/297-2582	Magni Systems, Inc.	97	62	503/626-8400
American Broadcasting System	140	98	800/950-2223	Markertek Video Supply	138	102	800/522-2025
Ampex Corp (AVSD)	50-51		415/367-2911	Matco	80	47	408/998-1655
Ampex Corp (MTD)	87	52	415/367-2911	MCL, Inc.	92	58	312/759-9500
AMS Industries, Inc.	45	24	206/633-1956	Midwest Communications Corp.	111	113	800/543-1584
Arrakis Systems, Inc.	21	13	303/224-2248	Midwest Corp. (DPS)	1	3	606/331-8990
Asaca/Shibasoku Corp. America	39	21	213/827-7144	Moseley Associates, Inc.	58	35	805/968-9621
Astre Systems	115	111	209/575-1000	Myat	100	65	201/767-5380
Audio Precision	119	85	800/231-7350	NEC America, Inc.	53	29	214/907-4710
Audio Technologies, Inc.	96	61	215/443-0330	Nemal Electronics	124	92	914/359-3333
Audio-Technica U.S., Inc.	75	43	216/686-2600	Nesbit Systems, Inc.	56	32	609/799-1482
Audiolab Electronics	104	70	916/485-0500	Nikon Corporation	5	4	516/222-0200
Avitel Electronics Corp.	104	69	801/977-9553	OKI Electric Industry Co., Ltd.	77	45	213/245-7708
Belar Electronics Laboratory Inc.	140	99	215/687-5550	Opamp Labs, Inc.	138	107	213/934-3566
Best Power Technology	76	56	800/356-5794	Orban Associates, Inc.	7,17	5,10	800/227-4498
Broadcast Supply West	130,139	88,110	800/426-8434	Otari Corp.	15	9	415/592-8311
Broadcast Video Systems Ltd.	116	84	416/764-1584	Paco Electronics	64	40	213/719-9065
BTC Test & Measurement	37	20	704/547-TEST	Panasonic Broadcast Systems Co.	121	104	201/348-7336
BTS Broadcast Television Systems	60-61,103,113	37,68,78	800/562-1136	Panasonic Pro Industrial Video	34-35	17	800/553-7222
Burle Electron Tubes	63	38	800/827-TUBE	Pesa America	79	46	305/556-9638
Cablewave Systems	47	27	203/239-3311	Philips Components	65,66-67,68	39	800/447-3762
Canare Cable, Inc.	30	19	818/840-0993	Pirod	120	86	219/936-4221
Canon USA Inc., Broadcast Lens	89	54	516/488-6700	Polyline Corp.	52	26	708/298-5300
Cellcast, Div. of Tri-Tech	52	25	800/852-1333	Polyphaser Corp.	80	48	800/325-7170
Clear-Com Intercom Systems	30,134	18,109	415/527-6666	QEi	31	15	800/334-9154
Comark	83	51	215/822-0777	Queue Systems	138,140	106,100	213/656-0258
Commodore Computer	81	49	800/627-9595	ROH	132	96	800/262-4671
Conex electro Systems	138	105	206/734-4323	Roscor Corp.	90	44	312/539-7700
Delta Electronics	82	50	703/354-3350	RTS Systems, Inc.	128,129	90,91	818/843-7022
Di-Tech Inc.	124	93	516/667-6300	Sachtler Corp. of America	71	42	516/867-4900
Discount Video Warehouse-Div. of Roscor	55	31	800/323-8148	Shintron Electronics	106	73	508/486-3900
Dolby Labs Inc.	13	8	415/558-0200	Shure Brothers Inc.	IFC	1	312/866-2553
Dynair Electronics Inc.	127	89	619/263-7711	Sony Communications Prod/ Broadcast Div.	40-41		800/635-SONY
Electro-Voice, Inc.	93	59	616/695-6831	Sony Communications Prod/ Pro Audio Div.	72-73,122,123		800/635-SONY
Ergo 90	140	101	714/632-7045	Sony Communications Products/Pro Video	24-25		800/523-SONY
ESE	110	80	914/592-6050	Standard Tape Laboratory, Inc.	138	108	415/786-3546
Faroudja Laboratories, Inc.	107	74	408/245-1492	Stanton Magnetics	98	63	516-349-0235
Fast Forward Video	108	75	714/852-8404	Strantron/Unit of Zero Corp.	101	66-67	800/821-0019
Full Compass Systems	116	83	800/356-5844	Studer Revox America Inc.	11	7	615/254-5651
Geleco Electronics Ltd.	138	112	416/421-5631	Tascam Div. TEAC Corp. of America	131,133	94,97	213/726-0303
Gentner Electronics Corp.	109	77	801/268-1117	Telex Communications, Inc.	43,59,95	22,36,60	612/887-555C
Grass Valley Group, Inc.	9	6	916/478-3000	Telmak	117	82	800/637-454C
Gray Engineering	64	41	912/883-2121	Thomson Tubes Electroniques	105	71	201/812-900C
Harris Corp.	27	115	800/4HA-RRIS	Utah Scientific Inc.	136-137	114	800/453-8782
Hitachi Denshi America Ltd.	3		800/645-7510	Vicon Industries	135	81	516/293-220C
Hybrid Cases	138	116	800/343-1433	Video Display Corp.	99	64	800/241-500E
Ikegami Electronics Inc.	84-85		201/368-9171	Videotek, Inc.	88	53	602/997-752C
Intraplex, Inc.	108	76	508/486-3722	Ward-Beck Systems, Ltd.	BC		416/438-655C
Jampro Antennas, Inc.	36	79	916/383-1177	Winsted Corp.	106	72	800/447-2257
Jensen Transformers, Inc.	140	103	213/876-0059				
JVC Professional Product Co.	19	11	800/582-5825				

For Your 601 and D2 Tool Box

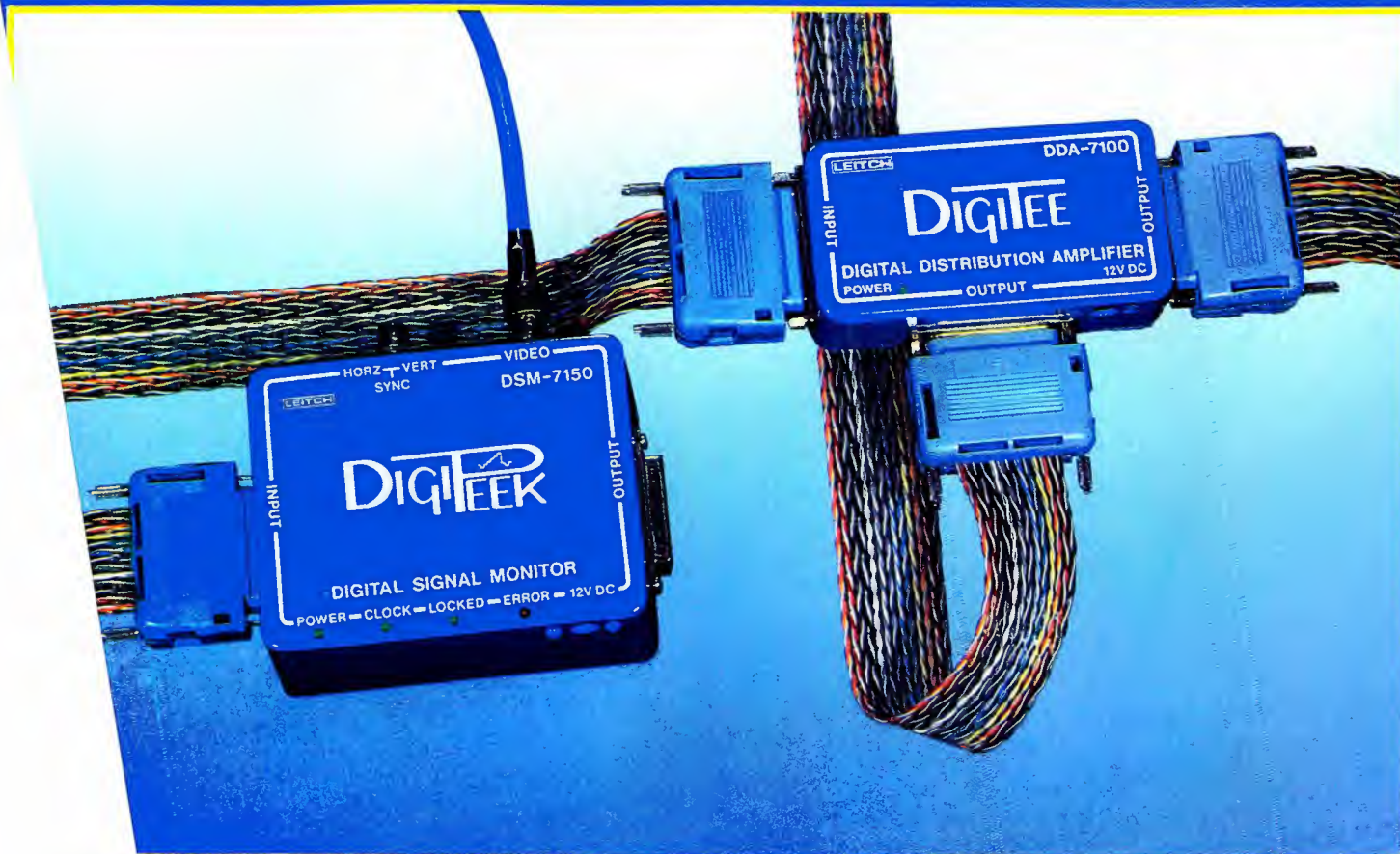

Installation and maintenance of digital equipment is one of the most exciting challenges of this decade. Leitch has developed two new tools specifically designed to simplify your digital installations.

The Digitee provides compact signal distribution. Since, according to CCIR 601 and D2 specifications, equipment must have terminating inputs, the Digitee provides a practical equivalent to looping inputs. The Digitee doubles as a line amplifier for long cable runs by re-synchronizing the full 10 bit data path, yet is small enough for cable troughs.

The DigiPeek's 1 volt composite output and LEDs provides monitoring and status of the digital signal. A re-synchronized digital output permits in-circuit monitoring. The compact DigiPeek is ideally suited for trouble-shooting complex digital systems.

To keep your digital tool box up-to-date, contact your Leitch dealer.

LEITCH

Circle (2) on Reply Card

Leitch Video of America, Inc., 825K Greenbrier Circle, Chesapeake VA 23320
Tel: (800) 231-9673 or (804) 424-7920 Fax: (804) 424-0639

Leitch Video International Inc., 10 Dyas Rd., Don Mills, Ont., Canada M3B 1V5
Tel: (800) 387-0233 Fax: (416) 445-0595 Telex: 06 986 241



Ward-Beck's Beltpack ... the mobile link for your professional intercom system!

Now total communications has become a reality with the new high-performance WBS Interphone Beltpack.

This superbly designed two-channel, single pair wired, compact unit interfaces with Ward-Beck's advanced four-wire, programmable MicroCOM system. It assures studio quality voice communications to your outermost mobile location.

Beltpack moves quality communications yet another step ahead of the rest of the pack ... and at a very attractive price!



Ward-Beck Systems Ltd., 841 Progress Avenue, Scarborough, Ontario, Canada M1H 2X4.
Tel: (416) 438-6500 Fax: (416) 433-2865.

Inspired Audio!

When the 5,000 seat Auditorium of the Akron Baptist Temple was planned, a console offering the ultimate in performance and flexibility was required for both sound reinforcement and broadcast functions. At the same time an unobstructed view forward of the controls was essential.

Ward-Beck responded by creating this unique low-profile mainframe design featuring a satellite meter unit.

An inspired solution to an interesting challenge!



First by Design.

Ward-Beck Systems Ltd.
841 Progress Avenue, Scarborough,
Ontario, Canada M1H 2X4
Tel: (416) 438-6550.
Tlx: 065-25399.

WBS Model
830695



To create the finest television audio mixing console, you have to do a lot of listening.

Neve's 51-series for television production.

To create great audio it's important to listen to and satisfy the needs of your marketplace. We know all about great audio. Neve has pioneered almost every major innovation in audio mixing from computer-assisted Necam systems to Digital (DSP) Systems. And we're very proud of that distinction.

That's why when we created a system designed to meet the growing needs of video post-production, we listened very carefully.

The result is that now video production facilities can enjoy the same superior audio quality that recording and film studios throughout the world have enjoyed, plus special features designed just for television production.

Human Engineered: First and foremost, from the size of the knobs and layout, to the straight-forward signal flow and powerful sub-grouping, the Neve 51-series is always easy to use, yet gives you all the features you want and need.

Four Band Equalizer and Filters: Our formant spectrum equalizer is renowned as the most musical sounding in the industry. No one else has the "Neve sound." Plus effective, high pass and low pass filters remove noises often encountered in live television production.

Dynamics Unit: Each input module contains a highly-regarded limiter/compressor and noise gate, perfect for processing those difficult tracks in post production or for use in live recording, from dramatic shows to musicals and sports.

Multitrack Capability: The 51-series separately controlled direct outputs, pre- or post-EQ, make simultaneous multitrack and live recording a snap.

Because Neve listened, the 51-series is what the television industry wants to hear.

For further information, call Neve's Television Production Sales Department at (203) 744-5230 or write:

51

S E R I E S

Demand Neve

RUPERT NEVE INCORPORATED: Berkshire Industrial Park, Bethel, CT 06801 (203) 744-6230 Telex 969638 • 7533 Sunset Blvd., Hollywood, CA 90046 (213) 874-8124 • RUPERT NEVE OF CANADA, LTD. represented by: Sonotechnique, 2585 Bates, Suite 304, Montreal, P.Q. H3S 1A9 Canada (514) 739-3368 Telex 055-62171 • NEVE ELECTRONICS INTERNATIONAL, LTD. Cambridge House, Melbourn Royston, Hertfordshire, SG86AU England Phone (0763) 60776 • RUPERT NEVE GmbH: 6100 Darmstadt Bismarckstrasse 114, West Germany Phone (06151) 31764.

Circle (2) on Reply Card