

# BROADCAST AN INTERTEC PUBLICATION June 1989/\$4.50

# ENGINEERING<sup>®</sup>

## NAB '89: New technologies, new products

53151 ---RANSUB200 XXXX BEQ  
F1020989000000 33 8 001  
RICK RYAN ENGR 4DIR4  
DUKAR LTD  
3820 S SUNNY RIDGE LA  
NEW BERLIN WI 53151

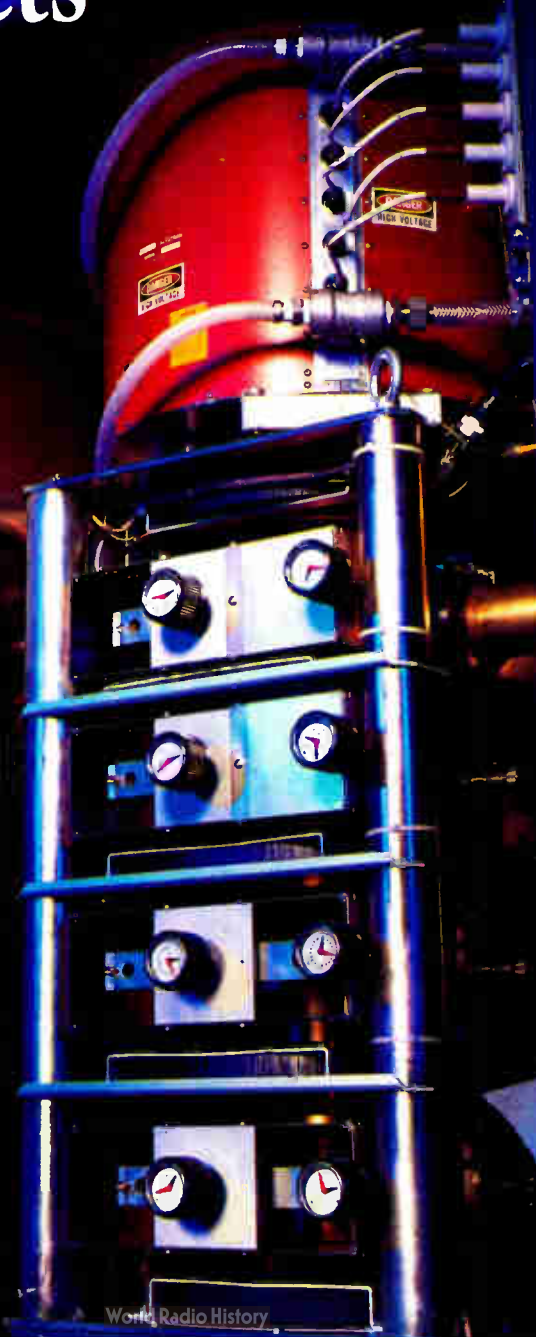

World Radio History

Engineering  
Conference p. 46

# Let Us Give You A Quote On Our Audio Switcher.

“When we designed our new 23,000 square-foot facility at KLBJ AM-FM, a primary goal was to maximize operational flexibility. So, we looked at the alternate ways to route audio signals. We compared features and specs, as well as costs.

“ITC’s AUDIO SWITCHER turned out to be an easy choice. One reason is it’s designed specifically for audio applications.

“With the AUDIO SWITCHER, we’re wired to and from every satellite, network, studio, and workstation. We’re even wired to the Program Director’s office. And installation was easy.

“That was September ’87. Since then? The AUDIO SWITCHER has worked out wonderfully, and staff reaction has been very, very positive. Changes are easy, and when we reconfigure something, we save both time and money. As far as our return on investment goes, it’s been excellent.”

—Bryan King,  
Chief Engineer, KLBJ AM-FM

What more can we say? If you’d like detailed information on how you, too, can easily and effectively route audio signals, call International Tapetronics, 3M Broadcasting and Related Products Department toll-free at 1-800-447-0414. In Alaska and Illinois, call collect, 309-828-1381.



# *the* **SOURCE**

***The Top of the Line Frame Synchronizers  
with the Best Bottom Line in the Business.***



***The DPS-165... Just \$4,990.  
or the DPS-165A... \$5,990.***

Get the bottom line on one of today's best values. The DPS-165 and 165A, high quality, full featured frame synchronizers at a price that's about half what you might expect from the competition

And complete with top-of-the-line performance features. Like a 525-line buffered memory to reliably synchronize any monochrome or direct color video feed. Plus auto diagnostic memory, internal test signal generator, and two true RS170A outputs.

Additional standard features include freeze frame/field with field 1 and 2 selectable and an adaptive comb filter on the DPS-165A. A multi-unit remote control is optionally available.

So add some top-of-the-line performance to your bottom line with the addition of a DPS-165 or 165A to your system.

As always backed by Midwest's nationwide service network.

For more technical and sales information contact your nearest Midwest office.

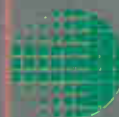

**DIGITAL**  
PROCESSING SYSTEMS INC.

From Midwest Communications –  
Exclusive U.S. Distributor.



**MIDWEST**  
Communications Corp

One Spert Drive  
Edgewood, KY 41017  
606-331-8990

Circle (3) on Reply Card

# Contents



Page 22

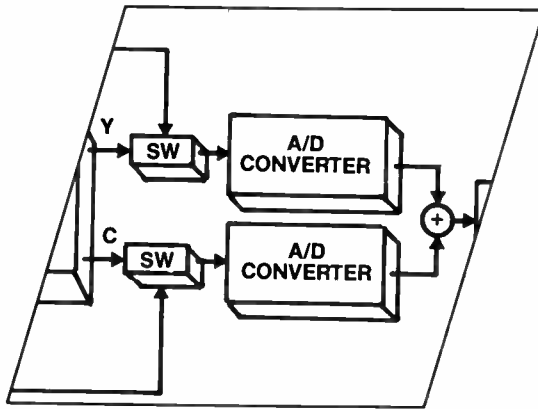

Page 42



Page 192

## BROADCAST ENGINEERING

### NAB '89 REPLAY:

The NAB convention is the "main event" for the broadcast and post-production industries. Our show replay covers the primary points of interest to readers. The NAB '89 package includes the following articles:

### 22 Perspective on NAB '89

By Jerry Whitaker, editorial director

Another record-breaking NAB leaves attendees with as many questions as answers.

- The HDTV Scorecard
- The Automation Equation

### 42 NAB Engineering Conference Report

By Brad Dick, technical editor

Future-oriented sessions address tomorrow's issues at the NAB.

### 72 Pick Hits of NAB '89

By Brad Dick, radio technical editor, and Rick Lehtinen, TV technical editor

Las Vegas was the perfect setting for our broadcast experts to pick the winners.

### 88 Show of Shows

Coordinated by Carl Bentz, special projects editor

Hundreds of new products are introduced at each NAB convention. Our "Show of Shows" report provides a complete, detailed listing of new products exhibited at the convention, organized by product categories.

## OTHER FEATURES

### 186 HDTV: Politics on a Grand Scale

By Jerry Whitaker, editorial director

High-definition television has evolved from a discussion of technical merits to an issue of national pride and national security.

### 192 The SBE Observes a Milestone

By Brad Dick, technical editor

The SBE celebrates its silver anniversary this year.

## ON THE COVER

The NAB convention provided broadcasters with an opportunity to examine the latest technologies and products. Our cover portrays just one of the many new products introduced in Las Vegas. We examine all the show's introductions in this issue. (Photo courtesy of Varian TVT.)

## DEPARTMENTS

|    |                      |     |                          |
|----|----------------------|-----|--------------------------|
| 4  | News                 | 16  | Circuits                 |
| 6  | Editorial            | 18  | Troubleshooting          |
| 8  | FCC Update           | 20  | Management for Engineers |
| 10 | Strictly TV          | 193 | SBE Update               |
| 12 | re: Radio            | 194 | New Products             |
| 14 | Satellite Technology | 196 | Business                 |
|    |                      | 201 | People                   |

# Hitachi makes it easy.



## **NOW, THE RIGHT CHOICE IN ADVANCED CCD CAMERAS IS CLEARER THAN EVER. THE NEW SK-F3 AND SK-F700.**

Hitachi presents two new 3-chip CCD broadcast cameras that give you higher resolution and better image quality than you have ever seen before in a broadcast camera.

The SK-F3 dockable and the SK-F700 studio cameras include the newest Frame Interline Transfer (FIT) CCD technology. Smear is virtually eliminated. Sensitivity is dramatically improved.

A 6-speed electronic shutter and contrast function are both built-in. And as for high resolution, the SK-F3 and SK-F700 hit a crystal clear 700 lines.

Your choice for a high performance camera system has never been easier. Learn more about the new SK-F3 and SK-F700. In the studio or in the field, they are clearly superior.

Contact Hitachi, 175 Crossways Park West, Woodbury, NY 11797, (516) 921-7200.

 **Hitachi Denshi America, Ltd.**  
NEW YORK • LOS ANGELES • CHICAGO • DALLAS • ATLANTA

Circle (4) on Reply Card

World Radio History

## Dolby demonstrates digital audio system

A compatible digital audio system was demonstrated at the NAB by Dolby Laboratories, San Francisco, to show how stereo TV sound can be brought into the home over existing regular broadcast and cable TV channels. The system, already in use in the United States, Australia and other countries for network distribution and teleconferencing, was used to broadcast NTSC with digital stereo sound over KBLR-TV, channel 39, Las Vegas.

Because digital audio is relatively immune to degradation as it passes through the transmission chain, the audio signal received in the home on an equipped television is comparable to a CD recording. The digital audio data is added to the TV signal by means of a QPSK carrier modulated with 512,000b/s. The Dolby system, based on adaptive delta modulation (ADM), can be adapted for a variety of transmission applications and could be

implemented almost immediately for regular NTSC broadcasts.

The broadcasts also demonstrated a compatible system for improved picture quality, SuperNTSC, developed by Faroudja Laboratories, Sunnyvale, CA.

## NPR, regional networks to present workshop

National Public Radio (NPR), Washington, DC, along with Pacific Mountain Network and the Southern Educational Communications Association, will offer an intensive workshop in stereo audio recording for television and radio July 24-27 in Denver. The workshop will cover digital audio systems and recording for stereo broadcast, including topics such as synchronization, interfacing multiple systems and multichannel TV sound (MTS).

Top radio and TV audio recording engineers will lead general and individual sessions that explore the technical and

aesthetic aspects of recording live music. Among the instructors will be: Ed Greene, Paul Blakemore, Neil Muncy, Skip Pizzi and Cary Wight.

The workshop is open to mid-level producers and engineers at public radio and TV stations as well as independent and commercial stations. The number of trainees will be limited, and selection will be on a first-come, first-served basis. For information, contact: NPR Training, Representation Division, 2025 M Street, N.W., Washington, DC 20036. The application deadline is June 30.

## Washington station to receive Klystrode-equipped transmitter

Comark Communications, Colmar, PA, will supply a new 120kW, Klystrode-equipped UHF TV transmitter to WETA-TV, channel 26 in Washington, DC. The station serves about three million viewers.

*Continued on page 185*

# BROADCAST engineering

Editorial and advertising correspondence should be addressed to: P.O. Box 12901, Overland Park, KS 66212-9981 (a suburb of Kansas City, MO); (913) 888-4664. Telex: 42-4156 Intertec OLPK. Circulation correspondence should be sent to the above address, under P.O. Box 12937. RAPIDFAX: (913) 541-6697.

### EDITORIAL

Jerry Whitaker, *Editorial Director*  
Brad Dick, *Radio Technical Editor*  
Carl Bentz, *Technical and Special Projects Editor*  
Rick Lehtinen, *TV Technical Editor*  
Tom Cook, *Senior Managing Editor*  
Paula Janicke, *Staff Editor*  
Dawn Hightower, *Associate Editor*  
Suzanne Oliver, *Editorial Assistant*  
Andrew Naugher, *Editorial Assistant*  
Pat Blanton, *Directory Editor*

### ART

Stephanie Swail, *Graphic Designer*

### EDITORIAL CONSULTANTS

Fred Ampel, *Audio*  
Nils Conrad Persson, *Electronics*  
Ned Soseman, *Video*  
Michael Heiss, *Consulting Editor*  
Don McCroskey, *Consulting Editor*

### BUSINESS

Cameron Bishop, *Group Vice President*  
Duane Hefner, *Group Publisher*  
Stephanie Hanaway, *Marketing Director*  
Evelyn Hornaday, *Promotions Manager*  
Darren Sextro, *Promotions Coordinator*  
Dee Unger, *Advertising Business Manager*  
Mary Birnbaum, *Advertising Production Supervisor*  
Sally Nickoley, *Advertising Coordinator*

### ADMINISTRATION

R.J. Hancock, *President*  
Chuck Rash, *Corporate Circulation Director*  
Sandra Stewart, *Circulation Director*  
Doug Wilding, *Circulation Manager*  
Customer Service: 913-541-6628  
Kevin Callahan, *Creative Director*

### TECHNICAL CONSULTANTS

Eric Neil Angevine, *Broadcast Acoustics*  
John H. Battison, *Antennas/Radiation*  
Blair Benson, *TV Technology*  
Dennis Ciapura, *Radio Technology*  
Dane E. Ericksen, *Systems Design*  
Howard T. Head, *European Correspondent*  
Wallace Johnson, *FCC/Bdct. Engineering*  
John Kean, *Subcarrier Technology*  
Donald L. Markley, *Transmission Facilities*  
Harry C. Martin, *Legal*  
Robert J. Nissen, *Studio/Communications*  
Hugh R. Paul, *International Engineering*  
Art Schneider, *A.C.E., Post-production*  
Elmer Smalling III, *Cable/Satellite Systems*  
Vincent Wasilewski, *Communications Law*

### MEMBER ORGANIZATIONS

#### SUSTAINING MEMBERS OF:

- Acoustical Society of America
- Society of Broadcast Engineers
- Society of Motion Picture and TV Engineers

Member,  
Association of Business Publishers

Member,  
Business Publications  
Audit of Circulation

BROADCAST ENGINEERING is edited for corporate management, engineers/technicians and other station management personnel at commercial and educational radio and TV stations, teleproduction studios, recording studios, CATV and CCTV facilities and government agencies. Qualified persons include consulting engineers and dealer/distributors of broadcast equipment.

BROADCAST ENGINEERING (ISSN 0007-1794) is published monthly (except in the fall, when two issues are published) and mailed free to qualified persons within the United States and Canada in occupations described here by Intertec Publishing Corporation, 9221 Quivira Road, Overland Park, KS 66215. Second-class postage paid at Shawnee Mission, KS, and additional mailing offices. POSTMASTER: Send address changes to **Broadcast Engineering**, P.O. Box 12960, Overland Park, KS 66212.

**SUBSCRIPTIONS:** **Broadcast Engineering** is mailed free to qualified persons in occupations described above. Others may subscribe at the following rates: United States, one year, \$50; all other countries (surface mail), one year \$60. Rates include postage. Foreign air mail and Canadian first class options are available at the annual subscription rate of \$115. Single copy price \$4.50, except for the annual Buyers' Guide/Spec Book, which is \$20. Back issues, when available, \$5; Buyers' Guide/Spec Book back issues \$23. Adjustments necessitated by subscription termination at single copy rate. Allow six to eight weeks delivery for change of address or new subscription.

Photocopy rights: Permission to photocopy for internal or personal use is granted by Intertec Publishing Corporation for libraries and others registered with Copyright Clearance Center (CCC), provided the base fee of \$2.00 per copy of article is paid directly to CCC, 21 Congress St., Salem, MA 01970. Special requests should be addressed to Cameron Bishop, group vice president. ISSN 0007-1794 \$2.00 + \$0.00.

© 1989. All rights reserved.

Advertising offices listed on page 207.

# LEADER

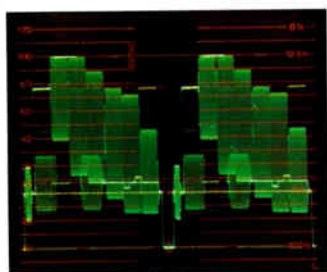

## THREE.



## IN ONE.

### And only in the 5870 Vector/Waveform Monitor.

Only the 5870 gives you a unique numerical readout of SCH phase. And waveforms from 2 channels, plus vector information - appearing at the same time or separately. All this in one half-rack!

### No compromises.

This unsurpassed unit performs like three superb instruments in one.

**2-channel NTSC waveform monitor:** Features simultaneous or separate display of both channels, and dual filter display, plus a CRT readout of SCH phase, full 525-line select capability with a CRT readout of the line and field selected, memory

preset and recall of nine lines. Add to this the unit's remote control capability and extra-bright CRT, and you have a terrific waveform monitor.

### Full-fledged NTSC vectorscope:

Boxes for error limits of  $\pm 2.5^\circ$  and  $\pm 2.5$  IRE units;  $\pm 1^\circ$  differential phase and  $\pm 1\%$  differential gain; internal Z-axis blanking for line selection and continuous phase adjustment. The 5870 is a great vectorscope, too!

### Designed to go anywhere.

Operating from any 11-20 Vdc or 85-264 Vac (48-440 Hz) power source, this 12-lb, half-rack unit is ideal anywhere that size and weight are critical.

Call toll-free  
**1 800 645-5104**

In NY State  
**516 231-6900**

Ask for our full-line Catalog, an evaluation unit, and the address of your nearest Leader Distributor.

**Leader Instruments Corporation**  
380 Oser Avenue, Hauppauge, New York 11788  
Regional Offices:  
Chicago, Dallas, Los Angeles, Boston, Atlanta  
In Canada call Omnitronix Ltd. 416 828-6221

**LEADER**  
FOR PROFESSIONALS WHO KNOW  
THE DIFFERENCE

Circle (5) on Reply Card for Product Demonstration

Circle (6) on Reply Card for Product Information

World Radio History

## Vaporware

*Look, up in the sky...it's a new product...it's a technology demonstration...no, it's vaporware!*



The computer industry has brought broadcasting countless technological advancements, countless new products, countless new ways of solving old problems. With the good, however, comes the bad. Enter vaporware, products that are more smoke and mirrors than substance.

There are many forms of vaporware. We have observed the following:

- **Front-panel-ware:** a product that consists of just a front panel. There are no guts behind the buttons and displays. The system is really running on a Cray II hidden behind a curtain in the booth.

- **Reboot-ware:** a product with more than the usual number of software bugs. Potential customers are told that if the system locks up, just reboot. For convenience, one of the keyboard function keys has been reassigned to *system reset*.

- **Not-ready-for-prime-time-ware:** a product that performs less than 50% of its advertised functions. The company figures that most users won't use the really elaborate stuff, so nobody will miss it.

- **Show-demo-ware:** an interactive product that provides a canned sales pitch whenever the customer turns it on. Unfortunately, self-demonstrations are the only thing the system does well.

"It's just a matter of software" is probably the great understatement of the decade. Software as a technology is extremely complex. In many ways hardware is simpler and more straightforward. Software development in the early 1980s usually revolved around hardware. It was a natural extension of traditional developmental work. Instead of designing a logic tree out of gates and flip-flops, it was implemented in software code.

As computer technology advanced and users became more demanding, software development became much more than simply a substitute for hard-wired chips. It became the essence, the soul, of the machine. Companies now routinely spend considerably more time and money on software development than they do on hardware. Certainly one reason is the move toward off-the-shelf computing platforms for system implementation. It is the software, by and large, that makes a computer-based box what it is. The same basic hardware can be used to make a graphics paint system, still store, audio editor or station automation system. Software is the key. Without complete, bug-free software, the system is of limited value. The customer gets cheated.

It is unfortunate that events such as the NAB convention focus primarily on *new* products. What is the first question an attendee asks when walking into a booth at this, or any other show? *What's new?* The implication is that unless a company brings a truckful of new goodies to a show, it isn't worth visiting. This new-is-better mindset places incredible pressures on manufacturers to develop new products; that is good for the industry, and in the final analysis it is also good for the company. This mindset, however, also places incredible pressures on companies to introduce and deliver products based on schedules that may or may not be realistic.

Sometimes the result is delayed shipments to customers. Other times products wind up in the field that function poorly, or not at all. Fixing bugs — minor or major — in a complex system easily can take as long as the original software design. That leaves the user with a box that doesn't live up to optimistic trade show promises.

Some of these problems are the result of well-intentioned but overenthusiastic vendors. Others are simply ploys designed to delay a customer's purchase decision, to buy time for a company until its competitor's advantage can be overcome.

There are no easy solutions to the software dilemma faced by this industry. In the final analysis, however, the ultimate power to control vaporware rests in the hands of equipment users. In this business, as in every other, the customer is always right. If customers refuse to accept vaporware, it will disappear. Guaranteed.

Jerry Whitaker,  
editorial director



# INSTANT SIGNAL PROCESSING



Orban's new digitally-controlled 787A Programmable Mic Processor integrates an unprecedented combination of vital signal processing functions into one powerful, compact package. It delivers fully programmable **mic- or line-level** processing with access to 99 memory registers through MIDI or RS-232 interfaces, or a console-mounted remote control. All you do is add the talent.

The 787A offers a space-saving, elegant solution to many annoying problems (voice deficiencies, poor room acoustics, noise, sibilance, wandering levels) in the broadcast control room, TV newsroom, or in commercial production, video post, audio-for-video, and film scoring facilities. The 787A gives you an important competitive edge by enabling you to repeat the same optimum sound every day for every voice, quickly and efficiently.

The 787A is complete audio processing arsenal in a box—a flexible parametric EQ, a smooth compressor, noise and compressor gates, and a handy de-esser. The 787A can be operated in mono or dual-channel/stereo (with the addition of a second-channel slave). An optional Jensen transformer mic preamp with 48V phantom power adds further flexibility.

Orban's 787A Programmable Mic Processor will help you remember tomorrow the way your talent sounded yesterday.

**Orban** a division of AKG Acoustics, Inc.,  
645 Bryant Street,  
San Francisco, CA 94107 USA  
(415) 957-1067 Telex: 17-1480  
FAX: (415) 957-1070

The Orban logo consists of the word 'orban' in a bold, lowercase, blue sans-serif font.

Circle (7) on Reply Card

## Renewal abuses to be curbed by reforms

By Harry C. Martin

The FCC has adopted reforms to its license renewal process to discourage the filing of sham competing applications and petitions to deny, both of which have been used to obtain large cash settlements from incumbent renewal applicants rather than to advance public interest goals. Also, the commission asked for comments on a proposal to establish a rebuttal presumption that a renewal applicant is entitled to a renewal expectancy.

Under the most significant reform, settlement payments in return for withdrawal of a competing application are banned prior to the issuance of an initial decision in the renewal hearing. Thereafter, cash payments are limited to the "legitimate and prudent" expenses of the withdrawing applicant. Under the old rule, there was no limit to the amount of money that could be paid to a competing applicant in return for withdrawal.

Payments made to someone who files a petition to deny a renewal application also will be limited to the legitimate and prudent expenses. This change is based on the commission's experience that many petitions to deny are filed for the purpose of extracting money from a renewal applicant, rather than to achieve reforms in the targeted station's programming or minority employment practices.

In this same connection, the commission will require that all citizens' agreements involving withdrawal of a petition to deny be reviewed by the agency to ensure that the payments are limited to the money the petitioner reasonably and prudently expended. Any agreement that involves other payments to a petitioner, such as for consulting fees, will be considered contrary to the public interest.

The Cameron doctrine, which previously permitted a renewal challenger to presume that an incumbent licensee's transmission facilities would be available to the challenger, has been repealed. Under the new rules, renewal challengers will have to secure their own transmitter sites and file all new engineering studies.

In a related notice of rulemaking, the commission is seeking comment on a pro-



posal to shift the burden of proof in renewal proceedings. In the past, incumbents who have been successful in showing they deserve a renewal expectancy have been renewed regardless of the comparative qualities of the challenger's proposal. But a renewal expectancy had to be earned by the incumbent through the presentation of evidence of past meritorious programming. Under the commission's new standard, the burden would be the challenger's to prove the incumbent has not presented enough quality programming to warrant a renewal expectancy.

### New FM Class C3 created

The commission has amended its FM allocation rules to create a new class ("C3") midway between Class A and Class C2. Class C3 stations, which will be authorized in Zone II only, will be permitted to operate with up to 25kW at an antenna height above average terrain of 328 feet.

This action was taken to provide upgrade opportunities for those Class A FM stations that were ineligible to upgrade to Class C2 (maximum facilities: 50kW at 492 feet AAT), but could meet the lesser spacing standards for the new Class C3.

The Mass Media Bureau has listed approximately 150 Class A stations, mostly in the western United States, that could be upgraded in this way. The agency proposes to authorize the substitution of C3 channels for these Class A channels by using a show-cause procedure. This would obviate the need for separate rulemaking petitions for each of the 150 upgrades.

In the same proceeding, the commission increased the minimum facility requirements for Class C2. Stations operating on C2 channels whose current facilities do not meet or exceed the new minimum requirements will be allowed two years to apply for improved facilities or face reclassification as C3s.

### FCC Form 301 is revised

In response to an initiative by the Federal Communications Bar Association (FCBA), the commission has revised its FCC Form 301 (application for commercial broadcast CP) to require that applicants disclose certain financial, ownership and

integration information not presently required.

The new form will require applicants to submit estimates of the cost of constructing and operating the proposed facility for three months, and to identify their funding sources. In the past, applicants have been able to certify their financial qualifications without providing any detailed information about costs and financing. This "blind" certification procedure has encouraged speculative applications by financially unqualified applicants. In the future, the commission will return any application that does not provide the required information to back up a financial certification.

With regard to ownership disclosures, the commission will require the identification of all equity owners in the applicant, unless the entity has more than 50 equity owners. The FCBA sought this change because the existing Form 301 does not require disclosure of the identities of non-voting stockholders or limited partners, even though they may exercise de facto control of the applicant. The change will help ensure that real-parties-in-interest are fully exposed and evaluated in the application process.

The commission also will require applicants to disclose any contracts, such as option or proxy agreements, that might affect an applicant's future ownership rights or integration.

Another requirement of the new Form 301 will be disclosure, early in application processing, of integration proposals. In FM proceedings, the deadline for such disclosure will be the 30th day after the FCC's notice of tenderability. For TV and AM proceedings, the integration disclosure deadline will be the "B" cutoff date. This reform was adopted so parties can evaluate the strengths and weaknesses of their competitors in an early stage of the process, thereby facilitating settlements prior to hearing. Also, early disclosure will eliminate integration gamesmanship and discourage contingent integration proposals.

Martin is a partner with the legal firm of Reddy, Begley & Martin, Washington, DC.

Editor's note: Additional information regarding FCC activities is available on CompuServe. IGO BPFORUM



# The **COST** of quality digital effects...



## ...just took a tumble!

GVG's exciting new DPM-100 Digital Picture Manipulator puts a full array of exciting digital effects at your fingertips — for an incredibly low price.

The newest member of GVG's popular Model 100 Production System family, the DPM-100 gives you standard effects only available as expensive options on other systems. Including spin and orbit around variable axes, skew, mosaic, posterization, solarization, false color and cropping.

And there's a lot more. The DPM-100 gives you an optional *full function, full bandwidth second channel*. Including a standard *priority dissolve combiner* for spectacular shadow and dissolve effects.

For even more power, the DPM-100 gives you a *recursive*

*memory* option for star, decay and strobe trails. Not to mention other standard high-end features like a luminance and linear keyer, **STREAMLINE™** Effects Controller with disk drive, and GVG's

**E-MEM®** Effects Memory System — all in a three rack unit frame.

Once you take the DPM-100 for a spin, you'll flip! Get all the details today from the GVG office nearest you.

**Grass Valley Group®**

A TEKTRONIX COMPANY

THE GRASS VALLEY GROUP INC.

P.O. Box 1114, Grass Valley, CA 95945 USA  
Telephone (916) 478-3000 TRT: 160432  
FAX (916) 478-3187

OFFICES: New York (201) 845-7988; District of Columbia (301) 622-6313; Atlanta (404) 493-1255; Miami (305) 477-5583; Chicago (219) 264-0931; Minneapolis (612) 483-2594; Dallas/Fort Worth (817) 483-7447; Los Angeles (818) 999-2303; San Francisco (415) 968-6680; GVG International Ltd. (U.K.) + 44-962-843939; Grass Valley Group Asia (HK) + 852-3-7874118; Grass Valley Group del Sud America (USA) (305) 477-5488.

Circle (8) on Reply Card

## Tape defects defined by "RF signature"

By Rick Lehtinen,  
TV technical editor

To most video engineers, tape dropout is something that happens when you don't clean the heads on a VTR. Whenever a lump of goo or a speck of dust gets between the head tip and the tape surface, RF is decreased and the signal is lost.

Some dropout can be caused by problems during manufacturing. Contamination in the tape formulation or rolling

process can leave imperfections in the tape's magnetic coating, causing dropout. For this reason, quality assurance is one of the top priorities for tape manufacturers.

The defects displayed here were captured by a digital oscilloscope that was triggered by fluctuations in tape RF. The VTR recorded a standard video test signal,

and the scope monitored the confidence head. This information was used in developing a system to identify defects by their signatures rather than by photomicrography.

Acknowledgment: Photos were provided by the Applied Technology Group, Magnetic Tape Division, of Ampex.

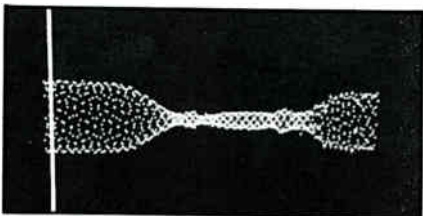
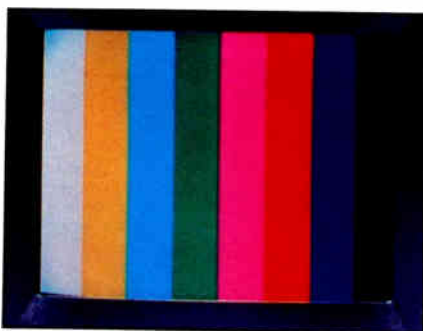

**Figure 1. Coating bump:** A clump of magnetic particles or debris has been coated onto the tape. The waveform shows the "RF shadow," in which a tiny defect causes a big RF loss, similar to the way a car running over a speed bump remains airborne for a time.

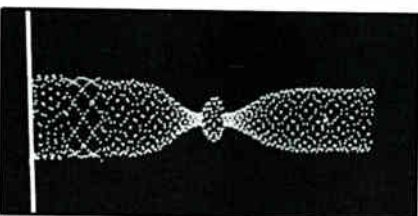

**Figure 3. Solvent bubble:** A bubble of undispersed solvent in the base coat mix has evaporated, leaving a "fisheye," which sometimes occurs in auto body painting.

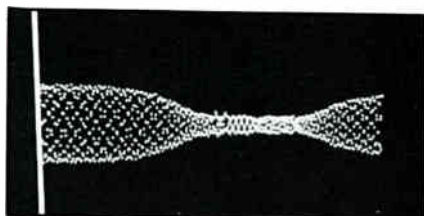
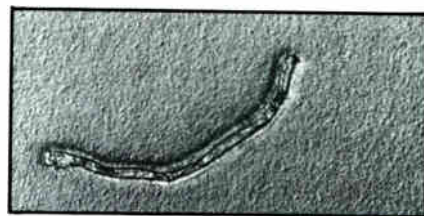

**Figure 5. Calender redeposit:** Some debris has landed on the calender roll and has been pressed into the tape.

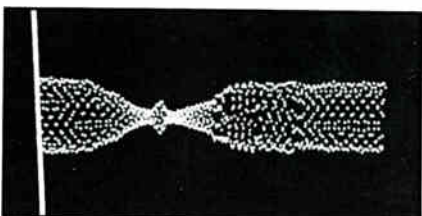

**Figure 2. Base film defect:** Base film gel, a bubble of liquid residue trapped in the tape's base film backing, has oozed up into the tape's magnetic coating, where it has been smoothed and calendered.

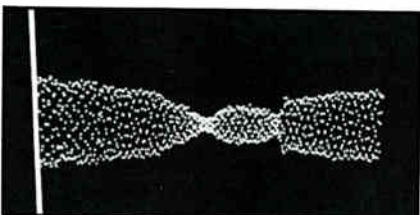
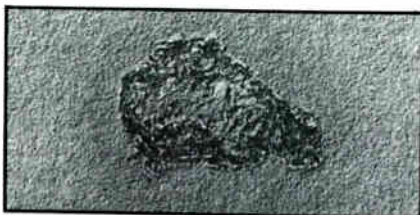

**Figure 4. Calender impression:** Debris, which adhered to a steel roller during processing, makes dents in the tape surface.

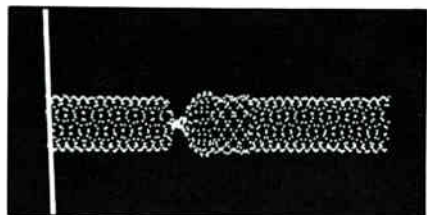

**Figure 6. Compliant roll defect:** During processing, the tape passes between hard rollers and compliant rollers, similar to pinchrollers and capstans in a VTR. Debris on the compliant roller can damage the tape. [:-(-)]

**NEW  
LOWER PRICE  
\$2,495.  
CALL YOUR DEALER**



# Radio's All-Terrain Vehicle

**A machine that pulls  
its own weight—and  
then some—the PR99  
MKIII delivers top  
performances over  
some pretty tough  
terrain ...**



The PR99 MKIII Headblock

Whether you're downlinking or uplinking satellite feeds, taping news call-ins, producing commercial spots, or using the Playback Only version of the PR99, the new MKIII is the vehicle you want. This is a machine that won't quit. And proves it everyday in radio stations throughout the world.

The PR99 MKIII reflects the same engineering expertise that has made Studer Revox the world standard for excellence in audio recording.

Compare these MKIII features with the competition:

- a solid die-cast aluminum transport chassis and head block
- record and playback heads machined to the same tolerances as the heads for Studer multi-track recorders
- easily accessible modular electronics for tough, reliable broadcast performance
- a true Autolocator with digital counter in hours, minutes and seconds
- speed configurations of 3 1/2 - 7 1/2 ips & 7 1/2 - 15 ips
- rack mounts standard.

In whatever terrain you operate—in radio production or on-air work—the PR99 MKIII is a no-nonsense machine that gets you where you want to go. Before you buy, check out the MKIII for value and performance. Over the long haul, the Revox PR99 MKIII leaves the competition in the dust.

Available from Studer Revox Professional Products Dealers. Or contact us directly.

## **STUDER REVOX**

**Studer Revox America, Inc.  
1425 Elm Hill Pike  
Nashville, Tn 37210  
Phone (615) 254-5651**

**Offices:**  
Los Angeles (818) 780-4234.  
New York (212) 255-4462.  
Chicago (312) 526-1660.  
Canada (416) 423-2831.

## Beyond the coverage map

By John Battison, P.E.

Most non-directional stations are not concerned with regular monitor point measurements. In fact, even directional stations today barely have any problem with monitor points.

However, just because the FCC does not require non-DAs to make regular measurements, don't forget radiation values. Many of today's stations are at least 40 years old. Some have more than half a century of service with their antennas. These stations were built when station engineering was at its peak in terms of good installations and first-rate equipment. Now, far too many of these old masters are falling into disrepair.

### Do your research

When new engineers — both contract and full-time employees — join such stations, often the first question they hear is, "Why is our signal so poor downtown (or wherever)?" Smart engineers will ask for the original service contour maps. These should be available in the original application for construction permit, amendments to the application, or modifications to the CP or license. Unless the owner had a good reason to require a coverage map of actual service contours, none would have been made as the result of measurements. Keep in mind that we're still talking about non-DA stations.

So you, the new station engineer, have nothing to compare with present-day service. You don't even have the original theoretical map showing the 2mV/m and 0.5mV/m contours. So what do you do? Don't panic, and don't be upset by the manager's statement that just a few weeks ago, in fact just about the time you came on board, the signal was much better downtown. (This, and the following, generally applies to DA stations as well.)

Get the manager's permission to order a copy of the engineering section of the original application from International Transcription Services (2100 M Street, N.W., Suite 140, Washington, DC 20037). This will take several weeks, depending on how far back into the archives the



researcher has to go. It will cost approximately \$50. Another approach is to call the station's attorney in Washington, DC, and ask for a copy of the original application from the commission. This sometimes costs less if the attorney has an efficient paralegal. You might even get lucky and find the original attorney who still has a copy in the files. In any case, get yourself a copy of this vital data.

When the engineering report arrives, locate the map showing the 0.5mV/m, 2mV/m and 25mV/m contours, and transfer these onto a modern map. Prepare for a shock. You probably will find that what were choice, high-priced residential areas now are slums, or vice versa.

### Take some measurements

Borrow a field-intensity meter, and make measurements at various locations where the old and new readings can be compared. You can get a reasonable comparison by selecting sites along contours of interest. Try to use locations where the contours are free from wires, buildings or other pattern-interfering construction.

Don't expect to find 0.5mV/m along that contour line on the map. The odds are that you won't, but the signal should not be too far off. One way to make an intelligent check is to lay off a radial of at least 10 points and make measurements. Plot these on standard log-log groundwave paper (available from NAB), following the instructions in the FCC rules.

Locate the 0.5mV/m value, and read along the bottom line to find the distance to this point. Locate this on your map. This is where the signal should be approximately 0.5mV/m. You may find that the location is some distance short of the original contour.

Repeat this process in as many directions as you have time and interest for. Most likely, your coverage has shrunk. It's also likely that it may have become extended in one or more directions as a result of local construction.

In any case, once you have made your checks with the field-intensity meter, be sure to record them for posterity. Keep a complete file in a loose-leaf book with numbered pages. Log everything you did, what was measured and the test results.

Designate monitor points, and list them by number, distance, description, time of day, weather conditions and measured field strength. Make it a point to check these monitor points every six months, and record the results. If levels decrease in one direction, look for an increase in another. Then look at the area, and determine what caused the pattern change.

### Inspect the ground radials

Look at the ground system, even if the base impedance appears to be correct, with a bridge. If the ground strap has pulled away from the tower base under the insulator, reinstall it. Check the 4-inch copper strap around the tower base and the radials emanating from it. Are the radials still there and firmly soldered? Or are there lots of sad-looking greenish strands just lying on the ground several inches or feet from the remains of the ground strap?

Now check the radials. Using a field-strength meter, walk along the radials with the unit held close to the ground. If you don't have a field-strength meter, use a small pocket radio and headset. Put the transmitter on low power, tune to your station, and walk out along the radials with the receiver close to the ground. To save your back, mount the receiver on the end of a light pole so it can be held close to the ground. As you move along a radial, the signal should increase. If you find a break in a radial, you should hear the signal decrease. Keep a record of how many breaks you identify and how far out they are.

Far-out breaks are not as bad as close-in ones. Recall that the space current is highest close in, and the heaviest current flows in the ground screen or short intermediate radials near the tower base. If many breaks appear to be close to the tower base, you've probably found the reason for your low field strength. The solution is obvious.

Other factors can affect a station's coverage area. We'll look at some of them next month.

Battison, BE's consultant on antennas and radiation, owns John H. Battison and Associates, a consulting engineering company in Loudonville, OH.

# Varian Eimac...



## SERVING THE BROADCAST WORLD!

For over 50 years Varian Eimac's tradition of quality and dependability has been firmly established, and continues to be the industry leader today.

Stringent manufacturing standards and controls reduce transmitter downtime and eliminate excessive operating overhead.

Varian Eimac tubes from watts to megawatts, cavities from megahertz to gigahertz, and a large selection of accessories support this complete product line in radio and television.

All Varian Eimac tubes are warranted 100% to be free of manufacturing defects. Specific warranties for individual tube types are available from Varian Eimac sales organizations worldwide:

Next to producing a wide variety of products, Eimac provides rapid customer service and support. Eimac people are trained in their field ready to offer the expertise needed in technical problem solving and special applications.

From design to final product, Eimac quality and reliability are carefully built in. Eimac is small enough to handle special orders, and large enough to handle large requirements.

We guarantee Varian Eimac products will be here today for tomorrow's applications. Varian Eimac's 50 plus years of outstanding performance stands as the benchmark for the industry.

varian  eimac

301 Industrial Way, San Carlos, CA 94070, Telephone: (415) 592-1221  
1678 S. Pioneer Road, Salt Lake City, UT 84104, Telephone: (801) 972-5000

Circle (10) on Reply Card

## The business world turns to VSAT

By Elmer Smalling III

As the data communication needs of broadcasters and cable system operators grow, VSAT (very small aperture terminal) satellite systems seem the logical choice over expensive common carrier alternatives. VSAT terminals, which use small, roof-mounted dishes, are becoming more common as businesses such as insurance companies, grocery chains and shipping lines use them to transmit large volumes of constantly changing data.

Early VSAT systems operated in a point-multipoint fashion, but present technology allows for combinations of mesh and star networks to serve from four to 4,000 destination points or nodes.

Many businesses and some broadcast and cable multiple system owners are turning to VSAT as a telco bypass, especially when their operations are located on opposite sides of the country and information such as logs, run-downs, commercial and slow data must pass back and forth during any given day.

If you're contemplating using a VSAT system, plan on having lots of data to keep a T1 circuit (1.5Mb/s) busy! This could be accomplished by using the VSAT system for telephone and audio feeds as well as data. The T1 circuits, with the proper hardware, can be used to transmit video slow scan (stills and advertising) as well.

A typical VSAT terminal requires a 5- to 7-foot dish, which usually is mounted on the roof of a building. A combination 35W to 100W transmitter and 140° to 160° receiver usually is mounted at the antenna site and connected to the user's computer center by a small control and data cable. The computer facility may be connected to the VSAT using RS-232, RS-449 or OSI interfaces.

Ku-band satellite time for SCPC VSAT communication channels may be leased from a satellite owner or broker.

### Sky stations

VSATs put many carriers on the same transponder through the use of special, advanced multiple-access modulation techniques. According to a recent engineering release from NASA and JPL, a planned



high-capacity aeronautical satellite communications system will use similar techniques to serve more than 85,000 aircraft and reduce the existing communications load on en route air control. The system, scheduled for implementation in the 1990s, will handle voice and data communications to and from commercial and general aviation planes on cross-country flights. In terminal areas, existing ground-based VHF communications facilities are deemed adequate.

The single-channel-per-carrier system will provide command, TDMA (time domain multiple access), air traffic control, emergency, DAMA (demand assigned multiple access) and reservation channels. The data rate for this system will be 4,800b/s using multistate trellis code 8PSK modulation. This complex modulation scheme will ensure maximum use of the relatively small bandwidth available. These signals require a channel spacing of only 7.5kHz.

The system will provide more than 5,000 forward channels (from ground to

aircraft) and more than 7,000 reverse channels (from aircraft to ground).

This new satellite-airplane communications system will use two Ku-band satellites in geostationary orbit located 30° apart in orbit at 95° and 125° west longitude (above the East and West Coasts). Each satellite will contain a Ku-band antenna for communications with ground stations and a large 35-foot-plus L-band antenna for communications with airplanes. (See Figure 1.) Commercial aircraft will be equipped with a flat, phased array antenna with 10dB of gain that will wrap around the top of the aircraft fuselage. General aviation vehicles will be fitted with a lower-gain omnidirectional antenna.

The ground control for this system will be based at the 20 existing air route traffic control centers around the country. Each will include a 15-foot Ku-band antenna and a multichannel receiver/transmitter. These ground stations will provide aircraft with timing information, monitor traffic loading and coordinate handover activities. [:-:~))]]

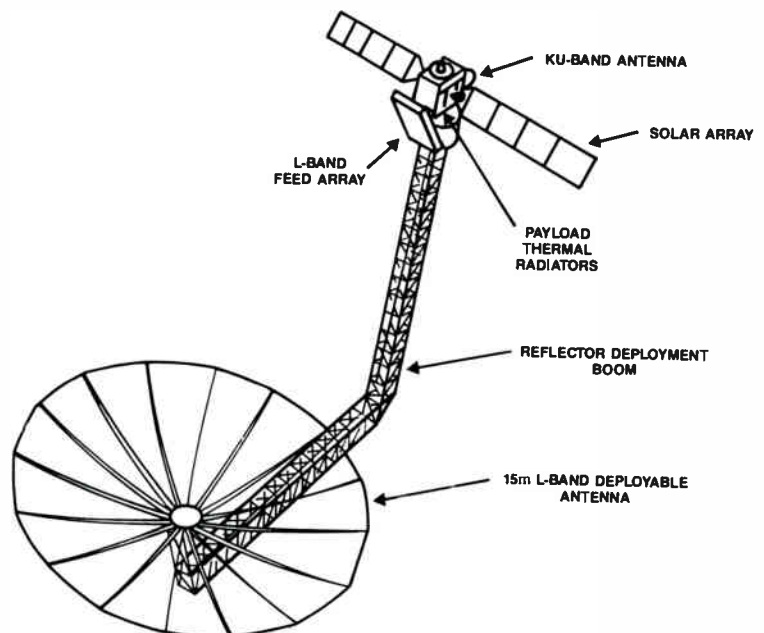

Figure 1. New Ku-band satellites will use large parabolic antennas to communicate air traffic control information to flying aircraft, easing the load on the current terrestrial system. (Graphic courtesy of NASA-JPL.)

Smalling, BE's consultant on cable/satellite systems, is president of Jenel Systems and Design, Dallas.



INTRODUCING THE NEW MX-55



© Otari 1988 \*Gapless, seamless, punch-in, punch-out is available only on some MX-55 models (GSPIPO is a trademark of Otari Corporation)

## THE NEXT "WORKHORSE."

Before you take us to task for trying to improve the BII, a design that has become the "workhorse" standard for two-channel audio machines, consider what the new MX-55 offers:

An integral autolocator; a voice editing mode that allows 2X speed playback at normal pitch; a built-in cue speaker; GSPIPO (gapless, seamless, punch-in, punch-out),\* and because you told us you wanted it, *all* adjustments are available through the front panel! These, and many more improvements will help make your job easier, and the results more creative.

And for those of you who still won't forgive us, we're keeping the BII in the line. So either way, you can get exactly what you need from Otari; Technology You Can Trust. Call Otari at (415) 341-5900 for information about the new MX-55. **OTARI**.

Circle (11) on Reply Card

## Have a taste of telephone soup

By Gerry Kaufhold II

The telephone customer can connect modems and fax machines to the Public Service Telephone Network (PSTN) via the universal modular jack. The signals travel down 26-gauge twisted-pair wires to the on-site junction block, and then on to the local central office. Each input to the local central office uses a subscriber line interface card — the ubiquitous SLIC. A typical central office will use tens of thousands of SLICs.

### About BORSCHT

The major functions of the subscriber line interface card are:

- Battery voltage supply.
- Overvoltage protection.
- Ringing (incoming call) signal.
- Supervision (for assessing long-distance and toll charges).
- Coding from analog to digital signals.
- Hybrid circuit.
- Test functions.

The popular acronym for these functions, derived from the first letter of each, is BORSCHT.

The primary purpose of the SLIC is to convert the 2-wire bidirectional telephone audio interconnection into a 4-wire signal. The SLIC uses a slightly unbalanced hybrid transformer to separate the send and receive audio on the incoming wire pair into two distinct signals, with send audio on one wire pair and receive audio on another.

In modern digital central offices, analog signals from the subscriber are pulse-code modulated (PCM) into digital form. The signals are distributed on high-speed links called T-1 carriers. The digital signals must be decoded from PCM back into analog for the final trip from the SLIC output to the user's telephone. The devices that encode and decode telephone information are called *codecs* (coder-decoder).

### Battery power

Since the days of Alexander Graham Bell, telephone systems have provided a dc power supply, typically -48V, a level chosen because it was strong enough to pull in electromagnetic relays. This voltage

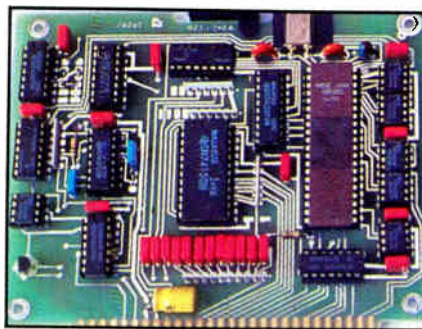

is now a standard, even though most telephones could supply safe operating power through transformer-isolated power supplies.

The primary reason telephone companies maintain their own battery voltage supply is safety of telephone company personnel. Although modern ac-to-dc power converters are much more reliable than the unbalanced transformer supplies of the 1950s, the risk of applying unlimited ac current into the telephone line is great enough that telcos probably will always provide their own power source. This is why you should NEVER connect non-certified equipment (even the station's oscilloscope) to telephone wires. You might put someone at the central office at risk of electrocution.

A secondary reason telephone companies are self-powered is public safety. Telephones still will operate during emergencies when normal utility power is not available.

### Overvoltage protection

Because telephone wires are strung above ground on poles, there is the possibility of lightning discharges destroying both telephones and subscriber line interface cards. SLICs include overvoltage protection in the form of high-power zener diodes, triacs or zener diode/SCR transient absorption devices. The telephone company will sacrifice a bank of SLICs to protect the rest of the central office electronics. Broadcasters may be wise to install overvoltage protection devices at remote transmitter locations to protect the remote-control equipment against lightning strikes or utility company power lines falling into phone lines during stormy weather.

### Ring and supervisory signals

The SLIC generates a 15Hz-68Hz, 50V-100V ringing signal. In many private branch exchange (PBX) systems, the ring signal is translated into an audible tone that gets decoded by a multifunction phone set.

Supervisory signals are used to engage long-distance or toll-call connections, and to keep track of line usage for billing purposes. Supervisory circuits also monitor

the incoming signals from user telephones and interpret them into commands for the central office signal switch.

### Test and safety

Over the years, telcos have enhanced SLICs with various features for the safety and convenience of central office workers. Requirements to support these features have been codified into the FCC rules, Part 68: telephone interface testing standards.

SLIC testing facilities include checks for longitudinal balance and circuit continuity. When the telephone is off-hook (a call is in progress) the dc currents flowing in the tip and ring parts of the line should be equal with respect to ground. This balancing of the tip and ring currents is tested as longitudinal balance of the telephone equipment, and the tolerances permitted are specified in FCC Part 68.

New rules have been added to Part 68 to cover dual-tone multiple frequency (DTMF) dialing circuits.

### ISDN

Even though telephone utilities have made huge investments in the existing base of subscriber line interface cards, a change is coming that will replace all SLICs with new all-digital telephone equipment.

Within the next five years, we all will begin hearing about the integrated services digital network, or ISDN. This is a new telephone technology that puts the codecs inside the end-user's telephone equipment and uses a wideband digital communications format between the user's telephone equipment and the central office.

ISDN will support many new services, including data communication rates of more than a million bits per second, telephone video conferencing, and maybe even compressed video programming, such as movies, available by telephone.

Kaufhold is a market development engineer for SGS-Thomson Microelectronics, Phoenix.

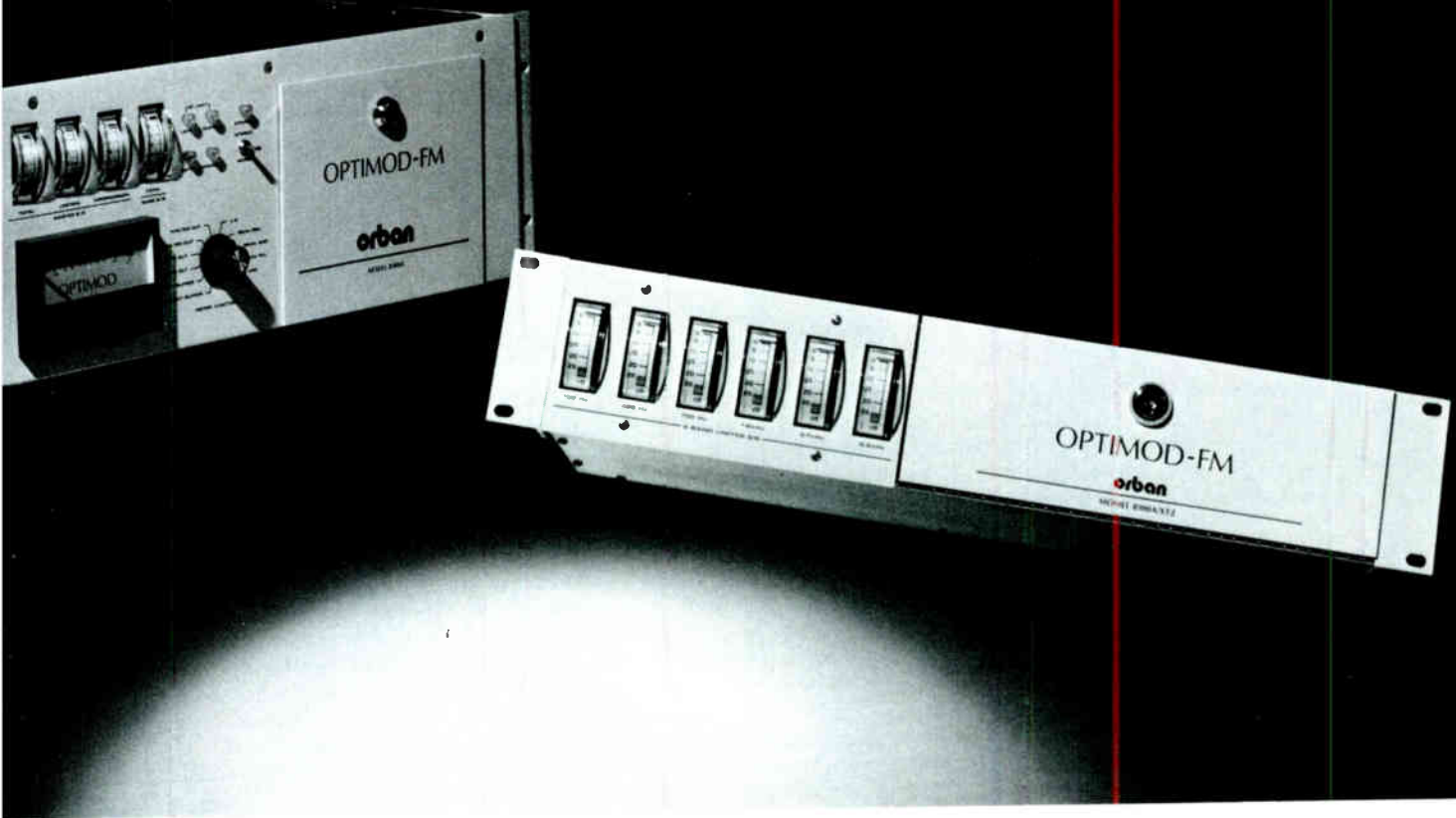

## First Class Sound. Affordable Price.

Orban's popular XT2 Six-Band Limiter Accessory for OPTIMOD-FM® 8100A has been chosen by many major-market stations seeking a "highly processed" sound that's also clean, natural, and easy to listen to. What's particularly significant is how many have chosen the XT2 after comparing it to "another unit" — which costs twice as much! (The XT2 costs only US\$2,075!)\*

How does Orban provide superior performance at a modest price? Simple — the XT2 uses your host OPTIMOD-FM's power supply and much of its circuitry to achieve efficiency, economy, and performance so high that the XT2 would be the processor of choice even if cost were no object.

The XT2 provides bass, presence, and brilliance equalization, plus density and clipping controls, to let you precisely tailor the sound to your station's format and target audience.

Ask your Orban Dealer for information about Orban's powerful First Class winner — the XT2. Or write, call, or FAX us directly.

**orban**

a division of AKG Acoustics, Inc.

645 Bryant St., San Francisco, California 94107 USA

Telex 17-1480 FAX (415) 957-1070

**Telephone (415) 957-1067 or (800) 227-4498**

Circle (12) on Reply Card

## CD troubleshooting

By Brad Dick,  
radio technical editor

**B**roadcasters and other compact disc users have been conditioned to believe that CDs are the perfect medium. CDs are supposed to offer infinite life, immunity to most damage and perfect audio reproduction. After more than three years in the professional environment, however, the compact disc has not lived up to some of the original claims.

More and more stations are relying on CDs as the primary source of audio. As CD usage increases, so does the number of complaints about disc and player quality. The most common complaints seem to be directed at the players. The CD players are blamed for skipping, jumping tracks, failure to cue properly and a host of other problems. It's true that some of the early players had their problems, but today's professional models are highly reliable. A close examination reveals that the source of the problems may not be the player; it could be the compact disc.

### Finger of blame

One engineer saw a salesman in a record store demonstrate the ruggedness of a CD by dropping it on the floor. The salesman then stepped on it and scooted it around on the carpet. When he placed the CD in a player, it worked perfectly. Everyone was impressed.

Such stories hide the fact that CDs are destructible, as many stations are finding out. You can damage a disc simply by labeling it with a ballpoint pen. Fingerprints, beverage stains, cigarette tar and dirt all can contribute to failures in the air studio. These failures usually are blamed on the players when, in fact, the disc is at fault.

Do the DJs at your station ever stack CDs together as if they were carts? Are the discs ever placed or scooted on counter-tops? Are the CD surfaces ever touched? Is smoking allowed in the studio? Any of these practices can result in enough damage to the CD that it will no longer play reliably.

### An issue of quality

User damage is not the only cause of failure. Poor quality control by the disc manufacturer is a cause for CD failure. Other times, such as when an 80-minute

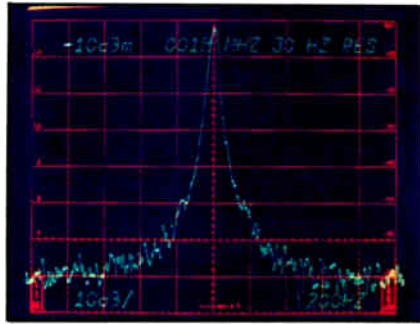

CD is released, the manufacturer produces a disc that does not meet all the Sony/Philips specifications for CD production. Your station may have been the victim of some of these types of defects, and you probably didn't even know that the disc was at fault.

Although CDs originally were considered the perfect medium, questions soon arose about their quality. The issue of "CD rot" was first raised just one year ago. Several newspapers carried stories questioning the durability of the CD. The scenario was that the reflective aluminum layer was being destroyed by the inks used in the disc-labeling process. The ink apparently ate into the lacquer designed to protect the aluminum coating.

Investigation showed that CD rot was traceable to the lacquer-curing process. At that time, two types of lacquer curing were being used — air drying and ultraviolet light drying. The discs showing damage turned out to be from manufacturers using the air-drying process. Once these companies changed to UV drying, CD rot was no longer an issue. UV drying is used for virtually all discs manufactured today.

### Real-world problems

In the beginning, professional players were not easily available. Stations, anxious to be able to promote the use of CDs, bought consumer units. Unfortunately, the consumer units had not been designed for the continuous demands of broadcasting. In addition, as most chief engineers would agree, DJs are notorious for abusing broadcast equipment. As the use of CDs increased, so did the wear and tear on the machines — and the discs. The myth that compact discs were almost indestructible resulted in excessive wear on the CDs.

Scratches and dents from improper handling began to cause on-air playback problems. Skipping, track jumping, failure to read the table of contents and miscuing were common complaints. In most cases, the player was blamed for the trouble.

### Tutorial series

With most broadcast equipment, the reasons for failure are obvious. If the

limiter quits, it's a good bet that the problem lies in the limiter. But this analogy does not apply when it comes to a CD player. Because the player is useless without the CD, both systems must be examined whenever problems occur. Improper playing of a CD does not necessarily mean that the player is defective. This fact has led many engineers down the wrong troubleshooting path.

This is the first in a series of "Troubleshooting" columns that will discuss the player and compact disc as a system. You will learn how to differentiate between many disc problems and player problems. Knowing this one technique may save you hours of frustration.

This series will examine three specific areas. The first is CD quality. Although all CDs look much the same, closer inspection reveals that not all disc manufacturers provide identical-quality products. Knowing when to blame the disc for a player problem can make a tremendous difference in your troubleshooting ability.

The second area is user damage to CDs. By understanding the physics behind CD reproduction, you'll better understand why scratches and dents can cause player failure. We'll also look at some ways to repair damaged CDs.

The third issue is CD player maintenance — both crisis and preventive. Several CD player manufacturers have agreed to share hints and procedures to help you service your equipment. Through block diagrams, schematics and photos, you will learn how to troubleshoot CD players efficiently and with confidence.

Next month we'll look at the construction of the compact disc. The disc is a marvel in technology with manufacturing and player tolerances far exceeding any you've ever encountered. By the time you've finished Part 2, you'll understand why quality manufacturing is the key to reliable CD player performance.

**Acknowledgment:** Appreciation is expressed to the following people for their help in preparing this article: Laura Tyson, sales engineer, Denon America; Martin Ledford, quality control manager, Denon Digital Industries; and Dave Bowman, director of professional products, Studer Revox.

|| :-=) |||

# “Incredible...A component MII recorder with built-in A/B roll editing at 3/4 inch prices.”

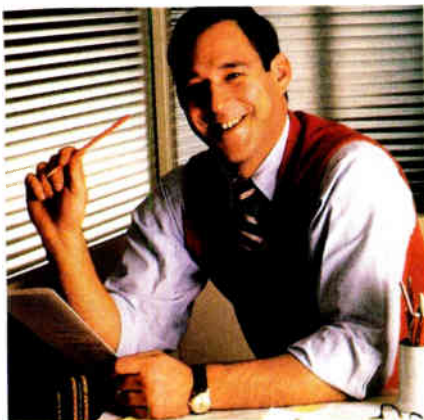

*“To stay competitive in the market you need certain basics. It's essential to have A/B roll editing, equipment compatibility and component picture quality. And with a limited budget it seems impossible.”*

## Discover JVC's KR-M820U Editing Recorder.

The KR-M820U is the FIRST and ONLY MII component recorder with a built-in A/B roll editing controller operable from it's front panel. This versatile recorder incorporates CTCM, component, composite, Y/C 358 inputs/outputs and serves as the perfect hub in a complete component or multi-format editing system. It offers both serial data and parallel control and has two channels of FM audio as well as two channels of linear audio with Dolby C noise reduction.

Other key features incorporated in this truly unique editing recorder are:

on screen display to show editing status and VTR diagnostics, an optional integral SMPTE LTC time code reader/generator, 90 minute record/playback, plus much more.

For further information call 1-800-JVC-5825 or write JVC PROFESSIONAL PRODUCTS COMPANY, 41 Slater Drive, Elmwood Park, NJ 07407.

**JVC**<sup>®</sup>  
**PROFESSIONAL**



## On being a leader

By Brad Dick,  
radio technical editor

Something about being promoted turns some people into Attila the Hun. Once the new title is conferred, the temptation to grab the reins, take control and try to single-handedly solve problems becomes irresistible.

You've seen it happen before. Dan gets promoted on Friday. On Monday he shows up at work in a suit and tie (although he wouldn't have been caught dead dressed like this before). He walks faster, talks louder and seems to have adopted an "I'm-in-charge" attitude.

But don't be too harsh on Dan. He just wants to look good and justify his promotion as quickly as possible. And anyway, after a person watches a couple dozen military or big-business movies where the hero always takes command and whips the troops into shape, what can you expect?

### Guaranteed failure

Acting like Attila the Hun guarantees failure, for several reasons. The newly promoted person is eager to produce quick reforms, instant cures, dramatic increases in productivity and — most important for the engineering manager — cost reductions. Leaders often mistakenly think that the way to achieve these desirable results is to immediately make changes in the work environment.

However, leaders cannot single-handedly legislate change. Although management can control the system imposed (specific tasks and procedures) it cannot control the effectiveness with which they are implemented. Groups resist change and hang on tenaciously to their habitual ways of doing things.

One way new leaders often try to legislate change is through information-gathering. The new manager often feels a desire to obtain more information about what is going on within the department. This desire is usually expressed through requests for detailed reports and by requiring advance approval for plans or decisions made. New managers often take away decision-making capacity from team members under the guise of making sure things are "done right." The last step in centralizing control is requiring team members to go through the leader before



making contacts with other departments. This is common especially when resources are involved.

The typical result of such actions by a new manager or leader is resentment by the team members. This animosity may be expressed in several ways. One common sign of passive resentment is that the requested reports never seem to get completed.

Team members may simply turn over all decision-making to an overpowering leader. The team becomes excessively dependent upon the leader, self-motivation drops, and initiative is stifled. Such leaders find out too late that they are no longer leading; they are pushing, lifting and doing practically every other task for the team. They eventually discover that they are overloaded and that the results they desired are unattainable.

### A sum greater than its parts

A far better approach is to develop a *management team*, composed of the individuals making up the department you supervise. Don't let the term management throw you. It simply means a group of individuals working as an integral unit within an organizational framework (the station). The team governs itself within that overall organizational structure. Broadcast stations are divided into management teams called departments, such as engineering, operations, news and accounting. Teams also may be formed by department heads or other less formal groups.

Let's say Tom, who has 10 years of broadcast TV experience as an assistant chief engineer, is brought in from another station. He has never worked on the kind of transmitter used at his new station. For several months, the transmitter has been acting up. Efficiency is down by 10%, which means the power bill is up. The general manager wants the problem fixed — now.

The GM comes unglued and rants at Tom for 15 minutes about how the problem had better be fixed. But is Tom in a position to do the same thing to Rick, the station's transmitter engineer who is also a 20-year veteran? Can Tom tell Rick how to fix the transmitter? Dwight D.

Eisenhower once said, "You do not lead by hitting people over the head — that's assault, not leadership." The last thing the chief probably wants to do now is become heavy-handed with Rick.

A better approach is for Tom to discuss the situation with Rick, seeking guidance about what steps can be taken to resolve the transmitter problem. In this instance, the leader seeks additional input from those more knowledgeable about the problem, the transmitter. Tom may suggest resources he's aware of for Rick to use. For example, Tom may know something about the transmitter from stories he's heard. He also may be able to provide needed test equipment or assistance to help Rick resolve the problem. Tom must work with Rick and anyone else who can help to resolve the problem.

### Team-building process

Newly promoted supervisors often underestimate the wealth of knowledge within their own staffs. If you supervise a group of people, identify the strengths of each person. This is especially important in technical environments. Learn to rely on different group members at different times. Customize the composition of your decision-making team to the problem at hand.

This approach can be helpful even to engineers who do not supervise others. You are still a member of a team, even if you're not a supervisor. A chief engineer is a member of a team composed of other station department heads.

The process of developing effective management teams is closely tied with meeting the needs of individuals. The more closely you meet their needs, the higher-quality performance you can expect.

Effective leaders recognize the wisdom of tapping the talents of as many people as possible. No one can know all the answers. Developing a management team is one effective way to broaden the base of support for making intelligent (correct) decisions. In other words, good management is sometimes just knowing who to ask for help.

||:~(=)))||

# ***NEW FROM ARRAKIS SYSTEMS***

## **10,000 SERIES**



For features, performance, price and reliability,  
***NOBODY BUILDS CONSOLES LIKE ARRAKIS.***

**Call (303) 224-2248**

Circle (13) on Reply Card

ARRAKIS SYSTEMS INC. 2619 MIDPOINT DRIVE FORT COLLINS, CO 80525



World Radio History

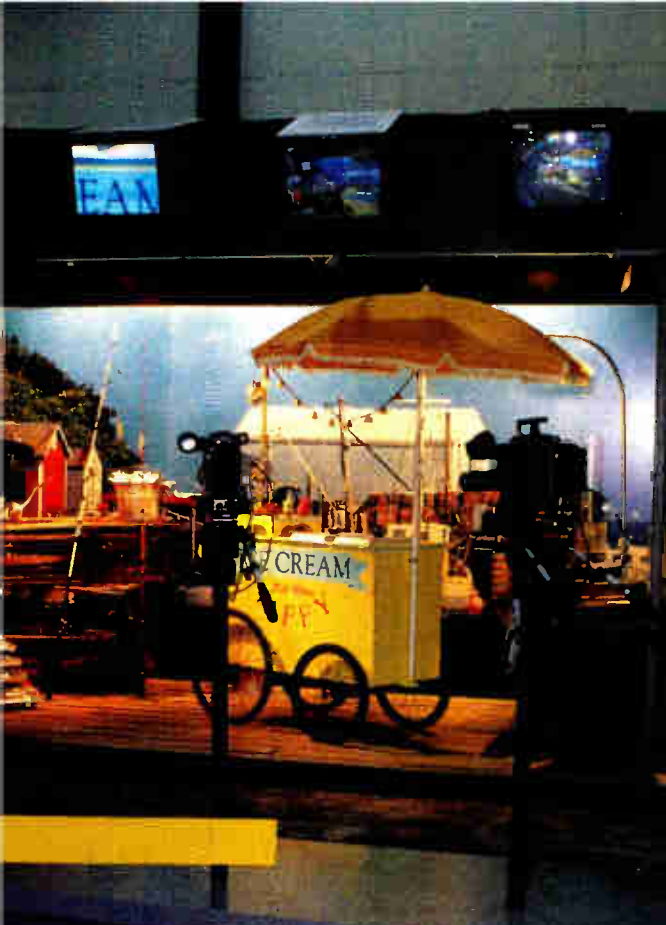

World Pacific History





# Perspective on NAB '89

By Jerry Whitaker, editorial director

**Another record-breaking NAB leaves attendees with as many questions as answers.**

The key players in the broadcast and post-production industries flocked to Las Vegas on April 28 hoping to find the answers to some very difficult questions: What is the future for HDTV? Can broadcasters and the local Bell operating companies peacefully coexist? Is the time right for capital improvements? How will alternative entertainment services affect the bottom-line performance of broadcast properties?

Many attendees left Las Vegas five days later more confused about the future than they were before the show. Broadcasting is not a simple business any more. There are more players, more options and greater financial pressures.

Still, attendees were treated to a convention that stressed the rich and successful history of broadcasting as well as the challenging and exciting future that awaits the industry. NAB '89 lived up to its billing: "On the Air: Proud Tradition, Dynamic Future."

#### **NAB's broadside to cable**

NAB president and CEO Edward Fritts delivered the state-of-the-industry address at the opening general assembly on Saturday (April 29). Fritts came out slugging at cable television. He said, "Together we are agreed that cable's unregulated monopoly must be reined in by a restoration of *must-carry*, with channel-positioning rules. The unfair competitive advantage Congress gave cable by virtual total deregulation of that industry must be rectified. A fair competitive landscape must be restored.

"The power has been unnaturally shifted to the balance of one competitor (cable). And the government's policy to

support free community television for the benefit of all citizens will function once again, as it was intended, only when the balance of power in the competitive marketplace is restored."

Fritts also warned members of the association to be alert to efforts by the local telephone companies to move into video delivery services. "Together we must consider and speak with one voice on the question of whether entry by the telephone companies into the television business will improve the competitive marketplace or will strangle it. The time for that decision is not upon us because there are too many factors yet to be analyzed. But the time for a decision is approaching. Together, we must assure that over-the-air television is on an equal footing with other video media when an advanced television system is chosen for this country."

Three days later at the joint radio/television/engineering luncheon (Tuesday, May 1), FCC chairman Dennis Patrick warned broadcasters that the winds of change are blowing over the United States, and that stations must prepare for whatever lies ahead.

"Our policy of open entry has led to an incredibly competitive environment for you, and a myriad of choices for the consumer. This competition may mean that some of you will not survive. As in any business, those who cannot compete, close. This naturally causes some anxiety, but we (the FCC) are not here to protect you from competition. We are here to ensure that you become competitive, that you listen to your audience. If your audience share is falling, if the bank is

*Continued on page 26*

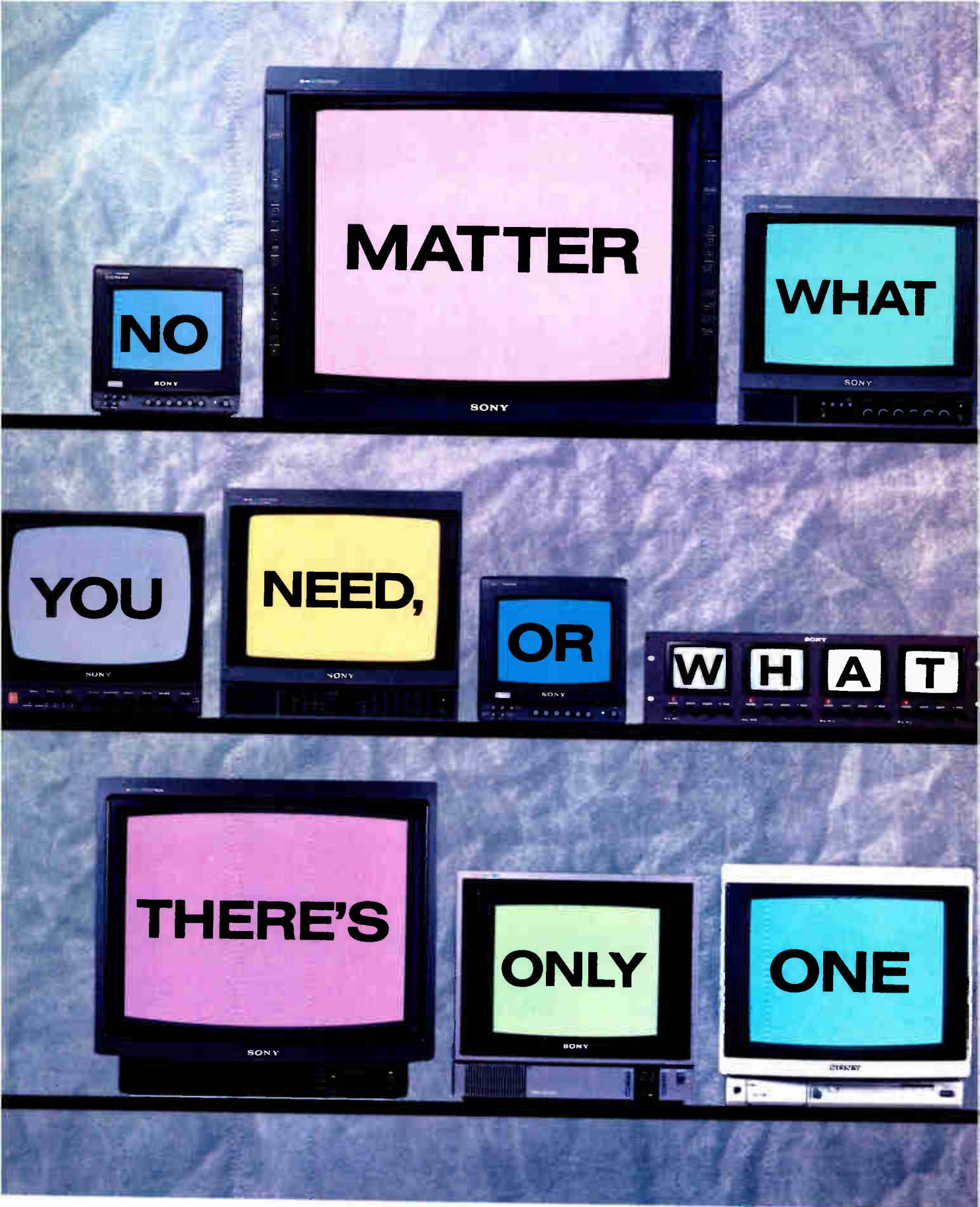

And only one number to call. For more information on Sony's latest innovations in its line of quality

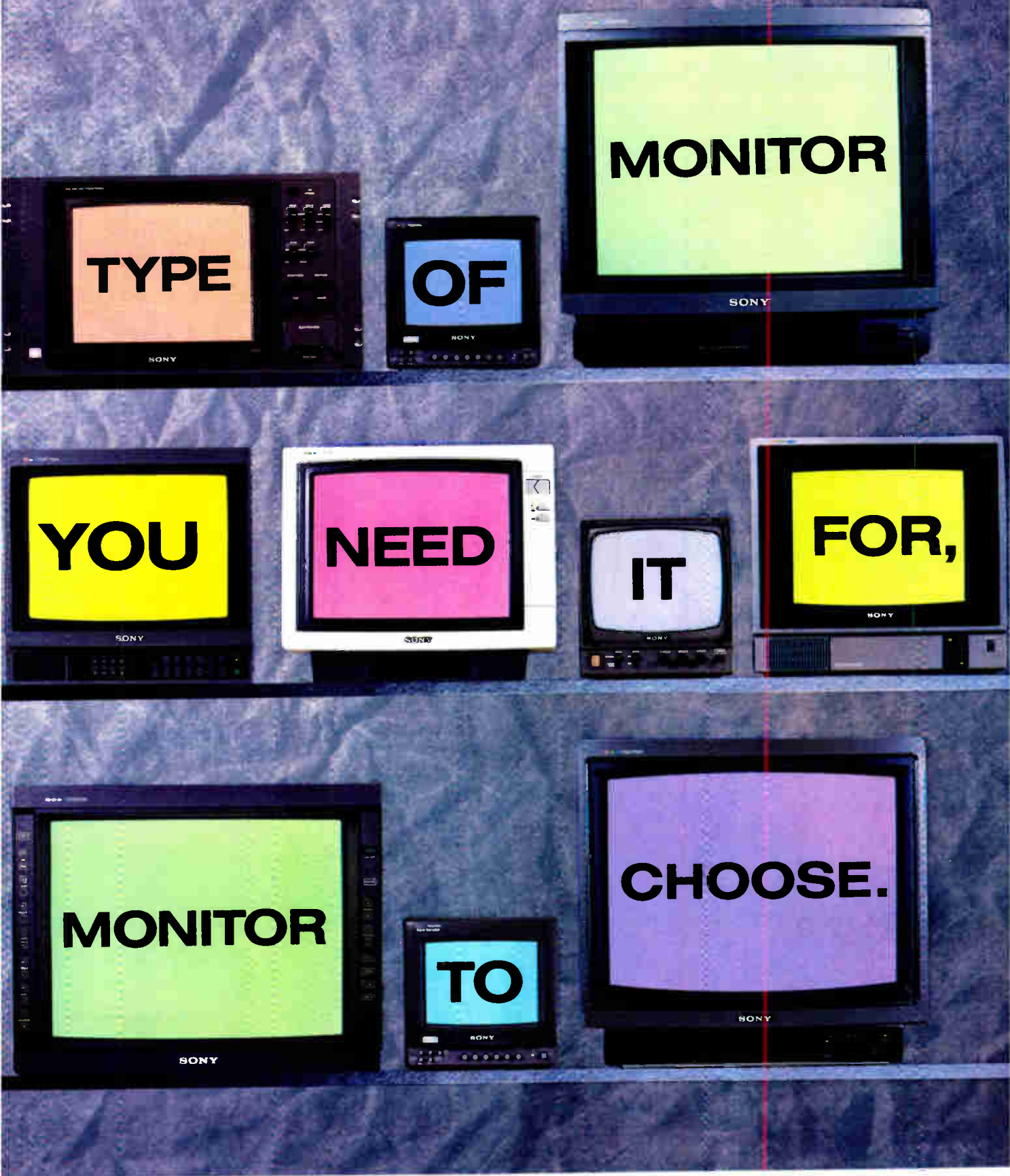

monitors, dial (800) 523-SONY.

# SONY®

Sony Communications Products Company, 1600 Queen Anne Road, Teaneck, NJ 07666. © 1989 Sony Corporation of America. Sony is a trademark of Sony.

PROFESSIONAL VIDEO

Continued from page 23

knocking on your door, don't look to the government for solace. Ask the audience what it wants — and deliver."

Patrick went on to urge broadcasters to look for ways to work with, rather than beat down, emerging technologies. "When entering this fray, do not automatically take up swords to slay old dragons — historical enemies may be extinct. As the global issues have shifted, so too have your potential allies. Perhaps network affiliates should work to forge a stronger bond with the networks, to move together into new areas of competition, rather than closing ranks against the network. Perhaps broadcasters can work together with cable to ensure survival, even in a world of fiber. Perhaps broadcast and production interests can work together to compete forcefully in global markets."

## ON THE AIR

Proud Tradition • Dynamic Future

### Free television

The NAB used the convention as a forum to launch a new campaign designed to, in the words of an association press release, "share with all Americans how they directly benefit from free television." The *Free Television* campaign was outlined by Milton Maltz, chairman and CEO of Malrite Communications Group, Cleveland. Maltz left little doubt about the primary target of the campaign: cable.

"The broadcasters of America cannot put the genie back in the bottle. It is not in our national interest to return the television industry to an economy based on scarcity of choice. Indeed, cable has extended the reach of most broadcasters, and even assured the success of many (stations) on the higher UHF band." Those were about the only nice words Maltz had.

"The implied lineage between the use of free copyright and *must-carry*, as well as channel stability, has not only been ignored but exploited by the relentless force of sheer greed. Stations have been dropped at will, and repositioned on whim, without even the courtesy of notice.

"We are dangerously close to having our national communications policy established not by the Congress, not by the FCC, but by Wall Street. Indeed, the pay TV industry is a financial creature born by deal makers and bred on junk bonds. Local broadcasters are now face to face with a vertically integrated monopoly, with a clear incentive to engage in anti-competitive behavior. The insidious crippling of selective local stations is part of ongoing pay TV policy."



*Las Vegas is a town designed for just two things: conventions and gambling. NAB enjoyed a record-setting crowd for this year's annual gathering. Reports on gambling were mixed. (Photos by Douglas Schwartz.)*

Maltz rejected the argument that free enterprise and marketplace forces will keep cable operators in check. "One might say...it is business; it is free enterprise. It is the new vs. the old. I say, baloney! It's a shakedown. It's an abuse of the public trust. This is not just business. Cable is the only First Amendment speaker with the right to dig up your front lawn."

Maltz went on to sound the battle cry. "We must act now, before the course of events overtakes us. Broadcasters must make the American public aware of the dangers facing our institution of free TV. It is time for the greatest marketers in the world — TV broadcasters — to start telling this story, selling the benefits of free television. We must educate the public that free TV is not a birthright. In many parts of the world there is no free television. Our broadcast system is a precious national resource that must be nurtured and preserved."

The NAB's free TV effort will kick off with an unprecedented prime-time announcement carried simultaneously on all TV stations and networks. The spokesman for the campaign will be none other than Walter Cronkite.

### Engineering luncheon

Leonard Feldman was the featured speaker at the annual engineering luncheon, the centerpiece of the NAB's engineering conference, which was held on Saturday, April 29. Feldman has been active in the field of high-fidelity audio for more than 35 years. He writes regularly on the topic of consumer electronics and

serves as a consultant to the Electronic Industries Association (EIA). Feldman offered his views on the technical issues of today and tomorrow. The talk touched on an area of great concern to broadcasters: the growing sophistication of consumers and the equipment that they purchase.

"The terrestrial delivery system for high-fidelity radio has lagged far behind such other home music delivery systems as...the digital compact disc," Feldman said. "Much the same holds true for the status of video broadcasting as it relates to home video products.

"Make no mistake about it. Consumers are able to compare the quality of both pictures and sound that they get using...new home video recording techniques with what they (receive) over the air. These days, what they see and hear over the air, or for that matter via cable — which has the same limitations — comes out a poor second."

Feldman urged that an industry consensus be reached on high-definition television. "Both the consumer electronics industry and the broadcast industry stand to benefit if the right choice, made purely on the basis of technical merit after thorough over-the-air testing, is made by the FCC. That choice must be based upon technical data supplied jointly by broadcasters concerned with transmission and consumer electronics firms concerned with delivering the benefits of HDTV to the public through the products they manufacture and distribute."

Feldman also touched on the hot topic of FMX, and the controversy surrounding a Bose-MIT report that questioned the benefits of FMX to broadcasters and



*This year the NAB moved exhibits into the Rotunda area of the Las Vegas Convention Center. Exhibitors in the Rotunda reported good traffic.*

listeners. "The thing that I would stress in the FMX issue is the need for careful study before any conclusion is drawn. If you are already on the air with FMX, try to determine for yourself whether the benefits of extended coverage outweigh possible problems that FMX may create for some percentage of listeners. If you are currently contemplating a switch to FMX, be sure to explore the benefits as well as the possible problems inherent in this system."

*Continued on page 30*

ABEKAS



## HOW AN IDEA BECAME A REALITY.

A team of Abekas engineers had an exciting idea. Combine time base correction, audio/video switching, digital effects and editing into one fully integrated machine. Today that idea is a reality. It's called the SOLO Integrated Digital Production System. With the Abekas SOLO, you get: an 8-input video switcher supporting a variety of signal formats and time base correctors permitting asynchronous video inputs. Plus comprehensive keying including digital linear keying, two channels of digital effects with 4:2:2/13.5 MHz internal processing and powerful, full function editing with many unique operational features. And to tie this exceptional product together the SOLO features a phenomenal control system. Driven from a single control panel, the SOLO allows all machine parameters to be stored on a single 3.5" floppy disk. Beautiful. As you can see, the Abekas engineers aim to please. Judge the extent of their ability with a demonstration of the new Abekas A34 SOLO. For details: **(415) 369-5111**

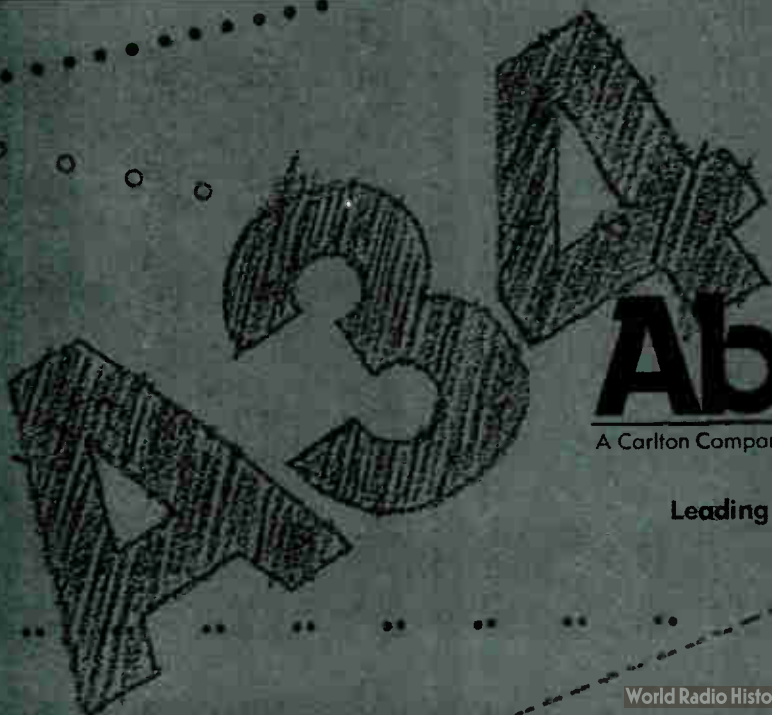

# Abekas

A Carlton Company

Leading in Digital Innovation

Atlanta (404) 451-0637 Chicago (312) 699-9400  
Dallas (214) 385-4544 Los Angeles (818) 954-8700  
New York (516) 829-0820 San Francisco (415) 369-5111

World Radio History

Circle (15) on Reply Card

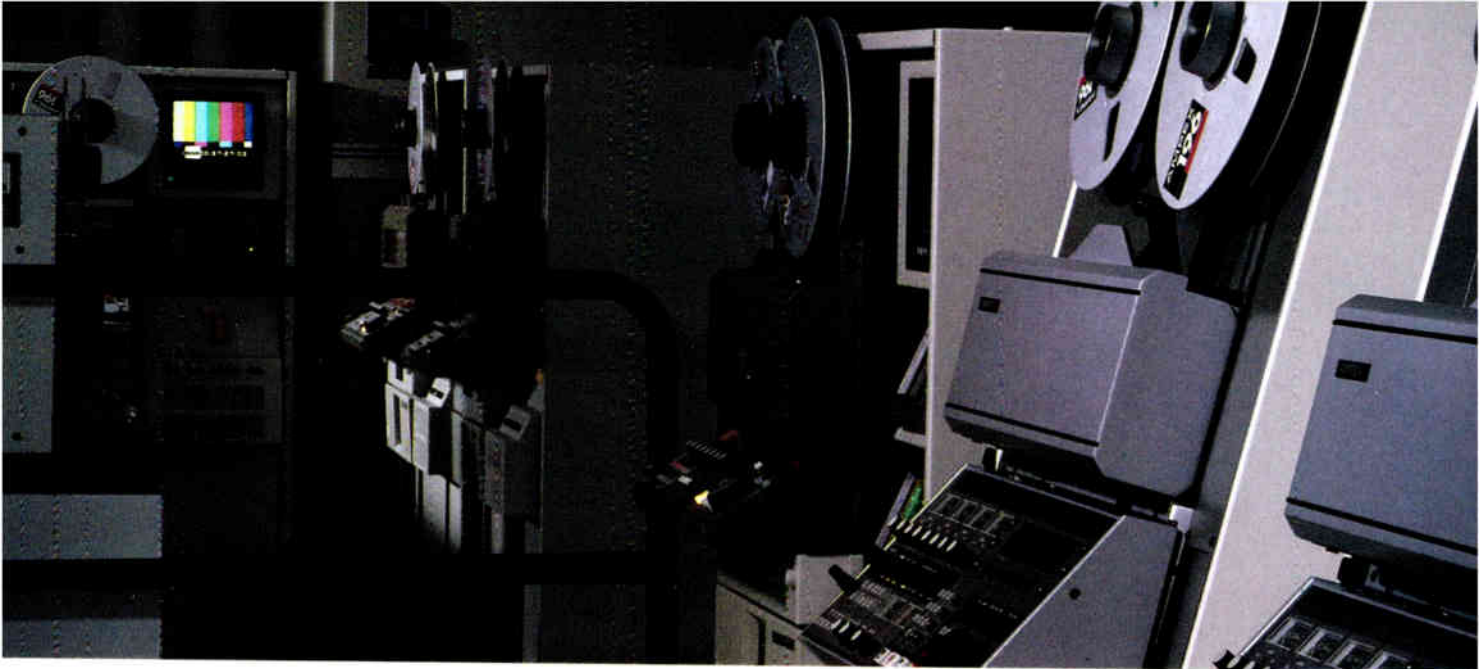

## A convincing argument for Type C from a company that invented D2.

We didn't spend five years pioneering the world's first D2 composite digital recorder just to win technology awards—selling D2 machines is one of our top priorities.

But another and even more important priority for us is to make sure that the video professionals we serve have appropriate equipment for their jobs. And that they continue to look to Ampex



*"... business more than tripled this year using Type C..."*

Bill Stokes,  
*Bill Stokes Associates*



*Ampex Zeus  
Advanced  
Video Processor*

for the straight story about that equipment and its applications.

A case in point is the question we recently asked several of our customers who purchased Type C *after* we introduced D2.

*"With the introduction of D2, why did you purchase Type C?"*

We think the answers we got may interest you if you're considering the purchase of *any* video machine.

Bill Stokes (*Bill Stokes Associates* in Dallas), came right to the point. "My business has more than tripled this year, and I'm using Ampex Type C machines. Is there any better reason to buy more? With the new TBC-7 or the Zeus processor they make perfect pictures. Besides, I like the service I get from Ampex."

Jerry McKinzie with *Cycle-Sat Communications Network* in Forest City, Iowa, (a satellite courier,

*The VPR-80's Automatic Scan Tracking head and its erase head are both easily removed and replaced with only a screwdriver.*





production, and post-production business), thinks it's important to be able to update easily as his business changes. "The hardware and software upgrades Ampex makes in their equipment allow me to keep my facility current, and to always give my customers the newest look. I like that, and my customers demand it."

Darrell Anderson, whose company *Anderson Video* in Los Angeles, recently purchased several

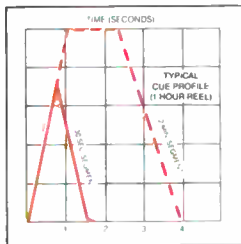

*The VPR-3's incomparable acceleration allows a 30 second segment to be re-cued and synchronously played in 2 seconds, using one hour reels.*



*"... Type C business is readily available..."*

Darrell Anderson, *Anderson Video*

VPR-3s, pointed out that the Zeus port allows interface with D2. Darrell believes that, "Type C and D2 will co-exist successfully in a well-managed

facility. Type C business is readily available." We were gratified to hear that he, "bought the best Type C machine he could find."

Consider your purchase decision carefully. When the excitement of a new equipment introduction passes, and you've put the pros and cons down on paper, Type C may be exactly the right machine for your application. After all, it's still the world's broadcast interchange and distribution standard.

*"... hardware and software upgrades keep my facility current..."*

Jerry McKinzie,  
*Cycle-Sat Communications Network*



And it is obviously the perfect choice for facilities that are moving up from 3/4-inch.

We'd like to be involved in your decision-making process, and we're as close as your telephone. Call Ampex at 1-800-25AMPEX for some real help with a difficult decision.

# AMPEX

BE-689-TYPEC

Continued from page 26

The high point of the engineering luncheon was the presentation of the 1989 NAB Engineering Achievement Award to William Connolly, president and CEO of Sony Advanced Systems. Connolly was recognized for his work on advanced technology at CBS and, later, Sony. During his acceptance speech, Connolly discussed the status of broadcast engineering.

"The changing economics of the broadcast business have permanently changed the realities of research and development funding. The originators of television programming today are simply not in a position to fund comprehensive R&D efforts.

"Programs at CBS Labs were run by people who were also directly involved with the broadcasting business. And the technology developed benefited the entire...business. Products like mini-cams and portable RF transmitters...put creative programming options in the hands of the whole industry, not just the companies that financed the research.



*This camera-equipped zeppelin hovered around the parking lot of the convention center throughout the show.*

"It was a fine system while it lasted. Networks were plowing some of their profits back into the industry. But that is a thing of the past. New competition and the fragmented marketplace have changed the dynamics of broadcast research. The three rich uncles can no longer carry the burden. Neither can any one of the 100 or so competitors who now offer video programming."

Connolly told the audience that "a serious vacuum" has been created by the cost-cutting efforts of the networks. He suggested that a new approach to technology development for the broadcast industry be considered. "It may be that the research of the future may have to come from a consortium of manufacturers with the active support of the...broadcast community. It would be no small task to put an effort like that together. But there is no doubt that a collective effort must be made to concentrate the splintered resources of this industry on the common goal of continued technical expansion."

#### **Distinguished Service Award**

The NAB's highest honor, the Disting-



*Booth traffic was good on the show floor throughout the convention. Product demonstrations such as this one offered attendees a welcome opportunity to rest their feet.*

guished Service Award, was presented to James Duffy, president of communications for Capital Cities/ABC. Duffy was recognized for a broadcasting and public service career that has spanned 40 years. The award, established in 1953, is presented to a person who has made "a significant and lasting contribution to the American system of broadcasting by virtue of a singular achievement or continuing service for, or on behalf of, the industry."

In accepting the award, Duffy stressed the importance of public service in broadcasting. "We are entering a new era of need in this country that demands the participation and commitment of all of us, as never before," he said. He added that the nation is "approaching a human resources crisis" because of the multiple problems that afflict young people and threaten "our economy, our communities and our quality of life."

Duffy stressed that "unless all sectors of our society start to work together to reverse this trend, the United States and its people are at risk of becoming a second-class nation...ill-prepared to face the 21st century."

Through Duffy's leadership, ABC, in association with PBS, developed Project Literacy U.S. (PLUS), a public service campaign to raise awareness of the problem of illiteracy and to stimulate community action to deal with the problem. Originally conceived as an 18-month project, PLUS is now in its fourth year and has established more than 380 community PLUS task forces across the nation.

Duffy expressed confidence in the strength of broadcasting and the potential of the medium. "Let us not get blind-sided by the shrill voices from the fringe proclaiming that the over-the-air commercial system — radio and television — is drastically losing its effectiveness. Obviously, when there are more competitors in the market, there will be some audience adjustment. The pie grows, but more pieces are cut. The circulation of the commercial system remains enormous — especially television — dwarfing all of its

competition.

"The American network system is one of the great inventions of the 20th century. It simply has too many unique values to fade away. It will remain strong, long into the future."

Duffy urged the audience to use the power of broadcasting to reach the youth of America. "Broadcasting is a powerful messenger in every community in America. We are one of the few links to many of our youth who have become disconnected from families, from schools, from society. We can be the facilitator, the unifier, the town crier and caller-to-action on the crippling problems that affect our youth, our work force, our quality of life."

#### **Convention stats**

NAB 1989 was a record-breaking convention by any measure of comparison. The association reports that there were more than 50,000 attendees, up by about 4,000 compared with last year. Foreign registration numbered more than 4,000 from 50 countries. The exhibit hall consumed a record amount of space — 419,000 square feet — with a record 709 exhibitors. Exhibit space included the usual Las Vegas Convention Center halls, plus the Rotunda, Hilton Center and outdoor areas. VIP guests included 35 members of Congress and three FCC commissioners.



*William Connolly, president and CEO of Sony Advanced Systems, addresses the NAB engineering luncheon. Connolly was awarded the 1989 NAB Engineering Achievement Award.*

A record number of technical and management sessions were offered during the five-day run of the show. Many focused on current problems and solutions; others focused on what the future would hold. High-definition television and station automation were major points of concern. (See the related articles.)



# It takes plenty of guts to back our products this solidly.

At QEI, we back our products — and our customers. Our power tubes, for example, carry the best warranty in the industry: 15,000 hours or 2 years. And only QEI includes a FREE comprehensive spare parts kit with every FMQ transmitter, exciter and remote control. Experience shows that you may never use more than 2 or 3 of these "guts". But since we can't be certain *which* 2 or 3, our kits include ICs, transistors, lamps, diodes, fuses — everything you're *unlikely* to need.

## 24 HOUR SERVICE HOTLINE

Giving you the most complete spare parts kits in the industry is just the first step in a customer support program that lasts as long as your QEI transmitter. If you need expert advice on installing a spare whatever, call us any time at 609-728-2020, day or night. And if you ever need factory parts support, we can deliver — fast. We're just 1/2 hour from Philadelphia International Airport, not out in the middle of nowhere.

## MAXIMUM EARNING POWER

You can count on it with every QEI transmitter, because we design them to stay on the air. And as a fully integrated company dedicated to RF and transmission products, we're able to build in quality and reliability — and still maintain our value advantage.

No wonder stations in both large and small markets have been using QEI products as long as we've been making them — since 1971. During that time we've put over 1300 exciters, more than 450 transmitters and over 1000 modulation monitors in service.

## GET THE FACTS

When it comes to standing behind our products — and our stations — we're way ahead of the competition. That may make other manufacturers nervous, but it makes QEI customers very satisfied.

Call us at 800-334-9154, toll-free, for all the facts on the transmitters that deliver a solid return on your investment: the QEI "New Reliables."



# QEI

## Quality • Engineering • Innovation

QEI Corporation • One Airport Drive, P.O. Box D  
Williamstown, New Jersey 08094  
Toll-free 800-334-9154 • Fax 609-629-1751

Circle (16) on Reply Card

## The HDTV scorecard

The HDTV image is sharp, but the big picture for high-definition is just a blur.

By Phillip Kurz

# Full Compression. No Depression.



If you're really depressed by the fact that broadcast quality full video compression systems start at \$17,000, ALTA Pictoris offers you a fresh start that will really impress you.

\$10,900. For broadcast quality infinite video compression, and so much more. Variable cropping and positioning over live background video. Colored borders. Auto zoom in and out. Dissolve. Programmable presets. GPI trigger. Digital effects that include negative video, vertical and horizontal inversion, posterization, mosaic and freeze. And spectacular 5.5 MHz, 450-line resolution video, with full 8-bit Y/C component processing.

ALTA Pictoris. Another example of ALTA's "Technology of Value" that designs a whole lot more into packages that cost a whole lot less. Call us for the dealer nearest you.



535 Race Street, San Jose, CA 95126  
TEL: 408/297-2582 FAX 408/297-1206



Circle (17) on Reply Card

If you attended NAB hoping to discover the direction of HDTV transmission and production, you probably walked away from Las Vegas with more questions than answers.

On the transmission side of the equation, broadcasters needed a scorecard to keep track of all the players. More than a half-dozen organizations displayed competing advanced TV transmission systems, many of which were, to greater or lesser degrees, compatible with NTSC transmissions.

Among the competing terrestrial transmission systems were 1125/60, 2:1; line-doubled 525/59.94, 2:1; 1050/59.94, 2:1; and even 787.5/59.94, 1:1. For satellite delivery, high-definition encrypted B-MAC and 1050/60, 2:1 systems were offered. On the production side, equipment based on the SMPTE 240M standard (1125/60 2:1) made a strong showing at the 1125/60 Group-sponsored HDTV Production Expo in the Tropicana Hotel Pavilion.

The menu of HDTV technology presented at the expo was filled with new and interesting devices, including second-generation HDTV studio cameras, new HDTV camera lenses, digital video effects, telecine and tape-to-film transfer devices, HDTV blue-screen technology, graphics and animation systems for both video and print output, standards converters for stepping down 1125/60 2:1 to NTSC and PAL, and numerous theaters featuring large-screen display technology.

Concurrently, NBC demonstrated that today's NTSC equipment, with certain modifications to maximize bandwidth, would be suitable for acquisition and post-production of material to be transmitted via its NTSC-compatible ACTV 1 (Advanced Compatible Television) system.

Absorbing the significance of these technologies and trying to understand where they will fit on the landscape of tomorrow's television would be difficult enough. However, when these developments are considered in the context of the politics of HDTV, the picture becomes even more muddled. If nothing else, the 1989 edition of the NAB convention gave broadcasters a taste of the difficult task facing the Advanced Television Test Center, which must evaluate competing systems to help set the course of high-definition television in this country.

### The tone of the show

Regarding HDTV, the tone of the show was far from upbeat. While the NAB convention provided a forum for facts and opinions to be aired, it also provided a sounding board for those who choose to view the competition among proponents

Kurz is a BE consulting editor.

Continued on page 36

# HMI Daylight for leading News Teams. Sachtler Reporter 125D.

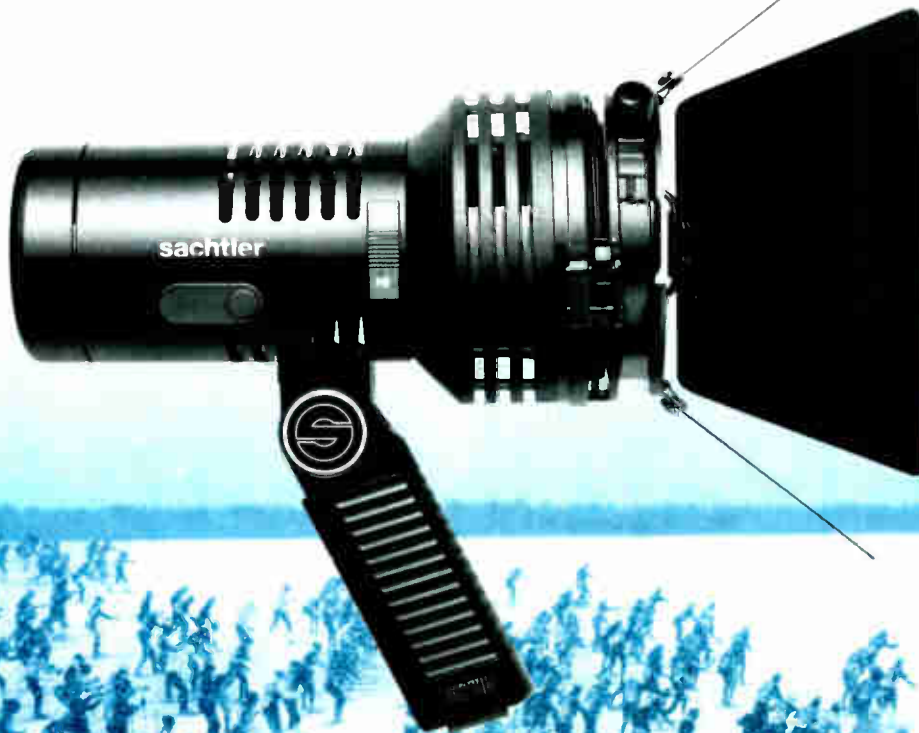

## The new dimension in lighting.

Reporter 125D, 270D, 100H, 250H, 300H, 650H; Production 575D, 1200D.

Sachtler's new product line brings innovation in lighting. Built with world-wide known Sachtler quality.

The new Sachtler Reporter 125D is all you need for first class reporting: lightweight, flicker-free HMI daylight, robust synthetic housing, and strong light output.

The 3-inch reflector produces 400–1800 lux (flood/spot) at a distance of 16.4 feet/5 m. You'll find even light distribution over the whole focusing range. Compare the Reporter 125D with existing 650-watt halogen bulbs.

With the integrated handle and camera mount, or stand adapter, the Reporter 125D will master any situation. It may be powered by battery, or AC with its featherweight Netronic, as well as by car battery.

The Reporter 125D features rotatable fourleaf barn doors, with an integrated compartment for the Sachtler "Swing Filters".

The Sachtler Reporter 125D is available in a compact carrying case. It puts HMI daylight for film and video productions, even for CCD cameras with electronic shutters, in your hands.

The Sachtler Reporter 125D. The new dimension in lighting.

**sachtler**<sup>®</sup>  
corporation of america

55 North Main Street  
Freeport, N.Y. 11520  
Phone (516) 867-4900  
Telex 140107 sac frpt  
Fax (516) 623-6844

California office:  
3316 West Victory Blvd.  
Burbank, CA 91505  
Phone (818) 845-4446

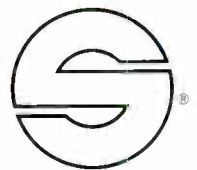

# *More and more people are lining up for the Panasonic SVHS Pro Series.*

One look is all it takes. And you'll see why more and more people are lining up for the Panasonic® SVHS Pro Series. Because anyone in the market for a high-quality professional video production system, simply can't afford not to look at what the Pro Series can do for them.

Take Cost-Performance. The Panasonic SVHS Pro Series delivers both. By combining the efficiency and systems flexibility of half-inch technology with the exceptional performance of Y/C component signal processing.

The result. A comprehensive video production system that provides two hours of operation on a single cassette. With over 400 lines of horizontal resolution. And signal integrity through five generations.

By now it should be obvious. The closer you look and the more you compare the Pro Series to historical video formats, the sooner you'll line up for the Pro Series.

As a Panasonic SVHS Pro Series user, you'll have direct access to Panasonic's nationwide network of engineering, service and technical support specialists. And with over 300 professionally trained dealers, many of whom are self servicing, you'll always get the most out of your Pro Series equipment.

Finally, a professional video format more and more people are lining up for. The Panasonic SVHS Pro Series.

For more information and your local dealer, call your nearest regional office.

Eastern Zone: (201) 348-7620 • Central Zone: (312) 981-4826

Southern Zone:

Dallas Region: (817) 685-1122 • Atlanta Region: (404) 925-6837

Western Zone:

Seattle Region: (206) 285-8883 • Los Angeles Region: (714) 373-7275



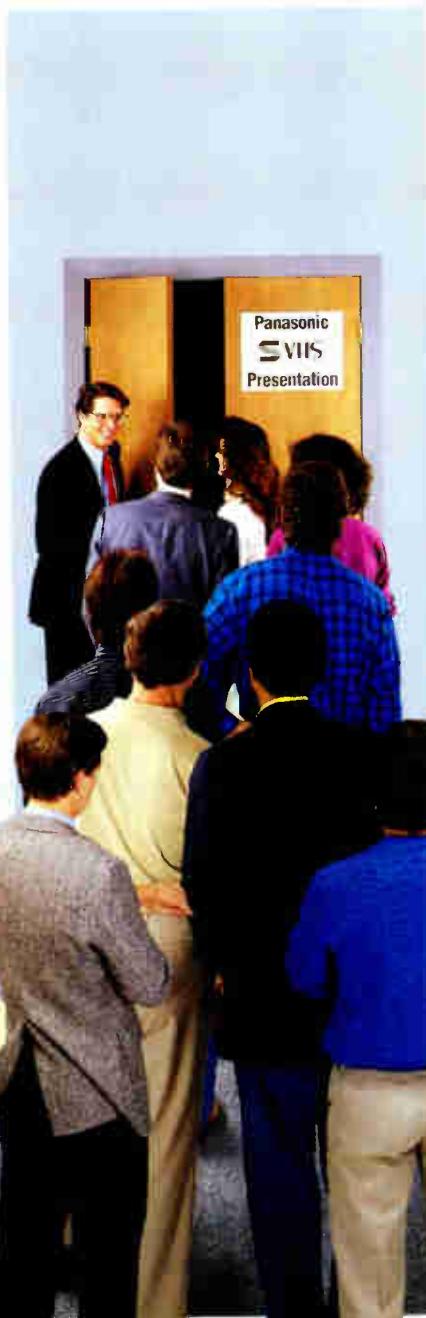

To assure excellent quality, support, service and professionalism, the Panasonic Pro Series is available through authorized dealers.

## **Panasonic** Professional/Industrial Video

Circle (19) on Reply Card

*Continued from page 32*

of various high-definition systems in terms of an industrial race between Japan and the United States.

At a press conference before the opening of the convention, Ampex president and chief executive officer Max Mitchell departed from his prepared remarks to emphasize his company's commitment to U.S.-based research and development of technology. He pointed out that the company invested \$57 million in R&D last year, and announced Ampex's commitment to developing HDTV technology.

"We're competing," he said, launching into impromptu remarks about Ampex's role as a major U.S. force in the market that is holding its own against competition from Japan.

Although Mitchell and others from Ampex stated that work is being done on high-definition technology, no HDTV products, prototypes or conceptual technology displays were to be seen at Ampex. The company did, however, supply existing equipment modified to maximize bandwidth for a display of high-definition production using Faroudja line-doubling technology by NBC, the David Sarnoff Research Center and RCA Consumer Electronics.

Speaking after a press conference held to demonstrate the progress made on the ACTV-1 and ACTV-2 transmission systems, Jim Carnes, vice president for consumer electronics and information sciences at the Sarnoff Center, was more blunt. "Transmission is the most important (thing). It's the hardest," he said. "When it comes to the most important and most technically difficult issue, we are way ahead of Japan."

Another indicator of the raw nerves being struck over the politics of HDTV was the response of many to the news that the American National Standards Institute (ANSI), had upheld an appeal by Capital Cities/ABC to deny approval of SMPTE 240M as an American national standard.

Privately, many at the convention said they viewed ANSI's decision as primarily based upon political considerations related to protecting U.S. industrial interests from losing the HDTV race before they have even entered the contest. Many also wondered if ANSI's action would change the way in which SMPTE has traditionally approached standards-setting in this country.

Denis Bieber, chief executive officer of Rebo Research, went one step further. Voicing his displeasure with the ANSI decision during a press conference held to introduce his company's new products, Bieber expressed "outrage and indignation at ANSI's illegal conduct."

"I am at a loss why ANSI is ignoring the hard work of SMPTE," he said, adding that his company is considering filing suit against ANSI to force a reversal of its decision on SMPTE 240M.

All these comments, taken together, typify the tone of the convention as it related to HDTV. The spirit of cooperation, if such a spirit ever existed, appeared to be evaporating as the proponents of competing systems anticipated clashing with each other over who indeed will cash in on the HDTV market in the United States.

#### **Transmission under the spotlight**

One of the bright spots of the convention was the transmission of SuperNTSC by local broadcaster KBLR-TV, channel 39. The Las Vegas station allowed a Faroudja Labs SuperNTSC encoder to be placed at its Television Technology Corporation transmitter for the duration of the convention.

KBLR transmitted programming encoded using the SuperNTSC hardware. At the TTC and Faroudja Labs booths in the convention center, Faroudja decoders and line doublers were used to present 1050/59.94 2:1 video on high-definition monitors.

According to the station, shortly after the test started, viewers began calling channel 39 to ask why the pictures they were receiving looked better than what they were accustomed to. It remains unclear whether the calls were in response to SuperNTSC's removal of artifacts traditionally associated with NTSC or the result of the crawl across the video informing viewers that a test was taking place.

What is clear, however, is that the KBLR test of SuperNTSC provided broadcasters with an example of how they could improve their signals today. Even if consumers don't have the decoder and line doubler, they benefit from the SuperNTSC removal of artifacts.

Faroudja Labs announced that it has begun talks with consumer set manufacturers in Taiwan and Korea about licensing the decoder technology for use in future products. According to Faroudja Labs, set manufacturers claim they can offer the public new sets with the line doubler and decoder technology that would cost \$300 more than today's TV receivers.

In their exhibit adjacent to the main convention hall, members of the Sarnoff Center, NBC and RCA Consumer Electronics were touting their successful over-the-air test of the NTSC-compatible ACTV-1. The test was conducted during a segment of WNBC-TV's "Live at Five" news program on April 20, 50 years to the day from the debut of television at the 1939 World's Fair.

From its antenna atop the World Trade Center in New York City, WNBC transmitted video acquired at the Rose Bowl Parade during the news show while researchers 53 miles away at the Sarnoff Center in Stamford, CT, gathered around the sole ACTV receiver and watched eagerly.

At the convention, NBC president of operations and technical services Michael Sherlock declared the test a success, adding that no WNBC viewer called to complain about any degradation to standard reception during the test.

Sarnoff, NBC and RCA also transmitted an ACTV-1 signal via satellite in Las Vegas. Broadcasters visiting the group's demonstration saw live and taped video fed through a Faroudja line doubler, uplinked to a Ku-band satellite and returned to the control room of the ACTV exhibit for display.

Determined to make its 1125/60 system compatible with NTSC transmission, NHK, Japan's national broadcasting company, showed a computer simulation of an NTSC-compatible MUSE system at last year's convention.

This year, the engineers from NHK brought to the show MUSE-6, an NTSC-compatible transmission system for HDTV that uses a frequency-interleaving method for bandwidth reduction and provides 16:9 aspect ratio, twice the resolution of NTSC and two channels of compact disc-quality digital sound. The system allows for future improvement through the use of a 3MHz-wide augmentation channel. In such a system, two additional channels of digital audio would be transmitted as well as additional picture information.

Perhaps one of the most intriguing displays of technology in the advanced TV area was shown by Production Services Inc., of Tucson, AZ. The company demonstrated a technique for transmitting two NTSC channels on an existing carrier. The Genesys system, which is an analog method of conveying digital information, relies upon five basic technologies, which include techniques borrowed from the field of neural network design.

Genesys works by moving inflections up and down the rising and falling slopes of a TV station's carrier wave. The inflections are created by a proprietary process of injecting extra sidebands into the IF section of modern TV transmitters. An inflection is placed in one of eight positions on the rising and falling slopes of each IF sine wave. This yields three digital (but not strictly binary) bits per slope, two sets of three per IF cycle.

The secondary video signal is A/D sampled to determine its value at any instant. The first set of three bits approximates the sample's value to three bits of binary resolution, and subsequent groups of three close in on the sample's value using either binary or delta coding, whichever will get the closest. In this way, the system constantly seeks to match the current sample's value and begin the approximation process anew when a fresh sample arrives. At the receiver, the Genesys inflections are decoded and returned to analog form.

If the system lives up to its billing, it will

# How Good is Our 3rd Generation? Take a Look at Our 5th!

## PERFORMANCE DATA (AG-7500A)

|                                       | 1st<br>Generation | 3rd<br>Generation |           | 5th<br>Generation |
|---------------------------------------|-------------------|-------------------|-----------|-------------------|
|                                       |                   | w/o TBC           | w/TBC-200 | w/TBC-200         |
| Horizontal Resolution<br>(Color Mode) | 400               | 370               | 360       | 350               |
| S/N Ratio (dB)                        |                   |                   |           |                   |
| Luminance<br>(Color Mode)             | 57.2              | 51.7              | 52.0      | 49.0              |
| Chrominance (AM)                      | 51.8              | 47.5              | 51.4      | 44.5              |
| Chrominance (PM)                      | 44.3              | 40.1              | 43.8      | 35.2              |

Data represents measurements by independent engineering evaluation VCRs taken at random from inventory

- Signal Source: Shibasaki TG-71
- Noise Meter: Rohde & Schwarz UPSF2 UPSF2E2
- Luminance: 50 IRE flat field w burst
- Y-S N: 200 kHz HPF subcarrier trap on
- Chroma: 50 IRE w 100 IRE p-p
- 4 2 MHz, LPF weightec
- Resolution: Monoscope Shibasaki 58A 1
- C-S N: 100 Hz HPF
- 500 kHz LPF unweight-d



From the first to the third, even to the 5th generation Panasonic® SVHS Pro Series specifications speak for themselves. And they say "outstanding." Here are some of the reasons:

**The AG-7500A editing VCR** with its new laminated amorphous heads produces superb quality generation after generation.

**The AG-A750 editing controller** has everything you need for highly accurate single event editing.

**And the AG-7400 portable 2-hour VCR** is a natural performer in the field.

**Our TBC-200 time base corrector** has a 16-line

correction window, chroma plus/enhancement, chroma noise reduction and no-roll circuitry. To make multi-generation recordings even better.

**The UTP-1 signal transcoder** is more than ready to transcode virtually any component signal into any other component signal. Saving you an extra generation.

**The IFP-44 editing interface** controls Pro Series decks on both the source and edit side. To easily integrate into selected 3/4" systems.

**Our CCD Cameras** are equally spectacular. And with the Panasonic SVHS Pro Series you not only get outstanding

performance, you also get the added economy of 2-hour operation in the field and in the studio.

The Panasonic SVHS Pro Series. In a word it's outstanding.

For more information and your local dealer, call your nearest regional office.

- Eastern Zone: (201) 348-7620
- Central Zone: (312) 981-4826
- Southern Zone:
- Dallas Region: (817) 685-1122
- Atlanta Region: (404) 925-6837
- Western Zone:
- Seattle Region: (206) 285-8883
- Los Angeles Region: (714) 373-7275



**Panasonic**  
Professional/Industrial Video

Circle (20) on Reply Card

World Radio History

be able to deliver multiple NTSC channels or, in an HDTV application, an NTSC channel and an augmentation channel over existing spectrum with existing transmitters and antenna systems, while maintaining full compatibility with existing receivers.

At the booth, the company showed Genesys feeding moving video on one channel and color bars on the second channel. Whether moving video on both channels would produce artifacts is unclear at this point; however, the potential of the system makes it a serious candidate for consideration in the mix of HDTV systems to be adopted.

Also on display in the enhanced video area were satellite delivery systems for high-definition television. Scientific Atlanta announced that Telesat Canada will begin use of its HDB-MAC systems in September as part of a Canadian high-definition test. A mobile HDTV production facility will produce programming and feed it with the HDB-MAC encryption system to downlinks set up at movie theaters nationwide in September.

The HDB-MAC system is fully compatible with the B-MAC transmission system used by hundreds of private network broadcasters worldwide. The system increases the vertical resolution by doubling line frequency and horizontal resolution through a spectrum-folding technique.

North American Philips showed its HDS-NA system. Although designed for both terrestrial broadcast and satellite feeder service, the latter was the only system shown. A presentation of material shot on film and transferred to a VTR especially modified for the system by Philips Labs played back the MAC time-compressed 1050/59.94 video.

Zenith's display of high-definition transmission technology was perhaps the most radically different from the pack. Zenith is proposing a system based on terrestrial simulcast of an enhanced service of 787.5/59.94 1:1 on a separate channel. The company has developed a technique for transmitting its proposed high-definition signal in taboo channels.

The Zenith system, called SC-HDTV for spectrum-compatible high-definition television, separates high-definition picture information into high and standard frequency bands. The highband information, above 200kHz, will be transmitted in analog. Video frequencies below 200kHz will be transmitted digitally. The digital transmissions require less power, reducing the likelihood of interference with other TV signals, the company said.

Zenith did not have a receiver on hand to demonstrate its high-definition picture; however, it demonstrated the worst-case interference problems broadcasters could expect from transmitting in taboo channels.

The New York Institute of Technolo-

gy came to the show with two items of interest: the VISTA signal processor and an HDTV camera with two pickup devices, essentially an NTSC camera with a special slow-scan Saticon for picking up picture detail.

Nippon Television, a private Japanese broadcaster, also displayed an enhanced-definition TV system.

Turner Engineering, Boonton, NJ, put together the advanced television using hardware and software from more than 35 companies. Turner also provided design and engineering services for the HDTV theater in the South Hall of the convention center, which used an Eidophor HDTV projector from Information Display Systems and the HDTV living room of the future. Work began in November 1988 to block out the setup.

Live HDTV pictures were fed to various exhibits in the advanced TV exhibit area from the BTS KCH-1000 multistandard high-definition camera.

#### HDTV production

Perhaps the biggest high-definition-related news of the convention was that the TV broadcaster won't have to scrap existing equipment to begin production of high-definition television. At least that's the case if a system is implemented throughout the industry that is similar to the one demonstrated by NBC.

"The studio of tomorrow," said NBC's Sherlock, "is possibly the studio of next week."

In a room adjacent to the advanced TV display area, NBC, the Sarnoff Center and RCA Consumer Electronics showed that minor modifications to today's ENG cameras, decks, switchers and effects units along with the signal-processing and line-doubling capabilities of equipment from Faroudja Labs could produce material suitable for transmission by the Sarnoff/NBC ACTV-1 Advanced Compatible Television system. Material to be transmitted by ACTV-2, however, could not be acquired or produced with existing technology.

The significance of the demonstration was apparent. The NBC/Sarnoff approach would not require TV broadcasters to abandon the capital investment in their plants and build anew. The demonstration provided broadcasters a taste of an evolutionary approach to high definition that would be much easier to swallow than the other options offered to them so far.

To that end, Bob Sutton, television manager of WFLA-TV, Tampa, FL, presented a check for \$1 million to the Sarnoff Center from the NBC affiliates for further development of the ACTV system. To date, Sarnoff, RCA and NBC have spent \$67 million to develop the transmission system, and another \$2 million is expected to be contributed by the network's affiliates in the future.

At the Tropicana Hotel, more than 30 manufacturers of high-definition equipment banded together for the 1125/60 Group-sponsored HDTV Production Expo. Although the expo was not officially part of the NAB convention, convention-goers who wandered over to the Tropicana Hotel got a look at working systems conforming to the SMPTE 240M standard.

The message was clear: Regardless of the ANSI decision announced before the show, the technology is in place to make the SMPTE 240M standard (1125/60, 2:1, 1,035 active lines, 16:9 aspect ratio) a de facto standard, if not an officially recognized American national standard.

A detailed description of all the hardware on display isn't possible in this limited space. However, a few of the significant hardware developments in the area point out that SMPTE 240M is gaining momentum.

On the production side, the expo showed an elaborate display of real-time HDTV Ultimatte technology. In a blue-screen room, attendees stationed behind a "garbage matte" were shot with an HDTV camera and matted from the waist up into video of a cartoon plane flown by Mickey Mouse.

"Mickey the Mail Pilot," a 1939 classic black-and-white cartoon of Mickey Mouse, was transferred to video, rotoscoped and colorized using a Symbolics HDTV paint and animation system. Successive cels in the animated piece were recorded on a prototype silicon multiple-frame recorder, called the Sony HDD-500. Four different cycles of cel animation, none of which were more than 32 frames, were built in the frame recorder and dumped to the new Sony HDD/HDDP 100 HD digital high-definition VTR. Various parts of the four cycles were intercut to create the 2-minute plane ride.

Video of the attendees shot live in the blue-screen room was matted into the passenger seat of the plane and fed to an experimental digital effects device for HDTV developed by the Sony Research Labs in Basingstocke, England. The unit, called the DME, controlled Mickey's flight, allowing the plane to engage in loop-to-loop maneuvers and other aerobatics for the wild ride. The output of the DME was fed to a second HDTV Ultimatte device, which matted the plane, Mickey and passenger over high-definition background video shot at four different locations.

DeGraf/Wharman, a computer graphics house in Los Angeles, provided much of the software needed to build the animated sequence; John Galt, director of high-definition video services, planned the project and brought the various pieces together. The demonstration clearly pointed out the new flexibility film producers will have if they take advantage of

*Continued on page 42*



# *The* AVS-2

**IT'S BEYOND ANY  
CURRENT ROUTING  
SWITCHER.**

The AVS-2 from Utah Scientific represents a significant advance in the design of routing switchers. The exclusive use of surface-mount technology results in a dramatic reduction in the physical size of the switcher, allowing you to put more crosspoints in your existing rack space. The AVS-2 is controlled by our existing range of control panels and accessories – the industry's best. And, of course, the AVS-2 is covered by our exclusive 10-year warranty.



*Somebody  
does!*

**US UTAH  
SCIENTIFIC**

DYNATECH Broadcast Group

1685 West 2200 South, Salt Lake City, Utah 84119  
(801) 973-6840 Toll Free: 1-800-453-8782

World Radio History

Ikegami's remarkable broadcast CCD, the HL-55, features three newly developed  $\frac{2}{3}$ " FIT (frame interline transfer) chips, each delivering an industry-first 400,000 plus individual pixels. This insures low FPN (fixed pattern noise), a reduced vertical smear, and enhanced resolution at over 700 TVL and high S/N ratio of 62 dB.

Compact and lightweight (6.81lb with viewfinder), the HL-55 features a six speed electronic shutter for improved dynamic resolution,

high sensitivity (+ 24dB), a newly developed optical low pass filter for reduction of noise and much more.

Our exclusively designed viewfinder provides complete setting data, a clearer picture than conventional viewfinders, and can add or delete a safe title area box, cross hairs and audio bar graph.

THE HL-55 BROADCAST CHIP CAMERA:

# TAKE YOUR BEST SHOT

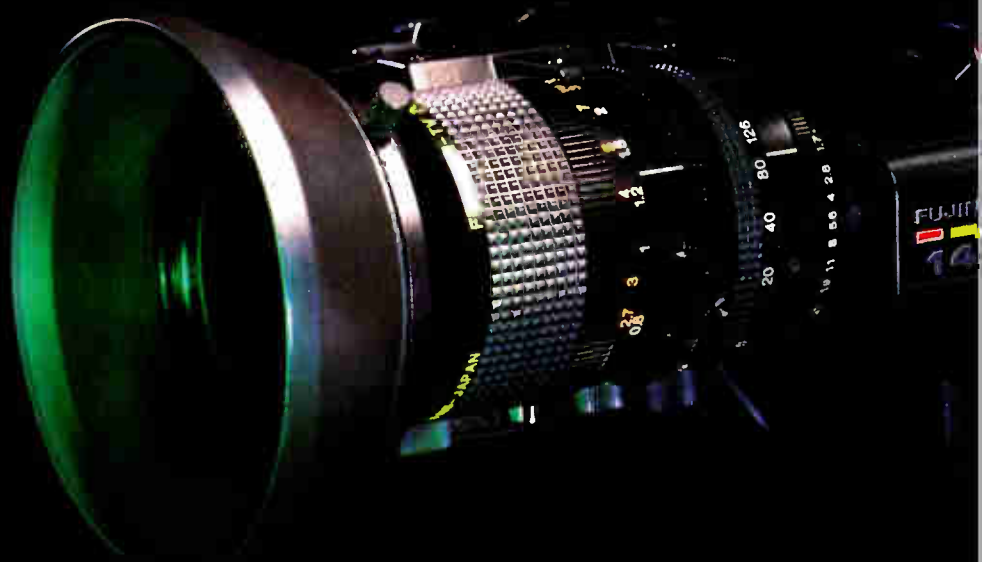

Ikegami

Look into an HL-55 and you'll see Ikegami's commitment to quality engineering extends beyond performance, right down to the construction of the camera body and boards.

The HL-55 belongs to Ikegami's UNICAM® family of cameras, and is compatible with all HL-95 accessories providing maximum oper-

ational flexibility and versatility in the ENG/EFP or studio configuration.

The HL-55 is your guarantee that chip technology won't let you down, unless of course you don't own an Ikegami.

For further information contact your Regional Sales Office or the Ikegami Dealer near you.



Ikegami Electronics (USA), Inc. 37 Brook Avenue, Maywood, NJ 07607  
East Coast: (201) 368-9171 West Coast: (213) 534-0050 Southeast: (305) 735-2203  
Southwest: (214) 869-2363 Midwest: (312) 834-9774 Hawaii: (808) 946-5955

Continued from page 38

the special effects afforded by HDTV in their film productions.

In another section of the display, Panasonic and Sony showed ½-inch HDTV VCRs that will be introduced in Japan in the fall. Both provide 20MHz for luminance and 7MHz for chrominance. The Panasonic unit is targeted at the business and ENG market. Record time will be 63 minutes.

The significance of these technologies as well as laserdisc systems shown by Sony and Sanyo show that although U.S. broadcasters and the industry at large are in the preliminary testing stages of advanced TV transmission systems, consumers will begin to have access to high-definition programming from off-air sources such as VCRs and videodiscs as early as September.

Displays of HDTV graphics technologies from Shima Seiki, Symbolics, Chyron and Quantel all pointed out that the line between graphics for video and graphics for print is vanishing and that some day the two may be indistinguishable from a quality point of view.

The new digital HDTV VTR from Sony, the HDD/HDDP-100 HD, and HDTV post-production switchers from Grass Valley Group and Sony demonstrated that 1125/60, 2:1 for post is possible. In fact, it is not only possible, but now can offer many of the same conveniences, such as multigeneration work without significant loss, that are becoming the norm in high-end post for NTSC.

Still the debate rages about the appropriateness of 1125/60, 2:1 for production of material to be broadcast in the United States. Carnes, of the Sarnoff Center, who said he doesn't think the SMPTE 240M standard is suited for acquisition and production of programming destined for transmission in the United States, put it this way: "I don't want to see any 1125/60 in any studio, period!"

It would be understandable if quite a few broadcasters left Las Vegas with a view of the HDTV picture that was much less clear than the images being produced by the high-definition systems shown at the convention.

## The automation equation

The incredible shrinking station fits into smaller and smaller packages as designers continue to streamline through automation.

By Rick Lehtinen, TV technical editor

Just as black holes — those big-mouthed, matter-crunching stellar twisters — gobble up whatever matter lies before them and squeeze it infinitely smaller, broadcast equipment designers are folding our tools into constantly tighter and tighter packages. Equipment that once filled a few racks now fits into a small chassis. What once took up a small chassis now fits on a chip. Gear that once required a console full of knobs and switches for each controlled device now can be addressed by multifunctional, intelligent controllers that configure themselves to the job at hand.

And today's equipment doesn't stand alone. Links have been forged among all kinds of devices, allowing computers in one part of the station to automatically roll tapes in another. This constant shrinking and smartening of production systems is one of the most earthshaking trends to rumble its way across the NAB landscape.

They call it "automation."

### One box does all

The "video workstation" or "desktop video" concept came into its own at NAB '89. Sure, the concept has been seen before, but never has it been implemented across so many levels of prices and manufacturers. There were workstations built on high-end proprietary hardware, less pricey mid-level platforms and inexpensive systems. Small computers seem to have found this niche. You could find video systems built around the Amiga, the Macintosh and the PC.

### Bigger, better cart machines

Manufacturers were aggressive in their marketing of cart machines. The theme hit hard this year: *connectivity to the station's traffic computer*. Several vendors featured these traffic-computer-to-cart-machine interfaces, touting such advantages as the elimination of error-prone retyping of play lists. When the traffic system has a log ready, it is sent to the cart machine either electronically — by direct connection or in the form of an electronic

queuing box — or on a floppy disk. The result is an effective shrinking of the station.

How the data is used varies by manufacturer. Some systems allow the traffic system to tinker directly with the play list. Other systems hold the new play list ready, but update the current list only when the operator requests it. In nearly every system, play list restructuring is automatic. If a given commercial is not found in the machine, the cart machine summons its operator.

Several machines this year featured the capability to generate their own dub reels, and to roll these as protection copies during important breaks. The cart machines also have been given the ability to control external VTRs, making them a sort of on-air automation system. Some systems even can control external routing switchers, preparing the way for the cart machine to record incoming programming, as well as play it back according to the log.

### Wander-cams

Three manufacturers came to NAB to demonstrate operational, full-freedom-of-motion, robotic camera-positioning equipment. Vying three ways for first place, each demonstrated the ability to move pedestals forward, backward and left and right, and to tilt, pan, pedestal up and down, zoom and focus cameras. Other manufacturers displayed various other pan and tilt head control systems.

Although the field is narrow, choosing a system could be troublesome. Of course, it is important to decide which system "looks" the best — the one that most closely mimics human operators. Beyond the basic "move-it-and-shoot-it" functions, however, comparisons of systems falter, as manufacturers become embroiled in a tug of war over protocols and procedures. Some automated camera systems control operational features beyond those usually undertaken by camera operators, such as camera iris or black level. It might be



## The mic mixer you would have designed yourself—the Shure M267.

The Shure M267 has become one of the most well-known and widely used mixers in the broadcast industry. One look at it will tell you why.

The M267 gives you the features you've told us were most important. Every channel has a mic line level switch for maximum flexibility. There's also a built-in limiter to keep the M267 from overloading at critical moments. The unit contains a built-in battery pack that utilizes three standard 9-volt batteries. Phantom power and a peak LED are standard, too.

The M267 oscillator provides a clean 1 kHz tone, and is located on the front of the unit for simple access. The headphone output is also on the front and includes a level control. IC design, along with active gain controls, provides greater headroom and quieter operation.

For location work or even studio post-production, the M267 carries on Shure's reputation for reliability and ruggedness.

For more information, call or write Shure Brothers Inc., 222 Hartrey Avenue, Evanston, IL 60202, (312) 866-2553.

# SHURE®

THE SOUND OF THE PROFESSIONALS... WORLDWIDE



# Puts your signal in it's place!

If you need a quality antenna, you need:  
**JAMPRO ANTENNAS, INC.**  
The really experienced one for over 30 years.

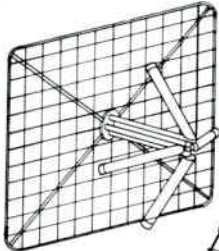

JAHD CP  
Arrowhead  
Screen Dipole

JSDP CP Spiral  
Broadband Antenna

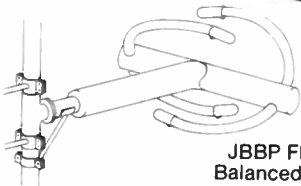
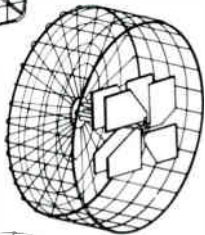

JBBP FM Antenna  
Balanced Excitation

**JAMPRO** is the world leader in custom-designed, directional, CP antennas.

- With over 1600 of our penetrators delivered, more stations have penetrated their market.
- Our custom-made directional antennas are operating world wide.
- Full-scale antenna measurements on **JAMPRO's** all-year, all-weather test range.
- We custom-make tower structures to duplicate your's, for optimum results.
- Ask about **JAMPRO's** low-power educational packages.

Give us your requirements and see how fast we produce.

## **JAMPRO Antennas, Inc.**

6939 Power Inn Road  
Sacramento, CA 95828  
(916) 383-1177 • Telex: 377321  
FAX (916) 383-1182

Circle (23) on Reply Card

necessary to bring these extra features into the decision. Also, some systems are intended to be operated by a camera operator, others by technical directors.

All the systems can move freely about the studio floor. One system navigates by dead reckoning, periodically recalibrating its sensors by dancing over a special mark on the floor. Another system shoots laser beams at ankle height around the studio, timing reflections off special devices placed around the studio perimeter. One system follows its guide tape for the most part, stepping off the beaten path only when so ordered.

Sorting out system pluses and minuses is not a job to be taken lightly. The first step in shopping for a camera robotics system may well be to carefully analyze your own facility. Rather than spending hours sorting out manufacturers' claims and counterclaims, develop a clear picture of how you run productions. This may help you determine which system is the best fit.

A ray of hope: The greatest advantage of camera robotics may come when a system is interfaced to a newsroom computer. Manufacturers now seem to realize that their equipment must interface with several different newsroom computer systems. Previously, choosing a robotic system may have forced a choice of newsroom computer systems, and vice versa. Letting go of the ties that bind a robotic system to a specific newsroom system may be one of the most important developments in robotics yet.

### Machine control

Station automation systems took a giant step forward. One important cost-saving, power-multiplying tool is local area networks (LANs). The impact for broadcasters is much greater flexibility at greatly reduced prices. Routing switcher control panels based on networking, for instance, can be sold at several times less than their previous cost. Also, previous control schemes may have faced limitations on how much physical distance could exist between a control panel and a switcher frame. Under a LAN, this distance can be greatly extended.

Although the major automation players have made great strides, the ubiquitous PC must not be overlooked. One company displayed a PC-based solution for machine control and station automation. The system's unique feature is its operator-friendliness. It can operate as the control panel for several different pieces of equipment, such as character generators from different manufacturers. The benefit from the operational point of view is that it obviates the need for operators to be expert in more than one system. All the controls look alike from the operator's end, and the little PC keeps track of unique button strokes required for the various systems.

In fact, utilities are provided so that experienced operators can design elaborate effects and commit them to the menu. Less experienced operators then can call up the effects and fill in the blanks as required. With such equipment, setting up a lower-third "storm warning" crawl is as simple as typing the text message, answering a few questions about playback speed and number of repetitions, and hitting the "go" button.

### Reach out and touch someone

Not all that is automation has a computer in front. One of the most novel automation applications was demonstrated by a monitor manufacturer. It took the form of a waveform-to-picture-monitor control link. Generally, a waveform monitor provides a switched output feed that presents the selected video input to the waveform's associated picture monitor. This output is used to save monitor input positions, and also to provide the "bright-up" 1-line or 15-line displays for users seeking information about a certain line on the screen.

Some facilities are not satisfied. In those that operate in more than one format — say, analog component and NTSC — having to switch monitor controls can be vexing. Allowing the waveform monitor, typically located just a few feet from the operator, to serve as a remote for the picture monitor, which is typically wall-mounted, can spare you a great deal of expense, fuss and bother.

### Onward and downward

Can we expect the trend of automation and shrinking to continue, producing in one system tomorrow what takes two systems today? Most likely, yes, if NAB '89 is any indicator. The automation-based communication links that bind a station together also tend to shrink it. This will lead broadcast engineers into what certainly will be a different world, but perhaps not a smaller one.

# WE'VE MADE DEAD AIR A DEAD ISSUE.

There are worse things in radio than dead air.  
But not many.

And if your CD players aren't built to resist tracking errors, you could find yourself listening to some very embarrassing silence.

Not with the new CD-701 from Tascam. Its unique disc clamping system is a technological triumph that virtually eliminates disc vibration. So you never hear the awful hush that means a tracking error has occurred.

What you do hear is the finest sounding CD unit you can buy, with the same proprietary "ZD Circuitry" praised by two of Japan's top audio magazines\* for eliminating low-level digital distortion.

Then there's the optional RC-701 Remote Control with Auto Cue so you can cue to the music instead of the track (for even less dead air). Or you can add the Ram Buffer for true, instantaneous startup.

And with four times oversampling and 16-bit D/A converters in an extra-rugged chassis, the CD-701 is superbly designed for the broadcast environment.

Can a CD player really deliver this kind of performance, track after track, disc after disc? Only if it's a Tascam.

Contact us or visit your Tascam dealer for more information about the CD-701. And take the sounds of silence off your playlist.

## TASCAM



©1989 TEAC America, Inc., 7733 Telegraph Road, Montebello, CA 90640, 213/726-0303.

\*Radio Technology Component Grand Prix '88, CD Division, Stereo Sound Component of the Year (1988) & Best Buy (1988)

Circle (24) on Reply Card

World Radio History

# NAB Engineering Conference report

By Brad Dick, technical editor

## Future-oriented sessions address tomorrow's issues at the NAB.

**P**acked sessions best describes the 1989 NAB Engineering Conference. From Friday until Tuesday, the sessions were well-attended, and reports indicate that the technical quality of the sessions was good.

Perhaps as a result of the changing nature of the broadcast business, this year's topics seemed more product-oriented than in years past. Most of the papers presented were given by manufacturers, and most represented new products.

A number of new ideas were floated during the sessions and usually were expressed in the form of equipment concepts, not actual working products. From completely digital FM exciters to new types of UHF transmitters, there was something for everyone.

If you missed the show, or couldn't attend a particular session, **BE** is here to help. The sessions were staffed by six engineers who attended in your place. Over the course of the next few pages, they will describe what they saw and heard.

Because space is limited, we will provide only an overview of some of the important topics. Most of the papers are printed in the "NAB Proceedings." If you desire more information on one of the papers, contact the NAB to purchase a copy.

### *Radio sessions:*

#### **Digital audio and radio**

The Friday morning session on digital audio and radio was filled to capacity. The first speaker was Skip Pizzi, National Public Radio.

In describing the typical radio station's audio chain, Pizzi pointed out that three links in the chain now are available in digital format: audio sources, tape recorders and STLs.

The analog or digital audio source is connected to a production mixer, which is analog. The output is then fed to a digital recorder. The recorder's output is routed to an analog broadcast mixer and then to audio processing, through an STL, and finally to the transmitter.

Currently, there is no digital-to-digital connection between any two steps, and therein lies a problem. Every signal must be converted to digital and back to analog several times. So, according to Pizzi, the full advantages of digital audio — fewer cables required, RF immunity and, of course, the high-quality audio itself — cannot be realized.

The recorder and the STL are available in digital formats now. Later, the audio processing and the transmitter will be

digital. Pizzi suggested that the production and broadcast consoles will be the last devices to become digital. Once the mixers are digital, new wiring techniques can be used, and that's an important advantage. The disadvantage is that along with the lower noise floors, better grounding and better shielding are mandatory to protect the remaining analog wiring from the RF fields generated by some digital signals.

In the future, the digital audio optical paths will be used for facility-to-facility connections. For long paths, serial datastreams are ideal. They have wide bandwidth, low loss and total immunity to ground loops and EMI generation or reception. "As soon as two consecutive blocks become predominantly digital," Pizzi said, "the floodgates to the world of digital interconnection will open."

#### **New measurement techniques**

Richard Cabot, Audio Precision, presented a paper describing a test equipment system that performs measurements on digital audio equipment while the signal is still in the digital domain. The test set eliminates the errors inherent in the use of A/D and D/A converters typically used as input and output devices to test digital equipment. His system also generates test signals and analyzes equip-



# Downlink Double Feature

Upgrade with our new VDP-8400 frame store synchronizer  
or our field-proven VDP-8000.

Lock up and synchronize noisy satellite and microwave signals for uninterrupted operation with our two high-performance frame store synchronizers.

The new VDP-8400 has the same reliable front-end circuitry as the dependable VDP-8000. And both come with outstanding features to match. Like a processing amplifier to enhance picture quality even in the freeze mode. Clean "hot switching" of non-synchronous sources, and a line select that lets you observe individual lines of video on any waveform or picture monitor. What's more, a blackburst output allows you to use

each of these units as a stand-alone sync generator. Want more? How about a price that's thousands less than the competition.

What's really uplifting about our down-link duo is their freeze-field/frame storage capabilities. The VDP-8000 lets you store two different fields or one field continuously, without interruption of live video. While the powerful VDP-8400 gives you enhanced storage capability of up to four fields.

So if you want to be in total sync, check out the VDP-8400 and VDP-8000 at your Videotek dealer today.

Line Select lets you observe individual lines of video on any waveform or picture monitor.

Multi-storage capabilities.

Display field or frame.

Processing amplifier controls with presets for video gain, pedestal, chroma gain and chroma phase.

**VIDEOTEK**  
VDP-8400

**POWER**

SYSTEM PHASE

H SC SC/H

PICTURE POSITION

H V

NORMAL  
BYPASS

STORE

FRAME A FRAME B FRAMES A & B

DISPLAY

FIELD 1-4 FRAME A/B FRAMES A & B

CHROMA

**VIDEOTEK**  
VDP-8000

**POWER**

SYSTEM PHASE

H SC SC/H

PICTURE POSITION

H V

NORMAL  
BYPASS

STORE

FIELD-1 FIELD-2 FRAME

DISPLAY

FIELD-1 FIELD-2 FRAME

CHROMA



**VIDEOTEK INC.**

American-made technology.  
And value

243 Shoemaker Road, Pottstown,  
Pennsylvania 19464 • (215) 327-2292  
TWX 710 653 0125 • FAX (215) 327-9295

Circle (26) on Reply Card

ment performance digitally via a micro-computer.

The analog measurements can be made with available test equipment. However, when you have a piece of digital gear, you can look only at the analog input and outputs. Without special measuring devices, there is no way of knowing where in the digital chain a problem is occurring or exactly what effect the many adjustments may have on the performance of the device's A/D converters.

The conventional measurement approach relies on the use of known-good A/D and D/A converters attached to the digital stage. Measurements then are made with existing analog test equipment. Unfortunately, inaccuracies can develop through the conversion process, such as response irregularities from anti-alias filters and the fact that digital gain limits the dynamic range of some tests. Some parameters are simply difficult to measure in the analog domain.

#### Planning the digital radio studio

Eric Gray, New England Digital, began his paper by asking, "What are the advantages of a digital radio studio?" Engineers must begin to consider this issue as the cost of digital recording, storage and

editing systems is lowered and more options become available.

Several important aspects should be considered when evaluating a digital editing/recording system. The first is memory, because this determines how much audio can be handled at once. Be sure the editing system can handle your load. One hour of mono requires a 360Mbyte hard drive. If your work requires stereo operation, double that requirement.

Decide how many tracks you need. The number of events you need to play back at one time should be at least the same as the number of tracks you are using now in an analog system.

Gray suggested that the most important factor in choosing a system is the human interface. There are two basic ways to interface. The first is through a computer terminal, which is easy to manufacture, and the second is to change the operating software. However, some people are not used to operating computer terminals. In addition, such terminals typically don't provide the speed of editing that's available from dedicated consoles. That's because a customized interface is generally more familiar (resembling a console and tape deck) and easier to operate.

In choosing the interface, the buyer must balance between soft and hard functions and between programmability and updatibility while keeping in mind cost and staff needs. Before you decide, use the system. Have the operators spend time editing on the system. The differences in interfaces will become obvious quickly.

#### Digital audio for STLs and SCAs

Harold Walker, Pegasus Data Systems, discussed a method to transmit digital data over STLs and SCAs using what he called *slip code*. His system makes it possible to transmit digitized information at rates approximately 10 times higher than now possible.

The slip-code scheme derives its name from the algorithm that adds a fraction of the bit-width time to each bit as it is transmitted. The process is similar to modified frequency modulation (MFM), which is used on double-density computer disks. The slip-code system has a Nyquist factor of up to 15. In other words, 15 times more data can be transmitted in the same bandwidth than with conventional frequency modulation.

Combining SSB FM modulation system and slip code generates a signal with a  
*Continued on page 57*

# We give you the power to choose.

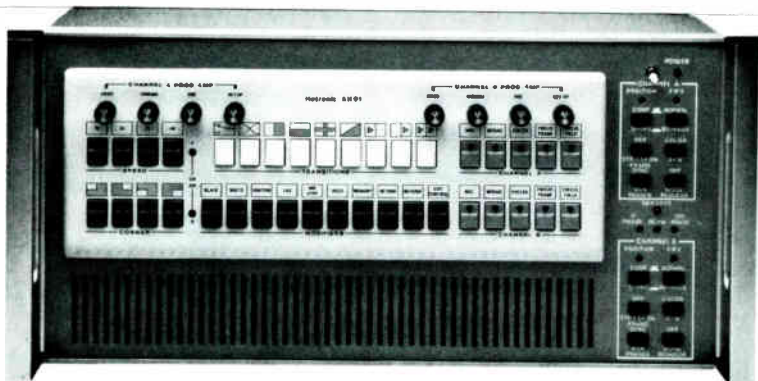

The flexibility of the Hotronic AH91 dual channel TBC with digital effects is designed to accommodate a wide variety of applications. Each channel can be configured as a TBC or Frame Synchronizer, and each is completely independent with full proc-amp control.

The AH91 features special effects such as wipes, tile, posterization, mosaic, negative, and more.

- Dual channel TBC Frame Sync configurable
- Full Proc-amp control for each channel on Remote unit
- Composite or Y/C 3.58 selectable input
- Infinite D.O.C. for each channel
- Editor controllable effects
- Chroma Noise Reducer
- Serial Interface RS422/RS232
- Audio Switcher

The AH91 also provides comfort and highly efficient production with the detachable remote control unit.

## AH91 Dual channel TBC with Digital Effects

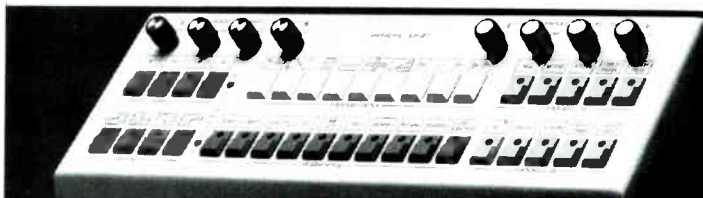

Ultimately, with your creativity and ingenuity, the use of the AH91 stretches as far as the imagination will go.



**HOTRONIC, INC.**

1875 So. Winchester Blvd.  
Campbell, CA 95008

Tel. 408/378-3883, Fax. 408/378-3888

Circle (25) on Reply Card

**A NEW ERA  
IS ABOUT TO OPEN.**

**SONY**



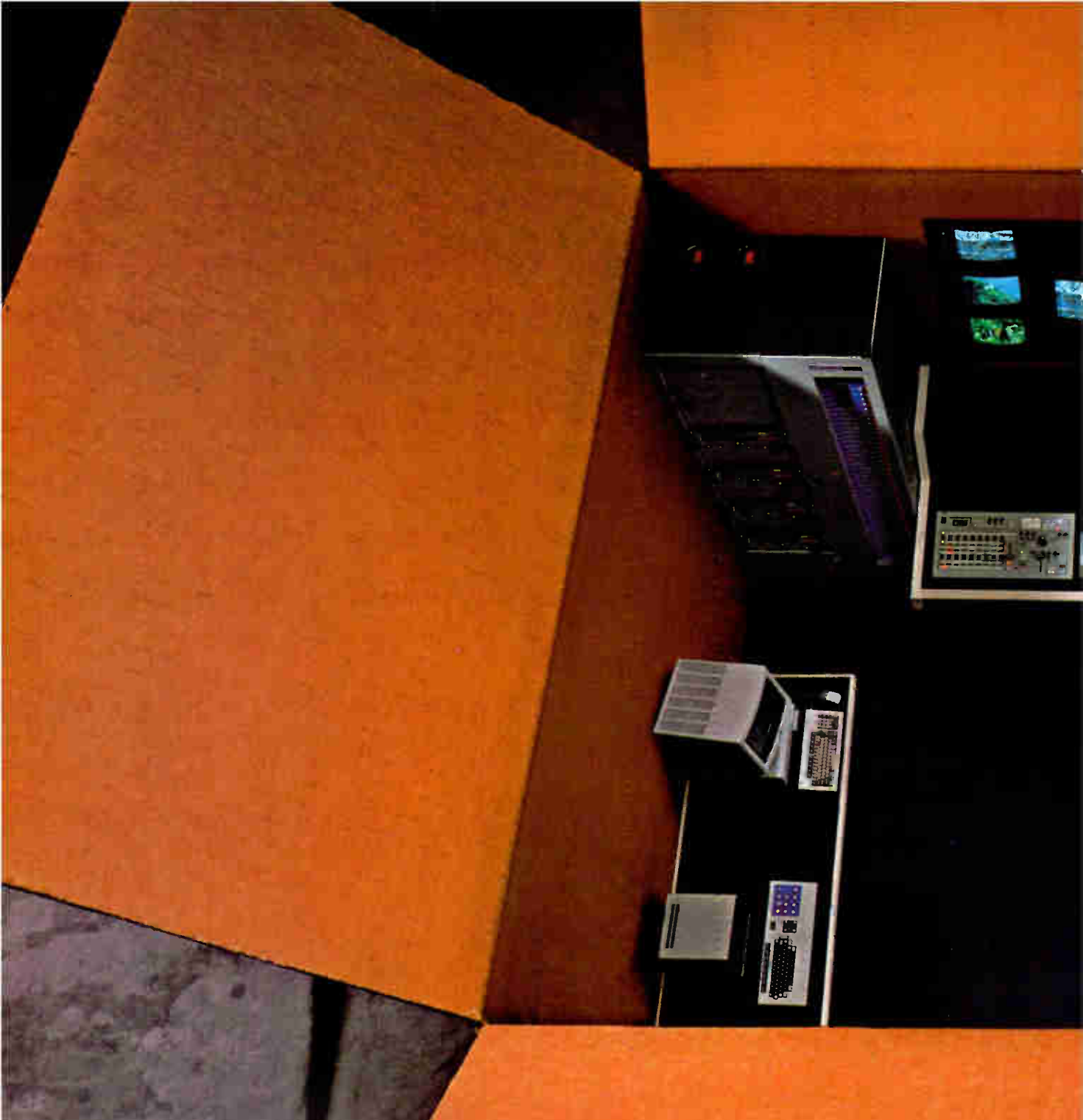

# THE COMPLETE SYSTEM.

It's the dawn of a new era in television: the era of Sony System Solutions™. It means the introduction of revolutionary systems products that together will shape the future

of broadcasting. Switchers. Digital effects. Digital audio. Stillstore. And our own dual-channel RAM recorder. All Sony products that have extended the most advanced

technology into a total system.

And it could only have come from Sony, the innovator in U-Matic® technology. CCD technology. Betacam® products. And ground-breaking

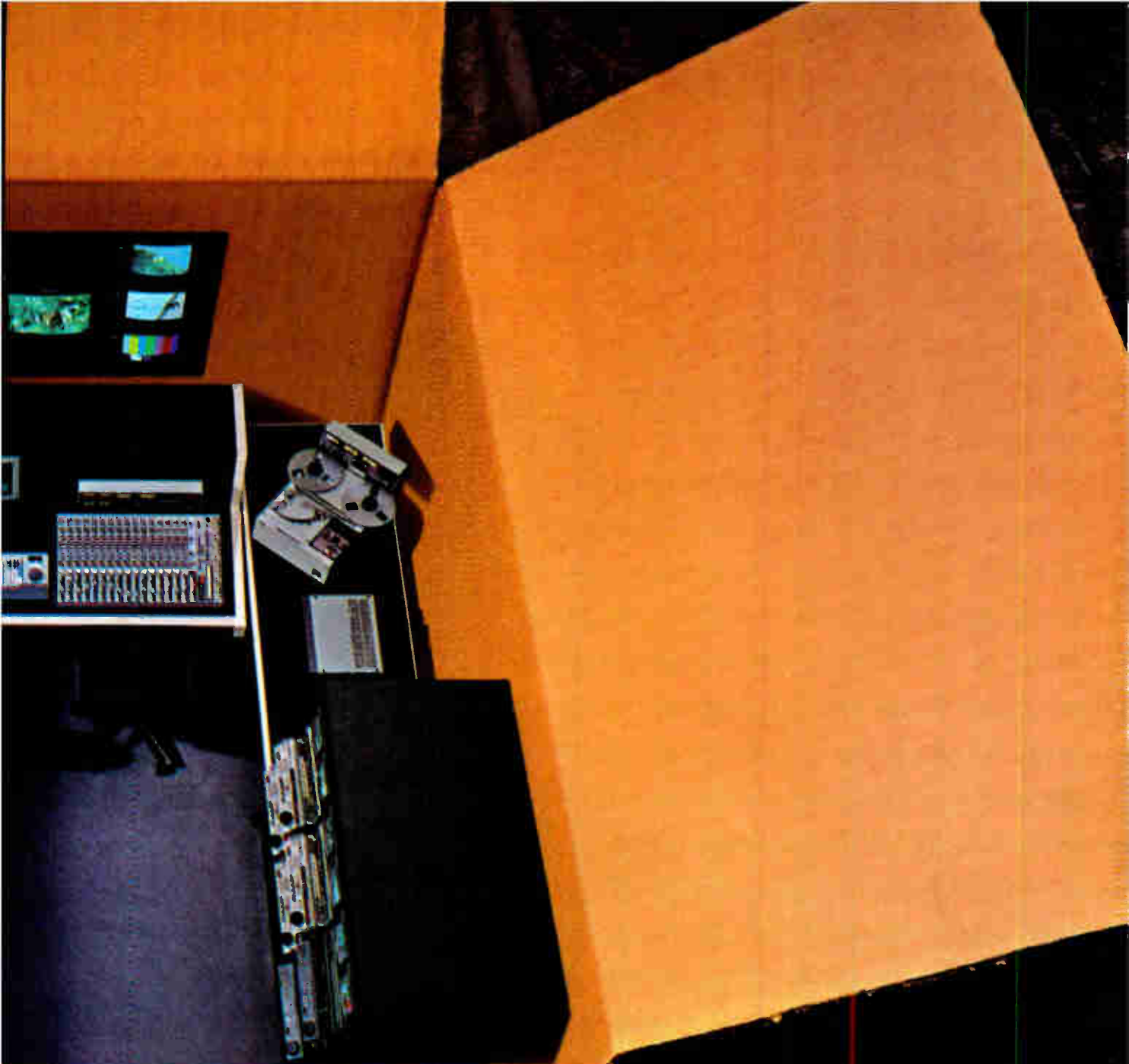

# ONLY FROM SONY.

digital technology. Advances that set industry standards. Advances backed up by traditional Sony service and reliability.

Now, Sony is setting stand-

ards for the future. Because, for the first time, you only have to look to a single source for your system needs. For products that are reliable. Products that prove themselves superior—

from the moment they're plugged in. Products that don't just give you system technology. They give you Sony System Solutions™ technology, the solutions you've been waiting for.

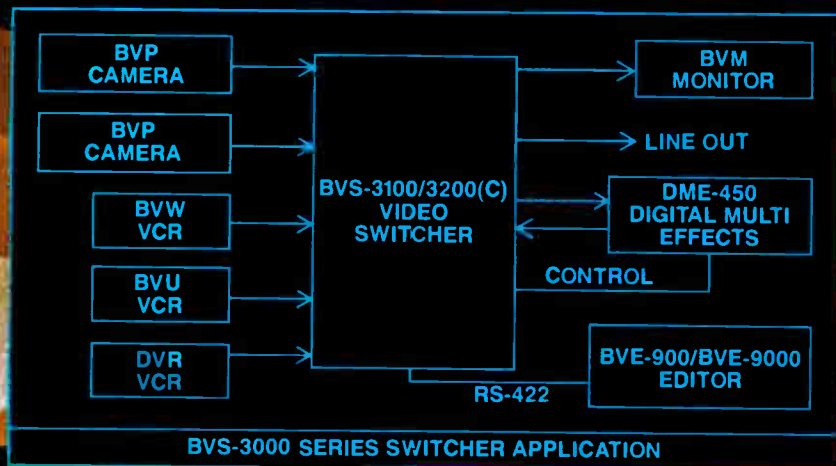

# SWITCHERS

Announcing Sony System Solutions™ line of smarter switchers. A line with some of the most advanced features ever engineered. A line designed to meet a wide range

of requirements and budgets.

Take the DME-450. As Sony's most basic switcher, it comes with over a hundred digital effects including true 3-D, cut, mix, and more than

one hundred-fifty wipes. Border and background color generators are also standard. Furthermore, no time-base correctors are required for any of the VCRs.

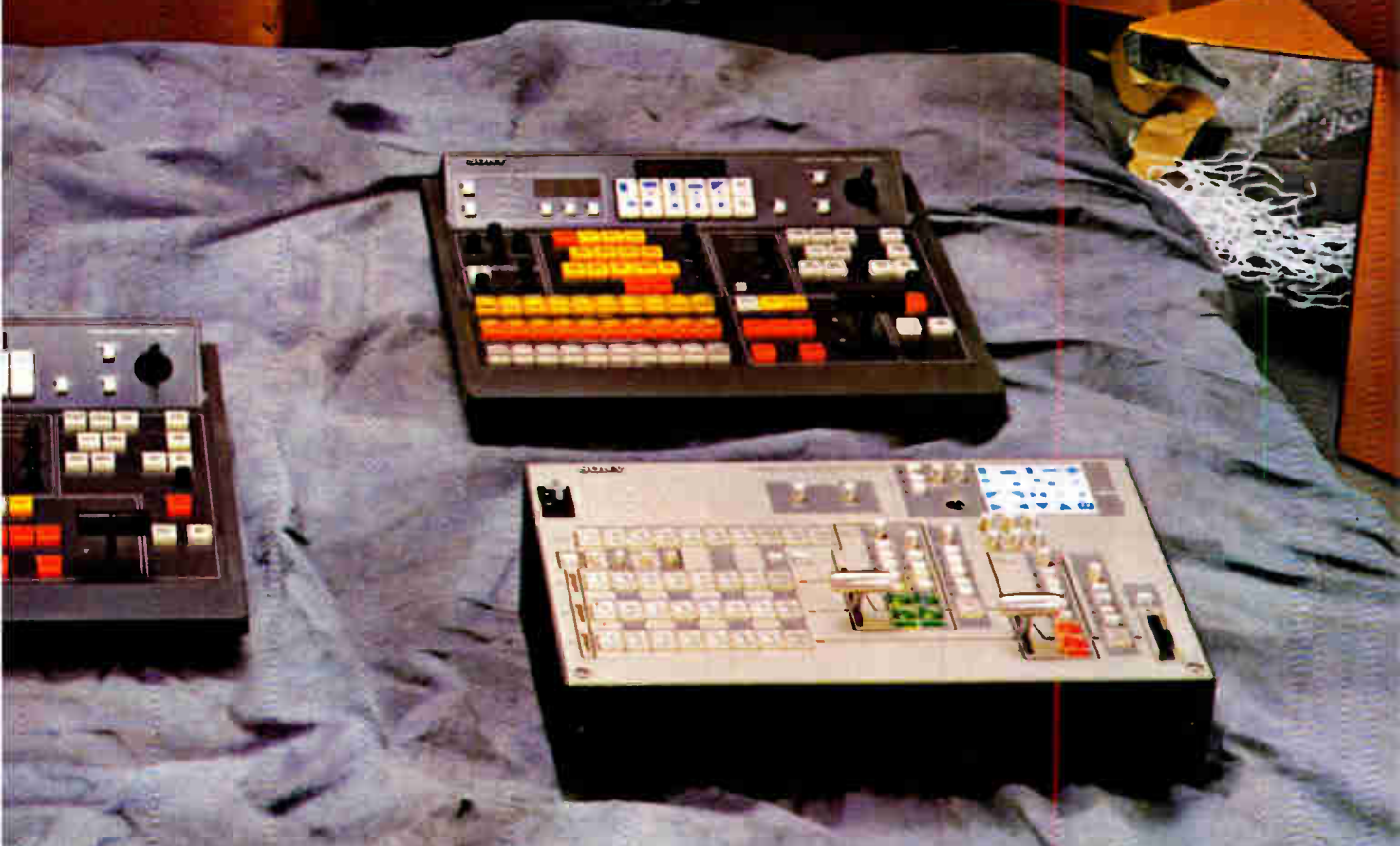
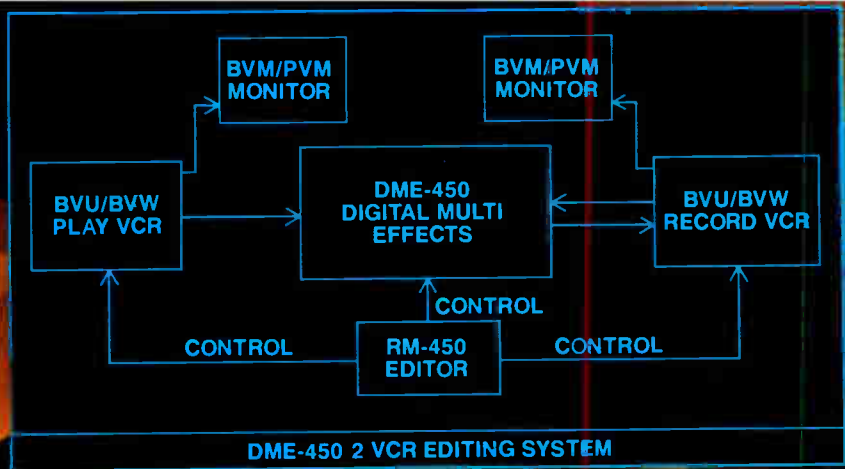

# FROM SONY.

Then there's the BVS-3000 series. Ten inputs plus all the wipe patterns and key effects you'd expect from a compact production switcher. But it can also give you digi-

tal effects with its unique link capabilities. When hooked up to the DME-450, this compact combination results in unprecedented power.

They're all switchers that know how to work with your other equipment. So they can not only do more, they do it all better. From the moment they leave the box.

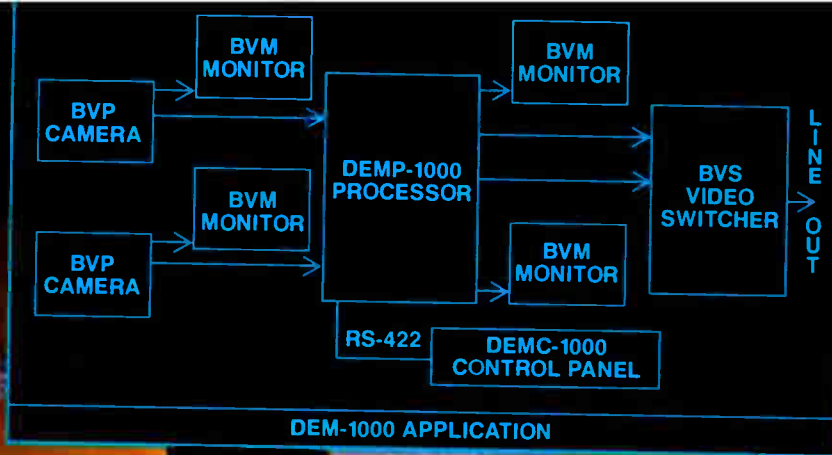

# SYSTEMS COMPONENTS AND

Sony opens up new possibilities with advanced digital technology like Stillstore and the DEM-1000. As well as peripherals that enable this uniquely modular system to work at

maximum efficiency today—and help you grow tomorrow. Because the Sony Stillstore's optical storage is on Write-Once-Read-Many (WORM), and erasable Mag-

neto Optical (MO) discs, its archiving capabilities and transportability are unparalleled. Additionally, the DNS-1000 distributed hardware is linked by a unique network-



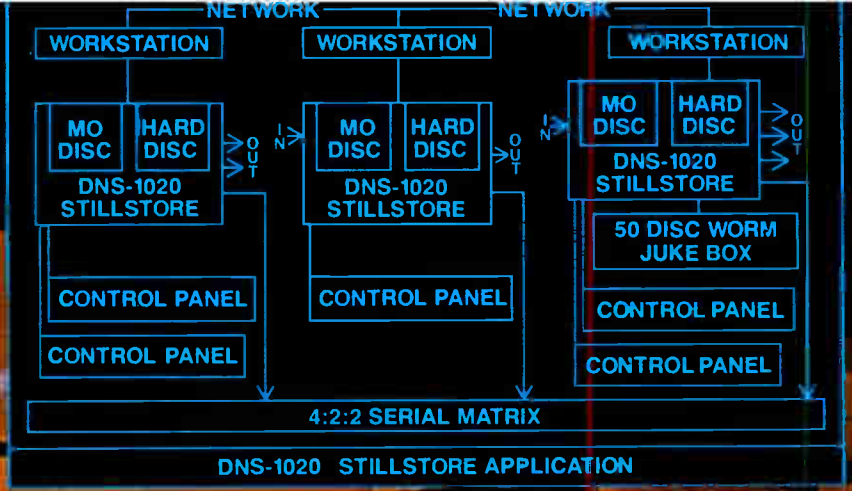

# PERIPHERALS FROM SONY.

ing system which lets each user take full advantage of all the resources on the network.

Then there's the DEM-1000, a remarkable achievement in motion manipulation.

With its simultaneous read-while-write capability, the DEM-1000 RAM based video recorder actually gives you real-time slo-motion. It also provides stunt motion, which

allows virtually unlimited manipulation of the video motion. You also get a host of other features—like instant recall, editor control, and two-channel simultaneous I/O.



**DESIGNED TO WORK WITH YOU.  
DESIGNED TO WORK TOGETHER.  
DESIGNED TO WORK RIGHT  
OUT OF THE BOX.**

Sony System Solutions™. It works better because it comes from one source. Better because it comes with the reliability, compatibility, and service you've always expected

from Sony. The number one name in broadcast.

**SONY**®

To find out how you can open a new era right in your own station or facility, call (800) 635-SONY.

Sony Communications Products Company, 1600 Queen Anne Road, Teaneck, NJ 07666 © 1989 Sony Corporation of America. Sony, U-Matic, Betacam, System Solutions are registered trademarks of Sony.

**BROADCAST PRODUCTS**  
World Radio History

Continued from page 48

narrow bandwidth and a narrow noise bandwidth. Because the signal is FM, it can be amplitude-limited like any FM signal. This affords the noise-suppression characteristics of FM transmission.

The system currently is able to transmit 192kb of data in a bandwidth of only 25kHz. Possible uses include mobile phones, facsimile, military tactical communication and, of course, FM SCA or video SCA. With a 200kHz bandwidth, transmission rates of up to 2.5Mb are possible. This would allow CD-quality audio to be transmitted in digital form over a single 950MHz STL.

### FM improvement

Leading the FM improvement session was Bill Hassinger, the assistant bureau chief of the Mass Media Bureau. During his presentation several topical questions were raised, including one concerning the issue of voluntary downgrading. Hassinger explained the process and said that stations providing first local service are required to continue providing that service. He noted that any desired downgrading can be obtained only by keeping the proposed operation mutually exclusive to the station desiring the change.

The new IF taboo now references the 36mV/m contour. Terrain roughness also is being examined in FM propagation studies involving short-spaced stations. Stations adjacent to the Mexican borders must still obey the pertinent agreements. This means they are not yet able to take advantage of short spacing.

### Receiver blend

Tom Keller, Broadcast Technology Partners, discussed the problem of receiver blend in FM signals. As the strength of the RF signals falls, receivers switch to blend to avoid the increase in noise. Keller suggested that the manufacturers should decide how to apply blend in their receivers.

Using a series of graphs, he demonstrated how different receivers switch to stereo and blend at different RF levels. The result is that activation of the stereo indicator has little to do with whether the receiver actually is producing stereo audio. In many cases, although the stereo lamp is on, the receiver may be producing blended mono audio.

The issue is important to FM stations because it affects the number of listeners that receive a stereo signal. If a particular receiver switches to blend at relatively high RF signal levels, then the station's effective stereo range is reduced. On the other hand, if blend is not used or not switched on until the RF level drops to a low level, the station's signal sounds noisy to the listener.

Keller's point was that FMX helps improve a station's overall stereo coverage.

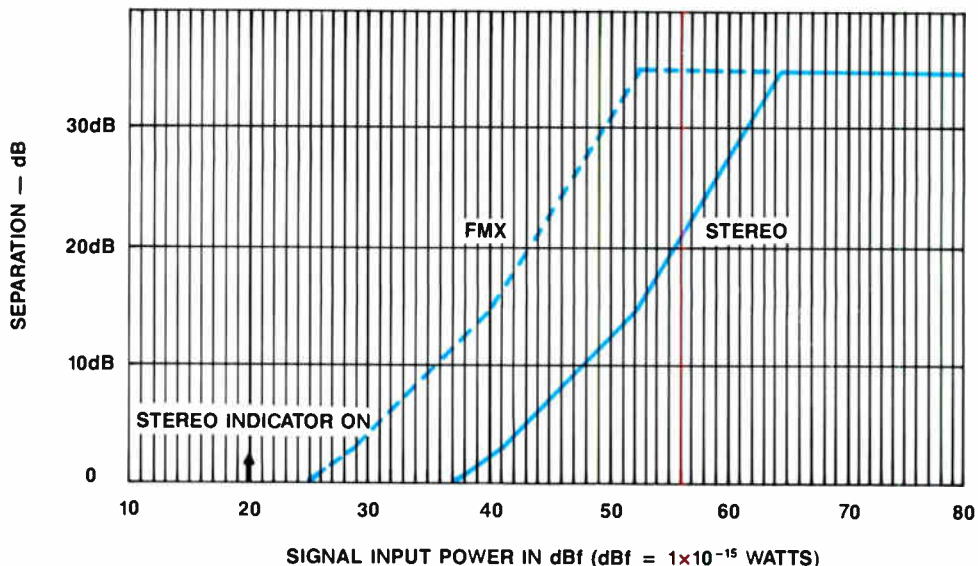

Figure 1. Many FM stations suffer loss of stereo coverage area because car radios switch to blend at relatively high RF levels. One suggested advantage of FMX would be the extension of this coverage by allowing the receiver to remain in stereo at lower RF levels.

The predicted improvement of FMX on a receiver's stereo performance is shown in Figure 1.

### FM synchronization

New types of signal synchronization are being tried by several manufacturers. The new processes are an attempt to synchronize the signals of two or more FM transmitters to fill gaps in a coverage area.

Martin Hadford, RF Specialties, gave a comprehensive explanation of the FCC rules that address the issue of FM synchronization. Under the rules, a booster station is limited to 20% of the class maximum power. Stations within 200 miles of the Canadian and Mexican borders are limited to 50W ERP.

The technology used in today's boosters is more sophisticated than previous attempts. The key to a high-quality signal is both frequency- and phase-synchronization of the carrier and, most important, the modulation of the transmitters. If you are investigating the use of FM boosters, obtain copies of the several papers on the topic, and contact the equipment manufacturers for more information.

### FM bandwidth

Ed Anthony, Broadcast Electronics, gave a masterly presentation on the topic of optimum bandwidth for FM transmission. This was a comprehensive speech where he used more than 60 scope photographs and performance data curves. He states that for theoretically perfect reception of FM, an infinite transmission and receiver bandwidth is required. In a perfect FM transmitter, the output power would remain constant, while the power distribution between the carrier and the sidebands changes. The receiver requires that everything except the desired signal be rejected.

Apparently, there is a diversity of opinion between various FM transmitter manufacturers concerning the amount of desirable bandwidth. However, a closer look at some practical considerations shows that "more is better" is not necessarily true.

Intermodulation in FM transmitters is becoming more a fact of life as the number of transmitters on any single site increases. Antenna farms and community towers hold the potential for creating severe IM problems.

Anthony coordinated a series of tests, with bandwidth varying from 400kHz to 3MHz, using a specially constructed test cavity. The results show that good audio can be obtained from an FM transmitter with as little as 800kHz of bandwidth. Excellent results are possible with a bandwidth ranging from 1MHz to 1.5MHz. Little improvement is seen once the transmitter bandwidth exceeds 1.5MHz. This amount of bandwidth still provides a lot of protection from RF IM problems.

### FM reception problems

The FM NRSC subcommittee was described by Wesley Whiddon of Group W Radio. Although the author referred to the adage, "If it ain't broke, don't fix it," he said that unless some preventive medicine is found, FM reception may be perceived by the audience as broken.

The NAB formed a subcommittee to investigate ways to improve FM. Four issues were placed before the subcommittee: multipath measurement, subcarriers, receiver performance and adjacent-channel interference. As a first step, the committee plans to prepare a bibliography on multipath. The issue of subcarriers will await the results of a Canadian study to take place this year.

The issues of receiver performance and

INTRODUCING OUR NEW BP325

USER PROGRAMMABLE.

MICROPROCESSOR ASSISTED.

LIGHTWEIGHT CONTOURED BODY.

KILLER CIRCUITRY.

GREAT SOUNDING.

AFFORDABLE. REVOLUTIONARY.

PORTABLE INTERCOM USER STATION.

OR, IN A WORD:

# WOW!

MODEL BP325 PORTABLE USER STATION

...PLEASE CALL OR WRITE FOR THE BROCHURE.

## **RTS SYSTEMS**

INCORPORATED

THE FIRST NAME IN

INTERCOMMUNICATIONS

1100 WEST CHESTNUT STREET

BURBANK, CALIFORNIA 91506

PHONE 818 566-6700 FAX 818 843-7953

World Radio History



adjacent-channel interference are somewhat related. The first issue will be addressed by recommending that "ANSI/IEEE 185-1975, Standard Methods of Testing Frequency Modulation Receivers" be updated to include measurements of the IF taboo, third-order IM, front-end input levels, stereo separation and SCA rejection. The committee also recommended that broadcast sites with IM problems be identified.

The issue of adjacent-channel interference seems to be partly related to modulation levels and the possible misuse of composite clipping. A working group of broadcasters and receiver manufacturers will evaluate new methods for measuring frequency modulation. The group could go as far as to propose an RF or composite audio mask.

#### Irregular terrain propagation study

The last paper on Friday afternoon was presented by Eldon Haakinson, NTIA Institute for Telecommunications Sciences. Modeling of FM transmission situations was shown along with the need for more accurate computing of the transmission path.

In 1950, a simple and quick method of calculating field strengths and contours was needed. Now, as the FM band becomes far more crowded, a better means of predicting coverage is needed.

Antenna height, direct and indirect paths, terrain profile and receiver antenna location all have a great effect on FM reception. Comparisons of FCC methods and the NTIA modeling methods show considerable variance when terrain is taken into account. Figure 2 shows the free space loss curve and the predicted values from the NTIA model. Note that the upper curve is smooth. However, when terrain is taken into account, large differences in predicted signal levels are noticed. Which chart would you prefer to have when planning a station?

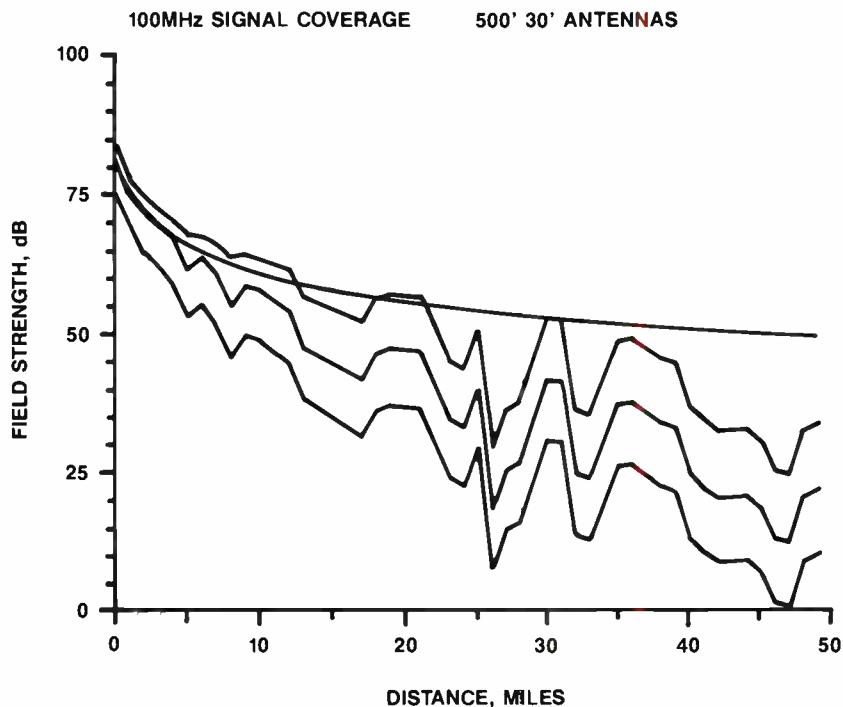

Figure 2. The top curve is the predicted free-space field strength of an FM signal. The bottom curve predicts the field strength while taking into account the effect of terrain. The model was developed by NTIA.

#### AM systems engineering

The Sunday morning engineering session began with a presentation by Lex Felker, Mass Media Bureau chief. He provided an overview of FCC actions regarding AM and noted that two general policy issues are under discussion. One concerns the interference environment, and the other is a plan to give licensees more discretion in accepting interference. He also provided information on the proposed extension of the AM band.

Six proceedings are currently in progress. The commission's main concern is on improving quality and reducing interference. Six hours after sunset for the

night reference hour is a possibility. Once again, the commission is considering providing a certain amount of latitude. A change in rss calculations, including even a possible lower-than-25% value and, perhaps, adjacent-channel consideration is a possibility. This proposal will delight those AM broadcasters who have been stymied by the presence of the outmoded 0.5mV/m 50% night protection contour. What's needed is a more realistic approach to using rss.

A proposed rulemaking is expected within several months to examine changes in protected contours, but more data is

*Continued on page 62*

# SBE 1989

**October 5-8  
Kansas City Convention Center**

The professional audio/video industry is changing rapidly. To stay ahead today, you need to know where technology is heading. Find out at the '89 SBE convention.

This year in cooperation with major manufacturers, special hands-on training sessions will be available. Other comprehensive sessions will bring you up to date on the latest developments important to your job including digital technology for audio and

video, satellite uplinking and high definition television. A seminar on worker safety is also on tap. Plus, a convention center full of the latest audio and video products.

Plan for your future now by attending the 1989 SBE National Convention and **Broadcast Engineering** Conference, October 5-8. Take in the show, and while you're in Kansas City, take in the sights!

# THIS ENGINEERING HAS VERY LITTLE COMPETITION.



BVU stands alone. No other 3/4-inch system offers the beauty and power, the sheer thrill of controlling this Sony U-Matic SP™ video equipment.

We could tell you about features that are state-of-to-

morrow's art. But that wouldn't really give you a feel for the amazing responsiveness and precision of BVU recorders.

Or we could tell you about the Dynamic Tracking® capability in the new BVU-920, giv-

ing you fingertip editing control of pictures from -1 to +3 times normal speed. And about the plug-in time-base corrector that lets you record the Dynamic Tracking® effect, and also brings you digital

# THIS ENGINEERING HAS NONE.

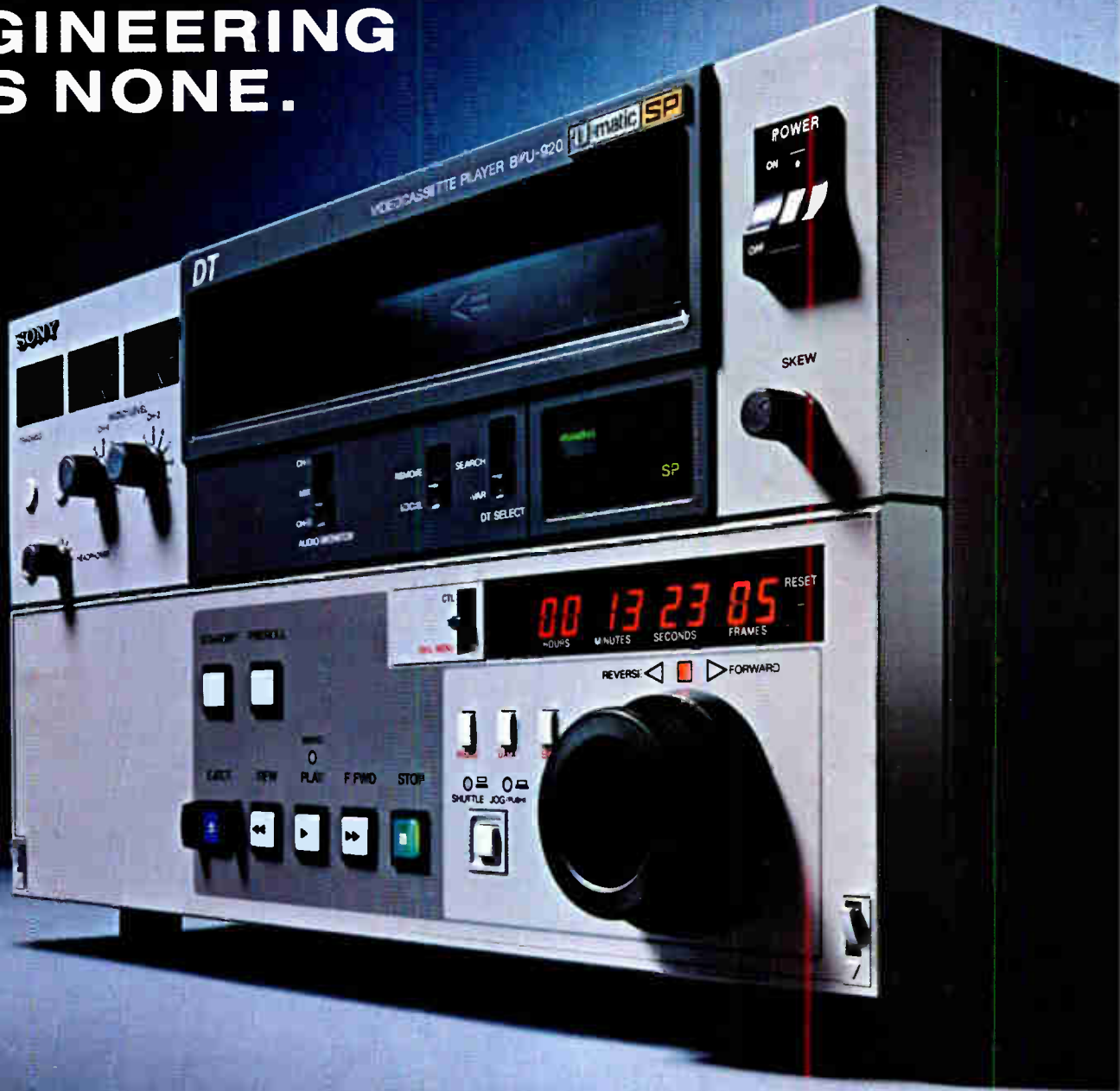

noise reduction in both luminance and chrominance picture components.

We could go on about shuttle speeds up to 40 times normal, with visible picture. And BVU U-Matic SP™ (Superior

Performance) picture quality, with 340 TV line resolution and Dolby® C noise reduction.

But these hot new BVUs must be experienced to be appreciated. Take the first step. Call Sony at 1-800-523-SONY.

Sony Communications Products Company, 1900 Queen Anne Road, Teaneck, NJ 07566 © 1989 Sony Corporation of America. Sony, U-Matic SP and Dynamic Tracking are trademarks of Sony. Dolby® C is a registered trademark of Dolby Licensing Corporation.

# SONY®

PROFESSIONAL VIDEO

Continued from page 62

directional array, and tests show that theory agrees well with practice.

Costs for an installed operating Pinzone antenna range up to \$150,000. A 3- to 5-year target cost is \$30,000 per element. The physical design has changed from last year and now has a Q between 30 and 100. A single antenna produces a modified figure 8 pattern.

A paper by Timothy Cutfoth, Vir James, PC, introduced a radically new antenna concept. The design relies on placing a 15m- to 30m-diameter loop of insulated wire on the ground and radiating a signal with practically no vertical component. The resulting transmitted wave is primarily groundwave. The vertical component of the antenna system is no more than a few millimeters and consists of the diameter of the wire only.

Measured efficiencies during the test ran only as high as 20mV/m, but the design theory appears to work when used with receiving antennas. Experimentation will continue, with the results to be reported next year.

#### AM splatter

The morning session ended with a dual presentation by John Bisset and Thomas Wright, Delta Electronics. Bisset compared the measurement process for a splatter monitor against that provided by a spectrum analyzer.

Test results and curves were presented along with the theory of operation for the splatter monitor. Based on the presented data, it appears that the average broadcaster can depend on splatter monitor measurements to ensure compliance with the new FCC NRSC rules.

The spectrum analyzer occasionally may provide poorer results than the splatter monitor. This might happen if a burst of energy is not recorded properly because of the analyzer's sweep characteristics. In the example shown, the splatter monitor would detect the burst of energy.

However, the commission insists that if there is any disagreement or non-compliance, the spectrum monitor has the last word.

### TV engineering sessions:

#### TV automation

Tom Mikkelsen, WTMJ-TV, said the purpose of his paper, "Multiplicity of Videotape and Satellite Delivery Formats," was to develop awareness and to focus on the problems related to satellite audio sub-carrier incompatibility in the TV industry. Mikkelsen reviewed the history of satellite transmission and a few of the milestones that occurred between 1945 and 1975. Broadcasters now must deal with 32 geostationary satellites. Using the current

satellite chart from Westsat, he showed that 14 separate audio subcarrier frequencies are in use with carriers varying from 5.38MHz to 7.6MHz.

Mikkelsen stressed the need for users to deliver input and support for the standardization of TV satellite subcarriers. There is now an active NAB subcommittee pursuing this problem. If you would like to participate or communicate with the subcommittee, please contact Lynne Claudy at the NAB or Tom Mikkelsen at WTMJ-TV.

#### Remote-control cameras

Richard Slenker and Robert Murch, WPIX-TV, described their station's use of the Vinten Microswift camera-control system. At WPIX-TV, the remote-control operator is housed in a separate room and also controls camera shading.

The authors stressed that teamwork was required to implement camera automation effectively. If you want to begin remote-control camera operation, consider your company's return on investment. Today's systems often can handle early morning newscasts or programs, which increases productivity and lowers cost.

Although many station employees were skeptical at first, the system has proved effective in the WPIX-TV operation. The station now uses the system for both newscasts and talk shows.

#### Graphics and animation

The blush is off the rose in computer graphics. Only about 350 people attended the Monday afternoon session, chaired by Cathy Galvin, a graphics consultant from Los Angeles. The session started off with a whimper when the first speaker didn't show up. It was learned later that his paper had been withdrawn because of potential patent disclosure problems.

The day's second paper, delivered by NBC's James Keane, dealt with the network's methods of providing graphics coverage for the 1988 Seoul Olympics. NBC engineers had to develop means for the network artists to integrate images from several sources: the official Swiss time clocks, the GIONS interface the Koreans used to keep track of the scores and standings, the many graphic segments and elements used as backgrounds, profiles of athletes, transitions to station breaks and show opens and closes, which were created and stored on many different machines.

Long-time graphics expert Steve Davis, WPRI, Providence, RI, lectured on the issues surrounding electronic graphic interface to newsroom computers. Davis began by profiling the levels of interface between graphics equipment and station automation equipment. Still-stores, for instance, can interface at either a low level, where the newsroom computer constantly directs the still-store to pull up slides,

or at a higher level, where the database on the still-store is updated by the database in the computer, then the still-store is left to display the desired slides autonomously. Character generation automation follows similar lines. The highest levels of automation entail the newsroom computer ferreting still-store, CG or other device requests, then sending them along to the respective equipment, updating the list automatically if the run-down order changes.

These high- and low-order interfaces can be achieved in a variety of ways. One is directly connecting the computer to the CG. Another is using a PC-type computer as an active interface between the CG and newsroom computer. A third method, increasing in popularity, is networking, where all the controlled devices communicate along a common link.

Quantel's Bill Aitken presented a paper, "Film-Style Creativity and Digital Power in Video Animation," in which he contended that a new level of creativity awaits the video producer. One intriguing demonstration was the compositing of an image and several mattes, which accomplishes two goals. First, a black matte can be repositioned electronically to form one or several shadows. Shadows are one of the keys to effective, realistic animation. Second, mattes can be used as a tool to introduce detail, say the whiskers on an animated mouse, where these details normally would be too hard to incorporate as part of the main animation.

An additional film-style element available with today's digital techniques is that of sound. Electronic audio-editing systems can manipulate and position production music and effects quickly, and if the action changes, the audio can be readily modified. This is a new level of flexibility for the video producer.

#### TV engineering and new technology

One of the most perplexing issues faced by today's TV broadcast engineer is the multitude of parallel and series types of interfaces for equipment. What the engineer wants is a single type of system that's able to communicate with all devices without requiring expensive interfaces.

One possible answer to the dilemma is a system described by William Stickney, Videomedia. Dubbed the *universal control network*, V-LAN, the system is based on a simple 2-byte ASCII code. Using a single RG-59 cable and the system, it's possible to interface a multitude of devices into an integrated control system.

The control even can be routed via inexpensive patch panels. A defective device can be isolated and removed from the network or bypassed within seconds. V-LAN is a building block for automatic network delay, animation system and remote-



# This is one reason we sell more cart machines than anyone else.

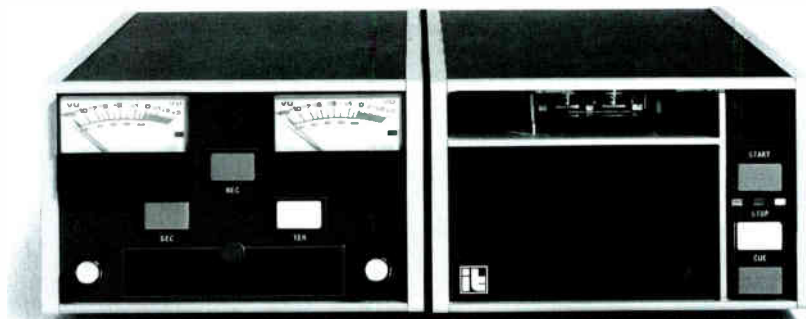

The 99B series Master Recorder features a patented erase, splice-locate and azimuth-adjust system (ELSA).

# And here are three more.

Our Authorized 3M Dealers

Allied Broadcast  
Equipment  
800/622-0022

Broadcast  
Services Company  
919/934-6869

Broadcast  
Supply West  
800/426-8434

*3M International Tapetronics — The World Leader In Cart Machines.*

control interfaces.

### Routing switchers

Dan Mazur, Di-Tech, reviewed how the changes in TV technology have placed new demands on routing switchers. The Betacam and M-2 component video formats do not impose new bandwidth demands. However, they do require the simultaneous switching of three video signals. Most routers in the field can accommodate these requirements only by slaving two additional video frames together. Few manufacturers offer any practical way of using the remaining frame capacity for systems in the field. Fewer still can reconfigure a single chassis to route the four channels of audio these tape formats provide. The D-1 and D-2 digital video formats are even more demanding and require an entirely new breed of routing switcher.

Ideally, switching crosspoints should be selected on the basis of their logical and operational relationship to a given device, rather than how each switching level is connected on a frame. It also must be possible to completely reconfigure the routing switcher via software. This can be accomplished by creating tables of source and destination names and mapping the crosspoints associated with each name.

Because a certain name could refer to a single-level or an audio-follows-video device, the control system must consult these tables before executing any switch. The term *virtual matrix* is used to describe this type of routing switcher system.

### Converting between digital standards

Converting video between the composite and component formats requires intensive digital-signal processing. In addition, the processing is subject to errors. Adaptive decoding and clean encoding can help minimize composite artifacts. And, adjustable filters and blanking help preserve the maximum possible active video content. The process often requires specialized rounding techniques to help make quantization errors less visible. The conversion process, when properly implemented, can provide excellent results.

Paul Salazar, Ampex, reviewed the company's DST-300 and how the device addresses the problems of digital signal format conversion. Digital decisions were made to provide high-quality conversion without the burden of excessive circuitry. The device permits the user to choose the method of encoding and decoding that best suits the particular task.

### S-VHS and time base correctors

David Acker, For-A, reviewed the history and development of 3/4-inch U-matic color-under processing and time base correctors. The point was made that with the heterodyne process, TBCs undo what

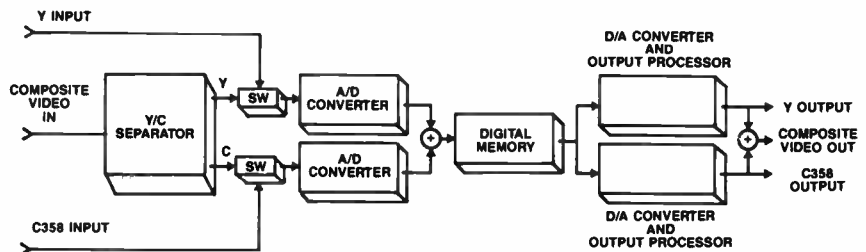

Figure 3. The advantages of S-VHS Y/C processing can be preserved through use of an S-VHS-based TBC.

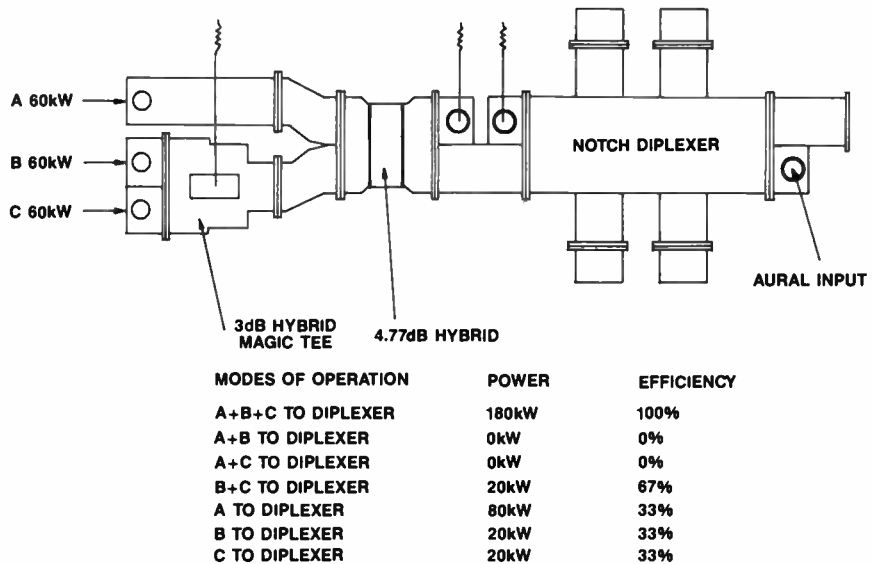

Figure 4. Simplified diagram of a 180kW diplexer. The advantage is that various combinations of transmitters can be routed to the antenna with a minimum of power loss.

already has been done in terms of signal processing. He claimed that S-VHS Y/C processing avoids some of the problems.

Some of the advantages afforded by S-VHS Y/C processing include minimum cross-color effects, elimination of decoding and encoding degradation, fewer NTSC artifacts and simple transcoding. A block diagram of a basic S-VHS TBS is shown in Figure 3.

The Y/C timing is controlled by adjusting the Y timing to match the chroma. The S-VHS time base corrector represents a parallel achievement in conjunction with the evolution of color-under processing that has produced the analog S-VHS recording technique. He suggested that the TBC is the best place to create transcoded interfaces because it affords the end-user the most flexibility in the use of station signals.

### UHF transmission systems

Traditionally, multitube systems using magic tees and notch diplexers suffered from limitations in the event of a tube failure. With the earlier systems, a single tube failure reduced power output and up to two-thirds of the generated power was

then dissipated in the system's reject loads.

In a paper presented by William DeCormier, Dielectric, the use of additional phase shifters in key locations was shown to address the problem of full redundancy with insignificant power loss. The combining system he described consists of hybrids, phase shifters and magic tees. It allows any tube to operate at full power into the system's output. In addition, any switch can be performed hot, allowing almost instantaneous backup. A 180kW diplexer is shown in Figure 4.

The stackable system is available in various configurations allowing up to a 5-tube system with one tube remaining in a hot standby mode. In addition, the switchless combiner is composed entirely of waveguide and, as such, will handle any realistic power levels for UHF television.

### High-power isolator for UHF

Tom Vaughan, Micro Communications, and Dr. E. Pivit, ANT Communications, presented a paper on high-power isolators for UHF television. This device, like its low-power microwave cousins, offers several benefits to UHF broadcasters.

The isolator provides four features not

# Here's another reason we sell more cart machines than anyone else.



The Delta series. The world's most popular cart machine over the last five years.

# And here are three more.

Our Authorized 3M Dealers

Allied Broadcast  
Equipment  
800/622-0022

Broadcast  
Services Company  
919/934-6869

Broadcast  
Supply West  
800/426-8434

*3M International Tapetronics — The World Leader In Cart Machines.*

available on waveguide diplexer systems. First, the isolator provides a constant impedance match despite widely varying antenna or line impedance. This constant load is frequency-independent, affording a more broadband response. This is an important criterion, as broadcasters try to determine how to accommodate the new ATV, EDTV and HDTV formats.

Second, isolators, by absorbing any antenna reflections, act as ghost eliminators. Third, the tuning stub of the isolator can be used to perform a hot switch to the station load. Also, with proper construction and tuning, these isolators can act as harmonic attenuators.

### Updating transmitters

The problems and advantages of rebuilding an old transmitter were addressed by David Folsom, WQTV-TV. He described how his station decided to rebuild, rather than replace, the current RCA-TTU60 transmitter. Once they decided to rebuild it, the next question was what sections most needed attention.

The upgrade covered three different areas: exciter, RF plumbing and power regulator and switching. The first change involved replacing the original RCA exciter with a modern one. The new exciter provided improved signal correction as well as multiplexed operation. The multiplexed operation let the station run at reduced power on one tube while the old coax filterplexer was replaced.

The station's original filterplexer operated on one of the higher UHF channels and was prone to arcing. One result was a lot of downtime. The filterplexer was replaced with a notch diplexer waveguide RF system providing reliable high-power operation. A new waveguide system provided quick switching for backup multiplex operation.

The power supply also received attention. The station's old GE single-phase voltage regulators were replaced with a 3-phase regulator. This new regulator eliminated the voltage cycling problem that occurred with the three old single-phase regulators.

The old high-voltage contactor was replaced with a new vacuum contactor that also increased reliability. The entire project cost \$174,000. The result is a transmitter that meets all of today's requirements for high-quality performance — without the price tag of a new transmitter.

### UHF transmitter update

The one hot topic at the UHF transmission systems session was the new forms of transmitters. Three different approaches to improved efficiency were presented during the session: the Klystron tube, UHF tetrode and the MSDC (multistage depressed-collector) klystron.

Comark's Nat Ostroff presented the case for the Klystron tube with a report on the company's first three installations. Station WCES-TV, channel 20, Wrens, GA, had the world's first Klystron tube transmitter. It went into service June 5, 1988. The 120kW installation uses three EIMAC 2KDW60LA water-cooled devices, two for visual and one for aural. Two other stations, WABW-TV channel 14, Pelham, GA, and WIIB-TV channel 63, Bloomington, IN, also went on the air in 1988.

Like the WCES-TV installation, WABW-TV also operates with two 60kW visual tubes and one aural tube. The WIIB-TV system represents a significant departure from traditional transmitter design. This design, although using the same tube, runs both output tubes in a parallel, multiplexed configuration. Each tube in the WIIB-TV system develops 40kW of visual power and, because of the design, can be considered effectively "bullet-proof" with the automatic switching feature.

Data as of Feb. 10 showed that the tubes have a combined time of 21,250 hours for the eight devices in service. Of the sites currently on the air, one operational tube failure has been reported. The failure occurred at WABW during a lightning storm.

The two 3-tube transmitters boast an impressive 1.20 and 1.31 figures of merit (FOM) for WCES-TV and WABW-TV, respectively. The WIIB-TV multiplex system showed a surprisingly good FOM of 1.45. This number, however, does not take into consideration the aural power output from the tube (16dB A/V ratio). At 10dB A/V ratio and 60kW peak visual output power, the measured FOM approached 1.20.

### MSDC klystron

MSDC klystron transmitters crossed from the theoretical to the practical stage in a paper by Earl McCune and John Wills, Varian Associates. The Vista series transmitter is the first to take advantage of the Varian VKP-7990 60kW MSDC klystron. To date, although no MSDC tube has been placed into commercial operation, five tubes have been constructed and are being used for development by transmitter manufacturers. The first delivery of an MSDC-equipped transmitter is scheduled for late summer. The MSDC tube takes the development of the klystron to its next stage in efficiency with a measured FOM of 1.36.

### Diplexed tetrodes

David White, Acrodyne, presented the paper, "IF Diplexed Tetrodes Vs. Multiplexed Klystrons/Klystrodes." He addressed the use of tetrode amplifiers in medium-power UHF applications.

After covering the history of klystron transmitters from non-pulsed through MSDC klystron technologies, White

discussed new amplifier designs using tetrode technology. To quantify the claimed higher efficiency, he reviewed the total estimated annual operating costs for three types of transmitters: 22kW tetrode, 15kW klystron and 30kW klystron, all operating at 10kW. He also offered comparison numbers for higher-power operation.

Acrodyne currently has a 25kW tetrode-based transmitter on the air in common amplification service. The entire rig, operating at 25kW peak-of-sync with 2.5kW aural, consumes a total of 46.3kW (including the cooling system) at 50% APL. At black picture, total ac consumption is 54kW.

White made the point in his paper that the key efficiency specification for a UHF transmitter is overall ac-to-RF efficiency. He said that comparisons based just on FOM numbers can be misleading. Some heated questions followed the talk, reflecting the varying opinions about how to efficiently generate RF for UHF stations, and about the appropriate standards of measurement.

### Progress report: ATV testing

Charles Rhodes, Advanced Television Test Center (ATTC), updated the audience on ATTC's progress. The test center is located in Alexandria, VA, near the Washington National Airport. It broadcasts on channel 58 and extends into channel 59 in the UHF band.

Channel 58 is used to simulcast WUSA-TV programs to compare propagation characteristics between VHF and UHF bands over the same path to hundreds of sites. The upper edge of channel 58 is used for double-sideband transmission of a wideband, dc to 6MHz, sin x/x test signal. The results of these propagation tests will be completed this month.

The ATTC hopes to determine whether TV signals propagated over such a wide bandwidth are practical. The group also will determine whether the characteristics of VHF and UHF paths are such that augmentation signal approaches to ATV may be technically feasible. The ATTC also will try to determine whether spectrum above 1GHz can be used for terrestrial TV broadcasting.

Some of the test results will be evaluated through the subjective viewing by people watching an HDTV monitor. To reduce costs, the ATTC is considering recording the tests on videotape so that all viewers can see the same tapes on the same monitor at different times, reducing the number of viewing rooms required for each test. It is interesting that the ATTC group does not plan to use any cameras in its testing work.

*Continued on page 197*

# Yet another reason we sell more cart machines than anyone else.

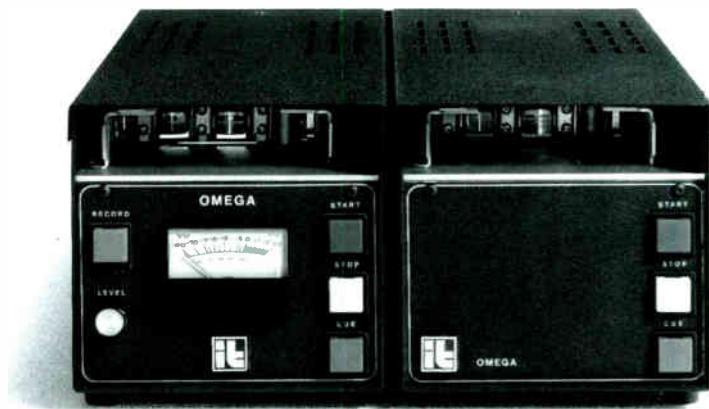

The OMEGA series. High quality performance at an affordable price.

# And here are three more.

Our Authorized 3M Dealers

Allied Broadcast  
Equipment  
800/622-0022

Broadcast  
Services Company  
919/934-6869

Broadcast  
Supply West  
800/426-8434

*3M International Tapetronics — The World Leader In Cart Machines.*

# The pick hits of NAB '89

By Brad Dick, radio technical editor,  
and Rick Lehtinen, TV technical editor

**Las Vegas was the perfect setting for our  
broadcast experts to pick the winners.**

Everybody likes a winner. With this in mind, **Broadcast Engineering** magazine convened its fourth annual "Pick Hits of the Show" panel at the recent NAB in Las Vegas. The result? They hit the jackpot, unearthing a rich selection of useful new production and transmission equipment.

The judges, independent experts from the broadcast industry, made their usual rounds at the show. In addition to shopping for their own facilities, they scouted out items they thought were of particular interest to a variety of broadcast facilities. After a meeting to count votes (and bash heads), they generated their list of pick hits — 10 items for television, 10 for radio.

A description of each pick hit follows:

## TV pick hits

Judges on the TV panel faced some difficulty narrowing their decision on two product groups. They all agreed that camera automation was an important show item, perhaps the single most easily justifiable expense for TV stations today. But there was no consensus as to *which* automation system should be the pick hit. Accordingly, a "shared award" was granted to TSM, Vinten and A.F. Associates. Similarly, both Grass Valley Group and Ampex came out with new, high-powered, low-priced digital effects systems, which the judges loved equally.

• **A.F. Associates: Roboped full-motion camera head-positioning system** (a shared award with TSM and Vinten)

The Roboped system is an integration of proven robotic elements. The system can be fully synchronized with Radamec EPO camera controls, which can control camera iris and black levels as well as camera-positioning functions.

Two versions of Roboped are available. The simpler one is designed primarily for off-air relocation of cameras to precise predetermined positions. The full-featured system can move a camera through on-air moves at variable speeds, either under computer control, or under the control of an operator using a joystick.

Roboped uses a unique laser guidance system. Ankle-height beams scan the studio, seeking special reflectors that are

placed around the studio perimeter. By timing the echoes from the reflectors, the robotics can update the camera position.

• **Abekas: Solo digital production system A-34**

The judges noted that they were seeing more power getting placed into fewer boxes. The A-34 epitomizes this trend. It's an editor, controlling six VTRs, four at a time, with a fifth rolling as a record slave (to give two edited masters). It's a switcher, with eight inputs, mix, wipe, cut and several different keying capabilities, plus audio. It's two channels of 2-D digital effects, which can control size, position, borders and times on a keyframe basis. It also is three independent fieldstore TBCs.

The A-34 can accept four asynchronous composite inputs, and has four more asynchronous inputs that can be configured to accept YUV/YC/RGB/DUB/S-VHS or composite. All the video signals in the Solo are first digitized, then time-base-corrected. This means that outboard TBCs are not required, and it also enables the inclusion of digital effects as part of Solo's repertoire. Outputs from the system are

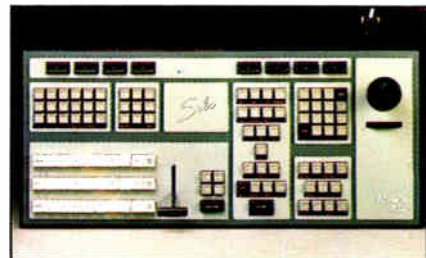

# THE NEW RPU



## Designed by its users.

TFT has responded to the needs of today's broadcasters by introducing the Model 8888 RPU System that offers unprecedented flexibility, versatility and reliability.

### FREQUENCY AGILITY

The RPU transmitter and receiver are frequency-synthesized for maximum versatility in the N1, N2 and S frequency bands. Two operating frequencies are programmed by internal DIP switches and are front panel selectable.

### SELECTABLE FREQUENCY DEVIATION AND RECEIVER BANDWIDTH

The Model 8888 system allows you to select  $\pm 5\text{kHz}$ ,  $\pm 10\text{kHz}$  or  $\pm 25\text{kHz}$  frequency deviation depending on frequency band or occasion.



In addition, selection of receiver bandwidths is possible via a front panel switch or DTMF signal. The 8888 also gives you full audio frequency response.

### DTMF CONTROL

Versatile DTMF control is provided for receiver activation, bandwidth and deviation selection, and security. All these plus more via a touchtone telephone handset.

### RF POWER OUTPUT VERSATILITY

The Model 8888 enables you to change the RF power output via a rear panel switch to suit your needs. It also features a switching power supply for lightweight, cool operation.

### THE RPU OF THE FUTURE. TODAY.

The new TFT Series 8888 RPU was designed by our customers to be the most flexible, versatile and easy-to-use RPU System available. Discover why the new TFT RPU System is the symbol of progress, inside and out. Contact your favorite TFT Radio Products Dealer today.

**TFT**  
INC

3090 Oakmead Village Drive  
PO Box 58088 Santa Clara, CA 95052-8088  
Tel: (408) 727-7272 TLX: (910) 338-0584  
FAX: (408) 727-5942

World Radio

Circle 24 on Reader Card

composite and YUV or Y/C. Audio output is 600Ω balanced.

The Solo chassis is 10.5 inches high. The control panel, including disk drive for EDL storage, takes up about as much room as a CG keyboard.

• **Ampex: ADO-100** (a shared award with Grass Valley Group)

After years of experience building popular, big-ticket, ADO effects equipment, Ampex condensed it all into a little-bitty box in its ASICs lab, then released it for a fraction of what it cost in its full-sized incarnation. The company even managed to bundle in Digi-matte, a linear keying option that allows the user to fly elaborate keys over backgrounds without a matte reel or second effects channel.



The ADO-100 also includes Digi-loop, a sort of digital pattern limiter that saves video a trip through an M/E bus, plus a disk full of popular effects to get production started. Furthermore, the unit can integrate with the Vista switcher, preventing the expense and clutter of an extra control panel.

The judges liked the power and low price of the ADO-100. They saw it as a way to gain digital effects capability in smaller edit rooms, as well as to get ADO effects into smaller-market stations that couldn't have supported it before.

• **Auditronics: 1900 mix-minus system**

As remote feeds become more important, an ever-increasing amount of audio console real estate gets tied up in multiple live satellite feeds. For this reason, the judges warmly welcomed the arrival of the 1900 mix-minus board. Compatible with any audio console, the 1900 can provide up to eight discrete mix-minus feeds (program mix *minus* the remote reporter's voice) to up to eight different remotes. Additionally, three IFB (interruptible fold-back) buses override the mix-minus with director's or producer's instructions.

The rack-mountable console, available



with an optional redundant power supply, can accommodate up to 16 inputs, each of which has an input-level control and a monitor position. Output assignment selection is by illuminated switches, which feed out through individual channel output modules, again with gain controls and monitor positions. An illuminated VU meter and a slate tone generator are built in as well.

• **BTS: LDK-91 camera**

The high-resolution (more than 700 lines) LDK-91 camera is the newest member of the popular LDK-90 system family, with which it is compatible. The camera uses Philips frame-transfer CCDs,

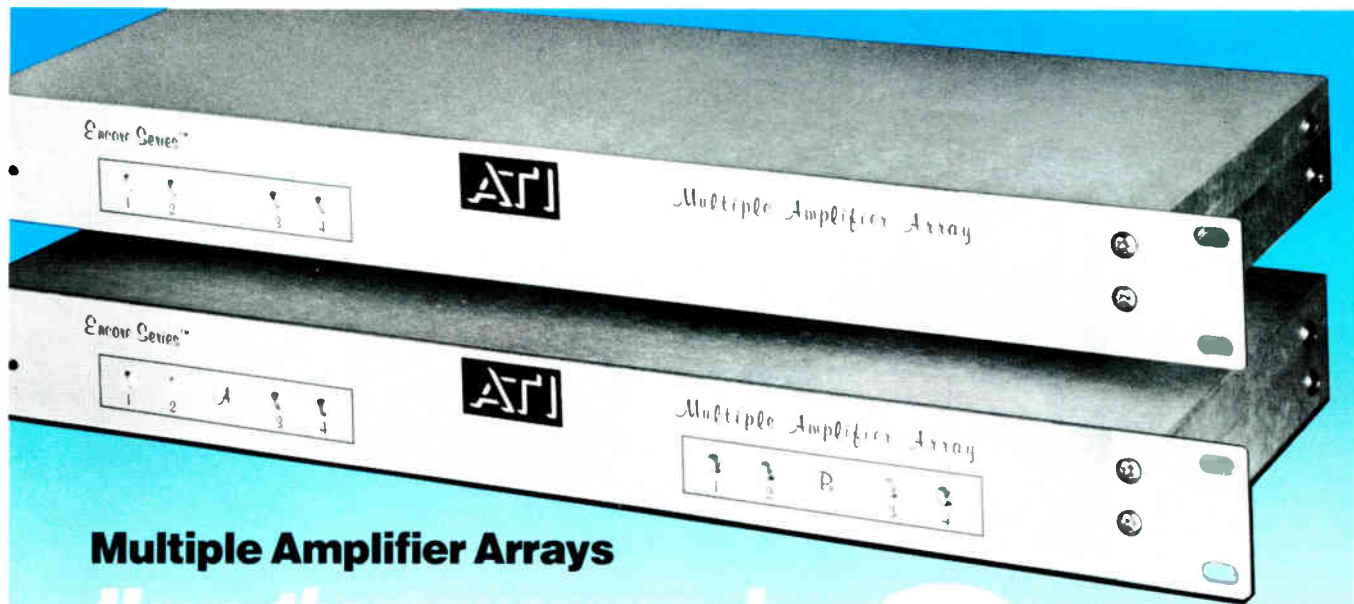

**Multiple Amplifier Arrays**

*Have them your way!*

Four or eight channels for **YOU** to easily configure as Microphone, Line Buffer, Distribution and Level Matching Amplifiers. Form sum and difference networks, Interface phone lines, Drive headphones, Make a

simple Mixer or Preamp. **FROM \$349** just by changing jumpers. Gains to 82dB, Low noise balanced inputs. Clean +24dBm active or transformer balanced outputs.

Configurable circuitry... to fit your needs.

Call or write for free detailed brochure.

**AUDIO TECHNOLOGIES, INC.**  
328 W. Maple Ave., Horsham, PA 19044  
(215) 443-0330 • FAX (215) 443-0394





# Where digital and analogue meet (to give you the best of both worlds.)

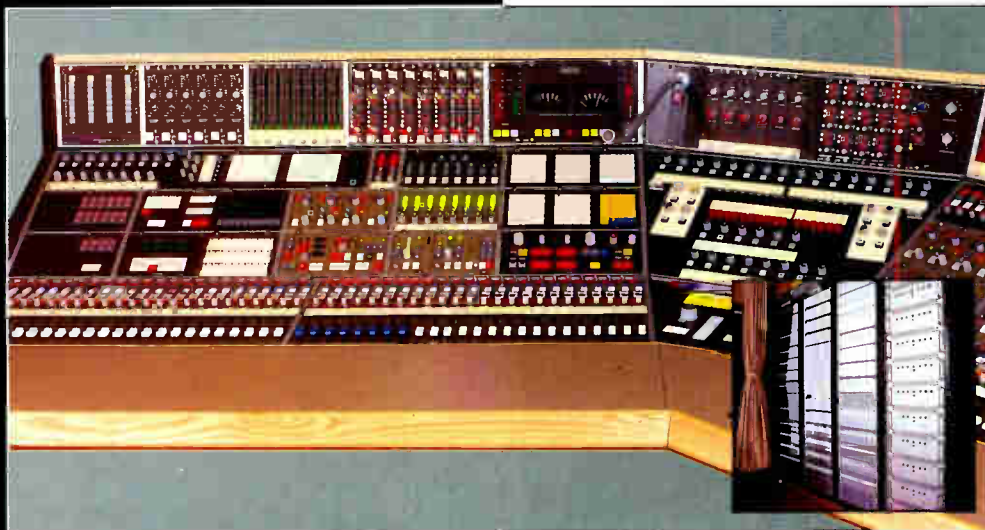

96 channel VCS at BBC TV Centre Studio 4

## The AMS/Calrec Virtual Console System

**ams**  
AMS Industries plc

AMS/Calrec, AMS Industries Park, Burnley, Lancs. BB11 5ES  
Tel (0282) 57011, Telex 63108 AMS-G, Fax (0282) 39542.  
AMS/Calrec, USA, 3827 Stone Way North, Seattle, WA 98103 USA.  
Tel (206) 633-1956, Fax (206) 547-6890.



The Queen's Award for Export Achievement to Edendeck Ltd 1984/85 and  
AMS Industries plc 1986. In July 1985 Edendeck Ltd became AMS Industries plc

Circle (99) on Reply Card

If your day starts with a wish that you had up to 128 different audio channels, instantly reconfigurable to provide different groups and outputs – each selectable for mono/stereo, microphone, line or tape input with a memory that can reset every function to what you were doing yesterday, or even last week; look no further.

Our comprehensive brochure explains the benefits of a digitally controlled analogue audio desk and details how to plan the layout of your own Virtual Console System. The VCS isn't just something on paper though – it is already offering reliable service to Thames Television (2 consoles) and the BBC (3 consoles), including a 112 channel desk working as the BBC Master Sound Control OB vehicle.

- Free assignment of faders for maximum flexibility.
- Ergonomic layout with high resolution displays/controls.
- Three RAM and multiple disc based memories.
- Instantaneous memory reset of all functions.
- 1 inch fader modules permit a large console to live in a small space.
- High performance, proven audio circuitry.
- Diagnostic self test for ease of servicing.
- Orders now being accepted for the Post Production version of the VCS with moving fader automation.

STOP PRESS... Systems currently under production for 1989 delivery for Turner Broadcasting, Atlanta, Scottish Television plc and BBC Television Centre 1... STOP PRESS



Multi-Recording Recording



Hard Disk Editor



Digital Addressable Controller



World Facto History



Cable Standard and Squared



Custom Broadcast Consoles



Digital Mixing Consoles

# More reasons to choose a Telemet Demod...

## Again.

**17.** The Telemet MTS Demod 3713 gives you a digital readout—to measure RF level, sound deviation and power supply voltages—and a built-in video response tester. All for thousands of dollars less!

**18.** Telemet introduced the first Broadcast Demodulator. And we've been first ever since—in quality, reliability and value.

**19.** With our brand new facility, our service is now more responsive than ever!

When you take a look at the **Telemet MTS Demod 3713**—and the price tag that hangs on it—you'll see that after 20 years Telemet is still the right choice.

**Call the experts in Demod quality and value. Call Telemet or your local Telemet dealer today.**

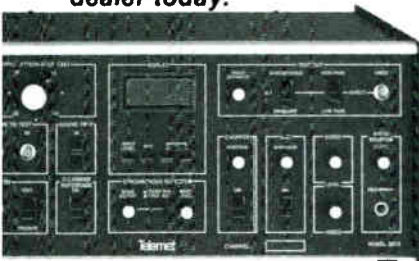

# Telemet

A GEOTEL COMPANY  
25 DAVIDS DRIVE  
HAUPPAUGE, NEW YORK 11788  
(516) 435-7260 TWX 510 327 9550  
FAX 516 231-7075

Circle (37) on Reply Card

which increase sensitivity by nearly an f/stop. Other improvements include anti-flare/reflection coatings and increased signal-to-noise ratio. The camera's images are quiet in dark areas of the picture, and show no vertical smear or comet-tailing.

Operator features include an adjustable shoulder pad and viewfinder improvements, including safe-area markers, character displays for f/stop, color-temperature setting and diagnostics. The camera also has presets, adjustable via a menu, for gamma correction, black level and exposure.



The unit can operate with a triax or multicore adapter, as a stand-alone deck for a VTR or in a docking configuration for either M-II or Betacam.

• **Grass Valley Group: DPM-100 digital effects system** (a shared award with Ampex)

The DPM-100 digital picture manipulator is a compact system that features many popular effects. The full-powered stand-alone device also can control a GVG model 100 switcher, through a dedicated slave port. Stations could marry the two and achieve production power previously available only on systems costing several times as much. All parameters of the system are keyframe-controllable, and sequences can be edited or changed through dedicated controls.



The DPM-100 includes many standard features, including 100 E-MEM Effects Memory System registers, linear and luminance keyers, a 3.5-inch disk drive

and an optional second channel, which fits into the unit's 3-rack-unit frame. Also available is a recursive memory option that allows trails, decays and full-frame montage effects. Inputs and outputs for the system are composite, analog component and D-1 and D-2.

• **Harris: Platinum series solid-state TV transmitter**

The Platinum series solid-state TV transmitters are available in highband and lowband versions up to 60kW. Reliability is achieved through parallel operation of major components. Modular power-amplifier modules are fault-protected against six failure modes. Distributed control architecture and cooling facilities further contribute to reliability.



The transmitter's control and status displays are straightforward. Components are front accessible. Platinum series transmitters also feature a patented combination visual/aural exciter that provides precorrector adjustments, frequency synthesis, digital control of power raise/lower functions and top-quality audio performance.

• **Lectrosonics: H185 plug-on wireless microphone adapter**

The H185 transmitter solves one of the headaches of ENG—the care and maintenance of wireless microphones. The 7-ounce transmitter simply clips to the back of whatever microphone is in use, in place of the mic cord. The compact companion CR185 receiver can mount to the record deck, and it uses an XLR for its output, as well as a separate headset monitor output.

Items of special note are the many options for powering the unit. Self-adjusting battery holders accommodate all conventional or lithium 9V batteries. On the



# The second CCD sensation.

## The SP-30 for ENG.

NEC introduced the first CCD camera with an electronic shutter for ENG back in 1986. Our SP-3A was an instant industry sensation.

Now the trendsetter in CCD cameras brings you the next generation. Our SP-30 uses the



latest CCD technology to give you higher resolution – 700 TV lines. Higher sensitivity – f6.2 at 2,000 lux. And better S/N ratio – 60dB. The SP-30 lets your crew shoot clear pictures with virtually no smear even under the most adverse conditions.

The SP-30 features an electronic shutter with seven speeds – from 1/60 to 1/1,500 sec. For greater functionality, both Betacam and MII VTRs are dockable to the SP-30.

Betacam is a registered trademark of Sony Corp.

### The EP-3 for EFP.

The EP-3 is the first CCD camera expressly designed for electronic field production. It gives you 700-line horizontal resolution, 62dB S/N ratio, and a seven-speed electronic shutter. For EFP or studio applications, the EP-3 comes with a complete line of accessories including a triax adaptor.

You hire the best people. Now give them the best cameras for the job. The SP-30 for ENG. And the EP-3 for EFP. For the full scoop on specs and prices, call NEC today.

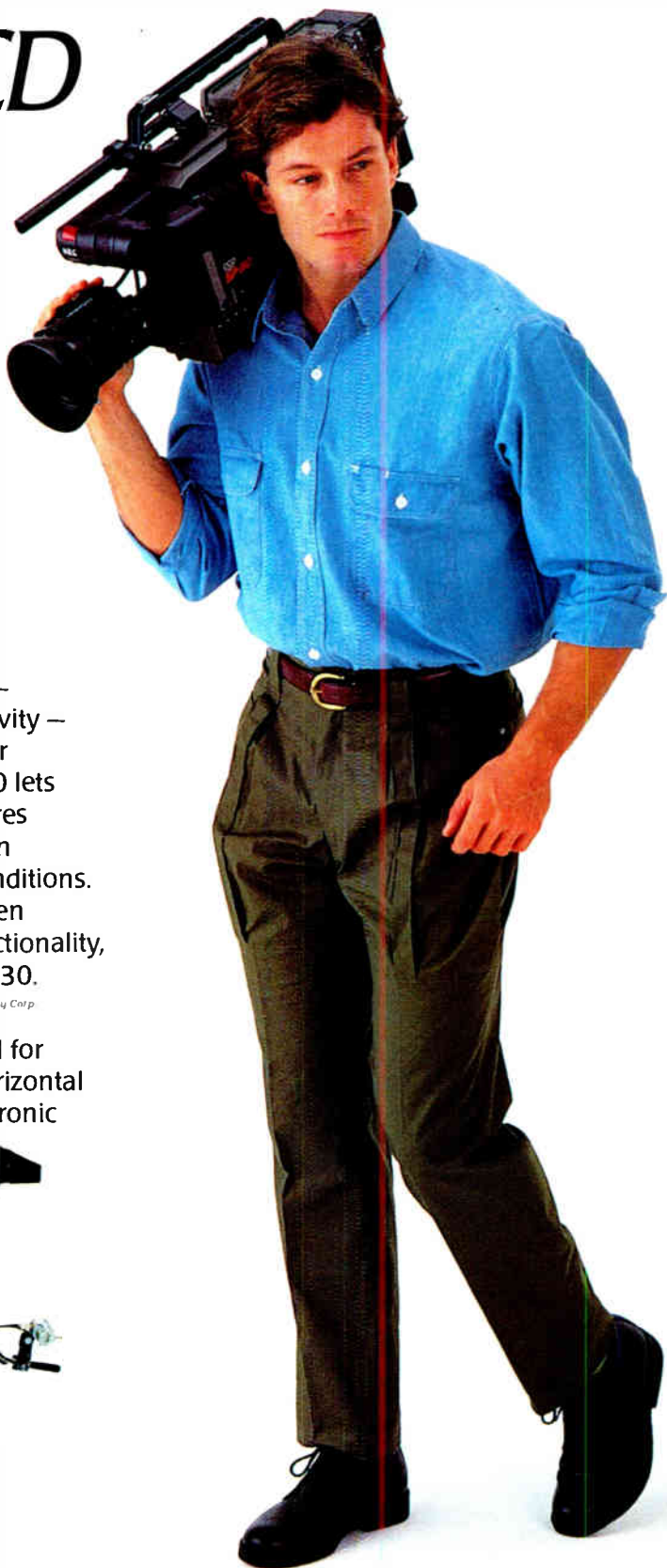

**For further information, please contact:**

NEC America, Inc. Broadcast Equipment Division 383 Omni Drive, Richardson, TX 75080-3545. U.S.A.  
Tel: 214-907-4710. Fax: 214-907-4711.

World Radio History  
Circle (38) on Reply Card

# NEC

receiver, a 12Vdc external supply (either polarity) or ac adapter can be used instead. The treatment of oscillator frequencies is noteworthy. A high (24.1MHz) IF throws receiver images well away from the carrier. This, plus an extremely selective front end, allows the units to operate in the proximity of other high-powered RF sources.

The transmitter controls include limit and level LEDs, a gain control (recessed to prevent accidental bumping), battery LED and mute switch. By using the LEDs, it is possible to accurately set levels without being near the receiver.

• **Mobile Data International: mobile data terminals**

One picture is worth a thousand words. The judges noted that the MDI series of mobile data terminals could go a long way toward eliminating crowded 2-way channels in the dispatch of news crews and the filing of news reports. The secure terminals make available up to 20 message pages (32 characters x 10 lines each), including simple graphics. News crews can be given the exact position of events, rendezvous points, uplink trucks, police barricades and other obstructions to travel.



The terminal also can remotely access databases, meaning a reporter could examine rundowns, scripts and listings of leads or contacts from the field. The unit's data output port could conceivably drive a printer or teleprompter.

The rugged, environmentally sealed units feature full-sized keyboards and adjustable CRTs that are viewable in most lighting conditions. The units can operate over most existing 2-way systems. Special data radio hardware also is available.

• **Tektronix: 1780R video measurement set**

The 1780R series measurement set is a compact and powerful test device. At a height of five rack units, the system provides for a great deal of testing in little space. Four video inputs may be displayed together or in combinations. A fifth front-panel input conveniently accepts high-impedance measurements via a standard oscilloscope probe. Vector displays can be overlaid for comparisons. The vector section also serves as a picture display for positive signal identification. A system of electronic cursors permits direct numeric readout of many measurements. Touch-screen buttons allow easy adjustment of monitoring functions.



*Continued on page 82*

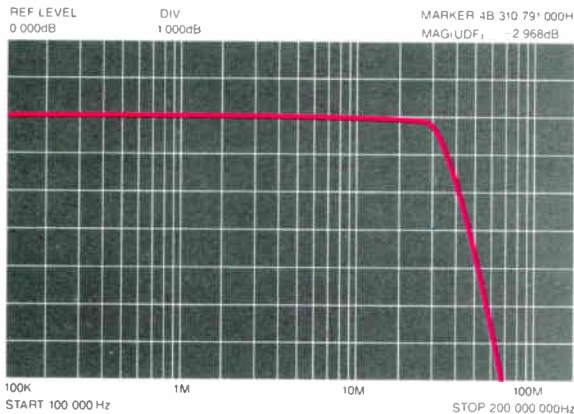

# AVITEL. THE BEST LINE IN THE BUSINESS.

Avitel introduces a new high performance, modular line of equalizing Video Distribution Amplifiers. Utilizing extensive hybrid-SMD technology, Avitel is setting the standard for VDAs with an impressive list of features which include: ■ integral 3dB cable equalization, ■ 7 matched 75ohm outputs per DA, ■ differential looping input, ■ 13 modules per frame, ■ front panel controls for gain and equalization. In addition, the Avitel DA has the following plug in, user installed module options: ■ variable clamp, ■ user adjustable video delay, ■ extended cable equalizer, ■ DARTbus sync signal monitoring, ■ dual power supplies, ■ 30 MHz HDTV bandwidth. But that's not all. Avitel, with over 10 years of worldwide product leadership, has put a highly competitive price tag on each of their new DA's. Now that's a line too good to resist.



AVITEL ELECTRONICS CORPORATION 3678 W. 2100 S., SALT LAKE CITY, UTAH 84120, (801) 977-9553

Circle (39) on Reply Card

## Versatility

*It's a Shame There is no Spec!*

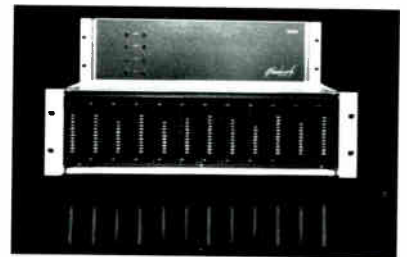

Were it possible to quantify versatility, the question of what to purchase would be easy. The technical performance of the System 1000 is superb, but our primary focus is to give you total flexibility. Our DA-101, for instance, can be a 2 in by 10 out mono DA capable of generating L+R or L-R, a timecode DA with a bandwidth of 200 kHz, a stereo 10 watt headphone amplifier, or a 40 watt bridged mono power amplifier. That's just the beginning. The DA-102 is a stereo 1 in by 5 out DA with a configurable sixth output that may be a 60Ω, direct, or mono mix out. Now add remote control of gain, stereo, mono, L, R, and matrix modes at master control, VTRs, downlinks, etc., to all four System 1000 DAs, and you've got versatility. Call now for full information.

Call 1-800-BNCHMRK (262-4675)  
Nationwide

*Benchmark*  
Media Systems, Inc.  
N. Syracuse, NY 13212  
315-452-0400

Circle (40) on Reply Card

# THE INTERCOM SOLUTION FROM

# McCurdy

Looking for an integrated communications system? Look to McCurdy for the affordable solution. McCurdy's advanced Digital Intercom Systems have set

a new standard for programmability, flexibility, expandability and reliability. We offer you cost-effective solutions to your intercom needs, large or small.

Our affordable, high performance intercoms are integrated communication systems with the following superior capabilities:

- Point-to-Point communications
- Programmable Party Lines
- Programmable IFB's (Program Interrupt)
- Programmable selective Group Calls
- 2-wire beltpack interface
- 2-way radio interface
- Telephone interface with auto answer
- Camera interface
- Camera ISO capability
- Relays for auxiliary equipment control.

Other features include:

- Ultra-reliable
- Instantaneous Cross point Access Time
- Fastest system reconfiguration time
- Disk based storage system or EEPROM
- Completely modular and field expandable
- 3-pair telco wire between matrix and control panels
- Wide choice of control panels
- Bright, easy to read 4 character alpha-numeric displays
- Easy to program
- All keys universally programmable locally or at central terminal
- System configuration can be changed by user at any time
- Very compact:  
CS9500  
50x50 matrix is only 3 RU (5 1/4") high

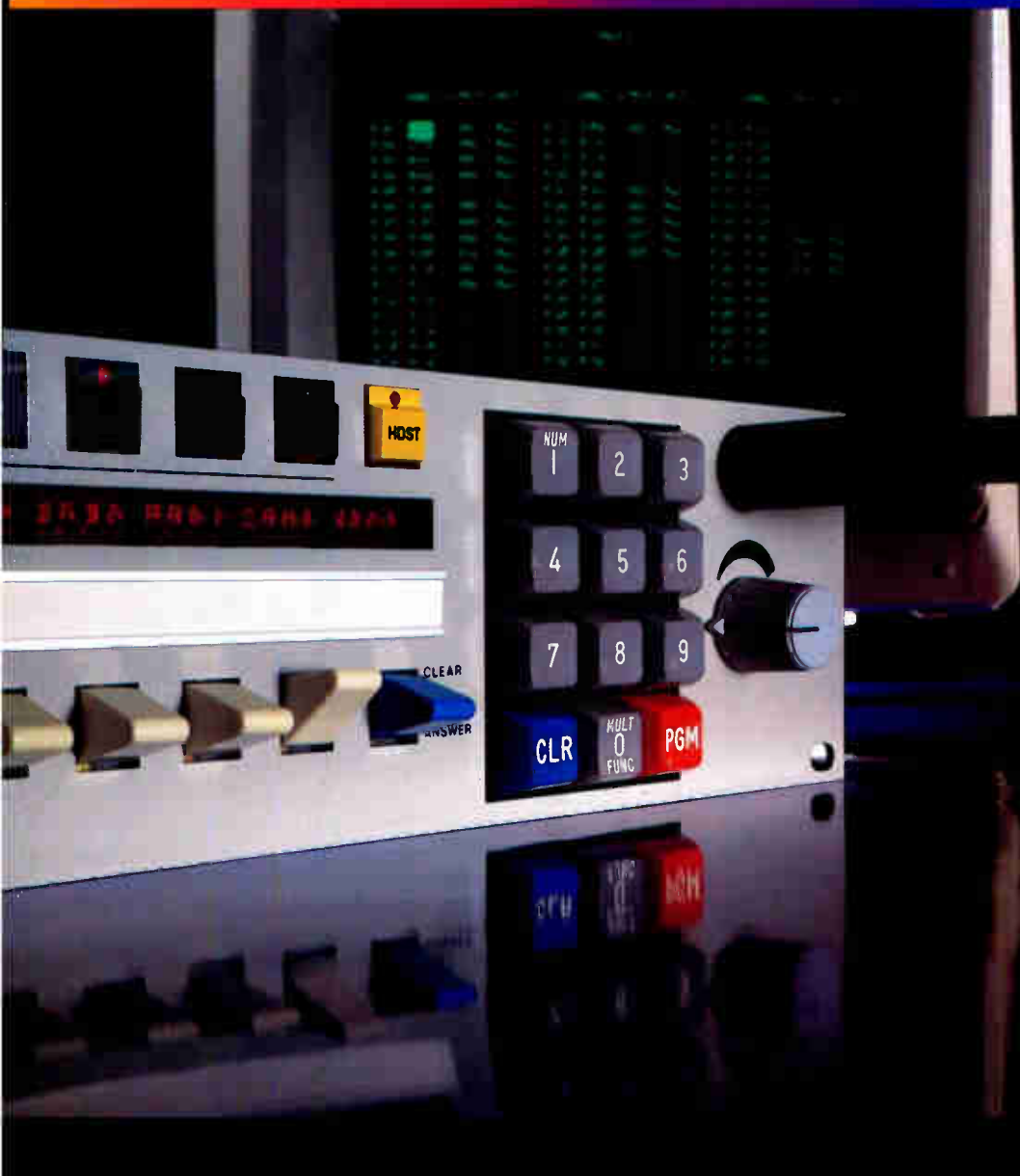

McCurdy's intercom systems are in use around the world; they range in size from 10x10 to 400x400 systems.

As the premier intercom supplier for the 1988 Calgary and Seoul Olympic Games,

McCurdy intercoms succeeded with flying colors!

Make it an easy choice. Select McCurdy's Digital Intercom System ... the Integrated Intercom Solution.

**40**  
YEARS OF EXCELLENCE

World Radio History

# McCurdy

**McCurdy Radio Industries**

108 Carnforth Road, Toronto, Ontario, Canada M4A 2L4 Tel: (416) 751-6262  
Telex: 06-963533 Telefax: (416) 751-6

1051 Clinton Street, Buffalo, New York 14206 Tel: (212) 772-0719

**ISS ENGINEERING, COMMITTED TO EXCELLENCE...**



## THE PRODUCTS

ISS Engineering offers the Broadcaster a full line of frequency agile Satellite Receivers, RF Modulators and Demodulators for use in the in-house RF distribution System, ENG vans, translators as well as many other applications. Each product is designed to provide two basic functions to the engineer: first, simple, reliable operation and with zero maintenance and second, a product which meets and exceeds specification and does not sacrifice quality in attaining any design objective.

**Satellite Receiver. The GL-5000A** • 950-1450mHZ input - External loops for TI filtering - Non-volatile "Last Channel" memory - 1 rack unit high - Optional Morales and Intelsat formats - Continuous 5-8mHZ audio tuning.

**COMING** Second quarter 1989, **GL-5020** a completely new professional receiver with a "nesting" slot for use of optional audio subcarrier cards for SAP or Pro Channel, Discrete Stereo. Programming encrypted utilizing Videocipher technology can be accessed with an optional module inserted in the nesting slot.

**Agile Demodulator, The GL-1000A/B** • Tunes the entire VHF, UHF as well as all CATV channels from simple front panel selections - Supports multiple signal source inputs - Accepts a wide range of input signal levels - 600 ohm balanced audio - BNC connectors - Non-volatile program memory to lockout undesired channels - Options include composite output, 4.5 audio, modulated test point as well as extended subchannel tuning below 54 mHZ.

**Agile Modulators, The GL-2610XT SERIES II** • Full front panel operation of all tuning (channels 2-WW and UHF 14-26), RF levels, depth of modulation and offsets. Full 60dBmV output - 600 ohm balanced audio - External IF loops - Dual crystal controlled synthesizers, each with its own oven control -  $\pm 3$ kHz stability -  $\pm 1$ kHz aural intercarrier stability. Options include Subchannel tuning - 4.5 mHZ audio.

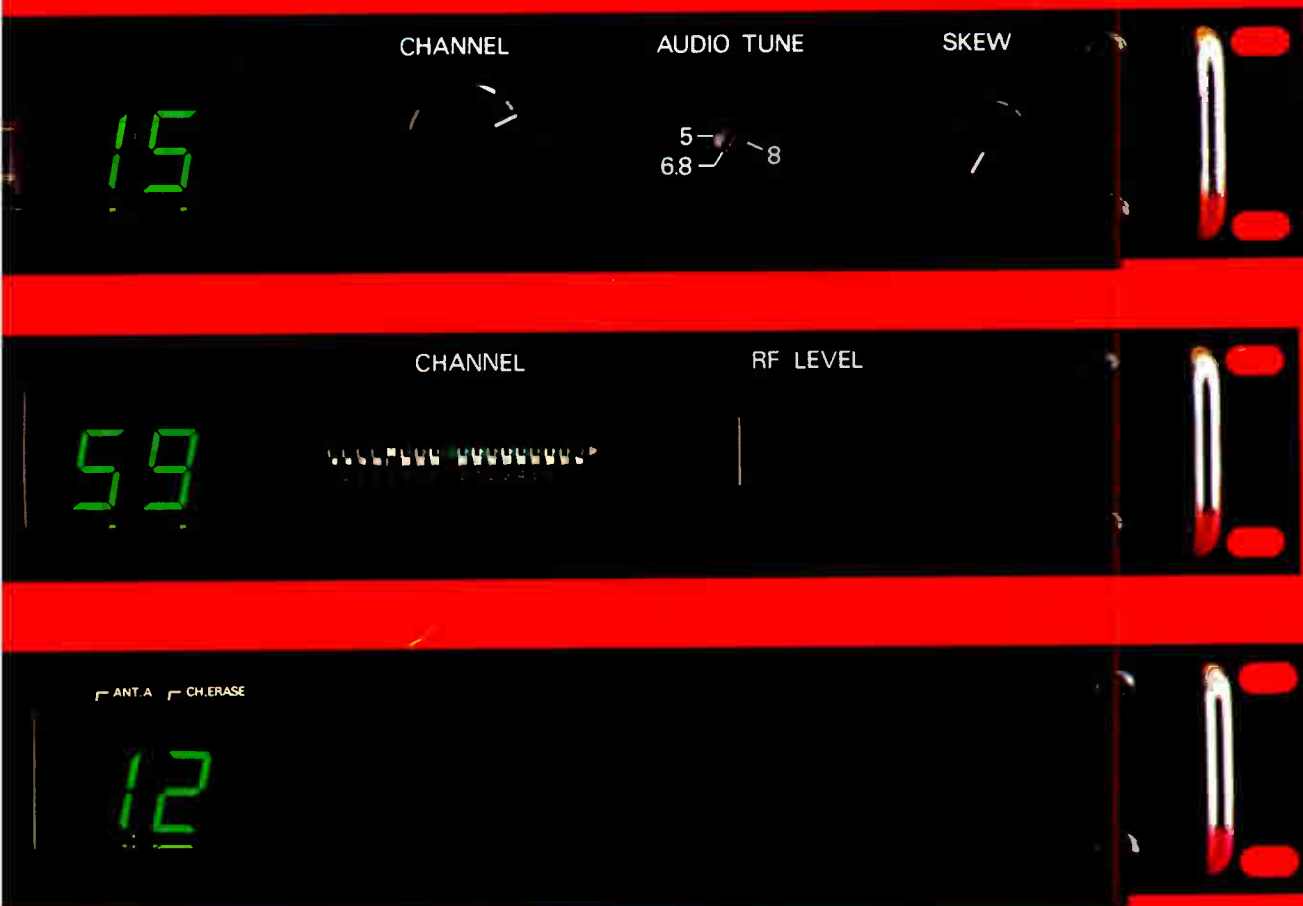

**SPECIAL OPTIONS**

S-232. Both the GL-2610XT SERIES II and our Specialty Agile Demodulator, the LAN-1001 allow for full remote tuning via RS-232, as well as expanded features. For complete information on these special option products, contact the factory.

**The Company**

ISS Engineering has earned a reputation for solid dependability and performance. Broadcasters have utilized our product line in ENG vans, covering the Summit Talks, Seoul Olympics, and the Papal visit. Many Government applications are fulfilled by ISS as well as commercial, school and industrial RF applications. In the professional world of video, wherever an RF application exists, chances are you will find ISS Engineering filling the requirement.

For complete information or to schedule a demonstration of the dependability of ISS, call ISS Engineering or the Representative in your area.

**Represented by:**

- Southeast** Jim Freeman Associates  
(404) 921-8687
- Northeast** Omnivue  
(212) 532-5576
- North Central** G.B. Morrison  
(313) 632-5847
- Midwest** Applied Technologies Mktg  
(312) 934-6262
- Southwest** The Enright Company  
(213) 595-4624

***ISS Engineering, Inc.***

1047 Elwell Court  
Palo Alto, California 94303  
(415) 853-0833  
East (800) 351-4477  
West (800) 227-6288

# ERASE IT!

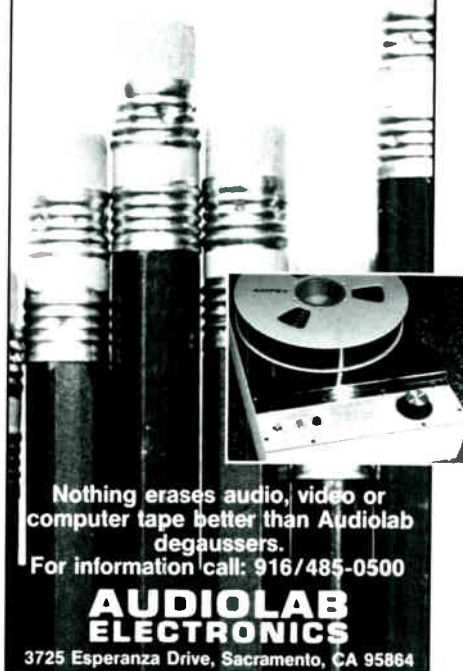

Nothing erases audio, video or computer tape better than Audiolab degaussers.

For information call: 916/485-0500

**AUDIOLAB ELECTRONICS**

3725 Esperanza Drive, Sacramento, CA 95864

Circle (150) on Reply Card

## IN OUR CONTINUING EFFORTS TO SERVE YOU...

From time to time, Intertec Publishing Corp. makes its subscriber lists available to carefully screened companies or organizations whose products, services, or information may be of interest to you. In every case, list users must submit their promotional material for approval. They may use the list only once.

No information other than name and address is ever divulged, although names may be selected by segments to which the particular offer might appeal.

We are confident that the majority of our readers appreciate this controlled use of our mailing lists. A few people may prefer their names not be used.

If you wish to have your name removed from any lists that we make available to others, please send your request, together with your mailing address label to:

Direct Mail Mgr.  
Intertec Publishing Corp.  
P.O. Box 12901,  
Overland Park, KS 66212

Continued from page 78

• **TSM: SP-200 camera pedestal with X-Y motion option** (a shared award with A.F. Associates and Vinten)

The TSM Autocam system robotic pedestals are ruggedly built from the ground up, using precision assemblies and materials. The system operates from a small control console that includes a touchscreen, which the operator uses to call shots. The console video is that of the selected camera's, with control symbols superimposed. Camera control is by means of two joystick handles, which have been carefully designed to have the "feel" of being at the camera's back.

The Autocam pedestals navigate by dead reckoning — keeping track of what



the drive wheels have been doing and calculating the pedestal position. Because there are bound to be irregularities in the studio floor that would cause errors, the camera is set up periodically by parking on a special pattern on the floor. All the sensors are zeroed to this location, a procedure that takes about 15 seconds. Then the dead reckoning begins anew.

• **Videotek: VDP-8400 framestore/synchronizer**

The VDP-8400 provides transparent signal processing and synchronization for incoming feeds. It also can store a frame of video in memory while continuing to process incoming video.

Proc-amp controls stay operative in the freeze modes. Furthermore, if the incoming signal fails or degrades unacceptably, the unit can be switch-assigned to fade to black, freeze on the last acceptable frame of video, or replace the input video with a standby video input.



A line-select feature can be used to repeat a given line throughout the frame. This can be used as a line selector for viewing a specific line on a waveform monitor.

The 1-rack-unit-high unit weighs in at just 17 pounds.

• **Vinten: Automotion pedestal** (a shared award with A.F. Associates and TSM)

The Automotion pedestal is built around the Fulmar pedestal. Height automation is attained by adding a servo assist to the existing pedestal. X-Y automation is achieved by having the pedestal follow an easy-to-stick-down aluminum tape on the studio floor. If there is a requirement

## Guidelines for the selection of "Pick Hits" of NAB '89

1. **They must be new products**, not shown at a previous NAB. In some cases, distinguishing a "new product" from a modified old product is difficult. For our purposes, a new product is one with a new model number or new designation.

2. **They must have some positive impact on the everyday work of the user.** The judges looked for equipment that would be used on a regular basis at a broadcast facility. The equipment should provide a new solution to a common problem.

3. **They must offer a substantial improvement in current technology.** The equipment does not have to include

unique circuit architecture, but it should include some new ideas on applying current technology.

4. **The prices of the products must be within reach of the intended users.** The judges looked for products marketed to a wide spectrum of broadcasters.

5. **The products must be available for purchase.** Equipment must be on display on the convention floor (not in suites) and be in production (or soon to be in production). Products demonstrated in private showings did not qualify.



# WHY WTVH-TV'S BRUCE LEVY LOVES HIS EPO ROBOTIC CAMERA CONTROL SYSTEM.



For more than 20 years, WTVH-TV, the CBS affiliate in Syracuse, N.Y., has broadcast its news using EPO remote camera control systems. During that time, the systems have outlasted four sets of cameras—a clear testament to EPO's durability and reliability.

For most of those years, as Bruce Levy, the production chief at WTVH-TV, will tell you, the station was virtually alone among American broadcasters.

Now, of course, all that has changed. Americans are beginning to wake up to what their European brethren have known for some time—that **EPO Camera Control Systems can save them money. Lots of money!**

But even EPO Robotic Camera Systems don't last forever. Recently, when WTVH-TV's 20-year-old unit began to show some wear and tear, Bruce Levy confidently ordered three new ones from A.F. Associates, thereby continuing his and WTVH-TV's long association with the EPO systems.

If you would like to know more about Bruce Levy's favorite way to save money, call A.F. Associates. In the east: (201) 767-1201; in the west: (619) 277-0291.

## **THE RADAMEC EPO ROBOTIC CAMERA CONTROL SYSTEMS.**

Distributed exclusively in the U.S. by



### **A.F. ASSOCIATES INC.**

ADVANCED SYSTEMS AND PRODUCTS FOR THE VIDEO INDUSTRY  
100 STONEHURST COURT, NORTHVALE, NJ 07647

A.F. Associates, Inc. is a Video Services Corporation company.

Circle (45) on Reply Card



to move the pedestal off the tape, it is easily done. The operator typically would take direct control of the camera, however, instead of leaving off-tape motion to the robotics. Although some judges indicated the aluminum tape was a problem, others

saw no difficulty with it.

The control system for the Automotion pedestal is the Vinten Microswift system. One- or 2-joystick versions are available. Graphics tablets or touchscreens are available for shot selection.

Other system features include analog and digital system outputs, for controlling functions other than camera motion.

## Radio pick hits

- **Alldesign: DAMS**

Alldesign is one of the first companies to release a digital product designed as a direct replacement for the analog cart machine. Relying on hard-disk storage technology, the system is designed for on-air presentation, especially in radio studios.

The system provides from 180 minutes to 540 minutes of 15kHz stereo audio. The basic system accommodates up to four user locations, with any two being usable simultaneously. One location is designated for recording; the other three are for play-

back only. The system is capable of simultaneous record and playback.

The control panel resembles a 4-cart machine playback panel, with start, stop and sequence keys. The memory redundancy feature duplicates all drives in the primary system and provides automatic changeover to the *mirrored* drive, if needed.

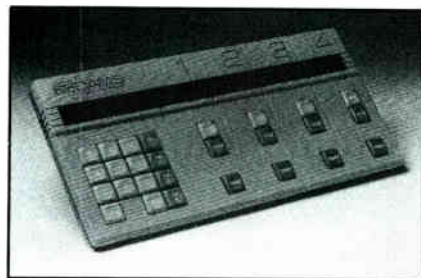

- **Broadcast Electronics: FX-50 FM exciter**

The new FX-50 FM exciter was selected by the panel of judges based on its audio performance. The exciter claims a dynamic range that rivals that of CD players, and THD and IM are typically less than 0.003%. The exciter is capable of pro-

# CAMERA REMOTE CONTROL THE SENSIBLE WAY

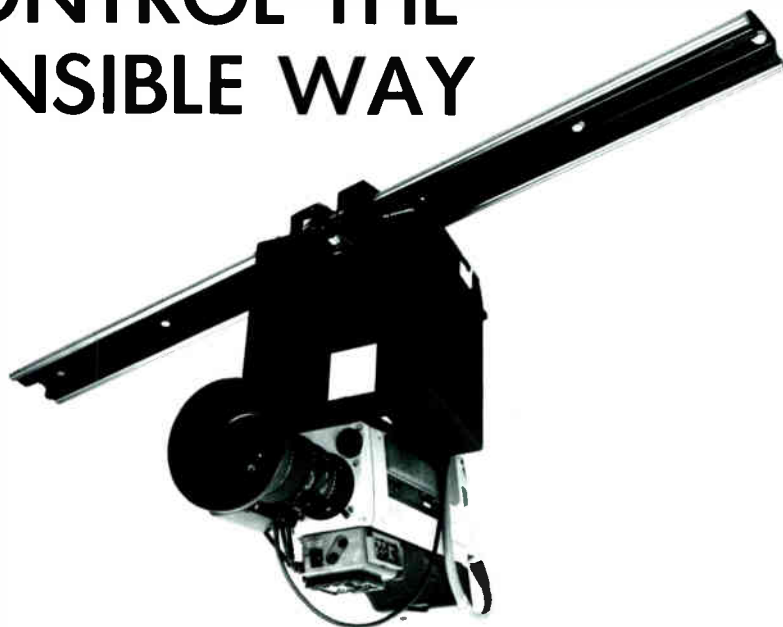

## Control Pan-Tilt-Trolley-Zoom-Focus

with

- Simple Joystick Panel
- Presetable Shot Panel
- Touch Screen Panel
- Computer RS-232/242

thru

- Multicore Cable
- Twisted Pair
- Telephone Modem

Telemetrics – for over 20 years the innovators of camera control systems.

## Telemetrics

7 Valley St. Hawthorne, N.J. 07506  
For Information Call (201) 423-0347

viding an impressive S/N of 93dB.

A 60W MOSFET is used in the broadband RF power amplifier. Because the MOSFET reduces its power dissipation as it gets hotter, the device's life is extended. Automatic control circuitry eliminates the need for adjustments, once the initial tuning is completed.



A front-panel LCD monitors five selectable parameters: forward power, reflected power, PA voltage, PA current and AFC voltage. The meter also can be used as a high-impedance voltmeter.

• **Delta Electronics: SNG-1 stereo noise generator**

The SNG-1 provides the required test signal for AM NRSC monaural and stereo transmission systems. The generator outputs a pulsed USASI-weighted noise source to measure both the spectrum of the audio delivered to the AM transmitter and the RF spectrum of the transmitter output. The generator offers two other types of noise: white and pink in both continuous and pulsed output modes.



The output signals are available in six combinations of left- and right-channel noise for alignment and troubleshooting. A stereo switch position provides independent left- and right-channel noise outputs at matched levels. In the NRSC position, the left and right channels are blended so the subchannel is 3dB below the main channel.

• **Dorrrough: stereo signal test set**

The Dorrrough model 1200 stereo test set permits easy stereo measurements of level, balance, crosstalk and S/N over the entire dynamic range of an audio system.

The unit contains dual input amplifiers, a 30dB step precision attenuator, a pair of B-scale meters and two buffered monitor outputs. The wide dynamic range is greater than 110dB, providing a measurement range of 90dB (-76dB to +20dB).

The front-panel B meters are marked in 1dB increments, over a 40dB range. Head-



phones or an oscilloscope can be connected to the rear monitoring jack. The test set meets the growing need for ac-

curate signal monitoring and testing as radio and TV stations find themselves faced with an ever-increasing number of both monaural and stereo audio signals.

• **Harris: DX-50 AM transmitter**

The Harris DX-50 AM transmitter combines two leading technologies — digital and solid-state — that, together, provide performance and reliability. The transmitter operates at 85% overall ac-to-RF efficiency. The PA efficiency is typically 90%.

The transmitter is capable of +145%

# YOU'VE GOT TO FIT THE FORMAT.

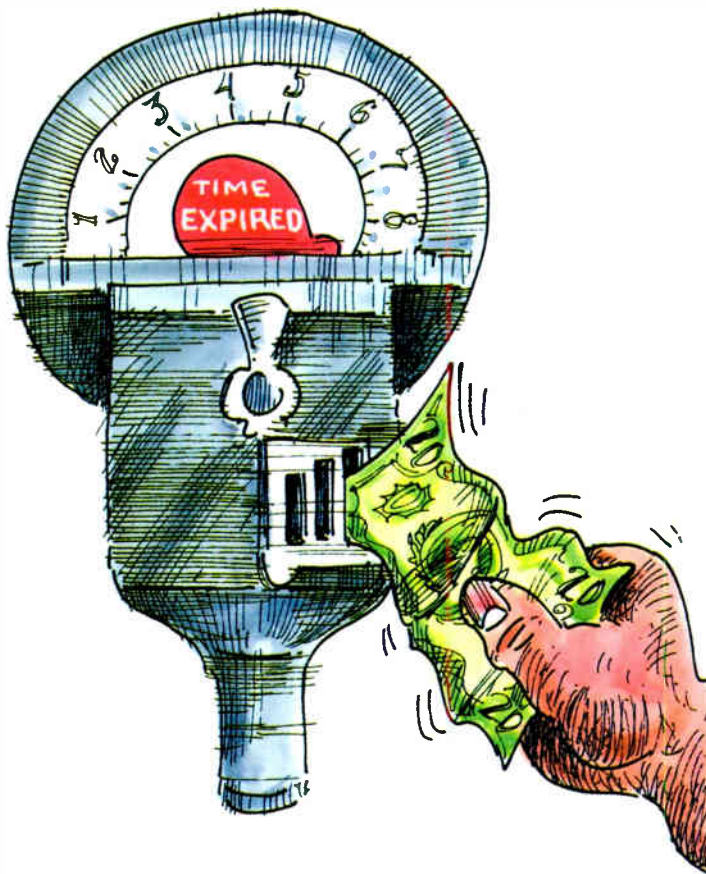

**Tektronix**  
COMMITTED TO EXCELLENCE

Copyright © 1989, Tektronix, Inc. All rights reserved TVG-093-1

Circle (47) on Reply Card

# Make order out of your audio cabling chaos



Cannon MASSCON Connectors:  
up to 216 contacts per cable

Get rid of your audio cabling chaos once and for all. Get massive, single-cable connection with field-proven MASSCON circular connectors from Cannon. Originally developed for hostile environment applications, these rugged and versatile mating devices are manufactured in 122, 176 and 216 pin versions.

Cannon MASSCON connectors have hermaphroditic polarization: their self-mating design incorporates hooded, closed-entry contacts with rear insulators for positive retention. Cable repair is quick and simple; protective caps are provided for use when connectors are unmated. All contacts are gold plated.

End cabling chaos now. Get in touch with ITT Cannon today for the information you need about MASSCON.

ITT Cannon, Dept. H-9  
Four Cannon Court  
Whitby Ontario  
Canada L1N 5V8  
Phone (416) 668-8881  
Fax (416) 668-4152



**ITT Cannon**  
*An ITT ElectroMechanical Components Worldwide Company*  
*Discover our strengths.*

Circle (48) on Reply Card

modulation at 50kW. Typical THD is 1% or less at 95% modulation from 30Hz to 10kHz. SMPTE 1:1 IM distortion is typically 0.8% or less at 50kW, 95% modulation, and 4:1 IM distortion is typically 1.3% or less at the same power level. Incidental quadrature modulation is typically -35dB.

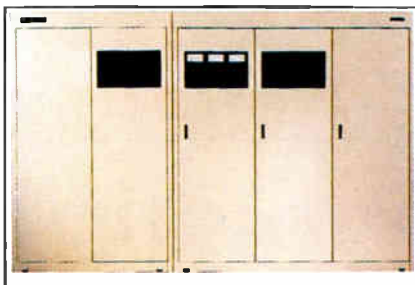

A flexible patching scheme allows any amplifier module to be bypassed if needed. The transmitter then continues to operate with full fidelity, but at a slightly reduced peak power capability.

- **Moseley: 8-channel multiplexer**

The Moseley DATAMUX allows the transmission of either four (DATAMUX 4) or eight (DATAMUX 8) data channels over a single 10kHz 450MHz P channel link. The data is transmitted at an aggregate data rate of 9,600b/s. There is no restriction on individual channel data rates as long as the aggregate rate does not exceed the 9,600b/s.

The system offers an alternative to the use of subcarriers and telephone lines for conveying multichannel control and telemetry data between the studio and transmitter sites.

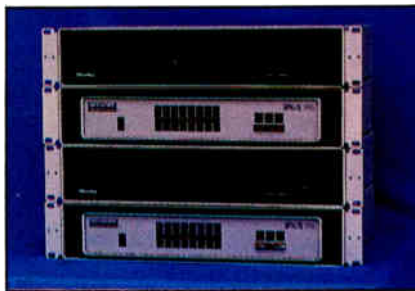

The real advantage of the system lies in its ability to provide up to eight TSL data paths with only one RF link. This would permit up to eight stations to receive telemetry while requiring only one TSL channel.

- **QEI: Cat/Link**

The Cat/Link provides a T1 compatible signal for use as a 2-way, wired STL. This allows stations to use cost-effective T1 phone company lines instead of Class A equalized, matched stereo loops. Using a



1.544Mb capacity, the Cat/Link provides transparent reproduction of composite signals over T1 lines with 16-bit compressed encoding and decoding.

The design permits the stereo and SCA generators to be located at the studio. The 2-way communications capability permits the Cat/Link to monitor operations and also to retrieve remote or satellite feeds from a remote site.

The unit can drive up to 6,000 feet of twisted-pair wire or two miles of optical fiber. Transmission via 22GHz STL also is possible.

- **TFT: 886/887 EBS system**

The judges seemed to share a concern about EBS monitoring. TFT's new EBS systems consist of either an AM (model 886) or FM (model 887) tunable receiver. Receiver tuning is accomplished by a front-panel push button, calibrated in 10kHz or 100kHz increments. Both receivers have built-in 2-tone decoders for the 853Hz and 960Hz EBS tones.



A 2-digit front-panel LED display shows the number of days, up to 12, since the last EBS test transmission was sent or received. This helps the station better follow FCC rules. This display was judged by the panel as a unique and important innovation.

Vertical LED stacks provide front-panel indication for both audio and RF signal levels. A front-panel speaker and volume control are standard.

- **TFT: 8900 synchronous FM exciter**

Using a relatively new approach to booster transmission, TFT introduced the synchronous FM exciter. The unit consists of a composite STL receiver, phase-locked loops and a 15W FM power amplifier. If higher power is required, an external power amplifier can be added.

The key to successful synchronous

operation is proper synchronization of both the frequency and phase of the booster carrier with the main transmitter. Unfortunately, providing this precise control has proved difficult.

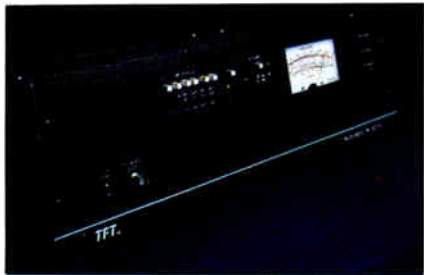

To obtain the needed control, TFT uses a super-high-stability 19kHz reference signal as both the stereo pilot and synchronizing signal. This approach avoids the group delays inherent in demodulation and remodulation. In addition, the ability to repeat exactly the modulation of the main transmitter adds to the unit's performance.

• **Tri-Tech: remote broadcast studio/RBS 801**

The portable RBS 801 is a compact device combining the functions of a microphone mixer, cellular telephone and standard telephone interface. The device provides remote broadcast capability from any location served by cellular telephone companies.

The mixer provides four balanced-microphone and two line-level inputs. The device uses a standard 832 cellular telephone with 3W RF output. Indicator lamps provide both tally of the cellular phone's operation and power-supply operation. The built-in keypad permits dialing and answering of both cellular and land-line calls.

A built-in battery provides up to 15-minute service without ac power. It weighs only 15 pounds, including carrying case.

**The judges**

**For radio:**

**John Battison**  
BE's consultant on antennas/  
radiation  
Owner, Battison and Associates  
Loudonville, OH

**John Dehnel**  
Chief engineer, KSL-AM  
Salt Lake City

**Andy Laird**  
Vice president of engineering  
Radio Group  
Heritage Media Corporation  
Los Angeles

**Marvin Born**  
Director of engineering  
WBNS AM/FM/TV  
Columbus, OH

**Dave Obergonner**  
Chief engineer  
KUSA/KSD-FM  
St. Louis

**For television:**

**Leon Anglin**  
Vice president of engineering  
KPNX-TV  
Phoenix

**J. Talmage Ball**  
Chief engineer  
KSL-TV  
Salt Lake City

**Robert P. Hess**  
Chief engineer  
KQVR-TV  
Sacramento, CA

**Karl Renwanz**  
Vice president of engineering  
and operations  
WNEV-TV  
Boston

**Doyle Thompson**  
Vice president of engineering  
The Weather Channel  
Atlanta

**Alternate**

**Charles Morris**  
Corporate director of engineering  
KIRO-TV  
Seattle

**YOU'VE GOT TO FIT THE FORMAT.**

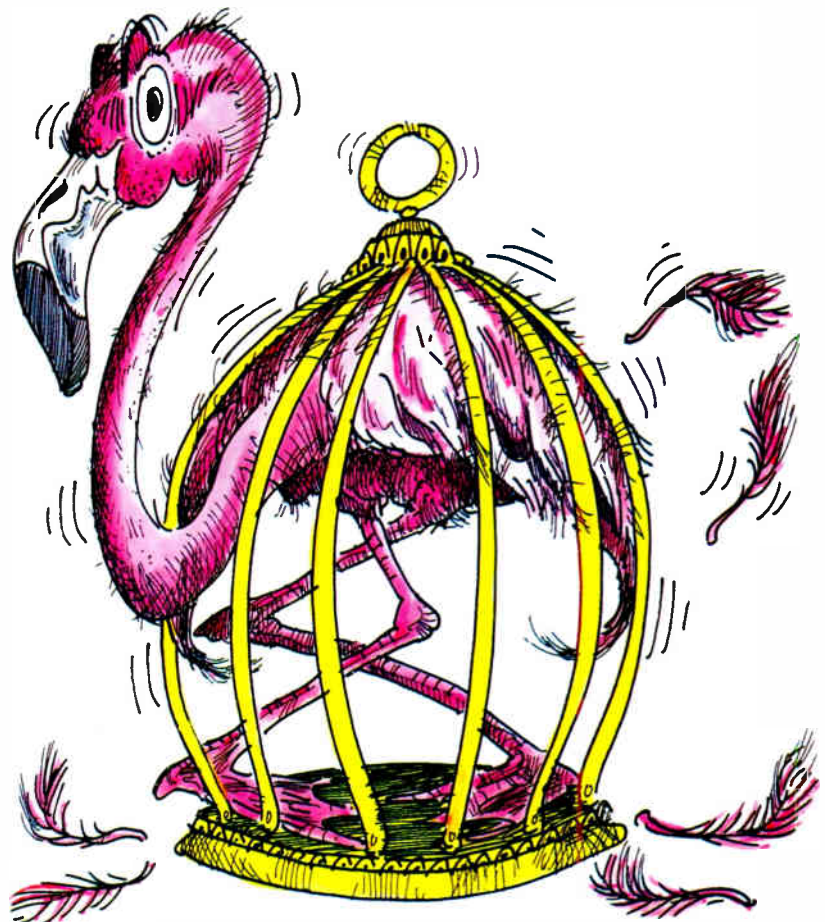

**Tektronix**  
COMMITTED TO EXCELLENCE

Copyright © 1989, Tektronix, Inc. All rights reserved. TVG-093-2

Circle (49) on Reply Card

# NEW AT NAB

Compiled by Carl Bentz,  
special projects editor

**If you're looking for something new and improved,  
you've found it.**

The following pages contain information about new products that were introduced for the first time at the '89 NAB convention. Included in the items are products brought to market since NAB '88, enhancements to previous products and some prototype models. The number of new introductions was extensive, but we have tried to present a short commentary on all new items found by the *BE* staff. The product information is organized into four general categories: audio, RF, support and video products. Each category is further subdivided according to the following category guide. Page numbers indicate where each of the product groupings begin. Within the listings are reader service numbers to assist you in getting product information from the manufacturers.

## Group A — Audio Products

- A1** (89): Audio/mic mixers, consoles, console automation.
- A2** (90): Processing systems (delay, effects, dynamics, noise reduction, telephone hybrids/interfaces).
- A3** (94): Recording systems (analog, digital, cartridge, cassette, reel, disk); audio editing systems; audio transport synchronizers.
- A4** (100): Ancillary (sources, mics, wireless, RPU's, phono, CD players, inter-

coms, headphones, headsets, speakers, audio line/power amplifiers, pre-amps).

## Group R — RF Products

- R1** (108): AM, FM, TV transmitters, antennas, transmission line, transmitter remote control equipment; towers, tower products.
- R2** (116): Terrestrial microwave electronics, antennas (ENG, STL, ITFS, MDS, MMDS).
- R3** (120): Power amplifiers, cavities, power devices.
- R4** (120): Receivers, demodulators, modulation monitors.
- R5** (120): Exciters, RF generators (SCA, MTS stereo, SAP, PRO, FM, AM).
- R6** (122): Satellite antennas, electronics.

## Group S — Support Products

- S1** (126): Cable, wire, fiber-optic material, connectors, patch panels, cords.
- S2** (128): Cases, racks, studio furnishings, acoustic material.
- S3** (130): Audio-video recording media, degaussers, tape and film maintenance products.
- S4**(134): Automation equipment; computer hardware, software (business, programming, newsroom, machine control); timers, clocks, data transmission equipment.

**S5** (138): Signal distribution systems, DAs, routing switchers.

**S6** (142): Test, monitoring equipment, meters, signal attenuators, tools, filters, video delay units; power-line conditioner, transient suppressors.

**S7** (146): Production facility and mobile unit design, construction, consultant services.

**S8** (148): Program services, music and effects libraries.

## Group V — Video Products

**V1** (146): Video cameras, lenses, tripods, pedestals, pan/tilt heads, robotic products.

**V2** (154): Recording systems (tape, disk, solid-state, analog, digital); still-stores, video editing controllers, transport synchronizers, animation equipment, time-code products.

**V3** (160): Cine, film cameras, telecines.

**V4** (160) Batteries, chargers, analyzers; lighting instruments, lamps; grip equipment.

**V5** (166): Digital graphics, titling, effects, prompters, captioning systems.

**V6** (176): Video switching equipment.

**V7** (176): Video processing, TBC, synchronizers; standards converters; sync generators, VID generators, linear keyers, compositers.

**V8** (182): Video monitors, projectors, video printers, computer/data CRTs and displays.

## Audio Products

### A1: Mixers

#### ✓ Console automation

##### Allen-Heath

*MBI series 16:* on-air, production mixers. *SABER:* 16-bus live sound, recording mixer; 32x8x16 configuration for recording; main-frames to 60 input channels.

*SCEPTER:* rack mixer; 12-input stereo.

*SIGMA:* in-line recording console.

Circle (527)

##### Allied Broadcast Equipment

*Autogram Pacemaker:* on-air, production, news mixing console.

Circle (528)

##### AMEK Consoles/TAC

*Bullet:* compact mixer; free-standing or rack-mount; meter hood, seven 15-segment LED meters; 10-4-2 configuration with mic/line inputs; 4-band EQ; stereo aux returns.

*BC-II configuration:* 24-module chassis size, allowing 16-4-2 and 18-4; available without meters or with meter hood for two to seven VU or PPM indicators; 16, 24, 32 mixing position.

Circle (538)

##### AMS/Calrec

*LOGIC 1:* digital mixer; models with full dynamic automation.

*EDIT 1:* digital mixer.

*ASSIGNABLES:* digitally assignable, analog mixing consoles for post production.

Circle (543)

##### Audio Kinetics

*REFLEX:* console automation; controls faders, mute, aux switching; snapshots, autofade, solo, grouping, programmable off-line mix edits; 64-channels; remotely mounted VCAs for retrofit to any console without physical modification.

*Mastermix II:* VCA console fader automation; MX884 mix computer, color monitor, AK2 VCA faders; upgrades kits for current systems.

Circle (572)

##### Audio Services Corporation

*Sonosax mixers:* portable units SX-S with 6, 8, 10 inputs; -PR stereo "shoulder" mixer with six inputs; -F2 talkback, communications unit.

Circle (574)

##### Auditronics

*1900 mix-minus:* eight outputs feed eight correspondents with separate mix-minus signals; selectable VU metering; use with any console; three IFBs; oscillator; input level controls.

*310TV:* on-air/production console optionally integrated to station A/V router; various main-frame sizes; four each aux send/return, group master faders; VCA fader control; submastering; accessories.

Circle (578)

##### Autogram

*Pacemaker series:* on-air, production mixers; 28-, 322-, 48-input; P&G sliders, VCA level control; no transformers; optional clock; VU meters for program, audition, mono mix channel; machine-control on each input; power amps for headphones, external cue speaker, monitor line

out.  
Circle (579)

##### Broadcast Audio

*Series VI consoles:* five modular on-air/production systems; 8- to 24-mixer models; LED clock/timer, peak level indicators; headphone EQ; three stereo, one mono bus; monitor dim.

Circle (608)

##### FOR-A

*AFV-500 Audio-for-Video:* 8-input, 2-output; EQ options; stand-alone or AFV for PVM, CVM video switchers; machine-bus memory retains 90 machine configurations.

Circle (749)

##### GML Inc.

*Series 2000/Ver. 6.0:* GML moving fader automation, intelligent master machine control; Ethernet communications; optional graphics display; extended editing capability.

Circle (765)

##### Graham-Patten Systems

*ESAM software:* for 600 series edit mixers; command set includes Save Mixer, Recall Mixer, Transfer Register; upgrade kits available.

Circle (768)

# YOU'VE GOT TO FIT THE FORMAT.



**Tektronix**  
LEARNING TO DO BETTER

Copyright © 1989 Tektronix Inc. All rights reserved TVG-093-3

### Grass Valley Group

*AMX-170*: 8-channel mixer; 4-band EQ; E-MEM controls audio levels from editing systems; 20 E-MEM registers available; four program channels; EQ delegated to mixing inputs.  
Circle (769)

### H&E Micro-Trak

*Sport 5*: portable mixer with integrated frequency extender; tone or DTMF telephone dial; 2-way talk; four mix channels for mics, line signals; recording output jack.  
Circle (1199)

### Harrison by GLW Enterprises

*AP-100*: broadcast consoles; tabletop, rack-mount versions.  
*Series TEN*: total console automation; based on Macintosh II, hard disk.  
*SR-490*: 24-track console for film scoring, rerecording; stereo monitoring; two pairs left, right, center, surround buses; Dolby stereo.  
Circle (778)

### Howe Technologies

*Model 10K*: "wireless" stereo console; mainframes to 36 positions, four stereo outputs standard; multilayer backplane interconnects modules; 65Vp-p to 150Ω, 0.003% THD.  
Circle (787)

### LPB

*Citation II*: console; enhanced Citation design with greater flexibility in operation; three inputs per channel, lock-out switching; mix-minus; 10-channel with remote starts.  
Circle (849)

### Neotek

*Audio consoles*: new frame design; various fader options support nearly all automation systems; GPI triggering, serial editor interfaces.  
Circle (903)

### Neve

*VR consoles*: memory recall of rotary, push-button, slider positions; optional high-resolution, graphics display of controls; 40Mbyte disk stores 2,000 complete settings.  
*VP consoles*: for TV, film, multitrack; routing eliminates extensive repatching; Dolby matrix monitor for 4-, 8-track video post; 24-track operation; Left-Center-Right Surround.  
*66 series*: mixers for radio/TV; Formant Spectrum Equalization; μP reset system; analog circuitry with digital control; 24-, 32-track configurations.  
*Flying Faders*: moving fader automation; 12-bit digital resolution stores data with 0.1dB accuracy; Mix Memory stores all fader moves; one-knob control of stereo is possible.  
Circle (984)

### Numark

*DM1912*: mixer with six stereo line inputs; all include assignable equalization.  
Circle (1151)

### Orion Research

*SoundStar*: software-based mixer for video-post production; Remem Recall Memory system; 4-channel output for D-2, Beta, M-II; full editor control; 16-input, 8-channels.  
Circle (921)

### Pacific Recorders & Engineering

*STX mixer*: stereo TV console; 26- and 34-input mainframes; mono modules for three mic and three line inputs; stereo modules for three inputs; EQ, four send, eight mix-minus, three stereo buses; 30dB headroom.

*Radiomixer*: on-air boards with 12 and 20 inputs in compact frame sizes; Mix Matrix; dual stereo output, transformerless distribution; control room monitor, auto-cue headphones.

Circle (925)

### Professional Sound Corporation

*Sonosax SX-PR*: mixer for video/TV, digital recording; 2, 4, or 6 inputs; lightweight for ENG/EFP sound requirements; conductive plastic potentiometers sealed against air, dust.  
Circle (946)

### Soundcraft/USA

*SAC200*: console for radio on-air, audio-visual production; mono/stereo inputs; cart start; EQ, aux sends; telco module with mix-minus output; 16-, 24-input; 6-way studio source selector.  
*SECK consoles*: recording and live performance systems; frame sizes to 24-input, two and eight subgroup configurations; 3-band EQ standard on all channels.

*Model 6000*: multitrack recording console; split architecture; 68dB continuously variable gain, low noise floor; 24-bus system can be expanded to 32-track monitoring.

*200B/VE*: console with video editor interface; VSA-24 interface links between series 200B console and video editor to control fading and effects independent from video transitions.  
Circle (1017)

### Ward-Beck Systems

*Model R 6100*: 16-channel console.  
Circle (1132)

### Wheatstone Broadcast Group

*SP-6A*: stereo production console.  
*A500as*: radio, on-air console.  
*TV500S*: master control console for MTS.  
Circle (1137)

### Whirlwind

*MIX-5*: 5-channel mixer; 20kHz response, 0.02% distortion; four input XLR or 1/4" TRS connectors, switch between mic, line; summed stereo input; 24V phantom power source.  
Circle (1139)

### Yamaha Music

*MR1642, MR1242, MR842*: consoles; four mix buses, stereo master bus; from 8- to 1- inputs; electronically balanced low-Z or balanced TRS phone jack inputs; 3-band EQ.

*PM2800M*: professional mixing console; 32 and 40 channel configurations; eight mix buses, stereo master bus; four additional buses for aux sends; multiple mute capabilities.

*DMP7D*: multilingual digital mixing processors; supports PCK, R-DAT, PD, S/PDIF (CD/R-DAT) recording formats; 8-input, 2-output with cascading for additional inputs; 92dB dynamic range, 0.01% THD.  
Circle (1147)

## Audio Products

### A2: Processors

- ✓ Compressors, limiters
- ✓ Noise reduction
- ✓ Delays, effects
- ✓ Telephone hybrids

#### Aphex Systems Ltd.

*Model 250*: Type-III aural exciter; two noise reduction modes; SPR spectral phase refractor enhances bass clarity, sound openness; increased definition, intelligibility, dynamics.  
*Model 612 upgrade*: expander/gate units with improved log detector circuitry for more consistency in decays over wider range.  
Circle (553)

#### Applied Research & Technology

*B-4000*: effector/pitch-time compressor; four simultaneous effects for vocal enhancement, production; pitch correction on time reductions to 33% in single pass.

*BDS-8000*: dynamics processor, effects; harmonic exciter, compressor, limiter, equalizer, expander, noise gate; more than 40 digital effects; 20kHz bandwidth; programmable.

*VE-200*: vocal enhancer, digital reverb; 16-bit processor; 200 vocal enhancement presets; 120 settings for ambiance, room character.

*BD-2000*: sampler, dump delay; 20Hz-20kHz bandwidth; for effects or obscenity delay; remote trigger or computer interface; 2s base delay.

Circle (555)

#### Audio Processing Technology/SSL

*apt-X 100*: digital audio compressor; converts 16-bit DCM to 4-bits; no audible degradation.  
Circle (1198)

#### Broadcasters General Store

*Dolby 363-SR*: 2-channel spectral recording noise reduction system.

*TAILOR*: 10-band VCA-controlled dynamic, EQ system; for on-air, production, reinforcement; true loudness control; selective peak frequency EQ shapes response; by Hit Design.  
Circle (615)

#### Circuit Research Labs

*MBL100*: shortwave audio processor; conforms to international bandwidth agreements.

*PMC450*: upgrade of PMC 400; triband limiting, input compressor and NRSC low-pass filter.

*IPPI100*: Instant Personality Processor; μP controller handles 18 presets for different on-air talents with quick recall when that talent goes on air; loop for effects processing.

*SMP950*: upgraded SMP900 product; includes triband limiting; implements NRSC standards with patented mix.  
Circle (647)

#### Comrex

*Multi-Line series*: frequency extenders; broadband 10kHz circuit from three standard telco dial lines; modular, upgrades to fully automatic 3-line system.

*PLX-Micro/Cellular*: portable 2-way frequency extender; interface to cellular phone for mics, recorders, headsets; duplex, one-line system.  
Circle (665)



### Dolby

*SDUA Surround Decoder*: monitor for Stereo/Surround production, recording; accepts 2-track matrix-encoded signal to generate left, center, right, surround components.

*Model 363*: 2-channel; switch to SR Spectral Recording, Dolby Type A noise reduction or unprocessed mode; transformerless, balanced inputs, outputs; auto encode, decode.

Circle (703)

### Eventide

*H3000 Ultra Harmonizer*: in two software versions; stereo pitch, diatonic pitch changes; reverbs, effects, MIDI implementation; Broadcast version is preset to operate out-of-the-box.

*BD941, BD942*: mono, stereo broadcast delays; 6s, 12s mono or 3s, 6s stereo; full-bandwidth performance; delete button energizes a relay to fill 3s, 6s or 12s, then reverts to normal.

*BD980*: delay; stereo system; maximum 10s delay; catch-up; dump button; Timesqueeze time compression; 20kHz bandwidth from 16-bit linear PCM; 50kHz sample rate.

Circle (735)

### Gentner Electronics

*Audio Prism*: digitally controlled audio processor for FM stations.

*Phoenix*: digital controlled audio processor for AM radio; NRSC compliant.

Circle (763)

### Gotham Audio

*Model BW 102*: Harmonia Mundi digital broadcast system for studio, transmission; interfaces for all digital audio formats; synchronizes to 32kHz, 44.1kHz, 48kHz; 16-channel digital mixing console with PFL, 6-band digital parametric EQ; limiting, compression and metering.

*Ferrograph Series 9*: digital cartridge recorder; computer control; music diskette playback unit.

Circle (767)

### Howe Technologies

*ATC-35 Phase Chaser*: audio time base corrector; for standard stereo or phase matrix-encoded Surround Sound; +28dB signal capability with  $\pm 150\mu\text{s}$  correction range.

Circle (787)

### International Music Company/IMC

*S1000*: stereo digital sampler; 16-bit, 44.1kHz or 22.05kHz; 2MByte RAM, expands to 8MByte memory; 16-voice; 200 samples maximum;  $3\frac{1}{2}$ " floppy drive; LCD display.

*S1000HD, S1000PB*: Akai samplers; *-HD* with 40Mbyte hard disk, SCSI port; *-PB* unit for playback only.

*S950*: 12-bit sampler; 750kbyte RAM, expandable; 8-voice; 99-sample memory.

*XE8*: 16-bit digital acoustic percussion.

*MX-76*: MIDI master keyboard.

*ME35T*: audio/MIDI trigger converter for expressive control.

Circle (806)

### Lexicon

*2400 V2.2*: time compressor/expander software; interfaces for Sony BVH-3000, -3100, Ampex VPR-6, -80, Panasonic AU-650, -660; Time Code Slave from menu.

*480L V3.0*: digital effects software; 2-band

stereo, 4-band mono parametric EQ, enhanced SME sampling, adjustable-rate reverse playback, two new pitch shift presets.

*Equalizer/Filter option*: for Opus digital audio production system; 12 channels of digital EQ; four independent filter sections; filters configure as parametric, shelf, notch, LP, HP.

*CP-2*: digital audio surround processor; converts standard audio to accurate, uncolored surround signals for two to six speakers.

Circle (842)

### Orban Division/AKG Acoustics

*290Rx*: enhanced noise reduction system; low-IM enhancement with intelligent single-ended,

dual-function noise reducer.

*460X*: studio, reinforcement limiter; wide effects control ranges; LED input/output level, gain reduction displays.

*9105A OPTIMOD-HF*: processor for international AM/SSB shortwave; increases loudness.

*Model 764B*: programmable parametric EQ, notch filter; 2-channel, RS-422/-232/MIDI.

Circle (920)

### Professional Sound Corporation

*MS-2 decoder*: Mid-Side stereo matrix decoder produces M-S from X-Y signals.

*NX-1*: crystal sync generator for sync-sound recorders; 50/60Hz or 59.94Hz.

# WE FIT THE FORMATS.

Analog or digital. Component or composite. High definition. When it comes to quality products, supporting any format or standard, video professionals peg Tek.

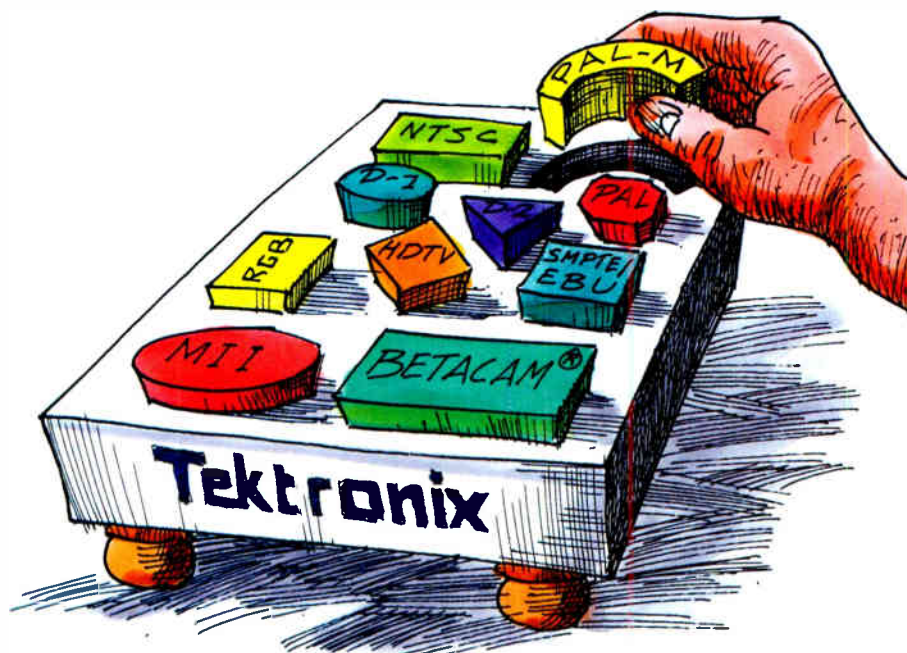

**Tektronix**  
COMMITTED TO EXCELLENCE

Copyright © 1989, Tektronix, Inc. All rights reserved. Betacam® is a registered trademark of Sony Corporation. TVG-093-4

Circle (51) on Reply Card

# The art of shaping sound.

SONEX is a high-performance acoustical foam that upgrades your studio inexpensively. Ideal for a temporary isolation booth, it can also eliminate slap echo and harsh resonances in the main room or silence noisy tape equipment in the control booth. Write for our color brochure today.



**Alpha Audio**  
**Acoustics**

2049 West Broad Street Richmond, Virginia 23220 USA  
(804) 358-3852 FAX: (804) 358-9496

Acoustic Products for the Audio Industry

Circle (52) on Reply Card

**NP-24:** Nagra power supply produces regulated, filtered 24Vdc with 1V 60Hz sync signal.

Circle (946)

#### Rocktron/RSP Technologies

**2200:** multiband dynamic processor; includes multiband compression, leveling, peak limiting and HUSH II for 50dB noise reduction.

**2400:** multiband psychoacoustic processor. HUSH II noise reduction.

Circle (975)

#### Studio Technologies

**Generation II Stereo Simulator:** creates fully mono-compatible stereo image from mono source; simulates space without reverb from random, non-recursive filter techniques with two incoherent signals from the single source which results in stereo perception by listener.

Circle (1033)

#### Taber/AVSC

**EA2651:** dual channel EQ amplifier, by McCurdy Telecommunication Products; separate controls for gain, phase EQ, low frequency EQ, high frequency EQ and Q.

**ST2613, ST2616:** spectrum translators; frequency extension transmitter, receiver system for 5kHz line quality from standard 3kHz voice-grade, dial-up telco lines; 250Hz offset.

**McCurdy TS2200A:** automatic telephone hybrid; analog audio circuitry, line matching with microprocessor control; full duplex operation without ducking and switching between caller and host.

Circle (1043)

#### UREI

**Model 7110:** audio limiter, compressor system; 1.5:1-∞:1 compression curve; multiple channel limiting link; program dependent attack, release; unbalanced output +22dB, 600Ω.

Circle (1099)

#### Valley International

**Model DCE:** digital compressor, expander; for on-air, production; multiple format I/O; independent compression, expansion functions; 99 user presets; RS-232/422 serial, MIDI.

**Model DDP:** digital dynamics processor for on-air FM; 16-bit linear PCM; multiband processing; FIR filters assure phase integrity; LCD display guides user through adjustments.

Circle (1105)

#### Vortex Communications

**Parametric equalizer:** modular devices for Vortex Eurogold modular system.

Circle (1130)

#### Yamaha Music

**AD808:** analog-to-digital converter.

**DA202:** digital-to-analog converter.

**SPX900:** multi-effect processors; 50 effects presets in ROM, 13 multiple programs for five simultaneous effects; reverb with control over room dimensions, pan effects, early reflections.

**RC7C1:** remote control for DMP7, DMP7D, DMP11 processors; centralizes control of four mixing processors with EQ functions simulating analog control; adds features to DMP series.

**SPX1100:** multi-effect processors; 40 factory presets with user-adjustable parameters; 59 programmable locations; 16-bit 44.1kHz sampling; stereo with MIDI control; digital inputs, outputs.

Circle (1147)

C2

## Free Catalog of

# Professional SOUND recording & duplicating SUPPLIES

POLYLINE™ EMPTY REELS & BOXES

BLANKLOADED CASSETTES

BOXES ALBUMS LABELS

AGFA AMPEX  
3M Scotch  
TDK maxell  
tapes

now from  
**STOCK**  
in  
**CHICAGO**  
and  
**L.A.**

Call Polyline  
**312 / 298-5300**  
8:30 am - 5 pm Central Time

**Polyline Corp.**  
1233 Rand Road  
Des Plaines, IL 60016

Circle (53) on Reply Card

# WINNING



# COMBINATION

Distribution amps, at best, give you one or two inputs, up to eight outputs per channel

and everything is hard wired. If your signal routing requirements change, as they often do, you're in for a major re-wiring job.

### Unlocking the Possibilities.

With eight inputs and twenty-eight outputs, our Routing Distribution Amplifier is light years ahead of the pack. Because any input, or combination of inputs, can be easily distributed to any output, or combination of outputs, the RDA is justifiably a winner.

But the advantages don't stop there. Changing signal

routing paths is simple. All you do is open the front panel, shift a few Berg jumpers and you're done. Level controls for each output are located adjacent to the selection jumpers.

### Unequaled Audio Quality.

With a signal-to-noise ratio of 98dB below the clipping threshold, the RDA gives you exactly what you're looking for—transparency. Plus, the RDA's exclusive Optimum

Level Control ensures the best compromise between headroom and signal-to-noise ratio.

Coarse matching the input level with four position dip switches and fine tuning with trimmer adjustment is visually aided with bi-color LEDs. The green light tells you that the RDA is operating at optimum level and the red light shows you that maximum level has been reached.

### One More Critical Input.

To find out more about the most versatile distribution amp in the business, route your input to your Gentner distributor or give us a call.



## GENTNER

AUDIO PRODUCTS

1825 Research Way • Salt Lake City, UT 84119 • (801) 975-7200 • FAX (801) 977-0087

©1989-Gentner Electronics Corporation

Circle (54) on Reply Card

# Audio Products

## A3: Recording

- ✓ Analog, digital
- ✓ Disk, tape
- ✓ Audio editing
- ✓ Audio duplicating
- ✓ Transport synchronizers
- ✓ Recording accessories

### Accurate Sound Corporation

*AS200A*: high-speed audio reel-to-reel 1/4" duplicator.

*AS4000*: audiocassette slow-speed logger.

Circle (505)

### Adams-Smith

*2600TMS*: Track Management System; automatic selection, logging and printing of track sheets.

*Transport emulator*: controls audio recorder decks from video editing keyboards.

Circle (509)

### ADx Systems

*ADX-25*: audio synchronizer, emulator; computer network interfacing.

Circle (1155)

### AKG Acoustics

*AKG DSE 7000*: digital sound editor; RAM-based digital workstation; 8-track capability with lossless digital track bouncing; 16-bit sampling, 4x oversampled.

Circle (521)

### Allied Broadcast Equipment

*Associate Producer*: dubbing center; self-contained unit; for conversion of records, CDs to tape; kiosk design includes mixer and cart machine, CD player or turntable.

Circle (528)

### Alpha Audio

*BOSS/2*: automated audio editing; serial track selection interface to multitrack recorders for bidirectional communication with RS-422.

*Retrofit time code reader*: for 1/4" VTRs; wide-band reader connects in line with serial data port; modification to equipment not required.

Circle (532)

### AMEK Consoles/TAC

*ESM32 serial interface*: links BC-II audio console to edit controllers using ESAM-I, ESAM-II protocols; controls mixer from Ampex, Paltex, CMX, FOR-A, Grass Valley systems.

Circle (538)

### AMS/Calrec

*AUDIOFILE*: digital workstation, Ver. 8 software; includes varispeed through digital port, faster lockup, digital de-emphasis, ADR, time code cut/splice; hardware options.

Circle (543)

### Audi-Cord

*S-series, DL-series* NAB cartridge record, playback systems.

Circle (567)

### Audio Kinetics

*ES 1.11*: ESBUS synchronizer; controls audio, video, film transport.

*ES Eclipse*: 16-machine ESBUS controller for video, audio post-production.

*ES SSU*: System Service Unit; provides 16 ESBUS-controlled event firing relays.

*ES Penta*: ESBUS controller/autolocator; controls five transports in conjunction with five ESBUS synchronizers; with *AK ES1.11*, allows enhanced AK-ESBUS operations; offsets, 10 loops or GO-TO points.

Circle (572)

### Audio Services Corporation

*Sound Assist*: displays tape time remaining; duration of last take; tape-near-end alert signal; for Nagra recorders; memorizes, relocates playback cue point.

Circle (574)

### Broadcast Electronics

*DuraTrak 90*: audio cart machines; Phase Lok-V head blocks; three cue tones, high-speed cuing; rugged construction.

*SpliceTrak 90*: splice finder and eraser; dual full-track erase heads for 90dB depth of erasure; gentle tape handling, precision splice location.

Circle (610)

### Cinedco

*AUDIFLEX*: digital dialogue track editing system; for feature films, television applications.

Circle (643)

### DHK Group

*Audisk*: digital audio recorder; storage on optical or magnetic disk drives; stereo or mono with 7kHz or 15kHz bandwidths; multiple format, flexible user interface.

Circle (1197)

### Digital Audio Research

*SoundStation II*: audio editor/recorder, production system; versions with 2, 4, or 8 channels; 800MByte WORM optical disks, each backup one hour; special features include *Timewarp* time/length modification; project *Reels*; *DAT backup*; *FIND* search for general category of sound or segment; *Integrated Machine Control/Chase*; *Auto segment positioning*.

Circle (697)

### Fidelipac

*CTR30R enhancements*: triple-deck cartridge recorder, player; 110/220Vac servo motor, 50Hz/60Hz; increased power supply efficiency, improved S/N ratio.

Circle (744)

### Fostex

*D-20*: R-DAT recorder with SMPTE time code, sync capability.

*Model 4020*: event controller.

*R-8*: 8-track recording system.

*F.A.M.E.*: Fostex Automation Media Editor; software package to control audio, video editing from Macintosh or IBM PC.

Circle (752)

### Gotham Audio

*PRODAT 1a, 2a*: Audio Design R-DAT transports; XLR connectors; Apogee filters; 44.1kHz, 48kHz sampling; copy protect switch; LED error status indicators; -2a with SDIF-2 interface to Sony 1610/1630.

Circle (767)

### Hybrid Arts

*ADAP II*: digital recorder, editor; writes data directly to the hard disk; 760Mbyte disk stores more than 50 minutes of digital stereo at 44.1kHz sampling; SMPTE cue list, EDL.

Circle (1196)

### Inovonics

*Model 397*: magnetic film record, reproduce electronics.

Circle (798)

### Integrated Media System

*Dyaxis*: disk-based audio edit, recording system; 2-track, multitrack, offline sound assembly; digital format conversion; with Apple Macintosh.

*Virtual machine control*: for Abekas A62; SMPTE serial control.

*Direct Digital Interface*: includes Yamaha Digital Cascade, Mitsubishi/Otari PD, IMS/D.

Circle (800)

### International Music Company/IMC

*DR1200*: 12-track digital tape recorder; 8mm videocassette format, 16-bit PCM; 44.1kHz, 48kHz sampling; rotary head x3; analog time code track; analog, digital I/O.

*U5*: portable personal recorder; 4-channel multitrack cassette recorder uses C-30 to C-60 cassettes; normal, CrO<sub>2</sub> equalization.

Circle (806)

### Lake Systems

*Digital Mix-to-Pix*: features Waveframe digital audio production system.

Circle (832)

### Nagra Magnetic Recorders

*Nagra D (Digital)*: open reel recorder; rotary head system with 6.35mm format; VHS or KSA scanner; mono A-D, D-A track with 16 bits at 48kHz; tape speed 4.75cm/s; no editing; technology display item.

Circle (896)

### Nakamichi

*Nakamichi 1000*: digital recorder; 44.1kHz, 48kHz, 32kHz sampling frequencies; expandable with plug-in modules; *1000p* audio processor; *1000r* remote controller.

Circle (1195)

### New England Digital

*Optical Disk Sound Library*: for Direct-to-Disk, PostPro; extends memory to 2Gbyte; contents cross-referenced in various categories; WORM disk lets users record material.

*MIDI-net*: enhanced system uses Synclavier as master controller in MIDI-based facilities; MIDI processor, routing module for NED workstations and Macintosh II graphic workstation.

*DESC remote*: for Direct-to-Disk, PostPro systems; expandable product operates similar to auto-locate/motion control units; forms control

Continued on page 98

**THIS IS NOT  
THE MOST  
IMPORTANT  
ADVANCE IN  
BROADCAST  
OPERATIONS.**





The key to successful station operation is more than hardware.

It's people. Sony people. Designers and engineers who understand the real problems of integrating a new system into your station.

When you invest in a multi-

cassette system, it is vital to plan for the 1990s and beyond. It's the only way to meet current needs efficiently while retaining the flexibility to grow.

You need a manufacturer with a range of products and expertise

covering the entire "on-air" operation. And with systems specialists to help you select and configure the right system for you.

You need Sony, the company whose Betacart® pioneered intelligent cart systems. Today Sony,



# THIS IS.

with the most complete line of Library Management System™ products available, is working toward a true network integrated system.

Sony offers you a choice. Formats, capacities and software. Analog or digital. For single- or

multi-spot operation. Direct-to-air or compiling. All with Sony quality and reliability. And with the engi-

## SONY®

BROADCAST PRODUCTS

neering resources, support, and service to protect your investment.

Check with the specialists in LMS. Contact your Sony Broadcast Sales Engineer. Or call (800) 635-SONY.

Sony Communications Products Company, 1600 Queen Anne Road, Teaneck, NJ 07666. © 1989 Sony Corporation of America. Sony, Betacart and Library Management System are trademarks of Sony.

Continued from page 94

center for all-digital recording, editing.  
**MaxTrax:** system enhancement doubles the number of tracks available to Direct-to-Disk and PostPro users; 8-track system reconfigures to 16-track or 4-track with double recording time.  
**Circle (906)**

#### Otari

**MX-50:** 1/4" 2-channel recorder; 7.5/15 or 3.75/7.5ips; VEM Voice Editing Module option.  
**DTR-900B:** 32-track digital recorder; redesigned auto-locator, remote software, hardware.  
**DTR-900 modules:** accessories for ATRs include

**EC-104** chase synchronizer, **CB503** PRODIGI-to-DASH format converter.

**Circle (923)**

#### Professional Sound Corporation

**Sound Assist:** tape timing, display device and electronic control unit for Nagra recorder; indicates time remaining on tape, last take duration, tape-near-end alert; autolocation of playback cue.

**Circle (946)**

#### Radio Systems

**RsDAT RS-1000:** controller for R-DAT recorder;

2-hour record time per cassette; integrates Sony DTC-1000 DAT machine with special control system for random order play, automation.  
**Circle (960)**

#### Ramware Designs

**SlaveDriver:** intelligent synchronization and control of multiple transports; hardware/software package; IBM compatible.

**Circle (1194)**

#### Saki Magnetics

**Long-life Ferrite:** replacement heads for audio cart machines in NAB and TOMCAT formats.

**Circle (986)**

#### Solid State Logic

**ScreenSound:** digital editor, mixer, recorder; interfaces to VTRs, film reproducers for off-line editing; for video, film post-production, audio-for-video; interfaces to Quantel Harry for interactive audio/video editing; 8-channel configuration.

**Circle (1008)**

#### Sony Pro Audio

**APR-5003V:** center-track time code, 2-channel ATR; interface for post production with 9-pin serial to BVE-900/9000 editors; IEC time code format; LTC/VITC; bit bump; play mode resolves to 60Hz tone.

**TCD-D10 PRO:** portable DAT recorder; XLR inputs, outputs; AES/EBU ports; twin A-D, D-A conversion.

**Editor interfaces:** for MXP-2000 console, PCM-3402 digital recorder; ESAM serial interface for CMX, Ampex, GVG; EI-9000 parallel interface for Sony BVE-9000 editing system.  
**Software upgrades:** for APR-24, improved synchronization facility; accepts CTL signal from VTR for faster synchronization during high-speed wind of VTRs.

**Circle (1013)**

#### Soundmaster

**Random Access Digital Audio:** 2-track modules and various hard disk configurations; interfaces to current Soundmaster systems or can operate as independent system without machine control component.

**Circle (1018)**

#### Studer Revox

**Studer A827:** multichannel recorder; internal time code option; parallel, RS-232/422 ports; 3-speed with  $\mu$ P control; 14"-reel capacity; switchable Dolby HX Pro.

**Revox C270:** enhanced models with 2, 4, or 8 channels; very low-speed logging recorders.

**Revox C270 remote:** autolocator, channel remote unit; 18 storable start/stop addresses; switchable, programmable rollback time 0-59s for each; foot switch, buffer battery.

**Revox C270-TC:** professional 2-channel recorder, center-track time code.

**Revox PR99 MK III:** includes autolocator, varispeed, fader start, VU meters with peak LEDs, zero locator.

**Studer A820-24 enhancement:** switched Dolby SR, Dolby A noise reduction on single plug-in card; software release for enhanced operation in TV/video post production environment.

**Studer A807 4-channel:** 1/2", 30ips recorder; overbridge metering; 3-speed, servo dc capstan; servo spooling motors; MDAC audio electronics; Dolby HX Pro recording process.

# BMS— The Systems Approach to Microwave Transmission.

smaller, lighter,  
more versatile and  
cost-effective



In the dynamic world of ENG, BMS versatility will get you there FIRST and keep you there LIVE with the most reliable news gathering systems available. Advanced technology and state-of-the-art designs provide trouble free setup and operation.

- **CENTRAL RECEIVE SITES:** Our AZ/EL Autotrack/Steerable Antenna Systems, microprocessor based controls and frequency agile central receivers provide solutions to meet the challenges of news gathering in frequency congested areas.
- **NEWS TRUCK SYSTEMS:** High powered, mast mounted transmitters, coupled with our 2 x 4 foot parabolic antennas mean reliable signals from your news trucks.
- **PORTABLE TRANSMITTER/RECEIVER SYSTEMS:** Frequency agile, self-contained transmitters and receivers, with user friendly controls and feedback characteristics at 2, 2.5, 7, 13, 18, and 40 GHz.

When it comes to microwave links, BMS is on track and on line for peak performance. For more information about our ENG systems, call (619) 560-8601.

**BMS** Broadcast  
Microwave  
Services, Inc.

BMS, P.O. Box 84630  
San Diego, CA 92138-4630

NAB Booth #1718

Circle (55) on Reply Card



# HERE ARE THREE WAYS TO CONVERT CASSETTES TO CASH

- ✓ **Add new profit opportunities** by starting your own high speed tape duplication department.
- ✓ **Increase production** of your current tape duplication department by adding modules as you grow.
- ✓ **Save the money** you're spending on cassettes now. Produce them yourself for only the cost of the tapes.

Telex is the leader in high speed audio tape duplication equipment with products ranging from the compact, economical

Copyette® series to the professional 6120XLP shown here.

The Telex 6120 series provides outstanding audio quality, unlimited expandability and profitable production capabilities. It's available in high production 16X speed or 8X speed for highly critical audio needs.

### Hearing is believing

For full details including specifications and a free demo tape, call or write today.



6120 High Speed Duplicator

**Call toll free: 800-828-6107**

Telex Communications, Inc.  
9600 Aldrich Av. So.  
Minneapolis, MN 55420

Name \_\_\_\_\_  
Company \_\_\_\_\_  
Address \_\_\_\_\_  
City \_\_\_\_\_ State \_\_\_\_\_ Zip \_\_\_\_\_  
Telephone \_\_\_\_\_

© 1989 Telex Communications, Inc.



# TELEX

**Studer A729:** controller for four A727, A730 CD players; editing command modules for four CD players optional; disk recognition capability with three start/end cue points per disc.  
**Circle (1032)**

**Symetrix**

**DPR-100:** digital processing recorder.  
**Model 111:** adaptive hybrid telephone interface.  
**Circle (1040)**

**TASCAM**

**Model 3030:** 1/2" recorder, reproducer.  
**TSR8:** 8-track 1/2" recorder, reproducer.  
**102, 103:** stereo cassette decks.  
**Model 202WR:** bidirectional, dual cassette deck.  
**Circle (1049)**

**TimeLine**

**Supervisor:** flexible communications network for unified, direct serial machine control with multiple transport editing systems.  
**Lynx VSI Film Module:** integrates sprocketed film transports into computerized audio, video editing systems.  
**Lynx Keyboard Control Unit:** for multimachine synchronization and audio editing; machine control for six transports with Time Code modules; expands with Supervisor.  
**Circle (1077)**

**WaveFrame**

**Hard disk recording:** for AudioFrame digital audio production system; disk recording

modules are plug-in with four or eight channels per slot, 32 channels maximum; disk recording in 16- or 24-bit format.  
**Circle (1133)**

**Audio Products**

**A4: Ancillary**

- ✓ Wired, wireless mics
- ✓ CD, phono equipment
- ✓ Headphones, headsets
- ✓ Intercoms, speakers
- ✓ Remote pickup systems

**Accurate Sound**

**Model 180:** Starbird mic boom and stand; air valve provides cushioning during lowering; adjusts 5-9 feet vertically, 4-8 feet horizontally.  
**CR3A:** professional condenser studio mic.  
**Circle (505)**

**Allied Broadcast Equipment**

**Denon DN-950FA** CD cart player; plays CDs housed in protective cartridges; real-time D-A linear converter eliminates zero-cross distortion; 4x oversampling.  
**Circle (528)**

**Alpha Video & Electronics/AVEC**  
**IFB101-B:** IFB system.  
**Circle (533)**

**AMS/Calrec**

**M-S mic, stereo control:** stereo mic for coincident signals to 10kHz; output signals L-R, M-S; omni, cardioid, Figure-8 variable patterns; variable angle control 8-180°; attenuator.  
**Condenser mics:** enhanced capsule and pre-amp designs.  
**Circle (543)**

**Aphex Systems Ltd.**

**Model 810 Impulse:** intelligent interface; trigger electronic percussion from audio signals; 12 analog inputs trigger MIDI Note On; other shaped outputs trigger non-MIDI devices.  
**Model 850 Feel Factory:** algorithmic feel composer; allows musician to manipulate MIDI timing, velocity of sequences or machine patterns intuitively for different musical feel.  
**Circle (553)**

**ATI Audio Technologies**

**M100 Ultimike:** mic preamp; eliminates dimmer noise, RF, hum, rolloff from long cables; servo-controlled amplifier inputs to +20dBu; 48V phantom power; remote gain trim.  
**Circle (566)**

**Audio Services Corporation**

**MP-12T:** 12V-T, AB power supply for mics; battery-operated; 0, -10, -20dB attenuation set-

**SYSTEM TIME, REAL-TIME, ROLL-TIME**

Model TSG-440

Sync  
Generator



Pattern  
Generator

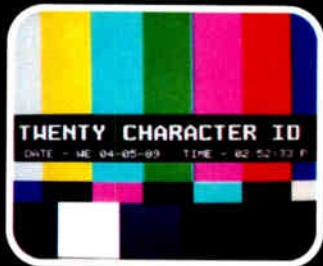

Source I.D.  
Memory for Ten



Count Down  
Generator



Vertical  
Interval I.D.



**SIGMA ELECTRONICS INC.**

1184 ENTERPRISE ROAD, P.O. BOX 448  
 EAST PETERSBURG, PA 17520-0448  
 Tel (717) 569-2681 FAX (717) 569-4056

*Perfect Timing for \$2395<sup>00</sup>*

Circle (57) on Reply Card  
 World Radio History



# WORRYLESS WIRELESS

Your mic is the last thing you should have to worry about when you are on the air.

Telex understands the broadcast and video production industry. After all we've been a leading manufacturer of broadcast quality microphones, intercoms and headsets for over fifty years. And, recently our wireless systems have become first choice among those who can't



afford to have their mics fail. When you clip on a Telex—don't worry.

We know that, in the serious business of television news, when the story is unfolding you've only got one shot at it. And, in production, when you make expensive talent wait for a new mic—you've just lost money.

Telex wireless microphone systems have been designed to stand up to the rigors of difficult remote ENG assignments as well as the daily abuse of studio and location work.



Shown above is our frequency selectable series featuring the FMR-4 rack mount receiver, ENG-4 portable receiver, HT-400 handheld transmitter/mic and WT-400 belt pack transmitter with lapel mic. For more information call or write to: Telex Communications, Inc., 9600 Aldrich Av. So., Minneapolis, MN 55420.

© 1989 Telex Communications, Inc.

## TELEX®

World Radio History  
Circle (58) on Reply Card

tings; switched bass rolloff; XLR connectors. *Mini Quad Box*: integrates four Vega R33 wireless receivers into one housing; powered from 12 C cells or external dc; multicoupler splits RF from single antenna feed. **Circle (574)**

#### Audio-Technica US

*AT877*: short shotgun mic; battery/phantom power operation.

*ATH900 series*: professional studiomics.

*ATM25*: instrument mic for high intensity sound levels.

*AT4031*: condenser mic designed for studio use. *RD303 TriPoint mic*: three permanently polarized condenser mics in one case; separate feeds; avoids mic cluster confusion; uses three 9V alkaline batteries or 9-52Vdc.

*Wireless system*: VHF system; *ATW1031* body pack, *ATW1032* hand-held; true diversity receiver; mute switch; 10 preset frequencies; with AT803A, AT831A or ATM73 mics.

**Circle (575)**

#### Benchmark Media Systems

*MDA-102*: dual mic preamp/DA, a System 1000 module; four outputs/channel with 1dB noise figure, 200kHz bandwidth, -2 to +73dB gain; power for +12/+48V phantom, AB/T mics.

**Circle (595)**

#### beyerdynamic

*SHM series*: podium mics; *SHM420* dynamic hypercardioid; *SHM422* dynamic supercardioid; *SHM10* condenser hypercardioid.

*MCE 86*: lightweight, shotgun condenser mic.

*SI86*: wireless hand-held mic.

*TS190*: wireless lavalier-design mic.

*DT770 PRO*: sealed-ear, studio, ENG, EFP monitoring headphone.

*DT990 PRO*: Semi open-ear, studio/ENG monitor headphones.

**Circle (597)**

#### Bradley Broadcast

*Telos One*: digital telephone interface; all processing in digital domain; high/lowpass filtering; trans-hybrid loss  $\approx$  45dB; second output for optional mix of caller/send signals.

*Control panels*: for Telos 100 family used with Pacific Recorders & Engineering consoles; duplicates all functions on Telos consoles except three "user" buttons.

*Telos 100 direct interface*: connected to central office lines without PABX or key system; capacity for 10 incoming lines; two announcers; music-on-hold provision; supports two hybrids.

**Circle (606)**

#### Broadcast Supply West

*HA-200*: Radix headphone amplifier; includes EQ capability.

*Radix 405*: telephone remote mixer.

**Circle (613)**

#### Bruel & Kjaer Instruments

*Model 4007*: phantom-powered, high-intensity mic.

*Model 4011*: first-order cardioid, phantom-powered, transformerless mic.

*Model 4003*: line-level, low-noise omnidirectional mic.

*Model 4004*: line-level mic; maximum intensity 168dB SPL.

*Model 4006*: phantom-powered, low-noise mic with adjustable acoustical response.

**Circle (616)**

#### Bryston

*Model 10B*: crossover network; independently selectable points for highpass, lowpass; slope selection from 6, 12, 18, 24dB/octave; 70Hz-4.5kHz; input 1V, 20k $\Omega$ ; output 100 $\Omega$ .

**Circle (617)**

#### Clear-Com Intercoms

*Matrix Plus*: point-to-point multiprocessor controlled intercom; digital control of digitized audio; complete operation over single, unshielded twisted pair; immune to hum, buzz, noise pickup, crosstalk; interface cards interconnect to IFB, ISO, wireless belt packs and other systems or equipment; 8-line $\times$ 80-column LCD system status display; DTMF phone dialing; station directory.

*Model 1020, 1020M*: stereo, bi-amplified monitor speaker systems; full-range sound from self-contained package; 19" rack-mount, 1 $\frac{3}{4}$ " high; 6" low, two 4" mid-high frequency speakers; 1020M includes peak-reading bar graph meters for input level.

**Circle (649)**

#### ComTek

*M-182*: hand-held wireless mic; full 50mW output, 50-hour operation; all metal package.

*MR-180*: portable wireless mic receiver; for use with television cameras.

**Circle (668)**

#### Countryman Associates

*ISOMAX headset mic*: dynamic sound from condenser capsule; cardioid or hypercardioid pattern; phantom power, wireless mic versions; headband fits back of head; telescopic adjustable mini-mic boom.

*Type 85 Direct Box*: FET circuitry to connect electronic instruments to recording or PA console without loss or distortion; battery or phantom power; mic output level.

**Circle (677)**

#### Crown International

*SASS-P*: stereo PZM mic; condenser type; 20Hz-18kHz; omnidirectional in each channel; EIA sensitivity -136dBm; maximum 150dB SPL at diaphragm produces 3% THD.

*US-1*: universal power supply; 13:1 impedance ratio; phantom power for 12-48Vdc; output connector is 3-pin professional type; battery life 1800 hours with 1mA current drain.

**Circle (679)**

#### Electro-Voice

*T-88 Pro Plus*: hand-held wireless mic; Electro-Voice N/DYM 757 element.

*T-38 Pro*: hand-held wireless mic; Electro-Voice N/DYM 457 element.

**Circle (1114)**

#### FOR-A

*ALM-40C*: audio level monitor displays as bar graph of four stereo audio channels keyed in-to video; ID insert; 10-step bars with red, green segments; balanced 600 $\Omega$  inputs.

**Circle (749)**

#### Fostex

*T-40*: RP ribbon headphones.

*F-45*: headphones with boom mic.

**Circle (752)**

#### Gefen Systems

*PX-240*: compact disc player, configured as 240-CD changer.

**Circle (759)**

#### Gotham Audio

*KM 100 series*: Neumann mics; miniature condensers with 40Hz-20kHz range; omni, cardioid, cardioid with bass rolloff, hypercardioid patterns; 10-15mV/Pa sensitivities.

*EMT-981*: professional CD player; balanced output at line level.

**Circle (767)**

#### H&E Micro-Trak

*Model 9918*: 1 $\times$ 8 audio DAs; input transformer isolation; 20dBm maximum output; individual level controls.

*10P monitor amplifier*: 10W per channel stereo unit; low distortion.

*303A-306A*: phono tone arms; 12" and 16" models; fluid anti-skate, jewel pivots; tracking as low as 0.1 gram.

**Circle (1199)**

#### HM Electronics

*RP735*: 2-channel intercom power station with speaker.

*RP743*: 4-channel power station.

*RP753, RP755*: 4-channel matrix power stations.

*PD100*: power distribution system.

*DN100*: antenna distribution system.

*RW760*: universal interface module.

*Systems 515, 525*: body-pac and hand-held, low-cost wireless mic systems.

*Systems 8100, 8150*: portable and rack-mounted wireless intercom systems; base station, two Communicator transceivers, battery charger and batteries; 2 channels, one between transceivers, second to base station.

**Circle (782)**

#### JBL Professional

*Control 10*: control room monitor system.

*Control 12SR*: loudspeaker system; 12" low frequency transducer and 1" exit compression driver on Flat-Front BiRadial horn.

**Circle (812)**

#### Lectrosonics

*M170-CTM*: conference table mic; combines wireless, boundary mic technologies; hand-rubbed walnut finish; omni pickup pattern; 12-14 hour operation on 9V battery.

*Model Pro 4-Mini*: VHF highband, 4-channel wireless mic field pack; removable receivers; antenna distribution module; rechargeable supply; XLR audio output from receiver.

*Model CR185*: enhanced VHF wireless receiver; mounts on ENG camera; 6-section helical resonator front end; XLR output jacks.

*H185*: plug-on transmitter makes any mic wireless; machined aluminum; internal 2:1 compandor circuit; phantom power.

*Model T185*: hand-held wireless mic; Shure SM58 cartridge; machined aluminum, double-tapered body; 20dB compression without distortion; integral antenna.

**Circle (837)**

#### LTM

*Model 0699-903062*: mic windscreen and muff.

**Circle (850)**

# HEADSETS AHEAD OF THE GAME— IN MORE WAYS THAN ONE

## For coaches and broadcasters alike— the pros pick Telex.

On the football field and in the broadcast booth high atop the stadium you'll find Telex Headsets are the choice of the pros. National Football league stadiums and major television networks use a variety of Telex Professional Headset models day-in and day-out.

Furthermore, thousands of colleges, high schools and local radio/television stations who have recognized the value

of clean, clear, dependable communications are also using Telex. If you're not already using a Telex, we urge you to take a closer look next time you have a requirement.

**A model for every purpose.** Whether your need is communication, camera, sportscaster, studio announcing or inconspicuous on-camera listening, Telex has a model that will fit your requirements perfectly. No other headset manufacturer has the tremendous model variation Telex offers.



Lightweight, full cushion, single sided or dual, boom mic or monitor headsets are all fully described in the latest Telex Headset Catalog. Full specifications are included and the catalog is free. Call or write today: Telex Communications, Inc., 9600 Aldrich Avenue South, Minneapolis, Minnesota 55420.

© 1989 Telex Communications, Inc.

## TELEX®

Circle (59) on Reply Card

World Radio History

### McCurdy Radio Industries

*CS9500*: digital intercom; 50x50 matrix; compact; redundant power supplies; programs for party lines, IFBs, selective group calls, 2-way radio use, telco interface, belt packs.  
**Circle (867)**

### Micron Audio

*MDR 550*: portable miniature single-channel, diversity wireless mic receiver.  
**Circle (875)**

### Moseley Associates

*RPL-4000*: remote pickup link; *RPL-4010* transmitter, 20W output; *RPL-4020* receiver sensitivity 1.2µV for 20dB quieting; audio bandwidth 7.5kHz or 15kHz; 25kHz, 50kHz, 100kHz channels.  
**Circle (890)**

### Nady Systems

*750VHF*: 2-channel VHF wireless receiver with integral mixer.  
*850VHF*: frequency-agile VHF wireless receiver; nine synthesized channels.  
**Circle (895)**

### Panasonic

*Pro R-DAT demonstration*: system of portable DAT recorder, DAT deck and digital audio editing controller; internal SMPTE time code processor converts code to running time code in sub-code area.  
**Circle (962)**

### Peerless Sales

*Radial Cube speaker mount*: wall, ceiling installation; high degree of directional adjustment dependent upon speaker enclosure involved; 4x4" opening for access to speaker wiring.  
**Circle (931)**

### Professional Sound Corporation

*CarCom*: portable dc-powered communications system; duplex talk, listen; multiple headphone outputs; C-cell operation; for standard mic cables, connectors; mute, summing amp, line-level output.

*van den Bergh mic boom poles*: extended sizes to 3' 11"-16' 5"; glass, carbon fiber composition; one-turn positive section lock action.

*Mini Quad box*: four Vega R33 wireless receivers with integral antenna splitter; powered from C cells or 12-24V dc supply.

*MP-12T/48-P mic supplies*: 12V AB(T), 48V phantom power for Sennheiser, Neumann, Schoeps mics; 9V and 22.5V batteries supply 60 hours of operations; 3-step pad, switchable low-frequency rolloff.

*SX-F2*: Sonosax communications module; slate mic, subtone; PL talkback mic; roll switches for two recorders; 48V phantom power; headphone volume for boom monitor; for SX-S6, -S8, -S10 mixers.

*MP-48PH-Stereo*: battery power supply for Neumann 190i stereo mic; six 9V Duracells for 60 hours of operation.

*MC-2*: monitor talkback system; for use with Nagra 4.2, IV-L recorders.  
**Circle (946)**

### R-Columbia Products

*TR-160*: FM wireless intercom headphones; range 1-2 miles; 144-174MHz; FM transmitter, receiver, antenna and NiCad battery; converse with multiple similar headphones.  
**Circle (956)**

### ROH/Anchor Audio

*Model 402*: PL master station.  
*Model 403*: PL headset station.  
*Model 460B*: lightweight headset.  
*SM200 wireless intercom*: remote transceiver belt pack, self-contained antenna; no cables.  
**Circle (977)**

### RTS Systems

*BP325*: portable station; µP-assisted 2-channel headset station; enhanced analog performance; call-signal disable, single-channel, momentary-action, mono mix modes.

*MCE 325*: programmable, 4-channel intercom headset/speaker user station; 4-way modular packaging, permanent-mount, portable use; optional IFB, SA circuits.

*\*2528*: dual-channel, remote gain control mic preamp; on card-cage package.

*CCD 214*: crosstalk canceler for TW intercom system without altering audio quality.  
**Circle (983)**

Continued on page 108

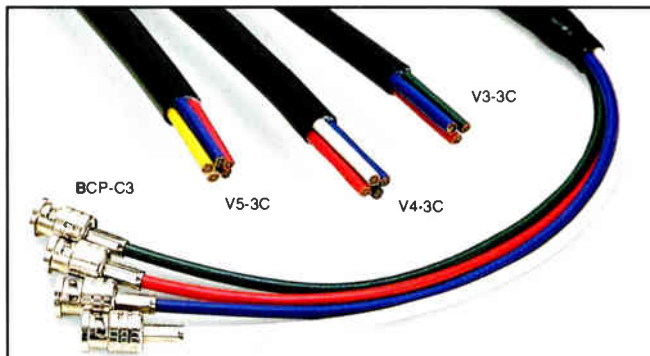

## CLEANER & SHARPER VIDEO RESOLUTION

- Optimize the signal to your video monitor with Canare high performance cables and connectors.
- Ideal for computer graphics, video projectors, component (RGB) broadcast and digital VTR's.
- Component coax cable: super flexible, 75 Ohm (<2.2 nanosecond differential delay time). Matched with 75 Ohm BNC connectors (<1.1 VSWR to 2 GHz).
- Available in bulk or pre-assembled fan-to-fan tails.

**CANARE**<sup>TM</sup>

**CABLES & CONNECTORS**

511 5th St., Unit G, San Fernando, CA 91340  
Phone: (818) 365-2446 FAX: (818) 365-0479

REQUEST  
FULL-LINE  
CATALOG

Circle (60) on Reply Card

## CANDYBOX SOLUTION SERIES

# A total solution to the nasty ground-loop hum

*A MUST for remote trucks.*

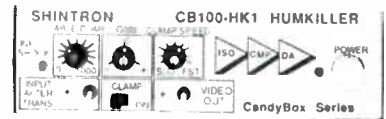

### CB 100-HK HumKiller

Isolates up to 1,000V AC of hum. • Compensates up to 1,000 ft. cable. • Clamps video with variable speed. • DG: < 0.25%, DP < 0.25 deg. • 6 isolated outputs.

# SHINTRON

80 TAYLOR ST., LITTLETON, MA 01460-2426  
TEL: 508-486-3900 FAX: 508-486-0782

Circle (61) on Reply Card

# Our "small revolution" is making big waves in shotgun microphone design!

**Model 4071**

Line - Gradient Condenser Microphone  
(Shown with AT3411 Shock Mount)



**Model 4073**

Line - Gradient Condenser Microphone



The Model AT4071 is just 15 1/2" long, while the AT4073 is a mere 9". Yet, both 40-Series shotguns perform far "longer" than their actual size. Because inside these two new Audio-Technica studio condenser microphones is a revolutionary approach to shotgun design.

## New Coaxial Tube Design

In effect, the ingenious coaxial interference tubes perform as though the microphones were half again as long. Our unique tube design goes far beyond the normal phase cancellation that occurs in a simple resistance-damped tube. There is actually a tube-within-a-tube, creating a separate, acoustically longer path for the lowest frequencies. Low frequency directivity (normally a simple function of tube length) is maintained, yet the microphone size is reduced to a far more practical length.

## The Result: A Better Working Tool

This shorter length for a given acceptance angle has practical benefits in the studio and the field. It's easier to avoid shadows and to stay well out of the frame. Cancellation from the back is also impressive, making exact mike

placement less critical. And the very light weight (far less than the others) will be appreciated by every user. As a bonus, the nested internal construction makes the 40-Series shotguns unusually resistant to accidental damage.

## Clean Transformerless Output

Listen carefully to the 40-Series sound. The transformerless output insures fast, distortion-free response to transients. You'll hear crisp, natural dynamics over an extended frequency range, even under high SPL conditions. Output of 40-Series models is extremely high, for a very favorable signal-to-noise ratio. A built-in high-pass filter is included, of course.

## Quiet in Every Way

The low noise of these new microphones is impressive. Self-noise is almost immeasurable. Equally important, the rejection of wind and handling noise is outstanding. Coupled with excellent sensitivity, the 40-Series design allows you to take

full advantage of the finest digital and analog studio electronics.

## Compatible and Competitively Priced

Finally, both can be powered from any 12-48V phantom power supply. They come complete with foam windscreen, stand clamp, and case. Yet, with all their advances and performance superiorities, the new A-T 40-Series microphones are priced competitively with the best known shotguns.

The significant performance advances of these new 40-Series microphones demand a trial in your most difficult environment. Heft them. Hear them. Compare them in every way. This bold new technology will change your expectations about shotgun performance!

Circle (62) on Reply Card

World Radio History



**audio-technica®**

1221 Commerce Drive, Stow, OH 44224  
(216) 686-2600

# The Ampex Digital Cart Machine . . .



It seems that nothing really good comes easy, but now our first ACR-225 customers have received their automated cassette systems. And they tell us they're glad they waited.

The birth of the ACR-225 was a longer process than we'd anticipated, and many video professionals exhibited patience and confidence in us throughout the extended shakedown phase of the ACR's development.



# “It was worth the wait.”



For that trust we'd like to say, "thank you!"

And for all of you who will someday own an ACR-225, we think you'll agree that the reliability and uncompromised signal quality of this advanced digital cart machine

was worth every minute of the time it took to do it right.

Call us at **1-800-25AMPEX** for more information about the ACR-225 and other D2 composite digital recording systems.

## AMPEX

Continued from page 104

### Samson Products

*MR-1*: micro receiver; 174-214MHz; 9V cell operates for 10 hours or use dc adapter; dbx noise reduction; 30Hz-16kHz with 100dB S/N ratio; 13 channels for simultaneous operation at same location.

*Stage II series*: *SR-2* non-diversity, *SR-22* true-diversity receivers; *SH-2* hand-held, *ST-2(G)* instrument/belt pack, *ST-2(L)* belt-pack lavalier transmitters; *CH-2* "Step-Up" hand-held, *CT-2* "Step-Up" belt-pack transmitters; dbx noise reduction system; 30Hz-18kHz range over the product series.

Circle (987)

### Sanken/Audio Intervisual Design

*CMS-7S*: field stereo Mid-Side mic.

*CU-44X*: transformerless, dual-capsule design, cardioid studio mic.

*CB-485*: portable phantom power supply unit.

Circle (988)

### Sennheiser Electric

*MKH70 P48F*: shotgun condenser mic; symmetrical push-pull transducer; eliminates IMD; transformerless output; 10dB pad available if pressure level exceeds 124dB.

*MD518*: hand-held dynamic mic; for reinforcement of high sound pressure signals; cardioid with frequency response from 50Hz to 16kHz; pressure gradient design.

*HD25*: dynamic headset; closed supraural design; lightweight with adjustable split headband for optimum fit for any user; one muff rotates off ear for single muff monitoring.

*ENG 2003*: portable wireless mic system; full-featured UHF true diversity receiver; canvas bag holds receiver, rechargeable battery; dual UHF antennas built into shoulder strap.

Circle (996)

### SESCOM

*RK-RACK*: rack system chassis, power supply.

*RK-MLD*: dual mic-line driver module.

*RK-ALC*: dual-channel ALC line amplifier.

*RK-SB*: stereo balance box.

*RK-PS-1*: power supply.

*RK-PA*: 5-channel monitor amplifier.

*RK-SC*: stereo phono/line preamplifier.

Circle (998)

### Shure Brothers

*Beta 58C*, *58M*: supercardioid dynamic mic for vocal use; humbucking coil.

*Beta 57*: supercardioid dynamic mic for instrumental use.

Circle (1003)

### Sony Pro Audio

*ECM-M55*: stereo electret condenser mic; ENG, sports, film, TV, audio production; operates from AA battery or external power; low-cut switch; 70Hz-20kHz.

*WRR/WRT-28*: wireless mics; 902-952MHz carrier with 30mW output; -45dB spurious radiation rejection; 4-hour AA battery operation; fits to Betacam camcorders.

Circle (1013)

### Stanton Magnetics

*890AL*: DJ PRO phono cartridge; highly polished diamond; extra stylus; 4-coil design; permits back-cue, tracks 2-7g.

*680EL-MP*, *500AL-MP*: back-cue cartridges,

matched performance, tracks 2-5g.

Circle (1023)

### Tannoy

*PBM 6.5*, *PBM-8*: playback reference monitors. *NFM-8 DTM*: 8" dual-concentric near-field monitor for critical mix, reference or broadcast.

Circle (1045)

### TASCAM

*CD-701*: professional compact disc player; optional remote control units; audio production, broadcast use; optional RAM buffer.

*CD-401*: production/on-air CD player.

Circle (1049)

### Television Engineering Corporation

*Model IFB-19*: audio controller; selects from eight IFB sources, four interrupt sources; provides three isolated outputs; individual gain control for IFB source, interrupt source.

Circle (1062)

### Television Equipment Associates

*Racal Neckset*: mic and speaker located on user's neck; received signal is fed to ear mold; for use with 2-way radio.

*Secrette*: strap-on earphone with boom mike; for 2-way radio users.

Circle (1063)

### Telex Communications

*HT-100 series*: hand-held mic; /10 with TE-10 condenser mic head; /11 with TD-11 dynamic mic head; /58 with Shure SM-58 dynamic; /87 with Shure SM-87 condenser.

*FMR-25*, *FMR-25TD*: wireless mic receivers; -TD with Pos-i-Phase true diversity.

*WT-25*: wireless mic belt pack transmitter with attached lapel mic.

*IC-2SP*: 2-line speaker station for intercom systems.

*ENG-4*: 4-channel wireless mic receiver.

*WT-400*: 2-channel wireless transmitter; 165-215MHz spectrum; for WLM-200 miniature lapel mic or equivalent.

Circle (1064)

### UREI

*6210*, *6211*: Energizer audio power amplifiers; two input connectors in parallel, active balanced inputs; -6210 with 3-pin XLR and 1/4" phone; -6211 with male and female XLRs.

Circle (1099)

### Ward-Beck Systems

*MiniCOM*: 24x36  $\mu$ P-controlled intercom system; 5-rack unit package; digital, programmable, based on MiniCOM II system.

*M8220 Interphone*: 2-wire to 4-wire interface to allow use of IPH series; 2-rack unit for two independent 2-channel interphone circuits; IPH-2 belt pack, IPH-3 desk stations, ISP-6 splitter unit.

Circle (1132)

### Whirlwind

*P-40/P-40B*: 40W/channel (8 $\Omega$ ) studio power amp; unbalanced or balanced (-40B) inputs; response to 20kHz; 0.02% distortion; 15V/ $\mu$ s slew rate.

Circle (1139)

### Wohler Technologies

*AMP-1A*: single 1RU powered stereo monitor.

*AMP-5*: tri-output stereo power amplifier.

*AMP-2*: deluxe 2RU powered stereo monitor.

Circle (1142)

### Yamaha Music

*MS101*, *MS202*: powered monitor speakers.

*NS10MC*: commercial speaker systems; optimized for typical permanent commercial sound systems; full 2-way 7" cone woofer, 1 3/8" soft-dome tweeter; 50Hz-20kHz; bookshelf size.

Circle (1147)

## RF Products

### R1: Transmission

- ✓ Antennas, masts, towers
- ✓ Radio, TV transmitters
- ✓ RF switching
- ✓ Transmission line
- ✓ Transmitter remote control

### Acrodyne Industries

*TRU-25KVC*: 25kW UHF TV transmitter.

*TLH/100T*: 100W VHF band-III transmitter; solid-state design.

*TRU/1000*: 1kW solid-state UHF transmitter; four 350W slide-out modules; integral troubleshooting diagnostics for amplifier boards, other components; slide-out design enhances maintenance.

Circle (508)

### Adelphon

*Model 700*: extra heavy Landmark tower series, from 700' to 1000'.

Circle (511)

### Andrew

*82RF*, *82RG*: 3 1/4" EIA flange connectors for 2 1/4" air dielectric HELIAX; -RF allows gas pressure to pass through the connector interface, -RG presents a gas barrier.

*HJ12-50*: 2 1/4" HELIAX; air dielectric; power capacity between 1 3/4" and 3" with attenuation similar to 3" line; polyethylene jacket permits direct burial, corrosive environments.

*GLW GUIDELINE series*: circular waveguide for UHF TV all channels; powers 60kW to more than 240kW; 13 1/2-17 1/2" diameter; improved polarization stability; eliminates field compensation.

*AGW GUIDELINER series*: waveguide antennas; minimizes beam steering for all applications; controls radiated signal level vs. frequency by reducing differential gain.

Circle (546)

### Bogner Broadcast Equipment

*No Steering*: antenna for HDTV, stereo, SAP broadcasting; beam steering factor eliminated.

Circle (602)

### Broadcast Electronics

*Series B transmitters*: solid state for 400W, 250W, 125W; one-tube 1kW to 35kW in eight



Some people aren't satisfied until everyone else is.

When the toughest critic in the audience is you, choose the tape products that compromise nothing. Ours. We won't be satisfied until you are.



Circle (64) on Reply Card

models; FX-50 exciter; 85dB S/N ratio; integral synchronous AM noise test.  
**Circle (610)**

**Broadcast Transmission Corporation**

*CST UHF series:* Computer Supervised Transmitters, based on TKA-60C amplifier cubicle; 15kW to 70kW with wideband klystrons; self-contained cubicle includes amplifier with metering, cooling, power, logic.  
*CST VHF series:* Computer Supervised Transmitters; single-tube design with YL1630 Amperex tetrode and 40792 cavity for band I (to 25kW), 40786 cavity for band III (to 35kW); solid-state aural.  
**Circle (1085)**

**Burke Tech**

*Enhancement options:* computer control options for ARC-16 remote control systems.  
*Cable kits* for TC-8, ARC-16 remote control systems; permits rapid installation for most current transmitters.  
*Accessories* for remote control systems.  
**Circle (515)**

**CCA Electronics**

*FM transmitters:* zero-bias grounded-grid triode PAs; *FM2500G* 1-3kW, *FM4000G* 0.5-4kW, *FM5000G* 0.5-5.6kW, *FM10000G* 0.5-10.5kW; 200-240Vac power; 3CX3000A7 (3CX10000A7

for 10kW) in PA.  
**Circle (631)**

**Comark Communications/Thomson**

*CTT-U-1SS:* 1kW solid-state, low-power UHF TV transmitter; ferrite diplexer combines visual, aural signals at output power level; four visual PA modules for 1kW, one PA module for 100W aural.  
*CTT-U-60SK:* 60kW Klystrode-equipped, UHF TV transmitter.  
*CTT-SKM series:* Klystrode-equipped, UHF TV transmitters to 90kW; common amplification or diplexed systems; air-cooled.  
*CTT-U-10SKA:* 10kW Klystrode, air-cooled UHF TV transmitter; common amplification system; Figure of Merit at 85%.  
**Circle (658)**

**Continental Electronics/Varian**

*814C:* 3.8kW FM radio transmitter.  
*816A-I:* 10kW FM solid-state transmitter; 802A exciter.  
*AMDATRAX, FMDATRAX:* computer-based transmitter monitor and control systems for AM, FM; menu-driven; allows advance programming of transmitter functions in advance; allows defined limits, alarms.  
*XL-310:* 10kW AM radio transmitter; solid-state design with efficiencies of 80% ac-to-RF; phase-coherent digital RF pulse modulation; controlled power reduction in event of fault.  
**Circle (673)**

**DSI Communications**

*STATSYSTEM* remote transmitter site monitoring and control equipment.  
**Circle (706)**

**EMCEE**

*TTU-100EE:* 100W solid-state UHF TV transmitter.  
*TTV-100EE:* 100W solid-state VHF TV transmitter.  
*TU-100EE:* 100W solid-state UHF TV translator.  
*TV-100EE:* 100W solid-state VHF TV translator.  
*TTS-10GA:* 10W solid-state ITFS/MMDS transmitter.  
*TTV-25-L:* 25W solid-state VHF TV transmitter.  
**Circle (726)**

**Energy-Onix**

*MK-50:* 50kW FM broadcast transmitter.  
*MK-7.5:* 7.5kW FM broadcast transmitter.  
**Circle (730)**

**Flash Technology**

*FTB 205.4A:* ElectroFlash system; meets FAA AC 150/5345-43 spec; FH 205-4 flash head for 200,000/20,000/2,000 candela illumination levels; PC 205-4 power converter, SC 110 controller.  
*SC 110 controller:* random access monitor display; continuously monitors each flash; integral memory for detection of intermittent failures; telemetry interface.  
**Circle (747)**

*Continued on page 114*



An RS422 Data Router that allows sharing of resources between multiple edit suites.

- A reliable, solid state design
- SVS is the *only* source for both conventional X-Y and "Port" configured systems.
- Flexible and easy-to-use control system, including RS232 interface.

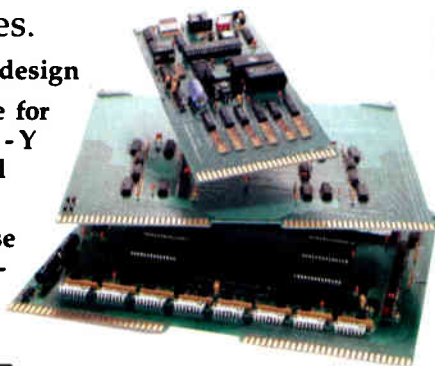

- Six standard sizes from 16 port to 64 x 64
- Extremely cost-effective — call SVS today and find out about the SERIES 42 DATA ROUTING SWITCHERS.



*Look to Sierra for the clear image.*

P.O. Box 2462, Grass Valley, CA 95945 • 916-273-9331 • Fax: 916-273-9390

Circle (65) on Reply Card

# LEITCH OFFERS MORE CHOICES

8 outputs from \$175



- Reliable video DAs for every application.
- 600/150 Ohm & Lo-Z audio DAs to match the performance of our video line.
- Two styles of one and two rack unit mounting frames.
- Six or eight outputs per card.
- Up to 12 cards per two rack unit frame.
- Full power supply back-up.
- Lowest cost per output with two-year warranty.

**Audio/Video Distribution Amplifiers  
to match all your needs...**

**LEITCH**

Leitch Video International Inc., 10 Dyas Rd., Don Mills, Ont., Canada M3B 1V5 - Tel: (800) 387-0233 Fax: (416) 445-0595 Telex: 06 986 241  
Leitch Video of America, Inc., 825K Greenbrier Circle, Chesapeake VA 23320 - Tel: (804) 424-7920 or (800) 231-9673 Fax: (804) 424-0639

Circle (66) on Reply Card

# WE'VE SEEN THE FUTURE AND IT FITS.

Just when broadcasters and professional users are shifting from one-inch and 3/4-inch video tape systems to 1/2-inch analog component video, along comes the specter of 19mm D2. First they made it smaller; now they want to make it bigger again.

When Panasonic set out to design Composite Digital recording systems, we had a big responsibility — to keep it small. Our customers have a right to expect their investment in 1/2-inch to be preserved. We know that a change in technology means more than a change in equipment; walls, racks, layouts, suites, vans and tape storage are all long-term investments that shouldn't have to be re-done every time there's a new chip on the block.

Panasonic's new Composite Digital system not only delivers superior multi-generation capability, long-term signal stability and unprecedented operating ease. It is designed to fit right where it should — into your existing facilities.

Panasonic's design philosophy is always to create products for the future with today clearly in

mind. Our editing recorders and systems work with all of today's existing standards for video, audio and control. When you're ready to convert your editing suite to Composite Digital video, Panasonic will fit in.

Panasonic cameras, from our new, all solid-state AK-450 to the new all-digital AQ-20 and AQ-10, are designed to slip transparently into the operators' experienced hands.

Today's mobile teleproduction requirements include everything from commercial production to fast-breaking news. That's why our system design is built around interchangeable components and true portability — and will remain so from today to digital to HDTV.

Here's the bottom line. Television in the 1990's demands technical advances and innovations — digital video and HDTV. But *your* demands are for systems that permit smarter, leaner operations. And that is why Panasonic's broadcast equipment, both for today and tomorrow, is designed to fit into your plant, your vision and your budget.

**Panasonic**  
Broadcast Systems

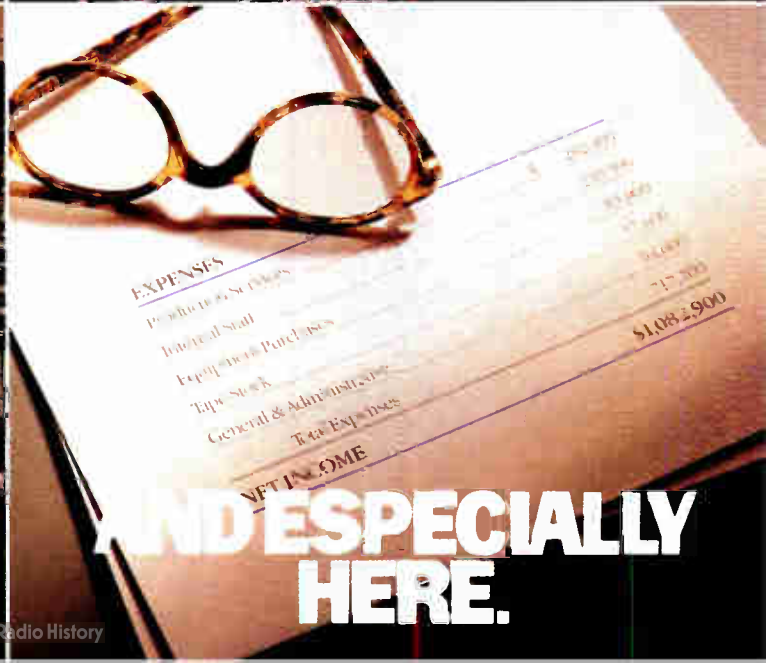

# SMPTE/EBU Time Code Reader & Character Generator

## Model DR-107B

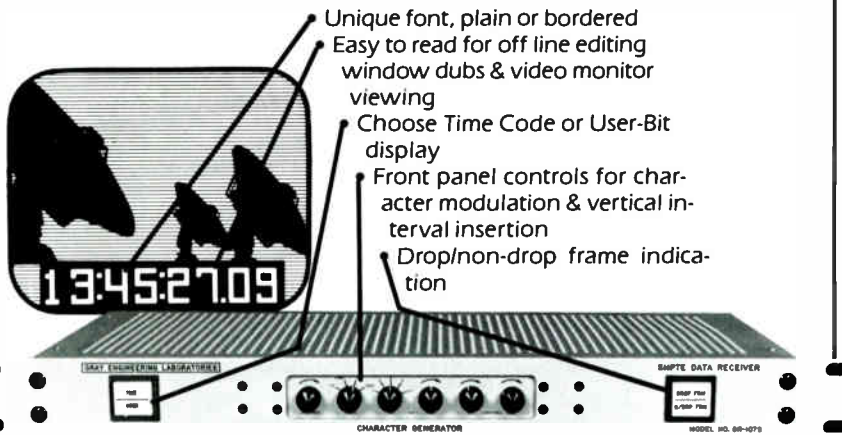

- Superior code reading using "The McFadin Window®"
- Reads 1/100 to 100 times play speed (machine dependent)
- Restored Time Code output for dubbing
  - Parallel BCD output
  - 1 3/4" Rack mounting
  - 5-Year warranty including parts and labor

**GRAY ENGINEERING LABORATORIES**  
 504-P West Chapman Avenue  
 Orange, CA 92668  
 714-997-4151

Circle (68) on Reply Card

# Camera cable information from the company that knows best...Mohawk!

## Mohawk offers superior broadcast camera cable and a free, newly expanded camera cable and connectors information kit!

If the job demands flawless broadcast transmission, order the best cable—Mohawk. Count on Mohawk's quick response to assembly orders and repairs to save you precious time.

Our expanded product line features:

- Ultra-flex VTR cable assemblies for Hitachi, Ikegami, Panasonic, Sony and others
- Slimline studio camera cables
- Waterproof, high strength three-piece connector design
- Customized lengths

Mohawk's entire team of engineers, technicians, and sales and service professionals are committed to providing product and service excellence. Our strict performance standards exceed even industry requirements.

Get your information from the reliable source! Mohawk's new edition of the TV camera cable and connectors information kit is available free. Just call or write Mohawk today!

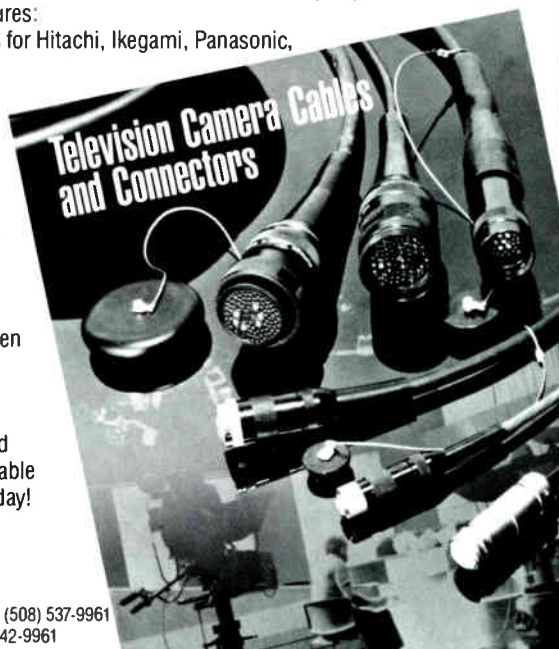

**MOHAWK**

Wire and Cable Corporation

9 Mohawk Drive • Leominster, MA 01453 • (508) 537-9961  
 Toll free: 1-800-422-9961 • In MA: 1-800-642-9961

Circle (70) on Reply Card

Continued from page 110

### Gentner Electronics

**VRC-2000:** remote AM, FM, TV transmitter controller; full control on telco, radio, data, bidirectional audio links; VRC antenna monitor reports on AM array; 32 command capability.  
**Circle (763)**

### Harris Broadcast Group

**TWS-30C-V:** Wavestar UHF TV waveguide antenna; loop over slots control vertical radiation polarization; standard narrow cardioid pattern, custom patterns; fiberglass radomes.  
**Platinum HT 30HS:** 30kW high-band VHF TV transmitter; solid-state; parallel operation of major components for reliability; NTSC, PAL-B available; IEC 215 safety spec.  
**HT 10FM:** FM transmitter family; powers of 3.5/5/10kW; one-tetrode with 1/4 cavity for wideband operation; THE-1 solid-state exciter; low velocity air cooling.  
**HT 20FM family:** models rated 20kW and 25kW; single tetrode in wideband 1/4 cavity; THE-1 solid-state exciter; low velocity direct-drive air cooling.  
**HT 35FM family:** FM transmitters rated 30kW and 35kW; single high-efficiency tetrode in 1/4 cavity; THE-1 exciter; sideband operation; proportional VSWR foldback protection.  
**UM Series:** UHF TV transmitters; 60kW, 120kW, 180kW, 240kW; external cavity MSDC klystrons for reduced input power costs; front LED panel displays status of system.  
**DX-50:** 50kW AM transmitter; solid-state design, digital modulation; 85% efficiency reduces power costs by one third; 128 RF modules controlled by modulation encoder; audio applied to A-D converter drives modulation encoder; RF amplifiers are turned on and off creating amplitude modulation; 145% peak positive capability, continuous 100% sinewave modulation; FlexPatch soft-failure design.  
**Platinum HT-50HS-U:** 50kW high-band VHF TV transmitter; single-tube, field-upgradable to solid-state; parallel operation to 100kW; NTSC/M, PAL/B; IEC 215 safety specs.  
**Circle (776)**

### ITELCO

**T234:** 20kW FM radio transmitter.  
**T254:** 30kW FM radio transmitter.  
**T233:** 2kW FM radio transmitter.  
**T314A:** 10kW VHF high-band TV transmitter.  
**T134B:** 20kW VHF low-band TV transmitter.  
**Circle (807)**

### Jampro Antennas

**JBBP:** balanced, omnidirectional CP FM antenna.  
**JSL, JSM, JSH:** low, medium, high power UHF slot antennas.  
**JSH/EP:** high power, elliptically polarized UHF system.  
**JCPT:** low power CP TV antenna.  
**Circle (811)**

### Kintronic Laboratories

**Shortwave display:** broadcast antenna for shortwave frequencies.  
**AM Triplexer.**  
**AM 50kW dummy load.**  
**Jennings vacuum capacitors, contactors.**  
**Equipment enclosures:** weatherproof housing



# inside

YOU GET THE RIGHT STUFF

Today's multi-format editing demands more from a TBC. So the Nova 900S delivers more: Professional TBC performance with true 4:2:2 component processing. Plus synchronized input switching and digital effects that will "supercharge" your video system's creative potential.

# outside

YOU GET THE RIGHT NAME

The Nova logo means proven performance, dependability and reliability: Our exacting test and burn-in procedures make sure of that. And we back every Nova TBC with a guaranteed 24-hour service turnaround, because you can't afford days of downtime or missed deadlines.

## nova 900S SUPER TBC™

Now get all the flexibility of S-VHS and composite inputs and outputs. All the creativity of digital effects. All the professional quality and reliability of a Nova TBC. All in one cost-effective Super TBC — the Nova 900S.

**NOVA SYSTEMS, INC.**

50 Albany Turnpike, Canton, CT 06019

Tel (203) 693-0238 • Fax (203) 693-1497

**nova**  
SYSTEMS, INC.

THE CLEAR CHOICE IN VIDEO TECHNOLOGY

Circle (71) on Reply Card

for FM and TV translator equipment.  
*Phasor*: for directional antenna systems.  
*Tower section*: aluminum knockdown design.  
**Circle (827)**

#### **LDL Communications/Larcan**

*TTS-5MH*: Larcan TV transmitter for CCIR Band I, III VHF; total solid-state design; available in 3kW, 5kW, 10kW, 20kW.

*TTS-30M*: 30kW VHF TV transmitter; solid-state design for low/high band; FET output modules provide high degree of linearity and reliability; self-contained; available as 60kW system.  
*Lambda*: circularly polarized TV transmitting antenna for VHF channels 2-6; low windload factor; replaces existing batwing types of similar gain; by Alan Dick & Company, Ltd.  
**Circle (834)**

#### **Marconi Communications Systems**

*B7549*: 70kW UHF TV transmitter.  
*E1706*: 1kW VHF/FM broadcast transmitter.  
*E1707*: 2kW VHF/FM broadcast transmitter.  
**Circle (860)**

#### **Micro Communications**

*SPI Super Power Isolator*: stabilizes impedance, absorbs reflections that otherwise degrade video performance; Hot Switch; uses ferrite material for loss less than 0.08dB; to 300kW.  
*LPTV Multi-channel Combiner*: for two or more UHF LPTV transmitters to drive one antenna; star configuration.

*Articulated Waveguide*: allows movement in E- or H-plane, provides structural strength to handle loads in compression and tension.

*UHF Waveguide Impedance Tuner*: for super power systems; any impedance at tuner output can be matched to the input; also operates as high power non-contacting phase shifter.  
**Circle (873)**

#### **Midwest Communications**

*Technalogix TX-60S*: 60kW UHF television transmitter; EEV high efficiency klystrons or Varian MSDC klystrons used for PAs.

*Toshiba 2000*: solid-state VHF TV transmitters; exciter, integral video processing; modulator switchable between mono, MTS sound; 1.2kW power amplifier; VSWR protection.  
**Circle (879)**

#### **Nautel**

*AMPFET ND5*: solid-state design AM transmitter, rated 5kW; integrated modular reserve; built-in duplicate exciter; on-air serviceability; PA contains four independent power blocks.  
**Circle (900)**

#### **NEC America/Broadcast**

*PCN 1430AH*: 30kW single-tube VHF TV transmitter; highband; new size; multichannel sound compatible; solid-state aural amplifier; 30,000 MTBF performance.

*PCN 1430SSH*: 30kW solid-state VHF TV transmitter; high-band; 6kW modules in PA.

*PCU 960HC*: 60kW UHF TV transmitter;  $\mu$ P-control readouts; IF-modulation; multichannel sound compatible.  
**Circle (901)**

#### **Potomac Instruments**

*1500-PC, 1500-CAS*: programmable controller, computer access software; real-time monitor-

ing, control from a PC; portables, laptops; logging, alarms; dial-up lines; password security.  
**Circle (944)**

#### **QEI**

*FMQ 20/30*: FM radio transmitter with all solid-state IPAs; 2-cabinet system is field-upgradable from 20kW to 30kW with an additional IPA module; grounded-grid final amplifier design.  
**Circle (949)**

#### **Rapid Deployment Towers**

*RapUp systems*: mobile, antenna support systems; quick setup; *RapUp 100*, 100ft 3-guy level; *RapUp 150ft* 4-guy level; *RapUp 225*, 225ft 6-guy level; *RapUp 300*, 300ft 8-guy level.  
**Circle (965)**

#### **SIRA**

*FMC-05*: broad-band FM panel antenna for all power levels; suitable for multiple station, multiple frequency operation.

*3VTV04 panels*: for VHF omnidirectional transmission; 96-panel array rated 1MW ERP.  
*UTV01*: UHF TV panel antenna; omnidirectional; 128-panel array for 8MW ERP.

*UC/U-AV10*: aural-visual diplexer for UHF transmission; accepts stereo/dual channel aural; tunable over all Band IV/V spectrum; dimensions allow 19" rack mounting.

*UTV-07/-08*: horizontal and vertical polarized receiving UHF TV panel antenna systems.  
**Circle (1193)**

#### **Thomson-LGT**

*EVH 2000 DD*: 20kW dual-drive, VHF high-band, solid-state TV transmitter; broadband tuning; integral regulated PSU, mains-insulating transformer; MTS-BTSC sound system.

*RUHF-200 S*: 200W UHF TV translator; very linear, very low noise.

*RUHF-10 S*: 10W low-power UHF TV translator; low-power consumption, designed for solar energy supply; in all input, output bands.

*EUHF 2000 DD*: 2kW, dual-drive UHF band IV/V solid-state TV transmitter; broadband operation; integral regulated PSU.  
**Circle (1075)**

#### **Toshiba**

*TV2000 series*: solid-state VHF transmitters; modular RF PAs based on power MOSFET devices; powers of 8kW, 12kW, 16kW, 24kW, 32kW, 48kW, 64kW, aural 10% or 20%.  
**Circle (1083)**

#### **TTC/Television Technology**

*XL10MFM*: modulated FM translator for satellite-feed applications.

*FM transmitters*: new series, solid-state design; power levels from 1kW to 4kW; ferro-resonant power supply; remote interface.

*XL1000U*: 1kW UHF LPT transmitter; cavity amplifier design; can be configured for translator operation with input selections from VHF, UHF, satellite, microwave or baseband audio/video.  
**Circle (1091)**

#### **Varian TVT**

*1891/90 VISTA*: 120kW UHF television transmitter; MSDC multi-stage depressed collector klystron; full waveguide combining system; increased efficiency over standard klystron devices.  
**Circle (1111)**

#### **Will-Burt/TMD**

*Model 6-25-357/367*: pneumatic telescoping mast assembly.  
**Circle (1080)**

## **RF Products**

### **R2: Microwave**

- ✓ Antennas, electronics
- ✓ ENG, STL, ITFS
- ✓ MDS, MMDS

#### **BEXT**

*STL amplifier*: for long, difficult paths; to 18W output from 300mW drive; circulator provides isolation from antenna conditions; 12Vdc operation possible.

*SDR/SDT composite STL*: programmable from front panel; selectable bandwidth; separate handling of subcarriers above and below 100kHz; 50dB separation; 12Vdc capability.

*SRD FM receiver*: composite design; wide, mid, narrow bandwidth selectivity; 50dB stereo separation in worst-case conditions; can operate from 12Vdc.

**Circle (596)**

#### **Broadcast Microwave Service**

*BMT-GP*: 18GHz and 40GHz frequency-agile transmitters; two audio subcarriers.

*BMR-KP*: 18GHz and 40GHz frequency-agile receivers; two subcarriers; baseband/composite video; 12-32Vdc/115Vac.

*AP-1*: camera-mounted, antenna pointer.

*TBT-50A*: frequency agile video transmitter; 10W output minimum, L, S or 4.5-5GHz bands; output protected against open or short; reverse polarity protected.

**Circle (611)**

#### **Cablewave Systems Div/CELWAVE**

*2.3GHz antennas*: 2-, 4-, 6-foot diameter microwave antennas; fine azimuth adjustment of  $\pm 5^\circ$ ; elevation adjustment  $-5^\circ$ ,  $+50^\circ$ ; meet EIA RS-195B, RS-222C.  
**Circle (621)**

#### **Communication Microwave/COMWAVE**

*Repeaters*: solid-state ITFS systems; *R-10S* 10W; *R-30S* 30W; *R-50S* 50W; *R-100S* 100W; output frequency for any 6MHz channel in 2.5-2.7GHz spectrum.

*TV amplifier*: for ITFS, MMDS, OFS; *Type A-100S* 100W rating; NTSC, PAL, SECAM systems; BRITE-LED diagnostic status display; ultra linear, solid-state; FCC type accepted.

*TV transmitters*: for ITFS, MMDS, MDS, OFS; *SB002MRC 2W*, *SB010-MRC 15W*, *SB020-MRC 30W*, *SB050-MRC 50W*, *SB100A-MRC 100W*; NTSC, PAL, SECAM; stereo or SAP; BRITE-LED diagnostics, status.  
**Circle (660)**

#### **Conifer**

*HLN series downconverter*: Interdigital input bandpass filter; *HLN, HLN-2* high-gain, *HSLN* high-gain, low noise; gains from 25dB to 40dB; noise figures to 2.0dB; for ITFS applications.  
*QL-3010*: dual-band, broadband block downconverters for up to 33 channels; compati-

# Give it your best shot with Ampex.

There are two kinds of videotape companies.

Those who commit all their efforts, resources and research to the video professional.

And those who don't.

Ampex is totally committed to the professional market. Which means we have to be dedicated to providing the best products and service in the business.

Our commitment begins with Ampex Process Management—an advanced quality program that assures you unmatched consistency. So you can count on superior picture quality. Tape after tape, year after year.

And we give you this exceptional dependability in over 100 configurations for commercial and broadcast production to electronic news gathering and corporate training.

And as hardware requirements change and new formats emerge, Ampex research and development ensures that you're always covered for the future.

Ampex's dedication to the professional also includes full technical support, immediate deliveries and the most personal service in the industry.

If Ampex sounds like your kind of videotape company, get in touch with us soon. Because anything less could be just a shot in the dark.

## AMPEX

*It's your best shot.*

Ampex Corporation  
Magnetic Tape Division  
401 Broadway  
Redwood City, CA 94063  
(415) 367-3809

Circle (72) on Reply Card

ble with scrambling, addressable systems; output at 116-128MHz or 222-408MHz; for MDS, MMDS, ITFS, OFS.

**Model QL-1010:** broadband MMDS block downconverter for US or international applications; 31-channel.

**HLN-RP, HLN2-RP:** HLN series downconverters for repeater and response (talkback) applications; high degree of undesired signal rejection. **Circle (670)**

**EMCEE**

**EMC-4:** ITFS/MMDS, low-loss channel combiner.

**Circle (726)**

**Enterprise Electronics**

**Complete radar packages:** narrow beam antenna, pedestal with radome, transmitter, receiver, servo amplifier, radar control, display console, RGB monitor, NTSC colorizer; Doppler subsystem upgrade for WSR-7RC, WR-100-2/77 EEC radars; 250kW peak power output; six calibrated rainfall rates; nine Doppler velocity levels; remote, co-located systems; high resolution graphics.

**Circle (731)**

**Ikegami Electronics (USA)**

**LINK 40:** unidirectional or bidirectional 40GHz

communications link; 0.01W output with variable reactance FM modulation; 12Vdc or 117Vac power; for various audio, video, data or fax uses.

**PP-70 enhanced:** 13GHz added to 2GHz and 7GHz system capabilities for portable miniature microwave link; 3-4 hour operation with conventional camera battery; video, two audio inputs; SAW IF filter.

**Circle (791)**

**ITELCO**

**LKFM01, L771:** 2GHz microwave transmitter/receiver repeater system.

**Circle (807)**

**ITS**

**ITS-1610D:** ITFS/MMDS transmitter; compact, integrated design.

**Circle (808)**

**M/A-COM**

**K-Line radios:** for 1.7GHz to 15GHz; KJ heterodyne, KG remodulating transmitters and common KR receivers with IF and baseband; 10, 20, 30MHz IF bandwidths; multiple subcarrier inputs.

**MA-23VX:** 23GHz microwave communication systems; versions for video or for video and data transmission; 1/2-way operation with two simplex or duplex subcarriers; optional T1 subcarrier.

**MA-23CC:** 23GHz wideband microwave system; range of 10 miles; 525/625 line video, up to three audio subcarriers; bandwidth to 10MHz at  $\pm 3$ dB; ac/dc operation; compatible with MA-23DR digital system.

**MA-18CC:** 18GHz microwave systems; meets EIA-250B short haul spec; field tunable RF frequencies; integral diagnostic alarms; receiver image rejection greater than 80dB; range 15 miles.

**Circle (856)**

**Marti Electronics**

**DR-10 receiver:** adaptive filter improves audio performance if used with compatible RPU transmitter; optional audio companding.

**RPT-30/CR-10:** RPU transmitter, receiver with high performance audio companding circuitry.

**Circle (862)**

**Microwave Radio**

**MicroLink I/II:** 18GHz, 23GHz short-haul microwave links for STL, ENG backhaul, teleconferencing; frequency agile units; audio, video connect directly to RF head; simplex, duplex or multiplex.

**FLH system:** heterodyne microwave system; 2-13GHz; meets EIA, CCIR spec; option for four audio program channels; for long haul applications; FLH 12 supports 12GHz A/B/K CATV channeling.

**FLR systems:** direct modulation microwave for 2-13GHz bands; EIA, CCIR spec; four audio subcarriers available; STL/STL, CATV, multiple hop/multiple channel broadcast; ETV networks.

**Circle (878)**

**RF Technology**

**Pathfinder antenna system:** offset-fed semi-parabolic antenna; transmit or receive with single, dual, quad polar options; to 13.25GHz.

**RF-223B:** miniature full-power transmitter.

**RF-203GL:** wideband portable ENG microwave systems; 1.7-13.25GHz; point-to-point ENG or

# Will your equipment survive outrageous fortune?

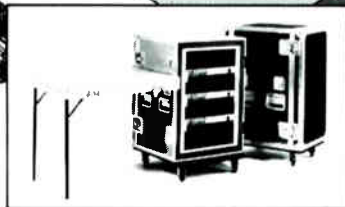
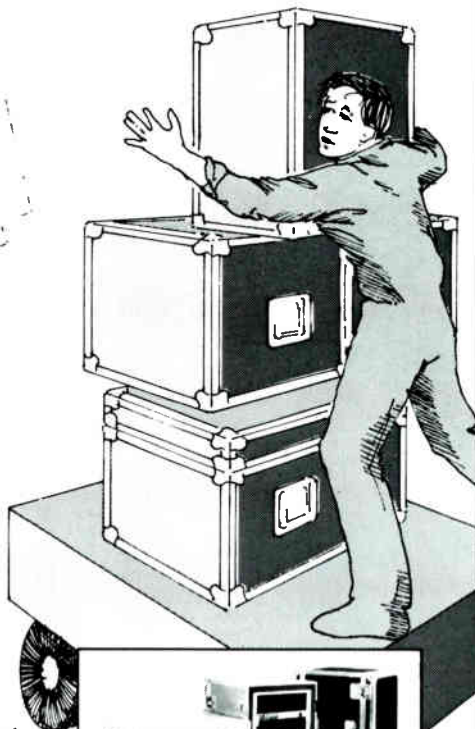
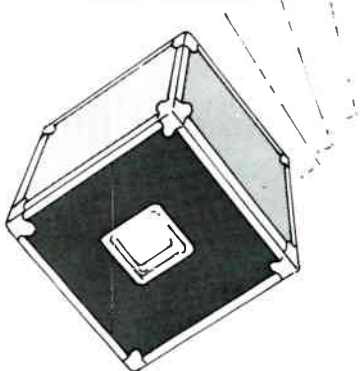

800 / 423-4279

CA: 800 / 242-4466

818 / 575-8614

+128 Temple City Boulevard, Rosemead, CA 91770  
© 1988, ANVIL Cases

ANVIL cases safeguard your critical gear from every bump, bang and jerk you'll likely encounter—both in the air and on the ground.

Our ATA cases meet or surpass all the shock and vibration criteria in the Air Transport Association's Specification 300, Category 1—the industry's toughest standard for reusable shipping containers.

An ANVIL case is like insurance for the equipment you depend upon. And isn't peace of mind worth the slight additional cost?

Or would you rather risk paying an outrageous fortune?

Circle (73) on Reply Card

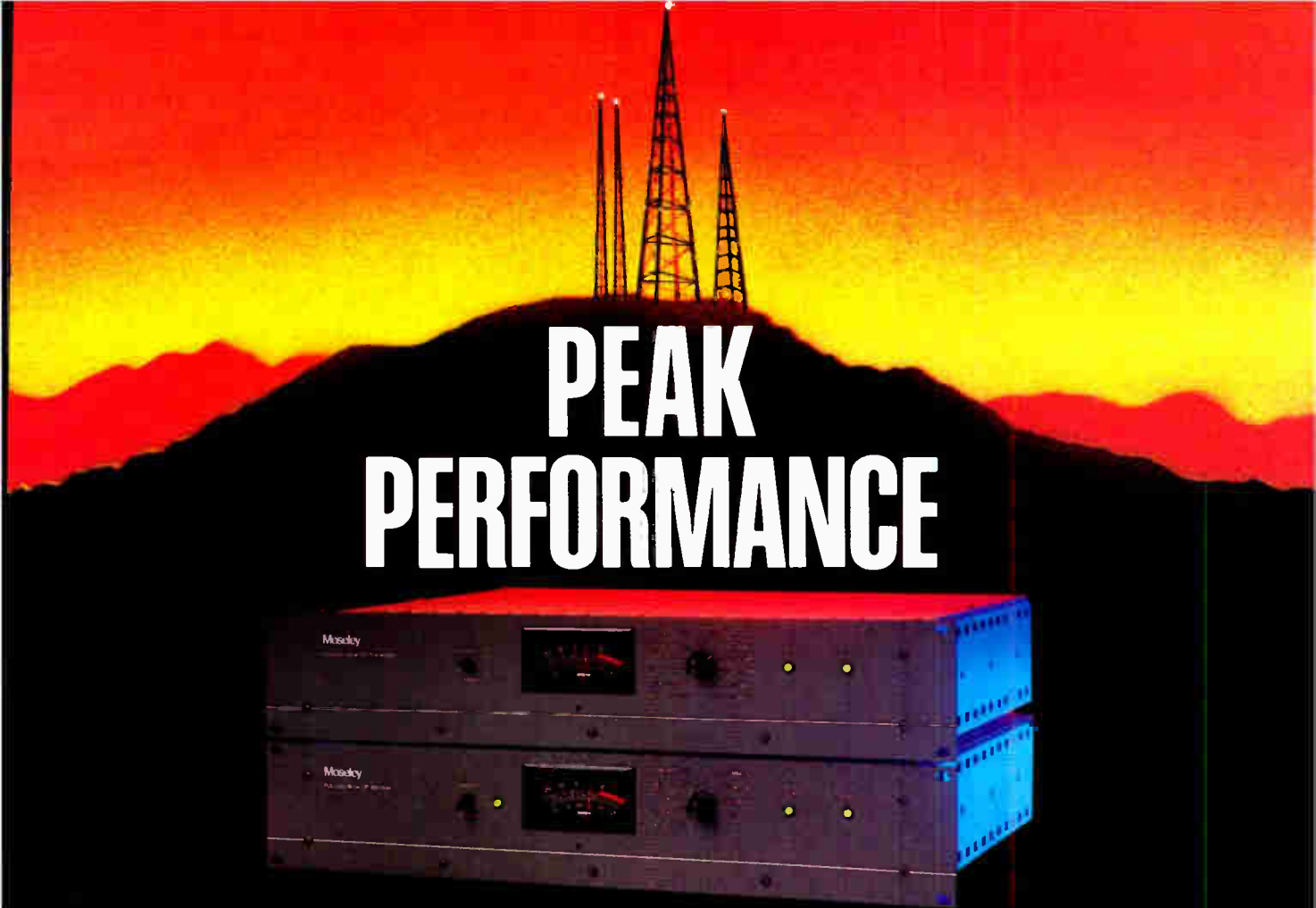

# PEAK PERFORMANCE

---

## Deliver the transparent audio you require with a MOSELEY PCL 6000 Series STL.

---

From high above the city lights, your transmitter is broadcasting the quality audio your listening audience demands.

Trust the delivery of the sound you've worked so hard to generate at the studio up to your transmitter with the virtual transparent audio characteristics of a Moseley 6000 Series STL. You can significantly increase your signal to noise ratio and stereo separation

by replacing your Moseley 505 or other older STL with either a Moseley 6020 or a Moseley 6030. If you are one of the remaining telco customers, you get the additional benefits of a short payback time and continued relief from the monthly bills.

Choose between the Moseley 6020 and Moseley 6030 based on the 950 MHz congestion in your area. The Moseley 6030 is designed for excellent

performance in extreme environments found in antenna farms on broadcast peaks around the country. Both systems feature full frequency synthesis and capability of handling either mono or stereo program material.

Best of all, these two STLs are Moseley STLs — price competitive and backed by both our two year parts and labor warranty and our knowledgeable service staff.

Circle (74) on Reply Card



# Moseley

111 Castilian Drive  
Santa Barbara, CA 93117  
805 968 9621  
FAX: 805 685 9638

sports; low profile rod or 3.8' parabolic antenna.

Circle (973)

#### **Wolf Coach**

*Self-coiling cable:* new concept for ENG masts. *QD2 portable mast:* for news cars; attaches to door frame, adjusts easily to 14 feet with positive locking sections; top loads to 25 pounds; alternate mount fits square receive type trailer hitch.

Circle (1144)

## **RF Products**

### **R3: RF amplifiers**

✓ Cavities

✓ Power devices

#### **BEXT**

*1989 Tex 20:* modular with external reference for phase lock to synchronous boosters or multiple translators.

*T-800, T-1500, T-2000:* 88-108MHz amplifiers; 800W, 1.5kW, 2kW ratings; no neutralization required; one-triode designs; FCC, CCIR compliant; single-phase power (T-2000 available in 3-phase).

Circle (596)

#### **BURLE INDUSTRIES**

*Y1400 cavity amplifier:* continuously tunable across all UHF channels; forced-air cooling; linear class AB, combined video, sound carriers; 15dB gain; uses 9017 tube.

*9017 power tube:* UHF linear beam power device; forced-air cooling; 1.1kW peak sync output; 15dB gain; full input to 860MHz.

Circle (620)

#### **California Tube Laboratory**

*Klystron rebuilding:* external, internal cavity types; new tube warranty provided.

Circle (1192)

#### **Econco Broadcast Service**

*Reflex klystrons:* low-voltage types.

Circle (716)

#### **EEV**

*K3755/K4755:* 5-cavity klystrons; high gain, high power, high efficiency; provides 74kW from same input power as previous 4-cavity 60kW devices; minimum 50% efficiency.

Circle (720)

#### **Energy-Onix**

*SSA-500:* 500W solid-state FM amplifier.

Circle (730)

#### **ITS**

*ITS-1657D:* 1TFS/MMDS 50W power amplifier.

Circle (808)

#### **Richardson Electronics**

*Cavities:* Philips power tube cavities for FM and TV applications.

Circle (974)

#### **SWR**

*Output Power Stack:* uses one-step procedure in refurbishing or changing the amplifier from the transmitter cabinet; special finger contact

design assures full energy transfer at linkage points.

Circle (1037)

#### **Varian EIMAC Salt Lake City**

*CV-8075:* CW amplifier; can be custom-made between 800MHz and 1200MHz.

*YU-121:* high-mu, power triode for low noise single-sideband applications.

*YU-181:* high-mu triode; thoriated tungsten, low-inductance grid flange; for HF operation and laser power amplifiers.

*YU-157:* water-cooled, HF oxide cathode tube; grid flange similar to Varian EIMAC 8938 for laser, RF amplifiers.

*YU-106:* water-cooled EIMAC 3CX3000A7; improved efficiency.

Circle (1107)

#### **Varian EIMAC San Carlos**

*2KDX15LF:* air-cooled UHF TV Klystron amplifier; designed for 15kW visual or 10kW multiplexed visual and aural.

*2KDX40LA:* air-cooled UHF TV Klystron amplifier; designed for 40kW visual or 30kW multiplexed visual and aural.

Circle (1108)

#### **Varian Microwave Equipment**

*VZU-6993S3:* 300W Ku-band HPA; 75dB minimum gain; video applications.

*VZU-6992A6:* 125W Ku-band 14.0-14.5GHz TWT power amplifier; 70dB gain minimum; power supply and RF modules.

Circle (1109)

#### **Varian Microwave Power Tube Div**

*VKP-7990:* MSDC 60kW multi-stage depressed collector klystron.

*VKP-7984:* 60kW high-efficiency, external-cavity klystron (PT-5093).

*VYW-7989:* continuously tunable circuit (PTE-5095).

Circle (1110)

## **RF Products**

### **R4: Reception**

✓ Demodulators

✓ Modulation monitors

✓ Receivers

#### **AVCOM of VA**

*Model SCPC-3000E:* frequency agile SCPC demodulator; 50-90MHz tuning module, 800 50kHz steps; switchable de-emphasis; 5kHz, 7.5kHz, 15kHz lowpass filters.

Circle (581)

#### **Belar Electronics Laboratory**

*FMM-4A:* digital FM frequency monitor; for automatic transmitter monitoring; indicates carrier, pilot, SCA frequencies; LED warning indicator of low level or loss of signal.

Circle (592)

#### **Broadcasters General Store**

*SMD:* stereo modulation monitor, by Hit Design.

Circle (615)

#### **Emergency Alert Receiver/EAR**

*Model ST:* FCC type-approved EBS receiver.

*Model CT:* EBS receivers for schools, hospitals, public service facility tornado warning systems. *SCA receivers:* with privacy channel decoders. *Fixed frequency receivers:* available for use as station promotion items.

Circle (728)

#### **Motorola C-Quam/AM Stereo**

*C-Quam AM stereo receivers.*

Circle (891)

#### **TFT Inc.**

*TFT 8900:* synchronous FM exciter; combines composite STL receiver, phase-locked loops and 15W FM amplifier; extends signal into areas in pattern not well covered by main transmitter.

Circle (1069)

#### **Titus Technological Laboratories**

*CAD/M:*  $\mu$ P-based FM stereo/TV stereo composite signal noise analyzer; includes FM/TV stereo demod, metering and 1x4 DA.

Circle (1079)

#### **Vector Technology**

*FMT-03:* 30W FM exciter; direct FM modulation with  $\pm 200$ kHz capability; double PLL frequency synthesis; -60dB asynchronous AM noise; FM noise to -80dB or below.

Circle (1113)

#### **Wegener Communications**

*Series 1800:* FM<sup>2</sup> subcarrier receiver for audio, data; 1GHz input; 16 or 30MHz IF bandwidth; accommodates multiple audio or data channels. *2600 SCPC system:* frequency agile automation system.

*2800:* single channel miniature receiver.

*Series 1800 receivers:* addressable graphic display for HR graphics transmitted as 9.6kb/s, graphics displayed individual or mixed with local video; multivoiced stereo audio, synthesized speech.

Circle (1136)

## **RF Products**

### **R5: Exciters**

**generators**

✓ Radio, TV

✓ Stereo

#### **Broadcast Electronics**

*FX-50 FM exciter:* 0.003% THD, IMD; 93dB S/N typical for wider dynamic range; 50W MOSFET output rating.

Circle (610)

#### **Energy-Onix**

*SST-30:* 30W output FM exciter.

*PROTECTOR:* NRSC AM filter, pre-emphasis.

Circle (730)

#### **Inovonics**

*Model 706:* FM/FMX stereo generator; 2nd generation system.

Circle (798)

#### **ITS**

*ITS-10A:* VHF exciter, modulator; retrofit product for VHF TV transmitters.

Circle (808)

1955  
 1956  
 1957  
 1958  
 1959  
 1960  
 1961  
 1962  
 1963  
 1964  
 1965  
 1966  
 1967  
 1968  
 1969  
 1970  
 1971  
 1972  
 1973  
 1974  
 1975  
 1976  
 1977  
 1978  
 1979  
 1980  
 1981  
 1982  
 1983  
 1984  
 1985  
 1986  
 1987  
 1988  
 1989

35 YEARS AGO WE PIONEERED  
 THE FIRST TRANSMISSION LINES...

# FLEXWELL

TODAY WE'RE STILL LEADING THE WAY!



Cablewave Systems 6-1/8", 8", 9" and 12" high power Flexwell coaxial cables represent the largest semi-flexible transmission lines of their kind in the world. Produced in continuous lengths, large capacity corrugated copper and aluminum Flexwell cables are designed to meet the high power requirements of medium wave and shortwave international broadcast installations.

The family of Flexwell transmission lines are produced and marketed worldwide by member companies of the Radio Frequency Systems Group. Flexwell corrugated transmission lines range in size from 1/4 inch jumper cable to 12 inch high

power broadcast cable with up to 9 megawatt RF power handling and Flexwell elliptical waveguide from WR42 through WR430.....Cablewave Systems covers the whole spectrum.

For more information on the Flexwell family of RF transmission lines, contact Cablewave Systems division of Radio Frequency Systems Inc. North America, 60 Dodge Avenue, North Haven, CT 06473. (203) 239-3311.



**Cablewave Systems**

Circle (75) on Reply Card

### Kahn Communications

*POWER-side*: modulation places majority of modulation energy in one sideband; weaker sideband supports normal pre-emphasis; reduces antenna null, fading, reradiation distortion; for AM.

Circle (818)

### Motorola C-Quam/AM Stereo

*Model 1400*: C-Quam AM stereo exciter.  
*Model 1410*: C-Quam modulation monitor; autorange metering for multiple level signal monitoring; analog meters, high resolution RF/pilot level displays.

Circle (891)

### TFT Inc.

*886/887 EBS System*: AM, FM EBS receivers; PPL tuning; two-tone decoders for 853Hz, 960Hz; crystal-controlled tone generators, crystal filters for receive.

Circle (1069)

## RF Products

### R6: Satellite

- ✓ Antennas
- ✓ Controllers
- ✓ Electronics

### ✓ SNV units

### Advent Communications

*Model 1500*: flyaway phase-combined satellite news-gathering system.

*Model 1900*: flyaway, single-thread satellite news-gathering system.

*Data up/down converters*, communications package systems.

Circle (516)

### Andrew

*TriFold*: 4.5m mobile receive/transmit antenna; compliant with FCC, EUTELSAT and INTELSAT; easily towed by pickup or van; operational setup within 30 minutes by one person. *ALC-series panels*: LNA/LNC alarm control panels; *ALC100* for LNA/LNC network; *ALC200* for 1:1 and *ALC300* for 1:2 LNA/LNC switching networks; compatible with ASC1000.

*GT/series 1.8m*: motorized TVRO; available with single Ku or dual C-/Ku-band feed; prime focus offset feed; anti-icing systems; optional positioning systems.

*7.3m G/T series*: a "2-in-1" receive, transmit antenna for uplinks in Ku-band, reception in C-/Ku-band; motorized system with 4 Ku ports, 2 C ports; dual polarized in both bands.

Circle (546)

### DX Communications

*DIR-647*: Ku/C-band commercial integrated receiver decoder.

*DSA-656*: Ku/C-band receiver; designed for satellite news gathering applications.

*DSA-525L*: 1.1dB noise figure Ku-band LNB.

Circle (710)

### Hallikainen & Friends

*SAT201 prototype*: remote control system for multiple satellite antennas, receivers; uses voice-grade telco circuit.

Circle (775)

### Marconi Communications Systems

*Satpax*: transportable INMARSAT terminal; two cases contain RF package with foldaway antenna, communications unit with telephone and interface for PC, FAX, Telex and PABX; usable worldwide.

Circle (860)

### MCL

*10950*: 1:1 redundant 25W C-band solid-state amplifier.

*10999*: 300W Ku-band TWT amplifier.

*10890*: VPC redundant 300W Ku-band TWT amplifier; hub-mount system with dual uplink/downlink feature.

*15357*: Ku-band test loop translator.

Circle (868)

Continued on page 126

CINE 60 SUN-GUN

# Beautifully Simple



Beautiful . . . because it's fresnel-soft and uniform — ideal for video. And simple because . . . if 250 Watts is too much, change to 150 Watts. Need more? Go to 350 Watts. Want to go really light? Use 100W (12V) or 70W (14.4V). Outdoors, swing-in the built-on Daylight Filter. You color correct instantly! Indoors, swing away Filter and you have tungsten light! Never a need to readjust camera color controls here! For focus, vary the beam from 8 to 14 ft. For power, choose from 84 Battery Belts and Battery Packs. And, to make it beautifully simple . . . we put it all together for you in any one of 48 Portable Sun-Gun Kits, including Switchable 30V/14.4V combination Kits. See your dealer or send for data, today.

## CINE 60

630 9th AVENUE NEW YORK, N.Y. 10036 212 / 586 8782  
1050 CAHUENGA BLVD HOLLYWOOD, CALIFORNIA 90038 (213) 461 3046

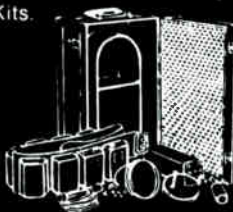

Circle (76) on Reply Card

## PRECISION MAGNETIC TEST TAPES

STL



Standard Tape Laboratory, Inc.  
26120 Eden Landing Road #5, Hayward, CA 94545  
(415) 786-3546

Circle (151) on Reply Card

### Free Catalog & Audio/Video Applications

Routing Switchers (St-A/V)  
(24, 16, 12, 8, 4, 2 stations)



Press Boxes  
1-in/16-out  
Video/Audio  
2-in/24-out Audio

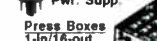

Video & Audio Dist. Amps.  
RGB-Sync Dist. Amps.

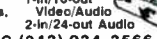

OPAMP LABS INC (213) 934-3566  
1033 N Sycamore Av LOS ANGELES CA, 90038

Circle (152) on Reply Card

Reconfirm  
your involvement in  
the broadcast industry!

Renew  
your subscription  
today.



# BORN IN THE U.S.A.

THE INNOVATIVE

## Matrix Plus

### DIGITAL INTERCOM SYSTEM

From single channel belt packs to microprocessor matrix—

**Clear-Com does it all!**

- 50 station point-to-point capacity plus IFB, ISO, and PL.
- Digitized audio eliminates hum and crosstalk
- Intercom station to matrix interconnects with only one pair of wires.
- Hidden "sound lens" speaker for superior sound quality.
- 8-line 80-character super-twist backlit display simplifies station operation.
- Programmable conference and group calls, paging, and direct telephone dialing from station.
- Plug-in interfaces to Clear-Com, RTS, Telco, two-way radio, and more.
- Complex systems configurations easily and quickly loaded from PC.
- Incorporates non-volatile memory, hot-patch frame cards, and redundant power supplies.
- Multi-processor design provides virtually instant crosspoint access time.

Circle (77) on Reply Card



## Clear-Com

S Y S T E M S

**"HEAR THE DIFFERENCE!"**

945 Camelia Street • Berkeley, CA 94710-1484  
Telephone: (415) 527-6666 • FAX: (415) 527-6699

INTERNATIONAL SALES: P.O. Box 302 • Walnut Creek, CA 94596 • U.S.A. • FAX 415-932-2171



VISTA MSDC UHF TV TRANSMITTERS.  
Now the vision becomes a reality.

**varian** 

*tvt division*

*World leaders in UHF TV transmitters.*

Varian TVT Division, 4212 South Buckner Blvd. PO Box 270879, Dallas, Texas 75227

Sales Telephone: 214 381 7161 24 hr Service Telephone: 214 388 9429



The VARIAN VISTA line of Multi-stage Depressed Collector (MSDC) klystron UHF TV transmitters are simply the most efficient available anywhere in the world today.

VISTA has evolved from proven technology. All major components including tubes, circuit assemblies, exciters, logic, power supplies and cooling have been designed by and are

manufactured by VARIAN to the highest standards of quality and reliability.

Its power consumption is half that of klystron transmitters manufactured recently. When a transmitter in service for ten or more years is replaced with VISTA a saving of up to 70% in electricity power bills can result.

The VISTA line enables all power requirements from 60 to 240kW to be configured. It includes a wide selection of emergency modes to keep the program on air in all circumstances.

VISTA is supported by station planning, factory trained installation experts and our 24 hour engineering assistance and spare parts service.



\*With approved credit, special terms apply written details on request.

UNDER  
10%  
LEASING  
AVAILABLE\*

**VISTA**  
M S D C <sup>TM</sup>

Circle (78) on Reply Card

World Radio History

Continued from page 122

### Microdyne

*1100-BKR receiver*: video unit for C-/Ku-band; 1MHz step tuning, two tunable audio subcarriers, selectable IF bandwidths; audio deviations to 250kHz peak deviation max.

*MAT II*: automated terminal; 200-presets recalled by setup number or user defined name; compatible with VideoCipher; AGC leveled video output; controls antenna positioning; RS-232 remote control.

*1100-BKR(R)*: remote satellite receiver; C- or Ku-band; same specs as 1100-BKR receiver.

Circle (874)

### Radiation Systems/SatCom Tech. Div.

*240AT*: SNV flyaway trailer.

*M.A.C.S. 5000 series*: PC-based earth station controller.

*180KS*: 1.8m antenna system.

Circle (959)

### Scientific-Atlanta

*HDB-MAC*: hard-scrambled HDTV video transmission system via satellite.

*9704IRD*: B-MAC integrated receiver-decoder; C/Ku-band signals received at L-band; video, two subcarriers.

*E9714/E9715 series*: mobile B-MAC encoders; high-level video security; accepts direct NTSC, component video, up to six audio data channels, two auxiliary data, one utility data channel.

Circle (993)

### Standard Communications

*CSG60 stereo generator*: BISC stereo encoder system for MTS stereo on existing CATV systems; dbx companding; 4.5MHz modulated RF to assure separation with maximum S/N ratio.

Circle (1022)

### SureShot Satellite Network

*SureShot mobile uplinks*: transportable uplink systems based in Youngstown, OH; Morehead, KY; Dallas, TX.

Circle (1034)

## Support Products

### S1: Interconnects

- ✓ Cable, wire
- ✓ Connectors, jacks
- ✓ Patch panels, cables
- ✓ Fiber optics

### ADC Telecommunications

*S-9 Patchmate*: modular patching matrix; conforms to SMPTE 9-pin machine control recommendations; three front-panel jacks, two rear connectors per module for interconnections.

Circle (510)

### Audio Accessories, Inc.

*Model 820PCM*: printed circuit board mounted mini-jack.

*Patch-panels*: prewired with KRONE punch-downs; in 24, 26, 32 jacks per row.

Circle (569)

### Belden Wire & Cable

*Brilliance series*: cable assemblies; 8241 75Ω RG-59/U video patch cord assembly with 95% shield coverage and Kings BNC plugs.

*Brilliance series*: cable assemblies; 1263A two 25AWG coax, three 22-AWG twisted pairs; 100% coverage tape on pairs; coax with Duofoil tape, 95% coverage tinned copper braid.

*Brilliance series*: cable assemblies; 1192A two white, two blue, 24AWG copper conductors; Neutrik 3-pin XLR connectors.

*Brilliance series*: cable assemblies; 1164A, 1167A three and four conductor 75Ω RGB miniature coax cables; Kings BNC plugs.

*Brilliance series*: 8281A 75Ω precision video cable; NEC CL2 approved installation in walls without conduit; 20AWG solid copper center conductor, dual tinned copper braid.

*Brilliance series*: cable assemblies; 8281F 75Ω precision video cable; increased flexibility; 22AWG bare copper center conductor, polyethylene insulation; BNC plugs.

*Brilliance series*: assemblies; *Mini Audio* twisted pair; 0.145" OD; five colors available for easy identification; conductors 22AWG tinned copper.

*Snake cable*: multipair audio cable, individual jackets, shields on pairs; 4-32 conductor pairs; 100% coverage Beldfoil; 22AWG 7×30 stranded tinned copper; loose-tube construction.

Circle (593)

### Canare Cable

*VWJ2-W*: 75Ω dual video jack.

*BCT-T*: 75Ω BNC termination plug.

*BCT-77S*: 75Ω crimp plug for LV-77S/8281 cable.

*BCT-RPC*: 75Ω BNC jack for direct mounting on PC boards.

*V-3C*: 3-, 4- or 5-channel component video cable.

*20IU-V22W-C*: dual video jack panel.

*MPAV Snake*: Multi Purpose A/Video snake; two video, two audio, two intercom, one power.

Circle (626)

### Chester Cable div/Alcatel

*Video RGB, Video RGB/SYNC*: component analog cables per NEC codes.

*Multiple pair* audio cables.

*Video, sync cable*: 75Ω material.

Circle (639)

### Connectronics

*J Bay*: patch bay; back, front panel options.

*X Bay*: patch bay; any plug configuration.

*Bodge Plugs*: emergency or service work XLR "easy connect" connectors.

Circle (671)

### Farrtronics

*M750-96-PP*: 1 1/4" panel; 96 bantam jacks; 14" deep chassis, back panel with punch-pin connections for external wiring; formed steel pan protects jacks; looped service harness.

Circle (740)

### Kings Electronics

*Tite-Pak series*: miniature video jack field; for component analog, high density composite video or computer graphic RGB+sync.

Circle (825)

### LEMO USA

*Triax*: improved 75Ω video triaxial connectors; black chrome, brushed chrome, hardened

nickel finish; for cable diameters from 8-15mm; gold-plated contacts; improved outer shield electrical continuity; optional protective rubber sheath provides strain relief.

Circle (840)

### MERET

*HDTV fiberoptics*: single-fiber *ReFlect* camera control system for full duplex RGB; *ReLay* intra/inter facility link simplex, duplex operation; venture with REBO Research.

*Fiber optic systems*: 820nm and 1300nm wavelength carriers with bandwidth from 50MHz to 350MHz; LED and laser sources; transmission ranges 15,000 and 30,000 feet; *RGB/SF50-FDM* supports HDTV video.

Circle (1182)

### Neutrik USA

*NC3FD/MD-L-I*: PC-mountable XLR receptacles.

*NK guitar cable*: high flexibility; 98% shield.

*NK2 mic cable*: highly flexible; 98% shield.

*NF2C/2 Pro FI*: professional RCA plugs.

*NL8FC/MPR*: 8-contact speaker connectors.

*NC3FP-I*: panel-mount XLR receptacle.

Circle (905)

### Pacific Radio Electronics

*RGB-809-0*: RGB cable, contains three miniature coax cables in a single sheath.

*RGBS-809-0*: 4-coax cable for RGB+sync.

*RGBSC-809-0*: RGB+sync+composite; 5-coax cable in a single jacket.

Circle (924)

### REBO High Definition Studio

*ReLay*: single optical fiber, bidirectional video transmission; greater bandwidth, lower noise, no ground loops, 12-mile range; with Meret. *ReFlect*: fiber optic HDTV camera control system.

Circle (967)

### RF Technology

*FOM-13L*: fiber optic system; video, multiple audio; 2Mb/s with 1300nm laser; range to 50 miles without repeater.

Circle (973)

### Switchcraft

*Z15J*: high-power speaker jack.

*Z15P*: high-power speaker plugs.

*APP334BNO*: complete audio patch panel;

*APPBK* rear panel; *APPMS334BNO* front & rear panels connected with 4 foot cabling.

Circle (1036)

### Union Connector

*SINE multipin devices*: 19-, 37-pin connectors; cable assemblies, tooling accessories.

*Transfer contactors*: automatic voltage sensor transfers lighting to emergency power.

*Fused 2-fer, 3-fer*: cartridge-type fuses; meet code requirements for branch circuit distribution, 20A-60A, 50A-100A ranges.

*EIA panels*: inlet/outlet panels, 2P&G, NEMA receptacles.

Circle (1095)

### VEAM/Div of Litton

*FOMS Fiber Optic Mic Snake*: up to 52 analog signals transmitted digitally on one fiber; lengths to 1/2 km; no hum, crosstalk; 0-20kHz response.

*VSC series connectors*. Socapex compatible, 19

# FUJINON WIDE ANGLES ARE THE WIDEST!

## HOW TO BE UP AGAINST IT, AND STILL GET IT ALL IN.

The lens famous for covering most of the world's news now covers more of it. FUJINON's new 14X zoom offers a wider 8.5mm wide angle for better than a 54° horizontal field of view. When you can't move back, you still get more in.

The new A14 x 8.5ERM meets the higher registration requirements of the most advanced CCD cameras. It gives you outstanding focus-color tracking and corner resolution with the lowest longitudinal chromatic aberration.

A 2X extender is built in. So is weatherized protection with construction strong enough to meet the demands of day in, day out news gathering. The F1.7 is flat from 8.5mm to 103mm; F2.0 at the full 119mm tele position. For the lighter side of the news--weight is reduced to 1.28kg.

If you're up against too much

distance, the A18 x 8.5ERM meets your needs. Same wide angle, same aperture, but with a 153mm tele that doubles to 306mm by flipping the extender lever. Despite the greater range, the 18X weighs in at only 1.56kg.

When your back is really against the wall, nothing matches the ultra-wide A8.5 x 5.5ERM. Horizontal coverage is better than 77° and the MOD is under 1 foot.

For all the times getting the right angle on the news depends on the lens, depend on FUJINON. One more advantage. Every FUJINON 2/3" lens meets the same CCD requirements which means every lens is interchangeable and performance matched. They're all available now. For more information or a demonstration, call your nearest FUJINON location.



New—  
A14 x 8.5ERM,  
Wider and Lighter.

FUJINON INC. 10 High Point Drive, Wayne, New Jersey 07470 (201)633-5600  
Southern 2101 Midway, Suite 350, Carrollton, Texas 75006 (214)385-8902  
Midwestern 3 N. 125 Springvale, West Chicago, Ill. 60185 (312)231-7888  
Western 12917 Savaona Way, Carson, California 90746 (213)532-2861



**FUJINON**

A subsidiary of Fuji Photo Optical Co. Ltd

Circle (79) on Reply Card

replaceable contacts; environment-proof seals; housing of machined aluminum.  
Circle (1112)

#### Ward-Beck Systems

*J8248Q dual jackfield assembly:* two rows of 24 professional telco type audio jacks in 2-rack package; quick connect, insulation displacement terminations.

Circle (1132)

#### Whirlwind

*Belden audio cable:* individually shielded and

jacketed, multiconductor snake cable.  
Circle (1139)

## Support Products

### S2: Cases, racks

- ✓ Studio furnishings
- ✓ Acoustical material

#### ALPS

*Cassette storage:* base, stackable storage cabinets; two base sizes with horizontal drawers; stacking section with four vertical "drawers."

Circle (1174)

#### AMCO Engineering

*Stylized cabinets:* radius cornered, wood grain side, top, rear panels; smoky Plexiglass doors.

Circle (537)

#### Apollo Audio Visual

*Furniture:* various mobile, metal A/V, TV tables.

Circle (554)

#### Bretford Manufacturing

*BB44, BBC48E, MP48E Wide-Body:* mobile equipment tables; for monitors, VCRs, TVs; some with electrical unit, pneumatic casters. *TVM series:* video wall mount brackets.

*A2642E, TVA3654E:* adjustable tables for TVs, video equipment; TVCA unit includes lockable security cabinet.

*VTRC30E, 70E:* TV VCR cabinet stand and video security cabinet; both lockable.

Circle (607)

#### Calzone Case

*Studio Series:* permanent installation racks; S-88 and S812; 3/4" Melamine laminate; tapped 19/32" steel rack rail; 2" double steel swivel casters; light oak, hi-tech gray.

Circle (623)

#### Compact Storage Systems

*Tape, film storage:* track-based shelving for increased storage capacity.

Circle (1173)

#### Duggan Manufacturing

*Case hardware:* standard and custom items; D06-0113ZE removable caster plate assembly; D06-0112ZE flush-mount, spring-loaded handle.

Circle (708)

#### EMCOR Products

*Emission Control Plus:* increased attenuation of electromagnetic energy in equipment racks, 19", 24" panel widths; three depths, six vertical heights.

Circle (727)

#### Ergo Industries

*Custom consoles, equipment racks;* patchbays, rack slides; 065 ga. welded steel tubing; 30" depth; tapped rails, EIA spacing; continuous grounds; vented tops; hardwood trim.

Circle (732)

#### Ferno-Washington

*Model 293 Freelancer:* A/V equipment transport cart; large tires; front swivel wheels; padded, adjustable shelves.

*Model 294 PC Cart:* for computer, small copiers; upper platform for CPU, monitor, keyboard; lower platform for printers, supplies.

Circle (741)

#### Fiberbilt Cases

*Model 909:* heavy duty molded shipping cases.

*Models 624, 725:* medium-duty carrying cases.

*Model 750:* heavy duty carrying case.

Circle (743)

# Today's finest video rental equipment comes with a valuable accessory.

## Free!



All our rentals come with an added no-cost PLUS. The expertise, experience and deep involvement of our dedicated video professionals. They'll help you choose the right gear for your job. Get it to you on time. And make sure it's in perfect working order. They're knowledgeable pros. Factory-trained—so they know the equipment inside out.

And do we have equipment! We can give you entire video systems. Everything you might need for studio or location. Video cameras, lighting, grip, audio and much, much, more.

And all the video formats.

In short, we have it all. So, call us. It's the only call you'll have to make.

**The Camera Mart, Inc.**  
SALES • SERVICE • RENTAL

456 West 55th Street, New York 10019 ■ (212) 757-6977 FAX: (212) 582-2498

#### Regional Offices:

Liverpool, New York 13088  
(315) 457-3703  
FAX (315) 457-3795

Evansville, In 47715  
(815) 476-6327

Miami, Florida 33172  
(305) 227-2975  
FAX (305) 227-0531

Burbank, Calif. 91506  
(818) 843-6644  
FAX (818) 843-2478

Las Vegas, Nv 89121  
(702) 435-9234  
FAX (702) 451-3229

Circle (80) on Reply Card

# A HIGHER LEVEL OF KEYING



Graham-Patten Systems, the performance leader in high quality video keyers, now takes you to a higher level. The new Model 1241 presents farsighted solutions to on air, remote, and post production demands. This advanced video keying system has functions usually found only in switchers. The Model 1241 is a cost effective choice that will significantly improve your production capabilities.

The Model 1241 is your key to extended video power. It offers six independent self or external key inputs, the cleanest keying edges and borders available, and external control of key and black auto-transitions. Plus, the Model 1241 has these additional advanced features:

#### Edging Effects

- Borders up to 15 lines wide
- Soft borders, shadow and glow effects
- Border fill from external source
- Shadow positioning
- Outlining effects
- Variable density borders, from transparent to full color

#### Additional Features

- Individual clip control for each input
- Mask with invert feature
- Non-sync indicators
- Separate preview capabilities
- Remote control interface
- Operates in either NTSC or PAL



Call us for a brochure,  
discover a higher level of video keying.  
800-547-2489  
In California 800-422-6662



**GRAHAM-PATTEN SYSTEMS, INC.**

D E S I G N E D            W I T H            V I S I O N

### H&E Micro-Trak

*Series L:* studio furniture; cabinets, racks, tables and equipment cabinets; color keying; Summer Pecan, Adobe Gold laminates.

Circle (1199)

### K&H Products/PortaBrace

*Camera case:* storages under airline seat or in overhead bin area; 1" padding; leather handles, over-the-top zipper; carry strap.

Circle (817)

### Kangaroo Video Products

*KAP-TCDD10:* audio pack for Sony TCD10.

*KAC-8020:* case for Sony PVM-8020/BVM-8021 monitors.

*KAC-Light Kit:* light kit case.

*KVP-8800:* case for Sony VO-8800.

Circle (819)

### Lucasey Manufacturing

*S-2 swivel:* monitor slide mount plate; device attaches to shelf of cabinet; allows monitor to slide out and swivel for best viewing angle; accepts all Lucasey holding plates, supports 60 pounds.

Circle (1156)

### Matthews Studio Equipment

*Water Repellent Sandbags:* to 35-pound weight as ballast for heavy objects, stands.

*Flag Clamp:* heavy duty clamp with flex arm for various equipment mounting purposes.

Circle (864)

### Nalpak Video Sales

*RP-series Rack Pod:* light-weight mobile rack cases; four sizes.

*TP-0742 Tuffpak:* 7 1/2" OD tubular tripod case.

*PV-1:* production vest for camera operators.

*TUFFTOTIES:* soft durable attache cases for production personnel; includes Laptop Computer Attache, Production Attache, Directors Attache.

Circle (897)

### Pacific Radio Electronics

*NSRL-1:* rack-mountable utility light.

Circle (924)

### Peerless Sales

*Tilt ceiling bracket:* adjustable ceiling mount; allows vertical installations with cathedral-type ceilings.

Circle (931)

### Professional Sound Corporation

*SC-4 sound cart:* fold-up cart; two adjustable, two fixed shelves; four boom holders, cable hangers; pneumatic tires; power bus.

Circle (946)

### Stantron Unit/Zero

*VC AS 5030:* vertical cabinet assembly.

*VC AS 5020:* sloping front consoles.

Circle (1024)

### Storell

*Mobile track system:* allows moving of longer lengths of storage units with less exertion.

Circle (1029)

### Telepak San Diego

*T-AGM bag:* protective nylon with extra padding for Panasonic AG-500/550/560 video monitor/player units; four standard, additional custom colors; water repellent; pocket for tape, accessories.

*T-88:* U-matic pack for Sony VO-8800 portable recorder; water, stain-resistant; for one-man operation of recorder; front-of-bag access to controls; available in various colors.

*T-1M:* metalized raincovers for Betacam.

*T-1, T-2:* equipment raincovers.

*T-GAFF:* gaffer bag for accessories.

*T-CAM:* carrying case for Betacam; soft-sided equipment bag.

Circle (1059)

### Wheatstone Broadcast Group

*Wheatstone Furniture:* complete studio cabinetry systems; chrome steel mounting rails; heavy-duty construction.

Circle (1137)

### Wheelit

*Projector stand:* accommodates most 3-tube video projector systems with loads to 250 lbs; adjustable shelf and restraint straps for projector; top shelf for VCR and control equipment.

*6100 monitor stand:* for monitors to 36"; low center of gravity; laminated platforms; straps to hold equipment during transit; 8" pneumatic or 5" solid rubber tires.

Circle (1138)

### Winsted

*TAPESTOR, TAPEHOOK:* videotape storage.

*Furniture:* Montreux 2000 series editing and production workstations.

*PREMIER:* videocart for large screen monitors.

Circle (1140)

## Support Products

### S3: Recording

#### media

- ✓ Audio, video
- ✓ Cassette, reel tape
- ✓ Cleaners, conditioners
- ✓ Degaussers

#### Accurate Sound

*AS6000:* tape conditioner for 0.15", 1/2", 3/4", 1"; to 16 1/2" reels.

Circle (505)

#### AGFA Corporation

*PEM 469 enhancements:* new backcoat, base film; cleaner running oxide surface; high output, improved stability; mastering tape.

Circle (519)

#### Allsop

*Cleaning kits, refills:* U-matic, 67000/67500; VHS, 62000/60210; Beta, 63000/68010.

Circle (531)

#### Ampex Recording Media

*Ampex 319:* D-2 videotape; cassette lengths from 3 minutes to more than 3 hours.

*\*298:* metal particle media for Betacam SP.

*\*198:* standard Betacam videocassettes.

*Ampex 467:* R-DAT media; DATapak storage mastering system; 2-cassette storage tray, label system, track sheets, J-cards.

*\*472:* studio audiocassette; for acquisition, dubbing; 5-90 minute lengths.

Circle (542)

#### Audico

*VHS label sheets:* combination face, spine labels; matte-finish in 7 colors; for audio, videocassettes; package of 100 sheets includes three each face and spine labels per sheet.

*Multiformat loader/reloader:* same system can be used for U-matic, VHS, Beta, 8mm, Betacam; change-over time less than five minutes; can be used for rewind, wipe, verify length.

Circle (568)

#### Carpel Video

*Recycled videotape:* 1/2", 3/4", 1"; evaluated, physically inspected, cleaned, delabeled.

Circle (628)

#### Comad Communications

*Data Security TC-14:* bulk degausser for magnetic tapes to 1,000 Oe.

*MP-14:* bulk degausser for reels, cassettes to 1,500 Oe.

*MP-7:* high-throughput degausser for metal particle cassettes.

*Data Security Type II:* high performance degausser for reels, cassettes.

Circle (657)

#### Fuji Photo Film

*D2001 D-2 tape:* Super Fine Metallix formulation; extended stop-motion, high-speed search capability; ABS resin cassette; lengths from 6 to 94 minutes.

*8mm MP Master:* metal videotape for 8mm recording systems; horizontal resolution exceeds 400 lines.

*H521E SP, H521E Pro:* U-matic cassettes; increased stop-motion capability; anti-static cassettes; improved dropout performance.

*M321 SP:* 1/2" metal videocassette media for Betacam SP; Super Fine Metallix; low surface electrical resistance reduces static buildup; minimal dropout.

Circle (754)

#### Garner Industries

*Eliminator 4000:* degausser system for high coercivity tape; erasure level to -75dB on 1500 Oe metal particle tape; conveyor belt design.

*Model 680:* degausser for Super-VHS cassettes.

Circle (757)

#### Japan America Electronics

*Digital Audio Recorder sales:* various models from Sony, Panasonic.

Circle (1171)

#### 3M Company

*480XST:* master broadcast type C videotape.

*TapeCare Library Box:* for 9-10 1/2" reels of 1" videotape; impact-resistant, double-wall; moisture resistant.

*Broadcast VHS cassette:* Color Plus oxide, stabilized polyester backing, decreased abrasion, static; lubeless roller avoids buildup.

*DCS digital videocassettes:* metal particle media

*DSC D-2 1,500 Oe* for D-2 VTRs; *DCN 4:2:2 850 Oe* small oxide particle formulation for D-1 VTRs.

Circle (1154)



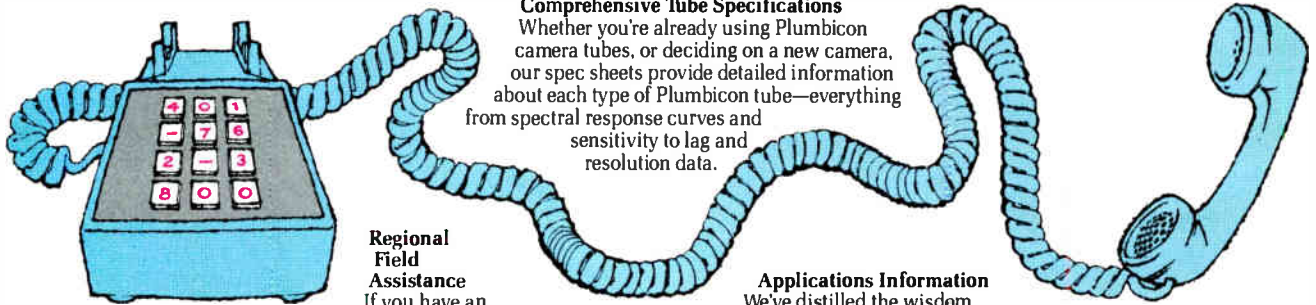

**Comprehensive Tube Specifications**  
 Whether you're already using Plumbicon camera tubes, or deciding on a new camera, our spec sheets provide detailed information about each type of Plumbicon tube—everything from spectral response curves and sensitivity to lag and resolution data.

**Regional Field Assistance**  
 If you have an application problem that we can't solve by

**Applications Information**  
 We've distilled the wisdom gathered from our installation and field service experience into a series of concise "Optical Perceptions" written by and for TV professionals.

**(401) 762-3800**

phone or talk you through, Amperex maintains a full staff of broadcast technicians on call for on-site service.

# ONE TELEPHONE NUMBER GIVES YOU ALL THIS INFORMATION ABOUT AMPEREX PLUMBICON® TV CAMERA TUBES.

When you specify Amperex Plumbicon TV Camera Tubes: you're never more than a phone call away from competent technical assistance, 24 hours a day, 365 days a year. So you never have to worry about winding up "in the dark"—faced with a technical riddle you can't solve.

Of course, we have a generous warranty, (company policy and our own engineers insist we interpret it in the customer's favor!) But more important, we're here when you need us. On the phone to talk you through minor technical problems. On a plane if your problem is more than just routine. At your desk with a print and video library of technical applications, specifica-

tions, training and troubleshooting seminars. Amperex Plumbicon TV Camera Tubes are made in Rhode Island, U.S.A. Delivered to you in twenty-four hours or less.

One telephone number is all you have to remember.

For more information call or write Imaging Products Group, Amperex Electronic Company, Slatersville, Rhode Island 02876. (401) 762-3800. A Division of North American Philips Corporation. Outside the U.S.A. contact: Philips Electronic Components and Materials Division, 5600 MD Eindhoven, The Netherlands.



**Amperex®**

IMAGING PRODUCTS GROUP

**PHILIPS**



Amperex Electronic Company, A Division of North American Philips Corporation, Providence Pike, Slatersville, RI 02876  
 (401) 762-3800 In Canada: Philips Electronics Ltd., 601 Milner Ave., Scarborough, Ontario M1B 1M8 (416) 292-5161

Circle (82) on Reply Card only

### Maxell Corporation

*1/2" Hi-Vision:* videocassettes for Hi-Vision recordings; ceramic armor metal particles; permits 1-hour recording of wideband signals without compression.

*P551 1" tape:* 5, 120, 180 minutes; Epitaxial magnetic particles; conductive backcoating; optimized for less friction.

*B-10BQ, B-20BQ, B-30BQ:* Betacam cassettes; formulation of fine-grain Epitaxial particles; low noise, high output; conductive backcoating reduces static.

*R-120DM DAT media:* low-noise formulation; extra strength for high-speed search handling; for recording or duplication.

*D-2 cassettes:* metal particle formulation meets SMPTE D-2 spec; ceramic armor for high output, low noise; conductive backcoating.

*VF-1 floppy disk:* 2" disks for use with electronic still cameras; high-coercivity metal particle; 50 images in field-recording mode or 25 frames per disk.

*Betacam SP carts:* ultra-fine ceramic armor particles; greater physical strength, resists corrosion; conductive back-coating.

*Digital audio mastering tape:* 1/4", 1/2", 1" with Epitaxial magnetic particles of composite gamma ferric and cobalt ferrite crystals.

*HDTV tape:* for 1" HDTV VTRs; low error rate, high C/N ratio; 30MHz bandwidth at 1.188 Gb/s

data rate; ceramic armor metal particle formulation.

*3/4" digital audiotape:* for mastering; reduced dropouts, proprietary binder, tensilized polyester base film for greater strength; heat, static resistant cassette housings.

Circle (1170)

### Quantum Audio Labs

*Special projects:* custom-designed high-speed, high-volume, high-coercivity degausser systems.

Circle (954)

### Research Technology Int'l/RTI

*Model D-11:* dropout analyzer.

*Lipsner-Smith:* ultrasonic film cleaners.

*Model V110:* conveyor degausser for Betacam SP, M-II, D-2 large cassettes; complete erasure of 1,500 Oe media; 1,000 cassettes/hour.

*TapeChek VT-series:* videotape evaluator, cleaner for M-II, Betacam SP, S-VHS, U-matic; reduce dropout by 80%; inspects, cleans, polishes, rewinds tapes at 30x playspeed.

*TapeChek 4150 analyzer:* identifies defects in bulk video pancakes; 24-channel *Micro-Plus* dropout detector; color CRT bar graph reports; hardcopy printout of analysis.

*Model V90:* bulk tape degausser for metal or oxide; 90dB erasure of conventional oxide, <75dB erasure on metal tape; for D-2, M-II, SP formulations.

Circle (971)

### Sony Magnetic Products

*BCT G series:* Vivax formulation for Betacam; increased S/N performance through special calendaring treatment.

*H18 Metal E:* 8mm pure metal alloy; vacuum evaporation.

*D-2 media:* additional lengths for D-2; 3, 208 minutes.

Circle (1012)

### Sprague Magnetics

*Ultralife heads:* wear-resistant; inorganically bonded cores reduces integral stress; gap integrity maintained beyond 4,000 hours.

Circle (1020)

### Videomagnetics

*Model VM 95000M:* degausser for 60-80dB minimum erasure level below recorded levels; 7000+ effective gauss levels for Beta-SP, M-II, VHS, U-matic, D-2 and film-type reels to 16" diameter.

*Model 9210A:* degausser; generates 3400 effective gauss level to erase tapes to 16" diameter, 2" width; ferro-tuned coil draws 14A current; 60-80dB erasure levels.

Circle (1123)

### Zonal

*920/960:* magnetic sound recording film, 75µ/125µ polyester.

*830 series:* broadcast tape, improved distortion, noise, HF characteristics.

*Logging tape* for most brands of communications recorders.

Circle (1149)

# Leaving the Users of MII, Betacam SP and DII Tape Speechless.

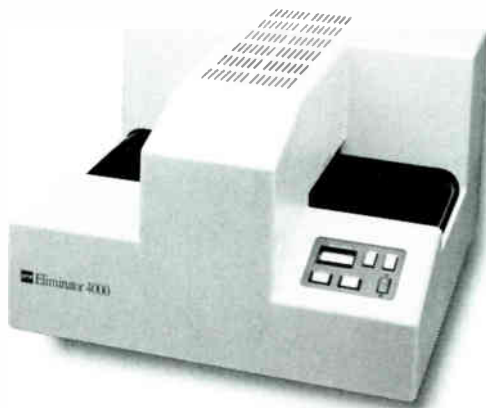

## The New Eliminator 4000

There's no one better at eliminating unwanted information than Garner. So we won't bore you with a lot of impressive talk about our new Eliminator 4000. All we'll say is that it's so effective at erasing low-end audio noise, it's the one degausser approved for use by the major television networks and production facilities. And it's the one bulk eraser that guarantees -75 dB erasure of completely saturated 1500 oersted metal particle tape in 12 seconds or less.

If you'd like to know more about everything the Eliminator 4000 can do for you, give us a call. We've got a lot to say.



4200 N. 48th Street / Lincoln, NE 68504 / Toll-free 1-800-228-0275 / TELEX 438068

Circle (83) on Reply Card

# A sporting challenge for the LDK 90 and LDK 900



Both of these Frame Transfer CCD-cameras are up to the challenge. Connected to the base station via light, inexpensive triax cable, they can operate at distances of up to 2000 metres without loss of picture quality. Sufficient range to cover all the action on the golf course. The advantages of Frame Transfer-CCDs have made the portable LDK 90 the most widely sold CCD broadcast camera in the world. The CCDs do not wear out, do not smear. And all of this is in a camera with outstanding ergonomic qualities.

The LDK 90 is the perfect companion to the LDK 900, the full-featured FT-CCD production camera with comprehensive communications for the most demanding studio

applications. These fully compatible cameras are connected to the same base station and the same operational control panel via triax cable.



Matching the cameras is extremely easy. They possess the same CCDs, the same camera optics, the same technical features. Both have electronic exposure control, automatic colour balance – which eliminates the need to change filters – and a contrast range greater than that of film.

If you don't want your viewers to miss any of the action, write to us:

**BTS**  
Broadcast Television  
Systems GmbH

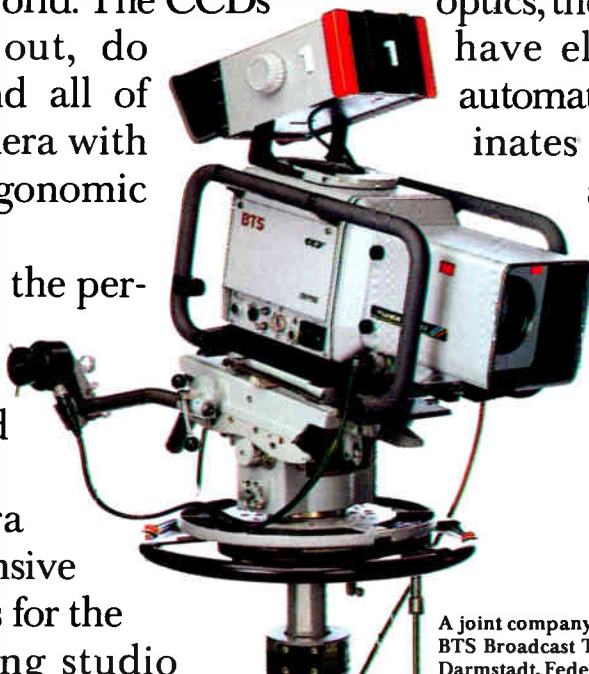

A joint company of Bosch and Philips.  
BTS Broadcast Television Systems GmbH, Postfach 110261, D-6100  
Darmstadt, Federal Republic of Germany, Tel.: 061 51/808-1, TX: 419256.

# Support Products

## S4: Automation

- ✓ Business, program
- ✓ Newsroom, equipment
- ✓ Hardware, software
- ✓ Clocks, timers
- ✓ Data transmission

### Adrienne Electronics

*PC-VITC*: VITC reader board for IBM PCs.  
*PC-LTC/CHK*: LTC error-checking software for PC-LTC boards.  
*PC-207M/BA*: ESBUS data analyzer hardware, software.  
**Circle (513)**

### Alamar Electronics

*MC-2055*: system integrates traffic, cart machines, all VTR formats, still stores, titlers, routing/master control switchers; IBM and compatible LAN with ESBUS; variable net delay.  
*LIP-100*: GP display, real-time clock, *next event* count down, *in event* count down; ESBUS.  
*TD-Assistant*: production automation support for technical directors; assures news, sports, entertainment productions are frame and content accurate during creation.  
*NDP-100*: network delay; unattended recording and playback with variable time added in playback for local message insertion; for one to 32 machines.  
**Circle (522)**

### American Broadcast Systems

*MicroCart 50*: self-programming, VTR sequencer; CRT display; operator enters number of spots to play in a break sequence; schedule 50 breaks in advance; auto eject after play.  
**Circle (1191)**

### AMX

*SX 232*: RS-232C controller.  
*SX VRG*: voltage ramp generator.  
*SX 8+*: 8-relay controller.  
*SX DCU*: infrared control interface.  
*KI One*: keyboard interface; wireless remote control from PC.  
**Circle (545)**

### Artel Communications

*S3501 VideoSnake*: coaxial video/audio/data transceiver.  
*TT/R 3200 series*: dual audio modules; 90dB dynamic range; subcarriers available on 7, 9, 11, 14, 17, 19MHz.  
**Circle (560)**

### Automated Business Concepts

*MAPS*: PC/AT software for Management, Accounting, Programming, Sales.  
**Circle (580)**

### BASYS

*PC Newsroom*: automated newsroom under PC DOS; wire-handling, assignments, script processing; independent split-screen displays; Rolodex, messaging, personal files; archiving.

*MCS One machine control*: production equipment control interfaced to newsroom automation.

*PC NewsDesk*: radio newsroom automation software; wire handling features support multiple wire services, filing and retrieval of stories by category, key words; advisory alerts, priority access.

**Circle (587)**

### Beaveronics

*Favag LED50*: digital clock operates from Favag-type second or minute impulses or integral time base; 2" numerals, 4", 8" options; use as UP timer; Day, Month display options.  
**Circle (591)**

### Brite Voice Systems

*Cityline*: 24-hour advertiser sponsored information service; free to callers; owned, operated by station on exclusive market basis.  
**Circle (1190)**

### Broadcast Automation

*Live Assistant*: controls eight sources for 24-event programming; silence sensor starts next source if one source loses audio; LED bar graph level indicators; remote mic input.  
**Circle (609)**

### Broadcasters General Store

*Sine Systems News Director*:  $\mu$ P-controlled radio news edit station.  
**Circle (615)**

### BTS

*BTA-2300*: television station automation; improved machine control, systems status display, auxiliary scheduling, event recording.  
*BCS-3000 JCS*: integrated control system; central computer, hard disk and set of general-purpose operator panels controls distribution switching, machine control system; soft keys; HP 9000 base.  
**Circle (619)**

### Calculated Industries

*Time Master calculator*: shirt-pocket unit converts time values as hours, minutes, seconds, HMS, HM, MS.  
**Circle (1189)**

### Century 21 Programming

*AutoSegue*: automation system using six CD players; encoding on GoldDisc and HitDisc media starts next song automatically for hands-free music blend.  
**Circle (636)**

### Channematic

*ACS-4A Cricket*: automatic A/V changeover switch; monitors loss of sync, frequency change, signal noise to initiate a switch.  
*NSS-4B Network Share Switcher*: includes disable function.  
*ADCART control units*: *CCU-412A* frame-code interface with Sony BKU-701 module for 7000/9000 series players; *CCU-422A* European counterpart of ADCART controls BVW-70P.  
*DTG-3001A*: DTMF tone generator; two sequences of four DTMF tones initiate start or end function; front panel switches, internal jumpers and control inputs select various output combinations.  
*Li'l Ben*: controller options; *LLC-2A*, eight Form C relay outputs; *LLC-3A*, 2x1 stereo audio/video switcher; *LLC-4A*, 4x1 stereo

audio/video switcher; *LLC-8A* stereo audio/video switcher; *LCC-5A*, capability of controlling four systems with rewind commands; *LLC-6A*, includes 2x1 stereo audio/video switching with two IF/RF switches.  
*NSS-4B Network Share Switcher*: inserts ads into four networks from one ad source; insertions made into one network at a time, first-come, first served; includes disable function.  
**Circle (638)**

### Comlux

*Telettra DTV-45*: 45Mb/s digital transmission system; for standard NTSC or 4:2:2 digital video; allows two NTSC composite signals on one DS3 circuit.  
**Circle (659)**

### Comprehensive Video Supply

*Script Master 2.0*: script writing software; allows importing of text; includes on-screen page, line numbers; supports underline, boldface character attributes and laser printers.  
**Circle (661)**

### Comprompter

*ENR-V2.0*: software update of ENR systems; features greater speed, wordprocessing, transaction tracking, assignment desk.  
**Circle (662)**

### Comsat World Systems

*Video codec*: digital encoder, decoder from KDD; 45Mb/s data rate.  
*Modem*: by Comsat Labs; operates at 140Mb/s.  
**Circle (666)**

### Concept Productions

*CAPS I, CAPS II*: computer-assisted programming systems for radio using DAT decks; 120 minutes random access material per cart; 120 hours random access system storage.  
**Circle (669)**

### Custom Business Systems Inc

*Interactive Accounting System*: station business software package; highly flexible, user-configurable system for all business and accounting requirements.  
**Circle (630)**

### Data Center Management

*NewsData V 3.0*: standard newsroom functions with multiple windows; prompter, closed captioning; sports ticket, automated camera, titling interfaces; PC/laptop compatibility; database access.  
**Circle (684)**

### Datacount

*Interface*: links DARTS commercial log with SELECTOR music log; DJ operates from single log contains all information.  
*Salescall*: sales tracking software, integrates with DARTS system.  
**Circle (685)**

### Dataworld

*Mapping studies, plotting*: depicts coverage contours, population density in selected contours, areas of terrain shielding; multicolor displays; supported by Population Count, Demographic packages.  
**Circle (687)**

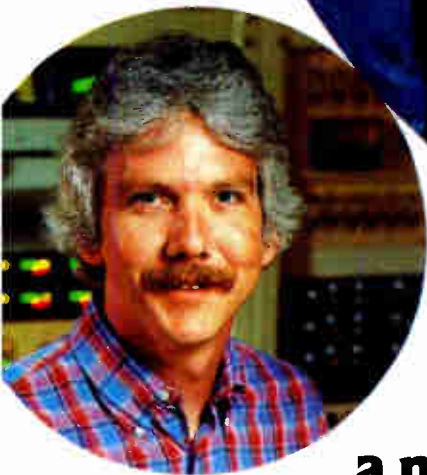

## “Auditronics’ 400 gives medium-market KZZP® a major-market sound,”

says Jim Kunowsky, Chief Engineer of Phoenix’ number one hit station. “Our 400 lets us do a lot of fancy promos and commercial production that most stations can’t do in-house. And it’s eight-track record capability with full EQ on every input channel gives us the creative latitude of a recording studio.”

“Yet the Auditronics 400 console is simple enough that the people who use it every day for dubbing from CD to cart for our on-air music find it very easy to use. A big value of the 400 for us is that it can be configured to do everything from simple dubbing to complex original productions with equal ease. Thus, it gives KZZP a whole level of performance above what you normally see in radio production.”

“When the 400 isn’t booked with our own work, we rent the room for a nationally-syndicated high-energy six-hour dance party called Hot Mix. The Hot Mix

producers love the 400 console because even though they don’t use it every day they can be up and running in about ten minutes, which is very time-efficient”.

“While we’re willing to spend money, Nationwide Communications Inc.’s philosophy is that what we spend the money on has to do its job. So far, the Auditronics 400 console is doing its job admirably.”

If you’d like to know more about why Jim Kunowsky likes Auditronics consoles for both on-air and production, call today toll free 1-800-638-0977, or circle reader service number for complete information.

 **auditronics, inc.**

3750 Old Getwell Road, Memphis, Tennessee 38118 • 901-362-1350

Circle (85) on Reply Card

### **Dynatech NewStar**

*STATMAN software*: in-game statistical software for football, basketball, baseball by Play-by-Play Corporation.

*Touch-Screen Option*: enhanced control software option for NewStar newsroom automation; EGA color monitor and Touch-Screen attachment used with PC/AT, 80386 or PS/2 computers; screen configuration may be customized for each user; machine control available for titling, still stores, cart machines, camera automation equipment; available for right- and left-handed operators.

**Circle (713)**

### **Feldmar Watch**

*Seiko Sound Producer*: time calculator, stop watch, timer, time of day, LCD display with quartz accuracy to  $\pm 0.001\%$ .

**Circle (1188)**

### **FloriCal Systems**

*MACS*: master automation controller; manages interconnects in TV technical and business operations.

**Circle (748)**

### **Gefen Systems**

*M&E Library Version 3.0*: Macintosh library software with editor and categories search.

*M&E*: the M&E Organizer system for Macintosh PCs.

*TRACKPLANNER*: sound effects cue sheet program.

*MULTIM&E version 3.0*: multiple station networking for M&E organizer system.

**Circle (759)**

### **Grass Valley Group**

*Series 87 data mux*: 3-channel support of balanced RS-422, unbalanced RS-423 data at 512kbps; FDM to 10MHz bandwidth carriers for transmission through WAVELINK or EZ-LINK fiber optic equipment.

**Circle (769)**

### **Hallikainen & Friends**

*TURBO:News*: PC software (640k RAM); classify, store stories from two newswires simultaneously; can be placed before or after wire service selector; most current weather always up.

*DRC190 computer control system*: transmitter status, telemetry applications; touch-screen transmitter control; speed increased 2.2x; battery-backed clock/calendar; new inter-system communications.

**Circle (775)**

### **Harris Broadcast Group**

*Sentinelal*: intelligent remote control; expanded system; six site capability with 64 telemetry ports, 96 status/control ports for single or multisite control requirements from studio.

**Circle (776)**

### **IGM Communications**

*IGM-SC*: program automation controller.

*IGM-EC*: economical program controller.

*48PBS Instacart*: random access multideck.

*GoCart 24*: multicart playback system.

**Circle (790)**

### **Image Video**

*EDAAS*: extensible distributed architecture automation system; 10Mb/s Ethernet bus;

device controllers link equipment to bus; 80386 industrial AT operates at 16MHz.

*LCP series*: control panels; numeric or alphanumeric per system requirements; breakout levels and display readout format per user's commands; programmable softkey operational panels.

**Circle (793)**

### **Innovative Automation**

*IA-450*: 25Hz detector; senses tones on 10 audio sources, delivers the signal to the automation system.

*IA-350 REPLAY*: initiates rewind of material on the transport after sensing 25Hz tone.

*IA-250 LATCHIT*: controller for lower-cost, non-automation ready cassette machines.

*Micro DI-TROL*: automation for four audio sources of any type.

**Circle (796)**

### **International Telesystems**

*TickeTV*: positive trap allows broadcasters to transmit pay-per-view programming; encoder generates and mixes scramble carriers into signal; decoder at home passes standard signals, but is activated for scrambled signals by a ticket inserted into the set-top descramble unit.

**Circle (1187)**

### **Intraplex Inc**

*DRR-1500*: digital rate reducer; interfaces with T1 communications equipment; links only needed channels of T1 signal required for transmission; RS-449 compatible.

**Circle (1186)**

### **Jefferson Pilot Data/JDS**

*BIAS/LINK*: total station automation; transfers schedule and log data between BIAS traffic system and intelligent video cart machines.

**Circle (813)**

### **Julian Systems**

*Rack II, IIx*: rack-mount Macintosh II, IIx computers; 340Mbyte hard drive internal storage; optional math processors.

*JET*: Julian Express Typesetting service.

**Circle (1185)**

### **LaKart Corporation**

*LaKart II*: automatic videotape machine control; for U-matic, Beta SP, M-II, D-2, S-VHS, optical disk; software options for Columbine, JDS/BIAS, Enterprise, VCI, Compulink; delay-record, compile.

**Circle (832)**

### **Leonardo Software**

*Professional Librarian*: modular software package; advanced features, sound supervisor, LAN option; CD Jukebox interface; search, catalog multiple effects, sound libraries into single database.

**Circle (1184)**

### **M&R Data Services**

*NewsMaker Electronic Newsroom*: PC TV, radio systems; MS-DOS/Novel Netware environment; stand-alone or networking; wire/script text file database; show rundown control.

**Circle (1183)**

### **Media Computing**

*T.E.N.*: newsroom software for IBM/PCs.

*ANGIS*: election/news graphics interface for titling equipment.

*TECKIE*: technical equipment computer keyboard interface emulation; automation with AT/PC for any remotely controllable equipment; off-site, equipment personality module options.

**Circle (870)**

### **Media Touch Systems**

*Search -n- Sync Workstation*: computer-based control systems with touch-screen terminals; for post-production area of the recording industry; for fast access to CD libraries.

**Circle (871)**

### **Merlin Engineering**

*ME-448 ATD*: automated tape delay system; allows up to three hour delay with four VTRs; UPS, A/V/TC DAs; turnkey installation; seven VTRs and 10x1 switcher controlled from basic system.

**Circle (872)**

### **Moseley Associates**

*PC Software*: TASKMASTER, MASTERCONTROLLER for remote control systems.

*MRC 1620*: remote control system with PC interface.

**Circle (890)**

### **Odetics**

*TCS2000 Cart Machine*: in D2, PAL versions. *Library Expansion Module*: increases the capacity of The Cart Machine by 600 or more videocassettes on-line.

*News Control Terminal*: for improved playback of news department video; allows individual control of VTRs in *The Cart Machine* including last-second changes to program schedule.

*External VTR controller*: for system control of VTRs physically outside of the TCS2000.

*Multi-Cut*: TCS2000 software enables use of cassettes containing more than one event; also permits smooth playlist entry, playback of multiple segments, such as movies, news clips, commercials.

**Circle (914)**

### **Panasonic**

*MARCUS*: combines Panasonic M.A.R.C. cart machine with Utah Scientific TAS total automation system; communications based on Dynabus protocol.

*AU-IA10 interface*: protocol translator allows use of external VTR with M.A.R.C. automation system; applicable to Sony or Ampex VTRs using RS-422 SMPTE bus protocol.

**Circle (928)**

### **Production Services**

*GENESYS transmission system*: based on waveform modulation; adds another signal to existing carrier for re-use of occupied spectrum; suggested for alternative HDTV terrestrial transmission.

**Circle (1181)**

### **Professional Sound Corporation**

*DS-3, DS-4*: three-digit digital slate device; reads 000-999 on 1" incandescent 7-segment indicators; battery powered; DS-3 includes announce mic for verbal annotation, tone for camera start/end.

**Circle (946)**

# words cannot describe the best in the business



# LEDDICON®

## tubes for all cameras

**EEV**

**USA:**

EEV Inc, 4 Westchester Plaza, Elmsford, NY 10523 Telephone: (914) 592 6050 Telex: 6818096 Fax: (914) 682 8922

**CANADA:**

EEV Canada Ltd, 67 Westmore Drive, Rexdale, Ontario M9V 3Y6 Telephone: (416) 745 9494 Telex: 06 989363 Fax: (416) 745 0618

**UK:**

EEV, Waterhouse Lane, Chelmsford, Essex CM1 2QU, England Telephone: (0245) 493493 Telex: 99103 Fax: (0245) 492492

Subsidiary of the General Electric Company plc of England **S&C**

® Leddicon is the Registered Trademark of EEV Lead Oxide Camera Tubes

Circle (86) on Reply Card

World Radio History

## QEI

*Digital Stereo Link*: uses telco T1 lines to link studio and transmitter; 16-bit digital encoding/decoding permits stereo generator at the studio; includes transmitter, satellite remote control.

Circle (949)

## Radio Computing Services

*Master Control Paperless Studio*: integrated display of broadcast schedule; SELECTOR music scheduler; live copy, liners, promos; live-assist; SAMPLER music research system; Music-BASE database.

Circle (1180)

## Register Data Systems

*Traffic Master I*: traffic, billing, accounts receivable software for IBM PC, XT, AT, PS/2, compatibles, most dot-matrix printers; 256kbyte RAM, minimum 5Mbytes of hard disk.

Circle (1180)

## Schafer World Communications

*Micro-floppy disk data recorder*: for Schafer 7000, 7000GLS program automation; recorders all use memory for standard system in 25; use as log storage device.

Circle (990)

## Solutec

*SOL-T*: traffic-able software for SOL-6800 automated broadcast system.

Circle (1009)

## Sony Broadcast Products

*DVC-80*: Library Management System using 84 D-2 cassettes; entry level system; *DVC-80S* uses only small size cassettes; options include external VTR control and spot reel backup.

Circle (1011)

## TAPSCAN

*GridONE*: supply-and-demand-driven electronic rate card software.

*Director Series*: traffic, logging billing software; multiuser, multitasking.

*SuperGRID*: reach-and-frequency scheduler.

Circle (1047)

## Telettra USA

*DTV-45*: video codec; 45Mb/s digital transmission system; interfaces for analog NTSC, 4:2:2 video; configures to transmit one or two NTSC composite signals over DS3 circuit.

Circle (1061)

## Tennaplex Systems

*The Music Manager*: PC-based digital audio automation system control up to 16 CD or DAT players; playlist storage on floppy disk, print playlists; foreground, background music broadcasting.

Circle (1067)

## Torpey Controls & Engineering

*CLK-20*: large digital time displays; AM/PM indicators, flicker-free, uses DQSB-6 serial code; 2.25" digits.

Circle (1082)

## Unique Business Systems

*RentTrace*: computer software tracks reservation scheduling and inventory management of rental equipment.

Circle (1179)

## Utah Scientific

*TAS-I*: total automation system with UNIX-type operating system, 68020 clocked at 16-20MHz; multiuser, multitasking; high-speed LAN; extensive machine control; intelligent interfaces use common time reference signal to simplify communications; allows advanced downloading of commands for time-sensitive operation; HOT-STANDBY backs up facilities run on LAN system.

*MARCUS*: Utah Scientific TAS automation system operating multiple Panasonic M.A.R.C. automated cassette systems for on-air operation.

Circle (1102)

## Video Communications

*VCI Traffic System*: full function software for IBM PS/2, AT/compatible PCs; disk shadowing duplication of data to another disk as backup; DOS resident software.

Circle (1117)

## Video Design Pro

*PEDS Vid386*: personal engineering design station; 2MByte RAM, expands to 16MByte; VidCAD software; 80386 math co-processor; 800×600, 1280×1024 pixel resolutions; 65MByte hard disk; 20MHz CPU.

*VidCAD 3.0*: 3-D library for automated systems, facilities design; realistic modeling of system designs, allows walk-through animation; interface to CableDOC and Intercon software.

*CableDOC Version 2.0*: manages complete cabling documenter; user points to ends of connection of interest; system uses data from VidCAD libraries to provide needed information.

Circle (1118)

## Videomedia

*V-LAN software expansion*: PC-LINK off-line edit decision lister; Time Shifter switches between active playback decks; Animator software with time code accuracy; Universal Control Network.

Circle (1124)

## Vortex Communications

*Master time clocks*: off-air referencing.

Circle (1130)

## Zaxcom Video

*DP800 Data Parrot*: GPI pulse to RS-232/RS-422 interface; device sends programmable data string to simulate keyboard keystrokes when triggered by GPI pulse.

Circle (1178)

## Zenith Corporation

*Spectrum Compatible HDTV*: TV transmission system offers twice the horizontal resolution of NTSC, squeezing 30MHz of information into 6MHz channel; non-compatible with NTSC.

Circle (1177)

# Support Products

## S5: Distribution

- ✓ Distribution amps
- ✓ Routing switchers

## ACE

*ARRAY*: video, audio, control signal router; configurations 64×64 to 128×128; dual redundant power; 30MHz video bandwidth; 150kHz audio includes time code; RS-232/422 control.

*AX164, VX164*: audio, video router; 16 sources × 4 destinations; RS-232/422 control; vertical interval switching.

Circle (506)

## Adrienne Electronics

*AEC-ISVHS*: 10×1 S-VHS router; Y, C, 2-A inputs, outputs.

*AEC-2*: 10×2 video, stereo audio router.

*AEC-BOX*: standalone interfaces for VITC, LTC, RS-422/232, MIDI.

Circle (513)

## Allen Avionics

*BAL 2800, 7600*: video, audio DAs; mix units in rack; wide bandwidths; plug-in delay modules; low noise; differential inputs; eight outputs.

Circle (526)

## AMX

*SX EL*: touch-sensitive control panel.

Circle (545)

## ASACA ShibaSoku

*ASW-88S*: A/V router; 8×8; random matrix control; video bandwidth ±0.3dB to 6MHz; RS-485, RS-232C serial interfaces for computer control; stereo audio.

Circle (561)

## ATI Audio Technologies

*MMA-400, MMA-800*: multiple mic amplifiers; interconnect as sum/difference or high-gain DAs; active balanced in, active or transformer balanced out; 1RU.

*MLA-400, MLA-800*: multiple line amplifiers; interconnect as sum/difference or DAs; active balanced in, active or transformer balanced out; 1RU.

Circle (566)

## Auditronics

*Model 1200*: stereo DA; 1×6 stereo with one mono sum output; 1 stereo input, 13 mono output; 1×13 mono; dual 2×6 mono.

Circle (578)

## BAL Components

*BAL 2800, 7600*: video, audio 1×8 DAs; units may be mixed in rack; plug-in delay modules; >30MHz video bandwidth.

Circle (584)

## Benchmark Media Systems

*IFA series*: interface amplifiers; eight configurations; 10kΩ inputs; modules fit IFA-R 1RU chassis with PS-series power supply.

Circle (595)

## Broadcast Video Systems BVS

*Minibox series*: lumped, pinnable, switched



**PLATINUM™ SERIES**  
1-60 kW SOLID-STATE VHF TV TRANSMITTERS

# Products of forward thinking

## **DX SERIES**

10-50 kW AND HIGHER\* DIGITAL SOLID-STATE AM TRANSMITTERS

85%  
EFFICIENCY

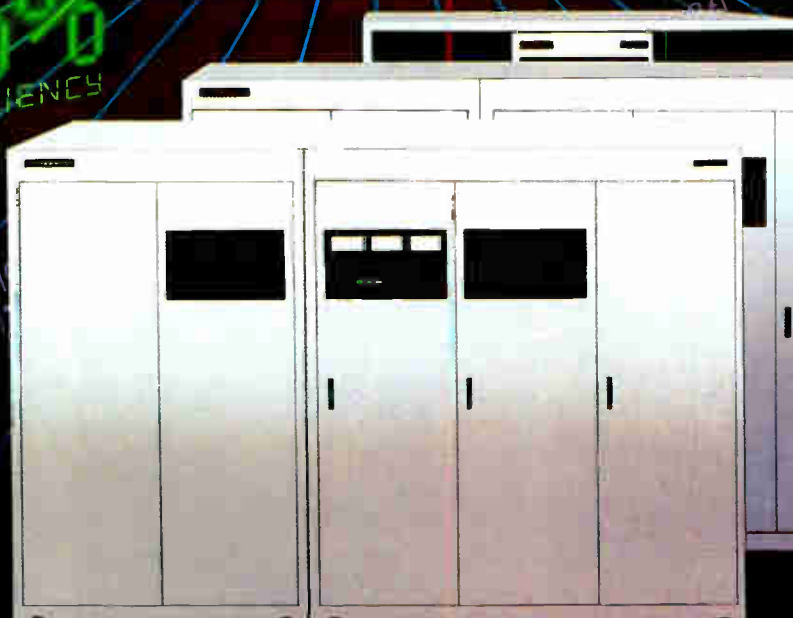

**THE-1**  
55 WATT SOLID-STATE FM EXCITER

At Harris, we've set our sights on the future of broadcasting. And every day, more AM, FM and TV broadcast stations around the world are reaping the benefits: Higher efficiency. Enhanced performance. Easier operation. Reduced maintenance. Increased reliability.

Harris' forward-thinking design engineers have worked with broadcasters to produce some of the most advanced—and most widely acclaimed—products in our history. Our patented digitally-modulated DX Series AM transmitters, all solid-state and single tube Platinum™ Series VHF TV transmitters, high efficiency MSDC UHF TV transmitters, and field-proven 55 watt THE-1 FM exciter are ready for you today. Each is a breakthrough product in its category.

For more information on these and other Harris RF products, call toll-free (800) 4-HARRIS, Ext. 3020. Outside the continental US, fax your request to (217) 224-2764.



## **HARRIS**

ENGINEERING THE FUTURE OF BROADCASTING

Harris Broadcast Division • Marketing Department  
P.O. Box 4290 • Quincy, IL USA 62305-4290

Worldwide leader in DX applications to 500 kW.

video/pulse delays and video filters; each in a small rack-mount box.

**Circle (614)**

### **BTS**

*DVA 7:* 4:2:2 video DA; 10-bit processing; clock regeneration; 12 ports; user may change the configuration for various I/O requirements.

*TVS/TAS-3000:* wideband AV router; matrices to 250×250; 30MHz; surface mount devices; monitoring of all out-going signals.

*BVA-351, BAA-351:* 30MHz video, 20kHz audio DAs; fit *RF-351* rack frame.

*CP-1410A control panel:* allows on-site programming of major TVS/TAS router functions.

*DRS-7:* Serie 7 4:2:2 digital router; 8,9, 10-bit processing; ESbus; 525/625 auto standards selection; autophasing option; 8×8/×12/×16 expansion under software control; menu control.

*Audio Patchbox BSB-3000:* solves mono, stereo problems; replaces larger router; allows swapping of L/R/mono/time code signals, if required, at a tape machine; mix-to-mono, split to stereo, fix out-of-phase; 10 memories with two 4×4 switch matrices; complete matrix, crosspoint control.

**Circle (619)**

### **Central Dynamics**

*SDS-2+:* routing switcher; control from IBM or compatible PC; virtual matrix allows configuration of any source to any physical input on any level; sequence, group switching; timed salvos.

**Circle (633)**

### **Datatek**

*D-861:* 10×1 relay switching module; four Form-A contacts per crosspoint; for machine control, RS-422 applications.

*D-2500 routing switcher:* 20×10 matrix; family of systems; independent or combinations as levels; *D-2511V* video; *D-2520S* stereo; *D-2513R* relay; *D-2514D* RS-422 data.

*D-800 series:* DA modules; mount in frames with 10×1 modules; 1×6, dual 1×6, 1×6 stereo audio; 1×6, dual 1×4, 1×10 video; optional plug-in cable equalizer.

*D-2400 enhancements:* keypad and button-per-source control panels; alphanumeric, numeric keypads with green LED status displays; BNC, 9-pin D connector for communications via RS-422; stereo enhancement; closely matched left/right channels; stereo path gain difference less than 0.1dB; path differential delay less than 0.5°; THD less than 0.005% at +22dBV.

**Circle (686)**

### **Di-Tech**

*5616:* 16×16 stereo audio router; configure as 16×16 or 16×32 mono; redundant power supplies, plug-in crosspoint and control cards; S-Y control port.

*5856:* wideband video router; bandwidth -3dB at 50MHz; configure for 60×20, 30×40, 30×20 dual channel or 20×20 RGB matrices; redundant power supplies; 9002 virtual matrix or RS-232 controller.

*9002:* virtual matrix controller.

*9100:* virtual tally system; can track four passes of a signal through routing switcher outputs, production switcher or keying devices; hard tallies returned for every device on the re-entry path.

*4000:* machine control system; 100ms response time; operate all commonly used serial, parallel machines; 16 delegation buses; programmable

with router on time event basis.

*5864, 5865:* 32×24 matrix video, stereo audio router; input, output, crosspoint cards identical with larger 64×32 frames; redundant power supplies.

**Circle (694)**

### **Digital Services/DSC**

*DD-4 digital DA:* flexible, user configurable system; 4-1×4, 2-1×4/1×8 or 2-1×8 digital paths; RP125, EBU 3246E compatible; 8-bit or 10-bit processing.

**Circle (701)**

### **DYNAIR Electronics**

*Series 1200:* modular video amps and fiber modems for coaxial, fiber optic cable distribution; 1×1, 1×2, 1×4, 1×6, 1×8, 1×10 configurations; 150MHz bandwidth with 300V/μs slew rate.

*DYNA MITE:* router; 60MHz bandwidth; 30×10 video or 10×10 video, audio; convertible to full-sized DYNASTY router; MiniStar or Series 1 controls.

**Circle (711)**

### **Future Productions**

*AVD-10, AVD-24:* A/V DAs; 1×10, 1×24 formats; audio configured for stereo.

**Circle (756)**

### **Grass Valley Group**

*DDA-202:* DAs supporting 10-bit data path; 1×4; auto input cable EQ to 150m; LEDs light in presence of D-1, D-2 signals; four fit in standard 2RU DDA tray.

*HORIZON, 20-TEN/TEN-20 enhancements:* source ID for HORIZON; 4-level status capability, new control option for 20-TEN/TEN-20 systems.

**Circle (769)**

### **HEDCO**

*HD1600A:* 16×16 audio router; expands to 64×64; manual or stereo in one rack frame; RS-422/485, RS-232 control options; 8-level control with numerous matrices per level.

*HD1600V:* 16×16 video router; 30MHz bandwidth; unit requires one rack unit; RS-422/485, RS-232 control; 8-level control with numerous matrices per level; expands to 64×64.

*HD1600D:* true 4-wire operationally transparent, regenerative digital router; 16×16 expands to 64×64; pinout for digital control per SMPTE/ANSI 207M-1984; RS-422/485, RS-232.

**Circle (779)**

### **Image Video**

*Model 6032, 6012:* S-VHS routers; two levels of video with mono or stereo audio; 10-in×1-out; RS-422 or RS-232 port.

**Circle (793)**

### **I-DEN Videotronics**

*IVD-10:* S-VHS video DA.

**Circle (809)**

### **Key Video**

*SRS-1000:* serial-controlled A/V router.

*AVS-101:* 10×1 stereo AFV passive switcher.

**Circle (824)**

### **Leitch Video**

*DDA-7100:* DIGITEE digital DA; 1-input, two relocked outputs; compatible with CCIR-601 and D-1 or D-2 VTRs.

*PDS-624:* program DA; 1×26 A/V duplication frame.

**Circle (839)**

### **3M Company**

*VDA-12, VDA-12D, VDA-24:* video DAs; high density packaging for 168 DAs per frame; 1×7, 1×10.

*Summing module:* for 3M Audio Switcher; user selects up to 16 inputs to summing module, then routes summed signal back through switcher to desired destinations.

*Machine Control Module:* accessory for 3M Audio Switcher includes 16 relay closures for multiple operations; LEDs confirm status; four programmable functions to close, open, toggle, pulse.

**Circle (854)**

### **MATCO**

*Remote controllable unit:* rack unit holds 16 PC cards for parallel, serial, 14-bit D/A converters; CPU card with remote control channel and spare serial channel required.

*MA-204 router options:* 12 or 24×1, 2-channel with audio-follow; 12×1 2 audio channels follow 2 video channels; also dual channel, triple channel systems; remote or PC remote control.

*Video router:* for teleconferencing; 10×10 to 20×20; RS-422 remote control; looping inputs; two outputs per channel.

**Circle (863)**

### **Media Touch Systems**

*ARC-2000 router management system:* audio routing, machine control from touch screen terminal, IBM compatible computers; allows time-shifting, real-time remote source selection.

**Circle (871)**

### **Midwest Communications**

*ARRAY routing:* ACE video, audio, control routing system, configurations to 128×128.

*AX164, VX164:* ACE A/V router; 16 sources × 4 destinations; RS-232/422 control; vertical interval switching.

**Circle (879)**

### **Progressive Computer Products**

*CP-10:* crosspoint adapter.

**Circle (947)**

### **ROH/Anchor Audio**

*Model ARMS7000:* audio router and mixing switcher system.

**Circle (977)**

### **SESCOM**

*Rack series:* audio DA modules; *RK-DAADJ* 6-channel with adjustable gain; *RK-AGDA* 6-channel with automatic control; *RK-LA* single channel; *RK-DA* 6-channel, fixed gain; *RK-VCADA* 5-channel VCA.

**Circle (998)**

### **Shure Brothers**

*Model FP-16A:* upgraded audio DA.

**Circle (1003)**

### **Sierra Video Systems**

*MAXIN:* 4-bus, maximum 80-input router; increments by 16 inputs; RS-232 or keypad control; 3RU package, inputs terminate inside the frame; integral power supply with optional backup.

STEREO  
FM

87.0 → 108.0 MHz

SIGNAL STRENGTH  
TUNED

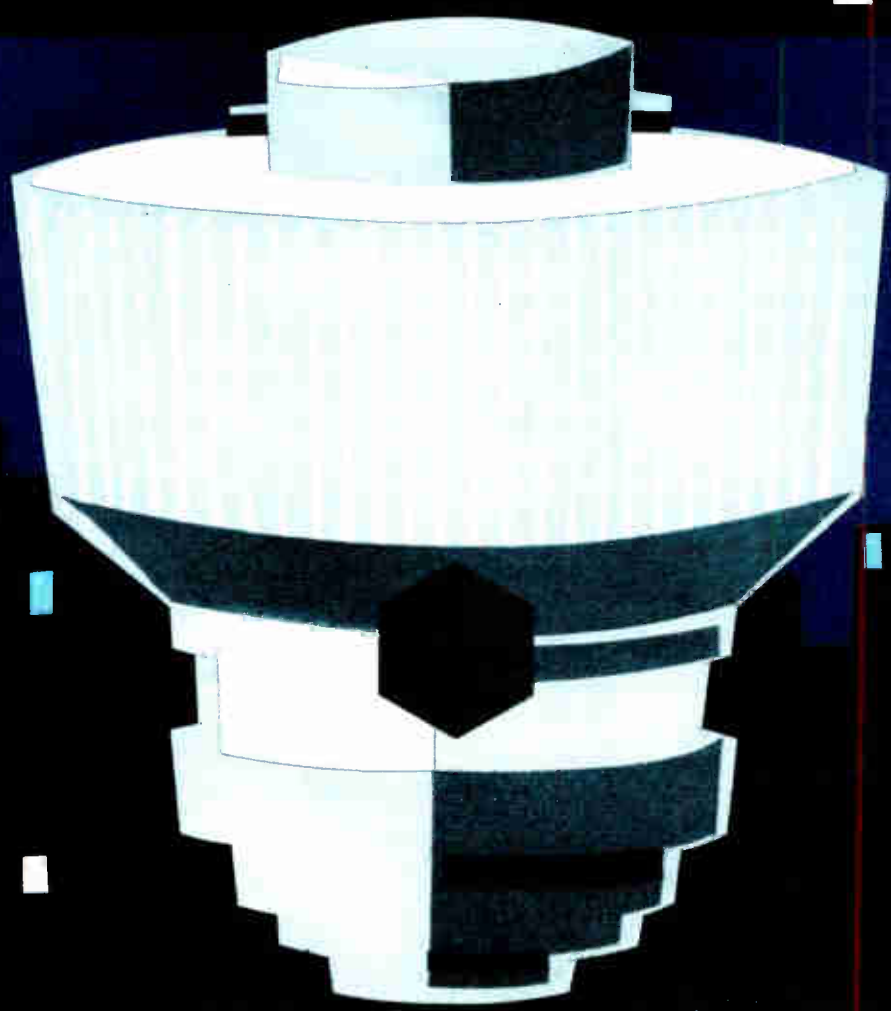

# WHO'S AT THE HEART OF DEPENDABLE FM POWER?

## Thomson Tubes Electroniques!

Guarantee the technical and price performance of your FM station with proven and innovative Thomson FM tetrodes. There's a complete range ready to meet your current and future needs.

Models range from 10kW up to an impressive 100kW. To optimize performance under all conditions, our tetrodes benefit from advanced Thomson technologies such as Pyrobloc® pyrolitic grids and Hypervapotron® vapor phase cooling.

Each tetrode is easily tunable from 87 to 108 MHz and is available with matched FM circuit (grounded grid or grounded cathode).

Make the right investment in dependable FM power with FM Tetrodes from Thomson. It's the best way to fine-tune your station's performance!



Circle (88) on Reply Card

**France:** BOULOGNE-BILLANCOURT  
Tel.: (33-1) 49 09 28 28  
Fax: (33-1) 46 04 52 09

**Brasil:** SAO-PAULO  
Tel.: (55-11) 542 47 22  
Fax: (55-11) 61 50 18

**Canada:** MONTREAL  
Tel.: (1-514) 874 00 88  
Fax: (1-514) 874 40 76

**Deutschland:** MÜNCHEN  
Tel.: (49-89) 78 79 - 0  
Fax: (49-89) 78 79 - 145

**España:** MADRID  
Tel.: (34-1) 405 19 15  
Fax: (34-1) 404 60 02

**Hong-Kong:** WANCHAI  
Tel.: (852-5) 865 32 33  
Fax: (852-5) 865 31 25

**Inde:** NEW DELHI  
Tel.: (91-11) 644 7883  
Fax: (91-11) 644 7882

**Italia:** ROMA  
Tel.: (39-6) 639 02 48  
Fax: (39-6) 639 02 07

**Japan:** TOKYO  
Tel.: (81-3) 264 63 46  
Fax: (81-3) 264 66 86

**Sverige:** TYRESÖ  
Tel.: (46-8) 742 02 10  
Fax: (46-8) 742 00 20

**United Kingdom:** BASINGSTOKE  
Tel.: (44-256) 84 33 23  
Fax: (44-256) 84 20 71

**U.S.A.:** TOTOWA, NJ  
Tel.: (1-201) 812-9000  
Fax: (1-201) 812-9050

*Series 32 router:* basic block of 32x8 video module with 32x16 stereo audio; RS-232, RS-422 or collision-elimination 38kbaud party-line control.  
**Circle (1004)**

#### **Solutec**

*SOL-333:* stereo audio, video DAs.  
**Circle (1009)**

#### **Telnox Telecommunications Products**

*Telnox AL switcher:* 50x100 matrix, user configurable switching size; full connection display; local, RS-232 control; one-hour memory battery backup; 50 position CHAMP connector.  
**Circle (1209)**

#### **Titus Technological Laboratories**

*MLWJ:* emergency, automatic audio router and audio switcher; three stereo inputs, one stereo output.  
**Circle (1079)**

#### **Toko America**

*HDA-5000 video DA:* for HDTV, NTSC, PAL, SECAM; flat response to 50MHz; three 1x3 sections.  
**Circle (1081)**

#### **Utah Scientific**

*AVS-2:* router with Series 2 packaging; significantly reduced physical size with SMD technology; less distributed capacitance and shorter circuitry increases video bandwidth; the actual circuit implementation is similar to previous systems; 1280x1280 matrix with eight separately addressable levels; unused signal paths are powered down to eliminate unneeded heat.  
**Circle (1102)**

#### **Video Accessory Corporation**

*VDA-2PC:* 1x6 video DA; capable of driving lines to 100 feet lengths;  $\pm 6$ dB gain adjustment.

*VDA-3PC:* clamping video DA in 1x6 configuration; 30MHz bandwidth.

*ADA-2PC, ADA-3PC:* audio DAs; 1x6 configuration; -2PC transformer output coupling for 20Hz-20kHz response; -3PC direct-coupled input, output; dc-50kHz.  
**Circle (1115)**

#### **Vortex Communications**

*DA modules:* for Eurogold Modular system; component video and broadband equalizing units.  
**Circle (1130)**

#### **Ward-Beck Systems**

*D8212 series:* audio distribution components; transformerless M8200 mic pre-amp; local, remote adjustment from 1,000 feet on single-shielded audio pair cable.  
**Circle (1132)**

#### **Wheatstone Broadcast Group**

*Model 822:* stereo selector.  
*SDA82a:* stereo audio DAs.  
**Circle (1137)**

#### **Zaxcom Video**

*GPI PulsePath:* 8-inx24-out crosspoint matrix for GPI pulse signals.  
**Circle (1178)**

## Support Products S6: Test Equipment

#### **AF Associates**

*WATCHDOG:* computer-based test and measurement system from Systems Video.  
**Circle (518)**

#### **Allen Avionics**

*HEC-1000, -2000:* 60Hz hum-stop units.  
*VNE-75:* hum eliminator for wideband video.  
*ZL series:* zero-loss delay lines.  
*FASTIME:* BAL Components automatic video timing system.

*Matchman:* BAL Components color patch generator; stored patterns to assess, calibrate video cameras.

*BAL DL 635/735:* active video delay system; maximum delay to 1945ns; various configurations possible; DL 735 buffer improves input return loss.

**Circle (526)**

#### **Allied Broadcast Equipment**

*Audiometrics equipment:* ac power distribution/lighting units; models feature power surge, spike protection; some include utility lighting, digital voltmeter, convenience outlets.  
**Circle (528)**

#### **Altronic Research**

*OMEGALINE dummy loads:* water-cooled 57100B 100kW, 57200B 200kW; air-cooled 6705 5kW, 6710 10kW, 6715 15kW, 6750 50kW, 6775 75kW.  
**Circle (535)**

#### **Amber Electro Design**

*AudioCheck 2:* PC software for 5500-series instruments for measurements, sweeps, comparison to pre-defined limits, data storage, control of other instruments; disk save, load, color graphs.  
**Circle (536)**

#### **Anritsu**

*MS9601A:* optical spectrum analyzer; 100MHz resolution in measurements of light spectrum with high modulation rates of laser diodes; measurement method uses sweep-type Fabry-Perot interferometer.

*MG6301 series:* digital video generator; NTSC, PAL; 100 standard test signals; adjustable APL; waveform/settings memory with 3 1/2" floppy disk; composite, Y/C option; digital output option.  
**Circle (549)**

#### **ASACA ShibaSoku**

*TG5601:* NTSC digital signal generator; programmable ID code; 31 RS-170A signals, 10-bit generation; combine 25 signals vertically for user-defined matrix signal; audio tone.

*VN30A, -31AX:* color video noise meters; NTSC or PAL (-31 auto selects); measures luminance, chroma AM/PM noise; auto level control; auto sag compensation; good/no-good evaluations.  
*CS81A:* white balance checker to adjust monitors; NTSC, PAL, HDTV, EDTV.

*U741A0:* zone plate module for TG-7 generator.  
*VLI4AX:* video signal meter; NTSC, PAL, SECAM.

*TG57AX series:* component signal generator for Betacam, M-II, other component plans; 10-bit

generation; wideband sampling; optional 4:2:2 digital output port.

*TP18C:* To-and-Fro Circular Zone Plate; eight motion speed selections; to check horizontal, vertical and temporal characteristics of signal processing equipment.

*TP21B6:* HDTV test pattern generator; 8 patterns; Y signal within  $\pm 0.5$ dB to 30MHz;  $P_R/P_B$  signals to 15MHz  $\pm 0.5$ dB; differential gain, differential time delay patterns.

*TG91E6:* HDTV signal generator; 13 standard patterns, signals; ITE high resolution, circular zone plate; 16:9 aspect ratio; generated from 74.25MHz clock.  
**Circle (561)**

#### **Audio Precision**

*System One Dual Domain:* integrated digital, analog audio test system; direct tests in and between domains; DSP enhanced analog measurements; FFT capability; AES/EBU digital I/O; analysis, synthesis of audio frequency signals in analog, digital domains; harmonic, spectrum analysis capability; dual channel digitizer.  
**Circle (573)**

#### **AVCOM of VA**

*PSA-65A:* portable spectrum analyzer; 2-1000MHz range; accessories include series of log periodic antennas.

*PSA-37D:* portable spectrum analyzer; 10-1750MHz, 3.7-42GHz covers C/Ku-bands.  
*LPA-1000:* low power antenna; for use with spectrum analyzer equipment.

*PTR-25 portable test receiver:* tunes 950-1450MHz; includes B/W picture display for positive ID of signal.  
**Circle (581)**

#### **BAL Components**

*FASTIME:* automatic video timing system for 16 channels.

*DL 635/735:* active video delay to maximum of 1945ns; various configurations; DL 735 buffer improves input return loss.

*Matchman Mk II:* color patch generator; stored patterns; for assessment and calibration of video cameras; Macbeth color chart; RGB inputs, outputs.  
**Circle (584)**

#### **Benchmark Media Systems**

*CMF-I:* common mode input filter installation accessory; 20k $\Omega$  input, >200kHz differential bandwidth, 26kHz common mode bandwidth; 0% THD; eliminates RF interference.  
**Circle (595)**

#### **BEST Power Technology**

*Micro-Ferrups:* UPS, standby power systems for 350VA to 2kVA range; power conditioning for LANs and other computer-based applications.  
**Circle (1202)**

#### **Boonton Electronics**

*Model 1130:* distortion analyzer; 5Hz-200kHz range; ac/dc levels to 300V; SINAD; low-pass, high-pass, weighted filters.  
**Circle (603)**

#### **Brabury/Porta-Pattern**

*HVI 203:* Hamlet Video multistandard videoscope; SC/H phase monitor option; IRU, portable packages; keys waveforms, vectors into NTSC, PAL, NTSC/PAL-M; individual or combined dual small displays.

# Let's compare automated audio test equipment performance:

| KEY PERFORMANCE SPECS                 | AUDIO PRECISION SYSTEM ONE                  | H-P 8903B                          | S-T 3100/3200                        | TEK AA5001/SG5010                  |
|---------------------------------------|---|------------------------------------|--------------------------------------|------------------------------------|
| Flatness 20-20kHz, gen/analyzer       | <b>0.03/0.03 dB</b>                         | 0.06/0.2 dB <sup>1</sup>           | 0.1/0.1 dB                           | 0.05/0.1 dB                        |
| Amplitude accuracy, gen/analyzer      | <b>0.1/0.1 dB</b>                           | 0.2/0.2 dB                         | 0.2 dB/no spec                       | 0.2/0.3 dB                         |
| Generator amplitude range             | <b>+30 to -90 dBm</b>                       | +17 to -68 dBm                     | <b>+30.6 to -90 dBm</b>              | +28 to -72 dBm                     |
| System THD + N 20-20kHz, 80 k BW      | <b>0.0015%</b>                              | 0.01%                              | 0.0018% <sup>2</sup>                 | 0.0032%                            |
| Min. amplitude for THD + N function   | <b>25 microvolts</b>                        | 50 millivolts                      | 30 millivolts                        | 60 millivolts                      |
| Residual noise (80 kHz BW)            | <b>3.0 μV</b>                               | 15 μV                              | 4.0 μV                               | <b>3.0 μV</b>                      |
| Analyzer stereo separation @ 20 kHz   | <b>140 dB</b>                               | function not avail.                | 100 dB                               | function not avail.                |
| Common mode rejection ratio           | <b>70 dB, 50-20kHz</b>                      | 60 dB, 20-1kHz                     | <b>100 dB @ 60 Hz</b>                | 50 dB, @ 50/60 Hz                  |
| Speed, THD function (autorange)       | 10 sec 16-pt sweep                          | 1.5 sec to 1st rdng                | 2.5 sec to 1st rdng                  | 2.5 sec to 1st rdng                |
| Speed, amplitude function (autorange) | 10 sec 30-pt sweep<br>(2 chan simultaneous) | 1.5 sec to 1st rdng<br>(1 channel) | 1.3 sec to 1st rdng<br>(per channel) | 2.0 sec to 1st rdng<br>(1 channel) |
| <b>PRICE (U.S. DOMESTIC)</b>          |   |                                    |                                      |                                    |
| Computer-interfaceable instrument     | \$6950                                      | \$5800                             | \$9985                               | total                              |
| Software package                      | included                                    | none available                     | \$575-\$1220                         | system                             |
| Typical controller                    | \$600-\$3000 <sup>3</sup>                   | \$5750 <sup>4</sup>                | \$1000-\$3400 <sup>5</sup>           | \$16490 <sup>6</sup>               |

<sup>1</sup> Analyzer flatness: not specified separately; analyzer accuracy 0.2 dB 20 Hz-20 kHz

<sup>2</sup> Total system THD + N not specified, generator THD plus analyzer distortion specs: added together equal 0.0018%

<sup>3</sup> Personal computer. Interface card included in instrument price.

<sup>4</sup> H-P Model 310M IEEE-488 compatible

<sup>5</sup> Personal computer plus IEEE-488 interface card

<sup>6</sup> Total of instruments, software, Tek 4041.4205 IEEE-488 controller

Competitive data compiled from H-P 1988 catalog, S-T data sheet 3000A 1987, Tektronix 1988 catalog.

For a much more complete comparison of these and other audio test systems, call or write Audio Precision.

## System One



## Audio precision

P.O. Box 2209, Beaverton, OR 97075  
503/627-0832 1-800/231-7350

FAX: 503/641-8906, TELEX: 283957 AUDIO UR

Circle (89) on Reply Card

World Radio History

**HVI 2020:** visual stereo meter; color video displays with PPM, VU, peak indications; L-R or M-S measurements; size, position adjustable with key or mix into picture display.

**HVI 204:** TV waveform monitors, vector displays; component, composite capabilities; SC/H phase option; displays in color; rack, portable package; sum, overlay, individual YUV or vector displays; full-screen or waveform and vector as inserts in video; 3H filter parade display of composite.

Circle (605)

#### Broadcast Transmission Corporation

**Philips PM5664:** component video waveform monitor.

Circle (1086)

#### Broadcast Video Systems BVS

**COX5054/30:** video sweep generator; operates to 30MHz.

Circle (614)

#### Bruel & Kjaer Instruments

**Model 4128:** head/torso for recording and audio measurements.

Circle (616)

#### BTS

**Test H-1000:** HDTV pattern, sync generator; tri-level, standard sync; user programmable setup; variable motion control; RGB, Y/R-Y/B-Y outputs; circular, hyperbolic zone plate signals;

eight full-screen, split screen color area signals, 16 additional signals.

Circle (619)

#### Camera Mart

**Test equipment:** Magni test generators, D/A converters; Tektronix 1780R waveform, vector, picture display.

Circle (625)

#### Coaxial Dynamics

**81400-A, 82600-A series:** RF directional wattmeters for 4 1/16" and 6 1/8" diameter rigid transmission lines; single, dual element systems covering 2.5kW-100kW power ranges.

Circle (652)

#### Control Concepts

**Isolatron:** expanded line of power protection systems; applications for studios, transmitters, remote control systems, computer-based products and surge/transient sensitive electronics.

Circle (674)

#### Current Technology

**MP240ERF:** extended range filtering for power conditioner systems.

Circle (681)

#### Delta Electronics

**SNG-1 stereo noise generator:** for NRSC spec; pink, white and USASI noise spectra in continuous, pulsed output modes; output controlled

through front panel control or external gain input.

Circle (690)

#### Dorrough Electronics

**Model 1200:** stereo signal test set; measures stereo program signals in left/right or sum/difference formats to -75dB; for maximum level set, cross-talk check, balance.

Circle (704)

#### Holiday Industries

**HI-5000-SX:** complete RF radiation exposure measurement system.

**HI-3600-02:** ELF/power frequency EMF survey meter.

Circle (784)

#### Jensen Tools

**Fluke 87:** digital multimeter, holster.

**JTK-2000:** technician service kit; more than 100 standard and specialized tools for servicing LANs, printers, copiers; various data processing equipment.

Circle (814)

#### Kay Industries

**T-series phase converters:** changes single-phase utility power to 3-phase; performs power line conditioning, eliminates transients.

**Portable converters:** single-to-three phase systems; for mobile equipment power needs in production, satellite uplinking, lighting.

Circle (822)

## THESE ENGINEERS HAD MANY REASONS TO CHOOSE COMARK'S KLYSTRODE® EQUIPPED TRANSMITTERS...

**WCES**

Georgia Public  
Telecommunications Commission

1540 Stewart Avenue, S.W. Atlanta, Georgia 30310  
(404) 756-4727 • 756-4700 • FAX 756-4713

Georgia Public Television • Peach State Public Radio

Director, Engineering & Technical Services  
**Al Korn**

**SBG**  
SINCLAIR BROADCAST GROUP

DAVID D. SMITH  
EXECUTIVE VICE-PRESIDENT

SINCLAIR BROADCAST GROUP, INC.  
3500 PARKDALE AVENUE BALTIMORE  
MD. 21211-1477 TEL. (301) 462-4500

**WABW**

Georgia Public  
Telecommunications Commission

363 Baker Place, Camilla, Georgia 31730  
(912) 294-9522

Guy Cochran  
Assistant Director, Engineering

Central Virginia Educational  
Telecommunications Corporation

**JOHN A. PRATHER**  
Vice President  
Engineering

23 Sesame Street  
Richmond, Virginia 23201  
804-320-1301



SINCLAIR BROADCAST GROUP, INC.  
3500 PARKDALE AVENUE BALTIMORE  
MD. 21211-1477 TEL. (301) 462-4500

WTCT  
**45**  
CHATTANOOGA

Bryan Fuqua  
ACTING CHIEF ENGINEER

WTCT - TV 45  
PBS MEMBER  
(615) 629-0045

411 AMNICOLA HIGHWAY  
CHATTANOOGA, TN 37406

Jack M. Hodin  
President

**KSLD-TV**  
LOS ANGELES

4522 Woodman Avenue, Suite C236  
Sherman Oaks, CA 91423 • FAX 818-906-0467

818-906-8834

### Leader Instruments

**Model 430:** video sweep generator; 100kHz-10MHz with five drop-out type markers; multiburst, full-field, SMPTE color bars, color rasters; NTSC, S-VHS signal outputs.  
**Model 5872:** combo waveform/vector monitor, simultaneous or dual-channel display; eight sweep rates; x5 vertical gain in R-Y mode; chroma, IRE filters; ac/dc powering.  
**2100R:** 100MHz CRT readout oscilloscope; on-screen cursors; 3-channel capability with alternate triggering to display two asynchronous signals or alternate time base and 6-traces.  
**5850C vectorscope:** NTSC 2-channel system; internally etched graticule; Z-axis input.  
**5860C waveform monitor:** NTSC unit; flat, IRE, chroma, differentiator filters; 1/2-rack size.  
**Model 1602:** RGB multiscan video generator; pixel clock to 60MHz; signals from ROM which can be burned with 1603A/LVG-1603 or 1604A/LVG-1604 systems or optionally provided by Leader.  
**Circle (836)**

### LEC Lightning Eliminators, Consultants

**SP-E, SP-D:** surge and transient prevention equipment for computer-based equipment; 100% protection with fast-acting dissipators to divert and dissipate surge, transient energy.  
**CDC-1 Guy Charge Dissipation Choke:** protects transmission electronics from static charges caused by blowing snow, dust, electrical storms; prevents arc-over, insulator failure.

**SBI Spline Ball Ionizer:** reduced-cost lightning prevention system based on Dissipation Array; prevents most strikes; suggested installation with Chem-Rod grounding electrode.  
**Circle (844)**

### Leitch Video

**MTG-2600N:** modular signal generator producing sync, black and tone for NTSC or component signals.  
**2600ES:** electronic still frame generator for SPG-1300 or MTG-2600N test generators; EPROM storage for one color frame for use in test signals.  
**Circle (839)**

### Logitek

**Bright-VU displays:** LED audio level indicators; **BF2C** 2-channel, **BV4** 4-channel, **BV6** 6-channel; rear-panel switch selects peak, average response; color-coded, balanced Hi-Z inputs.  
**Circle (847)**

### Magni Systems

**WV560, WV561:** waveform/vectorscopes; for NTSC, PAL; for component analog, composite video measurements; SC-H phase, color framing; six inputs; time, voltage, amplitude cursors; 1/2-rack unit.  
**2021, 2021PL:** programmable test signal generators; front panel switching for NTSC, PAL, SECAM, HDTV through "linked" modules from single keystroke.

**WFM530 waveform monitor:** adjustable cursors; alterate, parade functions; accepts 90Hz, 100Hz feeds from D-2 VTRs; gain settings for M-II, Betacam, SMPTE/EBU levels; component, composite 525/625.

**V5530, V5531 vectorscopes:** enhanced with SC/H phase, color-framing detection; 1-button control with on-screen readout; moving bar represents error relative to reference.

**2030 HDTV signal generator:** user-definable signals for any HDTV specifications; step-through menus for line rate, field rate, sync-level formats in interlaced and sequential standards.  
**Circle (857)**

### Matthey Electronics

**BPZL filter:** battery powered zero-loss filter; insertion loss eliminated with hybrid thick-film amplifier inside unit.

**Delay lines:** in DIP format for HDTV.

**Delay modules:** programmable and fixed; to 50ns delay, 30MHz bandwidth.

**DIP filters:** additional models; six cut-off rates, many with  $^{(1.5N \times)} / x$  correction.

**Brickwall filter:** zero-loss version.

**Audio filter:** with customer-defined specifications.  
**Circle (865)**

### Minolta Corporation

**LS-100, LS-110:** luminance meters; -100 measures range from 0.001-14,590 ft-L; -110 measures

# THEIR STATION MANAGERS HAD MANY MORE...



The Comark line of Klystrode equipped transmitters has established a coveted track record of documented cost savings in actual broadcast installations. **These transmitters incorporate simple support systems which eliminate pulsing and use normal water or air cooling techniques.** There is no need for costly deionization systems, high voltage on the cooling water, or two stage heat exchangers.

The superior linearity of the Comark Klystrode equipped transmitters permit the creation of a **WHOLE NEW GENERATION** of equipment using common amplification which **ELIMINATES THE SEPARATE AMPLIFIER STAGES FOR VISION AND SOUND.** Common amplification also eliminates the RF diplexer and most of the RF output system and its **ASSOCIATED COSTS.**

Additionally, the demonstrated broadband nature of Klystrode equipped transmitters makes them ideal candidates for future upgrade to **HDTV** applications.

For further information, on Comark's separate or common amplification Klystrode equipped transmitters call or write:



## COMARK

COMARK COMMUNICATIONS, INC.

A Thomson-CSF Company

Route 309 & Advance Lane, Colmar, PA 18915  
(215) 822-0777 • FAX: (215) 822-0129 • TELEX: 846075

Circle (86) on Reply Card

0.01-145,900 ft-L; color correction factor enables measurement from color sources.

*CS-100*: non-contact tristimulus spot colorimeter; allows spot metering of light sources, surface colors; acceptance angle of 1°; single-lens-reflex viewing system with LCD display in viewfinder.

*CM-1000 spectrophotometer*: high-speed processing circuitry receives spectral information from measuring head, displays alphanumeric and graphic data on LCD screen; xenon light source.

*TV Color Analyzer II*: provides objective white-balance adjustment of color monitors, regardless of phosphor characteristics; chroma mode shows chromaticity coordinates and luminance.

*XY-1 chroma meter*: measures chromaticity and illuminance of light sources; LCD panel indicates chromaticity coordinates (x,y), illuminance (Y), color temperature (°K); also for fluorescent lights.

Circle (1203)

### Modulation Sciences

*VMate-I*: interface Tektronix VM700 video measurement set to remote control or other equipment; 16 waveform parameters mapped to analog dc voltages; remote raise/lower functions select VM700 input.

Circle (885)

### Penny & Giles

*Motorized rotary faders*.

*Prototype*: endless belt fader; uses 2-channel optical incremental encoder module to count bar/window pairs per revolution of code wheel.

Circle (932)

### Prosonus

*SRD Studio Reference Disc*: turns any CD player into a test generator for all audio tests; sine wave, pink/white noise, bursts, 1/2-octave and full bandwidth, polarity, pitch references.

Circle (1204)

### RF Technology

*Faraday Tech.*: delay lines and filters.

Circle (973)

### Rohde & Schwarz

*RMS-100*: remote monitoring system; local, remote diagnostics; measures transmitter/head-end parameters; monitors all channels; real-time video parameter analysis; PC compatible, turnkey system.

Circle (978)

### Soltec

*SOL-20/20*: audio level metering devices, color keys bargraphs into video.

Circle (1009)

### Sony Broadcast Products

*DVTR diagnostics systems*: Unified D-1/D-2 diagnostics; Intrinsic Diagnostics, DVPC-1000 4:2:2 processor diagnostics; status/function display system.

Circle (1011)

### Sound Technology

*CD MiniTest*: provides 99 audio tests; stand-alone unit.

Circle (1015)

### Symetrix

*SX 205*: micro VU precision level meter.

Circle (1040)

### Tektronix

*1780R/1781R*: NTSC/PAL video measurement sets; multifunction, wideband, 4-input analog measurements; touch-screen interactively combines vector and waveform monitor functions, video image display mode for positive identification of video signals; polar SC-H phase display, tangential noise measurements; semi-automatic setup.

*TSG 370*: component/NTSC generator; 10-bit signal generation, six black burst outputs; available in Betacam/NTSC and M-II/NTSC versions; bars, gray scale, multiburst, bowtie, crosshatch, ramps.

*TSG-100*: test signal generator; includes transmission test signals.

*1730 D2/TSG170D*: digital analog waveform monitor and signal generator for D-2 digital equipment; comparison of digital, analog.

*2710 analyzer enhancement*: Mode Option 10, for demodulation of wideband FM and AM signals for visual identification of satellite signals; L-band tuning; Option 14, resolution bandwidth filter set.

*TSG for HDTV*: signal generators; *TSG1050* 525-line progressive scan, 1050-line interlaced; RGB, YPbPr; *TSG1125* for 1125-line/60-field RGB, YPbPr formats; *TSG1250* 1250-line/50-field interlaced.

*TEK 751*: BTSC aural modulation monitor/decoder; Weighted Peak Mode provides choice of True Peak or Weight Peak readings.

*PC 751*: PC software allows remote display of 751 aural monitor screen.

*SPD-300*: signal development program; software program allows creation of special test waveforms or modification of existing TSG-300 waveforms; for engineering, evaluation or manufacturing facility.

*SPD-1000*: signal development program for HDTV; similar to SDP-300; command line menus; waveform graphics; onscreen amplitude, timing information; on-line help screens.

Circle (1056)

### Television Equipment Associates

*MBW420B Brickwall*: filters in battery-powered, no-loss package; eliminates sync buzz for ENG applications when audio subcarrier is located at 4.5MHz or 4.8MHz.

*Audio anti-aliasing filters*: for assorted sampling frequencies; hybrid circuits combine lowpass elliptical with stopband attenuation >60dB. *HDTV delays*: 30MHz bandwidths; BNC connectors.

Circle (1063)

### Tentel

*TQ-1800*: motor-driven torque gauge; accurate readings in either direction; simulates 3.75ips pull speed on 100mm dummy reel pack.

Circle (1068)

### Toko America

*DCL 6 HDTV filters*: luminance, chroma and delay line devices; luminance units with 74.25MHz sampling frequency, 31.63MHz pass band; chroma to 15.3MHz.

Circle (1081)

### Veetronix/Reach

*Pushbutton switch*: low-profile, illuminated; 0.65" square, 0.5" height; in Form A, AA, latching, momentary; 100mA; mounts to PC board, panel mount available.

Circle (966)

### Video Accessory Corporation

*VL-2PC*: opto-coupled video line isolator; eliminates ground-loop interference; withstands 1,500V between input, output, ac ground; hazard indicator if potential difference is greater than 24V.

Circle (1115)

### Ward-Beck Systems

*M406P*: portable battery-powered, extended range meter; operates from 9V batteries; sensitivity range of 80dB.

Circle (1132)

### Wohler Technologies

*IPL-I*: instantaneous phase indicator for monitoring stereo audio signals.

Circle (1142)

## Support Products

### S7: Facilities

- ✓ Studio, mobile
- ✓ Construction
- ✓ Consultants

### Acoustic Systems

*BB-440*: prefabricated, acoustically engineered voice-over booth.

Circle (507)

### Allied Broadcast Equipment

*RBS 801*: portable remote broadcast studio; combines mic mixer, cellular telephone, standard telco interface in compact unit; 4-mic, 2-line; cellular unit is 832 channel telephone, 3W RF output.

*Flagship Studio*: complete, pre-assembled radio station building; includes all technical equipment including transmitter, studio package, office equipment; personnel amenities.

Circle (528)

### Alpha Video & Electronics/AVEC

*E350-1*: ENG microwave repeater van; pneumatic mast allows purging, rotation with unattended feed cable; microwave antenna folds down automatically.

*Enhanced safety mast*: current detection; obstructions sensed with Doppler radar system affixed to antenna.

Circle (533)

### Arben Design

*Video Kiosks*: standard units in different finishes.

*Shapeset*: freeform shapes to make Labensets even more versatile.

*FLATSET*: set pieces to create any type of room setting; 1x4 pine framework with luan faces; neutral beige painted finish; doorway, window units with trim and casings painted white.

Circle (556)



# THE UBIQUITOUS STANDARDS CONVERTERS



**ME 8800**  
BI-DIRECTIONAL  
NTSC, NTSC 4.43, PAL, PAL-M, PAL-N AND SECAM

- The world's only *complete* range of standards converters; featuring more than ten models – from simple unidirectional models to multi-standard, multi-featured 4-field machines and HDTV for the most demanding broadcast applications.
- Total upgrade path through the converter families – when your needs grow they grow with you.
- Six machines in one. Besides offering broadcast quality conversion, MSW converters also serve as time base correctors, synchronizers, color correctors, enhancers and as powerful noise reducers.
- All fully supported by our range of grade-one multi-standard decoding and monitoring equipment.
- The confidence and reliability of the best selling most trouble free professional standards conversion available.

**Designed, built and serviced  
by broadcast professionals**

**MERLIN SNELL & WILCOX**

1890 EMBARCADERO ROAD, PALO ALTO, CA 94303 TEL: (415) 856-0900 FAX: (415) 858-2302

### Cycle-Sat

*SNV Vehicle Two*: 23' diesel-powered truck; steerable 2.6m Vertex Ku-band T/R antenna; STS-300W phase-combined TWT HPA; SA video exciter; Standard Agile Omni/DX receivers; production equipment.  
Circle (682)

### Fort Worth Towers

*Mobile communications buildings*: optional roof-mounted crank-up tower to 100 feet.  
Circle (750)

### GE Support Services (RCA Broadcast)

*Technical and parts support* for RCA Broadcast equipment.  
Circle (1205)

### Hoffend & Sons

*FlyMaster 99*: control unit for motorized rigging equipment; direct or programmable control of 99 motors; target heights accurate to 0.01'; grouping of five motors for simultaneous operation.  
Circle (783)

### Industrial Acoustics

*Accu-Tone Studios*: designs for radio/TV broadcast; record/tape production; sound-controlled communications facilities.  
Circle (794)

### Mobile-Cam Products

*Ramcharger One*: 1989 Dodge Ramcharger 4-wheel drive, Mini news gathering truck.  
Circle (884)

### RF Technology

*ENG truck system*: complete package with 202B transmitter in 19" rack panel; 12Vdc mast-mounted PA; optional high/low RF output switching; antenna polarization control; Pathfinder antenna.  
*FlashBack LiveNews Car System (LNCS)*: 12W amplifier, choice of pneumatic masts to 40'; frequency agile equipment at 2GHz; Hi/Lo switch; 12Vdc operation.  
Circle (973)

### ROSCOR Corporation

*Star Fleet 21 Mark II*: satellite news vehicle; computer-aided design; for Ku-band transmission; Rigid-Rak design; rivetless construction; window shades; lighted stairs; dual con bays; power center.  
*Modular Systems*: facilities designs for operator flexibility and productivity; components related to specific functions groups in small mobile cabinets; system expansion, modification made easier.  
Circle (981)

### Shaffer Communications

*Industry services*: construction, installation; antenna site acquisition, management; special consulting services.  
Circle (1206)

### Shively Labs

*FCC directional pattern work*: for Class A stations.  
Circle (1001)

### Shook Electronics USA

*48-63*: mobile television production trailers.  
Circle (1002)

### Wolf Coach

*B-103 series*: satellite news gathering vehicles.  
Circle (1144)

## Support Products

### S8: Programming

- ✓ Production music
- ✓ Sound effects

### Associated Production Music

*Broadcast One* production music library with Sound FX library.  
Circle (563)

### Century 21 Programming

*GoldDisc, HitDisc*: compact disc music library; all formats; 2-week examination.  
Circle (636)

### Columbia Production Music

*Media Music*: various series on CD; *Broadcast Line, Hi-Tech Line, Contemporary Line, Special Line*.  
Circle (1207)

### Concept Productions

*Music formats*: A/C, CHR, Gold, Country and Contemporary MOR material available in DAT or 10.5" reel formats.  
Circle (669)

### deWolfe Music Library

*CD music library*: 68 CDs of variety of music styles; deWolfe and Rouge CDs.  
Circle (693)

### Gefen Systems

*BBC sound effects*: 18-CD library of sound effects from the BBC.  
Circle (759)

### Manhattan Production Music

*Production music on CD*: network news themes; new age, holiday, patriotic themes; mellow acoustic, spirited heavy metal; ambiance sound effects and station ID logos.  
Circle (859)

### Network Music

*Jingles Library*: 400 items on 30 CDs with new jingles added monthly.  
*ShowMusic Library*: musical elements for five complete multimedia shows; CD format available; vocal, instrumental.  
Circle (904)

### Omnimusic

*ScoreMaster*: production music index software by Computer Music Consortium; Macintosh-based package with icon-menu driven operation.  
Circle (918)

### Ramware Designs

*SearchFX*: locate, cue, loop, play selected CD

effects from entered libraries; can be used with SlaveDriver transport controller to sync, rehearse, record one or more effects at a destination point.  
Circle (1194)

(See page 184 for additional support products.)

## Video Products

### V1: Cameras

- ✓ ENG, EFP, studio
- ✓ Camera tubes, CCDs
- ✓ Lens systems
- ✓ Pan/tilt heads
- ✓ Pedestals, tripods
- ✓ Support automation

### AF Associates

*RoboPed*: production models of full-function, remotely controlled camera pedestal system; requires no tracks, floor tape or mechanical guidance mechanisms; integrates with EPO ARC camera control.

*ARC*: robotic camera control system; based on RCS-90 Radamec EPO camera controls.

*PCS-10*: portable control for lightweight cameras.

*EPO Touch-screen*: control system.

*Pan/tilt heads*: Radamec-EPO models 421, 423 and 424; remotely controlled from joystick type control panel; for broadcast, CCTV, surveillance; applicable to robotic camera control systems.  
Circle (518)

### Amperex Electronics

*XQ3487 series*: 2/3" Plumbicon tube; for ENG/EFP; magnetic focus, electrostatic deflection; LOC DG with dynamic beam control; 48% modulation at 400 TVL (5MHz).

*XQ3477 series*: 2/3" Plumbicon tube; for de-powered ENG cameras; electrostatic focus, deflection; increased resolution; LOC tetrode gun structure; 48% modulation at 5MHz.  
Circle (540)

### Ampex Corporation

*CVR-300*: one-piece SP camcorder; 3-CCD, 670-line resolution; weighs 15 lbs.

*CVC-70*: HADS CCD camera; 700-line resolution with reduced fixed pattern noise; 6-speed electronic shutter.  
Circle (541)

### Angenieux

*14x6, 14x7 lenses*: for 2/3" format; 6-84mm and 7-98mm zooms; each with 2x extender; 0.8m MOD, macro focus; designed for CCD use; 14x6 weight 4.2 pounds; 14x7, 3.3 pounds.

*Servo controls*: control systems for the 20x and 40x lenses.

*20x8.5 μP lens*: f/1.3 optical system for 2/3" CCD or tube cameras; weighs 39 pounds; 8.5-160mm range; MOD to 0m; field angle 54.74°-3.15°; five integral extenders; diascopes; internal shutter.

*40x9.5: 2/3" f/1.3 lens*; 2.1x, 1.45x extenders; 3-lamp diascopes; external readout of zoom, iris, extender, diascopes position; μP design;

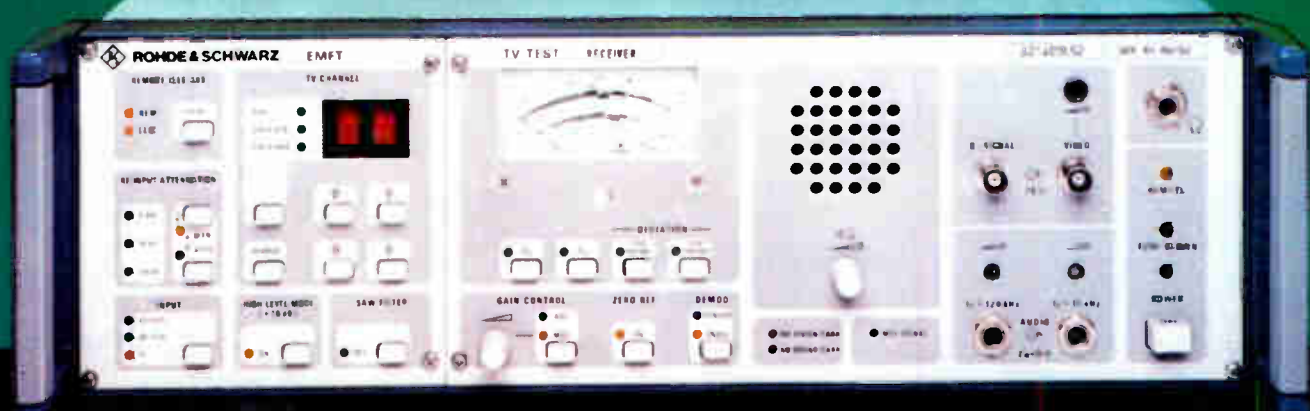
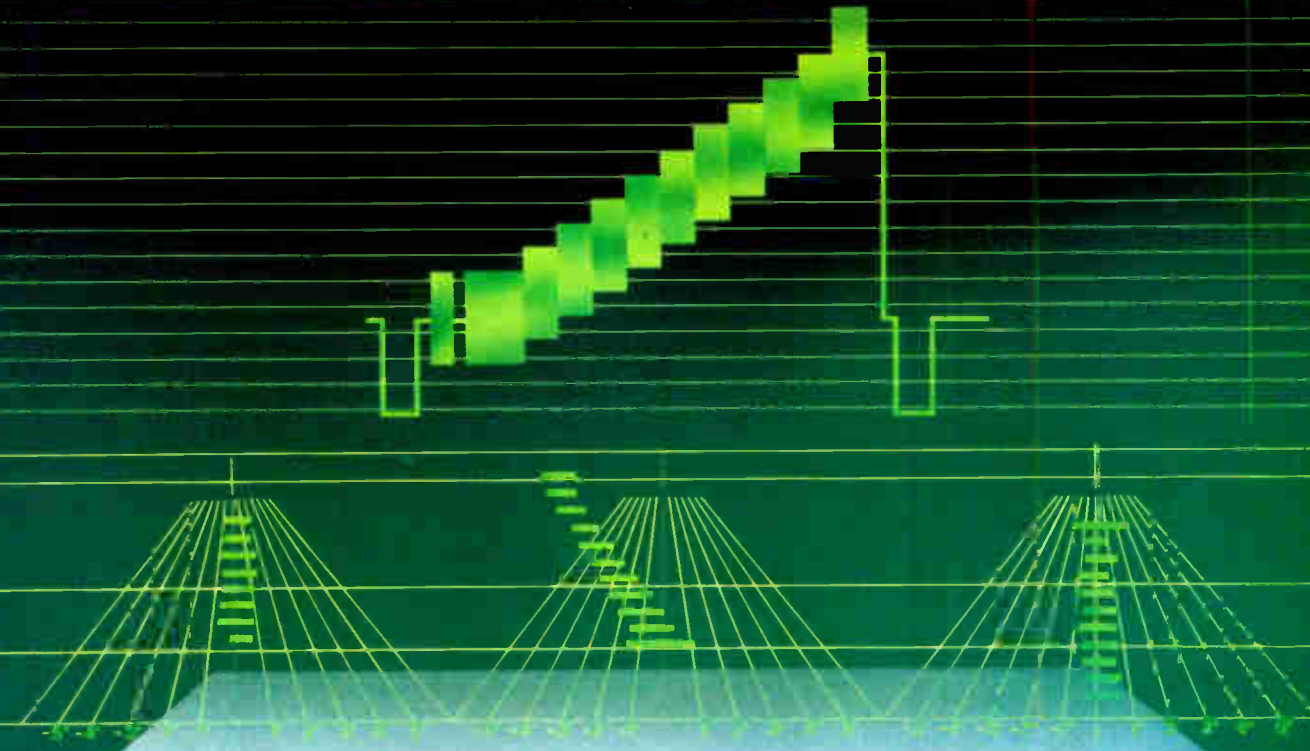

# A SUPERIOR TV DEMODULATOR NEEDN'T COST AN ARM AND A LEG!

At Rohde & Schwarz we've been selling high performance TV demodulators for years . . . and saving our customers thousands of dollars over competitive units. Our latest EMF series features envelope and synchronous detection. There's a Q signal output for ICPM measurements and an internal zero reference pulse for accurate modulation measurements. The EMF series also provides a wide-band (120 kHz) aural output.

Three feature-packed models to choose from:

Model EMFT. Synthesized all-channel receiver including CATV to 550 MHz. (Frequency is selected by channel number  $\pm 100$  kHz AFC). Switchable SAW filter for adjacent channel requirements.

Model EMFK. Single channel crystal-controlled receiver with a sensitive and selective front end for off air reception.

Model EMFD. The precision TV demodulator for every transmitter site.

Check with us to arrange for a demonstration . . . and keep your arm and leg!



**ROHDE & SCHWARZ**

4425 Nicole Drive, Lanham, MD 20766  
Telephone: (301) 459-8800

In Canada:

Rohde & Schwarz Canada Inc.  
Kanata, Ontario, K2K 1X7  
Telephone: (613) 592-8000

Outside North America:

Rohde & Schwarz Headquarters  
Mühldorfstr. 15, D-8000 München 80  
Federal Republic of Germany  
Telephone: (089) 41-29-0



If you are willing to pass up Q-signal outputs, the EKF2 series offers synchronous demodulation and optional wide-band aural output at 1/3 less cost.

World Radio History  
Circle (22) on Reply Card

49.75°-1.33° field angles; weighs 43 pounds. 14x8, 14x9 lenses: for 2/3" CCD or tube cameras; fluorophosphate glass and HEC coating; f/1.6 aperture; rod-in-groove zoom mechanism.

Circle (547)

#### Arriflex

*ARRI geared head:* full swing/tilt geared head for film, video cameras.

*ARRI Video Mattebox:* for video camera; bridge plate, follow focus, 4x4 filters.

Circle (559)

#### Bencher

*Model 430-11 copy stand:* work area 26" x 23", gray with alignment grid; backlight with opal Plexiglass for transfers from slides, small objects to video; movable copystage; holds 30 pound camera.

Circle (594)

#### BTS

*LDK-91:* ENG camera with frame-transfer CCD; 800 pixels per line, 700 TVL resolution; compatible with LDK-90/900 systems; anti-flare sensors; adjustable shoulder mount; diagnostics; operational status display in viewfinder; increase in sensitivity by approximately one f/stop.

*LDK-910:* improved frame-transfer CCD production camera; 800 pixels per line for greater than 700TVL resolution; increased sensitivity; compatible with LDK-90/900 cameras.

Circle (619)

#### Camera Mart

*Ikegami cameras:* CCD types, HL55, HC230; Plumbicon types, HL791.

Circle (625)

#### Canon Optics

*J20x7.5:* CCD compatible studio lens; 20:1 zoom ratio covers 7.5-150mm; internal focusing; MOD of 0.6m; diaspope.

*U-5L:* remote controlled pan-tilt head; for smaller ENG, EFP and studio cameras and lens; 32-shot memory includes pan, tilt, zoom, focus; 0.1-20°/s pan/tilt rotations; optional prompter mounting.

Circle (627)

#### Cinema Products

*WRC-4:* 4-channel wireless focus, iris, zoom lens control; 3 lens functions with camera ON/OFF. *Telescoping balance kit:* for Steadicam III; support post, camera base plate, balance control. *Steadicam III-A:* film/video camera stabilizer; adjustable telescoping support post, side-to-side balance base plate; fore/aft/rotate balance control; 5A external fuse holder kit.

Circle (644)

#### Comprehensive Video Supply

*DCA-325-410 adapter:* allows Sony DXC-325 CCD camera to dock with JVC portable S-VHS BR-S4100 VCR.

Circle (661)

#### FGV Panther

*Super Jib-a-Round:* rotatable, electronically controlled crane.

Circle (742)

#### Fujinon Optics

*EPT-10 pan/tilt head:* for 1/2", 2/3" cameras to

22 pounds; ±95° tilt, 300° pan; speeds 9°/s; *EOP-20* with joystick, rocker switch, rotary controls; *EOP-30* panel, programmable, joystick control.

*A55x9.5 ESM:* 2/3" image format lens; 55x zoom ratio; MOD 2.4m, aperture f/1.4 to 253mm ramps to f/2.9; 2x extender; weighs 38.5 pounds; CCD compatible.

*A14x8.5 ERD:* 2/3" format; 14x zoom ratio, 8.5-103mm, 238mm with lever-activated 2x extender; MOD 0.8m, f/1.7 aperture ramps to f/2; CCD compatible; macro focus; weighs 1.28kg; *S14x6.2 1/2"*.

*A24x11.5 ERD:* 2/3" image format; 11.5-276mm for 24x ratio; MOD 1.8mm, aperture f/2 to 207mm, 2x extender; full servo; CCD compatible; weighs 2.9kg; *S24x8.8 ERD* for 1/2".

Circle (755)

#### Hitachi Denshi

*SK-F1, SK-F3:* dockable 3-chip CCD ENG/EFP cameras; 2/3" FIT CCDs; -F1 300,000 pixel, 650 line; -F3 400,000 pixel, 700 line; 2000 lux f/5.6; 14W drain at 7.5 pounds with viewfinder.

*SKF-700/710:* CCD studio/field camera; 2/3" FIT CCDs; 6-speed shutter; 60dB S/N with 700 TVL; 2000 lux f/5.6; RGB triax to 4,000 feet with -700; multicore cable for -710.

*CK-2B professional CCD camera:* 3-chip design; 660-line resolution, 60dB S/N; variable electronic shutter to 1/2000s; dockable to many 1/2" VCRs or use as 2-piece ENG camera.

Circle (781)

#### Hoodman

*Sun Shades:* accessories allow glare-free viewing of monitors or camera viewfinders in outdoor operation; *H200* 2", *H450* 4", *H500* 5", *H789* 7-9", *H1214* 12-14", *H1721* 17-21".

Circle (785)

#### Ikegami Electronics (USA)

*HL-53:* interline transfer (IT) CCD camera; 400,000 pixel array; 62dB S/N; 6-step electronic shutter; docks to Betacam VCR; audio monitor speaker; iris offset; digital remote control option.

*HC-200:* three 1/2" CCD camera; direct docking with S-VHS, S-VHS-C VCRs; 530-line resolution with 58dB S/N; minimum illumination of 20 lux and +18dB gain; 2-speed electronic shutter.

*HK-355 CCD field/studio camera:* 2/3" FIT CCD design with 3-channel detail correction; electronic shutter achieves 700-line Y-channel resolution; 62dB S/N ratio; triax, multicore, FO cables.

*HK-323A:* full automatic camera; 1" Sta-Sta tubes for improved color resolution; 2/3" tube option; 700-line resolution; studio version or HK-323P portable operate with same control equipment.

*HC-230:* economy camera/recorder with three 1/2" CCDs; 3-speed electronic shutter; 600-line resolution; 60dB S/N for NTSC; available for PAL-B; 2000 lux sensitivity at f/4.5.

*HK-327:* studio camera based on 30mm Mag-Sta Plumbicon tubes; lowered center of gravity; full auto setup; Faroudja encoder; ±90° pan, ±60° tilt viewfinder; triax, multicore, optical fiber cables.

*HL-1125 Hi-Vision camera:* 200 lux f/2.8 sensitivity; 2/3" Harpicon tube by NHK/Hitachi; 16:9 aspect with 2:1 interlace; 1125/60 scan system; fiberoptic or multicore cable.

*VFC7-3:* 6" color viewfinder; designed for use with HK-323A, HK-327, HK-355 cameras; 0.27mm dot triad, in-line gun, 7" diagonal CRT; 700TVL at center.

*HL-55:* FIT CCD portable camera docks to Betacam without adapter; adapters for other VCRs, EFP systems, triax, multicore; 700-line resolution; 6-speed electronic shutter.

*HC-240:* three FIT CCD camera with 6-speed electronic shutter for 650-line resolution and 60dB S/N; digital remote control box for use with RS-232C computer graphics system; various adapters.

*MKC-300:* 3-D camera system; special CCD/prism and optical structure for left and right 525-line system with 120Hz vertical scan; system includes converter, projector and color monitor.

Circle (791)

#### Innovative TV Equipment/ITE

*ITE-T80 Autopod/C15 fluid head:* tripod height 25-58", leg angles to 34°; ENG fluid head with +50°, -60° tilt; load capacity 45 pounds.

*ITE-C20 fluid head:* +50°, -60° tilt angles; 360° pan; 9.8 pounds; 100mm base; hard black epoxy finish.

*ITE-P8:* pneumatic studio pedestal; for camera loads to 190 pounds.

*ITE-H48 fluid head:* camera load capacity to 22 pounds; ±90° tilt, 360° pan.

Circle (797)

#### Innovision Optics

*Special purpose lenses:* allow viewing from angles, locations not possible with standard TV lenses; available in direct, 90°, 45° and 110° angles of view.

Circle (1176)

#### Interactive Motion Control/IMC

*Model 3025 control:* for IMC 2D, 3D and Camera Mover systems; IMC serial net communication to console 4,000 feet from motion control device; QWERTY keyboard, jog knobs, EL display; dual 3.5" drives.

Circle (804)

#### JVC

*KY-25U:* 2/3" CCD camera; 700-line resolution for S-VHS or M-II recorders; docks directly to BR-S410U camcorder; optional MV-P602 stereo mic mounts on camera hot shoe; 3-speed electronic shutter.

*KY-15C1:* three CCD camera for computer graphic image capture; 668x485-pixel array; connects directly to TARGA, VISTA, RasterOps boards through 9-pin connector; positive, negative reversal switch.

*KY-17U:* three CCD camera; 640-line resolution at 59dB S/N; direct docking to BR-S410U S-VHS recorder; auto setup, preprogrammed white/black balance; 2H vertical contour correction; 2-channel audio.

*RM-P820:* remote control unit for KY-75U, KY-80U 3-tube video cameras; includes remote adapter, panel remote control unit and handheld local remote control; LCD status panel.

Circle (816)

#### Karl Heitz

*\*280 Gitzo fluid head:* 2-lb compact, quick release 100% fluid panning; smooth action for front/rear tilts; supports camera to 10 lbs. *Gitzo Giant Ball 5:* 2.5" diameter steel ball allows adjustment knob to change friction;

# 16 Bit Sampling, Total Midi, 150 Effects, ... And One More Thing.

**AKG's ADR 68K is the signal processing device that does it all.**

**SAMPLING.** 16 bit stereo or mono multi-sampling (up to 32 seconds) with pitch shift, adjustable attack and decay, flexible output mixing, up to 12 simultaneous voices, support for MIDI sample dumps, triggering by audio input. MIDI or foot pedals.

**MIDI.** Program changes, freely mappable parameter changes, total automation in conjunction with sequencers, real time changes of programs and parameters *without glitching or muting*, preset register storage and retrieval.

**EFFECTS.** Seven split programs, many allowing chained or split operation, 40 bit internal DSP processing for high accuracy and low noise, input level or foot pedal can control any effect parameter, Multi Effects Chain with eight simultaneous effects, stereo processing, chorusing, auto panning.

**... AND ONE MORE THING.** THE ADR 68K IS ALSO A WORLD CLASS REVERB: With smooth, natural reverb programs, easy to use factory presets, more than 40 adjustable parameters, integrated sampling, and versatile reverb gates.

**SYSTEM.** People-sized remote with six faders, a large 160 character LCD for easy operation, over 10,000 words of built-in context sensitive help, upgradeable software. And more. And more. And... well, we've made our point. The ADR 68K sounds like it does a lot, because it does and it sounds great doing it.



**Focusing on new technology.**  
77 Selleck St. Stamford, CT 06902  
(203) 348-2121



easy-lock positive tightening level; for extra heavy cameras; head weighs 13/4 lbs.  
*Gitzo Inter Pro Studex*: compact tripods; leveling balls, optional rapid or gearlift column; 7-lb; for cameras to 30 lbs.

*Black extensions*, columns; wingnuts for extensions.

\*480: fluid head with fluid control on pan, tilt.  
**Circle (820)**

#### Landy Associates

*Ikegami HL-55*: CCD broadcast camera.

*Ikegami HL-791*: three Plumbicon tube camera.  
**Circle (833)**

#### Matthews Studio Equipment

*MiniJim Arm*: redesigned to support camera packages of 98 pounds; mounts on dolly or tripod; camera mounting elbow attachable at various heights, orientations.

*MC 88 camera crane*: operates with Nettmann Cam-Remote system; look-up angle of 100°; three boom configurations from 10 feet to 24 feet; wheels run on camera tracks or floor.

*Tulip II*: auto ladder lock, bucket cam, platform leveler, dowing over weight bucket; folds to eight feet for transport; CAL-OSHA approved.  
**Circle (864)**

#### Micron Tool & Manufacturing

*Cam Mate*: camera boom extends to 12 feet for 80 pound camera, 20 feet for 40 pound camera; integral dc supply, charger; axis control of pan, tilt zoom and focus; speed, dampening controls.  
**Circle (1175)**

#### Miller Fluid Heads (USA) Inc.

*Model 355*: Miller System 80 for EFP applications; supports prompter, long lenses, to 80 lbs.  
**Circle (880)**

#### Nalpak Video Sales

*LC-1*: universal replacement lens cover.  
*ACCU-CHIART*: series of test charts for standard, HDTV and CCD cameras; packaged in book format; cover doubles as a self-standing easel.  
**Circle (897)**

#### NEC America/Broadcast

*EP-3*: CCD color EFP/studio camera; 700-line resolution; shutter; triax, multicore remote control; 62dB S/N, 2000 lux, f/5.6; 2/3" format; integral ND, color filter wheels.

*SP-30*: CCD color ENG camera; 700TVL resolution; 7-speed shutter to 1/1500s; 2/3" IFT CCDs; adapters for NTSC, Beta SP, M-II, multicore.  
*NC-120*: 3-CCD TV camera; 700TVL resolution; 728x492 pixel; 2000 lux, f/5.6, 89.9% reflectance; S/N 60dB; 5-speed shutter to 1/1500s; NTSC, RGB, Y/C with system adapter.  
**Circle (901)**

#### Nikon Electronic Imaging

*TV-Nikkor S15x8.5B*: 15x zoom ratio TV lens; 2/3" format; minimum focus of 8.5mm; weight 2.7 pounds; corrections for CCD cameras through extra-low dispersion glass.

*HDTV camera lenses*: 12.5-70mm R.5x12.5A-HD2; 12-84mm R7x12A-HD2; both f/1.8 TV-Nikkor units; for 16mm diagonal HDTV image format; macro capability provided.

*TV-Nikkor S13x9B*: 2.4 pound TV camera lens; lightweight optical glass; redesigned lens shapes for reduced size; servo integrated with extender; CCD lateral, longitudinal chromatic correction.

*QV-1000C*: still image video camera; high resolution monochrome image stored on 2" floppy disk; compatible *QV 1010T* monochrome portable transmitter sends image via telco line or radio channel.

*HDTV TV-Nikkor lenses*: 15mm RF-15A-HD2; 50mm RF50A-HD2; both f/1.2 fixed focal length systems; for 16mm diagonal image HDTV format.

*LS-3500*: 35mm color film scanner, color separation software; for desktop publishing; 35mm transparency area read in 8-bit code at a resolution of 6144x4096 pixels.  
**Circle (907)**

#### O'Connor Engineering Labs

*Model 127A Aeroped*: camera pedestal; full-floating pneumatic column; 20" column travel, 16" lift ring; capacity of 120 pounds; fits through 29" doorway; 2-piece construction for transportation.

*Model 35A*: quick release tripod; 100mm or multiple ball top casting; capacity 60 pounds, weight is 8 pounds; internal spreader; aircraft material construction; self-locking legs.

*Model 20-B*: pan/tilt head without counterbalance springs; tilt pivots around center pin; capacity of 20 pounds; ±45° tilt, 360° pan; drag control from 80-800 oz/in.  
**Circle (913)**

#### Panasonic

*WV-F70*: Y/C video camera using two CCDs; S-VHS compatible output; 335,500 pixel array from each CCD giving 500 line resolution; correlated double sampling circuit; 56dB S/N, 25 lux, f/1.6, +18dB.

*AK-450*: portable camera; 3 FIT CCD achieve 800-line resolution at 62dB S/N; vertical smear rated -105dB; 6-speed electronic shutter to 1/2000s; sensitivity 2,000 lux, f/5.6; docks to AU-400 VCR.

*AQ-10*: single 2/3" FIT CCD portable camera; digital signal processing; 650 lines at >60dB S/N; 7-speed electronic shutter; docks to AU-400 VCR; ENG, fiber optic, multicore cable adapters.

*AQ-20*: 3 FIT CCD camera; all-digital signal processing; 750 lines, 60dB S/N; LSI design cuts weight to approximately 7 lbs; docks to AU-400; optional adapter to support digital interface; electronic shutter.  
**Circle (928)**

#### QuickSet

*QKTH-30*: Husky tripod/fluid head; large-surface disconnect camera plate with safety lock; aluminum alloy construction with tubular legs; anodized black, scratch-resistant finish.  
**Circle (955)**

#### Radamec-EPO

*Pan/tilt heads*: models 421, 423 and 424; remotely controlled from joystick type control panel; for broadcast, CCTV, surveillance; applicable to robotic camera control systems.  
**Circle (958)**

#### Richardson Electronics

*Viewfinder CRTs*.  
**Circle (974)**

#### Sachtler

*Model 1000 Video 10*: complete support system with dolly, tripod, integrated spreader, elevator column; compact head for CCD cameras.

*Two-in-One Tripods*: for ENG, EFP; accept fluid heads with 100mm, 150mm bowl interface; available in Carbonfiber, Duraluminum.

**Circle (985)**

#### Schneider

*TV-71*: 20 wide-angle studio zoom lens; for 1/2" CCD cameras (8mm image diagonal).

*TV-81*: 20x wide-angle studio zoom lens; for 2/3" CCD (11mm diagonal) cameras.

**Circle (991)**

#### Schwem Technology

*GX-3*: production models of integrated mini camera with stabilizer; complete package is 4" diameter, 10" long cylinder; includes camera with remote controllable lens.

**Circle (992)**

#### Sony Broadcast Products

*I/O Network*: integrated broadcast operation; includes workstations linked to traffic system; Library Management Systems; A/V switchers; VTRs; VCRs; still stores and character generators.

*BVP-270/BVP-370*: engineering models of CCD studio cameras; 768 FIT CCD imager with 700-line resolution in -370; -270 uses 768 IT HAD CCD sensor; 2,000 lux sensitivity f/5.6, 62dB S/N.

*BVP-70*: FIT CCD camera with 700-line resolution, 62dB S/N ratio; variable speed electronic shutter; configures with Betacam SP VTR for EFP or with CCU-350/355 camera control units.

*BVP-7000*: CCD image intensifier camera; 768 interline-transfer chip array with intensifiers produces 370-line pictures with little lag and 59dB S/N ratio; quality color images in virtual darkness.

*BVP-T7*: 2-piece camera; removable pickup device with standard camera body; umbilical cord of 20m length connects two units; for close quarter requirements; uses 768 interline-transfer CCD.

*BVW-300*: one-piece camcorder; 768 interline transfer chip array; for ENG, EFP; 670-line resolution with 62dB S/N, sensitivity rated 2,000 lux, f/5.6; can be used with other VCRs as well.

**Circle (1011)**

#### Tamron Industries

*High resolution lenses*: C- and standard video camera mount lens systems for 2/3" cameras.  
**Circle (1044)**

#### Telemetrics

*TM8650 series*: triaxial camera control systems; M7 for Sony M7; 300CLE for Panasonic CLE; BVP-7 for Sony BVP-7; FPC for Hitachi FPC series; allows camera to operate 5,000 feet from CCU.

*TM8800*: pan/tilt systems with presets and computer interface; open-loop, servo modes; preset panel allows entry, recall of camera positioning within ±0.5°; 12°/s pan speed, 3°/s tilt speed; pan travel ±150°, tilt range ±45°.  
**Circle (1058)**

#### Television Equipment Associates

*VM-1*: low-light video multiplexer; miniature B/W camera operates in 0.02 lux; handles

# CHINA BIRTV '89

**Beijing International Radio &  
TV Broadcasting Equipment Exhibition '89**

Beijing Exhibition Centre, Beijing  
October 6 - 11 1989

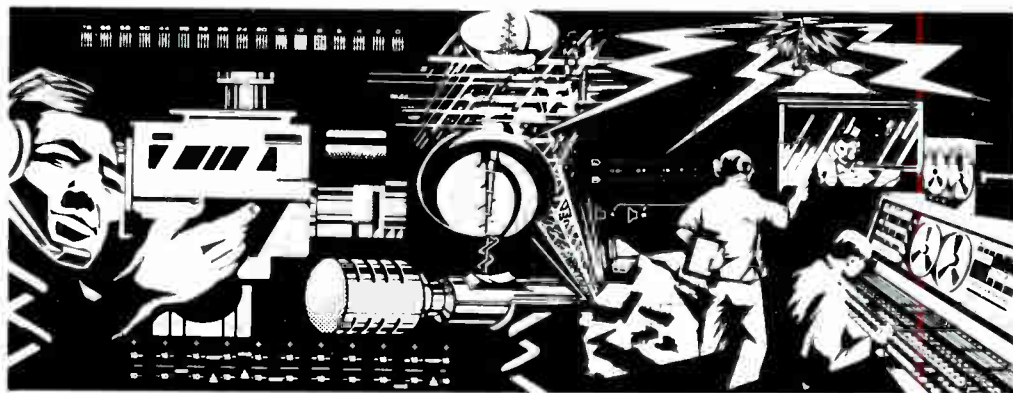

Organized By:



China Central Television  
Chinese Institute of Electronics

Authorised Overseas Agent:



---

**CHINA BUSINESS ENTERPRISES, INC.**

109 East 15th Street, New York, New York 10003  
Telephone: 212/682-1511 Fax: 212-953-0350  
Telex: 275725 CBE UR

---

Rm. 606B Hunghom Commercial Centre, Tower A,  
39 Ma Tau Wai Road, Kowloon, Hong Kong.  
Telephone: 3-7647750/1 3-7647771 Fax: 3-627390  
Telex: 47561 CBEEH HX Cable: CBETEI

---

vibration to 60G along any axis; over 450-line resolution; C-mount lens.  
**Circle (1063)**

#### Thomson Video Equipment

*PROSCAN*: EDTV studio camera; progressive-scan system; three Plumbicon or Saticon tubes; 2,000 lux sensitivity f/4; MTF at 11MHz is 60%; 49dB S/N unweighted.

*TTV 1647*: 3-CCD camera with electronic shutter; dockable with suitable VTRs; adapters for EFP, studio configurations; full triax available.  
*TTV 1532 studio/OB camera*: 4:3 or 16:9 models available;  $\frac{2}{3}$ " DG LOC tubes; 6MHz bandwidth triax system; autofocus based on 182 picture zones; TTV 1647/1624 cameras serve as portable companions.

*TTV 1645 SPORTCAM*: 3-CCD system; full triax capability; electronic shutter; 440,000 pixels per CCD with white compressor for high dynamic range.

**Circle (1074)**

#### Toshiba

*IK-M30/C30 series*: CCD miniature cameras; 300,000 element  $\frac{1}{2}$ " CCD,  $\frac{1}{1000}$ s shutter; auto tracking white balance; C-mount lens; line sequential color difference method.

**Circle (1083)**

#### Total Spectrum Manufacturing

*HS-105P, HS-110P*: pan/tilt heads; controlled from ACP-8000 controller; mount on SP-200 servo pedestals.

*AutoTrack*: talent tracker; maintains talent tracking with smooth movement.

*AutoCam SP-200*: servo pedestal with X-Y base option; includes studio floor tracking; collision avoidance and servo pedestal height; rotation repeatable within 20 arc-seconds.

*AutoCam ACP-8000*: automated touch-screen control panel; menu-driven control of eight cameras.

*Newsroom computer interface*: option of 2-way communications between AutoCam and newsroom computer.

**Circle (1084)**

#### Ultimatte

*Ultimatte Memory Head*: production model of computer-controlled pan/tilt head; uses 120V/60Hz, 220V/50Hz or dc; repeatable moves recorded on 3  $\frac{1}{2}$ " discs; EFP and Studio versions.

**Circle (1094)**

#### Video Services Unlimited

*ZOOM Creeper*: provides zoom rate adjustment.  
*Stanton Dolly*: tripod or track dolly system.

*Stanton Jimmy Jib-2* and *Stanton Jimmy Jib Jr.*  
*Giant extension*: for Jimmy Jib systems.

*Remote control*: improved controller provides camera iris and VTR start-stop functions.

**Circle (1121)**

#### Vinten Broadcast

*Vision Pedestal*: for lightweight cameras; 16.5" column movement; 44 pound capacity; self-charging for easy adjustment; casting wheels, independent brakes, cable guards; two configurations.  
*3277-3 Mark 7A*: pan/tilt head; for studio or remote;  $\pm 60^\circ$  tilt range; 11" fore/aft adjustment for balance; capacity 200 lbs; captive pan bar; improved fluid drag; wide cam track.

*Enhanced MicroSwift*: total control over *Track-ig Pedestal*, compatible to *Mark 4* and previous

pan/tilt heads; integral circuitry eliminates studio clutter; extends to all equipment in studio.

*Package system*: for the studio; *Vision 20 ENG/EFP* fluid pan/tilt head, single pan bar, clamp, 100/150mm ball base; options—2nd pan bar/clamp, 2-stage tripod; *Vision* folding/castering dolly.

*Penguin II*: track-mounted dolly to accommodate 630mm or 360mm track; low-noise PTFE and Duthane wheels; operate off-track with tiller bar; Midi-Ped pneumatic column or heavy-duty elevation unit.

**Circle (1127)**

## Video Products

### V2: Recording

- ✓ Analog, digital
- ✓ Editing, animation
- ✓ Time code equipment
- ✓ Transport synchronizers

#### Abekas Video Systems

*TOUCH-UP*: digital video, manual control interface links A60 digital disk recorder to Quantel DPB-7000 Paintbox; allows random-access and additional functions to Paintbox.

**Circle (502)**

#### Adams-Smith

*Motion controller*: for use with VTRs, bi-phase dubbers and Adam-Smith C:Sound displays.

**Circle (509)**

#### ADx Systems

*ADx-03*: time code analyzer with longitudinal reader, generator; VITS and RS-422 capabilities.

**Circle (1155)**

#### Ampex Corporation

*ESS 5T*: digital still store; for film-to-tape transfer work; dual format system selects standard from RGB, CCIR-601 inputs; 160Mbyte disk stores 200 NTSC, 160 PAL frames.

*ACE family*: enhancements; *TURBOTRACE* list management, audit trail; *ACE Micro V 3.6*, *ACE 200 V 8.6* ILC, GPI trigger firing, interface to Sony D-2, Panasonic M-II VTRs.

*ACR-225 upgrade*: software; multiple events per cassette; automatic break tape generation.

*VPR-300 M-GEN*: setup option for D-2 VTR shows preview of effects of video settings over 20 generations.

*ACE 25 V 2.0 software*: includes Sony SloMo; CMX 340 input/output; 4-machine system, optional internal A/V switching; EDL *TURBOTRACE* list management; Ampex, Sony, Grass Valley interfaces.

*SMC-200*: slow motion controller; for most Ampex, Sony VTRs, including Betacam/SP, U-matic, Type C and D-2; gang roll, multiple machine slow motion, variable speed adjustment, still frame.

**Circle (541)**

#### Amtel Systems

*E-Pix*: hybrid non-linear edit controller; integrates videotape, recordable videodisc; includes linear editing, 10-input video switcher, 8-input audio mixer; audio 400Hz, 1kHz tones.

**Circle (544)**

#### AMX

*DX 8*: video duplication control component.  
**Circle (545)**

#### ARTI/Advanced Remote Technologies

*Executive VP*: video publishing network for IBM/compatible or Macintosh computers linked to various devices through an expandable hardware-software network package.

*Video Publisher Plus*: advanced software editor for PC, Macintosh; A/B/C roll editing; 1000-line EDL in RAM; accuracy based on VTRs; application software for Executive VP.

*TR-1 IC*: time code reader; reads SMPTE/EBU LTC and VITC code.

*PC-LCII*: time code reader/writer; expansion card for PCs; reads, generates SMPTE/EBU longitudinal time code; Pop-log.

**Circle (1169)**

#### ASACA ShibaSoku

*ADS-300 disk system*: magneto-optical cartridge allowing rewrite; double-sided cartridge holds 1600 frames of color images; external drives available; cut, dissolve, wipe, push, roll transitions; 8-bit  $4 \times F_{sc}$  sampling; playlist sequences; random access, removable cartridges; RS-422, SCSI disk interfaces.

**Circle (561)**

#### Aston Electronics

*4:2:2 component digital interface*: allows Aston 4 or Caption systems to create, manage video effects in a digital environment; conforms to CCIR 601; 19", 3-RU package.

*Wallet*: general purpose still store; 84 full frame with key signals on removable hard disk; 1.5s access; CCIR-601 compatible sampling; NTSC, PAL; disk directory, stack facility; wipe, push-pull transitions; creates internal key to store text and logos created with Aston titling systems.  
**Circle (564)**

#### Audio Kinetics

*Striper*: time code generator; stripes code at 2x and 4x normal play speeds.

*Gearbox*: time code standards converter.

*VTL*: VITC to LTC standards converter.

*WIPER*: video wipe with countdown; provides visual cue for automatic dialogue replacement.  
**Circle (572)**

#### AVID Technology

*Avid/1 Media Composer*: real time, non-linear editing combines film techniques with frame-accurate digital video technology; video, two 16-bit 44kHz CD-quality audio; Macintosh IIx/IIcx.  
**Circle (1168)**

#### BHP

*Model 8100N*: TouchVision videotape editing system; non-linear film-style system; accommodates 24 VHS or U-matic VCRs; operation from icon-based touch-screen menus.  
**Circle (598)**

#### Bowen Broadcast Service

*TCR-100 kits and parts*: dynamic magazine brake kit; various hard-to-find mechanical parts for these videocart machines.

**Circle (604)**

#### Broadcast Electronic Services

*Edit-Tech GPI Network 410*: expands general purpose interface capability to ten; allows multiple devices to be triggered from one pulse or



# Our Network Ratings Are In.

Our clients have certainly appreciated the cost savings, and everyone has enjoyed the extra time satellite has provided us. Cycle-Sat has proven that satellite is a very viable method to distribute commercials.

—Dana Geiken, DMB & B

... ..  
... ..  
... ..

—Merle Welch, Foote, Cone and Belding

We have become accustomed to the ease and reliability of receiving commercial spots via satellite. We are also impressed with the flexibility of the system in regard to getting refeeds and special feeds. We look forward to a long working relationship.

—Karl Hagnauer, KPLR

Our experience at WGN-TV with Cycle-Sat has been quite positive. The system has been very reliable and the convenience of receiving the commercials in non-primetime has been helpful in scheduling our tape machines. Our equipment has been freed for production use during the prime hours.

—Robert Strutzel, WGN-TV

The quality and reliability of the hardware and software is outstanding. It's error free in its operation, and the speed with which we receive commercial feeds saves us make-goods and lost time.

—Jim Martin, WOAY-TV

If you haven't already joined the Cycle Sat spot delivery network, check out the reception we're getting from those who have. We guarantee network quality transmission of your spots, along with standardized traffic instructions. For service that's out of this world... Call 1-800-274-2728.

© Cycle Sat, 1989

**CYCLE-SAT, INC.**  
A COMMUNICATIONS NETWORK  
A SUBSIDIARY OF WINNEBAGO INDUSTRIES, INC.

routes single pulse to any output.  
**Circle (1153)**

#### **BTS**

*BBE-600*: VTR editing system; combines capabilities of BBE-900 editor with self-contained video switcher for dissolves and wipes.  
**Circle (619)**

#### **Camera Mart**

*ADx time code products*: range of time code analyzers, machine controllers, audio synchronizers, emulators.  
**Circle (625)**

#### **CEL Electronics**

*P159*: hard key controller for Eric editing system; LCD menu-driven displays; for multiple VTRs of mixed 1/2" and 3/4" format systems.  
**Circle (632)**

#### **Cinedco**

*CINEFLEX*: 24-frame video editing system; for feature film applications; insures accurate negative cut list.  
**Circle (643)**

#### **Cipher Digital**

*Phantom 4810*: VTR emulator, transport synchronizer; for interface between video editing systems and audio transports; RS-422 port; use U-matic VCRs designed for 1" VTRs through parallel output.  
*Softouch II edit controller*: dedicated synchronizer control system; works with Shadow, Shadow II units; controls CDI-750 time code reader, generator, event controller through serial interface.  
**Circle (646)**

#### **CMX**

*CMX 3600 enhancement*: hard disk option, for all existing 3600 systems.  
*CMX 300*: film-style or time code editing; AutoMark edit point preview; EDL to 999 time coded edits.  
*68KP*: R Serial Intelligent Machine Interface; to more than 50 VTRs; plug-compatible with Multi-I chassis; DM<sup>2</sup> and Motion Memory features.  
*CMX3100B*: large-scale editing system with Dynamic Motion Memory Control (DM<sup>2</sup>) to program variable speed changes; fit/fill mode manipulates scenes to fit designated time; pre-cue assembly.  
**Circle (651)**

#### **Comprehensive Video Supply**

*EDIT MASTER*: multiple source editing controller.  
**Circle (661)**

#### **Dwight Cavendish**

*CM-250, CM-250-5 Copymaster*: videocassette duplicators.  
*CM-7000QC*: automated quality-control station for video duplicator system.  
*Copymaster 10/50*: QC enhancements; wide range of QC checks at 400 cassettes per hours; operator can monitor video picture, waveform, RF envelope, HiFi RF, linear and HiFi audio signals.  
**Circle (709)**

#### **Editron USA**

*Sync mod kit*: allows Sony PCM-501, -601, -701 units to be locked to an in-house video black reference for full synchronous relationship between PCM video signal frames and time code.  
**Circle (717)**

#### **Evertz Microsystems**

*e<sup>2</sup> emulator II*: intelligent machine controller; for JVC CR-850, KR-M800 M-II, Sony Type 5 U-Matic; allows upgrade of editing controllers without changing VTRs interface to editors using Sony serial or CMX I<sup>2</sup> protocol.  
*4015 film footage encoder*: assists in transfer process of material originally shot on film; telecine bi-phase quadrature pulse output; generates time code while encoding film edge numbers into user bits; identifies film edge numbers with field-accurate precision; follows the 3/2 pulldown sequence.  
*Model 4500*: time code generator, mounts to camcorders.  
**Circle (736)**

#### **Fast Forward Video**

*Model P-1*: portable SMPTE time code generator and reader; drop/non-drop frame; starts, stops with camera; powered from VTR; jam sync with incoming time code; LCD display of hours, minutes, seconds.  
**Circle (1167)**

#### **FloriCal Systems**

*ShowTimer*: fully automated recording, run-down listing and playback from satellite feeds and film-to-tape transfers.  
*TimeShifter II*: low-cost version of established TV tape delay system.  
**Circle (748)**

#### **FOR-A**

*VC-1000 VTR controller*: produces time code accurate edited sequences; permits manual or automatic segmentation over specified time for time-lapse recording; various machine interfaces.  
**Circle (749)**

#### **Generic Designs/GDI**

*GD422 adapter*: serial communications adapter for some 3/4" and 1/2" VCRs; full duplex RS-422 channel and parallel port to control remote functions of VCRs; integral time code reader.  
**Circle (762)**

#### **Gray Engineering Labs**

*VR-221*: dual standard reticle generator; available in composite or component signal formats; automatic NTSC, PAL operation sensing; remote control and RS-232 interface.  
*EDL-230*: edit decision logger; based on VITC present on input video signal; detects edits by discontinuities in time code numbers or changes in footage/frame count of user bits.  
**Circle (770)**

#### **Grunder & Associates**

*P159*: hard key controller for Eric editing system; LCD menu-driven displays; operates with multiple VTRs in mixed 1/2" and 3/4" format systems.  
**Circle (773)**

#### **Harris Video Systems**

*IRIS II Plus*: digital still store; modular system serves up to 36 users; stores, catalogs 80,000 images; includes \*422 frame buffer, synchronizer; expands for paint, digital effects.  
**Circle (777)**

#### **Hitachi Denshi**

*VL-D500*: D-2 composite NTSC digital recorder; accepts 32-, 94-, 208-minute 19mm metal particle cassettes; 4x F<sub>sc</sub> 8-bit linear quantization; 48kHz 16-bit linear audio.  
*VL-S100*: S-VHS portable recorder; integral TBC; weighs less than 10 pounds; separate Y/C, composite inputs, outputs; flying erase head for insert, assemble edits; VL-EC10 edit controller.  
*HV-1200 HDTV recorder*: 14" reel provides 96 minutes recording time; 1125/60 system uses amorphous heads, metal tape; data rate 1.188Gbits/s; sampling frequency of 74.25MHz; 30MHz Y bandwidth.  
**Circle (781)**

#### **JVC**

*BR-S600U*: HiFi S-VHS recorder; Time-Go-To, VHS Index Search, Intro Search function; audio dub for voice-over commentary; variable speed search, still/frame advance; insert edit circuit.  
*KR-M820U*: M-II recorder, integral A/B roll edit control; accepts CTCM, component, composite, Y/C-3.58 inputs, outputs; SA-K12U time code reader/generator option; RS-422.  
*BR-S420CU*: camcorder docks to KY-25U, HY-17U and BY series cameras; S-VHS format; rotary erase head, auto editing function; integral audio monitor speaker; diagnostics; VITC recording option.  
*BR-9050U*: time lapse VHS-compatible recorder; 2-/6-hour standard play modes; 24 to 240 hour time lapse recording modes; alert when tape nears end; timer records eight programs in two-week period.  
*BR-7030U*: triple-deck HiFi VHS duplicator; allows increased deck density over most duplicator systems; all transports individually removable for maintenance; auto head cleaning mechanism.  
**Circle (816)**

#### **Lake Systems**

*Interformat editing*: suite designed for Betacam to digital.  
**Circle (832)**

#### **Landy Associates**

*Transedit-Beta*: editing system, custom-designed, multiformat composite videotape system; all contained in two transit, one utility case; SP VTRs with slow motion; titler; editor; monitor; more.  
*Editing system*: custom-designed, multiformat composite videotape system.  
*Transedit-Offline*: one roll-around transit, one utility case contains editing system based on CV Technology EditMaster.  
**Circle (833)**

#### **M&R Data Services**

*Symphony editing systems*: videotape editing software, interfaces for disk, DVE, VTRs; audio/video switchers; SCENE management, SCRIPT processing, VIDEO manager features; supports D-1, D-2.  
**Circle (1183)**

# Sennheiser Shotguns

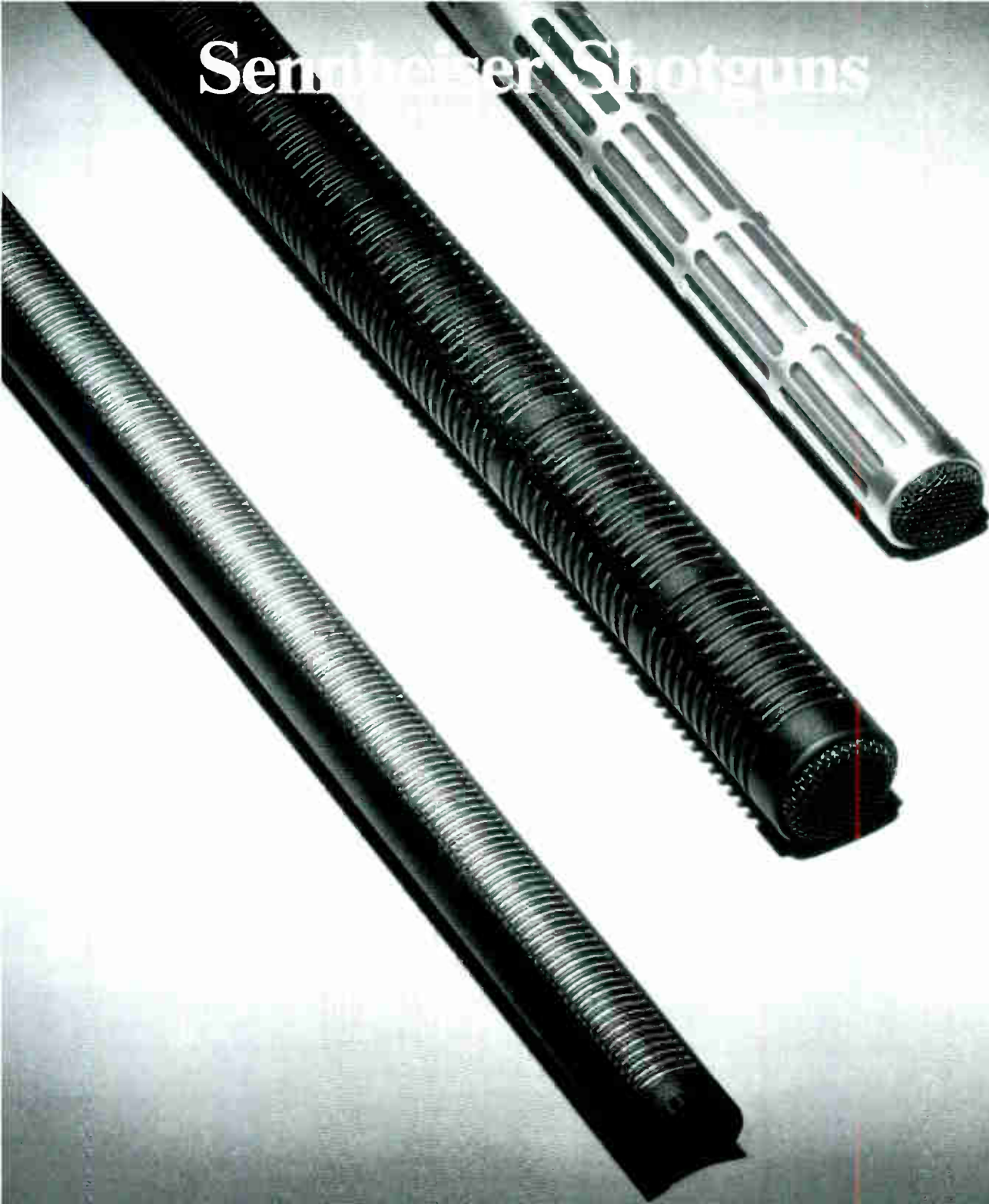

**Excellence Needs No Explanation.**

To learn more about the Sennheiser excellence in design and engineering,  
please call or write.

 **SENNHEISER**<sup>®</sup>

6 Vista Drive, P.O. Box 987

Old Lyme, CT 06371

Tel # 203-434-9190 FAX # 203-434-1759

Circle (96) on Reply Card

MICROPHONES • HEADPHONES • BOOM SETS • RF WIRELESS • INFRA-RED TECHNOLOGY

Manufacturing Plant D-3002 Wedemark, Federal Republic of Germany

## Montage Group

*System II Picture Processor*: random-access, non-linear electronic editing with multiple VCRs; for theatrical, television projects on film or NTSC/HDTV videotape.

*Portable Picture Processor*: mobile workstation-on-casters; self-contains modular system, operable in its shipping cases; CPU, console, three memory source modules, terminal with keyboard, printer.

**Circle (888)**

## NEC America/Broadcast

*VSR-10*: sports version of solid-state DRAM recording unit.

*VSR-10 enhancements*: digital video editing applications and control systems for post-production version.

*D-2 Interface*: for System 10 digital video effects system and VSR-10 solid-state video recorder.

**Circle (901)**

## Optical Disc

*Model 610A*: videodisc recording system.

*RLV*: recordable laser videodisc technology.

*Model 534*: digital audio converter, encodes, decodes for optical disc.

*Broadcast videodisc playback system*.

**Circle (919)**

## Otari

*T-700II*: high-speed video duplicator; operates 135x NTSC SP mode, 405x NTSC EP mode, 198x PAL mode, 270x NTSC LP/S-VHS mode; laser-based thermal magnetic duplication TMD process.

*DUPER*: PC compatible video duplicator productivity software; calculates productivity in cassettes per hour and cassettes per shift; PC-DOS, MS-DOS, one-floppy drive; 256K memory, printer.

**Circle (923)**

## Paltex

*E-series*: building block series from 3-machine to 8-machine system; VTR interfaces for any mix of 1/2", 3/4", and 1"; EDL from 250 events to 700 events.

**Circle (927)**

## Panasonic

*AG-180U VHS camcorder*: dual autofocus zones for large or small sections framed in viewfinder; autotrace white balance; piezo element controls focus between distant, close shooting.

*AG-460*: S-VHS HiFi camcorder; 2-CCD imagers, one luminance, one chrominance; 10 lux sensitivity minimum; amorphous video heads for wide frequency response; three-speed electronic shutter.

*AG-1400CR VHS player*: 12Vdc operation system; 4-head video system includes 2 rotary heads, helical scanning system and FM azimuth recording for maximum luminance, converted subcarrier phase-shift for enhanced color signals; resistant to heat and vibration often encountered in vehicles.

*AG-1240 VHS*: with Super 4-head video recorder for variable speed playback as well as field stills and field advance modes; programmable wireless remote control, on-screen display.

*AU-800U*: A/B roll editing controller; single-dial control; memorizes 128-event sequence with SMPTE time code or control track timing; split audio edits; remote control of external equipment by GPI.

*AG-1960 S-VHS recorder*: editing machine; HiFi

audio; high-speed transport; 400-line resolution; plays S-VHS, VHS; multiple search speeds, jog, shuttle; Super 4-head system; chroma stabilizer.

*AG-2510 VHS*: recorder; Super 4-head design for smooth natural slow motion playback in Double Super Fine Slow capability; Field Still, Frame Advance modes; digital tracking; linear time counter.

*AG-7330E S-VHS/VHS*: HiFi multistandard recorder, player; S-VHS/VHS in PAL; VHS for CCIR standard; VHS playback only in NTSC-4.43; optional time code reader, generator.

*AG-1730 VHS*: HiFi VTR; fast transport mechanism with shuttle, job; 28 cue/review search speeds; wireless remote; Double Fine Slow function for 1/3 to 1/30 speed slow motion.

*IFP-45 machine control*: interface box for 34-pin parallel remote control VCRs as source and AG-7500/7500A/6500 editing VCRs; interfaces Panasonic VCRs with Sony RM-440/450 controllers.

*AU-60*: M-II studio VTR; designed for industrial, business TV; integral 8-bit TBC, 47dB S/N; color framing, SMPTE/EBU time code reader, generator; 32-character display; optional S-VHS I/O.

*AG-ES10, AG-EP70, AG-ES100*: video floppy camera, video printer, floppy player with accessories; 25-image or 3 1/2 minute capacity on 2" disks; 360,000 pixel 1/2" CCD imager.

*AG-7450 S-VHS*: dockable recorder; integrate with docking adapter to 200CLE, 300CLE cameras; direct connection to WV-F70 2-CCD camera; two HiFi, two linear audio channels; operates as portable VCR.

*Digital 1/2" VTR*: uses M-II tape formulation; 6MHz bandwidth with 54dB S/N; Y/R-Y/B-Y video components with four PCM audio channels; 60x search, auto tracking; fits in same rack space as M-II deck.

*AU-CIF11*: off-line cassette dub system; software-based; uses AT-type PC to control dubs to M-II media for M.A.R.C. II use; accepts Make List from traffic department; A/V switcher; label printer.

**Circle (928)**

## PEP

*InterFormat NINE*: serial to parallel interface adapter; enables S-VHS VCR use with CMX, BVE-900, GVG edit controllers using 9-pin RS-422 serial control.

*JV450, PA450*: edit control adapters to allow S-VHS and VHS VCRs to be used with Sony RM-440, RM-450 edit controllers; units available for M-II and U-matic.

*SL-900 SHOTLISTER*: PC-based post-production system by DIGITEYES; graphic presentation of the finished master tape, shows video, audio relationships; EDL input/output.

**Circle (933)**

## Rank Cintel

*Slide File II*: dual-user stills workstation; high resolution; four display channels allow edit user and program user simultaneous access to system.

*Pocket*: 4:2:2:4 component digital still store; adaptation of Aston Wallet system conforms to CCIR 605/656 and SMPTE; dual output channel with full bandwidth linear key signal; 4RU chassis.

*Gallery*: picture management system; single user; 4:2:2 with 5 1/4", 12" optical storage;

30-image display; compatible with Gallery 2000 system disks; dual framestores, interfaces.

**Circle (964)**

## REBO High Definition Studio

*ReStore*: HDTV framestore; Macintosh II-based; captures and displays single frames from live or recorded HDTV source; 1/30s required; stores multiple frames.

**Circle (967)**

## Saki Magnetics

*Long-life Ferrite*: 1" audio post for BVH series recorder.

**Circle (986)**

## Seehorn Technologies

*MIDAS I*: allows cataloging of material; grabs, stores frames for reference; allows creation of EDL; creates a final EDL compatible with major editing systems; based on Macintosh II systems.

**Circle (1166)**

## Skotel

*TCG-311*: timecode generator, reader; half-rack package complements established reader products; reads 1/60x to 80x play speed; cross/jam mode; generates time code from 1/3x to 3x play speed.

*TCG-313*: time code generator, reader; same features as TCG-311 with simultaneous insertion of time and user bits into video on the display monitor.

*TCG-132*: includes LTC and VITC reader functions.

*TCG-80N-FT*: film-to-tape transfer time code generator; NTSC model identifies 16mm and 35mm film to single frame accuracy; graphically identifies 3/2 scan sequence within the foot and frame window.

*AV TC-20VI*: portable VITC, LTC timecode reader, character inserter.

*Remote Keypad*: replaces thumbwheel switches of TCG-80N/FT film-to-tape transfer generator.

**Circle (1006)**

## Sony Broadcast Products

*BVU-920 player*: U-matic SP play-only; dynamic tracking with modular BKU-901A TBC for ±10x play speed; 340-line resolution; reduced Y/C ringing effects; 72dB audio S/N and Dolby C noise reduction.

*DVR-18*: 3-hour capacity D-2 VTR; serial digital interface, variable speed options; BKDV-110 audio pitch corrector for ±15% change of play speed; BKDU-102 remote control panel; BKDV-108 provides for four DVR-10 or DVR-18 recorders with 99-event memory; 1,500m separation between controller and VTRs.

*DEM-1000 RAM recorder*: for instant slow motion replay; stunt motion and other special production requirements; can record four channels simultaneously; standard memory of 20s, expands to 3 minutes.

*DVR-1 prototype*: portable D-2 recorder; docks to BVP-70 or other 26-pin connection cameras, including Betacam SP units; backspace editing; 32-minute, 90-minute cassette capacity; produces broadcastable picture with full error correction/concealment.

**Circle (1011)**

## Sony Pro Video

*Type IX U-matic SP*: editor/feeder package VO-9850/9800 and portable VO-8800; 330 line resolution, 46dB S/N or greater; integral time

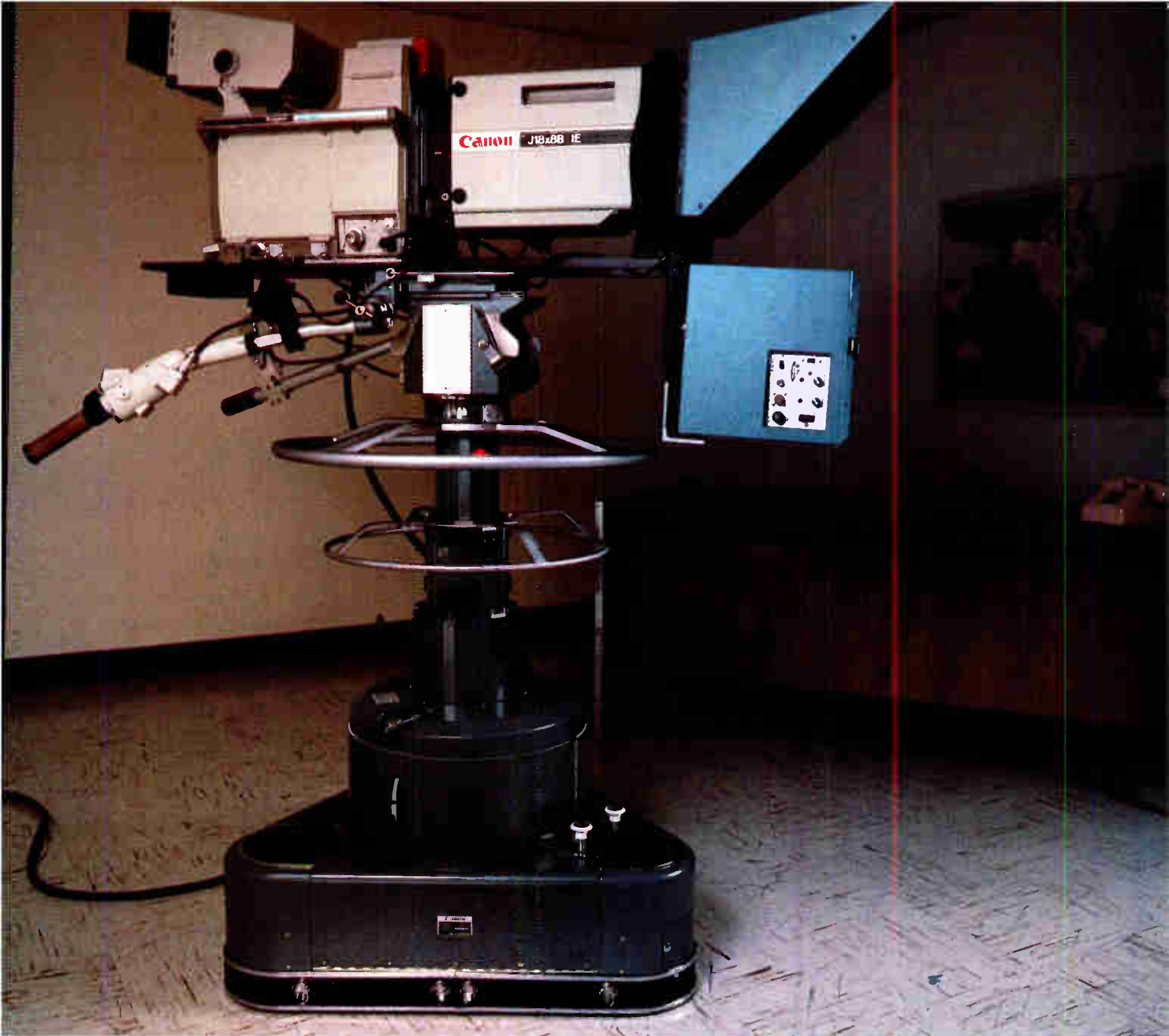

# Canon Puts You on a Pedestal

Canon professional support equipment is right at home in the world's most sophisticated studios. Finely finished, rugged and sturdy, yet designed for fluidity of movement, the Canon MC-200 and MC-300 pedestals can handle any camera/lens combination—teleprompters, too!

Canon pedestals are counterbalanced with unique energy cassettes that make set-up a breeze and eliminate the frequent adjustments and servicing necessary with systems dependent on compressed

gas. Their very short mounting height enhances low-angle shooting, and they offer the flexibility of 23-60 inch elevations.

Find out more about the quality and value in the entire line of Canon support equipment, including tripods and cam heads. All are sold, backed and serviced by the same people that made Canon the number one name in broadcast lenses. When we offer to put you on a pedestal, it's not a lot of hot air!

# Canon

Optics Division

Canon USA, Inc. New York Office: One Jericho Plaza, Jericho, NY 11753 (516) 933-6300 Dallas Office: 3200 Regent Blvd., Irving, TX 75063 (214) 830-9600 Chicago Office: 100 Park Blvd., Itasca, IL 60143 (312) 250-6200 West Coast Office: 123 Paul Drive, Costa Mesa, CA 92626 (714) 979-6000

Canon Canada, Inc. 6390 Dixie Road, Mississauga, Ontario L5T1P7, Canada (416) 678-2730

© 1987 Canon U.S.A., Inc.



Canon is a registered trademark of Canon Inc. in the U.S. and other countries. All other trademarks are the property of their respective owners.

Circle (97) on Reply Card

Worldwide History

code; audio S/N to 72dB with Dolby C noise reduction.

*EVO-9100*: single-chip, one-piece camcorder using Hi8 8mm recording format; tapes are played back through *EVO-9800* Hi8 feeder machine to U-matic SP editor such as VO-9850 or equivalent; also in Hi8 system is a dockable recorder for use with *DXC-325* 3-chip camera; Hi8 system increases luminance carrier by 2MHz and deviation by 0.8MHz over standard 8mm recording systems.

**Circle (1011)**

#### Sony Still Image Systems

*MVR-5600 ProMavica*: hi-band format still video recorder, player; 500-line resolution; NTSC composite, RGB, Y/R-Y/B-Y inputs, outputs; dub/TBC interface; program editor; remote controller.

**Circle (1200)**

#### Spectra Image/Spectra Systems

*Model D-160*: system-optimized videodisc player.

**Circle (1019)**

#### TEAC

*Auto-Turn*: laser videodisc player; plays both sides without turning disc over; computer peripheral or one hour video with 2-channel audio; 108,000 still frames; RS-232C; compatible with LV-series.

**Circle (1051)**

#### Toko America

*VT-300M*: store, manipulate, retrieve 3s of NTSC composite video; selectable sampling rates; 48Mbytes expandable to 96Mbytes; GPIB, DEC interfaces with digital VTR and other options; sequences.

**Circle (1081)**

#### United Media

*UMI 400 series (420, 430, 440)*: A/B roll, time code videotape editing systems; full feature, with A/V dissolve unit, independent dissolve rates; 250-event EDL, 3 1/2" MS-DOS drive time code generator; expansion of system for A/B/C roll; edit list management includes ripple; on/off-line editing applications.

**Circle (1097)**

#### VideoLab

*TCR-579, -680*: time code retrofit modifications for type 5, 7, 9, VO-8800 and BVU 3/4" VCRs; records LTC on time code address track.

**Circle (1122)**

#### Videomagnetics

*Refurbishing of VPR 1" heads*: AST, R/P, flying erase, sync, dummy and non-sync. 2" heads for RCA & Ampex VTRs.

**Circle (1123)**

#### Videomedia

*VLC-32 LAN Control*: modular, expandable; functions as 2-machine cuts editor or controller for 31 devices; upgrades to 6-machine sync roll, 6-track audio, integral dissolve, AFV mixer; multilevel transition control of switchers, multiple recording transports; animation, slow motion, auto math frame; 500-event non-volatile memory.

**Circle (1124)**

#### Vortex Communications

Time code products.

**Circle (1130)**

#### VTE

*DVSR 100*: digital video silicon recorder; real time simulation system for ATV, HDTV; RAM simulation system data rate of 312 Mbyte/s; internal RGB, YUV recording; 2Gbyte RAM for multiple users.

**Circle (1201)**

## Video Products

### V3: Film, cine

- ✓ Telecine systems
- ✓ Film-to-tape transfer
- ✓ Film editing systems
- ✓ Video-for-film systems

#### Apollo Audio Visual

*SV-7000*: 35mm slide-to-video transfer system.

*AY-4000A, AY-5000A*: video transfer units.

**Circle (554)**

#### Arriflex

*Zeiss prime lenses*: 10-100mm, 12mm, 40mm, 60mm Macro. 300/600mm focal lengths.

*ARR1 video door*: pivoting unit for 35-3 film camera.

*ARR1 Grip*: film, video grip equipment.

**Circle (559)**

#### BTS

*Film-to-tape transfer*: 4:2:2 digital system.

*FRP-60 upgrades*: dual master mode; auto insert; master, black sensitivity; PC event listing; interfaces to digital video recorders.

**Circle (619)**

#### CASCAM

*HomeLights, GlassDeco*: station image packages, IDs, background images.

**Circle (629)**

#### Cinema Products

*Showscan CP-65*: high-speed, variable frame rate 65mm camera; for Showscan process and 65mm cinematography features, matte, projection work.

*Cinevid CCD*: video-assist unit for CP-16R camera.

*CP-16R update*: electronic 30FPS conversion for existing cameras; electronic crystal 30FPS via toggle switch on panel.

*CP Keycode Reader*: for Rank Cirtel telecine; reads Kodak Keycode to automate transfer of film frame ID information to videotape; essential for conforming video edits back to film.

**Circle (644)**

#### Fuji Photo Film

*F-series film*: super fine-grain film for cinematographers; high definition, increased sharpness, true-to-life color reproduction under varying light; negative film emulsions.

**Circle (754)**

#### Marconi Communications Systems

*B3A10*: digital line array telecine system.

**Circle (860)**

#### Nytone Electronics

*New Vision System 1000*: combines digital color analyzer with a video production unit; analyze 35mm-8x10 film formats in all emulsions; VHS editing; effects, color correction; 3,000-frame memory.

**Circle (912)**

#### Rangertone Research

*Model 109*: high-speed, film dual-audio recorder/reproducer.

*Projector*: studio projection system, high-speed transport for 16mm, 35mm; carbo light source. *16/35mm holoscope projector*: for telecine, studio projection; high speed system.

**Circle (963)**

#### Rank Cintel

*FGR-I grain remover*: component digital system compatible with Digiscan 4, ADS-1, ADS-2 telecines; setup mode shows split screen of telecine and corrected image.

*MkIII HD update*: 1125/60 flying spot telecine with advanced Amigo preprogrammer color correction system; available for HDTV.

**Circle (964)**

#### Steenbeck

*ST-721*: 35mm film flatbed editing table.

*ST-660IV*: three MAG tracks interchangeable between 16mm, 35mm on editing table with videocassette player; intelligible speech between 1/2 and 2 1/2x normal sync speed, forward or reverse; cut sound track on magnetic heads, synchronized to 3/4" cassette.

*ST-701*: 35mm flatbed editing table, beamsplitter for film-to-video transfer without flicker.

**Circle (1028)**

#### Tamron Industries

*Fotovix II-X, Fotovix III*: film/video processors allows viewing of negative or positive film images to video; *III* for 35mm; *II-X* for 35mm, 2 1/4", and 8x11" formats, including prints.

*Fotovix Slide-Feeder L*: provides continuous feeding of slides to Fotovix processors; uses standard LKM or Kinderman type 35mm magazines.

**Circle (1044)**

## Video Products

### V4: Batteries, lighting

- ✓ Batteries, packs, belts
- ✓ Chargers, analyzers
- ✓ Lighting instruments
- ✓ Lamps, accessories

#### Alexander Batteries

*BPIA-11 battery*: increased capacity over BPI-11 to 1.8Ah with 11 cells for longer use between recharges; 13.75Vdc.

*7700 series*: ride-behind alternatives to Anton/Bauer Snap-On; *7700-10* 10-cell, 12V; *7700-11* 11-cell, 13.2V; *7700-12* 12-cell, 14.4V; in black, gray, white; 4.5Ah capacity.

*BP-90A*: direct replacement for Sony BP90;

# Aphex Makes Everyone Happy!

Stations that want to attract and keep a loyal audience realize audio quality is as important as programming. That's why sophisticated broadcasters avoid loudness wars and have gone to the state-of-the-art in signal processing . . . the Aphex Audiophile Air Chain™. This combination of the highly acclaimed Aural Exciter®, Compellor™ and Dominator™ delivers a signal that is competitively loud, yet doesn't sound processed, retaining a natural openness.

The Aphex Audiophile Air Chain will give your station a competitive edge in quality audio that sounds good on virtually any radio or high end audio system. And that covers all formats. KTWV-FM The Wave (Los Angeles), WHYI Miami-Ft. Lauderdale Top 40's, KKGO America's Jazz Station, KABC-TV Los Angeles, and WQXR New York's Premier Classical Station are representative of the different formats using the Aphex Audiophile Air Chain.

The best signal processing is also economical. The Compellor and Dominator will not only save your audio, they will save your budget.

AM, FM, TV, cable, or satellite uplink . . . rock to Bach or talk, the Aphex Audiophile Air Chain offers the best signal processing at any price. Contact your local Aphex dealer to arrange for a demonstration today. Be happy!



## APHEX SYSTEMS LTD.

11068 Randall Street • Sun Valley, CA 91352 • (818) 767-2929

© 1988 Aphex Systems Ltd.

All Aphex products are designed and manufactured in the U.S.A.

Circle (98) on Reply Card

FREE! *The Aphex Experience* Videotape. Send \$5 to cover shipping and handling to our address in this ad. Be sure to include your name, address and phone number. Allow 4-6 weeks for delivery.

### Matthews Studio Equipment

*Break-a-part frames:* 12' x 12' overhead and 6' x 6' butterfly frames; 8-pole units.

*Swivel J-Hook:* holds cords, cables, keeps load hanging vertically.

*Pin and collar:* 6" x 1/8" diameter.

*grifflector:* flexible reflector material; can be used as background and keylight source by reflection of single light source.

Circle (864)

### Mole-Richardson

*MSR lamp Fresnel instruments:* 575W, 1.2kW, 2.5kW; all use single-ended MSR type lamp and Fresnel lens.

*Type 633I:* 575W HMI Solarspot.

*Type 371I:* 1kW PAR-64 light.

*Solar-Arc:* 24 3/4" 12kW HMI Fresnel instrument.

*Solar-Arc Solarspot:* 18kW HMI instrument.

Circle (887)

### Musco Mobile Lighting

*LIGHT BAR:* 4-fixture unit on pre-wired, pre-assembled bar, versatile for sports arenas, stage, conventions, concerts, parades, news events or other large area lighting needs.

Circle (892)

### Osram Corporation

*Reporter 125D:* lighting instrument for ENG; joint project with Sachtler; uses HMI 123 light source.

*HTI lamps:* metal halide short arc discharge lamps; integral reflectors for daylight color

spectrum with dichroic reflector; 75 lumens/watt, 30-40kcd/cm<sup>2</sup>; single, double-ended types.

*Xenophot tungsten halogen:* lamps using xenon instead of krypton gas; 20% more light than conventional HMI lamps; constant color temperature with equal lamp life and power consumption.

*HMI PAR:* metallogen HMI 1200W PAR metal halide lamp; *gap-shortened* unit for higher luminance; center intensity greater than 1,000,000 beam candle power; 5,600°K color temperature.

*HMI 123W:* high luminance, compact lamp using *gap-shortened* technology; 8,500 lumens, approximately 3x greater than typical tungsten-halogen lamps; 5,600°K color temperature, 70 lumens/watt.

Circle (922)

### Paco Electronics USA

*NiCad batteries:* DP-10, 12V 1.9Ah; DP-11, 13.2V, 1.9Ah.

*KD-420A:* portable, 4-channel quick-charge system.

*KD220:* portable 2-channel quick-charge system; 1.8A charging current.

*KD11 charger:* consecutively charges four batteries or two DP-1240 batteries with selector switch; quick charge rate of 1.6A.

*KD-120A-II:* NiCad dememorizer; corrects "memory" problems followed by fast-charge

current of 1.8A; 4-channel system operates from 100-240Vac without switching.

Circle (926)

### PEP

*PEP Fast Charger Expander:* connects to appropriate charger and dc power source; sequences charging operation by stepping from one position to the next at approximately one-minute intervals; must only be used with battery and charger combinations meeting respective manufacturers' specifications; only for chargers with auto start and shut-off typically in current range of 2-6A.

*UMC Universal MicroCharger:* charge any ENG battery from ac or dc automotive power; *SQ490* sequencer option charges four ENG batteries.

Circle (933)

### Perrott Engineering Labs

*Super 90:* 12V, 4Ah NiCad pack; run time 1 1/2 hours; premium fast-charge cells encased in Kydex; chargeable on any system.

*PE 441/14:* discharger, charger series; accommodates four 14V NiCad packs; independent operation of four separate discharger and charge units in the system.

Circle (934)

### Philips Lighting

*MSR 1200/HR, MSR 2500/HR:* single-ended, medium-source, rare-earth discharge lamps; 1.2kW, 2.5kW; hot-restrike versions; 5,600°K.



## TDI 200 TIME/DATE/IDENT GENERATOR

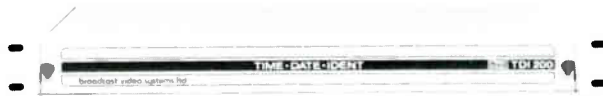

AN ECONOMICAL METHOD OF DISPLAYING TIME, DATE AND TWO ROW IDENT OVER PROGRAM VIDEO

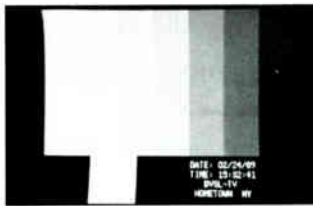

- User programmable
  - 16 characters per row
  - Non volatile memory
  - Custom logos to order
- See Us at NAB Booth #3426

## broadcast video systems ltd.

40 West Wilmot St., Richmond Hill, Ontario L4B 1H8  
Telephone: (416) 764-1584 Telex: 06-964652 Fax: (416) 764-7438

Circle (155) on Reply Card

## Highest Performance Audio Transformers!

- Wide bandwidth • Low hysteresis distortion
- Flat group delay • No overshoot or ringing

Call for free applications assistance  
(Mon-Thurs. 9am-5pm Pacific time)

## jensen transformers INCORPORATED

10735 Burbank Blvd. • North Hollywood, CA 91601  
FAX (818) 763-4574 Phone (213) 876-0059  
TELEX 6502919207 MC1 UW

Circle (156) on Reply Card

## VIDEO SUPPLIES

CABLES • CONNECTORS • CANARE • BELDEN • SWITCHCRAFT • D.A.S. • TIES • BATTERIES • NEUTRIK • 60 INTERFACE BOXES • TAPE • 500 DIFF. TAPE LABELS • GAFFERS TAPE • CASES • PATCH BAYS • LIGHTS • ACOUSTIC FOAM • FORMS • MICROPHONES • SONES • STANDES • MOUNTS • WIND SCREENS • ZEPPELINS • FIBRE OPTICS • RACKS • DUCT • REELS • TESTERS • FILTERS • CHEMICALS • TOOLS • ON-AIR LIGHTS • DEGAUSSERS • INTERFACE DEVICES • HEADPHONES • CLIPS • SWITCHES • CAM & S-VHS CABLE



MARKERTEK VIDEO SUPPLY  
145 Uster Ave. Saugerties, NY 12477 U.S.A.  
TOLL FREE 1-800-522-2025  
In NY: 914-246-3036

Circle (157) on Reply Card

# Want more information on advertised products? Use the Reader Service Card.



CHYRON

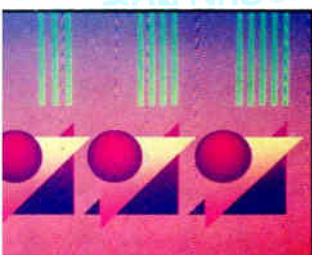

## Freedom of Choice

We set the industry standard with the Chyron SCRIBE. But at Chyron, we think one outstanding character and graphics generator doesn't provide freedom of choice. So we developed the Chyron SUPERSCRIBE and then, the Chyron SCRIBE JR. And like any happy family, they're all compatible. Interchange fonts, graphics and messages or connect them via a local area network.

Since you can never have too much of a good thing, we're now offering you a broader range of creative options — more flexibility — and even greater performance. *Freedom of choice just got tougher.*

Introducing the Chyron SCRIBE iNFiNiTi!. Two full bandwidth output channels, optional third internal channel, peerless character generation, world class paint, unique 3D animation, real time digital effects, full color still store and more....*infinite creative potential with the new SCRIBE iNFiNiTi!*

Your choices don't stop there. The SUPERSCRIBE now offers Business Graphics Software, Color Video Capture and the exciting new "Transformer" option for *real-time, object oriented animation.*

Want more choice? The SCRIBE JR. is now available in a dual channel configuration with mix and effects.

Find out why more than 1,000 SCRIBE Family products are in use worldwide.

*Exercise your Freedom of Choice.*



A member of The Chyron Group: Chyron • DSC • CMX • Aurora  
265 Spagnoli Road, Melville, N.Y. 11747 • (516) 845-2020/2022

World Radio History  
Circle (101) on Reply Card

© 1989 Chyron Corporation

**MSR Medium Source Rare earth lamps:** single-ended, 5,600°K; rated 400W, 700W and 1.2kW. **Circle (938)**

#### **Pro-Battery**

**"On-Board" type batteries:** 12.0V, 13.2V, 14.4V units.

**NPIA redesign:** Beta batteries, 12V, 1.8Ah units. **PB90s:** thermal breaker, automatically resets if there is a short in the system.

**Inserts:** pre-wired with connector; simplifies putting new cells in "On-Board" systems.

**PRO 500 recharger:** 4-port charger, 4Ah system; all ports independent, after charge goes to trickle current.

**Circle (945)**

#### **Red Line Research Laboratories**

**M12B Pro, M20B Pro:** 12V, 12Ah and 20Ah battery belts with meter.

**M630B Pro, M1030B Pro:** 30V, 6Ah and 10Ah battery belts with meter.

**M6E Pro:** 12V 6.5Ah battery pack with meter.

**CHF12, CHF30:** 12V 4A, 30V 1.7A fast chargers.

**CHM series:** maintenance chargers; 12V, 30V units.

**CH512, 912, 530, 930:** overnight chargers for 12/30V batteries; 500mA, 900mA current systems.

**6E Pro:** 12V 6.5Ah battery pack; self-resetting circuit breaker.

**Maximizer Pro:** 13.2V 4.8Ah NiCad battery; extra cell for longer running time.

**RL100/150 Pro:** ac/dc video lights; rated 100W dc or 150W ac; never gets hot.

**Circle (1222)**

#### **Rosco Laboratories**

**Pin connectors:** polycarbonate plugs, receptacles, adapters compatible with existing connection devices; 20A to 100A capacities.

**Circle (980)**

#### **Sachtler**

**Lighting accessories:** Netronic 270 ballast; Batronic 270 30V batteries.

**Production 575D:** lightweight, compact for 2-sided HMI burners; oval shape reduces volume, weight.

**Production 1200D:** open-faced HMI flood; wide focus range greater than 1:5.

**Reporter 100H:** 12Vdc tungsten light for CCD camera use or as eye light.

**Reporter 250H:** 30Vdc tungsten light for film, video camera use.

**Reporter 650H:** 600-1000W tungsten lights; hand-held or stand; 220- or 240Vac lamp.

**Reporter 270D:** hand-held or tripod-mount HMI open-face lights for studio or on-location.

**Reporter 125D:** compact HMI Daylight fixture for news team; flicker free; ac/dc.

**Reporter 300H:** ac-powered tungsten light; available in set case with three lamps, tripod.

**Circle (985)**

#### **Strand Lighting**

**Lightboard 90:** lighting control board; incorporates numerous features of Palette series with multitasking; desktop console capable of handling 4,000 dimmers on 4,000 channels, using a distributed processing array to speed information provided to dimmers; 48 submaster fader pots or 24 submaster wheels; storage for 600 average sized cues, 999 effects; supports DMX512, AMX192 protocols.

**PALS:** Precision Automated Lighting System; IBM PS/2 controller; Galaxy 3 motion control

panel; motorized instruments; Scroller color changer; data, power distribution.

**QUASAR:** 1.2kW HMI/CID PAR light system; QuartzColor unit with Sylvania BriteBeam Mk II PAR 64 or Thorn Sealed Beam CID lamp.

**PARSCAN II:** automated PAR fixture; remote controlled movement, color change; on-board microprocessor; low noise operation.

**CANTATA series:** variable focus spotlights; 11°-26°, 18°-32°, 26°-44°; 18-leaf diaphragm; pattern holder; color frame; FEL 1kW lamps.

**Circle (1030)**

#### **Synergistic Batteries**

**SCB-14, SCB-13, SCB-12:** NiCad batteries fit Snap-On mounting brackets; automatic resetting circuit breaker replaces 20A fuse; 14V, 13V, 12V.

**Switchable Power Vest:** runs cameras powered by 13.2V or 14.4V battery pack and 30V lights.

**SB-90L:** 13.7V 15Ah lithium battery; retains 80% capacity after 10 years storage; 3.5× capacity of NiCad.

**SCB-13L:** lithium battery, 13.7V 15Ah.

**Series 200:** smart charger; timed fast charge with trickle mode; fully charges battery in three hours; multiple positions operate independently.

**Series SS, SF soft belts:** 12V, 14V, 30V models; plug for charging SB-90 belt charger or fast charger for SF types; 4Ah, 7Ah capacities; one year warranty.

**Circle (1223)**

#### **Teatronics**

**Producer II+ enhancement:** optional color CRT and disk drive; stores and indicates status of lighting control system.

**Circle (1052)**

#### **Tekno**

**Galaxy lightbox:** fluorescent light source or flash/tungsten type; fluorescent available in 2700°K to 5000°K color temperatures; by Balcar.

**Circle (1054)**

#### **Theatre Vision/TVI**

**Electro-Diffusion:** LCD film on plexiglas; changes from transparent to translucent, based on setting of control dial between 0-88Vac; fully powered (0V) with 82% transmission, 74% color shift.

**Thermoguard:** multilayer, coated polyester heat film, reflects infrared energy from stage and studio lighting instruments; place between lamp and color or diffusion media; extends life of media.

**Circle (1071)**

#### **Tiffen Manufacturing**

**Soft/FX filter series:** tones down wrinkles, blemishes; no change in contrast; no out-of-focus results, retains overall image clarity.

**Pro-Mist filters:** removes hard edge of sharpness without out-of-focus; mild reduction in contrast; introduces controlled amount of flare to spread light.

**Circle (1076)**

#### **Times Square Lighting**

**Tratto F-1200:** 1.2kW Fresnel instrument.

**Acuto F-2000:** 2kW Fresnel.

**Tratto 22/40:** 1kW ellipsoidal spotlight.

**Acuto 9/15:** 2kW ellipsoidal spotlight.

**Talento 575:** follow spot.

**Circle (1078)**

#### **Union Connector**

**HMI remote control contactors:** modular unit provides remote control of HMI lights; silent mercury contactors and control station.

**Unitrol Dimtrak:** 6-foot wireway; integral Unitrol dimmers; Unistrut construction for spotlight mounting in various environments; lighting control signals transmitted via the power line.

**Dimmer bypass contactor:** transfer switch for manual control of lighting; bypasses dimmer systems; for maintenance, stage manager or others not at the dimmer console.

**Circle (1095)**

#### **Videssence**

**SPIL VID-12/8K, VID-6/4K:** sustained plasmatic ionic light sources; fluorescent arc-type lamp produces energy enhanced by infrared and ultraviolet improves dark detail; for chroma key blue work.

**Circle (1224)**

#### **Walter Brewer Corporation**

**WBC hanger:** remote controlled lighting instrument hanger; telescoping system includes high-torque motor to raise, lower hanger and load; C-clamp attaches unit to pipe; needs non-dimmed ac circuit.

**Circle (1131)**

## **Video Products**

### **V5: Digital effects, graphics, titles**

- ✓ Character generators
- ✓ Effects, graphics systems
- ✓ Prompting systems
- ✓ Video production systems
- ✓ Weather graphics systems

#### **Abekas Video Systems**

**A72 enhancement:** character effects added to digital character generator; Glow, Hollow, Soft Characters, Soft Shadows, Character Aspect; full color RGB scan-in; independent character movement.

**A34 SOLO:** integrated digital production system; 2-channel digital effects, A/V switching, mixing; TBCs, full function editor; menu control.

**Circle (502)**

#### **Accu-Weather**

**High Resolution:** weather graphics with RADARPLUS; precipitation types shown as Snow, Ice, Rain, available hourly as national graphic and six regional images.

**Amiga Graphics:** advanced version of weather display system; automatic log-in to database for access to more than 1,500 real-time color images daily.

*Lightning Data:* ready-for-air graphics through *Accu-Data* weather database.

*European/World* forecast model.

*UltraGraphix:* weather graphics shows high-color, high-resolution, with regional, national satellite and radar images; temperature band, weather maps, lightning displays; 4-D satellites.

Circle (504)

#### ACE

*DMG-1000:* digital matte generator; create sculptured mask shapes with stylus, bit pad; menu-driven; linear anti-aliased keying; NTSC, analog component, D-1 formats; Frame-grab; disk storage.

Circle (506)

#### Advanced Designs

*WDDS-1000:* Weather Data Display System; includes color mixer, map builder; NWS RRWDS radar imagery control panel; lightning control panel; graphics/paint option; *Acquire* for ESD, WSI, *Accu-Weather* graphics, data.

*DOPRAD II:* delta-frame animation with V2.02 software enhancement; pan, zoom, custom map generation, fast-frame looping with variable speeds; 10Mbyte hard disk storage for 200 images, sequencing.

Circle (514)

#### Alden Electronics

*Model C2000R update:* remote color weather radar display; access any of 120 NWS radars in country; four integral display ranges 25-200 miles; expanded memory stores 16 images; NTSC, RGB.

Circle (524)

#### ALTA Group

*Serial interface for Centaurus:* standard feature for effects/dual channel still-store system; Grass Valley 100 RS-422 protocol talks with Paltex, Convergence, Sony, United Media, Calaway.

*CYGNUS 5.5:* wideband TBC/synchronizer; 5.5MHz bandwidth, 450-line resolution; Y/C-3.58, composite; integrated production effects; 4x1 A/V routing switcher; meets RS-170A; 8-bit 4x $F_{sc}$

*ESD external disk:* expands storage of Centaurus dual-channel still store; removable Winchester cartridges; each holds 170 fields (85 frames); on-line fixed disk available for over 2,000 fields.

*Computer interface:* extender module option for Centaurus; RS-232 control from any PC; links to station automation, editing systems for A/B roll editing; three data rates; 4-way control selection.

Circle (534)

#### Ampex Corporation

*ALEX:* anti-aliased character generator; 256 levels of transparency; manipulation, animation of characters, symbols; typeface library of 1,500; 16.7 million colors; Dynamic Attribute Manipulation.

*ADO 100:* digital effects system; low-cost, upgradable to 3-D; Z-axis spins; 3-axis rotations; fly irregular objects; Digi-Matte key processing; AutoCube; live keyframe editing; 32-bit 4:2:2.

Circle (541)

#### Aston Electronics

*Aston 4B:* anti-aliased titling system; font processing, digital video effects, drawing facilities; unlimited roll, crawl timing; fast access times; hard disk, additional planes, shaded



# GLOBAL SUPPORT FOR GLOBAL COMMUNICATIONS

## C-Band and Ku-Band High Power TWT Amplifier Systems

For Video, Voice  
and Digital  
Communications  
50-3000 Watt



To meet expanding needs of the video, voice and data markets, MCL offers a host of C-Band and Ku-Band High Power TWT Amplifier Systems, 50-3000 Watt, with flexibility in configuration and consistently reliable power output. MCL is dedicated to manufacturing amplifiers of the highest quality, yet at competitive prices. The amplifiers are recognized and accepted worldwide for incomparable performance. They are designed to withstand interference from EMI-radiation/RFI-susceptibility, electrical (power source), mechanical stress, environment (temperature/humidity), or general maintenance and transportation.

MCL's C-Band and Ku-Band High Power TWT Amplifier Systems are designed with state-of-the-art engineering concepts, and options are available for customized applications. The C-Band units (5.850-6.425 GHz) operate at 50-3000 Watt power levels; and the Ku-Band units (14.0-14.5 GHz) operate at 50-2500 Watt power levels.

MCL is a primary source of amplifiers and allied equipment for satellite communications worldwide. Commonality in operation, design, and mechanical layout of all MCL equipment provides for interchangeability and keeps maintenance and repair time at a minimum, performance at a maximum.

Write for your FREE copy of MCL's New Brochure #6008 for additional details and technical specifications on the complete line of MCL High Power TWT Amplifier Systems.



# MCL

MCL, INC.  
501 S. Woodcreek Road  
Bolingbrook, IL 60439  
312-759-9500 TWX 910-683-1899

Manufacturers of TWT and Klystron Amplifiers for Satellite Communications.  
24-Hour Sales and Technical Support for Immediate Service Worldwide.

Circle (102) on Reply Card

World Radio History

backgrounds, camera capture options; fully anti-aliased dual channel mode.  
**Circle (564)**

#### AT&T GSL

*Graphics software applications:* including RIO design, layout; TOPAS 3-D modeling, animation; PANORAMA image sequencing; 35mmEXPRESS business graphics; video overlays, 2-D animation.  
**Circle (565)**

#### Aurora Systems

*AU/90:* graphics system; color-mapped with 80286 CPU; color cycling, palette, reveal, step animation; WSI, Accu-Weather support; two frame buffers; digitizer pad; 20Mbyte hard disk. *Aurora/3DS:* modeling, rendering, animation; files interchange with all Aurora full color systems; 25MHz, 33MHz clock; 348Mbyte disk; 60Mbyte streaming tape; multitasking. *AU/240:* graphic system with 145Mbyte fixed disk, 4Mbyte RAM, two frame buffers; 80386 with 80387 math processor operates at 16.7MHz; full color paint; icon-based menus; 32-bit/pixel, key out.  
**Circle (1225)**

#### Beaveronics

*ESE ES-CG89:* character generator.  
**Circle (591)**

#### Broadcast Video Systems BVS

*COX2036:* component title assembler, by Cox. *SA103:* safe area generator; dual  $\mu$ P control; 16-button remote keypad; safe action/title, center cross, blanking markers; countdown clock, slate; programmable rectangles. *TDI-200:* 24-hour time, date, user-programmable ID generator; 2-row, 28-character display; non-volatile memory; 9x16 dot matrix characters keyed into picture or black window.  
**Circle (614)**

#### BTS

*Vidifont Standard fonts:* anti-aliased with light-trapping techniques for smooth edges; 400 fonts in different sizes, edge, border treatments. *Alias/2 animation:* 3-D computer graphics with interactive software on Silicon Graphics workstation; interface to Pixelator rendering engine; trimmed surface modeling, object metamorphosis. *Vidifont LAN option:* networking and RS-232/422 interfaces to NewStar, BASYS, SISCOM and other newsroom computers. *PIX recorder:* machine control system for recording Alias animation files; upgrades to full Pixelator render engine; digital video I/O. *Vidifont fonts:* 50 Bitstream font masters allow resizing with font and logo compose feature. *CorrecText:* on-line spelling checker for Vidifont Veditext II; 45,000 word dictionary. *Vidifex-3D:* captures image in font/logo compose package, extrudes, rotates image in three dimensional space; tiles images onto characters for display, animation.  
**Circle (619)**

#### CEL Electronics

*MS831/832, MS851/852:* single, dual channel effects systems using P163 hard-key or P152A touch-screen controllers; sequence storage; incorporate P164-38 framestore/effects TBCs.  
**Circle (632)**

#### Chyron

*Chartist:* presentation graphics for SuperScribe. *Fonts-by-Wire:* through software maintenance agreement; for all Scribe systems; Bitstream fonts included. *Dual-channel:* Scribe Jr configuration. *ACG system:* combines character generator, graphics, animation and digital effects into single unit with open-end architecture; real-time operation; Bitstream fonts; NTSC/PAL; linear keyer/fader. *Scribe Toolbox:* six interchangeable graphics packages for use with Scribe, SuperScribe; Boxes, Bars, Sports/Weather; Signs/Symbols; Geometrics; Shapes. *Scribe INFINITI:* 32-bit/channel display; effects; 3-D animation, paint, frame store; dual-channel system; 4:4:4:4 internal processing; eight fonts/channel; hard disk; 4Mbyte memory; icon prompts. *Chyron IV Converter:* software converts Chyron IV fonts and graphics to files readable by Scribe products. *Transform:* creates animation, background shading; soft-edge masking on Scribe products.  
**Circle (641)**

#### Circuit Studios

*Velocity 3D:* modeling, video animation; turn-key graphics workstation; 80386-based system. *SuperComputer Velocity System:* AT&T Pixel Machine Graphics; with Sun 3/260 workstation; real-time texture mapping, multiple lighting, smooth shading; ray-tracing with HDTV quality.  
**Circle (648)**

#### ColorGraphics Systems

*da Vinci features:* expanded color vector control with geographic isolation; 16, 32, 64 vector secondary processing for hue, saturation, gray values; tape-to-tape color correction; editing control. *LiveLine 5 features:* 2-D object-based real-time animation; expanded image transition effects with Digital Video Mixing; Enterprise Electronics, R-Scan interfaces; request list editor data acquisition mode allows use of new products offered by weather data vendors, including WSI NOWRAD national radar network product. *ArtStar 3D features:* true 3-D cut/paste; true perspective; blend brush; dynamic text rotation, curves; luminance, chrominance-based stenciling, mattes; RGB Phong shading model. *DP 4:2:2 features:* 3-D modeling, animation with control of object attributes, light, camera movement; Morph 2-D Animator; video recorder control; History macro; multiplane motion; rotoscoping A/B roll editing for VTR, DVTR, DDR; real-time cel animation; digital video switcher interface; improved shape editing, management; perspective cut/paste; optional wireless pen/stylus.  
**Circle (655)**

#### Comprompter

*TOTA PLUS software:* for PC/compatible 286/386 XT/AT systems; electronic prompting; networking to five users; script writing, editing, show stacking; electronic mail, script archives.  
**Circle (662)**

#### Computer Prompting

*CPC-500:* CaptionMaker; applications for hearing impaired, foreign language subtitles; 2, 3, 4 caption lines; control of caption lengths, indents; upper/lower case; Spanish, French available.

*CPC-1000H:* SmartDisplay; flat-screen on-camera prompter display; weighs 7 pounds. *CPC-2000 SmartPrompter+:* now includes closed-captioning option; simultaneous prompt and Line 21 caption outputs. *CPC-1000:* SmartPrompter+; simultaneous prompt/edit or load new text while prompting; available for IBM PCs/compatible laptops; control number of prompt lines on screen, change fonts; 4-hour scroll.  
**Circle (664)**

#### Computer Prompting Services

*CPS Cue Card:* electronic, mobile cue card; available with shoulder harness or operates handheld; magnified screen for improved visibility.  
**Circle (1226)**

#### Cubicomp

*AutoPaint:* graphics software that gives a hand-painted look to the video frame; emulate water colors, oils, charcoal, reflective styles; stand-alone or add-on for PictureMaker 3D. *Vertigo Series 9:* 3-D graphics based on Silicon Graphics 4D workstations; integrates Extrude, Mesh, Choreographer, Makeup; 3-D Boolean, Tempo, Quick shade, Render speedup features. *VideoPak:* for Silicon Graphics 4D workstations; ports video images directly into 3-D graphics creation without external interfaces; major formats supported in PAL, NTSC; RS-232, IEEE-488.  
**Circle (680)**

#### CV Technologies/Comprehensive Video

*PC-2/S-VHS:* video titling generator; compatible with S-VHS video requirements; 26 fonts with italics; 64 colors for characters, backgrounds; 16 colors of shadows, edges; 40ns resolution.  
**Circle (661)**

#### Digital Arts

*DGS V.3.0:* expands features of 3-D animation system operating in PC environment; *DGS Build* creates models, *DGS Render, Transender* high-speed parallel rendering features.  
**Circle (696)**

#### Digital F/X

*Composium digital editing suite:* integrates DF/X 200 production system with 4:2:2 graphics, paint, recording equipment; uses 4:4:4:4 sampling for Y/R-Y/B-Y/key channels. *Removable Disk:* 40Mbyte cartridge drive package; 5 1/4" diameter unit allows file portability; building of image libraries, client archives; keeps primary system disk free for immediate storage. *DF/X 200 Version 1.2:* integrated digital production system; enhanced cut/paste, smudge brush. *Digital I/O:* links 4:4:4:4 DF/X 200 to 4:2:2 CCIR-601 environment; enhanced layering.  
**Circle (699)**

#### Digital Services/DSC

*Paragon:* digital video effects; D-1 processing; double-sided page turns, zipper effects; two video inputs with one key input; self-key; full bandwidth key path for chroma keys; RGB, Y/R-Y/B-Y.  
**Circle (701)**

#### Dubner Computer Systems

*GF-50:* Graphics Factory system with 3-D; en-

**INTRODUCING**

# DATATEK'S D-2400

# AUDIO/VIDEO ROUTING SWITCHER SYSTEM



## ...OPTIMIZED FOR STEREO.

The routing switcher you purchase today must be able to meet your requirements of tomorrow. Until now, this required compromises between versatility and cost.

Datatek's D-2400 switcher offers the flexibility to satisfy today's needs without sacrificing tomorrow's goals.

Systems start at 20x10 and expand all the way up to 800x800. Wide video bandwidth of 40 MHz allows HDTV and MAC compatibility. NTSC and PAL signals can even be switched in the same router. Optimized stereo performance, generous

headroom and wide bandwidth characterize the audio.

Datatek's wide choice of control panels allows you to select exactly what you need for each destination. No compromises because of system limitations or high price panels.

The D-2400 joins Datatek's complete line of quality switchers including: 6x1, 10x1, 16x1, 20x1, 25x1, 50x1, 120x4, 250x2, RS-422 data routing and digital audio.

When it is time to look at routing switchers, don't make compromises. Ask about the D-2400.

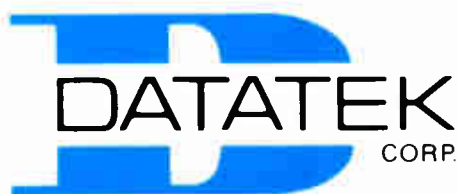

1121 BRISTOL ROAD, MOUNTAINSIDE, NJ 07092 • PHONE: 201-654-8100  
TOLL FREE: 800-882-9100 • FAX: 201-232-6381 • TELEX: 833541

hanced for dual-channel operation.

**Model 30-K:** dual-channel, dual-user character generator system.

**Model 20-KW:** with animated color weather software.

**Paint with D-2:** hardware option for Dubner Paint systems from Version 3.5; controls Abekas effects, Sony D-2, Type C 2000, 3000 analog; 4-field composite frame buffers, machine control.

**Circle (707)**

#### **Echolab**

**TEMPEST series:** effects units; provides zooms, keys, page turns; operates as stand-alone or option to ECHOLAB DV-5 video production switcher; various controllers allow expanded capabilities.

**Circle (715)**

#### **EEG Enterprises**

**Video Decoder II:** enhanced DE121 unit; for monitoring of encoded closed-caption signals; composite and RGB color outputs; generates white characters in dark surrounding field.

**EN270 Smart Encoder II:** inserts captions or text on line 21 which may or may not have data already present; if captions are present, text is interleaved into gaps between captions.

**Circle (719)**

#### **Electrohome Digital Video Systems**

**JAZZ:** digital video effects system; 14.3MHz, 4:2:2 component processing; composite or S-VHS inputs, outputs; accepts signals without time base correction; rotations; zooms; aspect ratio; borders cropping; drop shadows, pans, splits, mirror images; transitional effects.

**Circle (724)**

#### **Electronic Script Prompting**

**Laptop Field Prompter:** full-function prompting system based on laptop computer; 110V or dc power for remote operation; smooth scroll.

**Circle (1212)**

#### **ESD/Environmental Satellite Data**

**Advanced WeatherGraphic:** OS/2, 80386-based, weather image, data, graphics processing system, includes advanced art, animation, looping.

**True View:** dimensional perspective weather imagery; software option for Front End systems; 3-D airplane perspective of clouds, developing weather for increased realism.

**EasyData 9600:** weather data and imagery dial-up service; operates at 9600 baud.

**EasyData Imagery:** phone availability of TrueView, Full Spectrum and High Resolution weather images.

**Circle (733)**

#### **ESE**

**CG-89:** color digital effects/titler; 16-color palette; four upper, four lower case fonts; 10 display styles; 30-page memory; stand-alone or internal, external gen-lock feature; titles sprinkle onto screen, dissolve with Pixel digital effect; make pages tumble onto screen; double-buffered display graphics; 8MHz pixel clock.

**Circle (734)**

#### **Field Engineering**

**Model 389:** SMPTE safe action/title line generator; portable device allows precise pic-

ture framing in viewfinder; SMPTE, PAL spec; adjustment free circuitry.

**Circle (745)**

#### **FOR-A**

**Multiflex MF-1000:** digital effects system; includes TBC and dual channel capability handling color-under VCRs and S-VHS interfacing; memory for 18 effects sequences, more than 40 individual moves.

**Multiflex MF-2000:** 2-D effects generator; membrane control panel; dual-channel; effects memory for programming and recall of 6-second sequence; trajectories, flips, mirror, multifreeze, more.

**GRD-610:** background gradation effects unit for CVM-600 component mixer; produces graded light-to-dark or dark-to-light segments from top-to-bottom of image.

**VTW-800:** titler; select character size, font, color, effects; proportional spacing; eight colored edge types; separate background colors for each line; six fonts per page; RS-232C.

**VTW-120:** character generator; compatible with S-VHS video; character colorizing; 16 character sizes; 50-page memory with battery backup; 12Vdc power, sized for portability.

**Circle (749)**

#### **Grass Valley Group**

**\*8530 title inserter:** loop through video inputs with separate hole-cut and video fill inputs; luminance generator for luminance-filled keys or keys filled with video from another source.

**DPM-100:** digital effects system for Model 100 production switcher; design uses ASIC application specific ICs; 4:2:2 internal processing; interfacing for NTSC composite, analog component, D-1, D-2.

**Circle (789)**

#### **Greenberg Electronic Teleprompting**

**Telescroll PC:** MS-DOS PC teleprompter; enhanced color graphics, full word processing editor; multiple fonts; adjustable margins, text location; stores up to 6 hours of continuous reading time.

**LG-300:** camera prompter package for film, video use; universal baseplate does not require heavy counterbalancing; swing-away mirror for access to lens; 13" color monitor with reversed image.

**Circle (772)**

#### **Grunder & Associates**

**MS831/832, MS851/852:** signal and dual channel video effects systems using P163 hard-key or P152A touch-screen controllers; sequence storage; incorporate P164-38 framestore/effects TBCs.

**Circle (773)**

#### **Harris Video Systems**

**Vus graphic workstations:** Models WVS 5000, WVS 1000 32-bit system using 4:4:4:4 processing; browse with QuadraViews or MultiViews multiple images per screen options; software applications include Paint, Composition, Character Generator options which provide 2-D, 3-D modeling, animation, rendering; storage to 3.5 million on-line, off-line images; library cataloging.

**Circle (777)**

#### **Images Unlimited**

**Desktop video:** integrated systems; multiple source editing; networking; genlock, digitizer, animation, 3-D modeling options; integrated text and graphics; telecommunications options; Apple-based.

**Circle (1172)**

#### **Intelliprompt**

**Intelliprompt II+:** computer teleprompting; VCA support with NTSC output; Microsoft Windows, OS/2 multitasking, networking versions with Novell DECNET compatibility; supports foreign languages.

**Circle (705)**

#### **Julian Systems**

**Worx production system:** multimedia system with Audio Worx, Title Worx and Edit Worx modules; integrates audio, computer graphics for TV, video production and editing.

**Circle (1185)**

#### **Kavouras**

**4-Dimensional weather satellite imagery.**  
**1/2 mile high resolution visible satellite images.**  
**RADAC 2100:** color weather radar display system; includes NEXRAD compatibility, high resolution backgrounds.

**Triton A/P:** weather, production graphics system.

**Composite regional radar summaries.**

**Circle (821)**

#### **Knox Video Products**

**IMAGR I:** integrated MAP graphics system; combines high resolution character generator with complex dynamic motion, picture capture, full paint, 16 million colors with 4ns resolution.

**K40S:** Microfont component character generator; compatible with S-VHS equipment; component, composite outputs; upgrade to K40S from K40 systems possible.

**Circle (830)**

#### **Laird Telemedia**

**Legend options:** keyer fader 1035; paint 1540; software packages, Font Developer II, Augmentia auto-style, hard disk, camera entry, data tablet, composite/Y-C encoders; clock-calendar.

**LEGEND:** titler featuring auto-sizing, anti-aliasing of all fonts; pixel-by-pixel colorizing; 35ns (1506x483 pixel) resolution; 65,000 colors; 70-font library.

**Circle (831)**

#### **Listec Video**

**A-5000-B:** live, on-line prompter display for BASYS newsroom systems; remote control box; prompts from a terminal; continuous output to EEG encoder for closed captioning.

**A-5000-PC:** prompter display running live on personal computer.

**Circle (845)**

#### **3M Company**

**D-3600 dual channel:** titling generator with on-air, preview channels; can be used as independent channels from single keyboard.

**Circle (854)**

*Continued on page 174*

# More Odetics library management video cart machines are playing to air today than all others combined.

With more than fifty Odetics cart systems installed and operating in markets from #1 to #166, we're way ahead of the competition.

If you talk to the stations that are enjoying the benefits of an Odetics cart system, you'll learn that we're ahead in more than just number of units installed. You'll hear about dramatic reductions in makegoods, the easy interface with

traffic computers and a superior on-air look.

There's another advantage to investing in an Odetics cart system. Our leading-edge technology ensures that every Odetics' library management cart system will adapt to future station-automation plans.

To learn more about the number-one library management video cart system, call Odetics today.



## ***Odetics Broadcast***

1515 South Manchester Avenue, Anaheim, California 92802-2907 ☎ 800-243-2001 or 714-774-2200

Director of Sales  
Bill Keegan  
☎ 913-862-2824

Northeast  
Jesse Nickels  
☎ 608-754-2139

Southeast  
Emerson Ray  
☎ 813-960-0853

West  
Chuck Martin  
☎ 818-880-4165

South Central  
Phillip Smith  
☎ 214-250-4429

Midwest  
Bill Boyd  
☎ 612-894-2121

Circle 107 on Reply Card

# DYNATECHNOLOGY



*New*

## NEWSTAR PC

- Powerful AT or 386 workstations
- Full-color displays
- MS-DOS®, OS/2®, Novell® compatible
- *Advanced Production Software*® controls robotic cameras, cart players, CG still stores
- New "touch" screen live-on-air control
- Ethernet® interface to Utat Scientific's TAS System

**Dynatech**  
**NEWSTAR**

The World's Leading  
Electronic Newsroom  
Automation Systems

Dynatech NEWSTAR, Inc. • 6400 Enterprise Lane • Madison, Wisconsin 53719 • (608) 274-8686 • Fax: (608) 273-5876  
Dynatech Broadcast Group



# DYNATECHNOLOGY

New

## AVS-2 Router

- Flat 30 Mhz response—HDTV ready
- Flexible sizing to 1280 x 1280 with 8 levels
- Super high density packaging
- Advanced control system; redundancy available
- 10 year limited warranty

New

## Total Automation System

- High speed Ethernet® flexible assignment/control
- Intelligent control of Marc®, Betacart®, Odetics®
- Frame-accurate timeline control
- "Heartbeat" hot standby backup option
- Ethernet® interface to NEWSTAR®



**US UTAH**  
**SCIENTIFIC**

The World Leader  
in Reliable, High  
Performance  
Video Switching  
and Automation

Continued from page 170

### Magni Systems

**Model 4004S:** genlocking graphics encoder for Amiga computers; separate channel outputs for S-VHS and similar Y/C recording equipment; 4004 for NTSC, 4005 for PAL; composite output. **Circle (857)**

### Microtime

**IP-25 ImagePlus Graphics:** V5.11 operates on 25MHz clock PC; operates with TARGA and VISTA frame buffers; auto-page effects; 2-D reflectance; generated shadows; grid transformations; 3-D graphs select Truevision TIPS or Time Arts Lumena paint software.

**Genesis ACT 3:** 3-D digital effects; low-cost system; repertoire simultaneous rotation, perspective; page turns option; composite, component inputs/outputs; available in NTSC, PAL, PAL-M. **RP-1 3D Dual:** dual-channel video effects; compositor cards in mainframe for linear digital mixing with assignable priority, variable transparency; optional plug-in Post-Effects framestore. **Circle (877)**

### Midwest Communications

**DMG-1000:** A.C.E matte generator; stylus, drawing pad; multiple pens; disk storage. **Circle (879)**

### NEC America/Broadcast

**System 10 CFX enhancement:** Compression Effects package; hardware modification, software upgrade; 2-D effects giving 3-D simulations; menu with soft keys; offsets, skews. **Circle (901)**

### NewTek

**Video Toaster:** combines video effects, titling, frame store, frame buffer, 4-input video switcher with luminance keyer and frame grab system; RS-170A spec; Amiga 2000 PC add-in card. **Circle (1213)**

### Norpak

**TTX650:** NABTS teletext data receiver; serial, parallel interfaces for PCs, printers; non-volatile memory, RGB, composite outputs, keypad; for electronic mail, weather, commodity quotes, news wires. **Circle (908)**

### Pansophic Systems

**NIMBLE:** 2-D graphics animation; an action is an object, movement or collection of movements considered as one entity; isolates any action on screen for modification; MIDI sound; 32-bit processors.

**StudioWorks:** integrated presentation workstation; seamless multi-media processing; brings charts, text, paint, 2-D, 3-D animation, color separation into one system. **Circle (929)**

### Parallax Graphics

**VIPER series:** graphic processors for AT or VME bus; can be used with optional digitizer to import, display NTSC, PAL video signals in real time within window of high resolution display. **Circle (1214)**

### Pinnacle Systems

**3000R:** stand-alone 3-D rendering system; receives models, textures, animation scripts on digital network; when completed, frames

transferred back to 3000E design workstation for output to tape.

**2120 w/PRIZM:** broadcast still-store with digital effects; for stills and live images.

**2100 series:** production video workstation; digital adaptive comb filter decoder; H/V digital filtering; improved control system.

**PRIZM 601:** Digital Optical Workstation; digital effects with perspective, rotation, warp, curvilinear effects; 1/32 sub-pixel motion; 15-point filtering; meets CCIR 601 spec. **Circle (941)**

### Q-TV

**Newsprompter One:** Basys interface; stories, runorders downloaded to prompter system; rewrites, changes to runorder can be transmitted at any time during newscast through high-speed serial cable. **Circle (948)**

### Quantel

**Harry upgrades:** Clip Management 3-level package for transfer of material, directories to, from Harry on D-1 tape, 3.5" disk; Color match; Matte menu; E-motion VTR control.

**Harry Encore HUD:** Harry, Encore HeadUp Display from single menu control; editing, effects composition operated from one control station; all features of both devices are included.

**Presentation package** for Cypher Sprint 3-D, Sports; multichannel capability; graphics effects, page-to-page transitions, edit output with visible cursor; edit-on-air without cursor showing.

**Paintbox V-series:** based on ASIC application specific ICs; modular, expandable system; cordless pen; CCIR 601 ports; key channel; zoom magnify; animation, layering with Carousel. **MAVIS:** introduction of prototype paint system; smaller and faster than standard systems. **Circle (953)**

### R/Scan

**LDIS:** lightning data and information systems; data via satellite, PC/AT based; see storms in areas unavailable by radar; tracks, displays, archives lightning information. **Circle (957)**

### Rank Cintel

**Cloud File:** weather satellite receiving station; receives PDUS digital, WEFAX analog formats; step-free animated sequences covering 10 hours of data reception; 525/60 or 625/50. **Circle (964)**

### Sigma Electronics

**SAG-100A:** safe area generator stand-alone. **IGM-2.0:** integrated graphics module; for combining of 525-line graphics with video; decoders NTSC or S-VHS into RGB, encodes RGB to NTSC/S-VHS. **Circle (1005)**

### Sony Broadcast Products

**System G DEM-9000:** non-linear 3-D video effects, graphics system; mouse, keyboard. **DNS-1000 series:** digital networked still store system; maintains 1,600 images in transportable 12" WORM disk and 400 on 5 1/4" rewritable optical disk; 50-disk WORM jukebox holds 80,000 images. **Circle (1011)**

### Studio Spectrum

**Spectrum workstations:** Professional and Apprentice models; based on Commodore Business Machines AMIGA PC with 68000 CPU, 3Mbyte RAM, 7.16MHz clock; RS-170A encoder; digitizer camera; bit-pad. **Circle (1215)**

### Symbolics Graphics

**S-Convert:** for menu-based conversion of images to and from Scitex CT2T, Scitex Handshake and Truevision Type 2.

**IGES processor:** translates data from IGES CAD format to Symbolics S-Geometry files.

**Animation/Paint System V4.1:** enhanced in Color System, S-Frame, S-Colorize, S-Compositor, S-Dynamics, S-Geometry, S-Paint, S-Record and S-Render modules of the system. **Circle (1039)**

### Systemation

**CompuCast:** option to Systemation Informer interactive telephone system; delivers live-sounding weather forecast to radio station without taking up staff time for on-air or telco callers. **Circle (1042)**

### Tekskill Industries

**SpeakEasy:** prompting system allows speaker to maintain eye contact and have script available at all times; NTSC/PAL auto sensing; 110/220Vac, 12Vdc operation. **Circle (1055)**

### Telemet

**Telemet 2000:** 60-page non-volatile memory; sequenced playlists; proportional spacing, character kerning; two digital matrix-wipe effects; 16-color palette; nine page-display styles; four fonts. **Circle (1057)**

### Telescript

**Systems enhancements:** time/size display; setup save; all versions of Word Perfect; smooth scroll to 32 speed; redefined fonts; laptop compatibility. **Circle (1060)**

### Trilogy Software

**SIR RENDER:** software for Dubner CBG, TEX-TA users; allows light source designation, angles, surface constants for enhancement of original graphic files. **Circle (1216)**

### Videofonics

**VUES:** digital editing system; operates with NEC VSR 10 digital video sequence recording system; unlimited layering of effects; all editing, system functions controlled from a single workstation. **Circle (1217)**

### Wavefront Technologies

**Graphics System Software support:** for Tektronix XD88 2-D, 3-D workstations with digital video interface option; for Digital Equipment Corporations IVE Integrated Visualization Environment. **Circle (1134)**

### Weather Services

**Weather data, graphics:** custom weather information tailored to radio, TV stations. **Circle (1135)**

The Faroudja

**NTSC ENCODER**

***Ahead of its time***

**The Faroudja CTE-2 NTSC Encoder delivers to your viewers the best picture quality on screen. This is why so many broadcasters use it.**

**By pioneering the use of comb filters and detail processors within their encoders, Faroudja Laboratories has changed the nature of NTSC.**

***No more rainbow patterns***

***No dot crawl—no softness***

***No blurry reds (with DP option)***

**The Faroudja Encoder is one of the building blocks of the fully compatible SuperNTSC™ ATV System.**

---

**FAROUDJALABORATORIES**

Faroudja Laboratories Inc.  
946 Benicia Avenue  
Sunnyvale, California 94086  
Telephone 408/245-1492  
Telex 278559 MUHA UR  
Fax 408/245-3363

Circle (118) on Reply Card

## WSI

*NOWrad*: weather radar for TV; suppressed false images from ground clutter, atmospheric anomalies; image compositing from multiple radar sites for a specific point in time; single-site and regional images displayed at 2km resolution; annotation capabilities; for use with any WSI compatible graphics machine; local telco numbers for access to mainframe radar image computer.

Circle (1146)

# Video Products

## V6: Switchers

✓ Master control

✓ Production

### Abekas Video Systems

*A84*: digital post production switcher; 12-input, CCIR 601 compatible; eight digital key processors, ASPiK adaptive sub-pixel intelligent keying; 10-bit I/O, 32-bit processing; 32 independent color matte generators; eight independent keying layers, two keys per layer; luminance, chroma, matte keying; four aux, aux key buses; independent wipe/pattern generators.

Circle (502)

### Ampex Corporation

*AVC switchers*: XL upgrade kit adds 40 memory registers to standard AVC system; 68000  $\mu$ P chip for greater processing speed; sequencing, LEARN modes.

*AVC Component Vista*: 10, 18-input component or composite video production switcher; ADO interface; Digi-Loop for mix/effects equivalent to two or three mix/effects banks; NTSC, PAL. *AVC Vista switchers*: integrated ADO 100 digital effects; extended memory system; off-load effects to MS-DOS 3.5" diskettes.

*AVC Century enhancements*: key signal switching matrix; remote aux control panel; frame accurate transitions on all AVC Century keys; Bus Keyer with border modify, key invert.

*AVC production switchers*: 24-register Panel STAR Memory upgrade kit; faster operation and additional features.

Circle (541)

### Broadcast Video Systems BVS

*COX 2037-I*: component video switcher.

Circle (614)

### Comprehensive Video Supply

*Primebridge Micro-series*: keyer *PVK-I*; wiper *PVW-I*; mixer *PVM-I*; 3x1 switcher *PVS-I* distribution amplifier *PVA-I*; individually housed in small boxes; for remote, studio applications.

Circle (661)

### Crosspoint Latch

*6129BHK*: 16-input switcher; two mix/effects systems; low noise makes noticeable improvement in use with  $3/4$ " sources; five levels of keys, three colorizers; AUTODRIVE event memory and optional Smart Interface board. *6119YC*: a 6-input switcher with two levels of keys for S-VHS and composite signals; various border, edge effects.

*Model 6061*: pattern generator; adapts to any video switcher through an external key input;

32 matrix patterns; GPI-triggerable.

Circle (678)

### Echobab

*DV-7*: 6-input video production switcher with black and background; 10 wipe patterns; 3-bus, two linear keyers; 16-digit alphanumeric display; RS-170A sync with gen-lock; color wash; DSK fade.

Circle (715)

### Grass Valley Group

*MASTER-21 enhancements*: second audio program modules; routing switcher expansion with HORIZON or 20-TEN; event stacker software for IBM/compatible to build event list management file with RS-232.

*Model 200-2CV*: component production switcher; 2 mix/effects, 20 inputs; DSK, fade-to-black; fully programmable; for all international component standards; five keyers, dual background generators.

*Model 200-I*: 20-input switcher with one mix/effects level; E-MEM effects memory; key, wipe facilities; three key levels standard with linear, luminance keying; STREAMLINE effects, BORDERLINE key edge generator; eight component chroma keyers; enhanced analog, matrix patterns; four aux buses.

Circle (769)

### Intergroup Video Systems

*Model 9512-D*: 12-input production switcher; 2-MEs with seven video layers; 4 linear keyers, one aux bus to accommodate DVE, paint system; 2 titlers, 2 chroma keys in any of the key levels.

*Model 9524-D*: 24-input production switcher; 2-MEs give seven layers in one production sequence with background level transition, 2 linear keyers; 250-event REFEX effects memory.

Circle (805)

### Key Video

*VXP-4x1*: video switcher in a personal computer.

Circle (824)

### Omicron Video

*Model 546*: IGA video switcher; independently input gain adjustable.

Circle (917)

### Panasonic

*AG-SW800*: multisource switcher; S-VHS 4-pin and composite video input and output; complements AG-A800 A/B roll editor; expansion slots for VCR1, VCR2, Aux audio/video interface boards.

Circle (928)

### Polar Video

*PVM-2 vision mixer*: all features of previous PVM-1 mixer with S-VHS compatibility; Y/C, composite inputs; Y/C, U-matic dub, composite outputs.

Circle (943)

### Prime Image

*S-Switch series*: video/stereo audio switching systems for S-VHS, ED Beta and composite inputs; transcoders between Y/C, Y/C-688, composite; transitional effects; DSK option.

Circle (1211)

### Quality Video Supply

*Image Lab ES 2000*: production switcher with automatic effects; portable unit with H/V wipes; mix/dissolve; vertical interval cut between A/B; adjustable duration on automatic transitions; ac/dc.

Circle (951)

### Ross Video

*RVS-416*: production switcher; multilayer keyer with 4 primary levels of keys; multikeyer includes 8 additional keys; each has a mask generator.

*Downstream Multi-KEYER*: option for 416 production switcher; places eight keys from six sources on screen simultaneously; all keys are linear with independent border controls.

Circle (982)

### Sierra Video Systems

*CM-3 mixer*: component video mix between component video source or fade to black; frame accurate transitions set by 3-digit control; works with RGB, YUV, HDTV.

Circle (1004)

### Sony Broadcast Products

*BVS-series*: five models of video production switchers offer various levels of effects and features; BVS-3000, BVS-3100, BVS-3200 interconnect with DME-450 effects system; includes extensive keying; selectable transition rates; various wipes and E-File memory registers for use with BVE-900/9000 editors; -3200C provides component signal capability; *BVS-1100* is a 17 pound portable, battery operated system offering full switching capabilities, including RGB chromakey.

*Digital editing suite*: all operations are accomplished in digital 4:2:2 and 4:4:4 domains; includes D-1, D-2 VTRs, color corrector; character generator; PCM audio mixer; LMS system; composite digital video switcher, various interface devices and necessary encoders and decoders.

Circle (1011)

### Thomson Video Equipment

*TTV-5645*: analog component video mixer with digital (4:2:2) processing.

Circle (1074)

### VGV (Vital Electronics)

*D2500*: composite digital video production switcher; supports D-2 and proposed Panasonic  $1/2$ " digital format; 10 or 20 inputs; 5 or 10 external keys; layer priority keys; chroma keying; mattes.

Circle (1129)

# Video Products

## V7: Processing

✓ Compositors, keyers

✓ Signal correctors

✓ Standards, format converters

# Built on a Solid Base.

Successful shots are achieved when you can depend on your equipment to make only the moves required. Precision accuracy and smoothness of motion have made Vinten's CLASSIC Range of Equipment world renowned.

Look to us for engineering excellence backed by a total commitment to the marketplace seldom seen in today's fast-paced broadcast industry.

With Vinten, both the deadline and the bottom line are on a solid base.

Ask any user and you'll be convinced that only Vinten can provide the support and the equipment that can stand the test of time.



**3716 MARK 5 CAM PAN & TILT HEAD**  
Capacity: 180 lbs.

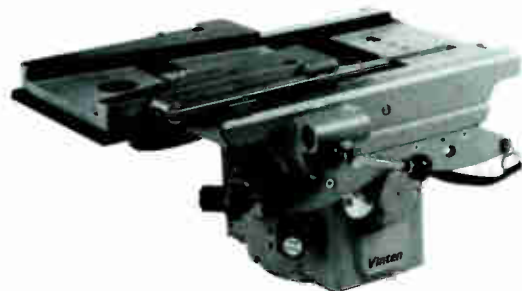

**3277 MARK 7A FLUID CAM PAN & TILT HEAD**  
Capacity: 200 lbs.



**3702 FULMAR PEDESTAL**  
Height Range: 21" to 59"  
Capacity: 350 lbs.

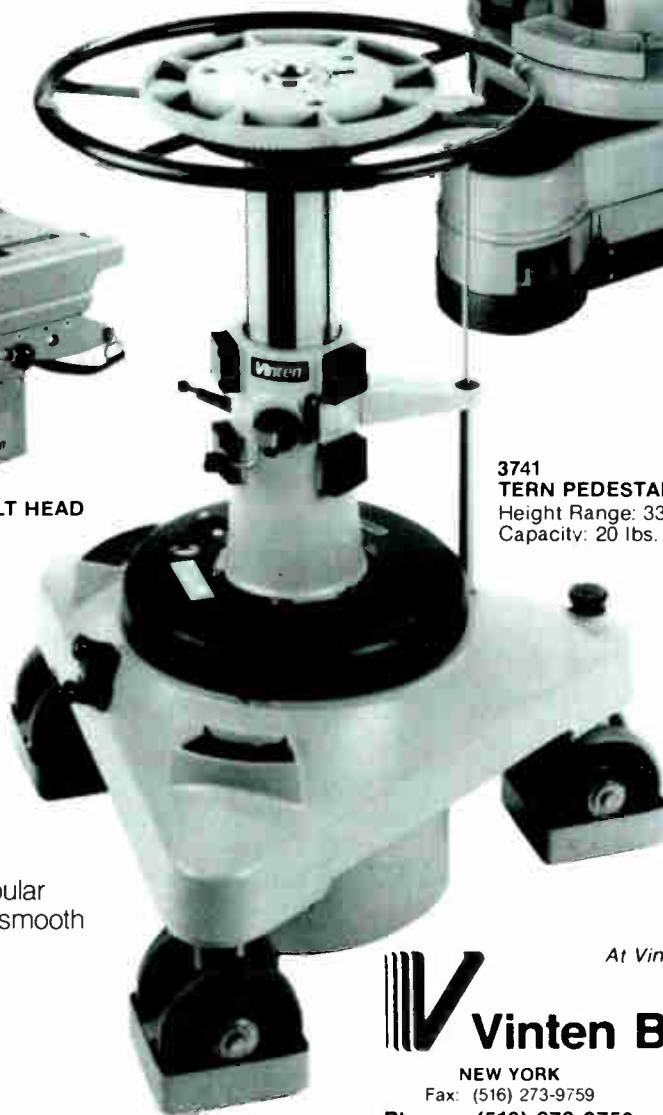

**3741 TERN PEDESTAL**  
Height Range: 33" to 54"  
Capacity: 20 lbs. to 290 lbs.

The **Tern Pedestal** is a single-stage pneumatic unit for cameras and accessories weighing up to 290 pounds.

Quiet and stable, it uses the popular center ring mechanism for ultra smooth steering and elevation control.

*At Vinten, we listen to our customers and support them with action.*



**Vinten Broadcast Inc.**

NEW YORK  
Fax: (516) 273-9759  
Phone: (516) 273-9750

CALIFORNIA  
Fax: (818) 767-0772  
Phone: (818) 767-0306

- ✓ Sync generators, VBI IDs
- ✓ TBC/frame synchronizers

**ACCOM**

*D-Bridge 221:* digital decoder system; decodes, converts sample rate from NTSC D-2 and RS-170 to D-1, RGB and Y/R-Y/B-Y; frame-based with 3-D adaptive decoding; eliminates cross-luminance/chrominance.

Circle (503)

**ACE**

*Series 600:* color corrector systems; component, composite versions.

*Model VSC-5000:* scan converter; computer video conversion to 1280x1024 pixel NTSC or Y/R-Y/B-Y format; 24-bit processing.

*ARENA:* production switcher; Alpha-Trak keys integrate with effects system for complex pictures within M/E; two-layer M/Es with luminance, chroma keying; nine patterns; Memory Controlled Effects.

*\*205 genlock encoder:* for NTSC, PAL; composite video; 32-pattern test generator.

*DV215:* encoder converts SMPTE. Beta. M-II.

RGB to D-2 format; 10-bit or 8-bit operation; optional test generator.

Circle (506)

**AF Associates**

*AVS ISIS:* television standards converter system; 3-field, 2-line system; upgradable to 4-field, 2-line.

Circle (518)

**Allen Avionics**

*DIGISTREAM:* BAL transparent parallel analog to digital interface, CCIR 601 spec.

Circle (526)

**Ampex Corporation**

*DST-300 digital translators:* converts signals between composite digital and CCIR-601 4:2:2 component digital for D-1/D-2 conversions and 4:2:2 telecine to D-2 videotape.

Circle (541)

**ASACA ShibaSoku**

*TS30B6:* HDTV sync generator; select bi-level or tri-level sync signals; color bars and crosshatch signals integrated into unit; for 1125/60 16:9 HDTV scheme.

Circle (561)

**AVS div/AVESCO**

*ISIS:* 3-field, 2-line standards converter; upgrades to 4-field, 2-line system for broadcast bandwidth applications.

Circle (582)

**BAL Components**

*DIGISTREAM Mk II:* transparent parallel A/D and D/A interfaces, CCIR 601 spec; transmitter and receiver; 8-bit conversion with 27MHz clock locked to external sync source.

Circle (584)

**Brabury/Porta-Pattern**

*T567/9 encoders:* NTSC, PAL systems; switch between dual inputs of RGB, Y/R-Y/B-Y, Beta components; integral sync generator with genlock; S-VHS (Y/C) output capable.

Circle (605)

**Broadcast Electronic Services**

*BetaBox:* allows integration of Beta or M-II formats with 1/4" equipment; one-button operation simultaneously switches video, audio, timecode, monitor and remote control between two playback decks.

Circle (1153)

**Broadcast Video Systems BVS**

*DE-500:* NTSC decoder, YC, Y/R-Y/B-Y, RGB outputs.

*MasterKey II:* downstream linear keyer; composite and RGB inputs.

*Multi-standard decoder:* NTSC, PAL, SECAM to RGB by Video & Interactive Products

*EN-300:* low-cost NTSC encoder.

*EN-350:* multiformat encoder; RGB to Y/R-Y/B-Y, YC and NTSC.

*EN-450:* broadcast NTSC encoder, RGB, YRGB, Y/R-Y/B-Y inputs.

*COX2045:* RGB component processor.

*Type 100, 300:* interformat translators; converts from S-VHS to Betacam/M-II or Betacam/M-II to S-VHS; NTSC, PAL versions; color transient correction on color difference signals.

Circle (614)



**THE RECOGNIZED  
LEADING MANUFACTURER OF  
ITFS/MMDS/WIRELESS  
CABLE RECEPTION EQUIPMENT**

- BLOCK DOWNCONVERTERS, ANTENNAS & ACCESSORIES
- STATE-OF-THE-ART MANUFACTURING TECHNIQUES (SMD)
- ADAPTABLE TO INTERNATIONAL FREQUENCY FORMATS

**CONTACT US NOW TO SEE WHY OPERATORS  
WORLDWIDE USE CONIFER PRODUCTS**



CONIFER CORP. • P.O. BOX 1025 • 1400 N. ROOSEVELT • BURLINGTON, IOWA 52601

800-843-5419  
319-752-3607  
FAX 319-753-5508

Circle (119) on Reply Card

#### Broadcasting Technology Associates

*Ghost Cancellor*: uses bar signals with  $(\sin x)/x$  risetimes inserted into transmitted video as reference signal; in-set filter requires automatic waveform equalizer based on reference signals.  
**Circle (1210)**

#### BTS

*DSY-7*: 4:2:2 synchronizer; variable delay to 1-frame in 10ns steps; selectable 8, 9, 10-bit processing; dynamic rounding.  
*FNR 7*: CCTV field noise reducer.  
**Circle (619)**

#### CEL Electronics

*PI63, PI52A controllers*: hard-key and touch-screen control panels for use with CEL effects systems.  
*PI65-40*: 8-bit bidirectional digital standards converter for component, composite and Y/C.  
*PI64 series*: 4:2:2 8-bit frame store with digital effects, TBC; ASIC technology; 4 composite inputs and switching for component, Y/C, YUV, digital; touch-button controller; 5-field.  
**Circle (632)**

#### Central Dynamics

*Stage★1*: family of digital encoders, decoders, format translators; enhances NTSC through digital signal processing to produce composited pictures of the original RGB signal quality.  
**Circle (633)**

#### Colorado Video

*Model 286C*: digital color still-frame transceiver in a briefcase; for narrow-band communications links; 9600b/s modem with fall back rates to 7200b/s and 4800b/s; EIA or NTSC compatible.  
**Circle (654)**

#### Comprehensive Video Supply

*CCD-35V, CCP-45V*: S-VHS color decoder and processor.  
**Circle (661)**

#### Corporate Communications

*Sunburst Gemini II*: electronic color correction system; simultaneous background, foreground element and scene-to-scene corrections; 64-bit per pixel D-1 interface; 24-bit 4x subcarrier CAPS/LAPS.  
**Circle (676)**

#### Digital Processing Systems

*DPS-275*: multiformat TBC/frame synchronizer; transcodes NTSC, Y/R-Y/B-Y, Y/C-688, Y/C-3.58; RS-232 control; ATR chroma noise reduction; freeze 2 frames, any four fields.  
*DPS-270*: S-VHS TBC; operates in NTSC or S-VHS with 5.5MHz bandwidth; accepts external sync, subcarrier; Y/C-NTSC encoding, NTSC-Y/C decoding; quasi-infinite window shuttling circuit.  
**Circle (700)**

#### Digital Services/DSC

*Collage*: D-2 compositor; direct interface to D-2 VTR in digital domain; five video, three key inputs; multichannel compositing of multi-layered effects; interface paint, VTRs, etc.  
*DiSC*: real time digital disc recorder for Collage D-2 compositor; 212s storage capacity; allows complex layering production.  
*Eclipse update*: 68020 32-bit processor.  
**Circle (701)**

#### Faroudja Laboratories

*CTE-2, CFD-N*: comb-filter encoder, decoder.  
*CTC-2*: bi-directional video component transcoder unit.  
*LD-1*: line doubler, motion artifact processor and luminance spectrum expansion.  
**Circle (739)**

#### FloriCal Systems

*ChroMatte*: RGB matte and compositing system; variable hue control.  
**Circle (748)**

#### FOR-A

*FA-800 Autocor*: TBC/synchronizer; multifunc-

tion signal corrector; C, U-matic, Beta; velocity compensation for type C, FM/TTL drop out compensation; full-bandwidth frame synchronization.

*ENC-200 encoder*: RGB or Y/P<sub>r</sub>/P<sub>b</sub> component video; black stretch; comb filter.

*MVP-2100*: converts non-interlaced signals to interfaced for use with computers; integral keyer for titles from PC.

**Circle (749)**

#### Graham-Patten Systems

*Model 1241 video keying system*: six inputs, independent selection of self, external key for insertion over one background; any or all inputs

# LARCAN

## "The difference is like night and day."



"The waveforms you see when you run a sweep generator through this transmitter are absolutely flat, and it holds power at 100%, day after day. Compared to the tubed transmitter we replaced, the difference is like night and day."

Roy Mitchell, Chief Engineer, KMSB-TV, Tucson, AZ

Why do dozens of CEs smile whenever they talk about their M Series 100% solid state VHF transmitters? Why do more stations choose LARCAN's proven third generation engineering every month? Find out—and put *your* station on the pathway to LARCAN M Series performance. Just call the RF experts of LDL Communications at (301) 498-2200. We'll send you full information on the many reasons why LARCAN M Series 100% solid state VHF transmitters from 3 to 60 kW are "your best choice for the long run."

#### LDL Communications Inc.

14440 Cherry Lane Court, Ste. 201, Laurel MD 20707  
Tel: (301) 498-2200 Fax: (301) 498-7952 Tlx: 821569

Circle (140) on Reply Card

can be selected; color borders with border fill, full shadow positioning; outlining effects, variable densities; key control for full linear key with soft edges, but harder edges; master clip; for NTSC and PAL.

Circle (768)

#### Grass Valley Group

*DXC transcoders*: interface converters between D-2 and D-1 signal formats; *DXC-122* digital component in, digital composite out; *DXC-221* digital composite in, digital component out; ASIC design.

*SCB-200N*: master sync, color bar generator; for corporate, industrial video; stereo audio tone with left channel ID locked to vertical frequency; SC-H phased; removable setup.

*DSK-101*: linear keyer for use with anti-aliased titling and digital effects units, additional keying requirements, BORDERLINE option shadows and outlines; programmable, PAL, NTSC; autotransitions.

*KADENZA upgrade*: advanced digital keying; optional chroma key derived from internal digital signal; controls for sensitivity, background hue suppression, positioning; external, self keys.

Circle (769)

#### Grunder & Associates

*CVS-450A*: scan converter for computer image conversion from 47kHz-80kHz to 38kHz to drive large screen projectors.

*PI64 series*: 4:2:2 8-bit frame store with digital effects, TBC; ASIC technology; 4 composite inputs and switching for component, Y/C, YUV, digital; touch-button controller; 5-field.

*RS1702RB*: rubidium dual sync generator.

*SG-3000B*: sync generator with genlock.

*ENC-3000*: color encoder with genlock.

*PI63, PI52A controllers*: hard-key and touch-screen control panels for use with CEL effects systems.

*PI65-40*: 8-bit bidirectional digital standards converter for component, composite and Y/C. *CVS-900*: scan converter to 38kHz maximum; 1024x520 pixel; converts VGA, MAC II, PGC640x480 video to NTSC RS-170A or EBU; RGB inputs; 8-bit processing to component, composite outputs.

*CVS-950A*: auto scan conversion from 47kHz-80kHz non-interlaced to RS-170A or EBU standards; Composite, component outputs; frame interpolation; adjustable aspect ratio, picture positioning; 8-bit.

Circle (773)

#### Harris Video Systems

*Model 642*: frame synchronizer; separate inputs to synchronizer, TBC; 12dB auto digital noise reduction; operates with noisy signals; 8-bit, 14.3MHz; TTL vertical sync input for variable tracking.

*550VT*: TBC for broadcast, CATV, post production; viewable pictures to 25x play; color lock to 5x play; variable tracking 1x to ±3x play and pause for BVU-820 or equivalent VTRs; 8-bit, 14.3MHz.

*VW-3*: frame synchronizer/multimode TBC; for direct 1", heterodyne 1/2", 3/4" formats; sideband subcarrier feedback mode; infinite window; field, frame freeze; optional remote control; 8-bit 14.3MHz.

Circle (777)

#### Hotronic

*AF75*: TBC, frame synchronizer; full bandwidth

in all modes, including stand-alone non-synchronized without subcarrier feedback; composite, S-VHS inputs/outputs; 400 line resolution; 58dB S/N.

*AF72*: wide bandwidth frame synchronizer.

*AH-91*: dual-channel TBC with digital effects; fades, wipes, reveal, push on/off; posterize; mosaic; freeze.

*AF-71*: TBC, frame synchronizer with freeze frame/field.

*AE61*: time base corrector.

Circle (786)

#### Intelvideo

*Video Flasher*: video gate; flashes a preselected number of fields (1 to 8) on screen for NTSC or computer-generated video when triggered; enables photographing of monitor screen.

*Model IV-4*: advanced TV NTSC color decoder; digital I/Q demodulation; anti-alias filters; multiple outputs include R, G, B, Y, C, I, Q, R-Y, B-Y, sync.

*Model IV-3*: NTSC encoder; extended performance for dynamic enhancement of color detail by 18dB based on hue/saturation; digital I/Q modulation; D-2 output option; advanced sync output.

Circle (803)

#### I•DEN Videotronics

*IVT-12*: portable TBC, BP-90 powered; for satellite news gathering use; Betacam, M-II, Y/C3.58, Y/C688, composite; 5.5MHz bandwidth; full frame memory; field, frame freeze; 450-line resolution.

*IVT-9 TBC*: for composite, S-VHS and ED Beta signals; 8-bit sampling; 450-line resolution video; full frame correction; frame, field freeze; 58dB S/N ratio; 13.5MHz sample rate.

*IVT-9 PLUS TBC*: 5.5MHz bandwidth component processing for Y/R-Y/B-Y, Y/C3.58, U-matic dub, NTSC signals; handles variable tracking; full frame correction; auto chroma control; advanced sync output.

*IVS10*: multiple video format transcoder; includes VHS video DA.

*IP-10 Image Path*: converts non-standard video from computers, still video players miniature CCD cameras to RS-170A NTSC signals.

*IVT-9B TBC*: serving composite, Betacam, M-II, Y/C3.58, Y/C688 signals; 5.5MHz bandwidth for 450-line resolution; RS-170A sync, full frame memory for synchronizer operation; auto chroma control.

Circle (809)

#### Julian Systems

*RGB decoder*: converts NTSC video signal to RGB components for frame grab in Macintosh desktop system use.

*HyperVideo drivers*: allow HyperCard control of video effects, overlays; for Macintosh.

*NTSC converter*: Macintosh II to NTSC video. *Genlock converter*: Macintosh II to NTSC video with effects.

Circle (1185)

#### Leitch Video

*PAL Module*: composite, component signal generator for SPG-1510P sync pulse generator.

Circle (839)

#### Lyon Lamb Animation Systems

*ENC-7*: color encoder, sync generator; composite, component, S-VHS outputs from RGB

sources; gen-lock, supports NTSC, Betacam, M-II formats; sync-delay and sync-advance adjustments; RS-170A spec.

*RTC Real Time Converter*: converts three independent high-resolution sources from scanning frequencies in 23kHz-75kHz range to NTSC, PAL composite signals; digital processing with VLSI design.

Circle (853)

#### Marconi Communications Systems

*B2022*: PAL standard digital frame synchronizer.

*B4002*: NTSC comb-filter design decoder.

Circle (860)

#### Merlin Engineering

*Vistek V1010*: matrixing amplifiers; designed for interconversions with RGB, YPrPb, YUV; options for Betacam output levels or PAL mathematical levels.

*Vistek V4000*: range of transcoders; includes Varicomb decoders; converts from NTSC to PAL-M, PAL-M to NTSC, PAL (I/B/G) to SECAM; 6MHz bandwidth ± 1dB; for composite video signals; RGB monitoring.

*Vistek VISION*: digital video mixer; CCIR 601 4:2:2 internal operation; analog inputs optional; trackball effects positioner; chroma, linear keying, wipe/pattern generator; for PAL I/B/G standards.

Circle (872)

#### Merlin Snell & Wilcox

*ME-9900*: 4-field multiple standard broadcast converter; advanced motion processing; supports all standards as well as component, Y-C and RGB; front panel control of all picture parameters.

*ME 2001*: high definition down-converter; for low-definition viewing copies of HDTV material; for all current HDTV formats to any output standard; pan, squeeze functions; aspect ratio, letterbox.

*9800FX4 upgrade*: for converters put in service since 1984; extends machines to 4-field operation with advanced motion processing.

*ME 8800*: universal standards converter; supports all component and composite standards; wide range of picture controls, noise reduction and color balance.

*ME-9910*: 4-field, 4-line aperture standards converter; PAL, NTSC, SECAM in, PAL, NTSC out; TBC, frame synchronizer function; motion interpolation.

Circle (1227)

#### Microtime

*A/B Roll Effects*: composite, U-matic dub, S-VHS, component inputs; composite, component, S-VHS outputs; framestore memory in each channel; extensive transition effects; can operate as two TBCs.

*Tx3 FIT*: format interchange TBC; full frame memory for extended bandwidth VTRs, with production effects.

*Tx4*: low-cost TBC; extended bandwidth processing; with optional production effects.

Circle (877)

#### Midwest Communications

*DPS-275*: Digital Processing Systems multi-format TBC/frame synchronizer; integral test signal generator.

*DPS-270*: S-VHS TBC; 5.5MHz bandwidth for NTSC, S-VHS signals.

*600 series*: ACE color correctors; composite,



component versions.

**Model VSC-5000:** ACE computer video scan converter; raster outputs to 525-line NTSC from 48-72Hz frame rates.

**\*205 ACE encoder:** for NTSC, PAL; composite video; 32-pattern test generator.

**DV215:** ACE encoder; SMPTE, Beta, M-II, RGB to D-2 format; 10-bit or 8-bit operation; optional test generator.

**ARENA:** ACE production switcher; Alpha-Trak keys integrate with effects system for complex pictures in M/E; two-layer M/Es with luminance, chroma keying; nine patterns; Memory Controlled Effects.

Circle (879)

#### **Nova Systems**

**NOVA 502:** EFP TBC; field portable direct TBC; for Betacam, M-II, U-matic, S-VHS; 12Vdc operation with dc loop-through allows power connection of other equipment to same source.

**Nova 710S:** wideband TBC; VTR-SC mode with external subcarrier input; S-VHS input for 5.5MHz bandwidth and 440-line resolution; 32-line memory; shuttle for  $\pm 20\times$  play; 14.3MHz 8-bit encoding.

**NOVA 900S Super TBC:** S-VHS and composite inputs; outputs also for ED-Beta, VHS, U-matic(SP), M-II, Betacam; 4:2:2 processing; 4x1 VBI switcher for composite, component; advanced sync available.

Circle (910)

#### **OKI Electric Industry**

**LT 2000:** TV standards converter; uses *motion-vector technique* for precision smooth movement; NTSC, PAL; PAL-M, SECAM options; performance beyond 4-field systems.

**LT 1250TSC:** portable standards converter; *motion-vector technique* bidirectional conversions between NTSC, NTSC-4.43 (input only), PAL; PAL-M, SECAM optional; TBC, synchronizer, picture freeze.

Circle (915)

#### **Omicron Video**

**Omni-Gen 701, 702:** Amiga computer genlocking unit NTSC, PAL.

**Models 416N, 416P:** NTSC, PAL sync pulse generators.

**Models 451N, 451P:** NTSC, PAL video encoders.

Circle (917)

#### **Panasonic Industrial/Broadcast**

**ET-100DS:** digital scan converter; noninterlace flicker-free; double scan line for 560-line horizontal, 450-line vertical resolution; three dimensional digital Y/C separation filter, noise reducer.

Circle (928)

#### **Polar Video**

**PCK-2:** chromakey and linear DSK device; includes RGB/YUV switchable inputs to chromakey section.

**RGB-Y/C transcoder:** converts RGB to S-VHS format.

Circle (943)

#### **Prime Image**

**HR600+ series:** systems with and without effects and synchronizer functions; 600 line resolution and 7.5MHz bandwidth; transcodes between U-matic/SP, M-II, Betacam/SP, ED-Beta; S-VHS, composite.

**S TBC+ series:** true component TBC, freeze frame synchronizers; with, without digital ef-

# Now, all of your ENG microphones are wireless.

Just selected for BE's  
"Pick Hits" of NAB '89.



... the PRO mini-H by Lectrosonics.

## XLR in . . . XLR out

The ingenious H185 transmitter simply plugs onto any of your hand-held, lavalier or shotgun microphones with XLR connectors. The battery powered CR185 compact receiver mounts on your camcorder and provides a balanced audio output via an XLR jack on the rear panel.

## Faster set up time

Your ENG crews can set up faster, cover more events than ever before, and use whatever mic they need. The operating range of this system allows a wide variety of camera angles and shooting distances, which generally produces more spontaneous interviews and makes covering large events simple and efficient.

## Highest reliability

Machined aluminum housings withstand rigorous daily use. The RF link is stable, without dropouts or interference. The audio is broadcast quality. The factory support is second to none.

If your ENG operations aren't wireless . . .  
... isn't it about time?

Call us now for the location of your nearest dealer.

(800) 821-1121



**LECTROSONICS, INC.**

P.O. Box 15900 • Rio Rancho, NM • 87174

Made in the USA

Circle (111) on Reply Card

fects; for S-VHS, ED-Beta; composite; for U-matic, 1/2" VCRs.  
**Circle (1211)**

### **Progressive Computer Technology**

*SuperGen 2000S*: S-VHS compatible genlock, overlay card for Amiga 2000 PCs; NTSC, S-VHS inputs, outputs; dissolve slider; SC/H phase adjustments; RS-170A sync; joint project with Digital Creations.  
**Circle (947)**

### **QSI Systems**

*Models 5400*: video processing amplifier; full sync, burst, blanking replacement; bypass on loss-of-lock; line-by-line selectable replacement in BVI of either field.

*Model 2048*: message generator for use with video SID systems; stores 6,300 characters in 99 messages; maximum individual message is 256 characters; sequences messages; front panel LCD display.

*Model 3000*: safe area generator; generates six different safe area patterns as well as two cross-hatch patterns over user video; adjustable marker level, pattern select push-button; marker delete.

**Circle (950)**

### **Quality Video Supply**

*Kramer products*: enhancers, correctors, encoders, distribution amplifiers.

**Circle (951)**

### **REBO High Definition Studio**

*ReScan*: HDTV-to-NTSC converter; develops NTSC signal for recording or display in 5:3 or 4:3 aspect ratios; joint project with Folsom Research.

**Circle (967)**

### **Sierra Video Systems**

*Delta CS, Delta SC*: converters from RGB or YUV to Y/C S-VHS and from YC S-VHS to RGB or YUV; separate models for NTSC/PAL and M-II/Betacam/SMPTE.

**Circle (1004)**

### **Sigma Electronics**

*TSG-440*: test, sync, countdown, ID generator system.

**Circle (1005)**

### **Snell & Wilcox**

*9800FX4 upgrade*: for converters put in service since 1984; extends machines to 4-field operation with *advanced motion processing*.  
*ME-9900*: 4-field multiple standard broadcast converter; *advanced motion processing*; supports all standards as well as component, Y-C and RGB; front panel control of all picture parameters.

*ME 8800*: universal standards converter; supports all component and composite standards; wide range of picture controls, noise reduction and color balance.

*ME 2001*: high definition down-converter; for low-definition viewing copies of HDTV material; for all current HDTV formats to any output standard; pan, squeeze functions; aspect ratio, letterbox.

*ME-9910*: 4-field, 4-line aperture standards converter; PAL, NTSC, SECAM in, PAL, NTSC out; TBC, frame synchronizer function; motion interpolation.

**Circle (1007)**

### **Teccom**

*CKM-4 cross key manipulator*: by Automation Associates; four input key expands key/layering capability; four clip controls; allow stacking of key sources.

**Circle (1053)**

### **Telmak Export**

*Image Master*: genlock system for AMIGA 500, 1000, 2000 A/B; provides 500-line NTSC video from RGB outputs of PC; 5.5MHz bandwidth with 48dB S/N; 23-pin D connector interface.  
*Desktop*: genlock system for AMIGA computers; RS-170A signal has 450-line resolution in NTSC; NTSC/PAL models; 5.5MHz bandwidth; auto key cuts into background; by Neriki/Australia.

**Circle (1065)**

### **Thomson Video Equipment**

*COLORADO*: component digital (4:2:2) color corrector; post-grading to monitor and modify colorimetry.

**Circle (1074)**

### **Toko America**

*MP-3000*: HDTV moving image processor; composite, component input; to 480Mbyte memory; reconfigurable to processing requirements; VAX, APOLLO, SUN-3 computer interfaces;  $2 \times / 4 \times F_{sc}$  variable sampling.

*HM-7000*: matrix translator for HDTV signals; RGB, YPbPr inputs/outputs, trilevel bipolar sync;  $\pm 0.1$ dB to 30MHz with 60dB S/N; for 1125/60 system; cable delay compensation.

**Circle (1081)**

### **Toshiba**

*Motion stabilizer*: image vibration correction system; corrects entire frame or a selected portion; NTSC input/output; maximum motion detection 32 pixels H, 24 lines V.

**Circle (1083)**

### **Ultimatte**

*Forematte*: peripheral device for linear keys; generates processed foreground and key signal to drive the keyer.

*Amusematte*: prosumer model of Ultimatte compositing system.

*Ultimatte-ARGB*: adapted compositing unit accepts RGB background signal; demonstrated with Betacam SP foreground with transcoder.

**Circle (1094)**

### **Video International Development**

*DTC-4500 converter upgrades*: improved noise reduction, motion interpolation software; EBU 4:2:2 sampling; for PAL, SECAM, NTSC, PAL/M, PAL/N, NTSC-4.43; 8-bit system; U-matic dub in/out; 4-field.

*DTC-3502 upgrades*: improved motion interpolation; EBU 4:2:2 sampling; for PAL, SECAM, NTSC, PAL/M(N), NTSC-4.43; 8-bit system; component and U-matic dub in/out options; 5.5MHz bandwidth.

**Circle (1120)**

### **Videotek**

*VDP-8400*: 4-field frame-store, synchronizer; for jitter-free lock to noisy feeds from satellite and other out-of-house sources; 8-bit composite processing at 14.31818MHz; Line-Select picks a single line from a particular field; adjustable vertical blanking end; slaves to a reference blackburst or operates as stand-alone sync

generator; single rack-unit height.

*VSG-21 sync/test generator*: four selectable NTSC test signals for setup, maintenance of TV equipment; SMPTE color bars, multiburst 10-step modulated and unmodulated stairsteps  
**Circle (1125)**

### **Vistek Electronics**

*V4000*: range of transcoders; includes Varicomb decoders; converts from NTSC to PAL-M, PAL M to NTSC, PAL (I/B/G) to SECAM; 6MHz bandwidth  $\pm 1$ dB; for composite video signals; RGBS monitoring.

*VISION V5001*: digital video mixer; CCIR 601 4:2:2 internal operation; analog inputs optional; trackball effects positioner; chroma, linear keying, wipe/pattern generator; for PAL I/B/G standards.

*V1010*: matrixing amplifiers; designed for inter-conversions with RGB, YP<sub>R</sub>P<sub>B</sub> YUV; options for Betacam output levels or PAL mathematical levels.

**Circle (1128)**

### **Vortex Communications**

*Eurogold modules*: comb filter encoders, decoders; intermatrix converters, transcoders for modular mix-and-match broadcast system.

**Circle (1130)**

### **Yamashita Engineering Mfr/YEM**

*RS1702RB*: rubidium dual sync generator.

*SG-3000B*: sync generator with genlock.

*ENC-3000*: color encoder with genlock.

*CVS-450A*: scan converter for computer image conversion from 47kHz-80kHz to 38kHz to drive large screen projectors.

*CVS-950A*: auto scan conversion from 47kHz-80kHz non-interlaced to RS0170A or EBU standards; composite, component outputs; frame interpolation; adjustable aspect ratio, picture positioning; 8-bit.

*CVS-900*: scan converter to 38kHz maximum; 1024x520 pixel; converts VGA, MAC II, PGC640x480 video to NTSC RS-170A or EBU; RGB inputs; 8-bit processing to component, composite outputs.

**Circle (1148)**

### **Zaxcom Video**

*SDR300, SDR400*: TBC remote controllers with TBC transition; memory retains settings for 15 different videotapes; dissolves between memories; -400 for D-2 processors; can be controlled remotely.

*MTBC 1000*: multiple TBC control system; remotely adjust eight TBCs from two locations; memories retain 25 tape setups; works with mix or match of TBC equipment.

*HUB100*: intelligent TBC control router for use with TBC control equipment; allows eight edit rooms to control 64 TBCs; RS-422 control port inquires on status of all TBCs.

**Circle (1178)**

## **Video Products**

### **V8: Displays**

✓ Video monitors

✓ Projection systems

#### Apollo Audio Visual

*CVP-8000*: Apollo compact video presenter.  
Circle (554)

#### ASACA ShibaSoku

*CM26A, CM46A*: Grade I monitors, 14", 20" CRTs, with setup.  
*CM65B6*: HDTV monitor; 26" CRT with 16:9, 4:3 aspect ratios; automatic selection between 1150/1050 line interlaced, 525 non-interlaced.  
Circle (561)

#### Barco Industries

*CVS monitors*: password protected, microprocessor-control system for 14", 20" diagonal CRTs; auto alignment; slots available for multiple decoders; analog, digital component options; remote control.

*CVM series*: monitors with 14", 20" diagonal screens on flat square CRTs; microprocessor control system; full remote control; auto kinescope bias for color temperature stability; modular design.

*HD monitors*: 16:9 aspect ratio on 20", 26", 30", 40" CRTs; horizontal scanning from 28kHz to 33.75kHz; delta-gun CRTs except in-line dot for 20" size; video response from 15kHz to 30MHz,  $\pm 0.5$ dB.  
Circle (585)

#### Conrac Display Products

*6545/6550 enhancements*: 13" and 19" color Class-A monitors; auto-select NTSC, PAL decoders; video component inputs;  $\mu$ P-based

control system with optional setup photometer.  
*Auto-Trak 7214*: 19" multiple resolution color monitor; Auto-Trak locks to horizontal frequencies from 15.75-37kHz, interlaced or non-interlaced; MDA, CGA, EGA, PGA/VGA, IBM 8514/A compatible.

*Model 2660*: 15" diagonal monochrome studio monitor; 25MHz bandwidth video amplifiers; switch selectable AFC for use with VTRs.

*Model 2620*: 9" monochrome monitor; 12MHz video bandwidth.

*Model 7550*: 19" multiresolution color monitor; 0.31mm or 0.26mm dot pitch; 150MHz bandwidth video amplifiers; for animation, computer graphics; resolution to 1600x1200.  
Circle (672)

#### Electrosonic Systems

*PICBLOC*: videowall system; an electronic control system presentable on any monitor format in any configuration.

*RMV-1000*: rear projection cube monitor; stackable for video wall presentations; 350 ft-L illumination; each cube has 40" diagonal screen with three 7" CRTs; composite, RGB, Y/C inputs.  
Circle (1150)

#### FOR-A

*MV-160*: displays 16 color pictures on screen simultaneously; select between inputs 1-16 or 17-32 for viewing; optional ID inserter to identify each image;  $4 \times F_{sc}$  sampling.  
Circle (749)

#### Hitachi Denshi

*HD rear-screen projectors*: seven display units; *C110"-5000R* 5:3, 4:3 aspect ratios, 1,280-dotx1,000-line resolution, 40 ft-L brightness; *C66"-4500R/C54"-3500R* 16:9 aspect ratio, high contrast.  
Circle (781)

#### Ikegami Electronics (USA)

*HTM2003*: high definition color monitor; 20" CRT with in-line gun 0.31mm dot mask CRT; beam feedback for white-balance stability; 6500°K, 9300°K and third temperature stored in memory.  
Circle (791)

#### Information Display Systems

*Eidophor HDTV* projection system; 1125/60Hz system with 16:9 aspect ratio; 4.2kW Xenon lamp operates at 160A; electronic keystone correction; horizontal resolution 1,500 pixel for 40" wide image.  
Circle (795)

#### Julian Systems

*Monitor Rack*: for video or computer monitors.  
Circle (1185)

#### JVC

*TM-1400SU*: color monitor for S-VHS, composite video; under-scan, pulse-cross, blue test, AFC; audio system; 0.5mm dot-pitch.  
Circle (816)

## "FIBER ACTIVE" VIDEO TRANSMITTER.

# WEIGH THE ADVANTAGES.

Weigh the advantages of this fiber optic video link and you'll definitely see the light.

Advantages that most broadcast engineers thought were not even a remote possibility are now a reality. Like 8 km of repeaterless audio/video transmission with zero loss in quality. Like unrestricted freedom of movement in a field-proven, portable, 2 lb. package. We call it the PCO-5050. You'll call it a real scoop.

#### The Facts of Light:

- Beats coax systems by 24,500 feet.
- Zero loss in signal quality.
- Picture perfect audio/video resolution.
- Unrestricted freedom of movement.
- Exceeds EIA RS-250B Standards.
- Ruggedized, impact resistant housing.
- Can be worn on belt or held in your hand.
- No heavy equipment, no cable jockeys, no location too remote.

#### Available now.

Call or write PCO today.

20200 Sunburst St. Chatsworth, CA  
91311-6289, Phone: (818) 700-1233  
FAX: (818) 700-9047 or (818) 882-7041



PCO-5050

Please Send Literature Circle (131) on Reply Card  
Call Me, I'm Interested Circle (132) on Reply Card

**PCO**

A Subsidiary of Corning Glass Works

**Mitsubishi Electric Sales**

*Autoscan:* 27" color video monitor.  
*P-75U video printer:* large format prints; 6x8"; 64-level gray scale; autoscan from 15kHz to 35.5kHz.  
*VS-1250:* autoscan projector; 675 lumen output.  
**Circle (883)**

**Panasonic Industrial/Broadcast**

*CT-2081Y, CT-2081VY:* 20" diagonal monitor, monitor-receiver; flat-screen CRTs with 450 lines horizontal resolution on S-video inputs; A/B/VTR/S-video input selections.  
*CT-1381Y, CT-1381VY S-VHS:* color 13" diagonal monitors, monitor-receivers; 420 line resolu-

tion; 2 BNC looping inputs, outputs, 2 phono jack audio inputs, outputs; 8-pin VTR jack.  
*AT-H1900, -H1300:* M-II HR 19" (0.44mm pitch) and 13" (0.31mm pitch) monitor; wideband comb-filter decoder; I/Q axial demodulation; auto setup option for white balance at five color temperatures; three inputs for RGB, Y/R-Y/B-Y, Y/C signals; NTSC correction matrix; switched AFC; aperture correction.  
*CT-2580Y:* 25" diagonal monitor for direct S-VHS viewing; S-VHS, video, audio input/output terminals; resolution to 450 lines; A/B/VCR input selector; tint, color push-button selection.  
**Circle (928)**

**Sony Communications Products**

*PVM-1944Q, 1942Q:* 19-inch color monitors with multiple inputs; -1942 includes composite, VTR, S-VHS, analog/digital RGB; -1944 offers composite, VTR, S-VHS, analog RGB and component inputs.  
**Circle (1011)**

**Sony Pro Video**

*PVM-4300:* 43-inch Trinitron monitor; IDTV (improved definition) electronics with digital frame memory; composite, Y/C, RGB analog inputs with audio; 45-inch CRT operates non-interlaced.  
**Circle (1011)**

**Videotek**

*Model RM-8:* portable color receiver/monitor; 8" CRT; ac/dc operation; *RM-8PR* professional version with dc-restoration, keyed back porch clamp, A/B inputs; optional DRC-8 double rack-mount case.  
**Circle (1125)**

*Additional support products continued from page 148.*

**San Francisco Satellite Center**

*Satellite relay services:* through Sky Valley facility, Vallejo, CA.  
**Circle (1208)**

**Sound Ideas**

*Hollywood Edition:* series 4000 sound effects collection; effects for comedy, Foley, special, horror, musical, space and other genre.  
**Circle (1014)**

**Valentino Production Music**

*Production music, effects:* CD libraries with 40 discs of music organized by tempo, themes, industrial, specialty categories; 15s, 30s, 60s selections; 30 discs of sound effects.  
**Circle (1104)**

**Weather Network**

*WXNET- series:* computer-based weather resource systems; can be shared with graphic production; basic system provides automatic reception, weather graphics playback; remote control image sequencing; 16-bit images with 32,768 colors; 50-image on-line capacity; expands to dual-channel system with storage for 200 images on-line and integrated operation from effects system.  
**Circle (801)**

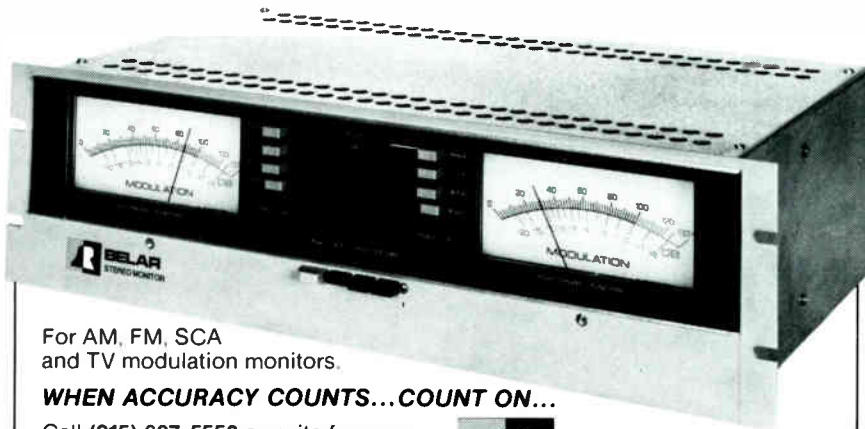

For AM, FM, SCA and TV modulation monitors.

**WHEN ACCURACY COUNTS...COUNT ON...**

Call (215) 687-5550 or write for more information on Belar AM, FM, Stereo, SCA and TV monitors.



**Circle (142) on Reply Card**

**RELIABLE ROTARY ATTENUATORS**

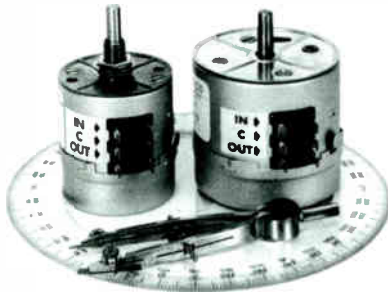

- PREMIUM MATERIALS
- QUALITY WORKMANSHIP
- PROVEN PERFORMANCE
- MANY STYLES
- ALL IMPEDANCES

**SHALLCO, INC.**

P. O. BOX 1089  
 SMITHFIELD, N. C. 27577  
 919/934-3135

**Circle (143) on Reply Card**

**BUY PERFORMANCE, BUY FEATURES, BUY PRICE  
 BIDIRECTIONAL Microwave Systems**

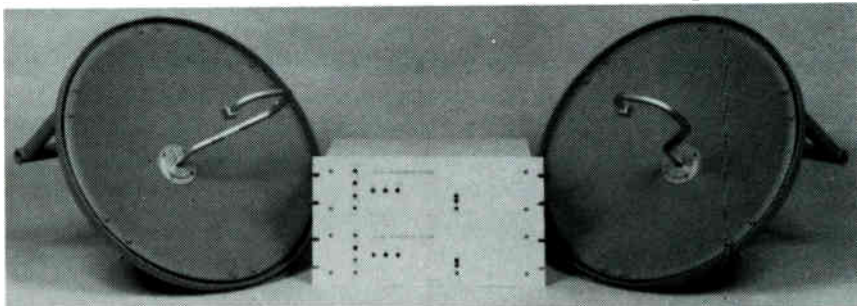

**DIVERSIFIED MARKETING**

3918 W. Clearwater Kennewick, WA 99336 (509) 735-6812

**Circle (144) on Reply Card**

## News

Continued from page 4

and as the third largest program producer in the PBS network, WETA produces "Washington Week in Review" and "The MacNeil/Lehrer NewsHour." WETA hopes to install the transmitter later this year.

## ANSI board turns down HDTV

The American National Standards Institute (ANSI) Appeals Board has voted to uphold the appeal of Capital Cities/ABC and deny approval of SMPTE 240M, a high-definition TV production standard developed by the Society of Motion Picture and Television Engineers. SMPTE had sought approval of its standard as an American National Standard.

The board said that the standard "lacked current consensus based on the latest information presented..." and that ANSI standards "are intended to represent national practice as defined by national consensus of U.S. opinion, for use in the U.S. industrial system." ANSI coordinates the voluntary standards system in the United States, working with standards developers, users and interested parties.

## News from Europe

By John Blau,  
European correspondent

## Snags in Scandinavian TV satellite plans

An Ariane rocket carrying the Scandinavian Tele-X TV was launched on April 1. The satellite, Europe's third DBS, once was viewed as a symbol of high-tech Nordic unity. It is now widely dismissed as a \$264 million white elephant. Previous attempts to sell it have failed. Sweden holds an 82% interest, Norway 15% and Finland 3%. Norway has announced that it may pull out of the consortium and start an ad-financed channel.

Private Swedish TV firms, clamoring to lease transponders, have gotten the cold shoulder from state broadcasting officials. Sweden's public service TV network is expected to take one of the three transponders. After years of banning commercial television, the Swedish government is expected to debate the issue after a report from a special consultative group has been completed sometime this summer.

1:2(=))

# Best Of Both Worlds

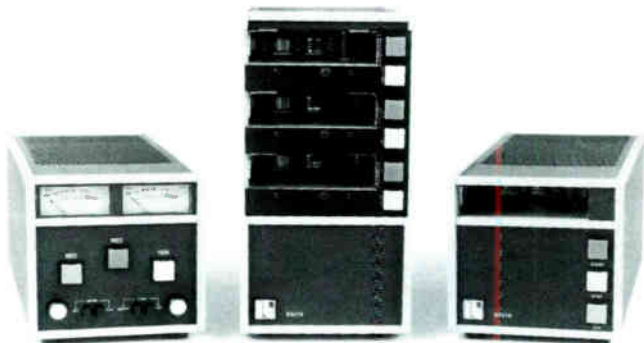

## ITC And BSW

For years, you've depended on the quality and durability of ITC Cartridge Machines. You have also depended on the fast delivery and accessibility from BSW. Now you can have the best of both worlds. BSW, America's full-time broadcast supplier, is now an authorized ITC cartridge machine dealer. Choose from the economy OMEGA series, performance packed DELTA series, or the premium 99 series machines.

BSW and ITC offer a winning combination for cartridge machines and accessories. Call us today for complete specifications and pricing.

# BSW

B R O A D C A S T S U P P L Y W E S T

America's Full-Time Broadcast Supplier

**1-800-426-8434**

ORDERS • INFORMATION • SPECIFICATIONS

BSW • 7012 27th Street W • Tacoma, WA 98466 • FAX 206-565-8114

Circle (149) on Reply Card

# HDTV: Politics on a grand scale

By Jerry Whitaker, editorial director

**High-definition television has evolved from a discussion of technical merits to an issue of national pride and national security.**

*"All products and services must fill a need. In addition, they must be politically and economically feasible. In telecasting, the public interest, first and foremost, must be served. You cannot legislate consumer demands or tastes. You must listen to the people and satisfy their needs."*

— Julius Barnathan, luncheon speech, 1989 Winter SMPTE conference, San Francisco

The clock is ticking on high-definition television. Japanese consumer electronics manufacturers plan to ship VCRs and TV sets to the United States as early as next year. Prices for the HDTV products will be high at first — maybe \$4,000 for a TV/VCR. Only a few videophiles will buy the sets. But with increased worldwide volume, the cost to consumers will drop, perhaps dramatically. (Remember how much the first home VCRs cost?)

The ramifications of HDTV have moved beyond marketing and technology, and into the realm of politics. The political questions raised by the push for high definition promise to be far more difficult to resolve than the technical ones.

At this year's NAB convention, we saw a dramatic display of the progress made in HDTV development. It was all there: full-resolution HDTV, advanced television (ATV), improved-definition television (IDTV), extended-definition television (EDTV), advanced compatible television (ACTV), high-definition NTSC (HD-NTSC), multiple sub-Nyquist encoding (MUSE)

transmission of HDTV, improved NTSC, and a handful of other approaches to delivering a better picture to the consumer.

The NAB exhibit featured HDTV in different environments. Equipment was organized into subsystems for demonstration purposes. A studio set provided a view of the broadcaster's end of the equation, and a living room of the future gave attendees an idea of what they may see one day in their homes. Then there was an HDTV theater that no doubt made some film people nervous. Any way you viewed the exhibits, it was clear that HDTV is not going to go away. It will, in fact, be here sooner than most people in the broadcast industry would like.

## Testing the systems

The Advanced Television Test Center (ATTC) is charged with the difficult task of evaluating the 21 proposed methods (from 15 different organizations) of transmitting some form of ATV over the airwaves. Shortly after the NAB convention, the ATTC sponsored what has come to be known as "hell week No. 2." The purpose was to test the strengths and weaknesses of the proposed systems. "Hell week No. 1" was held last November in Springfield, VA. Thirteen of the 15 systems proposed to the FCC's advisory committee on advanced TV service (ATS) were evaluated. An official report on the outcome of the first series of tests was due to be released at press time.

The ATTC work is difficult for two reasons. First, the 21 systems are in various stages of readiness. Most, if not all, are

undergoing continual refinement. Only a few systems exist as real, live black boxes, with "inputs" and "outputs." Computer simulation makes up the bulk of what's been demonstrated so far. The ATTC efforts may prove to be as much a test of computer simulation as a test of hardware. At some point, though, the computers will have to be turned off, and the black boxes turned on. (This observer is from Missouri, so they'll have to show me.)

The large number of system proponents and the delays in developing hardware make it unlikely that any decision on a new ATV transmission standard could be recommended to the FCC before mid-1991 or later that year. By that time, consumers will probably be able to purchase HDTV sets at the local Sears store. However, they probably will not be able to afford them — initially at least. From that standpoint, broadcasters have a shot at being in the ATV ball game on opening day.

## Mr. Chairman, point of order...

The most curious development in the battle over HDTV is the interest politicians have begun to take in the technology and its ramifications. Representative Ed Markey (D-MA) chairs the House Telecommunications Subcommittee, which recently invited comments from interested parties on the topic of high-definition television. Markey's subcommittee conducted two days of ATV hearings in February. There was no shortage of sources of input, including:

- *The American Electronics Association*, which suggested revised antitrust laws, patent policy changes, expanded exports

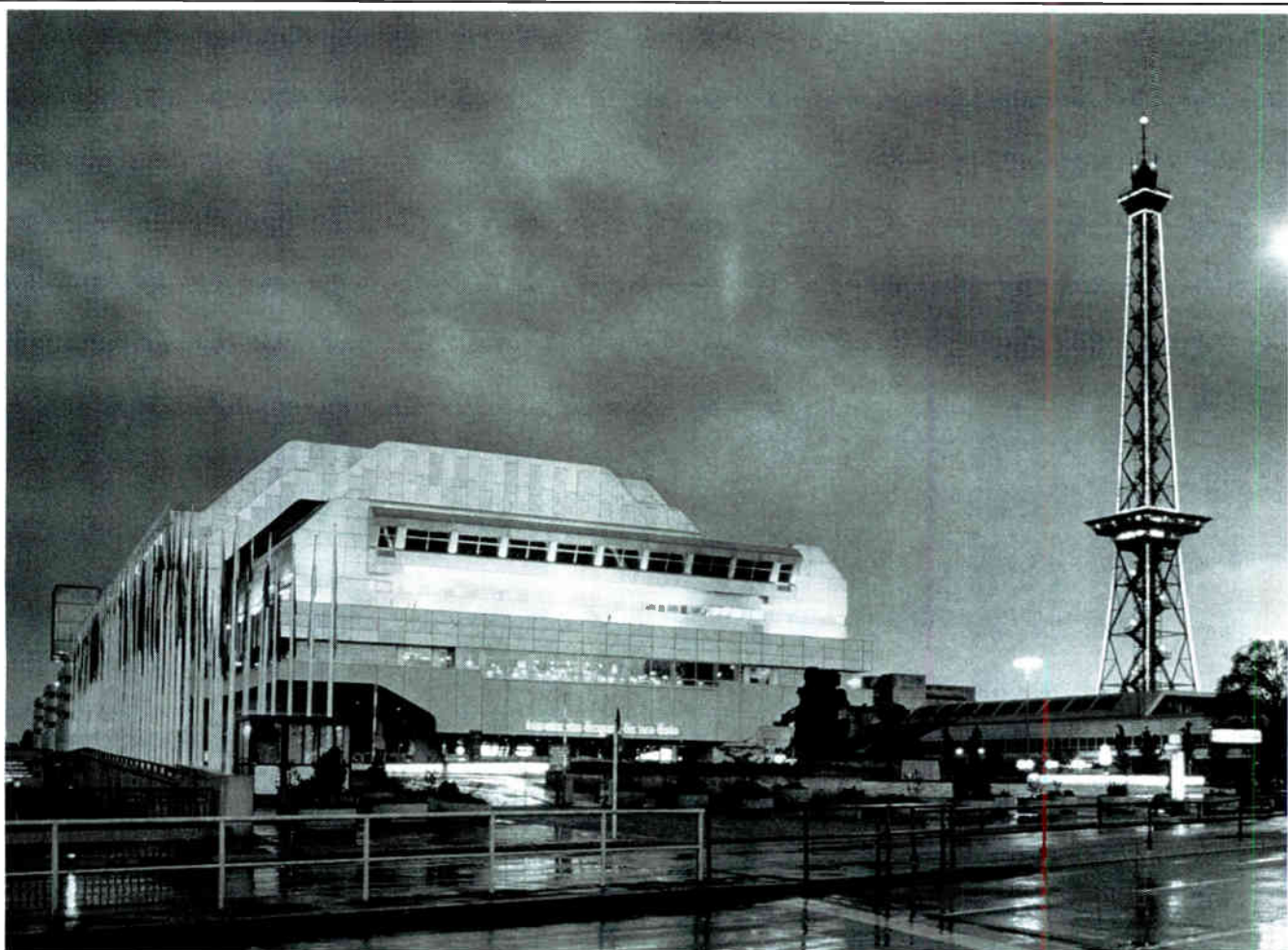

# On the Air with AEG Olympia.

First-class technological achievements are a tradition at AEG. These successes are based on wellfounded experience, since AEG can look back on 80 years of proven transmitter design experience.

Moreover, AEG has been building broadcasting transmitters since 1923, and today it is one of the leading manufacturers offering innovative expertise in broadcasting.

Modern high-power transmitters with ratings from 100 to 600 kW, a new program of long, medium and short wave broadcasting transmitters and more than 80 Pantel transmitters throughout the globe represent ultramodern engineering perfection.

Pantel is a PDM method of modulation having high overall efficiency. Significant savings of energy are achieved by using DAM (dynamically controlled amplitude modulation) conveniently applicable to Pantel transmitters. AEG supplies on a turn-key basis complete broadcast transmitting stations that guarantee high operational reliability, economic operation and long life.

Further advantages are full remote-control facilities suitable for unattended operation, and compact mechanical design.

In addition to the high-power transmitters, AEG also supplies complete broadcast transmitting stations for VHF FM and Band IV/V television including suitable antenna



systems satisfying all directivity and gain requirements. Of course, maintenance and thorough technical training by experts are considered natural elements of the total AEG service.

The information and communications technology of AEG and the office automation technology of Olympia AG have united to form AEG Olympia AG – representing a

new, international sphere of activity for the technology company AEG.

AEG Olympia · Sickingenstrasse 20–28  
D-1000 Berlin 21 · Telephone: (30) 34 63-0  
Telex 181 819 · Telefax: (30) 34 63 24 19

## Coupon

Please send me further information on high-power transmitters:

Name: \_\_\_\_\_

Company: \_\_\_\_\_

Address: \_\_\_\_\_

\_\_\_\_\_

\_\_\_\_\_

AO.WAK 312 E

**AEG**  
OLYMPIA

of high-tech products and government funding of research on high-definition television.

- *Citizens for a Sound Economy*, which argued for a relaxation of antitrust laws.
- *Committee to Preserve American Television*, which encouraged strict enforcement of trade laws and consideration of government research and development funds for joint projects involving semiconductor and advanced display devices.
- *Maximum Service Telecasters*, which suggested tax credits, antitrust exemptions and low-interest loans as ways of encouraging U.S. development of terrestrial HDTV broadcasting.
- *Committee of Corporate Telecommunications Users*, which suggested the creation of a "Technology Corporation of America" to devise an open architecture for the production and transmission of HDTV and other services.

Representative Don Ritter (R-PA) has expressed serious concern about the role that U.S.-based companies will play — or more to the point, will not play — in the development of high-definition television. Ritter thinks it is vital for America to have a piece of the HDTV manufacturing pie. "The development of HDTV technology by American industry is critically important to our economy and security," he said.

Senator Jack Danforth (R-MO), considered a leader on trade issues, thinks the government should consider encouraging certain high-tech businesses. "Japan makes government decisions in a way that helps their targeted industries," he said. "I think we're going to have to think more as they think."

Commerce Secretary Robert Mosbacher is concerned about how the lack of a strong HDTV industry in the United States might affect the domestic semiconductor business. "Someone has described HDTV as the food chain of the electronics industry. It is an apt description," he said.

The Pentagon, meanwhile, has expressed strong interest in high-definition technology for two reasons: direct military applications, and the negative effects that the lack of domestic HDTV expertise could have on the American electronics industry. The Department of Defense has allocated \$30 million for HDTV research over the next two to three years.

Not everyone is upset, however, about the perceived technological edge the Japanese (and the Europeans to a lesser extent) now have over the United States. A widely read and widely circulated article in "Forbes" magazine ("IBM-TV?," by George Gilder, "Forbes," Feb. 20, 1989) described HDTV as a technology that will be obsolete by the time it is introduced. "The whole issue is phony," Gilder said. He thinks HDTV products will hit the market "precisely at the time when the U.S. computer industry will be able to sup-

ply far more powerful video products at a lower price." The United States now holds about 70% of the world market in computers, and Gilder says the time and money would be better spent capitalizing on our lead there, rather than trying to play catch-up with the Japanese.

This view is shared by Andrew Lippman, associate director of the Massachusetts Institute of Technology's media lab. Lippman thinks American industry should look beyond HDTV to a new era of computer-based video information and entertainment systems.

#### Standardization battle lines

The economic, political and technical implications of HDTV have caused a frenzy of activity in standardization bodies around the world. To paraphrase Churchill, "Never have so many talked about so much for so long."

Serious interest in HDTV dates back to about 1974, when NHK (the Japanese National Broadcasting Company) gave its first successful demonstrations. By 1980, the United States started to follow the Japanese work. At about the same time, European countries also began to look into the matter. The Europeans were interested in narrowing the technological lead of the Japanese.

The first full-scale attempt at international HDTV standardization was made by the International Radio Consultative Committee (CCIR), in Dubrovnik, Yugoslavia, in May 1986. Japan and the United States pushed for a 1,125-line/60Hz production standard. The Japanese already had a working system. The 50Hz countries, caught with their technical pants down, demurred, asking for time to perfect and demonstrate a non-60Hz, presumably 50Hz, system.

The HDTV standardization fight is, by no means, simply a matter of North America and Japan vs. Europe. Of the 500 million receivers now in use worldwide, roughly half would feel the effect of any new frame rate.

The Dubrovnik meeting concerned itself mainly with a production standard. TV material can, of course, be produced in one standard and readily converted to another for transmission, thanks to modern standards converters. Still, a single, universal standard would circumvent both the bother and degradation of the conversion process.

The commercial implications of HDTV are inextricably intertwined with the technology. Even more in Europe than elsewhere, commercial considerations dominate thinking. The 1125/60 system is basically a Japanese system. The United States came in late and jumped on the Japanese coattails, aided greatly by the fact that the two countries have identical TV standards (CCIR System "M"). But the

Europeans don't want to have to buy Japanese or U.S. equipment; they don't want to pay any Japanese or U.S. royalties; and they don't want to swallow their NIH (not invented here) pride. This feeling also has emerged in the United States within the past year or so for basically the same reasons, only American manufacturers don't want to be locked into the Japanese and/or Europeans.

#### Eureka! We've seen it!

Any hope of a single worldwide standard for high-definition television did a slow dissolve to black at IBC in Brighton last year. Brighton was the site of the first public debut of the HDTV system developed by the European consortium known as *Eureka EU95*. The system is intended to be a direct competitor of the 1125/60 system developed by NHK.

The Eureka project was launched in October 1986 with the goal of defining a European HDTV standard of 1250 lines/50Hz that would be compatible with existing 50Hz receivers. EU95 brought together 30 TV-related organizations, including major manufacturers, broadcasters and universities. The Brighton showing included products and technology necessary for HDTV production, transmission and reception. HD-MAC is the transmission standard developed under the EU95 program. HD-MAC is an extension of the MAC-packet family of transmission standards.

The primary movers in EU95 are Bosch Philips and Thomson. The aim of the Eureka project was to define a 50Hz HDTV standard for submission to the plenary assembly of the CCIR next year. The work carried out under this effort involved defining production, transmission, recording and projection systems that would bring high-definition pictures into viewers' homes.

Supporters of the 1125/60 system also are planning to present their standard to the CCIR in 1990 for endorsement. The entry of EU95 into the HDTV arena will change the complexion of the plenary assembly meeting considerably. It will mean, certainly, that no worldwide HDTV production standard will be developed, let alone a broadcast transmission standard.

It may be the programs themselves that will play a dominant role in the ultimate acceptance of a common worldwide definition of production standard. The vast bulk of mass-appeal programming already available, or being shot now, comes from the United States. These are either on film at 24fps or on tape at 30fps. Original material in true HDTV will be produced first by the countries where HDTV is likely to first catch on, probably Japan and the United States. And the great bulk of this material probably will be produced in 60Hz.

Among the aims and claims for HDTV



# Rack up twice the performance in the same amount of space.



## The Problem

How to upgrade and increase your microphone mixing capability without sacrificing your valuable rack space or your budget.

## The Solution

The new ELX-1R.

## Here's Why

The ELX-1R is a portable, four-channel mic/line mixer.

It's half the size of our nearest competitor, the Shure M267, and fits into a single rack-mount space. Think of it. By utilizing two ELX-1R's, you can double your mixing capabilities in the same amount of space it takes to mount one M267.

Also, it's less expensive than the M267 because our rack mount is standard—you have to pay for theirs.

And it offers you the kinds of features that theirs doesn't . . .

Like half the distortion. Or individual input LED clip indicators. Or a 10-segment, three-color LED

PPM bargraph display. Or 1/4" auxiliary phone connections, as well as professional XLR input-output. Or positive action push-button switching.

And last but not least—better specs across the board and a two-year warranty opposed to one.

## You Decide

Naturally, we don't expect you to take our word on this . . . you have to see for yourself. Contact your local EV dealer today. Ask for our comparison chart and an engineering data sheet. Better yet, ask for a no-pressure demonstration.

We think you'll be pleasantly surprised.



**Electro-Voice®**  
a MARK IV company

600 Cecil Street  
Buchanan, Michigan 481107  
Phone: 616/695-6831

In Canada: P.O. Box 520  
Sanarogue, Ontario K7G2V1  
Phone: 613/382-2141

Circle (29) on Reply Card





# Winsted®

## SPACE SAVING TAPE STORAGE CABINETS

**DOUBLE YOUR TAPE STORAGE** capacity with exclusive Pull-Out Cabinets that save space, provide fast reference and immediate access. **IDEAL** for odd-shaped areas, alcoves, unused aisles. Pull out easily on low profile tracks. Modular or custom units to fit any space requirements. **DURABLE ALL-STEEL** construction accommodates heaviest loads.

**WINSTED ALSO OFFERS** Side-by-Side and By-Pass movable storage systems to maximize your tape storage capacity. Installations in many network and major station facilities. **WHATEVER YOUR NEEDS**, Winsted offers the most complete line of tape storage systems in the industry.



Sliding cabinets in 2-unit or 3-unit configurations fit easily beside aisle or in alcoves, pull out for immediate access.

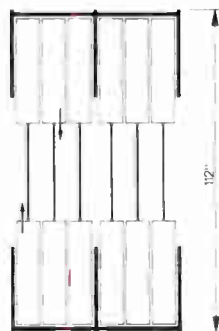

Cabinets installed directly opposite each other use common track and center aisle, pull out from left or right.

**FREE!** full color catalog. Write or call today toll-free.

**800-447-2257**

**FAX: 612-944-1546**



THE WINSTED CORPORATION, 10901 Hampshire Avenue So., Minneapolis, MN 55438 • 612-944-8556

**Preferred by Professionals Worldwide**

Circle (126) on Reply Card

# The SBE observes a milestone

By Brad Dick, technical editor

The SBE celebrates its silver anniversary this year.

The Society of Broadcast Engineers is observing its 25th anniversary this year. The first official meeting of the SBE was held on April 4, 1964. The organization actually began at the suggestion of John Battison, then editor of **Broadcast Engineering**. In the editorial column that appeared in the December 1961 issue, Battison pointed out the need for an organization devoted exclusively to radio and TV engineering personnel. He wrote:

"Perhaps a new organization is needed for broadcast engineers, one started in the same way as the Institute of Radio Engineers (IRE). Perhaps it should be called the Institute of Broadcast Engineers (IBE) and presided over by one of the great broadcasters of a few years ago. How many years has it been since a broadcast engineer was president of the IRE?"

"We leave you with that thought for this month. Your comments addressed to the editor will be welcome."

---

**"How many years has it been since a broadcast engineer was president of the IRE?"**

---

With that, Battison had issued the first public proposal that a national organization be formed for broadcast engineers. However, his call for response was only mildly successful. Over the next few months, he received 32 responses to his invitation, not all of which were positive.



*John Battison (left) was instrumental in the formation of the SBE through a series of editorial columns in **Broadcast Engineering** during the early 1960s. He was the first president of the society. Battison is shown in this 1966 photo handing over the reigns of the young SBE to Charlie Hallinan (right) at the Conrad Hilton Hotel in Chicago during the '66 NAB convention. (The man in the center of the photo cannot be identified.)*

According to Battison's editorial in the February 1962 issue of **BE**, only three-fourths of the letters he received were in favor of his suggestion to form a new broadcast organization.

At that time, the IRE was a large international society that included a number of technical disciplines. The group later merged with another engineering organization to form the Institute of Elec-

trical and Electronics Engineers (IEEE).

Despite the minority viewpoint, a new organization soon was started. The April 1963 issue of **BE** included a membership application blank and an invitation for readers to join the Institute of Broadcast Engineers. Letters of invitation were sent to almost 5,000 radio and TV engineers in the United States and Canada to drum up additional support.

The response was encouraging to Battison, and within a few months, people actually began to join the IBE. An informal meeting was held in late 1963 in Binghamton, NY. Deciding that there was sufficient interest, Battison scheduled the first official meeting of the IBE for the 1964 NAB Convention in Chicago.

On April 5, 1964, about 100 participants gathered in the Williford Room of the Conrad Hilton Hotel for the first meeting of the IBE. The first action of the fledgling organization was to change its name. There was strong membership opposition to the use of the name Institute of Broadcast Engineers, or IBE, because of the similarity to the name of the union, International Brotherhood of Electrical Workers (IBEW). Because of the concern about a problem with mistaken identity, the name was changed to the Society of Broadcast Engineers.

The SBE currently has a membership of 5,500, with more than 80 active chapters. The 25th anniversary of the organization will be observed at the SBE national convention in Kansas City, MO, this October.

Editor's note: For additional information on the SBE, write the Society of Broadcast Engineers, P. O. Box 20450, Indianapolis, IN 46220. The phone number is 317-842-0836.



## Specialty certification committees report

By Bob Van Buhler

A meeting of the National Conference on Engineering Specialty Certification, held April 18 in Alexandria, VA, was largely taken with committee reports. At its previous meeting in November 1988, the group had formed three committees to set goals, develop a tentative budget and propose an organizational structure. SBE vice president Bob Van Buhler attended the April meeting, along with representatives of other groups, including professional associations covering a broad spectrum of engineering and engineering-related disciplines.

### Committee reports

The strategic planning committee reported that it had developed the organization's goals, which include promoting credibility and recognition for engineers, specialty certification and providing a structure for the organizing process. The committee addressed these goals for several groups: professional engineers, graduate engineers, technologists, technicians and specialists. The proposed by-laws are weighted heavily for those holding state-administered professional engineer credentials.

The committee's original plan would have given permanent control of all officer positions and most of the executive committee positions to those holding professional engineer credentials. In addition, the votes were weighted 3 to 1 over other member groups. This proposal met stiff resistance by those in the manufacturing, broadcast, safety and other industries. The plan was rejected.

A compromise structure gives equal weight to electronic technology and other technical groups, professional engineer groups and graduate engineer programs. Less control was given to the public board members and engineering-related technologies.

Essentially, the group is a federation that defines engineering specialty certification, and proposes criteria for approval programs. This allows activities to be coordinated, thereby avoiding duplication of effort. The committees are designed to

help upgrade the various programs to uniform levels and provide credible assessment of engineering credentials.

The proposal was written so eight organizations are grandfathered as *approved specialty boards* without examination or program investigation. These organizations are as follows: Environmental Engineers, Cost Engineers, Civil Engineers, Plumbing Engineers, Safety Engineers, Forensic Engineers, Manufacturing Engineers and Noise-Control Engineers. No reason was given for the favored treatment to these groups.

Associations now belonging to the organization include most major accrediting groups that have certification programs. These include the Accreditation Board for Engineering and Technology (ABET), National Academy of Engineering (NAE), National Council of Engineering Examiners and the National Society of Professional Engineers. Although these groups would be awarded full voting rights, they would be under no obligation to financially support the organization.

Members of the SBE executive committee and the Ennes Foundation met at the NAB convention to decide whether active participation of the SBE in this federation is advisable. Membership in the organization is expected to cost approximately \$5,000.

### Texas situation

SBE counsel Chris Imlay recently contacted the Texas State Board of Registration to formally request a written opinion confirming that the use of job titles such as engineer, chief engineer, contract engineer, director of engineering or similar titles is permitted by persons working for a broadcast station.

Imlay made it clear that no representation is to be made that those with these titles are professional engineers or registered engineers. The persons are to limit their activities to FCC-licensed or FCC-regulated communications facilities. Imlay thinks that such a clarification will solve many of the problems perceived by some Texas broadcast engineers.

### Board vacancy filled

Paul Montoya, past chairman of

Denver's chapter 48, was appointed to fill a vacancy on the national board of directors. Long active in SBE affairs, Montoya was instrumental in coordinating the 1988 National SBE Convention and **Broadcast Engineering Conference** in Denver.

He will complete the remaining two years of Mary Beth Leidman's term. Montoya is chief engineer of KXKL-FM in Denver, and he may be contacted at 303-832-5665. Although evenly distributed across the United States, SBE board members serve at large.

### ITVA to attend SBE convention

The International Television Association (ITVA) plans to hold its technical sessions concurrent with the SBE national convention in Kansas City, MO. The group's members attending the convention should number about 400.

The SBE will share space with ITVA, whose national membership is almost 10,000, to make the event more valuable to both organizations.

### Reminder for frequency coordinators

A frequent complaint expressed by itinerant users of Part 74 frequencies is that local coordinating committees are difficult to contact. Often, these users come into town on short notice and work at weekend or after-hours events. It is important that local coordinating committees provide a 24-hour telephone number at which frequency coordinators may be reached.

The NFCC suggests that local committees consider using a commercial answering service to provide that access. The answering service always should know who is on duty to cover coordination. With proper scheduling, the coordinator and a back-up person could provide this service continuously. The cost would be a minor and legitimate expense for the local committee.

Editor's note: Additional information regarding SBE activities is available on CompuServe, IGO BPFORUM [:(~)]

June 1989 **Broadcast Engineering** 193

©1989 Debra Electronics, Inc.

Circle (148) on Reply Card

June 1989 **Broadcast Engineering** 195

OUR station transmitters and antenna systems because of the drastically reduced power.

The SC-HDTV system is being proposed as a simulcast system. The regular station NTSC broadcast would occur in its assigned channel, and the same program material would be broadcast in the SC-HDTV format on the adjacent taboo channel. To keep the NTSC signal from interfering with the high-definition signal, they would be interlocked, and the high-power

When you are the person responsible for monitor images, you will find one simple truth... cardboard is for boxes and Hoodman monitor sun shades are for perfect, glare-free monitor images. Hoodman's new line of monitor sun shades are available in 6 different sizes which fit 9-inch through 21-inch monitors. Prices start at \$9.95.

For more information, contact your Comprehensive Video Dealer or call us direct and we'll be happy to answer any questions. CALL (213) 379-6391. We can ship your order today. Your satisfaction is guaranteed.



P.O. Box 816, Hermosa Beach, CA 90254

Circle (110) on Reply Card

June 1989 **Broadcast Engineering** 197

June 1989 **Broadcast Engineering** 201

1712 Allied Street Charlottesville, Va. 22901

# New products Business

## Andrew completes antenna tuning facility

Andrew, Orland Park, IL, has completed a facility to be used during tuning of the company's line of GUIDELINER and TRA-

has begun worldwide marketing, under the Sony name, a Betacam SP format video studio player manufactured by Ampex. Ampex began delivery of the BVW-60 studio player to Sony in March.

moved into larger facilities. Magni doubled its space with the addition of 11,000 square feet to its current premises.

Magni also has announced its first patent. John Judge, a principal engineer and co-founder of Magni, was awarded the pat-

• Pineway Electronics • Pinnacle Systems, Inc. • Pinzone Communications Product, Inc. • Pioneer Communications of America • Pioneer Technology Corp. • Pisces Corp. • Plastic Capacitors, Inc. • Plattsbur...

## Professional services

**UNUSED  
CALL LETTERS**  
CALL  
**dataworld®**  
1-800-368-5754

## NETCOM (201)837-8424

NETWORK COMMUNICATIONS CONSULTANTS  
931 TEANECK RD. TEANECK, N.J. 07666

STATE-OF-THE-ART ENGINEERING FOR AUDIO & VIDEO

- FACILITY PLANNING
- SYSTEM DESIGN
- CAD SERVICES

JAMES TRONOLONE  
ENGINEER

## HIGH PRIORITY CONSULTING

CAD Documentation  
for the Audio/Video Industry  
Facilities, Product and Equipment  
Design, Schematics  
212-246-3811 X510 SVC

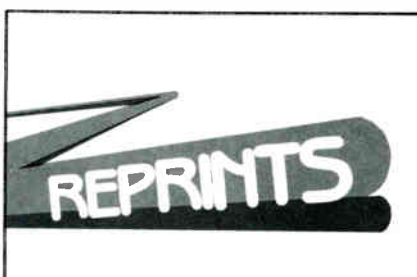

**Interested in ordering article reprints out of this or another issue?\***  
Reprints can be excellent learning tools for your staff and great marketing tools for your sales staff. Call or write Cheri Wells at Intertec Publishing Corp., P. O. Box 12901, Overland Park, KS 66212; (913) 888-4664  
\*Minimum order 1,000 copies

## Classified

Advertising rates in Classified Section are \$1.50 per word, each insertion, and must be accompanied by payment to insure publication.

Each initial or abbreviation counts a full word. Minimum classified charge, \$35.00.

For ads on which replies are sent to us for forwarding (blind ads), there is an additional charge of \$40.00 per insertion, to cover department number, processing of replies, and mailing costs.

**T-66 FILM PROJECTOR "NEW" 6K**, used fully refurbished pair 10K, TP-7 Slide Projector used fully refurbished w/acces. 1100. Projector assemblies, parts, and services. SIMBER BROADCAST SERVICES, INC. (609) 435-1091 6-89-11

**NEW LOGITEK AUDIO EQUIPMENT:** Mono DA's, \$250. Stereo DA's, \$300. Perfectionist Console, \$5800. Contact Darron Corriden, 407-283-6398. 6-89-11

## SERVICES

**TRANSMITTER TUBE REBUILDING SINCE 1941:** 3CX2500, 4CX5000, 4CX15000 and many others. Write for details. FREELAND PRODUCTS INC., Rt. 7, Box 628, Covington, LA 70433. (504) 893-1243 or (800) 624-7626. 6-79-tfn

## WE PLACE ENGINEERS

ALL CATEGORIES FOR TV, PRODUCTION, VIDEO, CATV (EXCLUDING OPERATORS)

America's Leading Source for a Decade  
(TV STATIONS, PRODUCTION FACILITIES, CORP TV MFG, CATV)

For information phone or write Mark Kornish



**key systems**

479 Northampton Street  
Kingston, PA 18704

Employer  
Paid Fees

(717) 283-1041

**TRANSMITTING AND CAMERA TUBES.** One stop for all of your requirements. All foreign and domestic brands, rebuilds, and obsolete material available at low, low prices. Large inventory means fast delivery. Daily Electronics, P.O. Box 5029, Compton, CA 90224, (800) 346-6667, (213) 774-1255. 3-89-61

**AUDIO AUTOMATION:** Computer controlled, 8-CD changers, music and commercial program software, hard disc for commercials. Complete: \$6900. BGM INTERNATIONAL, (904) 438-8054. 7-71-tfn

## TRAINING

**NAPA VALLEY COLLEGE** offers a 2-year telecommunication program with emphasis in 1-inch "C" format, T.B.C.S., component and digital video. Call or write Gary Vann, (707) 253-3258 Napa Valley College, Napa, California 12-88-9t

**FCC GENERAL RADIOTELEPHONE operators license** through cassette recorded lessons at home plus one week seminar in Boston, Washington, Detroit or Philadelphia. Our twentieth year teaching FCC license courses. Bob Johnson Radio License Preparation, 1201 Ninth, Manhattan Beach, Calif. 90266. Telephone (213) 379-4461. 8-81-tfn

## FOR SALE

**HIGHEST PRICES** for 112 Phase Monitors, vacuum capacitors and clean, one kw or greater powered AM and FM Transmitters. All duty and transportation paid. Surplus Equipment Sales, 2 Thorncliffe Park Dr., Unit 28, Toronto, Canada M4H 1H2, 416-421-5631. 6-89-tfn

**COMPLETE LIVE ASSIST AUTOMATION SYSTEM.** Includes 1-MEI Model 100, 48 event programmer, 4-Revoc PR99 1/4 inch, stereo playback reel to reel machines. Total system \$8,000. Contact Kyle D. Dickson (904) 636-0507. 6-89-11

## HELP WANTED

**SOUTH CAROLINA EDUCATIONAL TELEVISION** is seeking experienced and qualified technical personnel. **Maintenance Technician** to maintain, install and operate complex television and stereo equipment. Requires extensive knowledge of multiple format video recorders, studio and portable camera systems, production and routing switcher equipment, digital effects systems, monitoring and test equipment. May provide technical assistance, guidance and supervision to other technicians. Requires an associate degree in electronics and four years of progressively responsible experience in the repair and maintenance of complex television systems or an equivalent combination. Salary range approximately \$24,000-\$36,000. **Audio/Video Technician** to have thorough knowledge of and skills in operating complex stereo television production facilities including studio and remote technical operations. Must be thoroughly versed in complex technical setup and operation of studio and portable camera systems, audio post production, stereo recording techniques and telecine transfer systems, audio post production, stereo recording techniques and telecine transfer systems. May assist in training and supervising other audio/video staff. Requires an associate degree in electronics and three years related television technical experience or an equivalent combination. Salary range approximately \$21,000-\$31,000. EQUAL OPPORTUNITY EMPLOYER. Address all inquiries to: South Carolina Educational Television Commission, Personnel Department, Post Office Drawer L, Columbia, South Carolina 29250. 6-89-11

## CAREER SALES OPPORTUNITY

**AudioTechniques, Inc.** has an immediate opening for a broadcast sales engineer in the tri-state metro New York City area. Compensation package includes salary commission and full benefits.

If you're a self starter with radio and/or TV station experience, please send a current resume, in full confidence, to:

H.H. Brosious  
AudioTechniques, Inc.  
1619 Broadway, Dept. B  
New York, New York 10019

**AudioTechniques**  
A Manny's Music Company.

**LIMELITE VIDEO IN MIAMI, FLA.** has an immediate opening for a motivated engineer with strong post production experience, analog and digital VTRS, cameras and audio. Excellent benefits. Opportunity for advancement. Call Marcos Obadia (305) 593-6911. 6-89-11

**NASHVILLE TV STATION** seeking maintenance technician. Experience with installation and repair of professional broadcasting equipment required. Send resume to TW. Patterson, Chief Engineer, WTVF Channel 5, 474 James Robertson Parkway, Nashville, TN 37219. EOE. 6-89-11

**TV TRANSMITTER MAINTENANCE ENGINEER.** Fox Television, WFXT, Boston is seeking a qualified transmitter engineer with strong background in RF. Previous experience with RCA-TTU110 UHF transmitter and studio equipment preferred. FCC lic. or SBE certification required. Send resume/references to: Moses Primo, C.E., WFXT-TV, 100 2nd Ave., Needham, MA 02194. EQUAL OPPORTUNITY EMPLOYER. 6-89-11

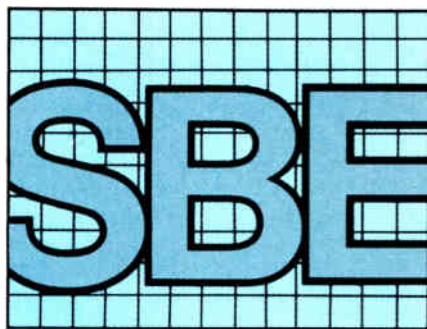

## Specialty certification committees report

By Bob Van Buhler

A meeting of the National Conference on Engineering Specialty Certification, held April 18 in Alexandria, VA, was largely taken with committee reports. At its previous meeting in November 1988, the group had formed three committees to set goals, develop a tentative budget and propose an organizational structure. SBE vice president Bob Van Buhler attended the April meeting, along with representatives of other groups, including professional associations covering a broad spectrum of engineering and engineering-related disciplines.

### Committee reports

The strategic planning committee reported that it had developed the organization's goals, which include promoting credibility and recognition for engineers, specialty certification and providing a structure for the organizing process. The committee addressed these goals for several groups: professional engineers, graduate engineers, technologists, technicians and specialists. The proposed by-laws are weighted heavily for those holding state-administered professional engineer credentials.

The committee's original plan would have given permanent control of all officer positions and most of the executive committee positions to those holding professional engineer credentials. In addition, the votes were weighted 3 to 1 over other member groups. This proposal met stiff resistance by those in the manufacturing, broadcast, safety and other industries. The plan was rejected.

A compromise structure gives equal weight to electronic technology and other technical groups, professional engineer groups and graduate engineer programs. Less control was given to the public board members and engineering-related technologies.

Essentially, the group is a federation that defines engineering specialty certification, and proposes criteria for approval programs. This allows activities to be coordinated, thereby avoiding duplication of effort. The committees are designed to

help upgrade the various programs to uniform levels and provide credible assessment of engineering credentials.

The proposal was written so eight organizations are grandfathered as *approved specialty boards* without examination or program investigation. These organizations are as follows: Environmental Engineers, Cost Engineers, Civil Engineers, Plumbing Engineers, Safety Engineers, Forensic Engineers, Manufacturing Engineers and Noise-Control Engineers. No reason was given for the favored treatment to these groups.

Associations now belonging to the organization include most major accrediting groups that have certification programs. These include the Accreditation Board for Engineering and Technology (ABET), National Academy of Engineering (NAE), National Council of Engineering Examiners and the National Society of Professional Engineers. Although these groups would be awarded full voting rights, they would be under no obligation to financially support the organization.

Members of the SBE executive committee and the Ennes Foundation met at the NAB convention to decide whether active participation of the SBE in this federation is advisable. Membership in the organization is expected to cost approximately \$5,000.

### Texas situation

SBE counsel Chris Imlay recently contacted the Texas State Board of Registration to formally request a written opinion confirming that the use of job titles such as engineer, chief engineer, contract engineer, director of engineering or similar titles is permitted by persons working for a broadcast station.

Imlay made it clear that no representation is to be made that those with these titles are professional engineers or registered engineers. The persons are to limit their activities to FCC-licensed or FCC-regulated communications facilities. Imlay thinks that such a clarification will solve many of the problems perceived by some Texas broadcast engineers.

Denver's chapter 48, was appointed to fill a vacancy on the national board of directors. Long active in SBE affairs, Montoya was instrumental in coordinating the 1988 National SBE Convention and **Broadcast Engineering** Conference in Denver.

He will complete the remaining two years of Mary Beth Leidman's term. Montoya is chief engineer of KXKL-FM in Denver, and he may be contacted at 303-832-5665. Although evenly distributed across the United States, SBE board members serve at large.

### ITVA to attend SBE convention

The International Television Association (ITVA) plans to hold its technical sessions concurrent with the SBE national convention in Kansas City, MO. The group's members attending the convention should number about 400.

The SBE will share space with ITVA, whose national membership is almost 10,000, to make the event more valuable to both organizations.

### Reminder for frequency coordinators

A frequent complaint expressed by itinerant users of Part 74 frequencies is that local coordinating committees are difficult to contact. Often, these users come into town on short notice and work at weekend or after-hours events. It is important that local coordinating committees provide a 24-hour telephone number at which frequency coordinators may be reached.

The NFCC suggests that local committees consider using a commercial answering service to provide that access. The answering service always should know who is on duty to cover coordination. With proper scheduling, the coordinator and a back-up person could provide this service continuously. The cost would be a minor and legitimate expense for the local committee.

Van Buhler is manager of engineering at KNIX-AM/FM, Phoenix.

### Board vacancy filled

Paul Montoya, past chairman of

Editor's note: Additional information regarding SBE activities is available on CompuServe. IGO BPFORUM



# New products

## Character generator

Quanta has introduced the Delta character generator for the broadcast and post-production segments of the industry. A full-color graphics tiling system, the unit is based on a frame buffer, so there are no restrictions on the number of characters on the screen. Freeform placement of the characters is possible, as is 360° rotation. An unlimited number of overlying planes permits a high degree of creative freedom in the development of attractive and dynamic graphics tiling presentations.

Circle (350) on Reply Card

## Color corrector

ColorGraphics da Vinci has introduced the da Vinci VT, a scene-by-scene color corrector targeted for the tape-to-tape market. The 16-vector processing design is expanded with geographic isolation to allow 32- or 64-vector secondary processing for hue, saturation and gray-scale modification of individual colors with similar hues. The system includes wide-band comb filtering, a multistandard input matrix and enhanced VTR control for editing.

Circle (351) on Reply Card

## RF power tubes

Thomson Tubes Electroniques division of Thomson-CSF has introduced several additional power amplifier devices to its line. The TH 582 is a coaxial metal-ceramic tetrode rated at 22kW invisual carrier service. The TH 539 tetrode includes a Pyrobloc grid structure and is rated at 1.2MW for long- and medium-wave radio broadcast service. The TH 337 tetrode is rated 350kW for long- and medium-wave or 300kW in short-wave service.

A series of three FM devices includes tetrodes with cavity; TH 341/TH 18108G and TH 341/TH 18108K are rated 10kW; TH 343/TH 18230 is rated 20kW.

The TH 563 UHF TV tetrode uses the Pyrobloc grid structure for a 50kW rating and uses Hypervapotron cooling.

Circle (352) on Reply Card

## Advanced machine control

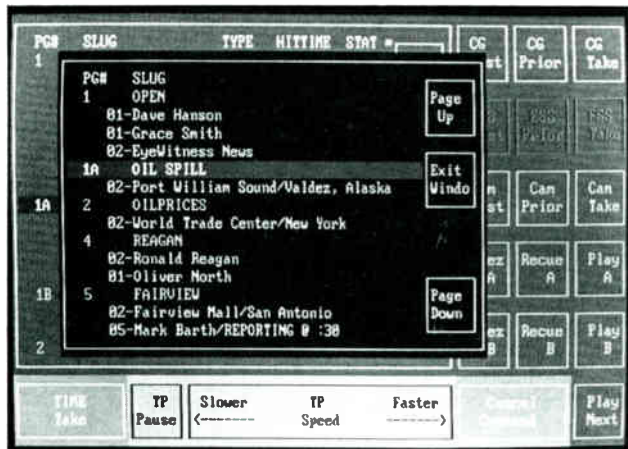

Dynatech NewStar has introduced a Touch Screen option for multiple device control from a single touchscreen monitor. From a workstation based on a PC AT, 80386 or PS/2, the option includes an EGA monitor with a touch-sensitive attachment and software that allows customized screen layouts for each user. Other software selections determine the equipment to be controlled, the colors to be displayed on the screen and recon-

figuration of touchpad locations for right-handed or left-handed operators.

Circle (353) on Reply Card

## Paint and animation system

ColorGraphics Systems has introduced the DP 4:2:2, a digital paint and animation system that allows transparent linking to any of the character generators, video recorders and other products of the D-1 environment. The system provides complete 2-D and 3-D modeling and animation through manipulation of object attributes, lighting and camera movement. Along with multiplane motion control and "History," a macro event tool for repetitive graphics applications, the system provides perspective cut and paste and an optional wireless pen for more natural painting.



Circle (354) on Reply Card

## Video production system

Alta Group has introduced Cygnus 5.5, which combines the functions of time base corrector, frame synchronizer, production effects and video router in one package. Designed for use with S-VHS Y/C and NTSC composite signals, the unit provides 5.5MHz bandwidth signal processing in all modes. Digital 8-bit sampling at  $4 \times F_{sc}$  produces high-quality 450-line resolution images. The 4-input routing switcher permits convenient signal selection from VTR, camera, satellite and remote source feeds.

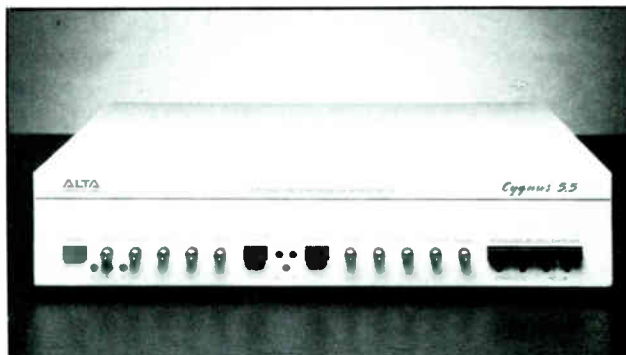

Circle (355) on Reply Card



## Routing switcher

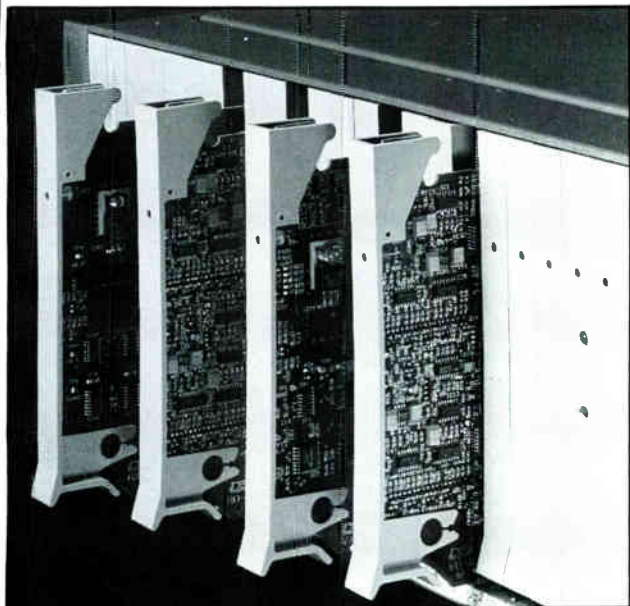

Utah Scientific has introduced the model AVS-2, a modular, multilevel routing switcher system. Because surface-mount component technology is used, the physical size is reduced,

allowing a complete 40×40 matrix to be housed in seven inches of rack space; a 200×100 system can be contained in a single equipment rack. System addressing has been increased to eight levels of 1,280 inputs by 1,280 outputs, with a capacity to "salvo" switch all outputs in a matrix within a single vertical interval.

Circle (356) on Reply Card

## Production automation

Alamar Electronics has introduced the TD-ASSISTANT, a production automation system. Prior to a production, timing and information is entered into shot sheets for automated recall and control of equipment involved in the production. Through remote-control panels, the shot sheet controls mixers, camera automation, lighting, titling, still-stores and even switcher memory setups. At any time during the production the technical director can take over manual control.

Circle (357) on Reply Card

1:7-)))

# Heart Monitor.

No matter how you look at it, the heartbeat of your TV station depends on a healthy transmission line. If a problem develops, how would you ever know until it's too late?

Now there's a way to check your line thoroughly and accurately before a simple problem becomes a major malfunction. It's the PRH-1 High Power Pulse Reflectometer from Delta Electronics.

The rugged PRH-1 puts out a low current, 5,000 volt variable pulse that overcomes the obstacles of long transmission lines, with no risk of damage. What you end up with is a series of echoes from the pulse displayed on your oscilloscope screen which represent your transmission line. The shape of the echoes determines the nature of any problem.

The PRH-1 operates like a champ in high RF fields, withstanding interference without any visible degradation of

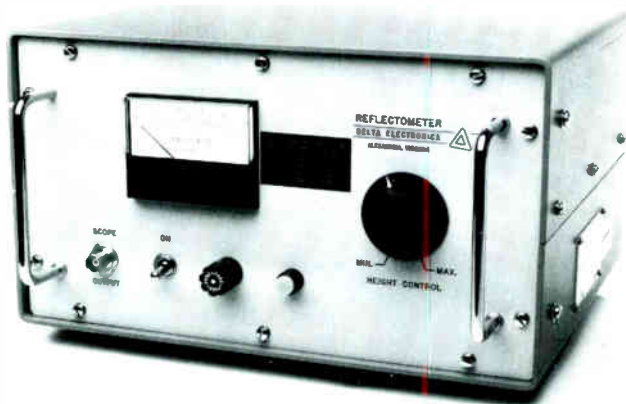

pulse echoes. This makes the PRH-1 ideally suited for crowded antenna farms and community antennas, unlike traditional time domain reflectometers. Its ability to measure AM and FM lines as well make the PRH-1 a sound investment.

What you don't know about your transmission line can hurt you. Considering the consequences you'll suffer being knocked off the air, shouldn't you consider buying the PRH-1 as your top priority?

To see actual PRH-1 test results, call or write today. Delta Electronics, Inc., 5730 General Washington Drive, P.O. Box 11268, Alexandria, VA 22312. Telephone: (703) 354-3350, FAX: (703) 354-0216, Telex: 90-1963.

The Above Standard  
Industry Standard.

DELTA ELECTRONICS



©1989 Delta Electronics, Inc.

Circle (148) on Reply Card

World Radio History

## Andrew completes antenna tuning facility

Andrew, Orland Park, IL, has completed a facility to be used during tuning of the company's line of GUIDELINER and TRASAR high-power broadcast antennas for UHF and highband VHF TV applications.

The facility provides approximately 10,000 square feet of enclosed area to eliminate the possibility of weather-related delays in the manufacturing/test cycle for these antennas.

Special construction techniques incorporate wood and fiberglass building products to assure minimum reflections in an environment suitable for conducting the required elevation pattern and VSWR measurement programs.

## Ampex Recording Media is formed

Ampex, Redwood City, CA, has announced that its Magnetic Tape Division has incorporated as a wholly owned subsidiary. Known as Ampex Recording Media Corporation, it will continue to be based at the headquarters in Redwood City.

Ampex also has announced that Sony

has begun worldwide marketing, under the Sony name, a Betacam SP format video studio player manufactured by Ampex. Ampex began delivery of the BVW-60 studio player to Sony in March. Both Ampex and Sony will sell the player worldwide with each company marketing it under its own company name.

The BVW-60 is the first unit manufactured under an enhanced Betacam agreement announced last year during the National Association of Broadcasters' convention. The agreement specified that the two companies would focus on manufacturing a part of the Betacam SP line for sale by both companies and that Ampex in particular would expand its manufacturing capacity to build Betacam SP products for Sony. In addition, Ampex agreed to concentrate its Betacam engineering efforts on projects that would enhance and expand the SP product line.

The agreement enables customers to purchase Betacam SP products from either supplier with the knowledge that all products are fully compatible.

## Magni expands headquarters

Magni Systems, Beaverton, OR, has

moved into larger facilities. Magni doubled its space with the addition of 11,000 square feet to its current premises.

Magni also has announced its first patent. John Judge, a principal engineer and co-founder of Magni, was awarded the patent for a color video signal phase detector in December 1988.

## PWA has been acquired by SAIC

Science Applications International Corporation (SAIC), San Diego, has acquired Powers, Wenhardt & Associates (PWA). The acquisition provides SAIC with the expertise necessary to advance its market penetration into TV systems integration.

SAIC also was awarded a contract to provide technical broadcast systems design, engineering, integration and relocation services for WMAQ-TV, channel 5 in Chicago. WMAQ will relocate from the Merchandise Mart to the NBC City Front Tower in Chicago. The on-air date for the TV station is Oct. 1.

## SSL acts as North American distributor for Sondor

The U.S. sales and service subsidiary of Solid State Logic, Oxford, England, is to act as a North American distributor for Sondor, a Swiss manufacturer of magnetic film recorders and reproducers.

The move reflects SSL's role in film sound, which started with the introduction of the SL 5000 M series console in 1987.

## BTC acquires Townsend product rights and customer contracts

Broadcast Transmission Corporation (BTC), Raleigh, NC, has reached an agreement to acquire product rights and customer contracts of Townsend Broadcast Systems, Townsend Electronics and its subsidiary, Townsend Test & Measurement.

BTC plans to occupy a 30,000-square-foot facility. The agreement enables it to purchase the rights to the Townsend Computer Supervised Transmitter series for both UHF and VHF service, including new solid-state aural and visual amplifiers.

## WaveFrame delivers AudioFrame to Master Sound Astoria

WaveFrame, Boulder, CO, has announced the delivery of the AudioFrame digital audio workstation to Master Sound Astoria, Astoria, New York City.

WaveFrame also has appointed Technology Consultants, Nashville, TN, as a representative for its AudioFrame digital audio workstation in the Southeastern United States.

**Mic Sale!!!**

AKG  
Audio-Technica  
Beyer-Dynamic  
Crown  
Countryman  
Electro-Voice  
HME  
Light Wave  
Nady  
Ramso  
Samson  
Sennheiser  
Shure  
Sony  
Stewart  
Telex  
Vega  
Williams

*Prices so low...  
we promised not to print them!*

**In Stock Now!**  
Call Toll Free  
(800) 356-5944  
(608) 271-1100

**FULL COMPASS SYSTEMS**  
6729 Seybold Rd. Madison, WI 53719-1393

Circle (134) on Reply Card

Continued on page 199

Continued from page 70

### Converting a station to HDTV

Robert Ross, WJZ-TV, Baltimore, presented a paper that examined the costs of transforming a TV station from NTSC to HDTV. He found there was no inexpensive way to install the ATV technology into a station with today's prices and technology. However, you can be optimistic that the price will fall in the future as competition and innovation enter the marketplace.

Ross aptly illustrated with the use of charts and graphs (using VTRs and cameras as examples), how price and performance trends always improve in favor of the broadcaster. This was the case with the first black-and-white and the first color broadcasts.

The first station to install ATV in the market really will pay a premium. Stations that can wait for five to 10 years will be able to install better equipment at a much lower price. It was interesting to note that the little incidentals would be a big cost factor during the installation of ATV. Such things as connectors (three times the number now used in NTSC), wiring, cable timing, transmitters and transmitter links all will add up to a bulging budget for the station ATV changeover.

Ross provided a comprehensive list of equipment needed to transform a station from NTSC to HDTV. This list and a list of the costs of HDTV technology are excellent references for any station contemplating HDTV.

### Spectrum-compatible HDTV system

Richard Citta, Zenith, is proposing a system that will replace the current NTSC system with a totally different transmission signal. The first, and most noticeable, attribute of the proposed spectrum-compatible high-definition TV system (SC-HDTV), is the lack of the power-consuming sync. The genius of the SC-HDTV system is its capability to limit the transmit power to picture power only and, additionally, to distribute it evenly over the 6MHz channel. This reduction in power has many benefits. One major advantage is its ability to co-exist, without interference, in adjacent channels (referred to as "taboo" channels in the TV spectrum). Other benefits include more economical operation and construction of UHF station transmitters and antenna systems because of the drastically reduced power.

The SC-HDTV system is being proposed as a simulcast system. The regular station NTSC broadcast would occur in its assigned channel, and the same program material would be broadcast in the SC-HDTV format on the adjacent taboo channel. To keep the NTSC signal from interfering with the high-definition signal, they would be interlocked, and the high-power

**O'Connor**  
CAMERA SUPPORT SYSTEMS

### MODEL 127A

- Free-floating column
- Adjustable counterbalance
- Position readout
- 120 lb. capacity

Shown with O'Connor Model 100C Fluid Head



## A E R O P E D

State-of-the-art... portable studio pedestal designed and manufactured by the people who created the first true fluid head over 35 years ago.



MADE IN THE  
**USA**

O'Connor Engineering Labs  
100 Kalmus Drive • Costa Mesa, CA 92626 • (714) 979-3993

Circle (109) on Reply Card

## Cardboard vs. HOODMAN

### Which Monitor Has the Better Outdoor Image?

When you are the person responsible for monitor images, you will find one simple truth... cardboard is for boxes and Hoodman monitor sun shades are for perfect, glare-free monitor images. Hoodman's new line of monitor sun shades are available in 6 different sizes which fit 2-inch through 21-inch monitors. Prices start at \$9.95.

For more information, contact your Comprehensive Video Dealer or call us direct and we'll be happy to answer any questions. CALL (213) 379-6391. We can ship your order today. Your satisfaction is guaranteed.

**HOODMAN**<sup>®</sup>

P.O. Box 816, Hermosa Beach, CA 90254

Circle (110) on Reply Card

NTSC sync interference would occur during vertical and horizontal blanking.

After 15 or 20 years, the NTSC transmission systems and home receivers would be phased out opening up these now active, non-taboo channels for more new SC-HDTV signals.

This proposed system, although still just on paper, takes an entirely new approach in the evolutionary process of changing from NTSC broadcasting to SC-HDTV broadcasting. It takes the undesirable old problems of our NTSC system and buries them without having to integrate them into our proposed systems of the future. It also provides for a healthy phase-out of the 160 million receivers in homes today. Once again, Zenith might just have the last word in tomorrow's TV technology.

#### NTSC-compatible MUSE system

Taiji Nishizawa, NHK, reviewed the five basic MUSE systems developed by NHK. The first system he touched on was the MUSE-T format that would be used for network interconnecting broadcasting. Normal MUSE is being used now for satellite broadcasting in Japan, representing the second MUSE system. He explained the remaining three MUSE systems in greater detail because they are being proposed for use in the United States.

The MUSE-6 requires 6MHz of bandwidth and is compatible with existing NTSC receivers. The system has a resolution of 750 lines and an aspect ratio of 16:9. The resulting signal would appear as a *letter box* effect on NTSC receivers. Two channels of digital audio are provided.

The MUSE-9 requires, in addition to the standard 6MHz TV channel, a 3MHz-wide augmentation channel. This channel carries the motion and high-frequency information. The compatible system provides 750 lines of resolution in still pictures, but a greatly increased resolution in motion. MUSE-9 provides viewers with four channels of digital audio.

Narrow MUSE is a non-compatible system that can only be considered RF for simulcasting with NTSC. This system can be viewed, however, on an NTSC receiver with a set-top converter. The Narrow MUSE system also employs a 6MHz bandwidth, but increases the resolution to 1,010 lines. Like its two companion proposals, Narrow MUSE has a 16:9 aspect ratio with four channels of digital audio.

#### Super NTSC: an ATV proposal

Yves Faroudja believes that NTSC still has some practical applications for the next 10 to 12 years. He suggested that any interim system selected in the next few years could be short-lived as a result of future innovations. His suggestion is to "squeeze as much juice out of the lemon" as we can now with our existing NTSC system.

His proposal is to stay with NTSC and enhance it with a future Super NTSC that is compatible with existing receivers. He covered the latest techniques in his encoders, decoders and transmission systems for improving NTSC.

Faroudja's line-doubling techniques are different from others used in the industry in that the process allows a choice between averaging adjacent lines and taking information from previous lines to provide the best representation of the original source material. This system has been adopted by the David Sarnoff Research Center for its studies.

#### HD-NTSC-compatible HDTV in a single channel

Richard Iredale, The Del Rey Group, addressed seven specific concerns he has about the entire HDTV discussion. The issues ranged from production standards to the amount of life remaining in NTSC. Iredale suggested that HDTV need not be immediately implemented.

The issues he raised ranged from the perception that any production standard can be made compatible with any transmission to the pressure for a rapid decision on an HDTV standard.

Iredale suggested that the long-term interests of the United States are best addressed through thorough discussion, not rapid decisions. An early conclusion may not result in the selection of the best system.

#### Improved NTSC

Denes Likovics, High Resolution Sciences, began with the premise that today's NTSC is far from the type of performance this system is capable of. He thinks that the 168 million receivers in use require that the industry put a lot of effort into improving the existing system. He introduced two systems for improving NTSC; the first is called Chroma Crawl Free (CCF) and the second is called Synchronous Path Modulation (SPM).

One problem with the present NTSC system is the 4-field interlace picture-scanning system. There are 227.5 color subcarrier cycles in each line and 119,437.5 cycles in each frame. Therefore, the subcarrier appears in each scanning line 180° out of phase, creating a 15Hz component that causes visible flicker, cross-color and chroma crawl. Dropping the last half cycle of chroma subcarrier in each line eliminates the problem, reducing the number of subcarrier cycles to exactly 227. The result is that the subcarrier remains in phase for each adjacent line in the picture, and chroma crawl is eliminated.

The SPM system can create a much higher vertical resolution picture that is compatible with NTSC by doubling the speed of the scanning spot in the camera.

However, instead of scanning two lines in that time period, its path undulates around the original position. This way, areas between the 525 lines will be scanned during the same 63.5s scanning rate. The standard NTSC receiver will ignore the higher-frequency information, and the higher-definition receiver will display a higher-resolution picture.

#### Genesys technology for HDTV

Richard Gerdes outlined a system called Genesys. The system is a complement of five technologies containing a modulation process, a method of detection, data conversion, bit compression and a flywheel error-correction system.

The *waveform modulation* is a new type of modulation that is transparent to all other forms of modulation. It is an analog method of conveying digital information. It transmits six bits per hertz bandwidth or six bits per carrier cycle. It is characterized by having moving bumps on the sides of the carrier on a spectrum analyzer. It cannot be detected by conventional AM or FM detectors.

The process requires a new type of detector. It has been named *Allmod*, and it uses the carrier as a reference to detect the changes going on inside the reconstructed carrier signal. As a side benefit, it will detect AM and FM out of a side port.

A new data-conversion system called *ADDA* provides three bits in the digital domain that are not binary-related. This aids the D/A conversion of the audio and video program information in HDTV technology. The process is now capable of providing 11 bits of video resolution and nearly 20 bits of audio resolution.

The bit-compression system mimics the function of *ADDA* by compressing an 8- or 16-bit word into Genesys bits, then takes these bits and drives a D/A converter to get analog information. The process would allow standard PC computers to add graphic overlays to the standard HDTV picture.

A subsampling, called *SICS* technology, produces a flywheel effect in the receiver. This system can provide video information between samples, thereby producing higher resolution by comparing pixels.

#### Bibliography

"1989 Broadcast Engineering Conference Proceedings," NAB, Washington, DC.

**Acknowledgment:** Appreciation is expressed to the following engineers for their contribution to this report: Talmage Ball, KSL-TV, Salt Lake City, UT; John Battison, Battison & Associates, Loudonville, OH; Marvin Born, WBNS-AM/FM-TV, Columbus, OH; Gary Krohe, KTKA-TV, Topeka, KS; Rick Lehtinen, BE; and Karl Renwanz, WNEV-TV, Boston.



Continued from page 196

### Thorn EMI-Varian venture dissolved

Varian Associates, Palo Alto, CA, and Thorn EMI Electronic United Kingdom, have dissolved their joint venture in the United Kingdom, known as Thorn EMI-Varian, Ltd. (TEV).

As a result, a product line formerly sited in the United Kingdom is being shifted to Varian's Microwave Power Tube Division in California. The products being transferred include tubes for UHF-TV broadcasting that will be supplied to U.S. and all world markets from Varian's Palo Alto manufacturing center upon completion of the move.

Varian Associates, a subsidiary in Walton-on-Thames, Surrey, has assumed responsibility for all marketing and support of Varian's tube and equipment products in the United Kingdom. Those activities formerly had been handled by TEV.

### Lexicon expands service network for Opus

Lexicon, Waltham, MA, has announced the expansion of its service network for the Opus digital audio production system on a worldwide basis. These measures are being taken to provide installation, service and support for the increasing number of sites using the Opus system. The service network will include a response program based on warranties and maintenance contracts anywhere in the world. Opus customers will receive a phone number that provides access to service personnel 24 hours a day, seven days a week. Response is immediate.

Both national and international service personnel will be trained by Lexicon at the Waltham facility. In addition, Lex-

# STOP GROUND-LOOP HUM!

## VIDEO HUM STOP COIL...HSC 2

Will ELIMINATE HUM and other INTERFERENCE in Video Lines caused by differences in Ground Potential.

- Rack Mountable.
- FLAT-DC to 20 MHz.
- No low-Freq or Hi-Freq. Roll-off.
- No Differential Phase Distortion.
- No Differential Gain Distortion.
- No Envelope Delay.
- Passive Device - Failure Free-Low Price.
- Small Compact Package

## ELIMINATES HUM AND INTERFERENCE:

### IN STUDIO

- Between Buildings
- On long runs in Buildings
- Between Studio and Transmitter
- On Incoming Circuits
- On Outgoing Circuits

### IN FIELD

- Betw. Remote Truck and Telco
- Betw. Remote Truck and Microwave
- For Intertruck Hookup
- For VTR Units
- For Monitoring Lines

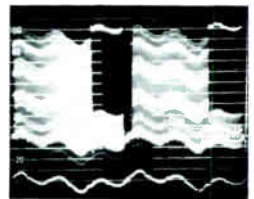

NEW!



\$225  
F. O. B.  
N.Y.

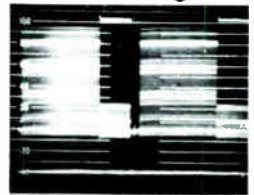

Available on  
10 day free trial

AUDIO-VIDEO ENGINEERING COMPANY  
65 Nancy Blvd., Merrick, N.Y. 11566  
Tel. (516) 546-4239

Circle (133) on Reply Card

## Radiation Systems, Inc. Mark Antennas Division

40 Years of EXCELLENCE & INNOVATION

From the Originator  
of Grid Antennas

- Standard Antennas
- High & Maximum High Performance Antennas
- Affordable
- Rugged Construction
- Superior Design
- High Quality

2180 South Wolf Road • Des Plaines, Illinois 60018  
Tele (312) 298-9420 • Fax (312) 635-7946 • Telex 28-2557

Circle (145) on Reply Card

## TIMECODE EDITING... LIVING DANGEROUSLY?



Not if you have the new ADx-02 Timecode Analyzer. This is a sophisticated test instrument, as well as a fully functional reader-generator with video Key and L.E.D. displays. It can save you time and money. Finding timecode errors on tape before an edit is attempted, or matching color frames and Sch phase, or tracking on a Betacam is easy. For the engineer, it can be the quickest way to set tape speed, re-align video play-back heads or check an audio synchronizer for wow. Each timecode bit is displayed graphically.

The ADx-02 is being used around the world in a variety of environments and applications. But the diagnostics function is not the end of the story, the ADx-02 is a very versatile timecode reader-generator-insert, with multiple screen displays, selectable fonts, three jam-sync modes, stable code generation, full speed range read and much more. So why buy just a timecode reader-generator?

### The ADx-02.

The only timecode unit that can safely save you money.

**ADx Systems Inc.**  
274 Madison Avenue, New York, NY 10016  
The World Leader in Timecode.

For more information contact your local dealer or call us at 1-800-444-4-A-O-X.

Circle (146) on Reply Card

## SINGLE TOWER- MULTICHANNELS

## THIS MULTICHANNEL TV/FM HIGH POWER ANTENNA FACILITY INSTALLED IN:

**DALIAN (PEOPLE'S  
REPUBLIC OF CHINA)**  
INCLUDES:

- \* 2 x UHF/TV  
omnidirectional  
antennas
- \* 1 x VHF/  
Band III/TV  
omnidirectional  
antenna
- \* 4 x FM + 1 VHF/  
Band I/TV  
omnidirectional  
antenna
- \* and all necessary  
high power TV and  
FM combiners.



**Comad**  
COMMUNICATIONS LIMITED  
1435 Bonhill Rd., Unit 34,  
Mississauga, ON L5T 1M1 (416) 670-9171  
FAX (416) 670-9175

*Our new test range  
facilities include two  
computerised rotating  
towers.*

Circle (136) on Reply Card

icon, by designating personnel from the home office, will continue to support both the U.S. and the European installations with on-site assistance.

Lexicon and its distributors also have established complete, working demonstration rooms for the Opus, located in Waltham, MA; New York; Los Angeles and Montreal. The New England facility is housed at the Lexicon headquarters.

The address given for McCurdy Radio Industries in the 1989 Buyers' Guide/Spec Book was incorrect. The correct address is: McCurdy Radio Industries, 108 Carnforth Road, Toronto, Ontario M4A 2L4 CANADA; telephone 416-751-6262; fax 416-751-6455; telex 06-963533.

1:~>)))

## HAVE YOU LOOKED AT YOUR SOUND LATELY ?

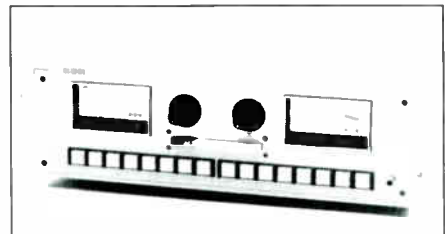

### AUDIO SWITCHER - LINE MONITOR

- MULTIPLE BRIDGING INPUTS, MONO OR STEREO
- SWITCHABLE VU OR PEAK METER ON INPUT OR OUTPUT
- SELECTABLE INPUT SENSITIVITY
- BALANCED LINE OUTPUT
- BUILT IN POWER AMPLIFIER
- MIX - MINUS AND REMOTE CONTROL OPTIONS AVAILABLE
- INPUT EXPANDERS AVAILABLE

THE BROADCASTERS'S CHOICE  
INTERCOM, DISTRIBUTION, MONITORING SYSTEMS

# ROH

Torrance, CA 90502  
(213) 533-5984  
FAX: 213-533-6050

Circle (135) on Reply Card

# People

**Curtis Chan** and **James N. Carro** have been appointed to new positions with Ampex, Redwood City, CA. Chan is senior product manager for new business development. Carro is vice president of the company's U.S. sales and service organization on an interim basis.

**Dan Lavry** has joined Apogee Electronics, Santa Monica, CA. He will head the design of high-performance A/D and D/A conversion systems. Lavry was instrumental in the design of the company's reference standard A/D conversion system.

**Jerry L. Rankin** has been appointed Southeastern regional sales manager for Barco Industries, Los Gatos, CA. He is responsible for developing the company's industries dealer network throughout the Southeastern United States and providing technical and sales support. He is based at the Atlanta sales office.

**Robert Harris** has been appointed national sales manager for the designer series for Boston Acoustics, Lynnfield, MA. He is responsible for managing the sales

of the company's line of designer series custom installation wall-mount products.

**Laura Lunceford** has been appointed director of marketing for the Telesystems and Video Products Division of Chyron, Melville, NY. She is responsible for the development and implementation of the company's marketing, advertising and public relations activities. She will coordinate trade shows and press relations with other Chyron Group members — DSC, CMX and Aurora.

**Joseph A. Zuba** and **Dr. Oded Bendov** have been named to positions with Dielectric Communications, Raymond, ME. Zuba is director of broadcast sales and marketing. Bendov is vice president of antenna operations.

**Perry Priestly** has been appointed sales manager, UHF TV klystrons for EEV, Elmsford, NY. He is responsible for the sale of UHF TV klystron systems to broadcasters in the United States.

**Larry Lamoray** has been named director of marketing for Fidelipac,

Moorestown, NJ.

**Linda Murray** has been appointed general manager of IDB Communications Group's new transportable division, Los Angeles, which will combine transportable operations and transportable maintenance. Murray makes the transition from director of operations of IDB.

**James Turner** has been appointed East Coast regional manager at JVC Professional Products Company, Elmwood Park, NJ. He will coordinate the sales and marketing efforts of the district sales representatives between Maine and Florida, including Puerto Rico.

**Olcott Mills** has been appointed Southeast regional sales manager for Magni Systems, Beaverton, OR. He will serve the region from an office based in Tampa. He is responsible for sales throughout the Southern United States, including the Florida film and video community and the Caribbean region.

||:~:~))|||

## RUNNING OUT OF RACK SPACE?

1 3/4" PANEL HEIGHT — SERIAL CODE OUTPUT, FOR DRIVING SLAVES

CLOCKS

TIMERS

ES192AP/194AP — 12/24 HOUR CLOCK \$278

ES362 AP — UP/DOWN TIMER \$463

ES520 60 MINUTE TIMER \$169



**PRACTICAL SOLUTIONS FOR 17 YEARS** 142 SIERRA STREET • EL SEGUNDO, CA 90245 • (213) 322-2136

Circle (129) on Reply Card

## Anywhere. Anytime.

\$7.95

**The P1 Portable SMPTE Time Code Generator/Reader**  
Includes: jam sync, drop/non-drop frame, and numbers preset

**Fast Forward Video**

CALL YOUR LOCAL DEALER OR CONTACT US AT:  
17255-F Sky Park Circle, Irvine, CA 92714 (714) 852-8404



Circle (130) on Reply Card









# Professional services

**VIR JAMES P.C.**  
**CONSULTING ENGINEERS**  
 Applications and Field Engineering  
 Computerized Frequency Surveys  
 3137 W. Kentucky Ave. - 80219  
 (303) 937-1900  
**DENVER, COLORADO**  
 Member AFCCE & NAB



**USED EQUIPMENT**  
*The Largest Dealer in The World*  
 PRO VIDEO & FILM EQUIPMENT GROUP  
 PHONE 214-869-0011 FAX 214-869-0145

**EVANS ASSOCIATES**  
 CONSULTING TELECOMMUNICATIONS ENGINEERS  
 AM-FM-TV-CATV-ITFS-LPTV SATELLITE  
 216 N. Green Bay Road  
 Thiensville, Wisconsin 53092  
 Phone: (414) 242-6000 Member AFCCE

FCC ON-LINE DATABASE  
**dataworld**<sup>®</sup>  
 Allocation/Terrain Studies  
 AM • FM • TV • LPTV • ITFS  
 P.O. Box 30730  
 Bethesda, MD 20814  
 (301) 652-8822 1-800-368-5754

**D. L. MARKLEY**  
 & Associates, Inc.  
**CONSULTING ENGINEERS**  
 2401 West Moss Ave.  
 Peoria, Illinois 61604  
 (309) 673-7511  
 Member AFCCE

**K. BLAIR BENSON**  
 Consultant  
**Television Technology**  
 23 Park Lane  
 Norwalk, CT 06854  
 203-838-9049

**TEKNIMAX**  
 TELECOMMUNICATIONS  
 DENNIS R. CIAPURA  
 PRESIDENT  
 11385 FORESTVIEW LN.  
 SAN DIEGO, CA 92131 (619) 695-2429

**SMITH and POWSTENKO**  
 Broadcasting and Telecommunications  
 Consultants  
 2033 M Street N.W., Suite 600  
 Washington, D. C. 20036  
 (202) 293-7742

Robert J. Nissen  
**THE NISSEN GROUP, INC.**  
 Communications Technology Consultants  
 32 Ridge Drive • Port Washington, New York 11050  
 (516) 944-5477

**DSI**  
 COMMUNICATIONS, INC.  
 • Radio and Television System Design  
 • Transmitter and Studio Installation  
 • Microwave and Satellite Engineering  
 and Installation  
 627 Boulevard  
 Kenilworth, NJ 07033  
 201-245-4833



**CHUCK JONES**  
 ANTENNA SYSTEMS SPECIALIST  
 618-564-2481  
**SOUTHERN ILLINOIS ANTENNAS**  
 ROUTE 3 BOX 114  
 METROPOLIS, IL 62960

**ERIC NEIL ANGEVINE, P.E.**  
 consultant in acoustics  
 specializing in broadcast studio acoustics  
 910 Lakeridge Drive Stillwater, OK 74075  
 405-744-6444 405-372-3949



**AMERICAN LASER SYSTEMS, INC.**  
 751 S. KeBogg Ave.  
 GOLETA, CA 93117 USA  
 ENG • STL LINKS • SPORTING EVENTS  
 Solutions to LICENSE-FREE, short range  
 video/audio transmissions via infrared  
 atmospheric links  
 LORRAINE SHALLENBERGER  
 MARKETING MANAGER 805/967-0423  
 FAX 805/683-4382

**MAILING LABELS**  
 AM, FM & TV  
 CALL  
**dataworld**<sup>®</sup>  
 1-800-368-5754

**PATCHPRINTS**<sup>®</sup> VIDEO TIE LINES  
 In 1 2 3 4 Aux  
**Custom Patch Bay Labeling**  
 By  
**PATCH BAY DESIGNATION COMPANY**  
 Div. of Glendale Rubber Stamp & Printing Co., Inc.  
 P.O. Box 6278, Glendale, CA 91205 Telephone  
 4742 San Fernando Road (818) 241-5585  
 Glendale, CA 91204 FAX (818) 507-5050

**East Coast Video Systems**  
 On-Line • On-Tape  
 A full service company providing...  
 • Consultation • Cable Systems  
 • Engineering & Design • Corporate Facilities  
 • Installations • Broadcast Facilities  
 • Training • Teleproduction Facilities  
 178 Casterline Road • Denville, NJ 07834 • (201) 751-5855

**Consultation Services**  
 Lightning • Power Conditioning • Grounding  
 Over 40 years experience, work guaranteed  
 Roy Carpenter  
 President  
 Lightning Eliminators and Consultants  
 13007 Lakeland Rd., Santa Fe Springs, CA 90670  
 (213) 946-6986 TWX 910-586-1381

**Franklyn R. Beemish & Co.**  
 Engineering for the Video, Motion Picture & Recording Industries  
 VIDEO POST, BROADCASTING, CONFERENCE CTRS, THEATERS, RECORDING  
 FACILITIES AND SYSTEMS DESIGN & IMPLEMENTATION  
 ANALOG & DIGITAL VIDEO, AUDIO, HDTV  
**ARCHITECTURAL ENGINEERING**  
 ELECTRICAL, HVAC, ACOUSTICAL  
 574 Sunrise Highway, Baldwin, NY 11510 516/867-8510

**JOHN H. BATTISON PE.**  
 CONSULTING BROADCAST ENGINEER,  
 FCC APPLICATIONS AM, FM, TV, LPTV  
 Antenna Design, Proofs, Fieldwork  
 2684 State Route 60 RD#1  
 Londonville, OH 44842  
 419-994-3849



**Stainless, inc.**  
 New Towers, Antenna Structures  
 Engineering Studies, Modifications  
 Inspections, Erection, Appraisals  
 North Wales, PA 19454  
 215-699-4871 FAX 699-9597



Got a hurt Miller? We can restore it  
 to factory original specifications.  
**MILLER FACTORY SERVICE**  
 • Economical • Thorough  
 • Fast • Guaranteed  
**MILLER FLUID HEADS (USA) INC.**  
 410 Garibaldi Avenue Telephone (201) 473-9592  
 Lodi, New Jersey 07644 FAX (201) 473-9693

**YOUR CARD HERE**  
 reaches 88,528 prospects  
 for as low as \$55 per insertion.  
 Call 913/888-4664.

**YOUR CARD HERE**  
 reaches 88,528 prospects  
 for as low as \$55 per insertion.  
 Call 913/888-4664.

**CALL US** For New and Rebuilt  
 Radio Broadcast Equipment  
**HE HALL**  
**Electronics**  
 (804)-977-1100  
 1712 Allied Street Charlottesville, Va. 22901

# Classified

**UNUSED  
CALL LETTERS  
CALL  
dataworld®  
1-800-368-5754**

Advertising rates in Classified Section are \$1.50 per word, each insertion, and must be accompanied by payment to insure publication.

Each initial or abbreviation counts a full word. Minimum classified charge, \$35.00.

For ads on which replies are sent to us for forwarding (blind ads), there is an additional charge of \$40.00 per insertion, to cover department number, processing of replies, and mailing costs.

**T-66 FILM PROJECTOR "NEW" 8K**, used fully refurbished pair 10K, TP-7 Slide Projector used fully refurbished w/access. 1100. Projector assemblies, parts, and services. SIMBER BROADCAST SERVICES, INC. (609) 435-1091. 6-89-1t

**NEW LOGITEK AUDIO EQUIPMENT:** Mono DA's, \$250. Stereo DA's, \$300. Perfectionist Console, \$5800. Contact Darron Corriden, 407-283-6398. 6-89-1t

**NETCOM** (201)837-8424  
NETWORK COMMUNICATIONS CONSULTANTS  
931 TEANECK RD. TEANECK, N.J. 07666  
STATE-OF-THE-ART ENGINEERING FOR AUDIO & VIDEO

- FACILITY PLANNING
- SYSTEM DESIGN
- CAD SERVICES

JAMES TRONOLONE  
ENGINEER

**HIGH PRIORITY CONSULTING**  
CAD Documentation  
for the Audio/Video Industry  
Facilities, Product and Equipment  
Design, Schematics  
**212-246-3811 X510 SVC**



**Interested in ordering  
article reprints out of  
this or another issue?\***  
Reprints can be  
excellent learning  
tools for your staff  
and great marketing  
tools for your sales  
staff. Call or write  
Cheri Wells at Intertec  
Publishing Corp., P. O.  
Box 12901, Overland  
Park, KS 66212;  
**(913) 888-4664**

\*Minimum order 1,000 copies

## SERVICES

**TRANSMITTER TUBE REBUILDING SINCE 1941:** 3CX2500, 4CX5000, 4CX15000 and many others. Write for details. FREELAND PRODUCTS INC., Rt. 7, Box 628, Covington, LA 70433. (504) 893-1243 or (800) 624-7626. 6-79-tfn

**WE PLACE ENGINEERS**  
ALL CATEGORIES FOR TV, PRODUCTION,  
VIDEO, CATV (EXCLUDING OPERATORS)  
*America's Leading Source for a Decade*  
TV STATIONS, PRODUCTION FACILITIES, CORP. TV. MFG., CATV  
For information phone or write Mark Kornish

**key SYSTEMS**  
479 Northampton Street  
Kingston, PA 18704  
**(717) 283-1041**  
Employer Paid Fees

**TRANSMITTING AND CAMERA TUBES.** One stop for all of your requirements. All foreign and domestic brands, rebuilds, and obsolete material available at low, low prices. Large inventory means fast delivery. Daily Electronics, P.O. Box 5029, Compton, CA 90224, (800) 346-6667, (213) 774-1255. 3-89-6t

**AUDIO AUTOMATION:** Computer controlled, 8-CD changers, music and commercial program software, hard disc for commercials. Complete: \$6900. BGM INTERNATIONAL, (904) 438-8054. 7-71-tfn

## TRAINING

**NAPA VALLEY COLLEGE** offers a 2-year telecommunication program with emphasis in 1-inch "C" format, T.B.C.S., component and digital video. Call or write Gary Vann, (707) 253-3258 Napa Valley College, Napa, California 12-88-9t

**FCC GENERAL RADIOTELEPHONE** operators license through cassette recorded lessons at home plus one week seminar in Boston, Washington, Detroit or Philadelphia. Our twentieth year teaching FCC license courses. Bob Johnson Radio License Preparation, 1201 Ninth, Manhattan Beach, Calif. 90266. Telephone (213) 379-4461. 8-81-tfn

## FOR SALE

**HIGHEST PRICES** for 112 Phase Monitors, vacuum capacitors and clean, one kw or greater powered AM and FM Transmitters. All duty and transportation paid. Surplus Equipment Sales, 2 Thorncliffe Park Dr., Unit 28, Toronto, Canada M4H 1H2, 416-421-5631. 6-89-tfn

**COMPLETE LIVE ASSIST AUTOMATION SYSTEM.** Includes 1-MEI Model 100, 48 event programmer, 4-Revox PR99 1/4 inch, stereo playback reel to reel machines. Total system \$8,000. Contact Kyle D. Dickson (904) 636-0507. 6-89-1t

## HELP WANTED

**SOUTH CAROLINA EDUCATIONAL TELEVISION** is seeking experienced and qualified technical personnel. **Maintenance Technician** to maintain, install and operate complex television and stereo equipment. Requires extensive knowledge of multiple format video recorders, studio and portable camera systems, production and routing switcher equipment, digital effects systems, monitoring and test equipment. May provide technical assistance, guidance and supervision to other technicians. Requires an associate degree in electronics and four years of progressively responsible experience in the repair and maintenance of complex television systems or an equivalent combination. Salary range approximately \$24,000-\$36,000. **Audio/Video Technician** to have thorough knowledge of and skills in operating complex stereo television production facilities including studio and remote technical operations. Must be thoroughly versed in complex technical setup and operation of studio and portable camera systems, audio post production, stereo recording techniques and telecine transfer systems, audio post production, stereo recording techniques and telecine transfer systems. May assist in training and supervising other audio/video staff. Requires an associate degree in electronics and three years related television technical experience or an equivalent combination. Salary range approximately \$21,000-\$31,000. **EQUAL OPPORTUNITY EMPLOYER.** Address all inquiries to: South Carolina Educational Television Commission, Personnel Department, Post Office Drawer L, Columbia, South Carolina 29250. 6-89-1t

## CAREER SALES OPPORTUNITY

AudioTechniques, Inc. has an immediate opening for a broadcast sales engineer in the tri-state metro New York City area. Compensation package includes salary commission and full benefits.

If you're a self starter with radio and/or TV station experience, please send a current resume, in full confidence, to:

H.H. Brosious  
AudioTechniques, Inc.  
1619 Broadway, Dept. B  
New York, New York 10019

**AudioTechniques**  
A Manny's Music Company.

**LIMELITE VIDEO IN MIAMI, FLA.** has an immediate opening for a motivated engineer with strong post production experience, analog and digital VTRS, cameras and audio. Excellent benefits. Opportunity for advancement. Call Marcos Obadia (305) 593-6911. 6-89-1t

**NASHVILLE TV STATION** seeking maintenance technician. Experience with installation and repair of professional broadcasting equipment required. Send resume to T.W. Paterson, Chief Engineer, WTVF Channel 5, 474 James Robertson Parkway, Nashville, TN 37219. EOE. 6-89-1t

**TV TRANSMITTER MAINTENANCE ENGINEER.** Fox Television, WFXT, Boston is seeking a qualified transmitter engineer with strong background in RF. Previous experience with TRU-110 UHF transmitter and studio equipment preferred. FCC lic. or SBE certification required. Send resume/references to: Moses Primo, C.E., WFXT-TV, 100 2nd Ave., Needham, MA 02194. **EQUAL OPPORTUNITY EMPLOYER.** 6-89-1t

## SOCIETY OF MOTION PICTURE & TELEVISION ENGINEERS

JOIN  
PARTICIPATE  
913-761-1100

**TV MAINTENANCE ENGINEER.** Fox Television, WFXT, Boston is seeking a qualified Studio Engineer. Three years experience in video tape machines and various studio equipment, RF, and maintenance and installation required. Electronic certification also required. Send resume/references to: Moses Primo, C.E., WFXT-TV, 100 2nd Ave., Needham, MA 02194. EQUAL OPPORTUNITY EMPLOYER. 6-89-11

**KBVO-TV IN AUSTIN, TEXAS,** is seeking a Chief Engineer with UHF transmitter experience plus satellite and production facilities knowledge. Send resumes to: Steve Beard, General Manager, KBVO-TV, P.O. Drawer 2728, Austin, Texas 78768. Phone: 512-835-0042. 6-89-11

**RADIO HELP WANTED: TECHNICAL.** Unique position for unique person available. AM/FM group seeking broadcast technical type to work with group chief. Must be flexible, responsible and able to travel. Prefer at least 2 yrs. experience. Headquarters in mid-south. Attitude most important. Send resume to: Broadcast Engineering, P.O. Box 12901, Dept. 706, Overland Park, KS 66212. 6-89-11

**WHMM TV, WASHINGTON, D.C.:** WHMM TV, the public station of prestigious Howard University in Washington, D.C. has several exciting career opportunities. **BROADCAST TECHNICIANS:** Operate broadcast equipment in studio and remote. Assist with video and audio post production activities. Assist with lighting activities and placement of cameras, cables and mics. Qualifications: B.A. Communications and 3 years experience or min. of 6 years experience without degree. (Several openings.) **MAINTENANCE ENGINEER:** Primary responsibility for repair and maintenance of all broadcast experience. Qualifications: BSEE desired with minimum of 3 years broadcast experience, and proficiency to solder to military specifications. FCC radiotelephone first class or SBE certification (two openings). **TRANSMITTER SUPERVISOR:** Primary responsibilities include maintaining the UHF transmitter, microwave, and two-way radio equipment. Qualifications: BSEE and 3 years progressively responsible television maintenance experience. (May substitute 3 years additional experience for degree.) Licensed as a first class or general radio/telephone operator or SBE certification is preferred. This is a contract position. Our employees enjoy a comprehensive salary and benefits package including free tuition for you and your children. For immediate consideration send resume or apply in person: **HOWARD UNIVERSITY, Dept. of Personnel Services, 400 Bryant Street, N.W., Washington, D.C. 20059. ATTN: Ms. Freeman-Evans. EOE.** 6-89-11

**Reconfirm your involvement  
in the  
broadcast industry!  
Renew your subscription  
today.**

**R.F. MAINTENANCE ENGINEER—KCPQ-TV** is seeking a television maintenance engineer with strong background in VHF-TV transmitters, broadcast microwave and satellite communication equipment. Five years full-time VHF transmitter maintenance experience required. Previous experience with RCA dual G-Line transmitters preferred. Valid drivers and FCC General Class licenses are required. KCPQ maintains a modern, well-equipped CP transmitting plant. Full benefit package and generous 401K plan are provided. KCPQ is an equal opportunity employer. Resumes: Larry Brandt, Chief Engineer, KCPQ-TV, POB 98828, Tacoma, WA 98499. No phone inquiries. 05-89-21

### Advertising sales offices

#### SANTA MONICA, CALIFORNIA

*Herbert A. Schiff*  
Telephone: (213) 393-9285  
Telefax: 213/393-2381  
*Jason Perlman*  
Telephone: (213) 458-9987  
Telefax: 213/393-2381  
*Schiff & Associates*  
501 Santa Monica Blvd., Ste. 504  
Santa Monica, CA 90401

#### CHICAGO, ILLINOIS

*Vytas Urbonas*  
Telephone: 435-2361  
Telefax: (312) 922-1408  
55 East Jackson  
Ste. 1100  
Chicago, IL 60604

#### NEW YORK, NEW YORK

*Diane Gottlieb-Klusner*  
Telephone: (212) 702-3404  
Telefax: (212) 702-7802  
*Mike Trerotoli*  
Telephone: (212) 702-3405  
Telefax: (212) 702-7802  
866 Third Ave.  
New York, NY 10022

#### FREWVILLE, AUSTRALIA

*John Williamson*  
*Hastwell, Williamson, Rep. Pty. Ltd.*  
109 Conyngham Street  
Frewville 5063  
South Australia  
Phone: 799-522  
FAX: 08 79 9522  
Telex: AA87113 HANDM

#### CLASSIFIED ADVERTISING OVERLAND PARK, KANSAS

*Renée Hambleton*  
P.O. Box 12901  
Overland Park, KS 66212  
913-888-4664

#### OXFORD, ENGLAND

*Nicholas McGeachin*  
Intertec Publishing Corp.  
Roseleigh House  
New Street  
Deddington  
Oxford OX5 4SP  
England  
Telephone: (0869) 38794  
Telefax: (0869) 38040  
Telex: 837469 BES G

#### TOKYO, JAPAN

*Mashy Yoshikawa*  
Orient Echo, Inc.  
1101 Grand Maison  
Shimomiyabi-Cho, 2-18  
Shinjuku-ku, Tokyo, 162, Japan  
Telephone: (03) 235-5961  
Telex: J-33376 MYORIENT

## TESTING ENGINEER

Mt. Vernon, New York

### CONSUMER REPORTS MAGAZINE Electronic Testing Laboratory

An immediate opening exists for a senior level Lab Technician with a strong background in VIDEO TECHNOLOGY.

The ideal candidate will possess BSEE or equivalent degree and 1+ years' hands-on experience in the use of advanced electronic test equipment. Position requires strong background in state-of-the-art television audio/visual theory and practice. Must be proficient in the use of IBM-PC or equivalent.

Salary commensurate with experience. We offer an excellent non-contributory benefits plan. To apply, please send your resume with salary history and requirements, in confidence, to: **Personnel Department, Box-HC, Consumers Union, 256 Washington Street, Mt. Vernon, New York 10553.**

## Consumers Union

Publisher of Consumer Reports

An Equal Opportunity/Affirmative Action Employer M/F/H/V

# Ad index

|  | Page<br>Number | Reader<br>Service<br>Number | Advertiser<br>Hotline |  | Page<br>Number | Reader<br>Service<br>Number | Advertiser<br>Hotline |
|--|----------------|-----------------------------|-----------------------|--|----------------|-----------------------------|-----------------------|
| A.F. Associates, Inc. (AVS<br>ADAC)      | 83             | 45                          | 201/767-1201          | Hotronic, Inc.                             | 48             | 25                          | 408/378-3883          |
| Abekas Video Systems                     | 27             | 15                          | 415/369-5111          | Ikegami Electronics, Inc.                  | 40-41          |                             | 201/368-9171          |
| AMS/Calrec                               | 75             | 99                          | 206/633-1956          | ISS Engineering, Inc.                      | 80-81          | 43                          | 800/227-6288          |
| ADX Systems USA                          | 199            | 146                         | 800/444-4239          | ITT Multicomponents/<br>Cannon Canada      | 86             | 48                          | 416/668-8881          |
| AEG Olympia Ag                           | 187            | 125                         |                       | JamPro Antennas, Inc.                      | 44             | 23                          | 916/383-1177          |
| AKG Acoustics, Inc.                      | 151            | 93                          | 203/348-2121          | Jensen Transformers, Inc.                  | 164            | 156                         | 213/876-0059          |
| Alpha Audio                              | 92             | 52                          | 804/358-3852          | JVC Professional Products Co.              | 19             | 14                          | 800/582-5825          |
| Alta Group, Inc.                         | 32             | 17                          | 408/297-2582          | LDL Communications                         | 179            | 140                         | 301/498-2200          |
| Amperex Corp. (Klystron Div)             | 63             | 30                          | 513/931-6200          | Leader Instruments Corp.                   | 5              | 5,6                         | 800/645-5104          |
| Amperex Electronic Corp.                 | 131            | 82                          | 401/762-3800          | Lectrosonics, Inc.                         | 181            | 111                         | 800/821-1121          |
| Ampex Corp. (AVSD)                       | 106-107        |                             | 415/367-2911          | Leitch Video of America, Inc.              | 111            | 66                          | 804/424-7290          |
| Ampex Corp. (AVSD)                       | 28-29          |                             | 415/367-2911          | 3M Broadcast & Related<br>Products         | IFC,67         | 1,31                        | 800/328-1684          |
| Ampex Corp. (MTD)                        | 117            | 72                          | 415/367-2911          | 3M Broadcast & Related<br>Products         | 69,71          | 32,33                       | 800/328-1684          |
| Anvil Cases, Inc.                        | 118            | 73                          | 818/575-8614          | 3M Magnetic Media Div.                     | 109            | 64                          | 800/328-1684          |
| Aphex Systems Ltd.                       | 161            | 98                          | 818/765-2212          | Markertek Video Supply                     | 164            | 157                         | 800/522-2025          |
| Arrakis Systems, Inc.                    | 21             | 13                          | 303/224-2248          | McCurdy Radio Industries                   | 79             | 42                          | 416/751-6262          |
| Associated Production Music              | 62             | 105                         | 800/543-4276          | MCL, Inc.                                  | 167            | 102                         | 312/759-9500          |
| Audio Precision                          | 143            | 89                          | 800/231-7350          | Midwest Corp.                              | 1              | 3                           | 606/331-8990          |
| Audio Technologies                       | 74             | 35                          | 215/443-0330          | Mohawk Wire & Cable                        | 114            | 70                          | 800/422-9961          |
| Audio-Technica U.S., Inc.                | 105            | 62                          | 216/686-2600          | Moseley Associates Inc.                    | 119            | 74                          | 805/968-9621          |
| Audio-Video Engineering Co.              | 199            | 133                         | 516/546-4239          | NEC Corp.                                  | 77             | 38                          | 214/907-4710          |
| Audiolab Electronics                     | 82             | 150                         | 916/485-0500          | Nova Systems, Inc.                         | 115            | 71                          | 203/693-0238          |
| Auditronics, Inc.                        | 135            | 85                          | 901/362-1350          | O'Connor Engineering                       | 197            | 109                         | 714/979-3993          |
| Avitel Electronics Corp.                 | 78             | 39                          | 801/977-9553          | Odetics, Inc.                              | 171            | 107                         | 800/243-2001          |
| Basys                                    | 163            | 36                          | 800/869-7009          | Opamp Labs, Inc.                           | 122            | 152                         | 213/934-3566          |
| Belar Electronics Laboratory,<br>Inc.    | 184            | 142                         | 215/687-5550          | Orban Associates, Inc.                     | 7,17           | 7,12                        | 800/227-4498          |
| Benchmark Media Systems                  | 78             | 40                          | 315/452-0400          | Otari Corp.                                | 15             | 11                          | 415/592-8311          |
| Beyer Dynamic Inc.                       | 62             | 106                         | 516/935-8000          | Panasonic Broadcast<br>Systems Co.         | 112-113        | 67                          | 201/348-7336          |
| Broadcast Microwave Services,<br>Inc.    | 98             | 55                          | 619/560-8601          | Panasonic Pro Industrial<br>Video          | 34-35, 37      | 19,20                       | 800/553-7222          |
| Broadcast Supply West                    | 185            | 149                         | 800/426-8434          | PCO, Inc.                                  | 183            | 131,132                     | 818/700-1233          |
| Broadcast Video Systems, Ltd.            | 164            | 155                         | 416/764-1584          | Polyline Corp.                             | 92             | 53                          | 312/297-0955          |
| BTS Broadcast Television<br>Systems      | 60-61          | 28                          | 801/972-8000          | QEI  | 31             | 16                          | 800/334-9154          |
| BTS Broadcast Television<br>Systems GMBH | 133            | 84                          |                       | Radiation Systems, Inc. Mark<br>Antennas D | 199            | 145                         | 312/298-9420          |
| Cablewave Systems                        | 121            | 75                          | 203/239-3311          | Roh  | 200            | 135                         | 800/262-4671          |
| Camera Mart, Inc.                        | 128            | 80                          | 212/757-6977          | Rohde & Schwarz, Inc.                      | 149            | 92                          | 301/459-8800          |
| Canare Cable, Inc.                       | 104            | 60                          | 818/840-0993          | RTS Systems, Inc.                          | 58             | 27                          | 818/843-7022          |
| Canon USA Inc., Broadcast<br>Lens        | 159            | 97                          | 516/488-6700          | Sachtler Corp. of America                  | 33             | 18                          | 516/867-4900          |
| China Business Enterprises/<br>BIRTV     | 153            |                             |                       | Sennheiser Electronic Corp.                | 157            | 96                          | 203/434-9190          |
| Chyron Corp.                             | 165            | 101                         | 516/249-3018          | Shallco, Inc.                              | 184            | 143                         | 919/934-3135          |
| Cine 60                                  | 122            | 76                          | 212/586-8782          | Shintron Electronics                       | 104            | 61                          | 508/486-3900          |
| Clear-Com Intercom Systems               | 123            | 77                          | 415/527-6666          | Shure Brothers, Inc.                       | 43             | 22                          | 312/866-2553          |
| Comad Communications                     | 200            | 136                         | 800/387-4991          | Sierra Video Systems                       | 110            | 65                          | 916/273-9331          |
| Comark                                   | 144-145        | 90                          | 215/822-0777          | Sigma Electronics, Inc.                    | 100            | 57                          | 717/569-2681          |
| Conifer Corporation                      | 178            | 119                         | 800/843-5419          | Snell & Wilcox                             | 147            | 91                          | 415/856-0900          |
| Cycle Sat                                | 155            | 95                          | 800/274-2728          | Sony Communication Prod/<br>Broadcast Div. | 49-56,95,96-97 |                             | 800/635SONY           |
| Datek, Inc.                              | 169            | 103                         | 800/882-9100          | Sony Communication<br>Products/Pro Video   | 24-25,64-65    |                             | 800/635SONY           |
| Delta Electronics                        | 195            | 148                         | 703/354-3350          | Standard Tape Laboratory, Inc.             | 122            | 151                         | 415/786-3546          |
| Di-Tech, Inc.                            | IBC            | 2                           | 516/667-6300          | Studer Revox America, Inc.                 | 11             | 9                           | 615/254-5651          |
| Diversified Marketing                    | 184            | 144                         | 509/735-6812          | Tascam Div. TEAC Corp of<br>America        | 45             | 24                          | 213/726-0303          |
| Dynatech Broadcast Group                 | 172-173        | 108                         | 608/273-5828          | Tektronix Inc.                             | 85,87          | 47,49                       | 800/452-1877          |
| EEV, Inc.                                | 137            | 86                          | 914/592-6050          | Tektronix Inc.                             | 89,91          | 50,51                       | 800/452-1877          |
| Electro-Voice, Inc.                      | 189            | 29                          | 616/695-6831          | Telemet                                    | 76             | 37                          | 516/436-7260          |
| ESE                                      | 201            | 129                         | 914/592-6050          | Telemetrics Inc.                           | 84             | 46                          | 201/427-0347          |
| Faroudja Laboratories Inc.               | 175            | 118                         | 408/245-1492          | Telex Communications,<br>Inc.              | 99,101,103     | 56,58,59                    | 612/887-5550          |
| Fast Forward Video                       | 201            | 130                         | 714/852-8404          | TFT, Inc.                                  | 73             | 34                          | 408/727-7272          |
| Fujinon Inc.                             | 127            | 79                          | 201/633-5600          | Thomson-CSF/DTE                            | 141            | 88                          | 201/812-9000          |
| Full Compass Systems                     | 196            | 134                         | 800/356-5844          | Utah Scientific, Inc.                      | 39             | 21                          | 800/453-8782          |
| Garner Industries                        | 132            | 83                          | 800/228-0275          | Varian                                     | 13             | 10                          | 415/592-1221          |
| Gentner Electronics Corp.                | 93             | 54                          | 801/268-1117          | Varian TVT Ltd.                            | 124-125        | 78                          | 214/382-7181          |
| Graham-Patten Systems, Inc.              | 129            | 81                          | 800/547-2489          | Videotek, Inc.                             | 47             | 26                          | 602/997-7523          |
| Grass Valley Group, Inc.                 | 9              | 8                           | 916/273-8421          | Vinten Equipment Inc.                      | 177            | 104                         | 516/273-9750          |
| Gray Engineering Laboratories            | 114            | 68                          | 912/883-2121          | Ward-Beck Systems Ltd.                     | BC             |                             | 416/438-6550          |
| Harris Corp.                             | 139            | 87                          | 800/44HARRIS          | Winsted Corp.                              | 191            | 126                         | 800/447-2257          |
| Hitachi Denshi America Ltd.              | 3              | 4                           | 800/645-7510          |  |                |                             |                       |
| Hoodman                                  | 197            | 110                         | 213/379-6391          |  |                |                             |                       |

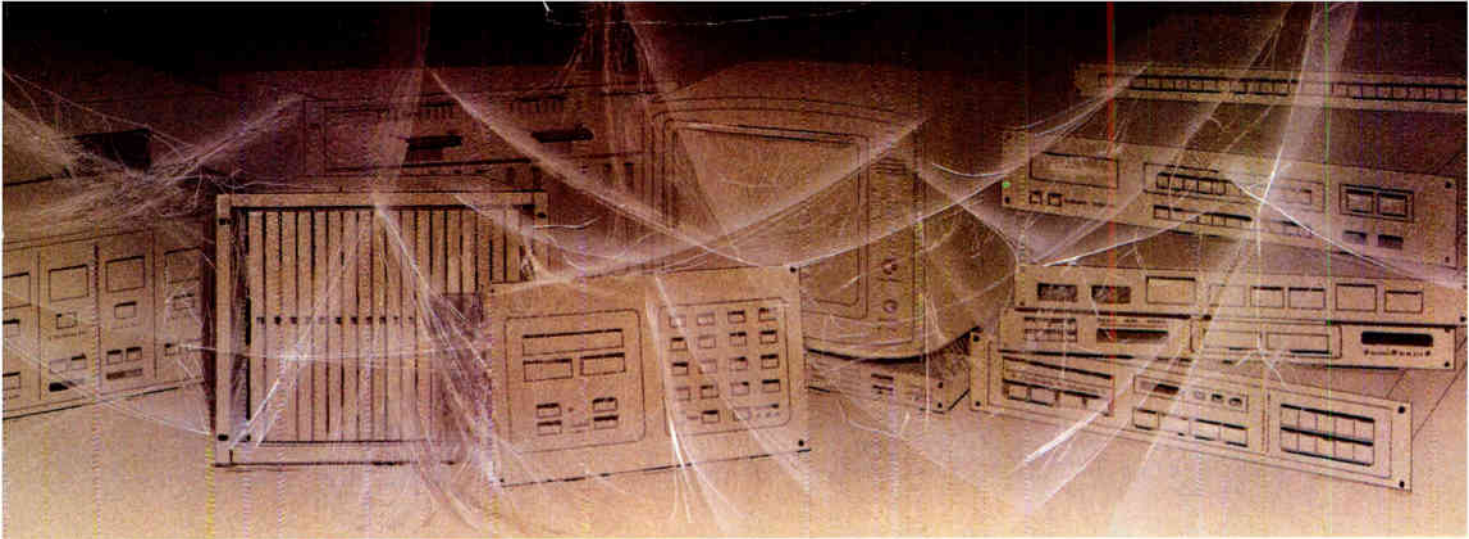

# DI-TECH'S VIRTUAL MATRIX MAKES OTHER ROUTERS VIRTUALLY PASSE

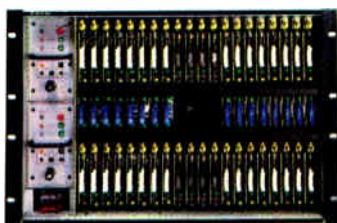

Model 5861  
64 x 32 Video Switcher

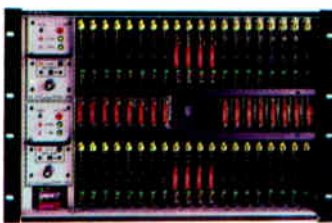

Model 5862  
64 x 32 Audio Switcher

Routing switchers are simple and efficient when all you need is a full AFV matrix. If you try reserving a few video only or audio only crosspoints, however, they can quickly become very clumsy and awkward. Now, you could play games moving switch cards around, tie up "spare" inputs with terminators, or rewire your router frames. But there is a better way.

Di-Tech's *virtual matrix* control system, Model 9002, maintains a software map of your router's hardware connections. This makes it easy to define single level crosspoints *anywhere* in a matrix, as well as preset breakaway switches. Special purpose routing – such as time code, RS422 or RGB – can be smoothly integrated into an 8 level master grid at any time.

Prepare for tomorrow with the company that can do it all today...Di-Tech.



**di-tech** inc.

48 Jefryn Boulevard, Deer Park, New York 11729  
(516) 667-6300, Telex No. 971806, FAX (516) 595-1012

Circle (2) on Reply Card

World Radio History





## Ward-Beck's Beltpack ... the mobile link for your professional intercom system!

Now total communications has become a reality with the new high-performance WBS Interphone Beltpack.

This superbly designed two-channel, single pair wired, compact unit interfaces with Ward-Beck's advanced four-wire, programmable MicroCOM system. It assures studio quality voice communications to your outermost mobile location.

Beltpack moves quality communications yet another step ahead of the rest of the pack ... and at a very attractive price!

**WBS**  
WARD-BECK SYSTEMS

Ward-Beck Systems Ltd., 841 Progress Avenue, Scarborough, Ontario, Canada M1H 2X4.  
Tel: (416) 438-6550. Fax: (416) 438-3865.