



SPECIAL ANTENNA SYSTEM ISSUE  
Every feature specifically oriented  
to provide needed technical data on  
various phases of antenna systems.

NEW — ENGINEERS' TECH DATA SECTION 41

# Broadcast Engineering

*the technical journal of the broadcast-communications industry*

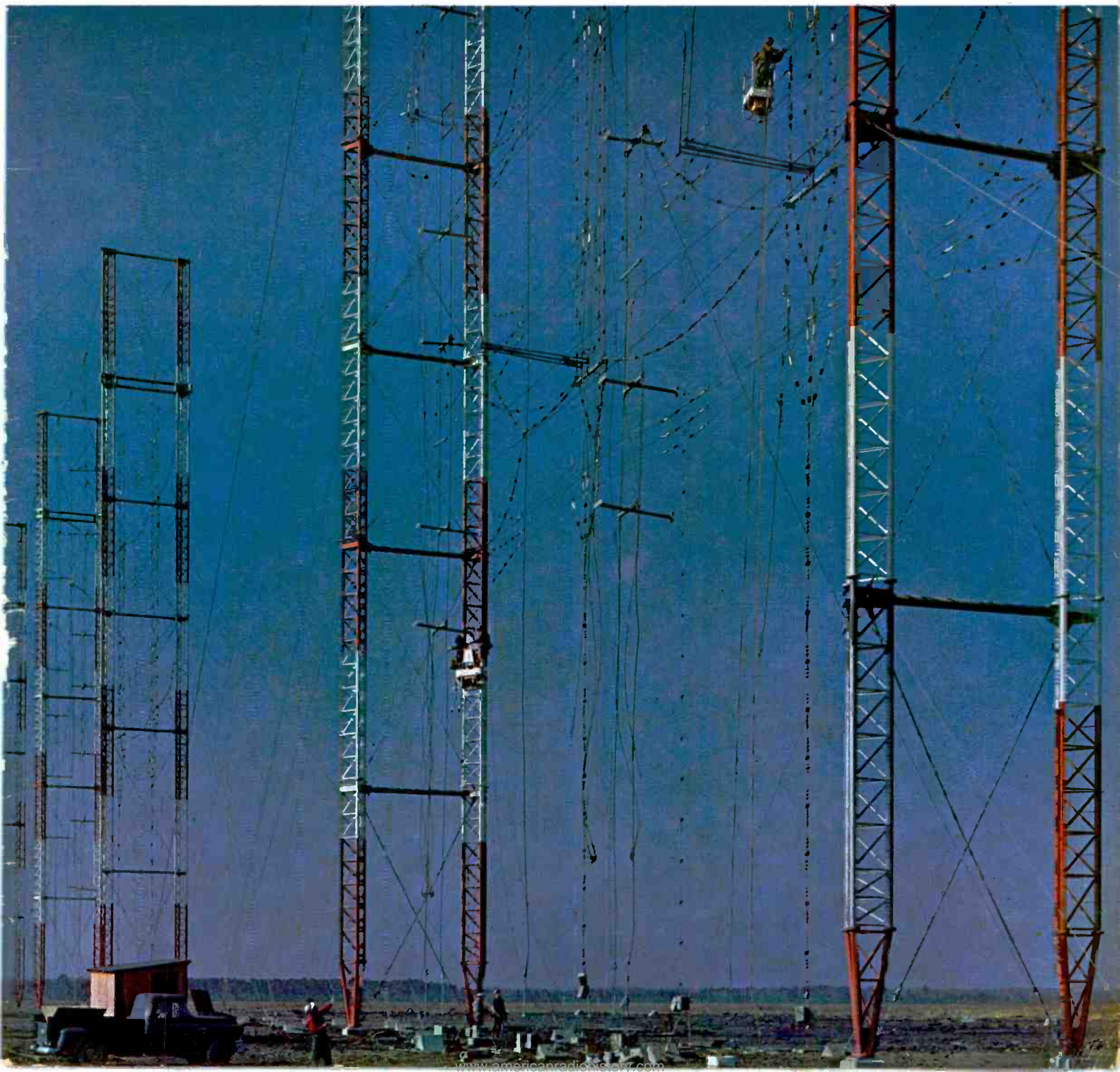

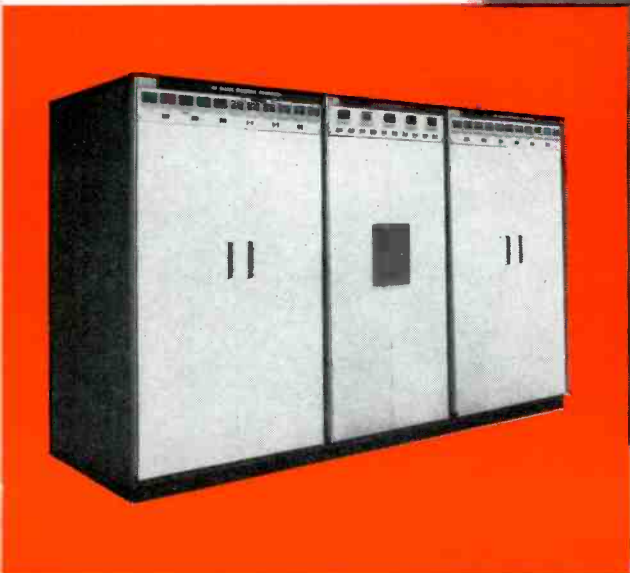

## **ITA 50 kw AM TRANSMITTER**

**Compact . . . Economical . . . Easy to operate!**

Featuring a new, single tetrode power amplifier that gives full output with minimum power consumption, this is the finest high power AM transmitter available. Extremely compact, the unit needs only 76 square feet of space *including transformers* . . . it's one-third smaller than transmitters of the same power built by other manufacturers! Silicon rectifiers, 11 tubes and 6 tube types, high level modulation and many other advanced features make it your *best buy* for high power AM broadcasting.

**ITA ELECTRONICS CORPORATION**  
 BROADCAST DIVISION • LANSDOWNE, PENNA.

ITA Broadcast Equipment is sold exclusively in  
 the United States and Canada by

**VISUAL ELECTRONICS CORP.,** 356 W. 40th St., N.Y., N.Y.

Circle Item 1 on Literature Card  
[www.americanradiohistory.com](http://www.americanradiohistory.com)

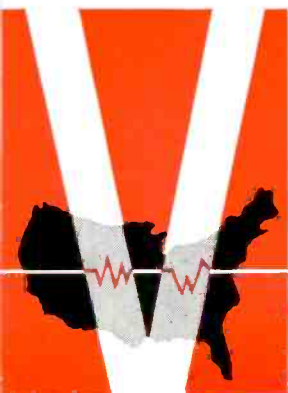

Keeps You in View!



Affiliate of Triangle Publications, Inc.

## At last! A spectacular **BREAKTHROUGH** in UHF TRANSLATORS by EMCEE



The many features indicated in this new UHF concept are just a small portion of the many new advances incorporated in this new EMCEE UNIT. PLEASE NOTE THIS FACT ALONE: EMCEE offers a complete 100 Watt UHF Translator ... at a price complete competitive with what you would expect to pay for a 100 Watt Amplifier alone! If you're looking for a UHF Translator ... try EMCEE and see!

- New concept in Translator UHF Circuitry increases reliability, ease of tuning minimizes costs all along the line.
  - Full metering of all important operating parameters, including separate measurements of visual and aural powers, visual measurement is true peak sync.
  - Visual-Aural power ratio control permits easy adjustment of ratio.
  - Built-in Plate Supply and Heater Voltage regulator ends line voltage variation problems forever.
- This is just a sampling of the new features available for the first time ever in any translator.

## FCC TRANSLATOR RULES AMENDED!

Now you can bring TV to problem areas!

**CLASS OF SERVICE**  
This is a four message service to be used for the purpose indicated by the proper symbol.

### WESTERN UNION

#### TELEGRAM

W. P. MARSHALL, President

**SYMBOLS**  
DL = Day Letter  
NL = Night Letter  
LT = International Letter Telegram

The time shown in the date line on domestic telegrams is LOCAL TIME at point of origin. Time of receipt is LOCAL TIME at point of destination.

---

**TO ALL BROADCASTERS**

NEW FCC RULES AMENDMENT PERMITS WIDER USE OF TRANSLATORS BY BROADCASTERS STOP LET EMCEE WITH THE WORLD'S MOST COMPLETE SELECTION OF VHF AND UHF EQUIPMENT SHOW YOU HOW TRANSLATORS CAN INCREASE COVERAGE STOP WRITE WIRE PHONE ELECTRONICS, MISSILES & COMMUNICATIONS INC., 262 EAST THIRD STREET, MT. VERNON, NEW YORK.



## VHF & UHF TRANSLATORS

Electronics, Missiles & Communications, Inc.  
262 East Third Street • Mount Vernon, New York • Dept. B-1

Gentlemen: Please rush

Detailed specifications of the all-new EMCEE Model HTU-100 UHF Translator just released.

Catalog B showing world's most complete line of VHF Translators.

New Rule change.

NAME \_\_\_\_\_

ADDRESS \_\_\_\_\_

CITY \_\_\_\_\_ STATE \_\_\_\_\_



## PROFESSIONAL'S STANDARD

Proven by Years of Service  
in the Broadcast Industry



**728 STEREO**  
The professional standard. 7½ and 15 ips. Superior performance in all areas.

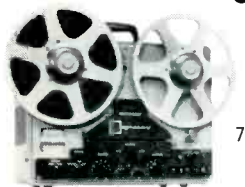

**748 STEREO**  
The Olympian . . . champion of recorders. 3¾ and 7½ ips. 4-track play and record.

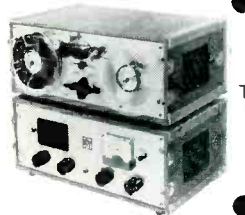

**THE PT 6**  
The rugged, reliable "Workhorse" of the broadcast industry.



**THE P 75**  
"The Editor" . . . includes all of the capabilities of the PT 6 plus extended performance and utility.

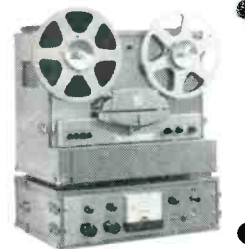

**THE M 90**  
"Mighty" in all performance characteristics. Magnecord's finest tape instrument.

In the professional sound and broadcast industry, Magnecord tape recorder/reproducers continue to set the standard for quality performance, versatility and reliability. Your own requirements will be met best by selecting from the full line of professional quality Magnecords.



Write today for more information.

### MAGNECORD SALES DEPARTMENT MIDWESTERN INSTRUMENTS

P. O. BOX 7509 / TULSA 35, OKLAHOMA  
Circle Item 3 on Literature Card

the technical journal of the broadcast-communications industry



# Broadcast Engineering

Volume 5, No. 1

January, 1963

## CONTENTS

### FEATURES

- World's Largest, Most Powerful Station!** . . . . . 10  
Cover Feature — Newest VOA facility includes 400 towers, 95 DA's, and 22 transmitters with a combined output of nearly 5 million watts!
- Remote Pickup Broadcast Antennas** . . . . . 12  
by Phil Whitney — For best results, here's what you should know about selection and installation.
- Techniques for Using RG-17/U Coax** . . . . . 14  
by Elton B. Chick — Installing heavy cable is a cinch . . . when you know how!
- Effects of VSWR on Stereo Separation** . . . . . 16  
by Peter Onnigian and Robert Stofan — Tests at Station KSFM, Sacramento, in the interest of improved stereocasting.
- The "Hot" Water Tank at WJIL** . . . . . 19  
by Robert A. Jones—Solving this antenna pattern distortion problem took some doing!
- Locating Directional Antenna Systems** . . . . . 22  
by John H. Mullaney, Peter V. Gureckis, and John R. McKenna — Part 2: How to use Polaris for establishing true meridians.

### DEPARTMENTS

- |                                 |    |   |    |
|---------------------------------|----|---|----|
| Letters to the Editor . . . . . | 6  | New Products . . . . .                    | 38 |
| Engineers' Exchange . . . . .   | 28 | Engineers' Tech<br>Data Section . . . . . | 40 |
| Technical Talks . . . . .       | 30 | Advertiser's Index . . . . .              | 42 |
| Book Reviews . . . . .          | 35 | Classified Ads . . . . .                  | 42 |
| News of the Industry . . . . .  | 36 | Professional Services . . . . .           | 42 |

**PUBLISHER:** Howard W. Sams

**GENERAL MANAGER:** Mal Parks, Jr.

**EDITORIAL:** Executive Editor, Verne M. Ray; Editor, Forest H. Belt; Managing Editor, Stuart Soll; Consulting Editor, John H. Battison.

**CIRCULATION:** Manager, Pat Tidd; Assistants, Katherine Smith; LaVon Willard.

**PRODUCTION:** Manager, Robert N. Rippy.

**ADVERTISING:** Sales Manager, John W. Groce; EAST: Charles Horner, Howard W. Sams & Co., Inc., 3 West 57th Street, New York, N. Y., Phone—MU 8-6350; MIDWEST—Hugh Wallace, Howard W. Sams & Co., Inc., 4300 West 62nd Street, Indianapolis 6, Ind., Phone AX 1-3100; SOUTHWEST—C. H. Stockwell Co., 4916 West 64th Street, Mission, Kansas, Phone—RA 2-4417; LOS ANGELES 57, CALIF., Maurice A. Kimball Co., Inc., 2550 Beverly Blvd., Phone—DU-8-6178; SAN FRANCISCO, Maurice A. Kimball Co., Inc., 580 Market Street, Phone—EX 2-3365; PARIS 5, FRANCE, John Ashcraft, 9 Rue Lagrange, Phone—ODEon 20-87; LONDON W.C. 2, ENGLAND, John Ashcraft, 12 Bear Street, Leicester Square, Phone—WHITEhall 0525; TOKYO, JAPAN, International Media Representatives, Ltd., Kisha Kurabu 14, 2-chome Marunouchi, Phone—(502) 0656.

**SUBSCRIPTION PRICE:** U.S. \$6.00, one year; \$10.00, two years; \$13.00, three years. Outside U.S.A. add \$1.00 per year for postage. Single copies, 75 cents.

**BROADCAST ENGINEERING** is published monthly by Technical Publications, Inc., an affiliate of Howard W. Sams & Company, Inc. Editorial, Circulation, and Advertising headquarters: 4300 West 62nd Street, Indianapolis 6, Ind.

A HOWARD W. SAMS PUBLICATION



BROADCAST ENGINEERING

## Maintenance for Collins FM transmitters



Collins' performance record of less down time than any other make of transmitter is a fact we can demonstrate. So, what maintenance amounts to is mostly regular dusting... with a good dust cloth. Keeps your Collins FM transmitter clean. And gleaming, as befits modern station decor. □ Of course, you don't have to dust (although we recommend it). In which case, your Collins FM transmitter will just stand there, dustily transmitting a clean, strong signal. Makes for great reception...happy listeners. And you know what that means to advertisers! □ Get complete information on Collins' complete line of FM transmitters. They're available in models from 250 to 20,000 watts (5 kw shown above). Call your Collins Broadcast Sales Engineer today. □ COLLINS RADIO COMPANY • Cedar Rapids, Iowa • Dallas, Texas • Los Angeles, California • New York, New York • International, Dallas

Circle Item 4 on Literature Card



# e's a CHILD MAX



## on top of the Empire State Building!

WNEW-TV Channel 5 in New York uses the FAIRCHILD CONAX to maintain high average audio levels despite pre-emphasis problems. The CONAX is silently at work minimizing problems created by sibilants, finger snapping, the shrill sounds of children, the rattling of dishes, muted trumpets and cymbals, which are all part of WNEW-TV's program schedule. No more reduction of apparent loudness because of these high frequency problems.

CONAX has been engineered by FAIRCHILD to cope with the problem of distortion produced in recording and broadcasting by excessive, instantaneous high frequency peaks. The FAIRCHILD CONAX "previews" program material in emphasized form for efficient high frequency control. The device is based on the integrating properties of the human ear. The CONAX action is inaudible and instantaneous — 1/40,000ths of a second.

- CONAX produces increased signal levels in recording and FM broadcast.
- CONAX reduces distortion in tape recording and tape duplication.
- CONAX minimizes channel crosstalk in stereo broadcasting.
- CONAX eliminates high frequency "splatter" between stereo channels and SCA channel.

Why not let the FAIRCHILD CONAX help you maintain high average audio levels.

FAIRCHILD RECORDING EQUIP. CORP.  
10-40 45th Avenue, Long Island City 1, N. Y.

### MAIL THIS COUPON FOR COMPLETE DATA

FAIRCHILD RECORDING EQUIPMENT CORP.  
10-40 45th Avenue  
Long Island City 1, N. Y.

Dear Sir:

Please send me complete information on the Fairchild Conax

Name \_\_\_\_\_

Firm Name \_\_\_\_\_

Address \_\_\_\_\_

City \_\_\_\_\_ Zone \_\_\_\_\_ State \_\_\_\_\_

Circle Item 5 on Literature Card

## LETTERS to the editor

DEAR EDITOR:

While browsing through the November issue of *Broadcast Engineering*, I turned to the article by Thomas R. Haskett on "Radio Transmitter Maintenance." Fig. 5 shows a drawing of a grounding stick with a battery clip used for a ground clamp. For safety's sake permanently ground that end! In the event the clip slipped off while the user was not looking, the broadcast industry might be short one promising engineer.

I enjoyed the article just the same. Thanks for a fine magazine.

ARTHUR L. VOILES

Staff Engineer,

KSWO-TV, Lawton, Okla.

Agree! "Spare the welding rod and spoil the engineer." Thanks for the safety tip, Art. We suggest readers take note and use welded permanent or bolted and soldered semi-permanent ground bonds.—Ed.

DEAR EDITOR:

A bit more information you should have with regard to my article, "Relay Switching for Remote FM Monitoring" (Nov. Engineers' Exchange column), is that the remote metering panel with the meters and controls is a Schafer Electronics product and may be obtained from them as a standard item.

MELVON G. HART

Chief Engineer, WIL AM-FM

St. Louis, Mo.

Thanks for the additional info, Melvon; it may simplify the procedure for some of our readers.—Ed.

DEAR EDITOR:

I am very interested in constructing the transistorized console shown on page 30 of your October edition.

However, there seems to be some discrepancy pertaining to the mike input

transformer designation. The schematic calls for a UTC-WF20. The WF20, however, is not a UTC number. Could you please clarify this?

DONALD E. CARTWRIGHT

Manager, KSUB Radio  
Cedar City, Utah

The transformer has been identified as Chicago-Stancor WF20 audio transformer. It has a primary impedance of 50, 125/150, 200, 250, 333, and 500/600 ohms. Secondary impedance is 50,000 ohms.—Ed.

DEAR EDITOR:

In the November installment of my article, "Planning a New FM Stereo Station," I noticed a small "boo-boo." On page 34, center of page, right column, two lines are juggled. The sentence involved should read: "The L + R and L - R signals would be fed directly into the STL transmitter, and from the STL receiver into the exciter."

I'm sure most readers would figure it out. Thanks for the nice handling of layout and editing.

LLOYD M. JONES

Santa Barbara, Calif.

And we thank you, Lloyd. We gave the linotype machine a swift kick, but instead of reassurance and consolation, we received a shot of hot lead!—Ed.

DEAR EDITOR:

In checking over my article, "Automatic Time Injector" (October, page 12), I found (4) errors, as follows:

Par. 8 reads M9—it should be K9. Fourth par. from end reads 1200 foot, 30 min cartridges—it should read 1200 series. The diode in series with plus 24 volts between K4 to K6 is shown with reversed polarity. The diode across coil of K1 is also reversed polarity. Cathode should be facing plus 24 volts. These diodes are for transient suppression.

PATRICK S. FINNEGAN

VP. Chief Engineer, WLBC-AM-FM-TV  
Muncie, Indiana

Our proofreader has finally condescended to wear glasses.—Ed.

### A New Service for B-E Readers

A good magazine does everything possible to help keep its readers informed; even to the extent of making it easier for them to obtain specific data available from other sources. One of the most important such sources is manufacturers' literature. As you probably noticed when you opened this front cover of this month's issue, we are inaugurating an Engineers' Tech Data Service, free of cost, to provide a convenient means for you to obtain information pertinent to your needs. Available manufacturers' literature has been listed on page 40. In addition, the New Products write-ups, as well as all the advertisements in the issue, have been keyed to the Free Literature card. And look! In case you're not the first person to read the issue, we've included two cards . . . one right up front and another at the very back of the book! Just tear one out (they're exactly alike) and circle numbers corresponding to the items of special interest. Be sure to indicate how many items you've circled, and to check your business classification. Print your name and address clearly in the space provided, and drop in the nearest mailbox.

Meanwhile, if you like this new service, drop us a card or letter. We'd like to know. (And no fair using both cards yourself—the other guys in the plant may have need for this service, too!)

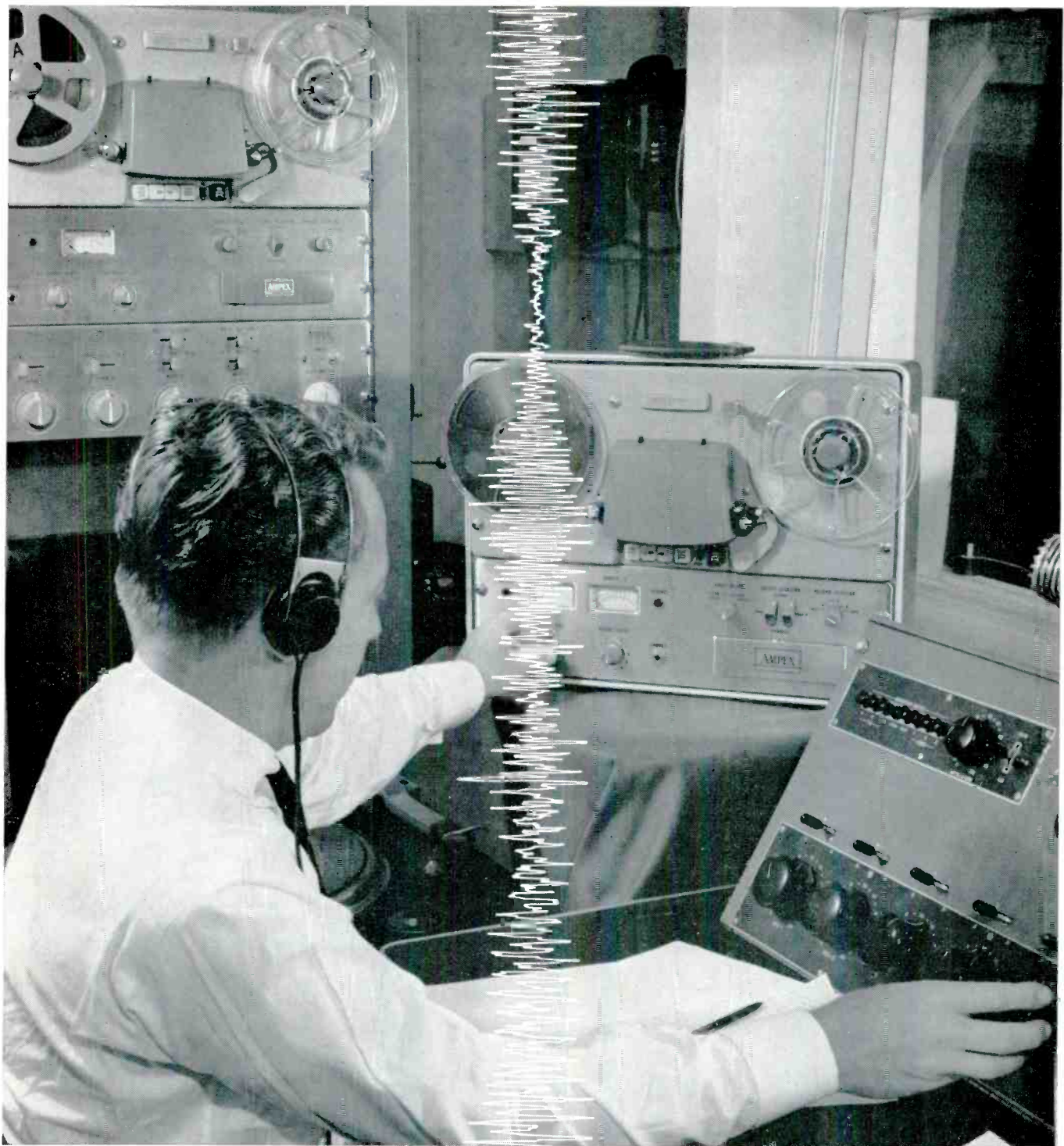

What compact can do everything a console recorder can?

**AMPEX PR-10**

The Ampex PR-10 gives you all the features, all the performance of a console recorder. Even remote control. And it's all wrapped up in a suitcase-sized package. That means you can take a complete recording studio out into the field, into the school, the church, industry—anywhere you need it. The PR-10 features positive push-button controls; record-safe switch; and separate erase, record and playback heads. And there's room for an optional 4-track stereo or additional playback head. There's also a new

electro-dynamic clutch system to give you fast, gentle starts and lower braking tension. If you want to monitor on-the-spot, the PR-10 has A-B switches, VU meters, phone jacks, output circuits. Moreover, electrical alignment controls are accessible through the front panel. You get all this plus a new Ampex "FourStar" one-year warranty. For data write the only company with recorders, tape & memory devices for every application: Ampex Corp., 934 Charter St., Redwood City, Calif. Worldwide sales, service. **AMPEX**



Circle Item 6 on Literature Card



**co el**

Why do we design and manufacture all related elements comprising a complete antenna system? As a world-wide supplier of antennas, we are called upon by broadcasters to provide everything from individual components to the complete antenna package . . . and guarantee performance under the most difficult operating and climatic conditions. In order to make such commitments, we felt that all the items affecting antenna system performance had to be manufactured under one roof — without any split responsibility. In this manner, we could personally supervise every phase of production, maintain the most stringent quality control and testing. That's why you can select a CO.EL diplexer, filterplexer, VSB filter, transmission line, or any other component with complete assurance that it meets the highest standards of the industry. As a result, the performance of our matched antenna "package" reflects the high quality of the individual components that have been integrated into the system. Write for further details.

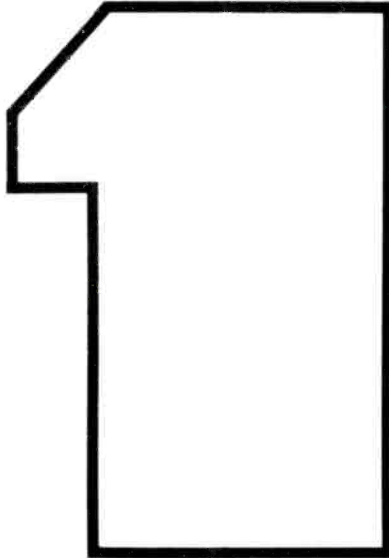

## **COMPLETE ANTENNA PACKAGE** **single source for all your TV and** **FM needs - No split responsibility**

- Low Band Broadband Dipole Antennas
- High Band Broadband Dipole Antennas
- UHF Broadband Dipole Antennas
- "Multi-guide" UHF Slot Antennas
- 10mc Bandwidth FM Antennas
- Filterplexers
- Notch Diplexers
- Sideband Filters
- Harmonic Filters
- Parabolic Antennas
- Rigid Transmission Lines

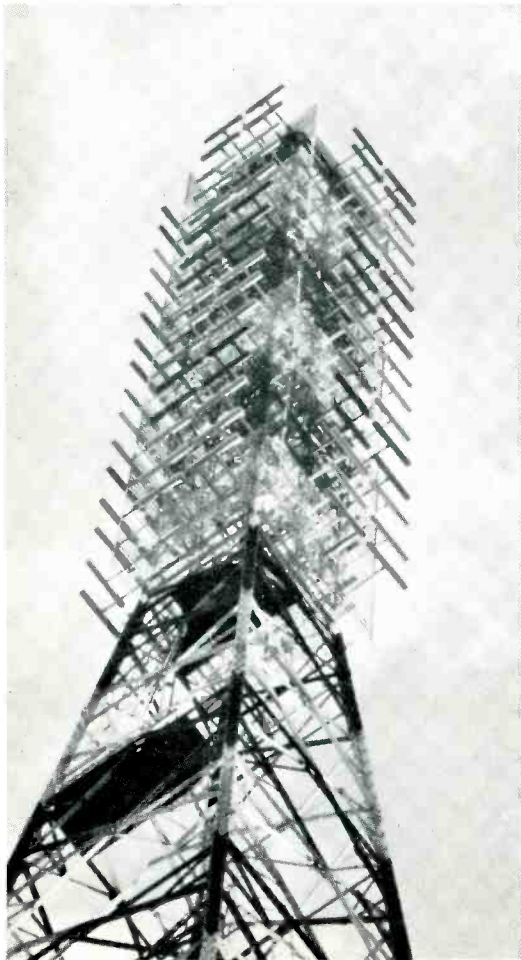

A

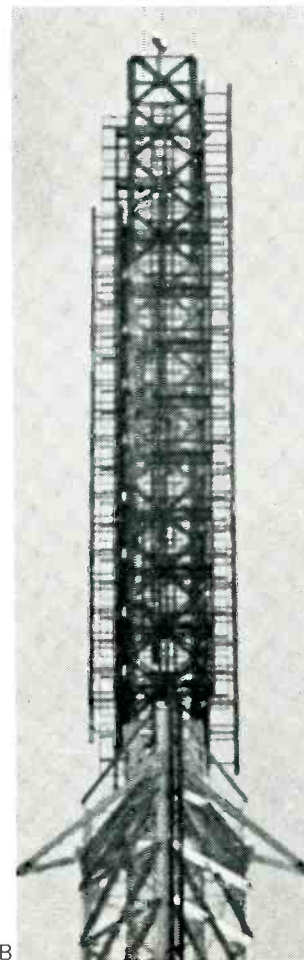

B

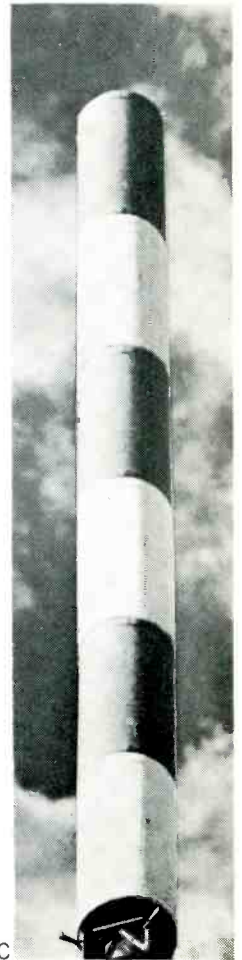

C



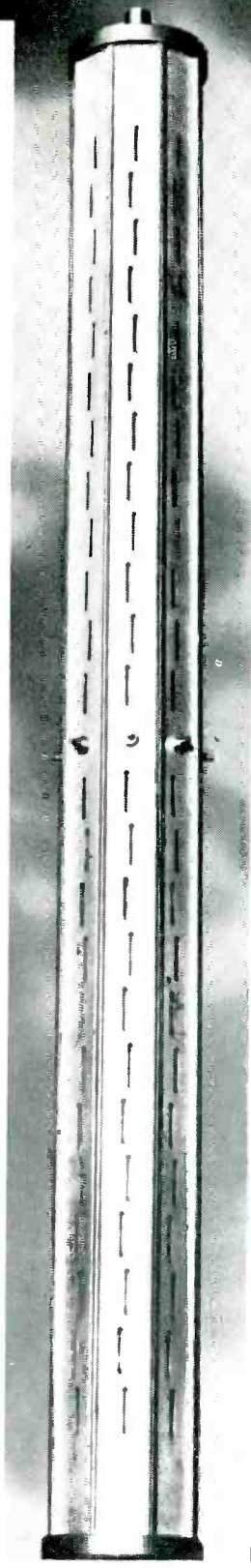

- A. Low Band Broadband Dipole Antennas for Channels 2-6, gains to 10.1
- B. High Band Broadband Dipole Antennas for Channels 7-13, gains to 23.7
- C. UHF Broadband Dipole Antennas for Channels 14-32, gains to 50.7
- D. Broadband FM Antennas with 10mc bandwidth, gains to 24.5
- E. Multiguide UHF Slot Antenna (shown with fiberglass cylinder cover removed) for Channels 14-83, gains to 33 (or higher), powers to 100kw
- F. Filterplexer (shown), VSB Filters and Notch Diplexers for all Channels and power ratings
- G. Microwave Parabolic Antennas for 2KMC, 4KMC and 7KMC
- H.I.J. Full line of EIA Transmission Line, with all accessories, for 1 1/8", 3 1/8", 6 1/8" and 9" diameters

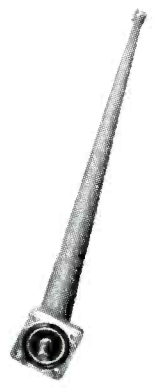

H

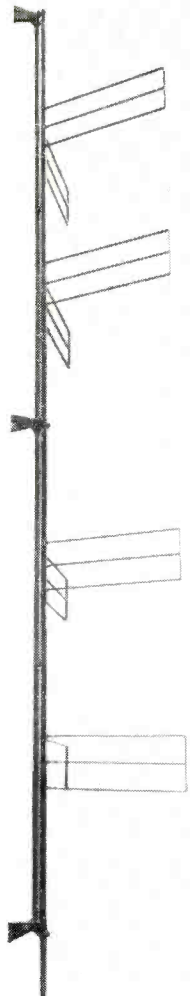

D

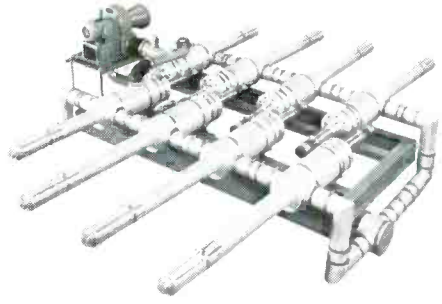

F

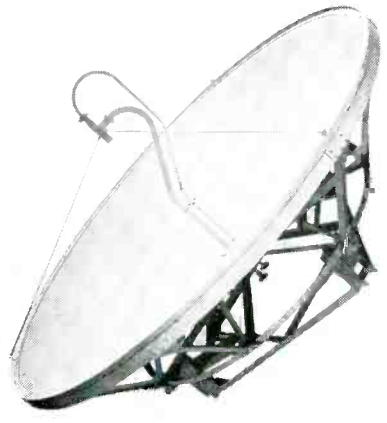
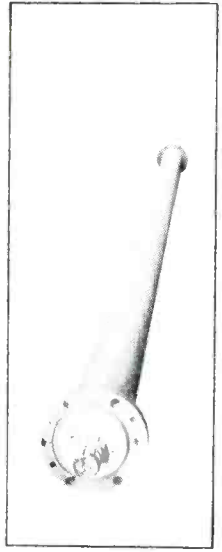

G



J



**Specialists in Advanced Antenna Systems**

**24 CAROL ROAD, WESTFIELD, NEW JERSEY / AD 2-0250**

January, 1963

Circle Item 7 on Literature Card

# WORLD'S LARGEST, MOST POWERFUL STATION

**Cover Feature**—The engineering involved in the VOA's latest mammoth "baby" makes AM seem like child's play!

Four hundred steel towers, capable of withstanding wind velocities up to 120 miles per hour, have been erected at Greenville, N. C., to support 95 directional antennas for the world's largest and most powerful short-wave radio broadcasting station.

The high-strength towers were specifically designed for the U. S. Information Agency's \$25 million Consolidated East Coast Facilities. Encompassing a total area of 6,000 acres, this huge installation consists of two transmitter stations and a receiving center located on three separate sites about 18 miles apart. Scheduled for completion early in

1963, the stations will operate 22 transmitters with a combined capacity of nearly five million watts!

Because of this extreme power it was essential to locate the installation where it would not interfere with commercial, government, and military radio broadcasts but still provide optimum propagation of Voice of America programs to Europe, Africa, and South America. This North Carolina area was selected after an exhaustive study of more than 30 possible sites.

The 50 to 400 foot towers and corresponding anchorages for the curtain, rhombic and log periodic antennas required careful considera-

tion by structural engineers of The Austin Company, international engineering and construction firm which designed the Consolidated East Coast Facilities in conjunction with Smith Electronics, Inc., of Cleveland, Ohio.

To eliminate the uncertainty of the large horizontal load distribution at the top of the rhombic and log periodic antenna towers, ball and socket joints were installed in the towers just above the next to top set of guy cables. Thus, antenna loads at the top of the towers are resisted by direct tension in the top guys, and tower bending due to wind and other loads on the antenna wires is virtually eliminated. Conventional design procedures were followed for those portions of the towers below the hinge. For similar reasons, hinges free to turn in the plane of the antenna were used in the curtain antenna towers.

Supporting the towers will be approximately 2,000 steel guy wires and cables attached to more than 1,600 huge, reinforced concrete blocks buried in the ground. In designing these anchorages, estimated soil resistance values were verified by jacking apart two full size anchor blocks in the field and using dial gauges to measure their movement for each increment of load. Movements were measured during both rapid and gradual loading and unloading of anchors (1) poured against undisturbed soil, (2) formed with no passive soil resistance, and (3) formed and backfilled with sand. The effect of submerging the anchorages in 100% water-saturated soil was also obtained.

To stabilize the ground at building sites, each building area was preloaded with a weight equivalent to one and one-half times the building

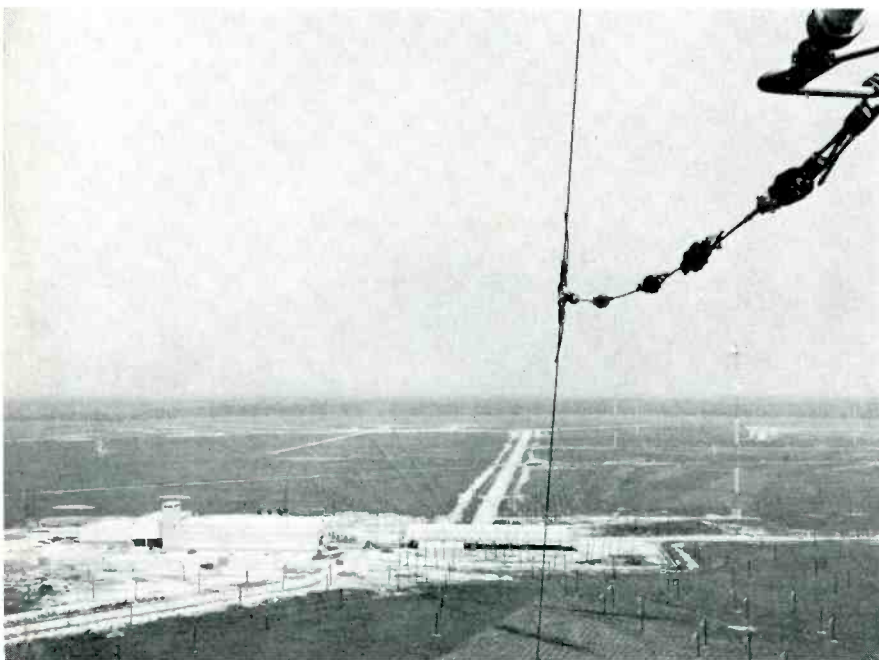

View from an antenna tower showing one of the two transmitter stations. The transmitter room contains three 500-kw, three 250-kw, three 50-kw and two 5-kw short-wave transmitters. The structure behind the antenna wind guy in the foreground is a remote-controlled electronic switching station which permits transmitter output to be directed to different antennas as desired. Several antenna towers are visible in the far background. Radiating from the switching station are rows of antenna feed line support poles.

weight for a three-month period. This was accomplished by stockpiling crushed rock which would be needed later for access roads.

The design of the large transmitter buildings presented a challenge because the area had to be entirely shielded to confine and neutralize the powerful radio signals emitted by the transmitters. The engineering groups specified that all metal within and surrounding each room be electrically bonded and grounded at four-foot intervals. This included the steel building frame, piping, ductwork, conduits, handrails, door-frames, etc. The intersections of all reinforcing bars in the concrete floor and precast concrete roof panels were welded to insure electrical bond. Steel plates were cast in the roof panels at four-foot intervals to serve as grounding points for piping, ductwork, etc., suspended from the ceiling. These plates were welded to the reinforcing bars. Similar plates cast in the panel corners enabled the panels to be bonded to each other and to the building frame.

The receiving center, which will serve as headquarters for the Consolidated East Coast Facilities, was similarly shielded. The purpose here, however, was to keep out external radiation which might interfere with the operation of short-wave receivers, tape recorders, teletype and microwave equipment. Programs originating at the Voice of America studios in Washington, D. C., will be received via telephone and microwave circuits and relayed to the two transmitter stations.

In designing this complex installation, The U. S. Information Agency, The Austin Company, and Smith Electronics, Inc., faced many unique problems for which there was no prior experience or research and engineering data available to aid them. The plans, however, were completed in 18 months by 100 engineers who, in total, expended 150,000 man-hours on the project.

Prime contractor for the Consolidated East Coast Facilities is Alpha Continental Co., a joint venture by Alpha of Texas and Continental Electronics Manufacturing Co. The antennas were erected by the John F. Beasley Construction Co. ▲

*Cover photo courtesy The Austin Company. Article photos supplied by U.S. Information Agency.*

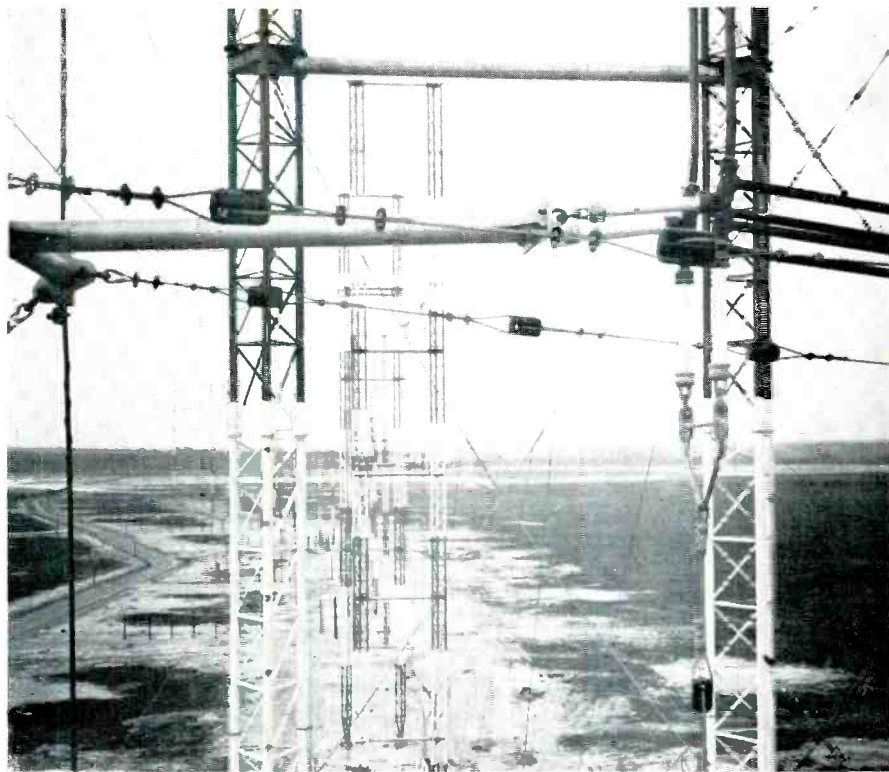

View from antenna tower showing a line of curtain antennas in one of the two 964-acre transmitting antenna fields at the Consolidated East Coast Facilities. Hinges free to turn in the plane of the antenna were installed in the towers just above the next to top set of guy cables to eliminate the distribution uncertainty of the large horizontal loads. Thus, antenna loads at the top of the towers are resisted by direct tension in the top guys, and tower bending due to wind and other loads on the antenna wires is virtually eliminated.



View of wall between receiver room and control room of the receiving center. Note wires welded to metal lath for electrical bonding and grounding. Similar wires, visible at top of wire glass, will be used to electrically bond and ground the wire mesh within the glass. For shielding purposes, all metal within the receiving center and two transmitter stations was bonded and grounded at four-foot intervals.

# REMOTE PICKUP BROADCAST ANTENNAS

by **Phil Whitney\*** — An experienced broadcast engineer gives some pointers on the proper antennas to use for remote pickup purposes, and how to construct them.

One of the most important items in a broadcast remote-pickup system is the antenna. The operation of this component can result in the success or failure of the service, and can determine whether the range of the system will be only 3 or 30 miles or more.

There are two popular remote pickup bands used by hundreds of stations throughout the country—26-mc and 150- to 170-mc. The lower frequency has many drawbacks. Among these are the severe tropospheric interference and the requirement of long antennas; a 26-mc beam is a ponderous piece of plumbing. Many stations, however, have found that the 26-mc band is good for short-hop news pickup and order-wire type of operations, except during periods of long skip.

In the 26-mc band, the Lewis group of stations uses converted Citizens band transceivers and "handy-talkies," plus a pair of 60-watt units for a talk circuit to the

remote FM transmitter. Base-loaded Citizens band whips are used on the mobile units, and the 19' heavy-duty vertical type of CB antenna is used for base stations. In both cases, the setscrews were loosened and the whip portion extended out as far as possible for more efficient operation at the lower 26-mc frequency.

Because of the lack of interference, smaller antenna size, and present availability of equipment, most stations prefer to use the 150-170 mc band for broadcast remote-pickup service. The lower frequencies in this band are shared with commercial services, and all licenses include a notation concerning interference therefrom. From 160 to 170 mc, there is a group of newly-opened frequencies assigned to broadcast remote-pickup stations only. This range has a bandwidth somewhat less than that of lower frequencies, but it is preferred in areas where frequency saturation is a problem. It is not difficult to obtain antennas having a gain of

12 db for the 150-170 mc band. Such antenna gain has the same effect as doubling transmitter power four times.

## Conversion

A station entering the remote pickup field might want to experiment with the construction of an antenna, or the conversion of an amateur 2-meter antenna.

For mobile use, it may be desirable to use a simple quarterwave whip mounted in the center of the vehicle roof. With the transmitter on, and while watching a field strength meter, the antenna is trimmed by means of a wire cutter for maximum radiated field. There is a half-wave whip now available which will afford 3-db gain and has been used with much success. On long hauls, however, a yagi beam can be connected to the transmitter to provide the necessary extra antenna gain.

The standard for measurement of antenna gain is a center-fed half-wave dipole, which is said to have "unity gain." Unfortunately, a good portion of the radiated signal is lost in high-angle radiation. By utilizing an antenna with a low radiation angle, more energy is concentrated near the ground where it is usable. The more energy that is directed toward the receiving antenna, the higher the gain of the transmitting antenna. This increase, however, is achieved at the cost of radiation in other directions. A collinear, half wave, or ground plane pulls the upward radiation downward. A yagi concentrates the energy into a cone so that it can be directed toward the desired coverage area.

There are many amateur 2-meter beams on the market, at reasonable prices; most of the country's large supply houses stock several lines. By checking catalogs, gains and measurements may be quickly de-

\*Director of Engineering, WINC Winchester, Va.

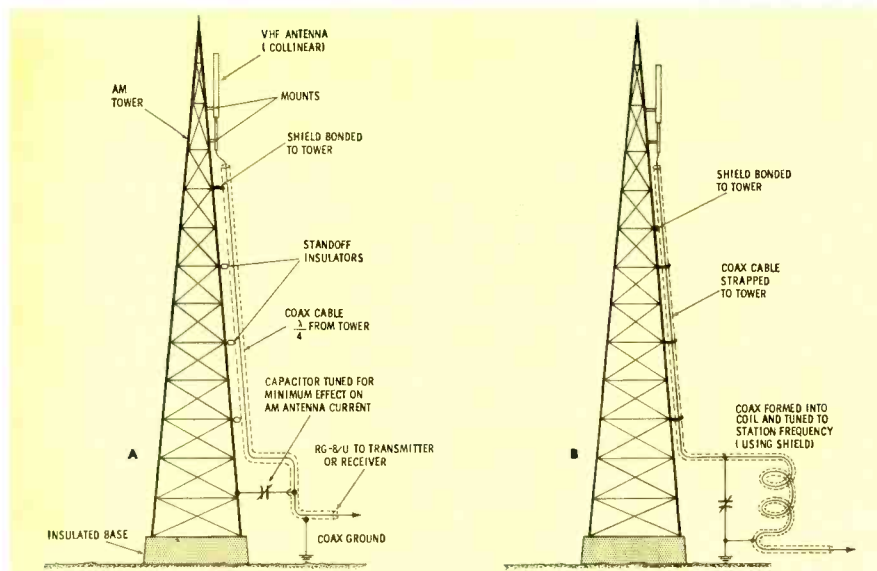

Fig. 1. Two methods of mounting remote pickup antennas on insulated AM towers. Method (A) is used for powers over 1 kw. Method (B) is used for powers under 1 kw, where tuned circuits can be employed for isolation.

terminated. Since the 150-170 mc frequencies are higher than the 2-meter amateur band, these antennas can be converted by simply cutting down the ends of the elements slightly. An amateur beam designed for 144.5 mc, for example, was cut down for 153-mc operation by removing 1" of material from both ends of all elements. This amount is figured on a percentage basis—the difference in frequency is a percentage of the original frequency (in this case 6%). Thus 3% of the element length is cut off each end. A setup similar to that described previously can be used to prune the elements for maximum field.

The WINC base antenna is a converted 12-element amateur 2-meter yagi, mounted on a rotator and installed atop a telephone pole. Many stations use nondirectional collinear antennas mounted on the side of the broadcast tower, isolated for the broadcast frequency by one of the methods illustrated in Fig. 1.

There is a time-honored argument among amateurs as to whether horizontal or vertical polarization is best. WINC uses vertical polarization for all remote broadcasts out to 5 miles, and horizontal beyond.

At 160 mc, coaxial lead-in loss becomes a factor to be seriously considered. For runs up to 100', RG-8/U is a good choice between the high-loss RG-58/U and the more expensive RG-17/U. The comparative losses per 100' for the three lines at 160 mc are:

RG-58/U—6.5 db  
 RG-8/U—2.6 db  
 RG-17/U—1.0 db

It can be seen that all the gain

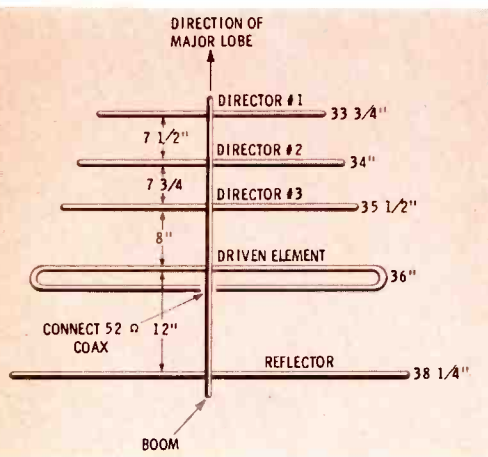

Fig. 3. Construction of 153-mc yagi.

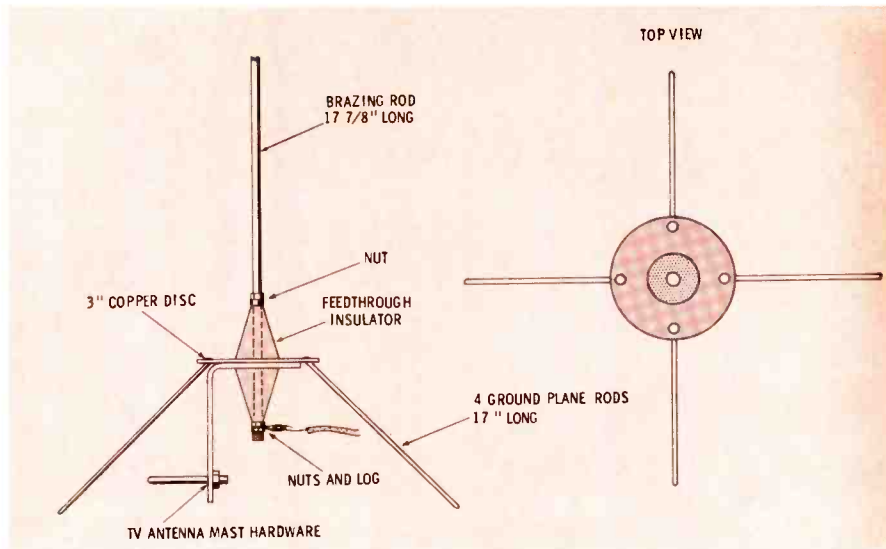

Fig. 2. Construction of 153-mc ground plane.

realized in an antenna can be lost in a long run of high-loss cable, or the transmitter power can be appreciably reduced before it ever reaches the antenna.

#### Construction

A ground plane can be easily made from a feed-through insulator, a 3" copper disc, a few pieces of brass brazing rod, and a TV antenna mounting fixture. The dimensions are shown in Fig. 2.

Thread about two inches of a 20" rod and run two locking nuts up to the end of the thread. Using a hole cutter, remove the center of the copper disc and assemble the conical feedthrough insulator so that the disc is between the two halves. Tighten the assembly with two more locking nuts at the bottom, inserting a lug between them for coaxial lead connection. Fasten this assembly to a modified TV antenna mount so that it can be quickly attached to a microphone stand, tripod, or mast.

Drill four equally spaced holes in the copper disc and solder in the four ground-plane rods; they should droop by about 45°. Trim the center rod to 17 7/8" and the ground plane rods to 17" from the center of the insulator. Round off the ends of coax to the center connector lug and to the copper ground.

A simple yagi for 153 mc is illustrated in Fig. 3. The boom is made of easily-obtained Reynold's Aluminum "Do-it-yourself" stock, or a similar material, obtainable in many hardware stores. The elements may also be made of aluminum, which

is also obtainable in 1/4" round solid rods, or of brass brazing rods. The boom may be fastened to a mast (TV thin-wall) with a common U-bolt. If the antenna is erected vertically-polarized, the top section of the mast can be made of wood doweling. Drill and bolt the director and reflector rods in two places for each element; metal cable-retainers or small U-bolts can also be used to fasten the elements to the boom.

Maximum efficiency for a specific frequency can be realized by setting up the antenna on a bench before tightening the elements. Connect the assembly to the transmitter, and while remotely monitoring a signal strength meter approximately 100' away, make spacing adjustments for maximum signal. Be sure that there are no metallic objects or persons in the antenna field while you are taking the readings.

Fig. 3 shows a general plan for building 3-element yagis. Compact folding beams, which collapse into a small package for easy transportation, can also be made by hinging the boom in one or two places and providing locking pins. ▲

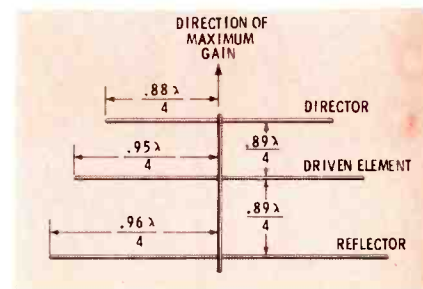

Fig. 4. Plan for 3-element yagi.

# TECHNIQUES FOR USING RG-17/U COAX

by Elton B. Chick\* — Suggestions for cutting, terminating, and splicing heavy coaxial cable for lowest losses and minimum down time.

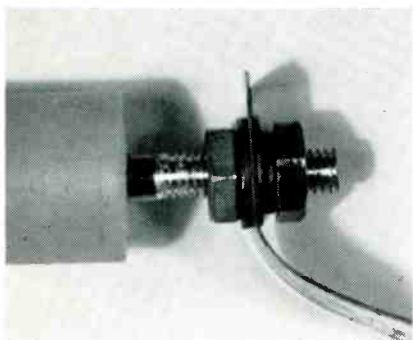

Fig. 1. Threaded inner conductor terminated with nuts and conducting strap.

One of the most widely used transmission lines in medium- and low-power radio broadcasting is RG-17/U coaxial cable. This line can handle powers in excess of 5,000 watts with modulation (if the SWR is low), has a nominal characteristic impedance of 52 ohms, a velocity factor of .66, and is very efficient at broadcast frequencies.

A good procedure in planning an installation of RG-17/U cable is to carefully measure the distance, allowing for bends and termination, and order a continuous length for the job. It is, of course, better to

\*Assistant Director of Engineering, Rounsaville Radio Stations

have a few feet left over than to come up short. When a line must be spliced, a factory connector should be used; however, where factory splices and terminal connectors are not readily available, a little ingenuity will help solve the problem.

## Cutting

One of the first difficulties encountered in either the termination or splicing of RG-17/U is cutting the cable. A rough cut can be made with a hacksaw or a small power saw; but where a neat, even cut is desired, a small tubing cutter such as used to cut copper tubing can be used. Care must be exercised to avoid cutting too deeply, however; a little practice with a piece of scrap cable helps in learning to use the tubing cutter.

The outer conducting braid cannot be cut successfully with the tubing cutter, but necessitates the use of a pair of tin shears. The smaller tubing cutters will not cut all the way through the inner insulation, but deeply enough so that a very neat cut can be made with a knife.

Once cut to the inner conductor, the insulation can be pulled off with

pliers. The tubing cutter can be used to cut the center conductor, but heavy cutting pliers will speed up the task. After cutting, the rough edges should be filed clean.

## Termination

There are several ways to terminate the inner conductor and the braid without use of connectors. One method is to expose about 1½" of the center conductor, and thread about ¾" with a number-10 or a 3/16" die, as shown in Fig. 1.

Another method of termination employs 50-amp solder lugs (Fig. 2), or clamp lugs (Fig. 3). If these are not available, suitable lugs may be fabricated from copper tubing or strap, as shown in Fig. 4.

When soldering lugs to either the center conductor or the braid, it is desirable to shield the insulation from heat to prevent melting and deforming which can occur at soldering temperatures. Several methods of heat protection have been tried (including the use of a copper heat shield), but the method we have found best involves tightly wrapping the insulation and part of

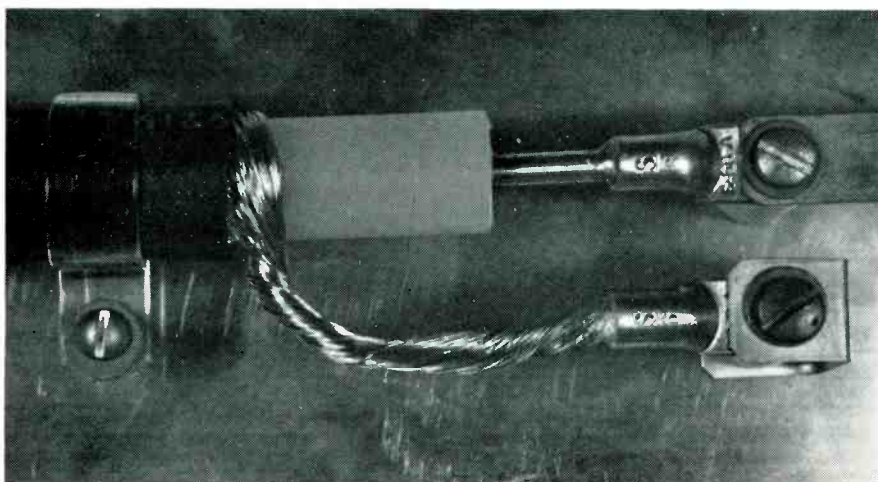

Fig. 2. Cable terminated with solder lugs.

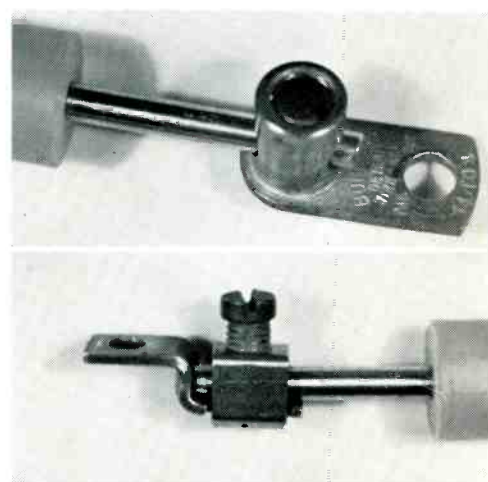

Fig. 3. Cable terminated with clamp lugs.

the conductor with a strip of wet cloth.

### Splicing

The installation of RG-17/U is usually planned so that splicing of the cable is not required; this results in a better job and eliminates one possible source of trouble. Although a factory connection should be used, if possible, satisfactory splices can be made by other means.

In splicing the center conductor several important points should be kept in mind. For example, the joint must be physically strong as well as electrically sound.

An emergency splice, suitable at standard broadcast frequencies, can be made with number-5 wire connectors as shown in Fig. 5. The connectors are then clamped together, soldered, and carefully covered with plastic electrical tape. If the splice must be protected from the weather it can be coated with tar. Although not the best type of splice, one we made and buried remained in operation at 1 kilowatt for more than three years without failing.

In making a permanent splice the first step, after cutting and stripping the cable, is to connect the center conductors. This can be done by using a short piece of 1/4" copper tubing as a connecting sleeve (Fig. 6). The two conductors and the sleeve are soldered together, and the joint is covered with a piece of inner insulation which is first drilled to fit the tubing, and then split into halves. Finally, the splice is wrapped with a layer of electrical tape.

Another technique for joining the two center conductors, providing better continuity but more difficult to use, utilizes a lap joint as shown in Fig. 7.

The outer conductor is usually the most difficult to splice. It should not depart from the original size and

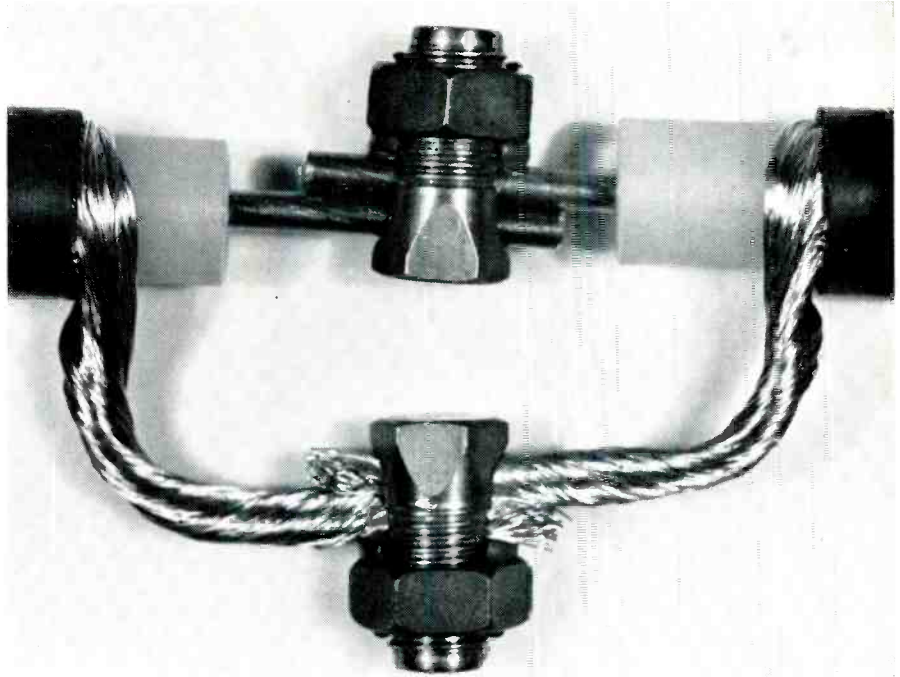

Fig. 5. Splice using No. 5 wire connectors.

shape any more than absolutely necessary, yet it must be as strong as the original cable. Fig. 8 shows a splice of the outer braid. To make this splice, the inner connection is made first, and taped. Next, the braid is pushed back over the outer jacket and a piece of soft copper sheet or strap is cut and formed into a sleeve around the inner insulation. The braid is then pushed back over the sleeve and clamped in place with a clamp, as shown. The braid is trimmed and soldered to the sleeve, while the outer jacket is protected from the heat by the damp cloth. During soldering, the inside insulation may be melted; therefore, it is important not to move the splice until it has cooled 20 or 30 minutes. Melting the inside insulation will cause very little change in its electrical characteristics and will help solidify the splice. However, excessive or prolonged heat applied to the splice will be carried to other parts of the coax and may cause distortion and other problems.



Fig. 6. Cable spliced with copper tubing.

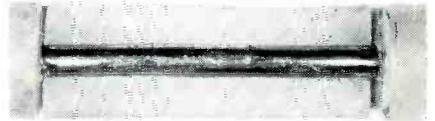

Fig. 7. Lap joint splice.

To finish the splice, the outside is wrapped with several layers of electrical tape while the splice is still warm enough to allow the tape to form to the irregular shape. A small bag of silica gel, or other dehydrant, could be wrapped under this tape to absorb moisture; but this is not needed if the joint is taped while warm. ▲

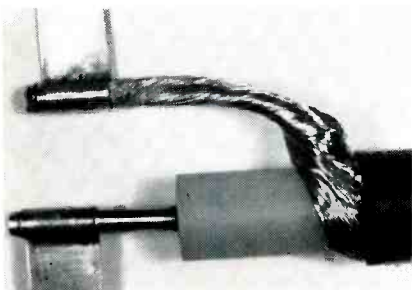

Fig. 4. Lugs made from copper strap.

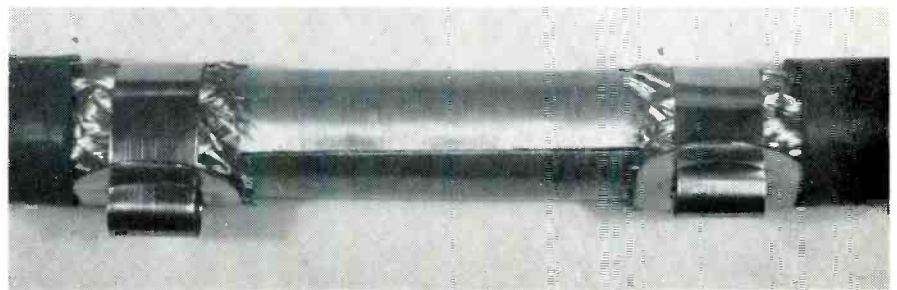

Fig. 8. Splice of outer conductor braid.

# EFFECTS OF VSWR ON STEREO SEPARATION

by Peter Onnigian\* and Robert Stofan\*\* — The procedures and results of an investigation into effects of transmitting antenna standing wave ratio on stereo separation.

The effects of antenna VSWR on stereo channel separation were recently investigated at an FM broadcasting station. The results are of great importance to FM broadcasters who are trying to achieve 30-db channel separation in accordance with recent FCC regulations pertaining to stereo broadcasting. The ability of the system to produce the largest ratio of left-channel to right-channel power, when transmitting only a left-channel signal, is of great significance. This ratio expressed in db is called stereo effect, stereophonic separation, or just separation.

## General

Factors which affect stereo signals in the audio equipment and transmitter are not covered herein. Suffice it to say, the amplitude linearity must be kept high and the phase distortion low, throughout the entire system.

The transmitting antenna system must have low VSWR to avoid limiting of the stereo separation which is usually accompanied by distortion in monaural reception. Antenna reflections thus reduce the otherwise good separation generated at the transmitter. It has been known

for some time that the antenna system should be flat with low VSWR; however, the numerical values have not yet been published.

## Tested System

The facilities of KSFM, Sacramento, California, were used for the tests. This station, which has an ITA stereo audio console, a 10-kw ITA transmitter, and an ITA stereo generator, operates on 96.9 mc with an erp of about 75 kw. The antenna system consists of an 8-bay Jampro antenna, mounted on a 300' guyed tower, and fed with about 300' of 1 $\frac{5}{8}$ " rigid coax line. A block diagram is shown in Fig. 1.

Note that the reflectometer, used for indicating the antenna system VSWR, is located after the harmonic filter. Nearly all of the harmonic filters manufactured for FM use today are of the reject type. If the reflectometer were located between the transmitter and the harmonic filter, it would read the second and higher order harmonics generated by the transmitter. Such harmonic reflection would result in erroneous readings of fundamental frequency VSWR.

It is sometimes more convenient to place the reflectometer probe in the output of the coax, just above the final amplifier and before the harmonic filter. While this is good for the transmitter manufacturer, it has caused problems for the antenna manufacturer because of erroneous readings. Another source of misleading VSWR data is the omission or improper operation of the harmonic filter.

One problem in making these measurements was to secure a suitable monitoring device for measur-

ing the stereo separation. A Scott type 350-B stereo tuner and a Scott Model 830 multiplex stereo generator were selected. The tuner was adjusted with the signal generator for maximum separation (Fig. 2). The tuner, when properly aligned, yielded 34-db separation at 10,000 cps.

To eliminate contribution of the receiving antenna to channel crosstalk, a 3-element wide-spaced yagi with a gamma matching device was used. The receiving antenna VSWR was adjusted, and measured to have a value of 1.1 to 1 at 96.9 mc  $\pm$  200 kc. The tuner input was also measured for 75 ohms, and adjusted to have a VSWR of under 1.15 to 1 at 300 kc.

Every effort was made to have the receiving equipment operate under ideal circumstances, including a reflection free antenna location, where both horizontal and vertical space-probing tests were conducted. The receiving location was in a residence at which measured antenna signal into the tuner was over 15 millivolts.

A word about receiving antennas for stereo. The FM stereo signal contains vital sideband information in the form of subcarriers. Ghosting effects on the received stereo signal show up as greatly reduced

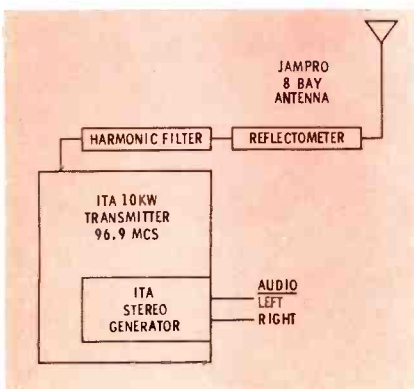

Fig. 1. Diagram of transmitting system.

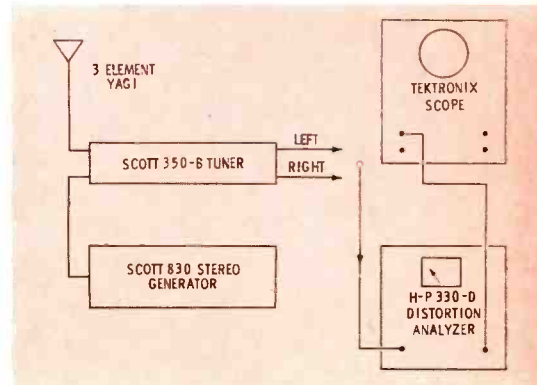

Fig. 2. FM receiver test setup.

*Editor's Note: This article is based on data presented by the author at the IRE PGB symposium in Washington, D. C., Sept. 27, 1962.*



separation because of cross-talk. Multipath signal pickup by the stereo receiving antenna cause both amplitude and phase distortion of the pilot and 38-kc subcarriers; the main carrier in monaural reception may not be affected as much. Fortunately, the solution to the problem of multipath or ghosting is easy—the receiving antenna should be directional and present a good impedance match.

### Sources of Stereo Deterioration

The basis of antenna VSWR effects on the stereo channels is cross modulation as well as amplitude and phase distortion. It is assumed, for the sake of simplicity, the FM system is ideal through the transmitter, and the only items under consideration are the final amplifier and the antenna system.

For example, a 1.7 to 1 VSWR represents a reflected power of 6.3%, or 630 watts in the test setup. This is considerable power, and would present a modest signal radiated from a 300' 8-bay antenna at 15 miles. It is understandable that part of the reflected power is absorbed in the final tank circuit as cross modulation, and the rest is reflected by the transmitter back to the antenna. It is improbable for the reflected power to totally add with the direct power, in phase. This is due to the fact that the transmission-line delay is fixed, and the frequencies under consideration vary with modulation.

This presents a question as to the effects of transmission line length on stereo. In these tests, 300' of 1 $\frac{5}{8}$ " teflon transmission line with a velocity factor of near unity was used. The transmission line was not changed in length to measure its effect on the stereo degradation. With a given VSWR, the stereo will be better with a shorter transmission line, while with a longer line, the time delay of the reflection becomes greater and more important. (This is also true in television.) The transmission line attenuation is not great enough in the average FM installation to absorb the reflection. About 3 db of line loss would be necessary for any great improvement. When load isolators or gyrators are feasible at 100 mc, they could be used to make a poor antenna VSWR look better than 1.1 to 1, and to absorb most of the reflected power.

Until such devices become available, the best answer is an antenna system with as low a VSWR as possible and uniform power and phase across its aperture.

FM antennas with phased line sections between bays for impedance matching may also be sources of stereo deterioration, since the phasing can be right for only one frequency. The manufacturing process usually limits this to frequencies in the 20-mc wide FM band. In addition to this fixed phase delay, there is further phase change with modulation of the FM carrier. The individual bay amplitudes are a function of their impedance ratios; the current amplitudes vary with modulation. Therefore, in a bridge type of FM antenna, there is phase and amplitude distortion taking place with frequency modulation.

In the corporate-type feed system, all bays receive the same amount of power at the same phase, regardless of FM deviation. The power divider is common to all bays, and interbay feed lines are all the same physical and electrical length. This type of feed system provides an antenna aperture with uniform phase and amplitude. Mutual coupling is so small at the one-wavelength spacing that its effect can easily be compensated for.

### Method of VSWR Change

The 8-bay antenna used for our test has one common power divider, feeding  $\frac{1}{8}$ th of the input power to each bay. The interbay feedlines and the individual radiating bays are 50 ohms. The power divider has

a step transformer to match the 50-ohm main transmission line to the 6 $\frac{1}{4}$ -ohm load.

The vee radiator consists of two quarter-wavelength arms, fed with a smaller diameter feed arm; the cold side is parasitically fed. The element is adjusted for 50-ohm operation by adjusting the end caps on each arm; bandwidth is attained by stagger tuning the arms. The elements were detuned for the tests by simply placing a flat bar of copper across the base of the vee and moving it outward in steps. All eight elements were so adjusted for each step of VSWR change. The final amplifier stage was retuned when necessary to maintain the best stereo separation (at 1,000 cycles only), using a scope and the demodulated output of another Scott 350-B in the transmitter room.

Some difficulty was experienced in loading the transmitter into the antenna system under high VSWR conditions (this is normal, since the load is reactive); the transmitter output power was reduced accordingly. Modulation percentages were checked at each VSWR setup to insure reliable test results. The measured VSWR curve is shown in Fig. 3. The point of measurement was the coax cable in the transmitter room; no transmission-line matching devices were used. Note that the carrier VSWR is 1.06 to 1, while the  $\pm 200$ -kc VSWR is under 1.1 to 1.

During each VSWR step change the antenna system was checked to determine precisely the amount of variation desired. The measure-

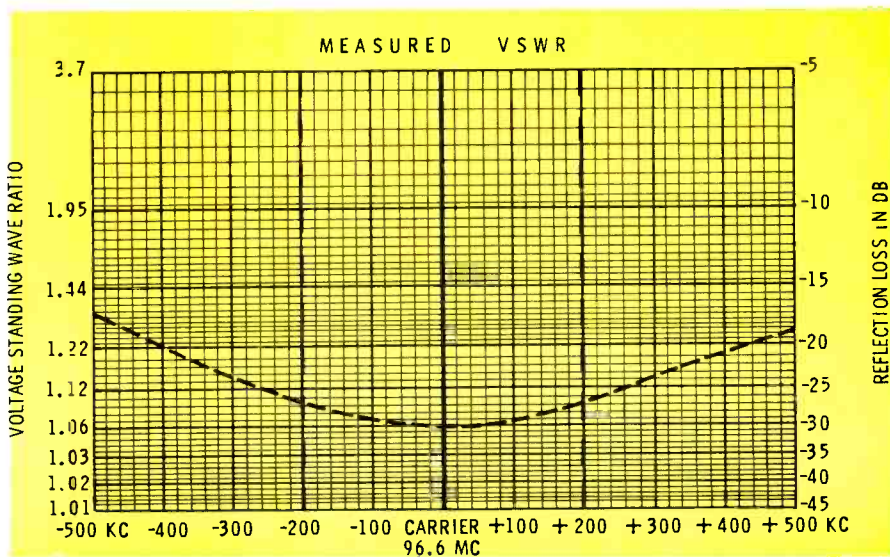

Fig. 3. Measured antenna VSWR curve.

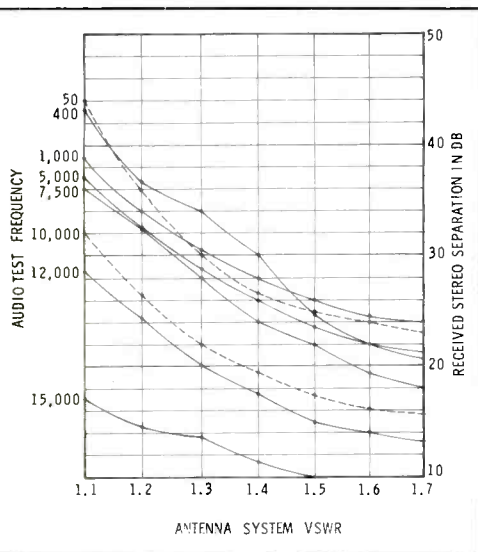

Fig. 4. Stereo separation versus VSWR.

ments were made with a directional coupler which has a directivity of 50 db. A Hewlett-Packard 415 VSWR readout meter was used to indicate the VSWR from the detected signal, which was provided by a modulated H-P signal generator. A frequency meter was used to determine the check frequency to an accuracy of 5 kc. The VSWR figures used in these tests are the maximums, occurring on the edges of a 400-kc channel, 200-kc each side of the carrier. (The VSWR is somewhat lower at the carrier frequency.)

#### Measurements

Fig. 4 shows the measured stereo separation as a function of the antenna system VSWR; note the separation decrease with an increase in VSWR. This decrease is quite rapid at the low end of the range and tends to flatten out with moderate VSWR. Note also the stereo degradation is not smooth—the total amount and ratio of stereo decreases at different rates for various audio frequencies.

The measurements with this particular station and receiver indicated good stereo, meeting FCC specifications, was available with a VSWR of 1.1 to 1, from 50 to about 11,000 cps. At 1.2 to 1, the upper end of the audio spectrum was reduced to approximately 8,500 cps at 30 db or better; and at 1.25 to 1 to about 7,500 cps. At 1.5 to 1, it was impossible to measure any audio tones having stereo separation better than 26 db.

An interesting effect was noted during the tests. While measuring

the left channel for separation, strong aircraft flutter was noted in both channels, although it did not show up as flutter on the receiver's signal strength meter with AGC set at the Mono position. With the left channel connected for testing, separation varied from 3 to 10 db. With flutter, the separation was reduced; however, it did not improve at any time from its steady state value. The conclusion is that reflections degrade stereo separation, whether they are caused by aircraft, buildings, terrain, or VSWR.

These figures do not necessarily represent absolute limitations by the transmitting station. They are, however, very much representative of the present state of the art in a typical complete stereo system, from transmitter to the output of a high quality tuner, at a distance of 15 miles. During these tests the only variable was the transmitting antenna VSWR.

The stereo modulation takes place in the front end of the transmitter, in the low level stages. The effects of the antenna system do not in any way degrade or reduce the stereo generated in the modulator section of the transmitter. Such degradation takes place in the final amplifier stage of the transmitter, and in the receiver. Since the reflected power due to poor VSWR is fundamental energy, there probably is very little difference in whether the final amplifier is single ended or push pull.

It is rather interesting to note that at 1.1 to 1 antenna VSWR, the lower audio frequencies yielded more stereo separation than the higher audio frequencies (44 db at 50 cps and 43 db at 400 cps out of the receiver).

Of further interest are the received noise levels in the various channels. The residual noise with no modulation was —55 db down in the right channel, and —61 db in the left channel. With the station's 67-kc SCA channel in operation, and with normal music modulation, the noise into the stereo channels increased to —52 db in the left channel and —51 db in the right channel. These tests were made at an antenna system VSWR of 1.1 to 1. (The stereo separation tests were made with the 67-kc subcarrier off.) The monaural noise level

from the stereo transmitter, over an antenna path of 15 miles into the Scott 350-B tuner switched to the monaural position, was —68 db.

#### Receiver Test Setup

The separation in the receiver was measured with typical noise measurement techniques. A 400-cps tone was broadcast in both the left and right channels and the transmitter phase, as well as the L—R and L+R levels, were adjusted. The receiver left and right channels were set for equal audio level out, then one audio channel at the transmitter was terminated. In the receiver, the level was again measured and the ratios of the two readings, in db, was the separation. The Hewlett-Packard distortion analyzer filter-dial was set at 19 kc to reject any pilot carrier which might affect the actual reading. In addition, an oscilloscope was connected to the scope output of the analyzer to observe the residual audio. The stereo filter in the receiver was switched out during all measurements.

Just prior to each test run, the receiver was checked for stereo separation, then connected to the antenna, tuned in, and the phase control adjusted to the 19-kc pilot of the transmitter on 400-cps audio test. The receiver controls, with the exception of the front tuning dial, were not readjusted further.

The audio runs began and ended with 400 cps to measure repeatability, which was found constant. As a matter of interest, the tests were made between 1 and 6 AM, during three mornings over a span of two weeks. The figures were found to be repeatable within 1 db during this period.

#### Conclusions

A method has been suggested for the measurement of effects on stereo separation caused by the transmitting antenna system VSWR. Using an actual system, 30 db of separation has been recorded from 50 to 11,000 cps with a transmitting antenna VSWR of 1.1 to 1. It was found that stereo separation improved when the antenna VSWR was reduced. Also, power reflected by the antenna into the transmitter was proved to limit the stereo separation by causing cross-talk between the channels. This cross-talk is additive to any other cross-talk which may be present in the system. ▲

# THE "HOT" WATER TANK AT WJIL

by Robert A. Jones\* — A method for detecting, isolating, and eliminating a re-radiating object which causes distortion in an antenna pattern.

One of the difficulties encountered in tuning a directional antenna system to a predetermined pattern is the presence of distortion or reflections. In some cases, like that at radio station WJIL (Jacksonville, Ill.), they can be great enough to completely prevent achievement of the correct pattern.

The solution of such problems is approached in two steps. First, the source of distortion must be found. Second, this source must be altered or eliminated. Sometimes the latter is the most difficult. Our solution of the reflection problem encountered at WJIL may be valuable to others who experience distortion not easily accounted for by theory.

WJIL, which operates on 1550 kc with a power of 1000 watts, employs a 4-tower directional array. The pattern design is such that all the nulls are placed close together over an arc of about 120 degrees, reducing radiation in that direction

\*Consulting Engineer, LaGrange, Ill. Credit is due Mr. Don Udey, owner and chief engineer of Radio Station WJIL, for his able assistance in solving this antenna problem.

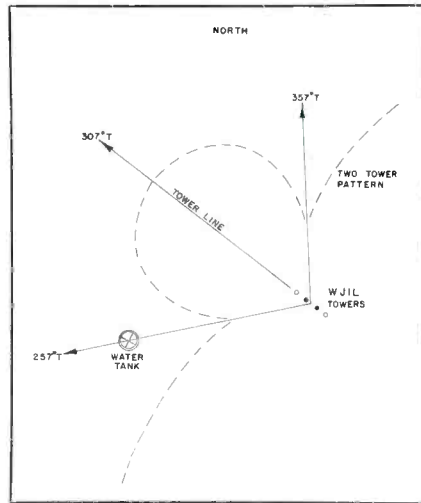

Fig. 1. Diagram of two-tower radiation pattern showing symmetrical nulls.

to a very low value. The antenna was first adjusted to the calculated base currents and phase angles. Then, after taking spot field-intensity measurements, it became obvious that a large amount of distortion existed in the null area.

Because the distortion was not symmetrical about the tower line and was of fair magnitude, we concluded that it was caused by some object close to the antenna, lying

off the tower line. Many items were tested and rejected as the cause of the distortion, such as AC wires, hi-line static drains, railroad track signal wires, etc. By a process of elimination, the only remaining object was a water tank 0.3 miles west of the transmitter site on the Anderson-Clayton Company grounds. This distance seemed to be too great (at the operating frequency) to account for the large reflection. Fig. 1 shows a sketch of the water tank in relation to the four towers.

We used an RCA Field Intensity Meter type WX-2, as a sensitive RF Probe in the vicinity of the tank. The actual re-radiation from the tank was measured by holding the meter loop perpendicular to a line between the tank and the towers. Readings were taken, every 9.6 feet while walking toward the tank. Fig. 2 shows the curve plotted from these measurements. An analysis showed re-radiation of 16 mv/m at one mile. This is greater than the intensity we expected to find, and can be explained only by the tank being resonant at 1550 kc. The tank is only 120' high, whereas a quarter

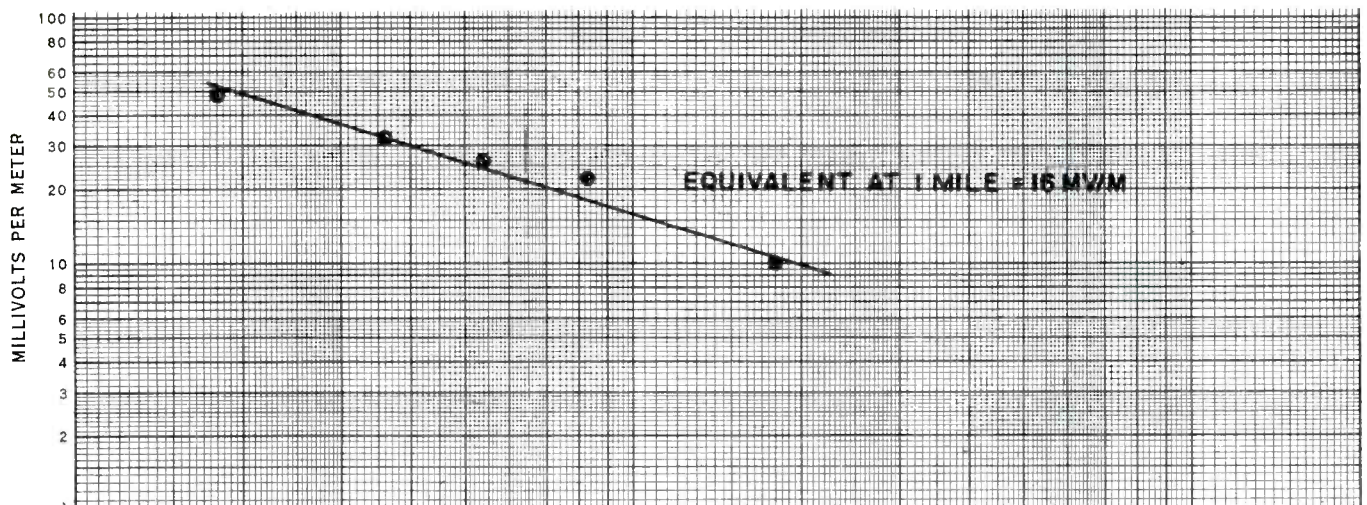

Fig. 2. Re-radiation at 90° to station.

TABLE I.

Monitor-Point Readings at Various Detuning-Capacitor Settings.				
Capacitor	Monitor Points			
	67°	107°	127°	177°
Dial	67°	107°	127°	177°
0	2.1	1.7	3.7	3.1
10	1.8	1.7	3.7	3.0
20	1.6	1.5	3.6	3.1
30	1.4	1.3	3.4	3.4
40	1.4	1.2	3.3	4.2
50	2.0	1.5	2.7	5.2
60	2.7	2.1	2.2	6.2
70	3.3	2.6	1.8	6.6
80	3.7	3.0	1.5	7.0
90	3.9	3.3	1.4	7.2
100	4.0	3.4	1.3	7.2

(Monitor Point readings shown in mv/m.)

wave at 1550 kc is 158'. Apparently the large effective diameter accounts for the resonance.

After proving that the water tank was the major source of trouble, we proceeded to determine whether it was the only one by conducting a simple experiment. The number 2 and 3 towers were connected as a two-tower pattern having a null at 257° in the direction of the water tank. We assumed that if a test pattern null was directed toward the tank, the least amount of re-radiation would be produced—the weaker field intensity presented to a reflecting object, the weaker will be its re-radiation. (The two-tower test pattern is represented by a dashed line in Fig. 1.) After adjusting the 257° null to 0.7 mc/m, we measured the companion 357° null and found it equally deep. It would have been impossible to get two deep nulls if there were strong reflections from some other source.

As a further check on the water

tank, we conducted another two-tower experiment. In this case we placed nulls at 77° and 177°, in the vicinity of the normal four-tower pattern nulls. First we adjusted the 77° null to a very low value and found considerable signal remained at 177°. When we adjusted 177° to a deep null we had a strong signal left at 77°. It was of interest to note that we had a stronger signal remaining at 177° when we tuned for a null at 77°, than vice versa. This proved two things—the reflection was west of the WJIL antenna; and when a strong signal was directed toward the water tank, a correspondingly strong reflection prevented achieving two deep nulls simultaneously.

The next problem was to eliminate or substantially reduce the reflection. Permission was obtained from the Anderson-Clayton Company to install a wire skirt on the tank and thereby tune it to resonance at some frequency other than 1550 kc. Fig. 3 shows the details of the skirt.

Basically, the eight wires are bonded to the catwalk near the top of the tank, and the bottom end of each is insulated from ground. A connecting wire runs horizontally around the bottom of the tank, connecting the vertical wires together. Radially from each vertical line, another wire connects to the tuning network, which is effectively a series capacitor to ground. The water tank, 120' high, and consisting of four legs around a central standpipe, acts as a quarter-wave antenna; the skirt acts like a folded half-wave antenna. The induced voltage in the tank cancels the voltage in the skirt.

To check for maximum detuning we set the field intensity meter near the water tank and adjusted the series capacitor for minimum signal. Then we went back to the station and reset the antenna to the calculated values. Some minor adjustments of the antenna phases and ratios pulled the monitor points within FCC limits.

To check the detuning effect of the wire skirt, we ran a series of tests taking note of the signal intensity at each monitor point with several settings of the series detuning capacitor. Table 1 shows the results. There is no one setting of the capacitor which has a minimum effect at all the monitor points, meaning the reflections from the water tank are not completely eliminated. We expected this since our wires do not run to the top of the tank, nor all the way to ground. The catwalk was the best point, mechanically, to locate the wires near the top. We were required by the company to keep our skirt 15' above ground to permit trucks to pass under the tank.

The final measured four-tower pattern in the nulls is shown in Fig. 4. There is considerable difference between this and the previous adjustment; in addition, the nulls are fairly symmetrical about the tower line.

I believe two important ideas developed from the solution of this problem. First, a wire skirt can be successfully used to detune a bulky object like a water tank. Also, a simple two-tower pattern is the best method of tracking down a source of reflection—when the object is located in a deep null, we find zero re-radiation. An important conclusion here is that it is best to stay away from reflecting objects when constructing a new broadcasting station. Or, if possible, locate the towers so that any suspicious and possible reflecting wires or structures will be located in a pattern null, not in the major lobe.

Radio reflections are like people—they come in all shapes and sizes. While the solution used at WJIL will not work for all reflection problems, it is hoped that some of the techniques will be helpful to chief engineers in solving their own reflection and distortion problems. ▲

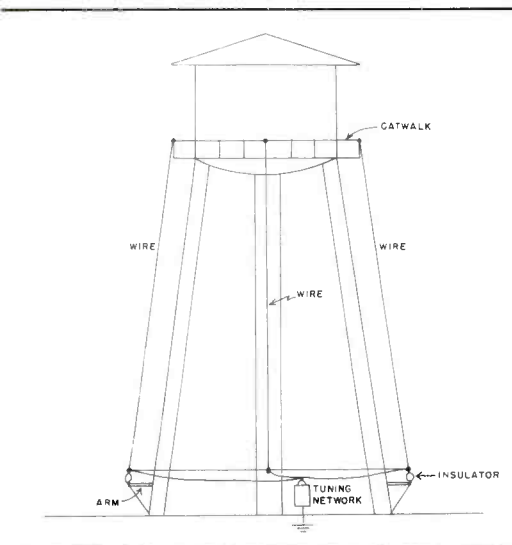

Fig. 3. Pictorial diagram of wire skirt.

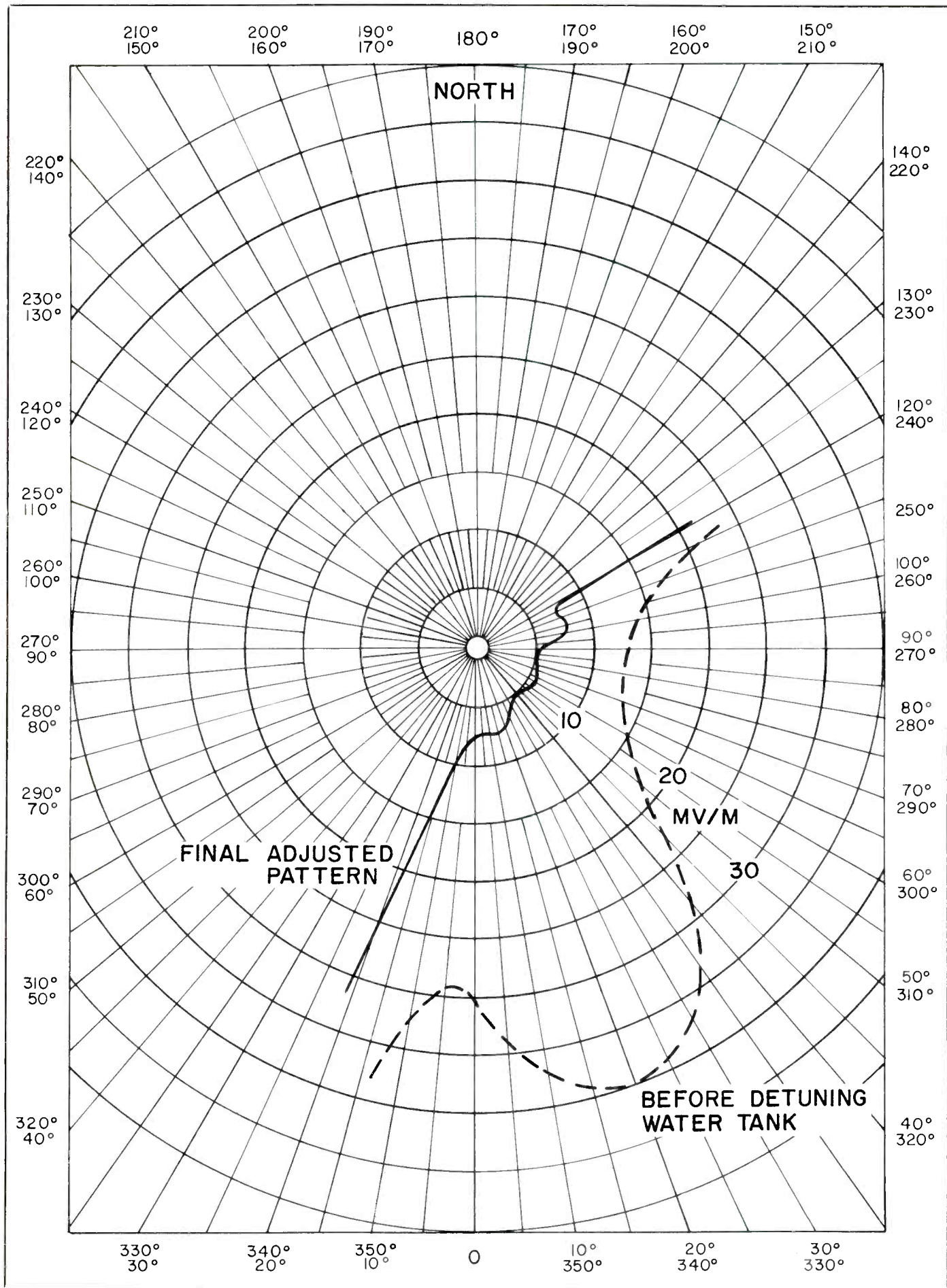

Fig. 4. Four-tower radiation pattern before and after detuning the water tank.

# LOCATING DIRECTIONAL ANTENNA SYSTEMS

by John H. Mullaney, Peter V. Gureckis, and John R. McKenna\*

—PART TWO. A discussion of orientation with Polaris and the sun, including equipment, time, correction factors, and accuracy, for establishing true meridians.

Last month antenna surveying principles were discussed with regard to accurate orientation of multi-tower arrays. In this article the determination of the precise references required, such as True North, will be examined.

The greatest reference accuracy can most readily be attained when the least complex measurement technique is employed. Because of this, the Bureau of Land Management of the U.S. Department of the Interior has specified the use of Polaris (the North Star), to establish true meridians for public land surveying. The Sun, of course, can also be used, but Polaris is preferred.

## Polaris and True North

Polaris has a diurnal circle about the earth's polar axis, similar to that of other stars, although Polaris has the smallest circle of any star visible to the unaided eye. Polaris crosses the meridian twice: once at upper culmination, or above the polar axis, and once at lower culmination, or below the polar axis (Fig. 1). Halfway between, the apparent position of Polaris is furthest to the west, in a position called West Elongation. Likewise, midway from lower culmination to upper culmination, Polaris is in the position of East Elongation. While both the positions of culmination and elongation offer definite advantages, the latter is favored, since highly accurate observations are more easily made at this time. As the star moves from upper culmination towards West Elongation its motion, as viewed through a theodolite or transit, is from right to left. At a moment before the star reaches the position of elongation and for a brief interval thereafter, its motion becomes vertical; then the star

moves from left to right towards the position of lower culmination.

Equipment necessary for observations on Polaris include a transit or theodolite, a plumb bob, two flashlights, stakes and tacks (for establishing the north-south line on the ground), a stop watch, and a precision timepiece. If a transit is used, the flashlights are necessary to illuminate the graduated dials, and the cross hairs in the telescope.

## Time

There are two normal time rates: mean solar time, as in civil uses, and sidereal time as employed by astronomers. Solar time is divided into three distinct classes—apparent time, local mean time, and standard time.

Our normal time is based on the 24-hour period which begins with the sun's meridian passage of one day (i.e., apparent noon to the next meridian passage), and is irregular. Mean solar time is based on an imaginary sun whose solar day is mathematically uniform. The mean-time clock and the ordinary watch are designed for a 24-hour period that conforms to the mean sun.

An altitude observation of the

sun, southeasterly or southwesterly, gives a determination of the apparent time, AM or PM. The difference between the apparent time and the local mean time is called the **equation of time**, which varies throughout the year. It is generally only a few minutes, but increases up to a maximum of about 16 minutes early in November.

On any meridian, local mean time and mean solar time are identical. But the local mean time on a particular meridian is correct there only. Points that are 1 degree apart in longitude differ by 4 minutes in the local mean time, and points that differ by an hour in the local mean time have a longitude difference of 15°.

Standard time is identical with local mean time on the central meridian of each time belt, as Eastern Standard Time on the 75th meridian, Central Standard Time on the 90th meridian, Mountain Standard Time on the 105th meridian, and Pacific Standard Time on the 120th meridian of longitude. The correction for longitude is all that is required for converting to local mean time; **additive when east** of the central meridian, and **subtractive when west**.

The interval of time between two successive upper or lower transits of a star over the same meridian is called a sidereal day. It has a 24-hour period which is equivalent to 23 hours, 56 minutes and 4.091 seconds in mean solar time. There are 366¼ sidereal 24-hour periods in the solar year of 365¼ days. The mathematical equations employed in the observations of the azimuths and altitudes of Polaris at various hour angles, are based upon sidereal time. (The Ephemeris contains a simple table for the conversion from sidereal time rate to mean time rate.)

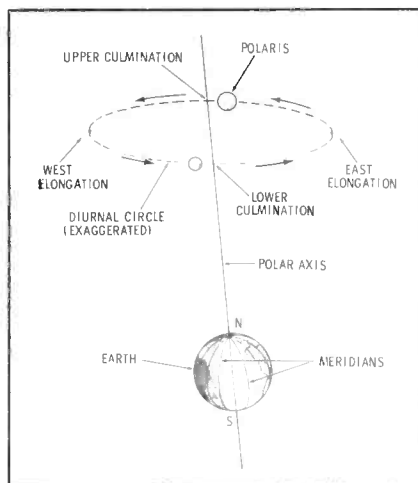

Fig. 1. The diurnal circle of Polaris.

\*John H. Mullaney and Associates, Washington, D. C.

# HOW YOU CAN DRAMATICALLY IMPROVE BUSINESS AND STATION PERFORMANCE FOR NEXT TO NOTHING...

How much more money could you make if you could...

- Increase your potential audience
- Quadruple radiated program power
- Sound much louder and clearer
- Increase received S/N ratio
- Offer the sponsor more listeners per dollar
- Increase listener loyalty
- Sound much better than competitors
- Reduce operating costs

And do it all for as little as \$495.00?

**AUDIMAX stations—more and more every day—do!**

**Here's how:** Audimax is your assistant broadcast engineer—an electronic brain that boosts your station's radiated program power and market coverage, greatly improves sound, and improves operating efficiency by automatically controlling program levels with near-human intelligence and superhuman speed and accuracy—all without objectionable side effects and distortion.

Audimax differs in *concept* from ordinary level controls (limiters, compressors, AGC's, etc.) and accomplishes what they attempt to, without the additional problems they introduce. With such devices, the gain is always either rising or falling. With fast recovery times, pumping sounds occur. Slowing the recovery time allows short bursts of sound to put "holes" in the program. Audimax, instead, works like a competent engineering assistant.

**Automatic Gain Riding**—When levels are too high, Audimax quickly and inaudibly lowers the gain without thumping—When levels are too low, Audimax raises the gain without pumping. With explosive sounds, (e.g., pistol shots, barking dogs) Audimax momentarily corrects the gain, then instantly returns to previous level, without leaving "holes." When levels are correct, the gain *remains constant*. Audimax's exclusive platform mode of operation preserves short-term dynamic fidelity.

**Automatic Program Control**—Audimax's exclusive logic monitors the incoming signal and compares it with previous program information in its memory, *deciding* whether to raise, lower or main-

tain constant gain. The result: Perfect levels every time. **Gated Gain Stabilization**—Audimax also *recognizes* noise and background effects and maintains *constant gain* during pauses, eliminating unnatural fade-out of the background effects and disturbing swish-up of background noise, completely preserving the natural sound of dramatic programs, sports-casts, etc. **Return-to-Zero Feature**—In standby conditions Audimax waits, and when convinced that the program has ended, slowly drops to normal gain.

**Magnified Modulation and Market Coverage**—While performing control functions automatically, Audimax boosts overall levels—to 6 db higher than normal manual methods—quadrupling radiated program power and potential audience. You "stand out" on the dial, your programs sound louder, clearer and better than ever before, increasing listener loyalty. All this means more value for the sponsor, and a *vast increase in your money-making potential*.

Prove it for yourself. Satisfaction guaranteed. Order *your* Audimax today!

Audimax II RZ . . . . . \$625.00  
Audimax I without Gated Gain Stabilization and Return-to-Zero feature . . . \$495.00

Dept. APE-163

**CBS LABORATORIES**

STAMFORD, CONNECTICUT  
A DIVISION OF COLUMBIA BROADCASTING SYSTEM, INC.

Another product of CBS Laboratories contributing to better Broadcasting.

Circle Item 8 on Literature Card



## The Ideal Speaker Baffles for Acoustical Ceilings



SQUARE ...



ROUND ...

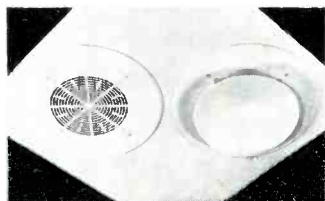

### WIDE DISPERSION DESIGNS Many Other Designs to Choose from

Fourjay lightweight baffles are the only speaker baffles specially designed for acoustical ceiling materials — even extremely low density materials. Molded of high impact fiber glass, styrene and similar materials, their attractive designs are available in milk white or desert sand which may be left plain or painted. Non-resonant materials assure much greater sound quality.

### FAST, LOW COST MOUNTING with Ingenious Mounting Ring



With this cleverly designed mounting ring, installation can be made in only seconds. Use for new construction,

or snap at preformed slot for threading into 10" hole in existing ceilings. Works with any type of ceiling material. Accommodates most 4J baffles including those shown above and accessories. No toggle bolts required. All hardware furnished.

WIDE CHOICE OF ACCESSORIES AVAILABLE



## FOURJAY INDUSTRIES

2801 ONTARIO AVENUE  
DAYTON 14, OHIO

IN CANADA: Len Finkler, Ltd, Toronto.  
2 Tycoos Drive • Toronto 19, Ontario

Circle Item 9 on Literature Card

Date of observation.....	June 4
Observer's latitude.....	35° N
Observer's longitude.....	67° E
Reference date, from Ephemeris.....	June 1
Reference time, from Ephemeris.....	12:05 AM
Correction for latitude 35° N., from Ephemeris.....	-0.9°
Date of observation.....	June 4
Reference date.....	June 1
Difference in dates.....	3 days
Daily time change.....	3.93 min.
Days difference.....	3
	11.79 min.
Reference time.....	12:05 AM
Total time change.....	- 11.79 min.
	11:53.21 PM
Since the observation goes through midnight, the computed time (11:53 PM) is therefore the true solar time on June 3 at which a correction of -0.9° will apply at a latitude of 35° N. for the date of June 4, an additional 3.93 minutes must be subtracted.	
Time—June 3.....	11:53.21 PM
Added daily time change.....	-:03.93 min.
Time—June 4.....	11:49.28 PM
True solar time.....	11:49 PM
Equation of time, June 4.....	-:03 min.
Local mean time.....	11:46 PM
Longitude correction, 4 min. × 7°.....	+ 28 min.
Local standard time.....	12:14 AM

Fig. 2. Log for Polaris observation.

The element of time enters into all azimuth determinations—apparent time for all observations upon the sun, and local mean time for all observations upon Polaris. The azimuth of Polaris varies with the local mean time of observation, which must be known to a degree of accuracy consistent with the result desired in the determination of the true meridian. Observations of Polaris at elongation are least demanding on the timing system, since the vertical motion (in the theodolite) of the star precisely indicates passage through this position. Hence, all that is necessary is an accurate logging of the time and subsequent correction to the exact value of local mean time.

### Correction Factors

A list of dates and times with the corresponding correction factors is included in the Ephemeris. True solar times are listed, and any convenient one shown under a given date may be selected.

The same correction given in the table for any date and time will apply 3.93 minutes earlier per day following the reference date selected. Therefore, 3.93 minutes

multiplied by the difference in the dates must be subtracted from the time selected. Thus, a correction of -0.8° required at the observer's latitude at 8:03 PM on May 1st, would also apply at 8:03 PM minus 3.93 minutes times 10 or 7:23.7 PM on May 11th.

An additional 3.93 minutes must be subtracted if midnight lies within the times determined by the previous method. Thus, a correction of plus 51 minutes required at 1:01 AM on January 1st, would apply at 1:01 AM minus 78.6 plus 3.93 minutes, or at 11:38.5 PM on January 21st.

The true solar time for the date of observation, determined by the preceding method, must be reduced to the equivalent local time. The correction given in the Ephemeris may be applied in the following manner: If the sign of the correction is positive (+), Polaris is west of North. The azimuth scale must therefore be set to read 360° minus the correction factor, in order for 0° or 360° to indicate True North. The azimuth scale must be set to read 0° plus the correction factor if the sign of correction factor is negative (—), to obtain the same result.



For example, assume the Ephemeris indicates a correction of  $-0.8^\circ$  for a north latitude of  $30^\circ$  at 8:03 AM on May 1st. To determine True North, an observer would set the azimuth scale of the theodolite to  $0.8^\circ$ , and center Polaris in the crosshairs at 8:03 PM true solar time, or the equivalent local time, on the above date. Zero on the azimuth scale will then indicate true north.

If solar observation is employed for orientation, the observation must be made as the sun crosses the zenith, which is noon, true solar time, at the observer's meridian of longitude. The corrections shown in the Ephemeris for variation of Polaris from True North are given in true solar time.

Apply the equation of time correction for the date of observation obtained from the Ephemeris. The appropriate graph is prepared for progression from lmt to tst, so the reverse process is employed in this instance; the sign of the correction value must be reversed.

For local standard time use this procedure: Determine the nearest standard time meridian to the observer's longitude, which is any multiple of  $15^\circ$ . Subtract 4 minutes for each degree east of the standard time meridian; add 4 minutes for each degree west of the standard time meridian.

#### Procedure for Polaris Observations

Set up the instrument before sunset, and focus on Polaris at least half an hour before the time for observation. At the specified time, set the vertical cross-hair accurately on Polaris. This direction should then be established on the ground by substantial markers. The True North line is at an angle equal to the correction given by the Ephemeris away from the line of observation, right or left, depending upon whether the correction is plus or minus. Fig. 2 shows a typical Polaris observer's log.

#### Procedure for Observations on the Sun

At true solar noon the sun is on the meridian (i.e., the north-south line through the observing station). True North is obtained, therefore, by sighting the sun at true solar noon. The time for the observation



## THE TURNER MODEL 58 STUDIO MICROPHONE

*For broadcasting excellence inside or outside the studio*

Designed for TV and broadcast use, the Model 58 has been specially engineered by Turner to withstand heat, rough handling and humidity. This modestly-priced microphone is rugged enough for sports remotes, studio or outside interviews, panel shows—anywhere freedom and mobility are required: yet it gives the quality performance you expect from stationary studio microphones.



The Model 58 is 4" long, weighs only  $3\frac{1}{2}$  ounces. Complete with lavalier; or it can be adapted to a desk or floor stand. Level (RETMA)  $-149$  db. Response 60—13,000 cps. Allows a choice of either hi impedance or 150 ohms selected at the free end of the cable. Model 58A: combination 50 or 200 ohms selected the same way. Net price \$34.20. For complete specifications, write:

THE  MICROPHONE COMPANY  
909 17th Street N.E., Cedar Rapids, Iowa

IN CANADA: Tri-Tel Associates, 81 Sheppard Ave. West, Willowdale, Ontario.  
EXPORT: Ad Auriema, Inc., 85 Broad St., New York 4, N. Y.

Circle Item 10 on Literature Card

# NEW JAMPRO BATWING ANTENNAS FOR VHF TELEVISION

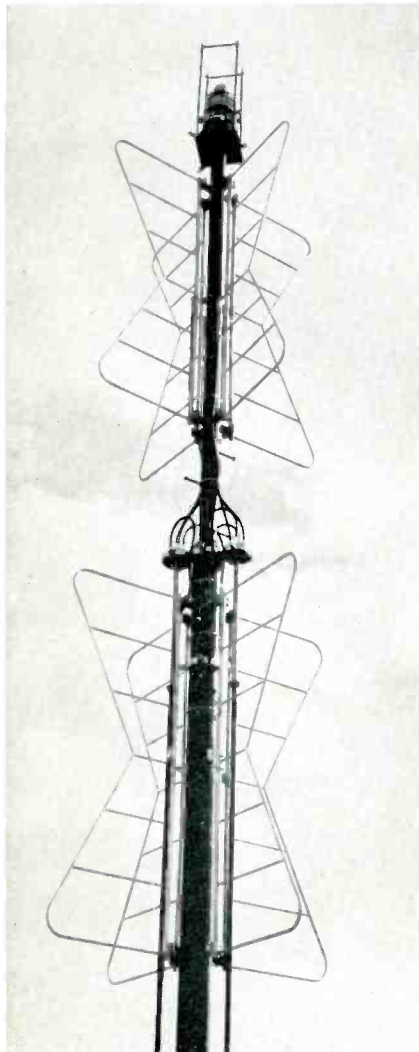

JAT2/5L CHANNEL 5

## IMPROVED INTERBAY CABLE AND END TERMINATIONS, LOW VSWR

Your choice of input power ratings. H series for 35 and 50 KW, L series with 2½ KW per bay.

Widest choice of VHF batwing antennas are now available only from JAMPRO. One through six bays for channels 2-6 and one, two, four, six, eight and twelve bays for channels 7-13.

Write for Catalog

**JAMPRO ANTENNA CO.**  
7500 - 14TH AVENUE  
SACRAMENTO 20, CALIFORNIA

Circle Item 11 on Literature Card

TABLE I.

Triangulation and Traverse Accuracy	
TRIANGULATION	
base-line checks	1 in 5000
triangle closures, avg.	5 sec.
triangle closures, max.	10 sec.
TRAVERSE	
closing error in position	1/5000
LEVELLING	
closing checks	0.050 feet $\sqrt{\text{miles}}$

(From the U. S. Federal Board of Surveys and Maps, 1933.)

must be known in local standard time. This can be determined by converting true solar time to local mean time, which is then corrected to obtain local standard time.

Equipment necessary for observation of the sun is the same as that needed to observe Polaris, with the exclusion of the flashlights. The instrument is set up at least 15 minutes before time for observation, and the cross-hairs focused on the sun. The observation is made through a darkened piece of glass or overexposed film negative. At the exact time for the observation, the vertical cross-hair is set accurately on the sun, and the transit clamped in this position. This direction is then established on the ground by substantial markers. For stations north of 23½° North Latitude, the sun will always be south, while for stations south of 23½° South Latitude, the sun will always be north.

### Special Comments

One problem associated with radio surveying is the matter of maintaining the surveyor's markers or monuments between the time the surveyor completes his work and the time the tower crew begins construction. Experience indicates that before the tower crew starts to pour concrete for the base foundation, the surveyor should be called back to make sure that the bases are properly located.

### Accuracy

Since quadrangular maps are used in conducting proof of performance, accuracy exceeding the ability to plot a given bearing or azimuth cannot be expected. Experience indicates that  $\pm 0.1^\circ$  is the best accuracy that can be reasonably expected for hand plotting. Hence, any greater accuracy than this exercised in the determination of the center line bearing would serve

no useful purpose. Plus or minus  $0.1^\circ$  is equivalent to stating the center line accuracy within  $\pm 6$  minutes.

Table I sets forth the accuracy requirements for triangulation and traverse in antenna surveying. The tolerances are for land surveying only and do not relate to the accuracy required for the determination of Polaris.

The base elevation of radio towers, which is to be specified on the FCC Construction Permit, must be maintained within  $\pm 1^\circ$  between adjacent towers. The reference for this measurement is the top surface of the concrete pier at the tower base foundation.

Each directional antenna has a ground system, generally consisting of 120 radials of copper wire buried 4 to 6 inches deep. The length of the radials, from the base of the tower, is dependent on the frequency, design, etc. In addition, a copper ground screen which has dimensions varying between 24' to 48' square is generally specified. Sometimes 120 short (50') radials are interspersed between the long radials to take the place of the ground screen. This ground screen is also buried from 4 to 6 inches below the ground. Its elevation should be maintained within  $\pm 2'$  for a horizontal distance of 25' in all directions from the base of the tower and the center line of the array. Beyond 25' Table 2 can be used as a guide in determining the grade for the ground radials. The broadcast band is divided into ten groups. Under "Grade 1 to 10," the reference starts at 25' from the base of the tower, or the center line. Beyond, the grade becomes 2 to 10 for the remaining length of the ground radial. ▲

TABLE 2.

FREQUENCY RANGE (In KC)	Antenna ground Radial Grades	
	DISTANCE Grade 1:10	Grade 2:10
540-600	25' to 215'	beyond 215'
610-680	25' to 190'	beyond 190'
690-770	25' to 170'	beyond 170'
780-870	25' to 150'	beyond 150'
880-980	25' to 130'	beyond 130'
990-1100	25' to 118'	beyond 118'
1100-1230	25' to 105'	beyond 105'
1240-1360	25' to 95'	beyond 95'
1370-1480	25' to 85'	beyond 85'
1490-1600	25' to 80'	beyond 80'

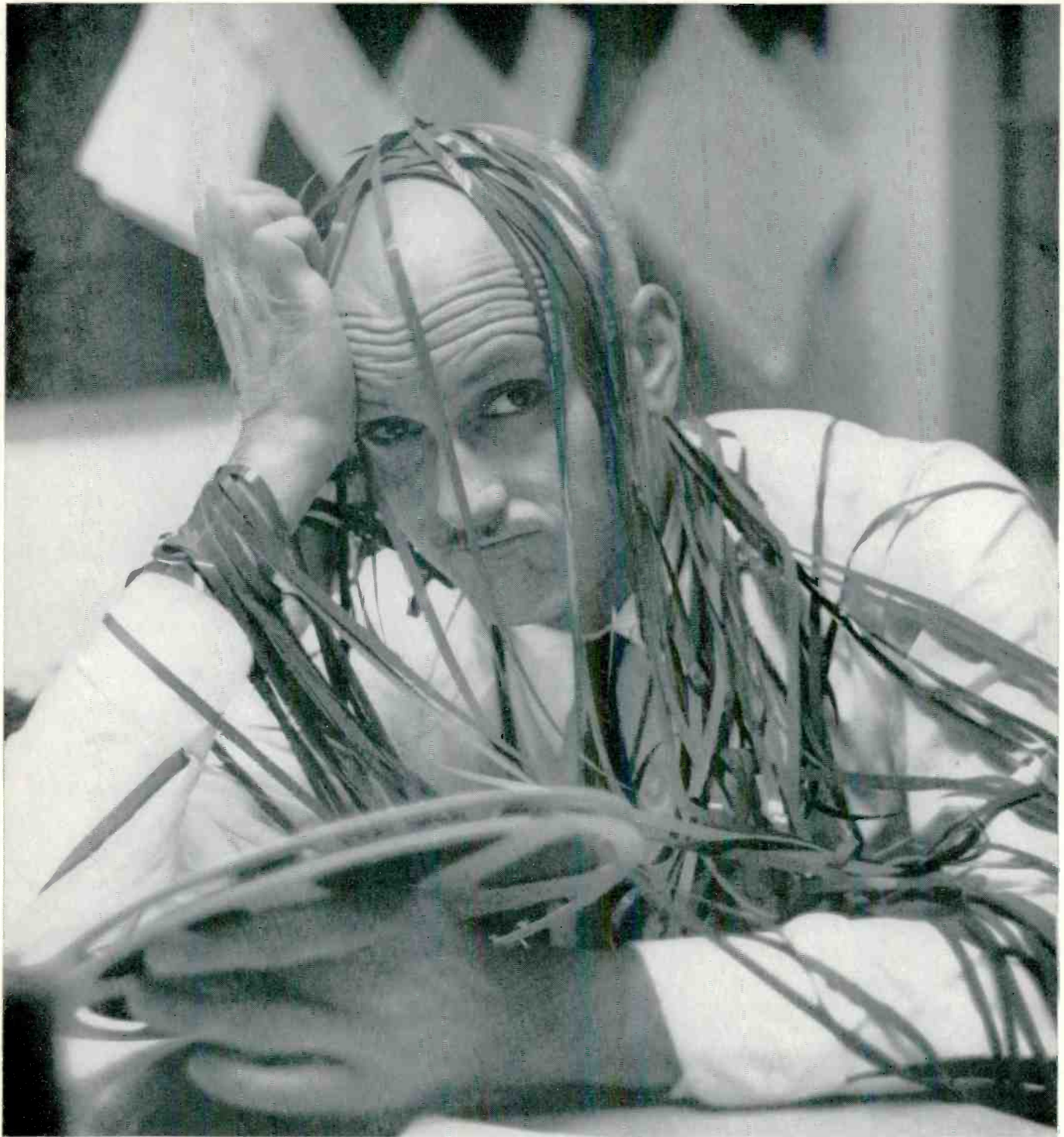

## ALL WRAPPED UP IN YOUR WORK?

Free yourself for just 20 seconds to check the advantages of using RCA Red Seal Magnetic Recording Tape:

- Developed by RCA sound engineers for their own professional use. (They insist on the very best!)
- Manufactured in the country's newest, most modern plant. (Everything's up-to-date in Indianapolis!)
- Supervised from basic oxide formulation to finished tape by skilled engineers. (All sticklers for perfection!)
- Quality control tested for frequency response, distortion, drop-out noise, print through. (Very rigid tests!)
- Mechanically tested for coating thickness, anchorage, layer-to-layer adhesion, aging, cupping, slitting. (It's got to measure up!)
- Precisely controlled to give every inch of tape the same magnetic properties, the same recording-bias characteristic. (So you can use tapes interchangeably!)
- Take another 20 seconds to make your job a whole lot easier—fill in the coupon for specifics on this great new tape!

**RCA VICTOR**   
The most trusted name in sound

Circle Item 12 on Literature Card

Magnetic Tape Products Marketing  
 RCA Victor Record Division  
 155 East 24th St.  
 New York 10, N. Y. BE

Please rush me specifics on RCA Red Seal Magnetic Tape including all essential physical and magnetic characteristics.

NAME .....

TITLE .....

COMPANY .....

ADDRESS .....

CITY ..... ZONE ..... STATE .....

# ENGINEERS' EXCHANGE

## Detuning An Idle Broadcast Tower

by Robert A. Jones, Consulting Engineer, LaGrange, Ill.

Most of us are acquainted with stations that operate nondirectional daytime and directional nighttime, or directional both day and night with two different patterns. In one of the two antenna configurations, one or more towers are not used, and must be detuned to prevent re-radiation and distortion of the pattern.

Usually, the consulting engineer detunes these idle towers at the time of the initial antenna adjustment. However, from time to time, the chief engineer may be called upon to adjust the nondirectional operation, or to make special measurements requested by the FCC.

For base insulated towers the problem is quite simple. If the electrical tower height is  $90^\circ$  ( $1/4$  wavelength) or less, simply open the lead from the tower to the tuning unit. This "floats" the tower. Since quarter-wave ungrounded towers are not resonant, they will not re-radiate any signal. For electrical tower lengths greater than  $90^\circ$ , the floating method does not always work.

In such cases, a series coil must be connected between the open tower lead and ground. By varying the inductance of the coil, a point can be found where the tower is non-resonant at the operating frequency.

The quickest way of determining when a tower is detuned is to observe the remote indication of current from the sampling loops on the antenna. These loops are originally installed at the maximum current points of the tower. When the indication of current is zero, the tower is properly detuned. The remote loop meters will also tell when an unused tower is not idle. Troubles like faulty insulators, shorted spark gaps, and misadjusted inductors will show up as small current readings on the meters.

Thus by either floating or grounding through a series coil, most broadcast towers can be isolated. Relays can be installed to switch these idle towers in or out. The remote sampling-loop meters provide the best indication of correct adjustment.

## Correcting Recorder Echo

by Joseph Kish, Jr., Chief Engineer, WTIG, Massillon, Ohio

A peculiar effect recently developed in our Ampex 601 recorder, which has been used in the control room about five years. The announcers complained about an echo that occurred while spots were being recorded. It was just audible enough to ruin the recording; however, it did not happen every time.

My first thought, after listening to one of the tapes, was print-through. But even when precautions were taken to prevent this, the echo was still there.

We next considered signal feedback through the board. This possibility was eliminated by disconnecting all external wiring and recording directly into the microphone jack of the recorder—the weak echo still was evident.

Digging into the recorder's electronics, we found the only component in a position to cause this effect was the monitor selector switch. Regardless of its setting, echo was present. When we turned the playback level control down to zero, however, the echo disappeared. Apparently an AC signal path had developed across the insulation between the terminals of the switch. Replacing the switch corrected the trouble completely.

With this problem in mind, it might be wise to check the switch earlier in the game. I hope our experience will save other engineers some time, should the same symptoms develop in their equipment.

## Dark Neon Lamps

by R. V. Tiffany, Chief Engineer, WBBX, Portsmouth, N. H.

We were changing neons every month because they became too black for use. Then we tried the new NE-51H's, and after 2 months found no signs of darkening.

The NE-51H is designed for higher currents than the NE-51, and is advantageous in our modulation-meter flasher circuit which dumps a hefty capacitor charge into the lamp.

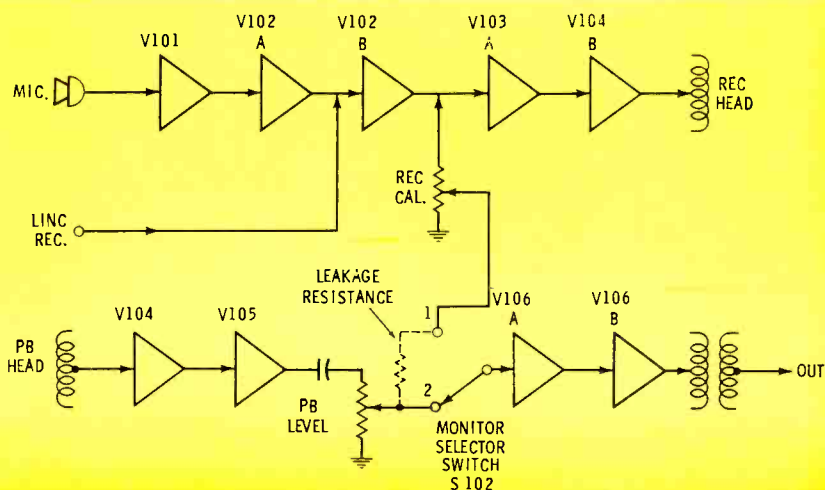
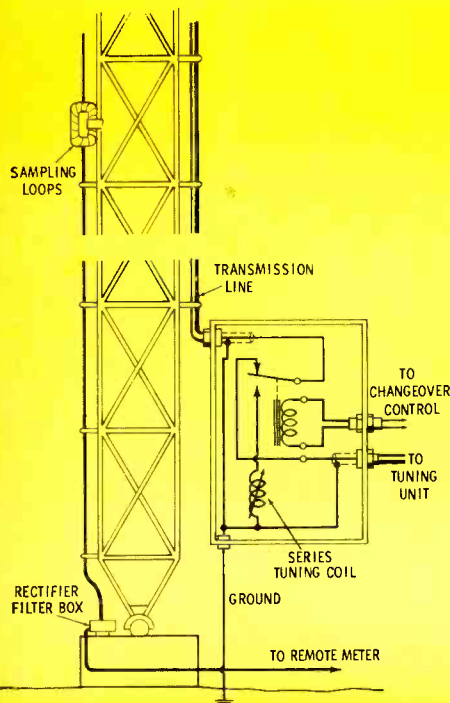

# TARZIAN

## SOLID STATE

### Electronic Products

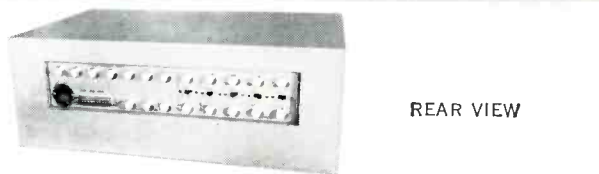

REAR VIEW

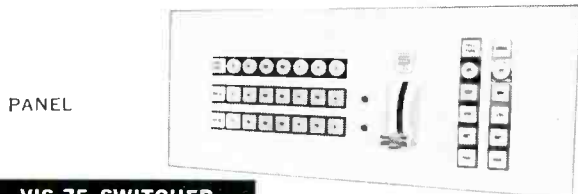

PANEL

**VIS-75 SWITCHER**

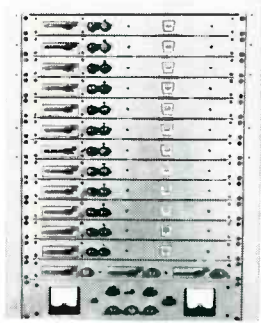

**VIS-88 MODULAR SWITCHER**

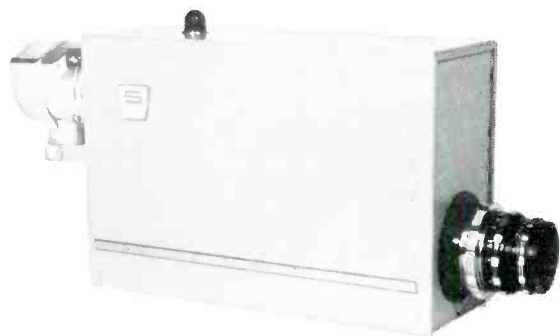

**FILM CAMERA**

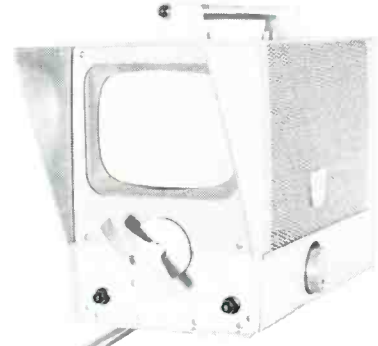

**STUDIO CAMERA**

**VIDEO DISTRIBUTION AMPLIFIER • PULSE DISTRIBUTION AMPLIFIER**

PROCESSING  
FRAME



POWER SUPPLY

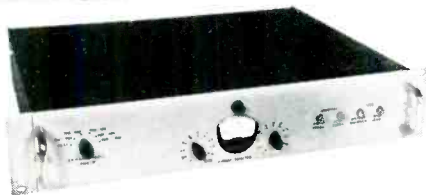

PROCESSING UNIT



Write or call for complete information  
**SARKES TARZIAN INC**  
 Bloomington, Indiana

*Broadcast Equipment Division*

# TECHNICAL TALKS

## Series and Shunt Fed Antennas

There are two methods of antenna feed generally used in the broadcast field—**series** and **shunt**. Each method has supporters, imagined value, and real merits. In this month's column, we shall examine the two methods, and compare their respective advantages and disadvantages. We shall not, however, attempt to draw a general conclusion in favor of either system, because there are situations where one is preferable to the other.

### Series Feed

The majority of broadcast antennas in use today employ the series feed method shown in Fig. 1. The illustration indicates the complications caused by the need to insulate the antenna from ground. The FM transmission line is run down the tower until it reaches a point approximately a quarter wavelength (or in many cases about 0.22 wavelength) from the base. This forms a quarter-wave transformer which effectively isolates the tower from ground.

The AC power for tower lights, or for any other purpose on base-insulated towers, has to be fed in one of two ways—through a carefully wound lighting choke which is decoupled by capacitors, or

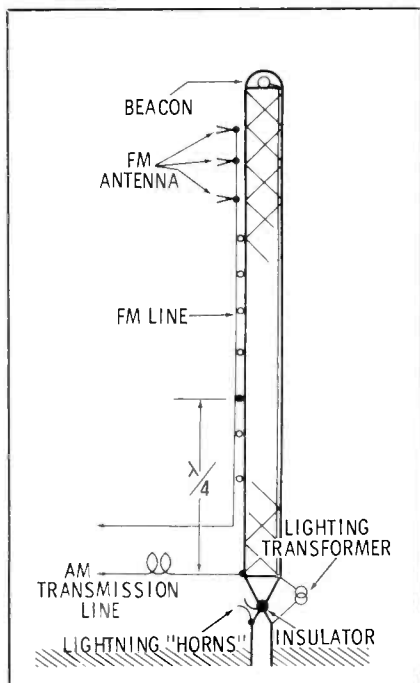

Fig. 1. FM antennas on Series-fed tower.

through an Austin-type lighting transformer. The latter is a little more expensive, but far simpler in operation. It consists of two separately wound coils whose windings are interlinked but do not touch. Thus, the power is transferred by air-core coils, rather than the customary iron-core transformer.

The AM transmission line is looped to form one or two large turns which act as a reactance, thus preventing any lightning surges from reaching the "dog house." Damage to the ammeter and other antenna equipment might otherwise occur in the event the horn gap across the base insulator should fail to arc. The purpose of the horn gap is to provide a path for any lightning strokes to be discharged to ground. The horn structure should be placed in a vertical plane so the center line of the gap will point in an upward direction. Then the air in the gap, which is heated by the arc, will rise up the horns. When the arc is no longer self sustaining due to increased length, it will extinguish. One cannot predict how a lightning stroke might behave. A direct hit could jump the coupler to the transmission line side—it is therefore wise to place the gap at the tower end of the line.

Finally, the base insulator and base support must be considered. This insulator, which is expensive and fairly fragile, has to bear the weight of the tower plus any other hardware fastened thereto. Another problem is tower movement in high winds, which also takes its toll of base insulators. In the case of a self-supported tower, four of these insulators must be used. Cracking of any one insulator necessitates the difficult task of replacing it without cracking the others. Generally, the tower has to be jacked up slightly for removal of the damaged insulator and insertion of the new one.

All these somewhat negative points may make the vertical series-fed antenna appear rather undesirable. Nevertheless, it is very popular—probably because most people know more about it than

the shunt-fed type. The series antenna also lends itself more readily to use in a directional array than does the shunt fed version.

Another very valuable property of the series-fed antenna is the ease with which predictions may be made as to the impedance, or antenna resistance, before construction. This data can be obtained from a typical impedance curve, or calculated. In actual practice, the value thus obtained is modified by the proximity of other objects, the ground system, and the addition of hardware on the tower.

The popular quarter-wave antenna has a resistance of approximately 36.6 ohms, and the half-wave antenna around 73 ohms. As the electrical length of an antenna decreases, the resistance also decreases. The reactance, which is positive between a little less than 0.25 and a little less than 0.45 wavelength, becomes negative above and below these electrical lengths. In the case of nondirectional antennas (single towers), the reactance is generally of little importance unless there is some unique factor which affects it severely.

Because a series-fed tower has to be maintained above ground potential, it is often necessary to raise the base insulator by means of a pedestal 4' high (or higher), if the tower is located in a flood area. On the other hand, a shunt-fed antenna can operate with a relatively

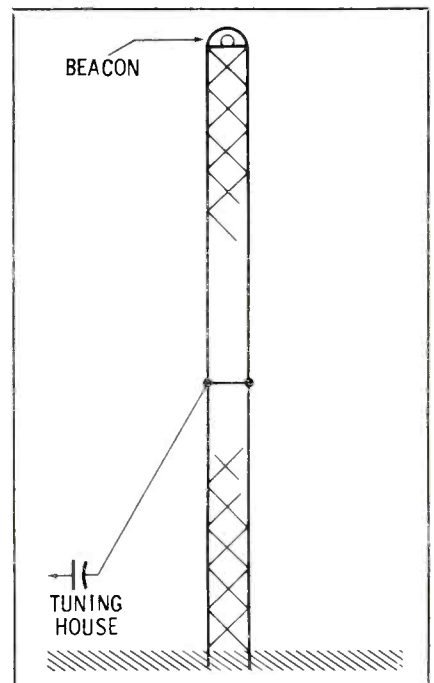
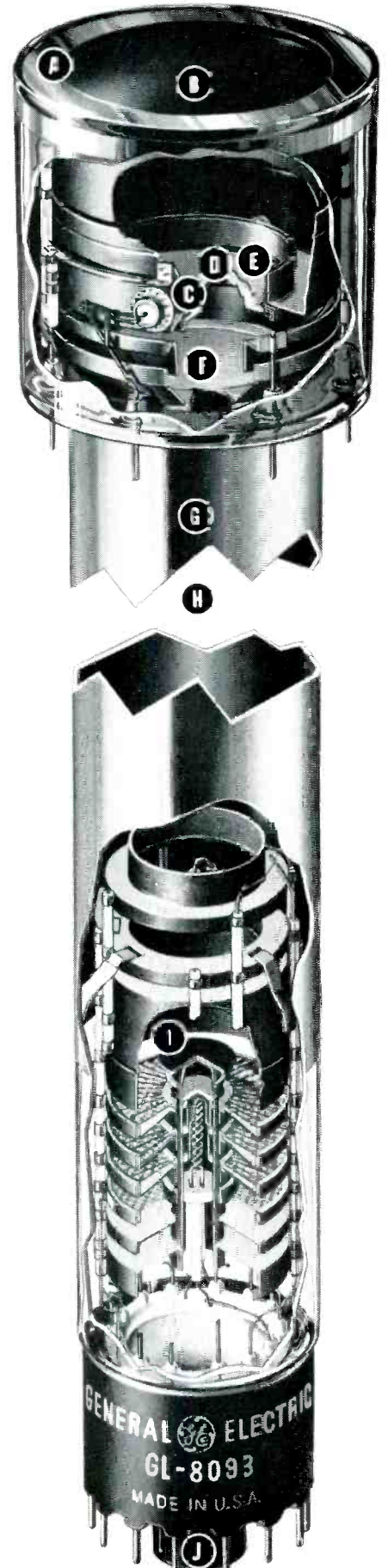

Fig. 2. Shunt-fed tower with direct line.

# 32 value analyzed benefits give G-E Image Orthicons 3 to 5 times longer life, highest sensitivity, and unsurpassed performance in your cameras

G.E.'s family of "station designed" Image Orthicons cover the complete spectrum of commercial and educational television. Individual types incorporate certain *value analyzed* benefits which optimize performance for any given program requirement, whether specialized or broad. These benefits can extend life to as long as 8000 hours . . . provide signal-to-noise ratios up to 50:1 . . . and allow high resolution pickup at 1 ft.-c for black and white, or 40 ft.-c for color.

- A** Distortion-free optical quality glass is used in all G-E Image Orthicon faceplates • Fibre-optics faceplates prevent picture distortion
- B** Photocathodes—Spectral response close to that of the human eye permits portrayal of scenes in nearly their true tonal graduation • Individual processing for each tube guarantees uniformity of characteristics and maximum sensitivity
- C** Semiconductor (MgO) thin-film target gives high sensitivity with only 1 ft.-c for black-and-white pickup . . . only 40 ft.-c needed for color • 0.000002" thick, MgO target gives: greater resolution • extremely long life • no stickiness • improved depth of focus • no target raster burns—GL 8092—GL 7629
- D** Glass target only 0.0001" thick prevents loss of resolution due to lateral charge leakage • Specially selected optical quality glass is free of imperfections—GL 5820A—GL 7293—GL 8093
- E** Electroplated target mesh, with 560,000 openings per square inch, improves picture detail, prevents moire and mesh-pattern effects without defocusing
- F** 750-line field mesh screen—makes the scanning beam approach the target perpendicularly over the entire area • improves corner resolution • diminishes white-edge effect • Shading and dynamic match for color pickup are excellent • Set-up time is reduced
- G** As an added precaution against moisture contamination, dry inert gas is blown through the envelope prior to exhausting and sealing • Longest tube life is assured
- H** To prevent contamination from dirt, dust or moisture: All personnel wear lint-free clothing • operators wear nylon gloves or finger guards • assembly rooms are pressurized, the air super-cleaned, and humidity controlled
- I** Precision manufacture, plus accurate spacing and alignment of all components, assures uniform signal gain in the multiplier section • Dynode material and design, plus a 0.0012" aperture, allow sharper target focus • No compromise between sharpest focus and dynode blemishes appearing in background • Less set-up time required
- J** Performance testing—Every tube tested prior to release to customer • Tests are made in G.E. and other-make cameras to guarantee highest picture quality and complete operational flexibility



For your free facts folder, containing data and application notes on G-E Image Orthicons, write to General Electric Co., Room 1783, Owensboro, Kentucky, or call your nearest G-E Industrial Tube Distributor, today!

*Progress Is Our Most Important Product*

**GENERAL  ELECTRIC**

Circle Item 14 on Literature Card

large portion of its base in flood water.

### Shunt-Fed Antennas

For use in areas where lightning is prevalent, the shunt-fed antenna (Fig. 2) offers better protection than the series type. However, nothing much can be done in case of a severe direct hit. (A word of warning with respect to lightning is in order. By virtue of the sloping feed, more lightning damage can occur through transfer to the wire in case of a direct hit, than with a series feed system.) Also, the shunt-

fed tower can have as many lighting cables and extra antennas as it will support without upsetting the resistance. Consequently, this type of antenna is often selected for an AM station when the addition of TV or FM is planned for a later date, and it is desired to avoid problems of quarter-wave matching. The shunt-fed antenna is about as sensitive as a telephone pole, and certainly makes for easy engineering changes.

Tuning the antenna initially, and measuring the desired resistance, is

more difficult and more critical than with a series-fed antenna. It is generally accomplished by selecting the desired impedance, and then adjusting the feeder wire slope and attachment point until the desired impedance is obtained. A series capacitor is used to balance out the inductive reactance. Taking another look at this antenna configuration, and remembering that since the vertical antenna is commonly considered to have a "ghost" component—a reflection in the earth—it resembles the Delta-match antenna used in HF work.

The shunt-fed antenna does not lend itself very easily to directional antenna work because the presence of the feed wire seriously distorts the radiation fields. Computation is more difficult because most tables are based on series feed. To overcome this effect as much as possible and to facilitate matching, the slope-feed wire is often brought up **inside** the tower, as shown in Fig. 3. It is securely supported from all sides of the tower, and a capacitor is used to balance the inductive reactance.

A further point against the shunt-fed antenna for directional work is the increased vertical radiation produced by the feed wire. There are few, if any, new stations going on the air today that can use a non-directional antenna at night. If any readers are preparing such an op-



## FM MODULATION MONITOR



FCC  
Type #3-116

TBM-4000  
\$1495.00

### FCC TYPE APPROVED Also Monitors SCA MULTIPLEX

- Modulation
- Frequency
- Crosstalk
- Injection

## FM FREQUENCY MONITOR



FCC  
Type #3-113

TBM-3000  
\$495.00

Write Dept. S or phone 402-342-2753 for complete specifications.

originality by

**McMartin Industries, Inc.**  
1612 California Street • Omaha, Nebraska



In Canada, Sold by: Canadian Marconi Company, Montreal 16. P. Q.

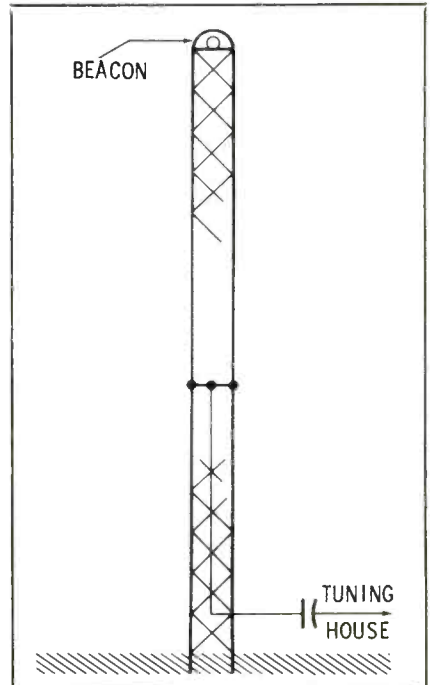

Fig. 3. Grounded antenna with insulated feedline run inside tower to feed point.



# NEW "CYCLOID" FM RING ANTENNA DESIGNED FOR FM STEREO AND MULTIPLEX BROADCASTING

Patent Pending on Unique Binary Tuning Feature

A new FM antenna featuring a major technological advance in ring type radiating elements has been introduced by the Gates Radio Company, Quincy, Ill., subsidiary of Harris-Intertype Corporation. It is available from single to sixteen element arrays and is factory pretuned.

"Cycloid" is the first ring antenna to offer binary adjustment, an exclusive tuning arrangement (patent pending) whereby the inductance of the ring is changed at the same time the antenna is adjusted for capacitive tuning. The advantage is uniform L/C for adjustment over the FM frequency range.

Binary adjustment permits tuning to an extremely low standing wave ratio. Fine tuning is achieved by moving the feed strap up or down the middle semi-circular element. Since this adjustment is incorporated in the antenna, it is not necessary to buy costly extras such as transformers or field tuning kits to achieve the optimum low standing wave ratio.

Where the antenna is mounted on a supporting pole and pretuned at the

factory, a voltage standing wave ratio of 1.2 to 1 or better at the one megacycle bandwidth points should be expected. A side mounted antenna, pretuned at the factory, should also provide an excellent voltage standing wave ratio. The one megacycle bandwidth of the antenna is superb for stereo and multiplexing. (See Fig. 1)

The most important determining factor for a good horizontal pattern is the circularity of the antenna element in free space. The Gates "Cycloid" FM antenna is circular within  $\pm 1$  db in free space to provide the best possible starting point for an optimum horizontal pattern.

Mounting brackets tailored to each installation are furnished for pole, side or inside tower mounting. The antenna's windload design will reflect a direct savings in maintenance costs.

Literature describing the technical characteristics of the "Cycloid" antenna is now available. Write Gates Radio Company, Quincy, Illinois, for Brochure No. 111.

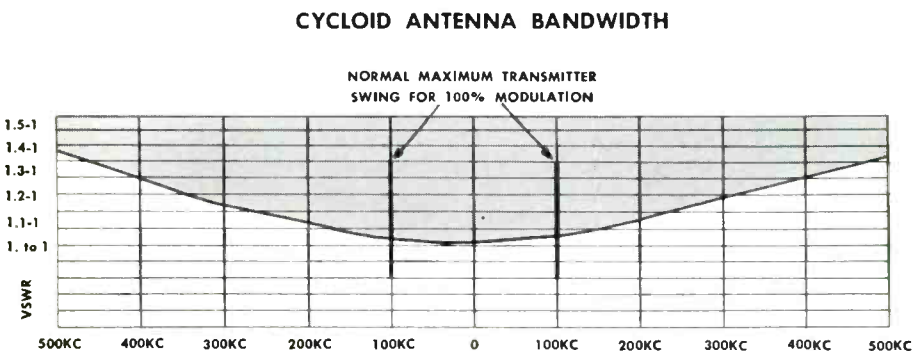
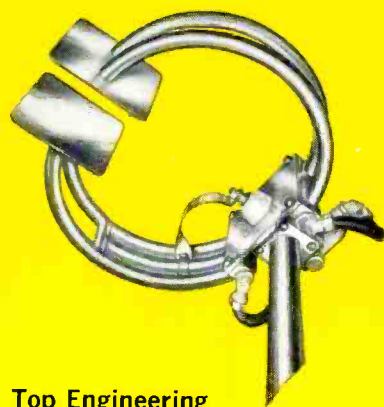

Fig. 1

Circle Item 16 on Literature Card

Entirely New!

## GATES CYCLOID FM RING ANTENNA



Top Engineering Features include:

- Designed specifically for FM Stereo and improved monaural performance
- Shunt Fed—Binary Adjustment (Pat. Pending)
- Lowest Possible VSWR
- Top, Side or Inside Tower Mounting
- Optional Deicing with High or Low Power Heaters
- Feed System Included
- No Extras Required for Tuning
- Minimum Windloading
- High Gain

The Cycloid is the newest and most advanced FM ring antenna on the market today. For complete engineering data, write for Brochure No. 111—yours for the asking.

**GATES**

**GATES RADIO COMPANY**

Subsidiary of Harris-Intertype Corporation

QUINCY, ILLINOIS

Offices in: Houston, New York, Los Angeles, Wash., D. C.

In Canada: Canadian Marconi Company

Export Sales: Rocke International Corp.

13 East 40th St. • New York City

**HARRIS  
INTERTYPE  
CORPORATION**

(ADVERTISEMENT)

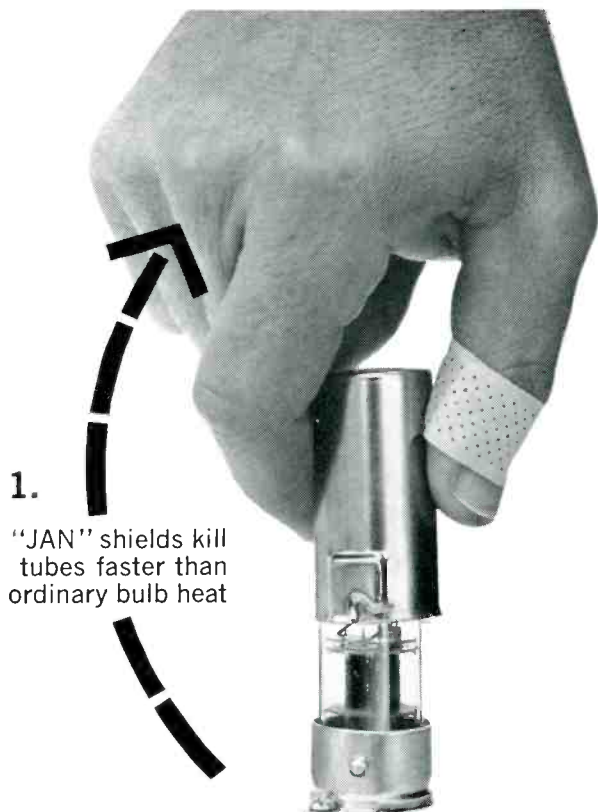

1.  
"JAN" shields kill tubes faster than ordinary bulb heat

## HERE'S THE WAY TO SAVE MAINTENANCE DOLLARS!

Electron tube failures account for 70% of electronic equipment failures. Extending tube life two to twelve times with **IERC heat-dissipating shields** can greatly reduce equipment maintenance and downtime costs.

TR series shields install as quickly as shown into your present equipment, giving failure-free performance proved in new military and industrial equipment using IERC shields.

WRITE FOR LITERATURE to help you order TRs—and reliability, **TODAY!**

**IERC**  **D I V I S I O N**  
*heat-dissipating electron tube shields.*

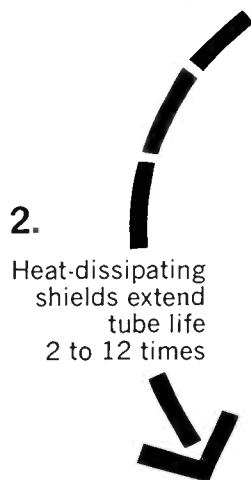

2.  
Heat-dissipating shields extend tube life 2 to 12 times



Patented

**INTERNATIONAL ELECTRONIC RESEARCH CORPORATION**  
135 West Magnolia Boulevard, Burbank, California • Victoria 9-2481  
Foreign Manufacturers: Europelec, Paris, France. Garrard Mfg. & Eng. Co., Ltd., Swindon, England

Circle Item 17 on Literature Card

eration, and consider the use of a shunt antenna, they should examine the effect of the feed on their proposed night radiation and RSS. This change must not be made without express FCC approval.

One interesting feature of the shunt-fed antenna is the high voltage which is often developed at the feed point. Another feature is the higher Q of the system, resulting in higher feed-point voltage and narrower bandwidth. If your station is one that operates with wide bandwidth, the sudden change to a shunt-fed antenna might result in some adverse frequency cutting. This is a point which must be considered in the light of individual requirements and conditions.

### Toroidal Antenna Coupling

Another technique is the **toroidal** coupling system, which has seen little (if any) use in the broadcast field. (This mention may spark some interest in it.)

In effect, the toroidal coupling system consists of a toroidal coil completely surrounding the base of the antenna. This coil forms the primary of a transformer, and the antenna serves as the secondary. By transformer action, a voltage is induced in the antenna; it can be shown mathematically that such a system will work. However, for broadcast frequencies the dimensions will be rather large. Some of the experimenters among our readers might like to try out this system at the higher frequencies.

### Towers

Some mention should be made as to the relative merits of tapered and constant cross section towers. Most engineers prefer to use constant cross section towers (uniform cross section) because all the engineering tables, and most formulae, are based on the use of this type of tower. A self-supporting tower is, of course, not uniform in cross section, but the effect of the taper is not generally too severe. The FCC requires that all tower resistances be measured (in the case of directional antennas reactance as well plays a large part in the system performance); therefore, the actual values are obtained and used in the final computations.

Next month, we'll discuss the relative merits of folded unipoles and anti-fading antennas. ▲

**BROADCAST ENGINEERING**

## BOOK REVIEWS

**NAB ENGINEERING HANDBOOK**, Fifth Edition; A. Prose Walker, Editor-in-Chief, Manager of Engineering, National Association of Broadcasters; 1664 pages, \$27.50. This book is a near complete source of information on methods, procedures, equipment, and data in the broadcasting fields. The profusely illustrated work is divided into nine sections beginning, logically, with one on rules, regulations, and standards. The second deals with antennas and associated devices, with nine parts ranging in coverage from wave propagation to structures, and from transmission lines to field strength measurements. The next five sections cover transmitters and transmission facilities, including relays, color TV, studios, special effects, remote pickup, etc. Section 8 discusses measurement and special applications and the last section contains charts and graphs useful in electrical, electronic, and mechanical calculations. In all, the book is a valuable reference text for solving problems in all phases of radio and television broadcasting.

**RADIO HANDBOOK**, Sixteenth Edition; William I. Orr, Editor; Editors and Engineers, Ltd., Summerland, Calif.; 808 pages, \$9.50. The sixteenth revision of this handbook for radio amateurs and engineers contains 34 chapters encompassing electronics, radio theory, and construction. Three completely new chapters cover computers, RF feedback amplifiers, and high fidelity techniques. The material on transistors and special vacuum-tube circuits has been expanded. Of interest is the information on antennas, including design, construction, and adjustment. The final three chapters discuss workshop practice, electronic test equipment, and radio mathematics. While this edition delves more deeply into principles of operation and design than did the previous one, it still provides more than a dozen chapters on radio equipment construction. Some of the devices for which complete details are given include: rotatable arrays, mobile transmitters, a transistorized 50-mc transmitter, kilowatt amplifiers, modulators, a 1500-volt 425-ma. power supply, and a balanced SWR bridge.



**H8**  
new  
large size  
**HELIAX**

## Flexible Coaxial Cable

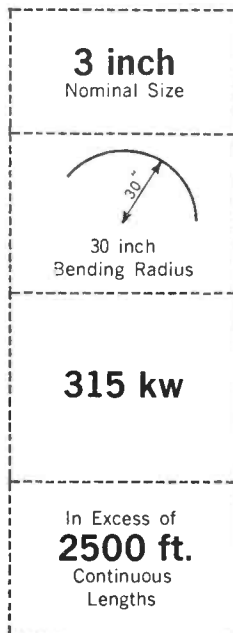

**H8, HELIAX** is available, both jacketed and unjacketed in standard and high average power designs. High power designs use high temperature polyethylene insulation.

**H8, HELIAX** features corrugated copper inner and outer conductor construction. The corrugations impart unusual strength and flexibility, while maintaining excellent electrical characteristics.

**H8, HELIAX** peak power rating is 315 kw. Average power ratings at 100 mc are:

<b>H8-50</b>	Unjacketed, 50 ohm	23 kw
<b>HJ8-50</b>	Jacketed, 50 ohm	26.5 kw
<b>H8-50A</b>	Unjacketed high power, 50 ohm	34.5 kw
<b>HJ8-50A</b>	Jacketed high power, 50 ohm	40 kw

Attenuation is 0.14 db/100 feet at 100 mc

**H8, HELIAX** is available in continuous specific lengths as limited only by receiving and handling facilities.

— WRITE FOR CATALOG H —

Other Andrew Products for Broadcast-Telecast Industry  
 • MULTI-V FM ANTENNAS • COAXIAL SWITCHES  
 • TRANSMISSION LINES • MICROWAVE, VHF/UHF ANTENNAS

*Andrew*

P.O. Box 807, Chicago 42, Illinois

BOSTON  
NEW YORK

LOS ANGELES  
TORONTO  
WASHINGTON, D.C.

Circle Item 18 on Literature Card

# NEWS OF THE INDUSTRY

## Portable Videotape Recorder

A portable television tape recorder weighing only 130 pounds and costing less than \$12,000 will be available from **Ampex Corp.**, Redwood City, Calif., after the middle of this year. The new Model VR-1500 records live action or off-the-air television programs on magnetic tape for later playback through television receivers. It is one-twentieth the size and one-fourth the cost of previous models. Operating on household current at a tape speed of 5 ips (one-third the speed of most previous recorders), the new unit uses standard 2"-wide television tape.

## Royal Society Honors American

**Dr. Alfred N. Goldsmith**, developer of the first commercial radio with only two control knobs and a built-in speaker, was elected a Benjamin Franklin Fellow of the Royal Society of Arts, England. Honorary Vice President of Radio Corporation of America, he has been active in the advancement of broadcast radio and television since he first started in his career as a professor of electrical engineering at the College of the City of New York. Dr. Goldsmith is also a co-founder, fellow, and life member of the Institute of Radio Engineers. The royal society, one of England's oldest institu-

tions, occasionally honors an American in commemoration of the contributions of Benjamin Franklin.

## Sound-Absorbing Material

**Desco International Assn.**, an organization of wall and floor coating dealers, will introduce a new sound-absorbing material line at the 1963 Plant Maintenance and Engineering Show, Jan. 28-31, McCormick Place Exhibition Center in Chicago. "Acousticote," a coating for interior walls or ceilings is spray-applied. It is a blend of resins, fibers, and sound-absorbing particles that form a continuous textured film, trapping sound waves of all normal frequencies. Desco products are available from franchised dealers throughout the U. S. and in Africa, Australia, Korea, New Zealand, the Caribbean area, and Canada.

## Radio for Spacemen Checks Medical Data

The **Bendix Corp.** recently displayed a new two-way data communication system that will enable doctors on earth to check the physical condition of astronauts while talking to them as they explore outer space. Termed a "biomedical belt pack" by its designers, the system fits around the upper portion of the body and transmits telemetered data to a cen-

tral control system aboard the space vehicle—thus freeing the astronaut from binding cables. In addition to transmitting physiological data, the compact equipment can serve as a two-way voice communication system.

## TelePrompTer Purchases Conley

**TelePrompTer Corp.**, in continuance of its 3-year expansion program, recently purchased **Conley Electronics Corp.**, Evanston, Ill. Established in 1960, Conley Electronics manufactures and distributes Fidelipac automatic tape cartridges, a patented tape-in-magazine system that provides continuous play without rewinding. The new subsidiary also manufactures background music equipment.

## Five-Megawatt Antenna System

One of the most powerful television broadcasting antenna systems ever built—capable of 5,000,000 watts ERP—has just been shipped by **RCA Broadcast and Communications Products Division**, to **WSBT**, South Bend, Indiana. **C. H. Colledge**, RCA Division Vice President and General Manager, said construction of the unique system is indicative of a trend among UHF broadcasters toward improved technical facilities. The high-power antenna, with 232 oblong slots fed varying amounts of power to shape the TV signal pattern, will boost the station's rated input power of 110 kw 46 times to produce the 5-megawatt maximum ERP permitted UHF stations by the FCC. The system uses an "elec-

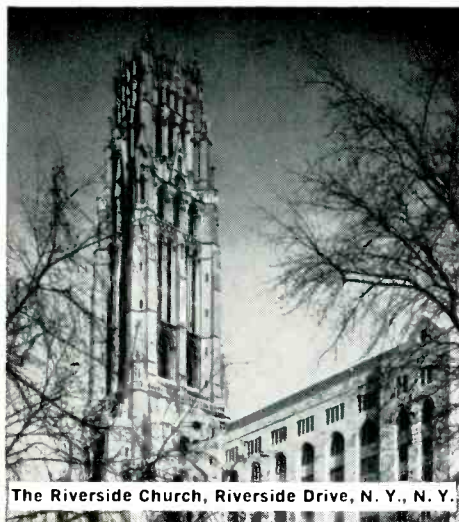

The Riverside Church, Riverside Drive, N. Y., N. Y.



KM-56  
Miniature  
Three Pattern  
Condenser  
Microphone  
in use at  
The Riverside Church  
(and its FM Station,  
WRVR, New York, N. Y.)

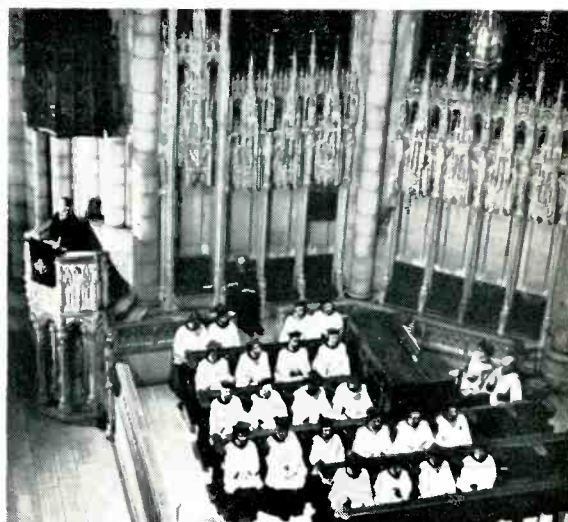

## A POSITION OF RESPONSIBILITY... NEUMANN MICROPHONES

Gotham Audio Corporation presents the complete line of Neumann microphones which have, over the years, achieved the position of leadership in those industries which will not compromise with quality.

Write today for brochure on Neumann microphones.

**GOTHAM AUDIO CORPORATION**  
2 WEST 46 STREET, NEW YORK 36, N. Y. • CO 5-4111



trical beam tilt" to depress the main signal beam so that it strikes the earth at a point near the horizon, keeping maximum energy in the useable areas.

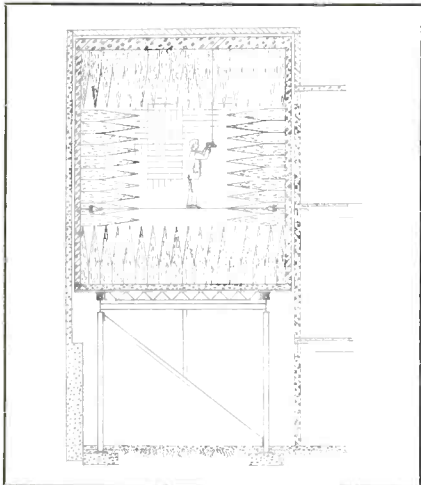

### Anechoic Chamber Uses Springs and Fiberglass Baffles

The Turner Microphone Co., Cedar Rapids, Iowa, has announced the addition of an Anechoic Chamber, a sound-proof room, to its plant facilities. The room, which combines isolation and insulation to shut out plant vibrations and other noises, measures 20 by 20 feet. The room is separated from the metal girders of the building with 24 springs. Sound inside the room is deadened by wedge-shaped fiberglass baffles that line

all four walls, the ceiling, and heavy mesh floor. A massive door, weighing 1,200 pounds, completely seals off the room. Turner will use the chamber for testing microphone sensitivity.

### Radio Stations Sold

Radio Station **KMO**, Tacoma, Washington, has been sold to **Broadcast House, Inc.**, Mr. Edward A. Wheeler, president. KMO operates on 1360 kc with 5,000 watts full time. Broadcast House, Inc., also owns **WEAW AM & FM** in Evanston, Ill.

Radio Station **KEYE**, 250 watts full time in Perryton, Texas, has been sold to **Radio Perryton, Inc.** The buying corporation is headed by Mr. Frank Junell of Lubbock, Texas, who also has interests in other West Texas radio properties.

Radio Station **KERN AM & FM**, Bakersfield, California, has been sold to **Radio KERN, Inc.**, a new California corporation, headed by Mr. Roger H. Stoner. A CBS affiliate, KERN operates 1,000 watts full time on 1410 kc, non-directional. Mr. J. Ward Wilkinson will join Mr. Stoner as an officer and director of KERN.

Radio Station **WERI**, Rhode Island, has been sold to **Westerly Broadcasting Company**. The station operates on 1230 kc at 250 watts.

Radio Station **KRIZ**, Phoenix, Arizona, has been sold to **Shamrock Broadcasters, Inc.**, a new Arizona corporation headed by Mr. Frank Flynn. KRIZ operates full time with 250 watts on 1230 kc.

# MAGNIPHASE



**MAGNIPHASE** — protects antenna system from damage caused by static discharge or transmission line faults.

**MAGNIPHASE** — will instantaneously squelch transmitter output, preventing arc from being sustained by RF energy. Immediately self-restoring, transmitter interruption goes unnoticed on the air.

*Continental Electronics*  
MANUFACTURING COMPANY

4212 SOUTH BUCKNER BLVD. DALLAS 27, TEXAS  
LTV Subsidiary of Ling-Temco-Vought, Inc.

Circle Item 24 on Literature Card

## NEW PORTABLE EQUIPMENT FOR STATIONS ON THE MOVE

SOLVE YOUR  
REMOTE, PRODUCTION  
AND AUXILIARY  
MAIN STUDIO  
PROBLEMS



**A-10  
AUDIO CONSOLE**

The unique Sparta A-50 Portable Studio handles all of these jobs with ease. Simply un-screw the steel tapered legs, clip them inside the bench, latch the bench to the studio top and you're on your way. A rugged solidly built unit designed for many years of continuous duty. Comes complete with TT-12 turntables, viscose damped tone arms, A-10 Audio Console..... **\$845.00**

The A-10 Audio Console provides a total of eight high or low level inputs. Up to date solid state design plus plug-in-modular construction. Can be battery operated..... **\$375.00**



**A-50  
PORTABLE STUDIO**

Call, Write or Wire Today

**SPARTA ELECTRONIC CORPORATION**

6450 FREEPORT BOULEVARD • SACRAMENTO 22, CALIFORNIA • GA 1-2070

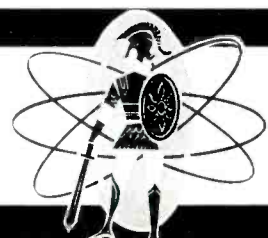

Circle Item 25 on Literature Card

# NEW PRODUCTS

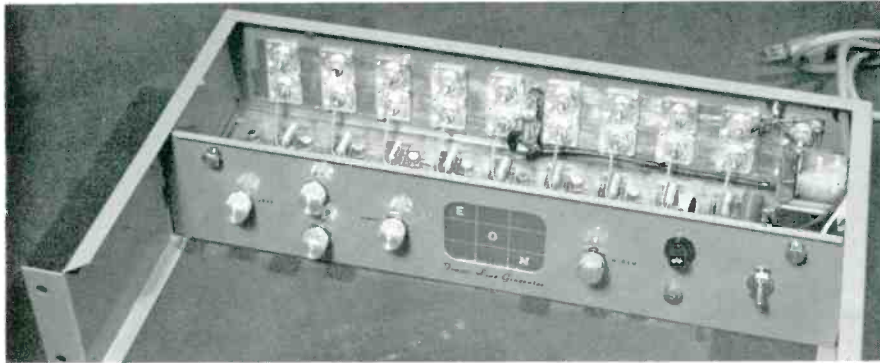

## Frame Line Generator

EON, Seattle, Wash., has begun production of a device for electronically marking the safe-title area on TV station monitor screens. Called the FLG-100 Frame Line Generator, the unit eliminates errors in height, width, linearity, centering, aspect ratio, azimuth, and parallax. These inaccuracies are not transferred to home TV sets, thus preventing undesired cropping of heads and titles. The fully adjustable FLG-100 has nine outputs, is compact, and is priced at \$475.

Circle Item 29 on Literature Card

## Triple-Play Magnetic Tape

Agfa Inc., Rockleigh, N. J., has announced the availability of PE-65, a new ultra-thin "triple-play" magnetic tape for professional and commercial sound re-



recording. The new tape enables 3600' to be contained on a standard 7" reel—three times the playing time of standard tapes. Virtually stretch-proof, new PE-65 has a .47-mil polyester backing, tensilized both crosswise and lengthwise to achieve the tensile strength of mild steel—40,000 psi. As a result, stretching is virtually eliminated and superior contact with the

recording or playback head is obtained. The Agfa coating, consisting of oxide and binder, is precisely applied to PE-65 delivering high quality sound reproduction, flexibility, and resistance to mechanical wear. With its polyester base, PE-65 is practically immune to extremes of temperature and humidity, and has an antistatic bath to render it dust repellent.

Circle Item 30 on Literature Card

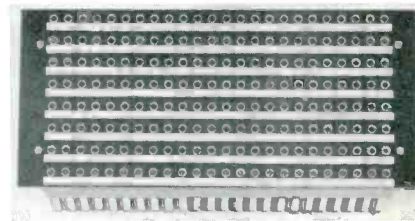

## Eight-Row Jack Panel

Audio Accessories of Amityville, L. I., N. Y., announces their new Audio-Line Model 398-B Jack Panel, claimed to be the first unit of its type featuring eight rows of jacks. Available with 24 jacks per row (total 192), the assembly can also be supplied in any configuration of single or double jacks on centers to meet custom specifications. Standard spacing covers eight different center-line jack mountings as may be required, for mounting up to 26 jacks. Panels 8 $\frac{3}{4}$ " and less in height are standard, while larger units can be supplied at a slight additional tooling charge. Model 398-B is priced at \$56.00 and special units are priced on request.

Circle Item 31 on Literature Card

# SMALLEST

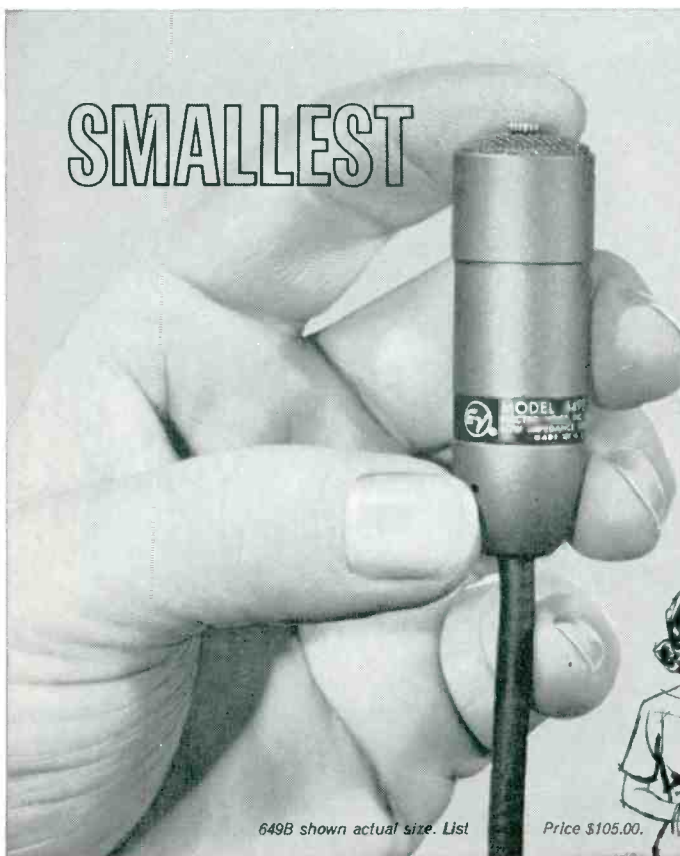

649B shown actual size. List

Price \$105.00.



This tiny handful is E-V's answer to studio requests for a truly miniaturized dynamic microphone. The Model 649B is just 2 $\frac{1}{4}$ " long, weighs but 31 grams, yet has the remarkably high output of -61 db! Although just half the weight and bulk of competitive lavaliers, the 649B response is smooth, peak-free and full-bodied so that you can mix its output with that of any standard microphone!

## DYNAMIC LAVALIER!

No fragile "toy", the E-V 649B uses the famous Acoustalloy<sup>®</sup> diaphragm and a sturdy dynamic mechanism that is guaranteed unconditionally for two years except for finish, guaranteed for life against defects in materials or workmanship. It is omni-directional, with response tailored for the slightly "off-mike" location of a lavalier.

A 649B in your studio will give your performers more freedom than they have ever had . . . while you get the fine sound and trouble-free operation that's traditional with all Electro-Voice microphones. Write for complete technical specifications today!

**ELECTRO-VOICE, INC.**, Commercial Products Division, Dept. 131V, Buchanan, Michigan  
Subscribe today to "Microphone Facts", fact-filled, free series on modern microphone techniques. Request on studio letterhead.

Circle Item 20 on Literature Card

**ElectroVoice**<sup>®</sup>

BROADCAST ENGINEERING

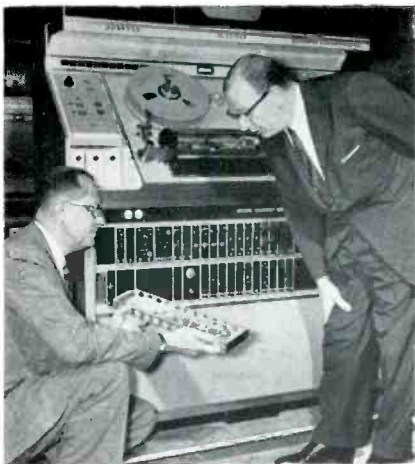

### Transistorized TV Tape Recorder

Availability of a fully-transistorized television tape recorder, has been announced by **RCA Broadcast and Communications Products Div.** The TR-22 recorders that are built for use in Europe, are capable of operation at various TV line standards by switch selection. The recorder employs 750 transistors and 350 diodes in the recording and playback circuits. The self-correcting circuits are contained in a bank of 44 plug-in modules accessible from the front. Shown in the photo, examining one of the modules, is Frank Marx (holding the unit), president of ABC Engineers, and C. H. Colledge, general manager of the RCA Broadcast and Communications Products Div. The use of solid-state components made possible a reduction of approximately 50% in weight, floor space, and power consumption over standard multi-track machines. In the \$60,000 price range, the TR-22 is capable of recording program material in color with the addition of a color-equipment module within the console.

Circle Item 32 on Literature Card

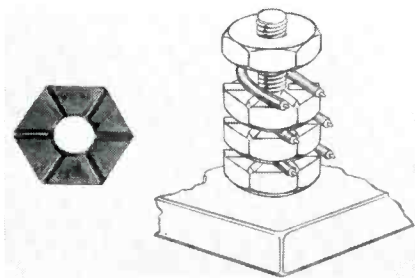

### Insulation-Cutting Nuts

A new insulation cutting nut developed by **Suttle Equipment Corp.**, Chicago, Ill. eliminates wire stripping and reduces wiring time for terminal blocks or studs by as much as 50%. The nut is formed with insulation cutting notches on its upper surface and has a flat washer underneath as an integral part. Individual wires are wound around terminal studs and electrical connection is made when the nuts are tightened. Designed for use on connecting blocks, wiring terminals, and studs widely employed in electronic and electrical applications, the nuts are now available in No. 8-32 and No. 10-32 thread and can be made in any size.

Circle Item 33 on Literature Card

January, 1963

# Meet the Work Horse of all Tape Cartridge Systems

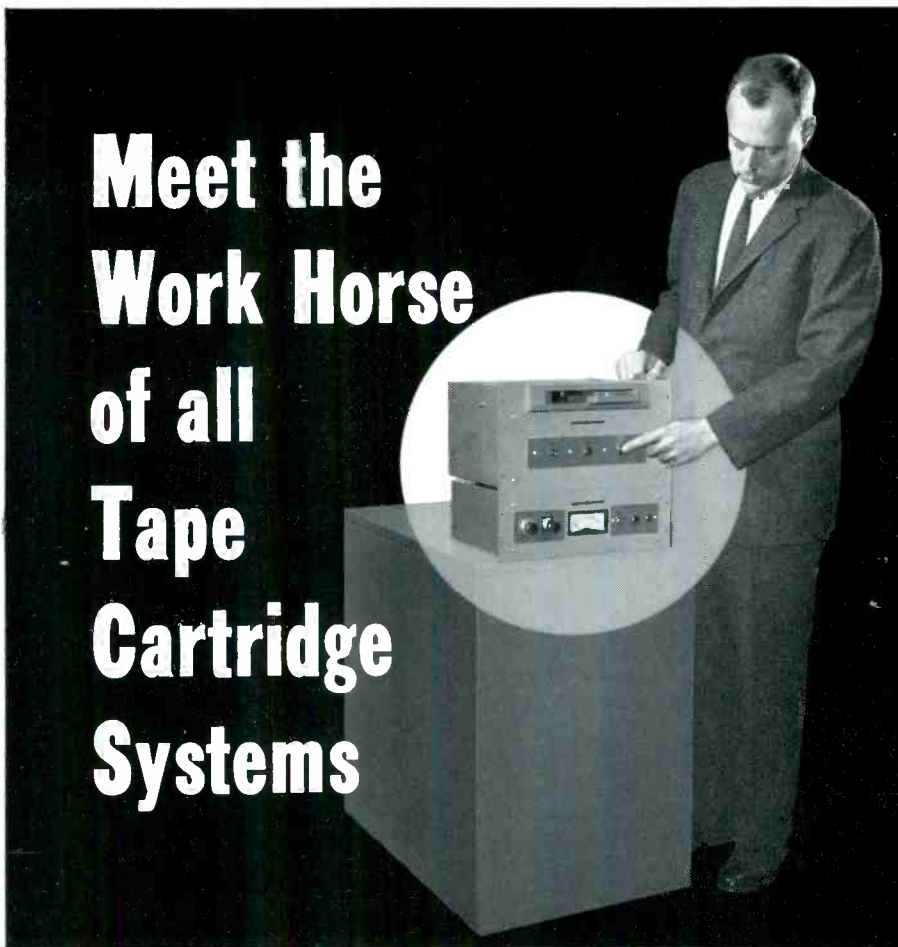

## More than 6000 ATC Standard Units now in use in over 800 stations

Current industry figures indicate that almost 50% of the nation's broadcast stations are equipped with some type of tape cartridge equipment. Better than 55% of that equipment was supplied by Automatic Tape Control, Inc. In fact, more stations use ATC equipment than all other makes combined. ATC standard dual-tone recording amplifiers and playback units are still the broadcaster's best tape cartridge buy. The high fidelity of reproduction is firmly established. And the years of actual performance in stations all over the nation and Canada have proven beyond a doubt that ATC units are rugged and dependable. Frequency response is  $\pm 2$  db from 70 to 12,000 cps;  $\pm 4$  db from 50 to 15,000 cps; signal-to-noise ratio is 55 db; wow and flutter are under 0.2% RMS. For complete details write, wire or phone us collect.

*Made by broadcasters for broadcasters*

**AUTOMATIC  TAPE CONTROL**

209 E. Washington St. • Dept. 131 • Bloomington, Illinois

Overseas sales (except Canada) CBS International, 46 E. 52nd St., New York 22, N. Y. Marketed in Canada by Canadian General Electric, Toronto 4, Ont.

Circle Item 22 on Literature Card

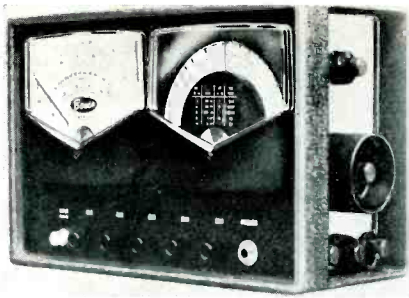

### Transistorized Field Strength Meter

A transistor field strength meter is the first unit in a new electronic test instrument line from **Blonder-Tongue Labs**, Newark, N. J. Manufactured by the firm's Canadian subsidiary, **Benco**, the FSP-3 uses eight mercury batteries, providing 180 hours of continuous operation. Designed to measure signal power as well as voltage, its varied applications also include measuring both field intensities and the attenuation of different traps and filters, checking amplifier gain, and measuring spurious signals in the output of transmitters and those arising from the interference of ham operators. In addition, the meter is designed to balance MATV and CATV systems, enabling the highest or lowest frequency output to be set to proper levels at the amplifier. This portable instrument weighs 10 pounds and is tested for lab use as well as field work. Net price is \$405.00.

Circle Item 34 on Literature Card



### Stereo Cartridge and Arm

The **Neumann Professional Dynamic Stereo Cartridge DST-62**, distributed throughout the U.S. and Canada by **Gotham Audio Corp.**, N. Y., N. Y., is now available with the matched **STA-12** tone arm. The cartridge incorporates an improved metal underside in place of the rubber used in the previous model, is sealed against dust and dirt, and is permanently aligned for maximum separation. The unit operates with all quality preamp inputs and may also be used with the **SME, ESL 310/N**, and **EMT** turntable arms. The **STA-12** arm minimizes extraneous resonances through an improved, special rubber damping which separates the arm from the counterweight. The balanced arm maintains a precise, consistent pressure against the groove wall of the record, even when the turntable is not level, and an integral calibrated gauge permits adjustment of the tracking force from 0 to 7 grams.

Circle Item 35 on Literature Card

# ENGINEERS' TECH DATA SECTION

USE THE FREE LITERATURE CARD TO OBTAIN ANY OF THE FOLLOWING MATERIAL, OR FOR FURTHER INFORMATION ON ITEMS DESCRIBED IN ADVERTISEMENTS OR NEW PRODUCTS

## AUDIO & RECORDING EQUIPMENT

36. **AMERICAN GELOSO** — Literature on microphones and recorders including portable transistorized, dictating, and hi-fi units, as well as dynamic microphones.
37. **AMPEX CORP.** — Catalogs describing line of audio and television tape recorders, duplicators, transports, and other audio and video products.
38. **ATLAS SOUND** — Catalog listing specifications on microphones and speakers for public address, commercial, and industrial use.
39. **BENJAMIN ELECTRONIC SOUND** — Brochure on manual/automatic turntable and accessories.
40. **BROADCAST ELECTRONICS** — Data sheets giving installation, lease, and purchase information on complete line of tape cartridge devices.
41. **CROWN INTERNATIONAL** — Descriptive data sheets giving full specifications for line of Crown professional magnetic tape recorders.
42. **ELECTRONIC APPLICATIONS** — Data sheets describing **AKG C-60** condenser microphone, **D-24** cardioid dynamic, **K-58** headset, **D-19** dynamic, **EMT 140** reverberation unit, and **Nagra** portable transistorized tape recorder.
43. **ELECTRO-VOICE** — Catalog 138 covering line of broadcast microphones and accessories; includes illustrations and specifications.
44. **3M CO.** — "Playback," a quarterly bulletin devoted to video tape techniques.
45. **RCA** — Brochure describing physical and magnetic properties of **Red Seal** magnetic tapes.
46. **H. H. SCOTT** — "A Guide to Custom Stereo," an explanation of stereo, with a catalog of audio kits and wired units.
47. **SCULLY RECORDING INSTRUMENTS** — Brochure on **Model 270** long play tape reproducer.
48. **SHURE BROS.** — Data on **Stereo Broadcast Equalizer**, tone arms, and cartridges, for **FM** stereo broadcasting.
49. **SUPERSCOPE INC.** — Brochure on line of magnetic tape recorders and condenser microphones; professional and miniature units are included.
50. **TALL CO.** — Catalog sheet on **Editall** block and instruction sheet on splicing tape.
51. **TURNER** — Five spec sheets covering microphones for broadcast applications.
52. **VISUAL ELECTRONICS** — Brochure containing complete technical specifications on the **Comrex Wireless Microphone System** designed for broadcast applications.

## COMPONENTS & MATERIALS

53. **AEROVOX** — Data sheet giving complete engineering and performance specifications on **Type AFT** premium grade electrolytic capacitors.
54. **AMPEREX** — 34-page electron tube catalog of power tubes, thyratrons, subminiature, microwave triodes, and several other types.
55. **CALVERT ELECTRONICS** — Data covering **CR192** VHF transmitting tetrode equivalent to the 6166.
56. **CHICAGO MINIATURE LAMP** — Information on complete line of **Bi-Pin** subminiature lamps.

57. **JAMES CUNNINGHAM & SON** — Bulletin on wideband compensated crossbars.
58. **FOURJAY IND** — Illustrated technical bulletin on styrene and fiberglass speaker baffles and accessories.
59. **GC ELECTRONICS** — 30-page catalog supplement for **Electrocraft** line of audio hardware including plugs, jacks, connectors, adaptors, switches, cable ties, and clamps.
60. **GENERAL ELECTRIC** — Technical booklets giving date, space, ratings, and other information on broadcast, industrial, and special purpose tubes; image orthicons; high reliability tubes.
61. **GREENLEE TOOL** — Catalog sheet listing chassis punches and accessories including ratchet and hydraulic drivers.
62. **INTERNATIONAL ELECTRONICS** — Descriptive literature covering the new **Mullard Master** series tubes.
63. **JENNINGS RADIO** — Vacuum components catalog on line of capacitors, coaxial relays, and power switches.
64. **SEMI-ELEMENTS** — Four catalogs describing laser materials and systems, and other semiconductor crystals.
65. **UNITED TRANSFORMER** — Catalogs and cross references covering entire line of transformers.
66. **WALDOM ELECTRONICS** — 32-page catalog of electronic components including knobs, dials, terminal strips, hardware, solderless terminals, and connectors.
67. **WALLACH & ASSOCIATES** — 6-page brochure on metal cabinets for storage of records, tapes, movie films, filmstrips, and microfilm.

## RADIO & CONTROL ROOM EQUIPMENT

68. **AUDIO ACCESSORIES** — Brochure on line of phenolic jack panels.
69. **AUTOMATIC TAPE CONTROL** — "Planning for Automated Radio Programming," an analysis for management explaining the automatic programming concept for radio, and how equipment can be adapted in tailor-made system for individual station.
70. **CLARK-ROOT** — Catalog describing **FM** and **AM** radio automatic programming equipment.
71. **FAIRCHILD** — Technical bulletin on **Conax** high-speed high-frequency pre-emphasis filter.
72. **ITA ELECTRONICS CORP.** — Information on audio consoles, **AM** and **FM** monitors, and the **Documentor**; data sheets list specifications of **AM**, **FM**, and **TV** transmitters.
73. **McMARTIN** — New catalog showing line of broadcast equipment, including receivers, monitors, amplifiers, etc.

## STUDIO AND CAMERA EQUIPMENT

74. **HOUSTON FEARLESS** — Brochure describing company's line of studio equipment; specs are given for tripods, dollies, mounting heads, and pedestal.
75. **KLIEGEL BROS.** — Catalog illustrates latest in studio lighting devices, **TV** lighting packages, and cross-connecting systems.
76. **TELEVISION ZOOMAR CO.** — Information and catalog cards giving data on 2 1/4" to 16", and 2 1/4" to 72" **Zoomar** lens.



## TELEVISION EQUIPMENT

77. BLONDER TONGUE—Complete explanation of CCTV equipment and how it is used today, 16 pages with illustrations.
78. CHRONO LOG CORP.—Ten page brochure describing the STEP system for low-cost TV station break automation.
79. COMMUNITY ENGINEERING—Data sheets on solid-state video line driving amplifiers.
80. CONRAC—Spec sheet on television monitor and scope housing for RCA 13-inch console.
81. EMI INC.—Catalog information on vidicon and orthicon camera chains, monitors, sync generators, solid state switchers, and distribution amplifiers.
82. GIANNINI CONTROLS—Flyer describing video monitor with scope housing for standard RCA console.
83. HARWALD CO.—Catalog for line of film handling and A-V devices including editors, inspection units, cabinets, and other items.
84. INTERNATIONAL NUCLEAR—Video/pulse distribution amplifier spec sheet with performance data for completely transistorized unit designed to replace vacuum-tube amplifiers.
85. MARSON IND.—Data sheets for closed-circuit camera, monitors, switch box, tripod, lenses, and other accessories for closed circuit TV.
86. STEREOTRONICS—Data sheets explaining system which converts any industrial TV to 3D in minutes.
87. TROMPETER ELECTRONICS—Catalog covering RF and video coaxial patching systems available for 75-ohm cable installations.
88. VICTOR ANIMATOGRAPH CORP.—Complete catalog of audio-visual products including 16-mm sound projectors, repeater projectors, filmstrip and slide-film projectors, and editing equipment.

## TEST EQUIPMENT & INSTRUMENTS

89. AMPLIFIER CORP OF AMERICA—Booklet entitled "Flutter: Its Nature, Cause, and Avoidance." Spec sheets on sensitive flutter meter, AVC amplifier, and solid-state plug-in modules.
90. EICO—32-page catalog of kits and wired equipment for professional testing, and for stereo and mono hi-fi, citizens band, amateur radio gear, and transistor radios.
91. HEUER TIMER CORP.—A stopwatch selection guide, describing Central Register precision timing instruments for broadcast and recording engineers and others in design, testing, and control.
92. KARG LABORATORIES—Catalog sheet describing device for testing and aligning stereo receivers.
93. RIKER INDUSTRIES—Two technical brochures describing sync generators and video test equipment.
94. STANDARD ELECTRICAL PRODUCTS—Catalog sheets and bulletins covering Adjust-A-Volt automatic voltage regulators.
95. VITRO ELECTRONICS—8-page catalog containing photos, specifications, and prices on complete line of phase meters, rebroadcast receivers, and accessories.

## TRANSMITTER & ANTENNA DEVICES

96. ADLER ELECTRONICS—8-page brochure with details on UHF translator systems for extending the range of VHF or UHF originating stations and for filling in coverage holes; also "UHF Translators for Expanding Television Coverage," a paper which was presented at the 1962 EIA fall meeting.
97. BAUER ELECTRONICS—Data bulletins containing specifications for three transmitters.
98. CONTINENTAL ELECTRONICS—Booklet describing device for protecting transmission lines and antennas from damage due to line faults, arcs, and overloads.
99. GATES—Technical bulletins for 1000/250 watt AM transmitter; FM ring antenna; single channel transistorized ten-channel, and dual-channel, audio console.
100. GENERAL ELECTRONIC LABS—Catalog listing broadcast and remote control equipment, and catalog sheets covering automatic logging devices, stereo transmitter equipment, FM receivers, SCA multiplex, and FM transmitter.
101. JERROLD—Brochure on microwave equipment for STL or retransmission.
102. MICROWAVE ASSOCIATES—An illustrated catalog gives details on semiconductor microwave control devices; technical bulletins covering individual solid-state components such as waveguide limiters, coaxial phase shifters, 10-kw waveguide switches, 10-kw coaxial switches, and coaxial limiters.
103. MOSELEY—Data sheets with details for 10 and 25 channel Wire Remote Control System, Model WRC-10/25, which incorporates a single control pair.
104. NEW-TRONICS—Data sheet listing several mobile antennas designed for 10 through 75 meters.

(Continued on page 42)

# LEADING BROADCASTERS ENDORSE

**Bauer Kit**

## 1 Kw TRANSMITTER

- ★ "It is, without a doubt, the nicest looking transmitter on the market, and it has a most desirable arrangement of parts." —CONSULTANT
- ★ "Again I want to say that I think that our selection of the Bauer transmitter was a wise decision and already other people in the broadcasting industry in this area have shown an interest in the transmitter and we are glad and proud to show it to them."—KTOC, JONESBORO, La.
- ★ "It was a real pleasure for me to test out the Type 707 transmitter in Tacoma, and your organization is to be congratulated on the excellent design of this unit."—CONSULTANT
- ★ "56 spare time hours to build —45 minutes to check out—it's terrific!"—KXXRX — San Jose, California
- ★ "The transmitter checked right out. We were all pleasantly surprised with the performance." —WDIG — DOTHAN, ALA.
- ★ AND MANY MORE.

*They are all talking about the Bauer Model 707 1000/250 watt AM transmitter available either factory assembled or in KIT form.*

**WRITE FOR THE COMPLETE ENGINEERING STORY TODAY!**



**Bauer**

**ELECTRONICS CORPORATION**

1663 Industrial Rd. • San Carlos, Calif.

PROFESSIONAL PRODUCTS IN KIT FORM

Circle Item 20 on Literature Card

## QRK PROFESSIONAL TURNTABLES

offer you more...

- QUALITY
- CONTINUOUS PERFORMANCE
- SIMPLICITY

Quality all the way with QRK. Full speed range—33, 45, 78. Built rugged with jewel precision. Plays 45's without adapters. Rocket acceleration — EZ queuing. Single idler maintains constant speed regardless of normal wear.



Priced from \$110. to \$235.

Send for detailed folder!

Western Distributor

**RUSSCO Electronics Mfg.** 1406 Clovis Ave. — Clovis, Calif.

Phone CY 9-4692

Circle Item 23 on Literature Card

## Professional Services

**VIR N. JAMES**  
CONSULTING RADIO ENGINEERS  
Applications and Field Engineering  
232 S. Jasmine St.  
Phone: (Area Code 303) 333-5562  
**DENVER 22, COLORADO**  
Member AFCCE

- SYNCHRONOUS MAGNETIC FILM RECORDER/REPRODUCER
- MAGNETIC TAPE RECORDERS
- NEW—THE portable MINITAPE synchronous 13 lb., battery operated magnetic tape recorder for field recording.

**THE STANCIL-HOFFMAN CORP.**  
845 N. Highland, Hollywood 38, Calif.  
Dept. B HO 4-7461

**JOHN H. BATTISON & ASSOCIATES**  
CONSULTING RADIO ENGINEERS  
Specializing in AM-FM-TV Applications and measurements.  
934-5 Munsey Building  
1329 E. St., N.W. Washington 4, D. C.  
DI 7-2330  
Established 1954

## Classified

Advertising rates in the Classified Section are ten cents per word. Minimum charge is \$2.00. Blind box number is 50 cents extra. Check or money order must be enclosed with ad.

The classified columns are not open to the advertising of any broadcast equipment or supplies regularly produced by manufacturers unless the equipment is used and no longer owned by the manufacturer. Display advertising must be purchased in such cases.

## EQUIPMENT FOR SALE

Transmission line, styroflex, heliax, rigid with hardware and fittings. New at surplus prices. Write for stock list. Sierra Western Electric Cable Co., 1401 Middle Harbor Road, Oakland 20, California.  
6-61 tf

Collins Tape cartridge machines \$275 ea. Gates Sta-Level \$150. Concertone Stereo Recorder \$375. Excellent condition. Write—Box 125, Lafayette Hill, Pa. 11-62 2t

Will buy or trade used tape and disc recording equipment—Ampex, Concertone, Magnecord, Presto, etc. Audio equipment for sale. Boynton Studio, 295 Main St., Tuckahoe, N. Y. 10-62 6t

**POSITION WANTED:** Will receive my BS degree in Speech, with Area Concentration in Radio and Minor in Psychology, Jan. 63. Have 3 years experience announcing and producing news, classical and popular music, sports, and commercials. Can run my own board. Seek permanent position on Broadcasting Staff—will relocate for right opening.  
**BROADCAST ENGINEERING** Box 1162-1

Commercial Crystals and new or replacement crystals for RCA Gates, W. E., Bliley and J-K holders; regrounding, repair, etc. BC-604 crystals. Also A. M. monitor service. Nationwide unsolicited testimonials praise our products and fast service. Eidson Electronic Company, Box 31, Temple, Texas. 9-61 tf

If you have need of used Kine Recording Equipment, contact Bradley Kemp. He can supply cameras, photo monitors, etc. Bradley Kemp, Inc., 5746 Sunset Blvd., Hollywood, Calif. Phone: HO 6-5254.  
1-63 1t

**GOVERNMENT SURPLUS, NEW 10 CM. WEATHER RADAR SYSTEM**—Raytheon, 275 KW peak output S band. Rotating yoke P.P.I. Weather Band 4, 20 and 80 mi. range. Price \$975 complete. Has picked up clouds at 50 mi. Wt. 488 lbs. Radio Research Inst. Co., 550 5th Ave., New York, New York. 1-63 6t

Ampex Head Assemblies for 300 and 400 series recorders reconditioned. Service includes lapping and polishing all three head stacks, cleaning entire assembly, readjusting and replacement of guides, and realignment of stacks as to azimuth and zenith. Full trace assemblies—\$60.00. Taber Manufacturing & Engineering Co., 2619 Lincoln Ave., Alameda, California.  
1-63 2t

## MISCELLANEOUS

**ENGINEERING And Art Degrees** earned through home study. Electronics, Mechanical, Liberal Arts. When writing specify course desired. Pacific International College of Arts & Sciences, primarily a correspondence school. Resident classes also available. 5719-W Santa Monica Blvd., Hollywood 38, California. 8-62 6t

## TECH DATA

(Continued from page 41)

105. RAYTHEON—Brochures on a one-watt dual-link microwave STL equipment covering the 6875-7125 mc range.
106. TELETRONIX ENG'G—Specifications for FM transmitters, 10 through 3000 watts, audio relays, leveling amplifier, automatic logger, and remote control device.
107. TRINITY EQUIPMENT CORP—Information on a line of miniature compressor-dehydrators designed for small-capacity dry air systems.

## MISCELLANEOUS

108. CLEVELAND INSTITUTE OF ELECTRONICS—Pocket electronics data guide of conversion factors, formulas, tables, and color codes; also career folder covering electronics training programs.
109. CLEVITE—12 page booklet entitled "Modern Piezoelectric Ceramics" includes charts, tables, and a listing of available literature on the subjects of piezoelectricity and piezoelectric ceramics.
110. PACIFIC INTERNATIONAL COLLEGE OF ARTS AND SCIENCES—Announcement sheets describing home study courses leading to degrees in electronics or mechanical engineering.
111. RCA ELECTRON TUBE DIV — Tube Tips, a quarterly newsletter to the broadcast industry, containing articles on broadcasting equipment—both radio and TV—tubes, test equipment, technical publications, and other subjects of interest to broadcasters.

## Advertisers' Index

Ampex Corp.	7
Andrew Corp.	35
Automatic Tape Control	39
Bauer Electronics Corp.	41
CBS Laboratories	23
CO.EL. Company	8-9
Collins Radio	5
Continental Electronics Mfg. Co.	37
Denson Electronics	42
Electronic Missiles & Communications	3
Electro-Voice, Inc.	38
Fairchild Recording Equipment Corp.	6
Fourjay Industries	24
Gates Radio	33
General Electric	31
Gotham Audio Corp.	36
IERC Div., International Elect. Research Corp.	41
ITA Electronics	Cover 2
Jampro Antenna Co.	26
McMartin Industries, Inc.	32
Magnecord	4
RCA Victor	27
RCA Tubes	Cover 4
Russco Electronics Mfg.	41
Sarkes-Tarzian, Inc. Semiconductor Div.	29
Sparta Electronics Corp.	37
The Turner Company	25

## FANTASTIC VALUE IN CLOSED CIRCUIT TELEVISION

BRAND NEW — COMPLETE SYSTEM SHOWN

**Low - Low \$495** Sold at a fraction of Mfg. suggested retail price.

Complete system with all tubes — wired and tested. Less Vidicon and Lens — with Schematics (connecting cables and plugs only — supplied, but not assembled).

**CONTROL MONITOR**  
12 Tubes & 21DAP4

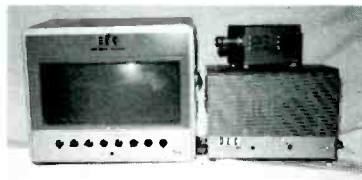

**CAMERA**  
4 Tubes & VIDICON

**ONLY \$649.50**  
Complete system with test vidicon, 1 inch normal lens, and assembled cables, schematics, wired and tested.

**Electrically Regulated POWER SUPPLY**  
115V-AC-60 Cycle  
11 Tubes & Transistor—31.5 Kc Crystal Controlled Oscillator

EIA Standards of 525 lines, 60 Fields, 30 Frames and 2:1 interlace — Aspect Ratio 7:3—Capable of 700 lines Horizontal resolution and 350 Lines Vertical

Write for Catalog No. 1273-BE—"HOW TO BUILD LOW COST TV CAMERAS," Industrial and Broadcast Cameras and equipment, Miscellaneous accessories, lenses, tripods, etc., **Only 50¢**

**DENSON ELECTRONICS CORP., Box 85, Rockville, Conn. Phone TRemont 5-5198**

Circle Item 26 on Literature Card

## The Ideal I.O. Tube For YOUR Needs

Fine quality, longer-lasting EEV Image Orthicon tubes have proven themselves throughout the world. Here's what just a few U. S. users have to say . . .

"Increased tube life"

... **ABC-TV**

Our replacement program with EEV tubes in our five o-and-o stations has indicated low noise, greater freedom from secondary re-distribution and increased tube life.

Merle C. Worster, Director  
Engineering Operations-TV

"Higher and more uniform  
qualities"

... **WTVD**

We have been impressed with the consistently higher and more uniform qualities of the EEV tubes over previous types we used.

Roy Fullen, Chief Engineer

"Unequaled as a picture source"

... **VIDEOTAPE  
CENTER**

Improved resolution, higher signal to noise ratio and a more faithful and extended grey scale reproduction have contributed to making the picture quality from all of the seven Videotape Center 4½" EEV type 7389 equipped cameras unequaled as a picture source for quality video recording.

Dan Collins, Chief Engineer

"Rapid delivery"

... **WNEW-TV**

I must compliment you on the rapid shipping and Warranty Service you are providing on the EEV I. O. tubes.

Bill Kelly, Chief Engineer

The advantages of EEV tubes have proven themselves in literally hundreds of installations like theirs . . . like yours! Why not return the coupon at right for complete details.



a  
4½"  
Missile  
lands  
in  
U. S. A. ...and its 3" sister too!

Bringing Superlative Pictures to U. S. Broadcasters—From English Electric, pioneer in quality image orthicon tube design, production, and quality control.

4½" IMAGE ORTHICON (field mesh)

3" IMAGE ORTHICON (field mesh)

These tubes, proven in performance by the majority of broadcasters around the globe—are now proving to surpass equivalent types heretofore available in the United States.

**NOW  
STOCKED, TESTED, WARRANTED  
IN THE UNITED STATES**

With the appointment of VISUAL ELECTRONICS CORPORATION as U.S. Distributors for English Electric Valve Co., Ltd.:

- tubes are available for immediate deliveries
- complete testing facilities are established
- the best warranty service... adjustments within 24 hours
- replacement from stock... overnight shipments
- and coast-to-coast engineering sales/ service

For the best and most modern broadcast systems and supplies, look to VISUAL the SOURCE—for Superior Equipment from Specialist Manufacturers.

MAIL COUPON FOR INTERESTING RECENT TECHNICAL ARTICLES ON OPERATION OF IMAGE ORTHICON TUBES **BE-12**

NAME \_\_\_\_\_  
STATION \_\_\_\_\_  
ADDRESS \_\_\_\_\_  
CITY \_\_\_\_\_ ZONE \_\_\_\_\_ STATE \_\_\_\_\_

**VISUAL ELECTRONICS  
CORPORATION**

656 west 40 street • new york 18, n. y. • pennsylvania 6-5840



Keeps You in View!

Circle Item 27 on Literature Card

# TV Camera of the Sixties!

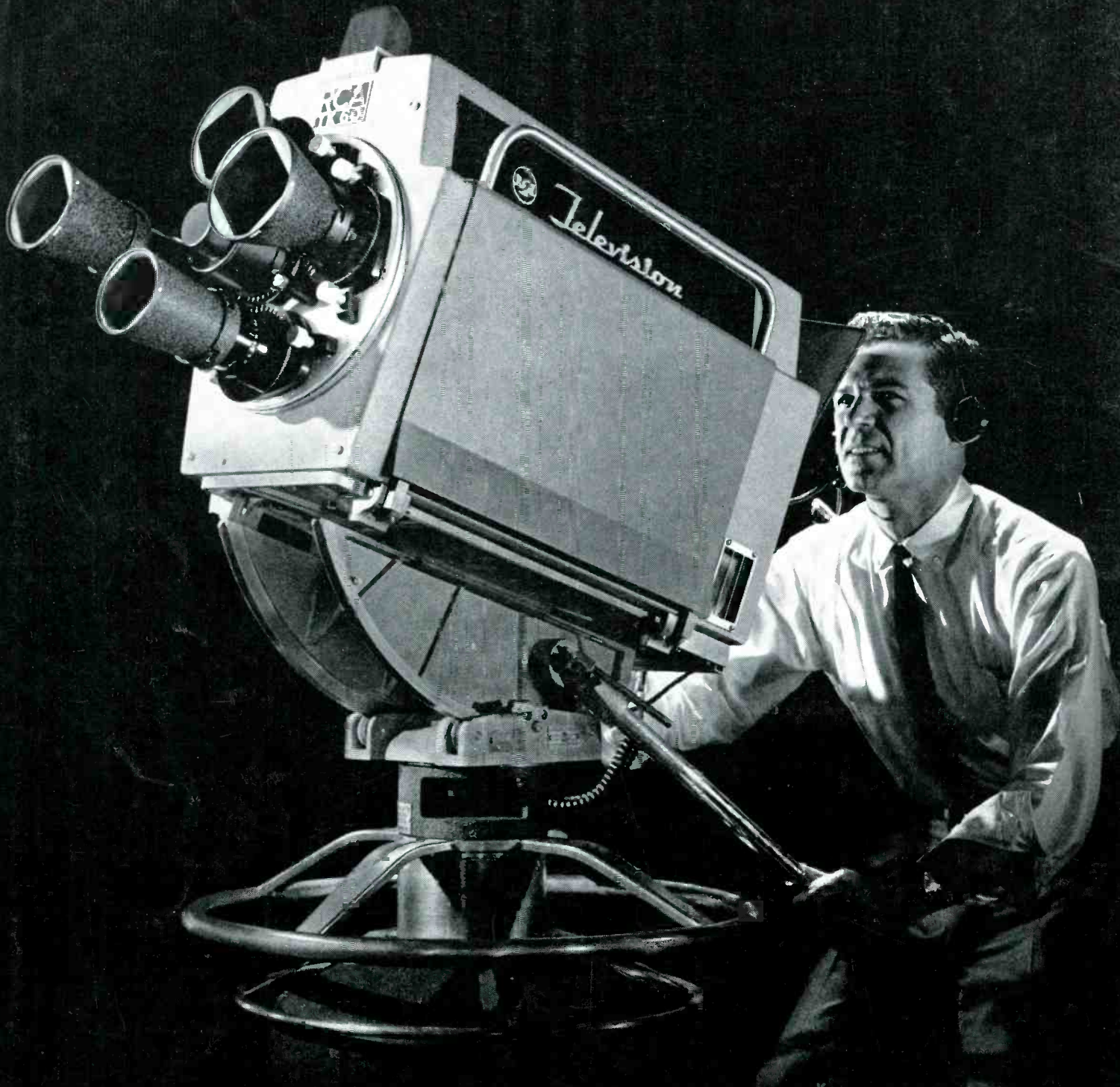

After five years of intensive development and two years of field testing, the TK-60 advanced studio TV camera is here! Big picture  $4\frac{1}{2}$ " image on 9" icon pickup tube combines with stabilized circuits, ease of camera set-up, and simplicity of operation to make it every inch the TV Camera for the "sixties". Here's a great new monochrome camera that's sure to be a success with producers and stat men alike! The TK-60 produces pictures of sensationally new quality...over extended periods, without alignment delays. You can control contrast and mood as never before. You can produce tapes and live commercials that show the client's product in sparkling, life-like detail, with effects not possible on any other camera. Where striking picture quality can mean stepped-up product sales, this is the camera that "says it" and "sells it" best! See the RCA Broadcast Representative for the complete story. Or write RCA Broadcast and Television Equipment, Building 15-5, Camden, N. J.

Distinctive silhouette of "TK-60", television studio camera that's years ahead in performance.



THE MOST TRUSTED NAME IN TELEVISION