

Broadcast Engineering®

THE JOURNAL OF DIGITAL TELEVISION

RF SYSTEMS

- **Monitoring transmission lines**
- **Pressurization systems**

Asset-management technology

It's all about organization

Rethinking workflow

What if there were no tape machines?

Digital Audio Network Router

The Bridge

The Bridge Router can hold all the electronics you'll need for a small console: I/O cards, mix engines, and DSP processors. Naturally it can also have automatic fail-over DSP and CPU cards to keep you on-air. You can expand the system with a simple cage-to-cage interconnect.



It's not just a Digital Console, IT'S AN ENTIRE AUDIO INFRASTRUCTURE

YOU CAN START with a simple AES router with analog and digital inputs and outputs. From there you can add logic I/O cards and scheduling software; you can link multiple master bridge cages together to achieve thousands and thousands of I/O ports; you can create a custom system that includes multiple smaller remote satellite cages— with everything interconnected via CAT5 or fiberoptic links.

BUT THAT'S JUST THE BEGINNING: you can also add mix engine cards, interface to your automation system; you can choose from two different WHEATSTONE series control surfaces (D-5.1 or D-9), each specially configured for production room, on-air or remote truck applications. We also provide a full complement of Ethernet protocol remote router control panels, as well as a complete family of plug-in modules that interface the routing system to existing Wheatstone digital and analog standalone consoles.



**The D-9 is
Compact yet Powerful:**

It can route, generate and monitor 5.1 surround signals and produce simultaneous 5.1 and stereo master signals for your dual broadcast chain. The console also provides extensive, rapid communication paths throughout your entire Bridge system. Motorized faders and control setting storage and recall make show-to-show transitions fast, easy and accurate.

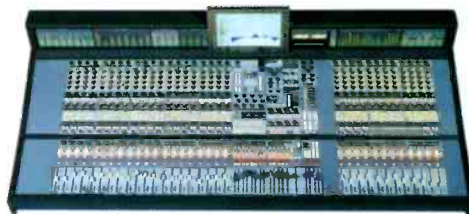

Wheatstone Knows Live Audio. The D-5.1 is loaded with MXMs, foldbacks, and clear easy-to-read displays. You'll have all the power you need when the news breaks! Its intuitive layout helps your operators work error-free, and it can handle and generate all the 5.1 content and simultaneous stereo capability any large or medium market station could need.

 **Wheatstone**

600 Industrial Drive, New Bern, North Carolina, USA 28562
tel 252-638-7000 | fax 252-635-4857 | sales@wheatstone.com



Made in USA

the digital audio leaders

www.wheatstone.com

Copyright © 2003 by Wheatstone Corporation



Gone fishing?
Not this Saturday morning.
You're on the hook.

Where Would You Rather Be?

Remote, in-depth transmitter, transmitter facility and studio analysis and management...anywhere, anytime...from Harris!

Tired of the personal sacrifices you make every time something's not right at the transmitter? Tired of watching your 50-hour week turn into 80?

We understand. And **we've got the solution: Harris Remote Management.** Now, take advantage of a fully integrated suite of remote tools that offer complete studio monitoring and control, transmitter monitoring, and transmitter facility monitoring. With an unmatched history as the technology leader for broadcast facility management, Harris provides the ultimate IP-driven control and intelligence products, products you can integrate as separate components (with later upgrades) or as complete solution. You'll enjoy web-based monitoring available through wireless laptop, cell phone, and PDA. You'll be able to solve problems with your counterparts dozens...or thousands of miles away. Best of all, you'll work more efficiently...and get your life back.

For more information about Harris Remote Management and ReCon, eCDi™ and HBM, contact your local District Sales Manager or visit us online at www.broadcast.harris.com.

eCDi™, ReCon and HBM are three separate packages that work great together.

eCDi™ - Transmitter Remote Management:
Transmitter status control and monitoring with transmitter signal performance monitoring.

ReCon - Facilities Remote Management:
Remote control power and flexibility along with ease of installation and use.

HBM - Network Remote Management:
Consolidate expert manpower, cut response time and increase broadcast system availability.

www.broadcast.harris.com

HARRIS

©2004 Avid Technology, Inc. All rights reserved. Product features, specifications, system requirements, and availability are subject to change without notice. Avid and make manage movie 1 media are either registered trademarks or trademarks of Avid Technology, Inc. in the United States and/or other countries. All other trademarks contained herein are the property of their respective owner.

Across

6 continents

In more than

35 countries

Proven at more than

125 end-to-end installations

Found in more than

750 broadcast facilities worldwide

Used daily by more than

70,000 broadcast professionals

Custom set design by BROADCAST DESIGN INTERNATIONAL, INC. www.broadcastdesign.com

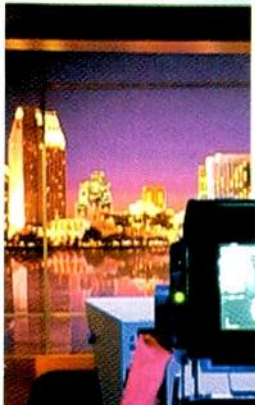

The numbers are in.

In an industry where numbers mean everything, Avid has delivered more all-digital, end-to-end news production systems than all of its competitors combined. Avid helps broadcasters improve the number that matters most – the bottom line.

Networks. Affiliates. Cable. Large, medium, and small markets. Around the world, more and more broadcasters are turning to Avid for a competitive advantage through integrated media asset management, editing, storage, and newsroom solutions.

- Designed to deliver true, real-time collaboration through seamless connectivity
- Integrated through an open, high-performance media network architecture
- Trusted by the people who make news happen
- Available today, engineered for tomorrow
- Find out more at www.avid.com/broadcast

Broadcast Engineering

THE JOURNAL OF DIGITAL TELEVISION

CONTENTS

FEATURES

48 A new way to monitor DTV transmission line

By Andre Skalina and William A. DeCormier
Find out how a new DTV transmission-line monitoring method can locate a problem on the line to within approximately 48 feet.

52 Pressurizing coaxial cable

By Rolin Lintag
Learn how to keep your facility's coaxial cables properly pressurized to prevent arcing and improve power-handling capacity.

56 Digital asset management: Process over product

By Edward Hobson, Bob Slutske and Blake White
To solve the digital-asset-management puzzle, treat DAM as a process, not a product.



BEYOND THE HEADLINES

- Download
- 16 Use it or lose it
- FCC Update
- 24 MSTV proposes DTV channel assignment plan

DIGITAL HANDBOOK

- Transition to Digital
- 26 The component digital standard
- Computers and Networks
- 32 Internet network protocols
- Production Clips
- 38 Digital spot delivery

ON THE COVER:
A new monitoring method could help DTV stations pinpoint problems in their transmission line more accurately. Pictured: Digital station KSWK-TV's Dielectric THA antenna, Bunker Hill, KS. Photo courtesy Lloyd Mintzmyer.

(continued on page 8)



instant access



In our "get the news first...and faster" world, Panasonic's DVCPRO P2 Series provides the instant advantage, with no moving parts, no consumed media and no need for digitization prior to editing. P2 solutions offer low operating costs and seamlessly connect original-quality DVCPRO data to laptop editors, servers and IT media. Just what you'd expect from DVCPRO. To find out how Panasonic can improve your news operation, call 1-800-528-8601 or visit www.panasonic.com/p2

DVCPRO

Panasonic ideas for life

Broadcast Engineering

THE JOURNAL OF DIGITAL TELEVISION

CONTENTS

SYSTEMS DESIGN & INTEGRATION

- Systems Design Showcase
- 40 KBWB-TV converts to a multichannel digital system
- Transmission & Distribution
- 46 Advances in transmitter technology

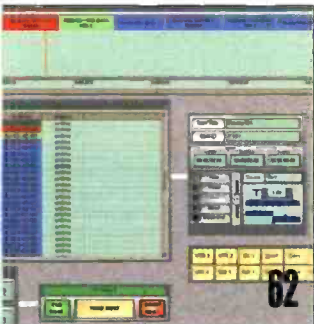

NEW PRODUCTS & REVIEWS

- Applied Technology
- 60 Nucomm's Analog Coder
- Technology in Transition
- 62 Playout automation
- New Products
- 64 Broadcast Microwave Services Carry-Coder II, plus other new products

DEPARTMENTS

- 12 Editorial
- 14 Reader Feedback
- 65 Classifieds
- 69 Advertisers Index
- 70 EOM

FreezeFrame

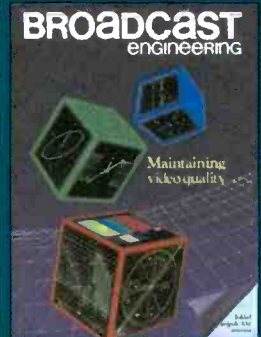

In 1986, NHK announced a high-sensitivity camera pickup device called the HARP. It was updated to the Super-HARP in 2001. What does HARP stand for and how much more sensitive was each version than a conventional Saticon? Correct entries will be eligible for a drawing of *Broadcast Engineering* T-shirts. Enter by e-mail. Title your entry "FreezeFrame-July" in the subject field and send it to: editor@primediabusiness.com. Correct answers received by Sept. 1, 2004, are eligible to win.

► **High Definition.**
Higher Standards.
Highest Performance.



© 2004 Maxell Corporation of America

As hi-def takes over the field, one media company is prepared to exceed your needs. At Maxell, we set a higher standard. Thus, each and every Maxell hi-def product, from D-5 to HDCAM, incorporates the most advanced technologies and manufacturing techniques to deliver the highest performance possible. To learn more about Maxell Professional Media, call 800-533-2836 or visit www.maxell.com.



maxell
Expanding Memory & Mobility ►

Recordable Media Data Storage Portable Energy Technological Partnerships





Video as data files



Edit in camcorder

PDW-530 Camcorder

XDCAM
HERE AND NOW!

SUPPORTED BY: AVID, EVS, INCITE,
LEITCH, OMNEON VIDEO NETWORKS,

© 2004 Sony Electronics Inc. All rights reserved. Reproduction in whole or in part without written permission is prohibited. Features and specifications are subject to change without notice. Sony, DVCAM, MPEG IMX, Professional Disc, Vegas, XDCAM, XPR1 and their respective logos are trademarks of Sony. *Offer is subject to credit approval by Sony Financial Services LLC.

SONY

THE XDCAM SYSTEM. AN INNOVATION THAT COMPLETELY REDEFINES THE WAY WE WORK.

After decades of recording on tape, professionals are discovering the sweeping significance of the XDCAM™ Professional Disc™ system.

XDCAM recording redefines "speed," with the ability to edit in the camcorder. Not to mention the power of the proxy. A frame-accurate low-resolution copy of your material, proxy A/V is an incredible tool for browsing, editing and transferring your footage virtually anywhere. Across the studio or across the world. You can rush proxy into an editor at up to 50x real time. So your office staff can start editing even before the disc arrives!

The XDCAM system redefines "video" by recording your clips as MXF data files, inherently friendly to IT networks and IT storage. Use your PC to browse the contents of an XDCAM disc located on another continent. Then transfer just the clips you need across the data network. Your workflow efficiency goes way up. Your cost of ownership goes way down.

And XDCAM recording redefines "robust" with a laser transport that resists bumps, jolts, shocks, temperature swings and humidity. The laser transport is so robust, it's protected by Sony's 7-year "Powertrain" warranty. (See actual warranty for details).

There's so much more to the story. You'll be amazed by the revolutionary, affordable, reusable Professional Disc media. You'll choose from DVCAM™ or MPEG IMX® codecs, shooting in interlace, progressive or 24PsF. You'll command multi-megabytes of metadata. And you'll leverage a world of compatible products from leading manufacturers.

You owe it to yourself to experience this powerful innovation. XDCAM. Here and Now.

FOR DETAILS, VISIT WWW.SONY.COM/XDCAM



Finish faster with Proxy A/V



0

Dollars Down

Percent Financing

Payments*

*Until January 2005 (on approved credit)***

OMNIBUS SYSTEMS LTD., PINNACLE SYSTEMS, QUANTEL, SGI,
SWE-DISH, TELESTREAM, THOMSON / GVG, VEGAS, AND XPRI.

**To be eligible for the 0% program, purchase any XDCAM PDW-series model between March 1, 2004 and September 30, 2005. No interest charges assessed if amount is paid in full by January 2, 2005. If payment in full is not received by then, the unpaid balance will be converted to a 24-month principal and interest term loan.

Another government entitlement

I've been saying for years that the federal government would make receiving TV a right — an entitlement. But no, many of you wrote to tell me I was wrong. Receiving TV would never become a freebie funded by Uncle Sam. Yes it will!

FCC Media Bureau Chief Ken Ferree recently confirmed that the only thing standing in the way of taking



back the analog spectrum was meeting the 85 percent-reception rule. That's the requirement that says 85 percent of the audience must be capable of receiving digital television signals.

Broadcasters had been operating under the assumption that, until 85 percent of their audience could receive OTA DTV, they'd have a lock on their analog channels. And, as most in this industry know, it takes a long time for viewers to replace their receivers. This meant that we'd have analog around for years to come.

But, in typical government parlance, if you can't win playing by the rules, just change the rules. The FCC is poised to change the rules, and the score will be politicians 1, broadcasters 0.

Eager to get their hands on the money that might be generated by TV-spectrum sales, politicians have been kicking the FCC to move things along faster. Here's where two significant rule changes come in.

First, what if, instead of just OTA reception, the FCC counted digital cable toward that 85 percent figure? That's exactly what Michael Powell's commission has proposed. Currently, the idea is awaiting a full commission vote. If the FCC approves the plan, broadcasters would have until Oct. 11, 2008, to elect either cable carriage of their signals in analog format or full-digital carriage — but not both.

Any station electing for digital cable carriage would see an immediate reduction in audience because only those viewers with DTV receivers (or digital cable) would be able to receive their signal. And, those stations that elected for analog downconversion would keep whatever cable audience they had — but would be unable to provide them with digital service.

Broadcasters used to think that such a cutoff plan wouldn't work because approximately 17 percent of viewers still get their television from OTA signals — virtually all in analog. Turning off the analog transmitters would doom those viewers to no television. Do you think politicians are going to take away granny's TV? No way!

Here's where the second part of the FCC's plan comes in. The government simply declares receiving OTA TV an "entitlement." Similar to welfare, housing, phones and other services for the poor, the ability to get OTA TV would basically become a civil right. As such, the government would guarantee that if you can't afford a new TV or STB, they would provide it for free. Once again, this is another government giveaway and bureaucratic boondoggle.

What's next? Will it be free HD television sets for the poor? After all, if receiving OTA TV is a "right," isn't seeing HDTV a right, too? We can't have the poor watching TV on 4:3 non-HD sets — that would be discrimination. Next up will be free HBO and STARZ.

Years ago, I said that the government would declare TV reception a right and provide free receivers. We're now only months away from big brother making that prediction come true. When it does, hang on to your wallet!

Broad Dick

editorial director

Send comments to: • editor@primediabusiness.com • www.broadcastengineering.com

DENSITÉ SERIES

ADVANCED INTERFACING CONTROLLED OVER IP

Miranda



How smart can interfacing get?

You may be surprised.

Take a look at Miranda's Densité Series which offers advanced control over IP from the desktop.

From a highly adapted interface, you can see thumbnails of signal feeds, waveform and vectorscope displays, as well as full proc-amp controls.

And the range has just been expanded with 23 new cards to cover all the essential interfacing and distribution functions.

So if you're looking for more intelligent interfacing solutions, call Miranda.

Miranda Technologies
tel.: 514.333.1772 - ussales@miranda.com

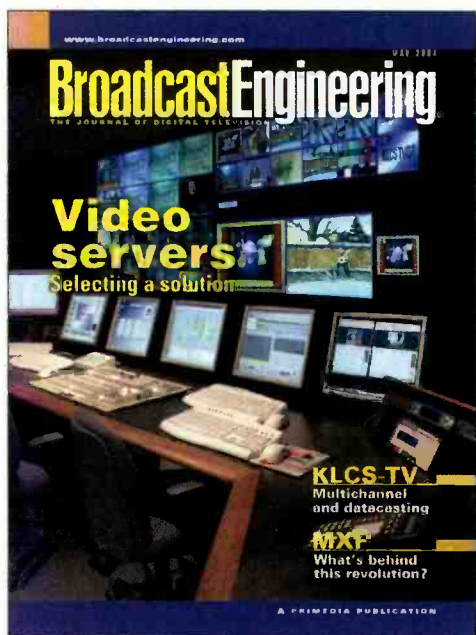

The value of a good engineer

Brad,

I enjoyed your May editorial. You're absolutely right: Given an intermittent that happens during air, most video engineers would just dive in and DO something (including "percussive maintenance" if that did the trick). I can personally attest to this, having held my thumb against a pinch roller for 30 minutes straight to get a videotape to play correctly. We should never lose sight of the ability to improvise in a tight spot.

Wondering where my thumbprint went,

JOANNE
CLEVELAND, OHIO

DTV tuner requirements

Harry,

Were the 2007 dates given in the recent "FCC Update" article on the requirement of digital tuners correct, or is that a misprint?

LARRY FRIDDLE
KHBS/KHOG-TV

Harry C. Martin responds:

Our report in a recent issue about DTV tuner requirements was correct but, perhaps, incomplete. Indeed,

2007 is the deadline by which all TV sets, VCRs and DVD players must be equipped with DTV tuners. But, for TV sets, the requirement is phased in over five years. By July 1, 2004, 50 percent of TVs manufactured with 36-inch or larger screens must have the tuners. The requirement for equipping such large sets goes up to 100 percent as of July 1, 2005. Sets with 25- to 35-inch screens must meet the requirement by July 1, 2006. July 1, 2007, is the deadline for smaller TVs (13 to 24 inches), plus all VCRs and DVD players.

FCC proposal to allow Wi-Fi on unused TV channels

Harry,

Speaking as a 35-year amateur-radio operator, I can say that this proposal is not a good idea. The potential for interference is just too great. My experience with operating amateur radio bands at 432, 903 and 1296MHz has shown that shared allocations are tricky to pull off, even with a limited number of users who understand and can tolerate the inherent interference problems. The trend in electronics for years has been to make wireless communication devices as inexpensively as possible, with minimal amounts of filtering (active or passive) to pass FCC-type acceptance rules, but just barely. A more sensible approach would be to carve out a block of contiguous channels from the current UHF spectrum and assign them solely to Wi-Fi and other wireless consumer devices (part 15, etc.) If the broadcast TV "core" shrinks to channels 2 to 51, why not assign 10MHz from about 700 to 710MHz exclusively for this purpose? This way, any potential interference would be among these restricted radiation devices, not to

broadcast television at lower frequencies. Empirical studies have already shown that DTV broadcast channels can be sited closer than analog channels. In many major markets, numerous two- and three-channel groupings of sequential DTV channels are operating with little difficulty. So, reducing the core of TV channels should work to free up spectrum space. But, the addition of scattered Wi-Fi services in and amongst DTV channel allocations is a wild card in terms of interference, due to problems with intermodulation products and the varied signal levels associated with OTA DTV reception. I am concerned that constant political pressure on the FCC to free up more television spectrum for consumer electronics (and other purposes) may lead to compromises in the solid and conservative RF engineering practices the FCC has followed in the past when determining spectrum allocations. Home wireless technology is a wonderful thing, to be sure, but "cheap" and "good filtering" are not usually found in the same sentence when it comes to consumer-grade receiver design.

PETE PUTMAN
DOYLESTOWN, PA **BE**

March FreezeFrame:

Q. What former TV automation company went by a name that rhymed with bake and marketed a product called ALS?

A. Lake, Automated Library System

Winner:

Tom Alderson

Test your knowledge!

See the FreezeFrame question of the month on page 8 and enter to win a Broadcast Engineering T-shirt.

Send answers to bdick@primediabusiness.com



K2 IOT and K3 MSDC IOT's from *Eimac*

EASE OF USE

No IOT system is easier to tune and maintain than the Eimac K2 and K3 MSDC IOT amplifiers.

K2 tube replacement and maintenance can be handled by one person without removing the cavity assembly from the cabinet.

RELIABILITY

Oil-cooled K3 MSDC IOT

- no electrolysis with oil.
- minimal maintenance.
- low pressure, low flow rate operation.

K3 three stage MSDC design simplifies the power supply requirements.

- simplicity = reliability

Eimac IOT's have documented lifetimes of up to 70,000 hours or more.

EFFICIENCY

Eimac's Klystode IOT pioneered high efficiency UHF-TV power amplifiers.

The K2 continued this leadership with enhanced ease-of-use.

The K3 three stage MSDC IOT demonstrates efficiency of up to 58%.



Eimac Division
301 Industrial Road
San Carlos, CA 94070

tel 650.592.1221

fax 650.592.9988

email.iot@cpli.com

www.eimac.com

ISO 9001:2000 Certified . Made In USA

Use it or lose it

BY CRAIG BIRKMAIER

For decades, broadcasters have been blessed with free access to some of the most desirable spectrum in the RF bands. But, because of the technical realities broadcasters encountered when they first constructed transmission facilities on this "beach-front property," they have used this spectrum inefficiently. The market-based approach to broadcasting and the potential for interference between stations operating on the same channel in adjacent markets (or on adjacent channels in the same market) has left much of the spectrum assigned to TV and radio broadcasting (at least half the spectrum in any market) unused to prevent interference.

The use of high-powered "big sticks" by TV broadcasters to cover large geographic areas makes this problem worse. For example, the rules for digital TV allotments specify minimum spectrum separations between co-channel stations ranging from 196.3 to 273.6 kilometers, and separations

of 110 kilometers between adjacent-channel stations that are not colocated or in close proximity.

The decision to continue with this approach to TV broadcasting as the industry makes the transition to digital may now be coming back to haunt TV broadcasters.

to support new services, including wireless telephony and broadband data services, has had broadcasters on the defensive for decades.

In the mid-'80s, the FCC proposed that land-mobile telephony be allowed to share some of the frequencies assigned to broadcasters. In markets

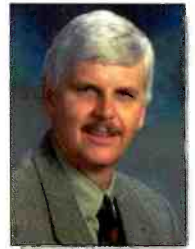

The demand for spectrum to support new services has had broadcasters on the defensive for decades.

The HDTV Trojan horse

For decades, other industries have coveted the spectrum occupied by TV broadcasters, partly because of the desirable propagation characteristics in these bands, and partly because of the general scarcity of spectrum resources. Advances in transmission technology have made it possible to develop services in higher-frequency bands, but the demand for spectrum

where a channel was unused because of potential interference with other broadcasters, the proposal would have allowed land mobile to operate low-power, two-way radio services. Broadcasters needed an excuse to prevent this erosion of their "property rights."

The genesis of the current transition to digital broadcasting is rooted in the perceived need to prevent other industries from sharing the TV bands. In 1987, TV broadcasters went to the FCC with a bold request. They suggested that it would be inappropriate to allow land mobile to share the TV bands because broadcasters would need this unused spectrum to offer a new service — HDTV. Each station would require a second 6MHz channel to carry an analog augmentation signal with the added information needed to upgrade NTSC broadcasts to HDTV. The FCC postponed the decision to allow frequency sharing while it investigated the broadcasters' request. As they say, the rest is history.

Thanks to the broadcasters' HDTV Trojan horse strategy, nobody knows for certain when broadcasters will return the frequencies assigned to analog NTSC broadcasts to the government for other uses. When the FCC

FRAME GRAB A look at the issues driving today's technology

HD use at stations gains popularity

Only one in five U.S. studios/facilities currently uses HD

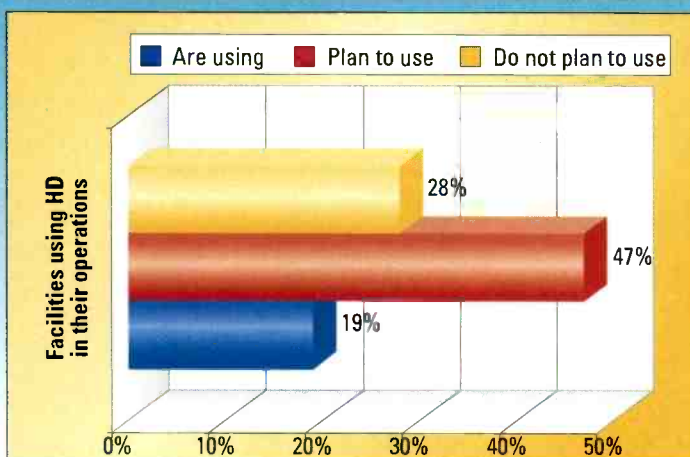

Source: TrendWatch

www.trendwatch.com

Teeing Up For Perfect Audio



Standing from left:
Steve Specht (Audio Operator),
Chuck Jones (Maintenance Engineer),
Jim McCabe (Audio Operator)
Seated: Derrick Beauregard (Audio Operator).

Performance shines as The Golf Channel chooses the SSL C100 Digital Broadcast Console

"It's the inherent design functionality that makes the SSL C100 the console of choice for The Golf Channel," states VP of Network Operations Andy Murphy. "The maximizing of console power in a compact space, while retaining the intuitive logic of one-knob-one-function control operation in a console with multiple layers is truly remarkable. Combine this engineering feat with SSL's great reputation for quality build, excellent service and great sound, and you have a product that is perfect for the live-to-tape and live-to-air programs we produce."

C100 delivers 'Next Generation' Digital Broadcast Features

- Secure operation with Self-Healing and Redundant features
- Future-proof investment (surround capable for HDTV)
- Dedicated broadcast design that is simple and powerful
- Network integration as standard
- Cost-effective, scalable design to fit a wide range of budgets



C100

Solid State Logic

BROADCAST AUDIO TECHNOLOGY

Begbroke, Oxford OX5 1RU, England. Tel: +44 (0)1865 842300 Fax: +44 (0)1865 842118 Email: sales@solid-state-logic.com Web: www.ssl-broadcast.com

NEW YORK

Tel: +1 (1)212 315 1111

LOS ANGELES

Tel: +1 (1)323 463 4444

TOKYO

Tel: +81 (0)3 5474 1144

PARIS

Tel: +33 (0)1 3460 4666

MILAN

Tel: +39 039 2328 094

authorized DTV broadcasts in 1997, it set a date of Jan. 1, 2007, for the return of the analog channels. Within months, broadcasters had used their considerable influence in Washington to render that date meaningless. Congress amended the 1997 Balanced Budget Act with a provision requiring 85 percent of the homes in a market to be capable

of receiving all of the DTV broadcasts in their market before the FCC could shut down analog service. Currently, less than 5 percent of U.S. homes have receivers that can pick up all these DTV broadcasts.

By any measure, the Trojan horse strategy has been a success. But pressure has been mounting to move the

transition along, and now there are noises coming out of the nation's capitol for imposing a new deadline. Meanwhile, the runaway success of a new unlicensed wireless data service is changing the competitive landscape again. Wireless Fidelity, or Wi-Fi, is making it possible for people to create small, low-power networks to deliver broadband data to portable and mobile devices.

In May, the FCC dropped another bombshell on broadcasters, announcing its intention to allow the unlicensed use of the TV bands for two types of data services. The first is a duplication of the Wi-Fi service that is currently using spectrum in the 2.5GHz band. In addition, the FCC would allow any wireless-Internet service providers (WISPs) to deliver broadband data services to consumers using low-power, point-to-point transmitters.

To do this, those who would share the TV frequencies must develop smart radio technologies that would detect the channels TV broadcasters are not using. This would protect current TV broadcasts and allow the FCC to assign new TV channels in the future. The technology to do this is already proven.

Now, broadcasters are going to have to prove that the unlicensed use of "their" spectrum will cause irreparable harm. Will broadcasters be able to stop this new attempt at frequency sharing as they did in 1987, when HDTV was used as a tactic to block the land-mobile proposal?

As long as broadcasters continue pushing to maintain the status quo of big, high-power transmitters, the spectrum will be used inefficiently. But it may be impossible to prevent the sharing of the underused spectrum for unlicensed, low-power services. To make matters worse, only a small percentage of U.S. homes actually use the free-to-air television broadcast service; 85 percent of U.S. homes subscribe to a multichannel cable or DBS service. The FCC has opened another inquiry to determine just how many people still rely on NTSC broadcasts,

4 OUT OF 5 CONTROL PHREAKS PREFER
SUNDANCE DIGITAL FOR STATION AUTOMATION!
AND THE FIFTH GUY? ...OUT MAKING A DONUT RUN.



SUNDANCE

D I G I T A L

PLAYOUT Automation
MEDIA Management
NEWS Automation
ASSET Management

Automation Solutions



Sundance Digital, Inc.
972-444-8442
sales@sundig.com
www.SundanceDigital.com





**Prime
Image**

Performance by definition.

HD/SD Universal I/O (HDSC)



Performance by definition.

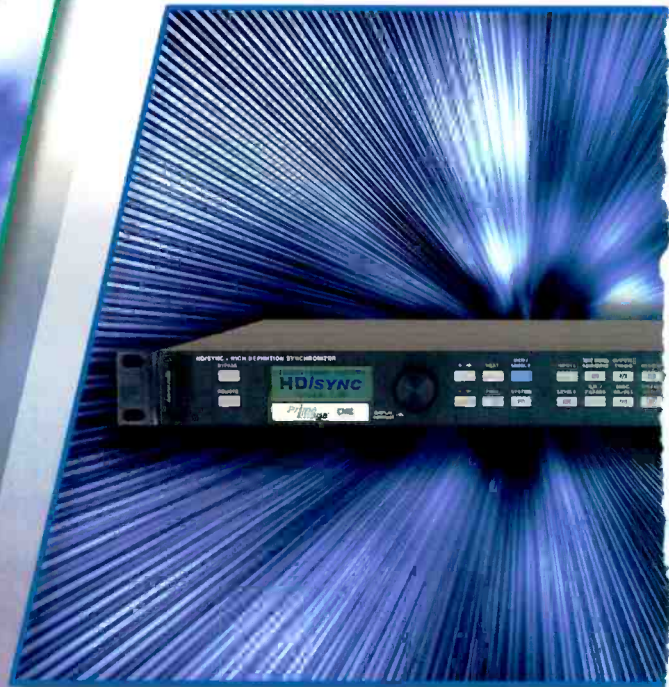

Anything in. Anything out.

Prime Image has more than 20 years of delivering industry leading high performance broadcast and production processing equipment.

"Providing to the industry some of the most **advanced technology** to meet the latest broadcast and professional media applications has made us number one in several markets," said Rodney Hampton, Prime Image's Vice President of sales and marketing based in San Jose, California. "Prime Image has a history of not just meeting basic standards within the market, but we truly **outperform industry** standards and expectations. We have truly earned the marketing statement: **Performance by definition.**"





If being the best in your *highly competitive* broadcasting industry is where you need to be, look to the experts to help you compete while *delivering results* with Prime Image's newest HD/SD Universal I/O (HDSC).

P *Prime Image* is setting the pace by offering to global broadcast market leaders dynamic and versatile equipment. Known for their award winning designs, Prime Image has recently released to the market a truly broadcast quality all-inclusive high definition, multi-functional converter. But the best part of this new release is that this box is affordable and designed for the future. The HD/SD Universal I/O (HDSC) is a high definition digital standard converter ideally suited for HD broadcasters and production facilities, or those planning to make the transition to high definition. Up conversion, down conversion and frame rate conversion are all possible with HDSC, utilizing motion adaptive de-interlacing technology and full frame interpolation. The HDSC offers unprecedented I/O flexibility, accommodating virtually any analog or digital source including computer graphics (optional). So why purchase multiple pieces of equipment? The HDSC is the ultimate signal integration solution for your broadcasting needs.

Today, we are helping broadcast professionals worldwide meet their needs through the new HD/SD Universal I/O. The HDSC supports all world standards from SD through HD in either analog or digital formats. Incorporating full 10-bit processing, digital FIR filtering, a three-dimensional adaptive COMB filter, motion adaptive noise reduction, full proc amp controls, and color correcting, the HDSC provides superior processing for analog to digital conversion. A built-in test signal generator, frame store with linear keyer, and an animated logo inserter, are just some of the extra features which make the HDSC the most versatile product in the industry.

Chris Gifford, designer and principal of California Media Engineering, emphasizes that the HD/SD Universal I/O is engineered to be future-proof, in that it will satisfy anyone's needs today as well as tomorrow. Prior to Launching California Media Engineering, Gifford worked as Senior Design Engineer with Prime Image, Inc. in San Jose for more than ten years.

To learn more about the HD/SD Universal I/O (HDSC), please contact us at (408) 867-6519.



The signal integration solution.



HD/SD Universal I/O (HDS)

General Features

- Standards Conversion** INPUT: NTSC, PAL, PAL-N, PAL-M, or any ATSC standards
to OUTPUT: NTSC, PAL, PAL-N, PAL-M or any ATSC standards
- Up/Down Conversion** INPUT: 480i, 480p, 576i, 575p, 720p, 1080i (640x480, 800x600, 1024x768).
to OUTPUT: 480i, 480p, 576i, 575p, 720p, 1080i
- Format Conversion** INPUT: Composite, SVHS, Component, RGB, SDI, DV*, (XVGA) and DVI)
to OUTPUT: Composite, SVHS, Component, RGB, SDI and DV*
- Genlock** REFERENCE: Composite Black Burst, or HD tri-level sync.
- Video Test Generator** SIGNALS: Various patterns + zone plate + size chart with circle.
- 4 Channel Audio Delay** SIGNALS: SDI-Embedded audio.
Analog Audio (balanced) 25 F Dsub (Industry standard pinout)
AES (unbalanced)
- Remote Control** SERIAL: RS232/RS422 (SONY pinout)
10/100 ETHERNET
2 Programmable BNC's for control inputs or outputs.

Miscellaneous Features



TBC/SYNC, Video AGC, Auto freeze/trouble slide, Hot switch, Auto Proc adjust, Noise reduction, Color correction, Audio/Video test signal generator, VITS inserter, Audio embedder/de-embedder, Animated logo inserter, User presets, 64 Meg user frame/logo storage, Upload/download stills through Ethernet to emulate still store with dissolve/clean cut. FLASH firmware/software upgradeable

1RU x 17 inches x 15 inches case
Power = 100 - 120 / 200-240 VAC 60 / 50 Hz Auto Switching



*DV (IEEE 1394) can be configured for input or output but not both simultaneously.
Specifications may change without notice.



Tel (408) 867-6519
Fax (408) 926-7294
www.primeimageinc.com

Performance by definition.

and members of Congress are talking about subsidies for the holdouts so that it can recover the analog channels in this decade.

Between a rock and a hard place

There is little doubt that broadcasters will try to use their waning power in Washington to block the latest FCC overture to enable frequency sharing. Already, the NAB is suggesting that the FCC delay the proposed sharing until broadcasters complete their DTV transition. During the transition, the new DTV service occupies many channels. Unfortunately, as these channels move to full power levels, broadcasters may become their own worst enemy. There are many

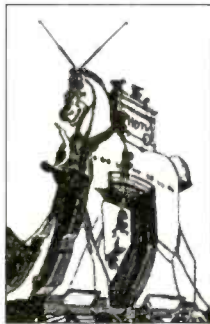

In 1987, TV broadcasters used HDTV as a Trojan horse in order to prevent land-mobile services from sharing their spectrum.

indications that interference between analog and digital broadcasts will be significantly greater than the industry projected when the FCC assigned these channels. It is going to be difficult to prove that unlicensed transmitters operating at low power levels on unused channels are going to create a bigger problem. It is beginning to look as if broadcasters may need to learn how to share.

But there may be a way out of this ugly mess —single-frequency networks (SFN). These could change the competitive dynamic in this spectrum war. They could allow broadcasters to deliver a competitive multichannel service in every market simply by using the TV spectrum efficiently.

So, perhaps a new strategy is necessary. Instead of falling back on the old reliable interference canard, it may be time to go on the offensive. With SFNs, broadcasters could return to their roots — free TV — offering SDTV, HDTV and data broadcasts, and enough channels in the free and clear to compete effectively with cable and DBS. This might give viewers compelling reasons to put up an antenna again.

For more information on this subject, see *FCC Proposes Rules to Facilitate Wireless Broadband Services Using Vacant TV Channels*, located at hraunfoss.fcc.gov/edocs_public/attachmatch/FCC-04-113A1.pdf. **BE**

Craig Birkmaier is a technology consultant at Pcube labs, and he hosts and moderates the OpenDTV Forum.



Send questions and comments to: cbirkmaier@primediabusiness.com



Holds color in captivity.

Introducing the new 8.4" diagonal ERG HDM-EV80D HD monitor with extremely accurate color. Its HD innovations include four inputs and one output, which allow it to be used with multiple cameras. The monitor's DC output and cost effectiveness make it ideal for rack mounting while its compact, rugged design and low power consumption make it perfect for location shooting. No matter how you use it, the monitor will capture your imagination. For more information about the HDM-EV80D, call or visit our website: erg-ventures.com, contact@erg-ventures.com, U.S.: +1-949-263-1630, Japan: +81-3-3760-8161

ERG HD Monitors



MSTV proposes DTV channel assignment plan

BY HARRY C. MARTIN

The Association for Maximum Service Television (MSTV), which represents more than 500 local television stations on technical issues, recently submitted a five-step plan to the FCC for moving all television stations to permanent digital channels in the core. The goals of the plan are to (i) allow stations to select their final DTV channel where possible; (ii) protect existing service to the fullest extent possible; (iii) promote a joint industry-FCC effort, with the industry taking the lead and the FCC issuing licenses and resolving conflicts; and (iv) encourage an orderly transition, minimizing disruption to existing DTV operations. The plan's five steps are:

Step 1: Correct the DTV database. MSTV wants the FCC to adopt a final DTV database by early 2005. MSTV observes that the FCC's DTV database is inaccurate and consists of several separate databases. Also, a number of coordination issues involving Canada and Mexico have yet to be resolved. MSTV would like the FCC to establish a single, reliable database.

MSTV proposes the FCC immediately freeze any new requests for DTV

channel changes, allotments or modifications of DTV facilities that would expand the existing service area or increase interference. The freeze would not affect pending proposals. Once such a freeze was in place, the commission would open a limited window for stations to review the existing database(s) and request corrections. Meanwhile, the commission would intensify its efforts to resolve all outstanding international coordination and interference issues.

Step 2: First round of channel selections. Once the final database is in place, stations would make final channel selections in two rounds. In the first round, stations with two in-core channels would select one to use for DTV. If the station selects the DTV channel, it relinquishes rights to its NTSC channel. If the station selects the NTSC channel, it retains rights to the DTV channel temporarily to allow it to evaluate digital operation on the channel.

Also in the first round, stations with both NTSC and DTV channels outside the core would specify three permanent channels, protecting in-core channels of stations with one out-of-core channel. MSTV anticipates that stations would complete their first-round selections by June 2005.

Step 3: Provisional authorizations. The FCC would then issue provisional authorizations based on the first round of channel selections. Stations receiving these authorizations would relinquish rights to all other channels, which would become available for the second round of channel selections. MSTV expects the majority of stations will at this time receive their channels of choice. The FCC would issue provisional authorizations at this time to:

stations that chose to keep their in-core DTV channels; stations that chose to move their permanent DTV operations to their in-core NTSC channels; and stations with two out-of-core channels, which could be accommodated on one of their three channel preferences. MSTV envisions getting to this point by October 2005.

Step 4: Second round of channel selections. At this point, there still may be some stations that have not yet received a channel, or that find their selection from the first round to be unacceptable. Those stations would participate in a second round of channel selections.

Step 5: Final DTV table. All of the foregoing would set the stage for the resolution of any conflicts in channel requests and issued licenses, resulting in a final DTV table of allotments in 2006. MSTV proposes that FCC use the following criteria to resolve remaining channel conflicts: (i) length of time station has been operating on DTV; (ii) population served by the station's digital signal and the percentage of the replication population served; (iii) whether one or both channels are in the low VHF band; (iv) whether coordination with Canada or Mexico is a problem; and (v) whether there are zoning, environmental or other problems.

There is no deadline for comments on MSTV's plan and no guarantee that the commission will hold off on adopting parts of it or imposing a freeze in the meantime. **BE**

Harry C. Martin is president of the Federal Communications Bar Association and a member of Fletcher, Heald & Hildreth, Arlington, VA.

SEND Send questions and comments to: harry_martin@primediabusiness.com

Dateline

Television stations in North Carolina and South Carolina must file their renewal applications, ownership reports and EEO program reports by Aug. 1, 2004. LPTV and TV translators in North Carolina and South Carolina must file their renewals by Aug. 1. Also by Aug. 1, stations in Florida, Puerto Rico and the Virgin Islands must begin their pre-filing renewal announcements.



ZETA 100

A DIGITAL CONSOLE FOR LOCAL TV AND RADIO PRODUCTION

As a broadcaster you can't afford to compromise. With the Zeta 100, you don't have to. Based on Calrec's field-proven Alpha architecture, the Zeta 100 provides exactly the same broadcast-specific features as our larger Sigma and Alpha 100 consoles. Over 30 years of broadcast experience in a console designed for local TV and radio production. No compromise, no problem. Just sound broadcast sense.

- Intuitive control surface designed for on-air operation
- Compact – up to 48 faders/88 signal paths, configured as 32 stereo and 24 mono channels
- Hot swappable cards and panels throughout
- Interrogation facility on every buss
- 2 stereo / 5.1 Surround Main Outputs
- 8 stereo/mono audio sub-groups
- 8 auxes, 16 Multitrack/IFB outputs
- Comprehensive Mix-minus/Direct Output per channel
- Powerful relay system
- Automatic redundancy on power supplies, DSP and control processors
- Power up and operation independent of the on-board PC
- Comprehensive buss structure. No restrictive buss allocations

The Sigma 100 medium format digital production console



The Alpha 100 large format digital production console



CALREC AUDIO LTD, NUTCLOUGH MILL, HEBDEN BRIDGE, WEST YORKSHIRE, HX7 8EZ, UK TEL: 01144 1422 842159 EMAIL: enquiries@calrec.com WEB: www.calrec.com

South and Mid West States - TEL: (615) 871 0094 EMAIL: ericj@redwoodweb.com

North East States and Canada – TEL: (212) 586 7376 EMAIL: dsimon@studioconsultants.com

Western States – TEL: (818) 841 3000 EMAIL: jschaller@audiospec.com



The component digital standard

BY MICHAEL ROBIN

North American and European digital standardization efforts resulted in CCIR Recommendation 601, Encoding Parameters of Digital Television for Studios, now known as ITU-R BT.601. This recommendation established an agreement on a component digital approach that is compatible with both the 525/59.94 and 625/50 scanning standards. It is at the root of all subsequent component digital developments.

The coded signals

The recommended and most commonly used digital coding is based on the use of one luminance (E'_Y) and two scaled color-difference (E'_{CB} and E'_{CR}) signals. The coded signals are defined by the following expressions:

$$E'_Y = 0.587 E'_G + 0.114 E'_B + 0.299 E'_R; \text{ referred to as Y in North America}$$

$$E'_{CB} = 0.564 (E'_B - E'_Y); \text{ referred to as } P_B \text{ in North America}$$

$$E'_{CR} = 0.713 (E'_R - E'_Y); \text{ referred to as } P_R \text{ in North America}$$

These signals have the following characteristics when representing a 100 percent color-bars signal without setup (known as a 100/0/100/0 color bars signal):

- The luminance signal has a peak positive value of 700mV and no setup.

Betacam and MII component analog VTR formats.

The sampling rates

Early proposals for the values of the sampling frequencies of the Y signal specified a multiple of the subcarrier frequency (f_{sc}) of the associated composite video signal. This resulted in the 4:2:2 concept, whereby the E'_Y signal

Scanning standard	f_H (Hz)	E'_Y sampling frequency (MHz)	E'_{CB} sampling frequency (MHz)	E'_{CR} sampling frequency (MHz)
625/50	15625	864 $f_H = 13.5$	432 $f_H = 6.75$	432 $f_H = 6.75$
525/59.9	15734.25	858 $f_H = 13.5$	429 $f_H = 6.75$	429 $f_H = 6.75$

Table 1. 4:2:2 component digital format sampling frequencies

- The scaling factors for the E'_{CB} and the E'_{CR} color-difference signals were chosen to obtain a bipolar signal with a p-p amplitude of 700mV. These scaling factors differ from those used with the composite analog PAL and NTSC signals or those used by the

is sampled at a frequency of $4f_{sc}$, and each of the two color-difference signals is sampled at $2f_{sc}$, hence 4:2:2. The major achievement of CCIR 601 is specifying a set of sampling frequencies common to both the 525/59.94 and the 625/50 scanning standards. The selected frequencies are common multiples of the horizontal scanning frequencies (f_H) of both standards, as well as 3.375MHz. Table 1 shows the derivation of the 4:2:2 standard sampling frequencies.

A family of sampling rates common to both scanning standards and based on 3.375MHz has evolved. Table 2 on page 28 shows how the sampling rates are derived.

The sampling frequency has a direct bearing on the frequency response and the number of horizontal picture elements (pixels) that the system can resolve. Recommendation 601 specifies the low-pass filter (LPF) characteristics of the anti-aliasing (ahead of the A/D converter) and reconstruction (after the D/A converter) filters, which determine the analog in/out frequency response characteristics. For the 4:2:2

FRAME GRAB

A look at tomorrow's technology

Digital video recorders (DVR) gain popularity

By 2005, 11 million households may have a DVR

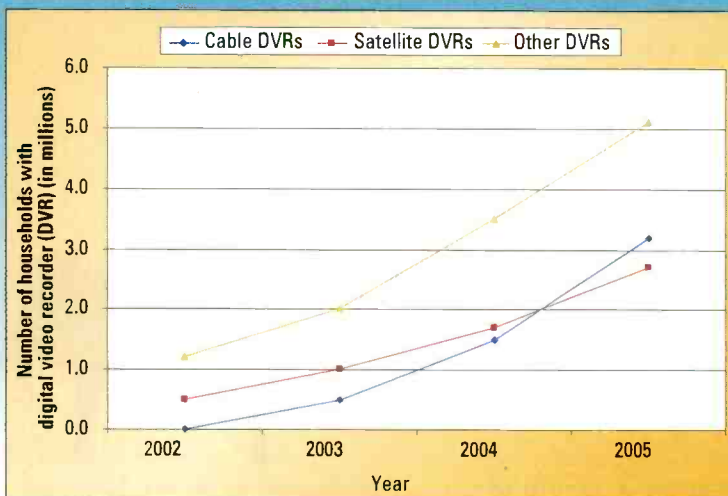

SOURCE: TrendWatch

www.trendwatch.com

signal integration solution.



General Features

Supported Standards

NTSC, PAL, PAL-N, PAL-M or any ATSC standards.
480i, 480p, 576i, 576p, 720p, 1080i, 1080sF

Format Conversion

INPUT: Composite, SVHS, Component, RGB, SDI, DV*
to OUTPUT: Composite, SVHS, Component, RGB, SDI, DV*

Genlock

REFERENCE: Composite Black Burst, or HD tri-level sync.

Video Test Generator

SIGNALS: Various patterns + zone plate + size chart with circle.

Optional 4 Channel Audio Delay

SIGNALS: SDI-Embedded audio.; Analog Audio (balanced)
25 F Dsub (Industry standard pinout); AES (unbalanced)

Remote Control

SERIAL: RS232 / RS422 (SONY pinout)

NETWORK: 10/100 ETHERNET

GPIO: 2 Programmable BNC's for control inputs or outputs.

Miscellaneous Features

TBC/Sync, Auto freeze/trouble slide, Hot switch, Auto Proc adjust, Noise reduction, Color correction, Audio/Video test signal generator, VITS inserter, Audio embedder/de-embedder, animated logo inserter, User presets, 64 Meg user frame/logo storage, Upload/download stills through Ethernet to emulates still store with dissolve/clean cut. FLASH firmware/software upgradable.

1 RU x 17 inches x 17 inches case.

Power = 100 - 120/120 - 240 VAC 60/50 Hz Auto Switching

*DV (IEEE 1394) can be configured for input or output but not both simultaneously

SPECIFICATIONS MAY CHANGE
WITHOUT NOTICE



HD/SYNC High Definition Synchronizer

The HD/SYNC is an ALL definition video synchronizer ideally suited for HD broadcasters and production facilities, or those planning to make the transition to high definition. The HD/SYNC supports all world standards from SD through HD in either analog or digital formats. Incorporating full 10-bit processing, digital FIR filtering, a three-dimensional adaptive COMB filter, motion adaptive noise reduction, full proc amp controls, and color correction, the HD/SYNC provides superior processing for analog to digital conversion. A built-in test signal generator, frame store with linear keyer, and an animated logo inserter, are just some of the extra features that make the HD/SYNC the most versatile synchronizer in the industry. Designed to be future proof, the HD/SYNC satisfies your needs today, and tomorrow.



Tel (408) 867-6519
Fax (408) 926-5177
www.primeimageinc.com

Performance by definition.

format, the resulting luminance bandwidth is 5.75MHz. This is a compromise between the slightly higher

Family member	E'_Y sampling frequency (MHz)	E'_{CB} sampling frequency (MHz)	E'_{CR} sampling frequency (MHz)
4:4:4	$4 \times 3.375 = 13.5$	$4 \times 3.375 = 13.5$	$4 \times 3.375 = 13.5$
4:2:2	$4 \times 3.375 = 13.5$	$2 \times 3.375 = 6.75$	$2 \times 3.375 = 6.75$
4:1:1	$4 \times 3.375 = 13.5$	$1 \times 3.375 = 3.375$	$1 \times 3.375 = 3.375$

Table 2. Sampling rates of various members of the family

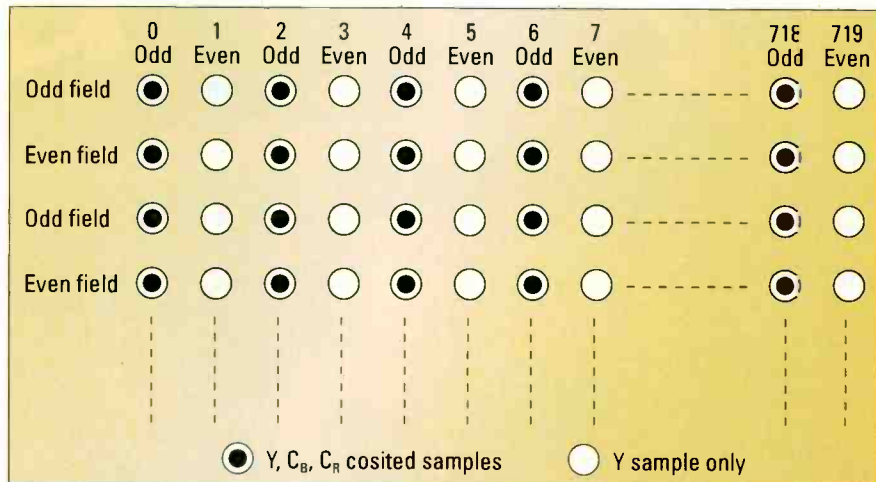

Figure 1. Details of the 4:2:2 sampling grid

requirements of the 625/50 scanning standard and cost-optimized A/D conversion circuitry. It is worse than the analog studio signal-distribution elements and state-of-the-art cameras. The color-difference signal bandwidth for the 4:2:2 format is 2.75MHz. This exceeds the chrominance bandwidth of the NTSC or PAL analog composite standards. Figure 1 shows details of the 4:2:2 sampling grid.

The specified sampling frequencies result in an integer and equal number of sample periods during the active line periods for the two scanning standards. The sampling strategy is called orthogonal sampling. In the 4:2:2 format, with twice as many luminance (Y) as chrominance samples, the chrominance samples (C_B and C_R) are time-coincident (cosited) with odd Y samples. Table 3 details the 4:2:2 format sampling structure and the LPF-related analog horizontal resolution. It shows that the two scanning standards have an equal number of samples per active line.

The sample resolution

The sampling process results in signal amplitude values measured periodically at the sampling rate.

Analog signals may assume an infinite number of amplitude values inside established limits. The quantizing process results in converting the

Scanning standard	525/59.94			625/50		
	E'_Y	E'_{CB}	E'_{CR}	E'_Y	E'_{CB}	E'_{CR}
Component	E'_Y	E'_{CB}	E'_{CR}	E'_Y	E'_{CB}	E'_{CR}
Sampling frequency (MHz)	13.5	6.75	6.75	13.5	6.75	6.75
Nyquist frequency (MHz)	6.75	3.375	3.375	6.75	3.375	3.375
LPF cutoff frequency (MHz)	5.75	2.75	2.75	5.75	2.75	2.75
Horizontal resolution (LPH)	≈455	≈218	≈218	≈449	≈215	≈215
Samples per total line	858	429	429	864	432	432
Samples per active line	720	360	360	720	360	360
Samples during H blanking	138	69	69	144	72	72

Table 3. 4:2:2 sampling structures and horizontal resolution

measured voltages into digital data. It results in "quantizing errors" (Q_c), inaccuracies in the digital representation of the analog signal related to the number of bits per sample. CCIR 601 specifies a resolution of eight bits per sample, which allows for 256 levels (2^8) of amplitude information to be represented

for each component. This number is reduced slightly by the need to provide headroom, which helps avoid analog signal clipping and results in a specified quantizing range. With eight or more bits per sample, Q_c manifests itself as random noise. The choice of eight-bit resolution was based on the state-of-the-art technology of the 1980s and is satisfactory only with analog source equipment having a signal-to-noise-ratio (SNR) of about 50dB, which effectively masks the eight-bit Q_c .

Figure 2 shows a simplified block diagram of a 4:2:2 encoder. The sampling of the three components results in three bit-parallel datastreams, which are time-divi-

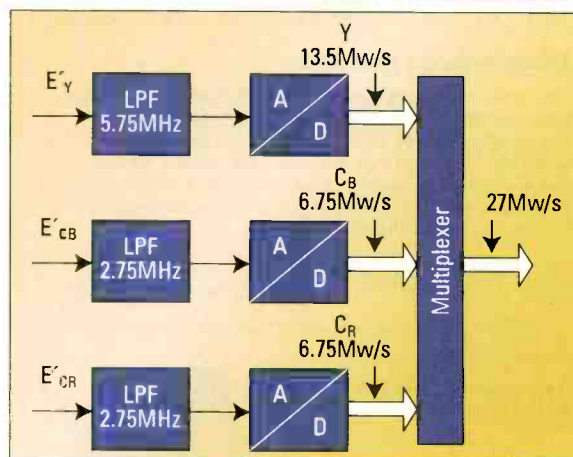
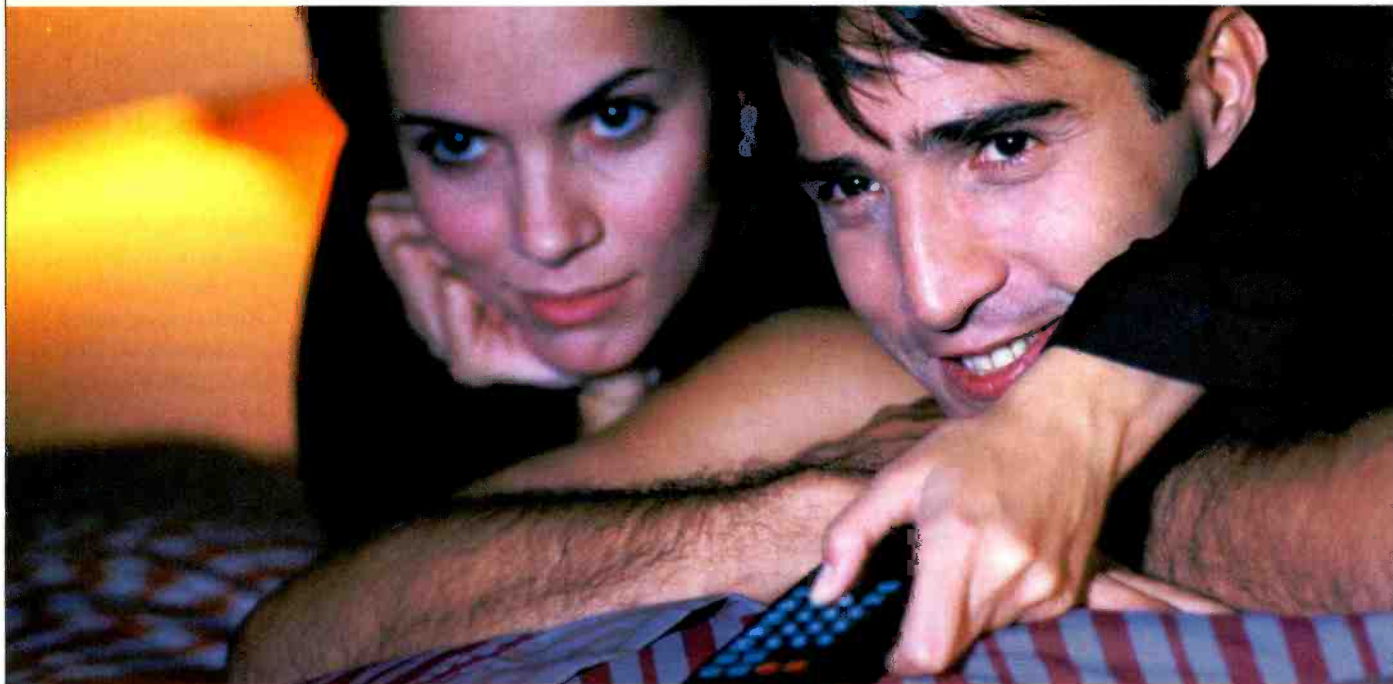

Figure 2. Simplified block diagram of a Rec. 601 component digital 4:2:2 encoder

Turn Up the Experience with Dolby Pro Logic II



DP563 Dolby Surround and Pro Logic II Encoder

Audiences love Dolby® Digital 5.1 discrete surround in digital entertainment such as DTV, DVDs, and video games. But what about surround sound for two-channel audio delivery?

Dolby Pro Logic® II offers the best matrix-surround experience for stereo-only television services, top-selling video games, or VHS tapes. With five full-range channels, improved steering logic for

greater channel separation, and an exceptionally stable sound field, Dolby Pro Logic II remains compatible with consumer decoders with Dolby Pro Logic, stereo, or mono outputs.

Encode your analog or digital two-channel productions in engaging Dolby Pro Logic II matrix-surround, now available with the DP563 Dolby Surround and Pro Logic II Encoder.

www.dolby.com/pro



27Mwords/s. Figure 3 on page 30 shows the relationship between the component signals representing a 100/0/100/0 color bars signal and 10-bit and eight-bit digital representations. It also shows the relationship between the E'_Y , E'_{CB} and E'_{CR} analog component signal levels corresponding to a 100/0/100/0 color bars signal and the 10-bit and 8-bit Y , C_B , C_R digital sample values.

Currently, studio equipment uses a resolution of 10 bits per sample. In a 10-bit system, there are 1024 digital levels (2^{10}), expressed in decimal numbers varying from 0 to 1023 or in hexadecimal numbers varying from 000 to 3FF, which can represent the sampled analog video signal amplitude.

Note that the sync portion of the luminance signal is not sampled. Digital levels 000, 001, 002, 003 and 3FC, 3FD, 3FE, 3FF are reserved to indicate timing references. The 700mV luminance signal occupies a range extending from blanking (64 decimal or 040 hexadecimal) to peak white (940 decimal or 3AC hexadecimal). The bipolar ($\pm 350mV$) color-difference signals are shifted up to fit the A/D converter, which requires unipolar signals. They occupy a range extending from

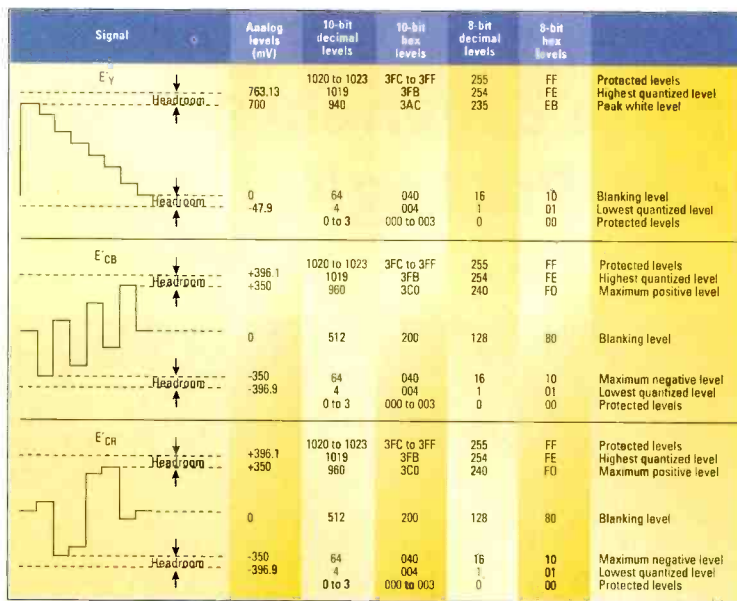

Figure 3. Relationship between 100/0/100/0 component color-bars signals and 10-bit and eight-bit digital sample values

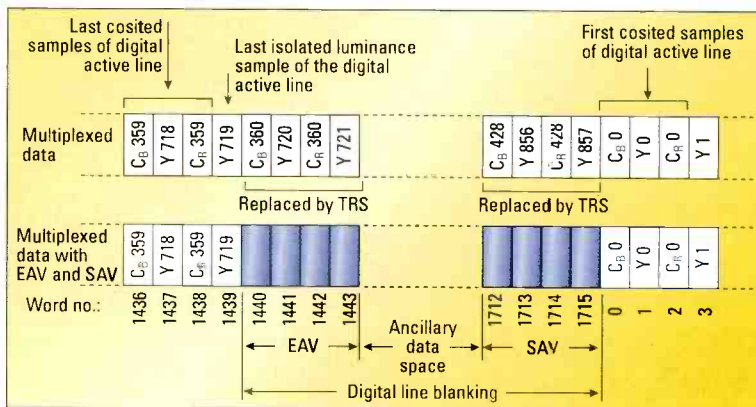

Figure 4. Details of the 525/59.94 scanning standard horizontal blanking interval showing the composition of the 4:2:2 digital data multiplex and the position of the timing reference signals, EAV and SAV

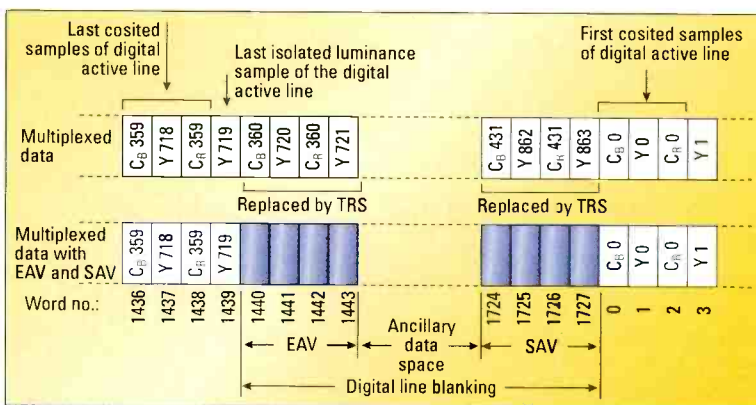

Figure 5. Details of the 625/50 scanning standard horizontal blanking interval showing the composition of the 4:2:2 digital data multiplex and the position of the timing reference signals, EAV and SAV

the digital equivalent of the maximum negative level (64 decimal or 040 hexadecimal) to the digital equivalent of the

maximum positive level (960 decimal or 3C0 hexadecimal). A small amount of bottom and top headroom allows for misadjusted or drifting analog component signal levels. The resulting Y SNR is 70.35dB for 10 bits and 58.3dB for eight bits.

As noted, the analog sync is not digitized. For synchronizing purposes, two four-word timing reference sequences (TRS) are carried. These are the end of active video (EAV) and the start of active video (SAV) TRS signals. Figure 4 (525/59.94 scanning) and Figure 5 (625/50 scanning) show details of the horizontal blanking interval. In both standards, there is a considerable ancillary data space that can be used to carry up to 16 audio signals (eight stereo signals) as well as other data such time code. In a future article, we will discuss the characteristics of bit-serial signals. **BE**

Michael Robin, a fellow of the SMPTE and former engineer with the Canadian Broadcasting Corp.'s engineering headquarters, is an independent broadcast consultant located in Montreal, Canada. He is co-author of Digital Television Fundamentals, published by McGraw-Hill and translated into Chinese and Japanese.



Send questions and comments to: michael_robin@primediabusiness.com



6:00 am

12:00 pm

6:00 pm

11:00 pm

System Configuration Made Easy

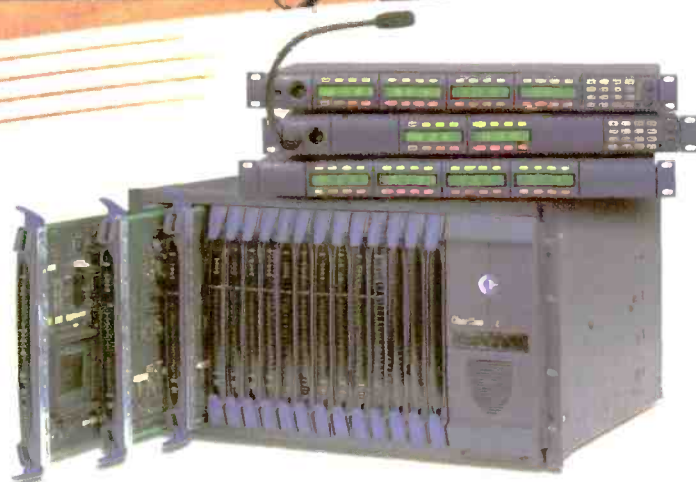

The Eclipse digital matrix intercom gives you amazing flexibility and responsiveness by combining a powerful communications platform with a highly intuitive interface and configuration program.

Just choose a station and the image appears on your PC screen. Select labels, drag and drop on the desired keys, and save your configuration. Up to 4 full-system configurations can be stored in the Eclipse frame for rapid changes.

Other Eclipse benefits include:

- Amazing port density—208 ports in 6-RU
- Intelligent linking among Eclipse systems
- Excellent audio with 24-bit sampling
- LAN or Internet access to system frames
- Built-in redundancy for failsafe use

Eclipse. News made easy.

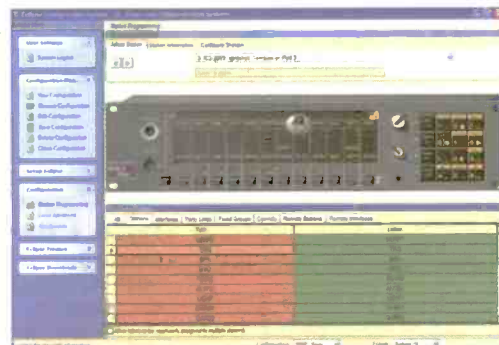

Drag-and-drop system configuration changes are fast and easy with Eclipse's intuitive software.



Internet network protocols

BY BRAD GILMER



Learning about network protocols is one of the challenges facing any video professional moving into the realm of computer networks. Protocols are formalized agreements about how different vendors will communicate over networks. Applications frequently use more than one protocol at a time to transport data. Protocols can be layered on top of one another in combinations called protocol stacks. (See Figure 1.)

Internet Engineering Task Force documents, called requests for comments (RFCs), codify many, if not all, protocols. You can obtain all of the RFCs related to a particular protocol from www.ietf.org/rfc.html.

Almost every protocol is known by a three-letter acronym (TLA), and this month's column uses more TLAs than usual.

Internet Protocol (IP). IP is the core of almost every LAN. It provides connectionless, unreliable delivery of datagrams. IP is connectionless, meaning that an application using IP can send packets immediately, without contacting the receiver ahead of time to establish a connection. This type of protocol doesn't require a two-way connection between sender and receiver. In this context, the term unreliable means there is no check in the protocol to be sure a specific datagram has been delivered.

IP knows nothing about the overlying application. It does not know the difference between streaming or file transfer; it supports either application. IP also doesn't guarantee that the network will deliver packets, or that, if it does deliver them, it will do so in the same order

in which an application sent them. Packets may be destroyed or even duplicated while in transit across the network. IP places no restriction on delay across the network.

After all this, you may wonder what IP actually does. One of its most important jobs is to describe a methodology for getting datagrams from one place to another. It also describes routing and addressing schemes that are absolutely fundamental for moving

transmission or whether a particular data packet made it to the receiver.

TCP running over IP (TCP/IP) is extremely common. Nonetheless, it is important for production professionals to understand that these are two separate protocols specified by two different documents.

TCP has limitations that can cause problems in professional production applications. It guarantees delivery by requiring the receiver to acknowledge

Learning about network protocols is one of the challenges facing any video professional moving into the realm of computer networks.

data across the network. Because of this, it is a key enabler of almost everything done on the Internet.

Transmission Control Protocol (TCP). TCP provides reliable transfer from one location to another. It also adds important functionality on top of IP. This includes guaranteeing delivery (although TCP will give up after a certain period of time if it fails to receive acknowledgement of packets), re-ordering packets so that the protocol presents them to the application in the same order that they were sent originally, and translating a stream of data generated by an application into IP

receipt of each packet. But heavy network traffic or congestion may delay these acknowledgements or lose them completely. TCP responds to congestion by cutting its transmission rate in half and then slowly increasing the rate over time as congestion decreases. With too severe a level of congestion or too large a network delay, the TCP transfer fails entirely. What is worse, even if the network has a large pipe, TCP's throttling behavior prevents data from filling the pipe. Another limitation is that the commonly available version of TCP limits file size to 2GB — an obvious problem when you are trying to move large video files. That said, TCP plays an important part in networked production.

Figure 2 on page 34 shows how an application might use TCP/IP to send data across an Ethernet network. As the application data works its way down the protocol stack, each of the protocols adds a header, and the subsequent protocol encapsulates both the data and the header from the protocol above it. This might seem like unnecessary overhead, but each of the

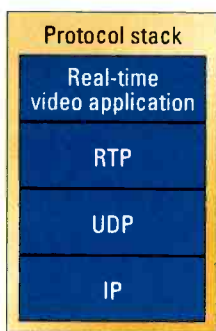

Figure 1. Different protocols, each with its own job to do, can be combined into a stack to move data across a network.

datagrams that the network can transport. TCP provides a bridge between applications and the structure of data flowing on the network, so the application does not have to worry about how protocols encapsulate data for

protocols performs an important function. Without IP, for example, you would not be able to route the packets using IP addresses. (Note that the drawing is not to scale. An IP header is 20 bytes long, but the datagram can be up to 65,516 bytes long.)

Unreliable Datagram Protocol (UDP). From its name, you would think that UDP would be totally unusable for video. Why would anyone want to use an unreliable protocol? UDP does not require a positive acknowledgment – it just sends the packets to the receiver without any feedback loop. This method might seem to be a problem but, in fact, it does not suffer from many of the issues related to TCP rate throttling.

Many critical applications that use UDP handle the issue of guaranteed delivery themselves.

Because UDP does not require acknowledgement from the receiver, it is useful in cases where one sender

real-time streaming with UDP combined with other protocols, such as RTP.

ReSerVation Protocol (RSVP). Network congestion can be a source of headaches for the production professional. When the Internet is congested, routers must drop packets if the next piece of equipment in the chain is not ready to accept them. This can be a problem for real-time applications such as streaming video, where the effects of packet loss are easy to hear and see.

A logical solution is to develop a protocol that reserves bandwidth along the way, so that the data you transmit is never dropped. This is the idea behind RSVP. Network

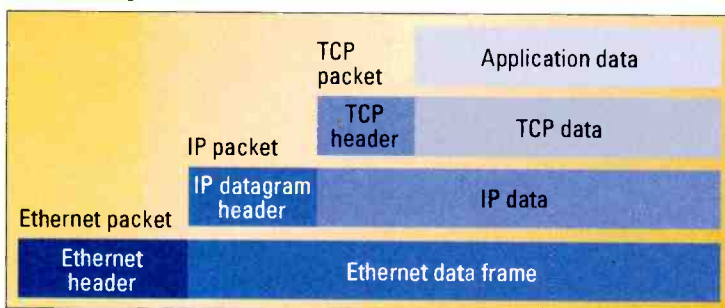
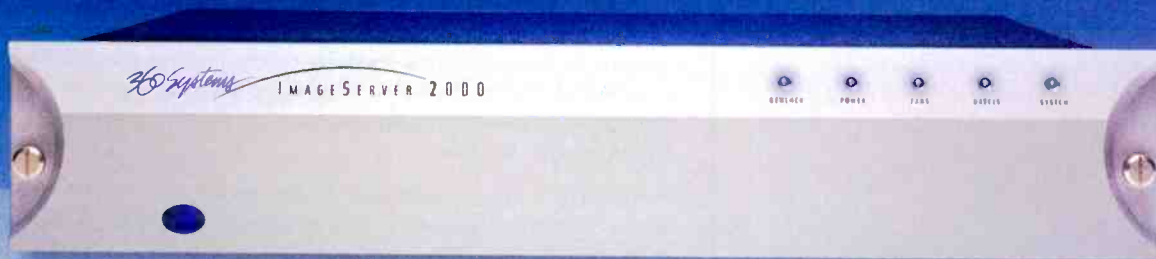

Figure 2. In this example, an application creates data and sends it via TCP/IP over Ethernet. Each protocol adds its own header to the payload data. Note that the headers are not shown to scale and are typically a small fraction of the total packet.

wants to send the same information to multiple receivers and is not too worried if some pieces get lost along the way. Broadcasters can perform

The Right Stuff. The Right Price. 360 Systems' Image Server 2000



WHEN THE VIDEO SERVER SALES GUY COMES CALLING, it seems there's always an Elephant in the room: *You know* storage should cost less now than ever before, but truth is, 90's-era servers can't make the change.

Which is why 360 Systems' Image Server employs a smart, next-generation design that delivers everything but the elephant-size price.

The Image Server 2000 is perfect for tape replacement, satellite ingest, graphics & animations,

or as a full-time play-to-air server. Of course it's fully compatible with most automation systems and desk-top controllers. Using FTP, you'll be able to move program content over Gigabit Ethernet, and share files with other MXF enabled products.

For just \$10,000, the Image Server 2000 delivers three video channels, impeccable images, great specs, and it also makes excellent business sense. Isn't it time to rethink what you're paying for video storage?

Check out the Image Server 2000 at www.360systems.com, and download the new user manual while you're there. Or call us direct to arrange a demonstration at your place.

360 Systems
BROADCAST

On Air Coast-to-Coast

Tel: (818) 991-0360

E-mail: servers@360systems.com

Workflow has never been this fluid.

Integrated workflow. Everyone claims they provide it. But do they truly deliver what your broadcast environment demands? Encoda does with its reliable, mission-critical transmission automation solutions based on advanced LINUX® technology. Fully integrated asset management supports nearly all existing and emerging industry metadata standards. Tie it all together with end-to-end broadcast monitoring and error detection that makes easy work of keeping a complex, multi-channel operation like yours on-air. Proven success in 29 different countries representing more than 4,000 channels demonstrates why today's largest broadcasters rely on Encoda Automation Solutions Group as their trusted advisor. To find out more, visit www.encodasystems.com/workflow



Encoda Systems™

Media Management & Automation Solutions



Phone North America: 1 866 478 9188 Sydney: 61 2 9975 9700 EMEA: 44 1256 379030

Encoda Case Study: Southern Cross Broadcasting, Australia

ASSETS:

4 sites
25 channels

MISSION:

Centralization
Improve ROI
Improve on-air quality

SOLUTION:

Encoda Automation
D-Series™



Raoul Prideaux, Southern Cross Broadcasting Director of Engineering and Technology

"With the rollout of digital television in Australia, we were faced with either rebuilding our 4 regional television stations scattered across eastern Australia or completely rethinking our workflow and centralize. We knew centralizing could save significant capital and operating costs. And after considering all major automation vendors, it became clear that Encoda offered us the features and rock-solid performance we needed for our style of regional affiliate operation. Better still, they provided the flexibility to configure multiple synchronous schedules on one screen. The D-Series automation solution has not only performed to our expectations, but so too has the after-sale support and training." Mission accomplished.

Dseries

devices that understand RSVP reserve a certain amount of bandwidth for you to use. While RSVP does provide some solutions, it presents two challenges. First, RSVP is not widely supported on the Internet so, beyond your ingress point, RSVP may fail to provide the needed bandwidth. Second, from a business perspective, there is some

question as to whether all bandwidth providers on the public Internet support RSVP. Some providers may argue that guaranteeing one user bandwidth that they may or may not use is a waste of bandwidth. Others see the potential for a new class of service in offering that type of bandwidth and believe customers will pay more for it. Time will tell

whether this protocol becomes as ubiquitous as UDP, TCP and IP.

MultiProtocol Label Switching (MPLS). An alternative to reserving bandwidth along the way is to specify the route the traffic should take through the network. This is called route pinning. The assumption is that the network engineer will choose a route with enough capacity to handle the traffic. Or, perhaps, specifying the route will allow the traffic to travel over a path where all the equipment understands a particular protocol, such as RSVP. MPLS provides this functionality, as well as giving users the ability to describe what should happen if a specified path fails.

Real-time Transport Protocol (RTP). RTP is used to move real-time streams including audio and video. It provides timing information that allows the receiver to reconstruct the original timing of the transmitted material in a way that identifies the content being sent, provides security, and notifies the overriding application of lost data. RTP frequently rides on top of a UDP/IP stack.

So many protocols are important to the industry that it was hard to choose just a few for this article. If I have omitted your favorite one, it is probably because of space limitations. The ones I list here are frequently discussed and relatively well-supported. Achieving interoperable support for lesser-used protocols is another challenge facing production professionals. **BE**

Brad Gilmer is executive director of the AAF Association and the Video Services Forum. He is also editor in chief of the "File Interchange Handbook."



Send questions and comments to:
brad_gilmer@primediabusiness.com



To order Brad Gilmer's book, *File Interchange Handbook for Images, Audio and Metadata*, from Focal Press, visit www.focalpress.com or call 800-545-2522.

The book is also available from most major booksellers.

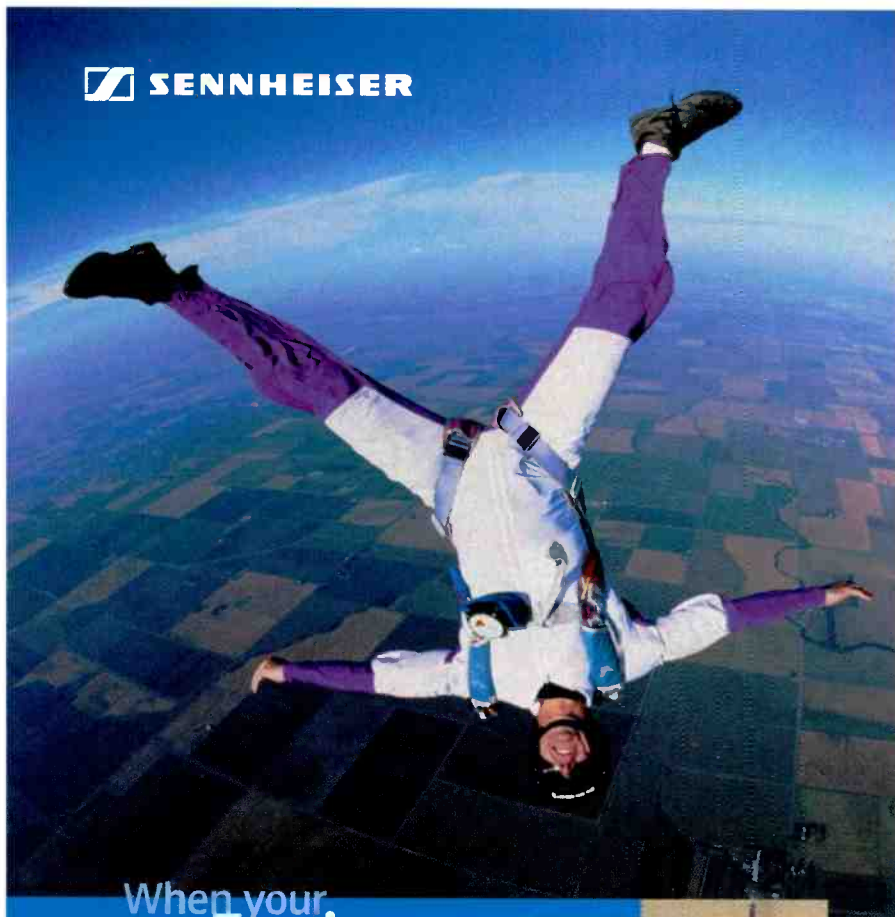

When your
Equipment
absolutely Has To Work

Must-Have Wireless: Sennheiser 3000 & 5000 Series In Real Life, there are no second takes. That's why you need Sennheiser 3000 and 5000 Series systems and components. Our benchmark products have garnered praise from every corner of the industry and an Academy Award® for our wireless technology. We've brought you such innovations as the Neumann KK105 vocal capsule and the SK5012 - the world's smallest professional bodypack. But more than that, Sennheiser gives you the best RF link and the most durable, dependable gear on the planet. When your life depends on reliable wireless, choose Sennheiser.



www.sennheiserusa.com

Sennheiser Electronic Corp., 1 Enterprise Drive, Old Lyme, CT 06371 USA • Tel: 860-434-9190 • Fax: 860-434-1759
Mexico: Tel: (525) 639-0956 • Fax: (525) 639-9482 • Canada: Tel: 514-426-3013 Fax: 514-426-3953



The Most Versatile IOT Transmitter Available



Axcera's Visionary transmitters lead the industry in versatility. These amazing transmitters offer broadcasters the choice of single- or multi-collector OT amplifiers from various manufacturers, with air, oil, water, or water/glycol cooling, for analog or digital operation, all in the same transmitter design. And to protect your investment into the future, systems can be configured for easy field conversion between analog and digital operation and between various tube technologies with nearly 100% re-use. Industry leading technology and the ability to choose - from Axcera, the RF experts.



Digital spot delivery

BY GEORGE KRUG

As Lifetime's network operations facility made the transition to digital technology, daily deliveries of commercial spot reels seemed increasingly anachronistic. The facility processed thousands annually, each reel requiring a technician to transcribe label data into the traffic system manually and perform an ingest step to encode it to digital file format.

Thousands of manually processed spots represented thousands of opportunities for error and thousands of boxes and reels to dispose of. The network kept two aging one-inch VTRs in operation solely to handle spot ingest. When satellite and IP-based digital spot delivery services began to appear, its motivation to investigate them was high.

DG Systems was the first such service the facility encountered, followed

in the facility via satellite or other connection. With this type of system, ingest was done by the delivery service. No more spot reels!

As is often the case with a transition to a new technology, the hardware was ready, but the software, the processes and the workflow needed careful adaptation, even total re-invention. Spot-prep processes had evolved over the years to include multiple quality-checking and gatekeeping operations. The network began an end-to-end process review to ensure that these needs continued to be met.

As the analysis began, some questions were as simple in nature as they were profound in their impact: When a spot is delivered electronically to an ever-waiting catch server, how will the channel know? If the facility drags the spot onto its on-air server, how does it update its traffic and automation databases? When does the network view the spot, or does it have to? Questions mounted, and an analysis took shape.

First steps

The evolution began with the network receiving small numbers of files via one of the services. Most processes remained the same, sans videotapes. Whereas the delivery of a spot reel in the morning's mail was self-evident, the delivery of a file to a server was heralded by a fax or e-mail to a designated recipient. That notification became the source for the label data, which still was transcribed manually into the traffic system.

This traffic system entry continued

to serve as the signal to the traffic department that the spot master was in-house. Traffic assigned house ID numbers to the priority spots so they would be included in that evening's dub order, which the librarian then generated in both hard copy and as a text file on diskette. Master control ingested the spots upon receiving the reels and the dub order. One change was that the dub order was amended to group the disk-based spots together for ease of processing and to ensure that the techs knew where to find the spot masters.

Initially, a catch server was interfaced to the automation ingest station to behave like a VTR. A tech first loaded the dub-order text file into the automation database. Then, commercial spots were ingested by decoding the file to video and re-encoding to the on-air content server in real time, matching the spot to a record in the dub order. While not as efficient as a file transfer, this was far more efficient than laying the spots off to tape for later ingest — a step the facility had no interest in taking. These measures were a step forward, but only a small one. Worse, the channel could process only a few spots this way because only one of the catch servers could emulate a VTR.

A leap forward

A great leap forward took place when the station installed the Telestream FlipFactory Traffic Manager (TM), which combines FlipFactory transcoding with tools to manage the flow of metadata.

The workflow automation system provides a clearinghouse for the catch servers, aggregating the metadata from arriving spots and transcoding the spot files for compatibility with



A technician prepares to push commercial spots from the Telestream FlipFactory Traffic Manager server to Lifetime's on-air playback server. This step in the spot-preparation process replaces the need to thread and play a videotape master copy of a commercial.

by FastChannel, Media DVX and Vyvx ADS. Though each has distinguishing features, the premise is the same: Commercial spots in digital file format are delivered to a catch server

the facility's play-to-air servers. Folders and reports, as well as proxy copies of the spots, were available on the TM server, viewable from desktops around the facility. This negated the need for faxes, e-mails and VHS screening copies.

In order for the traffic and library departments to access these features, the station's IT and engineering departments needed to create a gateway between the engineering and corporate LANs. With viruses and hackers a

as product names and spot titles being omitted or transposed. Also, the network wanted the data to move to its databases electronically, but not unattended. To solve these problems, the facility found helpful partners in its IT department.

LISA

To provide an opportunity for some gatekeeping and data grooming, IT developed Lifetime Information System Authority (LISA), which allows

automatically. Doing so, however, means that the spot could air without anyone first checking for quality, content or timing. The station wasn't ready to take that leap of faith. Therefore, it disabled the system's auto-flip feature and preserved the all-important operation of having a technician oversee the transcoding of files to the content server, viewing each one and making corrections as needed.

The new workflow has taken shape. Now, catch servers can receive spots and metadata that from there are aggregated onto the TM server. A librarian can use LISA to monitor and groom the metadata before it flows to the traffic system. The system then delivers dub lists and files to master control for ingest, where a technician supervises the delivery of spots to the on-air servers, quality checking them after the operation. The station will continue to "rack-and-roll" the dwindling number of tapes it still receives.

Thanks to ingenuity and invention, numerous obstacles were overcome, and the channel's goals were realized. The workflow changed, but the station maintained its "checks and balances" and can — at last — take full advantage of file-based commercial spot delivery. **BE**

George Krug is vice president of network operations at Lifetime Television.

Hours of daily, manual transcribing are reduced to minutes of "picking and clicking."

growing concern, they paid strict attention to network security.

A key goal was to eliminate manual transcription of spot data during processing. The TM server did a handy job of collecting and mapping that metadata, partially conforming it to the facility's needs. However, a key problem remained: The traffic system demanded that certain fields conform to a table of values, and the incoming metadata often didn't match those values. "Procter and Gamble" wouldn't work when "P&G" was required. A job that was intuitive for a person was complex for a software application. There were other metadata issues, such

the user to view the list of newly arrived spots and map values in the metadata to valid values in the traffic system tables. Lookup tables and check boxes make this a keystroke-free operation. This simple tool provides the best of both worlds, allowing the data to flow electronically while providing an opportunity to check and correct it. Hours of daily, manual transcribing are reduced to minutes of "picking and clicking."

LISA also associates a house ID (assigned by traffic) with each spot file on the TM server. Once traffic assigns a house ID, all conditions are met to move the content to the content server

network
t h e i n n o v a t o r



Contact Network Electronics
Phone: 800 420-5909
E-mail: ussales@network-electronics.com
11075 South State Street, Suite 27
Salt Lake City, Utah 84070

LATEST TECHNOLOGY

It's a competitive world. You need the latest and the best technology to stay at the top of your game. Our MTBF numbers are industry leading and will give you peace of mind.

QUICKEST DELIVERY

No more waiting! Our huge inventory guarantees speedy deliveries. 50-100 small routers usually ship in 5 working days; 10 routers or less can ship the same day.

FASTEST SERVICE

Through our Advanced Replacement Policy you will receive a new unit BEFORE you send the old one back — no questions asked!

HIGHEST INNOVATION

Need space? Need flexibility? Need expandability? Our compact routers, signal processing products and optical modules address every format in the most configurations available today.

3 YEAR WARRANTY

Worry free! Stress free! Our extensive warranty gives you peace of mind for 3 years. And if you want even more ask about our NET-CARE system that extends your coverage to 5 years or longer.

TOTAL PICTURE

A full range of products to accommodate every need, every format, every budget. Our TSS (Technical System Sales) Group is ready to design your system to suit your requirements at prices you can afford.

ROUTERS • FIBER OPTIC TRANSPORT • SIGNAL PROCESSING

www.network-electronics.com

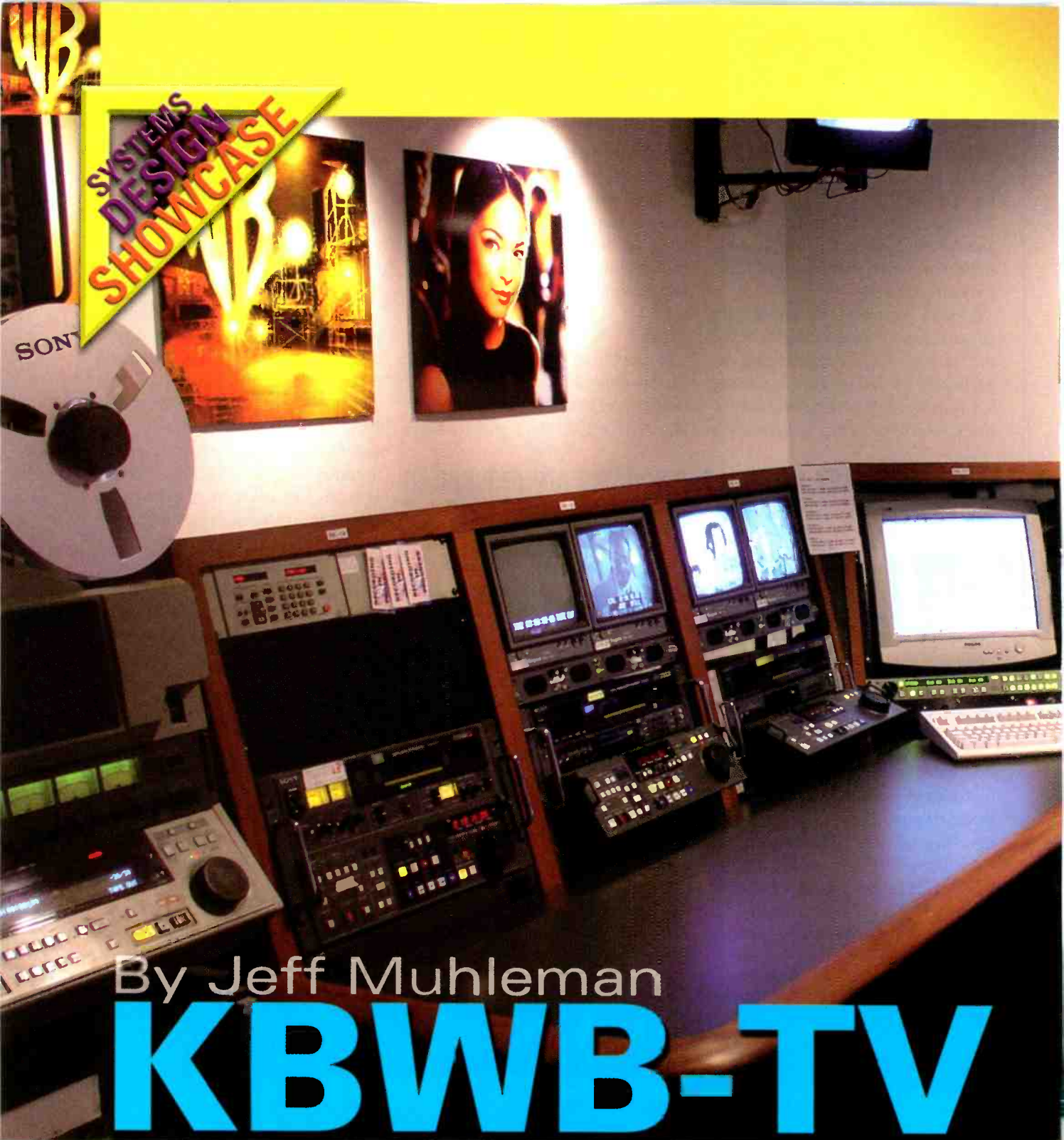

By Jeff Muhleman

KBWB-TV

converts to a multichannel digital system

Transitioning from analog to digital opens new doors, including one to multichannel operations. The bandwidth freed within the digital realm makes multichannel broadcasting an attractive option for building revenue through additional program streams.

Digital System Technology's (DST) most recent multichannel system project is integrating San Francisco station KBWB-TV. The station owner, Granite Broadcasting, hired DST in 2002 to work with station engineers on ways to improve cost-efficiency, reliability and on-air quality.

A preliminary study

DST began with a comprehensive study of the station's analog operation, focusing on reducing operational costs by eliminating cumbersome processes. The station's lack of a news operation enabled DST to shift its focus from production to program acquisition through



create cleaner transitions between programming and station breaks for a more consistent and pleasing on-air look.

The transition

The project focused on replacing aging analog master-control and ingest systems with a new digital master-control center, 10 associated equipment racks and a server-based ingest suite. Digital video servers replaced the station's analog videotape-based systems for interstitial and long-form playback. An automated on-air delivery system reduced operational costs and established a clear signal path for three channels, including one that could accommodate a high-definition channel.

KBWB continued broadcasting in analog as DST began work in an existing area designated for the digital master control and its technical core. DST built all equipment racks and systems on-site. Installers installed color-coded, HD-upgradeable Belden 1505 wiring so that signals can be identified readily throughout the facility as digital video, analog video and digital audio.

A Sundance FastBreak Automation system handles all master-control equipment central to the on-air output. A Miranda Presmaster 2 master-control switcher and Imagestore channel-branding system are integrated to accommodate automated multichannel operation. An SDI Leitch Integrator system routes signals into the Presmaster 2 for switching and the Imagestore for keying and insertion of stills, logos and other graphical elements. A signal path links multichannel streams with the microwave system for distribution. An existing KTech Performer HD switcher upconverts the HD stream.

Rather than manually pushing buttons for transitions, the master-control operator essentially plays a supervisory role in relation to the on-air product, including programming ingest, signal monitoring and other media management issues. In the event of automation failure, a Leitch 16x1 bypass switcher can accommodate manual operation with the press of a button.

Ingest operations for analog and digital formats are colocated in a space next to master control. DST rewired KBWB's existing analog ingest devices and adding A/D converters so they can be interfaced with the digital operation.

playback processes. The study encompassed the station's complete workflow process, from the initial receipt of media all the way through to air.

In the next stage, DST thoroughly researched technology and vendors for the best solutions, and the station made the final vendor selection. The team

determined that comprehensive automation would be the best way to streamline operations and improve the station's on-air look, reducing inaccuracies attributed to labor-intensive manual processes. By automating and tightening workflow, the station could reduce the risk of losing commercial spots and

**SYSTEMS
DESIGN
SHOWCASE**

Other master-control systems include a Chyron MAX CG and an Ikegami monitoring wall consisting of separate color and black-and-white monitors set up on adjustable shelving for easy reconfiguration. An Omneon SPECTRUM server sends audio into the Imagestore system for synchronization with the program stream.

Two Tektronix SPG422 sync generators synchronize all master-control equipment to avoid on-air glitches. A Tektronix changeover switch automatically switches to the backup unit if the main system fails.

The existing analog terminal-gear room on the other side of the master-control wall remains intact to accommodate analog streams within the system. Ten equipment racks in master control accommodate several VTRs and Leitch terminal equipment, including analog-to-digital and digital-to-analog audio and video converters, and audio and video DAs.

The digital and analog terminal-gear equipment connect in a separate room. Special tie lines connect the



DST replaced KBWB's analog master control with a new digital center capable of multichannel streaming. The station chose an automated on-air delivery system to reduce its operational costs while establishing a clear signal path for the three channels.

Leitch Integrator digital router and the analog system — each equipped with a corresponding A/D converter — to enable master control to input analog signals. Eventually, the station will remove these tie lines and the analog core as analog signals disappear from the system. The current 32x32 digital router is wired for 64x64 to accommodate future expansion.

The audio portion of the digital routing system features two layers of AES digital audio. This is unusual for many stations, but the additional AES layer allows the facility to produce four channels of audio and perhaps offer a second language for its broadcasts. This can be especially useful for San

Francisco's multilingual viewership.

An Intelli-Sat satellite ingest system controls existing KTech satellite receivers that receive and automatically record feeds coming into the Omneon video server. Snell & Wilcox IQ modular frame synchronizers condition incoming satellite feeds before the feeds proceed to the router. Three new controllable satellite dishes on the facility's roof interact with Intelli-Sat, allowing the ingest station to receive satellite feeds with minimal human operation. The dishes also feature a narrower angle of reception compared to the previous models, lowering vulnerability to interference.

The ingest station occupies a separate room close to master control. This

Design team

DST:

Mickey Kroll, design engineer
Jeff Muhleman, vp, contracts
Bill Hodson, lead installer
Garrick Huey, account mgr.

KBWB-TV:

Frank Brucks, chief engineer

"Omneon is the one server that fits our tight budget, meets all our requirements today and supports us as our needs change."

Helge Blucher

Vice President
Detroit Public Television

With Omneon SPECTRUM™ media servers, Detroit Public TV implemented a solution that works across their entire operation, was configured precisely to their needs, and can expand in smart, manageable increments—all without replacing the original system and in many cases, without taking the system off-line.

To learn more about the unique advantages of an Omneon SPECTRUM media server system visit www.omneon.com.

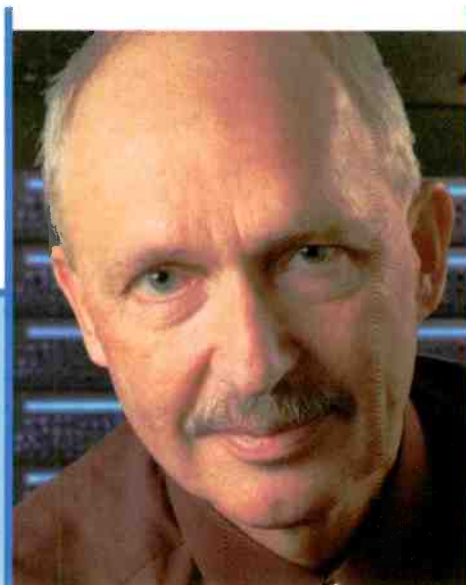

It's not just
what you serve.

It's who.

OMNEON
VIDEONETWORKS

HDTV

Time for an update...



FUJINON
HD
DIGITAL



HA22x7.2ESM



HA26x6.7ESM

*HA26x only

NO ONE DELIVERS MORE CHOICES THAN FUJINON!

- Digital control system
- Focus breathing compensation
- *Advanced backfocus
- *Focus fader
- "FND" diagnostics system
- New EBC coatings
- One shot preset
- RS-485 compatible

FUJINON

Broadcast and Communications Products Division

FUJINON INC. 10 High Point Dr., Wayne, NJ 07470-7434 Phone: (973) 633-5600. FAX: (973) 633-5216

FUJI PHOTO OPTICAL CO., LTD. 1-324 Uetake, Kita-Ku, Saitama City, Saitama 331-9624 Japan Phone: 81-48-664-2 52

www.fujinon.com

Come and
see us at IBC
Hall 1, Stand 249

just add water...



Expanding on e2v's current
broad ranges of IOTs and
Klystrons. Innovation, power unleashed.

Energy saving collector IOTs (ESCIOT[®]s)

Proven water
cooled designs

Increased efficiency
up to 60% in 5
stage designs

30kW average
digital power

60kW analog power

Plug-in style for ease
of maintenance



EEV-IOTs now with lives over 100k hours

e2v

e2vtechnologies

e2v technologies inc. USA
Tel: 1-914-592-6050
Email: enquiries@e2vtechnologies-na.com

<http://comms.e2vtechnologies.com>

Equipment list

Chyron MAX CG

Leitch

Integrator digital router

16x1 Clean Switch bypass switcher

Terminal equipment

Miranda

Presmaster 2 MC switcher

Imagestore channel branding

Snell & Wilcox IQ Modular satellite frame sync

Omneon SPECTRUM Media Server

Ikegami color/B&W monitor wall

Orban Optimod 6200 AES compressor limiter

Sundance Digital

FastBreak Automation system

Intelli-Sat satellite ingest system

Tektronix

SPG422 sync generators

WFM601A digital waveform monitor

Wohler 8x1 AES audio router

Dorrough 280-D AES audio meters

room also serves analog ingest, although Omneon video servers and a Sundance automation system (comprised of two prep stations and two air stations) have automated and simplified tape operations. Operators use the prep stations to ingest programming into the video servers, create playlists and finalize on-air schedules. The air stations recall programming from the servers and play broadcast materials out to air.

The room supports two ingest formats. The existing ingest system remains intact on a smaller scale and features several small analog video servers (DG System, Vyvx, Pathfire and Media DVX) and tape machines. These devices were rewired and integrated with analog-to-digital converters to feed the digital ingest system.

The Omneon video servers comprise the heart of the new ingest format and tie into the Sundance system to provide storage. The servers replace several VTRs. The VTRs still in service consist of DigiBeta, Beta SP and one-inch machines. The ingest room console also includes color and black-and-white monitors used to QC program materials as they are recorded. One person can handle the entire ingest operation at most times.

KBWB is currently using only its main channel but is fully prepared to move forward with multichannel broadcasts and take advantage of the cost and operational efficiencies offered by its modern automated system. Thanks to a wealth of modern digital equipment, the station is on its way to using its newfound bandwidth.

BE

Jeff Muhleman is vice president of contracts for Digital System Technology.

EXTREME Definition

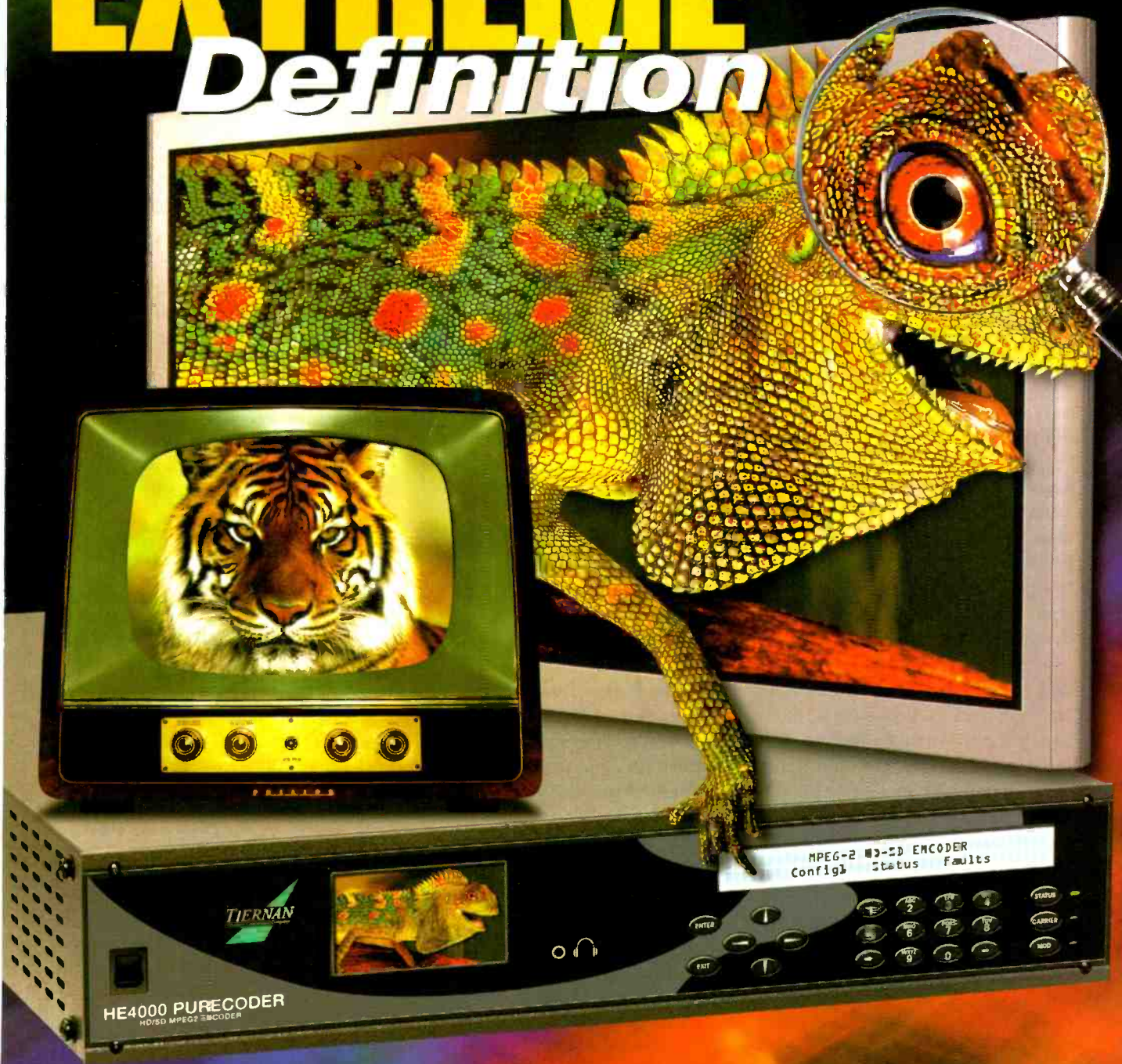

HE4000: HD AND SD Encoder

- HD and SD Encoding Simultaneously
- Front Panel Monitor
- Advanced "PUREPEG" Technology
 - Enhanced Low Bit Rate Performance
 - Absolute Finest Picture Quality
- Satellite and Terrestrial Interfaces
- 1 MB/s to 160 MB/s

TIERNAN
A RadynComStream Company

Phoenix: 602-437-9620
San Diego: 856-458-1800
UK: 44-1420-540233
America: 358-458-1800
Singapore: 65-6225-4016
Beijing: 85-10-65831975
www.radr.com
www.tiernan.com

Advances in transmitter technology

BY DON MARKLEY



At this year's NAB show, the most noticeable feature of the new television transmitters was their close resemblance to last year's models. There were differences, to be sure, but they were not earthshaking. Instead, they were smaller, sophisticated changes in design and operation.

Low-power DTV

Low-power DTV transmitters were abundant. Many stations have started broadcasting their DTV signals with low-power systems to provide immediate service to the city of license with the intention of upgrading to higher power to cover a larger area at a later date. Some good low-power transmitters have been introduced as a result. For example, Harris' Ranger series of DTV transmitters offer power up to 1kW. Their power level is low, but the quality and features on these transmitters are right up there with their big brothers. They use the same CD-1A exciter, produce the same signal as

high-power systems, and have full adaptive correction.

Cooling

Nearly all manufacturers now offer solid-state transmitters, most with power levels up to 10kW. They do this simply by combining multiple plug-in amplifier modules. Some manufacturers, such as Harris and Thales, offer higher-power transmitters by

As with solid-state systems, cooling continues to be a headache for makers of IOT transmitters. For a better understanding of transmitter cooling, you can find a technical paper at www.axcera.com that covers the subject in great detail. Axcera uses both liquid and air cooling in its transmitters, but the technical paper also briefly discusses the use of oil. Most other manufacturers primarily use air

As with solid-state systems, cooling continues to be a headache for makers of IOT transmitters.

providing higher power from each module. But, in attempting to increase the power of solid-state power modules, they run into the same old problems — primarily, cooling. The smaller the module, the harder it is to cool. Some manufacturers have solved this problem by liquid cooling each individual module.

cooling in their solid-state transmitters and liquid cooling in their IOT systems. Furthermore, most use what can be described as a single-loop cooling system. This uses a single liquid to cool the amplifiers. The system routes the liquid (usually a glycol-water mix) through an external heat exchanger to lose the heat to the outside air.

Thales now uses an oil-based cooling system for its MSDC-IOT devices. This application uses a relatively small amount (about 10 gallons) of synthetic oil similar to that used for cooling transformers. After flowing past the MSDC IOT, the oil passes through a heat exchanger that transfers the heat to a glycol-water mixture, which is cooled in the conventional manner through an external heat exchanger. This type of system offers several advantages over other methods. First, the oil is an efficient coolant, so only a small amount can be used to easily transfer the heat to the glycol and water. Second, the small amount of oil involved is easy to filter. Third, unlike de-ionized water, the oil does not permit electrolytic corrosion. In addition,

FRAME GRAB

A look at the consumer side of DTV

Digital TV sales on the rise

Nine million HDTVs and monitors have shipped since 1998

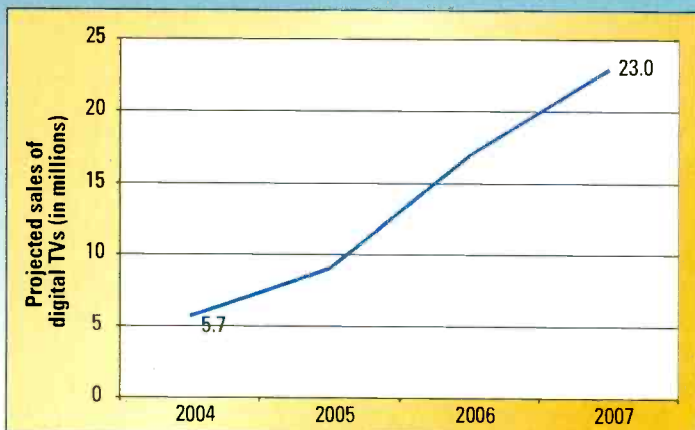

SOURCE: Consumer Electronics Association

www.ce.org



At Mount Wilson, near Los Angeles, four integrated rooftop heat exchangers provide cooling for up to eight dual-tube IOT transmitters. Photo courtesy Axcera.

many broadcasters are purchasing new transmitters to replace existing systems. Those existing systems usually have heat exchangers in place to deal with water-glycol coolants. Those same heat exchangers can be used with the new transmitter, saving the station a considerable amount of money.

So, which is the best cooling system? There is no single answer. Transmitter designers pick a cooling system and include the requirements of the system in their overall transmitter design. Is one better than the rest? Probably not. At least, there's probably not enough difference in performance from one cooling system to the next

to make it the deciding factor when you are selecting a transmitter, but it is one factor to consider.

The only setback that comes to mind is that inevitable day when the broadcaster will have to replace the coolant. Dumping many gallons of water into the transmitter building would be a real mess. Mixing that water with glycol would be even less pleasant. But 10 gallons of transformer oil running across the floor would be more than one could tolerate.

Adaptive correction, remote control

Another transmitter advancement is adaptive correction, which nearly all transmitters now use. The miracle of microprocessors has completely changed exciter design. The new exciters can correct almost any fault, nonlinearity or distortion in the amplifiers. The better systems also provide extensive displays, available either by modem or the Internet, to advise operators of the system's performance and allow them to adjust it extensively from the comfort and convenience of their family room. Even more significantly, the networking systems currently available allow the director of engineering to check and adjust all the transmitters in the system across the country in the

same fashion. Raise/lower arrows on the keyboard have replaced the old knobs and cranks. At least the station staff usually knew what was going on when they turned a crank. When the computer does it, it's more like some magical incantation.

Advanced translators

The other area of real change is in the development of DTV systems for television boosters or translators. Digital television offers some new possibilities for translators. Again, the reader is referred to the Axcera Web page for more information on this subject. The company's engineers have done some interesting work in the translator area. Perhaps the most significant point is that digital translators can be chained together for 40 or more consecutive hops. Analog systems degenerate to noise with bad audio after three or four hops. But digital systems clean up the received signal with error-correction circuitry at each receiver. The signal that is sent forward is then as clean as the original. **BE**

Don Markley is president of D.L. Markley and Associates, Peoria, IL.



Send questions and comments to:
don_markley@primediabusiness.com



Winner of the STAR award at NAB





Introducing Xenon

The Signal Processing Router

Multi-format Routing plus optional plug-ins

Initial plug-in functions include

- Channel Branding
- Master Control
- Embedded Audio Processing

888.638.8745 | sales@quartzus.com | www.quartzus.com

A new way to monitor DTV transmission line

A new system may help DTV broadcasters monitor the health of their transmission line and locate faults to within 48 feet. Photo taken at KSWK-TV in Bunker Hill, KS. Courtesy Lloyd Mintzmyer.



By Andre Skalina and
William A. DeCormier

To a broadcaster, the health of the transmission line, from the transmitter through the antenna, is a prime concern. The line, the antenna, combiners and other associated components carry high RF power and are constantly exposed to the weather and the seasons. The stress of this weathering and aging can eventually cause problems, so it's important to monitor the line and the other components. Currently available transmission-line monitoring systems are frequency-domain, VSWR-based systems. When such a system reports an increase in VSWR, say, from 1.10:1 to 1.20:1, the station cannot determine if the problem is in the transmission line, the antenna or the filters in the transmitter building. And detecting and locating problems in the transmission line is especially critical for DTV stations because they use different power safety margins than NTSC stations. The power levels that an NTSC station uses to specify its transmission system include both the peak-to-average ratio as well as the black-picture-to-normal-picture ratio. DTV stations have no such ratios and rely solely on the 10 percent margin of safety specified for all transmission systems.

This article discusses a new transmission-line monitoring method that allows DTV stations to locate a problem on the line to within approximately 48 feet. It uses the multipath-cancelling reference signal transmitted from the DTV station's antenna, along with the adaptive-equalization

filter in a demodulator, to estimate the location of anomalies on the station's transmission line.

The concept

To counter multipath effects, TV transmitters produce multipath-cancelling reference signals that receivers can use to detect and eliminate ghosts. NTSC transmitters send a ghost-canceling reference (GCR) signal; ATSC transmitters send a similar equalization signal. Inside the receiver, a demodulator with an integral equalization filter detects the reference signals. In ATSC receivers, a digital signal processor dynamically adjusts the taps in the equalization filter to compensate for detected anomalies. The NTSC GCR signal allows receivers to

minimum range of $-30\mu\text{sec}$ to $+45\mu\text{sec}$. Some DTV systems may have total forward and backward equalizer ranges greater than $90\mu\text{sec}$. But, in all cases, the receiver's equalizer filter contains taps 93nsec in duration.

Because the equalizer filter corrects for pre and post echoes, its tap values are a measure of the echoes (VSWR discontinuities) in both time directions. By connecting an equalizer-equipped demodulator to a directional coupler on the transmission line in the transmitter building, the tap values in the first 1- to $2\mu\text{sec}$ on the positive side will respond to reflection coefficients (discontinuities) in the line. Because the signal travels from the transmitter through the transmission line to the antenna at nearly the speed of light, 1000 feet of line represents approximately $2\mu\text{sec}$ of tap values. The coupler monitors the reflected signal in the line, which traverses a two-way path. Thus, the resolution from the 93nsec tap is approximately 48 feet.

connect the transmission line and the demodulator. The coupler sampling the reflected RF signal provides the primary RF feed to the demodulator. For normal, faultless transmission-line operation, the reflected signal is the only RF signal required. But, to maintain resolution and avoid losing the reference-signal equalizer lock, a forward coupler sends a second RF source into the reflected sample signal at a reduced level. The system provides a graph of dynamic-equalizer tap energy, which is proportional to TDR-like discontinuities in the entire RF transmission-line system, from the directional-coupler sample point through the antenna. The Visual Basic program interrogates the tap data provided by the demodulator software and compares the measured values to a site-specific set of warning and shutdown alarms. An experiment performed to test this concept set couplers at -50dB with -44dB directivity in a DTV transmission line with 4250W TPO at channel D38. At the levels these couplers provided, the demodulator operated at an AGC level of 40dB in a range of 0dB to 60dB . For DTV TPOs higher than that listed above, attenuators are necessary for optimum performance.

Figure 2 on page 50 contains four sets of data and illustrates several features of the system. Note the large signal at tap 1 that serves as an equalizer-locking signal for the demodulator. The resolution in the horizontal axis of the demodulator system is 48 feet

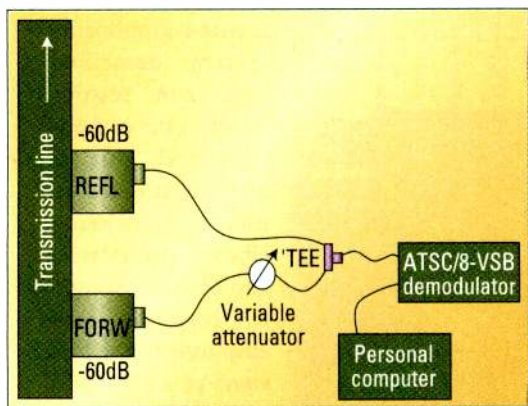

Figure 1. The basic components of the monitoring system include couplers, an attenuator, a tee, a demodulator and a PC.

detect ghost signals that arrive any time from $3\mu\text{sec}$ before the main signal to $45\mu\text{sec}$ after it. DTV equalization has expanded the range of correction to a

personal ATSC/8-VSB demodulator and a proprietary, menu-driven, PC-based Visual Basic program. Two high-directivity directional couplers

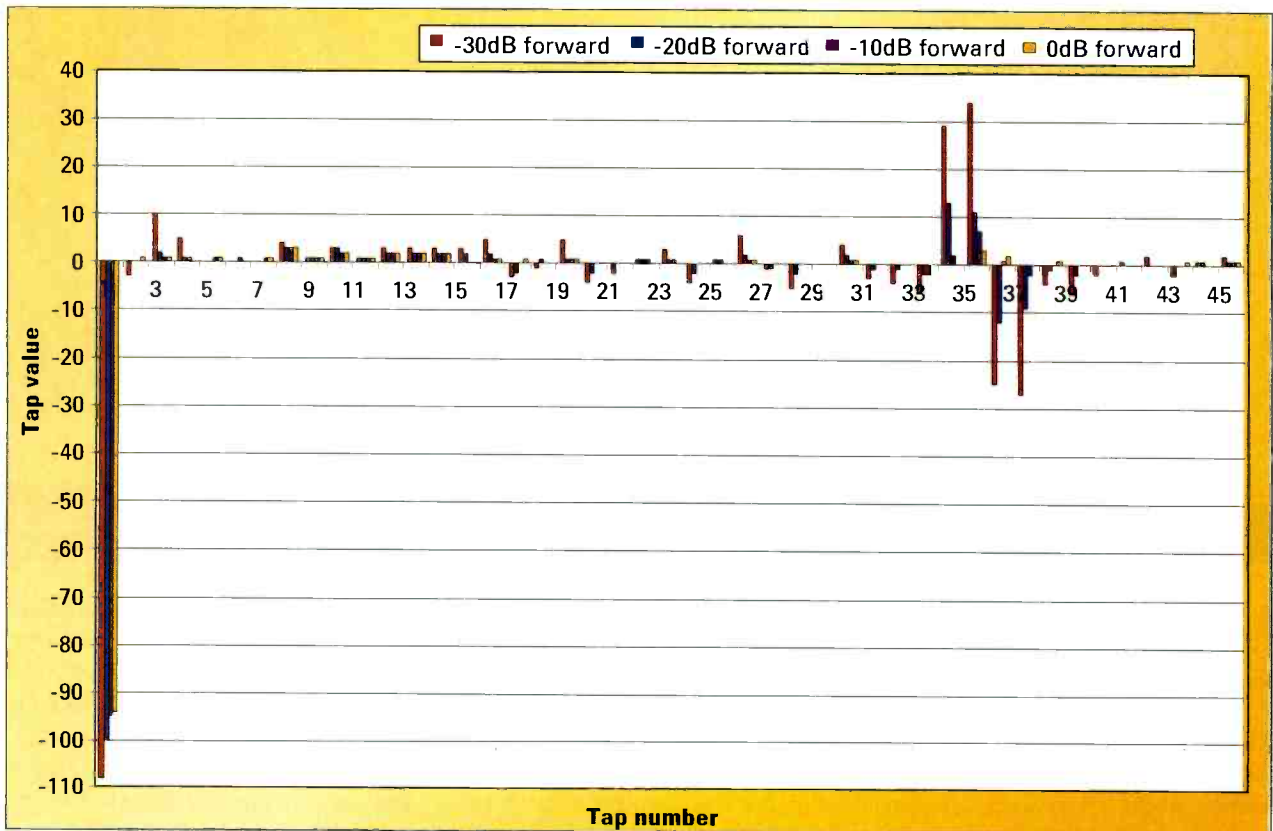

Figure 2. This graph shows the effects of introducing a forward-measured signal into the reflected measurement.

per tap. The distance resolution is related to the tap time constant. Tap 3 represents the tee combiner at the base of the tower. Taps 4 through 33 represent normal transmission line with two or three flanges and six or seven line insulators captured by the 48-foot tap interval. Those quantities of flanges and insulators will vary depending on whether or not the tap lines up with a flange. In this example, taps 34 and 35 represent a shared line-splitting tee that splits channel 13 from channel 38. The measured transmission path is the channel-38 path and, therefore, taps 36 and 37 represent the channel-38 antenna. These transmission-line discontinuities are different at each site. There also may be additional components and their associated discontinuities at other sites.

The four data sets in Figure 2 also depict the effects of increasing the forward signal content to the demodulator. Each subsequent data set shows the effects of increasing the forward component by 10dB. Since the equalizer locks onto the largest signal, this forward insertion level protects the equalizer lock by desensitizing the downstream signals.

The PC-based Visual Basic program retrieves the data shown in Figure 2, converts all numbers to their absolute values, and scales the graph to make the reference pulse 100 percent, as shown in Figure 3. The program also accepts a series of customizable warning and trip limits for numerous taps that identify special components, and

performs proprietary calculations on tap values and analyzes the result in an effort to find less-obvious sources of potential burn-up.

As stations convert to DTV and their income streams shift from NTSC to DTV, their need for pre-emptive maintenance will become more urgent to avoid costly shutdowns. The new high-

power, DTV, real-time, TDR-like transmission monitoring system described here can resolve down to the component level. This allows a station to monitor flange joints, elbows, gas barriers and the antenna and to respond pre-emptively to the first signs of a problem, before destructive burn-up has started or progressed to completion. It can allow visual analysis

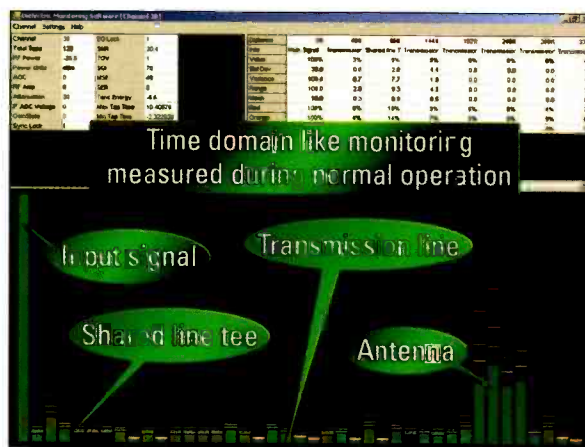

Figure 3. This monitoring system's Visual Basic display shows the data collected in the experiment used to test the system.

another set of warnings and trips to assign to all remaining components on the transmission line. The program

when an operator wants to know how far down he should turn the power. Is 50 percent power going to be sufficient

to stop the burning? Will 70 percent power be sufficient to maintain *status quo* until someone can do a visual inspection of the line? And, when the riggers and the field-service technicians arrive, they won't have to guess where the problem is.

This monitoring system also can detect previously undetected burn-up situations. In recent years, at least two sites experienced burn-ups in the middle of a vertical run, and no alarms sounded until the burn-ups destroyed a length of line. It's been theorized that, in these situations, the facilities didn't observe large frequency-domain VSWR because much of the missing reflected energy was absorbed as heat at the point of failure. The charred remains acted as a load. The proprietary algorithms built into the Visual Basic program in the monitoring system described here can detect these types of failures.

Site-specific configuration

Figure 4 shows the alarm levels a station can assign to elbows, transmission-line flanges, channel combiners, channel splitters, elbow complex and antenna. The reason for the differen-

tiation in alarm levels is that a small change of VSWR at the antenna can be a normal change due to temperature or weather conditions at the antenna. As long as the VSWR returns to normal, no alarm will sound. But, even a small change in the enclosed transmission-line components might

indicate a problem, so the system monitors them closely. The station assigns a specific tap point of the demodulator to each component at a site for a unique one-tapper-one-component, site-specific layout. The station can target any site-specific component between the directional-coupler monitor point and the antenna for special attention. Users at the station can program

and adjust the settings for alarm warning and trip levels. They can observe site-specific responses and adjust the proper alarm limits to allow for anomalies. And they can connect outputs to transmitter trip functions, remote monitoring or any other intranet-compatible device through a local intranet. When any of the alarms are triggered, the PC program alerts the station, the manufacturer and any site-specific contact personnel through modems or intranet. The system can e-mail alarm or warning conditions to the appropriate person's cell phone. Additional I/O for local control is available for transmitter interface, if required. Also, a station can use the monitoring system as an option in conjunction with many existing monitoring systems.

Customizing input and output

The station can set the program to retrieve data as frequently as every three seconds. The computer then will complete its analysis on all subsequent data and generate appropri-

ate responses. For periods of time when the system notes no anomalies, the program can retain limited sets of original data while discarding excessive quantities of repetitive data. (It can generate more complete and continuous data for anomalous events.) The retained data is available



Figure 4. This system's software allows the station to set and adjust alarm points and thresholds.

for historical records, analysis and reports. In the event of an alarm, the program can generate two types of responses: e-mail and I/O alarms. The program can send e-mail notifications to all addresses listed for notification by modem or local intranet. Two types of e-mail are available: one suitable for cell-phone notification and another for PCs that includes more detailed data, including copies of the plots depicting the alarm condition. Stations that install this monitoring system as a stand-alone system might require automatic trips. For these sites, a USB connection can supply a suitable number of I/O to provide sensors and control. Stations that also have existing conventional monitoring systems with integrated control can use this monitoring system's PC I/O to interface the two systems seamlessly so that only one of the systems reports alarms to the designated recipients. **BE**

Andre Skalina is vice president of research and development, and William A. DeCormier is associate principal electrical engineer, at Dielectric.



The proposed monitoring system uses a ZTechnology DM1010W professional ATSC/8-VSB demodulator and a proprietary, menu-driven, PC-based Visual Basic program.

Pressurizing coaxial cable

By Rolin Lintag

There are at least two good reasons why it is important to properly pressurize coaxial cables. First, it keeps moisture out and therefore prevents arcs inside the cable. Secondly, it improves the power-handling capacity of the coax by increasing the breakdown voltage between the inner conductor and the shield. Using nitrogen tanks, dehydrators or a combination of these devices can ensure that dry air at the proper pressure is present in the cables at all times, regardless of weather changes. The pressurization system should be capable of handling the load requirements, no matter the conditions.

When designing a cable-pressurization system, the first issue to consider is the behavior of air, which naturally expands when heated and contracts when cooled. For example, coax air pressure that is at 1psi during the cool of the evening can rise to 5psi in the heat of the afternoon, depending on the volume of the air inside the coax. Also, large coax cables, such as 4- to 6-inch diameter cables, can contain a significant volume of air. A large volume of air is good because, if there's a leak in the cable, it takes longer for the air to leak out. But, such a large volume of air also can experience drastic changes in air pressure between a hot day and a cold night. The important thing is not to exceed the maximum air pressure specified by the cable's manufacturer. This is especially critical for microwave waveguides because overpressure can actually expand the diameter of the cable, resulting in an impedance change and a corresponding increase in VSWR. Overpressure can also pop the pressure window on a microwave dish, necessitating a tower climb to repair the damage. Leaks often begin as small openings that let in moisture. They

usually go unnoticed until the facility detects a decrease in transmitted or received signal or an increase in VSWR.

Pressurization methods

There are different pressurization-system configurations that a facility can employ. The final choice depends on the size of the transmission-line system and the amount of manpower available to maintain it.

Nitrogen tank. A configuration using a nitrogen tank is the simplest pressurization arrangement, as well as the

most cost-effective, for a single-coax system. (See Figure 1.) The nitrogen tank directly feeds the gas barrier input of the coax. When the system reaches the desired pressure, you simply close a valve. The nitrogen tank should have a dual gauge; one gauge shows the tank pressure (and, consequently, capacity) and another displays the regulated pressure to the coax. The latter typically ranges from 0- to 15psi, which is suitable for most broadcast applications. When setting the pressure in such a system, make sure you

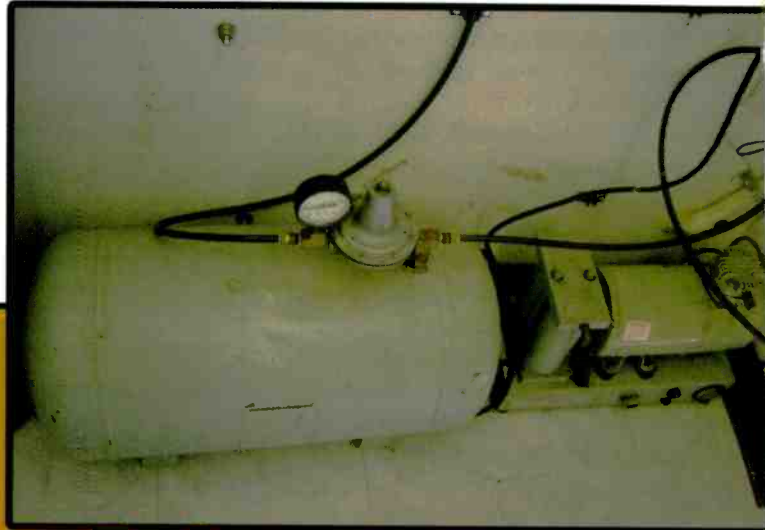

Keeping coaxial cables properly pressurized prevents arcs inside the cable and improves the cable's power-handling capacity.

A typical application might consist of just one dehydrator for the cables that serve a pair of 8-VSB and NTSC transmitters as well as the waveguides for STLs or RPU. The antenna and cable manufacturer can advise you as to the pressure required to protect the feedlines. Such a configuration is automatic; all you have to do is set the dehydrator's cut-in and cut-out pressure for the best operation. The cut-in

setting defines the pressure at which the dehydrator starts pumping air; the cut-out setting defines when it stops. Most systems allow a range of settings. A typical application uses a cut-in setting of 1psi and a cut-out of 4psi. Usually, there is an adjustable screw for each adjustment located at the dehydrator's pressure switch. It's a good idea to inspect the setting on a regular basis because the adjustment is mechanical and the unit vibrates when it operates. A

once-a-week inspection of the dehydrator (and the moisture desiccant/filter) may be enough to ensure proper pressurization on the system. As a rule of thumb, the dehydrator should not run more often than once every 15 minutes. If it runs more often, either the system was not sized properly or there is a leak.

Dehydrator, nitrogen tank and reservoir tank. The cable-pressurization system in Figure 3 on page 54 is an improvement on the previous two designs. The air-reservoir tank serves as a buffer, increasing the system's capacity without the expense of a large dehydrator. The additional cost depends on the size of the tank and the air-pressure regulator attached to it. A 20-gallon tank may cost from \$60 to \$100, and the regulator may cost up to \$600. The tank and regulator are quite heavy. So, to save on shipping and handling costs, it's best to shop around. Connect the lines you want to pressurize to the regulated output of the tank. Connect the reservoir tank to both the nitrogen tank and the dehydrator. You can set

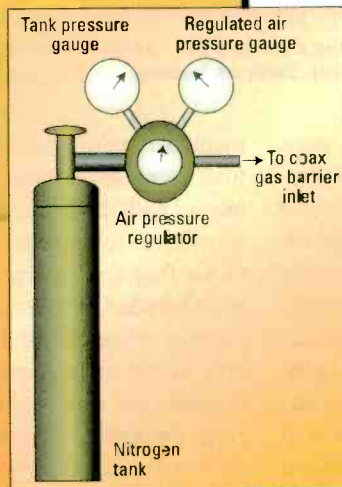

Figure 1. This diagram shows the simplest and most cost-effective arrangement for a single-coax system.

account for changes in temperature. This configuration is adequate if you can check it daily and detect any minor leaks right away. Adding a pressure monitor connected to the transmitter's remote telemetry can alert the master-control operator if a leak occurs.

As mentioned above, the main advantages of this setup are simplicity and cost-effectiveness. Nitrogen gas is dry and is readily available for less than \$20 per tank. Unless there is a leak in the system, you shouldn't need more than

two tanks per year. The main disadvantage of the system is that you have to add air manually as needed. It's not recommended for remote sites because, if a leak develops, the pressure may fall to zero before someone can come and do something about it.

Dehydrator and nitrogen tank. Figure 2 on page 54 illustrates a system that uses a dehydrator as the main supply of air and a nitrogen tank as backup. Dehydrators come in different sizes to accommodate the differences in air volume found in various cable systems.

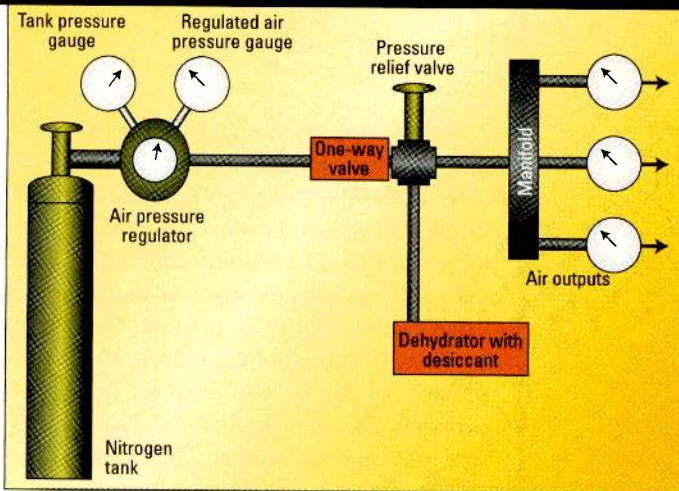

Figure 2. This configuration uses a dehydrator as the main supply of air and a nitrogen tank as backup.

the nitrogen tank's pressure two ways: just above the dehydrator's cut-in pressure setting so that the dehydrator pumps only when the nitrogen depletes, or just below the dehydrator's cut-in pressure so the dehydrator still pumps at regular intervals. In the latter case, the nitrogen tank can continue to supply the needed air even if the dehydrator suffers a power failure. A one-way valve at the output of the nitrogen tank allows air to flow only when the pressure drops lower than the regulated setting of the tank. Be sure to set the nitrogen tank's regulated setting as if it were feeding the coax lines directly.

Relief valves

To avoid overpressurizing the coax lines, use pressure-relief valves. They come in different relief pressures and should be rated below the maximum pressure that the coax system can handle. For example, KVTN-TV in Arkansas uses an Andrew UHX10 dish with EW62 cable and can handle a maximum of 10psi. The station chose to pressurize it at 3psi and use a 5psi relief valve to prevent overpressure during Arkansas' hot summer afternoons. When evening comes, the dehydrator starts pumping to compensate for the drop in pressure. With these settings, the waveguide pressure will never increase more than the pop-out pressure of the relief valve (5psi), thereby preventing damage to the

manufacturer's data and determine the total cubic feet volume per length (in feet) of each cable. Then, total the cable air volumes to arrive at the total volume of air that the pressurization system must handle. Considering the pumping capacity of the dehydrator and the volume of the air tank, estimate the time intervals the system should run for a given percentage of leakage. It's better to oversize the capacity (for a higher

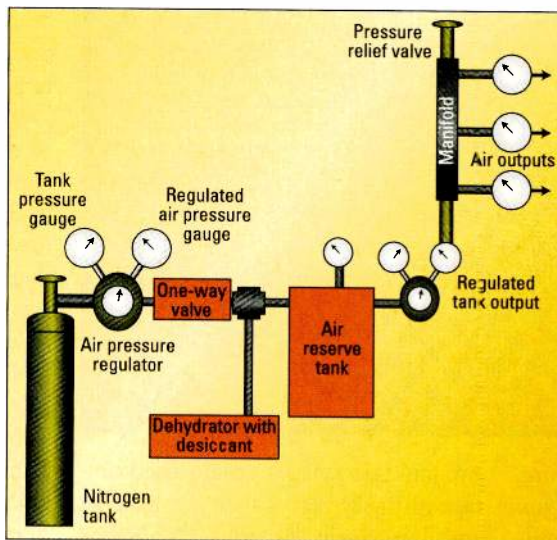

Figure 3. In this configuration, the air reservoir tank serves as a buffer, increasing the system's capacity without the expense of a large dehydrator.

cost) than to operate the dehydrator at a higher duty cycle because the latter would incur increased maintenance cost and reduce system life. Armed with the total coax air volume, consult the cable manufacturer for help selecting the properly sized dehydrator.

Increasing the air pressurization in

pressure window of the dish, which is located on top of the tower.

Sizing the system

To calculate the appropriate dehydrator size, list the cables and waveguides you want to pressurize with their corresponding lengths.

Then check the manufacturer's data and determine the total cubic feet volume per length (in feet) of each cable. Then, total the cable air volumes to arrive at the total volume of air that the pressurization system must handle. Considering the pumping capacity of the dehydrator and the volume of the air tank, estimate the time intervals the system should run for a given percentage of leakage. It's better to oversize the capacity (for a higher

the cable improves its power-handling capacity. It's possible to almost double the peak power rating of a coax cable by increasing the pressure to 11psi, as on page 633 of Andrew's catalog 38 and page 6 of Dielectric's *Transmission Line and Components*. But, if you do decide to go this route, don't exceed 20psi. Make sure that you install 15psi pressure-relief valves.

Final checks

Regularly inspect the color of the desiccant on the dehydrator. Usually, is it blue when dry and slowly turns to pink or red as it absorbs moisture from the compressed air. Ensuring that the desiccant is dry can prevent pumping moist air into a cable system. Remember, the goal is to keep moisture out of the line. For safety reasons, don't try to dry the desiccant and reuse it; just replace it, being careful not to inhale the dust.

Observe how often the dehydrator pumps. If it starts to pump more often than once every 15 minutes, use soapy water to check for leaks at all valves and couplings up to the gas barrier. If you can't locate the leak at ground level, it's time to climb.

After each tower or antenna work or inspection, observe the running time of the dehydrator. In one case, the antenna-match tuning slugs were adjusted too far out and it took another day before a serious leak became apparent. Chasing down the tower crew after they have left the site and arguing about who will foot the bill for the extra tower work is not the way to go.

Finally, it's always a good idea to talk to the manufacturers of the antenna and the coax. They can provide you with information that can help you plan for the pressurization configuration that best suits your installation.

BE

Rolin Lintag is an RF engineer for a TV network in Little Rock, AR.

Introducing The New
Fischer HDTV
Fiber Optic Connector

fischer
broadcast
connectors

Triax

fiber optic

series 1051

series 1052

series 1053

Fischer Connectors, Inc.

1735 Founders Parkway

Alpharetta, GA 30004

Tel: 800-551-0121

Tel: 678-393-5400

Fax: 678-393-5401

www.fischerconnectors.com

fischer
CONNECTORS

Digital asset management: Process over product

By Edward Hobson, Bob Slutske and Blake White

In the rush to benefit by repurposing digital assets, users often buy DAM products without considering basic issues that will impact their choices and results dramatically.

In planning for the deployment of a DAM system, a facility must consider many familiar in-house processes. A large, multichannel distributor may require a complex solution, but even smaller enterprises that require a less sophisticated system need to spend time planning the DAM before adopting and implementing it.

What is the ideal product for an asset-management solution? The answer is that DAM isn't a problem to be addressed by purchasing a product. Asset management actually comprises several processes within the facility that the station needs to deconstruct and understand. The first step is to

reinforce it. Analyzing internal workflow can help a station improve existing processes before it chooses a DAM system.

One challenge a facility faces is a lack of clarity regarding its existing asset-management practices. Facilities usually introduce digital technologies piecemeal into the workflow and, as a result, asset management becomes *ad hoc* and haphazard. As the work environment has become a hybrid of traditional and digital technologies, asset-management practices have failed to keep pace.

Asset management in the film-centric environment was as simple as attaching descriptive notes to strips of film, which users could readily access and understand by holding up to the light. With the advent of videotape, users began writing notes or titles on the

Digital asset management isn't a problem to be addressed by purchasing a product.

identify the material that the facility values as an asset.

Caution, pitfalls ahead

There are several reasons for approaching DAM in this way. Purchasing a product without first analyzing internal processes and business objectives often results in the product defining, and thereby limiting, workflow. The proper technology should support and enable current practices as well as offer flexibility for future expansion.

Adding DAM technology without first analyzing facility workflow for redundancies and faults can be destructive. Technology will amplify a bad practice as well as a good one — automating an existing bad practice

videocassette to identify its contents.

The move to digital files and server-based systems marked the beginning of an entirely new paradigm for asset management and, not coincidentally, more than a decade of confusion for operations managers and librarians. For the first time, users were forced to standardize naming conventions for their assets. A commercial or TV program was no longer contained on a videocassette that could be stored in the vault. It existed as data spread across 50 disks. Likewise, the move to server-based systems challenged traditional ways of tracking assets. If the writer slugs his story "automobile accident" and the editor writes "car wreck" on the tape, a machine-based

system without significant intelligence simply can't make the connection. Because of this, standardized language has become a necessity. SMPTE is currently developing a metadata dictionary to provide consistency.

Defining the puzzle

Many users find themselves hard-pressed to know where to begin the multifaceted task of choosing a DAM system. The best way is to think of a DAM solution as a puzzle. First, define a starting place from which to build. Identify all the pieces and "edges" of



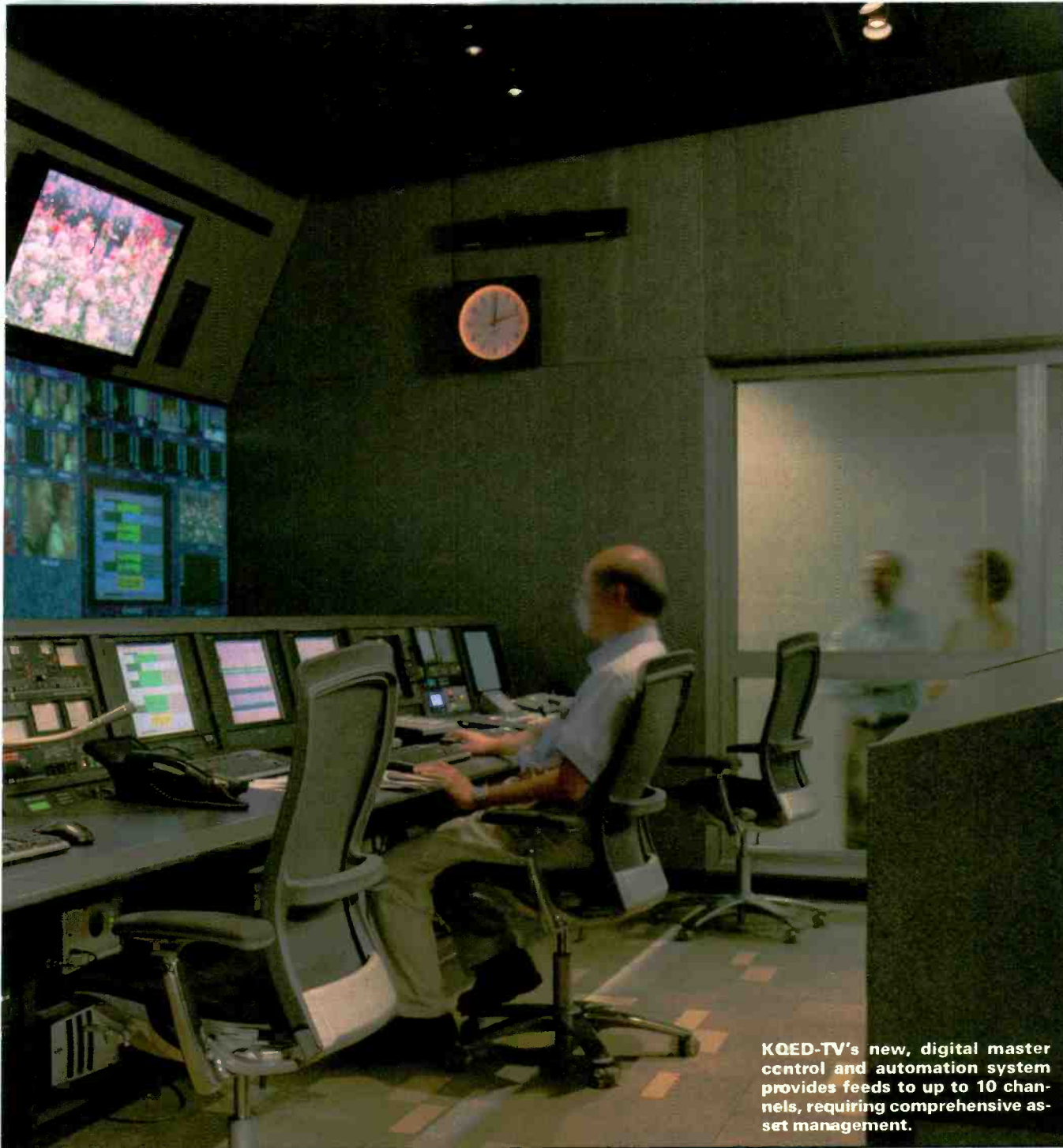

KQED-TV's new, digital master control and automation system provides feeds to up to 10 channels, requiring comprehensive asset management.

the solution. Know what the end solution looks like before putting the pieces together. Forcing a piece into place early on won't allow the other pieces to fit in smoothly as the solution progresses. See Figure 1 on page 58.

The first step toward understanding DAM is to ask some basic questions. What are the in-house materials that have value? How are they valued? What are the facility's current practices in naming them, cataloguing them and tracking their use? How does the facility keep track of when the asset creates or expends revenue?

How will the asset be viewed? Unlike videotapes, which are identified textually by a label on the cassette and box, digital assets can and should be identified not just by a text description, but by viewable proxies, ideally at different resolutions for multiple uses across a network.

The second step is to document the facility's workflow. Follow the journey of a commercial at the TV station, step-by-step, from the moment it arrives until it goes to air. What are the processes it goes through? How is it QCed? How does it interface with

the billing and traffic systems? How does the facility determine if it's no longer in use?

If the station has dozens of copies of one commercial, it's wasting storage space and tracking time. The same is true for versions. Re-versioning content will become increasingly important as multicasting comes into play. If assets aren't identified early on — even before they're produced — it may be impossible to find them or keep track of how, when and where they've been used. If a facility doesn't know how to name and find an asset,

its value is diminished. Identifying and naming assets early on becomes even more important with the trend of commercials and other to-air footage arriving at the station or facility electronically, rather than as physical media.

It's also important to identify business objectives for a facility's assets. Analyzing current and future objectives for monetizing assets, developing a roadmap for asset growth, and determining the best strategies to use will help a facility to implement a strong and scalable infrastructure.

Solving the puzzle

Once a facility identifies its assets and workflow processes, it will be able to improve the process by eliminating redundancies and streamlining its ability to track and store media. Then the facility can overlay the current workflow on the business plan and perform a gap analysis to create a conceptual solution.

Choosing a DAM solution requires a consensus among all those involved in using the assets. Several departments may struggle over the ideal workflow, redesigning it more than once. See Figure 2.

Adding DAM software is an expense that has to be justified by its returns. If a station simply implements DAM as a way to automate, it misses out on realizing the full potential of its assets. In a competitive market with more

and more channels available, he who knows where his assets are and can make use of them will reap the highest benefits and profits. The minute a competitor values his or her library properly, the value of yours falls.

Technology demos are good, but visiting a site with a working solution is better. Learn about the company's successes, but also learn about its failures. The vendor should be able to name the failures, describe what went

wrong and what it has done to prevent such failures from happening again.

There is no shrink-wrapped solution for DAM. Solutions are complex amalgams of well-thought-out plans, networks, hardware and applications. When successfully brought together, DAM solutions save money through efficiency and increase the value of the creative

content through reuse and repurposing, thus driving new revenue streams.

BE

Edward Hobson and Bob Slutske are vice presidents, and Blake White is vice president of strategic services, at National TeleConsultants.

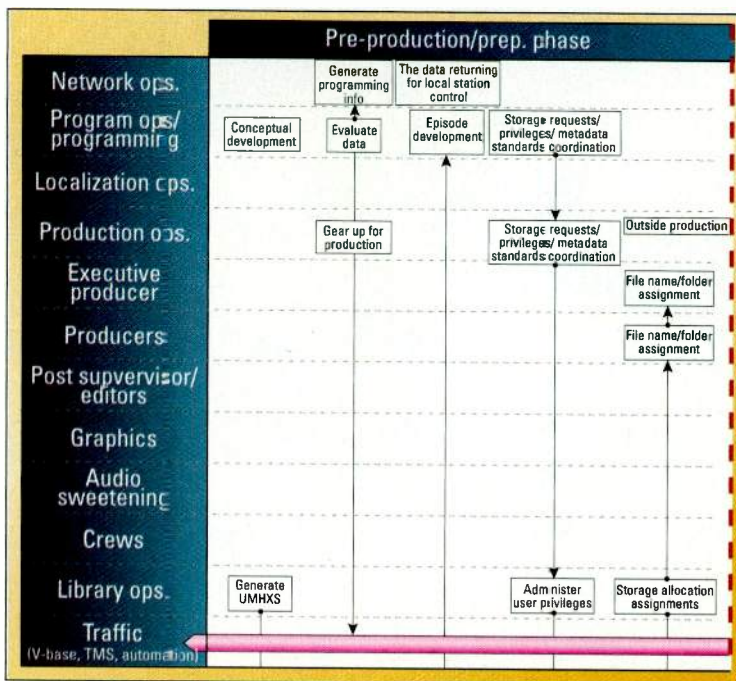

Figure 1. A diagram like the one shown here can help you visualize what might be a complicated or suboptimal workflow inconsistent with current business objectives.

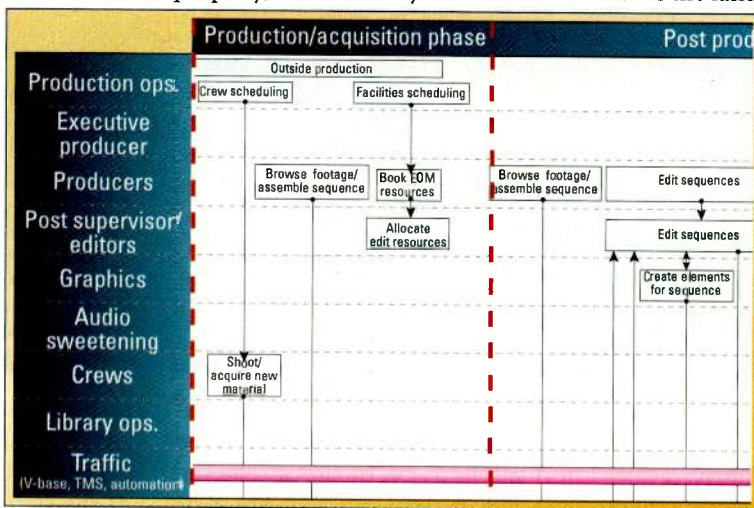

Figure 2. The workflow diagram will indicate the various stakeholders involved in defining enhanced workflow and the application of an asset-management solution.

A good knowledge of assets not only helps the bottom line in terms of cost savings, it also helps to open up new revenue streams. With potential revenue-creating applications such as interactive television, the ability to easily use assets allows for an inflow of new revenue.

rental solutions of all sizes

Top productions demand the very best: that technology has to offer and at Gearhouse Broadcast we provide a first class rental service.

Stocking the world's best digital wireless camera, the Link XPR has less than one frame delay, full camera control and no signal loss.

Whether its the red carpet or the winning touch down, this camera will take you where you thought you could never go.

From the latest RF camera systems to fully engineered all format, multi camera fly-packs, we can work with the biggest, to the smallest of budgets.

call for a demonstration today
818 955 9449
www.gearhousebroadcast.com

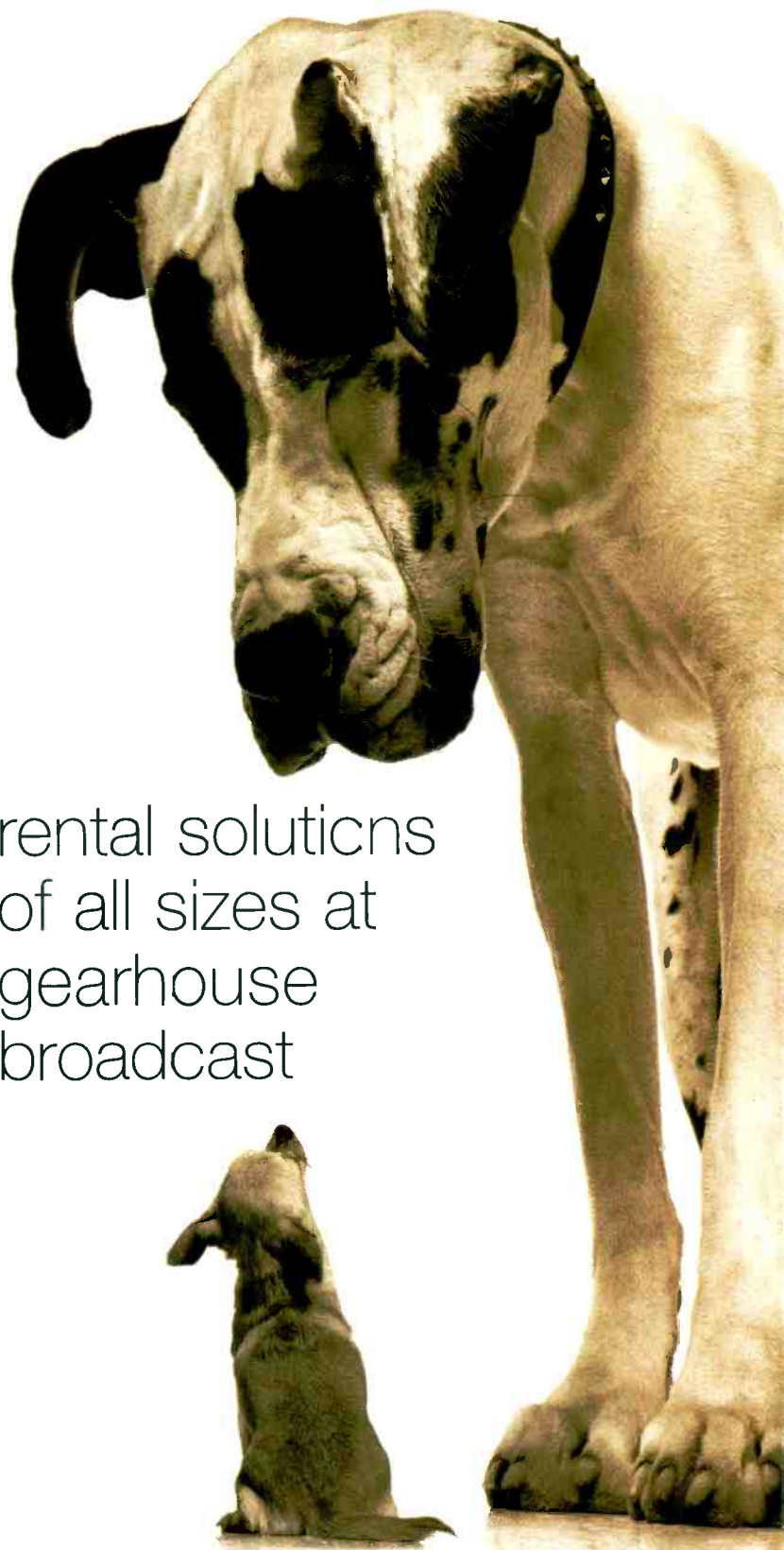

rental solutions
of all sizes at
gearhouse
broadcast

the world's best digital wireless
camera system - Link XPR



Nucomm's Analog Coder

BY DR. JOHN B. PAYNE

Broadcasters planning to transport digital television programming to remote facilities and transmitters face the cost of replacing their existing analog microwave links.

Instead of replacing analog microwave radios (and sometimes transmission line and antennas) with new digital systems, broadcasters can limit their investment by adding only a new digital-to-analog modem to their existing analog microwave system. This can be more economical for a single-hop STL and significantly less expensive for a multihop network.

The Nucomm Analog Coder allows analog microwave systems to carry a multitude of high-data-rate digital signals — such as the 19.39Mb/s ATSC transport stream and multiple standard-definition signals, plus a T1 data pack and other ancillary control channels — within a 17- or 25MHz broadcast auxiliary service (BAS) channel.

Remodulating and heterodyne systems

On the transmit side, the 1RU digital-to-analog modem accepts the 19.39Mb/s ATSC signal in DVB-ASI and SMPTE 310M formats, as well as two additional ASI signals. The total

signals together and applies forward error correction (FEC). Then the digital modulator encodes the multiplexed signal into a 1 Vp-p analog baseband waveform that outputs the baseband onto an existing analog transmitter. The only adjustments required for multihop systems are to turn off the

chip sets provide dynamic adaptive equalization to overcome frequency-selective multipath issues and other adverse environmental conditions.

Over time, digital plants may migrate between the SMPTE 310M and DVB-ASI standards for digital transport. The modem offers interfaces for both



Nucomm's Analog Coder digital-to-analog modem can provide broadcasters with a less expensive option for converting multihop transmission systems to digital.

audio subcarriers in the analog signal (or set their frequencies above 7.5MHz) and set the emphasis to flat. For single-hop systems, the emphasis can be left on.

For the heterodyne microwave system architectures typical of multihop links, the system offers an optional 70MHz output that connects to the 70MHz input of the transmitter.

standards and automatically selects the proper input. If both signals are present and valid, the unit defaults to the ASI input.

If an existing analog microwave link uses a dedicated T1 subcarrier modulator for a 1.544Mb/s G.703 data channel, that traffic, as well as two RS-232 channels and eight TTL logic inputs, are readily multiplexed into the digital television traffic.

The modem's RF output spectrum fits within the 25MHz bandwidth of the 7- and 13GHz BAS bands. A deviation adjustment also makes it possible to reduce the spectrum to the 17MHz bandwidth of the current 2GHz BAS band, as well as the FCC's new 12MHz channel plan. The output spectrum meets the analog mask requirements. Because the modulation format is analog, no change in FCC licensing is required.

At the final receive end, the system accepts either a baseband input or an

Broadcasters can limit their digital investment by adding only a new digital-to-analog modem to their existing analog microwave system.

input data rate is limited to 30Mb/s.

The system includes a T1 or E1 data pack for carrying additional digital data traffic across the link. The front end of the modem multiplexes the ATSC plus two ASI and T1 data pack

The Analog Coder uses a proprietary modulation design based on the ATSC standard FEC — including Reed-Solomon, Trellis coding and interleaving — through commercial demodulation and decoding chip sets. These

optional 70MHz IF and demodulates and error corrects the signal. Then it demultiplexes the traffic into digital television signals (two SMPTE 310M and one DVB-ASI output), T1, RS-232, and TTL logic signals. The system provides two SMPTE 310M outputs to feed redundant HD transmitters. The DVB-ASI output can easily become a third SMPTE 310M output.

An optional 8-VSB output, selectable between channels 3 and 4, allows personnel at the TV transmitter site to monitor the received picture quality, including link quality and packet error information, using a commercial or professional HD set-top box. The analog video and audio from the HD set-top box can even be used to feed the station's analog TV transmitter.

Multihop networks

With a single-hop STL installation, broadcasters should balance the cost of the modem against the cost of a new dual-carrier or DS3 microwave link. In many cases, they will find it is an appropriate solution.

For stations with multihop links to satellite stations and other remote facilities, the system can dramatically lower the cost of implementing digital television. It has proven to provide robust, air-quality ATSC and DVB-ASI signals to remote transmitters after crossing hundreds of miles and making two dozen hops over existing analog microwave links.

Because of the ease of installation and operation and the cost-effectiveness of the Analog Coder, it merits a close evaluation by any broadcaster seeking to transport digital television over microwave networks currently served by analog equipment. **BE**

Dr. John B. Payne is the founder and president of Nucomm.

ATTENTION READERS!
Sign up now for
BroadcastEngineering's
bi-weekly **RF UPDATE**
e-newsletter
at www.broadcastengineering.com

MEASURING THE DIFFERENCE in Video Cable Design...

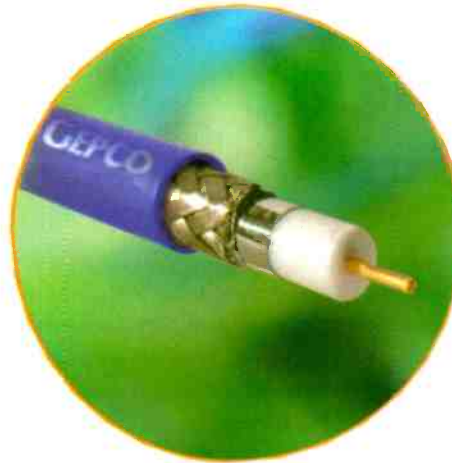

- All Reels 100% Swept Test & Certified
- 3 GHz Bandwidth for HDTV
- Gas-Injected, Crush Resistant Dielectric
- Zero Center Conductor Migration
- Exceeds SMPTE Specifications

The innovator and leader in video coax technology, Gepco continually advances and develops high-resolution video coaxial cables that ensure optimal picture quality and exceptional reliability in today's demanding High Definition, multimedia and broadcast video applications.

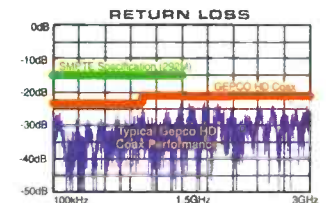

GEPCO
INTERNATIONAL, INC.

TRANSMITTING CLARITY

www.gepco.com email: gepco@gepco.com

800.966.0069

Wireless Headsets

for your Wired Intercom

TD 901 INT One Person Setup
2 TD 900 Radios, Wired Interface
Assembly, Proline Headset

\$585



EARTEC

www.eartec.com
800-399-5994

Full Duplex, Hands Free
No base station

Playout automation

BY JOHN LUFF

In a perfect world, everything would happen as planned. No human intervention would be needed, and perfection would be achieved 100 percent of the time. Such is the myth of television playout automation. A cynic might remind those who believe this myth that err is human; to really foul up requires a computer.

From many perspectives, computers have made extensive improvements possible in television operations. Station management seeks the Holy Grail of less labor and fewer make-goods. Chief engineers want the ability to supersede operator-training deficiencies that plague manual station operations. Traffic operators want to have it their way without listening to alternative ideas. Salespeople want the ability to sell a spot at 4:55 p.m. and go home at 4:59 p.m. safe in the knowledge that their sales will be fulfilled accurately. The general manager, if possible, doesn't want to do any make-goods.

In a perfect world, everyone could have his or her way. Indeed, automation can move a station towards those

ensure the right program plays to air at the right time with the right commercials, and add opportunities for enhanced revenue experiences and extra breaks in live programming.

The opposite, however, can also be true. A poorly implemented automa-

even if someone is present, he may no longer have the skills to figure out the smooth path to a clean transition.

Today, automation works by taking the log and parsing the log information into a database of events that processes at precisely planned times. It issues machine-under-

standable commands to devices usually connected by RS-422, or Ethernet remote-control connections. Automation also collects the responses from the devices (i.e. confirmation that the event really happened) and feeds that information back to traffic electronically as confirmation that the as-run log is the same as that allegedly planned. Sony protocols control VTRs, and servers and other devices use video device control protocol (VDCP) that permits more complex commands including selection of media and sophisticated cueing.

Each single event might be as simple as a cut on the master control switcher to server, play four spots back-to-back, and then a cutback to programming on the switcher. It might also include secondary events, such as voice-over and pushback to reveal a promo or other graphic, a key of the station logo in the corner on the hour, or other events. One problem that often complicates log management is that the log sometimes does not contain accurate machine commands that automation can translate effectively. For instance, at 2000, you want your DTV channel to

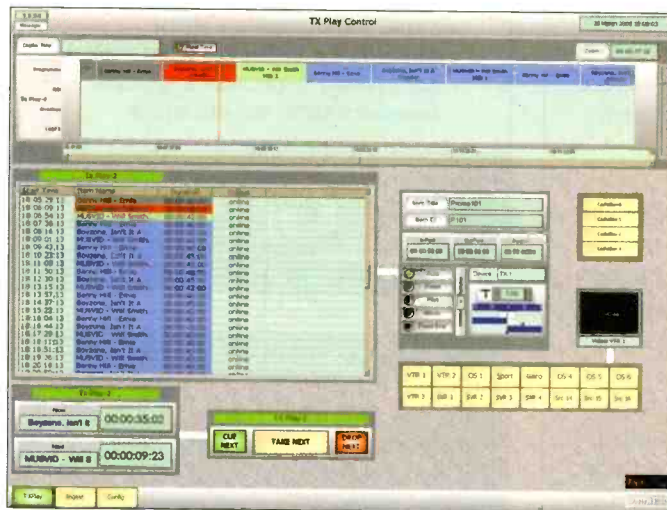

Facilities operating from one to 12 channels can use OmniBus Systems' TX>Play transmission automation system for playout. The system supports content ingest to video servers from live sources, tape or digital content delivery.

tion system will never improve workflow nor enhance the accuracy or look of the on-air operation. For instance, the master control room operators in many stations with stable (read old) equipment have learned how to get around any failure without undue impact on air ops.

To err is human; to really foul up requires a computer.

goals, but we must remember that automation simply replicates the decisions others have made in other software. It can streamline the workflow and ensure that dub lists are accurate,

When a VTR fails, they find a way around it. But, when a VTR fails under automation, there may not be a person standing by to ease the fears of the general sales manager. And,

go from four SD streams to one HD and one SD stream. Consider the number of individual changes that must occur: drop two streams in the multiplexer, increase the bandwidth for the HD channel, decrease the bandwidth for the remaining SD channel, send new information to PSIP, manage the statmux settings, and perhaps dozens of minor commands necessary to make it all work seamlessly. For most stations today, that information is not part of the log. Add the fact that frame accuracy is now critical, and many traffic systems are brought to their knees before they communicate the first byte to the automation system.

Until recently, all commands were generally passed to a device-control engine that kept a master clock synchronized so that all events would happen in lock step. Now, it is quite possible to let each device connect to a separate control interface by using Ethernet and network time protocol (NTP). The automation system can send commands to a local control buffer with the command and the time the command is to be executed. It then moves off to other business, safe in the knowledge that the device will take care of itself. The device controller communicates with an NTP server to ensure it has the precise time to which all other devices have synchronized. Using this structure, you could build up a distributed automation system where you could send commands hundreds of miles away and know they would execute at a precise time. This is ideal for a centralized operation with local automation events. With this structure, it is much harder for a single failure to totally disrupt the air-playback schedule.

One thing is true about all automation systems. Putting accurate metadata on each event is critical. Segmenting a show to get the timings perfect is a vital step in making a well-run system. Spots must be ingested with precise timings for the same reasons because, rest assured, no one is looking at the video to ensure all transitions happen in black — at least not yet.

Modern playout automation can vary from simple server-playlist automation — which controls only ingest and server playout — to global media asset management and playout control of dozens of devices for many channels with redundant control and fault-protected databases. It is still important to look at workflow and make sure that you are improving the on-air operation and not just making it more complicated than it needs to be. **BE**

John Luff is senior vice president of business development for AZCAR.

SEND Send questions and comments to: john_luff@primediabusiness.com

Read more technology reports in the
Special Technology Focus section
of our Web site, www.broadcastengineering.com.



US/Canada Edition
Broadcast Engineering

subscriptions



As the television industry continues to redefine itself, **Broadcast Engineering** is there. **Broadcast Engineering** is the industry's preferred resource for learning about the ever-evolving television market. Stay current on the latest technology developments, new players, products and decision-makers.

To start your **FREE** subscription with the industry's #1 authoritative source of technical information*, go to www.broadcastengineering.com and click on **SUBSCRIBE NOW**.

*2002, Paramount Research Study, World Edition.

redefining television



THE NLE BUYERS GUIDE
THE PRO CAMERA GUIDE
THE DAW BUYERS GUIDE

Free online guides to
video editing systems,
pro cameras and camcorders
and audio workstations.

<http://SYPHAonline.com>

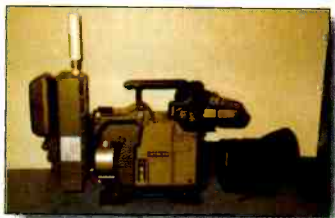

WIRELESS CAMERA SYSTEM

Broadcast Microwave Services Carry-Coder II: Portable, low-delay wireless camera system for video, audio and data transmission; mounts on the back of professional cameras or fits inside a backpack; standard features include 4:2:2/4:2:0 MPEG-2 encoding, ASI I/O, SDI out, RF amplification and COFDM modulation for non-line-of-sight operation; when paired with a Carry-DeCoder II (integrated receiver decoder for portable wireless reception), the CCII forms a portable stinger kit.

800-669-9667; www.bms-inc.com



WIRELESS MICROPHONE

Sennheiser Evolution wireless G2: Features a 36MHz switching bandwidth with 1440 channels available to the user; includes a scan function that automatically searches for free channels, a user menu and large backlit displays; features a pilot-tone squelch to ensure that the transmitter microphone can be switched on and off without noise.

860-434-9190 ; www.sennheiserusa.com



VIDEO CLIP SERVER

Video Technics Apella v2.5: Multichannel server with 1GB of DDR RAM; features fully redundant, hot-swappable power supplies, upgradeable components and storage, and an open architecture; requires no third-party system for playout or ingest; Windows service for client/server network operation; 20 metadata fields auto-created for each clip; internal reference clock; horizontal and vertical phase.

404-327-8300; www.videotechnics.com

IOT

Thales TH 792 CD: Is a water-cooled, depressed-collector IOT; in NTSC, it delivers 63kW in common amplification with 23dB minimum gain and a merit figure of 134 percent; in 8-VSB, it delivers an average of 30kW, along with 58 percent efficiency.

413-998-1100; www.thales-bm.com

SOLID-STATE ANALOG TRANSMITTER

LARCAN Eclipse series: Features LDMOS technology and multiple regulated power supplies; is hot-pluggable with a fully redundant design; has highly linear broadband PA modules and an extensive monitoring system; versatile cooling system features pull-through design for easy installation; fits 20kW of power in less than 25 square feet of space.

303-665-8000; www.larcan.com

TRANSMITTER/RECEIVER ANTENNA

Patriot 1.8 Meter: Features azimuth fine-tune +/-15 degree for pointing accuracy; has a single-piece, deep-drawn metal reflector; boom supports 50 pounds; includes az/el interface to 4-inch O.D. pipe; dual-side galvanized steel powder coated with a 10-year or 700-hour salt-spray warranty; includes two-port linear Tx/Rx Ku-band feed assembly.

800-470-3510; www.sepatriot.com



TRI-LEVEL HD SYNC GENERATOR

Sigma Electronics HD402: New option for the TSG470 model; provides three additional simultaneous reference outputs for NTSC, PAL and HDTV; outputs independently selectable for reference format and relative timing; all are clocked and locked together and timeable with respect to the master clock.

866-569-2681; www.sigmaelectronics.com



WIRELESS HAND CONTROL

BDL Autoscript Receive and Transmit (RAT): Has a range of 90 feet; features 10 user-selectable channels; works in the license-free band; has the usual features of a prompter controller including story, next/previous and top of rundown; includes an RS-232 trigger button that can be assigned to any compatible device; multiple RATs can be used to control a single prompter base station.

516-799-3869; www.bdlautoscript.com

Instantly edit profanity During a live Broadcast AY86

SDI/Analog Video/Audio Delay



- SDI/Analog input/output
- Simultaneous SDI/Analog output
- AES/EBU and Analog audio input/output
- Gen Lock
- SDI Proc Amp (LCD display)
- 10 bit video/24 bit audio
- Delay up to 21 seconds
- Frame by frame video delay adjustment on front panel
- Audio can be set ahead or behind

H HOTRONIC, INC.

1875 S. Winchester Blvd., Campbell, California 95008 USA
Tel: 408-378-3883 Fax: 408-378-3888
Web Site: www.hotronics.com E-mail: sales@hotronics.com

HORITA

Precision Color Bar & Test Signal Generators

CSG-50 \$379

- Digitally synthesized full/SMPTE color bars, blackburst, composite sync, 15 Hertz Ref.
- Built-in timer switches bars to black, tone to silence at 30/ 60 seconds.
- Crystal controlled, 1 Khz, 0 dB audio
- RS170A, SC/H phased. No adjustment needed.

CSG-50B \$538

- All features of CSG-50 PLUS
- 3-5 outputs of blackburst + subcarrier



TSG-50 \$469

- Generates 12 digitally synthesized video test signals/ patterns
- Built-in timer switches pattern to black, tone to silence at 30/ 60 seconds
- Outputs: video, composite sync, 400/ 1KHz, 0dB audio tone, 15 Hertz Ref.
- RS170A, SC/H phased. No adjustments needed

TSG-50B \$628

- All features of TSG-50 PLUS
- 3-5 outputs of blackburst, + subcarrier



Unconditionally Guaranteed!

HORITA

www.horita.com

Contact your local video dealer
or call (949) 489-0240

ELECTRONICS RESEARCH, INC.

EL Series UHF Antenna

The EL Series UHF
Transmitting
Antenna for either
DTV or NTSC
applications



ERI Your Single Source for Broadcast Solutions

Sales@ERInc.com | +1 (812) 925-6000 | www.ERInc.com

Time

to advertise in
*Broadcast
Engineering
magazine*



contact:

Jennifer Shafer
800-896-9939
jshafer@primedia.com
business
.com

TALLY MAPPER™

- ◆ Tally Routing & Mapping
- ◆ One Button Operation
- ◆ Store Maps Internally
- ◆ Edit From a PC/Laptop



A Compact Solution,
Ideal for Mobile Units and
Multiple Production Setups.

Videoframe™

Control System Solutions

Tel: 530-477-2000

www.videoframesystems.com

The HD Maestro™

Real-time, PC-based
High-resolution (1080i) HD
MPEG Encoding Workstation



- Input HD-SDI, output DVB-ASI
- Based on the LSI Logic DoMiNo™ chipset
- Perfect for post production HD content distribution
- PC platform provides flexibility and connectivity

For more information on the HD Maestro or any DVEO products, call 858 613-1818. Or visit www.dveo.com

DVEO
Pro Broadcast Division
by CMI

HDVI-10

SDI TO DVI CONVERTER



Convert your low cost
LCD Monitor into a HD/SD
SDI video monitor
for \$1,000!



doremi

tel. 818 562-1101

www.doremilabs.com

BROADCAST VIDEO Over IP

- Broadcast Quality at 1.5 Mbps
- Contribution Feeds
- Live News Gathering
- Portable DNG & SNG
- Advanced Error Correction
- Realtime or Store & Fwd
- Multi-Network TI, EI, IP

Streambox®



ACT-L3 Video Transport

Call or visit our website today!

www.streambox.com · sales@streambox.com · 206.956.0544 x222

Professional Services

The NLE Buyers Guide

A buyers guide to nonlinear video editing systems and disk recorders/servers for editing with a searchable database of over 200 products

<http://NLEguide.com>

JOHN H. BATTISON P.E.
CONSULTING BROADCAST ENGINEER,
FCC APPLICATIONS AM, FM, TV, LPTV
Antenna Design, Proofs, Fieldwork
2684 State Route 60 RD #1
Loudonville, OH 44842
419-994-3849 FAX 419-994-5419

Companies Wanted

COMPANIES WANTED

A newly formed group headed by the former CEO of a broadcast equipment manufacturer is interested in purchasing companies with niche products and sales of 3 to 10 million dollars, the company does not have to be profitable. If your company meets this criteria please respond with some initial information which will be held strictly confidential. Please respond to PO BOX 281, Bloomfield, MI 48303-0281.

Professional Services

GILMER & ASSOCIATES, INC.
TECHNOLOGY / MANAGEMENT CONSULTANTS

BRAD GILMER
PRESIDENT

2207 RINGSMITH DR.
ATLANTA, GA 30345
TEL (770) 414-9952
FAX (770) 493-7421
EMAIL bgilmer@atnet.com

D.L. MARKLEY & Associates, Inc. CONSULTING ENGINEERS

2104 West Moss Ave.
Peoria, Illinois 61604
Phone (309) 673-7511 • FAX (309) 673-8128
www.dlmarkley.com
Member AFCEE

For Sale

Training

SONY

DSR390L
DVCAM Camcorder
with Studio
Capability

New Type 1/2 inch
Power HAD CCD's
F13 at 2000 lx sensitivity
65 dB S/N ratio
0.4 lx min illumination
(F1.4)
TrueEye process
DyonLatitude
Skintone Detail
Black Compress and Stretch



Authorized
Professional
Reseller



The leading broadcast video sales company on the west coast!

Studio Exchange

818.840.1351

email for quotes Paul@studio-exchange.com

816 N. Victory Blvd. Burbank, CA 91502 FAX 818.840.1354

BRAND
NEW

PRE
OWNED

BUY

SELL

TRADE

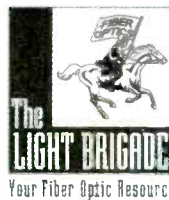

Fiber Optic Training

Hands On or Classroom

- Videos, CDs, DVDs
- National schedule
- Custom classes

Your Fiber Optic Resource.

1-800-451-7128

Employment

EMPLOYERS/EMPLOYEES

Click On

KeystoneAmerica.com

NO. 1 TECHNICAL / ENGINEERING
EMPLOYMENT SERVICE

Bookstore

**READ
ALL
ABOUT
IT!**

SOCIETY OF BROADCAST ENGINEERS

**SBE Members
can purchase
technical books
at up to
20% off retail**

www.sbe.org • (317) 846-9000. x23

Help Wanted

THE SYSTEMS GROUP

THE SYSTEMS GROUP,

a recognized systems integration firm (design/build), is seeking specialized professionals. Located across the river from Manhattan, we are under contract for several high-profile, DTV facilities serving top markets in broadcast/cable.

System Design Engineers: 5+ yrs experience in systems design and engineering (EE or PE a plus); strong foundation in teleproduction systems, technologies and operations; a solid background in or understanding of manufacturing/integration.

Project Managers: 3+ yrs television systems integration; project planning/implementation; strong interpersonal/creative problem solving skills.

Both positions require advanced proficiency in MS Office/AutoCAD.

We offer a competitive compensation and benefits package; high energy work environment; and an established team of dynamic professionals.

Forward resume/salary requirements to:
careers@tsg-hoboken.com or

TSG Human Resources

317 Newark St

Hoboken, NJ 07030

No calls or faxes please.



SKYLINE BROADCAST

QUALITY REFURISHED BROADCAST EQUIPMENT

**BUY
SELL
TRADE**

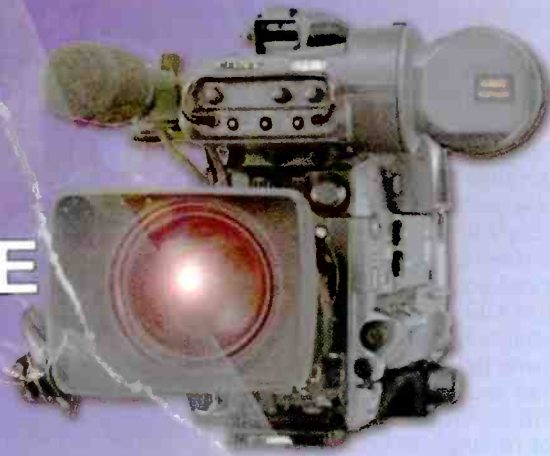

CALL: 866-804-1184 FAX: 866-804-1179

www.SkylineBroadcast.com

ELECTROXS.COM

* BROADCAST * POST * PRODUCTION *
* TEST * BUY / SELL / TRADE *
* SCOPES * EQ. RACKS * VTRS *
* & MORE! *

CALL 800-542-0646



AcousticsFirst

Toll-Free
Number: **888-765-2900**

Full product line for sound control
and noise elimination.

Web: <http://www.acousticsfirst.com>

A PRIMEDIA Publication

Broadcast Engineering

www.broadcastengineering.com

Editorial Director: Brad Dick, bdick@primediabusiness.com
Technical Editor: Donald Keller, dkeller@primediabusiness.com
Sr. Assoc. Editor: Susan Anderson, sanderson@primediabusiness.com
Sr. Assoc. Editor: Laura (Collins) Dixon, ldixon@primediabusiness.com
Asst. Editor: Chevonn Payton, cpayton@primediabusiness.com
Asst. Editor: Heidi Hueseman, hueseman@primediabusiness.com
Sr. Art Director: Michael J. Knust, mknust@primediabusiness.com
Assoc. Art Director: Robin Morsbach, rmorsbach@primediabusiness.com
Technical Consultants: Computers & Networking – Brad Gilmer
 Antennas/Radiation – John H. Battison
 Digital Video – Michael Robin
 Transmission Facilities – Donald L. Markley
 Legal – Harry C. Martin
 New Technology – John Luff
 Industry Watcher – Paul McGoldrick
 New Media – Craig Birkmaier

Sr. VP: Peter L. May, pmay@primediabusiness.com
Group Publisher: Dennis Triola, dtriola@primediabusiness.com
Marketing Dir.: Christina Heil, cheil@primediabusiness.com
Online Sales & Marketing Dir.: Samantha Kahn, skahn@primediabusiness.com
Vice President of Production – Lisa Parks, lparks@primediabusiness.com
Sr. Ad Prod. Coord.: Sonja Shaffer, sshaffer@primediabusiness.com
Classified Ad Coord.: Michelle Hooper, mhooper@primediabusiness.com
Dir., Audience Marketing: Barbara Kummer, bkummer@primediabusiness.com
Group Show Director/LDI: Sharon Morabito, smorabito@primediabusiness.com

PRIMEDIA

Business Magazines & Media

COO: Jack Condon, jcondon@primediabusiness.com
Executive Vice President: John French, jfrench@primediabusiness.com
Corp. Comm/Mktg.: Karen Garrison, kgarrison@primediabusiness.com

Primedia Inc.: 745 Fifth Ave., NY, New York 10151
Chairman: Dean Nelson, dean.nelson@primedia.com
President and CEO: Kelly Conlin, kelly.conlin@primedia.com
Vice Chairman & General Counsel: Beverly Chell, beverly.chell@primedia.com

MEMBER ORGANIZATIONS

Sustaining Member of:
 • Society of Broadcast Engineers
 Member, American Business Media, Member, BPA International



BROADCAST ENGINEERING, ISSN 0007-1994, is published monthly (except semi-monthly in June and December) by PRIMEDIA Business Magazines & Media Inc., 9800 Metcalf Ave., Overland Park, KS 66212 (primediabusiness.com). Current and back issues and additional resources, including subscription request forms and an editorial calendar, are available on the World Wide Web at broadcastengineering.com.

SUBSCRIPTION RATES: Free and controlled circulation to qualified subscribers. Non-qualified persons may subscribe at the following rates (Prices subject to change): USA and Canada, 1 year, \$70.00, 2 years, \$135.00, 3 years, \$200.00, Outside USA and Canada, 1 year, \$85.00, 2 years, \$165.00, 3 years, 245.00 (surface mail) (1 year, 155.00, 2 years, \$295.00, 3 years, \$440.00 airmail delivery). For subscriber services or to order single copies, write to Broadcast Engineering, 2104 Harvell Circle, Bellevue, NE 68005 USA, call 866-505-7173 (USA) or 402-505-7173 (outside USA), or visit www.broadcastengineering.com.

ARCHIVES AND MICROFORM: This magazine is available for research and retrieval of selected archived articles from leading electronic databases and online search services, including Factiva, LexisNexis and Proquest. For microform availability, contact ProQuest at 800-521-0600 or 734-761-4700, or search the Serials in Microform listings at proquest.com.

REPRINTS: Contact Wright's Reprints to purchase quality custom reprints or e-reprints of articles appearing in this publication at 877-652-5295 (281-419-5725 outside the U.S. and Canada). Instant reprints and permissions may be purchased directly from our Web site, look for the iCopyright tag appended to the end of each article.

PHOTOCOPIES: Authorization to photocopy articles for internal corporate, personal, or instructional use may be obtained from the Copyright Clearance Center (CCC) at 978-750-8400. Obtain further information at copyright.com.

PRIVACY POLICY: Your privacy is a priority to us. For a detailed policy statement about privacy and information dissemination practices related to Primedia Business Magazines and Media products, please visit our Web site at www.primediabusiness.com.

CORPORATE OFFICE: Primedia Business Magazines & Media, 9800 Metcalf, Overland Park, Kansas 66212 • 913-341-1300 • primediabusiness.com

Copyright 2004, PRIMEDIA Business Magazines & Media Inc. All rights reserved.

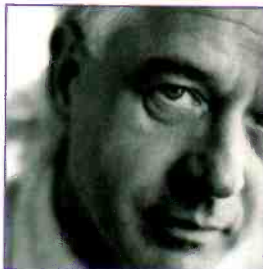

Facing Change?

We can help.

International Sales Manager - TV Broadcast Electronics; Europe	EURO 80-90k
Sales Manager, S.America - Pro-Audio; US - Mid-West/Flexible	USD 70-100k
Regional Sales Manager - Broadcast/Post-Production Audio; USA West	USD 80-100k
Engineering Director, Advanced Development - Pro-Audio; USA Mid-West	USD 100-120k
Director of Marketing - Professional Audio; US South West	USD 80-100k

Interested? Visit the website and contact us to find out more about these and other vacancies



global media technology recruitment

Experienced industry professionals helping to develop careers and finding the right faces for the job.

web : www.interfacio.com

email : facingchange@interfacio.com

telephone : USA 310 980 0090 Intl. +44 (0) 20 8986 5002

los angeles new york toronto london sydney singapore hong kong

ENGINEERING TECHNICIAN - This position requires a minimum of 5 years experience in broadcast television operations. The successful candidate will have demonstrated knowledge of and experience operating Master Control Automation systems, audio consoles for large productions and newscasts, and digital recording systems. In addition, this position requires an understanding of video server technology and the ability to perform light maintenance in computerized environment. Any camera, stage manager, or lighting maintenance would also be a plus. Must be willing to work a varied schedule. Send resume and cover letter (no calls) to James D. Gilbert VP of Engineering, WPVI-TV, 4100 City Ave., Suite 800, Philadelphia, PA 19131 FAX 215-581-4515 Email james.d.gilbert@abc.com EOE

UNIVISION 19, UHF TRANSMITTER ENGINEER NEEDED, KUVS-19 is looking for an experienced UHF transmitter engineer for multi location transmitter sites. Must be quality driven and a self-starter bilingual is a plus. (Spanish/English) Must be familiar with all FCC rules and regulations as well as test equipment operation for diagnostics of all digital and analog signals. Flexibility required to work all shifts and overtime when required. Excellent verbal and writing skills required i.e. Outlook, Word, Excel and Access. Good driving record is required. Other duties will be maintaining (but not limited to) VCR's, cameras, switchers, routers and editors. Email resume to (kuvjobs@univision.net) or FAX resume to 916 614-1907

WWSB, a small market ABC affiliate is seeking an experienced chief engineer to join our team. The candidate must have a minimum of 5 years experience in TV engineering management, a BSEE and a FCC general class license. SBE certification is a plus. A strong technical background is required, this is a "hands on" position and the applicant must be able to lead the engineering staff. The candidate must have extensive experience in repairing a wide variety of broadcast equipment (analog/digital video recorders, switchers, routers, servers, etc.) knowledge of Omneon servers, Sundance automation, Phillips Routers & Switchers, ENG, and RF equipment a plus. A strong work ethic, good verbal skills and the ability to prioritize and make frequent changes of tasks as directed without loss of composure. Must be self-motivated to learn and train others. The candidate needs to have budget and capital management experience. ABC 7 is an equal opportunity employer, women and minorities are encouraged to apply. Please send resume to, WWSB, Attn: Personnel, 1477 Tenth street, Sarasota, FL 34236 or fax to 941-923-6387 or email to: personnel@wwsb.tv. No Phone calls please.

WWSB, a small market ABC affiliate has an immediate opening for a production manager to be in charge of news and public affairs production. Candidate must possess strong background in news production management and have five years newscast directing experience. Must have a strong work ethic, good verbal skills and be able to prioritize. Must be self-motivated to learn and train others. The candidate needs to have budget and capital management experience. WWSB is an equal opportunity employer, women and minorities are encouraged to apply. Please send your resume to: Personnel / ABC 7, 1477 Tenth Street, Sarasota, FL 34236 or fax to 941-923-6387 or email to: personnel@wwsb.tv. No Phone calls please.

To advertise in the
 Classified section
 Contact Jennifer Safer
 800-896-999
 jshafer@primediabusiness.com

	Page #	Advertiser Hotline	Web site Address
Avid Technology	4-5	800-949-avid	avid.com
Axcera	37	724-873-8100	info@axcera.com
Calrec Audio	25	+441422842159	calrec.com
Clear-Com Intercom Sys.	31		clearcom.com
Computer Modules	66	858-613-1818	computermodules.com
CPI/EIMAC Division	15	650-592-1221	eimac.com
Dolby Labs Inc.	29	415-558-0200	dolby.com
Doremi	66	818-562-1101	doremilabs.com
Eartec-Porta Phone	61	800-399-5994	eartec.com
Electro XS	67		
Encoda Systems	35	866-478-9188	
ERG	23	949-263-1630	erg-ventures.com
ERI-Electronics Research, Inc.	65	812-925-6000	eriine.com
Evertz	IBC	905-335-3700	evertz.com
E2V	44	914-592-6050	comms.e2vtechnologies.com
Fischer Connectors	55	800-551-0121	fischerconnectors.com
Fujinon Inc.	43	973-633-5600	fujinon.com
Gearhouse Broadcast	59	818-955-9449	gearhousebroadcast.com
Gepco	61	800-966-0069	gepco@gepco.com
Harris Corp./Broadcast Div.	3	800-4HARRIS	harris.com
Horita	65		
Hotronic	65		
Inscriber Technology	33	800-363-3400	inscriber.com
Interfacio, Ltd.	68		
Leitch	BC	800-231-9673	leitch.com
Maxell Corp	9	800-533-2836	maxell.com
Miranda Technologies	13	514-333-1772	USsales@miranda.com
Network Electronics	39	800-420-5909	network-electronics.com
Omneon	42	408-585-5000	omneon.com
Panasonic Broadcast	7	800-528-8601	panasonic.com/p2
Prime Image	19-22,27	408-867-6519	primeimageinc.com
Quartz USA	47	888-638-8745	quartzus.com
Radyne-com Stream	45	602-437-9620	radn.com
Richardson Electronics	38 A-D	800-737-6937	rfengineered.solutions.com
Sennheiser	36	860-434-9190	
Skyline Broadcast	67		
Society of Broadcast Eng.	67		
Solid State Logic	17	212-315-1111	ssl-broadcast.com
Sony Business Systems	10-11		sony.com/xdcam
Streambox	66		
Studio Exchange	67		
Sundance Digital	18	972-444-8442	sundancedigital.com
Sypha	63,66		
Systems Group	67		
Videoframe	66	530-477-2000	videoframesystems.com
Wheatstone Corporation	IFC	252-638-7000	wheatstone.com
360 Systems	34	818-991-0360	360systems.com

US/CANADA

WEST

George Watts III
(360) 546-0379; Fax: (360) 546-0388
georgeww3@aol.com

EAST

Josh Gordon
(718) 802-0488; Fax: (718) 522-4751
jgordon5@bellatlantic.net

EAST/MIDWEST

Joanne Melton
(212) 462-3344; Fax: (913) 514-9249
jmelton@primediabusiness.com

INTERNATIONAL

EUROPE

Richard Woolley
+44-1295-278-407
Fax: +44-1295-278-408
richardwoolley@btclick.com

EUROPE

Tony Chapman
+44-1635-578-874
Fax: +44-1635-578-874
ARCintect@aol.com

ISRAEL

Asa Talbar
Talbar Media
+972-3-5629565; Fax: +972-3-5629567
talbar@inter.net.il

JAPAN

Mashy Yoshikawa
Orient Echo, Inc.
+81-3-3235-5961; Fax: +81-3-3235-5852
mashy@fa2.so-net.ne.jp

CLASSIFIED ADVERTISING OVERLAND PARK, KS

Jennifer Shafer
(800) 896-9939; (913) 967-1732
Fax: (913) 967-1735
jshafer@primediabusiness.com

REPRINTS

Wright's Reprints
(877) 652-5295;
International inquiries, (281) 419-5725
jbanda@wrightsreprints.com

LIST RENTAL SERVICES

Marie Briganti, Statistics
(203) 778-8700 x146
(203) 778-4839
primedia@statistics.com

Customer Service:
913-967-1707 or 800-441-0294

BROADCAST ENGINEERING July 2004, Vol. 46, No. 7 (ISSN 0007-1994) is published monthly and mailed free to qualified persons by Primedia Business, 9800 Metcalf Ave., Overland Park, KS 66212-2216. Periodicals postage paid at Shawnee Mission, KS, and additional mailing offices. Canadian Post Publications Mail Agreement No. 40597023. Canada return address: DP Global Mail, 4960-2 Walker Road, Windsor, ON N9A 6J3. POSTMASTER: Send address changes to *Broadcast Engineering*, P.O. Box 2100, Skokie, IL 60076-7800 USA. CORRESPONDENCE: Editorial and Advertising: 9800 Metcalf, Overland Park, KS 66212-2216 Phone: 913-341-1300; Edit. fax: 913-967-1905. Advert. fax: 913-967-1904. © 2004 by Primedia Business. All rights reserved.

Corporate acquisitions

BY PAUL MCGOLDRICK



Moving a company into acquisition mode is easy. Making the right acquisitions at the right time is not.

Acquisitions work best when a company has three things: a useful product, good profit margins and real difficulty in presenting a solid image to the industry. A solid image means that most buyers believe the company will be around a long while and will be able to support the product it sells. After all, many broadcast products are expected to be in service for a decade or more. If a company is unable to convince the market of its survivability — especially when there are competing products from a well-known brand name — soliciting acquisition can be a good idea. If the buyer is well-established in the industry, the useful product becomes much more desirable with the buyer's branding label.

A similar scenario plays out quite well, generally, when just the product and its intellectual property are transferred to a bigger name. But this leads to a future where improvements are unlikely because the design talent remains outside the purchaser's control.

Clashing cultures

When are acquisitions not the right way to go? The biggest no-no is to form an organization by plucking various small companies out of the broadcast yellow pages and pitching them into a common pot. Several unfortunate consequences follow. The enthusiasm of the individual organizations' original employees suddenly wanes. They resent working for a bunch of "suits" who don't understand the industry fully, and they are often put in an administrative chain where everything goes across the desks of one of the first acquisitions. Also,

arithmetic starts to break down. Although the gurus behind the whole operation can point to paper savings in combining operations and reducing overhead, the actual result is that two plus two no longer equals four.

When companies combine, they should never underestimate the effect different company cultures can have. A few years ago, the author watched a formal and by-the-book operation near Silicon Valley acquire a company in Dallas. In the Silicon Valley company, everyone on the customer side of the business wore a tie, and very specific control systems were in place to ensure that each product group was profitable in and of itself. Reports were formal, and routines were heavily scheduled and controlled. By contrast, the Dallas company was much more laid-back: no ties anywhere in sight, quite informal product meetings and report structuring, much more flexibility in goals, and the ability to change direction in a heartbeat if an opportunity presented itself.

It has been interesting to watch the two cultures vie for top place in Texas as a result of that acquisition. There were immediate victims (or, perhaps, escapees) who left the company straight away; they didn't want anything to do with the formality and the jerking of power westward. More left as they realized that the "marketing" titles they held were not real, and that all the power to make decisions and plan, launch and promote products had been stripped away. People generally don't like working with token authority. Today, the Dallas operation is a shell of its former self, with none of its original enthusiasm.

Why did the acquisition take place? For the same reasons that, unfortunately, influence many businesses: The

key man died, and the lack of a succession plan of any kind led to a completely rudderless ship.

The competition

The other absolute no-no in acquisitions is: Don't even think about taking over your competition. If it doesn't work out in the early stages of negotiation, you are often left with a pile of knowledge about the other company's operations that you can't legally use, but which you can't get out of your head either. If the acquisition does go through, you end up with a different set of problems. As far as your customers are concerned, you have taken a choice away from them. They regard your competition in the same way everyone regards discount airlines. You may not like the way they herd their customers like cattle at auction, but the fact that they are there makes the other guys more honest. Your customers may not consider the other company's products viable, but they feel the competition makes you keep your prices and features right. Often, too, when a choice is stripped from the market, someone else sees an opportunity to butt in. The author has seen a large customer of one product get so fed up with a lack of choice that it threw its own development into play so it didn't have to outsource at all.

Getting into acquisition mode is like getting into a sports car. It's pretty easy to slip into the seat but, as time goes on, it gets harder to get out. Don't listen to the salesman's patter, listen to your head.

BE

Paul McGoldrick is an industry consultant based on the West Coast.



Send questions and comments to:
paul_mcgoldrick@primediabusiness.com

Leitch – For HDTV.

Editing

VelocityHD™ NLE

Store and Serve

NEXIO MTS™ Transmission Server

Routing

Panacea™ / Integrator Gold™

Signal Processing

NEO™ and 6800+™ Modular Processors

Branding

DTP™ Digital Turnaround Processor / HD LogoMotion II™

Master Control/Transmission

DTP™ Digital Turnaround Processor / Opus HD™ Master Control /
NEXIO MTS™ Transmission Server / TrimStation™

Control/Monitoring/Display

CCS™ Command and Control System /
MediaNet™ Management / NEO SuiteView™

LEITCH®

For Your Integrated Content Environment

Products that improve workflow in your HD Environment

- VelocityHD™ Real-Time HD/SD Post Production Non-linear Editor
- NEXIO MTS™ MPEG Transport Stream Transmission Server
- Integrator Gold™ Large Multi-format HD/SD Routing Switcher
- Panacea™ Compact Multi-format HD/SD Routing Switcher
- NEO™ Modular Processor
 - HD Up and Down Converters
 - HD Frame Synchronizers
 - HD Distribution Amplifiers
- 6800+™ Modular Processor
 - HD Audio Mux/Demux
 - HD Frame Synchronizers
- Opus HD™ Master Control
- DTP™ Digital Turnaround Processor (MPEG-2 processor for localizing programs – motion logos, ads, clocks, stock and local news overlays, Emergency Alert Systems – EAS)
- TrimStation™ — Transport Stream Trim and Groom
- HD LogoMotion II™
- All HD products are fully integrated with Leitch's CCS™ Command and Control System applications
- NEXIO MediaNet™ Media and Asset Management
- NEO SuiteView™ — Multi-display Processors

www.leitch.com

 **LEITCH**