

# Broadcast ENGINEERING®

THE JOURNAL OF DIGITAL TELEVISION®

## DTV Update

- Antennas
- New IOTs
- Datacasting

Also:  
Routing Technology

##### 5-DIGIT 33155  
#02291789# 9999 39 02 BE Q 0491  
J R HEYERS PRES  
UNITED RADIO NETWORK  
4700 SW 75TH AVE  
MIAMI FL 33155-4475

# How Do You Handle DTV Surround Sound and TV Stereo at the SAME TIME?

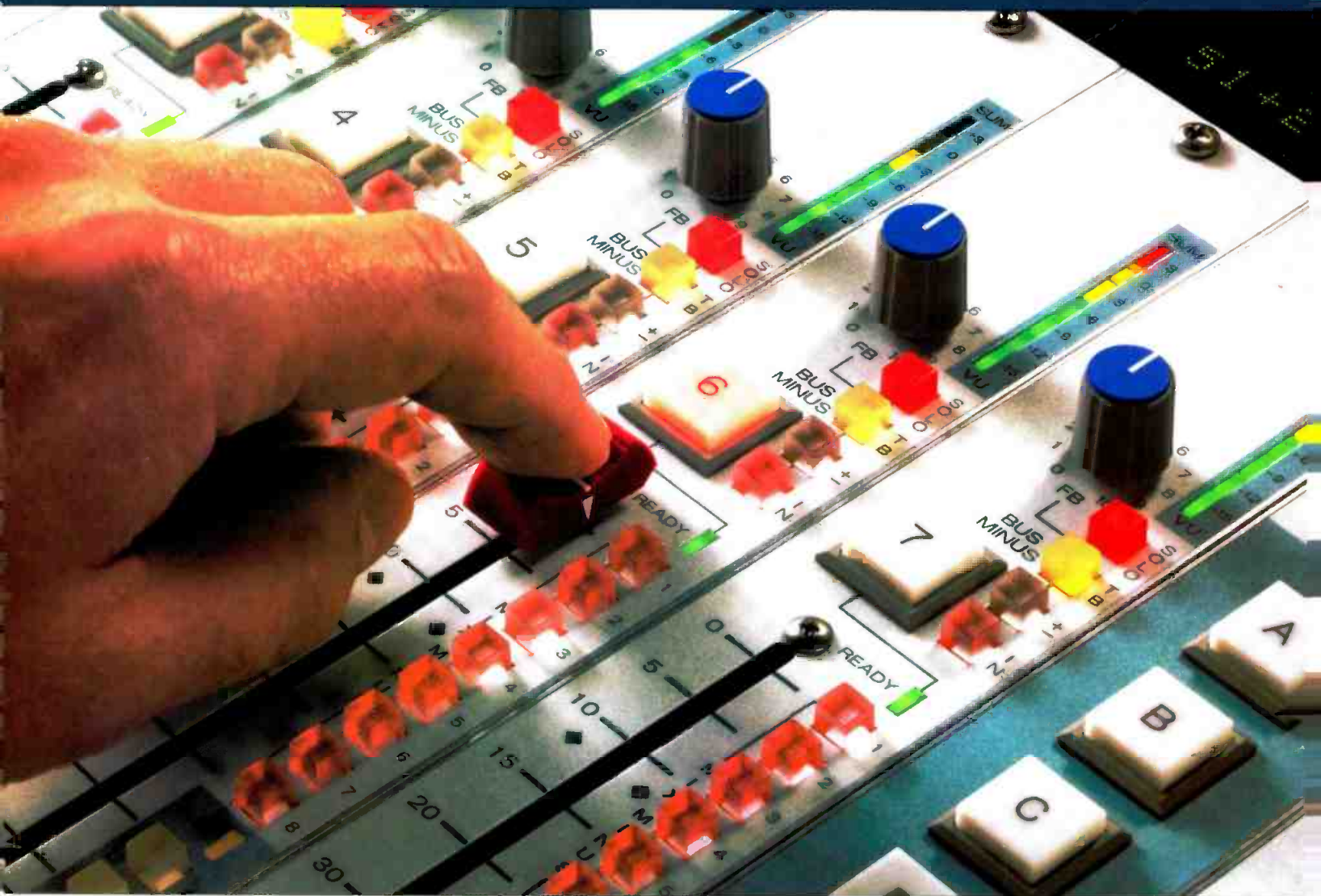

with **ONE FINGER!**

The TV-1000 Live Television Audio Console  
from WHEATSTONE CORPORATION.  
With 5.1 + 2 Surround Sound.



600 Industrial Drive, New Bern, North Carolina 28562  
tel 252-638-7000 / fax 252-637-1285 / sales@wheatstone.com

Circle (101) on Free Info Card



Bubblewrap, no challenge.  
Taking advantage of the technology  
inside, not so fast.

You have brand new, high-tech, shiny digital equipment. Now, how are you going to get the most out of it? Harris can help. Many broadcasters work with us to engineer transmitter systems, studios and mobile facilities with the latest digital technology. But we also reach beyond future-ready equipment solutions by leading the way with a unique package of support services—from transmitter installation and systems integration to round-the-clock technical support. And our Broadcast Technology Training Center provides customized DTV instruction to help your station make a smooth transition to digital. It's all from Harris. Because getting through the bubblewrap should be the hardest part of going digital.

*next level solutions*

WIRELESS

BROADCAST

GOVERNMENT

NETWORK SUPPORT

1-800-4-HARRIS ext.3042 ■ [www.harris.com](http://www.harris.com)

Circle (104) on Free Info Card

**HARRIS**

**MPEG IMX**



▲ 8 INDEPENDENTLY EDITABLE DIGITAL AUDIO CHANNELS

▲ BETACAM/SP/SX AND DIGITAL BETACAM PLAYBACK



# SONY

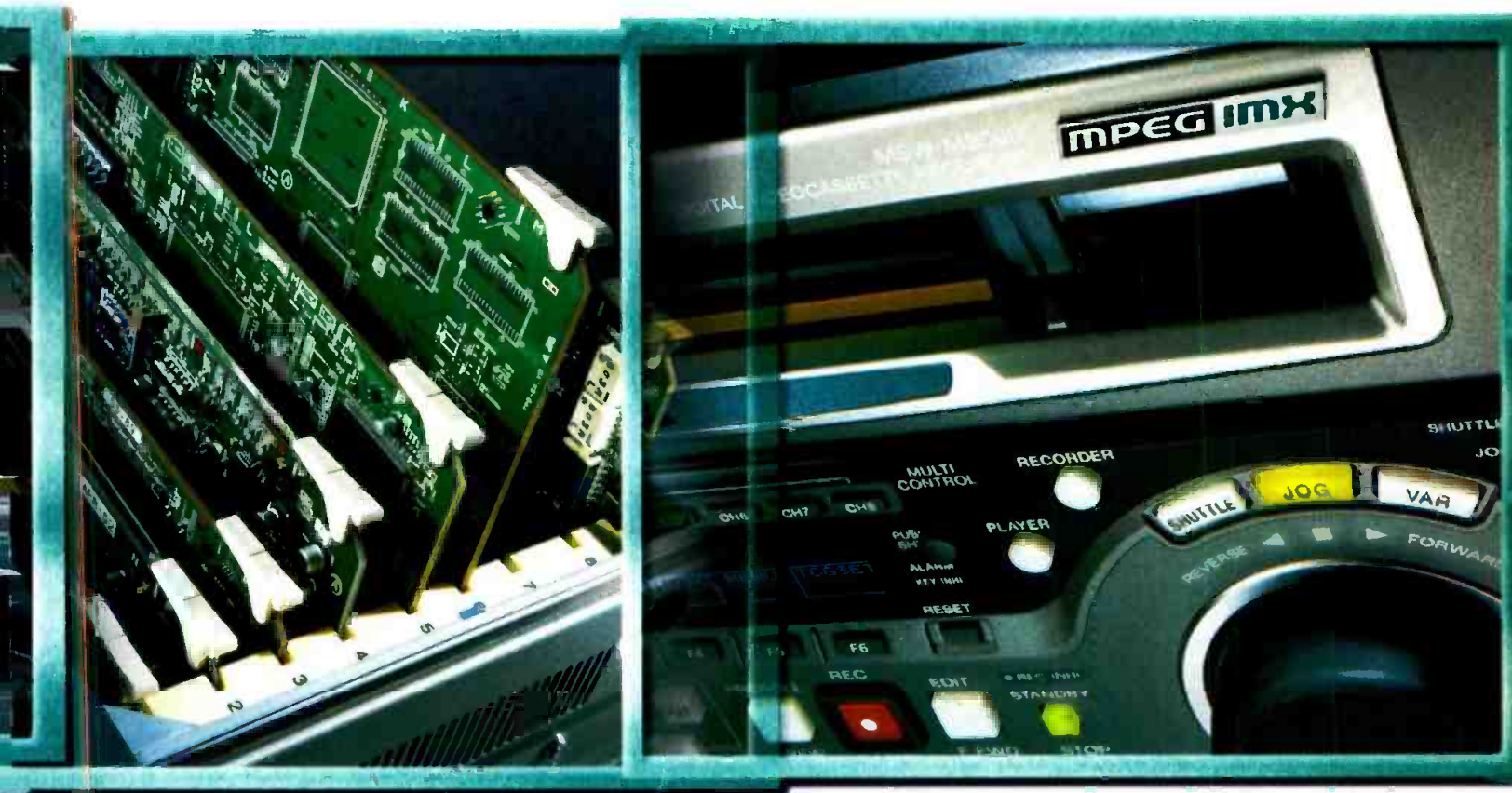

▲ NEW LOW CHASSIS PROFILE AND PLUG-IN BOARDS

▲ PREREAD EDITING AND DYNAMIC MOTION CONTROL

## Complete the picture with **MPEG IMX**

MPEG-2 technology is the open, common solution that broadcasters are choosing for their DTV operations. It's the one solution that's upward and downward scaleable, interoperable and cost-effective.

Now, with the introduction of the MPEG IMX™ studio editing VTRs, Sony offers powerful tools for easy migration into an open MPEG environment supported by leading manufacturers. MPEG IMX VTRs record and play back MPEG-2 4:2:2 P@ML at 50 Mbps for very high broadcast picture quality. Sony's networking solutions let you interface with a host of MPEG-2 equipment from the most experienced names in digital

nonlinear editing, routing, and servers: Avid, FAST Multimedia AG, Grass Valley Group, Leitch, Pinnacle Systems, Pluto Technologies, Quantel, Snell & Wilcox, Vibrant and others.

You'll be able to accept I-frame, single GOP bitstreams, at 30, 40, and 50 Mbps through the SDTI-CP interface. Output through SDTI-CP to Sony's MAV-555 and MAV-2000 servers. And do pre-read, dynamic motion control and independent editing of 8 channels of 16-bit audio (or 4 channels of 24-bit audio), for multichannel or multi-language broadcasting.

Another big advantage of the MPEG IMX approach is that you already have the acquisition tools. You can choose MPEG IMX models that play back Betacam SX®, Betacam®, Betacam SP®, and Digital Betacam® tapes, so your existing acquisition format becomes your MPEG acquisition format.

MPEG IMX gear lets everyone look in the same direction: toward an open, digital networked broadcast environment.

COMPLETE  
THE  
PICTURE

1-800-472-SONY ext. IMX  
[www.sony.com/professional](http://www.sony.com/professional)

## IN THIS ISSUE



## Features

### 66 New DTV antenna technology

*By Jay S. Martin*

Improvements in technology mean more antenna choices for broadcasters.

### 72 ATSC IOT performance

*By Michel Langlois*

A comparative look at 8VSB and COFDM using IOTs.

### 76 Datacasting: Is it legal?

*By Mitchell Lazarus*

Broadcasters may have to negotiate a regulatory minefield when offering datacasting services.

### 80 Routing systems technologies

*By Barry W. Albright*

Making the right choice in routing systems is essential to a successful digital transition.

### 90 News Tech: Election systems

*By Matthew Straeb*

Compelling, timely coverage is the key to better ratings during elections.

## Beyond the Headlines

### NEWS

- 14 Tuning in on DTV and decoding
- 18 WCPX-DT to begin multicasting six channels

### FCC UPDATE

- 26 FCC auction threatens stations on channels 59 through 69

### EXPERT'S CORNER/VENDOR VIEWS

- 28 NOAA forecast protocol changes

## Digital Handbook

### TRANSITION TO DIGITAL

- 34 Data multiplexing

### COMPUTERS AND NETWORKS

- 40 Video servers

### ASK DR. DIGITAL

- 46 Educational materials

*(continued on page 8)*

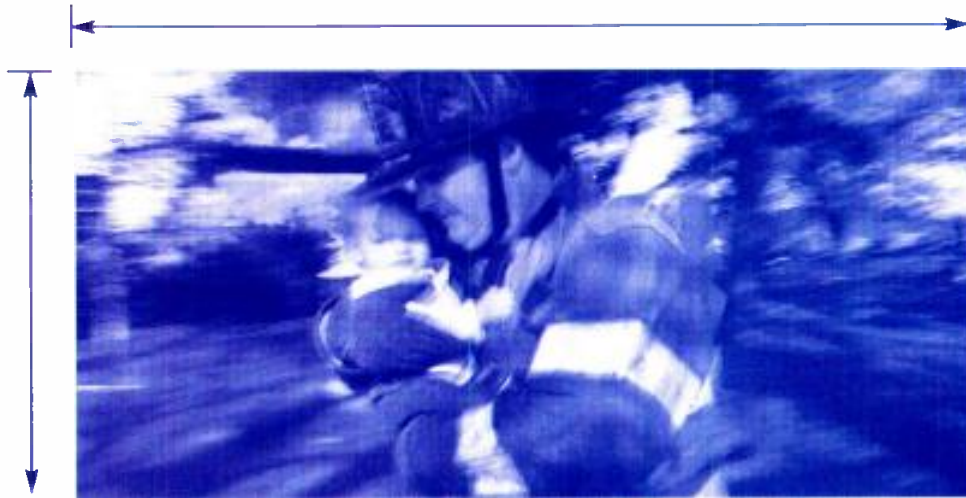

Today it's the news at 6:00.  
Tomorrow it's prime time.  
You need options for  
ENG economy and EFP quality.

You Could:

- A) Buy both and break the bank.
- B) Go Panasonic.



Introducing the AJ-D910WA DVCPR050 camcorder -- the new standard for ENG/EFP acquisition. Featuring both 4:3 and 16:9 widescreen, the AJ-D910WA offers both economical 25 Mbps DVCPR0 and studio quality 50 Mbps 4:2:2 DVCPR050 recording

in a single camcorder. The new AJ-D910WA enables a complete 50 Mbps I-frame recording and editing system without the need for transcoding, plus its optional Digital Triax system permits remote camera and VTR control. Call us today at 1-800-528-8601 or visit our web site at [panasonic.com/openminds](http://panasonic.com/openminds).

The AJ-D910WA, because you never get a second chance to make a first compression.

**Panasonic**  
Open systems. Open minds.™

[www.panasonic.com/openminds](http://www.panasonic.com/openminds)



# Systems Design & Integration

## SYSTEMS DESIGN SHOWCASE

48 Oxygen Media

## TRANSMISSION & DISTRIBUTION

58 Transmitter site safety

## PRODUCTION CLIPS

62 Audio for video -- analog, digital or embedded?

# New Products & Reviews

## APPLIED TECHNOLOGY

- 94 Vibrint digital news production applications
- 96 Pinnacle's PDS 9000: Integrating switcher and DVE technologies
- 98 Grass Valley Group's Kalypso video production center
- 100 Video Products Group's Virtual Studio Networks

## TECHNOLOGY IN TRANSITION

104 Production switchers: Mixing pictures and metaphors

## NEW PRODUCTS

108 Lighthouse Digital Systems' Navigator, plus other new products

## BUSINESS WIRE

128 Business highlights from broadcast and production



# Departments

- 10 Editorial
- 12 Reader Feedback
- 147 Classifieds
- 151 Advertisers' index
- 152 EOM

**ON THE COVER:** Baltimore, MD, is home to WBAL's, WJZ's and WMAR's new DTV/NTSC stacked antenna systems. This historic tower was the first three-antenna candelabra in the world when it was built in 1959. Photo courtesy of Dielectric Communications.

## WEBSITE DIRECTORY

[www.broadcastengineering.com](http://www.broadcastengineering.com)

Feature Articles

Departments

New Products & Reviews

Classifieds/Jobs

Marketing/  
Advertising

Reader Resources

- Editorial calendar
- Article archives

Contact the Editors

Questions? Contact:

Jim Saladin  
jim\_saladin@intertec.com  
913/967-1905 fax

## FREEZE FRAME

A look at the technology that shaped this industry.

### 1/4-inch VTR

"One of the most promising technologies" of the 1983 NAB convention was the new 1/4-inch VTR format. Two companies displayed working versions of the format, including field editors and detachable camera/recorder units. Hint: one company called its product the "Quartercam." Name the two companies. Correct entries received by Aug. 31 will be eligible for a *Broadcast Engineering* t-shirt. Send entries to [brad\\_dick@intertec.com](mailto:brad_dick@intertec.com).





# "OUR GOAL IS TO DELIVER BROADBAND SOLUTIONS THAT WORK FOR YOU."



## **Tom Lookabaugh**

*President, DiviCom*

"This merger is great for our customers, great for DiviCom and great for Harmonic. Our customers know the DiviCom name as being synonymous with open solutions for digital television.

They'll soon know us as Harmonic, and because of the merger, they'll get access to even more solutions and resources to meet their broadband needs.

There is enormous synergy between DiviCom's digital headend technology and Harmonic's advanced fiber optic system solutions. So from a single source, customers can leverage the expertise both companies bring to the party. Together, we'll be driving innovation in broadband from the headend across the entire broadband network."

## **Tony Ley**

*CEO, Harmonic*

"People around the world are demanding better and easier ways to communicate. Access to information is changing the way we live. Harmonic and DiviCom are joining forces to enable this new era in broadband communications.

Whatever the network, Harmonic will work with operators to build the infrastructure that makes the information age possible. And we will deliver the best technology and customer support the industry has to offer.

I look forward to service providers embracing our new company. Our customers can continue to expect the world-class broadband solutions they need to bring new services to market faster."

[www.harmonicinc.com](http://www.harmonicinc.com) 408.542.2500



Circle (105) on Free Info Card

[www.americanradiohistory.com](http://www.americanradiohistory.com)

## Is your station going dark?

**W**ant to increase your coverage area by three, four or even 1000 times? How much RF would that take? Maybe a few gigawatts? What if you could do it for \$50,000 or even less? Interested? I'm about to tell you how.

Streaming media is the current hot button on Wall Street. At last month's Streaming Media conference in New York, more than 13,000 broadcasting newbies gathered to check out the latest

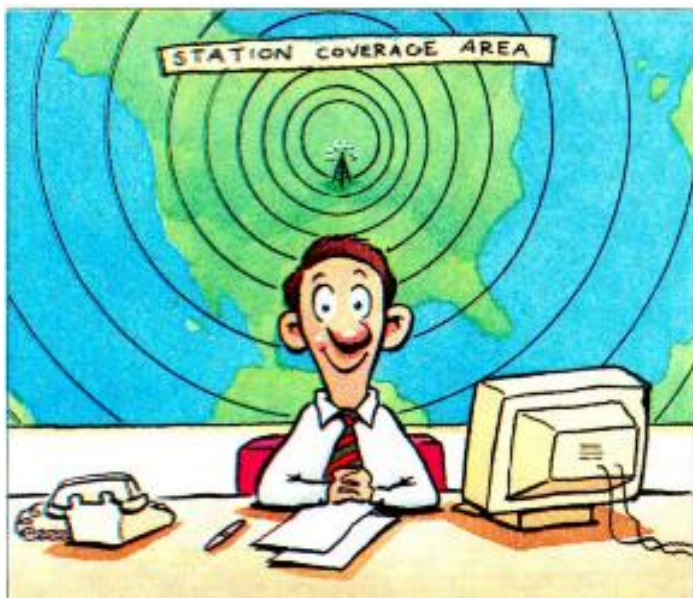

in streaming technology. Attendance was three times last year's number. There were twice as many exhibitors as the year before. Granted, this show has more smoke and mirrors than a magician's convention, but this new industry is still one to be reckoned with.

Let's look at some numbers. The Internet Research Group says streaming media services will grow by 20 times in the next three and one-half years. Total revenues by 2004 will be \$2.5 billion – that's a 2.5 with eight zeros behind it. Now you're getting an idea of how large this behemoth really is. And the number of users is growing rapidly, too.

According to Digital Technology Consulting, more than 11.3 million homes will have high-speed Internet connections by next year. That breaks out to almost eight million with cable modems and four million with DSL. The In-Stat group says some 49 million homes will have broadband service by 2004. Are you convinced that there's a new audience for your signal yet?

In my little burg, a start-up company called Digital Access just inked a deal with the city fathers to supply cable, Internet and telephone services via fiber. There are currently more crews installing fiber in Kansas City than flies at a picnic. The work represents a direct overbuild of two familiar monopolies, Time Warner and Southwestern Bell. Now we'll have some competition. Just watch the formerly sole providers react to the new competition with lower prices and improved services.

I liken the placement of a signal on the Internet to what Ted Turner must have thought about when he considered putting his unknown station, WTBS, on satellite for distribution by cable systems. He didn't say, "Why would I want anyone outside my terrestrial coverage area to watch my station?" Instead, he said, "How can I get my signal to the millions of viewers outside Atlanta?"

Stations that think their audience stops at the city limits are missing a great opportunity; they just don't know it. With the Internet, there is no defined *service area*. Your service area is as big as you want to make it. With streaming technology, it costs no more to cover the nation than it does your backyard.

So where does all this new technology, growth, competition and, most importantly, money leave broadcasters? It depends on your viewpoint. Some broadcasters have chosen to ignore the chaos outside the door, thinking it, like quad FM, will go away. It won't. Stations that choose to ignore streaming media and other new data delivery technologies are already going dark. They just don't know it yet.

*Brad Dick*

Brad Dick, editor

Send comments to:  
direct: [brad\\_dick@intertec.com](mailto:brad_dick@intertec.com)  
website: [www.broadcastengineering.com](http://www.broadcastengineering.com)

Solving the Digital Puzzle



Think Big, Choose Small

▷ Video A to Ds / D to As / DAs / Encoders / Decoders  
Composite / RGB / YUV / Y/C / HD / SDI

▷ Audio A to Ds, D to As  
24-bit

▷ Audio Demultiplexers  
Analog and Digital

▷ Aspect Ratio Converters  
16:9 to/from 4:3

Circle (106) on Free Info Card



NTSC/PAL/SECAM Decoder  
10.2 cm



HD Converter  
10.2 cm



Dual AES/EBU Demultiplexer  
10.2 cm



The

**picoLink**™  
Miniature Interfaces

™

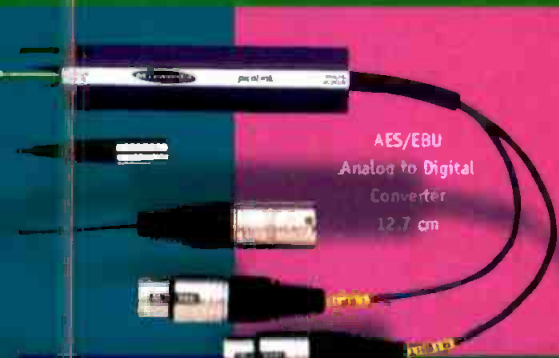

AES/EBU  
Analog to Digital  
Converter  
12.7 cm



NTSC/PAL Encoder  
10.2 cm

Composite to  
Component Converter  
12.7 cm



AES/EBU Digital to  
Analog Converter  
12.7 cm



Aspect Ratio Converter  
16:9 ↔ 4:3  
12.7 cm

Digital Video Distribution Amplifier  
10.2 cm



S-Video Decoder  
10.2 cm

## Community towers

Dear Brad,  
Your editorial ("Working together for community towers," April 2000) presents compelling reasons to co-locate DTV towers. DTV is exciting and has the headroom for functions and services way beyond HDTV. But it's still subject to the same physics of RF propagation we've all grown to know and love for 50 years, including those pesky things like antenna aperture gain and beam width.

The CEA AntennaWeb.org program simplifies receive antenna selection. I'm glad you found it useful to ID the type of antenna your soon-to-own-an-HDTV-set friend needs. If it predicts a rotor is needed, it's for the good reason you point out — lack of tower collocation. The site is a great (and free) tool not only for *BE* readers but also for the general public. More and more receive antennas are coming on market marked with the CEA antenna selector logo indicating their corresponding type. I'd be interested in other readers' experiences.

I agree using rotors in the DTV world is cumbersome, especially with lengthy signal capture/display latency, but there are alternatives. The obvious one is an "area special" antenna designed to receive diverse channels at set orientations. Another emerging approach is electronically steerable antennas. CEA's R5 (antennas) committee is exploring this and other approaches and may even devise a DTV receiver/antenna interface to make it all automatic. Now THAT is exciting.

RALPH JUSTUS  
V.P., TECHNOLOGY AND STANDARDS  
CONSUMER ELECTRONICS ASSOCIATION

## Dubbing tape to CD

I have hundreds of hours of DAT recordings of our two-hour radio show. I'd like to transfer them to CD-ROM for archiving.

Can you suggest a simple method of doing this on a Mac? I've got the CD burner and access to all kinds of software, but what is the quickest way?

I'd like to dub the DAT in its two-hour recorded format and then separate each hour later onto individual CDs. Can you suggest a simple solution or point me in the right direction?

IRA FLATOW  
HOST/EXECUTIVE PRODUCER - "SCIENCE  
FRIDAY"  
STAMFORD, CT



Ira:  
*Unfortunately, to my knowledge there is no quick way to transfer audio from an audio DAT to CD-R. (If you had audio files on a data DAT, it would be easy.) You have to record from DAT to a hard disk in real time, using a two-track audio recording program. Next, save a file for each hour of your broadcast, and then you are ready to burn the CD. I highly recommend using a Mac-compatible audio card with S/PDIF digital I/O so you can transfer the audio to the computer in the digital domain. The procedure is exactly the same for Windows and Linux users.*

*Best wishes,*

STEVE OPPENHEIMER  
EDITOR  
ELECTRONIC MUSICIAN

## "The first transistor" contest winners

Last month's contest resulted in a new record for number of entrants. While every entry identified the photo as the first transistor, there was some debate as to the actual date of the invention. Reader Bob Connelly at Wyoming Public TV provided a great resource for more information on the invention of the transistor at [www.pbs.org/transistor/album1/index.html](http://www.pbs.org/transistor/album1/index.html).

One note, several of the entries identified the first solid-state device as a *Geranium* transistor. Of course, the correct type name is *Germanium*. A partial list of this month's winners follows. Each correct entry received a *Broadcast Engineering* T-shirt. This month's contest question is on page 8.

Bob Connelly, Wyoming Public TV  
Paul Hart, HBO  
Tom Lahr, WOSU-TV  
John Mazza, San Francisco  
Vicki Kipp, Wisconsin Public Broadcasting  
Karl Nitschke, Ponte Vedra Beach, FL  
George Danner, WPEC-TV  
Richard Crowley, Hillsboro, OR  
Jason Mecklenburg  
Gary Sharpe, SCOTTY Tele-Transport Corporation of the Americas  
Ron Estes, KTLA-TV  
David Budwash, WAGA-TV  
Don Norwood, Hickory, NC  
Jaime Ananko, Rochester, NY  
Frank Anderson, Media City Teleproduction Center  
Allen Harmon, WDSE-TV  
John Szkudlarek, Sinclair Community College  
Dale Lamm, Canton, OH  
Mike Plott  
Larry Price, KMEX-TV

**More Forums**

**More Users**

**More Questions**

**More Answers**

the **wwug**<sup>TM</sup>  
World Wide User Groups  
[www.wwug.com](http://www.wwug.com)

With over 300 forums dedicated to digital content creation professionals, it all comes together on [DigitalMediaNet.com](http://DigitalMediaNet.com).

[DigitalMediaNet.com](http://DigitalMediaNet.com) helps you stay in touch with the issues, products and opportunities that can give that all-important competitive edge. Professionals from around the world, representing every discipline in the digital media market, tune into our media channels every day. Whether you are looking for the latest news, reviews, industry trends, a place to buy or sell your new product or even a new job, [DigitalMediaNet.com](http://DigitalMediaNet.com) has a solution!

**Digital Media NET**  
Where the Creative Community Meets

[www.digitalmedianet.com](http://www.digitalmedianet.com)



### Tuning in on DTV and decoding

BY LARRY BLOOMFIELD



The transition to digital television has problems at virtually every point along the delivery chain, from the pickup devices to the display device. There are many questions whether it's wise to move to a completely different system or keep putting Band-Aids on the one we have decided to use here in the United States, 8VSB.

Except for the last couple of years, little effort has been made to improve tuner capabilities. Once a tuner receives digital bitstreams and modulates the head as a matter of cleaning up those bitstreams, irrespective of the form of modulation, they can be decoded and their various aspects put to their proper use.

The distinction between the different generations of chips that grace the front-ends of the digital television tuners is somewhat blurred at this point. The problems have been many. Motorola's Frank Eory says, "Debugging an application like this, at

least to the point of discovering where it is 'breaking', would not take long. Fixing the problem is another issue."

A joint venture between ATSC, the Consumer Electronics Association (CEA) and test station WHD-DT in Washington, D.C., conducted tests for television set manufacturers on June 1. According to George Hanover, inde-

were cloistered in separate rooms or suites. The encoder people were at WHD-DT and, when all the receiver folks finished with one encoder, Hanover would cue the encoder folks to switch to a different encoder, until each had their opportunity to be online and be tested.

Although the media was not invited and most everyone involved at ATSC, CEA and WHD-TV declined comment, the off-record conversation was that these individuals didn't think the tests would have been attended if the results were made public or shared. C. P. Patel, a noted authority in the area of television front-ends and a 20-year veteran of Sarnoff Labs, said

this information had to be shared, otherwise the tests would have been worthless as far as the encoder manufacturers were concerned.

According to one participant, there is no test equipment available on the market at this time that can replicate the real-life conditions of terrestrial digital broadcasting. This unique opportunity should have proven very beneficial to all parties concerned.

Another issue is a list of requirements a consortium of broadcasters has submitted to the ATSC. It would seem that the well-trusting broadcasters should have had that list in to the ATSC long before all these standards for the nation's digital television system were to be cast in stone.

Eory in his comments on the broadcasters' requirements stated: "Under existing law, DTV broadcasters must transmit 8VSB signals with the defined ATSC framing structure."

Eory further stated if the ATSC is going to solve multipath problems, the digital framing structure must be

**There is argument that the gap between coverage and "receivability" must be narrowed.**

pendent consultant for CEA, the manufacturers of both encoders and decoders were invited to attend. Each set manufacturer wishing to test out the various parameters of their decoders

#### FRAME GRAB

A look at the issues driving today's technology.

#### When will iTV go mainstream?

Almost one-half say never!

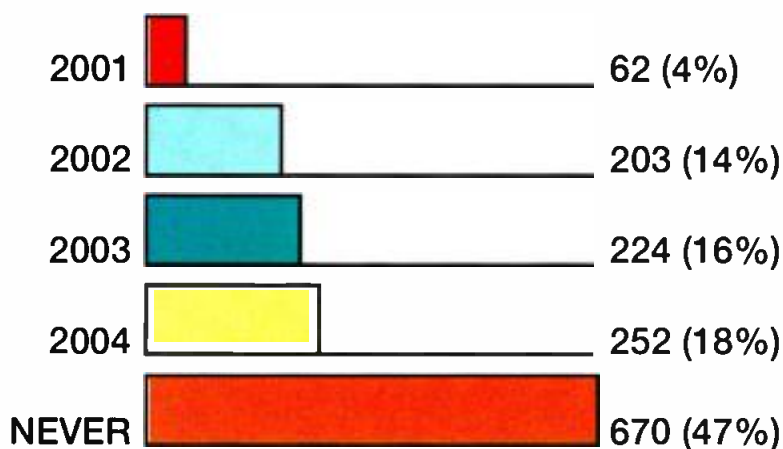

SOURCE: ZDNet on-line survey as of 6-18-00

**“To uplink 8 video feeds from the White House lawn, we put all our eggs in one basket.”**

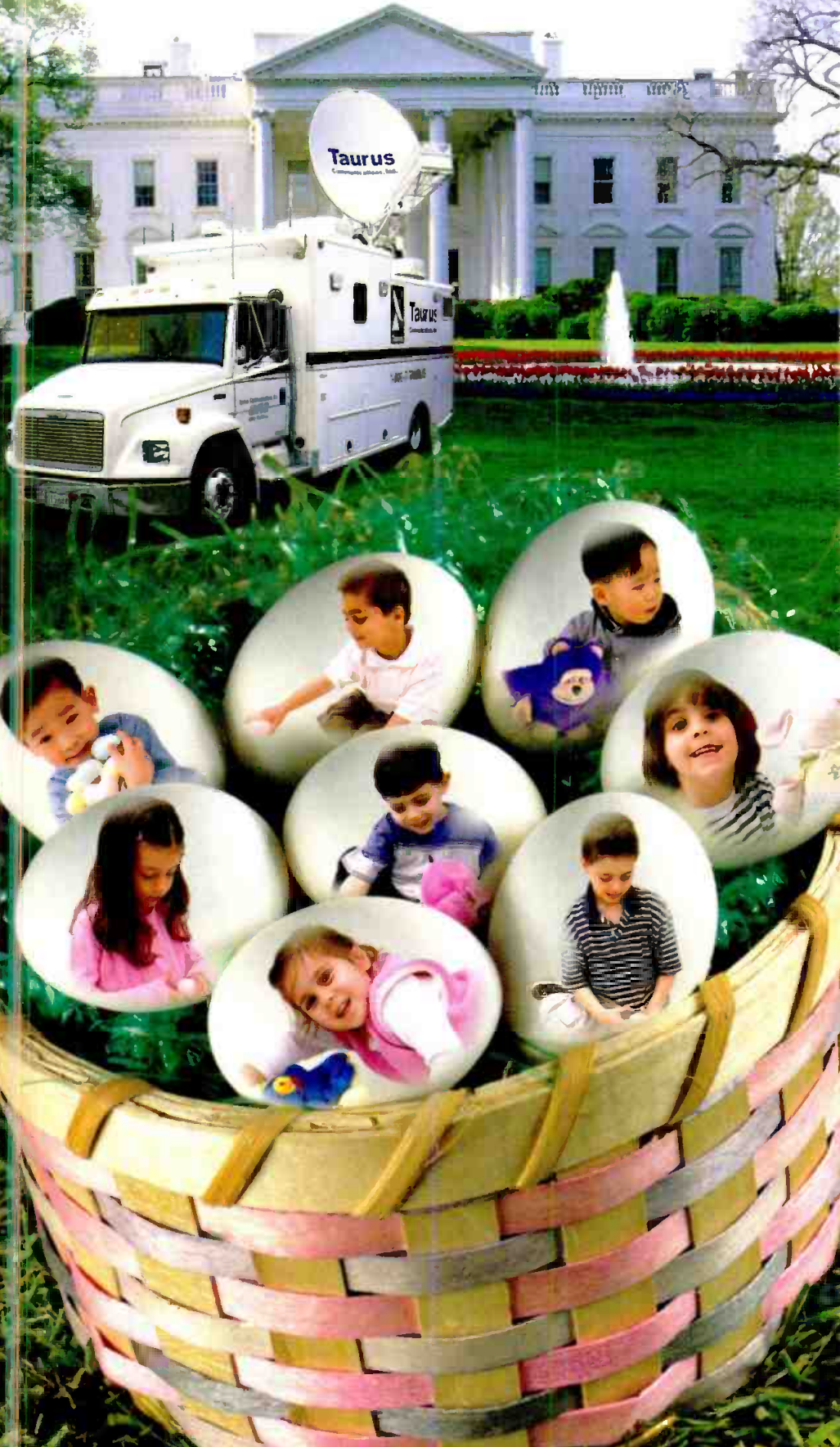

Dudley C. Freeman  
President  
Taurus  
Communications, Inc.

When Taurus Communications got the call to provide the DSN link for the White House 2000 Easter Egg Roll, it was apparent that the task would not be easy. Eight simultaneous video feeds were needed from a single truck, and no retakes were possible. This had to be a one-take, 8-feed, perfect satellite broadcast that could be distributed by Internet streaming video around the world.

*Taurus president, Dudley C. Freeman, says it best, "I knew we had to have equipment that we could count on, no matter what, so I turned to Tiernan and their THE1 HDTV/SDTV Encoder. There is simply nothing better on the market today."*

THE1 is a high-performance, modular MPEG, ATSC and DVB compliant encoder. Its future-proof, modular design makes it easily adaptable to changing requirements in contribution and distribution via satellite and terrestrial networks.

So, no matter what your area of digital broadcasting, when you need the kind of performance and reliability you can count on every time, put your eggs in Tiernan's basket, too.



info@tiernan.com  
www.tiernan.com

**USA**  
TEL +1 858 587-0252  
FAX +1 858 587-0257

**UK**  
TEL +44 1420 544 200  
FAX +44 1420 88 999

**Tiernan can take you wherever you want to go, however you want to get there.**

Circle (107) on Free Info Card

modified to accommodate a few additional data segments per data field, so better "training signals" can be provided for initializing the parameters of the adaptive filter used for equalization and ghost suppression. There are those, however, who take issue with this philosophy saying that adding three data segments per field results in a one percent loss in channel capacity.

However, Eory argues that without better training signals, the initialization requirements on the adaptive filter used for equalization and echo-cancellation are exceptionally difficult, especially for certain complex echo ensembles.

It would be an understatement to say that in the past most engineers underestimated the multipath problems DTV would encounter. The AHG addressing these broadcaster requirements has determined that the failure of current 8VSB receivers to operate in the presence of multipath reception is intolerable.

There is argument that the gap between coverage and "receivabil-

ity" must be narrowed. The AHG on receiver performance is where solutions must be found for as much of the multipath reception problem as is possible.

Other issues continue to plague re-

ceiver manufacturers. CEA faithfully promised to deal only with the now famous Table 3, but nothing in the FCC rules says a broadcaster must adhere to them. If a broadcaster chooses a different scan or frame rate it's not uncommon to find that sets can't deal with any of these other rates. Some sets even have difficulty dealing with 720 lines.

Both organizations involved said that they were fully ATSC compliant prior to the change from 704 lines to 720 lines. They each supposedly performed the same change and only that change; going from 704 lines to 720 lines. The net result was that one set of bitstreams caused problems in the receive and the other didn't. Reports from those involved in this testing found that much more surprising and scarier than the fact that any receiver might have problems with 720 lines. It therefore appears not to be a 720 lines issue, but rather an encoder-compliance issue or a standard issue.

Eory said there are bitstream and encoder setting issues other than just those that relate to Table 3 and non-Table 3 formats. Motorola's MPEG decoder firmware team, after making changes, were "totally taken by surprise

when the four local DTV stations went on the air and they found that with one of them, video was not decodable at all," he said.

The fix was relatively straightforward. After close scrutiny of the station's bitstream, it was discovered that this station was transmitting only P and B frames and no I frames. The software looks for an I frame to get started and never finding one, it never attempted to decode the video. Now that it is known that this situation can exist, chipmakers can deal with it.

The engineers at the Phoenix station in question said the condition was not intentional, because they were simply using the encoder the way it was originally set up for them.

It is apparent that fixes to the stan-

dard need to be addressed as these true-life scenarios come to light. Firmware upgrades can easily be developed to fix such problems, and Eory says that this would be one very useful application of those "extra bits" that are so far not being used for anything.

Although no specific tie-in was made with these problems, Sony, who announced in January that it would roll out six HDTV sets this fall, has announced it will delay the delivery "because of software problems and technical standards concerns." Sony executives say retailers have been notified that they will not deliver the products this year.

Vic Pacor, senior vice president for television and digital media products at Sony Electronics, said, "Software for the main set of chips inside the televisions is taking longer to finish than anticipated." Pacor also said that another factor was a recently announced standards-body review of the transmission method selected several years ago for digital TV signals.

Pacor said he wasn't sure when Sony would sell the new TV, which includes two tube-based and four rear-projections sets. Pacor did say that Sony expected little financial impact from the delay.

There are two main points that need to be considered. First, these issues are not based on the battle over modulation schemes. These are purely digital issues centered on MPEG encoding and other digital parameters. That's what the June 1 meeting in Washington, D.C., was supposed to be all about. Perhaps we need to rethink some of the bitstream construction irrespective of the modulation standard, simply as an insurance policy. It's clear that all the issues of even the bitstream encoding/decoding process haven't yet been resolved.

Second, a high-ranking executive at Sony said she had considered having the company install a giant antenna on the roof of its skyscraper in New York to get HDTV broadcasts for its showroom but found that the cost of providing a reliable signal was prohibitive. If Sony, which employs 100,000 engineers and technicians, could not get a reliable HDTV of its own, what chance do the rest of us have? ■

## **Motorola's Frank Eory said there are bitstream and encoder setting issues other than just those that relate to Table 3.**



# Stay Tuned.



**For nearly 100 years,** Belden has been providing the world's most innovative wire and cable solutions for the world's most challenging applications. From the high-tech leaders who are shaping the business world of the future...to the state-of-the-art stadiums and athletic facilities...to the broadcasters that bring the world closer together...to the industrial applications that are ushering in a whole new age of productivity...Belden has the products that perform and the expertise to help you make the right decisions. Like to know more about who we've helped? Stay tuned. Better yet, contact us today at **1-800-BELDEN-4** or on the Web at **www.belden.com**. And let's talk about what we can do for you.



1400-0100 6/00

© Copyright 2000, Belden Inc.

Circle (108) on Free Info Card

www.americanradiohistory.com

CABLE-E108998 4PR24

JZ BELDEN CABLE-E108998 4PR24

T4

# WCPX-DT to begin multicasting six channels

**P**axson's WCPX-DT will be multicasting six channels of network feeds for 24 hours a day.

The itinerary will be three channels of the PAX network, consisting of the local, central time zone on the primary feed with the East Coast and West Coast feeds on Channels 2 and 3 respectively. The other three channels will consist of the Worship network, Praise television network and the Total Living Network (TLN), a Chicago-based TV network, on Channels 4, 5 and 6.

Paxson says it wants local cable systems in the Chicago market to carry its digital local time zone feed on the same channel to all basic subscribers that the PAX analog station had been delivered to at that the same time.

In other words, cable operators would substitute the primary digital channel for the current analog signal so that the primary digital signal is available to all cable company's basic subscribers on the same channel where the analog signal resided. The other five channels being carried by WCPX-DT's digital signal would be available on the digital portion of the cable system serving homes equipped with set-top boxes that could decode the additional information. It is Paxson's intention that these additional channels will be available as free programming services as well. It would be necessary for the cable company's digital set-top boxes to be equipped with the channel mapping protocol (PSIP) to be able to retrieve the additional program material.

Lowell "Bud" Paxson said, "We're proud to be at the forefront of digital broadcast technology. The launch of WCPX's digital signal marks the beginning of our conversion of Paxson's television station group to digital broadcasting. As we continue to upgrade each of our stations' transmission facilities for conversion to DTV, we will be able to provide viewers with multiple digital channels of en-

tertainment programming, as well as data transmission and e-commerce opportunities."

There's little doubt in anyone's mind that digital carriage is the key to the success of the implementation and acceptance of DTV. In this light, Paxson said, "It is the company's goal to achieve must carry under the current 1992 must-carry law using the processes available to us and, if needed, to seek compromises to effectuate a digital must-carry plan, which I feel is an absolute requirement for the successful transition on a nationwide basis from analog television to digital television." Paxson said this must-carry plan has been presented to members of the cable industry, the FCC and NAB.

It's no secret that Paxson has a "strategic relationship" with the National Broadcasting Company (NBC) and carries some of its shows such as the game show "Twenty One," and weekly extended primetime coverage of "2000 U.S. Olympic Team Trials" leading up to this year's Olympic Games in Sydney in September.

Paxson's president and CEO Jeff Sagsansky added, "The conversion of the company's television stations to DTV opens the door to new and exciting opportunities for enhancing the quality and expanding the variety of programming networks available to our viewers. Digital television opens up new revenue streams for the company as we develop additional networks with our partner, NBC." ■

---

## Tech bits

**H**ardly a day goes by that someone doesn't record a new method or technical advance that will impact broadcasting sooner or later. Here's a brief look at some of the more notable announcements.

The Federal Communications Commission has announced it will be studying 90GHz band. The advantage of the super-high microwave frequency is its capability of extremely wide bandwidth systems. The

pressive is the fact that the antenna for these devices is actually part of the substrate on which the final amplifier is also mounted. At these frequencies, even a speck of dust can take on the characteristics of a capacitor or an inductor, tuning the circuitry substantially.

### Spray-on circuits

Researchers at Sandia National Laboratories have developed a process they call "intelligent spray-on materials" that have the potential to create self-assembling computer displays.

The material assembles into circuitry, within milliseconds, as the material solidifies. When the undoped material is sprayed into preformed vias, waveguides solidify. By doping with molecules that recognize specific conditions, sensor arrays are instantly built.

This process is called "surfactant-templated silica mesophases." The materials can self-assemble into photonic pathways. (Photonic is the quantum of electromagnetic energy, generally regarded as a discrete particle having zero mass, no electric charge and an indefinitely long lifetime.)

Jeff Brinker, project leader, senior scientist at Sandia and a professor at the University of New Mexico says:

## The advantage of the super-high microwave frequency is its capability of extremely wide bandwidth systems.

---

downside is its inability to cover any appreciable range. Distance could possibly change with the development of technology in that frequency range. The military has been using that frequency range for some time for range finding devices. Technologists at the FCC shared some rather unique characteristics of the 90Hz technologies. Probably the most im-

Wouldn't it be *nice*  
to get a server that  
doesn't **FORCE** you to  
acquire new skills?

Introducing  
the Abekas 6000,  
the server you  
already know  
how to use.



If you want a flexible, scalable, exceptionally versatile digital audio video server that will help you well into the next century *and* gives you the control you want without so much as a whimper, look at the Abekas 6000.

Simplifying your life starts at  
[www.accom.com/6000](http://www.accom.com/6000)

Circle (109) on Free Info Card

**Accom**

# Digital Media NET

Where the Creative Community Meets

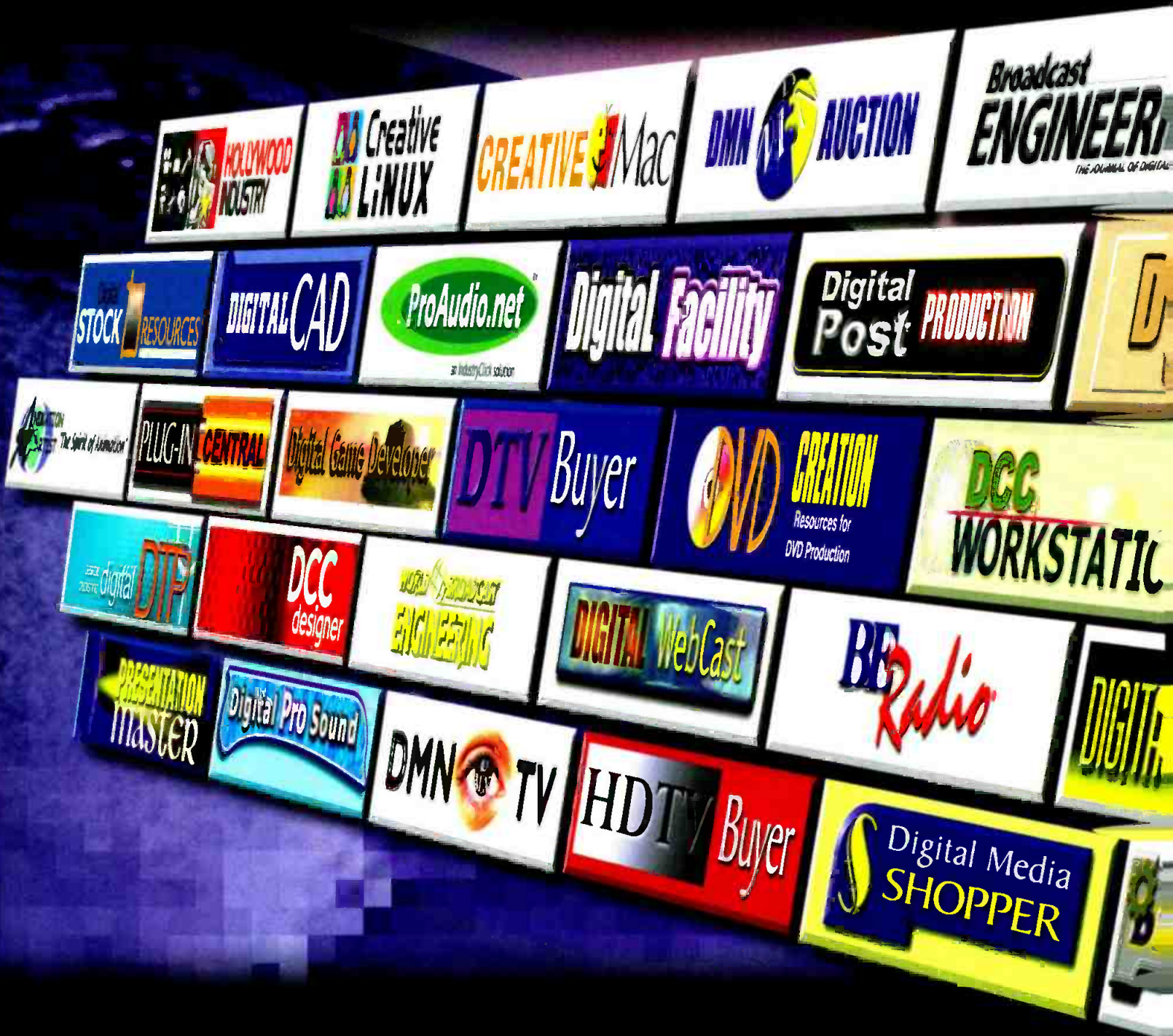

## It All Comes Together on DigitalMediaNet.com

DigitalMediaNet.com helps you stay in touch with the issues, products, and opportunities that can give that all-important competitive edge. Professionals from around the world, representing every discipline in the digital media market, tune into our media channels every day. Whether you are looking for the latest news, reviews, industry trends, a place to buy or sell your new product or even a new job, DigitalMediaNet.com has a solution!

SON



Digital Producer Magazine

Format



millimeter  
The Motion Picture and Television Production Magazine

VIDEO EDITING

DIGITAL ANIMATORS



www.DigitalMediaNet.com

"By adding ligands that exhibit molecular recognition, we can literally spray on sensor arrays." (A ligand is an ion, a molecule or a molecular group that binds to another chemical entity to form a larger complex.)

Brinker's team has harnessed the tendency of detergent-type molecules to exhibit two phases with opposite reactions to water, one hydrophobic (water-repellent) and one hydrophilic (water-soluble). During evaporation, those molecules form spherical cavities called pores. For instance, a drop of the material dries to form a hollow "dome" and a line of the material dries to form a hollow "tube" flattened on its bottom side.

So far, Brinker's team has focused on fluids and gases that lead to existing sensor chips, such as for handheld chemical analyzers, but this is only a start. With the addition of ligands that exhibit molecular recognition, such as molecules that change color in response to the environment, spray-on sensor arrays can be produced.

Brinker sees a bright future for his development in microelectronics. His team's immediate plans are to concentrate on microelectronic devices that can spray directly onto flexible silicon sheets. Eventually, the team envisions spraying whole computer displays onto a flexible silicon sheet from a standard ink-jet printer using color composition software to mix the materials as appropriate for different parts of the circuitry. "With ordinary color composition software, we can mix them together in 64,000 different combinations," said Brinker.

No matter how alluring "spray-on computer displays" might sound, it will likely be many years before even simple active devices make it out of the lab. To get the ball rolling, Brinker said the team's next accomplishment will be to create passive circuits with characteristics that are difficult to obtain using conventional means. Brinker believes that the ink-jet mixing strategy can be used to create devices with dielectric coefficients much lower than can be achieved with conventional lithography.

## Solar disturbances

Layer names like troposphere, ionosphere and the like have played a significant role in communications over the years. Ionosphere bounce has both helped and hindered worldwide communications. Hops across the Pacific have been performed using tropospheric scattered in the 300- to 400MHz range.

These and the other of the earth's layers are greatly affected by solar activity. Phenomena such as seeing KHOU-TV from Houston on the off-the-air receiver in Central Control at KCBS-TV in Hollywood stronger than its own (Hollywood's) transmitter approximately 19 air miles away, is the result of this kind of activity.

Since this kind of activity usually occurs with the cycles of the sun, they're not an everyday occurrence. It is why broadcast engineers need to be familiar with this phenomena so that once they are affected by it, or

## Hitachi is releasing its "rewritable" 4.7GB DVD-RAM this month.

viewers call to report unusual circumstances, they are aware of a possible cause.

It wasn't too long ago that one of these solar incidents wiped out one of the satellites many stations relied upon for the regular feeds of syndicated material. The rest of us who were affected by that wipeout know it sure can put some mighty big holes in your program schedule.

The sun, like the Earth, has its seasons, but its "year" equals approximately 11 Earth years. This is referred to as the solar cycle. According to Larry Combs, Space Weather Forecaster for NOAA/Space Environment Center in Boulder, Colorado, this year, the year 2000, Solar Cycle 23 reaches its peak period of increased output throughout the interplanetary medium, the 96 million miles between the sun and Earth. These intense releases of energy come in the form of X-rays, electrons, protons, neutrons and gamma photons.

They are released from the sun's magnetic field through violent explosions as solar flares or coronal mass ejections. More than a billion tons of matter at speeds of up to several million miles per hour is hurled through space carried in the solar wind, impacting any planets or spacecraft in its path. Severe storms can occur five times a year during solar maximum periods and even twice a year over the whole solar cycle.

The Earth's atmosphere and magnetosphere allow adequate protection, but solar storms do not go unnoticed. Energetic protons can reach the Earth in 30 minutes. These storms have and can cause havoc on our communication systems such as broadcast television and radio signals, long-distance telephones, cell phones, and pagers: widespread anomalous propagation problems with VHF, UHF and HF frequencies. Navigation systems can be affected causing delayed signals and tracking

problems with Loran and GPS receivers. Satellites can encounter increased drag, causing them to slow and change orbit, and experience charging

from the charged particles harming components on-board.

## Optical recording

Almost everyone is familiar with the compact disc. Whether your experience with them has been as a storage device for data, programs and the like, or for musical enjoyment, the CD has certainly gained its place in today's society. The average "data" CD holds somewhere in the neighborhood of 650MB of material or about 74 minutes of the audio material.

Gaining popularity is the distribution of films or other visual material on what looks like a normal CD but whose capacity is in the vicinity of 2GB. There are some distribution agencies that considered utilizing CDs for distribution of their movies and syndicated programs. These digital videodisc or DVD normally holds about 2GB of compressed video and

# Spotting the best Scan Converter should always be this easy.



You're looking at the best autosync video scan converter available anywhere. The CGC-4000 can turn your high-resolution desktop workstation, PC or Mac presentations into broadcast-quality videos.

## CGC-4000 features:

- Broadcast-Quality NTSC/PAL Output
- Full 24-bit Digital Signal Processing
- True Autosync Operation
- Dynamic Pan & Zoom
- Optional SDI Output (4:2:2)
- Betacam, S-Video (Y/C) Outputs
- Auto & User-Selectable Filtering
- RS-232 Interface
- 15-pin Connector for PC Applications
- Full 3-year Warranty

Enhance your image, put a Folsom Video Scan Converter to work for your next application.

**Serial  
Digital  
Output  
(4:2:2)**

**Computer  
-To-  
Video**

**Broadcast  
Quality  
Output**

**RS-232  
Interface**

To get information,  
see a free demonstration,  
or to order, call us or  
visit us online at: [www.folsom.com](http://www.folsom.com).

**Folsom**<sup>™</sup>  
RESEARCH  
*Enhance Your Image*

1-888-414-SCAN  
tel 916.859.2500 fax 916.859.2515

11101-A Trade Center Drive Rancho Cordova, CA 95670

audio information, or one movie.

Hitachi-Maxwell has announced a 4.7GB large capacity DVD-RAM disc. According to Hitachi, this new DVD-RAM media "provides high-quality two-hour digital recording and large capacity data recording." In addition to this, a small size (80mm) DVD-RAM disc for video camera views is also being released.

Hitachi is releasing its "rewritable" 4.7GB DVD-RAM this month. The disc holds up to two hours of digital recording or 4.7GB of computer data. In addition to this, a 2.8GB DVD-RAM disc for video cameras will be released next month.

This might not seem like such a big deal in big market television terms, however in smaller markets where costs are a constant consideration, the potential for device like this in news and or sports is certainly a very viable consideration.

It'll be interesting to watch this new DVD-based camcorder technology to see if it catches on any better than the Avid/Ikegami hard drive camcorder models that were

introduced a few years back. The two cases are not exactly comparable because the Cam Cutter was intended for professional broadcast ENG use while the Hitachi device is more aimed at the higher side of the consumer market. But again this is also not a very valid argument because we saw many S-VHS tape machines used both in the field and on the air at many small market television stations.

If you think that's great, hold on your hats because a New York-based company, Constellation 3D, Inc. (C3D) has announced further product advances in the development of their florescent multilayer disc or FMD for use with current standard red laser technology. Red lasers are pretty much the standard and an inexpensive component used in virtually all CD and DVD players in order to access the data stored on the disc to be played.

C3D has developed the FMD media capable of much higher data storage capacity, on the same sized discs and that can be played on CD/DVD drives which have been subjected to

"minor and inexpensive modification." Single FMD discs for use with these red laser-based drives will have capacities up to 25GB. You could get nearly a whole series of syndicated half-hour shows on one disk.

C3D has designed this new media to be backward compatible for use on any disc drive that can play all types of CD, DVD and FMD media. It also provides C3D with a clear road map for production of removable data storage media with high capacity applications beyond the reach of DVD (storing up to 9GB).

"Certain vertical market applications such as Digital Cinema players and Internet streaming servers will require higher capacities of over 70GB almost immediately and C3D will serve these markets using green and blue laser technology.

"We have extended our development efforts toward immediate exploitation of this 25GB red laser disc opportunity concurrently with our existing 100-plus gigabyte disc programs," says Patrick Maloney, senior vice president of Business Development. ■

# Follow the Leader, Not the crowd.

Another revolutionary Andrew **STACKER** ships for installation.



## Which company sets the pace for innovation in broadcasting?

The same company that wrote the book on UHF.

**Andrew Corporation.**

With new products like our **STACKER™** Optimized Antenna Structure (patent pending), we're providing innovative, advanced technology solutions that improve performance and save you money.

**With Andrew, there's a system for success.**

Take control of your DTV transition with **STACKER** and the many other Andrew broadcast system solutions. Call us at 1-800-DIAL-4-RF and request packet number 523.



Andrew Corporation, 10500 W. 153rd Street, Orland Park, IL 60462  
[www.andrew.com](http://www.andrew.com)

Circle (111) on Free Info Card





Remember, your digital signal is only as strong as its weakest link.

- EQUIPMENT
- SOFTWARE
- SERVICES



Don't fall for the idea that any old BNC will work for your DTV signal. Use the only true 75 Ohm BNCs on the market specifically designed for DTV applications – ADC BNCs. They're capable of outstanding electrical performance up to 3 GHz. They're equipped with positive locking center conductors and precision molded insulators to eliminate impedance mismatch. They're ZBER Certified. And they're only available from the people who have DTV down to a science. ADC.



To learn more about ADC BNCs, call 1-800-726-4266 in North America, or (952) 946-3000 worldwide. Or visit [www.adc.com/broadcast](http://www.adc.com/broadcast).



The **Broadband** Company

Circle (112) on Free Info Card

[www.americanradiohistory.com](http://www.americanradiohistory.com)



## FCC auction threatens stations on channels 59 to 69

BY HARRY MARTIN

**U**nder a Congressional mandate, the FCC is going to auction off frequencies currently occupied by stations on channels 60 to 69. The FCC scheduled these auctions for May and June; however, concerns raised by both incumbent broadcasters and wireless interests prompted the FCC to postpone the auctions until September. Broadcasters operating on these channels have expressed concern that the new services that the FCC has proposed for this spectrum will cause severe interference to current operations. They are also concerned that the standard for protection of stations occupying the affected frequencies is vague or inapplicable to television stations. The would-be wireless applicants have expressed concern regarding a parallel action for mobile phone frequencies that

may render the frequencies on channels 59 to 69 less valuable. The FCC is trying to reach a solution that will satisfy all parties by the Congressionally-imposed Sept. 30, 2000, deadline.

Applicants for new NTSC stations or NTSC allotments on channels 60 to 69 must still meet the July 17, 2000, deadline for amending their pending proposals (see Dateline, below). The postponed auction does not accelerate or extend the end of the transition period (Dec. 31, 2006) during which both NTSC and DTV channels assigned to 60-69 may continue to operate.

### LPTV window announced

The FCC will accept applications for new LPTV and TV translator stations, and major changes to existing LPTV and TV translator stations, during an application filing window to be opened July 31 - Aug. 4, 2000. A "major change" in an existing station is a change in output channel or any change that would increase a station's protected signal contour. Participation will be restricted to rural and small television market applicants to minimize disruption to existing LPTV and TV translator stations caused by the implementation of DTV. All technically conflicting applications received during the window will be subject to an auction.

Applications will not be accepted if they propose transmitter site coordinates less than 75 miles from specified city coordinates for 211 cities in large and medium television markets, with the exception of facilities that request a waiver of the geographic restriction. These requests must demonstrate that the proposed facility is completely shielded by terrain barriers, and the community it serves cannot receive signals from full-service TV stations licensed in any of the 211 cities. Alternatively, terrain shielding may be

demonstrated using the Longley-Rice terrain-dependent signal propagation prediction method.

### Court denies stay — EEO rules effective

The U.S. Court of Appeals denied a request for stay of the new EEO rules. The new rules went into effect on April 18, 2000. While denying the stay, the court put the underlying appeal on an expedited track. A decision will most likely be reached in the first quarter of 2001.

In the meantime, to comply with the new rules, all broadcasters with five or more full-time employees must immediately establish an EEO program, identify who in management will be responsible for implementation, and make certain the station's EEO policies are both well-known and regularly reviewed for compliance. The rules also require that broadcasters provide the widest dissemination of information on new full-time positions to reliable recruitment sources. Broadcasters need to randomly check to ensure that their sources are providing qualified candidates and to remove or add sources when appropriate. Minorities and females should appear in all applicant pools.

Reports under the new rules will cover station employment units, which the Commission defines as a station or group of stations commonly owned in the same market that share at least one employee. On the anniversary of their license renewal filing date, stations must place an "EEO Public File Report" in their public files and on their websites. Every second month stations in designated states must file their Broadcast Statement of Compliance (FCC Form 397). (See Dateline.) ■

*Harry C. Martin is an attorney with Fletcher, Heald & Hildreth P.L.C., Arlington, VA.*



Send questions and comments to:  
[harry\\_martin@intertec.com](mailto:harry_martin@intertec.com)

### Dateline

The deadline to amend pending NTSC applications for channels 59-69 to specify channels below Channel 59 is July 17, 2000. Amendments must be in the form of rule-making petitions and propose channels that protect all pending or operating NTSC and DTV proposals and stations, as well as qualified Class A LPTV facilities.

Stations in the following states must place their annual EEO Public File Reports in their public files and on their websites on or before Aug. 1, 2000: California, Illinois, North Carolina, South Carolina and Wisconsin.

Under the new EEO rules, on or before Aug. 1, 2000, television stations in North Carolina and South Carolina must file with the FCC a "Broadcast Statement of Compliance" on new FCC Form 397.

# Simultaneous 4:3 & 16:9 Production



The Real Shape of DTV

## SYNERGY SERIES

DIGITAL PRODUCTION SWITCHERS



**Huge Input Matrix**  
Up to 64 inputs

**Growth Pattern**  
The same 11 RU frame is used  
for the 2, 3, & 4 MLE systems

**"Aspectizer"**  
Internal aspect ratio converters for  
simultaneous 4:3 & 16:9 production

**"Squeeze & Tease" 2D DVE**  
Ideal for over-the-shoulder boxes

**Ultimate Insider™**  
The world's best matting device

**Unique Preview Overlay**  
Let's you see VTR time code, count  
up/down timer, source ID, safe title,  
and more on the PV monitor

**Video & Audio Server**  
Control a Video Server or  
360 Systems Digicart™

**Custom Control Macro Buttons**  
Recall any combination of switcher  
memories, button pushes,  
and external device control

**VTR Control**  
Available at a touch of a button

*... and much, much more*



Switchers, Keyers,  
& Terminal Gear



Synergy 2 (2 MLE)



Synergy 3 (3 MLE)

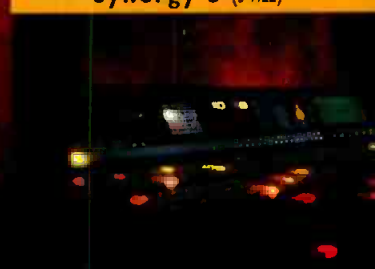

Synergy 4 (4 MLE)

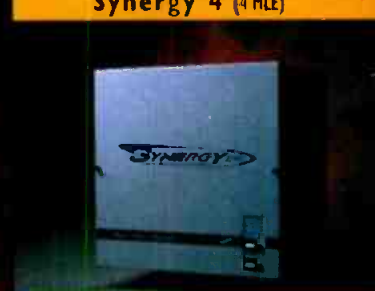

Synergy Rack Frame (all models)

Circle (113) on Free Info Card

Tel: (613) 652-4886  
Fax: (613) 652-4425

[www.rossvideo.com](http://www.rossvideo.com)

Email: [solutions@rossvideo.com](mailto:solutions@rossvideo.com)

[www.americanradiohistory.com](http://www.americanradiohistory.com)

## NOAA's change in direction

BY JIM SALADIN, SENIOR ASSOCIATE EDITOR

The National Oceanic and Atmospheric Administration (NOAA) recently announced a change in the delivery protocol, the NOAA Weather Wire Service (NWS), used to deliver National Weather Service forecasts to participating stations.

Service improvement was the impetus behind the change. The new system is said to provide a "reliable and timely" warning delivery sys-

tem, allows reception of graphics and has an improved GUI. A standard PC can be used to select and monitor weather forecasts. However, a change in NOAA's protocol equals a unilateral shift for broadcasters - change or lose service. Does this equal a capital expenditure to replace fully functional equipment? What are the alternatives?

To give us a better idea of what this

means for broadcasters, we asked Leonard Charles of Television Wisconsin and Dennis Gourley of Texscan MSI to weigh in on this month's question, "What does the change in NOAA protocol mean and are there steps to be taken for the average station?" ■



Send questions and comments to:  
[jim\\_saladin@intertec.com](mailto:jim_saladin@intertec.com)

**EXPERT** The NOAA Weather Service (NWS) conversion will affect all broadcasters who have been getting the weather wire data direct from GTE/Contel. It will also affect those stations that have custom NWS product filtering equipment monitoring the data obtained via a different vendor. For the latter, you should be working closely with your vendor to make sure your custom equipment will continue to function as desired. For the former, Contel is now DynCorp and with that comes a change in the NWS distribution system and the product coding of the transmitted data.

If your station has been a Contel customer and you wish to continue getting that service direct, an equipment change is in your near future. The familiar small satellite dish, receiver, and selector box that made up the customer equipment compliment of the old distribution system needs to be replaced. Unlike the old system, no longer does one size does fit all. You have options available to you from DynCorp. Ranging from most expensive to least, you can select a C-band system, a Ku-band system, or you can subscribe to an Internet distribution system of the NWS products. The C-band system most closely equals the old Contel system in capa-

bility. If you choose the C- or Ku-band system, you buy the hardware and pay an annual fee for the data. There are lease options offered as well as 24/7 maintenance coverage for an annual fee and installation for an additional charge. The Ku system offers additional data beyond the NWS including the Digital Facsimile System (DIFAX) and GOES satellite images of the National Weather Service (NWS). If you choose the Internet system, you pay the annual data fee plus a very small registration fee. You must supply your own Internet connection and "inside the plant" equipment. Go to [www.weatherwire.net](http://www.weatherwire.net) for full details and pricing to start sorting this out.

In the old system the selector box functioned to filter the incoming data so that you only received products specific to the region(s) you desired. Depending on which new system you choose, your filtering will now happen in either the receiver of the C-band system, a PC in the Ku-band system, or you must come up with your own if you choose the Internet system. The good news is that with either of the three options, the filtering process is now entirely in your control which will make desired changes much less painful and more immediate.

If you plan on writing your own filtering software, you need to be aware that the product coding of the data will also change. The old Prod-

uct Inventory Listing (PIL) protocol is being abandoned in favor the new World Meteorological Organization (WMO) protocol. This change will better facilitate the worldwide exchange of meteorological observation and archival data for the weather industry. It will also allow the National Weather Service to retire a very old product identity system. In the interim until May of 2001, both the PIL and WMO headers will be transmitted with each product/message. There are also tools available to convert between the two.

It is important to note that the new NWS is open architecture, which means there could eventually be additional vendors offering systems which may, in turn, mean lower pricing. Currently the new system is up and running simultaneous with the old. The latest deadline (there have been many) for turning off the old GTE/Contel system is August 31.

For other methods of getting the NWS information to your station go to [www.nws.noaa.gov/oso/oso1/oso15/newnws.htm](http://www.nws.noaa.gov/oso/oso1/oso15/newnws.htm). A click on Administrative Messages on that page will give you access to the latest progress and time line messages concerning the NWS distribution and protocol conversion. ■

*Leonard Charles is the chief engineer of Television Wisconsin Inc and is based in Madison, WI.*

It doesn't take rocket scientists to see the advantages of the RTS® Intercom System.

But they do.

NASA needs a lot of power to get its new X-34 Space Shuttle program off the ground. That's why they chose the RTS ADAM™, Advanced Digital Audio Matrix intercom system. Like NASA, RTS ADAM utilizes only the most advanced, reliable technology. Installed in mission critical applications throughout the world, RTS Intercom Systems provide flexible, open-ended, integrated communications solutions that work even under the most demanding conditions.

RTS advanced communications technology isn't just for NASA though. Just ask the "rocket scientists" at GM®, Lockheed Martin®, Microsoft®, Boeing® and thousands of other companies and government agencies around the world. From broadcast television to aerospace to industrial applications, RTS is the system of choice among communications professionals everywhere. Why not make it yours?

Call toll-free today **1-877-863-4169**.

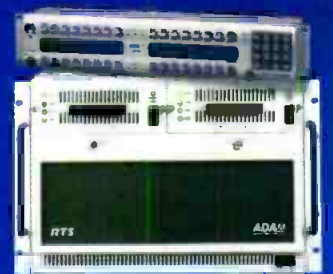

**RTS Direct**

*innovating the future of communications™*

## VENDOR

Dennis Gourley,  
Texscan MSI

**H**ow have changes in the NOAA delivery protocol affected the broadcast and cable industry through the years and where does it stand now?

In 1960, NOAA provided a text code called Baudo code at 150 Baud delivered via a dedicated 60mA telephone line to a special decoder. The forecast was a repeating string of all the forecasts for the entire country, and each area forecast had its own header followed by a close code.

Broadcast and cable television system purchased character generators that were designed to interface with this code and contracted with a delivery service to automatically receive a specific NOAA forecast for display to their viewing audience. The NOAA forecast service provided by the U.S. Government is free, however the delivery service and the equipment to process the NOAA forecast is paid for by the television system displaying the

NOAA forecast.

NOAA forecasts were changed to ASCII with the same header and stop codes and still utilized the 60mA wire service. The suppliers of the character generators were forced to change their software to accommodate the new protocol so that their character generators could continue to display the forecast information. When older character generators could not be retrofitted they had to be replaced.

Contel/GTE worked with NOAA and provided a satellite delivered NOAA forecast service. This new delivery service provided for wider bandwidth and faster baud rates, which increased the amount of information that could be delivered. This new service caused character generators to be replaced or be retrofitted and the broadcast cable system now had to buy a separate satellite dish and custom receiver to receive the new NOAA feed. Hardware costs for this service were approximately \$1500 along with an annual service contract.

As of August 2000, the NOAA delivery services will change again requiring a new satellite dish and receiver at a cost of approximately \$6000 along with an annual contract fee. The character generators the stations own are not likely to work with this new service, and again their character generators may need to be replaced or be retrofitted.

A station desiring to continue to automatically receive and display NOAA forecasts should check with its character generator manufacturer to see if their system will interface with the new NOAA delivery protocol or if it provides an upgrade for its equipment.

Texscan MSI is now providing an alternative NOAA delivery solution. Any future changes made by NOAA will be processed on Texscan's NOAA data server so that the data delivery to their character generators will always be compatible. ■

*Dennis Gourley is consultant with Texscan MSI, Salt Lake City.*

## The Broadcast Fiber Optic System That Does Just About Everything



### VIPER II™

The most widely used fiber optic system for television production and distribution just got better. With the most advanced electronics, electro-optics and packaging, the Viper II meets all challenges in your facility's video, audio and auxiliary communications. Name your fiber application—pre-fibered facilities, STLs, remote broadcasts, mobile field production, video backhaul, metropolitan video links—the Viper II handles the job.

- Multichannel video & audio
- HDTV serial digital video;  
19.4 Mbps to 1.5 Gbps
- 601 serial digital video
- Wideband NTSC/PAL video
- 24-bit digitized audio or AES/EBU
- Intercom, 2-wire or 4-wire
- Data, including RS232, RS422, CCU
- Universal 16-slot card cage
- Rack mount or "throw down" modules

It's not just a broadcast system, it's a multifaceted tool that's flexible, affordable, and easy to use. It's the reason why more facilities that choose fiber, choose Telecast.



The world leader in fiber optics for broadcast production  
(508) 754-4858 • [www.telecast-fiber.com](http://www.telecast-fiber.com)

Circle (115) on Free Info Card

# DOES YOUR PROFESSIONAL ATSC RECEIVER DO THESE?

## Inputs:

RF CH2 - CH69  
DVB-ASI  
DVB-SPI (LVDS)  
SMPTE-310M

## Outputs:

DVB-ASI  
DVB-SPI (LVDS)  
SMPTE-310M  
ATSC Video Decoding To 60MBPS  
RGBHV (1080i, 720p, 480p, 480i)  
HD-SDI Option (SMPTE-292m)  
NTSC (SDI, S-Video, BNC)  
AC-3 Audio (XLR)  
Analog Audio L&R (XLR)  
VGA Monitor  
PSIP Display  
EPG Display



# K Tech

TELECOMMUNICATIONS, INC.

15501 San Fernando Mission Blvd. Ste 100 Mission Hills, Ca 91345  
Phone (818) 361-2248 Fax (818) 270-2010  
e-mail: [sales@ktechtelecom.com](mailto:sales@ktechtelecom.com) web: [www.ktechtelecom.com](http://www.ktechtelecom.com)

© 2000 ktech telecommunications, inc.

Circle (116) on Free Info Card

[www.americanradiohistory.com](http://www.americanradiohistory.com)

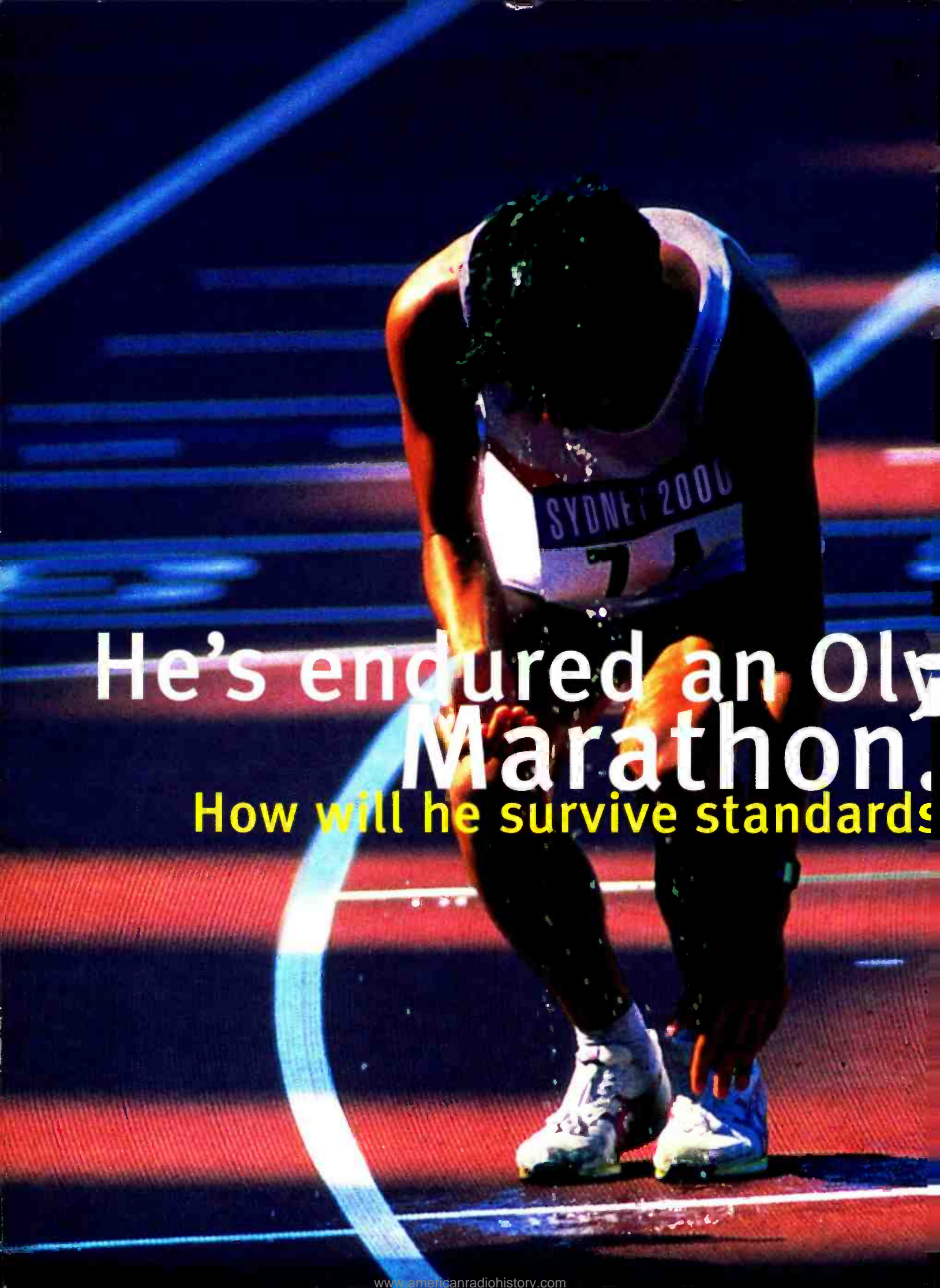

He's endured an Oly  
**Marathon.**  
How will he survive standards



mpic  
conversion?

No-one looks their best after a marathon. But after standards conversion he could look even worse.

Conventional standards conversion can really mess up the picture, with unpleasant side effects, such as jerks, judder and smear.

Thankfully there's a solution. Alchemist Ph.C from Snell & Wilcox.

Uniquely equipped with powerful "phase correlation" motion estimation technology, it's the most advanced standards converter ever built. No wonder it's used by the world's leading broadcasters and facilities to create virtually transparent results.

With CleanCut™ software to overcome the blurring caused by edits and RollTrack™ for perfect lip-synch, Alchemist Ph.C completely outperforms all competitors.

So if you care about picture quality, why not go the full distance and upgrade to Alchemist Ph.C.

## Alchemist Ph.C

### Motion Compensated Standards Conversion



ALCHEMIST Ph.C - MOTION COMPENSATED STANDARDS CONVERTER

THE ULTIMATE IN TRANSPARENT CONVERSION, WITH PHASE CORRELATION MOTION COMPENSATION, 27MHz INPUT OVERSAMPLING, FULL 10-BIT ALL-DIGITAL SIGNAL PATH AND PROPRIETARY POINT INTERPOLATION ALGORITHM.

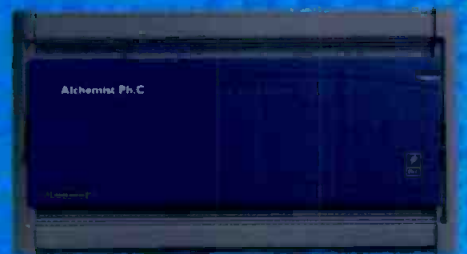

ALCHEMIST Ph.C TX - TRANSMISSION APPLICATION OPTION

EQUIPPED AS ALCHEMIST Ph.C, THIS IS THE COST-EFFECTIVE SOLUTION FOR TRANSMISSION APPLICATIONS WHERE MULTIPLE CHOICE OF INPUT AND OUTPUT STANDARDS ARE NOT REQUIRED.



COMPATIBLE WITH ROLL CALL, THE INTELLIGENT BROADCAST MANAGEMENT SYSTEM FROM SNELL & WILCOX.

Circle (117) on Free Info Card



Engineering with Vision

Tel: 408 260 1000 www.snellwilcox.com



### Data multiplexing

BY MICHAEL ROBIN

We live in a global village where communications play an important role. To be relevant, communications must be reliable, accurate and nearly instantaneous. Communications are translated into analog or digital data, which are sent using a transmission medium. The transmission medium, be it air (or lack of it as in vacuum), copper (as in bifilar or coaxial cable) or glass (as in fiber optics) is a precious commodity. Since the beginning of the modern age, the telecommunication industry has sought to maximize the data throughput of the transmission medium. The various methods used fall under the umbrella of data multiplexing.

#### Analog multiplexing

Analog multiplexing has been with us since the 1930s when the rapid increase in telephone traffic required the development of techniques allowing for the simultaneous transmission of multiple channels on a single tele-

communications medium. The method used was frequency division multiplexing (FDM). One of the most successful applications of FDM will likely be unusable in the U.S. in 2006.

ture modulated signal conveying the color-difference B-Y and R-Y information. The chrominance spectrum displacement by  $F_h/2$  is achieved by using a chrominance subcarrier whose

### One of the most successful applications of FDM will likely be unusable in the U.S. in 2006.

We are talking, of course, of the frequency interleaving of the chrominance and luminance information resulting in the composite NTSC video signal. This process allows the simultaneous transmission of luminance and chrominance values in a 4.2MHz bandwidth. The system takes into account the discrete spectrum clusters of the luminance signal with a spacing of  $F_h$  (horizontal scanning frequency) and inserts equally discrete but  $F_h/2$  displaced spectrum clusters of a suppressed carrier quadra-

frequency is a multiple of  $F_h/2$ . The chosen subcarrier frequency is  $F_s = 4.55 F_h/2 \approx 3.58\text{MHz}$ . The result is an interleaved spectrum with chrominance and luminance clusters spaced  $F_h/2$  as shown in Figure 1. While frequency division multiplexing is a relatively easy task, demultiplexing is relatively difficult to achieve. A perfect decoder requires complex filtering and separation of the luminance and chrominance spectral components. Unavoidable design compromises result in chrominance-to-luminance and luminance-to-chrominance crosstalk. In addition, less than ideal transmission-channel characteristics result in high frequency delays, resulting in chrominance vs. luminance delays and nonlinear distortions, resulting in differential phase and differential gain, which affect the accuracy of the color rendition.

#### Digital multiplexing

Digital multiplexing uses the concept of time division multiplexing (TDM). Here several related or unrelated signals are sampled at a rate high enough to ensure that no information is lost. The samples are shortened (relative to the original sample rate) as required and are time division multiplexed for sequential transmission through a common medium. Digital

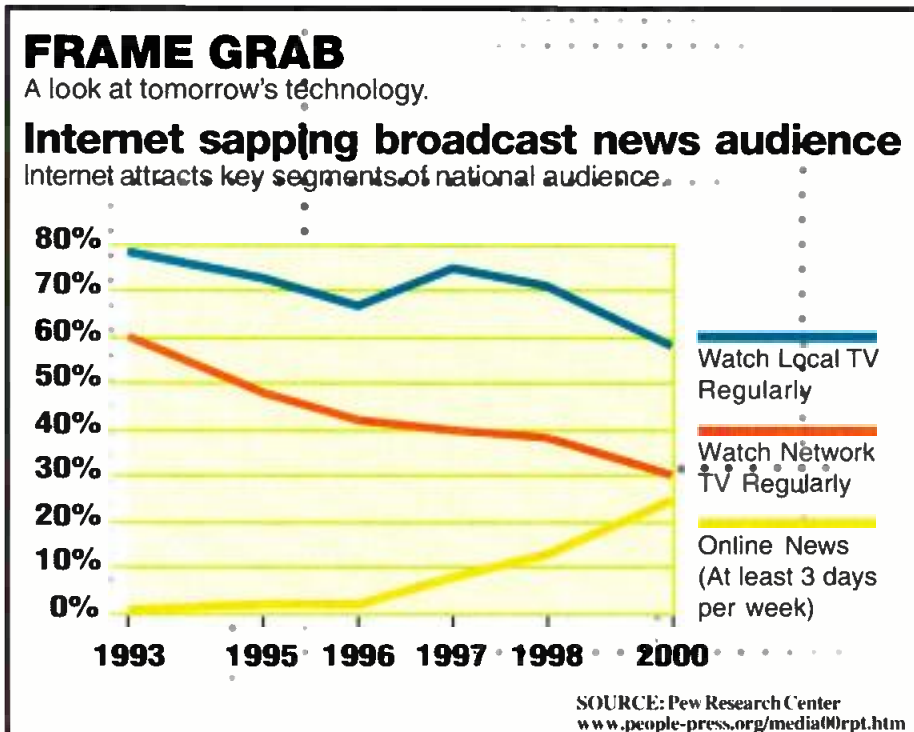

# THE OMNEON VIDEO AREA NETWORK™

601 HD DV MPEG AAF AES IP Data



IEEE 1394 SDI/SDTI Ethernet RS422 Fiber

## The Integrated Networking and Storage Infrastructure for New Media

Now a digital networking and storage infrastructure delivers the *flexibility* to connect all the leading distribution, production and media management technologies via standard networks to a scalable resource of multi-format storage; the *scalability* to provide more bandwidth in more formats to more channels and production suites than ever before; and *compatibility* to integrate seamlessly with current systems for easy upgrades today, while equipping your operation for the future. The performance of OMNEON'S VIDEO AREA NETWORK sets a new value standard for the industry. The unparalleled functionality makes the VIDEO AREA NETWORK the ideal networking and storage infrastructure for the digital television marketplace.

## Featuring

**Data-type Independence** - Supports MPEG, DV, AES/EBU, ITU 601, Metadata, HD, AAF/QuickTime™, IP Data **Linear Scalability** - Scales smoothly to hundreds of distribution channels and thousands of hours of storage **Shared Storage Productivity** - Enables collaborative production and distribution in multiple formats **Open Platform Compatibility** - Works with transmission, production, media management and Internet applications **Reduced Cost-of-Ownership** - Lowers acquisition cost and operational and maintenance costs **Reliability** - Offers both system-level and critical component redundancy **Increased Profitability** - Provides flexibility to utilize existing assets and expand into new revenue generating services

[www.Omneon.com](http://www.Omneon.com)



Circle (118) on Free Info Card

multiplexers interleave a number of lower speed signals to form a higher speed signal.

The advent of digital signal processing in studio environments has led to time division multiplexing of various data. The first TDM step in a studio environment is the sampling and quantizing of gamma corrected analog luminance ( $E'_Y$ ) and scaled color-difference ( $E'_{CB}$  and  $E'_{CR}$ ) signals. The latter are sometimes referred to as  $P_B$  and  $P_R$ . Figure 2 shows a conceptual application of the CCIR 601 4:2:2 concept as follows:

- The  $E'_Y$  analog luminance signal is 5.75MHz low-pass filtered and sampled at 13.5MHz with a precision of 10 bits per sample. This results in a bit-parallel digital luminance signal (Y) with a data rate of 13.5Mwords/s. The words have a duration of  $1/13.5\text{MHz} = 74\text{ns}$ . There are 858 Y samples per total scanning line numbered  $Y_0$  to  $Y_{857}$ .

- The  $E'_{CB}$  analog blue color-difference signal is 2.75MHz low-pass filtered and sampled at 6.75MHz with a precision of 10 bits per sample. This results in a bit-parallel digital blue color-difference signal ( $C_B$ ) with a data rate of 6.75Mwords/s. The words have a duration of  $1/6.75\text{MHz} = 148\text{ns}$ . There are 429  $C_B$  samples per total scanning line numbered  $C_{B0}$  to  $C_{B428}$ . The  $C_B$  samples are co-located with every other Y sample ( $Y_0, Y_2, Y_4 \dots$ ).

- The  $E'_{CR}$  analog red color-difference signal is 2.75MHz low-pass

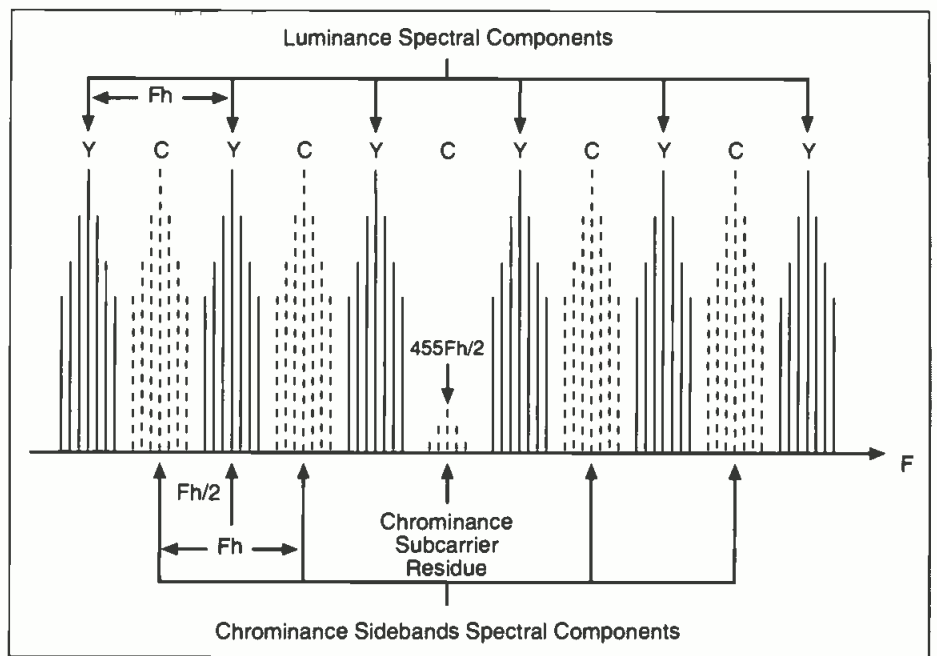

Figure 1. Details of NTSC the FDM spectrum around the chrominance subcarrier.

filtered and sampled at 6.75MHz with a precision of 10 bits per sample. This results in a bit-parallel digital red color-difference signal ( $C_R$ ) with a data rate of 6.75Mwords/s. The words have a duration of  $1/6.75\text{MHz} = 148\text{ns}$ . There are 429  $C_R$  samples per total scanning line numbered  $C_{R0}$  to  $C_{R428}$ . The  $C_R$  samples are co-located with every other Y sample ( $Y_0, Y_2, Y_4 \dots$ ).

Three multipair shielded cables can carry the three bit-parallel data streams, but it is cumbersome and costly. The adopted solution was to time division multiplex the Y,  $C_B$  and  $C_R$ . The 10-bit bit-parallel data words are sequentially clocked out starting with  $C_{B0}$ . The sequence is  $C_{B0}, Y_0, C_{R0}, Y_1, C_{B1},$

$Y_2, C_{R1}$ , etc. The last sample of the line is  $Y_{857}$ . The time division multiplexing of data results in the outgoing data rate being the sum of the incoming data rates. This requires only one multipair cable for signal distribution. The time division multiplexed bit-parallel data rate is 27Mwords/s and the duration of each sample is  $1/27\text{MHz} = 37\text{ns}$ . The distribution of 4:2:2 multiplexed digital data using a multipair cable is costly and cumbersome especially when a routing switcher is used. To facilitate the signal distribution, the bits can be read out sequentially and fed to a single coaxial cable resulting in a serial digital signal with a data rate

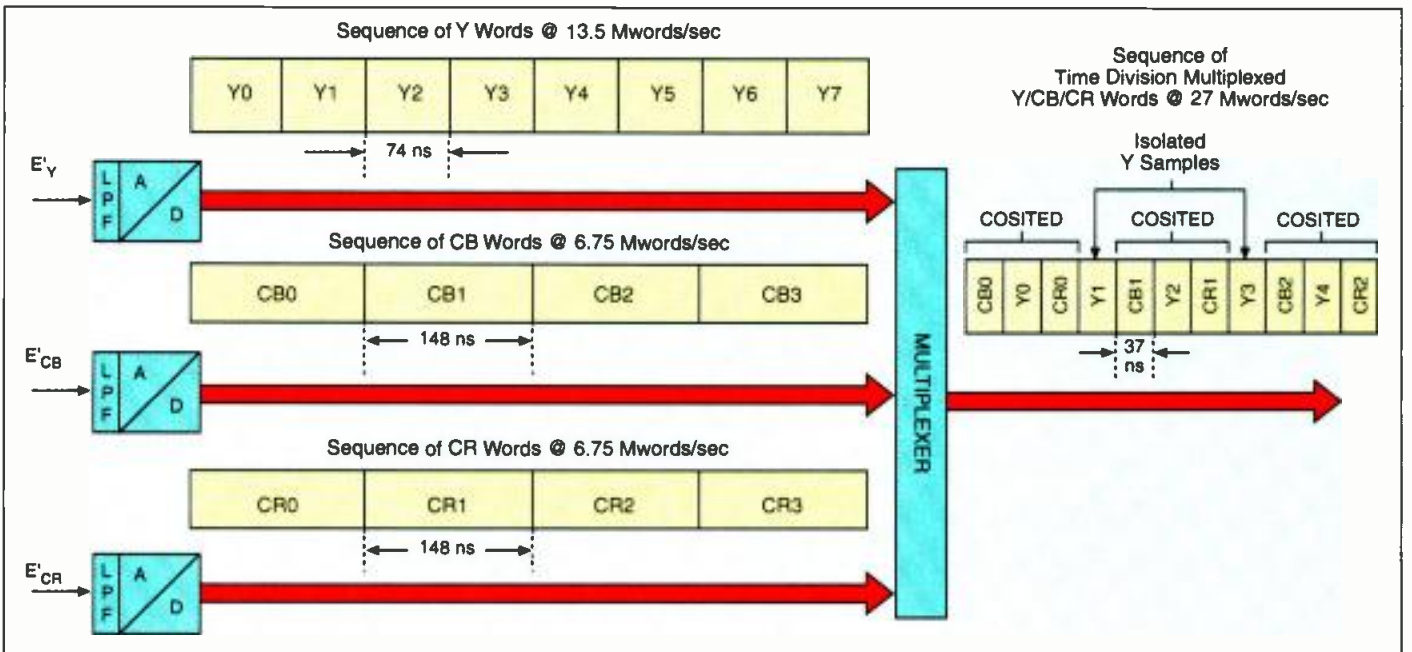
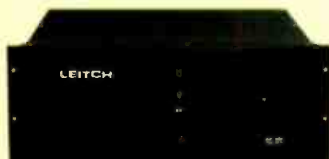

Figure 2. Time division multiplexing of digital 4:2:2 data.

# News doesn't just break — it explodes

Hit the air instantly while your rivals crash and burn. Thanks to Leitch, now you can record multiple feeds, browse and edit as you record, and play back instantly with **BrowseCutter™**, **Instant Online™** and **NEWSFlash™** — our digital newsroom.

The instant news makes impact, you have to be ready to launch your crew into the action. The first one on air is reporting the news; everyone else is just reporting history. As every second passes, you're in danger of missing your target. Leitch's news server ensures that you never crash and burn by supplying direct, unrestricted access to our V-SAN — the Video Storage Area Network. Your crew can simultaneously record multiple feeds, edit complete packages and instantly play to air. In no time you'll be shaping stories that once remained up in the air. Your crew will be on the air before the competition loads its tapes. It's all possible with **NEWSFlash™**, the only 'in-the-server' Non-Linear Editor designed specifically for quick, hard news. And you can simultaneously attack with a fully armed squadron using **BrowseCutter™** and **Instant Online™**, a complete set of ammunition allowing for browse, edit and instant story to rundown conformance of digital video and audio content right from the journalist's computer desktop. The sky's the limit with Leitch's integrated news system. Call 800-231-9673 for more information or visit our website at [www.leitch.com](http://www.leitch.com).



Using **NEWSFlash™** and **Instant Online™** newsroom generals can coordinate with outside forces using the following compatible newsroom interfaces: **ANN**, **AvStar**, **Comprompter**, **DCM**, **ENPS**, **Generation Technologies** and **Newstar**

International/Canada +1 (416) 445 9640 Europe +44 (0) 1483 591000 U.S.A. East +1 (800) 231 9673,  
U.S.A. West +1 (888) 843 7004 Latin America +1 (305) 591 0611 Brazil +55 (11) 3151 5093  
Hong Kong +(852) 2776 0628 Japan +81 (3) 5423 3631 Australia +61 (2) 9939 3355



think video @

[www.leitch.com](http://www.leitch.com)

of 270Mb/s. This simplifies the signal distribution at the expense of increasing the bandwidth.

There are a total of 1716 samples per total line (858Y, 429C<sub>B</sub> and 429C<sub>R</sub>) and a total of 1440 samples per active line (720Y, 360C<sub>B</sub> and 360C<sub>R</sub>). The horizontal blanking duration is equal to 1716 - 1440 = 276 samples. Horizontal sync is not sampled. Instead, two four-word Timing Reference Signals (TRS) are sent: one identifying the end of active video (EAV) and the other identifying the start of active video (SAV). This leaves an overhead of 268 horizontal blanking interval samples available for transporting other types of information referred to as horizontal ancillary data (HANC).

HANC data are formatted in packets consisting of a header, followed by the ancillary data and ending with a checksum (CS). In the absence of a header it is assumed that no ancillary data are carried. The header consists of six words. The first three, 000, 3FF, 3FF, values which cannot be assumed by other data, signal the presence of ancillary data. The following three words of the header are DID (data identification), DBN (data block number) and DC (data count). The ancillary data follow the header. A maximum of 255 words is permitted. Figure 3 shows details of the digital 4:2:2 horizontal blanking interval and the manner in which two AES/EBU digital

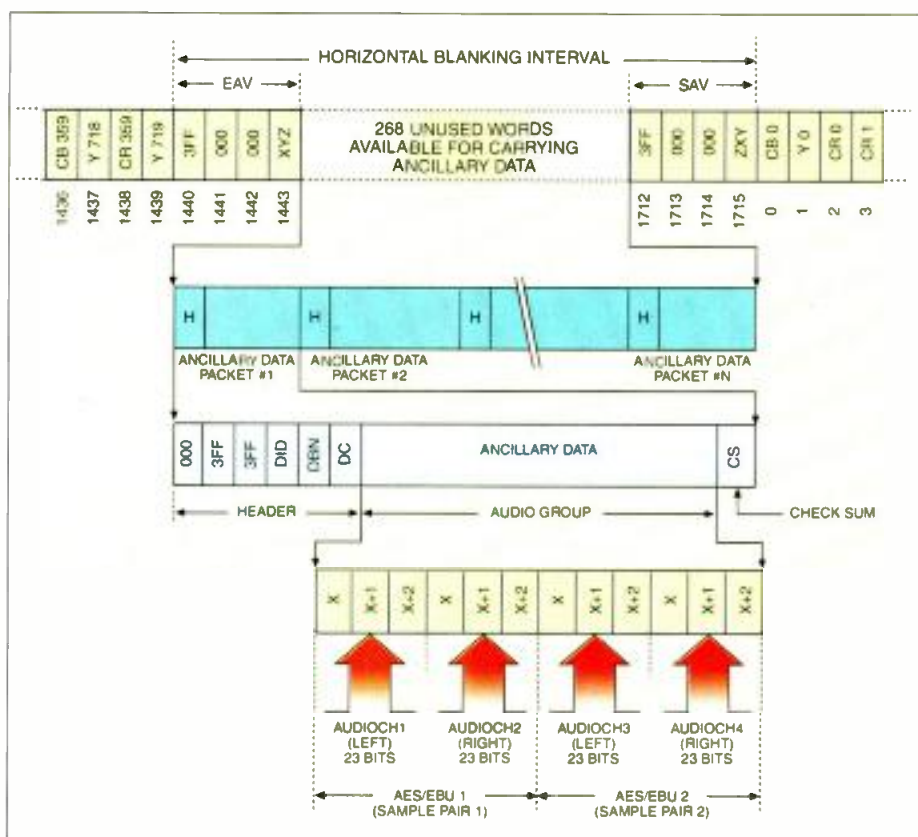

Figure 3. Time division multiplexing of two AES/EBU digital audio data streams mapped as a sequence of three words into the horizontal ancillary data space of a 4:2:2 data stream.

and 11, reduce this value by 10 percent to 20 percent. Given an AES/EBU data rate of 3.072Mb/s (before BPM encoding), eight AES/EBU data streams require  $8 \times 3.072\text{Mb/s} = 24.576\text{Mb/s}$ , leaving ample HANC space for other ancillary data:  $42.16\text{Mb/s} - 24.576\text{Mb/s} \approx 17.584\text{Mb/s}$ .

Ancillary data can also be embedded

simply does not carry HANC data. This requires that the audio be de-embedded, processed separately and, subsequently re-embedded. This is cumbersome and costly, especially if we take into account the need to maintain lip-sync, which is lost in separate audio and video processing. The majority of the teleproduction community feels that digital audio and video should be processed separately and distributed in parallel. Embedding, if required, should be carried out at the end of the production chain for distribution and/or pre-set (non-live) switching. ■

*Michael Robin, former engineer with the Canadian Broadcasting Corporation engineering headquarters, is an independent broadcast consultant in Montreal, Canada. He is the co-author of Digital Television Fundamentals, published by McGraw-Hill.*

## Digital multiplexers interleave a number of lower speed signals to form a higher speed signal.

audio datastreams can be formatted to fit in one ancillary data packet. SMPTE Standard 272M defines means of multiplexing (embedding) up to eight AES/EBU datastreams (16 individual audio channels) in the HANC data space. This is achieved by grouping the eight AES/EBU datastreams into four audio groups. The HANC capacity of the 4:2:2 digital format is of the order of 42Mb/s, which is obtained as follows:

$268\text{words/line} \times 525\text{lines/frame} \times 29.97\text{f/s} \times 10\text{ bits/word} \approx 42.16\text{Mb/s}$ .

Certain exclusions, such as lines 10

into the vertical-blanking interval (VANC). Among the VANC data are EDH (error detection and handling) as well as VITC (vertical interval time code). Audio is usually embedded only as active lines HANC.

Embedding ancillary data is a convenient signal distribution or transmission concept. In a studio environment, some difficulties resulting in audio clicks are encountered with live switching of bit-serial signals with embedded audio. This is unacceptable in the pristine professional audio world. In addition, some equipment

**SEND** Send questions and comments to: [michael\\_robin@intertec.com](mailto:michael_robin@intertec.com)

Michael Robin's book may be ordered directly from the publisher by calling 800-262-4729. It is also available from several booksellers.



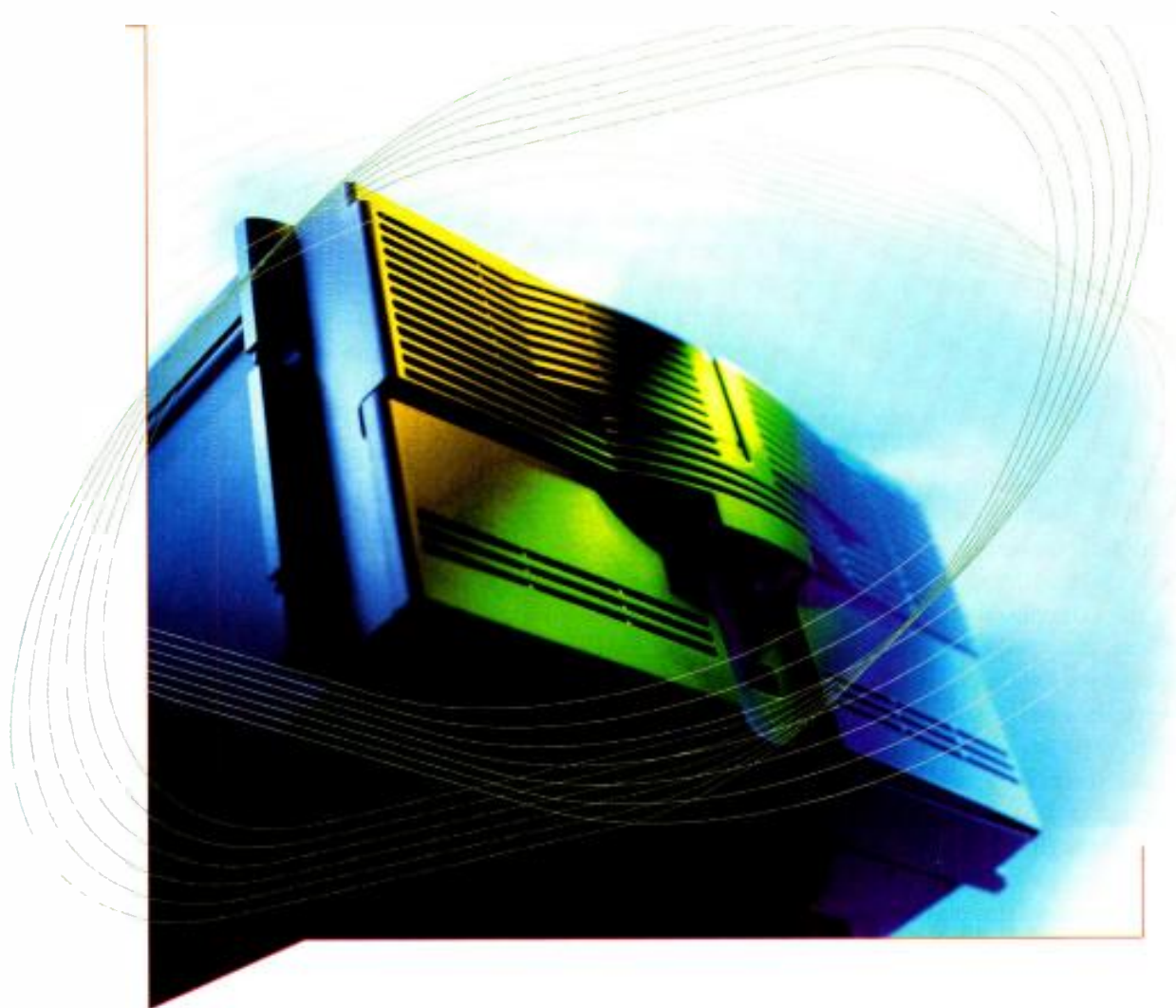

## WHEN YOU DIVE INTO AN UNCERTAIN FUTURE, MAKE SURE YOU DO IT FROM A SECURE PLATFORM.

Changing delivery systems. Proliferating standards. Asset management for any content, any time, any place. These are just a few of the rapidly emerging demands that can sink most video servers. Good thing the Profile™ XP Media Platform™ does much more than traditional video servers. The Profile XP features an advanced architecture capable of handling formats from SD and HD to the Internet for the ultimate in future-proofing. All combined with the world's most powerful digital media software platform that makes asset management a snap. And the Profile XP's built-in redundancies have zero tolerance for failure.

Of course, you'd expect nothing less from the company that invented both the video server and the next-generation media platform. Maybe that's why more broadcast and video professionals in more places throughout the world rely on Profile and the Grass Valley Group to produce, manage and deliver media content. So come on in, the future feels great. [www.grassvalleygroup.com/MediaPlatforms](http://www.grassvalleygroup.com/MediaPlatforms)

© Grass Valley G & W 2000

As users, we rarely want to play a file from beginning to end. Almost every time we call for the output from a video file server, we are actually asking for a piece of material to be played from start of message (SOM) to end of message (EOM). There usually are a few frames of black at the beginning and end of the program or spot, and in most applications we do not want to see these frames. Almost all server manufacturers allow the user to

select where playout begins and ends within a particular clip. However, there is some variation in just how precisely the user can specify the playback point.

While it would be natural to assume

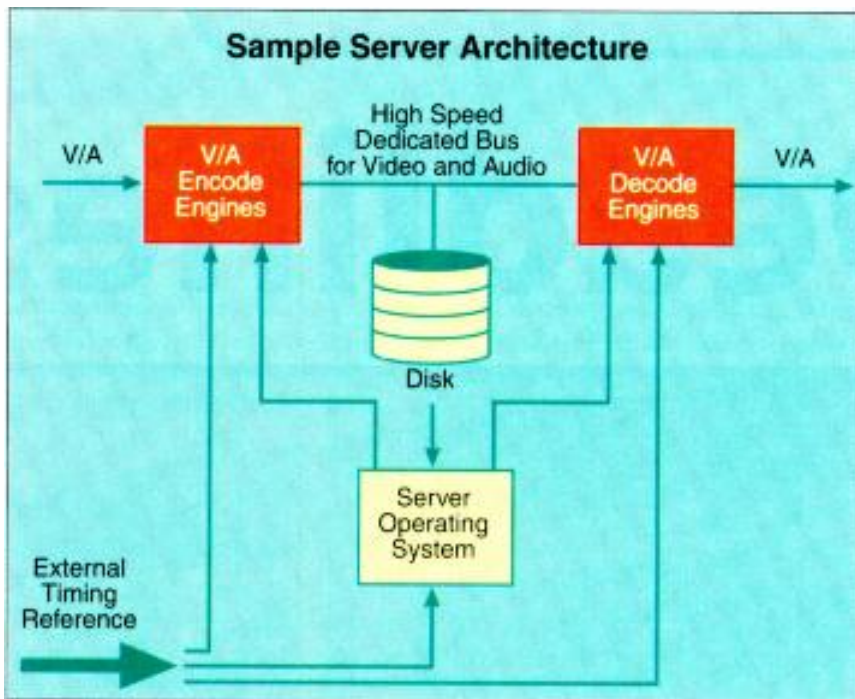

Video servers may have a dedicated bus used to move audio and video streams to/from the disk storage system.

that all servers allow a user to specify an SOM down to the field, this may not always be the case. Some servers allow the user to specify SOM down to half a second or so, and many times this is more than adequate.

upon performance. Access down to the field may mean an unacceptable decrease in system response. However, most server manufacturers now allow the user to specify playback down to the field or frame, so this is less of an

Being able to specify an SOM to plus or minus four frames may meet most broadcasters' needs. However, if you are trying to do cuts between pre-produced programs at a specific field or frame, you will quickly discover that this level of accuracy is inadequate. Why would a server manufacturer design a system that cannot specify SOM and EOM locations down to the frame? Many times this is a decision based

# YOU'RE SURROUNDED

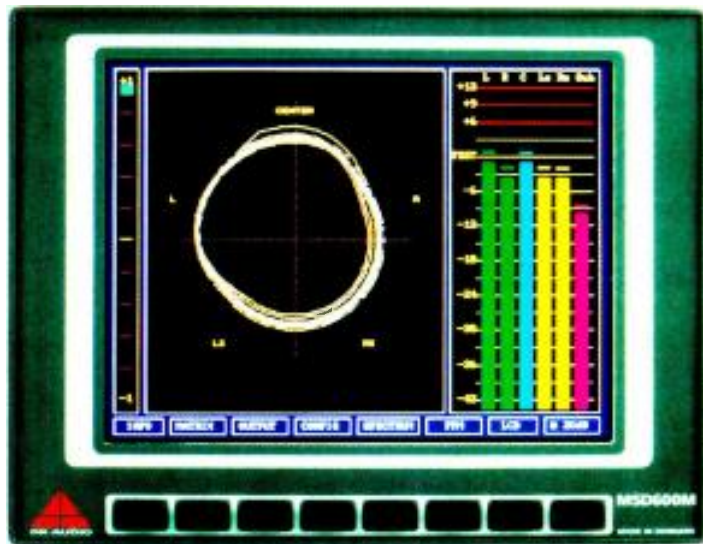

## SEE EXACTLY WHAT YOU HEAR

- Seven selectable PPM/VU scales as well as Leq(m)!
- Upgradable from 2 to 4, 6 or 8 channels
- 1024 band Spectrum Analyzer Option (5Hz-20kHz) and signal generator
- DK Meters are optional on SSL™, Studer™, Otari™ & other fine consoles
- VGA output standard
- 7.25"x5.5"x2", 12 VDC

Now there's an accurate way to display your Stereo, 4 channel, 5.1 and even 7.1 analog or digital mixes. The MSD600M combines an X-Y Audio Vectorscope, Phase Meter and "Jellyfish" LCRLsRs pattern in an ingenious and compact VGA display

Distributed and supported by

**t.c. electronic**  
ULTIMATE SOUND MACHINE



MULTI-CHANNEL METERS

Call 1-800 518 4546  
for a demo in YOUR studio

Circle (150) on Free Info Card



# ***Do You Know What's Happening In The Broadcast Market Today?***



World Broadcast  
**Engineering**  
[www.WBEonline.com](http://www.WBEonline.com)

Broadcast  
**Engineering**  
[www.BroadcastEngineering.com](http://www.BroadcastEngineering.com)

**Digital Webcast**  
[www.DigitalWebCast.com](http://www.DigitalWebCast.com)

**DTV Buyer**  
[www.DTVBuyer.com](http://www.DTVBuyer.com)

**HDTV Buyer**  
[www.HDTVBuyer.com](http://www.HDTVBuyer.com)

**BE Radio**  
[www.BERadio.com](http://www.BERadio.com)



[www.digitalmedianet.com](http://www.digitalmedianet.com)

issue than it was in the past.

While plus or minus four frames might be perfectly acceptable in an on-air playback situation, you can imagine that post production requires that the user be able to specify playback points much more accurately. In fact, it is very likely that being able to start playback at a particular field is not enough. Audio post production may require that the user be able to specify a playback as precisely as a particular audio sample. In a 48kHz system, that means 48,000 sample points per second. When you consider that the server must uniquely identify each audio sample in reference to not only the incoming video, but to an internal clock which is locked to a video reference, you can start to see that some creative engineering is required to make everything work.

#### Decompressing MPEG

Now for the real challenge. Few MPEG systems store material on a frame basis. In fact, because of temporal compression, many of the frames

are missing. You may recall that most MPEG encoders compress video in two ways – spatially and temporally. MPEG achieves temporal compression by sending a complete frame once and then only sending informa-

tion about areas of the picture that have changed in subsequent frames. After a pre-determined amount of time a complete frame is sent again. If a user requests a specific frame of video, that complete frame of video may or may not exist on the server. If the encoder created the complete frame, then the server need only retrieve the frame and display it. But what if the requested frame was a “P” frame, containing only predictive data about how the next frame should be constructed? In this case, the server can only display the requested frame by going back through previous

## The server builds an index table to keep tabs on the location of critical frames.

frames until it finds a complete frame and then recreating the requested frame on the fly. This is a little complicated, but not really too hard to do. But there is still a bit of magic to be done. How does the server know

where the nearest complete frame is? The answer is by using an external index table. When an MPEG stream is recorded, the server builds an index table to keep tabs on the location of critical frames in the stream. Then, when a user requests a specific field or frame, the server can quickly build the frame on the fly using the index table as a reference. ■

*Brad Gilmer is president of Gilmer & Associates and is executive director of the Advanced Authoring Format Association.*



Send questions and comments to:  
[brad\\_gilmer@intertec.com](mailto:brad_gilmer@intertec.com)

# “Synergize” your GVG\* 100/110

Two of the world’s most popular small analog production switchers, the GVG 100 and 110, can now be upgraded to **DIGITAL SYNERGY PERFORMANCE** by simply replacing your frame with a **ROSS SYNERGY I Digital Production Switcher Frame**.



Your  
GVG 100/110  
upgraded to  
**DIGITAL SYNERGY  
PERFORMANCE**  
by Ross  
**\$15K**

Get “Synergy 1”  
features including:

Squeeze & Tease 2D DVE  
Ideal for over-the-shoulder boxes

External DVE Integration

Powerful Border Generator

Preview Overlay

16 Digital Inputs

Chroma Keying

10 Aux Busses

... and more!

\*GVG is a trademark of Grass Valley Group.  
Ross and Synergy are trademarks of Ross Video Limited.  
Ross Video is an independent company  
and is not affiliated with GVG in any way.



Tel: (613) 652-4886  
Fax: (613) 652-4425

[www.rossvideo.com](http://www.rossvideo.com)

Email: [solutions@rossvideo.com](mailto:solutions@rossvideo.com)

Circle (122) on Free Info Card

**If you want to build the best headend,  
start with the best modulators.**

Standard's got you covered. Maximize your modulator choices without increasing your costs. Standard agile modulators give you the performance of fixed-channel systems, but with a lot more flexibility.

For example, our STRATUM System takes up less headend space per channel than any other system, but still offers advanced features such as remote control and automatic backup for lost signal or power. Or take our new TVM1000. It covers the entire spectrum from 54 to 1000 MHz, and lets you combine up to 158 channels while still holding out-of-band noise to less than 60 dBc.

In addition, Standard's TVM550H is the acknowledged agile workhorse of the industry, offering re-broadcast quality and minimized noise and spurs for extraordinary reliability and performance. And if cost is a concern, the SCM550HP offers the same high quality and reliability, but with an eye on your budget.

When you upgrade the headend, remember nothing delivers the signal like a Standard modulator.

 **Standard  
Communications**

*Meeting tomorrow's standards today.*

**STANDARD  
COMMUNICATIONS**



[www.standardcomm.com](http://www.standardcomm.com)

U.S.: (800) 745-2445 • Canada: (800) 638-4741 • Europe: 44 1923 800 510 • Latin America: 55 11 3887 6598

Circle (123) on Free Info Card

[www.americanradiohistory.com](http://www.americanradiohistory.com)

## Educational materials

BY STEVE EPSTEIN, TECHNICAL EDITOR



I am looking for a basic book on audio and video engineering. I have a small to medium post house (five suites) and am about to move and install a machine room.

I have a freelance engineer for this installation but his time constraints and my money constraints require me to handle many of the small issues myself. Can you recommend a good reference book? My main concern is the hookup of analog and digital decks through the A/D-D/A converters. Any suggestions are greatly appreciated.

Thanks,  
Ken Skaggs  
President, Frames Per Second  
Dallas, TX



Dr. Digital responds:

Let's handle the simpler issue first. The A/D conversions for tape machines can be easily handled with the VTR-100 from Miranda (it was featured as a Pick Hit winner in the June issue). It handles all the necessary conversions in a single box. Now, for the harder issue: a good reference book. The Ninth Edition of the NAB Handbook is good, as is Michael Robin's book "Digital Television Fundamentals." The problem with both books is that they will tell you everything involved and a lot more. However, they don't concisely tell you how to assemble a facility. Steve Lampen's book on Wire & Cable will tell you what you need to know for wiring, but there is no

equivalent book for building a full facility. Much of the problem is that no two facilities are alike, and therefore there are no easy answers to the many questions that face someone trying to build a facility.

I have built several facilities and strongly recommend you plan everything carefully with your freelance engineer or someone else that is technically proficient. Here's why:

1. Mistakes made in the design will be paid for over many years to come.
2. Time spent in the planning stages will be saved during the buildout.
3. Skipping the planning will result in considerable wasted time and energy (and money) during the buildout.
4. It is a lot easier to move a wall 12

### Much of the problem is that no two facilities are alike.

inches on paper than in the real world. This WILL happen somewhere in the project if it is not well planned.

If you can't afford to have the engineer do all the work, at least allow him to plan the facility. Pay his rates for a good design and then hire some lower-cost help to do the buildout to his specifications. Good luck, let me know if you need any additional help.

After sending Ken that response, I received the following:



Thanks for the response! I am definitely having my engineer design and install the new machine room. My issues are more with clients bringing in odd equipment with a project,

leaving me to wire it into the room. I am trying to have spaces left open to just plug a machine in, but can't plan for everything. I need to learn the basics myself because I cannot justify a full-time staff engineer.



Dr. Digital responds:

Have your engineer wire a panel in a convenient spot (machine room or edit suite) that is just for connecting those occasional pieces of equipment brought in by clients. Include

video out, video in, audio in, audio out, machine control and genlock connections as well as necessary interconnecting cables. That way it is ready to go when you need it. If there is a call for more than one, have him build two or three. Make it a digital panel and throw in the Miranda VTR-100 and you are ready to hook up almost anything you need. Most clients that carry machines around know enough to set them up if you can simply point them in the right direction. Good luck.

Having a problem with a supplier? Or, maybe you can't find that one-of-a-kind part. Let me help, send me a note at [drdigital@compuserve.com](mailto:drdigital@compuserve.com).



## SpectraSite Broadcast Group

**WE'VE PUT MORE THAN 100 YEARS OF  
BROADCAST TRANSMISSION EXPERTISE  
UNDER ONE BANNER.**



**VPI** Vertical Properties, Inc.



**Now the most trusted names  
in the tower business  
work as one.  
Together we are stronger.**

**[www.spectrasite.com](http://www.spectrasite.com)**

Circle (124) on Free Info Card

[www.americanradiohistory.com](http://www.americanradiohistory.com)

# OXYGEN MEDIA

BY DAVE HIGGINS



The heavily used Oxygen Production Control Room (Producer's desk in the foreground) also serves as an On-Line Edit Facility. In edit mode, the TD position can operate the entire room. Equipment complement includes Sony DVS 7200 Production Switcher with Shot Box, DME 7000 Core 2 Digital Effects Generator and FX Deko Character Generator. Photos courtesy of The Systems Group. Copyright 2000 Melabee M. Miller.



pure(oxygen)

The Systems Group recently completed construction of the Oxygen Media television studio facilities located in the Chelsea Market building complex in lower Manhattan. The initial design concept for the facility envisioned a DV-oriented, desktop production environment. However, Oxygen Media's broadcast strategy expanded the core facility requirements over the course of the project cycle. It quickly became apparent that office space would become a focal point for production backdrops and a more traditional, yet versatile, production control room would be needed. The facility's design focuses on production facilities that do not detract from its open, loft-like office space while maximizing the capabilities of hardware and systems. The success of the project depended upon these objectives being met while the Oxygen Media creative team, talent and production crews rehearsed in preparation for the Feb. 2, 2000, launch date.

Over time, design considerations were balanced against the need to maintain a workplace environment before, during and after live broadcasts from the facility. Conference rooms, cubicles and much of the work space environment are used as backdrops for show segments. Those segments are then packaged for use in the daily production of Pure Oxygen, a live broadcast that featured interviews, performances, pre-taped segments, impromptu chats with Oxygen staffers and a particularly strong focus on the Internet. To meet the demands of a live show, as well as minimize disruption to the surrounding office environment, the production crew and their equipment must move through the space as quickly and efficiently as possible.

Oxygen Media Engineering and The Systems Group developed a production plan for ambient lighting, acoustics, sets, crew movement, communications and the logistics of moving camera positions throughout an office space environment during a live broadcast. Broadcast service panels (BSPs), which are I/O panels with connectivity to various production systems, are extensively employed, integrating surface-mounted, custom-fabricated cable demarcation boxes in 14 different locations across two floors. All of the I/Os return back to jackfields in the Central Equipment Room for maximum flexibility. Camera triax connectivity is achieved through the use of minitriax connectors and jackfields. The result is any CCU can be easily and quickly patched to any camera or BSP in the facility.

Technology and logistical considerations notwithstanding, an effort was made to blend the production infrastructure into the architectural elements of the Oxygen office space. In many facilities drop ceilings or raised computer flooring are common approaches to "hiding" coax, twisted pairs, CAT 5 and related interconnections from view. At Oxygen, the cable raceways are an integral part of the overall office space look and can be

seen frequently on the daily broadcast of Pure Oxygen and Trackers as well as above, around and through the office environment.

Locating core production areas in close proximity was an important technical design goal for the project team. The need to mini-

**At Oxygen, the cable raceways are an integral part of the overall office space look.**

mize system cable runs, as well as centralize the activities of the primary production crew became a driving concern. To achieve the necessary results, the Central Equipment Room is located adjacent to the primary studio stage. Its placement requires 150 foot cable runs through the floor of Central Equipment Room, on cable trays through the seventh floor space and then to the rear of the Production Control Room monitor

is. The Production Control Room control booth next to the Audio Control Room and a small announcement Room. Camera Control Room immediately adjacent to the DVS 128 router 64x64, BVP 500 set two channels of Ultimate FX Deko and Leitch reference and timecode systems and Sony Digibeta as primary tape format. A Wheatstone SP 8 32x4x2 mixing console is employed in the Audio Control Room. A Mackie SR 40-8 console is located in the Trackers studio for sound reinforcement.

To achieve the post-produced "look" Oxygen sought in its live programs, several content acquisition methods were evaluated. Ultimately, miniDV, DVCAM and Beta SP were used as the remote platforms. There are both Avid and Media 100 nonlinear editing systems in use, as well as Apple's FinalCut Pro software running on G4 Macs. Oxygen uses Drastic Technologies' VVW 3000 and VVW 3500 digital video servers to translate and playback all three formats real time.



The Audio Control Room has a Wheatstone SP8 32x4x2 mixing console, ProTools 24 mix plus, Sony dual diversity WRR 840A UHF receivers, Tascam 40 MK II DAT, and 360 Systems 2730 Digicart.



No matter  
how high,  
how far,  
how fast,  
how clear,  
how icy,  
how windy,  
how wet  
or  
how many.

**PiRod's  
solutions  
are  
SOLID.**



PiRod can manage your unique tower needs with custom-designed solid rod, free-standing or guyed towers built to your specs and erected where you need them now. Our towers are solid—engineered to handle your most critical problems—and customers tell us that our turnkey design and erection services are pretty solid too. Like our record of providing tower solutions since 1952. So when you need a solid partner for your communication needs, call PiRod. When it comes to towers, there's just nothing hollow here.

**Solid Rod, Solid Service, Solid Value**

For a free guide to tower selection and a fast, courteous response to your request for a quotation, contact:



**PIROD INC.**

Solid Rod, Solid Service, Solid Value

PiRod, Inc.  
P.O. Box 128  
Plymouth, Indiana 46563-0128  
(219) 936-4221  
Fax (219) 936-6796  
[www.pirod.com](http://www.pirod.com)

Circle (125) on Free Info Card

## Production facility expansion

During the course of the project the Production Control Room design goals grew from relatively modest requirements to accommodating four hours of daily live production and producing short-form segments off-line throughout the day. To meet those demanding production goals, several factors were considered. First, the facility supports two separate studios with a total complement of 13 cameras. In addition, the Production Control Room must quickly and easily transform into an online edit suite. Finally, the Production Control Room is limited to a cozy 15-foot by 25-foot area. Space rapidly became a premium in the room and an aggressive plan was developed to use every unit of available rack space and console real estate as ergonomically as possible.

Time Base Consoles designed the rear producer's desk so it accommodates four people on the rear desk and provides valuable rack space for jackfields, tape machines and supplemental

audio equipment on its front side. The TD position has the Sony DVS 7200 production switcher/DME 7000 Core 2 digital video effects in the front desk, a removable Sony audio mixer 90 degrees to the right, and tape machines and jackfields 180 degrees behind it. This allows one person to "run the room" in an edit. By creating a break-away connection for the mixer and placing it on a roll-around cart, the room quickly converts to its "on-air" configuration, giving the TD more space to operate during live productions.

## Trackers studio

In November, the Trackers studio construction began, resulting in significant system expansion. The studio could not be located in any contiguous space in the existing Oxygen floor plan, so a site was selected in a different section of the Chelsea Market complex. The design goals were slightly different for this space, because it "piggy-backs" onto the existing Central Equipment Room, Audio Control Room and Production Control Room capacity in the core facility. To achieve the target on-air date, a second project team was chosen to implement the

Trackers facility. The two teams worked together, completing the core studio construction and building the new studio in time for the Feb. 2, 2000 launch date.

Architecturally, the Trackers studio more closely resembles a sound stage environment and requires less consideration for the nearby office space. A Telecast Fiber fiber optic system was selected to link the Trackers studio with the equipment and production rooms. Video signals, intercom, audio and return signal paths are transported more than 800 feet to the Central Equipment Room via fiber. The output SDI signals are then sent to jackfields and into the Sony router.

The goal was to be able to change from one studio configuration to the other within a small operating window every day. Pure Oxygen is broadcast live from noon to 2p.m., and Trackers is on-air from 4p.m. to 6p.m. Since both studios are being used for live productions, transitions need to occur as seamlessly as possible. As a result, the technology deployed must allow fast and accurate changeovers, without any noticeable signal degradation. The expansion of the minitriax patchbays and six BSPs in the Trackers studio satisfied the video changeover goals while remaining consistent with the existing core studio.

To accommodate the need to place talent throughout the two studios and move camera positions constantly and quickly, both the core studio and the Trackers studio utilize a wide variety of wireless communication devices. Frequency coordination for 24 Sony wireless microphones, 28 Clear-Com wireless PLs and 12 wireless IFBs in a relatively benign RF environment would be challenging, but implementing this platform in the heart of lower Manhattan presented a truly daunting task. The extensive use of these wireless systems allows for maximum flexibility within the studios, while allowing various groups of technicians, cameramen and producers to communicate seamlessly.

## Launch day planning

The construction timeline for the facilities was nearly seven and a half months. This is an aggressive timetable when one considers that general



The eighth floor multifunction office space (also known as "the zipper") features an easily reconfigurable cubicle system which provides multiple backdrops for "Pure Oxygen" show segments.



leading stations to digital integration  
takes us down a lot of

r o a d s .

We understand that the road to digital transition and integration for one station may be very different from that of another. Having been down a lot of roads in large markets and small, we bring a wealth of experience planning and managing the digital transition process, addressing the specific needs of the stations we work for and the unique markets they serve.

We have the resources: financial, technical and human. We have the experience. We have the relationships: architects, contractors, manufacturers. And we have the training systems to get your people up to speed in a hurry.

So whether you're managing in Mayberry or maneuvering in Megalopolos, we can make the road to digital transition and integration straight and smooth. Give us a call before you begin your journey.

Technology Evolves. We Take You There.



PROFESSIONAL COMMUNICATIONS SYSTEMS

A DIVISION OF MEDIA GENERAL, INC.

5426 Beaumont Center Blvd., Suite 350 • Tampa, Florida 33634

Toll Free: (800) 447-4714 • Fax: (813) 886-9477

[www.pcomsys.com](http://www.pcomsys.com)

Circle (126) on Free Info Card

## OXYGEN MEDIA

construction was not substantially completed until the end of the fourth month in the project cycle and rehearsals began less than a month later. This meant that most of the on-site technology integration took place while civil works construction was being completed. In addition, core facilities had to be completed first so rehearsals could begin and a production schedule established. Remaining systems integration was finished during off-hours and downtime. Close coordination among the various construction contractors, Oxygen technical and creative staff, and The Systems Group was key to successfully meeting the demanding project deadlines.

Oxygen Media went "on-air" the morning of Feb. 2, 2000. The first eight hours of programming were devoted to a single camera crew and

producer walking throughout the core studio, Trackers facility and the Atrium of Chelsea Market providing a live and unrehearsed "behind the scenes" look at launch day. At the same time, a complete dress rehearsal was taking place for Pure Oxygen and Trackers.

The remote crew bypassed the core studio facilities by using the BSP's and minitriax jackfields to patch their camera feed directly to the outbound signal path. This allowed the first live broadcast out of the facility to occur while the rest of the production crew was using the Production Control Room, Audio Control Room and both studios to simultaneously rehearse in their respective spaces. The flexibility designed and built into the system allowed all three production elements to work independently from day one. ■

*David Higgins is director of project development for The Systems Group located in Hoboken, NJ.*

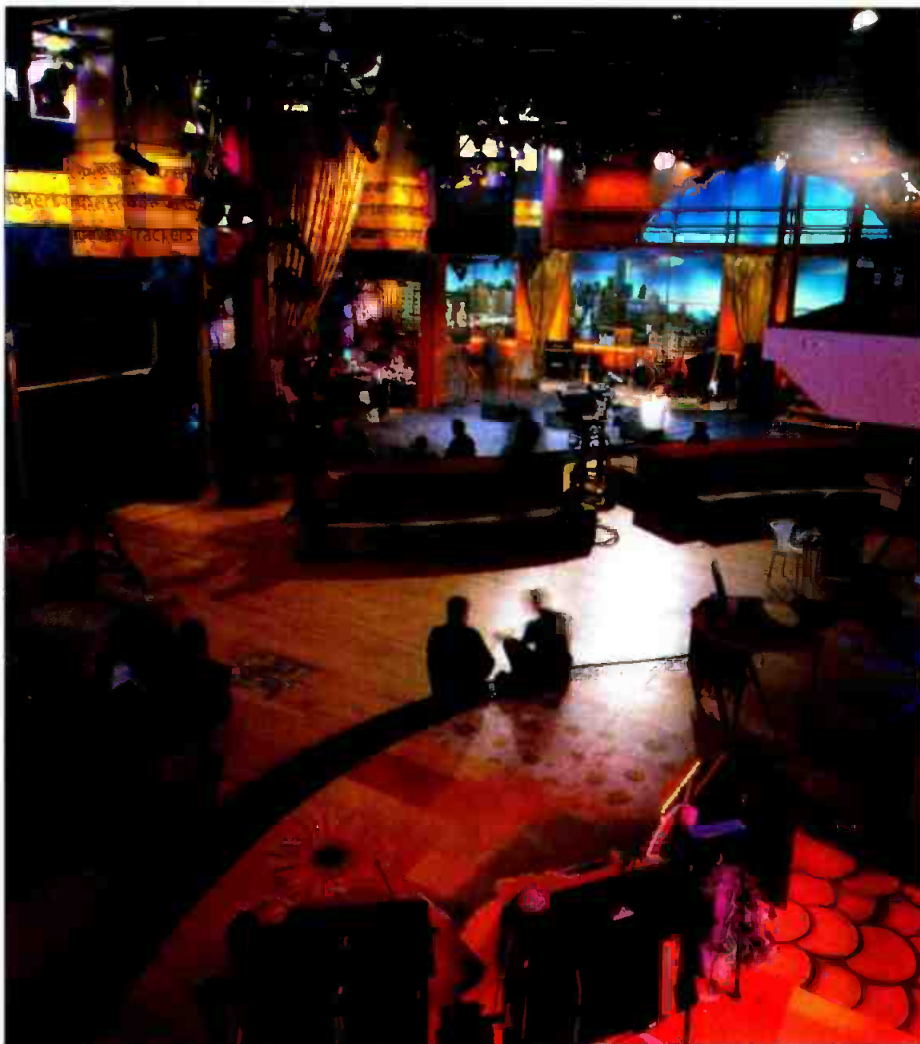

The Trackers studio located over 800 feet from the core production facility utilizes a Telecast Fiber Optic transmission system to provide interconnectivity to the central equipment room.

## Oxygen Media Project Team:

Geoffrey Darby, president of production/convergence:

Andrea Cummis, vice president of engineering and operations

Tom Burns, vice president of broadband technologies

Alison Murphy, director of facilities

## The Systems Group Project Team:

David Higgins, project manager

Bob Degnan, system engineer

Dave Stengel, assistant project manager

Paul Rogalinski, integration manager

Installation Crew:

Mattias Allevik

Alex Blanding

Darwin Clermont

Larry DeFazio

John Zulick

## Equipment List

Sony 64x64 SDI router

Sony DVS 7200 production switcher with shot box

Sony DME 7000 Core 2 digital video effects

Sony BVP 550 and 570 cameras

QTV teleprompters with AP News interface

Pinnacle FX Deko character generator

Pinnacle Lightning still store

Drastic VVW 3000/3500

Digital Disc Recorder

Clearcom Compact-72

Ultimate 9 Chroma keys

Wheastone SP 8 32x4x2

Mackie SR 40-8 mixing console

**NEW**

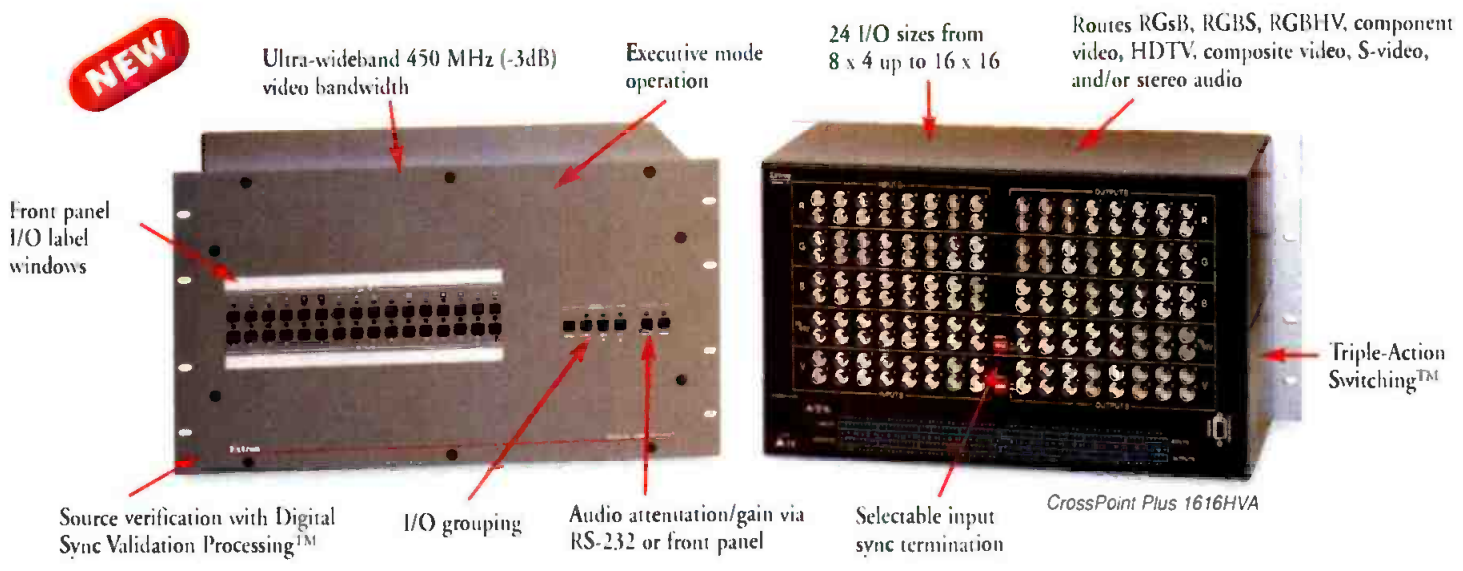

## Extron CrossPoint Matrix Switchers

# Switching has never been easier.

Extron's newly extended family of CrossPoint Matrix Switchers now includes 16 additional models for convenient control and centralized routing of multiple signal formats including RGB, RGBS, RGBHV, component video, HDTV, composite video, S-video, and/or stereo audio. The new CrossPoint Plus Series delivers more than twice the video bandwidth of the CrossPoint Series and includes other advanced features for even greater matrix switcher design flexibility. With 24 models to choose from, this complete line-up of CrossPoint and CrossPoint Plus single-box routers makes switching with Extron easier than ever before.

### CrossPoint Series

12 models to choose from

- **NEW**— Audio gain or attenuation (-15dB to +9dB) adjustments eliminate noticeable volume differences between sources
- **NEW**— Front panel I/O button label windows for easy and intuitive I/O selection
- 200 MHz (-3dB), minimum, wideband video bandwidth, fully loaded
- View I/O mode to show which individual inputs and outputs are active
- Audio follow or breakaway routes audio and video together or separately
- Individually buffered, independent outputs
- Global memory presets
- QuickSwitch Front Panel Controller™ for intuitive control
- RS-232/422 control

**24 Models**

I/O sizes:

- 8 x 4
- 8 x 8
- 12 x 4
- 12 x 8
- 16 x 8
- 16 x 16

all sizes are available with or without audio

### CrossPoint Plus Series

12 models to choose from

- **NEW**— 450 MHz (-3dB), minimum, ultra-wideband video bandwidth, fully loaded
- **NEW**— Extron's exclusive Digital Sync Validation Processing (DSVP™) verifies active sources by scanning all inputs for active sync signals
- **NEW**— Excellent isolation between channels and extremely low electromagnetic emissions to minimize signal leakage in high security environments
- **NEW**— I/O grouping allows specific outputs to be grouped together for convenient wiring and switching
- **NEW**— Triple-Action Switching™ (RGB delay) blanks the screen during switching to eliminate glitches
- **NEW**— Executive mode for protection in unsecured environments



Check out the CrossPoint Webcast demo at <http://www.extron.com/crosspoints>

# Extron Electronics

800.633.9876 • [www.extron.com](http://www.extron.com)



EXTRON ELECTRONICS/RGB SYSTEMS, INC.  
1230 South Lewis Street, Anaheim, CA 92805  
800.633.9876 714.491.1500 FAX 714.491.1517  
U.S.A.

EXTRON ELECTRONICS, EUROPE  
Beeldschermweg 6C, 3821 AH Amersfoort  
+31.33.453.4040 FAX +31.33.453.4050  
The Netherlands

EXTRON ELECTRONICS, ASIA  
135 Joo Seng Rd. #01-01, PM Industrial Bldg.  
+65.383.4400 FAX +65.383.4664  
Singapore 368363

EXTRON ELECTRONICS INFORMATION  
EXTRONWEB™: [www.extron.com](http://www.extron.com)  
EXTRONFAX™: 714.491.0192  
24-hour access—worldwide!

Circle (127) on Free Info Card  
[www.americanradiohistory.com](http://www.americanradiohistory.com)



### Transmitter site safety

BY DONALD L. MARKLEY

It was a dark and stormy night, as the famous story goes. In broadcasting, that often leads to a transmitter going down with the customary smell of burnt carbon and charred wiring. The natural reflex, supported heavily by management and the programming department, is to get the thing back on the air as soon as possible. That often leads to the chief engineer or transmitter supervisor being called to venture out into the storm to make repairs. Often, by himself. Bad idea.

Don't make the mistake of working on high voltage systems all by yourself. For this purpose, high voltage is anything above 24 volts. The most lethal voltage, based on the number of fatalities, is common 120V AC, primarily because it is everywhere and technicians are used to having it present. As familiarity tends to breed, at least carelessness, if not contempt,

that voltage being present on terminal strips or internal transmitter components tends to be largely ignored. This can, in turn, lead to bad consequences. Many transmitters will have that voltage present in the cabinets

disconnect to the building. Further, they should be specifically instructed to stay the heck (term used to please the editors, not to show the real significance here) away from you while the work is going on. The

### The most lethal voltage, based on the number of fatalities, is common 120V AC.

even when the main breaker is turned off. A separate breaker often feeds the exciter and control circuits.

#### Avoid working alone

When making that panic trip to work on equipment, call someone else, almost anyone else, to be present at the site. That person should be shown how to power down everything, even if by pulling the main

natural reflex upon seeing someone receiving a nasty shock, making strange noises and moving in unnatural ways, is to grab them to pull them out of the equipment. Another bad idea, because it can simply lead to two people demonstrating those characteristics.

It would be wonderful to have an assistant on site who is knowledgeable and who can make a real contribution to the repair process. If that is not practical, a warm body of almost any type will do as long as they are sufficiently smart to be able to pull a breaker and call 911. Administration of mouth-to-mouth would be a bonus. Remember that one of the first problems associated with severe electrical shock is temporary paralysis of the chest muscles. A little mouth-to-mouth action can keep all systems working until the paralysis has passed and normal breathing returns. A second problem from severe shock is ventricular fibrillation, where the heart seems to flutter rather than beat. Closed chest heart massage might be helpful, by a trained person, but more helpful is treatment with the appropriate equipment — the reason for 911. If nearby, medical treatment may arrive in a timely fashion to avoid your

### FRAME GRAB

A look at the consumer side of DTV.

### Handhelds gain computer market share:

Portable computing continues to gain users.

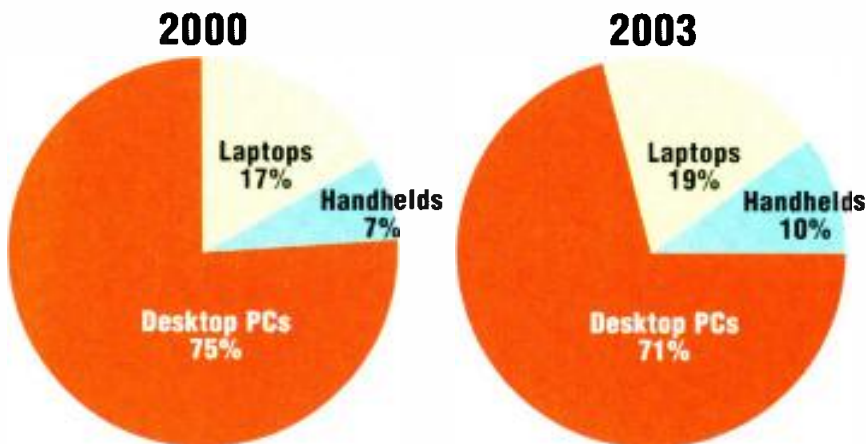

SOURCE: IDC www.zdnet.com

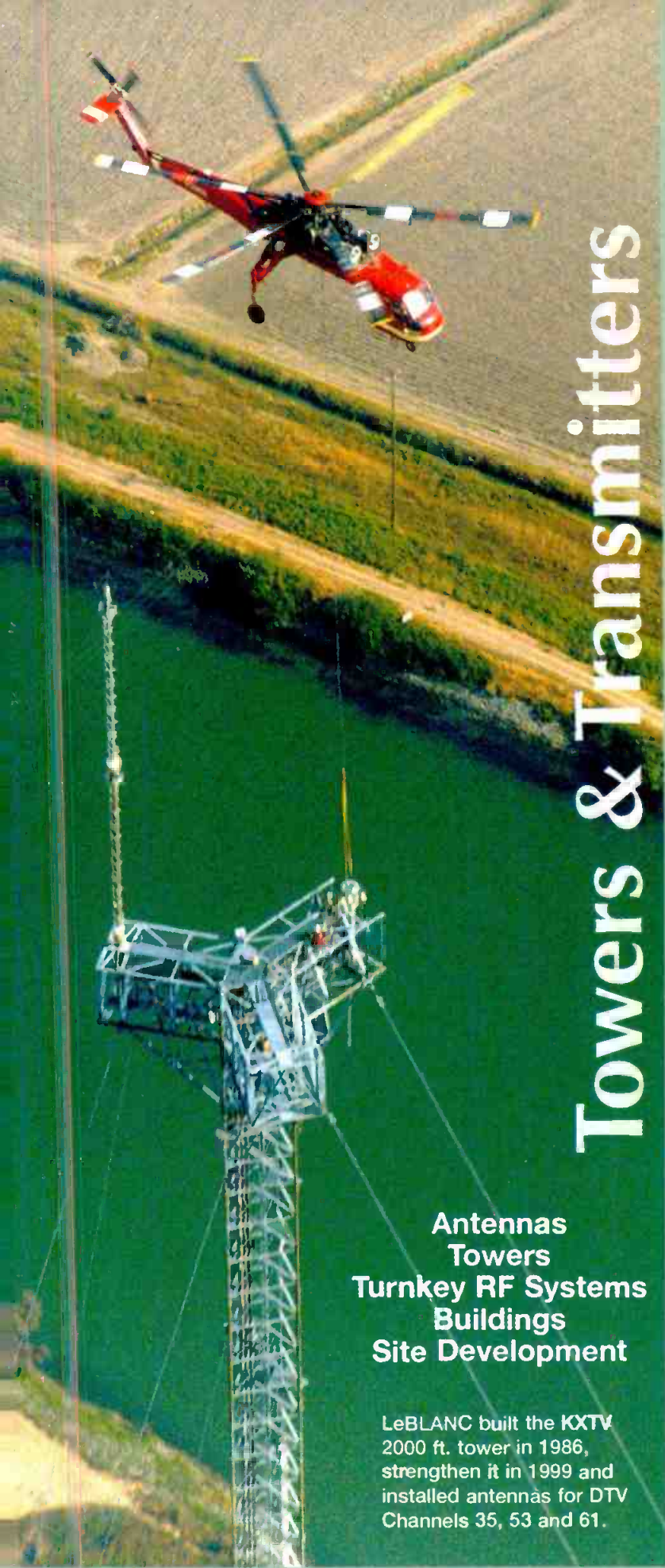

# Towers & Transmitters

Antennas  
Towers  
Turnkey RF Systems  
Buildings  
Site Development

LeBLANC built the KXTV  
2000 ft. tower in 1986,  
strengthen it in 1999 and  
installed antennas for DTV  
Channels 35, 53 and 61.

## LARCAN

Year 2000 Transmitter Lineup

### DTV<sup>Lite</sup>™

**1**  
NEW

Solid-State Digital UHF  
Transmitter. 75 to 300 W.

An easy and practical Jump-Start  
Solution for your DTV transition.



**2**

Solid-State UHF Transmitters.

- \* Digital \* Analog
- 1kW to 20kW

**3**

Solid-State VHF Transmitters.

- \* Analog - M Series
- \* Digital - MD Series

The perfect pair for  
transmitting Analog  
and Digital VHF signals.

Components and  
assemblies are  
interchangeable.

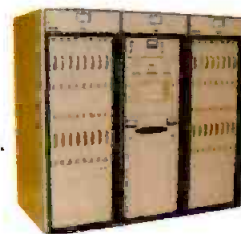

*If you have an M Series, or want to  
upgrade your analog transmitter,  
check out the M and MD Series.*

**4**

### LANDMARK SERIES

Hi-Power Digital UHF, IOT Transmitters.  
8kW to 100kW.

NEW

Hi-Power Analog UHF, IOT Transmitters.  
25kW to over 100kW.

Check out these features:

- \* Internal construction.
- \* Accessibility.
- \* Redundant Control System.
- \* LDMOS high-gain, broadband drivers.
- \* Soft Start.
- \* Diagnostics with fiber optic interconnects.
- \* Safety: IEC-215 compliant.



**5**  
NEW

Solid-State 1 Watt to 1000 Watt  
VHF and UHF Translators/Transmitters.

- \* Frequency agile Input and Output and provides on-site flexibility for mandated FCC channel changes.
- \* Linear/Ferroresonant Power Supplies.



All designed and manufactured  
in an ISO 9001 Registered Facility.

## LeBLANC BROADCAST INC.

Ray Camovale, President 905.844.1242 • LBI Denver, Sheryl Richmond 303.665.5016  
• West: Dave Hill 650.574.4600 • Bob Palmer 360.403.1960  
• Central: Tony Guess 940.682.4147 • East: Frank Davis 281.296.8132

[www.leblanc-group.com/lbi](http://www.leblanc-group.com/lbi) [www.larcan.com](http://www.larcan.com)

Circle (128) on Free Info Card  
[www.americanradiohistory.com](http://www.americanradiohistory.com)

transfer to the ECU (eternal care unit).

Even better, take care not to get shocked in a manner that would lead to such results. The worst shocks are through the head or from hand to

cable trays. Once inside, snake elementary school did not teach them not to crawl onto high voltage connections. Such activities lead to off-the-air time and really nasty messes

house in a directional array. Upon sensing movement above him, he saw a copperhead snake lying on the doorframe above the door. His first reaction was to place the end of the plastic tube on his shop vacuum over the snake's head upon which it was drawn into the tube until reaching the point where the girth of the snake exceeded the diameter of the tube. Now the problem was what to do with this closed system of snake and vacuum. The author would have performed a scientific experiment in which it could be determined if a shop vacuum motor would run until a large snake starved to death. The technician in this instance turned off the vacuum, pulled the snake from the tube and hit its head with a hammer. Bad choice, but he really wanted his vacuum cleaner back.

It is realized that dealing with snakes, insects and other animals really doesn't rank with working on a high voltage supply in terms of

## **Snakes have a great tendency toward the investigation of openings such as cable entrances into buildings or leading to cable trays.**

hand. Electrical current through the head can normally be avoided by reasonable care. However, the hand-to-hand problem is more difficult to avoid. The natural instinct is to steady oneself with one hand on the cabinet while reaching into the equipment with the other. That can result in a nasty shock with the current traveling through the chest, leading to the above-described heart and breathing problems. Use the age-old technique of putting the unnecessary hand behind you or in your pocket. That will keep it out of trouble and help avoid the worst of shock related problems. The other old technicians trick is to never grasp anything. Develop the habit of always touching terminals with the back of a finger before taking hold. If a voltage does exist, the natural reflex will be to draw away rather than gripping tightly. This technique will help you avoid being hung-up in a circuit until the local utility company decides to stop producing electricity.

### **Unauthorized visitors**

In another area of concern, nature's little creatures are all out and about this time of the year. Besides the fuzzy, loveable ones, there are the nasty crawly ones. Snakes have a great tendency toward the investigation of openings such as cable entrances into buildings or leading to

to clean up. The obvious solution is to be sure that no such openings exist. Canned foam products are readily available at electrical supply houses that will totally seal conduit ends or small openings in the building walls and foundations.

In addition to the problem of animals getting into high voltage systems, a real safety problem exists in their presence. The sudden appearance of a snake inside a cabinet can

## **Cleanliness and a well-maintained building will help relieve workers' concerns.**

lead one to forget electrical safety, especially if one is as upset by such occurrences as this author. A similar reaction may occur upon being greeted by bees or other groups of insects. Now that the famed killer bees are present in parts of this country, the problem is further aggravated. The solution is very simple. Good house-keeping and building maintenance will eliminate openings where such beasts might gather. Keep the buildings tight and closed to reduce the problems of animals.

We are reminded of an instance when a technician in western Missouri was vacuuming out an ATU dog-

safety. However, it goes directly to maintaining a safe workplace with minimal hazards affecting working conditions. Cleanliness and a well-maintained building will relieve workers' concerns regarding minor issues and allow them to concentrate on the bigger issues. ■

*Don Markley is president of Markley and Associates, Peoria, IL.*



Send questions and comments to:  
[don\\_markley@intertec.com](mailto:don_markley@intertec.com)

[www.broadcastengineering.com](http://www.broadcastengineering.com)



# FREE! The Industry's Hottest Newsletters

NEWS

VIDEO

REVIEWS

FEATURES

WHITE PAPERS

TUTORIALS

RESEARCH

CONTESTS



The CAD List -  
For CAD  
Professionals

loud! Newsletter -  
For Audio  
Professionals

DigitalMediaNet.com Newsletter -  
For Video, Animation, Special Effects,  
Imaging and Design, CAD, Broadcast  
and Post Production Professionals

**WIN a Viewsonic VP150 Flat Panel Display 15"**

Sign up for one of our **FREE** e-mail newsletters by Sept. 15, 2000 to be entered in the drawing.

Sign up at [www.DigitalMediaNet.com/register.htm](http://www.DigitalMediaNet.com/register.htm)

Digital Media **NET**  
Where the Creative Community Meets



## Audio for video — analog, digital or embedded?

BY MIKE BETTS

Many facilities use a combination of analog and digital audio signals when producing and delivering programs. New equipment may only accept or provide digital audio, and I/O signal conversion could be required if the existing analog infrastructure is to be used. Existing analog infrastructures still provide a useful method of connecting digital signals, but the conversion back and forth to analog introduces the drawbacks of analog into the digital path. The dynamic range of the digital path and the ability to interconnect digital signals without any loss are features that should be utilized wherever possible. When updating facilities to add digital audio, the use of embedded audio in the video channel should also be considered.

Changing paths to digital may not be economical, so the use of A/D-D/A conversion products and embedders and de-embedders warrants careful consideration. Picking a standard to conform to is one of the first requirements. With digital audio, the choice is normally the AES-3 standard. That standard, however, encompasses many variations and knowing which

and although different sampling rates of 32- and 44.1kHz with data resolution of 16 or 24 bits can coexist, it is good practice to keep to one interchange format. If planning for 24 bits in the future, make sure that all

### There is no real benefit in using one cabling system over the other.

equipment being purchased is 24-bit capable. All AES-3 variations can be embedded into digital video and deciding when to use embedding is usually a matter of economics and facility functionality.

#### Conversion

Converting from analog to digital has many advantages in data storage, transmission and processing. Probably the most important factor is that the signal is not changed as it passes from one piece of hardware to another. Therefore, it is important that the levels are set correctly at the point of conversion from analog to digital. These levels will then be maintained throughout the system

level (SOI) at -20dB. This reference level accommodates the range of most finished audio program material. Once converted to digital, the signal can be routed or distributed using an AES-3 router or audio DA using one

of the standard cabling systems: balanced XLR connectors or unbalanced 75Ω BNCs. There is no real benefit in using one cabling system over the other, although using coax with BNCs is often preferred. BNCs take up less connector space (important for large routing switchers) and unbalanced does not require the expense of transformers for coupling. When transporting data, either system will work and the choice of cabling becomes one of cost, space, convenience and distance to be covered.

#### AES-3 features

Besides the advantages of using digital signals, the AES-3 standard allows for easy routing and distribution of stereo (or two mono) signals. Additional paths can be used to route multichannel signals for multichannel operations such as a second language or the use of three AES-3 paths for transporting uncompressed Dolby Digital 5.1. Audio synchronization (audio to audio and audio to video) and any requirement to separate or process the audio channels individually (left, right, invert, mixing, etc.) must also be considered. Audio-to-audio synchronization is usually accomplished using a common reference, such as an AES-3 silent signal. This synchronizes the Z-flag reference at the start of the 192-frame block structure. Not all equipment locks to an AES-3 refer-

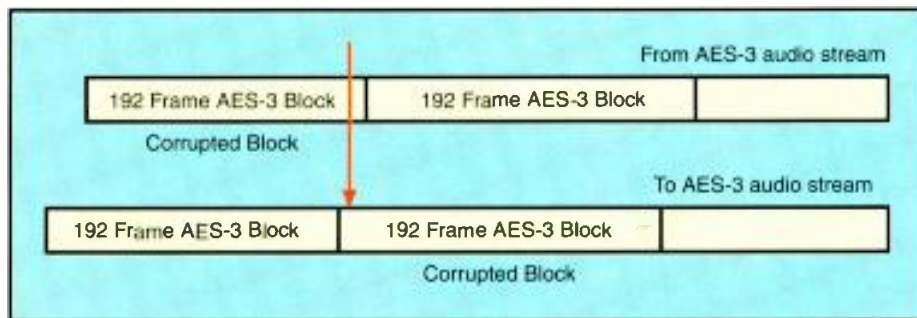

Figure 1. Illustration of a hard switch between non-aligned AES-3 audio blocks. The “from” and “to” blocks are corrupted at the switch point unless data is decoded, level controlled and the block structure rebuilt.

variation can be used by each piece of equipment is important. The default used by many facilities for AES-3 audio is stereo, 48kHz sampling at 20 bits. This default is accommodated by most production equipment,

until they need to be changed for production purposes. The dynamic range of digital audio when using 20 bits of data is 120dB. The maximum operating level (MOL) is referred to as 0dB with the standard operating

# Your Data Network is Now Your Audio Network.



## Route Multiple Audio Channels Easier and More Economically Than Ever.

### Simplified transport

RAVE is a revolutionary audio transport system that allows you to route multiple channels of audio over standard Ethernet hardware and cabling. A single RAVE network can now replace hundreds of analog cables, dramatically reducing installation time, effort and cabling costs while improving routing flexibility and audio performance.

### One network

RAVE now supports "switched" network topologies so you can run audio on your existing data network—completely eliminating the cost of installing a dedicated

audio infrastructure with separate hardware and cabling. Your network can be divided into "virtual LANs" or VLANs allowing audio channels to travel alongside asynchronous PC data and control traffic—without affecting the audio signal.

Ethernet switches also allow RAVEs to link to other types of networks, such as Gigabit Ethernet or Asynchronous Transfer Mode (ATM) networks, for added network capacity to route hundreds of audio channels on the network. Switched networks can also support Spanning Tree and Trunking that allow redundant links for failsafe operation.

### CobraNet™ compatible

RAVE uses Peak Audio's latest version of CobraNet, making it fully compatible with other CobraNet-based devices from other manufacturers.

### Proven track record

From San Francisco City Hall to the Sydney Opera House, RAVE has proven to be the ideal choice for solving complex audio routing challenges at venues worldwide. In fact, RAVE is ideal for broadcast facilities, arenas, theme parks, theaters, and other applications needing multiple audio channels routed over long distances free of noise and hum.

For a free application guide or for more information call (800) 854-4079 or visit our website at [www.qscaudio.com](http://www.qscaudio.com).

### RAVE Installations Worldwide

Super Bowl XXXI, XXXII  
Six Flags Over Georgia  
Edison Field, Anaheim  
Bellagio Hotel, Las Vegas  
San Francisco City Hall  
Safeco Field, Seattle

Imperial Hospital, London  
Legoland, Carlsbad  
National Exhibition Center, London  
Bally's Hotel & Casino, Las Vegas  
Southeast Christian Church,  
Kentucky

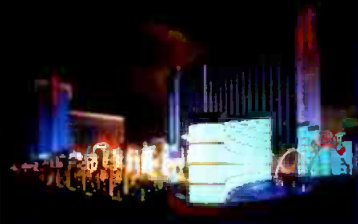

Bally's Hotel and Casino, Las Vegas



HEAR THE POWER OF TECHNOLOGY.

Circle (129) on Free Info Card

"RAVE" and "Hear the Power of Technology" are trademarks of QSC Audio Products, Inc. "QSC" and the QSC logo are registered with the U.S. Patent and Trademark Office.  
© QSC Audio Products, Inc., 1875 MacArthur Blvd., Costa Mesa, CA 92626 USA

[www.americanradiohistory.com](http://www.americanradiohistory.com)

ence and may only use a 48kHz word clock. This produces a block sequence with a random start point from when the equipment was turned on. Equipment

and the new audio block can be corrupted, causing a discontinuity of up to 8mS. (See Figure 1.) Ideally, downstream equipment should

transmitter all within the SD video signal. Processing the audio, if required, can be accomplished within the master control switcher by de-embedding and re-embedding the AES-3 data. This also provides for split video and audio effects as well as final level control and the ability to choose left- or right-only channels as required.

## Switching between video streams with embedded audio, however, also has problems.

that combines or switches between synchronous, but not block aligned, AES-3 streams should be able to handle this situation. It is also preferable for an audio mixer, for example, to accept and process non-synchronous streams without problems. Output streams should then be re-encoded as AES-3 compliant streams at the mixer output synchronous with the AES-3 reference.

Synchronous audio is also important when live switching between different audio signals is needed, especially if this is in combination with a video vertical interval (VI) switch. The relationship between the AES-3 frame sequence to video (525/60) covers five video frames using 8008 audio frames before repeating. This relationship, however, is not related to any particular video frame or the audio 192-frame blocks. Therefore, it almost impossible to know where the sequence is when a switch is required. Switching between digital audio streams should include a fade down and fade up of the audio at the switch point to prevent illegal audio level changes from being introduced into the audio datastream. Switching between audio datastreams requires the data to be decoded and the channel and other status bits rebuilt to maintain the 192-frame block structure in the output.

Non-synchronous audio often requires a hard switch to be used instead of a mix, and the data blocks at the switch point will be corrupted. Preserving the data structure is important to prevent unknown effects from being introduced by equipment that does not adequately process a non-conforming datastream. When a switch occurs between two non-aligned audio block sequences, both the out point of the old audio block

mute the audio stream when a non-conforming block structure is received so as not to introduce digital pops or clicks into the signal path. The response to a discontinuity, however, may vary greatly between products.

Switching between video streams with embedded audio, however, also has problems. It is impossible to prevent audio block sequence corruption at the switch point without de-embedding the audio and processing it separately. Providing on-air routing is not required, implementing embedded audio can save the cost of audio

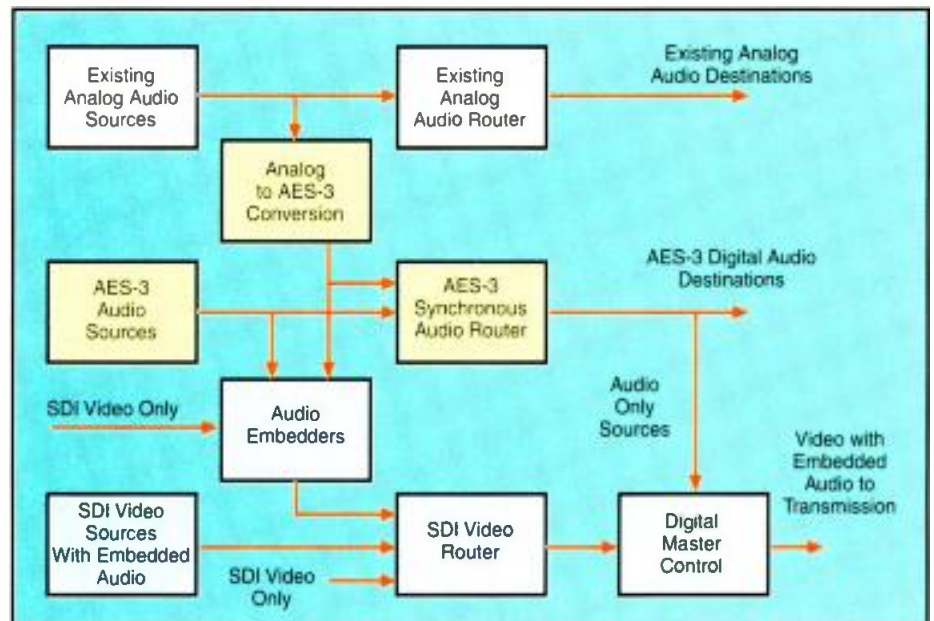

Figure 2. Hybrid facility showing combination of analog, AES-3 and embedded audio formats.

### Embedded audio

There are many cases when using embedded audio should be considered. These include routing audio and video over long distances, where up to 16 channels of audio (eight AES-3 streams) can be accommodated within the serial digital video signal, or when many pieces of equipment can accept or produce embedded audio. This can provide a cost saving in ancillary equipment for routing and converting audio separately from video. For instance, commercials played from media file servers can often be output with audio embedded in the video. This can be routed through a video router to master control and then on to the

routing and cabling especially in master control. (See Figure 2.) Embedded audio is usually too costly and would overly complicate operations where separate audio and video processing functions are used, such as in a studio or production suite.

With careful planning, a facility can migrate toward a fully digital facility without large expense and additional conversion costs. If HDTV or media file servers are being added, these often force the issue by determining where to target the use of digital. ■

*Mike Betts is the senior partner of Broadcast Training Partners, Nevada City, CA.*

Solid  
State

# Are You Ready?

IOT

You don't have to face the challenge of DTV alone...We can help.

DTV is an enormous challenge. Thomcast breaks it down with simple solutions that address your specific needs.

We offer the most affordable solutions available. Whether your needs are IOT or Solid State, our transmitters consistently exceed FCC specifications at higher power levels than our competition, and we achieve over 20 kW average power per IOT HPA with headroom to spare.

Our experience spans over 25 years. In fact, a Thomcast transmitter was used for the first over-the-air digital HDTV broadcast in 1992.



Our exclusive DAP™ (Digital Adaptive Precorrection) technology eliminates the costs and inefficiencies of countless hours spent in system setup and maintenance activities. Simply put, you get higher quality with lower operational costs.

We stand behind our two-time Emmy award winning products with support and educational programs that are unsurpassed in the industry.

Call us today and we'll show you that when it comes to your transition to digital . . . you don't have to face DTV alone.

 **THOMCAST**  
*Time Tested Technology*

**DAP**

"We invite you to join the Thomcast family. Our people have the knowledge and care . . . which truly makes the difference."

Richard E. Fiore, Jr.  
Vice President, Sales  
Thomcast Communications Inc.



Circle (130) on Free Info Card

104 Feeding Hills Road, Southwick, MA 01077 • (888) 872-8505 • www.THOMCASTcom.com



COMARK • CDS • COMWAVE

An aerial photograph of a city at night, with a large, red, lattice-structured antenna tower in the foreground. The tower has a central vertical mast and four diagonal legs. At the top of the tower is a platform with several white cylindrical antennas and other equipment. The city below is illuminated with lights, and the sky is dark. The text 'new DTV antenna technology' is overlaid in a bright green, bold, sans-serif font.

new  
**DTV**  
antenna  
technology

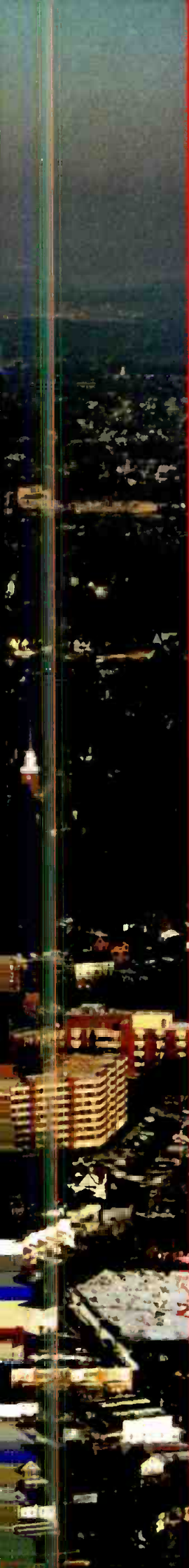

Photos courtesy of Dielectric

**BY JAY S. MARTIN**

**T**oday some 62 percent of American households have access to at least one digital television signal. Three years ago no home in America had access to this technology. The digital age has truly revolutionized television broadcasting, bringing about the most significant change since the advent of color television some 45 years ago. The antennas that transmit this digital bitstream have experienced a similar magnitude of change.

Until late in 1997, analog was still the primary means of television transmission. As a result, the transmission system, including the antenna, could be optimized at those specific frequencies where the majority of energy was present; picture, color carrier and aural carrier. These frequencies represent only a small portion of the full 6MHz bandwidth used by the station. Today, digital broadcasting requires that the full 6MHz bandwidth of the television channel have a linear response throughout the transmission system with minimal VSWR and group delay (transmission system includes transmitter, RF system, transmission line antenna and any associated interconnects). With digital, more bandwidth means more data transmission capability, a key issue in today's information age.

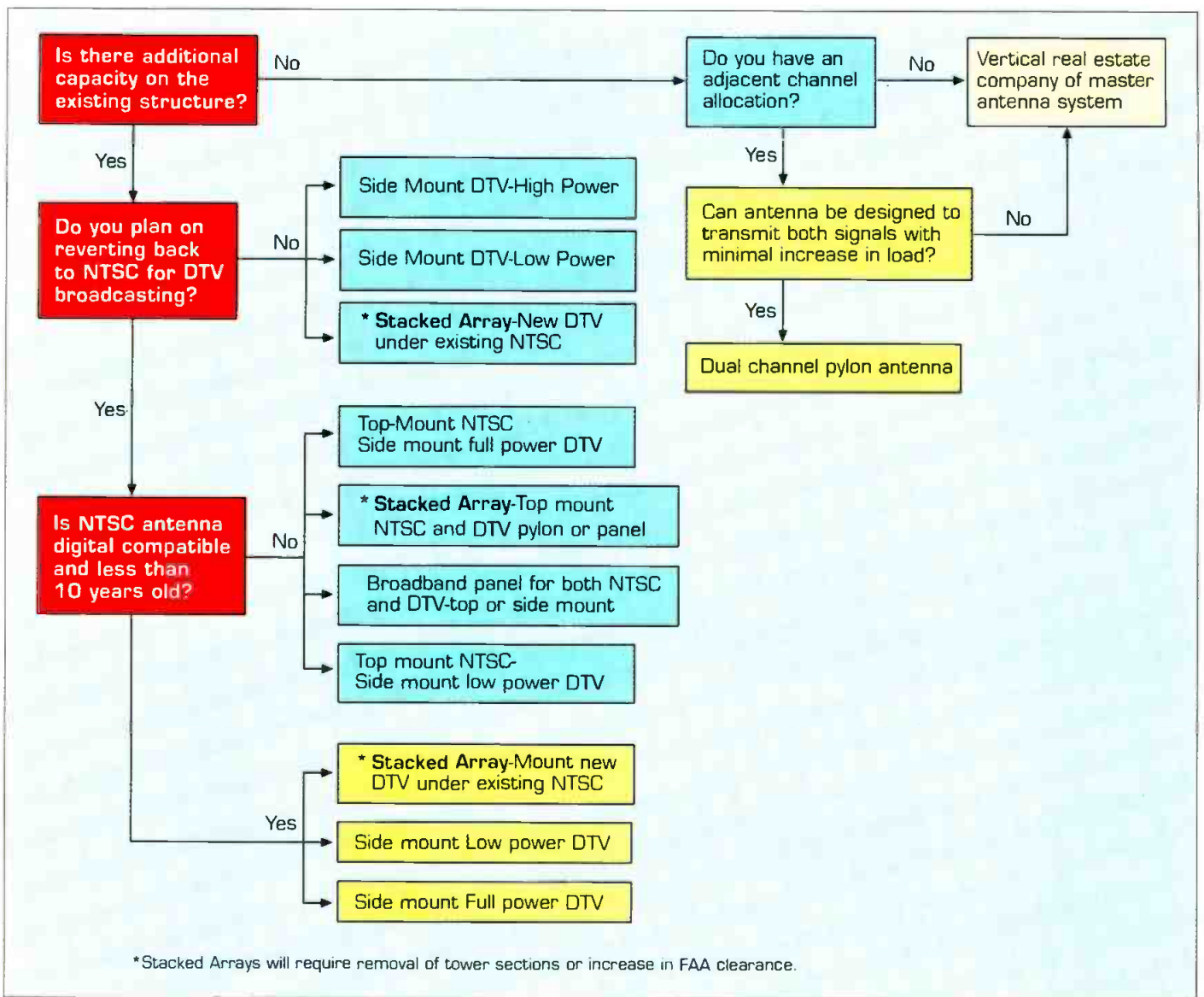

The broadcaster must go through a series of steps to determine what options are available for the implementation of DTV service.

There are a number of hurdles that must be overcome to ensure successful implementation of DTV. In addition to tower capacity and the cost of conversion to DTV, the modulation war, 8VSB vs. COFDM, must be resolved. Whatever the outcome of the latter battle, modulation scheme will not change antenna system design. Antenna systems designed today for digital broadcasting using 8VSB modulation will require no modification should COFDM or both modulation standards be adopted. Also, there are no firm business models in place today that will allow the broadcaster to immediately profit from digital transmission. This issue may be self-resolving in that new means for the transmission of data are always being sought. The medium capable of transmitting the great-

est data rate in the most economical manner will be the dominant medium; this may be the future of terrestrial broadcasting.

When designing an antenna system, several criteria must be considered. First, system linearity (otherwise known as output response or frequency

response) across the full 6MHz channel must be optimized. This is the gain and phase response vs. frequency across the channel. Whether the antenna is a top mount, a side mount, a pylon or a panel antenna the linearity must be such that this response is maximized. System non-linearity can result in gain variations across the channel in excess of 10dB. This variation in gain will result in an increased bit error rate. Although the receiver may be able to compensate for this, it will result in a reduced

## The adjacent-channel antenna has its pros and cons.

carrier-to-noise ratio and a total loss of coverage in the fringe areas. The goal should always be to minimize amplitude and phase distortion in the transmission system while saving the equalizer headroom in the receiver to

carrier-to-noise ratio and a total loss of coverage in the fringe areas. The goal should always be to minimize amplitude and phase distortion in the transmission system while saving the equalizer headroom in the receiver to



correct for propagation path defects. Specific causes for this gain variation (poor output response) will be examined further.

Directly related to the output response of an antenna is the beam sway. Beam sway is the term used for the variation in beam tilt across a given channel. End-fed antennas have an inherent tendency to have a beam sway in excess of 0.5 degrees depending on the antenna gain and "phase taper" from slot to slot. The resulting beam tilt is higher than desired at the lower edge of the band and lower than desired at the upper edge of the

band. This is due to the fact that pylon antennas are typically designed for a slot spacing of approximately one lambda at the center of the channel. As this spacing varies, a cumulative phase taper will result from slot to slot, creating a variation in beam tilt. At Channel 41 for example, the wavelength is 18.59 inches. If the radiating elements (slots) in the antenna are spaced at one wavelength in the center of the channel (360 degrees, or 0 degrees between elements), at the lower end a 1.7-degree phase taper will result (spacing of the elements is 358.3 degrees versus 360).

The opposite phase taper will occur at the upper end of the channel. The result, about 3.4 degrees total phase taper between each layer of the antenna. This is a cumulative taper in that between slots one and two, the phase taper is 3.4 degrees; between slots one and three, it is 6.8 degrees and so on. The higher the antenna gain (more elements or slots), the narrower the main beam and the more significant the resulting beam sway. Also, the associated group delay variation across the channel can approach 20 nsec. from the end-fed antenna alone. The only way to totally eliminate beam sway is to center feed the antenna with equal slot characteristics above and below the feed point. Each half of the antenna will have equal and opposite beam sway, thus having a total cancellation effect. This results in an elevation pattern main beam that is extremely stable. Beam sway is one of the most significant contributors to gain variation across a given channel. Also, by center feeding the antenna, the group delay can be reduced to less than 10 nsec.

Another critical parameter in the design of a pylon antenna is the antenna "illumination." Illumination refers to the phase and amplitude distribution to each slot of the antenna. The phase distribution is varied in part by changing the slot spacing from layer to layer. The amplitude distribution is varied in part by changing the coupler diameter within the antenna. To get the optimum frequency response out of a DTV antenna, a tapered illumination should be used with the power distributed at higher levels near the center or feed point of the antenna and reducing as you approach the end slots. A tapered illumination will yield a very stable elevation pattern throughout the null structure. The tapered illumination combined with a true center feed will generate a superior frequency response across the full channel in both the main beam and throughout the viewing area.

The DTV allocation table has 357 adjacent channel allocations, 195 N+1 and 162 N-1. N+1 refers to an allocation where the DTV is the NTSC



WRC, Washington, DC, chose to stack its NTSC antenna at 587 feet and its digital antenna at 637 feet. Shown are the antennas being raised into position.

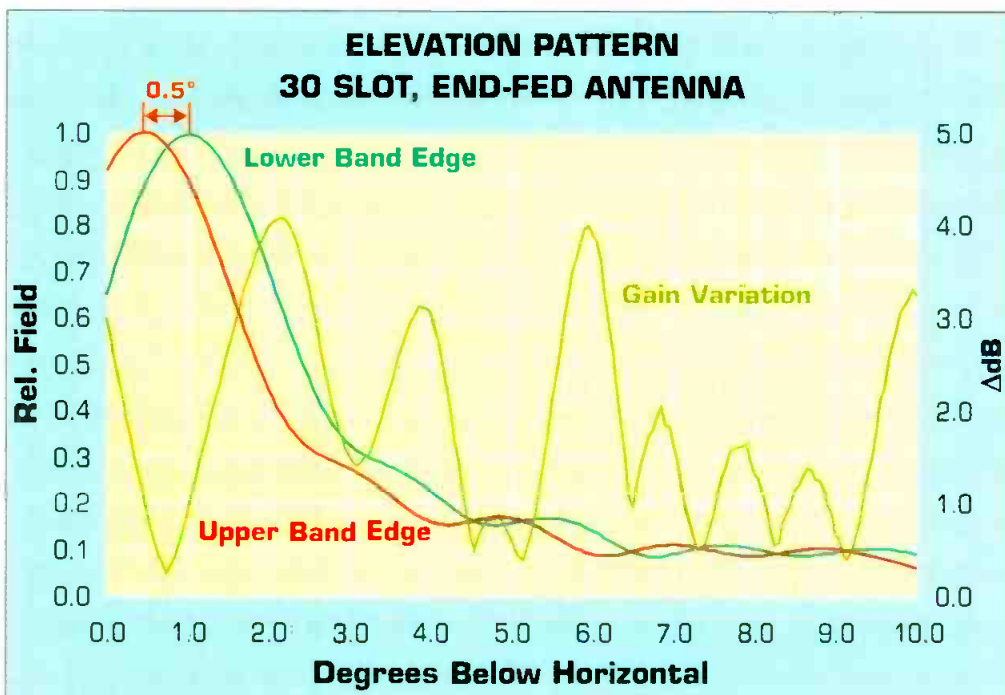

Figure 1. End-fed elevation pattern showing beam sway and resulting frequency response.

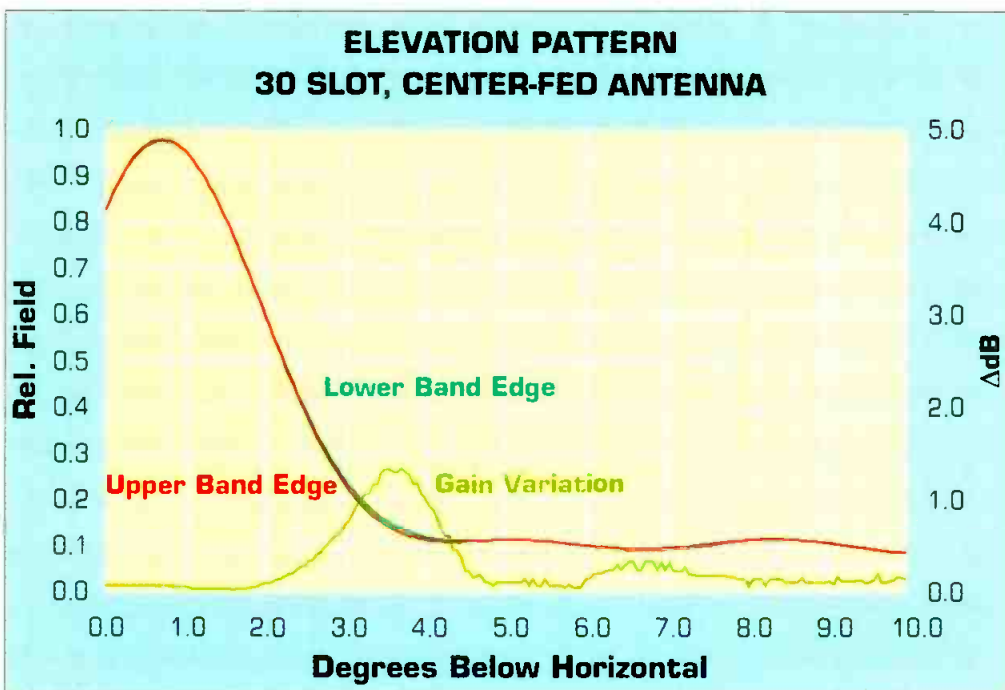

Figure 2. Center-fed elevation pattern with tapered illumination (G type) and resulting frequency response.

NTSC and 1MW DTV (maximized) could operate out of a common antenna because of the power handling. Also, if there is a problem with the antenna or the associated transmission line run, both the NTSC and DTV services would be off the air. For those stations with the adjacent channel allocation and sufficient tower capacity, a unique solution would be two adjacent channel antennas co-located. One antenna would be for primary NTSC service and backup DTV service and the second antenna would be for primary DTV service and backup NTSC service. Should either antenna or transmission line run fail, the backup system for both services is in place. This method of redundancy has been used by KSTR-49/DT48 of Irving, TX.

#### A panel alternative

An alternative to the pylon antenna is the broadband panel. This is the type of antenna that the majority of the international broadcasters are accustomed to using. International markets have embraced this technology with success because of the need for co-location within a major metropolitan area and the lower transmitter power levels used. In the domestic market, single transmitter power levels can exceed 50kW average and multiple frequency installations

can have combined transmitter power levels in excess of 100kW average. The same technology that was acceptable for Europe is not acceptable for the U.S. Major design changes in panel antennas and the associated power division/feed system have allowed this technology to extend to the domestic market, even at the power levels above.

As with all possible configurations, the adjacent channel antenna has its pros and cons. On the plus side is the load placed on the tower. In many

cases, both services can go on the tower with little or no tower modification. Also, when an adjacent channel antenna is installed, an immediate improvement to NTSC service should be realized. With the adjacent channel antenna, the elevation and azimuth patterns are nearly identical for both channels. This will ensure that a uniform signal is received throughout the viewing area over both channels. On the downside, there are power limitations to the adjacent channel antenna. With current technology it is unlikely that a 5MW

As mentioned earlier, the same issues that are considered for pylon type antennas must also be considered in the design of a panel antenna. The primary advantage of panel an-

tenna designs is the fact that multiple channels can operate in a common system allowing for a common master-antenna system shared by multiple broadcasters. Also, with a branch feed system the beam sway is minimized due to the fact that the path from the antenna input to the individual panel is nearly identical for all panels. There is no cumulative phase taper as with a pylon antenna and the relative phase to each layer in elevation remains constant as frequency changes keeping the beam sway at a minimum. Custom azimuth and elevation patterns can be generated with the panel antenna by changing the number of panels in elevation, orientation of panels, number of panels around the structure and the phase and amplitude feed to each panel. Custom patterns have been generated in both elevation and azimuth for both the World Trade Center and the Empire State Building in New York City.

When designing an antenna system, the feed to the antenna cannot be neglected, as this is part of the "system response" equation. As mentioned earlier, this response must be linear in that all components in the transmission path must be optimized across the full channel or channels of operation. To get the desired response, the feed should be coaxial transmission line vs. waveguide unless power handling prohibits the use of coaxial line. To minimize this as an issue, transmission line has been designed to handle the high power levels of even the largest master antenna systems. This is a proprietary product known as EHT Line. Although waveguide is a more efficient means of getting a signal from the transmitter to the antenna, the group delay added to the system by such a run must be compensated for at the transmitter. Coaxial transmission line does not have the group delay associated with it (in addition to having a fraction of the wind-area of comparable waveguide).

When choosing the method of DTV implementation, consideration should be given to the channel of operation after the transition period; post 2006. Many VHF broadcasters have been allocated an UHF digital channel at

1MW effective radiated power or ERP (1573 of all DTV allocations are UHF). Based on the current FCC ruling, VHF broadcasters have the option of going back to their VHF channel for digital broadcasting after 2006 (post 2006 all broadcasters will reside within the core spectrum of Channels 2-51 with Channels 52-69

and less than 10 years old? If the answer to both of these questions is yes, than a side-mounted aluminum DTV antenna for the interim period may be the best and most economical option. If plans are to go back to the NTSC frequency and the antenna is old or non-digital compliant (end-fed, simple illumination), a stacked

---

## **Antenna systems designed today will require no modification should COFDM be adopted.**

---

being returned to the FCC for auctioning). For the VHF broadcaster, the transition to DTV at the high power levels will be very costly. The VHF broadcaster has typically been accustomed to a utility bill of less than \$5000 per month, whereas transmitting at 1MW average ERP in the UHF band can generate a utility bill in excess of \$25,000 per month. This, in addition to propagation characteristics, is encouraging many VHF broadcasters to consider moving back to VHF for DTV broadcasting after 2006. Many high-band VHF broadcasters such as KCTS-9/DT41 of Seattle have chosen a stacked antenna system to allow them this flexibility in the future. Both factors may also encourage those same broadcasters to go on the air with DTV service today at lower power levels. Before going on the air at low power levels, broadcasters should confirm with their consultant that their authorized contours would remain protected from other channels by the FCC.

Both pylon and panel antennas offer many options including top mounting, side mounting, stacking and adjacent channel antennas. Choosing which way to go is not simple. Normally, the top mount position is taken up by the primary NTSC service. If this is the case and plans are to go back to the NTSC channel for DTV broadcasting in the future; is the NTSC antenna digital compatible

antenna may be the best option in which the DTV and NTSC service are top mounted. This option offers the highest centerline of radiation for both services while allowing both antennas to radiate in an obstruction free environment.

If the NTSC antenna is relatively new, the option exists to stack this antenna above a DTV pylon or broadband panel antenna. This would require additional aperture, which could be obtained through the removal of tower sections or an additional height clearance from the FCC.

In the first two years of the transition to digital television approximately 115 stations made the transition. The vast majority of these early adopters were in the top 30 markets and in many cases the DTV as well as a new NTSC antenna were installed simultaneously in a stacked antenna system. In the remaining three years, over 1500 stations need to make this transition. To date, there are over 1300 stations that have not ordered equipment for their facilities. Although the next deadline for the commercial broadcaster is May 1, 2002 — May 1, 2003 for the non-commercial broadcaster, waiting will not solve the problem. Plans should be well under way. ■

---

*Jay S. Martin is director of marketing for Dielectric Communications.*

# ATSC IOT Performance

Thomson TH770s in the Comark IOX Transmitter at WWVB, Louisville. The six tubes used can output 60kW each for a combined power of approximately 330kW. Photo courtesy of Thomson Tubes Electroniques.



BY MICHEL LANGLOIS

**A** major controversy exists among American TV broadcasters and regulatory bodies.

A few years ago, the FCC chose the ATSC system based on 8VSB modulation. Some people in the industry are questioning that choice, claiming that the European system, DVB-T (COFDM modulation), offers real advantages, such as easier reception inside buildings or by mobile devices.

Rather than offering a solution to the controversy, this article discusses the performance of tubes and cavities for the two different types of modulation. Use of the TH 770 IOT for both 8VSB and COFDM operation is examined. The TH 770 IOT from Thomson Tubes Electroniques (TTE) is already used by several manufacturers for their analog and digital transmitters. In analog transmission, it offers output power of 63kW for the picture (peak sync) and 6.3kW aural in combined amplification mode.

#### 8VSB performance

The TH 770 is also used as the final stage in 25kW 8VSB transmitters. In an attempt to improve performance, we acquired a modulator/corrector from Thomcast. This device supplies an ATSC signal on any UHF channel, starting from a real baseband bit stream, or a pseudo random bitstream generator.

The output signal is sampled after the final stage and compared to the output signal of the modulator. The transfer curve can be extracted from this measurement, for both phase and amplitude. The corrector then applies to the modulator signal a pre-distortion which is reciprocal to the calculated distortion of

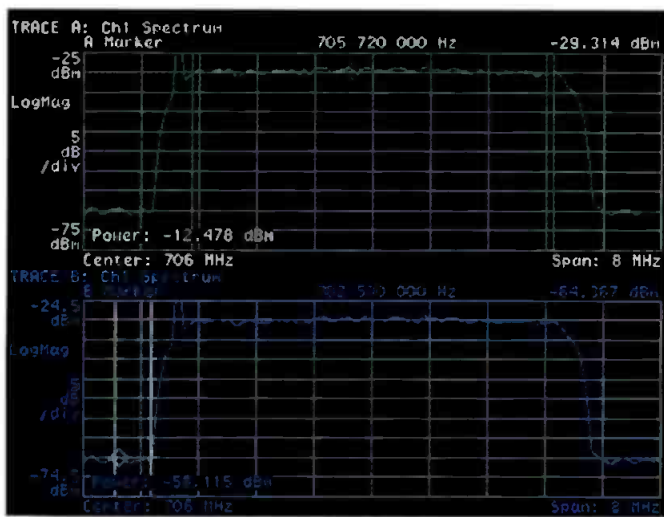

Figure 2. Left shoulder of the 8VSB signal at 30kW (avg).

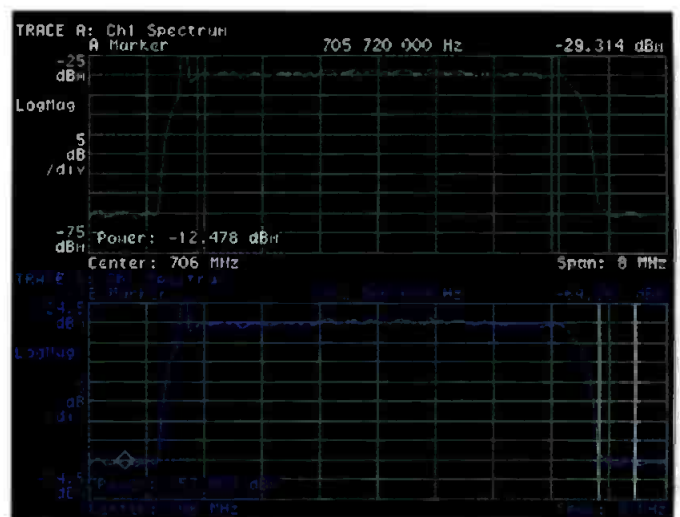

Figure 3. Right shoulder of the 8VSB signal at 30kW (avg).

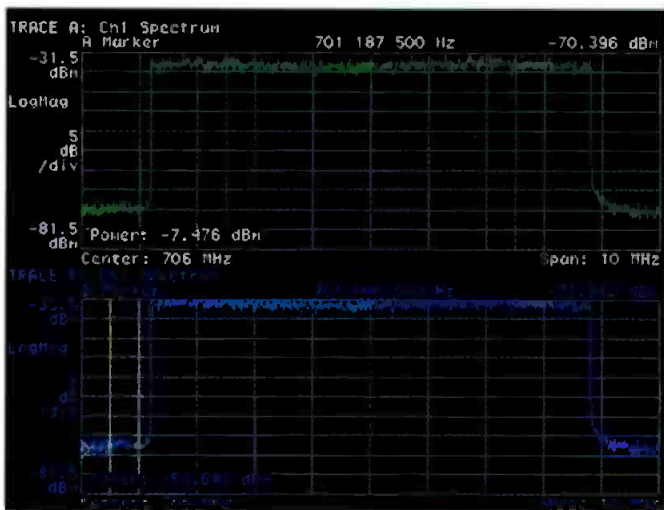

Figure 4. Left shoulder of the COFDM signal at 15kW (avg).

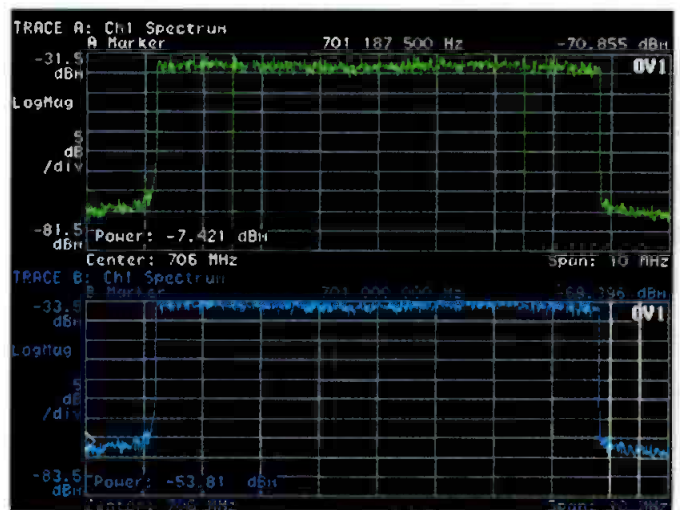

Figure 5. Right shoulder of the COFDM signal at 15kW (avg).

the cascaded amplifiers. The convolution of this pre-distortion and the amplifiers' distortion should theoretically provide a perfect signal to the antenna. Spectrum analysis is used to



Figure 1. Spectrum analyzer and power meter showing the results of 8VSB modulation through a TH770/TH18770 system at 30kW (avg.) output power.

assess quality.

Best results are reached by limiting the range of correction well below the peak power level. High power values are scarce and have only a very limited effect on intermodulation. This means that tubes should not be ranked in terms of peak power capability, but rather according to average power output.

These results are clearly summarized in Figure 1, which shows both the power meter and the spectrum analyzer. In addition, the shoulder levels were measured with a vector signal analyzer, by integrating the power spectral density over a 5MHz band in the middle of the channel, and over 500kHz along the edges of the channel. We used a flat top input window to ensure amplitude accuracy. The shoulders are shown in Figures 2 and 3.

At an average power of 30kW, the left shoulder = level in the middle - 10dB - left side level; i.e., left shoulder = -12.478dB - 10dB + 58.115dB

= 35.6dB. The 10dB factor compensates for the integration width of 5MHz in band, 500kHz out of band. Also at 30kW average power, the right shoulder = -12.478dB - 10dB + 57.803dB = 35.3dB.

### COFDM performance

The modulator can also output a COFDM signal, at 7- or 8MHz bandwidth, with 8000 carriers 64QAM modulated. We repeated the previous experiment, under the same operating conditions, and with the same channel 50 (706MHz central frequency in Europe), changing only the modulation scheme. We attained average power of 15kW, with slightly better intermodulation (36.2dB on the left shoulder and 36.4dB on the right shoulder; see Figures 4 and 5). This significant difference in average power is due to the difference in peak factor: 7dB for 8VSB versus 11dB for COFDM.

As for the 8VSB tests, we found that optimum results were obtained by

not attempting to correct the transfer curve up to the peak power. Under the same conditions, with comparable intermodulation, the TH 770 IOT offers twice as much average power with 8VSB as with COFDM (8000/64QAM). These good results were achieved using a clever setup.

### Test setup

In the output circuit, saturation plays a role in determining performance, whether in terms of voltage saturation (i.e. the slower electrons fly back in

the interaction gap) or current saturation (i.e. the peak current is not limited by space charge, but by the Richardson-Dushman law). Increasing the high voltage has an effect on both (even on current saturation which does not occur uniformly over the cathode). All of our measurements used only 34kV of beam voltage. The correct load impedance must be chosen to prevent voltage saturation. The S21 bandwidth of the final amplifier stage is a good indicator for the correct setting.

Figure 6 shows the output bandwidth

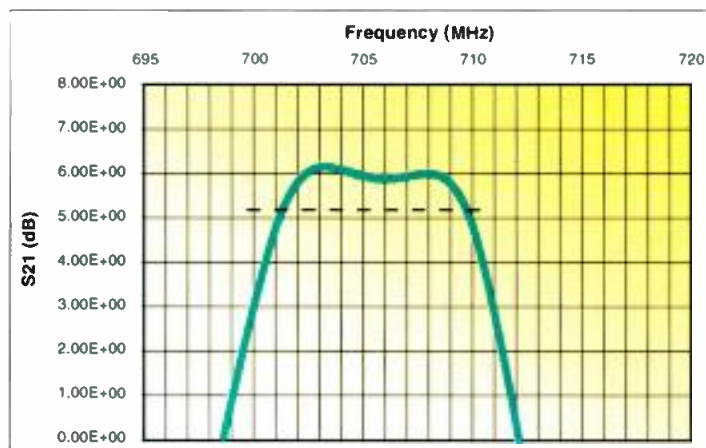

Figure 6. Standard NTSC forward gain (S21) shows a bandwidth of 8.8MHz 1dB below peak (dotted line).

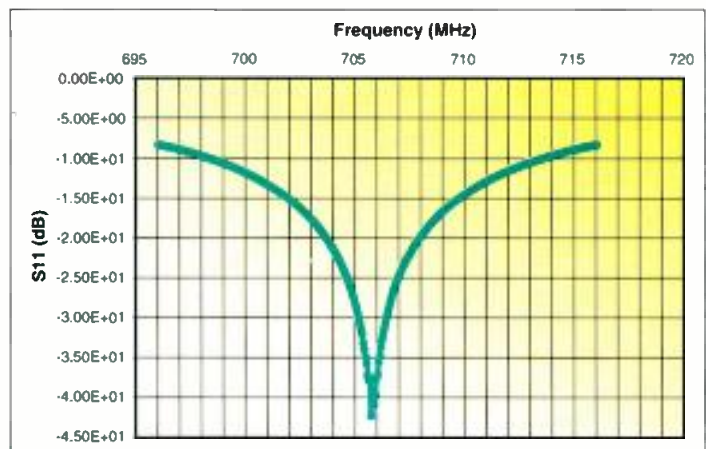

Figure 7. Reflected (S11) bandwidth used for NTSC.

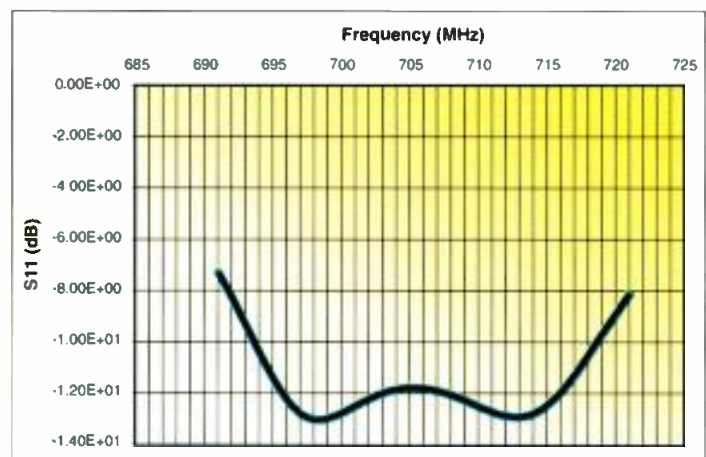

Figure 8. Expanded S11 bandwidth used for 8VSB or COFDM obtained through the use of a double slug tuner.

for an NTSC analog TV channel (8.8MHz 1dB below the peak). It was increased to 10.5MHz, 1dB below peak by changing the coupling between the two output cavities. A patented system on the TH 18770 cavity ensures that the bandwidth remains the same no matter what channel is used.

**Input circuit:** The spectrum of the corrected 8VSB signal is wider than the non-corrected 6MHz signal. In other words, the correction signal has spectral components outside the interval ( $f_c - 3\text{MHz}$ ;  $f_c + 3\text{MHz}$ ). These components must not be reflected by the IOT input circuit. Figure 7 shows the reflected (S11) bandwidth for NTSC. It has been expanded using a double slug tuner as shown in Figure 8.

**Driver:** Correction is not meant for the final high power amplifier stage only, but for the whole cascade

of amplifiers. For all of our experiments, we used a slightly oversized bipolar solid-state preamplifier from Iteco, rated at 800W (analog service).

**Video response:** Flat video response is needed for satisfactory intermodulation levels. This also applies to DTV, even though the term video response does not seem appropriate for digital modulation.

---

**We found that optimum results were obtained by not attempting to correct the transfer curve to the peak power.**

---

All resonances under 8MHz in the circuit formed by the cavity, the tube, the cables and the supplies have to be removed. For these applications, the TH 18770 has clear advantages. First, a capacitive short circuit for frequencies under 10MHz has been installed close to the tube, between the cathode and the grid. Secondly, both cathode and grid are connected to ground by a high-value capacitor, which is also used as a blocking capacitor for the beam voltage. This type of layout facilitates a flat video response.

Based on our findings, several conclusions can be drawn: First, COFDM is a more difficult signal to amplify than 8VSB. At a given average output power, a COFDM system requires twice as many tubes. Because IOTs and Diacrodes are used for high-power applications, our experiments on the TH 770 IOT could well apply in general. Second, peak power is definitely not the sole factor in component choice. Many other factors must be considered, such as the tube's video response, input and output bandwidth and intrinsic linearity. In the final analysis, only comprehensive measurements such as those described here can provide an understanding of power component performance. ■

*Michel Langlois is R&D manager, Digital UHF TV Products, Thomson Tubes Electroniques, France.*

# Datacasting:

## Is it legal?

Thomcast datacasting servers help facilities like Canal provide over-the-air data services. Domestic stations looking to move in the same direction need to use care to ensure they stay legal. Photo courtesy of Thomcast.

by Mitchell Lazarus

**A** digital television (DTV) channel has a lot of raw capacity. The FCC requires one free video signal of NTSC quality or better, which amounts to only about 20 percent of the potential payload. The rest can be used to provide any lawful service the licensee chooses, including the transport of data for pay -- sometimes called *datacasting* when carried over broadcast facilities. A particularly promising subcategory of datacasting is the use of excess DTV capacity to provide access to the Internet.

A DTV channel carries 19.4 million bits of data per second. A single NTSC-grade video signal occupies only about 18 percent of that capacity, about 3.5Mb/s, so a DTV channel can be used to carry about five NTSC-quality video subchannels. Alternatively, it can carry one high-definition video service, which needs a lot more data, or it can carry the FCC's minimum of one NTSC-grade video service and use the almost 16Mb/s left over for other services. That 16Mb/s is enough to down-

load an entire edition of a local newspaper in less than two seconds.

The FCC treats anything on a TV channel other than a free video signal as "ancillary service." The licensee may charge for ancillary services.

Special cases:

1. The FCC requires a DTV station to carry at least one free video signal at NTSC resolution or better on or after these dates:

- All major-network-affiliated stations in the top 30 markets now;
- All remaining commercial stations by May 1, 2002; and
- All non-commercial stations by May 1, 2003.

This free video service must air during the same time periods as the licensee's analog signal, although the programming need not be the same as on the analog channel.

2. After the applicable date listed above, a DTV station that carries its one free video signal can use the rest of its capacity for ancillary services. Before the applicable date, the sta-

tion can carry ancillary services regardless of other programming.

3. If the only signal the station carries is high-definition video, then that signal must be free, and there is no ancillary service.

4. If a station transmits more than one free video signal, all are subject to FCC broadcast regulation and none of them is ancillary.

5. Pay video services are ancillary and can only be provided in addition to the required free service.

In practice, any lawful service can be offered via DTV on an ancillary basis. Ancillary services may, but need not, relate to the video program then being broadcast. The FCC's examples of ancillary services include sports information, computer software, telephone directories, stock market updates, interactive educational and other services, data transmission of any kind, and even audio materials. Mobile wireless services such as paging also qualify as ancillary.

Ancillary service is not subject to



broadcast regulation. But if an ancillary service is analogous to some other FCC-regulated service, then it is subject to the same regulations as that other service. For example, a DTV licensee that offers paging as an ancillary service would be subject to the FCC paging rules.

Delivering ancillary services via DTV requires appropriate equipment at both ends of the communication. The broadcaster needs equipment to acquire the ancillary data and merge it into the MPEG bitstream for transmission. Each end user needs circuitry to receive, select and demodulate the channel, plus the means to separate out and use the ancillary data. Analysts expect future DTV receivers and set-top converters to have data ports that will simplify these functions.

### Common carrier issues

Providers of data transport are generally considered to be providing telecommunications services. Some telecommunications providers are deemed to be "common carriers," a status that imposes special legal responsibilities. A common carrier must provide service to all that request it (up to the limit of capacity), may not discriminate unreasonably among customers, and is subject to complaint proceedings at the FCC. A non-common carrier, in contrast, is free to negotiate any terms with any customers it pleases. Most DTV stations will probably prefer to avoid common carrier status.

A DTV station that carries data on an ancillary basis risks being treated as a common carrier if it meets all of these conditions:

- It offers service for a fee;
- It transmits information of the user's choosing;
- It transmits and receives the user's information without change;
- It transmits between or among points specified by the user; and,
- It offers service directly to the public.

A licensee engaged in datacasting is likely to meet the first four tests above. In that case, its common carrier status will turn on the fifth test, whether it provides service to the public. The licensee can minimize

the likelihood of being considered a common carrier if it sells services to other companies, rather than directly to consumers; if it markets its services in trade publications, rather than consumer media; and if it sells service under contracts that run at least a year, rather than monthly.

### Fees

A DTV licensee that provides ancillary datacasting services is potentially subject to several fees levied by the FCC.

**DTV ancillary fee:** DTV ancillary services may compete with more traditional radio-based services, some of which must buy spectrum at auction. Congress feared that DTV's free spectrum would give it an unfair competitive advantage, and so authorized the FCC to impose a special DTV ancillary fee to help level the playing field. The FCC set that fee at 5 percent of DTV revenues received from transmitting other entities' data. Licensees are required to file a return and make payment each Dec. 1 for the year ending on the previous Sept. 30.

**Universal Service Fund and TRS fees:** A DTV licensee that derives revenue from data transport may be subject to two additional fees, each calculated as a percentage of telecommunications revenues. One is the Universal Service Fund fee, which

---

**16Mb/s is enough  
to download an entire  
local newspaper  
in less than two  
seconds.**

---

subsidizes service in high cost areas and to low income consumers, schools, libraries, and certain health care providers. Presently at about five percent, it fluctuates quarterly. The other is the Telecommunications Relay Service fee, which supports special telephone services for hearing- and speech-impaired users. Adjusted annually, it has always been a small fraction of one percent. Both fees are subject to exemptions and have com-

plex rules for calculating the base amounts on which the percentages are levied. How these rules will apply in the DTV context is not yet fully clear.

In addition, a DTV licensee will ultimately pay a "regulatory fee" to the FCC. Today the regulatory fee imposed on its associated NTSC facility covers the station, but the FCC will doubtless impose a separate fee on DTV stations once licensees have relinquished their analog frequencies. So far there is no indication the fee will depend on whether the station offers ancillary services.

### Internet access

One potential business for DTV ancillary services is the provision of Internet access: hooking up homes and businesses to the Internet.

Today most residential and small-business users reach the Internet by dialing over an ordinary telephone line to an Internet service provider (ISP), which connects the user to the Internet backbone. Besides providing the all-important connection, most ISPs also supply end-user software, display a "portal screen" that links to popular sites, provide storage for the user's webpages, and offer technical support as needed. Most ISPs also store, or "cache," popular sites for faster access by customers. Some offer additional Internet-related services such as webpage design and e-commerce support.

An ordinary telephone line provides only relatively slow Internet service. Given a choice, users generally prefer broadband (high-speed) access. A broadband connection fills up the screen more quickly, downloads large files faster, and can play video and high-quality audio in real time. Two main forms of broadband access are presently available. The first, digital subscriber line (DSL), is a high-speed service that runs over ordinary telephone lines. It is available only to certain subscribers, most of them in densely populated areas. The second option is cable modems. They are also limited to certain areas, and leave many businesses unserved. In addition, many cable companies require the customer to subscribe to a cable-affiliated ISP that may not provide the full range of Internet services. Other emerging broadband options

include microwave radio and unlicensed "spread spectrum" radio, but these are not yet widely available. Internet delivery by satellite also may become feasible in the near future.

DTV is an alternative means of delivering broadband Internet service. Unlike DSL and cable, which require specific physical connections, DTV Internet is available to customers anywhere in the DTV station's coverage area.

A DTV station's ancillary capacity is the equivalent of almost 300 conventional telephone lines (at 56kb/s), or about 10 DSL lines. However, all users must share this capacity. If 300 custom-

---

## Ancillary service is not subject to broadcast regulation.

---

ers attempt to download at the same instant, each will receive data only at phone-line speeds. In practice, though, this limitation is less severe than it may seem. Only users who are transferring data at a given moment impinge on the capacity available to others. Customers who are reading the screen, printing data, or typing commands have no effect on others' download speeds. Nevertheless, the average speed available to each customer will tend to drop as more customers sign on.

**Uplink required:** Internet service is two-way. A downlink connection delivers Internet material to the user, while a return uplink channel communicates the user's keypresses, mouse clicks and outgoing messages back to the ISP. DTV can provide only a downlink, although at high speed. Fortunately, most users need only a low-speed uplink channel. An ordinary telephone connection usually suffices for the uplink unless the customer is one of those few who must transfer large amounts of data. Another uplink option is the wireless 218-219MHz service formerly called the Interactive Video and Data Service (IVDS), and originally intended as a return link from viewers to television stations. Other radio options may be available in particular areas.

### Internet roles for a DTV licensee

A DTV licensee interested in providing Internet access can take either of two roles.

**Carrier only:** The licensee can act solely as a carrier to deliver data from an ISP to end users. The DTV licensee would typically contract with the ISP, which in turn markets the service to end users as part of an ISP-provided package. The DTV licensee collects a fee for carriage from the ISP. The service can be priced in the aggregate, monthly per user, by the amount of data carried, or by any other agreed-on formula.

**Carrier and ISP:** Alternatively, a DTV licensee can itself function as an ISP. In addition to delivering data to the end user, it would receive the end user's uplink signals, interconnect the end user with the Internet backbone, and perform the various ISP support functions. Residential end users typically pay their ISPs a monthly fee in the \$25 to \$50 range for broadband service. In addition, some ISPs collect fees from unaffiliated commercial websites in exchange for prominent listings on the ISP's portal page.

**Common carrier issues:** We noted the disadvantages of common carrier treatment above. A DTV licensee can probably avoid being classed as a common carrier if it acts only as a carrier, and not also as an ISP. The licensee can then market its service to ISPs, instead of directly to the public, and sell service for a minimum period of one year. A licensee that also wishes to function as an ISP runs a greater risk of common carrier treatment, as it would probably wish to market directly to the public and offer service by the month. The licensee may nonetheless be able to avoid common carrier status by setting up its ISP as a separate corporation and selling the communications service to the ISP on a long-term basis, rather than providing monthly access service directly to the public. Caution: The legality of this approach has not yet been tested.

### Equipment for Internet access

Each DTV station offering Internet access will need equipment capable of receiving customer-bound data from the ISP over standard data lines,

adding customer address information and encryption, and merging the data into the MPEG-format bitstream for DTV transmission. A DTV licensee that also acts as an ISP will need the servers, storage and transmission facilities, and other equipment needed to maintain a connection with Internet backbone facilities.

Each customer will need equipment (a "DTV modem") capable of splitting off Internet data from the DTV signal, identifying data addressed to that customer, decrypting it, and converting it to a form compatible with the desktop computer. The plug-in computer cards with DTV tuners available now may not be able to identify and decrypt ancillary data correctly. As noted above, data ports on future DTV receivers and set-top converters should eventually simplify connection for the end user.

Privacy is a special concern in shared systems, like cable and DTV, in which each user's equipment monitors all the bitstreams directed to all users. Such systems require close attention to addressing, so that each user's equipment recognizes only the communications directed to it. Equally important, all transmission on the system must be carefully encrypted to protect each individual user from both inadvertent and intentional interception.

### Going forward

The excess capacity available on a DTV channel makes it possible for the licensee to offer a range of telecommunications services on an ancillary basis. One especially promising option is Internet access. The timing is right: The demand for broadband Internet access is outrunning available delivery systems, such as DSL and cable, just when DTV stations are going on the air. Providing a link to the Internet opens an opportunity for DTV licensees to broaden their service beyond the traditional viewing audience to people who have forsaken TV screens for computers. ■

---

*Mitchell Lazarus is an attorney with Fletcher, Heald & Hildreth, P.L.C. He can be reached at 703-812-0440, mlazarus@alum.mit.edu.*

# HDTV

## Tools for the Transition!



Alliance  
Digital Master Control



Cougar HD  
32x32 Matrix



Ocelot HD  
16x16, 16x8 Matrix



LNS-8 HD  
8x2 Matrix



Corporate Sales Office  
35 Pinelawn Road Suite 99E  
Melville, NY 11747  
Tel: 631-845-5020  
Tel: 800-328-1008  
Fax: 631-845-5023

Copyright©2000. All rights reserved.

**PESA** High  
Definition  
Solutions

HDTV won't replace all other formats anytime soon. That's why the PESA **Alliance** Master Control Switcher makes so much sense. The **Alliance** is designed for; 1) full-time SDTV; 2) full-time HDTV; or 3) mixed SDTV and HDTV broadcasting. Multi-format technology allows SDTV systems to be upgraded to HDTV, preserving your investment. The PESA **Alliance** also supports multi-channel capability, so you're ready to handle any programming strategy.

PESA's lineup of HDTV routers is right for today's needs. For maximum flexibility take a look at the **Cougar HD**. You can start as small as 4x4 and expand to 32x32 with plug-in cards. The **Ocelot HD** delivers a 16x8 or 16x16 matrix in only 1RU, making it great for field or studio use. The **LNS-8 HD** 8x2 switcher is perfect for monitoring, editing, telecine, and automated applications.

Ask about PESA's all-new HDTV distribution Amplifiers!

[www.pesa.com](http://www.pesa.com) / [salesInfo@pesa.com](mailto:salesInfo@pesa.com)

Circle (131) on Free Info Card

[www.americanradiohistory.com](http://www.americanradiohistory.com)

# Routing Switcher Technologies

By Barry W. Albright



By prioritizing the station's needs, evaluating its current routing system and determining future growth, broadcasters can choose a routing systems that best fits their facility's needs. Shown here is a Phillips Venus SDV 512x512 router controlled by Jupiter software at USA Networks broadcast center in Los Angeles. Photo courtesy of Phillips.

**C**hoosing the right routing switcher fabric and control system is one of the most important decisions a director of engineering or chief engineer must make when constructing or upgrading a television facility. This article explores the various technologies and topologies available today, and in the near future, to help guide decision-makers toward the right choices.

## MEET THE BEST DIGITAL AUDIO MULTITRACK MASTER RECORDER MADE.

*360 Systems*

360 Systems designed the TCR8 with one goal in mind: To deliver a Master Recorder that faithfully captures the results of your work.

### The Difference is in the Details

To provide the level of sonic accuracy that critical projects demand, you have to sweat the details. TCR's design specifies gold XLR connectors, metal film resistors, no capacitors in the audio path, and a patented low-noise circuit to suppress RF, hum and cable noise. Put all of this on shielded PC boards with double-regulated power, and the result is a 24-bit audio recorder of unprecedented quality.

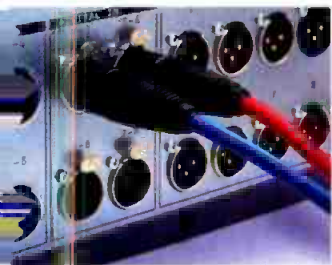

### Defining the Master Recorder

The TCR8 Master Recorder includes the tools you'll need for professional work—solid synchronization, the right connectors, and a feature-set focused on commercial audio production.

Today's high-resolution audio formats need a new generation of recorders that deliver on the promise of 24-bit audio. By actual measurement, the TCR8 Master Recorder far exceeds the specs of competitive machines, and actually approaches the limit of today's art.

Today's "24/7" studio makes very real demands on audio equipment. Which is why 360 Systems designs for reliability, just as we design for audio quality. But then, we also have 30 years experience building equipment for round-the-clock professionals.

From original recording to final mixdown, the new TCR8 Master Recorder delivers performance without compromise. Should you expect anything less?

### Superior Audio Quality

- Measurable improvement of 20-dB in SNR and dynamic range over conventional designs
- Bit-for-bit™ reproduction of 24-bit PCM, Dolby®-E and AC-3 recordings
- Record across all tracks, at any sample rate
- Workstation file interchange with SD-II and WAV files
- Complete Cut-Copy-Insert-Erase editing features
- The best digital scrub editing on the market
- Time offsets, track slip, varispeed and audio delays
- Up to 24-hours of recording time in a single file

### Standard Equipment

- DVD-RAM drive for 10 hours of 24-bit audio on low-cost disks
- Internal 9GB SCSI hard disk (up to 50 GB available)
- 250 MB Zip® drive
- A complete set of XLRs for analog and AES/EBU
- Rear panel SCSI port for external drives
- Large display for full length file names
- Multi-machine sync provides up to 64 tracks
- Flex-Format™ drive bay for removable media, such as DVD-RAM (standard), Magneto Optical or removable hard disks
- Complete SMPTE time code features:
  - > Support for all frame rates
  - > VTR emulation with P2 control
  - > Reads LTC or VITC
  - > Hard lock to Digital Betacam® for tight sync during scrub-edits
  - > Reference to Video, AES, Word Clock, or LTC
- \$5,995 complete



There is a difference. Click on [www.360systems.com](http://www.360systems.com) for a 20-dB improvement in *your* next project.

*360 Systems*

The pros know the difference.

Circle (132) on Free Info Card



5321 Sterling Center Drive, Westlake Village CA 91361  
Tel (818) 991-0360 Fax (818) 991-1360 E-mail: [sales@360systems.com](mailto:sales@360systems.com)

There are two basic topologies in common use today:

- A central equipment pool. Expensive pool resources are allocated as needed to the various functional areas in the facility, i.e., on-air broadcast, production, news, etc.
- Distributed resources or islands dedicated to the specific functions.

Real facilities usually have a combination of the two topologies. Most systems have evolved through a mix of factors: market forces, facility history, individual personalities and corporate culture. The choice of a new routing switcher fabric and control system will also be governed by these factors.

### Fabrics and control systems

Routing switchers were basically considered patch panel replacements. The control systems were very basic, consisting of simple control panels. Typically, the most sophisticated feature was the video/audio split.

Today's control systems, driven by user creativity, have evolved into highly flexible and therefore complex systems.

With the advent of digital video and the development of common ASICs, the hardware fabric performance is fairly uniform among reputable vendors. The control system is now the dominant factor that should drive the choice in choosing a new facility infrastructure.

The most basic topology for routing switchers is the X/Y matrix, with X inputs by Y outputs. It is easy to understand and control. It is ideally suited for the central equipment pool topology. Its main disadvantage is that the price tag grows with the number of inputs times outputs.

The enormous cost of large X/Y matrices led to the development of control system algorithms that allow for the reduction of the number of cross-points for larger fabrics. The algorithms were originally developed by the telephone industry and subsequently modified for broadcast use. There are three common techniques, each with its unique set of advantages and disadvantages. They are multistage cross-point arrays, path-finding or distributed fabric arrays, and time division multiplexing (TDM) virtual arrays.

Multistage systems: The most com-

mon implementation is a three-stage topology. This topology consists of small X/M input matrix blocks, moderately sized M/N middle or intermediate matrix blocks and small N/Y output matrix blocks.

Multistage topology can yield significant cost reduction for large fabrics. There are several three-stage routing switchers operating today at facilities such as ZDF in Germany, BT in London and USA Networks in Los Angeles.

One of the main concerns with three-stage architecture has to do with blocking, or not being able to complete a required connection through the fabric. For the telephone company, this was not a big issue – they simply give you a busy signal or an all circuits in use recording. For broadcasters, this is unacceptable, so sizing and control algorithms were developed to reduce the possibility of a block to extremely low probability. This need not be a major concern when considering a multistage fabric topology from an experienced multistage vendor.

One drawback of multistage topology is a slight degradation of performance. Each connection goes through the underlying X/Y blocks three or more times. This was a major concern for traditional analog audio and video fabrics, but is less of a concern for today's digital fabrics.

**Path-finding fabrics:** These are a physical distribution of small X/Y matrices, interconnected by trunk or tie lines. This topology can realize enormous cost savings in a facility where the island topology is dominant. While yielding the greatest savings in hardware, it is the most complex topology to control and requires careful planning before deployment.

One unique benefit of path-finding is the ability to complete format conversions within the

switch fabric. This is particularly important in today's transitional market, from analog to digital audio and video, or uncompressed vs. compressed digital audio and video. A small number of format converters can be integrated into the fabric and transparently routed through, based on source and destination format requirements. Modern control systems should have this capability.

Just as in the multistage, be sure to consider purchasing this type of system from an experienced vendor. Another topic that is closely related to the idea of pathfinding and tie-line management is the growing requirement to provide a seamless control system for routing switchers located in separate facilities. In choosing a control system, it is important to look for the ability to use standard local and wide area networking (LAN/WAN) architectures, including the Internet, to provide extended control functionality over long distances or local control over a LAN.

**Time division multiplex (TDM) fabrics:** While not yet economically feasible for full-bandwidth digital video transport, TDM fabrics are an attractive option for AES digital audio routing fabrics and possibly compressed video. The cost of designing and building this type of fabric continues to drop rapidly due to advances in ASIC technology and high-speed serial transports on copper and fiber. TDM can be used to implement a large virtual X/Y fabric in a central frame or a distribut-

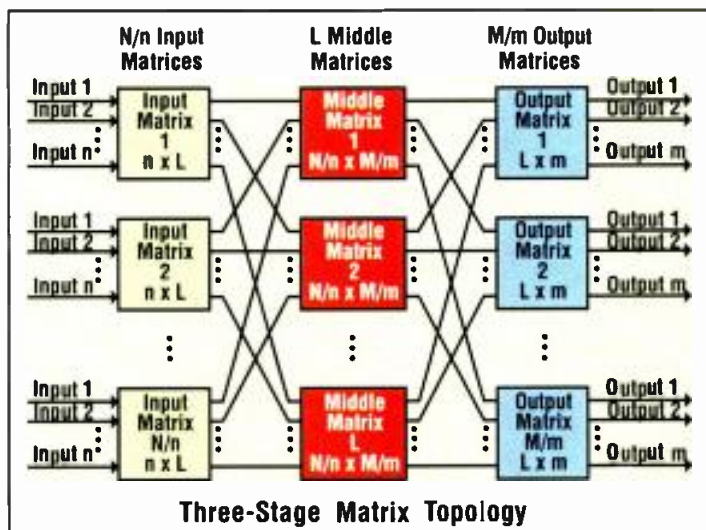

Figure 1. A three-stage matrix uses an intermediate set of crosspoints to provide connections from N inputs to M outputs using fewer crosspoints than an X/Y matrix.

# INTRODUCING A ROUTER LEAVES ITS MARK.

ECLIPSE

*Eclipse: Connect With Our  
Most Effective, Compact, Expandable Design.*



Pro-Bel's Eclipse family of routing switchers is connecting with more and more broadcasters, providing them with the muscle they require to manage their signal distribution needs in a changing environment.

The Eclipse SD serial digital video router is specifically designed as a compact and cost-effective SDI house router. **Starting at 128x128 in 15RU** for dual-BNC outputs (or 128x256 if you need only one BNC per output), Eclipse can expand in the field, while in-service, without affecting in-use signals. No one makes it easier; we even supply the expansion cables. The Eclipse SD/HD uses a 1.485Gb/s crosspoint

switching core with two types of input/output card sets: SD for standard definition serial digital signals; and HD for HDTV signals.

The Eclipse AES router provides high density and high performance at a low price. Start at 128x128 in 7RU and expand to 768x256 in less than one rack. With a powerful range of left/right channel control capability,

this is the perfect mate to maximize performance of Eclipse video routers.

Wrap Pro-Bel's highly-acclaimed control system around the exact Eclipse configuration to meet your specs and attach yourself to a worldwide leader.

**pro·bel**  
CHYRON

5 HUB DRIVE • MELVILLE, NY 11747 • PHONE: 631-845-2000 • FAX: 631-845-3867  
WWW.CHYRON.COM

Circle (133) on Free Info Card

www.americanradiohistory.com

ed fabric using add-drop mux/demux boxes interconnected by high-speed serial copper or fiber trunks.

There are always tradeoffs that need to be made, and this option is no exception. The virtual fabric created in a TDM router is based on uniform time slots. Each input or output corresponds to a specific time slot assignment for its sample transport. This normally implies a synchronous system architecture (there are exceptions) extending beyond the fabric and throughout the facility. If the system is not frequency locked, then the fabric must perform sample rate conversions, which inherently modify or distort the signal. In fact, the worst case distortion occurs for nearly identical input to output sample rates. Proper digital audio facility design is akin to system timing for NTSC or PAL analog video. Keep in mind that you will have to do some sample rate conversion due to the multiplicity of rates you will encounter, i.e., 32, 44.1, 48, 96, 192kHz, vari-speed or when encountering 29.97 vs. 30Hz frame rates.

Switching Dolby E will require a synchronous facility so that switching occurs within the time fences defined by Dolby E, based on video frames.

Make sure you understand your requirements and the vendor offerings before making a purchase decision for virtual or TDM routing fabrics. There are products available

**It is important to look for the ability to use standard LAN/WAN architectures, including the Internet.**

which offer a good compromise of synchronous vs. asynchronous features and control system flexibility.

**Packet, cell and/or network-based fabrics:** While packet-based switching has been around quite a while, it has only recently started to enter the broadcast infrastructure. Universal standardization of protocols, the Internet, inexpensive computers, and the availability of inexpensive networking components implementing the physical and

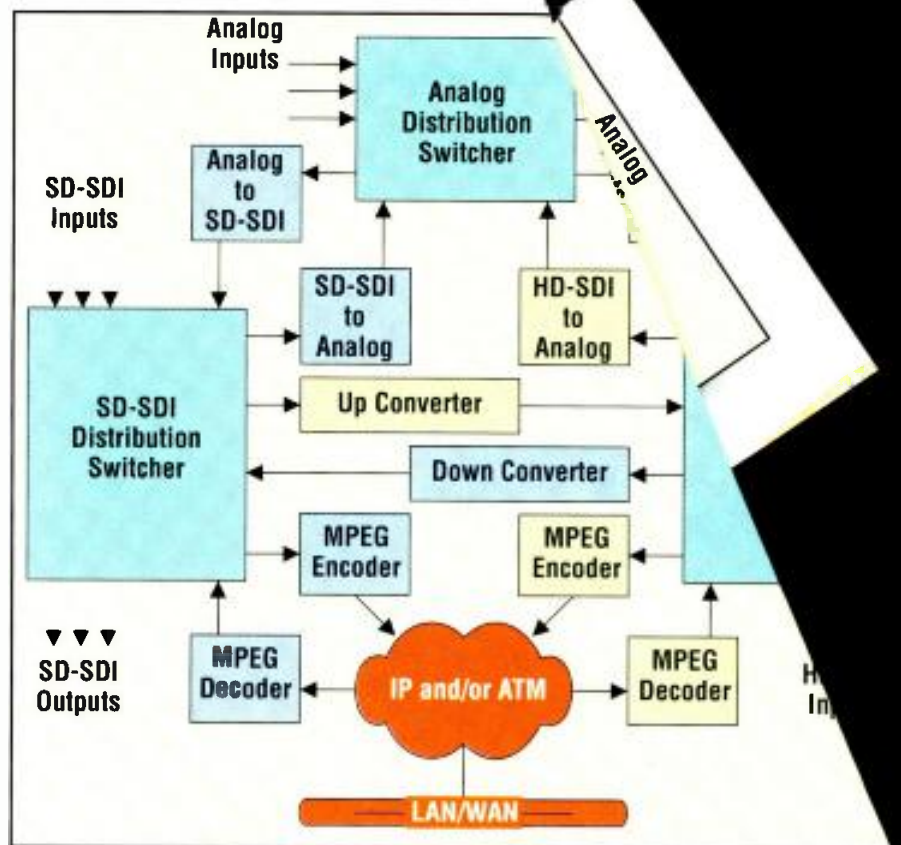

Figure 2. Path finding topologies can include format conversion within the fabric but require sophisticated control systems.

protocol layers have motivated this. Gigabit Ethernet, IEEE-1394, USB physical layers and IP and ATM protocol layers fit loosely into this arena.

The development of MPEG-2, -4 and -7 video compression and AC-3, MP3, and Dolby E for audio compression have added a whole new range of possibilities for distribution of video, audio and now metadata within facilities, using the packet-based fabric or network topologies. These technologies can be very useful for the distribution of non-real-time video as files or lower bit-rate, real-time transport for lower-quality requirements, i.e., desktop monitoring, Internet video streaming, or other imaginative applications like remote site monitoring. Keep in mind that high-quality, real-time signal transport will still require full-bandwidth signal paths.

Web-based control and monitoring of switching fabrics and distribution equipment is also starting to show up on the market. This is an easily leveraged technology available from the PC/workstation market, so look for it to become commonplace.

A designer of facility infrastructures needs to consider these technologies as viable players in the design. Beware

of becoming overwhelmed with the possibilities. Make sure you understand the tradeoffs in quality and content-delivery latency before jumping in.

**Asynchronous transfer mode (ATM) fabric:** Depending on the path parameters, ATM fabrics, while being cell-based, do have some nice characteristics that can be defined by the service requester. An ATM cell is analogous to an IP packet with a fixed 53-byte length, five bytes for the header and 48 bytes for the payload. ATM can guarantee quality of service (QoS) beyond the facility walls, and even internationally. ATM is independent of the physical layer. It is a method of transport within the synchronous digital hierarchy (SDH) and SONET. This author considers ATM a step above IP transport and believes you will see IP transported by ATM not ATM transported over IP. Therefore, when considering your networked infrastructure, look at ATM as a possibility. Look to ATM for inter-facility and inter-city transport of lightly compressed video and audio in the future, using the public networks.

**Optical fabrics and wavelength division multiplexing (WDM):** There have been several demonstrations of



# ON AIR ON AIR

## When there's no room for failure, choose a Ciprico storage solution.



For over 15 years, Ciprico has been providing reliable image data **storage solutions** for some of the biggest names in the entertainment and broadcasting industries.

Ciprico's complete array of direct-attached and networked storage solutions help you store image data with confidence, **increase your productivity**, and meet mission-critical performance needs.

Our systems support multi-channel processing, are reliable and **easy to install**. They're backed by a **team of top support professionals** with unrivaled technical and industry knowledge.

Visit our web site at [www.ciprico.com](http://www.ciprico.com) to read case studies about how we've helped some of the biggest names in the business maximize their visual computing applications. Or call 1.800.727.4669. Ask to receive a complimentary reference **pocket guide** that calculates the hours of storage time needed for the ATSC standard video formats.



Ciprico Inc. Headquarters:  
2800 Campus Drive, Plymouth, Minnesota 55441 • 763.551.4000 • Fax: 763.551.4002  
Ciprico International, Ltd.: United Kingdom • Singapore • Tokyo

optical switch fabrics in the past two decades. One would think that by now optical interconnect and optical switching would have replaced broadcast facility infrastructure. Why hasn't this happened? There is one fundamental reason: pure economics. While the technology exists, it is still far too expensive compared to traditional methods. Electrical/copper interfaces, even at 1.485Gb/s, are much cheaper than their optical counterparts. As the telecommunications industry progresses toward low-cost electrical/optical conversion, transport and switching, the television industry will leverage the technology. Don't hold your breath, full-bandwidth video transport is probably a decade away.

### Great debates and hazard warnings

Beware that the major routing and control system vendors are fierce competitors. Some of them are actively engaged in the propagation of FUD (fear, uncertainty, and doubt) regarding their competitors' products. This makes your job more difficult as you have to sort through the FUD. The section explains what you may encounter.

**Non-reclocked vs. reclocked serial digital video:** In the early days of serial digital video distribution, a great debate raged over non-reclocked vs. reclocked outputs. Today there are hundreds of thousands of installed non-reclocked signal paths, which operate without any problems. Non-reclocked paths work for three reasons:

- Good intrinsic signal fidelity in the fabric.
- The path normally exists from a processing device that generates a pristine serial output, to a processing device that subsequently de-serializes the signal, generally with a receiver that has good input jitter tolerance vs. frequency.
- A properly designed serial digital receiver/de-formatter has a much wider input jitter tolerance (IJT) transfer characteristic than an intermediate reclocker. The reason reclocking seems to be a good thing is that it does reduce jitter. This is normally accomplished by restricting the reclockers' PLL bandwidth. For a receiver/defor-

matter, however, one wants to maximize PLL bandwidth so as to maximize the receivers' jitter tracking range with respect to frequency. The PLL bandwidth of the reclocker placed in a router output is at best a compromise between conflicting requirements. It is entirely conceivable that a poor-quality input source could become erred in the router reclocker, but be accepted by the subsequent

---

### The PLL bandwidth of the reclocker placed in a router output is at best a compromise between conflicting requirements.

---

device's receiver/de-formatter without error due to its wider PLL bandwidth, i.e. better IJT, had the reclocker not been present.

A properly designed reclocking device must, by definition, have two PLLs and an elastic buffer between the wide-bandwidth PLL receiver side and the narrow-bandwidth PLL transmission side. There are no single chip ASIC reclocker ICs currently available that provide this functionality, either for SDTV or HDTV. Therefore, you may actually be better off without reclocking in your routing fabric for point-to-point and point-to-multipoint paths. See SMPTE Engineering Guideline SMPTE EG33, for a better understanding of this subject.

The requirements for HDTV fabric design obviate the need for reclocking when SDTV is passed through the HDTV fabric. If you insist on SDTV reclocking in an HDTV

product, you are going to pay for something totally unnecessary. The SDTV non-reclocked multipass performance of today's HDTV fabrics approaches that of the present generation of SDTV reclocked products.

At this infancy stage of HDTV SDI deployment, HDTV reclocking should be a user-selectable option. This is because some serializers and receiver/deformatters for HDTV are poorly implemented. The reclocker may actually help you in this case. Virtually all of the major vendors offer reclocking at HDTV rates.

**Synchronous AES vs. asynchronous AES:** The issue of synchronous vs. asynchronous AES fabrics is more a facility theology issue than a competitive vendor issue. There is a consistent lack of understanding of how to successfully implement digital audio. Digital audio routing is akin to analog video routing and system timing. If you don't synchronize your digital audio facility properly, you get pops, ticks and clicks at switch points, or all the time if you try to pass an asynchronous signal through a purely synchronous fabric. If you're a pragmatist, then you'll be happy with full-time sample rate conversion. But if you're a purist or perfectionist, then you need to think about



Large routing systems can take considerable rack space. Be sure to plan for sufficient rack space and cooling for the system chosen.

# Leader's LF 982 Measures Digital & Analog RF Signal Levels for TV/Cable/Satellite



**PICK HIT**  
Broadcast  
**ENGINEERING**  
**2000**

**\$2495, in Stock**

QAM	✓
QPSK	✓
8VSB	✓
OFDM	✓
NTSC	✓
PAL	✓

- VHF, UHF, FM, CATV and SAT Operation
- Analog, 8VSB, OFDM, QAM-256, QPSK, BPSK & 8PSK Modes
- Broadcast TV, CATV and Sat Tables
- Single/Multi-Bargraph/Spectrum Display Backlight
- Video/Sound Monitor Outputs (Analog Only)
- Stores 200 Measurements and Settings
- Compact, Lightweight with NiCd and Charger
- Satellite C/N Ratio, Coaxial AC/DC Volts
- Programmable Tables and Volts for LNB
- Flash Card Transfer Data and Cloning
- RS-232C, Print/Data Output

Circle (135) for Product Info    Circle (136) for Product Info & Demonstration

**1 (800) 645-5104 / [www.LeaderUSA.com](http://www.LeaderUSA.com)**

## LEADER

FOR PROFESSIONALS WHO KNOW  
THE DIFFERENCE

380 Oser Avenue, Hauppauge, New York, 11788 Tel: (631) 231-6900 Fax: (631) 231-5295  
6484 Commerce Drive, Cypress, CA 90630 Tel: (714) 527-9300 Fax: (714) 527-7490  
Regional Offices: Atlanta, Boston, Chicago, Cleveland, Dallas, Los Angeles

the old NTSC or PAL video timing requirements and do the same for your digital audio.

**Deterministic vs. non-deterministic control:** Deterministic control systems are those that have a guaranteed latency or delay between the time that a command is initiated and the time that the command is physically executed. For manual push button control, deterministic response is not important because the response of the control system is usually faster than human response time. It is most important when controlling multiple devices that need to be in synchronism, as is the case with legacy linear editing systems and perhaps frame-accurate automation systems.

Most of the modern control systems are based on Ethernet backbones, which are inherently non-deterministic. If the amount of traffic is kept low on the backbone, then there is a reasonable chance that commands will arrive within acceptable time fences. This is why the control system vendors want the control backbone isolated from your corporate LAN, using bridges and routers.

Once you claim Ethernet then you're also saying non-deterministic. The vendors can use time stamping and command queuing (event stacks) to minimize the effects of non-determinism, but there is always a probability that a command may not be delivered when expected.

### **Real-time vs. non-real-time & full bandwidth vs. compressed**

The explosive growth of the Internet and inexpensive, powerful, PC workstations in the past decade is radically changing the way we do things. Editing and graphics creation using workstations and LAN technology is common. This makes it difficult to determine how much full-bandwidth fabric vs. how much compressed, and/or non-real-time fabric is needed in a facility. The full-bandwidth fabric is usually quite expensive, while LANs, SANs, and VLANs are quite inexpensive, even for the Gigabit versions. Today, on one extreme there are those that predict the complete disappearance of the traditional full-bandwidth fabrics in the next five

years vs. those who insist that LANs, etc. just won't fulfill their distribution needs. It is already apparent that the industry is in transition toward the use of non-real-time and compressed material transfer, but at the same time, size and sales of full-bandwidth fabrics is actually increasing. It appears that full-bandwidth fabrics are here to stay for the foreseeable future.

### **Making the right choice**

Examine your present and future requirements, based on:

- Existing infrastructure – what are its limitations and strengths? Build on what works, change what doesn't. Can the new control system work with existing fabrics you may want to keep?
- Future expansion needs – how long do you plan to keep the new or upgraded infrastructure? Ten years is not unreasonable for the switching fabric and control system. Plan for expansion capability both in the actual fabric and the control system.
- Emerging technologies – how can they be applied to reduce cost or enhance capability? What are the market forces driving their emergence? Are they realistic or faddish?

### **What can you afford?**

Prioritize your requirements. You will most likely need to compromise some of them based on the available product offerings. It is unlikely that one vendor will meet every one of your requirements.

Research the available product offerings and the companies behind them that fit your requirements.

How well does the product fit the requirements? Utilize the free expertise of the vendor as a solution provider in clarifying the product vs. requirements match. They may have acceptable workarounds that you can live with, or better yet, a better way than yours to accomplish what you want to do. Let them know what your vision is. Usually, they have seen a much broader range of applications and solutions than you have. Observe how well the company works with you in this process.

Is it likely the vendor will still be around to support your future expansion needs? How well do they support

their legacy and current products? Look at their track record. Actively investigate several user references.

Does the product comply with industry standards and regulatory requirements, such as SMPTE, UL, FCC, and CE? Ask for proof of compliance/performance information if you have any doubts. This is important, because the end user, not the vendor, is responsible for compliance to some of the regulatory standards.

Consider cost of ownership: product reliability, facility real estate, power consumption, warranty and/or maintenance contract options. How much will it cost to expand the system in the future? Be aware of the size break-points where input distribution and/or output combiners become necessary. These will greatly affect the cost of your system. Brand X may have the lowest price for today's need, but there may be a real shock later when you want to expand your system, because of the added distribution amplifier and/or combiner costs.

Document your requirements so that your selected vendors can bid on them. Pick your top two or three vendors and seek competitive quotes from each one.

You may need to recycle through the process for the best fit of your objectives/requirements vs. your budget.

Make your purchase decision with confidence, knowing you've done your homework.

Making the right choices in your facility infrastructure is vital to your business and personal success. The worst mistake you can make is rushing into a purchase decision without understanding what you really want to accomplish. Understanding and applying the available technology choices can seem overwhelming, but is manageable and rewarding if the time is wisely invested. Use whatever resources are available to you, especially free resources from vendors you are considering purchases from. Once you have done your homework, you should be able to make your purchase decisions with confidence. ■

*Barry Albright is a member of the technical staff for Philips Broadcast, Media Networking and Control group, Salt Lake City, Utah.*

## Movies

8.00 *After Hours*  
9.30 *Raceway 2000*  
11.30 *Breakout*  
00.45 *Police Action*



Squeeze-back transitions of live-video, stills or animations for dynamic junctions

Now showing: **Space Station Zero**

6:30:25

Animated or still logos prepared on standard PC and imported using Oxtel Media Conversion Software and Ethernet

Digital or analogue style clocks designed by your graphics department and created using Oxtel Clock Builder software, synchronised (or offset) to station timecode

# Powerful master control and channel branding

In a channel-zapping world, you need to brand your station; to stand out from the crowd and keep viewers coming back. Oxtel plc provides a suite of products to suit your application, whether that's a highly automated low-budget channel or a prestige sports, film or news channel.

for automated...

*Imagestore* - Oxtel's unique IRU *Imagestore* product houses all the power you need for digital master control - no matter how demanding. *Imagestore* provides switching, mixing and two layers of keying from external sources or internally stored logos, animations and station-clocks. With the enhanced memory option, *Imagestore* even functions as a powerful slide-file store and *Imagestore's* *Squeezy* DVE option allows squeeze-back reveals of video or pre-prepared graphics, logos or stills.

And we haven't forgotten audio. *Imagestore's* *Easysound* option provides full-group embedded-audio mixing, AES mixing and provision for two voice-over inputs. Voice-overs can even be stored within the unit on hard drive for fully automated channels with the *Easyplay* option. *Imagestore* is fully automation friendly and is supported by all major automation vendors.



...and manual environments.

*Presmaster* - *Presmaster* is Oxtel's new presentation, master control concept. The *Presmaster* panel combines a compact control surface with highly ergonomic, intuitive operation. But here's the difference, **one Presmaster panel can control up to 200 Imagestores!** So you can provide the look and flexibility that only human intervention can give you, but share it between a group of otherwise highly automated channels.

In a channel-zapping world, you need to be outstanding at an operational cost you can afford. Choose Oxtel and be the envy of your rivals.



HDTV  
compatible

find out more  
on the web  
[www.oxtel.com](http://www.oxtel.com)

Oxtel plc (International)  
telephone +44 (0) 1491 820000  
email [sales@oxtel.com](mailto:sales@oxtel.com)

Oxtel France  
telephone +33 (0) 1 47 23 54 02  
email [sales-france@oxtel.com](mailto:sales-france@oxtel.com)

Oxtel Inc. (USA office)  
telephone +1-877-446-9835  
(toll free in USA)  
email [sales-usa@oxtel.com](mailto:sales-usa@oxtel.com)

# News Tech:



## Election Systems

BY MATTHEW STRAEB

The 2000 elections are yet another opportunity for local stations and national networks to garner increased viewership. The clear and constant presentation of poll numbers, candidate information and results can put you ahead in the ratings race. Images courtesy Orad.

**L**ive election-night programming presents a number of unique challenges and opportunities for broadcasters. No other programming, except perhaps for the Olympics, is quite as data-intensive. Elections require broadcasters to effectively communicate a torrent of numbers from local, state, and national voting districts — including not only the results as they come in, but projected exit-poll results from their own or outside polling organizations. Neither is the challenge diminished for a local station versus a national network, because the viewers of local stations will typically expect to see projections and returns reported on a county-by-county and city-by-city basis, in addition to statewide races and the results on a national level.

Election night programming

represents an opportunity to increase viewership, particularly if the returns are reported in a compelling manner. But like the Olympics, it is an opportunity that comes along only once every couple of years on average — such that networks and stations need to weigh carefully the benefits of an investment in special sets and graphics that will be used for one night and then retired. With the costs of conventional sets constantly on the rise, it is not surprising that a growing number of broadcasters in the U.S. and abroad are turning to virtual sets as a way to create visually striking election night coverage within the confines of a reasonable budget. Part of the attraction is the ability to situate newscasters in a novel, imaginative virtual environment. Even more important, virtual sets are being used to help

communicate election statistics more effectively, turning the numbers into an integral, eye-catching part of the setting.

### Real-time updates and total automation

Although virtual sets can and are used for nearly any type of TV programming, what makes them especially attractive for election coverage is that the raw data of election results can be directly imported and automatically converted to 3D objects that materialize into the same virtual space occupied by the program hosts. To make this happen within the context of a live broadcast requires a solution in which returns from Voter News Services and other online data sources can be fed into the system and then dropped automati-

# News

is made in an instant.  
Producing the story should be just as fast.



Chances are, you've heard that digital technology can help produce news faster and easier. With an SGI Media Server,<sup>™</sup> the evolution to digital can happen just as fast. Our new video server distributes media as data for browsing and sharing content over standard data networks, allowing you to leverage your existing infrastructure for repurposing content. Plus, our multi-format, resolution-independent solution delivers simultaneous input, serving, and play-out of video, eliminating the need for independent devices. These advantages—as well as 24x7 service and support—help make your transition to digital quick and easy. To learn more about SGI Media Commerce<sup>™</sup> solutions, go to [www.sgi.com/go/broadband/](http://www.sgi.com/go/broadband/) or call 1-800-800-7441.

## The new SGI Media Server

Up to 16 video channels • Video file transfers • Multi-format video I/O support

cally into templates that have been created in advance for immediate broadcast to air as finished graphics.

Automating the import of election data and transforming that data into graphical video elements is a capability offered by a number of graphics and character generator suppliers. Such automation requires template pages to be created in advance with pre-defined field styles and positions for subsequent completion by a remote control protocol. That is, the graphics product must be programmed to recognize and read the particular election data. For the most part, election data is supplied as simple ASCII files which the graphics products have been programmed to read and build into animated 3D images. Today's products are extremely sophisticated, and with advance planning and setup, in addition to the bar graphs and/or charts that are rendered, the products can automatically import head shots of the candidates, state maps, and other relevant graphics from a video library. This kind of

complex setup obviously calls for sophisticated templates, thought out well in advance, and able to handle multiple changes according to the data feed.

Combining the automated 3D election results with virtual set technology can be accomplished in a couple of different ways. The most straightforward solution is to integrate the on-air graphics capability with the virtual set itself, a capability provided by the leading virtual set suppliers. Using these systems, the 3D graphics for election returns are created as part of the set design and expressed as icons, bar charts, pie charts or other representations that are updated automatically when called to air.

Alternatively, a stand-alone on-air graphics system can be used downstream to create graphics and receive updated information from the wire services, which are then switched to a virtual set system. Because virtual set gear is widely available for hire, the first alternative will appeal to stations that may not have invested in

the computer hardware necessary to run an advanced 3D on-air graphics program — or those which prefer having integrated graphics, virtual sets, and chromakeying all within a single system. Downstream solutions, which can work well for stations with a seasoned on-air graphics department, can be combined with complete virtual set systems or with add-on products that enable a virtual set capability.

### Combining traditional and virtual sets

Another alternative for election night coverage is to combine conventional set and virtual set technology in the same scene, which provides a number of the benefits of a virtual environment at less than the cost of a specially designed conventional set for election coverage or even an entry-level virtual set system. In this type of application, one or more "virtual walls" are introduced into a conventional set and are used to display election statistics, candidate images, and remote and satellite video feeds. There are election systems available that use lightweight panels mounted in any conventional set in virtually any indoor or outdoor environment. Because camera information, and information about the panel's position and orientation, is extracted from the video feed itself using pattern recognition, handheld cameras can be used freely and even the panel itself can be mobile or handheld. Knowing the panel's exact position and orientation, the system maps any desired secondary video signal (D1 or analog) on to the particular panel in real time, transforming it into a virtual video screen. Graphic stills or animated election data charts, converted to a video signal, may be used as the video screen source. As a result, virtual elements can be placed in the same scene as a reporter reporting live from campaign headquarters or on-site at a local precinct, for example.

Of course, virtual walls and animated graphics based on fast-changing data have numerous applications beyond election night broadcasts. These include sporting events, home shopping channels, and real-time displays of financial information, and others.

*Matthew Straeb is president of Orad, Inc., New York City.*

# AJA VIDEO

*A good thing just got better*

## HD10C HD Serial to Analog Video Converter

*Now works with 1080p24!*

### HD10C Features

#### HD-SDI Inputs

1080i 50/59.94/60  
1080p SF 23.98.24  
720p 59.94/60

#### Outputs

HD Analog RGB/YPbPr  
SVGA (multi-sync)  
2 HDSDI Outputs

10 bit



television  
NAB 75th  
1936-2011

[www.aja.com](http://www.aja.com)

Circle (138) on Free Info Card

800-251-4224

Tel 530-274-2048

Fax 530-274-9442



# DPS-475™ / DPS-575™

The Baddest  
Multi-Function Digital/Analog  
A/V Synchronizers  
Known To Man



## Fear Not Any Feed!

Calling the DPS-475 and DPS-575 merely synchronizers is a bit of an injustice. We prefer the term "Audio/Video Synchronizer, Digital Noise Reducer, Bi-Directional Analog/Digital Transcoder, Framestore, Video Bandwidth Processor, Animated Logo Inserter, Linear Keyer, TBC, AGC, Audio/Video Test Signal Generator, VITS inserter and Serial Digital Audio Embedder/De-Embedder".

The DPS-475 (NTSC) and DPS-575 (PAL/NTSC) super synchronizers, with

their incredible array of features, are the hands-down next generation leaders. Let's talk facts. Proprietary DPS 12-bit adaptive 3D comb filter decoding and encoding ensure maximum signal transparency. Composite, Component, Y/C and SDI video I/O, optional 1394 (DV) I/O and available four-channel audio synchronizer modules provide unprecedented system interface flexibility.

For signal taming performance, reliability and economy, the DPS-475 and DPS-575 are in a class by themselves.



DPS DigiDuplex™  
Bi-Directional  
Processing

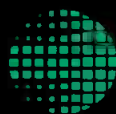

dps.com **DPS** 800-775-3314

DPS and the DPS logo are registered trademarks and DPS-475, DPS-575 and DigiDuplex are trademarks of Digital Processing Systems Inc. Features and specifications subject to change without notice.

Circle (140) on Free Info Card  
www.americanradiohistory.com

## Applied Technology

### Vibrint digital news production applications

BY ROLAND BOUCHER

The broadcast industry has finally reached the point where technology purchasers are no longer at the mercy of manufacturers who sell expensive and unnecessarily complicated proprietary solutions. More powerful computer solutions built on open, off-the-shelf and standards-based technologies are now available.

#### Broadcast technology evolution

Broadcast news has found it difficult to balance cost-effective, mass-market computer solutions with the requirement for dealing with massive amounts of video data. The industry experienced the first of three waves of technological change in the mid-1970s, when the advent of portable video cassette recorders, edit controllers and digital TBCs brought about the change from film production to tape. As digital video compression technologies improved in the mid- to late-1990s, some manufacturers introduced systems that relied on multiple proprietary elements. This was necessary because the standard technologies of the day were not powerful or fast enough to handle the demands of broadcast news production. Many of the proprietary solutions were designed around large and expensive central server systems. At the same time, much work was done to determine acceptable levels of compression and to establish standards for compression. Today, MPEG and DV/DVCPRO compression formats are routinely used for news acquisition and contribution. The formats used are similar enough that they may all be processed through the same networks and CODECs, greatly improving the economics of system design.

As a result of advances in standard off-tape data rates, drive capacities

and networks, we are today entering the third wave of broadcast technology. Using off-the-shelf PCs, networks and

be capable of 1-4X transfers when connected to tape decks, servers or routers with this feature.

### We are today entering the third wave of broadcast technology.

storage it is now possible to construct a third-wave digital news production system that rivals the performance of the central server systems of the second wave, but at a price point that reflects the use of mass-market computer tools and technologies.

#### A standards-based solution

The Vibrint product line of the Grass Valley Group offers an example of such a third-wave solution. The system is composed of individual PC workstations with Windows NT applications designed for feed capture, editing and playback. Each workstation is a standard off-the-shelf Intel Pentium PC running the NT operating and file system. The system supports standard storage solutions and standard TCP/IP file transfer and gigabit Ethernet networking protocols. Each workstation is equipped with standard SDI and analog inputs and outputs.

The workstations currently support MPEG-2 elementary stream video compression. MPEG-2 files may be transferred via network to the Grass Valley Group Profile or another video server. The application has the ability to search for clips and sequences and pull them from MPEG Profiles on the network. By the end of the year, a new off-the-shelf CODEC board will offer simultaneous support for both MPEG-2 and DV/DVCPRO. There will also be an optional SDTI/SDTI-CP I/O that will

The Vibrint applications include an interactive feed capture system, a non-linear hard news editing application and a low-cost, manual news playback system. As an alternative to the Vibrint applications, broadcasters can choose to interface with the Profile XP Media Platform for news ingest and playback, as well as other video servers.

With support for both MPEG and DV/DVCPRO, the workstations allow for integration with a wide range of broadcast systems and equipment. To that end, Grass Valley Group and Vibrint have played an active role in proposing standards for file transfers and metadata. As these and others are adopted and broadcast products evolve into more of a third-wave, standard computer model, broadcasters will see the cost curve decline dramatically and performance increase.

#### Benefits of standard technologies

A standards-based solution offers significant benefits to broadcasters beginning the move to computer-based news production, including:

- **Greater flexibility:** A system based on a standard platform offers the flexibility of choosing from a variety of applications that run on that platform and running multiple applications on a single system.

- **Simplified maintenance and easier upgrading:** As technology advances and new products become available,

they can be integrated more easily. Off-the-shelf systems parts and components are available from many sources in addition to the company that originally supplied them, making it easier and less expensive to repair and upgrade.

- **Distinct cost advantages:** As consumer and industrial use of PCs grows, the price point of standard technology drops tremendously, as well as the costs of corresponding peripherals.

- **Easier integration of new capabilities:** Traditionally, the broadcast news environment functioned as a loose collection of isolated work groups with discrete, yet parallel, tasks such as story writing and video editing. The third-wave workstations bridge the gap by providing links between video production and text-based systems such as Avstar and EPNS on a single PC.

Later this year, we will also see low-resolution, software-only applications offering journalist desktop browsing and editing functions. The new applications will run on the existing Windows NT desktop integrated with the newsroom computing system. Because

they will not require specialized video boards, many broadcasters will be able to rollout the new capabilities without investing in new hardware.

### An alternative to central server solutions

Today you will find second-wave digital news production solutions in operation. They will typically have proprietary computer elements. Most of these systems also use proprietary file and operating systems, as well as proprietary networks, and are not truly open and interchangeable. Many rely on now obsolete processing chips with no ability to upgrade, custom designed network protocols and a custom file system. If the system is truly open, you should be able to manage your media files on your PC, with the ability to copy and send them over a network just as you would with a Word document.



Advances in standard technologies make it possible to create a broadcast news production system, such as Vibrant NewsEdit, entirely with off-the-shelf products.

As you move your news production system to current computer-based technologies, make sure you invest in a system that truly capitalizes on and delivers all of the benefits of open and standards-based technologies. ■

*For more information on Vibrant's digital news production applications, circle (453) on the Free Info Card.*

*Roland Boucher is director of marketing for Grass Valley Group News Products.*

**TH 770 IOT**  
60 kW NTSC  
25 kW 8VSB

Whatever your application—*analog or digital*—our line of plug-in IOTs provides the solution. The same tube can be used either for NTSC or digital TV (8VSB and COFDM). Which means no more hassle with

## Analog & Digital

**A lot more versatility. A lot simpler for you.**

multiple references. In fact, no more hassle, period: The tube's easy plug-in installation means you don't have to remove the cavity. Making your life simpler from ordering to operation. The bottom line is our tubes save energy. Yours. For more information, e-mail us at: [info@tctus.com](mailto:info@tctus.com)

**THOMSON COMPONENTS AND TUBES Corp.**  
You need it, we'll supply it

[www.tctus.com](http://www.tctus.com)

Circle (141) on Free Info Card

# Pinnacle's PDS 9000: Integrating switcher and DVE technologies

BY PAUL TURNER

Production switchers as we know them have been around since the early 1960s. Using state-of-the-art analog circuitry, they evolved over approximately 20 years into highly complex video compositing engines. As their level of complexity grew, so did the difficulty of maintaining them. In the mid-1980s, digital production switchers started to make their entrance. By and large, these were merely digital copies of their analog counterparts. With the high cost of digital circuitry at that time and the enormous power consumption of TTL chips, only the wealthiest customers could afford to purchase and run these digital switchers. While the price has definitely dropped, production switchers today have added few new features to those of their analog ancestors.

DVEs are a more recent development. They grew from the technology of early frame synchronizers and were digital devices from the start. Based on the idea of storing an entire field or frame of video and then manipulating the physical location of each pixel in the stored image, they opened up a world of possibilities for effects in television.

Being so different in the basic nature of their functions — the production switcher to mix together elements to provide an entire look and the DVE to provide enhanced special effects — the

two devices have evolved separately. Once production switchers became digital in nature, however, this seemed to be an artificial boundary. It has long been the dream of manufacturers to produce a device that integrates

the operator needs them, because they are tied up in other areas of the switcher.

## Integration of M/E and DVE processing

The PDS 9000 is the first switcher to truly integrate DVE functionality into

## The M/E processing is the DVE processing.

the functionality of switcher and DVE into one processing engine. The PDS 9000 is the first production switcher to truly achieve this goal.

### Methods of integration

Many manufacturers integrate DVEs into their production switchers by connecting stand-alone DVE systems into the video path of the switcher through the use of aux buses, effects send systems, etc. The only real integration offered here is that the external DVE can be controlled from the switcher's control panel. The two devices remain physically separate entities, and much of the potential power of the combined system is lost. Moreover, this "box within a box" architecture usually dictates that the number of DVE channels within the switcher be limited, so some form of delegation is required in the switcher setup. This means that DVE channels may not be available when

its video path. The M/E processing is the DVE processing. This is due to the system's incredible "building block" ASIC. Pinnacle's proprietary video processing technology allows M/E functions and DVE functions to be combined in a single chip, the K2. K2 includes mixers, color correctors, keyers, filters, address generators and interpolators in a single building block. This building block is fundamental to the compact size and low power consumption of the system. (The video processor chassis draws approximately 400W with all options installed.) Every M/E in the system is equipped with three full-function DVEs — one on each keyer and one for the main transition engine. The user never has to delegate a DVE to a keyer — the keyer already has one.

### System architecture

The general architecture of the PDS 9000 is quite traditional in overview (see Figure 1). Serial digital signals are received, deserialized and equalized by the system's eight I/O boards, each providing processing for five inputs and three outputs. The input signals are then fed to a crosspoint matrix, which routes them to the M/E processors. There are three identical M/E processors in the system — one for each M/E and one for PGM/PST/DSK. All processing associated with an individual M/E resides on the M/E card itself. This leads to simplified maintenance requirements — in the event of a failure in an M/E system, the entire M/E is simply

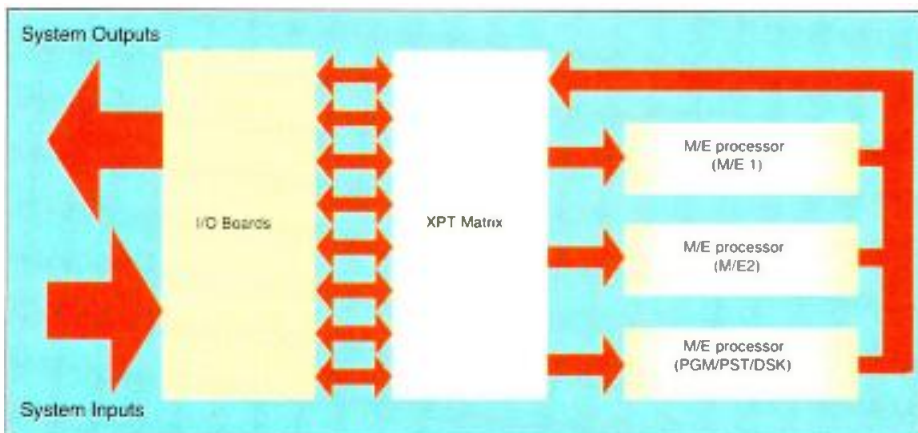

Figure 1. In the PDS 9000, serial digital signals are processed in the eight I/O boards and routed through the crosspoint matrix to three identical M/E processors.

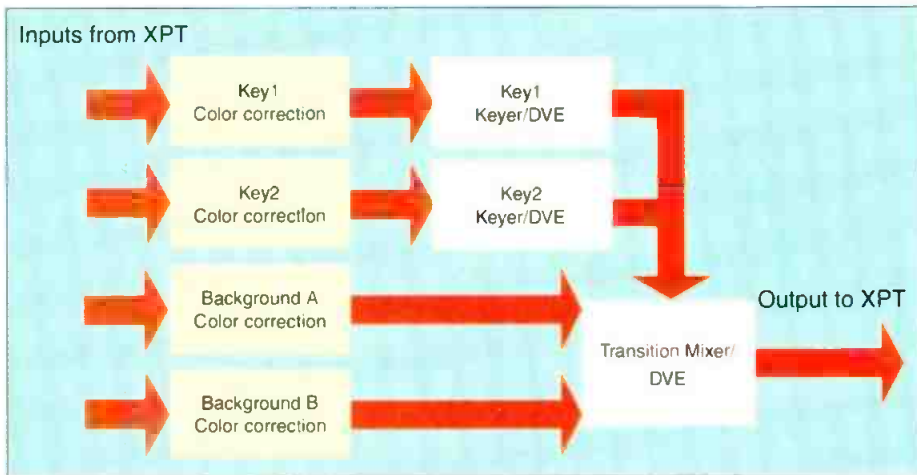

Figure 2. PDS 9000 M/E architecture. Key and background signals in the M/E pass through color correction circuits and are combined in the final mix/DVE stage.

replaced with a new board. Boards may even be swapped within the system to assist in more complicated troubleshooting tasks. Finally, the video outputs of the M/E boards are sent back through the crosspoint matrix to the I/O cards. Figure 2 is a simplified block diagram of the PDS 9000's M/E architecture.

#### M/E architecture

Each of the four buses in the M/E pass through a color corrector circuit. This is used for both input proc amp

functions and, in the case of the keyer paths, for YUV and optional RGB color correction functions. The A and B background signals (PGM and PST in the PGM/PST/DSK system) then pass on to the final mix/DVE stage.

The key signals are passed to the keyer/DVE portion of the M/E. If the DVE is not required, it is simply bypassed and adds no delay. If the DVE is required on an individual key bus, it is enabled before the key is passed on to the final mix/DVE stage. Note that the

DVEs operate on both fill and key signals, in 4:4:4 mode for the highest signal fidelity.

The two background signals, along with the two key elements, are combined in the final mix/DVE stage. This DVE is used purely for transition effects, allowing the user to perform DVE transitions in exactly the same way as they perform wipes. Finally, the output signals are passed back to the crosspoint.

This architecture truly combines DVE processing with traditional M/E processing. The DVEs do not use the I/Os of the system – they are simply part of the M/E itself.

Through the use of advanced signal processing technology, the PDS 9000 dispenses with the idea of picture transformation being separate from mixing, keying and wiping. By placing this technology deep in the video path of the mix/effects, the PDS 9000 allows the user creative freedom. ■

*For more information on Pinnacle's PDS9000, circle (452) on Free Info Card.*

*Paul Turner is broadcast business manager for Pinnacle Systems in Mountain View, CA.*

TH 755 IOT

The TH 755 IOT. A whole new replacement solution. It's 100 percent interchangeable with other makers' tubes of the same power class. And it's 100 percent easy to make the change because you can keep

**A new alternative.** **A direct replacement. A direct new way to save.**

your original cavity. But the benefits don't stop there. Like all our IOTs, the TH 755 delivers outstanding operating stability, constant gain, a long lifespan, and cost savings in both acquisition and operation. And it delivers them by design. For more information, e-mail us at: [info@tctus.com](mailto:info@tctus.com)

**THOMSON COMPONENTS AND TUBES Corp.**

You need it, we'll supply it

[www.tctus.com](http://www.tctus.com)

Circle (141) on Free Info Card

## Grass Valley Group's Kalypso video production center

BY MARK NARVESON

Today's live and post-production environments are increasing in complexity, placing heavier demands on production equipment. Customers who want to maximize production value and revenue streams are using existing installed equipment with varying degrees of success. Customers face four major challenges as they plan the production flow for new programming.

First, today's sophisticated look requires more graphics, animations and effects to be on-air simultaneously. These range from traditional graphics to newer looks that include identification logos, ticker tapes and sidebar animations. Second, some productions require more mix/effects (M/E) banks to pre-configure composited shots for the director to view and make course corrections before airing. In general, more M/E banks means more directorial choice and smoother production flow. Third, customers want customized feeds for multiple usages or end users, each with customized graphics and without the

need for extensive post production. Finally, technical directors increasingly need to have control over all the elements of live production, including VTRs and DDRs,

video buses for such applications as video in wipe border, masking from a video source and secondary background transitions. Also available are up to six

### Customers face four major challenges as they plan the production flow for new programming.

without taking attention away from the main switcher control and monitor wall.

It was with these challenges in mind that the new Kalypso Video Production Center from the Grass Valley Group was developed.

#### Increasingly complex production value

In today's production environment, there is a strong need for more video inputs, more keyers, more storage for still frames or animations and more flexibility in the output system. The Kalypso Video Production Center offers up to 80 CCIR-601 compatible inputs to accommodate large numbers of camera, VTR and other sources without the need to switch external router destinations during a live program. Up to 46 programmable outputs can be configured to provide any desired set of M/E or auxiliary bus outputs. A large number of auxiliary buses can be used for such applications as monitor wall control directly from the main switcher panel, in some cases reducing the number of facility router destinations into the control room. Each M/E features four keyers for more graphics layering capability, as well as two utility

channels of internal DVE; a 100-frame, eight-output frame store with integral hard drive storage; and animation capability. These features allow customers to reduce or eliminate their dependency on external DVE channels, still stores and logo animators.

#### Need for more M/Es

Many applications require more M/Es than current production switchers can offer. For example, in sports programming one M/E may be devoted to an ISO feed for recording the clean program with the game clock — useful in replay applications. Directors may also want to see four to six camera and/or VTR sources with the correct graphics simultaneously to have more options to take to air, rather than the one to three M/Es usually available. This is useful in news where a director may want to see both anchor shots, the weather chroma key, the live remote, the sports desk and the satellite feed — all ready to go to air with appropriate graphics. Kalypso's new Double-Take Split M/E technology allows any or all mix/effects banks to be divided into two separate M/Es with independent transition mixers, E-MEM Effects Memory systems and preview outputs. The power of eight M/Es is now available from a four-M/E system.

#### Multiple distribution streams

Clean feed systems are used to differentiate between two or more clients, distribution streams or purposes. For example, a taped version of an event

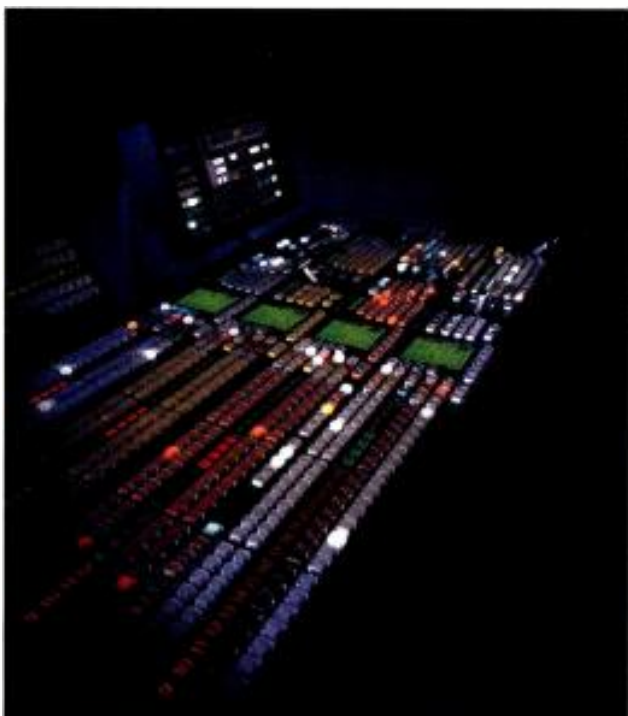

The Grass Valley Group Kalypso Video Production Center offers new DoubleTake Split M/E technology, allowing any or all mix/effects banks to be divided into two separate M/Es to allow more directorial choice.



## A Full House of Transmitters



We wish to thank everyone who visited our booth at NAB 2000 and experienced the zany exploits of Helga and Dr. Biterror and "DTV Science." At this very successful show, we showcased ADC's comprehensive line of transport and transmission solutions for the broadcast industry, including our "full house" of analog and DTV transmitter products.

With nearly twenty years' experience in the design and manufacture of television transmitters, we continually strive to build a product line that is responsive to the needs of broadcasters. The Innovator™ Series of high-power solid state transmitters is available in power levels up to 120kW or 60kW digital using the latest LDMOS transistors. If your application requires an IOT, our Visionary™ Series of High Power UHF transmitters at 420kW analog or 180kW digital power levels is the card to play. ADC's hand includes the 800 Series of low and medium power transmitters, available with either solid-state or Diacode amplifiers at power levels to 10kW analog or 5kW digital. With so many choices, you can bet that we have a product to meet your application.

Whether your needs include DTV transmitters, digital routers, signal management equipment or patching products, ADC provides the solutions to build your digital infrastructure. For additional information about our full line of broadcast products, please visit our web site at [www.adc.com/broadcast](http://www.adc.com/broadcast) or call (800) 215-2614.

EQUIPMENT  
SOFTWARE  
SERVICES



Circle (142) on Free Info Card

[www.americanradiohistory.com](http://www.americanradiohistory.com)

## Technology issues

Implementing these technologies is complex and must take into consideration key elements of a transmission network that was designed for voice traffic. There are also constraints within the video signals being transported which must be addressed. Addressing the following issues makes local area and wide area networks feasible:

- **Jitter.** Jitter is cumulative in nature and therefore aggregates in larger networks. Increasing signal jitter leads to reduced noise margin, which in turn produces higher error rates and less reliable communications. Jitter tolerance, jitter attenuation and intrinsic jitter characteristics are important considerations when selecting terminal equipment.

- **SONET/SDH pointer adjustment.** SONET/SDH networks use a synchronizing mechanism called pointer adjustment that can result in the insertion or removal of several bytes of information to compensate for clock drift between terminal equipment. This can lead to video transport problems such as loss of video synchronization and image tearing unless appropriate steps are taken in the design of the transport terminal equipment.

- **Pathological signals.** The SDI signal was not originally specified for fiber optic transmission, leading to conditions that can generate a long string of ones or zeroes. These signals can lead to loss of signal lock at the transmitter or receiver. Additional signal processing overcomes this problem, but any method used

must be reversible, so that the end user signal is identical to the transmitted signal.

- **Optical budget.** SONET/SDH networks have tightly specified optical characteristics. Local systems using fiber directly at 270Mb/s must also be carefully designed. The distance a signal can be carried on any fiber network depends principally on the optical power launched at the transmitter, the attenuation and dispersion characteristics of the fiber, and the sensitivity of the optical receiver.

Many companies offer fiber transport products designed only for short-haul or intrastudio applications. These products are generally not designed to meet stringent performance and reliability requirements for deployment in carrier networks.

- **Network management.** The efficient operation of large networks requires comprehensive network management facilities. The SONET/SDH network itself offers a network management system, so the use of this network as a back-bone holds additional attraction. However, the terminal equipment management system needs to be integrated so that monitoring, fault isolation and re-configuration of the network can be quickly and reliably performed.

- **ATM or IP Networks.** ATM and IP transport technologies offer some attraction to carriers since they can potentially transport mixed traffic services on a common network. However, there are some specific problems such as the potential for differential delays for real-time video signals.

Virtual Studio Networks has the potential to change the way movies and television are produced by permitting collaboration communities to be spread across the globe. Production effectiveness can dramatically increase. The same benefits that uncompressed digital video transport networks bring to the production community can also be extended to the broadcast community.

*For more information on Video Products Group's Virtual Studio Network, circle (454) on the Free Info Card.*

*Steven Storozum is vice president of Video Products Group Inc.*

# NOVA does it again!



# \$995

(direct price)

## SM 2000

Video Base Console

1RU Format Conversion



**NOVA**  
SYSTEMS  
SHILTON

CALL TO PLACE ORDER or for catalog  
1280 Blue Hills Avenue  
Bloomfield, CT 06002 USA  
800-358-NTSC [www.nova-sys.com](http://www.nova-sys.com)

Circle (143) on Free Info Card



## Video Product Group's Virtual Studio Networks

BY STEVEN L. STOROZUM

In the world of television technology, change tends to be revolutionary; witness the advent of digital television and new media. However, human nature prefers an evolutionary approach to change, and the human side of the television industry is clamoring for stability in the sea of changing technology. One of the most human processes in television is the editing process. Technology has been rapidly advancing in this area, but editing is still done by collaboration between the editor and other artists involved in the production.

One challenge in editing is gathering and considering the appropriate input given time and budget constraints. The approval process can be repetitious and long. A new editing tool, the Virtual Studio Network, has the potential to make the process smoother and more effective.

### Application examples

Applying a networked system to the editing process allows the client to interact with the editor while both are removed from the actual content. Until now, problems with video quality, timecode and audio synchronization have prevented the application of the system.

Quality levels in editing need to

Services exist which provide the feeds needed to connect studios to post facilities and enable real-time, contribution-quality video/audio editing with the required data signals.

Embedding audio and data maintains absolute synchronization on all

switched in and out at will or on schedule, gathering all long-haul interfaces in the central office.

Uncompressed long-haul interfaces are possible through the use of synchronous optical network (SONET)/synchronous digital hierarchy (SDH)



Video Product Group's VPG-8000.

## Editing is still done by collaboration between the editor and the other artists involved in the production.

be very high, as approvals are done on final output from the edit suite. Consequently, long-distance transport of contribution/mastering-quality video signals is required, along with the accurate, synchronized transfer of control and sound information.

signals. Since the video signal is uncompressed, video processing is in real time with no delay between the server or tape deck and the edit console or the client. This enables the use of a shared storage device across a

wide region and makes editing more efficient since sound, picture, special effects and other editing processes can share the cost of storage.

Permitting any user to connect to any other user on the network allows true collaboration on demand. Long-distance system connections can be

and dense wavelength division multiplexing (DWDM) technologies. SONET/SDH transport systems are currently provided throughout the world, delivering bandwidth in multiples of 155Mb/s between central offices and from a central office to customer premises. DWDM permits 40 or more independent signals to share a single fiber, with each signal having a bandwidth as great as 10Gb/s. DWDM greatly increases backbone bandwidth for voice, data and video applications.

When uncompressed video transport is combined with embedding technology, long-distance collaborative editing is feasible and easily implemented. As the cost of high-bandwidth SONET/SDH circuits is driven down by the advent of DWDM technology, this system becomes increasingly affordable.

may have different graphics than the live broadcast version or a live production may be simultaneously broadcast with graphics in two different languages. Clean feed systems typically offer customization over one to four keys, but this is often not enough. The fallback position is to utilize a second production facility with a second crew – doubling the control room expense. Kalypso's FlexiKey Programmable Clean Feed technology gives producers the ability to fully customize two program streams for two different clients. Automatic key substitution offers the ability to automatically bring up a Spanish graphic on the secondary output when the corresponding English graphic is taken to air on the primary output. One technical director can easily produce both programs on one production switcher.

#### More control from one location

Technical directors are often called upon to control more on-air devices such as VTRs and DDRs, requiring more powerful device control fea-

tures at their fingertips. This may be as simple as a customized button panel that plays VTRs to air at the appropriate time. More sophisticated configu-

## One technical director can easily produce both programs on one production switcher.

rations may employ an auxiliary control panel that can set cue points, jog forward or backward and manage DDR clip stacks. The Kalypso system's main control panel features a device control window next to the program/preset bank, allowing access to Profile video clips as well as VTRs. Clip stacks can be managed to auto cue the next clip once the current clip is taken off air. In addition, the user can choose to automatically play a clip when the corresponding device is taken to air.

The Kalypso also keeps the same look and feel as traditional Grass Valley Group production switchers, minimizing the training period for those familiar with other digital switchers

from the Grass Valley Group. More advanced operations can be added to the mix as the technical director becomes more familiar with the capabilities of

the system. This, coupled with integral control of external devices such as the Krystal and GVeous digital effects engines and SMS-7000 router destinations result in the most powerful production system on the market today.

The Kalypso Video Production Center is offered in a four-M/E version, as well as a new two-M/E version ideal for small- to mid-size live, post and remote truck production that was introduced at NAB2000. ■

*For more information on Grass Valley Group's Kalypso, circle (451) on the Free Info Card.*

*Mark Narveson is the product marketing manager of video production systems for Grass Valley Group.*



When you need support, you need it fast. At Thomson Components and Tubes we make sure you get it. In addition to our sales force, we also deploy a technical team that provides full support with timely consulting and assistance services during both equipment definition and

## Total availability in real time.

**You want it. You've got it.**

installation of our products. Across North America, coast to coast. Our broadcast tubes are directly available off the shelf from our extensive stocks in Totowa, New Jersey. Whenever you need them. For more information, e-mail us at: [info@tctus.com](mailto:info@tctus.com) or call us at (973) 812 9000.

[www.tctus.com](http://www.tctus.com)

**THOMSON COMPONENTS AND TUBES Corp.**

You need it, we'll supply it

Circle (141) on Free Info Card

# World Wide Audio, without leaving your studio.

Rocket Network takes audio production beyond the boundaries of studio walls, making connections that let you work with anyone, anywhere, anytime. It's like a global multi-track.

## On-line Flexibility.

Rocket Network uses the Internet to allow professionals to work together on audio productions without having to be in the same physical space. Instead of shipping tapes from place to place or renting high-capacity phone lines, you log into your Internet Recording Studio, where Rocket Network handles the details of passing your parts to others and vice versa. That leaves you free to concentrate on capturing the perfect take, using your own local system to record and edit. Whenever you're ready for others to hear your audio or MIDI parts, you simply post your work to the Internet Recording Studio, automatically updating everyone else's session.



## Professional Tools.

Through partnerships with leading audio developers, Rocket Network is bringing RocketPower™ to the professional tools you already use, starting with Steinberg Cubase VST and Emagic Logic Audio. A multi-level permission system lets you control access to your Internet Recording Studio. And our RocketControl™ client offers built-in chat capabilities, so everyone in the session can chime in with feedback as the project takes shape. The Rocket Network Web site offers additional resources and services for audio collaboration.



## Full Audio Fidelity.

With Rocket Network, there's no compromise in audio quality—the system handles files in a vast range of formats and compression levels, all the way up to uncompressed 24 bit/96kHz. And you don't need access to a super-fast connection; DSL or T1 is great, but you can also work productively over a humble 28.8 dial-up. The system supports multiple user-defined presets for posting and receiving, and handles all conversions, letting everyone participate in their own preferred format. That means you can conduct a session in a speedy, low bit-rate "draft" mode, then move on while the final parts are posted in the background at full-fidelity.



## A Powerful Connection.

Rocket Network adds a new level of freedom to creative collaboration, allowing you to choose your team—singers, musicians, voice-talent, composers, engineers, producers—based on who's right for the project, wherever they happen to be. With full fidelity, plus anytime, anywhere productivity, Rocket Network is a powerful new connection to the world of audio production.

Escape the boundaries of your studio walls.

Register at [www.rocketnetwork.com](http://www.rocketnetwork.com)

Source code: RN21

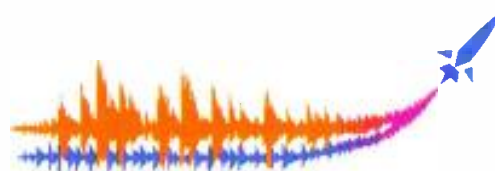

**rocket**  
NETWORK™

Internet Recording Studios

All rights reserved © Rocket Network, Inc. 2000. All other product and company names are TM or ® of their respective holders.

Circle (144) on Free Info Card

[www.americanradiohistory.com](http://www.americanradiohistory.com)



## Production switchers: Mixing pictures and metaphors

BY JOHN LUFF

Herbert Zettl would be extremely jealous of the options available to the program production professional of today. Zettl wrote the definitive textbook used for generations studying television production. Among his most creative ideas was a method to do a "wipe," using a single camera and a mirror carefully placed to show a second set when it was pushed in front of the camera. Imagine the care needed to be sure you weren't showing the public the production crew instead of the second set. Remember, this would have been live and in black and white. Zettl had plenty of other creative ideas that survived as common operational practices for decades.

Zettl would be truly amazed at many of the common video mixing tools available to every segment of the market. The recent maturation of computer-generated special effects would have been unthinkable, and even digital effects would have been hard to imagine. Live television remains a challenging arena for professionals, and in some ways even more creative, though perhaps less exacting than moving mirrors required.

The complicated nature of on-air production switching used for news, special events and sports broadcasts has continually pushed manufacturers to new heights. When the first GVG 1400 solid-state production switchers became available (one is on display in the lobby of the GVG headquarters for those of you who have never seen one), the effect on live production was immediate and predictable. If effects, limited to simple wipes and keys, as well as additive and non-additive mixes, could be done in such a stable platform then how much more could be pushed into the technology. GVG, Vital, CDI, Ampex and other manufacturers of that era moved the bar ever higher

with multiple effects banks, chroma keyers, memory recall systems, innovative layering techniques and more in a decade long push to wring the most out of analog switcher technology. In the 1970s, digital processing became possible and for a time the focus of producers looked towards emerging digital effects, innovated by the SqueeZoom from Vital. Switching has never been the same since. That advent of digital processing

allow vastly more complex capabilities for the same money, or alternatively prices that were unthinkable even a few years ago for capabilities that are quite remarkable.

In the last year even the complicated 3D computations and filtering that are required for digital effects manipulations have moved into the switcher itself, allowing seamless control over layering and transformations of three dimensional space. Transitions

**Digital techniques have become so powerful and cost effective that analog designs no longer have a place in the live market.**

pioneered by Vital allowed Zettl's creative visualizations to be accomplished in the quiet of the control room without complicated staging. Over the next generation, digital effects matured and digital processing moved into the mainframe of the production switcher.

Today, it is indeed hard to buy an analog production switcher because digital techniques have become so powerful and cost effective that analog designs no longer have a place in the live market. Analog production switchers were endowed with literally hundreds of intricately interrelated adjustments that had to be considered in the correct order to achieve adequate performance. As digital technology became available, reliable manufacturers were able to recast the assembly process. Instead of burn-in and labor-intensive tests and final adjustments at the factory, it became possible to burn in the digital processors without assembling into a complete system, and final test has become essentially a programming and performance verification process. The result has been to

between layers or scenes now can include special transformations as a normal course of production, without large price or flexibility trade-offs.

At the same time the increase in capability of new production switchers has spawned a rapid increase in the complexity of on-air product. Animated graphics are now the norm in sports production, and news programs have evolved into a production signature look that would be difficult to reproduce with technology available just 10 years ago. We have in fact entered the third generation of digital production switcher hardware from some manufacturers.

Much of the new capability in digital production switchers is driven by the integration of digital signal processing technology and custom-designed arrays, which allow the complexity to be reduced to a set of programmable "picture modifiers." For instance, the introduction in the 1980s of infinite re-entry to analog production switchers became possible only with considerable complexity. The same capability in digital switchers

8:27:35

LA TV transmitter engineer Matt Stevenson used to work late, very late. His station then fitted EEV IOTs supplied by Marconi Applied Technologies. Now Matt gets to sleep and his family has a life.

EEV IOTs have already achieved millions of trouble free operational hours.

Marconi's new high power plug-in IOTs mean that Matt will need to spend less time on site.

When will your finest hour be?

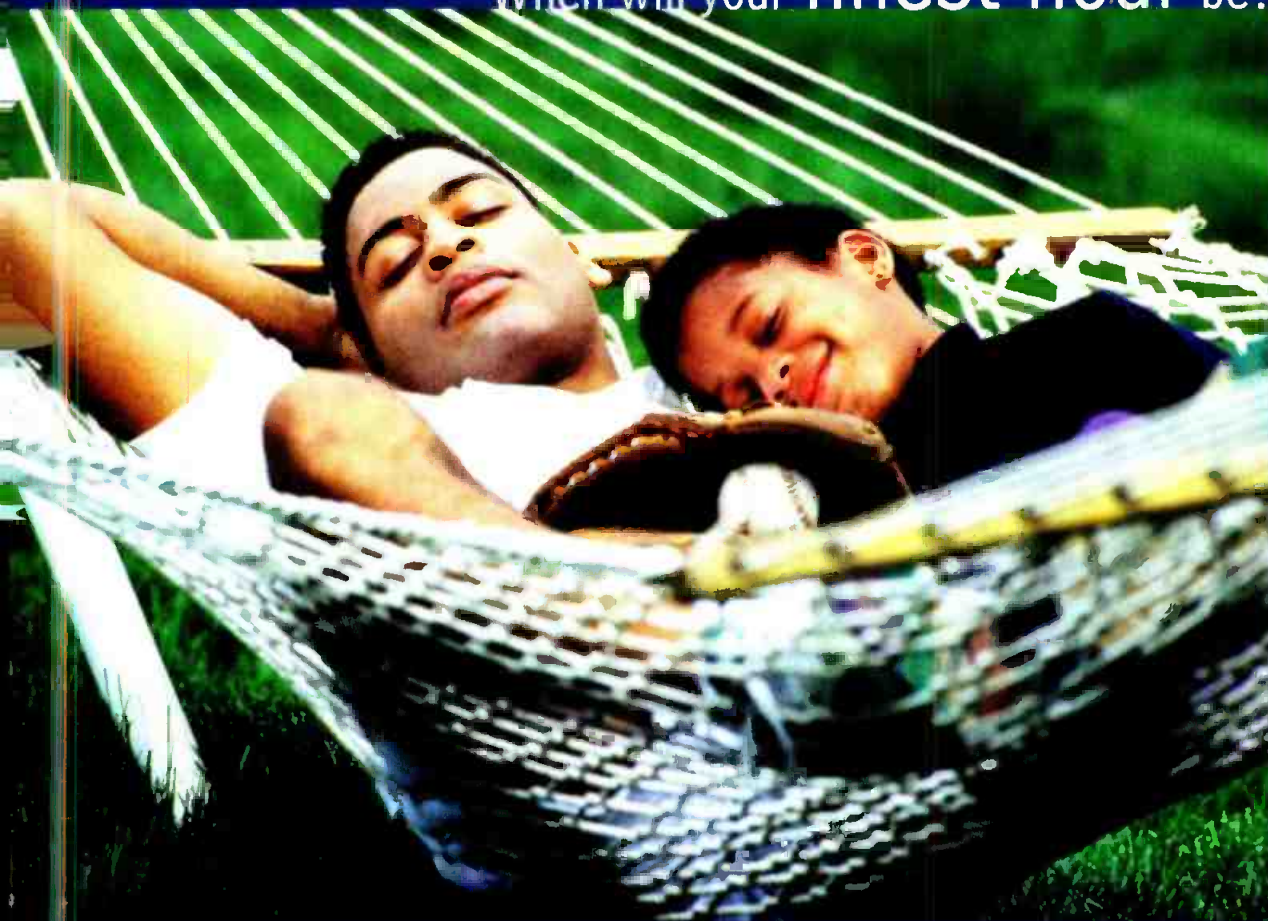

Analog and Digital

Unrivalled Support

Long Life

High Reliability

Marconi Applied Technologies

[www.marconitech.com](http://www.marconitech.com)

*Marconi*<sup>™</sup>

This could be your finest hour.<sup>™</sup>

US: Tel 1 800 342 5338 Fax (914) 592 5148 Email [info@eevinc.com](mailto:info@eevinc.com)

UK/RoW: Tel 44 1245 493493 Fax 44 1245 492492 Email [info@eev.com](mailto:info@eev.com)

Circle (145) on Free Info Card

[www.americanradiohistory.com](http://www.americanradiohistory.com)

is as much a matter of software as system architecture. Some manufacturers have licensed sophisticated chroma key capability as *software* for incorporation into switcher designs.

Some manufacturers have implemented their designs using general-purpose computer platforms and off-the-shelf operating systems like Windows NT. Others have chosen to use real-time operating systems like VXWorks. Neither choice should be viewed as inherently flawed, for it is the integrated whole that must be reviewed. At the risk of overstating the obvious, there is no such thing as bug free software. Every manufacturer has suffered some birthing pains with new hardware and software in production switchers. The most important question to ask the switcher salesman is whether

bugs cause either the loss of output video or potentially force a "reboot" that will take considerable time and certainly affect the output picture. At

with dozens of pins. Today, you can install a single Category 5 cable to control one manufacturer's control panel. It is possible to buy a second control panel on one manufacturer's design and then assign part of the



**Increasingly sophisticated production capabilities for news and sports, once accomplished with great difficulty on analog production switchers, can be done easily with new digital switching models. Shown here is a Ross Synergy switcher at WKOW in Madison, WI. Photo courtesy of Ross Video.**

switcher to each control panel. This has appeal where simple productions may originate from a second studio, at the same time as a more complex

## **The complicated nature of on-air production switching used for news, special events and sports broadcasts has continually pushed manufacturers to new heights.**

least one manufacturer has thought ahead and provided a cuts-only bus that can operate independently in the event the main switcher requires a "three finger salute." While clearly this is an admission of fallibility, it is a refreshing admission.

Remember the old analog switcher you installed in 1985? The control panel used multiple connectors each

production in the main control room. One electronics frame with two users is very appealing. To be fair, Abekas first implemented this idea in the 1980s.

Recently, the landscape of production switchers expanded with a crop of four mix effects designs, as well as families of switchers that include standard definition (525 and 625) designs, as well as HDTV variations. Two manufacturers

have shown this concept with identical operator interfaces for either electronics frame. This is particularly appealing when a control room might be installed for SDTV today and converted in the future for HDTV use. It is even

possible to switch between formats without disrupting the operator's interface, which is intriguing when considering system evolution implications.

It is valuable to note that one European manufacturer has implemented I/O capability that will accept not only all variations of HDTV carried in SMPTE 292M (1080i/30, 1080p/24 and 720p/60), but also 480p/60 and allegedly 480i/30. I say allegedly because I have yet to see it working, but the design seems capable of this enhancement. If other manufacturers implement similar de-

signs, clients will certainly win.

One recent design implements two operating modes that allow either conventional re-entry style compositing or extended layering. This concept is not new, having first been used in the 1980s in designs from GVG and Abekas (both products are no longer available). These designs were intended for post production, and are still used today.

It's pretty incredible when you consider the cost of current designs is lower (in almost all cases) than similarly sized and equipped analog designs. Modern designs are providing new capabilities, higher reliability, freedom from drift, and the highest possible picture quality, yet prices in deflated dollars are down considerably. Seems like digital switching has moved into the mainstream to stay. ■

*John Luff is president of Synergistic Technologies Inc. in Canonsburg, PA.*

- Best Price Guarantee\*
- Same Day Shipping\*
- Extended Hours\*
- Knowledgeable Sales Staff
- Flexible Terms

# Your Source for Professional Audio

Broadcast Supply Worldwide stocks the widest range of professional audio products suitable for the TV/Video industry. From the newest digital audio editing equipment to the tiniest lavalier microphone, you'll find it at BSW at a great low price. We've been serving radio and TV broadcasters for over 26 years. Let our knowledgeable sales staff help you find the right equipment for the job, with quick delivery. Call us today.



**FREE**  
**Pro Audio Catalog**  
Call BSW 800 426 8434

Let BSW work to your advantage!

We offer a best advertised price guarantee\*, same day shipping of in-stock items\*, sales professionals with real-world experience, and sales hours from 9:00 am to 9:00 pm Eastern Standard Time.

To Order Call BSW 1-800-426-8434

or Visit [www.bswusa.com](http://www.bswusa.com)

## COMPUTER-BASED SWITCHER

**Lighthouse Digital Systems Navigator:** PC control program giving users control of switching capabilities; functions of the system include multivendor switcher control, multiswitcher path-finding, programmable remote control panels; also, a Java-based virtual panel running on multiple platforms that can simulate the appearance of hardware panels or be configured by users to fit their needs; 800-323-8289; 530-272-8240; fax: 530-272-8248; [www.lighthousedigital.com](http://www.lighthousedigital.com)

Circle (350) on Free Info Card



## STUDIO EDITING VTR

**Panasonic AJ-D960:** allows 25Mb/s and 50Mb/s recording and playback in 525- and 625-line standards; records up to 92 minutes in DVCPRO50 or 184 minutes in DVCPRO modes and plays back consumer DVCAM and DV cassettes; other features included advanced digital slow motion and audio scrub capabilities for frame-accurate machine-to-machine or edit-controller-based editing; DVCPRO50 mode features provide 4:2:2 signal processing; 800-528-8601; 323-436-3500; fax: 323-436-3660; [www.panasonic.com/broadcast](http://www.panasonic.com/broadcast)

Circle (364) on Free Info Card

## HDTV DOWN CONVERTERS

**CValley SPH-100/SPH-150:** new downconverter models from CValley allow users to utilize an NTSC monitor to check frame sizes of images shot with an HD camcorder; 16:9 HDTV signals can be monitored on a 4:3 NTSC monitor and 16:9 signals can be monitored in full 4:3 size; 4:3 marker switch adds a white marker to 16:9 signals for 4:3 monitor check; 949-727-9161; fax: 949-727-9188; [www.cvalley.com](http://www.cvalley.com)

Circle (351) on Free Info Card

## DATABASE/SERVER SOLUTION

**Mixed Signals Technologies Spike ITV:** allows advertisers to access and control viewer response data from their interactive advertiser and programming; offers scalable and flexible architecture; is capable of interfacing with order fulfillment systems for e-commerce; supports viewer registration and financial transaction management using an integrated distributed database infrastructure; 310-838-4353; fax: 310-838-4354; [www.mixedsignals.com](http://www.mixedsignals.com)

Circle (352) on Free Info Card

## VISUAL EFFECTS SOFTWARE

**Discreet Logic combustion\*:** features include keying, motion tracking and color correction tools, as well as a fast caching architecture; allows users access to a unified paint, animation and 3D compositing environment; it also supports Adobe Photoshop and After Effects plug-ins; 800-869-3504; 514-272-0525; fax: 800-305-6442; [www.discreet.com](http://www.discreet.com)

Circle (353) on Free Info Card

## MULTIMEDIA DISPLAY

**Princeton Graphics AR3.6T:** new display in the ARCADIA T-series is a 4:3 direct-view 36-inch CRT; also supports NTSC video, 480p (DTV) and 1080i and 720p HDTV formats, as well as VGA, SVGA and XGA PC and Macintosh graphics; other built-in features include an NTSC tuner, a line doubler and a 12W x 2 amplifier; 800-747-6249; 714-751-8405; fax: 714-751-5736; [www.princetongraphics.com](http://www.princetongraphics.com)

Circle (357) on Free Info Card

## SIDE ADDRESS CONDENSER MIC

**AKG C2000B:** features a preset cardioid polar pattern, high sensitivity and low self-noise, as well as a switchable 10dB pad; also, microphone comes with accessories such as an SA41 stand adapter and an optional H100 spider shock mount system; C2000B's frequency response goes down to 10Hz; 615-360-0499; fax: 615-360-0275; [www.akg-acoustics.com](http://www.akg-acoustics.com)

Circle (354) on Free Info Card

## INTERNET VIDEO PLATFORM

**Virage Video Application Server 2.0:** provides a complete solution for creating and maintaining video-rich websites using a simple Web interface; serves as a platform for video web applications including advertising, personalization and syndication, and rights management; allows for seamless integration of video and other site content; 650-573-3210; fax: 650-573-3211; [www.virage.com](http://www.virage.com)

Circle (358) on Free Info Card

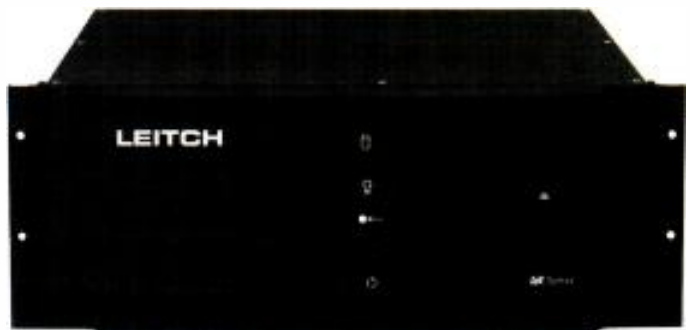

## MPEG VIDEO SERVER

**Leitch VR440:** features four bidirectional I/O channels in a 4RU frame; can be configured to more than 40 channels with simultaneous access to the video storage area network with capacity from 250GB to more than 3TB; offers redundant power supplies, main feeds and hot-swappable drives with RAIDSoft switchover; 800-231-9673; 757-548-2300; fax: 757-548-4088; [www.leitch.com](http://www.leitch.com)

Circle (363) on Free Info Card



# Turning the high-end wireless market upside down



**LECTRO™**

The UCR210D wireless microphone receiver is a compact assembly built around a solid aluminum, monoblock chassis. The chassis provides exceptional RF isolation between critical sections of the circuitry and the ruggedness to deal with the real world, wherever you have to work.

The receiver is powered by an aluminum battery cartridge (4-AA batteries) that slides onto the side of the housing, or from external 12 to 16 Volt DC.

A tracking front-end and 256 selectable UHF frequencies, a dual-band compandor and microprocessor controlled SmartSquelch™ and SmartDiversity™ optimize the signal to noise ratio under any conditions. The receiver adapts to changing signal conditions based upon an intelligent analysis of the incoming RF level and rate of change of RF level, plus audio level and audio content. Simply amazing. Simply LECTRO™.

**Call (800) 821-1121**

In the USA, Canada and Puerto Rico  
Talk with a human, not a machine.

 **LECTROSONICS®**  
The Wireless Company

visit: [www.lectrosonics.com](http://www.lectrosonics.com)

581 Laser Road, Rio Rancho, NM 87124 USA - ph (505) 892-4501 fax (505) 892-6243 - e-mail: [sales@lectrosonics.com](mailto:sales@lectrosonics.com)

# WELCOME TO A NEW WORLD OF CONVERSION

**ANALOG WAY® introduces the Leading Studio Scan XTD 820, a High Resolution WORKSTATION/PC/MAC to VIDEO SCAN CONVERTER for a broadcast quality conversion**



## Features :

- Professional GENLOCK
- COMPUTER INPUT up to 1 600 x 1 280 (Auto Scan up to 110 KHz)
- VIDEO OUTPUTS : COMPONENT (DVCAM™, DVCPRO™ recording), RGB/S. NTSC. PAL. S. VIDEO
- ZOOM up to 200 % (continuous)
- Front Panel LCD Window with Direct Touch Control for fast and easy adjustment
- 6 Anti-Flickering levels
- 16 user memory Presets
- Internal Power Supply
- Optional Digital Video Output (SDI)
- 16 million Colors Processing



Other Products available : Seamless Switchers®, Scalers, Line Doublers, Down Converters, Interfaces, Cables, DA's.

ANALOG WAY, 75 Maiden Lane,  
New York, NY 10038  
Tel: (212) 269-1902 - Fax: (212) 269-1943  
www.analogway.com



Circle (183) on Free Info Card

## GRAPHICS SOFTWARE PLUG-IN

**Inscriber Titemotion DV 4.2:** allows users to create video titles and motion effects in Adobe Premiere on Windows 98 and NT platforms; new features include over 200 pre-designed templates, more than 50 animation templates, blur filter and over 200 new text styles; with full key channel support, titles can be laid over digitized video with full transparency; 800-363-3400; 519-570-9111; fax: 519-570-9140; www.inscriber.com

Circle (359) on Free Info Card

## STREAMING MEDIA PRODUCTION SYSTEM

**Media 100 iFinish 3.0:** Windows 2000 will serve as the streaming media production solution's primary development platform offering; the move offers users the benefits available in the more stable operating environment, including dual-head support; with the system, users can utilize input from almost any video device or graphics application to create high quality video and audio content for streaming over the Internet; 800-773-1770; 508-460-1600; fax: 508-624-9384; www.media100.com

Circle (360) on Free Info Card



## COMMERCIAL-GRADE CD PLAYERS

**Superscope/Marantz PMD330, 331 and 340:** these CD players are able to play CD-RW discs recorded on CD-RW compatible recorders; models offer a high-performance CD mechanism and state-of-the-art signal processing technology, a multifunction programmable cue button that enables precise control of playback and a 10-digit keypad to access up to 99 tracks; also offers A-B point audio loop playback, audible frame-by-frame search control, single-tack play, index searching and 21 preset functions; each model includes RCA analog outputs, digital (SPDIF format) coaxial output and RC5 remote input/output; 630-820-4800; fax: 630-820-8103; www.marantz.com/product/professional

Circle (362) on Free Info Card

## GROUND LOOP RIPPLE ELIMINATOR

**Matthey Electronics MRE filter range:** available as single or triple channel boxes, the filter reduces 50- or 60Hz hum by up to 60dB; eliminates potential hum interference in the video channel of cameras, video effects generators and monitors; +44-1782 524 919; fax: +44 1782 524 977;

Circle (355) on Free Info Card

## PUBLICATION

**SYPHA NLE Buyers Guide:** new publication offering over 300 entries dedicated to nonlinear video editing systems; also covers disk recorders/servers aimed at editing applications; potential purchasers can use the guide to establish what is on the market and determine the most useful product for their needs; full listings include target markets, specifications and operational features; +44 1817 611042; fax: +44(0)181 244-8758;

Circle (356) on Free Info Card

## bvs SDI DOWNSTREAM LINEAR KEYS



### Masterkey 6

*The perfect, cost effective solution for flawless linear keys.*



### Masterkey 7

*Loaded with features: linear keys plus ~ A/B mix, wipes, split screen, fade to black, chroma key, safe area graticules, key masking, failsafe bypass, memory, preview output.*

*Front control panel of both models may be remoted.*

## broadcast video systems corp.

40 West Wilmot St., Richmond Hill, Ontario L4B 1H8  
Ph(905)764-1584 Fax(905)764-7438 E-mail: bvs@bvs.on.ca  
Website: www.bvs.on.ca

Circle (149) on Free Info Card

TO THE POWER OF MAXELL  
**PROFESSIONAL MEDIA**



Get blown away by the power of Maxell's professional digital media. Maxell's cutting edge portfolio includes products such as DVCPRO and Betacam SP and a full line of digital recording products such as Digital Betacam, D-2, D-3, D-5 and DLT. Maxell offers top reliability and performance and the brand name to drive sales and stimulate category growth. When you combine Maxell's history of delivering peak performance, outstanding reliability and category innovation with our technological leadership, it's no wonder we've been the industry's choice for over 30 years.

**TAKE YOUR PROFESSIONAL MEDIA TO THE POWER OF MAXELL**



**maxell**  
**PROFESSIONAL**

Circle (148) on Free Info Card

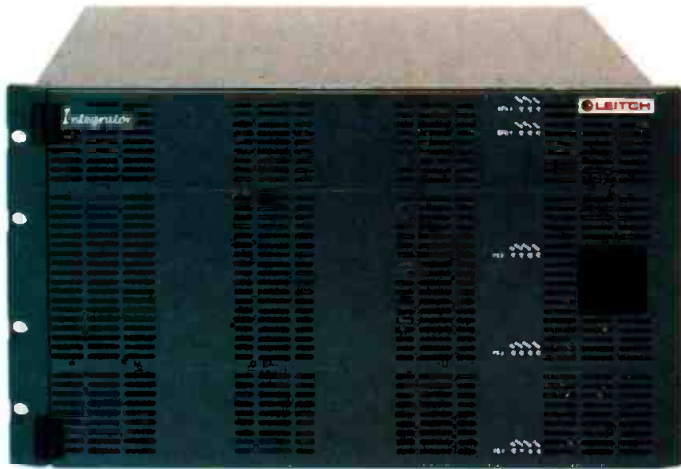

### 512X512 HD ROUTERS

**Leitch Integrator:** is available in HD, coaxial or fiber SDI analog video, AES audio, mono or stereo analog, offering field-accurate switching in 4-, 6- or 8RU frames; it also features dual outputs, references and individually configurable serial ports, as well as hot-swappable power supplies and control logic; 800-231-9673; 757-548-2300; fax: 757-548-4088; www.leitch.com  
**Circle (365) on Free Info Card**

### HDD/A CONVERTER

**Miranda Technology SDM0871p:** miniature HD digital to analog converter facilitates the monitoring of HD serial digital (HD SDI SMPTE 292M) video signals; RGBHV/YUV output with user-selectable sync type to enable use in a wide variety of HD component analog and multisync computer display monitors; 514-333-1772; fax: 514-333-9828; www.miranda.com  
**Circle (366) on Free Info Card**

### TV FACILITY AUTOMATION

**Columbine JDS Broadcast Master V.7:** new design and architecture allows for improved scalability, business integration, SQL database structure for open access to third part tools and simultaneous access to shared data within a workgroup; offers Break Explorer and Planning Plus facilities; an integrated suite of software modules for acquisitions, schedule planning, program and transmission scheduling, process control program management and sales and library management; 303-237-4000; fax: 303-237-0085; www.cjds.com  
**Circle (367) on Free Info Card**

### ROUTER PROTOCOL CONVERTER

**DNF Controls RPC:** converter allows routers from different manufacturers to work together under a main router control; slave routers can be mapped to any desired level on the main router; supports routers from Grass Valley Group, PESA, Sierra Video Systems and Telect as masters and/or slaves; 818-252-0198; fax: 818-252-0199; www.dnfcontrols.com  
**Circle (368) on Free Info Card**

## Analog Video Production Switchers

*Analog  
is Alive & Well  
at Ross*

RVS 630	2.5 ME	30 Inputs	Downstream MultiKeyer
RVS 424	2 ME	24 Inputs	Downstream MultiKeyer
RVS 416	2 ME	16 Inputs	◆ <b>Next Transition "GVG" Style Operation</b>
RVS 316	1.5 ME	16 Inputs	
RVS 216A	1 ME	16 Inputs	◆ <b>3 Year Warranty</b>
RVS 210A	1 ME	10 Inputs	

\*GVG is a trademark for Grass Valley Group



**Switchers, Keyers,  
& Terminal Gear**

**www.rossvideo.com**

Tel: (613) 652-4886  
 Fax: (613) 652-4425  
 Email: solutions@rossvideo.com

Ask about our complete line of  
**RossGear Terminal Equipment.**

Circle (162) on Free Info Card

### LC Fiber Optic Connector Products

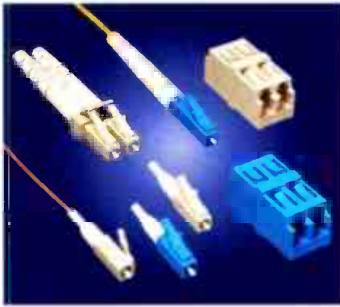

Methode Fiber Optic products manufactures a complete line of LC connectivity products for voice, video and data applications. The LC brochure details product specification and performance standards of this small form factor solution. Singlemode and multi-mode connectors, adapters, simplex and duplex patchcords, and cabling hardware are now available.

**Methode Electronics, Inc.**  
Fiber Optic Products  
7444 West Wilson Avenue  
Chicago, Illinois 60706  
(800) 323-6858 Fax: (708)867-9621

Circle (154) on Free Info Card

### Quick-Cure™ Connectors

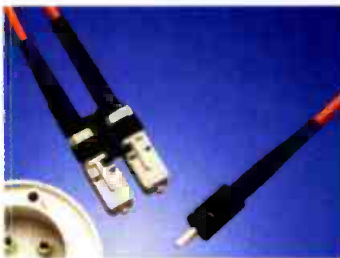

The Methode ST® and SC Quick Cure™ system combines patented polymer ferrule technology with a rapid cure adhesive. The pedestal tip reduces fiber breakage, and the 20 second curing interval decrease field termination procedure time.

**Methode Electronics, Inc.**  
Fiber Optic Products  
7444 West Wilson Avenue  
Chicago, Illinois 60706  
(800) 323-6858 Fax: (708)867-9621

Circle (155) on Free Info Card

### Quantum QX™ Backplane System



The QUANTUM QX™ fiber optic backplane connectivity system offers high-density connectivity in backplane applications such as telecom and datacom networking. QX trunk cables and assemblies are available in multimode and single mode versions and are compatible with other backplane systems.

**Methode Electronics, Inc.**  
Fiber Optic Products  
7444 West Wilson Avenue  
Chicago, Illinois 60706  
(800) 323-6858 Fax: (708)867-9621

Circle (156) on Free Info Card

### Angle Polish Connectors



Broadband Applications require the back-reflection reducing capabilities of Methode APC Angle Polish Connectors. Available in FC, SC, and LC configurations.

**Methode Electronics, Inc.**  
Fiber Optic Products  
7444 West Wilson Avenue  
Chicago, Illinois 60706  
(800) 323-6858 Fax: (708)867-9621

Circle (153) on Free Info Card

### MP™ Connectors



The Methode MP Ribbon Connector System offers a 12 fiber capacity in a miniaturized footprint patterned after SC styles. The MP is ideal for high-density LAN and data center applications.

**Methode Electronics, Inc.**  
Fiber Optic Products  
7444 West Wilson Avenue  
Chicago, Illinois 60706  
(800) 323-6858 Fax: (708)867-9621

Circle (152) on Free Info Card

### SC Fibre Channel Loopback



Methode offers several loopback products to test a variety of optical network and basic transceiver operations. Fibre Channel System (FCS) compatible loopback connectors are available with several attenuation levels.

**Methode Electronics, Inc.**  
Fiber Optic Products  
7444 West Wilson Avenue  
Chicago, Illinois 60706  
(800) 323-6858 Fax: (708)867-9621

Circle (151) on Free Info Card

# Stratos™ fiber optic connectors work where others fail.



### Expanded Beam technology lets your broadcast go through no matter what.

Whether you're trying to communicate through dirt, mud, water, grease – or even explosions – Methode's new Stratos fiber optic connectors can do the job. That's because they use Expanded Beam (EB) technology for unsurpassed performance in harsh environments.

Machined from advanced materials, Methode's Stratos EB connectors are easy to clean and easy to mate. They have the optical characteristics of the high-performance fiber optic connectors you'd find in a nice, clean computer room –

but with the ability to handle any unprotected environment no matter how rough.

All Stratos EB connectors are supported by Methode Fiber Optics offices and personnel located all over the world. It's just what you'd expect from Methode Electronics, a \$400 million company and developers of the advanced MP™ and Quick-Cure™ connectors.

Call 1-800-323-6858 today to learn more – or to place your order – for Methode Stratos EB fiber optic connectors.

**M**METHODE ELECTRONICS, INC.  
Fiber Optic Products

Methode Electronics, Inc. • 7444 W. Wilson Ave. • Chicago, IL 60706 • 1-800-323-6858 • FAX: 1-708-867-9621 • www.methode.com • fupinfo@methode.com

ST® is a trademark of Lucent Technologies

Circle (157) on Free Info Card

www.americanradiohistory.com

## BROADCAST COMBINER/MASK FILTER

**Andrew Trinity:** RF filter for television broadcast applications; providing thermal stability — cool operations up to 75kW; features aluminum construction and thermal compensation technology which reduces frequency drift; 800-DIAL-4-RF; 708-349-3300; fax: 708-349-5444; www.andrew.com

Circle (373) on Free Info Card

security/surveillance video, highway video/data collection, tunnel monitoring and airport security systems; offers adjustment-free RS-250C medium-haul video-quality performance; may be used as a stand-alone module with EMI/RFI shielding or adapted for use with a EIA 19-inch rack chassis; 800-732-5252; 540-382-0462; fax: 540-381-0392; www.forceinc.com

Circle (369) on Free Info Card

## MEDIUM-HAUL VIDEO PLUS 2-WAY DATA LINK

**Force Inc CCTV Linx RS-250C:** allows for the transfer of baseband video and bi-directional RS-232 data signals over a single fiber optic cable, with complete EMI immunity; the system can be used with no need for user adjustment in applications including

## PUBLICATION

**Hannay Reels Audio/video cable reels catalog:** new four-color catalog provide information and updated specifications on Hannay Reels audio/video cable reels, including its newest line designed for simplified set-up and tear-down; reels engineered for recording

facilities, live events and mobile broadcasting are featured; 800-GO-REELS; 518-797-3791; fax: 800-REELING; www.hannay.com

Circle (370) on Free Info Card

## AUDIO CONSOLE ACCESSORIES

**Otari ADVANTA accessories:** new line of accessories for the ADVANTA digital production system include seven options; the line features a 19-inch Rack Options section for an additional 19-inch work surface; other accessories include a TDIF/ADAT I/O unit providing 32 inputs and outputs in ADAT optical or TDIF formats and an ADVANTA fader panel with eight assignable Master Faders for use as dedicated group masters; redundant power supplies for phantom power, the server and the DSP engine are also available as options; 800-877-0577; 818-598-1200; fax: 818-594-7208; www.otari.com

Circle (371) on Free Info Card

## TRANSMISSION LINES

**Andrew Rigid Transmission Line:** now available with a new 7 3/16-inch 75 ohm line and patented technology for extending the life of a transmission line system; Andrew's rigid transmission line is made from high connectivity copper tubing; features a patented bellows section in each inner conductor allowing for differential expansion between the inner and outer conductors; the section eliminates mechanical wear and keeps metal shavings out of the line, extending transmission line life; 800-DIAL-4-RF; 708-349-3300; fax: 708-349-5444; www.andrew.com

Circle (372) on Free Info Card

# KRAMER - Solutions That Make Sense

**W**hether you are installing a Presentation System, Edit Suite, Control Room, Video Conferencing System or any application that needs multiple source audio or video display, Kramer's extensive line of cost-effective matrix switchers gives you the uncompromising quality and versatility to solve any installation problem. Call us for a free catalog, to choose the model that best suits your application, or for some free advice.



• Video Bandwidth 200+ MHz  
Audio Bandwidth 100+ kHz

• Video S/N 74 dB  
Audio S/N 84 dB



• Balanced or unbalanced audio models

• Kramer K-switch® software included

• Control manually, RS-232 or RS-485



### Kramer Family of Matrix Switchers

- Video • Serial Digital (SDI)
- Audio • S-video • Video and Audio



20 East Main Street • Clinton, New Jersey 08809  
(888) 275-6311 • info@kramerus.com  
In Canada, Call (800) 263-0733  
www.kramerelectronics.com

**Over 250 Switchers, DA's, Processors, VGA/XGA Interfaces, Encoders and Decoders You Can Count On!**

Circle (184) on Free Info Card



At 2000 feet up, 2<sup>nd</sup> best won't do.

And with over 1/2 a century of RF expertise, Dielectric can design the finest engineered DTV Antenna System available.



Raymond, Maine



Palmyra, Missouri

**A**s one company with two facilities — Raymond, Maine and Palmyra, Missouri — Dielectric offers you the world's most experienced team to get you on the air with DTV. Work with the RF leader in the broadcast business because it is our primary business. We offer you proven designs for the most fully engineered DTV systems in the world today.

- 700 years of combined broadcast engineering expertise
- 212 DTV antenna systems on air or in manufacture
- 80 DTV stacked antenna systems
- 2 DTV high power triple stacks

With more DTV experience than all other manufacturers combined, Dielectric assures you that your project will be done right and on time. Put our expertise to work for you and call us today.

**Dielectric**  
COMMUNICATIONS

*Engineering Excellence Since 1942*

Circle (158) on Free Info Card

1-800.341.9678 • 207.655.4555 • [www.dielectric.com](http://www.dielectric.com) • email: [dcsales@dielectric.com](mailto:dcsales@dielectric.com)

[www.americanradiohistory.com](http://www.americanradiohistory.com)

# DIGITAL

# TELEVISION 2000

## CONFERENCE & EXHIBITION

December 6 - 8  
Hyatt Regency  
Grand Hall  
Atlanta, Georgia

A MUST ATTEND EVENT FOR ALL  
DECISION-MAKERS INVOLVED IN  
TELEVISION & PRODUCTION

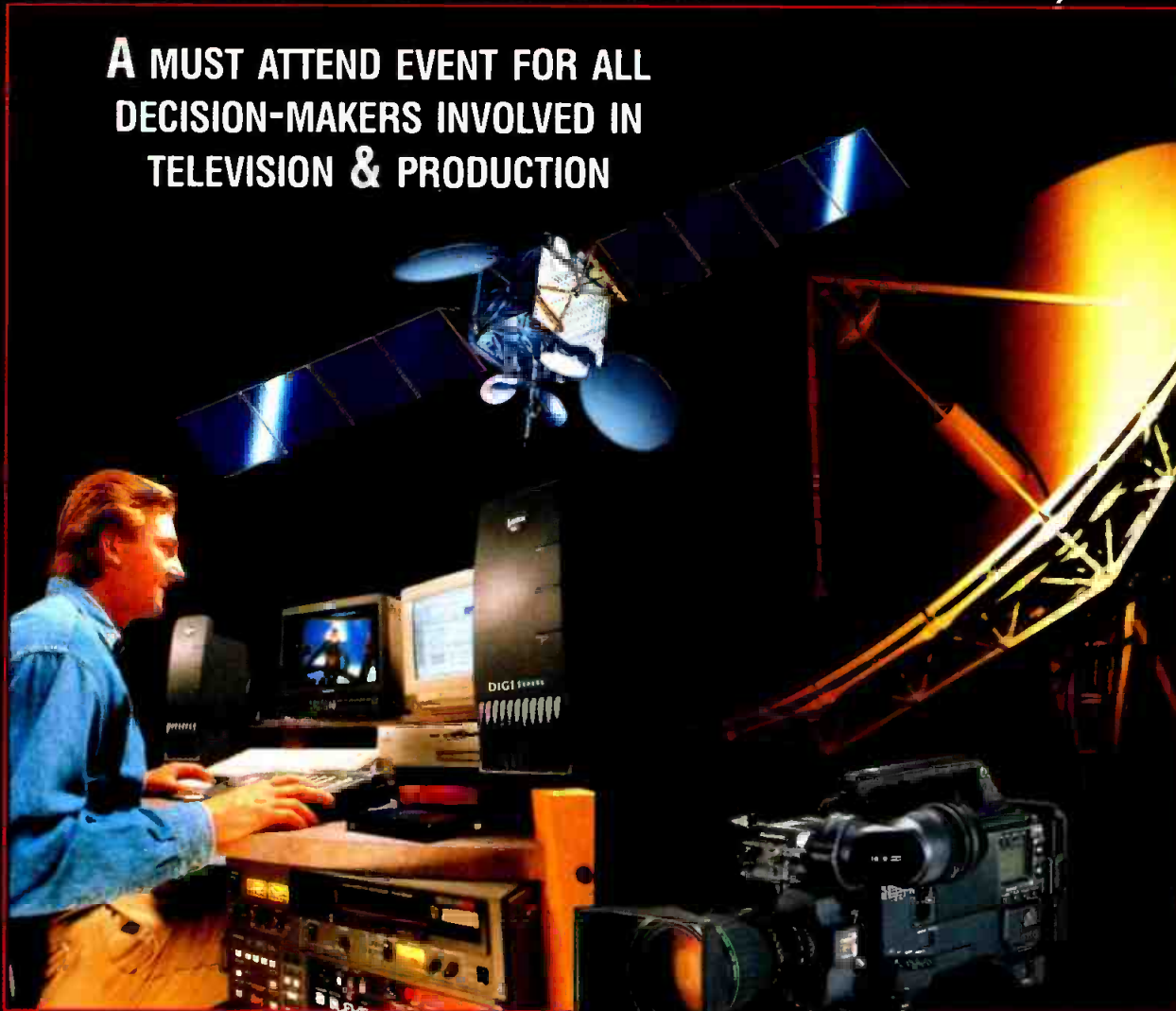

CALL 225.751.5626 OR RETURN COUPON

Fill out the form below to make sure you receive all the program and registration information as it becomes available:

I'm interested in attending DTV2000  I'm interested in Sponsoring/Exhibiting at DTV2000

Name \_\_\_\_\_ Title \_\_\_\_\_

Company \_\_\_\_\_

Address \_\_\_\_\_

City \_\_\_\_\_ State \_\_\_\_\_ Country \_\_\_\_\_ Zip \_\_\_\_\_

\*Phone \_\_\_\_\_ Fax \_\_\_\_\_

\*\*E-mail \_\_\_\_\_

\*International guests, please include city and country codes

\*\*Provide only if you wish to receive news and updates via e-mail

**Broadcast**  
**ENGINEERING**  
THE JOURNAL OF DIGITAL TELEVISION

**WORLD  BROADCAST**  
**ENGINEERING**

**millimeter**  
The Motion Picture and Television Production Magazine

**VIDEO**  
**SYSTEMS**

FAX: 225.751.6344  
MAIL: DTV2000 Customer Service • 16016 Perkins Rd. • Baton Rouge, LA 70810 • USA  
CALL: 225.751.5626  
VISIT: [www.dtvconference.com](http://www.dtvconference.com)



## VIDEO CARDS

**Digital Voodoo D1 Desktop 64 series:** series of uncompressed 10-bit SMPTE 259M SDI QuickTime video cards including D1 Desktop 64, D1 Desktop 64 Lite and D1 Desktop 64AV; the D1 Desktop 64AV is optimized for editing with Apple's Final Cut Pro and other such applications, with audio features rather than the key output featured in the other models in the series; D1 Desktop 64 and D1 Desktop 64 Lite models feature new dual channel video output allowing options including "video and audio," "video and alpha key" and full dual link 4:4:4:4; +61 3-9699-4633; fax: +61 3-9699-3226; www.digitalvoodoo.net

Circle (378) on Free Info Card

## PORTABLE MULTIDISCREORDER

**HHB Communications Portadisc:** optimizes the advantages of the mini-disc format, including exceptional sound quality, random access and straightforward editing using easy-to-handle, low-cost media; records on standard mini-discs and uses the latest ATRAC recoding algorithm to ensure optimum sound quality; balanced mic input circuits enhance the unit's sonic performance; circuits feature switchable phantom power and limiting, which can be stereo linked; records 80min stereo; 160min mono.; 310-319-1111; fax: 310-319-1311; www.hhb.co.uk

Circle (385) on Free Info Card

## INTERNET-ENABLED REMOTE MONITORING SYSTEM

**Euphonix Listen-In:** allows System 5 users to provide a live, secure Internet access for those involved in the recording/mixing process who are physically removed from the control room; users can log on through any audio capable PC or Mac and hear a near-CD quality mix; 818-766-1666; fax: 818-766-3401; www.euphonix.com

Circle (381) on Free Info Card

## ANALOG/DIGITAL TRANSMITTER

**Rohde & Schwarz NH7000/NV7000:** compact, medium-power transmitters with LDMOS transistors and integrated analog or OFDM/8VSB coders for analog and digital transmission; feature liquid cooling, a newly developed exciter and a special hardware concept; +49-89-41292931; fax: +49-89-41291211; www.rsd.de

Circle (386) on Free Info Card

## DIGITAL WIRELESS SYSTEMS

**TOA Electronics DK-7 series:** provide users with studio quality sound and a dynamic range of more than 110dB, with no pumping or breathing effects; systems are available in handheld, lapel or instrument forms for applications ranging from live performance to studio recording, electronic news gathering and pro audio; offers 24-bit analog-to-digital conversion for precise reproduction of the source signal, and seven selectable frequencies for simultaneous use of up to seven systems; 800-733-7088; 650-588-2538; fax: 650-588-3349; www.toaelectronics.com

Circle (387) on Free Info Card

## VIDEO DISTRIBUTION AMPLIFIERS

**Crystal Vision VDA series:** new series of analog video distribution amplifiers allows for 18 different combinations of boards and frame rear modules; the VDA210R, VDA110R, VDA210M and VDA110M provide users with a choice of different numbers of inputs, outputs, loop-throughs and manual or remote control to meet installation requirements; all feature GPI and LED indication of errors including input failure and power loss, adjustable gain and high quality equalization; +44 1223 506 515; fax: +44 1223 506 514; www.crystalvis.com

Circle (388) on Free Info Card

# SANIX®

**new concept**  
**"Capacitive-Discharge"**  
800Hz PULSE GENERATION  
**BULK ERASERS**  
**FAST**  
**COMPACT**  
**EFFICIENT**  
**RELIABLY ERASE**  
**METAL TAPES**

All Models operate on 117V at 3 Amp.  
24 hour continuous duty, no heat build-up.



REQUEST FULL-LINE CATALOG

U.S.A. DISSTRIUTOR  
RTI-RESEARACH TECHNOLOGY INT'L.  
4700 CHA SE AVENUE  
LINCOLNWOOD, IL 60646 U.S.A.  
**PHONE : 847-677-3000**  
**FAX : 847-677-1311**

**SANIX CORPORATION**  
TOKYO, JAPAN FAX: 81-3-3702-9654

Circle (159) on Free Info Card

## Interested in Digital Audio Workstations?



If you need to know what's on the market, **The DAW Buyers Guide** is your answer!

How many trade shows, magazines, telephone calls and Internet searches would it take to find everything that's out there? Then how long would it take to compile all that information into an easily comparable format? And then what about all that missing info?

Don't worry - we've done the hard work for you!

**The DAW Buyers Guide** from independent consultants SYPHA includes details of over 300 digital audio workstations and tapeless recorders and covers not only existing systems, but those yet to be launched.

It's comprehensive, it's invaluable and it's only \$34.95 + shipping and handling. For more details contact SYPHA Tel +44 20 8761 1042; Fax +44 20 8244 8758; email [sypha@compuserve.com](mailto:sypha@compuserve.com).

**The DAW Buyers Guide** is available through NAB Publications, [www.nab.org.nabstore](http://www.nab.org.nabstore), or direct from SYPHA and other booksellers worldwide.

## BETACAM SP VIDEOCASSETTE

**Quantegy BSP:** offer high quality picture and audio reproduction for professional ENG/EFP and studio applications; feature a dimensionally stabilized polyester backing for the prevention of skew errors; also feature quality assurance test plans including full-width laser scanning, real-time video dropout testing and laser scanning inspection of the coated web and individual strands to maintain surface uniformity; 800-752-0732; 334-745-7643; fax: 334-742-6091; [www.quantegy.com](http://www.quantegy.com)

Circle (390) on Free Info Card

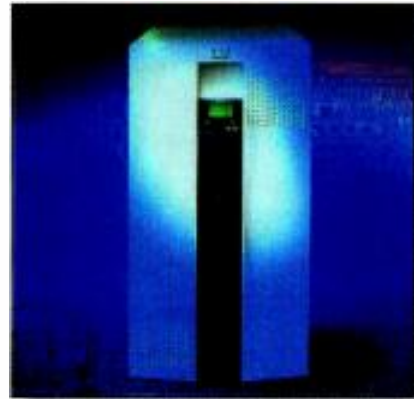

## UPS

**MGE UPS Systems Galaxy 3000:** three-phase, online 10- to 30kVA UPS is compatible with all major industrial and network communications protocols, offers a full graphical user interface display, and reports all input/output voltage combinations; offers a unique ECO mode operating at 97 percent efficiency; advanced inverter technology restricts total harmonic distortion to less than three percent; also features a contained, scalable design — extra options cabinets are not necessary; 800-523-0142; 714-557-1636; fax: 714-557-9788; [www.mgeups.com](http://www.mgeups.com)

Circle (392) on Free Info Card

## PANTILT AND LENS CONTROL SYSTEM

**Electronic Systems Integration Model 280:** features video preview and sync distribution; handles switching needs including teleconferencing, distance learning and theater instrumentation for small broadcast facilities; allows control of up to four remote camera sites by a single electronic solution through two auxiliary switches on the front panel; four RS-422 connectors interface with each of the remote sites; pan/tilt and lens control system also features a 9-Pin D connector for RS-232 serial interface, a 6-Pin Mini-DIN connector for remote CCU interface and a wall-mounted power supply; 407-956-0095; fax: 407-956-0610; [www.esi-inc.com](http://www.esi-inc.com)

Circle (393) on Free Info Card

## ISOLATOR

**Jensen Transformers ISO-MAX CO-2RR:** newest in Jensen's ISO-MAX line of isolators, eliminates hum in audio systems; neutralizes ground loop problems occurring within audio signals with a turnkey interconnect solution; the CO-2RR provides users with 15dB of headroom at 20Hz; 818-374-5858; fax: 818-763-4574; [www.jensen-transformers.com](http://www.jensen-transformers.com)

Circle (397) on Free Info Card

## FACILITY MANAGEMENT SYSTEM

**Xytech Systems Web Browser Module:** latest addition to the Enterprise facility management system allows film companies, broadcast studios and production houses to access

**It's here...  
Industrial Machinery  
AUCTIONS  
on the Internet!**

**Industry will never  
be the same.**

AUCTIONS  
Machinery and Property  
-Plus-  
Machinery for Sale  
Businesses for Sale  
Commercial Real Estate  
RFPs and RFQs  
Employment  
Funding and Capital  
E-mail Notification Services

**i-com  
industry**

**[www.i-comindustry.com](http://www.i-comindustry.com)**

Circle (160) on Free Info Card



## Unlock The Power Of Time Division Multiplexing



True power is the ability to control — and that's what the new ENVOY7256 router with Time Division Multiplexing (TDM) technology gives you; unequalled power to control your digital audio signals. With single channel switching with gain control, channel summing and phase inversion of up to 512 channels (256 AES) in a single 14 RU frame, the possibilities are endless.

The TDM matrix allows individual mono channels to be swapped from any input pair to any output pair regardless of size. Linear expansion to multiple frames now becomes effortless. With just one additional 14 RU 512<sup>2</sup> frame you've doubled your routing size to 1024<sup>2</sup>. With just four 14 RU 512<sup>2</sup> frames you're now at 2048<sup>2</sup>. There are no additional audio DAs or secondary switching systems to worry about and expansion interconnections use standard coaxial cables. In a digital environment where being out of control can spell disaster, the ENVOY7256 router gives you the power that puts you solidly in control. And it's only available from the people that have DTV down to a science. ADC.

For more information call (800) 726-4266 in North America or (530) 265-1000 worldwide, or visit our website at [www.adc.com/broadcast](http://www.adc.com/broadcast).

EQUIPMENT  
SOFTWARE  
SERVICES



facility information over the Internet; users of the system can access information such as studio and production schedules, and location information from anywhere in the world, as well as tracking their own information online; 818-767-7400; fax: 818-767-7430; [www.xytechsystems.com](http://www.xytechsystems.com)

Circle (398) on Free Info Card

### DIGITAL BETACAM VIDEO CASSETTES

**Quantegy DBC:** high impact cassette mechanism for ENG/EFP or post production applications; features a coactive site binder system to improve cross-linking and reduce debris; incorporates polyurethane molecular binder and matrix lubricant system for a smooth tape surface; small and large cassette sizes offer play times of six minutes to 124 minutes; 800-752-0732; 334-745-7643; fax: 334-742-6091; [www.quantegy.com](http://www.quantegy.com)

Circle (389) on Free Info Card

### DIGITAL TELEPHONE INTERFACE

**Telex Communications RTS TIF-2000:** designed for use with all RTS digital matrix intercom systems; features an auto/manual answer mode and direct call-in to party lines and IFB circuits, as well as direct audio input mixes with matrix audio; calls can be placed on hold and accessed individually or all at once through talk and listen keys on the RTS keypanels; TIF status is displayed on the TIF-2000 front panel; 800-392-3497; 612-884-4051; fax: 612-884-0043; [www.telex.com](http://www.telex.com)

Circle (396) on Free Info Card

### COAXIAL KEY PANEL INTERFACE

**Telex Communications RTS CSI-200:** allows users to connect RTS Matrix keypanels with intercoms via a single coaxial cable; interfaces provide two complete, independent

interfaces in a 1/2RU box, converting send and receive audio signals from balanced analog to a 48kHz, 24-bit signal, and a bi-directional data; all these are then transported over a single coaxial cable; 800-392-3497; 612-884-4051; fax: 612-884-0043; [www.telex.com](http://www.telex.com)

Circle (395) on Free Info Card



### ASSET MANAGEMENT SYSTEM

**Vecta AMS:** is an NT-based system providing backup and archiving to standard SCSI devices, C2-level security and multiple-criteria database searches; the system also offers seamless integration with Vecta DTV Stillstore; users can also view stored images from remote clients through an Internet browser, and utilize centralized reference storage and archival of still and graphic images; 800-706-0077; 310-581-8800; fax: 310-581-8808; [www.avicatech.com](http://www.avicatech.com)

Circle (401) on Free Info Card

## 'Comprehensive,' 'In-depth,' 'Vital'



*Dr. Corey Carbonara conducts research and performs consulting for HDTV/DTV conversion at Baylor University, Waco, TX.*

*When our readers tell us about Broadcast Engineering, they say it's the best place to get current and reliable information about the television, cable and production industries. Just ask Dr. Corey Carbonara:*

*"One of the biggest challenges of my job is keeping up with the developments in DTV.*

*"I believe it is vital to keep abreast of these new developments and technical breakthroughs. Broadcast Engineering always has comprehensive coverage and in-depth analysis of issues that are technical in nature.*

*"Broadcast Engineering provides a high-definition of clarity on DTV issues."*

*Dr. Corey P. Carbonara  
Associate Vice President for Technology Management; Executive Director, Institute for Technology Innovation Management, Baylor University*

**Broadcast  
ENGINEERING**  
THE JOURNAL OF DIGITAL TELEVISION®

An INTERLEC® /PRIME-DIVA Publication

# **Demo** an affordable **Precision** Video Demodulator

	<b>msi 320</b>	Tek/Rohde <sup>1</sup>	<i>Here's what you'll find when you compare the <b>msi 320</b> with the <b>Tektronix/Rohde</b> demodulator:</i>
Differential Phase	1.2°	2°	
Differential Gain	1%	2%	
ICPM Accuracy	±2° from 75° to 105°	not specified	
Aural Signal Demodulation	Visual carrier not required	Requires a sync modulated visual	
Zero Carrier Reference Line	User selectable between 11 and 36	Must be factory set	



But don't just take our word for it. Put the **msi 320** side by side with the demodulator you're using now. If it's a legendary 1450<sup>2</sup>, you'll find the performance of the **msi 320** nearly identical. If it is anything else, you'll find there's no comparison.

Don't wait. Just tell us you want to try the **msi 320** with absolutely no obligation. We'll send you a demo request form. Fill it out and return it, and we'll send you a demo unit that you can test and evaluate. It's that easy. If you have any questions, we'll even help you set up a valid comparison test.

**Make the comparison. Call us today.  
You'll be glad you did.**



Modulation Sciences Inc.

12A Worlds Fair Drive Somerset, NJ 08873

Toll Free: (800) 826-2603 Fax: (732) 302-0206

E-mail: sales@modsci.com www.modsci.com

1. Tektronix is a registered trademark of Tektronix, Inc. Rohde is trademark of Rohde & Schwarz GmbH & Co. KG, Germany  
2. 1450 is a mark of Tektronix, Inc.

### HD UNCOMPRESSED VDR

#### DVS Digital Video Systems Inc ProntoVision 2000:

successor of the ProntoVision allows real-time I/O and storage of uncompressed HDTV content; new generation fits into a 4HU case; contains built-in video disks holding up to one hour of video and audio; supports common HDTV rasters — 1035i/1080i, 720p, 1080p/24, 1080p/30 and 1080sF/24; features a real-time color space converter allowing for YUV/4:2:2 and RGB/4:4:4, with in and outputs in YUV and RGB; can be operated as a stand-alone device or in connection with a host computer running Windows NT 4.0, Windows 2000, Linux or Solaris platforms; 818-241-8680; fax: 818-241-8684; [www.digitalvideosystems.com](http://www.digitalvideosystems.com)  
Circle (394) on Free Info Card

### 225-450KVA UNINTERRUPTIBLE POWER SUPPLY

**MGE UPS Systems EPS6000:** offers large-scale, continuous operation power backup for broadcast facilities; protects Internet and broadcast facilities from power outages and provides power conditioning to smooth out periodic power line or weather-related disturbances; handles the "crowbar effect" caused by broadcast transmitters by means of high surge circuitry and a 100 percent rated static transfer switch; features Insulated Gate Bipolar Transistors with MGE's Digital Power Quality micro circuitry; 800-523-0142; 714-557-1636; fax: 714-557-9788; [www.mgeups.com](http://www.mgeups.com)  
Circle (391) on Free Info Card

### DTV TRANSMITTER TEST SYSTEM

**Harris CD Eye:** now shipping from Harris, an integrated digital transmitter test system; a software-based system that provides measurements for spectrum, out-of-channels mask, eye diagram, constellation, signal-to-noise ratio and error vector magnitude, pilot level, nonlinear analysis and real-time adaptive correction metrics; 800-622-0022; 513-459-3400; fax: 513-459-3890; [www.harris.com](http://www.harris.com)  
Circle (361) on Free Info Card



### MULTIMEDIA SERVERS

**Alex Temex Multimedia Libra servers:** now shipping with the Linux operating system; scalable, modular servers offer easy access to multimedia via LAN networks; parallel architecture eliminates duplication of stored data; +33 1 47 16 95 77; fax: +33 4 50 64 09 02; [www.alex.com](http://www.alex.com)  
Circle (399) on Free Info Card



### FIREWIRE STORAGE

**MicroNet Technology SANcube:** now shipping, the serverless storage network offers fast connectivity and fast, reliable storage for project collaboration on Power Mac G4, Power Mac G3, PowerBook and iMac DV systems; transfer rate is 30Mb/s; 949-453-0673; fax: 949-453-6071;  
Circle (400) on Free Info Card



## THE EQUIPMENT LIQUIDATION CHANNEL

BUY

SELL



### The Leading Marketplace for Professional Technology Tools

- 100% Satisfaction Guaranteed
- Secure Transactions
- Automatic Payment Escrow
- Over 20 years of Pro Experience
- Consignment or Buyout

**digibid.com**  
Auction Network  
an IndustryClick solution

[www.digibid.com](http://www.digibid.com)

e-mail your list to [liquidation@digibid.com](mailto:liquidation@digibid.com)  
or call 1.800.423.5499

Broadcast / Film / Pro Audio / Video / Lighting

Circle (164) on Free Info Card

[ No smoke. No mirroring. ]



You already have enough to think about when choosing a video server system. So here's some straight talk. The SeaChange Broadcast MediaCluster™ is the most reliable in the industry. Without costly mirroring. That's the better thinking engineered into SeaChange's entire family of MediaCluster servers, delivering MPEG-2, 4:2:2 video at bit rates up to 30Mb/sec. With rock-solid solutions starting well under \$100K, you can buy into open standards and networked solutions that offer real opportunities

for streamlining your single or multichannel operation. We won't dazzle you with the configuration diagrams here. Visit [www.seachangeinternational.com](http://www.seachangeinternational.com). And see why we're playing on 27,000 channels worldwide.

 **SEACHANGE**  
INTERNATIONAL  
[www.seachangeinternational.com](http://www.seachangeinternational.com)

Circle (165) on Free Info Card

## Business highlights from broadcast and production

BY LAURA COLLINS, EDITORIAL ASSISTANT

**Professional Communications Systems** was chosen by WTVC-TV to provide systems design and integration for its new broadcast facility in Chattanooga, TN. PCS installed equipment including Panasonic DVCPRO 25/50 VTRs and routers, and switchers from the Grass Valley Group in the new digital facility.

PCS is also providing systems design and integration services for NBC affiliate KCEN-TV in its transition to digital.

Total Video at Houston Studios recently purchased a DVCPRO camcorder and HD studio VTR from **Panasonic** for use in the production of feature films, trailer footage, video for plasma screen display and HD projection.

Panasonic's DVCPRO PV Series was purchased by WVNY-TV in Burlington, VT. The station is using the digital component camcorders, VTRs and studio players in the acquisition and production of two daily 30-minute newscasts.

Fox Sports Net will also be using DVCPRO 50 equipment from Panasonic. The equipment will be used to acquire, edit and playback sports programming in Fox Sports Net's regional networks.

**Panasonic, Tiernan Communications** and **Synergistic Technologies** have founded Digital Broadcast Resources. The alliance will provide broadcasters with end-to-end digital television solutions encompassing SD and multiformat HD production equipment and systems, critical encoding, and system integration capabilities.

Joint projects taken on by the three companies include an HDTV broadcast of "Monday Night Football" and the ABC HDTV Release Center.

NBC will use **Scientific-Atlanta's** PowerVu *Plus* digital video compression system to deliver four channels of backup broadcasts to its network affiliates in the United States.

ALLIANCE ATLANTIS chose **Columbine JDS** provided integrated management solutions for its four-channel lineup. CJDS' DMAS and Paradigm will be incorporated into a management and automation system for traffic, programming, material management and multichannel automation.

**THOMCAST Communications** and Evertz recently signed a reseller agreement. Under the agreement, THOMCAST will distribute and market Evertz products including keyers, logo inserters, timecode generators and universal data readers/decoders to the domestic broadcast market.

**Avstar** and **Sony** announced a joint solution for newscasters. The project introduces Active-X protocol into the Avstar Newsroom Computer System in order to allow it to coexist with Sony systems. The integration specifically allows for control of Sony's ClipEdit and NewsBase news server and enables newscasters to access news feeds and draft accompanying text simultaneously.

**Artesia Technologies** announced that Centerseat has chosen its Teams 3.0 digital asset management solution in its new entertainment and information website, [www.centerseat.com](http://www.centerseat.com). Centerseat will use the system to support secure syndication and content distribution to its broadcast partners, as well as to create a comprehensive digital media library of images, video and audio.

Artesia's Teams solution will also be used by 21e, a Web entertainment broadcasting network, to manage its streaming media content for scheduled and on-demand display.

NBC News recently purchased E5425 SNG encoders from **TANDBERG Television** to cover major news events worldwide.

## Screen Shot

### **Axiom-MT records New Orleans jazz**

Sheffield Audio Video Productions recently used Solid State Logic's 96-input Axiom-MT digital multitrack console at the New Orleans Jazz Festival. The MT was utilized in Sheffield's remote truck to capture Sting's performance in 5.1 surround sound.

The console was able to flawlessly combine Sting's audio with the HD video of his performance by interfacing effectively and cleanly with the equipment in the video remote truck. In addition, the Axiom-MT's automation enabled a quick changeover between performances, since producers were able to do a sound check in advance and recall the settings from that for each performance.

### **Virage offers interactivity for WB**

The WB television network chose Virage Interactive to allow viewers to interact with the WB's one-hour comedy series *Popular*. Virage's application services will be utilized to put the first 18 episodes from the first season of *Popular* on the Web.

Viewers can then view specific scenes by searching the material by character, date and episode at [www.TheWB.com](http://www.TheWB.com). They can participate in the Popular Purge by expressing their opinion on which character should be eliminated in the show's season finale, with the most humorous comments integrated into the broadcast of the show.

### **AMS Neve console supports Grammys**

Mobile recording specialist Effanel Music used a 128-input Capricorn digital mixing console from AMS Neve to record and mix this year's Grammy



# Why I'm Here.



**Nat Ostroff**  
EMMY award winner and  
Chairman of the Board of Acrodyne

*"I'm Nat Ostroff, Chairman of the Board at the new Acrodyne. I'm here because of you. As Vice President of New Technology with one of the largest commercial broadcasters in the United States, Sinclair Broadcast Group, we speak the same language. I know what you need.*

*I saw a good company with good people... Acrodyne had a lot of energy. And a unique opportunity was there to redirect (even recreate!) the company. Rather than making transmitters that large manufacturers want you to buy - designs overloaded with unnecessary complications - I saw a chance to meet the true requirements of broadcasters, like myself, by tailoring Acrodyne's products, services and support philosophies to broadcasters' needs. Something the managements of large domestic and international corporations are unable or unwilling to do.*

*So I brought the team of EMMY award-winning people that originally invented the IOT transmitter technology together again and created the QUANTUM Line of high power IOT solutions. Knowing what I know as a broadcaster, the Quantum's simple, elegant and reliable solutions will make your life easier and will set new standards. I believe it's remarkable.*

*Acrodyne also signed an exclusive agreement with Rohde and Schwarz, the world's leading manufacturer of solid-state transmitters, both air and liquid-cooled. This is the first opportunity for my fellow broadcasters to have access to the world's leading solid-state technology. Again, it's remarkable.*

*While we will continue to provide the equipment and support that you already count on from us, the new Acrodyne is committed to bringing you state-of-the-art high power television transmission equipment. At the new Acrodyne, we are anticipating your needs for the future by working along side of you.*

*We will be moving into our new multi-million dollar manufacturing facility this fall. A facility designed from the ground up to produce the latest transmission equipment for broadcasters.*

*I am not stopping there. Acrodyne makes it and stands behind it with 24-hour, 7 days-a-week service, technical support, including house calls, and direct access to myself and other members of senior management. This is what I expect from my vendors and you shouldn't settle for anything less.*

*As Chairman of the Board at Acrodyne, I'll talk with you about any new ideas or concerns. You can contact me at [nat.ostroff@acrodyne.com](mailto:nat.ostroff@acrodyne.com). I know what you need, we talk the same language, and I'll make sure that Acrodyne exceeds your expectations. That's why I'm here."*

**What's new at Acrodyne?  
Remarkably, just about everything.**

*new*  
**ACRODYNE**  
The Broadcaster's Company

ACRODYNE Industries, Inc.  
[www.acrodyne.com](http://www.acrodyne.com) | 516 Township Line Road | Blue Bell, PA 19422  
800-523-2596 | 215-542-7000 | Fax: 215-540-5837  
E-mail: [acroinfo@acrodyne.com](mailto:acroinfo@acrodyne.com)

Circle (166) on Free Info Card

[www.americanradiohistory.com](http://www.americanradiohistory.com)

FOX News has also selected TANDBERG to provide E5500 DSNG encoders and Alteia professional receivers for use in 110 FOX News affiliates across the United States. The equipment will be used this summer to cover all of the major political conventions.



Tandberg E5500 DSNG Encoder

TANDBERG's evolution 5000 digital broadcast equipment incorporating the E5611 encoder was recently installed for the first time in the United States, by FOX Broadcasting Company. The equipment is part of a digital satellite system worth more than \$1.5 million that FOX has selected to provide network programming to its affiliates around the country. The system uses four 36MHz C-band satellite transponders to handle the distribution of 16 MPEG-2 4:2:2 video channels.

Awards telecast. Effanel Music has used the console to record 62 live performances in four Grammy Awards shows, as well as a Dave Matthews Band DVD and the "Divas '99" DVD.

The company recently added a second Capricorn console for in-studio use, allowing Effanel to mix two projects simultaneously. Live events initially recorded in stereo on Effanel's remote Capricorn can also be remixed in surround on the in-studio console.

### Peak software provides museum graphics

Peak Broadcast System's Everest 3D rendering and Pilot template-based graphics software is being used to project HD graphical elements onto walls, video cube displays and plasma screens in the American Museum of Natural History's new Rose Center for Earth and Space. The software is also utilized on a seven-pipe, seven-processor Silicon Graphics Onyx System to composite graphics in the

center's Hayden Planetarium on the Digital Dome, the world's largest high-resolution flight simulator.

Pilot software is also used to produce "Science Bulletins" covering natural events and Hubble telescope images for widescreen, HD display in the Hall of Planet Earth and the Hall of BioDiversity.

### Ikegami cameras capture Mardi Gras festivities

WWL-TV, a Belo station in New Orleans, used Ikegami HDK-790D cameras equipped with new 2/3-inch 2.2-million-pixel FIT CCDs to capture the parades on Carnival Day during Mardi Gras. Eight hours of the festivities were shot in HD from in front of Gallier Hall.

Some of the footage was downconverted for use in the station's four-hour Carnival coverage. The station used HDTV D5 recorders to record footage for a one-hour show broadcast on Belo stations nationwide.

## AUDIO CROSSPOINTS ARE NOW OBSOLETE LIGHTHOUSE DIGITAL SYSTEMS

TODD A/O

Craig Nichols

Hollywood, CA

In front of an 848 x 848 OZ  
TDM & High Def Router.



### Audio Products

- 1024 x 1024 TDM/DSP Routing without tie-lines. Combine digital, analog, synchronous, asynchronous and remote frame/MADI inputs in a single system...and route them to any output. Up to 60% space savings over competitive models.
- Sample rate converters on all AES inputs.
- Mix stereo to mono and vice versa.
- MADI (56 channel) or 64 channel satellite I/O.
- RS422 and Time Code I/O.

### Video Products

- 64 x 128 I/O High Definition Routers with reclockers & equalization.
- 256 x 512 I/O Serial Digital Routers.
- Copper or fiber on any I/O module.

### Control Products

- Hardware Control Panels, Internet control, Java/Network Control Panels, NT Server, second party control and Touch Screens.



Founders Bob & Rick Grant

Please contact us

• Lighthouse Digital Systems • 888 494 7300 • FAX 530 272 8248 • <http://www.lighousedigital.com> •

Circle (167) on Free Info Card

# "the Time Machine"®

In broadcasting,  
the equation is simple:  
more time equals more money.

If you're a broadcaster, the Time Machine will allow you to make the most of the most valuable asset you have: time.

What if you could create additional time to put on the market every hour of every broadcast day? What if you could do it without affecting program content? What if you could do it without modifying audio or video in any detectable way? What if you could make it happen in real time, with no pre-recording or pre-processing? You can—if you have the Time Machine from Prime Image.

The Time machine means one thing for television broadcasters: more revenue. With our exclusive process, you can easily add a minute (or more) every hour. Which adds up to more availabilities, more sales, and more profits.

It's time to make more time that will make you more money. It's time to get the Time Machine from Prime Image.



**Prime  
image**

The Digital Video People

662 Giguere Court #C, San Jose, CA 95133 • Tel (408)867-6519 Fax (408) 926-7294 Service (408)926-5177  
Primeimagein@earthlink.net • www.primeimageinc.com

Circle (168) on Free Info Card



Kappell and Kostow MTV

Skywalker Sound, an audio post-production facility located at Skywalker Ranch in northern California, recently ordered two large-format System 5 high performance digital film consoles from **Euphonix**.

Chicago Recording Company also ordered four of Euphonix's System 5 digital consoles. The System 5 consoles will be replace existing mixing consoles in four of CRC's Audio-for-Picture Post Suites.

**Mindport** and **BARCO** recently announced a partnership involving technology integration and cooperative marketing activities. The agreement allows interoperability between BARCO's cable TV head-end and network

products and Mindport's end-to-end system solutions.

**Sennheiser** recently opened its first U.S. facility in Albuquerque, NM. The 45,000-square-foot facility currently employs 40 people, but as new products are added that number is expected to grow to over 150 employees.

**Kapell and Kostow Architects, P.C.** worked with Nickelodeon to design its 33,000-square-foot digital animation studio. Seventy digital animators work in the facility, which houses the production process for two animated children's television shows, "Little Bill" and "Blue's Clues." The facility produces the shows from concept initiation to final production of broadcast-quality tapes.

Elements of the project included production offices, an art department and 53 animation workstations. KKA had to take special lighting, power and communications needs into consideration, as well as creating a detailed system for wire access.

**Video Design Software** has created a set of applications that works with **Chyron's** Duet character and graphics generators to create a Media Object Server. The MOS is then used as an interface between the Media Object Server and an ENPS system using the MOS protocol. As media objects are created, information about them is transmitted to the ENPS, and ENPS users are able to use the objects in scripts and rundowns.

**Leitch's** DFS-3005 multiformat synchronizers were chosen to synchronize feeds for Societe Radio-Canada Montreal's facilities.

Henninger Video recently expanded its DVD production capabilities with technology from **Sonic Solutions**. Henninger will use Sonic's DVD Creator for high-end commercial production and feature film DVD encoding and authoring in its Elite Post facility in Nashville, TN.

Lifetime Television's new weekly game show "Who Knows You Best?" utilizes **Mixed Signals Technologies'**

# Windows to the Web



## www.rocketnetwork.com

**Rocket Network, Inc.** is the first and only company to provide Internet Recording Studios where audio professionals can meet online to collaborate and produce original audio from anywhere in the world. The Company's revolutionary network provides a cost-effective and convenient complement to traditional studios by reducing production expenses and increasing creative options for professional-quality audio in TV, film, radio, music and Websites.



## www.pinnaclesys.com

**Pinnacle Systems:** Pinnacle Systems' broadcast products give professionals the cutting edge tools needed to create dazzling productions faster and more affordably than ever before. These innovative digital video manipulation tools perform a variety of on-air, production, and post-production functions such as the addition of special effects, image management, capture, storage, and play-out, as well as graphics and title creation.

# *When Chicago's Tallest Building Needed 15 Channels\* - They Came To the Leaders in Broadband Technology!*

Chosen, by TrizecHahn Property Group, for over 30 years of global manufacturing experience, RFS is the leader in broadband technology.

Our broadband RF systems offer the most flexible and customized arrangements for the DTV Market and beyond.

RFS designs and manufactures broadband panel arrays, slot antennas, and combiners for adjacent and non adjacent channels designed to suit your needs.

Complimented by a full range of rigid and flexible line along with complete accessories which have been reliably manufactured and supplied to the broadcast market for decades. RFS is your Total Systems Solution provider - come take a fresh look, we will deliver.

**DTV Ready....  
DTV Proven!**

## **RADIO FREQUENCY SYSTEMS**

**RFS Broadcast**

59 Dodge Avenue

North Haven, CT 06473

Tel: 203-239-3311 Fax: 203-239-9260

email: [info@rfsbroadcast.com](mailto:info@rfsbroadcast.com)

web: [www.rfsbroadcast.com](http://www.rfsbroadcast.com)

\*Customer Requirements; 5 Channel, 7 Channel, and 3-Channel Systems

Circle (169) on Free Info Card



**First Sears Building Broadband Panel Array Antenna**

Interactive TV technology. The technology allows at-home viewers with set-top boxes running ATVEF-compliant platforms to become real-time contestants on the show.

Mixed Signals Technologies will also provide interactivity for Penn State Public Broadcasting station WPSX-TV. Mixed Signals' ITV DataFlo System will allow broadcasters to incorporate interactive web links into their programming.



**Hitachi Z-3000W camera**

System integrator TV Magic chose five Hitachi cameras for installation in a \$14 million news facility for San Diego FOX affiliate XETV Channel 6. Hitachi also provided three Z-3000W digital 4:3/16:9 switchable cameras to

KLCS-TV, a full-power PBS instructional station owned and operated by the Los Angeles Unified School District.

**Media 100** recently formed Stream-River Networks, a streaming media services division with regional centers serving Internet broadcasters, web designers and digital media content creators worldwide. In order to form the new division, Media 100 acquired 21st Century Media, a San Francisco-based provider of encoding, hosting, webcasting, interactive production and streaming media consultancy and J2 Digital Media, an encoding, hosting and streaming services provider based in New York.

**Virage** and PBS announced that PBS will be using Virage's Interactive application services to offer video content from the NewsHour with Jim Lehrer on PBS.org. The information will be continuously updated and searchable. PBS will also use the applications to distribute excerpts of the content to local PBS stations for use on their websites.

**Miranda Technologies** and Nortel Networks signed an agreement allowing Miranda to license Nortel Networks' broadband video technology. The agreement covers the DV-45 series of NTSC DV codecs and DV-MPEG SD7000 MPEG-2 codecs.

Cosmos Broadcasting Group will be installing **Crispin's** System 2000 station automation package at three of its stations — WFIE-TV in Evansville, IN; KPLC-TV in Lake Charles, LA; and WIS-TV in Columbia, SC. Three more of Cosmos' stations will have the automation systems by the end of the year. The systems will be used to automate master control functions including record and playback of syndicated and network programming.

Tonal Vision Studios, a sound-for-picture facility based in Baltimore, MD, recently purchased an MFX3plus digital audio workstation from **Fairlight**.

**Inscriber Technology** moved into a new headquarters, giving Inscriber's research and development, marketing, and production groups twice the space available to them before. The new building is located at 26 Peppler Street, Waterloo, ON N2J 3C4 Canada.

**Denon Electronics** recently moved from its previous headquarters in Parsippany, NJ, into a new 45,000-square-foot facility in Pine Brook, NJ. The new facility is located at 19 Chapin Road, P.O. Box 867, Pine Brook, NJ 07058-9777. The company telephone and fax numbers, e-mail addresses, and website remain the same.

Tigar Hare Studios used **3Dlabs'** Oxygen GVX1 graphics accelerator on *Mission Impossible: 2*. The workstation was used on the movie's title sequence, allowing for real-time approval on the project.

The Oxygen GVX1 system has been used by the studio for other projects as well, including work for Outback Steakhouse and Machines.

**Angenieux** has sold its 15 x 8.3 high resolution lenses to two Tribune Broadcasting stations — WPIX in New York City and WPHL in Philadelphia. Each facility will use three of the lenses for its ENG crews. In addition, Florida's News Channel selected the high resolution lenses with Assisted Internal Focus technology for use with the station's Sony BVP-550 cameras. WFMY, a CBS affiliate in Greensboro, NC, has also purchased Angenieux's 15 x 8.3 HR lenses, as well as 12 x 5.3 HR Wide Super Zoom lenses.

**MONITOR LOTS FOR LESS \$**

Serial Digital Video & Audio Converter with Alarm, Status & Audio Level Monitoring

- 801 to PAL/NTSC Conversion
- ARS/EBU to Analog Audio
- Audio Level & Phase Keying
- On-Screen Alarms
- Audio De-embedder
- GPI Alarms
- Closed Caption Decoding
- Logging of Errors

Up to 15 Modules in 3RU Frame  
Order 778AVM

**evertz**

www.evertz.com • Tel: 905-336-3700 • Fax: 905-336-3573

Circle (177) on Free Info Card

# SYNERGY 1

DIGITAL PRODUCTION SWITCHER



Synergy 1  
Control Panel  
+  
Synergy 1 Frame

## Synergy 1 Digital Performance Available with Your Choice of Control Panel

Until now, exciting features like "Aspectizers" dual aspect ratio converters & "Squeeze & Tease" 2D DVEs were only available on the award winning Ross Synergy Series line of big digital switchers.

Now you can have these Synergy type features and more on the new compact Synergy 1, a 16 input single MLE digital switcher, the new RVS 210D and 216D digital versions of the popular RVS 210A/216A analog switchers, and... even your GVG\* 100 and 110 production switcher.

That's right, you can now upgrade your GVG\* 100/110 to digital Synergy power by simply replacing your GVG\* frame with a new Synergy 1 digital frame.

Go ahead, say it ....Cool!

RVS 216D  
DIGITAL PRODUCTION  
SWITCHER



RVS 216  
Control Panel  
+  
Synergy 1 Frame

RVS 210D  
DIGITAL PRODUCTION  
SWITCHER



RVS 210  
Control Panel  
+  
Synergy 1 Frame

DIGITAL  
GVG\* 100/110  
UPGRADE TO DIGITAL



GVG 100/110  
Control Panel  
+  
Synergy 1 Frame



Switchers, Keyers,  
& Terminal Gear

Aspectizers for  
ous 4:3 & 16:9  
duction, Squeez  
ase 2D DVE, U  
Matching  
ew  
tion, Video

Audio Server Co

5000

GVG is a trademark of Grass Valley Group  
Ross and Synergy are trademarks of Ross Video Limited  
Ross Video is an independent company and is not affiliated with GVG in any way.

**Divicom** and **Geocast** have announced a partnership allowing broadcasters to merge Web content and local video content into their digital video streams for broadcast to PC users. As part of the alliance, Divicom will integrate the Geocast solution with DataTrack™. The Geocast service will enable users to instantly access local information and entertainment, while the DataTrack technology creates a transport stream between the head-end facility and consumers' set-top boxes.

**Columbine JDS** and **Triveni Digital** have jointly developed an interface between Triveni Digital's PSIP Builder Pro AE-10 and CJDS traffic and automation systems. The interface will allow DTV stations to use information from their CJDS systems to drive the PSIP, eliminating the need for PSIP data to be entered manually.

CJDS MCAS automation systems were also chosen for installation in five stations owned by the Sinclair Broadcast Group. Approximately 20

percent of Sinclair's stations currently have CJDS DAL systems installed. WEWS-TV in Cleveland, OH, has also purchased an MCAS-IV automation system from the CJDS DAL division of Columbine JDS.

Crown Media's Denver-based Hallmark Entertainment Network recently purchased a \$700,000 Image-store master control and channel branding system from **Oxtel**. The network will use the system for branding on its 15 new DTV entertainment channels, as part of a global playout system scheduled to be on-air this year. Hallmark Entertainment Network will transmit multilingual programming via fibre and satellite to the United Kingdom and Europe, as well as to Latin America and the Asia Pacific.

NBC affiliate WNDU-TV recently purchased a RapidAccess MPEG-2 video server solution from **Vela** to be used primarily for playback of spots and syndicated programs.

**Audio-Technica** has been selected by NBC and the Sydney Olympic Broadcast Organization to provide microphones for coverage of the 2000 Olympic Games. Audio-Technica will provide NBC with over 200 microphones, and SOBO with over 1000.

CBS-owned-and-operated stations will be the first to make use of **Utah Scientific's** new HD-2020 master control mixer. The system will interface with CBS's proprietary automation system.

**A.N.N. Systems** has provided its OpenMedia and StarDrive newsroom and asset management systems to FOX affiliate KKFY-TV for use in its new evening newscast.

A.N.N.'s OpenMedia and StarDrive systems will also be part of an integrated solution for the acquisition, management and broadcast/Webcast automation of digital media called "News-In-A-Box." A.N.N. formed a partnership with Leitch in order to provide the complete newsroom solution, which combines Leitch's digital

## Design and Mix a Cable Channel with Revolutionary Multimedia Insertion Technology!

CURRENT TEMPERATURES	
Amsterdam	10°
Berlin	28°
Cairo	36°
Dallas	32°
Geneva	24°
Johannesburg	25°
London	29°
Los Angeles	31°
Munich	28°
New York City	27°
Nice	26°
Paris	24°
San Francisco	10°

multiple scalable windows for MPEG-2 and analog video

vertically scrolling text or graphics

horizontally crawling text or graphics

graphic overlay with transparency

to Rome and Venice. Call Travel Network now for current holiday packages

### fundamentals

- Concurrent display of analog video input and MPEG-2 video in scalable, movable windows
- Scalable, 24-bit graphics overlays with 256 levels of transparency
- Back-to-back MPEG audio/video playback with genlock for seamless ad insertion
- Hardware-assisted scrolling and crawling of multiple graphics windows
- NTSC/PAL composite video support, optional S-video support

Single-slot PCI card • Supports multiple boards in a single system • Windows NT 4.0 support

**DVinci**™ - The Professional Broadcast, Multi-Source Video and Graphics Mixer



1-888-478-2687

sales@enseo.com

www.enseo.com

Circle (178) on Free Info Card



MRX

32 x 32 = 1 RU

**MRX**  
MIDSIZE ROUTING SWITCHERS

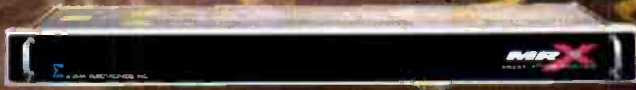

**MRX™ by Sigma. 32 x 32 = 1 RU, the formula for compact routing.**



Sigma Electronics has done it again. Introducing the new MRX Series™ of compact routing switchers. Only one rack unit high – perfect when space is at a premium. And, with specifications that meet the most critical applications.

Add levels and functions as required. Need a channel of audio? ...add a 1 RU, 32 x 32 frame. The MRX™ can switch eight control levels.

A variety of control panels including alphanumeric are available. For computer control via RS232/RS-422, check out our new SigMatriX™ software.

MRX™, the new formula for midsize compact routing switchers. As an added benefit, all components are covered by Sigma's 5-Year Parts & Labor Warranty.

Contact us now for product information or to locate your nearest Sigma dealer.

-   
Distribution
-   
Switching
-   
Timing
-   
Encoding  
Decoding
-   
Digital
-   
Transcoding



**SIGMA ELECTRONICS INC.**  
[www.sigmaelectronics.com](http://www.sigmaelectronics.com)  
1184 Enterprise Road  
PO Box 448  
East Petersburg PA 17520-0448  
(717)569-2681 TELEPHONE  
(717)569-4056 FAX

video servers and NLE technology with A.N.N.'s newsroom products.

Sunset Digital Studios, a post-production facility specializing in feature film mastering, made-for-television movies, music videos and commercials, installed the ARTEMIS digital audio workstation from SADIe in its digital mastering suite. The ARTEMIS is currently being used for DVD soundtrack mastering, Dolby E mastering, and digital restoration and mastering of motion picture/television soundtracks.

AMS Neve's Libra Live Series II digital broadcast console was chosen by Time Telepictures, a division of Warner Bros., for installation in its digital production facility. One will be installed in the existing Studio A, while the other is scheduled for installation in the new Studio B.

MTV Networks also purchased a Libra Live Series II for installation in their Studio B control room. The console will be used for MTV program

Total Request Live and live MTV studio performances. It was also be utilized for MTV's New Year's Eve special.

## PEOPLE

Solid State Logic appointed **Claire Hall** as national sales manager of broadcast products for the United States.



Claire Hall

**Jeff Gibson** was promoted to vice president of sales for Extron Electronics.



Jeff Gibson

Vela announced two executive promotions. **Bill Robertson** was promoted to vice president of technology, marketing and planning for Vela, and **Carl Gardner** was pro-

moted to vice president and general manager of Systems and Broadcast Products.

**Bart Petrini** was named president and CEO of Communications & Power Industries.

Hitachi recently appointed two top executives to its Industrial Video Division — **William Liento** as vice president and **Phil Gantt** as director of marketing.

**Bernard Lechner** was recently honored as the first recipient of the ATSC Outstanding Contributor Award. ATSC Chairman Robert Graves announced that the Bernard J. Lechner Outstanding Contributor Award will be given annually. ■



Bernard Lechner

# Axon.

Pushing the boundaries of fiber-optic transmission

## FIBER OPTIC TRANSMISSION SYSTEMS FOR UP TO 50 KILOMETERS

Whatever your fibre-optic transmission requirements, Axon has innovation solutions. For up to 50 kilometres, we have modular laser-based transmitter and receiver cards for single-mode or multi-mode fibres.

The transmitter and receiver cards feature an innovative contact block with precision optical connectors at the rear where they belong - out of potential danger. Forget about accidental breakage from fibres

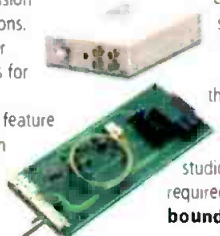

emerging from the front of routers or transmission systems. These converters can be used in the FR-2009/2002 frames.

For shorter distances (up to 2 kilometres), there are stand-alone LED-based transmitter and receiver units for multi-mode fibres (100 to 400 Mbit bandwidth). These are ideal for inter-studio connections or wherever galvanic separation is required. **To push your fibre-optic performance boundaries further, contact Axon.**



THE MARK OF DIGITAL ACHIEVEMENT

AXON DIGITAL DESIGN BY  
THE NETHERLANDS. PHONE: +31 (0)13 511 6666.  
UNITED KINGDOM. PHONE: +44 11 89 21 37 00.  
U.S.A. PHONE: (212) 265 6865.  
<http://www.axon.nl> Email: [axon@axon.nl](mailto:axon@axon.nl)

Circle (172) on Free Info Card



# The expert TOUCH

## NEXTORE Studio Server

### Welcome to the realm of productivity

**NEXTORE** is more than just a multichannel DDR with user-adjustable compression up to Lossless quality.

For live production, it features advanced control by instant clip access systems and switchers.

In post-production and broadcast facilities, it is the ideal digitization and pre-editing platform. At the core of your Fibre Channel SANs, **NEXTORE** links Non-Linear Editing, 3D Modeling, Special Effects and Paint applications for full-time creation and optimal workflow.

For a demonstration, please contact us at: [sales@thomsonbroad.com](mailto:sales@thomsonbroad.com).

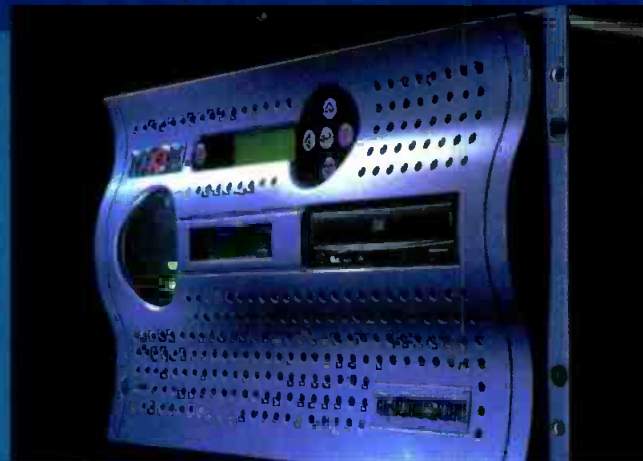

# THOMSON BROADCAST SYSTEMS

800 882-1824 • [www.thomsonbroad.com](http://www.thomsonbroad.com)

West Office  
Los Angeles, California  
Tel: (310) 479 1129

Midwest Office  
Indianapolis, Indiana  
Tel: (317) 587-5071

NY Metropolitan Office  
Englewood, New Jersey  
Tel: (201) 569 1650

South East Office  
Marietta, Georgia  
Tel: (770) 977-8980



**7530 HDTV Coax Cables  
Achieve Low Loss and  
Low Cost Results**

*The 7530 Digital Series is suited for larger facilities where longer and uncompressed transmission capability is required.*

- Transmits up to 1.5 GBs of HDTV-quality signal at a distance of 400 feet (using SMPTE 292M standard)
- Smaller size and low attenuation allows 7530 to be specified in place of more expensive fiber optic or larger size coax cables
- Easy to connect and install



**1-800-982-1708  
or [www.commscope.com](http://www.commscope.com)**

Circle (180) on Free Info Card

Did you remember to  
**RENEW**  
your subscription?

Don't miss a single issue of *Broadcast Engineering* magazine — The Journal of Digital Television.

For more than 41 years, *Broadcast Engineering* has shown readers how to successfully use new ideas and technology. Today, as the world begins to experience the benefits of digital technology, *Broadcast Engineering* is here to explain another new technology and explore the opportunities it presents to our readers today.

Don't risk doing business without *Broadcast Engineering* — renew today! Just visit our web site at [www.broadcastengineering.com](http://www.broadcastengineering.com) and continue benefiting from informative features focusing on topics such as:

- DBS & Satellite Services
- Systems Design & Integration
- Production & Post-Production
- Cable & Telecoms
- Television Stations & Networks

Don't miss a single issue!  
**RENEW TODAY!**

visit  
**Broadcast ENGINEERING**  
AN INTERTEC® PRIME MEDIA Publication  
THE JOURNAL OF DIGITAL TELEVISION®  
online

[www.broadcastengineering.com](http://www.broadcastengineering.com)

**Old-fashioned Perfection**

*State-of-the-Art Performance*

**The MicroFrame™**

The space saving MicroFrame™ houses up to 16 modules, and dual regulators. The LA-1 line amp is a one-in, two-out DA. The MP-1 is a one-in, two-out mic-pre with 48 V phantom power. All state-of-the-art performance and priced to fit most anyone's budget... from Benchmark, of course! Visit our web site today.

1RU High Chassis  
Up to 16 Line Amps  
Up to 12 Mic-Preamps  
Redundant Power  
Mix Amp Option  
Connector I/O Options

*Benchmark*  
The measure of excellence!™

[www.benchmarkmedia.com](http://www.benchmarkmedia.com)  
[sales@benchmarkmedia.com](mailto:sales@benchmarkmedia.com)

**BENCHMARK MEDIA SYSTEMS, INC.**  
Phone 800-262-4675, FAX 315-437-8119

Circle (179) on Free Info Card

# Discover the technology behind the broadcast.



This just in: Broadcasters around the globe race to join the digital revolution. And they turn to Intertec's broadcast publications to find out how. ☛ What's the latest word in DTV and HDTV? What about Internet broadcasting? How are the latest digital audio delivery systems helping stations stay competitive? What is Metadata anyway? ☛ Intertec has the answers. They're in *Broadcast Engineering*, *World Broadcast Engineering* and *BE Radio* magazines. Intertec's Entertainment Division is the leading information source in entertainment technology. Our informative, award-winning publications and timely events influence more than a quarter million key decision-makers around the world. ☛ We're proud to be your number one source for broadcast production technology. So, go ahead. Broadcast it to the world. We are.



Wherever there's entertainment technology, there's an Intertec publication.

#### PRO AUDIO

Mix / Mix Edición Español  
Electronic Musician  
Sound & Video Contractor

#### TELEVISION / RADIO

Broadcast Engineering  
World Broadcast Engineering  
BE Radio

#### CINEMA / VIDEO

Millimeter  
Video Systems

#### DESIGN

Entertainment Design  
Lighting Dimensions

#### EVENTS

LDI • ExpoLatina  
DTV Conference  
Studio Pro  
Broadway Lighting Master Class

[www.intertec-entertainment.com](http://www.intertec-entertainment.com)



**420 Ninth Ave.**

*Between 33rd & 34th Streets,  
New York, N.Y. 10001*

*Store and Mail Order Hours:  
Sun. 10-5, Mon. thru Thurs. 9-7  
Fri. 9-2, Sat. Closed*

*For Orders Call:*

**800-947-9928**  
**212-444-5028**

*or FAX (24 Hours):*

**800-947-9003**  
**212-444-5001**

*On the Web:*

**[www.bhphotovideo.com](http://www.bhphotovideo.com)**

*We Ship Worldwide*



**OUR NEW  
EXPANDED  
LOCATION**





# "THE PROFESSIONAL'S SOURCE"

FOR ORDERS CALL: **800-947-9928**  
 212-444-5028

OR FAX (24 HOURS): **800-947-9003**  
 212-444-5001

420 Ninth Ave. (Bet. 33rd & 34th St.) New York, N.Y. 10001

MOST ORDERS SHIPPED WITHIN 24 HOURS  
 OVERNIGHT SERVICE AVAILABLE  
 www.bhphotovideo.com



## SONY

### DSR-200A 3-CCD Digital (DVCAM) Camcorder

Combining a compact and lightweight body with the superior picture quality of DSP (Digital Signal Processing) and the DVCAM format, the DSR-200A is the ideal action tool for video journalists, event and wedding videographers, stringers and professional houses. 500 lines of horizontal resolution, 48kHz or 32kHz digital audio, 13-hour record time, and minimum illumination of 3 lux is only the beginning. Other features include 16 9/43 capability, Steady Shot, 3-line code operation, time date stamp, and an IEEE-1394 interface for direct digital output.

- Variable servo 10X optical power zoom lens goes from 5.9 to 59mm in 1.7 to 24 seconds. The manual zoom rocker is continuously available right up to when the digital 20X zoom kicks in.
- Sony's Super Steady Shot reduces high frequency camera shake without compromising image quality. SteadyShot uses horizontal and vertical motion sensors that allow it to work accurately while filming moving (even shooting from a car), and shooting in low light conditions.
- 15 digital effects including audio and video fade, overlap and cross dissolve.
- Automatic and manual focus, iris, shutter, gain and white balance. This is adjustable in 12 levels from F1.6 to F11, shutter from 1/4 to 1/10,000 of a second in 12 steps. Gain from -3dB to +30dB in 8 steps. Zebra Pattern indicator built-in ND filter.
- Custom Preset function lets you preset, store and recall custom settings for color intensity, white balance, (bluish or reddish) sharpness and brightness.



- Stores Photo, Date/Time, Shutter Speed, Iris, Gain and F-stop for easy recall. So if you have to re-shoot, you know your original settings for every scene and frame.
- Records Drop/Non-Drop Frame time code. Time code can be read either as RC time code or as SMPTE time code.
- Has a large 1-inch B&W viewfinder with 550 lines of resolution for easy focusing even in low contrast lighting situations. Separate information sub-panel displays time code, battery time, tape remaining and other camcorder functions without cluttering up the viewfinder.
- Records 16-bit 48kHz audio on one stereo track or 12-bit 32kHz with two pairs of stereo tracks (L1/R1, L2/R2), so you can add stereo music or narration.
- Automatic & manual (20-step) audio level record controls. Monitor audio with headphones or from the LCD panel which has an active VU meter.
- XLR input connectors for mics and audio equipment.

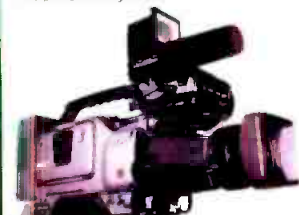

### DSR-300A 3-CCD Digital (DVCAM) Camcorder

Inheriting many of the same features and functions as the DSR-130, the affordable DSR-300A actually extends operational convenience with a range of new features and peripheral products. Remarkably compact and lightweight, the improved DSR-300A provides rich mobility without compromising picture quality and can be held comfortably on your shoulder through the longest shoots and gives videographers the ability to acquire their footage quickly and easily.

- The DSR-300A has three 1/2" IT Power HAD CCDs to deliver 800 lines of horizontal resolution, 620S S/N ratio and high sensitivity of F1.1 at 2000 lux.
- Power HAD CCDs also gives you a low smear level of -110 dB (DSR-300) allowing more freedom to shoot highlighted subjects.
- With built-in 26-pin VCR interface, they can feed composite or video output signals to an external recorder for parallel or back-up recordings. VCR recording modes including Parallel, Internal (only) and External (only) are selected via the trigger which is positioned on the operational panel.
- With the DSR-300A, a picture previously recorded on tape can be superimposed on the viewfinder screen (Freeze Mix function), allowing you to easily frame or reposition the subject just as in the previous shot. Combined with the Setup Log function, the relax shot becomes a breeze.

- LSI Digital Signal Processor (the very same one used by the DXC-030 cameras) for a high signal-to-noise ratio of 62 dB.
- Both mini cassettes (PDV series) and standard cassettes (PDV series) can be used with the DSR-300A. With PDV-184ME (Standard), a maximum recording time of 184 minutes can be achieved. They can also play back tapes recorded in the consumer DV format.
- For operational convenience while shooting, the Time Code is superimposed on the viewfinder screen or MONITOR OUT screen even during playback.
- DXF-801 viewfinder featuring variable peaking, 3-level tally light and a white LED light with 2 levels of intensity to illuminate the lens setting. • IEEE1394 i.Link (not only).
- Color Temperature Shift allowing the operator to manually shift the white balance either towards blue or red to compensate for conflictive (color temp mix) and because of the wide range it also provides creative artistic painting.

### DSR-20/40 DVCAM Player/Recorders

The DSR-20 and DSR-40 are versatile DVCAM VCRs with compact chassis and a variety of convenient functions for recording, playback and simple editing. They feature Auto Repeat Play, Jack, Power-On Recording/Playback, multiple machine control interfaces and i.Link (IEEE1394) input and output. And, of course, they offer the stunning image and sound quality inherent to the DVCAM format.



- **LINK** They both offer i.LINK (IEEE1394) input/output. In addition, the "Digital dubbing including IC Copy" mode, full information of date, audio and time code of the original tape can be copied to another copy. Especially useful when making working copies of the original.
- **Inputs and Outputs** They provide a full range of analog video inputs and outputs for integration into current analog-based systems. They both offer composite and S-Video input/output, while the DSR-40 (only) offers a component output as well. The DSR-20 is equipped with analog audio inputs and outputs (RCA), while the DSR-40 offers analog and XLR-balanced output. These connections in combination with their i.LINK interface allow a smooth transition to an all digital system in the future.
- **Record/Playback Functions** Automatic repeat function for repeated playback. After reaching the end of the tape, the DSR-20/40 automatically rewinds the tape, then starts playing back the segment again.

- They are capable of searching for index points and a variety of records on the tape as "pin-point" marks every time a recording starts. They can also search for photo data recorded on a DVCAM cassette by the DSR-200A/300/PD-100, or where the recording date has been changed.
- **Reference Input** External sync input enables synchronized playback with other VCRs. Especially important in A/B Roll configurations. In addition, the DSR-40 only allows adjustment of H-sync and SC phase via the menu.
- **Control S Interface** The DSR-20/DSR-40 have a Control S input allowing control via the optional DSRM-20 Remote Control.
- The DSR-20 adds a **Control S output** connector allowing two (or more) up to 50) DSR-20s to be daisy-chained and controlled from one DSRM-20.

**DSR-20 Only** - The DSR-20 can be powered by AC or DC equipped with Control L interface, the DSR-20 can perform simple Time Code-based editing when connected to another DSR-20 or other similarly equipped VCRs/cameras.

**DSR-40 Only** - Equipped with an RS-422A interface, it can perform as the editing player in A/B roll or cut editing system. It also has a simple recording function which can be controlled

- In addition to Control L, the DSR-20 also incorporates an RS-232 interface for remote control of basic VCR functions from a PC.
- Supplied with the RMT-DS20 Wireless Remote for control of basic VCR functions.

either manually or via its RS-422A interface.  
 • The DSR-40 is not equipped with a synchronization capability; the editing accuracy is performed by pre-roll and play.

### DSR-30 DVCAM Digital VCR

The DSR-30 is an industrial grade DVCAM VCR that can be used for recording, playback and editing. DV standard 4:1:1 sampling digital component recording with 3:1 compression ratio provides spectacular picture quality and multi-generation performance. It has a Control L interface for editing with other Control L based recorders such as the DSR-200A DVCAM Camcorder or another DSR-30. It also has a continuous auto repeat playback function making it ideal for kiosks and other point of information displays.



- Records PCM digital audio at either 48kHz (16-bit 2 channel) or at 12kHz (12-bit 4 channel).
- Equipped with Control L, capable of SMPTE Time Code based accurate editing even without an edit controller. Built-in editing functions include assemble and separate video and audio input by searching for either an index point or Photo Data recorded by the DSR-200A camcorder. The DSR-30 drastically cuts the time usually required for editing. The DSR-30 can record up to 135 index points or the Cassette Memory thanks to its 16K bits capability. Audio lock ensures audio is fully synchronized with the video for all source recordings when doing an insert edit.

- Built-in control tray has a jog/shuttle dial, VCR and edit function buttons. The jog/shuttle dial allows picture search at 1/5 to 1/5X normal speed and controls not only the DSR-30 but also a player hooked up through its LANC interface.
- DV In/Out (IEEE 1394) for digital dubbing of video, audio and data ID with no loss in quality.
- Analog audio and video input/outputs make it fully compatible with non-digital equipment. Playback compatibility with consumer DV tapes allows you to work with footage recorded on consumer-grade equipment. Tapes recorded in the DSR-30 are also compatible with Sony's high-end DVCAM VCR's.



## Panasonic

Broadcast & Television Systems



### AG-EZ30 3-CCD Camcorder with IEEE1394 Interface

- 3-CCDs (270,000 pixels each) with a large light-collecting area give the camera high sensitivity and wide dynamic range. Double-density pixel distribution and a gapless dichroic prism further ensure razor-sharp images and extremely faithful color reproduction.
- Selectable 2-channel 48 kHz/16-bit or 4-channel 32 kHz/12-bit PCM audio recording.
- Built-in stereo mic and external mic input as well.
- 180,000 pixel, 2.5-inch color LCD monitor. Also has a 0.5-inch color viewfinder.
- Digital Image Stabilizer for clear, shake and jitter free shots.
- 12X optical zoom as well as 30X and 120X digital zoom functions. Move from wide-angle to full zoom in 1.3 seconds allowing quick framing while in REC pause.
- Offers six digital effects: Wipe, Mix, Strobe, Gain-Up, B&W and still mode.

- Five program AE modes for shooting in a variety of different conditions. There is also a five-mode white balance: Set Fluorescent, Auto, Indoor and Outdoor.
- Large-diameter focus ring enables a high level of focusing precision. A Multi-Function Push Dial allows easy setting of the 16-step iris, 5-step gain control (+12dB maximum) and 14-step shutter (up to 1/8000 second). Mic input level can also be set in steps (-20/-10/0/+3/+6 dB).



## SONY

### DCR-VX1000

### 3-CCD Digital Camcorder

The DCR-VX1000 records 500 lines of horizontal resolution, and has a higher S/N ratio than cameras costing ten times more. Also records audio digitally, using PCM technology. The same as used in CDs for a breathtaking dynamic range of 96 dB. Most important though, since video and audio signals are recorded digitally, you can copy or edit multiple generations with no loss in quality. Analog tape artifacts like color bleeding, dropouts and generation loss are all a thing of the past.



B&H SPECIAL  
**\$2795**

- Eight-speed 10X optical zoom lens goes from 5.9 to 59mm in 4.1-20 secs. Also provides a digital 20X zoom.
- Records 12-bit/32kHz audio with two pairs of stereo tracks.
- Automatic and manual audio level record controls.
- Built-in time base corrector (TBC) delivers jitter-free playback and dead-perfect stills.
- Digital effects include audio and video fade (to black), overlap and slow shutter. • Time-lapse recording.
- Sony's Super SteadyShot reduces high frequency camera shake without compromising image quality.
- Records "extended data codes." Automatically stores date/time, shutter speed, iris and other data for easy recall.
- Records drop-frame time code for accurate editing.
- Record still image pictures with audio for up to seven secs.

- Focusing, exposure and white balance are all automatic or can be manually controlled.
- Zebra pattern indicator just like professional cameras.
- Preset store and recall your own custom settings for color intensity, white balance, sharpness, brightness and gain shift (0dB/-3dB).
- Precision 180,000 pixel color viewfinder incorporates a separate information sub-panel which displays time code, battery time, tape remaining and other camcorder functions without cluttering up the viewfinder.
- Control L terminal for communication between camera and edit controller.
- Built-in ND (neutral density) filter.
- Square lens hood reduces external light flare effects.

## JVC GY-DV500

### 1/2-inch 3-CCD Professional DV Camcorder

The world's first DV camcorder designed from the ground up for professional ENG work, the GY-DV500 combines the convenience and cost-effectiveness of Mini DV with the performance and features you need. Incorporate three 1/2-inch 380,000 pixel IT CCDs for superior picture performance (equivalent to 750 lines of resolution) superb sensitivity of F1.1 at 2000 lux and minimum illumination of 0.75 lux (LoLux mode). Rugged construction with a rigid diecast magnesium housing. Extremely portable, compact and light weight (less than 11 lbs. fully loaded). Additional features like the menu dial and Super Scene Finder assure ease-of-use and shooting flexibility, while the IEEE1394 and RS-232 interface allow integration into various non-linear and post-production systems. A professional camcorder in every sense, the compact, lightweight GY-DV500 redefines acquisition for corporate, educational, cable and broadcast production, as well as wedding videography and multimedia applications.



- **Professional Specifications**
- Applies JVC's DSP with advanced 14-bit video processing to bring out more natural details, eliminate spot noise, accurately reproduce dark areas, and restore color information in dark areas.
- CCDs are equipped with advanced circuitry to virtually eliminate vertical smear when shooting bright lights in a dark room. Ensures efficient light conversion with a sensitivity of F1.1 at 2000 lux.
- CCD Defect Correction function evaluates white defects with the lens closed and then stores their addresses in memory. When the camera is turned on, the data is sent to the DSP for storage and real-time correction.
- Black Stretch Compression function ensures accurate reproduction of black areas on the screen. Advanced color matrix circuits give even difficult images a very natural appearance.
- Multi-stream parallel digital pipeline processing at 40 MHz creates an ultra-smooth gamma curve, calculated using a true log scale algorithm. The result is a dynamic range of 600% to accurately reproduce fine details and colors in shadows or highlights.

- Adjustable gamma for adjusting the "feel" of the picture according to taste. Adjustable detail frequency for setting picture sharpness for a bolder or finer look.
- Viewfinder status display uses characters and menus to display selected information, including audio indicator, tape and battery remaining time, VCR operation and warning indicators. Camera settings and setup parameters can also be checked at a glance. A built-in menu dial lets you quickly navigate through the viewfinder menu.
- Highlight Chroma Processing maintains color saturation in highlights. The result is natural color reproduction, even in bright highlight portions of the picture.
- Smooth Transition mode ensures a smooth transition with no jump in color or light level taking place when manually changing gain or white balance settings.

- **Professional Performance**
- Multi-zone iris weighting system gives priority to objects at the central and lower portions of the picture for accurate auto exposure under any condition, even if a bright subject moves into the picture.

- **Professional Audio**
- To complement its superior video performance, the GY-DV500 offers outstanding digital PCM sound. You can choose between two 16-bit 48-kHz channels or two 12-bit 32-kHz channels with a dynamic range of 85 dB.
- In addition to camera mounted mic, has two XLR-balanced audio inputs with 48v phantom power and manual audio control. Phantom power can be switched off when not in use.
- Side-mounted speaker lets you monitor audio in playback and recording modes without headphones. The speaker also delivers audible warnings.



# THE PROFESSIONAL'S SOURCE FOR PHOTO,

FOR ORDERS CALL: **800-947-9928** OR FAX (24 HOURS): **800-947-9003**  
**212-444-5028** **212-444-5001**

**MOST ORDERS SHIPPED WITHIN 24 HOURS**  
**OVERNIGHT SERVICE AVAILABLE**  
[www.bhphotovideo.com](http://www.bhphotovideo.com)

## antonauber HyTRON 50 Battery

Weighing a mere 31oz (880 grams) and packing 50 Watt-hours of energy - enough to operate a typical ENG camcorder for two hours - the HyTRON 50 is the most advanced lightweight battery in the industry.

- Made possible by recent advancements in a cell technology originally designed for the mobile computing industry, it incorporates nickel metal hydride cells that provide the highest energy density of any rechargeable cylindrical cell available. High performance is further assured through the integration of Anton Bauer InterActive digital technology.
- Equipped with an on-board fuel computer which monitors energy input and output as well as critical operating characteristics and conditions. This data is communicated to the InterActive charger to ensure safety and optimize reliability.
- In addition, remaining battery capacity information is available by means of an LCD display on each battery and in the view-finder of the most popular broadcast & professional camcorders.
- Special low voltage limiter prevents potentially damaging overcharge.

**Specifications:** 14.4 V 50 WH (Watt Hours)  
 5.3" x 3.12" x 2.1" 1.9 lbs (880g)  
 Typical runtime: 2 hours @ 75 Watts 3 hours @ 17 Watts

### QUAD 2702/2401 Four-Position Power/Chargers

The highest and smallest full featured four position chargers ever. They can last charge four Gold Mount batteries and can be expanded to charge up to eight! They also offer power from any AC main in a package the size of a notebook computer and weighing a mere four lbs! The 40 watt 2401 can charge ProPacs in two hours and MiniPacs in one. Add the Diagnostic/Discharge module and the QUAD 2401 becomes an all purpose power and test system. The 70 watt QUAD 2702 has the module and is the ultimate professional power system.

## IDX NPH-50 50 Watt Nickel Metal Hydride Batteries

Packed with 50-watts of power, these batteries provide long run times. Using them as you would a traditional NP-type battery. Equipped with IDX's proprietary SF technology, they can even be charged in existing Negative Delta V style chargers, like the Sony BC1-WD or any IDX nicad battery charger.

**Both batteries are identical except that the NP-H50DX adds a power indicator.**

- High capacity NiMH cells • Standard thermal and short circuit protection, extra thermal fuse for safety, special plastic design for added strength.
- Environmentally safe • High efficiency/low temperature module • Capacity: 50Wh (13.2V/ 3.8Ah)
- Camera run time: 115min @26 Watts

NP-H50 ..... 129.95 NP-H50DX ..... 149.95

## JL-2 PLUS 2-Position Multi-Format Charger/Power Supply

Universal charger/Power Supply, 2-channel sequential quick charger and power supply for Lithium-Ion, NP/BP-type NiCad and NiMH battery packs.

**\$649.95**

## SONY 800 SERIES UHF WIRELESS MICROPHONE SYSTEMS

Consisting of 5 handheld and bodypack transmitters and 6 different receivers. Sony's UHF is recognized as the outstanding wireless mic system for professional applications. Operating in the 800 MHz band range, they are barely affected by external noise and interference. They incorporate a PLL (Phase Locked Loop) synthesized control system that makes it easy to choose from up to 282 operating frequencies, and with the use of Sony's pre-programmed channel plan, it is simple to choose the correct operating frequencies for simultaneous multi-channel operation. Additional features, like space diversity reception, LCD indicators, reliable and sophisticated circuit technology ensure low noise wide dynamic range, and extremely stable signal transmission and reception. Ideal for broadcasting stations, film production facilities and ENG work.

## SONY UJV-1200/UJV-1400A Betacam SP Player • Player/Recorder

The UJV-1200 and UJV-1400A are non-editing VCRs which deliver Betacam SP quality and offer features for a wide range of playback and recording applications. RGB and RS-232C interface make them especially ideal for large screen, high quality video presentation, scientific research and digital video environments.

- Ideally suited for work in computer environments, because RGB signals can be converted into component signals and vice versa with minimum picture degradation.
- 25-pin serial interface allows external computer control of all VCR functions based on time code information. Baud rate can be selected from between 1200 to 38,400 bps.
- Built-in Time Base Stabilizer (TBS) locks sync and subcarrier to an external reference signal as well as providing stable pictures. High quality digital dropout compensator further ensures consistent picture performance.
- Both read LTC Time Code and UB (User Bits). The UJV-1400A also generates LTC and UB (Free-Run/Rec-Run).
- Equipped with two longitudinal audio channels.
- Auto repeat of entire or a specific portion of the tape.
- Built-in character generator can display VTR status, time code, self-diagnostic messages, set-up menu, etc.
- Control of jog, shuttle, playback, record, pause, FF and REW with the optional SYRM-100A Remote Control Unit.
- Composite and S-Video as well as component via BNCs which are switchable to RGB output. The UJV-1400A has two switchable sync connectors and a Sync on Green.
- Built-in diagnostic function and hour meter.
- Initial set-up menu for presetting operational parameters. Settings are retained even after power is turned off.

## UJV-1600/UJV-1800 Betacam SP Editing Player • Betacam SP Editing Recorder

The UJV-1600 and UJV-1800 are the other half of the UJV series. They offer the superiority of Betacam SP with sophisticated editing features. They feature an RS-422 9-pin interface, built-in TBC, and Time Code operation. Inputs/outputs include component, composite and S-Video. All the features of the UJV-1200/1400A PLUS—

- Optional BVR-50 allows remote TBC adjustment.
- RS-422 interface for editing system expansion.
- Two types of component output: via three BNC connectors or a Betacam 12-pin dub connector.
- Frame accurate editing is assured, thanks to sophisticated servo control and built-in time code operation. In the insert mode of the UJV-1800, video, audio Ch-1/2 and time code can be inserted independently or in any combination.

## PVW-2600/PVW-2650/PVW-2800 BETACAM SP PRO SERIES

Whenever versatility and no compromise performance is needed, there is only one choice. Legendary reliability and comprehensive support for its many users has established the PVW series as the standard in broadcast and Post production. The PVW Series includes the PVW-2600 Player, PVW-2650 Player with Dynamic Tracking and the PVW-2800 Editing Recorder. They feature built-in TBCs, LTC/VITC time code operation and RS-422 serial interface. They also offer composite, S-Video and component video inputs and outputs. Most important they are built for heavy, every day duty.

- Built-in TBC's and digital dropout compensation assure consistent picture performance. Remote TBC adjustment can be done using the optional BVR-50 TBC Remote Control.
- The PVW-2600, PVW-2650 and PVW-2800 (generates as well) read VITC/LTC time code as well as User Bits. Exhibit time code, Regen/Preset, or Rec-Run/Free-Run selections.
- Built-in character generator displays time code or CTL data.
- Set-up menu for presetting many functional parameters.
- Two longitudinal audio channels with Dolby C-type NR.
- Recognizable monochrome pictures at up to 24X normal speed in forward and reverse. Color at speeds up to 10X.
- Two types of component connection: three BNC connectors or a Betacam 12 pin dub connector. Composite and S-Video.
- PVW-2650 only • Dynamic Tracking (DT) playback from -1 to .3 times normal speed.
- PVW-2800 only • Built-in comprehensive editing facilities • Dynamic Motion Control with memory provides slow motion editing capability.

## PVM-14M2U/14M4U & 20M2U/20M4U 13-inch and 19-inch Production Monitors

Sony's best production monitors ever, the PVM-M Series provide stunning picture quality, ease of use and a range of optional functions. They are identical except that the "M4" models incorporate Sony's state-of-the-art HR Trinitron CRT display technology and have SMPTE C phosphors instead of P22.

- HR Trinitron CRT enables the PVM-14M4U and 20M4U to display an incredible 800 lines of horizontal resolution. The PVM-14M2U and 20M2U offer 600 lines of resolution. M4 models also use SMPTE C phosphors for the most critical evaluation of any color subject.
- Dark tint for a higher contrast ratio (black to white) and crisper, sharper looking edges.
- True multi-system monitors they handle four color system signals: NTSC, NTSC 4.43, PAL & SECAM.
- Each has two composite, S-Video and component input (R-Y/B-Y, analog RGB) for more accurate color reproduction. The component level can be adjusted according to the input system. Optional BKM-101C (video) and BKM-102 (audio) for SMPTE 259M serial digital input • On-screen menus • Beam Current Feedback Circuit • 4.3/16.9 switchable aspect ratio.
- External sync input and output can be set for automatic switching to the selected input.
- Switchable color temp: 6500K (broadcast), 9300K (pleasing picture). User preset (3200K to 10000K).
- Blue gun, underscan and HV delay capability.
- Parallel remote control and tally via 20-pin connector.

## sachtler Tripods & Fluid Heads DV Systems - Digital Support for Every Budget

Today's compact digital cameras require light, fast and highly versatile camera support systems. Starting from the DV2 all the way up to the DV12, Sachtler has a solution tailored for just about every conceivable digital camera package available today. All feature Sachtler's patented counterbalance system and Touch and Go wedge plates. And all except the DV2 feature sliding camera platform to ease in the balancing of your camera.

### DV2 System

- The smallest head of the Sachtler's line
- Sachtler Touch and Go quick release with automatic camera lock and safety lever/drop protection
- One step of dynamic counterbalance
- Frictionless leak proof fluid damping with one level of drag • Built in bubble leveling
- Vibrationless vertical/horizontal brakes
- Single Stage 75mm tripod DA 75 Long
- Lightweight floor spreader SP 75

This system (0210) consists of: Fluid Head (DV-2) Long Tripod (DA 75), floor spreader (SP 75)

### DV4 System

- Sliding balance plate
- Touch and Go quick release with automatic camera lock and safety lever/drop protection
- One step of dynamic counterbalance
- Frictionless leak proof fluid damping with one level of drag
- Vibrationless vertical/horizontal brakes
- Built in bubble level horizontal leveling
- Single stage 75mm long tripod DA 75
- Lightweight floor spreader SP 75

This system (0410) consists of: Fluid Head (DV-4) Long Tripod (DA 75), floor spreader (SP 75)

### DV4XD System

Same as the DV4 PLUS —

- Five step of dynamic counterbalance
- Five step of vertical and horizontal drag

DV4XD System (0610) consists of: Fluid Head (DV-6) Long Tripod (DA 75), floor spreader (SP 75)

### DV8 System

Same as DV6 PLUS —

- Greater load capacity

DV8 System (0810) consists of: Fluid Head (DV-8) Long Tripod (DA 75), floor spreader (SP 75)

### DV12

Same as DV8 PLUS —

- Great Load Capacity
- Fits 100mm tripods

## PROFESSIONAL VIDEO TAPES

<b>QUICK DIAL 74</b>			
<b>Professional Grade VHS</b>			
PG-30	2.39	PG-60	2.39 PG-120 2.79
<b>Broadcast Grade VHS Box</b>			
BGR-30	3.29	BGR-60	3.99 BGR-120 4.49
<b>H471S S-VHS Double Coated</b>			
ST-30	6.69	ST-60	7.49 ST-120 7.69
<b>M221 Hi 8 Double Coated</b>			
<b>Metal Particles</b>		<b>Metal Evaporated</b>	
P630HMP	4.99	E630HME	7.69
P660HMP	6.29	E660HME	10.19
P6120HMP	8.29	E6120HME	13.99
<b>M321SP Metal Betacam (Box)</b>			
05S	11.99	10S	12.49 20S 12.99
30S	14.99	60L	24.95 90L 39.95
<b>DP121 DVC PRO</b>			
12M (Med.)	7.49	23M	8.79 33M 10.99
63M	19.99	64L (Lg.)	22.50
94L	30.99	123L	39.99
<b>maxell Hi8 Metal Particle (XR)</b>			
P6-120 XRM	6.99		
<b>Broadcast Quality Hi8 Metal Particle</b>			
P6-30 HM BQ	5.39	P6-60 HM BQ	6.09
P6-120 HM BQ	7.99		
<b>P/1 PLUS VHS</b>			
T-30 Plus	1.69	T-60 Plus	1.99 T-90 Plus 2.09
T-120 Plus	2.19 T-160 Plus 2.69		
<b>HGX-PLUS VHS (Box)</b>			
HGXT-60 Plus	2.69	HGXT-120 Plus	2.99
HGX1-160 Plus	3.99		
<b>BQ Broadcast Quality VHS (Box)</b>			
T-30 BQ	3.89	T-60 BQ	3.99 T-120 BQ 5.99
<b>BQ Professional S-VHS (In Box)</b>			
ST-31 BQ	6.79	ST-62 BQ	6.99
ST-126 BQ	7.45	ST-182 BQ	13.99
<b>Betacam SP</b>			
B30MSP	13.49	B60MLSP	19.99 B90MLSP 29.95

## Panasonic

<b>Mini DV Tape</b>			
AY DVM-30	6.49	AY DVM-30 (10 Pack)	ea. 5.99
AY DVM-60	7.99	AY DVM-60 (10 Pack)	ea. 7.49
AY DVM-80	12.99	AY DVM-120	20.95
<b>DVCPRD</b>			
AJ-P24M (Medium)	6.99	AJ-P24M	9.99
AJ-P33M	11.19	AJ-P66M	19.49
AJ-P66L (Large)	20.99	AJ-P94L	29.99
AJ-P126L	38.95		

## SONY Hi-8 Professional Metal Video Cassettes

P6-30 HMPX	4.59	P6-30 HMEK	7.99
P6-60 HMPX	6.49	P6-60 HMEK	10.99
P6-120HMPX	8.49	P6-120HMEK	14.99
<b>PR Series Professional Grade VHS</b>			
T-30PR	2.39	T-60PR	2.59 T-120PR 2.79
<b>PM Series Premier Hi-Grade Professional VHS</b>			
T-60PM	3.99		
<b>BA Series Premier Hi-Grade Broadcast VHS (In Box)</b>			
T-30BA	3.59	T-60BA	3.99 T-120BA 4.79
<b>MO Master Quality S-VHS (In Box)</b>			
MOST-30	7.49	MOST-60	7.69 MOST-120 7.99
<b>BRS 3/4" U-matic Broadcast Standard (In Box)</b>			
KCS-10 BRS (mini)	6.69	KCS-20 BRS (mini)	8.99
KCA-10 BRS	8.19	KCA-20 BRS	8.69
KCA-30 BRS	9.60	KCA-60 BRS	13.39
<b>XBR 3/4" U-matic Broadcast Master (In Box)</b>			
KCS-10 XBR (mini)	8.79	KCS-20 XBR (mini)	10.59
KCA-10 XBR	9.29	KCA-20 XBR	10.69
KCA-30 XBR	11.99	KCA-60 XBR	15.69
<b>KSP 3/4" U-matic SP Broadcast (In Box)</b>			
KSP-S10 (mini)	9.59	KSP-S20 (mini)	11.09
KSP-10	10.09	KSP-20	11.59
KSP-30	12.99	KSP-60	16.89
<b>BCT Metal Betacam SP Broadcast Master (Box)</b>			
BCT-5M (small)	11.99	BCT-10M (small)	12.49
BCT-20M (small)	12.99	BCT-30M (small)	13.49
BCT-30M (small) (10 Pack)	ea. 12.99		
BCT-30ML	15.99	BCT-60ML	21.99
BCT-90ML	28.99		
<b>Mini DV Tape</b>			
DVM-30EXM w/Chip	12.99	DVM-60EXM w/Chip	17.99
DVM-30EX "No Chip"	11.99	DVM-60EX "No Chip"	13.99
DVM-30PM "No Chip"	7.99	DVM-60PM "No Chip"	9.99
<b>Full Size DV Tape with Memory Chip</b>			
DV-120MEM	24.99	DV-180MEM	26.99
<b>PDV Series Professional DVCAM Tape</b>			
PDVM-12ME (Mini)	15.25	PDVM-22ME (Mini)	16.25
PDVM-32ME (Mini)	15.49	PDVM-40ME (Mini)	15.99
PDV-94ME (Standard)	33.49	PDV-124ME (Standard)	37.99
PDV-184ME (Standard)	44.95	PDVN-64N	24.95
PDVN-124N	31.95	PDVN-184N	39.95





TO INQUIRE ABOUT YOUR ORDER:  
 800 221-5743 • 212 239-7765  
 OR FAX 24 HOURS:  
 800 947-2215 • 212 239-7549

420 Ninth Ave.  
 (Bet. 33rd & 34th St.)  
 New York, N.Y. 10001

## Avid / IBM Xpress DV On IntelliStation

Avid Xpress DV on IntelliStation is a turnkey digital video solution designed for professional content creators in corporations, education and government institutions. The power to communicate with video. The solution consists of IBM's award-winning IntelliStation M Pro workstation, and Avid's Xpress DV digital video content creation software. Simply plug your DV camera into the IntelliStation workstation, launch Xpress DV and begin assembling a video. Using the high-powered and reliable IntelliStation M Pro and intuitive Xpress DV software, you'll be creating professional-looking video and multimedia content for a wide variety of uses including sales and marketing videos, training videos and web-based teaching solutions-in no time.



**The Hardware**  
 The redesigned IBM IntelliStation M Pro features a high-speed Intel 840 chip set, 600 MHz Pentium III processor, 133 MHz Front Side Bus, a Canopus DV Raptor and a Matrox display card designed with the Intel 840 chipset. The IntelliStation M Pro supports high-speed ATA-66 disk drives, as well as up to 1GB of ECC memory. The solution is pre-installed with the Matrox millennium G400 4X AGP graphics card (capable of 1GB p/s transfers) with 16MB of on-board memory, and the Canopus DV Raptor Adapter IEEE1394 interface for DV I/O. It also includes two Ultra2 SCSI hard drives: a 9.1GB drive for the operating system and programs, and an 18.2GB drive for capturing data.

**The Software**  
 Avid Xpress DV software combines powerful video and audio editing tools, digital mastering, and extreme ease of use. Xpress DV captures and edits DV video, adds effects, mixes audio, and outputs the finished results over IEEE1394 FireWire for impressive video. Drives encode the content to all major non-media formats: MPEG-1 (for CD-R) MPEG-2 (for DVD-ROM), QuickTime or AVI for computer based presentations or streaming on the web. As a member of the Avid Xpress Family, The Xpress DV offers the Avid graphical user interface (GUI) based on the 3.1 version, offering powerful audio and video tools including:  
 • 4 tracks of nested video with single track transitions  
 • 8 tracks of audio with real-time mixing  
 • Batch digitizing, and RS-422 deck control  
 • Integrated EDL support with built in logging  
 • 32 levels of undo/redo, making changes, painless!  
 • Tight timeline with precise timecode editing.

- Real time 3-band EQ, and rubber band gain adjustments.
- 22 and 48 kHz sampling rate, with down sample to 22 and 11 kHz for multimedia
- Over 50 transitions, including dissolves, motion & color effects, superimposition, horizontal and vertical wipes, chroma and luma keys, picture in picture, flips, flops, resizes, spins, peels, pushes, squeezes, and many more.
- Integrated, anti-aliased titling tool
- Export to MPEG1, 2, Microsoft Windows Media (ASF), AVI, QuickTime or RealMedia

**The Service**  
 IBM is maintaining a server where you can obtain disk space for approximately five hours of compressed streamed video, where your client can download your video from a customized web page, at no charge to you for the first three months (after three months it is fee based).

- IBM IntelliStation M Pro (6868-91U).
- 600 MHz Pentium III processor.
- 256MB Full Speed ECC memory.
- Matrox Millennium G400 4X AGP with 16MB of RAM.
- Ultra2 SCSI 9 GB (7200 rpm) drive for operating system
- 18.2GB drive for video and audio storage.
- CD-ROM (20x to -8x)
- Windows NT 4.0 with Service Pack 5.
- Complete system integration and testing.

All for the Unbelievable price of .....\$6795.00

Add an IBM 21 monitor, and Roland MA8 speaker set, For only an additional 1000.00 .....\$6895.00

## Avid MediaDrive rS Plus

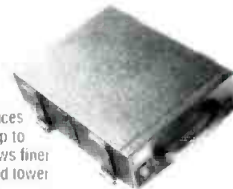

The MediaDrive rS Plus is the latest in the line of leading edge storage products from Avid. Designed exclusively for AV professionals, the MediaDrive rS Plus is available in 9 and 18GB capacities and utilizes the highest performance 10,000 rpm drives in the market today. Available in a stackable model with a rack-mount option, the MediaDrive rS Plus incorporates QuietDrive, a revolutionary sound dampening technology developed by Avid. The MediaDrive rS Plus 10K drives provide Avid customers with a very affordable, versatile, high-performance storage solution.  
 • Using 10,000 rpm drives, MediaDrive rS Plus offers 40% higher performance than 7200 rpm drives. The increase in data transfer rates results in fewer drives necessary to achieve higher resolutions. Real-time AVR 75 can be achieved on a single rS Plus drive. Stripping only two rS Plus drives across one dual channel controller can provide dual stream AVR 77 quality throughout the entire drive.  
 • Built-in thermal circuitry controls the speed of the fan for efficient cooling and an external indicator helps to protect your drive and critical data by signaling high temperature conditions.

- QuietDrive technology reduces drive noise by up to 15 dB. This allows finer audio editing and lower operator fatigue
- An innovative vertical Interlocking stacking feature provides the option to physically latch striped sets together permanently or temporarily
- With its own power and SCSI connectors (conforming to fast and wide SCSI standards), the rS Plus drive is ready to travel down the hall or around the world. You can hook up the rS Plus drive in any studio. No docking system is required
- Optional rack mount kit adds great flexibility by allowing two MediaDrive rS units to be mounted in a 2U rack format. Quick release allows drives to be removed easily for transporting or replacing with new project drives.

### Configuration

- MediaDrive rS enclosure 3.5 self-contained (power, cooling and connections) stackable unit SCSI-2 68-pin connection
- Rack mountable with MediaDrive rS rack mount option kit

rs-9 "MediaDrive" External LVD 9GB Drive .....	\$899.95	rs-36 "MediaDrive" External LVD 36GB Drive .....	\$1799.95	rs-36 "MediaDrive" External LVD 36GB Shuttle .....	\$1699.95
rs-18 "MediaDrive" External LVD 18GB Drive .....	\$1199.95	rs-18 "MediaDrive" External LVD 18GB Shuttle .....	\$1149.95	rs-18 "MediaDrive" Shuttle (Difer Station) .....	\$1149.95
"MediaDrive" rS Rack Kit (2 Drives) .....					\$99.95

## SONY ES-3 EditStation

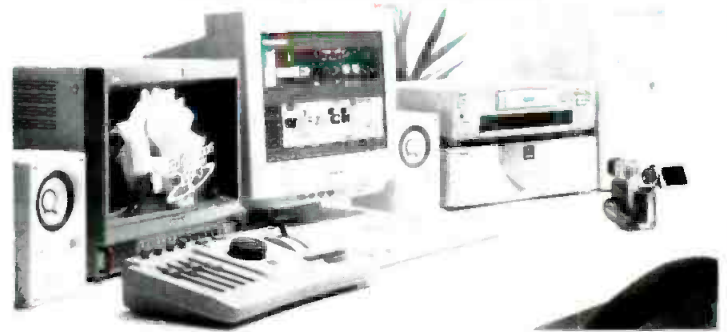

The Sony ES-3 EditStation is an extremely flexible, powerful and high picture quality non-linear video editing system. Its self-explanatory yet sophisticated editing interface is easy to use even for newcomers to the non-linear editing realm. Its open architecture also supports popular third-party software for graphics, paint, text and effects. The Sony ES-3 EditStation also offers the unique Sony "ClipLink" interface, allowing you to transfer only the clips you want for editing, since the Sony DSR-300/500 cameras mark the in/out points of each shot and a still frame of every in-point called the "index picture" is recorded on the cassette memory of the DVCAM tape.

- The video and audio files stored on the disk drive of the ES-3 system can easily be converted to AVI or QuickTime file format. Allowing you to create multimedia materials for CD-ROMs, or to be streamed to the web.
- Slow and fast motion are available. The playback speed for each clip can be set to be played back at the desired speed.
- Edits on the ES-3 TimeLine are converted to the Sony EDL format and displayed in a EDL window. Additionally the EDL can be printed out or saved to disk.
- Dual monitor display is available for more efficient operation.
- The ES-3 can be switched to operate in either 4:3 or 16:9 wide screen aspect ratio.

### Editor

You start with the Editor for uploading to create both video and audio clips. The Editor consists of the live picture window, In/Out point and duration windows, video audio 1/2 3/4 selection buttons for uploading, a record clip button and VCR control functions. Using the Editor, you can upload video (including live upload) with or without VCR control.

### ClipBin

This is where you store program material designated as clips. You can group clips and customize the ClipBin according to your needs. Two main display modes: picture mode and text mode. In picture mode you can select six different sub modes:

### Timeline

The timeline is where you build your project. Each track may hold video, graphics, titles or audio. To build your project, clips (from the ClipBin), effects and transitions are dragged and dropped onto the timeline in sequential order. There are various timeline views available. You can select any items displayed such as Index Pictures of the head or tail of a clip, marker, name, duration, reel number, mark in/out and many others.

### Trim Editor

A Trim Editor is available for precise trimming on the timeline. It is opened as an independent window, with the video of the out point of the "from" clip and the in point of the "to" clip displayed. Both single and dual trimming can be performed. Clips can also be played and trimmed directly in the Clip Monitor which is selected from the edit menu.

### Audio Editor

With the Audio Editor, eight channels of assigned audio can be monitored in real-time. Each input channel can be assigned to any track in the timeline. Each channel has its own peak meter, level fader, level trim, phase control, three band EQ, panning and filters (low cut, high cut, echo, etc.). Volume and pan are processed in real-time and can also be modified in real-time using the ESBK-7011 Control Panel. Audio level and panning for each clip can be controlled directly on the timeline with the rubber band editing function. Each track has its own rubber band control, which can be activated independently.

### Control Panel

In addition to controlling non-linear functions via mouse and keyboard, also includes the ESBK-7011 Control Panel for conventional operation. Combine familiar linear techniques such as Jog/shuttle control, effects transitions and audio fading with convenience of non-linear editing.

### Breakout box

The breakout box provides easy interfacing to analog or digital equipment. It offers analog composite, component and S-Video input and output. For digital video, an i-LINK input/output is standard, and OSDI(SDTI) can be activated via optional software and dongle. For audio, four input channels of XLR-balanced analog audio (two out) and AES/EBU digital audio I/O (XLR-balanced) are provided. Two RS-422 ports are provided for deck control. Finally, the ES-3 is also equipped with a genlock input and blackburst output for reference.

## Apple Computer Final Cut Pro

Professional Editing, Compositing and Effects Software for Macintosh

A breakthrough in non-linear video. Final Cut Pro combines professional editing, compositing, and special effects in one powerful application - turning a Power Mac into a powerful workstation. Designed from the ground up for DV, Final Cut Pro offers the easiest way to transfer material from DV sources to your hard disk, edit, composite, and add effects to the video and audio, and play the results. It has an advanced feature set that professionals will love, yet it's also easy enough for novice video producers who are just discovering DV and FireWire. Final Cut Pro supports DV and all QuickTime formats including M-PEG and web-ready streaming video. Provides plug-and-play capabilities with most digital video cameras. Just connect your computer to a DV camcorder, capture video and edit it with sophisticated tools. Create multiple layers of video using text, graphics, or additional video elements. Each layer can be still, or animated along a user-defined path using tools such as Bézier curves with acceleration control. Then you can output your results for TV videotape, QuickTime movies, or the Web.



**AG2**

**Digital Test Signal Generator**

- 10 bit Digital Processing
- Gen Lock
- 4 Configurable Sync Outputs
- 12 Test Patterns
- RS232 Interface
- Available in NTSC or PAL
- Attractive Pricing
- . . . and more

**HOTRONIC, INC.**  
 1875 S. Winchester Blvd., Campbell, CA 95008 (U.S.A.)  
 Tel (408) 378-3883 Fax (408) 378-3888  
 web site: www.hotronics.com e-mail: sales@hotronics.com

Circle (182) on Free Info Card

**MATCH IT!!**

**HENRY ENGINEERING**  
 503 Key Vista Drive  
 Sierra Madre, CA 91024 USA  
 TEL (626) 355-3656 FAX (626) 355-0077  
 FAX-on-Demand Doc #102 (626) 355-4210  
<http://www.henryeng.com>

**TWINMATCH™**  
 DUAL STEREO LEVEL & IMPEDANCE INTERFACE

*Twinmatch* is the "one-way Matchbox" that's perfect for matching unbalanced CD players and other "play-only" devices. There are *four channels* of -10 to +4 conversion, so you can match *two* stereo CD players with *one* Twinmatch! Direct-coupled circuitry and lots of headroom for absolute sonic transparency.

**HE HENRY ENGINEERING**  
 We Build Solutions.

Circle (181) on Free Info Card

**The Internet for Broadcasters**

This book covers the effects of the Internet on broadcasting. The content includes technology and management articles, case studies, and a directory of Internet resources, which lists Web sites and e-mail addresses for equipment suppliers, services, information sources and organizations, as well as newsgroups and search facilities of interest to broadcast, video, and audio professionals. Paperback, 92 pp. ISBN #0-95178-267-3.

**Call 800-543-7771 to order!**  
[www.internettelephony.com](http://www.internettelephony.com)

**Order #2673**  
**\$29.95**

**INTERTEC PUBLISHING**  
 A PERSEUS COMPANY

2673B

# Professional Services

## NETCOM

STATE OF THE ART ENGINEERING  
FOR AUDIO AND VIDEO  
ENGINEERING DESIGN • CAD DRAFTING SERVICES  
CABLE FABRICATION • PRE-WIRED PATCH PANEL RACKS  
SYSTEM INSTALLATIONS • EQUIPMENT SALES  
**(201)837-8424**  
FAX (201)837-8384  
1165 PAULINA DRIVE, TEANECK, NJ 07796

**JOHN H. BATTISON P.E.**  
**CONSULTING BROADCAST ENGINEER,**  
FCC APPLICATIONS AM, FM, TV, LPTV  
Antenna Design, Proofs, Fieldwork  
2684 State Route 60 RD #1  
Loudonville, OH 44842  
419-994-3849 FAX 419-994-5419

**GILMER & ASSOCIATES, INC.**  
TECHNOLOGY / MANAGEMENT CONSULTANTS

**BRAD GILMER**  
PRESIDENT

2207 RINGSMITH DR  
ATLANTA, GA 30345  
TEL (770) 414-9952  
FAX (770) 493-7421  
EMAIL: bgilmer@attnet.com

## "NAME YOUR OWN PRICE ON DUPLICATIONS"

AUDIO • VIDEO • CD-ROM • DVD • DISK

**WWW.QUOTEIT.COM**

"The First On-Line  
Name Your Own Price Web Site"  
A division of QuikBiz Internet Group, a publicly traded company.

## D.L. MARKLEY & Associates, Inc.

**CONSULTING ENGINEERS**  
2104 West Moss Ave.  
Peoria, Illinois 61604  
Phone (309) 673-7511 • FAX (309) 673-8128  
www.dlmarkley.com  
Member AFCCCE

**Want more information  
on advertised products?**

**Use the Reader  
Service Card.**

# Classifieds

## For Sale

## Shopping for Equipment?

Before you pay too much...check [www.digibid.com](http://www.digibid.com)

**digibid.com**  
Industry Auction Network

The Internet Auction Marketplace  
Best Deals On the Planet!

Circle (185) on Free Info Card

Buy, sell,  
consign or trade.  
We're the most  
flexible  
in the business.

**BROAD  
CAST  
STORE**

L.A. (818) 551-5858  
N.Y. (212) 268-8800  
[www.broadcaststore.com](http://www.broadcaststore.com)

Circle (186) on Free Info Card

Place your business on *top*  
of the world with 35,000+  
worldwide circulation!  
Advertise in  
*Broadcast Engineering!*

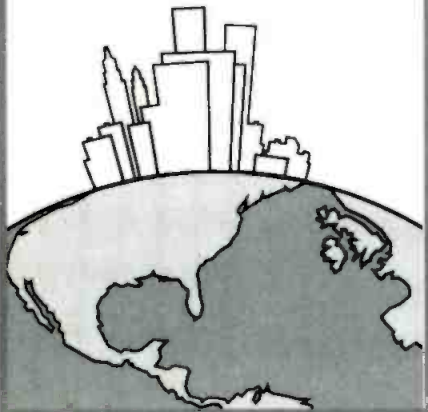

**AcousticsFirst™**  
Toll-Free Number: **888-765-2900**  
Full product line for sound control  
and noise elimination.  
Web: <http://www.acousticsfirst.com>

**WWW.VIDEOAUDIOSEARCH.COM**  
WORLDWIDE NEW AND USED  
BROADCAST EQUIPMENT SERVICES

30 AGENTS NATIONALLY TO SERVE YOU...  
INSTANT MATCHMAKING FOR USED EQUIPMENT  
COMPREHENSIVE NETWORK FOR  
NEW EQUIPMENT  
NON-LINEAR SPECIALISTS  
SPECIAL ACCOUNT MANAGERS  
WHAT ARE YOU LOOKING FOR?  
CALL 818-710-7506  
CHECK WITH US FIRST BEFORE YOU  
SPEND TOO MUCH!  
WE ARE FULLY NETWORKED WORLDWIDE.

**WhisperRoom INC.** PH: 423-585-5827  
SOUND ISOLATION ENCLOSURES FAX: 423-585-5831  
E-MAIL: [whisper@ics.com](mailto:whisper@ics.com)  
Vocal Booths WEB SITE:  
Broadcast Booths [www.whisperroom.com](http://www.whisperroom.com)  
etc... 116 S. Sugar Hollow Road  
Morristown, Tennessee 37813

# Classifieds

## Services

We specialize in systems integration, but what we're really about is solutions.



For details call us at  
(818) 551-5871  
or visit us at  
[www.b-bsystems.com](http://www.b-bsystems.com)

Circle (187) on Free Info Card

# Classifieds

## For Sale

1-800-638-9355

[controlnoise.com](http://controlnoise.com)

NETWELL



Don't buy a snake until you talk to the pros!  
1-800-939-1001  
[www.radialeng.com](http://www.radialeng.com)

### DIGITAL CABLE EQ

Keep Your **EYE** on the DIGITAL SIGNAL  
The CABLE-Q

Recovers data from 300+ meters of coax cable and maintains low jitter **EYE** pattern. The CABLE-Q Automatically Equalizes 601 / 259 SMPTE digital Signals. A real **EYE** Opener for Remote Broadcasting!

Call 732.516.1560 [www.gmzelectronics.com](http://www.gmzelectronics.com)

# READY WHEN YOU ARE



As soon as you're ready, you can put your ad message in the Help Wanted section of *Broadcast Engineering* classifieds! Promote your company and post a job opening!

Call Brian Huber today!  
1-800-896-9939  
Fax 913-967-1735

# Classifieds

## Help Wanted

**TELEVISION TECHNICIAN** - PBS is looking for a technician to perform quality and continuity control through the operations of the control room switcher and related equipment. BS or electronics school preferred. Requirements include 3+ years experience in operating broadcast equipment; familiarity with public television highly desirable. For more information, see [www.pbs.org/positions](http://www.pbs.org/positions). PBS offers a fast-paced work environment, a competitive salary, and an excellent benefits package. Please send resume with salary requirement to: PBS, 1320 Braddock Place, Alexandria, VA 22314-1698 or email to [jobs@pbs.org](mailto:jobs@pbs.org)

**MAINTENANCE ENGINEER** Major station in #2 market seeking maintenance engineers with experience with in 2 or more of the following area's: ENG/SNG repair, Panasonic DVC Pro, Tektronix 4k switcher, 7k router or Profile, Quantel, Avid, studio camera, DVE, SS, CG and robotics. Automation and file server experience a plus. Applicant should have a minimum of 5 years maintenance experience, be able to work all shift, and lift 50 lbs. SBE certification preferred. Send resumes to: Personal/Confidential, Classified Ad Coordinator, Broadcast Engineering Dept. 798, 9800 Metcalf Ave, Overland Park, KS 66212-2216.

Maximize your company's exposure in the marketplace by taking advantage of reprints.

Call Jenny Eisele for a quote:



Phone:  
913-967-1966  
Fax:  
913-967-1901

TELECOMMUNICATIONS

### A Revolution for the new century



**W**e've started a revolution in space. Five Direct Broadcast Satellites (DBS) orbit the Earth, enabling EchoStar to offer 500 digital video, data and audio channels to our customers. A sixth will join the in mid-2000, and we'll continue to build on our history as a DBS pioneer by expanding our services throughout the 21st century. For an exciting career with the company that's shaping the future of television, look to us.

We're sending out signals that you'll love working here at EchoStar Communications Corporation. We're currently recruiting highly motivated individuals who possess a high-energy level, show pride in their work and display a winning attitude to join our team at the following locations:

**Atlanta, GA**

- Communication Systems Engineer
- System Engineer
- Software/Hardware Engineers
- Digital Design Engineer
- Sr. Systems Engineer (Internet Technologies)
- Program Managers
- CAD Specialist
- Project Managers



**Cheyenne, WY**

- Field Engineers
- Broadcast Engineers
- Sr. Software/Systems Engineers
- Data Network Architect

**Gilbert, AZ**

- Earth Station Technicians
- Broadcast Engineers
- Video Compression Specialists
- Telephony Analyst

EchoStar offers a salary fully commensurate with experience and an excellent benefits package. If you're qualified and interested in becoming part of a powerful team that is changing the way the world communicates, please send your resume to: **EchoStar Communications Corporation, Attn: Human Resources, 530 EchoStar Drive, Cheyenne, WY 82007; Phone: (307) 633-5224; Fax: (307) 633-5633; For Atlanta, mail resumes to Human Resources, 1190 W. Druid Hills Rd, Atlanta, GA 30329 or Fax: 404-978-8076. E-mail: Hr.etc@echostar.com.**

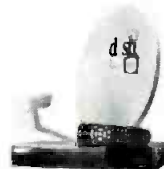
EchoStar is a drug-free work environment and is committed to the success of a diverse workforce.

**DESIGN ENGINEERS WANTED :** TGS is a rising presence in the DTV/HDTV systems integration industry. Our clients include broadcast and production facilities worldwide. We are currently looking for a design engineer for a variety of current and pending projects to work in our Washington, DC area office. TGS engineers have practical experience in digital video and audio, as well as a solid background in basic electronics. CAD experience is a plus. TGS not only offers a competitive salary, but the opportunity to work on the front wave of digital technology, with a staff that is talented, motivated, flexible, and team-oriented. Contact or resume to: Willy Halla, VP engineering, TGS, Inc., 4500 Southgate Place, Suite 400, Chantilly, Va. 20151. willy@tgsinc.net (703) 378-7850, (888) 296-5869

**BROADCAST ENGINEER SUPERVISOR -** Excellent opportunity for an experienced Broadcast Engineer at the ABC O&O in New York. Responsibilities include scheduling, purchasing, and supervising maintenance engineers. Also, installation/maintenance of studio, transmitter, and remote site broadcast equipment. Must have extensive experience supporting a large news organization and ENG staff. Should be familiar with a live television production environment. Must possess knowledge of analog/digital systems and a minimum of eight years broadcast television experience. Please send resume and cover letter to: Kurt Hanson, Chief Engineer, WABC-TV, 7 Lincoln Square, New York, NY 10023. No telephone calls or faxes please. We are equal opportunity employer.

**STUDIO MAINTENANCE ENGINEER** Must be able to perform the following duties: install and maintain studio transmission equipment including video switchers, audio consoles, DVE, CG, SS, cameras, and robotics. Familiarity with automation systems and master control environment. Should possess a general computer/networking background. Must be able to work on a rotating shift schedule. Candidate should have an engineering degree or equivalent technical training, SBE/FCC certification a plus. If you want to be a part of the exciting transition to HDTV in the most exciting city in the world, please send your resume and cover letter to: Kurt Hanson, Chief Engineer, WABC-TV, 7 Lincoln Square, New York, NY 10023. No telephone calls or faxes please. We are equal opportunity employer.

# ENGINEERS

Turner Broadcasting System has career opportunities for experienced television engineers. These career positions demand an extensive background in equipment maintenance, digital video and audio, and knowledge of computer systems and networks. Please mail or fax your resume and cover letter to:

**Jim Brown**  
**Assistant Vice President of**  
**Engineering Services**  
**Turner Broadcasting System, Inc.**  
**One CNN Center**  
**P.O. Box 105366**  
**Atlanta, GA 30348-5366**

Fax: 404-827-1835 • Phone: 404-827-1638  
 e-mail at: [cnn.engr.jobs@turner.com](mailto:cnn.engr.jobs@turner.com)  
 TBS is an equal opportunity employer.



**THE WORLD'S NEWS LEADER**

Place your business on top of the world with 35,000+ worldwide circulation! Advertise in *Broadcast Engineering!*



## WE PLACE ENGINEERS and Mfg. Sales/Marketing

*Employer Paid Fees.*  
 20 Years personalized & confidential service.  
 All USA States & Canada



MAIL & FAX:  
**KEYSTONE INT'L., INC.**

Dime Bank, 49 S. Main St., Pittston, PA 18640 USA  
 Phone (570) 655-7143 • Fax (570) 654-5765  
 website: [keystoneint.com](http://keystoneint.com)

We respond to all  
 Employee & Employer Inquiries  
**ALAN CORNISH / MARK KELLY**

**AUDIO OPERATOR** Major station in #2 market seeking audio engineers for live news operation. Be able to handle fast paced daily news broadcasts. Previous live news mixing a must. Euphonix audio console experience preferred. Applicant should have a minimum of 5 years experience, be able to work all shifts, and able to lift 50 lbs. Send resumes to: Personal/Confidential. Classified Ad Coordinator. Broadcast Engineering Dept. 799, 9800 Metcalf Ave, Overland Park, KS 66212-2216.

**MASTER CONTROL SUPERVISOR** wanted for HD/Digital facility. Responsibilities include development of digital/HDTV production facility, preparing schedules, training, quality control and daily operations. Qualified candidates must have a solid technical background, minimum of five (5) years master control switching experience, excellent supervisory skills, and experience with automation. Bachelor's degree in related field preferred. Send your resume to Personal/Confidential, Classified Ad Coordinator, Broadcast Engineering Dept. 800, 9800 Metcalf Ave, Overland Park, KS 66212-2216.

**TELEVISION ENGINEER** - Position to open at the Department of Veterans Affairs, Employee Education System, located in St. Louis, Missouri. ([www.usajobs.opm.gov](http://www.usajobs.opm.gov)) Karin Martinez ph: 314-894-6648 x6220, fax: 314-894-5765 email me.

### SENIOR TECHNICAL SPECIALIST

Responsible for deploying customer service systems in Latin America. Provide support for region countries after deployment. Conduct quality assurance checks. Develop staffing requirements and personnel proformas. Bachelor's Degree in Business Administration or International Business and three years related experience in managerial position with customer service experience in Latin America; Fluency in Spanish and Portuguese languages required.

In return for your professional abilities, we offer an attractive compensation and benefits package. For immediate consideration, please send or fax a cover letter along with your resume and salary history to Galaxy Latin America, **REQ# A20003**, P.O. Box 24800, Fort Lauderdale, FL 33307, Fax: (954) 958-3341. E-mail: [hr@directvgla.com](mailto:hr@directvgla.com) No phone calls please. Equal Opportunity Employer.

### MIS DIRECTOR

Direct and manage operations of satellite broadcasting company's full range of telecommunications, including computer hardware, software, network, databases, and desktop tools. Oversee all engineering and technical staff related to MIS functions. Interface with all levels of organization, customer and vendors throughout Latin America. Bachelor's degree in Systems Engineering, MIS or Computer Science and five (5) years related experience; fluency in Spanish and Portuguese languages required.

In return for your professional abilities, we offer an attractive compensation and benefits package. For immediate consideration, please send or fax a cover letter along with your resume and salary history to Galaxy Latin America, **REQ# A20005**, P.O. Box 24800, Fort Lauderdale, FL 33307, Fax: (954) 958-3341. E-mail: [hr@directvgla.com](mailto:hr@directvgla.com) No phone calls please. Equal Opportunity Employer.

## Broadcast ENGINEERING

THE JOURNAL OF DIGITAL TELEVISION

**Brian Huber**  
 1-800-896-9939  
 Classified Advertising Manager

	Page Number	Reader Service Number	Advertiser Hotline		Page Number	Reader Service Number	Advertiser Hotline
Accom Inc.	19	109	650-328-3818	Leader Instruments	87	135136	800-645-5104
Acrodyne Comm.	129	166	800-523-2596	LeBlanc Broadcast	59	128	
ADC Broadcast	25	112	800-726-4266	Lectrosonics	109	147	800-821-1121
ADC Broadcast	101	142	724-941-1500	Leitch Incorporated	37	119	800-231-9673
ADC Broadcast	123	161	800-726-4266	Leitch Incorporated	154	103	800-231-9673
AJA Video	92	138	530-274-2048	Lighthouse Digital Sys.	130	167	888-494-7300
Analog Way	110	183	331-644-7141	Marconi Applied Tech.	105	145	914-592-6050
Andrew Corp.	24	111	708-349-3300	Maxell Corp.	111	148	800-533-2836
Axon Digital Design	138	172	+3142414500	Method Electronics	113	151+	800-323-6858
B & B Systems	148	187	818-551-5858	Miranda Technologies Inc.	11	106	514-333-1772
Belden	17	108	800-BELDEN4	Modulation Sciences	125	163	800-826-2603
Benchmark Media	140	179	800-262-4675	NOVA Systems	102	143	800-358-NTSC
B&H Photo-Video	142-145	174,175	212-239-7500	Omneon	35	118	408-558-2113
The Broadcast Store	147	186	818-551-5858	OxTel	89	137	
Broadcast Supply Worldwide	107	146	800-426-8434	Panasonic Broadcast	7		800-528-8601
Broadcast Video Systems	110	149	905-764-1584	Pesa Switching	79	131	800-328-1008
Chyron	83	133	516-845-2000	Pirot, Inc.	51-53	125	219-936-4221
Ciprico	85	134	800-727-4669	Prime Image Inc	131	168	408-867-6519
Comm/Scope	140	180	800-982-1708	Professional Comm Sys	55	126	800-447-4714
Dielectric	115	158	207-655-4555	QSC Audio Products	63	129	714-754-6175
Digibid.com	147	185	301-571-0790	RFS Broadcast	133	169	
Digital Media Net	13		714-424-6100	Rocket Network	103	144	415-538-0123
Digital Media Net	20-21		714-424-6100	Ross Video	27,112	113,162	613-652-8886
Digital Media Net	43,61		714-424-6100	Ross Video	44,135	122,170	613-652-8886
DPS	93	140	606-371-5533	Sanix Corp	121	159	708-677-3000
DTV 2000	116		800-288-8606	Seachange	127	165	978-897-0100
Eneco	136	178	888-478-2687	Sigma Electronics	137	171	717-569-2681
Evertz Microsystems	134	177	905-335-3700	SGI	91	139	
Extron Electronics	57	127	714-491-1500	Snell & Wilcox	32-33	117	408-260-1000
Folsom Research	23	110	916-859-2500	Sony	4-5		800-472-SONY
Grass Valley Group	39	120	800-998-3588	Spectrasite	47	124	770-390-8959
Harmonic	9	105	408-944-6700	Standard Comm.	45	123	310-532-5300
Harris Corp./Broadcast Div.	3	104	606-282-4800	TC Electronic	42	150	805-373-1828
Henry Engineering	146	181	626-355-3656	Telecast Fiber Systems	30	115	508-754-4858
Hotronic Inc	146	182	408-378-3883	Telex Communications	29	114	877-863-4169
I-COM Industry	122	160	703-707-9094	Thomcast	65	130	888-872-8505
Industry Click	126	164	816-300-0323	Thomson Tubes	95,97,99	141	201-812-9000
Inscriber Technology	41	121	800-363-3400	Tiernan Communications	15	107	619-587-0252
Intertec Publishing	122,124		800-288-8606	Videotek, Inc.	153	102	800-800-5719
Kramer Electronics	114	184	888-275-6311	Wheatstone Corporation	2	101	252-638-7000
KTech Telecommunications	31	116	818-361-2248	Windows to the Web	132		
				360 Systems	81	132	818-991-0360

## Sales Offices

### WEST

*Duane Hefner*  
5236 Colodny Ave., Suite 108  
Agoura Hills, CA 91301  
(818) 707-6476  
Fax: (818) 707-2313  
dnhefner@worldnet.att.net

### EAST

*Josh Gordon*  
335 Court Street, Suite #9  
Brooklyn, NY 11231  
(718) 802-0488  
Fax: (718) 522-4751

### EAST/MIDWEST

*Joanne Melton*  
1775 Broadway, Suite 730  
New York, NY 10019  
(212) 333-4655  
Fax: (212) 459-0395  
joanne\_melton@intertec.com

### INTERNATIONAL

*Richard Woolley*  
*Tony Chapman*  
P.O. Box 250  
Banbury, Oxon OX16 8YJ U.K.  
+44 (0) 1295 278407  
Fax: +44 (0) 1295 278408  
richardwoolley@compuserve.com

### REPRINTS

*Jenny Eisele*  
(913)967-1966  
Fax: (913)967-1901

### JAPAN

*Orient Echo, Inc.*  
*Masby Yoshikawa*  
1101 Grand Maison  
Shimomiyabi-Cho 2-18  
Shinjuku-ku, Tokyo 162, Japan  
(3) +81 3235-5961  
Fax: (3) +81 3235-5852

### CLASSIFIED ADVERTISING OVERLAND PARK, KS

*Brian Huber*  
P.O. Box 12901  
Overland Park, KS 66282  
(800) 896-9939 (913) 967-1732  
Fax: (913) 967-1735

### LIST RENTAL SERVICES

*Lisa Majewski*  
9800 Metcalf  
Overland Park, KS 66212-2215  
(913) 967-1872  
Fax: (913) 967-1897

## Broadcast ENGINEERING

### EDITORIAL

*Brad Dick, Editor*  
*Steve Epstein, Technical Editor*  
*Jim Saladin, Senior Associate Editor*  
*Patrick Murphy, Associate Editor*  
*Laura Collins, Editorial Assistant*  
*Tom Cook, Dir., Editorial Development*

### ART

*Darlene Wilson, Art Director*

### TECHNICAL CONSULTANTS

*Brad Gilmer, Computers & Networking*  
*John H. Battison, P.E., Antennas/Radiation*  
*Michael Robin, Digital Video*  
*Donald L. Markley, Transmission Facilities*  
*Harry C. Martin, Legal*  
*Larry Bloomfield, News Technology Editor*  
*Paul McGoldrick, Industry Watcher*

### BUSINESS

*John Torrey, V.P. Entertainment Division*  
*Dennis Triola, Group Publisher*  
*Rachelle Thomas, Marketing Director*  
*Kathy Lewis, Advertising Coordinator*  
*Mary Mitchell, Classified Ad. Coordinator*  
*Sherri Gronli, Corporate Circulation Director*  
*Gayle Hutchens, Circulation Manager*  
**INTERTEC Publishing**  
*Cameron Bishop, President and CEO*  
*Ron Wall, Chief Operating Officer*  
*Stephanie Hanaway, Dir. Dir. of Marketing*  
*Doug Coonrod, Corporate Art Director*

### PRIMEDIA Business to Business Group

*David G. Fern, President/CEO*

### PRIMEDIA Inc.

*Tom Rogers, Chairman and CEO*  
*Charles McCurdy, President*  
*Beverly C. Chell, Vice Chairman*

### MEMBER ORGANIZATIONS

Sustaining Members of:

- Acoustical Society of America
- Society of Broadcast Engineers
- Society of Motion Picture and TV Engineers
- Society of Cable & Telecommunications Engineers

Member, American Business Media

Member, BPA International

Affiliate Member,

International Teleproduction Society



**BROADCAST ENGINEERING** is edited for corporate management, engineers/technicians and other management personnel at commercial and public TV stations, post-production and recording studios, broadcast networks, cable, telephone and satellite production centers and networks.

**SUBSCRIPTIONS:** Non-qualified persons may subscribe at the following rates: United States and Canada: one year, \$65.00. Qualified and non-qualified persons in all other countries: one year, \$80.00 (surface mail); \$145.00 (air mail). Subscription information: P.O. Box 12937, Overland Park, KS 66282-2937.

Photocopy authorization for internal or personal use is granted by PRIMEDIA Intertec, provided that the base fee of U.S. \$2.25 per copy, plus U.S. \$00.00 per page is paid directly to Copyright Clearance Center, 222 Rosewood Dr., Danvers, MA 01923. The fee code for users of the Transactional Reporting Service is ISSN 0361-0942/2005\$2.25+00.00. For those organizations that have been granted a photocopy license by CCC, a separate system of payment has been arranged. Prior to photocopying items for classroom use, contact CCC at (978)750-8400. For large quantity photocopy or reprint requirements contact Jenny Eisele, (913)967-1966. For microfilm copies call or write Bell & Howell Info., 300 N. Zeeb Rd., P.O. Box 1346, Ann Arbor, MI 48106-1346. Phone: (313)761-4700 or (800)521-0600.

©2000 by Intertec Publishing **INTERTEC PUBLISHING**  
All rights reserved.

**CUSTOMER SERVICE: 913-967-1707 OR 800-441-0294**

**BROADCAST ENGINEERING** (ISSN 0007-1994) is published monthly (except semi-monthly in May and December) and mailed free to qualified persons by Intertec Publishing, 9800 Metcalf, Overland Park, KS 66212-2216. Periodicals postage paid at Shawnee Mission, KS, and additional mailing offices. Canada Post International Publications Mail (Canadian Distribution) Sales Agreement No. 0956295. POSTMASTER: Send address changes to *Broadcast Engineering*, P.O. Box 12902, Overland Park, KS 66282-2902. CORRESPONDENCE: Editorial and Advertising: 9800 Metcalf, Overland Park, KS 66212-2216 Phone: 913-341-1300; Edit. fax: 913-967-1905; Advert. fax: 913-967-1904. © 2000 by Intertec Publishing. All rights reserved.



## The sand box is full of naughty kids

BY PAUL MCGOLDRICK

It used to be that broadcast engineers measured things using a meter, a scope or a spectrum analyzer and then agreed upon the readings. If we hadn't, there would never have been any completed acceptance tests for new equipment, and the FCC would never have been able to establish routines for proof of performance. When a new specification was required, one was invented or designed, approved in committee, and applied evenly in the broadcast workplace.

If there were differences of opinion in committee then it was not unusual for a practical demonstration to be set up at the next meeting so that a point, or practicality, could be proven to the other members. Of course, there were always things that came back to bite us at a later date — like measurements of subcarrier phase referred to lines where there was no subcarrier — but at least the decisions were made and we moved on.

However, we now seem to have entered a world where engineering has become opinionated, perhaps colored, by financial or political interests.

The principal arenas of dispute recently are low-power FM, 700MHz interference and, of course, 8VSB vs. COFDM. The first seems to be a basic argument about interference issues between the FCC on one hand and NAB/NPR (strange bedfellows) on the other. Both sides have produced figures that should be easily confirmed with independent testing, but there is absolutely no give from either side. Certainly from a casual look at the issues one would have to say that the NAB/NPR faction appears to be unaware of FM's capture effect. If the issues are really about squashing competition then we have a misuse of engineering information. But if the FCC side has fudged the numbers then we have a

political agenda being enforced with engineering complicity. We may feel one thing or the other, but only an independent audit can verify the numbers.

The NAB/NPR partnership's audacity in making a Congressional end run around the FCC's licensing powers probably had a direct bearing on the decision by Chairman Kennard to delay the May auction of the spec-

involved. This is an accusation that involves engineers as willing partners-in-crime.

Sinclair advocates COFDM. CBS advocates 8VSB. NBC abandoned its own plans for tests and is helping Maximum Service TV (MSTV) conduct tests, and PBS appears to be a part of that picture. Advice is coming from all over the place with countries like Brazil doing its

### **We seem to have entered a world where engineering has become opinionated, perhaps colored, by financial or political interests.**

trum from Channel 60 to 69 to mobile wireless companies. The official reasons given are that there are interference issues in the spectrum, adjacent channel interference primarily, and the "additional time will allow auction bidders to develop better business plans."

The cynical might say that because the channels are still legitimately in use by analog TV broadcasters, why should these wireless companies pony up the cash until they can use the spectrum. Or, even more cynically, one might wonder if the expected \$2.6 billion of revenues already included in the appropriations bill for the government's financial year is actually the issue. Delaying the auctions until September with a financial year completed at the end of September is an interesting embarrassment to Congress.

The largest of the "battle of the engineers" is 8VSB and COFDM. Do we have genuine technical issues that show one is better than the other across the board, do we have implementation delay tactics, or do we have political pressure? There have been direct accusations of the manipulation of data to suit the agenda of the companies

own testing. Anatel—Brazil's equivalent of the FCC— is favoring 4k COFDM, but the difficulties that it found with 8VSB "might be difficult to quantify in tables."

With the ATSC also involved in the MSTV testing, the FCC is rather out on a limb again with its very clear agenda to press ahead with DTV implementation. Despite the delay in the 700MHz auctions, the FCC knows that extensive delays in selling UHF spectrum will not be tolerated by Congress for very long. One way or another, those stations that are road-blocks in that to-be-sold space will go off the air. Torn between a national budget that politically has to be positive and a few small TV stations, there will be no choice.

In the face of these political realities, perhaps it's time for the engineers to come out of the sand box, and go back to a place where technical accuracy, rather than playground games, rule the day. ■

 Send questions and comments to: [paul\\_mcgoldrick@intertec.com](mailto:paul_mcgoldrick@intertec.com)



# Stay Tuned...



## With Videotek's High Performance Demodulator.

Videotek's DM-200 Series is the industry leader for high performance agile demodulators. With a signal-to-noise ratio of better than 58dB and differential gain and phase less than 1% and 1°, the DM-200 Series represents a unique engineering achievement packaged in a half-rack one RU size. A quarter century of agile demodulator experience has enabled Videotek to design the demod you have been asking for. The challenge has been met, and in the process, features such as BTSC stereo, SAP, and total computer control were engineered to meet today's sophisticated requirements.

Whether your applications include compliance testing, monitoring or recording off-air signals, or rebroadcasting by a cable plant, the DM200 Series is ready to take charge. Both the DM-200 and the new

DM-200A (no quadrature output) are proven performers for your laboratory bench, cable headend or broadcast facility.

Only Videotek offers all the performance, all the features, and all the controls in a single compact affordable package. Stay tuned with the new benchmark DM-200 and DM-200A.

For more information, see our web site at [www.videotek.com](http://www.videotek.com) or call one of our expert sales engineers at 800-800-5719.

**Premium Quality, Intelligent Design,  
Total Value...That's Videotek.**

**VIDEOTEK®**  
A Zero Defects Company

Five Year Warranty  
ISO-9001 Certified

243 Shoemaker Road, Pottstown, PA 19464 Toll Free: 800-800-5719 610-327-2292 Fax: 610-327-9295  
Visit us on the Worldwide Web: [www.videotek.com](http://www.videotek.com)

Circle (102) on Free Info Card

[www.americanradiohistory.com](http://www.americanradiohistory.com)

# think video, think Leitch

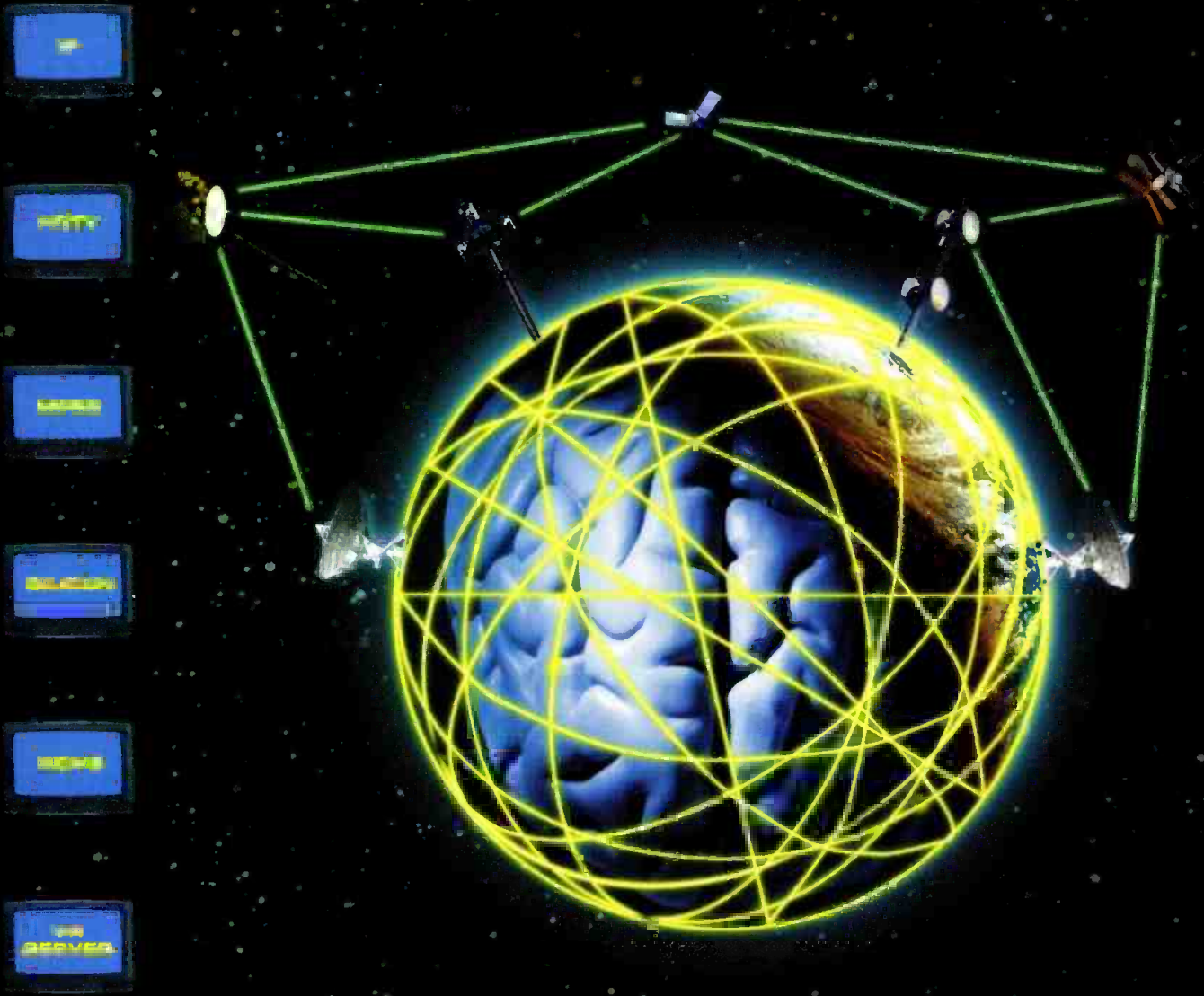

## *think IP @ Leitch*

Video over IP applications are exploding. Leitch is lighting the fuse using our VR™ servers which already run on a fiber channel video storage area network and will now be IP capable for downloading videos and news to the Internet and transporting video content over wide-area networks.

## *think HDTV @ Leitch*

Leitch has stayed the course to bring HDTV within reach of mainstream post and broadcast facilities. We have accelerated our lead by providing the industry with the most complete HDTV infrastructure solutions and expanding our already extensive range of products.

## *think MPEG @ Leitch*

Digital is increasing the use of MPEG-2 technology and Leitch responds with MPEG-2 transport solutions with control, pre-processors, encoders and decoders, including multiplexing and de-multiplexing. Leitch has also expanded the VR MPEG-2 video server line to 4 channels and added 50 gig drives to lower overall storage costs.

## *think silicon @ Leitch*

Leitch is applying video to silicon by taking its current technology assets and selected new video applications into silicon chips using Leitch chip design expertise. By making this silicon available to everyone, Leitch will expand the range and reach of high-quality video.

## *think news @ Leitch*

Leitch dominates the digital newsroom with its NEWSFlash™ non-linear editor built into the VR video servers allowing each editor simultaneous access to all media. By combining edit stations with acquisition and playback channels, we build an integrated all-digital system to meet your time critical needs with streamlined newsroom workflow.

## *think servers @ Leitch*

The Leitch VR video servers offer exceptional reliability and scalability using our VR technology. MPEG versions feature four bi-directional I/O channels in a 4RU frame and can be configurable to more than 40 channels—all with simultaneous access to the video storage area network with a capacity from 250 gigabytes to more than three terabytes.



*think video @*  
**LEITCH**  
www.leitch.com

International/Canada +1 (416) 445-9640, (800) 387-0233 • USA, East +1 (757) 548-2300, (800) 231-9673, USA, West +1 (818/888) 843-7004 • Europe +44 (0) 1453-591000  
Hong Kong +(852) 2776-0628 • Japan +81 (3) 5423-3631 • Australia +61 (2) 9939-3355 • Latin America +1 (305) 591-0611 • Brazil +55 (11) 3151-5000

Circle (103) on Free Info Card