

WELL LABORATORIES RECORD

NOVEMBER

1940

VOLUME XIX

NUMBER III



*Dead-ending open wires with
a rolled-sleeve joint.*



Regulation for the J-2 Carrier Telephone System

By R. S. CARUTHERS

Carrier-Telephone Development

the attenuation-frequency curve. To compensate for this variation in slope and attenuation, it is necessary to measure the loss at two frequencies—preferably near the edges of the frequency band involved—and then to provide a complementary repeater-gain characteristic.

IN THE J-1 carrier system, a single pilot frequency located near the middle of each of the 12-channel bands is employed for regulating the transmission gain. A single pilot channel is adequate under ordinary weather conditions because in the entire range of wet and dry attenuation over the normal temperature range, the slope of the attenuation curve bears a reasonably definite relationship to the loss at the mid-band frequency. A J-1 system 1000 miles long can be controlled so that all channels are within about 2 db for dry or wet weather from zero to one hundred degrees Fahrenheit.

Where severe ice, sleet, or snow is encountered, however, a single pilot for each band is not adequate. Conditions giving the same loss at mid-frequency may give losses over a single repeater section differing by more than 5 db at the edges of the band. Moreover, marked changes occur in both attenuation and slope of

Since the J-2 system was developed primarily to obtain better results on lines where these adverse conditions are encountered, two pilot frequencies are employed, one at each end of the band. The pilot at one edge is used to control a gain that is the same for all frequencies, and the pilot at the other edge, a gain that varies with frequency from practically zero at one edge of the band to a maximum value at the other. The action of the regulator for the east-to-west band, extending from 92 to 143 kc, is indicated in Figure 1. The flat gain is controlled by the pilot at 92 kc, and the slope gain, by a pilot at 143 kc. When the level of the 92-kc pilot drops, the regulator acts to raise the gain at all frequencies by the same amount up to a maximum of 45 db. When the level of the pilot at 143 kc drops, however, the regulator produces a gain that increases linearly with frequency from almost zero at 92 kc to any value between zero and a maximum of 35 db at 143 kc. It thus tilts the gain-frequency curve upward

at the right-hand end. The dotted curves show possible characteristics when the flat regulator has produced no gain, and the solid curves, when it has produced its full gain of 45 db. Intermediate curves might lie anywhere between these extremes.

For the west-to-east band, from 36 to 84 kc, a similar scheme is employed, but here the flat gain is controlled by the upper pilot frequency and the slope gain by the lower. This results in a set of curves as indicated in Figure 3. The complementary action of the slope and flat-gain regulators is illustrated by the following example. Assume that this west-east repeater is operating with a gain corresponding to the dotted curve marked 60 and that an increase in attenuation occurs—over a period of time—that requires an additional gain of 22 db at 84 kc but only 11 db at 36 kc. The

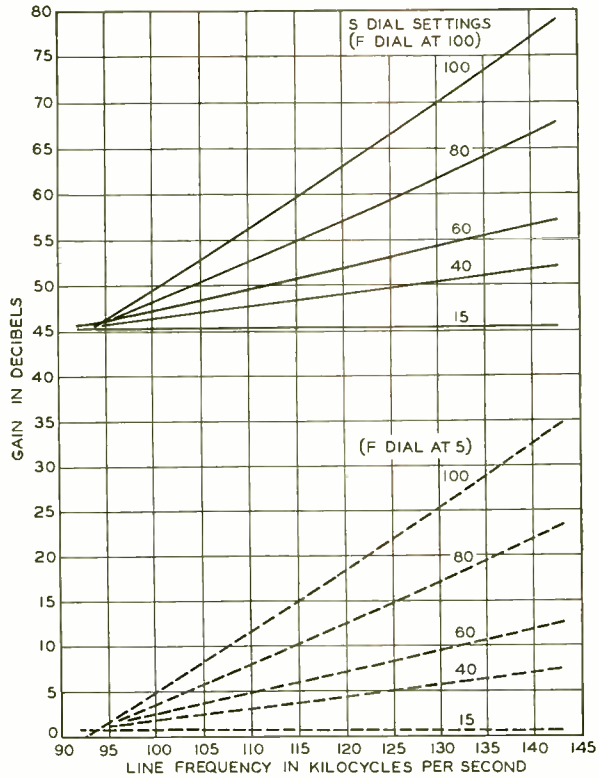

Fig. 1—Regulation available for east-to-west transmission: minimum and maximum flat gain and several values of slope gain

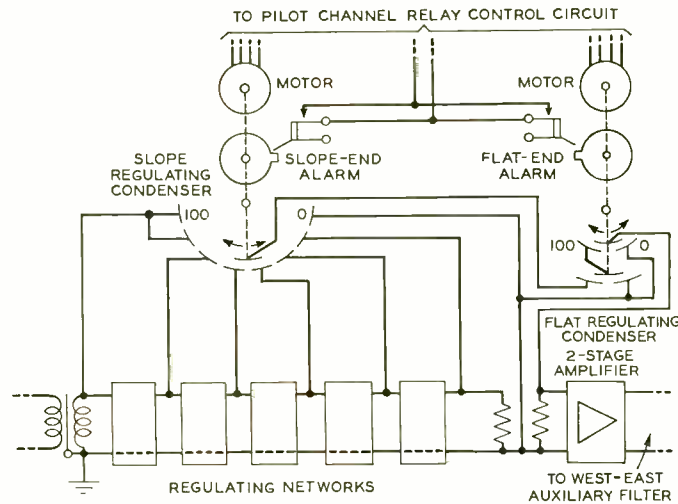

Fig. 2—Simplified schematic of circuit for west-to-east regulation in which both flat and slope regulators are used

flat regulator will act to insert the 22-db gain at all frequencies, but to keep the slope characteristics right, the slope regulator must remove about 11 db at 36 kc.

It will be noted that the flat-gain pilots are placed at the upper edge of the 36-84-kc band and at the lower edge of the 92-143-kc band, while the slope-regulating pilots are at the outer edges of these bands. This arrangement was selected be-

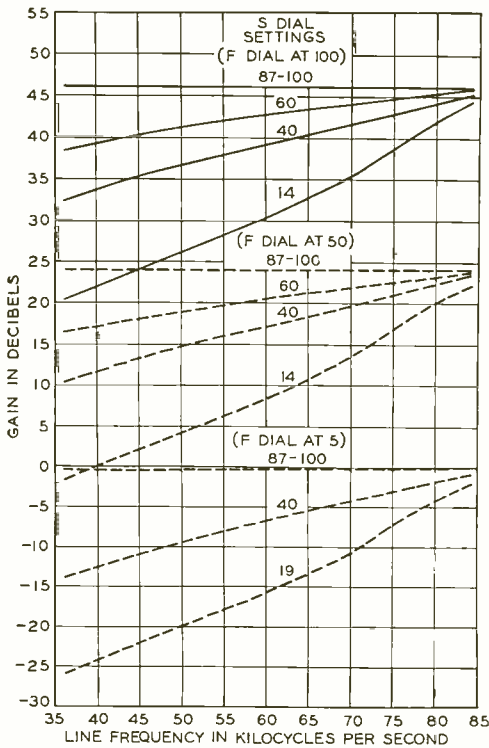

Fig. 3—Regulation available for west-to-east transmission: minimum, intermediate, and maximum values of flat gain

cause it imposes much less severe requirements on the directional filters than would be the case if either of the

slope-regulating pilots of the system were placed at the edge of the band that is adjacent to the crossover region of these filters.

In the regulator for the west-to-east, or low-frequency band, the flat and slope regulators operate condensers ahead of a two-stage feedback amplifier that in itself has a gain that is flat with frequency. The arrangement is shown in Figure 2. An increase in loss causes the flat regulator to rotate a double-stator condenser to increase the gain of the amplifier by increasing the potential on the grid of the first tube. The slope regulator moves a condenser with eight sets of stator plates that gradually introduce additional sections of series networks, each of which has a negligible loss at 84 kc and a linearly increasing loss that reaches its maximum value at the lower edge of the band, 36 kc.

The arrangement for the east-to-west, high-frequency band is shown in Figure 4. Here two amplifiers are employed: one for flat-gain and one for slope-gain control. The flat-gain amplification is controlled in much the same manner as for the low-frequency band. The networks for

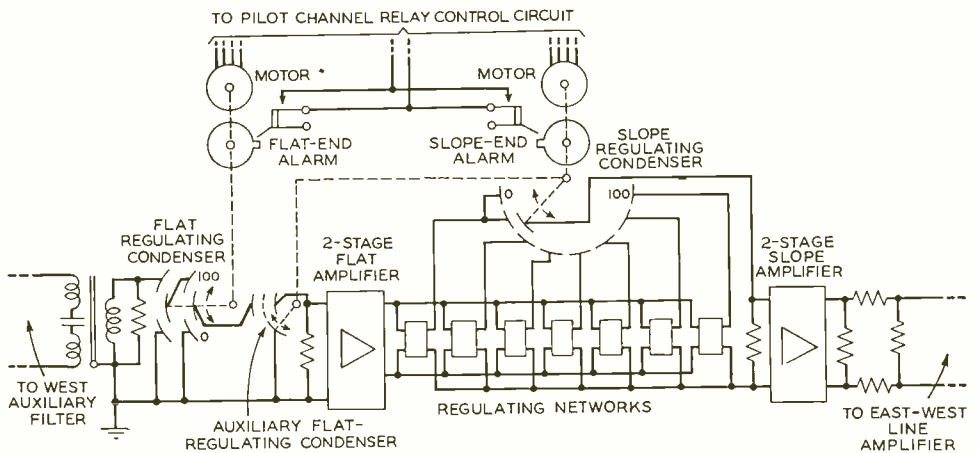

Fig. 4—Simplified schematic of circuit for east-to-west regulation

slope regulation differ in arrangement from those used with the west-to-east band in being cut into the circuit in parallel instead of in series. The slope of these various networks in combination with about 10 db of slope introduced by the line amplifier conforms to different slope characteristics of open-wire lines ranging from the coldest and shortest dry line to the steepest and highest-attenuation iced-line characteristic expected before noise renders further gain useless. In the flat-gain regulating circuit there is an auxiliary condenser driven by the slope control. It comes into play only for low-slope conditions, that is, when little or no gain is required from the slope control.

An example of the action of the regulator under adverse weather conditions requiring the use of the auxil-

iary condenser is shown in Figure 5. This consists of nine graphs side by side plotting signal level against frequency at the beginnings and ends of a series of repeater sections. In normal operation the output of each repeater would be flat with frequency, and at a level not greater than +17 db. Such an input to section 1 is shown, and the loss over section 1 results in a level at the end of the section that decreases with increasing frequency. The total loss is moderate, and the combination of flat and slope regulators restores the signal to a flat +17 db at the input to section 2.

Over sections 2, 3, and 4 it is assumed that the ice or snow that coats the wires causes a very large attenuation with only moderate slope. The loss at 92 kc is so great that the 45-db flat gain of the next three repeaters

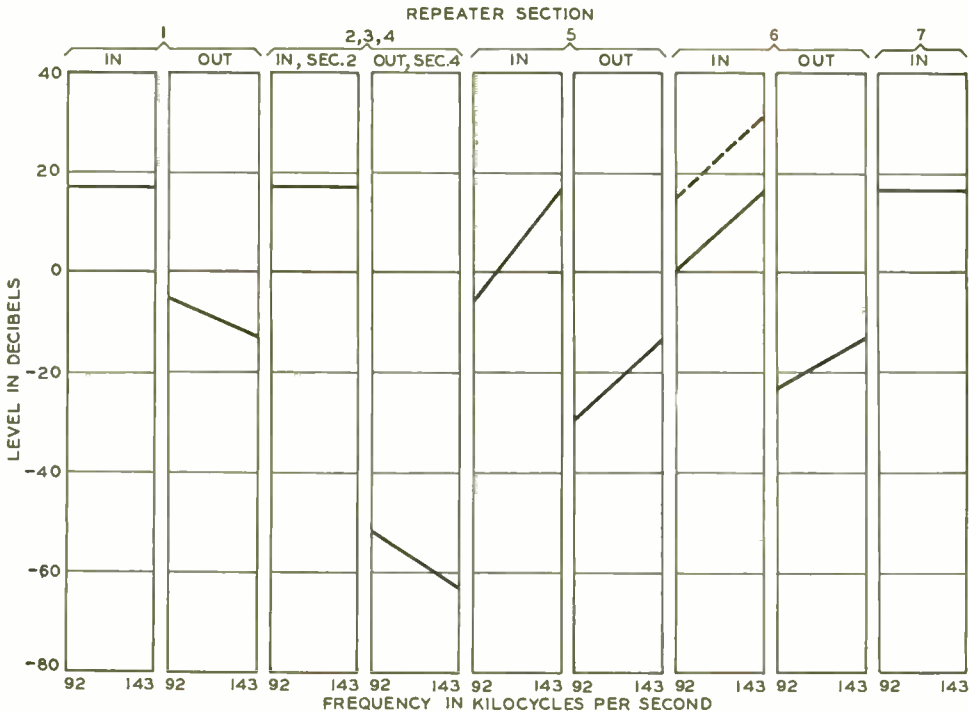

Fig. 5—Level-frequency graphs for the input and output levels over a number of sections in series under adverse weather conditions requiring the use of auxiliary condenser

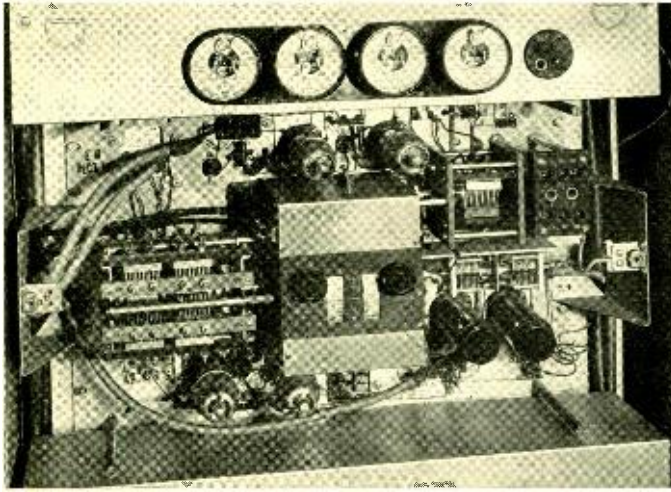

Fig. 6—The east-to-west band regulator with cover removed

can raise the level at the low frequencies to only -7 db at the input to section 5. The total of 80 db available at the high frequencies of each repeater, however—made up of 45 -db flat regulation and 35 -db slope regulation—is ample to bring the level of the high frequencies up to the desired $+17$ db. As a result the signal leaves the repeater at the beginning of section 5 with a level that increases with increasing frequency—a reversed slope, as compared with the preceding sections. This next section, it is assumed, is a comparatively short one, operating under ordinary dry or wet weather conditions. The reversed slope is therefore decreased, but the total attenuation is small. The flat regulator at the end of this section inserts its full 45 db in an effort to bring the level at 92 kc up to $+17$, but in doing so, it raises the level at 143 kc to

$+32$, as indicated by the dotted line, even without any slope gain added. This would put too high a level on the line, and it is for this reason that the auxiliary flat condenser is added. Coming into play when the slope regulator is at its low end, it introduces a flat loss that results in the solid line. The next sections take out enough of the reverse slope to enable the following repeater to re-

store the signal to a flat $+17$ db.

Both flat and slope regulators for both frequency bands are operated by circuits essentially the same. The pilot is picked off through pilot-channel filters at the output of the line amplifier and passed through an amplifier and rectifier to the windings of two relays—one to give the control and one for alarms under exceptional conditions. One of the two pilots of each band is carried to two relays associated with the flat control, and

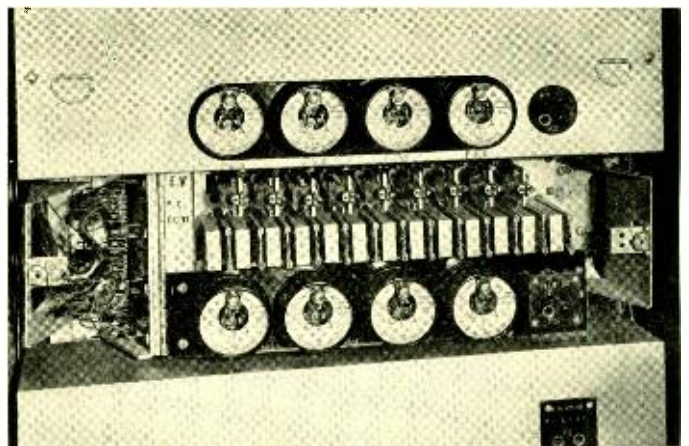

Fig. 7—Control circuit panel for both bands

the other, to two similar relays associated with the slope control.

The relays used for regulating purposes are on the panel, the front and rear views of which are shown in Figures 7 and 8. Since the relay circuit closely parallels the one used in the 2B pilot channel regulator for type-C carrier systems, a detailed description of the circuit and its functioning is not given at this time. Complete description of the 2B circuit will be given in an article to appear soon in the RECORD.

A test installation of these regulators in the Laboratories is shown in the photograph at the head of this article, and a close-up view of the high-group regulator with cover removed is shown in Figure 6. The flat-control condensers are at the right, with the auxiliary flat-control condenser above them, while the slope-control condensers are at the left. The dials near the center indicate the positions of the two sets of condensers. Knobs are provided for manual drive of the regulating condensers. The driving motors are mounted on the rear of the panel, in the manner shown in Figure 8.

Although this pilot-channel control circuit was designed to compensate for changes in line attenuation, it has the additional advantage of keeping continuous watch on the operation of the system as a whole. If the entire transmission circuit, clear back to the



Fig. 8—Rear view of bay shown in the photograph at the head of this article

originating terminal, is not intact, an alarm will at once be given. The simultaneous alarms caused by unstable or failing pilots will be the first indication of an overall circuit trouble.



Dielectric Properties of Pigmented Rubber

By D. B. HERRMANN
Chemical Laboratories

is usually the largest constituent except rubber hydrocarbon. For this reason and also because it is often a semiconductor its effects on the insulating characteristics of the compound are generally more marked than those of the other materials. A conducting pigment dispersed in rubber may form conducting paths and change the dielectric

GOOD insulation for wire is characterized by a low dielectric constant, low power factor, and a high resistance to the passage of direct currents. Its life should be measurable in years, for the longer an insulated wire or cable can be kept in service without repair or replacement the better. Pure rubber fulfills the dielectric requirements but to give it all of the requisite physical properties it must be compounded with other materials in various combinations and vulcanized by combining it with sulfur. These other materials are called accelerators, antioxidants or antiagers, plasticizers or softeners, and pigments. All affect the dielectric properties of rubber in varying degrees.

The pigment* in rubber insulation

*The word "pigment" is used here in a general sense, including not only true pigments but also inert fillers and reinforcing agents. The demarcation of these groups is indefinite.

properties more than an insulating pigment similarly dispersed. In most cases the pigments increase the dielectric constant, power factor, and conductivity, and decrease the direct-current resistivity of rubber compounds. Their use, however, reduces cost, increases toughness and tensile strength, and provides different colors.

Reinforcing pigments, which are used to strengthen rubber, have higher dielectric constants than rubber. Their addition therefore raises the dielectric constant of rubber compounds. There is no exact mathematical relation, however, for calculating accurately the dielectric constant of a rubber compound from the dielectric constants of its components. Many factors other than the dielectric properties of pigment probably affect the dielectric properties of rubber compounds. Among these are

size, shape, and uniformity of the particles, degree of dispersion in the rubber, wettability by the rubber, and impurities in the pigments including those adsorbed on particle surfaces. Various pigments contribute different characteristics and different grades also have different effects.

Vulcanized pigmented rubber in sheets or slabs about 6 inches square provide a convenient form for dielectric measurement. To them are attached tin-foil electrodes with a very thin layer of petrolatum as an adhesive to insure good contact. The upper electrode is guarded by a tin-foil ring cut to fit closely around it so that capacitance edge effects are reduced to a negligible minimum. The electrode dimensions are selected to give a reasonable capacitance value and to fit a brass disc and shield which connect the upper electrode and guard ring with the shielded capacitance-conductance bridge used for alternating-current measurements at low frequencies. The sheet and top electrode are set on a smooth steel plate which is in contact with the lower electrode and is also connected to the bridge. D-c resistivity measurements are made with a galvanometer

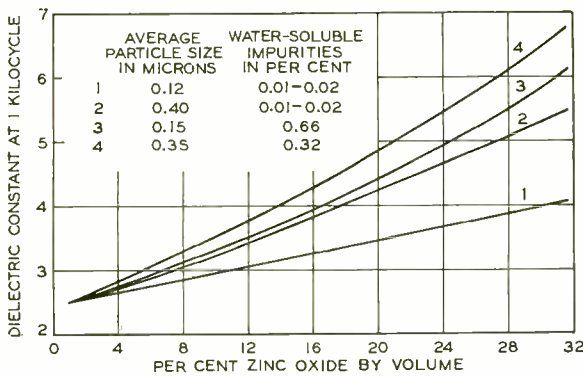

Fig. 1—The amount and kind of zinc oxide in rubber insulation are important in determining the dielectric constant of the insulation

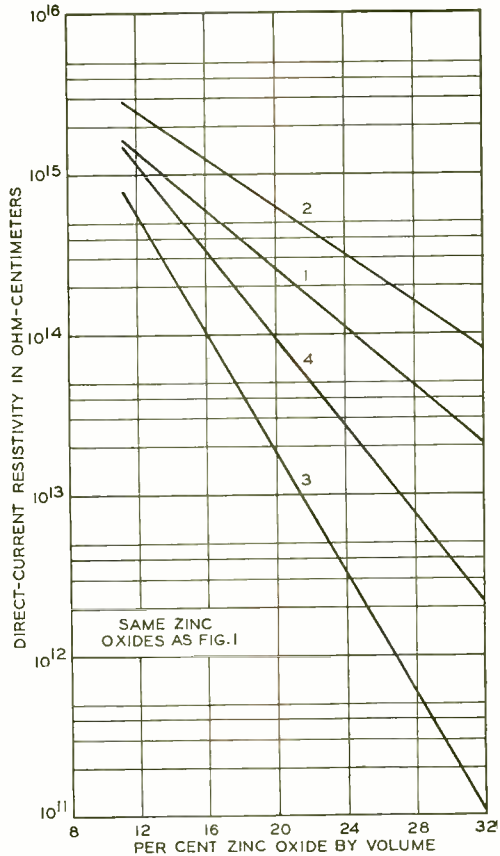

Fig. 2—The effect of various zinc oxides is shown by direct-current resistivity measurements of zinc oxide rubber compounds which have been soaked in water

by a direct deflection method.

Zinc oxide, which is both a reinforcing agent and a true pigment, finds considerable use in rubber insulation although it is a semi-conductor. Figure 1 shows that zinc oxides with the least water-soluble impurities give the lowest dielectric constants and that the grades with fine particles have less effect than those with coarse. The conductivity and power factor of rubber are influenced in a similar manner. In Figure 2

is shown the difference between the direct-current resistivities of compounds containing the same four types of zinc oxide as those of Figure 1. The measurements were made on test sheets which had been immersed in distilled water at 25 degrees Centi-

highest percentage of water-soluble impurities. The advantages gained by purifying rubber to remove water-absorbing materials are partly lost if pigments are used which contain soluble impurities.

That the adverse effects of water-soluble matter are increased by the presence of water for other pigments besides zinc oxide is indicated in Figure 3. The increase in dielectric constant with the amount of pigment in a rubber compound containing incompletely processed lithopone is greatly magnified by exposure to water as compared with the increase for the same compound when made with processed lithopone, because the processing removes soluble materials. The sheets were kept in distilled water at 25 degrees Centigrade for 28 days before the test, as was done with the zinc oxide rubber compounds. The difference between the effects of the two types of lithopone when the test sheets are dry is relatively small at even the highest volume percentage shown. Lithopone is a mixture of about thirty per cent zinc sulfide and seventy per cent barium sulfate and is an inert filler compared with zinc oxide. It is made by simultaneous precipitation of barium sulfate and zinc sulfide from solutions of barium sulfide and zinc sulfate. If water-soluble salts are not completely removed the pigment has a deleterious effect on the insulating properties and characteristics of rubber compounds.

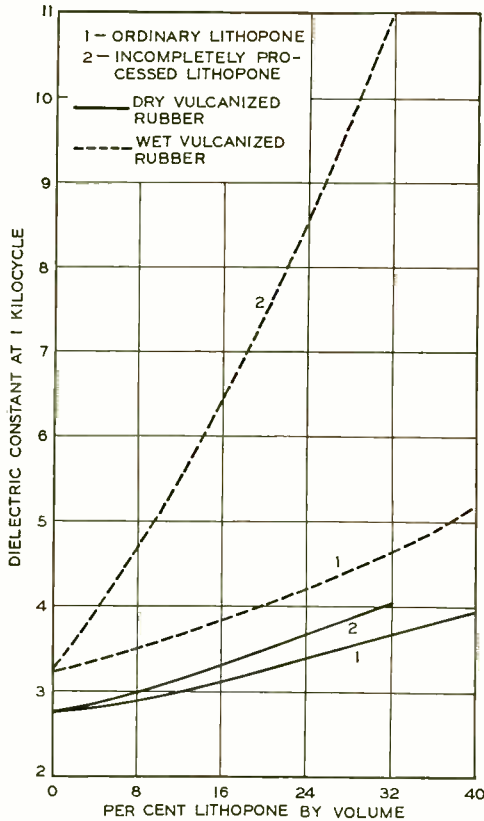

Fig. 3—A striking difference is found in the effect of two lithopone pigments on the dielectric constant of rubber insulation which has been exposed to water

grade for 28 days. Rubber compounds made with zinc oxides which contain very little water-soluble material have the highest resistivities and fine particles lower the resistivities somewhat. Dry sheets have much higher resistivities but the zinc oxide which causes the lowest resistivity in the dry as well as the wet compound has the

Whiting, or calcium carbonate, is a pigment frequently used in rubber compounding. It is coarser than zinc oxide and not as readily wetted by rubber. Unlike zinc oxide, it is an insulating pigment and therefore has less influence on the dielectric properties of rubber. In general, however, rubber compounds which contain

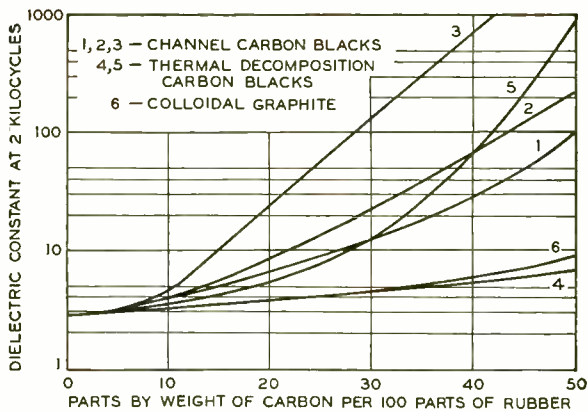

Fig. 4—The increase in the dielectric constant of vulcanized rubber varies considerably with the addition of different carbon pigments

whiting have dielectric properties close to those of insulation made with equivalent volumes of the better zinc oxides. Like other pigments, various whittings differ in the degree to which they affect dielectric properties of rubber compounds. For example, a ground limestone gave better insulating properties than a precipitated calcium carbonate when both pigments were well dispersed. The calcium carbonate had a smaller particle size and varied more in alkalinity. Alkalies are water soluble and are undesirable in insulation.

The effect of different types of carbon on the dielectric properties of rubber varies much more than does that of zinc oxide, as Figures 4, 5 and 6 indicate. The various carbon pigments include true pigments, reinforcing agents, and inert fillers. By their use rubber compounds may be prepared with widely different physical and dielectric properties. It is almost possible to

duplicate the entire range of properties attainable with other pigments by using carbon alone. Channel process carbon blacks, which are manufactured by incompletely burning natural gas against metal beams or channels, are by far the best reinforcing agents known, but unfortunately they affect the insulating properties of rubber more adversely than any other pigment. The coarser thermal-decomposition blacks, which are made by breaking down hydrocarbon gas into carbon and hydrogen, and colloidal graphite give relatively low reinforcement and act like inert fillers. Blacks made by

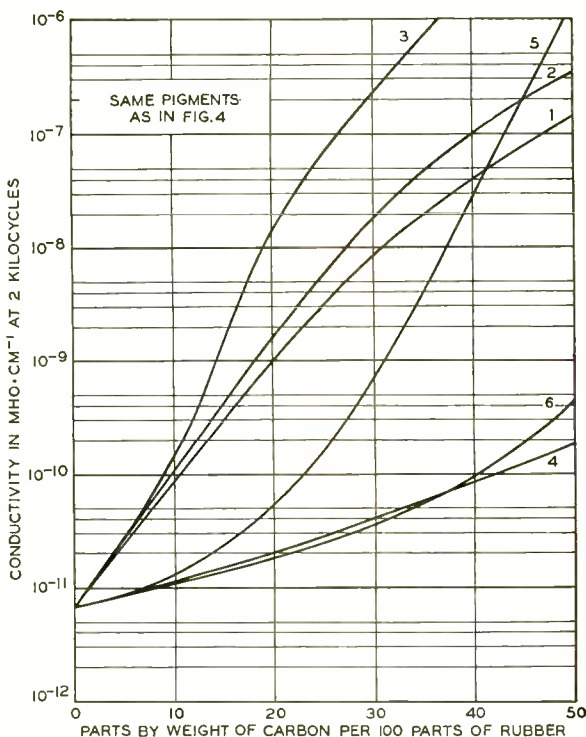

Fig. 5—The conductivity of vulcanized rubber can be increased over a million times by adding large amounts of certain carbon pigments

thermal decomposition are conducting and have particles of nearly the same size as zinc oxide. Channel black has an average particle size considerably smaller than that of soft (thermal decomposition) black or zinc oxide. The evidence implies that the dispersion of channel black in rubber is of a

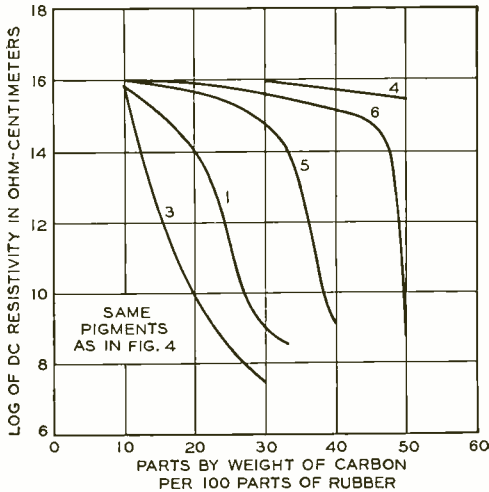

Fig. 6—There is a wide variation in the effect of carbon pigments on the direct-current resistivity of vulcanized rubber

different nature than that of other carbon pigments. The increase in dielectric constant caused by this black is augmented by increased working of the compound, which presumably corresponds with improved dispersion.

The finer the particle size of carbon the higher the dielectric constant and conductivity a given amount of it imparts and the lower the resistivity.

These effects are striking for larger amounts of pigment. The addition of carbon up to ten parts in one hundred of rubber has relatively little adverse effect on dielectric constant and resistivity as compared with higher proportions. The conductivity and power factor of rubber are increased by the addition of very small amounts of carbon black and are more sensitive than the dielectric constant or direct-current resistivity to these additions. They are also more sensitive as measures of particle size and degree of dispersion. The addition of ten per cent of the finer blacks increases the conductivity by about tenfold; the addition of fifty per cent may increase it more than a million times. In fact, certain types of carbon black convert rubber from an insulator to a semiconductor.

Many other pigments are added to rubber to alter its physical properties, including magnesium carbonate and oxide, lead and titanium oxides, barium sulfate, talc, and clays. Nearly all are available in various grades and these studies show that the effect of each grade, as well as each pigment, on the dielectric properties of rubber insulation must be considered.

These investigations of the effect of pigments, fillers, and reinforcing agents on the dielectric properties of rubber compounds have found practical application in the development of better-insulated wire that is used throughout the telephone plant.

Protecting Switchboard Lamps With Varistors

By W. E. DARROW
Local Central Office Facilities

IN 1931 a new switchboard, known as the No. 12,* was developed to furnish common-battery service in small towns formerly served by magneto equipment. One of the new features of this board was a simplified line circuit having the line lamp connected directly in series with the line conductors, so that no line relay was needed. Subscriber loops connecting with these central office switchboards may vary from virtually zero to six or seven hundred ohms, and prior to the No. 12 board, there had been no switchboard lamp available that would give satisfactory illumination over such a range of resistance. At the time the development of the No. 12 board started, however, the Laboratories had just completed the development of a new high-resistance tungsten-filament switchboard lamp that would stand over-voltages of fifty per cent for a considerable period of time, and would give good illumination down to sixty per cent of its rated voltage. It seemed ideal as a series line lamp, and was adopted for the No. 12 board. By using cut-off jacks with this lamp, a line circuit was designed that required no relays at all.

*RECORD, Dec., 1932, p. 94.

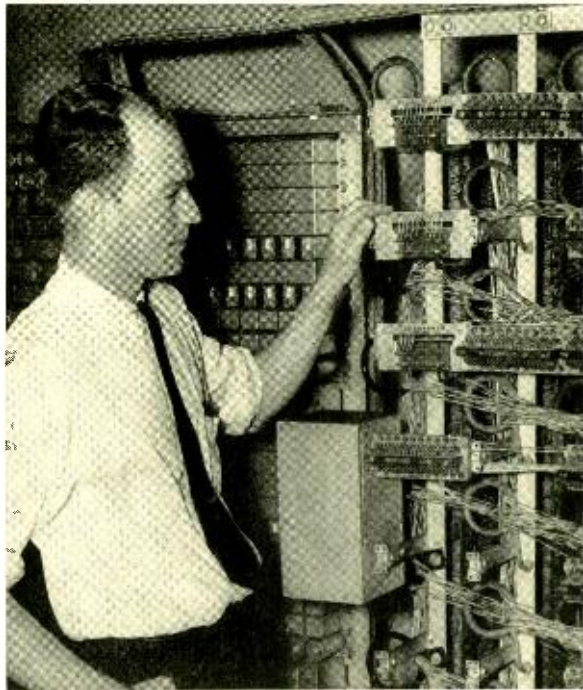

It was realized that line lamps in this type of line circuit would be exposed to any electrical disturbances that might be impressed on the outside lines, and that these disturbances might be of such severity in a few cases as to require line relays to prevent lamps from burning out. However, the new line circuit effected substantial economies over the line-relay type, and it was decided to employ it in all cases and, where required, add line relays or make such other modifications as experience might indicate would be necessary. On a number of early jobs recurring lamp failures during thunderstorms were experienced on some of the lines. Usually, not more than twenty-five per cent of the lines were involved, and the troubles were eliminated by equipping them with relays. Investigation showed that these lamp failures were caused by surges of very short duration, and this indicated that a simpler and more economical method

of preventing lamp failures could be devised. Bridging the lamps with some varistant material that would provide a low resistance shunt around them for the duration of the surge seemed to be the best solution.

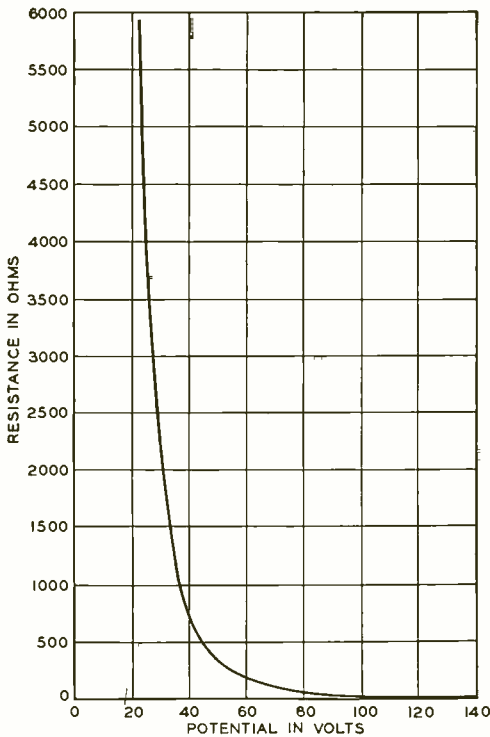

Fig. 1—Resistance-voltage characteristic of varistor used for protecting line lamps in the No. 12 type switchboard

Silicon carbide was proposed since its resistance decreases at a high rate and almost instantaneously as the voltage across it rises. If such an element shunted around the lamp could be given a high normal resistance so as to have no appreciable effect on the illumination, and if its resistance decreased sufficiently under high-voltage conditions, it would act as a very effective protection against burnouts by limiting the voltage across the lamp. In addition, of

course, the varistor should restore to its normal condition after each application of high voltage, and should not change appreciably with age.

Possible applications of silicon carbide varistors in the telephone plant had been under investigation, and a disk had been developed that had a tenfold decrease in resistance for each doubling of voltage, and that also met the resistance and voltage requirements. As shown in Figure 1, this varistor drops to a low resistance at the higher voltages, and should therefore adequately protect the lamps on all telephone loops of only moderate resistance.

The varistor element is a silicon carbide and clay disk. Each disk is placed between fairly heavy metallic plates, which provide the electrical connections to the disk and also dissipate any heat that might be developed in them. A substantial number of lamps are likely to need protection in an office, and because of the small space occupied by each element, twenty of them are mounted in a unit known as the 300A varistor, shown in Figure 2. The varistors are assembled in pairs—two disks and three metal plates. The center plate forms a common terminal for the two disks, and the two outside plates form the individual terminals. Ten such pairs form the 20-disk unit, and the common terminals of all ten pairs are strapped together. They are assembled on a metal rod with mica insulation between pairs and a ceramic bushing over the rod. End plates are provided for fastening the unit on a standard mounting plate. Four such assemblies can be mounted on a single mounting plate, and provide protection for eighty lines. The mounting plates can be located either in a switchboard section or on a relay

rack, if one is available. A mounting detail was developed to permit locating the 300A varistors between the verticals of the main frame. An installation of this type is shown in the photograph at the head of this article. Figure 3 shows the compactness of the 300A varistor as compared with twenty line relays.

The varistors were found to be very effective in protecting the line lamps in several trial installations, and they have been standardized for general use throughout the Bell System. When they are mounted in the switchboard section or on a relay rack, they are cabled to terminal punchings on the main frame—only one conductor being required for each varistor element. Thus, wherever the varistors are mounted, their protective elements are accessible at the main frame for cross-connection to the line-lamp circuits.

Only a very simple change was made in the wiring of the standard line circuit because of the addition of the varistors, and this was in the cable between the main frame and the switchboard. Originally, this cable had two conductors for each line, one serving as the tip and the other as the ring conductor—while with the varistors, three conductors are required per line, the additional one to extend the lamp lead to the main frame. The cable has therefore been changed for all new offices to one having three conductors per line. The

line circuit is of the lamp-in-the-multiple type, with a lamp socket associated with each multiple jack of the line. One terminal of the lamp is therefore accessible along with the tip and ring for connection to the three-conductor cables. The other terminal of the lamp is connected to battery, and, with the common terminals of the varistors also connected to battery, any varistor can be connected in parallel with any line lamp in the office by means of a single-conductor cross-connection. For offices already in service, the third lead between the main frame and the switchboard is

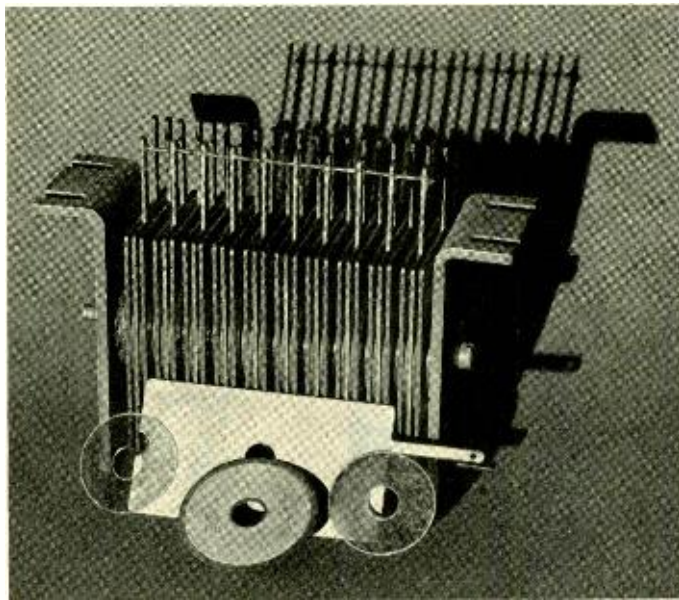

Fig. 2—The 300A varistor for protecting the lamps on twenty subscriber lines

taken care of by adding a separate cable containing one conductor per line for each group of twenty lines on the switchboard.

The battery lead to the varistors is equipped with a three-ampere alarm-type fuse. In general, this has been quite satisfactory. However, this fuse has operated in some offices during

storms of unusual severity, thereby removing the line-lamp protection until the fuse could be replaced. The varistor fusing was changed in a few of these offices to a three-ampere thermal circuit breaker to determine if the slight delay thus introduced in opening the circuit would be sufficient to maintain the varistor circuit closed through heavy surge conditions. To give an indication should the circuit breaker operate, a three-ampere

alarm-type fuse in series with a two-ohm resistance was bridged around the circuit breaker. This combination, under steady-current conditions, is approximately equivalent to a 3.2-ampere fuse, and therefore affords practically the same protection as a three-ampere fuse. This combination has proved very effective in reducing unnecessary circuit interruption for large-current surges, and is now being standardized for general use.

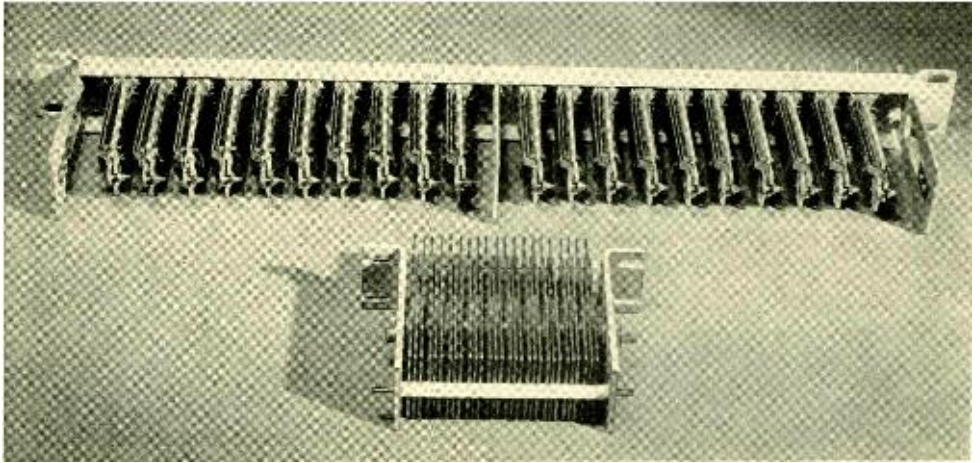

Fig. 3—The 300A varistor unit occupies much less space than twenty line relays



Wire-Joining Methods

By J. B. DIXON
Outside Plant Development

EARLY telephone lines on poles were commonly joined by twisting the two conductors together and wrapping the free ends closely about each other, but prior to 1906 this method gave way to joining with sleeves of copper or steel. The ends of the wires were inserted in two parallel bores and the assembly was twisted with tools known as sleeve twisters. This joint was a substantial improvement over the previous one because it was stronger and the sleeve afforded some corrosion protection to the joined ends. For many years, this twisted connection gave acceptable service on copper and steel lines as well as on insulated wires such as inside wire, drop wire and bridle wire.

With higher standards of transmission, and particularly the introduction of carrier frequencies, resistance unbalances were experienced in open-wire lines which were attributable to variable resistance in the twisted sleeve. These unbalances were generally small for each individual sleeve, but the accumulation of many such irregularities in a long line caused an excessive unbalance for circuits requiring high-quality transmission. It was also difficult to identify faulty joints because the very thin films of corrosion products, which were generally responsible for the trouble, broke down quite readily if the lineman moved the wires, or were

even eliminated by the relatively low voltages used in testing. As a remedial measure sleeve joints were soldered or renewed. In existing joints a small hole was filed through the shell near the end of each sleeve, so that the soldering could be done where the wire was not under tension. In making new joints the free ends of the two wires were left sufficiently long to permit bringing them together and they were then soldered to insure permanently low resistance. These methods confined the heating caused

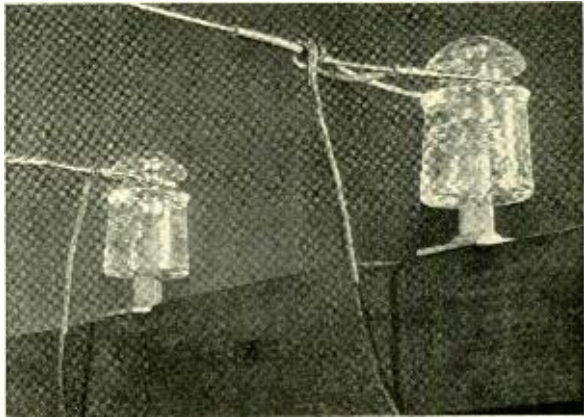

Fig. 1—Dead ends on open-wire lines are made by looping half-round wire around the insulator and bringing the flat surfaces together in a single sleeve

by soldering to sections of the hard-drawn line wires where the unavoidable annealing did not adversely affect the strength of the line. They were effective in overcoming the unbalance but the operations involved were costly.

To correct this condition the Lab-

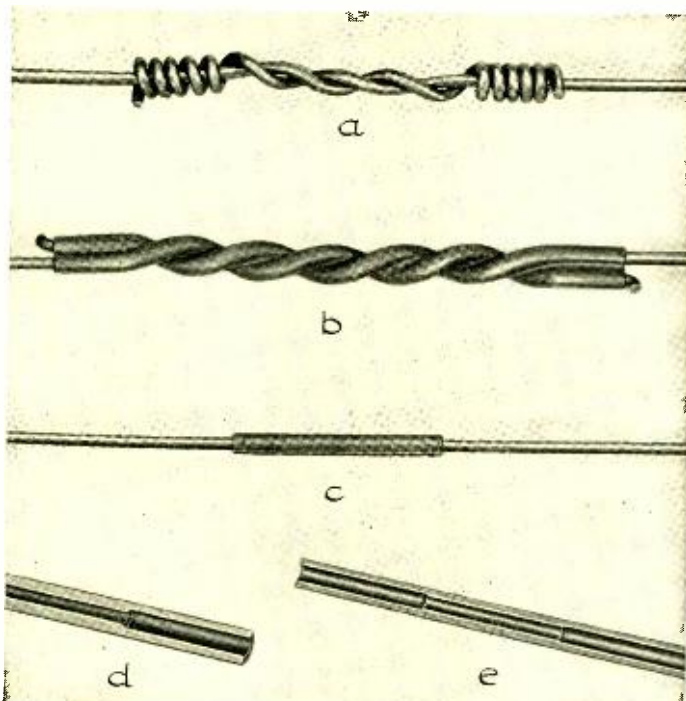

Fig. 2—Joints used on open-wire lines: (a) "Western Union" joint used before 1906, (b) twisted sleeve joint, (c) new rolled sleeve joint, (d) section of a sleeve for making dead ends and (e) section of a steel "maintenance" sleeve for joining steel wires, one of which has been reduced in size by corrosion

atories developed in 1927 an improved wire joint which eliminated troubles caused by corrosive action. The new method is used primarily for joining open wire and drop wire and may have substantial applications in other telephone plant wiring such as for joining cable conductors in lead-covered cable. Single tubes are used as sleeves to form a butt instead of a lap joint, such as was made with the two-bore twisted sleeve. The sleeves are applied on line wire with a small hand-operated rolling mill* which forces them under high pressures into intimate contact with the wire. Joints made with this tool provide a gas-tight union between the wire and sleeve which effectively

*RECORD, Nov., 1931, p. 74.

seals against corrosion. Many millions are now in service and no instance of corrosion within the sleeve has been reported.

In joining small-sized conductors, as in drop and station wiring, rolled joints are satisfactory but the sleeves are more conveniently applied with a small pressing tool because the work of constricting small sleeves is much less than for large ones and the joint frequently has to be made in inconvenient locations such as out-of-the-way corners and shafts.

To obtain optimum holding power in joints on wires strung in spans, a lacquer and emery coating is applied to the bores of the sleeves. The emery particles are imbedded in the wire and the sleeve when compressed forms an effective interlock. This increases the resistance to slippage. For copper line wires, the sleeves are made from soft copper tubing, which is readily rolled and develops adequate strength. Mild steel tubes, with the outer surfaces protected by a heavy coating of zinc, are used to join steel line wires. Annealed brass sleeves are used to join the conductors of insulated wires, because brass is preferable to copper for contact with rubber compounds. The higher strength of the brass is also advantageous when the wires are under tension.

Wires of different diameters are joined by a "combination" sleeve

which is like the one previously described except that the bore of each half is of different diameter. "Maintenance" steel sleeves are also provided for joining steel line wires whose diameters have been reduced by corrosion. This sleeve has two progressively smaller bores in tandem at one end to accommodate the corroded wire and a single bore at the other end for new wire.

Rolled sleeve joints have been adapted for dead-ending open-wire lines by looping a short length of half-round wire around the insulator and bringing the flat surfaces together in one end of the sleeve; the line wire is held in the other end. This loop develops the full strength of the line wire, after the joint is rolled, and its use simplifies material and tool stocks by eliminating entirely the double tube sleeves and sleeve twisters that were previously used.

Where open wire is dead-ended, the circuit often has to be extended to terminals through a length of insulated conductor. Heretofore, these two types of wire were joined by soldering or the insulated wire was attached to the line wire by a "bridging connector." For making "bridge" joints, where they do not have to be disconnected for testing, a rolled sleeve has been developed with two parallel bores. One accommodates the half-round dead-ending wire

and the other the conductor of the insulated wire. This sleeve has a soft copper core enclosed in copper tubing. To make the connection, the half-round wire is pulled through the



Fig. 3—Rolling the sleeve to the wires with a rolling tool

sleeve before the dead-end loop is completed; the insulated conductor is then placed and the sleeve rolled.

These new rolled joints reduce maintenance costs considerably by eliminating high-resistance joints and improving holding power. With them wire failures can sometimes be repaired without cutting in slack.



A Bridge for Measuring Core Loss

By H. T. WILHELM
Electrical Measurements and Design

Because of its precision, the a-c impedance bridge has been generally used in the Bell System for core-loss measurements. A coil of wire is wound on the material being investigated, and the resistance of the coil is measured with the bridge. This measured value includes the d-c resistance of the coil as well as the core loss. The d-c resistance, however, can be determined separately, and by subtracting it from the total effective resistance, the core loss remains. There is also a small resistance component due to the "skin effect," but this also may be determined separately and deducted, and need not be considered here.

If the core loss is large relative to the d-c resistance, the precision with which it can be measured is of the same order of magnitude as that of the bridge itself, while if it is small relative to the d-c resistance, the precision attained is much less than that of the bridge.

This condition is well illustrated in Figure 1. Here R_e is the total effective resistance, and the d-c resistance, R_{dc} , is subtracted from it to give the core loss ΔR . The total error in the measurement of R_e thus remains as an error in ΔR . Where ΔR is large compared to R_e , as is true for poor core material indicated at the left, the percentage error of ΔR is about the same as that of R_e , but where ΔR is small compared to R_e , as for the good core material

WHENEVER a varying magnetic flux is set up in magnetic material, various losses occur that are grouped together under the name core loss. In power work, these losses are large, and are measured in watts. In communication work, however, the actual amount of power wasted is usually negligible, but the effects of core loss on transmission are of the utmost importance in high-quality apparatus and circuits. They have the effect of increasing the effective resistance of the apparatus by an amount that varies with the strength and frequency of the component signals, and thus they result in distortion. Considerable work has naturally been done in the Bell System to devise methods of measuring core loss and to develop materials in which the core loss is a minimum.

shown at the right, the error becomes a much greater per cent of ΔR than it was of R_e .

In any such bridge measurement, the reactance component must be balanced as well as the resistance component, and in a high-quality coil the reactance may be more than 100 times the value of the resistance. This ratio becomes greater as the coils are improved because the quality of a coil, known as its "Q" value, is equal to the ratio of the reactance to the resistance. This fact also increases the difficulty in securing precise measurements of core loss of high-quality coils because the larger Q becomes, the more difficult it is to determine a small resistance component with any degree of accuracy.

The ratio of the voltage impressed across a coil to the current that flows in it is the impedance, which in Figure 1 is represented by the vector Z . The angle between the impedance and reactance vectors is the loss angle of the coil, and the tangent of the loss angle, R_e/x , is the reciprocal of Q. For small angles, such as the loss angles of ordinary communication coils, the tangent is equal to the angle measured in radians; and thus a coil with a Q of 100 has a loss angle of 0.01 radian or 10 milliradians. Since part of the total loss is due to the core loss, the core loss also can be expressed in radians, and if it is only one-tenth of the total resistance, its loss angle is only one milliradian. If it is to be measured to an accuracy of ten per cent, the angular error of the bridge can not be greater than 0.1 milliradian. This means that the loss angles of the standards used with the bridge must be known to at least this precision.

In considering possibilities for a bridge of improved accuracy, these factors were all kept in mind. A

bridge of the comparison type was rejected because with it the standards under test, while the purpose of this project was to develop materials better than any existing. The series resonance bridge was considered because it uses a condenser standard, which can be built with a much smaller loss angle than an inductance. This type of bridge is not direct reading, however, and the computation labor involved is a great handicap when numerous measurements are required. An investigation revealed, moreover, that a Maxwell bridge,* which has the advantage of being direct reading, could be built with equally good accuracy.

A simple schematic of the Maxwell bridge is shown in Figure 2. The condenser standard C_s balances the un-

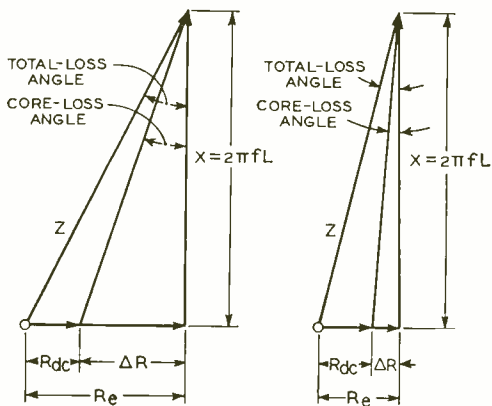

Fig. 1—With large core loss, indicated at left, ΔR can be measured with about the same precision as R_e , but with small core loss, its precision becomes less

known inductance L_x , and the conductance standard G_s balances the unknown resistance R_x . The factor R_1R_2 is designated the product constant, and is usually made equal to some power of ten to facilitate com-

*RECORD, June, 1938, p. 343

putation. In the new bridge the product constant is made 10^6 so as to permit using capacitance values giving the best accuracy for the usual frequency and inductance range. With a constant of this value, 0.1 micro-

slide-wire dial, all connected in parallel instead of the series connection used in resistance standards. With such an arrangement the capacitance remains substantially constant, independent of the conductance setting, and the bridge can therefore be readily compensated.

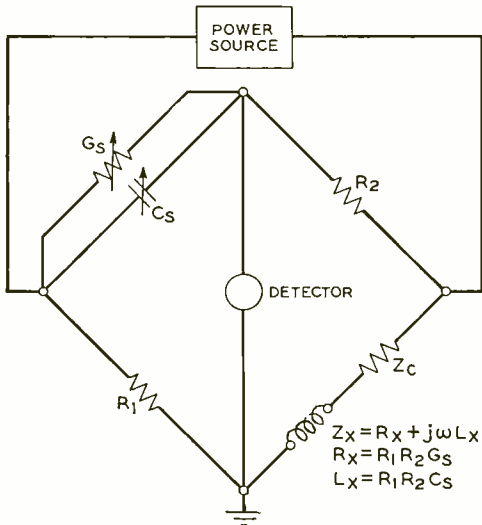

Fig. 2—Simplified schematic of Maxwell bridge for measuring core loss

farad in the bridge measures 0.1 henry of inductance. Since the capacitance and inductance values are numerically equal, the capacitance dials are engraved with the corresponding inductance values.

Formerly, resistance standards were used in Maxwell bridges for measuring resistance components. Since the resistance of the specimen is proportional to the conductance of the standard, however, it was necessary to take the reciprocal of the resistance standards inserted in the balancing arm. To eliminate this computation, a conductance standard was used for the new bridge as it has been in other recent Maxwell bridges. The conductance standard consists of three rotor-decade switches* and a

If the conductance arm were designed to read zero conductance at its minimum setting, extremely large resistances would be required for many of the steps. Resistances in the megohm range, however, do not have the requisite stability and accuracy for a bridge of this type. For this reason a residual conductance of 100 micromhos was decided upon to keep all resistances to reasonable values. To offset this 100-micromho residual conductance, a 100-ohm resistor is inserted in series with the test terminals. In series with this resistance is a 200-microhenry inductance coil to compensate for 200 micro-microfarad residual capacitance of the standards and of the shields and wiring. Both this inductance and resistance are incorporated in z , as shown in the schematic diagram, Figure 2.

Considerable electrostatic shielding is required as indicated in the complete schematic of Figure 3. One of the requirements for a Maxwell bridge is that the phase angle of the two product resistors R_1 and R_2 be exactly equal but of opposite sign. R_2 , as any large resistance wound non-inductively, is capacitive, and R_1 is made inductive by adding a small series inductance L_1 . To secure simple and precise adjustment of the inductance of the R_1 - L_1 combination, it is shunted by a small adjustable condenser. To set this condenser at its correct value, precise tests of the bridge are made with all shields in place, and the condenser is adjusted with a screwdriver

*RECORD, Jan., 1935, p. 136.

inserted through a hole in the shield.

The two product resistors are purposely made unequal to secure more efficient use of the test current and to facilitate metering it. By making R_1 one hundred ohms, and R_2 ten thousand ohms, the current divides so that nearly all of it passes through the test specimen. Under these conditions, a reading of the current from the test oscillator may be taken as a measure of the test current where an accuracy of about five per cent is satisfactory. Where more precise measurement of the test current is necessary, correction factors are applied that depend upon the magnitude of the test impedance that is used.

One of the advantages of the Maxwell bridge for this type of work lies in the fact that when used with direct current, it operates as a Wheatstone bridge. Keys are therefore provided which make it possible to switch the bridge network to battery and galvanometer for measuring the d-c resistance of the test specimen without altering any of the lead and contact resistances, and without an elapse of time during which temperature changes might affect the resistance value. This feature adds appreciably to the accuracy in measuring resistance increments.

The bridge is made for relay-rack mounting as shown in the

photograph at the head of this article. The three rotor decades and the slide wire of the conductance standard comprise the upper row of dials, and below them are the four dials for the capacitance standard. The former are engraved in ohms and the latter in millihenrys so that the values of the test specimen are read directly. The range is from 0.001 to 100 ohms, and from 0.001 to 100 millihenrys. The bridge is designed for use with the operator either sitting or standing, and with the bridge mounted vertically this required that the dial indices be above rather than below the dials which is

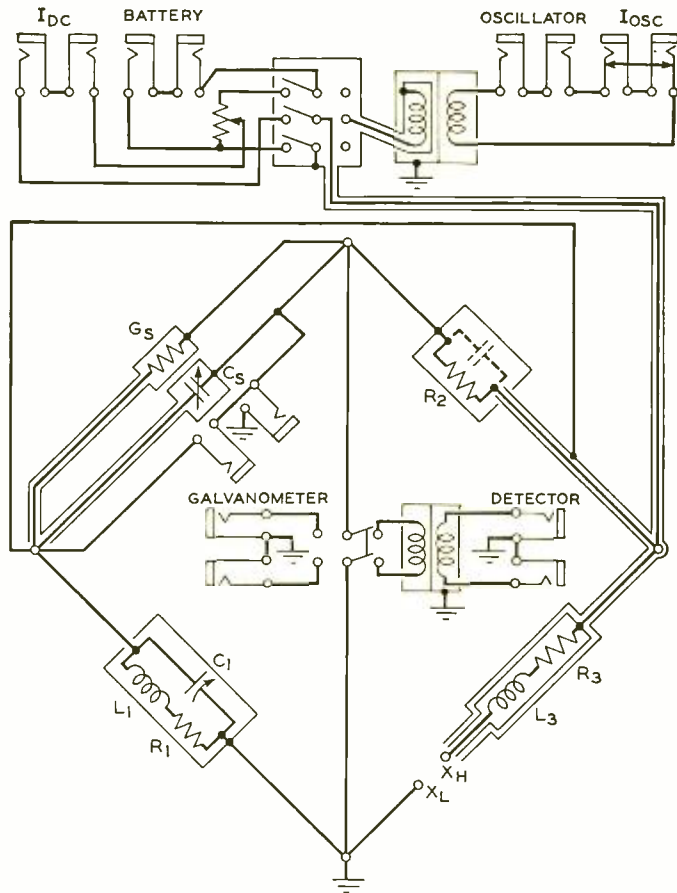

Fig. 3—Schematic of the new Maxwell bridge

common practice with horizontal bridges. This in turn made it necessary to change to a counter-clockwise rotation of the dial to maintain the left-to-right sequence of the dial markings. An adjustable apparatus shelf is provided at the left of the bridge to permit the test specimen to be near the bridge terminals and thus

to minimize corrections for long leads.

The bridge has demonstrated its value in furnishing precise core-loss data used in developing new magnetic materials. In addition, accurate frequency and current characteristics of completed filter and loading coils using these materials can be obtained with a minimum of effort.



“A Modern Aladdin’s Lamp”

A number of Laboratories engineers are members of the cast in the new Western Electric sound motion picture “A Modern Aladdin’s Lamp,” which describes the history, theory, manufacture and use of the vacuum tube. With Lowell Thomas as narrator, the film goes back to the discovery of the “Edison Effect” in 1883, through De Forest’s invention of the control grid, through the development of the telephone repeater, and on to the current research in our vacuum-tube laboratory. Steps in manufacture are illustrated by scenes from the Western Electric factory, and some of the varied applications by shots of ship-to-shore stations, broadcast transmitters, sound-picture studios, telephone toll offices, and the like. Ingenious animations are used to explain the behavior of electrons in vacuum tubes and metal conductors.

Enlargements of a few frames from

the film are shown on the opposite page: 1—T. L. Tuffnell testing a repeater tube. 2—S. B. Ingram, E. G. Shower, J. E. Clark and V. L. Ronci in conference over a power tube. 3—An automatic grid-winding machine. 4—J. J. Heil sealing two glass tubes together in cross fires. 5—Examining tube parts under a microscope, in the Western Electric factory. 6—C. H. Prescott, Jr., with equipment used for analysis of gases. 7, 8—Two frames of the animated sequence showing a rough analogy of the control of a vacuum-tube grid on the electron flow; (7) symbolizes the grid biased to cut-off, and in (8) the grid potential permits a free flow of electrons.

Both 16 and 35-millimeter prints of the film are available for loan or purchase through the Western Electric Motion Picture Bureau, 195 Broadway, New York.

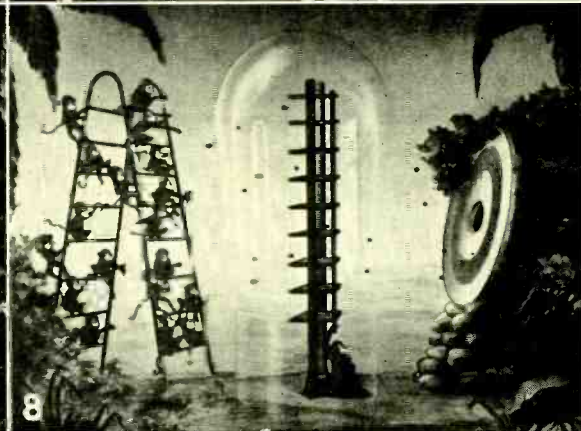
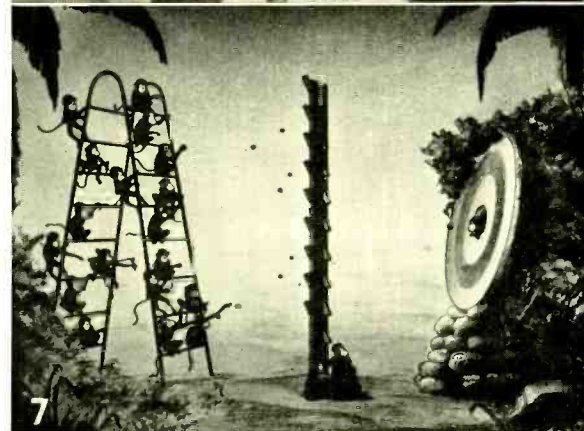
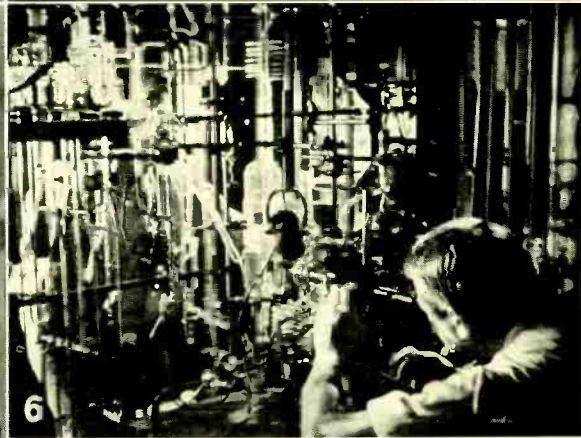
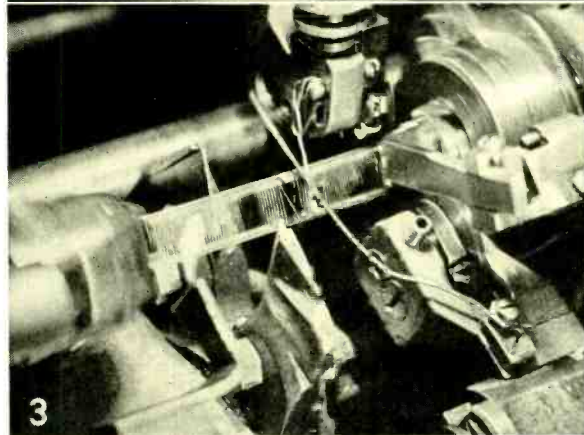

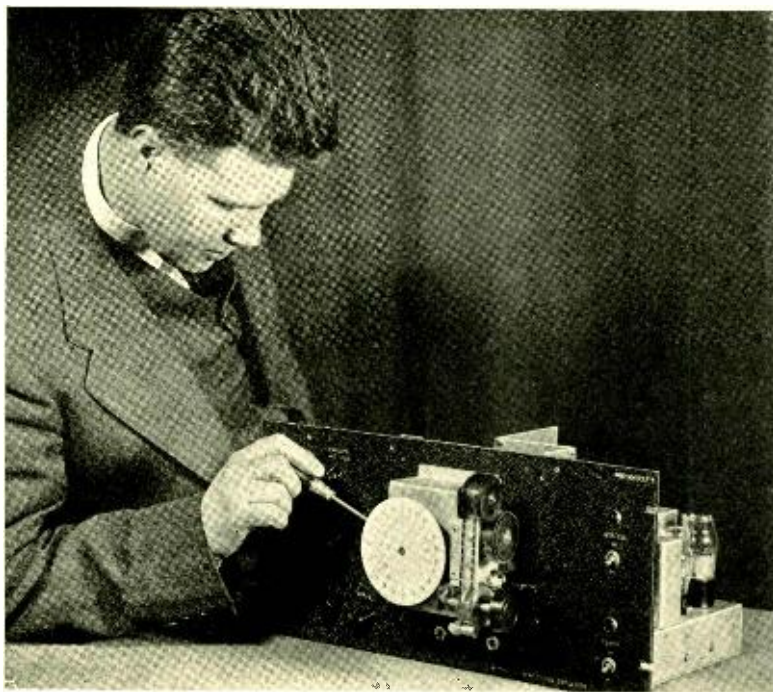

An Interpolation Method for Setting Laboratory Oscillators

By F. R. STANSEL
Apparatus Development

SINCE the introduction of vacuum-tube oscillators as common pieces of laboratory equipment more than two decades ago, their frequencies have been checked throughout the audio and carrier-frequency range by comparison against standard frequencies using Lissajous figures produced on a cathode-ray oscilloscope.* With these figures, frequency ratios of 1 to 1, 2 to 1, and in general n to 1 may be recognized and the oscillator may thus be set at integral multiples of the standard frequency. By providing standard frequencies of 100 cycles, 1000 cycles,

*RECORD, April, 1927, p. 281.

10,000 cycles, and 100,000 cycles these multiples cover a large portion of the calibration points required. Additional calibration points may be had by using other frequency ratios such as 3 to 2 or 4 to 5, but these patterns are not so easy to recognize as those of integral multiples and, except for the case of the $(n + \frac{1}{2})$ to 1 patterns, they are not generally of much practical importance.

Occasionally an oscillator must be set at an exact frequency which bears no simple relation to any standard frequency. The oscillator may then be calibrated at two or more points in the vicinity of this frequency, a curve

drawn between these calibrated points and the setting for the desired frequency read from the curve. This method has been widely used, especially in the lower carrier-frequency range where calibration points may readily be obtained every 100 to 500 cycles, but considerable time is required since a complete calibration may include over a hundred curves. Occasions also arise which demand greater accuracy than can be obtained by linear interpolation. More precise methods of frequency measurement are available,* but these methods have heretofore involved a large amount of apparatus and have been too complicated to be readily adapted to routine laboratory use.

Experiments showed that a simpler and less expensive method of measuring frequencies precisely would be to combine the unknown frequency of the oscillator under calibration with another frequency such that the difference between these frequencies is a multiple of a third known frequency. This can be done by applying these two frequencies to one pair of plates of a cathode-ray oscilloscope and observing the shape of the envelope of the complex wave form produced when a standard frequency is applied to the other plates. The W-10601 interpolation oscillator was developed on this principle. It provides a simple, fast and very accurate means of determining the setting of frequencies between the calibration points on a laboratory oscillator, or conversely of measuring the frequency interval between an unknown frequency and the nearest calibration point.

To explain the operation of this oscillator, let us first consider the shape of a complex wave composed of two frequencies. If these two frequen-

cies have equal amplitudes the wave appears like Figure 1a; if unequal like 1b.* In either case the frequency of the envelope is that of the difference between these two frequencies.

Let us now assume that we wish to set a laboratory oscillator at 323,383 cycles. The output of the interpolation oscillator is connected in series with the laboratory oscillator in the circuit shown in Figure 2. The interpolation oscillator is set at 11,383 cycles and a 1000-cycle standard frequency is applied to the oscilloscope. Next the laboratory oscillator is set

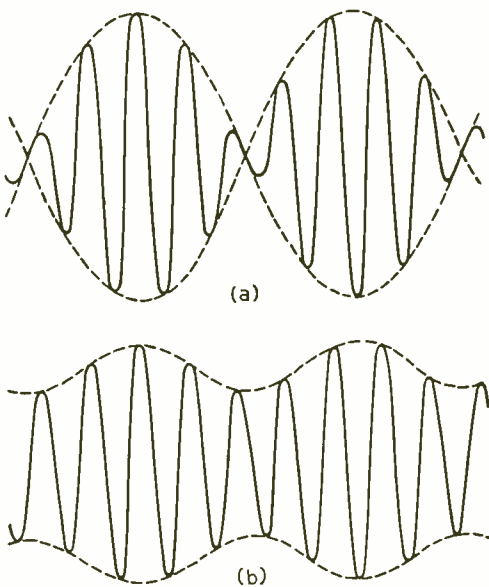

Fig. 1—Complex wave having two frequencies of equal amplitudes (a) and unequal amplitudes (b)

at 323,000 cycles from its previous calibration. This setting need not be accurate because it is made only to insure that the final setting is not in error by 1000 cycles or a multiple of

*The wave shape of Figure 1b should not be confused with that of an amplitude-modulated wave. Actually both waves appear very similar but there are fundamental differences.

*RECORD, Aug., 1931, p. 585.

1000 cycles. The frequency of the laboratory oscillator is then increased. The envelope of the composite wave now appearing on the oscilloscope is the difference between the frequencies of the laboratory and interpolation oscillators but no pattern is observed until the laboratory oscillator's frequency reaches 323,383 cycles when this difference frequency becomes 312,000 cycles. As this is a multiple of the 1000-cycle standard frequency a figure similar to Figure 1a or 1b is then seen in the oscilloscope, except that the individual oscillations are not distinguishable because of the high frequency. Actually two patterns appear, one moving from left to right and the "back trace" from right to left. They may be separated by one of the phase-splitting circuits used with Lissajous figures* although this is not

interpolation oscillator is varied until the pattern appears and the frequency increment read from its scale.

In the above illustration a frequency of 11,383 cycles was used but the patterns may be obtained with any frequency which gives a multiple of 1000 cycles when subtracted from or added to the desired frequency. For example, a pattern may be found with the frequency of 323,383 cycles by using an interpolation frequency of either 11,383 cycles (11,000 plus 383 cycles) or 10,617 cycles (11,000 minus 383 cycles). It is therefore necessary for the interpolation oscillator to cover a range equal to only half the value of the frequency standard. This allows the frequency scale of the interpolation oscillator to be spread out by a factor of 2 to 1, but introduces the complication of determining whether the increment frequency employed is to be added or subtracted.

When it is not apparent from the reading of the oscillator under calibration whether the increment is to be added or subtracted this ambiguity may be removed by increasing the frequency of this oscillator a few cycles. The interpolation oscillator is then varied until the pattern is again obtained.

If the interpolation frequency increases, the difference between the actual frequency of the interpolation oscillator and the nearest multiple of the standard is added to the reading of the oscillator under test.* If the interpolation frequency decreases, the increment is subtracted.

The interpolation frequency does not need to be as low as 11,383 cycles

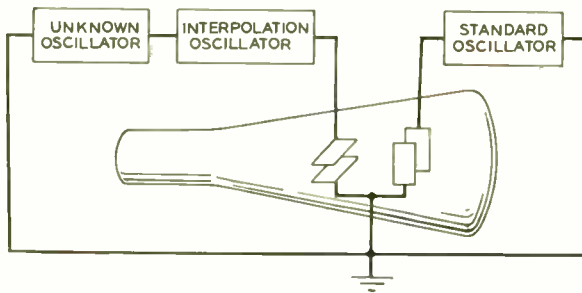

Fig. 2—Schematic circuit used in interpolating frequencies with a cathode-ray oscilloscope

generally necessary. When the laboratory oscillator is adjusted until this pattern is stationary, its frequency will be 323,383 cycles with an error in cycles numerically equal to the number of cycles that the interpolation oscillator is in error.

The circuit may also be used in a converse manner to find the frequency of an oscillator at an experimentally determined setting. In this case the

*RECORD, April, 1927, p. 281.

*It is assumed that the laboratory oscillator has been previously calibrated in multiples of the standard frequency.

but may be of the same order of magnitude as that of the oscillator tested. A high interpolation frequency would have the advantage that the frequency of the envelope of the pattern is lower and hence the pattern is easier to spread out for observation on the oscilloscope. The absolute accuracy of this method, however, depends on the accuracy with which the interpolation oscillator may be set and hence the lower interpolation frequency is desirable. By using an interpolation frequency of the order of 11,000 cycles, it is not difficult to build, without bulky and expensive coils and condensers, an interpolation oscillator which has an accuracy of better than plus or minus one cycle. With such an oscillator it is possible to set a laboratory oscillator at any frequency up to well over a megacycle with an absolute accuracy of better than plus or minus one cycle. For frequencies a few cycles either side of multiples of the standard, the Lissajous figures make observation of the envelope frequency difficult. In this region the frequency increment can be measured by timing the rate at which Lissajous figures proceed across the oscilloscope screen.

In the W-10601 interpolation oscillator, a 11,000 to 11,500-cycle oscillator is used in conjunction with the 1000-cycle standard frequency dis-

tributed throughout the Laboratories for frequencies up to about one megacycle. Above this range the patterns on the oscilloscope become crowded and it is difficult to obtain sufficient spread to make them recognizable.

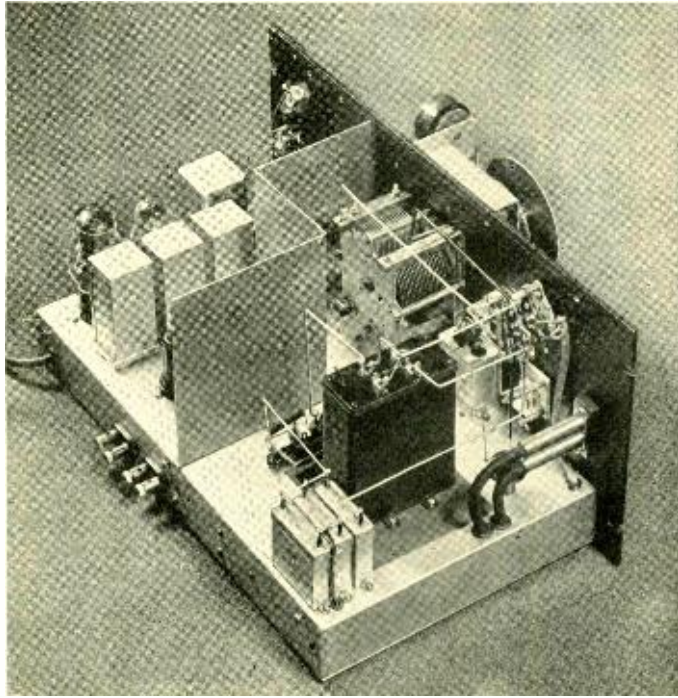

Fig. 3—The W-10601 interpolation oscillator determines accurately the frequency of settings between the calibration points of an oscillator or conversely measures the frequency interval between an unknown frequency and the nearest calibration point of the oscillator

Therefore a second range from 30 to 35 kilocycles is provided in the oscillator and this is used in conjunction with a 10-kc standard frequency. The absolute accuracy in this range is plus or minus ten cycles.

The scale of the interpolation oscillator does not indicate the actual frequency, but the frequency increment. The scale thus runs from 0 to .500 kilocycle on the low range and from 0 to 5.0 kilocycles on the high range. An additional set of scale markings reading

from .500 to 1.000 kilocycles on the low range and 5.0 to 10.0 kilocycles on the high range is used when the increment frequency must be subtracted.

To obtain a scale long enough to permit reading the frequency to better than one cycle, it is printed on 16-mm. film and connected by a worm-drive mechanism to a variable air condenser. The headpiece shows this scale with its cover removed to expose the drive mechanism and also an auxiliary coarse scale on a dial which is used to locate settings quickly. The worm drive covers each of the two frequency ranges by ten turns of a crank. The scale for both ranges is approximately 50 inches long, thus permitting the .5-kc scale to be graduated in one-cycle divisions and the 5-kc scale in 10-cycle divisions. Even longer film lengths can be accommodated by the mechanism. A light be-

hind the film illuminates the scale and it is read through a window in the housing. There are mechanical stops at each end of the film which operate without straining the condenser.

The W-10601 interpolation oscillator is mounted on a standard relay rack panel with the circuit components on a chassis fastened to the rear of the panel. The apparatus is designed for use with any three-inch cathode-ray oscilloscope of the types commonly found in the Laboratories. In addition to the oscillator for producing the interpolation frequency, it incorporates a mixing circuit, two amplifiers to give additional spread on the horizontal and vertical plates of the oscilloscope and a power supply for operation directly from an a-c line. This device has been found very useful in making accurate determinations of the setting of oscillators.

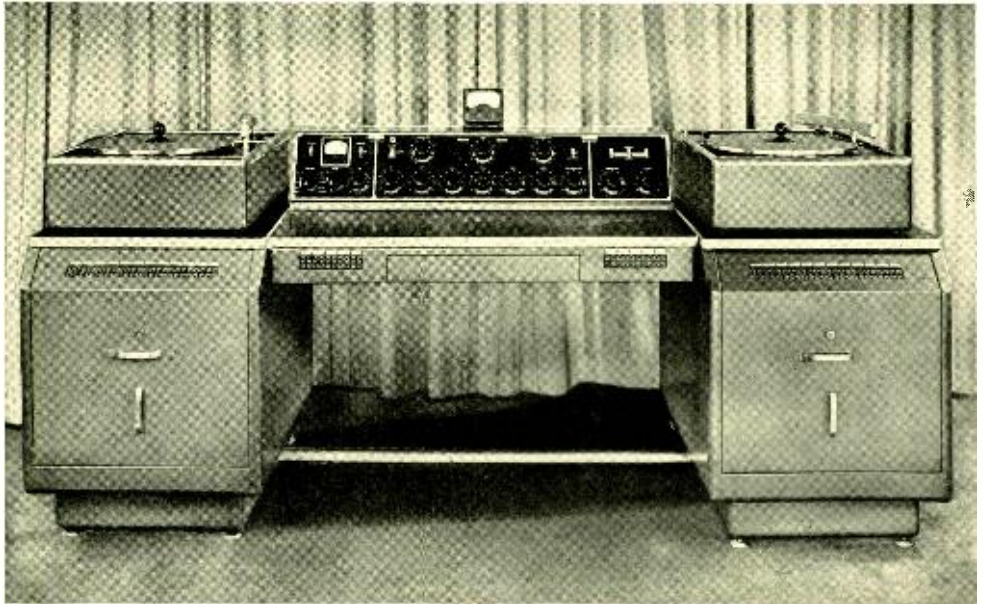

A new Western Electric "custom-built" speech-input equipment is assembled on a unit basis. The central member supports the control panel, and the flanking pedestals and turntables are added as required



Contributors to this Issue

H. T. WILHELM joined the electrical measurements group of the Laboratories in 1922. In 1924 he left to complete his studies at the Cooper Union Institute of Technology. Upon graduation in 1927 with a B.S. in E.E. degree, he resumed his work with his former group. He has been engaged in the preparation of testing specifications and the design and development of impedance standards, bridges and other test circuits. During this time he has taken graduate work in physics and electrical engineering. In 1936 he received the degree of Electrical Engineer from Cooper Union.

R. S. CARUTHERS received the B.S. degree from the University of Maryland in 1926, and then spent two years with the General Electric Company. During this period he studied for his master's degree under arrangement with the Massachusetts Institute of Technology and received the M.S. degree in 1928. Two years later he received an E.E. degree from the University of Maryland. He then spent a year with the Bureau of Standards and joined the Technical Staff of the Laboratories in 1929. Since then he

has been engaged exclusively in the development of carrier systems, chiefly the K, J, and coaxial systems.

W. E. DARROW received the A.B. degree from the University of Michigan in 1909 and the B.E.E. degree in 1911. He joined the Plant Department of the New York Telephone Company at Newark, New Jersey, in 1911, transferring nine months later to the Engineering Department in New York where he was engaged in the development of private branch exchanges. In 1919 Mr. Darrow joined the Engineering Department of the American Telephone and Telegraph Company and was placed in charge of a group responsible for the development of manual central office facilities. He continued this work in the Department of Development and Research when this was formed a few months later. When the Department of Development and Research was merged with the Laboratories in 1934, he became Manual Engineer of the Local Central Office Facilities Department.

F. R. STANSEL joined the Laboratories in 1926 after receiving the B.S. in E.E. degree from Union College that year.



H. T. Wilhelm



R. S. Caruthers



W. E. Darrow



F. R. Stansel



D. B. Herrmann



J. B. Dixon

Until 1936 he was engaged in the design of high-power radio transmitters for broadcasting and transatlantic service at the Whippany laboratory. Since then he has been associated with the development of oscillators and detectors for test purposes. In 1934 Mr. Stansel received the M.E.E. degree from Brooklyn Polytechnic Institute.

D. B. HERRMANN first came to the Laboratories in 1923 to work in the messenger service and Patent Department, and later in the Chemical Laboratories as a laboratory assistant. He left in 1925 to attend the College of the City of New York, but returned the two succeeding summers. In 1928 he rejoined the Laboratories' staff. Since then his work has been concerned primarily with problems relating to organic substances used as insulation on wire and cable, particularly rubber and similar materials, and with measurements of their dielectric properties. He has also studied the diffusion of water through organic insulating materials and, recently, the effect of various pigments on the dielectric properties of

rubber. In 1930 he received the Bachelor of Science degree from the College of the City of New York.

J. B. DIXON entered the student engineering course of the Westinghouse Electric and Manufacturing Company at Pittsburgh after graduating from Pratt Institute in 1918. He spent several years in the Engineering Department of this company on railway electrification problems and then transferred to the Public Service Electric Company of New Jersey, where he worked in their Plant Department on power and light distribution lines. In 1923, he was employed by the New York Telephone Company in the Outside Plant Engineering Department to work on cable-testing and cable-joining problems. Mr. Dixon transferred to the Development and Research Department of the A. T. & T. in 1926 for similar work. When the Outside Plant Department was formed in the Laboratories in 1927, he left the D & R to engage here in development problems pertaining to wire and wire products for outside plant use. He still continues in this line of work.