

BELL LABORATORIES RECORD

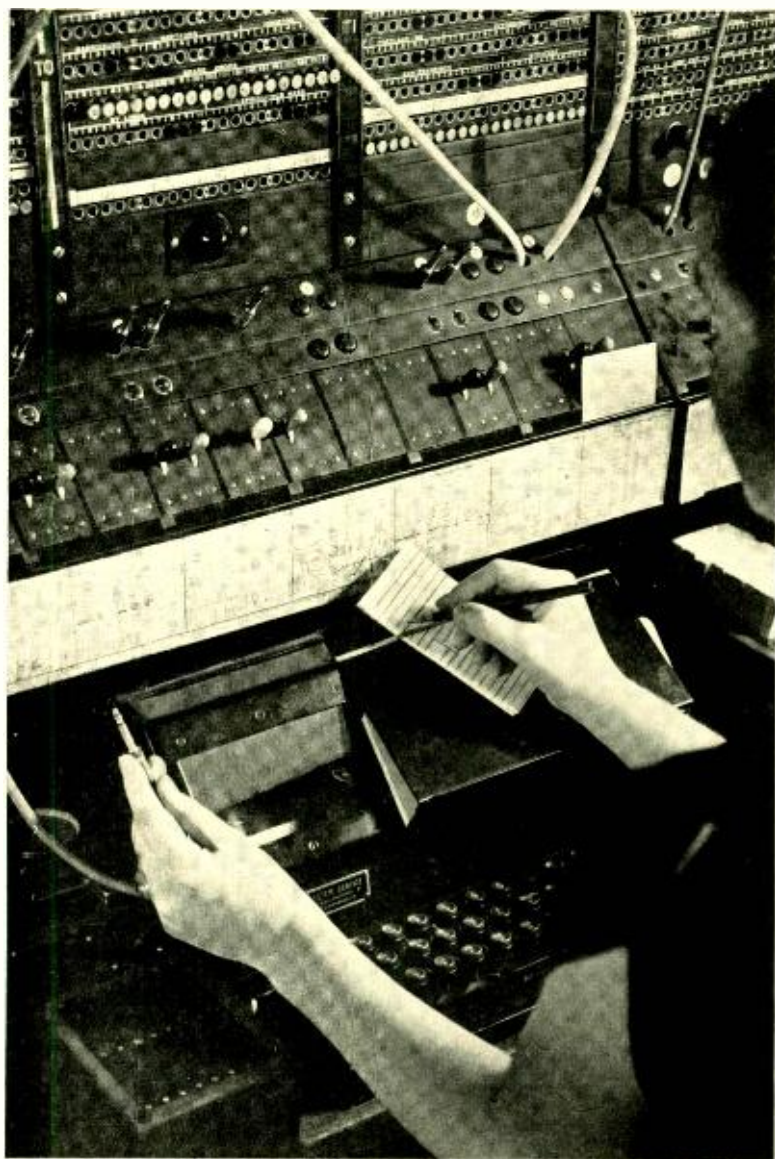

OCTOBER
1937
VOLUME XVI
NUMBER II

*Operation of the 1A tele-
typewriter switchboard is
facilitated by the recently
developed sloping keyshelf*

The 1A Teletypewriter Switchboard

By A. A. BURGESS
Equipment Development

TAKING advantage of improvements that have been effected during the last few years, the Laboratories have developed a new teletypewriter switchboard to be used with the earlier No. 1 board* in the larger teletypewriter central offices. This new board is called the 1A and is designed to be used for "outward" traffic, while the No. 1 board may be used for "outward," "inward," and "through" traffic. The photograph at the head of this article shows the initial installation in the Long Lines office in New York City, where the 1A board is at the left and the No. 1 board at the right.

Experience has shown that when the outward traffic at a teletypewriter switchboard requires more than about thirty operators to handle the peak load, service can be furnished more economically by segregating the outward and inward traffic. The operating functions of switchboards used for outward traffic differ appreciably from those of switchboards for inward traffic. At the outward board the operator must answer the calls as they are placed, determine the number wanted, make a connection to the required outgoing trunk, and then, after the called subscriber answers, time the beginning of the call. She also times the call at its termination, and throughout performs the usual supervisory func-

*RECORD, *January, 1932, p. 145.*



tions. The "inward and through" operator, on the other hand, merely makes a connection between a trunk and a subscriber line in her multiple, or between two trunks, according to the instructions passed to her over the trunk by another operator. Because of these differences in operating function, the "outward" operator can not handle as many calls as the "inward and through" operator, and thus requires fewer cords — probably not more than eight.

The No. 1 board had space for eighteen cords in each position; it was



answering lamps need be associated with the trunks and at the inward board no lamps need be provided with the subscriber lines.

An office with a single line of No. 1 board at which all traffic is handled will have answering lamps in the subscriber line multiple and both answering lamps and idle indicating lamps in the trunk multiple. Such an office will have a capacity of only 2040 lines and 600 trunks. Originally, to obtain an office with a larger capacity, it was planned to use two lines of No. 1 board for outward service, and one line of No. 1 board for inward and through service. With this plan, each outward board would have lamps for only half of the lines, but the multiple would be arranged so that the lines that did not have lamps in one outward board would have them in the other. No answering lamps, of course, would be provided with the lines in the inward and through board. By the use of three lines of No. 1 board in the manner described, a capacity of 3600 lines and 840 trunks could be obtained. With the present plan, which calls for the use of the No. 1 board for inward and through traffic and 1A boards for outward traffic, however, a capacity of 3720 lines and 1200 trunks may be obtained. The ratios of lines to trunks indicated by the foregoing capacities are, of course, nominal as the quantity of lines may be increased with a decrease in the quantity of trunks or vice versa, and for any particular office, the ratio of lines to trunks will depend upon the calling rate and distribution of traffic in that area.

In any manual switchboard, the multiple is an important factor in the initial switchboard cost, and it is important, therefore, that the operators be placed as close together as possible, so that the total length of the switch-

therefore well adapted for use as an inward and through board. In planning the future requirements for larger offices, it was decided therefore that economies could be realized by using the No. 1 board for the inward and through traffic and by designing a new board with fewer cords per position chiefly for outward traffic. This division into two types of switchboard, one for outward and one for inward and through traffic, has permitted an increase in the total number of lines and trunks available in the office, since at the outward board no

board for a given number of operators is a minimum. The teletypewriter with which each operator is provided is an important element in determining the width of the position. In the earlier switchboards, such as the No. 1, it was placed on a shelf alongside the keyshelf, and thus made the width of the position considerably greater than would have been required for the necessary number of cords. In the 1A board, the teletypewriter is placed below the keyshelf, which is made as shallow as possible and given a 45 degree slope to obtain the most convenient arrangement of keys and cords. With this design, which was pioneered with the 3A teletypewriter switchboard,* the teletypewriter does not add to the width of the position, which can thus be

*RECORD, January, 1936, p. 146.

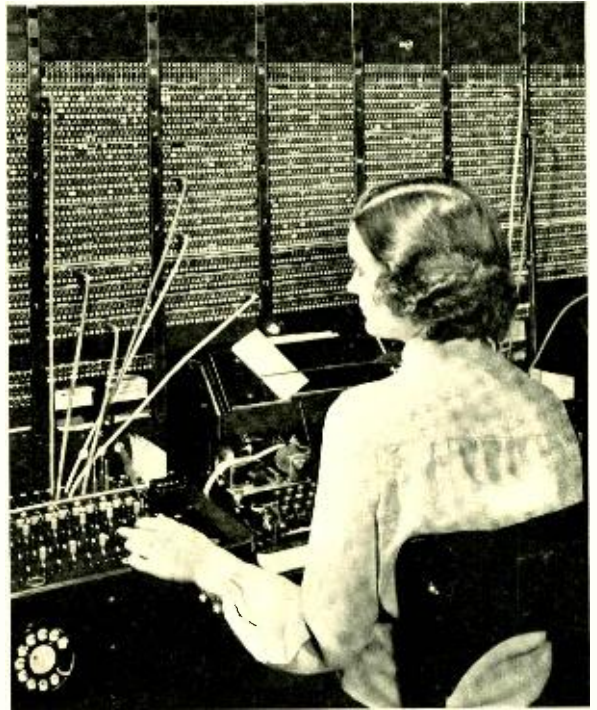

Fig. 2—The No. 1 type teletypewriter switchboard is distinguished by answering lamps for the trunks and by the teletypewriter on a level with the keyshelf

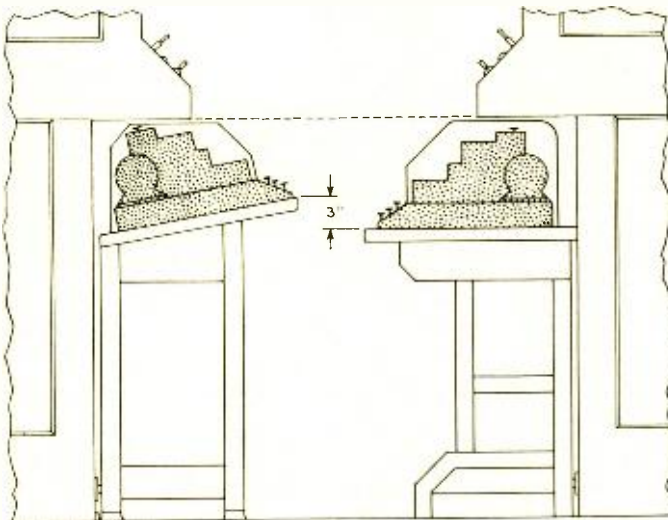

Fig. 1—By tilting the teletypewriter, the operator's position with respect to the multiple is raised three inches. This re-arrangement allows the operator to reach more jacks

made only wide enough for operating. This has permitted a position of the 1A board to be only 25½ inches wide; with three 8½-inch panels, while the No. 1 board position is 34 inches wide, with four 8½-inch panels.

While the placing of the teletypewriter below the keyshelf decreases the width of the position, it results in the operator being lower with respect to the multiple, and thus lowers the height of the upper row of jacks she can reach. To off-



Fig. 3—In the 1A board there are no answering lamps for the trunks, and the teletypewriter is below the keyshelf on a table with a sloping top

set this disadvantage, an improvement was made in the initial arrangement of a horizontal table used with the 3A board by mounting the teletypewriter on a table with a sloping top. As shown in Figure 1, this raises the operator three inches, and allows her to reach approximately 80 more lines per panel of multiple.

When a 1A board is installed in an existing No. 1 office, a number of lines already appearing in the No. 1 board, together with the new lines that may be required, are multiplied with answering lamps through the 1A board positions to provide a sufficient busy-hour load for the 1A operators. As the quantity of new lines is usually small enough to come well within the reach of the operators at the No. 1 board, a few multiple appearances of these

lines at the No. 1 board are also equipped with answering lamps. This makes it possible to abandon the 1A board during periods of light load and to answer all calls at the No. 1 positions.

When the installation of new lines with answering lamps would exceed the operator's reach at the No. 1 board, they are installed without lamps at this board, and operators must then be retained at the 1A board to answer these lines during light load periods. A gradual increase in the number of lines in the office eventually necessitates the removal of all answering lamps from the lines in the No. 1 board, which then becomes wholly an inward and through board rather than a combined outward and inward and through board. All calls from subscribers are then answered by the operators at the 1A positions.

The 1A board has a maximum capacity of about 1600 lines and 900 trunks, this ratio, as previously explained, being variable for any office. With a maximum office of 3720 lines three lines of 1A board would, therefore, be needed. An operator at any of these boards will answer any of the lines in her multiple and connect them to outgoing trunks or to local subscribers whose lines appear in her multiple. If the call is to a local line that does not appear in her multiple, the operator will connect the call to a trunk to the No. 1 switchboard, and the operator there will complete it. All incoming trunk calls will be answered at the No. 1 board, since there are no answering lamps for the trunk jacks at the 1A board.

The comparative appearance of the two boards is shown in Figures 2 and 3. The differences in keyshelf designs and in the width of the operators' positions of the two boards are readily apparent. Many of the answering lamps still appear in the multiple of the No. 1 board, but the added rows at

the top of the multiple are without lamps. It will be noticed also that the trunks at this board have answering lamps as well as the idle indicating lamps. At the 1A board, on the other hand, the trunks have no answering lamps, but the line multiple is fully equipped with them.

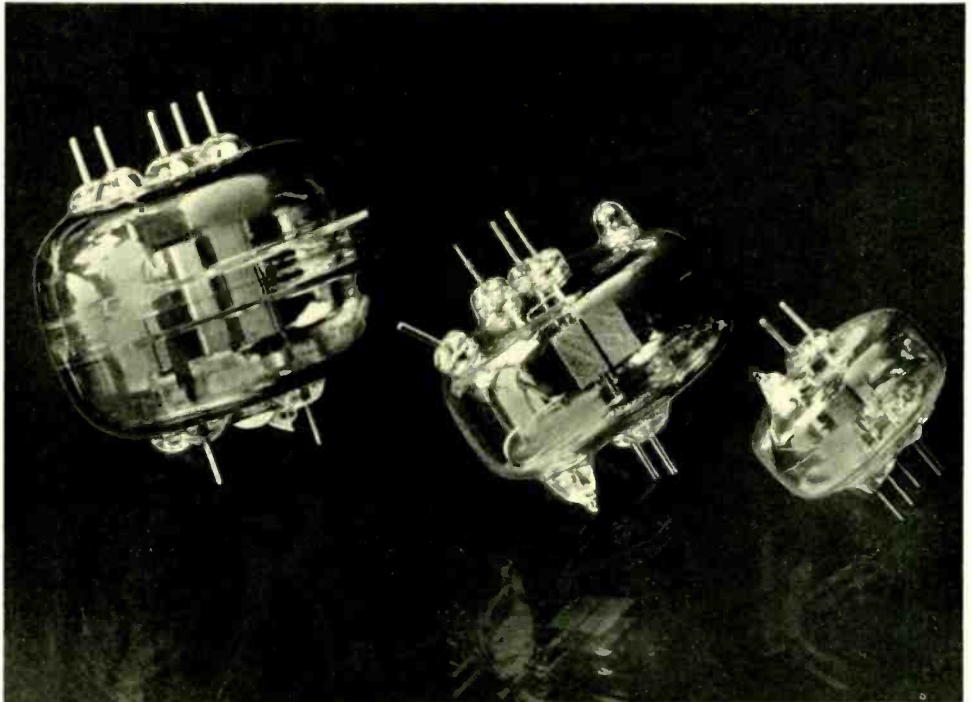

Experimental vacuum tubes developed in the Laboratories to extend the frequency range of the negative-grid type tube. The smallest of the three can be used as an oscillator at wave-lengths as short as sixteen centimeters

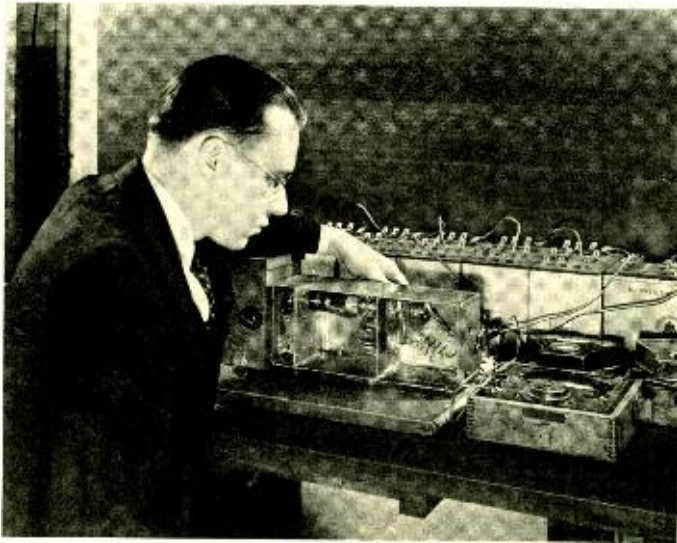

Equivalent Networks for Negative-Grid Triodes

By F. B. LEWELLYN
Circuit Research

THE equivalent network of a vacuum tube brings to the mind of practically every radio engineer a combination of resistances and capacitances together with an internal generator of voltage which can be used in calculating the effect of the tube in electrical circuits. When low frequencies only are involved, this network may consist simply of a resistance in series with a source of voltage. If higher frequencies have to be considered it has been found necessary to allow for capacitance between all three elements of the tube and now with the advent of very high frequencies a further modification is required. This consists of the addition of series resistors in the internal cathode-grid and cathode-plate paths.

The concept of the equivalent network for negative-grid vacuum tubes

was originally developed from the relation that the plate current of a vacuum tube is a function of the plate voltage plus a constant times the grid voltage. This constant is the well-known amplification factor μ , and when the non-linear relationship between current and voltage in the tube was investigated mathematically for straight amplification effects, it was found that the tube might be represented by the equivalent network shown in Figure 1. Here c represents the cathode and p the plate of the vacuum tube. Between them the internal plate resistance r_p acts in series with the fictitious generator $\mu_0 V_g$. This network satisfies conditions between the cathode and plate only at very low frequencies, where the impedance between the grid element and the other electrodes is so high that it can safely

be disregarded in making calculations.

With the advent of higher frequencies it became evident that the internal tube capacitances played an important rôle in the operation of the device. The lengths to which early workers went to include the capacitance effects are illustrated by the complicated formulas which they developed. Further study, however,

showed that the complexity could be largely overcome by modifying the simple network of Figure 1 to introduce capacitances between all three elements of the vacuum tube. The result is Figure 2, which has been adequate in the past for all purposes.

In comparatively recent years increasing frequencies have required that further changes be made. The

necessity for revision first became evident with the discovery that the impedance measured between grid and cathode, when a very large condenser was placed between plate and cathode, showed an important resistive component at very high frequencies. The simple combination of Figure 2 which involved only capacitances for the grid-cathode and grid-plate impedance was no longer valid.

A modification which overcame this difficulty was based on a theoretical analysis of the motions of electrons within vacuum tubes. With the reservation that it applies strictly to planar rather than cylindrical tube structures, the results should therefore require little further change for some time to come.

The theoretical analysis gave at first an equivalent network which, on the face of



FIGURE 1

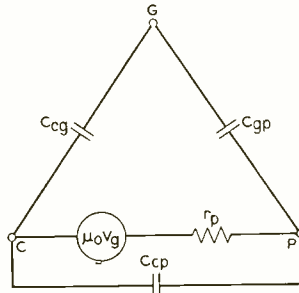

FIGURE 2

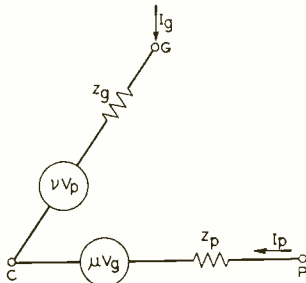

FIGURE 3

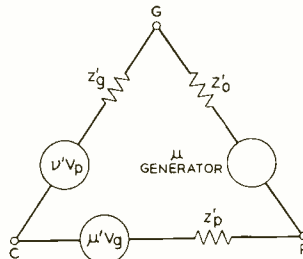

FIGURE 4

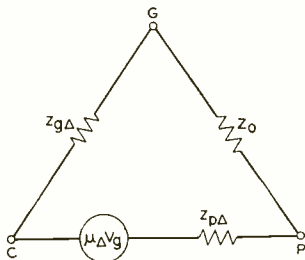

FIGURE 5

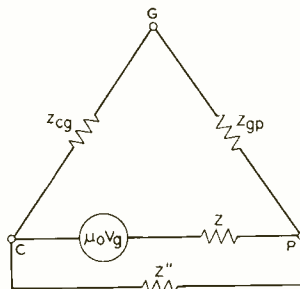

FIGURE 6

Figs. 1-6—Steps in the evolution of the equivalent network of negative-grid, three-element vacuum tubes shown in Figure 7

it, resembled Figure 2 only remotely, but which was in fact exactly equivalent to it at very low frequencies. This generalized theoretical network is shown in Figure 3. It consists of two branches only, which are located respectively between cathode and grid and between cathode and plate. Both branches contain internal generators and, in general, the impedance in neither branch is a pure resistance but depends on a number of factors, including the time required by electrons to traverse the vacuum tube.

Mathematical manipulation of the equations shows that the theoretical network of Figure 3 may be represented just as well by an infinite number of other equivalent networks. Naturally our aim is to choose the form which adapts itself to the greatest number of practical applications, and contains the smallest number of internal generators. A second consideration in the choice is that the network should resemble the familiar delta equivalent of Figure 2 as closely as may be, so that results based on that figure may be interpreted readily in terms of the more general network.

Figure 2 is actually a modified form of a delta network. The most general delta would be the one shown in Figure 4, which consists of three series branches, each containing an internal generator in series with an impedance. When the mathematical transformations from Figure 3 to Figure 4 are carried through, a proper choice of definitions for the various impedances reduces Figure 4 to the network shown in Figure 5. Here only one internal generator remains, and that generator acts in series with the internal plate impedance of the tube. Therefore, Figure 5 does not quite conform to the popular network where a capacitance is assumed to shunt the internal

generator by acting directly between plate and cathode. However, it can be shown that Figure 5 may be transformed to Figure 6; and by a proper choice of the two impedances z' and

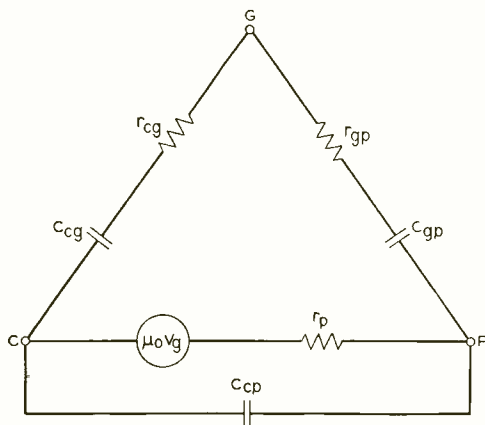

Fig. 7—Network equivalent of vacuum tubes valid both for low and for moderately high frequencies

z'' , the internal generator reduces merely to our familiar low-frequency amplification factor multiplied by the grid-potential variation.

Thus, Figure 6 with the associated definitions of impedance represents the generalized form of the equivalent network of negative-grid vacuum tubes and is valid until the velocity of the electrons approaches that of light or until the distance between elements of the vacuum tube becomes comparable to the free-space wavelength of any ultra-high frequency considered. The expressions in Figure 6 are naturally long and complicated. However, at frequencies where the effects of transit time of the electrons are only moderately important, the complication reduces enormously and we have Figure 7, which now replaces Figure 2 for all ordinary frequencies. The modification consists only of the addition of series resistors in the in-

ternal cathode-grid and cathode-plate paths, which avoid the necessity for a phase angle in the amplification factor at very high frequencies. At low frequencies, the resistances are masked by the high reactances of the capacitances in series with them, and this is the reason why the network of Figure 2 has served so well in the past. The impedance in series with the μ -generator is the well-known internal plate resistance as given by the slope of the static characteristic of the tube. The capacitances are likewise those we have used all along but the mathematics now enables their dielectric constants to be computed. Figure 7 is valid at any of the frequencies for which negative-grid tubes are now contemplated for commercial application, including those where the transit angle is about half a radian.

Perhaps the most interesting aspect of the equivalent diagram is the fact that the resistance in the grid-plate arm is negative in sign, while the one in the cathode-grid arm is positive. At first sight, the presence of such a negative resistance may seem disturbing. A rough explanation may be obtained by noting that the forces on the electrons which result from the grid potential are opposite in direction depending upon whether the electron is in the region between the cathode and grid or between the grid and plate. Thus, if the grid potential accelerates electrons near the cathode, it follows that those near the plate are decelerated by the grid, and vice

versa. Hence, the work done by the potential of the grid on the electrons in the two regions is opposite in sign.

The negative resistance in the grid-plate arm in many tubes is about ten ohms, while the positive resistance in the cathode-grid arm is about five times as large. The dielectric constant of the grid-plate capacitance is slightly less than unity, and that of the cathode-grid capacitance somewhere around $4/3$, while for the cathode-plate capacitance is slightly less than this latter value. The grid-plate capacitance varies in the opposite direction from the other two when the operating potentials are changed.

Much has been said and written of late years about the active grid loss. This would be determined in Figure 7 by placing a large condenser between the cathode and plate and measuring the input impedance. As shown by the figure, the resistive component arises from the resistances in the two arms of the delta which are now in parallel.

An interesting result of this investigation is the slight modification required in our conventional network for the negative-grid tube to make it accurate even in the ultra-high-frequency range. The amplification factor is the familiar one used for low frequencies, and at moderately high frequencies the only alteration needed in the conventional diagram is the addition of two small but very important resistances—one in the cathode-grid path and another, with negative sign, in that between the grid and plate.

Supplying Power to Central Offices

By H. T. LANGABEER
Equipment Development Department

TELEPHONE service so far as is humanly possible must go on regardless of adverse conditions. Since electric power is essential, not only for voice transmission but for signalling and switching as well, this means that all possible precautions must be taken to insure a supply of power under all conditions. In most common-battery central offices direct current is required at nominal potentials of twenty-four and forty-eight volts. The primary source of this power is normally alternating current from the commercial power lines, and motor-generator sets and rectifiers are provided at the central offices to convert the alternating current to direct current of the proper voltage. Since there is always the possibility of failure of the a-c power, batteries are provided in addition to take over the load on failure of the primary supply. During normal operation the battery acts as a filter to reduce the noise that is caused by the generators.

To maintain the batteries in the larger offices in constant readiness to take over the load on failure of the outside supply, they are floated across the terminals of the generators, with the voltage controlled so that a small trickle charge flows into the battery under normal operation to keep them fully charged. On failure of

the a-c supply, the generators are automatically disconnected, and the load is carried by the batteries. As the batteries discharge, their voltage drops, and to maintain the desired potential on the discharge leads emergency cells are provided in series with the main battery, two for the twenty-four-volt battery and four for the forty-eight. These are cut into the circuit when the voltage has dropped a specified amount.

After the batteries have been partially discharged during an emergency, it is necessary to charge them promptly so that they will be ready for the next emergency. During charging, however, the voltage across the battery must be considerably higher

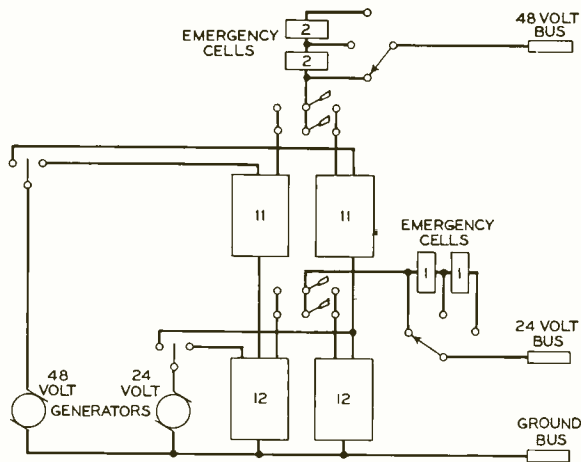

Fig. 1—In one form of manually operated power plant, an arrangement consisting of duplicate batteries is employed. The load may be carried by the two batteries in parallel, or one battery may carry the load while the other is being charged

than when floating, and to prevent this higher voltage from reaching the central office discharge circuits it has been necessary either to employ two batteries, one of which could be on

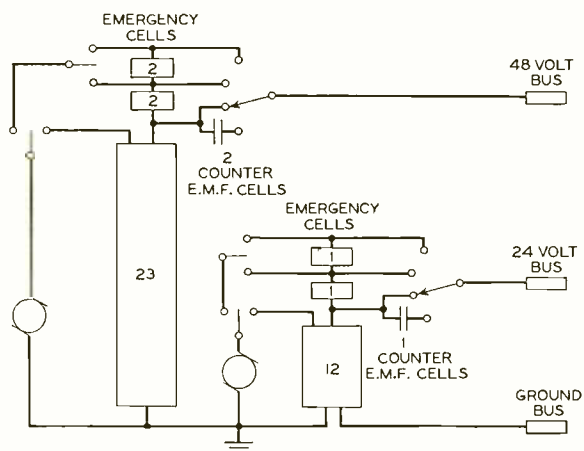

Fig. 2—In the 301C power plant a single battery is provided for each voltage, and counter-emf cells are provided so that the batteries may be charged while connected to the load

charge while the other was discharging, or to employ counter-emf cells between the battery and the load which reduce the potential to the desired value. An arrangement of duplicate batteries, emergency cells, and generators that has commonly been employed for dial central offices is shown in Figure 1.

The twenty-four-volt batteries consist of twelve cells, and the forty-eight-volt batteries of twenty-three cells. In this arrangement all twenty-three cells are connected in series but a connection is made between the twelfth and thirteenth cell for the twenty-four-volt supply. Emergency cells are provided for both the twenty-four and forty-eight-volt taps, with switches to permit their being connected into the circuit as desired. Double-throw switches are provided

so that the generators may be connected to either of the batteries for charging, and so that the office load may be connected to either or both batteries. Alarms are provided to indicate abnormal conditions, and the switches are all manually operated by the attendants. Automatic regulators are provided, however, to maintain the generator voltage at the correct value for floating the batteries. Ordinarily two or more motor-generator sets are provided for each voltage, the number which is required for use at any one time depending on the load.

These power plants have given very satisfactory results but experience in using them has indicated certain changes that might be desirable—one being provision for a greater or less degree of automatic operation. As a result a new power plant has recently been developed, which is known as the 301C. It is suitable for dial and toll offices requiring from 200 to 2000 amperes at twenty-four and forty-eight volts. The design includes full automatic operation, but manual or partly manual operation may be employed with the omission of part of the equipment. A typical layout of such a plant is shown in Figure 2.

Instead of employing duplicate batteries, with cells for the twenty-four-volt and forty-eight-volt batteries in series, one twenty-four and one forty-eight-volt battery consisting of two strings of lead tanks or two or more strings of glass-jar cells are provided. Emergency cells are employed as with the former power plant and the generators are arranged with double-throw switches so that they

may charge either the main battery alone, or the battery and emergency cells together. To maintain the central-office voltage at the proper value during charge, counter-emf cells are provided—two for the forty-eight-volt battery and one for the twenty-four-volt battery. The batteries are normally floated from the generators, and it is only after a discharge due to an emergency condition, or for occasional overcharging, that the generators are raised to their charging voltage. To maintain the emergency cells in proper condition, copper-oxide rectifiers are floated across them; these rectifiers allow a trickle charge to pass through the cells.

When this new power plant is arranged for manual operation, two of the generators of each voltage are arranged for automatic voltage regulation; but when both generators are in use one will be automatically regulated and the other manually regulated. The number of manually controlled generators in use will vary from time to time to meet the major variations in load during the day. These will be started and switched into the circuit by the attendant as needed, while either one of the automatically regulated generators will take care of all fluctuations in load up to the full

capacity of the generator. When this full capacity is reached, another manually controlled generator is started, and thus the load on the automatically regulated generator will be reduced so that it may again control the voltage.

The automatic regulation circuit for these generators is shown in Figure 3. Essentially, the regulating equipment consists of a voltage relay, connected across the battery terminals, which closes one pair of contacts at the lower voltage limit, and

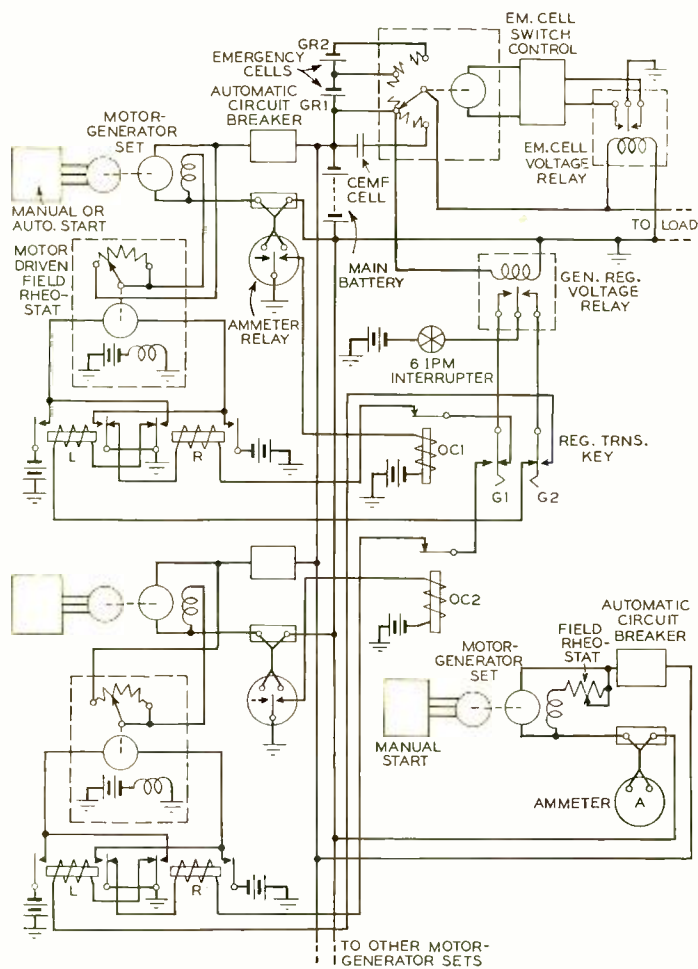

Fig. 3—Schematic circuit for automatic voltage regulation used with manual operation of the 301C power plant

another pair at the higher voltage limit. The generator is equipped with a motor-driven field rheostat the motor of which is run in one direction or the other depending on the action of two relays, each of which is actuated by one of the pairs of contacts on the voltage relay. When the office load becomes great enough to lower the battery voltage to the lower value, one of the contacts of the voltage relay closes and actuates a motor-

control relay to reduce the resistance in the field rheostat. When the voltage rises as a result, the contact of the voltage relay will open and the rheostat motor will stop. As the load decreases and the voltage tends to rise, the voltage is lowered in a similar manner through the other contact of the voltage relay and the other motor-control relay. There is also an ammeter relay in the output circuit of the generator, which—when

the generator is fully loaded—actuates a relay that opens the circuit to the field-control relay used for increasing the voltage. This prevents an overload on the regulating generator.

With this arrangement a regulated generator is operated throughout the entire twenty-four hours. Manually controlled generators are equipped with manually controlled motor starters but if desired those generators equipped for automatic voltage regulation may be provided with automatic motor starters so that if a power failure should occur during the unattended or light-load period, the generator would start again when the power supply was restored. This feature is desirable for partially attended offices where the greater cost of full automatic operation is

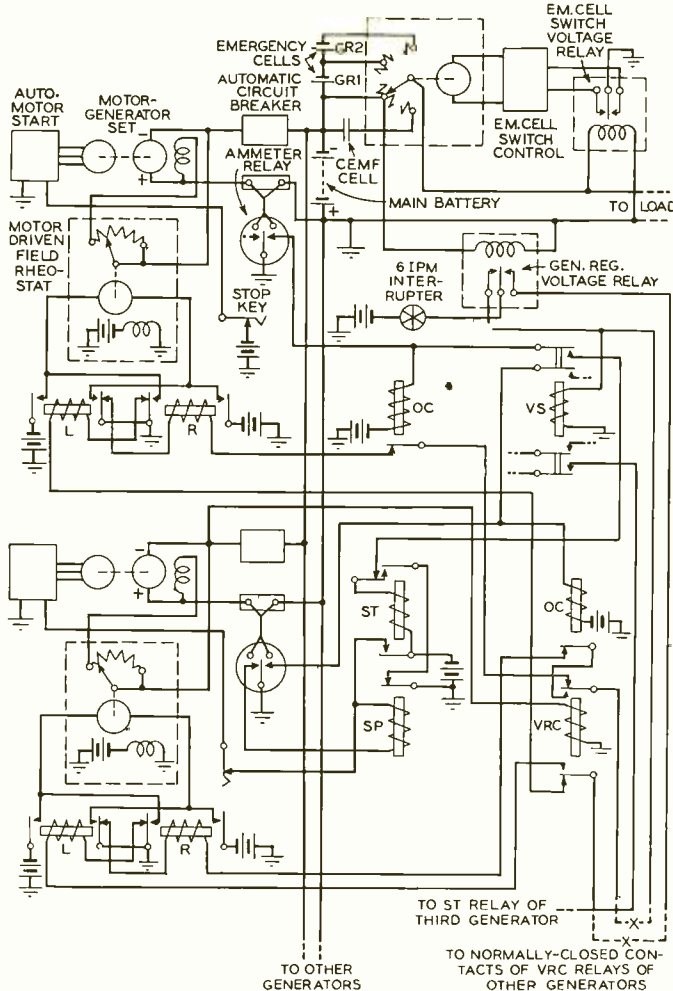

Fig. 4—When full automatic control of battery charging is employed, each generator has its motor-driven field rheostat, and is automatically stopped and started

stified. In some offices, however, it is desirable to have the complete power plant controlled automatically. With such an arrangement not only is the voltage automatically maintained at the correct value, but additional generators are started and connected to the busses as the load increases, and are disconnected as the load decreases.

The full automatic power plant differs in two major respects from the manual system. First, each motor-generator is provided with automatic starting equipment for the motor, and as the generators in use become fully loaded, another set is started and connected to the load. In a similar way these generators are disconnected and the motors stopped as the load decreases. Second, each generator is equipped with a motor-driven field rheostat, and provision is made for transferring the voltage regulator from one generator to another as the preceding generator becomes fully loaded. The circuit by which this is accomplished is shown in Figure 4.

One motor-generator set is running all the time and as long as the total load is no greater than can be carried by this generator, the voltage regulator will be associated with its field rheostat to regulate the voltage. When this generator becomes fully loaded, its associated ammeter relay closes a contact which, together with any further tendency of the voltage to decrease, will cause another generator to start, and will transfer the voltage regulator to regulate the next generator, the first remaining at its full load. Succeeding generators are started in the same manner and the voltage regulator transferred to them successively. As the office load decreases the reverse process is followed. As the load on the last generator falls to zero

the regulator is transferred to the preceding generator and the unloaded one is disconnected from the busses and stopped.

Keys are provided on each generator control panel to permit a generator to be removed from service or operated under manual control for testing purposes. When this is done the control of this set is automatically transferred to the succeeding motor-generator. In the event of a power failure all operating motor-generator sets will be disconnected, and their motor-driven rheostats rotated to the "all resistance in" position to prevent overloading the generators when power service is restored and the battery voltage is low. Upon restoration of power, the generators will start one at a time in regular order until a sufficient number are running to carry the load. At the floating voltage the partly discharged batteries will begin to charge slowly, but if it is desired to charge them at a more rapid rate, the attendant may operate a key which changes the value of the generator voltage from the floating value to a somewhat higher value used for charging. After the batteries are fully charged the attendant will restore the key to the floating position, the voltages will change correspondingly, and the counter-emf cells will be cut out.

Two arrangements of emergency and CEMF cell switching are available, namely, manual switching and automatic switching. With the manual switching it is necessary for the attendant to cut in or cut out the emergency or CEMF cells as required due to voltage changes under power failure or battery overcharge conditions. With the automatic switching the emergency or CEMF cells are cut in or out automatically under control of the discharge circuit voltage.

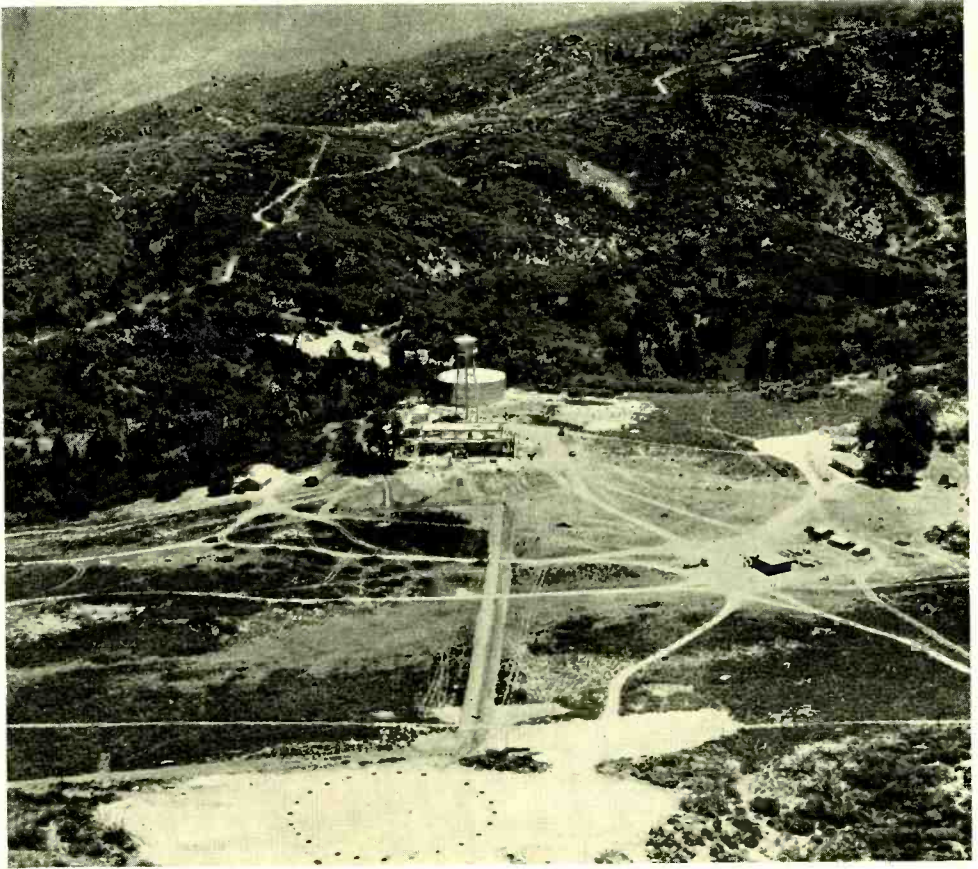

An Ultra-Short Wave Circuit for Palomar Observatory

By AUSTIN BAILEY
Transmission Development

THERE is under construction on the top of Palomar Mountain, in Southern California, a new astronomical observatory in which the world's largest telescope is to be installed. The establishment of the observatory represents a major construction project, for which a telephone "order wire" is required between the mountain top and the headquarters at the California Insti-

tute of Technology, which is situated about ninety miles away.

Members of the staff of the California Institute proposed establishing the desired telephone connection by means of an ultra-short wave radio link. As this seemed to be a favorable opportunity to try out ultra-short waves for telephone purposes over an unusual and difficult transmission path, the engineers of the Laboratories

became interested in it, and the project was undertaken on a coöperative basis. The Bell System agreed to contribute the apparatus and the Institute to carry out the work of setting up the circuit and operating it for their purposes, while both have joined in the experimental study of the propagation path.

The transmission path is characterized by its considerable length, ninety miles, and the fact that the peaks of an intervening range of mountains protrude into it. The situation is illustrated by the profile chart, Figure 2, where the solid line indicates the shortest path and the dashed one represents the mean path which the ultra-short waves would be expected to take under average conditions, were no barriers present. The curvature is due to atmospheric refraction which is caused primarily by water vapor in the air. It is difficult to predict results on a theoretical basis, but preliminary studies indicated that the obstruction of the mountains might insert a transmission loss of about eighteen db. The indications were that five-watt transmitters might serve if the local noise conditions were not too severe and if antennas of reasonable gain were employed.

The circuit has now been established and is used thirty or forty times on each work day. The transmission to Palomar Mountain proves to be fairly satisfactory with the five-watt transmitter and the directive antenna which were erected; but with similar equipment the transmission in the reverse direction, to the Institute, has been subject to considerable interference. This arises largely from the ignition systems of automobiles in nearby streets. For purposes of convenience and for economy the

Institute desired to locate the receiving antenna on a building in Pasadena rather than in the outlying country, where greater freedom from such interference could be obtained. To over-ride this noise and to fortify the circuit in general, the California Institute engineers have recently constructed forty-watt amplifiers which have been added to the five-watt transmitters at both terminals.

The equipment provided by the Laboratories consists of modified Western Electric apparatus of the type which was developed principally for mobile use and for operation in the frequency band of thirty to forty-two megacycles. One of the requirements of the project was that the transmitters and receivers be so stable in operation that contact could be maintained between the two terminals without continual

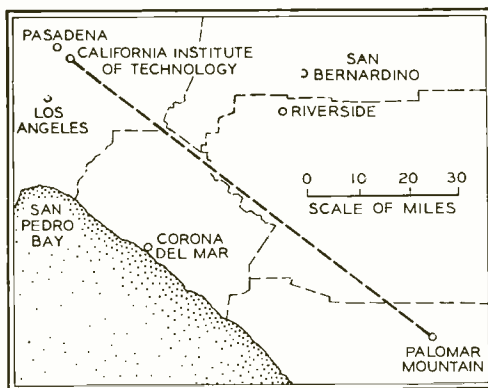

Fig. 1—Palomar observatory is about ninety miles southeast of Pasadena

attendance. The transmitters have quartz-crystal oscillators which maintain the frequency well within 0.025 per cent of the nominal value for a temperature range of zero to sixty degrees Centigrade. Each crystal is also provided with a thermostatically controlled heater which becomes opera-

tive for temperatures below zero. The receivers are a-c operated superheterodynes with beating oscillators which are crystal-controlled. A third d-c operated receiver was provided for mobile testing.

Arrangements were provided to connect several telephone stations to the radio circuit, and code ringing features were included to enable a person at any telephone to ring any of the other telephones, local or distant. Other arrangements permitted connection of extra telephones to the local circuit without access to the radio circuit.

Certain telephones were provided with special features which permit them to control the radio circuit. In placing a call over the radio circuit the calling party, if he finds the circuit idle, holds his handset and operates a key to energize the radio transmitter. After pausing for a few seconds until the filaments are heated, he operates another key, which controls the carrier and sends the code of the desired telephone as a series of dashes. This causes a sequence of operations at the distant radio receiver which ends in the ringing of call bells at the distant terminal, in

accordance with the transmitted code. The answering party then picks up his handset and momentarily depresses a key to start the radio transmitter so that conversation may begin. Power is automatically disconnected from the radio transmitters as soon as the respective parties replace their handsets, and a single ring on the magnetos by each party then indicates that the circuit is idle.

An important part of the project was an investigation of the advantages of directional antennas for increasing the effectiveness of transmission. Both horizontally and vertically polarized signals from Palomar Mountain were investigated by means of a simple half-wave antenna and reflector at Pasadena. For vertical polarization the antenna was supported about thirty feet above the roof of the penthouse on the laboratory at Pasadena and for horizontal polarization the height was about twenty-five feet. The results showed that both the signal strength and the automobile noise were lowered with horizontal polarization by about the same amount, so that there was no decided preference between the two orientations.

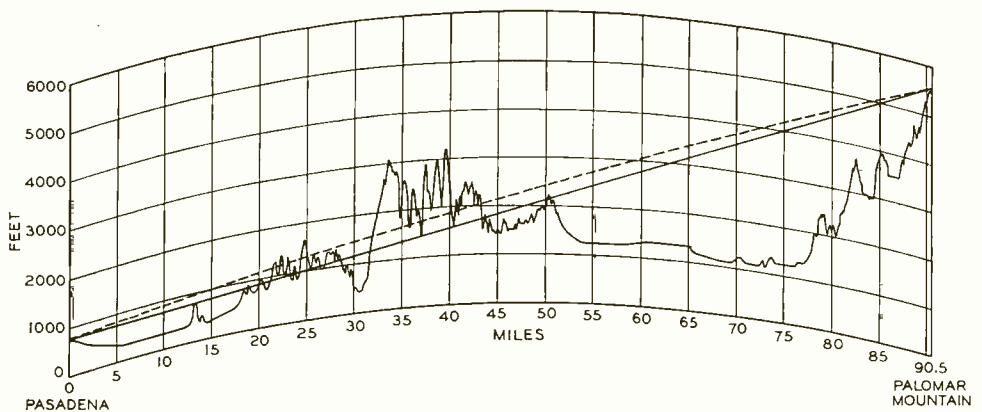

Fig. 2—Mountain peaks between Pasadena and Palomar force the radio waves to deviate somewhat from a direct course

periments were made with the receiver and a simple half-wave vertical antenna on the roof of the Optics Shop on the campus. These tests showed a maximum signal with the center of the antenna sixteen feet above the roof of the penthouse, and a gratifying decrease in noise from all sources. The advantage of this location was probably due to its being somewhat shielded by the building from nearby automobile traffic. To gain this improvement, the radio equipment was removed from the Astrophysical Observatory and installed in a convenient room on the first floor of the Optics Shop. A new permanent antenna has been installed sixteen feet above the penthouse roof. This height was re-determined and checked the optimum value previously found for vertically polarized signals. A concentric conductor transmission line connects this antenna to the radio equipment. The antenna consists of two vertical half-wave driven radiators spaced twenty feet apart at right angles to the line of transmission. A quarter wavelength behind these are two parasitically excited half-wave antennas which form a reflector. A back-end null for this combination is directed toward the High-Voltage Laboratory when the two driven antennas are excited in phase. Final adjustment of this system has not as yet been completed, but considerable improvement over the previous location of the apparatus has already been realized.

Experimental antennas were also installed at Palomar Mountain. A

single wire line 342 feet long was supported above the ground on thirty-foot poles down the slope in the direction of Pasadena and connected to the radio set through a quarter-wave matching section of line. This was about the proper height above ground to obtain phase reinforcement of the

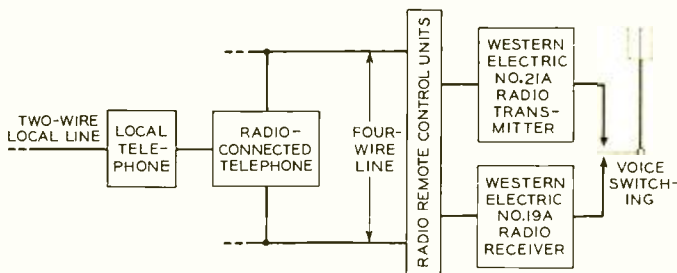

Fig. 3—Both local and radio-connected telephones have been installed. Remote control units are provided to establish radio connection with distant telephones

direct waves and waves reflected from the slope, but the length of the antenna was not the optimum required to use the maximum of the cone of receptivity. The topography of the ground prevented obtaining a wire length sufficient to place this cone correctly. The results were inferior to those obtained with a half-wave vertical and a reflector.

An eighty-five-foot water tower with a metal tank provided a location at a still higher elevation. The receiver and equipment were taken to the platform on the tower and a half-wave length vertical antenna mounted about $4\frac{1}{2}$ feet out from the tank, using the tank itself as a reflector. A null was found for a vertical antenna at a point about eight to nine feet from the tank. The local noise level was low and the results were so good that the antenna was located permanently on the tower. A single half-wave vertical in front of the tower is now in regular use.

This project, being a cooperative one, has been participated in by a number of individuals in California and New York, particularly by Dr. S. S. Mackeown and Emmet M. Irwin of the California Institute of

Technology, who have charge of the system, and by D. K. Martin and F. A. Polkinghorn, of the Laboratories, who were concerned with the apparatus that was required and the experimental program.



Sgt. Harry P. Goodwin, of American Legion Post 25, New Jersey, trains the Laboratories' "machine gun" microphone upon a brass band passing below the Empire State Building. An unusually successful broadcast of a difficult subject was accomplished by this experimental Western Electric device, which picks up a maximum of sound from the object upon which it is trained, but shuts out to a great extent sounds from other sources



Diphonic Loudspeaker for Mirrophonic Sound Systems

By R. C. MINER
Transmission Instruments

A SOUND picture reproducing system which gives aural effects approaching the clearness of a visual image in a perfect mirror has been introduced recently to motion picture producers and exhibitors under the name of Mirrophonic Sound. One of the outstanding features of this new system is the loud speakers, which have been named Diphonic because all sounds below 300 cycles per second are fed into one unit while those above 300 are carried by another. This distribution is accomplished by a crossover network.

The high-frequency speakers, of which either one or two may be used, are attached to a horn as shown in Figure 2. Both horn and speaker are commercial adaptations of those used in demonstrating the transmission and reproduction of symphonic music in auditory perspective between Philadelphia and Washington in 1934.

The horn consists of fifteen individual cells, each of which tapers exponentially from five-eighths inch square at the small end to eight inches square at the flared opening. The cells are

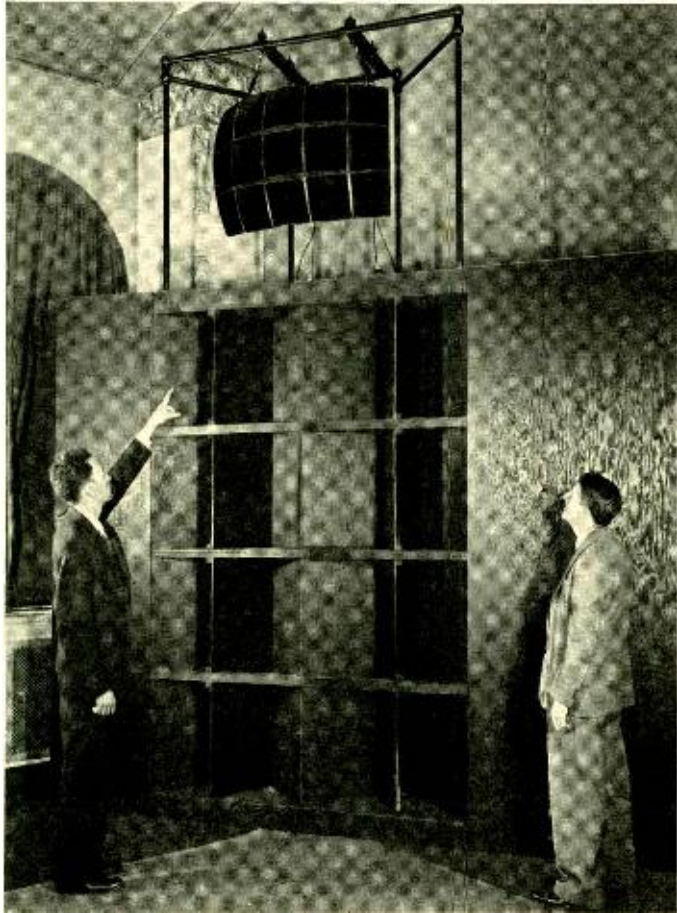

Fig. 1—The Diphonic speaker comprises two units. One of the units radiates all sounds below three hundred cycles per second and the other unit radiates those above that frequency

brought so close together at the small end that only a knife edge separates them and at the large end they are arranged as compactly as the geometry of the arrangement permits. This multi-cellular construction makes the horn non-directional. A horn which has only a single air passage distributes sound uniformly over a wide angle at low frequencies but concentrates the sound on the axis of the horn as the frequency increases. This condition is undesirable in a theatre since those sitting on or near the axis will hear too great a proportion of high frequencies compared to the low ones, while the reverse will be true for those sitting at the sides. In a multi-cellular horn of good design the various cells radiate sound of all frequencies and distribute it uniformly over a wide angle, thus giving a correct proportioning of all frequencies for all parts of a theatre.

The walls of the individual cells of the horn consist of two metal sheets with an intervening layer of felt, all

fastened together by a heat-softening cement. This makes a wall with very high damping to mechanical vibration and effectively prevents horn rattles. Assembly of the sixty similar walls into cells and of the fifteen cells and other parts into the completed horn is accomplished entirely by soldering.

The high-frequency speaker is shown in cross-section in Figure 3. The moving element consists of a diaphragm made of thin aluminum alloy to which is attached a cylindrical coil of many turns of aluminum ribbon wound on edge and held together by thin layers of varnish between adjacent turns.* To deliver the required amount of sound energy to the horn, the diameter of the diaphragm has to be considerably greater than the wavelength of the highest frequencies which it reproduces. If the diaphragm were coupled directly to the throat of a horn, the output at the higher frequencies would be greatly decreased because the phase of the sound coming from various parts of the diaphragm

would differ. To eliminate these differences sound is taken from the diaphragm through several concentric annular passages so that the distance from any portion of the diaphragm to one of the passages is small compared with the wavelength of any sound transmitted.

The magnetic field for the air-gap of the high-frequency speaker is provided by a field coil wound for twenty-four volts, the voltage

*RECORD, March, 1934, p. 203.

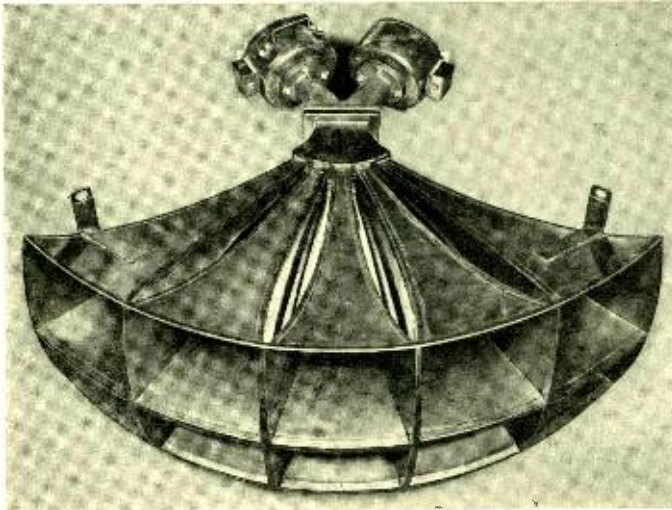

Fig. 2—The high-frequency speaker has a multicellular horn attached to the radiating units to distribute the sound uniformly throughout the theatre

which is generally used with theatre equipment. Safety features such as a cover over the field terminals and various factors for convenience in installation and ruggedness which have been built into this speaker contribute materially to its satisfactory operation in the field.

The low - frequency speaker of the Diphonic system is also an improvement over those used previously in theatres. The driving element consists of four dynamic speakers of the cone type connected in a vertical row to a shallow cavity which flares out to a flat baffle. An approximately square post is mounted in the cavity directly in front of the speaker units so that the surfaces of the post form angles of about forty-five degrees with the plane of the baffle. Two thin vertical vanes are mounted in the cavity between the post and the sides of the cavity to aid in the proper distribution of the higher frequencies radiated by the loud speaker. The construction of the parts which form the cavity and baffle is so rugged that it prevents the possibility of extraneous sound being radiated by mechanical vibration. The advantages of this loud speaker are good distribution of its higher frequencies, improved efficiency, and elimination of resonance effects which

tend to distort the quality of the sound by unnaturally prolonging certain tones.

The entire loud speaker can be installed easily and dismantled quickly if required. It occupies a minimum of space on the stage and has small

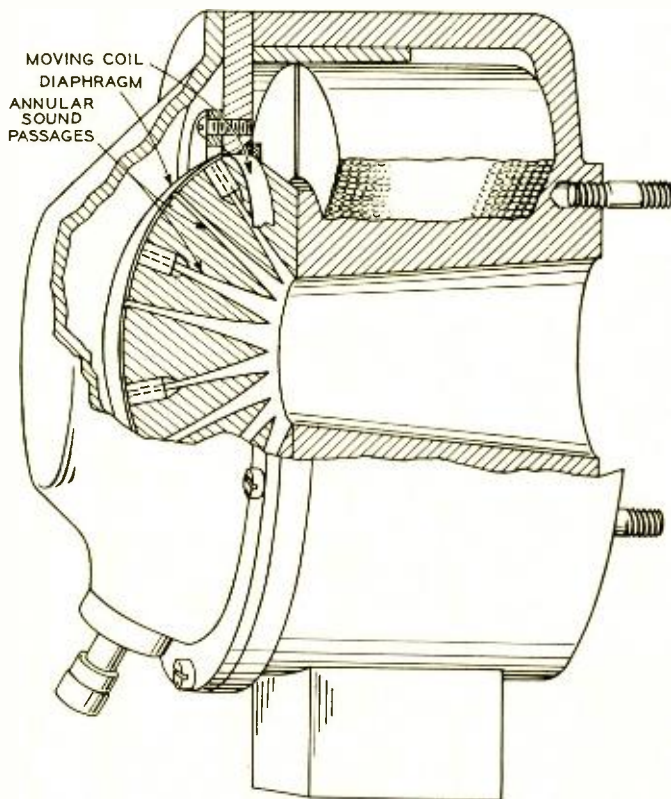

Fig. 3—Sound radiated by the diaphragm of the high-frequency units is conducted through concentric annular passages to prevent interference effects

depth—an important consideration because some of the older theatres have very shallow stages. With its greater capacity for sound volume and improved distribution of all frequencies over the entire theatre the Diphonic loud speaker is a notable improvement in sound reproducing equipment.



Limitations in High-Frequency Band Filter Design

By C. E. LANE

Telephone Apparatus Development

UNTIL about five years ago filters were used very little for frequencies above 150 or 200 kilocycles. In fact, at that time, the largest demand for filters in the Bell System was in the three-channel open-wire carrier-telephone systems with a top frequency of about thirty kilocycles. At radio frequencies, tuned circuits were generally employed to obtain the required frequency selectivity. This was the most practical and economical method at these high frequencies, because of the com-

panies will undoubtedly be needed to provide high-quality and efficient high-frequency carrier systems* utilizing cable, open wire, concentric conductor, and radio space. While filters are practically essential to single-sideband transmission, they may also be required where both bands are transmitted to provide efficiency and high quality, and to eliminate interference.

The requirements to be met in the design of band filters for high frequencies arise primarily from the needs of carrier systems. In their normal frequency allocation, the essential frequency components of signals—as, for example, those required for speech and music—fall in a definite band defined by an upper and lower frequency limit. For transmission in carrier systems this band is relocated by modulation to some higher frequency position. The band width in cycles, however, remains exactly the same after relocation as before.† A large number of channels may thus be provided in the same transmitting medium by locating the channels in adjacent frequency ranges. If the medium is to be used efficiently, the channels must be close together over the transmission path and must be

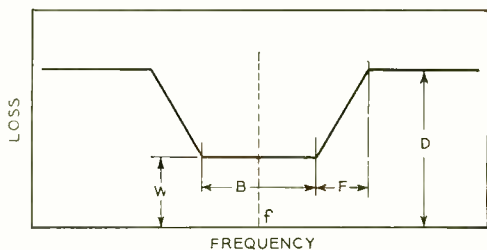

Fig. 1—Idealized loss-frequency characteristic for a band-pass filter

paratively ample frequency space and the narrowness of the transmitted band with reference to the mid-band frequency.

Today the situation is quite different. Filters with their sharp cut-offs and uniform transmission bands are now commonly used for frequencies as high as two or three million cycles and sometimes as high as fifty or sixty million cycles. More and more filters at higher and higher frequen-

*The term carrier system is here used in its broadest sense to include all radio systems.

†Except in the case of double-sideband transmission where the band width is twice that of the highest frequency of the original signals.

segregated from each other at the terminals by the use of filters.

There are three main requirements to be met by the filters used in carrier systems. First, they must restrict the frequency range of the signals by

are primarily of the band-pass type. If but one step of modulation is to be employed, and the filters are to be equally good, they should have the same band width in cycles at any frequency allocation; they should

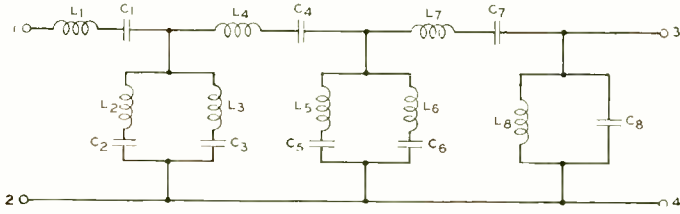

Fig. 2—Typical schematic for a band-pass filter

eliminating all components which otherwise would fall below or above the frequency range considered essential. If the frequency range provided by the transmitting medium is to be used efficiently, single sideband transmission must be used, and thus the second requirement is that the filters must eliminate either the upper or lower sideband arising from modulation and yet permit the free transmission of the opposite sideband. Regardless of the frequency range to which the signal is shifted for transmission, these two sidebands are exactly the same number of cycles apart, twice the number of cycles of the lowest frequency to be transmitted in the original signal. The third requirement, to minimize energy loss and distortion, sometimes exists because a number of the filters must work in parallel, and to meet it each filter must offer a high shunting impedance in the transmitting ranges of all the other filters.

have the same maximum loss for all frequencies in the transmitted band; they should provide the same discrimination against unwanted frequencies; and as the frequency allocation of the filter is increased,

there should be no greater number of cycles required for the loss to rise from the low value in the transmitted band of the filter to the high loss required outside the band. This definition of what constitutes equally good filters for use at higher and higher frequencies is rather idealistic but it provides a basis for studying the nature of the problems that are encountered.

An idealized loss-frequency diagram of a band-pass filter is shown in Figure 1, where B is the band width in cycles, f is the mid-band frequency, w is the loss over the pass band, D is the required loss outside the band, and F is the frequency space in cycles

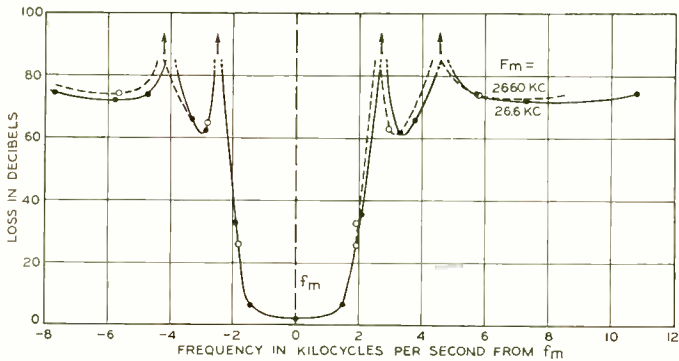

Fig. 3—Loss-frequency characteristics of a band-pass filter

Filters for such uses

in which the loss must attain this value D . If the requirements mentioned above are to be met, the values of B , F , W , and D , must remain the same regardless of the value of f . The impedance of the filter to pass-band frequencies, z , should also remain constant for any system.

The usual method of designing such filters is to connect together a number of ladder filter sections which have like image impedances at their junctions. The filter will consist of one or more sections having infinite attenuation at zero frequency and at infinite frequency; and of other sections having very high loss at frequencies

have been chosen for the filter, of course, but the same general statements about the relation between element requirements and frequency would still apply.

For the element values listed in Table I the mid-band frequency of the filter is 26.6 kilocycles. The loss characteristic of the filter in terms of cycles removed from the mid-band frequency is given by the solid curve in Figure 3.

While this same general schematic would apply to a different mid-band frequency, the values of the coils and condensers and certain of their characteristics would have to be different.

Thus, if over the pass band the impedance, z , of the filter is to be held constant, the maximum values of inductance, L , and of capacitance, C , would be the same for all values of f . In order to keep both B and F constant, the spread in element magnitudes—the ratio of the smallest to the largest values of inductance and capacitance—must vary directly as the square of f . Since the maximum values are constant, this means that the minimum values must also vary

inversely as the square of the frequency. To maintain the same loss, w , over the pass band, the Q of the coils, or the ratio of their reactance to their effective resistance, must vary directly with f .*

*The Q of the capacitances is not generally a matter of any concern since it is usually many times that of the inductances.

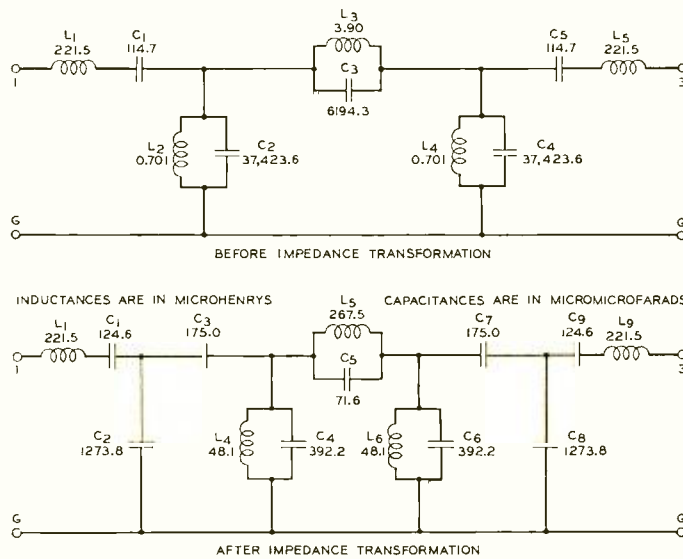

Fig. 4—A band-pass filter, without impedance transformation, above, and with it, below

not far from the edges of the transmitting bands of the filter. When this procedure is followed, the same filter schematic can be used, and hence the same number of elements, regardless of the position of the pass band in the frequency spectrum. A typical schematic for such a filter is shown in Figure 2. Another schematic might

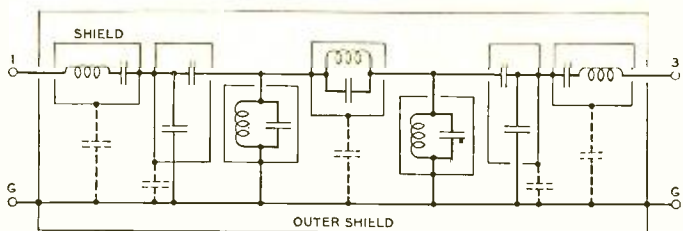

Fig. 5—By applying shielding to the filter of Figure 4, the stray capacitances are made to perform a useful service

On paper, using the same schematic one can obtain essentially the same characteristic as shown in Figure 3 at one hundred times the frequency. The small difference for perhaps the nearest practical approach is shown by the dotted curve in the illustration. To maintain the same values of r and w at these higher frequencies, however, it is necessary to assume a Q of 14,000. The element values of the 2660-kc filter are given in Table II. The spread is now ten thousand times what it was before, or a little over one million. The largest elements for both filters are practically the same. Of course it would not be possible to construct such a filter at 2660 kc. The limiting frequency for meeting such requirements with an ordinary coil and condenser filter would be about 50 kilocycles using inductances with Q of 280.

This illustrates the difficulties that are encountered as an effort is made to build equally good filters at higher and higher frequencies. The best Q obtainable at reasonable cost for inductance coils is usually between 200 and 300 in the frequency range from 1000 to 100,000,000 cycles, and the very small values of

inductance and capacitance required at the higher frequencies are of the same magnitude as the inductance of the short lengths of conductor used to connect the filter sections, and as the stray capacitances within the filter. When the in-

ductance and capacitance of the connecting leads of a filter become appreciable with respect to the actual coils and condensers, the filter ceases to be the same group of elements that its design called for, and it thus ceases to behave in the proper manner. Also, when very small inductances are required because of very high mid-band frequencies, it becomes difficult to obtain coils of precisely the value desired.

There are two means that can be employed to overcome partially some of these difficulties encountered with coil and condenser filters. These two means, however, do not affect the Q 's of the coils to any great degree, and their application, therefore, permits coil and condenser filters to be applied to higher frequencies than would otherwise be possible provided the value of Q obtainable is not the limiting factor.

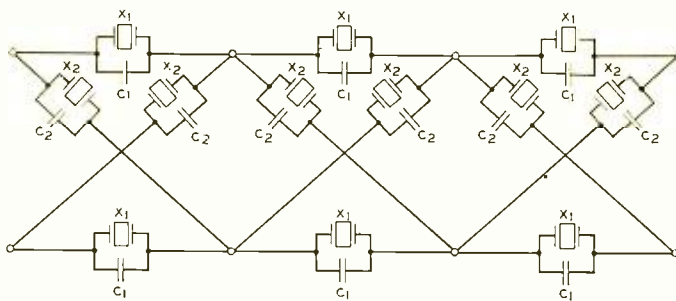

Fig. 6—Schematic for the crystal filter with a mid-band frequency of 2660 kc.

One of these means is the introduction of an impedance transformation within the filter itself. The results obtained are equivalent to the insertion of ideal transformers at desired points internal to the filter, so that the magnitudes of certain elements may be increased or decreased

use of shielding. By the proper use of shields, the effects of distributed inductances and capacitances, which exist between the inter-connecting leads, may be localized at definite points, and made to become part of the actual values required. Such shielding, applied to the filter of

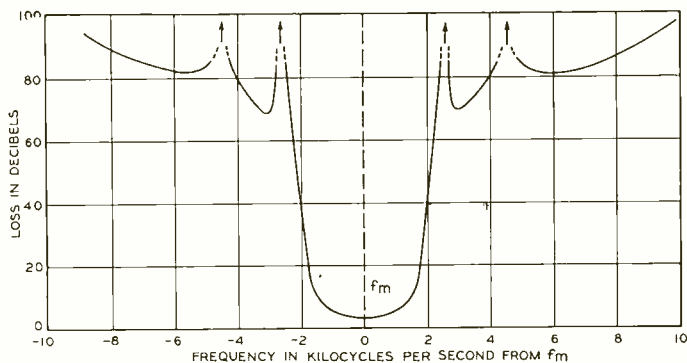

Fig. 7—Loss frequency characteristic for the filter of Figure 6

as desired within limits depending on the filter. This results in removing the restrictions due to the maximum and minimum values of inductance and capacitance. Impedance transformation usually results in a modification of the filter schematic, but the characteristics of the filter remain unaltered. The change it brings about, both in the schematic and the values of the inductances and capacitances, is illustrated by Figure 4. In the upper part of this illustration is a schematic of a band-pass filter with a mid-band frequency of about 1000 kc, while the lower part of the illustration shows the same filter employing impedance transformation. There is obviously a great improvement in the maximum and minimum values of the inductances and capacitances and in their spread.

The second means employed to make filters of coils and condensers applicable to higher frequencies is the

Figure 4, is shown in Figure 5. Here it will be noted that the capacitances between the shields and the connecting leads, indicated by dashed lines and condensers, are made to serve as actual circuit elements.

Another method of providing filters for higher frequencies is the use of sections of coaxial conductors as

the filter elements. The values of Q associated with the inductance of such conductors are some ten times greater than for ordinary coil inductances so that considerable improvement is possible. This method will be discussed more fully in an article in a later issue of the RECORD.

As it is necessary that Q vary with F if w is to remain constant, these methods all fail at high frequencies for band filters with sharp cut-offs, because coils with sufficiently high Q 's can not be obtained. Fortunately,

TABLE I

Inductance	Millihenries	Capacitance	Micro-microfarads
L_1	42.3	C_1	840
L_2	5.6	C_2	8700
L_3	4.1	C_3	6300
L_4	46.7	C_4	760
L_5	17.4	C_5	2490
L_6	14.3	C_6	2040
L_7	48.9	C_7	730
L_8	.46	C_8	77400

however, quartz crystals connected in an electrical circuit provide effective inductances that have Q 's a hundred times as great as those of coils. For frequencies from about fifty kc to two or three thousand kc, filters may be made which use quartz crystals in place of the coils and some of the condensers. Such a filter for a mid-band frequency of 266 kc is shown in Figure 6, and its loss characteristic in Figure 7. This compares favorably with the characteristics shown in Figure 3. The characteristics of these crystal filters have already been described in the RECORD.*

By these various means many of the inherent limitations to the use of

*RECORD, June, 1935, p. 305.

TABLE II			
Inductance	Millihenries	Capacitance	Micro-microfarads
L ₁	43.7	C ₁	.081
L ₂	4.5	C ₂	.79
L ₃	4.5	C ₃	.79
L ₄	48.4	C ₄	.074
L ₅	15.9	C ₅	.224
L ₆	15.9	C ₆	.224
L ₇	50.5	C ₇	.070
L ₈	.000045	C ₈	79700.

band filters at high frequencies have been removed. The particular means employed will vary with the conditions, but the overall result is that these filters, instead of being largely restricted to a mid-band frequency of perhaps one hundred and fifty or two hundred kilocycles, may now be employed for frequencies many times higher.

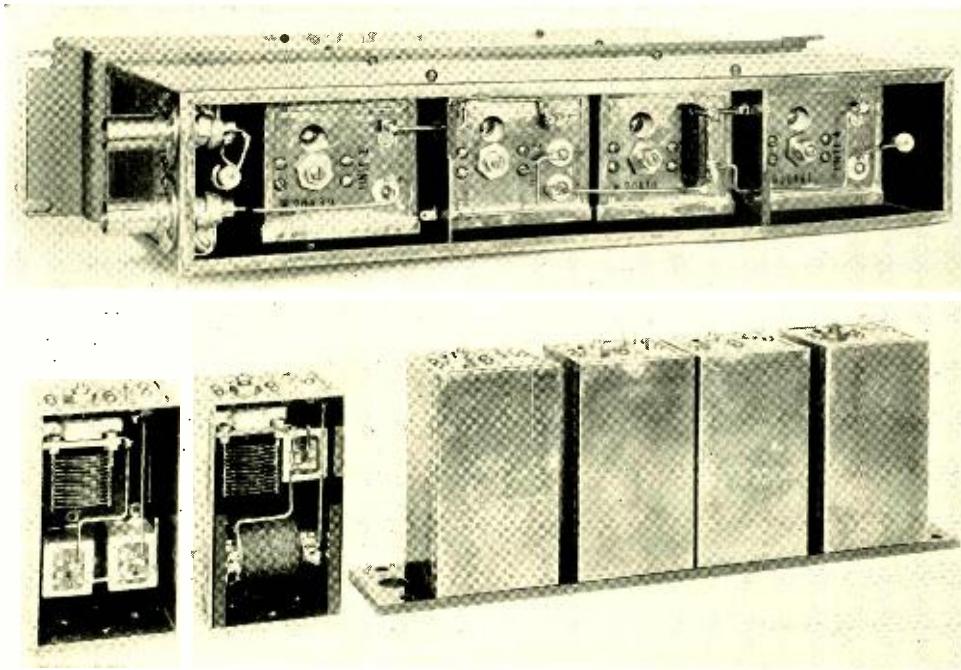

Fig. 8—The upper photo shows one of the electrical-grouping filters, with one side opened, used at the terminal of the New York-Philadelphia coaxial trial system. The lower photo shows the individually shielded filter arms and the arrangement of the elements. A schematic diagram of this type of filter is shown in Figure 5



A Multi-Channel Radio Monitoring System

By F. A. HUBBARD

Radio Research Department

DURING the past few years the Bell System has extended radio telephone service to a number of points across the Pacific Ocean. The calls to some of these points are infrequent, and to handle them economically it seemed desirable to provide some method of monitoring the channels other than by furnishing a complete receiver for each. Some years ago a system was provided in which the output of two high-frequency amplifier-detector units could be connected to a single intermediate- and voice-frequency amplifying system, thus enabling a single receiver to monitor two channels. The present Pacific radio-telephone service, however, furnishes communication to four widely separated points, each of which employs two or more frequencies, so

that more extensive monitoring equipment is required.

The receiving station for the transpacific radio telephone is at Point Reyes, California. Here three directional antennas are provided for receiving from four transpacific locations: Honolulu, Japan, the Philippines, and Java. The transmitting station is at Dixon, some seventy miles inland from Point Reyes, and interconnecting voice circuits are provided between the two stations and the central office in San Francisco. A view of the interior of the receiving station is shown in Figure 1. The multi-channel monitoring equipment comprises the three bays at the right. The jack panels at the top of two of the bays provide for connecting the various high-frequency amplifiers to



Fig. 1—The Point Reyes multi-channel monitoring receiver station

a number of antennas.

In developing a monitoring equipment for such service, it is desirable to make it flexible not only as to size, so that the number of channels it will handle may be varied, but as to use, so that the attendants will be free to determine the most effective operating procedure. With this in mind, the equipment was designed to provide a maximum of ten high-frequency amplifiers with associated detectors and beating oscillators, two intermediate-frequency amplifiers, and two voice-frequency amplifiers, together with whatever control and power circuits were necessary.

One pair of intermediate- and low-frequency amplifier units is used for monitoring, and the other is held available for completing calls as they come in. The general plan of operation is to keep a number of the high-frequency amplifiers tuned for the various frequencies in use at the time, and to connect these amplifiers in succession automatically to the monitoring receiver for an interval long enough for the attendant to hear any call coming in. The voice-frequency amplifier of the monitoring receiver is connected to a loud speaker so that the attendant can hear incoming calls from any point in the room, and a lamp on the panel will indicate which channel is calling. When the attendant hears a call, he merely operates a key associated with that channel, which transfers the high-frequency amplifier to the service receiver so that the call may be handled in the usual way. The monitoring equipment then continues

October 1937

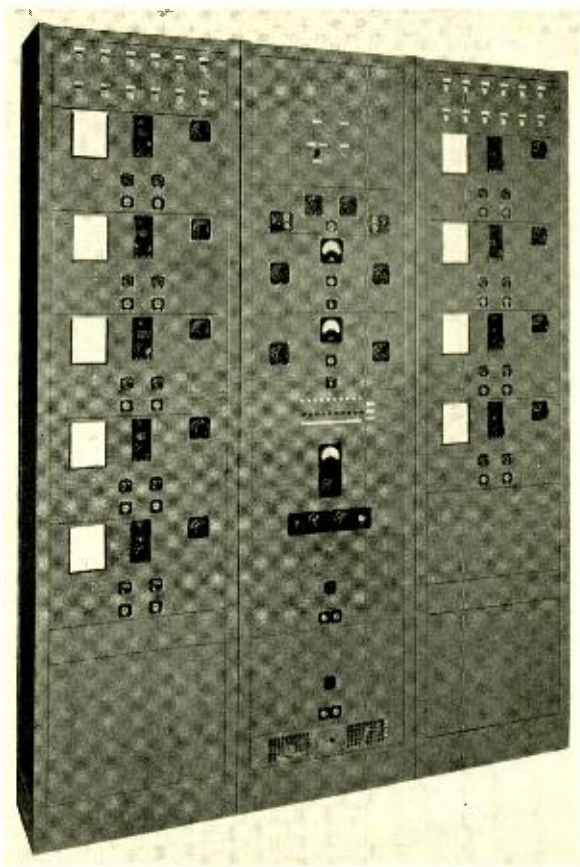

Fig. 2—The D-99167 Radio Receiver includes three bays and can monitor as many as ten radio channels

to monitor the remaining channels—automatically skipping the one in use.

The radio receiver proper is of the 13A type, which has already been described in the Record.* The high-frequency amplifiers are of the 83 type—one covering frequencies from 2.2 to 6.2 megacycles (83C Amplifiers), one from 6 to 13.5 (83B Amplifiers), and the other from 12 to 25 megacycles (83A and 83D Amplifiers). Various numbers of units of each range may be included depending on local conditions. At Point Reyes there are nine of the high-frequency amplifiers employed; five

*RECORD, August, 1933, p. 375.

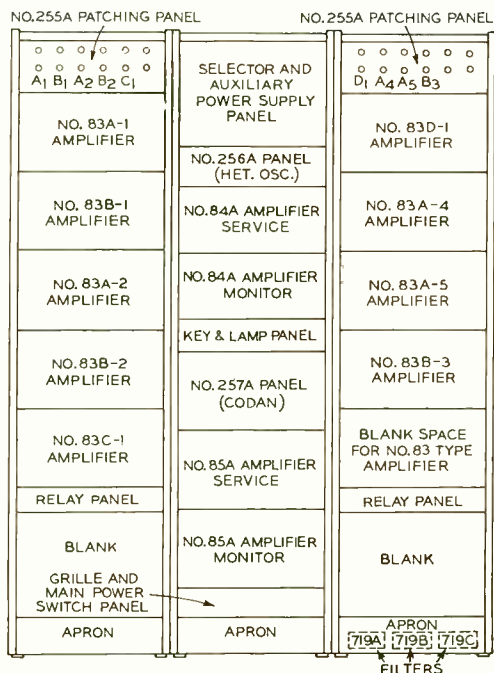

Fig. 3—Panel layout of the multi-channel monitoring receiver

are of the highest frequency range, three of the intermediate range, and one of the lowest. The two intermediate-frequency amplifiers are of the 84A type, and the two voice-frequency amplifiers are of the 85A type. The equipment used at Point Reyes is shown in more detail in Figure 2, where the two end bays carry the high-frequency amplifiers, and the central bay carries the two intermediate- and voice-frequency amplifiers. On this central bay are also the selector panel, at the top, a heterodyne oscillator panel below it for tuning adjustment, a

lamp-and-key panel in the middle, and a codan panel immediately below it. The type and position of each panel are indicated on Figure 3.

The successive connection of the various high-frequency amplifiers to the monitoring receiver is controlled by a 200-type selector actuated by a timing device. The selector has twenty-two points and is stopped on each of these long enough to enable the attendant to hear an incoming call and to note which channel is calling. Since there are only nine high-frequency amplifiers, each is connected to two points on the selector and thus will be connected to the receiver twice for each rotation, and in addition two of the highest frequency amplifiers are connected to two adjacent points of the selector at each position so that they have a double monitoring period. In this way all twenty-two points of the selector are utilized, and one of the incoming channels is connected to the monitoring receiver at all times.

Each high-frequency amplifier has associated with it a lamp and a key. With the keys in their normal position

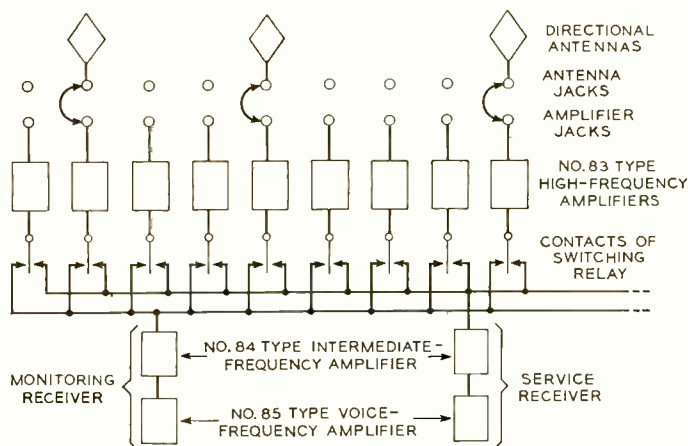
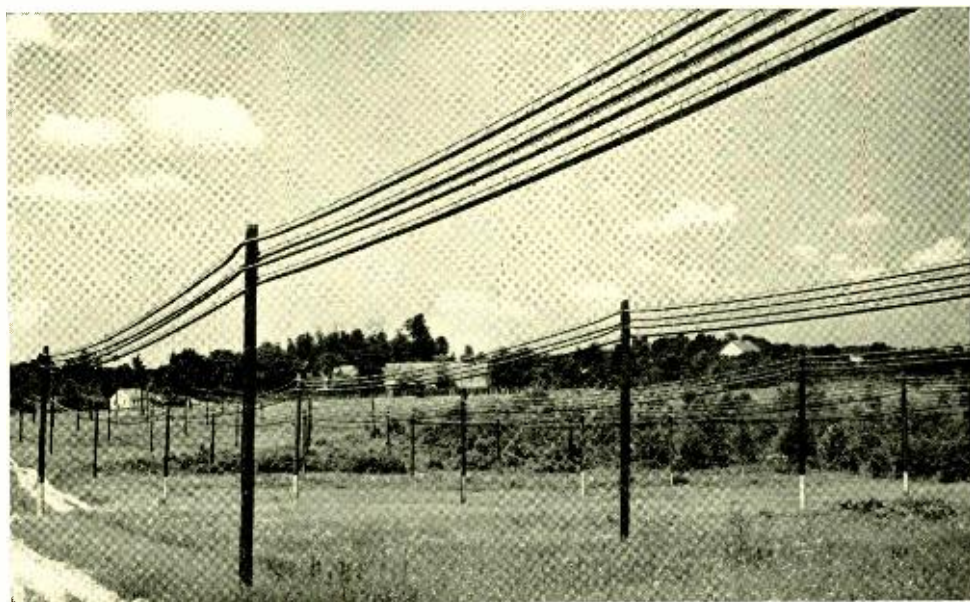

Fig. 4—Simplified schematic diagram of the switching arrangement of the multi-channel monitoring receiver

each lamp lights as its associated amplifier is connected to the monitoring receiver. When the key is operated to its monitoring position, the selector is stopped, and the associated amplifier remains connected to the monitoring receiver and its lamp remains lighted. This enables the attendant to check the tuning before transferring the call to the service receiver. When the key is operated to the service position, the associated high-frequency amplifier is connected to the service receiver, and the selector starts rotating again but skips that particular amplifier. A simplified schematic diagram of the switching arrangement

that is employed is shown in Figure 4.

This multi-channel monitoring receiver, known as the D-99167 Radio Receiver, is entirely a-c operated from the usual 115-volt sixty-cycle commercial supply, and incorporates an automatic voltage regulator to maintain a constant potential. Besides the apparatus already described a codan circuit is provided for use when desired. The receiver that was used at Point Reyes before the D-99167 was installed is maintained for use either in completing connections or as a spare unit. It is in the same line with and immediately at the left of the multi-channel receiver in Figure 1.



One of the cable test plots at the Chester Field Laboratory where the effects of climatic conditions on cable sheath of various alloys may be studied under service conditions



High Dispersion X-Ray Spectrometer

By F. E. HAWORTH
Research Department

WHEN a beam of X-rays falls on a crystal it is reflected by the equally spaced layers of atoms in the crystal much as ordinary light would be reflected from a series of regularly spaced parallel surfaces. But the re-

the spacing between atom-layers. If the wave length of the X-rays is known the spacing of the atoms can be determined by measuring the angles at which strong reflections occur. Extensive use has been made of this phenomenon in studying the arrangement of atoms in crystals and our knowledge of crystal structure has been greatly increased by this means.

In recent years an improvement in this technique for investigating crystal structure has been used at the Laboratories and elsewhere. It differs from previous methods in that the X-rays are directed onto the crystal at nearly normal instead of slanting incidence and are reflected back almost on themselves—hence the name “back reflection.” This procedure disperses the X-rays much more than the classical method of reflecting them at low angles of incidence and makes possible the resolution of lines which could not previously be separated. This increased dispersion is illustrated in Figure 2 which shows X-ray reflections from silver. The separation of the components of the double line is obvious for the higher angles at the left and gradually decreases until only single lines can be seen at the right side of the record.

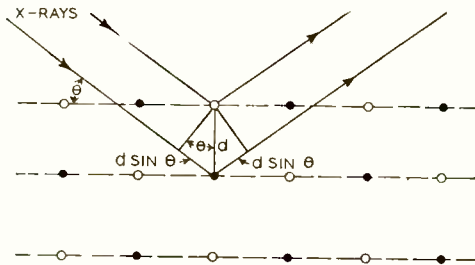

Fig. 1—Cross-section of a salt crystal showing how X-rays are reflected. The small circles represent sodium atoms and the dots chlorine atoms. Reflections occur when the difference in path for two elements of an X-ray beam, $2d \sin \theta$, is an integral multiple of the wave length, λ

fections will be strong only when the beam strikes the surface of the crystal at certain angles. This is because the waves, reflected from the different atomic layers, interfere with each other except when the paths differ by one or more wave lengths. As can be seen from Figure 1, the difference in path-length depends on the angle and



Fig. 2—X-rays from copper reflected by crystalline silver. The $K\alpha$ double is separated at the left, where the angle of reflection is almost 80° . This illustrates the high dispersion obtained for large angles of reflection

The Laboratories has taken advantage of this high dispersion to make accurate measurements of the lattice constants of various materials and to study the effect on the specimen of mechanical strains such as are introduced by cold rolling. For this purpose the camera is arranged so that the slit which defines the X-ray beam, the specimen, and the photographic film are all on the circumference of a circle, Figure 3. For a given angle of reflection θ , an element of the beam of wave length λ which strikes the specimen at any point, will then

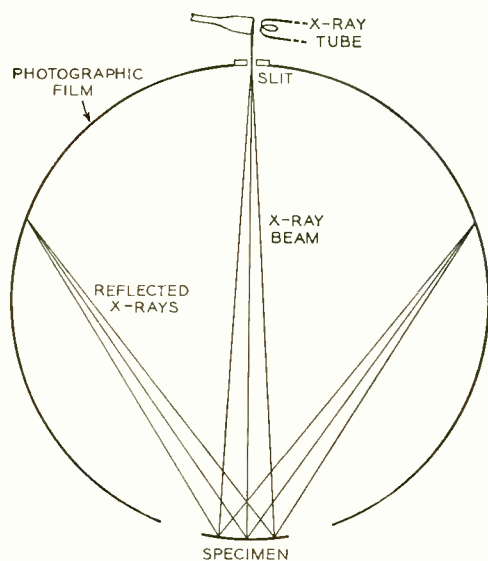

Fig. 3—The X-ray camera is constructed so that the specimen, the photographic film and the slit which defines the X-ray beam are all located on a circle. This gives sharp reflections from the specimen with a divergent beam

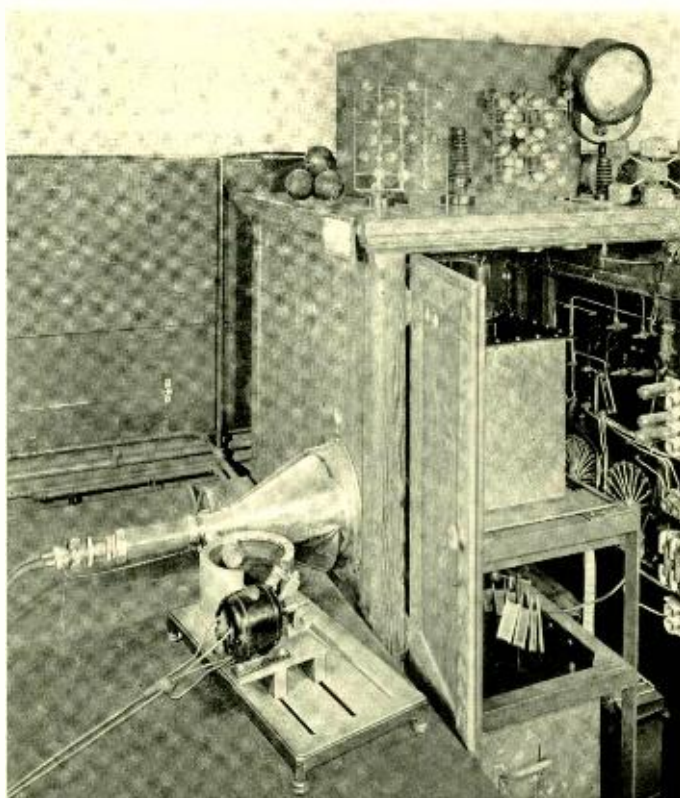

Fig. 4—The spectrometer is held against the small window near the target of the X-ray tube which is excited by the 40,000-volt transformer in the cabinet. The motor rotates the specimen to prevent coarse crystals from making the lines irregular

be reflected to the same position on the film as any other element of the same wave length. By this means lines are sharply focussed, and the distances between them on the film may be accurately measured.

The construction of the camera is shown in Figure 4. X-rays leave the tube through a small glass window at the side and pass through a pair of lead slits which confine the X-rays to a narrow beam. This beam falls on the specimen which is mounted on a plate located at the gap in the camera housing. The specimen is sometimes rotated slowly by the small electric



Fig. 5—Reflections from lead photographed in an X-ray camera which has been arranged as illustrated in the photograph of Figure 4

motor during exposure or moved slowly back and forth a short distance along the circumference of the housing to prevent coarse crystals from giving irregular spectral lines. The photographic film, on which the records are made, is wrapped around the inside of the camera housing, and covered with black cloth to exclude daylight. Another method of using the camera is to mount the specimen as a thin rod vertically at the center of housing. The spectra illustrated in Figure 2 were taken with this arrangement. A 40,000-volt transformer shown in the cabinet at the right in Figure 4 supplies power for the X-ray tube.

The increased accuracy attainable by the back reflection method is illustrated by the X-ray lines of lead shown in Figure 5. If the size of the unit of structure is calculated from each one of these lines values are obtained which differ slightly from each other. The differences are due to some extent to errors in measuring the distances between lines, but principally to shrinkage of the film, inaccuracies in measuring the diameter of the camera, and in locating the specimen and slit. A study of the latter errors shows that they tend to disappear as the angle of reflection increases. Hence by plotting the calculated spacings as a function of this angle, θ , and extrapolating to $\theta = 90$ degrees, these errors may be reduced substantially to zero. Figure 6 shows such an extrapolation. The atomic spacing of a crystalline substance may

be determined by this method to within 0.01 per cent from a single X-ray photograph, and if several are taken the error may be reduced to 0.002 per cent.

If a uniform strain like that caused by a steady tension or compression is applied to a specimen, the atomic spacings will be changed by definite amounts. This may be observed by the shift in position of the lines of the X-ray pattern. However, if the strain is non-uniform a reflected X-ray line which would otherwise be sharp will broaden because it is reflected from a group of planes with irregular spacings. Figure 7(a) shows an X-ray doublet, of iron, as reflected from permalloy which had been annealed to remove the strains, and 7(b) from the same material after it had been hard rolled. The broadening is so great in the second photograph that the doublet character of the reflection disappears entirely. A measurement of the breadth of the lines shown in

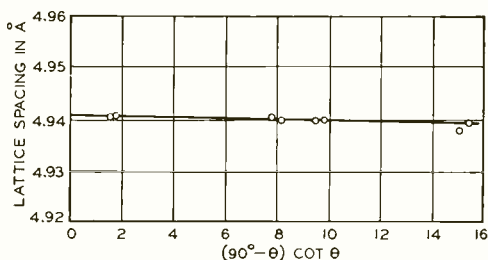

Fig. 6—Extrapolation of the spacings calculated from the lines shown in Figure 5. By extending them to $\theta = 90^\circ$ systematic errors in the calculations are greatly reduced

Figure 7(a), when corrected for the finite width of the slits which define the X-ray beam, agrees closely with the natural width of the same X-ray lines as measured by others with a two-crystal spectrometer — a method which is in some respects much more difficult.

The breadth as shown in Figure 7(b) is thus the result of both the strains in the material and the spread in wave length of the lines themselves. These effects

have been separated by a mathematical analysis and a calculation made of the distribution of the strain in the cold rolled material. From this the latent energy stored in the distortion has been computed for a series of specimens which were cold rolled and then annealed at various temperatures. The results indicate a

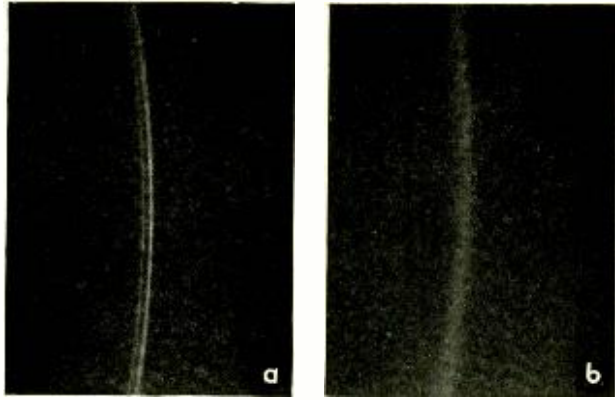
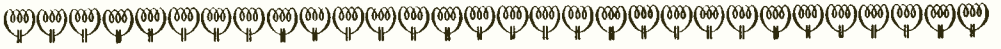

Fig. 7—The iron $K\alpha$ doublet reflected from permalloy (a) which has been annealed to remove the strains and (b) after cold rolling

correlation with other properties of the material, such as electrical resistivity, magnetic permeability and hardness. In investigations of this character the high resolution attainable by the back reflection method just described can very frequently be used to great advantage.



Contributors to this Issue

AUSTIN BAILEY graduated from the University of Kansas in 1915 with the A.B. degree and received the Ph.D. in physics from Cornell in 1920. He spent a year with the Corning Glass Works as Superintendent of the Apparatus Division and a year as Assistant Professor of Physics at the University of Kansas, after which he joined the D. & R. Department of the A. T. and T. Company in 1922. Here his work was largely concerned with long-wave transmission phenomena. From 1934 to 1937 he was a member of the Bell Laboratories staff where he was engaged in ultra-high-frequency transmission problems. Last January he transferred to the O. & E. Department of A. T. and T. Company to

continue work on radio communication. Dr. Bailey has published a number of papers on long-wave transmission phenomena and other radio subjects.

F. B. LLEWELLYN received the M.E. degree from Stevens Institute of Technology in 1922. Prior to that time he had several years of practical experience as a radio operator with the Marconi Company, the Navy and the Independent Wireless Telegraph Company. After spending a year with the Vreeland Laboratory he joined the Bell Laboratories technical staff where he has been engaged in investigations relating to radio detectors, constant-frequency oscillators, ultra-high-frequency electronics and more recently to amplifier cir-



Austin Bailey



F. B. Llewellyn



H. T. Langabeer



F. A. Hubbard



R. C. Miner

cuits. Dr. Llewellyn received the Ph.D. degree from Columbia in 1928 and was awarded the Morris Liebman Memorial Prize by the Institute of Radio Engineers in 1935.

H. T. LANGA-BEER joined the installation department of the Western Electric Company early in 1913, but after a little over a year with them

left to go into power substation work, and spent the next six years with subway and power companies in New York City. During this period he studied at Pratt Institute in the electrical course. He graduated in 1920, and at once joined the power development group of these Laboratories. Here he has engaged in a wide variety of developments pertaining to telephone power plants, his most recent work being on the large 301C plant described in this issue of the RECORD.

FRANK A. HUBBARD received his B.S. degree in Electrical Engineering from Pennsylvania State College in 1922, and shortly after joined the Technical Staff of the Laboratories. Here he was assigned to a group engaged in ship-to-shore and radio transmission studies, and in the development of short-wave field-strength



A. A. Burgess

measuring equipment. For the past eight years he has been especially concerned with the short-wave radio receiving equipment for use at the Netcong, Pt. Reyes, Platanos (South America) and Forked River receiving stations. Multi-channel monitoring and receiving system methods have engaged his attention for some time, and it was in this connection that the work on the system described in the current issue of the RECORD was done.

R. C. MINER received the B.S. degree in Electrical Engineering from the University of California in 1929, and joined the Research Department of the Laboratories that year. Previously, he had worked for the Pacific Telephone and Telegraph Company in and around San Francisco during college vacation periods and had thus gained practical experience in the telephone industry. At the Laboratories he has been engaged in the development of moving coil receivers and microphones, loud speaking telephones, and magnetic receivers.

A. A. BURGESS was graduated from the Sheffield Scientific School of Yale Uni-



C. E. Lane

versity with the degree of B.S. in June, 1928, and immediately joined the Technical Staff of the Laboratories. His initial experience was in the Systems Department, where he prepared the equipment, information and specifications for the first trial installation of teletypewriter switching equipment for New York, Boston, and Chicago, and supervised the installation at Chicago. After fifteen months of trial installation experience, he transferred to the Current Development group where for nine months he was concerned with the analyzation of orders for non-standard manual equipment for telephone central offices. In 1930, when standardization work on the No. 1 teletypewriter switchboard was begun, he joined the telegraph equipment development group, where he has been engaged in the development of teletypewriter switchboard equipment, particularly the Nos. 1, 1A and 3A switchboards referred to in this issue.

C. E. LANE received an A.B. degree from the University of Iowa in 1920 and an M.S. degree from the same university



F. E. Haworth

in 1921, and immediately joined the Engineering Department of the Western Electric Company, now Bell Telephone Laboratories. His first five years were spent in the Research Department engaged in general studies of acoustics pertaining to speech, hearing, and loud speaker development. Since that time he has been engaged in the development of transmission networks in the Apparatus Development Department. For some time he has been in charge of the development of special filters such as mechanical filters, filters in which quartz crystals are used as elements, and high-frequency filters of all types.

F. E. HAWORTH was graduated from the University of Oregon in 1924. The next year he spent as a Graduate Assistant in Physics at Columbia University. In 1925 he joined the Laboratories where he has since been engaged in experimental work on magnetic materials, dielectrics and crystal analysis with X-rays. He continued graduate study at Columbia University after coming to the Laboratories, and received the A.M. degree in 1929.