

# BROADCASTING

The Weekly Newsmagazine of Radio

## TELECASTING

LETTERS FROM THE FIELD  
 THE BROADCASTERS' UNION  
 THE NATIONAL ASSOCIATION  
 OF BROADCASTERS  
 THE NATIONAL ASSOCIATION  
 OF TELEVISION BROADCASTERS  
 THE NATIONAL ASSOCIATION  
 OF TELEVISION NEWS  
 THE NATIONAL ASSOCIATION  
 OF TELEVISION NEWS  
 THE NATIONAL ASSOCIATION  
 OF TELEVISION NEWS

### a peek inside the works...

RARE IS THE WEEK in which WOR doesn't receive a letter from a sponsor, or his agency, happily confirming the job that this great station does. And little wonder, when one comes to think of it; for WOR has nudged its way neatly into more homes with radios (3,440,000, to be exact) from 6:00 am to Midnight, than any other station.

The cost? Why, Gentlemen, in most cases it's... Well, bus fare, really. For instance, one man who makes something for people to buy, is now chatting pleasantly — and profitably — with very responsive listeners every day — in more than 198,000 homes\* — for the very comforting sum of less than 51¢ per-thousand homes.

That, we think, is not only in the best bargain counter tradition, but tends to confirm the extraordinary popularity of the programs WOR creates. For instance: According to the March-April Hooper report, 9 of the 15 most popular local shows (other than news) are WOR shows. Remarkable? In a way, but not to the more than 200 advertisers and their agencies who consistently make a habit of buying this more for less on WOR.

*\*and that's not the case one month, or two months, or three months, but based on an every day performance for a five months' average!*



# WOR

— that power-full station

at 1440 Broadway, in New York

mutual



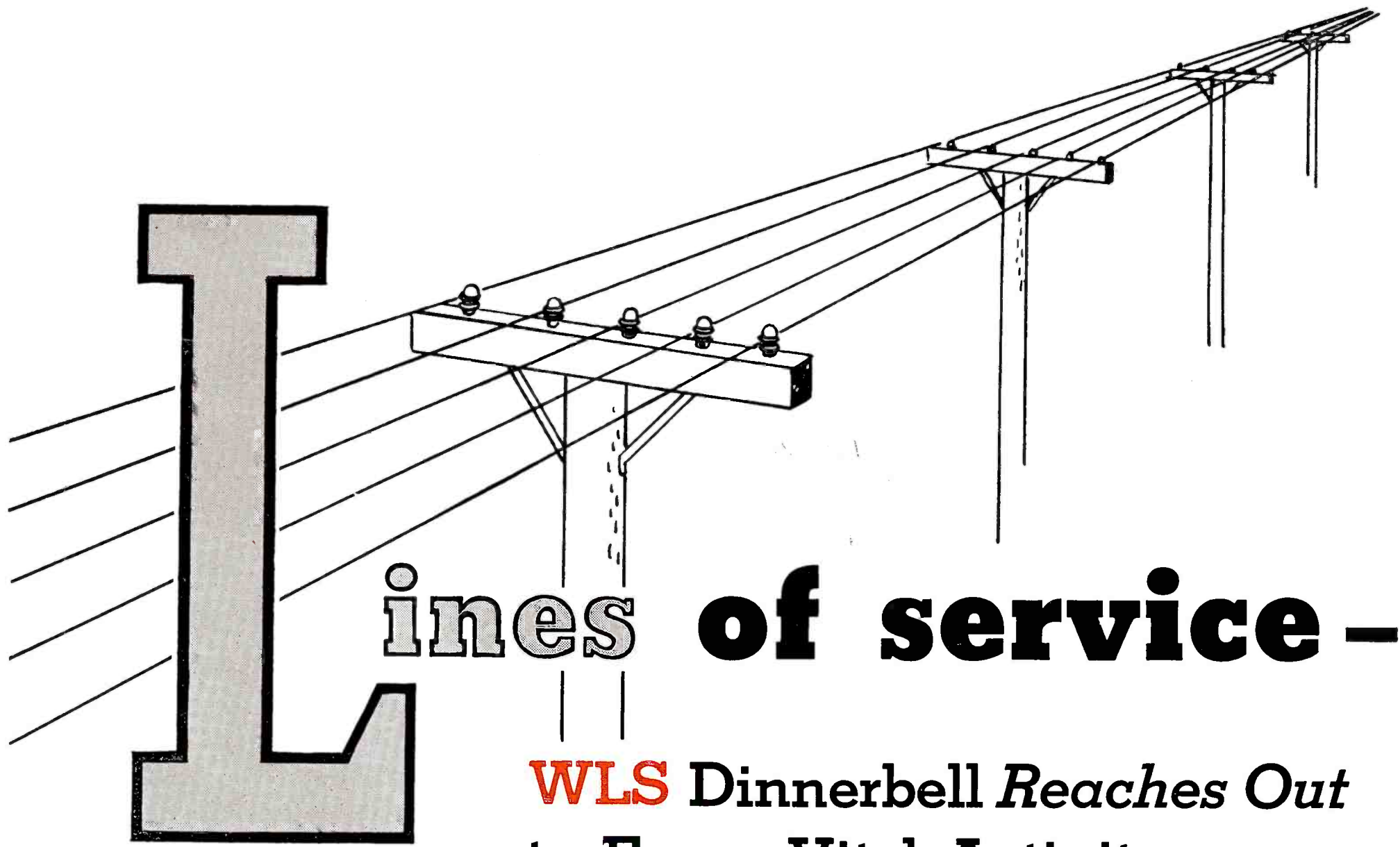

# Lines of service -

## **WLS** Dinnerbell *Reaches Out* to Every Vital Activity in Midwest America!



BROADCASTING DAILY for a week from each of three great state fairs—Wisconsin, Illinois, Indiana—that's just a tiny part of WLS Dinnerbell's summertime activity throughout fourstate Midwest America.

IF YOU WERE A REGULAR DINNERBELL LISTENER, you'd hear on-the-spot broadcasts from the Harvard Milk Day event at Harvard, Illinois—the Indiana 4-H Club Round-up at Purdue University—presentation of Youth Awards on the Michigan State College campus—the Lake County Dairymen's Picnic—Annual Sheep Day at the Otto Berlage Farm—Illinois Sports Festival.

AT THE SAME TIME, you'd hear such studio guest speakers as Claude Wickard, REA Director; Clinton Anderson, Secretary of Agriculture; O. E. Petersen, Executive Secretary of Kiwanis International; John Bickett, Illinois Director of Federal Crop Insurance—

IN FACT, you'd hear *every vital midwest* activity, mirrored on the air through WLS Dinnerbell, as it sends its lines out over four states in constant service to the people.

*WLS Dinnerbell* is America's Pioneer Farm Service Program, broadcast at the noon hour for 22 years.

*A Clear Channel Station*



The  
PRAIRIE  
FARMER  
STATION

HARRIDGE D. BUTLER  
President  
GLENN SHYDER  
Manager

CHICAGO 7

50,000 watts, 890 KC, American Affiliate, Represented by JOHN BLAIR & COMPANY, Affiliated in Management with KOY, Phoenix, and the ARIZONA NETWORK — KOY, Phoenix • KTUC, Tucson • KSUN, Bisbee-Lowell-Douglas



# INS Customers are SATISFIED Customers



ESTINGHOUSE RADIO STATIONS INC. - PITTSBURGH

May 31 1946

Mr A W Stark  
International News Service  
917 Weschler Street  
Erie Pennsylvania

Dear Mr Stark

We recently added International News Service to KDKA's other news services in order to give our many listeners complete news coverage.

I was talking to our newsmen the other day and I know you will be interested to hear what they had to say about INS. They are very highly pleased with the International News Service and were especially commendatory of your coverage of the recent coal, steel and railroad strikes. They tell me your coverage is first-rate, and they mentioned those extra services which INS is giving us such as immediate calls from the local bureau on big stories and the local drop service which supplements the wire service.

I thought you might be interested in hearing these complimentary remarks from the KDKA newsmen on the good service we are receiving from INS.

Sincerely yours

*J. E. Baudino*  
J. E. Baudino  
General Manager

JEB rg

PROPERTY U.S. AIR FORCE

# INTERNATIONAL NEWS SERVICE



# BROADCASTING... at deadline

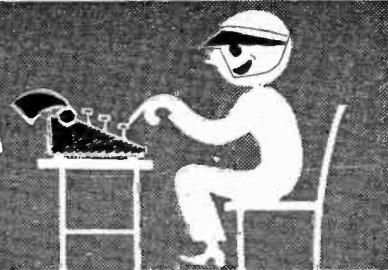

## Closed Circuit

YOU CAN chalk up KJR Seattle as Marshall Field owned, FCC willing. Birt F. Fisher has signed \$700,000 transaction with Field organization [CLOSED CIRCUIT, June 24] and only formality of filing with FCC remains. KJR, operating on 950 kc 5000 w, is ABC outlet and gives Field Enterprises its fourth station (WJJD Chicago, WSAI Cincinnati, KOIN Portland).

IS CANADA trying to emulate U. S. in radio regulation or vice versa? Each of 25 members of Canadian parliamentary committee now studying revised radio legislation was presented with copy of FCC Blue Book by Canadian Broadcasting Corp., which is both regulatory body and competitor of Canada's privately owned system. Understood Siepman's *Radio's Second Chance* also has been supplied committee members.

DAVID NILES, last of holdover New Deal anonymous assistants to President, expected to retire shortly. He has figured rather intermittently in radio, having been instrumental in promoting several FCC appointments.

WHAT MAY BE first court test of FCC Blue Book, probably winding up in Supreme Court, seen in litigation initiated by Mester Bros., over FCC decision denying transfer of WOV New York to them for \$300,000. One of main issues is FCC's right to determine proportions of commercial versus sustaining time, key to Blue Book encroachment upon program standards. Suit now pending before statutory three-judge court in New York [BROADCASTING, July 1] is earmarked for Supreme Court whatever way it may be decided. Segal, Smith, and Hennessey, Washington attorneys who have successfully prosecuted several Supreme Court appeals, represent Mesters.

IS COMMISSIONER C. J. Durr, chronic dissenter of FCC, actually proponent of Government ownership of American radio? He has never said so flatly or openly. But broadcasters visiting him invariably leave with impression he would like to see British system of nationalized radio operative here. They feel he condones radio by American Plan only because law doesn't permit it governmentwise.

RED TAPE holding up NAB occupancy of new Washington headquarters building now starting to unwind. Canadian Embassy, which has used NAB-owned structure as annex, believed to have another site available so association may put repairmen to work within month.

LOTS OF EARS in both New York and Texas radio are cocked toward Thousand Islands in St. Lawrence. Edward J. Noble, chairman of ABC board and owner of number of developments at resort, this week is playing host to Jesse H. Jones, former Secretary of Commerce, whose Houston holdings include station ownership. It isn't known whether either is in

(Continued on page 86)

## Upcoming

July 8: Further Clear Channel Hearings, FCC Hqtrs., Washington, D. C.

July 8: FCC Hearings on Commercial FM Applications in New York Area, U. S. Courthouse Bldg., New York.

July 12: NAB Public Relations Committee, Statler Hotel, Washington, D. C.

July 15-16: NAB Music Advisory Committee, Waldorf-Astoria, New York.

July 17-18: Freedom of Radio Committee, Waldorf-Astoria, New York.

(See page 50 for other upcoming.)

## Bulletins

WILLIAM F. BROOKS, NBC director of news and international relations, elected vice president Friday at meeting of NBC board. Mr. Brooks, director of news since 1942 and of international relations since 1944, becomes second network news chief boosted to vice presidency. Mutual's A. A. Schechter (whom Mr. Brooks succeeded as news chief for NBC) became MBS vice president two months ago.

SIX GUEST commentators, among them Harold Ickes and Frank Sinatra, will take over Drew Pearson's program, effective July 28 for six weeks. Harold Ickes scheduled for July 28 week; Frank Sinatra for Aug. 4 week; four other guest commentators not set as yet. Drew Pearson show, Sundays, 7-7:15 p.m. on ABC, sponsored by Frank H. Lee Hat Co., New York, through William Weintraub & Co., New York.

R. M. BUDD, with Campbell Soup Co. since 1924, named advertising manager. He has been assistant since 1929 except when on special assignments. He is in charge of all Campbell's soups, tomato juice, pork and beans, and baby soups, plus Franco-American spaghetti, macaroni and beef gravy.

LEO FITZPATRICK, resigned recently as vice president and general manager of WJR Detroit, after twenty years as operating head, established offices in Fisher Bldg., Detroit 2. Has not announced his business plans, but is expected he will reenter station ownership-operation.

### HERE WITH STORY

EYEWITNESS story of what happened at Bikini carried on WOL Washington and Mutual when Comdr. William C. Parks, director of photo release division, arrived in nation's capital with movies of bombing. Comdr. Parks, in charge of all pictures at bombing, narrated events at lagoon and told how photos were processed and transported by Navy.

## Business Briefly

PLACEMENTS ON "LEAGUE" ● New business placed by WBBM Chicago on *Housewife's Protective League* and *Sunrise Salute* with Paul Gibson include: Blue Moon Foods (Blue Moon cheese) 13 weeks, Monday through Saturday, through Reincke-Meyer-Finn, Chicago; Hills Brothers Co. (Dromedary Mix) 26 weeks, through Biow Co., New York; Bordo Citrus Products Co. (grapefruit juice), 52 weeks, through Decora Co., Chicago; J. I. Fancy Frozen Foods Co., 52 weeks, through Garfield & Guild, San Francisco.

TEST FOR 903 ● Brown & Williamson Tobacco Corp., Louisville, starts test for new 903 blend on WOOD WHO and WAVE, using live cutins on NBC *Evening With Romberg*. Test to be extended nationwide. *Vacation With Music* replaces *People Are Funny* for summer, Fri. 9-9:30 p.m. on NBC. Agency, Russel M. Seeds Co., Chicago.

KLAC APPOINTS YOUNG ● Adam J. Young Jr. Inc., New York, appointed national sales representative of KLAC Hollywood, according to Don Fedderson, vice president and general manager of station. Firm also represents KYA San Francisco, under same management.

SOUTHERN NAMES PECK ● Southern Co., Jacksonville ("Fruit O' the South" fruit division), appointed Peck Advertising, New York. Radio may be used.

### FM SET LAG, AUDIENCE LACK CITED IN TRIBUNE DROPOUTS

FAILURE of set manufacturers to release FM receivers in sufficient numbers to build potential audiences advanced as one of reasons for WGN withdrawing three of four FM applications.

Frank Schreiber, general manager of WGN and WGNB, *Chicago Tribune* stations, told BROADCASTING, "FM has not developed as fast as we thought it would. We do not feel that an investment in a medium which has little or no outlet is wise at the present time."

WGN, which operates WGNB, had announced at least year ago plans for elaborate FM network between Chicago, Milwaukee, Grand Rapids, Fort Wayne, and Peoria, all within WGN's own primary area and which contribute considerable share of station's audience.

Mr. Schreiber said WGN would not withdraw application for FM station in Milwaukee. "Right now, we are in a position of wanting to move forward but having no place to go," Mr. Schreiber declared in commenting on statements made by many leading set manufacturers at recent conventions that as little as 1% of total set production would be given over to FM receivers.

WARD Johnstown, Pa., effective Aug. 1 begins operations as CBS 158th station. With 250 w on 1490 kc, it is owned and operated by Central Broadcasting Co., with George D. Gartland, vice president and general manager.



5000 Watts Day and Night

# WDEL

wilmington, delaware

**SELLS** your product in a  
prosperous, free-spending market

WDEL is located in Wilmington, Delaware—the chemical capital of America. This city includes among its principal industries: E. I. du Pont de Nemours & Co. (Inc.), Hercules Powder Co., Atlas Powder Co., Pusey & Jones Corp., Joseph Bancroft & Sons Co., National Vulcanized Fibre Co., Bond Crown & Cork Co., Amalgamated Leather Co., Inc., Allied Kid Co., etc. The city's strategic location, transportation facilities and wide industrial diversification assure it a great, stable and prosperous future. WDEL covers this area effectively—profitably for many advertisers. Your advertising dollars are wisely and economically spent on this business-getting station.

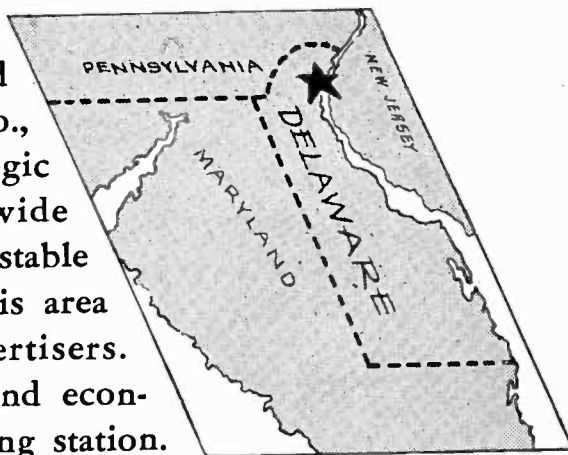

the **NBC** basic station in the land of plenty



"Now remember Jepson,  
OKINAWA is NOT in  
our primary area!"

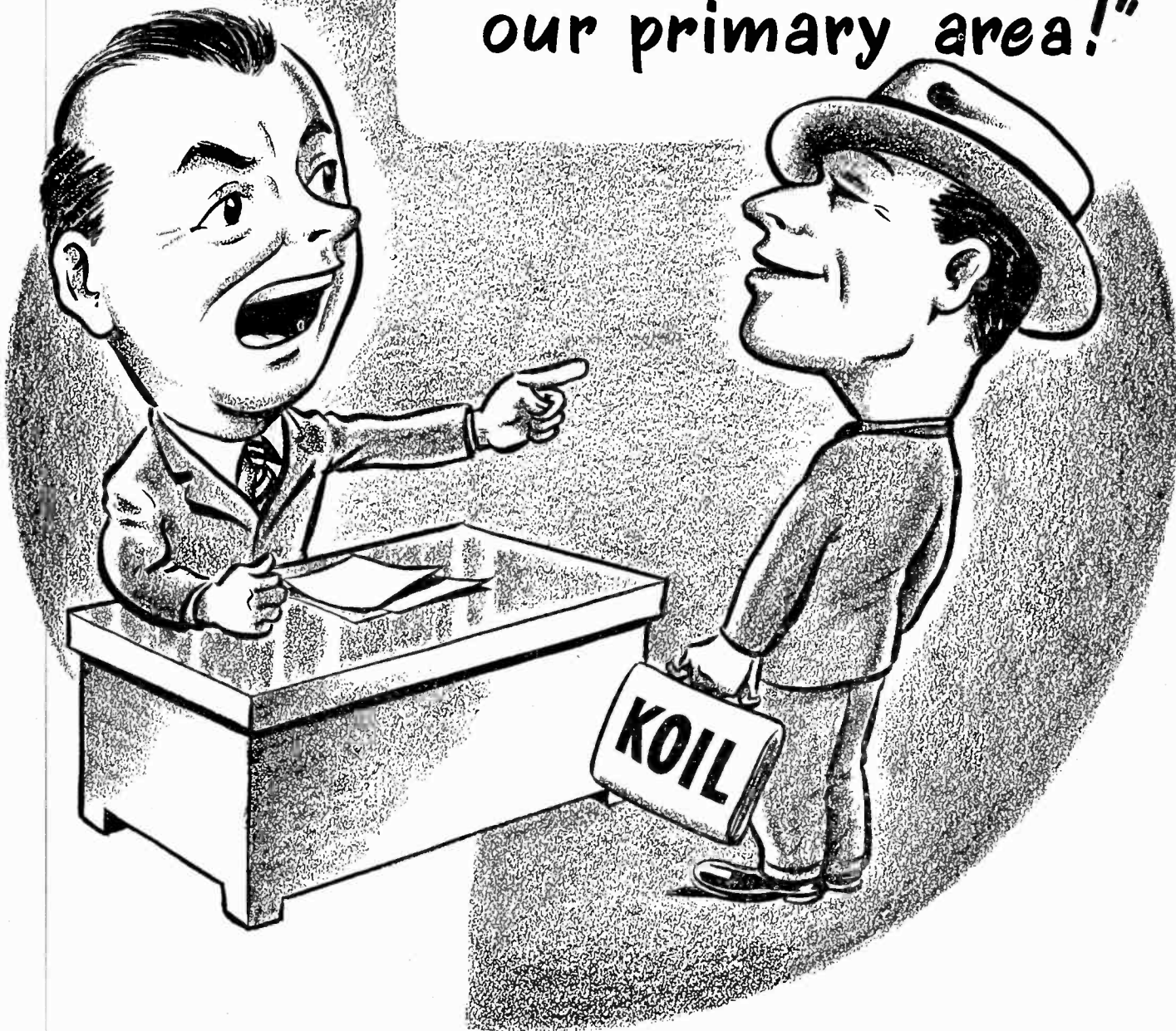

## BUT OMAHA AND COUNCIL BLUFFS—YES

In the biggest market between Denver and Chicago, Kansas City and Minneapolis, KOIL is selling for hundreds of advertisers. They get better service and real economy because KOIL concentrates on this high population center only. And remember, there are more people in this four-county area than in three times as many counties in any other section of Nebraska or western Iowa. KOIL can do a job for you where the number of listeners is high and cost per listener is low.

Represented by  
Edward C. Petry Co., Inc.

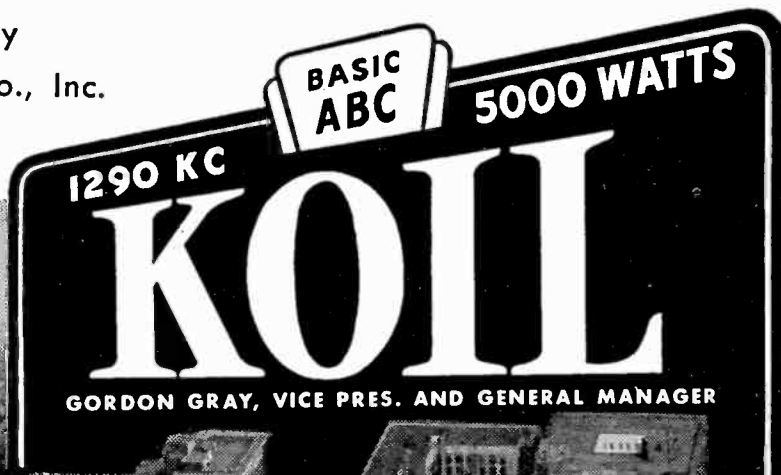

# BROADCASTING TELECASTING

Published Weekly by Broadcasting Publications, Inc.

Executive, Editorial, Advertising and  
Circulation Offices: 870 National Press Bldg.  
Washington 4, D. C. Telephone: ME 1022

### IN THIS ISSUE . . .

Denny, Clements Appointments Seen	15
FCC Hearing Procedure Radically Altered	16
Daytimers Organize to Seek Fulltime	17
Navy Snafued Atom Show, Nets Say	17
Shortwave Licensees Get 25% Control	17
Banks Learning How to Use Radio	
By John B. Mack Jr.	18
CCBS Attacks Census Rural Survey	20
Engineering Standards Revision Proposed	20
Radio Covers OPA Removal Reactions	29
NAB Standards Deemed Subject to Review	36
RMA Adopts Hold-Line Price Policy	48
Olympia Bureau Success Told Clinic	54
Commodore Matches Keller WTAX BID	72
No Bikini Static With FM Says Damm	76
Census Announces April Set Production	77
Changes Made in Blue Book Definitions	78
Nov. 15 Deadline for WCAU Sale	80
Glens Falls, Sandusky, Orangeburg Grants	81
NAB Group Studies Blue Book	83
Revocation of D. C. Station Grant Asked	84

### DEPARTMENTS

Agencies	68	Our Respects to	46
Allied Arts	58	Production	65
Commercial	54	Programs	62
Editorial	46	Promotion	56
FCC Actions	66	Sid Hix	16
Management	50	Sponsors	58
News	60	Upcoming	50

### At Washington Headquarters

SOL TAISHOFF  
Editor and Publisher

### EDITORIAL

ROBERT K. RICHARDS, *Editorial Director*  
Art King, *Managing Editor*; J. Frank Beatty,  
Bill Bailey, Rufus Crater, *Associate Editors*; Fred  
Fitzgerald, *Asst. to the Managing Editor*. STAFF:  
Lawrence Christopher, Mary Zurhorst, Adele  
Porter, Margaret Elliott, Eleanor Brumbaugh,  
Irving Kipnes.

### BUSINESS

MAURY LONG, *Business Manager*  
Bob Breslau, *Adv. Production Manager*; Harry  
Stevens, Eleanor Schadi, Cleo Kathas.  
AUDITING: B. T. Taishoff, Irving C. Miller,  
Mildred Racoosin.

### CIRCULATION AND READERS' SERVICE

BERNARD PLATT, *Director*  
Frank Bannister, Dorothy Young, David Ackerman,  
Leslie Helm, Pauline Arnold.

### PROMOTION

WINFIELD R. LEVI, *Manager*

### NEW YORK BUREAU

250 Park Ave. PLaza 5-8355

EDITORIAL: Edwin H. James, *New York Editor*;  
Florence Small, Dorothy Macarow, Patricia Ryden.  
Bruce Robertson, *Senior Associate Editor*  
ADVERTISING: S. J. Paul, *New York Advertising  
Manager*; Martin Davidson.

### CHICAGO BUREAU

360 N. Michigan Ave. CENTral 4115  
Fred W. Sample, *Manager*; Jean Eldridge.

### HOLLYWOOD BUREAU

6000 Sunset Boulevard, HEMPstead 8181  
David Glickman, *Manager*; Ralph G. Tuchman,  
Patricia Jane Lyon.

### TORONTO BUREAU

417 Harbour Commission Bldg. ELgin 0776  
James Montagnes, *Manager*.

BROADCASTING Magazine was founded in 1931 by  
Broadcasting Publications Inc., using the title:  
BROADCASTING—The News Magazine of the Fifth  
Estate. Broadcast Advertising\* was acquired in  
1932 and Broadcast Reporter in 1933.

\* Reg. U. S. Pat. Office  
Copyright 1946 by Broadcasting Publications, Inc.

SUBSCRIPTION PRICE: \$5.00 PER YEAR, 15c PER COPY

BROADCASTING • Telecasting



# A Tip to Time Buyers!

Broadcasting Corporation of America Stations give you the most effective and economical coverage of Southern California's three

## Rich Rural Markets

Surveys prove conclusively there's only one way to completely cover the prosperous Valley of Paradise, Imperial Valley and Coachella Valley—That's with Broadcasting Corporation of America Stations located right in the heart of these mountain-surrounded areas. These farm-wise stations are programmed specifically for their individual community and have the "know-how" to produce programs that keep the farmer and his family tuned in day and night.

# KPRO

### ● Covering the Valley of Paradise

KPRO's primary coverage of 584,321 gives you a big rural audience—big not only in numbers—but big in buying power created by a 1945 farm income of \$206,336,905. KPRO's 1000 watts of concentrated selling power is backed by American Network programs PLUS outstanding local productions.

### ● Covering the Imperial Valley

No "outside" station delivers a satisfactory signal in the Imperial Valley. KROP with its 1000 watt power—its fine American Network shows PLUS carefully tailored local programs, carries the majority of the audience day and night. A farm income of \$64,233,062 makes it a prosperous audience.

# KROP

# KREO

### ● Covering the Coachella Valley

KREO on the air July 15th to serve this fast growing market. Its 250 watts of power reaches all the Valley's 19,500\* regular inhabitants with an interference-free signal. A 1945 farm income of \$10,812,275 makes this a profitable audience for your sales message.

\* Winter population up to 50,000 in the Palm Springs-Indio resort area.

*If you have something to sell Southern California farmers secure your time franchise on these stations*

**KPRO** Riverside  
and  
San Bernardino

**KROP**

Brawley  
and  
El Centro

**KREO**

Indio  
and  
Palm Springs

KPOR-FM, located on 9,000 ft. Cucamonga Peak, is scheduled to take the air this Fall. For availabilities call John E. Pearson Company or wire Gene Williams, general sales mgr., Broadcasting Corp. of America, Riverside, Cal.

**JOHN E. PEARSON COMPANY**, National Representatives —New York, Chicago, Kansas City, San Francisco, Los Angeles



# WASHINGTON'S IN THE

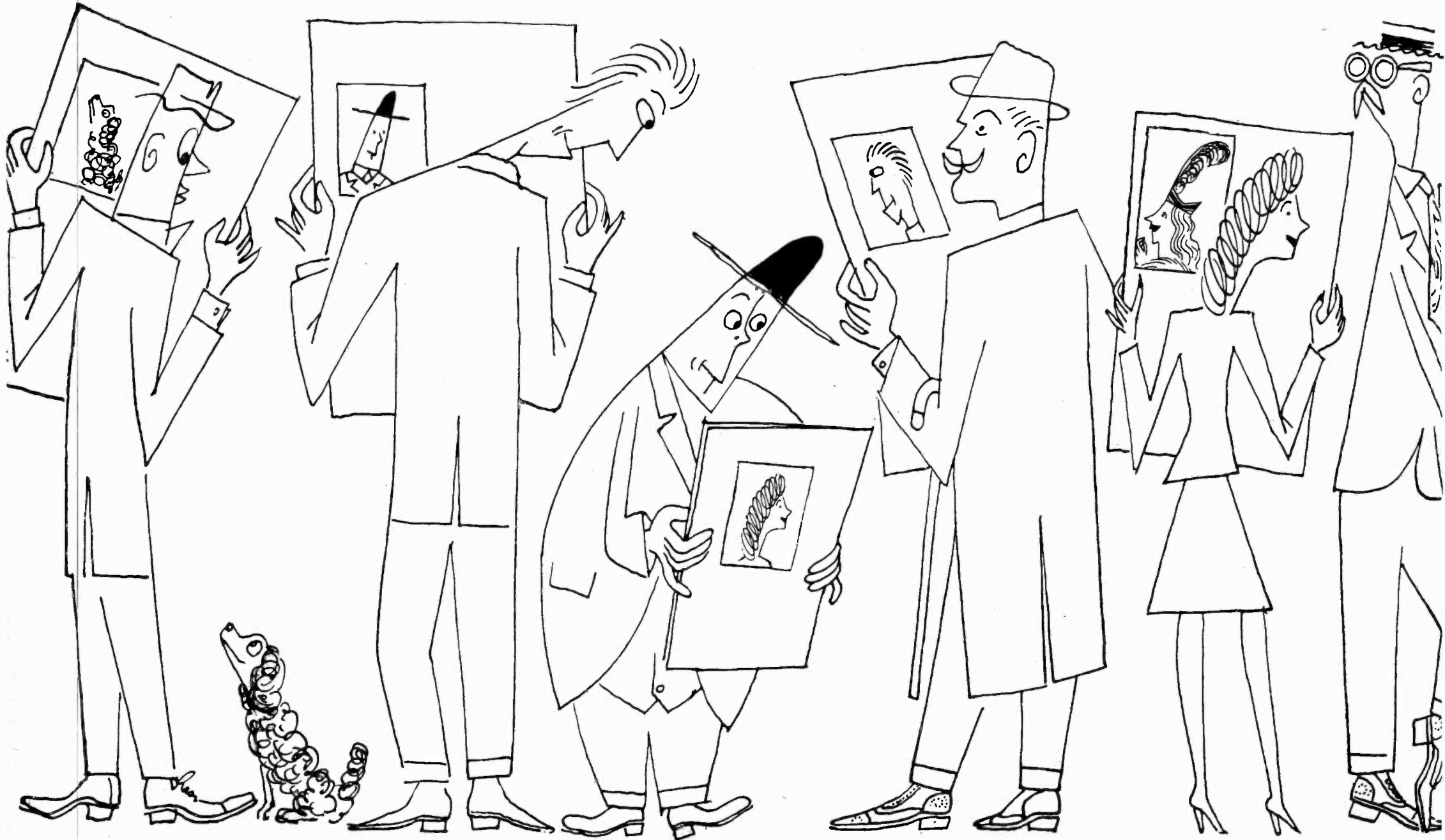

**T**AKE a quick look at the front page of any newspaper. Chances are that Washingtonians—by birth or by ballot—hit at least half the headlines. And odds are that more stories are datelined Washington than any other news center.

With so much history happening in their own 61-square-mile district, it's no wonder that D.C.ers are news minded. Nor is it surprising

that so many listen to WTOP to get that news.

WTOP carries a complete complement of Columbia Network news, plus an array of Columbia-calibre local newscasts. Prepared by the *combined* WTOP-CBS Washington staff, these originations are by-lined by some of the biggest names in radio journalism: Eric Sevareid, Bill Henry, Larry Lesueur, Claude Mahoney,

REPRESENTED BY RADIO SALES, THE SPOT BROADCASTING DIVISION OF CBS:



# NEWS... and listens to it on WTOP!

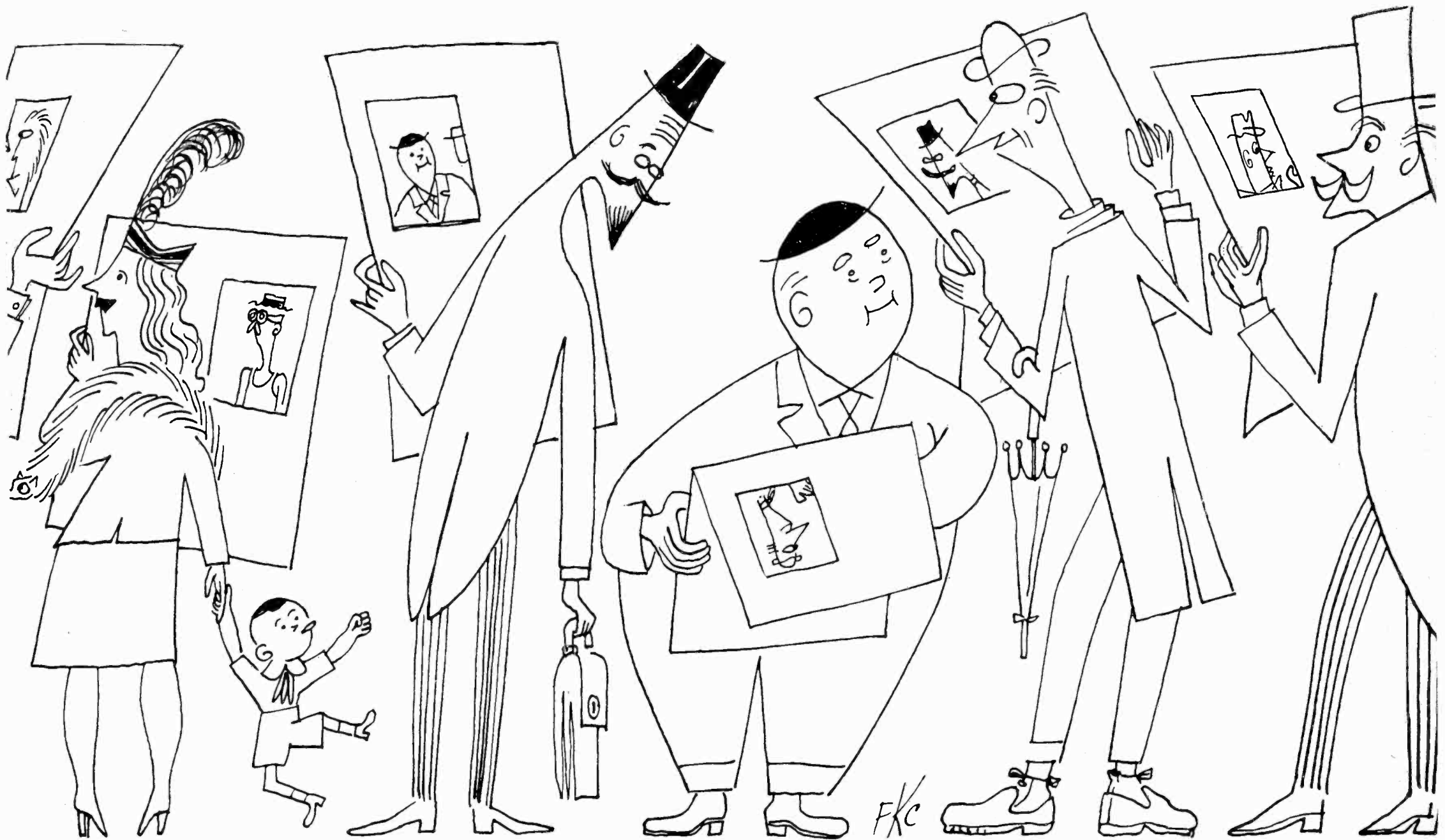

Tris Coffin, Gunnar Back, and Joe McCaffrey!

With WTOP devoting so much capital service to news broadcasting, there's no better way to spread the news about your product throughout Metropolitan Washington than on one of our network quality local newscasts. A few are now available for sponsorship. For details get in touch with us or Radio Sales—today.

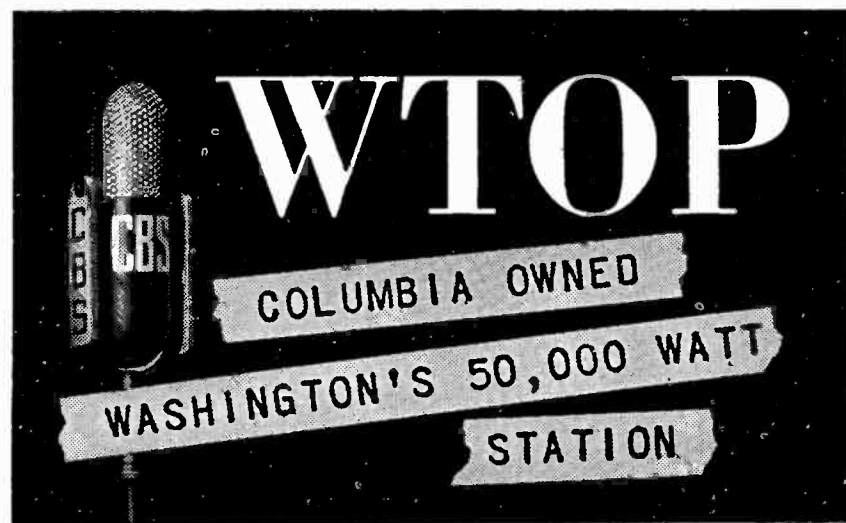

NEW YORK, CHICAGO, LOS ANGELES, ST. LOUIS, SAN FRANCISCO, ATLANTA



MORNING, AFTERNOON  
AND NIGHT ...  
**WFLA**  
LEADS IN LISTENERS.

**C. E. HOOPER, INC.**  
Dec., 1945 Thru April, 1946  
**STATION LISTENING INDEX**  
Tampa-St. Petersburg,  
Florida

	WEEKDAY MORNING 8 A.M. - 12:00 A.M.	WEEKDAY AFTERNOON 12:00 A.M. - 6 P.M.	EVERY EVENING 6 P.M. - 10 P.M.	TOTAL RATED TIME PERIODS
	%	%	%	%
<b>WFLA</b>	32.7	39.4	45.8	41.9
STA. "B"	21.5	29.6	29.8	28.1
STA. "C"	29.9	16.3	13.6	17.4
STA. "D"	15.3	14.3	9.7	11.9

FOR MORE  
LISTENERS per  
hour - ANY hour  
of the day -  
in the rich Tampa  
- St. Petersburg  
market, use ...

**WFLA**  
The TAMPA  
TRIBUNE STATION  
**TAMPA** → **NBC**  
National Representative  
JOHN BLAIR & CO.

## Feature of Week

By CARROLL CARROLL

Editorial Supervisor

J. Walter Thompson Co., Hollywood

AT LEAST once a year at an NBC lecture on comedy and variety shows, and sometimes oftener, radio tyros ask what the formula is for a sure-fire variety show. Nothing in any branch of show business is ever "sure-fire." Frequently, you hear certain things mentioned as being. But often "sure-fire" things done wrong backfire.

So the formula for a successful variety show, like the formula  $A+B+C=ABC$ , depends on the value of A and B and C. "A" may be a singing m.c., "B" may be a band and "C" may be a comic. But unless it's a good singing master of ceremonies, a good band and a good comic, your formula isn't worth much. And when you have the best of all three, there is still ABC plus that intangible X, the writing.

Whatever a variety show features, should be the best in its class. You must have what seems the best to some people and then by surrounding that one best with more of the best make it seem better to more people.

The only demonstrable point in variety, or let us say bigtime ra-



Mr. Carroll

dio, is that listeners are discriminating enough to demand the best of breed. Abbott & Costello tell old corny jokes but they tell them best. Bob Hope is the best fast-talking, glib, wise-guy comic in the business, Fred Allen the "smartest smart guy."

## Sellers of Sales

IT'S a wise Mann who knows his own media. Which, briefly, would tend to describe the career of Richard Mann, who for the last four years has held the post of assistant media director and time buyer at Ted Bates Inc., New York.

He was born on Nov. 14, 1907 in East Orange, N. J. and educated at Hamilton College and at William & Mary College, where he majored in English and French.

His first job was with *McCall's* magazine in the research and promotion department. From that magazine he transferred to *Liberty* magazine in a similar department. A few months later he joined the Title Guarantee & Trust in the mortgage department. In 1936 he returned to media research with the Assn. of National Advertisers, and two years later became associated with Buchanan & Co. In 1940 he joined Ted Bates Inc. as a media buyer. A couple of years later he was appointed assistant media director, a position he still maintains.

He is responsible for approximately a million dollars worth of billing in spot campaigns and two million in network billing. The fol-

lowing radio accounts are under his jurisdiction: Continental Baking Co., Wonder Bread, Hostess Cake, Brown & Williamson (Raleighs), Standard Brands (Royal Desserts & Baking Powder). In addition to his radio activity Mr. Mann also places advertising for those clients in newspapers and magazines.

Mr. Mann maintains that the radio industry should adopt "a standard and simplified rate card for radio stations."

"It would be a great help to the agency people, station representatives and the whole industry," he asserted.

Mr. Mann who is a firm believer in co-education, met his wife at William & Mary. She is the former Katherine

Rhodes. The Manns have been married for the past 15 years and have two children, Richard Jr., 7 and Katherine Rhodes, 9 months old. They live in their own home located at Douglas Manor, Long Island.

Mr. Mann says he is a "putterer" because he has so many hobbies he hasn't time to concentrate on any. Among them are swimming, boating, "cutting grass, and putting a few nails in the wall."



Mr. Mann



OUR LISTENERS  
GOT A  
50 MILLION  
DOLLAR RAISE

Those steadfast civil service workers in the U. S. Government got a raise!

Fifty million a year!

And if you've been reading these WWDC ads you know they're in the market for everything from washing machines to rugs.

WWDC is the way to reach this stable market. That's the entertainment station in Washington... that's the one they listen to.

# WWDC

the big sales result  
station in Washington, D. C.

represented nationally by

**FORJOE & COMPANY**





**TOPS IN LISTENER POPULARITY AMONG NEW YORK INDEPENDENT EVENING PROGRAMS . . .**

WOV's "1280 CLUB" program enjoys one of the largest metropolitan evening audiences listening to any New York independent station between the Hooper checking hours of 7:30 and 10:00 p.m. And what is more . . . this recorded show, mc'd by Fred Robbins, Professor of Thermodynamics, delivers this largest average audience at the lowest cost per listener. A few participating periods are available, three or six nights a week.

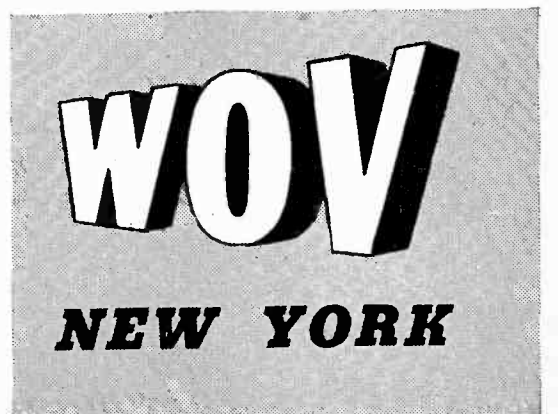

RALPH N. WEIL, General Manager  
JOHN E. PEARSON CO., Nat'l Rep.



Well, wouldn't you be proud!

# WGRC IS PROUD . . .

to have been singled out as the FIRST STATION in these United States to receive this award for public service. This time it's:

## "THE VETERAN'S GUIDEPOST"



If you had just received a fine compliment for your service to your countrymen—and incidentally had multiplied your listening friends—wouldn't you be proud?

Broadcasting in the Public Interest is our most important contribution to our listeners.

As in the past, we will continue to carry out in the future, our desire to make WGRC an outstanding leader in rendering an even greater Public Service to our Community; to make WGRC a true VOICE OF THE TRI-CITIES.

*Harter Brown*  
President

*Haris*  
General Manager

National Representatives  
THE WALKER COMPANY

Also mounted in our public service trophy room:  
**First Place Award** among local agricultural programs—presented by Ohio State University's 16th Institute for Education by Radio for  
**"MEET THE FARMER"**

Billboard and National Radio Editors Poll for  
**"TRI-CITY FORUM"**

The VOICE of the TRI-CITIES **WGRC** . . . MUTUAL in LOUISVILLE



*The Central Valleys Broadcasting Company*

**announces**

*the appointment of*

**Ralph Miller**

as

**Sales Manager of Station KCRA**



RALPH MILLER

**R**ALPH MILLER brings to Station KCRA a rich background of experience in the advertising field and a thorough understanding of the problems and needs of advertisers using the medium of radio.

Ralph Miller comes to Station KCRA from one of the nation's most successful and outstanding stations—WKY, Oklahoma City—where he served as Sales Manager for the past five and a half years. For 14 years preceding his entry into the radio field, he was Advertising Manager of *The Farmer-Stockman*, the Southwest's largest farm journal. Following service in the first World War, Mr. Miller joined the Media department of the Campbell-Ewald Company of which he was Director for three years.

With a man of Mr. Miller's background and experience directing its sales department, KCRA promises both its present and prospective sponsors unexcelled counsel and service in its area.

**KCRA** *Sacramento*

*NBC Affiliate*

Ewing C. Kelly, *General Manager*

# A LITTLE EXTRA EFFORT OFTEN GETS A BIG RESULT!

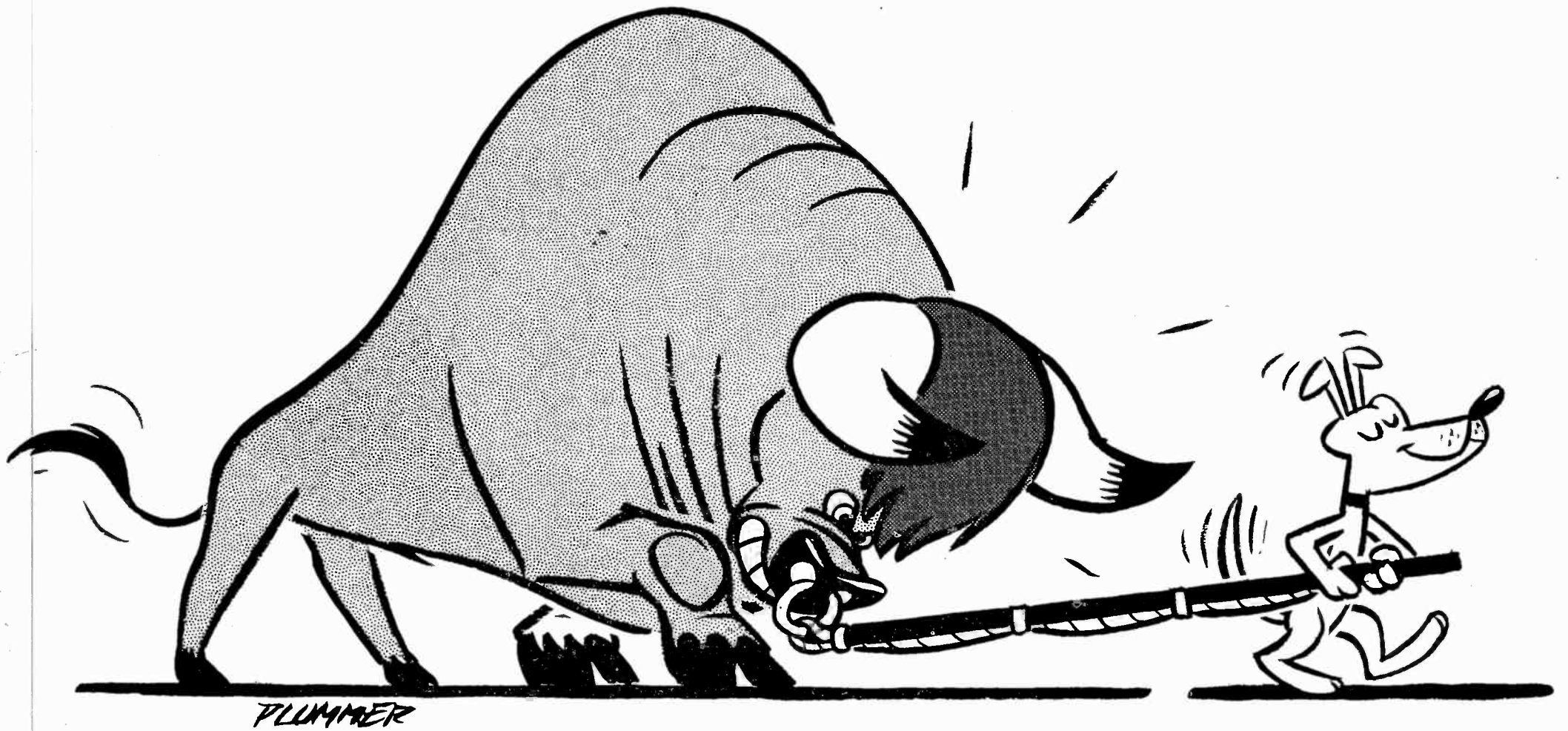

● One of the things we believe in, here at F&P, is that *know-how* beats noise and fury, ten times out of ten. Knowing the job to be done—knowing *how* to do it—then simply proceeding to *do* it!

What can we do for you? You tell us . . . then watch us perform it, quietly and easily, without breast-beating or bellowing, without getting breathless or even into a mild sweat!

It's merely a matter of where one *puts* the effort. We like to put it into *work*. Got a telephone handy?

#### EXCLUSIVE REPRESENTATIVES:

ALBUQUERQUE	KOB
BALTIMORE	WCBM
BROWNSVILLE	KVAL
BUFFALO	WGR-WKBW
CHARLESTON, S. C.	WCSC
CINCINNATI	WCKY
COLUMBIA, S. C.	WIS
CORPUS CHRISTI	KRIS
DAVENPORT	WOC
DES MOINES	WHO
DULUTH	KDAL
FARGO	WDAY
HOUSTON	KXYZ
INDIANAPOLIS	WISH
KANSAS CITY	KMBC
LOUISVILLE	WAVE
MINNEAPOLIS-ST. PAUL	WTCN
OKLAHOMA CITY	KOMA
PEORIA-TUSCOLA	WMBD-WDZ
RALEIGH	WPTF
ROANOKE	WDBJ
ST. LOUIS	KSD
SEATTLE	KIRO
SYRACUSE	WFBL
TULSA	KTUL



## FREE & PETERS, INC.

*Pioneer Radio Station Representatives*

*Since May, 1932*

CHICAGO: 180 N. Michigan Franklin 6373 NEW YORK: 444 Madison Ave. Plaza 5-4130 DETROIT: 645 Griswold St. Cadillac 1880 SAN FRANCISCO: 58 Sutter Sutter 4353 HOLLYWOOD: 6331 Hollywood Hollywood 2151 ATLANTA: 322 Palmer Bldg. Main 5667



# BROADCASTING

## TELECASTING

VOL. 31, NO. 1

WASHINGTON, D. C., JULY 8, 1946

\$5.00 A YEAR—15c A COPY

## Denny, Clements Appointments at FCC Seen

### President Expected To Name Seventh Commissioner

WITHIN the next fortnight President Truman may bring the FCC to its full complement of seven Commissioners through elevation of Charles R. Denny Jr. to the permanent chairmanship and appointment of J. Burke Clements, Democratic chairman of the Industrial Accident Board of Montana, to the remaining FCC vacancy.

These moves have been discussed in recent days at the White House. Interwoven in the discussions has been the status of OPA Administrator Paul A. Porter, who technically is on leave from the FCC chairmanship. The political situation in Montana also may have a bearing on the outcome.

If Congress moves to reinstate OPA, BROADCASTING learned last week, Mr. Porter will announce that he will stay on the job to

carry on the fight against inflation. If, on the other hand, OPA should die, it isn't certain that Mr. Porter will return to the FCC. More than likely, he will be prevailed upon by the President to accept a secretaryship or some other top post at the White House.

Once Congressional action on OPA is conclusive, Mr. Porter is determined to end all speculation about his return to the FCC. He has strongly endorsed the appointment of 34-year-old Mr. Denny as permanent chairman. He was instrumental in having the former general counsel designated acting chairman five months ago.

#### Wheeler Endorsement

Mr. Clements' appointment to the FCC was endorsed by Senator Burton K. Wheeler (D-Mont.), chairman of the Interstate Commerce Committee, last February [BROADCASTING, Feb. 25]. Mr. Clements personally visited with the President several weeks later. Senator Wheeler originally wanted Mr. Clements named chairman.

Senator Wheeler is running this year and the Democratic primaries are being held July 16. His opponent is former state Supreme Court Justice Lief Erickson, who is CIO supported. Senator Wheeler, however, has the AFL endorsement. It is doubtful whether the White House will move on the Clements' appointment or on the permanent chairmanship until after the primaries.

It is generally felt in administration circles that Mr. Denny has performed meritoriously as acting chairman. A portent of his imminent elevation to the chairmanship was seen in recent praise by President Truman [BROADCASTING, July 1] of the Commission's handling of its "greatly increased workload" and commendation "for its decision to scrutinize its procedures in an effort to give the public the best service, without delay and at a minimum cost." The President's letter was directed to Mr. Denny.

While the elevation of Mr. Denny

to the chairmanship would not entail Senate confirmation, filling of the existing vacancy would require action both by Senator Wheeler's committee and the Senate itself. So far as is known, there is no other strong contender for the vacancy, presumably because it has been generally felt that Mr. Porter might return to the FCC after he completed the onerous task of "trouble-shooting" OPA's Congressional battle.

When Mr. Porter took on the OPA assignment at the President's personal behest last Feb. 15, Mr. Denny was named acting chairman. His appointment at that time was interpreted to mean that he would be on trial as acting chairman and given permanent status if he "made good." Mr. Porter, who despite the pressure of OPA activity, has kept his eyes on FCC operations, is convinced that his youthful protege has performed acceptably. Mr. Porter has practically lived at the White House

(Continued on page 85)

## FCC Hearing Procedure Is Radically Altered

ADMINISTRATIVE procedure before the FCC and other Government agencies, particularly with reference to hearings before examiners, will be radically altered under terms of the Administrative Procedure Act (Public Law No. 404), sections of which become effective Sept. 11 with the full law to be in effect by June 11, 1947.

Scope of court review is broadened under the new law, which provides that any person "suffering legal wrong because of any agency action, or adversely affected or aggrieved by such action" is entitled to judicial review. The Act also provides that "every agency action made reviewable by statute and every final agency action for which there is no other adequate remedy in any court shall be subject to judicial review."

Known as the McCarran-Manasco Bill (S-2), the Act was signed June 11 by President Truman, thus terminating a study of nearly 10 years by the attorney general's committee and various bar associations, including the Federal Communications Bar Assn.

Of particular significance to broadcasters is Section 11, which

### What Procedure Act Means

THIS IS how the Administrative Procedure Act, now a law, affects broadcast matters before the FCC:

1. Effective June 11, 1947, hearing examiners will be responsible to Civil Service Commission instead of FCC.
2. Examiners will issue initial or recommended decisions. In the absence of objections, initial decisions shall be adopted by FCC as final.
3. All matters of policy must be published in Federal Register. Policy may not be used as rules.
4. Commission actions are given a broader scope for review by the courts.

creates hearing examiners who will be responsible only to the Civil Service Commission. This procedure is expected to expedite hearing matters, in many instances resulting in immediate decisions.

That section does not become effective until June 11, 1947, but beginning that date members of the FCC Law Dept. will no longer act as prosecutor and judge. Highlights of the Administrative Procedure Act, in addition to creation of independent hearing examiners, are these:

No hearing officer shall consult any person or party on any fact

in issue unless upon notice and opportunity for all parties to participate. Rate-fixing agencies such as ICC and FCC, with relation to common carriers, are exempt. Broadcast matters are not.

#### Policy Affected

Agencies must issue as rules certain specified information as to their organization and procedure. While this is no great departure from established FCC procedure, it does prohibit the use of so-called "policy" as rules. It provides that anything affecting the public—including formulation of policy—

must be published in the *Federal Register*.

Hearings on rule changes are mandatory, although FCC has been following that procedure as a matter of sound policy.

Every agency shall accord any interested person the right to petition for the issuance, amendment, or repeal of a rule, but the Act leaves with the agency's discretion the granting of such petitions.

Every agency shall afford all interested parties opportunity for (1) submission and consideration of facts, arguments, offers of settlement, or proposals of adjustment where time, the nature of the proceeding and the public interest permit and (2) to the extent that the parties are unable to determine any controversy by consent, hearing and decision upon notice. This section is a new departure in Commission procedure. Agencies are authorized to use "sound discretion" in issuing declaratory orders to terminate controversies or remove uncertainties. The declaratory judgment long has been urged by the Federal Communications Bar Assn. Sen. Wallace H. White

(Continued on page 40)

## Gillingham Resumes FCC Information Post

LT. COL. GEORGE O. GILLINGHAM resumed his position as FCC director of information last Monday after serving in the Army since 1942. Earl Minderman, who has held the post for the past three years, will undertake a special research assignment under the direction of the Chairman of the Commission.

Colonel Gillingham was FCC director of information from 1939 until he entered the Army. He served as chief of the Public Relations Division, Chemical Warfare Service. He is the author of *ABC of the FCC and Radio, A Public Primer*, which has been used as a text in public schools. (See Respects Sketch on page 46.)

## Seven Shows Sold

NBC radio-recording division last week announced the sale of seven syndicated shows to eight stations for a total of 429 programs. Sales were *Allen Prescott* to WDNC Durham, for 39 programs and KLO Ogden, for 156 programs; *Art Van Damme* to WCOL Columbus, 13 programs; *Five Minute Mysteries* to KCRC Enid, Okla., 39 programs; *Mercer McLeod* to KFI Los Angeles, 26 programs; *The Name You Will Remember* to WPRO Providence, 26 programs; *Playhouse of Favorites* to KSFT Trinidad, 26 programs, and WGOV Valdosta, Ga., 52 programs; *The Weird Circle* to WGOV Valdosta, Ga., for 52 programs.

## Campbell Promotion

CAMPBELL SOUP Co. has started a concentrated radio campaign to boost sales of Campbell's Strained Baby Soups. Throughout July, August and September, commercials featuring the five new baby soups will be heard five nights a week, Monday-Friday on *The News Till Now*, CBS Robert Trout program, 6:45 (EDST). In addition, 66 spot announcements a week will be used in nine major market areas. Later, there will be national magazine promotion on the soups. Campbell's are already using medical journals, and are continuing their merchandising to doctors.

## Veto Talk Rating

PRESIDENT HARRY S. TRUMAN'S OPA veto message on Saturday night was heard by an adult audience numbering 23,166,000, according to a survey made for CBS by C. E. Hooper Inc. The Hooperating for the address was 31.8.

## Curtis Renews

CURTIS Publishing Co., Philadelphia (*Saturday Evening Post*), has renewed sponsorship of participations on the *This Is New York*, *Bill Leonard Reporting* program, on WABC New York, Wednesday, Thursday and Friday, 9:15-10 a.m. Agency: BBDO, New York.

# Daytime Group Seeks Fulltime Using Mexican Clear Channels

A GROUP of U. S. daytime stations operating on Mexican clear channels met in Washington last week to lay the groundwork for a formal petition asking FCC and the signatories of NARBA for permission to use their frequencies fulltime.

Under the name Daytime Petitioners Assn., representatives of the 10 stations at the meeting named Howard B. Hayes, president of WPIK Alexandria, Va., as temporary chairman. Associated with the group temporarily as consulting radio engineers are the Washington firm of Weldon & Carr, and, as legal counsel, Cohn & Marks. James O. Weldon, of the engineering firm, was head of the OWI International Division during the war.

NARBA assigns 730, 800, 900, 1050, 1220 and 1570 kc to Mexico for clear channel operation, with the U. S. to use the frequencies only on a daytime basis. There are two exceptions: WHN New York uses 1050 kc fulltime with 50 kw and WGAR uses 1220 kc fulltime with 5 kw (and has an application pending for 50-kw operation).

### Would Protect Dominants

Maintaining that they can protect Mexican stations on these channels, the Daytime Assn. is preparing to petition FCC to change its rules and, in renegotiating NARBA, to secure permission in the next agreement to allow them to use the frequencies fulltime, as Canada does.

The petition is expected to be presented to FCC within 60 days. NARBA is slated to be renegotiated in September 1947, but the formal conference will be preceded by a meeting of technicians of signatory nations in Havana next January.

"We are just getting started,"

Chairman Hayes reported following the meeting. "We hope to get additional licensees on these frequencies interested in our effort.

"It is our hope to prove to the FCC and to the signatories of NARBA that our fulltime use of these channels would be possible without injury to any country. Permitting us to operate fulltime would undoubtedly enable us to serve large areas of the country which are now under-served at night."

### At Meeting

Attending the conference were Mr. Hayes and Carl L. Lindberg, vice president of WPIK; Frank U. Fletcher, attorney for WTIK Durham, N. C.; E. D. Johnston, attorney for WKAX Birmingham, Ala.; John S. Begley, treasurer of WACE Chicopee Falls, Mass.; Pierce E. Lackey and F. Ernest Lackey, owners of the Lackey stations in Kentucky, representing WCIF Madisonville and their new station at Mayfield; Robert L. Irwin, attorney for WMGY Montgomery, Ala. and WZD Tuscola, Ill.; J. S. Booth, co-owner of WCHA Chambersburg, Pa.; Omar L. Crook, attorney for Central Valley Radio, which holds a grant for a new station, KCVR, at Lodi, Calif.

Hecht S. Lackey, manager of WSON Henderson, Ky., observed the proceedings but did not participate since WSON, although a daytime station, is on 860 kc and not affected by the movement.

## C-P-P Sponsors

COLGATE-PALMOLIVE-PEET, Jersey City, will sponsor *A Day in the Life of Dennis Day*, 7:30-8 p. m. on NBC, the period vacated by Lever Bros. Bob Burns show. Starting date has not been decided yet. Format of show will include Charles Grant's orchestra. Agency is Ted Bates Inc., New York.

## Brunet Named Director Of RCA International

MEADE BRUNET, vice president in charge of engineering products of RCA Victor Division of RCA, has been promoted to the post of managing director of RCA International Division, succeeding Edwin N. Clark, who has resigned.

Mr. Brunet has been with RCA since 1921, when he joined the corporation as head of production and distribution of radiotrons and radiolas (trade names for RCA receiver tubes and sets). In 1930 he was appointed sales manager of the Radiola division and by subsequent promotions rose to be general manager of the engineering products department of the RCA Victor Division, of which he was elected vice president last December.

## Coulter to F.C.&B.

DOUGLAS COULTER, formerly vice president in charge of pro-



gramming for CBS and prior to that vice president and radio director of N. W. Ayer & Son, New York, has joined Foote, Cone & Belding, as manager of the New York radio department and special assistant to Hubbell Robinson Jr., vice president in charge of radio for the agency.

## Le Gear Adds

DR. LE GEAR MEDICINE Co., St. Louis, effective July 1 added the following stations to their summer schedule of nine stations: WWL KWKH KMOX WBT WCKY KTRH WAOI. Agency is Simmonds & Simmonds, Inc., Chicago.

## Rexall Test

UNITED-REXALL Drug Co., Los Angeles (national chain), has started test campaign in four major markets utilizing transcribed shows on local stations. Known as *Music From Hollywood* shows are heard five weekly, and twice daily on KFI Los Angeles, KPO San Francisco and WCOP Boston; once daily on WNEW New York and KHJ Hollywood. Transcribed program features Jeannie McKeon as vocalist with music by Buddy Cole and "Four of a Kind"; Jack Rourke is announcer. Contract is for 13 weeks. Agency is BBDO, Los Angeles.

## Renfro Renewed

BALLARD & BALLARD Co., Louisville, Ky. (Ballard's Obelisk flour), Aug. 4 for 52 weeks renews sponsorship of *Renfro Valley Folks* on 26 NBC stations, Sunday, 9:15-9:45 a. m. Agency is Henri, Hurst & McDonald, Chicago.

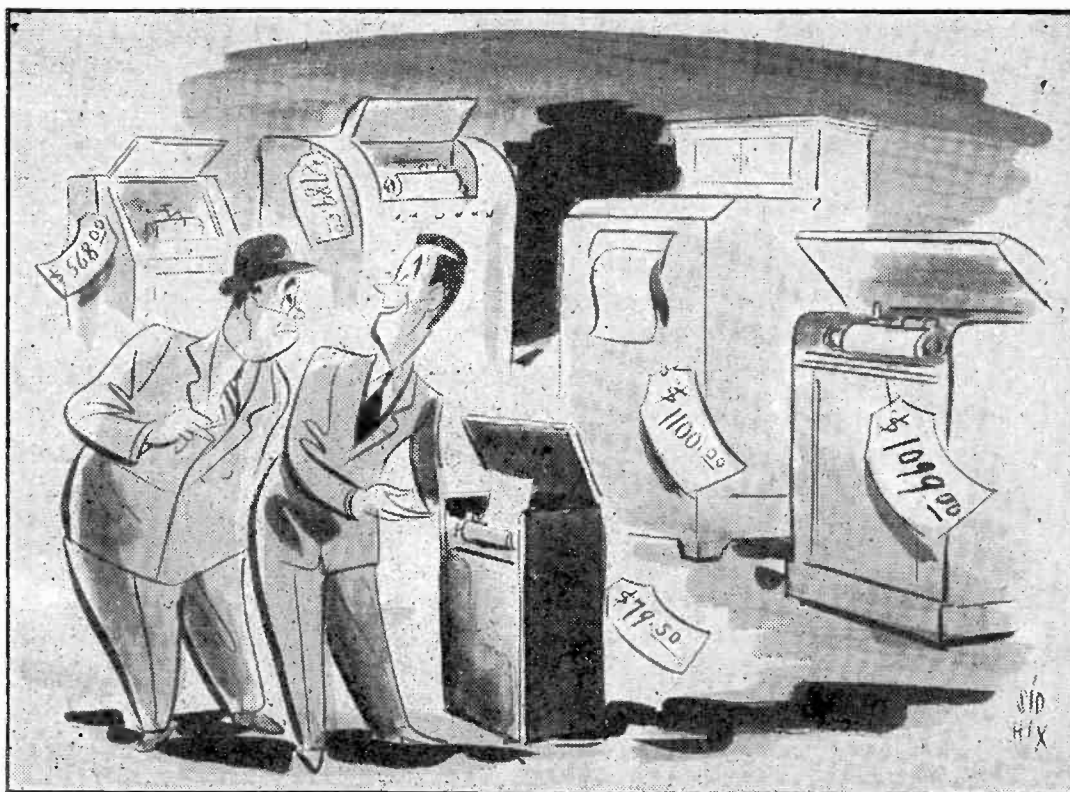

Drawn for BROADCASTING by Sid Hix

"Of course if you want a reasonable facsimile . . ."



# Navy Snafued Atom Show, Networks Say

## Request to Assign Army Vessel Unheeded

By EDWIN H. JAMES

IT WAS GOING to be a wonderful show, wonderful and a little frightening, and nobody wanted to miss it. The people quit their weekend play at beaches or lakes or in their own backyards that warm Sunday afternoon (June 30), to pay sober attention to the spectacle of mankind's tinkering with his newest and most fearful plaything, the atom bomb, postwar model.

Three of the things had gone off before, but the public knew of their awful potency only through the guarded descriptions which the Government and the Army, apprehensive lest wartime secrecy be breached, had released. This one, the Navy promised, would be unveiled for all America to see, if not through its own eyes, at least through those of professional observers.

The people clustered at their radio sets. Over them, they had been told, would come the eyewitness story, first-hand, of the awesome experiment at Bikini. It was a moment of high drama.

### Broadcast a Whisper

"We take you now to Bikini," announcers on all four networks said. Those were about the only intelligible words which listeners heard in an hour of broadcasting from the distant Pacific. The moment of drama vanished in an ear-bursting cacophony of static.

The bomb went off with a bang, but the broadcast went off with a whimper. The radio pickups from the press ship *Appalachian*, the command ship *Mt. McKinley*, the scientific observers ship *Panamint* and from the special observation plane bearing CBS Correspondent Bill Downs, the only correspondent to see the blast at a range favorable for reporting, were mostly lost in a garble of interference. Those from the rear echelon communications ship *Spindle Eye* at Kwajalein were, curiously, of excellent quality.

The average listener, in the frustration of the moment, blamed the networks for the inept show. But informed listeners knew the fault was not the networks'.

What or who was to blame for what many a listener would certainly be convinced was radio's greatest failure since the days of crystal sets and cat's whiskers?

Temperate radio newsmen were apt to charge it up to atmospheric interference. But many an angry network chieftain said that men, not God, had loused it up, and that the men were of the U. S. Navy.

Said one network news chief: "I

am convinced the Navy did not do a very good job of transmission."

Said a news executive of another network: "Engineers, before the test, had predicted that the relay system used by the Navy would not work. The predictions proved accurate."

### Navy Bobbled

Reports reaching New York last week indicated that the Navy, indeed, had bobbed the biggest news story it ever handled. One aspect of the communications plan with which some network newsmen quarrelled, was the Navy's assignment of transmission ships.

At least two of the networks had asked the Navy to use the *Spindle Eye* as the base communications ship at Bikini. The *Spindle Eye*, constructed for Army use in the projected invasions of Japan, carries powerful signal equipment designed especially for voice broadcasting. Two network news executives guessed that the Navy's insistence upon taking its own *Appalachian* forward and leaving the Army's *Spindle Eye* behind might have been dictated by traditional inter-service bickering. Well might Navy brass have recalled that the *Spindle Eye* was built for one of

the Navy's least loved Army leaders, Gen. Douglas MacArthur.

Network newsmen's anger grew during the pool broadcast when, after transmissions from the *Appalachian* had become incoherent, they heard NBC's W. W. Chaplin loud and clear from the *Spindle Eye* at Kwajalein, 240 miles from the scene of the story.

It was understood, but uncon-

### No FM Static

WALTER J. DAMM, chairman of the NAB FM Executive Committee and former president of FM Broadcasters Inc., said FM set owners in Milwaukee heard the Bikini atom broadcasts without static trouble (see page 76).

firmed, that the Navy had used a pee-wee transmitter of 250 w on the *Appalachian*, relaying through the powerful Navy radio station at Guam, 1,000 miles west of Bikini. Guam's radio was as powerful as any in the Pacific, but one detail of its construction may have diminished its efficiency for the Bikini broadcast: its directional

antennas were designed to pick up signals from the West, rebroadcast them eastward to the U. S. The Bikini signal came from the East.

A spokesman for the public information division of "Operation Crossroads" in the Navy Dept., Washington, said he had received no formal complaint from any network. He acknowledged that the *Spindle Eye* was considered a better communications ship than the *Appalachian*. "It's the best," he said. "That's why we put it on the Kwajalein job. It carries press traffic, radio photos, telecommunications as well as broadcasts."

### Net Men Aided

The Navy officer said that the designation of the ships to be used in radio communications was based on recommendations by network employes who had been called back into the service for the job. He specified particularly Lt. Comdr. Don Thompson, NBC West Coast special events director, who returned to service, on leave from the network, as radio director of "Operation Crossroads."

The *Spindle Eye*, broadcasting direct from its anchorage at Kwajalein to San Francisco, delivered (Continued on page 76)

## Shortwave Licensees Get 25% Control

### Renewal Revision Seen As Congress Limits U. S. Time

SHORTLY before the Senate last Monday passed the 1947 State, Justice and Commerce appropriations bill (HR-6056), limiting State Dept. to the purchase of 75% of time of international shortwave stations, the FCC telegraphed each licensee that its license was being renewed until Oct. 1, 1946, or "the first day on which its operations are not controlled" by the Government.

FCC officials said the telegram went out before the Senate acted on the House-passed measure which included the Ball amendment [BROADCASTING, June 24, July 1]. It appeared likely that the Commission would revise its license renewal, contingent upon 75% control by the Government, it was learned.

### WRUL Cooperate

Meanwhile WRUL Boston, operated by World Wide Broadcasting Foundation, whose officers appeared before a Senate Appropriations subcommittee [BROADCASTING, June 24], has notified the FCC in writing that the Foundation will cooperate with the State Dept. in the readjustment of international shortwave broadcast schedules, Walter S. Lemmon, Foundation president, said.

"We told the State Department that we did not want to interrupt

its schedules and agreed to the present setup for 60 days to give the Government an opportunity to readjust its programming before we resume our own programs," said Mr. Lemmon.

On the other hand it was pointed out at the Commission that should World Wide decide to program even 25% of its time before Oct. 1, the WRUL license would be automatically revoked, unless Order 110-C is modified. Since World Wide has voluntarily agreed to retain the status quo for at least 60 days, the Commission will "review the overall problem in light of the Act of Congress" before taking further steps, a spokesman said.

Both Houses of Congress voted to restore the full \$19,284,778 appropriation for the State Dept.'s Office of International Information and Cultural Affairs, thus assuring continued operation by the OIC of the nation's shortwave outlets. Mr. Lemmon said that as soon as the State Dept. readjusts its schedules to permit WRUL to do its own programming 25% of the broadcast time, the *World Radio University*, which was interrupted when the Government took over the World Wide stations in November 1942, will be resumed.

Published reports by the Federal Radio Education Committee that WRUL would resume its schedules July 1 were erroneous, Mr. Lemmon said.

Sen. Wallace H. White Jr. (R-Me.), Minority Leader who re-

quested that the Appropriations subcommittee hear Mr. Lemmon and Dr. Harlow Shapley, World Wide board chairman, in the Senate Monday warned that trouble lies ahead in the State Dept.'s domination of international shortwave stations.

### White Warning

"There is a serious question as to whether there is any legal authority whatsoever for what the State Department is doing," said Senator White. "In my own opinion, for whatever it may worth, there is no substantive law upon which the action of the House, the action of the Appropriations Committee of the Senate, or the action of the Senate itself, can possibly be justified."

Terming the procedure "utterly unwise," Senator White said: "I think it gives promise of great difficulties and troubles for us if we turn the State Department loose to broadcast to the world the material which the State Department has indicated it is to make known to the world . . . It is perfectly clear that the State Department is to undertake to instruct the world with respect to social, economic, political and governmental matters . . . I can see nothing but trouble. I can see nothing but friction. I can see nothing but resentment resulting from this effort of the State Department."

Text of a telegram sent Monday (Continued on page 77)

# Banks Learning How to Use Broadcasting

TEN YEARS ago a handful of banks were toying with radio, most of them in a half-hearted manner. A survey made by the ABA at that time revealed that of the 145 banks on the air only 59 had a favorable opinion of the medium. Thirty banks were definitely unfavorable and the rest were "on the fence."

The half-hour program was quite popular with banks 10 years ago; 55 used it. Thirty-five had 15-minute programs and five were on the air ranging from 10 minutes to one minute. Only two banks used one-minute spots; contrast that with the situation today, described later.

## Program Preference

Music plus talk or drama was the formula for most of these 1936 programs, with plain talks running second and news a very weak last with five users. Contrast this, too, with today's situation.

The general formula of program-frequency was once a week (70 banks) with 19 broadcasting daily, eight twice a week, seven three times weekly and the rest scattered from monthly to several times a day. Ninety banks used evening hours, 28 afternoons and nine mornings; others were scattered and irregular.

As for actual results obtained from radio, 40 of those giving opinions said "good," 40 said "fair" and 39 said "poor."

A check was also made in 1936 among 195 banks not using radio. They were generally lukewarm or negative, favored music and drama, liked 15-minute programs best (64 banks), half-hours next (23 banks), while only six banks liked programs shorter than 15 minutes.

One question asked in the 1936 survey was "Would you like to have the ABA prepare and supply transcribed radio programs?" Here's how banks voted then:

	Banks Not Using Radio	Banks Using Radio
Yes	78	46
No	82	52

This picture is really brighter than it appears because included in the 124 "Yeses" were 44 clearinghouses, 14 county associations, one state association and seven other banking organizations that included hundreds of banks.

This was certainly no rousing

**SURVEY** of bank use of broadcasting, current and prospective, was conducted by Advertising Dept. of American Bankers Assn., of which Mr. Mack is radio director. The results were carried in "Banking," official journal of the association, from which this article is reprinted. The ABA Advertising Dept. will soon start a radio service for banks. Mr. Mack reviews the plans in this article.

## Association Will Start New Service With Transcription Series

By JOHN B. MACK JR.

Manager, Advertising Dept., American Bankers Assn.

"mandate" from the banks. But there was an undercurrent of interest. And there was deep conviction on the part of men in the ABA that some day radio would become a major medium of bank advertising. The time seemed ripe to pioneer in this as yet uncharted field of bank publicity. Accordingly, and with plenty of trepidation, the Advertising Dept. of the ABA went to work and produced its first transcribed series, entitled *Money Matters*.

These programs were 15-minute transcriptions open at both ends for local announcements. Music

were based too much on what *bankers* liked and not enough on what the public wanted. The music was heavy, the dramas were long and somewhat dull in spots. The programs lacked lightness, entertainment and interest.

## Another Experiment

In 1939 ABA tried again. Building on our experience with the first series, we planned a new set of transcribed programs and arranged with NBC to produce them. Nat Shilkret was retained to supply the music and we used melodies in a popular vein, of the so-



Mr. Mack

cidental expenses came to just about \$1,000 per program.

More than 200 banks used this series; it wasn't bad, but still left much to be desired. The Advertising Dept. fell several thousand dollars short of recapturing its out-of-pocket expenses, but felt that it had gained much in the way of "know-how" and experience.

There was little change in the radio picture as far as banks were concerned by 1941, just before the war.

In 1943 John McCann of *Banking's* staff, as part of his work at The Graduate School of Banking, prepared a thesis entitled "Banking on the Air." It was the most comprehensive and intelligent analysis of bank radio advertising ever made and may some day be looked upon as the beginning of, or at least the turning point in, the use of radio by banking institutions.

## Trend in Thinking

The McCann survey showed that there were 340 banks using radio—about 2% of the banks in the country. It was still a negative showing and as Mr. McCann concluded: "It is evident that financial advertising has not made any appreciable mark in radio as a classification."

The survey showed a strong swing in bank thinking about radio. Almost half of the financial institutions surveyed used spots of 30 or 60 seconds, about 20% used 15-minute programs, 10% the five-minute unit; and there was little support for the half-hour idea, a big change from 1936.

We have just completed a nationwide survey to which about 2,200 ABA member banks contributed detailed data about their advertising plans and their thinking. We asked this simple question:

(Continued on page 22)

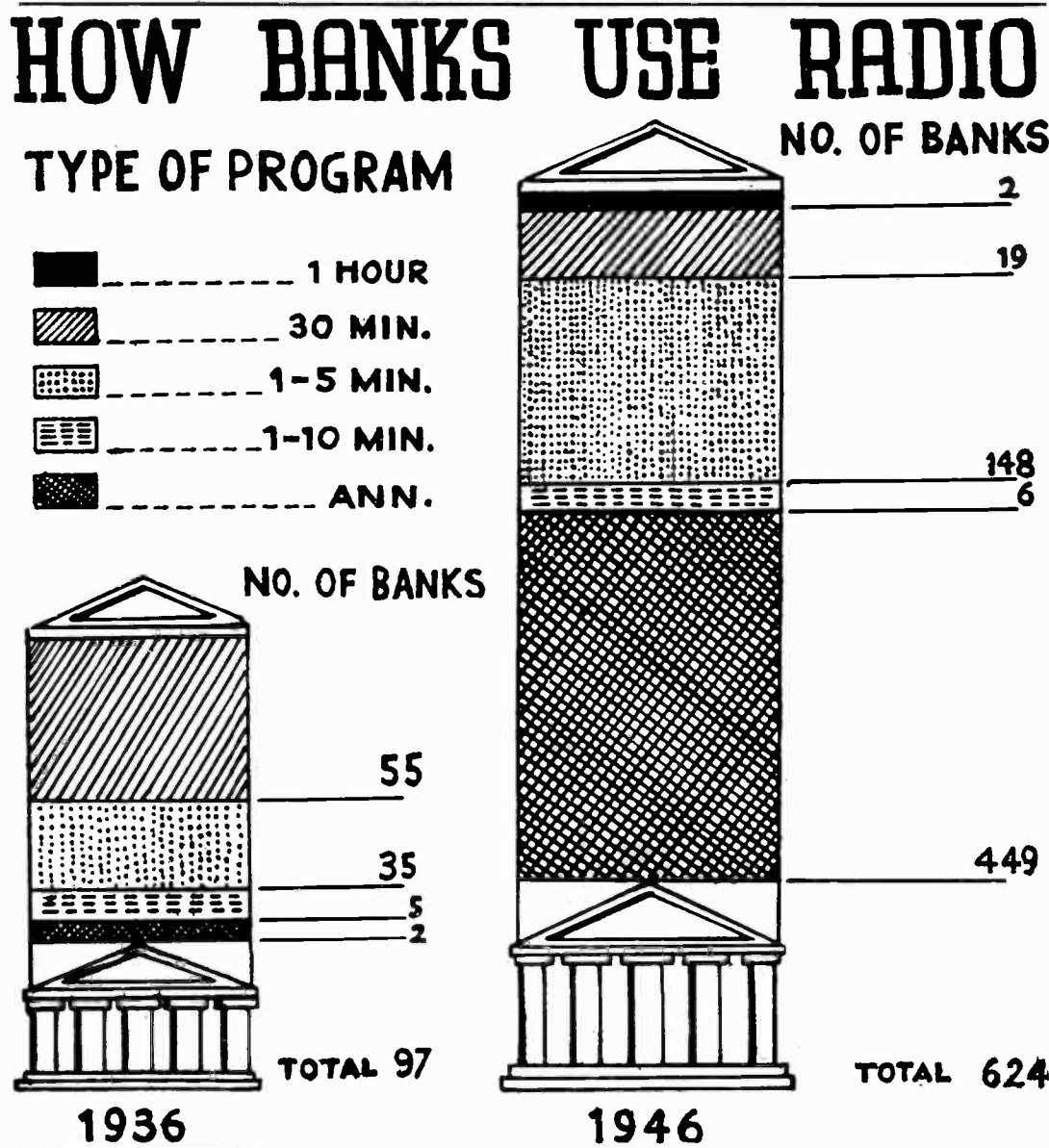

was semi-classical, by a string orchestra, and each show had a seven or eight-minute dramatization about some bank service, on an educational plane. The programs were technically good, produced with first-class actors and musicians. They achieved a moderate success and in retrospect it seems marvelous that they went as well as they did considering the apathy of banks toward radio. Thirteen clearinghouses with 153 bank members and 29 individual banks—a total of 182 banks—used the series.

It soon became apparent to us, however, that these first programs

called "standard" variety. The dramatizations were reduced to four or five minutes and livened up considerably. The situations were built around the *White Family*—husband, wife, son and daughter, and their financial problems and experiences. Various bank services were featured in the 13 programs we prepared. Space was provided at beginning and end for local bank announcements.

Top acting talent was used, including Selena Royal, Gene Leonard, Carleton Young and Mitzi Gould. Announcing was handled by Richard Stark. Production and in-





## Big Scoop

That big baby is capable of biting off 35 cubic yards of earth and rock in one dip.

That's delivering in the kind of quantity strip mining likes to see.

We've got a big scoop story too. It's this: down here in Baltimore W-I-T-H delivers more listeners-per-dollar-spent than any other station in this big 5-station town.

That's delivering in quantity and quality the way time buyers like it.

And remember . . . there are 5 stations in this 6th largest city.

W-I-T-H belongs on any smart list. Is it on that new sales program of yours?



# W-I-T-H

and the FM Station W3XMB

BALTIMORE 3, MD.

Tom Tinsley, *President* • Headley-Reed, *National Representatives*

# Clear Channels Attack Radio Survey

## Shouse to Give His Testimony This Week

MOUNTING its major rebuttal attack in its fight to maintain the clears, the Clear Channel Broadcasting Service loosed a broadside at the Census Bureau's massive survey of rural radio reception last week as the closing phases of the clear channel proceedings got under way.

The attack, led by CCBS Director Victor Sholis and ex-Col. John H. DeWitt, who "shot the moon" with radar for the Army, came shortly after FCC engineers introduced a proposed revision of engineering standards which prompted the calling of an engineering conference for mid-July, to be followed by an Aug. 5 hearing at which the fate of present standards will be decided (see story, this page).

The week's sessions ended on a dramatic note Wednesday with the presentation of recordings comparing reception of clear channel station broadcasts with that of regionals and intended to show superiority of the clears.

Testimony for CCBS will be resumed Monday and will include the appearance of James D. Shouse, vice president of Crosley Corp. in charge of broadcast operations, who is expected to plead for a return to higher power and ask specifically for permission for Crosley's WLW Cincinnati, only U. S. station ever to operate with power above 50 kw, to use commercially the 500 kw it once used developmentally.

### Other Witnesses

Other witnesses tentatively slated for Monday include representatives of KFAR Fairbanks, Alaska, Governor of Wyoming, and spokesmen for KXLA Pasadena.

The regional station group's reaction to the recordings played Wednesday also may be forthcoming, since Mr. DeWitt, who presented them, was not cross-examined on that phase of his testimony.

No clear channel session is slated Tuesday, when the Commission is to hold hearing on ABC applications for a \$14,000,000 stock issue and for the purchase of King-Trendle Broadcasting Corp. for \$3,650,000.

Scheduled for Wednesday's clear channel hearing is testimony for the Regional Broadcasters Committee by M. K. Toepfen, New York engineer and statistician, who will present exhibits designed to bring together some of the information gathered by the Census Bureau and coverage data on stations as worked out by engineers in cooperation with FCC.

Opening the attack on the Cen-



FIRST session of July hearings on clear channels opened Monday with Commission sitting *en banc* during testimony of Charles E. Nobles (left), Westinghouse engineer, who described stratovision tests at high altitudes with standard broadcasting. Seated behind large table are (l to r): Comr. Hyde, Comr. Durr, Comr. Walker, Acting Chairman Denny, Comr. Wakefield, Comr. Jett. In foreground is official stenographer.

sus survey, Mr. Sholis declared that although CCBS was "involved in the survey's paternity" by contributing \$10,000 toward it, "we must renounce 'the baby' as 'illegitimate.'"

"At the base of the survey are simply the opinions of unqualified persons," he charged. "But even this limited information was distorted beyond the realm of credibility by the errors and fallacies in the survey's methods. As a result, the entire project contributes virtually nothing to resolving the issues of this hearing."

Mr. Sholis asked FCC to "use the facts and standards evolved by its three technical committees" rather than rely upon the Census findings.

The CCBS director specifically

attacked the survey's projection of results from a survey in one county to apply to all counties in that particular group even though, he noted, the other counties may have been from 50 to 650 miles away from the one in which listeners were asked what stations they hear most.

The "basic error which wrecked the survey," he said, was "the disastrous assumption that stations heard in one area were heard exactly the same way in other areas great distances away." He said the "cardinal mistake" was "ignoring the fact that radio signals diminish with distance."

Mr. Sholis maintained that the survey "sought the impossible by asking listeners who are conditioned only to low-grade service

to appraise the quality of radio signals."

"Most of these listeners," he contended, "have never known anything better than the miserable grade of reception to which they have been doomed from the beginning. It is like asking backwoods folks who have never been elsewhere, whether their roads are good."

He cited instances of what he called "bias in favor of regional stations" and declared that "in choosing the area to be interviewed, the Census used a system wherein the county with the largest population had the best chance of being selected. Generally, a county with

(Continued on page 73)

## Standard Revision Suggested by FCC

### Commission Engineers Present Proposal At Hearing

A PROPOSED revision of engineering standards for AM stations was tossed into the clear channel hearings last week, precipitating the calling of a mid-July engineering conference and a full-dress hearing Aug. 5 to decide the future form of standards.

Drawn up by FCC engineers but not formally appraised by members of the three technical committees appointed for the clear channel proceedings, the 18-page revision of Part I of the standards brought only one substantial objection from the clear channel advocates but the practicality of the plan was questioned by the regional group.

Acting Chairman Charles R. Denny Jr., objecting at first to introduction of the proposal until the technical committees had an opportunity to study it, called an informal engineering conference for July 15-16 and a hearing before the Commission *en banc* for Aug. 5 to receive a report of the engineering conference and hear "final recommendations."

The conference and hearing will be open not only to participants of the clear channel proceedings but to all other interested persons.

### Seeks Comments

FCC Chief Engineer George P. Adair, in a Public Notice issued late Wednesday, asked that all comments on the proposed revision be submitted to the engineering department "in writing as far in advance of Aug. 5 as possible," and requested that "these comments be supplemented by specific proposals."

Among the departures suggested in the proposed revision are the following points which FCC said are "some of the more important problems to be discussed":

1. A new method of calculating resulting interference.
2. A new method of calculating urban populations served.
3. The revision of adjacent channel ratios. (30-kc separation is proposed instead of 40 kc.)
4. The revision of the method of determining permissible interference of skywave service.
5. Consideration of variation

of noise levels throughout the United States.

6. Consideration of latitude effects on skywave interference and service.

Acting Chairman Denny said the question of adopting new standards "is an issue which has an impact far beyond this [clear channel] proceeding." He emphasized that the new plan had not been approved by the Commission or by the technical committees, and said that in the engineering conference an attempt would be made "to iron out points of controversy."

A final decision will be made sometime in August regarding whether new standards will be adopted and, if so, what they will be, Mr. Denny announced.

### Duplication Not Touched

The proposal makes no attempt to solve the basic issue of the clear channel question: Whether or not there will be duplication of Class I-A clears. If adopted, it would be used in allocation matters to replace present standards "at some future date yet to be decided upon." It would also serve as a basis of U. S. recommendations

(Continued on page 85)



# Along the Inland California Beeline



*... giant food factories handle 60% of California's fruit and vegetable processing*

**T**HE BEELINE fruit and vegetable pack exceeded 33 million cases in 1945. That's big-time MANUFACTURING . . . industry teamed with agriculture. It helps explain why Beeline families have plenty of money to buy things.

Three of the largest canneries in the U. S. are in Sacramento. Fresno is the center of the world's dried fruit industry. Millions of tons of tomatoes, olives, asparagus, peaches, figs, pears and raisins are processed in these areas.

What is the Beeline? California's busy central valleys, plus Reno and western Nevada . . . a market that rivals Los Angeles in population and tops San Francisco in retail sales.

Mountains 6,000 to 8,000 feet high encircle the Beeline . . . often bar reception from outside radio stations. So here in California's third market you need our INSIDE-THE-MARKET stations! Facts prove Beeline stations do a good selling job.

## Facts for Time Buyers about the 5 BEELINE Stations

Each station in the BEELINE Group (not a network or chain) is dominant in its community, powered for THOROUGH COVERAGE. These stations TOGETHER blanket California's mountain ringed central valleys, plus Reno and wealthy western Nevada. Use all 5 stations at combination rates. Choose best availabilities on each station without line costs or clearance problems.

### K F B K

SACRAMENTO. ABC. Established 1922.  
Primary area coverage of 15 California Counties with population of 630,100.  
10,000 watts—1530 kc.

**K E R N**  
Bakersfield (CBS)  
Established 1931

**K M J**  
Fresno (NBC)  
Established 1922

**K W G**  
Stockton (ABC)  
Established 1921

**K O H**  
Reno (NBC)  
Established 1928



# McClatchy Broadcasting Company

Sacramento, California

Paul H. Raymer Co., National Representative

## Banks

(Continued from page 18)

"Are you interested in radio advertising for your bank?"

The answers: 546 said "Yes"; 1513 said "No"; 71 said "Don't know."

That is great progress. There are less than 3,000 banks in radio station cities. Let's bear in mind that all banks can't very well go on the air with programs of their own. Radio is best suited to the banks in the city or town where the station is located, with of course some exceptions. (However with the coming of FM stations the number of non-network locals which banks might use will increase enormously.)

Projecting the above figures of bank interest to the more than 15,000 banks in the country, we

would have about 4,000 banks interested in radio, a figure that holds much promise.

We asked the banks: "What length of program do you prefer?" The answers: 449 said spots; 148 said 15 minutes; 19 said half-hour; six said five minutes; and two said one hour.

### Music Choices

The half-hour show has dropped from top preference 10 years ago to almost the bottom today.

Here is how banks rate music: 119 popular; 64 classical; three hillbilly; and one church.

And this is how they rate program contents: 77 news; 10 sports; eight plays; three weather; two commentators; and two farm topics.

An interesting observation about musical and program preferences is that most banks have no clear-

## Flash

LIGHTNING is the name of the pony won by ten-year-old Peter Larson through WAAB Worcester, Mass. pony contest. The youngster was overjoyed when his 25-word letter gave the best reasons for "Why I want a pony from Badman's Territory." When asked why he called his new pet "Lightning," he replied, "Because he came to me so fast."

cut preferences—they say "We don't know." That's a typical reaction of banks in this whole field of radio and it's a logical attitude. Bankers like to base their decisions on facts, and there are as yet too few facts in this area of

bank use of radio. Much is still to be learned.

To the question "Do you prefer the selling portion of the program done by straight announcement or dramatization?" 313 said straight announcement and 38 said dramatization.

### Split Opinion

There is plenty of resentment among bankers toward the singing commercials and the overdone drippy dramatizations widely used in commercial radio advertising. This accounts in some degree for the poor showing of dramatization as a selling vehicle.

A big unresolved question in the minds of bankers is whether radio should be used for direct selling of bank services, for education about banks and banking, or a combination of both. A thousand said "sell" and 1,059 said "educate."

It would be difficult to imagine a more evenly split opinion, and in the answer to this question can be seen evidence that banks are confused or at least divided on the place radio should or could have in the banking picture.

Since the end of the war the ABA Advertising Dept. has been making an extensive study into all phases of radio advertising as it relates to banks. One thing we have done was to ask the 900 radio stations in the country to give us their thinking on the question: "How should banks use radio?"

I want to express deepest appreciation to the 303 radio station managers who supplied voluminous data, ideas, suggestions and such a wealth of valuable thinking that if we go wrong with our forthcoming radio service it will not be for lack of sound advice.

### Welcome Helps

The stations were nearly unanimous in welcoming help in the bank radio field. Two hundred eighty-eight were favorable to ABA supplying programs, 15 were sour on banks or did not like transcriptions. But mainly there is great enthusiasm because, as one station put it, "We just don't feel on safe ground when we try to prepare our own bank programs." A radio man told us: "Banks need some agency that can reach them from within and explain to them the benefits and value they can get from radio." Another expressed this belief: "Often local banks have had to restrict their radio advertising due to lack of proper copy that only agencies or the American Bankers Assn., thoroughly familiar with bank advertising needs, can prepare."

We asked the radio stations their opinion of an idea which, simply stated, would be production by the ABA of five-minute dramatizations on bank services open at each end for local announcements. The dramatizations would be entertaining, and could be the core of 15-

(Continued on page 24)



## FEED MILLS make jobs in the NASHVILLE area

Processing animal feeds is a million dollar business in the Nashville area. . . . From farm to feed store this important industry makes jobs for thousands. . . . Manufacturing activities like this, build a strong market for your product; and make a sales territory that is growing continually. . . . One million people in the Nashville trade area spend over 356 million dollars each year in retail stores alone. . . . Take advantage of this market. . . . Let WSIX do a selling job for you at reasonable cost.

American and Mutual

5,000 Watts 980 K. C.

National Representative

THE KATZ AGENCY, INC.



WSIX gives you all three: Market, Coverage, Economy



**more men**

**more offices**

**more facts**

**make**

**more sales**

STATIONS SERVED BY

*The* **KATZ AGENCY**

*North and Midwest*

WCOP	ABC	BOSTON
WCFL	ABC	CHICAGO
WKRC	CBS	CINCINNATI
KRNT	ABC	DES MOINES
WFBM	CBS	INDIANAPOLIS
WFEA	CBS	MANCHESTER
WISN	CBS	MILWAUKEE
WHOM		NEW YORK
WFIL	ABC	PHILADELPHIA
WCAE	ABC	PITTSBURGH
WFCI	ABC	PROVIDENCE-PAWTUCKET
WTAD	CBS	QUINCY, ILL.
WSPD	NBC	TOLEDO
WOL	MBS	WASHINGTON, D. C.
WMT	CBS	WATERLOO-CEDAR RAPIDS
WNAX	ABC	YANKTON-SIOUX CITY
THE NEW ENGLAND GROUP		

*South*

WGST	CBS	ATLANTA
WWNC	CBS	ASHEVILLE
KLRA	CBS	LITTLE ROCK
WMAZ	CBS	MACON
WREC	CBS	MEMPHIS
WSIX	ABC	NASHVILLE
WWL	CBS	NEW ORLEANS
WKY	NBC	OKLAHOMA CITY
WDAE	CBS	TAMPA
WTOC	CBS	SAVANNAH

*West*

KLZ	CBS	DENVER
KUTA	ABC	SALT LAKE CITY
KHQ	NBC	SPOKANE
KGHL	NBC	BILLINGS, MONT.
KVOR	CBS	COLORADO SPRINGS
KGU	NBC	HONOLULU, T. H.

*The* **KATZ AGENCY, INC.**

STATION REPRESENTATIVES

New York • Chicago • Detroit • Kansas City  
Atlanta • San Francisco • Los Angeles • Dallas

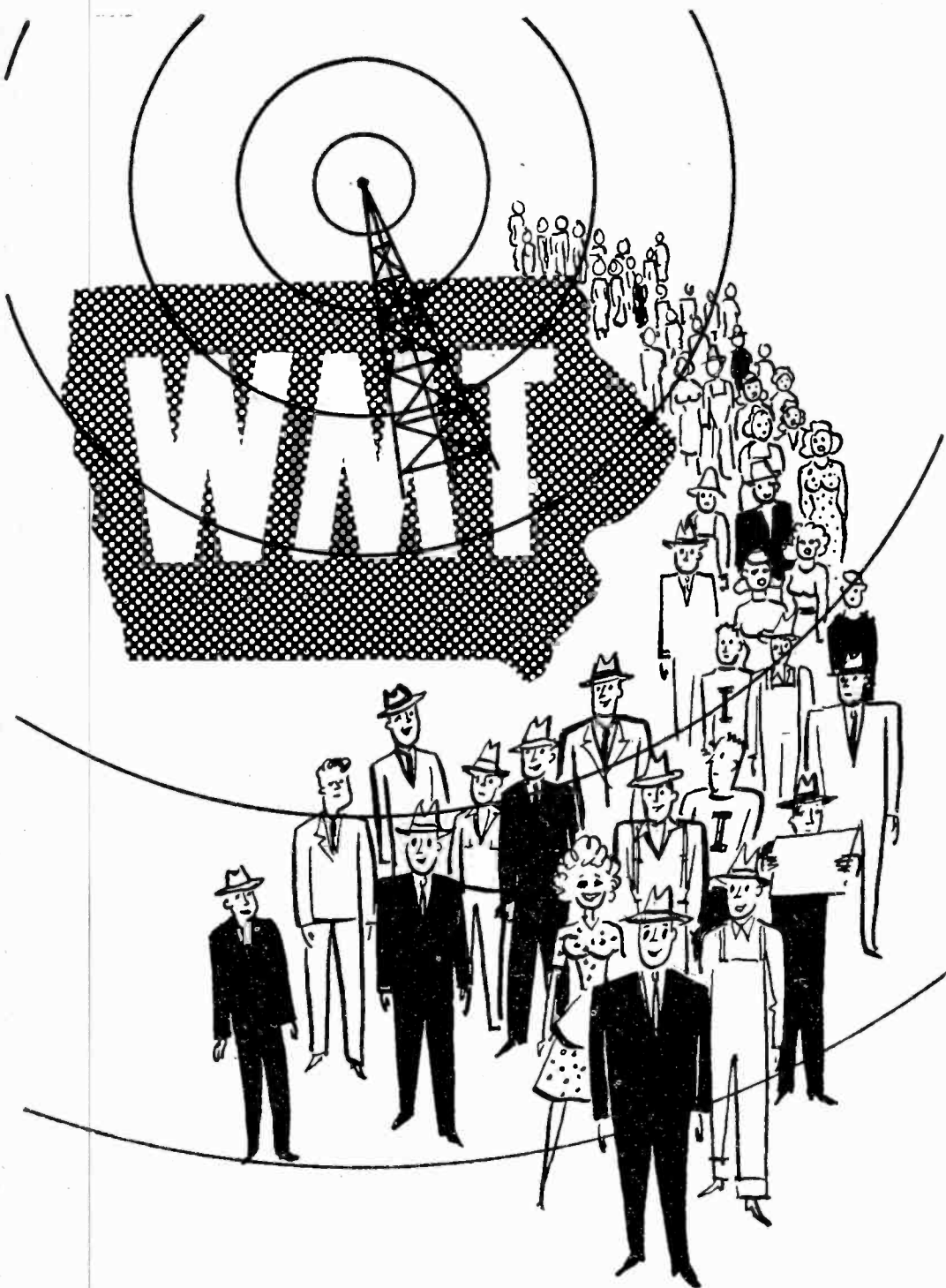

**With the LARGEST Population Coverage\* of ANY Station in the State REACHES the Sales-rich AGRICULTURAL-INDUSTRIAL Eastern Iowa Market Completely!**

\*3,500,000 consumers with the BIGGEST per capita income in the country PLUS the largest daytime primary area (within its 2.5 MV Line).

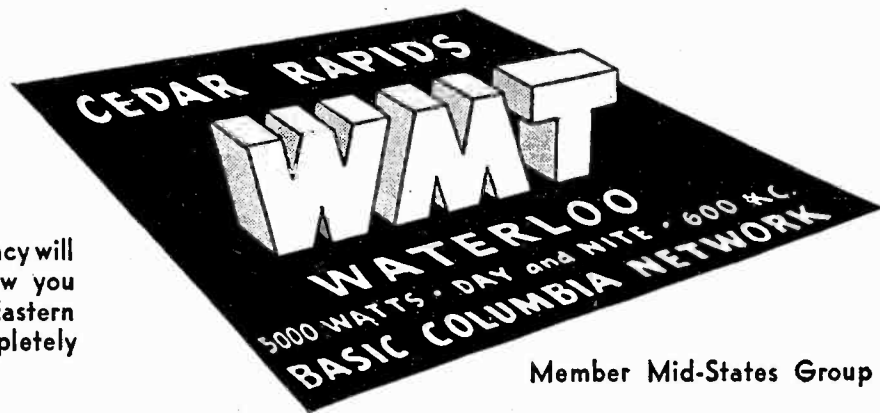

KATZ Agency will tell you how you can cover Eastern Iowa completely on WMT.

**Banks**

(Continued from page 22)

minute shows or used as five-minute programs.

One hundred thirty-eight stations were favorable to five-minute units, 37 favored 15-minute programs, 11 asked for one-minute dramatized spots, and six favored 10 minutes.

Many other stations suggested various periods up to 30 minutes. Quite a few said they would welcome typewritten spot copy. It is interesting to note the great spread between the banks' use of spots and the radio stations' recommendation of the short unit.

**Repetition Is Keynote**

There is by no means unanimous approval of the five-minute idea. "It leaves us dangling in the air with 10 minutes of unsold time," one station said, "Difficult for small stations to build 10-minute balance of show," another stated: "Radio programs are built in 15-minute units as a rule and a five-minute show is generally a pain in the neck," said another. However, 138 stations like the five-minute idea, and anyway with a little effort a station can build a 15-minute program around the five-minute unit. That's the whole idea.

Station after station, right down the line, insisted that for real results banks must repeat and repeat and repeat. Radio results thrive on repetition; they languish on hit-or-miss broadcasting. There is no doubt that radio stations feel the great weakness of bank radio advertising in the past has been lack of consistency. "Five-minute programs should be used daily, and at least three times a week the year around," one station director said "and a 15-minute unit should be used 52 or 104 times a year for real results." One operations manager said: "Repetition is the essence of local radio's effectiveness."

Asked how many programs the ABA should prepare in its initial postwar series, 79 stations said at least 26, 66 stations said 52, eight

**A Helping Hand**

A BLINDED war veteran is returning to his home with his rehabilitation partially aided by a promotional piece of WDAY Fargo. The man, Sgt. Peter McKenna, has been in a Connecticut convalescent hospital and wrote Fargo Mayor Charles Dawson for a city map so that he would be prepared to find his way around to all the important buildings, bus terminals, etc. Sent to him by the mayor was the comprehensive WDAY promotion piece with maps of Fargo and neighboring Moorhead, Minn. From this Sgt. McKenna will build a braille model of the city in clay and cardboard to serve his purpose.

said 104, five said 260, and three said 156.

Various other units were mentioned, but the big idea, expressed over and over, was: "We don't want banks to use radio and judge it on the basis of too few programs. There should be continuous year-round advertising and never less than half a year."

The owner of a small station wrote: "I don't advocate singing commercials for banks, but bring your approach down to the same intellectual level and your story will go over where it will do the most good." And the thought expressed by another station: "Banks have something to sell. They should take off the kid gloves and go after business as vigorously as any other business would."

(Another angle was expressed by one radio man who said: "We feel that when banks use radio they add to the prestige of the local radio station.")

The commercial manager of a large city station told us: "I find bankers hard people to talk to about advertising. I understand retailers and their problems. I don't

(Continued on page 26)

**RETAIL SALES**

**\$700,000,000 ANNUALLY**

WISR'S primary coverage area is a good potential market for you. It offers 9 county coverage . . . two million people in over 400,000 homes at a cost of less than one cent per thousand homes.

**WISR**  
**BUTLER, PENNSYLVANIA**  
**680 KC · 250 W**  
 "5,000 Watt Coverage at 250 Watt Rates"  
 NATIONAL REPRESENTATIVES · FORJEO & COMPANY



## DIOGENES

**SAID:** "The most beautiful thing in the world is freedom of speech."

Self-evident to thinking men—in the times of Diogenes as well as in this modern world—is the fact that all the freedoms of mankind are based on the freedom of thought and speech.

Restrict freedom of the air, or freedom of the press, and no freedom exists.

**AS TRUE TODAY  
AS IT WAS THEN**



# WJTR

THE GOODWILL  
STATION, INC.  
DETROIT

**"MICHIGAN'S GREATEST ADVERTISING MEDIUM"**

Columbia Broadcasting System Basic Station • Fisher Building, Detroit



## Banks

(Continued from page 24)

understand bankers and their problems, and no banker I have ever talked to yet has been able to tell me what he wants his advertising to do for him." "Bank advertising is terrible," opines another station director.

"Anything at all you could do to encourage banks to use some promotion will be wonderful—it will be more than that, miraculous!" is the sentiment of a third radio man. The assistant manager of one of the biggest stations said: "There are some fine banks doing a wonderful job, but in the parade of successful advertisers, I will stick my neck out and say that banks are at the end of the line—and I don't mean the front end."

### 1.8 Banks Per Station

But while a few radio stations were caustic, and many frankly critical, every one was genuinely

interested in helping banks to do a better job.

Their advice to banks could be summed up as follows:

(1) Set your sights on your objective.

(2) Get an expertly prepared program.

(3) Stick with it over the long pull.

The 303 radio stations supplying information in our 1946 survey listed 543 banks that were using their stations currently. That is an average of 1.8 banks per station and extending the average to the approximately 900 local stations in the country accepting advertising there would be a total of about 1,600 banks on the air right now! That is one out of each 10 banks, and these figures do not include group programs which would swell the total of banks on the air to well over 2,000.

A study of the subjects being offered by banks via radio at present shows that of the 308 programs on which data were given us, 153

## All Broken Up

LIKE A BULL in a china shop, Jim Goode, sound effects man on Mutual's *True Detective Mysteries*, astounded the manager of a New York department store when he proceeded to drop pieces of china all over the floor. He placated the manager when he told him he was looking for the china that had the "proper ring" for a sound effect, and ended up with a huge order for china—all to be broken.

cover their services in general, 99 stress loans, 25 institutional, 13 savings, 13 checking, three safe deposit and two trust.

An analysis of 197 programs being run by banks revealed that news is first choice as type of program (48% of the programs on which these data were given), music second (34% evenly divided

between classical and popular music), with sports, dramas and other features trailing well behind.

### ABA to Offer Service

As a natural evolution of its advertising services, the ABA Advertising Dept. is planning to offer a new radio service.

The purpose will be to help local banks in their use of radio as an advertising medium. One phase of the activity will be to gather and distribute data on bank radio advertising, and radio in general. Another will be to prepare actual programs in transcribed form for local broadcast by banks or groups of banks.

Based on all this survey information it seems quite probable that the first programs will be so-called open-end dramatizations, 4½ minutes long, built around situations involving people and their money.

There will probably be at least 52 such programs in the initial series. The dramatizations can form the core of 15-minute programs, with music or entertainment provided by the local stations.

Announcement of the first programs is expected in a month or so.

## Post With Westinghouse Is Resigned by Harder

GEORGE A. HARDER, director of public relations and formerly advertising and publicity director of Westinghouse Radio Stations Inc., resigned last Monday. Neither announcement of his successor by WRS nor Mr. Harder's future plans have been made public beyond an intimation that he would resume radio work in the fall.

Mr. Harder had returned to Westinghouse broadcast headquarters following his release from the Army last November. Previous to his armed forces service, Mr. Harder's experience in New England radio included acting as radio adviser to the Hon. John C. Winant, former ambassador to England, when Mr. Winant was governor of New Hampshire. He also served in a similar capacity for former Gov. Joseph B. Ely of Massachusetts, and handled numerous broadcasts by the late President Roosevelt and other national figures while in New England.

## War Secret on CBS

AUDIENCE attending the initial broadcast of the War Dept's *Sound Off* series, CBS New York, witnessed the unveiling of another war developed secret. The Inverted Fish Bowl pressure suit, resembling goldfish bowl, enables air crew members to ascend to 62,000 feet by maintaining normal pressure on the body.

### Wins WSYR Contest

WSYR Syracuse has chosen Charles F. Wheaton, student at Syracuse U. as winner of week-end air trip to England contest for his essay on U. S.-British relations. Contest was run in connection with WSYR program, "The New Horizon." Winner was accompanied to London by E. R. Vadeboncoeur, vice president of WSYR.



## Kansas Wheat and Corn—as far as the eye can see

Unending fields of golden grain are now being harvested in WIBW-land. A rising tide of new wealth is flooding every farm, town, and city. OUR listeners are buying as never before.

Yes OUR listeners! Because we've served them faithfully and honestly for over 20 years, they have absolute confidence in WIBW . . . accept our buying suggestions . . . act on them. Give this fact serious thought in making your sales plans for Kansas and adjoining states.

# WIBW

IN  
TOPEKA

"The Voice of Kansas"

BEN LUDY

COLUMBIA'S OUTLET FOR KANSAS

WIBW, Topeka

General Manager

KCKN, Kansas City

REPRESENTED BY CAPPER PUBLICATIONS, INC.

NEW YORK, CHICAGO, KANSAS CITY, SAN FRANCISCO



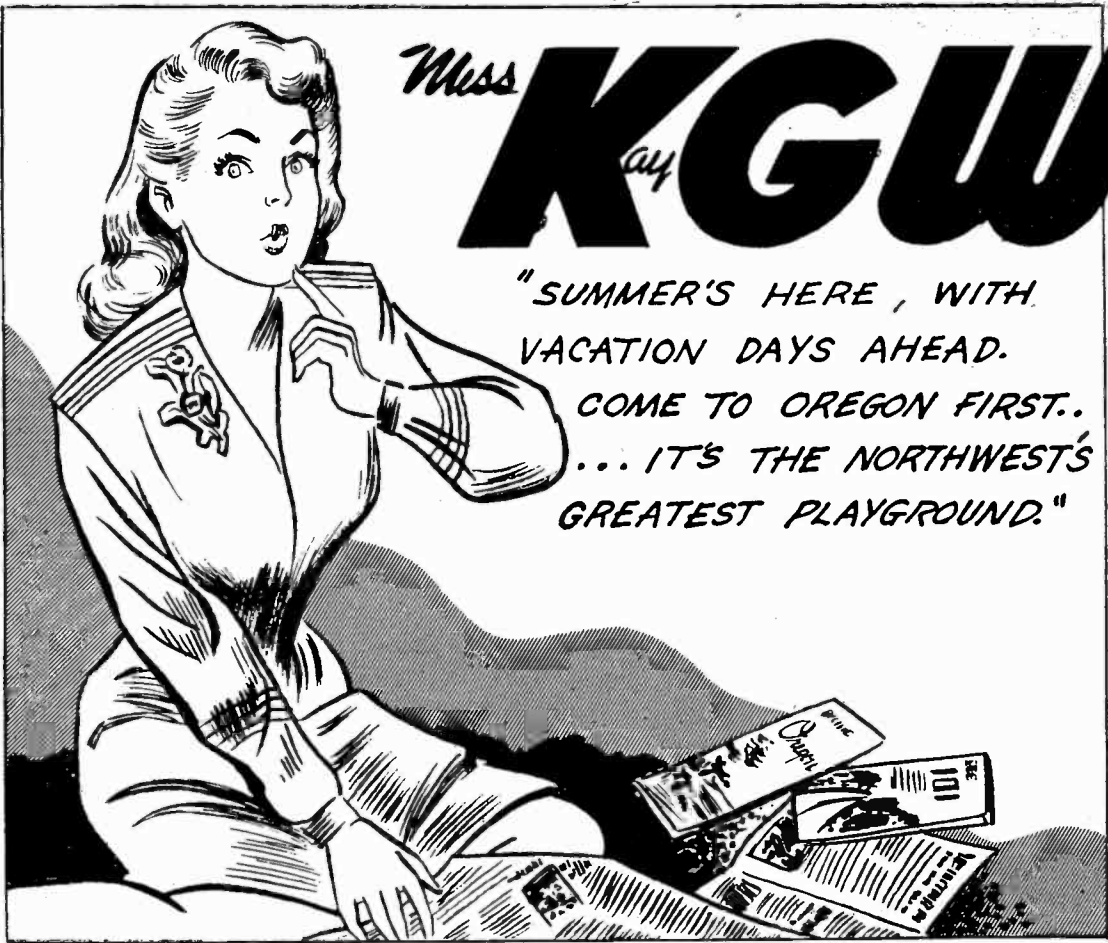

# Miss KGW

"SUMMER'S HERE, WITH VACATION DAYS AHEAD. COME TO OREGON FIRST... IT'S THE NORTHWEST'S GREATEST PLAYGROUND."

"SAILING ON FRESH WATER RIVERS AND LAKES AND INLETS AND RIVER MOUTHS ALONG THE COAST IS ONE OF THE MOST PLEASANT WAYS OF ENJOYING OREGON'S AIR-CONDITIONED CLIMATE."



"PORTLAND IS OREGON'S CONVENTION CAPITAL.... 25 TO 50 THOUSAND PEOPLE WILL ATTEND THE 61 MEETINGS DEFINITELY SET FOR 1946."



"TOURISTS WILL BRING \$100 MILLION INTO THE STATE THIS YEAR. THE AVERAGE TOURIST SPENDS \$12 A DAY.... EACH DOLLAR BRINGS 5.35 CENTS PROFIT TO THE COMMUNITY!"



"KGW ADDS TO THE MILLION PEOPLE IN ITS PRIMARY AREA THE HUNDREDS OF THOUSANDS OF TOURISTS WHO VACATION IN THE STATE. REACH BOTH THESE ECONOMICALLY IMPORTANT GROUPS WITH THE COMPLETE BLANKET COVERAGE OF KGW'S 5000 WATTS!"



"YOU'LL BE BUSY EVERY MINUTE..... FISHING DERBIES, FESTIVALS, RODEOS, REGATTAS, HIKING CAMPING, SKIING, SWIMMING..... AND OREGON'S HOSPITALITY IS AS FAMOUS AS ITS CLIMATE."





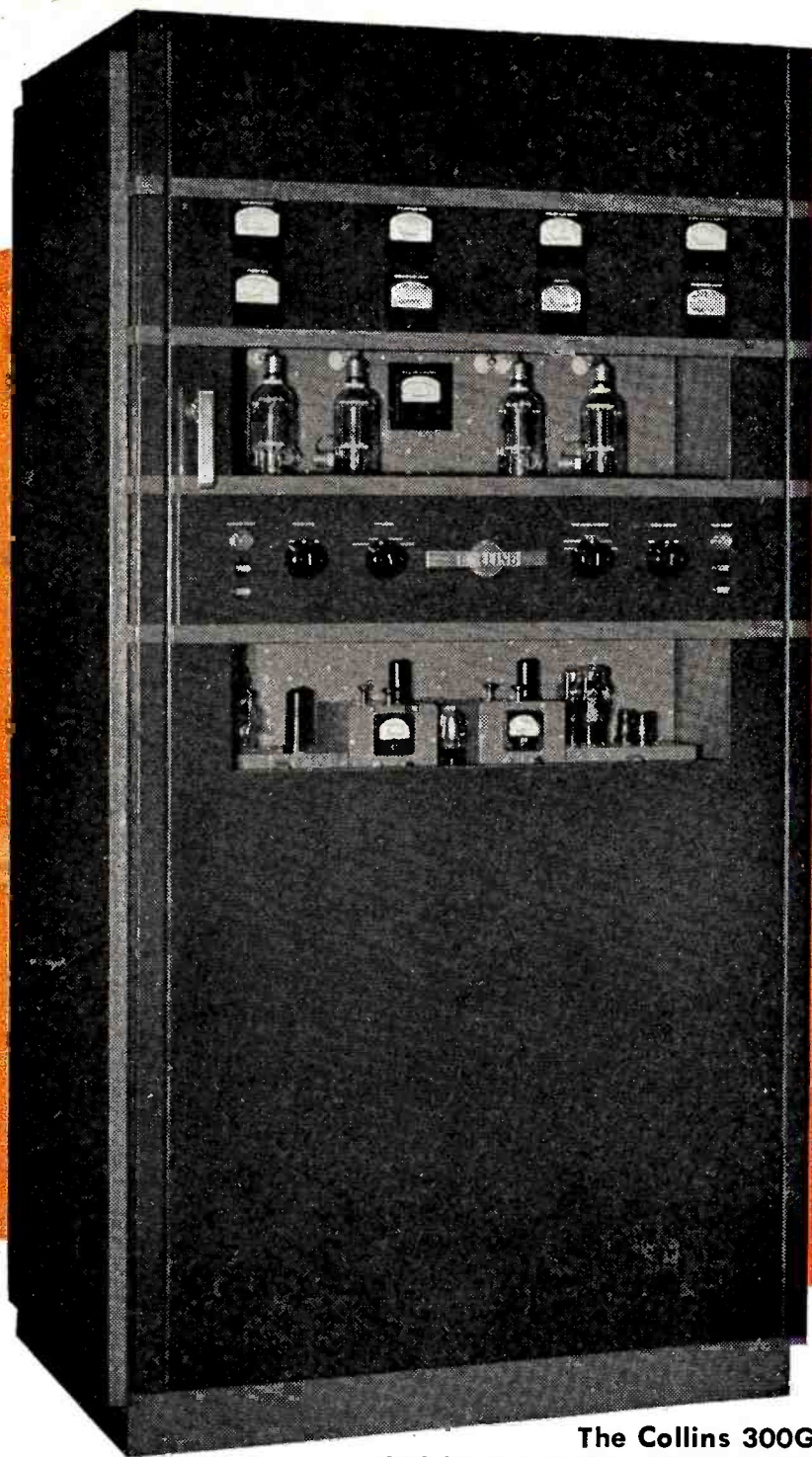

**The Collins 300G  
250 Watt Broadcast Transmitter**

The excellence of Collins broadcast equipment is an accepted tradition, backed by years of reliable service under continuous operation. During the war years, when maintenance was a major problem, owners and operators of Collins equipment found their faith thoroughly justified by the thousands of hours of uninterrupted operation logged on their stations.

The new Collins transmitters and speech equipment reflect the soundest principles of design and construction. By careful attention to detail, and by combining foresight with experience, we have developed high fidelity broadcast equipment that is outstanding for endurance, style, and accessibility.

The 300G 250/100 watt AM transmitter is designed for continuous high fidelity service. The frequency response is within  $\pm 1.0$  db from 30-10,000 cps, and distortion and noise are far better than FCC requirements. Stabilized feedback maintains the excellent performance over variations in operating conditions.

*Your audience  
deserves the  
best*



**The Collins 212A-1 Studio Console**

The Collins 212A-1 speech input console is a packaged unit providing simultaneous auditioning or rehearsing, cueing, and broadcasting from any combination of two studios, an announce booth, a control room announce microphone, two turntables, and six remote lines. The frequency response of 30-15,000 cps is ideal for AM, FM, and Television applications. The chassis rotates within the end supports, permitting maintenance during operation.

Write today for illustrated bulletins describing these and other Collins broadcast equipments.

**Collins Radio Company, Cedar Rapids, Iowa**

11 West 42nd Street  
New York 18, N. Y.

458 South Spring Street  
Los Angeles 13, California

**FOR BROADCAST QUALITY, IT'S . . .**





## Listening Revised By Summer Shifts

Hooper Lists Mr. District Attorney in Top Place

HOOPERINGS for June 30 showed many of the big name programs absent from the first 15 since most of the scheduled cancellations and summer replacements are now in effect. Mr. District Attorney is first, with Eddie Cantor second, Fred Allen third.

Evening sets in use were reported at 21.9, down 2.0 from last time, up 1.4 over last year. Average evening rating was 6.3, down 1.3 from the last report, unchanged from a year ago. Average available audience was 75.5, down 1.5 from last time and up 1.6 over last year. Current total sponsored hour index is 70, compared with 72.75 last report and 74.5 last year.

Top programs were: Mr. District Attorney 15.8, Eddie Cantor 14.7, Fred Allen 14.3, Radio Theatre 13.2, Walter Winchell 12.6, Screen Guild Players 11.7, Jack Haley with Eve Arden 11.4, Suspense 10.8, Aldrich Family 10.6, Take It or Leave It 10.6, Judy Canova 10.5, Fred Waring 10.5, Truth or Consequences 10.3, Abbott and Costello 10.2, Life of Riley 9.5, Inner Sanctum 9.5, People Are Funny 9.5, Man Called X 9.5.

Top ten daytime shows for June 30 were: When A Girl Marries 7.2, Ma Perkins (CBS) 7.0, Breakfast in Hollywood (Kellogg) 6.5, Young Dr. Malone 6.3, Portia Faces Life 6.0, Lorenzo Jones 6.0, Right to Happiness 5.9, Just Plain Bill 5.7, Guiding Light 5.6, Breakfast in Hollywood (P&G) 5.5, Widder Brown 5.5, Today's Children 5.5.

### ABC Video Change

ABC's video schedule has been revamped to permit the inauguration of two new programs: *The Society of Amateur Chess* which debuted July 5 on WPTZ Philadelphia with Russell Patterson, artist, as guest, and a video version of the radio series, *My True Story*, which will be telecast on WRGB Schenectady starting July 10.

HONOLULU

# KGU

**FOR FULL COVERAGE OF HAWAII**

N. B. C. IN THE PACIFIC SINCE 1931

Affiliated with  
THE HONOLULU ADVERTISER  
Represented by  
THE KATZ AGENCY, INC.

## Radio Tests Pulse of Nation In Aftermath of OPA Removal

THE TERMINATION of the OPA last week was discussed on all four networks and most of the New York independent stations by Government officials, heads of department stores, grocery chains, movie houses and veterans' organizations.

WNYC New York, on July 1, devoted the entire day to price control discussion giving retail store executives and heads of veterans' organizations five minutes each to voice their opinions. Among those who spoke were Frank Manley, head of the Catholic War Veterans; Elisha Walker, chief economist, R. H. Macy & Co., New York; Dorothy Shaver, president of Lord & Taylor, New York; and representatives from the American Veterans' Committee, American Legion, etc. Store executives pledged to keep prices at present levels while veterans' chiefs made pleas for price control on behalf of the returning GIs.

On July 2 MBS presented a half-hour program, *America Without Price Control*, 10:30-11 p. m., which reported the results of surveys of conditions in New York, Philadelphia, Boston, Chicago, Denver, Cleveland, Detroit, Washington, Indianapolis, Louisville and Los Angeles.

NBC, during the July 1 broadcast of *News of the World*, 7:15-7:30 p. m., broadcast summaries from its commentators in Cleveland, Chicago, San Francisco and Washington.

On June 29, as soon as the President's veto was announced, NBC switched to WRC Washington where commentator Richard Harkness introduced Chester Bowles, Stabilization Director, who spoke

### Publicity Club in N. Y. Elects Underhill Head

ARTHUR J. C. UNDERHILL, director of public relations, Rayonier Inc., New York, was elected president of the Publicity Club of New York last week. Other officers chosen were as follows: Mae Wagner Carlisle, advertising manager and publicity director of Dictograph Products Inc., New York, first vice president; Lt. Col. Dorsey Owings, Second Service Command, second vice president; Adrienne Minden, public relations director of Pratt Institute, New York, recording secretary.

Directors named were: Will H. Yolen, publicity director, WNEW New York; Shepard Henkin, publicity director, Hotel New Yorker; Mary Madeline Riddle, of Ames & Norr, New York, and Amy Blaisdell, public relations director of Helena Rubinstein Inc., New York.

FRANK DANZIG, former chief of operations of American Forces Network in Europe, is now producing his own radio shows. His first is "Justice," a half-hour dramatic program.

briefly praising President Truman for his stand on the bill. The network continued its coverage of the OPA situation interrupting programs all through that day with latest developments.

Reports from Detroit, Minneapolis, Dallas, Charlotte and New York were aired by CBS on the July 1, 11 a. m. news roundup and on July 2, at 7 p. m., the network presented Sen. E. H. Moore (R-Okla.), who spoke on the "Discontinuation of the OPA."

Joseph D. McGoldrick, New York State Housing and Rent Commissioner, was heard on the ABC New York State Network July 1, 6:30-6:35 p. m., discussing rent control, and at 9:30-9:55 p. m. the network presented interviews in 15 cities with housewives and retailers on the question "Are Prices Going Up in Your City," while Paul Porter, OPA Administrator, was heard the same evening, 10:15-10:30, speaking from Washington.

WEAF New York on July 1 broadcast an eye-witness account of the results of the first day's trading after removal of price ceilings, on Don Lerch's *Modern Farmer* program.

## Commissioner Assures Radio Coverage of Fires

ASSURANCE by the New York fire commissioner that radiomen would not be inhibited in covering fires within the city despite a resolution passed a fortnight ago by the Assn. of Eastern Fire Chiefs to limit radio coverage was received last week by Dave Driscoll, director of news and special features at WOR.

Mr. Driscoll, observing the fire chiefs association had charged that radio reporters had impeded fire department operations, wrote to William G. Wandras, fire chief of Kearney, N. J. and president of the association, for an explanation of the resolution and to New York Fire Commissioner Frank J. Quayle.

Chief Wandras at week's end had not replied, but Commissioner Quayle wrote Mr. Driscoll that broadcasting companies "who render a service at or during fires in New York City are of inestimable value . . . please be assured that you are at liberty to call upon me and my associates for any enforcement whatsoever."

CBS series "Assignment Home," dealing with returned servicemen's problems, July 21 switches time from Sat. 3-3:30 p. m. to Sun. 2-2:30 p. m.

**EXCLUSIVE**

**WITH LOCAL NEWS**

**FOUR**

**TIMES DAILY**

*that's why people*  
**STAY tuned**  
*to*

# WILM

**ON YOUR DIAL**

**1450**

**THE VOICE OF MUTUAL IN WILMINGTON, DEL.**



# The

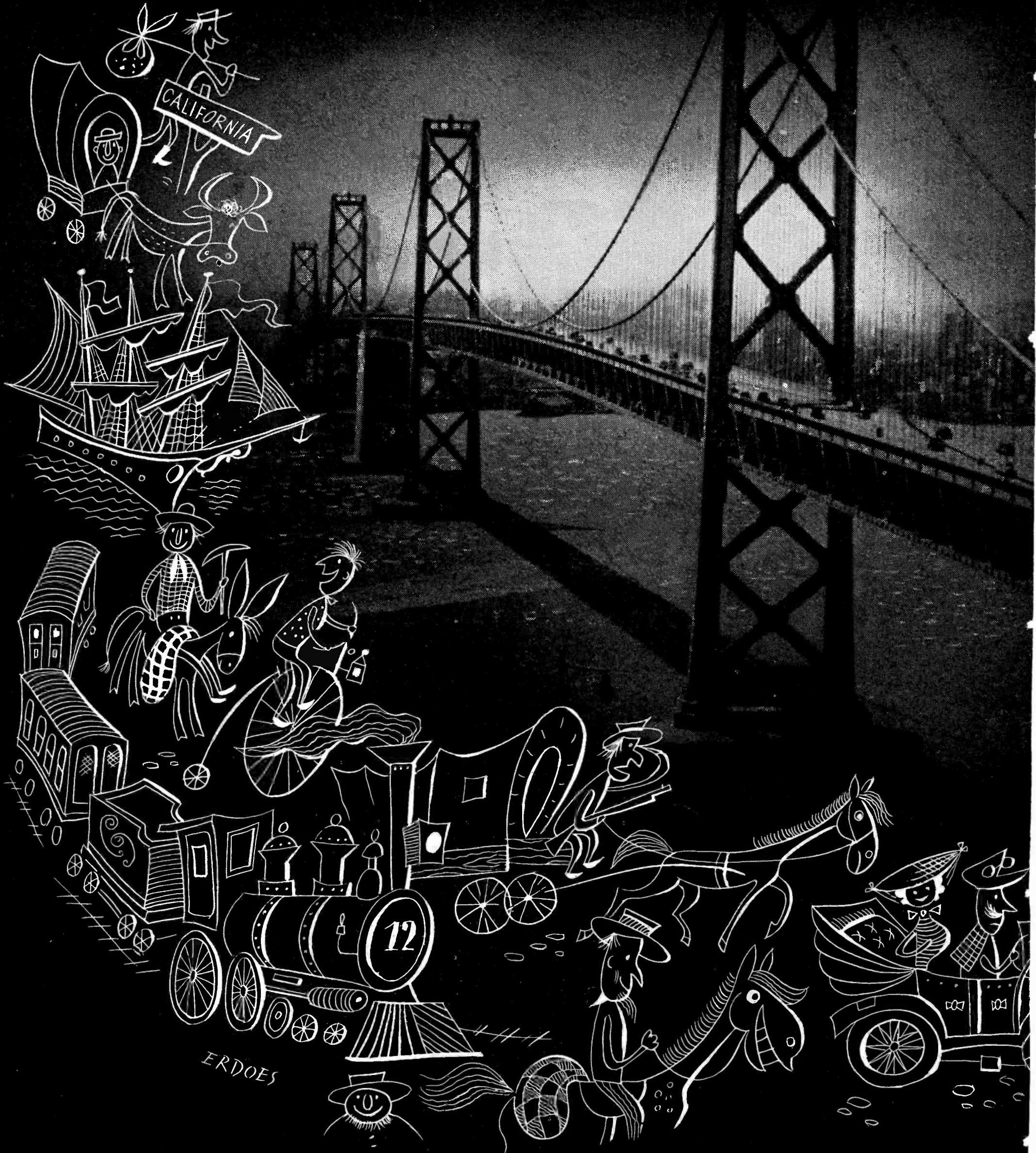



# *past is prologue*

Northern California is rich in tradition with a history that stands as tribute to the pioneer spirit of early America. Rich as this tradition is, it has always served as a background for continued progress. The past of Northern California is colorful—its future exhilarating.

Since 1940, the six-county metropolitan district of San Francisco has had the greatest population growth of any corresponding area in the United States—and the growth continues. Today, 4,500 diversified factories are operating in the Bay Region alone and every day brings new industry . . . new people . . . new markets.

Acutely aware of the blending of the old and the new, KPO brings to listeners in Northern California varied radio fare, skillfully presented. Here is one outstanding example of exciting local programming:

#### **THIS IS YOUR HOME**

. . . a half-hour dramatic history of San Francisco's rise as a great city of America

presented each Sunday morning by W. & J. Sloane, one of the city's leading furniture stores. Since 1941 both long-time residents and newcomers in Northern California have thrilled to the vivid stories of the early Golden Gate days . . . stories of the men and women who contributed to the building of the West.

Broadcast in the form of dramatic narration, with well-integrated sales messages, *This Is Your Home* has helped to build keen community spirit in the 40 wealthy counties of KPO's daytime primary area. W. & J. Sloane's constant renewals of sponsorship are striking evidence of the program's selling power.

#### **KPO, TOO, IS RICH IN TRADITION**

For over 24 years listeners in Northern California have looked to KPO for the best in radio programs. The NBC Parade of Stars, local features like *This Is Your Home* and 50,000 watts of power have given KPO a dominance for sponsors obtainable in no other way.



**FIRST IN NORTHERN CALIFORNIA**

**KPO** 

**50,000 WATTS 680 KC**

**Represented by NBC SPOT SALES**

THE NATIONAL BROADCASTING COMPANY

*The most sought  
after treasure in  
broadcasting is—*

# RADIO HOMES

**WWVA Primary Area Radio  
Homes number 1,747,955  
which are located in the Steel  
and Coal Belt of the Nation  
—that's western Pennsyl-  
vania, Eastern Ohio and  
West Virginia. There are  
1,350,417 more in an attrac-  
tive secondary area. 620,083  
pieces of mail within 12  
months prove WWVA's pop-  
ularity among those radio  
homes.**

**ASK A JOHN BLAIR MAN**

**BASIC A-B-C NETWORK**

ONE OF THE WORLD'S BETTER RADIO STATIONS  
**WWVA**  
50,000 WATTS WHEELING, WEST VA.

## TALENT FARM-OUT PLAN

**WKY and NBC Arrange for Promising Net Artists  
To Work at Station for Limited Periods**

WKY Oklahoma City claims another first with the consummation of a talent "farm-out" agreement with NBC. Plan was developed on WKY's initiative in conferences between P. A. Sugg, manager of the station, and Clarence L. Menser, NBC vice president in charge of programs.

Already loaned to WKY under the agreement is Tommy Allen, baritone and returned overseas veteran, who was given an NBC contract after auditioning on NBC's *Welcome Home*. Sponsoring Mr. Allen in Oklahoma City on a thrice weekly show for 13 weeks is the Oklahoma Gas & Electric Co., which has already expressed its satisfaction of the plan to WKY.

When Mr. Allen returns to the network at the end of 13 weeks, arrangements will be made for other network talent to come to WKY for limited periods.

The baritone was selected by WKY after audition records of four artists, culled from hundreds available in the *Welcome Home* series, had been sent to WKY. While at the station, Mr. Allen practices one hour daily with Allan Clark, director of WKY's music department who is assisting on the educational training project, and spends another hour each day in music selection and study. This is in addition to his regular program rehearsals and shows.

Arrangement, which is said to have the enthusiastic endorsement of Niles Trammell, NBC president, is also well received by Mr. Sugg who stated "We think the agreement a sound one, and are pleased, indeed, that NBC thinks enough of our operation to take first shot with us at it."

### Adler Starts Firm

PAUL F. ADLER, recently released from the Army Recruiting Publicity Bureau, has opened a radio advertising service to be known as Paul F. Adler Advertising, located at 385 Madison Ave., New York. As his initial venture, Mr. Adler has secured from Simon and Schuster, publishers, the exclusive radio rights to the book *Starling of the White House* which he has packaged as a half hour radio series. Prior to entering the army, Mr. Adler had been radio director of the War Finance Committee for Southern California and before that he headed the Eastern Advertisers' Service in Los Angeles.

NATIONAL ADVERTISING Agency Network, at their annual convention held in Colorado Springs, Colo., judged "Finders Keepers" show, conceived by WOL Washington, D. C. and the Henry Kaufman Adv. agency, that city, the best local radio show. Program is audience participation originating from local drug stores, with Bill Brundige and Dale Morgan m.c.'s.

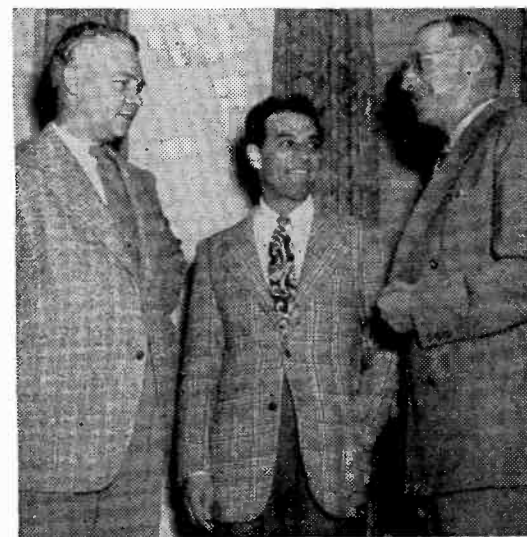

(L to r) Mr. Sugg, Mr. Allen and Paul Hoheisel, advertising manager of the sponsoring Oklahoma Gas & Electric Co.

### Kackley Resigns

OLIVE KACKLEY, WCKY Cincinnati women's commentator since 1938, has resigned effective August 1. Resignation will terminate a continuous service record, which started with initial broadcast in 1938 and heard seven days a week for the succeeding years. An authority on the works and interpretation of Shakespeare, Miss Kackley, upon conclusion of her *Wishing* series, will fulfill speaking engagements.

### New WABC Shows

LOUIS SHERRY Inc., New York (ice cream and candy), has started three participations weekly on the Arthur Godfrey program, WABC New York, Tuesday, Thursday, Friday, 6-7:45 a. m. Agency is Birmingham, Castleman & Pierce, New York. Borden Co., New York (Hemo), has expanded its WABC New York morning news program, 9-9:15 a. m., from Monday, Wednesday and Friday, to Monday-Saturday. Agency is Young & Rubicam, New York.

**No. 1 PHILADELPHIA'S Sports Station**  
BIG LEAGUE BASEBALL  
COLLEGE & PRO FOOTBALL  
HIGH SCHOOL BASKETBALL  
BIG TIME BOXING  
10,000 Watts **WIBG**

REPRESENTED: Nationally by Adam J. Young, Inc.  
In New York by Joseph Lang, 31 W. 47th Street



LOOK TO GATES for

LEADERSHIP...LOOK TO G

for LEADERSHIP

LOOK TO GATES for LEADER

GATES

ERSHIP...LOOK TO GA

TO

O GATES for LEADERSH

L

TO GATES fo

LOOK

AT LEADERSHIP...LOC

LOOK

IP...LOOK TO GATES for LEADI

LOOK

LEADERSHIP

GATES for

LOOK TO

for GREATER EFFICIENCY...  
for "FINGER-TIP" CONVENIENCE...  
in  
**STUDIO CONTROL**

FOR...  
EYE...  
APPEAL

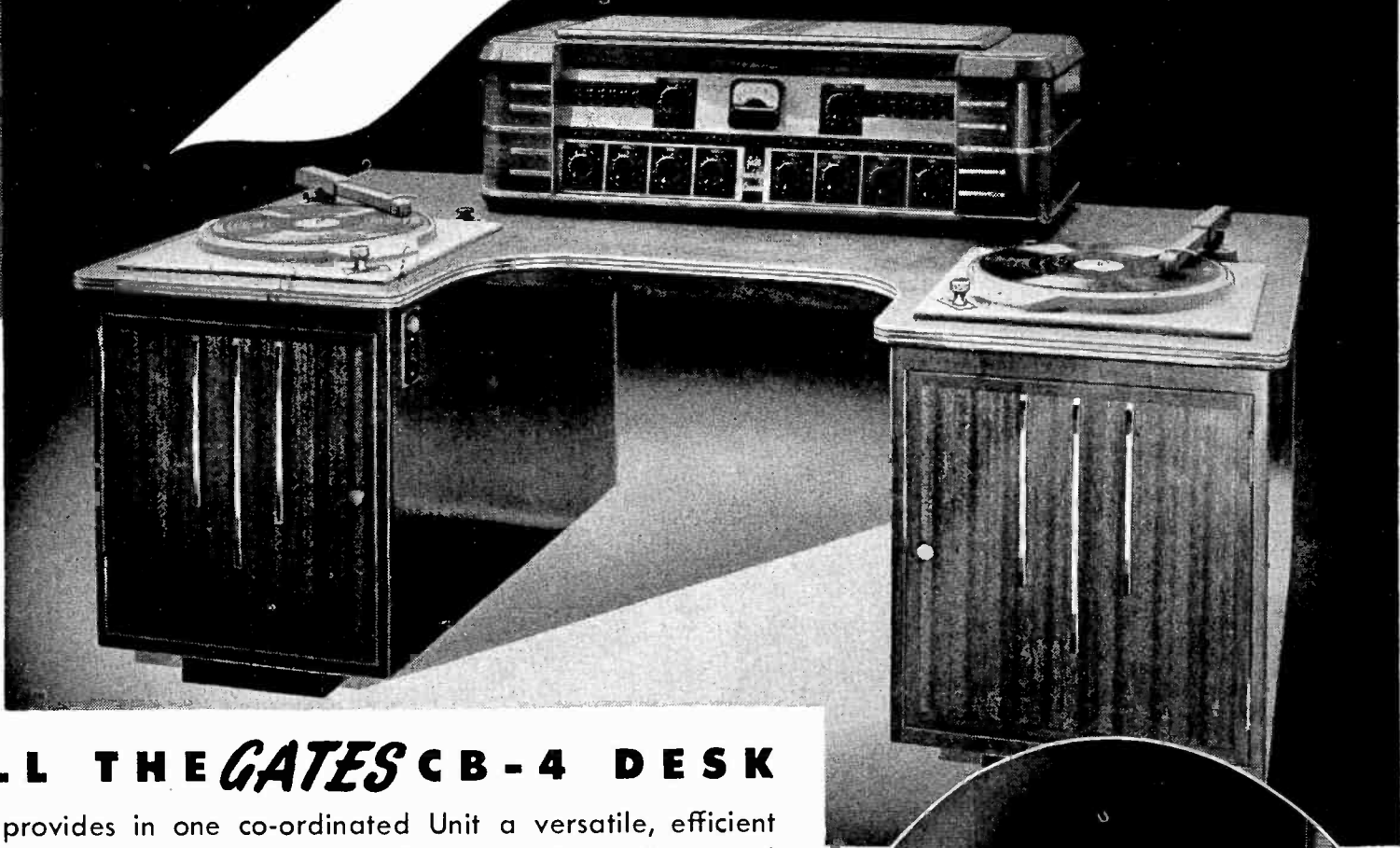

### INSTALL THE *GATES* CB-4 DESK

It's new... and provides in one co-ordinated Unit a versatile, efficient Speech Input Console and 2 Transcription Turntables (for split-second handling of re-broadcasts with greater convenience and ease of control. Table is styled in the modern manner of fine hardwoods to harmonize with any type installations. Adaptable to any medium or small size Station.

**30 SERIES CONSOLE**—provides 5 microphone channels, 2 transcription control channels, 1 channel for remote control. Six remote lines and two network lines are also accommodated. Power supply is installed in end compartment of Desk. This is a fine Unit with many other special features.

**TRANSCRIPTION TURNTABLES**—improved Gates CB-11s, installed at either end of Desk offered in your choice of "lateral" or "vertical-lateral" pickups. Accommodate any standard size recordings on either 33 1/3 or 78 R. P. Ms. Properly designed

Filters are installed to work with standard or orthoacoustic recordings.

**DESK**—Beautifully made for showmanship with end compartments constructed to mount any standard 19-in. panel equipment. Backs may be removed for examination of equipment when desirable. Compartments may be employed for filing transcriptions, etc. The CB-4 DESK is available with suggested equipment as shown, all wired for use when shipped. For any other requirements to suit your special needs, our engineers are available to discuss these needs.



Turntable equipment is conveniently located in the CB-4. The "On-and-Off" Switch and Pilot Light are just inside the knee-hole for finger-tip control, as shown.

(Write for detailed specifications)

NEW YORK  
OFFICE:  
9th Floor • 40 Exchange Place

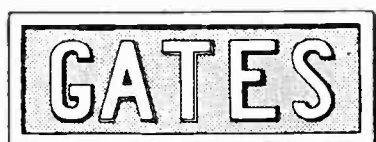

**RADIO CO.**  
QUINCY, ILLINOIS

SOLD IN CANADA BY:  
Canadian Marconi Co.,  
Ltd., Montreal

**EXCLUSIVE MANUFACTURERS OF RADIO TRANSMITTING EQUIPMENT... SINCE 1922**

## NBC Has Discontinued Comparative Schedule

DISCONTINUANCE of the NBC comparative network schedule, which has been printed for the past ten years, has been announced by Charles P. Hammond, NBC advertising and promotion director.

The schedule was originally planned to supply program ratings in time-table form for quick reference. Due to the temporary discontinuance of the CAB program rating service the network's schedule principal purpose is at an end, according to Mr. Hammond.

NBC comparative network schedule was also made available without ratings to advertisers, agencies and stations.

## KYW Workshop

KYW Philadelphia, in an introductory broadcast to its Radio Workshop course, aimed the program at acquainting educators with the various phases of the course. Among the speakers were: Gordon Hawkins, educational and program director of Westinghouse Radio Stations; Gertrude A. Golden, district superintendent and chairman of public relations for public school system; Dr. Merrill Bush of Temple U.; Dr. Leslie Cushman, asst. superintendent of public schools; Dr. Chester Stocker, U. of Pennsylvania; and F. M. Sloan, asst. manager of WRS.

## HAVANA RADIOCENTRO Cuban Capital's New \$2,000,000 Structure To House CMQ Network Headquarters

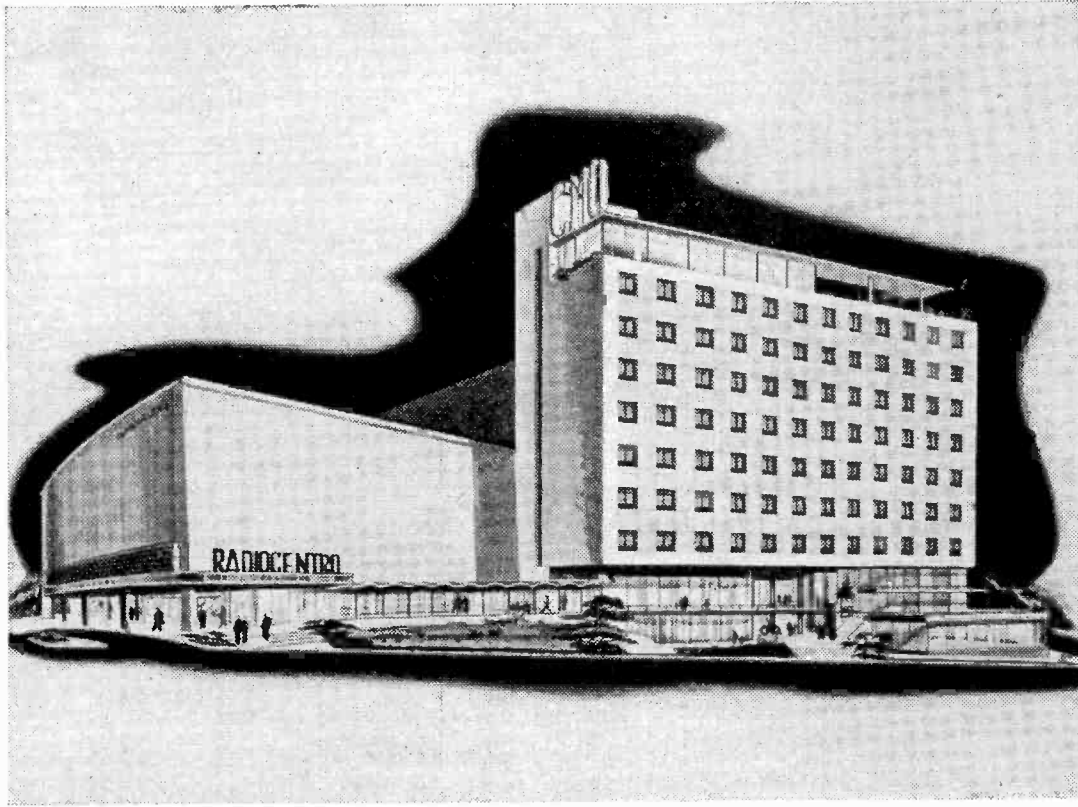

The Radiocentro when completed

CONSTRUCTION on the new \$2,000,000 Radiocentro in Havana, Cuba, is expected to be completed by next Spring. The edifice will occupy 60,000 sq. ft. in the Havana residential section of Vedado and will primarily house radio and television studios of the CMQ Network

as well as other entertainment activities.

Idea for the structure was originated by Goar Mestre, president of the CMQ Network. When finished, Radiocentro will include a 1,750 seat theatre for Warner Bros., a 500-seat newsreel theatre; 46,000 sq. ft. of office space, a rooftop night club, 10 store premises for a bank and lesser size business establishments, restaurants and cocktail lounges and a bowling alley.

Cornerstone ceremonies were held last March, attended by President Grau San Martin and high officials of the republic. In his speech then President Martin paid tribute to the many important services of CMQ Network since its founding in 1933.

Thirty-four-year-old Mr. Mestre, born in Cuba and a graduate of Yale U. in 1936, worked in the New York and Buenos Aires offices of National Carbon Co. from 1936 to 1938. Returning to Cuba in 1938, he founded Bestov Products, S. A.; in 1942 started Publicidad Mestre & Co., one of Cuba's largest advertising agencies.

In 1943 Mr. Mestre purchased controlling interest of Circuito CMQ, S. A., and has been running it ever since.

Circuito CMQ comprises the 25 kw CMQ and 5 kw COCQ in Havana; 10 kw CMHQ Sta. Claire; 10 kw CMJL Camaguey; 10 kw CMKJ Holguin; 1 kw CMKU Santiago de Cuba.

PHILIP LAMPKIN, former AFRS chief in Panama, has been recalled to active duty and recommissioned a major as officer-in-charge of the radio section, Recruiting Publicity Bureau, Governors Island, New York. He will be in charge of production of "Voice of the Army," 15 minute transcribed program distributed to 800 stations in the states and territories.

## Revised 'Retailing Ideas' Includes Air Advertising

3033 RETAILING IDEAS, by Emanuel Lyons (compiler and publisher, \$3.50.)

FIRST revision of this compilation of retail ideas in a decade includes a short chapter on radio advertising, along with a number of radio references scattered throughout the book. It was published first in 1933 as 2222 Retailing Ideas, revised in 1937 as 2800 Ideas.

Each idea is presented tersely in a few lines. Separate chapters cover various types of articles sold in stores. Foreword is by Paul H. Nystrom, professor of marketing, School of Business, Columbia U.

## WEAF News Service

PERMANENT radio telephone lines direct from the studios of WEAF New York to the editorial offices of the Newark (N. J.) Star Ledger, the Bronx Home News, Brooklyn Eagle, Long Island Daily Press and the news bureau of the Westchester County daily newspapers, located in the offices of the White Plains (N. Y.) Reporter-Dispatch, have been installed for the station's forthcoming new news program. Show, 15 minutes in length, will consist virtually of all local news.

## Appliance Guide

MANUAL has been published by Dept. of Commerce titled Establishing and Operating an Electrical Appliance and Radio Shop. Edited by Donald S. Parris of the Department, the manual states that rural districts are a relative unexplored source of business for dealers in electrical equipment, appliances and radios, whereas the field is overcrowded in most cities. Farm homes are declared to offer a tremendous market for radios. Suggestions are given on choice of location, market analysis and other factors.

PAN AMERICAN BROADCASTING Co., New York, has been appointed U. S. representative for Lacadena Azul, Ecuador's only network, with stations in Ibarra, Quito, Ambato, Cuenca, Guayaquil and Portoviejo and broadcasts over nine transmitters in six areas of concentrated population.

# KPAC

## Deepest in the Hearts of Texans

# MBS



Representatives

## Sears & Ayer, Inc.



---

*A*nnouncing—

**THE OPENING OF THE  
ATLANTA OFFICE OF  
EDWARD PETRY & CO., INC.**

*Managed by*

**Charles F. Grisham**

The New Palmer Building

Marietta St., at Forsythe

Atlanta 5, Ga.

# Standards Subject to Review, NAB Program Group Decides

NAB Standards of Practice adopted last summer will be subjected to constant review and interpretation, the new NAB Program Executive Committee decided at its July 1-2 meeting held at the Drake Hotel, Chicago.

The committee went into detailed plans for a new program department to be set up within the NAB. The plans were not made public but will go before the NAB board next month. Personnel selection is to be left to President Justin Miller and Executive Vice President A. D. Willard Jr.

Creation of the new standing committee was ordered by the board at its May meeting. It replaces the Agricultural Directors, Radio News, Music Use and Standards of Practice committees, with membership representing all these former groups.

## Up to Licensees

"In selecting this committee," President Miller said after the meeting, "great care was exercised to choose men whose experience and record justified the hope that they could contribute constructively to our industry program policy. This hope has been fully realized.

"In our deliberations we have had foremost in our minds that the responsibility for programs rests

with the individual licensee. We reviewed all phases of programming: news, agricultural, religious, controversial public issues, and particularly the NAB Standards of Practice as they have been amended from time to time—most recently in January 1946. It was the unanimous view of the committee that the Standards of Practice is not a static document but must, as in the past, be subjected to constant review and interpretation.

"I shall submit the detailed recommendations of the committee to the board of directors when it meets Aug. 5-7 and I am confident that the policy promulgated will meet with industry cooperation and public approval."

Attending the meeting besides Mr. Miller were: Edgar L. Bill, WMBD Peoria; Henry W. Slavick, WMC Memphis; Stanley Hubbard, KSTP St. Paul; Karl Koerper, KMBC Kansas City; Merle Jones, WOL Washington; Glenn S. Snyder, WLS Chicago; Adolph Hult, MBS Chicago; Clarence Menser, NBC New York; Herb Plambeck, WHO Des Moines; E. R. Vadeboncoeur, WSyr Syracuse; C. E. Arney Jr., NAB.

## Beville Honored

HUGH M. BEVILLE Jr., NBC director of research, has been awarded the Croix de Guerre with gold star by General Charles de Gaulle for exceptional war service rendered in the course of operations for the liberation of France. Serving throughout the European campaign on the staff of Gen. Courtney H. Hodges, commanding general of the First U. S. Army, Mr. Beville was chief of the counter-intelligence division of the army's G-2 section and directed the capture of Nazi leaders in territory overrun by General Hodges' army.

JOSEPH LEOPOLD, former manager of the copy department of Compton Advertising, New York, has been appointed vice president and director of copy of Federal Advertising Agency, New York.



Of course you weren't. You know a good radio buy when you see one. Next time you want to cover the Philadelphia market, look into the coverage WIP gives you in its 14,000 square mile area comprising nearly 8 million prosperous people.

WIP—FM  
**WIP**  
5000 WATTS IT'S MUTUAL  
610 ON DIAL

REPRESENTED NATIONALLY BY GEO. P. HOLLINGBERY CO.

\*CREDIT GARSON KANIN, PLAYWRIGHT

**KGHF**

Pueblo, Colo.

Walter's Beer

New  
New York Office  
475 Fifth Ave.

AN ARTHUR B. CHURCH PRODUCTION

Hotel Pickwick, Kansas City 6, Mo.

FREE & PETERS  
National Representatives

John Esau General Manager

**KTUL**  
5,000 WATTS • TULSA



# YOU MAY BE ABLE TO KNOCK A GOLF BALL 445 YARDS\* —

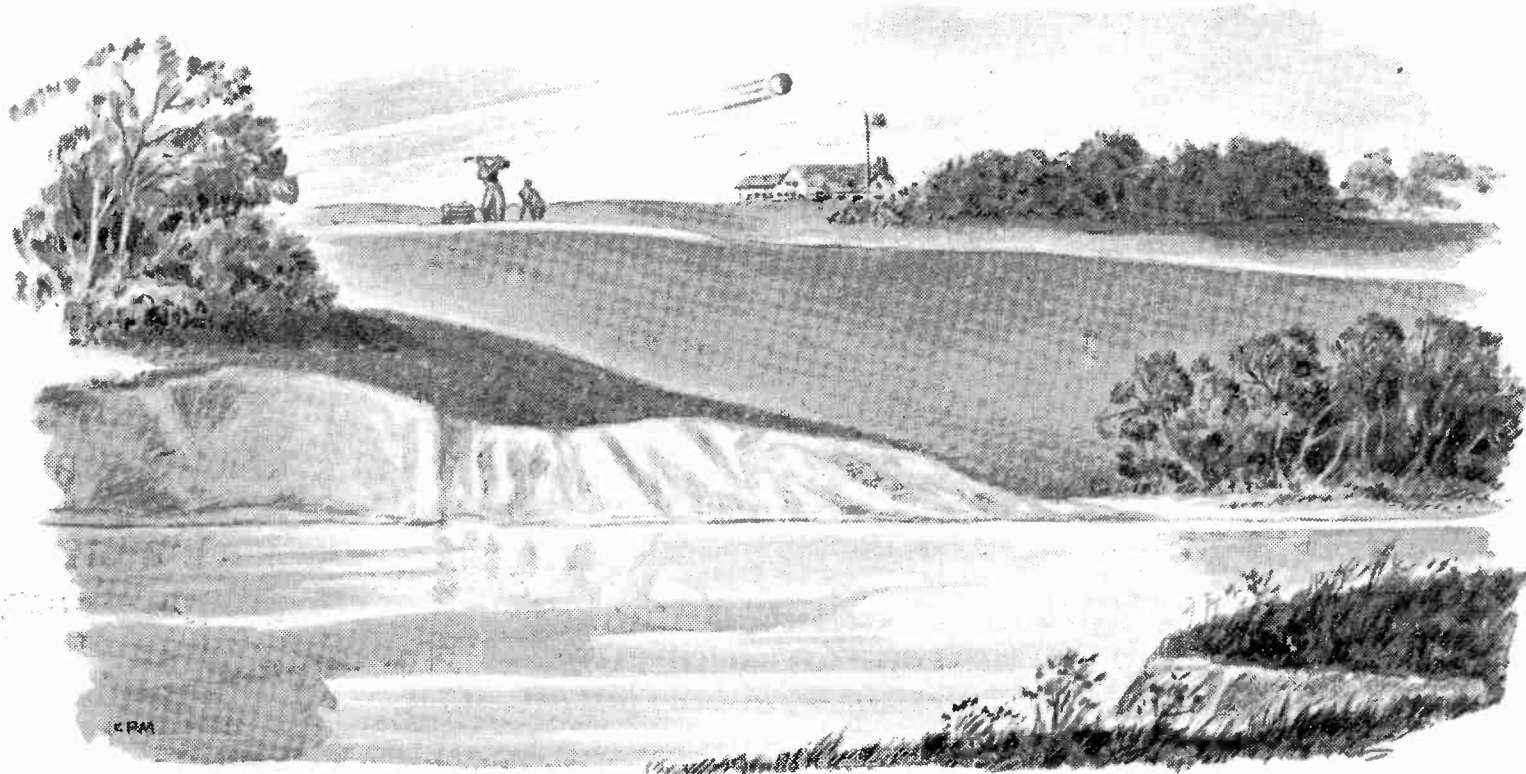

## **BUT**—YOU CAN'T “HOLE OUT” IN WESTERN MICHIGAN WITHOUT WKZO - WJEF!

A study of the latest network coverage maps for Western Michigan reveals some facts that show WKZO (Kalamazoo) and WJEF (Grand Rapids) as a *head-and-shoulders “stand out”* over any other station or combination of stations in this area.

The maps show that the WKZO-WJEF combination *delivers two-and-one-half times more radio homes (nighttime) than any other station or combination*

*of stations.* And this despite the fact that the CBS method (on which WKZO-WJEF coverage is computed) is the most exacting formula used by any network.

If you are buying time in Western Michigan, or considering it—you owe it to yourself to *study* the situation here, and get the *true* picture. We'll gladly send you the statistics as taken from the NBC and CBS data—or ask Lewis H. Avery, Inc.

\* R. C. Bliss did it in England, in 1913.



**BOTH OWNED AND OPERATED BY FETZER BROADCASTING COMPANY**

**LEWIS H. AVERY, INC., EXCLUSIVE NATIONAL REPRESENTATIVES**

## toward a practical definition of the public interest . . . .

"How did you get so good so fast? Now, I guess I'll have to start listening to the radio again. . . ."

"The program is a definite contribution to life in Cincinnati and fulfills a need long felt here."

"This is the best thing done in 10 years of radio—the time and the program . . ."

"We want to thank you . . . the best radio entertainment at the right time, we've had for a long time . . ."

". . . thought, consideration, and painstaking which went into the planning of this great civic gift which you have undertaken, to make Cincinnati a bigger, greater and nobler place in which to live."

"Aside from the value of Evening Concerts from a commercial or a purely public relations viewpoint, you are making what seems to be a measurable contribution to the cultural life of Cincinnati."

"Your recently inaugurated program of 90 minutes on WSAI of symphony without interruption, save for the mention of your names gives me new heart in the future of American broadcasting . . ."

"It is my opinion that your radio station is performing a valuable service to the public in presenting truly good music . . ."

"Sincerest congratulations to your fine station and the splendid public service you furnish to lovers of worthwhile music."

"We enjoy your program and greatly appreciate the policy which made it possible!"

"My radio has been on during the past week more than it has during the past six months."

"I enjoy your program 'Evening Concerts' very much. I hope that it will continue. I haven't always been an admirer of the finer types of music, but it's just such programs that have contributed to my liking classical music."

This is my first fan letter. I am so thoroughly delighted over your new program that I feel forced to thank you . . . and I salute the Mabley and Carew Company and WSAI for daring to rise above the so-called 'popular' radio to give the public something worthwhile."

"My sincerest congratulations on your new program over WSAI. At last we are getting a high class form of entertainment as well as radio advertisement . . ."

"I am not a regular member of the 'writing public', but I feel that the least I can do is to thank you for the excellent programs."

"For many years I have been a radio fan, but this is the first time I have written a 'fan letter' . . . Thank you so very much for the deep pleasure you are giving to a very lonely woman . . ."

"To the best of my knowledge, this is the first piece of fan mail I have ever written, but I think you deserve congratulations . . ."

"Please count me as one of your very enthusiastic listeners. You are performing a real service to the community."

"You hearten us. Perhaps we are wrong. Perhaps it may be worth while to turn on the radio once in a while to see what we can find . . ."

"Your recorded Symphony Concerts are a Godsend—a rare delight for which I am most grateful. I hope nothing may happen to lower their fine standards."

"It is a special pleasure and privilege to be able to hear concert music during the week, when formerly we could only have that kind of musical entertainment on the radio on weekends and Monday . . ."

"Just to let WSAI know that the Evening Concerts are greatly enjoyed—not only by myself, but by the entire family. At last one of our stations has taken the initiative to show that good music is really appreciated. Your selections are excellent . . ."



**A**FTER a quarter century of broadcasting, the term which epitomizes the responsibility of radio to the people, *the public interest*, still eludes definition.

Although many broadcasters, either intuitively, or through experience in serving the public, have an accurate sense of this interest, it is probable that the full implications of the phrase will never be captured by words.

However, some of the yardsticks by which this interest is measured are tangible, and are solid, sure indications by which we may be guided. And none is more sure than that found in natural, spontaneous expression on the part of the people themselves. When a radio program elicits this response we may be certain that *the public interest* is being served.

Reproduced on the opposite page are excerpts from letters written to WSAI and WSAF sponsors, expressing appreciation for the fine programs now an established part of our broadcasting schedule. Most of these refer to WSAI's new "Evening Concerts," sponsored by Mabley & Carew, Cincinnati's leading specialty store.

While these are but a few of many, it is not their volume, but the character of expression which gives them relevance. Each letter tells of the fulfillment of a personal *need*. Each speaks of a service which has enriched the *personal experience* of the writer. *None* of the hundreds received was prompted by an element of pecuniary gain. Most came from persons who seldom write radio stations, and many begin "This is my first 'fan letter' . . ."

Here is *the public interest* . . . voiced by the public itself. We do not imply that such response is the sole criterion of service to the public, but in the case of the letters shown here, the evidence of that service is irrefutable.

**A Marshall Field Station**  
Represented by Lewis H. Avery, Inc.

**W S A I**

115 EAST FOURTH ST. CINCINNATI, OHIO.



## FCC Procedure

(Continued from page 15)

suspicion of "political favoritism" in granting construction permits and licenses is Section 11, covering examiners, text of which follows:

Subject to the civil-service and other laws to the extent not inconsistent with this Act, there shall be appointed by and for each agency as many qualified and competent examiners as may be necessary for proceedings pursuant to Sections 7 and 8, who shall be assigned to cases in rotation so far as practicable and shall perform no duties inconsistent with their duties and responsibilities as examiners.

Examiners shall be removable by the agency in which they are employed only for good cause established and determined by the Civil Service Commission (hereinafter called the Commission) after opportunity for hearing and upon the record thereof. Examiners shall receive compensation prescribed by the Commission independently of agency recommendations in ratings and in accordance with the Classification Act of 1923, as amended, except that the provisions of paragraph (2) and (3) of subsection (b)

of Section 7 of said Act, as amended, and the provisions of Section 9 of said Act, as amended, shall not be applicable.

Agencies occasionally or temporarily insufficiently staffed may utilize examiners selected by the Commission from and with the consent of other agencies. For the purposes of this section, the Commission is authorized to make investigations, require reports by agencies, issue reports, including an annual report to the Congress, promulgate rules, appoint such advisory committees as may be deemed necessary, recommend legislation, subpoena witnesses or records, and pay witness fees as established for the United States courts.

This section is designed to afford greater prestige to the decisions of administrative agencies and to assure a higher caliber of administrative hearing officials. Examiners cannot be removed on complaint by an agency to which they are assigned without a hearing before the Civil Service Commission. Salaries are fixed by FCC and not the individual agencies.

Closely related to Section 11 are several other sections, which set

forth the manner of procedure. One of the most important to broadcasters is Section 5 (c) which provides for separation of functions.

Officers who conduct hearings shall, under the Act, make the recommended decision or initial decision. No hearing officer "save to the extent required for the disposition of ex parte matters as authorized by law" is permitted to "consult any person or party on any fact in issue unless upon notice and opportunity for all such parties to participate."

Hearing officers shall not be responsible to or "subject to" the "supervision or direction of any officer, employe, or agent engaged in the performance of investigative or prosecuting functions for any agency."

By the same token no officer, employe or agent "engaged in the performance of investigative or prosecuting functions for any

## One-Man Staff

GIVING his staff—producers, directors, writers and secretaries—a vacation from noon Wednesday (July 3) until today (July 8), Paul B. Mowrey, national director of television for ABC, single-handed ran his department last week. Among other duties, he personally handled ABC's video shows on WABD New York Thursday, and Friday on WPTZ Philadelphia.

agency in any case shall, in that or a factually related case, participate or advise in the decision, recommended decision, or agency review" except as "witness or counsel in public proceedings." It is intended to assure that no investigating or prosecuting officer shall directly or indirectly influence or control the operations of hearing and deciding officers, except as participants in public proceedings. In cases of mutually exclusive applications, for instance, the applicants concerned and FCC counsel will be given equal status before examiners.

Both Senate and House Judiciary Committees, which piloted the bill through Congress, reported considerable criticism of decisions where an agency is both prosecutor and judge on the grounds that there was little opportunity for impartiality. Section 5(c) was drafted to overcome those objections. It does not apply, however, to rate-making decisions where the advice and counsel of expert staff members is needed by the governing agencies.

## Congressional Intent

It was the intent of Congress to force a complete separation of functions on all administrative agencies by enacting Section 5(c), according to lawyers who have studied the new law.

Investigations beyond the jurisdiction of agencies are precluded by Section 6(b) which provides that every person "compelled to submit data or evidence shall be entitled to retain or, on payment of lawfully prescribed costs, procure a copy or transcript thereof, except that in a nonpublic investigatory proceeding the witness may for good cause be limited to inspection of the official transcript of his testimony." Section 6(b) also provides that no investigation shall be made "except as authorized by law."

Section 7(b) which defines hearing powers prevents the agency from conducting hearings from "behind the scenes." It provides that hearing officers shall have authority, subject to the published rules of the agency, to "(1) administer oaths and affirmations, (2) issue subpoenas authorized by law, (3) rule upon offers of proof (Continued on page 42)

Saluting

# KCRC

## ENID, OKLAHOMA



**Agriculture, wheat and milling, cattle, meat packing, oil and refining — are a few of the industries which have earned KCRC's market the title of "Golden Empire"—a market with an effective buying income of \$321,-824! On KCRC—Enid—your products are aggressively promoted to penetrate this rich area!**

**T.H.S. urges you to use this American Broadcasting and Oklahoma Network Affiliate—KCRC—for best results in the "Gold Spot of the South."**



T.H.S.

TAYLOR - HOWE - SNOWDEN  
RADIOLAND

THE GREAT MIDDLE  
WEST AND SOUTHWEST

SALES OFFICES

New York	Hollywood
Chicago	San Francisco
Dallas	Portland
General Offices—Amarillo	

TAYLOR-HOWE-SNOWDEN

Radio Sales





..... **RIGHT!** and **Al Jarvis**  
with his "Original Make-Believe Ballroom" is

on

**K L A C**

**570**

ON THE DIAL

**LOS ANGELES**

Represented by: Adam J. Young, Jr., Inc.  
New York - Chicago

**"Throw Your Voice Where  
It Will Do the Most Good!"**



**DETROIT...**

**the city with a billion  
dollar buying power!**

Tell Your sales story in Detroit where it will be assured to have a telling impact in the most progressive, receptive and fastest moving market in the world.

**P.S. WXYZ Completely covers the  
Detroit area at more reasonable rates  
than any other major Detroit radio station.**

(Key Station of the Michigan Radio Network)  
Owned and Operated by the  
**KING-TRENDLE BROADCASTING CORPORATION**

**WXYZ**

1700 Stroh Building • Detroit 26, Michigan  
Represented by the Paul H. Raymer Co.

## FCC Procedure

(Continued from page 40)

and receive relevant evidence, (4) take or cause depositions to be taken whenever the ends of justice would be served thereby, (5) regulate the course of the hearing, (6) hold conferences for the settlement or simplification of the issues by consent of the parties, (7) dispose of procedural requests or similar matters, (8) make decisions or recommend decisions in conformity with Section 8, and (9) take any other action authorized by agency rule consistent with this Act."

### Evidence Provision

Under Section 7(c) relating to evidence, the Act specifies that evidence must be "reliable, probative and substantial." The section provides that: "Any oral or documentary evidence may be received, but every agency shall as a matter of policy provide for the exclusion of irrelevant, immaterial, or unduly repetitious evidence and no sanction shall be imposed or rule or order be issued except upon consideration of the whole record or such portions thereof as may be cited by any party and as supported by and in accordance with the reliable, probative and substantial evidence."

Every party shall have the right to "present his case or defense by oral or documentary evidence, and to conduct such cross-examination as may be required for a full and true disclosure of the facts."

## Determined

A PRE-WAR courtship and a foxhole romance was climaxed on ABC's July 4 *Bride and Groom* show when Norma Bergh, concert violinist, and Carl-Trond Nedberg, of Voss, Norway, a noted Norwegian composer and leader of his country's wartime underground, were married. They met in 1937 when in Oslo. She was the student and he was the teacher. Separated by the war—she, as an American citizen, returned home—they were reunited a fortnight ago and married to the tune of Norwegian music specially composed for the occasion by the bride's composer-arranger brother, Haaken Berg, in New York.

The Administrative Procedure Act takes effect three months after its approval, except that Sections 7 and 8 become effective six months after approval and Section 11 one year after.

Section 7 has to do with hearings, Section 8 with decisions and Section 11 with hearing examiners.

At one time the FCC operated under the examiner system as provided in Section 409 (a) of the Communications Act, but Frank R. McNinch abolished it shortly after he became chairman Oct. 1, 1937 [BROADCASTING, Oct. 15, 1937]. During the examiner procedure days the FCC had eight lawyers assigned to conduct hearings. One of them was Rosel H. Hyde, now a Commissioner.

Under the old system, however, examiners made recommendations, which were reviewed by the assistant general counsel, the general counsel and the Commission before decisions. Procedure today where attorneys are assigned as examiners follows that routine. Under the new law an examiner's decision can be made final without the various reviews.

**2 BILLION \$ \$**  
—that's a lot of  
spending money

... and it's all centered in WLAW-  
LAND, progressive 3-state market  
in New England. Have you told  
your sales story to the two million  
listeners of WLAW? ... they're  
the SPENDERS in this market! Send  
for coverage map today.

5000 WATTS 680 Kc.

50,000 WATTS . . . SOON!!

Basic Station

American Broadcasting Co.

**WLAW**

LAWRENCE, MASS.

NATIONAL REPRESENTATIVES:  
WEED & CO.

**EL PASO  
TEXAS**

is the economic capital of a  
vitaly important empire embracing  
15 COUNTIES in  
4 STATES in  
2 NATIONS.

Only **KROD**

the "influential" station in  
El Paso covers it ALL.

DORRANCE D.  
RODERICK  
OWNER  
VAL LAWRENCE  
MANAGER

600 KC CBS 1000 Watts  
Howard H. Wilson Co. National Reps.

**For Results**  
IN THE EL PASO  
Southwest use KROD



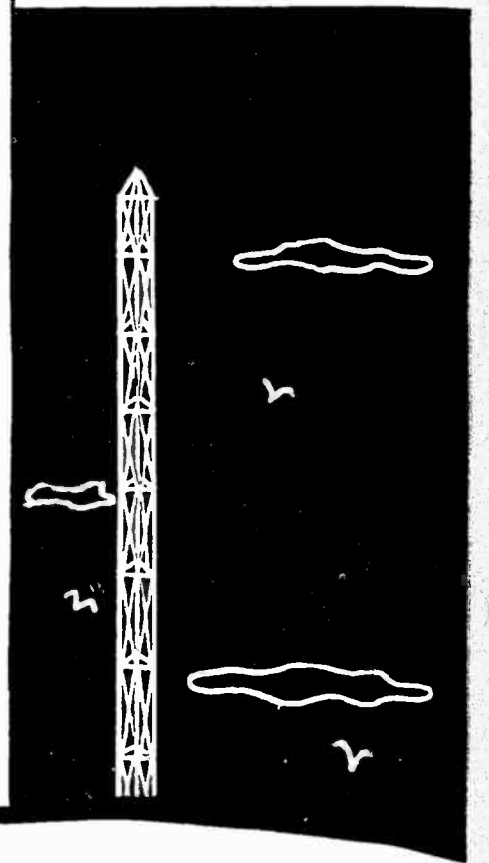

# MYSTERY HOUSE . . . . .



Nothing succeeds like success. An established show . . . an excellent rating . . . a choice time slot . . . and an outstanding radio station combine to assure successful commercial radio.

Such a show is Mystery House, on WGN each Friday evening at 9:30. Broadcast continuously on WGN since 1944, this top-flight program can well be the one right answer to effective middlewestern coverage.

*A Clear Channel Station . . . . .  
Serving the Middle West*



CHICAGO 11  
ILLINOIS  
50,000 Watts  
720  
On Your Dial



**MUTUAL BROADCASTING SYSTEM**

Eastern Sales Office: 220 East 42nd Street, New York 17, N. Y.  
West Coast: Edward S. Townsend Co., Russ Building, San Francisco, Calif.

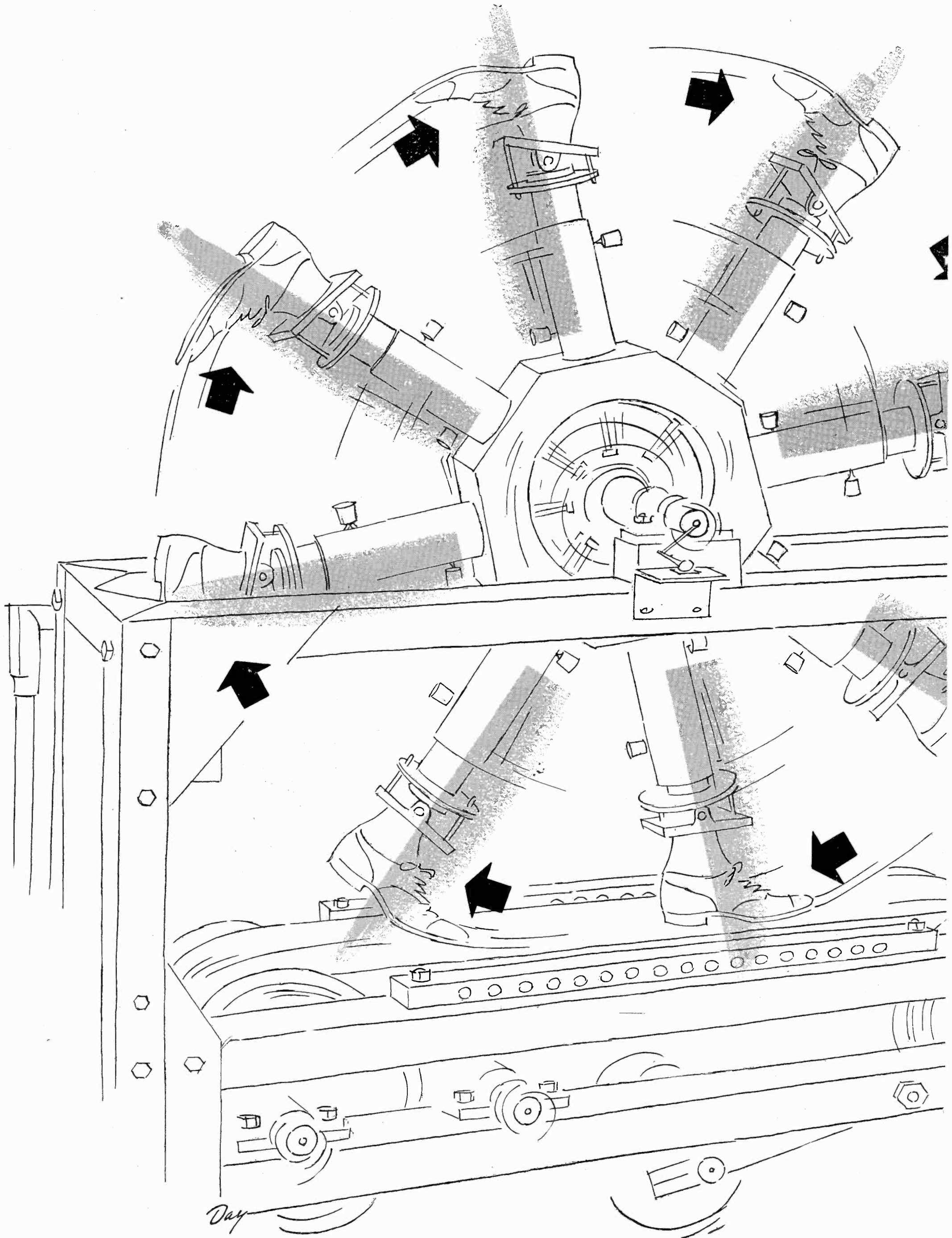





# The Best Way To Get Footwork

This fancy machine runs at a terrific rate. It piles up the miles in minutes, testing shoe leather. It provides much footwork.

As "one good man is worth a dozen bird dogs"—so one good head is worth a dozen feet. It is easy to get footwork but quite another thing to combine it with intelligent direction.

We are proud of the ground we "cover" from our seven offices. But more important is the way we cover it for the stations we represent.

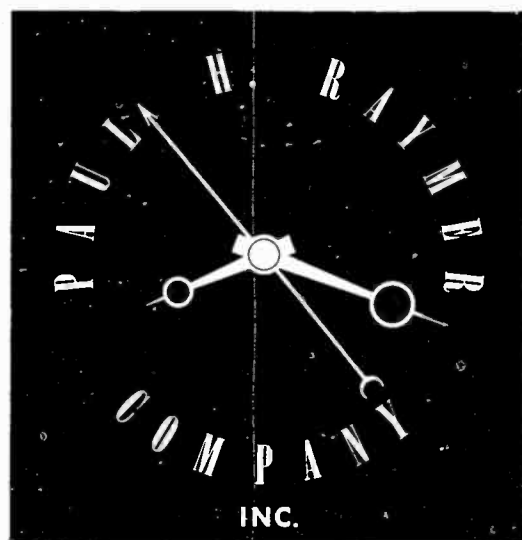
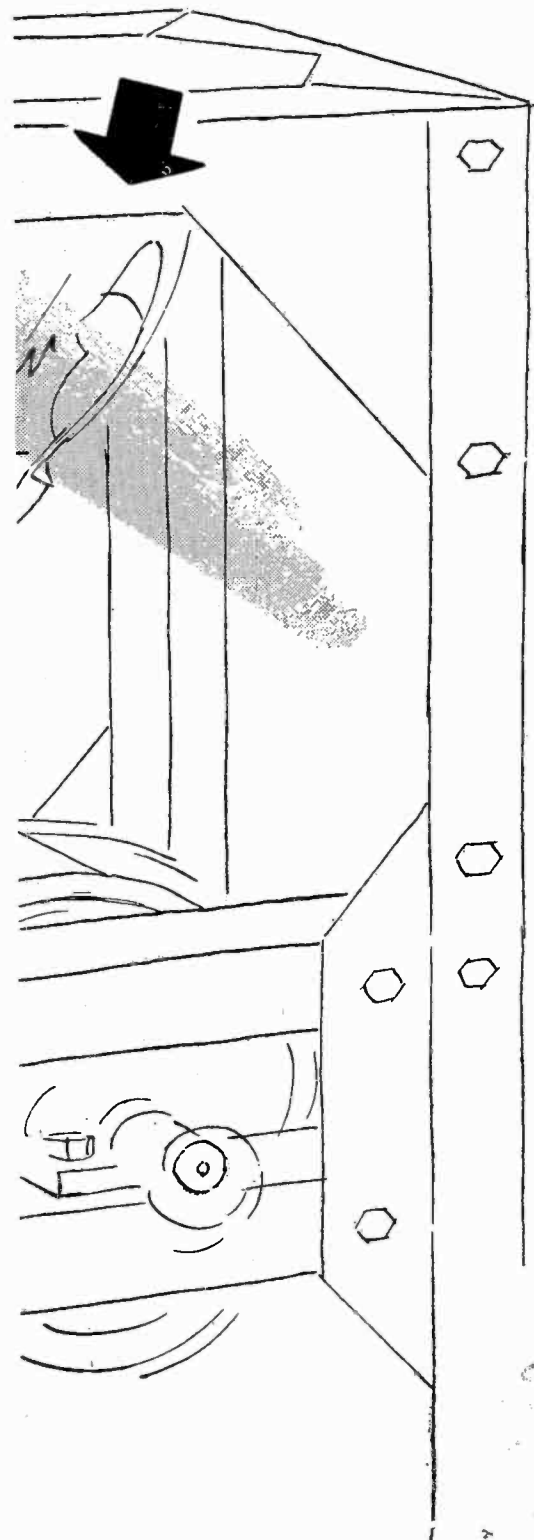

**PAUL H. RAYMER COMPANY, INC. • RADIO ADVERTISING**  
**NEW YORK • BOSTON • DETROIT • ATLANTA • CHICAGO • LOS ANGELES • SAN FRANCISCO**

# Editorial

## Who Does More?

AMERICAN radio is commercial.

That, say the broadcasters proudly, is why they are able to give the public, hour after hour, day after day, the finest in entertainment and information that can be obtained. That, say the critics of American radio, self-appointed or otherwise, is why the American broadcasters have greedily turned their facilities over to the advertisers, selfishly ignoring the public interest for the benefit of their own personal pocketbooks.

Perhaps the above paragraph oversimplifies the argument. If so, it matters little, for we are here concerned not with argument but with fact. And the fact is this:

Where public interest and personal gain conflict, the American broadcasters give public interest the right of way.

Here are some more facts: During 1945 a President died; a war was ended, first in Europe, then in the Pacific; a new international organization, dedicated to settling disputes between nations by legal rather than military methods, was born in San Francisco. These events—and many other of lesser magnitude—the American broadcasters considered more important to their listeners than the regularly scheduled programs. Without hesitation commercials were scrapped for special programs in accordance with what the broadcasters deemed the public interest.

In a system of commercial radio such cancellations cost the broadcasters hard cash, not only for the sales value of the time recaptured but for payments to advertisers for non-cancellable talent costs. NBC alone during 1945 sacrificed \$900,047 in time charges, \$495,314 in talent charges, or a total of \$1,395,361. For ABC the figures were \$439,800 for time, \$100,700 for talent, a total of \$540,500. MBS gave up \$154,652 in time charges, \$37,975 in talent rebates, a total of \$192,627.

The three-network total of \$2,128,488 would undoubtedly top the three million mark with the addition of the CBS cancellation costs, which could not be obtained in detail. It should be noted that these figures do not include the value of local time and programs cancelled to make way for the network public service sustainers, let alone the further cancellations by individual stations of commercials for public service programs from regional networks or of their own origination.

Five million dollars would be an extremely conservative figure of the total of commercial cancellations by American broadcasters in the single year of 1945 in order to broadcast programs in the public interest. You can make your own estimate of the cost of the replacement programs and add that to the total.

Yes, American radio is commercial. And the American broadcasters have proved by the ledger that when it comes to money they can not only take it but, with equal vigor, they can dish it out.

## Fission Expedition

WAS IT Operation Double-Crossroads?

There are some in radio who are saying it was. The bomb dropped. It exploded. But you could only deduce that intuitively from the broadcast coverage. You could not be sure.

The reception, atmospherically, was worse than it had been during any of the thousands of overseas wartime pickups. Yet probably more effort had been expended on this undertaking by radio than on any other single overseas pickup since D-Day.

Most of the commentators sounded like they were recorded at 33 and played back at 78. Faulty reception has been attributed variously to atmospherics, poor equipment and inexperienced monitoring.

Best deduction seems to be poor equipment on the *U. S. S. Appalachian*. This, as the news ship, was the focal point for transmission. It is learned now that the network engineers, long before the test, had asked the Navy to transfer its radio base of operations from the *Appalachian* to the *Spindle Eye*, the radio ship which had been equipped by the Army Signal Corps at the war's conclusion.

Network engineers contend that equipment aboard the *Spindle Eye* is better than the *Appalachian* could provide; that the latter craft was fitted with scientific gear which itself interfered with the signal.

What happened to the network appeal? Nothing, it is reported. It was not acknowledged by the Navy Dept. Yet the Navy certainly had full cognizance of this broadcast's importance. Admiral Blandy himself, the task force commander, was asked before he left the States, about the time the bomb would be dropped. He replied, adding: "It works out very nicely for anybody who wants to listen in on the radio."

And there are whispers that the Navy did not want to originate its show from the *Spindle Eye* because it was an Army-equipped ship.

Regardless of the circumstances, there's little doubt that something was wrong with the *Appalachian*—for signals from the *Eye*, anchored off Kwajalein, and from the *Mt. McKinley* presented much greater clarity.

If the broadcast is to be condemned on the basis of reception, the blame is not fairly leveled against radio. For radio supplied its people; the networks supplied the time at a combined cost of well over \$100,000; and individual stations cleared for the pickup. If the signal was distorted through careless preparation, the blame lies with the official sponsors.

Nor should the charge of George Moorad, CBS, and W. W. Chaplin, NBC, be overlooked. The commentators claimed that their copy was censored after they had attempted to report, following an airplane tour of the test area, the extent of damage. If this charge is substantiated, some censor's knuckles should be cracked. We cannot envision any military information that could be reported from flying elevation on the test of a bomb which has been well publicized on three former occasions.

The three-star performers on the broadcast were Mr. Chaplin, Admiral Blandy and the metronome. At least, they could be heard. Even that is not altogether true, for the metronome's tolling was not clearly audible until just before and during that dramatic instant when the bomb was falling.

Two additional atom bomb tests are coming up. Every possibility for any error in judgment should be eliminated. There's nothing the military can do about natural interference. But there can be no excuse for the man-made kind, such as is charged in Test No. 1, if the military brass will heed the advice of practical radio men on the scene.

## Our Respects To—



GEORGE OLIVER GILLINGHAM

IT'S PURE printer's ink that runs through the veins of George Gillingham, who returned to FCC as director of information July 1.

After he left grade school his only professors were city editors, his only finals were the five star variety. He says he left the Office of the Chief of Staff where he was stationed during the war, to go to Chemical Warfare Service because the Chief of Staff's office didn't have a typewriter.

He has strong convictions that an information man's first duty is to be of help to the newsmen he is serving, and to give that help as quickly and as simply as possible. He talks, writes, thinks the language of the press. To a newsman he is the personification of the best in an information director. And when things get dull, he can always fill in with his endless store of good yarns ranging from the sweepings of newsroom floors to the Gold Room of the White House.

Of course, Mr. Gillingham discounts his ability by insisting "Information men can come and go, but the people that really operate that FCC information department are Sally Lindo and Mary O'Leson. They are the ones that run the show (see story page 70)."

Following George Gillingham's style, and getting down to facts, he was born in Baltimore Dec. 15, 1896, hence he feels himself cheated of a birthday. Dec. 15 comes too close to the 25th.

Soon after, the family moved to Newark. He was going to school there when he heard that the editor of the Newark *Morning and Evening Star* wanted an assistant. "Not an associate editor or anything like that, but just somebody who could read his peculiar brand of shorthand," he says. The editor wrote all his editorials in longhand, but in a personalized code fashion. Young George Gillingham got the job and for a while deciphered the notes and typed them up.

It wasn't long before he had a reporter's job and later started doing a Question Box feature with the Newark *Sunday Call*. At the same time he covered North Jersey for several Philadelphia papers as stringer. He also did Sunday features for the New York *Sunday World*.

When World War I started, he was put in chemical warfare as a second lieutenant.

In 1920 he returned to the *Call*, stayed a year, then moved to Washington to join the *Pathfinder* magazine. He became managing editor, and stayed "in the slot" until 1933,

(Continued on page 48)



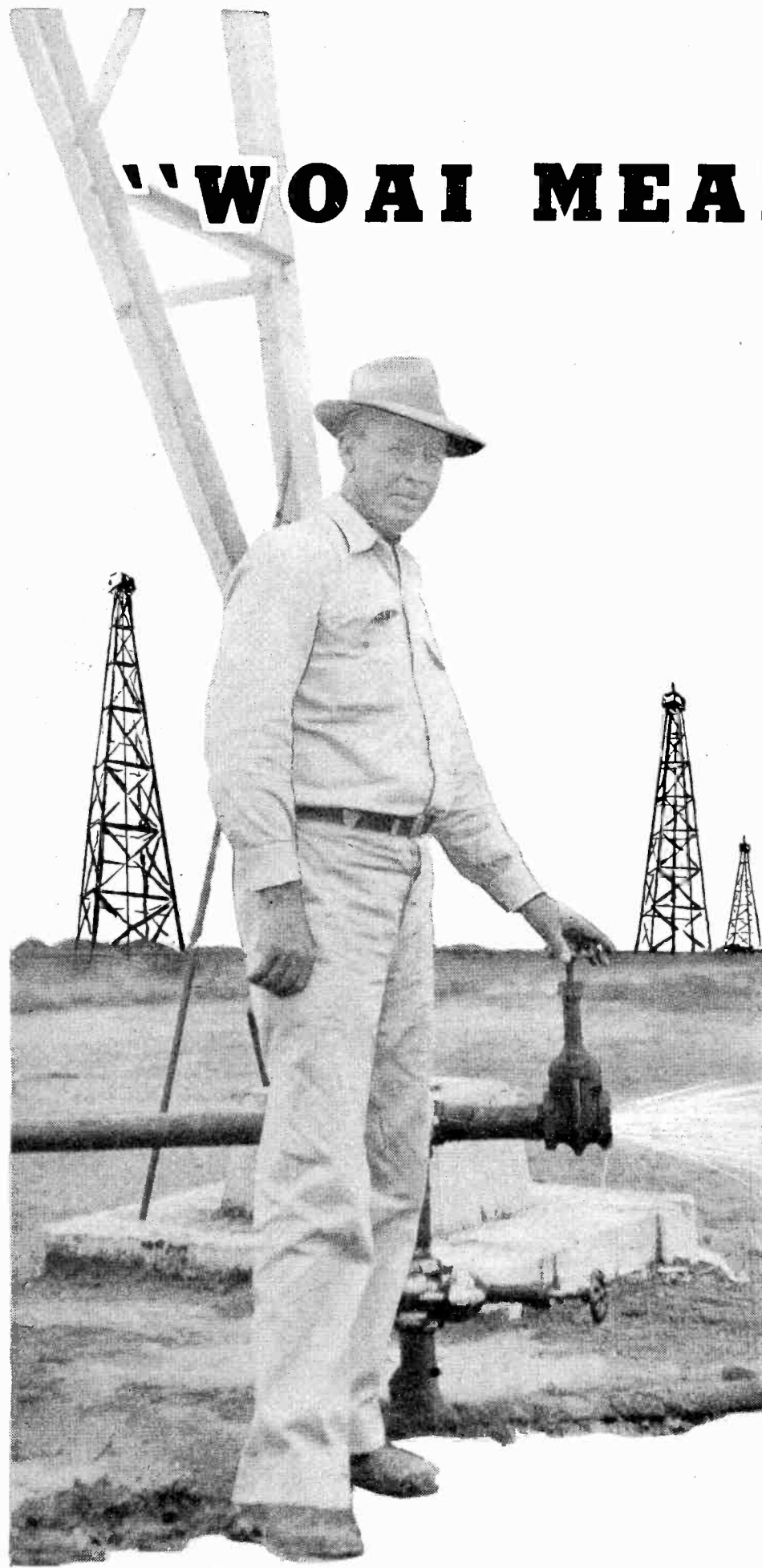

# "WOAI MEANS A LOT TO US IN THE GREAT OPEN SPACES"

The other day Bryan Weaver wrote us a letter. Bryan's an oilman out in Freer, Texas, and like so many folks who live and work in the "great open spaces," he's a great radio fan. He says in his letter:

"Oil fields, as you know, are usually located far from the more common fields of entertainment, and the only established thing a man can depend on is his radio.

"The full variety of your programs, music, sports, and above all, the news, are certainly appreciated and help us who are more or less isolated to keep up with things as they happen."

As the only 50,000 watt, clear channel station in southwest Texas, we have Mr. Weaver, and thousands of other folks like him in mind when we plan our programs . . . so he was all wrong when he closed his letter by saying,

"This letter may not mean much to you but I felt that you should know how much your station means to us."

His letter means more to us that we can express . . . among other things, it means we have had some measure of success in serving the vast audience who depend on clear channel stations for most of their information and entertainment.

There are lots of them. In WOAI's primary listening range last year . . . 1945 . . . oil men like Bryan Weaver processed over 140,350,000 barrels of oil. And this is only one of the occupations and professions followed by the families who listen to and depend on WOAI, only 50,000 watt, clear channel station serving the area.

**WOAI**  
*San Antonio*

REPRESENTED NATIONALLY BY  
EDWARD PETRY & CO.

THE POWERFUL ADVERTISING INFLUENCE OF THE SOUTHWEST

**50,000 WATTS** *Clear* **CHANNEL**

## Respects

(Continued from page 46)

when the Tennessee Valley Authority wanted him to handle public relations from Washington.

Enter the FCC . . . James Lawrence Fly was chief counsel for TVA, and when Mr. Fly was made FCC chairman in 1939, he took the able Mr. Gillingham to FCC with him as director of information.

"Mr. Fly and I agreed," he says, "that only in very special circumstances were releases to be issued as 'James Lawrence Fly announced today.' All actions were to be in the name of the Commission. We held to that, and I still believe in the policy. Personalized publicity in such agencies is bad for the man, the agency—and the information man."

In 1942 he returned to the Army as captain and Washington liaison officer for civil affairs with the Office of the Chief of Staff. Lacking a typewriter there—he gives this as the only reason for the change—he went to Chemical Warfare as chief of CWS public relations. His offices were at Gravelly Point, near Washington—"the poor man's Pentagon," he calls it, "with the heat 104 in the shade."

He was released as what he calls a "synthetic colonel" a few weeks ago.

In 1922 he married Marie Bresnahan, whose father was Wash-

ington manager of Western Union. They have "no children, three cats." One of the cats, Bessie, has been featured on the radio and in the newspapers. Bessie, it seems, crawled to the top of the radio each morning when Earl Godwin, ABC commentator, came on the air. Mr. Godwin told the tale on the air, proud as punch. Then the *Wall Street Journal*—of all papers—wrote an "expose" of the affair, claiming that Bessie listened to Mr. Godwin so faithfully only because he came on early in the morning, the house was cold, the radio the warmest spot in the house, and because the Godwin program was the only one the Gillingham household turned on in the morning.

Bessie falls in a complete swoon at the name "Sinatra," and will rise again only if someone calls out, "Bing Crosby," whereupon she stalks majestically across the room. The Gillinghams also collect cat figurines.

Mr. Gillingham belongs to the National Press Club, and was editor of the Club's publication, *The Gold Fish Bowl*, from '33 to '39. He is a member of the American Legion. He holds the Legion of Merit and Army Commendation Ribbon for public relations work.

He has written for many publications, including *The New Yorker*, *Saturday Evening Post*, the old *Golden Book*, and several newspapers.

## Legion of Merit

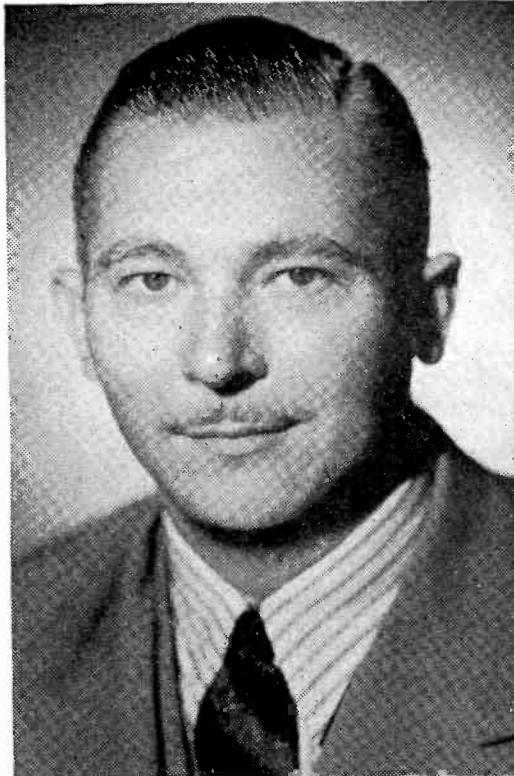

LEGION OF MERIT was awarded last week to James L. Middlebrooks, new NAB engineering director who took office July 1, by Secretary of the Navy James Forrestal. Award Citation reads:

"Comdr. Middlebrooks rendered invaluable service toward the great technical improvement established and maintained in the Naval Communication Service and in other electronic activities through efficient use of new antenna systems, application of modern electronic circuits and application of commercial techniques. By his leadership, tireless efforts and devotion to duty throughout, Comdr. Middlebrooks contributed materially to the successful prosecution of the war and upheld the highest traditions of the U. S. Naval Service."

## DUNVILLE SUBMITS LOCAL MUSIC PLAN

STATIONS and local music groups can work together to bring good programs to listeners, Robert E. Dunville, vice president of Crosley Corp. and general manager of WLW Cincinnati, told the American Symphony Orchestra League session in that city.

Mr. Dunville conceded station managers are often at fault in trying to cooperate with symphony promoters and then shunting programs to poor times when they turn out to be dry as dust. The station should develop a good program instead of merely turning over a block of time, he said.

Symphony groups also are at fault, he said, in failing to select promoters who have a sense of showmanship. Dry discussions of composers and music he described as lost motion. He told of the *Wintertime Concerts* series of WLW in which orchestra heads in the area served as guest conductors of a 35-piece WLW orchestra.

CHARLES T. AYRES, an executive with Ruthrauff & Ryan, New York, since 1938, has been elected vice president of the agency.

## Line Holding Policy Adopted by RMA

### Cosgrove Urges Set Makers To Keep 'Reasonable Prices'

HOLD-THE-LINE policy on set, tube and parts prices was adopted by Radio Manufacturers Assn. last week pending final action on OPA. Many individual manufacturers joined RMA in announcing that prices would be stabilized for the time being despite expiration of OPA controls.

R. C. Cosgrove, RMA president and vice president and general manager of Crosley Corp., Cincinnati, stated RMA's policy as follows:

"In view of the uncertain legislative situation and in response to inquiries of RMA members, I believe it advisable for all members of the radio industry to continue very reasonable prices, as near present prices as possible, on radio sets and parts."

### Westinghouse Holds

Gwilym A. Price, president of Westinghouse Electric Corp., was one of the first to announce exercising of "great restraint" in raising prices, with or without OPA controls. He said price increases would be initiated only where absolutely necessary, adding that Westinghouse has a policy of steady price reductions through its mass production methods.

Prices of some models of sets were expected to be the first to break, in the absence of controls. Set makers have contended that some models are made at a loss and these would be the first affected, it was indicated. Overall policy on set prices, will be influenced by prices of parts, materials and labor.

Many manufacturers contacted distributors and retailers last week to inform them that hold-the-line policies should prevail. Parts makers in general adhered to established prices.

## The Nunn Stations

SERVE AND SELL IN  
**5 GROWING MARKETS**

- WMOB—ABC  
Mobile, Ala.
- WBIR—ABC  
Knoxville, Tenn.
- WLAP—ABC  
Lexington, Ky.
- KFDA—ABC  
Amarillo, Tex.
- WCMI—CBS  
Ashland, Ky.  
Huntington, W. Va.

## A MUTUAL STATION

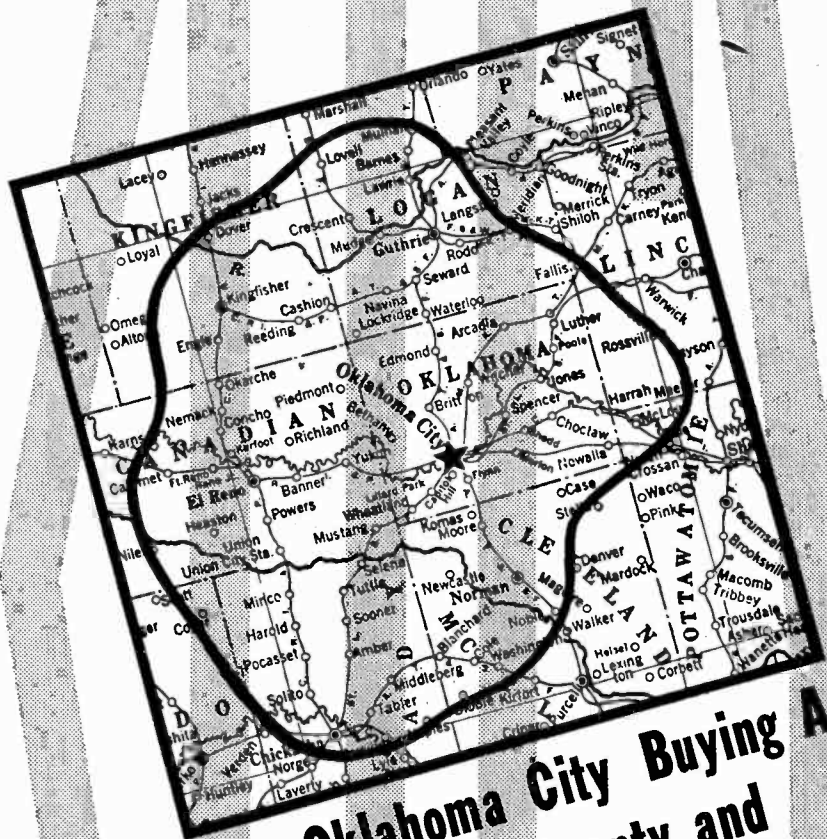

Covers Oklahoma City Buying Area—  
Oklahoma County and  
Six Adjacent Counties

which covers actually the heart of Oklahoma's buying power comprising Oklahoma City proper, its metropolitan area and the big buying power of these six centrally located counties.

Represented by the Walker Company



# Thinking of going into FM BROADCASTING?

Here are the A-B-C's of what you

need for a top quality station . . .

**A: YOU NEED A TRANSMITTER . . . . .**

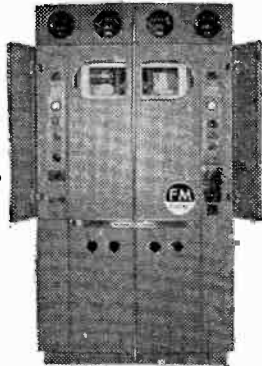

. . . . . that is easy to keep on frequency. In Western Electric Synchronized FM, the "Frequency Watchman" keeps your transmitter precisely on frequency, constantly, automatically.

**B: YOU NEED AUDIO FACILITIES . . . . .**



. . . that combine highest quality transmission with maximum operating flexibility and convenience. The Western Electric 25B console—which will handle your AM and FM programs simultaneously—is the most recent addition to Western's complete line of studio equipment.

**C: YOU NEED MICROPHONES . . . . .**

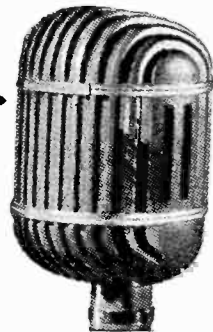

. . . . . that can handle every type of pick-up. Western Electric offers you the new 640 Double-A for high quality single mike pick-ups or the famous 3-way and 6-way Cardioids and the time tested Salt Shaker.

**D: YOU NEED AN ANTENNA . . . . .**

that can really cover your service area. That's the high gain Western Electric CLOVER-LEAF antenna which radiates horizontally polarized waves in a circular azimuth pattern.

**Yes** . . . you can count on Western Electric for your *complete* FM broadcasting equipment. And you can count on the equipment itself for high quality, trouble-free performance.

It's designed by Bell Telephone Laboratories—world's largest organization devoted exclusively to research and development in all phases of electrical

communications. It's made by Western Electric, manufacturing unit of the Bell System and a producer of the best in broadcast equipment for over 25 years.

Consult your nearest Graybar Broadcast Equipment Representative or write to Graybar Electric Company, 420 Lexington Avenue, New York 17, N.Y.

# Western Electric

**QUALITY COUNTS**

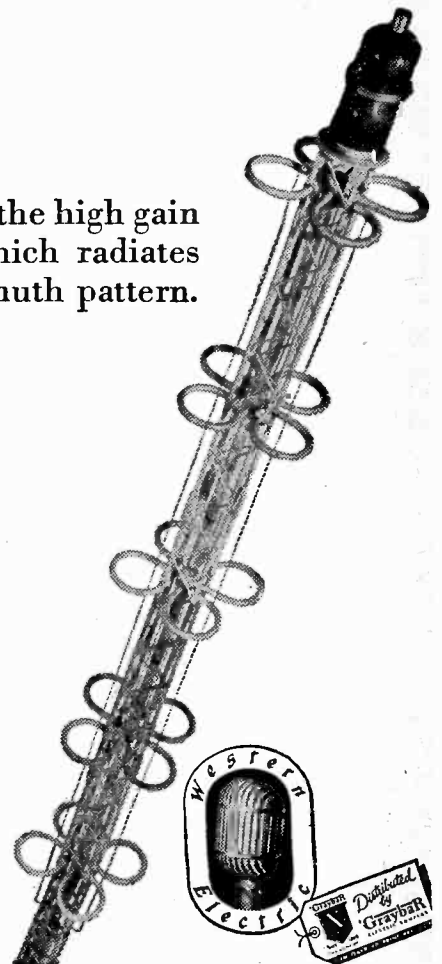

THE SELLING POWER IN THE BUYING MARKET

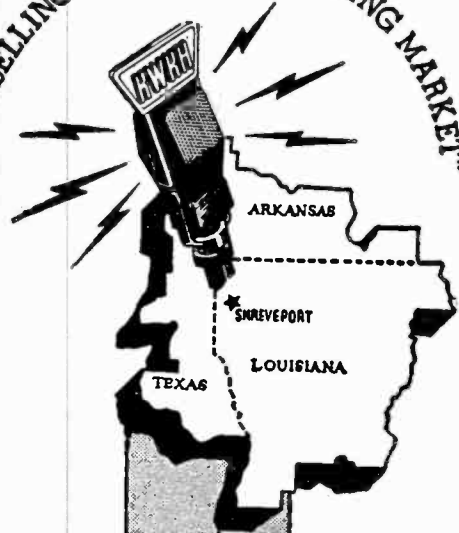

**K  
C  
W  
B  
K  
S  
H**

**THE SHREVEPORT TIMES  
STATION**  
Shreveport, La.

In the Ark-La-Tex  
Area, KWKH,  
with its  
**50,000 Watts**  
is the No. 1 Medium  
with full coverage  
and **SELLING  
POWER** in this  
prosperous market.

**The Branham Co**

## RCA Transfers

RCA has increased production of 16mm sound film equipment and transferred its activities in this field from the company's Indianapolis plant to Camden, N. J., it was announced by Meade Brunet, vice president in charge of the engineering department.

### Upcoming

- July 8: FCC Hearings on New York City area FM applications, U. S. Courthouse Bldg., New York.
- July 8-9: NAB Strategy Committee, Mayflower Hotel, Washington, D. C.
- July 9: FCC Hearings on ABC proposed stock issue; acquisition of King-Trendle Broadcasting System, et al), FCC Hqtrs. Washington, D. C.
- July 12: NAB Public Relations Executive Committee, Hotel Statler, Washington.
- July 12-13: Creighton U. Radio Education Institute, Omaha.
- July 15-16: NAB Music Advisory Committee, Waldorf-Astoria, New York.
- July 15-16: Engineering Conference on Broadcast Standards, FCC Hqtrs., Washington, D. C.
- July 15-19: Music Merchants Show, Palmer House, Chicago.
- July 15-Aug. 4: Second Radio Summer School, KFBK Sacramento.
- July 16: RMA Subcommittee Meeting on tentative plans for National Radio Week in 1946, Chicago.
- July 17-18: Freedom of Radio Committee, Waldorf-Astoria, New York.
- July 22: NAB Engineering Executive Committee, Washington.
- July 25: Opening of six-week course of NBC-Northwestern U. Summer Radio Institute.
- Aug. 3-4: NAB Board Finance Committee, Hotel Stanley, Estes Park, Colo.
- Aug. 5-6: Western Assn. of Broadcasters (Canadian) Annual Convention, Harrison Hot Springs, B. C.
- Aug. 6-8: NAB Board of Directors, Hotel Stanley, Estes Park, Col.
- Aug. 12-13: NAB Employee-Employer Relations Committee, Washington.
- Sept. 9-10: NAB Small Market Stations Executive Committee, Washington.

# MANAGEMENT



**BEN W. STROUSE**, general manager of WWDC Washington, has been appointed chairman of the membership committee of the Washington Advertising Club.

**HERMAN S. HETTINGER**, of the executive staff of Crowell-Collier Publishing Co., well known in radio research and economic circles, last week returned from his vacation and will direct the publishing company's planning for a new international publication, to be printed in several languages.

**BRIG. GEN. KEN R. DYKE**, who last week was separated from the Army at Fort Davis, N. J., plans to spend a month in Bermuda prior to returning to NBC in an executive capacity dealing with operating policy [CLOSED CIRCUIT, July 1].

**RAY E. DADY**, vice president and station director, KWK St. Louis, is recuperating from minor surgery performed last week in St. Louis.

**HUGH A. L. HALFF**, general manager of WOAI San Antonio, is vacationing in Colorado.

**PAUL WAGNER**, general manager of WPAY Portsmouth, Ohio, and his secretary, Uldene Dutiell, were married June 22 in Columbus, Ohio.

**HUGH TERRY**, manager of KLZ Denver, has been named a member of the board of judges, division of advertising and publicity for the State of Colorado, of the Colorado Civil Service Commission.

**WALTER M. WINDSOR**, manager of WKNB, new outlet for New Britain, Conn., scheduled to go on air about August 1, addressed local civic leaders at Hotel Sheraton, New Britain, outlining station's public service plans.

**E. R. VADEBONCOEUR**, vice president of WSYR Syracuse, will return tomorrow (July 9) from a weekend trip to London, where he accompanied Charles

F. Wheaton, winner of WSYR contest on how to promote better relations with Great Britain.

**JUSTIN MILLER**, NAB president, returned Wednesday from a month's trip to the West Coast during which he made a series of addresses. He spent a fortnight at Los Angeles where NAB maintains a West Coast office.

**WILLIAM A. FAY**, Stromberg-Carlson vice president in charge of WHAM and WHFM Rochester, has been elected a director of the Rochester Assn. for Support of the United Nations. The organization is designed to promote the spread of detailed information on UN activities via radio, newspapers and forums.

**KENYON BROWN**, general manager of KOMA Oklahoma City, has been installed as the president of the Oklahoma City Ad Club.

### Staff Changes

**RUFUS CRATER**, member of the editorial staff of BROADCASTING since October 1945 and formerly city editor of the *Winston-Salem (N.C.) Sentinel*, has been promoted to associate editor. Mr. Crater heads BROADCASTING'S FCC staff. Simultaneously, it is announced that Jack Levy, editorial staff member of BROADCASTING since 1943, has resigned to take over active direction of *Corps Diplomatique*, Washington semi-monthly journal catering to Embassy row.

### WMCA Decision

REGIONAL Labor Relations Board in New York today was scheduled to decide on whether the white collar workers at WMCA will be represented by United Office of Professional Workers (CIO) or the International Brotherhood of Electrical Workers (AFL). Both unions claim to have a number of cards indicating workers will join their individual unions. The board will decide today (July 8) which union has enough card checks for a majority or whether to hold a consent election.

Serving  
**The Third Largest Market**  
in the  
**Fourth Richest State**

**W C O L**  
COLUMBUS

**The Listening Habit of Central Ohio**

Represented by  
**THE HEADLEY-REED CO.**

**BEST 50,000 WATT  
BUY OF THE WEEK**

Jovial early-morning entertainer with a 10 year reputation for bringing results.



**ART BROWN**

Available on  
participation basis

**WHN** NEW YORK  
Rep. by **RAMBEAU**



# Cooking on the front burner...



## IN OREGON HOMES

If you're looking for a program that's *really cooking* in Portland.. step up and meet Kay West.

Her address? KEX, in Portland. Time? 2:30 to 3:00, each and every week-day P.M. Subject? Home suggestions, interviews with women in the news, gay and humorous chit-chat that day-time listeners love.

Audience? Bigger than any other local Portland women's program, because Kay West has been a radio favorite here for 15 years. Miss West (there she is in the picture, slaving over the hot stove) is known personally to thousands of women in the Portland area, as mail response proves.

The man from Paul H. Raymer Co. knows what's cooking, and will show you a menu of availabilities.

OREGON'S  
AMERICAN  
NETWORK  
STATION



**WESTINGHOUSE**  
**RADIO STATIONS Inc**

KDKA • WOWO • KYW  
WBZ • WBZA • KEX

Represented Nationally by  
NBC Spot Sales—Except KEX  
KEX represented Nationally  
by Paul H. Raymer Co.

# **KNOCKOUT ... Here's how Louis-Conn**

## **"a revolution as sweeping as sound pictures..."**

"From the standpoint of viewing sports, last night marked *a revolution as sweeping as sound pictures* . . . television won all eight rounds."

—PHILADELPHIA DAILY NEWS

## **"every detail could be followed . . ."**

"The action was clear and *every detail of the fight could be followed* . . .

"During the preliminaries, most of the guests . . . seemed somewhat awed by the occasion. There was a feeling of "What hath God wrought" in the room. But when the main bout went on, all seemed to forget they were watching a screen."

—PHILADELPHIA RECORD

## **"television history was made."**

"Television history was made last night.

" . . . the presentation . . . evoked words of praise far beyond anything yet heard regarding the almost limitless possibilities of video.

"The NBC—WNBT transmission of the fight was magnificently achieved by the use of the RCA image-orthicon tube in three cameras. Viewers were able to catch every motion, every scowl or grimace, with as much ease as that provided by good quality motion picture photography."

—RADIO DAILY, NEW YORK

## **"wonderful stuff, this television."**

" . . . Television . . . looked good for a thousand-year run. Many of Washington's highest dignitaries—some who couldn't get away for the actual Yankee Stadium scrap, and some who preferred to see the

battle the easy way—turned out. Louis' victory was almost overshadowed by the new medium.

"Wonderful stuff, this television."

—WASHINGTON POST

## **" . . . a hundred dollar seat."**

" . . . When the camera focused . . . on the actual battle you were there in *a hundred dollar seat*."

—THE BILLBOARD

## **" . . . a better seat than the front row."**

"With RCA's new image-orthicon camera, installed only recently and used almost for the first time for the heavyweight championship fight, television brings you a picture almost as sharp, although much smaller, than a newsreel. But, unlike a newsreel, you can sit three feet away if you like.

"Television gives you *a better seat than the front row*. It was as if you were sitting in an armchair at ring level . . ."

—N. Y. HERALD TRIBUNE

## **"action like that on a movie screen."**

"The images were in black-and-white, of course, and clear. *The fight action appeared like that on a movie screen*."

—N. Y. UP RADIO CORRESPONDENT

## **"the fight . . . came in clearly . . ."**

"*The fight picked up by five cameras in the stadium came in clearly* and it seemed as though you were sitting in an elevated chair about three or four rows away. Those at the fight may have been disappointed but not those via television."

—UNITED PRESS



# NBC's exclusive telecast of the title fight hit the press:

## "television's rooters . . . optimism justified."

" . . . television's rooters predicted that its success in handling the Louis-Conn fight would do for the new medium what the Dempsey-Carpentier bout in 1920 had done for radio. Based on what we saw last night, *their optimism was justified*. The camera work was excellent and the close-up telecast of the action in the ring was sharply defined, better than we have ever seen...The ringside pictures were tops."

—N. Y. NEWS

## "video has hit the bigtime"

"It took Joe Louis eight rounds to stop Billy Conn but television required considerably less time to establish its own lethal wallop. . . . Video has finally hit the bigtime."

—VARIETY

## "doubters kayoed by fight telecast"

"Billy Conn wasn't the only fellow knocked out at Yankee Stadium last Wednesday night. There was a clean left to the jaw scored against many of those who doubted that television is ready for the public . . .

"B-W video had been given its greatest impetus since the visual art sprang from the laboratory a score of years ago. The reception was practically perfect. Every blow, every move about the ring was followed."

—BROADCASTING

## "everyone there was sold"

"I saw the Louis-Conn exercises last night from all the best angles, in distinguished company and utmost comfort, as a guest of NBC-WRC and RCA at their demonstration of network television at the Statler Hotel. . . . In fact, any of you who have been withholding decision on television as an entertainment investment, pending word of this demonstration, may get in line at your nearest dealers, behind me or one of the 600-odd assorted Congressmen, Cabinet members and other top Government officials. *Everyone there was sold.*"

—WASHINGTON DAILY NEWS

## " . . . a booster for television"

"Speaking of the fight, we saw it televised . . . and must admit *it made us a booster for television* . . . we attended Louis-Nova several years ago, ringside seat, and saw Louis-Conn a lot better . . ."

—SCHENECTADY UNION-STAR

NBC's Louis-Conn telecast was seen through facilities of

**WNBT** (NBC) New York

**WPTZ** (Philco) Philadelphia

**WRGB** (General Electric) Schenectady

**W3XWT** (DuMont) Washington

# NBC television

NATIONAL BROADCASTING COMPANY

A SERVICE OF RADIO CORPORATION OF AMERICA

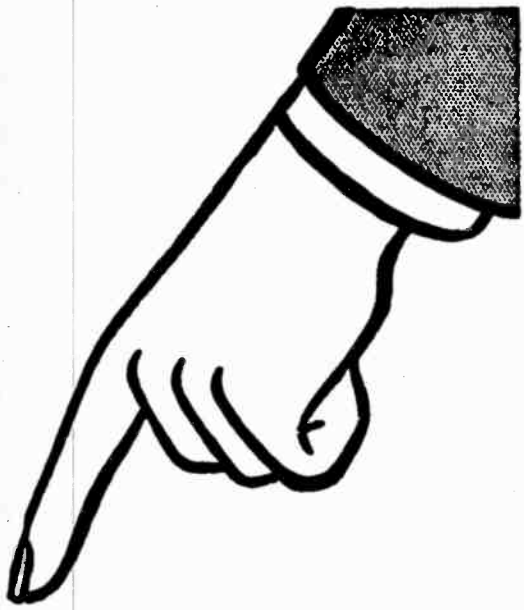

## COMMERCIAL

SIX more agencies will report their national and regional spot schedules to the N. C. Rorabaugh Co., New York, clearing house of spot radio statistics, it was announced last week by N. Charles Rorabaugh, publisher of the NRR Spot Radio Advertising Reports. The new members are the following: Calkins & Holden, New York; C. C. Fogarty, Chicago; The Jacobs Co., Chicago; A. W. Lewin Co., New York; Liller, Neal & Battle, Atlanta; Chas. Dallas Reach Co., Newark.

**GRANT THEIS**, after service with the Navy and previous to that with KNX Hollywood, has joined the promotion department of Radio Sales, New York, the CBS Spot Broadcasting Division. He succeeds **PEYTON AUXFORD**, who has joined the promotion service department of CBS owned stations.

**WTIK** Durham, N. C., new station 500 w 730 kc daytime only, has appointed Broadcast Sales, Chicago, as their representative. Station went into operation June 30.

**BARBARA (Babs) PELL**, of the commercial department of WMAZ Macon, Ga., is engaged to Cecil R. Godfrey, of Dun & Bradstreet Co., Macon. They are to be married Aug. 25.

**NEIL MULHERN**, ABC Detroit account executive, has been in Hollywood in connection with premiere of "Ford Festival of American Music."

**BOB ENGLER**, salesman for WTOP Washington, is the father of a boy.

**ALLAN TRENCH**, WWSW Pittsburgh salesman, is the father of a girl, Elizabeth Ann.

**WFOX** Milwaukee has appointed the Walker Co., Chicago, as national representative. Station, on 250 w, 860 kc, is expected to go on the air Aug. 1.

**KETTELL-CARTER**, Boston, has been appointed regional representative of the following stations: WHCU WPOR WELI WTVL WSYR WTRY WFEA.

**MERRITT R. SCHOENFELD**, ABC sales executive since 1942, has resigned. Currently on vacation, he will announce future plans upon his return to New York in near future.

**WHBF** Rock Island, Ill., has appointed Lewis H. Avery Inc., as national sales representative, effective Aug. 1.

### Housing Authority Cites WOR for Veterans' Aid

WOR New York was commended for its contribution to the veterans housing crisis last week in a letter to Theodore C. Streibert, president, from Maxwell H. Tretter, executive director of the New York City Housing Authority.

The station began its veterans' housing campaign last April by interviewing one veteran a day in need of a home, on the cooperatively sponsored *Daily Dilemmas* program, Monday through Friday, 2:30 p.m., which has brought in 100 vacancies. Success of this project led to the forming of a WOR "Housing Commission" of World War II veterans, headed by Tom Moore, program coordinator. The campaign consists of interviews with other house-seeking veterans on other WOR shows such as *Bessie Beatty*, *Martha Deane*, *John Gambling* and many others, in addition to spot announcements throughout the 23-hour schedule.

**REV. MICHAEL J. AHERNS**, scientist and conductor of "Catholic Truth Period" for 15 years on Yankee Network, sails for England July 18 on Queen Mary as delegate from National Conference of Christians and Jews in the U. S. to an international conference which the American group is sponsoring with the British Council of Christians and Jews at Oxford.

## Olympia Bureau Success Told Washington State News Clinic

OPERATION of a cooperative radio news bureau by Washington State broadcasters in Olympia, State capital, is proving successful, the NAB news clinic held June 27 at Olympia was told. The bureau was set up last Jan. 1 to serve stations with local news originating in the capital.

The Washington clinic was one of two held in the Northwest by Arthur C. Stringer, NAB director of special services. Other clinic was held June 25 in Portland.

The 17 subscribing stations pay the cooperative bureau from \$4.50 to \$26.50 per week, depending on rate card. Office space is provided by the State. Manager of the bureau is Carl Downing, former news editor of KPQ Wenatchee. He accepts assignments for capital stories from the stations, and releases spot news along with two news letters and a quarter-hour transcription each week.

Gov. Wallgren of Washington held a reception for attendants at Olympia clinic. Tom Olsen, licensee of KGY Olympia and president of Washington State Assn. of Broadcasters, was host.

### Station Newsmen Speak

Lively writing and origination of as much news as possible were urged by Sam Crawford, KGY newsman. Dick Crombie, KJR Seattle, said regional listeners want plenty of news of their own areas. Ted Bell, KRSC Seattle, said station covers sports thoroughly, especially high school events. They bring in many listeners, he said. Frank Adams, manager of KVOS Bellingham, said the station has a fulltime newsman and five stringers. A department store sponsors a six-weekly quarter-hour society program. Al Bond, KIRO Seattle, described methods of handling farm news.

General chairman of the Oregon clinic was Marshall Pengra, manager of KRNR Roseburg. On the arrangements committee were Harry Buckendahl, Arthur Kirkham, KOIN Portland; H. Quenton Cox, manager of KQW Portland.

Value of local news was outlined by Lee Jacobs, KBKR Baker, who said the station breaks any program for a top local story. Gordon Capps, KLBM La Grande, associated with KBKR, said a fulltime newsman was added some months ago. KBKR sells two news shows daily on a cooperative basis. Lester Halpin, KOIN, said the station has just added a fulltime street reporter. Ralph Hanson, KUGN Eugene, said KUGN will have a fulltime newsman soon after taking the air early this month. Several newsmen complained that press associations should supply more regional and state news, as

well as farm news, and move it promptly.

KALE Portland is concentrating on farm news, according to Burton Hutton, heading the farm service. William B. Smullin, manager of KUIN Grants Pass and NAB director, discussed freedom of the press. Clinic discussion leaders were Chet Wheeler, KWIL Albany; George Turnbull, acting dean of journalism, U. of Oregon; Mr. Stringer, Mr. Hutton and Mr. Halpin.

### At Oregon Clinic

Attending the Oregon clinic were:

L. W. Tromlitz, KORE; Harry H. Buckendahl, Lester Halpin, George Wann, KOIN; Marshall Pengra, KRNR; Cy Young, KEX; Arthur C. Stringer, NAB; Glen McCormick, KSIM; Gordon Capps, KLBM; Burton Hutton, C. E. Couche, Tom Decker, KALE; Chuck Foster, KGW; Paul Corbin, KUIN; Hal Byer, Chet Wheeler, KWIL; Ralph Hanson, John Craig, KUGN; Jack Richards, KWLK; Lee Bishop, John Keating Studios; Barney Kenworthy, KODL; Dan Crumley, Nick Bourne, UP; William B. Smullin, Ed Malone, KUIN; Lee Jacobs, KBKR; George Connor, KVAN; George Turnbull, U. of Oregon; J. A. Cour, AP.

Attending the Washington clinic were:

Joe Chytil, Les Keiter, Dudley Gaylord, KELA; Tom Olsen, Theresa Olsen, Sam Crawford, Eve Knutson, Margie Donnell, Vicki Draham, KGY; Carl Downing, Wash. State News Bureau; Peter Giovine, Dan Crowley, UP; LeRoy M. Hittle, Mark Knight, Will Lindley, AP; Dick Crombie, Bob Ackerley, Bob Ferris, Charles Herring, KJR; Harry Spence, Stan Craft, Fred Goddard, KXRO; Robert E. Priebe, Ted Bell, KRSC; Burke Ormsby, KTBI; Ann Shepard, Ted Knightlinger, Verne Sawyer, Jim Murphy, KMO; Harry Long, KVI; Jim McLaughlin, John Keating Studios; Oliver Runchey, KOL; Harry Jordan, KEVR; Al Bond, Ken Yeend, Ralph Thompson, Loren Stone, KIRO; Vern Mack, William Taft, Thelma Taft, Shirley Bartholomew, KRKO; Jim Wallace, Ralph Shotwell, Jim Foster, KPQ; Pete Wick, KIT; George Dunning, L. L. Lang, Ross McConnell, KOMO; Frank Adams, KVOS; Arthur C. Stringer, NAB.

C. TERENCE CLYNE, former account executive at Free & Peters, New York, has been elected vice president. He will continue to direct station sales promotion for the entire organization as well as handling a New York list of advertisers and agencies. Starting his 10th year with the radio representative organization, Mr. Clyne served as chief of supply for the Eighth Air Force Command in Europe during the war.

# NOTICE

You cannot cover the tremendous New York market without using WBNX, because . . .

### WBNX reaches

- 2,450,000 Jewish speaking persons
- 1,523,000 Italian speaking persons
- 1,235,000 German speaking persons
- 660,000 Polish speaking persons

STRENGTHEN your present New York schedules with WBNX. Our program department will assist you in the translation of your copy.



# IT'S A FACT!

You can cover Ohio's Third Market at less cost. American Network affiliate.

Ask HEADLEY-REED

**WFMJ**  
YOUNGSTOWN, OHIO



# That's Kansas City!

- Transportation hub of the Mid-West
- Home of one of the world's five largest railroad stations.
- Handling more through trains daily than any other city in U. S.
- Served by 12 major trunk line railroads, 3 air lines and river barge and pipe lines.
- Providing daily bus service by 13 companies; highway shipping by over 130 truck lines.
- Center of a vast highway network which includes six federal highways.

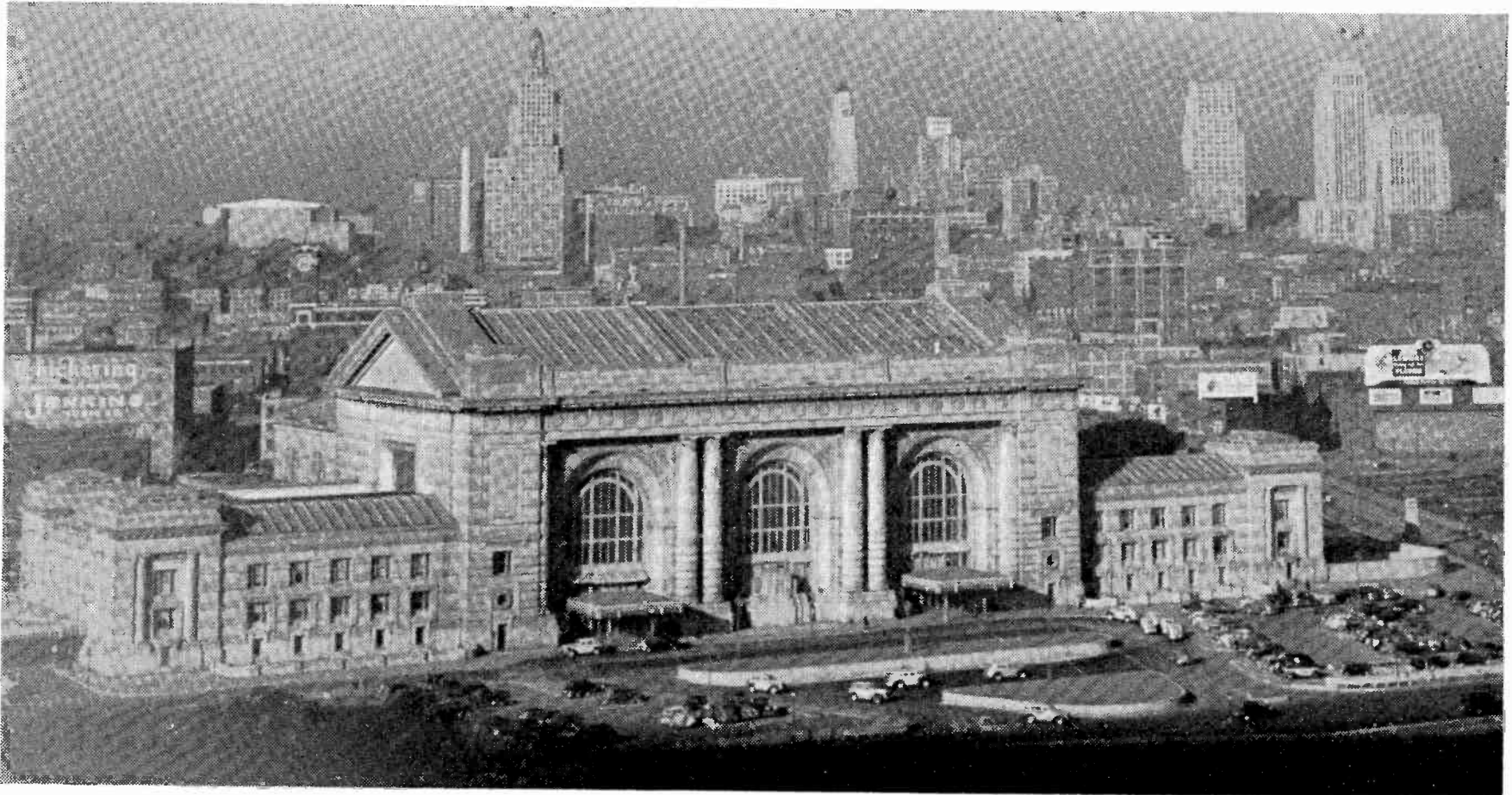

## **Radio • Responsive to** **WDAF** **The Kansas City Star Station**

**610**  
**Kilocycles**  
**BASIC NBC**

More than 5 million persons live within WDAF's half-milivolt area—and they listen to WDAF because of programming dominance.

WDAF coverage of the Kansas City market surpasses that of any other Kansas City station.

*Represented Nationally by* **EDWARD PETRY & CO., Inc.**

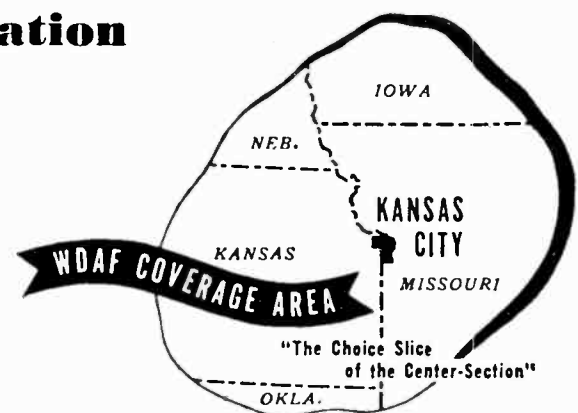

# KANSAS

# CITY

# IS

# A

# K

# O

# Z

# Y

# MARKET

PORTER BLDG.  
KANSAS CITY, MO.

EVERETT L. DILLARD  
General Manager

ELIZABETH WHITEHEAD  
Station Director



Pioneer FM Station in  
the Kansas City Area

Ask for Rate Card 3

## Iowa Schools Plan FM Education Net

### Link With Other States Seen; St. Louis Maps Program

EXTENSIVE use of FM is planned by Iowa and St. Louis education officials, according to the Federal Radio Education Committee of which John W. Studebaker, U. S. Commissioner of Education, is chairman.

State U. of Iowa, granted an FM CP in 1944 with call letters KSUI, will install equipment as soon as possible. Project had been deferred because of war shortages. Iowa State College is an applicant for a CP covering an FM station. City school systems plan applications when equipment becomes available.

Organization of an FM education network to supply the whole state is projected in Iowa, this network eventually to join networks of other states for regional or national broadcasting of programs.

### Network Plans

Tentative plans for the state network call for installation of three 10 kw stations, located at Iowa City, Ames and Cherokee, with four 3 kw stations at Fayette, Mason City, Atlantic and Chariton. These stations would form a basic network serving the entire state.

Also proposed by Iowa are a number of 250 w feeder stations located at the larger school systems or program origination points. When quality warranted, their programs could be fed to the network.

Postwar radio program for elementary and secondary schools has been worked out in St. Louis by the Committee on Radio Education, according to Philip J. Hickey, St. Louis superintendent of instruction. FM application already has been filed and time is used on KFUE. A radio library has been established and a monthly program guide is compiled. Radio workshops for students have been set up in four high schools and program of radio education for teachers has been developed.

St. Louis schools are participating in activities of the St. Louis Radio Council and are furnishing speakers on radio education to school, civic and religious organizations.

### Dr. William C. Bagley

DR. WILLIAM CHANDLER BAGLEY, chairman of the National Board of Consultants of the CBS *American School of the Air* and one of the country's outstanding educators, died at his New York City home Monday, July 1. His age was 71. CBS Counselor on Public Affairs Lyman Bryson paid tribute to the energy and help extended by Dr. Bagley in developing the *School of the Air*, saying that he had been one of the first educators to recognize the possibilities of radio in the field of public education.

# PROMOTION



### Savannah Posters

EXTENSIVE campaign promoting NBC program stars and shows is under way by WSAV Savannah, built about exclusive coverage of all city buses. Format of posters with slogan "Everybody Listens to . . . WSAV," is caricature of an outstanding NBC star. Present programs featured are: H. V. Kaltenborn, "Mr. District Attorney," Fred Waring and "Dr. I. Q."

### Congratulations to KOA

CONGRATULATORY message was received by KOA-NBC Denver from Eddie Cantor upon that station's promotion in exploiting personal appearance of "The Eddie Cantor Show" in Denver for its final broadcast of the season. Message said it was "one of the finest promotion and publicity jobs by a radio station I have seen in all my years of show business. . ."

### WOR Book Jacket

AS A PROMOTION piece on WOR's New York, programming, sales and goodwill, the station has issued a mock book jacket entitled "Life Began at 1440", by "A Keene Picker." Cover is complete with comments on the back flap by WOR executives with WOR success story on the front flap.

### Contest Winner Honored

CASH prizes of \$350 and \$150 were received respectively by William Traum, promotion director of WROK Rockford, Ill. and Hilda Woehrmeyer, promotion manager of WOWO Fort Wayne, Ind. at an ABC party in Chicago honoring winners of Schutter Candy "Counter Spy" promotional contest [BROADCASTING, June 24]. Winners also received bronze plaques and certificates of merit from sponsors.

### Hat Winner

WLAP LEXINGTON, Ky., was judged one of first prize winners in local promotion competition, built around Hedda Hopper-Tom Brennan Hat contest. Promotion included courtesy announcements, window placards, lobby displays

### Eaton to Europe

RICHARD EATON, Mutual commentator, left last Saturday for a trip to France, Germany, and Czechoslovakia for a first-hand report on postwar conditions in those countries. He will interview outstanding figures of the countries, including President Benes of Czechoslovakia. While touring Europe, Mr. Eaton plans to make recordings of the interviews and of his reports on conditions, and in addition will write a series of articles for North American Newspaper Alliance. Al Warner, WOL Washington news chief, will substitute during Mr. Eaton's several weeks' absence.

A fortnight ago, Mr. Eaton received the Norwegian Broadcasting Peace Medal as a token of respect and in appreciation for the cooperation given Norway during the war.

### Army Staff Chosen

EARLE MCGILL, producer-director of the Army program *Sound-Off with Mark Warnow*, 8:30 p.m. on CBS, has appointed Allan Sloane as program director and Edward Michelson as research specialist. Talent on program is paid for by Army through N. W. Ayer & Son, New York. Time on the network is donated by CBS.

and hats modeled by U. of Kentucky football players. Fred K. Augsburg is WLAP promotion manager.

### Program Folders

KASPER-GORDON, Boston, radio production firm, has issued folders on their transcribed programs, "Real Romances," and "One I'll Never Forget." Reproduction of Real Romances magazine is on cover of the "Romances" folder. Jack Stevens, sportscaster narrator, is featured on latter program folder.

### WIS Paper

WIS Columbia, S. C., is planning an 8-page promotional tabloid newspaper, to be issued monthly under guidance of Steve Libby, promotion-publicity chief.

### Scholarship

KCKN Kansas City and Prom magazine, local publication directed to teenagers, will join in awarding scholarships in acting to a new Summer Theatre School opening in Kansas City July 9.

**AID FOR QUADS**  
Pet Milk, WBIG to 'Sponsor'  
Four N. C. Babies

THE QUADRUPLETS of Reidsville, N. C., will be financially aided throughout their youth by the Pet Milk Co. with the support of WBIG Greensboro. The children, four girls, born May 23, will be in the hospital for three to six months, with all hospital bills paid by Pet Milk. WBIG will follow their progress and growth with periodic broadcasts. The babies are "doing fine" on their Pet Milk formula, according to Dr. Fred R. Klenner, who delivered them.

The children were born to a Negro couple, Annie Mae and James Newton Fultz, who have six other children. All the quads are named Mary, with different middle names, Ann, Louise, Alice and Catherine.

STEPHEN I. HALL, secretary, radio group, American Marketing Assn., New York, and Larry Hubbard, chairman of the Assn., have switched positions caused by Hubbard's inability to attend all meetings because of out-of-town business. Mr. Hall is merchandising editor of Radio and Television Retailing, New York, and Mr. Hubbard is director of research of Duane Jones Co., New York.

**THANK YOU**  
**GARDNER AGENCY**  
for your comments

**KFXJ**  
and  
**MBS**

•  
**A**  
**PEACH**  
**OF A**  
**PAIR**

"... KFXJ ranked 27th among 270 Mutual stations in the recent Tom Mix mail return analysis . . . ahead of 154 cities all larger than Grand Junction, Colo. . ."

**K F X J**  
Grand Junction,  
Colo.

920 KC 1000 W  
Represented by Griffith



# An Outstanding Success!



*Raytheon's*

## RC-11 STUDIO CONSOLE for AM or FM

The Most Versatile Unit of its Kind... Easily Controlling Two Studios,  
Announcer's Booth and Nine Remote and Two Network Lines.

FIRST UNVEILED at the I.R.E. Show last winter, this remarkable Raytheon Console has won a unique place in its field—commanding the attention of studio engineers and managers as few items of broadcast equipment ever have!

It provides *complete* high-fidelity speech-input facilities for the modern station—with all the control, amplifying and monitoring equipment contained in a single compact cabinet. It easily handles any combination of studios, remote lines or turntables—broadcasting and auditioning simultaneously, if desired, through two high quality main amplifier channels. It makes it a simple matter to cue an oncoming program and pre-set the

volume while another program is on the air.

Note the sloping front and backward-sloping top panel, giving maximum visibility of controls and an unobstructed view into the studio. Note the telephone-type, lever action, three-position key switches, *eliminating nineteen controls* and reducing operational errors to a minimum.

The beauty of this console, in two-tone metallic tan . . . the efficient, functional look of it . . . will step up the appearance of any studio, and yet blend easily with other equipment. And the low price of this Raytheon Console will amaze you.

*Inquire at once! Write or wire to:*

**RAYTHEON MANUFACTURING COMPANY**

Broadcast Equipment Division

7517 N. Clark Street, Chicago 26, Ill.

**RAYTHEON**

Devoted to Research and Manufacture for the Broadcasting Industry

### Compare THESE OUTSTANDING FEATURES WITH ANY OTHER CONSOLE

1. **SEVEN** built-in pre-amplifiers—*more than any other console*—making possible 5 microphones and 2 turntables, or 7 microphones, on the air simultaneously.
2. **NINE** mixer positions—*more than any other console*—leading to 5 microphones, two turntables, one remote line and one network line.
3. **NINE** remote and two network lines—*more than any other console*—may be wired permanently.
4. **TELEPHONE-TYPE** lever-action key switches used throughout — most dependable, trouble-free switches available. *No push buttons.*
5. **FREQUENCY RESPONSE** 2 db's from 30 to 15,000 cycles. Ideal speech input system for either AM or FM.
6. **DISTORTION** less than 1%, from 50 to 10,000 cycles.
7. **NOISE LEVEL** minus 65 db's or better. Airplane-type four-way rubber shock mounting eliminates outside noise and operational "clicks."
8. **ALL FCC REQUIREMENTS** for FM transmission are met.
9. **DUAL POWER SUPPLY** provides standby circuit instantly available for emergency use.
10. **POWER SUPPLY** designed for mounting on desk, wall or relay rack.
11. **INSTANT ACCESS** to all wiring and components. Top hinged panel opens at a touch. Entire cabinet tilts back on sturdy full-length rear hinge.

**PROCTER & GAMBLE**, Cincinnati, (Camay Soap) will sponsor a half-hour dramatic show based on motion picture adaptations with the original movie stars appearing on CBS. Show will originate in Hollywood with Hedda Hopper as m.c. Time is not set as yet. Pedlar & Ryan, New York, is agency.

**CAMPBELL SOUP Co.**, Camden, N. J. (Strained Baby Soup) during the last week in June for four weeks, started a spot campaign on nine stations in seven cities, consisting of 66 spot announcements weekly. Cities are Philadelphia, St. Louis, New York, Hartford, Baltimore, Buffalo and Indianapolis. Agency is Ward Wheelock Co., Philadelphia.

**MARLIN FIREARMS Co.**, New Haven, renewed three one minute announcements five times weekly over KYW Philadelphia, featuring razor blades. Placed by Craven, Hedrick, New York.

**MANHATTAN SOAP Co.**, New York (Blu-White), on July 1 started 12 participations weekly in "Housewives' Protective League" on KNX Hollywood. Contract is for 13 weeks. Agency is Duane Jones Co., New York.

**BAKELITE CORP.**, New York, has appointed J. M. Mathes Inc. as advertising representative. Firm was previously represented by Rickard Adv. Co., New York.

**WESTERN AUTO SUPPLY Co.**, Los Angeles (auto accessories), on June 22 started five weekly 15-minute news broadcast on KECA Hollywood. Contract is for 52 weeks. Agency is Arthur W. Stowe Adv., Los Angeles.

**ARDEN FARMS**, Los Angeles (dairy products), has started spot announcements schedule on KHJ KMPC KECA, all Hollywood. Stations respectively carry four, five and seven announcements weekly. Contract is for 13 weeks. Agency is Productive Adv., Los Angeles.

**WILSON LINE STEAMSHIP Co.**, Philadelphia, is a new account for KYW Philadelphia, placing seven announcements weekly for twelve weeks. Placed through John Falkner Arndt Agency, Philadelphia.

**NUTRITIONAL Research Prods.**, Los Angeles (Waytrol) has extended "Dusty Records" on KHJ Hollywood to include

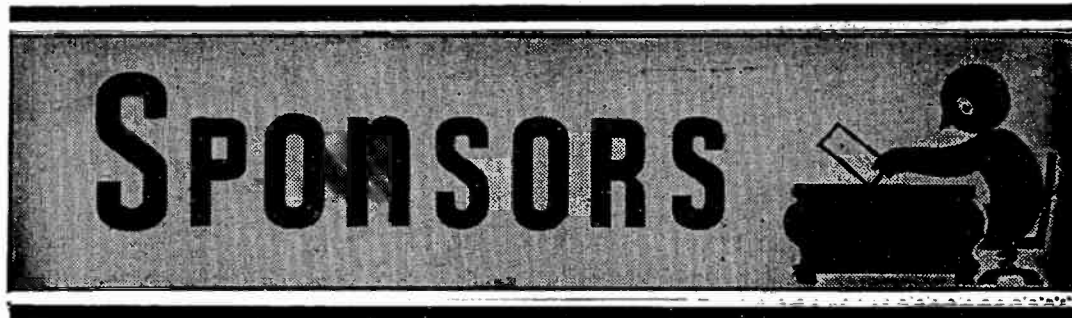

six Southern California MBS stations. Contract is for 52 weeks. Agency is Lockwood-Shackelford, Los Angeles.

**GEORGE S. MAY Co.**, through Jim Duffy Co., Chicago, July 28 sponsors All-American Golf Tournament broadcast on NBC, Sun. 5:30-6 p.m. Tourney is to be held at Tam O'Shanter Country Club. Advertiser will sponsor Saturday half-hour coverage on WMAQ Chicago. NBC is carrying program sustaining Thursday, Friday and Saturday.

**BROMO SELTZER** has placed a contract with CKNW New Westminster, B. C., for 260 transcribed announcements. F. H. Hayhurst Co., Toronto, is agency. **COLGATE - PALMOLIVE - PEET** has contracted for four transcribed announcements daily, three times a week, 52 weeks on CKNW, through L. J. Heagerty & Assoc., Toronto.

**WESTERN AUTO SUPPLY Co.**, Los Angeles (auto accessories), on July 1 started six-weekly "Breakfast Hour News" on KMO Tacoma. Contract is for 52 weeks. Agency is Arthur W. Stowe Adv., Los Angeles.

**ICECAPADES**, opening in Atlantic City, have scheduled nine commercials over a two week period over KYW Philadelphia. Account placed by N. W. Ayer & Son.

**HASSENSTEIN & Co.**, Hollywood (Movie Wave home permanent), on July 8 starts trial campaign for new product package with six 15-minute recorded music programs on KNAK Salt Lake City and KLX Oakland. Trial is for one week. Agency is Dean Simmons Adv., Hollywood.

**SEARS ROEBUCK & Co.**, Los Angeles (general merchandise), on July 4 started five weekly spot announcement sched-

uled. Agency is Mayers Co., Los Angeles.

**EASTERN AIR LINES Inc.**, has expanded participation in the WABC New York 6-7:45 a.m. "Arthur Godfrey" program, from Tuesday, Thursday and Saturday, to a six-a-week schedule. Agency is Campbell-Ewald Co., New York.

**PHILADELPHIA National League Baseball Club** is running announcements five times weekly over KYW Philadelphia. Account placed by N. W. Ayer & Son.

**STUDEBAKER Corp.**, South Bend, Ind. (automobiles), through Roche, Williams and Cleary, Chicago, has extended its contract sponsoring "Harry Marble and the News," 6-6:15 p.m. Monday and Wednesday, and 11-11:10 p.m. Sunday on WABC New York.

**BONAT & FRENCHEE Ltd.**, Toronto (cosmetics) has started weekly quarter hour transcribed program on CFRB Toronto. Agency is Frontenac Broadcasting, Toronto.

**IRON FIREMAN MFG. Co.** of Canada, Toronto (automatic firing equipment) has started spot announcement campaign six days weekly on CKEY Toronto. Account is placed by Frontenac Broadcasting Agency, Toronto.

#### Net Changes

**QUAKER OATS Co.**, Chicago, will cancel 19 stations signed to carry rebroadcasts of "Those Websters", Sunday 5:30-6 p.m. (CST) over Mutual [BROADCASTING, May 13]. Firm now buying farm programs on 18 to 20 stations to start August 5. Contracts will be for 52 weeks. Agency: Ruthrauff and Ryan, Chicago.



**ARTHUR H. MILLER** Public Relations Firm, New York, has moved from 1270 Avenue of the Americas to 151 East 50th Street.

**A. E. KESSLER**, former head of The Fishery Council, New York, has formed a public relations and advertising firm under his own name located at 81 Wiloughby Street, Brooklyn. Firm handles the Viewtone Television & Radio Corp. account with radio being considered as part of a fall campaign.

**KATHERINE HILGROVE**, formerly overseas for the OWI, has been appointed executive director of Veterans Guidance in Advertising & Selling, New York, succeeding MRS. RUTH C. PERRY who has resigned.

**RECORDING** division has been organized by MGM in New York under the direction of **FRANK WALKER**, former vice president of RCA Victor, New York. First star to sign a contract is **KATE SMITH**, who starts recording for MGM Oct. 1, for a three year period, when her Columbia Records pact expires.

**COMMITTEE** chairmen named for the coming year by **GEORGE T. SHUPERT**, president of the American Television Society are: **ALICE PENTLARGE**, reception; **JACK LEVINE**, program library; **MYRTLE HISLEY**, library; **EDWARD STACHEFF**, education; **CHARLES ALICOATE**, motion picture; **FREDERICK A. KUGEL**, program and **BUD GAMBLE**, ATS training.

**RALPH KISCH**, known to radio as Ralph Kollier, has returned to Metropolitan Television staff in New York after a War Dept. assignment as chief announcer-producer with AFN Frankfurt.

**J. R. LITTLE** and **BARTON KREUZER** have been named manager of RCA theatre equipment section and manager of RCA film recording activities, respectively. Prior to joining RCA, Mr. Little was engaged in sales promotion and merchandising for Montgomery Ward & Co., for 18 years. Mr. Kreuzer has been affiliated with RCA since 1928.

**F. RUSSELL GILBERT**, consultant on station operation and programming, is now with WLOG Logan, W. Va.

## Canada Dry to Resume Network Radio on CBS

**CANADA DRY** Ginger Ale, New York, will return to network radio in early fall when it starts a half-hour program on CBS, Friday, 7:30-8 p. m. The show will promote the company's sparkling water among other beverages in the Canada Dry Line, with ginger ale being featured when sugar supplies increase.

Format of the new series has not been decided upon as yet. Canada Dry has not been heard on the networks since sugar shortages in 1942 forced the cancellation of *Michael and Kitty* on the Blue Network. In the past the company was first sponsor of *Information Please* on the Blue Network and, in 1933, the *Jack Benny* show on CBS. Agency is J. M. Mathes Inc., New York.

## WJBW Renewal Is Set For Further Hearings

**TO INQUIRE** into alleged violations of the Commission's rules, the FCC last Tuesday designated for further hearing the application for renewal of license of WJBW New Orleans, 250 w station on 1230 kc. Hearings were held on the renewal application in New Orleans Nov. 8, 9 and 10, 1943 and in Washington on Dec. 30, 1943.

In ordering further hearings, the Commission listed 20 additional issues for investigation. These included questions of compliance with Civil Aeronautics Administration regulations, maintenance of tower lights, conformity with radio silence requirements of the Third Fighter Command, keeping to assigned frequency, and provision of suitable facilities for operator's welfare and comfort.

## Kalech Promoted

**PHIL KALECH**, formerly general sales manager of the Pepsodent Division of Lever Bros., Chicago, has been appointed director of sales of that division in charge of all Pepsodent sales and sales personnel.

# WROK

ROCKFORD, ILLINOIS

Gratefully Acknowledges

Two New Awards for Outstanding Promotion

## FIRST PRIZE

In The "Counterspy" Promotion Contest

THE BEST PROMOTION JOB OF ABC STATIONS  
IN COMPETITION SPONSORED BY SCHUTTER  
CANDY DIVISION OF UNIVERSAL MATCH CORP.



TOM BRENEMAN HAT CONTEST & DISPLAY

OUR EXPLOITATION OF THE BRENEMAN  
HAT PROMOTION WAS JUDGED ONE OF  
THE 10 BEST ENTERED BY ABC OUTLETS.

**WROK DELIVERS!**

1000 W

NATL. REP. HEADLEY-REED CO.

# KNOW

"Austin Gives You  
More Dollars Per  
Dialer ...

**KNOW** Gives  
You More Dialers  
Per Dollar."

**1<sup>st</sup> in AUSTIN, TEXAS**  
**WEED & COMPANY**  
Representatives



# Time Buyers!

## SWING IN ON A TOP PROGRAM WITH "Spot"

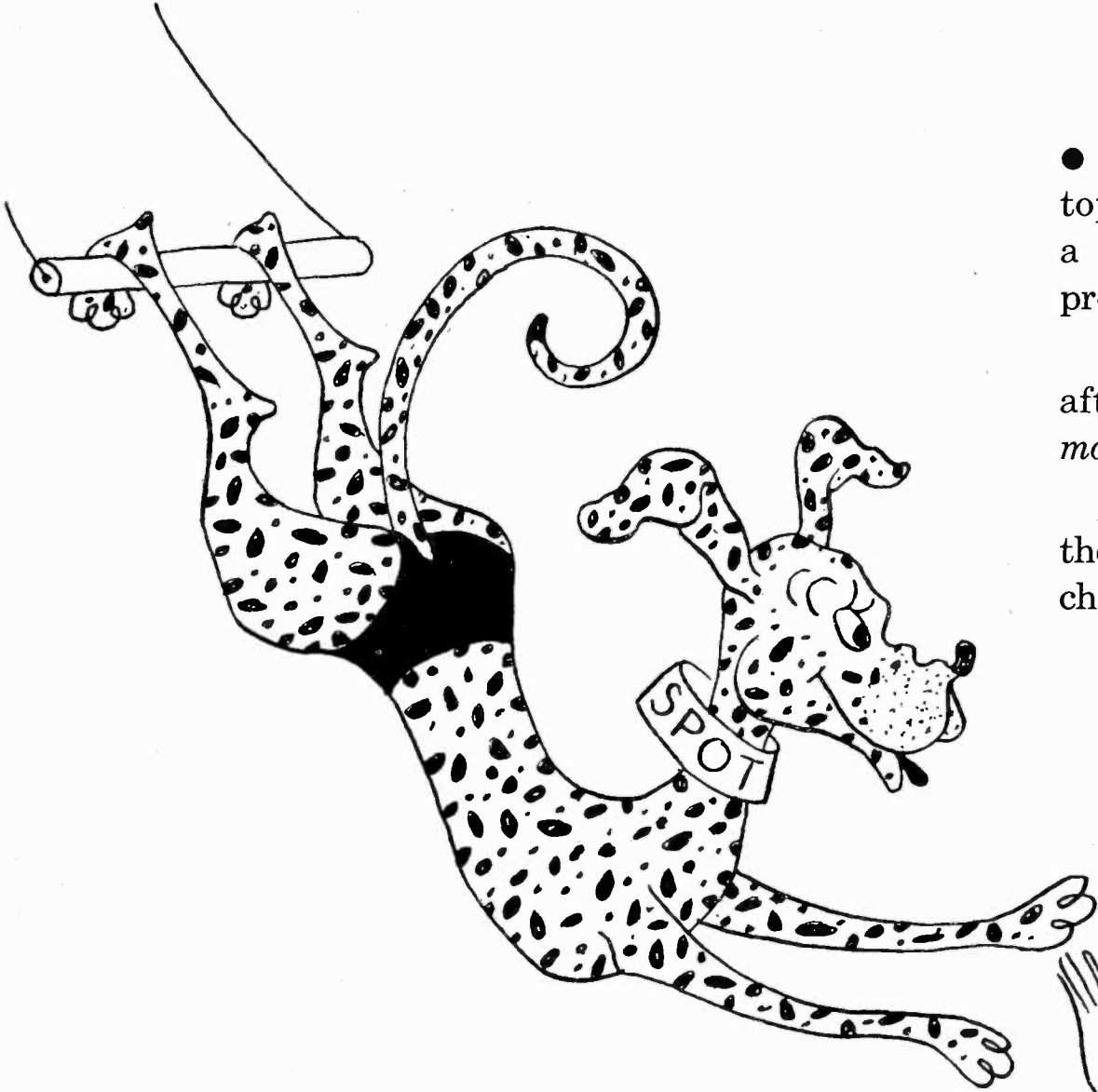

● Look below . . . latch on fast to your pick of these top programs on NBC key stations. You'll be taking a really big swing towards putting your client's product over the top.

For these are the 11 NBC key stations that day after day broadcast to 55% of the people with 34.2% more money to spend than the nation's average.

Don't wait another minute . . . get hold of one of these programs now! . . . and give your client this chance for a real sales alley oop!

**WEAF** . . . . . **New York**  
"Serenade to America"—a tested quality musical program of network caliber available for local sponsorship in the nation's first market, 6:15-6:40 pm, Monday thru Friday.

**WBZ** . . . . . **Boston**  
"Music Shop"—with Ray Dorey as singing proprietor, offers a high-rating program of music strictly on the solid side. 1:15-1:30 pm, Monday thru Friday.

**WGY** . . . . . **Schenectady**  
"Musical Breakfast"—delightful a.m. variety—musical show, with orchestra and vocalist. 8:30-8:45 am, Monday thru Friday.

**KYW** . . . . . **Philadelphia**  
"Music from the Theatre"—popular show tunes, past and present, given unique arrangement by Clarence Fuhrman and the KYW orchestra, featuring singer Frank Coleman. 1:00-1:30 pm, Sunday.

**WRC** . . . . . **Washington**  
"Stringtime"—rich, light concert melodies by the ten-piece NBC String Orchestra—Monday and Wednesday, 10:15-10:30 pm.

**KDKA** . . . . . **Pittsburgh**  
"11:05-11:15 pm Newscast"—This exceptionally popular late evening news program has been producing results for sponsors for over five years. Monday thru Sunday.

**WTAM** . . . . . **Cleveland**  
"Ed Wallace News Commentary"—Lucid comments by famed WTAM news analyst enjoy high rating according to special Hooper Survey. 11:05-11:15 pm, Monday thru Friday.

**WOWO** . . . . . **Fort Wayne**  
"Bob Shreve Show"—with orchestra and vocalist, provides 15 minutes of dinnertime entertainment. 6:15-6:30 pm, Monday thru Saturday.

**WMAQ** . . . . . **Chicago**  
"Music That Sings, with Norman Ross"—carefully selected recorded music and inimitable comments and quips by Ross. 8:30-8:45 am, Monday thru Saturday.

**KOA** . . . . . **Denver**  
"Harkness of Washington"—offers an authoritative analysis and review of activities in the nation's capital. 11:30 pm Monday, 11:15 pm Tuesday thru Friday.

**KPO** . . . . . **San Francisco**  
"News of the World"—John Vandercook co-ordinates this network roundup of global news events; available for local sponsorship. 3:15-3:30 pm Tuesday and Thursday.



# NBC SPOT SALES

New York, Circle 7-8300 . . . Chicago, Superior 8300 . . . San Francisco, Graystone 8700  
Washington, Republic 4000 . . . Cleveland, Cherry 0942 . . . Hollywood, Hollywood 6161  
Denver, Main 6211 . . . Boston, Hancock 4239



**LOVE FROM A STRANGER**



Out of the heavy unsolicited mail response that arrives at KFI daily for the program called "LADIES DAY," a goodly number of letters simply go all-out in telling the principals on the show how much their listeners lo-o-ve them. Only yesterday, emcee Bill Stulla dropped by with a note received from a little housewife in Glendale which went so far as to state that "LADIES DAY" actually made up for the fact that she has been without nylons for over a year!

**AND WHAT A SURPRISE**



Of course we're proud of this daily program (Mon. thru Sat. at 4:00 p.m.) and are quick to agree with listeners that the patter of Bill Stulla and the music of Bob Mitchell and the songs by Bill Shirley provide a lot of fine radio entertainment—but believe us, in our maddest moments we never dreamed that "LADIES DAY" could ever be compared with those two-thread puffs so near a woman's heart. Naturally we'd like to share this unmitigated flattery with you advertisers who are buying into "LADIES DAY" on an announcement basis. Bet you didn't know you'd get all this (and results too) when you made that call to KFI Sales or Edward Petry Company for details on costs and availabilities. P.S. Have you other guys tried "LADIES DAY" recently?

CLEAR CHANNEL  
 640 KILOCYCLES **KFI** 50,000 WATTS  
*Barb C. Anthony, Inc.*  
 NBC for LOS ANGELES  
 Represented Nationally by Edward Petry and Company, Inc.

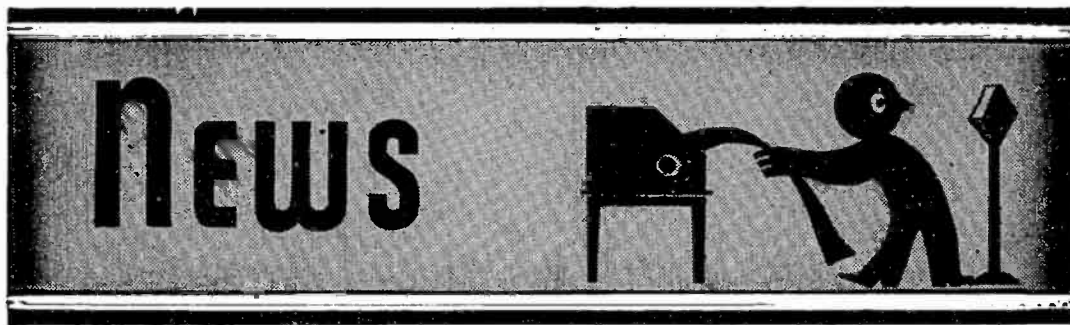

**ULMER TURNER**, news commentator of WJJD Chicago, has been appointed radio director of The Chicago Sun, succeeding **BETTY BURNS**, who is moving to Honolulu.

**JIM MOSER** of the KGO San Francisco newsroom June 15 married **BARBARA CONNER** of the KGO traffic department.

**CLIFFORD EVANS**, managing editor of WLIB New York news room, has been in Mexico covering the elections held July 7. Special interviews and highlights of the election were recorded and air expressed to WLIB for program scheduling.

**F. O. CARVER Jr.**, director of public relations and editor of a house publication for the State Highway and Public Works Commission of North Carolina, has been named news editor of WSJS Winston-Salem. He was released from the Navy, as chief petty officer in public relations.



Mr. Carver

**TOD BRANSON**, formerly with KMBC Kansas City, has been appointed news editor of WRRN Warren, Ohio.

**HENRY OUTLAND**, KLZ Denver news commentator, attended the Conference on Atomic Energy, sponsored by the U. of Denver at Estes Park, Colo., as an official delegate.

**WICK EVANS**, news director of WTMV E. St. Louis, makes his microphone debut July 8 with a news feature. "The World at One," analyzing the top news story of the day. Program will be heard Monday-Saturday, 1-1:15 p.m.

**Educators - NBC Meet**

THIRTY Michigan school superintendents and principals will attend an all day round table meeting at NBC's New York headquarters July 18. The purpose is to aid pupils in understanding the opportunities in the business and industrial world, and to provide educational programs which will aid Michigan students to meet present day employment problems. NBC officials from various departments will address the group.

**OPERATION SQUAB**  
 New England Industrialists Join  
 In Speedy Survey

QUICK industrial survey of New England was made by George C. Wiswell, treasurer of Chambers & Wiswell, Boston agency, and president of the ad club, with cooperation of WHDH Boston, Wakefield Racing Pigeon Club and Western Union.

Known as Operation Squab, the project utilized homing pigeons to bring messages from 100 industrial executives within 90 miles of Boston. Phil Johnson, WHDH special events reporter, covered arrivals at the birds' home loft with a wire recorder and parabolic mike. Entire survey was done in two hours.

**GORDON GRAHAM**, former president, Radio Washington and previously head of WLW Cincinnati Washington news bureau, on July 15 becomes director of public events of WIBC Indianapolis. He entered radio in 1938 with WSMK Dayton, later was with WLBC Muncie, then with Dayton Journal-Herald, before becoming assistant director of special events, WLW, in 1943. Mr. Graham will be responsible for new policies and a general broadening of WIBC's public service, special events and educational features.



Mr. Graham.

**RMA Amateur Group Is Headed by Andrews**

**RAYMOND W. ANDREWS**, merchandising manager, Radio Tube Division, Sylvania Electric Products Inc., has been appointed chairman of the parts subcommittee, Radio Amateur Section, Radio Manufacturers Assn.

The subcommittee has been formed to stimulate interest in establishment of reference standards and accurate product comparisons and to encourage the cooperation of parts manufacturers in improved advertising and cataloging for the radio amateur.

Mr. Andrews has appointed the following as members of his committee: W. W. Eitel, Eitel-McCullough; W. B. Swank, E. F. Johnson Co.; James Millen, James Millen Mfg. Co.

**Atom Test Comment**

WHILE all station newsrooms throughout the country remained on the alert to break any program for important news from "Operation Crossroads," WCBM Baltimore pointed to its community for significant analysis of the atom bomb experiment. Dr. David Inglis, associate professor of physics at Johns Hopkins U. and one of leading scientists who participated in development and original experiment of the bomb, was on hand at WCBM to report over the Maryland Coverage Network, which includes WBOC Salisbury and WJEJ Hagerstown. Dr. Inglis commented on the test immediately following Adm. Blandy's announcement, and later reports coincided with his interpretation.

**ROBERT MAXWELL**, producer of the MBS Superman Series, has received a letter from Gov. Ellis Arnall of Georgia commending the program on its crusade against the Ku Klux Klan. Series is heard Monday-Friday, 5:15-5:30 p.m. on MBS in behalf of the Kellogg Co., Battle Creek, through Kenyon & Eckhardt, New York.

**CBS Planning Program On Juvenile Delinquency**

A NATIONAL report on juvenile delinquency, to be aired sometime this fall, will be the culmination of several months of national research by Robert Lewis Shayon, CBS executive director. Mr. Shayon produced the CBS, hour-long *Operation Crossroads*, a pre-Bikini atom program.

The program on juvenile delinquency will attempt to point out how America can approach the problem. Mr. Shayon will tour the nation, visiting most U. S. big cities, and those areas where special efforts are being made to combat delinquency, interviewing outstanding U. S. authorities on the problem. At the end of his trip Mr. Shayon will develop his material into dramatic form for an hour's broadcast.

**Finch Expands Facsimile Service Throughout N.Y.**

A FACSIMILE newspaper *Air Express* will begin operation in at least 100 public places in New York City, such as hotel lobbies, bars and night clubs, within a week according to Capt. W. G. H. Finch, USNR, owner of WGHF New York's newest FM station.

Using United Press news reports, letter size, four column paper will be transmitted twice daily 12:45-1 p. m. and 5:15-5:30 p. m., seven days a week. Until now the paper has come out irregularly. Captain Finch, head of Finch Telecommunications Inc. is the producer of facsimile sending-receiving equipment.

**Rescinds Rule**

FCC last week rescinded subsection 8.115 (1) of the Commission's Rules Governing Ship Service, which had been issued as a wartime measure to provide a means for radio operators to test the ship's emergency transmitters under wartime conditions.

**CARL CAMPBELL**, discharged from Army, has rejoined CBS Hollywood engineering staff.

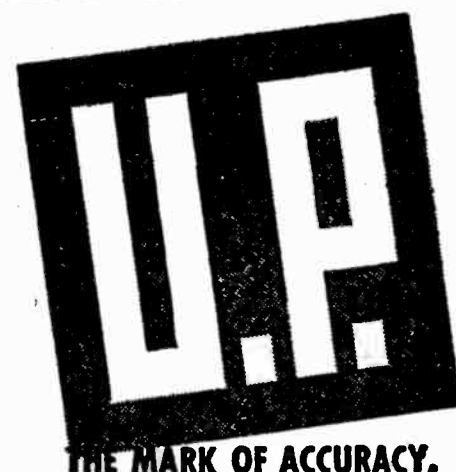

THE MARK OF ACCURACY,

SPEED AND INDEPENDENCE IN

WORLD WIDE NEWS COVERAGE

**UNITED PRESS**



*You'll find this  
exclusive circuit design only  
in Westinghouse Transmitters*

**equalized audio feedback  
to strengthen fidelity,  
reduce audio distortion**

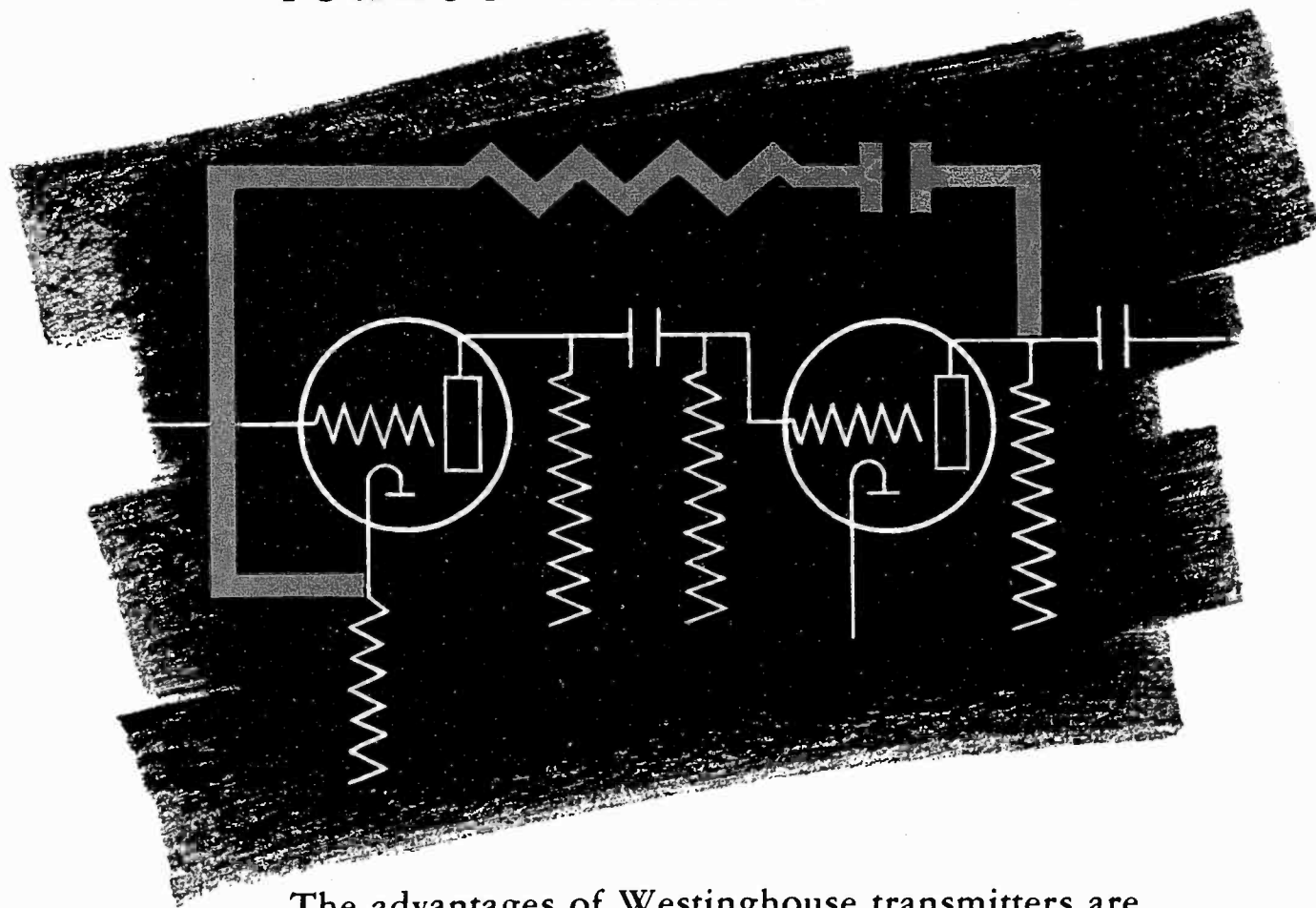

**Westinghouse**  
PLANTS IN 25 CITIES . . . OFFICES EVERYWHERE

*Electronics at Work*

The advantages of Westinghouse transmitters are proved by actual station operation experience unmatched by any other transmitter manufacturer. Ask your nearest Westinghouse office for all the facts . . . 5, 10 and 50 kw AM, 1, 3, 10 and 50 kw FM. Westinghouse Electric Corporation, P. O. Box 868, Pittsburgh 30, Pa.

J-08148

COMBINING music and good will in a Latin American format, KGFJ Hollywood is airing a weekly half hour, "Saludos Amigos." In addition to authentic music of country saluted, program will also feature interviews with governmental officials or visiting dignitaries. For past 15 years, program has been Spanish language broadcasts, but its conductor, Mrs. Elena Salinas, has returned to South America.

**Salute to Monterey**

CALIFORNIA Medical Assn.'s "California Caravan," on July 6 saluted Monterey, Cal. in connection with Flag Centennial there. Tie-in was arranged by Lockwood-Shackelford, Los Angeles, agency on account, in cooperation with KDON Monterey.

**June Bride 'Queen'**

SPECIAL June bride broadcast was presented June 28 on the "Queen for a Day" program, on MBS with the bride chosen as "Queen for a Day" receiving honeymoon trip to Hawaii. All those invited to the program on that day were

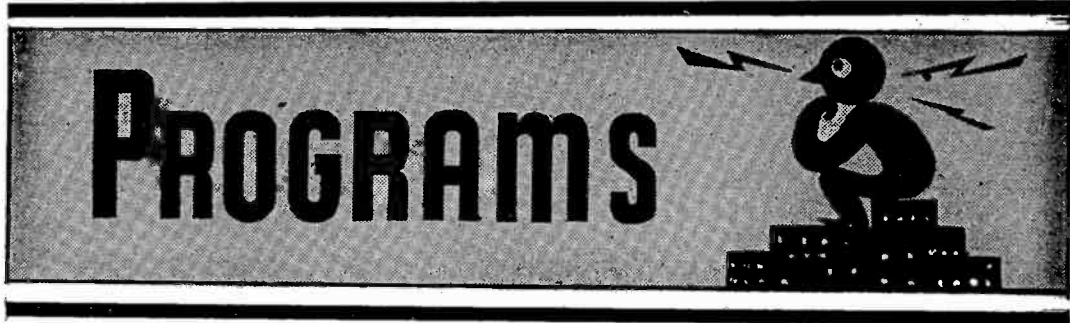

prospective June brides. Sponsors of the show, heard Monday through Friday, 2:30-3 p.m., are Procter & Gamble, Cincinnati and Miles Labs., Elkhart, Ind.

**Henie Show**

SERIES of transcribed quarter-hour programs, featuring news of the women's world, has been started by Sonja Henie, noted ice skating star, on WTON Staunton, Va., ABC outlet. Program is sponsored locally.

**Field Club**

WILM Wilmington, Del. July 10 begins "The Rod and Gun Club of the Afr." Bill Everman and Arnold Stewart, sports columnists, will conduct the show, with Del Parkes as announcer. Program will be heard Wednesday, 7:15 p.m.

**Airs Council Debate**

WTOD Toledo, Ohio, within a week after beginning to broadcast, aired the proceedings of the City Council on June 24. Hour and a half of debate on downtown traffic control plans was covered.

**J. Roosevelt Series**

JAMES ROOSEVELT, son of late President, has started as commentator, 6:45-7 p.m., PST, five-weekly on KLAC Hollywood and KYA San Francisco, with negotiations under way for airing on ABC. Show will also be transcribed for WLIB New York.

**Weather News for Racers**

AS A SPECIAL public service to yachtsmen entered in the Bermuda races this year, the news and special features division of WOR New York June 29 for a week started broadcasting weather reports especially slanted for the racers. Forecasts are heard on weekdays at 6:40 a. m., 11 a. m., 6:30 p. m. and 11:35 p. m., and on Sunday at 10 a. m. and 7:30 p. m.

**Singing Breaks**

IN A PROMOTION for listenership, WELI New Haven, Conn., is presenting 10-times daily a 15-second transcription featuring Vaughn Monroe and his orchestra. Musical station break, composed by Bud Finch of the station's announcing staff consists of call letters, dial setting and reason why "New Havenites should keep listening to WELI."

**Song Memories**

WRITTEN request musical program started by WJNO West Palm Beach, Fla., is "Echoes in Song," presented thrice weekly in morning period. Mather Furniture Co. is sponsor.

**WAAB Covers**

PANEL discussions and interviews highlighted coverage by WAAB Worcester, Mass., of June 25-28 athletic clinic of Holy Cross. Sports authorities of the major colleges attended.

**Baby Care Program**

WEEKLY quarter-hour series, "Babies Are Fun," has been started by KYW Philadelphia. Hints on the care and feeding of infants are presented.

**Citation for WLAW**

NATIONAL United Service Organizations has awarded to WLAW Lawrence, Mass., a citation for distinguished war service.

**Shortwave to Sweden**

CELEBRATION of the 50th anniversary jubilee of the Vasa Order of America, held in Hartford, Conn., June 27-28, was broadcast short-wave to Sweden by NBC international department.

**Program Ads**

DAN GOLENPAUL Assoc., package firm owning "Information Please," has placed ads in the New York Times and papers in Pittsburgh, Boston and Detroit announcing the last NBC broadcast under present sponsor (Socony Vacuum Oil Co.). Ad also stated that "Despite what you may have heard, 'Information, Please' will definitely be back on the air next fall although arrangements have not been completed." An official with Dan Golenpaul Assoc. admitted that negotiations were current but would not reveal the possible sponsor's name.

**Gospel Sing on CBS**

THE STAMPS Quartet Singing Convention, Dallas, June 29, carried annually by KRLD Dallas, this year was fed to CBS 12:30-1 a.m. Occasion was ninth annual all-night gospel sing. National quartets and chorus of 2,000 were heard.

**International Music**

CATERING to the city's cosmopolitan population, WHBC Canton, Ohio, is presenting weekly series, "Music of All Nations," Sun. 1-1:30 p.m., sponsored by R. & J. Furniture Co.

**Movie Roundtable**

EVENING session division of the City College School of Business, New York, is participating in a half-hour radio program "Hollywood Round Table" which began July 2 on WNYC New York, Tues. 8:30-9 p.m., first subject being "Who Should Control Movie Censorship?" Joseph Carleton Beal, public relations director of the school, has been selected as permanent City College panel member of the program with President Harry Noble Wright, Dr. Robert A. Love, Dean Thomas L. Norton, and Associate Dean John Gray Peatman asked to sit in Mr. Beal's place on future programs.

**Girl Scout Co-op**

WQAM Miami, in cooperation with the Miami-Herald and the local Girl Scout Council, is conducting a "Fun at Home" project, designed to keep youngsters at home in order to avoid crowds during current polio epidemic in Florida.

**I'LL FIGHT FER WDAY!**



WDAY is overwhelmingly the most preferred station in the Red River Valley. The latest Conlan Survey tells the story:

WDAY GETS 61.4% OF THE AUDIENCE IN ITS COVERAGE AREA

STATION B GETS 9.5% OF THE AUDIENCE

STATION C GETS 7.2%



**WDAY** FARGO, NORTH DAKOTA N.B.C. FREE & PETERS, Inc. National Representatives

**Real Heart Beats**

THROUGH a sensitive microphone a victim of a cardiac condition learned of it. When Thomas J. Lipton Inc., sponsor of *Inner Sanctum Mystery* on CBS, asked that a special *March of Time* famine broadcast be carried instead of one of the regular *Sanctum* programs, actual human heartbeats were used to make the opening muffled, thumping sounds. Healthy, rhythmic sounds belonged to one of five CBS announcers and actors who volunteered. Slow, faltering beat was that of another volunteer who learned for the first time of his cardiac condition when the different "takes" were compared. Heart beats will be used for future *Inner Sanctum* programs, Young & Rubicam, the Tipton agency, announced.

**Standards Takes Over**

RADIO propagation activity of the Government, operated during the war by the Interservice Radio Propagation Laboratory, was taken over last week by the Bureau of Standards. New unit, created May 1 [BROADCASTING, April 29], is called the Central Radio Propagation Laboratory, Division 14. It will coordinate and centralize basic research and prediction service.

5000 WATTS DAY AND NIGHT

**KGER'S FEATURE FOLKS**  
Hal Shideler, Sports Editor

For Availabilities, see Jos. H. McGillvra, Inc. Long Beach-Los Angeles

**KGER**  
OWNED by MERWIN DOBYNS



## WAR WINNERS

KOTA Promotion Picks Pair

For First Place

A PAIR of South Dakota mothers are winners of the contest conducted by KOTA Rapid City, S. D., to find the women who did the most to win the war on the home front.

Mrs. Evelyn Baker, 30, of Custer, whose husband was killed on Okinawa, won first place and the title "Woman of the War Years." Mrs. James Magee, a Gold Star Mother, of Belle Fourche, won second place. Both received expense-paid trips to Washington, where they visited President Truman, and to New York, where they appeared on CBS network programs.

As first-prize winner, Mrs. Baker also received a "dream kitchen" including an electric stove, refrigerator, dish-washer, garbage disposal unit, cabinets and sink. Mrs. Magee received her choice from the "dream kitchen" list.

KOTA planned its contest to give recognition to women's war-time work. The station prepared a series of questionnaires, each with a given value in points, and mailed them periodically to 630 women who registered in three states. Points were given for members of family in military service; for war work, and for assistance in various war-helpful projects.

## Summer Replacements

TWO NEW summer sustainers replaced NBC sponsored shows, *Travelin' Man* for *Cavalcade of America*, 8-8:30 p.m. EDST, Monday, effective July 1; *Carnival with Bernie West* for *Life of Riley*, 3-8:30 p.m., EDST, Saturday, effective July 13. *Cavalcade*, sponsored by E. I. duPont de Nemours & Co. Inc., returns to the network Aug. 26. Agency is BBDO. *Life of Riley*, sponsored by Procter & Gamble (Teel), returns Sept. 7. Agency is Biow Co.

BENNY GOODMAN, summer replacement for NBC "Information Please," has been withdrawn from Canada on CBC Dominion network. Reason given is that many Socony Vacuum products not sold in Canada are mentioned in program and format does not allow Canadian announcements to replace these commercials. Agency is Cockfield Brown & Co., Toronto.



*Fine* transcriptions are recorded on Audi discs  
AUDIO DEVICES, INC., N. Y. C.

## WLAU Laurel on Air; Names Staff of Station

PERSONNEL at the new WLAU Laurel, Miss., which went on the air June 15, has been announced by Southland Broadcasting Co., licensee. Outlet operates with 250 w on 1490 kc and is affiliated with Mutual.

WLAU manager is Hugh M. Smith, secretary and treasurer of the Mississippi Broadcasting Assn. and also former committee member of the NAB. Commercial manager is W. C. DeHority, 25-year veteran of radio and advertising.

Others include: James Travis, program director, formerly of KOMA and KOCY, Oklahoma City, and KBIX Muskogee, Okla.; Don Norman, announcer, from KXOK St. Louis; Lloyd Hilbun, chief engineer; Arnold Sundseth, formerly of KBTM Jonesboro, Ark.

Opening ceremonies were held in the new downtown studios, attended by radio officials of other state stations and Harry LeBrun, representative of Mutual.

## Oberfelder Promoted

TED OBERFELDER, ABC audience promotion manager, has been named assistant director of advertising and promotion for ABC. In addition, ABC's advertising and promotion department will be streamlined by bringing audience promotion, art and production and sales promotion under one department.

The only  
New Orleans Station  
using all these means  
to build Listenership  
continuously

- 24-Sheet Posters
- Newspaper Advertising
- Street Car Dash Signs
- Point-of-Sale Displays

Folks turn first to-



THE GREATEST SELLING POWER IN  
THE SOUTH'S GREATEST CITY  
50,000 Watts - Clear Channel  
CBS Affiliate  
Represented Nationally by  
The Katz Agency, Inc.

# FREE & PETERS, INC.

**A LITTLE EXTRA EFFORT  
OFTEN GETS A BIG RESULT!**

Snake charmers may have top audience ratings in Calcutta, or bull-fighters in Barcelona, or bag-pipers in Ballantree. Here in this country local tastes vary, too. No network, no program, is tops in every market, all the time.

But in every American market there are several locally-produced radio shows that are tops with local listeners, available to you national spot advertisers. It takes a little extra effort to line them up—but, Lordy, the job they do!

**FREE & PETERS, INC.**  
Pioneer Radio Station Representatives  
Since 1922

**EXCLUSIVE REPRESENTATIVES:**

ALBUQUERQUE	KOB
BALTIMORE	WCBM
BIRMINGHAM	KVAL
BUFFALO	WGR
CHARLESTON, S. C.	WCBC
COLUMBIA, S. C.	WIS
DAVENPORT	WOC
DES MOINES	WOW
DULUTH	WDAI
HOUSTON	WDAZ
INDIANAPOLIS	WIBC
KANSAS CITY	WIBW
LOUISVILLE	WIBC
MINNEAPOLIS	WIBC
NEW YORK CITY	WIBC
PEORIA	WIBC
PORTLAND	WIBC
RICHMOND	WIBC
ST. LOUIS	WIBC
ST. PETERSBURG	WIBC
TULSA	WIBC
WRIGHTSBORO, N.C.	WIBC

## PIONEER RADIO STATION REPRESENTATIVES

USES THE PRINTERS' INK NETWORK TO REACH ADVERTISERS AND AGENCIES WHO INFLUENCE THE BUYING OF RADIO TIME

78 other stations, networks and station representatives also use the P.I. network to reach the leading audience of buyers of advertising through the largest A. B. C. net paid circulation in the general advertising field.

# Printers' Ink

IN BUFFALO  
IT'S



WKBW  
1520 K.C.



FOR



AMERICAN



BROADCASTING



COMPANY



**BUFFALO BROADCASTING CORPORATION**

RAND BUILDING, BUFFALO, N. Y.  
National Representatives: Free & Peters, Inc.

## Five More Outlets Acquired by MBS

ZBM KSAM WDSG WENC WMVG Join the Network

MBS has announced addition of five new affiliates, including ZBM Hamilton, Bermuda, first commercial station established in the islands. Total list of Mutual stations is now 323.

ZBM operates with 250 w on 1240 kc and joined the network July 1. It is owned and operated by Bermuda Broadcasting Co. Ltd., with Cole E. Wylie, manager.

KSAM Huntsville, Tex., operating with 250 w on 1490 kc, joined MBS July 1. W. J. Harpole and J. C. Rothwell are joint owners.

Owned and operated by State Gazette Broadcasting Co., WDSG Dyersburg, Tenn., operating with 250 w on 1450 kc, becomes an affiliate on July 13.

WENC Whiteville, N. C., owned and operated by Whiteville Broadcasting Co., and managed by William Holm, joined MBS July 1 as did WMVG Milledgeville, Ga., WENC operates on 1240 kc with 250 w. WMVG operates with 250 w on 1450 kc and is owned by Jere N. Moore.

NEW TRANSCRIBED outdoors program called "Outdoor Life Time" packaged and produced by Richman Productions, New York, is locally sponsored on WTIC CJCH KOMA WBIR KVOA.



RADIO MEN searching for trout and salmon near Portage, Me., are (l to r): Seated, Adam J. Young of Adam J. Young Inc., station representatives; Elmo C. Wilson, CBS director of research. Standing: William B. Lodge, CBS director of engineering; Harold E. Fellows, general manager of WEEI Boston; Fred B. Simpson, general manager of WABI Bangor; Buster Simpson, WABI.

### In the Public Interest

#### KNX Housing

TO AID hard-pressed veterans in their housing search, KNX Hollywood devoted five hours of a broadcast day to project. Developed under direction of Chet Huntley, CBS Western Division head of public affairs and special

events, material ranged from drama through news to commentary, in addition to spot announcements. Results provided 210 offers of quarters including apartments, a few homes and many rooms. According to Mr. Huntley, a few conscientious listeners even offered spare couches and cots. Campaign has been so successful that station has now decided to continue housing hunt on twice weekly basis. Starting June 27, interview format led by Peter Robeck, veterans and their families is being heard Thursdays and Saturdays. Interviews are transcribed by wire recorder at Veterans Service Center in downtown Los Angeles; veterans are invited to be present during rebroadcast to follow leads coming through from listening audience.

#### Aids Community Chest

DEVISING a method of best serving the needs of the Community Chest, WDRC Hartford, Conn. is sustaining a 15-minute weekly program on Saturday night during 6:30 period. Show is wire recorded direct from each one of the 31 agencies served by the Hartford Community Chest. Roy Hansen, WDRC early morning man, is program m.c.

★ HEART OF EASTERN NORTH CAROLINA  
BRIGHT LEAF TOBACCO BELT

*this*  
**WASHINGTON**  
IS IN  
**NORTH CAROLINA**

*In Case you didn't know!*

This Washington, in the heart of Eastern North Carolina, is the home town of WRRF! Also perhaps you didn't know that Eastern North Carolina Bright Leaf Tobacco farmers sold their 1945 crop for over \$175,000,000.00.

We want you to know... that WRRF serves this market completely... a market of over 600,000 population... with 6,188 retail stores that do over \$100,000,000.00 annual sales volume.

You should know... that 67,144 radio homes depend primarily on WRRF for their favorite national and local programs.

Then you will know that WRRF is the only "buy" to cover Eastern North Carolina... WRRF will sell your product in one of America's richest agricultural belts... So remember WRRF... This Washington in North Carolina—and this "as good as gold"... market.

**WRRF**  
720 Kc. 1000 WATTS

TAR HEEL BROADCASTING SYSTEM, INC.  
"WE RADIATE REAL FRIENDSHIP"  
AFFILIATED WITH THE AMERICAN BROADCASTING COMPANY  
FORJUE & COMPANY • National Representative  
NEW YORK CHICAGO PHILADELPHIA

WASHINGTON  
NORTH CAROLINA  
"HOME OF WRRF"

**WHO**  
is "Listened-to-Most"  
in **74** of  
Iowa's 99 Counties

(No. 2 Station is "Listened-to-Most" in 11 Counties!)

Write for complete facts!  
50,000 Watts • Des Moines  
Free & Peters, Representatives



# PRODUCTION



**KENNETH MacGREGOR** last week joined NBC as senior producer. Mr. MacGregor was formerly with the William Esty Co., where since 1943 he had been producing top shows. One of the programs he will direct at NBC is "Carnival With Bernie West," a new talent development show.

**HARVEY OLSON**, program manager of WDRC Hartford, Conn., was elected second vice president of the Hartford Advertising Club. Station manager **WALTER HAASE** relinquished Ad Club presidency after serving one-year term.

## Breckenridge Is Critical Of Fat Salvage Figure

EDITOR, BROADCASTING:

The article "Free Radio Time Promotes Fat Drive" which appeared in BROADCASTING for June 17 has come to my attention. I am afraid I must take issue with you on your facts.

If you will refer to the article itself, the second paragraph says, "All this service has been donated by the broadcasting medium." This is untrue. An absolute minimum of 80%, on the basis of dollar value, has been time contributed by commercial advertisers who pay the broadcasting medium for the time and who, of course, pay their talent. The true figure is probably 95%.

The article goes on to say that the "Committee credits radio with only \$1,411,800 of free time in 1945." The Committee made no such estimate of "free" radio time. In fact, we have never attempted to make such an estimate.

The truth of this whole matter is that while Fat Salvage is one of the most heavily promoted of all war-created programs on the air, the overwhelming majority of the announcements are broadcast on commercial, paid-for programs by advertisers whose revenue is the very life's blood of broadcasting.

The article in question is wholly

**REGIS CORDIC** has returned to the announcing staff of WWSW Pittsburgh after two years in the Navy.

**LEONARD SAVORY**, released from the AAF after 19 months overseas as radio operator and gunner, has replaced **HARRY HAMER** as continuity director of WPAY Portsmouth, Ohio.

**GEORGE MARTIN Jr.**, discharged from Navy, has returned to KHJ Hollywood as announcer-producer-newscaster.

**CHARLES VANDA**, CBS Hollywood executive producer, is the father of a girl.

misleading and I hope you will correct the wrong impression that it was patently designed to leave with the reader.

**WILDER BRECKENRIDGE**,  
Director,  
Fat Salvage Committee

Editor's Note—The article Mr. Breckenridge questions contended that radio, doing a major part of the fat conservation job, donated its services whereas newspapers receive over \$100,000 a month in paid space. It conceded that part of the radio promotion is done through announcements on regular programs of soap sponsors, but this is the smallest part of radio's role in the drive. The figure \$1,411,800 free time in 1945 which Mr. Breckenridge disclaims, was obtained from the Fat Salvage Committee.

**CLYDE McLAIN**, released from the Navy, has rejoined the announcing staff of WIS Columbia, S. C.

**DOROTHY KALIFF**, WOAI San Antonio staff organist and formerly with Phil Spitalny's orchestra as "Louise," has announced her engagement to Benjamin Ruttenberg, San Antonio.

**JAY STEWART** has taken over as m.c. of ABC's "What's Doing Ladies" replacing Perry Ward.

**WARREN LEWIS**, NBC Hollywood producer-writer, is father of girl.

**JOHN NELSON**, m.c. of ABC "Bride and Groom" and announcer of "Breakfast in Hollywood," is father of twin boys.

**FRANK F. ATWOOD**, assistant editor of the U. of Connecticut Extension Service for the past eight years, has been named farm director of WTIC Hartford.

**WOODY PARKER**, for 2½ years with the Marine Corps as a radio combat correspondent in the South Pacific, has joined the cast of "Rosemary" on CBS.

**GEORGE MARR**, sports director of WHDH Boston, has resigned to free lance in sports. He broadcast the '46 basketball season for Coca Cola, sports summary daily for Lektrolite, and Red Sox-Braves baseball season for Herald Traveller.

**DAVID KENT**, released from the Army, has been named continuity director of WTON Staunton, Va. Prior to entry in the Army, he was associated with WDBJ Roanoke, Va. and WAIR Winston-Salem, N. C.

**PAUL ENRIGHT**, program director of WTMV E. St. Louis, is the father of a girl, Gearin Michele.

**PAUL E. MILLEN**, on inactive duty from Army as captain after more than four years' service, has joined KOA-NBC Denver as continuity editor. Prior to joining Army, he was guide in production and continuity department of NBC Central Division, Chicago. He replaces **MARGARET CAPERTON**, resigned.

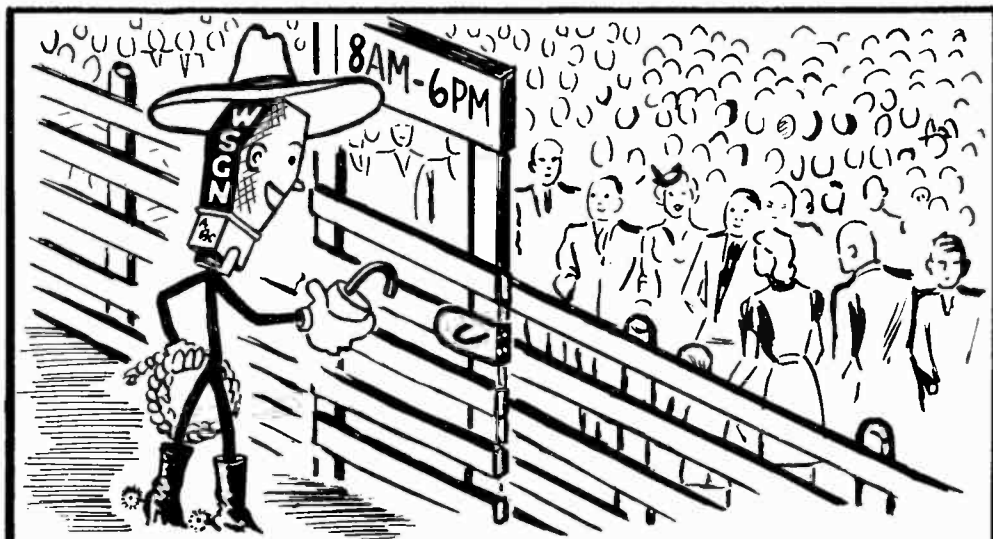

## WSGN Again Corrals the Listening Audience

For the last three months, WSGN has controlled the All-Day Listening Audience (8 A. M. to 6 P. M.). Our efforts to maintain this dominance are never relaxed.

WSGN . . . . .	34.4*	B . . . . .	34.0
A . . . . .	23.7	C . . . . .	7.7
OTHERS . . . . .		.2	

\*Figures from March-April 1946 Hooperatings

ALABAMA'S BEST BUY FAR!

# WSGN

AMERICAN BROADCASTING COMPANY

THE NEWS-AGE-HERALD STATION

Represented Nationally by Headley-Reed



**An All-Time Favorite**

**WHAT A DIFF'RENCE A DAY MADE**

Published by  
**EDWARD B. MARKS MUSIC CORP.**

Performance Rights  
Licensed Through  
**BMI**

**BROADCAST MUSIC, INC.**  
580 Fifth Ave., New York 19, N.Y.

**IN BUFFALO**

**IT'S**

**WGR 550 K.C.**

**FOR**

**COLUMBIA**

**BUFFALO BROADCASTING CORPORATION**  
RAND BUILDING, BUFFALO, N. Y.  
National Representatives: Free & Peters, Inc.

# SERVICE DIRECTORY

## FREQUENCY MEASURING SERVICE

Exact Measurements - at any time



RCA COMMUNICATIONS, INC.  
64 Broad Street, New York 4, N. Y.

MORE RF KILOWATT HOURS  
PER DOLLAR WITH  
**F & O TRANSMITTING TUBES**  
Freeland & Olschner Products, Inc.  
611 Baronne St., New Orleans 13, La.  
Raymond 4756  
High Power Tube Specialists Exclusively

## FREQUENCY MEASUREMENTS

One of the best equipped monitoring stations in the nation

### STANDARD

Measuring & Equipment Co.

Phones 877-2652 Enid, Okla.  
Since 1939

## TOWER SALES & ERECTING CO.

### Radio Towers

Erection, lighting, painting &  
Ground Systems

6100 N. E. Columbia Blvd.  
Portland 11, Oregon

C. H. Fisher, Agent Phone TR 7303

## Ralston Radio Engineering Co.

Supervision of constructing AM &  
FM Stations. Field measurements.

1448 N St., N.W. Office—DI. 2704  
Washington, D.C. Res.—Alex. 6957

## GREYER RADIO ENGINEERING CORP.

Julius L. Greyer — William P. Greyer  
118 BROOKE AVENUE  
NORFOLK 10, VIRGINIA

Phone Norfolk 26511—Nights 24408

CONSULTING RADIO ENGINEERS

AM INSTALLATION SPECIALISTS FM

## DeQuincy V. Sutton

Radio Business Consultant

2700 Conn. Ave. Columbia 8105

Washington 8, D. C.

## Custom-Built Speech Input Equipment

### U. S. RECORDING CO.

1121 Vermont Ave., Wash. 5, D. C.  
District 1640

## The Robert L. Kaufman Organization

Technical Maintenance, Construction  
Supervision and Business Services  
for Broadcast Stations

Munsey Bldg. Washington 4, D. C.  
District 2292



1031 N. ALVARADO • LOS ANGELES 26, CALIF

## Transmitter Installation

Field & Antenna Measurements

### BRADEN ENGINEERING CO.

3317 Kenmore Ave., Dayton 10, Ohio

Phone—Kenmore 6233

## GEORGE H. JASPERT

Consultant,

Broadcast Station Operations

Preparation and breakdown of pro-  
gram matters pertaining to AM-FM  
applications, estimates of station  
costs, annual operating expenses and  
income.

Little Building Hancock 4948  
Boston 16, Mass.

## Complete Technical and Management Consulting Service

Immediate VHF and FM Field Measurement  
Service Available

Engineering Research Associates, Inc.

Washington Office: 827-14th Street, N.W.

Phone: Executive 4742

Laboratories: St. Paul 4, Minn. Phone: Nestor 9601

## RADIO ENGINEERING CO.

Consultants

Installation • Allocation • Field  
and Antenna Measurements

Norwood J. Patterson, Owner  
1355 Market Street Room 1010  
San Francisco 3, California  
Phone: Market 8173

# ACTIONS OF THE FCC

JUNE 28 TO JULY 4

## Decisions . . .

JUNE 28

BY COMMISSION EN BANC

AM—1400 kc

Great Falls Bestg. Co., Great Falls,  
Mont.—Granted CP new station 1400 kc,  
250 w, unlimited time; engineering con-  
ditions.

AM—1400 kc

William E. Blake, Ronceverte, W. Va.  
—Granted CP new station 1400 kc, 250  
w unlimited time; engineering condi-  
tions.

AM—1450 kc

Redege Bestg. Co., Hendersonville,  
N. C.—Granted CP new station 1450 kc,  
250 w, unlimited time; engineering con-  
ditions.

AM—910 kc

Purchase Bestg. Co. Inc., Mayfield,  
Ky.—Granted CP new station 910 kc, 1  
kw, daytime only, subject to approval  
by CAA of antenna system and trans-  
mitter site.

AM—970 kc

Worth Bestg Co., Fort Worth, Tex.—  
Granted CP new station 970 kc, 1 kw,  
daytime only; engineering conditions.

AM—1490 kc

Pocatello Bestg Co., Pocatello, Ida.—  
Granted CP new station 1490 kc, 250 w,  
unlimited time; site to be determined;  
conditions.

AM—1450 kc

Eastern Idaho Bestg & Television Co.,  
Pocatello, Ida.—Granted CP new sta-  
tion 1450 kc, 250 w, unlimited time;  
engineering conditions.

AM—1240 kc

Radio & Television Bestg. Co. of  
Idaho, Pocatello, Ida.—Granted CP new  
station 1240 kc, 250 w, unlimited time;  
subject to CAA approval

AM—1450 kc

Chanticleer Bestg. Co., New Bruns-  
wick, N. J.—Granted CP new station  
1450 kc, 250 w, unlimited time; engi-  
neering conditions.

AM—1240 kc

WBAX, Wilkes-Barre, Pa.—Granted  
CP to increase from 100 w to 250 w;  
change type of antenna and change  
transmitter site, operating on 1240 kc,  
unlimited time.

Transfer Control

WPOR, Portland, Me.—Granted con-  
sent to transfer of control of Centen-  
nial Bestg. Co., Inc., permittee of sta-  
tion WPOR, from William T. Morris,  
deceased, to John H. Hilliard, Albert T.  
Morris, Thomas C. Davis and Arthur C.  
Laske, executors of the estate of Wil-  
liam T. Morris, deceased. No monetary  
consideration involved.

Assignment License

KALL, Salt Lake City, Utah—Granted  
consent to voluntary assignment of  
license of KALL from Abrelia S. Hinck-  
ley, George C. Hatch and Wilda Gen  
Hatch, a partnership, d/b as Salt Lake  
City Bestg. Co., to Salt Lake City Bestg.  
Co. Inc., a newly formed corporation  
composed of the same partners.

AM—1450 kc

McHenry Tichenor, Boulder, Colo.;  
Gifford Phillips, Denver—Designated for  
hearing application of McHenry Tiche-  
nor in a consolidated proceeding with  
application of Gifford Phillips both re-  
questing 1450 kc, 250 w, unlimited time.

AM—790 kc

KVOX, Moorhead, Minn.; Northern  
States Bestg. Co., Fargo, N. D.—Desig-  
nated for hearing application of KVOX  
requesting change in frequency from  
1340 to 790 kc, increase in power from  
250 w to 5 kw, installation of a new  
transmitter, change transmitter loca-  
tion, and install DA for nighttime use,  
to operate unlimited time, in a consoli-  
dated proceeding with application of  
Northern States Bestg. Co. for a new  
station to operate on 790 kc, 5 kw,  
unlimited time, employing a directional  
antenna for nighttime use, at Fargo.

AM—1490 kc

Beatrice Cobb, Morganton, N. C.;  
Nathan J. Cooper, Morganton, N. C.—  
Designated for consolidated hearing ap-  
plication of Beatrice Cobb for a new  
station to operate on 1490 kc, 250 w,  
unlimited time, with application of  
Nathan J. Cooper, for the same facilities.

AM—800, 810 kc

Ralph D. Epperson, Mount Airy, N. C.;  
Wilkes Bestg. Co., No. Wilkesboro, N. C.—  
Designated for consolidated hearing  
application of Ralph D. Epperson for  
a new station to operate on 800 kc, 250  
w, daytime only, with application of  
Wilkes Bestg. Co. for a new station to  
operate on 810 kc, 1 kw, daytime only.

AM—1280 kc

Rochester Bestg. Co., Rochester, N. Y.;  
Veterans Bestg. Co. Inc., Rochester, N.  
Y.—Designated for consolidated hear-  
ing application of Rochester Bestg.  
Corp. for a new station to operate on  
1280 kc, 5 kw, unlimited time, DA day  
and night, with application of Veterans  
Bestg. Co. Inc., requesting 1280 kc, 1 kw,  
daytime only.

LICENSE RENEWALS

WCED, DuBois, Pa.—Granted renewal  
of license for the period ending Feb. 1,  
1949.

KVCV, Redding, Calif.—Granted re-  
newal of license for the period ending  
Feb. 1, 1949.\*

WMCA, New York City.—Granted re-  
newal of license for main and auxiliary  
transmitter for the period ending May  
1, 1949.

KUTA, Salt Lake City, Utah.—Granted  
renewal of license for the period  
ending May 1, 1949.\*

WJBW, New Orleans, La.—Designated  
for further hearing application for re-  
newal of license.

WKBW, WGR, Buffalo, N. Y.—Tempo-  
rary licenses for the operation of stations  
WKBW and WGR were extended from  
July 1 to September 30, 1946.

Petition

No. Jersey Radio Inc., Newark, N. J.;  
Capital Bestg. Co., Annapolis, Md.—De-  
nied petitions of No. Jersey Radio Inc.  
and Capital Broadcasting Co. for re-  
moval of their applications from the  
hearing docket; North Jersey Radio Inc.  
and Capital Bestg. to remain in hearing  
not consolidated with each other.

AM—1050 kc

Ranier Bestg. Co. Inc., Seattle, Wash.  
—Application for a new station to op-  
erate on 1050 kc, 50 kw, unlimited time,  
DA, dismissed without prejudice as in  
conflict with Sec. 3.255 of Comm. Rules  
and Regulations.

JUNE 28

ACTIONS ON MOTIONS

By Commissioner Jett

Farnsworth Television and Radio  
Corp., Fort Wayne, Ind.—Granted peti-  
tion for leave to amend application for  
FM station so as to show revised infor-  
mation on estimated costs; service area;  
show complete engineering information,  
etc., and the amendment was accepted.

Miami Valley Bestg. Corp., Dayton,  
Ohio—Granted petition for leave to  
amend its application for a new FM  
station, so as to change certain engi-  
neering information, etc., and the  
amendment was accepted.

Mitchell G. Meyers, et al, Brockton,  
Mass.—Granted motion to dismiss with-  
out prejudice application for a new  
AM station.

International Union etc. (UAW-CIO),  
Newark, N. J.—Granted petition to dis-  
miss without prejudice its application  
for a new FM station.

Frequency Broadcasting Corp., Brook-  
lyn, N. Y.—Granted petition for leave  
to amend FM application, so as to show  
changes in amount of common stock  
authorized; recent changes in corporate  
ownership, revised engineering data,  
etc.

Plains Empire Bestg. Co., Amarillo,  
Tex.—Granted petition for leave to  
amend application for CP so as to  
specify frequency 940 kc with 1 kw,  
unlimited time, instead of 1520 kc, 1  
kw day, 500 w night, unlimited time;  
change paragraph to reflect engi-  
neering information, etc., the amendment  
was accepted and application removed  
from hearing docket.

Times-World Corp., Roanoke, Va.;  
Roanoke Bestg. Corp., Roanoke; Pied-  
mont Bestg. Corp., Danville, Va.—  
Granted petition to continue consoli-  
dated hearing scheduled for July 5 in  
re Dockets 7394, 7395 and 7396, and con-  
tinued same to Aug. 5.

United Broadcasting Co. Inc., Mont-  
gomery, Ala.—Granted petition for leave  
to amend its application for a new AM  
station, so as to change paragraph to  
show revised figures of installation cost;  
revised engineering information, etc.  
The amendment was accepted, the rec-  
ord reopened and the amendment made  
a part of the record in Docket 6828,  
without further hearing.

Lake Superior Bestg. Co., Duluth,  
Minn.—Granted petition for leave to  
amend application for new station so

(Continued on page 69)

\* Comr. Durr voting for hearing.

Worthy of an Engineer's Careful Consideration

## TYPE 114 - A AMPLIFIER

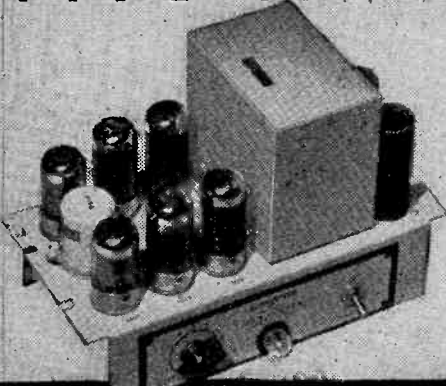

TYPE 114-A AMPLIFIER is a two-  
stage medium gain, 4 watt, power  
amplifier, for 110-120 volt AC or  
DC operation, which can be used  
with a 600 ohm terminating input  
impedance, or across 600 ohms  
as a bridging amplifier. The gain  
with 600 ohms terminating impedance  
is 61 db and with bridging 43 db.

## The Langevin Company

INCORPORATED

SOUND REINFORCEMENT AND REPRODUCTION ENGINEERING

NEW YORK

SAN FRANCISCO

LOS ANGELES

37 W 65 St. 23

1050 Howard St. 3

1000 N Seward St. 38



# PROFESSIONAL DIRECTORY

**JANSKY & BAILEY**  
*An Organization of  
 Qualified Radio Engineers  
 DEDICATED TO THE  
 SERVICE OF BROADCASTING*  
 National Press Bldg., Wash., D. C.

McNARY & WRATHALL  
 CONSULTING RADIO ENGINEERS  
 National Press Bldg. DI. 1205  
 Washington, D. C.

**PAUL GODLEY CO.**  
*Consulting Radio Engineers*  
 UPPER MONTCLAIR, N. J.  
 LABS: GREAT NOTCH, N. J.  
 Phone: LITTLE FALLS 4-1000

GEORGE C. DAVIS  
 Consulting Radio Engineer  
 Munsey Bldg. District 8456  
 Washington, D. C.

 Radio Engineering Consultants  
 Frequency Monitoring  
**Commercial Radio Equip. Co.**  
 • International Building, Washington, D. C.  
 • 321 E. Gregory Boulevard, Kansas City, Mo.  
 • Cross Roads of the World, Hollywood, Calif.

RING & CLARK  
 Consulting Radio Engineers  
 WASHINGTON, D. C.  
 Munsey Bldg. • Republic 2347

There is no substitute for experience  
**GLENN D. GILLET**  
 AND ASSOCIATES  
 Consulting Radio Engineers  
 982 National Press Bldg.  
 Washington, D. C.

**JOHN BARRON**  
 Consulting Radio Engineers  
 Specializing in Broadcast and  
 Allocation Engineering  
 Earle Building, Washington 4, D. C.  
 Telephone NATIONAL 7757

  
**RAYMOND M. WILMOTTE**  
 CONSULTING RADIO ENGINEER  
**PAUL A. deMARS**  
 ASSOCIATE  
 1469 Church St., N. W., Washington 5, D. C.  
 Decatur 1234

CONSULTING RADIO ENGINEER  
**JOHN J. KEEL**  
 EARLE BLDG., WASHINGTON, D. C.  
 NATIONAL 6513

  
**LOHNES & CULVER**  
 CONSULTING RADIO ENGINEERS  
 Munsey Bldg. • District 8215  
 Washington 4, D. C.

*Frank H. McIntosh*  
 Consulting Radio Engineers  
 710 14th St. N.W. ME. 4477  
 Washington, D. C.

**MAY and BOND**  
 CONSULTING RADIO ENGINEERS  
 ★ ★ ★  
 1422 F St., N.W., Wash. 4, D. C.  
 Kellogg Bldg. • Republic 3984

**HAROLD B. ROTHROCK**  
*Consulting Radio Engineer*  
 ●  
 1909 Eye St., N.W. NATIONAL 0196  
 Washington 6, D. C.

**GARO W. RAY**  
*Consulting Radio Engineers*  
 991 Broad St., Suite 9-11  
 Bridgeport 3, Conn.  
 Telephone 5-2055 Lab. Phone 7-2465  
 Instruments and Measurements

**LENT and POAST**  
 CONSULTING ENGINEERS  
 WASHINGTON, D. C.  
 1319 F St., N. W. DISTRICT 4127

**OUR 18TH YEAR** Herbert L. Wilson  
 Consulting Radio Engineers  
 1018 Vermont Ave., N.W. NA.7161  
 Washington 5, D.C.  
 1000 No. Seward St. HO.6321  
 Hollywood 38, Calif.

**HOLEY & HILLEGAS**  
 CONSULTING RADIO ENGINEERS  
 1146 Briarcliff Pl., N.E.  
 Atlanta, Ga. ATwood 3328

  
**ANDREW CO.**  
*Consulting Radio Engineers*  
 363 E. 75th St. CHICAGO 19  
 Triangle 4400

GOMER L. DAVIES  
 Consulting Radio Engineer  
 P. O. Box 71 Warfield 9089  
 College Park, Md.

**DIXIE B. McKEY**  
**ROBERT C. SHAW**  
 CONSULTING  
 RADIO ENGINEERS  
 1730 Connecticut Ave., N. W.  
 Washington, D. C. ADams 3711

**WELDON & CARR**  
 CONSULTING RADIO ENGINEERS  
 WASHINGTON, D. C.  
 1605 CONNECTICUT AVENUE  
 PHONE-MICHIGAN 4151

**CHAMBERS & GARRISON**  
 Consulting Radio Engineers  
 1519 Connecticut Avenue  
 WASHINGTON 6, D. C.  
 Columbia 8544

**KEAR & KENNEDY**  
*Consulting Radio Engineers*  
 1703 K St. N.W. REpublic 1951  
 Washington, D. C.

**Universal Research Laboratories**  
 ROYAL T. HOWARD, Director  
 1 NOB HILL CIRCLE  
 Pine & Mason Streets  
 SAN FRANCISCO  
 DOUGLAS 5380  
 A Division of Universal Broadcasting Company  
*Radio Engineering Consultants*

A. EARL CULLUM, JR.  
 CONSULTING RADIO ENGINEER  
 HIGHLAND PARK VILLAGE  
 DALLAS, TEXAS

*Colton & Foss, Inc.*  
 Electronic Consultants  
 • WASHINGTON, D. C. •  
 927 15th Street NW, REpublic 3883

*John Creutz*  
 Consulting Radio Engineer  
 328 Bond Bldg. REpublic 2151  
 Washington, D. C.

Broadcast - Allocation & Field Service  
**GILLE BROS.**  
 CONSULTING RADIO ENGINEERS  
 1108 Lillian Way Phone: GLadstone 6178  
 HOLLYWOOD 38, CALIF.

**WILLIAM E. BENNS**  
 Consulting  
 Radio Engineers  
 COLUMBIA, SOUTH CAROLINA  
 830 Gregg St. Phone 7342

**H. V. Anderson**  
 —AND ASSOCIATES—  
 • Consulting Radio Engineers  
 715 American Bank Bldg. Tel. RAYmond 0111  
 New Orleans 12, Louisiana

**GUY C. HUTCHESON**  
 CONSULTING RADIO ENGINEER  
 1100 W. ABRAM STREET  
 ARLINGTON, TEXAS  
 PHONE—1218

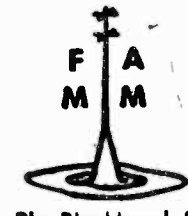
 **NATHAN WILLIAMS**  
 Allocation & Field  
 Engineering  
 20 Algoma Blvd.  
 Oshkosh, Wisc.  
 Ph: Blackhawk 22

SINGLETON AND BARNARD  
 Consulting Radio Engineers  
 AM FM Television Marine  
 2438 S.W. 4th Ave.,  
 ATwater 4594  
 PORTLAND 1, OREGON

**LAMAR A. NEWCOMB**  
 Consulting Radio Engineer  
 703 Albee Bldg. REpublic 3931  
 Washington, D. C.

BROADCAST ENGINEERING SERVICE  
 CONSULTING RADIO ENGINEERS  
 FM AM TV  
 Riggs Nat'l Bank Bldg. Washington  
 14th & Park Rd. D. C.

# WHO DECIDES

WHERE EVERSHARP'S  
4 MILLION DOLLAR  
AD BUDGET WILL GO?

It would be a tough assignment to name all the men whose voice will have a bearing on Eversharp's advertising plans. But we can name one of the most important . . . and he's a sales executive.

"Larry Robbins, Eversharp's sales chief told us . . ." about some of his company's media plans, says C. M. Sievert in his New York World-Telegram advertising column. Let's see what this sales executive had to say—

Larry Robbins, Eversharp's sales chief who began in the pen business 26 years ago with New Diamond Point, told us the other day that his company would pour \$160,000 into newspaper advertising for the mere launching of the "CA" pen, priced at \$15. These full pages will blossom in all key cities as its 23,000 dealers are supplied. Eversharp's '46 ad budget is \$4,000,000, the pen industry's most pretentious.

Remember: your one sure path to the sales manager's desk is a consistent advertising campaign in *Sales Management*, the only publication specifically edited for the sales executives of national advertisers . . . the magazine with more sales managers among its subscribers than all other publications in the sales-advertising field combined.

"IT'S **SM** 4 TO 1"  
Say the Nation's  
Leading Media Buyers

*Sales* MANAGEMENT  
386 FOURTH AVE., NEW YORK 16, N.Y.  
CHICAGO SANTA BARBARA

# AGENCIES

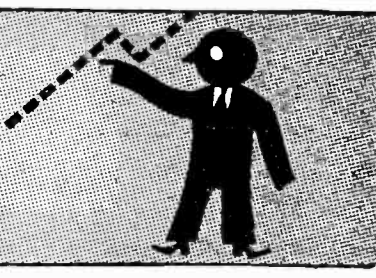

Mr. Bracken Mr. Case

**FRANK M. BAKER**, former freelance writer and producer and released from the Marines as lieutenant, has been appointed radio director of Reincke-Meyer & Finn, Chicago. **ROBERT H. HOLMAN**, former director of research and media for Campbell-Mithun, Chicago, has been named to a similar post at H. W. Kastor & Sons, that city. **WALTER H. KNIFFIN** continues as manager of media and **ROBERT J. WALLACE** as manager of research.

**JERE BAYARD & Assoc.**, Los Angeles agency, on July 15 moves to larger quarters at 2504 West Seventh St., same city.

**LEE TURCHIN**, copy writer, is leaving Dean Simmons Adv., Hollywood, to join her husband in San Francisco following his release from service. **MILDRED RISK** replaces her.

**JACK MELVIN**, west coast publicity director of Foote, Cone & Belding, Hollywood, is in Chicago for two weeks, working out details of a campaign on behalf of Southern Pacific Railroad.

**WILDA CARRUTHERS**, formerly with Hillman-Shane, Los Angeles, and Young & Rubicam, has joined Robert F. Dennis, Los Angeles, as time and space buyer.

**JOHN WHITEHEAD**, manager of Potts-Turnbull Adv. Co., Los Angeles office, is in Mexico City making distribution survey.

**GEORGE H. PATTON**, recently discharged from Seabees and formerly with advertising department of Liggett & Myers Tobacco Co., has joined The Tullis Co., Los Angeles, as radio account executive.

**LEONA D'AMBREY**, formerly time-buyer of Lockwood-Shackelford, Hollywood, has joined Hillman-Shane, Los Angeles, in similar capacity.

**CREATIVE AGENCY Assoc.**, Detroit, has moved to larger quarters in the Kales Bldg., corner of Adams St., and Park Ave., Detroit. G. J. Hopcraft is owner and general manager of agency.

**JOHN RAMSEY** and **ROBERT RENTZ** have been named creative and copy director and production manager, respectively, of Klitten & Thomas Adv., Los Angeles. Mr. Ramsey was formerly copy chief of Holden, Clifford & Flint, Detroit. Mr. Rentz, previous to service in the Army, was production and art director of the John Stover Adv. Co., Columbus, Ohio.

**JAMES W. FISHEL**, media director of Jasper, Lynch & Fishel, New York, has been elected a vice president of the agency.

**J. WALTER THOMPSON Co.**, Los Angeles, has moved to new offices at 645 South Flower St.

**JAMES A. RICHARDSON**, production manager and art director of Buchanan Co., San Francisco, has resigned.

**KFAC** Los Angeles has appointed Sudler Co., that city, to handle its advertising.

**JESSE M. LAUGHLIN**, discharged from Army and former West Coast advertising manager of Ziff-Davis Publishing Co., has joined J. W. Eccleston Jr. Adv., Los Angeles, as media director.

**CLANCY TOPP**, formerly on the editorial staff of Parade Magazine and prior to that a captain in the news division of the War Dept. Bureau of Public Relations, Washington, has joined the public relations department of Geyer, Cornell & Newell, New York.

**BBDO**, New York, is now closing its offices at 5 p.m. Previous closing time has been 5:30 p.m.

**ARTHUR L. MANNING**, former national sales manager of the San Francisco Call-Bulletin, and **ROYCE RUSSELL**, Navy veteran, have opened a new advertising agency in San Francisco under the name of Manning & Russell. The firm will operate on a general agency service basis.

**EDWIN A. ROBERTS**, formerly with Peck Agency, New York, has joined Sweetser, Byrne & Harrington, New York, as vice president.

**SOLIS S. CANTOR Adv.**, Philadelphia, has opened a branch office in Miami Beach, Fla., at 600 Lincoln Road Building.

**E. G. BROWN**, for the past three years advertising manager for the Hallicrafters Co., manufacturers of high frequency modulation equipment, has joined Burton Browne Adv. Co., Chicago as assistant to the president, merchandising consultant and market analyst. Mr. Brown, prior to joining Hallicrafters-appliances for Monters, was division sales manager for radio equipment and other major



Mr. Brown

gomery Ward. **SAM CARTER**, writer, **HARRY KERR**, talent buyer, and **LOU SILVERS**, musical director, all of J. Walter Thompson Co., Hollywood staff of "Lux Theatre," are in New York for four weeks.

**HARRIET SMITH**, formerly copy editor of the Californian and California Stylist publications, has joined Raymond R. Morgan Co., as copy writer.

## PHILCO GIVES RCA PATENT PERMISSION

PERMISSION for RCA to use the Philco FM Advanced System and approximately 600 other Philco patents and inventions relating to radio and television receivers and electrical phonographs was announced last Tuesday by John Ballantyne, Philco Corp. president. It was further stated that Philco was ready to grant non-exclusive licenses to other radio and electronic concerns.

"The agreement just concluded between Philco and the Radio Corp. of America is the first general patent license issued by our company and covers the results of almost 20 years of research and development work in the field of radio and television," Mr. Ballantyne said. "One of the most important inventions covered in the agreement is the

new Philco Advance FM System. This is an entirely new system of frequency modulation detection which is considered one of the fundamental advances in the radio art.

"The technical progress in radio, television and electronics in recent years is extraordinarily great and with our research and engineering facilities increased and strengthened, Philco is desirous of cooperating with others in the radio and television industries to share the fruits of its research."

## Video Service

**MAURICE DREICER**, conductor of *New York Panorama* on WWRL New York, and **Bob Emery**, television consultant, **WOR** New York, have formed Television Idea Service, New York, consultants on video to agencies, producers, stations.

H O L L I S T E R

# CRYSTALS

QUARTZ OSCILLATORS SINCE 1927

HOLLISTER CRYSTAL CO.  
Boulder, Colorado



## FCC Actions

(Continued from page 66)

as to specify power of 10 kw day, 5 kw night, unlimited time, instead of 10 kw, unlimited time; show a new DA design and make other changes, and the amendment was accepted.

**Hirsch Battery & Radio Co., Cape Girardeau, Mo.**—Granted petition to continue hearing on application for CP now scheduled for July 1, and continued same to July 31.

**A. J. Fletcher, Greensboro, N. C.**—Granted petition for leave to amend application for CP, so as to substitute the Capitol Bcstg. Co. Inc. as the applicant in place of A. J. Fletcher; change paragraphs so as to reflect information on new corporation, and the amendment was accepted.

**WPTF Raleigh, N. C.**—Granted petition for leave to intervene in the hearing on application of WCBM, Baltimore Broadcasting Corp.

**Queen City Bcstg. Inc., Boise, Ida.**—Granted petition insofar as it requests leave to amend application for CP and remove from hearing docket; the amendment to specify frequency 950 kc with 1 kw, U. time, instead of 600 kc, 1 kw, U., etc., was accepted and application removed from the hearing docket.

**Metropolitan Bcstg. Service, New York.**—Referred to the full Commission the motion to amend its application for CP.

**WCMI Ashland, Ky.**—The Commission on its own motion continued the hearing now scheduled for July 1 to July 22, 1946.

**W. Albert Lee, Houston, Tex.**—Denied petition requesting that the consolidated hearing upon his application and KHTH, Inc. now scheduled for July 18 at Washington, be transferred to Houston.

### JUNE 28 COMMISSION EN BANC FM

**Board of Missions and Church Extension of the Methodist Church, New York**—Designated application for a new Class B station for hearing to be consolidated with applications of WBNX Bcstg. Co. Inc., et al.

FM

**WABF, New York**—Granted request for authorization to operate station WABF six days per week, Tuesdays through Sundays, for a period ending no later than October 15, 1946.

### VIDEO

Granted request of Television Broadcasters Assn. Inc., to defer until Oct. 31, 1946, Section 3.661(a) of the Television Rules, which requires a minimum of 2 hours broadcast service in any given broadcast day and not less than 28 hours broadcast service per week; denied request to modify Sec. 3.661(a) so as to provide with respect to any new television broadcast station licensee a graduated compulsory minimum, commencing with not more than four hours of regular program service per week and reaching the present minimum (28) hours in a period of not less than one year, without prejudice to application from individual television station.

\*\*\*

Scheduled further hearing on the Los Angeles television applications to be heard before Commissioner Wakefield in Los Angeles on July 24, 1946.

\*\*\*

Removed from hearing docket the applications for television stations at San Francisco Calif., and cancelled hearing scheduled thereon.

### JULY 1 ACTION IN DOCKET CASES AM—1450 kc

**Northern Radio Inc., Glens Falls, N. Y.**—Final decision announced covering previous proposed grant of CP new station 1450 kc, 250 w, conditioned on filing of modification of CP specifying certain technical facilities; Commission simultaneously made final its denial of application of Glens Falls Bcstg. Co. for same decision, Comr. Jett voting to grant Glens Falls Bcstg. Co. application.

### JULY 2 ACTION IN DOCKET CASES AM—1450 kc

**Lake Erie Bcstg. Co., Sandusky, Ohio.**—Proposed decision announced towards grant CP new station 1450 kc, 250 w; also to deny mutually exclusive applications of The Sandusky Bcstg. Co. and The Bay Bcstg. Co., both requesting same facilities.

### JULY 3 ACTION IN DOCKET CASES AM—1450 kc

**Observer Radio Co., Orangeburg, S. C.**

## Hearings This Week

Subject to late changes by FCC

MONDAY, JULY 8, New York City

Hearings on applications for commercial FM facilities in New York area.

MONDAY, JULY 8, Washington, D. C.

Resumption of clear channel hearings.

MONDAY, JULY 8, Washington, D. C.

**Electronic Time Inc., New York**—CP for developmental high frequency station 25-30 mc, 2 kw.

MONDAY, JULY 8, Washington, D. C.

**Lake Bcstg. Co. Inc., Gary, Ind.**—CP new station 1560 kc 500 w night, 1 kw day.

TUESDAY, JULY 9, Washington, D. C.

**Ft. Wayne Bcstg. Inc., Ft. Wayne, Ind.**—CP new station 1030 kc, 1 kw daytime; **Marion Radio Corp., Marion, Ohio**—CP new station 1030 kc, 1 kw daytime.

TUESDAY, JULY 9, Washington, D. C.

Before Commission En Banc

Transfer of control of King-Trendle Bcstg. Corp. to ABC; Edward J. Noble to ABC.

WEDNESDAY, JULY 10, Washington, D. C.

**WHLS Port Huron, Mich.**—Renewal of license; complaint.

—Final decision announced covering previous proposed grant of CP new station 1450 kc, 250 w, condition of filing of modification of CP specifying certain technical facilities; Commission simultaneously made final denial of applications of Orangeburg Bcstg. Corp. and Edisto Bcstg. Co. for the same facilities.

JULY 3

### BY ADMINISTRATIVE BOARD

**WJTN Jamestown, N. Y.**—Granted CP to install a new transmitter (Gates 250-C).

**KXLR No. Little Rock, Ark.**—Granted license to cover CP which authorized a new station to operate on 1450 kc, 250 w, unlimited time; also authority to determine operating power by direct measurement. Licensee is granted a waiver of Sec. 3.55 (b) and 3.60 of the Commission's rules conditions.

**KROP Brawley, Calif.**—Granted license to cover CP which authorized a new station to operate on 1300 kc, 500 w night, 1 kw-LS, unlimited time; also authority to determine operating power by direct measurement. Licensee is granted waiver of Sec. 3.55 (b) of the Commission's rules, conditions.

**WAGC Chattanooga, Tenn.**—Granted CP to install new transmitter (Collins 300-G).

**WLAN Lancaster, Pa.**—Granted modification of CP which authorized a new station, to make changes in vertical antenna and install FM antenna on top, change transmitter location from Beanhill Road, 600' East of Intersection of Wabank Road, Lancaster, to Gypsy Hill Road near Rocky Spring Road, Lancaster, specify studio location as 248 North Queen St. Lancaster, and extend commencement and completion dates from 5-7-46 and 11-7-46, respectively, to 60 days after grant and 180 days thereafter.

**KFVD Los Angeles, Calif.**—Granted modification of CP, which authorized a new transmitter and antenna, increase in power and change transmitter location, for extension of completion date to 10-31-46. The authority is granted subject to express condition that permittee shall satisfy legitimate complaints of blanketing within the 250 mv/m contour, including external cross modulation.

**KSDJ San Diego, Calif.**—Granted modification of CP which authorized a new station, to change type of transmitter (RCA BTA 5-F) and change transmitter location from SE corner of 69th and Mount Vernon Sts., Berrytown, Calif. to West Side of Seminole Drive, near 62nd St., San Diego.

**KATO Reno, Nev.**—Granted modification of CP which authorized a new station, to make changes in vertical antenna and ground system, change studio location from 106 Sierra St., Reno, to 6th and Cassinelli Road, Reno, and extend commencement and completion dates from 5-7-46 and 11-7-46, respectively, to 30 days after grant and 90 days thereafter. Permittee is granted a waiver of Secs. 3.55 (b) and 3.60 of the Commission's rules; conditions.

**WEAF-FM New York**—Granted CP for an existing FM station to specify frequency 97.3 mcs. (No. 247); Metropolitan station; 1.4 kw Transmitter power output; 1.6 kw effective radiated power; antenna 1300 ft. install new transmitter, and make changes in antenna system.

**WGNB Chicago**—Granted CP to install new transmitter and antenna system and specify freq. 98.9 mc. (No. 255); 20.0 kw radiated power; antenna height 490 ft.

**WAAW Newark, N. J.**—Granted modification of CP which authorized a new FM station, for move of transmitter location from Montclair, N. J. to Corner Mt. Pleasant and Marcella Ave.,

West Orange, N. J.; studio location from 15 Hill St. Newark to 1020 Broad, Newark; change in transmitter and antenna system, and specify frequency channel No. 239 (95.7 mc). 13.5 kw radiated power; antenna 590 ft.; site subject to CAA approval; approved types of frequency and modulation monitors to be used; ext. of C. & C. dates from 3-27-42 and 9-27-42 to 60 days after grant thereof and 160 days thereafter, respectively.

**WBAM New York**—Granted CP to change frequency to Channel No. 243. 96.5 mc; make changes in transmitting equipment; install new antenna; specify coverage as 9,860 sq. mi.; class of station: Metropolitan; effective radiated power: 15 kw; antenna height: 559 ft.; approved types of frequency and modulation monitors to be used.

**KRLD Radio Corp. Area of Dallas, Tex.**—Granted CP for a new relay broadcast station to be used with standard station KRLD; frequencies: 156.75, 158.40, 159.30 and 161.10 mc; 25 w; subject to change in frequency assignment without advance notice or hearing.

**WEIT Area of New Orleans**—Granted CP to make change in transmitting equipment of relay station and increase power from 7 to 15 w.

**WEKY Area of Mt. Washington, N. H., WEOD Boston**—Present licenses for relay stations were extended upon a temporary basis only, pending determination upon application for renewal, for the period ending Sept. 1, 1946.

**W6XIS Salt Lake City**—Granted CP for reinstatement of CP which authorized a new exp. television broadcast station on frequencies to be assigned by Chief Engineer, aural power 200 w, visual power 400 w (peak), emission-visual: A5-Aural; Special for FM, and hours of operation in accordance with Sec. 4.4, and to specify frequency as channels No. 2 (64-60 mcs) and No. 9 (186-192), and to change transmitter location from 1st Natl. Bank Bldg. 1st So. and Main St., Salt Lake to 175 So. Main St., Walker Bank Bldg., Salt Lake City. Granted on an experimental basis only; condition.

**WIUN Madison, Wis.**—Granted modification of CP which authorized a new non-commercial educational station, to increase the antenna height by 50 ft. Channel: 91.5 mc. (No. 218); 9.3 kw.

**W1XCG Boston**—Granted special temp. authority to operate a Composite transmitter on Channel No. 11, 198-204 mc, Channel No. 12, 204-210 mc and Channel No. 13, 210-216 mc, for exp. television transmission and to operate a composite transmitter on 39.46 mc with 5 w, for inter-communication in connection with the above. Operation is subject to non-interference, especially to Nanek, Mass. police operating on 39.5 mc for the period June 28 to July 27. (Cancellation clause).

**W8XUB Seven Hills Village, Ohio**—Granted license to cover CP which authorized a new developmental broadcast station; frequency to be assigned by chief engineer from time to time; 1 kw. License is granted upon an exp. basis; condition.

### JULY 3 ACTIONS BY THE COMMISSION AM—580 kc

**KFXD Boise, Ida.**—Adopted an order granting application for CP to change location, change frequency from 1230 to 580 kc, increase power from 250 w to 1 kw; make changes in transmitting equipment, install DA for day and night use, subject to the condition that appropriate application be filed for modification of antenna to afford greater protection to stations KNJ Fresno, and CKUA Edmonton, Alberta, and subject to the further condition upon approval by the CAA of the proposed transmitter site.

(Continued on page 70)

???

# UNCERTAIN?

?

# CONFUSED?

By The Rapid Advances  
in BROADCASTING

## AM-FM-FAX

Electronics have entered many new fields of practice.

You

can be excused for not knowing everything about the latest developments which make your business possible

But

for more than 20 years we have kept up every day with electronic progress. We are qualified to consider your problems in the light of today's requirements.

GREYHER RADIO ELECTRONICS  
CORPORATION  
JULIUS L. GREYHER WILLIAM P. GREYHER  
TELEPHONE NORFOLK 26511

118 BROOKE AVE. NORFOLK VA

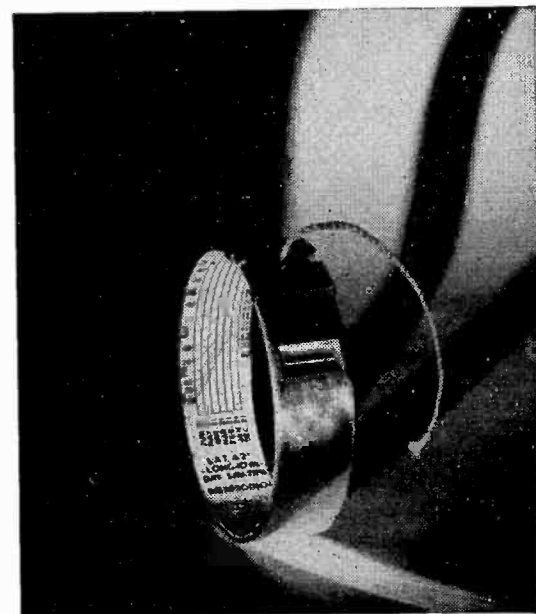

## Premiums are Customer Built by Robbins

THERE'S a reason why the Robbins Company has such an outstanding reputation for producing successful premium promotions.

That reason is best expressed by describing Robbins' premiums as "customer-built". For Robbins' premiums are not mass-produced for various uses by many concerns. They are carefully designed after exhaustive study to do a specific job for a specific company.

It is this combination of knowing what market to reach, and how to reach it most effectively, that produces ideas which spark premium campaigns to new highs—a policy which has brought amazing results for many of America's largest users of premiums.

The Robbins Co.

Ideas in Metal

ATTLEBORO, MASSACHUSETTS





**Over  
\* 2,530,600  
People**

**in KROW's Coverage  
Area**

Cover populous, prosperous Northern California with Oakland's own baseball station—

**KROW**

*960 on Your Dial*

\* U. S. Census Bureau estimate for July 1, 1944

**KROW**

**RADIO CENTER BLDG.  
OAKLAND 12, CALIF.**

**National Representatives:  
Radio Advertising Company**

## FCC INFORMATION—WITH A SMILE

Mary O'Leson and Sally Lindo Accumulate

—25 Years of Service—

TABLES WERE TURNED last week on the two stalwarts of the FCC's information division. Mary O'Leson and Sally Lindo gave out information to BROADCASTING about themselves. After 17 and 8 years respectively, of giving out news of Commission business on AM, FM, television and common carriers, talking about themselves to the press was a new experience. According to George Gillingham, information chief (see page 46), "they run the place."

Mary O'Leson has been with the FCC since October 1928, when it was the Federal Radio Commission with offices at 18th and F St. She went to Washington from Sioux Falls, S. D., as a young girl during the first World War, to work in the War Minerals Relief Commission, where she became acquainted with Judge Ira E. Robinson. When Judge Robinson was made FRC chairman in 1928, he took Miss O'Leson with him.

She was in the legal section at first, then in dockets and finally in the press section, as it was called then. There were less than 100 people in the Commission when she first arrived, "and everybody called everybody else by his first name."

Her proudest moment was when Joe Foss, first Marine ace of World



Sally (l) and Mary

War II—and Miss O'Leson's cousin—came down to Washington with his family to be awarded the Congressional Medal of Honor by President Roosevelt. They stayed at Miss O'Leson's home.

She has had a "lot of fun" at the Commission, she says, and still enjoys every minute of her work—from that ever-present smile, you can tell she means it.

Sally Lindo arrived at the FCC in 1938, and she also went first to the legal division. She had been working with the old NRA and its outgrowing organizations when she decided to join the FCC "to get away from politics!" She told that to one of the Commissioners a while back. He's still laughing.

Mrs. Lindo is from Litchfield, Ill.

The two of them somehow get out all public notices and releases in addition to keeping a ready reference file and answering the telephone "on an average of 200 times daily. You can never get in a rut in this office," they both agree.

### FCC Actions

(Continued from page 69)

#### BY ADMINISTRATIVE BOARD

**KVOE Santa Ana, Calif.**—Granted CP to install a new vertical antenna.

**WFTL Ft. Lauderdale, Fla.**—Granted modification of CP which authorized a new station, for approval of antenna and approval of transmitter and studio locations at So. side of SE 15th Street at Stranahan River, Ft. Lauderdale, and foot of SE 15th St. Ft. Lauderdale, respectively. Permittee is granted a waiver of Sec. 3.60 of the Rules; conditions.

**W2XMN Alpine, N. J.**—Granted extension of special temporary authority to operate High Frequency Exp. broadcast station for the period July 5 to Aug. 3, 1946, pending commencement of operation of station in accordance with terms of license granted under the call WPMN. Freq. etc. similar to previously granted authority.

**W2XMN Alpine, N. J.**—Granted extension of special temporary authority to retransmit the transmissions of High Frequency Broadcast Stations WDRC-FM and WGTR for a period beginning July 5 and ending in no event later than Aug. 3, in order to continue rebroadcasting experiments.

**WBCA Schenectady, N. Y.**—Granted extension of special temporary author-

ity to rebroadcast programs originating at High Frequency Exp. broadcast station W2XMN for the period July 6 and ending in no event later than Aug. 4.

**WNOE New Orleans, La.**—Denied petition requesting that a date certain be set in September, 1946, at New Orleans instead of Washington, upon applications in Dockets No. 6346 and 7117. (Action by Jett 6/28).

**Deep South Bcstg. Corp. New Orleans, La.**—Granted petition requesting that a date certain be set for the hearing upon applications in Dockets 6346 and 7117, prior to August 1, and scheduled the hearing on these applications for July 22 in Washington. (Action by Jett 6/28).

**Henry F. Fett, Dearborn, Mich.**—Granted in part petition for continuance of further hearing and continued said further hearing upon these applications insofar as it relates to the non-engineering phases only, to July 25, 1946. (Action by Jett 6/27).

**Ogden Bcstg. Co. Inc., Ogden, Utah**—Granted petition for leave to amend its application for CP so as to show the addition of two minority stockholders to the corporation; and to change paragraph 8 of application to reflect information re new stockholders and the amendment was accepted. (Action by Hyde 6/20).

### Applications . . .

JUNE 28

AM—1400 kc

**Edward L. Schacht, Oneonta, N. Y.**—CP new station 1400 kc 250 w and unlimited hours.

AM—1200 kc

**Scenic City Bcstg. Co. Inc., Middletown, R. I.**—CP new station 1200 kc 250 w and limited hours of operation.

AM—570 kc

**WASH Washington, D. C.**—Modification of CP which authorized a new standard broadcast station to change type of transmitter for approval of antenna and approval of transmitter location.

AM—1490 kc

**Rich Publishing House Inc., Midland, Mich.**—CP new station 1490 kc 250 w and unlimited hours.

AM—1170 kc

**Lincoln Operating Co., Miami, Fla.**—CP new station 1170 kc 5 kw directional antenna day and night use, and unlimited hours of operation.

AM—940 kc

**WMAZ Macon, Ga.**—CP to increase from 5 to 10 kw and make changes in transmitting equipment using directional antenna for day and night use.

AM—1450 kc

**WTOK Meridian, Miss.**—Modification of CP which authorized a new standard broadcast station to change type of transmitter for approval of antenna and approval of transmitter and studio locations.

AM—1010 kc

**Union Bcstg. Co., Monroe, N. C.**—CP new station 1010 kc 250 w and daytime hours.

AM—750 kc

**Democrat Printing Co., a partnership composed of R. F. Story and Bennett Story Durant, Okla.**—CP new station 750 kc 250 w and daytime hours of operation.

AM—1300 kc

**KOME Tulsa, Okla.**—CP to change from 1340 to 1300 kc increases power from 250 w to 1 kw-5kw-LS, install new transmitter and directional antenna for night use and change transmitter location.



"WFDF Flint is still plugging for the armed services."

21 YEARS *Young!*

**WDOD**

CHATTANOOGA, TENN.

CBS

5,000 WATTS DAY AND NIGHT

first IN ADVERTISING, LISTENER ACCEPTANCE, AND PUBLIC SERVICE

NATIONAL REPRESENTATIVES • PAUL H. RAYMER CO.



AM—1230 kc

Palmetto Radio Corp., Columbia, S. C.—CP new station 1230 kc 250 w and unlimited hours.

Developmental

W9XHZ Bloomington, Ind.—License to cover CP which authorized a new developmental broadcast station.

AM—1020 kc

KFVD Los Angeles, Calif.—Modification of CP as modified which authorized installation of new transmitter and antenna, increase in power, and change transmitter location for extension of completion dates.

FM—Unassigned

Sun Country Bestg. Co., Tucson, Ariz.—CP new FM (Metropolitan) station to be operated on frequency to be assigned by Chief Engineer of FCC, coverage not specified.—AMENDED: to specify transmitter location.

AM—1490 kc

Caldwell Bestg. Co. Inc., Caldwell, Ida.—CP new station 1490 kc 250 w and unlimited hours.

Relay

KWIC Salt Lake City, Utah—Modification of CP which authorized a new relay broadcast station to change power from .2 to 2 w and to change type of transmitter.

Applications Tendered for Filing:

AM—860 kc

Wolverine State Bestg. Service Inc., Detroit, Mich.—CP new station 860 kc 250 w and daytime hours.

AM—1600 kc

The Boston Bestg. Corp., Brookline, Mass.—CP new station 1600 kc 5 kw unlimited hours of operation and directional antenna for day and night.

JULY 2

AM—850 kc

Champlain Valley Bestg. Corp., Albany, N. Y.—CP new station 850 kc 10 kw, directional antenna for day and night use and unlimited hours of operation.—AMENDED: re additional directors and stockholders.

AM—1560 kc

WQXR New York—CP to make changes in transmitting equipment and increase power from 10 to 50 kw (DA)—AMENDED: to change type of transmitter.

AM—1450 kc

Bay State Beacon, Inc., Brockton, Mass.—CP new station 1450 kc 250 w and unlimited hours of operation.—AMENDED: re change in directors and stockholders.

Experimental

W9XEK Louisville, Ky.—Modification of CP as modified, which authorized change in frequency, transmitter, emission, antenna and increase power for extension of completion date.

AM—630 kc

WJMS Ironwood, Mich.—CP to change frequency from 1450 to 630 kc, increase power from 250 w to 1 kw, install new transmitter and directional antenna for fulltime use, change transmitter site.



## The Spartan Women and the Chambray

Jane Dalton, Women's Director, is on the air Monday through Saturday. The other morning she advertised some cotton goods that went on sale precisely at the end of her first broadcast at 10:00 a.m. At the end of her second broadcast at 10:30, Jane scurried off to buy some of the chambray she had just described. There wasn't enough left to make a doll's dress!

**WSPA** Spartanburg, South Carolina

5000 watts day, 1000 watts night, 950 Kc. Rep. by Hollingbery CBS STATION FOR THE SPARTANBURG-GREenville MARKET

BROADCASTING • Telecasting

AM—1150 kc

Northwestern Ohio Bestg. Corp., Lima, Ohio—CP new station 1150 kc 1 kw directional antenna for day and night use and unlimited hours of operation.—AMENDED: re change in directional antenna pattern.

AM—1600 kc

United Bestg. Co. Inc., Montgomery, Ala.—CP new station 1600 kc 1 kw and unlimited hours.—AMENDED: to install directional antenna for night use and change transmitter location.

AM—850 kc

A. J. Fletcher, Greensboro, N. C.—CP new station 850 kc, power 1 kw and daytime hours.—AMENDED: to change name of applicant from A. J. Fletcher to Capitol Bestg. Co. Inc.

AM—940 kc

Plains Empire Bestg. Co., Amarillo, Tex.—CP new station 1320 kc, power 500 w 1 kw-LS, directional antenna for night use and unlimited hours of operation.—AMENDED: to change frequency from 1320 to 940 kc, power from 500 w 1 kw-LS to 1 kw day and night, changes in directional antenna for day and night, change transmitter site.

AM—1590 kc

Caprock Bestg. Co., Lubbock, Tex.—CP new station 1590 kc, power 1 kw, directional antenna for day and night use and unlimited hours.—AMENDED: to make changes in directional antenna and change transmitter location.

AM—1060 kc

John H. Schultz, Marshall True, Paul A. Wnorowski, Marvin M. Mollring and John W. Lewis, Jr., d/b as WBEL Bestg. Co., Belleville, Ill.—CP new station 1060 kc 250 w and daytime hours.—AMENDED: add Joseph H. Yaegel as partner.

AM—1180 kc

WLDS Jacksonville, Ill.—CP to increase 250 w to 1 kw and install new transmitter.

AM—1080 kc

Lake Superior Bestg. Co., Duluth, Minn.—CP new station 1080 kc 10 kw for day and night use, DA and unlimited hours of operation.—AMENDED: to change power from 10 kw to 5 kw-10 kw-LS, change type of transmitter, changes in directional antenna and change transmitter location.

Video—174-180 mc

American Bestg. Co. Inc., Chicago—CP new commercial television station to be operated on channel 6, 82-88 mc, ESR: 1475 and unlimited hours of operation.—AMENDED: to change frequency from channel 6, 82-88 mc to channel 7, 174-180 mc, type of transmitter, transmitter location and make changes in antenna system.

FM—Unassigned

Daily News Publishing Co., Beloit, Wisc.—CP new FM (Metropolitan) station to be operated on frequency to be assigned by FCC, Coverage of 8070 sq mi.

AM—790 kc

WEAU Eau Claire, Wis.—CP to increase from 5 kw day and 1 kw night to 5 kw day and night, and make changes in directional antenna for night use.—AMENDED: re changes in directional antenna pattern.

Video—66-72 mc

Hughes Productions Division of Hughes Tool Company, Los Angeles, Calif.—CP new commercial television station to be operated on channel 2 change name from Hughes Productions Division of Hughes Tool Co. to Hughes Tool Co., frequency from channel 2, 60-66 mc to channel 4, 66-72 mc, type of transmitters, transmitter and studio location; specify directional antenna.

AM—1510 kc

San Diego Bestg. Co., San Diego, Calif.—CP new station 1510 kc, power 5 kw DA and unlimited hours of operation.—AMENDED: to change power from 5 kw to 1 kw, 5 kw-LS, directional antenna day and night use.

AM—950 kc

Queen City Bestg. Co. Inc., Boise, Ida.—CP new station 600 kc, power 1 kw, directional antenna for night use and unlimited hours of operation.—AMENDED: to change frequency from 600 to 950 kc, changes in directional antenna for day and night use and change transmitter location.

AM—1420 kc

KUJ Walla Walla, Wash.—CP to increase power from 1 kw to 5 kw, install new transmitter and directional antenna for night use.

Application Dismissed:

Video—204-210 mc

Comerford Publix Theatres Corp., Scranton, Pa.—CP for a new commercial television station to be operated on channel 12, 204-210 mc, ESR 2057, and unlimited hours.

Applications Tendered for Filing:

AM—740 kc

Balboa Radio Corp., San Diego, Calif.—CP new station 740 kc 5 kw, daytime

hours of operation and directional antenna for day.

AM—1240 kc

WTAX Springfield, Ill.—Consent to transfer of control of stock owned by Jay A. Johnson to Commodore Bestg. Inc.

AM—940 kc

Capitol Bestg. Corp., Indianapolis, Ind.—Construction permit to change frequency from 1310 to 940 kc, power from 1 kw, 5 kw-LS to 5 kw day and night using directional antenna night time, and approval of transmitter location and antenna system.

JULY 3

FM—99.1 mc

The Yankee Network Inc., Providence, R. I.—CP new FM (Metropolitan) station on channel 56, 99.1 mc, coverage not specified.—AMENDED: to specify coverage as 8500 sq mi, population as 2,457,192 and transmitter; change transmitter site from "To be determined at Bristol, R. I." to "Providence, R. I." and change antenna system.

FM—49.7 mc

Radio Projects Inc., West New Brighton, N. Y.—CP new high frequency FM (Community) station on 49.7 mc, coverage 2,250 sq mi.—AMENDED: to change corporate structure, and make changes in officers and directors.

FM—49.3 mc

Radio Projects Inc., Jamaica, Long Island—CP for new high frequency station on 49.3 mc, coverage 1,508 sq mi.—AMENDED: to change corporate structure and make changes in officers and directors.

FM—98.1 mc

North Carolina Bestg. Co. Inc., Greensboro, N. C.—CP new high frequency FM (Metropolitan) station on 43.9 mc, coverage 13,200 sq mi.—AMENDED: to specify type of transmitter, population of 1,094,246; change frequency from 43.9 mc to channel 251, 98.1 mc; coverage from 13,200 to 13,000 sq mi; make changes in antenna.

AM—1490 kc

WLOE Leaksville, N. C.—Modification of CP which authorized a new standard station for changes in transmitting equipment, for approval of antenna and approval of transmitter and studio locations.

AM—820 kc

WLBG Inc., Laurens, S. C.—CP new station 820 kc 250 w and daytime hours.—AMENDED: to change transmitter location and to designate studio.

FM—43.5 mc

International Union, United Automobile, Aircraft and Agricultural Implement Workers of America (UAW-CIO), R. J. Thomas, President, Chicago, Ill.—CP new high frequency FM (Metropolitan) station on 43.5 mc, coverage 14,600 sq mi.—AMENDED: to change name to UAW-CIO Bestg. Corp. of Illinois.

FM—Unassigned

Peoria Bestg. Co., Peoria, Ill.—CP new high frequency FM (Metropolitan) broadcast station to be operated on 48.7 mc, coverage 11,613.96 sq mi.—AMENDED: to specify population of 1,019,872; change class of station from Metropolitan to Rural; frequency from 48.7 mc to "to be assigned"; coverage from 11,613.96 to 21,335 sq mi; type of transmitter; changes in antenna system; and change in officers, directors and stockholders.

FM—95.5 mc

Farnsworth Television Radio Corp., Fort Wayne, Ind.—CP new high frequency FM (Metropolitan) station on 46.1 mc, coverage of 8,500 sq mi.—AMENDED: to change frequency from 46.1 mc to channel 238, 95.5 mc; coverage from 8,500 to 13,300 sq mi; transmitter location, specify type of transmitter; population of 891,255; and specify antenna system.

Applications Tendered for Filing:

AM—1240 kc

G. Lester Hash, N. Joe Rahall, Fred William Simon tr/as The Bluefield Bestg. Co., a partnership, Bluefield, W. Va.—CP new station 1240 kc 250 w and unlimited hours.

AM—1210 kc

WCAU Bestg. Co., Philadelphia—Consent to voluntary assignment of license of WCAU standard broadcast station and WCAU-FM, to Philadelphia Record Co.

AM—850 kc

Johnston Bestg. Co., a partnership (George Johnston and George Johnston, Jr.), Birmingham, Ala.—CP new station 850 kc 1 kw, 5 kw-LS, unlimited hours of operation and DA for night.

AM—1140 kc

Byrne Ross, d/b as Oklahoma City Bestg Co., Oklahoma City—CP new station 1140 kc 1 kw and daytime hours.

AM—910 kc

Miami Bestg. Co., Miami, Okla.—CP new station on 910 kc 1 kw, unlimited

(Continued on page 72)



Can't teach you to swim this afternoon, lady. WFPG you know!

## 52%\* more listeners . . .

It's a fact 52%\* more people listen to WFPG during the daytime than listen to any other station inside or outside of Atlantic City! More evidence why you should plan now to share in the tremendous amount of business that is heading for what looms as Atlantic City's greatest year.

\*Based on a Conlan Survey. Dec. 1945. 16,489 phone calls.



# KFMB

Sells SAN DIEGO

San Diego Leads Again! "Sales Management" Index places San Diego SECOND in U. S. in percentage of gain in total sales and services. You can reach this market "from within" completely and economically with KFMB.

# KFMB

BASIC AMERICAN NETWORK (Pacific Coast)  
SAN DIEGO, CALIF.

Owned and Managed by JACK GROSS  
Represented by the BRANHAM CO.

# Keller's Bid of \$100,000 for WTAX Is Matched by Commodore Broadcasting

THIRD COMPETITIVE bid for a station under FCC's "auction" plan was tendered to the Commission last week when Commodore Broadcasting Inc. matched the \$100,000 bid for WTAX Springfield, Ill., filed earlier by a group headed by Oliver J. Keller of WWSW Pittsburgh.

Under AVCO procedure, contesting applications must be filed with the Commission 60 days "after advertisement" is reported in the *Federal Register* and a local newspaper. The original proposal for the sale of WTAX was filed with the Commission on April 26, notice appearing two days later.

The Commodore Broadcasting Inc. licensee of WSOY Decatur, Ill., is also the parent organization of Radio Springfield Inc., applicant for a standard and FM station in Springfield. Standard application by Radio Springfield Inc. is at present held up due to the fact that the 1550 kc frequency requested is a Canadian allocation. Canadian authorities are undecided as to the use of the frequency. If the competitive application filed by Commodore Broadcasting Inc. is granted by the Commission, it is presumed the applicant will withdraw its Radio Springfield Inc. re-

quest for an AM station in view of the FCC duopoly ruling.

Commodore Broadcasting Inc. is 99.6% controlled by Decatur Newspapers Inc., publishers of the *Decatur Herald* and *Decatur Daily Review*; owner of all common stock of the *East St. Louis (Ill.) Journal* and operator of the *Urbana (Ill.) Evening Courier*. F. W. Schaub, treasurer of the Decatur Newspapers is president of Commodore Broadcasting; F. M. Lindsay Jr., vice president and treasurer is comptroller of Decatur Newspapers; Ida W. Zoch is secretary of both organizations and H. C. Schaub, president of the Decatur Newspapers, is a director.

Mr. Keller, in the original group bidding for WTAX, is vice president of WWSW and president and general manager of the *Pittsburgh Post-Gazette*, owner of WWSW. Should the FCC decide in favor of the competitive bid, Commodore Broadcasting Inc. must sign an agreement with the present owner, Jay A. Johnson, within 30 days on terms similar to those proposed by the original applicant and favorable to the Commission. WTAX, operating on 1240 kc with power of 100 w, holds a conditional FM grant for Springfield.

## FCC Actions

(Continued from page 71)

hours of operation and directional antenna for night use.

AM—1320 kc

WKIX Columbia, S. C.—CP to change frequency from 1490 to 1320 kc, power from 250 to 1 kw, install new transmitter and directional antenna for night use.

AM—590 kc

WOPI Bristol, Tenn.—CP to change frequency from 1490 to 590 kc, power from 250 to 500 w, 1 kw-LS, install new transmitter and directional antenna night.

AM—1230 kc

Del Rio Bestg. Co., Del Rio, Tex.—CP new station 1230 kc 250 w and unlimited hours.

AM—760 kc

Blue Bonnet Bestg. Corp., Fort Worth, Tex.—CP new station 760 kc 1 kw and daytime hours.

AM—1400 kc

Weldon Lawson, Soguin, Tex.—CP new station 1400 kc 250 w and unlimited hours of operation. (Contingent upon KONO grant to another frequency).

AM—1480 kc

Lincoln Bestg. Corp., Lincoln, Neb.—CP new station 1480 kc 1 kw, unlimited hours of operation and directional antenna for day and night use.

AM—1380 kc

KIDO Boise, Ida.—CP to change power from 1 kw 2½ kw-LS to 5 kw, install new transmitter and directional antenna for day and night use and change transmitter location.

AM—1450 kc

The Las Cruces Bestg. Co., Las Cruces, N. M.—CP new station 1450 kc 250 w and unlimited hours.

JULY 3

AM—1450 kc

WPRP Mayaguez, Puerto Rico—Modification of CP which authorized a new standard broadcast station to change transmitter and studio location.

AM—1290 kc

WNBF Binghamton, N. Y.—Modification of license to change name of licensee to Clark Associates Inc.

FM—Unassigned

Hearst Radio Inc., Baltimore—CP new high frequency FM (Metropolitan) station to be operated on 96.9 mc and coverage of 8,857.6 sq mi—AMENDED: to specify population of 2,044,605, change frequency from 96.9 mc to "to be assigned", coverage from 8,857.6 to 11,790 sq mi, transmitter location from Randallstown to Baltimore, and make changes in antenna system.

Experimental

W2XDK Brooklyn, N. Y.—Modification of CP as modified which authorized a new experimental television broadcast station for extension of completion date.

FM—Unassigned

Frequency Bestg. Corp., Brooklyn, N. Y.—CP new high frequency FM (Metropolitan) station to be operated on 43.7 mc and coverage of 14,400 sq mi—AMENDED: to change coverage from 14,400 to 9,000 sq mi, population from 11,900,000 to 12,200,000, frequency from 43.7 mc to "to be assigned by FCC", type of transmitter and make changes in antenna system, changes in corporate structure, officers, directors and stockholders.

AM—1510 kc

WMRP Flint, Mich.—Modification of CP which authorized a new standard broadcast station for approval of antenna, for approval of transmitter location and change studio location.

AM—1490 kc

Roy C. Kelley, Muskegon, Mich.—CP new station 1490 kc 250 w and unlimited hours.

AM—1400 kc

WBLK Clarksburg, W. Va.—Voluntary Assignment of license to News Publishing Co.

AM—1080 kc

West Virginia Radio Corp., Pittsburgh, Pa.—CP new station 1080 kc 1 kw and daytime hours.

FM—Unassigned

Miami Valley Bestg. Corp., Dayton, Ohio—CP new high frequency FM (Metropolitan) station to be operated on frequency to be assigned by FCC and coverage of 13,615 sq mi—AMENDED: to change type of transmitter service.

AM—900 kc

WKAX Birmingham, Ala.—License to cover CP as modified which authorized a new standard broadcast station; authority to determine operating power by direct measurement of antenna power.

AM—1450 kc

WHSC Hartsville, S. C.—Modification of CP as modified, which authorized a new standard broadcast station to

change transmitter and studio locations and extend commencement and completion dates.

AM—1230 kc

B. J. Barrier, Jr., H. T. Barrier, H. P. Holmes, Yazoo City, Miss.—CP new station 1230 kc 250 w and unlimited time.

AM—980 kc

Charles Wilbur Lamar Jr., Morgan City, La.—CP new station 980 kc 250 w and unlimited hours.

AM—1400 kc

KVOP Plainview, Tex.—Voluntary Assignment of license to W. J. Harpole.

AM—1340 kc

KVIC Victoria, Tex.—Transfer of control of licensee corporation from Morris Roberts to J. C. Long through sale of 250 shares of common stock.

AM—1490 kc

KVWC Vernon, Tex.—Modification of CP which authorized installation of new vertical antenna with FM antenna mounted on top to extend completion date.

AM—1230 kc

WMOI Moline, Ill.—Modification of CP for approval of antenna and approval of transmitter and studio locations.

AM—1450 kc

Palouse Empire Radio Inc., Moscow, Ida.—CP new station 1450 kc 250 w and unlimited hours.

AM—1230 kc

KANA Anaconda, Mont.—Modification of CP which authorized a new standard broadcast station to change type of transmitter.

AM—1230 kc

McEvoy Bestg Co., In or Nr. Roswell, N. M.—CP new station 1230 kc 250 w and unlimited hours.

AM—920 kc

KOLO Reno, Nev.—Modification of CP which authorized a new station to install new transmitter and to change from employing directional antenna night only to directional antenna for day and night use.

Educational

KWSC Los Angeles, Calif.—Modification of CP permit as modified, which authorized a new non-commercial broadcast station for extension of commencement and completion date to specify frequency as channel 219 91.7 mc, to change type of transmitter and make changes in antenna system.

Applications Dismissed:

Video 60-66 mc

E. Anthony & Sons, Inc., Boston—CP for a new commercial television station to be operated on channel 3 60-66 mc, ESR of 1515. (Request of the attorney.)

Video 76-82 mc

WAVE Inc., Louisville, Ky.—CP new commercial television station to be operated on channel 5, 76-82 mc and ESR of 1720 (Request of attorney.)

Video 60-66 mc

Radio Station WOW Inc., Omaha, Neb.—CP new commercial television broadcast station to be operated on channel 3, 60-66 mc and ESR of 1500 (Request of Attorney.)

Applications Tendered for Filing:

AM—970 kc

KHBC Hilo, Hawaii—CP to change frequency from 1230 to 970 kc, power from 250 w to 10 kw, install new transmitter and change transmitter and studio locations.

AM—1070 kc

WKVM Arecibo, Puerto Rico—CP to change frequency from 1230 to 1070 kc, power from 250 w to 10 kw, install new transmitter and change transmitter location and install directional antenna for day and night use. (Contingent upon transfer of control of WKVM)

AM—1390 kc

Arlington-Fairfax Bestg. Co., Arlington, Va.—CP new station 1390 kc, 1 kw and daytime hours.

AM—860 kc

Anderson Bestg. Co. Inc., Anderson, S. C.—CP new station 860 kc 1 kw and daytime hours.

AM—1450 kc

Daniels and Sons Bestg. System, John Daniels, Eli Daniels & Harry Daniels, co-partners, Deadwood, S. D.—CP new station 1450 kc 250 w and unlimited hours.

AM—1500 kc

Southern Idaho Bestg., a partnership of J. L. Peterson and Mark L. Checketts, Preston, Ida.—CP new station 1500 kc 250 w and unlimited hours.

ANCHOR HOCKING Glass Co., Lancaster, Ohio, Aug. 8 drops "Hobby Lobby" Thursday, 9:30-10 p.m. on CBS and replaces that show with "Crime Photographer." Latter program has been a CBS sustainer for two years. Anchor Hocking Glass Co., through William Weintraub Co., New York, has signed a 52 week contract.

# KCMC

## TEXARKANA

### U. S. A.

American and Mutual outlet to the 4 States Area, KCMC throws a strong, clear signal to a population of 359,000 people, 239,000 of which reside within the 0.5MV/M Contour.

For additional information, write Frank O. Myers, Manager.

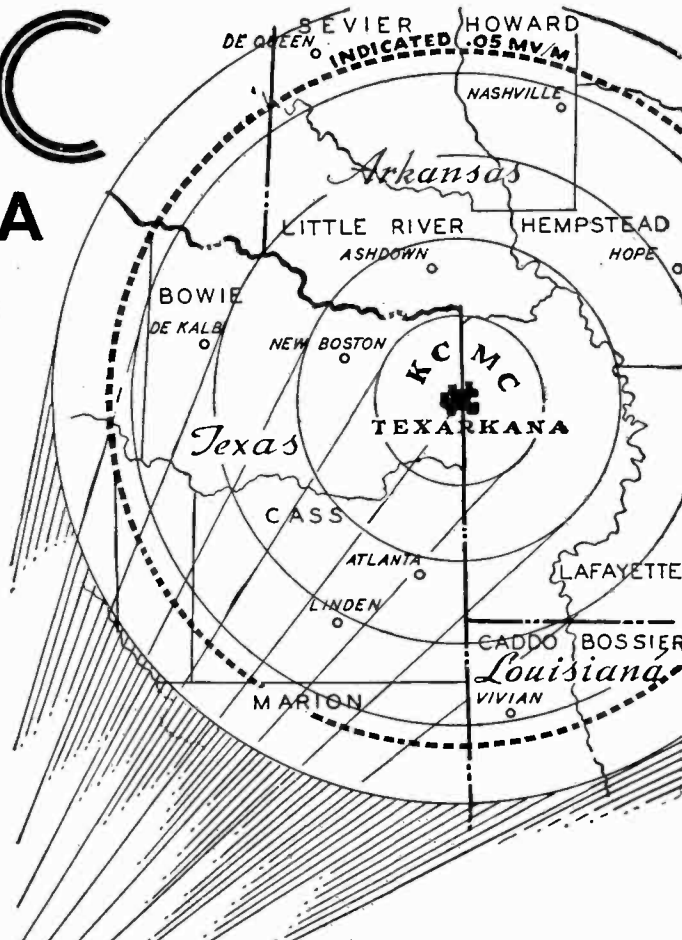

## RAILWAY AND HIGHWAY CENTER

Texarkana is served by a network of four modern U. S. hard surfaced highways and four railroads with direct Eastern, Western, Northern, and Southern freight and passenger service; and by regularly scheduled Air Express, mail and passenger service. It has highway, railroad, and airline facilities enjoyed by few American cities.

KCMC Inc.  
Texarkana, U.S.A.

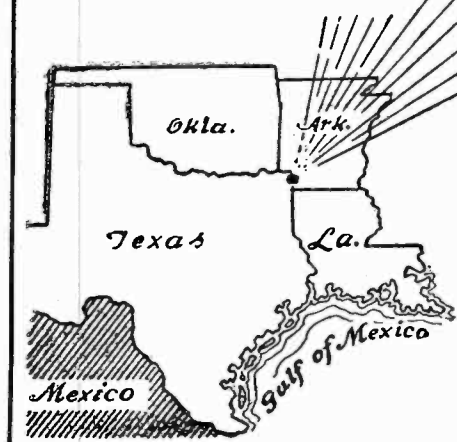



## Clear Channel

(Continued from page 20)

the greatest population would be either close to, or part of, a market area which could support a radio station."

### One Exception

He said the one exception in the Pacific region (Kane County, Utah, not near a regional station) "produced a picture which differed sharply from that compiled on the basis of interviews in the other five sampling areas. There is every engineering reason to believe the Kane County picture is much closer to the truth."

First, he said, the Kane County survey showed a "dearth rather than an abundance of daytime service for the listener in this remote area." Second, he added, it showed "an overwhelming dependence by these remote rural listeners upon clear channel stations for nighttime reception."

Contending that the same procedure used by Census in the Pacific region was followed in all five regions of the country, Mr. Sholis charged that "the nationwide results, therefore, represent nothing more than the basic error compounded 24 times."

On a technical basis, Mr. DeWitt continued Mr. Sholis' criticism of the survey, declaring that "it would appear that very little new knowledge was gained, and there does not appear to be any reason to throw out any of our past beliefs as a result of this survey."

He said that "when the survey was laid out, an opportunity was presented to develop a certain amount of scientific knowledge of radio listeners' habits and experience" but that "unfortunately, this opportunity appears to have been missed."

### No Liaison Claimed

He said the liaison needed between the various experts in a joint undertaking "does not appear to have been carried on. Had it been, the FCC engineers who participated in the original plans would have quickly seen the errors which eventually crept into the survey," he added.

Mr. DeWitt reiterated Mr. Sholis' charge that service areas were misclassified, maintaining that the classifications furnished the Census by FCC engineers were "enough to make the results . . . of dubious value, to put it mildly, particularly with respect to such matters as what stations or classes of stations are heard without trouble, or are listened to most, in the areas covered."

He charged, also, that the counties were incorrectly classified within the five types of service areas—and that in a majority of cases this error favors regional stations.

The hearings were held before the Commission en banc, with Acting Chairman Denny presiding. Louis G. Caldwell appeared as Counsel for CCBS, and Paul D. P. Spearman for the regionals. Harry

Plotkin was Commission counsel.

The hearings opened Monday morning with testimony by Charles Edward Nobles, Westinghouse engineer, on stratovision tests in the standard broadcast band. Presenting a report on tests undertaken at high altitudes over Baltimore and Pittsburgh, Mr. Nobles said the Westinghouse calculations indicated that "large coverages" could be obtained from an AM transmitter in an airplane flying at 20,000 to 30,000 feet.

The calculations also showed, he testified, that the nighttime "fading wall" might be extended from roughly 60 miles to 180 miles.

The witness described daytime measurements made over Baltimore of the field strengths received at altitudes of 10,000 feet, 15,000 feet and 20,000 feet from WJZ New York, WABC New York, WFMD Frederick, Md., WPEN Philadelphia, WRC Washington, KDKA Pittsburgh, WRVA Richmond, and WCAU Philadelphia.

### Why Chosen

These stations, ranging in distance from 50 to 230 miles from Baltimore, were chosen because each operates with a nondirectional antenna, the frequencies represent a fair coverage of the standard band, and the locations were such that data was taken on stations at distances from Baltimore varying between 40 and 200 miles.

In taking measurements on KDKA Pittsburgh, Mr. Nobles explained, Westinghouse engineers made field intensity versus distance from KDKA curves at altitudes of 10,000 and 20,000 feet. These curves he said, were taken under day and night conditions.

For the purposes of the tests, he said, and RCA Model 308-A field intensity measuring set was mounted in the test airplane with its receiving loop mounted on top and approximately amidships on the plane. An Easterline Angus tape recording meter was connected to the output of the Field intensity meter for a permanent record of the test results.

### Could Be Rotated

The loop was mounted so it could be rotated with respect to the ship, thus allowing for proper orientation of the loop. Distance from the center of the loop was 24 inches, he said.

Testifying regarding a chart showing the effect of the skywave combining with the ground wave, Mr. Nobles said that at distances up to approximately 60 miles, at 10,000 feet, the signal received is reasonably steady. From 60 to 100 miles, the skywave interference pattern steadily increases until the signal is not recognizable between 108 and 125 miles.

Beyond 130 miles, he said, the skywave predominates over the ground wave and the irregular received signal has an apparent "periodicity" believed to be caused by the reception of two skywaves at the plane.

At 20,000 feet, he testified, essen-

## Spoke Too Soon

WHEN Chicago Cub Bill Nicholson lifted one over the right field at Braves Field, Boston, Jim Britt, Yankee Network announcer, commented: "There's one ball we won't see again." However, Jim was compelled to retract that statement after the game. He went to his 1946 model car in the adjacent parking lot and found the ball on the front seat amid piles of shattered window glass.

tially the same results as at 10,000 feet were noted except that by increasing the altitude the distance at which the skywave started was moved back from approximately 60 miles to 100 miles.

The "fading wall" for this 20,000 foot altitude, it was found, lies roughly from 100 miles to 200 miles and is most serious past 160 miles. The nighttime "fading wall" for KDKA on this radial was 40 miles for receivers located on the ground as compared with somewhere between 100 and 200 miles from the airplane.

A report on distributions of grades of broadcast service was presented by Dr. Edgar F. Vandivere, Commission engineer. The

report covered services limited by interference of a single kind from a single source and interference from two or more sources of the same kind of interference.

A proposed revision of part 1 of the Standards of Good Engineering Practice Concerning Standard Broadcast Stations, intended for use in allocation matters before the Commission to replace the present Standards at some future date yet to be decided upon, was presented by H. Underwood Graham, FCC engineer. The revised standards will serve as the basis of the U. S. Government recommendations to the parties of the North American Regional Broadcasting Agreement for engineering changes in the new agreement to be drawn up in 1947.

### Based on Early Plan

The proposed revision of engineering standards (Exhibit 264) was based on an earlier plan for computing service and interference (Exhibit 109) which had been approved by the three technical committees for use in the clear channel proceedings. Mr. Graham, resuming testimony Monday afternoon, explained that the committees had been consulted before the FCC Engineering department prepared the revised draft (264) but that the committees had not had a chance to study and report on the

(Continued on page 74)

## CLEVELAND'S *Chief* STATION COMMANDS HEAP BIG

"LISTENER" *Ship*



Get aboard and let WJW Cleveland's *Chief* Station, a Commander of big listenership, guide you to Northern Ohio's billion dollar market. WJW brings in more daytime listeners per dollar in the Cleveland Area than any other regional station.

BASIC  
ABC Network  
CLEVELAND, O.  
**WJW**  
850 KC  
5000 Watts  
DAY AND NIGHT  
REPRESENTED NATIONALLY BY HALLY-REED COMPANY

# WHAT'S YOUR HURRY TO GET READY (Ky.)?

If you're working up a lather trying to get Ready (Ky.)—slow down and take it easy. The only place in Kentucky that's worth running a fever over is the Louisville Trading Area—where WAVE offers you (at lower cost) more wealth and buying power than you'll find in the rest of the State combined! We're willing and able, but we couldn't get Ready in a lifetime.

**LOUISVILLE'S  
WAVE**

5000 WATTS . . . 970 K. C. N. B. C.  
**FREE & PETERS, INC.**  
National Representatives



“You can  
**SPOT IT**  
in a minute”

ASK  
A  
JOHN  
BLAIR  
MAN  
**JOHN BLAIR  
& COMPANY**

REPRESENTING LEADING RADIO STATIONS

Page 74 • July 8, 1946

## Clear Channel

(Continued from page 73)

plan after it was completed.

It was decided to continue testimony on the revised plan (Exhibit 264) “with the clear understanding” that it was worked out by Commission engineers and had not yet been formally approved by the committees.

With a view to deciding “some time in August” whether new standards of engineering practice will be adopted and, if so, what they will be, Mr. Denny said an informal engineering conference would be held July 15-16, followed by a meeting August 5 to receive a report of the July 15-16 session and hear testimony on standards.

Final clear channel session, Mr. Denny said, will be held in September. Intention of deciding the clear channel question by early autumn was announced at the outset of the second phase of the proceedings [BROADCASTING, April 22].

### Not Retroactive

Chairman Denny said “it is assumed some changes in standards will be made” in the course of the clear channel proceedings, but that the revisions would govern future assignments only. Commissioner Jett questioned whether they should be made applicable to applications already filed but which will go into hearing or be decided after such changes are made.

“Can't we go so far as to say that if new standards are adopted, they would apply only to applications filed after they are adopted?” he asked.

Mr. Plotkin said such a statement “might create a stampede.”

Commissioner Jett said he thought it should be made plain that if no new standards are adopted, present standards would be one factor in determining the clear channel issue. Mr. Caldwell said apparently there had been some misunderstanding about the purpose of Exhibit 109, on which maps were prepared for the hearing, and that if the decision is to be made on the basis of present standards an opportunity should be provided to make presentations on that basis.

Mr. Denny ruled that while maps for the hearing were prepared on the basis of the methods outlined in Exhibit 109, use of existing standards is not precluded. If new standards are adopted after the August 5 meeting, he said, those will be applicable.

### Caldwell Opposes Grants

When the hearings resumed Tuesday morning, Mr. Caldwell asked that the Commission withhold action on applications for daytime stations on clear channels until the issues have been decided. He pointed out that such daytime stations within 750 miles of a clear channel would interfere with higher powered clear stations, if

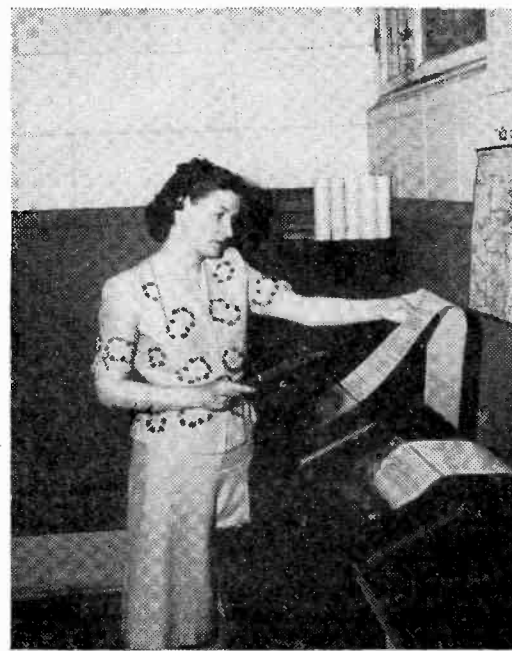

WINNER AGAIN, for the second successive year, is Lucille Hastings of KLZ Denver whose newscast entry in competition with those of other news women was awarded first prize at the annual convention of National Federation of Press Women, Estes Park, Colo. Miss Hastings' entry was judged the best selected and prepared newscast of the year by a woman.

authorized by the Commission.

Chairman Denny said he would take Mr. Caldwell's request under advisement.

Continuing his testimony of the previous day Mr. Graham, under cross examination by Mr. Caldwell, said the proposed standards would not affect service in the downtown areas of metropolitan cities and in the cities in which the stations are located.

Mr. Caldwell stated the position of the clear channel group as being that the standards for service should be higher than those set forth in the proposed standards.

### Reduced Coverage

Under questioning by Mr. Spearman, Mr. Graham said that the proposed standards would result in serving fewer people since there would be fewer stations.

In reply to a question by Commissioner Jett, he said he would recommend against licensing Class IV (local) stations for large cities.

Asked whether adoption of the proposed standards would not make it impossible to set up new local or regional stations anywhere in the nation where there is sufficient population to support such stations, he said he would not make such an interpretation.

Mr. Spearman contended that the proposed standards “in order to get rid of a little flea that has bitten us a time or two would burn down the house.”

Mr. Graham introduced into the record a series of maps showing daytime and nighttime service areas of all stations on regional channels as of Jan. 1, 1946.

A coverage study of local channel stations was submitted by Esterly C. Page, Mutual vice president in charge of engineering, who appeared at the request of the

Commission rather than as a Mutual witness.

Edward W. Allen Jr. of FCC, chairman of Technical Committee I, opened Tuesday afternoon's session by submitting surveys conducted by Crosley Corp. under the direction of Crosley Engineering Director R. J. Rockwell, on atmospheric noise and man-made noise.

A sharp attack on the Bureau of Census survey of listeners to determine the number and quality of signals heard, a massive report submitted at the outset of the April sessions, was delivered by Victor A. Sholis, director of the Clear Channel Broadcasting Service.

Charging that the survey contained “serious flaws and defects which completely invalidate the survey's results and any conclusions that may be drawn from it,” Mr. Sholis said he did not question the good faith or ability of the Census Bureau, but that, rather, the defects “stem from the package handed them through no fault of theirs. This package,” he added, “was bundled together and tied up by the Commission staff.”

### Sholis' Charges

He contended:

“1. The survey virtually sought the impossible by asking listeners who are conditioned only to low-grade service to appraise the quality of radio signals.

“2. The survey covered in the main those areas which receive less than primary service under the old standards, and only made a minor effort to learn the number and quality of radio signals within so-called primary service areas (within the 500 microvolt contour by day and the interference contours at night) in which most rural Americans live.

“3. The survey was conducted at a time of year—June and July—that made it virtually impossible to get an accurate appraisal of nighttime reception . . .

“4. The survey's basic purpose was defeated when . . . (a) counties were classified together into types of service areas in a manner which resulted in inclusion of counties that received a much stronger signal from regional stations than from clear channel stations; (b) counties placed in one type of service area actually belonged in another.

“5. The survey's cardinal mistake—a mistake so disastrous that even if other errors had not been made, it alone would have torpedoed the project—occurred when the elementary engineering fact that radio signal strengths decrease with distance was ignored.”

### Cites Examples

Mr. Sholis cited examples to support his contention that “the survey asked listeners in one area what stations they could hear and then made the astounding assumption that listeners 50, 100 or even many hundreds of miles from these stations were able to hear them



in exactly the same way."

As "perhaps the ultimate example," he referred to the survey of Terry County, Tex., where the findings, he said were "nimble applied" to such places as "Harding County, N. M., 200 miles away; Val Verde County, Tex., 230 miles away; Costilla County, Colo., 365 miles away; Sheridan County, Neb., 625 miles away; and Fall River County, S. D., 650 miles away."

Mr. Sholis said CCBS felt the "flaws and defects" should be exposed "because apparently the results of this survey are being exploited to deny the need for improving radio service in this country."

"The survey is further being used in an attempt to discredit the proposed new engineering standards on which the Commission's engineering staff, with the cooperation of the best technical talent gathered from the entire industry, labored for something over 15 months," he declared.

He listed several "choice evidences of bias and errors in the survey which stem from, or are part of, these five major defects." He mentioned "such phenomenal results as finding among the leaders of stations heard best at night, daytime stations which sign off at local sunset. Or finding that stations, say in Chicago, are reported heard without trouble by day in such distant places as Mississippi and Alabama. Or finding that extensive trouble from fading is experienced in the daytime."

#### With Misgivings

Mr. Sholis said CCBS "participated in and contributed to the survey with deep misgivings" which were "frequently voiced at meetings of Committee IV." Objections then, he said, were directed against the first two of the five "defects" he mentioned. He said the third did not become apparent until the tabulations were made available, and that the fourth and fifth were "completely unforeseen."

"The plan of classifying counties into types of service area, and then projecting the interview results from the 85 primary sampling units to apply to all 1040 scattered counties was not known to us. To the best of our knowledge, it wasn't known to any of the industry representatives. And certainly it was not understood or detected until the tabulations and description of the survey were first made available on the eve of the April hearing," he asserted.

Mr. Plotkin reserved cross-examination of Mr. Sholis until later, pointing out that further testimony by Census Bureau representatives is contemplated. Mr. Spearman, representing the regional group, questioned the clear channel witness particularly regarding the CCBS objections to projection of survey results from one county to apply to all counties in its group.

When the hearings resumed Wednesday morning, John H. DeWitt,

### Fourth Feature

READING of excerpts from the Declaration of Independence by a British subject was a Fourth of July feature on WNEW New York, 10-10:15 p. m., via BBC. Leslie Banks, British actor, who is narrator for the Theatre Guild presentation of Henry V, now at New York's City Center, offered the reading in the special broadcast originating in London.

ex-colonel in the Signal Corps who directed the Army experiments in "shooting the moon," testified for the clear channel group in opposition to Census Bureau survey on adequacy of rural radio reception.

Mr. DeWitt said the opportunity which had been presented to the Bureau to develop a certain amount of scientific knowledge of radio listeners' habits was missed.

#### 'Prejudicial Bias'

Since the question under investigation concerned the adequacy or inadequacy of radio service in terms of signals, Mr. DeWitt testified, "it is hard to conceive how a more prejudicial bias (in favor of regional stations and against clear channel stations) could have been injected into the survey."

Mr. DeWitt stated that the classifications of service areas furnished the Census Bureau by the FCC Engineering Dept. were in themselves "enough to make the results of the survey of dubious value, to put it mildly, particularly with respect to such matters as what stations or classes of stations are heard without trouble, or are listened to most, in the areas covered."

But, in addition, he said the counties were not correctly classified within the five types of service areas and many belonging to one type really belong to another and, in the majority of cases studied, the error in classification favors one or more regional stations.

Mr. DeWitt cited an analysis made of Census tabulations showing that station popularity in the white areas is in direct relation to

### PAA Changes Name

PACIFIC ADVERTISING Association, before close of its four day 43rd annual convention in Spokane on June 27, changed name to Advertising Association of the West. Under change, organization is enlarged to include four Western provinces of Canada, as well as the eleven western states.

signal intensity. His analysis showed, he said, that as far as daytime reception is concerned:

(1) Listeners prefer the station giving the strongest daytime signal.

(2) Listeners cannot possibly tell the difference between a regional, local or clear channel station by any inherent characteristic in daytime.

#### States Conclusion

He added that the preference for the strongest signal is valid only when dealing with marginal radio service. Obviously, he pointed out, if all of a group of stations produce grade A service over a given area listener choice would be governed by program preference only.

Mr. DeWitt declared that a listener tuning in to a I-A clear channel station at a distance beyond the primary service range of the station at night receives a signal free of other signal interference. "It may be marred by fading, man-made or atmospheric noise," he said. "It has, however, the inherent capability of giving good radio service at night. The regional station does not, and can never, have this capability. It is only necessary to increase the radiated field from the clear channel station to overcome noise interference. Regional stations, on the other hand, cannot overcome mutual interference by increase in radiated field."

Mr. DeWitt introduced a series of phonograph records made the previous week in typical primary sampling units which were played at the hearing to bear out contentions that (1) people do not know good radio service (2) they judge nighttime reception by daytime standards.

When a record of nighttime reception to KFI Los Angeles from Churchill County, Nevada, was played, Comr. Jett remarked that the signal seemed pretty good and pointed out that representatives of farm groups had testified during the April hearings that reception from KFI was unsatisfactory. He could see no need for higher power on the basis of the reception as recorded, he said.

#### Test Vote

A ballot test in which all present at the hearing participated was conducted by Edward W. Allen Jr., chief of the FCC technical information division, to ascertain listener reaction to arranged programs containing atmospheric noise. A phonograph record containing portions of five music programs and five speech programs was played with listeners being asked to mark "s" or "u" (satisfactory or unsatisfactory) in designated places on the ballot. The records will be combined with others to determine listener reaction to atmospheric noise.

At the conclusion of the tests, Acting Chairman Denny adjourned the hearings to July 8.



Efficient merchandising service plus complete town-farm coverage make KGLO a "must" on your radio time list.

1300 K.C. 5000 WATTS CBS AFFILIATE  
WEED & COMPANY, REP.

A **Lee** STATION

BALTIMORE'S  
*Listening Habit*

**W  
C  
B  
M**

**MUTUAL  
BROADCASTING SYSTEM**

John Eimer, Pres.  
George H. Rouser, Gen'l Mgr.  
FREE & PETERS, Inc. Exclusive Nat'l Rep.

*Sell More*  
in **LOUISVILLE**  
with  
**WINN**  
BASIC STATION  
**AMERICAN**  
BROADCASTING COMPANY  
HARRY McTIGUE General Manager

By actual survey  
**TORONTO'S**  
**MOST LISTENED-**  
**TO STATION**  
DIAL 580  
**CKEY**

ONE BIG MARKET  
SERVED BY  
**KFDM**  
BEAUMONT, TEXAS  
560 K.C., 1,000 WATTS  
MEANS BUSINESS  
REPRESENTED BY  
TAYLOR, HOWE, SNOWDEN  
Radio Sales  
AFFILIATED WITH AMERICAN BROADCASTING CO., INC.

**WLW**  
700 ON YOUR DIAL  
THE NATION'S  
MOST  
MERCHANDISE-ABLE  
STATION

## Atom Broadcast

(Continued from page 17)

a signal of such greater clarity than that sent from the *Appalachian* via Guam that many a network newsman was further angered at the Navy's choice of ships to do the most important job at Bikini.

Executives of another network complained that broadcasts other than the pooled report of the bombing had been hampered by the meddling of Navy brass and by the absence of proper coordination among radio officers at Bikini. And technical deficiencies, it was said, permitted such engineering faux pas as feed-backs and cut-ins when radio news circuits were operating.

"If the networks and RCA or Press Wireless had been permitted to run the show, we'd have had better broadcasting," one of these experts said.

To bring U. S. listeners the great story of the atom bomb, the four networks cancelled a total of \$105,575 worth of commercial programs. The added costs of lines, transmission charges, and other extraordinary expenses brought the total network expenditure to an unannounced but obviously impressive figure.

Last Monday morning, network officials looked at the balance sheets, remembered the discouragingly inadequate quality of the special broadcast, guessed the whole thing had hardly been worth while.

### Explosion Premature?

But the broadcast wasn't the only bust of the highly-heralded Bikini test. The atom bomb itself "through some human or mechanical error" exploded three seconds ahead of schedule, NBC's Mr. Chaplin said Wednesday in a newscast from Kwajalein.

"As far as the air force went," said Mr. Chaplin, "everything went perfectly. The bomb was delivered at the appointed place. But through some human or mechanical error the bomb detonated three seconds ahead of schedule. This means it blew roughly a mile and a half higher than planned and so the greatest force blew skywards and not down.

"This bomb," continued the NBC commentator who had charged that his copy was being censored, "burst approximately four times higher than the one at Nagasaki, which explains why the same bomb which tore the heart out of that city only sank five vessels, seared a few others and left the goats alive in the Bikini test."

### Marble Sponsored

METROPOLITAN Life Insurance Co., New York, July 4 for 13 weeks started sponsorship of *Harry Marble and the News* on WABC New York, Tuesday, Thursday and Saturday, 6-6:15 p. m. Agency is Young & Rubicam, New York.

# Damm Says FM Listeners Got No Static on Atom Broadcasts

WHILE owners of AM sets strained their ears June 30 in attempted to hear the garbled and static-punctuated descriptions of the Bikini atom bomb tests, FM set owners in Milwaukee sat quietly beside their radios, listening to every word, according to Walter J. Damm, vice president of the Journal Co., Milwaukee, and general manager of the *Journal's* radio interests, WTMJ and WTMJ-FM.

Mr. Damm, chairman of the NAB FM Executive Committee, and former president of FM Broadcasts Inc., gave BROADCASTING the following statement:

"If the atom bomb broadcast was the only program I ever listened to on my FM set, the service I got from WTMJ-FM last Sunday would have repaid me amply for the cost of the set."

"That statement is typical of the

many that resulted from the never-again-to-happen combination of a program which had the whole world by the ears and the worst electrical storm that Milwaukee has had in years. Black thunder heads had been gathering in the summer sky during the early afternoon of that memorable day. Just as the B-29 carrying the atom bomb began its history-making flight to Bikini the storm broke with a fury which made the superstitious sure that predictions of the world's utter annihilation were coming true. Soon the lightning crashing in loud speakers made reception virtually impossible.

### 'Operation' Account Unmarred

"Listeners who were hanging on every word that flashed from the Marshall Islands gave up in despair—all but a select number who had FM sets and could listen to the broadcast over WTMJ-FM, the *Milwaukee Journal* FM station. Those favored few received a demonstration of FM's freedom from static, the like of which may never again be duplicated in this community. To them the account of the epoch-making event on the far side of the world came absolutely unmarred by the smothering natural static of the thunderstorm at home. The intensity of the local disturbance would have made a striking demonstration at any time but the importance of the program was the factor that focused attention on the remarkable ability of FM to shut out interference.

"Judging by the reports received the situation made a lasting impression on FM listeners. Some seemed to regard the performance as a near miracle. Others said it was just what they would have expected on FM. Still others felt that the signal broadcast justified their investment in an FM receiver. All told, the team of Mother Nature and the armed forces put on a convincing show in Milwaukee that should warm the cockles of Major Armstrong's heart."

### CBS Time Switches

FOUR CBS sustainers will make time switches effective July 20 and 21. *Assignment Home*, program dealing with returned servicemen's problems and presented in cooperation with the Veterans Administration, on July 21 switches from Saturday, 3-3:30 p. m. to Sunday, 2-2:30 p. m. July 20 *Of Men and Books* switches from 2-2:15 p. m., Saturday, to 2:30-2:45 p. m., same day. *Adventures in Science* goes from 2:15-2:30 p. m. Saturday to the 2:45-3 p. m. period, same day and *Columbia's Country Journal* changes time from Sunday 8:30-9 p. m. to Saturday, 2-2:30 p. m.

## Peter H. Cousins Joins RMA Staff in Capital

PETER H. COUSINS, an assistant in the broadcasting division of the Office of Censorship during the last months of the war, July 8 joins the headquarters staff of Radio Manufacturers Assn. at Washington as assistant director of publications. Appointment was announced last week by Bond Geddes, executive vice president and general manager, and James D. Secrest, director of publications.

After working on New Orleans newspapers Mr. Cousins was on the staff of *Telecommunications Reports*, Washington, in 1937. He joined the NBC Washington news staff in 1941, going to WMAL in 1942 at the time of the Red-Blue separation. He began duties at the Office of Censorship in 1944 under John E. Fetzer, assistant director in charge of broadcasting, leaving last August to return to Mississippi where he was with Dixie Advertisers, Jackson, and Mid-Continent Oil & Gas Assn. Recently he had been with the NBC Washington news staff.

### KQW Rate Increase

INCREASE in the network evening hour rate of KQW San Francisco, CBS affiliate, effective July 15, from \$290 to \$325 was announced last week by William C. Gittinger, CBS vice president in charge of sales. The CBS Listening Areas, seventh series, announced the station's nighttime circulation has increased 44% in the past two years, from 425,642 in spring, 1942, to 612,711 in spring, 1944. Advertisers currently using KQW will be protected for the customary 12 months on all time periods used without interruption.



## Libel Law Case Hearing Will Be Held July 10

HEARING on a complaint against WHLS Port Huron, Mich., which FCC plans to use as a base for an interpretation of radio stations' liability under libel laws, is slated to be held in Washington Wednesday (July 10).

The case involves charges brought by Carl E. Muir, a member of the Port Huron city commission, who claimed that he bought political time from WHLS in 1945 but that the station cancelled the contract, after reading an advance copy of his first speech, on grounds that it was an "unwarranted attack" on the rest of the city commission, of which Herman L. Stevens, co-owner of WHLS, was then a member; and because it was unsure of the accuracy of some of the statements in the speech. FCC was reported several weeks ago to be planning to clarify the responsibility of broadcasters under libel laws insofar as possible in its decision in the case [BROADCASTING, June 10].

## Keit to Universal

BARRY H. KEIT, former national sales manager of cooperative program department of Mutual, has been named head of the San Francisco office of Universal Radio Sales. Prior to joining Mutual, Mr. Keit had spent 20 years with Headley-Reed Co., station representatives, and with Kelly-Smith Co., newspaper representatives. He assumed his new duties July 7 in the KSFO building, No. 1 Knob Hill Road, San Francisco.

## Shortwave

(Continued from page 17)

by the FCC to shortwave licensees follows:

On June 27, 1946 the Commission adopted Order No. 110-C which extends the licenses of every international broadcast station previously licensed until Oct. 1 or on the first day in which its operations are not controlled, by agreement or otherwise, by the State Dept. Office of International Information and Cultural Affairs, or other Government agency supervising the operation of international broadcasting. Section 4.3 suspended until further order of the Commission.

Order 110-C follows:

Order No. 110-C. At a session of the FCC held at its offices in Washington on the 27 day of June 1946 the Commission, having under consideration Order 110-B, adopted March 20, 1946, providing for extension of the licenses of international broadcasting stations;

It is hereby ordered that the license term for every international broadcast station presently licensed shall end at the earlier of the following dates: (a) Oct. 1, 1946, or (b) the first day on which its operations are not controlled, by agreement or otherwise, by the State Dept. Office of International Information and Cultural Affairs, or other governmental agency supervising the operation of international broadcasting.

It is further ordered, that the portion of Section 4.3 of the Rules & Regulations which established for international broadcast stations a normal license term of one year is hereby suspended until further order of the Commission.

## Production of 1,135,128 Sets in April Shown in U. S. Census Bureau Figures

APRIL production of radios totaled 1,135,128 sets, 23% above March and 11% above the 1941 monthly average, the Census Bureau announced Friday. Home radios, excluding battery and phonograph combinations, totaled 788,144 sets, 24% above March and 45% above 1941 average. Auto sets totaled 115,788, combinations totaled 110,752 sets and battery models (except auto) reached 120,444.

Shipments of radios and combinations rose 25% in April to a value of \$25,000,000 as compared to \$20,000,000 in March, the Bureau found, with home radios accounting for \$1,500,000 of the increase, battery models \$1,200,000 and combinations \$1,800,000. The Bureau says its data are believed to represent substantially complete coverage of the industry, but explains they are preliminary figures.

Total radio production in March was 916,701 units compared to 724,541 in February and 549,228 in January.

Product	Production (number)		Shipments	
	xxx	xxx	Number	Value
TOTAL.....	xxx	xxx	xxx	\$25,122,608
Radios.....	1,135,128	1,075,815	22,829,128	
Home sets (except battery).....	788,144	734,570	11,318,280	
Table models, AM:				
Factory value under \$12.50.....	253,101	241,319	2,664,820	
Factory value \$12.50 and over.....	531,849	489,915	8,507,417	
Console models, AM, all prices.....	3,194	3,336	146,043	
Battery sets.....	236,232	235,684	5,290,535	
Table models.....	68,843	61,539	1,130,380	
Portable models.....	51,601	50,289	1,234,120	
Automobile radios.....	115,788	123,856	2,926,035	
Radio-phonograph comb.....	110,752	105,561	6,220,313	
Table models, AM:				
Factory value under \$30.....	8,779	7,090	196,496	
Factory value \$30 and over.....	62,313	60,257	2,615,534	
Console models, AM:				
Factory value under \$65.....	14,309	13,234	777,546	
Factory value \$65 and over.....	24,361	24,249	2,392,239	
All other radio phonograph comb. (AM-FM and television wired).....	990	731	238,498	
Electronic phonographs (except coin operated).....	106,545	105,870	1,872,620	
Complete units (except coin operated):				
Factory value under \$20.....	11,601	11,251	183,597	
Factory value \$20 and over.....	33,392	32,275	831,042	
Record players (sold as separate units).....	61,552	62,344	857,981	
All other <sup>1</sup> .....	xxx	xxx	420,860	

<sup>1</sup>Includes AM-FM sets, television sets, recorders (separate units for home use), and radio chassis. The value of these items was combined to avoid disclosing the operations of individual companies. There was no activity in FM sets or FM converters during April.

## CBS Television Starts A-Bomb Film Program

AN A-BOMB film series started July 4 on WCBW New York, CBS television station, and will be a regular feature, Thursdays 8:45-9 p. m., for the next 10 weeks. Covering every phase of the dramatic operation leading up to the test on A-Day, official films are augmented by background color footage sent in by Leroy Phelps, television "pool" cameraman accredited to Operations Crossroads.

During the actual dropping of the A-Bomb on Bikini lagoon June 30, Bill Downs' official "pool" radio description was picked up on WCBW's audio channel and animated with films, maps, diagrams, and other visual material from the

"No activity in FM sets or FM converters during April" was found by the Bureau. A value figure of \$420,000 covers production of television sets, home recorders and radio chassis. Figures were not broken down because of disclosure of individual company operations.

Total production and shipments for June will be made public in mid-July by Radio Manufacturers Assn. under a new procedure. RMA members, who now supply figures to an auditing firm which discloses only industry totals, have complained about duplication of effort in providing data to U. S. agencies.

Civilian Production Administration recently estimated May radio set shipments at 1,075,000, which it said was 8% above April. This compares with the preliminary Census Bureau total for April of 1,135,128 sets.

Census Bureau production and shipment data for April follow:

New York studio. The television audience was briefed on the purposes of the bomb tests during the television broadcast by Lt. Comdr. Paul Hidding of Joint Task Force No. 1, with Elmer Wexler, former Marine combat artist-correspondent and currently with PM, illustrating the actual bombing from Mr. Downs' broadcast report.

## CPA Issues Cut

ALLOWANCE of Civilian Production Administration for conversion of residential buildings to stores or offices was cut last Tuesday from \$1,000 to \$200 as a step to safeguard the supply of housing. Conversions costing over \$200 require local CPA approval.

**MEASURE**  
YOUR ADVERTISING DOLLAR  
ANY WAY YOU LIKE



JOHN BLAIR & CO. - NATIONAL REPRESENTATIVES

*The Largest*  
**TRANSCRIPTION LIBRARY**  
OF  
**AMERICAN FOLK MUSIC**

**M. M. COLE CO.**  
823 S. WABASH AVE.  
CHICAGO 5, ILL.

**WDRC**  
HARTFORD 4 CONNECTICUT  
WDRC - FM

1946 Report on Hartford Market . . .  
Information you should have . . . based on Sales Management Magazine's Annual Survey of Buying Power. Write Wm. F. Malo, WDRC, Hartford 4, Conn., for your complimentary copy.

THERE'S PLENTY OF BUSINESS IN  
**DAYTON, OHIO**

Get Your Share By Using . . .

**WING** The Dayton Station

WEED & CO. National Representatives

# KOIN

It takes an informed  
community to do  
a community job.

**PORTLAND, OREGON**

**CBS Affiliate**

**LEWIS H. AVERY, Inc., Nat'l. Rep.**

## ..Profits UP

WTAR gives you more customers in the  
NORFOLK METROPOLITAN MARKET  
than all other stations  
combined

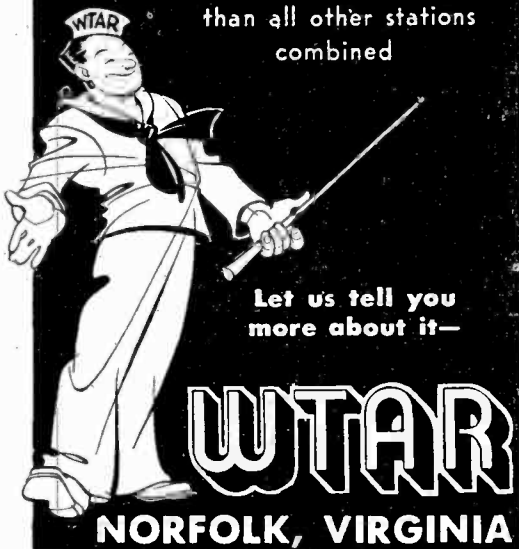

Let us tell you  
more about it—

# WTAR

**NORFOLK, VIRGINIA**

## PRE-WAR

... and very good!

William Winter, the  
West's most popular  
commentator before  
and during the war,  
is back from duty ...  
and again on KSFO.  
Ask for details.

UNIVERSAL'S KEY STATION  
FOR NORTHERN CALIFORNIA

# KSFO

SAN FRANCISCO  
Represented by

UNIVERSAL RADIO SALES

New York • Chicago • Los Angeles

## CKNW

has more listeners  
than any other 250  
Watt Station in Canada

# CKNW

**NEW WESTMINSTER, B.C.**

# Blue Book Definition Changes Made

## Amendments of Minor Nature Effected By FCC

A REVISED EDITION of the FCC's Blue Book was issued last week, amending definitions outlined in the March 7 report.

Made "pursuant to suggestions which the Commission has received from many interested persons," the changes:

1. Specify that a 14½-minute (rather than 15-minute) unsponsored program that is uninterrupted by a spot announcement is a sustaining program. (This change was made, FCC said, "in recognition of the fact that most 15-minute programs are only 14½ minutes in length.")

2. Specify that network "cooperative" programs are to be recorded as network, not local. If not locally sponsored, they are "network sustaining." If locally sponsored, they are "network commercial" even though the commercial is read by a local announcer.

3. Stipulate that local live programs transcribed for later broadcast by the station be counted as "local live," not "recorded." (The definitions already provided that transcribed delayed broadcasts of networks should be classified as "network" rather than "recorded.")

4. Change "Sustaining-Public Service Spot Announcement (PSA)" to "Noncommercial Spot Announcement (NCSA)."

The Commission said that in addition to these revisions "other minor changes have been made but are mainly editorial in nature."

Except for one slight difference in wording, the definition of "wire program," which had been challenged by International News Service [BROADCASTING, April 22], remains the same. The change qualifies the reference to "the reading verbatim of the syndicated wire text" by inserting three words: "or virtually verbatim."

The Commission's stand on this definition was made known last month in a letter to INS asserting that the language apparently had been misconstrued and reaffirming the Commission's belief in the Blue Book definitions as a "satisfactory and practicable solution" to the problem [BROADCASTING, June 17].

The changes were accomplished by insertion of single sentences or phrases into existing definitions, or by substituting figures or phrases, rather than by re-writing the definitions.

Following is the Public Notice (No. 95462) which announced the changes. Revised parts of the definitions are shown in boldface type:

Pursuant to suggestions which the Commission has received from many interested persons, several changes have been made in the definitions of terms as used in the Commission's report of March 7, 1946, entitled "Public Service Responsibility of Broadcast Licensees." These changes are four in number.

The first change makes it clear that

a 14½-minute unsponsored program that is uninterrupted by a spot announcement is a sustaining program. The definition previously related to 15-minute programs. This change was made in recognition of the fact that most 15-minute programs are only 14½ minutes in length. The second change makes it clear that so-called network cooperative programs are to be recorded as network and not as local. Where a network cooperative program is not locally sponsored then it is to be computed as network sustaining. If there is a local sponsor it is to be counted as network commercial even though the sponsored announcement is read by a local station announcer. The third change relates to local live programs produced by the stations but which are recorded for later broadcasting. Under the new definitions such programs are to be counted as local live and not as recorded. The fourth change deals with so-called public service spot announcements. Hereafter this category will be called "non-commercial spot announcements."

Other minor changes have been made but are mainly editorial in nature. The new definitions now read as follows:

A commercial program (C) is any program the time for which is paid for by a sponsor or any program which is interrupted by a spot announcement (as defined below), at intervals of less than 14½ minutes. A network program shall be classified as "commercial" if it is commercially sponsored on the network, even though the particular station is not paid for carrying it—unless all commercial announcements have been deleted from the program by the station. Cooperative programs furnished to its affiliates by a network which are available for local sponsorship are network sustaining programs (NS) if no local sponsorship is involved and are network commercial programs (NC) where there is local sponsorship even though the commercial announcement is made by the station's local announcer.

(It will be noted that any program which is interrupted by a commercial announcement is classified as a commercial program, even though the purchaser of the interrupting announcement has not also purchased the time preceding and following. The result is to classify so-called "participating" programs as commercial. Without such a rule, a 15-minute program may contain 5 or even more minutes of advertising and still be classified as "sustaining." Under the proposed definition, a program may be classified as "sustaining" although preceded and followed by spot announcements, but if a spot announcement interrupts a pro-

gram, the program must be classified as "commercial.")

A sustaining program (S) is any program which is neither paid for by a sponsor nor interrupted by a spot announcement (as defined below).

A network program (N) is any program furnished to the station by a network or another station. Transcribed delayed broadcasts of network programs are classified as "network," not "recorded." Cooperative programs furnished to its affiliates by a network which are available for local sponsorship are network sustaining programs (NS) if no local sponsorship is involved and are network commercial programs (NC) where there is local sponsorship even though the commercial announcement is made by the station's local announcer. Programs are classified as network whether furnished by a nationwide, regional, or special network or by another station.

A recorded program (R) is any program which uses phonograph records, electrical transcriptions, or other means of mechanical reproduction in whole or in part—except where the recording is wholly incidental to the program and is limited to background sounds, sound effects, identifying themes, musical "bridges," etc. A program part transcribed or recorded and part live is classified as "recorded" unless the recordings are wholly incidental, as above. A transcribed delayed broadcast of a network program, however, is not classified as "recorded" but as "network." A recorded program which is a local live program produced by the station and recorded for later broadcasting by the station shall be considered a local live program.

A wire program (W) is any program the text of which is distributed to a number of stations by telegraph, teletype, or similar means, and read in whole or in part by a local announcer. Programs distributed by the wire news services are "wire" programs. A news program which is part wire and in part of non-syndicated origin is classified as "wire" if more than half of the program is usually devoted to the reading verbatim, or virtually verbatim, of the syndicated wire text, and otherwise is classified as "live."

A local live program (L) is any local program which uses live talent exclusively, whether originating in the station's studios or by remote control. Programs furnished to a station by a network or another station, however, are not classified as "live" but as "network." A program which uses recordings in whole or in part, except in a wholly incidental manner, should not be classified as "live" but as "recorded." Wire programs, as defined above, should likewise not be classified as "live." A recorded program which is a local live program produced by the station and recorded for later broadcasting by the station shall be considered a local live program.

A non-commercial spot announcement (NCSA) is an announcement which is not paid for by a sponsor and which is devoted to a non-profit cause—e.g., war bonds, Red Cross, public health, civic announcements, etc. Promotional, participating announcements, etc. should not be classified as "non-commercial spot announcements" but as "spot announcements." War Bond, Red Cross, civic and similar announcements for which the station receives remuneration should not be classified as "non-commercial spot announcements" but as "spot announcements."

A spot announcement (SA) is any announcement which is neither a non-commercial spot announcement (as above defined) nor a station identification announcement (call letters and location). An announcement should be classified as a "spot announcement," whether or not the station receives remuneration, unless it is devoted to a nonprofit cause. Sponsored time signals, sponsored weather announcements, etc. are spot announcements. Unsponsored time signals, weather announcements, etc., are program matter and not classified as announcements. Station identification announcements should not be classified as either non-commercial spot announcements or spot announcements, if limited to call letters, location, and identification of the licensee and network.

HELEN BROCKMAN, formerly an account executive with Dundas & Frank, New York, and currently heard on WNYC New York on her own program "Women and the News", has joined the copy and contact staff of Hirshon-Garfield, New York.

## 'GUIDE' ANNIVERSARY KMA Publication Now Boasts —20,000 Circulation—

STARTING in 1944 with 7,671 copies, of which 7,000 brought in subscriptions, the *KMA Guide* of KMA Shenandoah, Ia., now has a paid circulation of over 20,000 at \$1 per year as it celebrates its second anniversary. The pocket-size 16-page publication follows a constant format to build reader following for departments.

Not a promotional idea, the *Guide* was conceived as a service, KMA desiring to let the small-town rural audience "see" the personalities they hear on the air.

Among features are a mail box, chat with Earl May, feature article on entertainers, farm and garden columns, personality features, farm tips by Farm Editor Frank Field, program listings, doings at KMA, network page, homemaker columns, plenty of photos. Editor is Owen Saddler. Feature editor is Doris Murphy, with Midge Diehl and C. R. Hillyer associate editors. W. H. Bailey is KMA promotion manager.



## KZRH, Casualty of War, Reopened Again by Silen

AFTER FOUR and a half years of silence, KZRH Manila went back on the air July 1. The station was reopened by Bert Silen, who was manager of the KPO San Francisco news and special events department during the past year. Silen left San Francisco for Manila in April to reopen the station which he and his staff blew up in order that it might not fall into the hands of the Japanese when the city fell.

KZRH is an NBC affiliate and Silen is NBC correspondent in the Philippines. The station is 10,000 w with 1,000 w shortwave power. KZRH shortwaved to NBC the festivities incidental to the signing of Philippine independence, July 4.

Silen and his family were interned in a Japanese prison camp during the war. His wife and three daughters expect to rejoin him in Manila later this year.

## Walter Johnson

WALTER JOHNSON, 38, radio director and general manager of A. & S. Lyons Agency, Beverly Hills, Calif., talent service and program packagers, died in his Pacific Palisades home following a heart attack on June 28. Mr. Johnson had been radio director of that firm since Nov. 1. June 19 he took on additional duties of general manager. He has been associated with Young & Rubicam, Don Lee Broadcasting System production division, and Music Corp. of America as Pacific Coast radio director. In Dec. 1942 he joined Marines, and was released as captain in June 1945. Besides his wife, Virginia, surviving are parents and a sister.

## United Uses VHF

UNITED AIRLINES has shifted its communications from the high frequency band to very-high frequency, using the 122.3 mc channel, J. R. Cunningham, director of communications, announced last week. Most of the airline's 60 ground stations have been equipped with 50 w transmitters. Tests show VHF transmissions are effective 75-100 miles, said Mr. Cunningham. UA plans to link all ground stations by radiotelephone.

## Hams Gain Bands

TWO new frequency bands, 7150 to 7300 kc and 14100 to 14300 kc, were added by the FCC last week to those already assigned for amateur operation. Order effective 3 a. m. (EST) July 1, permits only A1 type emission on bands 7150 to 7300 kc and 14100 to 14300 kc. Type A3 emission, the Commission said, may be used on frequencies 14200 to 14300 kc, subject to restriction. At the request of the ARRL, the Commission also made minor amendments to amateur operating requirements.

## P. H. GOULD NAMED MANAGER OF KSDJ

APPOINTMENT of Purnell H. (Mike) Gould, veteran Baltimore radio and agency executive, as general manager of the new KSDJ San Diego was announced last week



Mr. Gould

by Clinton D. McKinnon, editor and publisher of the *San Diego Journal*, and member of the licensee firm, Finley - McKinnon Broadcasting Co. Mr. Gould retired last Monday from the Gould & Kuff Adv.

Agency, Baltimore, to take over his new duties. He began his radio career 14 years ago as commercial representative for WBAL Baltimore, two years later joining WFBR Baltimore as commercial manager, a post he held until he was commissioned in the Army.

At the time of his discharge as a major late last year [BROADCASTING, Dec. 17, 1945] he was chief of the Broadcast Service Section, Armed Forces Radio Service, Los Angeles. Major Gould set up and supervised the Mosquito and Pacific Ocean Networks. He went into the agency field following his Army service.

KSDJ, which will be operated in conjunction with the *San Diego Journal*, was granted a construction permit last March to operate on 1170 kc, 5,000 w. Network affiliation has not been completed. Mr. Gould said the new station will emphasize public service and community talent participation programs. KSDJ will be housed in the new *Journal* building. Facilities include a 500-seat auditorium studio. Free & Peters will represent the station.

## Sam M. Levy Heads New Associated Adv. Agency

FORMATION of Associated Advertising Agency Inc., with offices at 208 Dixie Terminal Bldg., Cincinnati, was announced last week. Officers are Sam Malcolm Levy, president; E. L. Mehmert, vice president; I. C. Levy, secretary-treasurer. Sam Levy for the past 15 years has been vice president and director of Keelor & Stites Co., Cincinnati agency, for which he directed radio activities, and formerly was account executive with McCann-Erickson, New York. Mr. Mehmert was vice president and advertising manager of Sperti Inc., and former sales manager of the Hennegan Co., Cincinnati.

Alfreda S. Tillinghast, formerly with the Bert Johnston Co. and on the copy staff of the Kroger Co., has been named copy chief. Agency will handle all forms of advertising, including radio and television, and do complete merchandising.

## NARBA Changes

NOTIFICATIONS of proposed new stations and frequency changes have been filed with the U. S. by Mexico and Canada under terms of the North American Regional Broadcasting Agreement. Following are the notifications:

- Mexican Notification No. 63
  - 1340 kc—XEXS Toluca, Mex., delete.
  - 1400 kc—New, Torreon, Coahuila, 250 w unlimited, original assgt. 100 w, Class IV, to begin operations Sept. 10.
  - 1490 kc—New, Chihuahua, Chihuahua, 250 w, unlimited, Class IV, to begin Sept. 10.
  - 1500 kc—XERH Mexico, D. F., 2 kw nights, 5 kw days, unlimited, Class II, change from Class III-B.
  - 1590 kc—New, Nogales, Sonora, previously located at Tijuana, B. C.
- Canadian Change No. 29
  - 590 kc—CFAR Flin Fon, Man., 250 w, Class IV, changed from 1230 kc.
  - 800 kc—CHAB Moose Jaw, Sask., 5 kw, DA, day and night, Class III.
  - 810 kc—New, Yellowknife, Northwest Territory, 250 w, Class II.
  - 900 kc—CKBI Prince Albert, Sask., 5 kw, directional, Class II (correction to previous notification).
  - 980 kc—CKRM Regina, Sask., 5 kw, directional night, Class III-A.
  - 1150 kc—CKOC Hamilton, Ont., 5 kw, same directional pattern day and night, Class III-A; CHSJ St. John, N. B., 5 kw, DA night, Class III-A.
  - 1240 kc—CJCY Calgary, Alta., 100 w, Class IV, changed from 1230 kc.
  - 1440 kc—CHNO Sudbury, Ont., assignment of call letters.

## WQXR Changes Firm Name to 'Times' Station

WQXR changed its title last week. It became *The New York Times* Station, dropping its old name: Interstate Broadcasting System. The *Times*, on Monday, also began broadcasting daily three minute news summaries every hour on the hour between 7 a. m. and midnight, with one six minute summary at 11 p. m.

The *Times* reports are prepared by a special staff under the supervision of the *Times* news editors. They are compiled from the worldwide reports of correspondents of the *Times* and from the wires of the AP.

The *New York Herald Tribune* began its every hour on the hour newscasts last Monday on WMCA, in the spot just vacated by the *Times*. The *Tribune* will use its own news staff, and will run its three minute newscasts daily from 7 a. m. to 11 p. m. The last show will be a six minute round-up of the day's events. Promotion for the newscasts has been carried as news stories in the *Tribune*.

## G. E. FM Receivers

GENERAL ELECTRIC Co., Bridgeport, Conn., is scheduled to begin production of FM receivers this week, according to an announcement by Arthur A. Brandt, general sales manager for the G. E. electronics department. First receivers, styled on the console model and operating in the 42 to 49 mc band and the 88 to 108 mc band as well as the standard band (AM), will appear in retail stores "sometime" in August. Production on table models will begin in August, it was revealed.

## An All-Time Favorite

### LAZY RIVER

Published by  
PEER INTERNATIONAL CORP.

Performance Rights  
Licensed Through

# BMI

BROADCAST MUSIC, INC.  
580 Fifth Ave., New York 19, N.Y.

## WHAT A DIFFERENCE!

Some radio stations do an ordinary job of selling. Others stand out as volume producers. WAIR is known far and wide for its ability to influence a maximum audience.

# WAIR

Winston - Salem, North Carolina  
Representative: The Walker Company

You Can't  
**COVER  
THE  
WEST**  
without  
**KSL** 50,000 WATTS  
SALT LAKE CITY - CBS

# WMOH HAMILTON, OHIO

—MBS—  
A "SELLING STATION" IN  
A GROWING CITY—KNOWN  
IN THE WORLD'S MARKETS  
Sells Products or Prestige  
WRITE FOR CHOICE  
AVAILABILITIES  
SPOT OR PROGRAM

your MUTUAL friend

**TRY IT AND "SPOT" THE DIFFERENCE**

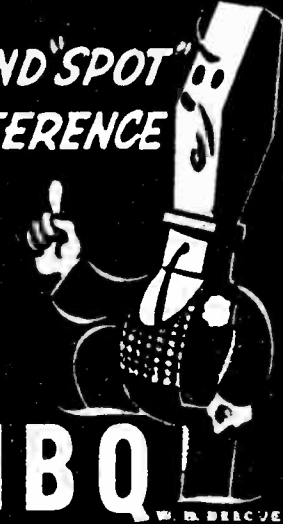

**WHBQ**

W. B. BEUCE  
 Memphis, E. A. Alburty, Gen. Mgr.  
 Represented by RAMBAU

**RATING-WISE BUYERS**

seeking audience-delivery  
 in Portland, Maine pick

**W C S H**

**YOUNG WIDDER BROWN**

1945-'46

Portland Hooperating  
 16.1

National Rating  
 6.7

The "ratings" station

**W C S H**

**PORTLAND, MAINE**

**EXCLUSIVE**  
 COVERAGE OF  
 THE CHAMPLAIN  
 VALLEY AREA

**W C A X**  
 BURLINGTON

VERMONT'S  
 ONLY CBS  
 STATION

1000 WATTS • FULL TIME

**WCKY**

the **50,000**

watt voice

of Cincinnati

**Nov. 15 Is Deadline for WCAU Sale**

**Six-Million-Dollar Sale To 'Record' Hinges On FCC Action**

FCC APPROVAL of the record-setting sale of WCAU Philadelphia to the *Philadelphia Record* for a gross figure of \$6,000,000 (a stripped price of approximately \$2,150,000) must be given by Nov. 15 or the contract will be terminated, it was disclosed last week as formal application for the assignment was filed with the Commission.

With 60 days required for public advertisement under the Avco plan, FCC cannot act upon the application before about Sept. 1. Whether the Commission will then hold a hearing, as it has done in many cases involving large sales prices, would not be predicted by FCC sources last week.

**5½ Million Loan**

To finance the purchase, the Courier-Post Co. of Camden, 91.33% owner of the *Record*, will borrow \$5,500,000 from Jefferson Standard Life Insurance Co. and Pilot Life Insurance Co., both of Greensboro, N. C., and lend most of this sum to the *Record*. After the purchase, the *Record* and *Post* companies will have a combined cash balance of about \$1,200,000. There will be no lien on any assets devoted to broadcasting.

Jefferson Standard, through subsidiaries, owns WBT Charlotte and WBIG Greensboro. Joseph M. Bryan, vice president of the insurance company, owns half interest in WORD Spartanburg, S. C. Pilot Life is a wholly owned subsidiary of Jefferson Standard.

The application points out that the *Courier-Post*, principally owned by J. David Stern, who is president of both papers, borrowed \$2,800,000 on Jan. 3, 1945, from the Society for Savings in the City of Cleveland. The loan, \$2,300,000 of which was then loaned to the *Record*, was for 10 years at 4% per year.

As of June 12 this year, the application reported, *Courier-Post* had reduced its indebtedness to the Society to \$2,481,620, and the *Record's* debt to *Courier-Post* stood at \$1,205,756.

Before its sale of \$5,500,000 face value 4½% bonds to Jefferson Standard and Pilot Life, *Courier-Post* plans a temporary loan of \$8,000,000 from the Philadelphia National Bank. Of this, \$5,500,000 will be advanced to the *Record* and the remainder will be used to satisfy the debt to the Society. The \$5,500,000 advanced to the *Record*, plus \$500,000 of the *Record's* own funds, will be used to buy WCAU.

When all contemplated transactions have been completed, *Courier-Post* will owe \$5,500,000 on the bond issue and the *Record* will owe the *Courier-Post* \$4,250,000. A total of \$2,750,000 in U. S. and

municipal bonds acquired from WCAU in the purchase of the station, plus the \$5,500,000 from the bond issue, will have been used to pay off the temporary loan from Philadelphia National Bank.

It was pointed out that WCAU, a 50-kw Class I-A clear channel station on 1210 kc fulltime, in 1945 showed a profit of \$625,000 before taxes. Profits before taxes for the period from Jan. 1 to May 18, 1946, totaled \$615,497, operating expenses were \$324,498 and broadcast income \$536,540. Liquid assets as of May 18 were \$3,250,000, principally in cash and U. S. Government bonds. Other assets total about \$600,000. Current liabilities are about \$500,000, of which \$485,000 represents Federal income tax obligations.

The sale, announced in May [BROADCASTING, May 13], was advertised in the *Record* starting July 3 under the Avco plan.

Smith Davis, of Smith Davis Co., radio and newspaper financing organization, of Cleveland, participated in the negotiations as consultant to Mr. Stern.

**Other Property Sold**

The sales agreement disclosed plans for sale by WCAU of two non-broadcast buildings in Philadelphia—one at 1716-20 Walnut Street and the Perry Building at 16th and Chestnut—for a total of \$1,025,000. This is apart from the WCAU station sale. Purchasers of the two buildings were not named.

In the sale of the station, \$100,000 earnest money was deposited by the *Record* at the time the agreement was reached. The rest of the purchase price is to be paid in cash at closing date, within 30 days of Commission approval.

Mr. Stern, who owns 66.68% of *Courier-Post*, has announced plans for a new \$3,000,000 building for operations of the newspaper, aural broadcasting, and television operations. WCAU-FM is part of the properties being sold.

While Dr. Leon Levy, president and directing head of WCAU, and his brother, Isaac D. Levy, Philadelphia attorney, are divesting themselves of all interests in WCAU, the application said "they have agreed to assist the management of the Philadelphia Record Co. in the operation of the station

**Army Sponsors**

U. S. ARMY recruiting service will sponsor *Spotlight Bands* three times weekly on Mutual during the eight week summer hiatus by Coca-Cola Co. effective July 15. The show, which features the three bands, Guy Lombardo, Xavier Cugat, and Harry James, on Monday, Wednesday, and Friday respectively, will plug Army recruiting. N. W. Ayer & Son, New York, is agency for Army recruiting. Coca-Cola Co. is handled by Darcy Adv., New York.

so long as their services are required."

The Levy brothers own 32.67% each in WCAU, and are substantial stockholders in CBS, as are all other WCAU stockholders. The others are: William S. Paley, CBS board chairman, 11.06%; Samuel Paley, 10.8%; Remraf & Co., trustee for Jacqueline Paley, minor daughter of Jacob Paley, 10%; Edna Bortin and Stanley A. Broza, 1% each; Jacob Paley, 0.8%. In selling their interests, they said they "desire to divest themselves of their holdings in individual radio stations and confine their interests to network holdings."

WCAU would remain a CBS affiliate under the new management and "the facilities and staff . . . will be maintained without substantial change."

Plans to "intensify and broaden the public service" of the station and to "inaugurate new services in such specialized fields as drama, art, news, education, music, science, economics, public hygiene and political science" were outlined in the comprehensive application submitted to FCC, which was prepared under the direction of the Washington law firm of Marcus Cohn and Leonard Marks.

**Program Plans**

Extensive use of editors and staff members of the various departments of the *Record* is contemplated. Program plans call for approximately 70% commercial programming and 30% sustaining. Plans include:

Literature—Weekly discussion of current literature by Charles Lee, *Record* literary editor, or some member of his staff.

Drama—Amateur and professional productions; lectures and discussion by *Record* Critic Edwin H. Schloss and his assistants; movie reviews by Len Morris, motion picture editor.

Music—"Significant local musical events."

Finance—Weekly analyses of financial news and economic trends by Joseph Livingston, *Record* finance editor.

Science—Weekly science summary by Science Editor Don Morris; formation of a committee of scientists to serve as consultants and participants in science programs.

Outdoor Life—Programs by William Wolf, outdoor events editor.

Education—Utilization of *Record's* reference library and assignment of an editor and staff to keep in contact with undergraduate activities at nearby schools and colleges.

Religion—A daily morning sermon prepared under the supervision of the *Record* church department.

Agriculture—"Special attention to agricultural news and market quotations," with *Record* Farm Editor Edwin Kemp presenting a weekly program supplementing the daily broadcast conducted by WCAU's Farm Editor Amos Kirby.

Gardening—"Special broadcasts in season" by Mrs. Jean Johnston, *Record* garden editor.

News—Broadcasts from the *Record* newsrooms; daily program of comments from newspapers, public officials, and prominent citizens; weekly broadcast from Washington by Col. Robert S. Allen, former co-author with Drev Pearson of Washington Merry-Go-Round, who will head the *Record's* Washington bureau upon discharge from the Army.

Miscellaneous—Services of the following other departments of the *Record* to be made available for special programs: Travel, veterans' information, women's interests, sports, industrial, editorial, etc.



## Home Town Applicant Awarded Station In Final Grant at Glens Falls, N. Y.

FAVORING the applicant who would devote full time to his station and would live in the town in which it is located, the FCC last Tuesday in a final decision decided on Great Northern Radio Inc. as its choice to operate a 250 w station on 1450 kc in Glens Falls, N. Y. Comr. E. K. Jett, dissenting, voted in favor of the competing applicant, Glens Falls Broadcasting Co. Commission action covers its proposed decision of April 10. Filing of proposed findings of fact and conclusions was waived by both applicants.

In another hearing case the Commission proposed to grant Lake Erie Broadcasting Co. a local station on 1450 kc in Sandusky, Ohio, preferring the applicant over two others because of local residence and desire to diversify control of media of mass communication. Competing applicants who would be denied are Sandusky Broadcasting Co., in which Brig. Gen. Robert L. Denig, U. S. Marine Corps, former resident of Sandusky, is a director, and Bay Broadcasting Co.

### Observer Is Victor

In a final decision on three applications for a 250 w station on 450 kc in Orangeburg, S. C., the Commission ruled in favor of Observer Radio Co. and denied Orangeburg Broadcasting Corp. and Edisto Broadcasting Co. Interest of the successful applicant in the community to be served and willingness to gather and broadcast local news, which Edisto seemed unwilling to do, were primary reasons for the Commission's decision.

Considerations of residence, knowledge of local conditions and other circumstances within the community to be served entered into a proposed decision granting Frank E. Hurt & Son, Boise, Ida. (KFXD) an increase from 250 w to 1 kw and change in frequency from 1230 kc to 580 kc. An application of Queen City Broadcasting Co. Inc. for a new station on 600 kc with 1 kw power was denied.

The Commission's decision on the Glens Falls applications gave weight to the plans of Martin Kaig Jr., president of Great Northern Radio, to move to Glens Falls and devote full time to the station and the fact that he owns 51% of the stock of his company and will be in a position of authority over operations. In the case of Glens Falls Broadcasting, the Commission found neither William F. Rust Jr., 20% owner, or H. Scott Millgore, 20% owner, intends to move to Glens Falls. The two intend to devote time to other interests and have not agreed with other stockholders on important policy questions.

The Great Northern grant was conditioned upon the filing of an application for modification of permit specifying exact transmitter

site and antenna system and further conditioned on the installation of an approved modulation monitor when available.

In proposing to grant a station in Sandusky to Lake Erie Broadcasting Co., the Commission noted that each of the four stockholders of the company is a director and will take an active part in the station's operation and management and that all but one have had radio experience. The proposed manager of the station, it added, would move to Sandusky. None of the principals of the Bay Broadcasting Co., on the other hand, is or would be a Sandusky resident.

### Lake Erie Preferable

As for the third applicant, Sandusky Broadcasting Co., the decision pointed out that two of the directors play a prominent part in the operation of the Sandusky Register Star-News, published by Sandusky Newspapers Inc., majority stockholder in the applicant corporation. The Commission therefore concluded a grant to Lake Erie would be preferable to Sandusky Broadcasting "for the reason that there would be added to the Sandusky area a new and independent medium for the dissemination of news and information to the public and afford a degree of competition to other such media in the area."

In selecting the successful applicant for Orangeburg, the Commission found that Observer Radio, with control residing in Orangeburg people, "will render a more representative service to the community" than Edisto. An additional reason for favoring Observer over Edisto was that the former stated he would disseminate local news while the proposed manager of Edisto stated that "a radio station in a city the size of Orangeburg should not concern itself with local news, although it is willing to give time to the local newspaper if it desires to broadcast a local news program."

On this point, the Commission concluded: "We do not believe that the business of dissemination of local news should be left solely to the local newspaper as proposed by Edisto, and we do not believe that the discharge of this function should prove unduly onerous to the owners of a radio station operating in Orangeburg."

The Commission disqualified the third applicant, Orangeburg Broadcasting Corp., on the grounds that its principal owner has had no experience in radio, that he would have to split his time between the radio and theatre business and that he is president and director of the Times & Democrat, only daily in Orangeburg.

In proposing a 1 kw grant to Frank E. Hurt (KFXD) in Boise, the Commission noted that its ap-

**KOAD, Nebraska's First FM Station, Now on Air**  
NEBRASKA'S first FM station went on the air last Monday when the Omaha World-Herald station, KOAD, was dedicated at 7:45 p. m. CST. Station will operate 16 hours daily, opening at 7 a. m. and closing at 11 p. m. on 92.5 mc.

Gov. Dwight Griswold, whose message was transcribed, said "sooner than many people expect FM will be firmly established." Henry Doorly, World-Herald publisher, said the FCC had "urged us to get started as soon as we could" and that "manufacturers tell us that soon there will be plenty of sets."

Frank E. Shopen, technical supervisor of radio for the World-Herald, will manage KOAD. Harvey Twyman, formerly of KOIL Omaha, is program director, and Richard F. Low, former manager of the Yale U. station, WYBC New Haven, is production manager. Mr. Shopen and his staff built KOAD in eight weeks. Because of equipment scarcity, some was made by Mr. Shopen and assistants. The World-Herald also operates KOWH, which carried the dedicatory program of KOAD.

### TB Programs

THE ANNUAL REPORT of the radio division of the New York Tuberculosis and Health Assn., issued June 28, credits WNYC New York with carrying more than 40 percent of the association's radio programs. Of a total of 279 programs produced by the organization and carried by nine stations in the New York City area, WNYC broadcast 104. The station also broadcast 712 public service announcements which had to do solely with the public health, with many of the announcements available to all N. Y. stations.

Applications for 580 kc and that of Queen City for 600 kc are but 20 kc apart and that a separation of 40 kc is required under the standards for assignment in the same community. In view of Mr. Hurt's greater community interests, the Commission said it "feels that the local growth of licensees should be encouraged."

"The present application for increased facilities while not only improving the radio service in the Boise area enables the present local licensee to grow and keep pace with the growth of his community. While Queen City Broadcasting Co. offers a valuable service to the Boise community, the wealth of local experience, the long local operation, and the Commission's policy of encouraging local growth where the licensee has been and is legally, technically, and financially qualified, favors the local applicant, Frank E. Hurt & Son."

The grant was conditioned upon antenna modifications to afford greater protection to KMJ Fresno, Calif., and CKUA Edmonton, Alta.

The  
**PACIFIC NORTHWEST**  
means  
**KIRO**  
The Friendly Station  
**50,000 Watts**  
**710 KC**  
**CBS**  
SEATTLE, WASHINGTON  
Represented by FREE & PETERS, Inc

**NBC**  
Station For  
**WINSTON-SALEM  
GREENSBORO  
& HIGH POINT**

★  
**5000 WATTS  
600 KC.**

**WSJS**

Representatives  
**HEADLEY-REED CO.**

**GOING PLACES FAST  
IN IDAHO**



**KSEI**

**POCATELLO · IDAHO**

The **SCHOOL of**  
**RADIO TECHNIQUE**

**NEW YORK • CHICAGO**  
America's Oldest School Devoted  
Exclusively to Radio Broadcasting  
Comprehensive Day and Evening  
Courses in all phases of Radio  
Broadcasting taught by Network  
Professionals. Moderate rates.  
Send for free Booklet B.  
G. I. Training in New York.

**NEW YORK 20, N.Y.; RADIO CITY, R.K.O. Bldg.  
CHICAGO 4, ILL.: 228 S. Wabash Avenue**

# Classified Advertisements

**PAYABLE IN ADVANCE—Checks and money orders only—Minimum \$1.00.** Situation Wanted 10c per word. All others, 15c per word. Count 3 words for blind box number. One inch ads, acceptable, \$12.00 per insertion, non-commissionable. Deadline two weeks preceding issue date. Send box replies to Broadcasting Magazine, 870 National Press Bldg., Washington 4, D. C.

## Help Wanted

**Good combination operator and announcer** with first class license. NBC station, intermountain west. Substantial salary and permanent affiliation for right man. Box 373, BROADCASTING.

**Wanted—Three combination announcers and engineers** for 250 watt southern station. Must have first class license. All replies confidential. Address Box 446, BROADCASTING.

**Radio time salesman** wanted to do constructive selling. Must write copy for own accounts. No high pressure selling. NBC station, well established. Rocky Mountain area. Box 449, BROADCASTING.

**New England network affiliate** now considering announcing and first class engineer applications. Opportunity to grow with a progressive station in a beautiful and prosperous community. Send qualifications, salary requirement. Box 475, BROADCASTING.

**Sports announcer**, experienced in play-by-play and straight announcing. Prefer man with college playing experience. Answer Box 503, BROADCASTING.

**Southern station** will have opening for announcer in near future. In application give background, experience and references. Box 504, BROADCASTING.

**First class ticket** with ability to announce. \$35.00 weekly. New England city. Box 507, BROADCASTING.

**Chief engineer—Local midwest ABC affiliate.** Must be familiar with RCA equipment and experienced in maintenance and construction. Prefer young aggressive man. In answering include details of education, radio experience, age, photograph, references, and other pertinent information. Starting salary \$300, opportunity for advancement. Write Box 510 BROADCASTING.

**Wanted—On or about August 15,** good announcer with first class operator's license. Prefer one who wants to learn all departments of radio. Job primarily announcing, with some operating and copy writing. State salary expected. Send full information and references to WOMI, Owensboro, Kentucky.

**Chief announcer** wanted by 5000 watt Intermountain Mutual affiliate. Can also use combination news and special events man. Send complete information to KLO, Ogden, Utah.

**First class engineer.** Single, veteran preferred. Broadcast experience unnecessary. KFJB, Marshalltown, Iowa.

**Wanted Immediately:** First Class operator, permanent position, salary \$40.00 for 40 hours. Send qualifications and snapshot to WNEK, Macon, Georgia.

**Engineer-announcer** wanted by NBC station in citrus belt of Florida. Experience in routine announcing required. No engineering experience necessary. First class license required. Good salary. Opportunity for advancement. Radio Station WLAK, Lakeland, Florida.

**First class ticket** with ability to announce. Pay \$40.00 weekly. WTMC, Ocala, Florida.

**First class operator,** 250 watt Mutual station. Write giving background information, salary expected. WSSV, Petersburg, Virginia.

**Combination announcer-operator** with first class license for regional NBC affiliate. Send snapshot first letter. KSEI, Pocatello, Idaho.

**Salesman,** preferably single, and who can write copy for 5000 watt NBC Rocky Mountain station. Send photo, references, Box 517, BROADCASTING.

**Announcer-continuity writer** and idea man for 1000 watt network affiliate in west. Appreciate transcription, photo, sample continuity, references. Box 518, BROADCASTING.

**Engineer-announcer.** NBC station has excellent opportunity for two good combination men. Must have first class license with emphasis on announcing ability. Married men preferred who want to settle permanently in one of California's most interesting cities. Weekly salary \$60.00 for forty hours. Wire, write or phone Manager, KCRA, Sacramento, California.

## Help Wanted (Cont'd)

**Chief Engineer—Must have complete knowledge and experience** in transmitter, maintenance and related work. Car ownership desirable. Give complete details education, experience, references. Small New England network affiliate. Box 526, BROADCASTING.

**Two Top Announcers—With first phone.** \$70 weekly guarantee. Send disc, photo, particulars to KATO, Reno, Nevada. Box 858.

**Salesman—Experienced all phases radio.** Must be capable of sales promotion, necessary have car. Excellent opportunity. Send references, photo and transcription. Louis N. Howard, WHIT, New Bern, N. C.

**Transmitter operator—First class license,** one kilowatt southeast NBC affiliate—\$40 on 50 hr. basis. Give full details in first letter. Box 530, BROADCASTING.

**Need 10 first class operators-announcers and sales managers.** Radio's Reliable Resources (employment agency), Box 413, Philadelphia.

## Situations Wanted

**Nine years experience** announcing, selling, managing. Want job on 250 watt in small town with chance to eventually buy interest. Capable, dependable. Box 392, BROADCASTING.

**News announcer—editor position** wanted. Can furnish proof of popularity. Employed 50 kw staff announcer. AFRA member. Versatile. Veteran. Transcription available. Box 473, BROADCASTING.

**Commercial manager—Twelve years** in present position, with excellent record of results and earnings. Prolific in ideas and showmanship and a believer in aggressive programming and local production. Desire change because station is changing ownership. Box 477, BROADCASTING.

**Young married veteran.** 1st class phone. Army communications up to 40 kw FM-AM installation maintenance. Broadcasting experience. Announcing ability. Desires chief position new station. Box 478, BROADCASTING.

**Announcer-veteran.** Graduate of course in all phases radio technique at leading school. Handles all types announcing. Also write continuity. Background in sports and music. Single, unattached, 26. Will travel. Box 482, BROADCASTING.

**Veteran** would like to tie up with progressive network station. Available July 30. Announcer, newscaster, production man four years, also handled successful record request shows. Can furnish excellent references. Box 483, BROADCASTING.

**General manager—Ten years** experience small, medium, metropolitan markets; network and independent stations. Let's talk business! Box 485, BROADCASTING.

**Chief engineer—Six years** experience installation, maintenance, operation AM and FM. Extensive experience wire and disc recording. Veteran. Available immediately. Box 487, BROADCASTING.

**Capable Engineer—First class** telephone, first class telegraph license, sixteen years experience. Will give special consideration for housing facilities for family of four. Box 490, BROADCASTING.

**Commercial Man,** 21 years in radio, 45 years old, seeks job in challenging market with aggressive station, new or old. Desire either stock interest or salary override. Background includes every phase of national, regional and local selling. Widely known among national agencies and advertisers. Best references. Box 496, BROADCASTING.

**I don't know anything,** but am very eager to learn. Vitally interested in all phases of radio. Willing to start at any level to learn. College graduate. 4½ years Army Air Force officer. Prefer Carolinas. Box 505, BROADCASTING.

**Chief engineer—Assistant chief** of kilowatt desires chief's position—anywhere. Thoroughly experienced. Box 506, BROADCASTING.

## Situations Wanted (Cont'd)

**First class announcer—With first class operator's license.** NBC audition recommendation. \$60.00 wk. for combination job. Prefer east coast. Box 508, BROADCASTING.

**Announcer—Veteran,** single, 24, Army Network experience, announcing; commercial continuity; ad lib, etc. Conscientious, dependable, eager to establish radio career. Go anywhere. Salary secondary to opportunity. Box 512, BROADCASTING.

**Announcer—experienced.** Veteran, dependable, handle all types commercials, newscasts, record shows, sports, remotes, can operate control board. Transcription available. Box 513, BROADCASTING.

**Announcer-program director—veteran;** 3 years AFRS program director, chief announcer, writer, programming, commercials, special events, etc. Civilian experience 5 kw NBC station. Ideas, ambition. Eager to get along. Married, hard worker, available now. Box 515, BROADCASTING.

**Law clerk position** with Washington law firm dealing with radio law desired by former Signal Corps and OSS paratroop officer. AB degree and presently G. W. law senior. Amateur and broadcast engineering experience. Desire connection with affiliation upon ascension to the bar. Box 516, BROADCASTING.

**Army veteran,** single, wishes sales job particularly southwest. Age 30. Radio background includes selling, promotion, merchandising and publicity in metropolitan major market for independent stations. Best references. Phil Reilly, 3200 16th St., N.W., Washington, D. C. Phone Decatur 6400.

**Engineer—First class license,** 8 years experience in Naval installation and maintenance. Good educational background. Harry C. Seyffer, 246 Portland St., S. E., Washington, D. C.

**Veteran—Announcer—program director.** Five years experience announcing, editing news, copy, air traffic, 5000 watt west coast station. Excellent references. Married. Min. \$50.00. Perry Carle, 120 N. Washington, Hinsdale, Illinois.

**Invasion! Young vet—Anxious** to make career in television commercial advertising or studio operation and production as studio assistant or camera dollyman. Needs a beachhead. Warren Richmond, Box 122, Flatbush Station, Brooklyn 26, N. Y.

**Operator—veteran.** First class phone and telegraph license. Served two years as chief radio officer aboard ship. Good radio voice. Marvin Skydell, 2106 Wallace Ave., New York 60, N. Y.

**Ex-Army Air Force** entertainment specialist, extremely interested in radio announcing, looking for an opportunity to prove himself. Married, 1 child. A letter to me will bring all desired information. Willing to go any place in United States. Will consider offers for training under the G. I. Bill of Rights. Address Scotty Van, 3943 North Farewell Ave., Milwaukee 11, Wis.

**Production man.** Ten years' experience includes network production of highest calibre. Box 524, BROADCASTING.

**News announcer.** 3½ years' experience 5 kw. Morning man; strong on musical productions. Versatile. Box 531, BROADCASTING.

**Announcer in Australia** wants position with American station. Should make good publicity, don't you think? Give me three months' trial, and I'll show results. Two years' experience announcing, acting, compering and program arranging. Further details, photo and audition disc. Apply Box 525, BROADCASTING.

**Engineer:** First class license. Single. Three years' experience. College graduate. Physics major. Desires position with educational or commercial station, or construction work. Will consider any section of the country or a traveling job. Box 529, BROADCASTING.

**Station manager.** Married officer veteran. Nine years network, seeks opportunity. Box 520, BROADCASTING.

**Announcer—Age 30,** married, M.A. degree, experienced disc jockey-control operator desires locate South or Midwest. Box 528, BROADCASTING.

**Veteran,** years of experience, Radio telephone first, available now. 5 to 50 KW station preferred. Box 527, BROADCASTING.

## Situations Wanted (Cont'd)

**Public service program director.** \$95 a week. References, educator. Box 521, BROADCASTING.

**Publicity man** available, veteran, slight disability, 25, 7 years' Broadway experience, radio, orchestra, screen, NBC pass; will locate anywhere, but prefer midwest. Box 519, BROADCASTING.

**Program manager.** A.B. degree, congenial, experienced three 50,000 watt stations, producer "Variety Award" winning series (twice), references. Box 522, BROADCASTING.

**Radio continuity.** Writer-creator. Children's shows, new talent, popular and classical music shows. Box 523, BROADCASTING.

**Available—Qualified announcers,** producers, copywriters. Radio's Reliable Resources, Box 413, Philadelphia.

**Announcer—Can write news** and handle special events. Box 532, BROADCASTING.

**Announcer—General staff** and news experience. 38, married, steady and dependable. Available immediately. For details write S. Parker, 917 13 St., Hermosa Beach, Calif.

## For Sale

**For sale—Western Electric 6-B,** 1 kw transmitter, clean and ready for immediate use. Crated for shipment. Modernized. Price \$3,975 f. o. b. Coeur d'Alene, Idaho. Coeur d'Alene Broadcasting Co., Coeur d'Alene, Idaho.

**For sale—300-B Collins** 250 watt transmitter; RCA 72-2 cutter. WMFF, Plattsburg, N. Y.

**WANT TO HELP experienced-owner-management** build new local in big midwest market into really fine station? Staffing now under way for approx. Sept. 1 sign-on. Need chief engineer, first class operators, control-announcers, newsmen, salesmen. No big salaries to start, but plenty of room for improvement. Want people willing to bank future on own ability, with permanency and fair-play assured. Apply Bruff W. Olin, Jr., 709 20th Avenue, Moline, Illinois.

## DISC JOCKEY

**Need a morning man?** I have a highly salable, personality disc jockey show with present job offering no future. Want northern progressive affiliation. 8 years radio and stage experience. Family man. Want permanent place with a future. Present salary \$4000.00. Box 514, BROADCASTING.

## LOOKING FOR A JOB?

**READ . . . "RADIO JOBS"**  
A weekly newsletter, devoted exclusively to news of current openings at stations throughout the country. Covers announcers, engineers, salesmen, writers, managers, etc. \$2.50 for 3 months (13 issues). Or, send 25 cents for latest issue.  
**RADIO JOBS**  
545 Fifth Ave., New York 17, N. Y.

## PROMOTION AND MERCHANDISING EXPERT

**Now employed 50,000 watt station** wants new connection — 15 years promotional experience. Write, stating salary.  
**BOX 509, BROADCASTING**

## PROGRAM MANAGER

**Looking for progressive station** needing sound programming and promotion. College graduate—four years' experience in all phases of radio, two years as program manager. Now studying programming and station promotion at NBC-Northwestern Radio Institute in Chicago under NBC directors. Available early in August. Best of references from all past employers. Box 533, BROADCASTING.



# NAB Group Studies FCC Blue Book

## Freedom, FM Policies, Music Are Slated For Airing

INDUSTRY POLICY on the FCC Blue Book and its threat to freedom of broadcasting will be discussed at a July 8-9 session of the NAB Strategy Committee, special group named by President Justin Miller to advise him on policy matters. The meeting is one of a long series of summer committee sessions at NAB.

Separate sessions of two strategy subcommittees will be held tonight at a dinner at the Mayflower Hotel, Washington. With President Miller as chairman, the committee is divided into public relations and legal subcommittees. Joint meeting will be held the following day.

Effect of the Blue Book on industry operations will be considered along with changes in definitions issued recently. Possibility of further changes by FCC will be discussed. The strategy group probably will take up work of the all-industry Committee on Government Forms, headed by Wayne Coy, WINX Washington. Mr. Coy has been in touch with FCC officials on provisions of license and renewal application forms.

The Coy committee, which acts

### For Sale (Cont'd)

**Kluge 1 kw transmitter, model K1000** ISC. Immediate delivery. Price, \$3,500 complete, FOB, San Jose, Calif. Write box 995 or phone Columbia 3248-M.

**Brand New Western Electric type 241-** double plug two ft patch cords \$7.00 each. Also brand new thirty inch two conductor type PL-55 patch cords \$2.00 each. Limited quantity General Electric WB meters. 3 inch rectangular case \$10.00 each. All orders shipped prepared upon receipt of check with order. Broadcast Equipment Co., Box 222, Evansville, Ill.

**For sale—Used Western Electric 71-A** 000 watt linear amplifier. Also one kit of parts for 250 watt composite transmitter: includes meters, transformers, condensers, chassis, cabinets, etc. Make an offer. WRLD, West Point, Georgia.

**50 watt RCA-Kluge AM transmitter** and composite speech input, in use here last year. Make offer, cash only. KONP, Fort Angeles, Washington.

**Fewlett-Packard 400A VT Voltmeters.** Price \$120.00. Perfect condition, immediate delivery, limited quantity subject to prior sale. Ace Electronics, 4403 Littlebeck Parkway, Little Neck, L. I., N. Y.

**For sale—250 watt composite transmitter.** For complete details contact Chief Engineer, WPAY, Portsmouth, Ohio.

**Studioette console Gates model 51CS** just taken out of service, ready for immediate shipment. Complete with tubes. Price \$295.00. FOB, Carlsbad, N. Mex. Write, wire or phone. Norman Coose, Mgr., KAVE.

**Transmitter—Temco 250 watt** in original crate with two sets of tubes. Converted by Kluge Radio Co. \$3,000.00. Box 365, Fort Worth, Texas.

### Miscellaneous

**Investment.** Newly-formed transcription company needs capital. An opportunity to invest and share in sound business idea. Complete facilities available. Live fine commercial shows in production. Replies held in strict confidence. Box 377, BROADCASTING.

**Veteran—Now with FCC** needs partner interested in applying for 250 watt station. Good spot. No station in city over 0,000. Partner with engineering experience preferred. Box 479, BROADCASTING.

**Disc jockey's comedy material.** Box 493, BROADCASTING.

in an advisory capacity to the Bureau of the Budget, is interested in the forms from two angles—do they give the FCC the information desired and can they be filled out with reasonable ease by applicants?

Members of the strategy group, with Mr. Miller as chairman, are: Public Relations—Paul W. Morency, WTIC Hartford; Frank Stanton, CBS New York; Edgar Bill, WMBD Peoria. Law — Louis G. Caldwell, Horace L. Lohnes, James Lawrence Fly, all practicing attorneys. Donald S. Elias WWNC Asheville, N. C., chairman of the NAB Legislative Committee, participates in the committee meetings as does A. D. Willard Jr., NAB executive vice president.

Industry policy on another FCC issue—reservation of one-fifth of FM channels allocated in the future—is crystallizing, following a June 25 meeting in New York at which the FM Executive Committee opposed the plan.

NAB has contacted members of its board as to the advisability of filing a brief in opposition to the FM policies of the FCC. Returns received last week indicated the board favors NAB participation in July 12 hearings on the subject. Don Petty, NAB general counsel, was prepared to file a brief and take part in the hearings.

### Freedom Meeting

Threats to freedom of speech in broadcasting, newspaper publishing and motion pictures will be considered at the first meeting of the Freedom of Radio Committee, to be held July 17-18 in New York. The committee is fostering preservation of freedom of expression along with other basic democratic rights. Membership represents all facets of broadcasting.

In recent weeks, President Miller has contacted Eric A. Johnston and Byron Price, president and executive vice president, respectively, of the Motion Picture Producers' & Distributors' Assn. on danger of Government interference in rights of that industry. Mr. Willard has been in touch with Wilbur Forrest, president of the American Society of Newspaper Editors. Both groups indicated concern over growing inroads on their freedoms.

Two aspects of the music problem are receiving attention at NAB headquarters. The first—Petrillo's AFM and its locals—has simmered quietly since the union head dramatically offered himself as a martyr to test the Lea Act in the WAAF case but the situation is expected to boil over before many weeks as local negotiations get under way.

Expiration of network music contracts next Feb. 1 and Petrillo's indication that he wants more money from recording firms are potential danger points. Meeting of the Industry-wide Committee,

representing both member and non-member stations, will be called some time in August, likely after the NAB board meeting Aug. 6-8 at Estes Park, Col., to go into the whole music employment situation.

### Music Advisory Committee

The second music problem, centering on copyrights, will get an airing July 15-16 at a meeting of the Music Advisory Committee in New York. Steps looking toward an examination of copyrights in advance of ASCAP contract expirations Dec. 31, 1949, will be discussed. Effort will be made to avoid the 1941 situation when stations operated many months without ASCAP music. President Miller serves as chairman of both committees.

Plans to set up a program department within the NAB were drafted last week by the new NAB Program Executive Committee at a meeting in Chicago (see story page 36). Committee chairman has not yet been chosen.

Meeting of the Public Relations Executive Committee will be held in Washington July 12. Members will confer with Ted Heffron, new executive assistant to Messrs. Miller and Willard in charge of public relations, and consider a program for the coming months.

Similar meeting will be held in Washington July 22 by the Engineering Executive Committee, of which G. Porter Houston, WCBM Baltimore, is chairman, when James L. Middlebrooks, new director of engineering, will meet with members.

The Employee-Employer Relations Committee, headed by John Elmer, WCBM Baltimore, will meet Aug. 12-13 in Washington. Coming up for consideration will be negotiating problems of stations and tendency of unions to insert new provisions in contracts along with inter-union bickerings in which radio is caught in the middle.

### O'Brien and Dorrance Issue Promotion Piece

O'BRIEN & DORRANCE, New York, radio consultants, has published a promotion piece entitled "And We're Just the People to Do It" which will be sent to every commercial station in the country. Piece includes biographical sketch of Harry O'Brien & Dick Dorrance.

The letter enclosed with the production piece explains the company's project as that of a consulting promotion service, based upon a modest monthly retainer, adjustable according to the size and needs of the station. Firm asserts that it will "sharpen up the angles, appearance and effectiveness of the promotion material, merchandising and sales aids" the station now has.

"GATEWAY TO THE RICH TENNESSEE VALLEY"

50,000 WATTS

WLAC NASHVILLE

REPRESENTED BY PAUL H. RAYMER CO.



JOS. WEED & CO.,  
350 Madison Ave., New York,

Know About the  
5000 WATT TRANSMITTER

Now Being Erected by

CHNS

HALIFAX NOVA SCOTIA

The Maritimes

BUSIEST

Commercial Station

✓ + ✓✓!

NBC on 590

WOW

OMAHA Plus

WRITE, WIRE OR PHONE  
JOHNNY GILLIN  
OR JOHN BLAIR

67th Market  
TRI-CITIES  
ROCK ISLAND - MOLINE  
DAVENPORT

Sell this prosperous 200,000  
market by using WHBF.

WHBF  
BASIC MUTUAL 5KW 1270KC

Hon. W. S. Walker  
Platt-Forbes, Inc.  
New York City

Dear Bill:

More figures . . . I reckon I got more than them Hollywood movie directors . . . this time it's a letter from the



state director of Savings Bond sales for W. Va. He just wanted the boss to know that once again, the folks right here in Kanawha County bought more savings bonds than any other county in the state. 'Course where you have the state's largest concentrated buying power, you're just bound to have more bond sales—and speakin' of sales—the retail sales in Kanawha County hit \$107 million for 1945, the only W. Va. city to make

the \$100 million class . . . yes sir, I sure got lots of figures.

Yrs.  
Algy

**WCHS**

Charleston, W. Va.

# FCC Is Asked to Revoke D.C. Grant

## Rival Applicant Says Metropolitan Not Qualified

CHARGING that the Metropolitan Broadcasting Corp. was unqualified to render service in the public interest, the Foundation Co. of Washington, headed by Elmer W. Pratt, Washington radio attorney and former Federal Radio Commission examiner, petitioned the FCC last week to set aside the Metropolitan grant [BROADCASTING, June 17] for a standard station in Washington, D. C. and designate it for consolidated hearing with the Foundation application.

In its petition, the Foundation pointed out that the Metropolitan grant was made without hearing to determine the qualifications of the applicant. This, the petitioner charged, was contrary to the requirements of the standard public interest, convenience and necessity.

The Metropolitan grant for a daytime station on 570 kc, it was alleged, would result "in a relatively inefficient and limited use of broadcasting facilities in the Washington area." In its accompanying application, Foundation Co. of Washington requests 5000 w fulltime on 580 kc, which it said it has found to be available in the Capital area, operating with a directional antenna. The new application could not be granted without vacating the Metropolitan grant since only 10 kc separates the assignments while present practice requires 40-kc separation.

Foundation Co. also charged that the grantee was not "legally, technically, financially" and otherwise qualified to hold a construction permit.

### Rep. Boren Charges

Rep. Lyle Boren (D-Okla.) has charged on the floor of the House that Edward Brecher, manager of the Metropolitan station, worked on the application while still employed by the FCC. Mr. Brecher, an ardent adherent of the Commission's Blue Book of which he is co-author, is a former economic analyst at the FCC.

Foundation Co. contended Metropolitan is not in position now to carry out the elaborate program and service proposals it had outlined. Foundation further claimed that Metropolitan is a "promotional enterprise designed to raise funds from numerous small investors without regard to their qualifications . . . and intention to devote their time and talents to the operation of the station they propose." Metropolitan is composed of some 75 stockholders whose professions have a wide disparity.

Mr. Pratt, president of Foundation Co., was one of the first trial examiners of the old FRC. Vice president is Cecil D. Kaufmann, president of Kay Associates, a

national jewelry firm and a large local station sponsor. Lawrence J. Heller, former majority stockholder of WINX Washington, and Comdr. Richard K. Lyon, former minority stockholder, are treasurer and secretary, respectively. Sylvan S. Strook, president of S. Strook & Co., New York woolen manufacturing firm, is a director.

The sale of WINX by Messrs. Heller and Lyon to the *Washington Post* for \$500,000 created considerable notice, for at that time it was the highest price asked for a local station without network affiliation, regardless of market.

Foundation Co. has estimated that construction costs for its proposed station would be about \$57,-

000, with monthly operation expenses in the vicinity of \$10,000.

Opining that the radio broadcasting industry has not kept pace with advances made, Foundation Co. proposes a "realistic" program policy, maintaining its desire is not purely "a commercial zeal." Program content will consist of approximately 42% commercial time and 58% sustaining. Forums discussions, intercollegiate and high school sports, debates, Congressional hearings and high school debates are included in program plans proposed by the petitioner. Two hours of classical music will be broadcast daily, with the omission of the so-called "hep-cat variety, it was emphasized.

## ABC Names Hagman Central Division Manager; Konynenburg Heads WTCN

CLARENCE T. (Swanee) HAGMAN, vice president and general manager of WTCN Minneapolis-St. Paul, has been appointed general manager of the American Broadcasting Co. Central Division, Chicago, effective Aug. 1, E. R. Borroff, ABC Central Division vice president, announced last week [CLOSED CIRCUIT, July 1].

At the same time WTCN announced that Mr. Hagman will be succeeded by F. Van Konynenburg, sales manager.

### Network Expansion

Mr. Hagman's appointment to ABC is in line with the network's general expansion in the Midwest, according to Mr. Borroff. James L. Stirton continues as assistant to the vice president with special supervision over programming.

Mr. Hagman was appointed manager of WTCN on July 8, 1937, after serving a year as acting manager and three years as St. Paul sales manager and commercial manager. A native of St. Paul he



MR. HAGMAN

had spent several years in the advertising departments of St. Paul newspapers before entering radio. WTCN is owned 50% by the Dispatch-Pioneer Press Co., St. Paul and 50% by Minnesota Tribune Co.

He has been active in NAB affairs and is District 12 member NAB Public Relations Committee.

Mr. Konynenburg, a graduate of the U. of Wisconsin School of Journalism in 1927, joined the advertising department of the *Madison (Wis.) Capitol Times* in 1928. A year later he was named national advertising manager of the *Minneapolis Tribune* and in 1931 he became affiliated with David Inc., an advertising agency.

In 1934 Mr. Konynenburg joined the sales department of WTCN under Mr. Hagman and two years later became manager of the St. Paul office, succeeding Mr. Hagman when he was named commercial manager and acting manager. In 1941 Mr. Konynenburg became sales manager of WTCN.



MR. KONYNENBURG

**W  
T  
E  
L  
E  
V  
I  
S  
I  
O  
N  
R  
I  
C  
H  
M  
O  
N  
D**

**RICHMOND'S  
TELEVISION  
STATION**

**YES,  
WTVR**

**Will be  
The New  
Television  
Station in  
Richmond**

**12160 Watts  
Visual Power  
6400 Watts  
Aural Power**

**Frequency  
Modulation  
in 1946  
Television  
in 1947**

**WMBG**

Richmond, Va.

Represented by JOHN BLAIR & CO.

N  
B  
C  
i  
n  
R  
i  
c  
h  
m  
o  
n  
d



## Denny

(Continued from page 15)

since the OPA crisis developed and unquestionably strongly urged the Denny promotion. He certainly did not interpose objection to Mr. Clements' appointment.

J. Leonard Reinsch, managing director of the Cox radio stations and radio adviser to the President, also was at the White House during most of the last fortnight and presumably participated in discussions relating to FCC organization.

Permanent organization of the FCC and the addition of the seventh member would tend to expedite handling of the terrific work load occasioned by the unprecedented volume of AM and FM applications and the clearing up of the heavy hearing schedule. It would also strengthen Mr. Denny's hand in the direction of that agency.

### Appointed in 1927

Mr. Clements has been chairman of the Industrial Accident Board, which is the Workmen's Compensation Board in Montana, since 1927, having been appointed to the post by then Gov. John E. Erickson whose campaign he managed in 1924. He has been reappointed to the position by three successive governors, including a Republican.

A native Montanan, Mr. Clements is an attorney and former newspaperman who covered politics on the *Helena Independent* from 1919 until 1927. He is popular with the miners and has been applauded by management and labor alike for his administration of the Accident Board, a highly important agency in a state in which mining is the principal industry. Since he took office, the Industrial Accident Fund, from which benefits are paid to workers injured on duty, has quintupled in size.

A six-footer in his middle fifties, he is a liberal Democrat and while closely associated with Senator Wheeler since 1922, he has disagreed with him on matters of international policy. He was a delegate to the Democratic National Convention in 1924 and was a delegate to the convention in Chicago which nominated Franklin D. Roosevelt president for a third term. In recent years he has been executive vice chairman of the Democratic State Central Committee.

He is married and has two daughters, both of whom live in the East.

### Denny Background

Mr. Denny has been with the Commission since February 1942. He has been assistant general counsel, general counsel, and Commissioner successively, having been named Commissioner in March 1945 for a seven-year term. He is the youngest man in the history of the FCC to have been named Commissioner, having not yet reached 33 when he received the appointment.

Born in Baltimore April 11, 1912, Mr. Denny was graduated

# FCC Orders Hearing July 12 In Dallas on Rainey-TQN Case

MOVING with seldom-equalled speed, FCC last week ordered a hearing in Dallas on Friday (July 12) on the charges of Dr. Homer P. Rainey, candidate for the Democratic nomination for governor of Texas, that the Texas Quality Network stations were restricting the sale of time for discussion of political issues. The Texas primary will be held July 27.

The hearing, ordered July 2, the day after Dr. Rainey's petition was filed, was first set for Wednesday (July 10) but was postponed to Friday after counsel of the four TQN stations requested continuance because of conflicting engagements and the shortness of time. Since only eight days separated the order for the hearing

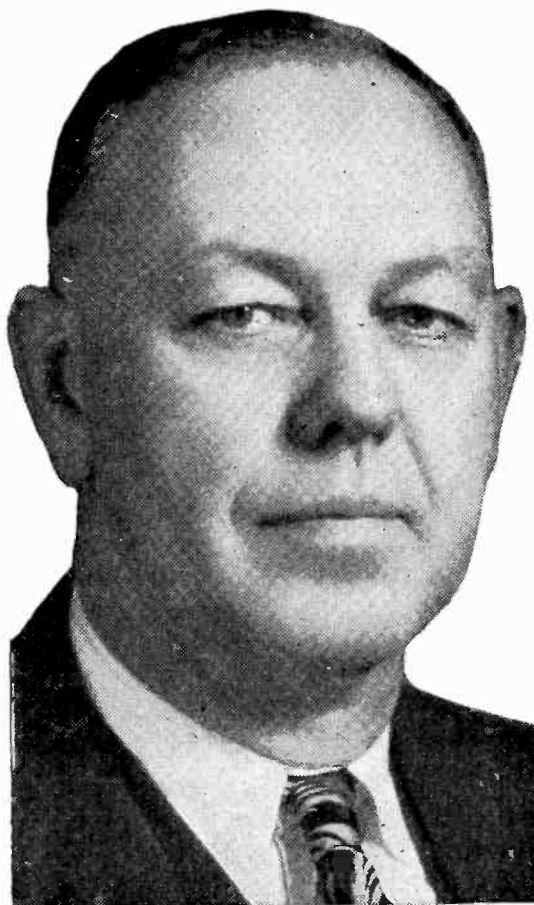

MR. CLEMENTS

from Amherst in 1933 and the Harvard Law School in 1936. Immediately afterward, he joined the Washington law firm of Covington, Burling, Rublee, Acheson & Shorb. In 1938 he entered the Dept. of Justice as an attorney in the condemnation section of the Lands Division, later becoming chief of the section and serving as special assistant to the Attorney General.

As assistant general counsel and general counsel of the FCC, Mr. Denny distinguished himself for his vigorous defense of the Commission while it was being attacked by the House Select Committee which investigated the agency. Since becoming a Commissioner and acting chairman, he has been active in streamlining procedures to expedite processing of applications.

Mr. Denny is married and is the father of three children.

and the original date, it was necessary to make the continuance requests orally.

### Cunningham Is Examiner

The hearing will be held in the Federal Courthouse in Dallas, starting Friday morning. James D. Cunningham of the FCC Washington office will appear as examiner, and John E. McCoy, also of the Washington headquarters, will be Commission counsel.

In addition to Dr. Rainey and the TQN stations, all other qualified candidates in the Texas gubernatorial nomination campaign will get an opportunity to testify.

Under Sections 308(b) and 312(a) of the Communications Act, FCC directed that the stations—WOAI San Antonio, WFAA Dallas, WBAP Fort Worth and KPRC Houston—file with the Commission on the hearing date "with particular reference to the allegations of the petition. . . ."

Dr. Rainey's petition [BROADCASTING, July 1], filed by the Washington law firm of Cohn & Marks, contends that the four stations, which "more effectively cover the State of Texas than any other combination of stations," agreed to sell no broadcast time to candidates before June 11; to make only 30 minutes available to each candidate between June 11 and July 13, and to prorate time "in an indefinite manner among the various candidates in accordance with their written requests to the stations" for the period from July 13 to July 27, primary date.

He charged that three of the four licensees publish newspapers which are opposing his candidacy. (WBAP is associated with *Fort Worth Star Telegram*; WFAA, with *Dallas News*, and KPRC with *Houston Post*.) He said that before this year, the four stations "have afforded ample opportunity to candidates to appear and present their views on the air." In the present arrangement, he charged they have "failed to exercise their individual responsibility by entering into a collusive agreement and have substituted the judgment of the Texas Quality Network, in violation of both the letter and spirit of the Communications Act. . . ."

### W & L for Pabst

WARWICK & LEGLER Inc., New York, is the agency for Pabst Sales Co. (Pabst Blue Ribbon beer), which on Sept. 26 starts sponsoring Eddie Cantor, 10:30-11 p.m. Thursday for 52 weeks on NBC. The July 1 BROADCASTING erroneously reported that Young & Rubicam handles the Pabst account. Young & Rubicam placed the account on Bristol-Myers, which has been sponsoring Mr. Cantor on NBC 9-9:30 p.m. Wednesdays.

## Standards

(Continued from page 20)

for engineering changes in the next NARBA.

Acting Chairman Denny emphasized at the outset that the new plan, if adopted, would not be retroactive. He said it was assumed that some changes in standards will be made in the course of the clear channel hearings, but that any revisions would apply to future assignments only.

In general, it was pointed out, the proposal makes no substantial changes affecting clear channel stations. For regionals, it would lessen the number of future assignments. The clear channel group indicated it had only one substantial objection. That was to the proposed lowering of the standard of what is considered a satisfactory signal in cities other than the one in which a station is located.

For the regionals, counsel brought out through cross-examination that the proposed revision would result in serving fewer people since there would be fewer stations. H. Underwood Graham, FCC engineer who presented the plan, said however that he would not interpret the proposal as having the effect of making it impossible to set up new local or regional stations anywhere in the nation where there is sufficient population to support such stations.

Paul D. P. Spearman, attorney for the regional group, claimed the plan "in order to get rid of a little flea that has bitten us a time or two would burn down the house."

### Report Provisions

Provisions of the highly technical report are proposed for application to the present domestic setup of channel assignments, station classification and power limitations. They would permit assignment of stations in the same area on channels as close as 30 kc (instead of the now-accepted 40-kc separation), but stipulate that in event of resulting interference "the permittee of the new station will be held responsible for making necessary adjustments" and the licensee of the existing station "will be expected to cooperate in every way possible."

The July 15-16 engineering conference will be held in Conference Room B of the Departmental Auditorium Building, Constitution Avenue between 12th and 14th Streets, N. W.

FCC's Public Notice on the conference and Aug. 5 hearing said that "in order to give scope and direction to the conference, Exhibit 264 [the proposed revision] which was introduced in the clear channel hearing will be used as the basis for the discussion. It should be pointed out that Exhibit 264, a copy of which may be obtained from the Commission's Information Division, is the basis for discussion only; it has not been approved by the Commission."

## BIKINI TELEVISION FILM SEEN BEATING NEWSREEL

IT APPEARED late Friday that atom bomb test would provide dramatic example of competitive influence television will have on newsreel operations in future.

Television pool, made up of six operators, busy processing through laboratories late Friday footage on Bikini test. NBC New York laboratories, where film was being handled for pool release, expected film to be ready for telecast same night.

Best estimate on newsreel release was next Thursday.

Telecast of dramatic pictures was scheduled for these pool members: WNBT (NBC); WCBW (CBS); WRGB Schenectady, to be serviced by ABC; WABD (Dumont); WPTZ Philadelphia (Philco); WBKB Chicago (Balaban & Katz).

Claude Collins, who represented newsreels in Washington during the war, viewed thousands of feet of footage at Washington showing to select final telecast footage. LeRoy G. Phelps, pool cameraman, responsible for some of film. First program expected to run about 30 minutes.

## MOVE UNDER WAY TO UNIONIZE CHICAGO PRODUCERS

ATTEMPTS to organize Chicago radio producers under way when Burr Lee, producer of *Bachelor's Children* on CBS, notified Frank Faulknor, assistant to H. Leslie Atlass, vice president, that majority of 15 staff producers signed by Radio & Television Directors Guild. Contract was presented, but terms not released.

Radio & Television Directors Guild understood originated in Chicago, and at present not affiliated with either AFL or CIO. Mr. Lee is president of Chicago local. A Columbia official said he understood Mr. Lee had also presented contract calling for collective bargaining with ABC and NBC offices in Chicago. NBC employs 15 staff producers, ABC 10. Radio Directors Guild, organized in New York and Hollywood, has no contract with Chicago stations and not directly connected with Radio & Television Directors Guild.

## COYLE GETS RASH POST

WILLIAM E. COYLE, of *Washington Evening Star* radio department, named successor to Bryson Rash who moves from WMAL as director of special features and ABC Presidential announcer to radio director of Democratic National Committee [BROADCASTING, July 1]. Before entering Navy early in war Mr. Coyle was radio liaison between NBC and its Blue affiliate, WMAL. He left Navy as lieutenant commander and has been doing special programs for *Star*. He's now on leave at WMAL from *Star* until Mr. Rash returns after conclusion of political campaign in autumn.

## SCHULLINGER TO P & R

KARL SCHULLINGER has resigned as radio director of Foote, Cone & Belding, New York, to become West Coast manager of Pedlar & Ryan Inc., effective July 15. With reestablishment of Hollywood offices, Pedlar & Ryan will handle CBS Hedda Hopper program, sponsored by Procter & Gamble Co., Cincinnati, for Camay soap, beginning in September.

## WATTS TO RCA POST VACATED BY BRUNET

W. W. WATTS, former sales manager, RCA Victor Division, elected vice president in charge of engineering products department, RCA Victor Division, succeeding Meade Brunet, newly appointed managing director of RCA International Division (see page 16).

Previous to his association with RCA, Mr. Watts served during war as commanding officer, Signal Corps distribution agency, and as Signal Corps procurement director. Was previously associated with Montgomery Ward & Co. as mail order sales manager for radio and electronic equipment and prior to that vice president in charge of Wincharger Corp., subsidiary of Zenith Radio Corp.

## RCA FILM PROMOTION

EXTENSIVE movie-phonograph record tie-in campaign to be undertaken by RCA in conjunction with Warner Brothers observance of the 20th anniversary of sound motion pictures. With Warner's release Aug. 6 of *Night and Day*, depicting life of Cole Porter, simultaneously in 32 cities, RCA will have record stories carrying two tie-in albums of Cole Porter tunes. Both albums will feature scenes from the movie and tag-line celebrating 20 years advance of sound motion pictures in which RCA Victor and predecessor, Victor Talking Machine Co., pioneered.

## KSTT MAKES DEBUT

KSTT Davenport, Ia., 750 kc 250 w on air yesterday. New station owned and managed by Hugh R. Norman, since 1940 manager of WNBH New Bedford and WOCB Cape Cod, Mass. Staff includes George Cremeens, formerly KRNT and WHO Des Moines, as program manager; Jacob Evans, graduate of NBC school of promotion, recently released from Army, promotion and commercial manager. Station operating at present without a network affiliation, appointed Advertising Time Sales as representative.

## NBC MEETING ON UN PROJECT

NBC this week to call together 43 of its executives to formulate plans for NBC-United Nations project. Meeting July 10 will discuss mainly machinery necessary to make long-range broadcast plan work. American Assn. for United Nations, National Education Assn., Radio Corp. of America invited to sit.

## LEGION ON 400 STATIONS

NEW transcribed series, *Play Ball*, placed on over 400 stations by radio branch of American Legion's national public relations division. Series of 10 quarter-hour discs publicizes legion's junior baseball activities. It was prepared in cooperation with major leagues as public service feature.

## ZENITH RADIO REPORTS LOSS

ZENITH RADIO Corp., and wholly-owned subsidiaries report net loss \$169,506 for fiscal year ended April 30. Calculation made before renegotiation of war contracts and refund of Federal taxes, said company. Annual meeting of stockholders to be held in Chicago July 23.

JOHN BARNES & ASSOCIATES, Hollywood advertising agency and talent representatives, moved to 6633 Whitley Terrace. Telephone: Hillside 5036.

GEORGE WHITNEY, for two years sales manager of KFI Los Angeles, has taken additional duties of business manager, assisting William B. Ryan, general manager. Mr. Whitney associated with KFI for nine years; prior to that on staff of KFRC San Francisco.

ALFRED R. BECKMAN, formerly sales service manager of ABC, joined Buchanan & Co., New York, as business manager and network time buyer of radio department.

ANGELA D. WALSH, former account executive and head of radio department, Tracy, Kent & Co., New York, joined Robert B. Grady Co., New York, in executive capacity.

DAVID BASCOMB, copy chief, BERNARD SCHNITZER, account executive, appointed associates in Garfield & Guild Adv., San Francisco and Los Angeles. Agency also announced appointment of CHARLES WALDEN, formerly account executive, as general manager with supervision of all firm's operations.

GEORGE W. GRIFFITH Jr., promoted manager General Electric Co., news bureau; Clyde D. Wagoner named director of broadcasting publicity and special events.

STEPHEN E. FITZGERALD, formerly with Earl Newsom & Co., joined New York office of N. W. Ayer & Son, in executive capacity in connection with public relations work for Army.

JEROME SILL, formerly Eastern station relations manager of Mutual and prior to that associated with CBS, joined J. D. Tarcher & Co., New York, as radio director.

RUSSELL WALKER Jr., discharged from Army, returned to WQXR New York sales staff.

TED SELLER, formerly with McCann Erickson, New York, joined William von Zehle & Co., New York as principal and account executive.

## Closed Circuit

(Continued from page 4)

buying or selling mood but station and network ownership certainly will be talked.

IN LINE with recommendation of Rep. Clarence F. Lea (D-Calif.), chairman of House Interstate & Foreign Commerce Committee and author of Lea Act, Attorney General Tor C. Clark expected to replace J. Albert Woll U.S. District attorney in Chicago as Government prosecutor in charges against James Caesar Petrillo, AFM president, of violating Lea Act. Mr. Woll is son of Matthew Woll second vice president of AF of L, with which Petrillo's AFM is affiliated. Best bet: Mr. Clark will assign assistant attorney general to handle Government's case, thereby relieving Mr. Woll of embarrassment.

HAVING disposed of WHOM New York, and Cowles brothers again casting eager eyes toward Minneapolis? They once applied for kw on 580 kc in Twin Cities and have looked longingly at CBS's 50 kw outlet, WCCO. John and Gardner Jr. publish *Star-Journal* and *Tribune* as well as *Times* in flour metropolis.





Caroline Ellis learned influencing of women from ground up as department store sales executive.

## *An Ideal Lady Next Door . . .*

You can't always pick your neighbors,  
but you can pick your radio programs.

—and thousands do in the Heart of America when it's time for Caroline Ellis and her neighborly quarter-hour, talking about typical *woman stuff* and "The Happy Home".

She's as friendly as she looks and sounds—the kind of people you'd like to have living right next door.

Remember her for "Caroline's Golden Store," on both the Columbia and NBC networks. She's famed for revolutionizing retail department store merchandising by radio with her original idea of *living dialogue*.

Now you can co-sponsor this network personality with a ready-made audience, as loyal as you'll find in radio, weekday mornings at 8:30!

# KMBC

OF KANSAS CITY



Free & Peters, Inc.

SINCE 1928 — BASIC CBS STATION FOR MISSOURI AND KANSAS



# WKY

OKLAHOMA CITY

*has everything*

FREQUENCY  
FACILITIES  
COVERAGE  
LISTENERS  
PROGRAMS  
KNOW-HOW  
POWER

930 KILOCYCLES — NBC AFFILIATE — OWNED AND OPERATED BY THE OKLAHOMA PUBLISHING COMPANY: THE DAILY OKLAHOMAN — OKLAHOMA CITY TIM  
THE FARMER-STOCKMAN — KYOR, COLORADO SPRINGS — KLZ, DENVER (Affiliated Management) — REPRESENTED NATIONALLY BY THE KATZ AGENCY, IN