

CASHBOX

January 21, 1978

NEWSPAPER

\$1.75

PERIODICALS
JAN 13 1978
PUBLIC LIBRARY OF
EAST WADE & ALLEN COUNTYS

ART AND RECORDINGS DEPARTMENT



High Energy

FIVE TIMES IN A ROW, "HEADS" COMES OUT ON TOP.

Here's proof that the record business is more than just a game of chance.

It's an album called "Heads" by Bob James. And for five weeks, "Heads" has been the number one jazz record on the Cash Box chart.

Getting the album up there took the collaborative efforts of the Columbia/Tappan Zee team. Keeping it up there took the combined excitement of the world's finest musicians, reaching the world's

fastest-growing market.

Now that the title cut has been released as a single, we expect "Heads" to be on people's minds for many weeks to come.

"Heads," by Bob James. Featuring the new single, "Heads." On Columbia/³⁻¹⁰⁶⁶⁸Tappan Zee Records and Tapes.

BOB JAMES HEADS



JC 34896

CASHBOX

THE INTERNATIONAL MUSIC RECORD WEEKLY

GEORGE ALBERT
President and Publisher

MEL ALBERT
General Manager

DAVE FULTON
Editor in Chief

J. B. CARMICLE
General Manager, East Coast

East Coast Editorial
KEN TERRY, East Coast Editor
PHIL DIMAURO
CHARLES PAIKERT
MARK MEHLER

West Coast Editorial
ALAN SUTTON
RANDY LEWIS
JEFF CROSSAN
CARITA SPENCER
PETER HARTZ
JOEY BERLIN
RAY TERRACE

CHUCK COMSTOCK
Account Director, West Coast

Research
MARK ALDERMAN
KEN KIRKWOOD
SCOTT ANDERSON
BILL FEASTER
LEN CHODOSH
STEVE HULEN
HARALD TAUBENREUTHER

Coin Machine
Chicago
CAMILLE COMPASIO, Manager

Art Director
LINDSAY BOLYARD

Circulation
THERESA TORTOSA
Manager

PUBLICATION OFFICES

NEW YORK
119 West 57th St., N.Y., N.Y. 10019
Phone: (212) 586-2640
Cable Address: Cash Box N.Y.

CALIFORNIA
6363 Sunset Blvd. (Suite 930)
Hollywood, Ca. 90028
Phone: (213) 464-8241

NASHVILLE
JIM SHARP
TIM WILLIAMS
BOB CAMPBELL
MELISSA ELLIOTT
21 Music Circle East, Nashville, Tenn. 37203
Phone: (615) 244-2898

CHICAGO
CAMILLE COMPASIO
29 E. Madison St., Chicago, Ill. 60602
Phone: (312) 346-7272

WASHINGTON, D.C.
JOANNE OSTROW
4201 Massachusetts Ave., NW
Washington, D.C. 20016

ENGLAND — ROB THORNE
97 Uxbridge Rd., London W.12
Phone: 01-749-6724

ARGENTINA — MIGUEL SMIRNOFF
Belgrano 3252, Piso 4 "B"
Buenos Aires, Argentina
Phone: 89-6796

BRAZIL — H. GANDELMAN
Av. Rio Branco, 156 Sala 627
Rio de Janeiro RJ

CANADA — KIRK LaPOINTE
56 Brown's Line
Toronto, Ontario, Canada M8W 359
Phone: (416) 251-1283

HOLLAND — PAUL ACKET
P.O. Box 11621 (Prinsessegracht 3),
The Hague
Phone: (70) 624621, Telex: 33083

ITALY — GABRIELE G. ABBATE
Viale A. Doria 10, 20124 Milano

BELGIUM — ETIENNE SMET
Postbus 56, B-2700 Sint-Niklaas
Phone: (03) 76-54-39

AUSTRALIA — PETER SMITH
6 Murrillo Crt., Doncaster
Victoria, Australia 3108
Phone: 848-7878

JAPAN — Adv. Mgr., SACHIO SAITO
1-11-2-Chome Shinbashi, Minato-Ku, Tokyo
Phone: 504-1651
Editorial Mgr., FUMIYO TACHIBANA
1-11-2-Chome Shinbashi, Minato-Ku, Tokyo
Phone: 504-1651

FRANCE — CLAUDE EM MONNET
262 bis Rue des Pyrenees
Paris, France 75020
Phone: 797-4261

EDITORIAL

MIDEM '78 — International Communication

With numerous music industry representatives from all over the world heading to Cannes, France for MIDEM, it is interesting to note the anticipation generated by the international gathering. New and established companies utilize this international meeting ground to set up new deals and change old ones, but the underlying significance of the gathering is communication on a worldwide scale.

The ties between American performers overseas and international talent in the U.S. are closing rapidly. The major domestic labels with overseas branches are investing in acts that have established massive followings internationally with hopes of breaking them in the U.S. while domestic performers are recognizing the importance of the international marketplace more than ever.

The worldwide successes of Frampton, Eagles, Abba and others graphically show that music is truly the international language. And those performers from foreign countries, unknown to most audiences in the U.S., are selling records in fantastic proportions overseas with unlimited potential here.

While the U.S. accounts for approximately half of the world's record sales we are only the major portion of a large pie. The rest of the world, with its varying cultures and tastes, has, for the most part, looked to this country for musical leadership, but it is also important for us to look at some of the innovative ideas coming from around the world.

MIDEM gives us that opportunity and brings the music world a little closer together.

NEWS HIGHLIGHTS

- Industry representatives from around the world meet at 12th annual MIDEM.
- Linda Ronstadt, Eagles top list of Grammy nominees.
- Supreme Court agrees to review WBAI case.
- WCI Group announces record revenues for 1977.
- Jerry Rubenstein, Charlie Minor form XETI Music.
- Cover art reproduction complicated by variety of factors.
- Salute to CAM.

POP SINGLE	<h1>NUMBER ONES</h1>	POP ALBUM
BABY COME BACK Player — RSO		SATURDAY NIGHT FEVER Bee Gees & Various Artists — RSO
R&B SINGLE		R&B ALBUM
FFUN Con Funk Shun — Mercury		ALL IN ALL Earth, Wind & Fire — Columbia
COUNTRY SINGLE	Player	COUNTRY ALBUM
MY WAY Elvis Presley - RCA		SIMPLE DREAMS Linda Ronstadt - Asylum
JAZZ		GOSPEL
REACH FOR IT George Duke — Epic		LOVE ALIVE Walter Hawkins & The Center Choir — Light

SUBSCRIPTION RATES \$70 per year anywhere in the U.S.A. Published weekly by CASH BOX, 119 West 57th St., New York, N.Y. 10019. Printed in the U.S.A. Second class postage paid at New York, N.Y., and additional mailing offices.
Copyright © 1978 by the Cash Box Publishing Co., Inc. All rights reserved. Copyright under Universal Copyright Convention.
POSTMASTER: Send form 3579 to CASH BOX, 119 West 57th St., New York, N.Y. 10019.

CASH BOX TOP 100 SINGLES

January 21, 1978

			Weeks On Chart						Weeks On Chart						
	1/14	1/7		1/14	1/7		1/14	1/7		1/14	1/7		1/14	1/7	
1 BABY COME BACK PLAYER (RSO 879) CPP	1	2	17												
2 SHORT PEOPLE RANDY NEWMAN (Warner Bros. WBS 8492) ALM	4	8	11												
3 WE ARE THE CHAMPIONS QUEEN (Elektra E-4544) CPP	5	10	14												
4 YOU'RE IN MY HEART ROD STEWART (Warner Bros. WBS 8475) WB	3	4	14												
5 HOW DEEP IS YOUR LOVE BEE GEES (RSO 882) WB	2	1	17												
6 SLIP SLIDIN' AWAY PAUL SIMON (Columbia 3-10630) BB	6	7	15												
7 HERE YOU COME AGAIN DOLLY PARTON (RCA PB 11123) CPP	8	9	16												
8 JUST THE WAY YOU ARE BILLY JOEL (Columbia 3-10646) AB/B	10	14	11												
9 COME SAIL AWAY STYX (A&M 1977) ALM	9	11	19												
10 DESIREE NEIL DIAMOND (Columbia 3-10657) WB	13	19	9												
11 TURN TO STONE ELECTRIC LIGHT ORCHESTRA (Jet Records JT-XW 1099) B-3	15	20	10												
12 DANCE, DANCE, DANCE CHIC (Atlantic 3435) WB	16	29	13												
13 SOMETIMES WHEN WE TOUCH DAN HILL (20th Century 2355) WB	20	28	8												
14 STAYIN' ALIVE BEE GEES (RSO 885) WB	26	31	7												
15 YOU LIGHT UP MY LIFE DEBBY BOONE (Warner/Curb 8455) CPP	11	5	22												
16 (EVERY TIME I TURN AROUND) BACK IN LOVE AGAIN L.T.D. (A&M 1974) ALM	7	6	19												
17 YOU CAN'T TURN ME OFF (IN THE MIDDLE OF TURNING ME ON) HIGH INERGY (Gordy/Motown G-7155) CPP	12	13	18												
18 (LOVE IS) THICKER THAN WATER ANDY GIBB (RSO RS 883) WB	22	24	12												
19 EMOTION SAMANTHA SANG (Private Stock 45-178) WB	23	25	11												
20 RUNAROUND SUE LEIF GARRETT (Atlantic 3440) ALM	18	22	12												
21 DON'T LET ME BE MISUNDERSTOOD SANTA ESPERANZA/LEROY GOMEZ (Casablanca NB902) B-3	24	26	12												
22 SERPENTINE FIRE EARTH, WIND & FIRE (Columbia 3-10625) CPP	25	27	11												
23 BLUE BAYOU LINDA RONSTADT (Elektra E-45431) AR	14	3	25												
24 POINT OF KNOW RETURN KANSAS (Kirsner ZS8-4273) WB	17	18	12												
25 NATIVE NEW YORKER ODYSSEY (RCA PB 11129) CH	28	32	12												
26 WHAT'S YOUR NAME LYNYRD SKYNYRD (MCA 40819) BEL/MCA	30	35	13												
27 HEY DEANIE SHAUN CASSIDY (Warner/Curb 8488) WB	21	23	11												
28 THE WAY I FEEL TONIGHT BAY CITY ROLLERS (Arista ASO272) CPP	19	21	16												
29 PEG STEELY DAN (ABC 12320) CPP	33	37	8												
30 LOVELY DAY BILL WITHERS (Columbia 3-10627) CH	34	38	13												
31 IT'S SO EASY LINDA RONSTADT (Elektra 45438) B-3	29	15	16												
32 FFUN CON FUNK SHUN (Mercury 73959) CPP	37	47	7												
33 SENTIMENTAL LADY BOB WELCH (Capitol P-4479) WB	27	12	16												
34 I GO CRAZY PAUL DAVIS (Bang B-733) WB	41	43	20												
35 I LOVE YOU DONNA SUMMER (Casablanca NB907) ALM	40	45	7												
36 LONG LONG WAY FROM HOME FOREIGNER (Atlantic 3429) WB	42	48	7												
37 DON'T IT MAKE MY BROWN EYES BLUE CRYSTAL GAYLE (Unitec Artists UA XW 1016) B-3	31	16	23												
38 HOW CAN I LEAVE YOU AGAIN JOHN DENVER (RCA JH-11036) CL	39	41	10												
39 (THEME FROM) CLOSE ENCOUNTERS JOHN WILLIAMS (Arista 0300) CPP	49	60	5												
40 STREET CORNER SERENADE WET WILLIE (Epic 50478) CPP	45	49	8												
41 GETTIN' READY FOR LOVE DIANA FOSS (Motown 1427) CPP	32	33	13												
42 THUNDER ISLAND JAY FERGUSON (Asylum 45444) WB	52	61	6												
43 BREAKDOWN TOM PETTY & THE HEARTBREAKERS (Shelter/ABC 62008) CPP	51	58	8												
44 MIND BENDER STILLWATER (Capricorn CPS 0280) CPP	46	52	12												
45 CURIOUS MIND (UM, UM, UM, UM, UM, UM) JOHNNY RIVERS (Big Tree 16106) WB	54	62	6												
46 SOUL & INSPIRATION DONNY & MARIE (Polydor 14439) CPP	48	50	10												
47 (THEME FROM) CLOSE ENCOUNTERS MECO (Millennium MM603) CPP	55	64	5												
48 FALLING LeBLANC & CARR (Big Tree 16103) CPP	56	59	14												
49 HEAVEN'S JUST A SIN AWAY THE KENDALLS (Ovation OV1103) B-3	47	51	15												
50 OOH BOY ROSE ROYCE (Whitfield/WB 8491) WB	59	69	8												
51 THE NAME OF THE GAME ABBA (Atlantic 3449) B-3	62	75	5												
52 ISN'T IT TIME THE BABYS (Chrysalis CHS-2173) CPP	38	39	16												
53 JACK AND JILL RAYDIO (Arista 0283) CPP	63	73	5												
54 YOU MAKE LOVIN' FUN FLEETWOOD MAC (Warner Bros. WBS 8430) WB	35	17	15												
55 WE'RE ALL ALONE RITA COOLIDGE (A&M 1965) WB	36	30	20												
56 TOO HOT TA TROT COMMODORES (Motown 1432) CPP	65	74	6												
57 GIRL'S SCHOOL/MULL OF KINTYRE WINGS (Capitol SPRO-8747) B-3	43	34	10												
58 HEAVEN ON THE SEVENTH FLOOR PAUL NICHOLAS (RSO E78) CH	50	40	18												
59 THE NEXT HUNDRED YEARS AL MARTINO (Capitol 4508) CPP	64	72	8												
60 EASY TO LOVE LEO SAYER (Warner Bros. 8502) ALM	66	66	7												
61 LAY DOWN SALLY ERIC CLAPTON (RSO 886) CH	72	79	4												
62 TAKE ME TO THE KAPTAIN PRISM (Arista 7678)	70	77	5												
63 HAPPY ANNIVERSARY LITTLE RIVER BAND (Capitol 4524) WB	73	80	6												
64 ALWAYS AND FOREVER HEATWAVE (Epic 8-50460) ALM	71	78	5												
65 REACH FOR IT GEORGE DUKE (Epic 8-50463) ALM	67	67	8												
66 GOOD-BYE GIRL DAVID GATES (Elektra 45450) WB	76	81	7												
67 MY WAY ELVIS PRESLEY (RCA PB11165) MCA/BEL	58	56	11												
68 SWEET MUSIC MAN KENNY ROGERS (United Artists UA8848) CL	74	76	6												
69 TRIED TO LOVE PETER FRAMPTON (A&M 1988) ALM	60	57	8												
70 SWINGTOWN STEVE MILLER (Capitol P4496) WB	53	42	15												
71 COCOMOTION EL COCO (AVI-147-S) ALM	81	91	5												
72 IF YOU'RE NOT BACK IN LOVE BY MONDAY MILLIE JACKSON (Spring/Polylor 175) B-3	44	36	9												
73 THE WAY YOU DO THE THINGS YOU DO RITA COOLIDGE (A&M 2004) CPP	—	—	1												
74 UNTIL NOW BOBBY ARVON (First Artists 41000) CPP	84	89	7												
75 NEVER MY LOVE ADDRISI BROS. (Bl. ddah 567) WB	69	71	8												
76 CALLING OCCUPANTS OF INTERPLANETARY CRAFT CARPENTERS (A&M 1978) WB	57	46	14												
77 THE LONELIEST MAN ON THE MOON DAVID CASTLE (Parachute RR505) B-3	80	85	3												
78 GALAXY WAR (MCA 40820) BEL/MCA	89	100	4												
79 CRAZY ON YOU HEART (Mushroom 7021) CPP	88	97	4												
80 WONDERFUL WORLD ART GARFUNKEL WITH JAMES TAYLOR & PAUL SIMON (Columbia 3-10676) CPP	—	—	1												
81 BELLE AL GREEN (Hi H77505) ALM	83	86	5												
82 IF IT DON'T FIT, DON'T FORCE IT KELLEE PATTERSON (Shadybrook 1041) CPP	87	90	6												
83 YOU MAKE ME CRAZY SAMMY HAGAR (Capitol 11706)	86	87	8												
84 SOMEBODY'S GOTTA WIN, SOMEBODY'S GOTTA LOSE CONTROLLERS (Juana 3414) CPP	85	88	5												
85 OUR LOVE NATALIE COLE (Capitol 4059) CH	99	—	2												
86 AS STEVIE WONDER (Tamla 54291) CPP	90	—	2												
87 LADY LOVE LOU RAWLS (Phila. Int./CBS 3634)	—	—	1												
88 LET IT GO, LET IT FLOW DAVE MASON (Columbia 3-10662) AB/B	98	—	2												
89 EVERYBODY LOVES A RAIN SONG B.J. THOMAS (MCA 40854) CPP	—	—	1												
90 SO LONG FIREBALL (Atlantic 3452) WB	—	—	1												
91 GOD ONLY KNOWS MARILYN SCOTT (Big Tree 16105) ALM	91	95	5												
92 AIN'T GONNA HURT NOBODY BRICK (Bang 735) WB	94	98	4												
93 SECOND AVENUE TIM MOORE (Asylum 45427) CH	93	96	7												
94 COME GO WITH ME POCKETS (Columbia 10632) ALM	95	99	4												
95 BOATS AGAINST THE CURRENT ERIC CARMEN (Arista 0295) WB	96	—	2												

Love me baby



SINGIN' IN THE RAIN

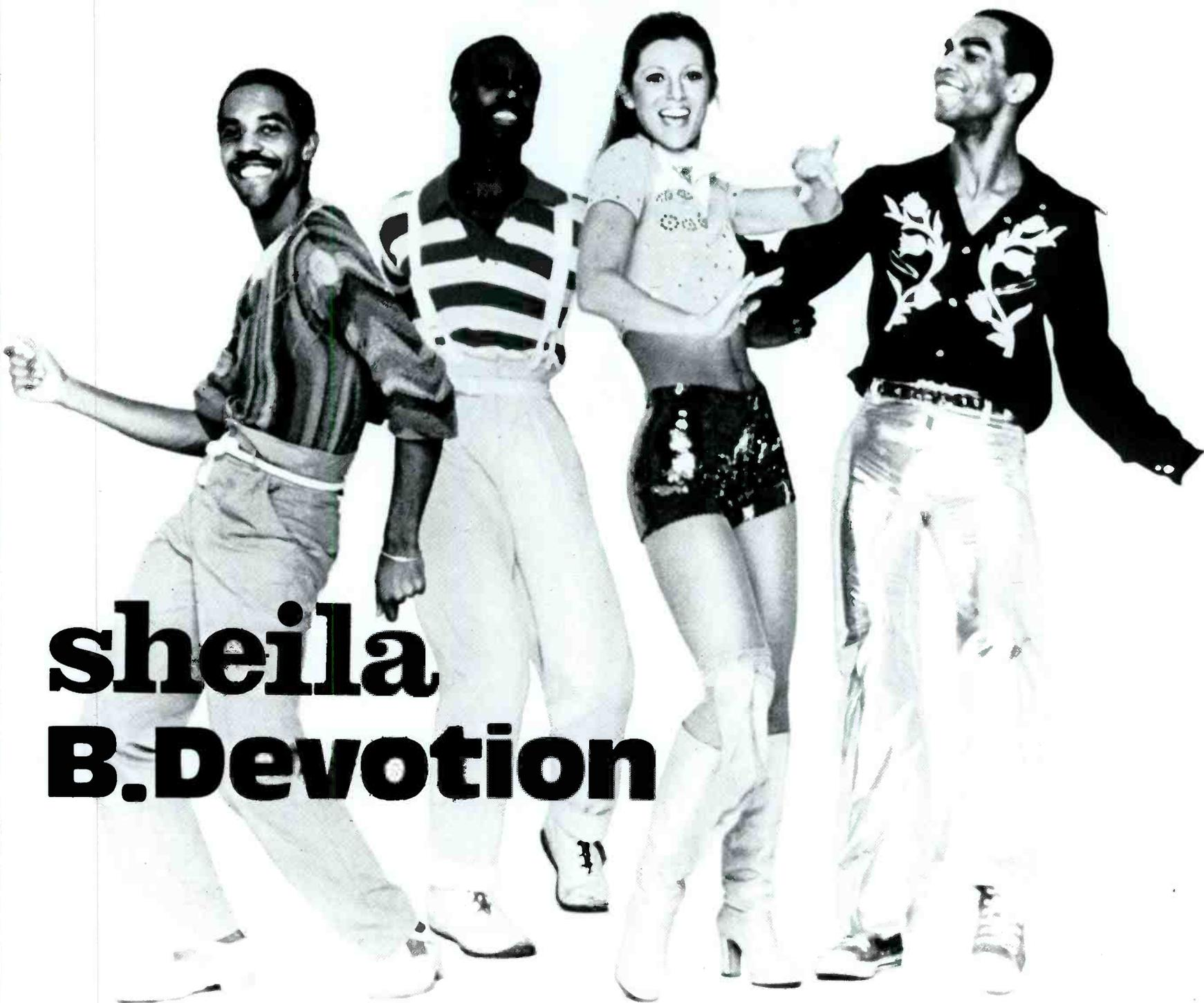

**sheila
B.Devotion**

INTERNATIONAL HITS

CARRERE

FROM
THE
BABYS

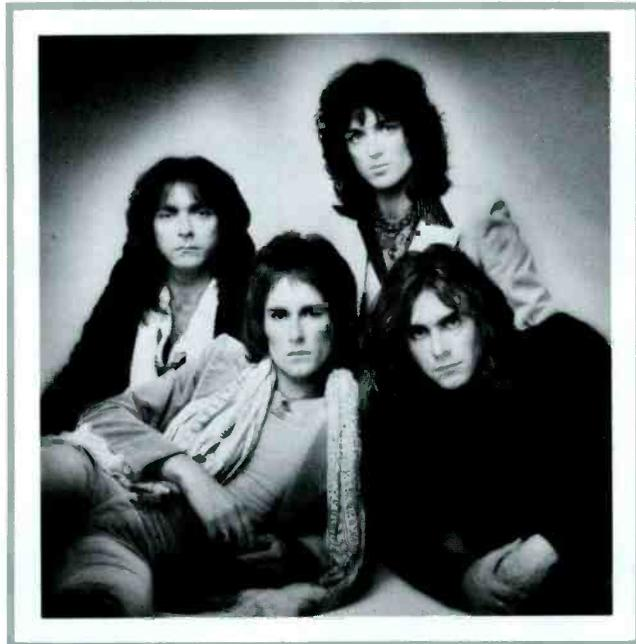

**SILVER
DREAMS**

WILL
MAKE
ALL
YOUR
DREAMS
COME
TRUE

"Silver Dreams." The new single from their second album, "Broken Heart." Produced by Ron Nevison



Chrysalis
records and tapes
CHS 2201 • CHR 1150

CASH BOX NEWS

1978 MIDEM Meet To Be The Largest In 12 Year History

CANNES, FRANCE — The 1978 MIDEM to be held at the Palais des Festivals Monday Jan. 20-Thursday, Jan. 26 is slated to be the largest gathering in the 12 year history of the annual international record and music publishing market. Representatives from over 1000 firms are expected with 5000 persons anticipated. The American contingent will be the single largest group with over 700 persons in attendance. Although the majority of the week is not scheduled for specific events and deliberately left open for spontaneous exchanges between the participants, the list of published events is as follows: Jan. 20 — an opening cocktail party with a disco theme; Jan. 21 — a gala of Italian artists coordinated by David Zard, an Italian promoter; an international lawyers meeting; Jan. 22 — concerts by Blood, Sweat & Tears and Lionel Hampton and his band; Jan. 23 — a gala of Japanese artists sponsored by Watanabe; screening of an Abba film; and the Hits of 1977 by Broadcast Radio Station Europe Number One; Jan. 24 — a Russian gala; a Variety Club special dinner; and a screening of "Saturday Night Fever"; Jan. 25 — a German gala featuring pop/rock; and a performance by George Benson.

Rubinstein, Minor Establish XETI



Jerold H. Rubinstein and Charlie Minor.

LOS ANGELES — Former ABC Records president Jerry Rubinstein and Charlie Minor, former vice president of promotion at ABC, have formed a new record label, XETI. Rubinstein is chairman of the new firm while Minor is serving as president.

A distribution pact has not been finalized, but Rubinstein said that arrangements would be set after he attends MIDEM in France.

Although no artists have been officially signed, Rubinstein explained that he plans to release "no more than eight albums" in the first year from eight different artists. He added that the tentative roster would include two established and six new artists, and expects four signings within the next 30 days.

Financing for XETI, which is ancient Egyptian for "scribe," is from foreign deals, a major label distribution agreement and from the two executives according to Rubinstein.

The company will utilize a regional promotion concept, noted Minor, with the basic six or seven regions of the nation being covered. Minor also said that the staff will be "total record men" with responsibilities in sales, marketing and merchandising as well as promotion.

"Being a part of a large and established record company previously, it's exciting to start fresh with no problems from the past. Also, it will be nice to have a small number of artists whom we can give individual time and attention which large companies have a hard time doing," said Rubinstein.

XETI has offices in Beverly Hills at 450 S. Beverly Dr.

Big 4th Quarter Helps WCI Group Increase Revenues More Than 30 Percent In 1977

LOS ANGELES — WCI Record Group revenues rose more than 30% in 1977, with domestic record and tape sales up approximately 30% and international revenues ahead a previously-announced 42%, according to their parent company, Warner Communications Inc. The WCI Record Group includes Warner Bros. Records, Elektra/Asylum Records, Atlantic Records, WEA Corp. — the distribution arm for the domestic labels — and WEA International. As a result of these gains, the group will show worldwide record and tape revenues for 1977 in excess of \$500,000,000.

Outstanding fourth quarter results aided in achieving the annual gains. For the final three months of the year, domestic label sales increased by approximately 40%, with WEA International showing a similar fourth quarter rate of gain.

Percentage Increase

The groups' percentage increase in 1977, as well as that of the domestic labels and WEA International, exceeded even the substantial rates of gain achieved in 1976. In putting these two successful years back-to-back, the WCI Record Group has increased its revenues by nearly 70% since 1975. This includes a two-year domestic sales gain of approximately 60% and a near-doubling of WEA International's volume.

"The numbers speak for themselves," commented David H. Horowitz, office of the president at WCI. "Although the entire industry clearly grew rapidly in 1977, WCI continued to outpace the industry, both here and abroad. All three of our domestic labels and every WEA company overseas achieved new highs in 1977, and they are all deserving of special thanks and recognition. Although it is customary and convenient to speak in terms of numbers, it is the qualitative aspect of the record group's performance that should be particularly noted. The combined artist roster of the group represents perhaps the finest assemblage of talent in the history of our industry. The music they produced in 1977, and will produce for many years to come, underlies the growing public demand for records and tapes. These artists, and the men and women at our record companies involved in every aspect of the creation and

RIAA Awards Reach New High During 1977

LOS ANGELES — The number of gold and platinum record awards certified by the Recording Industry Association of America reached all-time highs in 1977, the RIAA has announced.

The 293 gold record awards — signifying sales of one million units for a single and 500,000 for an album — bestowed in 1977 went to 55 singles and 238 LPs and/or their counterparts on pre-recorded tapes. This was an increase of better than 43% over the 204 certifications granted in 1976.

Platinum certifications — signifying sales of two million copies for a single and one million for an album — rose almost 75% to a total of 71, given to three singles and 68 album/tapes, compared with 1976 certifications to four singles and 37 LPs. Only recordings issued on or after January 1, 1976 are eligible for platinum awards.

The three singles that achieved platinum status last year were Rose Royce's "Car Wash," Debby Boone's "You Light Up My Life" and Heatwave's "Boogie Nights."

All certifications involve an audit of the record company's books by an independent firm of certified public accountants to determine that the sales criteria have been achieved. Any company in the industry may apply for certification whether or not it is a member of RIAA.

distribution of their music, are the real basis of our optimism for the future."

The record-breaking performance of WCI's three domestic labels is reflected in their total of 71 RIAA gold and platinum awards during 1977. Collectively, Warner, Elektra/Asylum, Atlantic and their distributed labels earned 54 gold awards, 40 for albums and 14 for singles. The 17 platinum certifications include 16 for albums, and 1 platinum single, Debby Boone's "You Light Up My Life," which has sold more than 3 million copies to date. The breadth of WCI's artist roster and the effectiveness of its distribution organization is indicated by this unprecedented total of RIAA certifications, the highest for any company in the industry.

Any examination of the achievements of individual WCI artists must begin with the industry's two largest selling LPs in 1977. Fleetwood Mac, whose "Rumours" album remained at the top of the **Cash Box** Top 100 Albums chart for a record 30 weeks of 1977, has sold to date over 8 million copies domestically, with an additional 2 million sold overseas, and has been included in virtually every critic's listing of the 10 best albums of the year. The Eagles also had phenomenal success during the year, as their "Hotel California" album — released in late 1976 — achieved total album sales of nearly 6 million copies in the U.S. and more than 2 million overseas. Their "Greatest Hits" collection, issued early in 1976, sold well throughout 1977, and is still in the "Top 100" 99 weeks after release.

Debut Platinum LPs

Another remarkable achievement by WCI's Record Group during 1977 was the release of four debut albums that earned platinum awards. Foreigner, which was named by nearly every major critic as the top new group of the year, is already double platinum, with sales continuing at high levels. Shaun Cassidy had LP/tape sales of more than two million units with his first release ever, and has followed up this initial achievement with a second album, "Born Late," that is already approaching the double platinum level in just two months. Debby Boone, in addition to the platinum single of the same title, went well over the million mark with the album "You Light Up My Life." Rose Royce, whose album "In Full Bloom" was their Warner Bros. debut, also went platinum.

A number of established WCI artists reached new levels of recognition in 1977. Linda Ronstadt had two platinum albums, and her latest release, "Simple Dreams," is well over the two million mark. Rod Stewart's popularity continued to increase, as "Foot Loose And Fancy Free" quickly

climbed toward the top of the charts, with sales well in excess of a million copies and rising. Crosby, Stills & Nash's double platinum "CSN" album expanded still further the enduring audience for their music. Jackson Browne, whose album "Pretender" went platinum in early 1977, has a new release, "Running On Empty," which has already achieved platinum status. The most recent Queen album, "News Of The World," exceeded the one million mark in just two months and is currently among the Top Ten charted albums. George Benson's "In Flight" became his second platinum LP for Warner Bros. Foghat earned its second and Leo Sayer earned his first platinum record in

(continued on page 14)

'Fever,' 'Player' Give RSO Fast Start In 1978

by Joey Berlin

LOS ANGELES — If the first few weeks are any indication, 1978 should be a banner year for RSO Records. Their "Saturday Night Fever" soundtrack album has exploded across the country, jumping the LP to the top of the **Cash Box** Top 100 Albums chart eight weeks after release. RSO has held the top spot on the singles chart all year so far, with Player's "Baby Come Back" succeeding the Bee Gee's "How Deep Is Your Love" last week.

(continued on page 67)

Carver Appointed President Of GRT

LOS ANGELES — Vinton D. Carver has been named president and chief operating officer of GRT Corporation by the board of directors. Carver replaces company founder, Alan J. Bayley, who will remain a member of the board.

Carver has been a director of the company, which manufactures and markets stereo tapes and records in the U.S. and Canada, since 1968 and chairman of the board since 1974. He will continue as chairman.

Previously Carver had worked for Litton Industries for 11 years and had served as president of the Atherton Division in Palo Alto, California. He also was with International Telephone and Telegraph Corporation for five years and was senior vice president of IT&T's general controls subsidiary in Glendale, California. He had also served as president of the Hi-Shear Corporation in Torrance, California.



JAILBREAK GETS GOLD — Mercury recording group Thin Lizzy recently received a gold record for U.S. sales for their album, "Jailbreak." Pictured in Birmingham, England after a concert are (l-r): Scott Gorham, Brian Robertson and Phil Lynott of Thin Lizzy; award presenter Mike Gormley, public relations consultant for the Polygram Record Group; and Thin Lizzy's Brian Downey.



SMILING TEMPTATIONS — After a recent show at L.A.'s Roxy, Atlantic recording group The Temptations were joined by some friends. Shown backstage (back row, l-r) are: Otis Williams and Louis Price of the Temps; Steve Rowland, local Atlantic promotion rep; actor Richard Roundtree; Lamont McLemore of the Fifth Dimension; Melvin Franklin and Richard Street of the Temps; and Sidney A. Seidenberg, the Tempts' manager. In front row (l-r) are: Primus Robinson, national R&B promotion director for Atlantic; Bob Greenberg, vice president and west coast general manager of Atlantic; actor Cleavon Little; and Glen Leonard of the Temps.

Ronstadt, Eagles Top List In Grammy Award Nominations

LOS ANGELES — The Eagles, with six Grammy Awards nominations, and Linda Ronstadt, with five, head the list of nominees for the 20th Annual Grammy Awards, which were recently released by the National Academy of Recording Arts and Sciences. The Academy's 5000-plus members, all creatively involved in the recording industry, will ballot again later this month to decide this year's winners.

The Eagles' "Hotel California" and Ronstadt's "Blue Bayou" both have been nominated for Record of the Year, along with Debby Boone's "You Light Up My Life," and Barbra Streisand's "Evergreen," both of which were also chosen as possible winners in the Best Pop Female Vocal Performance category. The final Record of the Year choice, Crystal Gayle's "Don't It Make My Brown Eyes Blue," is also in the final running for Best Country Female Vocal Performance.

Nominated for Album of the Year, along with the Eagles' "Hotel California," are Fleetwood Mac's "Rumours," John Williams' soundtrack to "Star Wars," Steely Dan's "Aja" and James Taylor's "JT."

Debby Boone, who received a total of three nominations, was voted one of five finalists in the Best New Artist category, along with Stephen Bishop, Shaun Cassidy, Andy Gibb and rock group Foreigner. The song that brought Boone to attention, "You Light Up My Life," was nominated for Song of the Year, a category which includes "Don't It Make My Brown Eyes Blue," "Hotel California," "Love Theme From A Star Is Born (Evergreen)," "Nobody Does It Better" and "Southern Nights."

Among classical artists, recordings by Sir George Solti have received five nominations, while the Houston Grand Opera recording of "Porgy & Bess," and Guilini/Chicago Symphony's version of Mahler's Ninth Symphony each received three nominations. Solti was chosen for Verdi's "Requiem," Wagner's "Flying Dutchman" and Ravel's "Bolero." The Solti "Bolero" was nominated for Best Classical Album of the Year, along with "Porgy & Bess," Mahler's Ninth Symphony, "The Concert Of The Century," Haydn's "Orlando Palladino" (conducted by Antal Dorati), and "Parkening And The Guitar."

Dolly Parton was nominated for two different recordings in the pop and country fields. In the Best Pop Vocal Performance category for females, she was nominated along with Linda Ronstadt, Barbra Streisand, Carly Simon and Debby Boone. In the Best Country Vocal Performance Category for female vocalists, other nominees were Barbara Mandrell, Crystal Gayle, Emmylou Harris and Janie Fricke.

Best Male Pop Vocal Performance nominees are Stephen Bishop, Andy Gibb, Engelbert Humperdinck, Leo Sayer and James Taylor, while in the country field, Larry Gatlin, Waylon Jennings, Ronnie

Milsap, Kenny Rogers and Jerry Jeff Walker were nominated for the award.

Previous winners Aretha Franklin and Natalie Cole are joined by Thelma Houston, Diana Ross and Dorothy Moore in the Best R&B Vocal Performance category for females, while B. B. King, Lou Rawls, Marvin Gaye, Joe Tex and Johnny "Guitar" Watson have been nominated for Best R&B Vocal Performance by a male performer.

Phil Woods and the late John Coltrane have each been nominated for two jazz awards.

Recordings associated with motion pic-

(continued on page 38)

Finding And Developing Acts Nempereor's Main Concern

by Jeff Crossan

(This is the third article in a series examining the relationship that custom labels share with their distributors.)

LOS ANGELES — "Our job is to find talent and develop talent and the job of CBS is to sell it."

That's how Nempereor Records' president Nat Weiss succinctly sums up the relation that his label shares with CBS, the company that has handled distribution for Nempereor since Sept. 1977, when the three-and-a-half-year-old label severed distribution ties with Atlantic Records.

A division of Nempereor Artists Management Company, which was established in 1966 by Brian Epstein and Weiss, Nempereor Records was formed in 1975 and is currently run by three men — Weiss, who oversees all operations as well as taking a hand in artist development; Ed Strait, who also aids in artist development, and Paul Happerett, who handles A&R responsibilities.

As Weiss pointed out, the responsibilities of the Nempereor staff are currently related only to the acquisition and development of talent. In these areas, Nempereor is

Reproduction Of Cover Art Complicated By Many Factors

by Joey Berlin

LOS ANGELES — Album covers, long merely containers for LPs, have become promotional tools and art objects subject to serious disagreement over copyright control. Although record jackets were not even copyrighted until the late 1960s, a whole mini-industry has grown up around them in the past decade. While the record company usually holds the copyright, visual artists who create the covers may have some rights in reproduction and record artists often have rights to the use of their name or likeness on a cover.

Three books about cover art have recently been published, Dennis Saleh's "Rock Art," Roger Dean's "Album Cover Album" and "Phonographics" by Gelatt Roland. Originals of cover designs are becoming valuable works of art — Phil Garris' "Blues For Allah" painting used for the Grateful Dead LP cover reportedly has a \$30,000 price tag. But the most important trend in cover art is their extensive reuse in advertising and spin-off products such as T-shirts, posters and belt buckles.

Who controls the copyright on an album cover is relatively simple. "If the cover was done by someone who works for the record company, then the company would take the copyright in its name," explains a senior record company attorney. "If the artwork is a reproduction of a copyrighted work, the copyright stays with the artist. And if we hire an independent contractor to do the

original artwork, then it becomes a matter of negotiation."

The problem is in secondary uses of cover art, both in promotion and spin-off products. Although the record companies benefit from the publicity generated by these secondary uses, the design artists

(continued on page 67)



"When you're hot, you're hot" — and a case in point is High Inergy, Motown Records' newest group of female singers.

In the group's short recording history, they have scored strongly on the **Cash Box** Pop and R&B charts. This is not easy, especially for a new group, but High Inergy has the vocal excellence that commands attention. And it's for this reason they are the Cinderella music story of 1978.

Composed of Linda Howard, 19, Michelle Martin, 18, and Vernessa and Barbara Mitchell, 19 and 17 respectively, the group was virtually unknown outside of their hometown of Pasadena, Ca., four months ago.

But now things are different, thanks to their super single, "You Can't Turn Me Off (In The Middle Of Turning Me On)," and album, "Turnin' On."

High Inergy was born after all four young ladies had been accepted into Pasadena's Bicentennial Performing Arts Program. The Mitchell sisters auditioned as singers while Linda and Michelle danced their way into the program.

The four girls soon got together and developed a one-hour show which they performed some 500 times during the eight months the federally funded program lasted.

Due to their many entertaining performances, the group was brought to the attention of Mrs. Gordy-Fuqua (who's responsible for Marvin Gaye, David Ruffin, Jr. Walker and a long list of others being with Motown), and they were quickly signed to the Gordy label.

entirely independent, he says.

No Consultation

"As far as A&R input goes, I don't have to consult CBS at all," Weiss says. "We never have to ask their advice and we don't have to account to them. Of course, I wouldn't want to give them a record that they didn't like. But if I had a record of Jimmy Carter singing a hit song, they would have to promote it."

And it's promotion that Nempereor is most dependent on its distributor for, according to Weiss, who believes "promotion is the bottom line." In fact, Weiss' philosophy concerning promotion played a part in Nempereor's decision to switch distributors, he says.

More Receptive

"I think people promote best, or sell best, what they like best," Weiss says, "and I think that CBS has a staff that can best relate to us. Columbia seemed to be more receptive to our type of music and their roster seemed more attuned to the sort of thing that we do."

Weiss describes the Nempereor five-act roster as jazz/rock and lists the artists as

(continued on page 62)



PARRISH PARTY — ABC Records recently kicked off the release of Paul Parrish's debut LP for the label, "Song For A Young Girl," with a listening party at ABC Studios attended by members of the press and radio community. Pictured (l-r) are: Louie Shelton, Parrish's producer; Parrish's parents; Jim Seals, member of Seals & Crofts; Parrish; Steve Diener, president, ABC; Marcia Day, Parrish's manager.

Index

Album Reviews	22
Classified	66
Country Album Chart	50
Country Singles Chart	53
East Coastings/Points West	14
FM Analysis	28
Gospel	60
International Section	32
Jazz	58
Jukebox Singles Chart	63
Latin	59
Looking Ahead	67
New Faces To Watch	10
Pop Album Chart	69
Pop Radio Analysis	27
Pop Radio Playlist Highlights	24
Pop Singles Chart	4
Radio News	23
Regional Album Action	30
R&B Album Chart	55
R&B Singles Chart	57
Singles Reviews	20
Top Ten's	30

al martino

THE NEXT HUNDRED YEARS

Al Martino, popular singer/performer extraordinaire, has recorded the perfect album—ten full-bodied love songs matching the many moods of romance—the highs, the lows, and the enchanting surprises. Includes his hit single, "The Next Hundred Years" (4508).

Produced by Joel Diamond
for Silver Blue Productions, Ltd.



ST-11741

—New Faces To Watch—



Eloise Laws

You may think Eloise Laws has had an easy time establishing herself in the recording industry since her brothers Hubert and Ronnie are well-known jazz artists. But Eloise says her brothers have only helped her recently, after she paid her dues for more than a decade.

"I wasn't really influenced by them until I moved out to Los Angeles two years ago," indicates Eloise. "I first came out here to replace Marilyn McCoo in the Fifth Dimension. But after one show with them — on Johnny Carson — I decided not to remain with them because I wasn't comfortable working with that many artists. Then Ronnie introduced me to my present company, Far Out Productions."

Eloise's career began in 1966 while she was studying to be a music teacher at Texas Southern University. A talent scout from Corinthian Broadcasting Company came to the school and Eloise auditioned. Six months later she won the national finals in New York.

"It was like a dream come true," remembers Eloise. "I quit school and studied music, dancing, acting, singing — the works. I wasn't sure what I was doing, but it was too good an opportunity to pass up. Finally I auditioned for the Playboy Club and 'Hair' at the same time and ended up getting both."

She decided to go on the Playboy circuit, and out of that came a record deal with Columbia. They released a couple of singles for her, but no albums.

"Columbia had so many big stars recording then — Dylan and Streisand and the like — that I could never get into the studio. So I never did an LP for Columbia, but I did start to do a lot of TV. I became a regular on Merv Griffin — who was helping a lot of young talent then — and I did that for about four years. Then Harry Belafonte saw me and asked me to tour with him."

Steady touring brought Eloise to the attention of Invictus Records. She negotiated a release from Columbia and signed with Invictus, but their financial problems kept her out of the studio for another four years. Then when she finally recorded her first LP, "it was not everything I expected it to be." Last year her contract with Invictus was dissolved by mutual agreement.

By this time ABC Records was interested in Eloise and she signed with them. They teamed her with songwriter Linda Creed and producer Jerry Goldstein and the result was "Eloise," a stylish mix of pop and R&B that is climbing on both **Cash Box** album charts. This time Eloise is quite pleased with the product.

"I'm ecstatic about the album getting on the charts," says Eloise. "I've never been on the charts before and it's a nice feeling. Far Out and ABC are great, I have nothing but praise for them. Linda and Jerry both worked very closely with me; in fact, Linda and I are co-writing songs now for my second album."

"I'm not an easy artist to produce because I don't really fit into any one category. I'm not strictly R&B, but I'm not totally pop either — I'm just a singer."



Dan Hill

"I certainly love singing and playing, but looking at my self-image, I really feel like I'm a writer. I almost feel funny being called a musician. What I emphasize is lyrics." There might be an extra dose of modesty in this statement from Dan Hill, the young Canadian songwriter/performer whose records appear on 20th Century Records in the U.S. It just so happens that his first U.S. Top 20 single, "Sometimes When We Touch," represents his first collaboration as a lyricist with a composer, Barry Mann. According to Hill, it represents the beginning of an extended, exclusive relationship that will continue with the LP he is currently recording in Toronto.

"It's a tribute to Barry that a lyric as heavy as 'Sometimes When We Touch' actually loosened up so much with his melody — the lyric would probably have been far too intense with one of my melodies. There's something about his music that made it lighter, and made the song even more universal." Dan sees his collaboration with Mann as something much deeper than a simple working relationship, and continues to turn down offers from other composers. "It would almost give me a feeling of promiscuity, like sleeping around," he remarks pointedly. "I just have to say no."

While Hill's love songs are often concerned with "romance and all its strategy," he also explores politics. One of the most arresting lyrics on his album "Longer Fuse" is "McCarthy's Day," which examines the conditions in the United States during the 1950s, which forced his parents, a racially mixed couple, to emigrate to Canada. "It's probably the most personal song I've ever written," Dan explains. "I wasn't even sure about putting it on the album. But then I felt that I almost had to put it on, just to express who I am."

Dan recognizes that the seriousness of his themes does not often coincide with general trends in American pop music, and he realizes that touring in the United States is the best way to get through to audiences here. "Performing, to me, is the final extension of songwriting," he says. "That's when you really find out whether the songs work. It's a vital part of being an artist."

Dan Hill will be touring the United States beginning in late February. Ideally, he would like to headline in small venues, probably accompanied only by his own guitar. "I've found through my experiences over the years that the starkness that I set up, the vulnerability of just going up by myself creates a one-to-one relationship with the audience. Working with my songs, it's more effective than the best band in the world."

ABC LPs Get Awards; Bishop, Buffett Cited

NEW YORK — ABC recording artist Stephen Bishop's debut album, "Careless," has been certified gold by the RIAA.

In addition, ABC recording artist Jimmy Buffett's album, "Changes In Latitudes — Changes In Attitudes," has been certified gold by the Canadian Recording Industry Association. The album had previously reached platinum sales status in the U.S.

E/A Confab Stresses Total Commitment To Jazz/Fusion

LOS ANGELES — The formation last summer of a jazz/fusion division at Elektra/Asylum Records was the company's "most significant move since Elektra merged with Asylum," according to E/A chairman Joe Smith.

Smith's remarks came at the opening of a two-day conference of sales, promotion, marketing and merchandising personnel from across the country, held Jan. 5 and 6 at the Beverly Hills Hotel.

The first day was devoted exclusively to the initial jazz/fusion release, slated for next month. Dr. Don Mizell, E/A's jazz/fusion manager, introduced the division's four new regional marketing coordinators. They are: Joseph Morrow, west coast; John Howard Brown, east coast; Alvin Thomas, midwest; and Ralph Bates, south.

Long-Term Commitment

Following Smith's opening statement, E/A vice chairman Mel Posner spoke about the label's long-term commitment to jazz/fusion. "We're in it," he said, stressing the importance of total company involvement.

E/A president Steve Wax called for a continuation of "the unity that has always characterized E/A's operation."

Mizell then described his division's goals as an inevitable result of the current direction of popular music. "It is not a black music department per se," he said. "Jazz/fusion is the most integrated music on the scene today. It is drawn from all races and nationalities, feeding pop musicians with ideas and inspiration — and that is good for the jazz field as a whole."

Ed Wright, a consultant working with Mizell, spoke about the viability of the jazz/fusion market and described the nature of the jazz/fusion customer.

After a break for lunch the meeting was turned over to Mizell, who showcased new

product and discussed future signings. He explained that the three artists in the first jazz/fusion releases — Dee Dee Bridgewater, Lenny White and Ubiquity — appealed to different audiences and indicated what the company can expect from them in terms of creative direction and market potential.

"We will have artists who appeal to all markets," he said.

Mizell also gave a preview of the second wave of jazz/fusion releases, which will include records by Donald Byrd, violinist Michael White (produced by George Duke) and the first American issue of "Twin House" by Larry Coryell and Philip Catherine, currently available only in Europe.

WEA Involved

Oscar Fields, vice president, director of black music marketing for WEA, discussed what his staff will be doing to assure an aggressive retail and merchandising campaign for the new releases.

When contacted at his office last week, Mizell termed the meeting "a working session, part presentation and part briefing." The purpose of the presentation, according to Mizell, was to acquaint everyone with the specifics of his phrase "a distinct but integral part of the E/A operation."

He said, "We'll try to strike a balance where we keep that distinct posture but at the same time get across-the-board participation and avoid the heavy demarcations that occurred with other companies."

Mizell went on to explain that the next project on behalf of the new jazz/fusion release will be a series of sales presentations at the branch level. E/A's three top executives — Smith, Posner and Wax — will accompany Mizell to various cities during an upcoming 10-day tour of WEA branches around the country.

UA Previews First Quarter LPs At Palm Springs Meeting

LOS ANGELES — New albums to be released by United Artists Records and its custom labels in the first three months of 1978 were previewed for over 150 UA staffers and independent distributors gathered in Palm Springs January 6-8. Billed as "UA's 1st Quarter Kick-Off," the confab brought together regional and local sales and promotion personnel, as well as the home office staff and custom label reps for a multi-media product presentation, an awards luncheon, as well as other smaller meetings. The presentation marked the first time the recently realigned UA administrative staff met with all field reps and independent distributors.

Artie Mogull, UA president, attributed the company's record performance in 1977 to the crossover tactics which brought both Kenny Rogers and Crystal Gayle to national prominence. Other major 1977 campaigns, according to marketing vice president Gordon Bossin, included Electric Light Orchestra's "Out Of The Blue," Ronnie Laws' "Friends And Strangers," the soundtrack from "Rocky" and R&B groups Enchantment and Morning, Noon And Night.

The unveiled first quarter release schedule included new product from Kenny Rogers — a 10-year retrospective — as well as country singer Dottie West's single, "Every Time Two Fools Collide," which features a duet with Rogers. Former Steeler's Wheel Gerry Rafferty's debut UA album "City To City" and "Billy Falcon's Burning Rose" LP on Manhattan Records were also spotlighted, as was UA's entry into the new wave movement, Doctors Of Madness.

UA/Roadshow Grammy winning gospel singer Shirley Caesar was singled out as a 1978 priority and it was learned that Roadshow Records has recently acquired the entire Hob gospel catalog featuring such artists as The Staple Singers, Reverend James Cleveland, Swan Silvertones, the original Blind Boys and the Shirley Caesar Singers. Much of the Hob acquisitions will be released in Best-of packages throughout the year.

Other debut artists introduced in UA's first quarter kick-off included Jericho Harp, Gringo, Vehicle, Daisy Dillman Band, Winners, Ellen McEllwaine, Trickster, Flower, Darts, Millington, Dutch Robinson and the Curtis Brothers. Additionally, new releases were announced from jazz/pop instrumentalists Horace Silver, Earl Klugh and Noel Pointer, Chi-Sound's Manchild and Roadshow Records' Enchantment and Morning, Noon And Night, as well as country singers, Billie Jo Spears and Melba Montgomery. Canada's Lavender Hill Mob will release their second UA LP, "Street Of Dreams," in January, while flutist Tim Weisberg's second on UA will ship in February. Chi-Sound vocalist Walter Jackson, whose third LP, "Good To See You," is set for January release, was noted as a special priority for the coming year, while LPs from disco singer Barbara Pennington and Jamaican reggae/jazz fusionist Rico, on Blue Note, were also featured.

A special LP release of the 1977 "Blue Note Meets The L.A. Philharmonic" Hollywood Bowl concert, with performances by several artists is also being planned.

(continued on page 58)

ABBA[®] 
THE ALBUM

ABBA[®] 
THE MOVIE

ABBA[®] 
THE FOLIO

WORLD-WIDE RELEASE JANUARY/FEBRUARY 1978
A POLAR MUSIC INTERNATIONAL PRODUCTION

A.V.I. RECORDS PRESENTS THE 1978 INVASION

COCOMOTION
El Coco AVL-6012

EL COCO COCOMOTION

LE SPANK
Le Pamplousse
AVL-6032

WHOLE WHEAT 100%
100% Whole Wheat AVL-6011

WHOLE WHEAT 100%

YOUNG AND MEAN
Baby Rocker AVL-6027

BABY ROCKER

NIGHT TALK
Doug Richardson AVL-6013

JERI FAKTOR & THE BACK PORCH SYMPHONY AVL-6020

JERI FAKTOR & THE BACK PORCH SYMPHONY

HEAVIER THAN YESTERDAY
Dave Benoit AVL-6025

HEAVIER THAN YESTERDAY

LONG TIME COMIN'
Mike Robbins AVL-6021

LONG TIME COMIN'

OFFONANISLAND
Paul Delicato AVL-6029

PAUL DELICATO

DISCOGNOSIS
Discognosis AVL-6026

DISCOGNOSIS

Attention Buyers

AVI RECORDS

By AVI Records Distributing Corp.
7060 Hollywood Blvd.
Hollywood CA 90028

Executives On The Move



Davis Sargent Ambrose Manzo

Davis Appointed At Capitol — Capitol Records, Inc. has announced the appointment of Randall Davis as director, merchandising & advertising for CRI. He replaces Don Grierson, who was recently appointed vice president of A&R for Capitol's new label EMI America. Davis joined Capitol in November, 1975, as editorial copywriter after four years as a newspaper reporter with the Pasadena Star-News. He was promoted to manager, press & editorial services in June, 1976.

Sargent Named At Mushroom — Rich Sargent has been named national promotion director of Mushroom Records. He will team with Mushroom national promotion director, Susie Gershon, at the label's Los Angeles offices. He replaces Marc Nathan who recently joined Sire Records. He comes to Mushroom from Roadshow Records, a United Artists custom label, where he was national promotion director.

Fisher Appointed At Polymusic — The appointment of Artie Fisher as director of special projects at Polymusic, Inc., the mail order division of Polygram Corporation, has been announced. His most recent position was with Roulette Records where he was an executive assistant. Prior to that, he was with the special products division at Columbia and RCA Records.

Chrysalis Promotes Ambrose — Chrysalis Records has announced the promotion of Rick Ambrose to director of national publicity. Prior to his promotion, he served as manager of national publicity for one and a half years.

Manzo To Bearsville — Bearsville Records has announced the appointment of Renee Manzo as national secondaries promotion for the label. She most recently held the same position at Janus Records.

Carr To Champion — Champion Entertainment Organization, Inc. has announced the appointment of Barbara Carr as director of public relations and special projects. She was director of publicity at Atlantic Records prior to joining Champion and previously held the post of east coast director of publicity for ABC Records.

Wright Promoted At ABC — Robert J. Wright, formerly manager of business information, ABC public relations, west coast, has been promoted to director, public relations, broadcasting, west coast, American Broadcasting Company. He has been with ABC in Los Angeles since he joined the company in January, 1965. In April, 1973, he was promoted to manager, business information, and has represented ABC in that capacity on the west coast until his current promotion.



Carr Sellers Tompkins Bernardo

DJM Names Arnovich — DJM Records has appointed Bill Arnovich as DJM Records' national promotion manager. He comes to DJM from ASI Records in Minneapolis and will headquarter in DJM's New York office.

Weismann To Ampex — Bill Weismann has been named national sales manager, consumer products, for Ampex Corporation's magnetic tape division. He comes to Ampex from the 3M Company, where he spent 15 years in various consumer sales and marketing management positions. Most recently, he was western area manager for 3M.

Sellers Named At CBS — The appointment of Marie Sellers as manager promotional services for CBS Records, black music marketing has been announced. She joined CBS Records in 1974. Prior to this, she was administrative assistant at WCBS-TV. She most recently served at CBS Records as promotion coordinator.

Two To Mercury — Phonogram, Inc./Mercury Records has announced the appointment of Earlean Fisher and Marty Mack to regional R&B promotion posts. Fisher, as east coast regional R&B promotion manager, will be based in New York City, but will also cover Boston, Philadelphia, Baltimore, and Washington, D.C., as well as surrounding territories. Before joining Phonogram/Mercury, she worked in a similar capacity at ABC Records in New York. She also worked for WLS and WJPC radio in Chicago, as well as working regional promotion in the midwest for Buddah. Mack joins Phonogram/Mercury as west coast regional R&B promotion manager, based in Los Angeles. He will cover the entire coastal region, as well as inland areas as far east as Denver. Previous to Mercury, Mack worked four years with RCA Records, both as national promotion manager for R&B in New York and west coast promotion manager in Los Angeles.



Habbaz Mitchell Davidson Verroche

Tompkins at CBS — Garcia (T.C.) Tompkins has been named as midwest regional promotion marketing manager, black music marketing for CBS Records. He joined CBS Records in 1977 as local promotion marketing manager in Chicago. Prior to this he was southwestern regional promotion manager for Capitol Records.

Bernardo Appointed At CBS Records — Black music marketing, CBS Records, has an-

(continued on page 26)



Walter Murphy. We're his Private Stock.

A brilliant young innovator. This energetic conductor, composer, arranger is the complete music man. The power of his personality and performance revitalized the big sound when he exploded on the pop scene with a burst of Beethoven. Now, in a highly creative new album, Walter Murphy will rock the music world with an even bolder beat.



He chose Private Stock Records because we are a very special reserve of record industry professionals. We know how to generate world-wide excitement for our artists. We're a close-working team that provides the highly creative and personalized support every artist's career deserves. Something's happening at Private Stock ...and it's our artists!

London Records Appoints McEwen To Executive Vice President Post

NEW YORK — Terry McEwen has been appointed executive vice president of London Records.

D.H. Toller-Bond, president of the company, called the appointment "the first step in our plans for the restructuring of London Records and the streamlining of the company's operations."

Bedell Named VP At Casablanca

LOS ANGELES — Steve Bedell has been appointed vice president of publishing at Casablanca Records. Bedell will be in charge of developing the label's entire music publishing operation, including Rick's Music, Cafe American, Starrin Music Publishing, Skydiver Music, Combat Music and Ramapo Music. Bedell has previously served as executive vice president and president of The Wes Farrell Organization where he worked for 10 years before joining Casablanca.



Shown (l-r) are Bedell and Richard Trugman, vice chairman of the board at Casablanca.

McEwen, formerly vice president in charge of London's classical division, will continue to handle overall supervision of that area. However, he stressed that his appointment does not mean a greater concentration by London on classical music to the exclusion of pop product. "The company is being restructured purely to make our operation more profitable," he said, adding that his job will be primarily administrative.

While McEwen doesn't expect to have direct input into London's pop A&R department — an area in which he admits to a lack of expertise — he believes that administrative changes in the company "will have an effect on pop A&R, and I hope a salutary effect."

McEwen's first priority in his new position, he said, will be to "unclutter" the label's operation. He indicated that this may involve some personnel changes. "There will undoubtedly be a reshuffling, with some new faces, and some of the old faces may go," he stated.

London has never before had an executive vice president. Explaining that his new title will give him "some extra heft," McEwen noted that "when we contemplated the restructuring of the company, someone obviously had to be put in charge of the job."

McEwen said he would have a "less detailed involvement" in the affairs of the classical division. Operational responsibility in that area will now be divided between Richard Rollefson, McEwen's administrative assistant, and John Harper, national sales manager for the classical division.

East Coastings/Points West

EAST COASTINGS — SAVANNAH DELIVERS — The arrival of "Dr. Buzzard's Original Savannah Band Meets King Penett" was long-awaited, and while several factors contributed to the lateness of release, the reasons were "mostly political," according to the band's closest confidant, Sussandra Minsky. The delay revolved around the dissolution of the Savannah Band's management agreement with **Tommy Mottola's** Champion Entertainment organization. Minsky explained that a lengthy, complicated legal process ensued before the band was able to "break away cleanly, without leaving too much of ourselves behind." Although the management situation was cleared up to the satisfaction of both parties, it left the band without an official recording contract, and a new deal had to be negotiated with RCA Records. The album is a completely self-produced, self-managed effort on the band's part, and as yet, they have not made any new management agreements. For the present, Minsky, who has been involved with members of the band for about 10 years, is really their official management representative. She is presently working out plans to put the group on the road, although it will be some time before an actual tour can be mounted. Also in the early stages is a possible solo album by Savannah Band's lead vocalist, **Cory Daye**.



GRAND PRIZE WINNERS — The American Song Festival's Fourth Annual Songwriting Competition in the Professional and Amateur Categories was announced recently. Pictured above showing off their award plaques are (l-r): Gary Griffin of Birmingham, Michigan; Robert Byrne of Muscle Shoals, Alabama; and Richard Brenckman of New York, New York.

whose legendary group (with **Steve Winwood**) scored the original hit. Straddling the fence, Spence?

DIRECTORY ASSISTANCE — One of the most bizarre LP credits seen in some time is found on **Seawind's** "Window Of A Child" on CTI Records: "L.A. Phone Book — Page 75, played by **Bob Wilson**." Wilson is the group's drummer, but it wasn't until we were paid a visit by Seawind's **Jeff Wild** and **Jerry Hey** that the mystery was solved. The group had decided to make a straight shot at a Top 40 single with the cut "One Sweet Night," and they felt that a steady four-beat on the bass drum would be in keeping with the style of many current hits. In playbacks, however, the members of the band decided that the bass drum itself was too strong a sound for the desired effect. After careful experimentation, it was decided that beating a telephone book with a drumstick — specifically, page 75 of the Los Angeles directory — produced just the right sound. It was worn through to page 78 by the end of one take!

A FOTO RETURN — They had done it once before; the only difference this time around was that the group playing at SIR's elaborate sound stage on 52nd St. was signed to Atlantic Records, with their debut album due for February release. **Fotomaker** played the room the first time as one step toward landing the recording deal. Although the sound stage is actually a very elaborate rehearsal studio, which allows a band the room to set up and re-create the conditions of a full-scale tour, it functions well as a showcase facility with the addition of a few tables and chairs. The group, which contains former **Rascals Gene Cornish** and **Dino Danelli** in addition to ex-Strawberry **Wally Bryson**, attracted remaining ex-Rascals **Felix Cavaliere** and **Eddie Brigati** to their most recent showcase, which was staged mainly for the benefit of Atlantic staff and booking agencies.

MEAT LOAF OWNS UP — On the first dates of his current tour, **Meat Loaf** seemed a bit uptight about one of his former personalities, namely **Eddie**, the motorcycle rocker who makes a vocal appearance in "The Rocky Horror Picture Show." At his New York appearances, he was accosted by "Rocky" cultists who showed up in costumes commemorating the film, and he made a special effort to remind them that Eddie was a remnant of the past as far as he was concerned. At this point, though, it seems that the "Rocky" cults which have sprung up in cities around the country (the soundtrack was recently reissued with Epic/Ode) have won a few points with Meat. At a recent appearance in St. Louis, he took some time to talk to fans at a "Rocky Horror" showing in town, and even signed autographs.



MILLIONTH MULL — **Wings** member **Denny Laine** (l) recently presented **David Ackroyd** with a gold copy of "Mull Of Kintyre" after Ackroyd purchased a copy of the record containing a certificate which listed his disc as the millionth copy.

SHORT SHOTS — **Robert** and **Sue Palmer** became parents for the first time with the birth of a son, **James Daniel**, in Nassau, Bahamas, on January 6. . . It looks like **Eric Carmen** will be ending his relationship with **Stan Poses** and **Aware Management**. . . **Marvin Hamlish** and **Carole Bayer Sager** have written a song especially for the 50th annual Academy Awards show, titled "Come Light The Candles." . . **Bob Marley's** next album, set for March 7 release, is titled "Kaya." Yes, it is Jamaican slang for marijuana, but, no, Island Records is not planning anything in the way of contraband promotional devices. Totally recovered from a foot injury, **Marley** plans a U.S. tour beginning in May. . . **Mick Jagger**, who seems to have split completely from spouse **Bianca**, is now reportedly housing with **Bryan Ferry's** former girlfriend, **Jerry Hall**. . . Big Sound Records has named some new distributors, including **MS** in Chicago, **Bib** in Charlotte, North Carolina; **Action Music Sales** in Cleveland and in Australia, none other than **EMI**. Big Sound also has appointed **Seth Tiven** (younger brother of president **Jon Tiven**) as software analyst in charge of computer systems. Yet another new Big Sound development is the new gold cover of the **Scratch Band's** LP release. Hopefully it will draw people to the magic inside. . . **Peter Gabriel's** new album, produced by **Robert Fripp**, nears completion. . . Polydor has begun re-merchandising two early **Ted Nugent** LPs recorded when he was a member of the **Amboy Dukes** in 1969 and 1970. They are "Marriage On The Rocks" and "Survival Of The Fittest — Live". . . New

(continued on page 16)

Big Fourth Quarter Helps WCI Raise '77 Revenues More Than 30 Percent

(continued from page 7)

1977.

In addition to the four debut platinum records already mentioned, 1977 saw many new WCI artists launch their careers with initial successes. These include **Firefall**, whose gold album "Luna Sea" was a fitting follow-up to their successful first release last year. **Slave** achieved gold record status with its first release, and its new album is off to a strong start. **Steve Martin's** "Lets Get Small" was a top comedy LP in 1977 and is fast approaching the platinum level. **Alan O'Day** had a number one single in "Undercover Angel," his first release for Pacific Records, the Warner Bros. label distributed by Atlantic. Other artists with successful first releases for various WCI labels include **AC-DC**, **Cerrone**, **Chic**, **C.J. & Company**, **Detective**, **Jay Ferguson**, **Peter Gabriel**, **Leif Garrett**,

The Ramones, **Carole Bayer Sager**, the **Sanford-Townsend Band**, **England's** much heralded **Sex Pistols**, **Stuff**, and **Undisputed Truth**.

A large number of established artists repeated past successes in 1977. Among these, all of whom notched gold album awards last year, are **Abba**, **Average White Band**, **Bad Company**, **Bootsy's Rubber Band**, **Bread**, **George Carlin**, **Doobie Bros.**, **Emerson, Lake & Palmer**, **Gordon Lightfoot**, **George Harrison**, **Manfred Mann's Earth Band**, **Montrose**, **Van Morrison**, **Rolling Stones**, **Marshall Tucker Band**, **Yes** and **Neil Young**. **Joni Mitchell** is adding new members to her following with the release late in the year of "Don Juan's Reckless Daughter." **Randy Newman**, after years of critical acclaim, has a best selling LP in "Little Criminals," spurred by the success of the hit single "Short People."



FOUR MORE YEARS — Country star **Kenny Rogers** recently signed a worldwide multi-million dollar pact with **United Artists Records**, his current label. Pictured at the signing are (l-r): seated, **Rogers** and **UA president Artie Mogull**; standing, **Bob Brenner**, **Rogers' attorney**; **Ken Kragen** of **Management Three**; **Mark Levinson**, **UA vice president of business affairs**; **Stan Kulin**, **president of UA Records Limited, Canada**; **Lynn Shults**, **UA director of country & western A&R** and; **Cliff Busby**, **managing director of UA Limited, England**.

GOLD SHIPPING GOLD

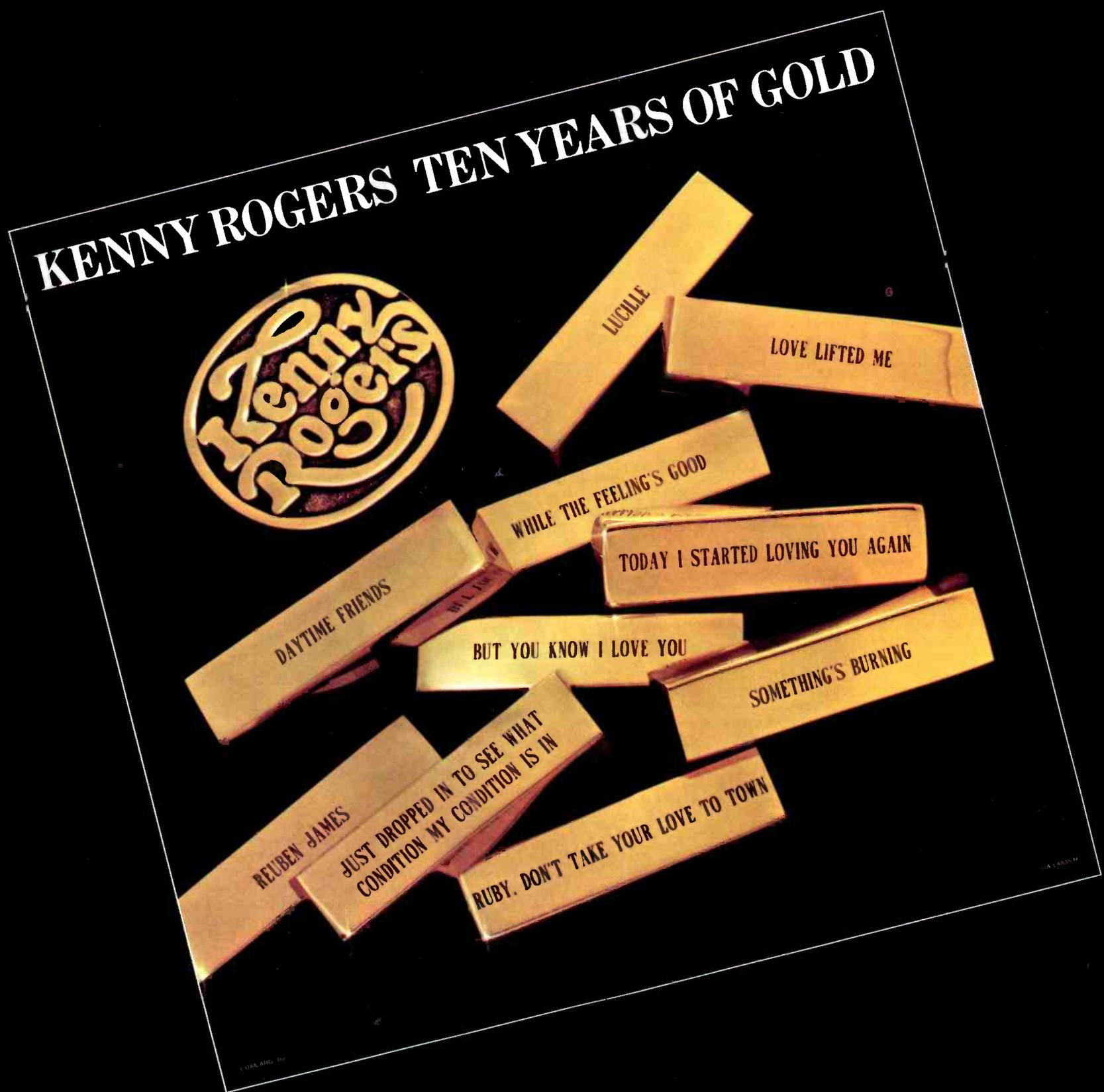

Kenny Rogers' last two albums have already gone gold. His new one is shipping gold. And we're taking every step possible to turn it into an alchemist's dream: gold into platinum. Watch for it soon.

ALL-TIME GREATEST HITS.
TEN YEARS OF GOLD. KENNY ROGERS
ON UNITED ARTISTS RECORDS AND TAPES.



Supreme Court Accepts WBAI Case

by Joanne Ostrow

WASHINGTON, D.C. — The Supreme Court has granted *certiorari* in the FCC vs. WBAI case which involved the legal definition of broadcast "indecent" and will now accept written arguments and replies. Oral arguments will probably be scheduled by March and it may be years before a final decision is made.

After the U.S. Court of Appeals reversed the FCC censoring of Pacifica Foundation WBAI-FM in New York last year, the commission appealed to the high court in order to force a judicial decision on the FCC's power to regulate profane language on the air. The case is an important one for broadcasters who want the government out of the programming business. It is also crucial for record producers and performers who, until now, had to guess at the legal definition of indecency without a ruling from the

Supreme Court.

Not Probably Obscene

The case concerns the listener-supported station's airing of the George Carlin comedy routine called "The Seven Dirty Words You Can't Say On Television." The words in question refer to human sexual and excremental functions. In its opinion, the Federal Appeals Court said the WBAI case did not fit the Supreme Court's definition of obscenity; the language was not probably "obscene" but only "patently offensive." It did not appeal to listeners' prurient interests even though it did relate in an offensive manner to sexual and excretory functions and was broadcast at an hour when children were likely to hear it.

The lower court said the FCC was going "beyond the protection of the public interest into the forbidden realm of censorship."

Weisner And Demann Form Management Co.

LOS ANGELES — Ron Weisner and Fred Demann have formed a new personal management firm, Weisner-Demann Entertainment. Weisner has headed Ron Weisner Management for the past two and a half years; Demann has been director of promotion at Elektra/Asylum for the past four years. Artists under the new banner are Sha Na Na, Bill Withers, Tanya Welk, Z.Z. Hill, Adrienne Barbeau, Stephanie Edwards, Alison Steele and Bob Crewe.

Bread Album Achieves Double Platinum Status

LOS ANGELES — "The Sound Of Bread" album has earned double platinum status in Great Britain two months after release. The special compilation album of 20 Bread hits, a WEA U.K. package, was released in mid-October. By Christmas, the 2-record set registered more than two million English pounds in sales. As a result of this success, negotiations for a Bread tour of the U.K. this spring are underway. In the U.S., Bread is on the Elektra label.

Fire Single Due On TK

LOS ANGELES — "Deeper In Love," a new single by Fire, the backup band that has recorded with KC & The Sunshine Band, is set for release by TK Records this week.

Elton On Spinners' Disc

LOS ANGELES — Atlantic recording group The Spinners have recorded a new song, "Are You Ready For Love," with some vocal and instrumental help from Elton John.

East Coastings/Points West

(continued from page 14)

Wave Name of the Week goes to **Alpo**, bassist and vocalist of **The Real Kids**, whose first album has just been released on Red Star Records.

phil dimauro

POINTS WEST — GRAMMY GRAB-BAG — Now that this year's Grammy nominations have been announced, everyone knows that the **Eagles** lead the pack with six nominations, followed by **Linda Ronstadt's** five. It is also well-known that, surprisingly, **Fleetwood Mac's** "Rumours" is listed on only a few categories, but that female recording artists, including Ronstadt, Debby Boone, Crystal Gayle and Barbra Streisand, have done especially well this year. But few people probably have noticed the interesting situation in the category for Best Engineered Recording. Four of the five albums nominated made it to number three or higher on the **Cash Box Top 100** Album Chart. Those LPs were **Steely Dan's** "Aja," **Fleetwood Mac's** "Rumours," **Linda Ronstadt's** "Simple Dreams" and **James Taylor's** "JT." While each of those albums reached at least number three, the fifth record nominated as the best engineered of the year never broke the Top 200. That album, "Discovered Again!" by **Dave Grusin**, is a direct-to-disc recording produced by the Sheffield Lab. Sheffield has had an album nominated in that category for the past five consecutive years and is the only direct-to-disc company which has received a Grammy nomination.

POLISHING THE WAX — Filming for Paramount's "American Hot Wax" finished last week and the film now goes into post-production. Rolling Stone writer **Cameron Crowe** stopped by the set to see how the picture was progressing and ended up with a part in it. Besides landing the role of a Chinese delivery boy, Crowe got his own trailer next to **Laraine Newman**, one of the film's stars. What's next: his own star on Hollywood Blvd? . . . Also headed for the big screen is the stage production "Beatlemania," the **Leber-Krebs** show for which three major companies currently are bidding for film rights. . . . **Paul McCartney** is not the only one to make British record history lately, now that **Wings'** "Mull Of Kintyre" has become the largest selling single in the history of the United Kingdom. Casablanca's **Donna Summer** has become the first woman to have the most hit singles in Great Britain in a single year. Summer also was recently nominated for a Golden Globe award for her recording of "Down Deep Inside" . . . All of us at **Cash Box** send our best wishes to mother-to-be **Susan Gassick**, who is leaving Casablanca shortly, perhaps this week. She has been in the business for more than 10 years and currently serves as director of publicity at Casablanca. She said she doesn't know at this point how long she will be out of the business, but that she definitely is not out of the industry for good.



BEACH BOY IN THE STUDIO — **Caribou** recording artist **Dennis Wilson** (r) of the **Beach Boys** is shown with label president **James Guericco** (c) and Grammy winner **Bruce Johnston** in *Brother Studio* while taking a break from recording his second LP for **Caribou**.

They will be working at CRC studios in their hometown of Chicago. Prine's last album, "Common Sense," came out in 1974 . . . **Jerry Jeff Walker** also recently began work on a new album for MCA, doing the recording at his home in Austin. The LP will be on MCA, although Walker reportedly will be signed to Elektra/Asylum shortly . . . **Joe Cocker** and **Dirk Hamilton** are each working on new albums for E/A, while **Bob McBride**, former lead singer with **Lighthouse**, has signed with MCA and will release his first product in February. Other signings include comedy team **Proctor And Bergman** to Mercury Records and **Snail** to Cream Records. The **Crusaders** are in the studio collaborating on a new album with blues master **B.B. King** . . . Newly-signed Ariola/Zombie group **The Heaters** are in the studio working on their first album with **Scott Shannon**, head of Zombie, producing . . . **Fella**, a Phonogram Records artist based in Nigeria, reportedly can't get out of that country because of political reasons. Any telephone interviews that he does must be set up with a three-day leeway because Fella never knows when he will be able to get to a phone. It was rumored that he had been assassinated around Christmas, but it turned out to be a false report . . . In the U.S., Phonogram/Mercury's **Lol Creme** and **Kevin Godley** are coming to an inventors trade show in Los Angeles to display their invention "The Gizmo" and officially put it on the market for people in the music industry who are interested in the device.

CASABLANCA 'HYPED' — A recent program on NBC entitled "The Land of Hype and Glory" discussed how various media products are promoted and publicized. The show, hosted by **Edwin Newman**, concentrated on three areas: music, books and films. Two of the three categories, however, featured Casablanca in examples. While discussing music, Newman used the example of rock group **Kiss** and how they have achieved their current success with relatively little radio airplay. During the movie segment, Casablanca's "The Deep" was used to show how films are publicized well in advance of their release so when they come out, everyone has already heard about them. It was noted that the average person had heard something about "The Deep" 15 times prior to its release . . . "Poor Poor Pitiful Me," a **Warren Zevon** composition, has been selected as the third single released from **Linda Ronstadt's** "Simple Dreams" LP. It was preceded by "Blue Bayou" and "It's So Easy" . . . A new single is coming soon from **Harry Nilsson** entitled "World's Greatest Lover," the theme song from **Gene Wilder's** latest film of the same name. Wilder wrote the music and the lyrics to the song, which is featured in the film as sung by Nilsson. RCA, Nilsson's label, will handle the single as well as the soundtrack album. Both are due by the end of the month . . . As soon as Capricorn's **Elvin Bishop** finishes his portion of a Feb. 5 concert at the New Orleans Superdome, he will head directly to the Rivergate Party Hall for a show before a group called Bacchus. The group helps put together the annual Mardi Gras celebration and the event will be hosted by **Ed McMahon**.

PRISONER GETS HELP — The flip side of the first single released in the U.S. by the **Tom Robinson Band** is a version of **Bob Dylan's** "I Shall Be Released." The song is dedicated to **George Ince**, who is serving a term in a British prison after being convicted of a silver bullion robbery. Robinson, who is gaining a reputation as a human rights campaigner, feels Ince did not receive a fair trial so he is bringing the case to attention on record. The "A" side of the single on EMI, distributed here by Capitol, is "2-4-6-8 Motorway." The Tom Robinson Band was recently voted "most important new band" in Britain's New Musical

(continued on page 62)

Capitol Outlines Pricing Policy

LOS ANGELES — In the wake of recent pricing po changes, Capitol Records, Inc. has issued this statement to clarify their pricing position: "The pricing policy for product manufactured and/or distributed by Capitol Records, Inc. is always determined in the context of competitive considerations. Capitol has a published dealer price, and a published lower functional discount price for wholesalers."

Australians Mine Gold

LOS ANGELES — "Diamantina Cocktail," the Little River Band's second North American album, has reached the gold record sales plateau. The Australia-based group, who recently captured eight awards in the "First Australian Rock Awards," record on the Harvest label and are distributed in the U.S. by Capitol Records.

Sales Of Eagles' LP Now Exceed 9 Million

LOS ANGELES — More than nine million copies of The Eagles' "Hotel California" LP have been sold since the album was released in December 1976, officials at Elektra/Asylum Records announced recently. Six million of those records, officials said, were sold in the U.S.

ELP Garners Gold

NEW YORK — "Works, Volume 2," the latest Atlantic LP by Emerson, Lake & Palmer, has been certified gold by the RIAA. "Works, Volume 1," released earlier this year, also went gold.



MOTOWN GETS GOODING — **Cuba Gooding** recently signed with Motown Records. Pictured (l-r) are: **Barney Ales**, president of Motown Records; **Dennis Lambert**, producer/writer; **Lee Young, Jr.**, vice president of business affairs; **Mike Lushka**, executive vice president, general manager-marketing; **Kevin Wall**, concert production; **Iris Gordy**, vice president of creative affairs, and **Berry Gordy IV**, executive vice president of creative affairs.

from the HOTTEST ALBUM OF THE YEAR!

SATURDAY NIGHT FEVER

ORIGINAL MUSIC FOR THE MOVIE WRITTEN BY BARRY, ROBIN & MAURICE GIBB



ANOTHER SMASH HIT SINGLE:

'IF I CAN'T HAVE YOU'

Produced by Freddie Perren

by

RS-884

Yvonne Elliman



From the Robert Stigwood Production
"SATURDAY NIGHT FEVER"
Distributed by Paramount Pictures
Management: Alive Enterprises, Inc.

The R S O Family

RS-2-4001



Records & Tapes

Jem Records Conf. Draws Nat'l Distributors, Retailers

by Charles Paikert

NEW YORK — Jem Records, a leading rock importer, has changed the name of its import label to Visa Records, and has also signed distribution deals with Kim Fowley's new Ego label and Greg Shaw's Bomp and White Noise labels. The company announced these moves at the first national distributor conference for its independent labels in South Plainfield, New Jersey last week.

The change of names from Import to Visa, according to Ed Grossi, a Jem principal, was made in order to eliminate confusion between Jem's import albums and the independent label. In addition, Grossi said, the name change signified an expansion of the label from strictly collector's items to albums released by name artists.

Visa's newest releases, Grossi announced, would include "Vision," by Peter Hammill; "A Favorable Garland," by Shirley Collins; "Rocka Rolla," by Judas Priest; "Through The Year," a double album set by Nektar; the debut album by the German band, Galaxy; and, on Bomp Records, "Kill City" by Iggy Pop and James Williamson. The price structure for Visa has been set at \$6.98 for reissues, \$7.98 for new releases, and \$9.98 for double albums.

Marty Scott, president of Jem, stated that Jem's other record label, Passport, would

change its focus and become a more commercial domestic label, concentrating on developing and signing its own acts. Previously, Passport made only single-album deals for import records.

"From Rats To Riches," the new album by Passport's recently signed act, The Good Rats, highlighted the albums Scott presented for spring release. Other Passport releases included "Wise After The Event" by Anthony Phillips; "Cords" by Synergy; and "Laughing In The Dark" by Pezband, as well as a reissue of "Rutland Times" by Eric Idle and Neil Innes.

Grossi revealed that over 50% of Jem's imports are now in the punk or "New Wave" category. Approximately 20% of Jem's total dollar volume, Grossi estimated, has been derived from punk sales. Jem currently controls nearly 75% of European rock imports, Grossi claimed, and did an estimated \$10 million business in 1977.

Although Grossi said he hoped that Jem would continue to achieve a 20% annual growth rate, he stressed the fact that the company would strive in 1978 to improve service relations with Jem's retail, wholesale and rack customers.

The major obstacles to Jem's growth, he said, were steadily increasing record prices in Europe, and the continuing devaluation of the United States dollar abroad.

Song Festival Presents Awards

LOS ANGELES — The American Song Festival recently presented the top awards for the Fourth Annual Songwriting Competition at an informal reception in the Grand Ballroom of the Sheraton-Universal Hotel.

The professional grand prize winner, "Bound To Know The Blues," came from the easy listening category and was written by Robert Byrne of Muscle Shoals, Ala., and Gary Griffin of Birmingham, Mich.

Amateur Winner

Richard Brenckman of New York City was the grand prize winner of the amateur competition with his easy listening entry "What Kind Of Friends We'll Be."

The rock/soul professional winner was "Lady Love Song," written by John Curtis Meyer of Brentwood, Tenn. The top award in the professional country competition went to the writing team of Bernie Wayne of Los Angeles and Marvin Moore of Ft. Worth, Tex.

Other category winners included Tom Benjamin of Nashville for his rock/soul entry, "Till You Love Someone" and Emmitt Jackson Jr. of Birmingham, Ala. for "That's The Only Way We Can Serve Him," which was entered in the gospel/inspirational category.

Amateur and professional category winners were all presented plaques at the Los Angeles gathering. Cash prizes were awarded to 675 contest winners, with \$1,000 going to each of the category winners and an additional \$5,000 awarded to the grand prize winners.

Since the competition began in 1974, more than \$400,000 has been presented to winners.

Carradine Tops E/A LP Roster Of 3 Releases

LOS ANGELES — "Lost And Found," the new album by Keith Carradine on Elektra Asylum Records, leads the list of three new LPs set for release by the label on Jan. 18.

Also slated are "All This And Heaven Too," Andrew Gold's third album for E/A, and "Excitable Boy," the latest from Warren Zevon.

Cohen Set To Speak At Int'l Tape Seminar

NEW YORK — Joe Cohen, executive vice president of the National Association of Record Merchandisers, will speak at the eighth annual seminar of the International Tape Association, "Audio/Video Update — 1978," to be held in Tucson, Arizona March 5-8.

Cohen's topic, "Partners in Profit — Rack Jobber and Retailer," will be angled to an audience of executives from more than 50 ITA member companies, as well as media representatives. Also on the agenda of the conference are addresses on such topics as "Video As The Emerging Home Movie Medium," "History Of Home Video Systems," "Blank Videocassettes," and "Marketing Home Video Software." Workshops will be offered for audio and video retailers and suppliers.

New Cisyk 45 On ABC

LOS ANGELES — Kacey Cisyk, the vocalist who sang the original soundtrack version of "You Light Up My Life," has recorded a new movie theme song, "The One And Only," from Paramount Pictures' new film of the same name. The single has been released by ABC Records.

Moffatt Tour Begins

LOS ANGELES — Columbia recording artist Katy Moffatt began a U.S. tour of 19 cities Jan. 13 along with Willie Nelson and Jerry Jeff Walker.

Record Plant Fire Causes \$1-2 Mil. Equipment Loss

LOS ANGELES — Fire gutted one of four studios in the Record Plant here Jan. 7, causing damages estimated between one and two million dollars to one of the city's largest independent recording facilities.

11 fire companies battled the blaze, which took its toll in expensive electronic equipment, for nearly two hours managing to contain the flames to just one of the building's four recording rooms. Fire company officials said that arson was not suspected and blamed the blaze on electrical malfunction.

Despite the loss of one studio, a spokesman at The Record Plant said the facility is "totally functional with three studios working" and added that "losses will be minimal in terms of business."

Two buildings adjacent to the two-story facility located at 8456 W. Third St. were also damaged by the fire. The buildings were used by The Record Plant for storage and office space.

A library of tapes recorded at The Record Plant during the last six months, including tapes of Steve Stills and Dave Mason, was saved. Stills' guitars were damaged in the blaze, however, according to his manager.

No injuries were caused by the fire.



MAYALL GOLD — Polydor recording artist John Mayall's "Turning Point" LP recently turned gold. Pictured **standing** (l-r) as Mayall receives RIAA awards are: Barry Oslander, A&R creative coordinator, and Mayall's manager John Gunnell. Shown **seated** (l-r) are: Mayall and Hal Yoergler, Polydor's vice president of A&R west coast.

CBS Records Set To Meet In New Orleans

NEW YORK — CBS Records has slated its annual beginning-of-the-year national marketing meetings for New Orleans January 25-29.

The meetings will feature sales, promotion, merchandising and A&R seminars, as well as new product presentations and live performances by selected CBS acts. The meetings and presentations will take place at the Fairmount Hotel in New Orleans.

Jack Craig, senior vice president and general manager of marketing for CBS Records, and Paul Smith, vice president of marketing/branch distribution for CBS Records, will be co-chairmen of the New Orleans meetings.



CURB AWARDS — Warner/Curb recording artists Shaun Cassidy, Debby Boone and Peter Pringle were on hand recently when the label held a year-end reception for Mike Curb to celebrate the label's achievement during 1977. Shown **seated** in the **top photo** (l-r) are: Boone, Cassidy and Pringle. Pictured (l-r) **standing** are: Stan Cornyn, executive vice president; Phil Gernhard, producer; Michael Lloyd, producer; Mo Ostin, board chairman and president; Curb; and Bob Gaudio, producer. Shown in the **bottom photo** (seated l-r) are: Curb, Ostin, Cassidy, Lloyd and Warner general manager Robin Rothman. Shown **standing** (l-r) are: Lou Dennis, vice president of sales; Derek Taylor, vice president of creative services; Russ Thyret, vice president of promotion; Mark Maitland, national singles sales manager, and Curb promotion director Mike Scotti.

America's Great Musical Heritage Is Now Our New Musical Heritage Series!

Springboard

January 16, 1978

AN OPEN LETTER TO ALL RETAILERS:

First of all let me wish you a happy and prosperous 1978 – all of us at Springboard look forward to helping make it the best music year ever.

To put our product where our thoughts are, Springboard – America's fastest growing economy company – is pleased to introduce the first two albums in its new and specially conceived, MUSICAL HERITAGE series. Two three record box sets (8-track tapes and cassettes also) featuring "FIFTY YEARS OF AMERICAN MOVIES MUSIC" featuring all the Academy Award winning songs and "FIFTY YEARS OF BROADWAY MUSIC" highlighting show stoppers from Berlin to Hamlisch.

Attractively priced to reach the mass market these albums will be backed by an extensive radio and T.V. advertising campaign in excess of \$350,000. In addition, this consumer promotion will be supplemented with posters, window displays, counter and floor dumps and all the other tools you need for sales.

Don't just take my word for it – get all the details from your Springboard salesperson. If you can't wait and want to get a jump on your competition, just give me a call at the Springboard West Coast office (213) 654-6240.

Something new and exciting – from the new and exciting Springboard family of labels.

Sincerely,

Len Levy
Len Levy
Vice President, Marketing

3-LP SET

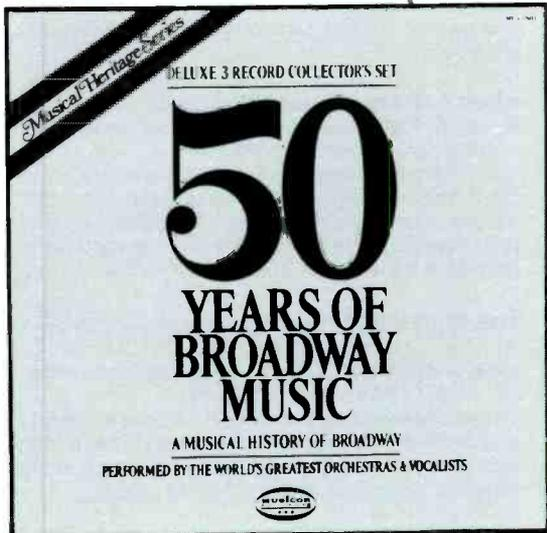

LP-MU3-3801

8T-MU3-3801

CA-MU3-3801



A MEMBER OF
The Springboard Family Of Labels

8295 SUNSET BLVD., LOS ANGELES, CA 90046

3-LP SET

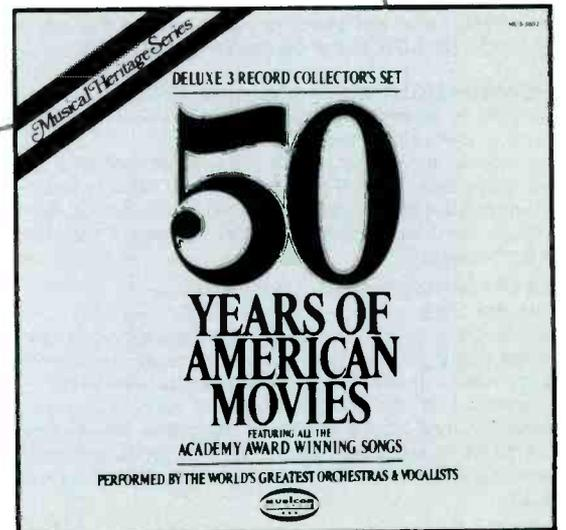

LP-MU3-3802

8T-MU3-3802

CA-MU3-3802

FEATURE PICKS



ART GARFUNKEL (Columbia 5115-2)
(What A) Wonderful World (3:00) (Kags Music — BMI) (H. Albert/L. Adler/S. Cooke)
 This cut from Garfunkel's new LP "Watermark" joins the considerable talents of Paul Simon, Garfunkel and James Taylor. The harmonies are pleasing in their gently stated simplicity. A strong pop and Top 40 candidate which is already receiving strong airplay.



JOHNNY GUITAR WATSON (DJM DJUS-1034)
Love That Will Not Die (3:43) (Vir-Jon — BMI) (Watson)
 The second single off the LP "Funk Beyond The Call Of Duty," this song is already getting strong R&B airplay and seems a sure bet to follow in the footsteps of Watson's earlier hits. This track features Johnny Guitar's distinctive funk riffs, staccato vocals and even chiming bells to create a sound with pop crossover potential.

KANSAS (Kirshner 6533-2)
Dust In The Wind (3:26) (Kirshner Music — BMI) (K. Livgren)
 This second cut off the group's successful "Point Of Know Return" LP features a strong acoustic sound which mixes the ingredients of solid melody, excellent vocals and harmonies, and an impactful lyric. The instrumentation is clean and effective. The cut is a sure addition to MOR pop formats.



MANHATTANS (Columbia 3-10674)
Am I Losing You (3:37) (Sumack Music/Scorpicorn — BMI) (A. Fields/B. Morr/D. Stender)
 Coming off their success with the R&B single "We Never Dance To A Love Song," the group has brought out another gentle ballad which again demonstrates their impeccable harmonies and solid lead vocals. The guitar work is clean and soft. A promising R&B chart contender.



ASHFORD AND SIMPSON (WBS 8514)
Don't Cost You Nothing (3:39) (Nick-O-Val Music — ASCAP) (Ashford and Simpson)
 Taken from the "Send It" LP, the duo's best to date, this cut features funky guitars and keyboards, a strong hook and the complementary sounds of Nick and Val. Ready to dance and receiving solid airplay, this one will be R&B charting soon.



BOOTSYS RUBBER BAND (WBS 8512)
Bootzilla (4:21) (Rubber Band Music — BMI) (Collins/Clinton)
 What do you get when you cross Bootsy and Godzilla? — that's right. Bootzilla, a funk attack cut off the new "Bootsy? Player Of The Year" LP. This kicker is a strong R&B chart contender featuring plenty-o-funk guitar and horns and Bootsy talking his "wind me up" player talk.

WAYLON JENNINGS & WILLIE NELSON (RCA PB-11198)
Mamas Don't Let Your Babies Grow Up To Be Cowboys (2:30) (Tree Pub/Sugarplum — BMI) (E. Bruce/P. Bruce)
 The old boys sing together real pretty. This cut off their country comer album "Waylon & Willie" features tasty pedal steel and a tale of the trials and tribulations of being a cowpoke.

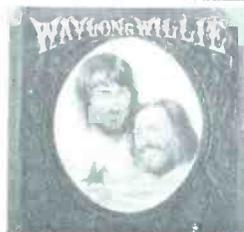

JAY ARTHUR (WBS 8513)
Nothing Like Your Loving In The Morning (2:54) (Venox Music/Blackwood — BMI) (Dick Monda)
 Arthur sounds a lot like David Cassidy from the Partridge Family on his first single produced by Dick Monda. Present are the breathy singing style that becomes increasingly effective in high octaves, string arrangement, and a moving beat. This cut has MOR and pop playlist potential.



SINGLES TO WATCH

SEX PISTOLS (WBS 8516)
Pretty Vacant (3:16) (Careers Music — BMI) (Cook/Jones/Matlock/Rotten)
 This first cut off the "Never Mind The Bollocks — Here's The Sex Pistols" LP to be released in the States is suited for AOR playlists interested in catching the new wave. Rotten's vocals are rhythmic, double-edged and snarling but also cleaned up for airplay. This is a straight forward rocker with upfront drumming, slashing guitar licks and a brash attitude.

PARLIAMENT (Casablanca NB 909 DJ)
Flash Light (4:08) (Rick's Music, Inc./Malbiz Music — BMI) (G. Clinton/B. Worrell/W. Collins)
 George Clinton's band of funk and merriment is back with a trobbing and highly danceable ditty dedicated to finding an errant lover by throwing more light on the subject. The tongue-in-cheek attitude suggests a mood of frivolity so just in case he doesn't succeed in his search he still will have a good time.

DOUCETTE (Mushroom M-7029)
Down The Road (2:50) (Andorra Music — ASCAP) (J. Doucette)
 Taken off Canadian rocker Doucette's debut album, "Mama Let Him Play," this cut features a double-timing guitar, funky keyboards and a high-stepping rock pace. The strong hook and effective vocals makes this one a contender for AOR and progressive pop playlists.

THE MOONLIGHTERS (Amherst AM-727)
Midnight In Memphis (3:26) (Harlem Music/Moonmaid Music — BMI) (T. Johnson)
 A ringing funky guitar lifts the listener into this up-tempo cut taken from "The Moonlighters" album. The instrumentation which utilizes violins, horns and guitars skillfully combines pop and country formats. A potential on both charts.

ALBERT KING (Tomato — TM10001B)
Call My Job (4:25) (Perks Music — BMI) (Al Perkins/Detroit, Jr.) Originally the back side of an expected single, R&B programmers jumped on this tune instead, which expressed a quite popular sentiment — frustration with one's daily occupation. While a currently charting country tune vocalizes the same annoyance, Albert's blues treatment places priority on enjoying his gambling windfall with his old lady — even if it costs him his gig.

THELMA JONES (Columbia 3-10675)
I'd Rather Leave While I'm In Love (3:30) (Irving Music, Inc./Woolnough Music, Inc./Jamava Music Corp. and Unichappell Music, Inc./Begonia Melodies, Inc. — BMI) (C.B. Sager/P. Allen)
 Though this is hardly an upbeat subject, the arrangement and Thelma's forceful but quivering vibrato give the tune a delicate sensitivity and a feeling of hope in the midst of heartbreaking reality. With a voice similar to a cross between Streisand and Cher, Thelma's powerful pipes convincingly put forth the aching ambivalence of her situation.

BAD BOY (United Artists UA-XW1063)
Thinking Of You (2:31) (Unart Music Corp./Grimm's Tales Music — BMI) (S. Grimm)
 A pervasive English sound dominates the clean guitar work and three-part harmonies on the second single from this mellow-rocking Milwaukee quartet. Their multi-layered arrangement and clever bridges sustain interest and give the tune the variety to bear up under repeated spins on Top 40 air waves.

PAULETTE REAVES (Blue Candle/T.K. — BC-1526-A)
Jazz Freak (3:45) (Sherlyn Pub. Co., Inc. — BMI) (Clarence Reid)
 As effective a "commercial" for jazz as we've heard, this bouncy and vibrant tune extols the virtues of the genre with some understandable name-dropping and instrumental emphasis. What makes it work so well is Paulette's silky smooth vocal treatment and her obvious and enthusiastic love for the style.

FANDANGO (RCA PB-11194)
Headliner (3:40) (Life And Times Music/Live Music — BMI) (D. LaRue/R. Blakemore)
 A boogie piano style and driving beat make this song about a headlining entertainer an intriguing addition to AOR or pop formats. A tight rocker with a good hook and gritty vocals, the cut is already receiving AOR airplay. The self-consciousness of the theme adds to the sound's merits.

BILL QUATEMAN (RCA PB 1180)
Wait Until Tomorrow (3:22) (Sea Lark Enterprises/Yameta — BMI) (Jimi Hendrix)
 This single taken from the "Shot In The Dark" album is characterized by Quateman's strong vocals, good guitar work and certain production embellishments such as introductory handclaps which make this an attractive rock cut for progressive pop and AOR playlists.

CISSY HOUSTON (Private Stock PS 45,171)
Things To Do (3:20) (Edward B. Marks Music — BMI) (H. Vanda/G. Young)
 If you feel a shiver snaking up your spine while hearing this record, don't bother to check the heater for the stimulus: It's coming from your speakers. Cissy's full-bodied vocal treatment is magnificently dramatic and absolutely scintillating with perfect instrumental accompaniment, and should do well in a variety of formats.

VAN HALEN (Warner Bros. WBS 8515)
You Really Got Me (2:36) (Jay Boy Music Corp. — BMI) (Ray Davies)
 An excellent choice for a debut single, a tight and fervent remake of the old Kinks tune by this high decibel heavy metal band out of California. Their tendency to blast away has been not so much curtailed as polished and refined by Ted Templeman's excellent production job.

NANCY SHANX (United Artists 1135)
Ready To Fall In Love Again (3:06) (Macomb/Patramani — BMI) (Shanx, Pitts, Smith)
 This pretty young singer-lyricist's second single is a disco-flavored love song that has chart potential on R&B, disco and pop stations. Top-notch studio musicians have laid down a strong instrumental background which heightens the effect of Shanx' lusty vocals.

THE GREEN BROTHERS (Tortoise Intl./RCA YB-11130-A)
Lack of Attention (3:46) (Groovesville Music/Poets Pub. Co. — BMI) (Roosevelt Johnson)
 This widened piece of blues funk uses trade-off vocals and smooth instrumentation to pass along a truth learned all too painfully by many men — "the lack of attention makes a woman do wrong." Top 40 potential.

WAYLON & WILLIE

MAMMAS DON'T LET YOUR BABIES
GROW UP TO BE COWBOYS

and

I CAN GET OFF ON YOU

PB-11198

DEBUT:

36 Billboard **25** Cashbox **40** Record World

THE HIT SINGLE FROM THE ALBUM

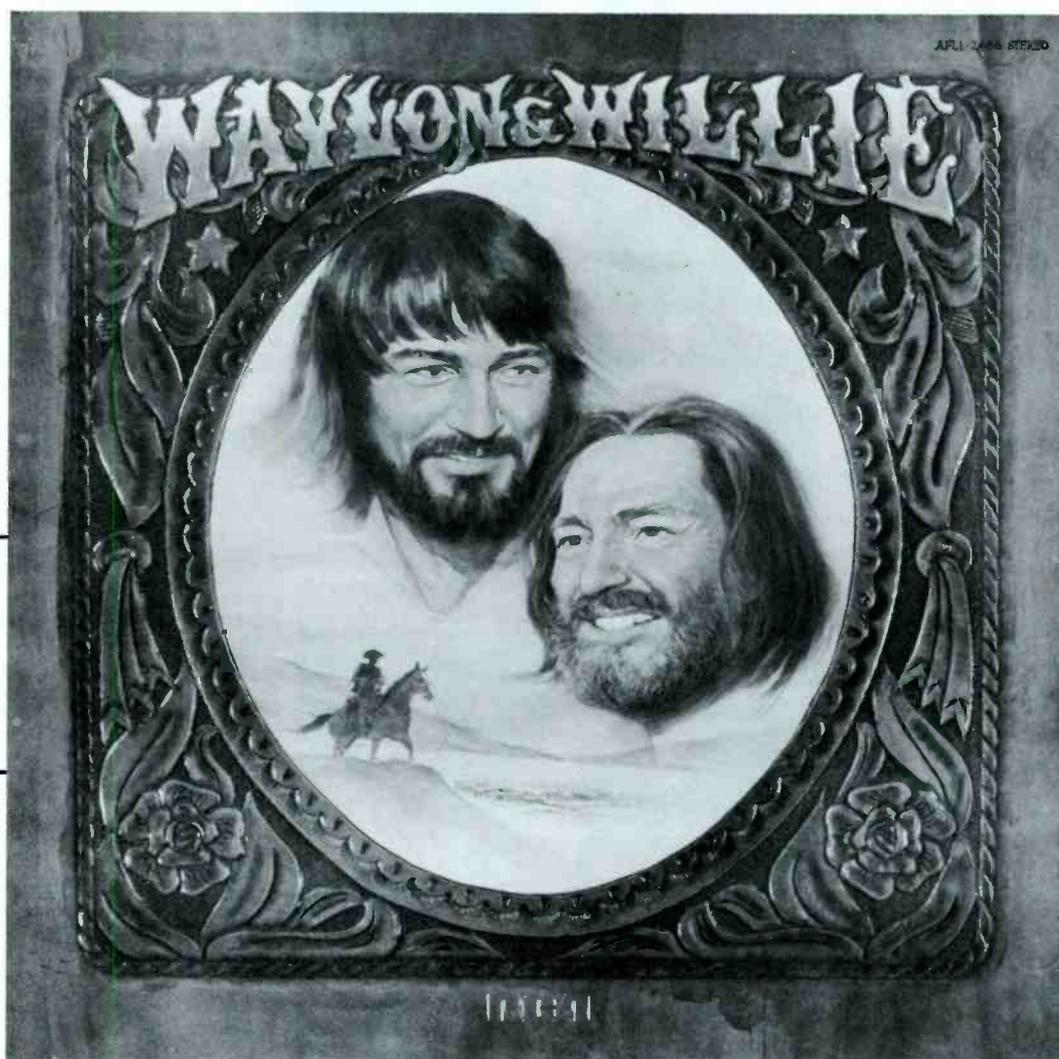

RCA
Records



AFL/AFS/APK1-2686

REVIEWS ALBUM REVIEWS

WATERMARK — Art Garfunkel — Columbia JC 34975 — Producer: Art Garfunkel — List: 7.98

Eleven of the 12 songs on Garfunkel's third solo album were written by Jimmy Webb. They range from the moody, nostalgic "Mr. Shuck 'N' Jive" to the upbeat "Paper Chase," although the majority are ballads. The one non-Webb song is a superb remake of Sam Cooke's "(What A) Wonderful World," featuring Garfunkel with Paul Simon and James Taylor. With each of the three taking the lead on one verse, the song should turn into one of the biggest singles of the year.

TEN YEARS OF GOLD — Kenny Rogers — United Artists LA835-H — Producers: Larry Butler and Kenny Rogers — List: 7.98

Rather than merely repackage the old records, Kenny Rogers chose to re-do his hits with the First Edition and combine those with his most recent single successes, "Lucille" and "Daytime Friends" on his greatest hits album. Because these are new versions of "Ruby, Don't Take Your Love To Town," "Reuben James" and "Something's Burning," the LP will appeal even to those who may have the original versions, but want to hear them as Rogers does them now.

WAYLON & WILLIE — Waylon Jennings And Willie Nelson — RCA AFL-1-2686 — List: 7.98

This collaboration of the two premiere outlaws in country music may be an even greater pop success than last year's "Ol' Waylon," which pierced the Top 30. Not that they have gone overtly commercial: Waylon and Willie haven't abandoned their country roots, it's just that teaming two of the most expressive voices in country has resulted in an irresistible LP. Included are Waylon's recent "Wurlitzer Prize," a duet on his classic "Pick Up The Tempo" and a cover of Fleetwood Mac's "Gold Dust Woman."

GOLDEN TIME OF DAY — Maze, Featuring Frankie Beverly — Capitol ST-11710 — Producer: Frankie Beverly — List: 7.98

Once again, Beverly exhibits his capabilities as a true singer-songwriter. This disc captures the group at their melodic best particularly on the title tune and the tender ballad, "I Wish You Well." Uptempo selections, "Travlin' Man" and "You're Not The Same," should also catch some ears. The album should be most popular with Top 40 and R&B programmers.

LET'S KEEP IT THAT WAY — Anne Murray — Capitol ST-11743 — Producer: Jim Ed Norman — List: 7.98

Anne Murray's latest work is perfect for late-night listeners, with its romantic songs of love lost and love found. But Murray treats even the ballads of love dying with a ray of optimism. The LP, however, is not all melancholy and on the rock songs her powerful voice is at its best. Considering the success she had doing the Beatles' "You Won't See Me," her cover of the Everly Brothers hit "Walk Right Back," sounds like it could do even better on Top 40 radio.

DUO-GLIDE — Sanford & Townsend — Warner Bros. BS 3081 — Producer: John Haeny — List: 6.98

Sanford & Townsend continue with the formula which produced their debut last year with catchy pop-rock songs built around the pair's vocal harmonies. Most of the songs lean toward R&B, so the album should pick up play at that level as well as Top 40. "Sometimes When The Wind Blows" is a strong ballad which could serve as a good follow-up to their last hit, while "Paradise" is an upbeat rocker much in the same vein as "Smoke From A Distant Fire."

ALL FOR A REASON — Alessi — A&M SP-4657 — Producer: David Lucas — List: 7.98

Alessi's last album met with an especially raucous reception across the sea but this well-crafted disc has the kind of strength that should make their Yankee brethren sit up and take notice as well. With influences as diverse as Paul Simon, 10cc, Eric Carmen and others, Billy and Bobby are keen vocalists who have surrounded themselves here with a fine supporting cast of players with some well-known names. An excellent second effort with more bite per groove than previously.

PUTTIN' ON THE STYLE — Lonnie Donegan — United Artists LA-827H — Producer: Adam Faith — List: 7.98

Several of today's biggest English rock stars list Lonnie Donegan as an important influence on their musical development, so in return many have helped out on this album, including Ringo Starr, Leo Sayer, Elton John, Queen's Brian May, Ron Wood, and Gary Brooker, to list a few. Donegan blends traditional American folk songs, jazz and pop with English influences for a unique brand of music. Donegan might even get a hit out of "Diggin' My Potatoes," a blazing rocker featuring Elton's pounding piano.

SONG FOR A YOUNG GIRL — Paul Parrish — ABC AA-1031 — Producer: Louis Shelton — List: 7.98

Parrish's debut album for ABC features 10 of his own compositions, the majority of which are pop ballads. His lyrics cover a wide range of themes, from the introspective ("Rock 'n Rollin' Star") to story-like tales of specific characters and people in general. Parrish is a strong lyricist whose words create powerful images. It should do well on MOR, AOR and some Top 40 lists.

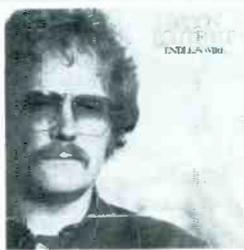
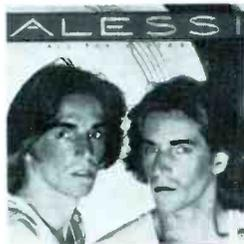
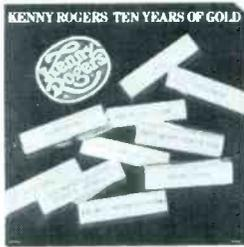

ENDLESS WIRE — Gordon Lightfoot — Warner Bros. BSK 3149 — Producers: Lenny Waronker and Gordon Lightfoot — List: 7.98

"Endless Wire" lives up to and exceeds the high level of quality we have come to expect from Lightfoot, one of the world's finest songwriters. It is one of those rare albums that doesn't have a weak cut. The title tune is an especially introspective, probing work. "Hangdog Hotel Room" and "Sometimes I Don't Mind" take Lightfoot further into the electric rock field than he has yet explored, while "The Circle is Small," examining the pain of a faithless love, may be the album's most affecting song.

QUARTER MOON IN A TEN CENT TOWN — Emmylou Harris — Warner Bros. BSK 3141 — Producer: Brian Ahern — List: 7.98

To paraphrase the current ad from a television manufacturer, Emmylou Harris keeps making records better and better. Her fourth album features most of the same musicians from her past LPs, but her vocals, if such a thing is possible, continue to improve. "Quarter Moon" features 10 songs by 10 writers, but her interpretations are so personal it is hard to think she hasn't written them. The songs range from country to pop ballads to rock and it is "Defying Gravity" and "Easy From Now On" which stand out.

DR. BUZZARD'S ORIGINAL SAVANNAH BAND MEETS KING PENETT — RCA AFL-1-2402 — Producer: Stony Browder Jr. — List: 7.98

It has been mentioned that this group has really started something. This second disc proves that they intend to continue what they started. This collection is an extra added dose of the fine vocals as well as arrangements blended into that nostalgic sound which is obviously their forte. Each and every tune is totally entertaining. Collectively: a sheer delight.

FORMERLY OF THE HARLETTES — Sharon Redd, Ula Hedwig And Charlotte Crossley — Columbia JC 35250 — Producer: David Robinson — List: 7.98

On their debut solo album, the three women who supported Bette Midler on stage and on record cover a variety of material in somewhat the same range as their former mentor, though slightly more R&B. The trio tackles some jazz along the lines of the Pointer Sisters with Herbie Hancock's "Maiden Voyage" and some straight pop ballads. The differences in each of their voices provides an interesting blend and the group sings with authority and precision.

FOSTER SYLVERS — Capitol ST 11716 — Producer: The Sylvers with Al Ross — List: 7.98

Look out Michael Jackson! Foster Sylvers' debut album (outside of his work with his family) is a dazzling pop jewel and should find a home in a multitude of record collections. Though it is fairly bubbling over with potential singles, our favorites are his covers of two familiar tunes, "Don't Be Cruel," (a gutsy choice) and "Goody Goody." "Super Scoop," written with his brothers, is a solid hit: an ebullient uptempo track that could make Mr. Sylvers gold real quick.

INFINITY — Journey — Columbia JC34912 — Producer: None Listed — List: 7.98

With so much attention being paid to punk and new wave these days, Journey's fourth album brings us a strong reaffirmation of classic mainstream rock in the tradition of Led Zeppelin or Bad Company. Lead singer Greg Rollie's high-pitched vocals add to the already powerfully intense arrangements and production. The five musicians play with authority on this LP which is already gathering airplay on several stations across the country.

HERB ALPERT & HUGH MASEKELA — Horizon/A&M SP-728 — Producers: Stewart Levine, Herb Alpert and Calphus Semanya — List: 7.98

These two trumpet/flugelhorn greats have joined for an album of seven tunes which explore the relationship of current popular music forms with their musical roots. "Skokiaan" and "I'll Be There For You" demonstrate the fine line between traditional African rhythms and disco, while "Ring Bell" goes reggae and "Happy Hanna" is a straight-forward, graceful pop ballad. Throughout, Alpert's and Masekela's horns complement each other to a "T."

DENNE & GOLD — MCA 2303 — Producer: George Lee — List: 6.98

New arrivals to American shores, British duo Micky Denne and Ken Gold have had much success in their native England, both as recording artists and as songwriters. Now that they have toured with Elton John and Cliff Richard in the U.K. and the U.S., they have issued their first album here. Their songs combine some of the pop of Elton John with the solid beat Leo Sayer has made use of lately. For Top 40, MOR and some R&B stations.

TERESA BREWER'S NEW ALBUM — Image Records IM 306 — Producer: Bob Thiele — List: 6.98

Teresa Brewer states in the LP's liner notes, that the songs and arrangements here show her feelings about the sounds of the 1970s. Such a collection would have to include disco, so she has disco versions of "Hello Dolly," Cole Porter's "I've Got You Under My Skin" and a disco medley from the movie "Picnic." She has also included pop ballads, an original gospel tune and a country-rock song, effectively covering all the major trends of this decade. As a result, the album would be suitable for a variety of radio playlists.

RADIO NEWS

PROMOTION IN MOTION

SKLAR SPEAKS — Introduced by **Juggy Gayles** at the Music and Performing Arts Lodge of the Sutton Place Synagogue's B'nai B'rith as being "more controversial than Yassir Arafat," Rick Sklar, vice president of programming for the ABC Radio division, pulled no punches in his speech. The man behind the superpower among America's AM stations, WABC in New York, focused on two themes: the critical importance that every song played on the air has for the station that programs it; and the need for stations to use accurate, scientific marketing data and research.

"Each song for a radio station is like a product on the market," Sklar said. "It's no different from a detergent." A station, Sklar went on, is "putting its audience and profits on the line with every single song because the button-happy listeners today won't sit still for one and a half seconds of radio irritation." And because the number of radio stations in the last 10 years has nearly doubled, but the number of listeners hasn't, Sklar noted, "the audience pie is cut up more, and the slice per station is ever thinner. Every listener, and every song, therefore, is extremely critical."

Since every song that drives away listeners from the station's crucial target audience has to be considered "harmful," Sklar said, tighter playlists shouldn't surprise anyone.

To ensure the most advantageous programming for each station, Sklar implored the radio industry to base their playlists on real research, which he termed "the orderly gathering of valid data." Rather than leaving playlists vulnerable "to emotional or promotional hype," or to "a program director's intuition," Sklar said, more emphasis should be put on marketing statistics, with the avowed purpose of bringing a specific product to a specific group of people. "Detroit relies on scientific research," Sklar emphasized, "and it's been a long time since they turned out an Edsel." Unfortunately, Sklar went on, the same could not be said of the record business, which with "all its supposed sophistication, is still prone to a lot of snake oil."



IN THE BOOM BOOM ROOM — MCA recording artists Willie Alexander and The Boom Boom Band recently brought their music to New York's Palladium. Pictured backstage are (l-r): Barry Goodman, New York promotion man for MCA; Alexander; Joy Hall, national FM promotion director for the label; Sammy Vargas, New York promotion man for the label; and Craig Leon, the producer of Willie's debut LP.

So far, Sklar said the industry's attempts at research "have been just that — attempts." In fact, Sklar lashed out when one lodge member asked him about passive research. "What is it?" Sklar demanded. "Whom do you call? What do you ask them? I'll tell you what it is — it's a lot of bullshit." One solidly proven form of research long practiced by WABC, Sklar noted, was the need to "test market" the newest songs in smaller markets before allowing a large metropolitan station to program them.

Sklar then answered the often-asked question, "How does WABC decide to go on a single?" The considerations, Sklar said, were 1) national sales for the single or album; 2) local sales; 3) ABC's "core artist concept," an in-house index that measures an artist's "recent performance"; and 4) consultation with other stations in the ABC chain. Also of note to trend watchers was Sklar's mention of radio's increasing "dependence on the growing adult market" and his opinion that Debbi Boone's "You Light Up My Life" was a "harbinger of things to come."

Despite Sklar's assertions that "much of the industry is moving away from the type of music vulnerable to old-fashioned promotional hype," he later softened his stand when asked how much difference a good promotion still makes. "Computers aren't infallible," he said. "It's still good to know what is believed to be coming along. Sometimes you'll catch something that falls through the cracks." So promotion reps are not out of a job yet, at least in Sklar's view.

PHOTOS IN PROMO — In the true spirit of promotion, a couple of free-lance photographers in Chicago, Bill Sosin and Paul Natkin, banded together last year and formed PhotoReserve, an agency servicing area promoters, managers and record companies. To celebrate their first anniversary, Sosin and Natkin have put out Bright Lights magazine, a compilation of PhotoReserve's best pictures, and many of them are really stunning. The mag has retail, manufacturer and club ads, and is being freely distributed to Chicago area stores and clubs. The idea, as far as we know, is a first, and hopefully will not be the last of its kind.

ON THE STREET — Salsoul is offering its promotion people \$50 if they pick the winning Super Bowl team within the point spread and \$100 if they pick the exact final score as part of their in-house "Salsoul Super Bowl Sweepstakes." . . . WOWO in Fort Wayne, Indiana recently collected over \$61,000 for needy families in their 29th annual Penny Pitch campaign . . . **Mark Mehler**, Mr. Promotion in Motion, spent the week lolling in Florida and recovering from the demanding pressure of being an ace music biz news hound . . . Also on the road starting January 16 will be Private Stock's **Harold Susman** and **Amanda Shuster**, who will be promoting the label's winter releases with a color slide show and a sampler album . . . To promote the **Ramones** recent appearance at the Palladium in New York, WNEW-FM recently gave away 50 albums, 50 T-shirts, and 10 black leather jackets. This raises a couple of questions. Were the T-shirts pre-ton? And when the Sex Pistols come to New York, what will they give away?

charles paikert

Car Radio Study Examines Prices

WASHINGTON — A study to determine how AM/FM automobile radio manufacturing costs relate to retail prices has been completed by Booz, Allen Applied Research for the Corporation for Public Broadcasting and the National Association of Broadcasters. This is the first time that such comprehensive data has been obtained and analyzed.

During the past decade, the number of FM stations has grown tremendously and the public has responded with a corresponding increase in its purchase of AM/FM radios for home use. The same increase cannot be cited for AM/FM radios in

automobiles, primarily due to the additional cost of an AM/FM car radio. The study was undertaken to examine the relationship between radio manufacturing costs and retail prices to determine the basis for the difference.

Most of the price difference between AM and AM/FM car radios is directly related to manufacturing costs, according to the study.

The study also indicates post-production costs are allocated as a percentage of product costs. This means inventory and distribution costs are also higher for AM/FM radios than AMs.

New Management, Format For WYLD In New Orleans

by Joey Berlin

LOS ANGELES — WYLD has announced far reaching changes in their management and programming in an attempt to be more competitive in the New Orleans radio market. The station's FM side has become jazz-oriented, while the AM is using charted singles along with some album cuts.

"We're not really an all-jazz station on the FM side," points out new operations director Ed Berkhalter. "The format is like WDAS in Philadelphia — we play some disco, a lot of jazz, and utilize a laid back type of announcer including three ladies."

Berkhalter, who says he is the only black Republican running for the state senate in Louisiana, was promoted from being director of marketing. Dennis Davis is the new program director, with Scharmaine Foster as the new FM music director and Moses Cage as the new AM music director.

"The reason we had to make changes is the station has made so many, many changes within the past year," explained Berkhalter. "We had to try and solidify the situation. I used to program our local competition, WBOK. Our news director comes from a relatively MOR station. We've increased our news staff and our sales department. We've had to make the necessary changes to compete with the three other black radio stations in our market."

Berkhalter is a native of New Orleans. He believes WYLD's mix of jazz, R&B, and disco is just what the market, which in-

cludes a large number of colleges, universities and vocational schools, is looking for.

"New Orleans hasn't really changed that much," he comments. "We're just giving people what they've been hungry for for such a long time. Programmers here have not been in touch with the community. The market is still the same, we're just giving people what they want as opposed to what other programmers have wanted."

"Especially in this market, black radio is getting more album oriented," continues Berkhalter. "Programmers used to put LPs on for a week or less and then pull them right off. I don't think that's programming. I also don't believe in giving things away on the air, because I don't think that increases listenership."

Beyond the immediate pressure to compete with other stations for ratings points and advertising dollars, Berkhalter is concerned with black radio announcers as a group.

"The respectability of black radio announcers is now at an all-time low in this city," says the state senate candidate. "I hope my campaign will help put some credibility and respectability back into black DJs, in New Orleans, at least."

"Of course, announcers around the country are going to have to realize that working at a radio station is both a job and a service to the community. Many are on an ego-trip and they don't know anything about radio — where the checks come from. Black announcers are really going to have to get their acts together."



FOUR TOPS AT THE STARWOOD — ABC recording artists the Four Tops celebrated their 20th anniversary as a group recently with a concert performance at the Starwood in Los Angeles. Pictured backstage (l-r) after the show are: Elaine Corlett, vice president of artists development, international division, ABC; Levi Stubbs and Lawrence Payton of the Four Tops; Suzy Blosser, administrative assistant, sales/promotion, ABC; Belinda Wilson, director of artist relations, special markets, ABC; Duke Fakir, member of the Four Tops; J. J. Johnson, program director, KDAY; Jay Morgenstern, president, ABC/Dunhill Music, Inc.; Dino Barbis, director of national promotion, ABC; Rich Shoemaker, vice president of publishing, ABC/Dunhill Music; Renaldo Benson, member of Four Tops, and Don Mac, music director of KKTT.

STATION BREAKS

Back again with more news. First, a new PD has been named to replace **John Sebastian** at **KDWB**. He is **Dave Thompson** and he will also remain in his position as morning drive personality until a replacement can be found. **Paul Childs** is the new PD and MD at **WIGO** in Atlanta. **Bo Raines** has left **WPEZ** to go to **WZZP** as the new program director. **E. Alvin Davis** has been named national program coordinator of **Affiliated Broadcasting, Inc.** and **Brian Stone** has been named national special projects coordinator. Both come from **WSAI AM & FM**, respectively.

A correction of an item in last week's column. **Meg Griffin** is doing a weekend show at **WNEW-FM**, not working in the music department.

The new lineup at **WBCN** in Boston is: **Charles Laquidaria** 6-10 am, **Tom Hodges** joins at 9-12 noon, **Tracy Roach** 12-3, **Matt**

Siegel 3-7, **John Brodey** 7-10, **Jerry Goodwin** 10-2 and **Jim Parry** 2-6. **John LaBella** has joined **KLOL** as the new morning man. John comes from **WHCN** in Hartford. **KDKB-FM**, Phoenix will go with the Burkhardt-Abrams "Superstars" format effective January 16.

The new lineup at **WYLD-FM**, New Orleans is: **Anthony Wilson** 6-10, **Scharmaine Foster** 10-3, **Dennis Davis** 3-7, **Ron Kelly** 7-12, **Pat Prescott** overnight and **Gwen Wilson** handles the weekends.

John Lund, PD at **WISN**, Milwaukee leaves for national PD host with **Rust Broadcasting**. **Michael Spears** has formed **New World Media, Inc.**, an independent radio consulting firm. The address for New World is 23205 Ostronic in Woodland Hills, California 91367.

scott anderson & ken kirkwood

Playlist Highlights contain the following information:
Number One Song, with last week's position;
New Numbered Additions;
New Hitbounds (*): records receiving highest frequency of rotation for current product without attaining numbered positions;
New Part-Time Records (**): LP cut rotations, day-only and night-only play;
Prime Movers; and
Debuts: records moving from hitbound or part-time rotations into numbered positions.

WCVE - AKRON

- 1-1 - Queen
36 - Tom Petty
37 - Heatwave
38 - Bill Withers
39 - Jay Ferguson
40 - Stillwater
28 To 21 - Dan Hill
33 To 26 - Foreigner
35 To 27 - Al Martino
38 To 31 - Meco

WTRY - ALBANY/TROY

- 9-1 - Bee Gees
*Gary Wright
*Donna Summer
*Alan Price
*Prism
14 To 8 - Billy Joel
16 To 11 - Neil Diamond
26 To 22 - Little River Band
28 To 15 - Dan Hill
Ex To 28 - Chic
Ex To 29 - Andy Gibb

KRKE - ALBUQUERQUE

- 10-1 - Bee Gees
22 - Rita Coolidge
*Tom Petty
*Little River Band
*Wet Willie
*Eric Clapton
**Chuck Mangione
**Bee Gees - Night Fever
8 To 4 - Randy Newman
19 To 9 - Billy Joel
21 To 10 - Chic
23 To 19 - Meco
Ex To 21 - Queen
Ex To 23 - Abba

WANS - ANDERSON

- 5-1 - Randy Newman
*Dave Mason
*Rita Coolidge
*Mother's Finest
*B.J. Thomas
7 To 3 - Queen
9 To 5 - Dan Hill
11 To 7 - E,W&F
14 To 10 - Raydio
15 To 11 - Santa Esmeralda/
Leroy Gomez
19 To 9 - Bee Gees
22 To 17 - Con Funk Shun
24 To 20 - Neil Diamond
27 To 22 - Andy Gibb
28 To 21 - Chic
29 To 24 - Bill Withers
32 To 26 - Odyssey
Ex To 27 - Heatwave
Ex To 30 - John Williams
Ex To 31 - Donna Summer
Ex To 32 - Johnny Rivers

WISE - ASHVILLE

- 3-1 - Queen
*Gene Cotton
*David Gates
*Stargard
*Little River Band
11 To 7 - Bee Gees
15 To 11 - Dan Hill
21 To 17 - Andy Gibb
27 To 23 - Jay Ferguson
Ex To 24 - Johnny Rivers
Ex To 25 - Bill Withers
WRFC - ATHENS
1-1 - Randy Newman
*Leo Sayer
*Little River Band
*LeBlanc & Carr
11 To 6 - Lynyrd Skynyrd
13 To 7 - Dan Hill
15 To 9 - Samantha Sang
17 To 10 - Con Funk Shun
23 To 18 - War
26 To 21 - Eric Clapton
29 To 25 - John Williams
33 To 28 - Chic
Ex To 30 - Queen
Ex To 34 - Meco
Ex To 35 - Heatwave

Z-93 - ATLANTA

- 1-1 - Queen
27 - Linda Ronstadt
28 - Commodores
29 - Rita Coolidge
30 - John Williams/Meco
10 To 2 - Bee Gees
22 To 13 - Dan Hill
23 To 19 - Lynyrd Skynyrd
25 To 17 - Samantha Sang
WQXI - ATLANTA
6-1 - Bee Gees
*David Gates
*Rita Coolidge
10 To 6 - Lynyrd Skynyrd
18 To 10 - Wet Willie
19 To 11 - Samantha Sang
20 To 8 - Eric Clapton
30 To 20 - Con Funk Shun
Ex To 30 - John Williams/Meco

WBBQ - AUGUSTA

- 3-1 - Rod Stewart
*Heatwave
*Abba
*B.J. Thomas
*Lou Rawls
10 To 5 - Randy Newman
14 To 10 - Lynyrd Skynyrd
Ex To 27 - Neil Diamond
Ex To 28 - Donna Summer
KERN - BAKERSFIELD
1-1 - Rod Stewart
*Jay Ferguson
*Little River Band
*Dave Mason
*John Williams
*Eric Clapton
17 To 13 - Bob Welch
19 To 14 - Randy Newman
22 To 17 - Kansas

23 To 19 - Samantha Sang

- 26 To 20 - Paul Simon
28 To 22 - Bee Gees
29 To 23 - ELO
Ex To 24 - Queen
Ex To 27 - Dan Hill
Ex To 28 - Steely Dan
Ex To 29 - High Inergy
Ex To 30 - Lynyrd Skynyrd
KAFY - BAKERSFIELD
1-1 - Randy Newman
25 - John Williams
27 - Jay Ferguson
*Eric Clapton
*Dave Mason
10 To 4 - Queen
17 To 10 - Samantha Sang
21 To 13 - Billy Joel
27 To 21 - Dan Hill
Ex To 29 - Little River Band

WCAO - BALTIMORE

- 2-1 - Rod Stewart
*Johnny Rivers
*Lou Rawls
10 To 3 - Bee Gees
13 To 6 - Styx
16 To 7 - Samantha Sang
17 To 8 - Billy Joel
20 To 14 - Paul Davls
22 To 16 - Andy Gibb
23 To 17 - Chic
27 To 22 - Odyssey
29 To 25 - Dan Hill
30 To 18 - Heatwave
Ex To 28 - Lynyrd Skynyrd
Ex To 29 - John Williams/Meco
Ex To 30 - Abba

KYFR - BISMARKCK

- 1-1 - Linda Ronstadt - Easy
7 To 3 - Rod Stewart
9 To 4 - Fleetwood Mac
11 To 6 - Dan Hill
12 To 7 - Steve Miller
18 To 9 - Randy Newman
Ex To 19 - Newman
Ex To 20 - Queen
WVBF - BOSTON
1-1 - Randy Newman
*Chic
*Neil Diamond
*Rita Coolidge
*Art Garfunkel
Ex To 21 - Andy Gibb
Ex To 26 - Styx
Ex To 29 - Leo Sayer
Ex To 30 - Foreigner

WRKO - BOSTON

- 2-1 - Randy Newman
*Jay Ferguson
*Abba
*Paul Davis
*Art Garfunkel
9 To 6 - Rod Stewart
10 To 7 - Dolly Parton
14 To 8 - Chic
15 To 10 - Samantha Sang
16 To 11 - Andy Gibb
18 To 9 - Bee Gees
21 To 17 - Santa Esmeralda/
Leroy Gomez
22 To 15 - Billy Joel
25 To 21 - Steely Dan
26 To 22 - Leo Sayer
29 To 24 - Neil Diamond
30 To 25 - Dan Hill
Ex To 26 - E,W&F
Ex To 28 - Styx
Ex To 29 - Lynyrd Skynyrd

WKBW - BUFFALO

- 3-1 - Billy Joel
*Van Halen
*Little River Band
*John Williams
*Meco
10 To 5 - Player
15 To 9 - Bee Gees
19 To 15 - ELO
20 To 14 - Dan Hill
25 To 17 - Queen
30 To 20 - Samantha Sang
Ex To 25 - Chic
Ex To 28 - Andy Gibb
WAYS - CHARLOTTE
2-1 - Rod Stewart
*Chic
*Rita Coolidge
*Eric Clapton
*Commodores
**Kansas
11 To 4 - Randy Newman
13 To 7 - Styx
23 To 18 - John Williams
25 To 10 - Bee Gees
Ex To 19 - Dan Hill
Ex To 24 - Lynyrd Skynyrd
Ex To 25 - ELO

WMET - CHICAGO

- 1-1 - Queen
26 - Lynyrd Skynyrd
28 - John Williams
30 - Dan Hill
12 To 7 - Player
15 To 10 - Shaun Cassidy
23 To 5 - Randy Newman
25 To 14 - Bee Gees
27 To 22 - Billy Joet
Q-102 - CINCINNATI
1-1 - Queen
13 To 7 - ELO
15 To 11 - Styx
Ex To 24 - Bee Gees
Ex To 30 - Dan Hill

WLS - CHICAGO

- 1-1 - Queen
17 - Bee Gees
26 - Foreigner
**Fleetwood Mac - Gold Dust
**Kansas - Portrait

**Kiss - Dr. Love

- 7 To 4 - Rod Stewart
9 To 6 - Shaun Cassidy
12 To 9 - Player
16 To 5 - Randy Newman
20 To 16 - ELO
24 To 13 - Billy Joel
WNCI - COLUMBUS
1-1 - Queen
19 - Styx
20 - Bee Gees
*John Williams
11 To 7 - Dolly Parton
14 To 4 - Randy Newman
19 To 12 - Billy Joel

Z-97 - DALLAS/FT. WORTH

- 1-1 - Neil Diamond
18 - Billy Joel
22 - Dan Hill
26 - Paul David
12 To 7 - Kansas
13 To 8 - Bee Gees
15 To 11 - Andy Gibb
17 To 9 - Samantha Sang

KLIF - DALLAS

- 2-1 - Rod Stewart
18 - Billy Joel
19 - Steely Dan
24 - Andy Gibb
26 - Dolly Parton
27 - Boz Scaggs
28 - Kansas
*Chic
*Dave Mason
*Bill Withers
*Art Garfunkel
*Gene Cotton
11 To 7 - ELO
16 To 13 - Santa Esmeralda/
Leroy Gomez
17 To 9 - ELO
19 To 10 - Bee Gees
27 To 20 - Queen

WMFJ - DAYTONA BEACH

- 2-1 - Samantha Sang
*Dr. Hook
*Rita Coolidge
*Bette Midler
16 To 6 - Lynyrd Skynyrd
22 To 17 - Johnny Rivers
24 To 20 - Little River Band
25 To 19 - Queen
27 To 22 - Wet Willie
31 To 21 - Jay Ferguson
32 To 23 - Meco
33 To 29 - Natalie Cole
34 To 30 - Bill Withers
Ex To 31 - Heatwave
Ex To 32 - Gene Cotton
Ex To 33 - Andrea True
Ex To 34 - Hot

KTLK - DENVER

- 1-1 - England Dan & J.F. Coley
*Andy Gibb
*Samantha Sang
6 To 2 - Bee Gees
8 To e - ELO
10 To 4 - Player
Ex To 24 - Fleetwood Mac - Gold Dust

KIMN - DENVER

- 2-1 - Linda Ronstadt
*Queen
*Rita Coolidge
*Chic
10 To 5 - Player
15 To 11 - Paul Simon
16 To 12 - Dolly Parton
18 To 13 - Leif Garrett
25 To 19 - L.T.D.

KIOA - DES MOINES

- 2-1 - Queen
16 - Linda Ronstadt
26 - Abba
12 To 4 - Bee Gees
17 To 9 - Paul Nicholas
21 To 10 - Dan Hill
25 To 13 - John Williams
CKLW - DETROIT
1-1 - Queen
*Art Garfunkel
*Andy Gibb
*Enchantment
8 To 4 - Billy Joel
17 To 13 - ELO
18 To 3 - Bee Gees
19 To 12 - Rod Stewart
25 To 18 - Heatwave
26 To 20 - Styx
29 To 25 - Meco
Ex To 30 - Kansas - Dust

KFMD - DUBUQUE

- 3-1 - Rod Stewart
*Johnny Rivers
*Rita Coolidge
*Wet Willie
8 To 2 - Billy Joel
14 To 10 - Styx
18 To 11 - Queen
21 To 17 - Jay Ferguson
22 To 16 - Neil Diamond
Ex To 22 - Paul Davis
Ex To 24 - John Denver
WDBQ - DUBUQUE
4-1 - Randy Newman
*Odyssey
*Bill Withers
*Jay Ferguson
*Alan Parsons
9 To 4 - Andy Gibb
16 To 8 - ELO
20 To 12 - Leif Garrett
23 To 15 - Billy Joel
30 To 10 - Samantha Sang
Ex To 20 - Bee Gees
Ex To 26 - Kenny Rogers

Ex To 28 - Chic

- Ex To 29 - Abba
KINT - EL PASO
2-1 - Player
22 - John Williams
23 - Samantha Sang
26 - Chic
27 - E,W&F
28 - Neil Diamond
29 - Bee Gees
30 - Paul Davis
*Foreigner
*Wet Willie
15 To 7 - Bay City Rollers
18 To 9 - L.T.D.
19 To 5 - Randy Newman
24 To 12 - Billy Joel
30 To 15 - Queen

KQWB - FARGO

- 1-1 - Shaun Cassidy
*Raydio
14 To 10 - Randy Newman
22 To 15 - ELO
23 To 19 - Dan Hill
Ex To 24 - Santa Esmeralda/
Leroy Gomez
Ex To 25 - David Gates

KYNO - FRESNO

- 1-1 - Rod Stewart
*Johnny Rivers
*Little River Band
9 To 3 - Styx
12 To 4 - Bee Gees
15 To 8 - Dolly Parton
18 To 12 - Bob Welch
19 To 10 - Shaun Cassidy
21 To 13 - Styx
24 To 14 - Billy Joel
26 To 16 - Steely Dan
28 To 17 - Chic
29 To 22 - Dan Hill
Ex To 24 - John Williams
Ex To 29 - Paul Davis
Ex To 30 - Odyssey

Z-96 - GRAND RAPIDS

- 5-1 - Styx
*Johnny Rivers
*Rita Coolidge
*Lynyrd Skynyrd
10 To 3 - Rod Stewart
22 To 15 - Paul Simon
23 To 10 - Randy Newman
25 To 20 - High Inergy
27 To 18 - Dolly Parton
28 To 22 - Billy Joel
30 To 25 - Neil Diamond
Ex To 28 - Queen
Ex To 30 - Foreigner

WDRC - HARTFORD

- 1-1 - Bee Gees
*John Williams
*E,W&F
*Foreigner
*Rita Coolidge
14 To 4 - Billy Joel
16 To 5 - Odyssey
19 To 9 - Dolly Parton
23 To 14 - Chic
29 To 20 - Bee Gees
Ex To 27 - Dan Hill
Ex To 28 - Al Martino
Ex To 29 - Lynyrd Skynyrd
Ex To 30 - Styx

KILT - HOUSTON

- 1-1 - Queen
39 - Chic
40 - Styx
*David Gates
*Art Garfunkel
13 To 4 - Bee Gees
20 To 9 - Billy Joel
23 To 11 - Samantha Sang
30 To 20 - John Williams
35 To 17 - Raydio
40 To 28 - Con Funk Shun
Ex To 30 - Dan Hill

KBEQ - KANSAS CITY

- 1-1 - Queen
28 - Kenny Rogers
29 - Jackson Browne
30 - Lynyrd Skynyrd
10 To 4 - Billy Joel
18 To 8 - John Williams
19 To 2 - Bee Gees
20 To 15 - Leif Garrett
24 To 16 - Chic
30 To 19 - Samantha Sang

WBLI - LONG ISLAND

- 2-1 - Player
25 - El Coco
*Tom Petty
*Rita Coolidge
*Hall & Oates
*Andy Gibb
14 To 9 - Dolly Parton
17 To 12 - Santa Esmeralda/
Leroy Gomez
18 To 11 - Randy Newman
19 To 13 - Chic
25 To 15 - Bee Gees
28 To 22 - Dan Hill
29 To 27 - Lynyrd Skynyrd
30 To 24 - Steely Dan
Ex To 27 - E,W&F

KRTH - LOS ANGELES

- 1-1 - Rod Stewart
19 - Art Garfunkel
20 - Paul Davis
21 - Meco
22 - Johnny Rivers
11 To 8 - Dan Hill
13 To 10 - Paul Simon
15 To 6 - L.T.D.
17 To 12 - Samantha Sang
21 To 15 - Odyssey

KHJ - LOS ANGELES

- 1-1 - Randy Newman
19 - Samantha Sang
22 - Dan Hill
23 - James Taylor
29 - Little River Band
30 - Steely Dan
14 To 7 - Rod Stewart
15 To 10 - ELO
23 To 3 - Queen
24 To 21 - Santa Esmeralda/
Leroy Gomez
28 To 20 - Billy Joel
Ex To 27 - Stevie Wonder

10-Q - LOS ANGELES

- 1-1 - Randy Newman
26 - L.T.D. - re-add
30 - Chic
*John Williams
*Little River Band
*Billy Joel
*Stevie Wonder
8 To 2 - Queen
9 To 4 - ELO
23 To 19 - Bay City Rollers
28 To 21 - Bee Gees
Ex To 10 - Player
Ex To 11 - Rod Stewart

WKLO - LOUISVILLE

- 1-1 - Queen
*Art Garfunkel
*Barry Manilow
*Andy Gibb
*Neil Diamond
WHBQ - MEMPHIS
2-1 - Con Funk Shun
29 - Natalie Cole
*ELO
*Eric Clapton
12 To 7 - Commodores
15 To 10 - Dan Hill
18 To 15 - Rose Royce
22 To 16 - Billy Joel
25 To 17 - Queen
24 To 21 - Styx
28 To 22 - Pockets
29 To 19 - Bee Gees

WQAM - MIAMI

- 3-1 - Bee Gees
9 To 2 - Billy Joel
12 To 7 - Bob Welch
23 To 11 - Odyssey
27 To 14 - Randy Newman
29 To 13 - Santa Esmeralda/
Leroy Gomez
34 To 16 - Samantha Sang
36 To 22 - Emotions
40 To 24 - Chic
Ex To 33 - Bee Gees
Ex To 34 - Con Funk Shun
Ex To 35 - Andy Gibb
Ex To 36 - John Williams
Ex To 37 - Dan Hill
Ex To 38 - Paul Simon
Ex To 40 - Styx

WOKY - MILWAUKEE

- 2-1 - Queen
28 - John Williams/Meco
29 - Art Garfunkel
30 - LeBlanc & Carr
13 To 8 - Billy Joel
17 To 10 - Bee Gees
22 To 17 - Andy Gibb
24 To 20 - Bay City Rollers
25 To 21 - Dan Hill
28 To 24 - Leo Sayer
30 To 26 - Johnny Rivers
32 To 25 - Lynyrd Skynyrd

WZUU - MILWAUKEE

- 1-1 - Queen
*John Williams
*Rita Coolidge
*Kiss
10 To 4 - Billy Joel
14 To 3 - Bee Gees
20 To 13 - Dan Hill
Ex To 19 - Steely Dan
Ex To 20 - Samantha Sang

KSTP - MINNEAPOLIS

- 2-1 - Bee Gees
*Rod Stewart
*LeBlanc & Carr
*Jay Ferguson
*Wet Willie
*Lynyrd Skynyrd
11 To 5 - Randy Newman
25 To 20 - John Williams
28 To 13 - Bee Gees
Ex To 29 - Little River Band
Ex To 30 - Odyssey

WHY - MONTGOMERY

- 1-1 - Queen
*Bill Withers
*B.J. Thomas
*Rita Coolidge
**Bee Gees
*Boz Scaggs
11 To 7 - Donna Summer
15 To 10 - Little River Band
19 To 11 - John Williams
21 To 13 - Wings
28 To 19 - Meco
Ex To 20 - Johnny Paycheck
Ex To 24 - Lou Rawls
Ex To 25 - Chic
Ex To 27 - Firefall

WLAC - NASHVILLE

- 4-1 - Player
38 - Little River Band
*Rita Coolidge
*Steely Dan
*Abba
*B.J. Thomas
**Foreigner
7 To 3 - Billy Joel
15 To 4 - L.T.D.
17 To 13 - Bee Gees
18 To 5 - Con Funk Shun
22 To 10 - E,W&F
28 To 15 - Neil Diamond
30 To 18 - Millie Jackson
32 To 23 - Dan Hill
33 To 20 - Rose Royce
34 To 19 - Chic
Ex To 34 - Ronnie Milsap
Ex To 36 - Queen
Ex To 37 - Eric Clapton
Ex To 39 - Meco

WMAK - NASHVILLE

- 2-1 - Randy Newman
*Rita Coolidge
*Tom Petty
14 To 10 - Bob Welch
18 To 14 - Bee Gees
19 To 11 - Dan Hill
25 To 12 - Santa Esmeralda/
Leroy Gomez
26 To 14 - Lynyrd Skynyrd
29 To 24 - Con Funk Shun
30 To 17 - E,W&F
Ex To 29 - Bill Withers
Ex To 30 - Heatwave

WAVZ - NEW HAVEN

- 1-1 - Queen
25 - Natalie Cole
27 - Wet Willie
28 - Donna Summer
29 - Leo Sayer
10 To 3 - Bee Gees
14 To 6 - Rose Royce
18 To 9 - Heatwave
22 To 10 - Dan Hill

WTIX - NEW ORLEANS

- 2-1 - Queen
*Rita Coolidge
*Heart
*War
**Linda Ronstadt
12 To 7 - Andy Gibb
23 To 10 - Bee Gees
24 To 11 - Billy Joel
33 To 12 - Bay City Rollers
Ex To 20 - KC & The Sunshine Bnad
Ex To 26 - John Williams
Ex To 36 - Jay Ferguson
Ex To 39 - Leo Sayer
Ex To 50 - Natalie Cole

WABC - NEW YORK

- 1-1 - Bee Gees
15 - Bee Gees
13 To 10 - Dolly Parton
14 To 5 - Randy Newman
21 To 14 - Styx
22 To 18 - Paul Simon
36 To 22 - ELO

99-X - NEW YORK

- 1-1 - Bee Gees
24 - Styx
33 - Lynyrd Skynyrd
34 - Dan Hill
35 - Con Funk Shun
36 - Wet Willie
15 To 6 - Dolly Parton
17 To 8 - Rod Stewart
18 To 11 - ELO
19 To 7 - Billy Joel
21 To 18 - Samantha Sang
27 To 20 - Donna Summer
28 To 16 - Bob Welch
29 To 25 - Santa Esmeralda/
Leroy Gomez
30 To 15 - Bee Gees
Ex To 17 - Paul Simon
Ex To 27 - Steely Dan
Ex To 28 - Billy Joel
Ex To 30 - Kiss
Ex To 31 - Linda Ronstadt
Ex To 32 - Commodores

WKY - OKLAHOMA CITY

- 2-1 - Randy Newman
*Chic
*Meco
*Stevie Dan
14 To 8 - Paul Simon
19 To 10 - Billy Joel
20 To 9 - Bee Gees
Ex To 18 - Dan Hill
Ex To 19 - E,W&F
Ex To 20 - Samantha Sang

BU105 - ORLANDO

- 12-1 - Bee Gees
27 - Styx
28 - E,W&F
29 - Neil Diamond
17 To 9 - Andy Gibb
22 To 16 - Leo Sayer
28 To 14 - Bee Gees

WOW - OMAHA

- 6-1 - Randy Newman
21 - Kenny Rogers
22 - Abba
*Tom Petty
19 To 14 - Samantha Sang
20 To 12 - John Williams
22 To 9 - Queen
23 To 11 - Andy Gibb

KDWB - MINNEAPOLIS

- 2-1 - Player
21 - Andy Gibb
22 - Steely Dan
25 - Little River Band
26 - Kansas
30 - ELO
19 To 6 - Randy Newman
21 To 10 - Dolly Parton
25 To 20 - Linda Ronstadt
30 To 12 - Bee Gees

WIRL - PEORIA

- 4-1 - Paul Simon
10 - Shaun Cassidy
26 - L.T.D.
28 - Bee Gees
30 - Jay Ferguson
8 To 3 - Player

WFIL - PHILADELPHIA

- 1-1 - Bee Gees
*Lou Rawls
*Andy Gibb
*Bill Withers
8 To 3 - Billy Joel
18 To 14 - John Denver
Ex To 17 - Bee Gees
Ex To 21 - Samantha Sang

WIFI - PHILADELPHIA

- 1-1 - Player
9 To 3 - Billy Joel
27 To 19 - Paul Simon
Ex To 28 - Chic
Ex To 29 - Samantha Sang
Ex To 30 - Dolly Parton
WPEZ - PITTSBURGH
1-1 - Bee Gees
*Prism
*Al Martino
*Abba
18 To 14 - Billy Joel
20 To 15 - Andy Gibb
28 To 22 - Bee Gees
Ex To 39 - E,W&F
Ex To 40 - Heatwave

13-Q - PITTSBURGH

- 4-1 - Queen
30 - Linda Ronstadt - Poor
*Eddie Money
*Foreigner
11 To 6 - Billy Joel
14 To 10 - Dan Hill
21 To 17 - Chic
26 To 18 - Randy Newman
30 To 24 - Bee Gees

(continued on page 26)

Clive Davis

Hope we sound as
good to you at Arista,
as you do to us!
(See you in February)



Filthy Rich Record Co.

Filthy Rich Record Co. is an independent record producer.

(continued from page 24)

Ex To 28 — Abba
Ex To 29 — Heatwave
KYTE — PORTLAND
4-1 — Randy Newman
*Queen
*Paul Davis
15 To 5 — Billy Joel
18 To 9 — Dolly Parton
20 To 1 — Bee Gees
23 To 15 — Dan Hill
25 To 19 — L.T.D.
28 To 21 — Neil Diamond
Ex To 28 — E,W&F
Ex To 29 — Samantha Sang

KPAM — PORTLAND
1-1 — Rod Stewart
*Johnny Rivers
*Diana Ross
*Rita Coolidge
*Stillwater
*Art Garfunkel
17 To 13 — Samantha Sang
20 To 16 — Neil Diamond
27 To 23 — John Denver
28 To 18 — Queen
30 To 25 — John Williams
Ex To 27 — Wet Willie
Ex To 28 — Steely Dan
Ex To 29 — Lynyrd Skynyrd
Ex To 30 — Little River Band

WPRO — PROVIDENCE
1-1 — Player
*Johnny Rivers
*Rita Coolidge
*Steely Dan
*Yvonne Elliman
13 To 8 — Billy Joel
14 To 10 — Odyssey
15 To 11 — ELO
19 To 12 — Bee Gees
26 To 22 — John Williams
Ex To 21 — Chic
Ex To 25 — Leo Sayer
Ex To 26 — Diana Ross

WPRO-FM — PROVIDENCE
3-1 — Bee Gees
29 — John Williams
30 — Lynyrd Skynyrd
9 To 5 — L.T.D.

WKIX — RALEIGH
2-1 — Rod Stewart
*Lynyrd Skynyrd
*Eric Clapton
*Rita Coolidge
31 To 25 — Meco
10 To 6 — Leif Garrett
12 To 7 — Samantha Sang
13 To 9 — Randy Newman
18 To 13 — Ronnie Milsap
19 To 15 — Bay City Rollers
24 To 20 — Paul Simon
27 To 17 — Queen
28 To 20 — Dan Hill
30 To 23 — Heatwave
Ex To 26 — Chic
Ex To 27 — Andy Gibb

KKLS — RAPID CITY
5-1 — Neil Diamond
*Leo Sayer
*Wet Willie
*Rita Coolidge
*Prism
17 To 13 — Dan Hill
22 To 17 — Queen
Ex To 20 — Little River Band
Ex To 22 — Jay Ferguson

O-94 — RICHMOND
1-1 — E,W&F
*Lynyrd Skynyrd
*Dolly Parton
*Rita Coolidge
*Steely Dan
16 To 6 — Styx
17 To 6 — Bee Gees
20 To 11 — Dan Hill
22 To 15 — Santa Esmeralda/
Leroy Gomez
23 To 16 — Samantha Sang
Ex To 21 — Andy Gibb

KNDE — SACRAMENTO
1-1 — Randy Newman
*Van Halen
*Bobby Arvon
*Cowboy
*Rita Coolidge
**Fleetwood Mac — Gold Dust
16 To 8 — Shaun Cassidy
19 To 11 — Billy Joel
22 To 14 — Con Funk Shun
26 To 15 — Andy Gibb
Ex To 13 — Chic
Ex To 16 — Dolly Parton
Ex To 22 — Samantha Sang
Ex To 27 — Prism
Ex To 30 — Little River Band

KROY — SACRAMENTO
3-1 — Player
*Steely Dan
*Foreigner
*Kansas
11 To 7 — Bob Welch
12 To 5 — Randy Newman
15 To 10 — Styx
28 To 24 — Samantha Sang

KSLO — ST. LOUIS
1-1 — Queen
32 — Dan Hill
33 — Con Funk Shun
*Jackson Browne
*Prism
**Styx
11 To 4 — Rod Stewart
19 To 14 — Lynyrd Skynyrd
21 To 16 — Chic
30 To 13 — Bee Gees
32 To 28 — Heatwave

KXOK — ST. LOUIS
2-1 — Queen
30 — Meco
33 — Dan Hill
34 — Rita Coolidge

36 — Leo Sayer
37 — Natalie Cole
38 — Bill Withers
39 — Abba
40 — War
10 To 5 — Player
17 To 10 — Chic
22 To 11 — Rod Stewart
24 To 17 — ELO
27 To 21 — E,W&F

KCPX — SALT LAKE CITY
4-1 — Rod Stewart
*Paul Davis
*Chic
**Kansas — Dust
16 To 12 — Dan Hill
19 To 15 — Paul Simon
27 To 22 — KC & The Sunshine Band
28 To 23 — John Williams
30 To 24 — Samantha Sang
Ex To 26 — Andy Gibb
Ex To 27 — Rita Coolidge
Ex To 28 — E,W&F
Ex To 30 — Lynyrd Skynyrd

KRSP — SALT LAKE CITY
2-1 — Styx
*E,W&F
*Rita Coolidge
15 To 11 — Samantha Sang
16 To 10 — Bee Gees
24 To 19 — Jay Ferguson
25 To 20 — Little River Band
26 To 21 — John Williams
Ex To 23 — Firefall
Ex To 24 — Leo Sayer
Ex To 25 — Wet Willie

B-100 — SAN DIEGO
11 — Queen
23 — Neil Diamond
**Rod Stewart
10 To 3 — Bee Gees
13 To 8 — Dan Hill
17 To 10 — Styx
20 To 15 — Santa Esmeralda/
Leroy Gomez
22 To 17 — Dolly Parton
24 To 19 — Samantha Sang
28 To 21 — L.T.D.
30 To 25 — Little River Band

KCBO — SAN DIEGO
1-1 — Randy Newman
*Eric Clapton
*Rita Coolidge
31 To 25 — Meco
10 To 6 — Leif Garrett
12 To 7 — Samantha Sang
13 To 9 — Randy Newman
18 To 13 — Ronnie Milsap
19 To 15 — Bay City Rollers
24 To 20 — Paul Simon
27 To 17 — Queen
28 To 20 — Dan Hill
30 To 23 — Heatwave
Ex To 26 — Chic
Ex To 27 — Andy Gibb

KFRM — SAN FRANCISCO
1-1 — Randy Newman
24 — Lynyrd Skynyrd
*Samantha Sang
*Donna Summer
*Johnny Rivers
*KC & The Sunshine Band
13 To 7 — Bee Gees
14 To 10 — Dolly Parton
15 To 12 — ELO
21 To 17 — Tom Petty
22 To 15 — Chic
25 To 21 — Santa Esmeralda/
Leroy Gomez
26 To 18 — Billy Joel
28 To 25 — Paul Davis

KYA — SAN FRANCISCO
1 — Bee Gees
21 — Samantha Sang
22 — Dan Hill
24 — Bay City Rollers
KJR — SEATTLE
4-1 — Randy Newman
*Samantha Sang
*Chic
*Queen
14 To 8 — E,W&F
17 To 12 — Andy Gibb
20 To 16 — Bee Gees
Ex To 23 — Karla Bonoff
Ex To 24 — Rita Coolidge
Ex To 25 — Eric Clapton

KING — SEATTLE
2-1 — Rod Stewart
*Wet Willie
*Meco
*Samantha Sang
*Queen
*Art Garfunkel
15 To 4 — Billy Joel
18 To 10 — Bob Welch
24 To 13 — Dolly Parton
25 To 14 — Dan Hill
Ex To 15 — Neil Diamond
Ex To 16 — Andy Gibb
Ex To 23 — Paul Davis
Ex To 25 — Lynyrd Skynyrd

KJRB — SPOKANE
1-1 — Rod Stewart
*Steely Dan
*Wet Willie
*Rita Coolidge
*Stillwater
**Bee Gees — Night Fever
9 To 3 — ELO
10 To 4 — Samantha Sang
13 To 7 — L.T.D.
15 To 8 — Dolly Parton
17 To 10 — Dan Hill
25 To 19 — Bee Gees
Ex To 25 — Abba
Ex To 26 — Chic
Ex To 27 — Eric Clapton

KEEL — SHREVEPORT
6-1 — Rod Stewart
23 To 16 — Samantha Sang
26 To 21 — Johnny Rivers
29 To 22 — Neil Diamond
32 To 27 — Bill Withers
33 To 28 — Queen

WSPT — STEVENS POINT
1-1 — Jay Ferguson
*Little River Band
*Gene Cotton
*Abba
*Jackson Browne
17 To 10 — Samantha Sang
18 To 9 — Queen
22 To 17 — Lynyrd Skynyrd
28 To 22 — Steely Dan
Ex To 28 — Eric Clapton
Ex To 29 — Rita Coolidge
Ex To 30 — Meco

KTAC — TACOMA
3-1 — Barry Manilow
*L.T.D.
*Rita Coolidge
*Samantha Sang
*John Williams
*Stillwater
11 To 6 — Linda Ronstadt
12 To 7 — Rod Stewart
20 To 15 — ELO
21 To 17 — Paul Simon
Ex To 23 — Bee Gees
Ex To 24 — Queen
Ex To 25 — Dan Hill
Ex To 26 — Andy Gibb
Ex To 27 — Santa Esmeralda/
Leroy Gomez

KFOX — TULSA
2-1 — Bee Gees
29 — Chicago
30 — Con Funk Shun
10 To 3 — Queen
11 To 4 — Wings
14 To 8 — Samantha Sang
15 To 7 — Tom Petty
17 To 13 — Dan Hill
21 To 15 — Leo Sayer
26 To 20 — Raydio
30 To 22 — Donna Summer

KELI — TULSA
4-1 — Paul Simon
*Abba
*Heatwave
*Rita Coolidge
17 To 10 — Bee Gees
23 To 17 — Andy Gibb
25 To 20 — Queen
Ex To 27 — Dan Hill
Ex To 28 — Millie Jackson
Ex To 29 — Chic
Ex To 30 — Wings

98-Q — VIDALIA
5-1 — Randy Newman
*B.J. Thomas
*Heatwave
*Abba
*Rita Coolidge
*Tom Petty
11 To 6 — Elvis Presley
17 To 7 — Lynyrd Skynyrd
19 To 12 — Dan Hill
23 To 13 — E,W&F
24 To 18 — Samantha Sang
26 To 21 — David Gates
29 To 19 — Queen
31 To 25 — Commodores
32 To 22 — Chic
33 To 27 — Raydio
Ex To 30 — Lou Rawls
Ex To 31 — Eric Clapton
Ex To 33 — Steely Dan
Ex To 34 — Johnny Rivers

WPGC — WASHINGTON
3-1 — Bee Gees
29 — Andy Gibb
15 To 7 — Billy Joel
22 To 17 — Chic
28 To 19 — Dan Hill
Ex To 28 — Con Funk Shun
Ex To 30 — Abba

KLEO — WICHITA
1-1 — Santa Esmeralda/
Leroy Gomez
26 — Little River Band
27 — Kenny Rogers
10 To 2 — Bee Gees
15 To 8 — Billy Joel
16 To 10 — Wet Willie
26 To 17 — Andy Gibb
28 To 18 — Diana Ross

WAIR — WINSTON/SALEM
1-1 — Bee Gees
*David Gates
*Eric Clapton
*Rita Coolidge
*Gene Cotton
*The Babys
*Al Martino
*Meco
7 To 2 — Randy Newman
9 To 5 — Andy Gibb
11 To 5 — Dan Hill
13 To 8 — ELO
14 To 9 — Neil Diamond
15 To 11 — Lynyrd Skynyrd
20 To 16 — John Denver
22 To 18 — Chic
23 To 19 — Stillwater
24 To 14 — E,W&F
26 To 22 — Ronnie Milsap
27 To 21 — Odyssey
28 To 23 — Bill Withers
29 To 25 — Donna Summer
30 To 24 — Johnny Rivers
34 To 29 — Jay Ferguson
Ex To 32 — Mother's Finest
Ex To 33 — Commodores
Ex To 34 — Raydio
Ex To 35 — Prism
Ex To 36 — Leo Sayer

Executives On The Move

(continued from page 12)

nounced the appointment of Mike Bernardo as northeast regional promotion and marketing manager. Bernardo is the first woman at CBS Records to become a regional promotion marketing manager. She joined CBS Records in January 1976 as local promotion manager. Prior to this she was vice president of Buddy Scott Productions for seven years.

Barnes Upped At AVI — Andrew Barnes, who joined AVI Records staff two years ago in the production department, has been upped to west coast promotions coordinator, it was announced by American Variety International's recording subsidiary. Before joining AVI, he organized and directed the Consumer Affairs Program of the University of California at Los Angeles.

Ardrey To Drake-Chenault — Bob Ardrey, former FM group vice president of Merv Griffin Radio, has been appointed a regional manager for Drake-Chenault, the Canoga Park, California, based radio syndication company. He will headquarter in their California office, managing the program consulting services in the midwest including Minnesota, Wisconsin, Illinois, Iowa, Missouri, Kansas, Oklahoma and Texas.

Habbaz Promoted At MCA — Murray Habbaz has been promoted to sales manager of the Nashville branch for MCA Records. He joined MCA Records in 1973 as salesman in the Charlotte office, a position he held until this promotion.

Borowski Upped At Springboard — Springboard International Records, Inc. has announced the promotion of Barbara Borowski to regional credit manager for the west coast. She started in the accounting department of the company's Rahway, New Jersey home office, and moved to California to become regional credit representative.

Mitchell Promoted At CBS Records — CBS Records has announced the appointment of Emily Mitchell as manager, A&R, CBS Records, Nashville. In her new A&R managerial capacity, Ms. Mitchell's areas of concentration will be artist relations and administration, to include the scheduling of singles and album recording sessions for signed artists and managing of departmental budgeting and expenditures. She began her career with CBS Records in 1966 as an A&R staff assistant in Nashville.

Changes At Atlantic — Joanne Feltman Davidson has been appointed as assistant to the director of business affairs at Atlantic Records. In 1972, she began her music industry career with Albert Grossman Management and joined Atlantic's publishing department in 1974.

Verroche Named At Atlantic Records — Lorraine Verroche has been appointed as licensing manager for Atlantic Records and its custom labels. She joined Atlantic's publishing department in 1973. Before the music business, she was with the McGraw-Hill Book Company in their production department.

Blumer Leaves New Art — Lee Blumer is leaving her position as director of public relations at New Art Management/Chick Corea Productions. Her plans for the future will be announced shortly. In the meantime, she can be reached at (213) 933-1725.

Willen At Calliope And Festival — Phil Willen will be doing independent marketing and sales in the western region, and also will work as a consultant for the Calliope and Festival labels. Willen will be operating from 15910 Ventura Blvd., Suite 603, Encino, Calif., 213-981-9340.

Vinton Names Polotowsky — Andrea Polotowsky has joined Bobby Vinton's personal staff as his publicity manager. Previously she was an account executive at Noreen Jenney Communicates.

New Direction Names Mousari — New Direction Management has announced the appointment of Ellen Mousari as record company coordinator. Prior to joining New Director Mgmt. she was at Ariola Records where she was national secondaries coordinator. She was also with ABC Records where she was an executive secretary to the vice-president of corporate relations.

Joffee Promoted — The promotion of Eve Joffee to administrative assistant to the president at Levinson Associates, Inc. has been announced. She joined the company at its Los Angeles headquarters office last year, following prior affiliations with Katz-Gallin-Cleary and television producer Chris Bearde.

Barte Promoted — Helene Barte has been promoted to account director at The Howard Bloom Organization, Ltd. Barte, who joined the Howard Bloom Organization in 1976, was previously publicity coordinator at the organization and was director of publicity at the Acupuncture Information Center of N.Y. and the Hebrew Home for the Aged.

Rowe To Secret Sound — The Secret Sound Studio has announced the addition of Rick Rowe to their engineering staff.

Fontana Expands — Joe Fontana Associates has announced that Steve Altman has joined his office. He was formerly an agent with Associate Booking Corp. He also worked at one time with Somerset Talent.

Costello To AVI — Erin Costello has joined AVI Records as production manager for the west coast label, a subsidiary of American Variety International. She previously served in the same capacity for Polydor/MGM, as well as at Chelsea, where she was also assistant to the sales vice-president. Previously she was a production assistant manager at Atlantic and an A&R coordinator for Elektra in New York.

Joe Smith To Host Rock Sports Classic

NEW YORK — The "First Annual Rock 'N Roll Sports Classic," a two-hour prime time special produced by Aucoin Productions and Teram Productions, has been set to air on the NBC-TV network in the spring.

The show, featuring rock stars who will compete in athletic events, will be hosted by Joe Smith, chairman of Elektra/Asylum Records. Executive producer for the show will be Bob Finkel, president of Teram Productions, and Tony Vera has been selected as the show's director. Billy Miller will serve as executive talent coordinator.

The show was created by Al Ross, president of The Press Office, Ltd.

Di Martino Named VP At Velvet Frog Label

LOS ANGELES — Andy Di Martino has been named executive vice president of the newly formed Velvet Frog Record Label. Recently Di Martino, a 17-year veteran of the music industry, has been producing in Canada.

One Stop Gets Sylvers

LOS ANGELES — ZIV International Inc. has licensed the manufacturing rights to posters, buttons and belt buckles bearing the name and likeness of Capitol recording group The Sylvers to One Stop Poster Company, a Los Angeles-based company.

POP RADIO

A N A L Y S I S

MOST ADDED RECORDS

1. **THE WAY YOU DO THE THINGS YOU DO** — RITA COOLIDGE — A&M
2. **(THEME FROM) CLOSE ENCOUNTERS** — JOHN WILLIAMS — ARISTA
3. **THE NAME OF THE GAME** — ABBA — ATLANTIC
4. **WONDER WORLD** — ART GARFUNKEL WITH JAMES TAYLOR & PAUL SIMON — COLUMBIA
5. **(THEME FROM) CLOSE ENCOUNTERS** — MECO — MILLENNIUM
6. **WHAT'S YOUR NAME** — LYNRYD SKYNYRD — MCA
7. **DANCE, DANCE, DANCE** — CHIC — ATLANTIC
8. **PEG** — STEELY DAN — ABC
9. **(LOVE IS) THICKER THAN WATER** — ANDY GIBB — RSO
10. **EMOTION** — SAMANTHA SANG — PRIVATE STOCK
11. **HAPPY ANNIVERSARY** — LITTLE RIVER BAND — CAPITOL
12. **I GO CRAZY** — PAUL DAVIS — BIG TREE
13. **SOMETIMES WHEN WE TOUCH** — DAN HILL — 20TH CENTURY
14. **DESIREE** — NEIL DIAMOND — COLUMBIA
15. **OUR LOVE** — NATALIE COLE — CAPITOL
16. **LAY DOWN SALLY** — ERIC CLAPTON — RSO
17. **CURIOUS MIND (UM, UM, UM, UM, UM, UM)** — JOHNNY RIVERS — BIG TREE
18. **THUNDER ISLAND** — JAY FERGUSON — ASYLUM

This To
Week Date

STATIONS ADDING THIS WEEK

- | | | |
|-----|-----|---|
| 23% | 23% | WRKO, WQXI, WLAC, WAYS, Q94, KXOK, WZUU, WTI, WDR, WMAK, Z93, KNDE, WVBF, KIMN, KTAC, WING, KJRB, WHHY, KPAM. |
| 14% | 42% | WKBW, Z93, WPRO-FM, WDR, 96X, WZUU, 10Q, WOKY, WMET, WNCI, KERN, KTAC. |
| 12% | 51% | WRKO, WBBQ, KGW, KXOK, WPEZ, WLAC, KIOA, WOW, WING, WISM. |
| 12% | 12% | KLIF, KILT, CKLW, KING, KGW, KRTH, WOKY, KPAM. |
| 10% | 49% | WKBW, Z93, KING, WDRQ, KRTH, KXOK, WOKY, WKY, KCBQ. |
| 10% | 52% | KFRC, 99X, WPRO-FM, 96X, KSTP, Q94, WMET, KCBQ, KBEQ. |
| 10% | 70% | KLIF, KILT, 10Q, KCPX, WKY, WAYS, KJR, WVBF, KIMN. |
| 9% | 10% | KLIF, KHJ, KDWB, WKY, Q94, WLAC, KJRB, KCBQ. |
| 9% | 85% | WPGC, KLIF, CKLW, WFIL, KDWB, KYA, WKLO. |
| 8% | 86% | KHJ, KFRC, KING, KYA, KTLK, KJR, KTAC. |
| 7% | 32% | WKBW, 10Q, KDWB, WLAC, KERN, KLEO. |
| 7% | 47% | KHJ, WRKO, KRTH, KCPX, KYA, KXXK. |
| 7% | 79% | KHJ, 99X, KYA, KSLQ, KXOK, WMET. |
| 7% | 86% | B100, WKLO, KCBQ, WVBF, KXXK, BJ105. |
| 5% | 8% | WPGC, KXOK, WDRQ, WHBQ. |
| 5% | 37% | WHBQ, WAYS, KERN, WING. |
| 5% | 49% | KFRC, KRTH, WCAO, KPAM. |
| 5% | 50% | WRKO, KSTP, KERN, WISM. |

RADIO ACTIVE SINGLES

1. **STAYIN' ALIVE** — BEE GEES — RSO
CKLW 18-3, WFIL ex-17, WRKO 18-9, KFRC 13-7, KLIF 19-10, KHJ 26-5, WKBW 15-9, WLAC 17-13, WQAM ex-33, 13Q 30-24, WAYS 25-10, Q94 17-8, WKY 20-9, WCAO 10-3, B100 10-3, KSTP 28-13, KDWB 30-12, WPEZ 28-22, KCPX 15-9, WOKY 17-10, 10Q 28-21, KSLQ 30-13, WZUU 14-3, WMP 28-22, 96X 29-18, WDRQ 15-3, KGW ex-20, WTI 23-10, WHBQ 29-19, WDR 29-20, Q102 ex-24, Z93 10-2, WMAK 18-4, 99X 30-15, KIOA 12-4, KJR 20-16, WOW 8-3, KERN 28-22, KJRB 25-19, KLEO 10-2, KNDE 28-4, KBEQ 19-2, KTAC ex-23, BJ105 28-14.
2. **JUST THE WAY YOU ARE** — BILLY JOEL — COLUMBIA
WLS 24-13, CKLW 8-4, WFIL 8-3, WPGC 15-7, KILT 20-9, WRKO 22-15, KFRC 26-18, KHJ 28-20, WHBQ 22-16, WLAC 7-3, WQAM 9-2, 13Q 11-6, WMET 27-22, WKY 19-10, WCAO 17-8, WPEZ 20-15, WOKY 13-8, WFI 9-3, WZUU 10-4, WMP 17-9, KGW 13-6, WTI 24-11, KING 15-4, WDR 14-4, 99X 19-7, WNCI 19-12, KLEO 15-8, KNDE 19-11, KCBQ 23-13, KBEQ 10-4.
3. **SOMETIMES WHEN WE TOUCH** — DAN HILL — 20th CENTURY
WPGC 28-19, KILT ex-30, WRKO 30-25, WKBW 20-14, WHBQ 15-10, WMAK 19-11, Q102 ex-30, WDR ex-27, KING 25-14, WDRQ ex-29, WMP 18-13, WZUU 20-13, KRTH 11-8, WOKY 25-21, KCPX 16-12, B100 13-8, WCAO 29-24, WKY ex-18, Q94 18-11, WAYS ex-19, 13Q 14-10, WQAM ex-37, WLAC 32-23, KIOA 21-10, KERN ex-27, KJRB 17-10, KCBQ 24-17, KTAC ex-25.
4. **EMOTION** — SAMANTHA SANG — PRIVATE STOCK
WQXI 19-11, WFIL ex-21, KILT 23-11, WRKO 15-10, KLIF 7-3, WKBW 30-20, Z93 25-19, 99X 21-18, 96X 10-2, WZUU ex-20, KRTH 17-12, WFI ex-29, KCPX 30-24, B100 24-19, WCAO 16-7, WKY ex-20, Q94 23-16, KEEL 23-16, WQAM 34-16, WLAC 13-6, KPAM 17-13, WOW 19-14, KERN 23-19, KJRB 10-4, KNDE ex-22, KCBQ 28-14, KBEQ 30-19, KIMN ex-30.
5. **(LOVE IS) THICKER THAN WATER** — ANDY GIBB — RSO
WRKO 16-11, WQAM ex-35, Q94 ex-21, WCAO 22-16, WPEZ 18-14, KCPX ex-26, WOKY 22-17, 96X 20-9, WDRQ 27-22, KGW 19-15, WTI 12-7, KING ex-16, WKBW ex-28, KJR 17-12, WOW 23-11, KLEO 16-10, KNDE 26-15, KCBQ 16-12, WVBF ex-21, KTAC ex-26, BJ105 17-9.
6. **TURN TO STONE** — ELO — UNITED ARTISTS
WABC 36-22, WLS 20-16, CKLW 17-13, KFRC 15-12, KLIF 11-7, KHJ 15-10, WKBW 19-15, 99X 18-11, Q102 13-7, KING 22-17, KGW 25-21, WDRQ 13-9, 10Q 9-4, KXOK 24-17, KTLK 8-3, WAYS ex-25, KEEL 9-5, KERN 29-23, KJRB 9-5, KTAC 20-15.
7. **DANCE, DANCE, DANCE** — CHIC — ATLANTIC
WPGC 22-17, WRKO 14-8, KFRC 22-15, WDR 23-14, WKBW ex-25, KSLQ 21-16, KXOK 17-10, WFI ex-28, WOKY 31-27, WCAO 23-17, 13Q 21-17, WQAM 40-24, WLAC 34-19.
8. **HERE YOU COME AGAIN** — DOLLY PARTON — RCA
WABC 13-10, WRKO 10-7, KFRC 14-10, B100 22-17, KDWB 21-10, WFI ex-30, 96X ex-24, WDRQ 10-6, KGW 18-14, KING 24-13, WDR 19-9, 99X 15-6, WKBW 10-6, KNDE ex-16, KIMN 16-12, WNCI 11-7, KJRB 15-8.

SECONDARY RADIO ACTIVE

Titles listed below are receiving strong radio support from key secondary stations around the country.

1. **THE WAY YOU DO THE THINGS YOU DO** — RITA COOLIDGE — A&M
Adds: KRKE, WANS, WMFJ, Z-96, WKIX, 98Q, WAIR, KFMD, WPRO, KKLS, KRSP. Jumps: WSPT ex-29.
2. **THUNDER ISLAND** — JAY FERGUSON — ASYLUM
Adds: WCUE, KAFY, WIRL, WDBQ. Jumps: KFMD 21-17, KRSP 24-19, WMFJ 31-21, KKLS ex-22, WISE 27-23, WAIR 34-29.
3. **HAPPY ANNIVERSARY** — LITTLE RIVER BAND — CAPITOL
Adds: WSPT, KYNO, WRFC, WISE, KRKE. Jumps: WTRY 26-22, KRSP 25-20, WMFJ 24-20, KKLS ex-20, KAFY ex-29.
4. **(THEME FROM) CLOSE ENCOUNTERS** — JOHN WILLIAMS — ARISTA
Adds: KAFY, KFMD. Jumps: WAIR 25-20, KRSP 26-21, KKLS ex-21, WPRO 26-22, KYNO ex-24, WRFC 29-25, WANS ex-30.
5. **STREET CORNER SERENADE** — WET WILLIE — EPIC
Adds: WAUZ, KKLS, KFMD, KYTE, KRKE. Jumps: WANS 25-19, WMFJ 27-22, KRSP ex-25.
6. **ALWAYS & FOREVER** — HEATWAVE — EPIC
Adds: WCUE, 98Q. Jumps: WAVZ 18-9, WKIX 30-23, WANS ex-27, WAIR 36-31, WMFJ ex-31, WRFC ex-35.
7. **(THEME FROM) CLOSE ENCOUNTERS** — MECO — MILLENNIUM
Adds: WAIR, KYTE. Jumps: WMFJ 32-23, WKIX 31-25, WCUE 38-31, WRFC ex-34, WSPT ex-38.
8. **CURIOUS MIND** — JOHNNY RIVERS — BIG TREE
Adds: Z-96, KYNO, WPRO. Jumps: WAIR 30-24, WISE ex-24, WANS ex-32.
9. **LAY DOWN SALLY** — ERIC CLAPTON — RSO
Adds: WAIR, WKIX, KAFY, KRKE. Jumps: WRFC 26-21, WSPT ex-28.
10. **BEFORE MY HEART FINDS OUT** — GENE COTTON — ARIOLA
Adds: WSPT, WAIR, WISE. Jumps: WMFJ ex-32.

FM ALBUM CHART

TW	WKS	Actv. Reg.	TITLE	ARTIST	LABEL	CB LP Chart Pos.	PRIME CUTS
1	3	N	Running On Empty	Jackson Browne	Asylum	11*	Various
2	9	N	Out Of The Blue	ELO	Jet	5	Turn To Stone, Thunder, Standing In
3	7	N	Slowhand	Eric Clapton	RSO	20*	Cocaine, Sally, Peaches, The Core
4	8	N	Foot Loose & Fancy Free	Rod Stewart	WB	3	Hot Legs, You're Insane, In My Heart, Title
5	10	N	News Of The World	Queen	Elektra	4*	Rock You, Champions, Who Needs You, It's Late
6	3	N	Don Juan's Reckless Daughter	Joni Mitchell	Asylum	23*	Various
7	15	N	The Stranger	Billy Joel	Columbia	12*	Italian Rest., Just The Way, Moving
8	10	N	Street Survivors	Lynyrd Skynyrd	MCA	24	That Smell, I Never Dreamed, Got That Right
9	14	N	Aja	Steely Dan	ABC	15	Black Cow, Deacon, Home, Peg
10	8	N	My Aim Is True	Elvis Costello	Columbia	54	Working Week, Miracle Man, Alison, Detectives, Zero, Red Shoes
11	6	N	Down Two Then Left	Boz Scaggs	Columbia	14	1993, Hard Times, Still Falling
12	12	N	Point Of Know Return	Kansas	Kirshner	19	Dust, Paradox, Lightning's, Title
13	13	N	Little Criminals	Randy Newman	WB	30	Short, Einstein, Germany, Coppers
14	15	N	Simple Dreams	Linda Ronstadt	Asylum	8	Poor, Bayou, Carmelita, Dice
15	15	N	French Kiss	Bob Welch	Capitol	25	Sentimental, Ebony, Mystery
16	3	N	Draw The Line	Aerosmith	Columbia	13*	Hand That Feeds, Kings And Queens, Milk Cow, Title
17	12	N	Eddie Money	Eddie Money	Columbia	98	Two Tickets, You've Really Got, Jealousy
18	16	N	Seconds Out	Genesis	Atlantic	74	Squonk, I Know What, Supper's, Cinema Show, Los Endos
19	4	N	All 'N' All	Earth, Wind & Fire	Columbia	7	Magic Mind, Jupiter, Fantasy, Song For You
20	7	N	The Grand Illusion	Styx	A&M	16	Come Sail Away, Fooling Yourself, Castle
21	9	1,3,5	Spectres	Blue Oyster Cult	Columbia	119	Godzilla, Leather, Fireworks, Love The Night
22	7	1,3	Works Volume II	ELP	Atlantic	44	Tiger, Brain Salad
23	6	1,3,5	Rick Danko	Rick Danko	Arista	104	Java Blues, Small Town Talk
24	—	1,4,5	Player	Player	RSO	41*	Baby Come Back
25	5	1	Bat Out Of Hell	Meat Loaf	Epic	84	Paradise, Words, Revved Up, Title
26	10	1,3,5	Moonflower	Santana	Columbia	65	She's Not There, Black Magic Woman
27	7	3,5	Touch And Gone	Gary Wright	WB	134	Night Ride, Title
28	6	1,3,5	Decade	Neil Young	Reprise	56	Broken Arrow, Mr. Soul, Clancy
29	8	1,5	Heroes	David Bowie	RCA	121	Joe The Lion, Beauty, Title
30	—	1,3	Mama Let Him Play	Doucette	Mushroom	—	Title
31	15	N	Rumours	Fleetwood Mac	WB	2	Various
32	7	1,3,5	Manorisms	Wet Willie	Epic	138	Street Corner, Rain Man, One Track Mind
33	—	1	Love On The Wire	Clover	Mercury	—	
34	—	4	Longer Fuse	Dan Hill	20th Century	53*	Sometimes When We Touch
35	3	3,4	It Takes One To Know One	Detective	Swan Song	196	Help Me Up, Warm Love
36	11	1,4,5	Show Some Emotion	Joan Armatrading	A&M	95	Woncha, Opportunity, Title
37	5	1,2,3	Broken Heart	The Babys	Chrysalis	62	Isn't It Time
38	6	1,3	I, Robot	Alan Parsons	Arista	82	I Wouldn't Want To Be, Some Other Time
39	4	1,3	Live And Let Live	10cc	Mercury	107	Wall Street Shuffle, Not In Love
40	7	5	Expect No Mercy	Nazareth	A&M	142	Shot Me Down, Busted, Place In You Heart
41	13	1,5	Karla Bonoff	Karla Bonoff	Columbia	114	Someone To Lay, Can't Hold On
42	13	3,4	Livin' On The Fault Line	Doobie Brothers	WB	161	Echoes, Heartache, Title
43	14	3,5	Rough Mix	Townshend/Lane	MCA	169	My Baby, Streets
44	—	3,4,5	Galaxy	War	MCA	28*	Senorita, Title
45	4	1	Tom Petty And The Heartbreakers	Tom Petty	Shelter	109	Breakdown, Fooled Again, Strangered
46	6	1,3	Putting It Straight	Pat Travers	Polydor	125*	Life In London, Dedication
47	5	3,5	Levon Helm & The RCO All Stars	L. Helm & RCO	ABC	157	Washerwoman
48	—	5	Saturday Night Fever	Various	RSO	1*	Stayin' Alive
49	3	1	Girl's School/Mull Of Kintyre	Wings	Capitol	—	
50	3	4,5	Oxygene	Jean-Michel Jarre	Polydor	129	

KEY FOR FM LP CHART 1 - NORTHEAST REGION 2 - SOUTHEAST REGION 3 - MIDWEST REGION 4 - CENTRAL REGION 5 - WESTERN REGION N - NATIONAL AIRPLAY

Capitol Open House To Display Necam Console

LOS ANGELES — Capitol Recording Studios will host a special studio open house on Feb. 6 to acquaint the industry with the multi-million dollar facility's latest technical and cosmetic advances. The open house will be held at Capitol Studios, in the Capitol Records Tower in Hollywood.

Highlighting the open house will be the unveiling of Capitol's newly-designed studio B, which includes a new, custom-built 24-track Neve Necam V computer assisted mixing and recording console. The Necam's memory banks can retain up to 999 complete 24-track mixes, and at a touch of the button the console's operator can recall and/or merge any single track or group of tracks to reach the final 24-track mix desired.

Lester Forms Company

NEW YORK — A new independent production company, Sonny Lester Productions, Inc., has been formed to produce artists other than those recorded exclusively by Sonny Lester for TK Records under a contract between TK and Lester Radio Corporation. The first artist signed by the new company is jazz guitarist Jimmy Ponder, who has previously recorded for ABC's Impulse label.

Headliners Talent Acts

NEW YORK — Slave, Ritchie Havens, Melanie, Phyllis Hyman, Wild Cherry, The Paul Winter Consort, Hot, David Sanborn, Fairport Convention, James Cotton, Norman Connors and Pharoah Sanders have signed for representation with Headliners Talent Agency, Inc.



SILVER EMOTIONS — Sheila Whitt, Wanda Hutchinson and Pamela Hutchinson, better known as the Emotions, were recently presented with silver discs by CBS in London for their single "The Best Of My Love." Pictured (l-r) at the presentation are: Whitt; Tony Woolcott, director of marketing, CBS Records, U.K.; Wanda Hutchinson; Rick Chiaro, manager; Pamela Hutchinson; Peter Robinson, director of international A&R, CBS Records, U.K.



SEA LEVEL
Cats On The Coast
Capricorn
(21 stations)



JOURNEY
Infinity
Columbia
(13 stations)

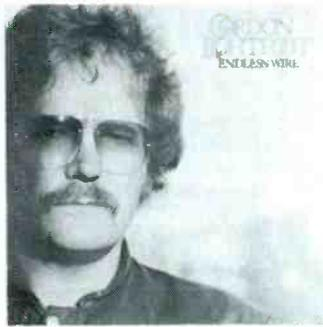

GORDON LIGHTFOOT
Endless Wire
Warner Bros.
(12 stations)



ANGEL
White Hot
Casablanca
(9 stations)



RONNIE MONTROSE
Open Fire
Warner Bros.
(7 stations)

WNEW-FM — NEW YORK — Tom Morrea
Gordon Lightfoot
Emmylou Harris
Alessi
The Hometown Band
Herb Alpert/Hugh Masekila
Hoyt Axton
George Thorogood and The Destroyers
Angel
Groove Holmes
Shirley Aulson
The Hollies (imp)
Art Garfunkel (45)
WRNW-FM — WESTCHESTER — Harris Allen
Seawind
Peter Allen
Dave Loggins
Dan Hill
Gordon Lightfoot
Steve Winwood
War
WPLJ-FM — NEW YORK — Gloria Ehrenfeld/Kathy Young
Dan Hill
Eric Clapton
Art Garfunkel (45)
WBAB-FM — LONG ISLAND — Bernie Bernard
Angel
Horslips
Alessi
Journey
Gordon Lightfoot
The Hometown Band
Emmylou Harris
The Hollies (imp)
WLIR-FM — LONG ISLAND — Denis McNarmara/Larry Kleinman
Alessi
Starz
The Sweet
Sea Level
Roy Wood's Whizzo Band (imp)
Robert Gordon (imp EP)
Art Garfunkel (45)
WJKL-FM — CHICAGO — Wally Lelsrlng/Tom Marker
Horslips
Journey
Al Green
Fenton Robinson
WXRT-FM — CHICAGO — Bob Gelms
Sea Level
KLOS-FM — LOS ANGELES — Ruth Pinedo
Aerosmith
The Bee Gees (45)
Eric Clapton (45)
KNX-FM — LOS ANGELES — Michael Sheehy
Gordon Lightfoot
Emmylou Harris
Hoyt Axton
Alessi
Joni Mitchell
Baby Grand
Aztec Two Step
Mark Gaddis

KWST-FM — LOS ANGELES — Charlie Kendall
Player
Journey
Sea Level
KNAC-FM — LONG BEACH — Bill Clay
Starz
Angel
Ian Dury (imp)
WIOQ-FM — PHILADELPHIA — Helen Leicht
Sea Level
The Sweet
Journey
Angel
Willie Loco Alexander and The Boom Boom Band
The Hollies (imp)
Art Garfunkel (45)
WABX-FM — DETROIT — Joe Krause
Sea Level
Sanford and Townsend (45)
KMEL-FM — SAN FRANCISCO — Tom O'Hair
Journey
Sea Level
Ronnie Montrose
Jay Ferguson
WBCN-FM — BOSTON — John Brodey
Willie Loco Alexander and The Boom Boom Band
Aztec Two Step
Sea Level
Horslips
KFWD-FM — DALLAS — Tim Spencer
Journey
Ronnie Montrose
Emmylou Harris
Detective
Van Halen (45)
Waylon Jennings and Willie Nelson (45)
Art Garfunkel (45)
KZEW-FM — DALLAS — Mike Hedges
Bill Withers
Sea Level
The Bee Gees (45)
KADI-FM — ST. LOUIS — Pete Parisl
Gordon Lightfoot
Emmylou Harris
Clover
Sea Level
Journey
KSHE-FM — ST. LOUIS — Ted Habeck
Ronnie Montrose
Angel
Journey
Horslips
WYDD-FM — PITTSBURGH — Steve Downes/Jack Robinson
Sanford and Townsend
Journey
Emmylou Harris
Gordon Lightfoot
KLOL-FM — HOUSTON — Sandy Mathis/Jackie McCawley
Taj Mahal
Ronnie Montrose
Gordon Lightfoot

June Tabor (imp)
The Enid (imp)
John Martin (imp)
Steeleye Span (imp)
Music From The Penguin Cafe Orchestra (imp)
John Denver (45)
Art Garfunkel (45)
WKIS — ATLANTA — Keith Allen
Sea Level
KZAM-FM — SEATTLE — Jon Kertzer
Emmylou Harris
Sea Level
Gordon Lightfoot
Fred Holstein
Lonesome Sundown
Bo Hansson
WGRO-FM — BUFFALO — John Velchoff
Rick Danko
Angel
Van Halen (45)
KOME-FM — SAN JOSE — Dana Jang
Sea Level
Journey
The Jam
KSJO-FM — SAN JOSE — Paul Wells
Horslips
Angel
Journey
Ronnie Montrose
Hawkwind
Emmylou Harris
Willie Loco Alexander and The Boom Boom Band
Starz
WCOL-FM — COLUMBUS — Guy Evans
Sea Level
WLVO-FM — COLUMBUS — Tom Teuber/Steve Runner
Sea Level
Supertramp
Santa Esmeralda/Leroy Gomez
WMC-FM — MEMPHIS — Ron Olson
Art Garfunkel
Sea Level
Companion
Chuck Mangione
Art Garfunkel (45)
Eric Clapton (45)
Jay Ferguson (45)
Bill Withers (45)
WKDA-FM — NASHVILLE — Jack Crawford/Clark Rogers
Ronnie Montrose
George Thorogood and The Destroyers
Gordon Lightfoot
Sanford and Townsend
Levon Helm and The RCO All-Stars
KZEL-FM — EUGENE — Stan Garrett
Sea Level
Angel
Linda Tillery
Starz
Journey
WCCC-FM — HARTFORD — Bill Nosal
Jan Hammer

WAIV-FM — JACKSONVILLE — James Brooks
Nazareth
Ramsey Lewis
Sea Level
WSAN-FM — ALLENTOWN — Rick Harvey
Sea Level
Eddie and The Hot Rods
Angel
Talking Heads
George Thorogood and The Destroyers
WLAV-FM — GRAND RAPIDS — Doc Donovan
Margaret Singana
Grover Washington Jr.
Becky Koch
Angel
Sea Level
Journey
John Hartford
Gordon Lightfoot
Ronnie Montrose
Sanford and Townsend
Bo Hansson
Dan Hill
Barry Melton (imp)
Eddie Money (45)
Crosby, Stills and Nash (45)
Johnny "Guitar" Watson (45)
Rita Coolidge (45)
Van Halen (45)
Firefall (45)
WPLR-FM — NEW HAVEN — Ed Michaelson
Fandango
Gordon Lightfoot
Sanford and Townsend
Art Garfunkel (45)
KRST-FM — ALBUQUERQUE — Bill Stambaugh
Al Stewart
Talking Heads
Clover
Prism (45)
Grinderswitch (45)
WOUR-FM — UTICA — Tom Starr
Horslips
Sea Level
Rosalie Sorrells
Stanley Cowell
Cowboy
Fred Holstein
Angel
Willie Loco Alexander and The Boom Boom Band
The Hollies (imp)
Van Halen (45)
WBLM-FM — PORTLAND — Jose Diaz
Gordon Lightfoot
Room Full Of Blues
Bill Chinook
Willie Loco Alexander and The Boom Boom Band
Sea Level
WUSB-FM — STONYBROOK — Jimmy Lieblich
Clover

Finding & Developing Acts Are Nemperor's Main Concerns

(Continued from page 8)

Stanley Clarke, Andy Pratt, Charlie Ainley, Jan Hammer and Robbin Thompson.

Should Participate

Because the promotion of Nemperor product is Weiss' top priority, he believes the label should participate in the related responsibilities. So Weiss plans to add to Nemperor's staff.

"Some of the responsibility should be ours," Weiss says. "There should be a special input on our side. Not that CBS doesn't have a good promotion department; there's just always room for imagination. So we hope to add about three promotion people to serve on our own level and to act as a liaison with CBS."

Cover Gaps

Weiss says the addition of a promotion department to the Nemperor staff will not cause a duplication of efforts problem but will "cover up the gaps and make sure that our records are not left behind."

The new promotion staff is part of a move to enlarge the entire Nemperor operation within the next two months. In February the label will open new offices, Weiss says, with plans to boost the artist roster to eight acts by the middle of March and to 12 acts by 1979.

"We rely on CBS for a lot of things at this moment," Weiss says, "but gradually as we acquire more people and enlarge, we are going to take on some of those responsibilities."

Not Merchandising

Merchandising, however, is not one of the jobs that Nemperor plans to become involved in, according to Weiss. That responsibility, he says, will be left to CBS.

"Merchandising is not high on the priority list for us," Weiss says. "I think CBS does a very good job and I really don't think that merchandising is often a very significant factor in the success of an artist. I think that standard merchandising is all that is

needed. CBS does a good job of merchandising for us. If we have an artist in a certain city, they do everything from the billboards to the store windows. That's good, garden variety, solid merchandising."

Weiss also plans to allow CBS to handle the bulk of Nemperor's publicity, although he says that job "can only at best be done adequately" by a large company. "I'm aware of all the people that CBS has to do publicity for," he says.

Individual Attention

Unlike a large record company, Nemperor is able to give each of its artists individual attention, at least in the area of career development, Weiss says. And this individual attention, he says, is the primary advantage of a custom label.

"It's the difference between going to a private doctor and a clinic," he says. "You get medical attention in both places, but a private doctor is going to care more and get more involved. At a custom label you cease

to be a statistic."

"I think artists need input," Weiss continues. "The first thing they say after they tell you what they want to do is 'What is your reaction?' They want a personal opinion from someone they respect. And unless I was a major artist in a big label, it might be difficult to get any personal input. I don't care who you are, unless you're one of the top 10 artists at CBS or Atlantic or Warner Bros., you might only see someone from the label twice a year."

Big Vs. Small

Weiss compares the evolution of the record business to the movie industry.

"Instead of the big studios, it's the small independent companies that are doing best now. I think that distribution and sales have to be big — and that's why we have huge companies like CBS and WEA. But I think the record company and the personnel should be small."

REGIONAL ALBUM ACTION

Northeast

1. JONI MITCHELL
2. DOLLY PARTON
3. PARLIAMENT
4. "CLOSE ENCOUNTERS"
5. NATALIE COLE
6. DAN HILL
7. CHIC
8. BETTE MIDLER
9. BILL WITHERS
10. MECO

Baltimore/ Washington

1. NATALIE COLE
2. PARLIAMENT
3. LOU RAWLS
4. ROBERTA FLACK
5. WAR
6. JONI MITCHELL
7. BILL WITHERS
8. CHIC
9. DAN HILL
10. PLAYER

Southeast

1. DOLLY PARTON
2. JONI MITCHELL
3. "CLOSE ENCOUNTERS"
4. SANTA ESMERALDA/
LEROY GOMEZ
5. ERIC CLAPTON
6. PARLIAMENT
7. PLAYER
8. GROVER WASHINGTON, JR.
9. WAR
10. DAN HILL

South Central

1. ERIC CLAPTON
2. JONI MITCHELL
3. "CLOSE ENCOUNTERS"
4. DAN HILL
5. PARLIAMENT
6. LEIF GARRETT
7. BETTE MIDLER
8. NATALIE COLE
9. WAR
10. GROVER WASHINGTON, JR.

Midwest

1. LEIF GARRETT
2. "CLOSE ENCOUNTERS"
3. JONI MITCHELL
4. ERIC CLAPTON
5. DOLLY PARTON
6. PLAYER
7. WAR
8. NATALIE COLE
9. MECO
10. PARLIAMENT

West/ Northwest

1. ERIC CLAPTON
2. SANTA ESMERALDA/
LEROY GOMEZ
3. JONI MITCHELL
4. WAR
5. PLAYER
6. SEAWIND
7. DOLLY PARTON
8. DAN HILL
9. "CLOSE ENCOUNTERS"
10. NATALIE COLE

Denver/ Phoenix

1. "CLOSE ENCOUNTERS"
2. ERIC CLAPTON
3. PLAYER
4. SANTA ESMERALDA/
LEROY GOMEZ
5. DAN HILL
6. JONI MITCHELL
7. CHIC
8. DOLLY PARTON
9. MECO
10. WAR

North Central

1. "SATURDAY NIGHT FEVER"
2. STORY OF STAR WARS
3. JACKSON BROWNE
4. "CLOSE ENCOUNTERS"
5. MECO
6. PLAYER
7. DAN HILL
8. DONNY & MARIE
9. STEVIE WONDER
10. STYX

National Breakouts

1. JONI MITCHELL
2. ERIC CLAPTON
3. "CLOSE ENCOUNTERS"
4. DOLLY PARTON
5. PLAYER
6. DAN HILL
7. NATALIE COLE
8. WAR

9. PARLIAMENT
10. SANTA ESMERALDA/
LEROY GOMEZ
11. LEIF GARRETT
12. CHIC
13. GROVER WASHINGTON, JR.
14. BILL WITHERS
15. BETTE MIDLER

TOP TEN ACCOUNT REPORTS

ABC Record & Tape/National

1. FLEETWOOD MAC
2. SHAUN CASSIDY — OLD
3. SHAUN CASSIDY — NEW
4. STEVE MILLER
5. ELVIS PRESLEY
6. KISS — II
7. LINDA RONSTADT
8. LONDON SYMPHONY ORCHESTRA
9. BARRY MANILOW
10. FOREIGNER

Wherehouse — Los Angeles

1. JACKSON BROWNE
2. FLEETWOOD MAC
3. LINDA RONSTADT
4. ELECTRIC LIGHT ORCHESTRA
5. KISS
6. BOB WELCH
7. QUEEN
8. RANDY NEWMAN
9. NEIL DIAMOND
10. "SATURDAY NIGHT FEVER"

Richman Bros. — Philadelphia

1. "SATURDAY NIGHT FEVER"
2. FLEETWOOD MAC
3. QUEEN
4. BILLY JOEL
5. FOREIGNER
6. KANSAS
7. EARTH, WIND & FIRE
8. ROD STEWART
9. STEVE MILLER
10. AEROSMITH

Everybody's — Portland

1. "SATURDAY NIGHT FEVER"
2. JACKSON BROWNE
3. BILLY JOEL
4. STEELY DAN
5. KARLA BONOFF
6. EARTH, WIND & FIRE
7. ERIC CLAPTON
8. BOB WELCH
9. ROD STEWART
10. KANSAS

Music Stop — Detroit

1. QUEEN
2. "SATURDAY NIGHT FEVER"
3. FOREIGNER
4. KANSAS
5. ELECTRIC LIGHT ORCHESTRA
6. NEIL DIAMOND
7. SHAUN CASSIDY
8. FLEETWOOD MAC
9. ALAN PARSONS
10. BEE GEES — LIVE

All Records — Oakland

1. ROD STEWART
2. QUEEN
3. "SATURDAY NIGHT FEVER"
4. BOZ SCAGGS
5. EARTH, WIND & FIRE
6. STORY OF STAR WARS
7. LINDA RONSTADT
8. AL GREEN
9. RANDY NEWMAN
10. DOLLY PARTON

Dan Jay — Denver

1. "SATURDAY NIGHT FEVER"
2. BILLY JOEL
3. ROD STEWART
4. STEVE MARTIN
5. FLEETWOOD MAC
6. JACKSON BROWNE
7. ELECTRIC LIGHT ORCHESTRA
8. FIREFALL
9. DOLLY PARTON
10. HEATWAVE

Camelot — National

1. "SATURDAY NIGHT FEVER"
2. QUEEN
3. SHAUN CASSIDY — OLD
4. KISS
5. BILLY JOEL
6. ROD STEWART
7. JACKSON BROWNE
8. AEROSMITH
9. ELECTRIC LIGHT ORCHESTRA
10. "CLOSE ENCOUNTERS"

Korvettes — National

1. "SATURDAY NIGHT FEVER"
2. FLEETWOOD MAC
3. LINDA RONSTADT
4. KISS
5. BILLY JOEL
6. ELECTRIC LIGHT ORCHESTRA
7. JACKSON BROWNE
8. QUEEN
9. AEROSMITH
10. BOZ SCAGGS

Music Plus — Los Angeles

1. "SATURDAY NIGHT FEVER"
2. QUEEN
3. JACKSON BROWNE
4. AEROSMITH
5. ELECTRIC LIGHT ORCHESTRA
6. STYX
7. FLEETWOOD MAC
8. ROD STEWART
9. BILLY JOEL
10. STEVE MILLER

Aura Sound — Memphis

1. JACKSON BROWNE
2. ERIC CLAPTON
3. STEELY DAN
4. ELECTRIC LIGHT ORCHESTRA
5. JONI MITCHELL
6. STEVE MILLER
7. AEROSMITH
8. LINDA RONSTADT
9. LYNRYD SKYNYRD
10. QUEEN

Rose Records — Chicago

1. "SATURDAY NIGHT FEVER"
2. QUEEN
3. LINDA RONSTADT
4. EARTH, WIND & FIRE
5. SHAUN CASSIDY — NEW
6. ELECTRIC LIGHT ORCHESTRA
7. ROD STEWART
8. KISS
9. RANDY NEWMAN
10. STEELY DAN

Cavages — Buffalo

1. "SATURDAY NIGHT FEVER"
2. STYX
3. BILLY JOEL
4. FLEETWOOD MAC
5. LINDA RONSTADT
6. ROD STEWART
7. KISS
8. EARTH, WIND & FIRE
9. NEIL DIAMOND
10. QUEEN

Harmony House — N.J.

1. "SATURDAY NIGHT FEVER"
2. BILLY JOEL
3. LINDA RONSTADT
4. ELECTRIC LIGHT ORCHESTRA
5. DEBBY BOONE
6. QUEEN
7. STYX
8. LYNRYD SKYNYRD
9. STEELY DAN
10. AEROSMITH

Lieberman — Minneapolis

1. STEELY DAN
2. STYX
3. LYNRYD SKYNYRD
4. LINDA RONSTADT
5. FLEETWOOD MAC
6. JACKSON BROWNE
7. ROD STEWART
8. EARTH, WIND & FIRE
9. BILLY JOEL
10. QUEEN

Waxie Maxie — Washington

1. "SATURDAY NIGHT FEVER"
2. QUEEN
3. EARTH, WIND & FIRE
4. STYX
5. KISS
6. ROBERTA FLACK
7. KANSAS
8. ROD STEWART
9. DOLLY PARTON
10. NATALIE COLE

Harvard Coop — Boston

1. JACKSON BROWNE
2. "SATURDAY NIGHT FEVER"
3. STEELY DAN
4. FLEETWOOD MAC
5. JONI MITCHELL
6. BILLY JOEL
7. STEVE MILLER
8. RANDY NEWMAN
9. TALKING HEADS
10. ERIC CLAPTON

Western — Amarillo

1. FLEETWOOD MAC
2. KISS
3. ROD STEWART
4. NEIL DIAMOND
5. AEROSMITH
6. DOLLY PARTON
7. DEBBY BOONE
8. LINDA RONSTADT
9. "SATURDAY NIGHT FEVER"
10. SHAUN CASSIDY — NEW

Disc — Texas

1. "SATURDAY NIGHT FEVER"
2. QUEEN
3. EARTH, WIND & FIRE
4. ROD STEWART
5. BOZ SCAGGS
6. KISS
7. NEIL DIAMOND
8. SHAUN CASSIDY — NEW
9. LINDA RONSTADT
10. JACKSON BROWNE

Soul Shack — D.C.

1. PARLIAMENT
2. ROBERTA FLACK
3. NATALIE COLE
4. LOU RAWLS
5. CON FUNK SHUN
6. BAR-KAYS
7. HEATWAVE
8. EARTH, WIND & FIRE
9. SLAVE
10. "SATURDAY NIGHT FEVER"

1812 Overture — Milwaukee

1. "SATURDAY NIGHT FEVER"
2. STYX
3. FLEETWOOD MAC
4. ALAN PARSONS
5. KANSAS
6. BILLY JOEL
7. STEELY DAN
8. QUEEN
9. JACKSON BROWNE
10. FOREIGNER

Record Shack — Atlanta

1. ROD STEWART
2. JACKSON BROWNE
3. BOZ SCAGGS
4. "SATURDAY NIGHT FEVER"
5. QUEEN
6. AEROSMITH
7. PARLIAMENT
8. ERIC CLAPTON
9. ISAAC HAYES
10. SHAUN CASSIDY — NEW

Record Theatre — Cleveland

1. "SATURDAY NIGHT FEVER"
2. QUEEN
3. EARTH, WIND & FIRE
4. KISS
5. ROD STEWART
6. LINDA RONSTADT
7. AEROSMITH
8. WAR
9. BILLY JOEL
10. ELECTRIC LIGHT ORCHESTRA

Specs — Miami

1. SEA LEVEL
2. BILLY JOEL
3. FLEETWOOD MAC
4. STEELY DAN
5. BOZ SCAGGS
6. ROD STEWART
7. JACKSON BROWNE
8. JIMMY BUFFETT
9. KANSAS
10. PAUL SIMON

Tiger — Detroit

1. PARLIAMENT
2. EARTH, WIND & FIRE
3. "SATURDAY NIGHT FEVER"
4. HEATWAVE
5. ASHFORD & SIMPSON
6. TEMPTATIONS
7. CHIC
8. NEW BIRTH
9. WAR
10. ODYSSEY

Record Bar — National

1. "SATURDAY NIGHT FEVER"
2. FLEETWOOD MAC
3. ROD STEWART
4. SHAUN CASSIDY — NEW
5. SHAUN CASSIDY — OLD
6. JACKSON BROWNE
7. QUEEN
8. EARTH, WIND & FIRE
9. KISS
10. STYX

Sound Warehouse — Dallas

1. "SATURDAY NIGHT FEVER"
2. PARLIAMENT
3. ELECTRIC LIGHT ORCHESTRA
4. DOLLY PARTON
5. ERIC CLAPTON
6. BOB WELCH
7. BAR-KAYS
8. WAR
9. STEELY DAN
10. "CLOSE ENCOUNTERS"

Father's & Sun's — Ind.

1. "SATURDAY NIGHT FEVER"
2. QUEEN
3. KANSAS
4. STYX
5. ROD STEWART
6. "CLOSE ENCOUNTERS"
7. BILLY JOEL
8. PARLIAMENT
9. PLAYER
10. GINO VANNELLI

Record Shack — New York

1. EARTH, WIND & FIRE
2. PARLIAMENT
3. "SATURDAY NIGHT FEVER"
4. COMMODORES
5. ROSE ROYCE
6. MILLIE JACKSON
7. CHIC
8. LENNY WILLIAMS
9. EL COCO
10. BARRY WHITE

Sam Goody — Philadelphia

1. QUEEN
2. BILLY JOEL
3. FLEETWOOD MAC
4. AEROSMITH
5. LYNRYD SKYNYRD
6. "SATURDAY NIGHT FEVER"
7. STEELY DAN
8. ELECTRIC LIGHT ORCHESTRA
9. ROD STEWART
10. BOB WELCH



ENCHANTMENT

ONCE UPON A DREAM

In the midst of a fantastic concert tour
Enchantment is creating tremendous excitement everywhere.
Now let them cast their spell over *you* with their second album,
"ONCE UPON A DREAM" . . . a natural follow-up to their
super-successful debut LP which contained
the smash hits "Gloria" and "Sunshine."
So, delight in the sound thrill created by ENCHANTMENT.

ENCHANTMENT
Once Upon A Dream
Including: You Must Be An Angel
Here It Comes / It's You That I Need
Angel In My Life

RS-LA811-G

Produced by Michael Stokes

www.americanradiohistory.com

on
Roadshow/UA
RECORDS UNITED ARTISTS RECORDS

MIDEM Shows International Growth According to Uttal

NEW YORK — Every year, the music industry becomes more truly international, and MIDEM is a symbol of that spirit. As Larry Uttal, president of Private Stock Records and a participant in many past MIDEMs, points out, "The basic thread that's running through all the conferences (this year) is the final realization on the part of almost everybody in the business that we are an international industry, rather than a domestic (U.S.) or chauvinistic one."

"All along MIDEM has exemplified this, and since this is the largest MIDEM ever, it exemplifies it even more. There's a hell of a world market out there."



Larry Uttal

Uttal, who recalls making "some very solid deals" over the years at MIDEM, intends to meet with all of Private Stock's foreign licensees at the worldwide conference in Cannes, France. Outside the U.S., the U.K. and Canada, Private Stock product is licensed to EMI. In the U.K., Uttal owns a separate company, Private Stock Records, Ltd., which is distributed by EMI.

Private Stock will also have a booth to display its merchandise at MIDEM, and this, says Uttal, is one of the key differences between MIDEM and other international

music business meetings. "Apart from having seminars and conferences, it is a true marketplace. It's like a world's fair of music. You go in, buy and sell and peddle your wares; 'I have a master, how much do you bid for this?' That's really what is."

'Everybody Goes'

MIDEM is a great place to make deals, Uttal states, because "it is a totally business-like atmosphere. People go there to work, not to play. There is a very pleasant atmosphere, due to the surroundings, and it is conducive to people getting together, lunching, socializing and doing business at the same time. And the marketplace — the festival — is so attractively set up, in terms of music, equipment and booths, that it is also conducive to deal-making. Everybody goes."

Last year, Private Stock had gold records in Mexico and Spain, and this year the label expects to receive similar awards in Japan, New Zealand, Australia, Germany, Holland, Belgium, and Scandinavia. "It's a pretty worldwide market for us," Uttal comments.

Private Stock's president foresees a steady rise in third-world record sales. "They (third-world nations) are coming up in records just as they are in every other aspect. There's a realization on the part of the people in the third world that they want to join the rest of the world — and they want to buy records."

Within 10 years, predicts Uttal, worldwide record sales will be significantly larger compared to U.S. sales than they are now. "I think they're growing. There's a greater awareness (of the international field), and the whole business is growing."

'Mull Of Kintyre' Is Biggest Single In U.K. History

LOS ANGELES — "Mull Of Kintyre," the most recent single from Paul McCartney And Wings, has become the best-selling single ever in the United Kingdom, according to EMI Records England.

EMI reports the single is rapidly approaching the two million mark in sales, and has replaced The Beatles' "She Loves You" as the largest selling single in British history. "She Loves You" held the record for 15 years.

The British music publication *Melody Maker* reports only 16 singles ever having sold more than one million copies since it began keeping charts. "Mull Of Kintyre" becomes number 17. *Melody Maker* also said no singles had sold more than one million units between 1968 and 1974.

First Number One

Wings' single entered *Melody Maker*'s chart at #18 last Nov. 26 and went to number one the following week, where it has remained since then. "Mull Of Kintyre," written by Paul McCartney and Denny Laine, is also the best-selling single in Australia and currently is number one in Germany, Holland and Belgium. The record was McCartney's first number one single in Britain since he left the Beatles in 1970.

Four From ASCAP To Attend MIDEM

NEW YORK — Four ASCAP officers, including Paul Marks, managing director, Paul Adler, director of membership, Arnold Gurwitch, head of the foreign department, and Lawrence Ross, who represents ASCAP in the United Kingdom, have been selected to represent the music licensing society at the annual MIDEM meeting in Cannes, France.

1977 CRIA Awards List Topped By CBS

TORONTO — During 1977, the Canadian Recording Industry Association certified 216 records: one quadruple platinum album, one triple platinum album, 7 double platinum albums, 64 platinum albums, 115 gold albums, 2 platinum singles and 26 gold singles. CBS topped the list with 58 certifications.

During the month of December, "Boston" by Boston (CBS) went over the 400,000 mark to qualify as the first quadruple platinum album to be certified by CRIA, and "A Star Is Born" by Barbra Streisand and Kris Kristofferson (CBS) qualified as the first triple platinum (300,000 units) album.

The first double platinum album to be certified by CRIA was awarded to United Artists in October for ELO's "A New World Record."

To qualify for gold status in the album category, sales in Canada must exceed 50,000 units. For gold status in the singles category, sales must exceed 75,000.

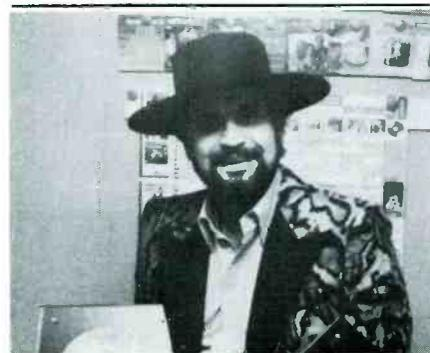

DRAFI DEUTSCHER BOOGIE GOLD — Drafi Deutscher recently received gold records as writer and producer of "Be My Boogie Woogie Baby," which was recorded by Mr. Walkie Talkie. The awards represented sales in Holland and Belgium.



MOTOWN AND EMI SIGN DEAL — Motown Records and EMI have signed a new licensing deal for continental Europe (except Spain and Portugal). Pictured (l-r) at the signing are: Wilfried Jung, EMI European coordinator; L.G. Wood, director, Group Records; Ken East, vice-president of international operations of Motown Record Corporation; and Ron Harris, EMI international repertoire acquisition manager.

WB Releases MacNeal Cover Version Of Theme From 'The One & Only' Film

by Peter Hartz

LOS ANGELES — In an effort to duplicate the success of Debby Boone's cover version of "You Light Up My Life," Warner Brothers has released a cover version of the soundtrack theme from "The One And Only," a new film by Paramount Pictures starring Henry Winkler. The single is sung by Maggie MacNeal from Holland. A series of radio promotions teaming MacNeal and Winkler are slated for February.

David Franco, director of artists and repertoire for WEA International, who was responsible for signing Boone to WB, was also instrumental in teaming MacNeal and the soundtrack theme.

"The selection of material is crucial. I look for a song that carries a very strong melody and appeals to an age bracket from 60 down to 10. My most important job is to bring the correct material to the right artist and then assemble the professional team. I selected Steve Barri, who is a staff producer at WB and Steve and I began looking for material. At the last moment, a representative from Famous Music, Paramount Pictures' music publisher brought us the theme from 'The One And Only.' We are very excited by the prospects. This record is being released by WB as a number one priority."

Mouth & MacNeal

MacNeal is not a newcomer. Ben Bunders, vice president of WEA/Holland, signed MacNeal in 1975. She had been a member of the duo Mouth And MacNeal whose "How Do You Do" reached #5 on the **Cash Box** Top 100 Singles Chart in August 1972. When Mouth And MacNeal broke up in 1974, Maggie was left without a contract. She was one of the first artists signed to the WEA affiliate in Holland.

"During the first year of Maggie's association with us," Bunder recalled, "I did not shoot for an American audience. It was necessary for her to build up her career in

Holland. And then add Germany and England and other European countries. Several months ago, we released a single of hers in Brazil called, 'When You're Gone,' a tune which Maggie wrote, and it was a great success. It takes a while for an American company like Warners that has more records from American artists put on their desk than they can put out, to get interested in a Dutch artist. However, I am regularly over here and every time in the last two years, I have been telling Warners about Maggie MacNeal. So the whole company was aware of the name. Then David and Stan Cornyn became involved."



Franco, MacNeal, Bunders

"Part of our policies at WEA International," Franco said, "is to develop artists not only in the country of original signing but on an international scale as much as possible. Maggie is an excellent example of this strategy. We realized that she had potential to go outside her own borders. To show you how fast we are working on this project, Maggie recorded the theme 'The One And Only' on a Saturday and the record was scheduled for release the next week."

Immediate plans for MacNeal include taping a German television show in Munich, participating in the San Remo Song Festival in Italy and promoting another film theme from the Italian production of "Winter In Berlin," a made-for-television piece starring Henry Fonda. She will then return to begin promotions of "The One And Only" with Winkler.

Where In The World . . .

Frankie Laine will tour Britain at the beginning of March, undertaking an extensive 17-date concert and cabaret tour which will culminate in an appearance at the London Palladium on April 23. Prior to the commencement of the tour, Frankie Laine will make a special guest-star appearance on BBC Television's series "Saturday Night At The Mill" on March 11.

Private Stock recording artist **Robert Gordon** is set to make his first major European tour. Beginning Jan. 10 in Munich, Gordon will tour Germany and Scandinavia and conclude the tour with a London engagement Jan. 26-Feb. 5. In addition to concert appearances, Gordon will also be taping television performances.

The Lettermen will headline a tour of Japan which starts Feb. 5 in Hamamatsu. The tour consists of 19 cities in 15 days. This is the sixth time the trio has toured the Orient.

Millie Jackson has been set for three venues in England later this month. Ms. Jackson's current album, "Feelin' Bitchy," was recently certified gold. Her tour concludes with performances at Hammersmith Odeon in London on Jan. 28-29.

Martha Reeves returned to the U.K. for a four week tour which began January 15. With two new Vandellas, **Vonclele Faggett** and **Francine Howard**, Martha has recently signed a contract with Fantasy Records and is recording her new album.

MIDEM 78 is the excitement of Cannes.
It is wine, people and songs.
And it is talking business with the representatives
of the world-wide CBS Music Publishing Group.
Which is always a pleasure.

Argentina

Howard Dean McCluskey — Manager
 Melograf S.R.L.
 Suipacha 476 (Subsuelo)
 Buenos Aires, Argentina
 Cable: Melograf Baries
 Phone: 49 6651/55

Australia

John Anderson — Manager
 April Music Pty. Ltd.
 Box 941, P.O. 2060
 North Sydney, N.S.W. Australia
 Cable: Colrecord East Sydney Australia
 Phone: 31-0255
 Telex: (790) 21246

Brazil

Luis A. Ferri — Manager
 Antonio Pinheiro De Silva
 Editora Latino Americana De Musica
 "Elam" S.A.
 Caixa Postal 7035
 ZC-58
 Rio De Janeiro, GB
 Brazil (ASCAP)

Belgium

Alain Olivier — Manager
 April Music Belgium/N.V.
 20 Rue Adolphe La Valle
 1080 Brussels
 Belgium
 Cable: Colrecord Brussels (Belgium)
 Telex: (846) 22642
 Phone: (02) 428-8007

Central America

Luis N. Salas — Manager
 Mundo Musical S.A.
 c/o Indica S.A.
 Apartado 4093
 San Jose, Costa Rica
 Cable: Indica Sanjose (Costa Rica)
 Phone: 21-31-22

Canada

Vivien Hicks — Manager
 Wayne Patton
 Director
 April Music (Canada) Ltd.
 1121 Leslie Street
 Con Mills, Ontario
 M3C 2J9 Canada
 Cable: Colrecord Canada Don Mills
 Phone: (416) 484-4448

France

Jean Claude Desmarty — Director
 Editions April Music
 3, Rue Freycinet
 75116 Paris, France
 Cable: Colrecord Paris
 Telex: 842 620646
 Phone: 720-5263

Greece

Sol Rabinowitz
 A.M. Feinberg
 Blackwood Music
 19 Syngrou Ave.
 Athens 403, Greece
 Cable: Colrecord Athens
 Telex: 216220
 Phone: (21) 9223168
 (21) 9233543

Germany

Hans Jorg Fischer — Manager
 April Musikverlag GMBH
 Ander Alster 83
 2000 Hamburg 1
 West Germany
 Cable: Colrecord Frankfurt
 Telex: 216 1240
 Phone: (040) 24 07 45-47

Israel

Ran Kedar — Manager
 April Music Limited
 P.O. Box 681
 Tel Aviv, Israel
 Cable: Colrecord Tel Aviv
 Phone: 840-191
 Telex: 33422

Italy

Antonio Marrapodi — Manager
 Edizioni April Music
 Via Amedei 9
 Milan, Italy
 Cable: Colrecord Milan
 Phone: 87 88 55
 Telex: 34343

Japan

Toshio Nirazuka — Managing Director
 April Music, Inc. (Japan)
 P.O. Box 17
 Tokyo International Airport
 Tokyo, Japan
 Cable: CBSSONYRECORD TOKYO
 Phone: (03) 585-2809, 1392
 Telex: (781) 24766

Mexico

Manuel Cervantes Rivers — Manager
 Mundo Musical, S.A.
 P.O. Box 24-471
 Mexico 7, D.F. Mexico
 Cable: COLRECORD MEXICO 7, D.F.
 Phone: 533-2080

The Netherlands

Bas Mul — Manager
 April Music Holland B.V.
 Stationsplein 82-84
 Haarlem-1501
 The Netherlands
 Cable: Colrecord Haarlem
 Phone: (023) 320525/(023) 319250
 Telex: (844) 41051

South Africa

John Edmond — Manager
 April Music Publishing Co. (PTY.) Ltd.
 P.O. Box 6216
 Gallo Centre
 Johannesburg 2000
 Republic of South Africa
 Cable: Aprimusic Johannesburg
 Phone: 28-2400
 Telex: 960 430153

Spain

Antonio Perez Solis — Manager
 April Music, S.R.L. (Spain)
 Avd. Generalisimo
 25-10 Pt.
 Madrid 16, Spain
 Cable: Colrecord Madrid
 Telex: 831 22890
 Phone: 248-6059 (direct)
 248-8000 (Ext. 26)

Sweden

Rolf S. Persson — Manager
 April Music Scandinavia AB
 Mariehallsvagen 40
 Box 20037, 161 20 Bromma
 Sweden
 Telex: (854) 17736
 Phone: 08-980250

United Kingdom

Len Beadle — Manager
 April Music Limited
 17-19 Soho Square
 London W1V 6HE
 England
 Cable: Aprimusic London W1
 Telex: (851) 24203
 Phone: (01) 734-8181

United States

April Blackwood Music, Inc.
 51 West 52nd St.
 New York, New York 10019
 Cable: Colrecord New York
 Phone: (212) 975-4321

Venezuela

Victor M. Oliver — General Manager
 Mundo Musical
 A Division of CBS/Colombia C.A.
 Apartado 70-169 Los Ruicés
 Caracas, Venezuela
 Cable: Colrecord Caracas
 Phone: 35-87-00

Yugoslavia

Dragan Smiljanic — Manager
 Favorite Music
 41000 Zagreb-PP 543
 Marticeva 21/11
 Yugoslavia
 Cable: Metalektro-Suzy, Zagreb
 Phone: 041-411-695
 041-447-992

INTERNATIONAL

Argentina

TOP TEN 45s

- 1 **Una Lagrima Y Un Recuerdo** — Grupo Miramar — Microfon
- 2 **Cara De Gitana** — Daniel Magal — CBS
- 3 **Amigo** — Roberto Carlos — CBS
- 4 **Por Muchas Razones Te Quiero** — Palito Ortega — RCA
- 5 **Morena De 15 Anos** — Adolfo — TK
- 6 **Siento Amor** — Donna Summer — Microfon
- 7 **Vestida De Novia** — Pomada — RCA
- 8 **Morir Al Lado De Mi Amor** — Demis Roussos — Philips
- 9 **Que Pena Me Da** — Danny Daniel — Microfon
- 10 **Fiesta** — Raffaella Carra — CBS

TOP TEN LPs

- 1 **Festival De Exitos** — Selection — CBS
- 2 **Los Consagrados** — Selection — RCA
- 3 **En Castellano** — Roberto Carlos — CBS
- 4 **Uno, Dos, Tres** — Cuarteto Imperial — CBS
- 5 **Lo Mejor** — Paul Williams — EMI
- 6 **Amor En Venta** — Boney M. — RCA
- 7 **Unicamente** — Los Wawanco — EMI
- 8 **Habia Una Vez** — Donna Summer — Microfon
- 9 **Ruidos En Espanol** — Selection — Philips
- 10 **Arabian Nights** — The Ritchie Family — RCA

France

TOP TEN 45s

- 1 **Singin' In The Rain** — Sheila & B. Devotion — Carrere
- 2 **Salma Ya Salama** — Dalida — Sonopresse
- 3 **La Java De Broadway** — Michel Sardou — Trema/RCA
- 4 **Fais Un Bebe** — Michel Delpech — Barclay
- 5 **Mille Colombes** — Mireille Mathieu — Phonogram
- 6 **L'indifference** — Gilbert Becaud — EMI/Pathe Marconi
- 7 **L'en Ai Marre Du Quotidien** — Joel Dayde — Phonogram
- 8 **Don't Let Me Be Misunderstood** — Santa Esmeralda/Leroy Gomez — Phonogram
- 9 **Pense A Moi** — Eric Charden — Discodis
- 10 **Silent Night** — Marion Williams — Phonogram

TOP TEN LPs

- 1 **Brel** — Jacques Brel — Barclay
- 2 **Hollywood** — Veronique Sanson — WEA
- 3 **Raconte-moi Des Mensonges** — Dave — CBS
- 4 **La Derniere Seance** — Eddy Mitchell — Barclay
- 5 **Le Rock 'N' Roll Est Ne** — Johnny Hallyday — Phonogram
- 6 **Le Vin Me Saoule** — Nicolas Peyrac — EMI/Pathe Marconi
- 7 **Bande Originale De "Star Wars"** — Discodis
- 8 **Une Chanson** — Charles Dumont — Pathe Marconi
- 9 **A Star Is Born** — Barbra Streisand — CBS
- 10 **Death Of A Ladies Man** — Leonard Cohen — CBS

Canada

TOP TWENTY FIVE 45s

- 1 **You Light Up My Life** — Debby Boone — Warner Bros.
- 2 **My Way** — Elvis Presley — RCA
- 3 **You're In My Heart** — Rod Stewart — Warner Bros.
- 4 **Girl's School** — Paul McCartney & Wings — Capitol
- 5 **How Deep Is Your Love** — Bee Gees — RSO
- 6 **Star Wars** — Meco — Millennium
- 7 **Sometimes When We Touch** — Dan Hill — GRT
- 8 **Blue Bayou** — Linda Ronstadt — UA
- 9 **Don't It Make My Brown Eyes Blue** — Crystal Gayle — UA
- 10 **You Make Lovin' Fun** — Fleetwood Mac — Warner Bros.
- 11 **Turn To Stone** — ELO — UA
- 12 **Baby Come Back** — Player — RSO
- 13 **Calling Occupants** — Carpenters — A&M
- 14 **Swingtown** — Steve Miller — Capitol
- 15 **Here You Come Again** — Dolly Parton — RCA
- 16 **Baby What A Big Surprise** — Chicago — CBS
- 17 **Boogie Nights** — Heatwave — Epic
- 18 **I Feel Love** — Donna Summer — Casablanca
- 19 **Hey Deanie** — Shaun Cassidy — Warner Bros.
- 20 **We're All Alone** — Rita Coolidge — A&M
- 21 **The King Is Gone** — Ronnie McDowell — GRT
- 22 **Send In The Clowns** — Judy Collins — Elektra
- 23 **Spaceship Superstar** — Prism — GRT
- 24 **Slip Slidin' Away** — Paul Simon — CBS
- 25 **Sentimental Lady** — Bob Welch — Capitol

TOP TWENTY-FIVE LPs

- 1 **Foot Loose & Fancy Free** — Rod Stewart — Warner Bros.
- 2 **Rumours** — Fleetwood Mac — Warner Bros.
- 3 **Simple Dreams** — Linda Ronstadt — Asylum
- 4 **Shaun Cassidy** — Warner Bros.
- 5 **Born Late** — Shaun Cassidy — Warner Bros.
- 6 **Allive II** — Kiss — Casablanca
- 7 **News Of The World** — Queen — Elektra
- 8 **I'm Glad You Are Here** — Neil Diamond — CBS
- 9 **Out Of The Blue** — Electric Light Orchestra — UA
- 10 **Star Wars** — Soundtrack — 20th Century
- 11 **You Light Up My Life** — Soundtrack — Arista
- 12 **Even In The Quietest Moments** — Supertramp — A&M
- 13 **Boston** — Epic
- 14 **Longer Fuse** — Dan Hill — GRT
- 15 **Elvis In Concert** — Elvis Presley — RCA
- 16 **Greatest Hits** — Olivia Newton-John — MCA
- 17 **The Grand Illusion** — Styx — A&M
- 18 **Greatest Hits Vol 2** — Elton John — MCA
- 19 **JT** — James Taylor — CBS
- 20 **Crime Of The Century** — Supertramp — A&M
- 21 **Love Songs** — Beatles — Capitol
- 22 **A Farewell To Kings** — Rush — Anthem
- 23 **Draw The Line** — Aerosmith — CBS
- 24 **Book Of Dreams** — Steve Miller — Capitol
- 25 **Greatest Hits** — Paul Simon — CBS

— Canadian Recording Industry Association

Japan

TOP TEN 45s

- 1 **UFO** — Pink Lady — Victor Musical Industries
- 2 **Wakareuta** — Miyuki Nakajima — Canyon
- 3 **Wana** — Candies — CBS/Sony
- 4 **Shiawasw Shibayl** — Junko Sakurada — Victor Musical Industries
- 5 **Enka Chanchakachan** — Masaaki Hirano — Teichiku
- 6 **Wanted** — Pink Lady — Victor Musical Industries
- 7 **Teens Bruce** — Shinji Harada — For Life
- 8 **Sake To Namida To Otoko To Onna** — Eigo Kawashima — Warner/Pioneer
- 9 **Tugarukaikyo Fuygeshiki** — Sayuri Ishikawa — Columbia
- 10 **Nikumikirenayl Rokudenashi** — Kenji Sawada — Polydor

TOP TEN LPs

- 1 **Pink Lady Best Hit Album** — Victor Musical Industries
- 2 **Danryu** — Sayuri Ishikawa Best 14 — Columbia
- 3 **Omoikiri Kizana Jinseyl** — Kenji Sawada — Polydor
- 4 **High Figh Friend** — High Figh Set — Toshiba/EMI
- 5 **News Of The World** — Queen — Warner/Pioneer
- 6 **Olivia Newton-John's Greatest Hits** — Best Collection — Toshiba/EMI
- 7 **Oolnaru Hito** — Takuro Yoshida — For Life
- 8 **Hanazakari** — Momoe Yamaguchi — CBS/Sony
- 9 **Kiss Alive II** — Victor Musical Industries
- 10 **Without** — Kentaro Shimizu — CBS/Sony

Italy

TOP TEN 45s

- 1 **Solo Tu** — Matia Bazar — Ariston
- 2 **Don't Let Me Be** — Santa Esmeralda/Leroy Gomez — Philips
- 3 **Samarcanda** — Roberto Vecchioni — Philips
- 4 **L'Angelo Azzurro** — Umberto Balsamo — Polydor
- 5 **Dammi Solo Un Minuto** — Pooh — CGD
- 6 **Moonflower** — Santana — CBS
- 7 **Unlimited Citations** — Cafe Creme — EMI
- 8 **Oxygene** — J.M. Jarre — Polydor
- 9 **Star Wars** — Meco — RCA
- 10 **Piccola Luisa** — Quinta Faccia — UIM

TOP TEN LPs

- 1 **Burattino Senza Fili** — Edoardo Bennato — Ricordi
- 2 **Santa Esmeralda** — Leroy Gomez — Philips
- 3 **Rotolando Respirando** — Pooh — CGD
- 4 **Samarcanda** — Roberto Vecchioni — Philips
- 5 **Star Wars** — Soundtrack — 20th Century
- 6 **Moonflower** — Santana — CBS
- 7 **Seconds Out** — Genesis — Charisma
- 8 **L'Angelo Azzurro** — Umberto Balsamo — Polydor
- 9 **Tecadisk** — Adriano Celentano — Clan
- 10 **Oxygene** — J.M. Jarre — Polydor

Australia

TOP TWENTY-FIVE 45s

- 1 **Mull Of Kintyre/Girl's School** — Wings — Capitol
- 2 **You** — Marcia Hines — Miracle
- 3 **April Sun In Cuba** — Dragon — Portrait
- 4 **Star Wars Title Theme** — Meco — RCA
- 5 **You're In My Heart** — Rod Stewart — Warner Bros.
- 6 **Silver Lady** — David Soul — Private Stock
- 7 **The Name Of The Game** — Abba — RCA
- 8 **Black Betty** — Ram Jam — Epic
- 9 **It's Your Life** — Smokie — Rak
- 10 **You Light Up My Life** — Debby Boone — Warner Bros.
- 11 **In The Flesh** — Blondie — Chrysalis
- 12 **We Are The Champions/We Will Rock You** — Queen — Elektra
- 13 **I Just Want To Be Your Everything** — Andy Gibb — Interfusion
- 14 **From New York To L.A.** — Patsy Gallant — Attic
- 15 **Rockin' All Over The World** — Status Quo — Vertigo
- 16 **Float On** — Floaters — ABC
- 17 **Turn To Stone** — Electric Light Orchestra — United Artists
- 18 **So You Win Again** — Hot Chocolate — Rak
- 19 **Stay (While The Night Is Young)** — Ol' 55 — Mushroom
- 20 **Baby What A Big Surprise** — Chicago — CBS
- 21 **She's Not There** — Santana — CBS
- 22 **It's All Over Now Baby Blue** — Graham Bonnet — Mercury
- 23 **Angelo** — Brotherhood Of Man — Astor
- 24 **Surfin' USA** — Leif Garrett — Atlantic
- 25 **You To Me Are Everything** — The Real Thing — Astor

TOP TWENTY-FIVE LPS OF 1977

- 1 **Silk Degrees** — Boz Scaggs — CBS
- 2 **A New World Record** — Electric Light Orchestra — UA
- 3 **Rumours** — Fleetwood Mac — Warner Bros.
- 4 **Hotel California** — Eagles
- 5 **Endless Flight** — Leo Sayer
- 6 **Diamantina Cocktail** — Little River Band
- 7 **Even In The Quietest Moments** — Supertramp
- 8 **In Your Mind** — Bryan Ferry
- 9 **Deceptive Bends** — 10CC
- 10 **Foot Loose & Fancy Free** — Rod Stewart
- 11 **A Star Is Born** — Soundtrack/Streisand/Kristofferson
- 12 **Fleetwood Mac**
- 13 **Frampton Comes Alive** — Peter Frampton
- 14 **A Night On The Town** — Rod Stewart
- 15 **Wings Over America** — Wings
- 16 **Works Volume 1** — Emerson Lake & Palmer
- 17 **Arrival** — Abba
- 18 **Carole Bayer Sager**
- 19 **Animals** — Pink Floyd
- 20 **Evita**
- 21 **I Remember Yesterday** — Donna Summer
- 22 **Book Of Dreams** — Steve Miller Band
- 23 **Shining** — Marcia Hines
- 24 **I'm In You** — Peter Frampton
- 25 **Moody Blue** — Elvis Presley

— The Kent Music Report

BEST SELLERS

**OUR MUSIC
GETS AROUND.**



Around the world, that is. April·Blackwood: The total music company.

THE MAGIC OF MOTOWN!

"A Great '77..."

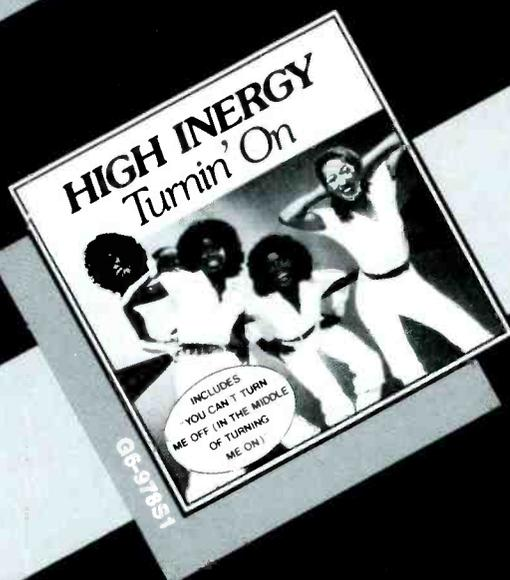
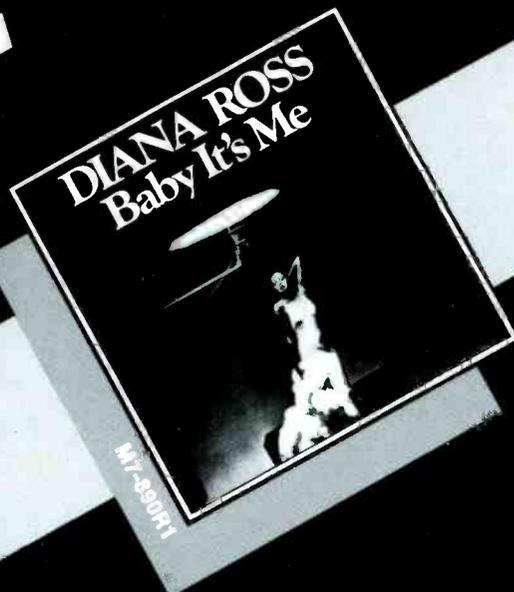
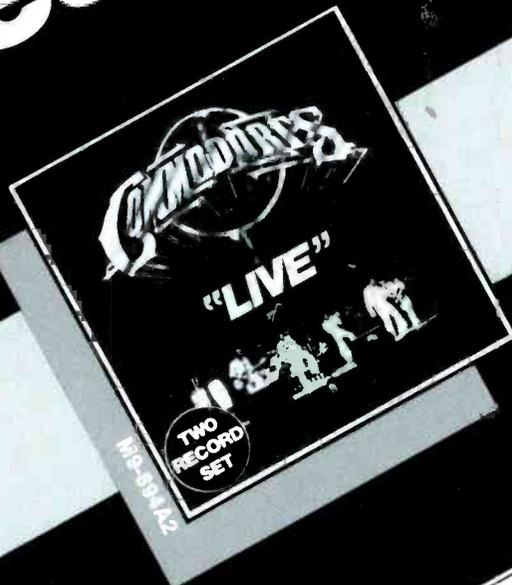

Makes Us Bullish On '78!

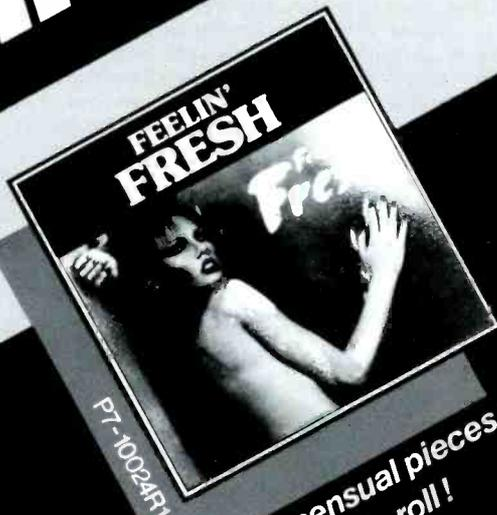

Eight sassy, sensual pieces of Refreshing rock 'n roll!

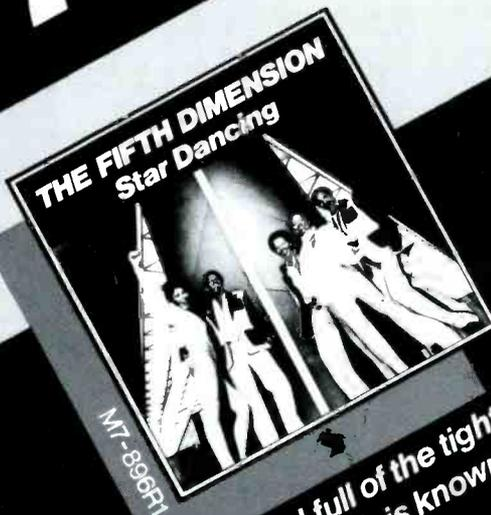

Brand new and full of the tight harmonies the 5TH Dimension is known for!

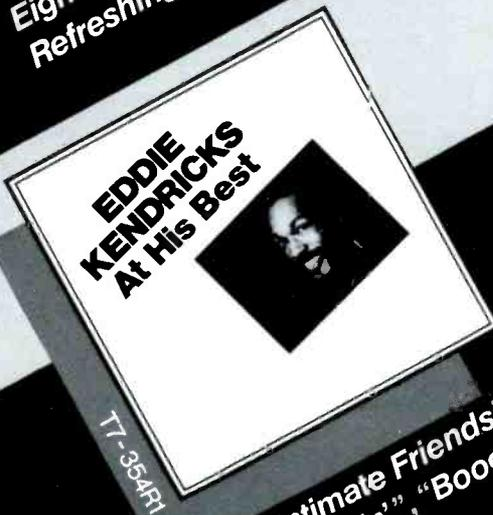

Includes "Intimate Friends", "Keep On Truckin'", "Boogie Down" and more!

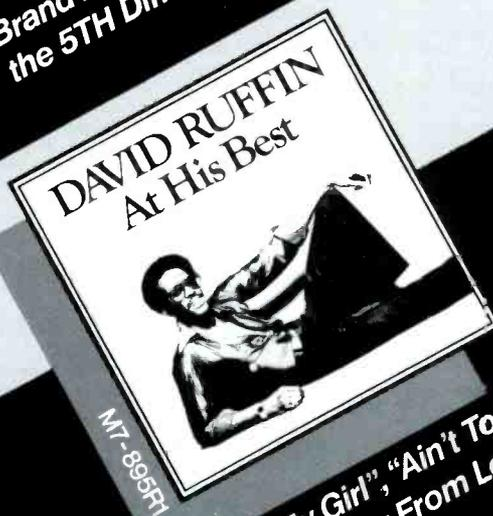

Includes "My Girl", "Ain't Too Proud To Beg", "Walk Away From Love" plus seven more!

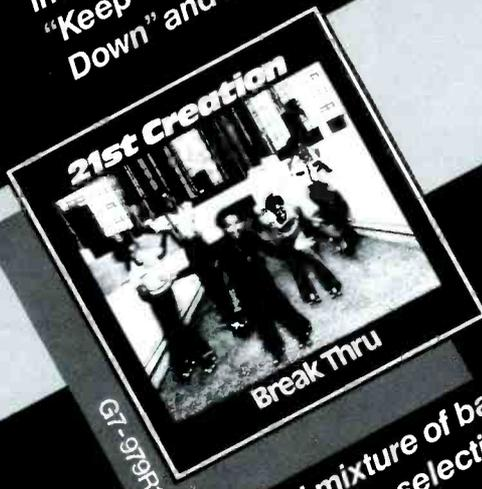

A well balanced mixture of ballads and up-tempo disco selections!

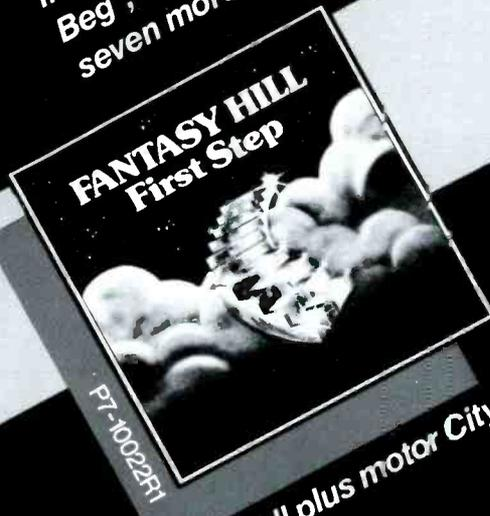

Rock 'n Roll plus motor City Soul!



Ronstadt, Eagles Top List In Grammy Award Nominations

(continued from page 8)

tures and film scores were cited often this year with "Star Wars" nominated in five categories, and "Rocky," "Roots," and "A Star Is Born" each receiving four nominations.

The 51 categories include nominations from a total of 77 different record labels. Results of the balloting to determine this year's winners will be announced during the Academy's annual two-hour television special, the Grammy Awards Show, which will air at 9:00 p.m. (EST) on Thursday, February 23, over the CBS network.

GENERAL CATEGORIES

Record Of The Year

BLUE BAYOU. Linda Ronstadt. Peter Asher. Producer. (Asylum). **DON'T IT MAKE MY BROWN EYES BLUE** Crystal Gayle. Allen Reynolds. Producer. (UA). **HOTEL CALIFORNIA.** Eagles. Bill Szymczyk. Producer. (Asylum). **LOVE THEME FROM A STAR IS BORN** (EVERGREEN). Barbra Streisand. Barbra Streisand. Phil Ramone. Producers. (Columbia). **YOU LIGHT UP MY LIFE.** Debby Boone. Joe Brooks. Producer. (W.B./Curb).

Album Of The Year

AJA. Steely Dan. Gary Katz. Producer. (ABC). **HOTEL CALIFORNIA.** Eagles. Bill Szymczyk. Producer. (Asylum). **JT.** James Taylor. Peter Asher. Producer. (Columbia). **RUMOURS.** Fleetwood Mac. Fleetwood Mac. Richard Dashut. Ken Caillat. Producers. (Warner Bros.). **STAR WARS.** The London Symphony Orchestra. John Williams. Conductor. George Lucas. Producer. (20th Century).

Song Of The Year

DON'T IT MAKE MY BROWN EYES BLUE. Richard Leigh. Songwriter. **HOTEL CALIFORNIA.** Don Felder. Don Henley. Glenn Frey. Songwriters. **LOVE THEME FROM A STAR IS BORN** (EVERGREEN). Barbra Streisand. Paul Williams. Songwriters. **NOBODY DOES IT BETTER.** Marvin Hamlisch. Carole Bayer Sager. Songwriters. **SOUTHERN NIGHTS.** Allen Toussaint. Songwriter. **YOU LIGHT UP MY LIFE.** Joe Brooks. Songwriter.

Best New Artist Of The Year

STEPHEN BISHOP. (ABC). **DEBBY BOONE** (W.B./Curb). **SHAUN CASSIDY.** (W.B./Curb). **FÖRIGNER.** (Atlantic). **ANDY GIBB.** (RSO).

POP, ROCK & FOLK FIELD

Best Pop Vocal Performance, Female

BLUE BAYOU. Linda Ronstadt. (single). (Asylum). **HERE YOU COME AGAIN.** Dolly Parton. (single). (RCA). **LOVE THEME FROM A STAR IS BORN** (EVERGREEN). Barbra Streisand. (single). (Columbia). **NOBODY DOES IT BETTER.** Carly Simon. (single). (Elektra). **YOU LIGHT UP MY LIFE.** Debby Boone. (single). (W.B./Curb).

Best Pop Vocal Performance, Male

AFTER THE LOVIN'. Engelbert Humperdinck. (album). (Epic). **HANDY MAN.** James Taylor. (single). (Columbia). **JUST WANT TO BE YOUR EVERYTHING.** Andy Gibb. (single). (RSO). **ON AND ON.** Stephen Bishop. (single). (ABC). **WHEN I NEED YOU.** Leo Sayer. (single). (Warner Bros.).

Best Pop Vocal Performance By A Duo, Group Or Chorus

AJA. Steely Dan. (album). (ABC). **CSN.** Crosby, Stills & Nash. (album). (Atlantic). **HOTEL CALIFORNIA.** Eagles. (album). (Asylum). **HOW DEEP IS YOUR LOVE.** Bee Gees. (single). (RSO). **RUMOURS.** Fleetwood Mac. (album). (Warner Bros.).

Best Pop Instrumental Performance

GONNA FLY NOW (THEME FROM "ROCKY"). Bill Conti. (single). (UA). **GONNA FLY NOW** (THEME FROM "ROCKY"). Maynard Ferguson. (Columbia). **NADIA'S THEME** (THE YOUNG AND THE RESTLESS). Barry DeVorzon. (album). (Arista). **STAR WARS.** London Symphony Orchestra. John Williams. (album). (20th Century). **STAR WARS THEME/CANTINA BAND.** Meco. (single). (Casablanca).

RHYTHM & BLUES FIELD

Best R&B Vocal Performance

BREAK IT TO ME GENTLY. Aretha Franklin. (single). (Atlantic). **DON'T LEAVE ME THIS WAY.** Thelma Houston. (single). (Motown). **I BELIEVE YOU.** Dorothy Moore. (single). (Malaco). **I'VE GOT LOVE ON MY MIND.** Natalie Cole. (single). (Capitol). **YOUR LOVE IS SO GOOD FOR ME.** Diana Ross. (track). (Motown).

Best R&B Vocal Performance, Male

AIN'T GONNA BUMP NO MORE (WITH NO BIG FAT WOMAN). Joe Tex. (single). (Epic). **GOT TO GIVE IT UP** (PART I). Marvin Gaye. (single). (Motown). **IT'S JUST A MATTER OF TIME.** B.B. King. (track). (ABC). **A REAL MOTHER FOR YA.** Johnny "Guitar" Watson. (track). (DJM). **UNMISTAKABLY LOU.** Lou Rawls. (album). (PIR/Epic).

Best R&B Vocal Performance By A Duo, Group Or Chorus

ASK RUFUS. Rufus Featuring Chaka Khan. (album). (ABC). **BABY DON'T CHANGE YOUR MIND.** Gladys Knight & The Pips. (track). (Buddah). **BEST OF MY LOVE.** Emotions. (track). (Columbia). **BOOGIE NIGHTS.** Heatwave. (single). (Epic). **EASY.** Commodores. (single). (Motown).

Best R&B Instrumental Performance

FUNKY SEA. Funky Dew. Brecker Brothers. (track). (Arista). **GETAWAY.** Salsoul Orchestra. (single). (Salsoul). **MORE STUFF.** Stuff. (album). (Warner Bros.). **Q.** Brothers Johnson. (track). (A&M). **UNFINISHED BUSINESS.** The Blackbyrds. (track). (Fantasy).

Best Rhythm & Blues Song

BEST OF MY LOVE. Maurice White. Al McKay. Songwriters. **BRICK HOUSE.** Milan Williams. Walter Orange. Thomas McClary. William King. Lionel Richie. Ronald LaPread. Songwriters. **DON'T LEAVE ME THIS WAY.** Kenny Gamble. Leon Huff. Carry Gilbert. Songwriters. **EASY.** Lionel Richie. Songwriter. **YOU MAKE ME FEEL LIKE DANCING.** Leo Sayer. Vini Poncia. Songwriters.

COUNTRY FIELD

Best Country Vocal Performance, FEMALE

AFTER THE LOVIN'. Barbara Mandrell. (track). (ABC/Dot). **DON'T IT MAKE MY BROWN EYES BLUE.** Crystal Gayle. (single). (UA). **MAKING BELIEVE.** Emmylou Harris. (single). (Warner Bros.). **WHAT'RE YOU DOING TONIGHT.** Janie Fricke. (single). (Columbia). **(YOUR LOVE HAS LIFTED ME) HIGHER & HIGHER.** Dolly Parton. (track). (RCA).

Best Country Vocal Performance, Male

I DON'T WANNA CRY. Larry Gatlin. (single). (Monument). **IT WAS ALMOST LIKE A SONG.** Ronnie Milsap. (single). (RCA). **LUCILLE.** Kenny Rogers. (single). (UA). **LUCKENBACH, TEXAS.** Waylon Jennings. (single). (RCA). **MR. BOJANGLES.** Jerry Jeff Walker. (single). (MCA).

Best Country Vocal Performance By A Duo Or Group

DYNAMIC DUO. Loretta Lynn. Conway Twitty. (album). (MCA). **HEAVEN'S JUST A SIN AWAY.** The Kendalls. (single). (Ovation). **NEAR YOU.** George Jones. Tammy Wynette. (single). (Epic). **THE WHEEL.** Asleep At The Wheel. (album). (Capitol). **Y'ALL COME BACK SALOON.** Oak Ridge Boys. (single). (ABC/Dot).

Best Country Instrumental Performance



PLATINUM UPON DOUBLE PLATINUM — Kirshner Records artists Kansas were recently presented platinum record awards for their most recent album, "Point Of Know Return," their second platinum LP of the year. This follows the double platinum "Leftoverture," also on Kirshner, an associated label of CBS Records. Currently wrapping up a U.S. tour, the group will embark on an extensive tour of Europe and Asia in March. Pictured at the reception held for Kansas in New York (standing, l-r): Dave Hope of Kansas; Steve Slutz, director of west coast product management for Epic/Portrait/Associated Labels; Jeff Glixman, Kansas' producer; Phil Ehart, Robby Steinhardt, Steve Walsh, Rich Williams and Kerry Livgren of Kansas; Gordon Anderson, director of national promotion of Epic/Portrait/Associated Labels; and Tony Martell, vice president and general manager of CBS Associated Labels. (Seated, l-r): Cheryl Bordogary; Sylvia Nestor, publicist for Kansas; Terry Ehart; Mary Steinhardt; Budd Carr, Kansas' manager; Donna Williams; and Vicki Livgren. Seated in the foreground is Don Kirshner, president of Kirshner Records.

Tabackin Big Band. (album). (RCA)

INSPIRATIONAL & GOSPEL FIELD

Best Gospel Performance, Contemporary Or Inspirational

ADAM AGAIN. Michael Omartian. (album). (Myrrh/Word). **HART AND SOUL.** Larry Hart & The Soul Singers. (album). (Genesis). **MIRROR.** Evie Tornquist. (album). (Word). **MORE FROM THE ASTONISHING OUTRAGEOUS AMAZING INCREDIBLE UNBELIEVABLE GARYS.** Gary S. Paxton. (album). (New Pax). **REBA/LADY.** Reba Rambo Gardner. (album). (GreenTree). **SAIL ON.** Imperials. (album). (Day-spring/Word).

Best Gospel Performance, Traditional

BILL GAITHER SONGS. Blackwood Brothers. (album). (Skyline). **CORNERSTONE.** The Speers. (album). (Heart-warming). **HAVE A LITTLE TALK WITH JESUS.** Oak Ridge Boys. (track). (Rockland Rd.). **NATURALLY.** The Rambos. (album). (Heartwarming). **THEN AND NOW.** The Cathedral Quartet. (album). (Canaan). **TILL HE COMES.** The Lefevres. (album). (Canaan).

Best Soul Gospel Performance, Contemporary

BORN AGAIN. Jessie Dixon. (single). (Light). **GOD IS NOT DEAD.** Mighty Clouds Of Joy. (track). (ABC). **HE IS KING.** Danniebelle. (album). (Light). **MORE.** Larnelle Harris. (album). (Word). **WONDERFUL!** Edw. Hawkins & The Edwin Hawkins Singers. (album). (Birthright).

Best Soul Gospel Performance, Traditional

I'M JUST ANOTHER SOLDIER. Five Blind Boys Of Mississippi. (single). (Jewel). **JAMES CLEVELAND LIVE AT CARNEGIE HALL.** James Cleveland. (album). (Savoy). **THE LORD IS MY LIFE.** James Cleveland & The Greater Metropolitan Church Of Christ Choir. (album). (Savoy). **SATISFACTION GUARANTEED.** Rev. Cleavant Derricks & Family. (album). (Canaan). **STAND UP FOR JESUS.** The Savannah Choir And Rev. Isaac Douglas. (album). (Creed).

Best Inspirational Performance

HOME WHERE I BELONG. B.J. Thomas. (album). (Myrrh/Word). **HOW GREAT THOU ART.** Ray Price. (album). (Word). **OH LORD COME BY HERE.** Quincy Jones Featuring James Cleveland Conducting The Watts-line Choir. (track). (A&M). **TELL ALL THE WORLD ABOUT LOVE.** Carol Lawrence. (album). (Word). **YOUR ARM'S TOO SHORT TO BOX WITH GOD.** Original Cast Album. (album). (ABC).

ETHNIC/TRADITIONAL/LATIN FIELDS

Best Ethnic/Traditional Recording

BLUES HIT BIG TOWN. Junior Wells. (album). (Delmark). **HARD AGAIN.** Muddy Waters. (album). (Blue Sky/CBS). **RIGHT PLACE, WRONG TIME.** Otis Rush. (album). (Bullfrog). **THINGS THAT I USED TO DO.** Joe Turner. (album). (Pablo). **WHAT HAPPENED TO MY BLUES.** Willie Dixon. (album). (Ovation).

Best Latin Recording

DAWN. Mongo Santamaria. (album). (Vaya). **FIREWORKS.** Machito Orch. With Lalo Rodriguez. (album). (Coco). **LA LEYENDA.** Tito Puente. (album). (Tico/Fania). **MUY AMIGOS/CLOSE FRIENDS.** Eydie Gorme & Danny Rivera. (album). (Gala/Coco). **TOMORROW.** Barretto Live. Ray Barretto Band. (album). (Atlantic).

CHILDREN'S, COMEDY, SPOKEN FIELDS

Best Recording For Children

AREN'T YOU GLAD YOU'RE YOU. Sesame St. Cast. (album). (Sesame St.). **A CHARLIE BROWN CHRISTMAS.** Various. (Charlie Brown). **DOPE! THE DOPE KING'S LAST STAND.** Arther Morrison. Producer. (Lily Tomlin, Billie Jean King, Muhammad Ali, President Jimmy Carter, etc.). (album). (Cornucopia). **RUSSELL HOBAN: THE MOUSE AND HIS CHILD.** Read by Peter Ustinov. (album). (Caedmon). **THE SESAME STREET FAIRY TALE ALBUM.** Jim Henson's Muppets. (Sesame St.).

Best Comedy Recording

ARE YOU SERIOUS??? Richard Pryor. (album). (Laff). **THE ERNIE KOVACS ALBUM.** Ernie Kovacs. (album). (Columbia). **LET'S GET SMALL.** Steve Martin. (album). (Warner Bros.). **ON THE ROAD.** George Carlin. (album). (Little David). **SATURDAY NIGHT LIVE.** NBC's Saturday Night Live Cast. (album). (Arista).

Best Spoken Word Recording

ALEX HALEY TELLS THE STORY OF HIS SEARCH FOR ROOTS. Alex Haley. (album). (Warner Bros.). **THE BELLE**

(continued on page 62)



20th CENTURY CONVENTION — 20th Century-Fox Records held a convention featuring new product presentations and artist performances at the Newporter Inn in Newport Beach Dec. 13-16. Pictured (l-r) in the top row of photos are: Dennis Stanfill, chairman of the board, 20th Century Fox Film Corp., and Harvey Cooper, senior vice president, A&R and promotion, 20th Century Records; Lenny Beer, vice president, A&R and promotion; Arnie Orleans, senior vice president of sales and marketing, and Cooper; and Jack

Hakim, vice president, international, 20th Century Records; Rynichi Suziama, King Records, Japan, the interpreter and Alan Livingston, president, 20th Century-Fox Entertainment Group. Shown (l-r) in the bottom row of photos are: Rock group Rubicon; Barry Goldberg, national FM promotion director; Rick Sidoti, manager of new artist development; Mark Aeiss, field promotion director, southeast; and Elmer Hill, director, R&B development, and Cooper.

CASHBOX

Salutes



CAM's Benedetto Launched His Business With Soundtracks, Now Expanded Into Many Facets Of Music Industry

by Ken Terry

NEW YORK — "You don't have to be able to read or write music to succeed in this business; but you have to be able to *feel* music, and you have to know the law and the business, including publishing, production and recording. If you can hold all those things together, I think you can be a successful music man."

These are the ingredients which have made Victor Benedetto, head of CAM Productions Publishing, the success he is today. Known internationally as "The Man Who Delivers," Benedetto supervises the licensing of more than 7,000 motion picture and television scores which are published by CAM-U.S.A. Through CAM Productions, Benedetto as executive producer also oversees the production of a steady stream of records by such groups as Eric Carmen (Arista), Eric Mercury (Columbia), Samantha Sang (Private Stock), Bruce Foster (Millennium), Bay City Rollers (Arista), the Nobles (Columbia), Snapper (UA), and Octavian (MCA). CAM has also been involved in production for Blood, Sweat & Tears, Billion Dollar Babies, Lighthouse, Grand Funk Railroad, Three Dog Night, the Raspberries, Sha Na Na and Oregon. Additionally, several Eric Carmen songs in its publishing catalog have been covered by Shaun Cassidy.

At the same time, CAM is constantly developing new talent and helping emerging artists find the right record label and the right management. Among current CAM acts which have yet to be signed by record companies are Lorraine Frisaura (formerly on Prelude Records), the Brats, Michael Bruce (formerly with Alice Cooper and the Billion Dollar Babies), Donnie Harper, England, Alaina Reed, Striders, Paper Cup, D.C.-8, White Lightning, Left Banke (recently re-formed), Orchestra 88, Bruce Wooley and Matthew Fisher.

Since getting into popular music production in 1970, however, Benedetto and CAM have not neglected the foundation of their business: soundtracks. According to Benedetto, "We now handle 65% of all European film music, and 85% of all Italian motion picture scores. Over 100 soundtracks are added to our catalog each year." Many of these properties are produced and/or published by CAM's sister companies, including CAM Music of Rome, which celebrated its 20th anniversary last year.

Five film scores published by CAM-U.S.A. have won Academy Awards: "Amarcord," "La Strada," "Investigation Of A Citizen Above Suspicion," "Garden Of The Finzi-Continis," and "8½." Also included in CAM's catalog are the soundtrack scores to such famous movies as "La Dolce Vita," "The White Sheik," "Divorce Italian Style," "L'Avventura," "Red Desert," "Juliet of the Spirits," "Stavisky," "Providence," and "Casanova."

Doing It His Way

It was the soundtrack to the Italian film, "Mondo Cane," and its famous theme, "More," that gave Benedetto his first big boost in the U.S. Born in Rome, he had traveled to Paris, Madrid and London while still in his early 20s, placing and acquiring copyrights and catalogs for CAM Music. Then in 1963, he came to New York, convinced that "Mondo Cane" was right for the U.S. market. He placed the sub-publishing rights with E.B. Marks and sold UA the recording rights to the soundtrack. The following year, he opened an office in New York, which was the first CAM office outside of Italy.

Despite his affiliation with CAM Music,

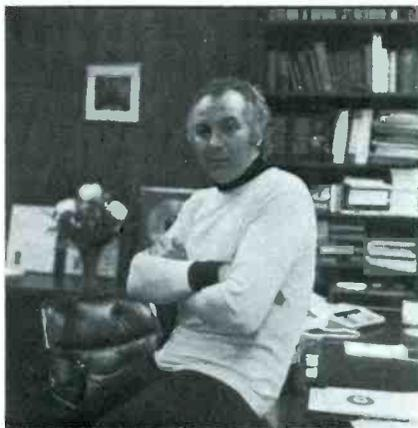

Victor Benedetto

Benedetto notes, he essentially started CAM-U.S.A. from scratch. "When I came to America, I started with the films. I established a catalog which now consists of over 7,000 motion pictures. . . I was a one-man operation, and I'm very proud because I started something by working hard. I was not backed by huge amounts of money, the way most people do it today. And I wanted to do it that way: establish something from nothing."

"It was very hard to be a publisher with the competition you had in the mid-60s. That was when all the performers started to be their own publishers and became self-contained and so forth. You almost had to have luck in order to cover records."

In 1970, Benedetto decided to plunge into the popular music field, where, he says, "my heart had always been." Observing that an increasing number of the hits were coming from independent producers rather than the record companies' own A&R departments, he also made up his mind to go beyond publishing for the first time.

"I saw the need in the industry for production companies," he recalls. "Back in the late '50s and early '60s, the record labels had exclusive control over production and artist development. Now, though, they have trouble covering all ends of the business, so there is more need for production companies."

Company Of Tomorrow

CAM Productions is a rather unique firm. As Benedetto points out, it does everything a record company does except press and distribute LPs. The staff evaluates unsolicited material, finds producers and managers for artists, arranges placement of finished masters, arranges signings, promotes and publicizes new records, and works with all concerned parties to help artists reach their career goals. In addition, if an artist is self-contained, Benedetto will usually offer him a publishing deal with CAM-U.S.A.

Many artists come to CAM without either a manager or a record label. In that case, Benedetto uses a two-phase approach. First he signs the artist to CAM, showcases him and produces a master. Then, after the master has been accepted and the artist has been signed by a record company, CAM works with the label to promote and develop the artists and his music. Meanwhile, Benedetto himself will operate as the artist's manager "up to a point"; usually, by the time he has been signed to a label, he has found a manager, sometimes with Benedetto's aid.

Few production companies are this comprehensive, and no other publisher, to Benedetto's knowledge, is doing the same thing. "It's been said that I am the publisher of tomorrow," Benedetto comments. "The publishers haven't always had much con-

rol over music. They've lost power in the industry while self-contained artists writing their own material started their own publishing companies. Many of them didn't think publishers had anything to offer them — although I feel that anyone who wants to collect fully on their rights and fully exploit their compositions has to have an organization behind them." Benedetto added that CAM's promotional aspects contribute greatly to this exploitation, although other publishers also do a fine job.

Production Deals

At present, CAM has 35 artists signed to production contracts, and Benedetto says that his company could handle almost 100 productions. "I would just have to increase the number of people in various departments. If I were a record company, I couldn't take that many artists at once."

Another reason why Benedetto wouldn't want to start a full-fledged label is that "as a record company, you're limited to how many similar kinds of acts you can have, but I don't have that limitation. For instance, I could handle three or four female vocalists, and one could be with CBS, one could be with Capitol and another with Warner Bros."

CAM will handle any kind of music, from rock and R&B to country and MOR. Benedetto says he would even like to produce a classical record someday. "I don't want this company to have just one kind of sound — rock 'n roll or R&B, for example. I want to handle all phases of music, so that I can develop all kinds of artists."

Every week, Benedetto says, he receives a "huge" amount of unsolicited material from artists. "I receive more material sometimes than a record company does." He stresses the fact that, although he listens to everything that comes in, A&R decisions are made by the whole CAM staff. "We have special meetings every week (about the material we've received). We dedicate hours and hours to listening. . . We all listen together to all the new tapes. Then we practically vote on the new artists. Certainly I have the final say, but I give a lot of credit to my own people; if someone has a good argument about someone, I listen to him. I don't just go with whatever I like."

Naturally, CAM has been receiving a lot of new wave tapes recently. But Benedetto has his doubts about the movement's viability in the U.S. "In England, it (new wave music) is very sincere. Over here, I don't know how sincere it is. It becomes almost what I used to call when I was a kid, 'a la mode.' It is not really an American movement. It was an English movement because of what the country's going through, and the whole condition of the country. Over here, it's just chic."

Artists who sign with CAM Productions share production costs on a 50-50 basis with the company. Naturally, if they don't have a recording contract, an artist might not have the cash in hand. But Benedetto says that he is willing to advance the full cost of production, since he eventually sells about 95% of the masters he produces.

Benedetto noted that "when an artist signs here, he has nothing to lose," because he will receive the same amount of royalties he would get if he were only signed to a record company. "He has more to gain than anything else, because behind him he will have two record companies (the label and CAM). And instead of just being produced, he will have promotion and people really looking after his interests."

Executive Producer

Although he knows production inside and out, Benedetto rarely gets directly involved with the details of recording. In-

stead, he acts as the "executive producer," which is a term used in the movie industry to describe the person who puts together the whole package and supervises the actual producer. "I am the executive producer on all our productions," he explains, "and the one who finally selects the songs — together with all our people and the artist and producer."

"I like to know exactly what we're doing. When one of my groups is down in the studio, I like to go down there and see what's going on and put some of my expertise and knowledge into the recording. I try to help, instead of just being master of ceremonies. . . I never get a credit personally on albums. I don't go for that — to me it's mainly a business. I make stars; I am not a star. Other people are my stars."

Benedetto even helps some of his artists write their songs. But again, he doesn't care to take credit as a co-author. "As executive producer, I am the man in charge, so I know my power and know where I stand," he remarks.

CAM has an A&R department headed by Corky Abdo, who supervises productions and has himself produced albums by DeJa Vu, Octavian and Strider for CAM. However, CAM has not had a full-time in-house producer since Jimmy Ienner left the company to become president of Millennium Records. Ienner produced Eric Carmen's debut LP, a Bay City Rollers album, and discs by Blood, Sweat & Tears and Grand Funk Railroad, among others.

Benedetto decided not to maintain an in-house producer after Ienner left mainly because he wanted to increase his flex-

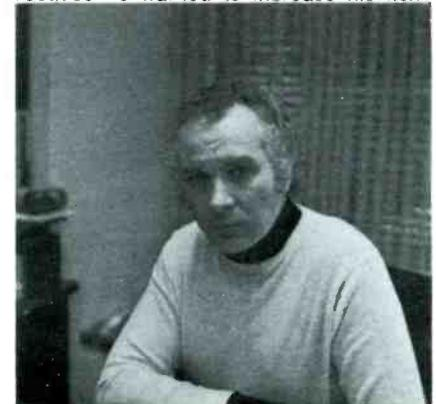

ibility. "If you keep just one top producer in-house," he explains, "then people might think you only want the kind of material that producer is known for. That's wrong, unless I can have five or six top producers on staff. At the moment, I don't think it's advisable for me to do it. Today I'm in a position to find the best producer for each particular artist."

Publishing Arrangements

While CAM will publish self-contained artists whom it also produces, the firm doesn't hesitate to seek out material from other publishers which might be appropriate for particular artists. Thus CAM-U.S.A.'s competitors feed CAM Productions with music for its artists to cover. However, Benedetto emphasizes, CAM does not try to lure writers away from other publishers.

95% of the groups with which CAM has worked were "discovered" and developed by the company, including the Raspberries, from which Carmen emerged, Lighthouse, Three Dog Night, Grand Funk, Blood, Sweat & Tears, Sha Na Na and Lorraine Frisaura. Since it got in on the ground floor, CAM has an open field to exploit the material it publishes by these artists around the world.

(continued on page 42)

Congratulations

Eric Carmen

CAM Encourages Worldwide Subpublishers To Promote And 'Look After' Properties

by Mark Mehler

NEW YORK — The philosophy of CAM's operation outside the U.S. is identical to its philosophy in America: namely, that a truly successful music publisher and producer ought to be doing much more.

The dozens of publishers around the world who have agreements with CAM-U.S.A. and Camerica (CAM's ASCAP publishing arm) take their cue from Victor Benedetto. "I'm in constant touch with all our subpublishers," says CAM-U.S.A.'s vice president and general manager. "Our overseas companies are given complete instructions in working with their record companies, and we make sure they are adequately supplied with all materials." Like CAM-U.S.A., subpublishers also function as mini-record labels, getting involved in artist development, promotion, A&R, and other areas.

"If an Eric Carmen LP goes to Germany," Benedetto explains, "we're looking for much more than just having proper collections made. We want to make sure that our subpublisher is really *looking after* the product. That is the reason we rely on these firms. They have the same contacts with their labels that we have with ours."

Demos Sent Out

The majority of CAM-U.S.A.'s overseas business consists of having its American songs subpublished. However, unlike most American publishers, Benedetto believes in having world markets covered with product before the music becomes commercially successful here. "If I've got

something that is good, why not send demos to all our people abroad? Maybe we can get it started in Germany or Italy at the same time that it starts to break in the U.S."

While most of his worldwide contact is through the mail and telephone, Benedetto also travels extensively. In addition to establishing important personal contact with subpublishers and foreign labels, Benedetto also uses his travels to cement already strong relationships with foreign licensing organizations.

A key in breaking American songs abroad, notes Benedetto, is "getting the right music to the right people." He prides himself on having an intimate knowledge of the record people, the regulations, and the markets in every worldwide territory. Benedetto regularly receives, in addition to foreign product, lists of the top hits in each country, and announcements of key trends in those nations. He says he further pays close attention to weekly overseas trade charts.

While a standard arrangement generally calls for the subpublisher to pay the U.S. publisher 50% of all income collected from a song, CAM-U.S.A. generally receives from 60% to 75%.

In some markets, subpublishing rights automatically go to companies with which CAM-U.S.A. has exclusive catalog arrangements. In territories where contracts are "looser," says Benedetto, he may choose between various publishers. He prefers to take his product where it will find the most acceptance, and the most

enthusiastic response.

One aspect of artist development abroad that Benedetto finds himself becoming increasingly involved in is foreign television, which, unlike U.S. TV, has become a prime means of breaking new artists.

To exploit foreign TV's potential, CAM-U.S.A. has prepared videotapes of American artists like Smanatha Sang, featuring two or three album cuts. CAM's foreign publishers are encouraged to develop close ties with television programmers, who are, according to Benedetto, "desperate for stuff from any U.S. artists." He points to one weekly series in Brazil which highlights a new American song on each show.

"Most people (in the American record industry) tend to see the rest of the world as just an addition to the U.S.," Benedetto asserted, "but it can be much more than that."

The other side of CAM-U.S.A.'s worldwide operation is subpublishing songs and catalogs, which come from overseas sources. Among the over 7,000 soundtracks that CAM-U.S.A. handles are the music from such foreign film classics as "La Strada," "8½," "Red Desert," and "La Dolce Vita."

CAM currently represents over 65% of all European film and TV music publishers. With the exception of "Mondo Cane" (the recording rights to which CAM Music sold to United Artists,) Benedetto notes that no European soundtracks have yet hit with the impact of a "Rocky" or a "Star Wars." Still, he says, domestic unit sales of European soundtrack LPs often reach tens of thousands.

The major problem on all foreign records in America, Benedetto laments, is the language barrier. Toward eliminating this difficulty, he often has his foreign artists re-record the songs in English.

Presently, Benedetto is working some new foreign artists, trying to interest American labels in licensing the product when it arrives. "There is not yet a mass market for foreign music in the United States," Benedetto conceded. "But I think it will eventually come. There is a great deal of European music, for example, with pop potential — they have good melodies and rhythm ..."

CAM-U.S.A.'s duties as a soundtrack subpublisher are made considerably easier by the existence of the company's unique "computer tracking system," which keeps tabs on all movies shown on North American TV stations. This system, years in the making, has made it possible for the original European publishers and songwriters to be sure they are collecting reasonable royalty payments.

Benedetto, who is assisted by two CAM staffers in his daily international chores, suggests another reason why CAM's worldwide operations are often less chaotic than domestic dealings. "The sense of professional loyalty, particularly in European countries," Benedetto says, "is greater than it is in America. Executives in Europe think of their jobs as their lives' work." This makes for the kind of long-term business relationships that can cut through foreign red tape.

The key to CAM's worldwide operation, however, is the music. As the world community is brought closer through a web of monetary maneuvering and communications technology, music is showing itself to be at least as universal a language as money. "A beautiful composition in Japanese, or Italian," concludes Vic Benedetto, "is a beautiful piece of music, and I'll exploit it for you."

CAM's Benedetto Launched Business With Soundtracks

(continued from page 40)

The international CAM network includes offices in London, Paris, Tokyo, Stockholm, Sydney, San Paolo, Munich, Madrid, Geneva and Montreal. However, these sister companies specialize in distributing European soundtrack scores, and Benedetto doesn't feel bound to give them sub-publishing rights for all of his material. "Any given copyright will go to the publisher who can do the best job," states Benedetto.

The Personal Touch

Despite the magnitude of Benedetto's operation, he has only 10 full-time employees (supplemented, of course, by independent producers and promotion men). Benedetto could expand CAM, but he wants to avoid a complicated corporate setup. "I believe that people should love product," he comments, "and I like to work with people I know. Our industry is so complex that sometimes, if you lose a particular man ..."

The need to exercise his personal touch in every aspect of CAM's affairs is another reason why Benedetto has no intention of starting a record company. Even the thought of making more money has not been enough to push him into labelhood. "If I could have made more money by starting a label but I wouldn't have been happy, what's the point?" he asks rhetorically. For similar reasons, he says, he has turned down offers of top jobs at record and publishing companies. "I want to prove to myself that I can do something unique and be the company of tomorrow. And that's what I'm working towards."

A great believer in the School of Life, Benedetto learned business by doing it and law by participating in numberless contract negotiations. A feeling for music, his third requirement for success in the industry, was acquired early in life, and has persisted ever since.

Loves All Music

"I look into anything new, because I'm a music man myself," he says. "When I was a kid, my hobby was collecting records. My heart was always in music. And even though I'm not a teenager, I love the music of every single generation. I love the music of the '50s, the '60s, and the '70s, and I will be loving the music of the '80s and '90s and the year 2000, if I'm still here."

"I can like any kind of music, if I feel the particular piece. It can be anything from opera to hard rock: The genre is no block to me as long as it is music."

"A man like me in his late 30s is supposed to listen to ballads or soft melodies and things like that. But I will come into my office at nine in the morning and put on a record and listen to hard rock or whatever. It doesn't disturb me at all."



Stan Poses of Aware Management.



congratulates

VICTOR BENEDETTO

"the Man who delivers"

Georges Bacri & Pema Music launch a luxurious collection of albums dedicated to previously unreleased Soundtracks from important films. Covers are all designed by Raymond Moretti.

PEMA MUSIC 35, rue Washington, 75008 PARIS



Samantha Breaks Through With Help Of CAM, Bill May

by Charles Paikert

NEW YORK — A few years ago, Samantha Sang and Bill May were both popular Australian entertainers. Both had television shows, and one day Sang and May were filming in adjacent studios. They met and, May recalls, "we hated each other at first sight."

But May also met Samantha's mother, who invited him over for dinner later. They listened to some of Sang's records, and soon enough Samantha and May's "hate" turned to mutual respect. Within a few months, May dropped all of his other activities and became Sang's manager.

"I believed in her," May says today, "and I knew that with her voice and talent she was going to be an immense star. And the most important thing at the time was the fact that there was an intuitive, honest communication existing between us."

May flew to New York with a sampling of Samantha's Australian records, and proceeded to buttonhole every A&R man he possibly could, taping their opinions of Samantha's voice with a microphone he had concealed in his briefcase. "I discovered that you have to find a musical direction that's in vogue at the moment. That's the secret."

Impressed Barry Gibb

Armed with this information, May set up a meeting with Barry Gibb, who was impressed by Samantha's tapes. Later Gibb agreed to produce a single for Sang as his first independent production project. The only stipulation was that Gibb insisted on an open budget.



Samantha Sang; Bill May

May again took to pounding Manhattan streets in search of an interested record company. "The crazy thing is," May says, "no one wanted to know. Nobody wanted to commit themselves to an open budget, even though it would be Barry Gibb's first independent production."

Prospects were so bleak, in fact, that May was about to leave New York for California when Helaina Bruno at Chappell Music told him to go over and see Victor Benedetto at CAM Productions. May kept his packed bags at Chappell and went over to CAM. As May tells it, "Victor came out of a meeting, went into a room with us, closed his eyes, listened to a tape, walked over, stuck out his hand and said, 'Congratulations. You have a deal.'"

'Expensive Single'

Gibb not only selected Criterion Studios in Miami as his recording site, but decided to fly in some of the best studio and working-band musicians he knew to sit in on the sessions. "The money was flying," May recalls. "It had to be one of the most expensive singles produced all year. But Victor was great, and understood the importance of doing the best job possible. He trusted my watching over the budget, and was really encouraging and supportive."

The result of the session was "Emotion," an upbeat ballad that currently is bulleting in the Top 20 of *Cash Box's* Top 100 Singles chart. After the single was cut, however, the next step was for CAM Productions to find a suitable record company. "Victor and I stayed up until 5 a.m. going over the offers," May says, "and we finally decided our best opportunity was to go with Private Stock. We knew we wouldn't get lost there, they made us a good deal, and we were impressed with Larry Utall's reputation."

Looking back, May expresses enthusiasm for his working relationship with CAM. "Victor doesn't put you through a whole game," May exclaims. "There's a very straight rapport at CAM, and the only thing is that you have to have your act together when you walk in there."

Sang is currently finishing up work on "Emotion," her debut album for Private Stock. Gibb is contributing songs, and production is being done by Gary Klein and Nick DeCarlo. The release date is Valentine's Day, a rather ironic turn of affairs, considering Sang and May's first reaction toward each other.



Morty Wax, President of Morton D. Wax & Associates, Benedetto, Sang

A&R Department Helps Select Artists, Songs, Producers

by Phil DiMauro

NEW YORK — Corky Abdo, CAM's director of A&R, is assured of his most important criterion in the evaluation of new talent. "I personally concentrate right away on the songwriting," he exclaimed, "because I firmly believe that the key is finding the hit song. Then, hopefully, you'll have the vehicle to bring that song out, but it's always the song first."

Abdo's major responsibilities include the supervision of CAM's productions, both of new acts and of artists already signed to labels. Working with those acts who have signed with CAM before being placed with a record label takes up the greater part of his time. "We try to be a record company with everything except the actual physical product," he explained. "Once we decide that the potential is there, CAM's function is to provide whatever the artist needs." While just about every newly signed artist needs a producer, studio time and, eventually, contacts with record company A&R departments, Abdo explained that CAM has always been willing to provide artists with many other requirements, including new songs, studio arrangers, studio musicians, stage musicians for artists on tour, and even new equipment for groups who need it.

Individual Attention

From the time an artist signs with CAM, the steps involved in the eventual release of product on a record label vary in individual situations. In the case of the recent Samantha Sang single, "Emotion," the master recording was completely produced before CAM began taking it to record companies. Usually, Abdo explained, "CAM will sign an act, then help select material for the direction that the act will take initially: what really makes sense in breaking the artist. Then we initiate first recordings to show the artist's potential, with which we approach the labels." Abdo emphasized that CAM never brings an artist to a label without fulfilling its essential supportive role in nurturing an act for recording.

Final decisions on the signing of any artist are made by CAM head Victor Benedetto in consultation with Abdo and Faye Rosen, CAM's professional manager. "We try to be unanimous in anything we do," said Abdo, "because it increases the percentage of successes."

According to Abdo, CAM often profits by a sharing of responsibilities that functions across departmental boundaries. "There are no rigid lines that separate publishing from production," he stated. "In the general course of my business day, I'll often sit with songwriters, and I may even initiate steps to sign songs to CAM publishing myself." At the same time, Abdo is aided by the entire CAM staff whenever an act is coming up for recording. "Everybody here gets involved in looking for material and casting; getting on the phone and calling other publishers, going back to old albums, and checking all the other sources."

While Abdo realizes that the CAM catalog and international publishing contacts put him at a tremendous advantage in finding material, he emphasized that CAM artists are in no way restricted to the CAM catalog. "My main concern is the strength of the song," he explained. "If I hear a hit song, it doesn't matter who the publisher is."

Choosing A Producer

The choice of producers for CAM's artists is another area that is not governed by any hard-and-fast rules. "There are a lot of very talented producers who might not have an impressive track record," said

Abdo. "It's a challenge to try to find these people, but, like the challenge of finding talented new groups, it can be rewarding. We want to find producers to develop and sponsor, as well as artists." If the situation calls for it, CAM will also seek out well-known professional producers, such as Kenny Vance, who produced Eric Mercurio's album for Columbia.

While Abdo stressed that "the greatest potential is always in the self-contained artist, who writes, performs, and has all the other ingredients," he recalled that Samantha Sang, who is not a writer, proved her exceptional vocal ability after one short performance up at CAM's offices.

Left Banke Reunion

CAM is currently involved in a number of projects that demand Abdo's attention, including one of his own productions: the Striders, a local Woodstock band which includes five songwriters. An unusual project that is currently in its beginning stages is the reuniting of the Left Banke, which was entirely arranged by CAM. After all the members were sought out (one even had to be flown in from Spain), the company rented a house for them in upstate New York, where they are now writing material in anticipation of recording.



Corky Abdo

Yet another project Abdo described is a trio known as White Lightning. "I like to find holes, or openings in the business," he explained, "and one day it suddenly occurred that a 'female Three Dog Night', three female singers doing rock, not pop or R&B, would be something different. We went through lots of auditions, and picked the women that would bring in vocal sounds and personalities that were complimentary. After nearly a year's planning, the group is now recorded and looking for a label deal."

Long Experience

Corky Abdo is more than qualified to make the creative decisions he faces every day, based on his years of experience in and out of the studio, as a performer as well as a producer. As a Long Island youth in the 1960s, he played with the Salvation Navy, a local band which performed on bills with the Vagrants, which included Leslie West, the Hassles, which included Billy Joel, as well as Vanilla Fudge and the Illusion. One of the first people he met in the industry was Jimmy Ienner, who did some work with the band while with Peer Southern.

When the band broke up, Abdo began doing sessions on guitar and vocals, and found that he liked the studio, but soon was out on the road again with a group called Tranquility. While touring, he met some people from Nimbus Nine Productions in Toronto, and before long found a job there working with Jack Richardson, who was producing the Guess Who and Poco at the time. Abdo was also exposed to Bob Ezrin while he was working with Alice Cooper. After producing some Canadian acts, Abdo became Jimmy Ienner's assistant at CAM just about two years ago. When Ienner left CAM in the spring of 1977 to form Millennium Records, Abdo was named director of A&R.

Head Of Artist Development Is A Musician, Producer



Mike Corbett

NEW YORK — It's appropriate that Mike Corbett, director of artist development for CAM Productions, was an artist himself before defecting to the other side of the studio partition. During the '60s, Corbett worked as a studio musician for groups like Hugh McCracken and recorded on his own for Columbia and Atlantic Records. After nearly 10 years in the rock business, Corbett took a breather for awhile, only to find himself still preoccupied with rock — as a high school geology teacher in New York City public schools.

In 1972, Corbett got back in the business as a production coordinator for CAM's publishing arm. After a few years he moved over to A&R, working with Corky Abdo, and in September 1977, he was named head of CAM's artist development department.

"My function is really getting involved with young talent and with acts that have minor flaws in their material, personnel, or production techniques," Corbett says. "The defects are usually a symptom of inexperience, because we feel the groups have tremendous potential. My job is to iron out the defects."

(continued on page 48)

THE SIGN OF MUSIC



To CAM-USA and
CAMERICA —
Congratulations from
CAM
Around the World!

CAM-Argentina

CAM-Italy

CAM-Australia

CAM-Japan

CAM-Brazil

CAM-Spain

CAM-Canada

CAM-Sweden

CAM-France

CAM-Switzerland

CAM-Germany

CAM-United Kingdom

The No. 1 Production and Publishing Company Of The Year

SHAUN CASSIDY (WARNER BROTHERS)
THE NOBLES (COLUMBIA)
ERIC CARMEN (ARISTA)
ERIC MERCURY (COLUMBIA)
SAMANTHA SANG (PRIVATE STOCK)
SNAPPER (UNITED ARTISTS)
BRUCE FOSTER (MILLENNIUM)
OCTAVIAN (MCA)
BILLION DOLLAR BABIES (POLYDOR)
GRAND FUNK RAILROAD (CAPITOL)
BAY CITY ROLLERS (ARISTA)
THREE DOG NIGHT (ABC/DUNHILL)
LIGHTHOUSE (GRT)
DEJA VU (CAPITOL)
LORRAINE FRISAURA (PRELUDE)
BLOOD, SWEAT & TEARS (COLUMBIA)
SHA NA NA (BUDDAH)
OREGON (VANGUARD)
RASPBERRIES (CAPITOL)

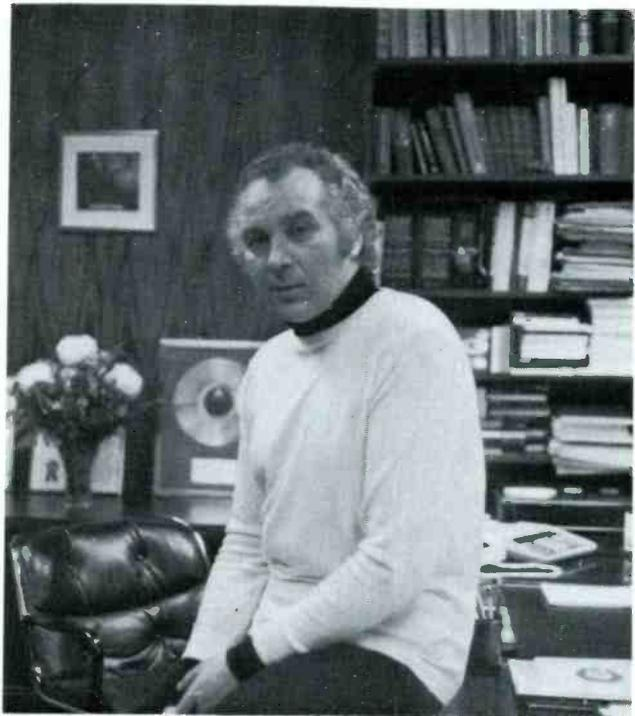

C.A.M.-U.S.A., Inc. (BMI) • Camerica Music, Inc. (ASCAP)
CAM Productions • Camerica Productions

489 FIFTH AVENUE, NEW YORK, N.Y. 10017 TELEPHONE:
(212) 682-8400

TELEX: 236920 CAM UR CABLE: CAMUSAINC

**GENEVE • LONDON • MADRID • MONTREAL • MÜNCHEN •
NEW YORK • PARIS**

ROMA • SÃO PAULO • SYDNEY • STOCKHOLM • TOKYO



CAM Nat'l Promotion Dept. Helps Labels Work Records

NEW YORK — "My definition of promotion is basically trying to just get radio people to listen to a record that ordinarily would be just one of 190 other new releases that came into a station that week," states Arty Simon, head of national promotion for CAM Productions/Publishing. "Promotion is also building a personal relationship with the radio personnel, so that when you call, they'll know you wouldn't be bothering them unless you thought you had a hit on your hands."

Having a knowledge of the basics of record promotion is not enough to guarantee any airplay. Insight, personality and salesmanship are just as important in this competitive field. And Simon displays these qualities abundantly. "I don't promote the small stations and then wait until they play the records before hitting the primary stations," he notes. "If I think a record is a hit, I go right for the big stations. So far it's worked for Samantha Sang's 'Emotion' on Private Stock Records. It also clicked with Eric Carmen's Arista single, 'She Did It.' Many stations were hesitant to go with it at first, since he wasn't coming right off of a hit. It was a long time between records."

Can handling national promotion by phone reduce one's chances of building that personal relationship which Simon spoke of earlier? "It would be ideal to spend six months on the road each year," comments Simon, "for I would like to meet all of the radio people around the country with whom I speak on the phone. But it would

have to be on a one-to-one basis, and not at some record convention where everyone runs around shaking hands and only knows your name by the tag stuck on your label. I'm really not in the business to make new friends, but to get records played. I already have my friends."

Working For Several Labels

Working for CAM also means working for a plethora of labels, ranging from the majors to the smaller, individual ones. "Often an independent promotion man is working a record," says Simon, "and the oldest theory of promotion is that whoever gets to the phone fastest will make the boss think he got the record on. I don't really care about that, as long as the record goes on. I have no desire to get involved with politics, and I just do my job as best I can. I don't deal directly with the record companies who have put out the singles I am working, and can only assume they are doing their jobs."

"Yet it can't hurt if a lot of people work the same record," adds Simon. "I've had radio personnel scream back at me, 'Man, you're the fifth person who's called me today on that damn record!' My immediate response is that maybe I shouldn't have called that station today. But I'll usually tell them something that the other didn't. Anyway, guys like myself are hired to do what music directors don't do anymore, and that's just to listen objectively to everything new that comes in. I don't care what label it's on. Who

(continued on page 48)

Professional Manager's Job Is To Administrate Catalogs

NEW YORK — "In this business, when you come down to it, the song itself is the true key to success," states Faye Rosen, general professional manager for CAM. "People know the value of a copyright. It is one of the most fruitful means of revenue in the record industry for just about everybody concerned. It probably brings in the most money, outside of the actual sales of the records. I find that today's young writers are very bright and know all about ASCAP and BMI."

In her capacity as general professional manager, Ms. Rosen runs CAM's publishing division. Her responsibilities include the exploitation of CAM's two publishing catalogs, CAM-U.S.A. (BMI) and Camera (ASCAP), in terms of cover ver-

sions by other artists, as well as scouting the untapped talent that exists. "I am constantly searching for talent — anywhere and everywhere," says Rosen. "Sometimes it's word of mouth, and I think it's terrific if you can turn others on. I deal with many music publishers all the time. Or I might pick up the *Village Voice* or the *Soho Weekly News* to check out New York City's club scene, and then I'll head downtown that same evening. I've trekked to California as well to check out some artist or writer, and I wish I had more time to travel."



Benedetto and Fay Rosen

motion picture industries. "Publishing is casting," Rosen states. "A part in a movie is there to be filled by the appropriate actor or actress. In the music business, it is hearing a song and saying something like, 'That would be dynamite for Kenny Rogers.' You really have to know the contemporary market to make it big in the publishing business."

Works With A&R

"If a songwriter comes in to CAM," Rosen continues, "and I find merit in the tape he or she brings along, I'll probably want to sign the individual song. But suppose this writer is also a performer — then I'd bring in one of our A&R people to hear the tunes. We would then consider the songs' value as well as weigh the person's chances of making it as an artist."

Samantha Sang, one of CAM's many artists, is a perfect example. "Helaina Bruno of Chappell Music called me and said she'd just met this lovely lady," Rosen says. "When I told her I was interested, she sent Samantha Sang over to CAM. While Samantha was auditioning, I immediately detected something about her, and so did my boss, Victor Benedetto, after I called him in. Now remember — she came to us strictly as a performer, but already she's started to write. Maybe after working with Barry Gibb in Miami it all came to her naturally."

The showcasing of a new writer or performer at CAM is another important aspect of successful publishing. "We've had two great showcases for the press at the Copa," Rosen adds — "the Nobles and Lorraine Frisaura."

CAM publishes a great many foreign soundtracks, especially those that originate in Italy. "Sometimes there is a single release from one of these soundtracks," says Ms. Rosen. "Or perhaps we'll sit down and take a song, or even a melody, from the foreign soundtrack and we'll add an English lyric. The next step is to try for a cover, or possibly have one of our artists record it. Samantha Sang's 'When Love Is Gone,' which is the flip of 'Emotion,' is from



Vince Marchese, manager of The Nobles.

'Bilitis,' one of our overseas soundtracks. We'll also get involved in trying to sell the soundtrack to an American label, as it's often only available on the European label. Incidentally, nearly all of these soundtracks are published via Camera."

Cover Versions

Ms. Rosen spends a great deal of her time attempting to secure cover versions of CAM's catalogs, and demos are sent to the various producers and artists on a daily basis. "However, sometimes they'll call us," she claims. "We got a call from Michael Lloyd, Shaun Cassidy's producer, requesting material by Eric Carmen."

"Shaun has the highest respect for Eric,

(continued on page 48)

Congratulations to

Victor Benedetto

an

outstanding leader in the music industry



CONGRATULATIONS
CONGRATULATIONS
CONGRATULATIONS
CONGRATULATIONS
CONGRATULATIONS
CONGRATULATIONS
CONGRATULATIONS
CONGRATULATIONS
CONGRATULATIONS
CONGRATULATIONS

CAM and Victor Benedetto
from

Barry Gibb and Samantha Sang
for their
smash hit
"EMOTION"



Artist Development Head Mike Corbett Also Involved As Musician And Producer

(continued from page 43)

A good deal of Corbett's time is spent in the studio as a producer. In order for a production to be successful, Corbett believes, two elements are necessary. The first is a sound pre-production plan. "I believe in an organized attack on the thing," Corbett says. "The basics should be rote by the time you get inside the studio. That way you leave yourself room for the fine little twists and turns which add up to a superior recording."

Handle With Care

Psychology, Corbett feels, is also an essential part of any smooth recording session. "Musicians are such a high-strung bunch," Corbett exclaims, "that they have to be handled very carefully in order to get a maximum performance. Since I was a musician, I hope that I'm able to relate es-

pecially well to them about their aesthetic concerns. What I do is work with them on a personal basis, and on a technical basis in the studio."

Environment

The intimate environment of the CAM organization, Corbett feels, is a key to understanding its success. "I'm able to work closely with the artists and spend more time with them than I would at a record company because that's the way Victor Benedetto has structured things, and that's his genius."

"There's a genuine sympathy for the well-being of the artists, and it comes down from Victor. I guess the crucial thing is that there's an atmosphere of concern around here that pleases me very much, especially because when I was an artist I simply did not like a lot of record company people. Here, I think things are different."

Manager Administrates Catalogs

(continued from page 46)

both as an artist and as a writer," adds Rosen. Cassidy's admiration has led to two Top 10 tunes penned by Carmen, "That's Rock And Roll" and "Hey, Deanie" on Curb/Warner Brothers Records.

With all the attention paid to its publishing catalog, however, CAM also devotes a lot of time to its performing artists. "In this company, and maybe because we're not a label, we're very much a family," says Ms. Rosen. "This is a very progressive publishing company, since we are so heavily involved with production. A new songwriter/artist can come in here and have his or her talent nurtured.

"I'm very happy at CAM," she concludes. "Victor Benedetto is just great to work with. He gives me the opportunity to be creative. He takes input from everybody, and listens to everything you say. He digests it all. The mere fact that he allows creativity from everyone is a superb and rare quality. If you have a specific talent outside of your regular job here, Victor will go out of the way to develop that. I'm always honest with Victor about my feelings and opinions regarding an act or material. He's always been equally as open, and it's a give-and-take relationship. There's no finer way to work, when you come down to it."

Cam Nat'l Promotion Dept. Helps Labels Work Records

(continued from page 46)

ever heard of T.K. before George McCrae's monster, 'Rock Your Baby?' KC & The Sunshine Band wrote the tune and backed McCrae on the record before they were an established act, and it went on to sell millions."

Track Record

Simon's track record since he entered this business nearly a decade ago justifies his claims. Earlier in his career, Simon promoted records locally in New York for several firms. Among the records he worked were "Green Eyed Lady" by Sugarloaf, "Proud Mary" by Ike & Tina Turner, "Mr. Bojangles" by the Nitty Gritty Dirt Band, "Watching Scotty Grow" by Bobby Goldsboro, "Having My Baby" by Paul Anka, "Looking For A Love" by Bobby Womack, Joe South's "Walk A Mile In My Shoes," Paul McCartney's "Another Day," John Lennon's "Instant Karma," and the Beatles' last two singles, "Let It Be" and "The Long And Winding Road." Other hits that Simon has promoted include Barry White's "What Am I Going To Do With You" and "Satin Soul" by the Love Unlimited Orchestra, and "Good Morning Starshine" by Oliver (Crewe) and "Smile A Little Smile For Me" (Congress), while he was employed by Empire State Distributors. "Also at Empire, which was my first real gig in the business," adds Simon, "I handled a single by an unknown artist at that time — Elton John — on the Congress label. The tune was 'Border Song,' which no one wanted to play. That's one record I've got filed away in my collection, and nobody is going to get it for any price."

Since joining CAM nearly a year ago, Simon has had a hand in promoting Eric Carmen's "She Did It" and "Boats Against The Current" (Arista), Samantha Sang's "Emotion" (Private Stock), and Shaun Cassidy's "That's Rock And Roll" and "Hey, Deanie" (Curb/Warner Brothers). Both of the Shaun Cassidy tunes are compositions by Eric Carmen, who has been under an exclusive production/publishing pact with CAM since the days when he headed the popular Raspberries (Capitol).

"I use as many successful elements as I

dling five different instruments with expertise. And he even finds time to write some songs of his own. "Victor Benedetto is the first boss I've had that is open-minded enough to acknowledge that my songwriting abilities exist and not let that jeopardize my job as a national promotion man for CAM," claims Simon. "He's been



Shawn Slevin, publishing department.

hip enough to know that I can do both.

"Two of my songs are published by CAM-U.S.A.," continues Simon. "One in fact was sent to Barry Gibb, and he in turn suggested it for Toni Tennille. When CAM signed my first song, entitled 'Light My Way Again,' I wound up playing piano and organ on the demo. Lorraine Frisaura handled the vocals, and I sang harmony. Slowly but surely, Victor has realized that I can help out CAM in the studio. It's one less person to pay. I've also worked with some of the artists on their tunes by just playing piano, and in the process have added a few chords here and there.

"Another one of my tunes, 'Welcome To My Life,' was covered by Bob Crewe on Elektra/Asylum, though it was never released on his album. Maybe I'm lucky, because the LP bombed. But I have been getting into more musical areas than just promotion."

Simon has also been able to devote some time to A&R while at CAM. "When a song comes into CAM in demo form," says Simon, "I usually can judge what artist that song could be good for. Victor Benedetto's main criterion with people that work here is that they've got to know their music. I have found that many people in this industry are not really into music, which has turned me off to them, and likewise them off to me."

Rapport With Radio

Arty Simon, at the age of 30, still has a full career ahead in the business. "I feel that I've had a lot of success in securing some kind of credibility with those in radio," says Simon. "Hopefully, they believe that when I make a phone call to them, it's not just a hype. It's not high-pressure time. I really believe it's a hit. My idea of longevity in this end of the business is to get to a point where I can call someone like WABC's Rick Sklar and tell him, 'Rick, it's a hit. The sooner you can go on it, do it. It's beneficial for your station, and you'll eventually play it anyway.'

"Promotion people are typecast, unfortunately," Simon concludes. "Try holding a normal conversation about radio with the station's music director, or anyone else there for that matter, and they think you're just giving them a hype. I guess it's because in the end they know I'm going to say, 'It's 37 with a bullet. When are you going to play it already?' I just want the music directors to know that once a week they're going to get this one phone call on a particular record, and maybe it will be all right to take a shot with it."

Additional CAM Photos



Gertrude Lefker, office manager and controller, Benedetto.



Robert Leiggi, publishing department.



Ann Lamort, receptionist.



Benedetto, Abri.



Minola Abri, assistant to Benedetto.

can when promoting a record," states Simon. "For instance, the Beach Boys sang background vocals on Eric Carmen's 'She Did It,' which was an added plus. Shaun Cassidy, besides being an established television star via 'The Hardy Boys,' also has a brother, David, who is a successful recording star. Barry and Robin Gibb of the Bee Gees wrote Samantha Sang's 'Emotion,' while Barry produced the tune and even sang vocal accompaniment."

Former Music Director

Earlier in his career, Simon was music director for WKOY-AM in Bluefield, West Virginia. The station programmed primarily R&B tunes within a Top 40 format. Simon is also a versatile musician, capable of han-

And that's just what's happening with Isaac Hayes' new single.

Just a few weeks ago Isaac's new album "New Horizon" exploded on the R&B charts and has since crossed over to the Pop charts. Now he's

released his first single in a long time, "Out Of The Ghetto," and we suggest that nobody stand in the way. Because if the album is any indication, "Out Of The Ghetto" is heading straight for the top.

PD 14446

"Out Of The Ghetto"
only the first single
from Isaac Hayes' new
album "New Horizon."
On Polydor Records
and Tapes.

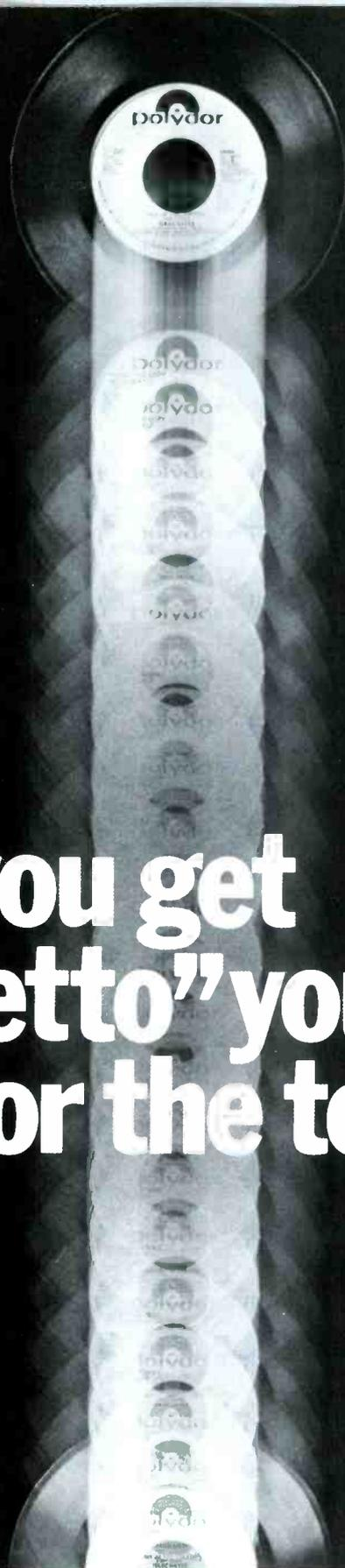

**When you get
"Out Of The Ghetto" you head
straight for the top.**

PD-1-6120

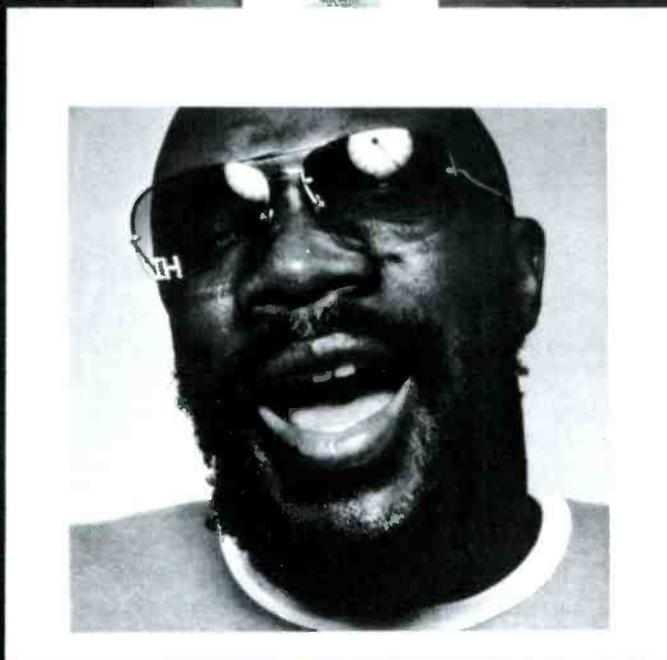

Aphex Aural Exciter

New Recording Device Gains Momentum On Music Row

by Bob Campbell

NASHVILLE — The winds of change blow subtly on Music Row. A fresh breath of air here and a burst of air there punctuate the physical and mental growth of Nashville as a recording center. A quick gulp of that fresh air is called an Aphex Aural Exciter, a relatively new piece of equipment that enhances the quality of live and recorded sound and is being utilized more frequently here by producers and engineers.

Available on the national market on a lease basis since March, 1975, Aphex (an acronym for Aural Perception Heterodyne) has been marketed here for less than a year. The unit is being used extensively in Los Angeles by artists such as Linda Ronstadt, James Taylor and Jackson Browne, but some producers here have not been aware of its existence. However, Waylon Jennings has leased a unit to use

on personal appearances, and local producers Jimmy Bowen, Neil Wilburn, Chips Moman, Brent Maher and Jack Gilmer have all worked with the Aphex unit.

Most of the producers who have used the unit are pleased with the results. And some producers feel the Aphex, which adds brightness, warmth and fullness to sounds by addressing the psychoacoustic circuitry of the listener's brain, is the type of equipment that should be utilized more often here. Gilmer, who along with T. G. Shephard, produced Shephard's first album on Warner Bros. titled "T.G.," likes Aphex and feels the unit will be used more here in the future.

"I have used the Aphex several times, and we used it on T.G.'s latest album," Gilmer said. "There is a definite difference in the sound. You can hear all the difference in the world. It makes a much better record. I don't like it on all instruments, but overall, I really like the unit. It will probably catch on here as more people find out about it. A lot of established people seem to shy away from using things like this and use the old ways, but that will change."

Shephard has been extremely happy with the results. "I think it is absolutely incredible. It is one of many gadgets to come along. It gives any record depth and makes it sound better. When you compare the Aphex sound on a record and then listen to the same songs without it, the difference is unbelievable."

Leased for \$30 a minute for the finished product, eight Aphex units are available here through Aphex South Ltd., a month-old corporation owned and operated by Tom Irby and John Gardner. Irby believes Nashville is ready for more sophisticated recording equipment.

"I think Nashville is growing up," Irby said. "Some of the guys here who do straight stuff don't really need the sophisticated equipment, but Aphex is a

(continued on page 52)

Capitol Announces Craddock Signing

NASHVILLE — Country artist Billy "Crash" Craddock has signed an exclusive long-term recording contract with Capitol Records, announced Don Zimmerman, president and chief operating officer, Capitol Records, Inc.

Commenting on the signing, Zimmerman said, "We're delighted to have an artist of Billy 'Crash' Craddock's stature on the label. Not only does he give us a great presence in the country marketplace, but we feel he's an artist and musician with wide appeal and great potential both in the United States and abroad."

Craddock, a native of North Carolina, said, "I'm really excited about the new recording deal with Capitol. I'm looking forward to a long and successful career with the label."

Dale Morris, Craddock's manager and producer, echoed the singer's remarks, saying, "I really believe 1978 will be Billy 'Crash' Craddock's biggest year."

Frank Jones, Capitol's vice president, country division, commented, "Having been in the position to watch Billy 'Crash' Craddock's career at close range in Nashville, I feel that his talents — combined with Capitol's enthusiasm and marketing capabilities — will surge forward to expand his career to even greater heights."

Craddock's first single for the label, "I Cheated On A Good Woman's Love," will be released Jan. 23. His self-titled debut album for Capitol, which was recorded in Nashville, is slated for March release.



STURDIVANT TO TREE — John Sturdivant, a past president of the Nashville Chapter of the National Academy of Recording Arts and Sciences, has been named to the newly created position of vice president, creative services, at Tree Publishing. Pictured above are (l-r): Jack Stapp, chairman of Tree International; Sturdivant; and Buddy Killen, president of Tree.

Waylon & Willie Debut At #25 On CB Singles Chart

NASHVILLE — The new Waylon Jennings and Willie Nelson single, from their just released "Waylon & Willie" LP, debuted this week at an unprecedented number 25 bullet on the Cash Box Country Singles Chart, making it the highest debuting record in the history of the chart.

More than 80 percent of the reporting stations added the record, with many of the stations giving it a chart number. "Mamas Don't Let your Babies Grow Up To Be Cowboys" is the side most stations are adding, although a number are also programming the flip side, "I Can Get Off On You."

Not since Jennings' "Ol' Waylon" album debuted last May at number one has a record entered at such a high position on either the singles or album chart.

According to RCA officials, the two-sided single is the only one that will be released from the album.

Songwriters Vote On Final Ballot

NASHVILLE — The Nashville Songwriters Association is now in its final round of balloting to select a total of 25 songwriters who will receive Songwriter Achievement Awards in February.

At the same time, NSA members are also selecting a "Songwriter of the Year," determined by the writer who receives the largest number of votes from his peers.

All ballots are being confidentially tabulated by the accounting firm of Peat, Marwick, Mitchell & Co., and results will not be revealed until February 14, during NSA's 11th Annual Songwriter Achievement Presentation & Dinner.

	Weeks On 1/14 Chart		Weeks On 1/14 Chart
1	3	26	18
2	2	27	23
3	5	28	28
4	1	29	27
5	4	30	31
6	8	31	34
7	6	32	33
8	7	33	36
9	9	34	—
10	11	35	35
11	15	36	37
12	13	37	40
13	14	38	38
14	12	39	—
15	10	40	41
16	22	41	—
17	17	42	39
18	20	43	43
19	16	44	30
20	19	45	46
21	21	46	47
22	24	47	48
23	29	48	32
24	26	49	49
25	25	50	42



CRADDOCK SIGNS WITH CAPITOL — Billy "Crash" Craddock has signed an exclusive long-term recording contract with Capitol Records. Pictured above at the signing are standing (l-r): Ed Keeley, Capitol's national country promotion manager; Dan Davis, Capitol's vice president, creative services/merchandising & advertising/press & artist relations; Rupert Perry, Capitol's vice president, A&R; Dale Morris, Craddock's manager and producer; Frank Jones, Capitol's vice president, country division; Vince Cosgrave, Capitol's director, country A&R marketing; and Bob Young, Capitol's vice president, business affairs. Shown seated are (l-r): Craddock; and Don Zimmermann, president and chief operating officer, Capitol Records, Inc.

EMMYLOU



QUARTER MOON IN A TEN CENT TOWN
EMMYLOU HARRIS

Warner Bros. Records
is pleased to announce the release of
Quarter Moon In A Ten Cent Town
Ten superb new performances
by Emmylou Harris



Produced by Brian Ahern for Happy Sack Productions On Warner Bros. records & tapes. BSK 3141

MARTY ROBBINS (Columbia 3-10673)

Return To Me (2:55) (Southern Music Pub. Co. — ASCAP) (C. Lombardo/D. DiMinno)
Marty handles this tune better than anyone since Dean Martin recorded his hit version in the early '50s. There is also a slight touch of Spanish flavor for which Marty is famous.

TERRY TIGRE (Gusto-Stardy SD 174)
Before The Feeling Slips Away (2:05) (Power Play Music — BMI) (Charlie Craig)

Although Terry has an album of Elvis songs out on Gusto-Stardy Records and for some time has been an Elvis imitator, he performs this song in his own style. Production by Tommy Hill is excellent.

DON GIBSON (ABC/Hickory AH-54024)

Starting All Over Again (2:55) (Muscle Shoals Sound Pub. — BMI) (Philip Mitchell)

This is a different direction for Don Gibson and possibly for the better. For his first time producing Gibson, Ronnie Gant has blended this artist with pop and the R&B hit of Mel and Tim.

Singles To Watch

BILL ANDERSON & MARY LOU TURNER (MCA MCA-40852)

I'm Way Ahead Of You (3:04) (Tree Pub. Co. — BMI) (Curly Putman/Sonny Throckmorton)

MOE BANDY (Columbia 3-10671)

Soft Lights And Hard Country Music (2:50) (Acuff-Rose Publ. Inc. — BMI) (S.D. Shafer)

FREDDIE HART (Capitol P-4530)

So Good, So Rare, So Fine (3:47) (ATV Music Corp./Welbeck Music Corp. — BMI/ASCAP) (S. Stone/H. Shannon)

JIM REEVES (RCA JH-11187)

You're The Only Good Thing (That's Happened To Me) (2:12) (Golden West Melodies Inc. — BMI) (Jack Toombs)

JUDY ALLEN (Polydor PD 14440)

Sweet Little Devil (3:03) (Highball Music — BMI) (D. Goodman/M. Sherrill)

DON KING (Con Brio CBK129)

Music Is My Woman (2:59) (Con Brio Music — BMI) (Scott Summer)

PEGGY SUE (Door Knob WIG-8-045)

To Be Loved (2:16) (Door Knob Music Pub. — BMI) (Berry Gordy Jr./Tyran Carlo)

DAVE DUDLEY (Rice RR-5077)

One A.M. Alone (3:22) (New Keys Music Inc. — BMI) (Dave Dudley/Ronnie Rogers)

AVA BARBER (Ranwood R-1083)

Bucket To The South (2:40) (Beechwood Music Corp./Dickerson Music — BMI) (Gail Davies)

COLLEEN PETERSON (Capitol P-4535)

Bucket To The South (2:43) (Beechwood Music/Dickerson Music — BMI) (Gail Davies)

MARK JAMES (Private Stock PS 45 179)

Everybody Loves A Rain Song (3:01) (Screen Gems-EMI/Stratton House Music/Baby Chick Music — BMI) (Mark James/Chips Moman)

B. J. THOMAS (MCA MCA-40854)

Everybody Loves A Rain Song (2:33) (Screen Gems-EMI/Baby Chick Music /Stratton House Music — BMI) (Mark James/Chips Moman)

COUNTRY ROUNDUP

What do **Jessica James**, **Bill Anderson**, **Jonathan Fricke** and **Tim Williams** have in common? Well, they've either had or are going to have a new baby very soon. MCA's **Jessica James** had a little baby boy, **Bruce Ryan Harris**, on Dec. 21. **Bill Anderson's** wife, **Becky**, is expecting in late June. **Jonathan Fricke** of **Promotions Plus** has been calling his wife every five minutes for the past two weeks to see if it's time yet... and **Tim's** wife, **Lee Ann**, is due in the next week or so... maybe by the time you're reading this. So wish them all lots of luck... they'll need it. Babysitters of Nashville get ready...

Columbia recording artist **Katy Moffatt** performed here at the *Exit/In* Jan. 10 and 11. **Katy**, just coming back from a successful European tour with **Leo Kotke**, will join **Willie Nelson** and **Jerry Jeff Walker** for a mid-America tour of 19 cities beginning Jan. 13. Her second album, *"Kissin' In The California Sun,"* produced by **Glen Spreen**, was recorded in Los Angeles and should be in the stores by now. **Katy** says Columbia plans to release a single entitled "Um... Um... Um... Um... Um... Um," an old **Major Lance** tune.



Katy Moffatt

RCA's **Danny Davis** and **The Nashville Brass** have just completed their 23rd album for the label. "How I Love Them Old Songs" was co-produced by **Bob Ferguson**.

With so many Nashville stars going "Hollywood," it comes as no surprise that **Loretta Lynn** will soon have her "star" placed in the famous Hollywood "Walk of Fame." The MCA artist was selected for the honor by the Hollywood Chamber of Commerce. The installation will coincide with **Loretta's** appearance on the "Tonight Show," "Merv Griffin Show," "Dinah," and the "Mike Douglas Show."

Merle Haggard spent his spare holiday time recording the finishing touches on his new MCA single, tentatively scheduled to be released in Feb. **Merle's** current release on Capitol, "Running Kind," jumps to 55 bullet on the **Cash Box** Country Singles chart this week.

Rumors have been circulating around Music Row for the past couple of weeks that **Dave Dudley** would be taking over the all-night jock duties at a major Nashville radio station. A press release from WSM this week confirms the rumor. **Dudley** will begin working 10 p.m.-4 a.m. on the air this week.

Con Hunley's new single for Warner Bros. has just been shipped to stores and radio stations this week. "Cry, Cry Darling" has also been recently recorded by Groovy artist **Glenn Barber**. **Barber's** version of the song moves to # 79 on the **Cash Box** Country Singles Chart this week.

Two other artists are bumping heads on the chart with the same song this week. **David Houston's** "It Started All Over Again" moves to # 64, after six weeks on the chart, while **Vern Gosdin's** version debuts at 89 bullet this week.

Columbia recording artist **Barbara Fairchild** will be appearing at the Frontier Hotel, Las Vegas, with **Roy Clark** through Jan. 18.

Tom and **Ted**, the LeGarde Twins, were in Nashville's Sound Stage Studios recently, putting the finishing touches on a new album before flying back to L.A. to tape a television pilot for CBS. The show is produced by **Chris Bearde**, who created "The Gong Show." The pilot is called "The Cheap Show," and features **Dick Morton** and **Tab Hunter**. If CBS picks it up, **Tom** and **Ted** will have a spot as regulars in the cast.

tim williams

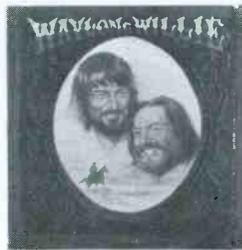

WAYLON JENNINGS AND WILLE NELSON — Waylon & Willie

— RCA AFL-2686 — Producers: Willie & Waylon — List: 7.98

By now it ought to be scrawled in solid steel — Waylon and Willie don't make outlaw music, they just make great music. Both of these men of Texas have lived, loved and lost hard. And somewhere in between they have mastered the delicate art of recorded sound. With five full-fledged duets on this album, Waylon and Willie have refined the interplay of their voices to near perfection. Packed with hand-tooled tunes like "Mama, Don't Let Your Babies Grow Up To Be Cowboys," "Gold Dust Woman" and two Kristofferson gems, this record has platinum painted all over it.



TOM T. HALL — New Train, Same Rider — RCA APL1-2622 —

Producer: Roy Dea — List: 6.98

It could be that changing labels has charged Tom T. Hall with new energy... or it could be that the man's vision is just naturally more keen than the rest of us. But Hall has again drawn on a seemingly endless well of creative talent and recorded another in a long string of excellent albums. True, not all of the songs are his, but Hall's new tunes still brim with his interesting turn of lyrical insight. "New Train, Same Rider" gives The Storyteller a good push down the rails of RCA.



STEVE YOUNG — No Place To Fall — RCA APL-1-2510 —

Producer: Roy Dea — List: 6.98

There surely will come a time when the general public will discover the brilliant artistry of Steve Young (Waylon Jennings will tell you Steve is his favorite singer). Young's debut album for RCA was praised by many critics as the country album of 1976. This record may be better. A man of soul, substance and a true son of the south, Young attacks the very marrow of a song and brands it his own. He has recorded new versions of his haunting "Montgomery In The Rain" and "Seven Bridges Road" and has added a scorching track of Dylan's "Don't Think Twice, It's All Right."

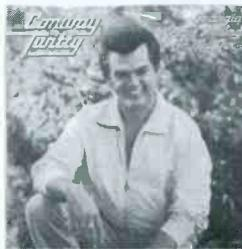

CONWAY TWITTY — Georgia Keeps Pulling On My Ring —

MCA MCA-2328 — Producer: Owen Bradley — List: 6.98

With all the concern and confusion in Music City about crossover records and what is country music and what is not, Conway Twitty seems to be oblivious to the fuss. He just goes into the studio, records the music he knows best, and sits back and waits for the Twitty name to appear at the top of the charts. His voice is as full and rich as ever on songs like "Georgia Keeps Pulling On My Ring," "Let It Ring" and "The Grandest Lady Of Them All."

New Recording Device Gains Momentum On Music Row

(continued from page 50)

unit that you can play with and work with a different sound. Most of the people who have heard the results seem to like it."

Jimmy Bowen, who moved here from Los Angeles in the last couple of years and who produces Mel Tillis, Tompall Glaser and Roy Head, believes new innovations like the Aphex should be used more here.

"Nice Tool"

"The Aphex is an interesting piece of equipment," Bowen said. "It is an added plus to recording. It is a nice tool when properly used and it adds presence to a recording. The big problem is that down here they don't use things like that. I'm from L.A. where the competition is stiff and you have to get into new things that come out on the market in order to keep up. Country music must start using these aids. Down here people are mostly concerned with the song. Production is five-to-ten-years behind."

Bowen added that he has used the Aphex unit on the last two Tillis albums and on Roy Head and Tompall Glaser.

Bob McGraw, assistant supervisor of recording equipment maintenance for CBS, gave a more technical explanation of Aphex's function. But he believes a piece of equipment can't help a bad song.

"Not A Miracle-Drug"

"It adds a liveness or realness and tends to expand depth in terms of front-to-back sound," McGraw said. "It basically controls the gain of circuit. It creates an effect and must be used tastefully. I don't think anyone at CBS has actually used it on a record. I don't personally feel it would make or break a record. It is not a miracle-drug. It won't make a bad song good. It does add brilliance and enhances depth of perception."

Brent Maher of Creative Workshop

Studio used the Aphex Unit in recording Dave Loggins' album, "One More Ticket To Paradise." He also feels the Aphex will be used here in Nashville, primarily because of the influx of pop groups who record here.

"For some things it's very good," Maher said. "But it can be easily overused. Actually it is a high-end exciter which adds different harmonic structures to the high end of music. One of the big reasons for its use here is the big boost in pop music being recorded here. At my studio we record probably 70% pop and 30% country. I have talked to people from all parts of the country and even England and they love recording here. Nashville has the best studios and the best pickers anywhere. So I think everybody will start picking up on newer recording techniques as more pop acts start recording here."

Other groups who have leased the Aphex Aural Exciter from the Nashville office have been The Amazing Rhythm Aces and The Atlanta Rhythm Section.

In practice, the Aphex unit is processed during the sound mix. Each component (vocals, keyboards, etc.) is channelled through Aphex at a desired level and then returned to a console main output channel where it takes on the character of a 'sub-carrier,' about 20 decibels below the program signal level. A differential input is created and this affects the listener through the aural circuitry.

Diamond To Produce Arnold's Next Album

NASHVILLE — Eddy Arnold, RCA Records artist, will have his next album produced by Joe Diamond, who recently produced Engelbert Humperdinck's "After The Lovin'." It will be the first time that Arnold and Diamond have worked together.

CASH BOX TOP 100 COUNTRY

January 21, 1978

	Weeks On Chart	1/14		Weeks On Chart	1/14		Weeks On Chart	1/14
1 MY WAY ELVIS PRESLEY (RCA PB-11165)	2	11	32 LONELY STREET REX ALLEN JR. (Warner Bros. WBS 8482)	16	12	66 IF I EVER COME BACK PAL RAKES (Warner Bros. WBS 8506)	74	6
2 WHAT A DIFFERENCE YOU'VE MADE IN MY LIFE RONNIE MILSAP (RCA PB-11146)	3	11	33 TWO DOORS DOWN ZELLA LEHR (RCA PB 11174)	50	4	67 MOUNTAIN MUSIC PORTER WAGONER (RCA PB-11186)	73	4
3 OUT OF MY HEAD AND BACK IN MY BED LORETTA LYNN (MCA-40832)	5	8	34 YOU KNOW WHAT JERRY REED AND SEIDINA (RCA JG-11164)	38	6	68 YOU READ BETWEEN THE LINES BILLY PARKER (SCR SC 153)	76	5
4 TAKE THIS JOB AND SHOVE IT JOHNNY PAYCHECK (Epic 8-50469)	1	12	35 SHINE ON ME (THE SUN STILL SHINES WHEN IT RAINS) JOHN WESLEY RYLES (ABC/Dot DO-17733)	37	5	69 AFRAID YOU'D COME BACK KENNY PRICE (MRC 1007)	72	4
5 I WISH YOU WERE SOMEONE I LOVE LARRY GATLIN (Monument 45-234)	7	7	36 GOD MUST HAVE BLESSED AMERICA GLEN CAMPBELL (Capitol P-4515)	34	3	70 GOTTA TRAVEL ON SHILO (Columbia 3-10647)	70	9
6 DON'T BREAK THE HEART THAT LOVES YOU MARGO SMITH (Warner Bros. 8508)	12	6	37 BARTENDER'S BLUES GEORGE JONES (Epic 8-50495)	63	4	71 BROKEN DOLLS NEED LOVE TOO CATHY O'SHEA (MCA-40843)	71	5
7 TO DADDY EMMYLOU HARRIS (Warner Bros. WBS 8496)	8	9	38 I'VE CRIED THE BLUES RIGHT OUT OF MY EYES CRYSTAL GAYLE (MCA 40837)	41	8	72 YOU LIGHT UP MY LIFE DEBBY BOONE (Warner/Curb 8455)	57	14
8 YOU'RE THE ONE OAK RIDGE BOYS (ABC/Dot DO 17737)	9	8	39 PLEASE NARVEL FELTS (ABC/Dot DO 17131)	40	8	73 DON'T LET ME TOUCH YOU MARTY ROBBINS (Columbia 3-10820)	62	15
9 SOMETHING TO BRAG ABOUT MARY KAY PLACE (Columbia 3-10844)	10	10	40 I'VE BEEN LOVED THE CATES SISTERS (Caprice CA-2041)	43	6	74 DON'T LET THE FLAME BURN OUT RITA REMINGTON (Plantation PL-167)	77	5
10 MIDDLE AGE CRAZY JERRY LEE LEWIS (Mercury 55011)	4	13	41 ANGEL OF THE MORNING MELBA MONTGOMERY (United Artists UA-XW 1115)	48	7	75 YES MA'AM TOMMY OVERSTREET (ABC/Dot DO-17737)	—	1
11 WOMAN TO WOMAN BARBARA MANDRELL (ABC/Dot DO-17736)	20	5	42 THE LONGEST WALK MARY K. MILLER (Inergy I-304)	44	5	76 DOWN THE ROADS OF DADDY'S DREAMS DARRELL McCALL (Columbia 3-10653)	78	3
12 MAY THE FORCE BE WITH YOU ALWAYS TOM T. HALL (RCA PB 1158)	14	8	43 ALWAYS LOVIN' HER MAN DALE McBRIDE (Con Brio 127)	45	9	77 THE FIRST TIME BILLY "CRASH" CRADDOCK (ABC/Dot DO-17725)	46	11
13 MISTER D.J. T.G. SHEPPARD (Warner/Curb WBS 8490)	13	11	44 IT DOESN'T MATTER ANYMORE R.C. BANNON (Columbia 3-10655)	52	6	78 SAVIN' THIS LOVE SONG FOR YOU JOHNNY RODRIGUEZ (Mercury 65012)	53	12
14 WHAT DID I PROMISE HER LAST NIGHT MEL TILLIS (MCA-40836)	26	5	45 I'LL GET OVER YOU NICK NIXON (Mercury DJ-517)	36	13	79 CRY, CRY DARLING GLENN BARBER (Groovy G-103)	86	2
15 STANDARD LIE NUMBER ONE STELLA PARTON (Elektra E-45437A)	18	11	46 WHAT KIND OF FOOL (DO YOU THINK I AM) EDDIE M. DOLETON (Epic/Cleve. Int. 8-50481)	47	54	80 WALK RIGHT BACK ANNE MURRAY (Capitol P-4527)	—	1
16 COME TO ME ROY HEAD (ABC/Dot DO-17722)	17	17	47 I JUST WANT TO BE YOUR EVERYTHING CONNIE SMITH (Monument 45-231)	30	12	81 CARLENA AND JOSE GOMEZ BILLY WALKER (MRC MR-1009)	88	3
17 I DON'T NEED A THING AT ALL GENE WATSON (Capitol 10-45)	22	8	48 GEORGIA KEEPS PULLING ON MY RING CONWAY TWITTY (MCA-40805)	11	13	82 SOMETIMES I DO/HALF MY HEART'S IN TEXAS ERNEST TUBB (First Generation 001)	89	4
18 BABY, LAST NIGHT MADE MY DAY SUSIE ALLANSON (Warner/Curb WBS 8473)	19	12	49 THROWIN' MEMORIES ON THE FIRE CAL SMITH (MCA-40839)	49	6	83 SMOKE! SMOKE! SMOKE! (THAT CIGARETTE) TOM BRESH (ABC/Dot DO-17738)	—	1
19 WE GOT LOVE LYNN ANDERSON (Columbia 3-10850)	21	8	50 I LIKE TO BE WITH YOU RONNIE SESSIONS (MCA 40831)	51	8	84 DON'T WORRY ('BOUT ME) GLENDA GRIFFITH (Ariola America 7680)	92	3
20 COME A LITTLE BIT CLOSER JOHNNY DUNCAN (WITH JANIE FRICKE) (Columbia 3-10834)	6	13	51 BEDROOM EYES DON DRUMM (Churchill CR7704)	56	5	85 RED HOT MEMORY KENNY DALE (Capitol P-4528)	—	1
21 HOW CAN I LEAVE YOU AGAIN JOHN DENVER (RCA JH-11038)	24	9	52 IF I HAD A CHEATING HEART MEL STREET (Polydor PD 14448)	79	2	86 DEEPER WATER BRENDA KAYE PERRY (MRC MR 1010)	96	2
22 THINK ABOUT ME FREDDY FENDER (ABC/Dot DO-17730)	23	10	53 FEELIN' BETTER HANK WILLIAMS JR. (Warner/Curb WBS 8507)	59	5	87 JAMBALAYA (ON THE BAYOU) SASKIA & SERGE (ABC/Hickory AH-54020)	87	4
23 SOME I WROTE STATLER BROS. (Mercury 55013)	25	8	54 CHAINS OF LOVE MICKY GILLEY (Playboy ZS8-5818)	15	13	88 SO GOOD, SO RARE, SO FINE FREDDIE HART (Capitol P-4530)	—	1
24 DO I LOVE YOU (YES IN EVERY WAY) DONNA FARGO (Warner Bros. WBS 8509)	39	4	55 RUNNING KIND MERLE HAGGARD (Capitol P-4525)	67	3	89 IT STARTED ALL OVER AGAIN VERN GOSDIN (Elektra E-45411)	—	1
25 MAMAS DON'T LET YOUR BABIES GROW UP TO BE COWBOYS WAYLON JENNINGS AND WILLIE NELSON (RCA PB-11198)	—	1	56 I'LL PROMISE YOU TOMORROW JERRY WALLACE (BMA 7-005)	29	11	90 NYQUIL BLUES ALVIN CROW (Polydor 14437)	90	4
26 HOLD TIGHT KENNY STARR (MCA 40817)	27	10	57 HERE YOU COME AGAIN DOLLY PARTON (RCA JH-11123)	42	14	91 LEONA JOHNNY RUSSELL (RCA PB-11160)	91	3
27 YOU AND ME ALONE DAVID ROGERS (Republic REP 011-A)	28	10	58 LONELY HEARTS CLUB BILLIE JO SPEARS (United Artists UA-XW1127)	80	2	92 HONKY TONK TOYS A.L. "DOODLE" OWENS (Raindrop USD010)	95	3
28 GOD MADE LOVE MEL McDANIEL (Capitol P-4520)	31	6	59 I'VE GOT A FEELIN' (SOMEBODY'S STEALIN') JOHN ANDERSON (Warner Bros. WBS 8480)	61	5	93 SWEET COUNTRY GIRL MACK SANDERS (Pilot PR-45-101)	97	2
29 SHAKE ME I RATTLE CRISTY LANE (LS/GRT GRT-148)	35	6	60 THE WRONG SIDE OF THE RAINBOW JIM CHESNUT (ABC/Hickory AH-54021)	64	7	94 LITTLE TEARDROPS LINDA CASSADY (Cin Kay AA026CK 127)	—	1
30 I LOVE YOU, I LOVE YOU, I LOVE YOU RONNIE McDOWELL (Scorpio/GRT GRT 149)	32	6	61 GET DOWN COUNTRY MUSIC BRUSH ARBOR (Monument 45230)	60	9	95 UNDERCOVER MAN LANEY SMALLWOOD (Monument 45-237)	93	6
31 I PROMISED HER A RAINBOW BOBBY BORCHERS (Playboy ZS8-5823)	33	7	62 I'M KNEE DEEP IN LOVING YOU DAVE & SUGAR (RCA PB 11141)	54	13	96 A GIFT IN THE NAME OF LOVE JIM OWEN AND THE DRIFTING COWBOYS (Epic-8-50498)	—	1
			63 SWEET MUSIC MAN KENNY ROGERS (United Artists UAST-18848)	55	14	97 TAKE MY LOVE TO RITA TOMMY CASH (Monument 45-238)	—	1
			64 IT STARTED ALL OVER AGAIN DAVID HOUSTON (Gusto-Starday SD-172)	69	6	98 IT SHOULD HAVE BEEN EASY DOTTSY (RCA PB 1138-A)	58	13
			65 ANGELINE MUNDO EARWOOD (True 111)	68	4	99 IS IT WRONG GILBERT ORTEGA (LRJ 1050)	—	1
						100 AGREE TO DISAGREE LITTLE DAVID WILKINS (Playboy ZS8-5822)	65	14

ALPHABETIZED TOP 100 COUNTRY SINGLES (INCLUDING PUBLISHERS AND LICENSEES)

Afraid You'd Come (Tree — BMI)	69	God Must (Warner Tamerlane/Marcaine — BMI)	36	I Wish You (First Generation — BMI)	5	Sweet Country Girl	93
A Gift (House Of Love Music — BMI)	96	Gotta Travel (Sanga Music — BMI)	70	Jambalaya (Fred Rose — BMI)	87	Sweet Music (Jolly Rogers — ASCAP)	63
Agree To (Little David Music — BMI)	100	Half Vy Heart's (Window/Beachwood — BMI)	82	Leona (No Exit Music — BMI)	91	Take My Love (Tree Pub. Co. — BMI)	97
Always Lovin' (Harold Kinman)	43	Here You Come (Screen Gems-EMI/Summerhill — BMI)	57	Little Teardrops (Electric Mule/Sher Kay — BMI)	94	Take This Job (Warner Tamerlane — BMI)	4
Angeline (Music Of The Times — BMI)	65	Hold Tight (Kipahula Music Co. — ASCAP)	26	Lonely Hearts (ATV Music/Blackwood — BM)	58	The First (Pick-A-Hit — BMI)	77
Angel O' The (Blackwood — BMI)	41	Honky Tonk Toys (Unichappell Music)	92	Lonely Street (Four Star — BMI)	32	The Longest Walk (Advanced — ASCAP)	42
Baby, Last Night (House Of Gold — BMI)	18	I Just Want (Stigwood/Unichappell — BMI)	29	Mama's Don't Let (Tree/Sugarplum — BMI)	25	The Wrong Side (Acuff-Rose — BMI)	20
Bartender's Blues (Country Road Music — BMI)	37	I Like (Chriswood — BMI)	47	May The Force (Hall Tone — BMI)	12	Think About Me (Cajon Music — BMI)	60
Bedroom Eyes (Zoobe — ASCAP)	51	I'll Get (Sheiby Singleton — BMI)	21	Middle Age (Tree — BMI)	10	Throwin' Memories (Stone Porch — BMI)	49
Broken Dolls (FIA Music — ASCAP)	71	I'll Promise You (Edwin H. Morris/Chip 'N' Dale — ASCAP)	17	Mister D.J. (Jop — ASCAP/Pointed Star — BMI)	13	To Daddy (Owepub Pub. — BMI)	7
Carlena And Jose (Metamoros Music — BMI)	81	I Love You (Brim — SESAC)	56	Mountain Music (Owepub — BMI)	67	Two Doors Down (Owepub — BMI)	33
Chains Of Love (Belinda/Unichappell — BMI)	54	I'm Knee Deep (Tree — BMI)	62	My Way (Spanka — BMI)	67	Undercover Man (Al Gallico — BMI)	33
Come A Little (Morris Music — BMI)	20	I Prom sed Her (Chappell — ASCAP)	31	Nyquil Blues (Lone Grove — BMI)	90	Easy Listening — ASCAP	95
Come To Me (Acoustic/Longstreet — BMI)	16	Is It Wrong (Brother Karl's/Mandina — BMI)	99	Out Of (Hello Darlin' SESAC)	3	Walk Right (Warner Tamerlane — BMI)	80
Cry, Cry, Darling (Acuff-Rose — BMI)	79	It Doesn't Matter (Spanka — BMI)	44	Please (Narvel The Marvel — BMI)	39	We Got (Tree — BMI)	19
Deeper Water (Millstone Music — ASCAP)	86	It Should Have (Hall-Clement/Vouge — BMI)	98	Red Hot Memory (Publicare — ASCAP)	85	What A Difference (Chess — ASCAP)	2
Do I Love (Spanka — ASCAP)	24	It Started (Garparx — ASCAP/Kaysey — SESAC)	89	Running Kind (Shade Tree Music — BMI)	55	What Did I (Sawgrass — BMI)	14
Don't Break (Gyrus — ASCAP)	6	I've Been Loved (Sound — ASCAP)	40	Savin' This Love (Window — BMI)	78	What Kind Of Fool (Low-Twi — BMI)	46
Don't Let Me (Mariposa — BMI)	73	I've Cried (Sure Fire — BMI)	38	Shake Me (Regent — BMI)	29	Woman To Woman (East Memphis — BMI)	11
Don't Let The (Hawill/Plain & Simple — ASCAP)	74	I've Got (Al Gallico — BMI/Easy Listening — ASCAP)	59	Shine On Me (Narvel The Marvel — BMI)	35	Yes Ma'am (Tree Pub. — BMI)	75
Down The Roads (High Ball Music — BMI)	76			Smoke! Smoke! Smoke! (Belinda — BMI)	83	You And Me (Singletree Music Co. — BMI)	27
Feelin' Better (Bocephus — BMI)	53			So Good (ATV — BMI/Welbeck — ASCAP)	88	You Know What (Vector — BMI)	34
Georgia Keeps Pulling (Emerald Isle/Battleground — BMI)	48			Some I (American Cowboy — BMI)	23	You Light Up (Big Hill — ASCAP)	72
Get Down (Combine Music Corp — BMI)	61			Something To Brag (Tree Pub. Co. — BMI)	9	You Read (Sawgrass — BMI)	68
God Made (Combine/Music City — BMI-ASCAP)	28			Sometimes I Do (Tree — BMI)	82	You're The (Glenwood/Arcane — BMI)	8

THE COUNTRY MIKE

Music director **Max Garder** and everybody at **KKYX** in San Antonio are busy getting ready for their 6th annual Great Country River Festival, to be held Feb. 3-5. Last year, the concert drew over 175,000 people, and they are expecting about 200,000 this year. The neat thing about this event is that admission is free. This year's festival will feature **Kenny Dale, Bobby Borchers, Dotsy, Nick Nixon, Vern Gosdin, Gene Watson, Johnny Bush, Jim Chesnut, Barbara Fairchild, Ronnie Sessions, Narvel Felts**, and many others. Max says it's just their way of thanking San Antonio and Texas for listening to **KKYX**. Sounds like a pretty good way.

The latest lineup at **KFDI** in Wichita has music director **Don Walton** on the air from 8:30-noon; **Jerry Adams** noon-3; **Terry Burford** 3-6; **Dick House** 6-midnight; **Willie Wheelchair** midnight-6; and **Ol' Mike** 6-8:30 a.m.

KLAK in Denver has a new operations manager from across town at **KOA**. **Don Martin** replaces **Lindsey English**. Also new at the station is midday announcer **Johnny Harding**.

Joe Ladd from **KIKK**, **Arch Yancy** from **KNUZ** and **Dr. Bruce Nelson** from **KENR**, have been named co-chairmen of the entertainment committee for the 1978 Pasadena Livestock Show in the Greater Houston area.

Speaking of Texas, **KUFO** in Galveston started off the new year by sending listeners on all-expense paid ski trips to Colorado. They also began broadcasting on a 24-hour-a-day schedule. **KUFO** is now Galveston County's only full-time radio station. Music director at the station is **Al Clarke**.



Jerry Adams

WSLC in Roanoke is a big station, in case you weren't aware of that fact. Talking with music director **King Edward Smith**, we discovered that **WSLC** and **WSQL**, their FM, employ 42 people, and the stations are number one and two, respectively, in the ratings. Another interesting fact is that **WSQL** is one of only eight 200,000 watt FM stations in the country, coming under the 1949 FCC Grandfather Clause. **WSLC's** lineup includes **Jim Cash** 6-9; **King Edward IV** 9-noon; **"Swifty" George Gillock** noon-3; **Steve Akers** 3-7; **Dave Bailey** 7-midnight; and **Terry Slusher** midnight-6.

WIL in St. Louis is giving their listeners a chance to win big bucks in their "Shove It" contest. Contestants may register at area record stores to have **WIL** match their weekly paycheck, up to a \$500 dollar limit. Music director **Walt Turner** is in the process of trying to get **Johnny Paycheck** to give the grand prize away on the air. **KOOO** in Omaha joined the CBS Radio Network last week. We will not even try to list all the stations running **Elvis** specials and giveaways during the past couple of weeks, because most of them did.

The new operations manager at **KCKN** in Kansas City, **Chris Collier**, has beefed-up their personality lineup. **Ed Brown** performs the morning duties from 6-10; **"Uncle" Don Rhea**, who has been morning man at **KCKN** for years and years, moves to middays 10-3 on the AM. **Tim Wallace** works middays on the FM. The rest of **KCKN's** talent includes **John Conrad** 3-7; **Dave Bryan** 7-midnight; and **Noel Scott** midnight-6.

There have been some changes going on at **WINN** in Louisville. **"Moon" Mullins** was promoted from PD to operations manager and **Jack "Bucks" Braun** takes over the PD chores, as well as continuing to keep the music duties. **WINN** also has a great promotion going in cooperation with the Brown & Williamson tobacco company. The first annual **WINN/KOOL Country Shindig**, being held Feb. 9, will feature **Ronnie Milsap, Crystal Gayle, Jerry Clower**, and **Jackie Ward**. Brown & Williamson, who make Kool cigarettes, will be promoting country concerts in two other cities next month.

Here in Nashville, **WKDA** played basketball for charity with the Music City Hotshots last week. The Hotshots were made up of **Larry Gatlin**, the **Oak Ridge Boys**, **Ron Blackwood**, and a bunch of others. By the way, **KDA** lost by 10 points.

KIKK has moved their offices from nearby Pasadena, into the city limits of Houston. Their new address is 6306 Gullton, Houston, Texas 77081. The phone is 713-772-4433. Just one little plea from us before we close this week. **Cash Box** needs your playlists every week before Tuesday. Send your advance playlists, along with your news and photos, to **Cash Box**, 21 Music Circle East, Nashville, Tenn. 37203.

country mike

ABC Name Shortening Party



THE DISAPPEARING DOT — **ABC/Dot Records** recently became **ABC Records** during a name shortening ceremony at **Richland Country Club** in Nashville with 300 industry execs, artists and local dignitaries on hand. Pictured in the top row of photos are (l-r): **Steve Diener**, president of **ABC Records**; **Ron Chancey**, vice president, A&R, Nashville operations, **ABC Records**; **Jim Foglesong**, president Nashville operations, **ABC Records** and **Larry Baunach**, vice president of **ABC Records**, Nashville operations in charge of sales and promotions; **Gary Davis**, vice president, sales and promotion, **ABC Records**; **Barbara Mandrell**; and **Barry Grieff**, vice president of marketing and creative services, **ABC Records**. Shown in the bottom row are (l-r): **Linda Chesnut**; **Jim Chesnut** (**ABC Hickory**); **Davis**; and **Duane Allen** of the **Oak Ridge Boys**; **Jim Sharpe**, **Cash Box** director of Nashville operations and **Tim Williams** of **Cash Box**.

MOST ADDED COUNTRY SINGLES

- MAMAS DON'T LET YOUR BABIES GROW UP TO BE COWBOYS — WAYLON & WILLIE — RCA**
KLAC, KUZZ, KGBS, KSON, KCKN, WDAF, KRAK, KHAK, KENR, KKYX, WUNI, KMPS, KFDI, KBOX, WMC, KIKK, WSLC, WIL, WYDE, WAME, WUBE, KEBC, KHEY, KCUB, KXLR, WTSO, WWOL, WHK, KRMD, KFTN, WKDA, KNEW, WSDS, WXCL, WPNX, KGA, WWOK, WRCP, WPOC, WBAM, WLOL, WHN, WAXX, WNRS, WPLO, WJJD, KLAK, KJJJ, KERE, KNUZ, WINN, KXOL, WWVA, KCKC, KYNN.
- IF I HAD A CHEATING HEART — MEL STREET — POLYDOR**
KGBS, WMC, WSLC, WSHO, WAME, KEBC, KXLR, WTSO, WWOL, KLAK, KFTN, WKDA, WXCL, WPNX, KERE, WNUZ, KXOL, KVOO, KYNN.
- YES MA'AM — TOMMY OVERSTREET — ABC**
KRAK, KHAK, KENR, KKYX, KMPS, KIKK, WSLC, KD JW, WCMS, WYDE, KEBC, KCUB, WTSO, WAXX, KNEW, WSDS, KXOL, WWVA, KVOO.
- BARTENDER'S BLUES — GEORGE JONES — EPIC**
KUZZ, KBOX, KIKK, WUBE, KEBC, KHEY, WMNI, WLOL, WPLO, KLAK, KRMD, KFTN, KNEW, KERE, KXOL, KVOO.
- TWO DOORS DOWN — ZELLA LEHR — RCA**
KLAC, KSON, KCKN, KHAK, KKYX, KBOX, WUBE, WTSO, WBAM, WDEE, WHOO, WHK, KGA, KERE, KVOO.
- DO I LOVE YOU (YES IN EVERY WAY) — DONNA FARGO — WARNER BROS.**
KUZZ, KWJJ, KENR, WMC, KHEY, KPOC, WHN, WXOX, WDEE, KLAK, WHK, WKOA.
- LONELY HEARTS CLUB — BILLIE JO SPEARS — UNITED ARTISTS**
KLAC, KGBS, KFDI, WAME, KEBC, WWOL, WJJD, KRMD, KFTN, WSDS, KVOO, KYNN.

MOST ACTIVE COUNTRY SINGLES

- DON'T BREAK THE HEART THAT LOVES YOU — MARGO SMITH — WARNER BROS.**
KLAC 38-29, KSON ex-41, KWJJ 28-19, KCKN ex-26, WDAF ex-19, KRAK 42-35, KHAK 34-27, KENR 35-22, KKYX ex-38, KBOX 24-18, WMC 27-14, WSLC 33-19, KD JW 20-12, WIL 32-25, WCMS 34-25, WAME 29-24, KEBC 55-38, KCUB 39-31, KXLR 29-18, WRCP 27-19, WMNI 15-8, WLOL 34-22, WHN 28-9, WAXX 24-16, WPLO 20-14, WDEE ex-29, KLAK ex-34, WHOO 27-19, KFTN 18-13, WKDA ex-34, KNEW 37-29, WSDS 23-15, WSLR 35-30, WPNX 38-31, KJJJ 15-10, KNUZ 29-18, WINN ex-19, KXOL 38-30, WWVA 34-28, KVOO 51-19, KCKC 16-11.
- WHAT DID I PROMISE HER LAST NIGHT — MEL TILLIS — MCA**
KLAC 43-33, KUZZ 49-34, KSON 38-27, WDAF ex-28, KRAK 43-37, WUNI ex-30, KMPS ex-29, KBOX 28-22, KIKK ex-38, WSLC 13-3, KD JW 47-40, WSHO 16-8, WYDE 6-1, WAME ex-30, WUBE 32-25, KEBC 56-39, KCUB 40-33, KXLR 45-36, WMNI 38-32, WLOL 36-26, WHN ex-29, WAXX ex-29, WXOX 45-38, WNRS 34-24, WPLO ex-28, WDEE ex-44, WJJD ex-30, WHOO 29-23, WHK ex-37, KRMD ex-39, KNEW 36-27, WSDS 44-19, WXCL ex-34, KERE ex-26, WINN 20-15, WWVA 33-27.
- WOMAN TO WOMAN — BARBARA MANDRELL — ABC**
KLAC 48-39, KUZZ 58-52, KSON 28-22, KRAK ex-41, KHAK 32-26, KENR ex-31, KMPS ex-30, KBOX 33-25, WMC 26-18, WSLC 41-22, KD JW 35-28, WIL ex-36, WCMS 49-44, KEBC ex-55, KCUB ex-37, WTSO 36-20, KOYN 36-26, WLOL 46-33, WHN ex-30, WAXX ex-35, WDEE ex-36, WHOO 36-30, KFTN 27-19, WKDA 32-26, KNEW ex-31, WSDS 25-20, WXCL ex-33, WPNX ex-37, KGA ex-29, WWOK ex-26, KJJJ ex-32, KERE 22-15, WWVA 35-29, KVOO 67-25.
- I WISH YOU WERE SOMEONE I LOVE — LARRY GATLIN — MONUMENT**
KLAC 29-24, KUZZ 38-29, WDAF 25-17, KRAK 32-25, KHAK 27-18, KENR 39-30, KMPS 19-14, KFDI 39-30, KBOX 26-21, WMC ex-19, KD JW 23-14, WSHO 18-12, WUBE 31-22, KEBC 29-21, KCUB 27-20, KXLR 32-24, WRCP 38-28, WMNI 20-13, WLOL 19-12, WAXX 37-26, WDEE ex-24, WHK 38-30, KRMD 17-9, KNEW 30-24, WSDS 21-13, WSLR 30-24, WXCL 20-10, KJJJ 26-21, KERE 21-16, KXOL 32-23, WWVA 32-26.

Postmaster General Unveils Rodgers Commemorative Stamp In Nashville

NASHVILLE — A United States postage stamp bearing the likeness of legendary country singer Jimmie Rodgers was unveiled Jan. 6 at the Country Music Hall of Fame here by Postmaster General Benjamin F. Bailar.

The commemorative stamp, the first in a series on American performing arts and artists, depicts Rodgers (1897-1933), who was country music's first recording star, and a performer whose influence on style and repertoire has been of paramount importance. Known affectionately as the Singing Brakeman, he was the first member elected to the Country Music Hall of Fame in 1961.

The unveiling was presided over by Postmaster General Bailar; Bill Ivey, executive director of the Country Music Foundation; Ralp Peer II, head of Peer-Southern Organization, the publisher of all Rodgers' songs, and the head of the Country Music Association committee which spearheaded the drive to obtain this stamp; Joe Talbot,

representing the C.M.A. as president of its board of directors; and Frank Jones of Capitol Records, chairman of the Country Music Foundation's board of trustees.

Historical Event

Ivey noted that the occasion marked a unique historical event: "The issuance of the Jimmie Rodgers stamp is an important symbolic event. Back in the late 1960s, when the idea for a Rodgers commemorative was first considered, I really think the concept was rejected because of the prejudice against honoring 'hillbilly' music in this way. To have this stamp in 1978 shows just how far country music has come in gaining recognition as an important part of American music."

The entire event was recorded on videotape by Joe Cates Productions, which will broadcast a replay of the unveiling to the national public on January 22, as a part of a three-hour NBC-TV special, "Fifty Years of Country Music."

RHYTHM AND BLUES

TOP 75 ALBUMS

	Weeks On Chart	1/14		Weeks On Chart	1/14
1 ALL 'N' ALL EARTH, WIND & FIRE (Columbia JC 34905)	1	8	38 IN CONTROL THE CONTROLLERS (Juana X698)	41	9
2 LIVE! THE COMMODORES (Motown M9-894A2)	2	11	39 LOOKING BACK STEVIE WONDER (Motown M-804LP3)	44	4
3 FUNKENTELECHY VS. THE PLACEBO SYNDROME PARLIAMENT (Casablanca NBLP 7084)	4	7	40 HEAR TO TEMPT YOU THE TEMPTATIONS (Atlantic SD 19143)	27	8
4 MENAGERIE BILL WITHERS (Columbia JC 34903)	3	15	41 SEND IT ASHFORD & SIMPSON (Warner Brothers BS 3088)	43	16
5 BEE GEES AND SATURDAY NIGHT FEVER VARIOUS ARTISTS (RSO RS-2-4001)	24	4	42 SOMETHING TO LOVE L.T.D. (A&M SP 4646)	35	26
6 GALAXY WAR (MCA 3030)	6	9	43 DO YOU WANNA GET FUNKY WITH ME? PETER BROWN (Drive 104)	51	4
7 THANKFUL NATALIE COLE (Capitol SW 11708)	8	7	44 BRASS CONSTRUCTION III (United Artists UA-LA755-H)	42	11
8 REACH FOR IT GEORGE DUKE (Epic JE 34883)	5	15	45 PATTI LABELLE (Epic PE-34847)	45	21
9 IN FULL BLOOM ROSE ROYCE (Whitfield/WB WH3074)	9	23	46 WE ARE ONE MANDRILL (Arista AB 4144)	39	12
10 ONCE UPON A TIME . . . DONNA SUMMER (Casablanca NBLP 7078-2)	7	10	47 COLLECTOR'S ITEMS O'JAYS (Phila. Intl. PZG 35024)	50	6
11 FLYING HIGH ON YOUR LOVE THE BAR-KAYS (Mercury SRM-1-1181)	10	11	48 HAVANA CANDY PATTI AUSTIN (CTI 7-5006)	48	10
12 SECRETS CON FUNK SHUN (Mercury SRM-1-1180)	11	20	49 ONLY THE STRONG SURVIVE BILLY PAUL (Phila. Intl. PZ 34923)	49	9
13 DON'T LET ME BE MISUNDERSTOOD SANTA ESMERALDA/LEROY GOMEZ (Casablanca NBLP 7080)	12	9	50 SUPERNATURE CERRONE (Cotillion SD 5202)	55	7
14 WHEN YOU HEAR LOU, YOU'VE HEARD IT ALL LOU RAWLS (Phila. Intl./CBS JZ 35036)	14	8	51 ELOISE ELOISE LAWS (ABC AB 1022)	57	4
15 MR. MEAN OHIO PLAYERS (Mercury SRM-1-3707)	17	6	52 MAXIMUM STIMULATION THE JIMMY CASTOR BUNCH (Atlantic SD 19111)	52	8
16 CHIC (Atlantic SD 5202)	18	7	53 LE SPANK LE PAMPLEMOUSSE (AVI 6032)	58	5
17 THE TRAMMPS III (Atlantic SD 19148)	15	8	54 HEADS BOB JAMES (Columbia/Tappan Zee JC 34896)	46	10
18 FEELIN' BITCHY MILLIE JACKSON (Spring/Polydor SP-1-6715)	16	20	55 NOW IS THE TIME HAROLD MELVIN AND THE BLUE NOTES (ABC AA 1041)	59	7
19 ODYSSEY (RCA APL 1-2204)	13	20	56 ONCE UPON A DREAM ENCHANTMENT (Roadshow/UA RS-LA811-G)	63	2
20 SUNSHINE EMOTIONS (Stax STX-4100)	20	9	57 ON FIRE T-CONNECTION (Dash 30008)	62	5
21 THE HARDNESS OF THE WORLD SLAVE (Cotillion SD 5201)	22	6	58 THE FORCE KOOL & THE GANG (De-Lite DSR-9501)	64	2
22 TOO HOT TO HANDLE HEATWAVE (Epic 34761)	21	26	59 WINDOW OF A CHILD SEAWIND (CTI 7-5007)	60	5
23 SONG BIRD DENIECE WILLIAMS (Columbia JC 34911)	19	11	60 BIONIC BOOGIE (Polydor PD-1-6123)	—	1
24 BARRY WHITE SINGS FOR SOMEONE YOU LOVE (20th Century T-543)	25	20	61 VILLAGE PEOPLE (Casablanca NBLP 7064)	53	16
25 LIVE AT THE BIJOU GROVER WASHINGTON JR. (Kudu KUX-3637 MZ)	29	6	62 PLAYER (RSO/Polydor RS-1-3026)	—	1
26 ACTION THE BLACKBYRDS (Fantasy F-9535)	26	16	63 OPEN UP YOUR LOVE WHISPERS (Soul Train/RCA BVL 1-2270)	61	28
27 TRUE TO LIFE RAY CHARLES (Atlantic SC 19142)	23	13	64 ENCOUNTERS OF EVERY KIND MECO (Millennium 8004)	67	3
28 NEW HORIZON ISAAC HAYES (Polydor PD-1-6120)	32	9	65 BORN TO DANCE PLAYERS ASSOCIATION (Vanguard VSD 79398)	70	3
29 SPINNERS/8 (Atlantic SD 19146)	30	7	66 BABY IT'S ME DIANA ROSS (Motown M7-890R1)	66	16
30 THE BELLE ALBUM AL GREEN (Hi/Cream HLP 6004)	34	6	67 THE BITCH IS BAD DENISE LaSALLE (ABC AB 1027)	—	1
31 BLUE LIGHTS IN THE BASEMENT ROBERTA FLACK (Atlantic SD 19149)	37	4	68 TWO HOT FOR LOVE THP ORCHESTRA (Butterfly FLY 005)	69	2
32 FUNK BEYOND THE CALL OF DUTY JOHNNY GUITAR WATSON (DJM DJLPA-8714)	31	8	69 MAGIC LOVE MICHELE (West End WE 103)	68	5
33 COME GO WITH US POCKETS (Columbia PC 34879)	28	17	70 LOVE CONNECTION THE DELLS (Mercury SRM-1-3711)	—	1
34 BRICK (Bang BLP-409)	36	21	71 BEHOLD THE MIGHTY ARMY NEW BIRTH (Warner Bros. BS 3071)	72	14
35 TURNIN' ON HIGH INERGY (Gordy/Motown G6-978S1)	33	15	72 REJOICE EMOTIONS (Columbia PC34762)	71	31
36 COCOMOTION EL COCO (AVI 6012)	38	15	73 KING ALBERT ALBERT KING (Tomato TOM-6002)	—	1
37 GOIN' BANANAS SIDE EFFECT (Fantasy F-9537)	40	7	74 THE DEVIL IN ME THELMA HOUSTON (Tamlia/Motown T7-358R1)	54	11
			75 RIDING HIGH FAZE-O (She SH740)	—	1

Impact of Album Covers On Sales/Consumers Explored

by Carita Spencer

LOS ANGELES — Judge a book by its cover? Judge an album by its cover? The latter question seems to illustrate the effect that an album's cover has on the sales of a particular album.

Cash Box explored this phenomenon from various points of view and found that for the most part, a great many record buyers are sensitive to and affected by what is displayed or implied in album artwork. Individuals who see something that is offensive to them on covers will refrain from making a purchase, while something that is viewed as appealing will no doubt encourage a purchase. Tantamount to this is the fact that artwork is sometimes the deciding factor in cases where the buyer knows nothing or very little about the product.

Several retailers admit that album covers are, in fact, a sales stimulus and that this is emphatic in the final decision as to what will go where in the design of the cover.

Reactions

Responses from some individuals concerning this issue point to the fact that selling records is the paramount concern with record companies and feel that because of this record companies fail to exercise proper controls inhibiting album art which may be considered offensive. Women, in particular, have individually and collectively expressed concern in reference to this since the influx of album covers "displaying female bodies or parts of bodies and even worse incorporating violent or degrading acts along with it."

Julia London, member of Women Against Violence Against Women (a group which staged demonstrations against record company policies in reference to this last year), voiced her opinion saying that the question is not one of being suggestive but, "Is it violent? Is it making violence against women a trivial issue?" As specific examples, she cited several covers which exemplify violence against women adding that, "We are not just saying get rid of this LP or that one. We are saying get rid of a policy that allows for using violence against women and incorporating it with sex on album covers as well as in advertisements promoting the sale of discs."

Among the explicit covers mentioned were the following with titles and descriptions of the illustrations:

- "Climax" — a woman and man appear to be lovingly embracing each other from the outside of the cover but when opened it

reveals the woman plunging a dagger in the man's back.

- "Wild Angel" — a woman gagged with a heavy chain.

- "Thriller" — a woman sprawled on the floor after an assault, clothing awry, contents of her purse scattered about.

- "Best of New York City" — a cartoon/caricature-like illustration of a group of men approaching a woman with a terrified expression on her face indicating that she is attempting to escape them.

"These images," she said, "depict women as sexual monsters, playthings and targets for violent acts and this is degrading."

London also pointed out that a number of covers depicting this same thing are artistically created in terms of technique so that certain implications are concealed by color, light and form. Two albums which she made reference to were termed as "pretty and innocent graphically" but in her opinion, "refer to sodomy from a male point of view, a humiliating, demeaning and subjugating act."

"People have to realize," continued London, "that no matter what kind of package it is, the message is what is important. This culture is very technologically style-oriented and tends to respond in that fashion before thinking. Also, if you look at the history of laws and social traditions of this country, violence against women and sex violence in the home and in personal relationships between men and women is condoned and advocated."

Push

A spokesman for Operation PUSH (People United To Save Humanity) commented on the subject stating that the organization is "against the exploiting of women or men's bodies to sell records. Album covers are overly suggestive and the companies should be more responsive to the needs of our children in terms of putting their product out."

Bill Cherry, executive director of Operation PUSH, Los Angeles, went on to say that these types of albums along with some of the contents have contributed to the increase in premature pregnancies among youth. In his opinion, teens spend more time listening to radio and TV than they do studying and this is reflected in their attitudes, which are derived from what they hear and see.

"It is my philosophy," Cherry said, "that the major record companies need to hire

(continued on page 67)



SPINNERS IN STORE — While in New York for a recent party held in their honor at the executive offices of Atlantic Records, the Spinners made side-trips to record stores in Manhattan and Philadelphia for a series of autographing sessions and in-store promotions. Pictured at Disco-Mat in New York (l-r) are: Clarence "CB" Bullard, Atlantic local R&B promotion representative; John Edwards of the Spinners; Bill Cataldo, New York branch marketing coordinator for WEA; and Pervis Jackson and Henry Fambrough of the Spinners.

Add
(EX) Extra
(LP) LP Cut
(HB) Hitbound
(New) New release by artist with charted record.

WIGO — ATLANTA — Paul Childs
#1 — Bar-Kays
*Raydio
*Manhattans
*Morris Jefferson
*Enchantment
*Ashford & Simpson
*Maze
20 To 8 — Stargard

WWIN — BALTIMORE — DON BROOKS
#1 — Stargard
*Peabo Bryson
*B.T. Express
*Marlena Shaw
*McCoo & Davis
*Sylvers
10 To 4 — Le Pamplemousse
16 To 11 — Lou Rawls
19 To 10 — Deniece Williams
24 To 9 — Brick
Ex To 17 — Dorothy Moore
HB To 20 — Barry White
LP Adds: Donald Levy, Dells, Roberta Flack, Chic, Players, Assoc., Phoebe Snow, Lorraine Johnson, T-Connection

WILD — BOSTON — Sunny Joe White
#1 — War
*Peabo Bryson
*Ashford & Simpson
*Joe Simon
*Parliament
15 To 10 — B.T. Express
16 To 11 — Donna Summer
18 To 12 — Le Pamplemousse
19 To 14 — Lou Rawls
22 To 18 — Deniece Williams
25 To 13 — T-Connection
28 To 20 — Ray Charles
LP Adds: Roberta Flack, Slave

WGIV — CHARLOTTE — Manny Clarke
#1 — Earth, Wind & Fire
*Bob James
*Brook Benton
*Leo Sayer
*Luther Ingram
*O.V. Wright
19 To 12 — Dorothy Moore
20 To 3 — Chic
23 To 16 — Natalie Cole
41 To 9 — Stargard
46 To 4 — Player
47 To 13 — Heatwave
LP Adds: Kool & The Gang, Stevie Wonder, Chuck Mangione, Meco, Peter Brown

WJMO — CLEVELAND — Lynn Tolliver
*T-Connection
*Raydio
*Earth, Wind & Fire — LP cut
14 To 7 — Natalie Cole
16 To 10 — Con Funk Shun
17 To 8 — Enchantment
26 To 23 — Donna Summer

WDAO — DAYTON — Lankford Stephens
#1 — Mother's Finest
*Ashford & Simpson
*David Ruffin
*Jimmy Castor
*Brass Construction
11 To 7 — Heatwave
12 To 8 — Dorothy Moore
14 To 10 — Raydio
15 To 11 — Blackbyrds
16 To 12 — Bar-Kays
17 To 13 — Brick
18 To 14 — Commodores
19 To 15 — Player
20 To 16 — Ohio Players
21 To 17 — Billy Paul
22 To 18 — Ramsey Lewis
23 To 19 — Joe Simon
24 To 20 — Peabo Bryson
25 To 21 — Bee Gees
26 To 22 — Stargard
27 To 23 — T-Connection
28 To 24 — B.T. Express
29 To 25 — Barry White
30 To 26 — Enchantment
30 To 26 — Staples
31 To 27 — Enchantment
32 To 28 — Don Thompson
33 To 29 — Steezy Dan
34 To 30 — Brook Benton
35 To 31 — Luther Ingram
36 To 32 — Hodges, James & Smith
37 To 33 — Dells
38 To 34 — Archie Bell
39 To 35 — Carl Carlton
40 To 36 — Ronnie Dyson
HB To 37 — Leon Heywood
HB To 38 — Isaac Hayes
HB To 39 — Joe Tex
HB To 40 — Eddie Kendricks

WGPR — DETROIT — George White
#1 — Brian & Brenda
*Livin' Proof
*Lorraine Johnson
*Eloise Laws
*Gene Page
11 To 6 — Denise LaSalle
14 To 8 — Archie Bell
20 To 9 — Billy Preston
25 To 18 — Commodores
33 To 25 — Melba Moore
Ex To 15 — Player
Ex To 33 — Chocolate Milk
Ex To 35 — Bill Brandon
HB To 17 — Enchantment
HB To 20 — Willie Hutch
HB To 32 — Donna Summer

WJLB — DETROIT — Al Perkins
#1 — Al Hudson
20 — Commodores
27 — Eddie Kendricks
28 — Heatwave
30 — Barry White
31 — Dells
32 — Lenny Williams
33 — Al Green
34 — Mandrae
35 — Joe Simon

36 — Bar-Kays
37 — Gene Page
38 — Carrone
39 — C.B. Overton
40A — Kirkland/Davis
40B — Slave

WGOK — FAIRHOPE — Chris Turner
#1 — Blackbyrds
*Brass Construction
*Manhattans
*Ashford & Simpson
*J.G. Watson
32 To 20 — Santa Esmeraldalero Gomez
LP Adds: Bill Summer, Luther Ingram, Lonnie Jordan, Herb Alpert, Faze-O

WQMG — GREENSBORO — Big Daddy
#1 — George Duke
24 — Eric Gale
25 — Bob James
26 — Emotions
27 — Donna Summer
28 — Blackbyrds
29 — Brick
30 — Player
5 To 2 — Odyssey
9 To 6 — War
11 To 8 — Chic
26 To 16 — Stargard
27 To 22 — Billy Preston
28 To 21 — Raydio

33 To 25 — Patti LaBelle
35 To 30 — Le Pamplemousse
36 To 26 — David Oliver
37 To 31 — Barry White
38 To 32 — Gino Vannelli
39 To 29 — Player
40 To 34 — Joe Smith

KVOV — LAS VEGAS
#1 — Al Green
*James Brown
*Brook Benton
*O.V. Wright
*Livin' Proof
*Brian & Brenda
*Peabo Bryson
LP Adds: Checkmates, Timmy Thomas, James Brown, David Ruffin

KOKY — LITTLE ROCK — J.D. Black
#1 — Rose Royce
*Ashford & Simpson
*Manhattans
*Parliament
*Brass Construction
22 To 18 — Enchantment
Ex To 19 — Peabo Bryson
Ex To 20 — James Brown
Ex To 24 — Maze
LP Adds: Natalie Cole, Johnnie Taylor

KDAY — LOS ANGELES — J.J. Johnson
#1 — Whispers

WAWA — MILWAUKEE — Larry O'Jay
#1 — Con Funk Shun
*Bee Gees
*Player
*Black Ice
*Krystal
11 To 6 — Deniece Williams
21 To 11 — Lorraine Johnson
22 To 15 — Blackbyrds
23 To 18 — Commodores
26 To 19 — Willie Hutch
32 To 20 — Stargard
30 To 23 — Pointer Sisters
35 To 12 — Heatwave
39 To 33 — Lenny Williams
40 To 32 — Muscle Shoals Horns
Ex To 24 — Manchild
Ex To 29 — Morris Jefferson
Ex To 35 — C.B. Overton
Ex To 36 — Albert King
Ex To 37 — David Oliver
Ex To 38 — Lou Rawls
Ex To 39 — Livin' Proof
Ex To 40 — Impact

WGOK — MOBILE — Chris Turner
#1 — Blackbyrds
*Ashford & Simpson
*Penguin Feet
*Manhattans
*Bob James
*Ona Watson
*Brass Construction
*J.G. Watson
*Temptations
*Trammps
15 To 10 — McKinley Mitchell
19 To 13 — Barry White
20 To 14 — Donna Summer
30 To 25 — Stargard
38 To 30 — B.T. Express
LP Adds: Luther Ingram, Checkmates, Herb Alpert, Faze-O

WVOL — NASHVILLE — Fred Harvey
#1 — George Duke
*Peabo Bryson
*Parliament
*Manhattans
19 To 14 — Commodores
25 To 20 — Bill Withers
28 To 23 — Dorothy Moore
34 To 29 — Enchantment
35 To 27 — McKinley Mitchell
39 To 33 — Bee Gees
LP Adds: Al Green

WNAT — NATCHEZ — Haynes Ford
#1 — Kellee Patterson
*Joe Tex
*Brass Construction
*Gene Page
*Denise LaSalle
*Eloise Laws
6 To 2 — Con Funk Shun
11 To 3 — George Duke
13 To 9 — Dorothy Moore
15 To 6 — Natalie Cole
24 To 10 — Low Rawls
28 To 14 — Blackbyrds
29 To 4 — Bill Withers
HB To 25 — Melba Moore

WBSL — NEW YORK — Wanda Ramos Charres
*Parliament
*Manhattans
*Machael Zager Band
*McCoo & Davis
*Ronnie Dyson
LP Adds: Lonnie Jordan, Walter Bishop, Jr., Stanley Cowell, Herb Alpert, Hugh Masekela, Sonny Rollins

WWRL — NEW YORK — Sonny Taylor
#1 — Bill Withers
*B.T. Express
*Bar-Kays
9 To 3 — Donna Summer
12 To 8 — War
14 To 9 — Commodores
19 To 15 — Meco
21 To 16 — Dorothy Moore
24 To 18 — Player
29 To 19 — Enchantment

WAMO — PITTSBURGH — Matt Ledbetter
#1 — Heatwave
*Ashford & Simpson
*Maze
*Kirkland & Davis
*Bar-Kays
19 To 15 — Phoebe Snow
35 To 19 — Bee Gees
38 To 34 — Gene Page
LP Adds: Roberta Flack, Parliament
KSOL — SAN FRANCISCO — J.J. Jefferies
#1 — Con Funk Shun
13 To 7 — Raydio
21 To 10 — Commodores
LP Adds: Le Pamplemousse, Livin' Proof, Brick, Bar-Kays, Heatwave, Enchantment, Lou Rawls

WESL — ST. LOUIS — Jim Gates
#1 — Chic
*Isaac Hayes
*Joe Tex
21 To 15 — Heatwave
31 To 28 — Enchantment
32 To 28 — Enchantment
40 To 29 — Brick
LP Adds: Bob James, Ramsey Lewis, Bunny Sigler, Spinners, Grover Washington, Jr., Joe Simon

WVDM — SUMTER — Barbara Taylor
#1 — Raydio
Hot: Peabo Bryson, Player, Phoebe Snow, Isaac Hayes, Deniece Williams
LP Adds: Enchantment, Kool & The Gang, Voltage Bros., Peter Frown

WSOK — SAVANNAH — Sharon Love
#1 — Natalie Cole
*Sylvers
*Steve Kahn
*Jimmy Castor
*Chuck Mangione
*Maze
*Eddie Kendricks
Hot: Rose Royce, Deniece Williams
LP Adds: Kool & The Gang, Lonnie Jordan
OK100 — WASHINGTON — David Tate
Heavy Rotation: Con Funk Shun, Earth, Wind & Fire, Natalie Cole, Stargard, Chic, Player, Heatwave, Barry White
LP Cuts: Parliament — Flashlight, Earth, Wind & Fire-Fantasy, Slave — Baby Sinister

MOST ADDED R&B SINGLES

1. **CLOSE ENCOUNTERS OF THE THIRD KIND — GENE PAGE — ARISTA**
WOL, WBSL, WILD, KDAY, WJLB, WVON, WNAT.

INTIMATE FRIENDS — EDDIE KENDRICKS — TAMLA
WDAO, WJLB, WSOK, WTLC, WGOK, KDKO, WLOU.

LET ME PARTY WITH YOU — BUNNY SIGLER — GOLD MIND
WDAO, KYOK, WILD, WKND, WVON, WGOK, WAMM.

LET'S HAVE SOME FUN — BAR-KAYS — MERCURY
KYOK, WJLB, WILD, WKND, WEAM, WAMM, WAMO.

PLAYING YOUR GAME BABY — BARRY WHITE — 20th CENTURY
KYOK, WWRL, WILD, WKND, WVON, WOL, WTMP.

2. **RUB DOWN — JOE TEX — EPIC**
WDAO, WNAT, WGOK, KOKY, WLOU, WESL.

IT'S YOU THAT I NEED — ENCHANTMENT — ROADSHOW
KYOK, WILD, WEAM, WGOK, WWDM, WQMG.

3. **PRIVATE PROPERTY — THE DELLS — MERCURY**
WDAO, WJLB, WTLC, WVON, WLOU.

OUT OF THE GHETTO — ISAAC HAYES — POLYDOR
WDAO, WVON, WGOK-FM, WESL, WTMP.

STAY BY MY SIDE — BO KIRKLAND & RUTH DAVIS — CLARIDGE
KDAY, WDAO, KYOK, WJLB, WAMO.

AIN'T GONNA HURT NOBODY — BRICK — BANG
KSOL, KYOK, WEAM, WILD, WQMG.

BABY COME BACK — PLAYER — RSO
WAWA, WIGO, WWRL, WBSL, WDAO.

MOST ADDED R&B LPs

1. **ONCE UPON A DREAM — ENCHANTMENT — ROADSHOW/UA**
KDKO, WGOK-FM, WSOK, WJLB, KUTE, KYOK, KACE, WDAO, KSOL.

2. **ON FIRE — T-CONNECTION — DASH**
WWDM, KKDA, WWIN, WGOK-FM, WGOK, WSOK, WJLB, WDAO.

3. **THE FORCE — KOOL & THE GANG — DE-LITE**
WOL, WGOK, WSOK, KYOK, WGOK-FM, WDAO.

LOVE CONNECTION — THE DELLS — MERCURY
WWIN, WGOK, WEAM, WGOK-FM, WJLB, WSOK.

BLUE LIGHTS IN THE BASEMENT — ROBERTA FLACK — ATLANTIC
WWIN, WAMO, WQMG, KDKO, WWRL, KDAY.

29 To 20 — Southroad Connection
30 To 23 — Deniece Williams

WKND — HARTFORD — Bob Scott
#1 — Con Funk Shun
19 — Blackbyrds
24 — Barry White
27 — New Birth
28 — Bunny Sigler
29 — Brian & Brenda
30 — Parliament
10 To 5 — Stargard
19 To 11 — Brick
25 To 18 — Player
27 To 23 — Morris Jefferson
LP Adds: Kool & The Gang, THP Orchestra

WTLC — INDIANAPOLIS — Roger Holloway
#1 — Deniece Williams
35 — Eddie Kendricks
36 — Roberta Flack
37 — Phoebe Snow
38 — Carl Carlton
39 — Narada Micheal Walden
40 — Dells
21 To 16 — Brian & Brenda
25 To 20 — Willie Hutch
26 To 19 — Bar-Kays
27 To 21 — Blackbyrds
29 To 24 — Morris Jefferson
31 To 22 — Enchantment
32 To 23 — Staples

*Bo Kirkland & Ruth Davis
*Bee Gees
7 To 4 — Odyssey
18 To 14 — Player
27 To 18 — Heatwave
LP Adds: Saturday Night Fever, Roberta Flack, Ohio Players

KUTE — LOS ANGELES — Lucky Pierre
LP Adds: Phoebe Snow, Seawind

WDIA — MEMPHIS — Maxx Fortune
#1 — George Duke
*Frank Lucas
*Peabo Bryson
*Ray Charles
11 To 3 — Natalie Cole
13 To 9 — Pockets
14 To 7 — Dorothy Moore
20 To 12 — Player
23 To 17 — B.T. Express
30 To 24 — Enchantment
Ex To 11 — Stargard
Ex To 13 — Eddie Floyd
Ex To 20 — Heatwave
Ex To 21 — Morris Jefferson
LP Adds: Roberta Flack, Spinners

WMBM — MIAMI — Cedric Anderson
#1 — Parliament
Hot: Deniece LaSalle, El Coco, Barry White, Emotions, Enchantment, Peabo Bryson

CASH BOX TOP 100 R&B

January 21, 1978

	Weeks On Chart	1/14		Weeks On Chart	1/14		Weeks On Chart	1/14
1 FFUN CON FUNK SHUN (Mercury 73959)	1	13	38 WRAP YOUR ARMS AROUND ME KC & THE SUNSHINE BAND (TK 1022)	34	8	70 DON'T LET ME BE MISUNDERSTOOD SANTA ESMERALDA/LEROY GOMEZ (Casablanca NB902)	71	6
2 GALAXY WAR (MCA 40820)	3	10	39 YOU AND I (PART 1) LIVIN' PROOF (Ju Par JP 532-S)	50	8	71 DO YOU LOVE SOMEBODY LUTHER INGRAM (Koko 728)	77	5
3 OUR LOVE NATALIE COLE (Capitol 4059)	7	11	40 SORRY DOESN'T ALWAYS MAKE IT RIGHT GLADYS KNIGHT AND THE PIPS (Buddah 584)	36	13	72 IF YOU FEEL LIKE DANCIN' AL HUDSON AND THE SOUL PARTNERS (ABC 12317)	73	8
4 OOH BOY ROSE ROYCE (Whitfield/WB 8491)	4	10	41 REACHING FOR THE SKY PEABO BRYSON (Capitol 4522)	56	6	73 GOOD LUCK CHARM (PART 1) OHIO PLAYERS (Mercury 73974)	79	5
5 DANCE DANCE DANCE CHIC (Atlantic 3435)	6	13	42 DANCE TO THE MUSIC MUSCLE SHOALS HORNS (Ariola 7674)	45	9	74 A PIECE OF THE ACTION MAVIS STAPLES (Curton CMS 0132)	57	13
6 REACH FOR IT GEORGE DUKE (Epic 8-50463)	2	12	43 CHOOSING YOU LENNY WILLIAMS (ABC 12289)	43	7	75 WHAT YOU GONNA DO AFTER THE PARTY? WILLIE HUTCH (Motown M1433)	81	5
7 LOVELY DAY BILL WITHERS (Columbia 3-10627)	8	14	44 LADY LOVE LOU RAWLS (Phila. Intl./CBS 3634)	54	7	76 IT'S ECSTASY WHEN YOU LAY DOWN NEXT TO ME BARRY WHITE (20th Century T-2350)	58	25
8 JACK AND JILL RAYDIO (Arista ASO 283)	10	10	45 THE NIGHT THE LIGHTS WENT OUT THE TRAMMPS (Atlantic 3442)	46	7	77 AIN'T NOTHING WRONG RONNIE DYSON (Columbia 3-10667)	85	2
9 SERPENTINE FIRE EARTH, WIND & FIRE (Columbia 3-10625)	5	15	46 CHEATERS NEVER WIN LOVE COMMITTEE (Gold Mind GM 4033)	41	11	78 FOR YOUR LOVE, LOVE, LOVE JOE SIMON (Spring SP 178)	83	4
10 (THEME SONG FROM) WHICH WAY IS UP STARGARD (MCA 40825)	15	9	47 LET'S HAVE SOME FUN THE BAR-KAYS (Mercury 73967)	59	5	79 THAT'S ALL RIGHT TOO BRIAN AND BRENDA RUSSELL (MCA 40809)	86	5
11 COME GO WITH ME POCKETS (Columbia 10632)	11	12	48 IF YOU DON'T GIVE A DOGGONE ABOUT IT JAMES BROWN & THE NEW JB'S (Polydor 14438)	49	7	80 INTIMATE FRIENDS EDDIE KENDRICKS (Tamlam T54290F)	—	1
12 SHOUTING OUT LOVE THE EMOTIONS (Stax/Fantasy STX-3200A-S)	13	12	49 IF YOU'RE NOT BACK IN LOVE BY MONDAY MILLIE JACKSON (Spring/Polydor 175)	33	21	81 THANK YOU FOR THE LOVE MOTHER'S FINEST (Epic 8-50483)	84	6
13 BABY, BABY MY LOVE'S ALL FOR YOU DENIECE WILLIAMS (Columbia 3-10648)	14	8	50 I'M GONNA MAKE YOU MY WIFE THE WHISPERS (Soul Train/RCA JB-11139)	52	12	82 RUB DOWN JOE TEX (Epic 8-50494)	—	1
14 BELLE AL GREEN (Hi H 77505)	12	13	51 WAS DOG A DOUGHNUT CAT STEVENS (A&M 1971-S)	47	11	83 DON'T ASK MY NEIGHBORS EMOTIONS (Columbia 10622)	75	19
15 COCOMOTION EL COCO (AVI-147-S)	17	11	52 IF IT DON'T FIT, DON'T FORCE IT KELLEE PATTERSON (Shadybrook 1041)	44	19	84 PRECIOUS, PRECIOUS O.V. WRIGHT (Hi H-77506)	91	2
16 TOO HOT TA TROT THE COMMODORES (Motown M 1432F)	18	7	53 KISS ME THE WAY I LIKE IT GEORGE MCCREA (TK-1024)	38	11	85 WHAT'S YOUR NAME, WHAT'S YOUR NUMBER ANDREA TRUE CONNECTION (Buddah BDA 582)	87	5
17 WITH PEN IN HAND DOROTHY MOORE (Malaco/Tk 1047)	19	8	54 WIDE STRIDE BILLY PRESTON (A&M 1980-S)	51	5	86 I'M HERE AGAIN THELMA HOUSTON (Tamlam/Motown 54287)	60	16
18 NATIVE NEW YORKER ODYSSEY (RCA PB11129)	9	15	55 CLOSE ENCOUNTERS OF THE THIRD KIND GENE PAGE (Arista 2523S)	—	1	87 NEW HORIZON THE SYLVERS (Capitol 4532)	—	1
19 SHOUT IT OUT B.T. EXPRESS (Columbia/Roadshow 10649)	21	8	56 GETTIN' READY FOR LOVE DIANA ROSS (Motown 1427)	40	12	88 OUT OF THE GHETTO ISAAC HAYES (Polydor PD 1-4446)	—	1
20 BABY COME BACK PLAYER (RSO 879)	28	9	57 THE MIGHTY ARMY NEW BIRTH (Warner Bros. WBS 8499)	62	5	89 CALL MY JOB ALBERT KING (Tomato TM 10001)	94	2
21 LE SPANK LE PAMPLEMOUSSE (AVI 154)	24	8	58 DON'T TAKE AWAY YOUR LOVE HODGES, JAMES AND SMITH (London 5N-260)	61	10	90 MAKIN' LOVE IS GOOD FOR YOU BROOK BENTON (Older World OWR 1100)	96	2
22 ALWAYS AND FOREVER HEATWAVE (Epic 50490)	32	5	59 EMOTION SAMANTHA SANG (Private Stock PS 45, 178)	63	6	91 WORKIN' TOGETHER MAKE FEATURING FRANKIE BEVERLY (Capitol 4531)	—	1
23 AIN'T GONNA HURT NOBODY BRICK (Bang 735)	31	6	60 YOU ARE MY FRIEND PATTI LABELLE (Epic 8-50487)	66	4	92 PRIVATE PROPERTY THE DELLS (Mercury 73977)	—	1
24 SPANK YOUR BLANK BLANK MORRIS JEFFERSON (Parachute/Casablanca 504)	25	8	61 MELODIES MADE IN U.S.A. (Delite DE-900)	48	15	93 SUPERNATURE CERRONE (Cotillion 44230)	—	1
25 ON FIRE T-CONNECTION (Dash/TK 5041)	27	9	62 EASY COMIN' OUT (HARD GOIN' IN) WILLIAM BELL (Mercury 73961)	64	10	94 BLOAT ON CHEECH AND CHONG (Epic 850471)	78	10
26 BOP GUN (ENDANGERED SPECIES) PARLIAMENT (Casablanca NB 900)	16	14	63 LET ME PARTY WITH YOU (PART 1) (PARTY, PARTY, PARTY) BUNNY SIGLER (Gold Mind 4008)	74	5	95 YOU LIKE IT, WE LOVE IT SOUTHROAD CONNECTION (Mahogany M-1277-2)	—	1
27 SOMEBODY'S GOTTA WIN SOMEBODY'S GOTTA LOSE THE CONTROLLERS (Juana/TK 3414)	20	16	64 SHAKE DOWN (PART 1) BLACK ICE (HDM-503)	69	10	96 STANDING RIGHT HERE MELBA MOORE (Buddah BDA 589)	100	6
28 IT'S YOU THAT I NEED ENCHANTMENT (Roadshow/UA 19370)	42	5	65 THE END OF THE RAINBOW MCKINLEY MITCHELL (Chimneyville/TK 10219)	65	10	97 BABY, YOU GOT MY NOSE OPEN HAROLD MELVIN & THE BLUE NOTES (ABC 12327)	—	1
29 25th OF LAST DECEMBER ROBERTA FLACK (Atlantic 3441)	22	8	66 STAYIN' ALIVE BEE GEES (RSO 885)	93	2	98 1000 LAUGHS ELOISE LAWS (ABC AB-12313)	95	4
30 LOVE ME RIGHT DENISE LASALLE (ABC 12312)	35	9	67 I CAN SEE CLEARLY NOW RAY CHARLES (Atlantic 3443)	72	6	99 I'M AT THE CROSSROADS VERNON GARRETT (ICA 003)	88	18
31 I LOVE YOU DONNA SUMMER (Casablanca NB 907)	37	6	68 ESPECIALLY FOR YOU MANCHILD (Chi Sound/UA CH-XW 1112)	70	9	100 WHAT I DID FOR LOVE INNER CITY JAM BAND (Bareback BBR-535)	53	15
32 SOFT AND EASY BLACKBYRDS (Fantasy F-809-A-S)	39	6	69 STAY BY MY SIDE BO KIRKLAND AND RUTH DAVIS (Claridge 432)	80	3			
33 MORE THAN A WOMAN TAVARES (Capitol 4500)	26	12						
34 IN A LIFETIME TEMPTATIONS (Atlantic 3436)	30	13						
35 YOU CAN'T TURN ME OFF (IN THE MIDDLE OF TURNING ME ON) HIGH INERGY (Gordy/Motown G-7155)	23	22						
36 BACK IN LOVE AGAIN L.T.D. (A&M 1974)	29	20						
37 PLAYING YOUR GAME, BABY BARRY WHITE (20th Century TC-2361)	55	4						

ALPHABETIZED TOP 100 R&B (INCLUDING PUBLISHERS AND LICENSEES)

Ain't Gonna (Caliber/Good High — ASCAP)	23	Especially (Gaetana/Serpente — BMI)	68	Love Me (Warner-Tamerlane/Ordona — BMI)	30	Stayin' Alive (Stigwood/Unichappell — BMI)	66
Ain't Nothing (Jay Enterprises/Chappell — ASCAP)	77	Ffun (Val-le Joe — BMI)	1	Makin' Love (Tennessee Swamp Fox — ASCAP)	90	Supernature (Cerrone — SACEM)	93
Always (Almo/Rondor — ASCAP)	22	For Your (Razzle Dazzle — BMI)	78	Melodies (Delightful/Cabrini — BMI)	61	Thank You (Satsongs — ASCAP)	81
A Piece Of (Mayfield/Primus Artists/Verdon — BMI/All Rts. Admin. By Warner-Tamberlane — BMI)	74	Galaxy (Far Out — ASCAP)	2	More Than (Stigwood/Unichappell — BMI)	33	That's All Right Too (Kengour — ASCAP)	79
Baby, Baby (Verdangle/Kee Drick — BMI)	13	Gettin' Ready (Braitree/Show/Golde's Gold — BMI)	56	Native New Yorker (Featherbed/Desiderata/Unichappell — BMI)	18	The End	65
Baby Come (Touch Of Gold/Crowbeck/Stigwood — BMI)	20	Good Luck Charm (Playone/Tight/Unichappell — BMI)	73	New Horizon (Rosy — ASCAP)	87	The Mighty Army (Irving-BMI/Screen Gems-EMI — BMI/Colgems-EMI — ASCAP/Traco — BMI/Spec-O-Lite — ASCAP)	57
Baby You Got (Hal-Mel/New Beginning — BMI)	97	If It Don't (Funks Bump — BMI)	52	On Fire (Sherlyn/Decibel — BMI)	25	The Night (Six Strings/Golden Fleece — BMI)	45
Back In Love (Ice Man — BMI)	36	If You Feel (Perk's — BMI)	72	Ooh Boy (May Twelfth/Warner-Tamberlane — BMI)	4	1000 Laughs (Mighty Three — BMI)	98
Belle (Jec & Al Green — BMI)	14	If You're Not Back (Tree — BMI)	49	Our Love (Jay Enterprises/Chappell — ASCAP)	3	Too Hot (Jobete. Commodores — ASCAP)	16
Bloat On (ABC/Dunhill/Woodsongs — BMI)	94	I Can (Clayman — ASCAP)	67	Out Of The Ghetto (Afro — BMI)	88	25th Of (Sky Forest — BMI)	29
Bop Gun (Rick's/Malbiz — BMI)	26	I Love You (Rick's/Say Yes — BMI)	31	Playing (Sa-vette — BMI)	37	Was Dog (Colgems-EMI — ASCAP)	51
Call My Job (Perks Music — BMI)	89	I'm At The (Alzert — BMI)	99	Precious, Precious (Cotillion — BMI)	84	What I Did (American Compass — ASCAP/Wren — BMI)	100
Cheaters Never	46	I'm Gonna (Spectrum VII — ASCAP)	50	Private Property (Dajoye/Top Bound/Six Strings — BMI)	92	What You Gonna Do (Stone Diamond — BMI)	75
Choosing You (Len-Lon — BMI)	43	I'm Here (Jobete — ASCAP/Stone Diamond — BMI)	86	Reach For (Mycenae — ASCAP)	41	What's Your Name (Dick James/Christwood — BMI)	85
Close Encounters (Golden Horizon — BMI)	55	In A Lifetime (Burma East — BMI)	34	Reaching For (WB/PB — ASCAP)	6	Which Way (Warner-Tamerlane/May Twelfth/Dutchess — BMI)	10
Cocotion (Equinox — BMI)	15	Intimate Friends (GAB — ASCAP)	80	Rub Down (Tree Pub. — BMI)	82	Wide Stride (Irving/Wep — BMI)	54
Come Go (Verdangle/Pocket — BMI)	11	It's Ecstasy (Sa-Vette — BMI)	76	Serpentine Fire (Sagfire/Free Delivery — BMI)	9	With Pen (Unart — BMI)	17
Dance, Dance (Cotillon/Kreimer — BMI)	5	It's You That (Desert Moon/Willow Girl — BMI)	28	Shake Down (H&H Team — ASCAP)	64	Workin' Together (Pecle — BMI)	91
Dance To The (Desert Moon Songs/Willow Girl — BMI)	42	Jack & Jill (Radiola — ASCAP)	8	Shouting Out (East/Memphis — BMI)	12	Wrap Your (Sherlyn Harrick — BMI)	38
Don't Ask My (Unichappell — BMI)	83	Kiss Me (Sherlyn — BMI)	53	Shout It (Triple O/Bilee/B.T. — BMI)	19	You And (Lenise/Black Girl)	39
Don't Let (Ben E. Benjamin — ASCAP)	70	Lady Love (Mighty Three — BMI)	44	Soft And (Blackbyrd — BMI)	32	You Are (Zuri/Gospel Birds — BMI)	60
Don't Take Away (El Patricio — BMI)	58	Le Spank (Equinox — BMI)	21	Somebody's Gotta Win (Every Knight — BMI)	27	You Can't Turn (Jobete — ASCAP)	35
Do You Love (Klondike — BMI)	71	Let Me Party (Lucky Three/Henry Suemay — BMI)	63	Sorry Doesn't (Jobette — BMI)	40	You Like It (Harrindur/Ensign — BMI)	95
Easy Comin' (Bell Cat/Beinda — BMI)	62	Let's Have (Barkay/Warner-Tamberlane — BMI)	49	Standing Right (Mighty Three — BMI)	96		
Emotion (Barry Gibb/Flamm/Stigwood/Unichappell — BMI)	59	Lovely Day (Golden Withers Chappel — BMI)	7	Stay By (Claridge/Bo-Kirk — ASCAP)	69		

JAZZ

ON JAZZ

TOP 40 ALBUMS

	Weeks On 1/14 Chart		Weeks On 1/14 Chart
1 REACH FOR IT GEORGE DUKE (Epic JE 34883)	2	22 CAPETOWN FRINGE DOLLAR BRAND (Chiaroscuro/Audio Fidelity CR 2004)	25
2 HEADS BOB JAMES (Columbia/Tappan Zee JC 34896)	1	23 NIGHTWINGS STANLEY TURRENTINE (Fantasy 9534)	15
3 TEQUILA MOCKINGBIRD RAMSEY LEWIS (Columbia JC 35018)	3	24 ALONE (AGAIN) BILL EVANS (Fantasy F-9542)	27
4 FEELS SO GOOD CHUCK MANGIONE (A&M SP 4658)	4	25 AL JARREAU LIVE IN EUROPE/LOOK TO THE RAINBOW (Warner Bros. WB 2BZ 3052)	23
5 LIVE AT THE BIJOU GROVER WASHINGTON JR. (Kudu KUX-3637 MZ)	10	26 QUINTET VSOP (Columbia C234976)	18
6 ACTION BLACKBYRDS (Fantasy F-9535)	6	27 BRIDGES GIL-SCOTT HERON & BRIAN JACKSON (Arista AB 4147)	26
7 RUBY, RUBY GATO BARBIERI (A&M SP 4655)	5	28 TIGHTROPE STEVE KAHN (Columbia JC 34857)	29
8 ENIGMATIC OCEAN JEAN-LUC PONTY (Atlantic SD 19110)	7	29 HAVANA CANDY PATTI AUSTIN (CTI 7-5006)	31
9 BLOW IT OUT TOM SCOTT (Ode/Epic PE 34966)	8	30 FRIENDS AND STRANGERS RONNIE LAWS (UA BNLA 730)	32
10 MONTREUX SUMMIT (VOL. 1) VARIOUS ARTISTS (Columbia JC 35005)	12	31 OXYGENE JEAN-MICHEL JARRE (Polydor PD 1-6112)	28
11 SURVIVORS SUITE KEITH JARRETT (ECM 1-1085)	13	32 IN FLIGHT GEORGE BENSON (Warner Bros. BSK 2983)	33
12 SOPHISTICATED GIANT DEXTER GORDON (Columbia JC 34989)	14	33 WINDOW OF A CHILD SEAWIND (CTI 7-5007)	36
13 NEW VINTAGE MAYNARD FERGUSON (Columbia JC 34971)	9	34 FREE AS THE WIND THE CRUSADERS (Blue Thumb/ABC BT-6029)	30
14 MAGIC BILLY COBHAM (Columbia JC 34939)	11	35 WATERCOLORS PAT METHENY (ECM/Polydor 1097)	—
15 TRUE TO LIFE RAY CHARLES (Atlantic SD 19142)	16	36 CAYENNE BILL SUMMERS & SUMMERS HEAT (Prestige P-10103)	38
16 MULTIPLICATION ERIC GALE (Columbia JC 34938)	22	37 GUARABE CAL TJADER (Fantasy F-9533)	—
17 LIFELINE ROY AYERS UBIQUITY (Polydor PD 1-6108)	17	38 THE PEACOCKS STAN GETZ & JIMMY ROWLES (Columbia JC 34873)	37
18 SKY ISLANDS CALDERA (Capitol 11658)	20	39 ONE OF A KIND DAVE GRUSIN (Polydor PD-1-6118)	39
19 INNER VOICES MCCOY TYNER (Milestone M-9079)	24	40 TAILGUNNER JIMMY McGRUFF (LCR 9316)	35
20 HEAVY WEATHER WEATHER REPORT (Columbia PC 34418)	19		
21 I CRY, I SMILE NARADA MICHAEL WALDEN (Atlantic SD 19141)	21		

The hottest ticket in New York was for the **Benny Goodman Reunion Concert** held at Carnegie Hall January 18. The show was a sell-out with no advertising, and longtime Goodman fans were offering more than \$50 for a single ticket. The performance was recorded by London Records.

As a parallel development, Columbia is remastering the famous original concert of 1938. Originally there were plans to include two selections left off the original package because of sound quality problems, but they have not been found. Anyone with information on the missing performances should contact **Michael Brooks** c/o Columbia.

"I Hear Some Blues Downstairs" is the latest from **Fenton Robinson** on Alligator.

Axis In Soho, one of the busiest cafes in New York, will have **Muhai Richard Abrams, Chico Freeman** and **Lee Konitz** later this month.

The **Crusaders** are producing and playing on the next ABC album by **B.B. King**. This is good news because King's recent albums have lacked solid performers supporting the blues master.

Freddie Hubbard's next Columbia will be recorded in New York. Rumor has it that **George Cables, Ron Carter** and **Jack DeJohnette** will be the rhythm section.

Also on the Columbia front is news that a second double album from last summer's Montreux bash is forthcoming. Among the highlights will be an entire side of **Dexter Gordon** and a duet which features **Hubert Laws** and **Bob James**, the latter on acoustic piano.

Is the world ready for five more years of **Jack Kleinsinger**? The New York promoter will present his fifth anniversary concert at Loeb Student Center on February 2 featuring **Marian** and **Jimmy McPartland, Buddy Tate, Vic Dickenson** and **George Duvivier**.

The latest from India Navigation includes "Chico," the long-awaited American debut of reedman **Chico Freeman**, and "Birthright" by **Hamiet Bluiett**.

The Musicraft label, a powerhouse jazz and pop label of the mid-1940s, is being resurrected. Among the first albums to appear will be albums by **Georgie Auld's** big band, **Teddy Wilson** and **Sarah Vaughan**.

bob porter



MARKETING FUSION — Elektra/Asylum Records recently hosted a two-day conference at the Beverly Hills Hotel in Los Angeles. A highlight of the meeting was a product presentation of the first release from the label's jazz/fusion division, headed by manager Dr. Don Mizell, and introduction of the division's new regional marketing coordinators. Pictured above are (l-r): Joseph Morrow, regional marketing coordinator, west coast; Alvin Thomas, regional marketing coordinator, midwest; Mizell; Joe Smith, chairman of E/A; Mel Posner, vice chairman of E/A; Ralph Bates, regional marketing coordinator, south; and John Howard Brown, regional marketing coordinator, east coast.

JAZZ ALBUM PICKS

KRAL SPACE — Irene Kral — Catalyst CAT 7625 — Producers: Pat Britt and Dennis Smith — List: 6.98

With uncommon style and grace, vocalists Irene Kral shows that she is a splendid interpreter of good music. Blessed with fine material, mostly ballads, she exhibits a superb range and exquisite phrasing. A bossa nova tune, "Wheeler's And Dealers," and the jaunty Tommy Wolf-Frans Landesman composition, "Nice Weather For Ducks," provide a nice change of pace.

BUDDY RICH/CLASS OF '78 — The Great American Gramophone Company — GADD-1030 — Producer: Norman Schwartz — List: 13.95

The album's liner notes state that Rich has always been searching for the right band. The problem is that he likes the power of a big band as well as the freedom of a combo. With his latest LP, he has the best of both. The incomparable big band goes all out on Joe Zawinul's "Birdland," while Buddy leads a trio through Chick Corea's Spanish-flavored "Fiesta." The no-tape direct-to-disc recording process has effectively captured the live, intense feel of one of this great drummer's sessions.

WARNE OUT — Warne Marsh — Interplay 7709 — Producer: Toshiya Taenaka — List: 7.98

Marsh has been more active in the past five or six years than at any time in his career (which goes back to the '40s). His membership in Super Sax has brought him to the attention of many new listeners. His LPs are always stimulating and adventuresome, and this one (with bass and drums only) is no exception. Of special interest is "Duet" which features the tenorman in overdubbed conversation with himself. The label is new and L.A.-based.

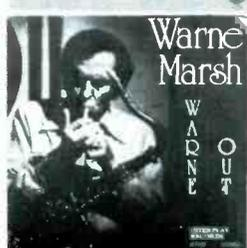

AFTER THE DANCE — Harold Vick — Wolf 1020 — Producer: Joel Dorn — List: 6.98

Saxophonist Vick's latest album has all the elements for success in today's pop-oriented market: plenty of straight-ahead blowing by the leader, lush horn and string arrangements by William Eaton, evocative background vocals and guest appearances by most of the east coast session heavies. The material is a tempting blend of Vick originals and jazz treatments of '70s pop and R&B tunes. Vick's talented playing is showcased best on the rousing "Things Ain't Right" and the plaintive "Blue In The Face."

SCOTT HAMILTON — Concord Jazz 42 — Producer: Carl Jefferson — List: 7.98

Hamilton is the major arrival of the past year in terms of personal development and interest he has created within the jazz community. His playing is strong and inventive throughout, and the support he has from the likes of Nat Pierce, Bill Berry and Jake Hanna is exemplary. Eight standards make up the bill of fare and each is rendered with verve and imagination. Watch Hamilton, he's on the move.

TOMMY FLANAGAN 3 — Pablo Live 2308 202 — Producer: Norman Granz — List: 7.98

What with 15 LPs from the Montreux bash recently issued on this label, it is possible that some will get lost. This highly stimulating trio session proves to be another reminder of how well Flanagan is playing these days. His renditions of well-known compositions by Charlie Parker, Dizzy Gillespie and Kenny Dorham provide the highlights, but in truth there is little here that isn't piano trio jazz of the highest quality.

L A T I N

L A T I N B E A T

Joe Cain, vice president, general manager of Mericana and Salsoul, has informed me that their new releases are **Raul Marrero, Cachó Vol II, Roberto Torres, Manuel Bastisa and his Estrella and Saoca**, whose first albums met with such success that they have been promoted to the higher priced Salsoul label.

Puerto Rican All-Stars producer, **Frankie Gregory**, has been in Los Angeles doing a big promotion on their new Fama album "The Professionals." The group will be going to Mexico and Los Angeles for concerts only. Press release from R & J in New York shows that Puerto Rican All-Stars' album has already sold 10,000 LPs in two weeks.

Fama president, **Ron Sproehle**, has signed actor and singer **Jaime Moreno** for a long-term contract.

Ruben Valentine, local d.j. on Radio Express AM, has expanded his one hour show to three and a half hours on salsa. The ratings have gone way up.

Rene & Rene are back with Falcon Records after signing a new contract for five long years. Their new debut album "Quando Vuelva A Mexico" is doing very well.

Promoter **Mark Taft**, from San Francisco, has been negotiating for **Tito Puente, Cal Tjader** and the **Judges Nephew** for two days of concerts in Miami on February 3 and 4.

Caytronics artists **Edwardo Segundo, Hermanas Huerta**, and **Gilberto Valenzuela** appeared at the Million Dollar Theater on January 16.

Rico Records president, **Ralph Cartagena**, announced that all sales for El Gran Combo on EGC Records will be handled through Musimex Records on the west coast.

Ralph Mercado and **Ray Aviles** have come up with the Salsa Perfect Combination for Feb. 10 at Madison Square Garden in New York City. The following headliners will be included: two time grammy winner, **Eddie Palmieri** Orch. with **Ismael Quintana** and **Lalo Rodriguez**, **Roberto Roena** And His Appollo Sound, **Papo Lucca** with the **Sonora Poncena, Los Hijos Del Rey**, from Santo Domingo, **Charanga 76**, and **Angel Canales**.

Cuban vocalist **Lisette**, formerly with

Borinquen Records, has recently signed a contract with Coco Records. Another Borinquen Records artist singer **Ednita Nazario** has left the company too.

National Academy of Recording Arts & Sciences have nominated the following bandleaders and singers for their LP achievements of the year in the Latin category: **Mongo Santamaria** for "Dawn," **Machito**, "Fireworks," **Tito Puente**, "La Leyenda," **Ray Barretto**, "Tomorrow," and **Eydie Gorme & Danny Rivera** for "My Amigos." The final tabulation for the winners will be on Feb. 23, on CBS Television.

Microfon has two winners in **Aldo Monges** and **The Pasteles Verdes**. Both are doing well in their new releases.

ray terrace

Argentinian News

BUENOS AIRES — Carmusic Records has released the first albums of the label's recently contracted by the company's president **Jorge Esperon** during his recent trips to the United States. The LPs have been recorded by **Michele, Brenton Wood** and **Lovequake**, and several others will be released in a few weeks.

CBS is releasing the new LP by guitar player **Cacho Tirao**, a steady seller in this market through his instrumental versions of pop tunes, evergreens and even light classical music. **Tirao** is very popular as an artist for conventions, parties and other dates, and has traveled three times to Europe to perform there.

Microfon's president **Mario Kaminsky** traveled to Spain to hold talks regarding the representation of his company there and to get in touch with people of Hispavox, represented here by Microfon. After his return he will get back to Europe, this time to attend the **MIDEM** in Cannes.

Music Hall has released a three-LP set with the "History Of Tango," a detailed work written and selected by **Jorge Montes**, with recordings comprising all the stages of the music from Buenos Aires. The set includes a book in Spanish and another one in English, and makes a wonderful souvenir for those who visit Argentina. Reportedly it will also be released in European countries.

miguel smirnoff

TOP 20 ALBUMS

LOS ANGELES (SALSA)

L.A. (Pop)

	Weeks On 1/14 Chart		Weeks On 1/14 Chart
1 ONLY THEY COULD HAVE MADE THIS ALBUM CRUZ/COLON (Vaya 66)	— 1	1 HOMBRE NAPOLEON (Raff 9066)	— 1
2 PRESENTANDO ANDY MONTANEZ LA DIMENSION LATINA (TH-2018)	— 1	2 LA VOZ RANCHERA CHELO (Musart 10638)	— 1
3 MITIENDO MANO WILLIE COLON/RUBEN BLADES (Fania 500)	— 1	3 A MIS 33 ANOS JULIO IGLESIAS (Alhambra 38)	— 1
4 NO VOY AI FESTIVAL ISMAEL MIRANDA (Fania 508)	— 1	4 LA FERIA DE CEPILLIN (Orfeon 12-005)	— 1
5 SUPER SALSA SINGERS (Fania 509)	— 1	5 LA MUERTE DE UN GALLERO VICENTE FERNANDEZ (Caytronics 1492)	— 1
6 FIREWORKS MACHITO (Coco 131)	— 1	6 PAJARILLO NAPOLEON (Raff 9065)	— 1
7 RECONSTRUCCION RICARDO RAY/BOBBY CRUZ (Vaya 57)	— 1	7 SIEMPRE EN MI MENTE JUAN GABRIEL (Arcano 3388)	— 1
8 EL 15 TO ANIVERSARIO EL GRAN COMBO (EGC 014)	— 1	8 LLAMARADA MANOLO MUNOZ (Gas 4153)	— 1
9 EL NEGRO CHOMBO TOMMY OLIVENCIA (Inca 1055)	— 1	9 CON MARIACHI CHELO (Musart 10585)	— 1
10 RHYTHM MACHINE FANIA ALL STARS (Columbia 34711)	— 1	10 A MEXICO JULIO IGLESIAS (Alhambra 21)	— 1
11 EL GIGANTE DEL SUL LA SONORA PONCENA (International JM-INT-1954)	— 1	11 JOYAS RANCHERAS VICENTE FERNANDEZ (CBS-Mexico/Caytronics)	— 1
12 THE ARTIST JOHNNY PACHECO (Fania 503)	— 1	12 BESITOS LOS HUMILDES (Fama 554)	— 1
13 LOS DOS MOSQUETEROS PUPI & PACHECO (Vaya 63)	— 1	13 OTRO OCUPA MI LUGAR MIGUEL GALLARDO (Latin Intl.)	— 1
14 BUYU JOSE MANQUAL Sr. (Turnstyle T-433)	— 1	14 VIVE NAPOLEON (Raff 9055)	— 1
15 ROBERTO ROENA (International JM-INT-924)	— 1	15 REENCUENTRO JOSE-JOSE (Pronto 1026)	— 1
16 TWO SIDES OF TIPCA 73 (Inca 1053)	— 1	16 AMERICA JULIO IGLESIAS (Alhambra 27)	— 1
17 SALSA DISCO PARTY (TR-130)	— 1	17 EL QUINTO COMPAS EMIR BOSCAN & SUS TOMASIONOS (Top Hits 2013)	— 1
18 LA LEYENDA TITO PUENTE (Tico 1413)	— 1	18 UNA LAGRIMA & UN RECUERDO GRUPO MIRAMAR (Accion 4014)	— 1
19 ENCORE CHARANGA 76 (TR-128)	— 1	19 VIVAN LOS MOJADOS LOS TIGRES DEL NORTE (Fama 554)	— 1
20 FANIAS GREATEST HITS FANIA ALL STARS (Fania 511)	— 1	20 LA HIJA DE NADIE YOLANDA DEL RIO (Arcano 3202)	— 1

LOS DOS MOSQUETEROS — Pupi And Pachero — Vaya JMVS-63 — Producer: Johnny Pacheco — List: 6.98

At a first listen, the music on this LP will seem subdued, but don't let that fool you. That's the way it's supposed to be. Relaxed and smooth, but still exuding a certain funkiness. Pupi, who has long been one of my favorite interpreters of charanga music, is a masterful violinist. Pupi also composed two tunes in this LP — "Salsa" and "Estoy A Mil" which features a piano solo by Sonny Bravo. All the arrangements are by Pupi. This album is highly recommended to anyone who digs the flute and violin sound of charanga music.



THE BIG KIMBOS — Los Kimbos — Cotique JMCS-1091 — Producer: Ralph Lew — List: 6.98

Although this is only Los Kimbos' second release, it will be their last album together as the group plans to break up in the near future. Good dance music and good vocals by Adalberto Santiago and some great soloing throughout the album. Good potential, it could go to the top.



NO VOY AL FESTIVAL — Ismael Miranda — Fania JM-00508 — Producer: Ismael Miranda — List: 6.98

This is the young superstar's fourth solo LP since separating from Harlow's Band as lead singer. "No Voy Al Festival" is arranged and conducted by musical director Jorge Millet who also composed a few tunes. "A Mexico Con Amor" begins with a ranchera trumpet style playing and immediately turns into salsa guaguanco. "La Puerta Esta Abierta" is another bolero with mellow keyboard work by Millet. The ten songs on this album are in the right direction for Miranda.



Latin Picks

PUERTO RICO ALL STARS — Fama GVJM-F-S 1001 — Producer: Juancito Torres — List: 6.98

Puerto Rico All Stars outshines their musicianship in this album. Their first album was voted in Latin New York Magazine as the best salsa LP of the year. What can you say when you have the top musicians from the island of Puerto Rico! The arrangements are very modern a la Kenton with their jazz riffs. Honorable mention goes to the piano player in "A Quitarse." All arrangers are excellent. Should be another winner for Puerto Rico.

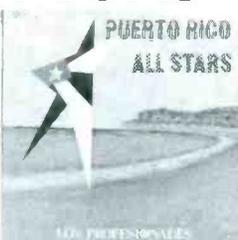

A MIS 33 ANOS — Julio Iglesias — Alhambra ACS-38 — Producers: Calvair, Arcusa, and Iglesias — List: 6.98

Spain's super star turns out another block-buster for his fans all over the world. Every album he has done has turned gold for him. The female chorus is excellent with a touch of disco feel. The musical arrangements by Ramon Arcusa & Rafael Ferro are superb. The best cuts on this album are "33 Anos," "Si Me Dejas No Vale," "Soy Un Truhan, Soy Un Senor." This LP should be # 1 all over Latin America.



FELIZ Y DICHOSO — Tito Allen — Alegre ASLP-6005 — Producer: Louie Ramirez — List: 6.98

This is Tito's second solo album. Tito formerly sang with Tito Puente and Tipca 73. In this album he uses an old Tito Puente cha cha, "Mi Chiquita Quiere Bembe." The vocals are in English on "Good Morning Heartache." One of the swingiest tunes on this album is "Por Eso." The arrangements all sound very tight and credit must do to Louis Ortiz, Mary Sheller and Louie Ramirez. All in all there are 10 good tunes to dance to for your pleasure.



GOSPEL

Ray Repp Appointed As Director Of OSV's New Department Of Music

HUNTINGTON, IND. — Folk-guitarist and composer Ray Repp has been named director of Our Sunday Visitor's newly established music department. Under Repp's direction, Christian music to serve a wide range of needs — including general family listening, worship settings, religious education programs and classical arrangements — will be developed.

"Benedicamus," the first album now in production, is scheduled for release in March. Two other albums, as yet unnamed, are also scheduled. All records will bear OSV's Jubal label.

Best known for his "Mass For Young Americans" album, Repp has written hundreds of songs and released a number of albums since he first started composing music and lyrics as a young seminarian.

Repp is considered by many to be the one person most responsible for introducing folk music into churches. Now a veteran and pioneer of the folk-liturgical, Repp expects to continue in this tradition by producing more of his work and that of other talented Christian musicians and composers.

Repp has done many concerts, lectures and workshops both here and abroad. Upcoming plans call for a concert in March, at the National Catholic Educational Association convention in St. Louis, where Repp will be introduced as the first director of OSV's new music department.

Shaw Joins Maranatha As Director Of Sales

COSTA MESA, CA. — Charlie Shaw has been appointed director of national sales of Maranatha Music, according to an announcement from the Christian record and concert ministry.

A veteran of retail record marketing, Shaw worked with Tower Records for 13 years, including six years as manager of the chain's largest store on Sunset Boulevard in Los Angeles.

Shaw will be responsible for U.S. distribution of records and tapes for Maranatha, dealing directly with the company's sub-distributors and supervising the national sales force.

Vokes' Album Out Again

NASHVILLE — Starday Records has reissued Howard Vokes' "Tragedy & Disaster In Country Songs" album. The LP will be marketed by Mooresville, Indiana-based Golden Memories Records.

Lexicon Youth Musical Transcribed To Braille

LOS ANGELES — Lexicon Music has granted permission to the Chicago based Johanna Bureau for the Blind and Visually Handicapped, Inc. to transcribe the youth musical "Tell It Like It Is" into braille.

Composed by Ralph Carmichael and Kurt Kaiser, this folk musical about God has been performed by several thousand sighted young people the world over.

Top Spiritual Albums

- 1 **LOVE ALIVE** WALTER HAWKINS & THE LOVE CENTER CHOIR (Light 5705) (Word)
- 2 **FIRST LADY** SHIRLEY CAESAR (Roadshow RS 744R) (UA)
- 3 **LIVE AT CARNEGIE HALL** JAMES CLEVELAND (Savoy 7014) (Arista)
- 4 **TONIGHT'S THE NIGHT** GOSPEL KEYNOTES (Nashboro 7181)
- 5 **JOY REV.** BRUNSON & THE THOMPSON COMM. CHURCH CHOIR (Creed 3078) (Nashboro)
- 6 **THIS IS ANOTHER DAY** ANDRAE CROUCH & THE DISCIPLES (Light 5683) (Word)
- 7 **FROM AUGUSTA WITH LOVE** SWANEE QUINTET (Creed 3077) (Nashboro)
- 8 **SEE YOU IN THE RAPTURE** SENSATIONAL NIGHTINGALES (Peacock 59227) (ABC)
- 9 **THE COMFORTER** EDWIN HAWKINS SINGERS (Birthright BRS 4020)
- 10 **AMAZING GRACE** ARETHA FRANKLIN (Atlantic 2-906)
- 11 **JESUS CHRIST IS THE WAY** WALTER HAWKINS (Light 5705) (Word)
- 12 **HE'S STANDING BY** INSTITUTIONAL RADIO CHOIR OF BROOKLYN, N.Y. (Savoy 14458) (Arista)
- 13 **RIDE THE SHIP TO ZION** GOSPEL KEYNOTES (Nashboro 7172)
- 14 **WHEN JESUS COMES** SARA JORDAN POWELL (Savoy 14465)
- 15 **WONDERFUL** EDWIN HAWKINS SINGERS (Birthright BRS 3005)
- 16 **STAND UP FOR JESUS** SAVANNAH COMMUNITY CHOIR (Creed 23076) (Nashboro)
- 17 **THESE ARE THE DAYS** DOROTHY LOVE COATS AND HER SINGERS (Savoy 14466)
- 18 **JAMES CLEVELAND PRESENTS** THE RUTH SCHOEFIELD EDITION (Savoy 14445) (Arista)
- 19 **GOTTA FIND A BETTER HOME** ANGELIC GOSPEL SINGERS (Nashboro 7178)
- 20 **TAKING GOSPEL HIGHER** SENSATIONAL WILLIAMS BROS. (Savoy SGL 14436) (Arista)

Top Inspirational Albums

- 1 **HOME WHERE I BELONG** B.J. THOMAS (Myrrh 6571) (Word)
- 2 **MIRROR** EVIE TOURNQUIST (Word WST 8735)
- 3 **GENTLE MOMENTS** EVIE TOURNQUIST (Word WST 8714)
- 4 **FOR HIM WHO HAS EARS TO HEAR** KEITH GREEN (Sparrow 1015)
- 5 **DALLAS HOLM & PRAISE LIVE** (Greentree R3441)
- 6 **LIVE FROM NASHVILLE** JIMMY SWAGGART (Jim 126) (Word)
- 7 **HIS HAND IN MINE** ELVIS PRESLEY (RCA ANL 11319)
- 8 **MOMENTS FOR FOREVER** BILL GAITHER TRIO (Impact 2R3457F)
- 9 **LIVE! THE VERY BEST OF THE HAPPY GOODMAN FAMILY** (Canaan CAX 9812/2) (Word)
- 10 **EVERGREEN** NANCY HONEYTREE (Myrrh MSA 6553)
- 11 **THIS IS NOT A DREAM** PAM MARK (Asian ARS 1003)
- 12 **COME ON RING THOSE BELLS** EVIE TOURNQUIST (Word WST 8770)
- 13 **LADY REBA** (Greentree R3430)
- 14 **MY HEART CANSING** BILL GAITHER TRIO (Impact R3445)
- 15 **CORNERSTONE** THE SPEERS (Heartwarming R3456)
- 16 **RAMBO COUNTRY** THE RAMBOS (Heartwarming R3429)
- 17 **ALLELUIA** BILL GAITHER TRIO (Impact R3408)
- 18 **LET ME HAVE A DREAM** DANNIEBELLE (Sparrow 1016)
- 19 **PRAISE BE TO JESUS** BILL GAITHER TRIO (Impact F3408)
- 20 **I HAVE RETURNED** KEN COPELAND (KCP 1002)

Gospel Reviews

THE KINGS TEMPLE CHOIR — Now — Creed 3083 — Producer: Shannon Williams — List: 5.00

Benny Cummings directs The Kings Temple Choir through a repertoire of moving original compositions. The human voice has been called the greatest musical instrument and Cummings has some two dozen fine singers to lend credence to showcasing vocal harmonies. Longtime gospel producer Shannon Williams gives The Kings Temple Choir free rein and the group's creativity is unhampered by overproduction, allowing a full choral sound. There is one exceptional song on the album, "Love Song (A Life Of Love)," and it should see several covers.

JIMMY MILLER — Lovin' Him — Day Spring DST-4002 — Producer: Buddy King — List: 6.98

The newest addition to The Word Family, Day Spring Records, was created to be a platform for "the candor of Jesus Music, the exuberance of southern gospel, and the lyrical beauty of traditional church music." Jimmy Miller's new release, "Lovin' Him," touches all those bases yet maintains a core of soft folk rock somewhat akin to John Denver's musical style. The title cut, "Lovin' Him," should be a chart-buster and the poetic ballad, "Watchman Nee," tells a moving story of a martyred Christian in Communist China.



IMPERIALS GO SESAC — Members of the Imperials gospel group recently signed writer contracts with SESAC. Pictured above at the signing are (l-r): Imperials members James Holihan, Russ Taff, Jim Murray and John Lutz. Shown kneeling is Jim Black, director of gospel music for SESAC.

Girard's Third Solo LP Out On Myrrh Records

LOS ANGELES — Myrrh Records has released Chuck Girard's third solo album, "Written On The Wind." All the songs on the album were written and performed by Girard.

A native of Los Angeles, Girard has been involved in music since his teens. He began his career singing rock and roll. In addition to singing backup for the Beach Boys, Girard was the lead singer in the Hondells, who had a national hit with "Little Honda."

Although his singing career was blooming, he felt his life was not complete until 1970, when he found Jesus Christ. He was then playing in a rock band called Love Song, whose music gradually began to reflect this entry into gospel.

Despite Love Song's success, in 1974 the members decided to disband to further their individual ministries. This gave Girard an opportunity to write more songs and to pull together his own solo albums.

Currently, Girard is in one of the busiest phases of his career. He just completed a major city tour, including performances in Dallas, Seattle and Portland.

"Written On The Wind" is a mellower statement than Chuck's earlier albums, with a sound appealing to a secular as well as a religious audience.

Myrrh is part of Word Records, a division of Word, Inc., which is a subsidiary of American Broadcasting Companies, Inc.



WRITERS HONORED — Gospel recording artist Cynthia Clawson and her husband, writer Ragan Courtney, were honored during a recent recording session at Nashville's Woodland Studio for their work on "Bright New Wings," a musical they wrote with Buryl Red. The couple was presented with the original woodcarving commissioned for use in the artwork for "Bright New Wings." Pictured above are (l-r): Elwyn Raymer, vice president of Triangle Records; Clawson; Courtney; and Red, who is president of Triangle Records.

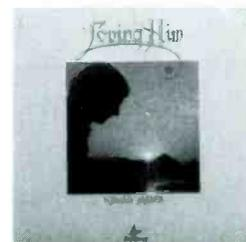

PICKED

GOSPEL

*in RECORD WORLD
and CASHBOX*

PLAYED

**POP, COUNTRY,
GOSPEL, and M.O.R.**

All over the world!

Tony Alamo

sings:

MISTER D.J.

and others

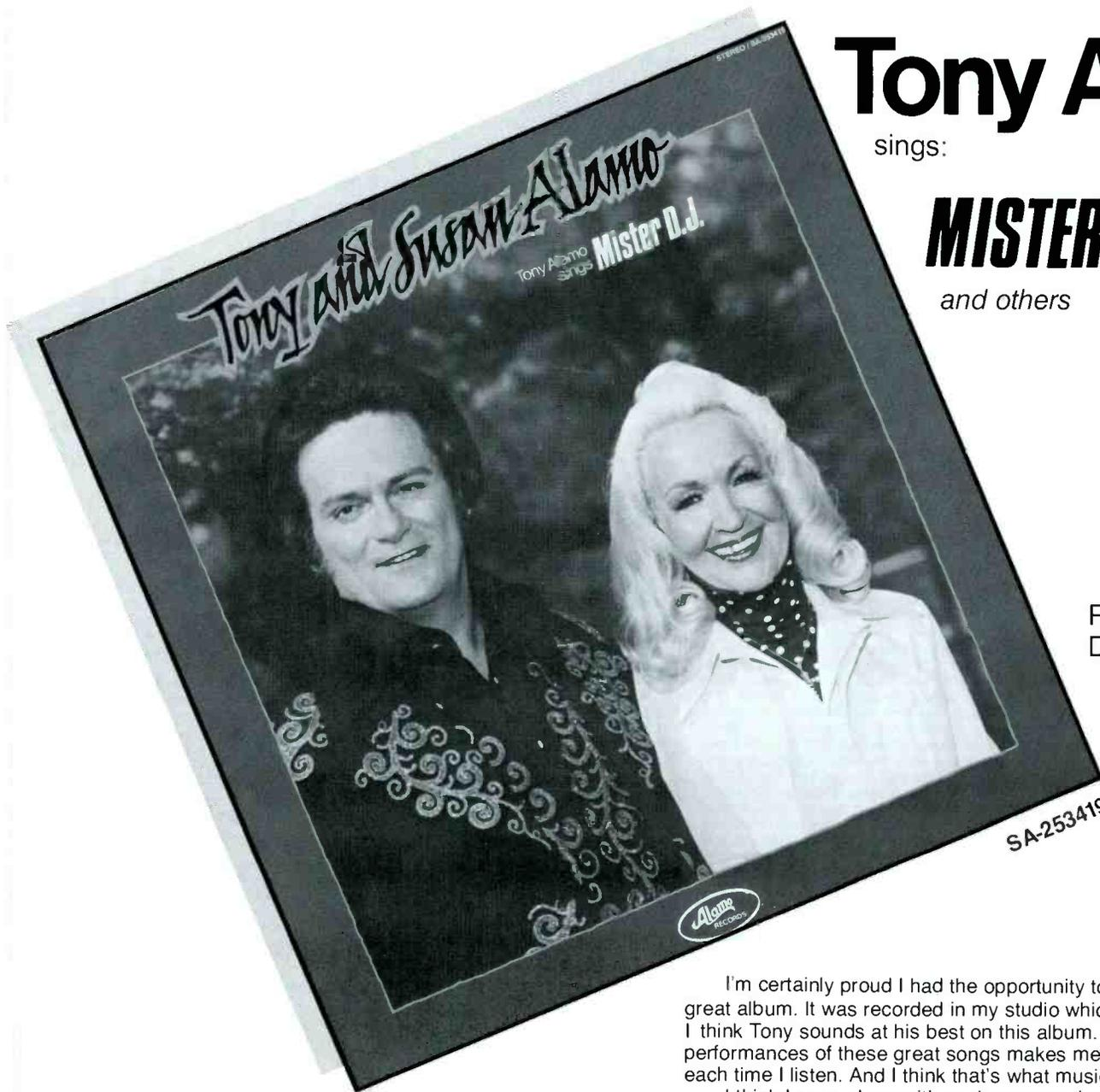

Produced by
Dan Hoffman

Distributed by
Pickwick International

**ALAMO
RECORDS**

325 BROADWAY • NASHVILLE, TENN. 37201 • (615) 256-9727

I'm certainly proud I had the opportunity to contribute some to this great album. It was recorded in my studio which makes me very proud. I think Tony sounds at his best on this album. Listening to his performances of these great songs makes me feel a little closer to God each time I listen. And I think that's what music and song is all about.

I think I sang along with each song as they were being recorded either from the control room or in the studio. Maybe my voice leaked into some of the microphones? Who knows?

Tony and Susan mean a lot to my life as friends and I'm certainly proud to recommend this album to you. When you listen, I think you'll feel as I do, a little closer to God from these inspiring performances.

PORTER WAGONER

Ronstadt, Eagles Top List In Grammy Award Nominations

(continued from page 38)

OF AMHERST, Julie Harris. (album). (Credo): FOR COLORED GIRLS WHO HAVE CONSIDERED SUICIDE WHEN THE RAINBOW IS ENUF. Ntozake Shange. Writer (album). (Buddah): J.R.R. TOLKIEN: THE SILMARILLION OF BEREN AND LUTHIEN, read by Christopher Tolkien. (album). (Caedmon); THE TRUMAN TAPES, Harry S. Truman, Ben Gradus. (album). (Caedmon).

COMPOSING FIELD Best Instrumental Composition

BIRDLAND, Joe Zawinul, Composer; BOND '77/- JAMES BOND THEME, Marvin Hamlisch, Composer; GONNA FLY NOW (THEME FROM "ROCKY"), Bill Conti, Carol Connors, Ann Robbins, Composers; MAIN TITLE FROM STAR WARS, John Williams, Composer; "ROOTS" MEDLEY (MOTHERLAND, ROOTS MURAL THEME), Quincy Jones, Gerald Fried, Composers.

Best Original Score Written For A Motion Picture Or A Television Special

ROCKY, Bill Conti, Composer. (U.A.); THE SPY WHO LOVED ME, Marvin Hamlisch, Composer. (U.A.); A STAR IS BORN, Kenny Ascher, Alan & Marilyn Bergman, Rupert Holmes, Leon Russell, Barbra Streisand, Donna Weiss, Paul Williams, Composers. (Columbia); STAR WARS, John Williams, Composer. (20th Century); YOU LIGHT UP MY LIFE, Joe Brooks, Composer. (Arista).

Best Cast Show Album

ANNIE, Charles Strouse, Martin Charnin, Composers, Larry Morton, Charles Strouse, Producers. (Columbia); GUYS AND DOLLS, Frank Loesser, Composer, William Goldstein, Producer. (Motown); I LOVE MY WIFE, Cy Coleman, Michael Stewart, Composers, Cy Coleman, Producer. (Atlantic); STARTING HERE, STARTING NOW, Richard Maltby, Jr., David Shire, Composers, Jay David Saks, Producer. (RCA); YOUR ARM'S TOO SHORT TO BOX WITH GOD, Micki Grant, Alex Bradford, Composers, Esmond Edwards, Producer. (ABC).

CRAFTS

Best Instrumental Arrangement

FREE AS THE WIND (The Crusaders) Crusaders, Arranger. (ABC); MUSICMAGIC (Return To Forever), Chick Corea, Arranger. (Columbia); NADIA'S THEME (THE YOUNG AND THE RESTLESS), (Barry DeVorzon), Harry Betts, Barry DeVorzon, Perry Botkin, Jr., Arrangers, (Arista); ROOTS MURAL THEME (Quincy Jones), Herb Spencer, Arranger. (A&M); SCHEHEREZADE (Hubert Laws) Bob James, Arranger. (CTI).

Best Arrangement Accompanying Vocalist(s)

BESAME MUCHO (Joao Gilberto), Claus Ogerman, Arranger. (Warner Bros.); CALLING OCCUPANTS OF INTERPLANETARY CRAFT (Carpenters), Richard Carpenter, Arranger. (A&M); THE DEVIL IS A LIAR (Seawind), Seawind, Arrangers. (CTI); LOVE THEME FROM A STAR IS BORN (EVERGREEN) (Barbra Streisand), Ian Freebairn-Smith, Arranger. (Columbia); NATURE BOY (George Benson), Claus Ogerman, Arranger. (Warner Bros.).

Best Arrangement For Voices

ALL YOU DO IS DIAL (Heatwave), Heatwave, Arranger. (Epic); BABY, I'LL GIVE IT TO YOU (Seals & Crofts), Gene Page, Arranger. (Warner Bros.); GO YOUR OWN WAY (Fleetwood Mac), Fleetwood Mac, Arrangers. (Warner Bros.); NEW KID IN TOWN (Eagles), Eagles, Arranger. (Asylum); OH LORD, COME BY HERE (Quincy Jones), Quincy Jones, James Cleveland, John Mandel, Arrangers. (A&M).

Best Engineered Recording

AJA (Steely Dan), Roger Nichols, Elliot Scheiner, Bill Schnee, Al Schmitt, Engineers. (album). (ABC); DISCOVERED AGAIN! (Dave Grusin), Bill Schnee, Engineer. (album). (Sheffield Lab); JT (James Taylor), Val Garay, Engineer. (album). (Columbia); RUMOURS (Fleetwood Mac), Ken Caillat, Richard Dashut, Engineers. (album). (Warner Bros.); SIMPLE DREAMS (Linda Ronstadt), Val Garay, Engineer. (album). (Asylum).

Best Album Package

COLOR AS A WAY OF LIFE (Lou Donaldson), Abie Sussman, Bob Defrin, Art Directors. (Cotillion); GINSENG WOMAN (Eric Gale), Paula Scher, Art Director. (Columbia); HEJIRA (Joni Mitchell), Glen Christensen, Art Director. (Asylum); LOVE NOTES (Ramsey Lewis), John Berg, Art Director. (Columbia); SIMPLE DREAMS (Linda Ronstadt), Kosh, Art Director. (Asylum); SINGIN' (Melissa Manchester), Kosh, Art Director. (Arista); WINGS OVER AMERICA (Wings), MPL/Hipgnosis, Art Director. (Capitol); YARBIRDS FAVORITES (Yarbirds), Paula Scher, Art Director. (Epic).

Best Album Notes

BING CROSBY: A LEGENDARY PERFORMER, George T. Simon, Annotator. (RCA); GUY LOMBARDO: A LEGENDARY PERFORMER, George T. Simon, Annotator. (RCA);

JEFFERSON AIRPLANE — FLIGHT LOG (Jefferson Airplane), Patrick Snyder, Annotator. (Grunt/RCA); THE LESTER YOUNG STORY VOL. I, Michael Brooks, Annotator. (Columbia); STORMY BLUES (Billie Holiday), Chris Albertson, Annotator. (Verve/Polydor).

Best Producer Of The Year

PETER ASHER: THE BEE GEES, ALBHY GALUTEN & KARL RICHARDSON; KENNETH GAMBLE & LEON HUFF; RICHARD PERRY, BILL SZYMZYK.

CLASSICAL FIELD

ALBUM OF THE YEAR — CLASSICAL

CONCERT OF THE CENTURY — Recorded Live at Carnegie Hall May 18, 1976 Leonard Bernstein, Vladimir Horowitz, Isaac Stern, Mstislav Rostropovich, Dietrich Fischer-Dieskau, Yehudi Menuhin, Lyndon Woodside, Thomas Frost, Producer. (Columbia); GERSHWIN: PORGY & BESS — John De Main cond. Houston Grand Opera Principal Solists: Dale, Smith, Shakesider, Lane, Brice, Smalls, Thomas Z. Shepard, Producer. (RCA); HAYDN: ORLANDO PALADINO — Antal Dorati cond. Orchestre de Chambre de Lausanne/Principal Solists: Auger, Ameling, Killebrew, Ahnsjo, Luxon, Trimarchi, Shirley, (Philips); MAHLER: SYMPHONY NO. 9 IN D MAJOR — Carlo Maria Giulini cond. Chicago Symphony, Gunther Brest, Producer. (DG); PARKENING AND THE GUITAR — Christopher Parkening, Patti Laursen, Producer. (Angel); RAVEL: BOLERO AND DEBUSSY: LA MER & APRES MIDI D'UN FAUNE — Sir Georg Solti cond. Chicago Symphony, Ray Minshull, Producer. (London).

BEST CLASSICAL ORCHESTRAL PERFORMANCE

BARTOK: THE WOODEN PRINCE — Pierre Boulez cond. New York Philharmonic, Andrew Kazdin, Producer. (Columbia); BRUCKNER: SYMPHONY NO. 8 IN C MINOR — Herbert von Karajan cond. Berlin Philharmonic, Hans Hirsch, Producer. (DG); MAHLER: SYMPHONY NO. 3 IN D MINOR — James Levine cond. Chicago Symphony Orchestra, Thomas Z. Shepard & Jay David Saks, Producers (RCA); MAHLER: SYMPHONY NO. 9 IN D MAJOR — Carlo Maria Giulini cond. Chicago Symphony Orchestra, Gunther Brest, Producer. (DG); RAVEL: BOLERO — Sir Georg Solti cond. Chicago Symphony Orchestra, Ray Minshull, Producer. (London); TCHAIKOVSKY: SWAN LAKE — Andre Previn cond. London Symphony Orchestra, Christopher Bishop, Producer. (Angel).

BEST OPERA RECORDING

GERSHWIN: PORGY & BESS — John De Main cond. Houston Grand Opera, Principal Solists: Albert, Dale, Smith, Shakesider, Lane, Brice, Smalls, Thomas Z. Shepard, Producer. (RCA); HAYDN: ORLANDO PALADINO — Antal Dorati cond. Orchestre de Chambre de Lausanne — Principal Solists: Auger, Ameling, Killebrew, Ahnsjo, Luxon, Shirley, Trimarchi, Erik Smith, Producer. (Philips); JANACEK: KATYA Kabanov — Charles Mackerras cond. Vienna Philharmonic Orchestra — Principal Solists: Soderstrom, Kniplova, Dvorsky, James Mallinson, Producer. (London); MUSSORGSKY: BORIS GODONOV — Jerry Semkow cond. Polish National Radio Symphony Orchestra & Chorus — Principal Solists: Talvela, Gedda, David Mottley, Producer. (Angel); PUCCINI: TOSCA — Colin Davis cond. Chorus & Orchestra of Royal Opera House, Covent Garden — Principal Solists: Caballe, Carreras, Wixell, Ramey, Erik Smith, Producer. (Philips); WAGNER: DIE MEISTERSINGER VON NURNBERG — Eugen Jochum cond. Deutsche Oper Berlin Orchestra & Chorus — Principal Solists: Fischer-Dieskau, Domingo, Ludwig, Ligendza, Gunther Brest, Producer. (DG); WAGNER: THE FLYING DUTCHMAN — Sir Georg Solti cond. Chicago Symphony Orchestra & Chorus — Principal Solists: Bailey, Martin, Talvela, Kolto, Krenn, Jones, Ray Minshull, Producer. (London); WEILL: THREE PENNY OPERA — Original Cast — New York Shakespeare Festival, Stanley Silverman, cond. — Principal Solists: Julia, Alexander, Greene, Larry Morton, Producer. (Columbia).

BEST CHORAL PERFORMANCE, CLASSICAL (OTHER THAN OPERA)

BERLIOZ: L'ENFANCE DU CHRIST — Colin Davis, Conductor — John Alldis Choir & London Symphony Orchestra. (Philips); BRITTEN: SAINT NICHOLAS — David Willcocks, Conductor — King's College Choir, Cambridge & Academy of St. Martin-in-the-Fields. (Seraphim); BRUCKNER: TE DEUM — Herbert von Karajan, Conductor — Vienna Singverein & Berlin Philharmonic. (DG); DVORAK: STABAT MATER — Rafael Kubelik, Conductor — Chorus of Bavarian Radio & Bavarian Radio Symphony. (DG); PURCELL: FUNERAL MUSIC FOR QUEEN MARY — Philip Ledger, Conductor — King's College Choir, Cambridge & Academy of St.

East Coastings/Points West

(continued from page 16)

Express. The single comes almost exactly two years after Dylan's own "Hurricane" spotlighting the case of boxer Reuben "Hurricane" Carter . . . Dylan is said to be having some trouble getting musicians for his upcoming tour because of the reported \$300 a week he is offering as pay. (By the way, Bob, if you need a good woodwind man, you can reach me at (213) 464-8241). . . MCA's Loretta Lynn and Elektra/Asylum's Neil Sedaka will receive their stars on Hollywood's Walk of Fame within a week of each other. Loretta got hers Jan. 11, while Neil gets the honor Jan. 18. While in Los Angeles, Sedaka is taping the Merv Griffin show, which will air Feb. 17.

THE SILVER BULLET MAN — Bob Seger's long-awaited follow-up to "Night Moves" is expected from Capitol sometime in February. Capitol also has signed the Lost Gonzo Band, Jerry Jeff Walker's backup band, and expects an album from the group in March. . . **Chick Rains And Greg Harris**, a new RCA duo, are rehearsing in Los Angeles in preparation for their upcoming tour, which will consist mostly of club dates. . . Because of the unusually heavy rains in Southern California recently, residents of the Malibu area, including the Eagles' Don Felder, Linda Ronstadt, Martin Mull and Chicago's Jim Pankow have been helping sandbag each other's homes, to keep them from slipping away. . . Capitol is considering putting together a Natalie Cole live album. . . **Kenny Rogers**, whose "Ten Years Of Gold" album shipped gold last week and is one of Cash Box's most added LPs of the week, has re-signed with United Artists in a four-year, multi-million dollar recording contract. **TOY SEX PISTOLS?** — The Sex Pistols, currently on their first tour of the United States, have given merchandising rights for the U.S. and Canada to Image Factory, Inc., a Hollywood-based merchandising firm. The company, which has created merchandising and marketing campaigns for motion pictures ("Star Wars," "Rocky") and other rock groups (Bee Gees), will develop a complete line of promotional products to be marketed within the next 30 days. Once the products are developed, they will be available through mail order, record store display, head shops and boutique stores. The possibilities that come to mind are limitless: 8-inch tall Johnny Rotten dolls (tattered clothing and safety pins sold separately); little houses for the Pistols' replicas to live in with all the comforts of home, with the exception of toothbrush and toothpaste for Johnny Rotten; maybe even toy pistols with the group's name on them. And instead of using real bullets, they would shoot Cash Box bullets.

randy lewis

Martin-in-the-Fields. (Angel); ROUSSEL: PSALM 80, FOR TENOR, CHORUS & ORCHESTRA — Serge Baudo, Conductor — Stephen Caillat Chorus & Orchestre de Paris. (Conn. Soc.); VERDI: REQUIEM — Sir Georg Solti, Conductor — Margaret Hillis, Choral Dir. Chicago Symphony Chorus & Orchestra. (Philips).

BEST CHAMBER MUSIC PERFORMANCE

BARTOK: QUARTETS FOR STRINGS (6) — Guarneri Quartet. (RCA); A CONTEMPORARY ELIZABETHAN CONCERT — David Munrow cond. Early Music Consort of London. (Angel); DVORAK: QUARTETS NO. 8 IN E MAJOR, OP. 80 AND NO. 19 IN E FLAT MAJOR, OP. 51 — Prague String Quartet. (DG); DVORAK: QUINTET FOR PIANO IN A MAJOR, OP. 81 — Emanuel Ax & Cleveland Quartet. (RCA); IMPROVISATIONS — WEST MEETS EAST — ALBUM 3 — Ravi Shankar, Yehudi Menuhin, Jean-Pierre Rampal, Martine Gelliot, Alla Rakha. (Angel); RACHMANINOFF: SONATA FOR CELLO & PIANO IN G MINOR, OP. 19 — ANDANTE — TCHAIKOVSKY: TRIO FOR PIANO IN A MINOR, OP. 50 — PEZZO ELEGIACO — Vladimir Horowitz, Isaac Stern, Mstislav Rostropovich. (Columbia); SCHOENBERG: QUARTETS FOR STRINGS (COMPLETE) — Juilliard Quartet. (Columbia).

BEST CLASSICAL PERFORMANCE INSTRUMENTAL SOLOIST OR SOLOISTS (WITH ORCHESTRA)

BEETHOVEN: CONCERTO FOR PIANO (5) — Alfred Brendel, Piano — (Haitink cond. London Philharmonic). (Philips); BEETHOVEN: CONCERTO FOR PIANO NO. 4 IN G MAJOR — Maurizio Pollini, Piano (Bohm cond. Vienna Philharmonic). (DG); BRAHMS: CONCERTO FOR PIANO NO. 2 IN B FLAT MAJOR, OP. 83 — Solomon, Piano — (Dobrowen cond. Philharmonia Orchestra). (Vox/Turnabout); CONCERTOS FROM SPAIN — Alicia de Larrocha, Piano — (de Burgos cond. Royal Philharmonic). (London); ELGAR: CONCERTO FOR CELLO, OP. 85 — Jacqueline Du Pre, Cello — (Barenboim cond. Philadelphia Orchestra). (Columbia); RACHMANINOFF: CONCERTO FOR PIANO NO. 3 IN D MINOR — Lazar Berman, Piano — (Abbado cond. London Symphony Orchestra). (Columbia); SCHUMANN: CONCERTO FOR CELLO & ORCHESTRA IN A MINOR — BLOCH: SCHELOMO — Mstislav Rostropovich, Cello — (Bernstein cond. Orchestre National de France). (Angel); VIVALDI: THE FOUR SEASONS — Itzhak Perlman, Violin — (Perlman cond. London Philharmonic Orchestra). (Angel).

BEST CLASSICAL PERFORMANCE INSTRUMENTAL SOLOIST OR SOLOISTS (WITHOUT ORCHESTRA)

BACH: THE ENGLISH SUITES (COMPLETE) — Glenn Gould, Piano. (Columbia); BACH: PARTITAS FOR HARPISCHORD NOS. 1 IN B FLAT MAJOR & 2 IN C

MINOR — Igor Kipnis, Harpsichord. (Angel); BEETHOVEN: SONATA FOR PIANO NO. 18 IN E FLAT MAJOR, OP. 31 NO. 3 — SCHUMANN: FANTASISTUKE, OP. 12 — Artur Schnabel, Piano. (RCA); GRANGER: PIANO MUSIC OF PERCY GRAINGER — Daniel Adni, Piano. (Seraphim); GRANADOS: GOYESCAS — Alicia de Larrocha, Piano. (London); KREISLER: ITZHAK PERLMAN PLAYS FRITZ KREISLER — ALBUM 2, Itzhak Perlman. (Angel); MESSIAEN: 20 REGARDS DE L'ENFANT JESUS — Michel Beroff, Piano. (Conn. Society).

BEST CLASSICAL VOCAL SOLOIST PERFORMANCE

BACH: ARIAS — Janet Baker (marriner cond. Academy of St. Martin-in-the-Fields). (Angel); BUT YESTERDAY IS NOT TODAY — Donald Gramm (Donald Hassard, Accompanist). (New World); FAURE: SONGS — Gerard Souzay (Dalton Baldwin, Accompanist). (Conn. Society); IVES: SONGS — Dietrich Fischer-Dieskau (Michael Ponti, Accompanist). (DG); LUCIANO PAVAROTTI — O HOLY NIGHT — Luciano Pavarotti (Adler cond. National Philharmonic Orchestra). (London); RACHMANINOFF: SONGS — Volume Two — Elisabeth Soderstrom (Vladimir Ashkenazy, Accompanist). (London); ROSSINI/MOZART: OPERA ARIAS — Frederica von Stade (de Waart cond. Rotterdam Philharmonic). (Philips); SCHUBERT ON STAGE — Ely Ameling (de Waart cond. Rotterdam Philharmonic). (Philips); SHOSTAKOVICH: SYMPHONY NO. 14 — Galina Vishnevskaya & Mark Reshetin (Rostropovich cond. Moscow Philharmonic). (Columbia).

BEST ENGINEERED RECORDING — CLASSICAL

BARTOK: THE WOODEN PRINCE — Boulez cond. New York Philharmonic — Bud Graham, Ray Moore & Milt Cherin, Engineers. (Columbia); BERLIOZ: L'ENFANCE DU CHRIST — Davis cond. London Symphony Orchestra — S.J.W. Witteveen & Dick van Kijk, Engineers. (Philips); GERSHWIN: PORGY & BESS — De Main cond. Houston Grand Opera — Paul Goodman & Anthony Salvatore, Engineers. (RCA); MAHLER: SYMPHONY NO. 2 IN C MINOR ("Resurrection") — Abbado cond. Chicago Symphony Orchestra — Heinz Wildhagen, Engineer. (DG); MAHLER: SYMPHONY NO. 9 IN D MAJOR — Giulini cond. Chicago Symphony Orchestra — Klaus Schiebe, Engineer. (DG); RAVEL: BOLERO — Solti cond. Chicago Symphony Orchestra — Kenneth Wilkinson, Engineer. (London).

Crusader Takes Solo

LOS ANGELES — "Rainbow Seeker," the first solo album by Joe Sample, keyboard player with the Crusaders, is scheduled for release on ABC Records this month.



CONTRACT SPORT — Football was the theme of United Artists Records 1st Quarter Kick-Off Product Presentation Jan. 6-8 at Palm Springs Canyon Hotel. More than 150 UA staffers, regional representatives, independent distributors and custom label personnel were on hand to hear upcoming product and discuss the game plan for the coming year. Pictured (l-r) are: Stan Monteiro, vice president of artist relations and promotion; Ursula Nelme, artist relations; Mark Levinson, vice president of business affairs; Jerry Winston,

Malverne/New York, and Gordon Bossin, vice president of marketing; Danny Crystal, vice president of soundtracks; Wally Schuster, vice president/general manager of UA Publishing; Romelle Dunas; Suzanne Logan, manager of international operations, and Tim Reed of United Artists; and Dan Alvino, vice president of sales; (standing) Ken Sawyer, west coast regional sales manager; Artie Mogull, UA president, and Bossin. The presentation was followed by a luncheon.

COIN MACHINE

Midway Revises Cleaning Procedure For Hologram On 'Top Gun' Video

CHICAGO — Andy Ducay, service manager at Midway Manufacturing Company, has issued a special service bulletin outlining the correct measures for cleaning the hologram on the current Midway "Top Gun" video game.

The present instructions, contained on the game, have been labeled "incorrect" and Ducay recommends the following procedure: for removing dust, a soft cloth should be applied; however, if further cleaning is required, the Kodak film cleaner #195-6986 is the only solution to be used. He cautioned that the use of water or alcohol can cause damage, since in a large percentage of the machines the emulsion is on the outside, so both of these liquids are prohibited for use.

In explaining the costly hologram

process, Ducay said it is a "true, three dimensional photograph, in color, which is made with a laser beam and viewed with ordinary incandescent, or clear, light. The hologram is recorded on film in such a way as to store all of the information of a particular object. In the case of Top Gun, the object is the cowboy and when a light beam passes through the hologram the light is reshaped into a wave form identical to the reflected object. The object is viewed by the observer in 3-D and in color. Turning the hologram drum will then cause a motion sequence."

Operators requiring further information on the cleaning process may contact their distributors or the Midway factory at 10750 W. Grand Avenue in Franklin Park, Illinois. The phone number is: (312) 451-1360.

Gottlieb Names Field Service Engineer

CHICAGO — D. Gottlieb & Company announced the appointment of Richard F. Finger as field service engineer. "Finger will conduct service seminars on all of Gottlieb's solid-state games, test equipment and procedures," according to C. Marshall Caras, vice president of marketing. Gottlieb recently launched its first in the series with a special session for distributor personnel, which was held in Chicago, and is currently scheduling seminars in cities across the United States as well as in Canada and Europe.

Wayne Neyens, vice president of engineering, said, "Dick's strong

(continued on page 64)



Richard F. Finger

THE JUKE BOX PROGRAMMER

TOP NEW POP SINGLES

- 1 LET IT GO, LET IT FLOW DAVE MASON (Columbia 3-10662)
- 2 SO LONG FIREFALL (Atlantic 3452)
- 3 EVERYBODY LOVES A RAIN SONG B.J. THOMAS (MCA 40854)
- 4 I GIVE YOU GIVE BLIND CROSBY, STILLS & NASH (Atlantic 3453)
- 5 THE WAY YOU DO THE THINGS YOU DO RITA COOLIDGE (A&M 2004)
- 6 SHOT ME DOWN NAZARETH (A&M 2009)
- 7 SILVER DREAMS THE BABYS (Chrysalis 2201)
- 8 WALK RIGHT BACK ANNE MURRAY (Capitol 4527)
- 9 I DO GEILS (Atlantic 3454)
- 10 (THEME FROM) CLOSE ENCOUNTERS JOHN WILLIAMS (Arista 0300)

TOP NEW COUNTRY SINGLES

- 1 WOMAN TO WOMAN BARBARA MANDRELL (ABC 17736)
- 2 BARTENDER'S BLUES GEORGE JONES (Epic 8-50495)
- 3 RUNNING KIND MERLE HAGGARD (Capitol 4525)
- 4 IF I HAD A CHEATING HEART MEL STREET (Polydor PD 14448)
- 5 SHINE ON ME JOHN WESLEY RYLES (ABC 17733)
- 6 LONELY HEARTS CLUB BILLIE JO SPEARS (United Artists 1127)
- 7 MAMAS DON'T LET YOUR BABIES GROW UP TO BE COWBOYS WAYLON JENNINGS & WILLIE NELSON (RCA PB 11198)
- 8 YES MA'AM TOMMY OVERSTREET (ABC 17737)
- 9 ANGELINE MUNDO EARWOOD (True 111)
- 10 RED HOT MEMORY KENNY DALE (Capitol 4528)

TOP NEW R&B SINGLES

- 1 IT'S YOU THAT I NEED ENCHANTMENT (Roadshow/UA 19370)
- 2 AIN'T NOTHING WRONG RONNIE DYSON (Columbia 3-10667)
- 3 YOU'RE MY PIECE OF MIND DAVID RUFFIN (Motown 1435)
- 4 DOUBLE MY PLEASURE LEON HEYWOOD (MCA 40840)
- 5 STAY BY MY SIDE KIRKLAND & DAVIS (Clairidge 432)
- 6 NEW HORIZON THE SYLVERS (Capitol 4532)
- 7 L-O-V-E-U BRASS CONSTRUCTION (United Artists 19266)
- 8 INTIMATE FRIENDS EDDIE KENDRICKS (Tamla 54290)
- 9 WORKIN' TOGETHER MAZE/FRANKIE BEVERLY (Capitol 4531)
- 10 BABY, YOU GOT MY NOSE OPEN HAROLD MELVIN & THE BLUE NOTES (ABC 12327)

TOP NEW MOR SINGLES

- 1 EVERYBODY LOVES A RAIN SONG B.J. THOMAS (MCA 40854)
- 2 WALK RIGHT BACK ANNE MURRAY (Capitol 4527)
- 3 MAKIN' LOVE IS GOOD FOR YOU BROOK BENTON (Old World 1100)
- 4 UNTIL NOW BOBBY ARVON (First Artists 41000)
- 5 FEELS SO GOOD CHUCK MANGIONE (A&M 2001)

Electronic Flipper Update

by Bernie Powers
Bally Manufacturing Corporation

CHICAGO — The Bally electronic flippers have been out for over a year now and a few questions that recur are on interchangeability. The printed circuit boards of our games are almost totally interchangeable. The Lamp Driver Module (AS2518-14), Display Driver Module (AS2518-15), Solenoid, Driver/Voltage Regulator Module (AS2518-16), and Rectifier Board Assembly (AS2518-18) are completely interchangeable between games.

That means that you can use any of these boards in any of our electronic games: Freedom, Night Rider, Evel Knievel or Eight Ball.

The one board that does need modification to be interchangeable is the Micro Processor Module (AS2518-17). This module contains the personality chips that are for the particular playfield of the game. The particular 'Personality Chips' are inserted in plugs labeled on the MPU Board in positions labeled U1 through U6. These combinations are listed on the accompanying diagram. (See page 65.)

There are a few other combinations on Freedom and Night Rider. If a problem arises on Freedom with chips in sockets U3 through U6, remove them all and replace with one chip, E-720-13 in position U-6. On Night Rider, if you have an MPU which has an E-720-13 in position U-5, if a problem arises, do not replace it. Remove it and use E-720-20 in position U-6.

It should be noted that even though E-720-20 is a personality chip it has remained

constant in the last three games: Night Rider, Evel Knievel and Eight Ball.

The jumper requirements are wires between solder junctions labeled in the MPU board. Again you can see they remain fairly constant.

There has been only one significant electronic change to the electronic games and that was on the Solenoid Driver/Voltage Regulator Module. It has been discovered that a few of the +5VDC regulators used in the Solenoid Driver/Voltage Regulator Module may, under certain combinations of temperature, line voltage and load, go into oscillation. symptoms of this occurrence are:

- The game may appear to go dead and then come back on by itself.
- The game may go dead periodically and not come back on until the power switch is turned off and on.
- The game may refuse to power-up. The LED on the MPU Module will be on continuously.

The fix on this problem is to add a .1 microfarad ceramic disc capacitor, 25 VDC or greater, across the leads of C-24 (2 microfarad). This is recommended for all machines as it was put into production models of Eight Ball.

There were a few other modifications that took place on Eight Ball that will help eliminate problems on older games.

The first (see diagram 1) is a change of the flipper assemblies. The plunger and link assembly has been changed to A-3714-3 and a new spring, SP-200-212. This change should eliminate sticking flippers.

The second is a new thumper bumper

(continued on page 64)

\$ A JUKE BOX MUST \$

"Shake Me I Rattle"

LS GRT 148

b/w

"I Can't Tell You"

B/B
29



C/B
29

CRISTY LANE

Projected #1

HOT REQUEST & SALES

1978 State Association Calendar

Jan. 13-15: Music Operators of Minnesota; annual conv.; Holiday Inn Central; Minneapolis, MN.
 Jan. 20-21: Oregon Amusement & Music Operators Assn.; annual conv.; Embarcadero, Newport, OR.
 Feb. 3-5: South Carolina Coin Operators Assn.; annual mtg.; Carolina Inn; Columbia, SC.
 Mar. 31-Apr. 1: Music Operators of Michigan; annual conv.; Michigan Inn; Southfield, MI.
 Apr. 7-9: Florida Amusement Merchandising Assn.; annual conv.; Marriott Olym-

pic Villas; Orlando, FL.

April 21-23: Wisconsin Music Merchants Assn.; spring conv.; Abbey Resort; Fontana, WI.

May 19-21: New York Music & Amusement Assn.; annual conv.; Stevensville Country Club; Swan Lake, NY.

June 2-3: Ohio Music & Amusement Association; annual conv.; The Columbus Hilton Inn; Columbus, OH.

June 8-10: Music Operators of Texas; annual conv.; La Quinta Royale; Corpus Christi, TX.

Electronic Flipper Update

(continued on page 63)

skirt. The skirt has been changed to a stronger nylon material to prevent breakage. The new skirt is interchangeable and stocked under the same part number — C-790.

The last change is to prevent multiple component replacement. This is when a solenoid diode failure occurs. The diode is placed on the solenoid in a particular configuration to stop frequency spikes from returning to the transistor.

The diode not functioning properly will not prevent the frequency spikes from go-

ing on the return line to the solenoid transistor. The frequency spike can be as much as 250V, the buildup of voltage in the solenoid. These spikes, over a period of time, will then short out the solenoid transistor.

The transistor being shorted will then turn the momentary solenoid on continuously until it shorts out and causes an excess draw on the +43 VDC line which blows the fuse (F4). This, as you can see, causes the replacement of four components: transistor, solenoid, diode and fuse.

What we have done on Eight Ball is to place an "in line" fuse on the +43V line to catch a diode at initial failure. This fuse (see diagram 2) is a 1 Amp slow blow fuse on the bottom of the playfield.

It should be noted that I have found the quickest and easiest way to check a diode in line is with a power off test probe. Since the diode passes current in one direction only, and a battery operated continuity (power off) test probe cannot read through the resistance of a solenoid, you place it in one direction and you get a light. Reverse it and you do not get a light.

The other major question that comes up is on tools for troubleshooting the electronics. The only special tool required is a small module, called Aid 1. It is especially useful in determining continuity between modules under actual digital operating conditions.

Aid 1 is a small, plug in module that connects to the male connector (J5) on the MPU module. This is contained in Bally Kit #485, available at Bally distributors.

The other tool necessary is a volt/ohmmeter, Simpson model #260 (20,000 Ohm/VDC) or equivalent.

These tools, in conjunction with the test procedures F.O. 560 Module on Component Replacement Repair Procedures, are contained in every Bally game.

There are also repair spare parts kits available for Bally games. These kits should be treated as an initial stock item with the necessary parts to make component level replacements on any of the modules.

After an initial purchase, a stock level is maintained by replacing in the kit any components that are used for repairs.

The recommended kits are: Kit #490 Power Transformer Module Kit #492 Solenoid Driver/Voltage Regulator Module Kit #493 Display Driver Module Kit #494 Lamp Driver Module Kit #503 MPU Module The kit for the MPU Module (#503) does not include the personality chips which are in Positions U1 — U-6 as described above.

Empire Announces New Appointments

CHICAGO — Mac Brier has been appointed to the newly created post of director of customer services at Empire Distributing, Inc. Brier has 31 years experience in the coin machine industry and was formerly sales manager at National Coin. His early experience was on the distributor level and prior to joining National, he operated his own route in the Chicago area.

In line with Empire's current expansion of export activities, Ben Har-El, formerly on the Empire sales staff, was promoted to assistant export manager. In this post, he will be working closely with Empire's president Joe Robbins.

Gottlieb Names Finger

(continued from page 63)

background in engineering and field service adds another measure of strength and a new element to 'the Gottlieb System' for solid-state pinball games. It is without a doubt the finest in the world and we are delighted that Dick is aboard. We spent a long time looking for the right man."

Amazing Memory & Recall

MAKES

Bally® EIGHT 8 BALL

greatest pinball pool table in history



ELECTRONIC
4-PLAYER FLIPPER
 CONVERTIBLE TO ADD-A-BALL
Ask Your Distributor
 to
Demonstrate
Memory & Recall
 and
Solid or Striped Ball
Competition

Be Price Wise!
 1 PLAY
 1 QUARTER
 3-BALLS PLAY

See Distributor or write **Bally** 2640 Belmont Avenue, Chicago, Illinois

ASE 1587-101 Flipper Unit

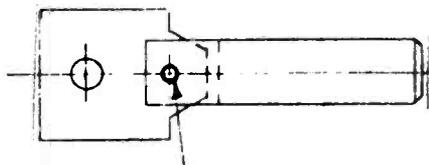

A-3714-3
PLUNGER & LINK ASSEM.

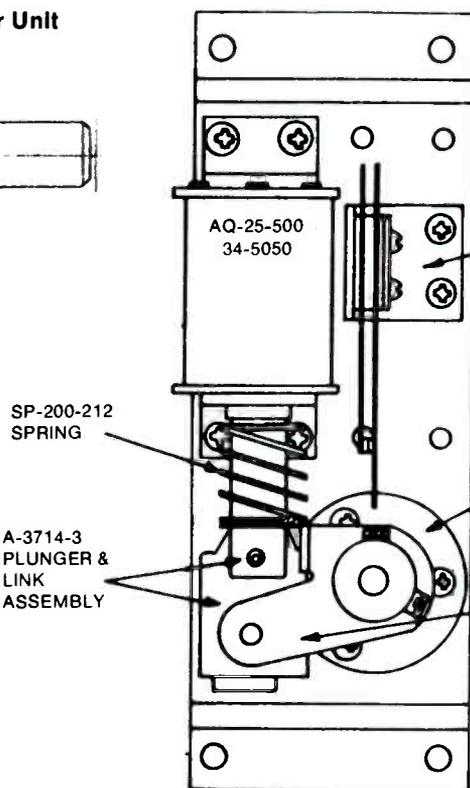

Diagram 1

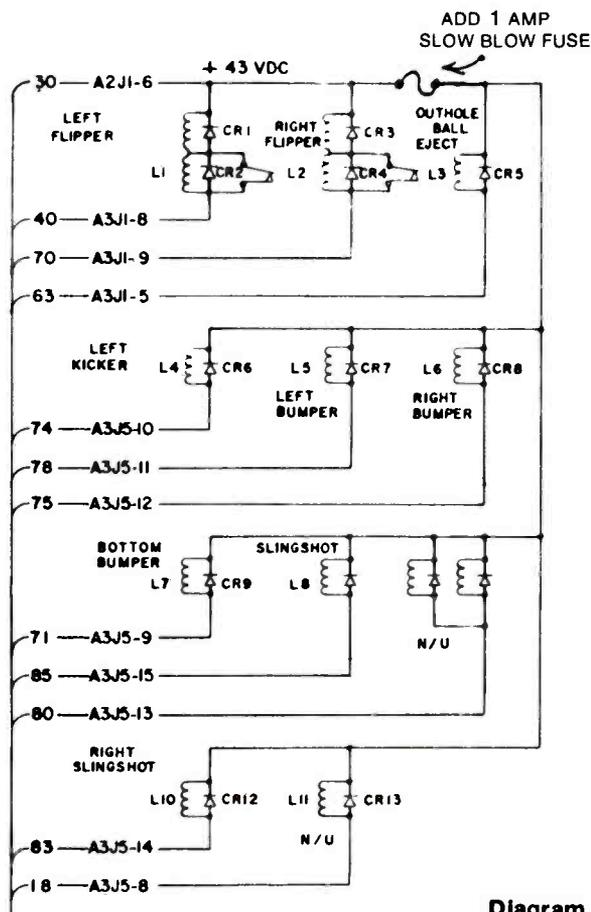

Diagram 2

SOCKET LOCATION						JUMPER REQUIREMENTS				
U1	U2	U3	U4	U5	U6	E1-E2	E3-E4	E6-E7	E8-E9	E-9-E10
FREEDOM										
E720-8	E720-10				E720-7	Yes	Yes	No	Yes	No
E720-8	E720-9				E720-7	Yes	Yes	No	Yes	No
E720-1	E720-2				E720-7	Yes	Yes	No	Yes	No
NIGHT RIDER										
E721-12	E721-13				E720-20	Yes	Yes	No	Yes	No
E721-10	E721-11				E720-20	Yes	Yes	No	Yes	No
E721-3	E721-7				E720-20	Yes	Yes	No	Yes	No
E721-5	E721-6				E720-20	Yes	Yes	No	Yes	No
E721-3	E721-4				E720-20	Yes	Yes	No	Yes	No
EVEL KNIEVEL										
	E722-17				E720-20	Yes	Yes	Yes	Yes	No
	E722-11				E720-20	Yes	Yes	Yes	Yes	No
E722-14	E722-15	E722-16			E720-20	Yes	Yes	No	No	Yes
EIGHT BALL										
E723-14	E723-15	E723-16			E720-20	Yes	Yes	No	No	Yes
	E723-17				E720-20	Yes	Yes	Yes	Either	Either
E723-18	E723-19	E723-16			E720-20	Yes	Yes	No	No	Yes
	E723-20				E720-20	Yes	Yes	Yes	Either	Either

CHICAGO CHATTER

As a special membership service, AMOA is supplying members with the necessary forms and applications for registering jukeboxes, in compliance with the new copyright law which went into effect at the first of the year. The national association is also requesting that state groups provide a similar service so that operators will receive as much assistance as possible in the first year of the law's implementation.

AMONG AREA COIN PEOPLE who were in Las Vegas for the Jan. 5-8 CES convention were Bally's **Ross Scheer**, **Tom Nleman** and **Bob Wiles** . . . **Steve Heckmyer** headed the Brunswick contingent.

DATELINE PHOENIX: home of Mirco Games, Inc. where sample shipments of the factory's new one on one "21" single player upright machine are currently in progress. Company president **John Walsh** said the new model contains all of the great features of Mirco's popular "Super 21" cocktail table and looks like it will be a very big seller. On the planning board out there are four additional new games which should be hitting the market within the next month or so. Walsh said that he and marketing director **Bernie Shapiro** are currently mapping out an itinerary for a cross country trip to visit the firm's network of distributors.

ON THE SUBJECT OF Midway's "Laguna Racer" and "M-4," the factory's director of sales **Larry Berke** notes that both machines have been maintaining outstanding earnings, in such locations as arcades, entertainment centers and the like. According to his reports, they've been far out-earning some of the industry's top machines. Midway's new "Clowns," by the way, is in the process of being sample shipped to distributors, following which full production schedules will be in order.

SEEBURG ENGINEER **Ed Urgitis** is conducting a series of music service schools for the Phil Moss organization. Classes began the week of Jan. 9 at the Kansas City and Wichita premises and concluded the following week with sessions in Des Moines and Omaha.

EASTERN FLASHES

Phonograph sales are on the rise at Betson Enterprises in No. Berghent, attributable to the fact, as the distrib's **Jerry Gordon** pointed out, that the new Rock-Ola line is being widely accepted. **Jerry** said he is extremely impressed with the new Atari "Airborne Avenger" solid-state pin and is most anxiously awaiting delivery of the new electronic "Stingray" by Stern. Ramtek's "M-79 Ambush" mini version was also mentioned as "outstanding" and, among the distrib's most consistent sellers are Atari's "Super Bug" and "Breakout" and Midway's "Laguna Racer" . . . Business is a little slow at Bilotta Dist-Newark but **Pat Bilotta's** not complaining, 'cuz it's the norm for him at this time of the year. Besides, in a month or so he'll be experiencing the big rush by ops who'll be doing their seasonal buying . . . **Sid Gordon** of See North Dis.-Albany was back in his office last week after traveling across the state. He said that See North is currently in the process of beefing up its service and parts departments. New parts staffer in the Albany branch is **Elaine**, who is doing a fine job. In the sales spotlight, as **Sid** mentioned, are the new Seeburg jukeboxes and the popular United "Nuggett" shuffle alley, with the latter a very much in demand item. Williams' "Hot Tip" electronic pin is on display and attracting a lot of attention. **Sid** sees a "changing trend," especially on the operator level, in the new year; with the operator, hopefully, getting a bigger share of the profit via an improved location arrangement . . . Exidy's "Circus" is a top seller at Robert Jones Int'l.-Dedham, according to **Bob LeBlanc**. Solid-state pinball machines are also doing very well and **Bob** noted that Ramtek's "M-79 Ambush" has been a "high income" piece for operators and a most outstanding seller for RJJ. A Bally school is currently on the planning board out there for late February.

STATE ASSOCIATION NEWS

The Illinois Coin Machine Operators Association is about to launch its third annual coin-operated pool tournament. Operator members have been signing up locations for the past several weeks and competition is expected to begin this month. As association prexy **Kem Thom** enthused, "Last year we had 76 locations participating; this year we're going for 100" . . . Would like to extend congratulations to ICMOA's **Walt Lowry**, who recently welcomed a strapping 8 lb. 12 oz. grandson . . . The Wisconsin Music Merchants Association has rescheduled its Spring meeting to April 14-16 at a new location, namely, the Playboy Resort and Country Club in Lake Geneva, Wis. AMOA president **Don Van Brackel** will be in attendance, to show the new slide presentation which was premiered at the national association's '77 exposition. Also invited is AMOA's executive veepee **Fred Granger** who will assist members with any questions regarding the new copyright legislation . . . The copyright bill, by the way, was also to be a prime topic at the Music Operators of Minnesota convention, which was in progress as we went to press last week. The state group sent out special flyers announcing that **Fred Granger** would preside over a special breakfast meeting, to explain the new law and provide information on dealing with the various forms and paperwork involved . . . WMMMA director **Elmer Schmitz, Jr.** and his wife, **Sherry**, announced the December arrival of 6 lb. 11 oz. **Shana Mary**. Congratulations . . . **Jim Farnsworth** of the So. Carolina Coin Operators Assn. items that the state group has a full agenda lined up for their Feb. 4-5 meeting and trade show in Columbia and a very entertaining banquet planned with country artist **Ray Griff** headlining.

CALIFORNIA CLIPPINGS

Pat Karns is the new vice president of marketing for Ramtek. Formerly associated with Sega, Fun and Atari, **Karns** will report directly to **Mel McEwan**, vice president and general manager of Ramtek. One of **Pat's** first duties will be to accompany **Mel** at the upcoming ATE show in London, where the firm will be showing its video product line as well as "Boom Ball," a large scale piece introduced recently for the amusement park market.

"CLEOPATRA," D. Gottlieb & Co.'s first solid-state pinball game, is in big demand at Portale Automatic Sales in Los Angeles. As the distrib's executive vice president **Tom Portale** noted, "We've got a substantial number of advance orders" — and that's before the shipments have arrived at the showroom. **Tom** also said business has been brisk since the first of the year and predicted that 1978 will be "a fantastic year for phonographs," led by Rock-Ola's new model 474.

CLASSIFIEDS

CLASSIFIED AD RATE 25 CENTS PER WORD

Count every word including all words in firm name. Numbers in address count as one word. Minimum ad accepted \$6.25. CASH OR CHECK MUST ACCOMPANY ALL ORDERS FOR CLASSIFIED ADVERTISING. If cash or check is NOT enclosed with order your classified ad will be held for following issue pending receipt of your check or cash. NOTICE — \$148 Classified Advertisers (Outside USA add \$75 to your present subscription price). You are entitled to a classified ad of 40 words in each week's issue for a period of one full year. 52 consecutive weeks. You are allowed to change your Classified each week if you so desire. All words over 40 will be billed at the rate of 25c per word. Please count words carefully. Be sure your Classified Ad is sent to reach Hollywood publication office by Wednesday, 12 noon, of preceding week to appear in the following week's issue.

Classified Ads Close WEDNESDAY

Send all copy to: CASH BOX, 6363 Sunset Blvd., Hollywood, CA 90028

COIN MACHINES WANTED

WANT Seeburg AY 160, DS 160, LPC-1, LPC-480, Electra Fleetwood, SS 160, LS-1, LS-2. We pay cash and pick up our truck unpacked. UNITED STATES AMUSEMENTS, 2 W. Northfield Road, Livingston, N.J. 07039. (201) 992-7813.

WE ARE ALWAYS INTERESTED in new and used pinballs, billiard tables, bingos, guns, arcade, kiddie rides, all makes, all models. Quote F.O.B. to: SUN MONG CO. LTD., Sun Mong House, 1st Floor, 50-56 Mongkok Road, Kowloon, Hong Kong.

WANTED: Cash paid for late model used pins. Premium paid for Wizards, Fireballs, Four Million B.C., Champ, Nip It, Wurlitzer 1050's and 1015's (any jukebox antiques). Call collect 1-313-u92-2131.

WANT TO BUY: Auto Phono Model 11, 12, 14 & 17, reconditioned. UNITED STATES AMUSEMENTS, 2 W. Northfield Road, Livingston, N.J. 07039. (201) 992-7813

WANTED: Will pay cash for old slot machines, pinballs and jukeboxes, pre WW II, working or not. Mail description to Si Redd, Box 6418, Reno, NV 89513.

COIN MACHINES FOR SALE

CONVERSION CARTRIDGES — Play stereo records on Seeburg monaural phonos B thru 201. No adjustments required — just plug in — eliminate sound distortion, needle skipping, excessive record wear. \$24.95 postpaid. Satisfaction guaranteed. Quantity discounts. C.A. THORP SERVI, 1520 Missouri, Oceanside, Ca. 92054.

FOR SALE: Keeney Red Arrow, Keeney Twin Dragon, Bally Deluxe Gold Cup, Bally Super Jumbo (export only). UNITED STATES AMUSEMENTS, 2 W. Northfield Road, Livingston, N.J. 07039. (201) 992-7813.

JUST OUT!: Bally "Fireball" home professional pinball game, 4-player (no coin required), solid state electronics, easy diagnostic test circuits, LED digital scoring, plays seven songs. \$800 brand new — sealed carton. Request circular. ANIMATED PROD., INC., 1600 Broadway, New York 10019. (212) 265-2942.

ATTENTION metropolitan & upstate New Yorkers: We have a large selection of new & used add-a-balls and arcade equipment. Also jukeboxes, pool tables, shuffles, cigarette & candy. We deliver & accept trades. COIN MACHINE DISTRIBUTORS, INC., 213 N. Division St., Peekskill, N.Y. 10566. Call (914) 737-5050.

NATIONAL WHITENBURG MODEL 400 FOOD VENDER 1 National 21CE candy machine — Vendo Visi-Vend Rowe cigarette machines 20 700 \$175 or 7 for \$1000 — Rowe 20 800 \$295, crating extra. Arcade equipment. Motor Cycle, Funland, Pennant, Sami, Sea Raider and Dune Buggy, pool tables, pinballs and many other items. VATHIS VENDORS, Call (214) 792-2806, 793-3723 or 792-1810.

SALES: 400 assorted Gottlieb, Bally, Williams flippers, 70-76, Bingos, Bally, Stockmarket, Tickertape, Wallstreet, Mysticgate. UNITED STATES AMUSEMENTS, 2 W. Northfield Road, Livingston, N.J. 07039. (201) 992-7813.

FOR SALE: We have in stock a great quantity of 5-year-old pinball machines Gottlieb. Write to: SOVODA 51 Rue de Longvic, 21300 Chenove, France telex 350018.

FOR SALE: Silver Sails, Red Arrows, Ticker Tapes, Blue Chips and stock markets. Also Sweet Shawness, Bally Jumbos and Super Jumbos, Big Threes, Blue Spots and Mt. Climbers, Antique slots for California area. Call WASSICK NOVELTY, Morgantown, W. Va. (304) 292-3791.

IMMEDIATE DELIVERY — Hollycrane motors, Bally Bingo Control Motors, Bally O.K. Games, Lido, Roller Derby, Circus Queens, Bikini, New Sweet Shawnee, New Twin Knight Used Uprights, New Big Three blackglasses. LOWELL ASSOCIATES, P.O. Box 386, Glen Burnie, Md. 21061 (301) 768-3400.

BUY a spare Trapshoot transmitter. \$39.95 each, or buy two and we'll send one receiver unit free. Call Dave, HANSON DISTRIBUTING CO., (612) 884-6604.

FOR SALE: Rock-Ola 504 wallbox \$100; Rock-Ola Receivers, 1725-B-2, 1765, 1721, 1769 \$65 each. WESTERN DISTRIBUTORS, 1226 SW 16th Avenue, Portland, Ore. 228-7565

FOR SALE: Travel Time, Satin Doll, Wild Life, Flying Carpet, Super Star, Playball, Sky Jump, 2001 Mibs, Super Shifters, Tankers, Ramtek Baseball, TV Ping Pongs, World Series, Batting Champ, Sega Sea Devil, U Boat, Drag Races, Flying Carpet, Gun, Speedway, SAMI, Invaders, Winners, Paddle Battle, Pong, Computer Quiz, Brunswick Air Hockeys, Wurlitzer 3110, Seeburg DS 160 and Model R, D&L DISTR. INC., Box 6007, Harrisburg, Pa. 17112. Phone (717) 545-4264.

SEEBURG LPC 150, AMI 200, N 150. Johnson coin sorter & counter 295, Tennis Tourney 200, Electro Dart 100, BROWSER, 2009 Mott Ave., Far Rockaway, N.Y.

FOR SALE: Jacks Open \$595, Big Hit \$650, Volley \$550, Solar City \$625, Target Alpha \$670, Spirit of '76 \$695, Top Score \$525, Night Rider \$925, Kick Off \$775, Evel Knievel (E.M. model) \$965, Evel Knievel (S.S. model) \$1260, Alladins Castle \$750, Bow And Arrow \$735, Space Mission \$865, Wild Card \$675, Valencia \$650, Shoot Out \$375, World Series Baseball \$425, Speakeasy \$825, Thunderbolt (S.S. model) \$775, Tornado Baseball \$795, Wheels \$775, Top Gun \$750, Air Attack (as is \$275, Gun Fight \$225, Atarians \$1050, Outlaw \$445 Jet Fighter \$695, LeMans \$1150, Drag Race \$1375, Breakout \$995, Pool Shark \$1145, Old Time Basketball \$695, Bazooka \$825, Meadows Lanes \$975, Dynamo Football (used) \$275, Dynamo Model E (new) \$475, Penny Bowl \$650, New World \$475, Death Race \$1065, Lazer Command \$625, Cranes, Iron Claws and Pushers (write), Quarterback \$765. NEW ORLEANS NOVELTY CO., 1055 Dryades St., New Orleans, La. 70113. Tel: (504) 529-7321.

RECORD BINS FOR SALE: 4 LP wide step-ups \$80 each; 5 LP wide step-ups \$100 each; extra large browser bins \$125 each. Contact: Jack Baker (213) 240-6290.

FLIPPERS: At all times more than 400 late model Gottlieb, Bally, Williams, Chicago, Spanish mfr. available, immediate delivery call for lists. UNITED STATES AMUSEMENTS, 2 W. Northfield Road, Livingston, N.J. 07039. (201) 992-7813.

ALL TYPES OF COIN-OPERATED EQUIPMENT. Flippers, shuffle alleys, guns, TV games, Williams, Gottlieb, ChiCoin, Ramtek, Allied, Natting Phonographs (large selection) Wurlitzer, Seeburg, AMI, Rock-Ola, Rock-Ola vending, Cigarettes, candy, cold drink, National Smoke-shop, Rock-Ola. All kinds shipped to perfection or by air as-is and save. We have the right price and equipment on hand to serve your needs. Write or call: FLOWER CITY DISTRIBUTORS, INC., 389 Webster Ave., Rochester, N.Y.

WURLITZER Model 1100, Rockola model 2, Seeburg models B and C, Motoscope Candy Shoppe Grabber, Western Sweepstakes — Make offer. BRENON'S COIN MACHINES, INC., P.O. Box 117, Brownville, NY 13615.

FOR SALE: Completely reconditioned: Bally — 1 Amigo (4 pl) \$595, 1 Ro-go (4 pl) \$595, 1 Knockout (2 pl) \$695, 1 Flicker (2 pl) \$595, 1 Capt. Fantastic (4 pl) \$895, 1 Champ (4 pl) \$495, 2 Air Aces (4 pl) \$695, 1 Boomerang (4 pl) \$645, 1 Sky King (1 pl) \$395; Gottlieb — "300" (4 pl) \$795; Williams — Pat Hand (4 pl) \$795. MICKEY ANDERSON, INC., P.O. Box 6369, Erie, Pa. 16512. Phone (814) 452-3207.

Electronic Test Equipment: Books & Home Study Courses. Immediate delivery on B&K oscilloscopes, digital multimeters, transistor checkers & power supplies.

INST. Instruments bugbooks & training aids for home study including the Digi-Designer, the Innovator Series & MMD-1 microprocessor system. Call for free catalog & prices. BankAmericard & Master Charge accepted. CENTRAL DISTRIBUTORS, INC., 2315 Olive St., St. Louis, Mo. 63103. Call toll free in U.S.A. 1-800-325-8997 (in Missouri) call 1-800-392-7747.

FOR SALE: Bally's Bingo "Bally Balli," new 10 units and used 9 units, prices negotiable. OVERSEAS LIAISON & TRADING, LTD., 1-20, Tsukiji 4-chome, Chuo-ku, Tokyo 104, Japan. Telex: J25362.

SALE: 1,000 Bally super continental slot machines. Excellent condition, \$1,250 each. F.O.B. Antwerp, Belgium. Machines subject to inspection. UNITED STATES AMUSEMENTS, 2 W. Northfield Road, Livingston, N.J. 07039. (201) 992-7813.

FOR SALE: Stunt Cycles, LeMans, Tornado Baseballs, Checkmate, Sega Road Race, Winners, Zodiacs, Gottlieb & WMS pingames, Seeburg Electras, LS-1, SS-160, Wurlitzers 3510, D & L DISTRIBUTING CO., INC., Box 6007, Harrisburg, Pa. 17112. (717) 545-6264.

FOR SALE: 50 Seeburg 160 selection wall boxes \$25 each; 20,000 used 45 rpm records 1000 or less 10c each, over 1000, 9c each. Walling 200 scale \$200; Rock-Ola Lowboy \$60. One-third down balance C.O.D. CENTRAL MUSIC CO., Box 284, Killeen, Texas 76541.

BINGOS FOR EXPORT ONLY. Available 25 Big Wheels. Write for special price. Also OK games and Ticker Tapes Late pinballs and Arcade equipment. D&P MUSIC CO., 1237 Mt. Rose Ave., York, Penn. 17403. P.O. Box 243. (717) 848-1846.

EMPLOYMENT SERVICE

HELP WANTED: Listening Booth record and hi-fi stores. We are a multi-unit retail chain, looking for individuals with a record of achievement in retail management and sales. You must be able to direct people, have experience in merchandising and be a well organized person. We have management positions open in Penn., New Jersey and other eastern states. We offer excellent salaries, company benefits and tremendous growth potential. Qualified applicants send detailed resume to: Steve Bell, Shulman Record Co., Inc. 7030 Colonial Hwy., Pennsauken, N.J. 08109.

SCHOOL FOR GAMES AND MUSIC, two and three week courses. Phonos, Flippers and Bingos. By schematics! CAL'S COIN COLLEGE, P.O. Box 810, Nicoma Park, Okla. 73066. (405) 769-5343.

YOUNG WRITER-PRODUCER with sources for artists and material desires association with a progressive record company needing same and prepared to make offers. Write C.K. Aspinwall of 652 Azalea Drive in La Grange, Ga. 30240.

JO-BAR MUSIC PUBLISHING CORPORATION and BAR-JO Records, Inc. needs investors and stockholders to re-open music business. Write BAR-JO at 83-45 Viotor Ave., Suite 2B, Elmhurst, NY 11373 or call (212) 898-1628 or 243-5668.

BMI SONGWRITER-COMPOSER who has written for Tavares, Righteous Bros., Grass Roots and others now auditioning soulful keyboard players for composing-collaborati. Also have contemporary soul and disco catalog for A&R men and producers. Willie H. Wilson (213) 299-6649.

WANTED: Route mechanic, three to five year's experience in music-games-cigarette machines, with forty-year-old company. Salary open. Send resume to: FLORIDA MUSIC COMPANY, 418 Park Place, West Palm Beach, Fla. 33401.

SERVICE SCHOOL FOR GAMES AND MUSIC. Ten-week night course teaches practical theory, schematics. \$575 full price. COMMIT, 2115 Beverly Blvd., Los Angeles, Ca. 90057. (213) 483-0300.

FORMER RADIO ANNOUNCER, A&R dir., R&B promotional manager and record producer would like to be picked up by a record company, or would like to have a R&B record label distribution deal. Call Mr. Cee: (215) 365-8573.

LEGAL

IF YOU NEED A LAWYER call L. ROB WERNER, Attorney (213) 469-7047, 462-7227, UCB Building, 6255 Sunset Blvd., 20th Floor, Hollywood, Calif. 90028. — Personal service for your legal needs. — Special arrangements made to meet the demanding needs of the industry.

HUMOR

DEEJAYS! Here's top drawer comedy for you! 11,000 one-line gags for radio; only \$10! Unconditionally guaranteed! Catalog of one-liners, funny stories, put-downs, trivia, breaks, and lots more, free on request. Edmund Orrin, 41171-C Grove Place, Madera, Calif. 93637.

DEEJAYS! Top comedy writers offering total humor service. Monthly gag letters, monologues, deejay specials and more. PLUS — individual CUSTOM GAGS just for you! Satisfied clients around the world agree it's the best. FREE information. PETER PATTER, P.O. Box 402-C, Pinedale, CA 93650.

SERVICES COIN MACHINE

ACE LOCKS KEYED ALIKE: Send locks and the key you want them mastered to: \$1.25 each, 10% D/C in lots of 100 or more. RANDOL LOCK SERVICE, 61 Rockaway Ave., Valley Stream, N.Y. 11580, (516) 825-6216. Our 38th year in vending.

CLASSIFIED POWER!

Got machines to sell? Is there something you're looking to buy? Maybe you'd like to move some used 45's or need a route mechanic? See ad rates above.

Classified Ads Close WEDNESDAY

Send all copy to: CASH BOX, 6363 Sunset Blvd., Hollywood, CA 90028

Make sure your check is enclosed

RECORDS-MUSIC

HOUSE OF OLDIES — We are the world headquarters for out of print LPs and 45s. Also, the largest selections of old rock 'n' roll and rhythm and blues albums. Our famous 3 in 1 catalog. \$1.25. HOUSE OF OLDIES, 267 Bleeker St., N.Y., N.Y. 10014. (212) 243-0500.

442 OLDIES ON TAPE — available to radio stations. Chart hits from 1955 to 1977 in stereo or mono. For a complete listing and full information write: THE MUSIC DIRECTOR PROGRAMMING SERVICE, Box 103, Indian Orchard, Mass. 01151. (413) 783-4626.

CHICAGO based record company with worldwide distribution seeking 45 and LP masters for release, all demos submitted must be original and copyrighted, publishing available. Include full resume of group or artist; seeking rock, R&B, jazz, country, gospel. Once in a lifetime opportunity. Offer expires without notice. LE BRU RECORDS AND TAPES, 7311 North Lowell, Lincolnwood, Ill. 60466.

ALREADY OPEN & ACTIVE New Wave rock club looking for investor(s) for expansion. Lots of possibilities. Dawn: (213) 472-9389.

LEADING TAPE AND RECORD DISTRIBUTORS OF all labels. Will sell current & cut-out merchandise at lowest prices. Member of NARM. Send for free catalogues. CANDY STRIPE RECORDS, INC., 371 South Main Street, Freeport, New York 11520. (516) 379-5151. (212) 895-3930. Telex 126851 Canstripe Free.

RECORD/MUSIC POSITION wanted by young single male. B.A. (Economics), J.D., in management, promotion or production. Creative, highly motivated. Resume: CHRIS JOHNSON, 7220 Hollywood Bl. #234, Los Angeles 90046.

WANT: 45s/ALL TYPES 1955-1976 (Pop, R&B, C&W, MOR). Will deliver cash if you got enough of what we want. Call Martin Cerf/Phonograph Record Magazine, P.O. Box 2404, Hollywood, CA 90028.

INTERNATIONAL RADIO STATIONS, MUSIC PUBLISHERS, discotheques and fanclubs subscribe to our Automatic Airmail Service for all singles and LPs from the charts. The fastest and most dependable service in the world. AIRDISC SPECIAL SERVICES, Box 835, Amityville, New York 11701.

WANT RECORDS & TAPES, 45s AND LPs, surplus returns, overstock cut-outs, etc. Call or write Harry Warner at KNICKERBOCKER MUSIC CO., 101 Gedney St., Nyack, N.Y. 10969 (914) 358-5086.

FREE CATALOG — COMPLETE ONE STOP: Specializing in oldies-but-goodies. Wholesale only. PARAMOUNT RECORDS, INC., 1 Colonial Gate, Plainville, L.I., N.Y. 11803.

KING OF MUSIC RECORDS is looking for masters. Send copies to KING OF MUSIC RECORDS, 806-16th Avenue South, Suite 217, Nashville Tenn. 37203, or call (615) 242-2023.

FOR SALE: 5,000 jukebox 45s, 100 different \$8.50; foreign \$13. Choose Rock, Disco, Polka, Country, AL's 2249 Cottage Grove, Cleveland Heights, Ohio 44118.

OPERATORS — We buy used records not over 1 year old — 10c each plus postage. JOHN M. AYLESWORTH & CO., 9701 Central Ave., Garden Grove, Calif. 92644 (714) 537-5939.

RARE RECORD SHOPS AND FINDER. List of 31 United States shops. Up to date list personally compiled \$2. MACLEAN'S, 312 Belanger St., Houma, La. 70360.

FOR EXPORT: All labels of phonograph records, cartridges, cassettes. Also excellently priced selections of close-outs. Nearly 30 years of personalized service to importers world over. Wholesale only. DARO EXPORTS, LTD., 1468 Coney Island Avenue, Brooklyn, N.Y. 11230. Cable: EXPDARO, NEW YORK.

Impact Of Album Covers On Sales/Consumer Explored

(continued from page 55)

more black artists/art directors who are aware of what our social priorities are. Additionally we need to make the black artists more responsive to the needs of their people because they should have some control over what goes on those albums and they should be sensitive to that.

For Instance

"Some time last year the record company wanted Bill Withers to take a picture for his album cover ("Naked And Warm") with his shirt off and naked to the belly button and he refused and he brought this to Jessie's (Rev. Jackson) attention and they dealt with it straight ahead when he confronted the company. As it turns out Bill is fully clothed on the album because he said no, that's not my thing, that's not what my people want to see and the album has done very well too. So it's how the artist projects him/herself."

Cherry contends that an artist, "If he is any type of artist, doesn't have to get over like that. We, as black people, have to set our own values and not be led to think that. Stevie Wonder doesn't get over like that."

Other statements on the issue came from spokesmen for some area record stores and from record company personnel. One manager of marketing stated that she "would like to see record companies reflect a more mature attitude in marketing their product." The consensus on the part of the record companies seemed to be that either the artist decides alone or in conjunction with other people (manager/art director/producer) as to what will go on the cover. The former, according to one executive, occurs in one out of every four cases.

Policies

"Our policy," said Bob Merlis, director of publicity at Warner Brothers, "is basically never to, if we can help it, have an album cover that will inhibit the potential exposure of an album. We routinely try to steer artists in the direction of an album cover that will be more economically viable for the artist."

Merlis also pointed out that he feels a hit single has a greater impact on whether or not an album is purchased and that the back cover/liner notes also influence sales. He also said that it is not in the company's

economic interest to have covers that "will run into trouble" and that they are hurt when an album is the center of controversy because high volume locations are usually the first to react to this. Merlis affirms that this was made clear in the wake of the initial controversy months ago, but "apparently, they didn't believe us."

"I told them," he stated, "that I thought the way to effect some kind of change in the industry is not to have album cover submitted to a censor board, but that they should raise the consciousness of the recording artists who ultimately control what their album covers look like. They rejected this. It is a narrow view based on incomplete knowledge on how the record business works. Ultimately it's not a record business issue, it's a societal, cultural issue."

"We are trying to be responsible to the people who depend on us to make a profit," Merlis concluded. "We want to have records that we can merchandise, market and sell with no problems. That's our bottom line and it happens to coincide with having album covers that do not upset people. There are situations where we do not have control and there are also situations that are subject to wide interpretation and we're not about to let the graphics of our album covers or advertising or for that matter the contents of our records be scrutinized by anyone outside."

One record store employee, who is a photographer and has worked for record companies, told CB that "unless an artist specifically wants otherwise, he is contacted by the art director for photo sessions which are handled exclusively by the art director." He added that it's usually the case that the status of an artist has a bearing on who decides what. The employee agreed that there are some "very suggestive" covers (even extending an invitation for a tour of the store as evidence) and that the "suggestion is not always sexual, but it is there."

Another employee suggested that certain female artists exploit themselves to a certain extent. He said that the albums didn't bother him at all and that they were just a "reflection of the times, a change in what is accepted by people." In his opinion, "It's the music that counts."

Reproduction Of Album Cover Art Complicated By Various Factors

(continued from page 8)

and the recording artists on a given album may have contractual rights over reproduction.

Cover By Cover

Dennis Saleh experienced firsthand the difficulty in determining who controls the copyright to cover art while seeking permissions to reproduce covers in his book. "It's a cover by cover decision," says Saleh. "The record companies are so jealous of their rights, when someone comes along with a commercial venture everyone begins to think in terms of who's going to get what for what. In general the record companies were very hospitable, but not all."

"Free advertising is fine with them," comments John Kosh, a cover design artist who has worked with the Beatles, Rolling Stones, Linda Ronstadt and the Eagles among others. "But when people are actually making money off these spin-offs it becomes a very touchy area. Graphic artists find their work on billboards, posters and mirrors and they ask themselves, 'What's going on?'"

"The standard now is for the album and promotional use, advertisements and in-store displays. Things like posters and belt-buckles and billboards are extra because otherwise they take you for a ride and you find the most amazing stuff being sold all over the place. You did the artwork three years ago and now they're charging \$25 for it. So we're just very careful with our wording on the invoices now."

Merchandising Rights

"Even if we own the copyright," points out a record company attorney, "usually the contract will say that the artist is doing his work for the purpose of using it on the album cover and for the sale of records — because he doesn't want to get ripped off. It will provide that if we use it for other types of uses we have to work out some kind of negotiated settlement with the artist. Our contracts usually do not provide for the grant of merchandising rights to us."

"On the secondary uses — posters and belt-buckles and stuff — a token will be enough to know that we're appreciated," suggests Kosh. "It shouldn't be allowed to turn into a giant industry where tens of thousands of dollars change hands because someone has decided to put out a belt-buckle. But it is nice to pay the guy who originally came up with the idea."

Many cover artists, especially those without extensive track records, feel they are at a disadvantage when negotiating with a giant record company.

"The record company would like you to give up all rights for a tiny sum of money so they can reproduce your work anywhere they want, forever and ever, so they can get the widest possible exposure," explains Roger Ressmeyer, a cover artist for the Jefferson Starship and Hot Tuna. "It's the kind of thing where the artist is the little man and there's a lot of pressure on him to give

everything up for very little money."

Ressmeyer says record jacket photography is really advertising photography and should be compensated as such.

The copyright control question is further complicated by the rights of recording artists. Some major artists have contractual agreements giving them a say in decisions concerning the use of cover designs from their albums. In addition, if the musician's likeness is used on the cover he may have legal recourse if the cover is reproduced without his consent.

For example, Saleh wanted to use the Eagles' "Hotel California" and Boz Scaggs' "Slow Dancer" covers in his "Rock Art" book. The labels had given their tentative approvals, but the artists' representative, Front Line Management, vetoed the reproduction.

Howard Kaufman, a partner in Front Line, expressed a firm conviction that the musicians and their representatives have the right to prevent unauthorized reproductions.

"I think it's great that the recording artist has the right to decide if graphic work on his album can be reproduced," stated Kaufman. "They're the ones who make the picture famous. If they put it out on someone else's album no one might ever see it."

"Front Line doesn't own the copyright, but they manage the Eagles and Scaggs which gives them quite a bit of power," notes Saleh. "After hearing from Front Line, the labels told us in no uncertain terms that we could not reproduce the covers in question."

Kosh was the artist for the "Hotel California" cover. He says the cover was being reproduced all over the place until Front Line put a stop to it.

"I was upset at one point because I thought it was one of my best pieces of work being stopped," reveals Kosh. "But then it dawned on me that once the floodgates were open anyone could reproduce the bloody thing. All that work — shivering atop a 100-foot crane trying to take those pictures — for nothing."

Likeness Is Property

"The personal likeness of a rock musician can itself be a property," adds Saleh. "We have the cover from the 'Performance' album that came from the movie with Mick Jagger. In that case I formally applied to Jagger to allow us to use it — and he gave us his personal signature."

It took Saleh almost two years to collect permissions from all the involved parties to reproduce 52 LP covers. Only five of the covers originally selected for the book could not be used due to lack of authorization.

"Considering the complexities of some of these contractual agreements and understandings and vested interests," concludes Saleh, "I think 47 out of 52 is a pretty good batting average."

'Saturday Night Fever,' 'Player' Give RSO Fast Start In 1978

(continued from page 7)

The "Saturday Night Fever" album — featuring the Bee Gees, Tavares, Yvonne Elliman, KC & The Sunshine Band, Kool & The Gang, The Trammps, M.F.S.B., Walter Murphy, Ralph McDonald and David Shire — is already double platinum and nearing three million units in sales. It's bulleted number one pop and number five R&B on the latest **Cash Box** album charts. The movie, starring John Travolta, opened in mid-December and is a box-office smash nationwide.

Four singles were released off the album in the last quarter of 1977, starting with "How Deep Is Your Love," which has already sold well in excess of one million copies. "Stayin' Alive," another Bee Gees song, is currently the fastest rising single in the country, standing at 14 bullet on the pop chart and 66 bullet on the R&B chart. Tavares' "More Than A Woman" is number 33 on the R&B singles chart. Yvonne Elliman's "If I Can't Have You" is the fourth single off the soundtrack LP and RSO officials have high hopes for that one, too.

Two other number one hits by the Bee Gees, "You Should Be Dancing" and "Jive Talkin'," are on "Saturday Night Fever," but they were first released on earlier LPs. Retailers around the country report the

whole Bee Gees' catalog is selling well as a result of the "Saturday Night Fever" boom.

Player's "Baby, Come Back" is enjoying its second week atop the **Cash Box** Top 100 Singles chart, and is 20 with a bullet on the R&B chart. Their self-titled debut LP is nearing the gold sales plateau and is bulleted on both the pop and R&B album charts.

Player will soon go on tour with another RSO recording star, Eric Clapton. Clapton also has an album climbing the pop charts for RSO, "Slowhand," currently 20 with a bullet. His "Lay Down Sally" is bulleted at 61 on the singles chart.

Rounding out the RSO list of current hits is Andy Gibb's "(Love Is) Thicker Than Water," now number 18 with a bullet. A spokesman for RSO said the song is "a few weeks away from being gold."

Demand To Release Mirror 'Elvis' Single

HOLLYWOOD, FLORIDA — Demand Records has signed a contract with European singer, Danny Mirror, for the immediate release of his single, "I Remember Elvis." The single will be distributed by Request Records which manufactures and distributes Demand product.

REFLECTIONS 'N BLACK

"Street Player," the new album for **Rufus And Chaka Kahn** on ABC Records, will be released shortly. **Tony Maiden** provides some ear catching lead vocals on the title tune, while he and Chaka go duo on "Blue Love." Chaka, incidentally, will be recording on her own for Warner Brothers and something new is expected from her in the not too distant future. She will, however, continue to record and tour with the group.

Atlantic recording artists, **The Spinners**, will return to Los Angeles for a limited three-day engagement February 3-5 at the Pantages Theatre. **Ronnie Dyson** will also be performing on the show.

Kellee Patterson will entertain at Southern University in Baton Rouge, Louisiana next week at a dinner honoring NFL Player of the Year, **Walter Payton**. She will also be involved in the judging of the school's annual beauty pageant. **Fred Williamson**, **Archie Griffin**, **Isiah Robertson**, and **Vida Blue** will also participate.

Al Green will be appearing at the Mark Hellinger Theatre in New York on January 24-28 and at the Dorothy Chandler Pavilion in Los Angeles, February 13. He celebrated the sixth anniversary of his first million selling album, "Let's Stay Together," on January 15.

Spring recording artist, **Millie Jackson**, is set to tour the U.K. where she will perform at three venues in England, January 26-29. "All The Way Lover" is the single recently released from her latest LP, "Feelin' Bitchy."

carita spencer

**He's Still One Of The Sylvers
But In This Album He Sings His Favorite Songs**

Solo.

**F
O
S
T
E
R**

**S
Y
L
V
E
R
S**

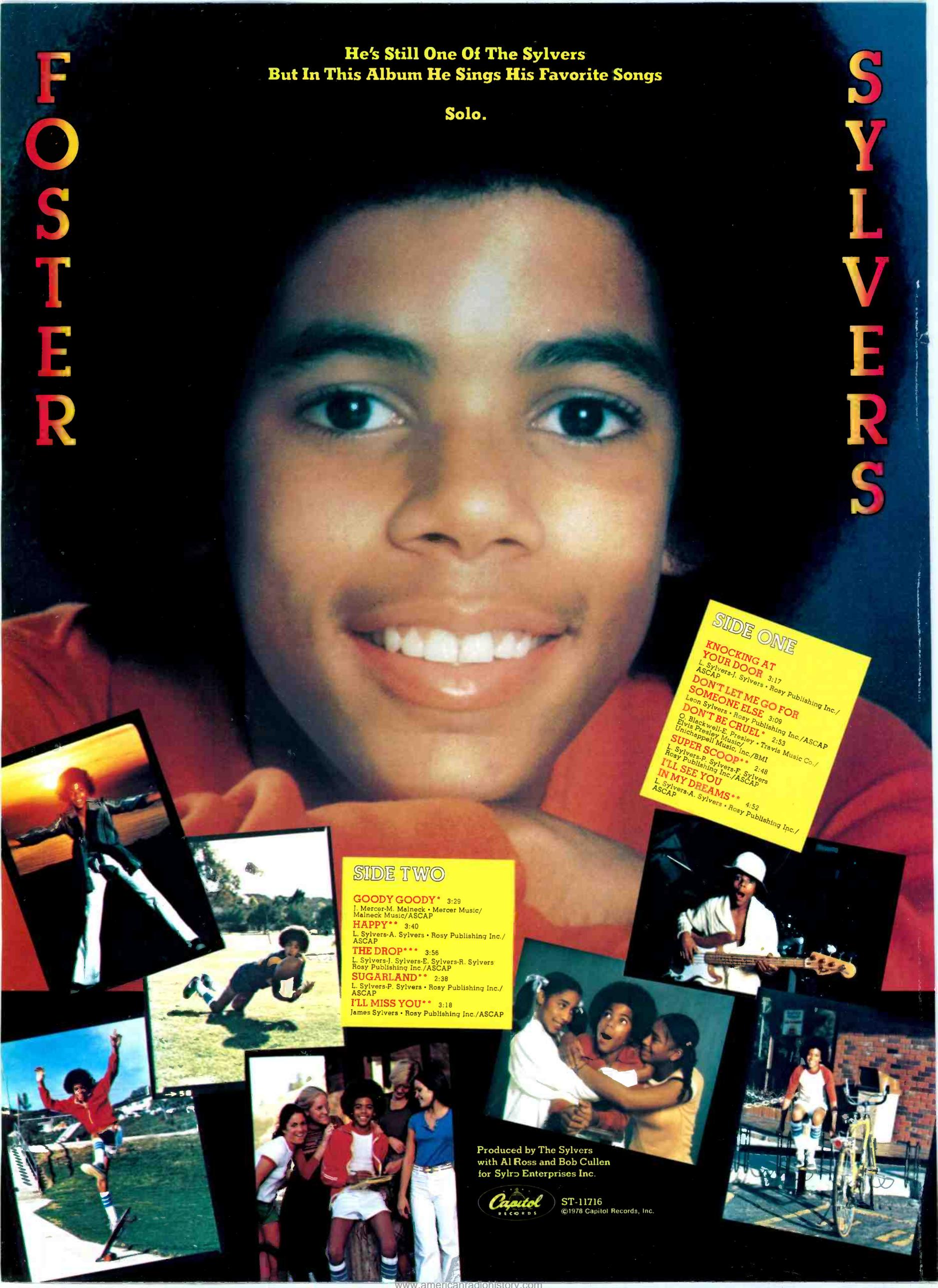

SIDE ONE

KNOCKING AT YOUR DOOR 3:17
L. Sylvers-J. Sylvers • Rosy Publishing Inc./ASCAP

DON'T LET ME GO FOR SOMEONE ELSE 3:09
Leon Sylvers • Rosy Publishing Inc./ASCAP

DON'T BE CRUEL* 2:53
C. Blackwell-E. Presley • Travis Music Co./Elvis Presley Music/Unichappell Music, Inc./BMI

SUPER SCOOP** 2:48
L. Sylvers-P. Sylvers-F. Sylvers • Rosy Publishing Inc./ASCAP

I'LL SEE YOU IN MY DREAMS** 4:52
L. Sylvers-A. Sylvers • Rosy Publishing Inc./ASCAP

SIDE TWO

GOODY GOODY* 3:29
J. Mercer-M. Malneck • Mercer Music/Malneck Music/ASCAP

HAPPY** 3:40
L. Sylvers-A. Sylvers • Rosy Publishing Inc./ASCAP

THE DROP*** 3:56
L. Sylvers-J. Sylvers-E. Sylvers-R. Sylvers • Rosy Publishing Inc./ASCAP

SUGARLAND** 2:38
L. Sylvers-P. Sylvers • Rosy Publishing Inc./ASCAP

I'LL MISS YOU** 3:18
James Sylvers • Rosy Publishing Inc./ASCAP

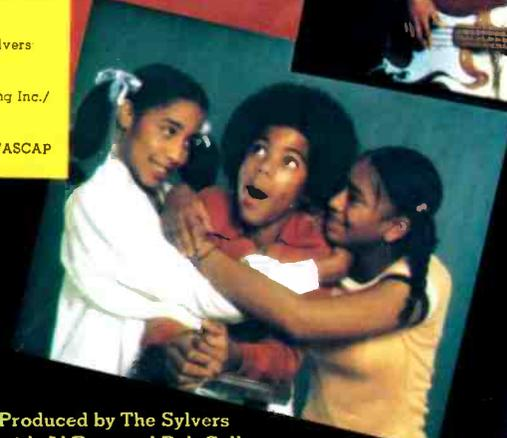
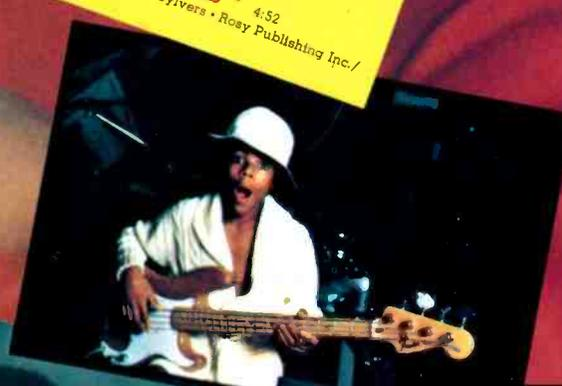
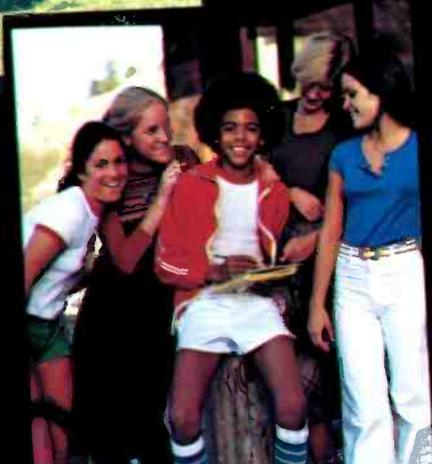
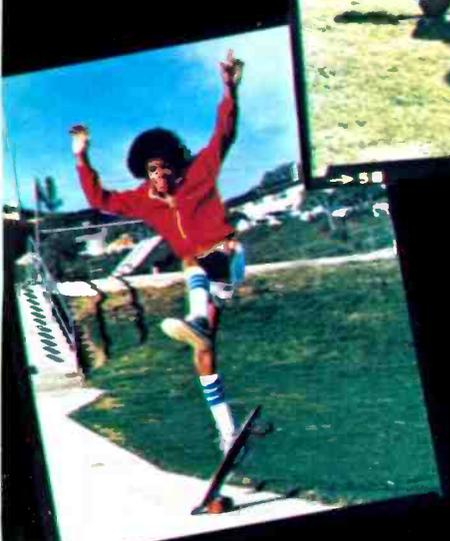
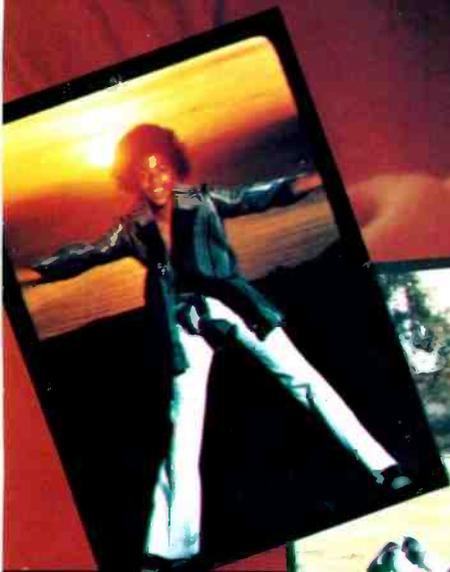

Produced by The Sylvers
with Al Ross and Bob Cullen
for Sylr Enterprises Inc.



ST-11716
©1978 Capitol Records, Inc.

CASH BOX TOP 100 ALBUMS

January 21, 1978

		Weeks On Chart				Weeks On Chart				Weeks On Chart				
		1/14		1/14		1/14		1/14		1/14				
1	SATURDAY NIGHT FEVER BEE GEES AND VARIOUS ARTISTS (RSO RS 4001)	12.98	9	8	35	TURNIN' ON HIGH INERGY (Gordy/Motown G6-97851)	7.98	27	13	68	WE MUST BELIEVE IN MAGIC CRYSTAL GAYLE (United Artists LA 771G)	6.98	59	26
2	RUMOURS FLEETWOOD MAC (Warner Bros. BSK 3010)	7.98	1	48	36	BOOK OF DREAMS STEVE MILLER BAND (Capitol SO-11630)	7.98	38	35	69	SECRETS CON FUNK SHUN (Mercury SRM-1-1180)	7.98	71	20
3	FOOT LOOSE AND FANCY FREE ROD STEWART (Warner Bros. BSK 3092)	7.98	3	10	37	STAR WARS ORIGINAL SOUNDTRACK (20th Century 2T-541)	9.98	33	32	70	BARRY WHITE SINGS FOR SOMEONE YOU LOVE (20th Century T-543)	7.98	66	20
4	NEWS OF THE WORLD QUEEN (Elektra 6E-112)	7.98	7	9	38	THANKFUL NATALIE COLE (Capitol SW 11708)	7.98	43	7	71	MENAGERIE BILL WITHERS (Columbia JC 34903)	7.98	84	11
5	OUT OF THE BLUE ELECTRIC LIGHT ORCHESTRA (Jet/United Artists JTLA-823-L2)	11.98	5	9	39	LET'S GET SMALL STEVE MARTIN (Warner Bros. BSK 3090)	7.98	37	17	72	A PAUPER IN PARADISE GINO VANNELLI (A&M SP4664)	7.98	72	11
6	BORN LATE SHAUN CASSIDY (Warner/Curb BSK 3126)	7.98	6	10	40	FUNKENTELECHY VS. THE PLACEBO SYNDROME PARLIAMENT (Casablanca NBLP 7084)	7.98	47	6	73	MOODY BLUE ELVIS PRESLEY (RCA AFL 1-2428)	7.98	67	28
7	ALL 'N' ALL EARTH, WIND & FIRE (Columbia JC 34905)	7.98	4	8	41	PLAYER (RSO/Polydor RS-1-3026)	7.98	52	12	74	SECONDS OUT GENESIS (Atlantic SD 2-9002)	9.98	75	8
8	SIMPLE DREAMS LINDA RONSTADT (Asylum 6E-104)	7.98	2	19	42	OLIVIA NEWTON-JOHN'S GREATEST HITS (MCA-3028)	7.98	41	13	75	ANYTIME... ANYWHERE RITA COOLIDGE (A&M SP 4616)	7.98	60	43
9	ALIVE II KISS (Casablanca NBLP 7076-2)	11.98	8	10	43	DON'T LET ME BE MISUNDERSTOOD SANTA ESPERALDA/LEROY GOMEZ (Casablanca NBLP 7080)	7.98	50	10	76	CHIC (Atlantic SD 5202)	7.98	94	6
10	I'M GLAD YOU'RE HERE WITH ME TONIGHT NEIL DIAMOND (Columbia JC 34900)	7.98	10	9	44	WORKS — VOLUME 2 EMERSON LAKE & PALMER (Atlantic SD 19147)	7.98	36	8	77	TOO HOT TO HANDLE HEATWAVE (Epic PE 34761)	6.98	79	26
11	RUNNING ON EMPTY JACKSON BROWNE (Asylum 6E-113)	7.98	16	4	45	LOVE SONGS THE BEATLES (Capitol SKBL-11711)	11.98	39	12	78	NEVER MIND THE BOLLOCKS, HERE COME THE SEX PISTOLS (Warner Brothers BSK 3147)	7.98	81	8
12	THE STRANGER BILLY JOEL (Columbia JC 34987)	7.98	14	16	46	LOOKING BACK STEVIE WONDER (Motown M-804LP3)	9.98	57	5	79	HERE AT LAST... BEE GEES... LIVE (RSO 2-3901)	11.98	83	34
13	DRAW THE LINE AEROSMITH (Columbia JC 34856)	7.98	15	5	47	THE BAY CITY ROLLERS GREATEST HITS (Arista AB4158)	7.98	49	9	80	ACTION BLACKBYRDS (Fantasy F-9535)	7.98	82	17
14	DOWN TWO THEN LEFT BOZ SCAGGS (Columbia JC 34729)	7.98	11	8	48	IN FULL BLOOM ROSE ROYCE (Whitfield WH-3074)	6.98	45	21	81	GREATEST HITS LINDA RONSTADT (Asylum 6E-106)	6.98	68	58
15	AJA STEELY DAN (ABC AB-1006)	7.98	12	15	49	YOU LIGHT UP MY LIFE DEBBY BOONE (Warner/Curb BS-3118)	6.98	40	12	82	I, ROBOT THE ALAN PARSONS PROJECT (Arista AL 7002)	7.98	69	14
16	THE GRAND ILLUSION STYX (A&M SP4637)	7.98	17	26	50	FLYING HIGH ON YOUR LOVE BAR-KAYS (Mercury SRM-1-1181)	6.98	51	10	83	THE BEST OF ZZ TOP (London PS 706)	7.98	85	8
17	SHAUN CASSIDY (Warner/Curb BS 3067)	6.98	13	32	51	LIVE BARRY MANILOW (Arista AB 8500)	11.98	44	34	84	BAT OUT OF HELL MEAT LOAF (Cleve. Intl./Epic PE 34974)	6.98	87	12
18	THE STORY OF STAR WARS (20th Century-Fox T-550)	7.98	25	7	52	FEELIN' BITCHY MILLIE JACKSON (Spring/Polydor SP-1-6715)	6.98	53	20	85	BLUE LIGHTS IN THE BASEMENT ROBERTA FLACK (Atlantic SD 19149)	7.98	99	5
19	POINT OF KNOW RETURN KANSAS (Kirshner/Epic JZ 34929)	7.98	20	14	53	LONGER FUSE DAN HILL (20th Century T-547)	7.98	105	6	86	ENCOUNTERS OF EVERY KIND MECO (Millennium MNL 8004)	7.98	114	2
20	SLOWHAND ERIC CLAPTON (RSO RS-1-3030)	7.98	22	8	54	MY AIM IS TRUE ELVIS COSTELLO (Columbia JC 35037)	7.98	56	9	87	MR. MEAN OHIO PLAYERS (Mercury SRM-1-3707)	7.98	92	6
21	LIVE! THE COMMODORES (Motown M9-894A-2)	7.98	21	11	55	JT JAMES TAYLOR (Columbia JC 34811)	7.98	54	29	88	BOSTON (Epic JE 34188)	7.98	80	72
22	GREATEST HITS, ETC. PAUL SIMON (Columbia JC 35032)	7.98	18	9	56	DECADE NEIL YOUNG (Reprise 3RS 2257)	14.98	46	10	89	WHEN YOU HEAR LOU, YOU'VE HEARD IT ALL LOU RAWLS Phila. Intl./CBS JZ 35036)	7.98	103	8
23	DON JUAN'S RECKLESS DAUGHTER JONI MITCHELL (Asylum BB 701)	12.98	28	4	57	LEIF GARRETT (Atlantic SD 19152)	7.98	73	5	90	FOGHAT LIVE (Bearsville/Warner Bros. BRK 6971)	6.98	74	20
24	STREET SURVIVORS LYNYRD SKYNYRD (MCA-3029)	7.98	19	12	58	THE CAPTAIN & TENNILLE'S GREATEST HITS (A&M SP-4667)	7.98	58	8	91	FEELS SO GOOD CHUCK MANGIONE (A&M SP-4658)	7.98	78	14
25	FRENCH KISS BOB WELCH (Capitol ST 11663)	6.98	26	17	59	BROKEN BLOSSOM BETTE MIDLER (Atlantic SD 19151)	7.98	70	7	92	THEIR GREATEST HITS EAGLES (Asylum 6E-105)	7.98	77	98
26	HERE YOU COME AGAIN DOLLY PARTON (RCA APL1-2544)	6.98	30	13	60	HOTEL CALIFORNIA EAGLES (Asylum 6E-103)	7.98	48	57	93	I'M IN YOU PETER FRAMPTON (A&M SP 4704)	7.98	86	31
27	ELVIS IN CONCERT ELVIS PRESLEY (RCA APL 2-2587)	13.98	23	14	61	ODYSSEY (RCA APL 12477)	7.98	61	16	94	CHICAGO XI (Columbia JC 34860)	7.98	88	16
28	GALAXY WAR (MCA MCA-3030)	7.98	32	8	62	BROKEN HEART THE BABYS (WBS/Chrysalis CHR 1150)	7.98	63	15	95	SHOW SOME EMOTION JOAN ARMATRADING (A&M SP-4663)	7.98	89	14
29	CLOSE ENCOUNTERS OF THE THIRD KIND ORIGINAL MOTION PICTURE SOUNDTRACK (Arista AL9500)	7.98	42	4	63	ELTON JOHN'S GREATEST HITS VOL. II (MCA MCA-3027)	7.98	55	15	96	FUNK BEYOND THE CALL OF DUTY JOHNNY GUITAR WATSON (DJM DJLPA-714)	7.98	97	7
30	LITTLE CRIMINALS RANDY NEWMAN (Warner Bros. BSK 3079)	7.98	31	15	64	LIVE AT THE BIJOU GROVER WASHINGTON, JR. (Kudu KUX-3637M2)	7.98	76	6	97	THE BELLE ALBUM AL GREEN (Hi/Cream HLP 6004)	7.98	116	5
31	ONCE UPON A TIME DONNA SUMMER (Casablanca NBLP 7078-2)	11.98	24	10	65	MOONFLOWER SANTANA (Columbia C2-34914)	9.98	64	13	98	EDDIE MONEY (Columbia PC 34909)	6.98	102	12
32	FOREIGNER (Atlantic SC 18215)	7.98	34	44	66	HEADS BOB JAMES (Columbia/Tappan Zee JC34896)	7.98	65	10	99	BRICK (Bang BLP-409)	7.98	101	20
33	REACH FOR IT GEORGE DUKE (Epic JE 34883)	7.98	35	13	67	SOMETHING TO LOVE L.T.D. (A&M SP 4646)	7.98	62	26	100	FLEETWOOD MAC (Warner Bros. MSK 2281)	7.98	91	130

Cash Box Top 200 Albums/101 to 200

January 21, 1978

		Weeks On Chart	1/14			Weeks On Chart	1/14			Weeks On Chart	1/14			
101	WINDOW OF A CHILD SEAWIND (CTI7-5007)	7.98	120	5	135	ONE MORE FROM THE ROAD LYNYRD SKYNYRD (MCA 2-8011)	9.98	130	11	169	ROUGH MIX PETE TOWNSHEND & RONNIE LANE (MCA 2295)	6.98	160	16
102	SUNSHINE THE EMOTIONS (Stax/Fantasy STX-4100)	7.98	104	7	136	COMMODORES (Motown M7-884R1)	7.98	124	43	170	TEQUILA MOCKINGBIRD RAMSEY LEWIS (Columbia JC 35018)	7.98	179	3
103	BRASS CONSTRUCTION III (United Artists LA755-H)	7.98	93	10	137	LITTLE QUEEN HEART (Portrait/CBS JR 34799)	7.98	131	37	171	ROCKET TO RUSSIA RAMONES (Sire/Warner Bros. SR6042)	7.98	176	6
104	RICK DANKO (Arista AB 4141)	7.98	96	11	138	MANORISMS WET WILLIE (Epic JE 34983)	7.98	138	6	172	THE BEST OF JOAN C. BAEZ (A&M SP 4668)	7.98	178	2
105	BEST OF THE DOOBIES DOOBIE BROTHERS (Warner Bros. BS2978)	6.98	98	61	139	PART 3 KC & THE SUNSHINE BAND (TK 605)	7.98	139	66	173	PETE'S DRAGON ORIGINAL SOUNDTRACK (Capitol SW-11704)	7.98	174	5
106	COME GO WITH US POCKETS (Columbia PC 34879)	6.98	95	16	140	AMERICA LIVE (Warner Bros. BSK 3136)	7.98	125	9	174	THIS ONE'S FOR YOU BARRY MANILOW (Arista AB 4090)	7.98	175	74
107	LIVE AND LET LIVE 10CC (Mercury SRM-2-8600)	11.98	90	5	141	SONGS IN THE KEY OF LIFE STEVIE WONDER (Tamla/Motown T13-340C2)	13.98	137	66	175	THE ALICE COOPER SHOW (Warner Brothers BSK 3138)	7.98	163	8
108	GOIN' BANANAS SIDE EFFECT (Fantasy F-9537)	7.98	111	7	142	EXPECT NO MERCY NAZARETH (A&M 3D-4666)	7.98	136	10	176	NIGHT MOVES BOB SEGER (Capitol ST 11557)	6.98	170	64
109	TOM PETTY AND THE HEARTBREAKERS (Shelter/ABC SRL 52006)	6.98	112	18	143	WINNING COMBINATION DONNY & MARIE (Polydor PD-1-6127)	7.98	171	2	177	SUPERNATURE CERRONE (Cotillion SD 5202)	6.98	—	1
110	DO YOU WANNA GET FUNKY WITH ME? PETER BROWN (Drive 104)	7.98	128	2	144	PASSAGE CARPENTERS (A&M SP 4703)	7.98	135	15	178	ELOISE ELOISE LAWS (ABC AB 1022)	6.98	185	2
111	LET IT FLOW DAVE MASON (Columbia PC 34580)	6.98	113	39	145	LIVE AT THE ROYAL FESTIVAL HALL GLEN CAMPBELL (Capitol SWBC-11707)	9.98	146	7	179	REJOICE EMOTIONS (Columbia PC 34762)	6.98	172	31
112	BABY IT'S ME DIANA ROSS (Motown M6-890R1)	7.98	106	17	146	PATTI LABELLE (Epic PE 34847)	6.98	143	20	180	BREEZIN' GEORGE BENSON (Warner Bros. BSK 3111)	7.98	181	14
113	SEND IT ASHFORD & SIMPSON (Warner Bros. BS 3088)	6.98	115	16	147	OUTSIDE HELP JOHNNY RIVERS (Atlantic/Big Tree BT 76004)	7.98	151	7	181	LEFTOVERTURE KANSAS (Kirschner/Epic PZ 34224)	7.98	—	1
114	KARLA BONOFF (Columbia PC34672)	6.98	108	18	148	THE OSMONDS GREATEST HITS (Polydor PD 2-9005)	9.98	148	11	182	COCOMOTION EL COCO (AVI 6012)	7.98	187	11
115	HAVANA CANDY PATTI AUSTIN (CTI 7-5006)	7.98	140	10	149	SONG BIRD DENIECE WILLIAMS (Columbia JC 34911)	7.98	141	11	183	THE DEVIL IN ME THELMA HOUSTON (Tamla/Motown T7-358R1)	7.98	166	11
116	STAR WARS AND OTHER GALACTIC FUNK MECO (Millennium/Casablanca MNLP 8001)	6.98	122	26	150	THE HARDNESS OF THE WORLD SLAVE (Cotillion SD 5201)	7.98	159	5	184	TIGHTROPE STEVE KAHN (Columbia JC 34857)	7.98	190	2
117	TRUE TO LIFE RAY CHARLES (Atlantic SD 19142)	7.98	107	12	151	BING CROSBY'S GREATEST HITS (MCA 3031)	7.98	155	7	185	IT WAS ALMOST LIKE A SONG RONNIE MILSAP (RCA APL 1-2439)	6.98	180	4
118	CATS ON THE COAST SEA LEVEL (Capricorn CPN 0198)	7.98	—	1	152	TWILLEY DON'T MIND DWIGHT TWILLEY BAND (Arista AB 4140)	7.98	147	18	186	A PLACE IN THE SUN PABLO CRUISE (A&M SP 4625)	7.98	183	48
119	SPECTRES BLUE OYSTER CULT (Columbia JC 35019)	7.98	119	12	153	WELCOME TO MY WORLD ELVIS PRESLEY (RCA APL 1-2274)	6.98	150	21	187	LOVE YOU LIVE THE ROLLING STONES (Rolling Stones Records COC 2-9001)	11.98	173	16
120	DREAMBOAT ANNIE HEART (Mushroom 5005)	7.98	109	95	154	NEVER LETTING GO PHOEBE SNOW (Columbia JC 34875)	7.98	145	15	188	BEAUTY ON A BACK STREET HALL & OATES (RCA AFL 1-2300)	7.98	184	19
121	HEROES DAVID BOWIE (RCA AFL1-2522)	7.98	100	11	155	IN CITY DREAMS ROBIN TROWER (Chrysalis CHR 1148)	7.98	152	17	189	NIGHT AFTER NIGHT NILS LOFGREN (A&M SP-3707)	9.98	177	14
122	ELVIS' GOLDEN RECORDS VOL. 1 ELVIS PRESLEY (RCA LSP-1707)	6.98	110	18	156	WE ARE ONE MANDRILL (Arista AB 4144)	7.98	161	11	190	HOW GREAT THOU ART ELVIS PRESLEY (RCA LSP-3758)	7.98	191	14
123	SPINNERS/8 (Atlantic SD 19146)	6.98	129	6	157	LEVON HELM AND THE RCO ALL-STARS (ABC AA-1017)	7.98	158	10	191	SINGER OF SONGS/TELLER OF TALES PAUL DAVIS (Bang BLP-410)	6.98	—	1
124	RUBY, RUBY GATO BARBIERI (A&M SP 4655)	7.98	121	13	158	NEW HORIZON ISAAC HAYES (Polydor PD-1-6120)	7.98	182	2	192	RECKLESS ABANDON DAVID BROMBERG BAND (Fantasy F-9540)	7.98	193	9
125	PUTTING IT STRAIGHT PAT TRAVERS (Polydor PD-1-6121)	7.98	142	6	159	RAIN DANCES CAMEL (Janus JXS-7035)	7.98	154	14	193	DIAMANTINA COCKTAIL LITTLE RIVER BAND (Capitol SW 11645)	7.98	196	24
126	LUNA SEA FIREFALL (Atlantic SC 19101)	7.98	126	24	160	LOVE GUN KISS (Casablanca NBLP 7057)	7.98	162	29	194	EVEN IN THE QUIETEST MOMENTS SUPERTRAMP (A&M SP 4634)	7.98	188	40
127	CAT SCRATCH FEVER TED NUGENT (Epic JE 34700)	7.98	132	31	161	LIVIN' ON THE FAULT LINE DOOBIE BROTHERS (Warner Bros. BSK 3045)	7.98	157	20	195	FLOWING RIVERS ANDY GIBB (RSO RS 1-3019)	7.98	198	32
128	COLLECTOR'S ITEMS O'JAYS (Phila. Intl. PZG 35024)	7.98	144	2	162	MUSICAL CHAIRS SAMMY HAGAR (Capitol ST-11706)	6.98	168	5	196	IT TAKES ONE TO KNOW ONE DETECTIVE (Swan Song/Atlantic SS 8504)	7.98	—	1
129	OXYGENE JEAN-MICHEL JARRE (Polydor PD 1-6112)	7.98	133	17	163	HEAR TO TEMPT YOU THE TEMPTATIONS (Atlantic SD 19143)	6.98	165	5	197	LIVE AT MADISON SQUARE GARDEN ELVIS PRESLEY (RCA LSP-4476)	7.98	195	9
130	SILK DEGREES BOZ SCAGGS (Columbia JC 33920)	7.98	118	98	164	TEN YEARS OF GOLD KENNY ROGERS (United Artists LA835-H)	7.98	—	1	198	A NEW WORLD RECORD ELECTRIC LIGHT ORCHESTRA (United Artists LA 679Q)	7.98	197	64
131	THE JOY TONI BROWN AND TERRY GARTHWAITE (Fantasy F-9538)	6.98	134	13	165	STREISAND SUPERMAN BARBRA STREISAND (Columbia JC 34830)	7.98	167	30	199	ALOHA IN HAWAII ELVIS PRESLEY (RCA VPSX-6089)	8.98	200	15
132	THE TRAMMPS III (Atlantic SD 19148)	6.98	117	7	166	LIVE CROSBY AND NASH (ABC AA-1042)	7.98	156	10	200	THUNDER IN MY HEART LEO SAYER (Warner Bros. BSK 3039)	7.98	199	15
133	CSN CROSBY, STILLS & NASH (Atlantic SC 19104)	7.98	123	29	167	FRAMPTON COMES ALIVE PETER FRAMPTON (A&M SP3703)	9.98	169	104					
134	TOUCH AND GONE GARY WRIGHT (Warner Brothers BSK 3137)	7.98	127	8	168	FINALE LOGGINS & MESSINA (Columbia JG 34167)	7.98	164	12					

ALPHABETIZED TOP 200 ALBUMS (BY ARTIST)

Aerosmith	13	Cassidy, Shaun	6.17	Flack, Roberta	85	Little River Band	193	Player	41	Styx	16
America	140	Cerrone	177	Fleetwood Mac	2,100	Lofgren, Nils	189	Pockets	106	Summer, Donna	31
Armatrading, Joan	95	Charles, Ray	117	Foghat	90	Loggins & Messina	168	Presley, Elvis	27,73,122,153,190,197,199	Supertramp	194
Ashford & Simpson	113	Chic	76	Foreigner	32	L.T.D.	67	Queen	4	Taylor James	55
Austin, Patti	115	Chicago	94	Freempton, Peter	93,167	Lynyrd Skynyrd	24,135	Ramones	171	Temptations	163
Babys, The	62	Clapton, Eric	20	Garrett, Leif	57	Mandrill	156	Rawls, Lou	89	Townshend/Lane	169
Baez, Joan	172	Cole, Natalie	38	Gayle, Crystal	68	Mangione, Chuck	91	Rivers, Johnny	147	Trammps	132
Barbieri, Gato	124	Commodores	21,136	Genesis	74	Maniow, Barry	51,174	Rogers, Kenny	164	Travers, Pat	125
Bar-Kays	50	Con Funk Shun	69	Gibb, Andy	195	Martin, Steve	39	Rolling Stones	187	Trower, Robin	155
Bay City Rollers	47	Coolidge, Rita	75	Green, Al	97	Mason, Dave	111	Ronstadt, Linda	8,81	Twilley, Dwight	152
Beatles, The	45	Cooper, Alice	175	Hagar, Sammy	162	Meat Loaf	84	Rose Royce	48	Vannelli, Gino	72
Bee Gees	79	Costello, Elvis	54	Hall & Oates	188	Meco	86,116	Ross, Diana	112	War	28
Benson, George	180	Crosby, Bing	151	Hayes, Isaac	158	Midler, Bette	59	Santa Esmeralda/Leroy Gomez	43	Washington, Grover	64
Blackbyrds	80	Crosby & Nash	166	Heart	120,137	Miller, Steve	36	Santana	65	Watson, Johnny Guitar	96
Blue Oyster Cult	119	Crosby, Stills & Nash	133	Heatwave	77	Milsap, Ronnie	185	Sayer, Leo	200	Welch, Bob	25
Bonoff, Karla	114	Danko, Rick	104	Helm, Levon	157	Mitchell, Joni	23	Scaggs, Boz	14,130	Wet Willie	138
Boone, Debby	49	Davis, Paul	191	High Energy	35	Money, Eddie	98	Sea Level	118	White, Barry	70
Boston	88	Denver, John	34	Hill, Dan	53	Nazareth	142	Seawind	101	Williams, Deniece	149
Bowie, David	121	Detective	196	Houston, Thelma	183	Newman, Randy	30	Seger, Bob	176	Withers, Bill	71
Brass Construction	103	Diamond, Neil	10	Jackson, Millie	52	Newton-John, Olivia	42	Sex Pistols	78	Wonder, Stevie	46,141
Brick	99	Doobie Bros.	105,161	James, Bob	66	Nugent, Ted	127	Side Effect	108	Wright, Gary	134
Bromberg, David	192	Duke, George	33	Jarre, Jean-Michel	129	Odyssey	61	Simon, Paul	22	Young, Neil	56
Brown, Peter	110	Eagles	60,92	Joel, Billy	12	Ohio Players	87	Slave	150	ZZ Top	83
Brown, Toni and Terry Garthwaite	131	Earth, Wind & Fire	7	Kahn, Steve	184	O'Jays	128	Snow, Phoebe	154	SOUNDTRACKS	
Browne, Jackson	11	El Coco	182	Kansas	19,181	Osmonds	143,148	Spinnners	123	Close Encounters	
Camel	159	Electric Light Orch.	5,198	KC & The Sunshine Band	139	Pablo Cruise	186	Steady Dan	15	Of The Third Kind	29
Campbell, Glen	145	Elton John	63	Kiss	9,160	Parliament	40	Stewart, Rod	3	Pete's Dragon	173
Captain & Tennille	58	Emerson Lake & Palmer	44	LaBelle, Patti	146	Parsons, Alan	82	Story Of Star Wars	18	Saturday Night Fever	1
Carpenters	144	Emotions	102,179	Laws, Eloise	178	Parton, Dolly	26	Streisand, Barbra	165	Star Wars	37
		Firefall	126	Lewis, Ramsey	170	Petty, Tom	109				

Splendid.

A year like never before.
Our thanks to all the men
and women in our record
companies around the world
who made it happen.

Steve Ross
Warner Communications Inc.



SEA LEVEL

Cats On The Coast



The musical tide has just rolled in with Randall Bramblett, Davis Causey and George Weaver joining ranks with Chuck Leavell, Jai Johanny Johanson, Jimmy Nalls and Lamar Williams to **EVOLUTIONIZE** the already successful **SEA LEVEL** on their newest LP, **Cats On The Coast.**

**CATS ON
THE COAST
EVOLUTIONARY
MUSIC ON
CAPRICORN
RECORDS AND
TAPES,
MACON,
GA.**

Produced by Stewart Levine
for Outside Productions, Inc.



CAPRICORN RECORDS