

October 1988

Understanding
actives and passives

IT INSTALLER TECHNICIAN

The cable magazine for installers and technicians.

Formerly CATJ, Cable Tech.

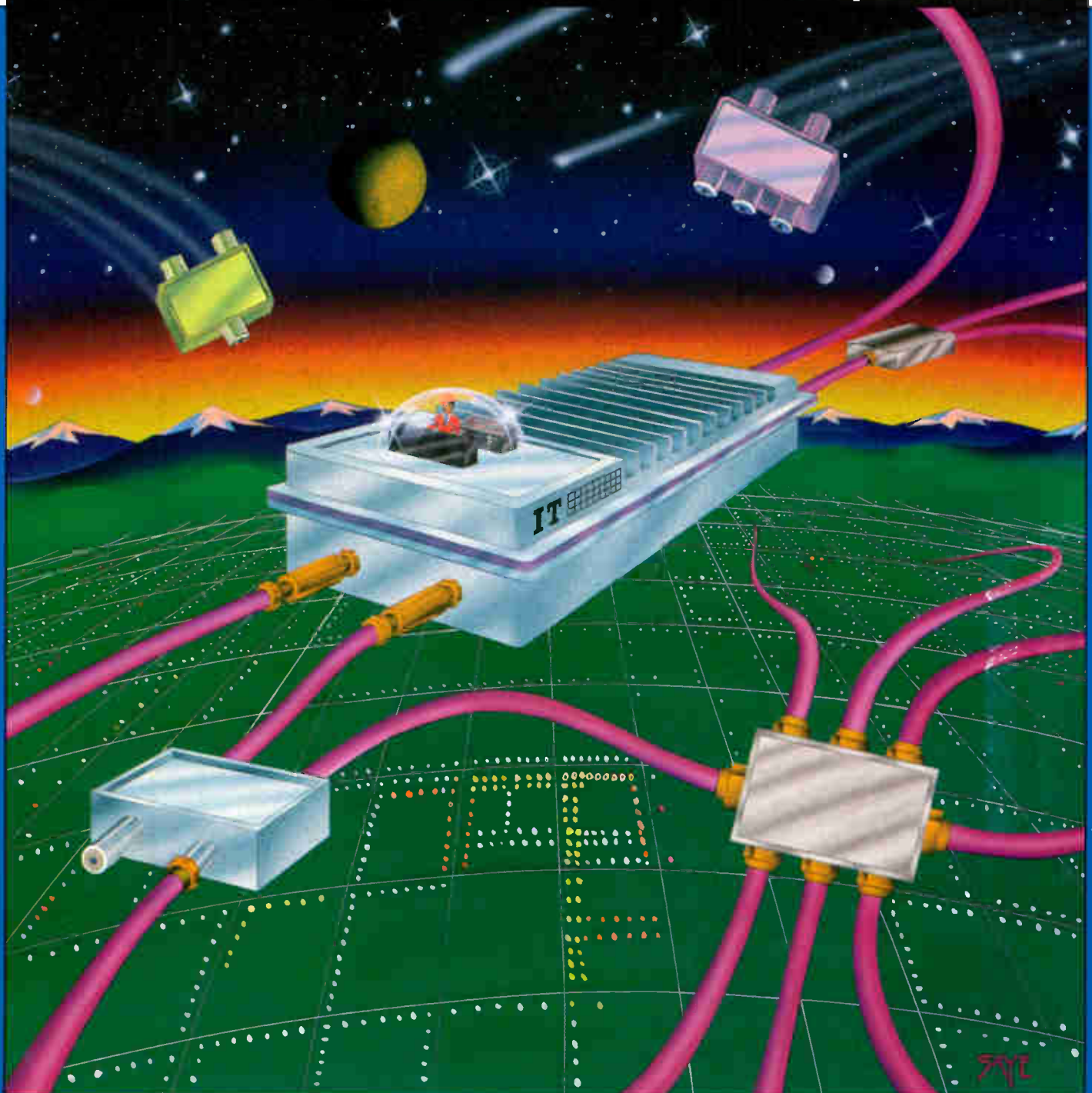

791

From Raychem's EZF Connector to Regal's Passives...

Hook up a new subscriber today...



...with **ANIXTER**'s top quality products.

ANIXTER COMMUNICATIONS®

Call us — We'll ship today!

WEST-ANAHEIM: (714) 779-0500, (800) 854-0443; **ANCHORAGE:** (907) 274-8525; **DENVER:** (303) 373-9200, (800) 841-1531; **SEATTLE:** (206) 251-6760, (800) 426-7665; **MIDWEST-CHICAGO:** (312) 364-7000, (800) 544-5368; **DALLAS:** (214) 446-7337, (800) 231-5006; **IRON MOUNTAIN, MI:** (906) 774-4111, (800) 624-8358; **SKOKIE, IL HDQTRS:** (312) 677-2600; **EAST-ATLANTA:** (404) 449-6533, (800) 241-5790; **EAST FARMINGDALE, NY:** (516) 293-7788, (800) 645-9510; **NEW JERSEY:** (201) 328-0980, (800) 631-9603; **TAMPA:** (813) 626-7115, (800) 237-6466; **CANADA-CALGARY:** (403) 250-9646; **MONTREAL:** (514) 636-3636; **TORONTO:** (416) 625-5110; **VANCOUVER:** (604) 321-5885.

In an emergency, weekends and holidays or after 5 P.M. call toll free 1-(800) 323-8167.
CORPORATE OFFICES, ANIXTER BROS., INC., 4711 Golf Road, Skokie, IL 60076, (312) 677-2600

© 1988 Anixter Bros., Inc.

Reader Service Number 1.

**See us at the Atlantic Show, Booth 339.
See us at the Mid-America Show.**



"IT'S SO EASY TO INSTALL EVEN I CAN DO IT..."

Leonard DeRenzo, Director of Sales

And if you know Len you know that LRC has done the impossible, developed an easy-to-install connector with LRC quality components. LRC introduces Snap-N-Seal™, the revolutionary new "F" connector designed and produced exclusively by LRC.

Snap-N-Seal™ simply snaps on instead of having to be crimped. All that's required is our convenient tools for cable preparation and connector installation. And only Snap-N-Seal™ can claim:

- our 360 degree compression on the cable jacket ensures a complete radial seal, virtually eliminating RF leakage
- a triple seal for maximum environmental protection
- longer dependable service life with reduced maintenance

Snap-N-Seal™. It's easy, effective, and exclusively LRC.

For more information, call us at 607-739-3844, or write to Augat Communications Group, LRC Electronics, P.O. Box 111, Horseheads, NY 14845.



WE'RE AUGAT COMMUNICATIONS GROUP... WE TIE IT ALL TOGETHER... WITH EASE.

See us at the Atlantic Show, Booth 40E.
Reader Service Number 22.

Contents

Departments

From the Publisher 6

News 8

You and the SCTE 12

The Society highlights Ralph Haimowitz's "Technology for technicians" seminar.

Business Directory 31

Installer Input 38

Dana Eggert of Performance Plus concludes a two-part series on customer relations.

From the Manufacturer's Side 40

Corning's Scott Esty reveals the production processes of single-mode optical fiber.

Installer's Tech Book 45

From the NCTI 47

Technical training for customer contact personnel can save time and money.

Products 49

Calendar 50

Ad Index 50

Cover

Active and passive devices drive the signals home.
Art by Geri Saye.

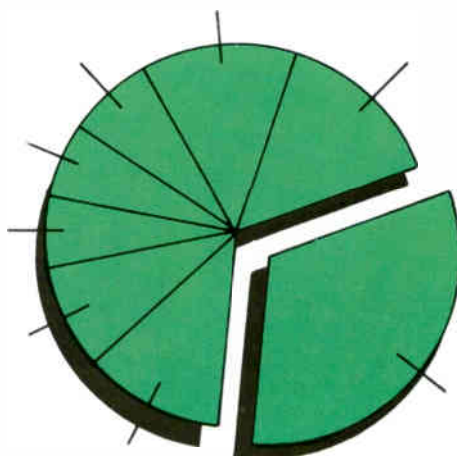

The cable drop 20

Figure 2: Ohm's law

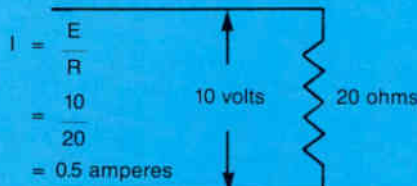

Powering CATV systems 24



From the Manufacturer's Side 40

Features

**RF splitters—
What do they do?** 16

Pico Macom's Michael Holland begins a two-part series.

**The cable drop:
No big deal?** 20

The ingredients in preparing a proper F fitting are discussed by TCI's Barry Smith.

**Video depth
of modulation** 22

Zenith's William Cohn provides a step-by-step process of adjusting video levels using a spectrum analyzer.

**Fulfilling
powering needs** 24

Correct placement of amplifiers during the design stage is examined by Bill Grant of GWG Associates.

Basic electronics 32

Ken Deschler of Cable Correspondence Courses describes AC and DC generators and motors in Part VI of his series.

**Understanding
trunk passives** 35

Equalizers, splitters, filters and other devices in the trunk are illustrated in this NCTI course lesson.

IT-Installer/Technician © 1988 by Communications Technology Publications Corp. All rights reserved. Installer/Technician (ISSN 104-1253) is published monthly by Communications Technology Publications Corp., 12200 E. Briarwood Ave., Suite 250, Englewood, Colo. 80112—or—P.O. Box 3208, Englewood, Colo. 80155, (303) 792-0023. October 1988, Volume 1, Number 6. Office of publication is 12200 E. Briarwood Ave., Suite 250, Englewood, Colo. 80112. Change of address notices should be sent promptly; provide old (or copied) mailing label as well as new address, including ZIP code; allow 6 to 8 weeks for change. Second-class postage paid at Englewood, Colo., and additional mailing offices. POSTMASTER: Please send address changes to Installer/Technician, Box 3208, Englewood, Colo. 80155.

The New Kid on the Block !



**Pathmaker
Feedforward /
Power Addition**

Texscan

COMMUNICATION PRODUCTS DIVISION

EL PASO, TEXAS 79935
(800) 351-2345

See us at the Atlantic Show, Booth 621.
See us at the Mid-America Show.

Reader Service Number 3.

Training the technician



In last month's "From the Editor," Toni Barnett ran through a list of several opportunities available through the Society of Cable Television Engineers. This time I'd like to pick up where she left off and talk about another excellent service provided by the SCTE, the "Technology for technicians" seminar series.

This course is designed for installer technicians and covers such topics as pole climbing safety, customer relations, the drop installation, VCRs, MDUs and much, much more. Even more important, each afternoon provided a hands-on lab where attendees practiced tasks such as preparing cable with different tools, using signal level meters and detecting leakage.

Coordinating the seminar series is CATV veteran Ralph Haimowitz, the SCTE's Director of Chapter Development and Training. His first presentation of the seminar was held Sept. 12-14 at the Harvey Hotel in Dallas. Representing CT Publications was Editorial Assistant Shelley Bolin, who took the course along with nearly 20 others.

According to our correspondent, "The course helped me understand the various aspects of what was involved in the day-to-day responsibilities of an installer tech. Think of what it could do to improve the abilities of someone who actually works with these tools, climbs poles and hooks up cable to a subscriber's set. It certainly is one of the best classes in CATV training I've attended. The SCTE and Ralph have done a fantastic job!

"What was interesting was that the participants ran the gamut of levels of experience. There were people who'd been in the industry for 20 years, but others had been on the job for only a couple of years. This added to an informative if not detailed question-and-answer period in which

Ralph addressed individual real-life situations."

It would be difficult to pinpoint one particular area of the installer tech's job that is more important than another. And yet, this course gives valuable information on areas that are not usually dealt with, such as the element of customer relations. This topic cannot be overemphasized. Every time you meet the customer—whether a new install or a trouble call—every bit of training you have, your personal appearance and body language show the sub your degree of professionalism.

In the seminar, Haimowitz discusses three qualities that all installer techs must have: accuracy, clarity and empathy—the "ACE skills." Accuracy includes providing correct information and asking the right questions. Clarity involves speaking clearly and logically. Empathy embraces understanding (yet not adopting) the feelings of the customer.

I could go on and on about "Technology for technicians," but there's once again not enough room. Please investigate this seminar. The next one is scheduled for Nov. 14-16 at the Luxbury Hotel in Charlotte, N.C. For more information, see the ad on page 11 or call the SCTE national headquarters at (215) 363-6888.

Paul R. Levine
President/Publisher

Robert C. Stuehrk
Associate Publisher

Lu Ann Curtis
Account Executive

Nell Anderson
Account Executive

Marla Sullivan
Production Coordinator

Carroll A. Barnes
Production Assistant

Kenny Edwards
Controller

Geneva Hobza
Assistant to the Publisher

Toni I. Barnett
Vice President of Editorial

Wayne H. Lasley
Editor in Chief

Rikki T. Lee
Managing Editor

Shelley Bolin
Editorial Assistant

Sharon F. Lasley
Art Director

Brad Hamilton
Assistant Art Director

Mary L. Sharkey
Circulation/Data Manager

Office: Communications Technology Publications Corp.,
12200 E. Briarwood Ave., Suite 250, Englewood, Colo.
80112, (303) 792-0023. Mailing Address: P.O. Box 3208,
Englewood, Colo. 80155.

Advisory Board

Alan Babcock
ATC National Training Center

Wendell Bailey
National Cable Television Association

Richard Covell
Society of Cable Television Engineers

Dana Eggert
dB Associates

Joseph Girard
Cooke Cablevision Inc.

Roland Hieb
National Cable Television Institute

Ron Hranac
Jones Intercable Inc.

Patrick K. McDonough
United Cable Television Corp.

Stan Wleciński
NaCom Corp.

Celeate Rule Nelaon
Television Publications Inc.

David Pangrac
American Television and Communications Corp.

Dan Pike
Prime Cable

Rex Porter
Pyramid Industries

Jon Ridley
Jerrold Division/ General Instrument Corp.

William Riker
Society of Cable Television Engineers

Prevent Broken Tap Ports!

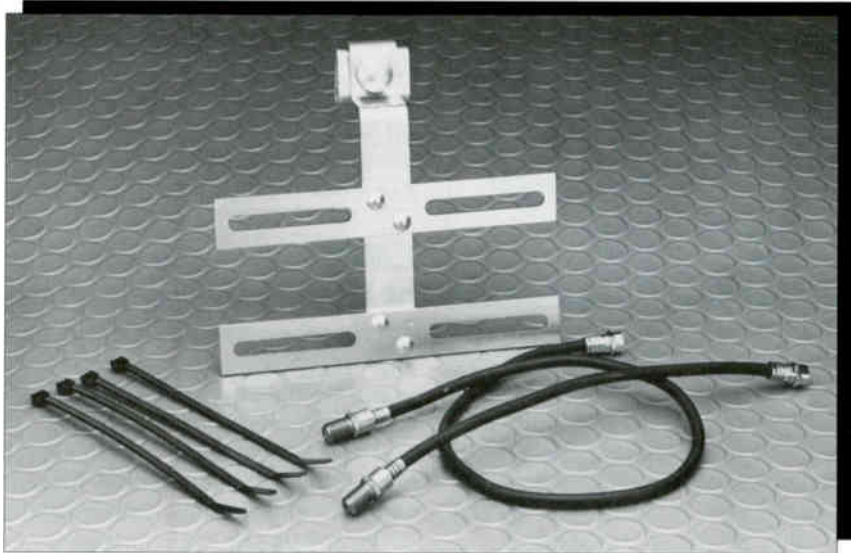

It's easy with the new trap support bracket.

Yes, now you can easily and safely attach multiple traps without the fear and expense of broken tap ports.

If you're like many systems, trapping multiple pay services, you know the problems of attaching 3, 4 and 5 traps. An inadvertent bump and the tap port is broken.

Now, thanks to the Trap Support Bracket, you can easily avoid these problems. The lightweight aluminum bracket quickly attaches to the strand adjacent to the tap. You then have a convenient mount-

ing bracket to which you can attach multiple traps.

Call us today and learn more about this and other innovative products and services from Cable TV Supply Company.

**Ask for your free sample today.
Part No. 1020-T includes
two special jumper cables.**



Call toll-free:
1-800-421-4692
1-800-252-2098
(Calif. only)

© 1987 Cable TV Supply Co.

YES! I'd like more information.

IT 10/88

Trap Support Bracket Price Sheet Catalogue

Name _____ Title _____

Company _____

Address _____

City/State/Zip _____

Phone No. () _____

Mail to: Cable TV Supply Co., P.O. Box 80393, Los Angeles, CA 90009

See us at the Atlantic Show, Booths 651 & 752.
Reader Service Number 4.

News

First SCTE seminar ropes 'em in Dallas

DALLAS—The Harvey Hotel was the site for the Society of Cable Television Engineer's premiere "Technology for technicians" seminar Sept. 12-14. Director of Chapter Development and Training Ralph Haimowitz presented the seminar to 20 industry personnel, ranging from 20-year veterans to relative newcomers.

The lectures were enhanced by a manual (also developed by Haimowitz), several video presentations and hands-on laboratories. The labs allowed attendees to prepare cable using different tools, sample various signal level meters and test for signal leakage. Haimowitz also answered individual questions about specific system problems, from ghosting to dealing with management and budgeting.



Bill Riker

Director of Chapter Development and Training Ralph Haimowitz developed the SCTE's "Technology for Technicians" seminar.

In addition, attendees received solar-powered calculators and were treated to two cocktail parties sponsored by the Texas Cable Television Association. The next "Technology for technicians" seminar will be held Nov. 14-16 in Charlotte, N.C. For more on this program, see this month's "You and the SCTE."

vision of Central Florida under the direction of John Walsh. It is based on a technology developed by AT&T and adapted for the CATV industry. The electronics of the Laser Link are being manufactured by AT&T and marketed by Anixter.

CATV "goes for gold" at 1988 Summer Olympics

SEOUL, South Korea—Fiber optic and cable technology is playing an important role in the 1988 Summer Olympics. Catel Telecommunications installed a fiber-optic TV transmission system providing links from the International Broadcast Center to three sites—Main Stadium, Olympic Park and the International Olympic Committee headquarters. The Korean Telecommunications Authority selected the Catel 3000 Series system, which carries 16 channels for distances up to 23 kilometers.

Also, Jerrold supplied \$250,000 of cable television delivery equipment for use in a 36-channel cable system that also is disseminating information to key sites. The system was constructed by Goldstar, a Korean electronics company, but two Jerrold engineers, Jon Ridley and Jim Jackson, are responsible for seeing that the system runs smoothly during the games. ■

Anixter unveils fiber-optic link

ORLANDO, Fla.—On Sept. 6, Anixter Cable TV unveiled its Fiber-Optic Laser Link CATV system at the Cablevision of Central Florida facility. The new technology allows for the transmission of multiple amplitude-modulated analog TV signals over long distances. It is expected that a number of MSOs, including Amer-

ican Television and Communications Corp. and Tele-Communications Inc., will be making initial installations of the system this year. Jones Intercable is also considering installation.

The system was first tested by ATC's Dave Pangrac at their Denver labs. It was then successfully field tested by Cable-

THE LOOK OF QUALITY

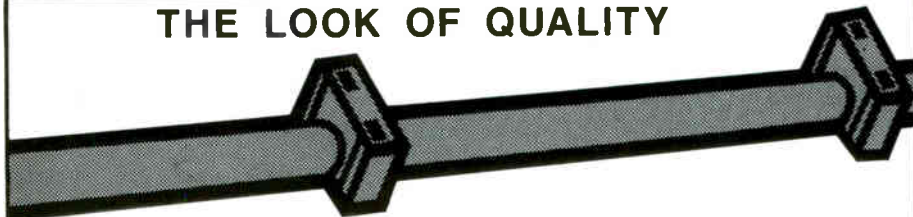

With RB-2 Cable Clips, your drop cable will be installed absolutely positively correctly every time.

The RB-2 Clip Gun System eliminates any chance of damaging the cable and it lasts the life of the drop. No signal degradation. No trouble calls. Just a quality installation delivering a quality signal.

For information call 800-548-7243. Reader Service Number 5.

 **Telecrafter Products**

Products creatively designed for the cable industry

REPRINTS

Communications
Visibility
Knowledge
Information

Reprints work for you!

For more information
call Marla Sullivan at
CT Publications today!
(303) 792-0023.

The Society of Cable Television Engineers
proudly presents the second in a series of three-day
"hands-on" technical training seminars:

TECHNOLOGY FOR TECHNICIANS

SCTE

Nov. 14-16, 1988

Luxbury Hotel

Charlotte, North Carolina

SCTE

*Join SCTE Director of Chapter Development and Training
Ralph Haimowitz in covering such important topics as:*

- *Customer Relations*
- *Installation Materials*
- *Standard Housedrop Procedures*
- *Customer Education*
- *Safety*
- *Cable and Connectors*
- *The Service Connection*
- *Testing and Troubleshooting*

PLUS in the "Hands On" Lab:

- *Cable Preparation*
- *Proper Fitting Installation*
- *Working with Signal Level Meters*
- *Working with Volt-Ohm Millimeters*
- *Testing for Signal Leakage*

The *SCTE Technology for Technicians Training Seminar* is designed for installer/technicians, service technicians and their field supervisors.

It offers a combination of comprehensive technical theory with actual "hands on" training presented in a laboratory environment.

REGISTRATION (limited to 40 people):

\$245 - SCTE MEMBERS

\$285 - NON-MEMBERS (includes SCTE membership)

Hotel Rate: \$50.00 per night

To make hotel reservations call (704) 596-9229. Please specify that you will be attending the SCTE Seminar when you call. All reservations must be made at least two weeks prior to the event to ensure guaranteed room and pricing.

***If you wish to register, or would like to see
TECHNOLOGY FOR TECHNICIANS presented in your area,
please fill out the coupon below and return it to:
SCTE, 669 Exton Commons, Exton, PA 19341.***

Reader Service Number 6.



- Please send me registration materials for the Nov. 14-16 **Technology for Technicians** seminar.
- I would be interested in attending **Technology for Technicians** if it were held in: _____

Name _____
Address _____
City _____
State _____ ZIP _____
Phone _____

IT 10/88

You and the SCTE

Technology for technicians

The Society of Cable Television Engineers (SCTE) is proud to present a new series of technical training seminars entitled "Technology for technicians." Designed to provide proper training for the broadband industry's installer/technicians, service techs and field supervisors, the seminar premiered Sept. 12-14

at the Harvey Hotel in Dallas. The next seminar will be held Nov. 14-16 at the Luxury Hotel in Charlotte, N.C.

"Technology for technicians" is conducted by SCTE Director of Chapter Development and Training Ralph Haimowitz, who developed the program. This three-day seminar offers a combination of com-

prehensive technical theory and actual hands-on training presented in a laboratory environment.

"In addition to just teaching the normal technical mechanics of cable," Haimowitz says, "this program also instructs attendees on proper relations between technicians and customers, as well as on-the-job driving and climbing. These are important facets of a technician's duties that we feel are not emphasized enough in other training programs.

"Another thing that no other program offers," he continues, "is instruction on how to tune a television set, including the things to look for to achieve optimum reception for the customer."

The first portion of the seminar deals with customer relations and includes information on initial customer contact, the importance of appearance, proper identification, communicating effectively and handling the problem customer.

The period on safety covers tools and test equipment (their use and care), taking care of your vehicle, proper ladder use, how to climb poles safely and how to take care of yourself while on the job.

The section on materials discusses aerial drop materials, underground drop materials and house drop materials.

The next topic, cable and connectors, includes material on understanding coaxial cable, the manufacture of cable, new drop requirements (according to the National Electrical Code), three methods of cable preparation and the proper installation of connectors.

When standard house drop procedures are covered, the focus is on building pre-wires and post-wires, wiring multiple outlets, bonding and grounding, installing multiple dwelling units, and aerial, underground and interior drops.

"The service connection" is a portion of the program devoted to converters, interfacing with VCRs and stereo adapters, hooking up video games and personal computers and connecting and tuning the TV set.

The period on testing and troubleshooting covers the proper use and care of meters, finding the right cable, testing for drop-related problems and the finding, fixing and reporting of signal leakage.

The period on customer education explains how to educate customers on how

The SIGnal System

CATV Design Utilities Package
for the IBM PC and Compatibles

For Those Who Simply Need Power
Version 4.0 The Next Generation

SIGnal combines speed and ease, with accuracy and reliability into an inexpensive integrated design software specially created for the communications industry. Using your specifications, SIGnal can design, power and report a bill of materials with a simple touch of one or more keys.

Upgrades are easily attached. User-specified enhancements are also available and encouraged — "Together we can make the best CATV design solution."

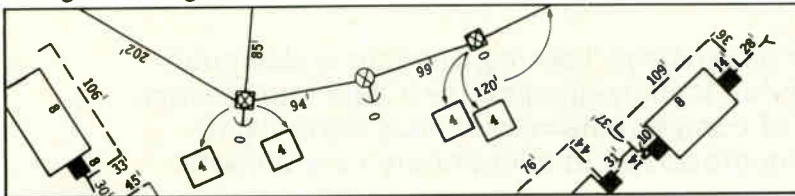

SIGnal Package-A Includes:

- SIG-MASTER** Priced for 1988 \$1195.00
Sign On, Specifications, Data Utilities. Complete system recalculations (headend check) of design data base.
- SIG-DESIGN** Aerial & Underground designs, w/reverse capabilities, rebuild capabilities, multiple vendors, and trunk design tools. Add the SIG-BOM for equipment totals.
- SIG-POWER** DC theory constant current-based powering or a powerful wattage-based powering program. Power an entire power supply quickly. Even move a power supply quickly and see the results.
- SIG-BM** As-built-checker program, which can also be used to design. Input existing design and check it, as well as getting an equipment totals report.

Options are also available.

Friction Design offers services to include: system design, base, strand, design transfer drafting and consultation. A complete drafting/design digitizing service is also available.

Friction Design Company

P.O. Box 5314, Englewood, Colorado 80155, (303) 792-2447
The SIGnal System © Copyright 1987, 1988, Signal Communication, Inc.

See us at the Atlantic Show, Booth 858. Reader Service Number 7.

**Free Stereo
To Your Subscribers**

Music To Your Ears.



That's the sound of profits without the investment. We are so confident that your subscribers will love their new stereo sound that we'll provide the STV stereo decoder to you at no cost, for each new subscriber to try for 30 days, free! If they decide not to keep the unit? Just return it to us, no charge. What could be easier?

You've already made the substantial investment required to bring stereo broadcasts to your subscribers. Why not also provide them the means of enjoying your investment? You'll be doing them a favor while bringing music to your own ears.

Earn \$50.00 profit on each new install. The nationally advertised retail price is \$99.00 and for each subscriber deciding to retain their STV after the 30 day trial

period, you will be billed \$49.00. The promotional possibilities are limitless!

Call our toll-free number and we'll send you a trial supply of our new, great sounding STV decoders to leave behind on each new install. Then wait for the profits to come in.

To make the music begin, call:

ABC
CABLE
PRODUCTS

A Company of the CBLX Group
1-800-777-CBLX (2259)
In Colorado call 303-694-6789

to use the equipment, what to do when the pictures are bad, tests they can conduct, available program services and potential service upgrades, and preventing a customer from disconnecting.

The hands-on laboratory sessions feature cable preparation, volt ohmmeters, proper connector installation, testing for signal leakage and signal level meters.

SCTE Chapters and Meeting Groups

As a service to SCTE members, the following is an up-to-date listing of the Society chapters and meeting groups,

with each group's contact person and phone number. Members should take this opportunity to join a local group.

For more information on becoming a member, contact Pat Zelenka at the SCTE national headquarters, (215) 363-6888.

Appalachian Mid-Atlantic Chapter
Contact: Ron Mountain, (717) 684-2878
Cactus Chapter
Contact: Harold Mackey, (602) 866-0072
Cascade Range Chapter
Contact: Norrie Bush, (206) 254-3228
Central Illinois Chapter
Contact: Tony Lasher, (217) 784-5518
Central Indiana Chapter
Contact: Steve Murray, (317) 788-5968;

or Joe Shanks, (317) 649-0407
Chattahoochee Chapter
Contact: Richard Amell, (404) 394-8837
Delaware Valley Chapter
Contact: Diana Riley, (717) 764-1436
Florida Chapter
Contact: Dick Kirn, (813) 924-8541
Gateway Chapter
Contact: Darrell Diel, (314) 576-4446
Golden Gate Chapter
Contact: Tom Elliott, (408) 727-3900
Great Lakes Chapter
Contact: Daniel Leith, (313) 549-8288
Greater Chicago Chapter
Contact: William Gutknecht, (312) 690-3500
Heart of America Chapter
Contact: Wendell Woody, (816) 474-4289
Hudson Valley Chapter
Contact: Wayne Davis, (518) 587-7993; or Bob Price, (518) 382-8000
Iowa Heartland Chapter
Contact: Dan Passick, (515) 266-2979
Miss/Lou Chapter
Contact: Rick Jubeck, (601) 992-3377
New England Chapter
Contact: Bill Riley, (617) 472-1231
North Central Texas Chapter
Contact: Vern Kahler, (817) 265-7766
North Country Chapter
Contact: Douglas Ceballos, (612) 522-5200
North Jersey Chapter
Contact: Art Muschler, (201) 672-1397
Ohio Valley Chapter
Contact: Robert Heim, (419) 627-0800
Oklahoma Chapter
Contact: Gary Beikman, (405) 842-2405
Old Dominion Chapter
Contact: Margaret Harvey, (703) 238-3400
Piedmont Chapter
Contact: James Kuhns, (704) 873-3280
Razorback Chapter
Contact: Jim Dickerson, (501) 777-4684
Rocky Mountain Chapter
Contact: Steve Johnson, (303) 799-1200
Tip-O-Tex Chapter
Contact: Arnold Cisneros, (512) 425-7880
West Texas Chapter
Contact: Jerry Whitehead, (915) 655-8911
Central California Meeting Group
Contact: Andrew Valles, (209) 453-7791; or Dick Jackson, (209) 384-2626
Chaparral Meeting Group
Contact: Michael Gormally, (505) 761-6200
Chesapeake Meeting Group
Contact: Thomas Gorman, (301) 252-1012
Dairyland Meeting Group
Contact: Jeff Spence, (414) 738-3180
Dixie Meeting Group
Contact: Greg Harden, (205) 582-6333
Inland Empire Meeting Group
Contact: Michael Lajko, (208) 263-4070
Michiana Meeting Group
Contact: Thomas White, (219) 259-8015
Midlands Cable Training Association
Contact: John Page, (712) 323-0420
Mt. Rainier Meeting Group
Contact: Bill Donaldson, (206) 742-5811
Palmetto Meeting Group
Contact: Rick Barnett, (803) 747-1403
Southeast Texas Meeting Group
Contact: Harold Null Jr., (713) 645-3738
Southern California Meeting Group
Contact: Tom Colegrove, (805) 251-8054
Tennessee Meeting Group
Contact: Joe Acker, (205) 932-7264
Upstate New York Meeting Group
Contact: Ed Pickett, (716) 325-1111
Wyoming Meeting Group
Contact: Jim Niswender, (307) 324-2286

60/30 VAC POWER SUPPLY TESTER

(LOAD TYPE)

MODEL VSPSLT-60

Specifications:

- Load Voltage: 60 or 30 VAC (Sine or Square Wave)
- Load Current: 0A, 5A, 10A, 15A (Selective)
- Dimension: 11" X 9" X 5 1/2"
- Weight 5 lbs.

Features:

- RMS Voltage and Current Reading Meters
- Selective Load
- Voltage Wave Form Reading Port with test probe supplied
- Light weight (portable)
- Over-heating protection
- Fan Cooled
- No External Power (Bench or Field Use)

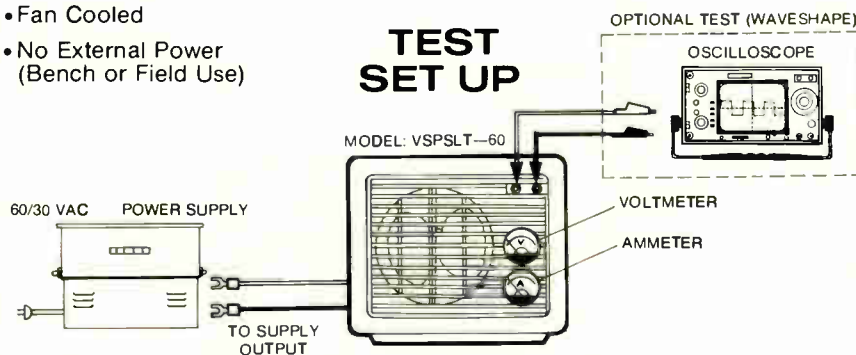
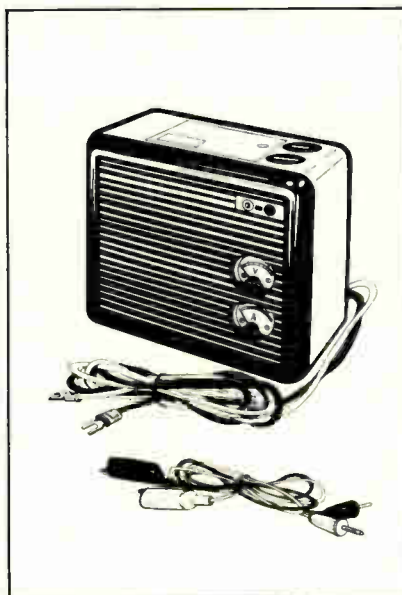

VS Viewsonics inc.
"PRODUCTS WITH INTEGRITY"

170 Eileen Way, Syosset, NY 11791
Call Toll Free: 800-645-7600
In New York City: 516-921-7080
FAX: 516-921-2084

See us at the Atlantic Show, Booth 603. Reader Service Number 9.

tap, tap, tap

who's there?

toner.

toner who?

TONER TAPS™

who has the
best multi-taps
at great prices!

oh, that toner.

XMT SERIES
2-Way, 4-Way, 8-Way
5-550 MHz Multi-Taps

- Plated Solid Brass F Connectors
- Baked Acrylic Corrosion Coating



- Stainless Steel Mesh RFI Gasket
- Neoprene Weather Gasket
- Stainless Steel Hardware
- Sealed F Ports
- Plastic Cover Over PC Board

toner
cable equipment, inc.

800-523-5947

IN PA 800-492-2512 / FAX 215-675-7543
969 Horsham Road / Horsham, Pennsylvania 19044

RF splitters—What do they do?

This is the first article of a two-part series on RF (radio frequency) splitters. This installment will define what a splitter does. In part two, the specifications and parameters used in splitters will be covered.

By Michael Holland

President, Pico Macom Inc.

Passive devices such as splitters and taps have been traditionally overlooked to the interest of more sophisticated devices and systems. Today, with the need to upgrade cable systems to more channels, with greater shielding and new services such as data, it is time to go back to the basics to understand what is available.

Today's splitters have the same basic electrical design as those made 10 years ago. Due to the rapid growth of the cable industry during this period, a lack of attention toward the real purpose of each feature has caused a runaway specsmanship

game resulting in present prices reflecting unneeded features, while those needed features go minimized and misunderstood.

For simplicity, we will limit this article to two-way splitters, in that multiport splitters are for the most part combinations of two-way devices hooked together to form the desired number of outputs. (See Figure 1.) CATV taps are either multiport directional couplers or directional couplers with a four-way splitter. Directional couplers are basically a two-way splitter designed for uneven loss between ports. It is important to note that as the number of two-way splitters or directional coupler sections are increased to form multiport devices, the resulting problems of physical and electrical interconnection (as well as case cavity sizes) add a level of degradation to overall performance.

The main purpose of a splitter is to "split" and direct an incoming signal from one source to two or multiple loads that have the same impedance. This must be done:

- with minimum loss,
- maintaining a wide frequency range, and
- with equal or balanced outputs to each port.

Meeting these requirements seems easy but only a few designs can accomplish all three. We need to decide which of the three requirements is most important in that it will affect the final cost and overall performance. Do we have enough signal from a cable drop to allow the use of a slightly leakier, less expensive splitter? Is equal balance critical? One may have two set-top addressable converters, which, by having a small dynamic range, will not function if too much or too little signal is available from the splitter output.

As with most devices, "you get what you pay for." For a fixed price you can only improve one feature by weakening another.

What is the highest frequency used in your system? Does the dynamic input level requirement of your converters, modems and line amps determine a worst-case system dynamic range over the frequency range used? The engineer who sets product requirements for his system must consider the above choices with cost in mind. If he spends money to pay for non-essential features, he may be giving up other beneficial ones such as thicker seizing pins, silver-plated pins, better corrosion plating, or higher shielding.

Isolation

Why is splitter isolation needed and how is the required isolation level set? Isolation is needed to prevent the local oscillators (LOs) in devices such as TVs, set-top converters or modems from "talking to one another" or causing one to interfere with another. It should be noted that in applications using passive devices such as traps, isolation also is required but will not be discussed due to the minimum requirement. Isolation also prevents transference of direct pick-up from one device to another. Depending upon the local conditions, this can be a matter of concern but, in most cases, the minimal isolation of today's splitters will be sufficient to prevent a problem. The level of isolation can be improved at an additional cost by using PC boards, tighter windings, high permeability cores and more ground points.

What is our goal? A perfect picture with no interactive interference. To determine the isolation requirement that will guarantee a perfect picture, the following questions must be answered:

- 1) What is the LO output level at the input terminals of a TV, set-top converter or modem?
- 2) What is the LO frequency?

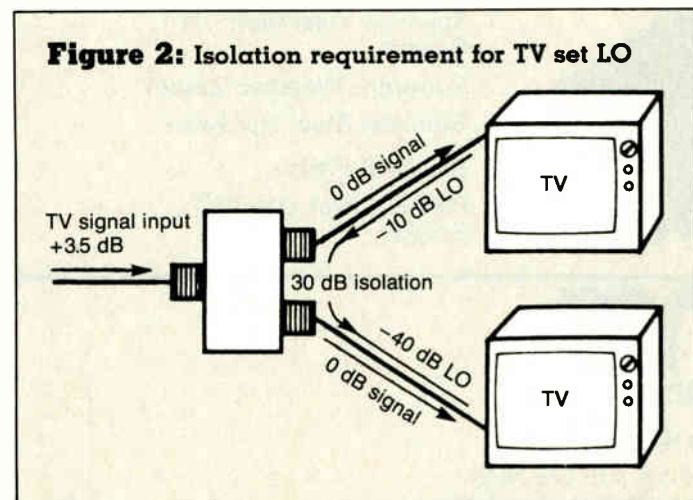
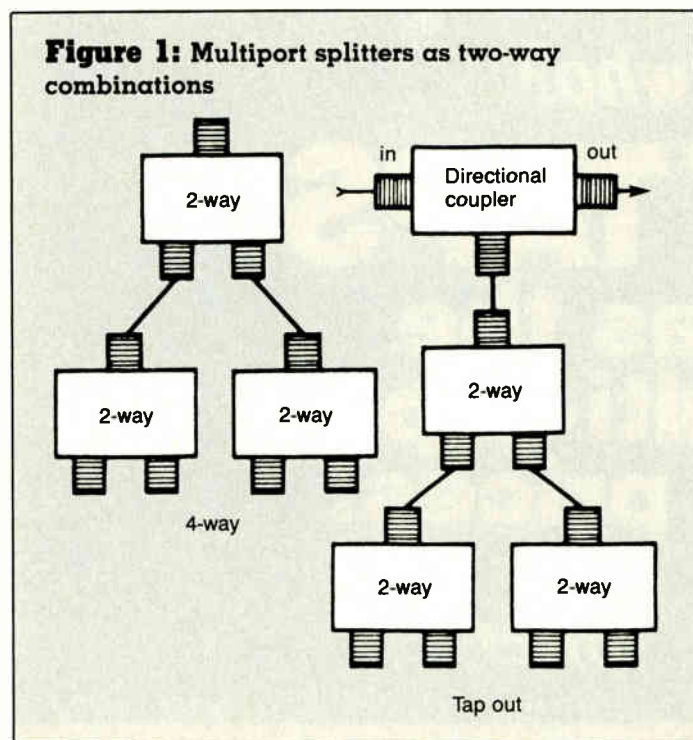

3) What is the minimum input level of an interfering carrier (or LO) that will cause interference in a TV picture?

Let's treat each of these in turn.

Output level—A TV emits a LO output of approximately -10 dBmV at a single frequency that is 45 MHz higher than the channel being viewed.

LO frequency—A set-top converter usually has its LO set above the entire band of viewing (over 500 MHz).

Input interference levels—Much research has been done on TV and set-top converter tuner interference levels. In general, an interfering carrier, or second TV signal on the same channel, needs to be attenuated a minimum of 50 dB to prevent visual picture degradation. Most surface acoustic wave (SAW) filtered modulators specify 60 dB attenuation on out-of-band harmonics to provide a safety factor to prevent this type of interference.

Therefore, with a 0 dB signal going into the TV set and a 10 dB LO signal out of another set (at one frequency), we have a condition requiring the splitter to provide 40-50 dB isolation at all frequencies to be effective. (See Figure 2.)

Fortunately, the only situation in which this problem would occur would be when the two TVs were tuned to programs that were seven channels apart (45 MHz), and then only one (the higher one) potentially would have a picture that had been interfered with.

If this rarely occurring situation is not present, then almost any level of isolation would be satisfactory. Remember, we are looking at real world situations where funds are spent to accomplish our goal: a clear picture. Once this is done, need we spend more or allocate those resources to improve another spec?

In situations with two set-top converters, with LOs above the viewing band, the problem doesn't exist, requiring minimal splitter isolation. In situations with one TV and one set-top converter only the TV LO could affect the converter at signal levels previously discussed with channels of viewing 45 MHz apart.

When we consider how much splitter isolation is required in the rare statistical case mentioned, no splitter presently available can provide isolations over 40 dB across the required CATV frequency range. When our interference condition does not exist, virtually all CATV splitters on the market are sufficient with 25 dB typical isolation.

Is the splitter isolation level a specification that should be accepted on an absolute scale of pass/fail? Would there be a value to increasing the splitter cost for a few more dBs of isolation? How many service calls or poorly performing systems were caused by insufficient splitter isolation? Was the problem solved with another splitter having 5 dB more isolation? Isolation is not a "make or break" feature and does not require extensive selection or allocation of funds. Remember, the system engineer's goal is to provide a chosen level of performance at the best price. In cases of subchannel subscriber origination or upstream data applications, the same evaluation logic applies. The output level and frequency of the data generator against the minimum interfering input level of the TV, converter or other data device determines the isolation requirement.

Note that between 5-50 MHz most splitters provide equally high isolation levels ranging from 35-45 dB. In this frequency range, a higher performance level is not possible. It's at the higher frequencies of 400-600 MHz that we can pay for better isolation. Therefore, improved return path transmission capabilities at sub-frequencies are not important considerations when choosing splitters.

Return loss

Return loss (RL), a decibel representation of standing wave

Figure 3: Ideal and actual return loss mirroring

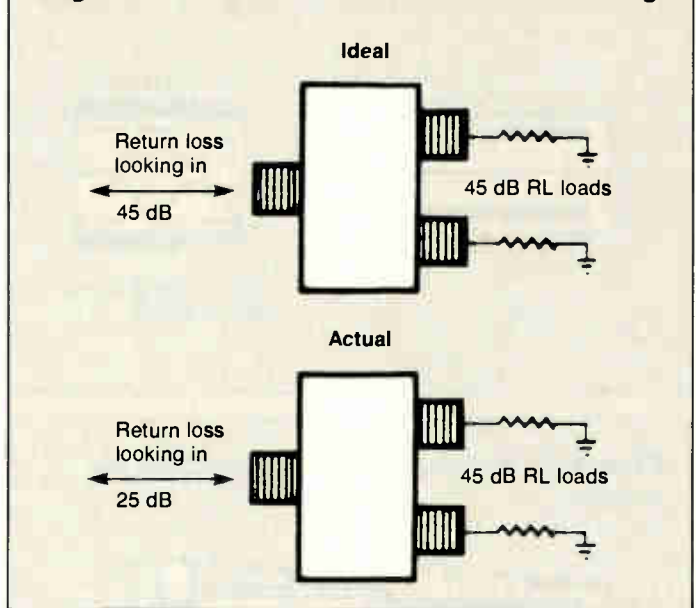
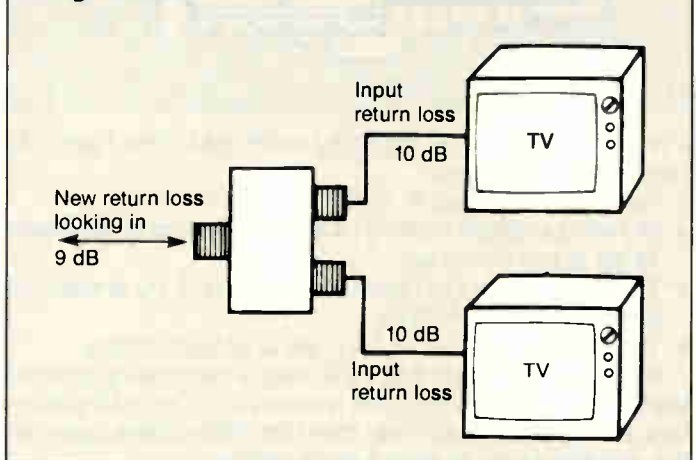

Figure 4: Return loss with real world TV sets



ratio, is the degree to which a device or load matches to 75 ohm (for CATV devices).

Why is a good match an important feature in passive components? Poor matching (low return loss) results in reflections that produce ghosting, the possibility of signal loss (due to energy in the reflected wave) and the increased possibility of leakage (due to discontinuities acting as antennas). For most cable devices, a RL over 16-18 dB is acceptable. As the weakest link of a chain determines its overall strength, the TV set and set-top converter's RL of approximately 10 dB becomes the weakest link of the CATV system. As this feature is fixed by design the only means to limit the low RL effects on a system is through the use of good directional couplers in the distribution portion.

In a cable system, a splitter only deflects the RL of the load (TV) to the splitter input.

If we use a 45 dB RL load on the splitter's output and the input shows 25 dB, it becomes apparent that the splitter's inability to reflect the full RL of load impedance is the weak link. (See Figure 3.)

No matter how high the RL of the load is, the best return loss a splitter can "mirror" would be typically 25-30 dB.

In the real world, splitters are used primarily to connect two

Figure 5: Port end stake edge affects return loss

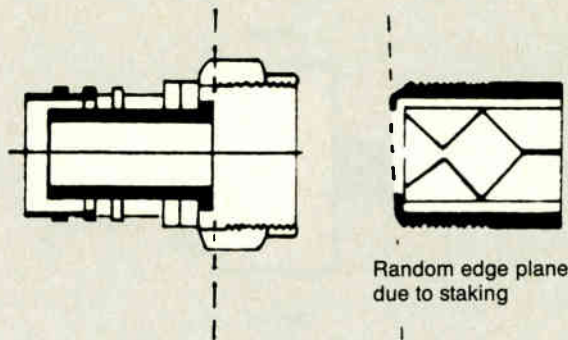
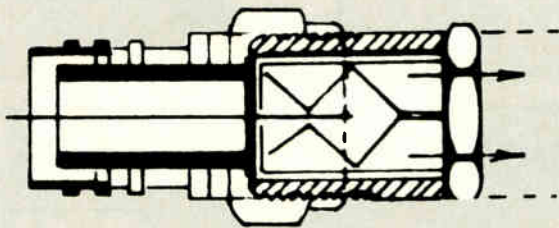

Figure 6: Port end stake edge can affect pin tension



TVs or converters to an incoming cable feed. (See Figure 4.) Consider the following:

- Our load RL is fixed at 10 dB.
- Our worst available splitters have a RL mirroring ability of over 16 dB at any frequency.
- The worst splitters still have 25 dB minimum RL at most frequencies under 350 MHz.
- The final mirrored RL is 10-12 dB in all applications.

It becomes apparent that the splitter's inefficiency to mirror the output loads (RL) is not the weakest link. The load's return loss, being substantially lower than that of the splitter, becomes the deciding factor in overall performance.

Is it a justifiable expense to purchase a splitter with a 16, 20, 25 or 30 dB RL? It costs an additional 10 percent to get a RL of 16 dB up to 18-20 dB at 600 MHz. Again, it is essential to determine how money can best be spent. Has a problem ever been solved by substituting one splitter with another having a higher RL of 5 dB?

In some applications using data equipment on cable or local area networks, the receiving device used could have error rates that increase in conjunction with the degree of a splitter's return loss. In these cases, it is important to review the input return loss specifications for data terminals, amps or modems. If the data device has a specified minimum RL on interface devices, it may be worth spending additional money on these splitters.

Shielding

The subject of splitter shielding requirements is not as clear as others previously discussed. We would like to buy a device that will not result in any leakage problems, however, a correlation between tested performance levels on the bench and actual leakage in the field cannot be determined. The additional variables of corrosion, cable lengths and signal levels make selection even more difficult. Our selection of a splitter, from a

leakage consideration, must be made with the knowledge that higher shielding is more secure.

The only way to select the proper shielding level is to become completely familiar with the perhaps 10 different methods used today for case closure and apply our judgment from relative tests. The present industry methods used for testing are only relative at best, showing only possible differences between case closure methods. For our selection, this is sufficient in that there have been no detailed studies made correlating pure on-line leakage with lab test results.

Mechanical functions

By examining splitters used over the past 20 years, much has been learned to ensure better connections, mounting, grounding and reliability. What remains to be decided is of all these features which can we afford and which are really needed for our system. The following are some general mechanical features available today as options:

1) *Case plating*—Used to protect the splitter from mechanical and electrical degradation and corrosion. Platings are available in traditional zinc chromate (gold or silver color) or a more advanced tin, nickel or chrome plating. The chromate is an oxide coating more prone to corrosion and inherently less expensive. Nickel and tin are used in all forms of high quality connectors and more readily form non-corrosive bonds between connector and case. The goal is to have good electrical continuity and mechanical integrity in the environment used.

2) *Connector seizing (contact) pins*—Used to secure contact with the cable center conductor. Standard pins typically have a tin flashing and are sometimes found not to be plated at the point where the cable center conductor touches. This is caused by plating after pin stamping. An advanced feature found in some splitters is a thick silver plating, plated with the contacts apart. Another available feature is a thicker seizing pin that provides more than a 200 gram retention force on the cable center conductor.

What is desired is the guaranteed, reliable contact between the cable's center conductor and the splitter despite the possibility of moisture and twisting of the center conductor.

3) *Connector port end staking*—Used to hold the insulator in place and to make a secure RF contact between connector and splitter. Horizontal port splitters usually require the insulator and pin assembly to be staked from the outside, resulting in a non-perpendicular plane at the connector contact point. The quality of this staked edge will determine the return loss at higher frequencies. (See Figure 5.)

This might even allow a wrench-tightened connector to push on the insulator changing or even removing pin tension on the center conductor. (See Figure 6.)

To step up in quality use one of the new flat end horizontal port splitters whose port approximates a brass-quality line tap connector. Again, the choice is between reliability and cost. A large percentage of system problems are caused by an intermittent connection between drop connector and splitter at this junction.

4) *Ground block thickness*—Used to maintain a reliable connection with a ground wire. One unreliable section of the splitter is the thickness of diecast material below the ground wire hole. A few manufacturers have spent the extra cost to beef up this section with more material. If technicians break this junction by using too much torque when tightening down the ground screw, then this extra cost is warranted. ■

This article was presented at the 1988 Cable-Tec Expo.

**Better
Than Ever...**



**20 YEARS!
AND STILL GROWING!**

**Total Student Enrollments: 27430
1987 Total Student Enrollments: 3350
1988 Student Enrollments to Date: 2715**

The National Cable Television Institute

Our Credentials:

- 20 Years of Training Excellence
 - Created In 1968 For The CATV Industry By Industry Leaders
 - Acknowledged Leader In CATV Technical Training
 - 24 Of The Leading 25 MSOs Are Actively Engaged In NCTI Training Programs
 - Well Over 4000 Students Representing 2600 Systems Are Currently Enrolled

Send For Your Free Training Kit Today

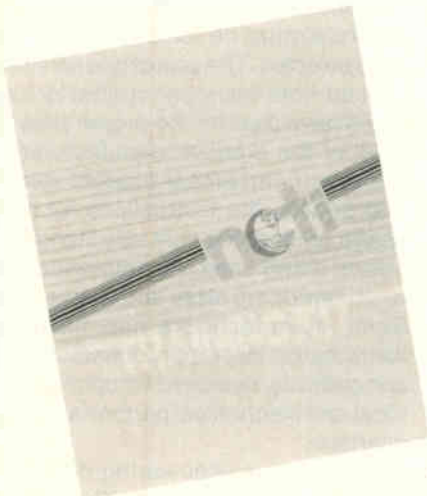

Name _____ IT 10/88

Title _____

Company _____

Address _____ Phone _____

City _____ State _____ ZIP _____

Mail this form to: NCTI, P.O. Box 27277, Denver, CO 80227.
For more information call (303) 761-8554.



The CATV Training People Since 1968

The cable drop: No big deal?

By Barry Smith

Technician, Tele-Communications Inc.

The cable drop, it's just a piece of wire with a connector on the end, no big deal. It doesn't take anything special, anybody can install it, right? Wrong! If you want the drop to last, it takes training and the selection of compatible parts. You can use all of the latest state-of-the-art electronics, the best construction techniques, finest test equipment and procedures, even fiber-optic distribution, but if you can't deliver the pictures to your subscribers, who cares?

With the ever increasing competition from telephone companies, direct broadcast satellites, multichannel MDS (micro-wave) and video rentals, along with rising subscription fees, our subscribers will not continue to put up with marginal quality pictures and unreliable service. Just cutting on a new fitting may correct picture quality while the technician is there, but if the drop cable *interface* is not protected from the environment, he may be back to the subscriber's home within weeks. The cable interface is considered to be the means by which the cable is physically and electrically connected to a device.

The industry and equipment manufacturers have made great progress in extending the life and quality of the trunk and distribution plant. We now can realistically expect a 15- to 20-year life out of the aluminum cable plant, but most of us are lucky to average a two-year life out of our drops. A failure in the cable plant may disrupt service to hundreds or thousands of subscribers at the same time. This part of the system is continually monitored and failure is promptly repaired. On the other hand, only the subscriber can continually monitor the drop, and a slow picture degradation could go undetected for months.

As an average, assume the following:

- 1) In the trunk system, with amplifiers spaced every 2,000 feet, plus directional couplers, splitters and power inserters, there are approximately eight trunk line connectors per mile.
- 2) In the distribution system, with taps, amplifiers, splitters, etc., there are typically two connectors every 150 feet and approximately 80 distribution connectors per mile.

- 3) In the typical drop system there are at least six F-fittings per drop (one at the tap, two at the ground block, two at the converter and one on the TV), with 50 percent penetration (two drops per pole) there are at least 400 F-fittings per mile of distribution.

In a typical 20,000-subscriber system with 100 miles of trunk and 350 miles of distribution (yielding a distribution-to-trunk ratio of 3.5:1) there will be 800 trunk line connectors, 28,000 distribution system connectors, and 140,000 F-fittings. The numbers for your particular situation may vary, but the cost to the industry is undeniable.

The cable TV industry buys somewhere in the neighborhood of 2 billion feet of drop cable per year. That is 378,787 miles, enough drop cable to stretch to the moon and over halfway back, or to go around the Earth 15 times. With 43 million subscribers at approximately 150 feet of cable per drop, we can replace every drop in the United States every 3½ years. Where does it all go?

Some drop problems are caused by nature and are unavoidable, but the majority of drop-related service calls are self-induced and could be avoided by using the right parts the right way.

Problems with the drop interface can be: improper F-fitting selection for the cable's braid coverage, which could cause difficult installation; improper cable preparation, which could short the center conductor or reduce shielding; F-fitting over-crimped, which could increase return loss and attenuation, or even crack the fitting; F-fitting under-crimped, which could reduce fitting pull off or increase the chance of moisture ingress; F-fittings not properly tightened, which could reduce the shielding and increase the chance of moisture ingress. Even if you do all these right, the lack of, or improper use of environmental protection will soon bring a service call. Many of the F-fittings in use today, especially the two-piece ones, were not designed for the long-term reliability and high shielding requirements needed today.

Right from the start

There are a number of factors that need to be considered when purchasing and

using drop hardware. These include:

- 1) *Training*—Proper usage and technique are essential. Don't just open the box and throw the instructions away, read them! With all of the new products available, and even with the ones that have been around for years, education and compatibility can not be overemphasized.

- 2) *Selection of compatible materials*—The simple adage "just put an RG-59 fitting on a RG-59 cable" is not true. There are six different braid coverages for a common RG-59 drop cable (40 percent, 53 percent, 67 percent, 95 percent, Tri-shield, and Quad-shield). The common RG-59 crimp type F-fitting has at least eight different crimp ring inside diameters, (.275", .285", .290", .294", .312", .316", .342", and .344"). And there are as many as five different RG-59 hex crimp sizes (.262", .324", .326", .360" and .384"). There are 240 possible cable to F-fitting to crimp tool combinations—and only one is right for the cables you are using.

Each cable has been designed for specific shielding requirements. Each F-fitting has been designed for a particular cable and braid coverage and does not perform properly on others. Even like cables from different manufacturers don't always use the same F-fitting. The dimensional differences in cables and F-fittings are usually undetectable without a set of calipers. Because of this, it is critical to limit the number of different braid coverages used in a system and purchase only fittings that are designed to be compatible with the braid coverage selected. Tools also must be compatible with the fittings selected. The cost of one service call caused from improper connectorization could have paid for the proper prep tool.

All of the product manufacturers will assist you with proper product selection and provide the instructions for proper usage, such as the right size fitting for the cables being used, recommended prep tools, hex crimp sizes and torque forces. Some manufacturers now have color identification for proper connector to cable compatibility, designed for optimum electrical and mechanical performance of the interface.

Ideally, your engineering department should provide the purchasing department with a parts list to ensure the pur-

chase of compatible drop components. You have to start the job with the right parts.

3) *Mechanical protection*—The best way to support an aerial cable is with an integral messenger. With some types of aerial attachments, the cable's braid can be damaged and shield effectiveness reduced even under minimal loading.

Underground cables must be protected from rock damage and kinking during installation, and buried deep enough to avoid cuts from things like rototillers and aerators. Cable used for underground installation should have a polyethylene jacket with a flooding compound under the jacket. Ideally, the underground service entrance should be in conduit.

When wiring the home, avoid kinking the cable or exceeding the cable's minimum bend radius. Cable clips should always be used to attach the cable; it is generally accepted that staples are not worth the risk of being improperly installed.

4) *Environmental protection*—F-fittings used outdoors must have environmental protection. Our studies have proven that an unprotected drop interface can corrode and lose shielding effectiveness in a matter of weeks. There are many products currently available to seal the drop interface.

Some of the F-fitting manufacturers have designed environmental protection as an integral part of the fitting. Others require the installation of grommets or parts essential to the environmental performance of the fitting. Some forms of environmental protection, like heat shrink tubing, can be added to existing fittings to encapsulate the entire interface. The cable manufacturers also have addressed this environmental problem by offering protected cables for aerial and indoor use. This is a non-flowing compound applied under the cable jacket to inhibit the migration of moisture if it does enter the cable or interface.

Applying a thin layer of silicone dielectric on the female F-port threads prior to installing the environmental protection and F-fitting helps to keep moisture migration and oxygen from entering the thread area and also reduces the chances of the fitting permanently corroding to the port. Do not fill the fitting with a wad of dielectric.

No matter what style of environmental

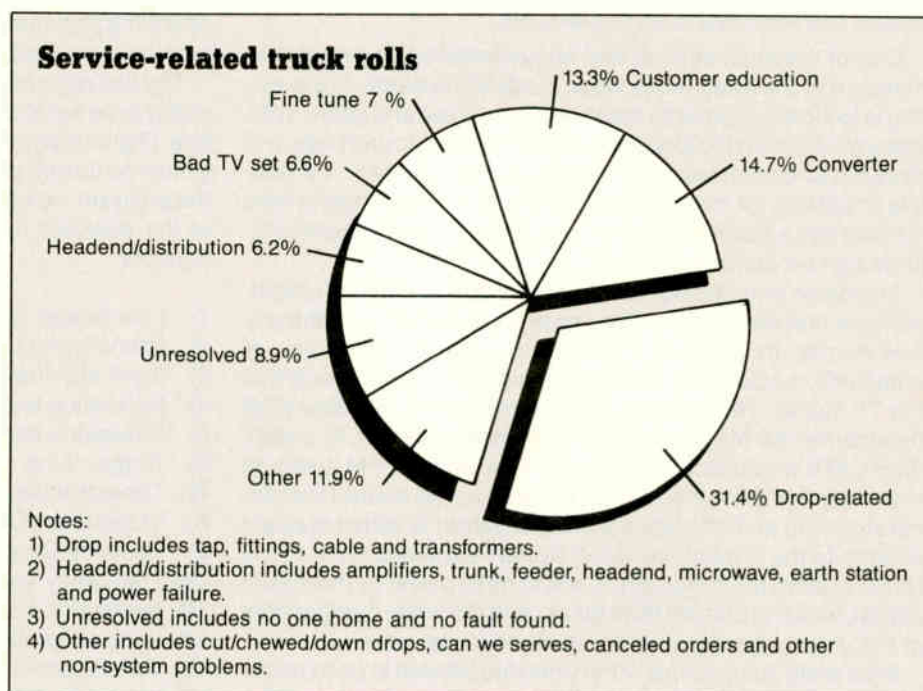

protection is selected, proper usage is a must. Always refer to the manufacturer's instructions when using any of these items.

5) *Proper cable preparation*—It is time to leave your pocket knife at home. Between all the new fittings with varying preparation dimensions and some of the new cable jacketing requirements, cable preparation has become very critical. There are a few cable prep tools that work very well to prepare the cable end in a single step without damaging the center conductor or cutting off the braid at the jacket. Shop around since some tools dull quickly and some tools with variable blades may do more harm than good if they are incorrectly set.

The National Electrical Code requirement for the new flame resistant cables went into effect July 1, 1988. Most manufacturers have not changed the cables' dimensions, but they have changed the feel of connectorization. With these new cables it is more important than ever that the cables be correctly prepared. These new cable jackets are noticeably stiffer than the PVC jackets most of us are used to. Because the jacket is stiffer and has a higher tensile strength, it is less forgiving than PVC if the cable preparation is sloppy. All of the braid must be cleared away from the dielectric core and the braid should not be cut at the jacket end.

6) *Tight fittings*—All fittings must be

wrench tightened. Finger tightened fittings will not provide long-term mechanical integrity or shielding effectiveness required in today's harsh environments.

There is continuing research and product development on extending the life and reducing the long-term costs of the drop portion of a cable system. With each new subscriber increasing a system's value by as much as \$2,500, the drop is a *big deal*. We can no longer consider it "just a piece of wire."

Rolling a truck for a service call costs approximately \$30 at the system level. In a typical 20,000 subscriber system with 3 percent service calls per month, there will be 7,200 service calls per year, costing \$216,000. Reducing service calls by just 1 percent would save \$72,000 per year.

Our studies have shown that a typical drop may fail in as little as two weeks. But, with the proper education, techniques, tools and materials, a life of five years or more can be realized. ■

Author's notes: The SCTE has formed an Interface Practices Committee to address these and other problems by defining the aluminum and drop cable interfaces and standardizing testing and evaluations. The next meeting of the Interface Practices Committee will be held at the Atlantic Cable Show in Atlantic City, N.J. on Oct. 4. A special thanks to Tom Elliott and the TCI research and development staff.

The importance of video modulation

By William Cohn

Manager, Field Installations, Zenith Electronics Corp.

One of the most difficult and misunderstood parameters to measure in the headend is video modulation depth. If the setting is too low the pictures could be washed out and jittery. With video modulation too high it is possible to have sound buzz and streaked and compressed whites on the subscribers' TV sets. It is important for the headend technician to understand how to make this adjustment properly so that the highest quality pictures can be delivered.

In order to understand how to set up video modulation depth, we must first see how a video signal is impressed onto the picture carrier. In the NTSC system we use the technique of amplitude modulation (AM) for the picture or video portion of the TV signal. The audio signal is frequency modulated (FM) on a carrier 4.5 MHz higher than the picture carrier. In a standard CATV modulator the sound carrier with the FM audio on it is mixed with the video carrier to make up the entire TV channel signal. In an AM system the video carrier is varied in direct relation to the level of the video signal modulated on it. In the NTSC system the sync signals are at peak power or maximum carrier, which is blacker than black, and the white components of the video signal are near minimum carrier power.

If the white components of the video are allowed to go too high, the video carrier could actually disappear during this time. If the picture carrier goes to zero the 4.5 MHz sound signal also will disappear. If the sound is not present for part of the time, a buzz related to the picture content will be noticed. The buzz has a 60 Hz component because the field rate of the picture is 60 Hz. This also will cause picture components that are near white to be clipped off, causing a loss of detail in bright scenes.

With video modulation set too low the contrast of the picture will appear washed out. If this condition is excessive some TV sets will not find sufficient sync signals to properly lock up the TV horizontal and vertical oscillators. TV design engineers expect to find the sync signals at a certain amplitude. If they are too low, the sync separator may start to mix picture information with the sync information, thus causing jitter and rolling in the picture.

Proper adjustment

Now that we see what can happen if video modulation is im-

properly set, what can we do to properly adjust this important operating parameter? There are several techniques that could be used to set modulation depth; two of them are presented here.

The first requires the use of a spectrum analyzer that has the ability to be set to zero span and a linear vertical amplitude setting. Digital storage is not needed for this measurement; in fact it must be turned off to use this measurement technique. To use the analyzer we will need to preset several controls on the front of the analyzer first. With no signal input, set the following controls:

- 1) Line power: On
- 2) Intensity, focus, scale: set for comfortable viewing.
- 3) Input attenuation: 40 dB
- 4) Reference level: 10 dBmV
- 5) Reference level fine: 0 dBmV
- 6) Trigger: Line
- 7) Time/division: 2 ms
- 8) Video filter: Off
- 9) Baseline Clipper: Off
- 10) Frequency span/division: 0
- 11) Resolution bandwidth: 3 MHz
- 12) Vertical amplitude linearity selector: Linear
- 13) Vertical position: Adjust so that scan line lands on the bottom graticule line.
- 14) Horizontal position: Adjust so that scan line starts left edge of graticule.
- 15) Magnifier: X1

The analyzer should be allowed to warm up for at least 30 minutes. The RF input of the analyzer is now connected to the -20 dB test point on the modulator. With the tuning control of the analyzer the output should be displayed on the screen. For example, if you were trying to set Channel 2 you would tune the analyzer to about 55.25 MHz. Using the tuning control you peak the signal (maximum vertical deflection). It may be necessary to reduce the input attenuator in order to keep the signal on the screen. When the tuning is correct the input attenuator and fine adjust are used to put the sync tips of the video waveform at the top of the display graticule. You should now have the video waveform on the screen. This will be a very similar display that would be seen on a video waveform monitor except that it will be upsidedown as shown in Figure 1.

Since there are eight graticule lines on the front of the analyzer, we have set up a calibrated display in IRE units (20 IRE units per division) or 12.5 percent per division ($8 \times 12.5 = 100$ percent). The video should have 40 IRE units of sync (2 div.) and peak white no more than 100 IRE units (5 div.) for a total of 140 IRE (7 div. total) units or 87.5 percent modulation. Peak white may be found by looking for a white reference signal in the vertical interval of the video signal. Since sync tips are constant you should always have 40 IRE units of them. If you cannot get 40 IRE of sync without causing the video to go over 100 IRE there is a non-linearity problem in the modulator or video source. The video source should be checked before it goes into the modulator with a calibrated waveform monitor. If it is normal the non-linearity is in the modulator. The video portion of the waveform must never be allowed to get all the way to the bottom of the graticule, as this is an overmodulation condition.

Each channel in the cable system can be checked in this way.

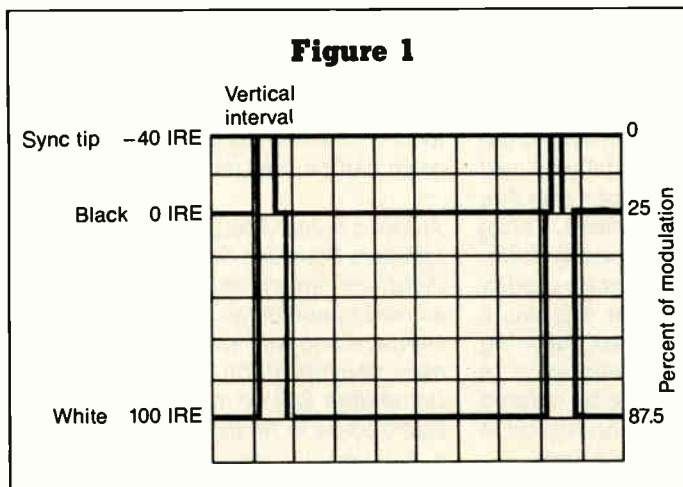

By going from channel to channel, attaching the analyzer to the various modulator RF test points and retuning the analyzer, you check each channel. If any of the channels to be tested are scrambled, the scrambling should be temporarily shut off while this measurement is made.

As an alternate possibility (Figure 2) if a spectrum analyzer is not available, a calibrated channel demodulator may be used. A Ch. 2 or 3 demodulator preceded by a good RF converter can be used to set modulation depth. The demodulator should be set to manual gain—automatic gain control (AGC) off—and have a zero chopper signal available in order to set the manual gain control. The output of the demodulator will be connected to a calibrated video waveform monitor.

The RF converter should be tuned to the channel that you want to measure. Observe the video waveform on the waveform monitor. The vertical position is set so that the sync tips are at the baseline on the display. The sweep time is set for frame or field rate. The demodulator AGC is set off (manual gain), the zero chopper on. Set the manual gain control so that the zero chopper pulse is just at the 120 IRE line at the top of the waveform monitor graticule. Adjust video modulation for 40 IRE of sync and 100 IRE of peak white. You will have to turn off scrambling for encoded channels. The DC clamp may have to be turned off on the waveform monitor. The same information about video linearity described for the spectrum analyzer operation also holds true for the demodulator technique.

The meter modules that come with some CATV modulators have a modulation function. They are only useful as a guide, but the techniques presented here are more accurate. The same can be said of the white clip lights on modulators. These lights must be calibrated properly to give a useful indication. If the light

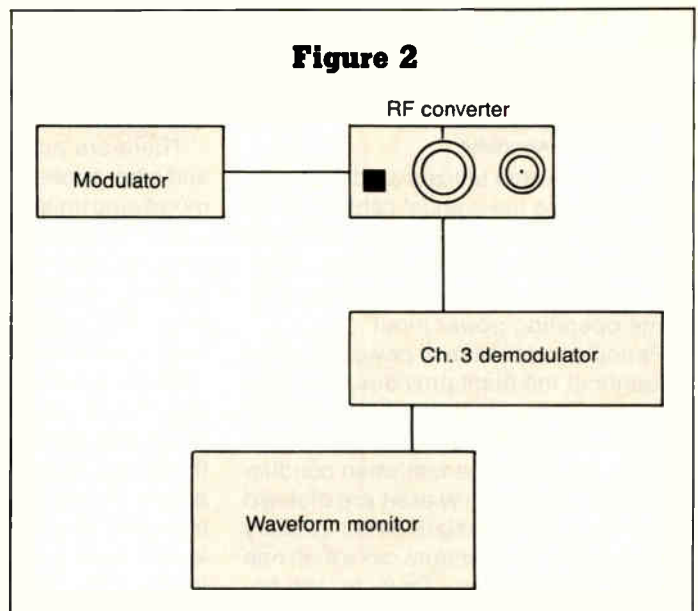

is lit with proper modulation this indicates that the white clipper needs to be readjusted. Refer to the manufacturer's recommendations on how to readjust the modulator. These guides on the modulator are sometimes fooled when baseband scrambling is used, so only check when you have turned off the scrambling.

If one of these simple techniques is used regularly by the headend technician, modulation problems will be a thing of the past. Subscribers will not have problems with sync buzz, picture instability, washed-out pictures or white clipping. ■

EXTENDED VALUE

BROAD APPLICATION *Mini Trunk* LINE EXTENDER

Triple Crown Model: LA4229

- 50-450 MHz Bandwidth
- Dual Integrated Circuit Design
- Automatic Level Control (LA4229ALC)
- 29dB Gain
- Two way capability
- Single "snap-in" module
- 18-60 Volt switching mode high efficiency power supply
- All Set-up Controls built in
- External test points
- Corrosion resistant housing with stainless steel hardware

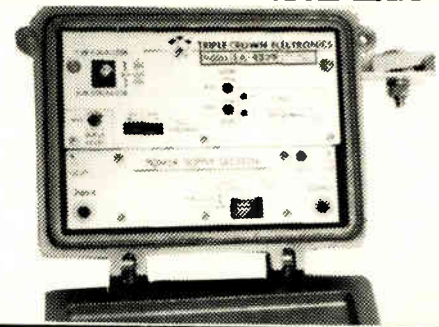

ONLY \$250.00 \$275.00 with ALC

Over two decades of innovative electronics experience is built into each and every Triple Crown amplifier. This assures you of dependable performance and excellent value.

TRIPLE CROWN

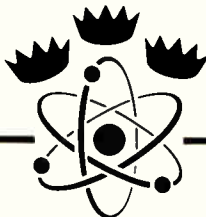

ELECTRONICS

4560 Fieldgate Dr.
Mississauga, ON L4W 3W6

(416) 629-1111
1-800-387-3205

Reader Service Number 13.

Powering CATV systems

By William O. Grant
President, GWG Associates

A CATV system utilizes amplifiers distributed along the coaxial cable to compensate for transmission losses within the cable and other system devices. Each amplifier is an active unit that requires some operating power input.

Periodic installation of power supplies throughout the plant provides operating power to each active amplifier, using the coaxial cable center and outer conductors also as the power transmission conductors. Amplifiers so powered are blocked by low-frequency (60 Hz) isolation circuitry from receiving power from more than one system power supply. Thus, for low-frequency transmission (60 Hz), the plant is isolated into several or many relatively small subsections, and all amplifiers within a subsection receive power from a single, central power supply within that subsection.

Power consuming system elements

Earlier CATV systems provided only one-way transmission capability from the point of signal origination (headend) out to all subscriber stations. Subsequent technical developments now permit two-way (bidirectional) transmission throughout the system. When such capability is provided, either initially or at a later date, then some periodic reamplification of the return path signals is necessary, and the return path amplifier modules are active devices that require powering. When engineering a system for amplifier powering, it is essential that sufficient power capacity is provided at every equipment location to accommodate any power consuming units that may be added subse-

quently, such as return amplifier modules.

There are automatic control modules and other accessory items such as status monitoring units, for example, that may be added to some or all amplifier installations, increasing the amount of operating power these installations will require. When designing the system power distribution, it is essential that sufficient power capacity to accommodate such units be provided at every equipment location.

In many systems, mainly urban applications, bridger amplifier modules are added at trunk amplifier locations to escalate transmission signal levels to create higher level feeder cable plant, and within the feeder cable plant itself, line extender-type amplifiers are required to offset cable, tap and other device losses. Both bridger and line extender amplifiers are active units that require powering.

Most generally, power is distributed to these units through the trunk amplifier installation itself and then through the feeder plant coaxial cables. When designing the system power distribution it is essential that sufficient power capacity to accommodate bridger and all line extender requirements is provided at every trunk amplifier location.

In some systems the subscriber tap units perform a number of functions other than simply distributing the transmitted signals to subscriber service drops. Some examples include taps that perform the functions of subscriber converters, and some taps are capable of descrambling previously scrambled TV signals upon commands or authorization received from the system headend. Such units are individually addressable by digital signals from the headend, and many are also

capable of digital response back to the headend. Such taps are active units in the sense that they require some operating power, and in some systems this power is provided through the coaxial cable plant itself just as amplifier power is provided.

The power requirements for any individual unit of equipment can be found in the equipment technical data provided by the manufacturer. It is necessary to clearly establish the maximum power that might be required at each type of installation. That is, one must include all modules that will be installed in the station ultimately even if some modules will not be installed initially, such as return amplifier modules, for example. The system power distribution design should provide adequate powering for completely loaded station installations and sufficient capacity to power all modules that the station may eventually be equipped with.

The actual power consumption of a station will depend upon various factors such as the type of station power module provided (series or switching regulating power supply, for example), the input voltage as applied to the station power module, etc. All this data is available from the equipment manufacturer.

Amplifier module powering

All modern amplifier modules and other active devices are transistorized or integrated circuits. They require a relatively low DC voltage for powering, typically 24 volts DC. In the early days of CATV development, attempts were made to use direct current over the coaxial cables to power amplifiers. Electrolysis problems with dissimilar metals in cable connectors, etc., eliminated this rather quickly. The approach used for years was to power the equipment with 30 volts alternating current (AC) applied over the center and outer conductors of the coaxial cables.

Later, for economic reasons, coaxial cables using copper clad aluminum center conductors were introduced to replace solid copper center conductor cables. The inherent resistance of copper clad aluminum was higher, of course, and

Figure 1: Power bypass

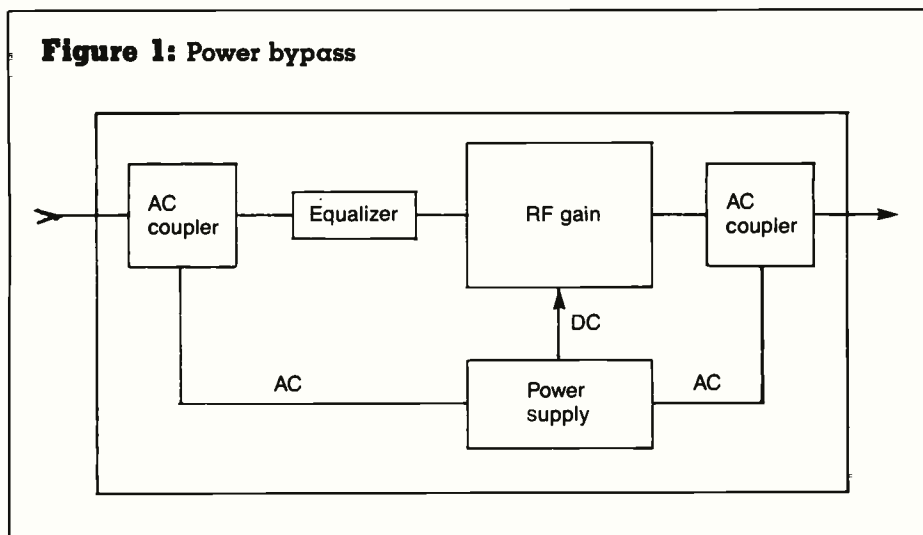
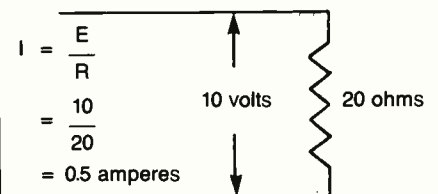

Figure 2: Ohm's law



the voltage drop introduced was such that 60 volt (60 Hz AC) operation was developed. This is the technique used almost universally in CATV systems today. To improve the efficiency of power transmission, however, a modified square wave rather than a sinusoidal 60 Hz voltage is often employed.

Then every device inserted into the coaxial cable anywhere in the system actually must provide two independent transmission paths through it. One is for RF energy, which we will qualify as being signals above 5 MHz in frequency, and the second is a low-frequency path to handle the 60 Hz energy. In any device the low-frequency path can be interrupted without affecting RF transmission at all. Thus, it is a simple matter to isolate sections of the system for low-frequency transmission (60 Hz) with no effect at all on the RF transmission through that system. Sections of a system not requiring any power at all can be isolated for 60 Hz also.

Note that although the previous discussion identifies all coaxial plant as providing two discrete transmission paths, one for RF frequencies and one for low frequency, in some systems the RF transmission spectrum may be further divided into two bands with one functioning for

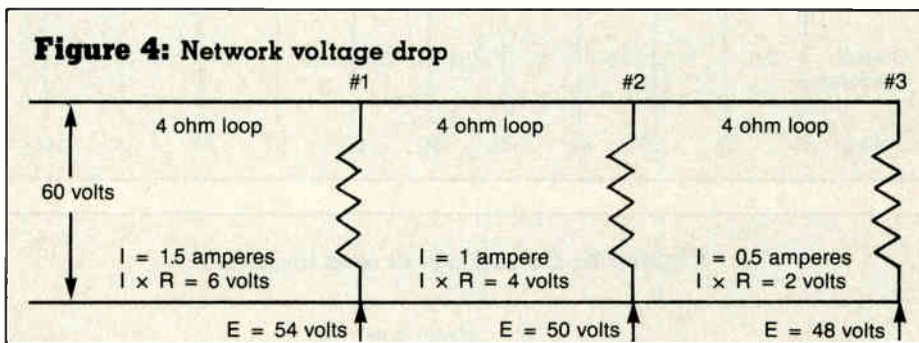
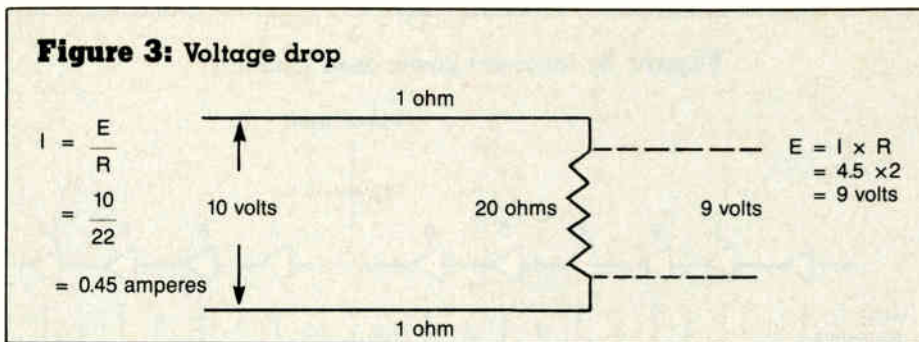

transmissions in one direction and the second for transmissions in the opposite direction. When 60 Hz energy is present in a coaxial cable, the terminations that are necessary at ends of the cable must be AC blocking; that is, they cannot be

simply resistive terminations.

Figure 1 shows 60 Hz power applied to a section of coaxial cable that includes an amplifier. The 60 Hz bypass capability of the amplifier is shown in block diagram level. As shown in the figure, any 60 Hz

Lemco
the
tools
of the
trade

Call for your free
catalogue.

(800) 233-8713

NOW AVAILABLE

LIGHT DUTY TRUCK EQUIPMENT

- VANGUARD Pick-Up & Van Racks
- ADRIAN STEEL CO. Van Interiors
- DELTA Crossover & Sidemount Boxes
- TOOL VAULT Storage Chests
- WHELEN Strobe Lights ● UNITY Spotlights
- GROTE Rotating Lights ● GEM TOP Truck Caps
- THUG BUG Alarm Systems

Installation Available
VISIT OUR SHOWROOMS
"ALL UNITS ARE IN STOCK"

LYN/LAD TRUCK EQUIPMENT
Div. of Lynn Ladder & Scaffolding

We offer the Largest Selection of Werner Fiberglass Ladders & Accessories in the Northeast.

EASTERN NEW ENGLAND
220 SOUTH COMMON ST., WEST LYNN, MA 01905 1-800-225-2510 • 1-617-598-6010

WESTERN NEW ENGLAND
164 WESTERN AVE., WEST SPRINGFIELD, MA. 01089
1-800-338-0303 • 1-413-733-8899

Figure 5: Incorrect power feed location

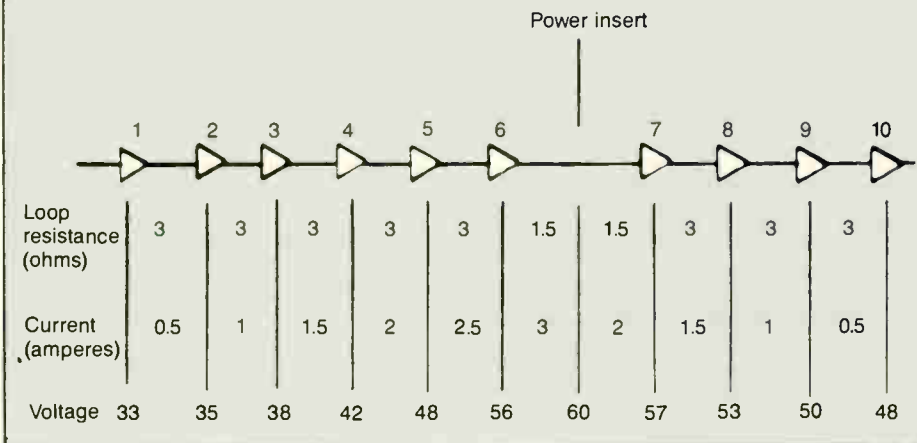

Figure 6: Correct power feed location

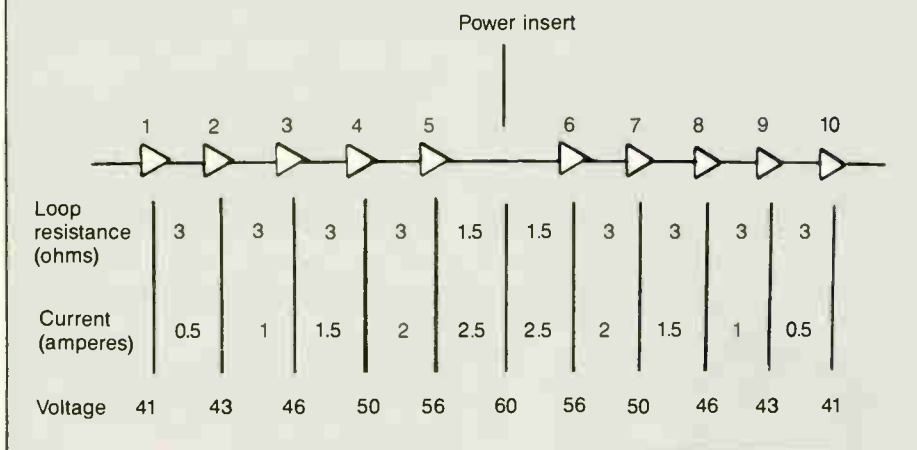
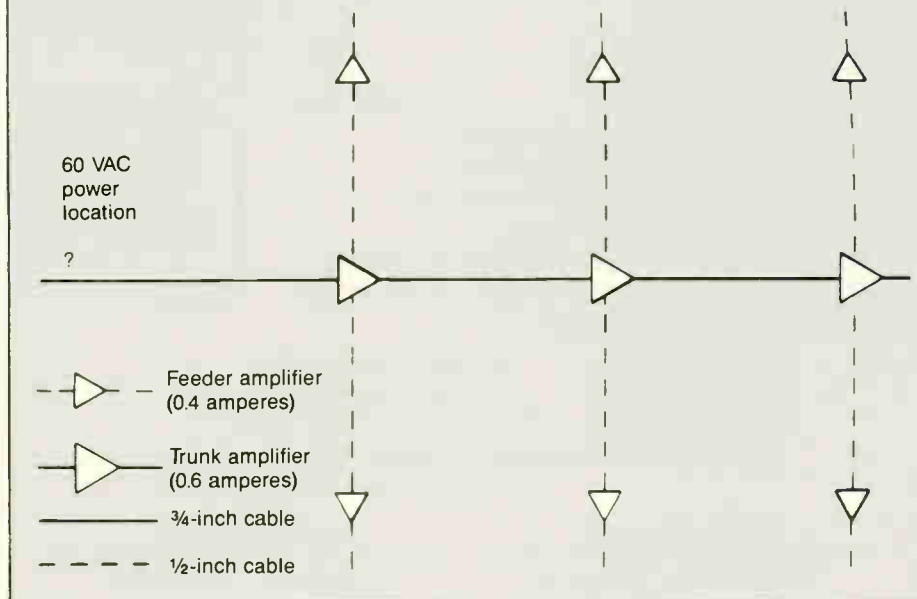

Figure 7



transmission path may be individually interrupted without altering the RF transmission characteristics of the unit.

The system power supplies are located periodically throughout the plant as required. They accept an input of 117 volts AC commercial power and output 60 Hz, 60 volt power, usually in the form of a modified square wave. Such power supplies include a variety of regulating, over-voltage and current limiting features to accommodate surges on the commercial power line from which they are fed. Lightning arrestors are commonly provided and various backup capabilities, through the use of batteries and battery chargers, are available to improve system reliability.

Earlier philosophy in CATV systems did not include backup powering of this nature on the assumption that if commercial power was out, the subscribers' sets would be inoperative also. The fallacy of this reasoning is that commercial power may be interrupted in only a small section of the community. But if that interruption shuts down the CATV system by removing operating power in only a small section of the system, everyone beyond that point would have a functioning set, but would not receive any input signals at all. As we add other non-TV services such as load management, alarms, data transmission, etc., the reliability of the system becomes more significant also.

The power module at each amplifier installation accepts 60 Hz AC input above some threshold voltage level, usually 40 volts or so in a 60 volt system, and rectifies the AC to produce a regulated and filtered DC voltage, usually 24 volts, for operation of all the active modules located in the station. Power modules are generally protected with a fuse or circuit breaker, and often gas tube arrestor-type protection also is provided on the coaxial cable center conductor to protect against voltage surges from lightning or other system irregularities.

Depending upon the design and type of a power module, there is some 60 Hz input voltage level below which the unit will drop out of regulation. When the input voltage level is below this regulating threshold, the amplifier modules may no longer perform within their specifications, and end-of-system transmission quality may be compromised.

System voltage drop

As we are applying the 60 Hz power to the coaxial cable, using center and outer conductors to transport 60 Hz power some distance along the cable, the resistance of both conductors becomes a fac-

tor in power distribution design.

Basic Ohm's law applies. If a finite amount of current is passed through a circuit with a finite DC resistance, then a drop in voltage will result. In Figure 2 we show 10 volts applied across a 20 ohm resistor. Applying Ohm's law as shown, the current flow through the resistor will be 0.5 amperes. The figure ignores the interconnecting lead resistance between the load resistor (20 ohms) and the 10 volt source. Consider the same load separated some distance from the source, with interconnecting leads that have 1 ohm of resistance each, as shown in Figure 3.

The total circuit resistance is now 22 ohms as shown in the figure, and will now draw 0.45 amperes, as calculated. If 0.45 amperes flows through 2 ohms of interconnecting lead resistance, the voltage drop through the interconnecting leads will be:

$$E = I \times R \\ = 0.45 \times 2 \\ = 0.9 \text{ volts}$$

where:

E = voltage (volts)
I = current (amperes)
R = resistance (ohms)

Then the voltage actually applied across the load (resistor of 20 ohms) will be the source voltage of 10 volts less the 0.9 volt drop, or 9.1 volts. Then the current flow through the 20 ohm resistor will be:

$$I = \frac{E}{R} = \frac{9.1}{20} = 0.45 \text{ amperes}$$

This, of course, is to be expected. The condition shown in Figure 3 is directly analogous to the problems we face in cable systems except that the cable system will have several loads, all separated by some significant cable length, and each length with its own significant DC resistance.

Figure 4 shows three circuit loads representing three CATV amplifier stations, with each load separated by 2,000 feet of coaxial cable. Let's assume that each load draws 0.5 amperes if the input voltage across it is 40 volts or higher. If the coaxial cable had 0.4 ohms resistance in the outer conductor per 1,000 feet of cable, then the outer conductor resistance between each load would be 0.8 ohms. If the center conductor had 1.6 ohms resistance per 1,000 feet of cable, then the center conductor resistance between each load would be 3.2 ohms. The operating current must flow through both the outer and

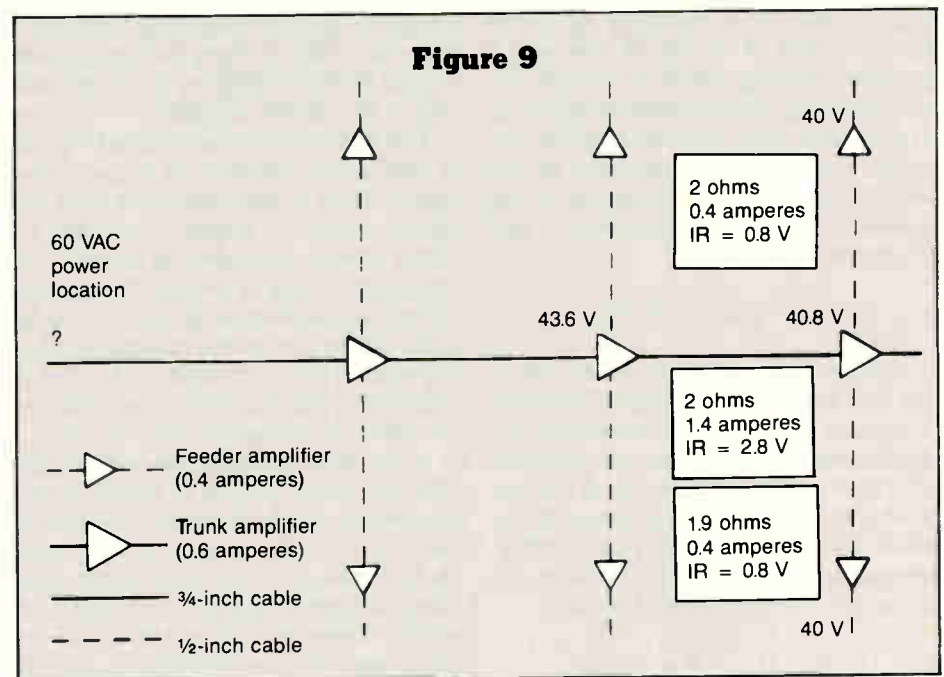
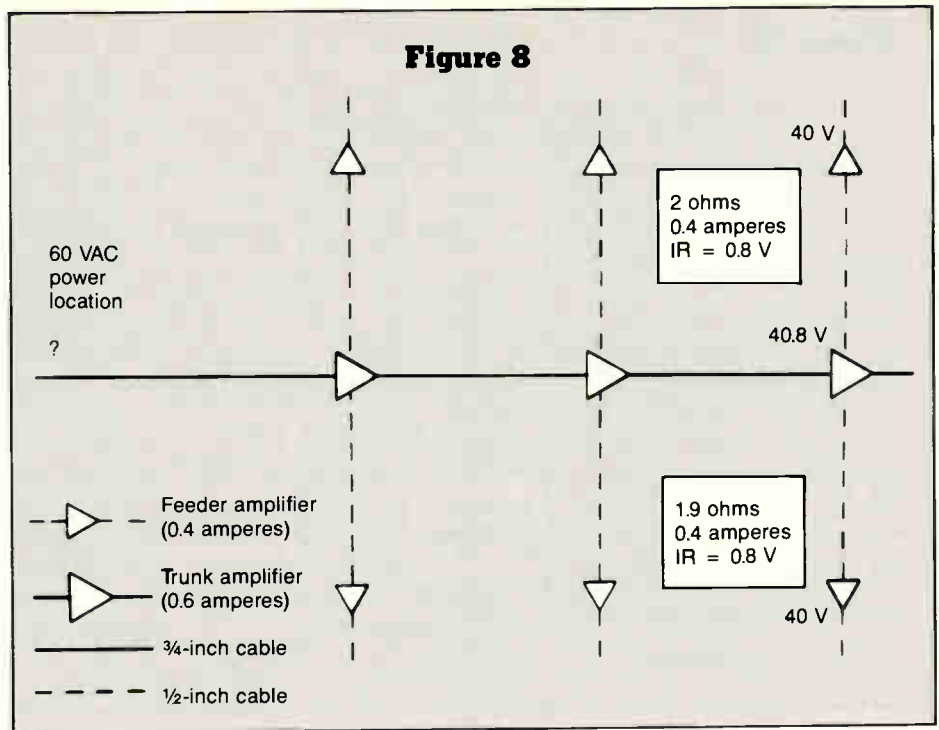

center conductors as a complete circuit, thus the loop resistance between loads would be the sum of the center conductor resistance (3.2 ohms) and the outer conductor resistance (0.8 ohms), or 4 ohms.

Let's assume the source voltage to the network was 60 volts, as shown in the figure. If each load actually draws 0.5 amperes, then 1.5 amperes is flowing through the cable conductors connecting the power source with amplifier #1. Given a loop resistance in this cable of 4 ohms and drawing 1.5 amperes, the voltage drop

through this first section of interconnecting cable would be:

$$E = I \times R = 1.5 \times 4 = 6 \text{ volts}$$

Then the voltage applied across load #1 is the 60 volt source voltage less the 6 volt voltage drop in the cable, leaving 54 volts applied across amplifier #1. Since the unit power module was specified to be able to accept 40 to 60 volts and still produce a regulated 24 volt DC output, this is acceptable.

Now let's consider the interconnecting

Figure 10

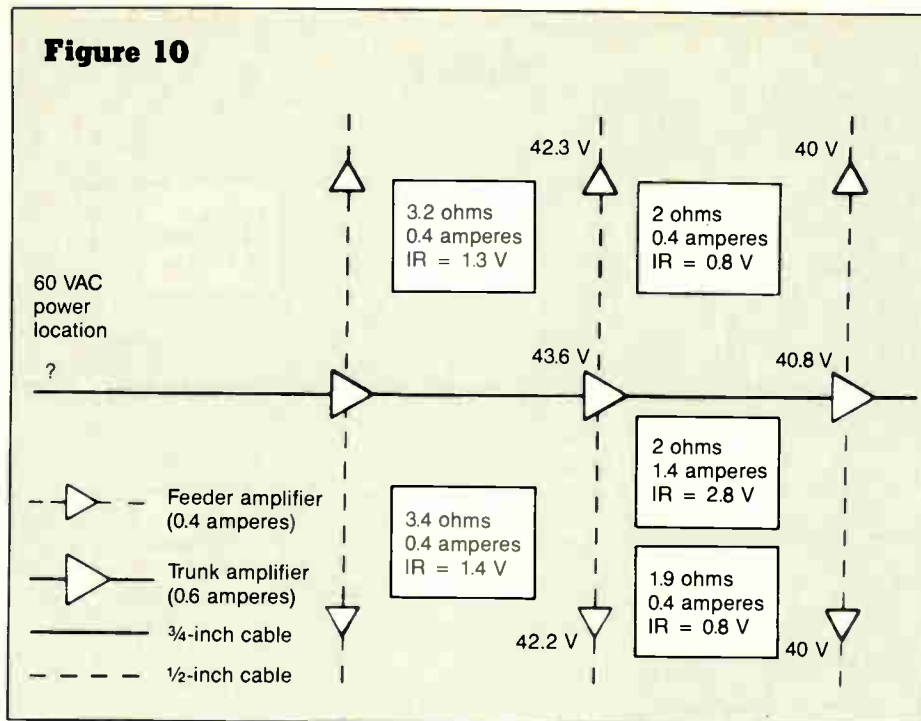

cable between amplifiers #1 and #2. The loop resistance is the same as in the previous case (4 ohms) but now only 1 ampere is flowing, which is the total current drawn by both amplifiers #2 and #3. The voltage drop between amplifier #1, which may now be considered as the voltage source for the remainder of the network consisting of amplifiers #2 and #3, and amplifier #2 is:

$$E = I \times R = 1 \times 4 = 4 \text{ volts}$$

Then the voltage applied across amplifier #2 is the source voltage of 54 volts less 4 volts, or 50 volts. This represents the source voltage to the cable serving amplifier #3, the remaining portion of the network. Again the loop resistance of this cable is 4 ohms but the only current flowing now is the 0.5 amperes drawn by amplifier #3. Then the voltage drop is:

$$E = I \times R = 0.5 \times 4 = 2 \text{ volts}$$

The voltage applied across load #3 then will be 50 volts less the 2 volts of IR drop in the cable, leaving 48 volts across amplifier #3. By specification all three loads will provide a 24 volt DC regulated output given a 40 volt AC input or higher. We had AC input to all loads of 54 volts, 50 volts and 48 volts respectively, so all loads, which were CATV amplifiers in this case, will operate satisfactorily.

For our example we used nice round figures, but let's examine Figure 5, which shows 10 stations. We assume the loop resistance between all stations is 3 ohms.

Let's examine what happens if we try to locate the system power supply midpoint between Stations 6 and 7. Power source output voltage is taken to be 60 volts AC with a 12 ampere capacity.

The total current drain of Stations 7, 8, 9 and 10 is 2 amperes as shown in the figure. Then 2 amperes flows from the power supply to Station 7 through 1.5 ohms of loop resistance as shown. The resultant IR drop is 3 volts, making the voltage applied across Station 7 to be 57 volts. We won't show the calculations, but the applied voltage to Stations 8, 9 and 10 are shown, with the worst case at Station 10 being an acceptable 48 volts AC.

In the other direction the current flow from the power supply to Station 6 is 3 amperes through 1.5 ohms. Then the IR drop is 4.5 volts producing 55.5 volts across Station 6. The subsequent operating voltages for Stations 1 through 5 are shown. Note that Stations 1 through 3 are presented with less than 40 volts, and by equipment specifications, cannot operate properly and provide a regulated DC output at the required level.

If we relocate the power supply midway

"The power distribution design problem is tedious and time-consuming and requires a series of calculations, but isn't particularly sophisticated."

between Stations 5 and 6, the individual station applied voltages are as shown in Figure 6. These are all acceptable voltage levels based upon the previous premise that the units will function properly with an input voltage of 40 volts or higher. Note that in both Figures 5 and 6, the total current drain of all 10 stations is only 5 amperes. With a system power supply capability of 12 amperes we were certainly not current limited, but we did have insufficient operating voltage at three stations in Figure 5.

And in Figure 6 we have no remaining margin to power any stations beyond #1 and #10. We were voltage limited in this case due to the long amplifier spacings and the IR drop in the long interconnecting cable runs.

This condition of voltage limiting may be commonly experienced in rural systems using higher gain amplifiers and relatively long physical spacing between amplifiers. In such instances the power supply may be unavoidably inefficiently used since its capacity (12 amperes) could not be fully utilized. It is often difficult to power a long, wide spaced system efficiently for these reasons.

Trunk plus feeder design

Examine Figure 7, which shows a small section of a trunk plus feeder system. We show three combination trunk/bridget stations with two feeder amplifiers (line extenders) powered from each trunk station. We will assume each trunk station will draw 0.6 amperes and each feeder station 0.4 amperes. We also will assume that the manufacturer's specifications on this equipment states that every amplifier must be fed a minimum AC input voltage of 40 volts.

The question to be resolved is where can we locate the 117 volt AC system power supply to feed this section of system. We start the design process by powering the most distant amplifier correctly, and in Figure 7 this would be the line extender amplifier in the upper right hand corner. The manufacturer's specifications tell us this unit must be provided with an input voltage no lower than 40 volts. We note this in Figure 8.

The amplifier locations were all previously established by the RF transmission design process. From the system layout drawings we can easily determine what length of .500-inch cable is in place connecting our line extender to the trunk/bridget unit that feeds it. From the cable manufacturer's specification sheet we can easily determine the loop resistance (inner plus outer conductor

resistance) for this length of cable. We find this loop resistance to be 2 ohms and we have entered this on the drawing inside the box as shown in Figure 8.

We previously determined that each line extender would draw 0.4 amperes of current. If a current of 0.4 amperes is passed through a resistance of 2 ohms, then the voltage drop introduced will be 0.8 volts from:

$$E = I \times R = 0.4 \times 2 = 0.8 \text{ volts}$$

Since we know we need a minimum of 40 volts applied across the amplifier, and we know we will incur a 0.8 voltage drop through the interconnecting cable, it follows that we must apply at least 40.8 volts across the network at the point where the trunk/bridger amplifier is located. We note this voltage on Figure 8.

We can now take a quick look at the other feeder amplifier fed from this trunk location in order to make certain it will receive at least 40 volts, as required. We note the length of the cable from the system design drawings and establish the loop resistance for .500-inch cable of this length. We entered that figure, 1.9 ohms, in the box on the drawing. We know this amplifier will also draw 0.4 amperes and we entered this figure as well. The voltage drop in this cable is $1.9 \times 0.4 = 0.76$ volts, which we round off to 0.8 volts. Then a voltage of 40.8 volts applied across the trunk/bridger unit would ensure 40 volts across each of the line extender amplifiers. We can proceed in the design effort to ensure 40.8 volts at this point in the trunk plant.

From the layout drawings we can determine the cable footage between the last two trunk/bridger amplifiers in Figure 9. We note that this is .750-inch cable and we determine the loop resistance of such a length of this cable. We enter this figure, 2 ohms, in the new box in Figure 9.

Since we will be feeding two line extenders that draw 0.4 amperes each, plus one trunk/bridger amplifier that draws 0.6 amperes, we add these together to determine that 1.4 amperes will flow through this section of the system. We enter this figure in the new box in Figure 9. With 1.4 amperes flowing through 2 ohms, the voltage drop through this interconnecting cable will be:

$$E = I \times R = 1.4 \times 2 = 2.8 \text{ volts}$$

If we require at least 40.8 volts across the last trunk amplifier, as we determined and notated earlier, then we will require 43.6 volts across the preceding trunk unit

Figure 11

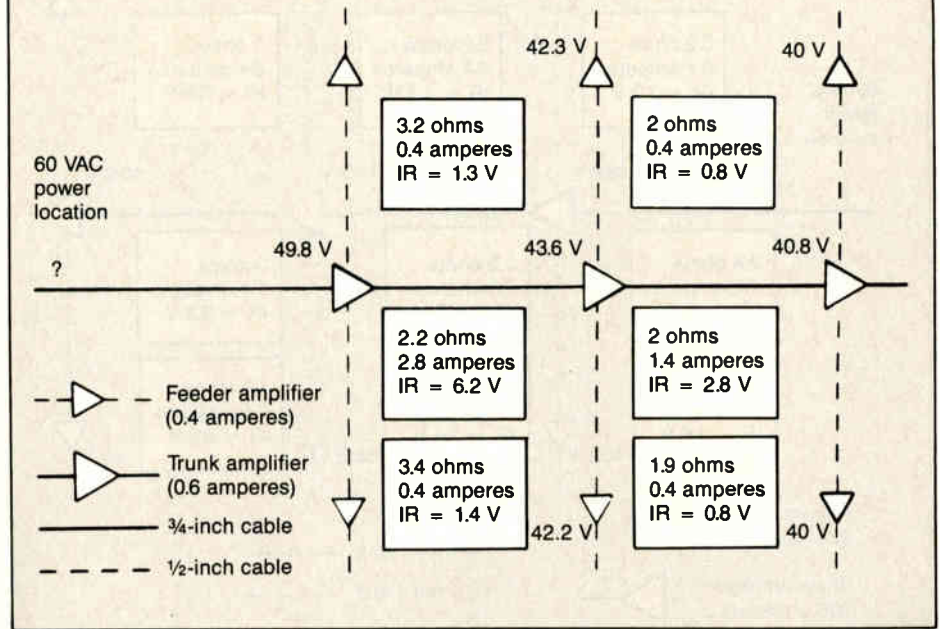

to accommodate this 2.8 volts of drop and still produce 40.8 volts at the required point. We note this figure, 43.6 volts, in Figure 9.

We can easily verify if this voltage, 43.6 volts, applied across this point, can adequately handle both the line extender amplifiers served by this point. In the new boxes in Figure 10 we show a 1.3 and 1.4 voltage drop respectively, providing 42.3 volts and 42.2 volts across these two units. This is fully compliant with the requirements so we can proceed with the design process.

In Figure 11 we have added a box indicating a loop resistance of 2.2 ohms for the next section of .750-inch trunk cable. This was determined by the amplifier spacing on the RF system layout drawings. Note that we show in this new box a current flow of 2.8 amperes. This was established by the fact that past this point we are feeding two trunk/bridger units drawing 0.6 amperes each, plus four line extender amplifiers drawing 0.4 amperes each. This totals 2.8 amperes.

The voltage drop through this section of trunk cable will be $E = I \times R$, or $2.8 \times 2.2 = 6.12$ volts, which we will round off to 6.2 volts. Quite obviously we must apply 49.8 volts across the network at this point if we are to absorb a 6.2 voltage drop and still produce the required 43.6 volts across the next amplifier. We noted this in Figure 11.

We are sufficiently experienced now to make a quick judgment that 49.8 volts across the network at this point will easily accommodate both line extender ampli-

fiers fed from this point, but just to reinforce our understanding, we can quickly review the boxes that have been added to Figure 12 to show loop resistance, current flow and consequent voltage drop. We can see at a glance in Figure 12 that both line extenders receive voltage well above the specified minimum of 40 volts even though one of these is fed through a fairly long cable run that introduces 4.1 ohms of loop resistance.

We have established that the entire network we have examined will be adequately served if we apply a potential of 49.8 volts across the first trunk/bridger amplifier. The question remains as to how far from this point we can locate the system AC power supply and not compromise this figure of 49.8 volts.

If we know that our AC power supply will output 60 volts, and we know we need 49.8 volts applied across the first amplifier in the network, then we know we can accept up to a 10.2 volt drop in the cable between the AC power supply and the first amplifier. Using Ohm's law we can determine how much loop resistance we can tolerate since we know this cable will be carrying 4.2 amperes. This current represents the total of six line extenders drawing 0.4 amperes each ($0.4 \times 6 = 2.4$ amperes), plus three trunk units drawing 0.6 amperes each ($0.6 \times 3 = 1.8$ amperes).

$$E = I \times R \text{ and } R = \frac{E}{I}$$

$$R = \frac{10.2}{4.2} = 2.43 \text{ ohms}$$

Figure 12

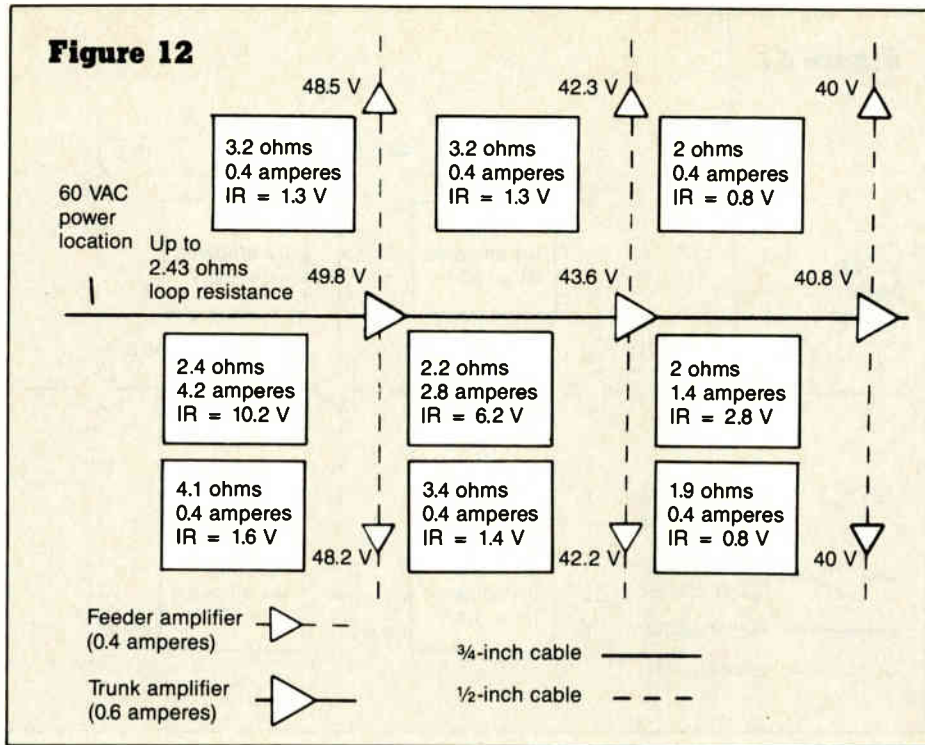

We can locate the system AC power supply up to 2.43 ohms of cable loop resistance away and still produce the required potential of 49.8 volts across the first amplifier. Since we know from the manufacturer's specifications, the loop resistance of .750-inch cable per 100 feet of length, we can easily calculate the cable footage at which the AC power supply can be spaced. We can locate it closer than this if necessary, but we cannot exceed this distance without compromising the AC voltage applied across some of the system amplifiers.

It must be recognized that stations operating at lower input voltages will draw more current and this additional current flow may produce an unacceptable IR drop in some portion of the power design. Another factor is that the loop resistance of coaxial cable will be increased at higher ambient temperatures; thus in calculating network voltage drops, some consideration must be given to the temperature extremes that the cable can logically be expected to experience.

The figure 40 volts as the minimum operating voltage input for an amplifier is arbitrary and was selected for demonstration purposes only. The reader is cautioned to review the manufacturer's specifications for the particular units that may be under consideration for a particular application.

It should be noted that any amplifier will operate satisfactorily with an applied voltage of 60 volts. Some amplifiers may require a minor manual adjustment for in-

put voltage if the input voltage is high, that is, close to 60 volts. It may be necessary to switch in some circuitry to assure that the amplifier power supply can adequately regulate its DC output with this level input. Thus some equipment provides a coarse switch adjustment, often called "local" or "remote." This allows the amplifier to be employed in locations where the applied voltage is lower, perhaps 50 volts and lower, or installed in a location where the input voltage is higher, perhaps between 50 and 60 volts, and in either case, still produce a regulated, dependable 24 volts DC for proper operation of all station modules.

Positioning system power supplies

The selection of a power supply location is often dictated by physical plant conditions. For example, commercial power secondaries must be available at that pole to feed the power supply, and adequate pole clearance must be available for mounting the unit, etc. In practice, a tentative location is marked on the pole line drawings after the system powering process has been completed, but a field visit is made to determine if that location is actually practical before the installation is made.

Note in our example that locating the power supply closer to the first amplifier location would not present technical problems, but locating it farther away would affect amplifier input voltages somewhat and could affect amplifier performance or service life.

There is some latitude in relocating power supplies, but it requires judgment, and sometimes an engineering review is necessary. Usually a repositioning of a pole span or two is quite acceptable.

Our example was a rather simple problem, but the methodology is clearly shown. In practice, we might expect to find more complex combinations involving many more line extenders, for example, but the basic technique and technical limitations would remain the same. The power distribution design problem is tedious and time-consuming and requires a series of calculations, but it isn't particularly sophisticated. In computer-assisted system designs, the power design is usually produced by the software program as the design work progresses and no special effort is required. It is still important that the engineer and system service technicians understand how power is provided to all equipment locations at the proper levels. The factors involved that must be identified with some precision are:

- 1) The loop resistance of all sizes of coaxial cables involved.
- 2) The output voltage and current rating of AC power supplies.
- 3) The current drain of all types of equipment involved, including modules that may be added to the equipment at some later date.
- 4) The minimum input voltage requirements of all types of equipment involved, including increased current drain if lower voltages are provided.
- 5) Any possible system extensions that might require powering at a later date, but have been deferred as initial construction projects, for any reason.

Powering CATV plant is less complex than developing the RF transmission design itself, and although time-consuming, should not present problems to the competent system designer. An inadequate power distribution design can have undesirable effects on long-term operation and maintenance costs. For example, if seasonal temperature changes are not anticipated and provided for in the power design, the system may operate erratically in hot weather.

If the power design is too conservative, that is, if individual power supplies are not efficiently employed, then both the initial construction cost and the operating cost of the facility may be higher than actually necessary. ■

Reprinted with permission from "Cable Television" (Second Edition, 1988) by William O. Grant.

Business Directory

Quality Reconditioned Test and Measurement Instruments

Signal Level Meters Spectrum Analyzers
Network Analyzers Sweep Generators
Microwave/Waveguide Components

hp Tektronix Riser Bond Texscan Wavetek

Calibration and Repair Service

EMS Instruments 800-234-7434



CONTRACT INSTALLERS, INC.

UHF Radio Equipped Trucks • Uniformed Installers

HOUSE INSTALLATIONS
Aerial - Underground - Pre-wire
APARTMENT INSTALLATIONS
Post wire - Pre-wire - Commercial Building
Tap Audits

Install or Remove Traps and/or Converters
Drop change over for System Rebuilds

LENNY FISCHER
(414) 582-7087

P.O. Box 1564
Appleton, Wisconsin 54913-1564

SIGNAL LEVEL METER REPAIR

Prompt, Professional Service
at Reasonable Prices

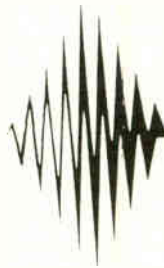

JGL
ELECTRONICS, INC.

4425 BLACKSTONE DRIVE
INDIANAPOLIS, INDIANA 46237
317-783-6130

RITE CABLE CONSTRUCTION, INC.

Aerial and Underground Coaxial and Fiber
Optic Cable Installation Nationwide



Contract Installers Also Available

1008 Main Street West
Valdese, North Carolina 28690
704-874-4202

EARNEST E. BLISS
Operations Manager

L.C.E.

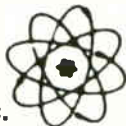

Long Cable Electronics, Inc.
"For the Finest in Converter Repair"
"Equipment Brokered"

Call Ned:
518-393-5415

1228 Albany Street, Schenectady, NY 12304

See us at the Atlantic Show, Booth 609.
See us at the Mid-America Show.



Communications



Construction, Inc.

"Committed To Service Excellence."

Customer Installations • Multiple Dwelling Units
Plant Construction and Maintenance

(714) 542-1055 • (619) 442-0713

CONTRACTOR'S LICENSE NO. 526824-A/SUPERCC 121M2

IT'S HERE!

THE MAGAZINE FOR INSTALLERS AND TECHNICIANS

From CT Publications Corp.

Basic electronics theory

This is Part VI of a series about basic electrical and electronic principles, designed for the individual with little or no training in either electricity or electronics.

By Kenneth T. Deschler

Cable Correspondence Courses

This month we will study the basic principles that govern the operation of both direct current (DC) and alternating current (AC) generators and motors. We also will cover the terms used when dealing with AC.

Direct current generators

In our first lesson we saw that current could be induced in a conductor if it were passed through a permanent magnetic field. Last month we saw that if the lines of force of an electromagnetic

field cuts across a conductor, current also could be induced into a conductor.

A generator is a device that changes mechanical energy into electrical energy by magnetic induction. The amount of energy delivered to the output of a generator is dependent upon:

- 1) The strength of the magnetic field.
- 2) The angle of the conductor within the magnetic field.
- 3) The speed of the conductor within the magnetic field.
- 4) The area of the conductors within the magnetic field.

Figure 1 shows a basic DC generator. In its present position, the ends of the loop of wire (armature) are connected to a two-piece commutator. Making contact with each half of the commutator are graphite blocks called brushes, which are part of the output circuit of the generator. In the output circuit are contained a load resistor and an ammeter. As the loop is rotated clockwise it enters the magnetic field and current begins flowing from the left hand brush through the ammeter and load resistor to the right hand brush, through the loop of wire and back to the left hand brush. This rise in current flow is shown by the dark line going from zero to a maximum value on the graph. This maximum value is reached when the coil is parallel with the magnetic field.

Continuing rotation, the value of current decreases to zero when the loop is again straight up and down. As the coil continues to rotate until it reaches its starting position, another increase and decrease of current occurs. Because a complete rotation represents 360°, we can then say that maximum current is generated at the 90° and 270° points and that minimum current is present at zero and 180°.

If an additional conductor is added to the armature, the changes in the output current (ripple) become less pronounced as shown in Figure 2. Notice that we now have maximum values every 90° of rotation of the armature. Because generators used commercially contain many conductors in their armature, ripple is very small.

Alternating current generators

The only difference between a DC generator and an AC one is that an AC generator uses slip rings instead of a two-piece commutator. Figure 3 shows an AC generator and its output waveshape. In most AC generators, electromagnets replace the permanent magnets.

The waveshape shown indicates that as the armature is rotated clockwise, current flows from zero to a maximum positive

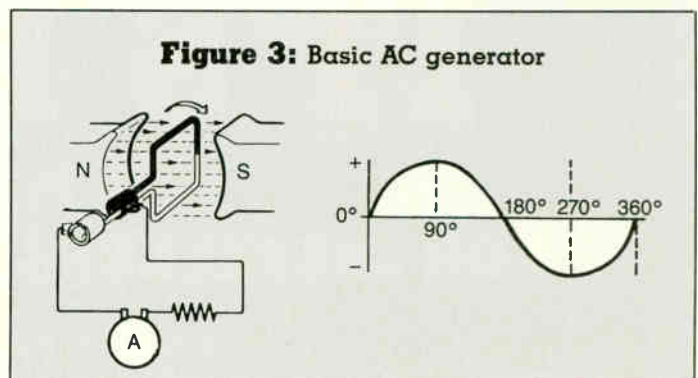
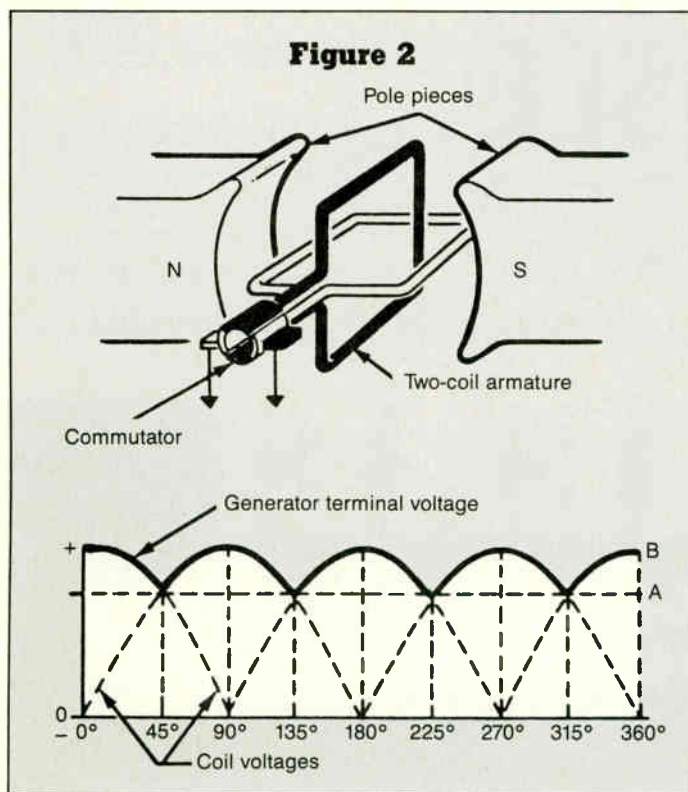
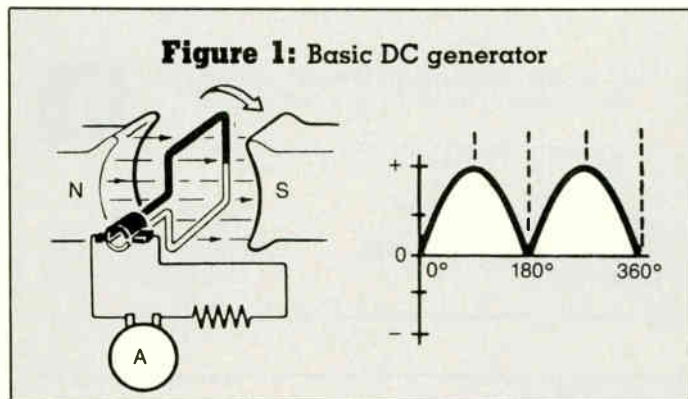

value at 90°, falls to zero at 180° and continues to a maximum negative value at 270° where it decreases in value and returns to zero at 360°. This waveshape is known as a *sine wave*.

Alternating current

Alternating current is defined as a current that continually changes in magnitude and periodically changes in direction. One rotation of a conductor within a magnetic field is called a cycle. A cycle contains one positive and one negative alternation. The number of cycles that occur within a specific amount of time, generally one second, is called the frequency of the generator's output. The unit of frequency is the *Hertz*. The time required to complete one cycle is called its *period*.

With this in mind, a frequency of five cycles in one second would mean that one cycle would have a period of one-fifth of a second. The physical distance traveled by one cycle of a sine wave is called its *wavelength*. Figure 4 shows these units.

Figure 5 shows the various designations used to refer to sine wave amplitudes. The first designation to be covered is the *peak* value. This is the maximum value of either the positive or negative alternation of the sine wave. The *peak-to-peak* value of a waveform is the difference between the maximum positive peak or amplitude of the waveform and its maximum negative peak. The *instantaneous* value is the value of current or voltage at any instant along the sine wave. The instantaneous value is always given at a specific angle. The *average* value of voltage or current is the sum of all of the instantaneous values divided by the number of samples taken. The *effective* or *RMS* value is the value of AC that will result in the same amount of heat produced in a resistor by an equal value of DC. The abbreviation RMS stands for root mean square. Most voltages used in electronics are in RMS values.

To convert from one value to another, the following relationships exist:

Average	=	.636 × peak
RMS	=	.707 × peak
Peak	=	1.57 × average
Peak	=	1.414 × RMS
Peak-to-peak	=	2.828 × RMS

The term *phase* is used to designate the angular separation between two or more cycles of alternating current. In Figure 2 we can see that the two alternations are 90° *out of phase* because one starts when the other has achieved its maximum value (90°). Voltages or currents are *in phase* when their maximum values occur at the same time. The term *polyphase* means that two or more cycles of AC are flowing at the same time within the circuit.

Direct current motors

A motor is a device that changes electrical energy into mechanical energy. The operation of a motor is based on the principle that when a current-carrying conductor is placed within a magnetic field, perpendicular to the lines of flux, the interaction between their fields will cause the conductor to be either attracted or repelled. The principle that like poles repel and unlike poles attract is the reason for the rotation of the armature.

Figure 6 shows the reaction of the armature to the field magnets in a DC motor. Note that as a new segment reaches the brushes, the current is reversed in the loop causing a reversal of the north and south poles of the loop. In a practical

motor, the permanent magnet fields are replaced by electromagnets. Motors are classified by the method of connection of armature and field windings. Figure 7 shows the three main methods of connections for motors.

A *series wound* motor has both the field and armature windings in series. The advantages of a series wound motor include large turning force (torque), variable speed characteristics and the ability to be connected to either AC or DC sources. Series wound motors are sometimes called *universal* motors.

A *shunt wound* motor has the field winding in parallel (shunt) with the armature. Once adjusted, a shunt wound motor will

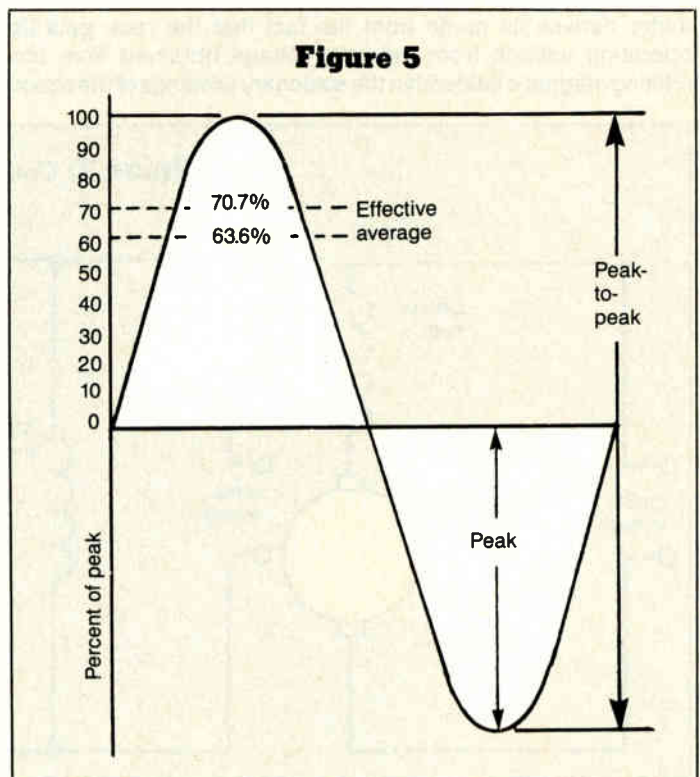
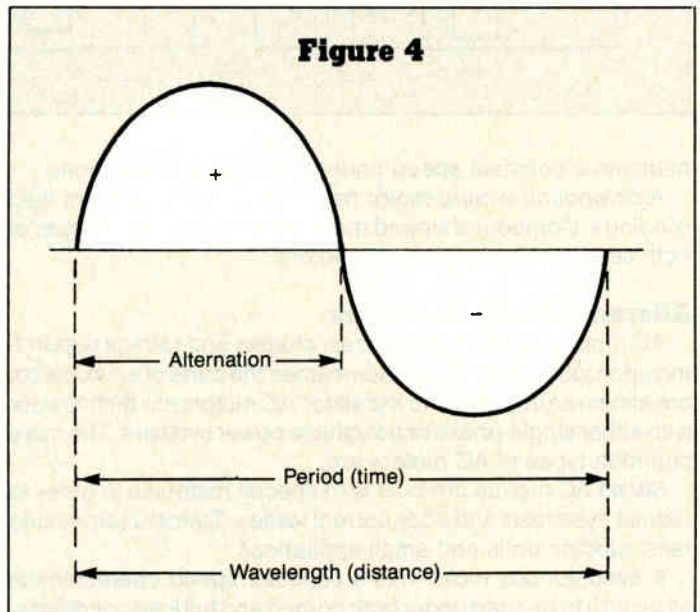
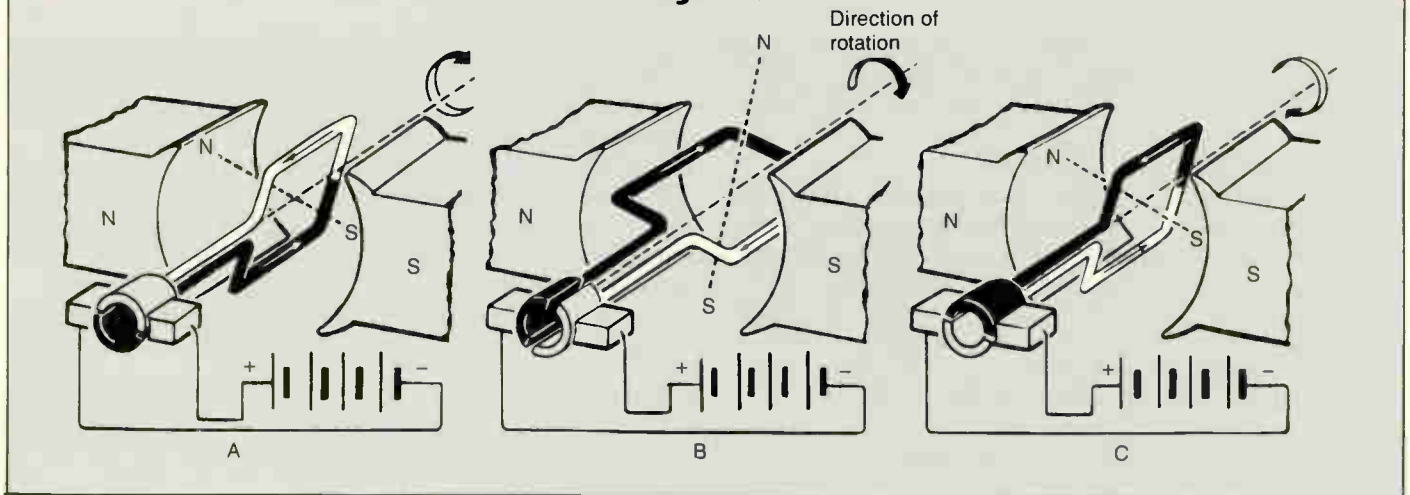

Figure 6



maintain a constant speed under varying load conditions.

A *compound wound* motor has both series and shunt field windings. Compound wound motors exhibit the advantages of both series and shunt wound motors.

Alternating current motors

AC motors come in many sizes, shapes and ratings depending upon job requirements. Sometimes the parts of an AC motor are known as the rotor and the stator. AC motors are built to work with either single-phase or polyphase power systems. The more common types of AC motors are:

Series AC motors are built with special materials in order to reduce hysteresis and eddy current losses. Typical uses include fans, electric drills and small appliances.

A *synchronous* motor has a constant speed characteristic allowing it to be used under both no load and full load conditions.

An *induction* motor is the most commonly used AC motor. This motor derives its name from the fact that the rotor gets its operating voltage from induced voltage obtained from the rotating magnetic field within the stationary windings of the stator.

A self test

- 1) DC generators have _____ rings and AC generators have _____ rings connected to their armatures.
- 2) Define AC.
- 3) How are a sine wave's period and frequency related?
- 4) How are DC motors classified?
- 5) A motor that can be operated on either AC or DC is called a _____ motor.

Answers

- 1) Split, slip
- 2) A current that continually changes in magnitude and periodically changes in direction.
- 3) Frequency is the amount of cycles that occur in a time period. A period is the amount of time to complete one cycle.
- 4) By their method of winding.
- 5) Universal.

Figure 7: Connections for motors

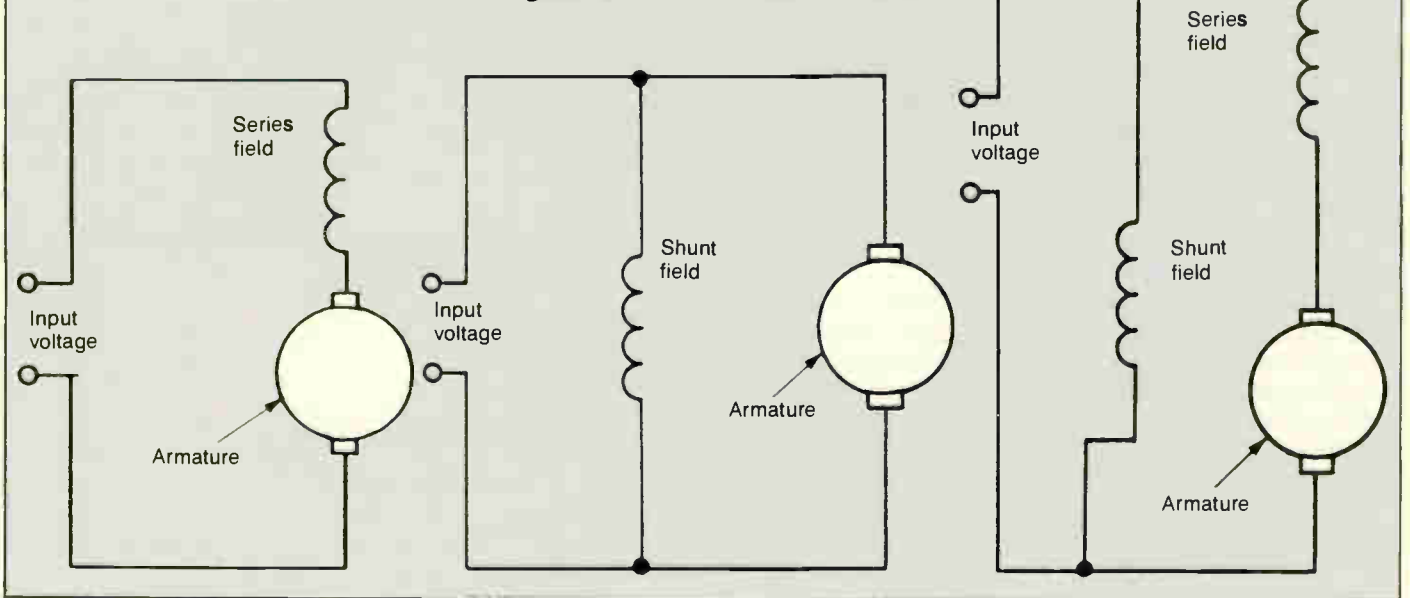

Trunk system passives

The following material is designed to provide a basic understanding of the function and characteristic of each passive device that is used in the trunk portion of the CATV distribution system. It is an edited excerpt from the "Signal Distribution" lesson contained in the NCTI CATV System Overview Course. Graphs, illustrations, electrical characteristics and signal level calculations are included to demonstrate the actual effect each passive device has on the trunk system RF signals. The actual RF signal levels, amplifier characteristics, cable, insertion and tap losses presented in this article are purely for illustration purposes and may or may not reflect your actual trunk system characteristics or specifications.

By Ray Rendoff

Technical Training Director
National Cable Television Institute

And Lowell Williams

CATV Technical Consultant, Versacom Inc.

Passive devices can reduce signal level, compensate for cable slope or divide the signal equally or unequally. They are passive because they do not use external electrical power. Those passive devices commonly used in the trunk system include *power inserters*, *filters*, *pads*, *equalizers*, *splitters* and *directional couplers*.

Power inserters—The power inserter couples the 60 Hz AC from the CATV

Figure 1: Power inserter block diagram

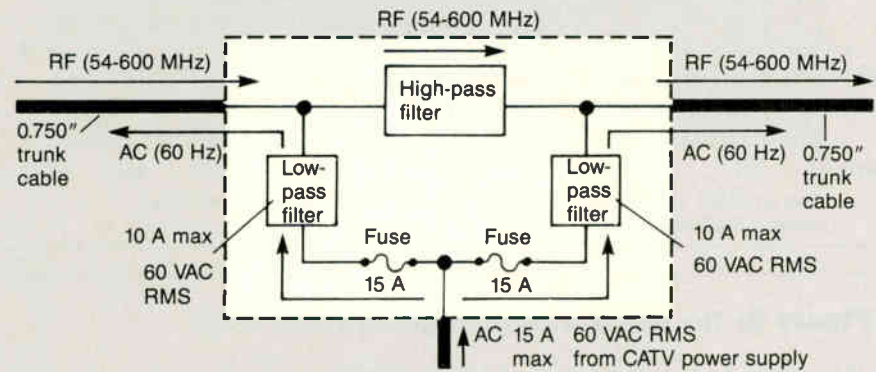

Figure 2: Downstream trunk input duplex filter

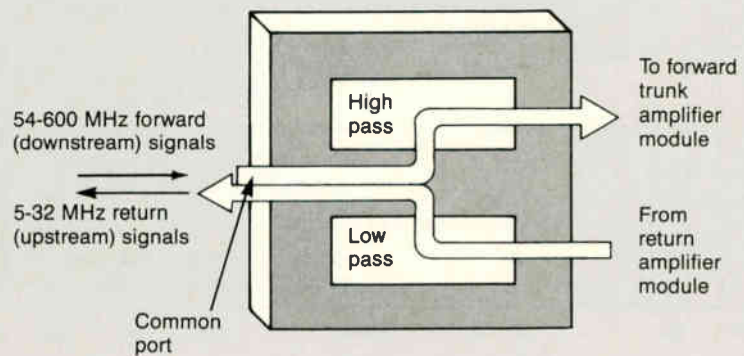
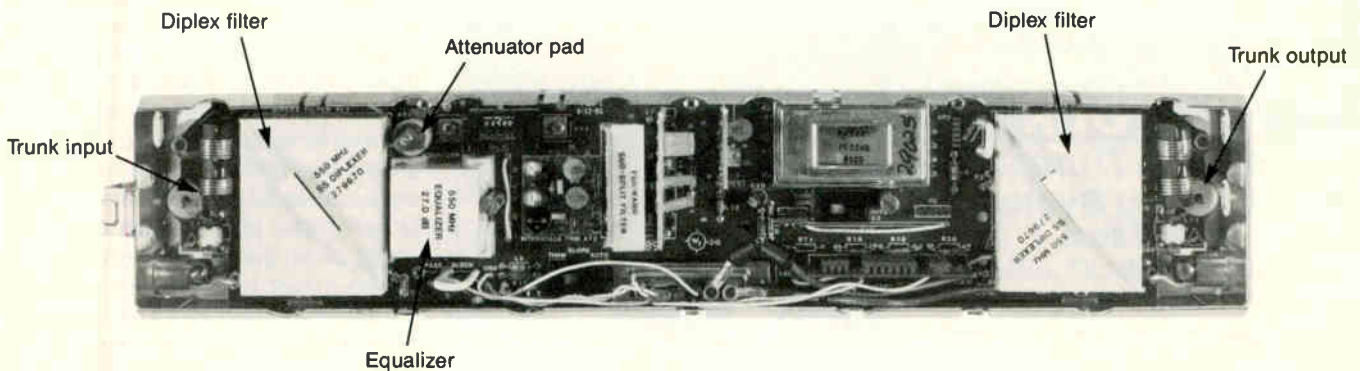

Figure 3: Trunk amplifier module



(Courtesy of Scientific-Atlanta)

Figure 4: The effects of a pad on signal levels

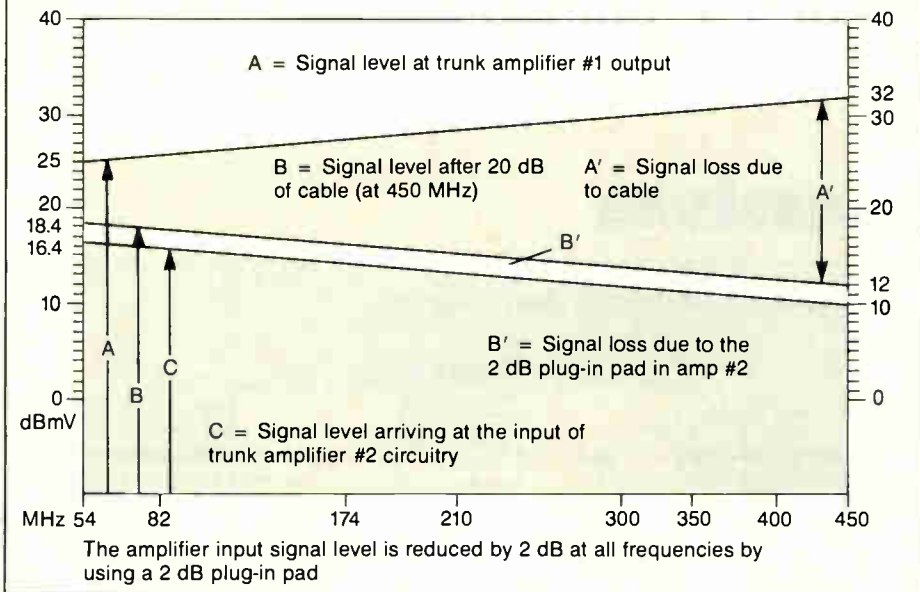
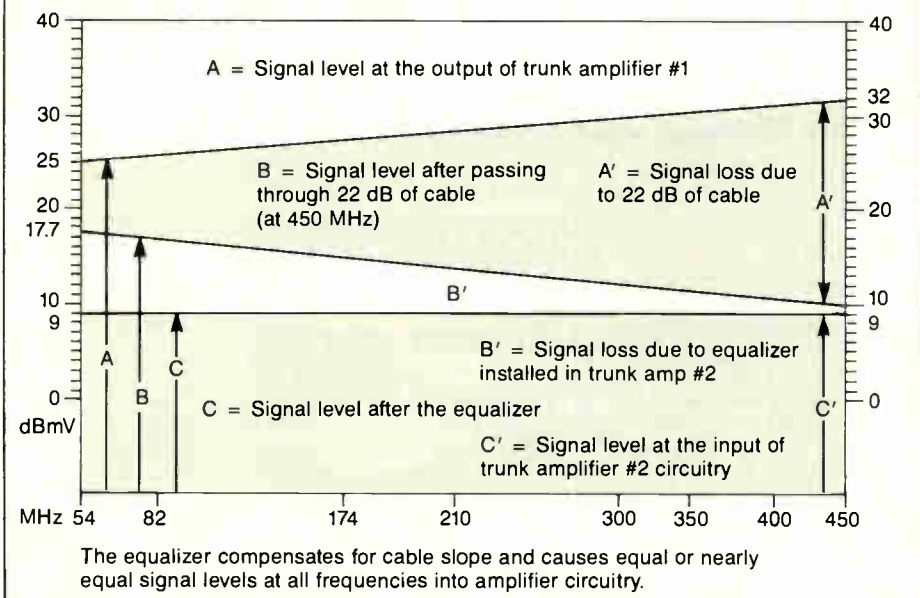

Figure 5: The effects of an equalizer on signal levels



power supply onto the trunk cable. (See Figure 1.) It directly connects to the trunk cable. The power inserter possesses important filtering abilities that allow the electrical power to enter the trunk cable but prevent the RF signals on the cable from escaping into the power supply.

Filters—Diplex (high-/low-pass) filters are installed at the input and output of each trunk amplifier module or housing in two-way systems to separate the downstream (forward) and upstream (return) signals (Figures 2 and 3). High-pass filters pass the downstream (forward) signals (54-600 MHz), whereas low-pass filters pass the upstream (return) signals (5-32 MHz).

Pads—If the input signal levels to all amplifiers were equal, all trunk amplifiers would have exactly the same gain. This is desirable, since trunk amplifiers work best when set for a specific amount of gain. When the signal is higher than the optimum level at a trunk amplifier input, it is usually attenuated to the correct level by means of a pad, a passive device inside the trunk amplifier module (Figure 3) that adds attenuation. The pad (resistive attenuator) reduces the overall level of the signal coming into the trunk amplifier at all frequencies as shown in Figure 4.

Equalizers—The equalizer is installed within the trunk amplifier module (Figure 3) or housing preceding the actual amplifier circuits to compensate for the attenuation slope of the cable only. The slope of an equalizer is opposite in direction to the slope of the trunk cable (Figure 5). The equalizer attenuation value can be selected to combine with the cable attenuation to cause equal or nearly equal signal levels at all frequencies at the input of the amplifier circuitry. The trunk amplifier gain at all frequencies is set by adjusting the gain and slope controls to replace the signal that is lost in the trunk cable and equalizer. These adjustments "balance" the output signal level of each amplifier to the output of the preceding amplifier.

Splitters—When designing the layout of a cable system, it is sometimes necessary to send the signal from the headend or a trunk amplifier in different directions on two or more trunk lines. A two-way splitter used for this purpose is a signal power divider that splits the RF signal into two signals of equal value. If there were no internal splitter losses, each output level would be 50 percent or 3 dB lower than the input level. However, all trunk splitters do actually have internal losses that somewhat vary with the frequency. This internal loss, known as insertion loss, for an SAS2F splitter is 3.8 dB at 300 and 330

10,000 MDU Enclosures IN STOCK At ALL Times

Most Locking Systems and Sizes

Lockinator™, Pedlock™, Intertite, Vendor, Padlock, etc.

Viewsonics inc.

170 Eileen Way • Syosset, N.Y. 11791 • Toll Free: 800-645-7600 • In NY: (516) 921-7080

See us at the Atlantic Show, Booth 603. Reader Service Number 16.

MHz, 4 dB at 400 MHz, 4.1 dB at 450 MHz and 4.2 dB at 550 and 600 MHz. The example in Figure 6 specifies a 4.1 dB insertion loss at 450 MHz. With a +28 dBmV trunk input level at 450 MHz, this two-way splitter would have +23.9 dBmV at 450 MHz at each output port.

Directional couplers—Another method of dividing the signal on the trunk line is with a directional coupler. A directional coupler is a signal power divider that produces unequal output signal levels. With this device, a small amount of signal (low-level output) is removed from the trunk line, allowing most of the signal (high-level output) to continue along the trunk cable (Figure 7A). A directional coupler inside the amplifier housing is used at the output of the trunk amplifier module to feed signal to the input of the bridging amplifier module (Figure 7B).

Figure 6: A two-way splitter equally divides the trunk signal

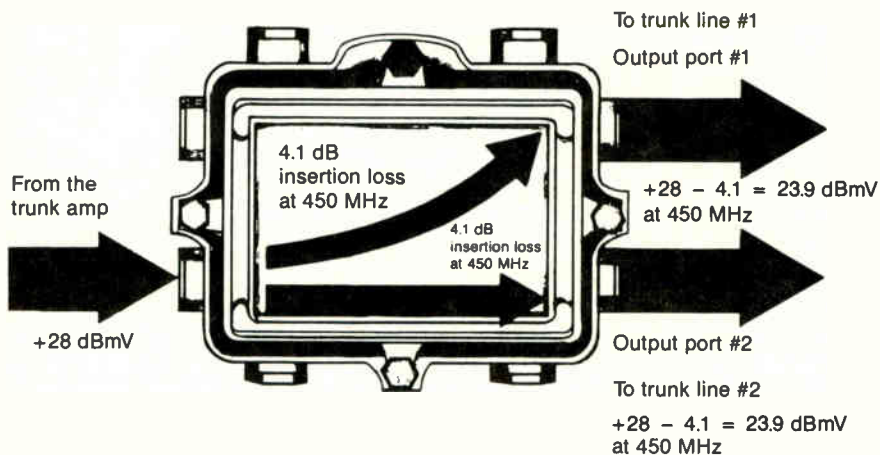
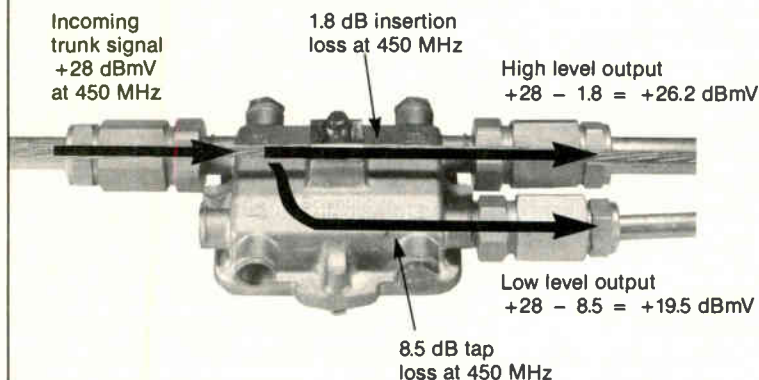
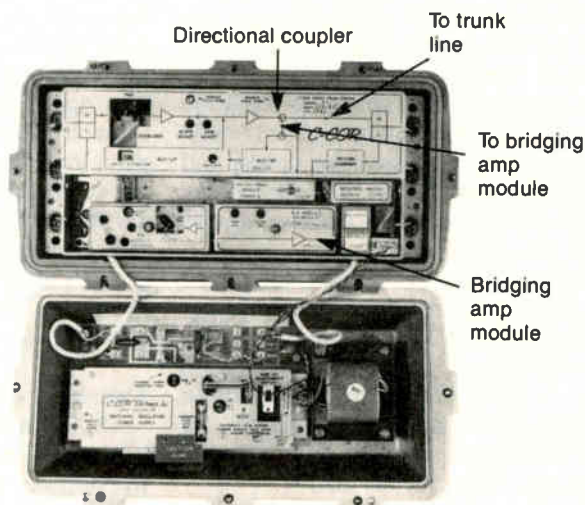

Figure 7: Trunk line directional coupler applications



A (Courtesy of Scientific-Atlanta)



B (Courtesy of C-COR)

MIDWEST CABLE SERVICES

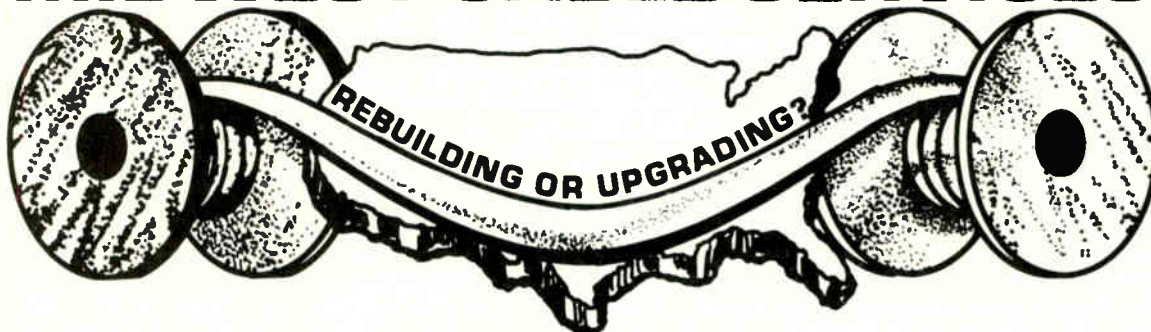

— **NATIONWIDE BUYERS** —
CATV SCRAP CABLE AND USED LINE GEAR

322 N. Michigan Street, Plymouth, IN 46563
 Phone (219) 936-2545 FAX (219) 936-5749

Reader Service Number 14.

Installer Input

Customer relations in two acts: Act II

Taken from the *Performance Plus Installer Manual*, this is the second part of a two-part article that discusses ideas and methods of customer relations for installers and field personnel.

By Dana Eggert

President, Performance Plus

Scene I: Difficult customers

Action: The installer parks his truck in front of the house, known to all back at the cable system as the "Bates Motel." Having drawn the shortest straw, the installer slowly opens his equipment bin, puts on his tool belt and proceeds cautiously to the front door and rings the doorbell. Stepping back, almost to the edge of the porch, the installer braces himself for the onslaught. The door opens and violently slams into the wall behind it—it's Mother Bates! (Audio under: *Psycho* show music)

"Where in the \$\$*#@ have you been? I've called your office 16 times. You people don't know what you're doing, otherwise you'd have been here two weeks ago when I called the first time. What is your problem? Can't you do anything right? I've had a lousy picture for two weeks! Somebody's going to pay for this!"

Even though you would like to turn and run, unfortunately, you don't have that option. Granted, these types of customers are not easy to deal with, but since you do have to deal with them occasionally, it is important to have the customer relations skills necessary to get the job done.

Purpose and focus

When you arrive at a job site, you usually have a single purpose for being there—either to install cable, reconnect, disconnect or troubleshoot. Focusing on that purpose or job order helps you to organize your actions—where to start, what equipment will be needed, what information to give to the customer, how long it may take, etc.—to get that specific job done.

Maintaining focus is important when dealing with difficult customers. After a battery of insults and complaints, it is easy to lose sight of your goal. In fact, all your defense shields go up and all you want to do is get out of that uncomfortable situation, whether or not you finish the job or

solve their problem.

Where do you start? You start by keeping a very clear focus on why you are there. Some tasks are obviously going to be easier to maintain focus on than others, for example, installing new cable. Even though every new connect is a little different, there is still a starting and stopping point, and at the end of your efforts there should be a quality signal on the customer's set with a certain number of channels.

If you are there to fix a "snowy" picture it may be harder to maintain your focus, especially since different customers have different expectations of what an acceptable picture is and some customers may be altogether dissatisfied with any picture. Difficult customers can confuse that purpose even further by adding complaints and problems not originally reported. First it is the snowy picture, then the audio isn't working right, then the VCR doesn't work properly and it's all the cable's fault. In any event you are there to solve the customer's problems.

Two-way information

All customers need a certain amount of information to feel comfortable about you working in and around their home and about purchasing the cable service—what is involved with your visit, how it will affect their property, how long you will be there, how to operate new equipment, what services they will be receiving, etc. Because difficult customers seem to attack everything you say, you start to realize it may be easier not to say anything at all. Nevertheless, these customers may be operating with little or no knowledge about cable TV and perhaps with preconceived biases about the service. It is important to provide the customers with the same information regarding the purpose of your visit and the cable service itself.

Show and tell

Explaining or simply telling difficult customers something is not as effective as showing them. For example, if you are explaining the process of setting the audio level through the converter, telling a customer becomes too lengthy and possibly too complex. Showing the customer how to set the audio, then asking him if he has

any questions or if he would like to try it while you are still there, keeps the conversation focused on the completion of the task rather than more complaints or verbal attacks.

Just as you will provide information to the customer, you want to gain information from the customer in situations such as troubleshooting. Frequently, difficult customers spend much of their energy complaining rather than providing information that will help you complete your job. In these situations, it is to your advantage to focus their attention to neutral territory—simple, factual information that helps you achieve your ultimate purpose. Asking open-ended questions, or those questions that require more than a simple "yes" or "no" response is key in achieving that focus.

While some customers may continue to be uncooperative, perseverance usually pays off. For example, you may ask the customer to describe the problem. If it is a snowy picture, ask him to describe the picture he originally called about before turning on the set. Then ask him to turn to the channel that has the most snow and verify that this is, in fact, the problem he described. Next, verify with the customer a satisfactory solution to the problem, for example, to eliminate the little white sparkles from the picture.

By asking open-ended and verifying questions about the specific problem and a satisfactory solution, you keep the customer's attention focused on the final objective—to solve the problem.

Protecting your mental health

When you are exposed to a Mother Bates, you may start to wonder, "Why me? What have I done to deserve this?" You are simply in the wrong place at the wrong time. It would not matter who was standing at her door—she will unload on the next living, breathing, reacting human being. So, don't take the insults or verbal abuse personally. They are not aimed at you necessarily; they are aimed at anyone who will react. By reacting personally to the difficult customer, you frequently only encourage the steady flow of nastiness.

Another approach to protecting your own well-being is to mentally prepare before each job. For those Mother Bates

who have established a reputation in the cable system, you know what you are getting into and can think about your attitude and review the customer relations skills on the way to the job site. But difficult customers that take you off-guard can trigger those personal defenses that tend to get in the way of focusing on your purpose. Getting into the habit of preparing for a potential difficult customer will protect you from being taken off-guard.

Finally, always be courteous. Even though you would like to say, "It's your own TV, you old hag," it is imperative to maintain an unemotional outlook and demeanor. Being courteous with a difficult customer helps keep your personal feelings out of the situation, which makes it hard for the customer to elicit any reaction.

Scene II: Difficult situations

Action: As the deluge of complaints begins to subside, the installer inches his way forward on the porch toward the door. Mother Bates begins to open the door for him, but as he starts to enter he is overwhelmed by the smell of alcohol coming from her. The installer hesitates, "If I go, she'll be even madder, but if I stay..."

Certain difficult situations may be encountered in your normal day-to-day work activities, some more frequently than others. Many of the correct procedures for dealing with these situations are for your own protection. Unfortunately, in this day and age of lawsuits and because you are on and off personal property all day long, you could potentially be blamed for activities you did not do. In any case, you will need to exercise your customer relations skills to handle and solve these problems.

Inconvenient/awkward situations

When you are greeted at the door, you must determine if the situation is acceptable for you to begin the installation. If there is anyone who is partially dressed, too sleepy or drunk to understand you, if a party is going on or there is loud angry shouting, indicate to the customer the possibility that you have come at an inconvenient time. Then suggest that you come back at another time and leave immediately.

If you are greeted at the door by a person under the age of 18, ask to speak to a parent or an adult over 18. If no adult is present, *do not* proceed with the installation and briefly explain that it will be re-

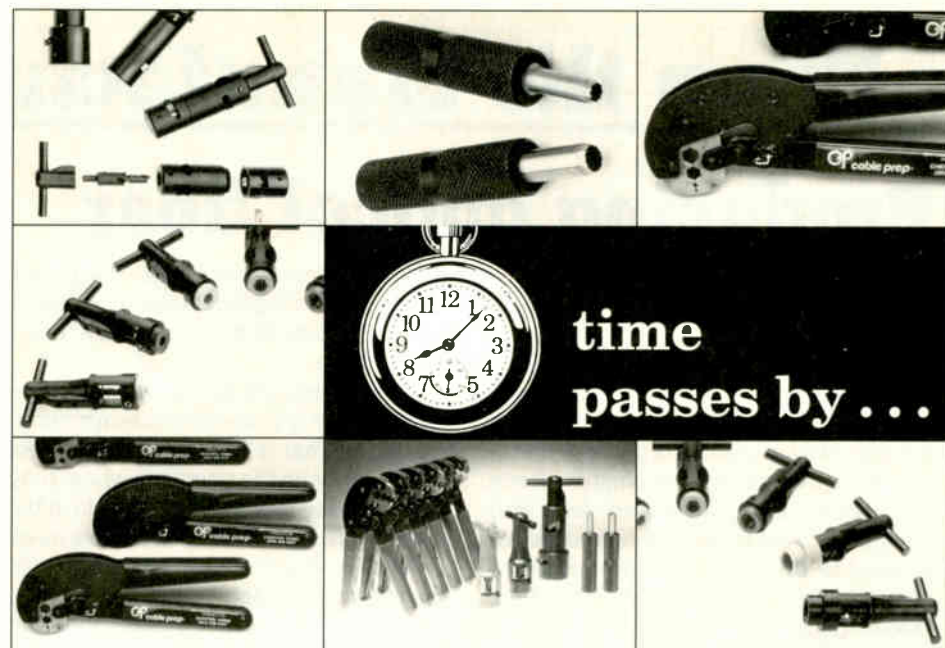

but our tools are here to stay!

- Made in the U.S.A.
- Proven in the field for durability
- Hand-crafted from precision parts
- Service-oriented manufacturer



207 Middlesex Avenue
Chester, CT 06412-0373
(203) 526-4337 FAX: (203) 526-2291

scheduled. This is to protect you from any inappropriate accusations.

At times, a customer may become too friendly and make inappropriate advances toward you. *This is a serious situation.* Do not hesitate to leave the installation as quickly as possible. Collect all your tools immediately and politely explain to the customer that you have to go back to the office. Then leave immediately. Indicate the exact reason for leaving the job site on the work order and report the situation to your supervisor so that other arrangements can be made to complete the installation.

Sometimes these situations can be so uncomfortable that an installer may be embarrassed to report the problem. But, these same situations can become so serious legally that it is imperative to report the problem. If you have difficulty dealing with a situation ask your supervisor for help.

Some customers may seem overly interested in what you are doing, particularly to their property. Others may want to know about the technical aspects of CATV and question each part of your installation procedures. These customers tend to watch you at all times, both outside and inside the house. Be patient; quickly answer all the customer's questions while you con-

tinue to work. If the customer follows you around, make sure he does not hurt himself on your equipment. Do not let the customer help you, even if he offers.

If a child is following you, be even more cautious and do not hesitate to ask the parent to assist in maintaining the child a safe distance away from you, explaining that you are concerned for the child's safety.

The missed appointment

A common situation for the installer is for a customer not to be home or not answer the door when the installer is on time for the scheduled appointment. If no one answers the door, contact the system office so that the customer can be telephoned in case he is sleeping or doesn't hear you. If no one answers even after the system telephones the customer, leave a door tag indicating your name, the date and time that you were there.

If you are late for an appointment, be honest and apologize for the delay and any inconvenience. Do not make excuses for your lateness or become defensive. Shift the customer's focus by getting right to work. If you know you will be late, contact your dispatcher and ask that the customer be notified, rescheduling the installation if necessary. ■

From the Manufacturer's Side

Producing optical fiber

By Scott A. Esty

Market Development Supervisor
Telecommunications Products Division
Corning Glass Works

The principle of communicating with light is not new. In fact, using light as a medium of transmission is perhaps one of the oldest forms of communication. Early signal fires and smoke signals, reflecting sunlight off a mirror and semaphores are all ways in which light has been used to communicate. Alexander Graham Bell, following his invention of the telephone, actually considered his invention of the photophone to be one of his greatest tech-

nological accomplishments. The photophone uses reflected beams of sunlight to communicate from one point to another distant point.

Unfortunately, the sun is not always present, nor are the elements always cooperative. Neither is everyone in the direct line of sight with the person to whom they want to send a message. In order to make light communications effective, we need a way to bend light around corners and get beyond solid objects.

Contemporary with Alexander Graham Bell, a British scientist, John Tyndall, demonstrated a way to confine light and ac-

tually bend it around corners. His experiment reflected light out through a hole in the side of a bucket of water. He was able to demonstrate how the light was confined to the curved stream of water, actually re-directing the path of the light. The physics principle at work here is the one of total internal reflection.

The physical property of a transparent material, which results in total internal reflection, has been quantified as its refractive index (n). It is defined as the ratio of the speed of light in a vacuum to the speed of light in that specific material:

$$n = \frac{C_{vac}}{C_{mat}}$$

where:

C_{vac} = speed of light in a vacuum

C_{mat} = speed of light in that material

Light travels fastest through a vacuum, but as light starts to travel through denser materials, it actually slows down a little. Each transparent material has its own

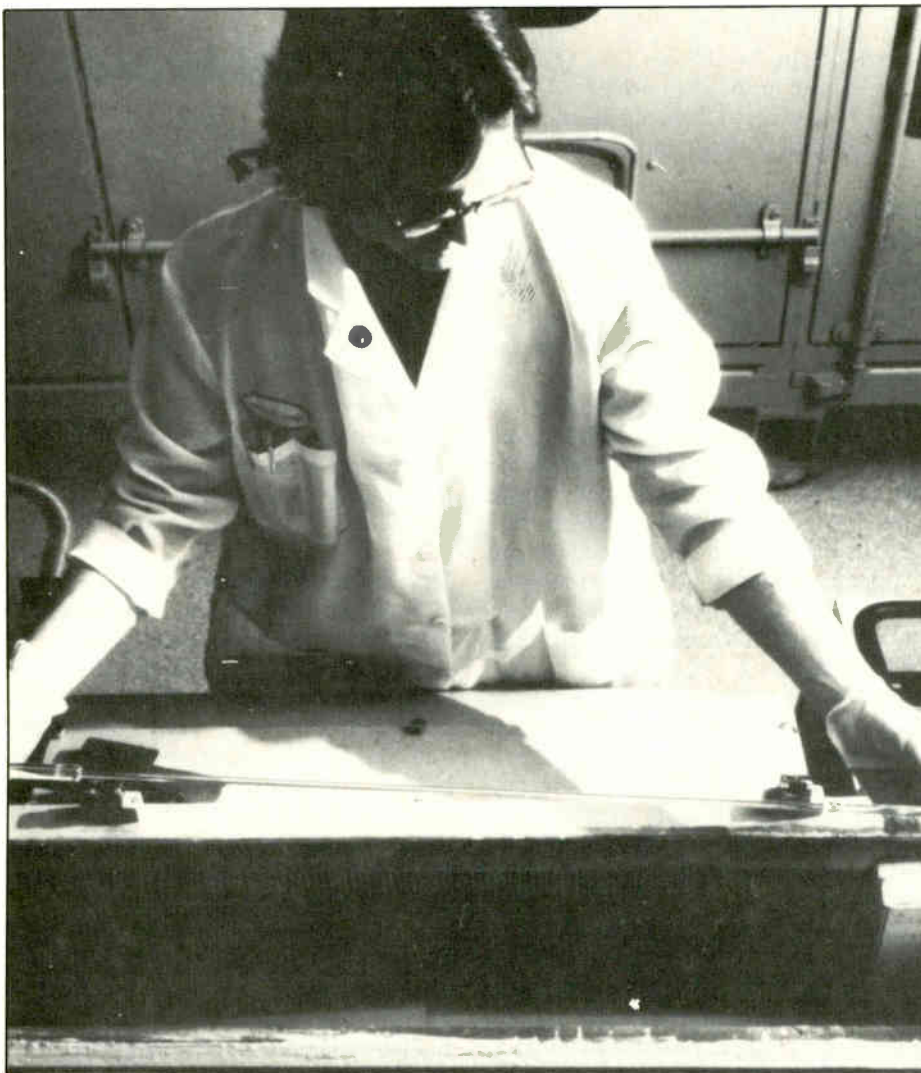

Courtesy of Corning Glass Works

At Corning Glass Works' optical fiber manufacturing facility in Wilmington, N.C., a technician places a "bait" in a lathe, the first step in the outside vapor deposition process.



Courtesy of Corning Glass Works

The completed preform is removed from the lathe.

unique refractive index value.

Associated with the index of refraction is a corresponding critical angle of incidence. The reference plane for this angle is the surface of the material in which the light is traveling, if the bordering substance has a different refractive index. If the rays of light strike this interface at an angle smaller than the critical angle of incidence, almost 100 percent of the light is reflected back into the medium.

All of us have experienced this phenomenon when looking across a still pond. In looking out across the water we can see the opposite shore reflected off the surface back to us. However, as our line of sight comes closer to our feet, at some point we actually can see through the surface of the water to see the fish swimming below. This effect is even more pronounced when swimming under the water where it was almost impossible to see up out of the water.

Similarly, rays of light traveling parallel in a strand of glass would have a difficult time escaping from that strand so long as their angle of incidence remained small. There are two keys to making such a glass path that would transmit light for communications purposes. The first requirement was to make a glass sufficiently clear that enough of the initial light power (about 1 percent) could be detected after 1 kilometer (half a mile). This was recognized as the minimum distance that would be required to make optical communications over glass fibers economically cost-effective. The greater problem was designing a refractive-index structure that would sustain the transmitted signal definition over the required distance.

Although glass appears to be perfectly clear, most glass, as we know it, has many impurities and quickly attenuates or reduces light power. For example, ordinary window glass has so many impurities that just a 1/4-inch thick pane reduces the light power by 50 percent. Optical glass (which is made much purer for use in glass lenses) is pure enough that it would take up to 10 feet of optical glass to attenuate 50 percent of the light power.

Back in the late 1960s, after the invention of the laser, there was a renewed effort underway to try and refine glass to achieve the goal of getting at least 1 percent of the light through a kilometer of glass. In 1970, scientists at Corning developed a process to manufacture glass fibers that would transmit definable pulses of light this threshold distance. The breakthrough matched ultra-pure glass with a unique glass structure.

To confine the light within the interior of

the fiber, the glass fiber design actually consists of a core glass, with one refractive index, and a concentric cladding glass with a lower index of refraction. Corning scientists included a dopant in the core glass to raise its refractive index above that of the cladding glass. The core/clad interface also has to be perfectly smooth and round in order to eliminate any possible inconsistencies that could bounce the light out of the core.

In contrast to the well-known procedure of manufacturing glass by melting sand and then molding or forming it, the technique for making optical fibers took an entirely different approach. Corning scientists already had developed a process for manufacturing high-purity glass. The basic raw material for glass is silicon dioxide (SiO_2), also known as silica. In nature, silica is the molecular building block of quartz crystals. Silicon also reacts with other materials, one of which is chlorine, to form a liquid or gas, silicone tetrachloride. By reacting ultra-pure silicon tetrachloride in the presence of oxygen a silica glass of the finest purity attainable can be produced.

The original fiber-making process, which the Corning scientists also invented, began with a silica-glass tube to confine and direct the glass-forming reaction process. This tube-dependent method is the inside vapor deposition (IVD) process, one version of which is also known as the modified chemical vapor deposition (MCVD) process. The silica-glass tube was pre-made by a melting process and thus contained impurities, but this was not initially critical since the glass tube would ultimately be outside of the light carrying region of the fiber, on the outside surface.

In the currently used MCVD process the glass tube is placed in a lathe, reminiscent of a wood lathe, only more technologically advanced. In this lathe the tube spins while a flame burner traverses back and forth along the length of the tube to heat it. While both these operations are taking place, control valves allow a mixture of gaseous silicone tetrachloride and other dopant chemicals to enter the inside of the tube. In the presence of heat and oxygen these gases react and form a very fine glass dust known as "soot" along the inside surface of the tube.

Over a period of time, while the flame traverses back and forth with the tube spinning, layer upon layer of this fine glass soot is deposited on the inside surface of the tube until nearly all of the void is filled up. The heat of the passing burner also changes the soot layers to clear glass. At

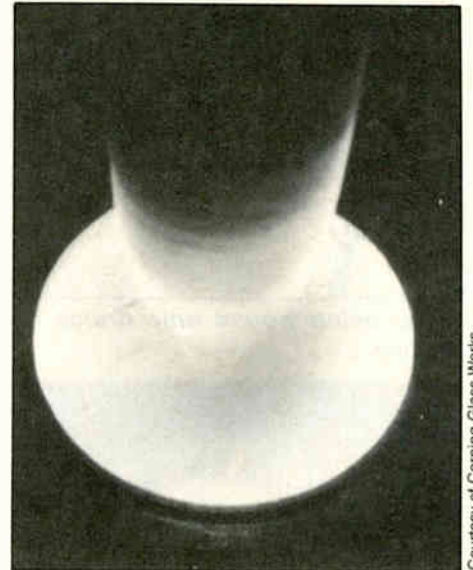

A soot preform is lowered into the consolidation furnace.

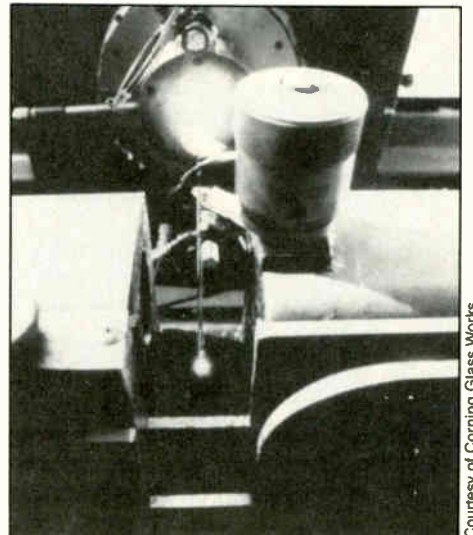

Hair-thin optical fibers are drawn from drawing tower.

the point where the glass tube is full, the chemicals are turned off and the heat on the burner is turned up. This increased heat collapses the remaining center hole and draws the tube down to a thinner diameter. The resulting clear glass rod then awaits the next step of the process, which will be explained later.

This IVD process, which was the earliest fiber manufacturing process, has some inherent limitations. To begin with, there are some obvious concerns over the fiber's strength. Glass is inherently a very strong material when it is pure. However, the presence of impurities or flaws on the surface of the glass greatly diminishes ultimate strength. Since the tube that initiated the process eventually becomes the outside surface of the glass fiber, this was a limiting factor in terms of the fiber's ultimate strength. This tube was pre-

Courtesy of Corning Glass Works

Courtesy of Corning Glass Works

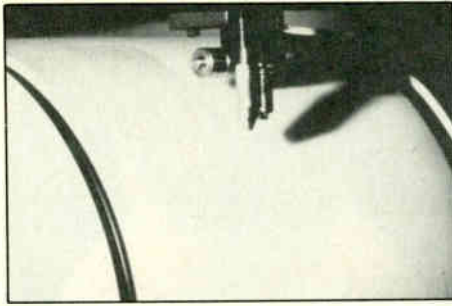

Courtesy of Corning Glass Works

Fiber being wound onto drums for testing.



Courtesy of Corning Glass Works

The optical measurement bench provides precise measurement capability.

made by a melting process, which makes it practically impossible to completely remove all impurities. The physical dimensions of the tube (less than a 2-inch diameter) and its heat-transfer limitations also were obstacles to a consistent, cost-effective product.

Corning scientists were anxious to get beyond the constraints imposed by using a tube. After several generations of improvement, the outside vapor deposition (OVD) process was developed. Corning was able to retire all of its MCVD manufacturing equipment by the early 1980s.

The OVD process begins with a rod that also is placed in another specially designed lathe. This rod is used as a target for the accumulation of layers of glass soot on its outside surface. Again, the raw materials are introduced in a gaseous form through precise control valves. However, they are introduced into the flame where the reaction takes place. As the reaction occurs, the glass soot deposits

itself on the rotating rod in the lathe. As the reaction flame traverses back and forth along the rod, layer upon layer of glass soot is deposited. The resulting soot structure is called a preform.

In order to form the core and the cladding of the fiber, the ingredients or composition of the materials that are being reacted in the flame is changed. The core glass is laid down first with one mixture of ingredients and the cladding glass then has a different recipe. The entire structure is ultra-pure deposited glass, increasing the fiber's strength and purity.

After the preform is completed, it is removed from the lathe and the original rod is removed from the preform. The preform, appearing a white chalky color, is then taken to the next step—consolidation. At consolidation, the white chalky preform is lowered into a consolidation oven where, at high temperatures, the glass soot is consolidated to a clear glass "blank." This process step also removes any water molecules that could attenuate light around the 1,380 nanometer wavelength.

After this point in the process, both the inside vapor deposition and the outside vapor deposition processes proceed along similar lines. Either the glass rod with the tube as its outside surface, or the glass blank made by the OVD process, are taken to the top of a drawing tower. Here these solid glass cylinders are lowered into the drawing furnace by a speed-controlled machine.

The end of the blank is heated and begins to melt. As it melts, a gob of glass drops away from the blank and falls down through the drawing tower, trailing a thin strand of glass behind it. This gob of glass is caught at the bottom of the drawing tower and attached to a tractor assembly—and what happens then is analogous to a very high-tech taffy pull. This thin strand of glass is pulled out of the blank with the same core/cladding dimensional ratios as existed in the blank. An interactive sensor monitors the diameter of the fiber as it leaves the blank. This sensor controls the diameter by adjusting the speed of the draw, resulting in diameter control to within ± 2 microns.

In order to protect the fiber's glass surface from contamination, which potentially could induce flaws and thus decrease its strength, an acrylate-plastic coating is immediately applied to the fiber as it's drawn. This coating is applied in two layers—a soft inner layer that is in contact with the fiber and a harder outer layer that will become the outside surface of the fiber for protection in later cabling and

handling situations. The coating is cured with ultraviolet light.

Fiber lengths vary. Most manufacturers produce lengths from 1.1 to 2.2 km for multimode optical fibers and 2.2 to 12.6 km for single-mode fibers. Corning's process enables manufacture of unspliced 25 km fiber lengths, with even longer lengths available on special request.

The finished glass fiber with its protective coating is then spooled onto reels and is now ready for a series of specific quality checks.

One of the first tests is a strength or proof test. Every inch of the fiber is actually stretched to identify any possible flaws. This tensile testing is done at a level of 50,000 lbs. per square inch, and is a destructive test, breaking the fiber at any point weaker than this.

After the proof test for fiber strength, the fiber is tested optically. The tests characterize its level of purity or attenuation, its information-carrying capability and a number of other parameters depending on the specific product type. Each wavelength of light interacts with the specific glass materials in a unique way. Consequently, glass is more transparent to some wavelengths than others. This is the case in the silica-based glasses where the glass is most transparent to wavelengths of light in the 1,300 nm through the 1,550 nm region. Each wavelength region of low attenuation is known in the industry as a "window" for transmission.

The finished fiber is then wound on shipping spools to be sent to a cable manufacturer for the next steps of the process, where the fiber is actually stranded into a cable for use in the outside plant environment.

We have come a long way since the first optical fibers practical for signal transmission were made in 1970. Today, attenuation levels are so low that 1 percent of the light power is still present over 56 miles (91 kilometers) of fiber. Altogether, manufacturers regularly produce well over a million miles of optical fiber annually. In fact more than 7 million miles of fiber are now installed worldwide.

In the historical perspective, cable TV operators were among the first fiber pioneers. Some of the earliest optical systems were built by cable companies in the late '70s.

And today, fiber supertrunks are an accepted standard. Interest in fiber optics is exploding again, aimed at exploring fiber's potential advantages deeper into cable TV networks for feeders and distribution—and potentially all the way to the home. ■

Installer's Tech Book

Decibels (Part 5)

By Ron Hranac
Jones Intercable Inc.

One form of the decibel commonly used when measuring signal power is dBm (decibel-milliwatt), where 0 dBm equals 1 milliwatt across a reference impedance. Ohm's Law tells us that 1 milliwatt across 75 ohms is 273.86 millivolts:

$$\begin{aligned} E &= \sqrt{WR} \\ &= \sqrt{0.001 \text{ watt} \times 75 \text{ ohms}} \\ &= \sqrt{.075} \\ &= 0.27386 \text{ volt, or } 273.86 \text{ millivolts} \end{aligned}$$

273.86 millivolts converted to dBmV (see the August 1988 "Installer's Tech Book") is +48.75 dBmV. Therefore, to convert between dBmV and dBm when both measurements are made across a 75 ohm impedance, one of the following formulas can be used:

$$\text{dBmV} = \text{dBm} + 48.75$$

$$\text{dBm} = \text{dBmV} - 48.75$$

The following table provides dBmV to dBm conversions from -20 dBmV to +20 dBmV. Examples are on the next page.

dBmV	dBm	dBmV	dBm
-20	-68.75	0	-48.75
-19	-67.75	+ 1	-47.75
-18	-66.75	+ 2	-46.75
-17	-65.75	+ 3	-45.75
-16	-64.75	+ 4	-44.75
-15	-63.75	+ 5	-43.75
-14	-62.75	+ 6	-42.75
-13	-61.75	+ 7	-41.75
-12	-60.75	+ 8	-40.75
-11	-59.75	+ 9	-39.75
-10	-58.75	+10	-38.75
- 9	-57.75	+11	-37.75
- 8	-56.75	+12	-36.75
- 7	-55.75	+13	-35.75
- 6	-54.75	+14	-34.75
- 5	-53.75	+15	-33.75
- 4	-52.75	+16	-32.75
- 3	-51.75	+17	-31.75
- 2	-50.75	+18	-30.75
- 1	-49.75	+19	-29.75
		+20	-28.75

Problem

A spectrum analyzer manufacturer specifies -85 dBm sensitivity for his 75-ohm test equipment. What is that sensitivity in dBmV?

Solution

Use the formula

$$\begin{aligned} \text{dBmV} &= \text{dBm} + 48.75 \\ &= -85 + 48.75 \\ &= -36.25 \text{ dBmV} \end{aligned}$$

Problem

The output of a headend processor has been measured at $+55$ dBmV. What is that signal level in dBm?

Solution

Use the formula

$$\begin{aligned} \text{dBm} &= \text{dBmV} - 48.75 \\ &= +55 - 48.75 \\ &= +6.25 \text{ dBm} \end{aligned}$$

Problem

The microwave input to an AML receiver is -37.1 dBm. If the receiver has 20 dB of gain, what is its VHF output in dBmV (receiver AGC turned off)?

Solution

First, convert dBm to dBmV using the formula

$$\begin{aligned} \text{dBmV} &= \text{dBm} + 48.75 \\ &= -37.1 + 48.75 \\ &= +11.65 \text{ dBmV} \end{aligned}$$

Next, add the receiver gain to $+11.65$ dBmV

$$+11.65 \text{ dBmV} + 20 \text{ dB} = +31.65 \text{ dBmV}$$

From the NCTI

Technical training for customer contact personnel

A recently published multiple system operator (MSO) study of customer service calls indicated that 14.7 percent of the calls were related to converter problems, 13.3 percent to customer education problems, 7 percent to fine-tuning problems and another 11.9 percent to other miscellaneous problems. Depending upon how you view these problems, somewhere between 35-46.9 percent of the service calls could be handled over the phone if the customer service person understood the technology of the system well enough to educate customers and lead them through some simple troubleshooting over the phone.

The previously mentioned number of service calls translates into \$446,940 to

\$600,210 per day at \$30 per truck roll or from \$116 million to \$156 million for the year industrywide.

If only 20-25 percent of these calls could be handled over the phone, the industry could save from \$23 million to \$30 million per year. NCTI believes that such savings could easily be achieved by providing technical training for your customer contact staff. Training would begin with customer service representatives and extend to salespeople and dispatchers.

NCTI's System Overview Course

NCTI has developed a six-lesson System Overview Course. This course takes the customer service person through an introduction to CATV to a very graphic ex-

planation of the system's technical operation. All lessons are clearly illustrated to help visualize the workings of a cable system. Each lesson concludes with review questions and a glossary of terms. It is carefully designed to help customer contact personnel understand the CATV system's operation from the headend to the drop cable. It will provide enough background in system operation so they can ask the right questions and solve a certain percentage of customer problems without the expense of a truck roll.

The first lesson, *Introduction to CATV*, discusses cable TV as one of the most important and fastest growing concepts in communications today. It traces the history of CATV, through the development of

Now Cable TV Can Be More Than Meets The Eye. Introducing Galactic Radio

Cable TV has always stood for great home video entertainment. But now there's more than meets the eye!

Introducing Galactic Radio, high quality FM stereo available for your subscribers. Galactic Radio gives you seven great stations to choose from, from contemporary to classical. Plus up to 56 minutes of music per hour, so you enjoy less talk and more of your favorite tunes.

If you're a cable operator, call Jeff Hansen or Beth Adams for more information about the latest and greatest addition to cable TV. With Galactic Radio, we make music magic.

Phone:
(303) 792-3111



GALACTIC RADIO™ INC.

Reader Service Number 17.

SECURITY ENCLOSURES FOR SINGLE & MULTIPLE DWELLINGS

MTE



- No rusting ever
- Super-tough strength
- Easy installation

MSE



- Excellent chemical resistance
- Non-conductive



TUFFBOX



CABLESAFE

CABLETEK CENTER PRODUCTS, INC.
850 TAYLOR STREET, ELYRIA, OH 44035
1-800-562-9378 • ELYRIA 216-365-3889



See us at the Atlantic Show, Booths 809 & 811.
Reader Service Number 18.

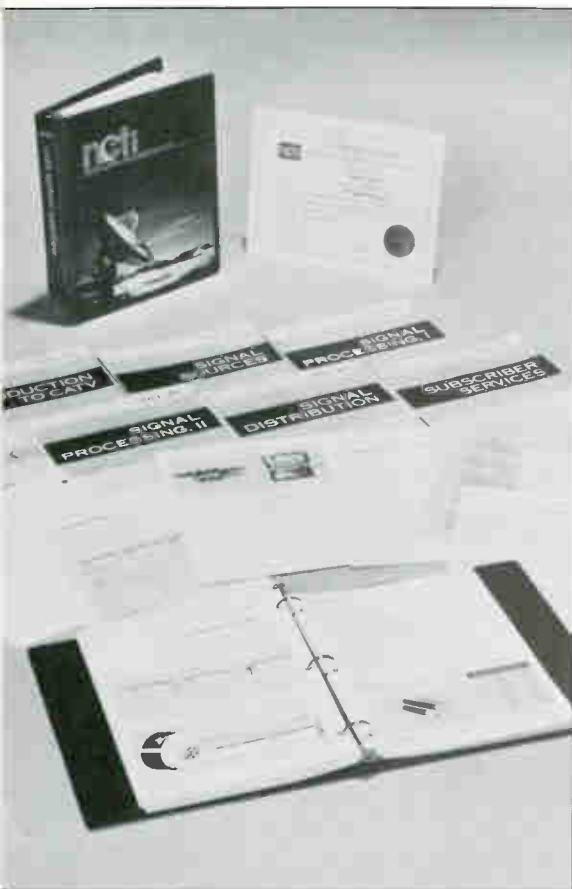

NCTI's System Overview Course.

"Somewhere between 35-46.9 percent of the service calls could be handled over the phone."

the first system, to some of the current services offered to cable subscribers.

Lesson two, *Signal Sources*, defines frequency and discusses frequency bands, broadcast frequencies and cable TV frequencies. Considerable effort is spent in explaining signal sources: over-the-air, microwave, satellite and locally originated signals. Also included is the concept of interactive two-way service possibilities—teletext, videotext, X*PRESS Data Services and other two-way services.

Lesson three, *Signal Processing I*, presents television signal components, processing requirements and processing

of over-the-air broadcast television signals.

Lesson four, *Signal Processing II*, discusses how single-channel FM terrestrial microwave, television receive-only (TVRO) satellite, off-air FM radio, local origination, commercial insertion, satellite stereo TV audio, data services and amplitude-modulated link (AML) signals are processed.

Lesson five, *Signal Distribution*, explains how television and FM signals are transported over the CATV distribution system to each subscriber by way of the trunk, feeder and drop line systems.

Lesson six, *Subscriber Services*, is an overview of the components of the drop, available programming and service options.

Small investment—Big dividends

The cost of this course is \$85. If a customer service person is able to save three truck rolls, they have paid for the course! This is an investment that will continue to pay large dividends.

If you would like to discuss training your customer service personnel, please contact Byron Leech or Jerry Neese at (303) 761-8554, or write to National Cable Television Institute, P.O. Box 27277, Denver, Colo. 80227. ■

You're in the right direction with **RMS** directional couplers

Whatever your directional coupler requirement is— RMS has them in every configuration from mini to fit raceway moulding ducts to large size— with single output, and in 2-way, 4-way, and 8-way. Call your RMS Account Executive for price and prompt delivery!

40 years of experience
RMS ELECTRONICS, INC.

621 Route 46, Hasbrouck Heights, N.J. 07604
 CALL COLLECT: (201) 288-8833 (New Jersey)
 TOLL FREE: (800) 223-8312
 (Continental U.S.A., Puerto Rico, U.S. Virgin Is.)
 FAX: (201) 288-1625

See us at the Atlantic Show, Booth 761. Reader Service Number 19.

Products

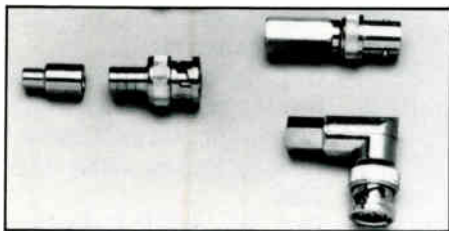

Coax connectors

Now available from Cambridge Products, the Fasfit line of coaxial BNCs includes field-installable twist-on and crimp-on types. The field-installable one piece twist-on connector needs no soldering or crimping and uses no loose clamp nuts, contacts or ferrules. Its threaded and tapered back-end opening enables the connector to screw onto the cable braid and jacket forming a termination that can withstand 50 pounds axial pull, according to the company.

The two-piece crimp-on version has a self-energizing center contact preassembled into the body between two insulators. A bifurcated contact grabs the solid center conductor of a cable for a secure connection.

For additional details, contact Cambridge Products, 244 Woodlands Ave., Bloomfield, Conn. 06002, (800) 243-8814; or circle #128 on the reader service card.

VC mainframe

Nexus Engineering is offering its VCMB, a commercial VideoCipher (VC) mainframe. The product houses six VC descrambler modules in 10 inches of rack space and provides better cooling efficiency, according to the company. To complement the VCMB, Nexus also has designed a new line of headend equipment to further reduce rack space requirements. A typical Series 100 16-channel headend with 12 VC scrambled channels occupies less than 40 inches of rack space.

For more details, contact Nexus, 7000 Lougheed Hwy., Burnaby, British Columbia, Canada, V5A 4K4, (604) 420-5322; or circle #134 on the reader service card.

Modulators/processors

Qintar introduced its QSFM-45 and GHP matched modulators and processors for use in adjacent channel headends. The SAW filtered modulator features output Chs. 2-13, midband and

superband at up to +45 dBmV with adjacent channel interference of 57 dB down minimum. Output frequency is crystal controlled at ± 5 kHz and aural carrier controls are set at 15 dB below video carrier level.

The heterodyne processor features input Chs. 2-13 VHF and 14-70 UHF. Input AGC range is -10 dBmV to $+20$ dBmV with ± 1 dB and an image and off-air alternate channel rejection of 57 dB.

For additional details, contact Qintar, P.O. Box 8060; Moorpark, Calif. 93020-8060, (805) 523-1400; or circle #126 on the reader service card.



Cable stripper

The Model CX-700 cable stripper from Western Electronic Products features rotary cutters and a foot switch, allowing it to strip coaxial and concentric multiple pair cable, including semi-rigid. It will accept cable ranging from .040 to .450 inch.

The module can be adjusted for depth and length of cut and the cable holder adjusts to any size cable. A speed control and timer also are included.

For further details, contact Western Electronic Products, 915-G Calle Amanecer, San Clemente, Calif. 92672, (714) 492-4677; or circle #125 on the reader service card.

Safety tool catalog

A new illustrated catalog featuring more than 30 safety products for use in areas with high vehicle traffic or near aerial power equipment is available from General Machine Products Co.

The eight-page catalog includes a selection of rigid and flexible roadside warning signs; combination sign, signal and flag outfits; flags, stands, masts, brackets and clamps; hand signaling devices; flashers and beacons; manhole guardrails and shields; and equipment for

locating potentials on hardware and equipment near power utility areas.

For more details, contact General Machine Products Co., 3111 Old Lincoln Hwy., Treose, Pa. 19047-4996; (215) 357-5500; or circle #127 on the reader service card.

Tilt compensator

Multiplex Technology is offering the TC200 tilt compensator, a passive device that compensates for the imbalance in attenuation and restores signal balance by attenuating the lower frequencies. It readjusts signal strength, biasing attenuation effects in favor of the higher frequencies. According to the company, this unit is low cost and works with any amplifier.

For more information, contact Multiplex Technology, 251 Imperial Highway, Fullerton, Calif. 92635, (714) 680-5848; or circle #132 on the reader service card.

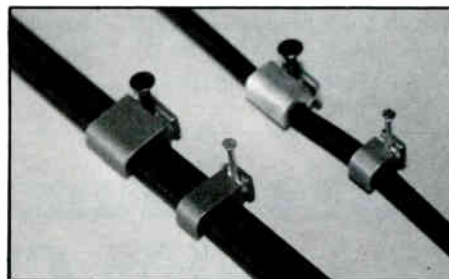

Cable clips

M & B Manufacturing is offering a line of aluminum cable clips for all-weather outdoor installation. The clips are manufactured from 100 percent aluminum and a hardened steel nail. According to the company, this combination means no corrosion, softening under exposure to the sun or chipping in freezing weather. It is also said to prevent damaged cable from hammer blows.

The clips are available with 2p tempered steel nails for use in wood, mortar, brick and stucco, and with heavy-duty concrete nails for use in young or aged concrete. The concrete clips are supplied double-width for extra protection of the cable. Standard sizes of single and dual 7 mm clips are available to secure all RG-6 and RG-59 single cables as well as RG-6 dual.

For more information, contact M & B Manufacturing, P.O. Box 206, Pleasanton, Calif. 94566, (415) 426-8631; or circle #133 on the reader service card.

Calendar

October

Oct. 4-6: Atlantic Show, Convention Hall, Atlantic City, N.J. Contact (609) 848-1000.

Oct. 5: SCTE Rocky Mountain Chapter seminar on professionalism and management. Contact Steve Johnson, (303) 799-1200.

Oct 6: SCTE Gateway Chapter technical seminar. Contact Darrell Diel, (314) 576-4446.

Oct. 11: SCTE Central Illinois Meeting Group technical seminar on data networking and review session for BCT/E Category V, Sheraton Inn, Normal, Ill. Contact Tony Lasher, (217) 784-5518.

Oct. 11: SCTE Chattahoochee Chapter technical seminar on connectors, Perimeter North Inn, Atlanta. Contact Dick Amell, (404) 394-8837.

Oct. 12: SCTE Oklahoma

Meeting Group technical seminar. Contact Herman Holland, (405) 353-2250.

Oct. 12-14: Magnavox CATV training seminar, Kansas City, Kan. Contact Amy Costello, (800) 448-5171.

Oct. 13: SCTE Central California Meeting Group technical seminar on methods of corrections/distortions. Contact Andrew Valles, (209) 453-7791; or Dick Jackson, (209) 384-2626.

Oct. 16-18: Wireless Cable Association annual conference and equipment expo, Hyatt Regency, Crystal City, Va. Contact (202) 343-4253.

Oct. 18: CaLan sweep seminar, Holiday Inn, Ontario, Calif. Contact Mary Chudoba, (717) 828-2356.

Oct. 18-19: SCTE Heart of America Chapter technical seminar. Contact Wendell Woody, (816) 474-4289.

Upcoming

Dec. 7-9: Western Show, Convention Center, Anaheim, Calif.

Feb. 22-24: Texas Show, Convention Center, San Antonio, Texas.

May 21-24: NCTA Show, Convention Center, Dallas.

June 15-18: Cable-Tec Expo '89, Orange County Convention Center, Orlando, Fla.

Aug. 27-29: Eastern Show, Atlantic Merchandise Mart, Atlanta.

Oct. 18-20: Mid-America Show, Hilton Plaza Inn, Kansas City, Mo. Contact Rob Marshall, (913) 841-9241.

Oct. 18-20: Magnavox CATV training seminar, Charlotte,

N.C. Contact Amy Costello, (800) 448-5171.

Oct. 18-20: C-COR Electronics technical seminar, Worcester, Mass. Contact Shelley Parker, (800) 233-2267.

Oct. 19: SCTE Delaware Valley Chapter technical seminar on fiber optics, Williamson Restaurant, Horsham, Pa. Contact Diana Riley, (717) 764-1436.

Oct. 20: SCTE Greater Chicago Chapter technical seminar on new broadband technologies. Contact William Gutknecht, (312) 690-3500.

Oct. 21: CaLan sweep seminar, Alameda County Fairgrounds, Pleasanton, Calif. Contact Mary Chudoba, (717) 828-2356.

Oct. 22: SCTE Razorback Chapter technical seminar. Contact Jim Dickerson, (501) 777-4684.

New Aluminum Cable Clip

Tempered Steel Nail

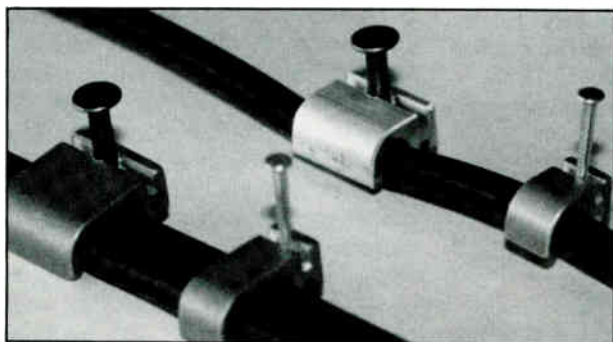

Attaches All RG6 & RG59 Cables
Standard Duty for Wood, Mortar, Brick
Heavy Duty for Aged Concrete

100% Aluminum. No more Cracking,
Softening or Chipping.

Contact your distributor or

M&B Mfg., Box 206, Pleasanton, CA 94566

Reader Service Number 20.

Ad Index

ABC Cable Products	13
Anixter	2
Augat LRC	3
Authorized Parts	52
Cable Prep/Ben Hughes	39
CableTek Center Products	47
Cable TV Supply	7
Friction Design	12
Galactic Radio	47
Lemco Tool Corp.	25
Lynn Ladder	25
Midwest Cable Services	37
M&B Manufacturing	50
NCTI	19
RMS International	48
SCTE	11
Sencore	51
Telecrafter Products	8
Texscan Communications	5
Toner Cable Equipment	15
Triple Crown Electronics	23
Viewsonics	14 & 36

Track Down Tough To Find CATV, MATV And RF Distribution Troubles

- All Channel Digital Tuner (5 - 890 MHz)
- 5 Microvolt Sensitivity With Autoranged Attenuator
- Exclusive Frequency Offset Readout
- Automatic S/N And Hum On In-Use Channel
- Integrated Wideband Monitor
- AC/DC Volts Measurements Through RF Input

100% American Made and backed by Sencore's 100% "Made Right" Lifetime Guarantee

With The FS74 CHANNELIZER SR.™

TV-RF Signal Analyzer
\$3495 Patented

Reader Service Number 21.

Send For Free FS74 Brochure

Call 1-800-843-3338

In Canada 1-800-851-8866

SENCORE

3200 Sencore Drive, Sioux Falls, South Dakota 57107

LEADING
THE INDUSTRY
WITH STAR PRODUCTS...



Authorized Parts Company

CATV Converter Repair Parts and Supplies.
208 Berg Street • Algonquin, IL 60102 • 312-658-6900 • 518-868-2033