



# Magna™ 440. The system of the future is here.

## And it works.

**We're proving it every day.** Proving it with Magna 440 systems up and operating, and in our Magnavox Mobile Training Centers.

We're proving it to cable-system operators everywhere. We're showing them how Magna 440 components—mainstation amplifiers, digital system sentry-status monitoring system, line extenders, directional taps, couplers, connectors and subscriber passives—are all engineered for full 440-MHz, 64-channel performance.

We're demonstrating to technicians, in practical hands-on seminars, how Magna 440 components are designed to work together as a system under the most severe field conditions.

We're proving how Magna 440 systems' modular design can save on installation costs and labor by eliminating adapters and field modifications. And we're proving how dependable Magna 440 performance means less maintenance, more profits.

We back up all Magnavox products with system design and engineering assistance. Experienced customer-service personnel smooth out any rough spots in your system purchases. Our technicians and engineers will help you with any highly specialized requirements.

If you have been holding off, waiting to see where system equipment was heading, wait no longer. The future of cable-TV system equipment is here now in Magna 440, and it works.

A NORTH AMERICAN PHILIPS COMPANY, 100 FAIRGROUNDS DRIVE, MANLIUS, N.Y. 13104 • Phone: Toll-free, West of Mississippi: 800-448-5171 • East of Mississippi: 800-448-9121 • New York State: 315-682-9105 • Telex 937329 • SWITZERLAND CATEC AG (Lucerne). Phone: 041-22 66 19 • CANADA: rf communications Ltd. (Markham). Phone: 416-495-1030

**Magnavox**  
**CATV** SYSTEMS, INC.



WE'RE BRINGING THE FUTURE OF CATV TO YOU.



# ***Ripping up a potential subscriber's front lawn isn't the only way to bury cable.***

***Let's do it  
in the road.***

**GTC**

You've got to have a lot of nerve to dig up a man's yard and then smilingly invite him to subscribe! For operators who would rather use their nerve in more crucial negotiations, we have the answer. Make a neat slit in the street, and leave their lawns alone. Consider the other benefits of GTC's in-street burial techniques. Because we go straight up the street, with small right angle cuts to the vaults, you use 40% less cable than with the traditional "loop" method. And we do it at the rate of about 67 homes passed per day. There's only one vault installation for every two

homes passed, getting you out of the lawn restoration business. No more accidental dig-ups. No need to interface with utilities. And you no longer have to deal with homeowners who never wanted a trench through their much-loved lawn.

If you'd like to spend more time getting in the door and less time standing apologetically out in the yard, contact GTC. A note or telephone call will bring you our capabilities brochure.

**GTC.**

1772 East Jericho Tpk.  
Huntington, NY 11713,  
(516) 462-9810

**GTC**

**Underground Systems  
Group**

# We've Got It!

## IN STOCK AT BOOTH 1502



—The New  
Satellite Receiver  
From Microdyne

—Look For The  
Toner Tower

# TONER

969 Horsham Rd. • Horsham, PA 19044  
800-523-5947 (In Pa. 800-492-2512)

### OFFICERS

Ben D. Campbell, Chairman of the Board  
 Ben V. Willie, President  
 Peter Athanas, Vice President  
 G.H. Dodson, Secretary/Treasurer

### DISTRICT DIRECTORS

One	Clarence Dow (Maine)
Two	Ed smith (New York)
Three	David Fox (West Virginia)
Four	Pat McConnell (Florida)
Five	Joe Bain (Oklahoma)
Six	Wayne Sheldon (California)
Seven	Carl Schmauder (Oregon)
Eight	Neil Webster (Iowa)
Nine	Peter Athanas (Wisconsin)
Ten	Jim Hays III (Kentucky)

### VICE DIRECTOR

Lee Holmes (Guam)

### ASSOCIATES' DIRECTORS

Raleigh B. Stelle III, Texscan/Theta Com  
 Ernie Larson, Larson Electronics

### DIRECTORS EMERITUS

Gene Edwards (Ohio)  
 Chuck Kee (Oregon)  
 William Ridsen (Kentucky)

### CATJ STAFF

**President and Publisher**  
 G.H. Dodson

**Business and Managing Editor**  
 Celeste Rule

**Executive Assistant To The Editor**  
 Diane Howard

**Circulation Manager**  
 Rose Capshaw

**Contributing Editors**  
 S.J. Birkill, Stephen Effros,  
 Ralph Haimowitz

**Art Director/Marketing**  
 Phyllis Crumpler

**Assistant Art Director**  
 Dianna Johnson

### OFFICES

National Headquarters  
 CATA/CATJ  
 Celeste Rule, Managing Editor  
 4209 N.W. 23rd, Suite 106  
 Oklahoma City, Okla. 73107  
 (405) 947-7664; 947-4717

CATA (Washington Office)  
 Stephen R. Effros, Executive Director  
 3977 Chain Bridge Rd.  
 Fairfax, Va. 22030  
 (703) 691-8875

CATA (Engineering Office)  
 Ralph Haimowitz, Director  
 518 21st Street S.W.  
 Vero Beach, Florida 32960  
 (305) 562-7847

The Community Antenna Television Association, Inc. is a nonprofit organization formed under Chapter 19, Title 18 of the Statutes of the State of Oklahoma. As such, no part of its assets or income shall be the property of its members, such assets and income shall be devoted exclusively to the purposes of the Corporation.

The Community Antenna Television Journal (CATJ) — ISSN-0194-5963 — is published monthly by Television Publications, Inc., 4209 N.W. 23rd, Suite 106, Okla. City, OK 73107. Subscription price: \$18.00 per year, \$22.00 per year Canada, Mexico, and foreign is \$25.00 per year. Second class postage paid at Oklahoma City.

POSTMASTER: Send address changes to 4209 N.W. 23rd, Oklahoma City, OK. 73107.

CATJ, The Official Journal for the Community Antenna Television Association is published as a service for Association Members and others providing services to the industry.

## on the inside . . .

### FEATURES

- CABLE OPTION AVAILABLE AT SOUTH OKLAHOMA CITY JUNIOR COLLEGE** — Got a High School Graduate That's Interested in Studying Cable Television Theory and Accumulating College Credit Hours? South Oklahoma City Junior College Has Developed Such An Association Degree Program . . . . . **6**
- STATUS MONITORING: FOR MORE EFFICIENT FIELD TECHNICAL SERVICE AND LESS DISCONNECTS** — Magnavox' Jay Staiger explores the use of a digital system for status monitoring and the advantages . . . . . **12**
- ALL ROADS LEADING TO NASHVILLE!** — more information on the plans and detailed scheduling on the technical and mangement sessions for CCOS '82 . . . . . **17**
- BUILD YOUR OWN DECODER** — John Lazar, the Harris Corporation, and Richard Kirn, Wire Teleview, cooperated on this presentation of how to build a simple tone operated switch for \$125. parts . . . . . **35**
- JOIN THE SOCIETY TO PREVENT CRUELTY TO TEST EQUIPMENT** — a simple, how-to article with instructions on constructing equipment to transport test equipment safely from place to place . . . . . **36**
- SWITCHING MAY BE A MATTER OF PRIORITY** — Walter H. Tietjen, Jr., provided this information on dealing with limited channel capacity . . . . . **48**
- THE FILTERED EARTH STATION** — Part 9 — a Summary and Terrestrial Troubleshooting Chart prepared by Glyn Bostick of Microwave Filter Company, Inc. . . . . **52**

### DEPARTMENTS

- CATA-TORIAL** — CATA President, Ben V. Willie, discusses "Out Of The Mouths Of Congressmen" and copyright legislation . . . . . **4**
- BIRKILL ON EXPERIMENTAL TERMINALS** — May Miscellany and Mr. Birkill's comments . . . . . **58**
- WASHINGTON UPDATE** — Steve Effros, CATA Executive Director, lays it on the line about what has happened on copyright; an interesting series of events . . . . . **70**
- ASSOCIATES SHOWCASE** . . . . . **76**
- ASSOCIATE ROSTER** . . . . . **82**
- CLASSY CATS** . . . . . **84**

## on the outside . . .

### ABOUT THE COVER

Thanks to the Harris Corporation for this lovely night shot of Las Vegas and a Harris Dish.

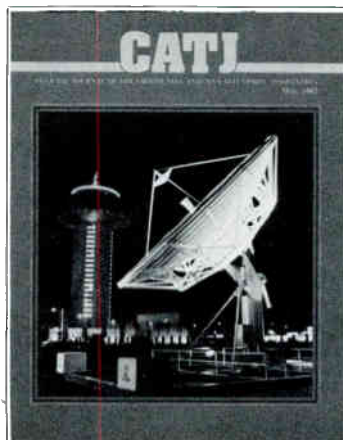

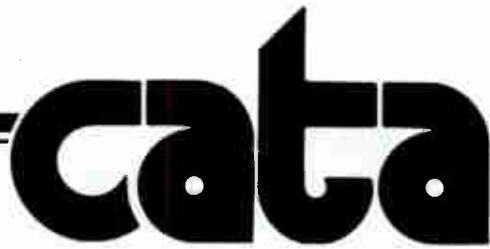

# Membership Application

Please enroll my CATA system(s) in the  
COMMUNITY ANTENNA TELEVISION ASSOCIATION (CATA).

I understand that we have the right to cancel our membership at  
anytime. Please see that I receive all of the initial CATA material.

System Name \_\_\_\_\_

(group owner if any)

System Address \_\_\_\_\_

City \_\_\_\_\_ State \_\_\_\_\_ Zip \_\_\_\_\_

Individual Authorizing Membership \_\_\_\_\_

Telephone ( \_\_\_\_\_ ) \_\_\_\_\_

**About Your System— CONFIDENTIAL—  
For CATA use Only**

- Number of current subscribers (FCC count) \_\_\_\_\_  
Projected number of subscribers \_\_\_\_\_
- Number of homes in franchise area \_\_\_\_\_  
 Top 50 Market (35 mile zone)  
 Second 50  
 Smaller TV Market  
 Outside All Markets
- Channel capacity \_\_\_\_\_  
System start-up date \_\_\_\_\_
- Do you plan to build a TVRO earth station?  Yes  No
- Congressional District \_\_\_\_\_

**Note on Corporate Membership:**

Dues for systems or MSOs with more than 16,666 subscribers are established with a dues limitation of \$5,000 annually.

**ABOUT YOUR CATA DUES STRUCTURE**

SURCHARGE scale is \$5.00 for systems with subscribers up to 500; \$10.00 for systems with subscribers between 500 and 3500; \$15.00 for systems with more than 3500 subscribers. The surcharge, PLUS 3 cents per subscriber per month determines the monthly dues charge.

Numbers of Subs \_\_\_\_\_

X .03 \_\_\_\_\_

Sub Total \_\_\_\_\_

+ Surcharge \_\_\_\_\_

Total \_\_\_\_\_

PLEASE ATTACH CHECK FOR THAT AMOUNT WITH APPLICATION.

**Personal memberships for those in related industries are available at \$50.00 annual dues.**

CATJ SUBSCRIPTION RATE FOR CATA MEMBERS IS \$14.00 per year.

If you are not presently a subscriber and wish a new subscription, enclose \$14.00 for your CATJ magazine.

# Cable Option Available At Junior College

As we approach graduation time for many of our young people, the thoughts of direction occur for many of them, now knowing just what they want to do. College perhaps? Trade school? Perhaps you have a high school graduate candidate that is interested in your cable system operation, but you really would like for him (or her) to expose themselves to higher education. We think we have found a unique and fulfilling answer to that particular question.

For the past few years, South Oklahoma City Junior College in Oklahoma City has been offering what is called an "Associate Degree Program" in Cable Television; this is essentially a two year program, which includes cable courses, but other academic subjects required of a beginning college student. This program prepares the student for transfer to a baccalaureate institution if they so desire, but offers the Associate Degree for immediate employment in the cable television field.

As a member of the Advisory Committee for the school, it has been most gratifying that the direction of this study should have the high objectives of providing competent cable TV technicians to deliver high-grade television signals to the home or customer. The school recognizes that cable television is one of the most dynamic, and fastest growing industries today, and that well trained technical personnel are needed as the industry continues to grow.

With these goals in mind, South Oklahoma City Junior College has instigated a complete cable television training program which covers instruction ranging from correct pole climbing to understanding earth stations. Courses are designed not only for those just entering the field, but for people in the cable industry who

know **how** the system works, but not exactly **why** it works!

As a compliment to a work-study program, an apprenticeship program in conjunction with local cable companies in the area has been developed which enables students to be employed by the cable companies by day, participate in their classes at night, and receive their credit hours while earning wages.

As far as our research goes, South Oklahoma City Junior College (in the area it is shortened to SOCJC) is the only school teaching theory and application of the complete cable system for college credit, combining other required academics to provide a solid two-year course for an Associate Degree.

The curriculum for the cable study program was designed and administered with the advice of an ad-

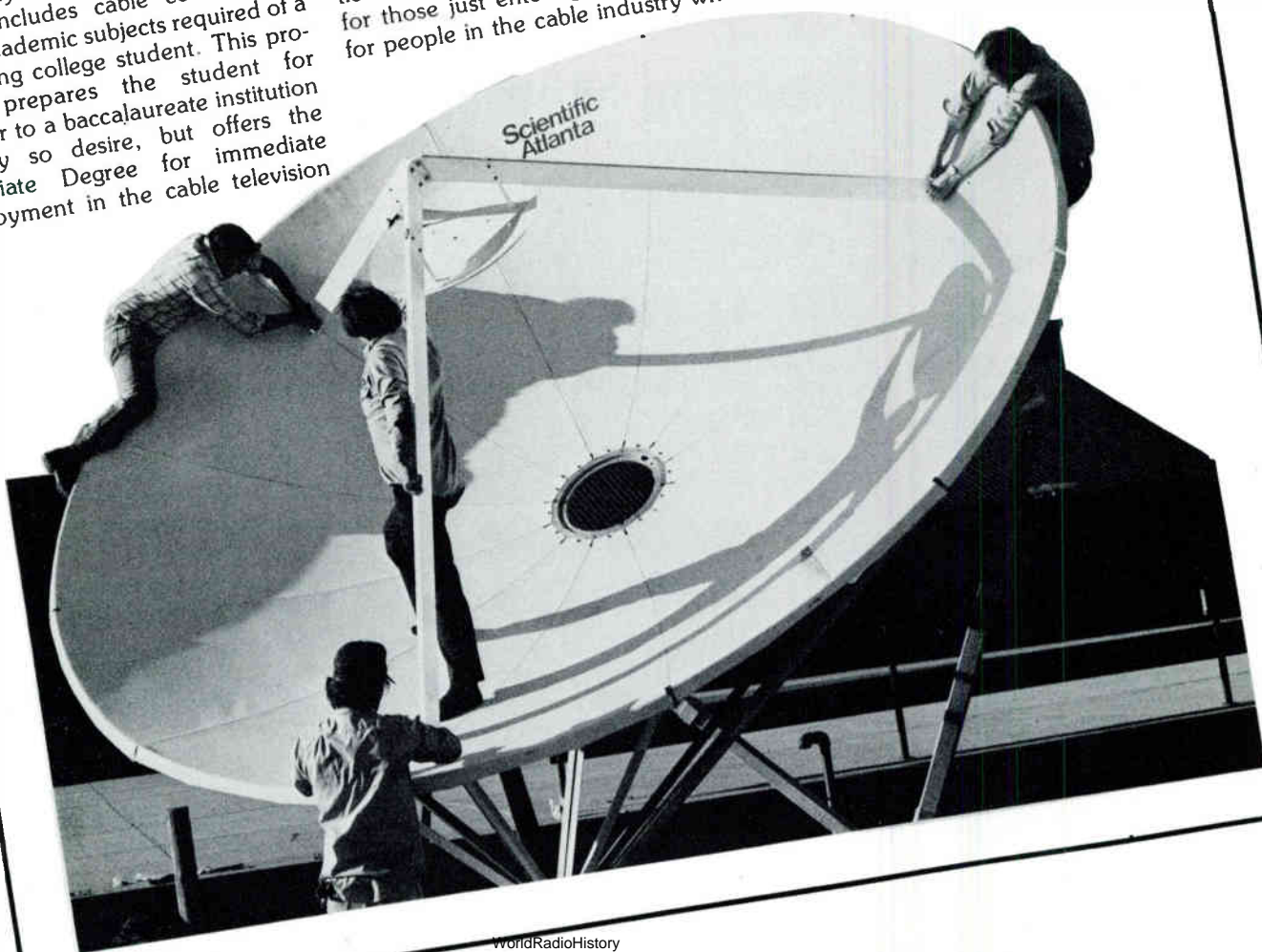

# How to offer tomorrow's services with today's equipment

## Offer two-way transmission.

Hughes AML delivers video and data in both directions for local origination, institutional and subscriber interactive services. And AML also accommodates the latest multiple tier and addressable converter scrambling systems.

## Offer expanded services.

Whether it's a new build or a rebuild AML helps you satisfy the toughest franchise requirements as well as generate added revenue. You can lease data channels to commercial users and provide local loops for satellite data networks. You can also use



AML for security systems, teleconferencing and traffic light control. In addition to delivering high quality video signals, AML offers the perfect system to access data banks and computer time share services.

## Offer the newest improvements.

Even if you have our first 12 channel model introduced in 1971, you can upgrade to provide all of the expanded services above and more. Any AML can be retrofitted with 440 MHz bandwidth, single or dual 60 channel capac-

ity and receivers with noise figures as low as 7 dB. Upstream transmission is easily added to existing one-way systems. AML is one of the few things in this world designed to improve with age.

For more information on Hughes AML systems, write or call:  
Hughes **MICROWAVE™  
COMMUNICATIONS  
PRODUCTS**

P.O. Box 2999, Torrance, CA 90509,  
(213) 517-6233. After hours  
emergency service (213) 534-2170.  
In Canada: Micro-Sat  
Communications, Ltd., 975 Brock  
Road South, Pickering, Ontario  
Canada L1W3A4, (416) 839-5182.

*NEW  
AML system designs  
provide more than 160 channels*



visory committee consisting of personnel in several major cable television companies with franchises in the state of Oklahoma, as well as representatives from other cable-related organizations (such as this editor).

Four courses are offered in the cable television area, with other courses supporting the requirements for an associate degree in electronics with an option to major in cable television. The four cable courses offered, which include all phases of the cable industry are: Broadband Communications I and II; CATV Design and Construction, and CATV Instrumentation.

**Broadband Communications I** teaches the student the correct way to install and test trunk amplifiers, line extenders, directional taps, scramblers, converters and other hardware used in cable TV; also included in this course is the use of basic measuring instruments for testing and trouble-shooting systems.

**Broadband Communications II** students demonstrate knowledge of microwave theory, microwave antenna installation and adjustment techniques, earth station antenna adjustment for satellite signal reception, and channel processor equipment used at the system's headend site.

**CATV Design and Construction** covers amplifier spacing, feeder-to-trunk ratio, automatic gain control, automatic slope control, multi-unit building design, graphs and charts, system mapping, con-

struction safety, and systems turn-on and alignment.

**CATV Instrumentation** includes information on sweep generators, field strength meters, oscilloscopes, installer's meters, alternators, detectors, channel filters, wave analyzers and spectrum analyzers in the evaluation of FCC Proof of Performance tests.

### **CABLE TELEVISION LABORATORY AT SOCJC**

The laboratory at SOCJC includes a complete CATV system consisting of Magnavox MX 404 Series Trunk/Bridger Amps and Line Extenders with others on hand to be interchanged. RCA, Sylvania, and other manufacturer's active and passive devices are used in the lab, as well as Scientific Atlanta's 4.6 meter Earth Station and a 12-channel headend.

### **DETAILS ABOUT SOCJC**

Located in south Oklahoma City, convenient from all areas of Oklahoma City and surrounding areas by a interstate by-pass system, this is a community college, state accredited, sensitive to the needs and aspirations of the community it serves. This is demonstrated by its commitment to accessibility, comprehensiveness, flexibility, quality and accountability. Enrollment is open to any person over 18 years of age, regardless of previous education, and to all high school graduates.

To enroll, the student must complete an application form and pro-



vide copies of ACT scores, a highschool transcript, or GED certificate, and, where applicable, a college transcript. Educational program fees are \$10.25 per credit hour for Oklahoma residents and \$26.25 per semester hour for non-residents.

Economy in Oklahoma is very good, and there are jobs available for the aspiring student. Housing is moderately priced.

If you have an interested person, perhaps this Associate Degree program would be the answer. If you have further questions or you want appropriate paperwork for application, contact Bill Gough, Professor of Electronics, (405) 682-7547 Extension 320, or write the Office of Admissions, 7777 S. May Avenue, Oklahoma City, OK. 73159. □



**MORE PEOPLE  
LISTEN TO  
COUNTRY MUSIC  
THAN EAT  
AT McDONALD'S,  
GO TO  
THE MOVIES,  
DRIVE  
JAPANESE CARS,  
OR CHEER AT  
FOOTBALL GAMES.**

# AND NOW, NASHVILLE GOES NETWORK.

Take a wild guess. How many people listen to country music every day? Twenty million? Forty million? Keep going!

More than 60 million people listen to country music, every single day.

"Country music has become the most vital and influential sound in the world," says the Hollywood Reporter.

From every source, the evidence mounts.

While total record sales remain constant, country record

sales grow at 20%, actually doubling in the last five years.

Over 2,100 radio stations broadcast country music full time. Another 1,300 feature country music.

In 1981, nearly one million people from every part of the country paid up to \$8 to see the Grand Ole Opry.\*

Nashville becomes the capital of the music world, thousands of records produced in sophisticated sound studios.

Commercial television sees a gold mine in Nashville and digs in: Tuesday night prime time devoted to "Barbara



Mandrell and the Mandrell Sisters," dozens of specials are produced there, country performers appear in television shows of every description.

And now comes the first real opportunity for the cable operator to benefit from this grassroots groundswell.

It's called the Nashville Network. And it can turn Nashville into Cashville.

**COUNTRY IS A LAND OF OPPORTUNITY.** Group W Satellite Communications, along with WSM\* and Opryland Productions,\* is making the Nashville Network available to every cable operator in America.

The programming will be the ultimate in country music. With authentic live performances at clubs and on stages, special variety shows, retrospectives of classic country performers of the past, and much more.

But you won't be able to sing along with the whole network. Because our original programming offers much more than terrific singers. Like a sit-com, a game show. Plus in-depth interviews with country's biggest names.

Everything will be produced by WSM and Opryland Productions, the same people who so successfully produce the Grand Ole Opry. This is the real thing. From the home and heart of country music.

**AMERICA IS A FREE COUNTRY. AND NOW COUNTRY IS FREE IN AMERICA.** There is no charge for the Nashville Network. Even better, you'll have at your disposal regular commercial positions which can readily be sold to an eager advertiser community.

For example, syndicated country shows like "Hee Haw" and "That Nashville Music" pull high ratings and are eagerly sought after by prestigious advertisers seeking to reach their target audience. After all, country music audiences have shown themselves to be profoundly loyal to their country.

The service is scheduled to begin in Spring of 1983.

For more information, and a complimentary copy of *Nashville's Grand Ole Opry* book, call Lloyd Werner at Group W Satellite Communications, (800) 243-9141.

The Nashville Network. The channel for people who really love their country.

© Group W Satellite Communications 1982



Opryland Productions, WSM and the Grand Ole Opry are entertainment properties of NCT Corp



# STATUS MONITORING: For More Efficient Field Technical Service and Less Disconnects

By Jay Staiger  
Product Manager, Special Products  
Magnavox CATV Systems, Inc.

CATJ wishes to thank Jay G. Staiger, Product Manager, Special Products for Magnavox CATV systems, for the effort and time involved in the preparation of this article.

No newcomer to CATV, Mr. Staiger joined Magnavox as Manager of the Systems Design Department after five years with Jerrold Electronics holding positions in applications engineering and systems design. His credits include a B.S. in Electrical and Electronic Engineering from Pennsylvania State University, having pursued additional studies in Electronic Engineering at Temple University. He is a member of the SCTE and the American Radio Relay League.

Should you have questions or comments to make regarding this material, and you would like to request further information from him, you may contact him at Magnavox CATV systems, Inc., 100 Fairgrounds Drive, Manlius, New York 13104; telephone (315) 682-9105.

As cable systems become more complicated and skilled technical help still remains scarce, operators have even greater need of the benefits provided by an efficient status monitoring/trunk and feeder disconnect system. Status monitoring lets the operator know that his system is performing properly. The obvious benefit is faster turnaround when checking for an solving transmission and interference problems.

The operator might well ask, "What's wrong with preventive maintenance?" In my opinion, there are two things wrong with it: 1) Preventive maintenance is performed periodically, at best. 2) Maintenance programs are usually the first to be superseded when time and manpower are at a premium.

By implementing the use of a status monitor, such as the Magnavox Digital System Sentry (DSS), performs two functions: 1) status monitoring and reporting; 2) trunk and bridger switching of the return signals.

Of course, the ultimate status monitor is the subscriber. He or she will tell you if your system is

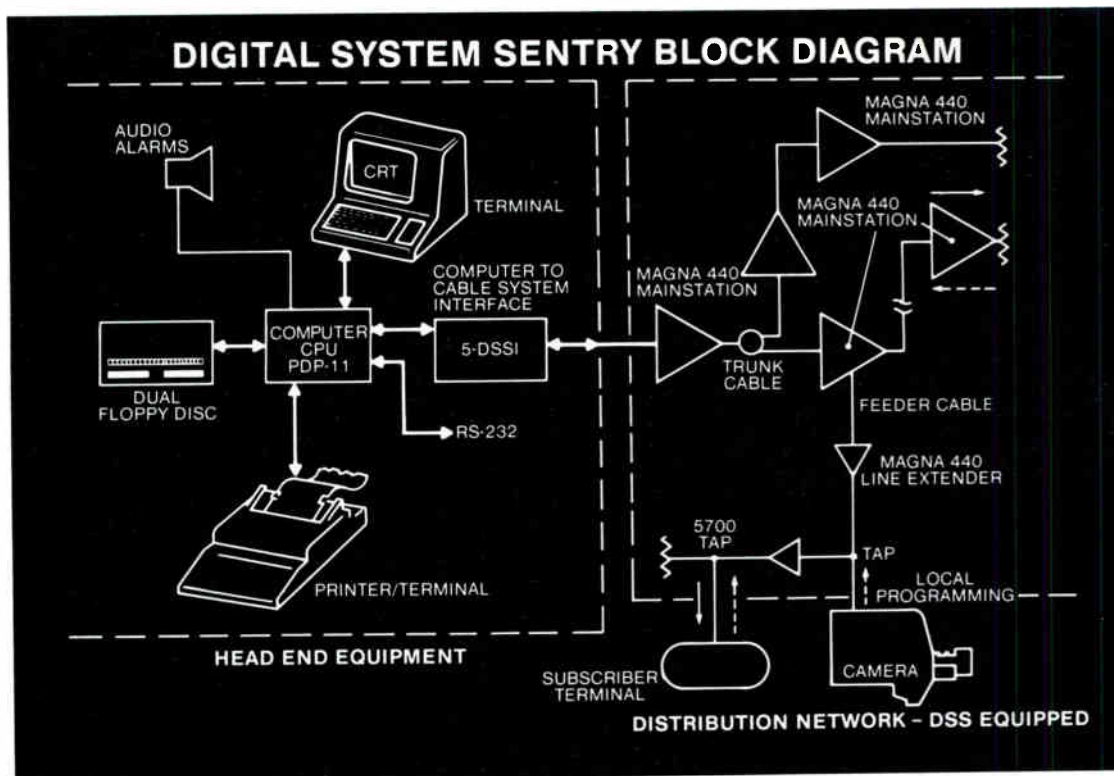

# When we say fast... we mean **FAST!**

Whatever your CATV operation needs,  
Midwest has it in stock and ready to ship!

Midwest is your best source of supply for everything from an earth-station antenna to a tap ... or whatever you need. For 20 years Midwest has been a CATV products distributor and has grown into one of the nation's largest distributors of the industries finest RF equipment manufacturers. But we're not limited to RF products. We're also the country's top distributor of video equipment and supplies. We can provide you with cameras and recorders for community access, turnkey remote telecast vehicles ... even complete color broadcast facilities! Our services include everything from planning and installation to servicing and training. Best of all, Midwest maintains an extensive inventory of all the leading brands, in-stock and ready to ship within 24 hours. And our prices are competitive with anyone in the business.



If you're reaching for the world,  
Midwest can give it to you ... from  
stock. Call today, toll-free, for complete  
information and our CATV and Video  
Products Catalogs.

Midwest Corporation  
1021 West 8th Street  
Cincinnati, Ohio 45203  
1-800-543-1584  
1-513-651-1904 (In Ohio)



A UNR Company

Midwest Corporation  
307 Sandy Blvd.  
Clarksburg, West Virginia 26301  
1-800-624-3845  
1-304-624-5459 (In West Virginia)

Midwest Corporation  
1395 Air Rail Avenue  
Virginia Beach, VA 23455  
1-800-368-3032  
1-804-464-6256 (In Virginia)

# A TERRIFIC BUY!

## Electroline Drop Amplifiers

Electroline's economical, transistorized amplifier, model ELE-215, facilitates adding anywhere from 1 to 20 TV and/or FM sets to a single

source. This drop amplifier is suitable for use in homes, dealer displays and multiple outlet units. It has extremely low power consumption.



Model ELE-215  
50 - 500 MHz

### SPECIFICATIONS:

Impedance	75 Ohm
Bandwidth	50 - 500 MHz
Gain	10 db
Return loss Input	20 db (50 - 300 MHz) 18 db (300 - 400 MHz)
Return loss Output	16 db (50 - 400 MHz) - 57 db for 35 channels at + 34 dbmv output
Noise figure	8 db
Hum modulation	≥ 60 db
Power	117 vac 60 Hz



## ELECTROLINE Television Equipment Inc.

8750, 8th Avenue . St-Michel  
Montreal, Que. H1Z 2W4

or phone **collect**  
(514) 725-2471

Representatives across  
Canada and the U.S.A.

- TAPS
- FILTERS
- COUPLERS
- SPLITTERS
- SPECIAL AMPLIFIERS
- ADDRESSABLE SYSTEMS
- SWITCH-TRANSFORMERS

degrading. But I'm sure no operator wants to depend on that kind of warning system. Too often customer complaints turn into customer disconnects.

The problem, of course, is to locate the fault in the system. Is it at the home, in the drop cable, in a line extender amplifier, or a trunk amplifier?

If you conduct a manual search, you usually wind up sending several technicians, in ascending order of skills, out to locate the problem. You start with the less skilled technicians checking out the subscriber's TV and the drop cable. If the fault is not there you send out your feeder technician. If he doesn't find the fault, you wind up sending your most skilled man to check out the trunk amplifiers. By the time he finds that the trouble is in a trunk amplifier, much time and expense has been wasted. Status monitoring on the trunk would have saved all that.

From the foregoing, we can see that a big benefit of status monitoring is more efficient use of technical staff. We estimate that status monitoring of the trunk line increases technician efficiency by 25%.

Equally important is the fact that you can catch problems before the customer even knows there is a problem. Thus, you can prevent customer complaints, which can lead to disconnects and loss of revenue.

Trunk and bridger switching is the other main function of a system, such as the Magnavox Digital System Sentry. As you know, especially if you operate a 2-way system, ingress is a major problem. Locating ingress manually requires a technician going out on the line to search.

Trunk and bridger switching, on the other hand, lets you locate the bridger or amplifier where ingress passes through, or the span of trunk where ingress leakage occurs. And it does this in minutes versus the hours it might take manually. I've heard estimates of 1000% technician time saved in the maintenance of return systems.

As systems become more and more saturated with services, a status monitoring system should become more and more valuable to the operator, increasing his efficiency and profits.

### HOW A DIGITAL SYSTEM SENTRY WORKS

For example, the Magnavox Digital System Sentry shown integrates both standard and specially designed equipment at the headend and out on the cable distribution system itself.

**Computer Controller:** This unit operates at the headend, along with a CRT Terminal, Printer, Dual Floppy Discs, Computer to Cable System Interface with Audio Alarm. The function of the Computer

continued on page 20

JULY 3-6  
DON'T DELAY . . . REGISTER NOW FOR



TAKE ADVANTAGE OF REDUCED REGISTRATION  
AND HOTEL RATES

PRE-CONVENTION  
RATES:

CATA MEMBERS* .....	\$ 75.00
NON-CATA MEMBERS .....	\$125.00
SPOUSES .....	\$ 25.00
CHILDREN OVER 16 .....	\$ 25.00

**AFTER JUNE 15th, REGISTRATION FEE WILL BE \$175.**

*\*Must Furnish System Name for Verification*

---

**CCOS '82**

JULY 3-6

Enclosed is \_\_\_\_\_ to cover registration for:

Name \_\_\_\_\_

System \_\_\_\_\_

Address \_\_\_\_\_

City \_\_\_\_\_ State \_\_\_\_\_ Zip \_\_\_\_\_

Telephone ( \_\_\_\_\_ ) \_\_\_\_\_

Name of Spouse \_\_\_\_\_

Names of Children (and ages) \_\_\_\_\_

Send to: CATA CCOS '82

4209 N.W. 23rd, Suite 106

Oklahoma City, OK. 73107



# CCOS '82

## SCHEDULE OF EVENTS

### SATURDAY, JULY 3RD

1:00 - 5:00 p.m.	Registration	Ryman Hall
4:00 - 6:30 p.m.	Exhibits Open	Ryman Hall
8:00 - 9:00 p.m.	Welcoming Reception sponsored by Group W. Satellite Communications which brings you THE NASHVILLE NETWORK, SATELLITE NEWS CHANNELS, and THE DISNEY CHANNEL.	Knoxville
9:00 p.m.	Buses leave for Opryland	Opry House
9:30 p.m.	Grand Ole Opry	

### SUNDAY, JULY 4TH

10:00 a.m.	Opryland Theme Park opens Celebrate the 4th!	
1:00 - 4:00 p.m.	Registration	Ryman Hall
4:00 - 7:00 p.m.	Exhibits Open	Ryman Hall
6:00 - 7:00 p.m.	Exhibitors Host Cocktail Party	Ryman Hall
7:30 - 9:00 p.m.	CATA Membership Meeting	Cumberland

### MONDAY, JULY 5TH

9:00 - 10:00 a.m.	"Solving Bad Debt Problems"	Johnson	9:00 - 11:30 a.m.	"What Is A Cable System"	Cumberland
10:00 - 11:30 a.m.	"Surely Insured"	Johnson	9:00 - 11:30 a.m.	"Let's Analyze the Situation"	Judges' Parlor
2:30 - 5:00 p.m.	"Open Forum - Refranchising"	Cherokee	2:30 - 5:00 p.m.	"Big Bucks In A Small Town"	Commodore
			2:30 - 5:00 p.m.	"Let's Analyze the Situation"	Judges' Parlor

#### EXHIBIT HOURS

12:00 - 2:00 p.m.  
7:00 - 9:00 p.m.

### TUESDAY, JULY 6TH

9:00 - 10:00 a.m.	"Advertising on Cable Pays"	Johnson	9:00 - 11:30 a.m.	"What Will Two or Three Degree Satellite Spacing Do To Your TVRO Reception?"	Natchez Trace
10:00 - 11:30 a.m.	"Ad Spots on Satellite Programming"	Johnson	9:00 - 11:30 a.m.	"Let's Analyze the Situation"	Judges' Parlor
2:30 - 5:00 p.m.	"Dungeons and Dragons — The Copyright Monster Breathes Fire Again"	Johnson	2:30 - 5:00 p.m.	"Keep That System Equipment Operating Properly"	Cherokee
2:30 - 3:45 p.m.	"Equipment and Interface"	Cherokee			
4:00 - 5:00 p.m.	"Can We Afford To Finance Rebuilds and System Upgrading?"	Cherokee			

#### EXHIBIT HOURS

12:00 - 2:00 p.m.  
5:00 - 7:00 p.m.

7:00 - 8:00 p.m.	Cocktail Party sponsored by Warner Amex	Nashville Lobby
8:00 - 9:00 p.m.	Banquet	
9:00 p.m.	Entertainment sponsored by Group W Satellite Communications which brings you THE NASHVILLE NETWORK, SATELLITE NEWS CHANNELS, and THE DISNEY CHANNEL.	

\*This session will have limited attendance; please register for your space in this session immediately. Contact the Oklahoma City office (405) 947-7664 for space reservation.

MANAGEMENT SESSIONS

TECHNICAL SESSIONS



# CCOS '82

As the final plans and sessions are being firmed up for CCOS '82, interest is running high in planning extra time for visiting the area to take advantage of the tourist features in and around Nashville and the World's Fair, opening soon in Knoxville. Again, we are very pleased with the opportunity that this year's CCOS affords its attendees; not only the importance of the technical and management sessions figures into the enthusiasm and response for CCOS '82, but the historic appeal and musical magnetism of the area make this year's CCOS presentation another popular selection for cable enthusiasts and their families.

Also, you will find the schedule of technical and management sessions printed in this issue, with a short description of each session so that you may make your choices and plans for attending.

We also want to emphasize the limited capacity for the Spectrum Analyzer session, and we ask that you request the time slot you wish for that session (we'll be running three) **immediately** so that your reservation can coincide with the other sessions you wish to attend. There is room for thirty in these spectrum analyzer sessions, and CATA Associate Director, Raleigh B. Stelle, III, of TEXSCAN, will be conducting these. Many of you may remember the labs and sessions he has taught at previous CCOS meetings, and, if so, you also recall what a terrific teacher he is. This type session has been requested as a back to "hands-on" approach to CCOS, and the CATA Board of Directors, and CATA Director of Engineering, Ralph Haimowitz has plans for the sessions materialized, asked Mr. Stelle to participate once more with a teaching lab for attendees.

As you go over the program, you will notice other familiar names — like **Fred Rogers** of Quality RF Services — one of the

most popular sessions ever presented at CCOS was Fred's at Snowmass — not only did he have standing room only both times it was presented, but the tapes of this session were sought after for private libraries. Fred will be back to assist with maintenance of equipment problems — a simple subject, but a vital one!

Now that advertising on cable is such a controversial subject, a complete study of how to go about using this means to generate additional revenue will be presented that will include how to get assistance in planning your advertising program, whether local, regional, or national; sideboarding this session will also be one dealing with spots on satellite programming and what equipment you will need to interface advertising into your cable system. All of these subjects are timely and represent areas where assistance to the cable operator is definitely warranted.

**Chris Flor** of Heller Oak . . . **Richard Kirn** on Rural Cable Systems . . . **Steve Effros** on the ever-ominous Copyright . . . and another Effros Open Forum on Refranchising . . . all the subject are pertinent ones and vital to the smooth operation of your cable systems. If you haven't registered, do so today!

One of the highlights of the entire program will be the last night's banquet, when **Warner Amex** will host the reception prior to the banquet. After the banquet, entertainment presented by **Group W Satellite Communications** will feature **Bill Anderson**, the host of the national syndicated TV show, "**BACKSTAGE AT THE GRAND OLE OPRY**", which is the first regularly scheduled TV show ever to feature the Opry.

**Bill Anderson**, a man of many and diversified talents, including song writing, network game show host, daytime soap opera ("One Life to Live") appearances, and frequent appearances on today's top variety and game shows, has

## CCOS with CATA

As they would say in the South,  
y'all come!!!!



his roots in radio and country music. Although his studies gained him a degree in journalism, he broke into the music business as a disc jockey and began performing, which eventually developed into song-writing, and ultimately into being named a member of the Country Music Songwriters Hall of Fame. He has written literally hundreds of songs, receiving more than 50 BMI awards, which is more than any other country music composer, and has received other numerous awards.

CATA is extremely appreciative to **Group W** for providing this outstanding entertainer as the culmination of CCOS, and we know the attendees, the suppliers, and the families accompanying them will thoroughly enjoy this last night's spectacular and look upon it as the perfect climax to another meaningful and memorable CCOS.

If you haven't decided whether to join us in Nashville, consider the sessions, both technical and management . . . consider the exhibit time when the suppliers will have more than **thirteen** hours of display time to give every cable operator and technician ample time to visit the various booths and examine the equipment . . . consider all the new areas in the cable business that you need to be able to settle . . . consider the new avenues of generating revenue that you haven't decided about yet . . . consider the help you need when you get close to refranchising . . . when you consider all of these, plus what the area and the program holds for your families' entertainment, you won't have to think twice . . . you'll decide to join us in Nashville for another . . .

# ...About the management sessions



## "SURELY INSURED"

Representatives of Franey & Parr Insurance, as well as the Firemen's Union Insurance Co., will explore insurance coverages for cable television systems, including specific insurance plans tailored to the needs of small, medium, and large cable systems. This session will cover what insurance you should have, participation in safety and inspection programs to reduce rates, Workmens' Compensation, classification of employees, etc. This session is designed to appraise your insurance coverage, to determine if you have enough or not enough, and ways to save money on premiums. This could prove to be a very valuable session for managers!

## "THERE IS A WAY TO HELP SOLVE NON-PAY, BAD DEBT PROBLEMS"

If you have been having difficulty collecting your monthly subscriber dues, this presentation should help you work out the problems with those "non-pay" subscribers. A representative of Transworld Systems, Inc. will give you helpful information and facts to tell you how to approach this problem of collecting bad debts.

## "ADVERTISING ON CABLE PAYS!"

Saralee Hymen, representing the CABLE TELEVISION ADVERTISING BUREAU, will discuss how to go about earning additional revenue through advertising, regardless of the size of your system. Covered will be details about local, regional, and national advertising on cable and information on how to get assistance to get your advertising program initiated on your system.

## "AD SPOTS ON SATELLITE PROGRAMMING"

Speakers for this session will be representatives from TBS and ESPN, explaining the availability of ad spots on satellite programming, the use of these spots for local advertising to a successful and profitable result, and the training of your cable system staff to sell advertising spots on your system.

## "EQUIPMENT AND INTERFACE"

Are you wondering about what equipment you will need for using advertising spots on satellite programming and local origination channels? How are you going to interface this equipment into your cable system? This session will provide that information; plan to attend all three seminars dealing with advertising, and you will have the answers as to what to do, how to do it, what it will cost, and how much it can return in revenue. No doubt about it, this is a real dollars and sense session!

## "OPEN FORUM — REFRANCHISING"

Again, an Open Forum will be presided over by CATA Executive Director, Steve Effros, and presented with representatives from various factions present (such as a representative from the National League of Cities) to discuss important cable issues (excluding Copyright — there's another session for that!), focusing on refranchising, community ownership and legal problems facing the cable industry. The format of the open discussion was very well received at CCOS '81, and it was suggested that we again provide the forum to exchange viewpoints with open discussion. Having representatives from other groups should lend itself to a healthy and informative discussion!!

## "DUNGEONS AND DRAGONS — THE COPYRIGHT MONSTER BREATHS FIRE AGAIN"

Don't miss this one! Steve Effros have vital information for you concerning Copyright, and this session will bring you up to date. This is an important and vital issue, and at this time, Steve will explain what CATA's plan of action will be on this matter and what you need to do to protect your interests.

## "CAN WE AFFORD TO FINANCE REBUILDS AND SYSTEM UPGRADING?"

Chris Flor, Heller Oak Communications Financing Corporation, presents an in-depth study of where the smaller and independent cable operator stands when the time comes to sell or rebuild/upgrade his cable system. Don't sell out until you attend this session — it could make a big difference to your profits!



# ...the technical sessions

## "WHAT IS A CABLE SYSTEM?"

One of the most popular sessions at CCOS '80 was the session presented by CATA Director of Engineering, Ralph Haimowitz on "back-to-basics". This session will be an expanded version covering equipment familiarity and the basic technology of a cable television system from the signal sources to the subscribers' TV sets. This seminar was designed for the non-technical owner/operator cable television office personnel, and new sales personnel from the suppliers group, and will prove to be an invaluable tool of learning and understanding for those attending. Perhaps you have some one new with your company; this will be the ideal exposure to a basic approach to the "hows and whys" of a cable system. We want to emphasize that this will be tremendous assistance for manufacturers and distributor sales personnel to enable them to better understand the needs and uses for their products and services as they apply to a cable system.

## "BIG BUCKS IN A SMALL TOWN"

Richard Kirn, Sarasota, Florida, an expert in the field of small cable systems, will present this in-depth session on rural cable television systems, including new system design concepts, expansion of existing systems, inexpensive re-design and rebuild, exploring the when and where to use line extender trunks, etc. Be confident in the small, independent cable system is not a thing of the past. Do not miss this one if you are interested in big savings continuing to meet or exceed technical standards.

## "KEEP THAT SYSTEM EQUIPMENT OPERATING PROPERLY"

Once more the ever popular Fred Rogers will return to the CCOS program to share his expertise in the maintenance of your cable system equipment. This one is guaranteed to be another "Rogers Super Spectacular" technical session and one you absolutely should not miss. Come early or you might not find an empty seat.

## "WHAT WILL TWO OR THREE DEGREE SATELLITE SPACING DO TO YOUR TVRO RECEPTION?"

A troublesome question!! Our panel of experts will present their views, facts, and data on what 2° or 3° spacing will do to your satellite signals should this spacing be approved. This is a most controversial subject, and from this session you will learn what is required to meet minimum technical standards, as well as options open to cable operators. If you have a five meter dish, or smaller, you won't want to miss this session. It will include information on sizes and types of earth station antennas, including multiple satellite receiving antennas. Representatives from HBO, Harris Corporation, Antennas for Communications and Microdync Corporation will participate in this presentation.

## "LET'S ANALYZE THE SITUATION"

Do you remember the early CCOS days and the lab sessions that were packed with cable operators? This session has been requested continually, and we have scheduled this, with the cooperation of Raleigh Stelle, TEXSCAN CORPORATION, who will teach how, when, and where to use a spectrum analyzer in this "hands-on" session. For many of the new people in the cable industry, this technical session will afford them the opportunity to learn how to work a spectrum analyzer and understand what information the equipment provides by doing it. Because of the nature of this session, if you are interested, register for this class immediately. We are running this session three times to accommodate those who will want to participate in the lab. We cannot stress this too much — register now by dropping a note to the address below, requesting your registration for this spectrum analyzer lab. It will be a first come, first served basis; check the schedule and request the specific lab that you wish, but do it today, so you won't be disappointed!!!! ☐

Spectrum Analyzer Lab  
 CCOS '82  
 4209 N.W. 23rd, Suite 106  
 Oklahoma City, OK. 73107

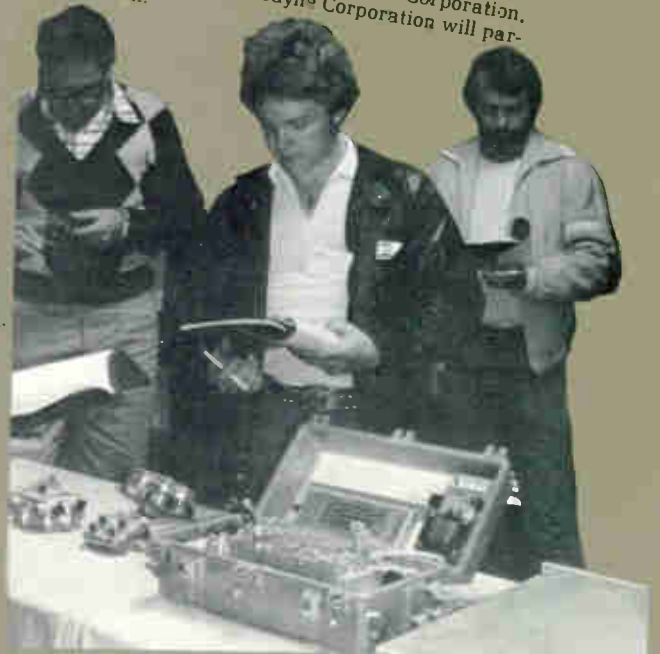
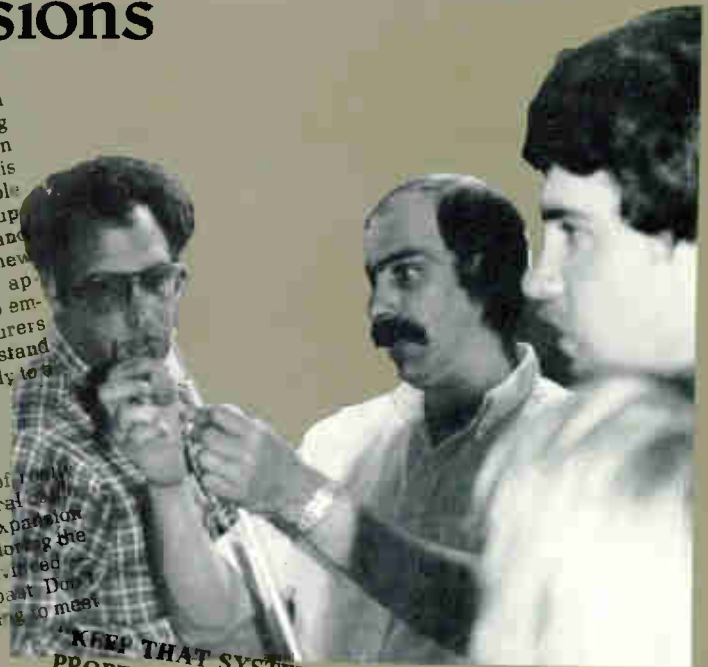

continued from page 16

Controller is to store and interpret data, and command the amplifiers.

**CRT Terminal:** The CRT Terminal provides the means for data entry to the computer controller, and displays the system status as interpreted by the computer controller. It is used to communicate and control the individual amplifiers on a manual basis.

and street location, viz. corner of 1st and Main Sts, and status of disconnect switches, DC power supply, operating levels and auxiliary ports.

**5DSSI Computer to Cable Interface:** This is a device that converts digital information output from the computer into a digitally modulated RF carrier suitable for transmission on a CATV distribution network. Inversely, it converts the returned response

DSS equipped Magna 440 mainstation amplifier.

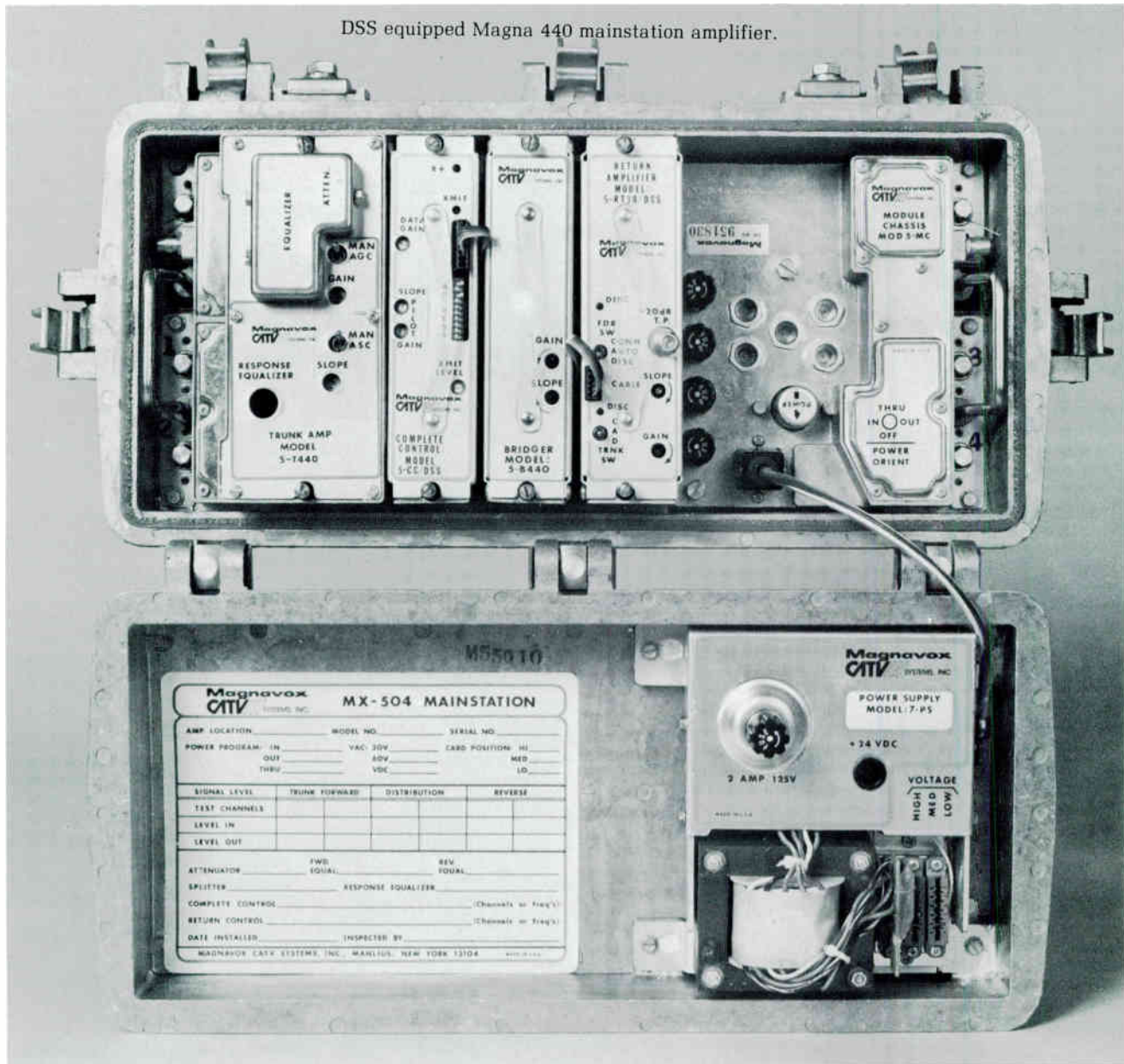

**Printer:** The Printer turns out hard copy, reporting on the status of the cable system for unattended monitoring.

**Dual Floppy Discs:** This facility stores the programs which operate status monitoring and the data generated by amplifiers reporting their status. For example, the location of amplifiers by their number

signal from each amplifier from a digitally modulated RF carrier to base band digital information for input at the computer.

In addition to the above functions, the 5DSSI unit has facilities for stepping the output and input RF amplitudes (with a precision digitally controlled at-

continued on page 24

# TRIPLE CROWN ELECTRONICS offers more than the most extensive amplifier line in the industry . . .

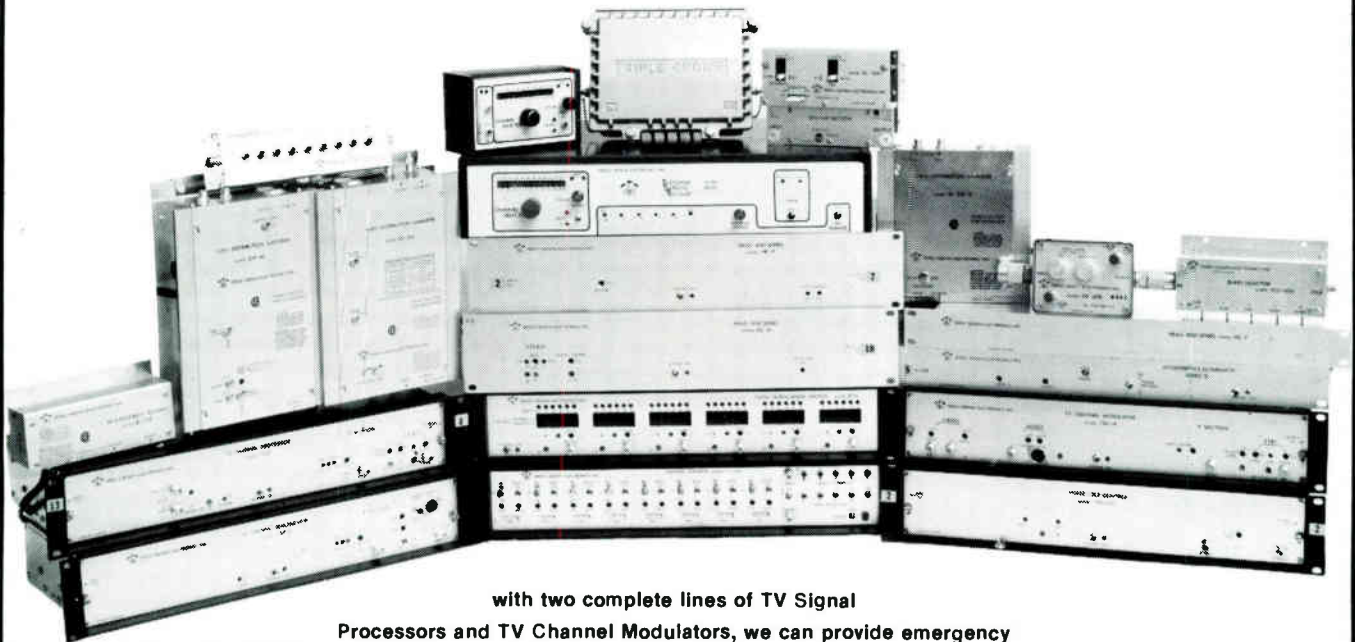

with two complete lines of TV Signal

Processors and TV Channel Modulators, we can provide emergency override for under \$30/channel (20 CH system). Our TCS 1800 multichannel signal source has been expanded to 400 MHz for one of the most cost effective test and maintenance packages of its kind. Add our Television Satellite Receivers and Amplifiers with feed-forward correction and you'll find that Triple Crown Electronics has the equipment you need . . . at prices you can afford.

## CANADIAN DISTRIBUTION

### REPRESENTATIVES

#### QUEBEC / MARITIMES

Incospec Electronics Inc.  
4651, dou, des Grandes Prairies Blvd.  
Sy.-Leonard (Quebec) H1R 1A5  
Tel: (514) 322-5540

#### TRIPLE CROWN ELECTRONICS

4560 Fieldgate Drive  
Mississauga, Ontario L4W 3W6  
Tel: (416) 629-1111  
Telex: 06-960-456

#### WESTERN CANADA

Tech Comm Sales Inc.  
5349 Imperial Street  
Burnaby, British Columbia V5J 1E5  
Tel: (604) 437-6122

## UNITED STATES DISTRIBUTION

### REPRESENTATIVES

B.E. Duval Company  
29619 South Western Ave.  
San Pedro  
California  
90732  
Tel: (213) 833-0951

TR Pitts Company  
P.O. Box 57  
501 West Fifth Street  
Winona, Minnesota  
55987  
Tel: (507) 452-2629

Ind. Co. Cable-TV Inc.  
P.O. Box 3799  
755-23rd Street  
Batesville, Arkansas  
72501  
Tel: (501) 793-4174

#### IN MEXICO

FAG, S.A.  
Calle 15 No. 81  
San Pedro de los Pinos, Mexico 18, D.F.  
Tel: (905) 516-1075

#### IN EUROPE

HF Transmissie Techniek B.V.  
P.O. B 385, De Smalle Zijde 8  
3900 AJ Veenendaal, Holland  
Tel: 08485-17231

## U.S. REPAIR SERVICE

Superior Electronics Center Inc.  
2010 Pine Terrace  
Sarasota, Fla. 33581  
Tel: (813) 922-1551

Lee Dorman Repair Service  
Tressler Street  
Pleasant Gap, Pa., 16823  
Tel: (814) 359-3161

**Addressability isn't  
equipment.  
It's a marketing  
concept.**

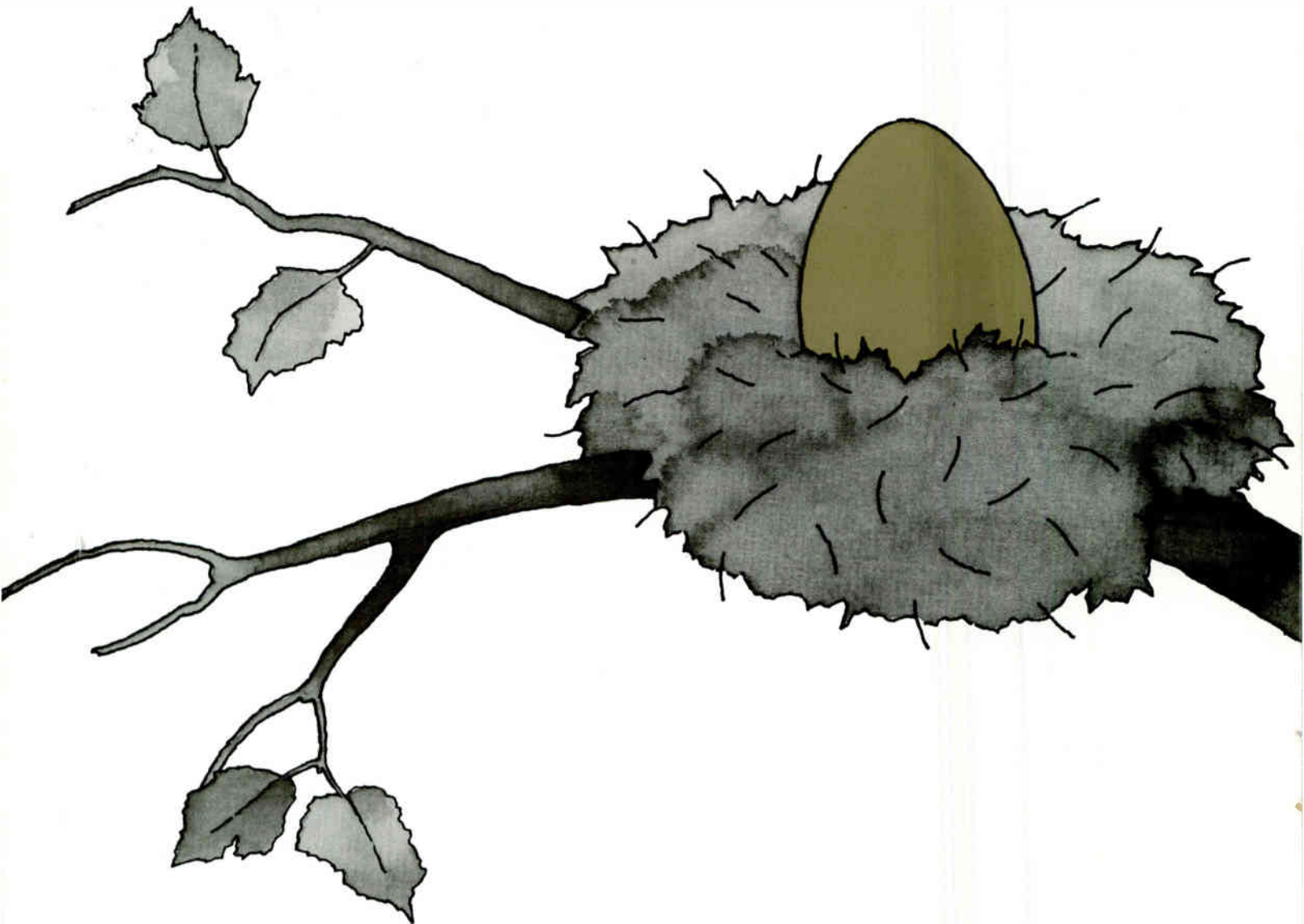

It's time to think about addressability in terms of how you market your product. Your business may be great today. But subscriber tastes can quickly change, creating a new market that's not satisfied with yesterday's programming.

**Addressability delivers more specialized entertainment.**

Your subscribers will want selections tailored to their personal needs. They'll want a wider assortment of programming to choose from. In short, they'll want everything only addressability offers.

**It pays you to go with addressability**

There's almost no limit on the advanced program packaging you can sell with an addressable system. Like college courses, hobby classes, job enrichment

programs, even business and personal financial programs. Plus all the revenue-building opportunities from pay-per-view, multi-pay marketing and tiering.

**Make a change for the better.**

With addressability, you can run cost analyses on all your programs to determine profitability. You can track viewing trends to change your offerings as the audience changes its tastes.

And when they do, you can change service levels quickly and efficiently right from the office. Only addressability puts at your fingertips an almost limitless number of ways to expand your market opportunities as well as your profit potential.

**You'll be sold on Oak.**

Of all the people selling addressable systems,

why should you choose Oak Communications Systems (formerly Oak Communications CATV Division)? Experience. We've been involved in the cable industry as hardware/software designers and builders for over 15 years. We invented state-of-the-art addressability and introduced it in 1977.

Today, over 300,000 cable subscribers and 600,000 STV subscribers have Oak addressable systems.

When you select Oak, you're in good company.

For more information on how you can profit from an Oak addressable system, call our toll-free phone number: 800/323-6556 (in Illinois 800/942-6345). Let us show you how Oak addressability can be the golden egg in your cable system.

**Oak: The first choice in addressability.**

**OAK**

**Oak Communications Systems**  
P.O. Box 517 Crystal Lake, Illinois 60014  
**Subsidiary of Oak Communications Inc.**



continued from page 20

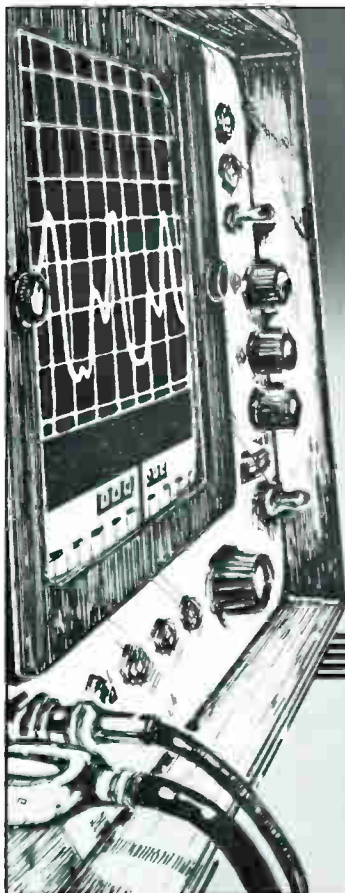
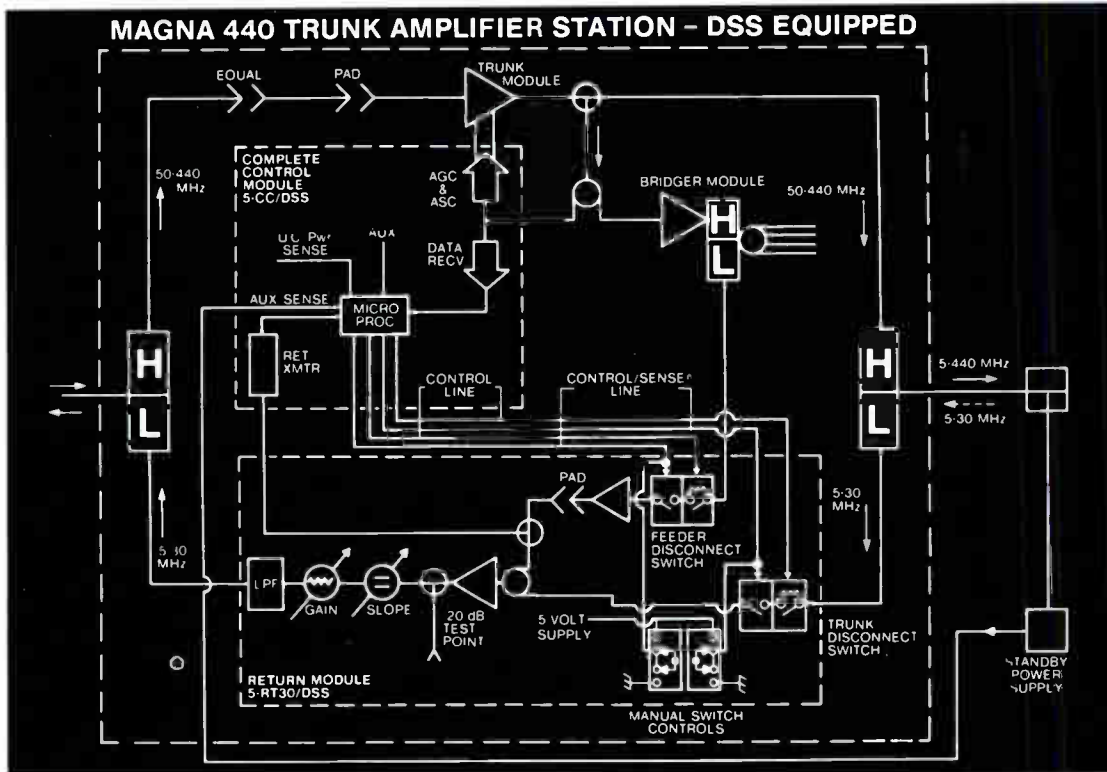

**We do more  
than just stock and ship.  
We service what we sell.**

Like other distributors, we carry everything from head-end to tools. And ship same-day.

Unlike the rest, we don't have to send equipment back to the factory. We can service everything in-house. You'll have your equipment back — or replaced — immediately.

**Call toll-free to order, ask questions, or get your free catalog. Or drop us a line. 800-233-8452 • In Pennsylvania: 800-332-8545**



**Cable Services Company/Inc.**

2113 Marydale Avenue, Williamsport, PA 17701 • Telephone 717/323-8518  
 Bashlin • Belden • Bishop • Blonder Tongue • Cablematic • Carlton • Comscope •  
 Diamond • Jerrold • Joslyn • Klein • LRC • Lemco • Louisville Ladder • Multiplier •  
 Preform • Pyramid Ind. • Scientific Atlanta • Taco • Texscan • Times • Weaver and many more

See us at NCTA Booth 1926



tenuator). This is applied for both forward and return level measurements.

The architecture of the 5DSSI is compatible with phase locked systems such as Harmonically Related Carrier (HRC) or Incrementally Related Carrier (IRC) systems. This is accomplished by providing a separate input for a phased locked C.W. Carrier with a minimum amplitude of 45 dBmV, which is subsequently modulated with a digital address and command code.

Where phase locking is not required, the 5DSSI can use a built-in C.W. oscillator which is modulated to provide the forward RF data carrier.

The block diagram is for a typical DSS equipped MHz trunk amplifier. However, as the diagram shows, this amplifier has two components unique to the DSS system: Complete Control Module 5-CC/DSS, and Return Module 5-RT30/DSS.

**Control Module 5CC/DSS:** This plug-in unit serves two functions: 1) Automatic Gain Control and Automatic Slope Control; 2) Data Receiver, Microprocessor and Transmitter for control of status monitoring, disconnect systems and response to the headend controller.

**Return Module 5RT30/DSS:** Also plug-in, this module has switches for feeder and trunk paths. The

switches turn the feeder or trunk paths completely on or off. Or you can set 6dB attenuation in a trunk or feeder path.

As the block diagram shows, the microprocessor controls the switches. This can also be done by another device, which is externally installed. The amplifier station was designed to be compatible with other computer control systems, such as Pioneer or

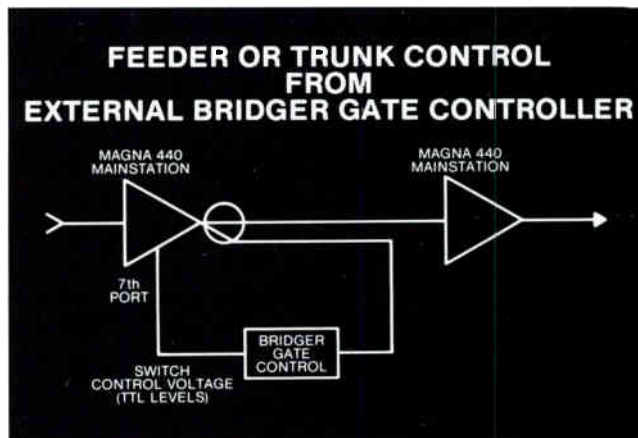

Qube, where an external bridger gate control (BGC) is used.

Bridger gate control is similar to the microprocessor in our amplifier that feeds back control signals to the return module in the trunk amplifier to change the status of the switches.

## DOW-KEY 66 SERIES

# THE AFFORDABLE SWITCHING SOLUTION

Liberate Tight Budgets  
With New Savings On  
Dow-Key Coaxial Relays.

Now you can meet a variety of high isolation switching requirements and reduce your spare parts inventory with just one competitively priced relay. The Dow-Key 66 Series.

Developed for Cable Television, the 66 Series features specially designed 75 ohm "F" connectors which provide a minimum of -100 dB isolation DC to 500 MHz. It can be counted on to provide second-to-none performance and reliability in:

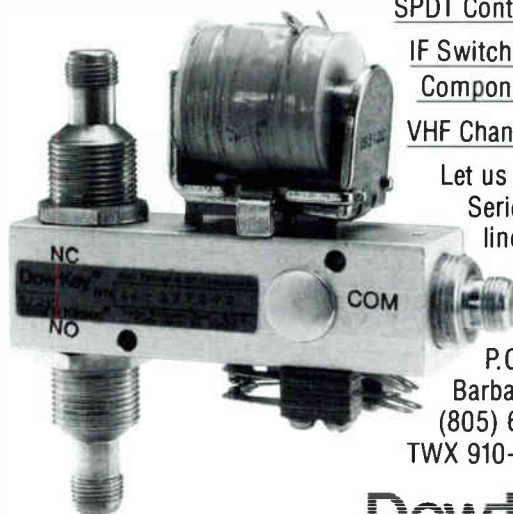

Video Source Switching With Two SPDT Contacts for Audio Follow-On;

IF Switching Between Head-End Components;

VHF Channel Switching to 500 MHz.

Let us show you how the Series 66 and the complete line of Dow-Key Coaxial Switches and Relays can save you money. Call or write Dow-Key, P.O. Box 4422C, Santa Barbara, CA 93013, USA, (805) 684-4560, TWX 910-336-1141.

**DowKey**  
Division of Kilovac Corporation

On the Return Module there are toggle switches which provide manual control of on/off status. Thus, the return module can stand alone and be used manually, without involving the Computer Controller.

### THE MICROPROCESSOR

Functions performed by the microprocessor, which is in every amplifier, include:

**Forward Level Measurement:** The microprocessor measures the level of the data carrier at the output of the trunk amplifier. As a result, you can, at any given point in time, determine the output level and make a judgement on picture quality at the subscriber's set.

The microprocessor uses the level of the forward data carrier for measurement. For example, consider a system where the output level is drifting with the temperature in the winter. If the level drifts up fairly high, you can assume that the customer's signal is degrading, provided head room is insufficient. If the level is drifting lower, you can assume that the picture is getting "snow" or is noisy.

DSS monitors switch positions of the feeder and trunk disconnect switching system. A typical example: a technician, maintaining an amplifier, inadvertently changes the position of a switch. The Computer Controller immediately determines this and reports that the switch is in the wrong position.

DSS also monitors DC voltage in system amplifiers. This can help you determine faults in the trunk amplifier power supply. Or it can indicate line power problems. A fault indicated by this function could also imply an improperly installed power plug.

The microprocessor also provides two auxiliary control lines, which can be used at your option. For example, you can connect them to the standby power supply, which has connections for cycling batteries. This, in effect, exercises the batteries. The auxiliary control lines are normally used to control the 6dB switches.

**Sense Lines:** In addition, DSS provides auxiliary sense lines that can be connected from an amplifier to a standby power supply to determine if a utility power failure has occurred, and whether or not the system is operating on batteries. You can monitor and time such a failure. If it persists beyond the safety margin for standby batteries, you should, of course, decide how to supplement the battery power to assure operation of the cable system.

The microprocessor also does error checking on received data; and it modulates the return transmitter with response information that gives the status of the amplifier.

### COMPUTER CONTROLLER

On the headend side, the Computer Controller determines whether the alarm reported by the amplifier is major or minor. A major alarm is

serious, viz: complete failure of the amplifier. Or discovering that the standby power supply is operating in the standby mode. Major faults, such as these, must be monitored closely, or be corrected right away.

A minor alarm is one that doesn't require attention right away.

#### Alarm notifications

Major alarm notification occurs three ways:

- 1) Display on CRT
- 2) Display in hard copy from the Printer.
- 3) Notify by audio tone. Audio tone can be modulated on an FM carrier and routed to your chief technician's home via the cable network.

Potential additions to DSS could be a "dumb" terminal, where the operator can access the status of the system through the headend computer. This is not part of DSS but we do provide an additional serial port on the computer.

### SYSTEM INITIALIZATION

This is what provides flexibility in a digital system, such as the one illustrated. It is a program for the computer controller, which gives the operator complete control of all set up parameters. For example, major and minor windows for classifications of RF level related faults.

The major window can be set at  $\pm 6$ dB from the nominal operating level. If the operating level changes by more than 6 dB, an audio alarm sounds and continues to sound until acknowledged by the operator. This window can be changed at any time to any value desired.

The program also provides for the classification of faults as either major or minor. For example, one type of fault reported by DSS is a feeder switch status. If a technician should inadvertently change the switch to "off" when it should be "on" the computer would actuate an audio alarm as well as report via hard copy printout. This would be classified as a major alarm because the audio alarm sounded and required attention. The operator has the option of changing the classification to a minor fault, which would not sound the audio alarm and would not require immediate attention.

Other functions of the Initialization Program are:

- 1) Add amplifier location data
- 2) Set switch states
- 3) Define nominal amplifier level
- 4) Define auxiliary port application
- 5) Define fault description and fault code number

### HISTORY REPORTS

You can select a certain number of amplifiers which you want to monitor for drift over a given period of time. For example, select amplifiers #1 through #20 and request that the status of the amplifiers be stored at 30 minute intervals for the next 12 hours. DSS will sample each amplifier and store the reported status for printouts on request.

*continued on page 31*

***HOW TO  
CREATE  
AN  
ALL-NEWS  
CABLE  
SERVICE.***

# ***IN OTHER WORDS: HOW TO CREATE SATE***

---

**1.** *Program news, all news and only news. 24 hours a day. When viewers tune in, they'll receive news not dated fashion reports, cooking tips or syndicated advice on caring for their pet. SNC is a news service not a news and feature service.*

**2.** *Present the news live, always, 24 hours a day, 7 days a week. When viewers tune to SNC, they won't see video-taped repeats of stories that ran live hours earlier.*

**3.** *Present the news in lean and trim 18 minute blocks. Your viewers can tune in anytime (day or night) and know that what they get will be news and only news. No interview shows, no telephone call-in programs, no lengthy documentaries. You don't need a program guide to watch Satellite News Channel.*

**4.** *Organize the country into 24 regions. Dedicate five minutes each hour to regional reports provided by top award-winning news gathering organizations from each area. When your subscribers tune in, they'll receive up-to-date news that's close to home.*

# **LLITE NEWS CHANNEL.**

---

**5** ■ *Bring together a force of 3,200 news professionals including award winning reporters, correspondents, producers, directors, and production personnel. When subscribers turn to this channel, they'll be turning to experience and a tradition of accuracy, speed, and innovation.*

**6** ■ *Utilize the resources and expertise of Group W and ABC News, organizations recognized as outstanding and innovative leaders in news gathering and news-casting. Combine the talents and production capabilities of 9 U.S. news bureaus, 13 foreign bureaus, and 23 regional news gathering associates.*

**7** ■ *Produce and market a channel exclusively for cable operators and their subscribers. Don't repackage the news for use as a secondary cable network or for use by any other competitive media. If an operator asks if we are a cable-only news service, answer yes emphatically.*

*For a step-by-step introduction to what  
Satellite News Channel is all about, call Lloyd Werner  
at Group W Satellite Communications: 800-243-9140.*

**YOU GIVE US 18 MINUTES.  
WE'LL GIVE YOU THE WORLD.**



continued from page 26

The amount of history data is limited, based on the number of samples required. However, these history reports can provide information on amplifier drift due to temperature.

#### INGRESS LOCATION PROGRAM

Semi-automatic, the program will sequence through the amplifiers without the need to key the address of each amplifier manually. This saves the technician a substantial amount of time over conventional methods. To illustrate, the conventional method requires setting a thumbwheel address and then pressing a separate button to toggle the switch. Then the same procedure is repeated to return the switch to its original position. This has to be done for several trunk amplifiers in the system, which could take a substantial amount of time, but this system performs this manual function automatically.

The technique for locating ingress involves a monitor at the headend, with a spectrum analyzer or frequency selective volt meter tuned to the frequency of the interference.

As you operate the ingress locating program, the technician at the headend views the amplitude of the ingress on the monitor while the computer sequences through each amplifier. At the point where the technician detects a 6dB shift in the amplitude of the interference, he commands the computer to halt. The computer can then be instructed to display the exact amplifier location where ingress is entering the trunk network.

The microprocessor in the 5CC/DSS Control Module as illustrated has a 10 pin DIP switch used for identifying the amplifier address. This indicates that DSS has the capability of 1,024 unique amplifier addresses. Actually there are 1,023 different addresses; one is reserved for the system balancing procedure. However, this does not mean that your system is limited to monitoring 1,023 amplifiers. There is no limit to the number of amplifiers. This DSS can handle blocks of 1,023 amplifiers by segmenting the system and by adding an additional 5-DSSI computer to cable interface for each segment.

#### BENEFITS OF THE 6dB SWITCH

This component was designed to supplement return signal switching. The original concept behind bridger or feeder disconnect was to reduce noise amplitude in the return system. It was found, in implementing a 2-way system, that all the return amplifiers contributed noise. The noise accumulated on the return trunk line, eventually funneling back to the headend. (All amplifiers, not just a direct cascade.) This is unlike forward systems, where noise accumulates only from the cascades of amplifiers directly in the path between the headend and the subscriber's TV.

continued

## TRS-80 Model II Microcomputer System



Streamline  
your cable  
operation  
with a

### CATV BILLING SYSTEM

written by

**Dr. Snowden Bunch**

**President of Cable TV of Carolina, Inc.**

starting  
at

**\$850.00\***

**Radio  
Shack**

(207)-496-2281

Associate Store

P.O. Box 749

Caribou, Maine 00736

\*Free with purchase of TRS-80 MODEL II

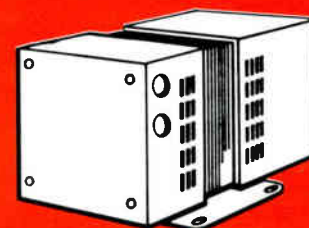

**SHAPE**  
MAGNETRONICS INC.

**STOP THE  
DAMAGE AND  
DOWNTIME  
CAUSED BY  
LINE LOSSES,**

**VOLTAGE FLUCTUATIONS,  
BROWNOUTS AND LINE NOISE WITH**

## Line Tamer

**FERRORESONANT TRANSFORMERS  
FOR COMPUTER, INDUSTRIAL  
AND ELECTRICAL APPLICATIONS**

- VA ratings from 15VA to 250KVA
- complete power line isolation
- instantaneous response
- single phase or three phase, 60Hz or 50Hz
- short-circuit protection
- no step up/down transformers required
- no maintenance; one-year-factory warranty

CWY Electronics  
405 N. Earl Avenue  
Lafayette, IN 47904

Toll Free (800) 428-7596  
Indiana (800) 382-7526



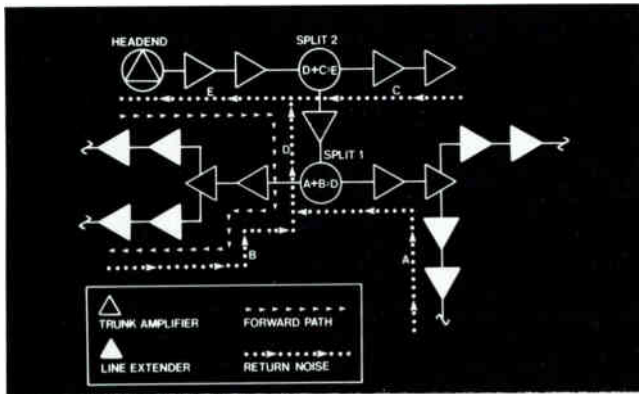

Return noise funneling diagram.

There are a total of 9 trunk amplifiers. Four line extenders off each trunk amplifier give you a total of 36 line extenders.

Thirty six line extenders plus 9 trunk amplifiers equal 45 amplifiers contributing to return noise at the headend. (Only 5 trunk amplifiers plus 2 line extenders contribute to noise in forward direction.)

Like the forward system involving a single cascade (arrow line in drawing), we can - with a bridger switch-reduce noise to a single cascade. This is accomplished by switching off the unused legs of the system. All bridger switches in the unused area are turned off, with the result that only a single cascade contributes to return path noise accumulation.

As a solution, it was decided to use a switch that would isolate the feeder portion, and eliminate all of the noise contributed by line extender amplifiers. Since the return path is only capable of handling four TV channels, it was thought that only four bridger switches had to be left on. This reduced the number of bridgers which had to pass signals (or noise).

This was fine until it was realized that continuous data was coming back from every feeder line, viz. a security system with modulators in every home. These cannot be switched off and on because it would interrupt the data communications path.

As time went by, system designers concentrated on the noise funneling problem. Systems were segmented via separate trunks or hubs for the purpose of minimizing the amount of noise at the headend. This proved to be a satisfactory solution. As a result, the bridger switch evolved from a tool to reduce noise funneling to a tool to isolate ingress.

However, there was still a problem in turning return feeder lines off and on when data services, such as security, were active. It wasn't long before a better method of locating ingress was developed. This is the 6dB attenuation switch found in every 5RT30/DSS module.

The 6dB switch is applied as in the following example: Suppose there is a CB transmitter leaking into the cable system through an improperly installed connector on the feeder line. Using our ingress location program, we systematically attenuate individual return bridger paths by 6 dB. Unlike other systems which require complete shutoff of return bridge paths, DSS avoids disruption of critical data communications carried by the return system.

### LEVEL MEASUREMENTS

Accurate measurements are important, and this system has a unique method for accurately measur-

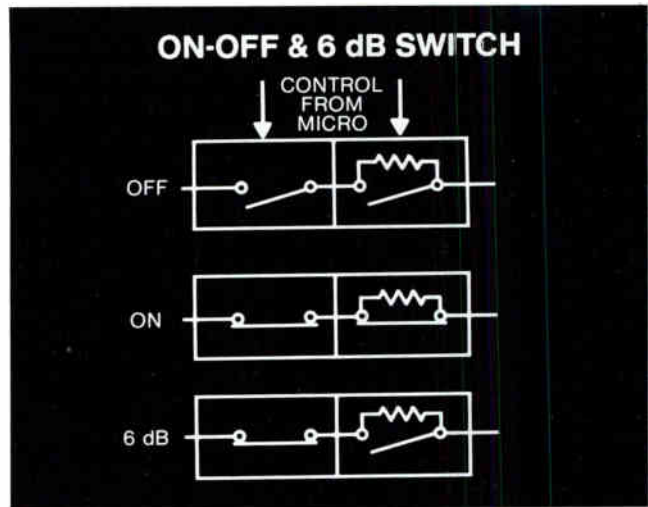

ing the trunk amplifier output level of the forward data carrier. A threshold detector in each trunk amplifier and a precision digitally controlled attenuator in the headend controller are applied to maintain a  $\pm 0.5$  dB level accuracy. This method is unlike conventional methods employing analog to digital (A/D) techniques.

A/D techniques can be a very accurate process. However, for CATV trunk level measurements, another degrading factor plays a major role. Without getting into detail, it will suffice to say that this method requires the definition of the transfer characteristics of the amplifiers' active gain and slope control circuits. This can be done accurately for one amplifier, but each different amplifier exhibits a slightly different transfer characteristic, (it's impractical to define characteristics for all amplifiers). This is the pitfall for the typical method and causes a greater tolerance for level measurement than the technique employed.

As mentioned previously, Magnavox does not employ the A/D technique and is not affected by varying amplifier characteristics. The Digital Systems Sentry technique is a function of the accuracy of the digitally controlled precision attenuator (included as part of the Model 5-DSSI computer to cable interface). It is a known fact that attenuators are available with accuracy to a tenth of a dB. Since the one attenuator is in the headend, it is a common component to all amplifiers and, therefore, level measurement tolerance is equally accurate for all amplifiers in the distribution system.

### SUMMARY

The Digital System Sentry is a multi-function system providing operation and maintenance efficiency improvement for the CATV system operator. Installation provides better service to the subscriber. The ultimate result is increased operating profits and maximum viewer satisfaction, for continued and stable income from the subscriber base. □



# Introducing Broadband's family of flexible, high performance amplifiers for apartment and house-drop distribution systems.

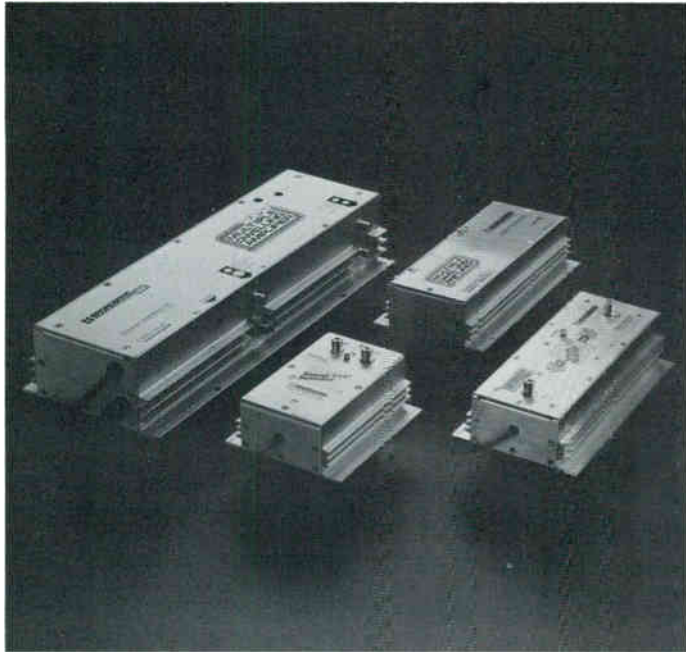

Super Multiple Dwelling Amplifier      Multiple Dwelling Amplifier      Signal Stretcher™ — Two-Way  
Signal Stretcher™ — One-Way

Model	Gain	Bandwidth	Output Capability*
<b>Super Multiple Dwelling Amplifier</b>			
SMDA-300	20 to 40 dB	50-300 MHz	+49/44 dBmV
SMDA-440	20 to 40 dB	50-440 MHz	+47/42 dBmV
Reverse Amplifier	10 to 30 dB	5-32 MHz	+5C dBmV
<b>Multiple Dwelling Amplifier</b>			
MDA-300-30-T	30 dB	50-300 MHz	+49/44 dBmV
MDA-440-30-T	30 dB	50-440 MHz	+47/42 dBmV
<b>Signal Stretcher™ — Two-Way</b>			
SS-300-15-T-2W	15 dB (flat)	50-300 MHz	+45/40 dBmV
SS-440-14-T-2W	14 dB (sloped)	50-440 MHz	+41/36 dBmV
Reverse Amplifier	0 dB	5-32 MHz	N/A
<b>Signal Stretcher™ — One-Way</b>			
SS-300-15-T	15 dB (flat)	50-300 MHz	+45/40 dBmV
SS-440-14-T	14 dB (sloped)	50-440 MHz	+41/36 dBmV

\*Output specified at -60 dB CTB @ 54-channel loading for 440 MHz units and 35-channel loading for 300 MHz units.

We now offer you a complete line of one- and two-way apartment and house-drop amplifiers to fill all your requirements for home, apartment, condominium, hotel and motel distribution systems.

**Super Multiple Dwelling Amplifier (SMDA):**

New! Topping off our product line, the SMDA is super-flexible to meet your changing apartment distribution needs. Easily convertible to two-way operation, it features a variety of gains up to 40 dB at 300, 440 MHz bandwidths.

Controls include gain and slope as well as plug-in pads and equalizers. Powering is also flexible with 120-volt line and 30/60-volt cable power options.

**Multiple Dwelling Amplifier (MDA):**

New! Available in 300 MHz and 440 MHz bandwidths, the MDA has 30 dB of gain and plug-in pads and equalizers. It's one-way and is powered by a U.L.-approved Class II transformer that may be located away from the unit itself.

**Signal Stretchers™ (SS):** Introduced last year, Signal Stretchers™ are designed for house drops requiring additional signal to feed a number of TV sets. Available in 300 MHz and 440 MHz one- and two-way models, they are also effective for long drops where the signal loss is great.

Because of their high output capability, Signal Stretchers™ may also be used to feed small apartment buildings of ten to fifteen units.

Broadband engineered and guaranteed, all our amplifiers are equipped with push-pull circuitry and are capable of full channel loading at the design bandwidth.

For free specification sheets and pricing, call our toll-free number (800-327-6690) or write Broadband Engineering, Inc., P.O. Box 1247, Jupiter, Florida 33458.

See us at the National Show — Booth No. 1608.



# AUTOMATIC COMMERCIAL INSERTION CHARACTER GENERATOR



The BEI Marquee-800 offers you a low cost method for inserting commercials on tone commands. Marquee-800 detects the tones sent by the satellite service. It can be programmed to display as many commercial spots as desired within the time available and will return to the satellite service automatically.

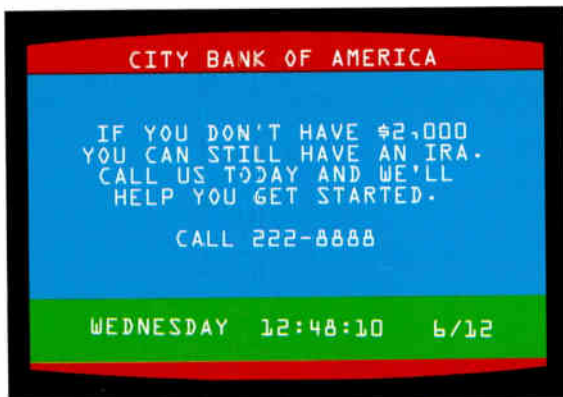

## SYSTEM I \$4,295.00

- 16 pages of 8 lines
- Title lines
- 4-color background
- Programmable tone decoder

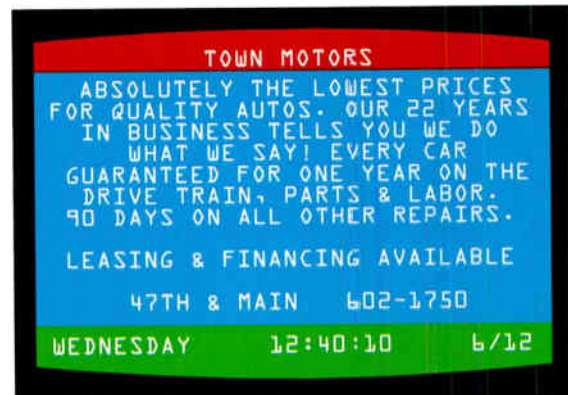

## SYSTEM II \$5,095.00

- Over 100 pages of 12 lines
- Title lines
- 4-color background
- Programmable tone decoder

For more information call Rod Herring, Jim Sherry or Jim Shaw today toll-free 1-800-225-6226



Toll-free 1-800-255-6226  
In Kansas 913 764-1900  
TWX 910-749-6410  
P.O. Box 937 Olathe, Kansas 66061

**SEE MARQUEE-800 AT NCTA... BOOTH 901**

# Build Your Own Tone Decoder

John C. Lazar, Harris Corporation  
Richard Kirn, Wire Tele-View Corporation

## INTRODUCTION

Many satellite programmers use a 4-digit tone pair sequence to indicate start, stop, begin scramble, insert commercial, etc. in the tone system each of the 12 characters (0-9, \*, #) are transmitted as two simultaneous superimposed tones. The general practice is to transmit a sequence of 3 digits plus a (\*) or a (#) signal with the (\*) usually indicating a start/on and the (#) indicating a finish/off.

We will detail a simple tone operated switch that can be built for about \$125.00 in parts and will make a good spare time project. The tone control switch is programmed to receive and decode a string of sequential tone pairs. No action will occur until a recognized sequence has been detected at which time action (relay open, close or remain same) is taken. If the correct string of characters (tone pairs) stops part way through the sequence, the switch waits a predetermined time ( $\approx 30\text{ms}$ ) and begins looking again for the first character in the sequence.

## CHARACTER (TONE PAIRS) RECOGNITION

The basic building block of any tone switch is a device for detecting discrete tones. The LM567 integrated circuit provides a simple and inexpensive tone detector.

The basic building block for the switch is the LM567 tone decoder integrated circuit. The LM567 utilizes a phase locked loop to detect input frequencies within a user settable passband. When frequencies within this passband are present the output is shorted to ground. Other-

wise the output is left floating. Figure 3 shows the LM567 with all external components needed to complete a single tone detector. The circuit's center frequency,  $F_c$ , is determined by resistor  $R_f$  and capacitor  $C_f$  and is approximately equal to

$$F_c = \frac{1}{R_f \cdot C_f}$$

The bandwidth of frequencies to which the circuit will respond is set by the input signal amplitude,  $V_i$ , and the capacitor  $C_2$  and can be approximated as

$$BW = 1070 \sqrt{\frac{V_i}{F_c \cdot C_2}} \quad \% \text{ of } F_c$$

Resistor  $R_2$  is used to pull the output up to +5 volts when the output is floating. The other components form the loop and output filters for the LM567.

## THE TOUCH TONE DECODER

The 12 characters of the standard touch tone system are represented by seven different tones at frequencies of 697, 770, 852, 947, 1209, 1336, and 1477 Hz. Each character is represented by a waveform which is a simultaneous combination of two of these frequencies. A system which will decode each of the 12 characters is built by using 7 LM567s and 12 digital NOR gates. Each of the LM567 circuits is tuned to one of the seven touch tone frequencies. For each of the 12 possible touch tone waveforms only two of the LM567 outputs will go low. These two low outputs are detected by one two input NOR gate. As shown in Figure 1 when both the NOR gate's inputs are low its output is high. All other combinations of inputs result in a low output.

The complete touch tone decoder with all LM567s and NOR gates correctly connected is shown in the left hand portion of Figure 3.

The amplitude of the input signal to the tone decoder must be in the range of about 300-600 mV p-p for the LM567s to operate properly. Since much CATV equipment provide audio output test signals in the range of only 200-400mV p-p an amplifier has been added before the tone decoder. For convenience a 4069 digital inverter is used for this purpose by biasing it in its linear hi-

A	B	OUT
L	L	H
L	H	L
H	L	L
H	H	L

FIGURE 1

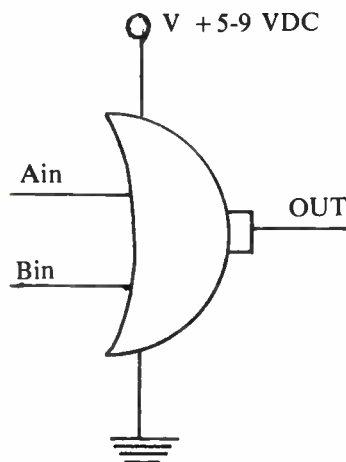

continued on page 39

---

# JOIN THE SPCTE

## Society to Prevent Cruelty to Test Equipment

---



Preventative Maintenance includes treating your test equipment with TLC (tender loving care). Without your test gear, you might as well pack up your tools and go home. Every technician in cable always takes good care of his equipment on the job. You know how you always keep it protected from the sand, rain, and snow when you are using it, and, when you are done, always insure that the power switch is turned off, remove any stray items from the case such as connectors, cables, screwdrivers, etc., return it to the carrying case, close and latch the covers, and place it gently in a safe, protected place in your vehicle.

The unhappy truth is that cable technicians rarely do these acts of kindness to their test equipment. The normal procedures are to set up the equipment in the dirt, and open it up to rain, sleet, snow, hail, or anything else that Mother Nature might provide. When they are through using the equipment, they just bundle it up along with dirt, water, "O" rings, cable cuttings, and anything else that landed there, and toss the equipment into the back of the vehicle, letting the "chips fall where they may".

Let's take a look at a few things that we can do to protect our test equipment, insure its accuracy, and prolong its operational life.

Transporting test equipment in our vehicles is a major source of problems through equipment damage and can seriously degrade its calibration accuracy. A simple solution is to designate a specific location for each item of equipment, protect it with tie-down straps and insulation materials, and suspend the equipment in a shock absorbant holder. The cost investment to purchase a manufactured or custom-made unit is quite high, but you can get around this problem by making it yourself.

Starting with aluminum or steel channel (one make is known as "Angle Flex" but you may use the aluminum type that is used to construct storage bins), you will need to cut the lengths required to build the frame. The channel has a 90° angle with one side at least 1" wide and the other side 2 or more inches wide.

I use the type that is already perforated with holes for ease in bolting it together, but solid channel will work fine and you drill your own holes for putting it together. The wider of the two sides must be at least 2 inches wide, but a four inch width is even better.

Cutting lengths depend upon the length and width of the equipment that it is designed to hold. For example, a Wavetek-Midstate SAM II meter is 11" x 10" and you would cut two pieces 16½ inches long and the other two pieces 13 inches long to form an inside measurement of 13" x 16" when bolted together. You must be careful when using the pre-perforated channel that the holes will match-up for boltings hardware on the corners. Inside dimensions are not so critical that they must be exact, but should be within 13" x 16" to 13½" x 16½" allowing up to a ½" margin for error on both length and width.

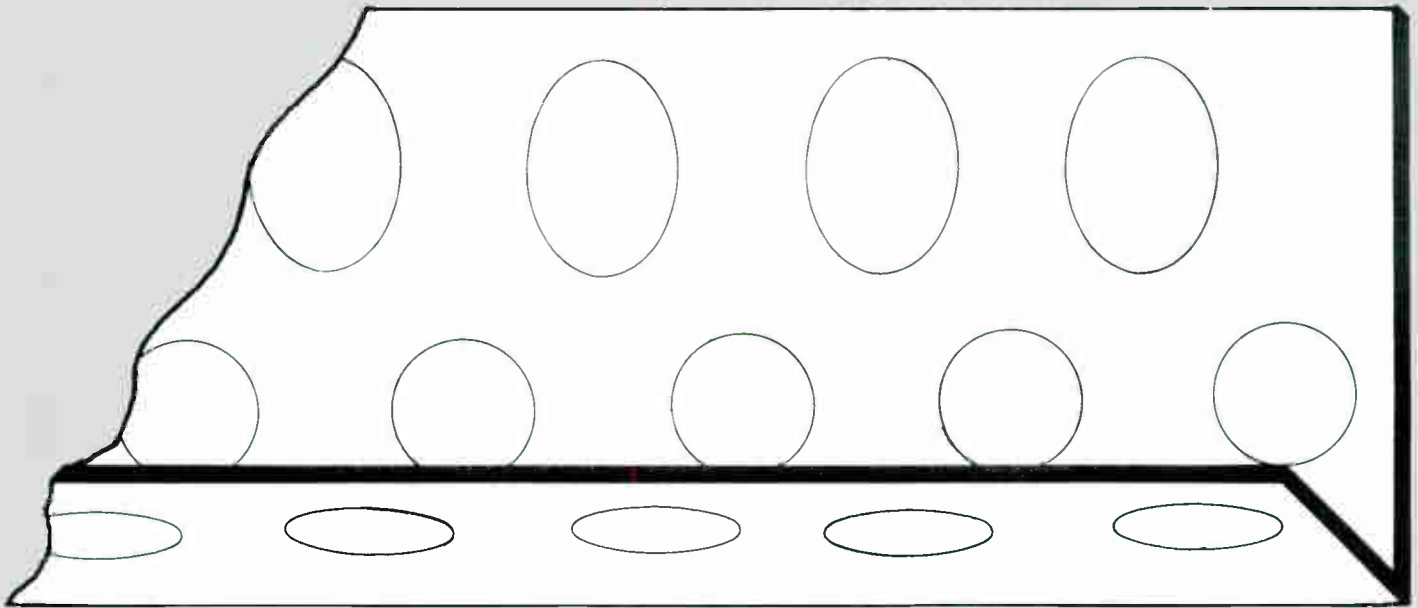
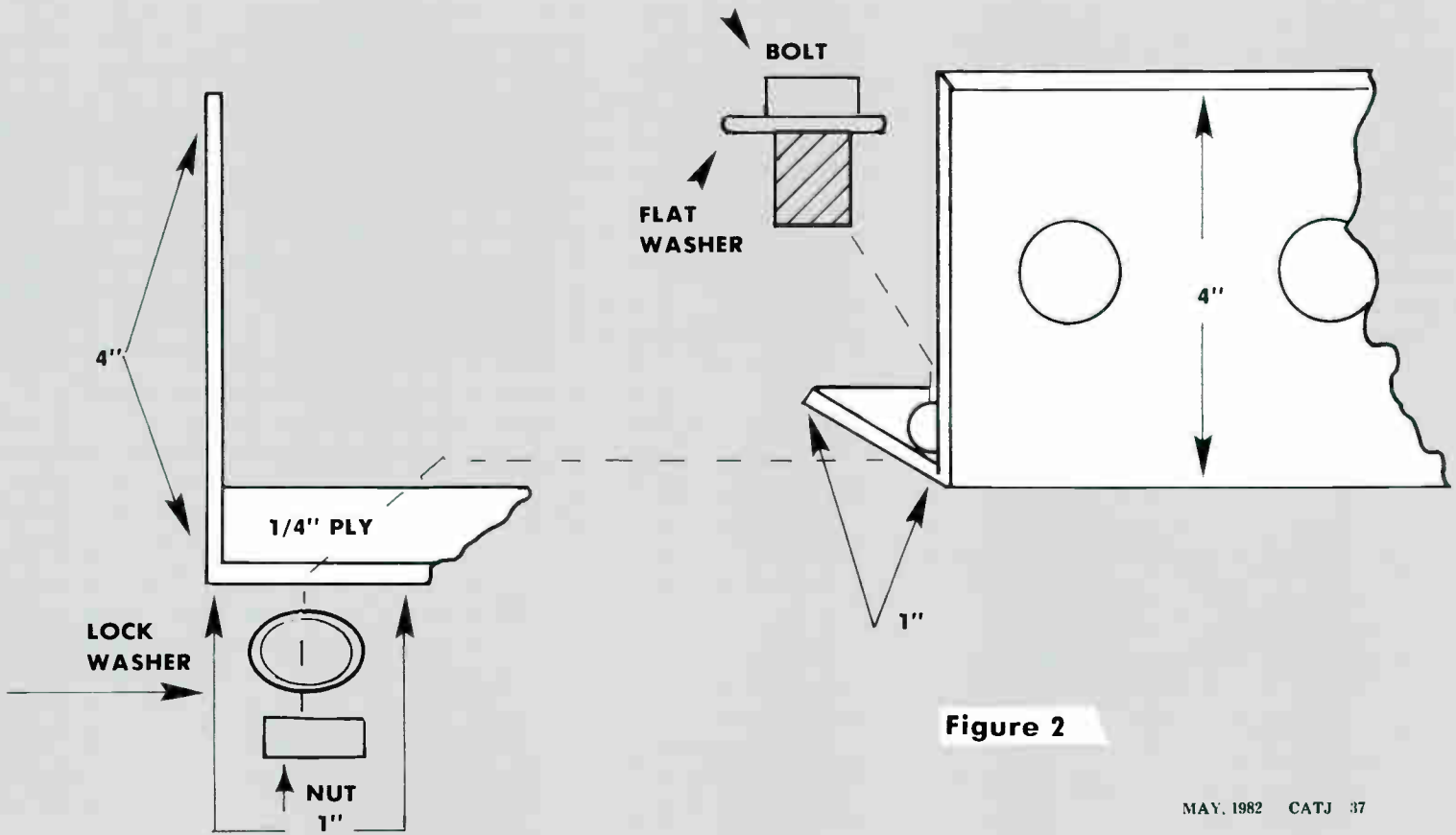

**Figure 1**

Next, cut a piece of 1/4" plywood to fit the interior dimensions of the frame, drill four corner holes to match the corner holes in the frame, and attach the four corners

of the frame together with, the 1/4" plywood base and hardware (4 each bolts — about 3/8" x 1 1/2" fit holes in channel, 4 lock washers, 4 flat

washers, and 4 nuts). The narrower side of the channel is on the bottom with the 4" side up.



**Figure 2**

Tighten all hardware finger tight at this time.

To further protect the equipment I lined the inside of the frame and plywood base with 1½ inch thick convoluted urathene foam cushioning material (about \$22 for a 20 square foot roll) and secured the foam to the frame with a spray adhesive (about \$2.95 a can).

The next step was to mount the unit on springs to absorb the shocks of on and off road travel. You may buy coil type springs from your local hardware store or do what I did. I found an old inner-spring mattress at the local dump and cut out the coil springs from it. Only four springs are required for each frame, but I made frames for each piece of the equipment in each vehicle and stored the remainder in a box for future use.

Mount the small end of the coil spring to the four corners of the frame by removing the nut and lock washer on the frame bottom. I used a flat washer inserted into the small end of the coil spring and then secured that end to the frame with the lock washer and nut. Tighten all hardware to maximum.

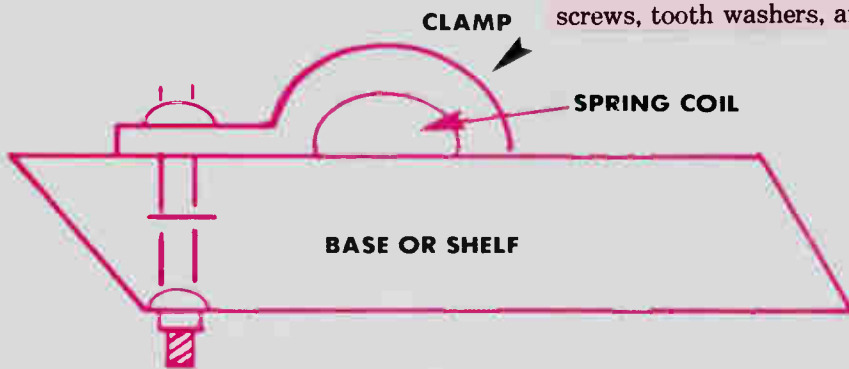

Figure 4A

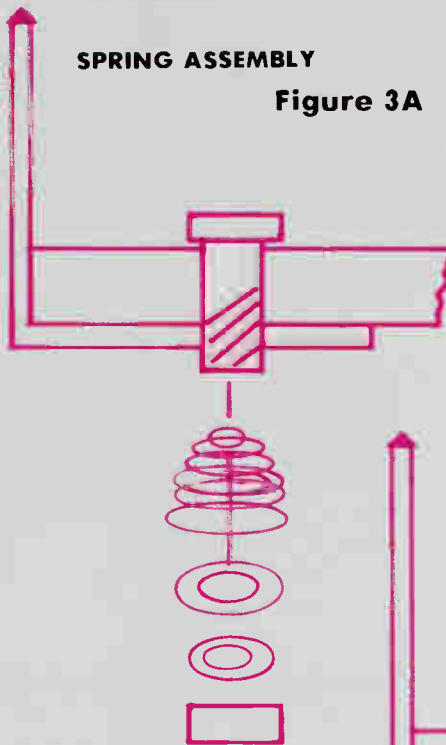

Figure 3A

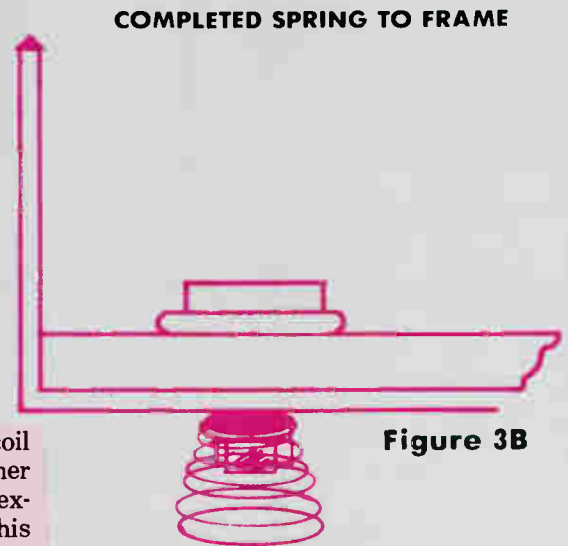

Figure 3B

The bottom (large) end of the coil springs are fastened to another plywood base or directly to existing shelving in the vehicle. This mounting is accomplished by using four 3/16 clamps, and #6 machine screws, tooth washers, and nuts.

The final step is to place an elastic or rubber stretchable strap, similar to luggage straps, and hook it to each side of the frame after passing one end through the carrying handle of the test equipment. Obtain the proper length of strap to insure that it is stretched tightly and will hold the piece of test gear snugly into the frame.

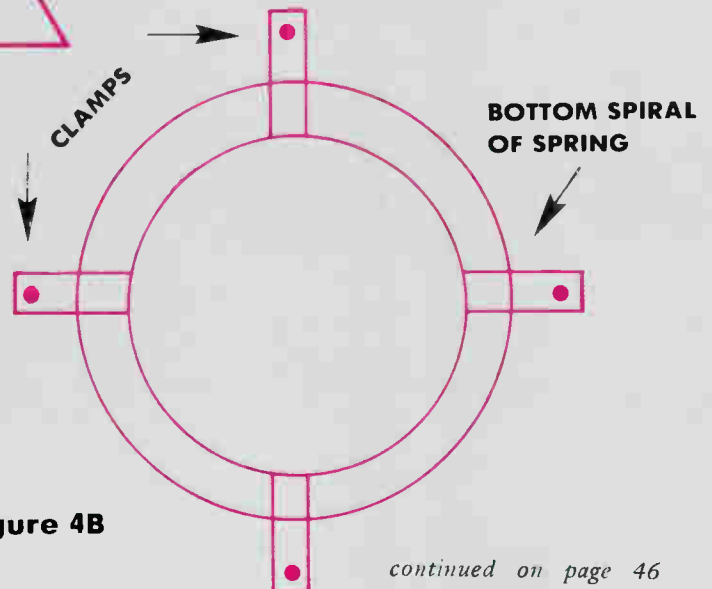

Figure 4B

# SPCTE

continued from page 35

to transistor region. The amplifier shown in Figure 3 was designed for input signals in the range of 250-350mV p-p but its gain can be easily adjusted to fit your needs by changing the ratio of the 1Meg and 100K resistors.

### SEQUENCE RECOGNITION AND DELAYED RESET

Now that a circuit for decoding the 12 characters has been devised

some way must be found to test the order in which the string of four characters arrive. A logic section that will recognize a particular combination of characters, within a certain length of time, and then activate a relay is required. Otherwise the circuit should reset until another burst of characters starts. This function is performed by the circuitry in the right hand portion of Figure 3. The heart of this section are the four R-S flip flops (4044) and several

NAND gates which together remember the sequence in which the characters come. The R-S flip-flop has an output (Q) and two inputs (R) and (S). When the (R) input goes low and the output (Q) also goes low and stays there until a low is detected at the (S) input at which time (Q) goes high and stays there until (R) goes low . . . and so on. The output of the NAND gate is low only if all inputs are high. The

continued on page 40



## It's a Small World . . .

At CWY we've built our business by providing all the small items so necessary to the Cable TV industry. One phone call from anywhere in the U.S. will get you not only solid advice from experienced professionals, but an order that's filled quickly and accurately. There is a **big** difference when you deal with CWY. Contact us today!

405 N. Earl Avenue  
Lafayette, Indiana 47904

Call Toll Free 1-800-428-7596  
Indiana 1-800-382-7526







Performance...Operator Efficiency...Maneuverability..

# THE NEW 350SX: THE PLOW

The new Ditch Witch 350SX is a compact, mid-range lawn plow with new features that let it outperform and outproduce anything in its class.

The superior 350SX performance starts with Ditch Witch design: a variable speed shaker system delivers the force needed to maintain maximum blade movement at cover depths



from 12 to 24 inches, and allows you to build to maximum power as soil conditions become more difficult. You'll hold your traction while you're doing it: greater weight — up to 4,250 pounds — and better weight distribution keeps the 350SX working when others slip or stall.

The 350SX is loaded with innovative features that make it a standout in its class... features that give you outstanding plow performance, more maneuverability, and greater operator efficiency.

New chute design and blade choice offer wide-ranging versatility. Handle delicate TV cable with a 10-to-1 bend on a floating chute. Standard telephone or electrical

cable goes down efficiently through either fixed or floating chutes. Pull blades are available for plastic pipe. Cover depths for all blades are 12, 18 or 24 inches.



Unitrolley design provides a one-piece trolley for the shaker system for longer life and less maintenance.

You get increased stability from the new hydraulic plow assembly. When moving into position, hold the plow assembly in place until you start to plow, then position it for best balance. There's no back-and-forth movement.

Standard 26-inch tires offer added stability and traction, and optional 23-inch high-flotation tires make the 350SX the only machine



in its class that can clear a 36" yard gate. Maneuverability

## Ditch Witch®



# YOU'VE ALWAYS WANTED.

and control is increased by standard 4-wheel-steer: you can steer front and rear wheels independently, to work more effectively on slopes. Dual-lift cylinders provide the force required to vary depths in even the most difficult plowing conditions.

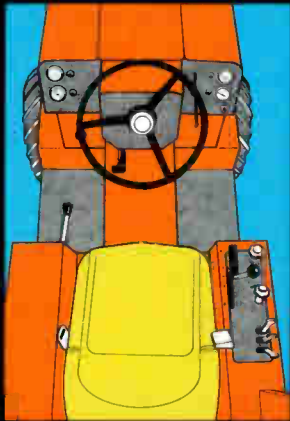

The plow lift linkage provides greater blade clearance and allows a greater angle of departure on uneven terrain.

And the 350SX is "human engineered" for its operator. He sits in a rider module, facing the front. There's no body overhang, no awkward movements to reach the controls. They are grouped on the right rear fender in easy reach.

The steering wheel is adjustable, up and down. Retractable seat belts add to the efficiency of operation. Maintenance is at a minimum, and the "instant-test" warning monitor offers early warning to potential problems.

Choose the 350SX with 35-HP-class

diesel or gasoline engines, and equip it with optional reel carrier or horizontal boring attachment.

Call your nearby Ditch Witch dealer to arrange a demonstration. When you see it in operation, you'll understand what we mean: the 350SX is everything you've ever wanted in a plow — and more. The Charles Machine Works, Inc., P.O. Box 66, Perry, Oklahoma 73077



**Ditch Witch.  
Don't settle for less!**





# INVITES YOU TO ATTEND CATV TECHNICAL TRAINING SEMINARS

## BASIC SEMINAR

This series of Seminars about CATV Tests and Measurements will be conducted by the CATA Engineering Office in association with TEXSCAN/Theta-Com CATV and Wavetek/MID STATE. CATA gratefully appreciates RMS Electronics, Inc., Times Wire & Cable Co., Sadelco, Inc., and Triple Crown Electronics Inc. for the use of equipment in these seminars.

## ADVANCED SEMINAR

This series of Seminars about CATV Tests and Measurements will be conducted by the CATA Engineering Office in association with TEXSCAN/Theta-Com CATV and Wavetek/MID STATE, and Sadelco, Inc. CATA gratefully appreciates RMS Electronics, Inc., Times Wire & Cable Co., Microwave Filter Co., and Triple Crown Electronics Inc. for the use of equipment in these seminars.

### TECHNICAL SUBJECTS TO BE COVERED IN THESE SEMINARS ARE:

- 1 How a Cable Systems Works
- 2 Coaxial Cable, Connectors, Faults
- 3 Service Installation Techniques
- 4 Field Strength Meters
- 5 Common Cable Problems & Trouble Shooting Techniques
- 6 Field and Bench Applications (Hands-On)

- 1 CATV Distribution — Theory and Practice
- 2 Distortion Products — Causes and Cures
- 3 Catastrophic Failure — Causes and Cures
- 4 Test Measurement Techniques — Spectrum Analysis
- 5 FCC Compliance
- 6 Field and Bench Applications (Hands-On)

### BASIC SEMINAR DATES

OKLAHOMA CITY, OKLAHOMA  
April 5-7  
WINSTON-SALEM, NORTH CAROLINA  
June 7-9  
BOISE, IDAHO  
August 2-4  
HOT SPRINGS, ARKANSAS  
November 1-3

### ADVANCED SEMINAR DATES

ALBANY, NEW YORK  
May 3-7  
AUSTIN, TEXAS  
June 21-25  
SCOTTSDALE, ARIZONA  
August 30-September 3  
INDIANAPOLIS, INDIANA  
October 4-8  
ORLANDO, FLORIDA  
December 6-11

WRITE OR CALL

Please send me more information on the CATA training seminars

NAME	COMPANY	
ADDRESS	PHONE	
CITY	STATE	ZIP

BASIC SEMINAR COST IS \$175.00

ADVANCED SEMINAR COST IS \$250.00

**CATA**  
**4209 NW 23 SUITE 106**  
WorldRadioHistory  
**OKLAHOMA CITY, OKLAHOMA 73107**  
**405/947-4717**

continued from page 40

operation of the NAND gate is illustrated in Figure 2.

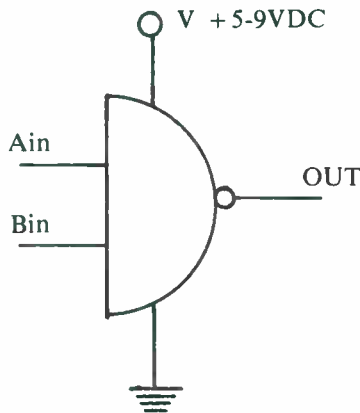

FIGURE 2

A	B	OUT
L	L	H
L	H	H
H	L	H
H	H	L

The tone decoder outputs (0-9, \* and #) are routed to the sequencer inputs (A-D, on and off) with the first character expected in the string connected to A, the second connected to B, and the third to C. The characters which represent on and off (the fourth character in the string) are connected to on and off. The circuit of Figure 3 is programmed to respond to the sequence 729\* for on, and 729# for off. To understand how the sequencer works assume all flip-flop outputs are reset (low) to start with. Nothing happens until a (7) is detected by the tone decoder. At this time input A goes high and the S input of the first flip-flop goes low. This causes the output Q1 to go high. Now nothing happens until a (2) is detected causing input B to go high. This, combined with the high at Q1, causes the first NAND gate output to go low which in turn sets Q2 high. Now only the detection of a (9) will do anything. A (9) sets Q3. At this point the string 729 has been

detected and all that's needed is a (\*) for on or a (#) for off. The output Q4 is set or reset depending on which one shows up. Q4 drives a 2N2222 transistor which in turn powers a relay. The two momentary contact switches provide a manual set-reset function for the relay.

The only function left in the sequencer is an automatic reset if the full sequence does not arrive within a fixed time frame (30ms for the circuit of Figure 3). The 4082 4-input NAND gate, 4016 MOS analog switch, 4069 digital inverters, and several capacitors and resistors serve this function. Each time a flip-flop is set, a pulse is applied to the 4016 switch. The switch closes charging the 0.2uF capacitor. After the pulse switch opens discharging the capacitor through a 10meg resistor. The two 4069 inverters sharpen the edges of the pulse. The network composed of two more inverters, a 20K resistor, and a 0.1uF capacitor creates a short falling edge triggering pulse which is delayed about 30mS. This pulse resets the three

flip-flop outputs to a low state. If the next character received is within the delay period the 4016 switch is again closed and the whole process is repeated without any reset action. The tone burst may be any length as the 30mS delay starts only after the end of the tone burst.

### POWER SUPPLY

The power supply consists of a simple fullwave bridge circuit regulated to 5 and 12 volts by two LM340 regulators. The regulated 5 volts is used to power all circuitry. The 12 volt supply charges 6AA Nicad batteries at a constant 10MA. If the 120V primary power fails, the batteries will continue to supply power to the circuit retaining the proper on/off switching position during a power outage.

The tone decoder will accept the 4 digit tone pair sequence used by satellite programmers and the output may be used to operate a RF switch, switch a processor/modulator, switch an agile satellite receiver, insert local advertising, etc.

## FOR UNDERGROUND HOUSE DROPS

**TRACKS AND CENTERED BLADE DOES IT**

140 F.P.M. MAX.



**The Line-Ward L-1 Cable-Line Layer "Explodes" the Myth Big is Better & Outperforms Units 3 Times its Size Only 24 1/2" Wide**

- Mud or Fine Lawns (It Will Go Where The Others Will Not)
- No Trailer
- No Lawn Damage

**Discover what compact performance can mean to you!!**

**LINE WARD CORP.**

157 Seneca Creek Rd. Buffalo, N.Y. 14224  
Phone 716-675-7373

# SPCTE

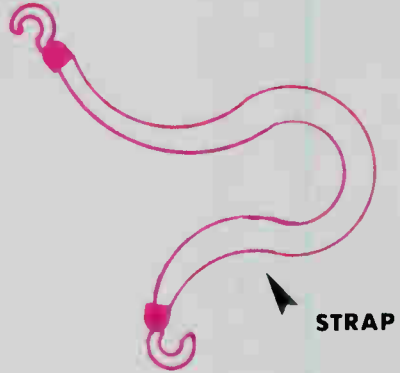

Total cost for materials to construction a shock absorbant vehicle rack for a SAM II meter is less than \$20.00, certainly well worth

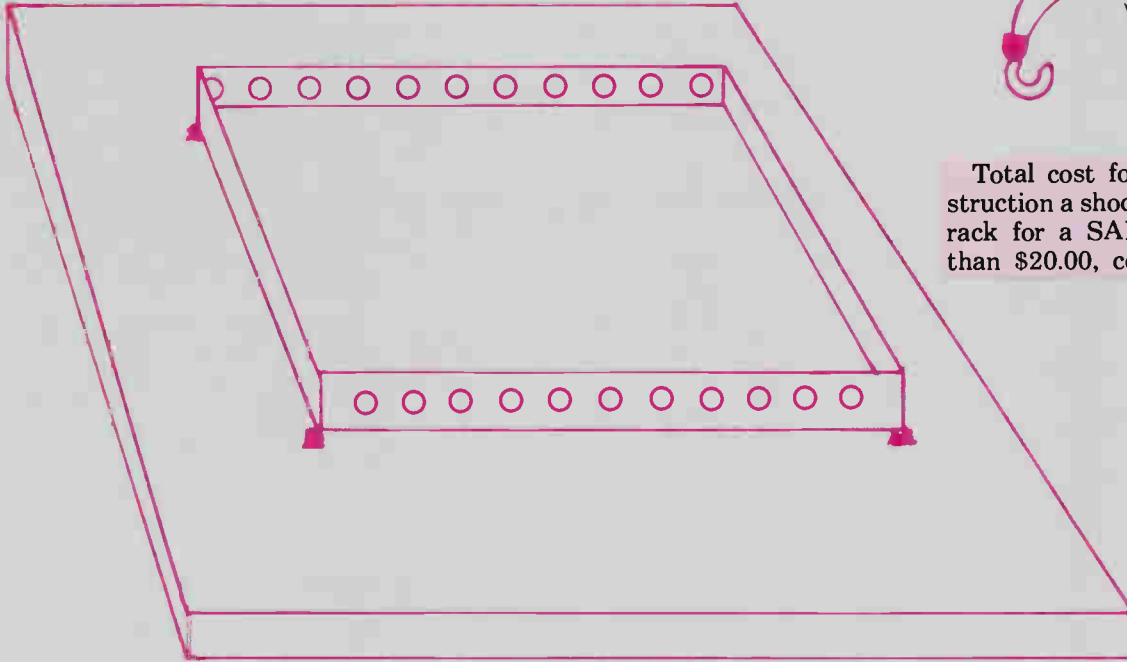

**TEST EQUIPMENT CARRIER MOUNTED TO VEHICLE SHELVING**

**Figure 5**



**After you've made one great little receiver, what do you do next?**

**Make a greater little receiver**

Automation Techniques, Inc., presents the GLR-750, the second in a series of great little satellite receivers. Like the GLR-500 before it, the 750 is state-of-the-art technology at an unbelievably low price.

The GLR-750 uses crystal controlled frequency synthesis for clear, steady reception. Our great little receiver also features:

- Thumb wheel selection of 24 transponders.
- Two audio subcarrier demodulators, each thumb wheel frequency selectable to the nearest .01 MHz.

- Four separate front panel meters: relative IF/Signal level for dish optimization; video level meter; and two independent audio VU meters for both audio channels.
- Proven imageless mixer design.

With features like these and our affordable price, you'll have to agree we've made another great little receiver. For more information on the GLR-750, call us today:

**918-836-2584.**

**AUTOMATION TECHNIQUES, INC.**

**We make technology affordable**

1846 N. 106th E. Ave. Tulsa, Oklahoma 74116

See us at NCTA booth 404-405

the price to protect a \$1,500.00 piece of equipment. The same construction procedures and materials,

of course, can be used for sweep generators, sweep system re-

ceivers, spectrum analyzers, and TDR's.

Quantity	ITEM	Materials List	Cost
As needed	Angle-Flex 1" x 2"		About \$2.00 per foot
4 each	3/8" x 1 1/2" Hex Bolt		About .17¢ each
4 each	3/8" Flat Washers		About .06¢ each
4 each	3/8" Lock Washers		About .08¢ each
4 each	3/8" Nuts		About .18¢ each
As needed	1/4" plywood		may use scrap
4 each	Coil Springs		from discarded box springs
As needed	1 1/2" Convoluted Foam		\$22.00/roll-24" x 120"
1 can	Spray Adhesive		\$2.95 per can (Red Eagle R102-4600)
4 each	3/16" Clamps		About .10¢ each
4 each	#6 x 1" Machine Screw		About .2 1/2¢ each
4 each	#3/8 x 1 1/2		About .49¢ pkg. of 4
4 each	#6 Toothed Washers		About .1 1/2¢ each
4 each	#6 Nuts		About .03¢ each
1 each	Retaining Strap		From \$1.89 to \$7.00 dependent on size and material.

# SPCTE.

(1-24) 110°K NOISE TEMPERATURE

(1-24) 100°K NOISE TEMPERATURE

- IMMEDIATE DELIVERY
- MILITARY QUALITY: MIL-I-45208
- 12 MONTH GUARANTEE
- FACTORY REPAIR SERVICE

POWER

MODEL NO. RF 1088A  
SERIAL NO.  
LOCUS, INC.

**LOCUS, INC.**

P.O. BOX 740 • STATE COLLEGE, PA 16801  
PHONE JAMES HESS (814) 466-6275

PRICES SUBJECT TO CHANGE WITHOUT NOTICE  
ALL SHIPMENTS C.O.D. WITH PRIOR ARRANGEMENT

# Switching May Be A Matter Of Priority

by Walter H. Tietjen, Jr.

Some cable systems with limited channel capacity may wish to carry two satellite signals such as C-Span and USA Network on the same cable channel. A problem arises when both are active as to which one gets priority.

If you decide that you want to give C-Span priority from 9 a.m. to 6 p.m. Monday through Friday, and USA Network priority at other times, you need some easy method to accomplish this action. All that is required is a timer and a simple 4 I C plus 2 transistor circuits added to your existing tone switcher. Note that a second timer will be needed if some of the sporting events are subject to blackout.

The circuit diagram I have designed is based upon the use of Monroe #3185 tone decoders. Slight modification may be required for those using the Gardiner Channelcue switching system. Figure #1 is a block diagram of the interconnections required for the Priority Module. The output of the Monroe #3185 modules is through a single pole/double throw set of relay contacts, with module contact 10 being common. For proper operation of the priority module cir-



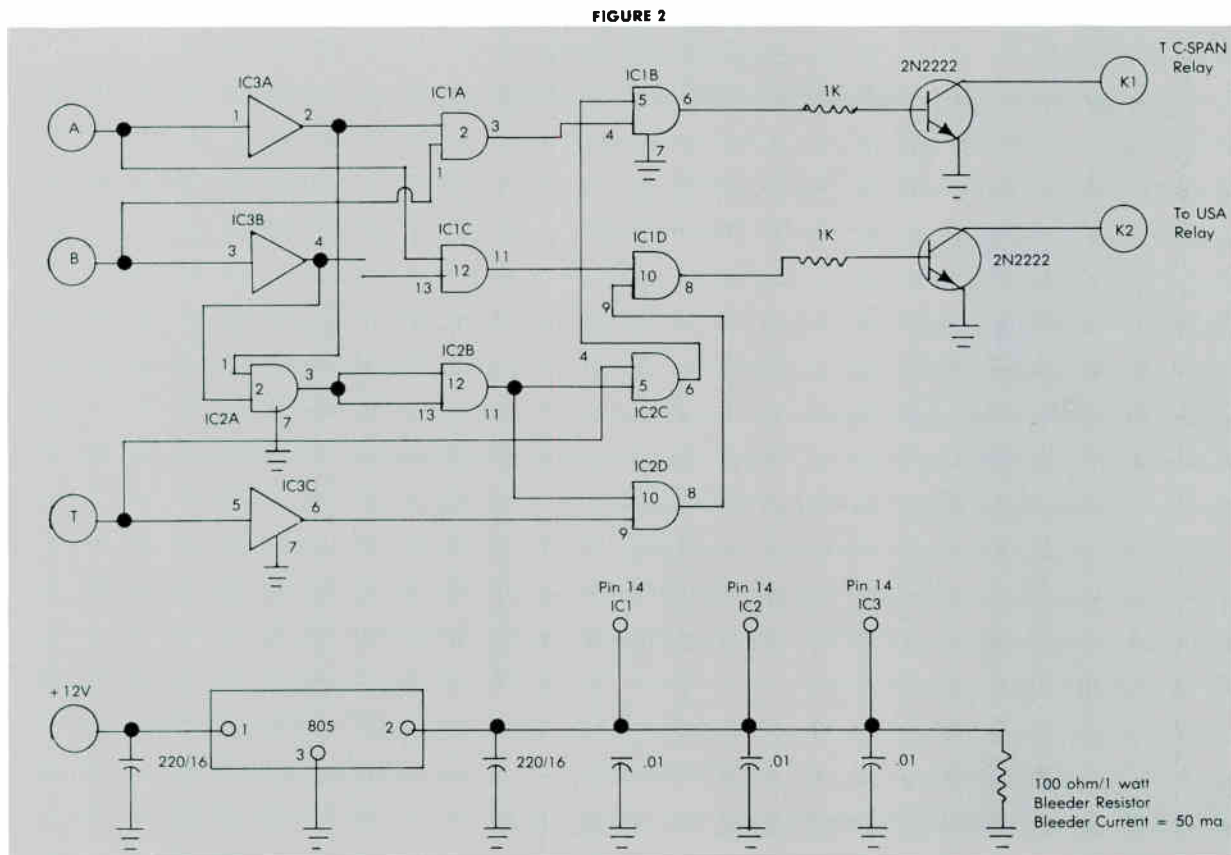
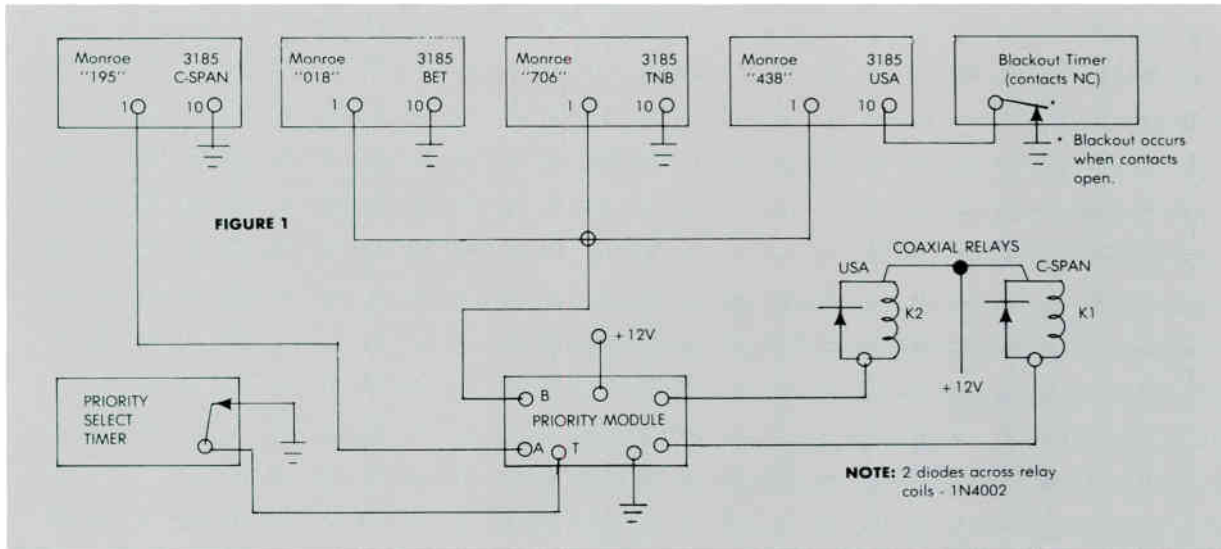

PARTS LIST *	
2 each	7400 Quad 2 input NAND gates
1 each	7404 Hex inverter
1 each	7805 3 terminal regulator
2 each	2N2222 transistors
2 each	1K resistors
1 each	bleeder resistor (value selected to maintain minimum regulator current)
2 each	220 $\mu$ FD, 16V capacitors
3 each	.01 $\mu$ FD ceramic disc capacitors
2 each	1N4002 diodes

\* Note that K1 and K2 are pre-existing coaxial relays used to switch either video and audio or IF.

cuit, connection is made to the contact which connects to the common when the relay is energized. A quick method to determine which is the proper contact connection (1 or 9) is to slide a #3185 module from the cabinet/power supply and probe contacts 9 & 10 with an ohmmeter. If the circuit reads an open, use contact 9, and if reads a short, use contact #1.

Figure #2 is the schematic diagram for the Priority Module.

Inputs A (C-Span) and B (WIRE ORed USA Network) are active low. If neither transponder has a desired program, the open (HIGH) inputs are triple inverted with a logic LOW at the bases of the relay driver transistors, relays de-energized. If one service has a program of interest, a LOW will be applied to A or B (but not both), and, with the triple inversion, a logic HIGH will be applied to the base of the relay driver causing the relay for the active transponder to energize and places active service on line.

If both transponders have desired programs, both A and B are LOW. A LOW at pin 1 of IC1A forces unconditional HIGH on pins 3 & 4. A LOW at pin 12 of IC1C forces unconditional HIGH at pins 11 & 12. Therefore, BOTH direct response paths are blocked. However, pins 1 & 2 of IC2A are now HIGH and pins 3, 12, & 13 are pulled LOW. Pins 5, 10, & 11 are also HIGH enabling the priority select gates. If the priority select timer is open (HIGH), pin 4 joins pin 5 (IC2C) in a HIGH state with pin 6 LOW. Since pin 6 (IC2C) is LOW, so is pin 5 (IC1B). Pin 6 (IC1B) goes HIGH (C-Span on line). Since pin 5 (IC3C) is HIGH, pin 6 (IC3C) is LOW as is pin 9 (IC2D). Pin 8 (IC2D) remains HIGH (USA network off line).

When the priority select timer contacts are closed, a LOW is applied to

# Power off? keep going...

with  standby power

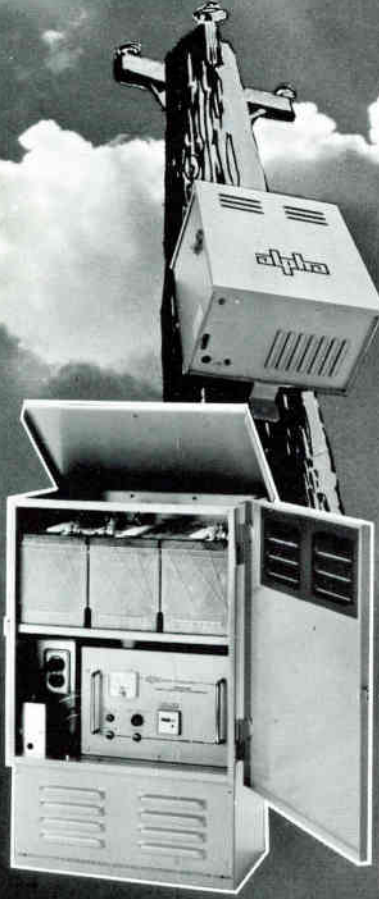

**OVER 10000 UNITS  
OPERATING AND FIELD  
PROVEN COAST TO COAST**

**New Franchise or Rebuild?  
ALPHA offers you  
unsurpassed reliability  
along with these features:**

- Automatic battery cycling.
- Extended battery life due to temperature compensated float and equalize charging.
- Less than 1 cycle transfer time.
- Inverter crystal controlled and line synchronized. 20-30 second time delay before synchronized retransfer to utility.
- Epoxy coated aluminum enclosure for maximum durability.
- All batteries on top to keep vapours and corrosive emissions away from electronics.

**And for state-of-the-art systems  
these options:**

APM (Automatic Performance Monitor)  
Performs selftesting and monitoring functions.  
Saves costly maintenance time.  
For even better operating economy, talk to us about the new Micro Processor Status Monitoring and Control.

**ALPHA TECHNOLOGIES**

 <p>1305 Fraser St, D-6 Bellingham, WA 98226 (206) 671-7703</p>	<p>Scottsdale, Arizona (602) 948-4484</p>	<p>Monterey, California (408) 646-0727</p>
<p>7033 Antrim Ave. Burnaby, B.C. V5J 4M5 (604) 430-1476</p>		

pin 4 (IC2C) and pin 5 (IC3C). The LOW at pin 4 (IC2C) keeps pin 6 HIGH (C-Span off line). However, the inverted T signal (HIGH) at pin 6 (IC3C) and pin 9 (IC2D) with the HIGH at pin 10 (IC2D), produces a LOW at pin 8 (IC2D). This LOW is passed to pin 9 (IC1D), and pin 8 (IC1D) goes HIGH (USA Network on line).



Currently, only the 10 a.m. (Eastern) to 6 p.m. (Eastern) portion of C-Span is live. Therefore, a suggested setting of the priority select timer is:

- Contacts Open, Monday - Friday,
- 10 a.m. - 6 p.m. —  
(Eastern Time Zone)
- 9 a.m. - 5 p.m. —  
(Central Time Zone)
- 8 a.m. - 4 p.m. —  
(Mountain Time Zone)
- 7 a.m. - 3 p.m. —  
(Pacific Time Zone)

Contacts closed at other times and all day Saturday and Sunday.

In areas where Thursday Night Baseball is subject to blackout, DO NOT connect TNB tone decoder terminal 10 directly to ground. Connect the USA Sports tone decoder terminal 10 to the TNB tone decoder terminal 10.

Why interrupt only one (or two), but not all ground paths on the tone decoder outputs with the blackout timer? Suppose a particular event subject to blackout in your area is pulled from the USA Network lineup at the last minute (this happened during the 1980-81 basketball season with a

Maryland game). The substitute program is NOT subject to blackout. As long as you have at least one tone decoder free of blackout timer blockage on the USA Network control line, call your MONROE #3137A phone line coupler and inject the tone code for no blackout service (018\* in the example shown by the schematic) to override the timer

mistakenly programmed ignoring the last minute change. When the scheduled time for the misprogrammed blackout has passed, a second call is placed and, in this example, tone code 018# is injected to clear the override.

No touch-tone service? Use a phone with two dials when calling the tone switcher as shown in the photograph. □

## The PHASECOM MODULATOR & The SAW FILTER. A perfect match.

They're a natural. The Phasecom 2000 Series Modulator and the new solid state SAW (Surface Acoustic Wave) Filter.

Top technical performance. Exceptional reliability. It's what they're both all about. We had to put them together.

So now, every Phasecom Modulator has a SAW Filter at IF. For a perfectly shaped vestigial sideband signal. For flat group delay. Without tuning or maintenance.

And better yet...at no increase in price. It's all part of our ongoing efforts to bring you the best value in headend electronics in the industry today.

**PHASECOM CORP.**  
The Headend Experts  
6365 Arizona Circle  
Los Angeles, CA 90045  
Tele: (213) 641-3501

# The Filtered Earth Station

## Part 9

### Summary and a Terrestrial Troubleshooting Chart

By: Glyn Bostick  
Microwave Filter Company, Inc.

#### Summary

There are (at least) three types of terrestrial interference. Each of these was described and its cure recommended and illustrated in the series of CATJ articles summarized in Table 1.

Here we present a Troubleshooting Chart which permits us to proceed in a simple, logical manner to identify and cure any of these three types of interference.

#### The Troubleshooting Chart

See Figure 1. The chart assumes that you cannot identify the type of interference you have just by looking at the picture.

We proceed down the chart, starting with Step A.

**Step A:** We want to locate the general frequency: Is it in the earth station band (3.7-4.2 GHz) or out of it? So, we install a bandpass filter between the LNA and DOWN-CONVERTER. This filter should pass all 24 transponder signals and roll-off sharply to suppress all out-of-band signals.

If the problem goes away, the interference frequency is out of the earth station band and, incidentally, we've cured the problem. End of exercise.

If we still have the problem, we go to Step B. We now know that the interference frequency (or frequencies) is within the earth sta-

**TABLE I**  
Summary of  
CATJ's "Filtered Earth Station" Series

PART ①	<i>THE FILTERED EARTH STATION</i> Three types of terrestrial interference described and explained.	AUGUST '81
PART ②	<i>MORE ABOUT IF TRAPPING</i> Explains use of IF traps to combat Microwave Telephone carriers.	SEPTEMBER '81
PART ③	<i>MORE ABOUT NOISE FILTERING</i> Reducing strong carriers outside the earth station band by use of a bandpass filter.	NOVEMBER '81
PART ④	<i>NOISE-PRESELECTION</i> Using bandpass filters of various widths: from a single channel to the entire 3.7-4.2 GHz band.	DECEMBER '81
PART ⑤	<i>IF TRAP ADJUSTMENT FOR OPTIMUM INTERFERENCE REJECTION</i> Adjusting traps for best trade-off of interference reduction and picture distortion.	JANUARY '82
PART ⑥	<i>THE ABOMINABLE SNOWMAN</i> Very strong Microwave Telephone signals and how to protect the downconverter with microwave traps.	FEBRUARY '82
PART ⑦	<i>EARTH STATIONS HATE HARMONICS</i> Using phasing technique to remove harmonics of microwave signals below 3.7 GHz.	MARCH '82
PART ⑧	<i>BOB MEETS THE SNOWMAN</i> A case history of strong Microwave Telephone interference and its removal using microwave traps before the downconverter.	APRIL '82



EIGHT PAGE STANDARD MEMORY WITH STATIC WEATHER INTERMIX

**WEATHER/MEMORY**

**Standard:**

- Entire system in one keyboard housing
- Weather uses Texas Electronics sensors
- Field proven reliability
- More flexible format
- One thousand character crawl
- Eight colors
- Four character sizes
- Random page access
- Variable page time
- Built in fail-safe

**Options:**

- Sequential weather available with separate keyboard memory region
- Optional 24 pages of additional memory
- Sixteen additional formats available
- And much more

**Computer Video Systems**  
**3678 West 2150 South #2**  
**Salt Lake City, UT 84120**  
**801-974-5380**  
**800-453-8822**

**Eastern Regional Sales Office**  
**and Service Center**  
**Suite 16**  
**2131 Kingston Court**  
**Marietta, GA 30067**  
**404-952-3177**  
**800-241-1453**



## Checking response flatness?

It's easy with Sadelco's  
SC 450 Spectrum Calibrator

**1/4 dB  
ACCURACY  
4.5-450 MHz**

MHz Ratio: 100 to 1

Covers the complete  
CATV range, present  
and future.



## Checking signal levels?

do it accurately with Sadelco's  
FS 3D-VS Signal Level Meter

**450 MHz  
60 Channels**

PLUS . . .

the FS 3D-VS Professional SLM  
has Built-in Quality Features . . .

- $\pm 1.0$  dB Accuracy
- Electronic Auto. Shut-off
- New High-Impact case
- AC/Battery Operation:  
3 types of Battery Options;  
Nicads, Alkaline or  
Carbon Zinc

See us at the NCTA Booth 301  
Call or Write for Free Color Brochure

## Sadelco, Inc.

75 West Forest Ave., Englewood, N. J. 07631 201-569-3323  
General Rep. for Europe: Catec AG-Luzern/Switzerland, Habsburgerstr 22, Tel. 041-23-90-56 Telex: TELFI 78168

### Distributors in U.S.A.:

#### ANIXTER PRUZAN

**Alaska:**  
Anchorage 907-274-8525  
Fairbanks 907-456-1815  
**California:**  
Los Angeles (Irvine) 714-556-6270  
**Colorado:**  
Denver (Englewood) 303-741-2900  
**Georgia:**  
Atlanta 404-449-6533  
**Illinois:**  
Chicago (Elk Grove Village)  
312-640-1156  
Skokie (Headquarters) 312-677-2600  
**New Jersey:**  
Wharton 201-328-0980  
**Missouri:**  
St. Louis 314-423-9555  
**Oregon:**  
Portland 503-285-2245  
**Texas:**  
Houston 713-674-8035  
**Washington:**  
Seattle 206-251-6760

#### CABLE TV SUPPLY CO.

**California:**  
Los Angeles 213-204-4440  
**Georgia:**  
Decatur 404-981-9220  
**Illinois:**  
Addison 312-543-9800  
**Massachusetts:**  
Woburn 617-938-1221  
**New Jersey:**  
Cinnaminson 609-829-0100  
**Ohio:**  
Brecksville 216-526-0919  
**Texas:**  
Grand Prairie 214-988-1841  
Houston 713-681-6141

#### DAVCO ELECTRONICS CORP.

**Arkansas:**  
Batesville 501-793-3816

#### ELECTROTEX

**Texas:**  
Houston 713-526-3456

#### GULF ELECTRONIC SUPPLY INC.

**Florida:**  
Miami 305-592-6583

#### HURLEY ELECTRONICS INC.

**California:**  
Inglewood 213-678-7644  
Long Beach 213-537-5375  
Oceanside 714-722-7694  
San Bernardino 714-885-0721  
San Diego 714-235-6245  
Santa Ana 714-971-2203  
Van Nuys 213-781-8410

#### KLUNGNESS ELECTRONIC SUPPLY

**Michigan:**  
Iron Mountain 1-800-682-7140  
All other States 1-800-338-9292

#### MIDWEST CATV SYSTEMS

**West Virginia:**  
Clarksburg 304-622-4700

#### MIDWEST CORP.

**Florida:**  
Miami 305-592-5355  
**Indiana:**  
Indianapolis 317-251-5750

#### Kentucky:

Lexington 606-277-4994  
Louisville 502-491-2888

#### Maryland:

Lanham 301-577-4903

#### Michigan:

Troy 313-689-9730

#### Ohio:

Cincinnati 513-651-1904  
Cleveland 216-871-3116  
Columbus 614-476-2800

#### Virginia:

Virginia Beach 804-464-6256

#### West Virginia:

Nitro 304-722-2921

#### NELSON ELECTRIC SUPPLY CO.

**Texas:**  
Dallas 214-741-6341

#### NORTH-SUPPLY CO.

**Kansas:**  
Lenexa 313-888-9800

#### POLELINE CORP.

Subsidiary of RMS Electronic Corp  
**New York:**  
Bronx 212-829-1070

#### S.A.L. COMMUNICATIONS

**California:**  
Chatsworth 213-341-9100

**Georgia:**  
Decatur 404-981-0050

**Indiana:**  
Indianapolis 317-244-2477

**New York:**  
Melville 516-694-7110

**Texas:**  
Dallas 214-348-8811

#### TELE-WIRE SUPPLY CORP.

**Florida:**  
Sarasota 813-371-3447

**Michigan:**  
Three Rivers 800-253-2069

**New York:**  
Great Neck (Headquarters)  
516-829-8484

**Pennsylvania:**  
Simpson 717-282-2340

**Texas:**  
Grand Prairie 800-527-1646

**The Drop Shop Ltd.**

**California:**  
Hayward 415-887-7474

**New Jersey:**  
Roselle 201-241-9300

**TONER CABLE EQUIPMENT**

**Pennsylvania:**  
Horsham 800-523-5947

**Pennsylvania Only** 800-492-2512

**TVC SUPPLY CO. INC.**

**Pennsylvania:**  
Hershey 800-482-2398

**East of Mississippi:**  
800-233-2147

### Distributors in Canada:

**ANIXTER PRUZAN**  
Montreal, Quebec 514-637-3511

**INCOSPEC ELECTRONICS, INC.**  
Montreal-Nord, Quebec 514-322-5540

**R.F. COMMUNICATIONS LTD.**  
Ontario 416-475-1030

**TECH COMM SALES, INC.**  
Burnaby, British Columbia 604-437-6122

tion band. Chances are 90% or better that these are Microwave Telephone signals off-set  $\pm 10$  MHz from transponder center frequency. Therefore, we will see them at  $\pm 10$  MHz from the IF center frequency, or at 60 MHz and/or 80 MHz in the case of 70 MHz IF.

At this point, we should use an analyzer to look at the IF signal as it exists from the downconverter to verify "tear ups" at 60 and/or 80 MHz. If this is not feasible, query the telephone people to verify the presence of a Microwave Telephone carrier in the general vicinity.

If verification is made, or if you are unable to do either of these, then let's assume we have "Ma Bell" and put IF traps between the downconverter and the IF amplifier: one cut to  $-10$  MHz and one to  $+10$  MHz of the IF center frequency.

If the IF traps do the trick, the exercise is over. If they don't, then go to Step C.

### Step C:

If you have not identified the frequency of the interference, you must do it now. Otherwise, we have run out of general fixes.

If the interference frequency is identified and is not a "Ma Bell" ( $\pm 10$  MHz offset Microwave Telephone carrier), go to Step D.

If the interference is "Ma Bell," then its sheer strength is driving the downconverter into its non-operating range, and this accounts for the in-

EARTH STATION OWNERS & DEALERS:

## You've got terrestrial interference... We've got filters!

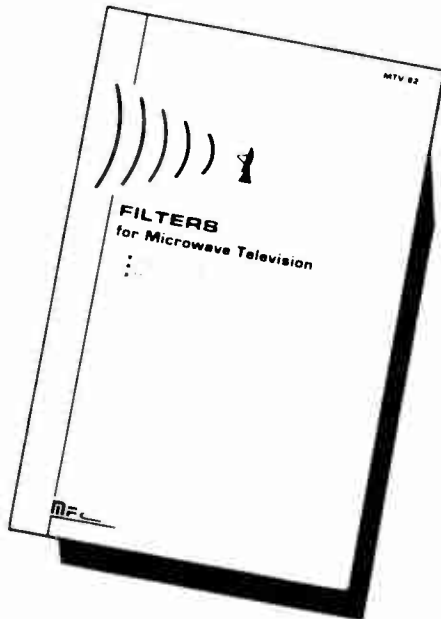

The concrete under your new earth station isn't hard yet, but you've got trouble already—unwanted microwave signals are destroying your picture. Your customer is throwing tantrums, and you have two choices: Tear it down and eat the installation costs, or filter it.

We can help. Call us and we'll send you MTV/82, which tells how to eliminate terrestrial interference on earth stations and lists a complete line of filters designed and tested for this purpose. Created for effective use by novice and experienced earth station operators alike, MTV/82 explains each type of interference, describes the symptoms and recommends specific filters to solve your specific problems.

- Products include:
- microwave & IF bandpass filters
  - IF traps
  - waveguide adapters
  - power dividers
  - coax adapters
  - specials!

Call or write today and we'll also send you FG/82, "Earth Stations & Terrestrial Interference: A Filtering Guide for the Installing Dealer."

**NFC**  
MICROWAVE FILTER COMPANY, INC.

6743 Kinne St., East Syracuse, NY 13057  
Toll Free 1-800-448-1666 — TWX 710-541-0493  
NY/MI/AK/Canada (Collect) 315-437-3953

## CATV indoor distribution amplifiers from Blonder-Tongue

Backed by more than 30 years of technical and manufacturing experience, Blonder-Tongue sets a standard of quality in the industry that's hard to beat. These DA series amplifiers are no exception.



### DA-30 Wideband Distribution Amplifier

- Flat Response - 50-300 MHz
- 40 dBmV Output per Channel for 21 Channels
- Front Panel Gain and Slope Controls
- Slim Line Design - Easy to Install

### DA-51 2/3 Wideband Distribution Amplifiers

- Specifically Designed for CATV "Drop" Distribution Systems
- Wide Frequency Range for Incorporating MID/SUPER Bands with VHF/FM



### DA-33 Wideband Amplifier

- Ultra-Wide Bandwidth 0.5 MHz-300 MHz
- Push-Pull Hybrid IC Amplifier
- Exceptionally High Output

CWY Electronics  
405 N. Earl Avenue  
Lafayette, IN 47904  
Toll Free (800) 428-7596  
Indiana (800) 382-7526

### DA-21 CATV Distribution Amplifier

- Ideal CATV Distribution Amplifier in Small Apartment Buildings



For more information on these fine DA Series Amplifiers, give CWY a call.



effectiveness of the IF traps.

Procure a microwave notch filter for each "Ma Bell" frequency. Place these between the LNA and the down-converter. This should solve the problem.

**Step D:**

If you get to this step, then your problem is no doubt a harmonic emission from a microwave transmitter whose fundamental frequency is below 3.7 GHz. You might luck

out if the harmonic is close enough to the IF band edge to permit use of an IF trap. But, in general, it will land in the middle of the band and you must apply the phasing technique. □

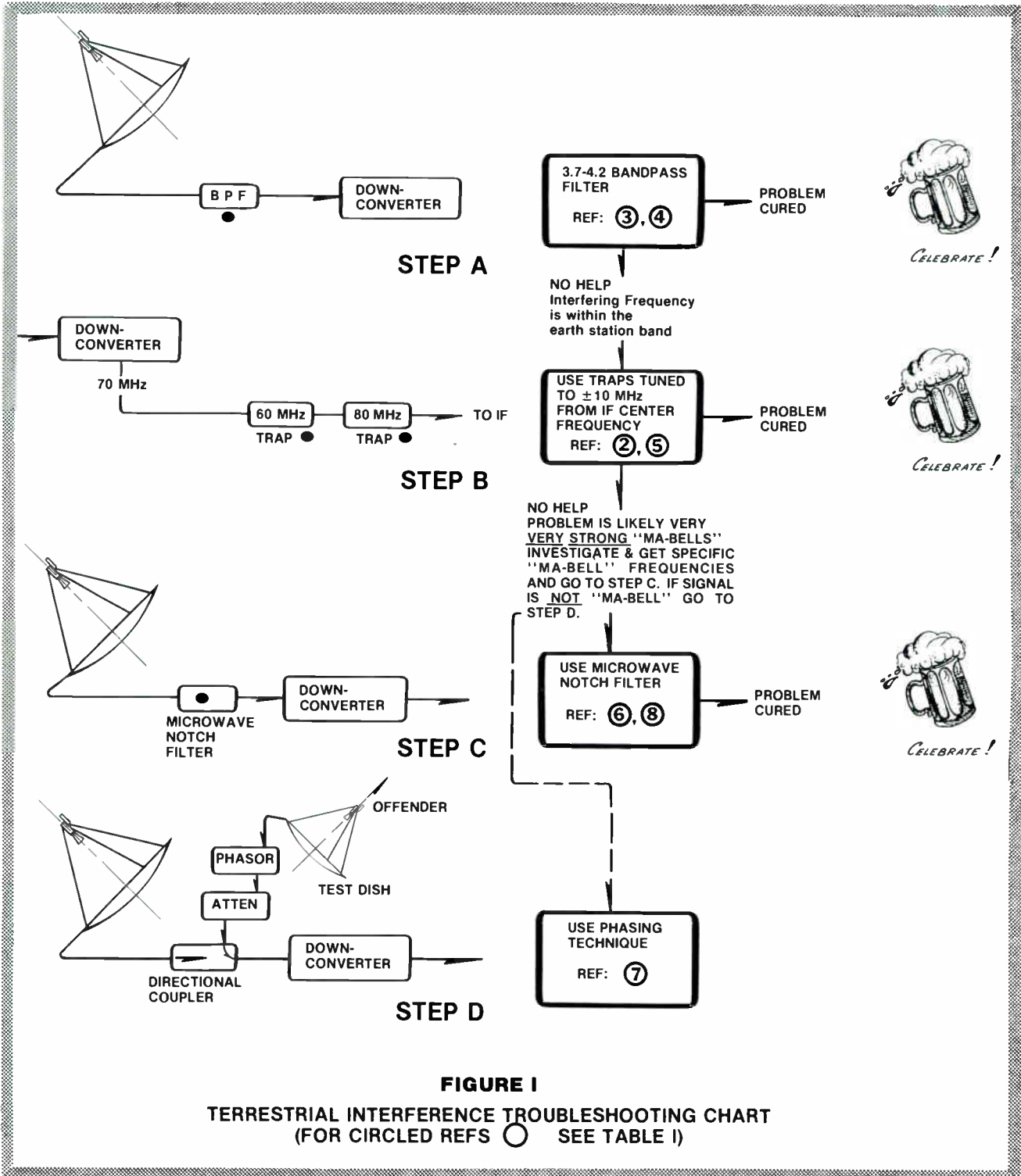



# 1982—FIRST QUARTER OVER \$41 MILLION OF TRANSACTIONS

January 1982

**Landmark Communications, Inc.**  
Has acquired an eighty percent interest  
in  
**MARGATE VIDEO SYSTEMS, INC.**  
Margate, Coconut Creek, Parkland,  
and Broward County, Florida

The undersigned initiated this transaction and represented  
the seller. This notice appears as a matter of record only.



**Communications  
Equity  
Associates**

851 Lincoln Center • 5401 W. Kennedy Blvd.  
Tampa, Florida 33609 • 813 877-8844

January 1982

**SOLD**  
**Black River Falls Cable Television**  
Black River Falls, Wisconsin

The undersigned represented the buyer in this transaction.  
This notice appears as a matter of record only.



**Communications  
Equity  
Associates**

851 Lincoln Center • 5401 W. Kennedy Blvd.  
Tampa, Florida 33609 • 813 877-8844

January 1982

**SOLD**  
**United Antenna of Boone, Inc.**  
Boone, North Carolina

The undersigned represented the buyer in this transaction.  
This notice appears as a matter of record only.



**Communications  
Equity  
Associates**

851 Lincoln Center • 5401 W. Kennedy Blvd.  
Tampa, Florida 33609 • 813 877-8844

January 6, 1982

**SOLD**  
**Saline County Cable Television, Inc.**  
Benton, Arkansas

The undersigned represented the Seller in this transaction.  
This notice appears as a matter of record only.



**Communications  
Equity  
Associates**

851 Lincoln Center • 5401 W. Kennedy Blvd.  
Tampa, Florida 33609 • 813 877-8844

February 1982

**SOLD**  
**Florida Cable Video, Inc.**  
Mulberry & Polk County, Florida

The undersigned represented the buyer in this transaction.  
This notice appears as a matter of record only.



**Communications  
Equity  
Associates**

851 Lincoln Center • 5401 W. Kennedy Blvd.  
Tampa, Florida 33609 • 813 877-8844

March 1982

**\$925,000 Senior Secured Debt  
Due 1990**  
**TURNER HILL TELEVISION, INC.**  
Barre, Vermont

The undersigned represented the borrower in this transaction.  
This notice appears as a matter of record only.



**Communications  
Equity  
Associates**

851 Lincoln Center • 5401 W. Kennedy Blvd.  
Tampa, Florida 33609 • 813 877-8844

March 1982

**SOLD**  
**Franklin Cablevision**  
Ft. Bliss U.S. Army Base, Hbrazon City,  
Santa Teresa, Socorro, Moon City, Fabens,  
Anthony and El Paso County, Texas  
Dona Ana County and Anthony, New Mexico

The undersigned represented the seller in this transaction.  
This notice appears as a matter of record only.



**Communications  
Equity  
Associates**

851 Lincoln Center • 5401 W. Kennedy Blvd.  
Tampa, Florida 33609 • 813 877-8844

March 1982

**SOLD**  
The Assets of  
**Telemedia of Key West**  
Comprising Cable Systems Serving  
Homestead Air Force Base  
Key Largo, Marathon, Little Torch, Key West, Florida  
Serving over 27,000 basic subscribers  
and 29,000 pay television subscribers

The undersigned represented the buyer in this transaction.  
This notice appears as a matter of record only.



**Communications  
Equity  
Associates**

851 Lincoln Center • 5401 W. Kennedy Blvd.  
Tampa, Florida 33609 • 813 877-8844

March 1982

**\$700,000  
Industrial Revenue  
Development Bond  
Due 1992**  
**PLEASUREVISION, INC.**  
Bushnell & Sumter County, Florida

The undersigned represented the borrower in this transaction.  
This notice appears as a matter of record only.



**Communications  
Equity  
Associates**

851 Lincoln Center • 5401 W. Kennedy Blvd.  
Tampa, Florida 33609 • 813 877-8844

During the first three months of 1982 CEA completed nine separate transactions for a volume of over \$41 million. If you are interested in buying, selling, financing or expanding a cable system call the results oriented investment banking firm.



**Communications  
Equity  
Associates**

851 Lincoln Center • 5401 W. Kennedy Blvd.  
Tampa, Florida 33609 • 813 877-8844



# May Mis

This month an assortment of topics, including replies to a few questions from readers of this column.

## **RCA-D, 1981-114A**

RCA's third successful communications satellite launch took place on November 19th, 1981, atop a Delta 3910 from Cape Canaveral. The spacecraft, renamed Satcom III-R (or F3R) once in orbit, took over operational service from F1 on December 28, from a new orbital slot at 131°W. Hopes were high among small terminal operators. Twenty-four new transponders to carry all the old Cable feeds plus some new ones. Twenty red-hot, beginning-of-life five-watt amplifiers plus four extra-hot 8•5 watt units. And the three

degrees or so higher elevation occasioned by F3R's more easterly location could do nothing but good, especially for marginal installations in the elevation-starved north-east.

In practice, it seems not all changes have been positive. Reports reaching me from the U.S., including a detailed survey conducted by a leading satellite journal, suggest that the average improvement, across all states and all transponders, is some 2 dB. This corresponds to the difference between a 10 ft and an 8 ft antenna, or between a 13 ft and a 10 ft — a significant improvement. But certain transponders in certain areas have lost ground, and these are not always the ones that would be predicted by reference to the antenna set or saturated power outputs. That is, the power flux densities 'on the ground' don't tally precisely with RCA's antenna boresight and ERIP predictions. Transponders 3, 7 and 11 are among the strongest on

average, with transponder 22 being reported well down at several locations, to the point where its health may be questioned. Interestingly, transponder 3's good report is obtained despite its heavy loading with auxiliary subcarrier services (5 subcarriers in addition to the WGN 6.8 MHz audio), which might be expected to reduce the video carrier/noise ratio.

We might expect, within the next few weeks, a 'real-world' set of F3R footprints to be published, as was done by Compucon in 1979, for F1. Any such analysis will be presented in these pages as soon as it becomes available.

## **F4**

Hard on the heels of F3R came Satcom F4's launch. Stationed at 83°W, F4 was scheduled to take over the existing video services on the Comstar D1/D2 combination on April 1st, plus a handful of new services, including those which acquired transponders in last year's controversial auction. Western Union's own 24-channel bird, Westar 4, will be the next chunk of domestic space segment, at



# cellany

S. J. Birkill  
on Experimental  
Terminals

But we cannot reduce noise bandwidth indefinitely or we run into problems. Carson's rule gives an estimate for FM channel bandwidth at twice the sum of peak deviation frequency and maximum modulating frequency. For a deviation of (say) 11 MHz peak, and a baseband extending to 6.8 MHz (audio sub-carrier), Carson predicts a modulated signal bandwidth of 35.6 MHz. In practice we can stand to reduce this somewhat, making a slight gain in C/N, before we overdo it and distortion becomes intolerable. 25 MHz is about the minimum bandwidth that will pass a standard US domsat signal without untoward effects, and most receivers design for an IF filter bandwidth of between 27 and 34 MHz. Naturally, choice of this basic receiver parameter comes first, and the terminal G/T is adjusted (by choice of antenna size, LNA noise temperature etc.) to bring the C/N of the wanted signal above threshold. Only in the case of G/T-limited TVROs (such as my own 8-foot terminal looking at Intelsat) does the IF bandwidth selection have to be 'forced' by C/kT con-

sideration (see my column in CATJ October 1978). 99°W, and may well have made a showing with video traffic transferred from W3 by the time you read this.

## Resolution

With reference to the F3R footprint levels, a reader asks whether it is possible to define the video bandwidth, or equivalent horizontal resolution, to be expected for any given ERIP level. The answer becomes apparent when we clear up the confusion between RF (or IF) bandwidth and video bandwidth.

Consider first the RF bandwidth. If we calculate the downlink power equation for any combination of transponder EIRP and receive terminal G/T, we arrive at a figure called C/kT or  $C/N_0$ , the carrier to noise den-

sity, which is a measure of the carrier/noise ratio per unit bandwidth. Now this is noise bandwidth of the system, which is usually set by the receiver's IF filter. The C/kT figure tells us what noise bandwidth corresponds to a demodulator threshold condition, with the signal level available, assuming we know the threshold performance of our demodulator. Thus with a C/kT of 84 dBW/K/Hz and receiver threshold occurring at a C/N of 10 dB, IF bandwidth (noise bandwidth) should not exceed 25 MHz or the signal falls below threshold.

So what are the degradations which occur as a result of excessive narrowing of the IF bandwidth? Two principal ones, truncation noise and intermodulation. Truncation noise occurs when the deviation of the FM signal exceeds the band available to it. It shows therefore on the peaks of deviation, which with pre-emphasis are the transient edges in the picture, particularly where the color saturation is high. So perhaps the worst case is with chroma-keyed lettering of high contrast. On the vertical edges of the letters the FM carrier can deviate right outside the filter bandwidth, producing a burst of noise or 'sparklies' rather than a crisp

video transition. The same effect occurs with many phase-lock loop demodulators, as a result of the loop losing lock on these portions of the video waveform. This is not an inherent defect of the phase-lock loop, rather a limitation of the performance of certain commonly-used circuits.

Intermodulation is a side-effect of amplitude non-linearity of the video transmission chain. In an FM system it can be caused by modulator or demodulator non-linearity, multipath effects such as may be caused by reflections on long cable runs, or bandwidth restriction. Its probable first manifesta-

tion is in the form of patterning, due to difference-frequency components (third-order intermodulation products) being generated by audio and color subcarriers. Another effect can be buzz on sound, due to phase-modulation of the audio subcarrier by the video signal.

But what of video resolution? Those readers familiar with AM TV practice (all CATJ readers I hope) will know what happens if the channel bandwidth is narrowed excessively. The definition of the picture goes — the highs are lost and all becomes fuzzy and smeary. In the black and white days we all played with narrow-band filters to try

# First In Reliability

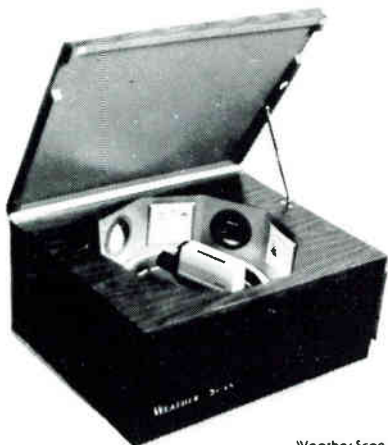

Weather Scan III

**Impressive quality . . . surprisingly low price. Just \$3295 for the most reliable unit available (at any price!).**

We have been in the cable television business for 23 years . . . and providing weather information systems for the past 16 years. We know what you need and we know how to manufacture it. For reliability and performance.

The Weather Scan III comes complete with Sony AVC-1400 camera with separate mesh vidicon and 2:1 interlace sync. Includes Time, Temperature, Barometric Pressure, Wind Velocity, Wind Direction, plus four card holders. Compact cabinet is just 28" wide, 23" deep and 14" high. For complete information call or write.



## Weather Scan, Inc.

An R.H. Tyler Enterprise

Loop 132 and Throckmorton Hwy. Olney, Texas 76374 Ph. 817-564-5688

Who's the best bet in cable test equipment? Come to booths 919 and 921 at this year's NCTA Show in Las Vegas. May 3, 4 and 5.

Wavetek is the leader in CATV equipment. And you'll see why when you visit our exhibit.

We've expanded our product line, increased the

performance of existing models and have added some anxiously awaited options. You'll see the best in everything, from complete sweep systems to tunable filters.

Remember our booth numbers. When you go with Wavetek, you're going with the odds-on favorite.

Contact Wavetek Indiana, 5808 Churchman, P.O. Box 190, Beech Grove, IN 46107, Phone Toll Free (800) 428-4424, TWX 810/341-3226.

**WAVETEK®**  
**MID STATE**

**Wavetek predicts the best numbers  
to bet on in Las Vegas.**

**919-921**

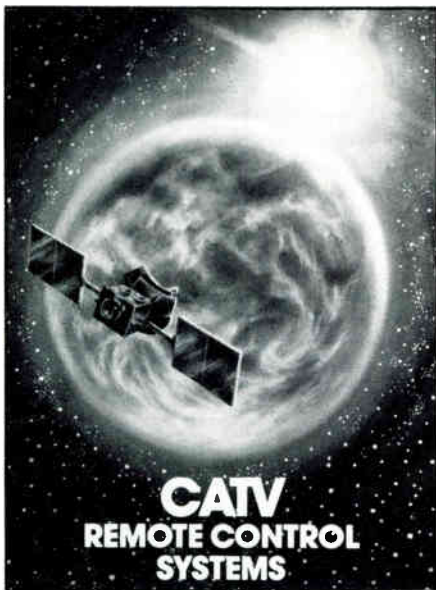

## CATV REMOTE CONTROL SYSTEMS

**From Monroe Electronics, Inc.**

### Satellite Cue Tone Receiver Model 3000R-64



- Features up to 8 cue tone decoders
- Monitors 4 program channels
- Provides 4 balanced audio and
- 4 co-axial SPDT switches for base band video or IF switching
- Isolation in excess of 80 db at 4.5 MHz  
60 db at 41.25 MHz



See Monroe 6-page brochure  
**Satellite Cue Tone  
Signaling Products**

Also ask for data on Emergency Access Units 3000R7-R71-R72. They provide for dial up access to cable audio for emergencies.

### NEW DEVELOPMENT AGILE RECEIVER CONTROLLER 3000R-82

for dial-up telephone remote control of most brands of frequency agile receivers. Permits selection of channel and polarization by telephone call.

Phone Monroe for all your tone signaling needs:

Northern CATV Representatives:  
800-448-1655

Monroe Electronics Factory:  
716-765-2254



MONROE ELECTRONICS, INC.

214 Housel Avenue  
Lyndonville, NY 14098

and pull the weakest off-air signals out of the noise, even if it meant a video bandwidth of 1 MHz. Well this just isn't relevant in an FM system. Looking back at Carson we see the bandwidth requirement is dominated by the deviation factor, and even after that the highest baseband frequency is that of audio subcarrier, itself well above the highest video component. The fact is that the FM system bandwidth (and hence carrier/noise or anything else) has negligible effect on the recovered baseband width, unless it is reduced to such an extent that other distortions could not be tolerated. So the video bandwidth (and hence resolution) at your receiver's video output jack is to all intents and purposes determined not by the FM transmission system but by such factors as the video filtering in the uplink exciter and in your receiver, the bandwidth available from the programming source, via tape, radio link, off-air reception at the uplink site, or whatever. So if the whole chain is flat to (say) 4.5 MHz, and the fixed filtering elements in uplink and receiver pass this frequency without attenuation, then there's no reason that 4.5

MHz, with a corresponding resolution of 470 lines, (picture elements) should not be available out of your receiver, independently of footprints, EIRPs etc, provided you're above threshold so you can see it through the noise. The satellite link is essentially transparent to the video signal.

So if you see resolution variations between transponders, you can be sure those differences are present at the inputs to the various uplink terminals. If your video resolution is generally poor then either your receiver is sick, or else you're going through an AM modulator into a standard TV set, and that's where your bandwidth is deficient.

Note also that, when using a US domsat receiver, with 525-line de-emphasis, on foreign 625-line (PAL or SECAM color format) TV signals, you will find a certain smearing of video at the low frequency (tens of kilohertz) end, which may be interpreted as loss of resolution. This is due to mismatch of the de-emphasis characteristic with the transmitted pre-emphasis. A similar mismatch can occur where sharp cut-off video low-pass filtering is incorporated in the receiver. On a 525-line receiver this may chop the video



highs as close as 4.5 MHz rather than the 5.5 MHz bandwidth required to do full justice to the higher resolution 625-line system. Both these problems can be modified out of the receiver — if high-quality viewing of both standards is required, switchable de-emphasis networks need to be built in.

#### Antenna problems

I'm still getting letters from readers unsure of how to cope with circular polarization. A common requirement is to adapt the Birkill horn (CATJ February 1979) to a standard LNA with CPR 229 flange. I have suggested in the past that a transition section be made from sheet copper (or similar — even tinplate would do) to go between the 2-inch circular waveguide and the WR229 rectangular. This can be done, though with difficulty as the circumferential measurements of the two guides are different. It results too in a very long feed assembly. With the availability of good circular feeds like the Chaparral, I would strongly recommend the Teflon polarizer detailed last month, rather than adapting the Birkill horn.



If fixing the Teflon slab in place presents problems, try two small set-screws or self-tapping screws, through holes drilled across a diameter just inside the opening of the horn. These need to be just long enough to enter the polarizer material by a millimeter or two, to hold it firmly in place without affecting the field inside the horn themselves. Teflon has a high coefficient of expansion around room temperature, and what seems a tight push fit for the polarizer on a warm day can be slack enough for it to fall out of the horn (at high elevations) on a cold day!

The  $f/D$  ratio of an antenna is a fundamental parameter not understood by all. The figure refers to the ratio of focal length to dish diameter, measured of course in the same units. So a dish three meters in diameter with a focal length of 1.26 meters has an  $f/D$  of 0.42. The  $f/D$  ratio also determines the depth of the dish itself, that is the curvature, the amount of wrap

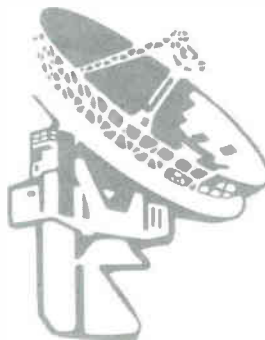

## CORES & STRIPS IN ONE QUICK OPERATION

Complete Cable Prep Tool  
Priced Much Less Than Two  
Separate Tools



Patent  
Pending

See Us  
At The  
NCTA  
Booth 1315

The SCT Blade is made of High Carbon Tool Steel for a much longer life. Others on the market which are of low carbon steel have a short cutting life and cannot be re-sharpened.

- Lighter in weight but stronger
- Time saving
- Use with 3/8 variable speed drill or manually, no accessories to buy.
- Easy clean out
- Available in all cable sizes
- No Replacement Blades required. Re-sharpening service available at a nominal charge

In Stock Now!

Contact Cable Prep Distributor  
Standard Coring Tools and HCT-659  
Hex Crimp Tools also available from  
Cable Prep.

**Cable  
Prep®**

Ben Hughes Communication  
Products Co.

P.O. Box AS Old Saybrook, CT 06475  
203/388-3559

around of the paraboloid surface within its fixed diameter. So a long focus (high  $f/D$ ) dish has a shallow contour, while a short focus dish resembles a deep bowl. The deepest dish commonly used as an antenna has an  $f/D$  of 0.25, placing the focal point in the plane of the aperture. If the parabolic curve is defined as

$$f = \frac{D^2}{16c}$$

where  $f$  = focal length  
 $D$  = dish diameter  
and  
 $c$  = depth of dish,

then it is apparent that when  $f/D = 0.25$ ,  $c = f$ . A large value of  $f/D$  requires a feed horn of narrower beamwidth to maintain the dish's edge illumination at the design value (usually between 10 and 15 dB below the center) and conversely a small  $f/D$  needs a wide angle feed. This is why the feed horns for

spherical antennas are so large: the reflector  $f/D$  is comparatively high.

To those brave souls making their own experimental antennas, I would suggest considering a 12 dB illumination taper for dishes of three meters or less (at 4 GHz), or a 15 dB taper for larger dishes. It's a matter of trade-off between antenna gain and noise temperature, balancing the terrestrial noise due to feed illumination 'spillover' with that due to side-lobes in the forward pattern. See feed horn design data in CATJ March 1981.

The question of how to test the TVRO system performance in the absence of a satellite signal was covered in these pages from September to November 1979. In some parts of the world there just aren't any high ERIP satellite TV signals, and experimenters need some way of knowing when their developing system is approaching adequate sensitivity to detect the satellites.

An IF signal level meter is required, either independent of AGC and limiting, or as a measurement of AGC voltage. If the meter is not meaningfully calibrated, a step attenuator is required prior to the metering point. Point the dish at a well-elevated region of sky, away from the sun and away from the geostationary orbit arc. Take an IF signal reading. Then aim the dish precisely at the sun (you will have taken the precaution of painting the dish with matt, ray-scattering paint to avoid melting your feed horn) and measure the increase in IF noise level. If that increase is less than 6 dB you've got problems. 10 dB would be a good figure for an average TVRO, assuming quiet sun conditions. CATJ October 1979 gives full details.

On the subject of previously-published articles, readers still come to me for reprints or copies. I did have some of these

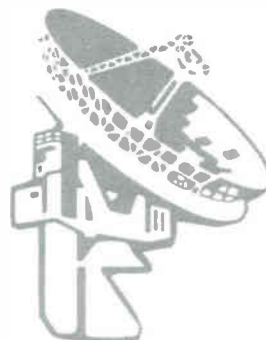



---

a long time ago, but they are no longer available. CATJ's Indexed Volume however is available with reprints of all these columns. Other journals I have written for are providing a similar service.

### The British scene

Here in the U.K., the go-ahead was given recently for a full DBS service, with at least two and possibly as many as five channels, according to the 1977 WARC-ST plan, and beginning as soon as the hardware can be made available, 1986 being perhaps the earliest possible date. Not everyone wants to wait so long, though, and 'interim' systems are emerging. One of these is a channel run by Satellite Television Ltd., a British company with its own program service funded by international advertising, delivering its output to CATV systems or approved individuals on the continent of Europe, via an 11 GHz downlink from Europe's Orbital Test Satellite at 10°E. Being a telecommunications satellite with a spot beam covering Europe, OTS's footprint is not up to DBS levels, and a 2.5 to 3-meter terminal is required for reception.

OTS's controlling body, Eutelsat, demand that the service be protected against unauthorized viewers, so scrambling is mandatory, the Oak Orion system being used. Additionally, the operator's British Home Office license does not permit service to be delivered to terminals within the U.K. itself, so Britain does not see any public benefit from its first commercial satellite TV channel. A peculiarly British situation.

Those seeking satellite TV have the consolation of the world's hottest 4 GHz footprint, albeit carrying Russian TV. Since mid-1979 the Russians have maintained a Borizont (Horizon) -class spacecraft at the Statsionar-4 location, about 14°W. Gorizont-4 took over from Gorizont-2 in time for the Moscow Olympics of summer 1980, and delivered EIRPs as high as 38 dBW into England, on those of its six transponders connected to its European spot-beam antenna. After that event it settled back into providing Moscow-1 programs to Russia's 'Moskva' rebroadcast terminals

in the western Soviet Union, on its spot beam at 3675 MHz. During 1981, commercial interests started to take notice of this, with US home TVRO hardware being imported to Sweden, Holland and the U.K., and used in unmodified form for reception of the Soviet programs. The lack of receiver modification meant that the Russian 'super'-energy dispersal was not removed, resulting in flicker and cyclic sparklies. The companded audio was not processed, so it sounded compressed with tinkling pilot tone accompaniment, and the de-emphasis time-constants were set for 525 lines, so a smeared picture resulted. Add to this the fact that the antennas were generally ex-terrestrial 2-meter dishes, putting the whole system at threshold, and satellite TV could have been given a bad name. The entrepreneurs' problems did not end there. Over the period from their launch until very recently, the EIRP level from the Soviet spot-beam transponder has declined by some 3 dB, until it approximated 34 dB here in England. The 2-meter dishes and

*continued on page 67*

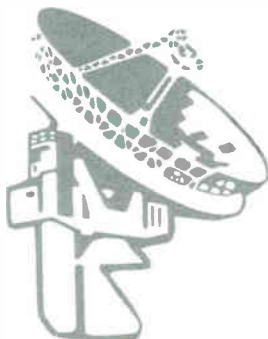

# Satcom III R-Is Better

A series of comparative signal strength tests, recently completed at Harris Electronics Corporation, Satellite Division in Melbourne, Florida, proves that SATCOM III-R is definitely delivering better signals to this area than SATCOM I.

The tests were performed with a Harris 6.2 meter satellite antenna located at the Melbourne facility and produces the following results:

**NOTE #1** — This location experiences a very high level of radio frequency interference from an operating telephone microwave path that severely interferes with signals from transponders 1, 2, 9, 17, 18, 19, 21 and 22 preventing accurate measurement comparisons for these transponders.

The end results, even with the problems with RFI and taking into consideration those transponders that had no signal transmission at the time of measurements, shows that SATCOM III-R had an

average improvement of 1.4 dB over SATCOM I.

One factor that may alter this limited data is that SATCOM III-R was not in final orbital position at the time that simultaneous uplink service started. RCA Americom advised all of the uplink stations that SATCOM III-R would be allowed to drift into final orbit rather than waste approximately four pounds of fuel that would be required to position the satellite in its' proper orbit on December 28th. The uplink facilities were advised to re-position their antennas two weeks after the simulcast start date and we do not know at this time if all of these final adjustments had been accomplished at the time the measurements were taken. This could mean that one or more of the uplink stations may not have been perfectly aligned with SATCOM III-R when the measurements were taken and the signals from those transponders would improve.

A more detailed comparative analysis is currently in progress. This study will provide signal comparisons from various areas throughout the United States. CATJ will provide the results of these in-depth tests as soon as they are completed.

Transponder	Results
1 & 2	RFI - See Note #1
3	2 dB better than SATCOM I
4	No Signal at time of measurement
5 & 6	Not determined
7	1½ dB better than SATCOM I
8	No signal at time of measurement
9 & 10	RFI - See Note #1
11	5 dB better than SATCOM I
12	Same level as SATCOM I
13	1 dB better than SATCOM I
14	Same level as SATCOM I
15 & 16	No signal at time of measurement
17, 18, & 19	RFI - See Note #1
20	Same level as SATCOM I
21 & 22	RFI - See Note #1
23	2 dB better than SATCOM I
24	1/2 dB better than SATCOM I

## Upgrade your SLE line extenders with push-pull hybrid electronics - Broadband now offers the BMK-53 in ready-to install modules.\*

With our BMK-53 now in ready-to-install modules, it's a relatively simple matter to upgrade your Jerrold® SLE-1, 20 2P line extenders to 300 MHz push-pull hybrid electronics. Another cost effective option from Broadband, it features:

- Push-pull hybrid electronics
- 300 MHz - 35 channel capacity
- 30 or 60 volt powering options
- 28 dB gain (standard module)
- 32 dB gain (high gain module)
- Three levels of surge protection
- 12 to 20 dB of equalization at 300 MHz

Pricing as low as \$99.50 for more than 50 pieces.

\*Also available as a replacement assembly ready to install in your existing module.

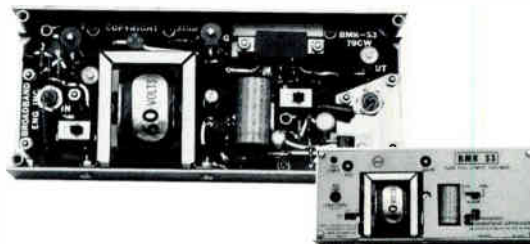

For free specification sheets and pricing, call our toll-free number (800-327-6690) or write Broadband Engineering, Inc., P.O. Box 1247, Jupiter, Florida 33458.

**BROADBAND™**  
A SUBSIDIARY OF **AUGAT**

See us at the National Show — Booth No. 1608.

*continued from Page 65*

120°K LNAs were obviously in trouble. With four systems delivered, the British operation could not muster much of a picture to show prospective customers, and their carefully-circulated rumours (that the Russians were transmitting to England and Holland with entertainment programs and English subtitles) did nothing to help.

Now a leading London video marketing corporation, Sonic Sound PLC, has decided to approach all aspects of satellite TV in a professional manner. With my assistance they have converted low cost American receiver units to match the Russian signal formats, and have obtained a 3-meter SatFinder antenna, which they are mounting permanently on the roof of their premises in central London as a demonstration terminal. With this they will be able to resolve noise-free pictures from the Soviet Atlantic satellite on all three TV transponders, as well as acceptable results from other birds, and cable the results around their various West End premises. Already top London hotels are seeking service.

But the latest news is that the Russians have launched a new satellite. The launch of Gorizont-5 was announced on March 14, but without information as to its designated orbital slot. On March 25 I was optimizing an LNA, using a small

12-inch square horn antenna looking out through the lab window, and bemoaning the state of the Soviet spot beam, which at times looked weaker than the assumed hemi beam, channel 9. Going back to the project on March 26, I was amazed to see the analyzer display of the spot-beam carrier had increased by at least 6 dB, and perhaps as much as 8 dB. Even on the tiny horn the picture was recognisable, using the narrow-band receiver, and the spectrum analyzer display was visible with just the LNA flange pointed towards the southern sky. So the EIRP to England on the 3675 MHz channel is now in the region of 41 dBW, and the pictures far better than I ever see from my local BBC/ITV relay transponder at UHF.

I think the Russians are to be congratulated for getting a new geostationary bird on station and operating in just eleven days from launch. Their problems seem to be in keeping the things working for more than two years. The U.S.A. might take six weeks to check out a new bird and hand over to it, but at least we get a seven to ten-year life from our satellites.

So those European two-meter terminals are back in business, but the wise buyer will be looking for a 2.5 to 3 meter antenna, to ensure continuity of service throughout the life of the satellite. Now commercial interests are looking towards the exploitation of the TV lease channels on Intelsat, with full-time TV from such nations as Saudi Arabia, and French TV on Symphonie. Of course they will

need much larger antennas, with autotracking capability, for those services. And they will need a new class of receiver, able to cope with a large variety of video and audio formats. Antennas in the 6 to 10 meter range are being considered for these, and cost-effective approaches are being sought.

But what many people in Europe seem to want is American TV, and they ask when some visionary American is going to put his service on an Atlantic Intelsat (or even on a European semi-DBS) to make it available in their country. Ted Turner we need you! □

**DISTRIBUTING  
FEATURES,  
SHORTS,  
SPECIALS  
AND SERIALS TO  
PAY & CABLE TV**

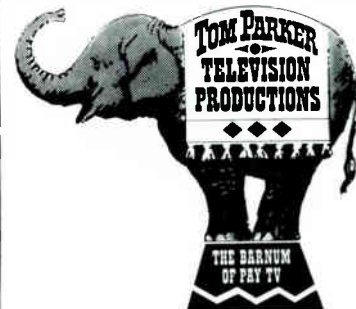

18321 VENTURA BLVD.  
TARZANA, CALIFORNIA 91356  
213/881-9115 • TELEX 181149 WLA

BOOTH 1438 & 39 AT NCTA '82  
HOSPITALITY SUITE IN THE HILTON

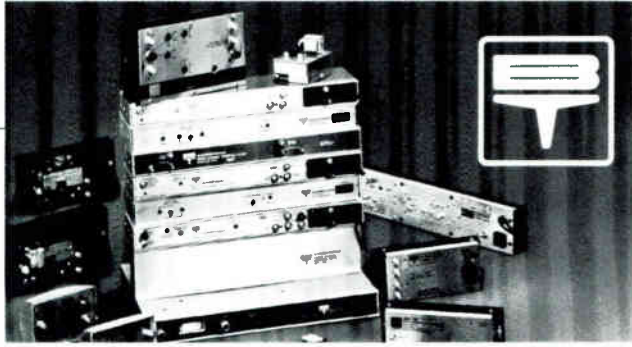

**Look to us for high quality B-T  
no-wait CATV equipment.**

We have it in stock for immediate delivery.  
Or pick-up.

Blonder-Tongue stock items include:  
antennas, amplifiers, modulators, con-  
verters, filters, headend accessories, traps,  
processors, preamps, and more. Call us for  
what you need.

**Davco, Incorporated**

**America's Oldest CATV Distributor**

- Same day shipment
- Help when you need it
- Everything you need in one stop
- In business since 1949!



Authorized  
Blonder-Tongue  
Stocking  
Distributor

P.O. Box 2456

Batesville, Arkansas 72501

(501) 793-3816

**In  
Memoriam**



It is with great sadness that we note the passing of our good friend, Jim Baker, (Van Ladder, Inc.), who succumbed on March 31st in California, being buried on April 6th in Spencer, Iowa. Our heartfelt condolences are extended to his wife, Paula, and his family. His friends will miss him, and surely the cable industry, to which he was dedicated, will too.

As we analyze our loss of Jim, our sadness is truly for ourselves. The fact that so many people really care that Jim is gone is testament to how enriched our lives were with him as our friend. It does matter that Jim lived in our midst. Without question, association with him was always interesting; remembering our first encounters with Jim in the early CCOS days brings to mind his keen wit, his fine sense of humor, and his professional approach to his customers and the Van Ladder products.

Comfort comes from knowing Jim is no longer in pain — that now Jim Baker is resting at peace. We will remember his friendship always and draw strength from his courage these past few months. □

**NOW**  
**SPECTRUM  
ANALYZERS**  
for monitoring, service and testing  
communication equipment  
100 kHz - 2 GHz

The Model 632B-1 is well suited  
for wide range distortion and  
noise measurements, test

equipment calibration, EMC  
tests, and other frequency do-  
main applications up to 2.0 GHz.



Send for our new catalog.

polarad polarad polarad

Polarad Electronics, Inc. 5 Delaware Dr., Lake Success, N.Y. 11042 TEL 516-328-1100 TWX 510-223-0414

# STANDARDIZE

## WITH THE NATIONAL STANDARDS FOR CATV SYSTEMS — GRAPHIC SYMBOLS

In order to help you standardize your grid and map preparation Television Publications is now offering a brochure of National Standards for CATV systems Graphic Symbols.

The symbols in this publication present cable television systems operators and engineers with a uniform means of schematic and system map design throughout the Cable Television Industry. Order one for each of your operators and engineers and get standardized!

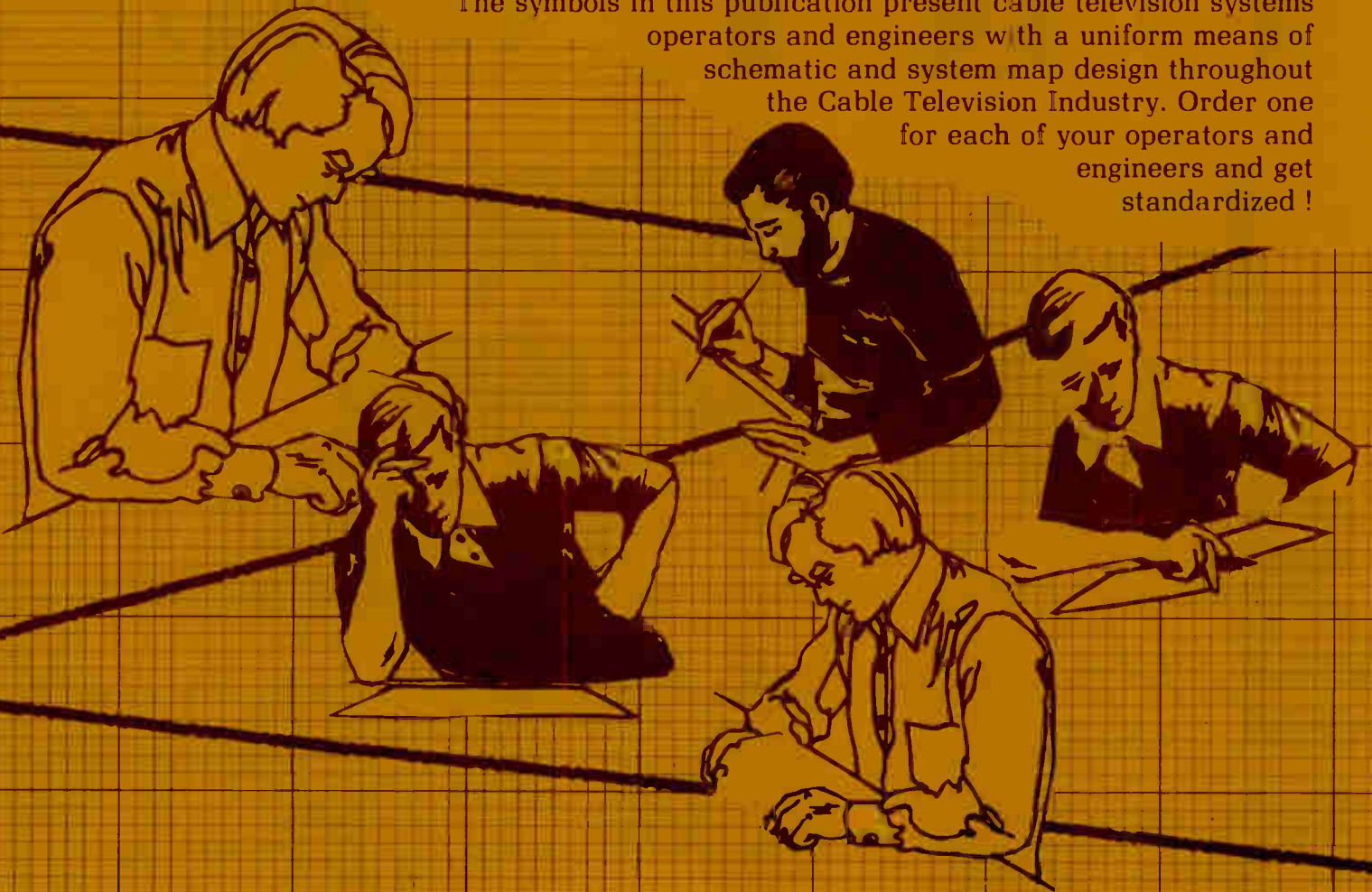

YES! I WANT THE NATIONAL STANDARDS FOR CATV SYSTEMS — GRAPHIC SYMBOLS GUIDE  
SEND TO:

NAME

SYSTEM NAME

ADDRESS

PHONE

CITY

STATE

ZIP

PRICES

5.00 each

40.00 for 10 guides

90.00 for 25 guides

PLEASE SEND \_\_\_\_\_ SYMBOLS GUIDES. ENCLOSED IS \$ \_\_\_\_\_ FOR MY ORDER.

MAIL TO: TELEVISION PUBLICATIONS, INC. SUITE 106 4209 NW 23 OKLA. CITY OKLA. 73107 405/947-7664

# KEEP

# PACE with the Industry All New 1982

Name

Address

City

State

Zip

CATA MEMBER

NON-MEMBER

\$14.00 enclosed for 1 year  \$18.00 enclosed for 1 year

\$40.00 enclosed for 3 year  \$50.00 enclosed for 3 year

NOTE: CANADA/MEXICO SUBSCRIBERS: Add \$4.00 per year to rates given above. All other Foreign Countries add \$7.00 per year to rates given above. Special handling arranged upon request. U.S. CURRENCY ONLY.

\* MUST FURNISH SYSTEM NAME:

WorldRadioHistory

# CATJ

# SUBSCRIBE

# H.R. 3560 is Dead!

## LONG LIVE

### Washington update Washington update

You are not going to believe what happened toward the end of March! Just to get you to sit down before you read the rest of this complicated explanation, we'll give you the punch line first; CATA wound up supporting the adoption of copyright legislation in the U.S. House of Representatives! As we said, this has been an unbelievable few weeks, so let's see if we can get everybody up to date. We are going to do this in a rather comprehensive way this month because everyone seems to be so confused (especially on Capitol Hill) about the current status of things. So please, if you are the administrative assistant to a Congressman or Senator and you are reading this, please save it, it will come in handy later when the issue finally comes to a vote!

#### BACKGROUND

By way of review, you all now that there was a "Copyright Compromise" that was being considered by the House Subcommittee on Courts, Civil Liberties, and the Administration of Justice. For simplicity sake we refer to that subcommittee as the "copyright subcommittee" or the "Kastenmeier subcommittee". The "compromise" came about because of a series of events that will always remain controversial. First, the Federal Communications Commission eliminated two sets of rules that had restricted cable television operators since 1972. These two rules, the "distant signal importation rules", which restricted the number of distant television signals a cable operator could bring in to his community, and the "syndicated exclusivity rules" which allowed certain broadcasters to force cable operators to delete certain programming from signals they were importing, were eliminated by the FCC because the Commission found that it had no data or other justifiable reason to retain rules that had initially been imposed based on a political compromise in

1972. The broadcast, sports, and motion picture interests fought the FCC decision through the Courts and lost at every level, including, finally, the Supreme Court's decision not to even hear the case.

The result of the elimination of those rules was that the interests mentioned above decided that the Commission's action gave them the perfect "political" reason to go back to Congress and try to get alterations to the Copyright law, as it applied to cable television, that had only gone into effect in 1978. The bottom line here was that the motion picture folks wanted more money, the broadcasters wanted protection from competition, and the sports interests wanted to perpetuate their government granted monopoly and exemption from the antitrust laws (that is, they don't want competition). So off to Congress they went. The political atmosphere was right, and they were able to persuade the copyright subcommittee that SOMETHING had to be done! The question was what.

While all this was going on, the cable operators were relatively secure in the knowledge that the **FACTS** supported cable's position on the copyright issue, as the FCC had finally determined, and that given the opportunity to present those facts, and present a unified position in the industry **AGAINST** any changes in the present copyright law it was unlikely Congress would change that law. Then something happened.

#### THE COMPROMISE

Without so much as a telephone call warning to its own major members, the National Cable Television Association, representing the large, multiple system operators, announced that they had reached a "compromise agreement" with the NAB and the MPAA regarding copyright legislation! The shock wave in the cable television industry nearly ripped the industry apart. Why agree to a compromise, was the question on many lips. The answer came back that it was a political necessity, that the

# H.R. 5949



Steve Effros  
Executive Director, CATA

## te Washington

## update Wa

copyright subcommittee would eliminate the cable "compulsory license" for carriage of television broadcast programming, thus throwing the cable industry and its subscribers into chaos if we did not agree to a compromise.

CATA took the lead in disputing that political judgment — particularly since it was made by a group of people that had other good reasons to compromise for their own benefit. We will not rehash all of that here, you can look at your back issues of the magazine if you really want to get the full flavor of all this. Suffice it to say we yelled, and we yelled very loud! We were not alone. Ted Turner, the originator of the "Superstation", the most popular satellite-transmitted programming in many parts of the United States immediately recognized, as did we, that the satellite carriage of independent distant signals would have been doomed under the so-called "compromise". We could not accept that. The most important thing CATA must protect, particularly for non-urban systems, is the ability to carry distant independent television signals on an economical basis. That is not to say, as we have explained many times in the past, that these signals will always be the top priority for us, but for now, and at least for the new few years they certainly are. We were not about to agree to any "compromise" that destroyed the benefits of those signals.

The yelling and screaming worked. A great number of NCTA system members joined us in the effort to convince the powers that be on Capitol Hill that the "compromise" was not acceptable. They heard us, as did the negotiators for the NCTA, who had very little choice but to listen. They went back to the drawing board and came up with a new set of agreements, which we dubbed "Son of Compromise". This was a far better proposal, and one that at least protected distant signal importation via satellite. It also eased up some of the onerous provisions of the

original compromise with regard to the "must carry" rules that were included in the deal to give the broadcasters their "pound of flesh" in the proposed legislation. Why were they included at all? Because everyone was willing to acknowledge, at least in the back rooms, that if any one of the major industry segments disagreed with the bill it would not be politically viable, and would never get through Congress. (We still believe that is true, and therefore we still think the original "justification" for the compromise, that we were about to lose the compulsory license, didn't hold water — unfortunately, now it does, as will be explained later.)

### SON OF COMPROMISE

For reasons that defy explanation, Chairman Kastenmeier of the copyright subcommittee had decided during this whole process that one way or another he was going to get a cable/copyright bill out of his subcommittee during this session of Congress. To his credit, it was only through his tenacious adherence to that goal that anything happened. In essence, throughout the process he convinced the cable negotiators (the NCTA) that if they didn't agree the sky would fall, and he convinced the MPAA (Jack Valenti) that if he didn't compromise he wouldn't get anything! The broadcasters were just in the negotiations to get whatever they could out of it, since, as far as copyright is concerned they really don't get very much money anyway — they had communications issues, not copyright issues that they wanted pushed. So "Son of Compromise" was finally hammered out. CATA maintained its position that there was no need for copyright legislation at this time, but we focused not on the copyright aspects of the proposed bill but rather on the "must carry" provisions.

### THE JURISDICTIONAL FIGHT

There were several basic problems with "Son of Compromise". First of all, it looked nothing like the original



legislation that Congressman Kastenmeier had introduced as a "trial balloon" months earlier. That bill, H.R. 3560, was simply a vehicle that ultimately was totally amended

marketplace" should prevail. He seems to ignore the fact that there cannot be a "free" marketplace when one of the competitors for the programming, the broadcaster, is

# Washington update Washington update W

by the subcommittee to conform with the industry-created and Kastenmeier shepherded "Son of Compromise". The difficulty, as CATA, among others, pointed out at the time, was that the amended bill had provisions in it, particularly the "must carry" stuff, that had nothing to do with copyright, and nothing to do, jurisdictionally, with the Judiciary subcommittee. The "must carry" provisions, at the very least, were "communications" matters that had to be considered by the Communications Subcommittee headed by Rep. Tim Wirth. As you know, that subcommittee is part of the Commerce Committee. We were acutely aware of all that because after the "Compromise" was announced we argued for and won the right for hearings before the copyright subcommittee. When we testified, however, we were told NOT to testify about the "must carry" portions of the proposed amendment because they weren't within the jurisdiction of the copyright folks, that would have to await the sequential referral of the bill that was planned to the communications subcommittee. Do you have all that? It is important to understand all this preliminary stuff in order to fully appreciate what happened next!

## H.R. 3560

CATA opposed the amended H.R. 3560 even after its adoption by the Kastenmeier Subcommittee by a 4 to 3 vote. The "close" vote was used as "proof" by some that had we not had a "compromise" the subcommittee would have voted for a complete elimination of the compulsory license, as was proposed by the minority on the subcommittee. Interestingly, that "minority" included Cong. Barney Frank of Mass. who had originally proposed eliminating the compulsory license AND the must carry rules. That was a proposal that CATA made many months ago, linked with a guaranteed minimum signal carriage complement as the ultimate solution to the whole mess — don't be surprised if that doesn't wind up to be the result of all this in a year or two!

So H.R. 3560 headed for the full Judiciary Committee. On the way, several things happened. First, everyone knew that Rep. Railsback was going to introduce a proposed amendment for the sports people that would impose a black-out for "same league" sports within a 35 mile zone around stadiums where games are being played. It was also pretty clear that if the amendment passed the NCTA would have to "jump ship" on supporting H.R. 3560. Also, Rep. Sawyer was going to introduce the "minority" proposal from the subcommittee to simply eliminate the compulsory license. He had decided that this was a pure copyright matter, and that the "free

given a **MASSIVE** subsidy by the federal government by way of free spectrum space! In any event, the elimination of the "must carry" rules was not going to be a part of his proposal.

Everyone was set for the big event in the Judiciary Committee. Sides were being drawn, strategy was complicated, and the nose counts were under way when the bomb hit.

## CANCEL ALL BETS — THE EMI CASE DECISION

A new player suddenly appears on the scene. A judge in New York decides a case that none of us were really watching very closely because nobody thought there would be anything other than a favorable decision for cable. Boy were we wrong! Without going into all the details of the case, the Court decided that Eastern Microwave IS subject to the copyright law for carrying the METS baseball games, that they DO NOT qualify for the "common carrier" exemption to the copyright law, and that therefore they are infringing on copyrights by carrying the game (on WOR) via satellite, and "performing" it to the "public" (the cable system) without permission. A full analysis of that case will be included in next month's issue of CATJ, but the import of it is that the way cable has done business for the past decade is being threatened. EMI, Southern Satellite, and United Video as well as any other microwave or satellite carrier of independent television programming to cable television systems now has to wonder when the next suit will be filed, when the next show will drop.

It is hard to estimate the full impact of the "EMI case". This is so because as yet it is not clear if the infringement will be considered, for penalty purposes, to have started years ago or only after requests from the programmer were made to stop carriage. There are also many other questions. Needless to say the case is being appealed, and many legal-types who have looked at it say that it will be reversed — particularly since one of the main points that the judge made, that EMI was providing the program to the "public" when it delivered the program to the cable operator is directly contradicted in another case in another Federal District Court (the "WGN case"). But all of this does not really address the issue, since an appeal could take many months, if not years, and in the meantime the entire industry is caught in a situation that may result in the sudden black-out of all distant signals! This we cannot accept. Hence, it was a quick trip back to the drawing boards for the copyright legislation to make it clear that the judge in New York had misread the law. The change proposed by Mr. Kastenmeier only modifies a

few words in the current (1976) law to make it clear that the cable subscriber, not the cable operator is to be considered the "public" within the meaning of the copyright

would, if it stands, effectively kill all distant signal importation, the sports folks would love to make sure that no bill passed that would affect that decision! They pulled out all

# Washington update Washington update

law, and that the carriers, EMI, SSS, United Video, etc. DO qualify for the common carrier exemption in the law.

## BALANCING ACT

The result of all this was that the cable industry, including those of us who opposed changing the current law at this time, were forced to reassess. While we still oppose the imposition of the "must carry" rules via legislation, is it more important to kill the legislation or is it more important to solve the "EMI problem". The answer was clear. We had to protect the ability of cable operators to bring independent television signals to their subscribers. When we were asked for a clarification of our position by the Kastenmeier subcommittee just prior to the Judiciary Committee vote, CATA Executive Director Steve Effros wrote a letter to the Chairman of the subcommittee saying that **CATA did not object to the COPYRIGHT portion of H.R. 3560.**

**CATA totally supports that amendment.** As we said earlier, the one clear mandate from our membership is that we must do anything necessary to assure the continued availability of distant independent television signals. It should be noted that even our original copyright proposal that would contemplate the elimination of the compulsory license also would have a provision guaranteeing the right for all Americans to see a minimum complement of television signals, including independent signals.

## THE ADMINISTRATION PLAYS ITS SONG

CATA was not the only one writing letters, however. The Justice Department sent a long memo to the Judiciary Committee saying that it, speaking for the Reagan Administration, was against H.R. 3560 and was in favor of the total elimination of the compulsory license. This did not come as a surprise. The Administration had been orchestrating this comment for the past few months, first with statements from the NTIA, then from Chairman Fowler of the FCC and finally the Justice Department statement. Congressman Sawyer, a Republican, of course, could not have been happier with the timing of the JD letter. As he well knows, it was no coincidence!

## A PARLIAMENTARY PLOY

While this next step is a little complicated, read it carefully, it may be the most important move in this particular political battle. Remember, please, that throughout all of this maneuvering the sports folks are still trying to get more protection for themselves. They don't like the public being able to see competing sports matches on television via imported distant signals. Since the EMI case

stops to see if they could stop any Copyright legislation that would deal with the EMI case.

Here is where you have to understand a little of the rules and procedures of the House. To begin with remember that we mentioned that because H.R. 3560 had BOTH copyright and communications issues in it it had to go through both the Judiciary and the Commerce committees. As it originally was introduced the bill did not have communications matters in it, but the amended bill did, so there was an agreement that it would be SEQUENTIALLY referred to the commerce committee. Normally, under sequential referral the second committee has a limited amount of time to deal with the bill. In this case there was a tentative agreement that Commerce would take up the bill within 60 days of passage by the Judiciary Committee.

Another rule that you need to know is that in the House, all amendments to bills must be "germane", that is, they must pertain to the same issue as the originally introduced bill, or they are subject to challenge. Now, knowing all

**ALL PARTS IN STOCK**



## METERS

Completely Repaired  
and Calibrated  
in five to ten days!

One Hundred Day  
Guarantee



**Superior electronics center, inc.**  
2010 PINE TERRACE • SARASOTA, FLORIDA 33581  
Telephone: 813/922-1551

Our Business is Improving your Image

that, we can get on with what happened.

While it is just speculation, we suspect that it was the sports interests that convinced Rep. Dingell, the Chairman

#### H.R. 5949 — A QUICK TURN-AROUND AND COUNT

The Kastenmeier Subcommittee met less than 24 hours after H.R. 5949 was introduced. But this was a somewhat

# Washington update Washington update

of the Commerce Committee, that he ought to play a hand in slowing down or killing "Son of Compromise". In any event, the night before the Judiciary Committee met to discuss H.R. 3560 reports have it that he contacted Rep. Sawyer, the leader of the opposition, and suggested that he raise a "Point of Order" regarding the "germane" of the amended H.R. 3560.

That is what happened. It wasn't Mr. Sawyer, but his cohort Mr. Butler (who is not running for reelection) who raised the point. He said he was raising it because the subcommittee had not taken up the issue of the EMI amendment, but for whatever reason he knew very well that his move would kill H.R. 3560 even though he had NOT raised the same objection as a member of the subcommittee that had considered the compromise. The Point of Order was accepted by Chairman Rodino of the full Judiciary Committee (he had no choice), and he ordered that the bill be sent back to the subcommittee to be "cleaned up", that is, the non-germane parts were to be taken out. Rep. Kastenmeier stated publicly that that could not happen since the compromise was a "package deal" and taking out any part of it would result in the bill not being politically viable. It was the death of H.R. 3560.

But, as we all know, that is not the end of the story. Within four hours Mr. Kastenmeier had introduced a "new" bill. This one had the number H.R. 5949, and it was ESSENTIALLY identical to H.R. 3560. There were several changes, one, of course, was the addition of the EMI amendment, and the other was a change from two to three in the number of local PBS stations a cable system must carry under the new "must carry" rules. That change also explained that cable operators could delete one duplicating network signal for each PBS station so carried, but the deletion had to be the most distant station first.

Why introduce a "new" bill? Again, you have to understand the procedures and politics of the situation. First, while a "Point of Order" on "germaneness" does work on amendments to bills, as was the case here, it does NOT work on a bill that has the various provisions in it from the very start. Second, what this entire maneuver was really all about was to get **JOINT as opposed to SEQUENTIAL** referral of the bill to the Commerce Committee. Joint referral means there is no time limit within which the Commerce Committee must act. Hence, with the sports interests obviously having considerable clout in the Commerce Committee, they might be able to simply "bottle up" the bill in that committee this year even though the cable, broadcast, and movie folks are all now in favor of the bill for their own reasons. **Isn't Congress fun?**

different subcommittee than the one originally voted out H.R. 3560. The biggest difference was that Cong. Danielson from California, one of the original four votes that approved "Son of Compromise" was no longer a member of Congress, having been named a Judge in California in the interim. So now we could have been looking at a three to three tie, which would have doomed the legislation.

It didn't happen that way. Barney Frank, who is in a very tough race in Massachusetts, abstained, thus allowing the bill to go to the full committee where he announced he would vote with the minority to kill the bill and instead eliminate the compulsory license. Railsback said he would bring his sports amendment before the full committee too, so back we all went!

#### FINALLY! THE JUDICIARY COMMITTEE VOTE!

Less than a week after all this juggling took place the "new" bill, with the EMI amendment was before the full Judiciary Committee. The big concern was whether the Railsback sports amendment would be adopted, and all the parties in favor of passage of H.R. 5949 were working hard to make sure it would not. Of course there was also the question of the Sawyer substitute that would simply eliminate the compulsory license. That was the question that came up first.

It is there that some very interesting things were said. Both Mr. Kastenmeier as Chairman of the subcommittee and Mr. Railsback as senior Minority member of the subcommittee spoke out against the Sawyer substitute. They said, in essence, that while in an "ideal world" they would agree that there should be no compulsory license, this was not nearly such a world, that the market was already seriously warped by other factors, and that the simplistic solution of throwing out all the laws would not work. What is more important, they said that adopting the substitute would guarantee that no copyright legislation would pass since it was politically highly unlikely that any bill which simply proposed the elimination of the compulsory license would make it through Congress! Now we do not hesitate to point out that **THIS IS WHAT CATA HAS BEEN SAYING ALL ALONG!** The Sawyer substitute was resoundingly defeated by a 20 to 7 vote. So much for the theory that the "... sky was falling".

The Railsback sports amendment was another story. It was a much closer vote and it is indicative of the fight that we have ahead of us in the Commerce Committee, where the sports folks are even stronger. That amendment lost this time around by a 13 to 11 vote. And that is where we are today (Whew!)

## ON TO COMMERCE!

What is CATA going to do about all this? Be very up front about it, that's what! We still oppose the "must

that would kill off cable completely, and new developments in programming that it seems a shame to have to spend so much time on the issue of copyright legislation.

# te Washington update Washington U

carry" portions of the bill. We will continue to say so, and we expect to have the opportunity to explain why. We do not, however, intend to try to kill the bill because we agree with those who day that a solution to the Eastern Microwave problem is the paramount issue right now. Is H.R. 5949 the best way to solve EMI? Probably not. We would rather see a simple fix of EMI and no cable/copyright bill. However that is not the option right now. We already have a "vehicle" (H.R. 5949) half-way through the process. It might just make it all the way. If it doesn't, if it gets stalled, then rest assured that we are preparing contingency plans. But for now, let's see what happens with H.R. 5949.

## AN APOLOGY

There are so many things happening in the cable television industry right now, including new legislation introduced by Senator Goldwater, proposals in California

However we have devoted this WASHINGTON UPDATE to a full explanation of what has gone on before and where we are now so that everyone will know what is happening, not just a few folks in the New York and Denver corporate offices.

No one would like it more than the author of this article if we could get back to dealing with the issues in the cable industry OTHER than copyright. However we have often been told by not only CATA members, but non-members, including Congressman as well that the CATAcable is the only short-form explanation they have found of this very complex situation we all find ourselves in. We urge CATA members to send a copy of this month's issue to their Congressmen if there is a need to explain, once again, what has happened, and where the independent cable television industry stands on the situation. You might also show a copy to your Mayor or City Council so they are up to date on the problem too. We may need their help before this is all over. HELP! □

# THE ORIGINAL



U.S. Patent No. 4,072,899

## Field Proven RF Leakage Detection System



An Employee Owned Corporation

### COMSONICS, INC.

P. O. Box 1106 Harrisonburg, VA 22801  
(703) 434-5965

Ask about our National Show Special Booth 1614

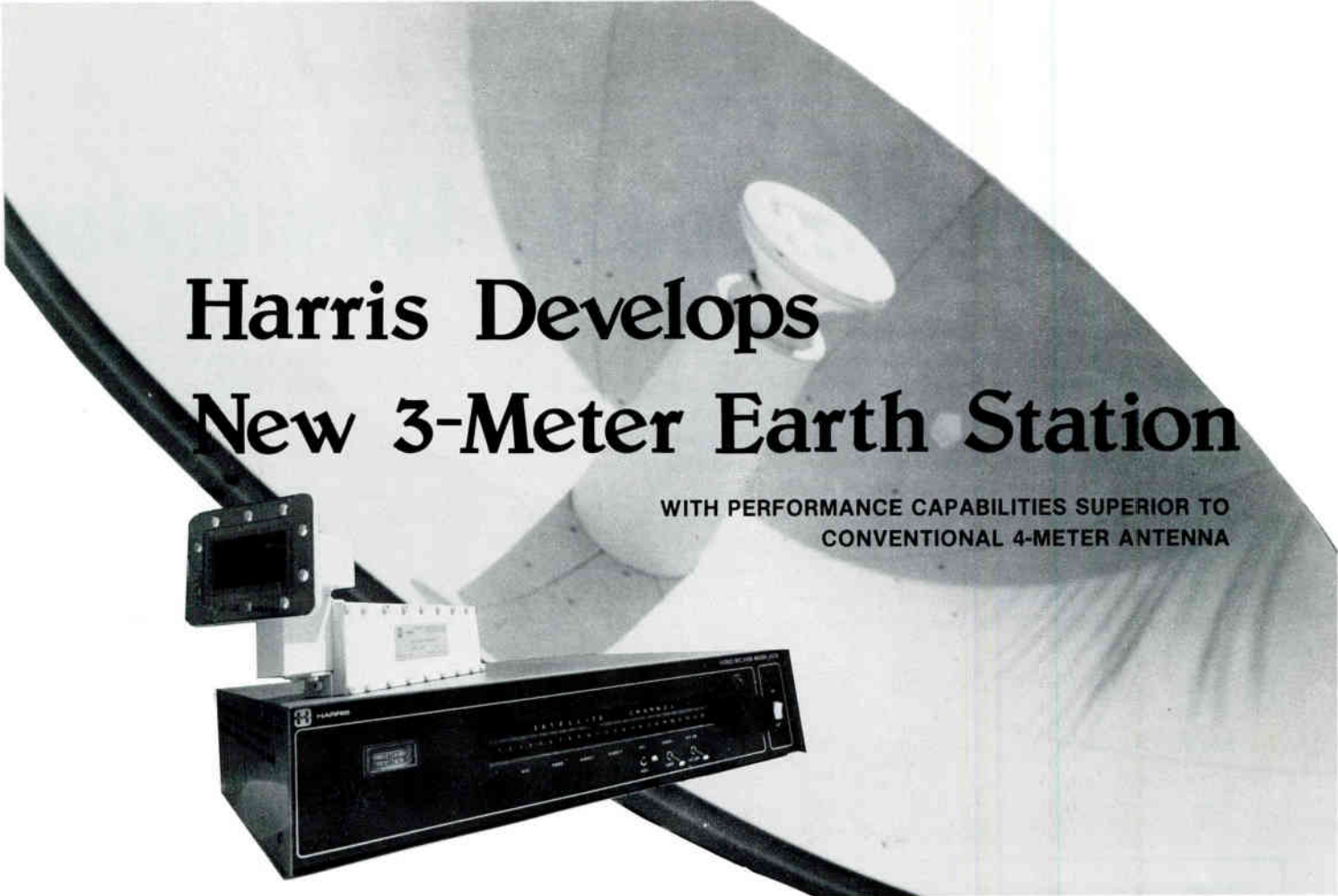

# Harris Develops New 3-Meter Earth Station

WITH PERFORMANCE CAPABILITIES SUPERIOR TO  
CONVENTIONAL 4-METER ANTENNA

The Harris Corporation's Satellite Communications Division has developed a new 3-meter earth station capable of outperforming conventional 4-meter stations.

This new system, called the Harris Delta Gain Earth Station, features a unique 3-meter "deep dish monopod" antenna that provides unusually high gain and low noise temperature. The Delta Gain System, which is designed for both the CATV and MATV markets, can pick up high quality signals everywhere in the United States, including the outer regions.

Other components of the Delta Gain System include Harris' new Model 6528 Video Receiver, and an LNA (Low Noise Amplifier). The three components — antenna, receiver, and LNA — are designed to work as a complete Earth Station System, but each is compatible with other earth station equipment.

The package price of the Delta Gain Earth Station System is about 20 percent less than equivalent earth station systems. Other accessories, such as the RF TV channel modulator and electronic polarization rotator, complement the system.

#### 4.5-Meter Performance in a 3-Meter System

Earth Station performance can be measured in terms of G/T — the ratio of antenna gain (a

measure of the directionality of the antenna) to system noise temperature (total noise generated by the universe). The higher the G/T, the better the receive capabilities of the earth station.

As shown in **Figure 1**, the Delta Gain 3-meter system outperforms conventional prime-focus 3-meter earth stations by 1.75 dB, and performs as well as 4.5-meter station.

As a result, users can save money and space by using a smaller, less costly Delta Gain System in place of a 4.5-meter system. Structural requirements and shipping costs are reduced because of the weight savings (the shipping weight of a 3-meter system is 600 pounds versus 1400 pounds for a 4.5 meter system). Also, there is less wind load on the smaller diameter antenna.

With the introduction of the Delta Gain, Harris now offers a complete line of earth stations, from 3 to 32 meters in diameter.

#### New Antenna is 78% Efficient

The new Delta Gain antenna has a deep-dish, modified cassegrain monopod design which results in increased antenna efficiency. The efficiency of the Delta Gain antenna is greater than 78 percent, versus an efficiency of 50 to 55 percent for prime-focus systems. This means the Harris System uses more of its antenna surface area, resulting in higher gain. The Harris 3-meter anten-

na has a gain of 41 dB, which is 1.5 dB higher than most prime-focus systems.

According to Harris, the new antenna design is called "deep dish" because the focus-to-diameter ratio ( $f/d$ ) is 0.25. (The  $f/d$  of Harris' 6.1-meter antenna is 0.38.) Because the satellite dish is deeper, it surrounds the feed system, reducing terrestrial interference and preventing spillover of microwave radiation to the surroundings. The feed is a unique monopod subreflector support that does require spars system that reduces noise temperature and sidelobe interference. This reduction in noise temperature adds an additional 0.25 dB to the 1.5 dB gain efficiency resulting in a carrier-to-noise ratio improvement of 1.75 dB.

The entire antenna system is mounted on an "AZ/EL" (azimuth/elevation) pedestal with optional polar mount). The az/el pedestal amplifies installation and allows the antenna to be mounted low to the ground.

Features and benefits of the new antenna are presented in Table I. Table II describes the antenna's electronic polarization rotator, a device that allows remote alignment of polarization to the satellite.

#### New Receiver As Easy To Use As An FM Radio

The Harris Model 6528 Video Receiver features a slide-rule frequency tuning dial that puts all 24 channels at the user's fingertips. It is as easy to use as an FM radio.

All functions can be controlled with accessible front-panel switches. Direct interconnections on the rear panel allow the receiver to be hooked up to TV, monitor, or composite video output for terrestrial microwave relay.

The receiver has a built-in threshold extension that takes advantage of the antenna's high efficiency to allow the earth station to receive high quality signals everywhere in the United States, including the outer regions.

The receiver can power two LNA's through the rear panel. The LNA can be powered through either an independent rear-panel terminal or through a coaxial cable.

All Harris receivers and electronics are "burned in" at 122°F (50°C) — for 168 hours — to eliminate premature failures.

Table III presents additional features of the model 6528 receiver.

#### Harris LNA Reduces System Noise Temperature

An earth station consists of three basic components: antenna, receiver, and LNA.

Harris offers LNA's in the noise temperature range of 70 to 120°K. Harris is the only manufacturer with an uncooled LNA below 80°K. Low noise temperature increases system G/T for better receive capability.

Power for the LNA feeds in through a type "N" input connector, so no external wires or cables

## G/T COMPARISON

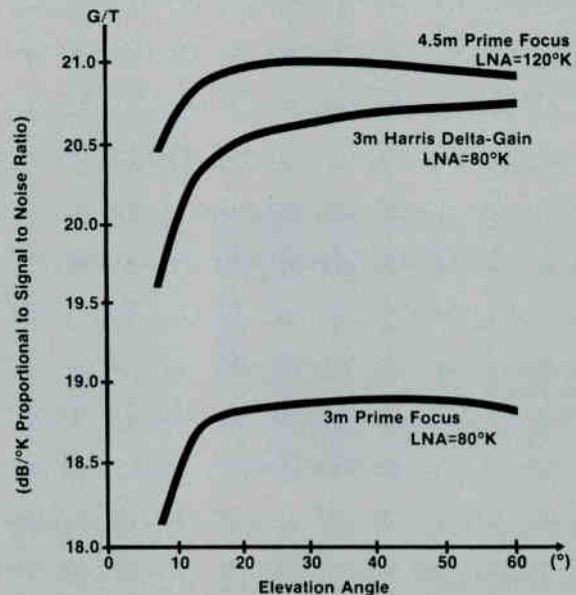

Figure 1.

G/T Comparison. The 3-meter Harris Delta Gain System outplays the 3-meter prime focus system, and performs as a 4.5-meter system.

are required. O-rings are used in the LNA's seals to make the unit completely waterproof. The LNA is housed in an assembly that also contains the electronic polarizer and feed system. Table IV highlights the advantages of Harris' line of LNA's.

#### Delta Gain System Offers Savings

By equaling the performance of a 4.5-meter system, the Harris 3-meter Delta Gain Earth Station System offers CATV and MATV users savings in cost, weight, and space coupled with improved reception, long life, and high reliability.

The Delta Gain System comes in eight sections for quick and easy installation. The antenna itself is attractively designed, but can be hidden from sight if necessary. The system requires minimum maintenance, and is easy to operate.

For more information on the Delta Gain Earth Station System, write: Harris Corporation, Satellite Communications Division, Al Jones (305) 724-3445, P.O. Box 1700, Melbourne, Florida 32901.

# SHOWCASE!

## BROADBAND ENGINEERING ANNOUNCES MULTIPLE DWELLING AMPLIFIERS

Broadband Engineering has announced the latest two amplifiers in its line of house-drop and apartment amplifiers, the Super Multiple Dwelling Amplifier (SMDA) and the Multiple Dwelling Amplifier (MDA-30).



Available in 300 and 440 MHz bandwidths, the MDA-30, designed for use in distribution systems and apartments, condominiums, hotels, and motels, is a one-way amplifier with slope control, optional plug-in equalizers and plug-in pad for gain control. This unit is powered by a UL-approved Class II transformer that may be located remotely from the amplifier.



Designed to meet a system's changing requirements, the SMDA may be purchased in a one-way configuration and later upgraded to two-way. This is done by inserting a plug-in return amplifier with gains up to 30dB. Forward gain is available in ranges of 20 to 40dB. The SMDA is available with 300 and 440 MHz forward bandwidths. Line-power or 30/60V cable-power options may be selected.

For more information concerning this equipment, contact Broadband Engineering, Inc., P.O. Box 1247, Jupiter, Florida 33458; telephone (305) 747-5000. Broadband will be exhibiting at the NCTA, as well as at CCOS '82 in Nashville. See them there!!

## Booklet on Communication Networks Is Available From Harris Corp.

A 20-page booklet reviewing the status of three major types of communication networks has been published by Harris Corporation.

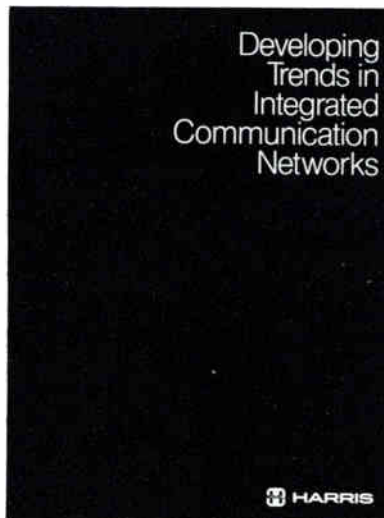

Titled "Developing Trends in Integrated Communication Networks," it reports a recent major presentation by the company's chairman, Dr. Joseph A. Boyd. It is illustrated with color charts, graphs and photographs.

Dr. Boyd's thesis is that advancing technology is paving the way to productivity gains and cost containment via network integration. He defines the principal network categories as local area networks, switch and access networks, and wide area networks. He discusses the present position and probable future directions of each.

Copies of the booklet are available free to those writing on company letterhead to "Networks Booklet," Harris Corporate H.Q., Melbourne, FL 32919.

## RMS INTRODUCES CONVERTER-MATIC™ CONVERTERS

RMS Electronics, Inc. has introduced the Converter-Matic™ series of set-top converters. They are available in both block and regular types with 29 channel configurations.

The block converters offer 1, 2, 3 or 7 channel conversion capabilities, Model CA-2DE-IKL, CA-3GI-UKL and CA-7AG-IKL are offered with "parental-key-lock" to control viewing of certain types of programming by children.

The regular converters provide 20, 32, 36, 40 or 60 channel conversion capabilities with output on channels 2, 3 or 4. These converters work on an input frequency range of 50 - 324 MHz.

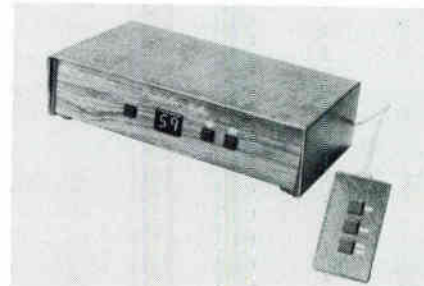

The 20, 32 and 36 channel converters have a frequency stability of less than 1.0 Mhz when in operation from 5 minutes to 3 hours and isolation of -70db, in-out.

The Models CA-40, CA-40LED and CA-60LED are crystal controlled through frequency synthesizing circuits (FSC), which eliminates the need for fine tuning. The frequency synthesizing circuits (FSC) are addressed by an extremely reliable mechanical switch with precious metal contact points. Models CA-40LED and CA-60LED offer a digital read-out which consists of 1/2 inch LED characters. The Model CA-60LED also comes complete with a jack for optional remote cable control (CA-60RCC). This control comes with a 25ft. cord to enable the subscriber to control channel selection from the comfort of his easy chair.

The Models CA-40, CA-40LED and CA-60LED converters must be factory aligned for standard or HRC frequencies and are available with output frequencies aligned to channels 2, 3 or 4.

For information, contact: RMS Electronics, Inc., 50 Antin Pl. Bronx, New York 10462; 800-223-8312 toll free or 212-892-1000 (collect-New York State only).

## SCIENTIFIC-ATLANTA INTRODUCES PRIME FOCUS FEED OPTION

Scientific-Atlanta, Inc., has announced the introduction of an optional prime focus feed on its 4.6- and 5-meter earth station antennas. The new optional feed was available March 1, 1982.

The prime focus feed option provides cable-TV customers with a lower-cost alternative to the company's Cassegrain feed antennas. With the new, high-powered satellites, many users are finding that a lower-efficiency focal point feed antenna is a suitable, economical antenna for many earth station installations.

With a prime focus feed antenna, rays are reflected directly to a feed at the antenna's true focal point. This antenna type exhibits lower sidelobes, yet provides the gain necessary for efficient reception of high-powered satellites.

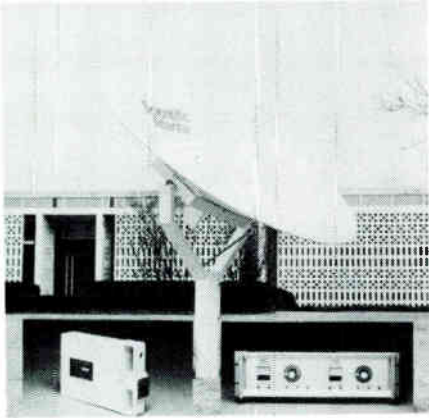

Scientific-Atlanta, Inc., is an international equipment manufacturer for the satellite communications, cable television, energy management and home security industries. The company's other area of concentration is the manufacture and sale of test and measurement instruments for industrial, telecommunications and government applications. For more information contact Patrick Miller, Marketing Manager at One Technology Parkway, Box 105600, Atlanta, Georgia 30348 or call (404) 441-4000.

#### SCIENTIFIC-ATLANTA NEW KU-BAND EARTH TERMINALS

Scientific-Atlanta, Inc., is now offering small, economical earth terminals to receive satellite television transmissions from Ku-band satellites. Different configurations are available depending on which of two antenna sizes is selected or which satellite frequency plan is required. Each configuration includes the following: a manually steerable antenna with prime-focused feed, a series 361 Ku-band low noise converter and a series 6650 video receiver. Both 1.8 meter (6 foot) and 2.8 meter (9.2 foot) antenna sizes are available. The receiver can be configured for SBS, Anik and OTS satellite frequency plans.

The series 361 Ku-band low noise converter is a combination low noise amplifier and block downconverter that generates an IF signal over the same band as Scientific-Atlanta's model 360 C-band low noise converter. Because the output of the low noise converter is the same for both the C-band and the Ku-band models, the 6650 video receiver is used for earth stations at both frequencies.

The products in Scientific-Atlanta's Ku-band earth stations were developed from the technology base that Scientific-Atlanta has established in L-band and C-band terminals. Units are available

now, and demonstrations can be arranged.

For additional information contact: H. Allen Ecker, Scientific-Atlanta, Inc., Vice President-Telecommunications 404/449-2171.

#### A NEW ADDRESSABLE SYSTEM FOR MULTI-UNIT BUILDINGS

Electroline Television Equipment Inc. has issued a new four-page brochure with all pertinent information about EAS (Electroline's Addressable System).

EAS is a truly cost-effective system designed to control access or premium service to cable subscribers in apartments, hotels, hospitals, etc. EAS is modular in design. Effective and constant security is easily maintained by means of continuous scanning. A visual audit of each subscriber's status is thus provided.

Cable operators will find that Electroline's Addressable System is compatible with all other systems.

For a free copy of this catalogue or other information please write to: Electroline Television Equipment Inc., 8750 8th Ave., St-Michel, Montreal, Canada H1Z 2W4 or phone collect (514) 725-2471.

#### MICROWAVE FILTER INTRODUCES NEW PRODUCTS

The engineers at Microwave Filter have been busy, and they are pleased to announce the following products, now available.

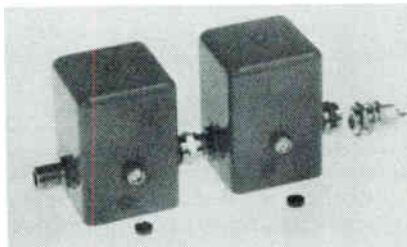

#### Parallel Terrestrial IF Traps

Type 3969 IF tunable traps are available to notch out 60 or 80 MHz interference on earth station receivers to combat Bell telephone microwave carriers. They are intended for use where down converter and IF strip are printed on a single board and series insertable traps are not usable. 3969 traps are connected in shunt with the down converter IF circuit board lead by means of a chassis-mounted connector furnished with the traps. A 60 MHz and 80 MHz trap can be connected together to give tunable notching capability at both frequencies. Notch depth is 25 db, 3 db bandwidth is 4 MHz maximum and tunability is  $\pm 5$  MHz. Complete installation instructions

are furnished with the traps. Price and delivery (for a single trap) are \$110.00 and 10 days respectively.

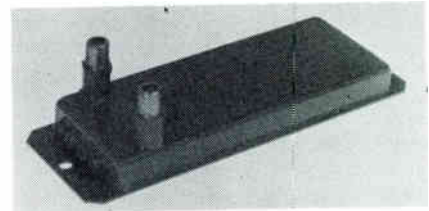

#### Earth Station Receiver IF Bandpass Filter

Series 3974 IF Bandpass Filters are designed for use in earth station receivers. IF center frequency is 230 MHz while bandwidth is 23 MHz or 33 MHz (models 3974-(20) and 3974-(30) respectively. Insertion loss is less than 1 db and impedance is 75 ohms. 30 db bandwidth is  $\pm 25$  MHz and  $\pm 30$  MHz respectively. Connectors are type F. Case size is 6" x 2 1/8" x 1" with mounting provisions. Price is \$110.00 and delivery is three weeks.

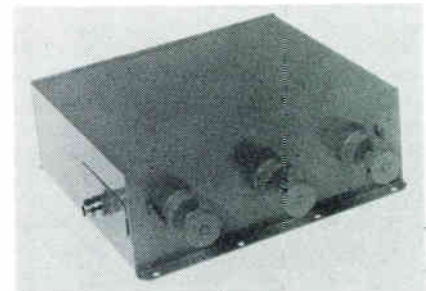

#### UHF TV Broadcast Bandpass Filter

UHF Bandpass Filter series 3854 (channel #) contains a filter for each UHF TV channel. They are intended for use with broadcast transmitters and feature low channel loss (0.5 db maximum) and 500 watt power-handling capability. Suppression of semi-adjacent channels (second channel removed and beyond) is 20 db (minimum). Although each unit is delivered factory-tuned to channel, controls are provided for customer adjustment in order to optimize performance with a specific transmitter and antenna. Price and delivery are \$480.00 and three weeks, respectively.

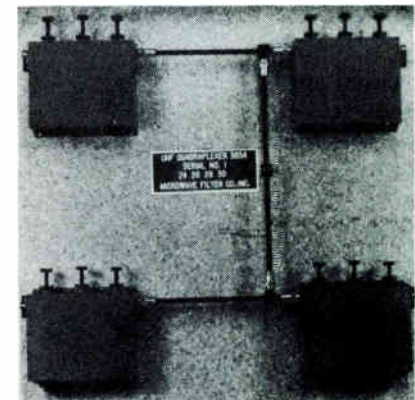

#### UHF TV Channel Combiner



# showcase!

A series 3854 quadruplexer is available to combine any series of "every other" UHF channel in the UHF band 470-806 MHz (channels 14-69). Typical channel loss is approximately 0.6 db and mutual channel isolation is 20 db. Power handling is 500 watts per channel. Connectors are type N, 50 ohms. Price and delivery are \$2700.00 and six weeks, respectively.

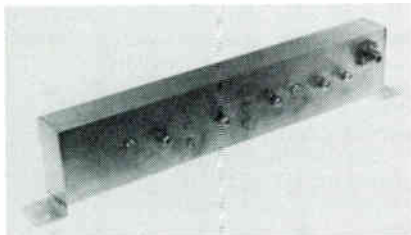

### Microwave TV Channel Filters

The 3977 series are single-channel bandpass filters. They are available for each instructional television fixed service channel in the allocated 2500-2680 MHz band (groups A-H). The typical filter has a 0.5 db insertion loss at centerband and a 1 db loss at band edges. Bandwidth is 6 MHz and adjacent channel isolation is 20 db. The extremely low loss is achieved by the use of high Q waveguide cavities. The filters are available with an option of: type N (coaxial) connectors or waveguide flanges. Price and delivery are \$1520.00 and four weeks, respectively.

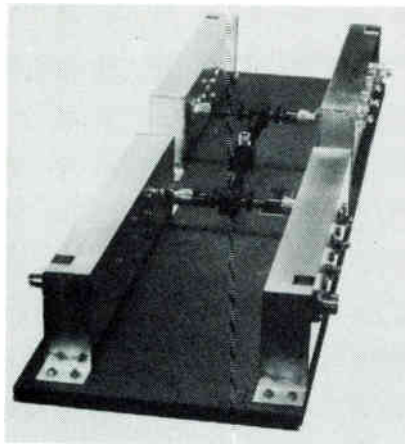

### Microwave TV Channel Combiner

A type 3977-( ) quadruplexer is available to combine the four instructional television channels in each authorized group (A-H) in the 2500-2680 MHz band. Typical channel loss is approximately 1.25 db and mutual channel isolation is 20 db. Power handling is 100 watts per channel. Combined output type N coaxial connector, while there is an input option of type N connector or waveguide flange. Price and delivery are

\$6500.00 and six weeks, respectively.

For more information, contact Emily Bostick, Microwave Filter Co., Inc. 6743 Kinne Street, East Syracuse, NY 13057. US TOLL-FREE 1-800-448-1666 (COLLECT 315-437-3953 in NYS/CAN/HI/AK).

### CABLE '90 — A PLANNING WORKSHOP BY GARDINER

A comprehensive approach to system premium programming, tiering and basic service expansion will be developed in a series of workshops announced by Clifton H. Gardiner, President of Gardiner Management Corporation, of Houston, Texas. The workshops will also feature an examination of all available converter and security hardware. Gardiner will be joined in the series by G. Douglas Smith, a cable industry hardware veteran. The sessions will also feature ten nationally recognized cable authorities in special videotape presentations on critical topics.

"Cable programming services and hardware technology have advanced at an incredible rate," said Gardiner. "The workshops will examine all available and upcoming satellite services, including program content, contract terms, and advertising support.

"New major market franchises and programming innovations are complicating the operations of many systems. The CABLE '90 PLANNING WORKSHOP is a comprehensive two-day in-depth study of program and hardware selection. A cable system can thus be properly positioned to fully realize its profit potential and to compete successfully into the '90's with the many outside forces that could have a serious impact on a cable market.

"Attendees will develop plans during the workshop that can be implemented in their systems, by organizing available information about the area in which they operate, nearby market conditions, tiering approaches, hardware capabilities and limitations, costs and local management practices.

Below is the list of workshops and locations:

- May 17-18  
Dallas; Marriott Market Center
- May 20-21  
New Orleans; Marriott
- May 27-28  
Atlanta; Marriott Downtown
- June 3-4  
Kansas City; Marriott KC International Airport
- June 10-11  
San Francisco; Holiday Inn Fisherman's Wharf

June 21-22

Chicago; Marriott Lincolnshire Resort

June 24-25

New York; The Waldorf-Astoria

June 19-20

Los Angeles; Marriott

July 22-23

Denver; Stouffer's Denver Inn

July 26-27

Nashville; Hilton Airport Inn

July 29-30

Minneapolis; Marriott

August 9-10

Pittsburgh; Marriott

August 12-13

Tampa; Marriott

August 16-17

Houston; Marriott West Loop

### TOCOM RESTRUCTURES CABLE SECURITY PRODUCTS AND SERVICES

TOCOM has restructured its TOCOM III Central Data System (CDS) Products and has announced new prices for its security product line that were effective in February.

Central Data Systems are now priced to include installation of the hardware and software at the customer's site. Installation had previously been furnished as a separate service. Spare parts, test equipment and training services, which had been bundled with the systems, will now be sold separately.

These changes have resulted in an overall price decrease of \$2,350 for the TOCOM III-A system, now priced at \$29,500. The TOCOM III-C system is now priced at \$24,300 and the TOCOM III-B system is \$155,000.

According to Wayne Churchman, director of marketing, the changes were made to provide additional marketing flexibility, particularly for major customers who buy multiple systems. Some of these customers have inhouse training programs, or they may wish for TOCOM to train personnel for multiple systems at one time. The result will be a substantial cost savings over the previous approach.

In addition, Churchman said that the training services which have now been added to the price list as separate items, represent the initial move to establish a new customer education center. The center will continue to provide field training but may also offer many of the same courses in TOCOM's facility for a lower cost.

For more information contact Mr. Churchman at 3301 Royalty Row, P.O. Box 47066, Irving, Texas 75062 or call (214) 438-7691.

# Microdyne Featuring

# 1100 CSR at the NCTA

Microdyne has already begun deliveries on their 1100 CSR, and will feature this satellite receiver at the NCTA. As a special incentive, all of the major cable equipment suppliers will have the 1100 CSR available for immediate delivery at the NCTA. The price on a direct from factory basis is \$2,400. for a one-time purchase.

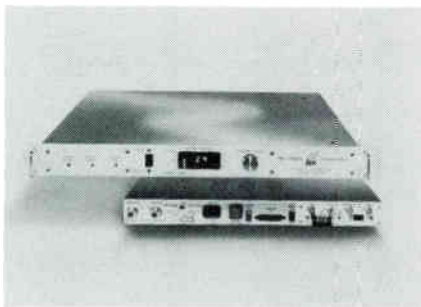

Microdyne's 1100 CSR is technologically advanced for increased performance. The CSR surpasses industry standards in threshold performance with increased reliability and simplicity of design which results in the most superior receiver available. Microdyne's CSR is a compact 1 3/4" unit and is 24-channel frequency synthesized. It includes automatic polarity selection in both 12- or 24-channel modes of operation. The CSR's channel readout shows either 12-channel or 24-channel indication and the proper polarity to accommodate the transponder selected.

CSR features include advanced patented FM demodulation, remote control capability with BCD input and FM demod output for use with external sub-carrier equipment. It also provides dual video outputs, 70 Mhz output and LED strength indicator. Audio subcarrier demodulators are optional. The CSR's high performance features provide the versatility necessary for present and future requirements.

Dual conversion, Local or Remote Control, 12/24 channel operation.

### Synthesizer

Stability  $\pm 0.001\%$  from 0° to 50°C one part in 10<sup>6</sup> per three months

### Down Converter

Input Frequency 3.7 - 4.2 GHz  
Input Impedance 50 OHMS  
RF Bandwidth 40 MHz nominal at 1 dB  
Output Frequency 70 MHz

### IF Demodulator

IF Frequency 70 MHz  
IF Bandwidth 30 MHz  
IF Rejection 80 dB  
AGC Range 45 dB  
Demodulator Type FM  
Demodulator Linearity Linear to within  $\pm 1\%$  over  $\pm 18$  MHz  
Video S/N vs C/N Threshold occurs at <8.0 dB C/N ratio.

### Video Performance

Operating Parameters Format System (v Maximum 525/60 M 4.25 MHz  
Deviation Range 5.0° to 13.0° MHz peak at de-emphasis crossover frequency

### Video Output

Freq. Response 10 Hz to 4.25 MHz, + 0.5 dB  
Impedance 75 OHMS  
Level 1 volt peak-to-peak  
Level Adjustment (front panel)  $\pm 0.5$  V continuous  
De-emphasis 525 lines per CCIR Rec. 405.1

Polarity Black to white transitions positive going. Polarity changeable — jumpers or option remote  
Clamping >40 dB for 30 Hz Triangular dispersion waveform

### Metering and Controls

#### Rear Panel:

Power On/Off  
AGC/MGC Selects either AGC or manual gain mode

Manual Gain Control Adjusts manual gain level (45 dB range)

Accessory Connector Mode Select Remote Control Interface Selects either 24 channel operation, 24 channel mode with reversed polarization, or 12 channel mode

#### FM Demod output

For use with external subcarrier; demodulator systems

#### IF Output

Two Video output jacks 70 MHz

#### Front Panel

##### Channel Select

24 Position coded rotary select switch

##### Channel Selected

LED display indicates locally or remotely selected channel. LEDs to indicate polarization (vertical or horizontal)

##### V/H

##### Signal Level

10 Segment LED to indicate signal level.

### Remote/Local Switch

Selects remote or local control of channel selection and mode selection. Remote control of channel selection is accomplished by using BCD coded six wire inputs thru accessory connector on rear panel of receiver. A 7th and 8th wire can be used to remotely select one of three modes of channel polarization selection.

### Audio Gain

Adjust audio output level 0V to 6.8V peak-to-peak (+10 dBm). Adjust video output level to  $1 \pm 0.5V$ .

### Video Gain

### Meter Calibration

Calibration control of 10 segment LED signal strength indicator.

### Environmental

#### Temperature

Operating: 0° to 50°C  
Storage: -60° to 60°C

#### Atmospheric Pressure

Operating: to 10,000 feet  
Storage: to 50,000 feet

#### Mechanical Dimensions

#### Weight

1 1/4" H x 19" W x 18" D

#### Power Consumption

Approximately 40 watts

### Non-Linear Distortion

#### Differential Gain

$\pm 2\%$  maximum, 10% to 90% APL  
Less than  $\pm 1^\circ$ , 10% to 90% APL  
Less than 2%

#### Differential Phase

#### 2T Pulse Distortion

#### Linear Distortion

#### Line Time Distortion

Less than  $\pm 1.5\%$   
Less than  $\pm 1.5\%$

#### Field Time Distortion

#### Audio Outputs

#### Subcarrier Frequency

6.8 MHz standard

#### Frequency Response

20 Hz to 15 KHz  $\pm 0.5$  dB

#### De-emphasis

75 use time constant

#### Output Level

Continuously adjustable, 0V to 6.8V peak-to-peak (+10 dBm)  
600 OHMS balanced  
1% Maximum

#### Impedance

#### Harmonic Distortion

#### Options

#### De-emphasis

PAL 625 lines and other de-emphasis filters available.

#### Additional Audio

#### Subcarriers

An external Model SCB-1 subcarrier demodulator is available to provide up to four separate audio subcarriers covering the range from 4.5 to 7.5 MHz (See SCB-1 brochure).  
DC Power supply 17.5, 20, 25, 36 and 40 MHz in place of standard 30 MHz  
Available from 4.5 to 7.5 MHz in place of standard 6.8 MHz

#### Other Power Source

#### Other IF Bandwidths

#### Non-Standard Audio

#### Subcarrier

Authorized Distributor:

For more information, contact Alan Greenlaw, Communications Director, Microdyne Corporation, P.O. Box 7213, Silver

Springs Shores Industrial Park, Ocala, Florida 32672-0213, or call (904) 687-4633.

# Associate Roster

Alpha Technologies, 1305 Fraser St. D-G, Bellingham, WA 98225 (M9, Standby Power Supplies) 206—671-7703  
AMCOM, Inc., Bldg. E, Suite 200, 5775 Peachtree-Dunwoody Rd., N.E., Atlanta, GA 30342 (S9, Brokering & Consulting) 404—256-0228  
Amplica, Inc., 950 Lawrence Dr., Newbury Park, CA 91320 (M4) 805—498-9671  
Anixter-Pruzan, Inc., 4711 Golf Road, Skokie, IL 60076 (D1) 312—677-2600  
The Associated Press, 50 Rockefeller Plaza, New York, NY 10020 (S9 Automated News SVC) 212—262-4014  
Avantek, Inc., 481 Cottonwood Dr., Milpitas, CA 95035 (M8, 9 TVRO Components) 408—946-3080  
B E I (Beston Electronics, Inc.), P.O. Box 937, Olathe, KS 66061 (M9 Character Generators) 913—764-1900  
Belden Corp., Electronics Division, P.O. Box 1980, Richmond, IN 47374 (M3) 317—966-6661  
Ben Hughes Communications Products Co., P.O. Box AS, Old Saybrook, CT 06475 (M8, M9) 203—388-3559  
Broadband Engineering, Inc., P.O. Box 1247, Jupiter, FL 33458 (D9, replacement parts) 1-800-327-6690  
Broadcast Equipment Leasing, 7 Wood Street, Pittsburgh, PA 15222 (S3), 412—765-0690  
Budco, Inc., 4910 East Admiral Place, Tulsa, OK 74115, (D9, Security & Identification Devices), 800-331-2246  
CATEL-Division of United Scientific Corp., 1400-D Stierling Rd., Mountain View, CA 94043, 415—969-9400  
C-COR Electronics, Inc., 60 Decibel Rd., State College, PA 16801 (M1, M4, M5, S1, S2, S8) 814—238-2461  
CBS Cable, 1211 Avenue of the Americas, 2nd Floor, New York, NY 10019 (S4) 212—975-1766  
CCS Hatfield/CATV Div., 5707 W. Buckeye Rd., Phoenix, AZ 85063 (M3) 201—272-3850  
CRC Electronics, Inc., 2669 Kilihau St., Honolulu, HI 96819 (M9 Videotape & Headend Automation Equipment) 808—836-0811  
CWY Electronics, 405 N. Earl Ave., Lafayette, IN 74904 (M9, D1) 317—447-4617  
CableBus Systems Corporation, 7869 S.W. Nimbus Avenue, Beaverton, OR 97005, (M1) 503—543-3329  
Cable-Text Instruments Corp., 705 Avenue K, Suite #4, Plano, TX 75074 (M9 Generators) 214—422-2554  
Cable TV Supply Company, 5933 Bowcroft Street, Los Angeles, CA 90016 (D1, D2, D3, D4, D5, D6, D7, D8, M5, M6) 213—204-4440  
Century III Electronics, Inc., 3880 E. Eagle Drive, Anaheim, CA 92807 (M1, M3, M4, M5, M7, M8, S1, S2, S8) 630-3714  
Capscan, Inc., P.O. Box 36, Adelphia, NJ 07710, (M1, M3, M4, M5)  
Channel Master, Div. of Avnet, Inc., Ellenville, NY 12428 (M2, 3, 4, 5, 6, 7) 914—647-5000  
Collins Commercial Telecommunications, MP-402-101, Dallas, TX 75207 (M9, Microwave) 214—690-5954  
Comm/Scope Company, Rt. 1, Box 199A, Catawba, NC 28609 (M3) 704—241-3142  
Communications Equity Associates, 651 Lincoln Center, 5401 W. Kennedy Blvd., Tampa FL 33609 (S3) 813—877-8844  
Communications Supply/Communications Construction, Inc., 319 J Westtown Rd., P.O. Box 1538, West Chester, PA 19380, (D1, 3, 4, 5, 6, 7, 8, 9, S1, 2, 8, 9) 800—345-8286  
Computer Video Systems, Inc., 3678 W. 2105 S. Unit 2, Salt Lake City, UT 84120 (M9) 801—974-5380  
ComSearch Inc., 11503 Sunrise Valley Drive, Reston, VA 22091 (S8, S9, Earth station placement frequency coordination) 703—620-6300  
ComSonic, Inc., P.O. Box 1106, Harrisonburg, VA 22801 (M8, M9, S8, S9) 703—434-5965  
DF Countryman Co., 1821 University Ave., St. Paul, MN 55104 (D1, S1, S8) 612—645-9153  
Davco, Inc., P.O. Box 861, Batesville, AR 72501 (D1, S1, S2, S8) 501—793-3816  
Ditch Witch, P.O. Box 66, Perry, OK 73077, (M9), 405—336-4402  
The Drop Shop Ltd., Inc., Box 284, Roselle, NJ 07203 (D3, 4, 5, 6, 7, 8, 9, M5, 6, 7, 8, 9 Plastics) 800—526-4100  
Durnell Engineering Inc., Hwy 4 So. Emmetsburg, IA 50536 (M9) 712—852-2611  
Eagle Com-Tronics, Inc., 4562 Waterhouse Rd., Clay, NY 13041 (M9 Pay TV Delivery Systems & Products) 313—622-3402 and 800-448-7474  
Eales Comm & Antenna Serv., 2904 N.W. 23rd, Oklahoma City, OK 73107 (D1, 2, 3, 4, 5, 6, 7, S1, 2, S7, 8) 405—946-3788  
Eastern Microwave, Inc., 3 Northern Concourse, P.O. Box 4872, Syracuse, NY 13221 (S4) 315—455-5955  
Electroline TV Equipment, Inc., 8750-8th Ave., St. Michel, Montreal, Canada H1Z 2W4 (M4, 5, 7, 9, D7, 9) 514—725-2471  
Electron Consulting Associates, Box 2029, Grove, OK 74344, (M2, D1, S1, 8) 918—786-5349  
Entertainment and Sports Programming Network, ESPN Plaza, Bristol, CT 06010 (S9) 203—584-8477  
Ferguson Communications Corp., P.O. Drawer 1599, Henderson, TX 75652 (S1, 2, 7, 8, 9) 214—854-2405  
Franey & Parr of Texas, Inc., (Formerly Doherty & Co.), One Turtle Creek Village, Suite 524, Dallas, TX (S9, Insurance) 214—528-4820  
GTE Products Corp., Sylvania CATV Trans. Systems, 10841 Pellicano Dr., El Paso, TX 79935 (D7, M4, M5, M8, S4, S8) 800—351-2345  
Gardiner Communications Corp., 1980 S. Post Oak Rd., Suite 2040, Houston, TX 77056 (M9 TVRO Packages, S1, S2, S8) 713—961-7348  
General Cable Corp., 1 Woodbridge Center, P.O. Box 700 Woodbridge, NJ 07095 (M3) 201—636-5500  
Gilbert Engineering Co., P.O. Box 23189, Phoenix, AZ 85063 (M7) 1-800-528-5567, TWX 910-951-1380  
Group W Satellite Communications, 41 Harbor Plaza Dr., P.O. Box 10210, Stamford, CT 06904 (S4) 203—965-6219  
H & R Communications, Rt. 3, Box 102G, Pocahontas, AK 72455 (M2, D1, S2, S3, S8) 501—647-2291  
Harris Corporation-Satellite Communications Division, P.O. Box 1700, Melbourne, FL 32901 (M2, M9, S2) 305—724-3401  
Heller-Oak Communications Finance Corp., 105 W. Adams St., Chicago, IL 60603 (S3) 312—621-7661  
Hoarty & Raines Assoc., Inc., 8637 O'Neal Rd., Raleigh, NC 27612 (S7, S9 Consultants) 919—781-1734  
Home Box Office, Inc. 7839 Churchill Way—Suite 133, Box 63, Dallas, TX 75251 (S4) 214—387-8557  
Hughes Microwave Communications Products, 3060 W. Lomita Blvd., Torrance, CA 90505 (M9) 213—517-6233  
Jerry Conn Associates, Inc., P.O. Box 444, Chambersburg, PA 17201 (D3, D4, D5, D6, D7, D8) 717—263-8258  
KMP Computer Services, Inc., 703 Central Ave., Los Alamos, NM 87544, (S4, 5) 505—662-5545  
Karnath Corporation, 2001 Westridge, Plano, TX 75075 (S1, 2, 8, 9) 214—422-7981 or 7055  
Katek, Inc., 134 Wood Ave., Middlesex, NJ 08846 201—356-8940  
Klungness Electronic Supply, P.O. Box 547, 107 Kent Street, Iron Mountain, MI 49801 (D1, D8, S2, S8) 906—774-1755  
LRC Electronics, Inc., 901 South Ave., Horseheads, NY 14845 (M7) 607—739-3844

Larson Electronics, 311 S. Locust St., Denton, TX 76201 (**M9 Standby Power**) 817—387-0002  
Lemco Tool Corporation, Box 330A, Cogan Station, PA 17728 (**M6, 9 Tools**) 717—494-0620  
Lester Kamin & Company, 2020 North Loop West, Suite 111, Houston, TX 77018 (**S9 Brokers, Consultants**) 713—957-0310  
Lindsay Specialty Products, Ltd., 50 Mary Street West, Lindsay, Ontario, Canada, K9V 4S7 (**M1, 2, 4, 5, 7, 9**) 705—324-2196  
Magnavox CATV Division, 100 Fairgrounds Drive, Manlius, NY 13104 (**D4, 5, 7, M4, 5, 6, 7, S3, 8**) 315—682-9105  
McCullough Satellite Systems, P.O. Box 57, Salem, AR 72576 (**M2, 9, D3, 4, 6, 7**) 501—895-3167  
Microdyne Corporation, 471 Oak Road, Ocala, FL 32672 (**M9 Satellite TV Receivers**) 904—687-4633  
Microwave Associates Communications Co., 777 S. Central Expwy., Suite 1G, Richardson, TX 75080 (**M9 Microwave Radio Systems**)  
214—234-3522  
**Microwave Filter Co.**, 6743 Kinne St., Box 103, E. Syracuse, NY 10357 (**M5 Bandpass Filters**) 315—437-4529  
Midwest Corp., CATV, Divn., P.O. Box 226, Clarksburg, W. VA. 26301 (**D1, 2, 3, 4, 5, 6, 7, 8**) 304—624-5459  
Miralite Corp., 1331 E. St. Gertrude P1, Santa Ana, CA 92705 (**M2**) 714—641-7000  
Modern Cable Programs, 5000 Park St. N., St. Petersburg, FL 33709 (**S4**)  
National Com-Service, Inc., 2255-E Wyandotte Rd., Willow Grove, PA 19090 (**D1, 2, S8, 9 repair service**) 215—657-4690  
National Screen Service Corp., 1600 Broadway, New York, NY 10019 (**M9**) 212—246-5700  
North Supply Company, 10951 Lakeview Ave., Lenexa, KS 66219 (**D1, 2, 3, 4, 5, 6, 7, 8**) 913—888-9800  
Oak Industries Inc/CATV Div., Crystal Lake, IL 60014 (**M1, M9 Converters, S3**) 815—459-5000  
Octagon Scientific, Inc., 476 E. Brighton Ave., Syracuse, NY 13210 (**M9**) 315—476-0660  
Power and Telephone Supply Company, Inc., 530 Interchange Drive N.W., Atlanta, GA 30336 (**D1**) 404—691-6813  
Prodelin, Inc., 1350 Duane Avenue, Santa Clara, CA 95050 (**M2, M3, M7, S2**) 408—244-4720  
Pyramid Industries, Inc., P.O. Box 23169, Phoenix, AZ 85063 (**M7, 8**) 602—269-6431  
Q-BIT Corporation, P.O. Box 2208, Melbourne, FL 32901 (**M4**) 305—727-1838  
**RMS CATV Division**, 50 Antin Place, Bronx, NY 10462 (**M4, M5, M6, M7, M9**), 212-892-1000  
Reuters, 1212 Avenue of the Americas, 16th Floor, New York, NY 10036 (**D9**) 212—730-2715  
Rockwell International, Collins Transmission Systems Division, M.S. 402-101, Dallas, TX 75207 (**M9, Microwave/Satellite**) 214—996-5954  
S.A.L. Communications, Inc., P.O. Box 794, Melville, NY 11747 (**D1**) 516—694-7110  
Sadelco, Inc., 75 West Forest Ave., Englewood, NJ 07631 (**M8**) 201—569-3323  
Scientific Atlanta Inc., 3845 Pleasantdale Rd., Atlanta, GA 30340 (**M1, M2, M4, M8, S1, S2, S3, S8**) 404—449-2000  
Shafer Associates, Inc., 9501 Briar Glen Way, Gaithersburg, MD 20760 (**S9, consultant**) 301—869-4477  
Showtime Entertainment Inc., 1633 Broadway, NY 10019 (**S4**) 212—708-1600  
Southern Satellite Systems, Inc., P.O. Box 45684, Tulsa, OK 74145 (**S9**) 918—481-0881  
Station Business Systems, 600 West Putnam, Greenwich, CT 06830 (**S4, 5, 9**) 203—622-2400  
T.E.S.T., Inc., 16130 Stagg St., Van Nuys, CA 91409 (**M9 Encoders & Decoders**) 213—989-4535  
TV Guide, Radnor, PA 19088 (**D9**) 215—293-8500  
TeleCom Systems, Inc., P.O. Box 5214, Charlotte, NC (**S1, 2, 7, 8, 9**) 704—332-6064  
Teledac, Inc., 1575 Taschereau Blvd., Longueuil, Quebec, Canada J4K 2X8 (**M9 Character Generators**) 514—651-3716  
Tele-Wire Supply Corp., 122 Cutter Mill Rd., Great Neck, NY 11021 (**D1, 2, 3, 5, 6, 7, 8, 9**) 516—829-8484  
**Texscan Corp.** 2446 N. Shadeland Ave., Indianapolis, IN 46219 (**M8 Bandpass Filters**) 317—357-8781  
**Theta-Com CATV**, Division of Texscan Corporation, 2960 Grand Avenue, Phoenix, AZ 85061 (**M1, M4, M5, M7, M8**) 602—252-5021  
**Times Wire & Cable Co.**, 358 Hall Avenue, Wallingford, CT 06492 (**M3**) 203—265-2361  
Tocom, Inc., P.O. Box 47066, Dallas, TX 75247 (**M1, M4, M5, Converters**) 214—438-7691  
Tomco Communications, Inc., 1145 Tasmin Dr., Sunnyvale, CA 94086 (**M4, M5, M9**)  
**Toner Cable Equipment, Inc.**, 969 Horsham Rd., Horsham, PA 19044 (**D2, D3, D4, D5, D6, D7**) 800—523-5947, In Penna. 800—492-2512  
Triple Crown Electronics Inc., 4560 Fieldgate Dr., Mississauga, Ontario, Canada, L4W 3W6 (**M4, M8**) 416—629-1111, Telex 06-960-456  
Turner Communications Corp. (WTBS-TV) 1050 Techwood Dr., Atlanta, GA 30318 404—898-8500  
Tyton Corp., P.O. Box 23055, Milwaukee, WI 53223 (**M6, 7**) 414—355-1130  
USA Network, 208 Harristown Rd., Glen Rock, NJ (**S4**) 201—445-8550  
United Press International, 220 East 42nd St., New York, NY 10017 (**S9 Automated News Svc.**) 212—682-0400  
United States Tower & Fab Co., P.O. Box 1438, Miami, OK 74354 (**M2, M9**) 918—257-4257  
United Video, Inc., 5200 S. Harvard, Suite 4-D, Tulsa, OK 74135 (**S9**) 918—749-8811  
VU-TV, Inc., 4201 N. 16th St. #250, Phoenix, AZ 85016 (**S4**) 602—277-8888  
Video Data Systems, 40 Oser Avenue, Hauppauge, NY 11787 (**M9**) 516—231-4400  
Viewstar, Inc., 705 Progress Ave., Unite 53, Scarborough, Ontario, Canada M1H 2X1 (**M9 Cable Converter**) 416—439-3170  
Vitek Electronics, Inc., 4 Gladys Court, Edison, NJ 08817 201—287-3200  
Warner Amex Satellite Entertainment Corporation, 1211 Avenue of the Americas, New York, NY 10036, (**S4**) 212—944-4250  
**Wavetek Indiana**, 5808 Churchman, Beech Grove, IN 46107 (**M8**) 800—428-4424 TWIX 810—341-3226  
Weatherscan, Loop 132, Throckmorton Hwy., Olney, TX 76374 (**D9, Sony Equip. Dist., M9 Weather Channel Displays**) 817—564-5688  
Western Communication Service, Box 347, San Angelo, TX 76901 (**M2, Towers**) 915—655-6262/653-3363  
Winegard Company, 3000 Kirkwood Street, Burlington, IA 52601 (**M1, M2, M3, M4, M5, M7**) 319—753-0121

**Note: Associates listed in bold are Charter Members.**

# classycats

Classy-Cat advertising is offered as a service by CATA for its membership. ANY member of CATA may advertise in the Classy-Cat section FREE of CHARGE (limit of 50 words per issue - 3 issues per year.)

- CATA offers three types of memberships:
- 1.) Systems - paying regular monthly dues based on number of system subscribers.
  - 2.) Associate Members - pay an annual fee.
  - 3.) Individual Members - pay an annual fee.

NON MEMBERS may also use the Classy-Cat section at the rate of 50 cents per word with a minimum charge of \$20.00. Add \$2.00 for blind-box. Non-members should include full payment with the ad insertion.

Deadlines for all Classy-Cats is the 1st of the month for the following month's issue.

Address all Classy-Cat material to: CATJ, Suite 106, 4209 N.W. 23rd, Oklahoma City, Okla. 73107.

## HELP WANTED

BISHOP, CALIF.

Ch. Engineer responsible for major microwave system & 4 head-ends. 2nd Phone required. Salary low to mid-20's. Send resume to: Bishop Cable T.V. Ltd., P.O. Box 1288, Bishop Calif. 93514.

## MANAGER/TECH

In addition to management skills, the job requires someone with strong technical experience in system maintenance, headend work and system proofs. Excellent salary and benefits.

Send resume to:  
P.O. Box 857  
Rolla, Mo. 85401

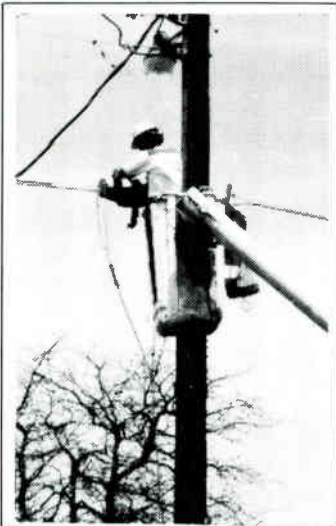

## ATTENTION! SYSTEM MANAGERS — TECHNICIANS NEEDED

Excellent opportunity for system managers and technicians for our systems in Colorado, Texas, and Oklahoma. Need qualified personnel for these Southwestern locations; good working conditions and opportunity for the right people who want to work and stay actively involved in the cable business. These systems have good equipment to work with and offer excellent situations to grow in the cable business. If interested, send resume to the box number indicated below.

Box 71080  
c/o CATJ  
4209 N.W. 23rd  
Suite 106  
Okla. City, OK 73107

## All You Should Know About SLM's...

...Is covered completely in the new NCTI 28-minute Video Cassette, **Signal Level Meters: Use, Care and Maintenance.**

Train on the job about the purpose, design, use and care of SLM's. Write today for full information on this effective new educational tool.

**NATIONAL CABLE TELEVISION INSTITUTE** P.O. Box 27277  
Denver, CO 80227  
(303) 697-4967



**WHAT  
HAPPENS TO  
EMPLOYEES  
AFTER THEY  
LEAVE THE  
BUSINESS  
SHOULD BE  
YOUR  
BUSINESS.**

Tell them about Direct Deposit. It's a way to have their Social Security or other Government checks sent straight to their personal checking or savings account. For information, write to: Dept. of the Treasury, OPRS-A3, Annex 1, Room 226, Washington, D.C. 20226.

**DIRECT DEPOSIT**



**IT'S ADDRESSABLE  
IT'S AFFORDABLE  
IT'S PAY-PER-VIEW  
IT'S 15 TIERS OF SERVICE  
IT'S PROVEN TECHNOLOGY  
IT'S CONVERTER COMPATIBLE  
IT'S SECURITY  
IT'S TOTAL SERVICE DISCONNECT**

# IT'S & PLAIN SIMPLE

Addressability is here and Eagle's addressable descrambler is ready now for systems seeking return-on-investment addressability.

Applying proven in band sync suppression technology, Eagle's addressable scrambling system provides superior pay TV security and is compatible with any HRC, ICC or standard system configuration.

Protect your investment in converters! Eagle's addressable unit can be used with any single channel output converter (channel 2, 3, or 4) and descrambles under computer control up to 15 tiers of service. Pay per view, tiered channels, disconnect services, and billing systems are all at your control.

It's the answer, addressability ... converter compatible ... proven technology ... security ... a solid investment. Most important, **It's An Eagle!**



OFFICE ADDRESS: 4562 Waterhouse Road, Clay, N.Y. 13041 (315) 622-3402

MAIL ADDRESS: P.O. Box 2457, Syracuse, N.Y. 13220

IN CANADA: Deskin Sales • Montreal • Toronto • Vancouver (416) 495-1412, 77D Steelcase Road West, Markham, Ontario L3R2M4

**CALL TOLL FREE TO ORDER  
800-448-7474**

