

In the Land of Terabytes

New issues to consider when shopping for audio systems.

Page 23

A Different Kind of Kids' Radio

Receiver is intended as lifeline for African children.

Page 26

Radio World



\$2.50

The Newspaper for Radio Managers and Engineers

January 2, 2004

INSIDE

HD RADIO

▼ Inside Crawford's HD Radio project at Power92 in Chicago.

Page 8

▼ Dick Fry delves into dual-input antennas.

Page 16

ENGINEERING

▼ Giant coils at the NSS Naval Radio facility; Skip Pizzi on the past year in HD Radio; and why the Grundig name is safe in North America.



In This Issue

STUDIO SESSIONS

▼ Wireless remotes: Ross du Clair tries the Comrex Matrix GSM Module.



Page 28

▼ The next time money talks, ARP will be listening more closely.

Page 33



DUAL DIGITAL

▼ We close out our New Technology Sweepstakes by sending a Sonifex Dual Digital Mic Amp to a reader in Illinois.

Page 4



Sign Up For NewsBytes Weekly Digest at www.rwonline.com

NEWS MAKER

Savoldi Exploring Columbus

by Randy J. Stine

COLUMBUS, Ohio Most six-year-olds learn to spell words like *cat* and *dog* first. For Greg Savoldi, it was *transmitter* — thanks in part to his disc-jockey dad and an early interest in broadcasting.

Savoldi would tag along with his father Richard for weekend stints at WOMP(FM) in Wheeling, W.Va., where he was fascinated with the glowing orange tubes in a 1949 General Electric 1 kW transmitter used by the station's AM counterpart, which shared the same call letters.

"To get to the studios you had to walk past the transmitter rooms. The FM had an old Gates rig. I just thought transmitters were really neat," said Savoldi. "My job at the station was to change the carts in the Broadcast Electronics Spotmaster cart machine during the newscasts for my dad since the studio only had one cart machine. Those were the ones where you had to flip the black lever up so the pinch roller could start the cart. Then I would give him the thumbs-up. It was fun."

See SAVOLDI, page 6 ▶

FIRST PERSON

HD Radio Receivers Reach Stations

by Thomas R. Ray, III

More stations that have converted to HD Radio can hear their digital signals now that the first commercial receivers have arrived at facilities. Tom Ray, corporate director of engineering for Buckley Broadcasting/WOR(AM) in New York, has installed a radio in his vehicle and shares his impressions of the digital audio quality and coverage.

NEW YORK Santa arrived at the WOR studios a little early this year. As a matter of fact, he looked a lot like a FedEx guy. But in his bag, what wonders he carried! A Kenwood KDC-722 radio with Kenwood KTC-HR100 HD Radio tuner.

Since WOR installed an Ibisquity IBOC exciter and became New York's first digital AM radio station on Oct. 11, 2002,

See WOR, page 14 ▶



The author installs the HD Radio.

Networked Audio from Harris? You Betcha!



Want to maximize your facility and studio capacity? Leverage your existing equipment to do more for your talent, station — and bottom line? You can with the power of VistaMax™ from Harris.

VistaMax is a digital audio management system that lets you network your audio studios together. With universal access to all of your resources simultaneously you increase productivity and quality while decreasing maintenance. You can smoothly migrate from a dedicated analog studio to a digital networked infrastructure with this distributed approach — on your timeframe. Benefits include:

- Autonomous console operation, when needed
- Easily share resources to gain economies of scale

- Quickly reconfigure your facility when program or format changes occur
- Reduce installation time and cost for any reconfiguration

As a natural extension of our BMXdigital™ expertise, VistaMax is built on field proven technologies such as familiar user interfaces without the complexity of a PC.

Empower your audio management with VistaMax.

Contact Harris today.

1 800.622.0022 | www.broadcast.harris.com



DIGITAL NEWS

WNNK to Install Dielectric Interleaved HD Radio Antenna

RAYMOND, Maine Dielectric Communications plans to install what executives say is its first interleaved analog/HD Radio FM antenna to be used at a radio station. The gear was slated for installation at Cumulus Radio's WNNK in Harrisburg, Pa.

The mountainous terrain and multipath issues will make a good test of the antenna to see how it performs in "severe multipath locations," Cumulus Corporate DOE Gary Kline stated.

Dielectric says the design has creat-

ed a significant improvement in isolation between the antenna elements. As a result of that increased isolation, the company says, the electrical performance of the antenna is stable and effectively eliminates elevation and azimuthal pattern deviation between the analog and digital signals.

Combined with the use of circulator technology in the RF system, Dielectric expects this design to meet or improve on the 36 dB HD Radio specification for isolation. Models and full-size tests of the interleaving scheme have shown no change in the antenna patterns by adding the HD Radio bays to an existing analog antenna, according to Dielectric.

Delivered to the Cumulus facility was a two-bay, full-wave-spaced Dielectric DCR-M side-mounted

antenna. This antenna radiates the Class B FM's analog signal. The interleaved two-bay HD antenna and HD transmitter were to be installed in December.

Cumulus Radio Executive Vice President John Dickey, Kline and WNNK(FM) Engineering Manager Dave Supplee worked with Dielectric on the installation.

DRM Markets To Smaller Companies

NEW DELHI, India Seeking to involve smaller companies, the Digital Radio Mondiale consortium has

unveiled a \$100 participation option.

Created to foster rapid adoption of the technology, the DRM "supporter" label is designed for companies and individuals interested in any aspect of digital radio, from broadcasting to manufacturing, publicity and sales. It offers broadcasters, publishers, content providers and others a way to showcase their DRM involvement. DRM supporters will receive implementation information and the rights to display a DRM supporter logo, and will be listed on DRM's Web site.

DRM is a digital radio technology for AM, shortwave and longwave that debuted in June.

The consortium will continue to offer existing membership options for companies that wish to have full, proactive involvement and voting rights on technical and commercial matters.

"Our new DRM supporter option opens the doors of DRM promotion and involvement to smaller companies, and those in developing markets," says consortium chairman Peter Senger.

Applicants may register their interest at supporter@drm.org.

The option was unveiled at the Asia-Pacific Broadcasting Union and All India Radio Regional Symposium on digital radio.

Sirius Launches Home Units

NEW YORK Sirius has debuted its first dedicated home satellite receivers from Audiovox, Antex Electronics and Kenwood.

The Kenwood DT-7000S retails for \$299. The system features a four-line See DIGITAL NEWS, page 3 ▶

Audioarts R-90

The Perfect Console for Multi-Studio Buildouts!



OUR NEW R-90 HAS THE FEATURES ENGINEERS WANT:

Two stereo program busses and two mono busses—one pre and one post-fader (perfect for backfeeds or on-the-fly mix-minus); dual phone caller support using Wheatstone's exclusive Bus-Minus™ circuitry, which generates mix-minus caller feeds with the simple push of the module's MXM bus assignment switch. Both control room and studio monitoring with talkback are provided, including both pre and post studio and headphone level pot monitor feeds. You can even choose a second monitor module for studio two/headphone two output feeds, giving you plenty of monitoring flexibility. And while the frame is compact, it can accommodate up to 23 input or accessory modules in any combination. Because all switching is electronic (and all switches are LED illuminated) you can count on the ultimate in reliability. THIS IS A TRULY VERSATILE AND COMPACT AUDIOARTS CONSOLE!



Made in USA

tel 252-638-7000/fax 252-635-4857
sales@wheatstone.com
copyright © 2003 by Wheatstone Corporation



AUDIOARTS ENGINEERING
www.audioarts.net

NEWS

Savoldi Exploring Columbus	1
HD Radio Receivers Reach Stations	1
Digital News	2
Commercial HD Radios Debut at CES	3
Thanks to All, From A to Z	4
Newswatch	5

HD RADIO

Building an FM HD Radio Station	8
Dual-Input Antennas For HD Radio: An RF Systems Analysis	16

FEATURES

Workbench: Care and Feeding of Broadcast Gear	17
Giant Coils	18
A New Year's IBOC Scorecard	19
In the Land of Terabytes	23
Grundig Licensee Thrives	25
A Different Kind of Kids' Radio	26

STUDIO SESSIONS

KFBK Files on Matrix GSM Module	28
More Stereo Microphone Techniques	28
The World According to ARP	33

OPINION

Reader's Forum	37-38
----------------	-------

Commercial HD Radios Debut at CES

First HD Radios Available; Supplemental Audio Channels to Be Demonstrated

by Leslie Stimson

LAS VEGAS Terrestrial radio will achieve parity of sorts with its satellite compatriots at this year's Consumer Electronics Show, Jan. 8-11.

This is the year Ibiqity Digital's receiver partners have commercial HD Radios ready for retailers and the general public to buy. Up to 12 receiver companies plan to show HD Radio products to be launched this year.

At the same time, partners working on the second-channel concept using HD Radio technology are pleased with test results and coverage of the digital signal on the supplementary channel. Harris, Kenwood and National Public Radio will have an update about this project at CES, including the first public listening demo of the concept.

Ibiqity will have a 5.1 surround sound demo with a partner company to be identified soon. The music source material will originate from an encoder in the booth; listeners can hear the digital audio from a decoder in a receiver in a GM Hummer.

Ibiqity also plans a traffic-based demo, with a receiver in a Chevy Tahoe.

The idea is to show broadcasters, retailers and consumers what's possible with scrolling text on HD Radios, said David Salemi, Ibiqity vice president of marketing.

The first generation of HD Radio data services will be supported by protocols called Main Program Service and Station Information Service.

MPS, the station's primary aural service, consists of digital audio and program-associated data. MPS data uses file-tagging software called ID3 to provide text information such as artist name and song title.

Information sent over SIS includes station identification and location, which may be useful in the future for receivers for position determination; identification of services available in the digital signal; and time synchronization information.

ID3 also supports text descriptions with ads, such as phone numbers and Web addresses.

Tuners galore

Four manufacturers are expected to show HD Radio front-end tuner modules: Toko, Alps, TBK and KiRyung.

Also at CES, the organizations working on the second channel concept plan to reveal results of their tests and present the findings to the National Radio Systems Committee. Tomorrow Radio partners Kenwood, Harris and NPR expected to wrap up the so-called "regression" tests with the new Ibiqity codec in mid-December.

"We're not seeing any surprises,"

Digital News

► Continued from page 2

scrolling display, a song-peek feature allowing listeners to browse what is playing on other streams and a memo feature allowing listeners to bookmark song titles and artist information they want to remember. The DT-7000S connects to Kenwood home audio receivers or pre-amps.

The Audivox CE-1000SR lists at \$249.95. The unit's design features an LCD display with multiple-user presets, a user menu with stream add or skip, parental controls, a memory capture feature and RS232 control port.

Designed for use in multi-room, multi-zone audio systems, the three-zone Antex SRX-3 TriplePlay receiver consolidates multiple tuners into one component allowing listeners in different rooms to play different Sirius streams simultaneously over a single distributed audio system. The multi-zone unit retails for \$1,999. The system has a graphical LCD, backlit display and 10 music presets for each zone. An antenna is included.

XM Introduces Universal Satellite Tuner

WASHINGTON XM Satellite Radio has developed a universal tuner that can be connected to any satellite radio-ready car stereo, including Sirius models, with digital adaptors

developed and distributed by third-party companies.

The device is called XM Direct. Third-party adaptors connect the XM Direct to an in-dash stereo system so drivers can receive the satellite radio service using their existing stereo controls.

With XM Direct and smart digital adaptors, auto dealers and retailers can install XM for customers who want to hear the service through their in-dash stereo, regardless of vehicle or car radio brand, stated XM's Dan Murphy, senior vice president, product marketing and distribution.

Blitzsafe and Terk Technologies are developing digital adaptors for XM Direct. Blitzsafe has shipped the first adaptor for 2003 and '04 BMW and Mini vehicles; it is sold through Satellite Radios Direct.

Consumers will be able to purchase XM Direct from participating BMW and Mini dealers for \$299 plus installation. Installed price with the satellite radio antenna is roughly \$350.

Blitzsafe is working with Alpine to develop an adaptor for its aftermarket car stereos, available early this year.

Terk plans to introduce adaptors for other applications at the 2004 Consumer Electronics Show. All of these adaptors for XM Direct will connect the tuner to the manufacturers' equipment.

Satellite Radios Direct will sell both the XM Direct tuner and the Blitzsafe BMW/Mini adaptor to provide dealers with one distributor contact for both components through its Web site, www.satelliteradiosdirect.com.

— Leslie Stimson

said Mike Bergman of Kenwood USA. Some radio engineers were worried that, without the analog fallback, the ability to tune quickly between the main channel and the supplemental channel would be hampered. That's not the case, said Bergman.

The music source material will originate from an encoder in the booth; listeners can hear the digital audio from a decoder in a receiver in a GM Hummer.

"The audio is great and the system switches back and forth from the main to the supplemental channel pretty quickly."

Kenwood plans several Tomorrow Radio demos. Harris equipment will generate two FM hybrid signals and one AM hybrid signal using Harris AM, FM and HD Radio Digital exciters. Harris

representatives will participate in the Kenwood booth.

Dexstar exciters will be used to generate the HD Radio signals. One will be running at the full hybrid mode 96 kbps main channel audio while the second will generate the signals for the supplemental channel. This Tomorrow Radio Dexstar will feed the 64 kbps main and 32 kbps supplemental audio channels.

A Harris Neustar DAB Audio Processor will preprocess the compressed HD Radio bitstream.

The demo will show a Kenwood KTC-HR100 HD Radio receiver supporting HD Radio and Tomorrow Radio. NPR will supply content for all the demos, and the supplemental channel at 32 kbps will show a mix of speech and music.

Kenwood will show several HD Radio receivers, including the KTC-HR100, the first commercially available HD Radio receiver.

For satellite radio, Kenwood will show its line of Sirius products. The booth will include a demo of the KVC-915DVD controlling both a KTC-HR100 HD Radio receiver and the KTC-SR902 Sirius Radio receiver. The unit has dual zone controls for front- and rear-seat audio sources.

XM Satellite Radio plans to introduce a head unit with an integrated tuner, eliminating the need for the second box during an install. XM claims it is the first integrated head unit for satellite radio.

SCMS, INC.

YOU-KNOW-WE-KNOW-RADIO!



SPREAD TOO THIN AND FEELING DRAINED?

- Experienced Staff
- 26 Years of Personal Service
- Competitive Prices for over 600 Quality Manufacturers of New Equipment
- Huge Stock of Rebuilt RF and Audio Gear
- Extensive Rental Fleet (Audio, RF, Codecs, Test Equipment, and more!)
- Trade-Ins Welcomed

TRY SCMS ON FOR SIZE - WE CAN FILL YOUR NEEDS

<p>WEST COAST Doug Tharp Voice 866.673.9267 Cell 818.398.7314 Email dtharp@san.rr.com</p>	<p>CENTRAL Bernie O'Brien Cell 731.695.1714 Email bernieob@earthlink.net</p> <p>MID-WEST Mary Schnelle Voice 1.800.245.4307 Fax 513.583.1343 Email mschnelle@maryschnelle.com</p>	<p>NORTH-EAST Dan Lohse Voice 908.722.6015 Fax 908.722.4359 Pager 877.792.8024 Email scmsnorth@aol.com</p>
<p>SOUTH-WEST Tyler Callis Cell 817.312.6338 Email tylercallis@integrity.com</p>	<p>MID-SOUTH Bob Mayben Voice 877.391.2650 Fax 256.543.0595 Email bobmayben@usa.net</p>	<p>SOUTH-ATLANTIC Art White Voice/Fax 770.632.1295 Cell 770.630.9942 Email whitearthur@bellsouth.net</p>

CORPORATE SALES OFFICE - PINEVILLE, N.C.

Toll FREE 800.438.6040 Fax 704.889.4540

Email sales@scmsinc.com

www.scmsinc.com

Thanks to All, From A to Z

This publication literally would not exist without the contributions of those people who write it and whose opinions appear in these pages.

Allow me to use this space as we begin a new year, to thank all those who in 2003 wrote for Radio World, allowed us to feature them or wrote to us to share their opinions for publication.

This is my world of Radio World:

Kathleen Abernathy, Mike Adams, Jonathan Adelstein, Cameron Adkins, Conrad Agte, Cris Alexander, David D. Allen, Andreas Amoros-Koehler, JT Anderton, Emie Ankele, Joaquin Araya, John Arndt, Jerry Arnold, Susan Ashworth, David Baden, Willem Bagchus, Bill Bailey, Michael Baldauf, Ron Bartlebaugh, Bruce Bartlett, Stuart Barton, Fred Baumgartner, Linda Baun, Frank Beacham, Raymond C. Benedict, Rick

Benson, Oliver Berliner, the remarkable John Bisset, David Black, Michael Black, Steve Blodgett, Steve Blum, Richard Bohn, Ken Boone and Jeffrey Bosworth.

Shari Boulanger, Rick Brancadora, Ralph Brancato, Julian Breen, Bill Brooks, Kelly Brooks, Joseph Brosk, Read Burgan, Ken Burns, Todd Busteded, Jack Buttram, Mark Carbonaro, James Careless, Ralph J. Carlson, Tom Carpenter, Tom Carten, Ralph Chambers, Naina Narayana Chernoff and Rob Chickering.

Also Thomas Chrapkiewicz, Steve Church, Todd J. Ciske, Brian Clark, Glen Clark, Marguerite Clark, Scott Clem, Scott Clifton, Deana Coble, Harry Cole, Paul Courson, J.B. Crawley, John Crigler, Don Crisp, George W. Crowe, John Curtis, Joseph D'Angelo, Don Danko, Michael Davis,

Brian Dee, John Dehnel, Scott Dennis, Andy Disterhaft, Lynn Distler, Ross du Clair and Mark Durenberger.

Joe Dysart, Dave Dzurick, Don Elliot, Bruce Elving, Laura Erickson, Mike Erickson, Derek Evanston, Doug Fearn, Francis Fisher, Buc Fitch, Jill Fitzpatrick, Jason Ford, Ty Ford, David S. Forsman, Frank Foti, Craig Fox, John Francioni, Mark Fratrick, Clay Freinwald, Michael Friend, Eddie Fritts, Peter Frost, Richard Fry, Scott Fybush, William Gaddis, Robert E. Gagne, Philip E. Galasso, Mike Gannon, Gregg Garcia, John Gardner and Dom Gentile.

Also Al Germond, Karl Goehring, Elmer A. Goetsch, Lyssa Graham, Mark Greenhouse, Bob Grubic, Blažo Guzina, Lawrie Hallett, Harold Hallikainen, Elizabeth Hamrick, Omar Alaoui Hanafi, Terry Hanley, Keith Harrison, Ed Harvey, Maurice C. Hately, Jim Hawkins, Bob Heckler, Mike Hedrick, Bob Henning, Mario Hieb, Don Hobson, Kim Hodgson, Richard Hoffmann and John Hogan.

William K. Hoisington, Jon Holiday, David Hollyer, Dave Immer, Dennis Jackson, AJ Janitschek, Holly Jensen, Steve Jess, Efrain Jimenez, Jeff Johnson, Craig Johnston, Clarence Jones, Terry Jordan, Björn Jost, Mark Kalman, Paul Kaminski, John Katonah, Nicholas Keefe, Gary Keener, Al Kenyon, John Wells King, Jim King, Tom King, Vicki Kipp, Gary Kline, Alex Kolobielski, Bob Kovacs, Michele Kramer Peterson, Ed LaComb, Roger Lamb, Steve Lampen, Jennifer Lane, Mark Lapidus, Michael LeClair, Neil Leibowitz, Andy Levin, Reed Lewis, Scott Liebers, Carl Lindemann and Andy Linton.

Also Jeff Littlejohn, Russ Long, Paul S. Lotsof, Cecil Lynch, John Lyons, Tom MacDonald, Larry Magne, Barry Magrill, Daniel Mansergh, John Marino, Dennis Martin, Michael Martindale, Marty Martinson, Peter G. Matthews, Christopher Maxwell, Mark Mayfield, Mike McCarthy, Jon McClintock, Brian McConnell, David C. McCrork, Tom McGinley, Chris McKay, Doug McLeod, Dee McVicker, Steve Meng, John Merli, Maynard Meyer, Bob Millard

From the Editor



Paul J. McLane

and Bill Miller.

Frank Montero, Ed Montgomery, Gerald Moore, Gary Morgan, Jack Morgan, Ginny Morris, Brett Moss, Dave Moulton, Paul Mueller, Steve Murphy, Ted Nahil, Brad Niemcek, Ty Noble, Frederick Noronha, Rick Nudd, William O'Shaughnessy, Mike O'Shea, Dave Obergoenner, Craig Oliver, Bob Orban, Tom Osenkowsky, David P. Otey, Gary Palamara, Mark Pallock, Bill Pasco, John Pavlica Jr., John Pecore, Mark Persons, Al Peterson, Sharon Rae Pettigrew, Carol Pierson, Skip Pizzi, Rimantas Pleikys, Robert Polhamus, John Poray, Christophe Poulain, Elizabeth Prevatt, Stephen Provizer, Bob Puttre, Ken R., Ron Rackley, Rick Rapalee and Rich Rarey.

Also Tom Ray, Robert Reams, Edgar C. Reihl, John Reiser, Mike Repheune, Kerry Richards, David Richardson, Robert E. Richer, Ed Ritchie, Andrew Roberts, Carter Ross, Stephen Rutherford, Bill Ryan, Jim Ryan, Donald Sabatke, Greg Savoldi, R. Scott Sparks, Mike Seaver, Noe Sepulveda, Al Sergi, Paul Shinn, Eric Shoars, Laveme Siemens, Paul Signorelli, Pete Simon, David M. Sites, Dave Skalish Sr., Dan Slentz, Joe Snelson, Craig Snyder, Marc Sophos, Gabriel Sosa Plata, Martin Spencer, Christopher Springmann, Bill Stachowiak, Don Stevenson, Mike Stevenson, Dave Stewart, Gary Stigall, Leslie Stimson, Randy Stine, Russ Stonier-Hamnett, Mike Stosich, Shelly Strickler, Steve Sullivan and Linda Sultan.

And Bob Surette, Tom Taggart, Carey Taylor, Chuck Taylor, Rolf Taylor, Kevin Tekel, Keith Tela, Winson Tharp, Paul

See A TO Z, page 5 ▶

Dara Singh, president of Desi Junction Radio, is the winner of the final prize in our New Technology Sweepstakes. Desi Junction, which airs on WJJG(AM) in the Chicago area, believes itself to be the first live Indian and Pakistani radio program in the Midwestern United States.

He wins a Sonifex RB-DMA2 Dual Digital Microphone Amplifier from Sonifex and its U.S. distributor Independent Audio. This is a 24-bit/96-kHz-compliant unit consisting of two independent low-noise preamps for converting mic-level signals to digital AES/EBU or S/PDIF, and analog line-level outputs.

The RB-DMA2 can be used as a front end for digital mixers or routers that do not have microphone inputs. The analog outputs can be used for routing to talkback systems.

The mic inputs are electronically balanced XLR3 type. Each input has individually coarse and fine gain adjustment controls, a level indicator, a switchable high-pass filter and phantom power at +48V. The RB-DMA2 has four synch modes depending on whether internal or external synch is used, and AES/EBU, S/PDIF and Word Clock synch inputs. Retail value: \$895.

I'm delighted to report that the combined retail value of prizes given away in this space over the past three years is just over \$150,000. I'd like to tip my hat to all of the supporters of our New Technology Sweepstakes and the staff who helped make it happen.



Get online with the new solution for IP control and monitoring.

Access your remote site over the Internet.

Simultaneous operators and multiple access levels.

Installs at the studio or transmitter site.

Alarm notifications by email and SMS.

Customizable HTML-based interface.

You need an IP solution for remote facility control that's adaptable and easy to manage. One that will work whether your transmitter site has T1 or no network connection at all. And you need something that's easy to implement.

The Web Interface from Burk Technology adds IP control to the GSC3000 and VRC2500 transmitter remote control systems, allowing access from any Internet connection and a standard web browser. SNMP-enabled, with multi-operator support, the Web Interface installs at the studio or transmitter site - wherever an Ethernet connection is available. Enjoy the benefits of a totally integrated solution that offers the flexibility needed by today's broadcasters.



BURK TECHNOLOGY 800-255-8090 (Main Office) | 800-736-9165 (Kansas City) | WWW.BURK.COM

NEWSWATCH

FCC Sees Net Platforms Ahead

WASHINGTON The FCC has formed a committee to study policy issues that arise as telecommunications services move to Internet-based platforms.

The Internet Policy Working Group comprises commission employees from several bureaus who will contact state regulators, consumer groups and public safety organizations about these issues.

"Internet-based services are already revolutionizing the way consumers do things. By forming this working group, we hope to gain a greater understanding of how policymakers can create rational policies to encourage growth in Internet services," stated Chairman Michael Powell.

Co-directors of the group are Robert Pepper, chief of policy development, and Jeff Carlisle, senior deputy chief of Wireline Competition Bureau. For information, visit www.fcc.gov/ipwg.

Infinity Fined \$27,500 for Indecency

DETROIT The FCC imposed the maximum penalty, \$27,500, on Infinity Broadcasting for airing indecent material during afternoon drive on the "Deminski and Doyle Show" on WKRK(FM) Detroit. The case stems from Jan. 9, 2002.

The commission proposed the penalty last April after an investigation triggered by a complaint concerning a broadcast in which station personnel invited listeners to call to discuss sexual practices, including anal and oral sex. The broadcast included graphic sexual and excretory references, and the agency said the material appeared to have been used to pander, titillate and shock. Thus, it said, the material was indecent and warranted a significant sanction.

Infinity was warned that similar

actions in the future could warrant license revocation.

Infinity did not dispute that the material was indecent, but had argued that the commission's definition of indecency is unconstitutional. The agency disagreed and told Infinity it had 30 days to pay.

FCC Chairman Michael Powell called the material "filth" of "an extreme nature" and said it had no place on the nation's airwaves. He cautioned broadcasters to take the agency action as a signal that the commission will continue to "rigorously enforce" its indecency regulations.

Fellow commissioners Kevin Martin and Michael Copps said the fine should have been as much as \$247,500 because the indecent material involved nine callers.

Copps called the FCC response "tepid" and said it would not dissuade such broadcasts in the future, specifically citing Infinity for the still-pending case of a stunt involving alleged sex in St. Patrick's Cathedral.

Two Noncoms Warned For Airing Ads

WASHINGTON The FCC has slapped two noncoms on the wrist for airing underwriting announcements that sounded like commercials.

Contributors of funds to noncoms may receive on-air acknowledgements, but those must be for identification purposes only and should not promote a service, product or business.

The agency began investigating after it received complaints about Jones College licensee WKTZ(FM) in Jacksonville, Fla., and Great Lakes Community Broadcasting licensee WAAQ in Onsted, Mich.

For WAAQ, the agency stated, "The announcements encourage or invite business patronage, make prohibited price references or depict the underwriters in a comparative and qualitative manner."

For example, the FCC stated, announcements on behalf of an appliance store, cellular vendors and an audio center "provide price or other information concerning product discounts, rebates or warranties that encourage business patronage, and are thus specifically prohibited."

The commission said it appeared that WKTZ promoted products and services of for-profit entities. While Jones does not dispute the announcements aired, it couldn't "confirm or deny" that the transcripts accurately reflected what aired. Jones stated the announcements were contained in a program supplied to the station and that the station does not pay the provider for the show, nor does it receive anything from the underwriters mentioned.

Since the FCC inquiry, the program provider now shortens the announcements to come into compliance with the rules and the station has begun internal procedures to ensure more consistent review of its underwriting

announcements.

In separate cases, the FCC said the announcements were ads, but because the stations had prior unblemished records, admonishment was a sufficient sanction rather than a fine.

MacBride to Head NAB Legal Team

WASHINGTON Marsha MacBride, a former staffer for FCC Chairman Powell, is the new head of the legal department at NAB.

MacBride replaces Jeff Baumann, who is retiring from the trade association in February following a 20-year stint.

As executive vice president of the association's legal and regulatory affairs department, MacBride will oversee its legal team, which represents broadcasters before the commission and the courts and provides counsel to stations.

MacBride served as chief of staff to Powell from 2001 to September of 2003, during which time she also chaired the FCC Homeland Security Policy Council. In addition to a two-year stint as vice president in the Walt Disney Co. Washington office, MacBride has served in high-level jobs at the FCC since 1991. Among her positions: legal advisor to Powell

when he was a commissioner; executive director of the Task Force on Y2K Conversion; acting deputy of the Cable Services Bureau; legal advisor to Commissioner James Quello; and staff attorney for the Political Programming Branch.

Convicted Murderer May Lose Ham License

WASHINGTON About six months after the FCC granted a ham radio license to Roger Thomas Scaggs, he was convicted of beating his wife to death with a lead pipe and stabbing her several times. Now, the commission is trying to determine if Scaggs remains qualified to remain the licensee of amateur radio station W5EBC or whether his authorization should be revoked.

Scaggs was convicted in 1998 of felony murder, sentenced by a jury to 32 years in prison and fined \$10,000. His conviction was affirmed and his request for a rehearing denied in 2000, according to the commission.

The FCC assesses character qualifications before granting a license, especially evidence a felony conviction. Scaggs murder conviction, states the agency, "raises very serious questions as to whether he possesses the requisite character qualifications to be and remain a commission licensee."

A to Z

► Continued from page 4

Thurst, Larry Tighe, Edward Tise, Scott Todd, Don Tolson, Jenny Toomey, Eddie Torres, Shave Tovén, Jim Trapani, Travis the V/O Guy, Bernd Trutenau, Kurt Tuckerman, Ralph Ullrich, Barry Umansky, Carl Van Orden, Tom Vernon, Paul Virts, Rick Volpatti, Raymond Voss, Jason Walther, Dick Warren, George Whitaker, John White, David Whitehead, Ben Wilkins, Jack Williams, Jeff Williams, Paul Wilson, Jeff Winkless, Guy Wire, Kathy Wiskur, Jim Withers, Jim Wood, Tony Wortmann, Jonathan R. Yinger, Hans Zimmer and John Zondlo.

To all those who make Radio World possible, including any I may have failed to mention here, thank you. 🌐

Recommended Daily Allowances

- Optimod-AM 9200
2-3 SERVINGS
- Optimod-FM 8300
NEW!
- Optimod-FM 2200
2-3 SERVINGS
- Optimod-TV 8282
3-5 SERVINGS
- Optimod-AM 6200
2-4 SERVINGS
- Optimod-FM 8400
6-11 SERVINGS
new with HD radio outputs!
- DAB & AM HD radio

Seattle WA: 800.735.7051
 Northern CA: 888.737.7321
 Santa Barbara CA: 800.346.6434
 Kansas City MO: 800.467.7373
 Richmond IN: 888.968.1990
 Edensburg PA: 814.472.2000
 Monroeville PA: 886.412.7373
 Southampton PA: 888.260.9298
 New Ipswich NH: 800.485.8684
 Valparaiso FL: 800.476.8943
 Amarillo TX: 800.537.1801
 Ft. Worth TX: 888.839.7373

RF Specialties Group

RF is good for you...and so is Orban.

www.rfspecialties.com

Savoldi

► Continued from page 1

Savoldi, 43, has gone from loading carts for his father, who was a full-time educator, to planning a seven-station buildout for a cluster of stations in Columbus, Ohio, where he is Clear Channel Radio's director of engineering for the Columbus region.

These days he directs a staff of four engineers at WTVN(AM), WNCI(FM), WFJX(FM) and WCOL(AM-FM) in Columbus. He will add move-in station WFCB(FM) from Chillicothe, Ohio, the tower of which is approximately 30 miles south of Columbus, once the buildout is complete early this year. Clear Channel expects to add another move-in station from Marion, Ohio, pending a city of license change.

of all of them. This job is not for people who want to fly a desk and work 8 till 5. No two days are the same," said Savoldi. He reports to Dan Mettler, Clear Channel's regional engineering service manager in Indianapolis.

The buildout project in Columbus consumes most of Savoldi's time these days. The 32,000-square-foot facility, a former state office building, will have 20 studios, including a mix of on-air, production, voice tracking and master control studios and newsrooms. Clear Channel has approximately 125 employees in Columbus, Savoldi said.

Columbus build

"We started the project in August. The entire second floor was stripped to the concrete and roof deck, so we started with a clean slab.

"We expect to have three stations on air by Feb. 1. That is a very compressed

Columbus, will feature Pacific Products Legacy series consoles from Harris and a Sierra Automated Systems 32KD digital audio network and router system, Savoldi said.

"The facility is being built with a digital backbone, so that implementation of HD Radio will not be an issue," Savoldi said, adding that none of the Columbus stations is scheduled to go HD Radio yet.

KQKQ(FM) in Omaha, Neb., was the first full-time engineering stop for Savoldi in 1982. That's where he met Andy Laird, now vice president of radio engineering for Journal Broadcast Group.

Laird was the technical consultant to the station and hired Savoldi after a phone interview.

"Andy is a brilliant engineer. I learned a lot on the fly. I was young

'I still love driving down the road listening to a freshly tweaked station kicking everyone's butt on the dial.'



Savoldi With Cat-5 cable for the Columbus Buildout

In total, Savoldi has engineering oversight at 20 Clear Channel stations in the region, which includes Ohio markets like Mansfield, Ashland and Tiffin.

"I oversee budget and technical facilities and direction. I'm hands-on with some of them and in directorship

time frame and aggressive schedule. The remaining stations should be turned over by April 1. We are in two separate buildings right now, which we have just outgrown," Savoldi said.

Studios in the new broadcast complex, located just west of downtown

Savoldi was born in Wheeling and raised in Benwood, W.Va., near the Ohio River. He attended John Marshall High School, which happened to have a closed-circuit radio station on campus. He was on the air with his own show by his sophomore year.

"Within a year of that, in 1976, I was working on air at my first commercial station, (the former) WEIF(AM) in Moundsville, W.Va. It was an AM daytimer. I would work the sign-off shift and then meet the chief engineer on Thursday nights when he pulled maintenance on the transmitter. He'd hand me a rag and let me go at it," he said.

Off to Nebraska

Savoldi attended Belmont Technical College in Wheeling after high school, then got his first real taste of broadcast engineering when he took a job with 50,000-watt WWVA(AM) in Wheeling.

"Tech school gave me a real good foundation in electronics and electricity. I joined WWVA in the late 1970s, where it was not uncommon for me to work an air shift, cut a bunch of commercials and then wire a studio late at night. It was about that time I decided my future was in engineering."

and single, and just put everything I had into it," Savoldi said.

After just a year at KQKQ, Savoldi joined what was then WYMJ(FM) in Dayton, Ohio, as chief.

"It was a short stay of about a year at WYMJ. Jeff Bennett was director of engineering for Great Trails Broadcasting in Dayton and told me he was looking for a CE for WCOL(AM) and the old WXGT(FM) in Columbus. It was too good to pass up."

After six years with Great Trails in Columbus, Savoldi moved across the street to Taft Broadcasting's WTVN(AM) in 1990.

It turns out Savoldi has been in the same building for the past 13 years — working for the same radio stations but under a multitude of corporate owners. Taft Broadcasting became Great American Radio, later known as Citicasters, which was sold to Jacor, which was eventually purchased by Clear Channel.

Clear Channel, often criticized for its size, has a bullseye on its back like any company its size, Savoldi said.

"I've seen Clear Channel tackle the tasks of accommodating employees, listeners, community, Wall Street,

See SAVOLDI, page 7 ►

The Sound of Solid Ground

A great remote needs a great home base. And there's nothing better than the Matrix Rack. It's compatible via POTS and ISDN with all Comrex codecs as well as those from nearly everyone else. Perfect for receiving those GSM calls from the field.

Make Matrix Rack the center of communications for ALL your remotes.

Doing a remote? Put Comrex on the line.

COMREX

Toll Free: 800-237-1776 • www.comrex.com • e-mail: info@comrex.com
19 Pine Road, Devens, MA 01432 USA • Tel: 978-784-1776 • Fax: 978-784-1717

Savoldi

► Continued from page 6

stockholders, ratings — and do it through some tough economic times,” he said. “We work hard to deliver a great product for our communities and stockholders.”

Savoldi said consolidation has meant covering a lot more ground with fewer bodies.

“Technology is allowing us to do that, though. The days of aligning carts and reel-to-reel decks is over, which was very time consuming. Transmitters are much more reliable these days. You can do more with less. And we’re doing it and doing it very well.”

However, challenges do arise as a result of working for a major corporation.

“This is an ever-changing industry. Because of that, we are constantly in forward momentum and evolving. We are literally on the bleeding edge of technology much of the time. We can afford to do some things other companies cannot. That’s exciting to me.

“You can strain yourself and your staff when you get an unforeseen challenge thrown at you. But I think people who want to be challenged will grow through it and learn from each experience,” Savoldi said.

He had an unanticipated problem during the buildout project last fall when Rohn Industries informed Clear Channel it would not be able to deliver a STL tower for the new facility. Rohn filed for Chapter 11 bankruptcy protection in September and is in the process of being sold.

“That is one of those things that can happen. We have another company

coming in to do it now. It will cost more and we’ll need a bigger hole for the tower foundation. But that is the

senior vice president of consolidation projects and technology, for helping him with the critical design and initial

missed, most certainly,” Savoldi said.

Despite the occasional engineering headache, he still has a passion for radio.

“I still love driving down the road listening to a freshly tweaked station kicking everyone’s butt on the dial. It’s magic. The only difference is that now I do not have enough presets on my car stereo for all of my stations.”

Another sure sign of consolidation is when you reach the point of referring to your stations only by their frequencies, instead of call letters, Savoldi said.

“Call letters and formats come and go. Frequencies remain the same.”

Savoldi lives with his wife Michele and their children, Hadley and Michael, in Delaware, Ohio, just north of Columbus. ●

The first word he spelled was ‘transmitter.’

kind of thing you need to get through. We got it resolved,” he said.

Savoldi credited Al Kenyon, recently dismissed as Clear Channel Radio’s

build phases of the buildout.

“Al was ready with guidance and answers at every turn. He is a brilliant engineer and great person. He will be



What Does It Sound Like At The Top?



Delivering the sound of the summit to listeners around the world is as simple as pressing a button. The Comrex Matrix, equipped with our optional GSM Module, combines an integrated mobile phone and an advanced Comrex codec to deliver broadcast quality 7kHz audio over standard cellular connections (15kHz over POTS).

The results? Your listeners hear fingernails digging into rock — the sound of a successful climb with detail that’s simply unprecedented.

Grab your audience by their ears and give them the full experience — not just a story.

Doing a remote? Put Comrex on the line.

Savoldi’s Peers Say:

“Greg moved to Omaha in the early 1980s as chief engineer of KQKQ(FM), a client station of mine that I was consulting technically. He had ultra high energy, walked and breathed radio, wanting to do it all, and KQKQ needed his full-time attention.

“KQKQ was a *dump*, but was the huge No. 1 Omaha station, with shares in the 18s. Greg took advantage of both his ‘ear’ and deep involvement in ‘the mess’ to grow professionally.”

Andy Laird
Vice President, Radio Engineering
Journal Broadcast Group

“I’ve known and worked with Greg for over 20 years and I can truly attest to the unmatched zeal, dedication and expertise that he brings to his every effort.”

Jeffrey Bennett
Director of Engineering
Clear Channel Dayton

“I have known Greg since he hired me in 1988 as his assistant chief engineer at WCOL(AM) in Columbus. ... His tenacity stands out. I have seen Greg fix broken transmitters that others have left for dead. Once Greg starts something, he doesn’t quit until it’s completed.”

Mark Bohach
Program Director
WRFD(AM), Columbus
Salem Media of Ohio Inc.

COMREX

Toll Free: 800-237-1776 • www.comrex.com • e-mail: info@comrex.com
19 Pine Road, Devens, MA 01432 USA • Tel: 978-784-1776 • Fax: 978-784-1717

FIRST PERSON

Building an FM HD Radio Station

by W.C. 'Cris' Alexander

CHICAGO Crawford Broadcasting recently implemented HD Radio at WPWX(FM) in Chicago. I planned this project, then oversaw it from the sidelines.

Our front-line employees, headed by market chief engineer Art Reis, were the people who made it happen. With many of our readers planning to undertake similar projects in the next few years, our experiences may be of some help.

Power92, WPWX, is a full-power Class B FM serving the Chicago market from a 500-foot tower on the east side. The site dates back to the early 1960s, although the tower was built in 1987.

The antenna is a DA, an ERI three-section G4D-3B, fed with 3-1/8-inch rigid transmission line.

No more room

The configuration of Power92 left us with no real choice for the HD Radio transmission system. We had to go with high-level injection. The TPO of the analog system was close to 25 kW, so we would need 2.5 kW average TPO out of the HD transmitter.

We selected a Broadcast Electronics FMi-703, which comes with the FSi-10 IBOC signal generator and the FXi-60 digital exciter. The footprint of the digital transmitter was a prime consideration in the overall design because of limited floor space.

This configuration made it clear early on that our first and biggest obstacle was the current transmitter building; it was too small. It was built in a day when WPWX (then WYCA) operated with a 9 kW TPO feeding a much larger antenna.

The 30 kW main and 27.5 kW auxiliary transmitters filled the existing building to capacity; there was no room for a digital transmitter, let alone an additional

equipment rack for the additional ancillary equipment.

Rather than constructing a new transmitter building on site, we opted for a cellular-type pre-cast concrete shelter. Over the past few years, we have gone this route a number of times with excellent results, and I would recommend it. The advantages of using the pre-cast

will deliver the shelter and the crane that will unload it and set it in place.

Otherwise, the shelter will come ready to go. Quite literally, you can be on the air from the new building, which comes complete with HVAC and electrical, within a few hours.

Most of us have been involved in transmitter projects at some time during



The RF Plumbing With the HD Radio Injector

shelter over building on-site are lower cost, faster lead time, sturdier construction and better insulation.

Pre-cast shelters are available from a number of sources and are custom-configurable at the time of order. You must provide a foundation, which can often be crushed aggregate (although we have always poured a slab on-grade), and you must prepare the site for the truck that

our careers, so I won't dwell on the details of moving two large transmitters from the old building to the new. It was a challenge that our Chicago engineering crew handled well, completing the switchover with just one overnight of downtime.

Considerations included new ice bridge and transmission line pieces and parts to make the run from the new build-

ing to the tower; a temporary studio-to-transmitter-link to operate the station while the main transmitter, equipment rack and ancillary equipment were being relocated; and a second audio processor for the same purpose.

Installing new gear

The BE FM-30T main transmitter was moved first. This is a new transmitter, installed in 2002. Since it was the last transmitter to go into the existing building and thus closest to the door, it was the logical choice for the first transmitter into the new shelter.

Once the FM-30T was in place, BE delivered the FMi703 digital transmitter on one of its own trucks. BE's Quincy, Ill., headquarters are a five-hour drive from Chicago.

A new equipment rack was installed; then the RF plumbing, including the IBOC injector, was installed overhead and the main transmission line run was completed to the tower. With that basic complement of equipment in place, the station was ready to switch over to the FM-30T in the new building.

One consideration for any high-level injection HD Radio system is reject heat. Roughly 90 percent of the power of the digital transmitter is dissipated in a dummy load in the form of heat along with 11 percent of the power of the analog transmitter. In our case, that was close to 5 kW (17,000+ BTU) of total heat to be disposed of.

We did *not* want to heat our new transmitter building with the reject load. We contemplated placing the load outdoors in a vented National Electrical Manufacturers Association enclosure, which was a pretty good option. A better option presented itself, however: the old transmitter building.

The team installed a run of 1-5/8-inch rigid transmission line from the Shively IBOC injector reject port to the reject load in the old transmitter building. The

See FM IBOC, page 10 ▶



Finally, an RDS/RBDS solution built for the US radio market, offering consumer-rich programming and revenue generating interactive services. And also at the best price, Free!

dMarc Networks™ is the market leader in data services.

To start generating revenue today, call (949) 791-1200 ext. 13

dMarc Networks™ is HD Radio Ready™!



Turning Data Into Profits™

www.dMarcNetworks.com
www.RadioGreetings.com

Wish you had more

up top?

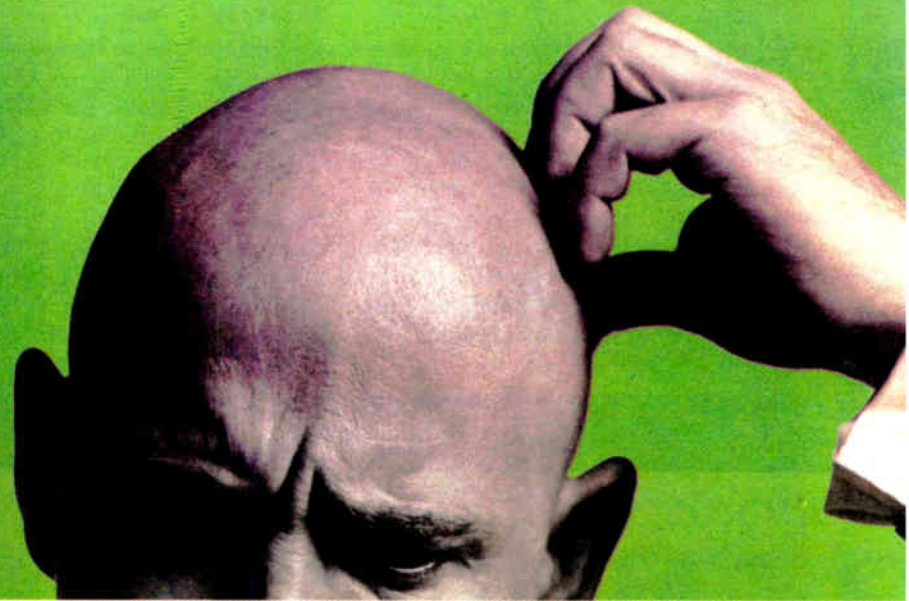

Announcing Omnia-6EX.

There's a lot of buzz about the new HD Radio codec. We've heard it and agree with the many others who like it and say it's now time to get on with radio's transition to digital.

Because HD Radio can transmit audio frequencies up to 20kHz, listeners will finally be allowed to hear the full CD spectrum – if their radio stations choose the right on-air processor. On this point, you should know something important: Some “HD” processors simply hack off everything above 15kHz... robbing listeners of the full HD Radio experience and keeping our industry in a fidelity backwater.

The new Omnia-6EX won't short-change your listeners. We've built Omnias with sampling rates of 48kHz and higher from the start. All along, we've needed the sampling headroom to keep analog FM audio grunge-free. Now it's essential for HD Radio. Even if some listeners wouldn't notice the missing high frequencies, there's a fair chance they would hear a sharp 15kHz low-pass filter operating within HD Radio's codec range.

Omnia-6EX is also full of processing enhancements that result in yet more bass punch, yet more voice clarity, than the original Omnia-6. A sound so powerful and free of artificial constraints, you'll crave it for your station the first time you hear it.

More than 50% of the US' Top 100 FM stations have already upgraded to Omnia. Maybe you're next?



The new Omnia-6EX has enhanced processing for analog FM, and is ready for HD Radio with a second limiter section and digital output. Both FM and HD limiters and outputs are included as standard.

Omnia
A Telos Company
omniaaudio.com

FM IBOC

► Continued from page 8

air conditioning in the old building was shut down, but thermostatically-controlled vent fans still move a good bit of air through the space, providing adequate waste heat removal.

Linear amplifiers such as those employed by HD Radio transmitters are necessary, but quite inefficient. That means there is a considerable amount of transmitter waste heat to dispose of.

In the case of the FMI703, cooling is provided by a number of low-velocity fans, exhausting the waste heat out of the entire top of the transmitter. It would be just about impossible to hood and vent the transmitter, so that waste heat must be compensated for inside the room.

Both analog transmitters, however, were hooded and vented easily. A big consideration here is make-up air. The HVAC system provided with the building comes with outside air dampers so that up to 20 percent of the total air volume can be drawn from the outside.

What if AC fails?

This is not quite enough, however, to compensate for the 1,200 cubic feet per minute being vented outside by each analog transmitter. A means of drawing in additional filtered outside air was necessary, and we addressed this with a 20-by-24-inch filtered, louvered opening in one wall of the building. While this make-up air is not cooled or dehumidified, it is not such a large volume that it has any real impact on the overall HVAC equation.

Another consideration was the emer-



Chicago Market CE Art Reis and the BE FMI-703 at WPWX(FM).

gency condition that would exist when both air conditioner units fail. In that case, the air inside the building needs to be exchanged with outside air rapidly to carry away waste heat from the transmitters and prevent heat buildup inside the building.

To address this, we installed a louvered exhaust fan high on one wall (on the "lee" side of the building, so that it would not have to fight the prevailing winds). Intake air was provided by means of another louvered, filtered intake on the opposite side of the building.

TAKE YOUR STATION TO THE NEXT LEVEL.

Listeners, advertisers, and technology...that's what keeps Radio stations alive. Attend NAB2004 and take your revenues to the next level! Targeted conferences, on-floor educational pavilions and the world's largest broadcast marketplace offer insight, cost-saving solutions and alternative technologies to keep you competitive.

Whether you're a station owner, general manager, program director, news director, sales manager or radio engineer...you need to be at NAB.



"Music and the Spoken Word" featuring The Mormon Tabernacle Choir

NAB Broadcasting Hall of Fame, Radio Inductee; Radio Luncheon, Tuesday, April 20.

GO BEYOND
www.nabshow.com

For Sponsorship information, contact us at 1.202.429.5426 or advertising@nab.org
For Exhibit information, contact us at 1.202.595.2051 or exhibit@nab.org
For Membership information, contact us at 1.202.429.5300 or membership@nab.org

SHOP THE GLOBAL CONTENT MARKETPLACE See the World's Leading Suppliers – 1,300+ Exhibitors!

ANS NEVE – Amakis Systems – Belar Electronics – Broadcast Electronics – Broadcast Tools – Calrec Audio – Crown Broadcast – Dolby – Elektronika SRL – Harris Corporation – Kemwood – Killer Tracks – MediaTouch – Muesley Associates – Musicam – Otban – Professional Sound Corporation – RCS – Shivaly Labs – Sierra Automated Systems – SRF Labs – Tainis Systems – Wheatstone Corporation – and more!

Visit www.nabshow.com for a complete list.

STAY AHEAD OF THE COMPETITION Learn From the Industry's Leading Experts

Radio Management Conference
Broadcast Engineering Conference
Business Law & Regulation Conference
RTNDA@NAB
NEW! Satellite Business & Technology Pavilion

NAB

THE WORLD'S LARGEST
ELECTRONIC MEDIA SHOW

April 17-22, 2004 · Las Vegas, NV
Exhibits: Monday, April 19 - Thursday, April 22

REGISTER TODAY ONLINE!

Stations can expect interference from first- and second-adjacent-channel HD Radio stations beyond the protected contour.

The thermostat is mechanical and is not connected in any way to the rest of the HVAC system. Set at 80 degrees or thereabouts, if the temperature in the building rises above that point for any reason, the emergency fan will come on and flush the building with outside air.

Each transmitter's exhaust vent was equipped with a barometric damper that will open should the pressure inside the duct rise above a certain level. This will allow the transmitter exhaust to be vented back into the building should the exhaust opening become blocked for any reason.

During the cold season, the damper can be opened manually to provide auxiliary room heating from transmitter waste heat.

The audio "plumbing" for an Ibiqity HD Radio system is something of a challenge. Most broadcast engineers are accustomed to a "linear" signal path, e.g. STL out to processor in, processor out to exciter in, etc. This is not the case with the HD Radio system.

AES digital audio out of the STL goes into the HD FM/IBOC processor. The IBOC output of the processor goes into the HD Radio exciter, where it is sample rate-

See FM IBOC, page 12 ►

Another late night at the station?

You need iMediaTouch.

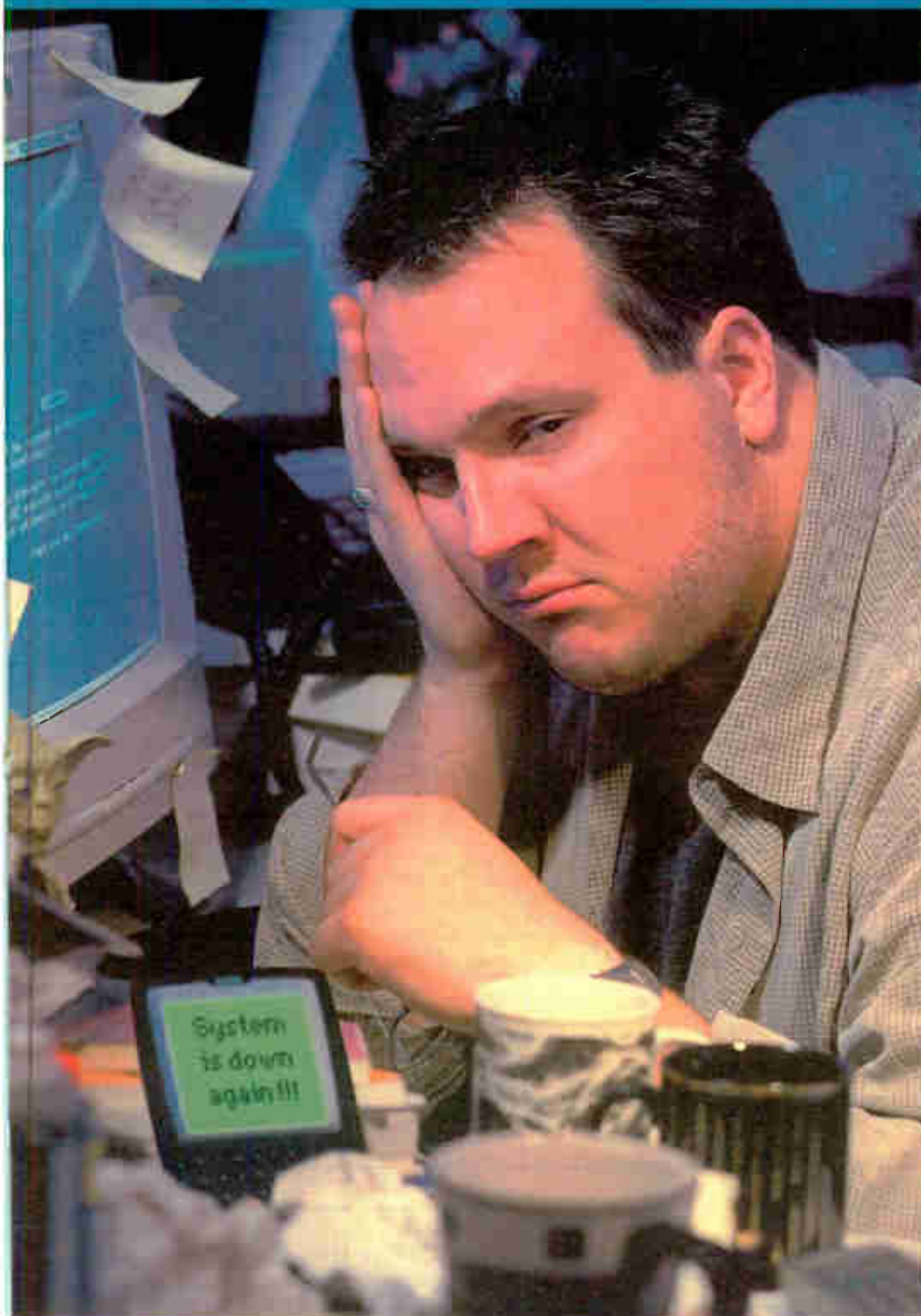

Is your digital audio delivery system keeping you up at night?

Since 1984, over 500 radio stations around the world have trusted iMediaTouch broadcast automation software. With a host of award winning features designed to save both time and resources without breaking the bank, the iMediaTouch digital audio delivery system is easy to use and dependable time after time.

iMediaTouch broadcast automation software.
Connecting radio groups through superior technology.



To find out more call us
Toll Free 888 665 0501 or visit www.omt.net

FM IBOC

► Continued from page 10
converted and sent on to the IBOC signal generator.

The FM AES output of the processor goes into an AES DA and router that is "normaled" to the FM AES input of the IBOC signal generator, where it is delayed to match the latency of the IBOC signal path. The delayed FM AES then is fed to the FM exciter.

I think a good compromise is somewhere in the middle, with less processing than the analog audio but not so little that the desired "signature sound" of the station is lost. Perhaps the best way to achieve this is to keep the same settings in the multiband processing as the FM side while backing out the clipping and most of the limiting and compression.

Modulation in an HD Radio system is really a matter of making certain that the digital carrier levels are correct and that the occupied bandwidth does not exceed the

west side of Chicagoland that "reach" into the market. For years, these stations have enjoyed some west-side coverage beyond their protected contours. When Power92 fired up its HD Radio transmitter, those stations began reporting interference to the FCC.

We checked and double-checked our occupied bandwidth and found it to be in full compliance with 47 C.F.R. §73.317. Broadcast Electronics sent an engineer up to Chicago from Quincy with an analyzer and he found the same thing. The licensee of the

on a VSWR overload. Only 10 percent of the power of the analog transmitter was being dissipated into the reject, however, and the resulting reflected power was not enough to cause it to trip off.

As a result, the digital transmitter became an expensive dummy load, dissipating the 2.5 kW or thereabouts from the analog for a period of time. It got very hot, but amazingly, no damage was sustained.

Clearly, some additional protections and interlocks are needed in the area of the reject load. We have added a Bird ThruLine

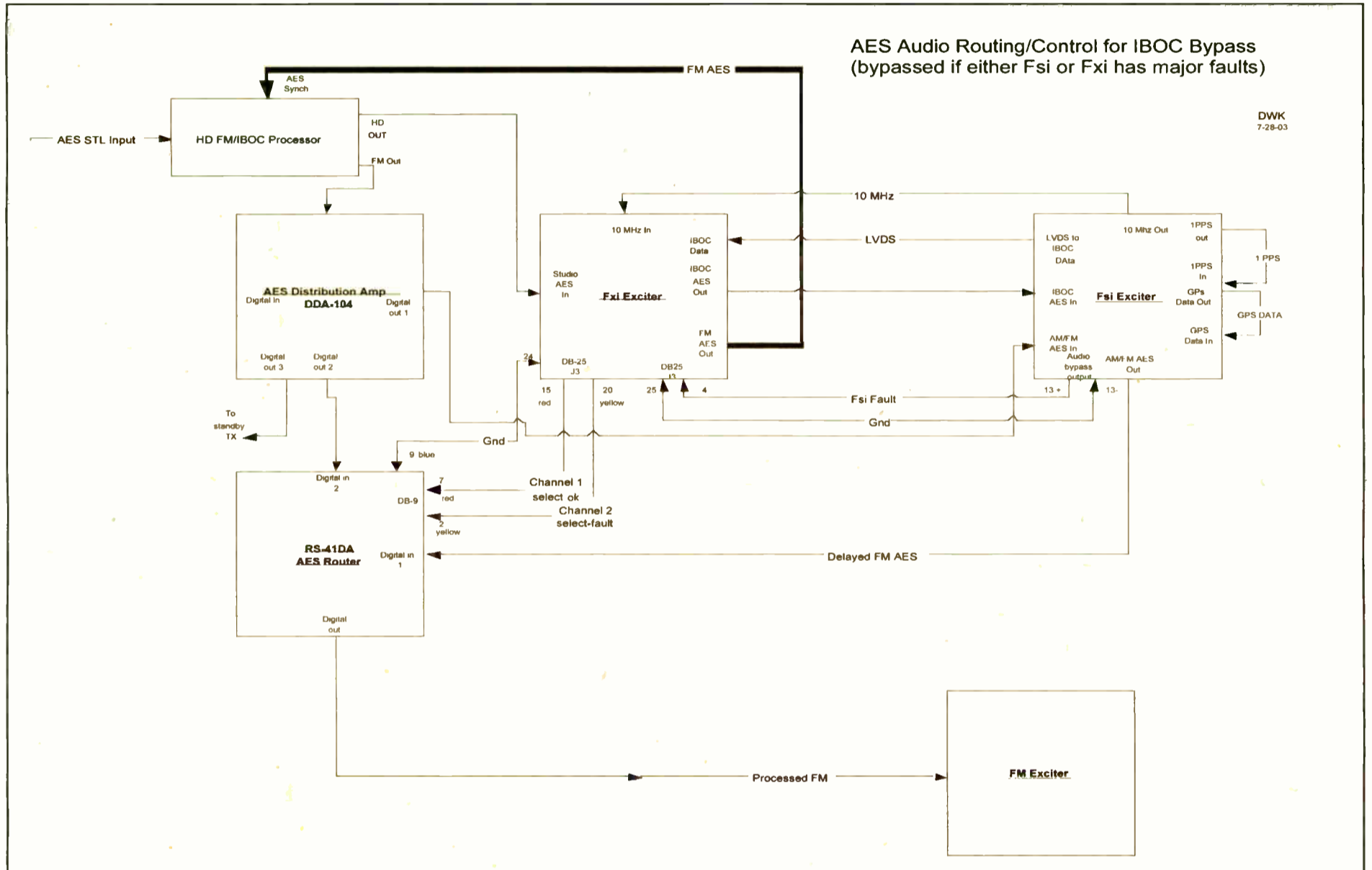

AES Audio Routing/Control for IBOC Bypass

(I would be amazed if anyone could follow that signal path from this narrative!)

It took a little doing to finalize the signal paths. The original configuration was simpler, but it had the disadvantage of killing the FM AES feed anytime the IBOC exciter or IBOC generator was turned off or had a fault. The final scheme bypasses the FM AES delay in the event of a fault or power off condition, feeding processor FM AES out directly to the FM exciter AES in.

To process or not

The only anomaly that occurs when this switch is made is the "dump" of the nominal eight-second FM AES delay, which sounds like a CD skip on the air.

The final steps in commissioning an FM HD Radio station are processor adjustment and setting of the FM AES delay. Ibiqity provided us with a test receiver that we used for both tasks.

One thing that has yet to be defined is what the HD Radio audio is supposed to sound like. Some would argue that it should be CD-clean, with very little processing. I could go along with that; but we are, after all, broadcasters. We've got to punch it up a little.

FCC-specified mask. This is done with a spectrum analyzer.

With the resolution bandwidth on the analyzer set for 1 kHz, the digital power is adjusted so that the digital carriers are exactly 43 dB below the level of the unmodulated FM carrier. Forget about modulation monitors and all the stuff that is displayed on them for the HD Radio side of things. Your limits are all ones and all zeros, and that is pretty much determined at the studio (or in the A/D converter, wherever that may be located).

How does the Power92 HD Radio system perform? Using the Ibiqity test receiver with a whip antenna on top of the vehicle, clearly the primary analog coverage exceeds the digital coverage by a good margin. However, some of our employees have factory-installed HD-capable receivers in their cars, and they report that the digital coverage exceeds the analog by a good bit. I suspect that the front end in the test receiver is not as good as those in production receivers.

One issue that some anticipated with the rollout of HD Radio has come up at Power92: adjacent-channel interference. There are a number of first- and second-adjacent channel stations around the

adjacent-channel stations complained of the interference to the commission, and FCC field agents came with two analyzers and found Power92 to be in full compliance.

The long and short of it is that stations can expect interference from first- and second-adjacent channel HD Radio stations beyond the protected contour. This won't be a factor in most cases, where those areas are located in rural or unpopulated areas.

Some interference

In the case of certain "rim-shot" adjacencies that are "reaching" into a market from some distance away, it will be a significant factor. Crawford is working with Broadcast Electronics to install mask filtering on the HD Radio transmitter to see if it improves the interference picture.

We have learned another lesson during this project, one that we won't soon forget: that really bad things happen when the injector reject load fails.

A bad transmission line bullet in the Power92 reject line failed after a few weeks of operation and that transmission line opened up. With 90 percent of its power being dissipated into the reject load, the digital transmitter immediately shut down

section in the reject line to allow us to keep an eye on the forward and reflected reject power, both of which will be a good check of overall system performance.

We may also put a Bird Watcher on this line that would shut down both transmitters should the reflected power become too high. A thermal interlock on the reject load also is in order. It could be disastrous if the cooling fans fail.

For the immediate future, we have two additional stations in our Chicago cluster to convert. By the time you read this, both stations should be transmitting in HD Radio.

One station will use common amplification; the other, like Power92, will use high-level injection. Hopefully, we will be able to take everything we learned from our Power92 experience and apply it to the other conversions.

For those contemplating an HD Radio conversion, Frank Foti of Omnia Audio has prepared an HD Radio Installation Checklist. Much of this helpful document contains came out of the Power92 experience. The checklist is available online at www.crawfordbroadcasting.com/~cbc/Eng_Files/HD%20Radio%20Checklist.doc.



It's Zephyr's 10th birthday (But you get the present).



Get two award-winning codecs – Zephyr Xstream & Zephyr Xport POTS – for just \$4,995 US MSRP. Add ISDN capability (with G.722 and low delay MPEG AAC-LD coding) to your Xport for just \$399 more, or...



...Upgrade to the Ultimate Remote Bundle: a rack-mount Zephyr Xstream for the studio and a portable Zephyr Xstream MXP with 4-channel DSP mixer and onboard audio processing by Omnia, for only \$7,294 US MSRP.

When we first married MP3 with ISDN in 1993, we had no idea that their offspring would grow up to be the most-loved audio codec ever. But it has, and its popularity keeps growing – there are now more than 10,000 Zephyr codecs in radio stations and production studios around the globe.

A birthday this significant deserves a special present, so here it is: the Zephyr 10th Birthday Bundle, a complete codec package at a once-in-a-decade price.

You'll get the best-selling Zephyr Xstream for your studio, and the satisfaction of knowing you can make CD-quality ISDN connections to virtually anywhere using industry-standard MPEG Layer 3 or MPEG AAC coding. And for your remote kit, the award-winning Zephyr Xport with built-in two channel mixer — perfect for sponsored remotes, sporting events, interviews and live appearances. Just plug in to any POTS phone line for an *aacPlus*[™] link to your Zephyr Xstream; you'll get stunning audio and rock-solid connections.

Best of all, you'll receive your Zephyr 10th Birthday Bundle for the special price of just \$4,995 US MSRP. (There are more special Zephyr bundles to fit specific needs; just ask your Telos dealer.) But don't delay — this special offer is only good through February, 2004.



Telos
AUDIO | NETWORKS



telos-systems.com

Telos, the Telos logo, Zephyr, Zephyr Xstream, Zephyr Xport are all registered trademarks of TLS Corporation, © 2003, TLS Corporation. All rights reserved. *aacPlus* (TM) Coding Technologies.

WOR

► Continued from page 1

we have had an Ibiqity reference receiver to listen to WOR-HD. That radio, however, is not conducive to portability. It weighs about 35 pounds. It is at least 30 x 17 x 7 inches. It runs on 120 volts AC. It would not fit in any dashboard I know of; and having to pull around a generator on a trailer hitch to power it didn't excite me.

The Kenwood, however, did. I think I can safely say that I am the proud owner of the only commercial digital radio in New York, at least as I write.

This first-on-the-market HD Radio is part of Kenwood's high-end system. If you are installing an aftermarket radio in your auto, not necessarily HD Radio-capable, you would be looking at Kenwood from among the many brands on the market.

Most of the Kenwood head units will accept Kenwood's add-on Sirius tuner. You would be looking at spending a fair amount of cash if you were to go this route. As configured, the KDC-722 head unit retails for around \$350. The HD Radio tuner retails for around \$350.

Some cussing

The Kenwood radio head fit right into the dashboard of my 2003 Ford Explorer, with a little help from a \$33 install kit from Crutchfield, which included a wiring harness that plugs right into the factory wiring in the dash. Marry it to the harness that comes with the KDC-722, and the system is pretty much plug-and-play.

Installing the HD Radio tuner part was a little bit of a challenge. The cabling that came with the tuner was more than adequate, with proper routing, to place it behind the first back seat. The HD Radio tuner, however, has a set of RCA jacks that I wanted access to so I can record audio samples while driving around.

After looking at several locations, I settled on putting the tuner in the glove box with hook and loop fasteners. The excess cabling was bundled and tied to a dash-

board support located behind the glove box.

Installation took about an hour. Cuss word quotient: 2 on a scale of 5.

I live in WOR's null, about 46 miles from the transmitter. Signal level in my front yard is just around 0.4 mV/M.

The Ibiqity system is designed to run to the 0.5 mV contour. My home is also in an RF black hole. I get cell phone coverage there, on a good day. Forget over-the-air TV. Radio? The only station that comes in well is an FM with a tower about three miles from my house.

Even my satellite TV dish is fussy, working only when mounted on the southwest corner of the deck. (Yes, I tried it in various locations, and there are no obvious blockages to the sightline). WOR is very noisy in my neighborhood, as could be expected 46 miles from the transmitter in the null.

I generally drive a route into the city that follows the null pretty well. There are locations about 30 miles from the transmitter where the HD Radio will do a graceful blend from analog to digital.

These are also places where I wouldn't expect to hear the analog well, but the digital blends right in. I don't receive the station fully in digital until I hit the New York/New Jersey border, and this is about where the 0.5 mV contour is located in the null.

It should also be noted that the pattern bandwidth of our null is not great. On a spectrum analyzer, WOR's upper sideband does not exist north of Paramus, N. J.

The blend factor

All the way down Route 17 from the New York/New Jersey border to the Lincoln tunnel, I listen to WOR-HD Radio. There are two bridges I go under in Mahwah, N.J., where the radio will blend to analog quickly, then blend back to digital.

The rest of the trip, I have a solid digital signal. Under bridges. Under street signs. No fading, and no glitches. And the audio quality, in my humble opinion, is better than listening to analog AM. WOR's analog signal fades, hums and buzzes at various points down Route 17. WOR-HD Radio simply plays.

We process the hell out of the analog signal. Let's just say we check our modulation monitor to make sure some joker hasn't tied batteries across the meters. It is compressed and loud.

The processing on WOR-HD Radio is gentle. I have found that it is no longer possible to cover our sins on the digital signal.

A few of our hosts love to walk into the studio and drop a pile of stuff right in their work area last minute, then they shuffle through it looking for things, occasionally turning off-mic. You don't hear this on the analog signal. On the digital, however, you hear every paper shuffle, and it's obvious when someone turns away from the mic but keeps talking.

isn't as blatantly obvious as it is with AM, but here is the FM "wow" factor. You can punch up WNEW while driving up the West Side Highway, and hear the signal spitting with multipath, in some places severe. Then the blend occurs. You get a solid signal. No spitting. If there is silence in the song, you get silence. All the way up to the George Washington Bridge.

If that's not worth the installation on FM, I don't know what is.

I just wish there were other stations in the New York Metro operating in HD Radio right now. WNEW(FM) is the only FM station. WOR is the only AM station, though WPAT and WZRC run HD Radio



Tom Ray is saying 'Is it on?'

One morning, Ed Walsh, host of "The WOR Morning Show," played a bit of "Santa Claus Is Coming to Town" by Frank Sinatra and Cyndi Lauper. Wow. Flipping over to analog and letting the radio blend into digital is like night and day.

I plan on making some measurements to find where this radio actually loses the HD Radio signal; but driving in the null every day, the performance is impressive.

My only disappointment with the radio is that there is no light or anything on the display that comes up and screams "You're Listening in HD Radio!"

The only way you would know you were locked onto a digital station, besides the obvious better frequency response on an AM facility, is when you change stations.

Punching up our competition, you see only their frequency before the clock comes back up. Punch up WOR, however, and you get the frequency, 710 kHz, followed by the call letters, WOR. If you set the radio to look at title and artist information, the display will tell you that you are listening to "710 WOR-HD: New York's FIRST Digital AM Radio Station."

The FM 'wow'

Of course, I had to check out the FM band, too. WNEW(FM) is transmitting a digital signal. Its antenna is on the Empire State Building. Atop the tallest building in New York, you'd think they would have a hell of a signal. Now, plot your car on the West Side Highway and the signal path to Empire.

You can't see the Empire State Building from most of the West Side Highway. There are too many buildings to contend with. So WNEW's signal picket-fences all the way up the West Side Highway.

The blend from analog FM to digital

carriers on a sporadic basis. I have yet to catch them operating in digital, and I'd love to. I have a new toy, and I want to play!

I will, however, have a chance to see how far into Connecticut WOR's digital signal goes. We will be doing the "family run" straight out I-84 from Newburgh, N.Y. to Hartford, Conn.

The coverage map Ibiqity made for me shows that we have digital coverage up to Waterbury, where my mom lives. Being a quasi-scientific study, I intend to do this run with a field strength meter in the car connected to a mag-mount whip antenna on the roof, calibrated to the actual received signal level using the FIM correctly.

I wonder how my wife will feel taking the drive with a field strength meter in her lap? (Note to self: buy coal-burning appliance to utilize items left in my stocking by my wife).

It's interesting listening to "The WOR Morning Show" on the drive into the city every morning. I'm used to hearing our signal highly compressed and in-your-face. And you have to contend with the fading that occurs under the bridges and electrical power lines that are a staple of driving Route 17.

The HD Radio signal is not highly compressed. You can hear a difference between certain elements in the program, like the business report that comes in on G.722 ISDN. You definitely hear a quality difference that you don't pick up on with the analog signal.

Our newscasts are done from the middle of the newsroom. With the digital signal, you can hear people coming through and things going on in the background that comes across as simply a noisy environment on the analog signal.

And we discovered that the hinges on

See WOR, page 16 ►

The Wizard™ has gone STEREO!

The new DIGITAL FMSA-1 gives The Wizard System unmatched stereo monitoring capabilities. . .



Superlative stereo performance. Linear-phase filters that reveal the true performance of your audio processing. The stability of digital stereo demodulation. The sophisticated graphical presentation of The Wizard. And—with the RS-232 port—operation on site or off.

Contact Belar today for more details on what should be your next modulation monitor



BELAR ELECTRONICS LABORATORY, INC.
119 LANCASTER AVENUE • P.O. BOX 76 • DEVON, PA 19333-0076 USA
(610) 687-5550 • FAX (610) 687-2686

Call, write or FAX for more information on Belar AM, FM, Stereo, SCA, and TV monitors.

www.belar.com

New Simian 1.6

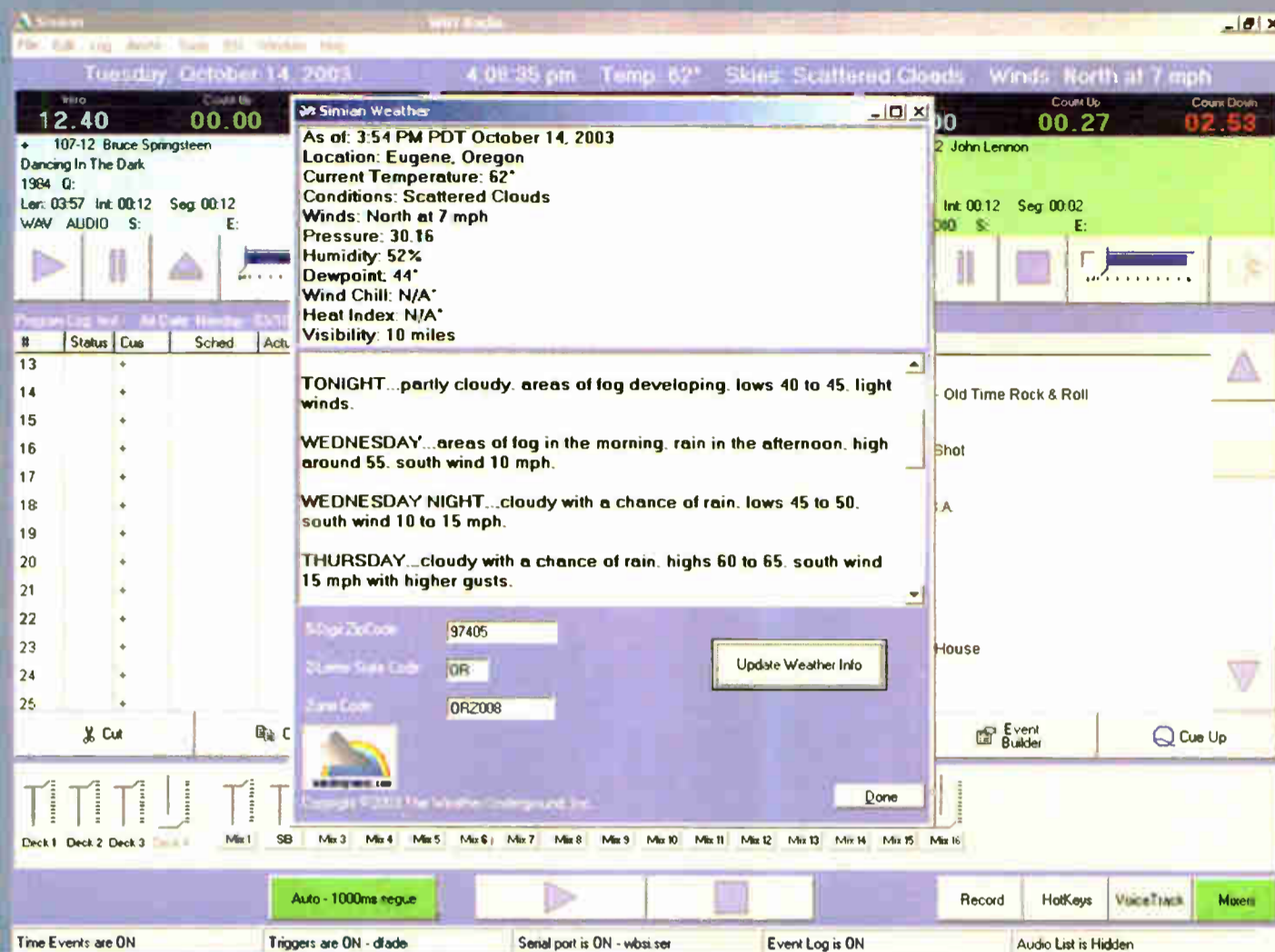

Simian
broadcast
automation

Just \$1499 including technical support and updates for 1 year

Simian 1.6 is the result of input from numerous BSI users. Thanks to their input, Simian now includes an on-screen weather display that updates from the internet.

The new Simian also includes sophisticated new Voice-Tracking functionality allowing Voice-Tracking days in advance, even from remote studios, and an improved ability to verify logs before air play.

Simian is still the most feature-rich automation system in the industry and provides powerful, reliable broadcast automation for stations in the US and around the world.

Thousands of users have discovered how easy and versatile BSI Simian really is.

Broadcast Software International
1925 Bailey Hill Road, Suite A
Eugene, OR 97405
www.bsiusa.com
888-BSI-USA1 (888-274-8721)
info@bsiusa.com

**Test and try
before you buy.**

Dual-Input Antennas for HD Radio: An RF Systems Analysis

by Richard J. Fry

Three main methods have been used so far to combine the analog and digital components of FM HD Radio. The methods could be summarized as high-level, low-level and dual antennas (or space combining). Each method and its implications have been fairly well covered in various papers and periodicals.

Another method has been introduced by an antenna manufacturer recently, with the promise of overcoming some of the undesirable characteristics of earlier methods. In this new method, a single antenna is used and has separate inputs for the digital and analog signals, while maintaining a nominal 30dB isolation between those inputs.

This has two immediate benefits:

- It eliminates the high losses required in high-level combining.
- It ensures that the ratio of analog to digital energy will not be changed from the required 20 dB value at the receiver, by differences in the radiation patterns of separate antenna systems

The RF system in the diagram shows a typical installation using the dual-input antenna as described. The power levels, gains and losses correspond to a 50 kW analog operation in the middle of the FM band.

At first, the 30 dB of isolation between the analog and digital inputs of the anten-

na appears to be sufficient for good performance of this RF system. However, as the antenna has equal gain for both the analog and digital signals, the digital input power at the antenna input must be 20 dB below the analog power at the antenna in order for the A+D signal to be radiated in the correct ratio.

This means that 20 dB of antenna input isolation is offset by the fact that the analog input power must be 20 dB higher than digital. Therefore the amount of analog power present at the output of the digital transmitter is considerably higher than that "30 dB" isolation number first implies.

The powers shown in Fig. 1 are based on 33 dB of antenna isolation, to be liberal. Yet even then, the digital transmitter sees the equivalent of ~ 1.35:1 voltage standing wave ratio as a result of the analog power, alone.

This allows little or no "headroom" for any system VSWR that the digital antenna input port and interconnecting line might have, or for antenna system icing that might temporarily degrade the antenna input VSWR.

Most transmitters are designed to begin reducing their forward power when reverse power at their output connector exceeds about 1.3:1, in which case they may not be able to generate their licensed ERP. *Therefore when using a dual-input antenna, additional equipment, such as an isolator, may be needed at the output of the digital transmitter.*

HD RADIO RF SYSTEM ANALYSIS

Using Dual Input Antenna (Gain = 3.3X)
ERP (AVG) = 50kW Analog, 500 W Digital

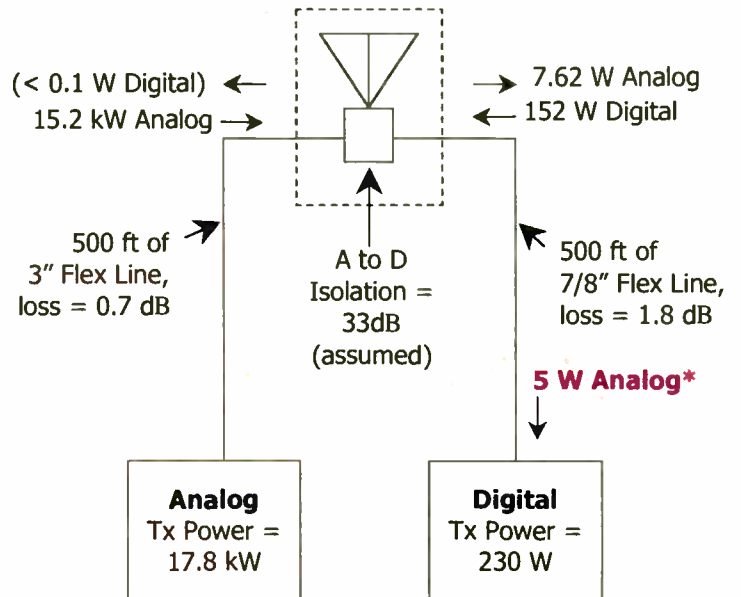

*** 5 W reverse power with 230 W forward power = 1.35 VSWR seen by the digital tx, which may require it to operate in a power foldback mode to protect itself (see text).**

R. J. Fry

To prevent "surprises" during and/or after its installation, stations considering the use of a dual-input antenna should review the complete RF system with their consultant and/or equipment supplier to ensure that their

system is well-defined and will include all the hardware needed to perform as required.

Richard Fry, CPBE, is an RF systems analyst and retired FM applications engineer. Email: rfry@adams.net

WOR

► Continued from page 14

the doorway between Talent Studio 2 and Control 2 needed to be oiled. You couldn't hear the squeak in the analog signal. You do on the HD Radio signal. God forbid anyone should report that the hinges are squeaking.

like shelling out \$5,000 for an HDTV. Let's face it; if you're going to put a good radio into your car, you're going to spend \$350 to \$1,000 with or without HD Radio capability.

And there is no mandate that we shut off the analog channels, so there is no necessity for the public to go out immediately and buy an HD Radio. Our analog radios will not be obsolete, as some



Part of WOR's Digital Display

I'm told that HD Radios will be in stores in the first quarter of 2004. There is a home radio in the works, along with portable versions. I think we'll see the price drop quickly. And I think there's a very good chance the public will go for it.

While the first generation of radios available will be a little pricey, it's not

have stated.

But once the public hears the benefits of non-fading AM and multipath-less FM, I think you will see them start flying off the shelves. This Kenwood is impressive. And the technology works.

Tell us about your own experience with HD Radio. Write to radioworld@imaspub.com.

**Experience Exceptional Quality, Reliability and Service!
Experience Armstrong Transmitter!**

Our single tube high power FM transmitters offer you exceptional quality at affordable prices.

Built for the "real world" environment, these RF workhorses offer long term reliability and features not found in any other single tube transmitter available.

Features Include:

- 1/4 Wave Grounded Grid Tetrode PA
- Fiber Optic PA Arc Detection
- PA Temperature Protection
- Advanced Control System with remote computer interface
- More internal status sensors than any other transmitter
- CD Quality Audio (AES/EBU optional)
- Available from 20 to 35 kW. Combined systems to 60 kW

FM 30000 TX

Armstrong Transmitter.. the best RF products, the best around the clock support and the best prices

....because you deserve nothing less!

ARMSTRONG
TRANSMITTER CORPORATION

4835 North Street, Marcellus, NY 13108 (315) 673-1269 Fax 315 673-9972 www.armstrongtx.com

Care and Feeding of Broadcast Gear

by John Bisset

When buying equipment, I've always made it a practice to choose companies that make reference resources available to customers. Whether it's training, white papers, applications notes or maintenance

what has become an engineering classic, Eimac's "Care and Feeding of Power Grid Tubes." This softcover book is chock-full of good information for anyone maintaining a tube-type transmitter.

In addition to discussing tube construction and operation, the section on cooling is especially useful. Because vacuum-tube education has long been abandoned by most college engineering curricula, or is at best an hour-long lecture in a semester-long course, finding good resource material about the workings of these important broadcast components is imperative.

Eimac's update reflects tubes in common usage, and, for television engineers, an entire new section on inductive output tubes (IOTs) has been added.

Individual copies are available at no charge through Eimac's worldwide distributor, Richardson Electronics. Requests should be made to Richardson at (800) 882-3872 or by e-mail at broadcast@rell.com.

When you call, tell them you heard about the book from Radio World's *Workbench* column.

Since we're on the topic of tubes, have you ever had an FM transmitter that started dropping output power?

Winston Hawkins, technical director for the Baker Family stations, writes to us about a CCA FM 5000G transmitter that exhibited this condition.

Except for the transmitter power output, all parameters were as per the spec sheet. Winston twice replaced the IPA tube (3CX800A7) with a new tube, and tried three new (rebuilt) 3CX6000A7s. The

TPO was supposed to be 4.7 kW and all he could get out of the rig was around 4.2.

Curiously, if he increased the exciter power or rotated the power control, all he got was an IPA-ik that was on the peg, with just a small indicated increase in TPO. Winston uses the transmitter's

with him. They painstakingly covered everything to be checked in the transmitter. During their thorough inspection, they discovered several large, wire-wound resistors that had cracked, as well as several connections in the high-voltage section that were not properly tightened. Although they discovered and corrected a number of small problems, they were disappointed to find that none improved the TPO.

Their search even extended to the out-



Fig. 1: An excellent reference book for maintaining tube-type transmitters is provided by Eimac.

and troubleshooting supplements, these resources help expand our knowledge of a product, making us better engineers. As anyone who has tried to troubleshoot equipment with a blurry photocopied schematic knows, the least expensive is not always the best investment.

A number of years ago, I picked up

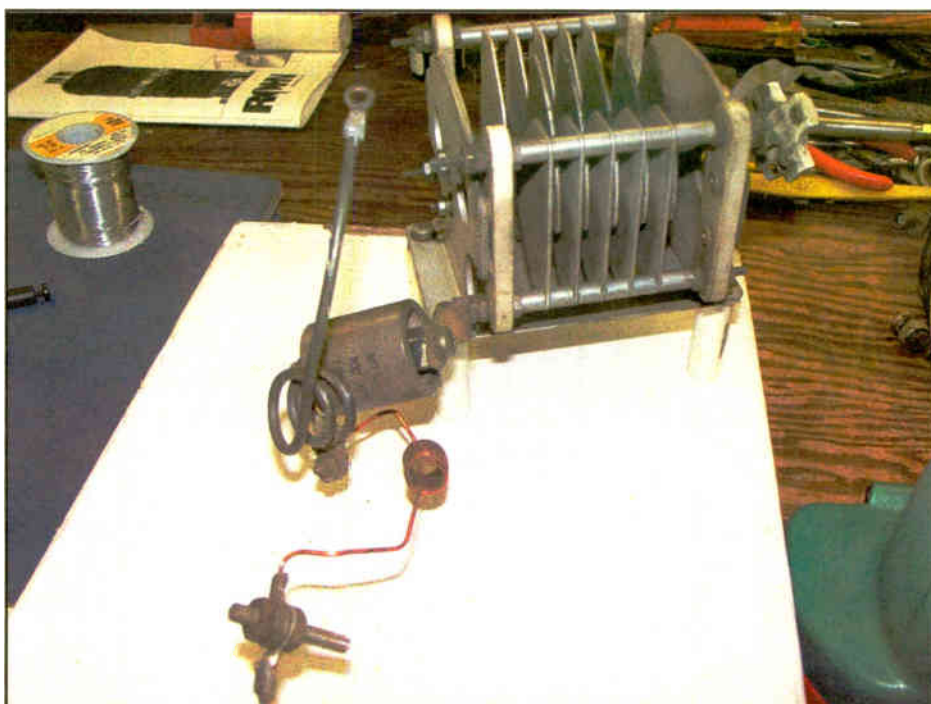

Fig. 2: When inspecting a transmitter, check every component carefully.

directional coupler/meter for forward/reflected power indications, as well as a Bird Watcher coupled to a separate line section. Both meters tracked.

Operating under the premise that two heads are better than one, Winston contacted Larry Schropp, a very capable contract engineer, to go over the transmitter

put harmonic filter, so they placed a dummy load on the RF output of the transmitter through the Bird line section, and saw the same power level as before, 4.2 kW. To eliminate the Bird Wattmeter, they sent the line section, cables and meter panel back to Bird for calibration.

See *Workbench*, page 18 ▶

NEW!

**PREVENT LIGHTNING DAMAGE!
IMPROVE RELIABILITY!
STAY ON THE AIR!**

NEW! PowerClamp surge suppressors prevent lightning-induced AC spikes and surges from damaging your equipment!

PowerClamp virtually eliminates the transients, surges, and waveform distortions that cause transmitter and studio gear failures, computer lockups, and unexplainable malfunctions.

PowerClamp will protect your investment and keep you on the air!



For user testimonials and detailed information, visit www.henryeng.com or contact any Henry Engineering dealer.



POWERCLAMP

Tel: 626-355-3656

Giant Coils

This is part of a series of photographs of radio broadcast facilities and radio history from the collection of Jim Hawkins.

In 1998 I was invited to a tour of the NSS Naval Radio facility in Annapolis, Md., just after its closing. As we entered the 1 megawatt transmitter, some unique, giant components that appeared to be out of a science fiction movie were visible. One of those components was a variometer, which consisted of two concentric coils of approximately five feet in diameter in a giant 10- or 12-foot-high wooden frame.

In the Nov. 5 Radio World, I discussed capacity hats as a means of reducing capacitive reactance for antennas that are shorter than the transmitted wavelength. Because of the very long wavelength, approximately 8 miles (22 kHz), Very Low Frequency stations such as NSS use a combination of capacity hat and variometer to cancel out capacitive reactance.

The photos show one of the variometers used in the NSS transmitter. A variometer is a variable inductor, consisting

of a fixed "stator" coil and a movable "rotor" coil inside the stator.

In variometers, the coils are wired in series. Rotating the inner coil either adds to or cancels part of the total inductance. If the two coils are not connected, it is called a variocoupler or shunt variometer. Small variocouplers were common in early radio receivers.

In the variometer, the total inductance is the sum of the two individual inductances and the two mutual inductances: $L_T = L_1 + L_2 + 2L_M$. When the rotor is turned, the mutual inductance for both coils L_M varies, with L_1 and L_2 remaining constant. The variometers were continually readjusted by engineering personnel to compensate for varying weather conditions, because the Q of the antenna system was so high. It did not take much ice, moisture or wind to detune the narrow bandwidth tuned circuits.

Note that the physical form of the coils is spherical rather than cylindrical to keep the coil coupling distance consistent and close throughout the angle of rotor position. Also, the coils use litz wire, a bundle of thousands of fine insulated wire strands. This provides a vastly larger amount of conducting surface, reducing

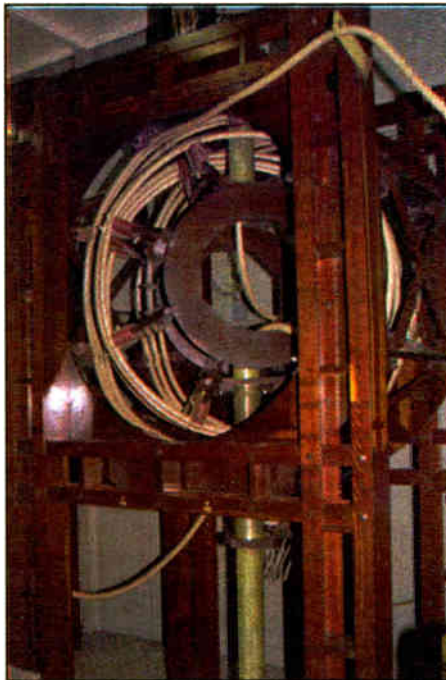

the resistance and therefore increasing the Q of the tuned circuit.

When NSS was decommissioned and dismantled in 1998, the variometers at NSS were salvaged for use at time station WWVB in Boulder, Colo. WWVB sup-

plies the 20 kHz time signal that synchronizes the increasingly available "atomic" consumer clocks and watches.

Visit the author's Radio and Broadcast Technology Page online at www.jphawkins.com/radio.html.

Workbench

► Continued from page 17

Although the calibration ran around \$350, they could not say if they had found anything wrong with the unit, another disappointment.

In the meantime, Winston had read somewhere of someone having a problem with a transmitter making full power with rebuilt tubes. The engineer chose a new Eimac tube and was able to get full power. Having exhausted his other options, Winston ordered a new Eimac 3CX6000 A7. With that installed in the transmitter, he was able, with no adjustments, to make full power immediately.

Winston's experience is not a condemnation of rebuilt tubes; in many cases they work just fine. But if you experience trouble making full power using a rebuild, you may want to try a newly manufactured tube.

Winston Hawkins can be reached at winhawk@parfm.com.

★★★

Does your SBE chapter have a problem finding good programs for your

monthly meetings? Finding a good program that's interesting and informative can be a challenge, so here's an idea: Contact Terry Baun of Criterion Broadcast Services.

Terry has developed a series of tutorials for broadcast engineers. Most recently, he delivered a session to the Ohio Broadcasters on the duties for a Designated Chief Operator as well as a review of FCC rules. More than 60 radio and television engineers registered. The course qualifies for SBE recertification credit, and certificates of completion are available.

Terry has developed a broad spectrum of course subjects. They include broadcast RF fundamentals for the non-engineer; broadcast engineering for broadcast managers, helping non-engineers understand the technical plant; management skills for the broadcast engineer; and broadcast networking fundamentals, which prepares the attendee for the SBE Broadcast Networking Technologist Certification Exam.

To help defray the cost of the sessions, most SBE chapters either combine forces with other chapters in the area, or work with their state broadcast association to co-sponsor the meeting. Terry has put together an informative brochure on his

tutorials. You can request a copy from tbaun@critterion-broadcast.com or telephone (414) 559-5303.

★★★

Remember that dusty computer that's been stuffed in a corner of the studio or under the console? It needs as much attention as any other component in the studio.

Radio World columnist Alan Peterson shares the picture in Fig. 3, a macro view of a hard-disk controller chip that has been removed from a drive on an audio workstation.

The chip has been zapped into oblivion. From what Alan could tell, a dust bunny got drawn into the PC by the fans, along with a fine strand of something that was conductive. It came to rest between this drive and the one below it and eventually grounded out, leaving the pitted scar you see on the chip package. Under magnification, it looks like a high-speed aviation impact with the ground.

Needless to say, up to 30 GB of important audio was lost on this drive. When something like this happens, it's every man and woman for themselves. All the more reason to keep a good supply of canned air, dust brushes and a mini-vacu-

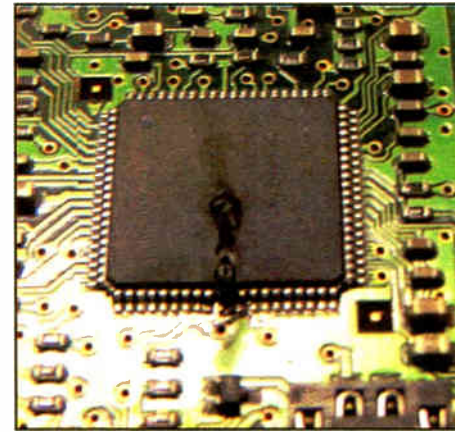

Fig. 3: This looks like the work of a dust bunny.

um in the shop. It's astounding what 5 VDC can do, a good reminder that everything needs routine maintenance.

John Bisset has worked as a chief engineer and contract engineer for more than 30 years. He is the northeast regional sales manager for Dielectric Communications. Reach him at (571) 217-9386, or john.bisset@dielectric.spx.com.

Submissions for this column are encouraged and qualify for SBE recertification credit.

Digitally Different Omega_FM - \$5880

NEW!
v2 Software

OUR GOAL WAS TO DEVELOP A DIGITAL PROCESSING SYSTEM FOR FM THAT WOULD RIVAL ANYTHING ON THE MARKET. WE MET THAT GOAL...AND THEN SOME.

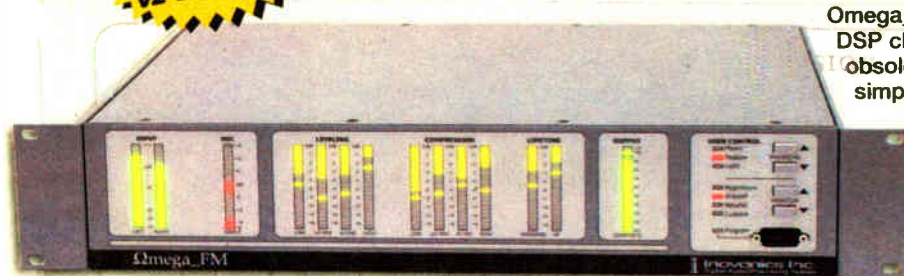

Omega_FM is a 100%-digital, software-based design. It doesn't use DSP chips or other application-specific parts that rapidly become obsolete. Upgrades don't plug into 'expansion slots,' they're simply uploaded.

Omega_FM is straightforward and uncomplicated. Hardware simplicity keeps the signal path short and your audio clean. Low latency lets you monitor off-air.

Omega_FM is loud, clean and versatile. We don't expect you to take our word for this, and you shouldn't. Schedule a demo at your station through an equipment supplier of your choice.

Inovonics
1305 Fair Ave. • Santa Cruz, CA 95060
TEL: (831) 458-0552 • FAX: (831) 458-0554
www.inovon.com • e-mail: info@inovon.com

SEE IT... Hear It... Processing doesn't get any better than this.

A New Year's IBOC Scorecard

An Active Year for Digital Radio Comes to a Close; Here's a View of HD Radio's Ups And Downs

by Skip Pizzi

The past year certainly was a tumultuous one for digital radio. Here's how this observer rates the performance of progress toward transition for the period just ended. It's a classic case of good news/bad news.

The good first

In September, Ibiquity announced that its PAC codec would be replaced with a new proprietary codec called HDC, and by all accounts its performance is improved over PAC's at all bit rates. No actual subjective test results have been provided, however, so this conclusion is so far based on hearsay from listeners who were carefully selected by Ibiquity (I was not among them).

Nevertheless, many of these listeners are widely trusted names in the industry, and their results are highly corroborated. This announcement ended the hiatus on standardization work that the National Radio Systems Committee had imposed due to dissatisfaction with the PAC performance at bit rates below 96 kbps.

The path to data broadcasting, Ibiquity style, also was initiated in mid-year, as the company released some basic documentation on how it foresees data and applications being incorporated into the HD Radio format.

and Harris all report that Ibiquity staff was helpful and supportive in these tests.

On the receiver side, Kenwood has begun shipping its first HD Radio receivers in small quantities, and the first OEMs have announced Ibiquity's certification of their components, meaning that high-volume production likely will begin in mid-2004.

Now the bad news

Although the NRSC's suspension of its standardization work officially ended in September, the IBOC Standards

Development Working Group (ISDWG) has held only one meeting since, and no additional progress toward a standard has been made since the hiatus was initially called in May 2003. The codec flap at the ISDWG immediately was replaced by a conflict over intellectual property disclosure and general openness of the HD Radio system (particularly on its new and still proprietary audio codec, as well as its datacasting architecture).

Although there has reportedly been some progress in subsequent discussions between Ibiquity and the NRSC, the standardization process remains at a standstill. While 2003 saw significant movement for

See IBOC, page 23 ▶

The Big Picture



Photo: Gary Hayes, BBC

by Skip Pizzi

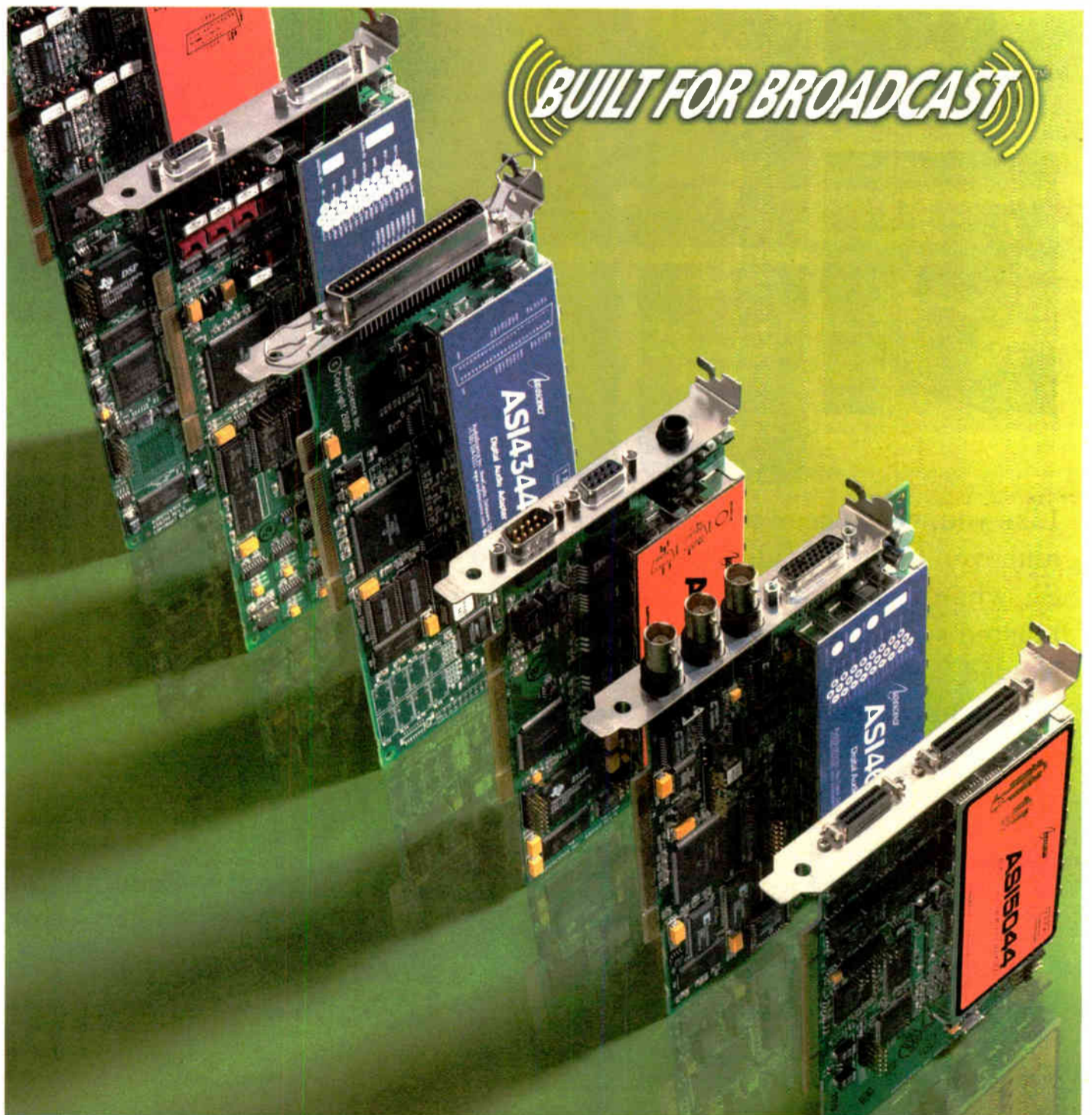

While it now seems nearly certain that HD Radio will reach fruition, there are still a few lurking issues that could slow its adoption or even derail it.

Dual antenna testing also presented positive results. Within certain guidelines — which are strict but not untenable — this option may reduce implementation costs significantly for some FM stations. After some additional work is completed, rule changes will need to be made; they are not expected to encounter strong opposition.

Meanwhile, tests of the Tomorrow Radio project seem to be showing a good outcome. Much of the detailed data is still being processed, but initial results show favorable performance for supplemental, digital-only audio service(s) on FM-IBOC, with coverage that largely duplicates Grade A analog contours. Project principals from NPR, Kenwood

Every AudioScience soundcard is Built for Broadcast™ to expand your audio options and automation capabilities. Features like new **TSX™** time scaling algorithm* give you pitchless stretch and squeeze by up to 20%. With **MRX™** multi-rate mixing you can record, play and mix multiple audio streams to 1Hz precision. And advanced **SoundGuard** multilayer Transient Voltage Suppressors (TVS) dissipate power peaks of over 1000W. Our onboard DSPs let you record and play the latest compression formats including MPEG-1 Layer II and MP3, with multistream capability. Expand your sonic options. Call us at +1-302-324-5333 or go to www.audioscience.com.

*Contact your AudioScience dealer for this feature



Huge Selection. Low



Like you, we've been doing this broadcast gig a long time. Tight budgets and even tighter deadlines make your, and our jobs...well...interesting. So, when you've cut it right down to the wire, depend on BSW to be your trusted supplier. We have a large warehouse with all the gear you needed 'last week' and people who will make the extra effort to get it to you quickly. And at low prices that will leave enough in the budget for that quad tall nonfat light whip mocha* for the 'late night' install.

*These days it is almost impossible to order a "cup of coffee". What is this world coming to?



Secret Undocumented BSW Employee #52: Jim travels extensively making deals with manufacturers in even the most remote locations, to bring you the best possible selection. We aren't quite sure what helicopter airlifts and climbing gear have to do with consoles, but they're on his expense reports...



NEW

Distinctive New Broadcast Condenser Mic

Neumann designed the distinctive new BCM104 large-diaphragm condenser microphone from the ground up specifically for broadcasters, resulting in an impressive piece of professional equipment that will look great in the booth and sound even better. It features a large-diaphragm K07B capsule, an integrated pop screen and a quick-release head grille

for easy cleaning, with optional individual grilles available for each user. 20 Hz-20 kHz frequency response; dynamic range 133 dB. Limited availability.



BCM104 List 999⁹⁹

799⁹⁹

Industry-Leading Codec Delivers 15 kHz Over Dial-Up Phone Lines

The Comrex BlueBox combines a high speed modem with a digital audio codec to produce 15 kHz audio from a standard dial line. For a super economical price you also get a cellular hands-free interface to send high-quality audio over wireless services. And at just 1.5 lbs., it won't weigh you down. The BlueBox offers one mic/line switchable input, one headphone output and one line level output on XLR, providing direct connection to mics and headphones or a mixer. A -10 dbu tape input allows connection to a MiniDisc or DAT player.

Purchase any Comrex codec between November 6, 2003 and January 31, 2004 and receive a FREE BeyerDynamic DT290 headset (a \$189.00 value)! This is an exclusive BSW offer. Call today.

BLUEBOX List 2,800⁰⁰

Call for Price



FREE Beyer DT290 Headset



COMREX

Hurry - Time is Running Out!

VoxPro E2

Only \$149⁰⁰!

Cut Your Audio and Get On The Air Fast with Affordable New VoxPro Software

Audion Labs, the makers of VoxPro PC, now have a great introductory, two-track digital audio recording software package that can be used on any laptop or desktop PC using most sound cards, for fast, easy editing. VoxPro E2 lets you cut your audio and get it on the air right away, at a great low price. **Features:** record instantly in any mode; shows file most recently recorded in sound window ready to edit; imports and exports

Telos

Save Over \$1,800⁰⁰ with bundle!

Incredible Offer on Telos Xport and Xstream Bundle

Telos' Xport/Xstream combination is a perfect, trouble-free way to cover any remote event that comes your way. By buying the rackmount Xstream studio codec and the POTS-only Xport field codec with BSW's limited-time special bundle pricing you save over \$1800.00!

You'll get the best-selling Zephyr Xstream for your studio, and the satisfaction of knowing you can make CD-quality ISDN connections to virtually anywhere using industry-standard MPEG Layer 3 or AAC coding. And for your remote kit, the award-winning Xport has a built-in two-channel mixer - perfect for



Sim
The per
ability
media
progr
CD-R
output
search
PMD9
Por
Dev
Thi
the d
disast
at all
no fat
15 Hz
mini-
K240S

Prices. Real People.



popular file types including .wav and .mp3; records and plays back in stereo and mono; in two-track mode automatically separates host/caller talk-over with "Voiceslip"; much more.

VOXPROE2 List 179⁰⁰ **149⁰⁰**



sponsored remotes, sporting events, interviews and live appearances. Just plug in to any POTS phone line for an aacPLUS link to your Xstream back in the studio, and you'll get stunning audio and rock-solid connections.

BSW has special pricing on this limited-time bundle. Call today and talk to your sales representative for more details and to get in on this fantastic deal before it's gone.

XPORT-XSTREAM List 6,850⁰⁰ (if purchased separately)

Call for Special Bundle Pricing



Single-Space Rackmount Pro DVD Deck

The new PMD910 from Marantz delivers professional, reliable DVD performance in a single-space rackmount unit. With the PMD910's ability to also play CDs and MP3s, this will become your most versatile DVD player. This professional deck boasts top-of-the-line features like progressive scan; 3:2 pull-down; compatibility with DVD-R, MP3, AAC, and more; 48 kHz and 96 kHz PCM audio; optical/coax digital I/O; RC6 I/O; component and S-video output; rapid track and time search; and IR remote. Includes custom rackmount kit.

List 429⁹⁹ **369⁰⁰**

Popular Headphone with Detachable Cable

This is our most popular semi-open headphone, and its detachable single-sided cable prevents equipment damage. The AKG K240S offers accurate reproduction of listening levels and good comfort with virtually no fatigue after prolonged use. Frequency response is 20-20 kHz, and impedance is 55 ohms. Includes carrying case with 1/4" screw-on adaptor for secure use.



List 159⁰⁰ **99⁰⁰**

BROADCAST tools inc.



Affordable Six-Line Call Director

The Broadcast Tools TeleSwitch 6 routes up to six phone lines to most telephone hybrids. It can handle one hybrid and a standard single line call screening telephone set. If full call screening is not required, a second hybrid may be connected. The TeleSwitch 6 is supplied with one desktop switch console and a 1-RU controller. It even includes free screening software! Talk to our knowledgeable sales reps today.

TS-6 List 1,059⁰⁰ **899⁰⁰**



Your Choice Only \$199⁰⁰

Powerful Amp and Precision Studio Monitors

Get ART's popular SLA1 power amp and SLM1 monitors in this great offer from BSW - only \$199.00 each!

The ART SLA1 offers 100 watts of power in a compact 1U rackspace design. It provides clean, quiet power with low noise/distortion and features balanced XLR and 1/4" TRS inputs, a ground lift switch, fan cooling, Toroidal Transformer, and power/clip/signal/protect LEDs.

The SLM1 passive studio monitors are shielded for near-field use and deliver sonically-neutral sound for truly accurate monitoring. Well-balanced interaction between low/mid/high frequencies results in solid mixes that translate well to other systems. These speakers feature wide frequency response of 40 Hz-20 kHz, 6.5" woofers, 1" soft-dome Ferrofluid-cooled tweeters, and tuned cylindrical ports.

SLA1 power amp List 279⁰⁰ **199⁰⁰**
 SLM1 speakers List 299⁰⁰ **199⁰⁰/pair**

MACKIE.



Top-Selling Compact Mixer

This 12-channel mixer is excellent for smaller projects, home recording or broadcast remotes. Superior microphone preamps deliver even lower noise and higher headroom than Mackie's previous design. The 12-channel 1202VLZPRO includes 4 XLR inputs with extended dynamic range preamps and phantom power, 12 high-headroom line inputs (4 mono and 4 stereo pairs), advanced DC pulse transformer RF rejection, 3-band EQ and more. Order today.

1202VLZPRO List 489⁰⁰ **399⁰⁰**



Stock Up On Quality Middle Atlantic Rack Accessories

The Middle Atlantic U2 heavy-duty metal 2-space rack shelf will hold your critical recording and audio processing equipment. It fits equipment up to 17-3/8" wide. Save a bundle by purchasing the special BSW U2 4-pack!

The EB2 is a 2-space metal blank rack panel, available in a money-saving 10-pack. Other sizes available.

The HW500 is a cup of 500 3/4"-long screws with 10-32 threads. A pre-installed nylon cup washer speeds installation and provides a clean, professional appearance for your rack equipment.

U2PACK	4-pack, 2-space rack shelves	89⁰⁰
EB2PACK	10-pack, 2-space blank panels	69⁰⁰
EB1PACK	10-pack, 1-space blank panels	49⁰⁰
HW500	500 screws/washers	89⁰⁰

BSW offers package pricing • Let us save you money on your next quote

800 • 426 • 8434 or online @ www.bswusa.com

Broadcast Supply Worldwide.
Your Best Source for Professional Audio Products.



The 61st Annual NATIONAL RELIGIOUS BROADCASTERS

Convention & Exposition

February 13–18, 2004

Charlotte, NC



NRB

Faith and family programming is gaining audience share, and NRB's Annual Convention & Exposition is the best place to meet the foremost producers of quality, faith-based, family friendly programming.



With a new peer-to-peer Innovation Exchange, intensive Boot Camps, crucial Super Sessions on Public Policy and Leadership, and more than 40 Educational Sessions, NRB provides serious communications training.

But the Convention is only half of the attraction. NRB's award-winning Exposition – named one of the **50 Fastest Growing Expositions by *Tradeshaw Week Magazine*** – is a vibrant marketplace of nearly 300 vendors. Browse 140,000 square feet of exhibit space to find the vital tools and services to grow your audience.



Don't miss this opportunity to meet the people who can give your audience what it wants: quality, faith-based, family friendly programming.

Register today and grow your audience with NRB 2004!

www.nrb.org • 703-330-7000

Radio in the Land of Terabytes

*Managers Must Consider New Issues
When Shopping for Audio Storage Systems*

by Tom Vernon

The rapid march of technology sends echoes reverberating through the broadcast industry, including the area of digital audio storage systems.

Just a few years ago, the merits of different audio compression schemes were being debated hotly, and the storage capacity of hard drives was measured in megabytes.

Times have changed. Managers need to weigh entirely different issues when looking at replacements for these systems. We checked several industry experts to comment on those issues.

Perhaps the biggest change in recent years is in the storage capacity and reliability

of hard drives.

Once specified in megabytes, or million-byte units, systems now are measured in terabytes. A TB is a unit of information storage equal to 1 trillion bytes.

For audio storage applications, a RAID — Redundant Array of Independent Disks — typically is used. This is an arrangement of several hard drives in the same system that act as if they



Jim Hauptstueck



Ron Paley

were a single drive. The result is increased protection against drive failure.

Older SCSI controllers have been replaced by IDE controllers, meaning hard disks in RAID arrays are hot-swappable, adding even more reliability.

Gavin Lawrence, manager of BSI operations in the United Kingdom, notes that drives themselves are more reliable and affordable.

"Older drives had a mean time between failures of 6 to 9 months, but current drives have a MTBF of 13 years. At the same time, prices continue to drop."

Increased capacity and falling prices mean users essentially can purchase as much storage capacity as they need.

Meanwhile, the debate over audio compression standards seems to be over.

According to Ron Paley, co-founder of OMT/Media Touch, the advent of IBOC digital radio, with its requisite for unsurpassed audio quality, and the expansion of available storage space has made linear PCM the choice for most broadcasters. Dolby AC3 is a recently popular contender, Paley said.

Uncompressed audio easily can be converted to other standards when transmission over limited bandwidth becomes necessary. However, there are still a few places where compression will be necessary or acceptable, Lawrence said.

"64K MP3 files will continue to offer satisfactory performance for shortwave broadcasters, and compression may be used for transfer of data from rural sites."

The needs of clusters and network operations are specific.

Mark Kalman, who heads Sirius Satellite Radio's engineering department,

emerge in upcoming years, and HD Radio rides the coattails of demand for new satellite radios into consumers' cars and homes.

As another measure of comparison, Eureka-147 DAB receivers in Canada and Europe are showing some signs of life, as prices drop to broadly affordable levels. Although the DAB story is still a mixed bag from country to country, the regions showing the most success are, not surprisingly to readers of this column, those where new services available only via DAB are offered, such as the United Kingdom. Spurred by the snowball of increased demand, these are also the same regions where receiver prices are lowest. The mantra of this column continues to be proven: "Quantitative, not qualitative, change drives the mainstream market toward adoption of new services."

Finally, although Ibiqity's engineering staff has been effective in producing much of the good news noted above, the company has lost some key and veteran staff in 2003, ostensibly due to downsizing. Most notable was the departure of Glynn Walden, officially called a resignation but widely believed to be a RIF. His absence has left a void, and it will likely be long felt.

Split decision

So while it now seems nearly certain that HD Radio will reach some sort of fruition in the U.S. radio industry, there are still a few lurking issues that could slow its adoption or even derail it. Although the outlook is more stable and upbeat than it was last year at this time, HD Radio's prospects and timeframe for wide-scale adoption by consumers are still anyone's guess. Meanwhile, deployment continues, albeit quite cautiously, with the likely additional option of dual-antenna installation ahead, and a potentially improved ROI thanks to the Tomorrow Radio project. Receiver availability and penetration will be key issues to watch in the coming year.

Clearly it's been a mixed year for HD Radio, with high marks for engineering developments, but less stellar results for business issues. An optimistic assessment might consider any forward movement as positive, given the length of the process vs. its progress to date. Nevertheless, a more balanced approach is needed in 2004 and beyond if this transition is to be ultimately successful.

Skip Pizzi is contributing editor of *Radio World*, which welcomes other points of view.



TECHNOLOGY FOR MANAGERS

said, "Our system supplies 250 to 300 users, including workstations, on-air playout and in-office machines, and feeds over 100 radio stations."

The Sirius system has 8 to 9 terabytes of storage and contains hundreds of thousands of files. Many of the daily operations are automated, including the remote recording and playback of audio feeds.

Big and small

"Our architecture contains primary and backup audio servers, primary and backup database servers and a network automatic reroute feature for port failures. There are 120 playout servers with hot standbys."

If a playout server fails, the system automatically will switch to a hot standby, which will take the identity of the server that failed and route data to the proper destination. The entire system has been designed so that there is no single point of failure.

Kalman noted that the Sirius system survived the recent New York blackout without a glitch.

A phrase heard more often now is "asset management." As consolidation continues and media companies merge, radio broadcasters will face a growing need to store and retrieve other types of files from the database, such as graphics, still pictures, text, animations and video.

See STORAGE, page 24

HIGH VOLTAGE RECTIFIERS

WE HAVE CCA RECTIFIERS

Nobody Knows Them Better Than We Do

Once again, HV Components/CKE brings you a reliable retrofit rectifier package for your transmitter that saves you money and delivers the performance and reliability you've come to expect from us. Our Model 51016 shown here is a three-phase full wave bridge designed to easily drop into your AM, FM or television transmitter. Conservatively rated for power supplies of up to 12 KV and 9 amps output, this retrofit package fills the bill for most any application.





Quick, Cost-Effective & Expert Solutions

www.rectifiers.com

800-649-6370

Storage

► Continued from page 23

Tracking these resources requires an asset management system, which will index media and create meaningful meta-data, encapsulated information about data, which is vital for future repurposing and usability.

Features to look for include voice recognition searching and audio-to-text conversion. Asset management systems have been available for several years, making inroads in large network television and multimedia operations, but they remain largely neglected by radio broadcasters.

'Info Viz'

As the number of assets stations must manage continue to grow, the current Graphical User Interface or GUI will become strained, and a more visual, less text-based means of displaying search results will become necessary, industry experts say.

At present, there is little cross-pollination between the worlds of asset management software and information visualization, the latter remaining in university research labs and military applications. This situation should change as the science of "info viz" matures and demand for a better interface increases.

Strategic planning

As managers contemplate purchases of digital storage systems, they need to compare features and try to anticipate future applications.

Paley said efficiency is a hot issue.

"The 'do more with less' maxim is only going to continue, and customers

need to ask what new systems can do to make operations more efficient."

This ease-of-use factor should be considered from perspective of both the operator and the engineer. A "plug and go" installation may be desirable.

Jim Hauptstueck, resale products manager for Harris Corp's Broadcast Communications Division, said that as bandwidth explodes and demand for content increases, radio managers need to recognize their content as a valuable asset.

content, there are a lot of untapped opportunities out there."

Hard drive vs. Flash

Hard drives have been the de facto standard for mass storage and retrieval of data, but will they be a few years from now?

The buzz in IT trade publications and Web chat is centered on Flash memory, a technology that stores data in silicon chips and has no moving parts. It has made great strides, but industry experts

Kalman of Sirius also has a wait-and-see attitude.

"There is a danger in being too cutting-edge. What's important for us is staying on the air. Flash has no proven track record for broadcast audio applications."

Backup and recovery

One point on which industry experts agree is the need for a formal disaster recovery strategy.

Some stress that many stations and groups don't seem to take this issue seriously. While the failure of hard drives themselves may be less likely, broadcasters should be prepared for natural disasters, fires, hacker attacks, employee sabotage or terrorist threats. Stations also need to consider that in the case of larger facilities, the value of the media assets can exceed the cost of the storage system.

Paley recommends a three-tiered strategy for recovery. First, operate twin servers for instant backup. Second, copy all data to workstations. Third, keep copies of all information off-site. He also urges users to keep key applications and data available on a notebook computer, which can be used to run the station in a pinch.

Hauptstueck urges users to consider full storage greater than 50 miles from the main site, and to account for the amount of time it would take for a full recovery of data. Although not part of the audio storage system, a backup generator and UPS should be the first line of defense against power outages.

Where do you see the science of audio storage headed? Tell us at radioworld@imaspub.com.

Just a few years ago, the merits of audio compression schemes were debated hotly, and storage capacity was measured in megabytes. Times have changed.

"When planning for new systems, managers need to understand that the value of content can more than double over time. It may be important to make a comparatively low capital expenditure now in order to capitalize on the opportunity to generate revenue down the road."

This is an area where taking the 50,000-foot view is important.

"Most broadcasters aren't thinking outside the box as much as possible. Today we use the technology to share talent and commercials between stations, but when you think about repurposing

remain skeptical.

"Flash technology will continue to gain acceptance for field recording applications," Hauptstueck said, "but won't be a serious contender for mass storage of audio any time soon."

Paley of OMT said that with a half-gigabyte capacity (and growing), chip technology holds great promise, but the long-term stability of the medium is still unknown.

BUSINESS DIGEST

Lawo Moves Into North America

German manufacturer Lawo is seeking to increase its presence in the North American market.

The company has opened a subsidiary, Lawo North America Corp., in Toronto on the heels of a similar move into Australia.

Lawo makes digital mixing consoles and routers. Its lineup includes large production and broadcast consoles of the mc² series, diamond and zirkon series for mid-sized



Constantinou Prodromos

applications and the z4 mini mixer for editorial workplaces and dubbing studios.

Philipp Lawo, the CEO of Lawo AG, named Constantinou Prodromos as president of the subsidiary. Prodromos has worked for several pro audio and broadcast suppliers since 1966.

Maria Xithalis was named general manager and Doug Smith is technical director.

The company's phone number is (888) 810-4468.

STATION/STUDIO SERVICES

WISHFUL THINKING
WON'T INCREASE
YOUR BILLING....
...but market-exclusive
GBS SALES BOOSTERS WILL!

Don't Drink & Drive Winter Safety Tips
Shop Your Hometown Merchants Lots More!
CALL TOLL-FREE 1-888-472-2388

FREE DEMOS & INFO www.gracebroadcast.com

WINTER SAFETY TIPS
THIRTY (30)
ONE MINUTE
FEATURES
(:40/:20)
Home Emergencies
Car Emergencies
Recreation
Health & Safety
Market Exclusive
\$299 buyout
(Call for
Market Availability)

DON'T DRINK & DRIVE
Market Exclusive!
FIFTEEN (15) :30-sec. FEATURES
Fully Produced Compelling!
Room for SPONSOR TAG
at end of each cut
USE IT PROFITABLY YEAR ROUND!
FREE DEMOS at
www.gracebroadcast.com

100% Royalty-Free Commercial Production Music
Buy any single CD for \$49.
Get any 4 for \$149.
Get 8 for \$249.
Get all 16 for \$399.
Complete track listings
and demos are online at
www.radio-mall.com
or call 1-800-759-4561

ATTENTION PROVIDERS!

Promote your services to **Radio World's** readers. Reach Radio Station and Recording Studio owners/managers and engineers with your message.

For information on affordable advertising call **Simone** at **1-703-998-7600, ext. 154.**

WE GIVE YOU HAWKINS

Name: Jim Hawkins

Role: RW photo series on broadcast technology

Experience: Technical writer and scientific software developer; 3D modeler and animator; photographer. Developed Jim Hawkins' Broadcast and Radio Technology Web Site in 1994, presenting images of transmitting facilities.

Interests: Radio amateur (WA2WHV) for 43 years. Enjoys learning difficult concepts and explaining them. Vacuum-tube collector.

Mentors and heroes: "Emil Rudat (W8MCC), electrical engineer at RCA Tube Division, Harrison, N.J.; Carl D'Esposito, EE; Philo T. Farnsworth; and Clive Knowles, my first manager in software development."

Favorite stations growing up: AMs WNEW, WABC, WPAT, WQXR for a wide mix of formats. "Rock to Bach."

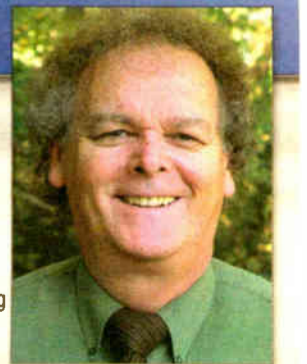

Radio World's pages are home to the finest writers and columnists in the industry. Like Jim Hawkins. Just one more reason we're the newspaper for radio managers and engineers.

Grundig Licensee Thrives

by James Careless

Famed German radio maker Grundig may have gone bankrupt, but in North America the Grundig name lives on.

The reason? Since the mid-1980s, Grundig shortwave radios sold here have been designed, manufactured and distributed by Eton Corp.

"Eton is independent of Grundig Germany and is a licensee for Grundig AG shortwave radios in the North American markets, as well as certain markets outside of North America except EEC markets," explained a news release issued shortly after Grundig's April bankruptcy by the Palo Alto, California-based radio firm.

"Eton, as an independent company, will continue to supply products and fulfill all obligations to its customers as usual."

Eton won't just continue to sell Grundig-branded shortwave radios in North America, but it will likely also remain the continent's dominant player. Thanks to the business savvy of founder, president and CEO Esmail Hozour, Eton has transformed North America into "the one region in the world where Sony is not number one," said Larry Magne, editor-in-chief of Passport to World Band Radio.

The company "has taken the market, and walked away with it. They own North America, pure and simple," he said.

Radio powerhouse

Few would have foreseen Eton's rise to dominance 19 years ago, when Hozour founded the company under the name Lextronix.

"Our primary emphasis was to distribute Grundig-branded products," he said, "TVs, VCRs and some audio products including shortwave radios."

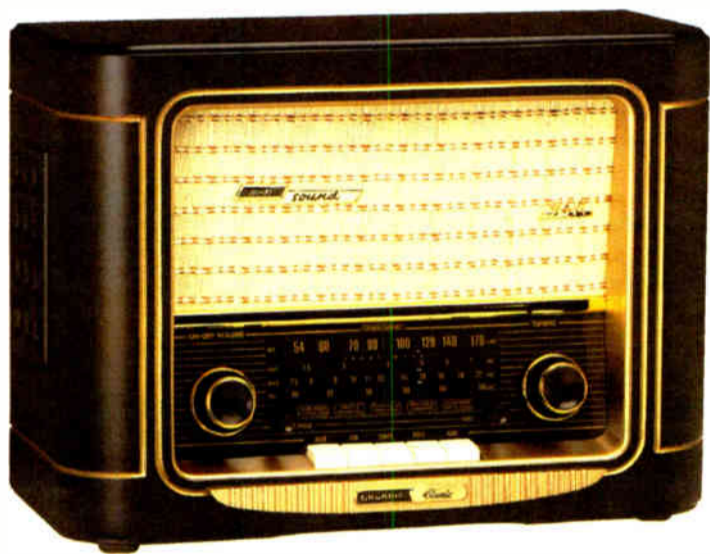

The Grundig Classic 960 is a remake of a 1950s million-seller.

In general, Grundig products didn't sell in North America. They cost more than the competition's, without offering consumers clear reasons for paying extra. As a result, by 1990, Hozour decided to stop carrying Grundig video products and "instead concentrated 100 percent on our shortwave radios."

Why? It's a good question; by the mid-1980s, shortwave radio was viewed as a dying medium. It was the province of DXers — people who hunt for distant broadcasts, DX being an old Morse Code



Eton's biggest seller is the FR200 receiver that includes an LED flashlight and hand-cranked generator that tops up its batteries.

term for distant station reception — and other fringe hobbyists, not the general public. Small wonder that Zenith had exited the market and that Panasonic eventually pulled out in 1997.

Today, there are only three big names in shortwave radio manufacturing: Grundig, Sangean and Sony.

However, shortwave radio still commanded 600 million listeners worldwide,

Magne said. "Technology that you could charge \$20-30 for in an AM/FM radio can easily be priced at \$100-\$200 in a

line \$500 Satellit 800 digital receiver. The \$79.95 Grundig P2000 is a sleek silver slab designed by Germany's F.A. Porsche. In contrast, the \$149.95 retro-styled Grundig Classic 960 — a remake of the 1950s million-seller Grundig 960 — comes in a real wood, glass, cloth, and brass-trimmed case.

Right now, Eton's biggest seller is the homeland security-targeted Grundig FR200. For \$39.95, the FR200 comes with AM/FM/SW, a built-in LED flashlight and a hand-cranked generator that tops up the set's rechargeable batteries. Despite its mock military styling, the FR200 is a solid performer with good audio, and even a SW fine-tuning dial.

Another prong is quality outsourcing; Eton says it has reduced costs by contracting production to offshore firms. "They are very reliable, and provide high-quality products," said Hozour.

The third prong is promotion. Eton's success is based on "marketing, marketing and marketing," Magne said, including large ads in Time, Newsweek, the New York Times and the Wall Street Journal, plus radio and TV.

The result? "Through our intensive advertising, we generate 500 or more calls a day to our 800 number," Hozour said. "When they call, we send them a catalog. Based on the Zip code they give us, we refer them to a local dealer."

Magne said, "Hozour once did a marketing trial on CNN's FNN in 1989. He priced Satellite 650s, which normally cost \$650, at \$999.95 just to see if they would sell on TV. They did; hence the reason Hozour quickly grasped that shortwave could be a very lucrative business."

They own North America, pure and simple.

— Larry Magne,
Regarding Eton Corp.

shortwave radio, and people will happily pay for it."

Three-fold strategy

Of course, margins alone are useless if nobody buys your product. To make these margins matter, you've got to manufacture and sell in volume, a fact Esmail Hozour soon grasped.

To do this, he developed a three-pronged approach.

The first prong is "something for everyone." Eton has developed a wide range of SW radios, from the \$29 Mini World 100 PE portable to the top-of-the-

With a solid grasp on the Grundig name and the North American market, Europe could be next on Eton's list. After all, "If our formula works so successfully in North America, which is the most competitive market in the world, it should work in Europe," Hozour said.

Time will tell if Eton will tackle Europe on its own or under the Grundig banner. Hozour isn't revealing his plans. However, the fact that his new Grundig S350 receiver box is labeled as being made by "Eton Corp./Grundig" may give some clue to Hozour's branding intentions. 🌐

Product Showcase



Model TAS-1 Telephone Announcement System

- digital message storage—no moving parts
- variable outgoing message format
- inactive or defective telephone line indicator
- resettable incoming call counter
- temperature delivery in Fahrenheit or Celsius
- battery backed AC synchronized clock

Sine Systems, Inc.

615.228.3500
more information: www.sinesystems.com

A Different Kind of Kids' Radio

Freeplay Receiver Is Seen as a 'Lifeline' for 31 Million African Households Run by Children

by James Careless

Could radio be the salvation of Africa's millions of child-run households? Kristine Pearson thinks so. As executive director of the non-profit Freeplay Foundation (www.freeplayfoundation.org), Pearson has spearheaded the design of the Freeplay Lifeline Radio. It is a rugged self-powered multi-band receiver meant to bring news, health information and even distance learning to 31 million African children orphaned by war and AIDS.

"This is the only radio in the history of the world that has been created for this sector," Pearson has said. "I believe the Lifeline radio will be the one relief tool that makes the greatest difference to the most people."

Genesis of the Lifeline

The Freeplay name has long been associated with Africa. The original Freeplay spring-driven generator was designed to power a receiver without batteries, one that would serve refugees lacking electricity and the money to buy batteries.

Since its incarnation, the Freeplay radio has evolved. So has the Freeplay company; today, it has been split into a commercial manufacturer and the non-profit Freeplay Foundation. It is the foundation that is now charged with distributing Freeplay radios, such as the 1,600 Freeplay Global Shortwave receivers donated three years ago to Rwandan child-run households.

Due to the genocidal war on Tutsis and moderate Hutus a few years ago, "Rwanda has the very sad distinction of having the largest percentage of its population — more than 10 percent — living in child-headed households," Pearson said.

"Children and young people don't trust the adults around them and they want a voice they can count on, like the

BBC, VOA or Radio Rwanda.

"One girl recently heard that when a man stole a cow, he was punished," Pearson said at the time. "This may seem like a small thing, but it shows that justice is starting to return to Rwanda. After all, this girl's parents had been killed by the neighbors down the road, and nothing had happened to them as a result."



The front of the receiver is eye-catching; the rear has a crank.

After the donation, Pearson returned to Rwanda to assess how well the Global Shortwave receivers were faring in Africa. What she learned from that trip — combined with a \$50,000 "Technology Benefiting Humanity" award from NASDAQ, and donations from The Body Shop Foundation and The Vodafone Group Foundation — spurred her and Freeplay's engineers to create the Lifeline.

Visually, the Freeplay Lifeline is about the shape and size of a bag of Wonder bread sat on end. The top is a semi-circular carrying handle, with a removable hard-wire antenna inside. Below the handle is a large half-moon tuning dial clearly marked with AM, FM and two SW bands (3-10 MHz and 10-18 MHz). The dial indicator is controlled by a sturdily-gear knob in the middle. Meanwhile, a heavy-duty band switcher is located on the right side, in line with the tuning dial.

Radio that can take it

Beyond this, the Lifeline features a plastic gridded speaker below with an embedded volume knob, a heavy-duty handcrank at the back and a removable solar panel with extension cord under the handle. All of this is housed in a tough plastic case that can be dropped six feet onto hard concrete and survive.

"We looked at everything that had gone wrong with previous generations," said John Hutchinson, Freeplay's technology director. "First of all, we learned that you couldn't include a single-direction windup spring on a relief radio, even with a large direction arrow printed on the case. Inevitably, someone would wind it the wrong way and break it. So, in the Lifeline, we replaced the spring with a bidirectional, handcrank-driven generator."



Devotte Hasfashimana holds a Lifeline.

organizations. Although it is not commercially available, Freeplay did send Radio World a sample to try out. In fact, as I write this, the Lifeline is playing happily in the background.

My take on it? The Lifeline is as tough as they say. Moreover, it has great sound — not surprising, since the Lifeline is designed to be heard by groups of people at a time. The Lifeline's solar panel is highly reliable. It has been my receiver's sole power source for the last month,

This is the only radio in the history of the world that has been created for this sector.

— Kristine Pearson

Having identified conventional antennas as "the single biggest breakage item," Freeplay used a push-in antenna that could be replaced "using an ordinary piece of wire found anywhere," Hutchinson said. As for the ergonomics, the Lifeline is meant to be used by children unfamiliar with technology. This is why the volume knob is embedded in the speaker, to make it intuitive. Meanwhile, the tuning dial is marked clearly, and the tuning knob allows fine tuning even on shortwave.

The realities of climate also come into play. Mindful that Lifelines will have to survive in wet, humid conditions, "we didn't make it water proof," Hutchinson said. "Instead, we drilled holes in the bottom of the case, and positioned the electronics so that water could drain past it safely." Freeplay also used lubrication-free mechanisms, because anything with grease on it clogs up with the ever-present African dust.

Evaluation

As for lifespan? The Lifeline's metal hydride batteries have been tested through 10,000-plus discharge/charge cycles, Hutchinson said, "and we've still got the same basic battery capacity." Freeplay expects a typical Lifeline radio to last through five hours' daily use over five years before failing. However, even when the batteries do pack it, the Lifeline can run directly off solar once the batteries are removed.

The Lifeline costs \$40 to \$50 and is made available through humanitarian

without a single dropout.

The Lifeline's coat-hanger wire antenna takes a bit of getting used to. At first, I thought it was a mistake. However, even when housed in the handle, the coat-hanger antenna delivers decent AM and FM reception. For SW, I found it necessary to stick a length of heavy-duty speaker wire into the hollow antenna sleeve. The Lifeline is designed for this kind of improvised antenna.

In service

The Freeplay Foundation distributed 500 Lifeline radios to three United Nations Burundian refugee camps in Tanzania. In all three camps, the radios went to youth groups, with one young person per group designated as the Lifeline's custodian. To solemnize the arrangement, the young people signed contracts promising that the Lifelines would not be sold, and that the radios would remain in the camps at all times.

The Freeplay Foundation has committed to more than 20 other distribution projects in Africa, Asia and Mexico. More radios will be built as donations come in; fundamentally, the Lifeline is a self-supporting, "pay as you go" project.

"To date, the Lifeline has been an unqualified success," Pearson said last month. "Thousands have already been distributed and many more tens of thousands are on order for projects to be implemented next year across Africa."

James Careless is based in Ottawa, Canada. 



Radio World
The Newspaper for Radio Managers and Engineers

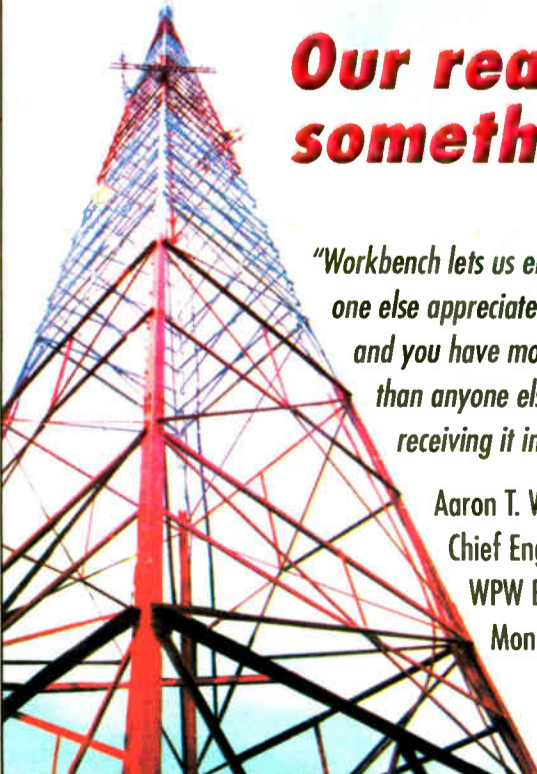













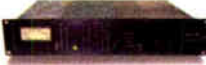









Our readers have something to say









"Workbench lets us engineers share ideas that no one else appreciates. I enjoy the product reviews; and you have more classifieds and for-sale ads than anyone else. I truly look forward to receiving it in the mail."

Aaron T. Winski
Chief Engineer
WPW Broadcasting Inc.
Monmouth, Ill.

Chapter One

Once upon a time, a radio engineer  and talk show host named Steve  grew frustrated with the awful sound of his telephone  system. So, he read lots of books  about Digital Signal Processing and invented the  Telos 10. After that, Steve's phones sounded great, and he was happy. Lots of other radio stations that used it were  happy, too, and Steve's company grew large and hired more  smart engineers. They partnered with the MPEG folks  and introduced MP3 to the world with  Zephyr. And Zephyr sounded so good, it made *lots* of people  very happy.

About the same time, another radio engineer named Frank  was figuring out how to make audio sound both loud  and clean . Frank began building processors for lots of important  big-market radio stations. Soon, Frank teamed his audio chops  with Telos' DSP gurus , and built the first digital audio processor  that gave stations the loud, clean, punchy sound they wanted without the digital "grunge" – which made lots of Program Directors and engineers at even more radio stations happy . And Frank's processors became the choice of top stations like , , , ,  and many more.

Now, Steve and Frank's companies have the biggest R&D team  in the industry, with respected broadcast engineers like Jeff Keith , scientists like Greg Shay , and studio-audio experts like Mike "The Catfish" Dosch . These guys think up  lots of innovative gear together; cool stuff like the Zephyr Xstream  ISDN Transceivers with leading-edge MPEG AAC , and Omnia-6 , the broadcast audio processor preferred by major radio stations around the world, and the world's first broadcast phone system, TWOx12 , that takes advantage of the digital clarity of ISDN, and the truly amazing little Zephyr Xport  POTS+ISDN codec which features aacPlus® , and is winning lots of awards.

...and that's just the *beginning* of the story! 

Omnia
A Telos Company

Telos
AUDIO | NETWORKS

telos-systems.com
omniaaudio.com

The Telos logo, Zephyr, Omnia, TWOx12, Zephyr Xstream and Zephyr Xport are all registered trademarks of TLS Corp. ©2003. TLS Corp. All other trademarks property of their respective holders. All rights reserved.

Studio Sessions

The World
According to
ARP

See Page 33

Radio World

Resource for Radio On-Air, Production and Recording

January 2, 2004

PRODUCT EVALUATION

KFBK Files on Matrix GSM Module

by Ross du Clair

Modesto is a farming community in Northern California. While small in population, it has been the center of national news for two years thanks to the Gary Condit/Chandra Levy story and the Laci Peterson murder trial. The media focus in that city has been tremendously heavy.

Beyond line of site

For Clear Channel's News Talk 1530, KFBK, a major news talker in Northern California, the distance between Modesto and our RPU receive sites is beyond line of site, and phone/ISDN lines are not always available. Our reporters are forced to file stories and sound bites using cell phones, which can sound like talking into a paper cup. A new tool was needed.

That new tool was introduced to us by Eric Aiese of Comrex at an SBE (Chapter 43) luncheon. The Matrix GSM Module looked like a gift from heaven.

The GSM module, named after the Global System for Mobile Communications, attaches to the Matrix platform — either a POTS or ISDN codec — with just the change of a module.

The station owned a Matrix with the POTS and ISDN codecs, so we had everything we needed. When the beta test

set arrived, we set up GSM service with a vendor, T-Mobile, who offered 3,000 minutes per month at a reasonable flat rate. Insert the vendor-supplied SIM card and the module is ready to go.

No time to lose

The afternoon the beta set arrived, the FM promotions department grabbed it for a remote scheduled for later that day. With about five minutes of training for the operator, out the door it went; it was an instant success.

I could hear a slight digital artifact, but the audio was more than acceptable for FM quality. Ease of setup and reliability were qualifying factors. Two

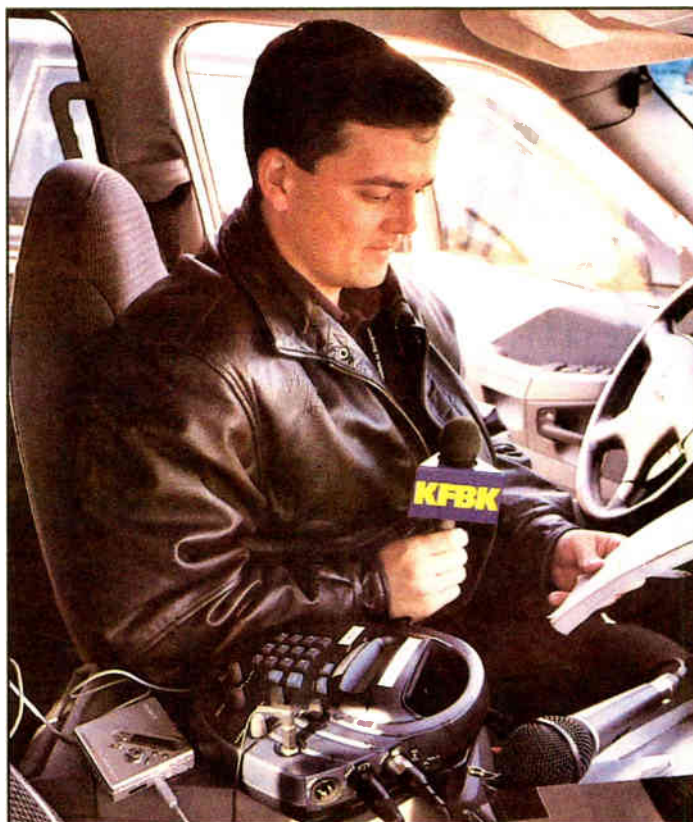

KFBK(AM) Reporter Chris Filippi files a story and location sound via the Matrix GSM module.

more FM remotes were completed with the Matrix that week.

The next week the KFBK newsroom pressed it into service for news feeds around town. Greater confidence was building for the GSM Matrix. A couple of days later the Matrix went to Modesto with KFBK reporter Chris Filippi. He immediately started filing live reports from the Stanislaus County Court House in Modesto.

The Matrix was used as well for the gubernatorial inauguration of Arnold Schwarzenegger. The location for radio reporters did not allow for an RPU shot, and no phone lines were available. The GSM performed well for a long-form broadcast by the KSTE(AM) morning show hosts, Armstrong & Getty.

The audio quality was fine for this format. On this broadcast there was no hint of digital artifacts on the live audio. The other radio reporters, who had to file on cell phones, were envious.

As a side note, cell service in the heart of downtown Sacramento was so heavy, making calls was nearly impossible. But the GSM service was clear of users, with signal strength of more than 27 on a meter of 0-32. Comrex suggests a minimum of 20 for a stable connection, but beta testers have reported success at signal strengths as low as 10.

The change in quality was incredible. We were finally airing audio that did not sound like a cell phone. Filippi was able to play his sound bites into the Matrix mixer instead of holding the cell phone microphone at some outboard speakers from his mini disk recorder. Again, the quality was fantastic.

We experimented with other cell phone interfaces, but it was just mixed audio over the regular cell circuits; no real improvement. Comrex has perfected a 7 kHz sound algorithm (9600 baud) over GSM service.

KFBK is part of the Clear Channel News Network and we feed pieces to the ABC Radio Network. The filed pieces were being heard on other Clear Channel stations and at the top-of-the-hour feeds from ABC. Again, we were pleased with the sound quality, and the reporters liked the portability of the unit and its ease of use. An optional battery pack is available and is a good idea for remote news applications.

Little to tweak

The basic kit we assembled was: Matrix, GSM module, small mag-mount antenna, EV 635A microphone and cord, ear phones, adapter cord for MiniDisc output, accessory cord (to run the Matrix from a power outlet in car) and battery pack. The kit fits in a small hard case. I have the JL-2 quick charger but it is not with the kit.

There is not much I would change with the Matrix GSM module. The

See MATRIX, page 29

TIPS AND TRICKS

More Stereo Microphone Techniques

by Bruce Bartlett

We recently covered coincident-pair stereo miking in these pages (Nov. 5, 2003). Such a technique — or any stereo miking method — is useful when you need to record or broadcast an orchestra, string quartet or pipe organ.

Let's look at spaced-pair, near-coincident and baffled-omni methods of miking.

Spaced pair

The spaced-pair stereo miking technique uses two microphones placed several feet apart, aiming straight ahead toward the musical ensemble as in Fig. 1. The microphones can have any polar pattern; but the omnidirectional pattern is most popular for this method. The greater the spacing between mics, the greater the stereo spread.

Instruments in the center of the ensemble produce an identical signal from each microphone. During playback of this recording, a phantom image of the center instruments is heard midway between the stereo pair of loudspeakers.

If an instrument is off-center, it is closer to one microphone than the other, so its sound reaches the closer micro-

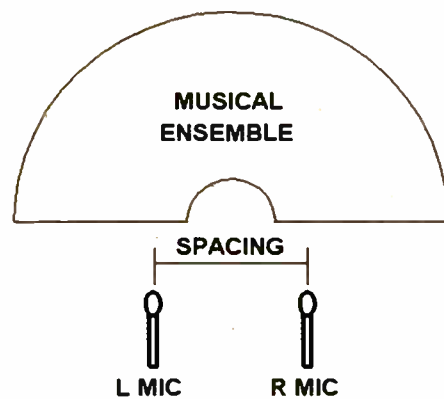

Figure 1: Spaced-Pair Method

phone before it reaches the more-distant one. Consequently, the mics produce approximately an identical signal, except that one mic signal is delayed with respect to the other.

If you send an identical signal to two stereo speakers with one channel delayed, the sound image shifts off center. With a spaced-pair recording, off-center instruments produce a delay in one microphone channel, so they are

reproduced off center.

The spaced-pair array codes instrument positions into time differences between channels. During playback, the brain decodes these time differences back into corresponding image locations.

It takes only 1.2 milliseconds of delay to shift an image all the way to one speaker. So, if we want the right side of the orchestra to be reproduced at the right speaker, its sound must arrive at the right mic about 1.2 milliseconds before it reaches the left mic. In other words, the microphones should be spaced about 2 to 3 feet apart. This spacing produces the appropriate delay to place right-side instruments at the right speaker.

Instruments partway off center produce interchannel delays less than 1.2 milliseconds, so they are reproduced partway off center.

The ping-pong effect

If the spacing between mics is, for example, 12 feet, instruments slightly off center produce interchannel delays greater than 1 millisecond, placing their

See STEREO, page 31

Matrix

► MATRIX, continued from page 28
reporters like the intuitive controls. All they need is good signal strength to call the studio Matrix receiver.

We had only one lock-up of the studio unit, but it was the beta unit. Our original unit was sent back to Comrex for upgrading and we have had no further trouble.

One thing I would like to see is an input that will take the lower output levels from digital sources like a MiniDisc, which has peaks in the -12 dB range.

Another Take: Beta-testing Matrix GSM In Washington

Alan Peterson is a technical advisor to RW, and production/imaging director for WMET(AM), Washington, D.C.

I was asked to take part in a test of the Matrix with GSM module for Comrex in the heart of the nation's capital.

The technical folks in Devens, Mass., were anxious to check out the wireless performance aspects of the Matrix in areas with fairly high cellular RF density.

It is an indisputable accomplishment to be able to pump fully airable audio content over a cell connection.

The company had performed tests in many major cities both at home and around the globe, all to satisfying ends. Washington was no exception.

In many situations, the Comrex Matrix was mounted in an automobile with a magnetic antenna on the roof. The car was then driven through the city through live and dead spots of cellular activity, and put through its paces in that manner.

I opted instead for a stationary indoor test; this being Washington, there are indoor press conferences all the time. For a news/talk station, a live unwired feed with good fidelity means victory in the race to get the story on the air. If the Matrix with the GSM option could punch through the walls here, news stations everywhere would want to know.

See BETA TEST, page 31 ►

Also, the Matrix platform has only one headphone output. If we have two talents, a headphone amplifier has to be carried



Mounted on a Dashboard

along, requiring power and an additional patch cord.

(According to the manufacturer, the Matrix features a -10 dB minijack input, which is designed for use with consumer-level equipment, such as MiniDisc players. Also, Comrex said, the second output on XLR has enough gain to drive most headphones.)

The A-Team methods for FM remotes and news reporting are still RPU, ISDN or Comrex Vector, but the versatility and ease of use from the Matrix GSM module expands the ability to set up remotes or file fast breaking news with the quality required for our stations.

Ross du Clair, Ph.D., CSRE, is chief engineer for Clear Channel stations KFBK(AM), KSTE(AM), KHYL(FM) and KGBY(FM) in Sacramento.

Product Capsule:
**Comrex Matrix Codec
GSM Module**

Thumbs Up

- ✓ Better-than-FM quality on speech in GSM mode
- ✓ Quick and easy to learn
- ✓ Compatible with HotLine, Bluebox and Vector codecs

Thumbs Down

- ✓ Performance may be affected in high RF areas; see sidebar.

Price: \$3,700

For information, contact
Comrex in Massachusetts
at (978) 784-1776
www.comrex.com

Starlink SL9003T1 Digital T1 STL



**STL AND TSL Together on a
Single, Low-Cost Digital Link!**

TOGETHER AT LAST!

Opt for compatibility and convenience with the Moseley Starlink SL9003T1! The Starlink gives you digital transport of 20 kHz IBOC-ready program audio channels, voice channels for phones or data circuits for Ethernet, plus transmitter control, all over a single low-cost digital link.

Because it uses T1 lines (microwave or spread spectrum radio), its added bi-directional payload capacity saves you money on program line costs.

The Starlink T1 system is perfect for interconnecting remote studios and transmitters over any distance. And it's digital, so your clean, crisp on-air sound will stand out from your competition.

Call us today to plan your system. Moseley can help you put it all together.

- STL/TSL/ICR with no terrain or mileage restrictions
- Bidirectional payload saves on program line costs
- Be IBOC-ready now to ensure future compatibility
- Digital STLs sound great!

Moseley

Corporate Headquarters - (805) 968-9621 East Coast Sales Office - (978) 373-6303
WEB: <http://www.moseleysb.com> EMAIL: Sales@moseleysb.com

Products & Services SHOWCASE

Mini Mix 8A

Proven...Affordable...

Reliable



AUTOGRAM

800.327.6901

www.autogramcorp.com

Control Solutions by CircuitWerkes



The SEN-6 Subaudible Tone Encoder

The SEN-6 is a single channel Subaudible tone encoder with integral audio filtering that can produce 25Hz, 35Hz and combination tones from external closures.



Control your world with CircuitWerkes DTMF Tone decoders and controls

The DTMF-16 and DS-8 DTMF tone decoders provide economical remote control over audio lines. The DTMF-16 decodes single or dual codes while the programmable DS-8 accepts up to 8 four-digit sequences. Silencer option removes DTMF tones from audio.



The SUB-03 Subaudible Tone decoder

The SUB-03 is a single channel subaudible tone decoder that can detect 25Hz, 35Hz and combination tones on audio channels. Each tone gives a distinct relay closure. Integrated filters strip each tone from the SUB-03's audio output so no one hears it.



The DR-10

Perfect for Studio & Automation Control

Dial-up remote control with audio interface lets you control anything over regular phone lines. Interfaces with most studio automation systems. Control it from a dial-up line or external audio path. The DR-10's active, balanced, telco audio output lets you do live remotes, remote announcement recording and...much, much more!

CircuitWerkes - (352) 335-6555 / Fax 380-0230 <http://www.circuitwerkes.com> 2805 NW 6th Street, Gainesville, FL 32609

AM Antenna Solutions



LBA Tunipole™
Folded Unipole Systems



RF Components



Vacuum Capacitors



Diplexer, Triplexer and
Phasor Systems

COMET
Sold Here!

LBA Technology, Inc. is your proven supplier of innovative, digital-ready AM antenna systems. Our products include tuning units, phasing systems, multiplexers, AM/wireless isolation systems and components for every power level. We help hundreds of broadcasters in the USA and worldwide to --

Reach further –
sound better!

LBA Technology, Inc.

3400 Tupper Drive, Greenville, NC 27834

800-522-4464 / 252-757-0279 / Fax 252-752-9155 / Email Lbotech@Lbagroup.com / www.Lbagroup.com



LBA
Since 1963

WEATHER RADIO

Model CRW



Price \$540.00

Sensitivity .28 microvolts for 12 dB quieting. All 3 frequencies. Alert tone demutes receiver, closes relay and gates audio to 600 ohm rear terminals. Another set of rear terminals has continuous 600 ohm audio output. Double conversion crystal controlled, crystal filter in first I.F., ceramic filter in second I.F. Dual gate MOS FET front end. 50 ohm coaxial input. Adjacent channel (± 25 kHz) down to 70 dB. 19" rack mount, 3.5" H, all metal enclosure. In stock—available for immediate delivery.

GORMAN REDLICH MFG. CO

257 W. Union St. • Athens, Ohio 45701

Phone 740-593-3150 • FAX 740-592-3898

www.gorman-redlich.com/jimg@gormanredlich.com

The Simple Cell Phone Interface Solution

FJ-500 FlipJack

CELL PHONE INTERFACE



Connect To Standard Telephone In Event Of Poor Cell Phone Connection



CONEX
ELECTRO-SYSTEMS

Call For More Info
800-645-1061
www.conex-electro.com



MAGER
SYSTEMS, INC.

Custom
Studio Furniture

Since 1979 Mager Systems, Inc. has been custom designing and fabricating award winning furniture for the broadcast industry nationwide. We are still the innovators and leaders in solid surface tops and applications which comes with a 10-year warranty. Our complete one-stop-shop includes installation, turakye prewiring, switches and components, conference rooms, reception desks, and office furniture. Our blending of art form with cutting edge techniques, and a clear understanding of each client's application allows us to produce your showplace tailored to your budget.



COOL STUFF AWARD 2002
Radio World



WBAA
Purdue University

Touch Sensitive Switches & Keyboards

TEL: 623-780-0045

FAX: 623-780-9860

mager@magersystems.com

www.magersystems.com

Visit our website for more information

MAGI
Introduces
our new
award winning
"Sound Choice"
furniture. Our
modular in stock
furniture boasts
unsurpassed quality
for the economical
budget with a 10-year
limited warranty.
See details on
our website.

Mic Tips

► Continued from page 28
images at the left or right speaker. This could be called an "exaggerated separation" or "ping pong" effect.

On the other hand, if the mics are too close together, the delays produced will be inadequate to provide much stereo spread. In addition, the mics might favor the center of the ensemble because the mics are closest to the center instruments.

The microphones need to be placed about 10 or 12 feet apart to record a good musical balance, but this creates a problem; the spacing results in exaggerated separation. One solution is to place a third microphone midway between the outer pair and mix its output to both channels. That way, the ensemble is recorded with a good balance, and the stereo spread is not exaggerated.

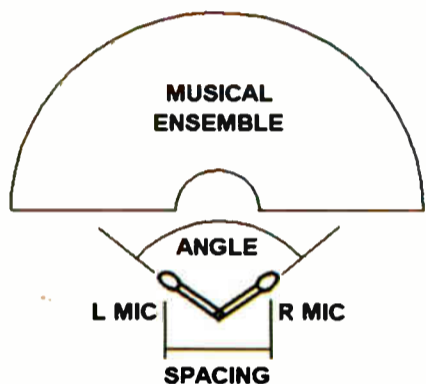

Figure 2: Near-Coincident Technique

The spaced-pair method tends to make off-center images relatively unfocused or hard to localize. Why? Spaced-microphone recordings have time differences between channels, and stereo images produced solely by time differences are unfocused.

Centered instruments still are heard clearly in the center, but off-center instruments are difficult to pinpoint between speakers. This method is useful if you prefer the sonic images to be diffuse, rather than sharply focused — say, for a blended effect.

Beta Test

► Continued from page 29

The Matrix unit I had was set up in a third-floor office at 19th and M Streets in downtown D.C., only a couple of blocks from NAB headquarters. The magnetic antenna was mounted on a large metal file cabinet and placed near a window.

I dialed in to the Comrex test line in Massachusetts on the Matrix, and called the office on my own cell phone to coordinate the test and conduct troubleshooting if necessary.

At first, audio quality through microphones at both ends was quite good, but I was experiencing several dropouts, and the line integrity shown in the display was at 5, considerably low.

As it turned out, my own cell phone, which was being used less than three feet from the antenna, was the culprit.

There is another problem with spaced microphones. The large time differences between channels correspond to gross phase differences between channels. Out-of-phase low-frequency signals can cause excessive modulation of your station's stereo-difference signal unless the stereo separation is reduced. In addition, combining both microphones to mono sometimes causes phase cancellations of various frequencies, which may or may not be audible.

The spaced miking advantage

There is an advantage with spaced miking, however. Spaced microphones are said to provide a "warm" sense of ambience, in which concert-hall reverberation seems to surround the instruments and, sometimes, the listener.

The reason is that the two channels of recorded reverberant sound are incoherent; that is, they have random phase relationships. Incoherent signals from stereo loudspeakers sound diffuse and spacious. Because reverberation is picked up and reproduced incoherently by spaced microphones, it sounds diffuse and spacious. The simulated spaciousness caused by the phasiness is not necessarily realistic, but it is pleasant to many listeners.

Another advantage of the spaced-microphone technique is the ability to use omnidirectional microphones. An omnidirectional condenser mic has more-extended low-frequency response than a unidirectional condenser microphone.

Near-coincident technique

As shown in Fig. 2, the near-coincident technique uses two directional microphones angled apart, with their grilles horizontally spaced a few inches apart. Even a few inches of spacing increases the stereo spread and adds a sense of ambient "warmth" or "air" to the recording. The greater the angle or spacing between microphones, the greater the stereo spread.

Angling directional mics produces level differences between channels; spacing mics produces time differences. The interchannel level differences and time differences combine to create the stereo effect.

If the angling or spacing is too great, exaggerated separation results. If the angling or spacing is too small, the result is a narrow stereo spread.

Once it was turned off, line integrity jumped to 25 and I enjoyed a stable and good-sounding connection.

There was some subtle and distant gurgle in the headphones, as might be expected from a digitized and compressed audio stream, but it was well below any disagreeable threshold.

It is an indisputable accomplishment to be able to pump fully airable audio content over a cell connection. My static test in what is a highly charged RF region came out quite satisfactory.

Comrex representatives say the GSM wireless capabilities of the Matrix are not appropriate for music transmission, and there are still a number of telephone devices and services that remain incompatible. Moreover, interference from my own phone revealed that the Matrix with GSM is susceptible to cell phone interference, but only when up close to the antenna.

This is not a condemnation of the technology. Wireless interference is

The most common example of the near-coincident method is the ORTF system. ORTF stands for Office de Radiodiffusion Television Francaise, the French Broadcasting Network.

The ORTF system uses two cardioids angled 110 degrees apart and spaced seven inches (17 cm) apart horizontally. This method tends to provide accurate localization. That is, instruments at the sides of the orchestra are reproduced at or very near the speakers, and instruments halfway to one side tend to be reproduced halfway to one side.

Some microphone manufacturers offer near-coincident stereo mics.

Baffled

The baffled omni pair method uses two omni microphones, usually ear-spaced, and separated by either a hard or soft baffle

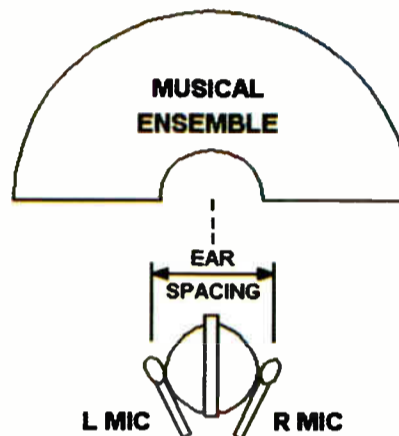

Figure 3: Baffled Omni Pair Method

le (Fig. 3).

To create stereo, it uses time differences at low frequencies and level differences at high frequencies. The spacing between microphones creates time differences. The baffle creates a sound shadow (reduced high frequencies) at the mic farthest from the source. Between the two channels, there are spectral differences — differences in frequency response.

Placement

Some examples of baffled-omni pairs are the Schoeps KFM6 and KFM360 sphere microphones, the Jecklin Disk and the Crown SASS-P MKII.

Once you have decided on your stereo

becoming quite widespread, and at least 27 states have experienced situations where emergency police and rescue radio services have been blanked out by RF interference from strong wireless sources such as cell towers. This may not change in the immediate future.

The Comrex Matrix does exactly what it was designed to do, especially when used in a wireless fashion. However, one must be prepared to deal with environmental and technical issues at a remote broadcast site. If you are at a ballgame or at an outdoor promotional event with no cell tower in sight, you should be home free.

If you are doing a live hit from the airport concourse or a concert where up-close or concentrated cell activity may clobber your line integrity, you might be best off having a POTS or ISDN backup in place for safety.

— Alan R. Peterson

miking method, you are ready to place the microphone pair relative to the musical ensemble.

A good starting spot is 12 feet behind the conductor, 14 feet high on a stand or hung from the ceiling. One radio station placed a spaced pair of microphones on stands sticking out from the balcony.

You want a tasteful blend of direct sound from the orchestra and ambient sound from the hall. If the sound is too distant or muddy, move the microphone pair closer to the ensemble. Do the opposite if the sound is too close, detailed, or edgy.

If the stereo spread is too narrow, increase the angle or spacing between microphones until the reproduced orchestra spreads from speaker to speaker. If you hear exaggerated separation, reduce the angle or spacing between mics.

Each stereo miking method has its own advantages and disadvantages. The method you choose depends on the sonic compromises you are willing to make.

Bruce Bartlett is a technical writer/microphone engineer, recording engineer and audio journalist.

Four Techniques Compared

Coincident pair

- Uses two directional mics angled apart with grilles touching
- Level differences between channels produce the stereo effect
- Images are sharp
- Stereo spread ranges from narrow to accurate
- Signals are mono-compatible

Spaced-pair

- Uses two mics spaced several feet apart
- Time differences between channels produce the stereo effect
- Off-center images are diffuse
- Stereo spread tends to be exaggerated unless a third center mic is used
- Provides a warm sense of ambience
- May cause difference-channel over-modulation

Near-coincident-pair

- Uses two directional mics angled apart and spaced a few inches apart
- Level and time differences between channels produce the stereo effect
- Images are sharp
- Stereo spread tends to be accurate
- Provides a greater sense of "air" than coincident methods

Baffled-omni pair

- Uses two omni mics, usually ear-spaced, with a baffle between them
- Level and time differences (spectral differences) produce the stereo effect
- Images are sharp
- Stereo spread tends to be accurate
- Good low-frequency response
- Good imaging with headphones
- Provides more air than coincident methods
- Tends not to be mono-compatible, but there are exceptions (SASS-P MKII)

— Bruce Bartlett

Broadcast Devices Switcher System Offers Flexibility

The AES-302 Digital Audio Switcher System is a two-input AES3-compatible switcher with four independent AES3 outputs. It also has an XLR left/right output for professional digital to analog conversion of the input signal.

Broadcast Devices says the AES-302 can be used to accept digital codec or STL outputs and distribute them to digital or analog equipment. The AES I/O comes with XLR connectors, but any digital input or output can be ordered with S/PDIF, BNC or optical interfaces. Optional connectors systems are available.



Features include an automatic switch function that switches to the alternate path upon failure of the selected path. This switching activation can be triggered by loss of clock, digital error flags or via optional silence sensor. Other features include front-panel error status,

headphone jack and remote control.

For more information from Broadcast Devices, contact the company in New York state at (914) 737-5032 or go to www.broadcast-devices.com.

Lynx Card Incorporates SynchroLock

The AES16 from Lynx Studio is a 192-kHz, multichannel AES/EBU interface, a half-size PCI card that provides 16 channels of 24-bit AES/EBU digital audio at a 192 kHz sample rate. It works with single- and dual-wire AES devices.

The AES16 incorporates SynchroLock, a Lynx technology that permits the PCI card to output low-jitter digital audio from severely degraded signals, ensuring what the company calls bit-perfect digital transmission and low distortion in signals converted to analog.

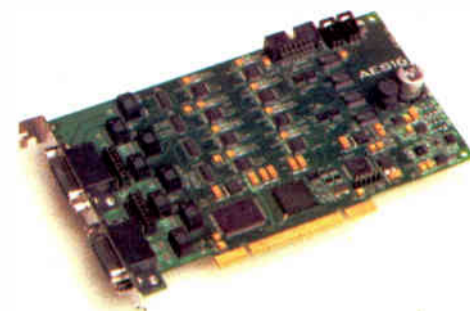

The card ships with a hardware-based 32-channel digital mixer controlled with its own software application.

Two models are available.

The AES16-XLR ships with two six-foot cables with professional XLR and BNC and retails for \$795; the AES16 ships without cables for \$695.

For more information from Lynx Studio Technology, contact the company in California at (949) 515-8265, or go to www.lynxstudio.com.

Products & Services SHOWCASE

Audio Distribution. Done Right.

MIC	Line
Analog	Digital
Balanced	Unbalanced
Active	Transformer
Metered	Monitored
Remote	VCA

See why more Engineers and Installation Professionals are specifying ATi.

Call us at 1-800-922-8001 or visit ATi on the Web.

www.ATIaudio.com

May we present... **YOUR AD**

RADIO WORLD'S Products and Services Showcase provides a perfect medium for marketing your products and services.

For more information, call Simone at 703-998-7600, ext. 154 to request a media kit.

Is Someone Calling You??

Find Out with the Telco-6 Ringer Interface

New Problem Solver!

- Accepts up to six independent telephone lines.
- Each incoming ring causes the associated relay to close for the duration of the ring.
- Each relay has *two independent sets* of form "c" contacts rated at 24Vdc and 1 Amp.
- High quality metal enclosure can be wall or table mounted. Optional, low cost, rack mount (1RU) available.
- All interface connections are on standard screw terminals

CircuitWerkes - 3716 SW 3rd Place, Gainesville, Florida 32607
(352) 335-6555 / fax 380-0230 - <http://www.circuitwerkes.com>

Broadcasting to the World

COMET NORTH AMERICA
421 Wards Corner Road
Cincinnati, Ohio 45140
Ph: (513) 831-5000
F: (513) 831-7000
www.cometna.com

- A full range of vacuum capacitors for broadcasting:
 - Fixed and Variable
 - Air and Water Cooled
- Standard equipment in all major AM & SW transmitters
- Professional HV test equipment to regularly test spares
- Teamed in North America with Kintronic Labs to provide engineering expertise to broadcasters

Kintronic Labs, Inc
144 Pleasant Grove Road
Bluff City, TN 37618
Ph: (423) 878-3141
F: (423) 878-4224
www.kintronic.com

If Money Talks, I Must Be Deaf

by Alan R. Peterson

It's been many a year since I approached the topic of money on this page. The last time had to be around 1990 or so; and back then I took it on with my usual light and humorous approach.

Not this time.

Since before November 2002, I have been irked by a couple of money issues. One was of my own doing and involved my friends at the IRS. The other was caused by a less-than-scrupulous employer.

Not one day has gone by this past year that I have not felt an ill gurgle in my stomach from the former and had the desire to drive by and moon the latter. Now it is high time to cleanse myself of these feelings and move on with my life.

And lucky you: you get the full brunt of my spleen-ventery. Cover yourself with a Gallagher-sized sheet of plastic and get ready.

Sounded good at the time

I was tapped last year for a job that (ever so briefly) put me in the driver's seat at an AM station that ran with a very lean staff.

I will not mention the calls or the company that owns them, for legal reasons but also because I feel these are inept broadcasters who do not deserve one speck of favorable publicity now or ever.

The two and a half months I spent there were hell. My production was done on my own equipment and software from home. I was not allowed to answer the station phones in the absence of the owners. In fact, the owners removed the phones from my work area.

I was called untrustworthy and told I was not at all good at my job and that the owner's dog could do better audio production than I.

They did not provide me with passwords or DTMF codes to regulate the transmitter. I had cellphone numbers for everyone, but my calls generally went ignored.

Some job. And it only got worse.

In November of 2002, a paycheck bounced. I had just refinanced my house, and my family took quite a costly hit when the bum check came back from the bank.

The owners were out of town for several days and out of reach. I was not a happy boy. When I finally reached one, I registered my displeasure about the whole situation. They called a conference for Friday — fittingly enough, the end of the next pay period — to set things right.

I had rehearsed what I wanted to say, wanting to keep it cordial and all-business. But I was ambushed. The meeting became a free-for-all on their favorite topic: what a screw-up I was.

Barely a mention of the paycheck issue was made, except for, "If you wait until Tuesday, we can pay you then." Everything else was abusive and vicious.

I should have kept my mouth shut. But there comes a time when even the most patient traffic cop whips out the mace and presses the button.

For some reason, the owners invoked the name of their high-profile lawyers. I said something to the effect of, "Yeah, if you're able to pay them!"

Next thing I knew, I'm gathering up my mixer and my CDs and heading for the door.

Do you suppose I got my check? Nope.

They also did not pay me for half of November. I had given them a month of free work and I was mad.

Later on, I found out I was not alone. The phone was off-limits because they were ducking creditors. The station owed a bundle on outdoor advertising, engineering work, office space and satellite providers, and owed money to a former account manager who also was let go. Dropping me saved them lots of money they did not have anyway.

As I was a salaried employee, the local Department of Labor office intervened. It has taken a year, but the parent company recently sent me payment in the amount of the bounced check. I am still owed that

amounts I owed. Once it was down to \$2,000, then it popped up again close to four, then fluttered down again. These guys wanted money, but they themselves did not know how much. It was as if they were flinging darts at random amounts.

Finally, I called the IRS and asked the phone representative point-blank: What did I owe them for tax year 2000? To my surprise, the rep looked my file up and said *they owed me* \$200!

Well, that was a relief. The monkey was off my back at last. Or so I thought.

Thanks

When President Bush's tax break came a few months ago, the IRS sent me a letter

There comes a time when even the most patient traffic cop whips out the mace and presses the button.

second check, as well as penalties of 100 percent as defined by law. I also never received a W-2 for 2002, so the IRS was notified.

Sure, it's the season of forgiveness and giving, and I should put it all behind me. My friends say, "Forget it. Take the loss and move on." If I were functioning as a contractor, I would. But I was an employee, which means my employer has a legal obligation to pay me for my work.

Needless to say, I ain't letting go. But there may be a line of folks forming in front of me, all looking to get paid by this company, so this may take a while.

My own screw-up

Meanwhile, the hole I dug for myself began in 2000. I had become a casualty of a softened local economy and had to meet the mortgage with free-lance work. Most of my income that year was 1099 stuff.

Deutsche Welle German TV paid me for slinging a mic boom, Radio Free Asia dropped me into Master Control for a while, and of course Connecticut School of Broadcasting put me to work right away as a teacher and engineer.

Free-lance bucks are always meager at the beginning, so I held onto what I could, not fully aware of the special tax requirements foisted upon free-lancers and small business owners ... especially quarterly estimated tax payments and the self-employment tax.

When April 15 rolled around, I did the E-Z form and thought I paid everything. The tax bite hurt a lot, given the scarcity of work, but I believed I paid it all. That is, until the nice man from the IRS notified me that I was considered a "small business" and owed a little more money.

Like about \$4,000.

That ripple in the ground you felt in 2001 — the one that triggered seismographs from here to Oregon — was my heart sinking. *Four grand?* I didn't think I *made* four grand in free-lance that year!

I sent them what I could along the way in timed payments. Some months I could make it, some I could not. I often hoped I would get lost in the shuffle of thousands of other taxpayers and buy a little time. But the interest and penalty clocks were running.

The odd thing was, along the way, I would get contradictory letters as to the

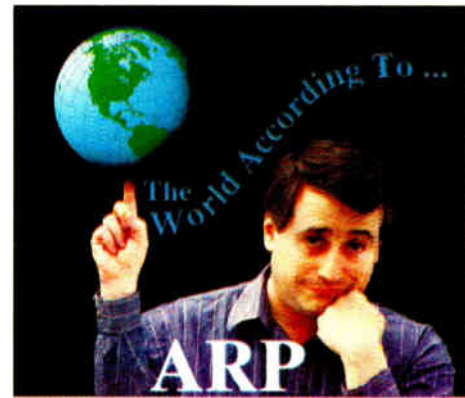

About six weeks ago, a letter came from the IRS with a check. It seems that, in spite of my paying *exactly* the amount printed on their last letter — the *exact* amount they said I had to send them — it was actually \$41 too much.

It took three years to hammer the whole thing out. In the end, my late Dad was the one who paid my outstanding tax, in a cosmic sort of way, and the amount they wanted was wrong.

At least it's over.

Happens to the best of us

I like to think everybody makes a huge tax mistake once in his or her life, pays through the nose and gets it out of their system. I also believe that everybody takes *one* absolutely horrible job in their careers that they forever regret.

With 2003 past, it well may be that my own double-whammy of a lousy job and a tax snafu is behind me. I know the tax laws a lot better, I ask a lot more questions when looking into work and if something smells foul early on, it gets passed by early on.

If all goes well, 2004 will be a great year for both you and me. The papers say the economy is rebounding, so the money issues may be a thing of the past, or at least until the next downturn in, what, seven to 10 years?

Perhaps now when money talks, I'll be listening a lot closer. 🌐

Genex Accessories Available for GX9000 Digital Series

Three new accessories are available for the Genex Audio GX9000 eight-track and GX9048 48-track high-resolution multiformat digital multitrack systems.

The GXR948 Remote Controller enables individual direct control of up to 48 channels of record arming and monitoring with no bank switching. The large control surface has dedicated buttons for each function and dedicated displays for critical parameters. Price: \$2,500.

The GXPC Edit is a plug-in waveform editor for the Genex GXR PC control software that enables cut, copy, paste and erase operations on up to 48 channels of audio data. The GUI-based application has an interface that permits single element or block moves between tracks. Price: \$500.

The GX9MB Meter Bridge provides up to 48 channels of 24-segment level metering organized in two rows of 24 channels. The chassis is 19-inches wide, 4U high and has a brushed anodized case. The unit can be freestanding, rack-mounted or mounted to the GXR948 Remote Controller. Features include integral timecode display, recorder-status and signal-present LEDs. Price: \$1,100.

For more information from Genex Audio, contact the company in California at (310) 828-6667 or go to www.genexaudio.com.

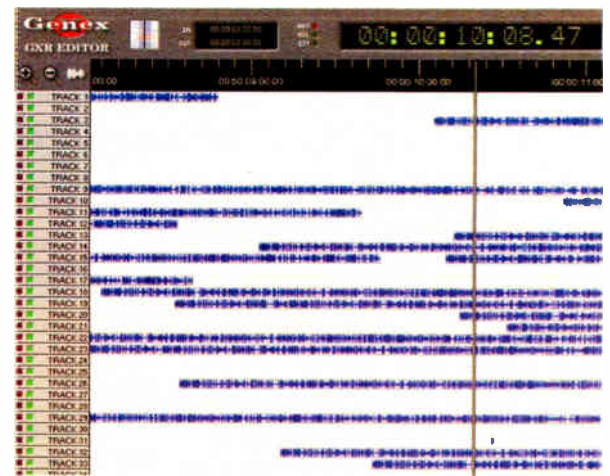

GXPC Edit Screen Display

BROADCAST

Equipment Exchange

"Broadcast Equipment Exchange" accepts no responsibility for the condition of the equipment listed or for the specifics of transactions made between buyers and sellers.

ACOUSTICS

Want to Sell



Full product line for sound control & noise elimination.

www.acousticsfirst.com

ANTENNAS/TOWERS/CABLES

Want to Sell

AM Ground Systems

Reliable, On-time Installation
Quality Workmanship
Ground System Evaluation
and Repair

www.amgroundsystems.com
1-877-766-2999

Cablewave 3-bay 92.1 mHz medium power antenna, BO. Ken Diebel, KGGM, Rayville LA 71269. 318-728-2370.

FREE! Six AM towers, (5) 200', (1) 380', located in Las Vegas NV. Call Broadcast Associates, 702-499-1388.

Harris/ERI FMH-4AE four-element high power antenna, 107.1 mHz, used less than 2 yrs, stored indoors following frequency change, \$4500. Roy Robinson, Lake Country Radio, POB 600, Graham TX 76450. 940-549-7800.

Rohn 65G, 440', freshly painted on ground with red aviation lights & controller, \$16,000. Ken Diebel, KGGM, Rayville LA 71269. 318-728-2370.

263' guyed Rohn AM tower. Lighting package included. Well maintained. Buyer arranges take-down, shipping. Phil Mueller, KCYN, 2575 N Radio Hill Rd, #6-1, Blanding UT 84511. 435-259-1035, 435-260-8033 (cell), email: exnews@frontiernet.net.

Want to Buy

FM Antenna, on or near 94.1. Can be in the 93.5 to 94.7 range. ERI, Jampro, Shively, Dielectric or SWR. Todd Mohr, WWKR, POB 855, Ludington MI 49431. 231-869-7402 x11.

AUDIO PRODUCTION

Want to Sell

PATCHBAYS: audiolvlg@gte.net

(2) Denon DNM 1050R pro mini-disc Rec/PB deck, has low impedance & headphone jack. Can email (2) pics & main features portion of the manual, \$570 each +shpg/handling. Mike Raley or Ron Muffley at 704-523-5555 or email: Mraley@rrb.org for pics.

AUTOMATION EQUIPMENT

Want to Sell

Smartcaster Jock in the box/live assist CD automation includes 8 Pioneer 18 disc changers, computer and new rack, use 24/7 or as live assist, \$2900 +shpg. John Wilsbach, WMSS, 214 Race St, Middletown PA 17057. 717-948-9136.

CD PLAYERS

Want to Sell

12 Pioneer F509 100 pack cd players. Can be used for AXS automation, \$150 each plus shipping. Cale Tharp, 270-766-1035.

COMPLETE FACILITIES

NEW OR USED COMPLETE PACKAGES
STUDIO/STL/TRANSMITTER/ANTENNA OR ANY COMBINATION OF ABOVE.
-LEASE OPTIONS-
-EMERGENCY RENTALS-
-REMOTE BROADCAST RENTALS-
SCMS, Inc. (800) 438-6040
"You Know We Know Radio"

CONSOLES

Want to Buy

Manual for a Rockwell Collins MARK 8 dual channel console, monaural. Marvin Walther, KHPA, 1600 S Elm St, Hope AR 71801. email: radiocowboy10@hotmail.com

Buying used equipment?
Selling used equipment?
YOU'RE IN THE RIGHT PLACE!
Radio World
Broadcast Equipment Exchange
For more information, call Simone Fewell at 703-998-7600, ext. 154

LIMITERS/AUDIO PROCESSING

Want to Sell

Inovonics Model 222 NRSC peak limiter, \$350. Roy Robinson, Lake Country Radio, POB 600, Graham TX 76450. 940-549-7800.

Want to Buy

Teletronix LA-2A's, UREI LA-3A's & LA-4's, Fairchild 660's & 670's, any Pultec EQ's & any other old tube compressor/limiters, call after 3PM CST, 972-271-7625.

MICROPHONES

Want to Buy

RCA 77-DX's & 44-BX's, any other RCA ribbon mics, on-air lights, call after 3PM CST, 972-271-7625.

www.rwonline.com

MISCELLANEOUS

Microphone Flags

Custom & Blank
www.micflags.com
800.450.6275

Want to Sell

ROTRON BLOWERS AND PLATE BLOWERS, new & rebuilt for Elcom, Harris, CCA, CSI, McMartin. Goodrich Ent. 11435 Manderson St. Omaha, NE 68164 402 493 1886 FAX 402 493 6821

K-Y Filter Company
3010 Grinnel Place
Davis, CA 95616



ELIMINATE BROADCAST BAND RFI

Plug-in telephone/modem RFI FILTERS

(530)757-6873

www.ky-filters.com/rw.htm

BAY COUNTRY BROADCAST EQUIPMENT

BUY - SELL - TRADE
Your #1 Source For Quality Used Radio Broadcast Equipment
View The Latest List On Line At: <http://www.baycountry.com>
Or Call And We Will Fax It To You
7117 Oliva Rd. Baltimore MD 21220
Toll Free: 877-722-1031 • FAX 443-596-0212 • E-mail: info@baycountry.com
Member of BBB

Want to Buy

Record pressing machine to make 45s. Must be in good working order. Michael Cardillo, 151 Morgan St, Cranston RI 02920. 401-942-8341 after 6PM EST.

Records: 45s, doo-wop, R&B, Jump, J:UE. Looking to buy bulk if possible, only 45s. Michael Cardillo, 151 Morgan St, Cranston RI 02920. 401-942-8341 after 6PM EST.

RECORDERS

Want to Sell

Several MCI J110B and C and Otari MX 5050 r-r recorders recently removed from NPR control rooms. No reasonable offer refused. You pay shipping. Bill Hineman, NPR, 635 Mass Ave, N.W., Washington DC 20001. 202-513-2494.

REMOTE & MICROWAVE

Want to Sell

GENTNER DH20 Digital Telephone Hybrid Interface, like new, \$800.00, negotiable. Phone: Joe, 863-382-9554 or email: jsdonelan@earthlink.net.

WE RENT FOR LESS

Hotlines FM Exciters
Zephyrs STL's
Nexus FM Pwr Amps
Audio Test Equipment

If we don't have it, we will get it!
SCMS, INC. (800) 438-6040
"You Know We Know Radio"

Marti STL-10 monaural STL system, 950-375 mHz, in excellent condition, late model with gray panels, removed from service October 2003. Roy Robinson, Lake Country Radio, POB 600, Graham TX 76450. 940-549-7800.

TFT 9100 composite STL system, 948.00 mHz, in good condition, removed from service October 2003, \$3500. Roy Robinson, Lake Country Radio, POB 600, Graham TX 76450. 940-549-7800.

Marti STL 15C frequency agile, transmitter and receiver, excellent condition with manuals, \$3500. Dennis Everson, Susquehanna/Kansas City, 5800 Foxridge Dr, #600, Mission KS 66202. 913-208-3280.

SATELLITE EQUIPMENT

Want to Sell

Comtech 3.8 M satellite receiver antenna dish with 1 NB, buyer removes. \$1800. Jim Campana, WSRV, 6558 Main St, Gloucester VA 23061. 804-672-6726.

Wegener DR96 satellite digital receiver, \$750. Ken Diebel, KGGM, Rayville LA 71269. 318-728-2370.

STEREO GENERATORS

Want to Sell

Marti SCG-10, 67 kHz SCA generator, \$250. Roy Robinson, Lake Country Radio, POB 600, Graham TX 76450. 940-549-7800.

TALENT

Is your radio show ready for a National Audience? We want unique already produced radio shows to distribute Nationwide on a JOINT VENTURE basis. We provide the uplink, satellite distribution, clearance and national sales. YOU provide the Show and share the revenue. E-mail description of your show to talent@DOTcommunications.com

SERVICES

Vinyl Records DE-NOISED & DIGITIZED on CD

We specialize in professional sound services, & can clean up all your recordings, from wire to cassette tape to 78's to LP's & transcriptions.

Our lab utilizes a complete 'Cedar' system as well as the Sound Forge computer program.

Audiophonic Corporation
POB 4390, Woodland Park, CO 80866
719-687-6357

PROMOTE YOUR BUSINESS!



To advertise, call 703-998-7600,

ext. 154

or e-mail:

sfewell@imaspub.com.

STATIONS

Want to Buy

Translators: AM's or FM's in western US. Contact Dougs@ihradio.org or 530-584-5700 ext 11.

Buy into partnership, AM, FM, translator or CP. Areas in RI, CT, MA, FL. Michael Cardillo, 151 Morgan St, Cranston RI 02920. 401-942-8341 after 6PM EST.

Radio World

5827 Columbia Pike, 3rd Floor Falls Church, VA 22041
PHONE: 703-998-7600 • FAX: 703-671-7409

Classified Advertising Rates Effective January 1, 2004

	1x	6x	13x	26x
1-9 col inch (per inch)	\$105	100	95	90
10-19 col inch (per inch)	\$90	80	70	60
Distributor Directory	\$130	125	120	115
Professional Card	\$100	95	90	85
Station/Studio Services	\$195	165	140	119
Classified Line Ad	\$2/word			
Blind Box Ad	\$15 additional			

Call Simone Fewell, Ext. 154, Classified Ad Manager, to reserve space in the next issue. Use your credit card to pay, we now accept VISA, MASTERCARD and American Express.

www.rwonline.com

RW Online

TAX DEDUCTIBLE EQUIP

A non-profit 501(c)(3) Christian Ministry, seeks tax deductible donations of working professional grade live/post radio production equipment of studio automation systems, modulation monitors, DAT, CD players, mikes, turntables, mixing boards, and other radio production equipment. Also, need transmitters, translators, transmission lines, and antennas to be used in our Youth Radio Ministry Training Program. All donations will receive a tax deductible receipt and God's blessings for their donations. Minister Dr. R. Hodges, 916-721-3285 or info@lwcr.org.

TRANSMITTERS

Want to Sell



BEXT
From the toll to the small
WWW.BEXT.COM
888 239 8462
Transmitters & Antennas

OFF THE AIR?
Emergency Back-up Rentals
FM Exciters - STLs -
FM Pwr Amps - Antennas -
Studio & Test Equipment
SCMS Inc (800) 438-6040
"You Know We Know Radio"

CCA 1000DS, 10KW FM Transmitter. Excellent condition, retired as main transmitter on major Chicago station, \$9500/BO. 800-678-4762.

McMartin BF-5K, 5kW FM. Factory rebuilt in perfect, like new condition, includes new tubes, tested & tuned on your frequency. Guaranteed, fully adjustable from 0 to 5.5 kW. Goodrich Enterprises Inc, 402-493-1886.

RANGEMASTER AM: Legal FCC Part 15 type accepted transmitter, 1-2 miles range possible! 919-367-0607 or go to www.am1000rangemaster.com.

RCA 10E1, 10KW FM Transmitter. Excellent condition, great for start up or backup, \$6000/BO. 800-678-4762.

CCA HELP
▪ Rotron Blowers ▪ Rebuilt Plate Blockers ▪ Tubes
▪ Tube sockets/parts ▪ most all transmitter parts
▪ rebuilt tuning line assemblies
Goodrich Ent. Inc
402-493-1886
www.goodrichenterprises.com cgoodrich@tconl.com

Collins tube type stereo generator & exciter, BO. Ken Diebel, KGGM, Rayville LA 71269. 318-728-2370.

(5) Five KW FM's; (5) 10 KW AM's; CSIT-25-F 25 KW (GG) FM; (5) 5KW AM Harris MW-5-B. Continental Comm., 314-664-4497, ContComm@sbcglobal.net.



You're in the right place!
Buying Or Selling Used Equipment?
Radio World
Broadcast Equipment Exchange

Radio World
Equipment Exchange

CSI FM 3000E/FM T-25-F, complete 25 KW FM xmtr, 3 KW driver & amp, no exciter, was running at 20 KW when removed from service 9 mos ago, have pics & spares, \$12,000/BO. Dan Thomas, KUAY, 90 W Linden Ave, Pueblo West CO 81007. dan.Thomas@puebloc.edu.

RCA BTA1S 1000/500 watt broadcast band xmtr. New matched pair of 4-400c power tubes in xmtr. New PA tubes in xmtr with spares & manual. Tubes in service 6/15/03. RCA AM modulation monitor AMN-1 with manual. Inovonics Model 222 NRSC AM audio processor with IMO manual. Total package price \$8500. Don De Rosa, WAMF, 315-593-1300.

CCA 2500 FM, 2.5KW w/Gentner remote controller, \$1200, pick up only. Danny Br4ou, KJMJ, 601 Washington St, Alexandria LA 71301. 318-445-4843.

Transmitters for Part 15 FCC. FM, in good working order, must be complete. Michael Cardillo, 151 Morgan St, Cranston RI 02920. 401-942-8341 after 6PM EST.

Classic Collins 20v2 transmitter. Operating when removed from service. Tuned to 790. Buyer arranges shipping or pickup. Phil Mueller, KCVN, 2575 N Radio Hill Rd, #6-1, Blanding UT 84511. 435-259-1035, 435-260-8033 (cell), email: exnews@frontiernet.net.

Collins 830-1D 1 KW FM xmtr. Circa 1974, tuned to 89.1 MHz. Includes 310-Z1 exciter, located 30 miles south of San Jose CA, \$3100/BO, FOB San Jose location. Brant Herrett or Terry Green at KUSP radio, 203 8th Ave, Santa Cruz CA 95062. 831-476-2800; email: brant@kusp.org.

Want to Buy

AM lower powered transmitters, used, complete & in good working order. Michael Cardillo, 151 Morgan St, Cranston RI 02920. 401-942-8341 after 6PM EST.

www.rwonline.com



Your Company
To advertise,
call 703-998-7600,
ext. 154
or e-mail:
sfewell@imaspub.com

Check out the web site!
www.rwonline.com

CONSULTANTS

EVANS ASSOCIATES
Consulting Communications Engineers
FCC Applications • Design • Field Engineering • Tower Detuning Upgrade & Relocation Studies • AM Directional Array Tuning & Proof
EXPERTS IN:
TV • DTV Transition • FM • Directional Antennas • RF Exposure
210 S. Main St., Thiensville, WI 53092, (262) 242-6000, FAX (262) 242-6045
<http://www.evansassoc.com> Member AFCEE

Consulting Communications Engineers EMC Test Lab
• FCC Applications and Field Engineering
• Frequency Searches and Coordination
• AM-FM-CATV-ITFS-LPTV
• EMC Test Lab-FCC and European (IEC)
OWL ENGINEERING, INC.
E-mail: info@owleng.com **651-784-7445** Fax (651) 784-7541
5844 Hamline Ave. N., Shoreview, MN 55126 *Member AFCEE*

DISTRIBUTOR DIRECTORY

The following distributors serving the broadcast industry would be glad to help you with any of your requirements.

CORNELL-DUBILIER MICA CAPACITORS
FROM STOCK
JENNINGS VACUUM CAPACITORS
FROM STOCK
JENNINGS VACUUM RELAYS
SURCOM ASSOCIATES
2215 Faraday Ave., Suite A
Carlsbad, California 92008
(760) 438-4420 Fax: (760) 438-4759
e-mail: hmk@surcom.com web: www.surcom.com

...Some people get hooked on broadcast equipment big time...they think about it...dream about it...talk about it all the time...for example...us...
RADIO! The beat goes on!
CROUSE-KIMZEY OF ANNAPOLIS
tops in broadcast equipment
1-800-955-6800
ask for Kathleen
kkannapolis@worldnet.att.net

FASTER... MORE ACCURATE RADIO COVERAGE
• Real Time 3-D Displays
• Interference calculations
• Cost effective mapping
• Fully integrated databases
• Used by the FCC
• Latest standards built-in
RADIO SOFT
Visit us on the web at www.radiosoft.com
109 West Knapp Ave. • Edgewater • FL • (386) 426-2521

System One Communications
Broadcast Constructors & Consultants
Houston, Texas
888-625-5649
► AM-FM Site Construction Specialists
► Complete Tower Service
► Antenna & Transmission Line Diagnostics

GRAHAM BROCK, INC.
BROADCAST TECHNICAL CONSULTANTS
Full Service from Allocation to Operation AM/FM/TV/ATX Services:
Field Work/Antenna and Facilities Design
Over 35 years engineering and consulting experience
912-638-8028
202-393-5133
www.grahambrock.com

M Celenza
Communications Consultants
FM-AM-TV-LPTV-LPFM Applications, Amendments, Upgrades, Frequency Searches, Directional Antennas
Field Work (Station Inspections)
631-928-0077
Fax: 631-928-1905
41 Kathleen Crescent, Coram N.Y. 11727

MULLANEY ENGINEERING, INC.
Consulting Engineers
• Design & Optimization of AM Directional Arrays
• Analysis for New Allocation, Site Relocation, And Upgrades
AM-FM TV LPTV
Wireless Cable (MDS/MMDS/ITFS/OFS)
• Environmental Radiation Analysis
• Field Work
• Expert Testimony
9049 Shady Grove Court
Gaithersburg, MD 20877
Phone: (301) 921-0115
Fax: (301) 590-9757
email: mullengr@aol.com

Communications Technologies, Inc.
Radio Frequency / Broadcast Engineering Consultants
AM FM TV LPTV
Cellular/PCS Site Analysis
P.O. Box 1130 / Marlton, NJ 08053
Tel: 856/985-0077
Fax: 856/985-8124
web: commtechrf.com
Clarence M. Beverage
Laura M. Mizrahi

Doug Vernier
Telecommunication Consultants
Broadcast Engineering Consulting
AM/FM/TV/LPTV/DTV
Custom mapping service
Frequency searches
Propagation prediction
FCC application preparation
V-Soft
SOFTWARE FOR YOUR PC
(800) 743-3684
www.v-soft.com

David C. Schaberg
Allocation Specialist
FM & AM Frequency Searches
Move-ins, upgrades, allocations
Maximization of signals
"I do the tough ones!"
Contract engineering in the Midwest, build-outs across the country and equipment repairs.
800-393-1037
www.starradio.net

dataworld
Market Analysis
Engineering Software
Ethnic/Demographic Data
Custom Full-color Mapping
Sales Marketing Packages
www.dataworld.com info@dataworld.com
800-368-5754 fax: 301-656-5341

Structural Analysis
ERI
Electronics Research, Inc.
7777 Gardner Road
Chandler, IN 47610
(812) 925-6000
www.ERInc.com
REGISTERED PROFESSIONAL ENGINEERS
STRUCTURAL ANALYSIS
ERI Incorporated 1943
TOWER REINFORCING

R. MORGAN BURROW, P.E. & ASSOCIATES, P.C.
ALLOCATION STUDIES
AM, FM, TV, LPTV, New to all, site relocation, FM upgrade, etc.
FIELD WORK A SPECIALTY
• AM Directional antenna adjustment, measurement & proof
• RADIHAZ measure, mds, RADData, HAZ, and web, etc.
• FM & TV field intensity & other measurements
• Facility inspections for public hearing purposes
• ATX coverage testing
ELECTROACOUSTICS
OSHA measurements
304-258-7921 • Fax 304-258-7927

Planck Technical Services, Inc.
Broadcast Construction/Service
909-370-4515
www.plancktech.com
• AM-FM-LPTV-SW Station construction
• Tower Construction
• Transmitter/Antenna Service

TURN THAT DYING AM INTO A CASH COW!
WWW.METROBROADCASTING.COM
571-531-5958

SPACE IS AVAILABLE!
To advertise, call
703-998-7600,
ext. 154.

Are You a Distributor?
ADVERTISE HERE!
Space is available.
Call 703-998-7600, ext. 154.



POWER TUBES
REBUILT

1/2 THE COST
OF NEW!

ECONCO

TEL: 800-532-6626
 INTL: +1-530-662-7553
 FAX: +1-530-666-7760
 www.econco.com
 SE HABLE ESPAÑOL



TUBES

Want to Sell

FOR THE BEST PRICE
 & 24 Hr service on transmitting tubes & sockets/parts, new & rebuilt call Goodrich Ent. at 402-493-1886 day or night, www.goodrichenterprises.com.



Alison Payovich: willing to move anywhere! Enthusiastic, creative and dependable team player. News, traffic, digital production and copywriting. I want to become part of your team. 214-532-1669 or Alison-21@eminemworld.com.

Dependable, hard-working radio rookie looking for opportunity to start and grow. Ultimate dream is to deliver news or jock any format. Lynden, 817-329-9608.

Multifaceted rookie would love to work in Texas but will go to Alaska, Hawaii, Canada or anywhere. Give me the change. Preston 817-426-0846 or jospbs@juno.com.

Radio School graduate, 10 years as a vocal artist, interested in on-air and production. Comfortable in front of people, hard worker and dependable. Ready to relocate. Kayka 918-734-5381.

RF PARTS COMPANY • Broadcast • Industrial Communications

• EIMAC • TAYLOR • ECONCO • SVETLANA

Also
 Motorola • Toshiba • SGS-Thomson & Mitsubishi Semiconductors

Catalog: www.rfparts.com
 Se Habla Español • We Export

760-744-0700 • 800-737-2787
 Fax: 760-744-1943 E-mail: rpf@rfparts.com

Don't FedEx anymore! Let the Mel-Mann entertain you. For more info call 972-237-0795 or email me at bigmel90@yahoo.com.

Energetic, good spirited, funny, willing to learn and expand on abilities learned. Hardworking, people person, wanting to travel. Amanda, 405-601-5737.

Lively, outgoing, young rookie, ready to work, willing to relocate. Up for DJ, boards, promotions, production, energized to boost your ratings. Lindsey, 405-401-7080.

Radio rookie looking for work in eastern Tennessee. On-air personality, news, or production. Get along with and work well with everyone. Nicci, 865-368-6862.

Recent radio grad. Terrific board-op and creative writer. Will move anywhere you need, just point the way. Shaun, 918-293-9100.

Responsible, professional and organized define my work ethic. Personable and relatable define my personality. Drawing listeners, increasing ratings. Don R Kelly, 817-501-6519 or drkat@juno.com.

Big time rookie out of ABS looking for fresh start in broadcasting. Willing to learn and relocate and blast off in radio. 817-909-6071 or DesmaJR@hotmail.com

www.rworld.com

D And C Electronics

An International Distributor of RF Components
Tubes
 NEW & REBUILT

TRANSMITTERS, STUDIO EQUIPMENT, STLS, ANTENNAS,
 RADIO DATA SYSTEM (FOR CAR RADIO DISPLAY)
 EXCITERS-TRANSMITTERS, TRANSLATORS, MIXERS-CONSOLES, RADIO LINK
 RPU, MOSFETS, VACUUM CAPACITORS, SOCKETS

Eimac **Pro-Tek**
 SVETLANA **OMB** **EEV**

BEST PRICES **To Order:** FROM OUR STOCK
 1-800-881-2374
 Outside U.S. (352) 688-2374
 Se Habla Español

3089 Deltona Blvd. 352-688-2374
 Spring Hill, FL 34609 BEST SERVICE Fax 352-683-9595
 Website: www.dandcelectronics.com

POSITIONS WANTED

ACTION-GRAM

EQUIPMENT LISTINGS
 Radio World's Broadcast Equipment Exchange provides a FREE listing service for radio stations only. All other end users will be charged. This FREE service does not apply to Employment Help Wanted ads or Stations For Sale ads. These are published on a paid basis only. Send your listings to us by filling out the form below. Please be aware that it takes one month for listings to appear. The listings run for two consecutive issues and must be resubmitted in order to run again. Thank you.

Please print and include all information: Are you currently a subscriber to Radio World?
 Yes No
 Signature _____ Date _____

Contact Name _____
 Title _____
 Company/Station _____
 Address _____
 City/State _____
 Zip Code _____
 Telephone _____

Brokers, dealers, manufacturers and other organizations who are not legitimate end users can participate in the Broadcast Equipment Exchange on a paid basis. Line ad listings & display advertising are available on a per word or per inch basis.

WTS WTB Category: _____
 Make: _____ Model: _____
 Brief Description: _____
 Price: _____

WTS WTB Category: _____
 Make: _____ Model: _____
 Brief Description: _____
 Price: _____

WTS WTB Category: _____
 Make: _____ Model: _____
 Brief Description: _____
 Price: _____

WTS WTB Category: _____
 Make: _____ Model: _____
 Brief Description: _____
 Price: _____

WTS WTB Category: _____
 Make: _____ Model: _____
 Brief Description: _____
 Price: _____

*Closing for listings is every other Friday for the next month's issue. All listings are run for 2 issues unless pressed for space or otherwise notified by listee.

Broadcast Equipment Exchange
 PO BOX 1214, Falls Church, VA 22041 • Tel: 703-998-7600 • Fax: 703-998-2966

TRANSCOM CORP.
 Serving the Broadcast Industry Since 1978
 Fine Used AM & FM Transmitters and Also New Equipment

USED FM TRANSMITTERS			
2.5kw	1978	Collins 831D2	
5kw	1983	Harris FM5K	
10kw	1988	BE FM 10A	
10kw	1997	BE FM 10T	
10kw	1980	Harris FM 10K	
20kw	1978	Collins B31G2	
20kw	1982	Hams FM20K	
20kw	2000	Hams Z20 CD	
20kw	1989	QEI FMQ20,000B	
25kw	1991	Continental 316R3B	
25kw	1980	CSI T-25-FA (Amplifier Only)	
25kw	1982	Hams FM25K	
30kw	1986	BE FM30A	
35kw	1987	Hams FM35K	
50kw	1982	Hams Combiner w/auto exciter-transmitter switcher	

USED AM TRANSMITTERS			
400w	1988	Nautel P400 (solid state)	
5kw	1995	Harris "Gates 5"	
5kw	1982	Hams MW5A	
5kw	1996	Nautel ND5	
50kw	1985	Continental 317C2	
50kw	1986	Nautel AMPFET 50	

NEW TV TRANSMITTERS	
VHF AND UHF, 10 w TO 10kw	
TV Antennas	
TV STL	

Contact us for a quote

USED MISC. EQUIPMENT	
BE FX30 Exciter	
Continental 802B Exciter	
Belar AMM3 Mod. Monitor	
Denon 720R Cassette Recorder	
Harris AMS-G1 AM Stereo	
Inovonics AM Stereo Processor, Model 250-01	
Kintronics 50kw AM RF Switch, Model RFC8-1	
Potomac Phase Monitor AM1901, Digital, 2 Tower	
Potomac Phase Monitor AM19, 2 Tower	
Potomac TU-16 Remote Control	

2655 Philmont Ave #200, Huntingdon Valley, PA 19006
 800-441-8454 • 215-938-7304 • FAX No. 215-938-7361
 VISIT OUR NEW INTERNET SITE: www.fmamtv.com
 SEND YOUR E-MAIL REQUESTS TO: transcom@fmamtv.com

ADVERTISER INDEX

This listing is provided for the convenience of our readers. Radio World assumes no liability for inaccuracy.

PAGE	ADVERTISER	WEB SITE URL
16	Armstrong Transmitters	www.armstrongtx.com
32	ATI	www.atiaudio.com
19	AudioScience	www.audioscience.com
30	Autogram Corporation	www.autogramcorp.com
14	Belar	www.belar.com
15	Broadcast Software Int'l (BSI)	www.bsiusa.com
20, 21	BSW	www.bswusa.com
4	Burk Technology	www.burk.com
30	Circuit Werkes	www.circuitwerkes.com
32	Circuit Werkes	www.circuitwerkes.com
23	CKE/HVCA	www.rectifiers.com
32	Comet North America	www.cometna.com
6	Comrex	www.comrex.com
7	Comrex	www.comrex.com
30	Conex Electric Systems	www.conex-electro.com
8	dMarc Networks	www.dmarcnetworks.com
30	Gorman-Redlich Mfg. Co.	www.gorman-redlich.com
24	Grace Broadcast Sales	www.gracebroadcast.com
1	Harris	www.broadcast.harris.com
17	Henry Engineering	www.henryeng.com
18	Inovonics	www.inovon.com
30	LBA Technology	www.lbagroup.com
30	Mager Systems	www.magersystems.com
29	Moseley Associates	www.moseleysb.com
9	Omnia, a Telos Company	www.omniaaudio.com
11	OMT Technologies	www.omt.net
5	RF Specialties of Missouri	www.rfspecialties.com
3	S.C.M.S.	www.scmsinc.com
25	Sine Systems	www.sinesystems.com
13	Telos Systems	www.telos-systems.com
27	Telos Systems	www.telos-systems.com
2	Wheatstone	www.audioarts.net
39	Wheatstone	www.wheatstone.com
40	Wheatstone	www.wheatstone.com
24	www.radio-mall.com	www.radio-mall.com

◆ READER'S FORUM ◆

Radio World, January 2, 2004

RW in the Classroom

Sharon Rae Pettigrew's story ("College Media Face New Set Of Obstacles," Oct. 22) was most interesting to me and to my class of students at IsoThermal Community College in Spindale, N.C. I am a part-time instructor at this school, which has an FM station that covers the western third of North Carolina. We've read the article and discussed our observations.



I've been involved in educational and commercial radio since 1949. Ms. Pettigrew's interviews with major figures covered the ground quite well. While none of my students are in a position to attend the show you promoted, I am hoping that some of the sessions will be audiotaped so that I may acquire them for the students.

My thanks to Radio World for helping me prepare these students for broadcasting careers.

*Jack Buttram
Rutherfordton, N.C.*

You Talkin' to Me?

I have read and received Radio World for well over a decade, and have never written a letter to the editor of any publication. However, the Oct. 8 issue moved me, but not in a good way.

I'll start with the front cover. The text underneath the heading "Radio at Risk" read, "John Gardner of Texas Instruments says a switch to HD Radio must occur soon." This statement bothers me. Nobody tells me what must or must not occur — except the Redwood City Police Department or the San Mateo County Sheriff's Office.

Also, the letter from Paul Shinn frustrated me. He doesn't know the difference between a pirate and a Part 15 broadcaster. Who made him the judge of who is and who is not a "real" broadcaster? What he does not understand is that there are some people who are interested in receiving low-power signals like Provizer's. Has Mr. Shinn ever heard of QRPP?

*Robert Polhamus
RF Engineer
Loral Space Systems
Redwood City, Calif*

Satellators and More

Michael Baldauf's letter (*Reader's Forum*, Nov. 5) discussed station downgrades and relocations in Colorado. Clear

Channel is pulling a similar "shell game" with rural stations in Marion and Hillsboro, near Columbus, Ohio. They are reducing power *and* abandoning their long-standing cities of license to instead cover the Columbus metro.

The FCC will probably rubber-stamp this transparent ruse to provide "first service" to the Columbus suburb of Dublin, Ohio.

Another sad chapter in the commission's history is unfolding. The FCC stonewalled many LP100 CP applications for third-adjacency issues, and a study was commissioned. Before this issue was settled, an FM translator window opened, resulting in an avalanche of thousands of CP applications, primarily from religious organizations. Adjacency separation requirements are more liberal for translators.

For example, FM translators of 99 watts ERP or less are allowed to ignore the IF minimum distance separation requirements that pertain to LPFM. Therefore, translators of 99 watts will fit where an LP100 or even an LP10 would not.

It is conceivable that every possible hole in the FM spectrum of any value is now claimed. Regardless of whether the LPFM studies prove the interference issues to be moot, there will be little spectrum left to apply for.

**The Orwellian
Commission ...
has declared, 'Some
RF is more equal
than others.'**

Was this the idea in the first place? To plug holes in the spectrum with religious "satellators," whose economic threat to commercial interests is minimal and conveniently renders moot the potential threat of competition from LPFMs? Could this sequence of events really be coincidental?

The Orwellian Commission, via unbalanced rules for technically identical FM services and opportunistic practices, has declared, "Some RF is more equal than others."

*Kurt Tuckerman
Chokoloskee, FL*

You're Excused

I've enjoyed Frank Beacham's reviews in Radio World for years, so it's easy for me to excuse him for omitting any discussion of the radio reception quality offered among the products he reviewed for his article about new recorders ("Radio Gets Its First Taste of TiVo," Oct. 8).

Sometimes we get so swept up in computer-based technology as applied to radio, that we forget the radio itself. I would enjoy a follow-up article comparing the bandwidth, distortion, frequency response and other reception parameters that are so crucial to the end-result quality of any of these recording devices.

*Paul Courson, WA3VJB
West Friendship, Md.*

◆ READER'S FORUM ◆

Pretty as a Picture

As one who's photographed countless tower sites through the years and who is always on the lookout for extraordinary angles, I must compliment John Bisset on the fine shot from his *Workbench* column in the Nov. 19 issue.

I've had many of my tower photos printed in *Radio World*, but they were just "glamour shots." I always attempted to make the towers look as pretty as possible. It never occurred to me to include an outdoor plumbing fixture for added visual interest. Your photo trumps all of mine.

J T Anderton
Clear Channel Radio
Covington, Ky.



Who's on First?

Ed Harvey's piece on his experiences in the early days of talk radio was interesting ("Talk Radio: The Beginning," Oct. 8). Lest readers get the impression that he was the first talk show host in the country, we should note that a couple of Web sites and a book list Barry Gray of New York's WMCA(AM) as being the first, in 1945.

Readers can follow up at www.kenmillsagency.com/prti/historyoftalk.html and www.talkers.com/greatest/8rgray.htm, and in the 1993 book "All Talk: The Talk

Show in Media Culture" by Wayne Munson, from Temple University Press.

Winston Tharp, CPBE
Creative Arts Technical Services
San Francisco State University
San Francisco, Calif.

Grammar Police

I enjoyed Skip Pizzi's online-archived article, "Techno-Speak Can Drive a English Teacher Crazy." I only wish you had written "an English Teacher" instead.

Bob Grubic
Long Beach, Calif.

The editor thought it would be amusing to insert the incorrect usage in the headline as a joke.

Remember The Victrola

There's never been any doubt in my mind that Charles Herrold was "Radio's Real Founding Father" (*Reader's Forum*, Nov. 5). However, I think the final line in the story should say that he "created" rather than "invented" the radio station.

The "windup phonograph" described in the photo caption is a gramophone, model VIII, made by the Victor Talking Machine Co. In the early 1920s my uncle Herbert was head of the Berliner Gramophone Co. in Canada, a Victor affiliate founded by his father Emile Berliner, inventor of the microphone and gramophone with its disc records.

He used a then-current model Victrola to do exactly as Herrold did. His may have been the world's first disc-jockey remote broadcast, as he played records and talked between them from his home via telco line to Montreal radio station XWA, which may by then have changed its call to CFCF.

Oliver Berliner
SounDesign Engineers
Bozman, Md.

History Lesson

I enjoyed Professor Adams' story (*Reader's Forum*, Nov. 5) putting KDKA(AM) in its place as an early radio broadcasting pioneer, but not the first.

However, I was disappointed by the

Re-Evaluate Web Experience for '04

As we bring you to the back pages and close out our first issue of 2004, there are any number of regulatory, technical or community standard issues we could address here.

We would like to start the year with a friendly suggestion: take a fresh and objective look at your station Web site and ask if it is doing you any good.

Since the late 1990s, the Web experience has been essential to any station's overall image and an adjunct to its strategy and success. Flashy, splashy graphics are eye-catching; audio imaging tickles the ear. But getting right to the point is of paramount importance — as it is on the air.

Consider a research item from *comScore.com*. The majority of online households in the United States — 67 percent — still access the Web via dialup telephone lines. Here in the nation's capital, subscribers still using POTS dialup stand at 68 percent.

Those complicated pages your Webmaster creates, filled with graphics, ads, logos, artist info and maybe a blast of audio imaging, may launch in a flash at your office. But those same pages take an eternity to download on a dialup, and it is a good bet most of your listeners still use one. All it takes is one slow-loading JPEG and your potential visitor is gone.

The placement of "cookies" to track listener patterns is essential, but be judicious in their use. One FM station's Web site we visited at random took nearly two minutes to download on a dialup and attempted to put no less than 20 cookies on the machine. As we clicked across to the "meet the DJs" page, a pop-under ad appeared, and another dozen or so cookies tried to get across. This goes beyond excessive to ridiculous.

The process is transparent to the listener/surfer. But should they decide to turn on their browser's cookie blocker and witness the traffic being turned away, they may get suspicious of your intentions. Should you try using advertising spyware, word will get around fast once discovered.

A visit to a favorite station should not be like a trip to a mall where clerks ambush you with bad-smelling cologne at every step.

We won't tell you how to author a Web page or how to present it. But we all listen to radio, and are tempted now and again to click the little box to win those concert tickets. We like good-looking Web sites, and we know enough to avoid the bad ones. We hope this does not describe your site.

While many of your listeners may have treated themselves to fancy new computers for the holidays, they are likely to remain on POTS lines for a little longer. Let your Web guru know your site should work for the benefit of the station, not to show off to other Web gurus. Don't give your audience any reason to turn their backs on you. 🌐

omission of another early pioneer, Professor Earle M. Terry of the University of Wisconsin at Madison physics department, whose federally licensed experimental broadcast station, 9XM, began regular broadcasting in 1915 from an old power-plant building on campus. While 9XM received the call letters WHA(AM) after KDKA in 1922, its record of continuous broadcasting from 1915 earned it the rightful claim to be "the oldest station in the nation."

I was also surprised by an error within the statement, "The entry of the United States into the World War caused all radio transmitters and receivers to be shut down and sealed until 1919." In fact, 9XM was exempted from that shutdown so it could provide the "experimental service to the nation, communicating telephonically with naval stations on the

Great Lakes (605)."

Unfortunately, those call letters exist today only as WHA(TV), a station of Wisconsin Public Television. Its audio broadcasting activities were relicensed as WERN(FM), now a station of Wisconsin Public Radio. Radio and TV programming now originate from Radio Hall on the UW campus, a far cry from the long gone power plant.

The aforementioned information appears in H. Russell Austin's "The Wisconsin Story: The Building of a Vanguard State," first published in part as a daily serial in the *Milwaukee Journal* in 1948.

Elmer A. Goetsch
Chief Engineer
WXPR Public Radio
Rhineland, Wis.

—EDITORIAL STAFF—

Paul J. McLane	ext. 117	Editor
Leslie Stimson	ext. 129	News Editor/Wash. Bureau Chief
Michele Kramer Peterson	ext. 149	Studio Sessions Editor
Kelly Brooks	ext. 136	Buyer's Guide Editor
Thomas R. McGinley	—	Technical Adviser
Alan Peterson	—	Technical Adviser
John Bisset	—	Contributing Editor
Skip Pizzi	—	Contributing Editor
T. Carter Ross	ext. 120	Editor-In-Chief (International)
Marguerite Clark	—	Editor (International), Milan
Rogelio Ocampo	ext. 121	Latin America Editor in Chief
Karina Gerardi	ext. 137	Latin America Editor
Terry Hanley	ext. 130	Editorial Assistant & Listings Coordinator
Peter Finch	—	Editorial Assistant, Milan

—EDITORIAL CONTRIBUTORS—

W.C. Alexander, Bruce Bartlett, Frank Beacham, Naina N. Chernoff, Harry Cole, Troy Conner, Vince Ditingo, Mark Durenberger, Charles Fitch, Ty Ford, Scott Fybush, Harold Hallikainen, Jeff Johnson, Craig Johnston, Paul Kaminski, Peter King, Mark Lapidus, Mark Persons, Sharon Rae Pettigrew, Michael LeClair, Carl Lindemann, Frank R. Montero, Ted Nahil, Tom Osenkowsky, Ken R., Rich Rarey, Randy Stine, Travis the V/O Guy, Barry Umansky, Tom Vernon.

Radio World

Vol. 28, No. 1 January 2, 2004

Telephone: (703) 998-7600 • Business Fax: (703) 998-2966 • Editorial Fax: (703) 820-3245
E-mail: radioworld@imaspub.com • Web site: www.rwonline.com

—ADVERTISING SALES REPRESENTATIVES—

US East: John Casey	330-342-8361	Fax: 330-342-8362	e-mail: jcasey@imaspub.com
US West: Dale Tucker	916-721-3410	Fax: 815-352-1698	e-mail: dtucker@imaspub.com
Product Showcase & Classified Ads: Simone Fewell	703-998-7600 x154	Fax: 703-671-7409	e-mail: sfewell@imaspub.com
European Sales Mgr., Africa, Middle East: Raffaella Calabrese	+39-02-7030-0310	Fax: +39-02-7030-0211	e-mail: rcalabrese@imaspub.com
Japan: Eiji Yoshikawa	+81-3-3327-2688	Fax: +81-3-3327-3010	e-mail: callem@msn.com
Asia/Pacific: Wengong Wang	+86-755-5785161	Fax: +86-755-5785160	e-mail: wvw@imaschina.com
Latin America: Alan Carter	703-998-7600 x111	Fax: 703-671-7409	e-mail: acarter@imaspub.com

NEXT ISSUE OF RADIO WORLD JANUARY 14, 2004

For address changes, send current and new address to RW a month in advance at P.O. Box 1214, Falls Church, VA 22041. Unsolicited manuscripts are welcomed for review: send to the attention of the appropriate editor.

—ADMINISTRATION & PRODUCTION—

Stevan B. Dana	President/CEO
Carmel King	VPI Group Publisher
Marlene Lane	Editorial Director/COO
Chuck Inderrieden	CFO
Eric Trabb	Sales & Marketing Director
John Casey	Associate Publisher
Annette Linn	Production Director
Melissa SE Robertson	Production Publication Coordinator
Kathy Jackson	Ad Traffic Manager
Milagros Castañeda	Classified/Product Showcase Layout
Robert Green	Circulation Manager

Radio World (ISSN: 0274-8541) is published bi-weekly by IMAS Publishing (USA), Inc., P.O. Box 1214, Falls Church, VA 22041. Phone: (703) 998-7600, Fax: (703) 998-2966. Periodicals postage rates are paid at Falls Church VA 22046 and additional mailing offices. POSTMASTER: Reprints of all articles in this issue are available. Call or write Joanne Munroe, P.O. Box 1214, Falls Church, VA 22041; (703) 998-7600; Fax: (703) 998-2966. Copyright 2004 by IMAS Publishing (USA), Inc. All rights reserved.

—Printed in the USA—

WHEATSTONE D-4000

DIGITAL AUDIO CONSOLE



Based on the technical architecture of our popular D-5000, this new D-Series console is totally modular, offering features to satisfy the most demanding engineers—but at a lower price point than its predecessors.

- Hot-swap design
- Four stereo mix buses
- Six pointer-style true VU meters
- Any mix of digital and analog inputs
- AES and balanced analog outputs
- Choice of master clock rates
- Up to 4 mix-minus outputs using SPD-4000 phone remote modules
- 24 bit A-to-D conversion on analog inputs,
- A/B source switching with fully independent logic and machine control
- Mode selection on stereo inputs
- Low profile drop-through counter design
- Multiple studio outputs with talkback interrupt

*Wheatstone has more digital audio experience than most of our competition combined. The D-4000 is a truly high performance, reliable console that will make your transition to digital a pleasure. Benefit from our expertise—**CHOOSE WHEATSTONE**—the Digital Audio Leaders!*

 *Wheatstone*



GENERATION 9 DIGITAL CONTROL SURFACE

Designed to integrate flawlessly with the Wheatstone BRIDGE digital audio network router, the Generation 9 control surface allows you to easily create large or small platform-based systems that are exceptionally user-friendly and flexible. Wheatstone BRIDGE network cages house all I/O ports and engine cards, and may be wired in tandems within a single equipment room or interconnected to separate remote locations by means of fiberoptic or CAT-5 cables to provide single wire studio integration schemes.

Once configured, the system operates entirely independently of external computers. Configuration itself is intuitive and carried out onsite by means of user-friendly graphic interfaces provided by Wheatstone desktop software. We have gone to great lengths to make these setups easy for your field engineers, allowing expansions and changes to be achieved painlessly. Naturally, the Generation 9 system also takes full advantage of Wheatstone's exclusive VDIP® configuration

software as well, so that studio functions (like mutes, fader and timer starts, tallies, etc.) are easily accomplished right at your desktop. Once set-up is completed the desktop is disconnected; all settings are retained in nonvolatile storage and the entire system runs standalone. Ethernet protocol is built in, providing interface with automation, scheduling, and hardware controllers as you require.

Whether you're planning a small, centrally located studio network or a large, multiple format build-out, the Generation 9 Digital Control Surface can form the basis for a fully integrated, reliable and user-friendly broadcast system that will handle your most demanding requirements *and* be able to change with your varying needs as they arise.

At Wheatstone we have more combined digital design expertise than anyone. **Benefit from our hard work!** Choose **WHEATSTONE—the Digital Audio Leader.**

 *Wheatstone Corporation*

600 Industrial Drive, New Bern, North Carolina, USA 28562
www.wheatstone.com / sales@wheatstone.com

copyright © 2003 by Wheatstone Corporation

tel 252-638-7000 / fax 252-635-4857