

*****AUTO**3-DIGIT 857
 S117298 DOB 0306
 TOM MILLER
 ASST CHIEF ENGINEER
 KTZR
 2033 S AUGUSTA PL
 TUCSON AZ 85710 7905

595

HD Radio

USC stations go digital, and Dick Fry talks about interleaving.

One, Two, Three

Tivoli Audio aims for a new standard with its Model Three.

Page 26



Radio World

December 3, 2003

\$2.50

The Newspaper for Radio Managers and Engineers

INSIDE

NEWS & ENGINEERING

▼ What Raymond Benedict has in store for SBE.

Page 28



▼ How many engineers does it take to keep a station running?

Page 45

STUDIO SESSIONS

▼ Read Burgan tries out audio restoration software from Tracer Technology; Carl Lindemann reviews two CD DVD Printers; and cabinetry details are a big part of a facility project for Jefferson Pilot.

In This Issue

YOU NEED ANALYSIS

▼ NTI and Radio World send a hand-held digital audio analyzer to a station manager in Mississippi.

Page 4



Sign Up For NewsBytes Weekly Digest at www.rwonline.com

Suppliers Prepare for Digital Data

by Leslie Stimson

Are the wireless data capabilities promised by HD Radio proponents reality, or so much smoke and mirrors? We'll soon find out.

Now that transmitter and receiver manufacturers are working on HD Radio products, studio automation companies and data service suppliers are joining in. Several have been working with Ibiqity Digital Corp. on software to support the more advanced wireless data services that proponents say will be possible with terrestrial digital radio.

Automation vendors working with Ibiqity are in various stages of integrating the HD Radio software into their systems. This will allow stations, using their studio infrastructures, to support whatever HD Radio data services they choose to conduct, beginning with program enhancements such as text-based data services. The initial software upgrades also will lay the foundation for future, more complicated, data applications, said Joe D'Angelo, director of wireless data for Ibiqity.

Most of the automation companies and

See DATA, page 16 ▶

SPECIAL REPORT

RFE/RL Shifts Focus To Muslim Countries

Critics Call It a Cold-War Relic, But Its Mission Has Evolved Since 9/11

by Randy J. Stine

WASHINGTON After years of broadcasts behind the Iron Curtain, Radio Free Europe/Radio Liberty officials say the international radio broadcaster has shift-

ed its focus from former Communist countries in eastern Europe to Muslim countries in southern Europe, Central Asia and the Middle East.

Despite funding cutbacks throughout See RFE/RL, page 8 ▶



Just seconds before Radio Free Afghanistan's first broadcast on Jan. 30, 2002. From right: Veteran RFE/RL Tajik Service broadcaster Iskandar Aliev, technician Aman Amiri and RFE/RL Afghan Service broadcasters Sohayla Hasrat-Nazimi and Sayid Abass.

Photo by Ron Symonitz

Are you ready for a breakout performance?



www.broadcast.harris.com

The notion of "perfect sound" is always going to be fodder for debate among radio pros far and wide. But regardless of what you hear as "perfect" most PD's and engineers agree that major market radio sound demands consistent loudness, punch, and clarity. In fact, more than ever, it demands the Orban Optimod-FM 8400. With five times the raw processing power of its predecessor, the Orban Optimod-FM 8400 delivers a consistently louder signal with lower distortion than any other product on the market, analog or digital...and at lower cost. The "look ahead" intelligent design means you'll pump out polished, balanced sound regardless of the input - be it speech or music - and you have the flexibility of customizing that sound with over 20 expertly designed preset audio textures. The Orban Optimod-FM 8400 also features three levels of password-protected access control and full TCP/IP network and PC dial-up remote control. What a package. But then...you wanted perfect, didn't you?

For more information on the Orban Optimod-FM 8400 call us today at 1-800-622-0022.



DIGITAL NEWS

XM Hits 1 Million; Calls Localism a 'Myth'

WASHINGTON XM satellite Radio has surpassed 1 million subscribers, and predicts it will add 300,000 in the fourth quarter.

"We're here. We ain't going anywhere," said XM Satellite Radio President/CEO Hugh Panero as the company celebrated its millionth customer in November. "There's wannabes in this business. We are the real deal," said Panero, before a crowd of new listeners,



XM's Hugh Panero (left) with music artist Quincy Jones before the celebration for the satcaster's 1 millionth subscriber.

Photos by Leslie Simmons

vendor partners, reporters and employees. "We are dashing the myth that nobody would pay for radio — and the myth that it has to be local," said Panero.

XM honored several new subscribers on hand for the festivities. Each received an XM Delphi SkyFi boombox and a lifetime subscription to the digital satellite-delivered radio service.

Eighteen thousand listeners participated in a contest in which they described their XM experience. Thirty were chosen for a video that played during the event.

One listener from Radford, Va., credited the service for giving him vital information during a tornado. Because of mountains in the area, Eric Baynes said he couldn't receive any terrestrial radio stations during the tornado. He credited XM for "saving my life" and helping him to get home. The Weather Channel is one of XM's information channels.

Panero said many employees have been working on the product launch for four years. The satcaster launched its service nationally less than 24 months ago.

XM, Sirius Still Losing Money

XM Satellite Radio lost more money in the third quarter. But it says its business performance may be better gleaned from subscriber growth, falling subscriber acquisition costs, improved operating margins and stable fixed expenses.

"We execute the hell out of this business," said President/CEO Hugh Panero.

XM reported a third-quarter net loss attributable to common stockholders of \$145.6 million compared to \$114.7 million for the same period a year ago. For the first nine months of the year, its loss was \$434.7 million.

See DIGITAL NEWS, page 5 ▶

Audioarts R-90

The Perfect Console for Multi-Studio Buildouts!

OUR NEW R-90 HAS THE FEATURES ENGINEERS WANT:

Two stereo program busses and two mono busses — one pre and one post-fader (perfect for backfeeds or on-the-fly mix-minus); dual phone caller support using Wheatstone's exclusive Bus-Minus[®] circuitry, which generates mix-minus caller feeds with the simple push of the module's MXM bus assignment switch. Both control room and studio monitoring with talkback are provided, including both pre and post studio and headphone level pot monitor feeds. You can even choose a second monitor module for studio two/headphone two output feeds, giving you plenty of monitoring flexibility. And while the frame is compact, it can accommodate up to 23 input or accessory modules in any combination. Because all switching is electronic (and all switches are LED illuminated) you can count on the ultimate in reliability. THIS IS A TRULY VERSATILE AND COMPACT AUDIOARTS CONSOLE!

Made in USA
tel 252-635-7000/fax 252-635-4857
sales@wheatstone.com
copyright © 2003 by Wheatstone Corporation

AUDIOARTS ENGINEERING
www.audioarts.net

NEWS

| | |
|---|---|
| Suppliers Prepare for HD-R Data | 1 |
| RFE/RL Shifts Focus to Muslim Countries | 1 |
| Digital News | 2 |
| Don't Ease Up on Interference | 3 |
| From the Editor | 4 |
| Newswatch | 5 |
| Philly Station Strives to Rebuild | 6 |

HD RADIO

| | |
|---|----|
| USC Stations Go HD Radio | 12 |
| Radiation Patterns Key With Dual-Antenna Approach | 14 |
| CPB Awards HD Radio Grants | 14 |

FEATURES

| | |
|---|----|
| Workbench: Holiday Lights for Your Rack | 17 |
| Armed and Ready to Rock | 18 |
| For One Singer, Life Irritates Art | 19 |
| Catalogs Trace Equipment History | 20 |
| VOA Antenna Switch at Bethany, Ohio | 23 |
| One, Two, Three Goes Tivoli | 26 |
| Benedict Outlines SBE Priorities | 28 |

STUDIO SESSIONS

| | |
|--|----|
| Miami Cluster Gets Studio Upgrade | 34 |
| So Bad, It's Good: Dead Radio | 35 |
| Diamond Cut Takes Quantum Leap | 36 |
| Epson Makes Pro Impression for CD-R Printing | 37 |
| Classic Console Comes to Roost | 39 |
| Two New Books Take on Pro Tools | 40 |

OPINION

| | |
|--------------------------------------|----|
| The Engineer-to-Station Ratio System | 45 |
| Reader's Forum | 46 |

December 3, 2003

GUEST COMMENTARY

Don't Ease Up on Interference

by Mario Hieb, P.E.

The FCC should not ease its interference rules, even if those rules limit the number of low-power FM stations that can fit on the dial. That's my conclusion after reading the reactions from the NAB and National Public Radio to a report from Mitre Corp. commissioned by the FCC.

Once allies on the LPFM issue, NAB and NPR are taking divergent approaches to the report, which suggests that more LPFMs could be allocated if third-adjacent-channel protections were dropped. NAB opposes that notion, while NPR seems to be straddling the fence.

In a filing of comments with the agency, NAB issued a scathing criticism of the Mitre report on the feasibility of the proposed low-power FM service. National Public Radio also had criticisms, but was qualified in its comments and generally supports the idea of trying to fit more LPFMs in the FM band.

NAB

NAB charges that the Mitre report wholly ignores two key congressional mandates — listening tests and an economic analysis on the impact on full-power FM stations. In passing the Radio Preservation Act of 2000, Congress instructed the FCC to conduct field tests to determine, in real-world conditions, whether LPFM stations would interfere with existing FMs if the low-power stations were not subject to third-adjacent-channel spacing requirements.

The NAB alleges that, due to cost considerations, Mitre used a single listener to judge whether harmful interference was present in the audio. Additionally, the NAB told the agency that the report does

Finally, the association argues that the Mitre test site selection processes, driven by administrative convenience, was flawed and the selection of test locations was improper. The comments state that Mitre's tests revealed that interference to

station likely caused."

But, surprisingly, NPR does not come to the same conclusions as NAB and goes so far to state that it "believe(s) third-adjacent-channel LPFM stations might be authorized without causing undue inter-

NAB claims that the Mitre report failed to address key statutory requirements mandated by Congress.

full-power FM stations from third-adjacent-channel LPFM interference exists and is significant and that Mitre's formulas for waving third-adjacent-channel distance restrictions have no basis in fact.

For these reasons, NAB argues that the commission cannot recommend to Congress the elimination of third-adjacent channel protections for LPFM service.

NPR

Although it too found flaws in the study, NPR came to a much different conclusion, recommending that the FCC allow experiments with LPFM.

While saying it agrees with the LPFM mission of producing and disseminating programming to unserved and underserved listeners, NPR filed comments expressing the view that the Mitre study suffers from significant methodological flaws. NPR feels that the public interest

ference, so long as certain safeguards are implemented."

Another view

I agree with the NAB: the Mitre report is flawed. The report lacks the touch of experienced broadcast engineers in determining the true technical issues. The Mitre study neglects FCC policy in analyzing our system of FM radio broadcasting.

Like NAB, I feel that the LPFM pro-

ponents, including NPR and Mitre, ignore more than 50 years of FCC policy and long-established technical principals such as the effect of antenna height on FM-band signal propagation. For example, under the proposed LPFM system, I could design a *legal* LPFM site with much larger coverage area and interference zones than the Mitre report suggests, just by selecting a site with favorable HAAT characteristics.

The NAB position is more intellectually honest than the "cafeteria" approach of NPR, which "picks and chooses" the parts of the report it likes — despite its own admission that the study "suffers from significant methodological flaws." Perhaps NPR sees an opportunity to distribute programming and increase audience size if more LPFM stations were on the air?

There is a clear, time-established principle that interference is bad for FM radio. To quote from the NAB comments, "Existing broadcasters have a legitimate expectation that they can and will reach their audiences ... these listeners should not be deprived of their ability to receive free over-the-air service, including vital weather and other life-saving emergency information."

If Congress and the FCC are serious about LPFM, they should start over and perform a scientifically rigorous test on the effects of third-adjacent interference.

Mario Hieb, P.E., is a Salt Lake City-based consulting broadcast engineer.
RW welcomes other points of view.

The NAB comments are more intellectually honest than the 'cafeteria' approach of NPR.

not include the "statutorily mandated economic analysis of the impact LPFM stations would have on full-power stations" were third-adjacent-channel requirements to be eliminated.

Technical flaws

The NAB asserts that the Mitre report is "replete with technical flaws."

First, the "sample of one" listening test was not scientifically valid because it shunned properly designed subjective listening tests and relied on the judgment of a single individual.

Next, the NAB states that an understanding of a test receiver's ability to accept or reject third-adjacent-channel interference is crucial. The trade association claims that Mitre failed to use a sufficient number of receivers and neglected to characterize the performance characteristics of the devices it did use. NAB then suggests that Mitre failed to test those receivers properly.

should not come at the expense of existing non-commercial educational services.

It is encouraged at the conclusions of the study, but NPR stated that "we are constrained to conclude, however, that the Mitre study's methodology and testing were less than perfect." NPR goes on to claim that Mitre and Comsearch "utilized a limited test bed of receivers and failed to establish through technical performance, sales volume, cost or other relevant factors that the chosen receivers were, in fact, representative of the universe of receivers now in common use."

NPR found similar methodological flaws in the testing of third-adjacent interference to radio reading services; Comsearch tested only a single reading service.

Finally, NPR stated that "the imprecision of the interference perception and measurement methodology significantly obscured the nature and extent of the interference that the third-adjacent LPFM

SCMS, INC.

YOU-KNOW-WE-KNOW-RADIO!

SPREAD TOO THIN AND FEELING DRAINED?

- ▶ Experienced Staff
- ▶ 26 Years of Personal Service
- ▶ Competitive Prices for over 600 Quality Manufacturers of New Equipment
- ▶ Huge Stock of Rebuilt RF and Audio Gear
- ▶ Extensive Rental Fleet (Audio, RF, Codecs, Test Equipment, and more!)
- ▶ Trade-Ins Welcomed

TRY SCMS ON FOR SIZE - WE CAN FILL YOUR NEEDS

| | | |
|--|---|--|
| WEST COAST Doug Tharp Voice 866.673.9267 Cell 818.398.7314 Email dtharp@san.rr.com | CENTRAL Bernie O'Brien Cell 731.695.1714 Email bernieob@earthlink.net | NORTH-EAST Dan Lohse Voice 908.722.6015 Fax 908.722.4359 Pager 877.792.8024 Email scmsnorth@aol.com |
| SOUTH-WEST Tyler Callis Cell 817.312.6338 Email tylercallis@integrity.com | MID-WEST Mary Schnelle Voice 1.800.245.4307 Fax 513.583.1343 Email mschnelle@maryschnelle.com | SOUTH-ATLANTIC Art White Voice/Fax 770.632.1295 Cell 770.630.9942 Email whitearthur@bellsouth.net |

CORPORATE SALES OFFICE - PINEVILLE, N.C.

Toll FREE 800.438.6040 Fax 704.889.4540
 Email sales@scmsinc.com
 www.scmsinc.com

So It's Time to Play Radio Santa?

Stuck for gift ideas? With the holidays upon us, here are a few for the radio person in your life (or for yourself).

I'm a big fan of "Riverwalk, Live From the Landing," a weekly show featuring The Jim Cullum Jazz Band, now in its 15th year. The program is produced by Pacific Vista Productions for Texas Public Radio and is heard on 140 or so stations via Public Radio International.

The producers write that "Riverwalk" is produced "with a passion and love for the music, and offers listeners a glimpse of the cultural context and historical setting in which jazz first reached out to a national audience." Yes. It's also damn good fun.

A super gift for your favorite jazz fan would be one of the radio broadcasts that have been released on CD and cassette. Themes include the spirit of gospel in jazz, American love songs and, most timely, "Hot Jazz for a Cool Yule." Its Web site also offers numerous studio CDs and soundtrack recordings featuring the band. Most of the CDs are in the \$15-\$17 range.

You can learn more at www.riverwalk.org. Tell them Paul McLane at Radio World sent you. And if you love the music as much as I

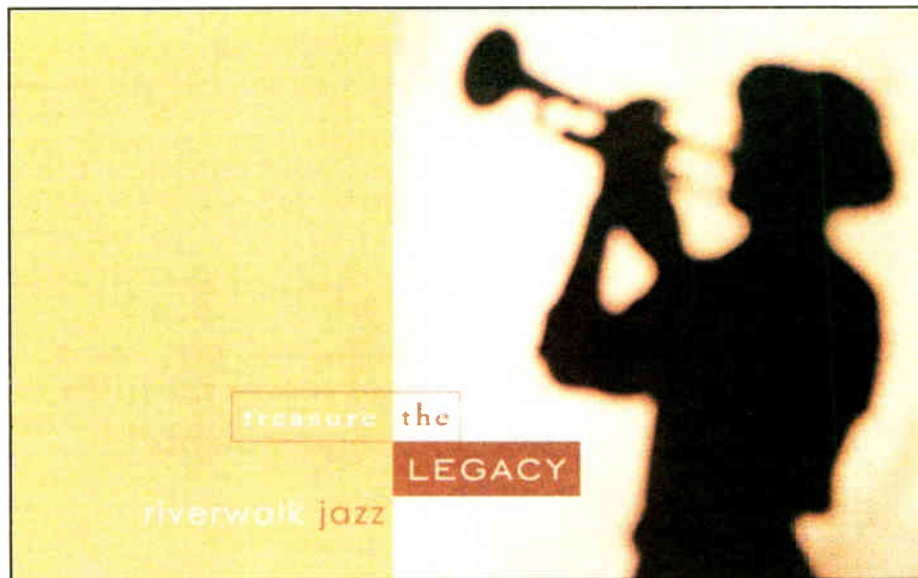

do, let your local public radio station know.

★ ★ ★

How about a subscription to *Antique Radio Classified* as a gift?

If your friend or family member knows what an Air King Skyscraper is, or thinks it would be fun

to plan a trip to Lake Ronkonkoma, N.Y., for the GNYVWA Swap Meet, this one's for them (but make sure they don't already get it!). ARC calls itself the national publication for buyers and sellers of old radios and related items.

John V. Terrey is the editor. A subscription is \$39.49 per year, or \$57.95 if you choose first-class mail. Visit www.antiqueradio.com.

★ ★ ★

"All Songs Considered" is the most popular of NPR's CD offerings. The series features music heard on the network's online music show by the same name.

The third compilation in the series was put together by the director of "All Things Considered," Bob Boilen, and includes cuts from classical accordionist Daniel Barski, guitarist Ry Cooder, Bob Brozman, Sigur Ros and Dirty Three. "All Songs Considered 3" costs \$14.95 and can be purchased at <http://shop.npr.org>.

Also check out a separate, three-CD set called "I Heard It on NPR," a nice \$30 gift for the flaming liberal on your musical shopping list.

★ ★ ★

Radio World contributor and jingle

From the Editor



Paul J. McLane

archivist Ken R. — the man with the mysterious initial — has a new book coming out, his second, as we speak. (I had a small editing role in the book but am not commissioned on its sales.)

In "Up and Down the Dial," Ken relates funny and sad stories from his life and his career in radio and TV in a series of short sketches such as "Amok in Las Vegas" (Ken at the NAB show), "Here, Eat This" (Ken is almost poisoned live on the air by a national advertiser) and "Audio Restoration Gets Personal" (Ken listens to a real murder happening on tape).

The book includes an audio CD with a send-up of top-40 radio circa 1962 and a montage of air checks from the early '60s.

The price is \$39.95 plus shipping. I have it on good authority that Ken will include a personal message to the recipient inside the front cover, if you ask nicely. Visit www.kenr.com.

★ ★ ★

And a tribute to broadcast facilities destroyed in a fire on Mount Washington, N.H., is part of a calendar for 2004, produced by another RW contributor, Scott Fybush.

The calendar, in its third year, is aimed at fans of broadcast transmitter sites. Fybush also operates the "Tower Site of the Week" and NorthEast Radio Watch.

"Even after more than tripling the press run from the inaugural 2002 edition, the 2003 edition sold out within months," he said.

Each month features an 8-by-11-inch color photo of a transmitter site taken by Fybush.

Calendars cost \$16 postpaid. Info and orders: www.fybush.com.

Happy holidays! 🌐

Mike Davis, general manager of WUSM at the University of Southern Mississippi in Hattiesburg, is the winner of a DL1 96k

Handheld Digital Audio Digilyzer from NTI and Radio World. (A nice aside: Mike told us in his entry that he spends "every spare moment I have at work trying to find more time to read this newspaper more intently.")

The DL1 weighs less than a pound but is a complete digital audio analyzer, with inputs for AES3, SPDIF, TOS-Link and ADAT audio signal interfaces. A speaker allows monitoring of the embedded digital audio.

The device measures the digital interface carrier signal as well as the embedded audio, including audio level, distortion (THD+N) and frequency, and provides VU/PPM meter and scope display modes for monitoring. At the interface carrier level, it measures sampling frequency, carrier level and channel status bits; and it displays data in a "bit-meter" mode.

Retail value: \$1,590.



Get online with the new solution for IP control and monitoring.

Access your remote site over the Internet.

Simultaneous operators and multiple access levels.

Installs at the studio or transmitter site.

Alarm notifications by email and SMS.

Customizable HTML-based interface.

You need an IP solution for remote facility control that's adaptable and easy to manage. One that will work whether your transmitter site has T1 or no network connection at all. And you need something that's easy to implement.

The Web Interface from Burk Technology adds IP control to the GSC3000 and VRC2500 transmitter remote control systems, allowing access from any Internet connection and a standard web browser. SNMP-enabled, with multi-operator support, the Web Interface installs at the studio or transmitter site — wherever an Ethernet connection is available. Enjoy the benefits of a totally integrated solution that offers the flexibility needed by today's broadcasters.

Digital News

► Continued from page 1

Subscriber acquisition costs in the quarter averaged \$76 per customer, compared to \$131 last year. Total revenue grew from \$5.6 million to \$26.9 million. Its liquidity including cash on hand totaled \$553 million.

Like its competitor, Sirius is growing its subscriber base. It reduced its net losses, but it remains behind in number of subscribers, and its operating losses grew.

Sirius said it ended the third quarter with 149,612 subscribers, an increase of 42 percent in the quarter. It said its cash position is "the strongest in satellite radio." It ended the quarter with \$479 million in cash and equivalents.

While Sirius President/CEO Joe Clayton told analysts the company's retail unit share increased by 48 percent over the previous quarter, XM

stockholders of \$166.7 million.

Another comparison of the companies' relative financial situation is found in the statistic of operating losses. For the year, XM has lost \$323.7 million, up 9 percent from last year at this time; Sirius lost \$312.4 million, up 41 percent.

Kahn Defends Cam-D at AES

NEW YORK "Over my cold, dead body will I back away from Cam-D."

Leonard Kahn made this statement in a digital radio session at the Audio Engineering Society convention in New York in October. Of Ibiquty's IBOC system eventually being authorized for nighttime operation, he said, "It ain't going to happen." He claims the Ibiquty system will have audible artifacts at night and interfere with neighboring stations.

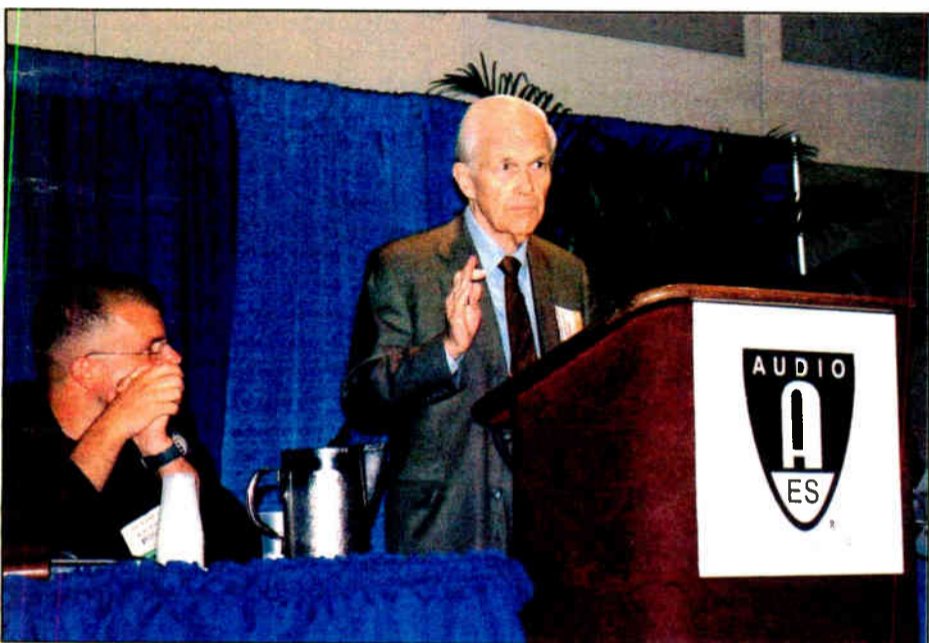

Leonard Kahn at AES

President/CEO Hugh Panero said his company "continues to capture the dominant share of all new growth" in the satellite radio market.

Sirius reported revenue of \$4.3 million, compared to \$17,000 for the third quarter of 2002 and \$2.1 million for the second quarter of 2003. It reported a third-quarter net loss applicable to common stockholders of \$106.7 million, down from \$119.7 million for the same period a year ago.

Year to date, Sirius had revenue of \$7.9 million and had a loss to common

But Kahn wasn't giving away much about how his system works. Asked by an attendee where the digital energy is inserted in the signal using Cam-D, Kahn didn't answer the question directly.

Ibiquty did not have a representative on the panel, but David Layer, director of advanced engineering for NAB Science and Technology, said the National Radio Systems Committee anticipates the FCC will issue a second notice about IBOC in 2004, with more details about how stations may implement the service.

Group Targets Latin America For Eureka-147

LONDON The consortium dedicated to selling the Eureka-147 digital radio technology is focusing its efforts on Latin America. With Eureka relatively established in Europe and Canada, the WorldDAB Forum seeks potential markets in Central and South America.

Together these regions represent a large potential audience for digital radio.

Forum representatives were in Brazil this fall at Futurecom 2003 for the Alliance for the Information Society, a five-year program to reduce the digital divide between Europe and Latin America. The European Commission has financed the AIS with \$88.7 million.

WorldDAB is participating in the project to promote the Eureka-147 standard. Eighteen countries in Latin America are targeted: Argentina,

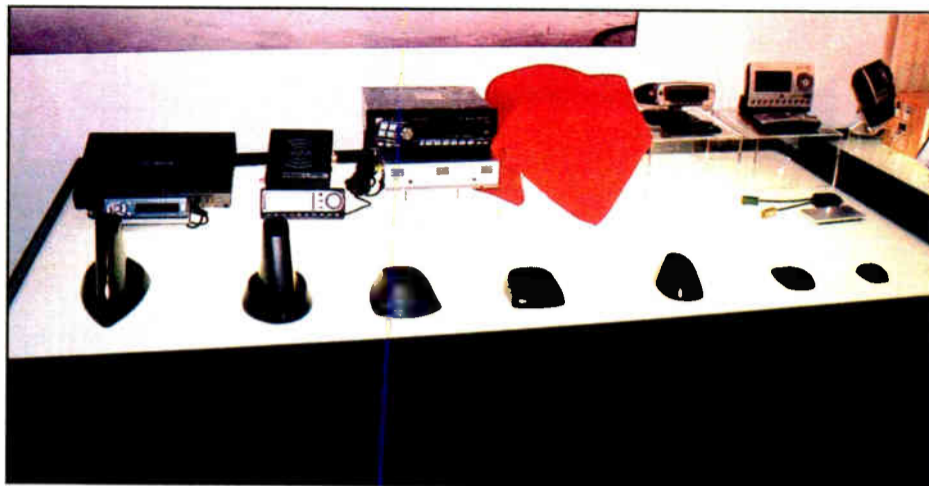

A display shows XM's antenna progression from the first antenna, left, to the newest, right. Hidden is a receiver the company plans to introduce at CES.

A total of roughly 345 million people live in South America, 78 percent in urban areas, according to the WorldDAB Forum, the majority in Brazil. Central America's nations have a combined population of 38 million with the majority living in rural areas.

Bolivia, Brazil, Chile, Colombia, Costa Rica, Cuba, El Salvador, Ecuador, Guatemala, Honduras, Mexico, Nicaragua, Panama, Paraguay, Peru, Uruguay and Venezuela.

— Leslie Stimson



Buy one of our DA's, Phone Hybrids or Silence Sensors any time this year and get a

CT-2002 Clock - up/down Timer FREE!
(a \$135.00 value)

radio SYSTEMS 601 Heron Drive, Logan Township, NJ 08085
(856) 467-8000 • (856) 467-3044 FAX
www.radiosystems.com

CALL ONE OF THESE PARTICIPATING DEALERS

- BROADCASTERS GENERAL STORE
 - ESW
 - Crowe Kimzey
 - SCMS INC
 - Technet Systems Group
- (352) 622-7700 (800) 426-8434 (800) 433-2105 (800) 438-6040 (888) 832-4638

WE GIVE YOU PIZZI

Name: Skip Pizzi

Column: The Big Picture

Experience: 31 years in broadcasting, audio, music, computer and publishing industries

Certifications and industry honors: Member SMPTE, SBE, AES; former chair of AES D.C. chapter; winner of AES Board of Governors Award; winner Public Radio Regional Organizations' PRRO Award

Mentors/heroes: Don Davis; Ed Greene; Neil Muncy; William Zinsser; Nick Negroponte; Bill Gates

Quote to live by: "Our generation will always speak digital with an accent."

Radio World's pages are home to the finest writers and columnists in the industry. Like Skip Pizzi. Just one more reason we're the newspaper for radio managers and engineers.

Philly Station Strives to Rebuild

by Tom MacDonald

PHILADELPHIA "The Voice of the African-American Community" in Philadelphia, WHAT(AM), was back on the air within a week of Hurricane Isabel passing through in September. Now station officials are planning construction of a new tower to replace a structure that collapsed during the hurricane.

ICBC Broadcast Holdings, formerly Inner City Broadcasting, owns the station.

WHAT Chief Engineer John Heal was at home in Cinnaminson, N.J., about a half-hour's drive from the station, when he got the call that the station was off the air. Winds were blowing at peaks of about 50 miles per hour through Philadelphia.

"I thought it was a power failure and was going to go start the generator," said Heal.

The operator on duty called Heal to report that the number used to notify the Federal Aviation Administration that the tower lights were out was busy. A fire department captain then arrived at the studio and told the staff that their fallen structure, located about a mile from the studio, was a safety hazard. Studio personnel called Heal, who realized at last that he had a fallen tower on his hands.

He drove to the station, dodging branches and heavy rain.

WHAT has one antenna location, at the former studio site it used to share with FM station WWDB, now WPTP, on Conshohocken Ave., near the edge of Philadelphia.

The stations moved into separate buildings more than a decade ago when the Banks fam-

ily sold them to separate companies. The transmitter site for WHAT had been sold to a church that had been using the parking lot for overflow parking for Sunday services. Thus WHAT's only transmission facility occupies what once had been its studios, and its studios

inspected about a year before it fell, taking advantage of a voluntary self-inspection program run by the Pennsylvania Association of Broadcasters and the FCC.

After the station went off the air, employees manned a phone bank to



The WHAT tower collapsed in two sections. It broke about halfway up; then the insulator broke and the base gave way.

now are at 54th and City Line Ave.

A tree had hit a guy wire, Heal found. WHAT personnel had trimmed the trees around the guys and worked hard to keep branches trimmed, he said. He had had the tower

answer the constant calls from frantic listeners. Staff at stations offered engineering assistance, including Dave Skalish, engineer for WPHT(AM); Bill Sullivan, chief engineer of Mega Communications' Philadelphia cluster; Jim Perry, director of tower operations for American Tower in that city; Larry Paulausky, Philadelphia region engineer for Greater Media; and William Stallman, chief engineer for fellow ICBC Broadcast Holdings facility WLIB(AM)/WBSL(FM) in New York.

But without a tower, the station could not broadcast.

Help came in the form of a portable bolt-together tower and monopole antenna brought by truck from Texas. Jim Hill, president of Hill Industries, drove cross-country with the emergency equipment after getting a phone call from Heal. He left hours after the tower fell.

While waiting for the tower and antenna, contract workers from ST Associates cleaned the site, clearing the old tower and fallen tree. When the antenna arrived, the crew was ready to install it. The antenna arrived Sunday night Sept. 21, and work started Monday morning; but rain and inclement weather Tuesday caused another day's delay in getting WHAT back on the air.

Workers attached a 100-foot skirted unipole antenna to the temporary tower. The structure was less than half of the original tower's 250 feet, creating a 1/8-wave signal.

Installers ran into a problem when they tried to mate their early-model Nautel 1,000 W solid-state transmitter to the antenna tuning unit.

The transmitter would not stay on the air during testing, and the station brought in an engineering consultant, Morgan Burrow of R. Morgan Burrow & Associates.

The station got back on the air using a 50-year-old RCA 1R1 tube transmitter that has been sitting in the transmitter room since the early 1960s. "Who says tubes aren't good for a backup?" Heal said.

Without the old transmitter, the station could have been off for an additional week. Heal says that, in today's market, with a hot political election for mayor of Philadelphia approaching, the station wanted to get back on as soon as possible.

In early November, station employees were still working to return the station to full signal strength. But back on the air is long-time Philadelphia personality Mary Mason, who returned on Sept. 24 with afternoon drive host Reggie Bryant. Also back is a weekly broadcast of Philadelphia City Council meetings.

The station has made up most of the money it lost during the time it was off by running spots that were purchased after the station came back on the air, according to Heal. The final cost of the outage is still being totaled, but Heal says the station has insurance to cover at least part of the loss. He is looking for a replacement antenna and tower and expects construction to begin in 2004.

Ferree: Radio's Digital Transition Could Be a Snap

WASHINGTON FCC Media Bureau Chief Ken Ferree predicts radio's digital transition will go much more smoothly than TV's.

"We've learned a lot from the TV transition," he told Radio World. He said the commission would be able to take what it has gleaned from TV and apply that knowledge to radio.

Ferree addressed members of the Institute of Electrical and Electronics Engineers at the members' annual convention in Washington this fall. He spoke mainly about the DTV transition, saying it has "reached a watershed."

In 2000, the median price of a digital TV was around \$2,000, according to the Consumer Electronics Association. Now, the median price of a digital TV set is around \$1,500, and there are more than 1,200 DTV stations on the air.

In October, the FCC acted on third-extension requests from TV stations needing more time to make the transition. The 104 stations that were granted a third extension demonstrated that their requests were warranted and showed progress on construction of their facilities since the grant of their previous extension. Seven stations failed to adequately justify another extension; the FCC admonished these stations and gave them six months to complete construction of their DTV facilities or face financial sanctions.

Ferree predicted "significant" DTV household penetration in the next two to five years. Radio topics at the IEEE symposium included sessions about audio coding, the Kin-Star low-profile AM antenna, theories on how to implement FM IBOC using separate antennas, a new method to determine AM coverage and an update on NPR's Tomorrow Radio project.

— Leslie Stimson

AUDIO RINGMAIN | MONITOR SELECT | OFFICE MONITORING

Broadcast Multiple Channels of Live Audio over any LAN or WAN Network

... ANY COMPUTER ON THE NETWORK CAN TUNE IN

AudioTX MULTIPLEX

1 The AudioTX Multiplex Server runs on one or more PCs and Broadcasts multiple channels of live audio.

2 Install the AudioTX Multiplex Receiver on all of your office, newsroom and even studio PCs.

- Superior replacement for Audio Ringmain or Monitor Select systems for office/station listening.
- Greater capacity and better flexibility than RF modulated coax or multi-pair wired systems.
- Requires no additional cabling - uses your existing computer network.
- Easy and instantly add extra listening points or new channels.
- Broadcast quality, low delay audio - can be transmitted as MP2, MP3 or uncompressed.

www.audiotxmultiplex.com
(FREE TRIAL VERSION AVAILABLE FOR DOWNLOAD)
email: sales@audiotxmultiplex.com

ISDN & IP Codec for your PC or Laptop

The AudioTX Communicator™ software turns your PC or Laptop into an easy to use, high quality, ISDN Codec - it also connects live over any IP network: LAN, WAN or the Internet.

- Compatible with CDQ Prima, Telos Zephyr and almost all other ISDN codecs
- File playback during live connections - allows you to playback pre-recorded WAV files during a live connection
- Low-cost, portable software solution - requires just a standard sound card and compatible ISDN card in your existing PC or Laptop
- Also works over any IP-based network for multi-point audio conferencing and more... (Supports SIP, H.323, and more...)
- Live IP connections, low delay audio - transmitting and receiving broadcast, studio and more... (Recording and more...)

AudioTX Communicator
Download a FREE, fully working trial version today
www.audiotx.com
Tel: +1 121 558 0810 (GMT) Email: sales@audiotx.com

£500
\$799
€699

The Best Just Got Better!

With new rock solid, fully digital modem technology, the Matrix is the most reliable, best sounding codec available. And now the Matrix offers another tool for your remote kit: **The GSM Wireless Module.**

- New** Built-in GSM Phone.
- New** Aggressive Algorithm delivers 7 kHz on GSM.
- New** Error Handling Technique.
- New** External Antenna.
- New** Increased Power for More Reliable Connections.
- New** Remarkably Stable Modem Technology.

All this adds up to better stability, improved audio, and greater flexibility. Already own a Matrix? *Call us and we'll upgrade you to the newest modem technology for FREE!* Plus we'll be happy to set up a demo of the new GSM module.



Here is what some of our numerous Beta Testers had to say:

Clear Channel Director of Engineering for St. Louis Daryl McQuinn said: "Sounds much better than a bad [RPU], almost as good as a good [RPU], and way better than you should ever expect from a cell phone remote!" but all KLOU's Program Director Al Brock could say was, "Wow!"

Shaun Kassity from Salem Communications' 104.7 The Fish in Atlanta: "Thanks to Matrix GSM we had the best sounding remotes ever on our station!"

Steve Kirsch of Silver Lake Audio: "The feed was rock solid. I'm very impressed—it sounds much better than I thought it would."

Collin Mutambo, Radio Simba, Kampala, Uganda: "We are indeed quite impressed."

But our personal favorite, from Jerry Dowd of Jefferson Pilot's WBT in Charlotte, NC: "We hope to keep the betas until you get nasty with threatening letters." Thanks Jerry. We'll take that as a compliment!

Testing has been successful in 25 US states and on 6 continents with more results coming in every day. The Matrix with the optional GSM Module delivers 7 kHz on GSM wireless. Now accepting orders.

Call us today at 800-237-1776 to learn more about the Matrix!

COMREX

19 Pine Road, Devens, MA 01432 USA

Tel: 978-784-1776 • Fax: 978-784-1717 • Email: info@comrex.com • www.comrex.com

World Radio History

RFE/RL

► Continued from page 1

the late 1990s — often at the hands of Capitol Hill critics who wondered if the pro-democracy message delivered by RFE/RL was needed in a post-Communism world — observers contacted for this article agree that RFE/RL has gained importance as a means to address U.S. concerns in the Muslim world and the war on terror.

Since the Sept. 11 terrorist attacks, RFE/RL has added language services to southern Europe, including Kurdish for populations in Afghanistan and northern Iraq with Radio Free Afghanistan, launched in 2002. RFE/RL research shows that half of its listenership now resides in Muslim countries.

RFE/RL is a private, nonprofit organization funded through federal grants. Since its launch in 1949, its goal has been to foster democracy and a free marketplace in European countries. Radio Liberty was founded in 1951 to broadcast to areas inside the Soviet Union. The services were combined in 1975.

Director of Communications Don Jensen said the foreign-language news service is run by the Broadcasting Board of Governors, a panel appointed by the president, and is funded by the government with a yearly grant of approximately \$80 million.

Congress is discussing a proposal from the Bush administration that would end language service to a number of Central and Eastern European countries. The proposed funding cutbacks would result in a further realignment of services, Jensen said.

"We are currently operating under a continuing resolution, like the rest of the federal government is, until a new budget is agreed upon," said Jensen. "Congress is looking at a proposal for the 2004 budget to discontinue language services like

Romanian, Bulgarian, Croatian and the three Baltic States (Estonian, Latvian and Lithuanian)."

Jensen said for RFE/RL to continue broadcasting at current levels in 14 languages to Eastern European countries, it needs to receive an additional \$6 million from the current proposed allocation.

Its Hungarian and Polish services were closed in the 1990s. The Czech language service was discontinued in 2002.

Any cuts to broadcasts in Central and Eastern Europe mirror changes in America's foreign policy, Jensen said.

In a statement released by the BBG earlier this year, Chairman Kenneth Tomlinson stated that "budget reductions would mean the end to most Radio Free Europe/Radio Liberty broadcasting to the democracies of Eastern Europe where free speech is practiced and where the process of joining the NATO alliance is

It could be a good time to reexamine the budget and eventually cut back the radio services where democracy has taken hold.

— Lynne Weil
Spokeswoman,
Rep. Tom Lantos

underway."

Though some European services are expected to be cut back, the overall budget for BBG, which includes Voice of America and Radio Free Asia, is expected to rise due to programming increases to the Middle East and Southeast Asia to fight the war on international terrorism, the press release stated.

Lynne Weil, director of communications for Rep. Tom Lantos, ranking Democrat on the House International Relations Committee, said, "The sense is that it could be a good time to reexamine

the budget and eventually cut back the radio services where democracy has taken hold. It is maybe time to let the indigenous stations in those countries take over the role Radio Free Europe has filled. The geography is changing. There is now a greater need in certain areas of Central Asia and the Middle East."

Lantos was co-sponsor of a provision in the State Department authorization that would prohibit the BBG and RFE/RL from ending broadcasts in 14 Eastern European languages for two years, Weil said.

Senate Foreign Relations Committee Chairman Richard Lugar, R-Ind., has proposed a one-year prohibition on ending broadcasts to Eastern Europe. A House-Senate conference committee was expected to meet on the Commerce, Justice and State Appropriations bill in late November, Jensen said.

RFE/RL targets its programming to Europe. It broadcasts more than 1,000 hours of programming in 30 languages via shortwave, FM, AM and streams its programming on the Internet from its broadcast headquarters in Prague in the Czech Republic. RFE/RL has been headquartered there since 1995, when it moved from Munich to save money.

Its Prague headquarters is considered a possible target for terrorists, Jensen said. Armed guards and concrete barriers are in place outside the former Communist Federal Parliament Building. Safety measures were increased prior to the war with Iraq when U.S. government sources said Iraqi agents may have been targeting the headquarters for attack, Jensen said.

RFE/RL runs the Arabic-language Radio Free Iraq and originates programs for Radio Farda, a venture with Voice of America, for broadcasts aimed at Iran.

"(The security) is certainly something you are mindful of when you go to Prague. The protection of our employees comes first," Jensen said.

RFE/RL has 500 employees in Prague, and 100 in Washington handling public affairs and finance.

Jensen said the lease in Prague expires in December of 2004. The government has considered moving it to a less exposed location outside of Prague. The cost could approach \$20 million, he said.

New gear

When RFE/RL moved to Prague, the news service was presented with a chance to reinvent itself as a high-tech organization, said Luke Springer, director of the technology division.

"We did a major overhaul of our technical capacity at the time. We are focusing on digital technology so that we can 'produce once and distribute many,' while removing the single point of failure from any system's configuration," Springer said. "We are as proactive as our budget and operations can afford."

The Prague studios are equipped mostly with Klotz Digital consoles and Shure mics, Springer said. Digital delivery sys-

tems from D.A.V.I.D. handle audio storage and playback duties.

"Dealing with the costs and limitations of telecommunications in Prague and the bureaus in our target countries poses unique and challenging problems. It is often difficult to receive the bandwidth and service we need."

The International Broadcasting Board is the technical support structure for U.S. international broadcasting, providing administrative and engineering support for U.S.-sponsored foreign-language news services.

"Broadcasts from Prague are distributed through IBB's satellite and shortwave system. We send some programming to Washington, D.C., for distribution on their system," Springer said. "Programs are distributed by satellite or land line to broadcast bureaus across Europe."

The bureaus air programming on shortwave, but RFE/RL uses local radio stations to reach listeners, too.

"We currently use shortwave, medium-wave (AM), FM and DTH (Direct to Home) satellite to distribute our product. Local FM distribution is preferred in countries where it's possible. As Eastern Europeans have become more sophisticated, so has their preference for better audio quality."

Web factor

RFE/RL increasingly is relying on streaming audio to reach listeners through its Web site, www.rferl.org. "We are averaging about 6 million page views per month, mostly from the West but increasingly from Russia and elsewhere. The importance of the Internet has grown to almost parallel what we do with over the air broadcasts," Jensen said.

Jensen said RFE/RL listenership is up, though he declined to disclose figures. According to RFE/RL's Web site, an estimated 35 million listeners in the broadcast region tune in weekly.

"We reach about 5 percent of the adult population in the regions we broadcast to. That's listening at least once a week. It's higher in some countries and lower in others," he said. "Our research tells us people want programming that is relevant to them ... social issues, cultural issues and news."

A typical one-hour RFE/RL foreign-language broadcast consists of five minutes of headlines, a 20-minute domestic news block and 20 minutes of international news and then discussion.

The effectiveness of overseas broadcasting by the federal government has been argued since the services began. Many observers believe the threat of terrorism will bring a broader role.

"It would seem more important than ever to get the U.S. point of view out. RFE is the ideal outlet to counter the bias and inaccuracies that can foster terroristic views," said Gary Reid, senior specialist in the Department of Telecommunication, Information Studies and Media at Michigan State University. "The more broadly we can disseminate a democratic message, the better the understanding."

Reid said spending taxpayer dollars on RFE/RL will always spur debate.

"For countries emerging from totalitarian control, radio offers an easy and cost-effective method to help shape their future and foster democracy and free markets. It seems to me that the money spent on positive, proactive messages is money well spent." 

RFE/RL: A Brief History

Radio Free Europe/Radio Liberty is a private, non-profit organization that receives funding from the government through grants issued by the Broadcasting Board of Governors, a nine-member panel appointed by the president.

RFE/RL broadcasts more than 1,000 hours a week from its operations center, located in Prague, the Czech Republic. The radio service maintains 30 bureaus across 13 time zones in Central and Eastern Europe and the former Soviet Union. Listeners can hear its programs in 30 languages on shortwave and streamed audio from the Internet. In addition, RFE/RL has 290 affiliate partner organizations and 590 transmitter sites that relay programs on the AM and FM bands.

According to the RFE/RL Web site, "The mission of RFE/RL is to promote democratic values and institutions by broadcasting factual information and ideas."

An estimated 35 million listeners in the region tune in RFE/RL broadcasts for news and current events. The service also is gaining listeners through the Internet. In 2002, nearly 1.2 million visitors downloaded audio on www.rferl.org.

Radio Free Europe was founded in 1949, originally operating under the auspices of the Central Intelligence Agency, to broadcast news and information to Eastern European countries behind the Iron Curtain. Radio Liberty was created in 1951 to broadcast to nations inside the Soviet Union. The operations were merged into a single RFE/RL in 1975 to streamline services and save money.

Some journalistic and political skeptics, pointing to the service's past connections to the CIA and its continued government sponsorship, consider it a propaganda arm of the U.S. government, promoting American values and ideas. An RFE/RL spokesman said that although Congress watches how RFE/RL spends money, it has no input on the content of the material that is broadcast.

"While we are funded by the government, we have independent status when it comes to reporting," said Don Jensen, RFE/RL director of communications.

Gary Reid, senior specialist in the Department of Telecommunication, Information Studies and Media at Michigan State University, said, "RFE/RL is uniquely positioned to offer Europeans a model of what a free and open society can be. To the extent our government can use radio and other media to offer alternative point of view ... we all win."

— Randy J. Stine

Wish you had more

up top?

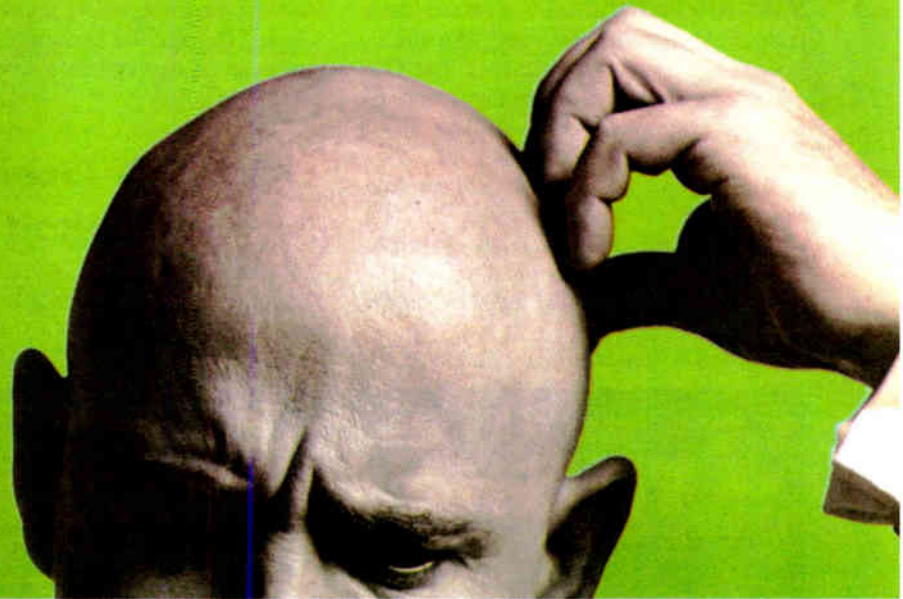

Announcing Omnia-6EX.

There's a lot of buzz about the new HD Radio codec. We've heard it and agree with the many others who like it and say it's now time to get on with radio's transition to digital.

Because HD Radio can transmit audio frequencies up to 20kHz, listeners will finally be allowed to hear the full CD spectrum – if their radio stations choose the right on-air processor. On this point, you should know something important: Some “HD” processors simply hack off everything above 15kHz... robbing listeners of the full HD Radio experience and keeping our industry in a fidelity backwater.

The new Omnia-6EX won't short-change your listeners. We've built Omnias with sampling rates of 48kHz and higher from the start. All along, we've needed the sampling headroom to keep analog FM audio grunge-free. Now it's essential for HD Radio. Even if some listeners wouldn't notice the missing high frequencies, there's a fair chance they would hear a sharp 15kHz low-pass filter operating within HD Radio's codec range.

Omnia-6EX is also full of processing enhancements that result in yet more bass punch, yet more voice clarity, than the original Omnia-6. A sound so powerful and free of artificial constraints, you'll crave it for your station the first time you hear it.

More than 50% of the US' Top 100 FM stations have already upgraded to Omnia. Maybe you're next?



The new Omnia-6EX has enhanced processing for analog FM, and is ready for HD Radio with a second limiter section and digital output. Both FM and HD limiters and outputs are included as standard.

Omnia
A Telos Company
omniaaudio.com

◆ NEWS WATCH ◆

AM Stations Get Options From FCC

WASHINGTON Those who would like to own an AM station, and some who already have one, may wish to take note. The FCC will open a window to accept applications for new AM stations at auction, as well as major modifications to existing stations.

A filing window for certain AM construction permit applications opens Jan. 26, 2004, and closes Jan. 30. The window is for proposals for new AM stations and major modifications to authorized AM facilities, such as a transmitter move.

"Due to current transmitter locations, AM

station signals often reach only part of their target audiences," stated Chairman Michael Powell. "By opening this filing window, we will enable all AM radio station licensees, many of whom represent minority interests, to apply for approval to move their transmitters to locations that better serve their local communities."

WMGA License Revoked

WASHINGTON A license revocation for Moultrie Georgia's WMGA(AM) could become final soon. The FCC has decided to revoke the license of Radio Moultrie Inc.,

saying it lacked "the basic character qualifications" to be a commission licensee.

In 2001, a field agent inspected the station and found evidence that the Elder family had abdicated control to several parties since its last license renewal. The agency has no records that Moultrie had filed an agreement to sell the station or filed for transfer of control.

The inspection revealed Moultrie did not repaint its towers, left them unlit at night and failed to report this to the Federal Aviation Administration. Moultrie's EAS equipment was not working and the station had no log; the owner left the main studio unattended and failed to designate a chief operator, the commission stated.

Moultrie did not answer several letters from the FCC and did not appear at a license revocation hearing, according to the agency.

DBI, one of the parties believed by the FCC to be running the station, told the commission it planned to buy the station and had a time brokerage agreement in place so it could run the station while the parties agreed on a price. That never happened.

The FCC said a local marketing agreement is not recognized an authorized transfer of control.

The revocation was to become effective in 40 days unless Moultrie asked the agency to reconsider its decision.

Continental Has New Owner

DALLAS Broadcast transmitter manufacturer Continental Electronics has a new owner. The Dallas-based company was part of the \$543 million purchase of Integrated Defense Technologies Inc. by defense electronics supplier DRS Technologies Inc., headquartered in Parsippany, N.J.

The transaction was completed in early November following approval by a majority of IDT stockholders, the buyer said.

A Continental spokesman told Radio World that the impact of the sale on Continental was not yet known; but, he said, "I think it can only be positive." Continental has 140 employees.

DRS, the new parent company, employs 5,700 people. Its announcement of the acquisition of IDT did not mention Continental.

Powell: Disaster Plans on Paper Aren't Enough

WASHINGTON "If you have a disaster recovery plan and you don't rehearse it, you don't have one." So said FCC Chairman Michael Powell to representatives of the broadcast, cable and satellite industries. And according to statistics, fewer than one in 10 radio stations have rehearsed disaster plans.

Powell spoke to a group gathered in Washington to present recommendations for ensuring that stations remain on the air or quickly can regain the ability to transmit a signal in the event of terrorist attacks or natural disasters.

The group, the Media Security and Reliability Council, is patterned after a similar one serving the telephone industries.

In an assessment of radio, TV and cable outlet that have disaster recovery plans, MSRC found that only 7 percent of radio, 17 percent of TV and 58 percent of cable outlets surveyed had rehearsed those plans. Powell called the figures "disturbing." He said it's imperative for broadcasters to open discussions with competitors about helping each other in catastrophic situations.

Bruce Allan of Harris Broadcast Communications said the group found few reciprocity agreements in place for studios or transmitters to ensure signal availability among competitors. "None of the manufacturers can make a transmitter overnight," he cautioned participants.

He said the group believes there is enough equipment redundancy in place if stations would coordinate efforts.

Members planned to vote on the recommendations by late November and conduct a workshop on the recommendations in Tampa on Dec. 2.

Tieline is the "Clear" choice for POTS, ISDN and Wireless Codecs



Clark Dixon, Chief Engineer Clear Channel Tulsa.

"We do numerous remotes and have had great success using Tieline codecs. Tielines codecs give us a lot of control we previously didn't have. They are versatile and they perform very well".

The Essential Codec Checklist

- ☑ Compatible with other 15kHz POTS codecs
- ☑ Unrivalled link stability over POTS (Used for STL's)
- ☑ Connects to other ISDN codecs via G.722 (ISDN option)
- ☑ 15kHz audio bi-directional over POTS
- ☑ 15kHz audio bi-directional over ISDN (optional)
- ☑ GSM Wireless Connectivity for mobile phones
- ☑ Automatic Intelligent Gain Control
- ☑ Low 100ms POTS latency
- ☑ Music/Voice + up to 9600bps data simultaneously
- ☑ Remote relay, RS232 control and remote audio level control
- ☑ Auto Reconnection on power or line loss
- ☑ Upgrade over the Internet
- ☑ Rugged Metal Construction

A small selection of network users

- | | | |
|------------------------------|--------------------------------|---|
| ■ Clear Channel | ■ Jefferson-Pilot Broadcasting | ■ University of N. Alabama Sports Network |
| ■ Entercom | ■ Tribune Broadcasting | ■ Tennessee Titans Radio Network |
| ■ Talk America Radio Network | ■ Simmons Media | |
| ■ Sandusky | | |



Ask your favorite dealer for a FREE demo today!

Tieline 
TECHNOLOGY

www.tieline.com

Tieline Technology - 7202 East 87th Street, Suite 116, Indianapolis, IN 46256. Toll Free (888) 211-6989
email: sales@tieline.com

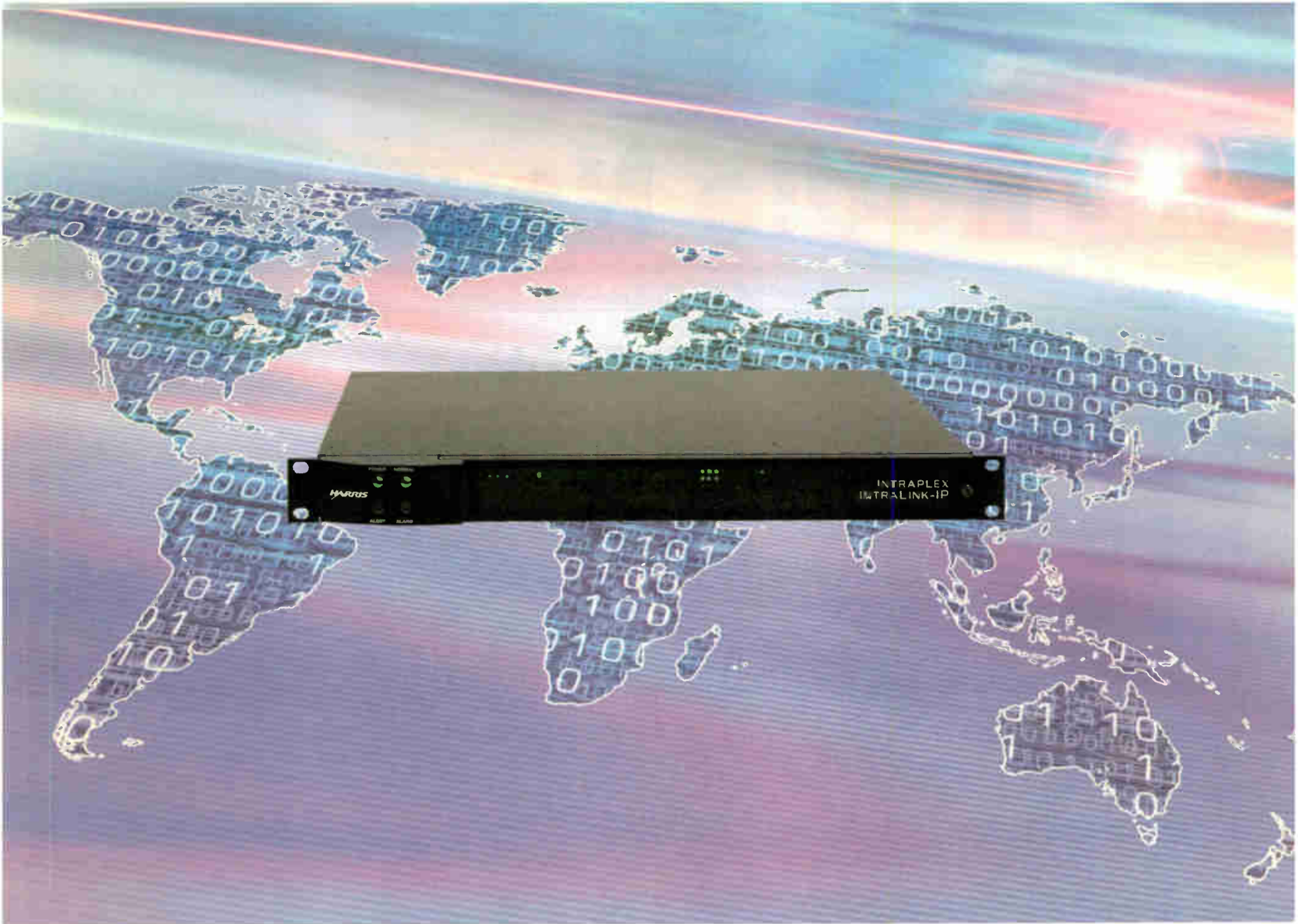

Reliable Program Audio Over The Internet?

IntraLink-IP™ Streaming Multiplexer

Create a program audio circuit wherever an Ethernet jack exists with the **IntraLink-IP** streaming multiplexer. The QoS of packet switched networks has improved dramatically signaling the beginning of a new low-cost means of professional audio transport.

IntraLink-IP has a Harris exclusive forward correction scheme which takes advantage of these networks. It delivers robust streaming for critical STL/TSL and general purpose broadcast audio transport. Contact your Harris sales representative today.



Save money on program circuits with IntraLink-IP.

- Make the Internet into your virtual STL
- Turn low-cost public and private packet switched networks into program audio circuits
- Ethernet jacks, DSL and cable modems become instant RPUs

www.broadcast.harris.com/network-access

HARRIS®

USC Stations Go HD Radio

by Daniel Mansergh

LOS ANGELES While many radio engineers are still scratching their heads about when and how to implement HD Radio at their stations, Pablo Garcia has left those questions far behind.

ations of multiple stations and the Classical Public Radio Network, a partnership with Colorado Public Radio that serves classical stations around the country.

"It's gone very well," Garcia said of the installations. He pointed to the simi-

and system maintenance are performed remotely with pcAnywhere.

Contact closures from the ABR202 data receiver control the ENCO system and a Broadcast Tools AES switcher to allow automation of local inserts. The output of the switcher feeds a Broadcast

transmitter and FXi 250 exciter for its 4.8-kilowatt signal.

"Every part of the chain was replaced," Garcia said. "We've been planning this for a number of years, even before HD Radio was ready. The timing worked in our favor, and BE made it possible to go with all-new digital transmitters."

John Morton is a Broadcast Electronics engineer who worked with Garcia on

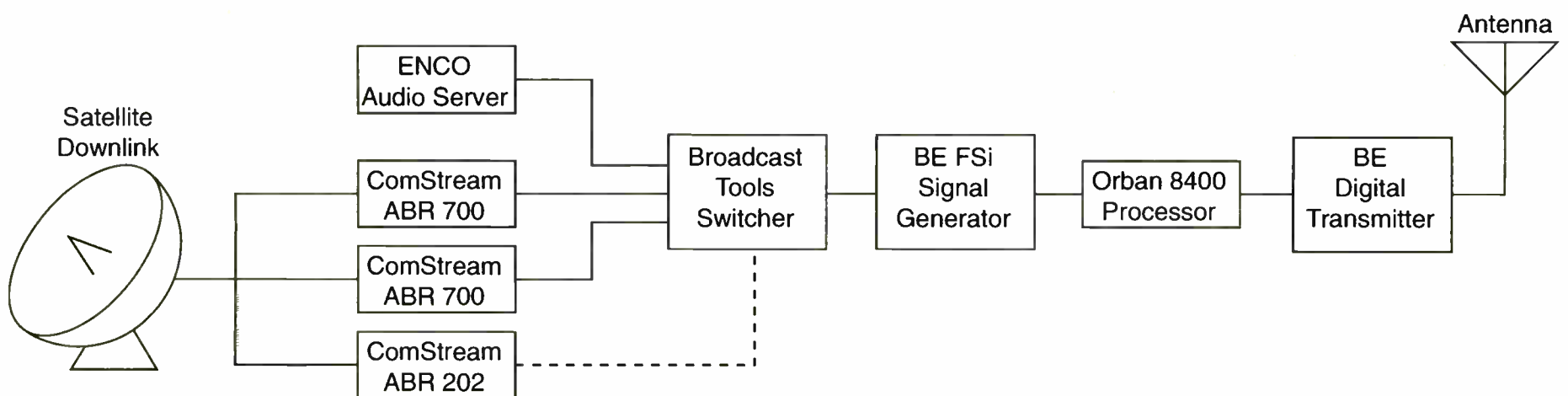

Garcia, the director of engineering for classical-formatted public radio powerhouse KUSC(FM) in Los Angeles, has completed total rebuilds and digital upgrades of the transmission plants for three of the four full-service noncommercial FM stations owned by the University of Southern California.

KPSC(FM) at 88.5 MHz in Palm Springs, KFAC(FM) at 88.7 MHz in Santa Barbara and KCPB(FM) on 91.1 MHz in Thousand Oaks have new transmission facilities built around Broadcast Electronics digital transmitter packages and are broadcasting IBOC signals.

The three stations simulcast the programming of KUSC via satellite from new studios in downtown Los Angeles, completed in 2001 to support the oper-

larity of the transmission plants and the use of one equipment vendor as factors that allowed him to complete three transmitter replacement projects within two months. The three stations have virtually identical air chains, varying only in the size of transmitters and antennas.

The satellite feed of KUSC programming is received at each site on two redundant Radyne ComStream ABR700 digital audio demodulators, while an additional ComStream ABR202 receives a data channel containing cue signals.

A local single-box ENCO Systems automation system at each site stores localized underwriting spots and station IDs in 6:1 MPEG Layer II format, the same used at the KUSC production center in Los Angeles. Updates of audio files

Electronics Fsi 10 signal generator, through an Orban 8400HD audio processor and into the station's exciter.

Three-kilowatt KPSC in Palm Springs was the first to receive an upgrade, beginning digital broadcasts on Aug. 1 with a BE FXi 250 exciter and FMi 402 transmitter feeding an ERI LPX two-bay, half-wave-spaced antenna.

KFAC in Santa Barbara followed on Sept. 1, delivering 12 kilowatts ERP through a new ERI LPX four-bay fully-spaced antenna, FMi 703 transmitter and FXi 60 exciter.

ERI, BE gear used

KCPB's installation was completed on Oct. 1, also receiving a new four-bay ERI LPX antenna along with an FMi 301

the project.

"It's not difficult, just different. There are more connections, done in different ways than what engineers might be used to," Morton said. "But that just means more cables and new terminology."

Morton characterizes his experiences with digital conversions to date as "very easy. We just haven't had a lot of problems" with IBOC. He said the combining method is the biggest variable, advising "if you can do it with low-level (combining), that's much more efficient."

The total project cost for the three conversions was \$400,000, with half provided by the Southern California-focused Weingart Foundation as a challenge grant

See KUSC, page 14 ►



Finally, an RDS/RBDS solution built for the US radio market, offering consumer-rich programming and revenue generating interactive services. And also at the best price, Free!

dMarc Networks™ is the market leader in data services.

To start generating revenue today, call (949) 791-1200 ext. 13

dMarc Networks™ is HD Radio Ready™!



dMarc Networks

Turning Data Into Profits™

www.dMarcNetworks.com
www.RadioGreetings.com



Now with G.722

More reliable Xport doesn't rely on the off-the-shelf modems found in other POTS codecs. Instead, we developed a custom DSP modem optimized for live audio.

Easier and lower cost Xport's ISDN option lets you use it as a universal field codec.

Better sounding Xport's aacPlus is the finest low-bitrate codec on Earth – and Xport is the only POTS codec to have it. You'll be stunned at how good an analog line can sound.

Now, your POTS and ISDN remotes are more reliable, better sounding, easier, and cost less.

Zephyr Xstream owners, hear the clarity of aacPlus for yourself!
To get an instant demonstration of Zephyr Xport, visit telos-systems.com/xport/

More reliable Zephyr Xstream's pure-digital ISDN connection on the studio side eliminates a lot of the analog line problems that can make a modem unstable. An Xport call is converted to digital by the nearest Telco central office, and continues through the network to your studio in digital form. Working as a tightly integrated system, Xport and Xstream extract maximum performance and reliability from real-world Telco lines.

Easier and lower cost Your studio Zephyr Xstream is now universal, linking with both POTS and ISDN codecs in the field. You need only one box and one line for everything, so you save money, your operators have only one interface to learn, and you conserve console inputs and outputs. Now with G.722 to allow ISDN connectivity with virtually every ISDN codec.

Today, Zephyr Xport and Xstream are *The Best Way to Hear from Anywhere.*

Telos
AUDIO | NETWORKS



telos-systems.com

Telos, the Telos logo, Zephyr, Zephyr Xstream, Zephyr Xport. The Best Way To Hear From Anywhere are all registered trademarks of TLS Corporation. © 2003, TLS Corporation. All rights reserved. aacPlus (TM) Coding Technologies

World Radio History

Radiation Patterns Key With Dual-Antenna Approach to IBOC

Should radio stations be allowed to use dual rather than single antennas to implement IBOC? The NAB continues to wait for a reply to such a request.

RF systems analyst Richard Fry provides some observations on the practical aspects of the concept.

The NAB submitted a report to the agency on the results of experiments with FM stations using one antenna for IBOC and another for analog, compared with stations using a single antenna for both (RW, Sept. 10, page 12).

An antenna group formed by the association believes the dual-antenna approach for FM might be a more cost-effective

implementation for IBOC than high- or low-level combining. The FCC does not now allow stations to use separate antennas for broadcasting analog and digital signals without getting special permission to do so.

As commonly proposed, separate antenna implementation radiates the analog and digital signals from independent antennas installed at different locations on the same supporting structure. The risk in this approach is that the patterns of the separate antennas may not overlay each other well, which can cause the ratio of analog to digital energy at some receive locations to depart from the required 20dB value — perhaps substantially, as shown in the NAB study.

Recently some suppliers have proposed that radiation patterns from the separate antennas will be “the same” if a cross-polarized HD Radio antenna is interleaved in the same aperture as the analog antenna. But evaluation of this approach in a pristine configuration shows a fair amount of asymmetry between the two patterns,

especially for vertical polarization.

The patterns shown in the graphic on this page were generated using Numerical Electromagnetics Code (NEC-2) for the interleaved antennas and conditions shown, and illustrate this effect.

These pattern differences could be accentuated by differences in tower geometry near each bay. Such differences are likely unless the interleaved arrays are mounted on an aperture of electrically uniform construction, such as an untapered pole.

The NAB study showed fairly large variations in received A-to-D ratio even

when a single transmit antenna was used for A&D. Adding the pattern differences likely when separate antennas are used could produce additional variation — even if they are interleaved.

Cross-polarizing the A&D transmit antennas when interleaved should reduce the coupling and interaction between the analog and digital transmitters, however the radiation patterns of the interleaved antennas may not match each other as well as first expected.

— Richard Fry

KUSC

► Continued from page 12

and the remainder secured through a targeted capital fundraising effort begun in 1998. The dedicated funding helped to speed the project.

“Since this funding was specifically for the digital conversion of these stations,” Garcia said, “we could do them much more quickly” than a project on

Garcia doesn't foresee KUSC carving out a possible second audio program channel from the HD Radio bit-stream, a goal of NPR's Tomorrow Radio Project and something of interest to many public radio stations. “We want to use the full 96 kilobits to get the best quality, since we're a classical station.”

Next up for Garcia: bringing flagship station KUSC into the HD Radio age. He's still deciding whether to upgrade or replace KUSC's Harris Z20



Pablo Garcia in Palm Springs

this scale funded through the normal capital replacement cycle.

As an extra benefit, KUSC took advantage of Ibiquity's conversion incentive program, which waived the stations' licensing fees for HD Radio.

Like other engineers who have taken the HD Radio plunge, Garcia is eager for the day he can monitor his digital broadcasts off-air.

“I heard the signal with BE's test receiver when we put the Palm Springs station on the air, and it sounded great.”

Garcia says detailed tests of digital coverage, availability and audio quality were scheduled in November, when BE engineers were expected to return with a mobile HD Radio receiver.

In the absence of HD Radio receivers, the greatest result of the project so far is in improvements to the analog signal. “The noise floor is so much lower,” Garcia said. “It's really fantastic.”

transmitter and is awaiting funding, some of which may come from the Corporation for Public Broadcasting's seed market digital conversion funding program (see story at right).

Garcia said these three classical public radio signals were the first stations to go on the air with HD Radio in their respective communities of Santa Barbara, Palm Springs and Thousand Oaks. “We're the first ones, period.”

As he reflected on his experience with the three stations, Garcia said it's important to remember that the 1s and 0s of digital broadcasting fundamentally alter the responsibilities of transmitter engineers.

“You're dealing with a computer more than a transmitter,” he says, although the process of setting the various delays in the signal chain reminds him of tuning tube transmitters. “Once you find the sweet spot, everything's happy.”

NEC-2 Radiation Patterns of Interleaved Antenna Elements and Adjacent Transmission Lines (proposed for HD Radio)

- * Elevation Patterns at Zero-180 Degree Azimuth Bearing
- * LH & RH CP Elements at 1/2-wave Vertical Spacing



Transmission lines extend to a point 25 feet below the bottom bay.

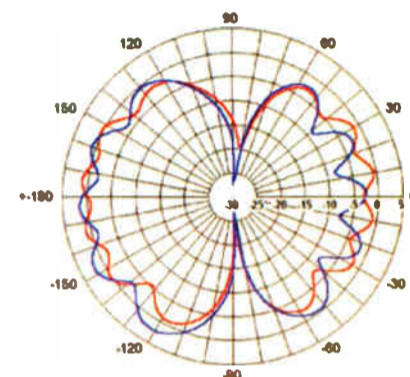

— V-pol, Upper Bay Driven
— V-pol, Lower Bay Driven

CPB Awards HD Radio Grants

WASHINGTON The Corporation for Public Broadcasting has awarded more than \$3 million in digital conversion grants to 42 noncommercial radio stations in 13 markets. The grants are CPB's first for digital radio. They will help stations buy HD Radio transmission equipment.

“Digital public radio holds great promise to serve listeners in ways never before possible. For the first time, radio will be able to provide data in addition to sound — which could change how everyone uses radio,” said CPB Broadcasting President/CEO Robert Coonrod.

CPB is encouraging noncoms to go digital by providing matching funds to eligible stations in 13 seed markets targeted by Ibiquity Digital, developer of the terrestrial digital radio technology. Stations going digital license the technology from Ibiquity, although the stations getting the grants received a waiver under Ibiquity's early-adopter program.

Final grant amounts are contingent upon final equipment costs and contract negotiations.

CPB also earmarked \$6.75 million in another round of funding allocated by Congress for fiscal year 2003. This funding is to assist stations serving rural and minority markets. Noncommercial stations may apply for this money later this fall.

Here's the station breakdown for CPB digital radio conversion grant money by city:

Atlanta: WABE(FM) and WJSP(FM)

Boston: WBUR(FM), WGBH(FM), WUMB(FM) and WFCR(FM)

Chicago: WBEZ(FM) and WDCB(FM)

Dallas: KERA(FM)

Denver: KGNU(FM), KUNC(FM), KUVO(FM), KVOD(FM), KCFR(AM) and KCFC(AM)

Detroit: WDET(FM), WUOM(FM), WKAR(FM) and WEMU(FM)

Las Vegas: KNPR(FM) and KUNV(FM)

Los Angeles: KPCC(FM), KCSN(FM), KKJZ(FM), KLON(FM), KCRW(FM) and KUSC(FM)

Miami: WDNA(FM), WXEL(FM) and WLRN(FM-TV)

New York: WBGO(FM), WFUV(FM), WNYC(AM), WNYC(FM)

San Francisco: KALW(FM), KQED(FM), KPFA(FM) and KCSM(FM-TV)

Seattle: KPLU(FM) and KUOW(FM)

Washington: WAMU(FM), WETA(FM) and WPFW(FM)

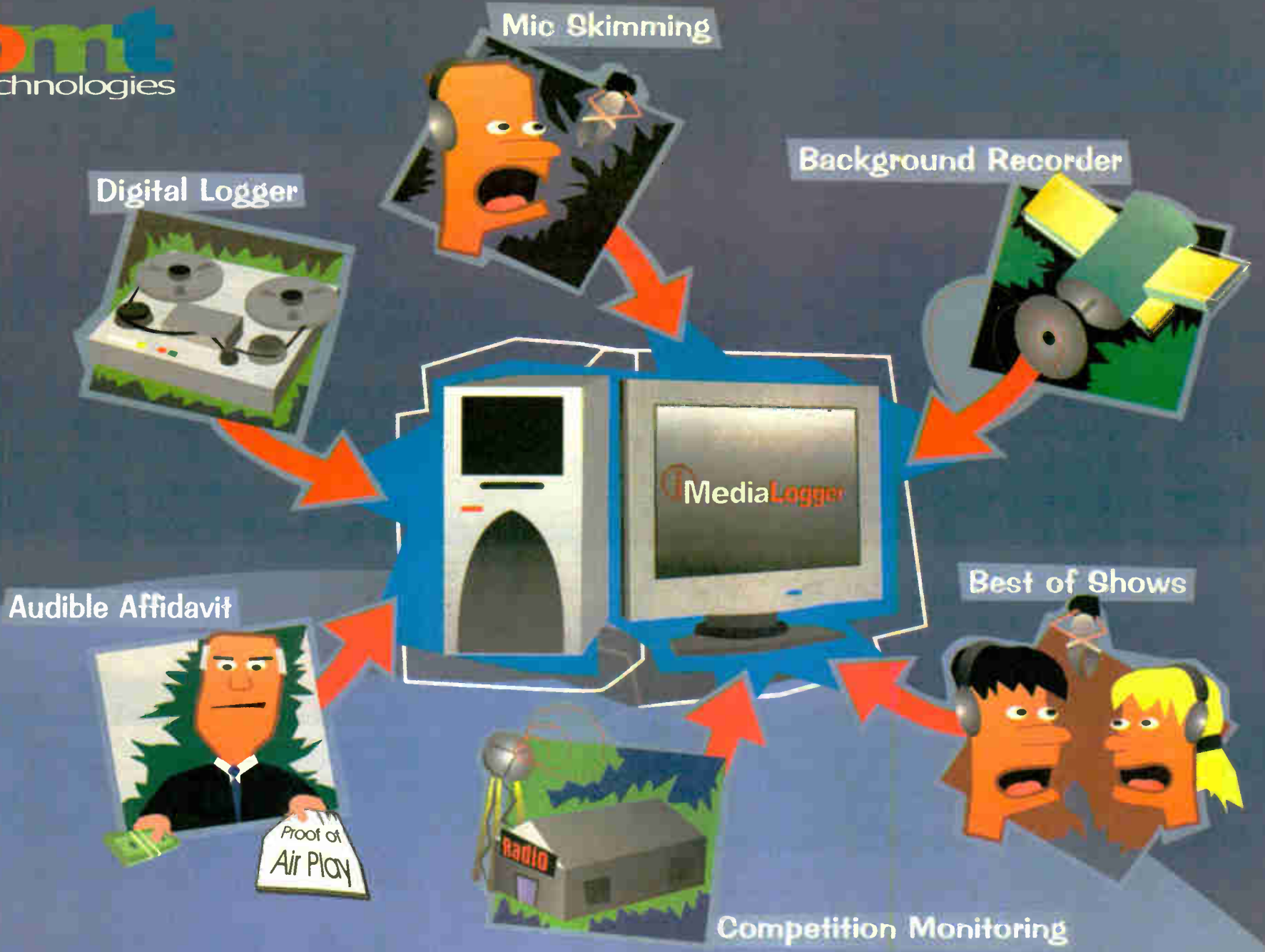

iMediaLogger

(ī-mē'dē-d-ə lô'gər) *definition:* The most complete, affordable, and easy-to-use automated audio recording solution available.

With today's ever increasing workload you have to do more with less and that's why having a multipurpose tool like iMediaLogger is key. Using a single computer workstation, iMediaLogger frees you from the costly maintenance of conventional and outdated equipment used for logging, recording, and skimming including reel to reel, DAT, and VCR recorders.

Used in hundreds of stations including all of the top 10 markets, this award-winning product allows you to:

- Simultaneously record up to 12 stereo or mono audio sources or streams
- Multiple compression formats
 - MP2, MP3, Windows Media Audio, Real Audio, PCM, and ADPCM
- Access your recordings anytime, from anywhere using its built in web browser interface
- Schedule time or closure based recordings
- Remotely configure and manage your iMediaLogger system

The next time you need to log, skim, or record, save yourself - and your station - plenty of time, money and headaches. With iMediaLogger, you will never have to change a tape again.



Winner of the NAB 2000
Radio World Cool Stuff Award

To learn more about iMediaLogger,
visit www.omt.net or call 1-888-665-0501

Data

► Continued from page 1

data service suppliers interviewed for this article planned to have the software integration complete by the end of December.

"They're now integrating software so they can deliver a retrofit to their existing customer base," said D'Angelo said of the suppliers. "As the stations get their digital exciters and they look to support data services, they go to their studio automation platforms and get a software upgrade to support the program-associated data."



ENCO Systems was the first company to partner with Ibiqity to deliver data services, the company says. Don Backus, vice president of sales and marketing, demonstrates the DADpro32 system.

Broadcast systems providers that have licensed Ibiqity's technology are Broadcast Electronics, Dalet Digital Media Systems, D.A.V.I.D., ENCO Systems, Prophet Systems Innovations and Radio Computing Services. dMarc Networks has also licensed Ibiqity's technology. dMarc is a software and service company that provides subcarrier management and data delivery mechanisms for stations.

The vendors also will integrate the software into new products, he said.

Such companies expect consumer demand for advanced data services, which in turn will create demand for HD Radios.

Philippe Generali, president of RCS, said, "The bottom line is that people will want more content together with a traditional broadcast signal. Just the (digital) audio is not going to be enough."

Generali said RCS has been looking at associated data possibilities for a long time. The company has a Web-based product for content delivery and sees HD Radio's associated data software as an extension of that product line.

it into the right format to distribute it over the air to the respective receivers," Steelberg said.

Ibiqity recently released information describing its building blocks for developers to use to enable multimedia pro-



RCS President Philippe Generali holds a cell phone to demonstrate that Ibiqity's SMIL protocol will work on HD Radio, the Internet and, eventually, advanced 3G cellular services.

Several of the automation companies licensed to Ibiqity also provide Radio Data System services now and see RDS as laying the groundwork for more advanced data possibilities for HD Radio.

dMarc Networks President Ryan Steelberg characterized interest in RDS from the major radio groups as heavy in the past 18 months. "The automation companies are focusing, not just on RDS, but on data services in general."

dMarc aggregates content and distributes that content to either the RDS interface or the HD Radio interface. "We're agnostic to the format. Our job is to deliver the content in the appropriate format to the largest audience," said Steelberg. Clear Channel, Cox Radio and Cumulus are some of the groups with

programming and services to be transmitted using HD Radio. The documents are Ibiqity's Advanced Application Service, which is a programming interface, and an updated version of the HD Broadcast Multimedia Language protocol.

The protocols focus on three types of data services: Main Program Service, Station Information Service and Advanced Application Service.

The first generation of HD Radio data services will be supported by MPS and SIS. MPS, the station's primary aural service, consists of digital audio and program-associated data. MPS data uses an industry-standard file-tagging software called ID3 to provide text information such as artist name and song title.

The Wizard™ has gone STEREO!

The new **DIGITAL** FMSA-1 gives The Wizard System unmatched stereo monitoring capabilities. . .



Superlative stereo performance. Linear-phase filters that reveal the true performance of your audio processing. The stability of digital stereo demodulation. The sophisticated graphical presentation of The Wizard. And—with the RS-232 port—operation on site or off.

Contact Belar today for more details on what should be your next modulation monitor



BELAR ELECTRONICS LABORATORY, INC.
119 LANCASTER AVENUE • P.O. BOX 76 • DEVON, PA 19333-0076 USA
(610) 687-5550 • FAX (610) 687-2696

Call, write or FAX for more information on Belar AM, FM, Stereo, SCA, and TV monitors.

www.belar.com

The automation companies are focusing, not just on RDS, but on data services in general.

— Ryan Steelberg
dMarc Networks

which dMarc is working on RDS.

He said stations now using their FM subcarriers to transmit RDS would need an upgrade for HD Radio. "They're not really set up to manage or take advantage of the additional throughput or bandwidth capabilities of HD Radio." dMarc can do that for a radio station, he said, because its system is integrated with Ibiqity's data technology as well as with automation systems from vendors such as Prophet Systems, Scott Studios and Broadcast Electronics.

"We synch up our programming, take an XML or binary data feed from the majority of those automation systems and then we target against a playlist or against the clock with all of our content. In real-time, (we) convert

Information sent over SIS includes station identification and location, useful in the future for receivers for position determination; identification of services available in the digital signal; and time synchronization information.

ID3 also supports text descriptions with the ads such as phone numbers and/or Web addresses. Ibiqity demonstrated this ability at the NAB Radio Show in Philadelphia using local phone numbers for certain ads as the text messages scrolled across the top of a receiver airing an HD Radio station.

Future data services include the ability to pause, fast-forward, index and replay audio, breaking weather or traffic reports, secondary audio services and supplemental data delivery, HD Radio proponents say.

Workbench

Radio World, December 3, 2003 Past columns are archived at www.rwonline.com/reference-room

Holiday Lights for Your Racks

by John Bisset

Mike Seguin, the chief at WXXX(FM) and WVMT(AM) in Vermont, is one of several engineers who found the StarGuide test box useful for the 16-relay cards like ABC (*Workbench*, Nov. 5).

But Mike adds that the box isn't really necessary for the standard four-relay cards found in StarGuide II and IIIs. There's a "relay test function" in the system menus on these receivers that works the same way as the push-button box.

This test function is accessible through:

- Port Menu
- A-F
- Card Settings
- Relay Port
- Test Relays
- 1=active
- 0=inactive

If you activate a relay to test, make sure to deactivate it, as the command is a toggle. Thanks, Mike for passing on this information. Reach Mike at mike@95triplex.com.

★★★

Most satellite receivers are located inside dark equipment racks. I've had numerous suggestions from engineers who have used "rope lights" inside a rack to illuminate the equipment, as pictured in Fig. 1.

These lights use minimal power and

generate minimal heat, but provide quite a bit of light. The photo shows rope lights used in a dark rack room. The advantage over bulbs or fluores-

the small parts described in Chris Kelley's test box, with all the Radio Shacks limiting their stock of parts. Al says whenever he enters a Radio Shack,

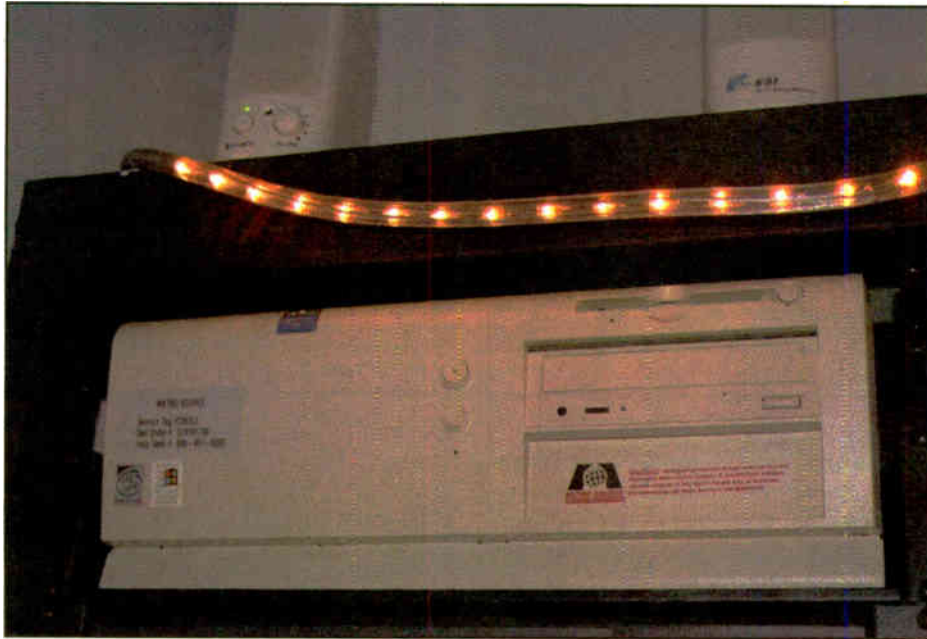

Fig. 1: Rope lights can help illuminate those dark rack interiors. Festive, too.

cent tubes is the evenness of light. There's also less chance the bulbs will break as you remove and install equipment.

★★★

Chris Kelley's StarGuide test box also brought an interesting question from Al Kazlauskas at Radio One's cluster in Cleveland.

Al asks where an engineer can find

he's offered a deal on a cell phone, but the stock of spare parts keeps shrinking. This is indeed a problem.

For what it's worth, I'd try getting close to the manager of the store. There was a time when most of the stores were franchised that the local manager would do handsprings for your business. Although the managers of company-owned stores might not have the financial incentive of years past, it never hurts to ask.

If the manager knows that he'll sell a stash of XLR or TRS connectors each month, he'll stock them. Explain that you're a radio station, operating 24/7, and you will pay the higher Radio Shack prices to have these small parts at hand. I'm aware of stores that gave the engineer the manager's cell phone, so he could meet late at night or on the weekend to fill an emergency parts order. Now that's service.

Take the manager out to lunch, outline your needs and see what he's willing to do. If there are several stations near the store, get the word out and maybe involve your local SBE chapter.

Al raises a good point. What sources do you use for your small parts supplies? E-mail them to me, and we'll help everyone find those elusive parts.

★★★

Speaking of satellites: Winston Hawkins is the technical director for the Baker Family Stations Group and a Radio World contributor. Winston's group carries CNN news at one of their stations, and Winston got a report that the feed was not working.

The station is some 300 miles from the home office. From the symptoms described, Winston thought the receiver might be at fault. After sending the receiver to the repair depot, the receiver was returned with a report that it was OK. With new LNB in hand, Winston made the trip to the station, fairly confident that this would solve the problem.

It wasn't long before Winston found that the new LNB didn't solve the problem, either. So he checked the markings that he always makes on the

See WORKBENCH, page 18 ▶

NEW!

PREVENT LIGHTNING DAMAGE!
IMPROVE RELIABILITY!
STAY ON THE AIR!

NEW! PowerClamp surge suppressors prevent lightning-induced AC spikes and surges from damaging your equipment!

PowerClamp virtually eliminates the transients, surges, and waveform distortions that cause transmitter and studio gear failures, computer lockups, and unexplainable malfunctions.

PowerClamp will protect your investment and keep you on the air!

For user testimonials and detailed information, visit www.henryeng.com or contact any Henry Engineering dealer.

POWERCLAMP
Tel: 626-355-3656

Workbench

► Continued from page 17

mounting post, to make sure that the wind had not blown the dish off course and that the actuator brackets had not slipped.

Next step was checking for birds and

What went wrong? It seems the digital receiver's power supply had degraded to the point that the current capacity was not capable of powering the LNB (even though the voltage to the LNB was correct). The system worked fine with the consumer receiver providing the power, until the power supply could be replaced.

Once resolved, head-scratchers like

fully to ensure enough room in front and behind equipment. Don't forget the dimensions required to open front and rear transmitter and rack doors.

Tom Shedlick leads a crew of engineers at the Clear Channel cluster in Washington. They're putting the finishing touches on a three-station multiplexed project. As you can imagine, when you add those combiners to the

look at Fig. 3. Some transfer switches can weigh 70 pounds or more. Anchoring the strut with lag bolts into the wall secures the installation. By pointing the channel down, so the mounting bolts slide in place, there's enough wiggle room or tolerance between the switch mounting tabs.

Reach Tom via e-mail to tomshedlick@clearchannel.com.



Fig. 2: How Tom Shedlick handled a space problem.



Fig. 3: Anchor the strut with lag bolts to secure the installation.

bees in the feedhorn; then the voltage to the LNB, but that was OK. The coax and fittings were like new.

Winston brought along a consumer satellite receiver, which he hooked up to the antenna just to see if the connections and alignment were working. The television connected to the receiver popped up a picture immediately. This was getting to be crazy.

Winston then connected the digital receiver with a DC pass/block splitter, with the consumer receiver powering the LNB. When he did this, all the lights went green on the digital receiver and he had an ebno of 10.0.

this appear easy to diagnose. But it's only a diligent, step-by-step troubleshooting method, as outlined by Winston, that permits you to effectively solve the problem. He can be reached at winhawk@parfm.com.

★★★

Those pre-fabricated equipment shelters, made so popular by the cellular industry and now being used for broadcast applications, make for clean transmitter buildings. Perhaps the only drawback is the space. You've got to prepare your transmitter and rack layouts care-

fully to ensure enough room in front and behind equipment. Don't forget the dimensions required to open front and rear transmitter and rack doors.

transmitter building, space is tight. Fig. 2 shows what Tom did with his dehydrator. Unistrut and Kindorf products make support of even dehydrators an easy task. Getting the dehydrator up in the air gives you more floor and wall space, while the unit is still accessible using a step stool.

If you have any questions about the weight this strut material can handle,

John Bisset has worked as a chief engineer and contract engineer for more than 30 years. He is the northeast regional sales manager for Dielectric Communications. Reach him at (571) 217-9386 or john.bisset@dielectric.spx.com.

Submissions for this column are encouraged, and qualify for SBE recertification credit.

Armed and Ready to Rock

Jason Steinberg, director of marketing and promotion for Cox station WBAB(FM) in West Babylon, N.Y., sent this photo along with an explanation. We'll let him tell the story:

"The attached pictures were taken at the Hammurabi Pistol Factory in Al Hillah, Iraq, this past August. These guys are from the 304th Civil Affairs Brigade, attached to the First Battalion 4th Marine Regiment.

"They are, from left, Maj. Robert Jones from Bay Shore, Long Island; Maj. Craig Bennett from Rhode Island; Staff Sgt. David Pittari of Connecticut; Maj. Dave Menegon of New York City; and Lt. Colonel Martin Bischoff of New Jersey.

"They are the liaisons between the military and the Iraqi civilians. None of them speak the language and they depend on native translators every step of the way.

"While on a very short leave, Robert Jones stopped by the WBAB studios and dropped off these pictures, along with the actual flag and banner that they were holding. He also hooked us up with a bunch of Saddam money, which is currently being burned all over Iraq.

"A couple of months ago, we had sent Robert (through his brother-in-law) about a dozen CDs of WBAB, complete with music, DJs and commercials, to give him a little feeling of the comforts of home. After being a part of rebuilding the TV and radio station in central Iraq, Rob aired an hour of WBAB each day on Iraqi Radio for troops and Iraqis to enjoy.

"After just over a week at home on Long Island with his family and friends, Rob headed back to Ar Ramadi, Iraq, for another seven-month tour of duty. Then, in 2005, he heads off to Afghanistan. Keep in mind, this guy is an Army Reservist! His normal life includes working at a Long Island software company and being a husband and a father."



HIGH VOLTAGE RECTIFIERS

Nobody Knows Them Better Than We Do

Once again, HV Components/CKE brings you a reliable retrofit rectifier package for your transmitter that saves you money and delivers the performance and reliability you've come to expect from us. Our Model 51016 shown here is a three-phase full wave bridge designed to easily drop into your AM, FM or television transmitter. Conservatively rated for power supplies of up to 12 KV and 9 amps output, this retrofit package fills the bill for most any application.

Quick, Cost-Effective & Expert Solutions



www.rectifiers.com
800-649-6370

For One Singer, Life Irritates Art

A Petty Lament for the Lost Art of Radio Doesn't Get Much Airplay

by Skip Pizzi

Last year's Tom Petty album "The Last DJ" is a largely undiscovered gem, at least in part because it was generally avoided by radio stations. Petty's material routinely is played on a range of formats, but not so much this record. A quick look at the lyrics to the title cut explains why.

For example, the first verse establishes the character of a rogue DJ who rails against the preferences of today's corporately controlled radio:

*Well you can't turn him into a company man
You can't turn him into a whore
And the boys upstairs just don't understand anymore*

*Well the top brass don't like him talking so much
And he won't play what they say to play
And he don't want to change what don't need to change*

Petty laments the loss of independent programming and the reduced range of music choice on today's radio, from the perspectives of both the listener and the artist. His commentary on the increasingly narrow and controlled music selection on U.S. radio is unusually frank, particularly coming from a successful rock star. Of course, this trend in radio is nothing new, but apparently it has reached a level so pervasive and broadly entrenched in the culture that it becomes grist for a pop songsmith's mill.

The song becomes a dirge for the loss of an entertainment style that was once highly valued, but now seems gone forever, as he decries radio's robotic replacements in the song's chorus:

*There goes the last DJ
Who plays what he wants to play
And says what he wants to say ...*

*There goes your freedom of choice
There goes the last human voice
There goes the last DJ*

Nor does satellite radio, with its far-broader content choices, escape Petty's critique. The song is a requiem to the accessibility of programming variety on free-to-air radio, as it condemns listeners' need for a subscription service to avail themselves of such content today:

*As we celebrate mediocrity
All the boys want to see
How much you'll pay for what you used to get for free ...*

Petty's elegy to a radio past doesn't mention the exceptions that still exist, such as college radio and a few atypical public and commercial stations around the country. These stations' audiences may be small, but they are fiercely loyal, and they are likely where most of the airplay for this song has occurred.

Petty also doesn't limit his tirade to radio. He extends his disparagement to the music industry in general with the song "Money Becomes King." It must strike close to home with its deeply belittling observations of today's rock music milieu.

Thereafter the record settles into a good old rock-and-roll groove, without much reference to the initial theme — until the last song. In "Can't

Stop the Sun," Petty reprises his commentaries with an optimistic rebuke to the corporate types:

*Hey mister business man
Be sure to wash your hands
Be careful where you stand
'Cause life goes on and on*

*And you may think it's all over
But there'll be more just like me
Who won't give in, who'll rise again
Can't stop a man from dreaming
On and on and on*

There is subtle irony in the fact that Petty generally receives no shortage of radio airplay on the stations he condemns in "The Last DJ." Yet under those circumstances, his courage for releasing the song is all the more laudable, and his selection of this trend as subject matter gives testimony to its cultural importance. The record's success in the past year despite its relatively low airplay may bespeak consumers' concurrence with Petty's sentiments.

An era has passed, and radio survives — but not without some obviously unfavorable impressions and negative social impact.

Skip Pizzi is contributing editor of Radio World. 

The Big Picture



Photo: Gary Hayes, BBC

by Skip Pizzi

"If you can think it, Logitek can do it."



WKDF / WGFX Studio Console Configurations

Two Logitek Audio Engines, with a total of eight IO24A cards (up to 96 analog inputs and 96 analog outputs), five IO8D cards (up to 40 stereo digital inputs and 40 stereo digital outputs), and network cards providing fibre optic connections between Engines

- 24 mix-minus buses available per studio
- Supervisor software for complete control of fader assignments and router functions
- Custom scripting provided by Logitek to pass audio and control from the Numix to other studios in the facility that have old analog boards
- vRoute "virtual" router controllers

WKDF: 1 Numix-12 Console with 12 fully assignable faders, easy access to 8 stereo buses

WGFX: 1 ROC-5 Console, 1 ROC-10 Console, 1 RTE-3 Router Controller

"The limitations of average consoles and routers just don't apply."

—Cameron Adkins, Citadel Broadcasting, Nashville, Tennessee

Take what you know about the average audio router and console and throw out the normal limitations. The Logitek Audio Engine not only can accommodate any input or output standard, analog or digital, but automatically handles all remote machine control functions within the engine and routes those functions to whatever room or control surface at the same time. *This is not your father's router!*

With Logitek at the heart of this facility, I am most proud of what it has allowed me to accomplish here. The Logitek system has taken away the boundaries of the traditional project and allowed me to be a better engineer.

Logitek Electronic Systems, Inc.

5622 Edgemoor

Houston, TX 77081 USA 713.664.4470 1.800.231.5870 www.logitekaudio.com



Logitek

© 2003 Logitek Electronic Systems, Inc.

ROOTS OF RADIO

Catalogs Trace Equipment History

by Tom Vernon

It seems like only yesterday. I came home from school one day to find that the latest edition of the Gates Radio catalog had arrived in the mail.

I didn't get any homework done that night, or for the next several nights, for that matter. Sales catalogs and flyers that arrived after bingo cards were mailed in were a major part of my introduction to electronics and the exciting world of top-40 radio in the 1960s.

proof studios. Where I worked, there were egg cartons glued to the walls, the floors creaked and you had to bang on the glass so the guy in the next studio would turn the monitor down enough for you to cut a few spots. You often shared your work space with mice, squirrels and a variety of insects.

It always smelled funny, too.

The board operators pictured behind those gleaming rows of black knobs in the catalogs were well-groomed men wearing sports jackets and ties. In

small-market radio, the only people wearing coats and ties were the salesmen. For the jocks, the usual dress code was tee shirt, no shoes and dark sunglasses.

reproduced the circuit theory section from the company's instruction manuals.

Other catalogs contained technical discussions about why a patented or innovative design was better than the status quo. RCA's literature compared high-level plate modulation with its patented Amplitude Modulation system, and attempted to persuade the reader that theirs was a better way to modulate



Gates designed custom audio consoles for WABC, New York, as pictured in its 1970 catalog.

In addition to the illustrations and descriptions of consoles, cart machines and transmitters, these equipment catalogs usually featured pictures of typical equipment installations. Often these were turnkey studios, equipped with one manufacturer's gear. Other spreads were an opportunity for a company to show off its ability to design custom broadcast equipment.

What was great about these pages of the catalog is they gave those of us living outside large cities a glimpse of what broadcasting was like in the "Big Time."

Pictures don't smell

As a teenager growing up in small-town America, I went on nickel tours of every radio station in the area, some of them twice. It didn't take long until I noticed that there was a big difference between what I saw in the catalogs and what I viewed on my tours, and later while working in small-market radio.

In the catalogs, equipment was housed in modern, attractive, sound-



Cover of the 1967 RCA broadcast audio catalog. Note the RCA 'new look' logo, which was in use for only a short time.

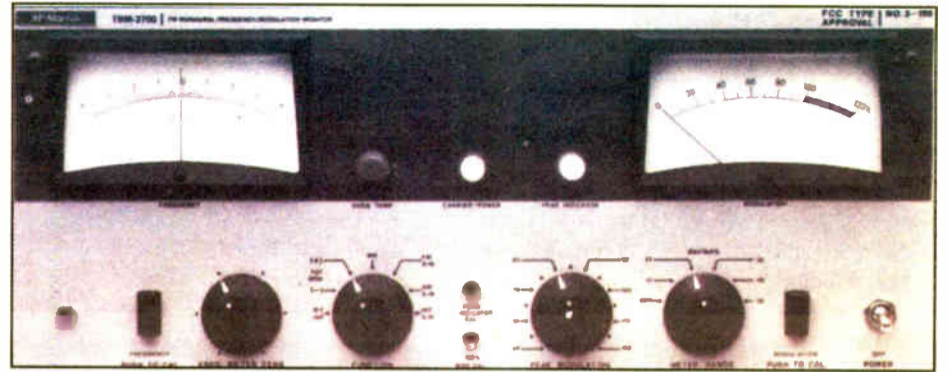

The McMartin TBM-3700 FM frequency and modulation monitor was a workhorse at many stations in the 1970s.

Studios in the Big Time had neat bundles of numbered wires running in troughs under the floor, terminated on solder blocks. Where I worked, wiring was chaotic, tacked to the baseboard or strung over the ceiling, and terminated in a rat's nest under the console. Occasional outages were caused by the nocturnal gnawing of mice on the cables

AM transmitters.

CCA's sales literature touted the advantages of its "dual reliable" series of AM transmitters, really two separate transmitters operating at one-half output power with an intelligent combiner circuit. The likelihood of being off the air was reduced greatly. Additionally, the cancellation properties of the combiner resulted in superior noise and

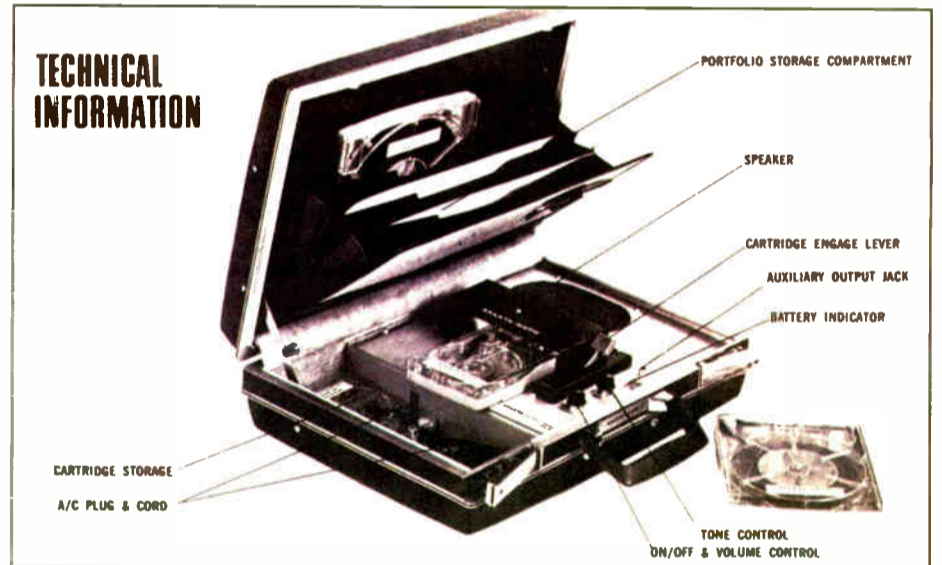

Possibly the most unusual cart machine ever, the battery-powered Sparta BP-22 was built into an attaché case so that salesmen could take it on the road and play commercials and station demos to clients at a time when cassette technology was in its infancy.

Many of the catalogs I received pictured the latest thing in broadcast technology: solid-state consoles. It wasn't till the late 1970s that transistorized equipment fully permeated the small-market environment. Vacuum-tube gear in unventilated buildings made for cozy studios in the winter and sweatboxes in the summer. Still, the pictures were an inspiration to strive for something better; and while my earliest studio constructions weren't picture perfect, I was better off knowing how things should go together.

Information source

These old equipment catalogs also highlight some more serious points about the history of broadcast equipment.

Some catalogs contained detailed circuit theory and signal diagrams and additional educational resource for the novice. The Wilkinson Electronics catalogs of the early 1970s, for example,

distortion figures, typically noise better than -60 dB, and distortion of 1 percent or less.

Another nice feature of many of these catalogs was the reference section in the back. Here you could find common formulas for resistance, inductance, capacitance and frequency/wavelength. Resistor values for commonly-used "T" and "H" pads were included, as well as information on frequency of AM stations vs. tower height. Some catalogs contained information on FCC and FAA specifications for tower lighting.

Many of those old catalogs, such as the Gates and RCA offerings, were hard-bound. A pocket was provided in the back to keep the current price list, usually mailed yearly. While there were occasional circuit tweaks or cosmetic changes to make equipment look more modern, many items were manufactured for 20 years or more.

Product Showcase



Model DAI-2 Dialup Audio Interface

- perform unattended remote broadcasts
- DTMF operated controller with relay outputs
- fully programmable output on any key press
- momentary and/or maintained relay outputs
- four logic inputs with programmable output
- balanced audio input and output with ALC

Sine Systems, INC.

615.228.3500

more information: www.sinesystems.com

In today's Internet-savvy world of streaming media, product life cycles of six months to a year are more common, and the idea of hardbound equipment catalogs that never really went out of date seems almost unthinkable.

A different time

The big equipment manufacturers, Gates, General Electric, RCA and Western Electric, designed and manufactured virtually everything, from consoles to cart machines to transmitters, in-house. For the most part, equipment from any of the big manufacturers was top-notch.

This was a time when a handful of circuits — power supplies, amplifiers, oscillators and filters — was used in every piece of equipment. Approximately 20 types of vacuum tubes were used everywhere, and the same team of engineers designed all of the equipment a company manufactured.

To a large degree, the advent of the integrated circuit and competition from overseas manufacturers changed all of that.



A collector's item now, this Western Electric 25B console was new when the company's 1947 catalog was published.

Eventually, specialty companies that manufactured one product line well became the norm, and most of the large manufacturers got out of broadcast equipment altogether. Many found lucrative government contracts for electronics gear as the war in Vietnam escalated. Finally, Gates/Harris was about the only large manufacturer left in broadcasting, and its emphasis shifted towards acquisitions and distribution of radio equipment.

Eventually, I got my first job in Boston radio. I looked around and the studios looked a lot like the ones I'd seen in those catalogs many years before. It was then I realized I had made it to the Big Time.

Tom Vernon is a multimedia consultant who collects vintage radio gear. Reach him via e-mail to TLVernon@blazenet.net.

THE IDEAL PAIR

HERE'S A MATCHED SET OF BATTERY/ON A.C.-POWERED AUDIO AMPLIFIERS FOR LOW-BUDGET/HIGH-GRADE REMOTE BROADCASTS: ARA-11 BOOSTS A DYNAMIC MIC. UP TO +8 LEVEL WITH 10db HEADROOM. INCLUDES COMPRESSOR FOR HANDS-FREE 1-MAN USE; INTERNAL OR EXTERNAL POWER. ADD ARM-31 3-MIC. MIXER WITH VU METER THAT READS COMPRESSION OR LEVELS. SWITCH-OFF COMPRESSOR IF DESIRED. RUGGED, VIRTUALLY DAMAGE-PROOF AND FOOL-PROOF.

Ultra Audio Products
P.O. BOX 921 • BEVERLY HILLS
CA 90213 • 213/276-2726

In a flyer that might raise a few eyebrows if it were published today, Ultra Audio Products used models to help sell its line of audio and video products.

The IC made possible complex circuit designs that would be difficult if not impossible to create with discrete components. As digital techniques began to make their way into circuit design, and complexity continued to increase, it no longer was possible for a small design team to create top-of-the-line products in every category.

At first, manufacturers responded by private-labeling equipment from other companies for some categories, and concentrated their efforts on core products, usually consoles and transmitters. Gradually there were more private-labeled items than manufactured items in the catalogs, particularly the final ones published by RCA. Equipment manufactured overseas usually was less expensive than anything made in America, and the big manufacturers increasingly were unable to offer competitive prices for equipment.

New Simian 1.6

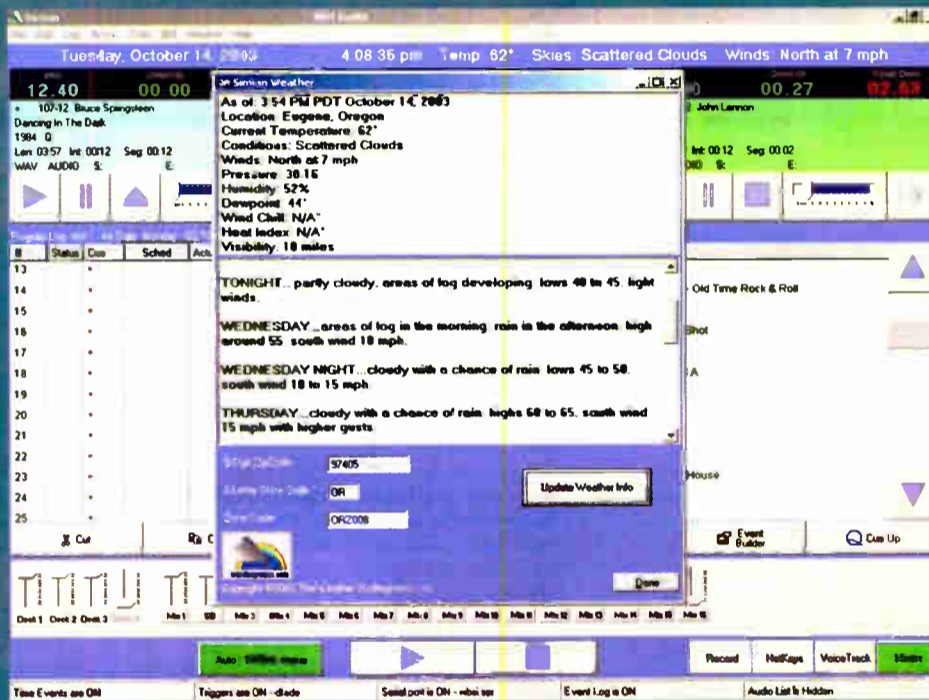

Simian
broadcast automation
Just \$1499

Simian 1.6 is the result of input from numerous BSI users. Thanks to their input, Simian now includes an on-screen weather display that updates from the internet.

The new Simian also includes sophisticated new Voice-Tracking functionality allowing Voice-Tracking days in advance, even from remote studios, and an improved ability to verify logs before air play.

Simian is still the most feature-rich automation system in the industry and provides powerful, reliable broadcast automation for stations in the US and around the world.

Thousands of users have discovered how easy and versatile BSI Simian really is.

Broadcast Software International
1925 Bailey Hill Road, Suite A
Eugene, OR 97405
www.bsiusa.com
888-BSI-USA1 (888-274-8721)
info@bsiusa.com

**Test and try
before you buy.**

Products & Services SHOWCASE

Telephone Solutions by CircuitWerkes



The HC-3 hybrid telephone auto coupler

The HC-3 is ideal for many tasks like listen & concert lines, remote broadcasting, IFB interfaces, & More.

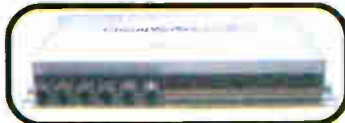

The New Telco-6, six line, incoming, ring detector

Is someone calling? Find out with the new Telco-6! The telco-6 detects telephone ring signals from one to six lines and provides a dry relay output for each line.

More Features,
Better Price



CP-1 & CP-2 call progress decoders

Did you ever connect a telephone coupler to a phone line or PBX only to discover that it won't hang up? CircuitWerkes' call progress decoders can save the day on most systems. They listen for dial-tone or busy signals and, when present, force your couplers offline.

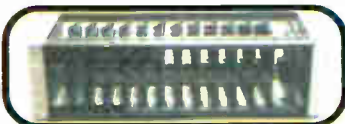

The AC-12 telco auto coupler bank

Get up to a dozen, full featured, telephone auto couplers in just 5.25" of rack space. The coupler bay features a common power supply and two audio busses for easy mass feeds. Individual couplers can be used for sending or receiving separately from the rest - perfect for IFBs. Newly updated design improves audio performance and overall reliability to a new standard of excellence!

CircuitWerkes - (352) 335-6555 Fax 380-0210 http: www.circuitwerkes.com 2605 NW 6th Street, Gainesville, FL 32609

Affordable, Flexible,
and Dependable???

You Bet!

PACEMAKER

III

Shown: PM-218

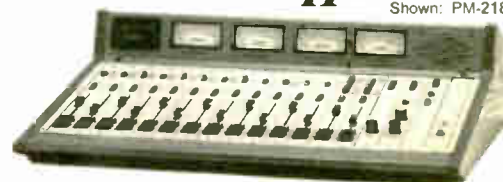

AUTOGRAM
800.327.6901

www.autogramcorp.com

WEATHER RADIO

Model CRW



Price \$540.00

Sensitivity .28 microvolts for 12 dB quieting. All 3 frequencies. Alert tone demutes receiver, closes relay and gates audio to 600 ohm rear terminals. Another set of rear terminals has continuous 600 ohm audio output. Double conversion crystal controlled, crystal filter in first I.F., ceramic filter in second I.F. Dual gate MOS FET front end. 50 ohm coaxial input. Adjacent channel (± 25 kHz) down to 70 dB. 19" rack mount, 3.5" H, all metal enclosure. In stock—available for immediate delivery.

GORMAN REDLICH MFG. CO

257 W. Union St. • Athens, Ohio 45701

Phone 740-593-3150 • FAX 740-592-3898

www.gorman-redlich.com/jimg@gormanredlich.com

AM Antenna Solutions



LBA Tunipole™
Folded Unipole Systems



RF Components



Vacuum Capacitors



Diplexer, Triplexer and
Phasor Systems



LBA Technology, Inc. is your proven supplier of innovative, digital-ready AM antenna systems.

Our products include tuning units, phasing systems, multiplexers, AM/wireless isolation systems and components for every power level. We help hundreds of broadcasters in the USA and worldwide to --

Reach further –
sound better!

LBA Technology, Inc.

3400 Tupper Drive, Greenville, NC 27834

800-522-4464 / 252-757-0279 / Fax 252-752-9155 / Email lbatech@lbagroup.com / www.lbagroup.com



LBA
Since 1963



Custom Studio Furniture

Since 1979 Mager Systems, Inc. has been custom designing and fabricating award winning furniture for the broadcast industry nationwide. We are still the innovators and leaders in solid surface tops and applications which comes with a 10-year warranty. Our complete one-stop-shop includes installation, turnkey prewiring, switches and components, conference rooms, reception desks, and office furniture. Our blending of art form with cutting edge techniques, and a clear understanding of each client's application allows us to produce your showplace tailored to your budget.



COOL STUFF AWARD 2002
Radio World



WBAA
Purdue University

Touch Sensitive Switches & Keyboards

TEL: 623-780-0045
FAX: 623-780-9860
mager@magersystems.com
www.magersystems.com
Visit our website for more information

NES introduces our new award winning "Sound Choice" furniture. Our modular in stock furniture boasts unsurpassed quality for the economical budget with a 10-year limited warranty. See details on our website.

May we present...

YOUR AD



RADIO WORLD'S

Products and Services Showcase provides a perfect medium for marketing your products and services.

For more information, call Simone at 703-998-7600, ext. 154 to request a media kit.

VOA Antenna Switch at Bethany, Ohio

by Jim Hawkins

This is one in a series of photographs of radio broadcast facilities and radio history from the collection of Jim Hawkins.

Unlike medium-wave AM (540 to 1700 kHz), shortwave AM radio (3 MHz to 30 MHz) covers the world. In the former, shared frequencies are handled by directional antennas and by limiting power to shape local and skywave coverage. Shortwave radio stations use highly directional antennas and "take turns" using frequency and time slots by international agreement.

This makes it necessary to shut down and fire up transmitters regularly, while switching frequencies and direction using numerous antennas. Recent technology has simplified these functions with rotating antennas, computer-controlled switches and automatic tuning of the transmitters.

Prior to the closing of the Voice of America transmitter site at Bethany, Ohio, newer transmitters had been added to automate tuning and frequency change, but the switching of antennas remained a manual operation until it closed down in 1995.

building. Animals, especially birds, sometimes would land in critical places of the switch, causing short circuits and small fires.

The Bethany VOA station was shut down in September of 1995 and has been converted to the "Veterans' Voice of America" museum, founded by trustees of VFW Post 7696 of West Chester, Ohio. The antenna switch remains as part of the display. A Web site is available at www.veteransvoa.com for information and visiting times.

Thanks to Clyde Haehnle, former engineer of VOA and WLW, for technical information, and John Vodenik, VOA Bethany technician, for information on operations.

Visit the author's Radio and Broadcast Technology Page online at www.jphawkins.com/radio.html.

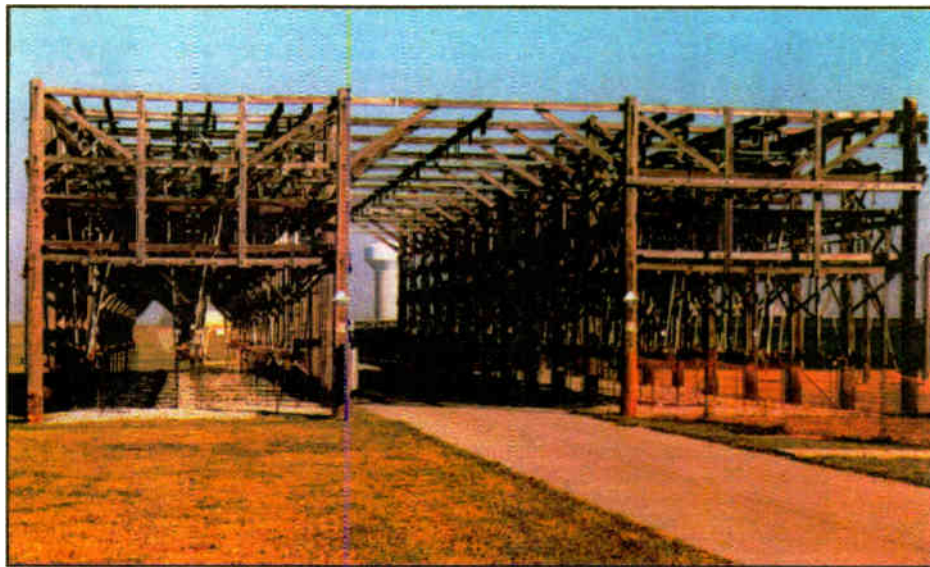

The VOA Antenna Switch Matrix

The Bethany VOA station closed in 1995 and is now a museum.

The manually operated antenna selector switch, designed by Robert Uphaus under the direction of Ronald J. Rockwell, is a crossbar design. Engineers had to leave the building, enter the structure and set up the individual switches to change antenna configurations. It has a characteristic impedance of 300 ohms. It consists of approximately 34 balanced line inputs and outputs with a maximum of 250,000 watts of 100-percent modulated power. There are 336 balanced, two-line switches.

Operation of the switch went smoothly most of the time, but could be challenging. Operators would have to wade through unplowed snow to get to it. The wooden rods connecting the handles to the switches would rot over the years and break, forcing operators to use "hot" sticks to manipulate the switches until the rods were replaced.

These hot sticks were also used when parts of the switch iced up. A blowtorch would be attached to the end of the stick to melt the ice. Once, an attempt was made to control the switch remotely by tying nylon cords to the handles and running them to the back of the transmitter

The Dorrrough Loudness Monitor



Two 40-A2 meters in an optional dual rack

Today's audio requires careful attention to precise level control...

Simultaneous display of Peak & Average. See the actual loudness of program content with the Dorrrough ballistics based on Time and Amplitude. Select from 6 different models including AES/EBU meters.

Features common to all models:

- Peak hold functions • Sum/Difference • Alarms for audio loss and full scale
- Scale selection for 14dB and 20dB of headroom
- AES/EBU includes more features



Remote

A wired remote for accessing phase from the 280 analog and 280 digital reading meters. Display the functions of L_rR, Sum/Diff, Phase, Overs Display/Overs Reset, 3 sec. Peak Hold, Peak Hold Permanent, and Reference Mode. Red alarm status lights for Phase, BSC, and Full Scale.

Model RW-100



Please visit our web site www.dorrrough.com

Dorrrough Electronics Inc. 5221 Collier Place • Woodland Hills CA 91364
Tel: (818) 998-2824 Fax: (818) 998-1507



The best brands: You'll find



When we're talking brand names, we're not talking "designer labels", as is evidenced by our sensibly-dressed sales staff. In front from left to right: John McDonald, Ricardo Espinoza and Paul Schweiger. In back from left to right: John Lynch, Shannon Nichols, Gary Beebe, Ryan Olsen, Steve Thomas and Laz Harris.

A company is only as strong as the people and products behind it. And here at BSW, we're proud to have what we feel is the most experienced sales team in the business. And unlike our "drop-ship-happy" competitors, BSW stocks over a million dollars worth of broadcast gear in our warehouse. When you call, chances are we'll have the brands and products you trust right here and can get them out immediately. It's another one of the many reasons BSW is your best source for professional audio products. Call and talk to our friendly sales reps today.



We planned on doing a gratuitous holiday ad with bright shining lights, jolly Santas and reindeer. But even after we got all the lights untangled, we couldn't get them to work - this despite having so many talented engineers in the building. Go figure.

BSW
BROADCAST SUPPLY WORLDWIDE

Fostex



Single Rackspace Stereo Monitor System

The RM-1 from Fostex is the ideal solution for monitoring in tight environments. The unit is single-rackspace and ruggedly designed, utilizing robust construction for around the clock operation. The aluminum front panel has a multitude of user options so that the audio output may be configured for the application at hand. **Features:** mode selection: Mute, Left Channel, Right Channel, Mono, Signal; independent left and right volume control; two stereo left and right inputs designated as Input A and Input B; A/B input selector; stereo headphone jack; power output each amplifier 15 watts into 8 ohms; robust construction; fully shielded to prevent interference; outstanding frequency response.

RM1FOSTEX List 599⁰⁰ **385⁰⁰**

Industry-Leading Codec Delivers 15 kHz Over Dial-Up Phone Lines

The Comrex BlueBox combines a high speed digital audio codec with a digital audio codec to produce 15 kHz from a standard dial line. For a super economy price you also get a cellular hands-free interface. It sends high-quality audio over wireless service just 1.5 lbs., it won't weigh you down. The BlueBox offers one mic/line switchable input, one high level output and one line level output on XLR, plus a direct connection to mics and headphones. A -10 dbu tape input allows connection to a DAT or DAT player.

Purchase any Comrex codec between November 1, 2003 and January 31, 2004 and receive a Free BeyerDynamic DT290 headset (a \$189.00 value). This is an exclusive BSW offer. Call today.

BLUEBOX List 2,800⁰⁰ **Call for Price**



Fast 2-Channel Editing

Short/Cut Editor offers fast editing of single channel audio. It offers all the features you need to capture and edit audio for radio commercials, voice-overs, quick rehearsal mixing, etc. **Features:** high-resolution waveform display; real-time editing including cut, copy, insert, erase; insert record; crossfades; fade-in/fade-out; gain changes and ramping; one-touch instant record; title and clip select with built-in keyboard; assign cuts or clips to 10 Hot Keys per directory; 10 directories with password-protect; hard disk stores 12 hours audio; D-NET File Transfer Network capability; you transfer finished audio; balanced XLR and EBU digital I/O; IEC-958/II input; D-NET output.

SC182 List 3,495⁰⁰ **Call for Price**

Digital **AUDIO**

24-bit/96 kHz 2-Ch. Audio Card

The CardDeluxe gives you the ability to record audio at up to 24-bit/96 kHz resolution. **Features:** analog 2-channel I/O via 1/4" TRS connectors; S/PDIF digital I/O via RCA connectors; 8- to 24-bit resolution; 96 kHz sampling rate; +4/-10 balanced/unbalanced operation; full duplex; 4 channel operation using both analog and digital I/Os; slaving of multiple CardDeluxes to a single sample clock; Windows 98 and NT drivers; DirectX support.

CDX01 List 595⁰⁰ **399⁰⁰**

and them in stock at BSW.

COMREX



FREE
Beyer DT290
Headset



eed modem
z audio
omical
rface to
ces. And at
BlueBox
adphone
roviding
or a mixer.
MiniDisc

ember 6,
REE
alue!)

rice

marantz



Single-Space Rackmount Professional DVD Deck

The new PMD910 from Marantz delivers professional DVD performance in a single-space rackmount unit. With the rise in DVD popularity, and the PMD910's ability to play CDs and MP3s, this will become your most versatile media player. This deck boasts top-of-the-line features like progressive scan; 3:2 pull-down; NTSC/PAL conversion; compatibility with DVD-R, MP3, CD-R/W, and more; 48 kHz and 96 kHz PCM audio; optical/coax digital output; RC6 I/O; RCA analog outs; component and S-video output; rapid track and time searching and IR remote. Includes rackmount kit.

PMD910 List 429⁰⁰ **369⁰⁰**

APHEX



Popular Compellor Now with Digital I/O

Now you can get the popular Aphex 320A Compellor with digital input/output! If there's a digital input the output slaves to the same clock, up to 96 kHz. If there is no digital input (audio or clock), then the unit defaults to a pre-selected frequency.

Not strictly a compressor or limiter, the Aphex Compellor is an incredibly intelligent dual channel leveler. It automatically gives you dynamic control over your mix, letting you maintain optimum average levels at all times. Extremely easy to use, you only need to set the Drive level to generate the desired amount of processing, set the Process Balance control between Leveling and Compression and adjust the Output level for unity gain. The 320 is then ready to provide complete dynamic control – smooth, inaudible compression, increased system gain and the freedom from constant “gain riding” – automatically! **Features:** dynamic silence gate and quick compression recovery; 3 modes of stereo/dual mono operation; comprehensive metering; balanced or unbalanced I/O via XLR connectors; digital input/output.

320D List 1,495⁰⁰ **1,149⁰⁰**

Voice-Over Mic Known For Its Unpronounced Proximity Effect

SHURE

Top Seller



An all-time best-seller, the Shure SM7B dynamic cardioid microphone is known for its warm sound and unpronounced proximity effect. **Features:** classic cardioid polar pattern, symmetrical about axis, to provide maximum rejection and minimum coloration of off-axis sound; flat, wide-range frequency response; bass roll-off and mid-range emphasis (presence boost) controls with graphic display of response setting; improved rejection of electromagnetic hum, optimized for shielding against broadband interference emitted by computer monitors; internal “air suspension” shock isolation.

SM7B List 619⁵¹ **349⁰⁰**

orban

Get Louder, Brighter FM Sound



The Optimod-FM 8400 comes equipped with more than five times the raw processing power of its predecessor, with sophisticated new processing algorithms. The 8400 retains many proven Optimod-FM 8200 features such as the five-band and two-band processing structures, but with a noticeably louder and brighter signal which has the smoothness and pristine clarity needed to hold listeners for extended periods. Reduced input/output delay makes off-air monitoring practical for talent, and DSP improvements have significantly enhanced sound quality. In addition, version 3.0 software permits the user to switch the band-1-to-band-2 multiband crossover frequency between 100 and 200 Hz, emulating the bass texture of the legendary Gregg Labs 2540 analog FM processor.

8400 List 10,900⁰⁰ **Call for Price**



“Broadcast Host” Digital Hybrid

JK Audio's new Broadcast Host allows you to send mic and line level signals into the phone line while maintaining excellent separation between your voice and the caller's. The stereo output jack on the back of the unit provides your voice on one channel and only the caller's voice on the other. The balanced XLR output jack contains only the caller's voice. **Features:** auto answer/disconnect; balanced XLR input with Mic/Line pad switch; 3.5 mm mono input; balanced XLR output; 3.5 mm stereo output (left=send, right=caller); 3.5 mm stereo output (mixed send and receive audio).

HOST List 495⁰⁰ **459⁰⁰** **JK Audio**

BSW offers package pricing • Let us save you money on your next quote

800 • 426 • 8434 or online @ www.bswusa.com

Broadcast Supply
Worldwide.
Your Best Source
for Professional
Audio Products.



PRODUCT EVALUATION

One, Two, Three Goes Tivoli

Tivoli Audio Sets New Standard With Model Three Radio Sound System

by Frank Beacham

After a manufacturing drought of high-quality home radios that dated back almost to the tube era, radio aficionados have in recent years had the pick of some of the finest new AM/FM receivers ever built. Now there's a new addition to the connoisseur's collection: Tivoli Audio's Model Three Clock Radio.

Not surprisingly, the magnificent Model Three has its roots in a concept by the late Henry Kloss, the notable audio designer who created the KLH Model Eight, the first truly outstanding FM table radio and now much-desired collectable. Take a close look at the Tivoli Model Three and you'll see that it's clearly an offspring of Kloss's definitive Model Eight.

Good listening

In the years prior to his death in January of 2002, Kloss and his business partner, Tom DeVesto, left Cambridge Soundworks to form Tivoli Audio, the first product of which was the Model One table radio.

Priced at a modest \$100, the Model One became an instant classic. It has a discrete component FM tuner featuring GaAs MESFET mixers, a heavy-magnet, long-throw 3-inch speaker driver, and an ample, smooth-as-silk 5:1 ratio analog tuning knob. The radio is housed in a furniture-grade handmade wood cabinet.

The Model One's diminutive size and deceptively simple interface often mask the fact that it's widely considered — price no object — one of the best monaural AM/FM table radios in the world. Its bare bones, uncluttered design is pure Henry Kloss, a man who studiously avoided adding what he considered unneeded gadgetry to any product.

To appreciate the Model Three's design fully, it helps to understand how Kloss and his successors got there.

Quirky philosophy

During a 1994 interview with Radio World, Kloss revealed that he was working on a new table radio design that would take him back to his roots. That radio would eventually become the Model One.

Kloss said his biggest design struggle had been over features. He abhorred bells and whistles that interfered with a product's essential functionality, yet was aware that many buyers demanded them.

"There's all the choices to be made about alarms, clocks, bands, pre-programming," Kloss said. "Before, it was easy. You had a tuning knob, a treble and a volume knob. One of the things holding me up is uncertainty about how simple you make it and then how appealing you make it because of the features it has. I'm obviously leaning toward simplicity. But I don't know how many people get turned off when you drop off these features."

On the Model One, Kloss dropped virtually all the bells and whistles. It has just three knobs on the front panel. If you want pre-sets or any form of automation, this radio is not for you.

The Model Three, on the other hand,

represents a nod to limited automation within the philosophy of a purist. It's a bit like when Leica, the most conservative camera company in the world, finally added an internal light meter to its basic, but revered, "M" rangefinder. The ground shook, but ever so gently.

This orthodox design approach is a key reason the Model Three adds up to such a unique and fascinating radio, one that I predict will also be an instant classic. Though the mind of Henry Kloss is no longer with us, his quirky, spirited philosophy lives on in the Model Three. It's an approach a Luddite can love.

Think analog

First, the key technology of the Model One lives on in the Model Three, even though the new model has stereo recep-

tion capability with the addition of an optional companion speaker. Kloss's tuner with GaAs MESFET mixers and 5:1 ratio analog tuning dial are retained. But the new radio adds a wider range of inputs and outputs on the rear panel, and — because it's a clock radio — there's a 20-minute sleep timer, a snooze button, optional wake-up modes and an innovative mechanical thumbwheel to set the alarm wake-up time.

Forget glowing digital readouts, this is a clock radio for those who think analog. To the left of the big tuning knob is an elegant analog clock with a quartz mechanical movement. The clock face is illuminated by a cool blue light. It's powered by a single AA battery. Dimensions of the radio's wooden case are 4.5 inches high x 8.375 wide x 5.25 deep. It weighs 4.25 lbs.

The clock's outer rim is a movable ring. As you turn it, an arm on the clock face follows as you adjust it to your preferred wake-up time. Once set, push a small button under the clock to activate the alarm function, which allows wake-up to AM, FM or tone. A large snooze button on the top of the radio allows a five-minute temporary reprieve from the alarm.

I set up a Model Three system in my bedroom. By system, I mean the radio with two of its optional features, the companion stereo speaker and subwoofer. I placed the radio on one side of the bed and the stereo speaker on the opposite side. I placed the subwoofer on a shelf below the radio. Though the radio has internal AM and FM antennas, I attached a Terk FM Pro antenna to the radio's

external FM antenna connector for improved reception.

At first I tried just the radio, without the accessory components. As a stand-alone radio, the Model Three's superior off-air reception and excellent sound quality ranks close to its premium competitors. The receiver, just as with its companion Model One, handled New York City's congested RF jungle with ease. AM and FM reception was excellent, even on stations that are normally difficult to receive with cheap radio receivers. Tuning is a pleasure, requiring only the gentle twist of the big silky knob until a tiny yellow LED achieves maximum brightness.

For those desiring station presets, this is not your radio. Perhaps you'd be better off with the new Boston Acoustics Receptor, another first-rate table radio with comparable reception capability that features pre-sets.

Finally, I hooked the Model Three's

mium radios we've tested in the dust. With Tivoli's accessory stereo speaker and subwoofer, the Model Three creates a cocoon-like field of sound that's ideal for small listening areas like bedrooms or workspaces.

Off the top

I had one minor issue. The Model Three radio's internal speaker fires from the top, to make room for the clock, while the companion stereo speaker fires from the front of the cabinet. Depending on how the listener is positioned, this can cause a slight imbalance in sound levels between the two devices. It's adjustable with the balance control on the back of the radio, but one wonders why Tivoli Audio didn't design the companion speaker to fire from the top as well.

Obviously, when the pieces are put together, the Model Three expands to more than a small radio. It becomes a high-quality component sound system in miniature, one that exceeds for low- to medium-volume listening in compact spaces. Tivoli also offers an accessory CD player, but we didn't audition it. A Sony portable CD player plugged into the Model Three's auxiliary input sounded just fine, however.

Tivoli Audio's Model Three advances the premium radio genre while maintaining the classic design characteristics advocated by Henry Kloss. Some might want more automated features like station presets; but for those who savor great sound with Kloss's penchant for simplicity and minimalism, the Model Three radio system simply can't be beat.

The radio retails for \$199.95. A basic companion stereo speaker is \$49.99, while a companion stereo speaker with second clock/alarm unit is \$99.95. The subwoofer is priced at \$79.99. An optional remote-controlled CD player is \$199.95.

Tivoli also offers the Model Two AM/FM radio (minus clock/alarm capability) with companion stereo speaker for \$159.99.

For information, visit the company Web site at www.tivoliaudio.com.



components together. In this three-piece configuration, the results were breathtaking. The system's sound quality excels, leaving all of the new generation of pre-

MARKET PLACE

V-Soft Software Updates Probe

Probe 3 is updated propagation prediction software, available from V-Soft Communications.

The company said its interface has undergone modifications to enhance the usability of the program, including a new look with an upgrade to Windows XP themes. It also maintains features of its predecessor, Probe II.

Features include a polygon creation tool that allows users to define a shape on the map and calculate its area and population, as well as a "D/U Ratio Study" that allows for color coded D/U ratios to be plotted on the map, useful in booster studies.

Probe 3 includes a new database search engine, allowing the user to search the database by criteria such as service type, licensee, city of license and distance.

"FCC curve methodology has been added as a propagation model for calculation of grid-based signal and interference," the company said. "This allows users to easily visualize and quantify where FCC D/U ratios are not being met."

Separate "printers" can be defined for use with graphical and text output. Other features include support for NAD27 and NAD83 datums; a new mapping engine that allows for solid and dashed lines of any width; plotting of census density using gradient shading, with race selection; importation of MIF files as a separate layer to be plotted on the map; and a study edit window that allows global modifications of transmitters and contours.

For information contact the company in Iowa at (319) 266-8402 or via e-mail to www.v-soft.com.

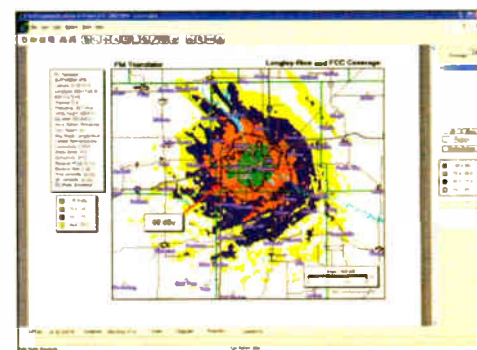

This Probe 3 display shows a Longley-Rice and FCC coverage map of an FM translator over Des Moines, Iowa.

MUSICAM USA

500 gives you more reasons

to own a new

NETSTAR™

Codec



The new NetStar IP & ISDN Codec gives you all these benefits:

- AAC, AAC-LD, MPEG 2, MPEG 3, G.722 and G.711 algorithms for the best audio and full compatibility
- Bi-directional audio over IP and ISDN
- Linear, uncompressed bi-directional audio over IP
- Ancillary Data and 8 Contact Closures over IP & ISDN
- Simultaneous connections on IP and ISDN
- Automatic backup of IP with ISDN, and vice-versa
- Full remote control and status monitoring from any Web Browser
- ...and lots more

Now, through December 31, 2003, we'll give you \$500 for every NetStar you purchase. Owning the world's best Codec has never made more cents!



Model 500 shown



MUSICAM USA

MUSICAM USA
670 North Beers Street, Bldg #4
Holmdel, NJ 07733 USA
732-739-5600
732-739-1818 fax
sales@musicamusa.com
www.musicamusa.com

MUSICAM USA is the d/b/a of Corporate Computer Systems, Inc

\$500 MUSICAM USA Rebate valid with proof of purchase from any authorized U.S. based MUSICAM USA Distributor. Contact factory for details.

STATION/STUDIO SERVICES

Be compliant with the new **BAS Prior Coordination Notification Procedures!**

Point. Click. Done.

Hundreds of people have told us they need a service that will:

- ★ Perform a Path and Interference study for each application.
- ★ Send all the Prior Coordination Notices to others in the spectrum.
- ★ File the FCC Form 501.
- ★ Make it easy to start the process.
- ★ And do it for half what other services charge.

So we've created your inexpensive, one-stop solution for RPU and STL licensing needs!

Point. Click. Done.

visit www.terrestrialrf.com
or call 888-373-4832

WISHFUL THINKING ...to finally take a moment to thank GBS for the excellent revenue opportunities you provide. We are a dual FM station group ... always on the lookout for NTR possibilities to increase sales revenue. We started our relationship some 3 years ago with the Holiday Shop Local package. Sales of Holiday Shop Local that first year surpassed our every expectation ... \$6,000 total NTR for the 4th quarter. This led to our purchase of the Shop Local Annual package that we continue to sell out (annual contracts totaling over \$9,000). Last year's Holiday Shop Local sold out at \$7,000 total for the 4th quarter ... and this year's package is currently at \$4,000 with half of the sponsorships left to sell during the next 16 days. Oh ... and we have over an 80% repeat client ratio (most all by phone) with our GBS package sponsors. Thank you Rod and GBS for an excellent means of NTR. We're already budgeting... your 2004 GBS packages. Thank you!

WON'T INCREASE YOUR BILLING....
...but market-exclusive

GBS SALES BOOSTERS WILL!

Don't Drink & Drive Shop Hometown Merchants
Christmas New Years Winter Safety Tips More!
CALL TOLL-FREE 1-888-472-2388

FREE DEMOS & INFO www.gracebroadcast.com

©2003 Grace Broadcast, Inc. All rights reserved.

- GM (CA)

Because Christmas is **HIStory...**
Heb. 10:7

"CHRISTMAS TREASURES"
Thirty (30) 30-sec. Features
—commemorating—
THE BIRTH OF JESUS CHRIST
\$130 complete
FREE DEMOS at
www.gracebroadcast.com

100% Royalty-Free Commercial Production Music

Buy any single CD for \$49.
Get any 4 for \$149.
Get 8 for \$249.
Get all 16 for \$399.

Complete track listings and demos are online at
www.radio-mall.com
or call 1-800-759-4561

ATTENTION PROVIDERS!

Promote your services to **Radio World's** readers. Reach Radio Station and Recording Studio owners/managers and engineers with your message.

For information on affordable advertising

call **Simone** at 1-703-998-7600, ext. 154.

SBE NEWS

Benedict Outlines SBE Priorities

by Raymond C. Benedict, CPBE

The author is president of the SBE.

First, I would like to thank all who supported my election as president of the Society of Broadcast Engineers. I also thank those who have called and written since the election with congratulations and offers of help.

I am fortunate that the society, under the leadership of Troy Pennington and the other past presidents, has continued to grow financially, and has a strong growing membership and growing sense of recognition among the broadcast community.

This position of strength makes it possible for me and the newly-elected board

vides broadcast technical professionals with recognition and verification of experience and knowledge.

The SBE Certification Committee is constantly examining the Certification Program to ensure it continues to serve the needs of the broadcast community. Members now are working on new interactive training materials that will replace the current DOS-based system with one compatible with existing computer operating systems. Next year, they are planning a strategic planning session to map out the long-term direction of certification. As president, I intend to work closely with the Certification Committee to ensure it has the support and materials necessary to keep our program the industry leader.



Outgoing SBE President Troy Pennington presents Raymond Benedict with his president's pin at the SBE National Membership Meeting in Madison, Wis., in October. Newly-elected board member Dane Ericksen, left, looks on.

of directors to move forward with plans to grow activities of the society that we consider to be areas of concern to our membership and the broadcast community.

These areas of concern in which I intend to concentrate our efforts are certification, frequency coordination, education and the Emergency Alert System.

5,000 certified

The SBE Program of Certification started in 1977. It is now the most recognized and accepted certification program in the broadcast industry and is recognized by the National Skills Standards Board. More than 5,000 broadcast engineers now hold a certification from the SBE — an exciting number if one looks at the number of broadcast engineers in the United States. SBE certification pro-

SBE's national effort in frequency coordination began in 1975. I still remember that SBE Board Meeting in the 1970s when Richard Rudman, considered by many to be the father of the SBE Frequency Coordination Program, made a presentation to the board regarding national frequency coordination.

Volunteers

The SBE acted on Richard's recommendations and developed a private, volunteer-run service that has helped the industry, licensees and members. There are now more than 175 volunteers involved in the SBE local/regional frequency coordinator network. The program has grown to the point where we have a frequency coordination director as a national staff position.

The BAS bands that SBE volunteers



coordinate help make possible breaking news coverage, sports telecasts and generally help broadcasters meet their public service responsibilities.

Because of this involvement in BAS frequency coordination, SBE has become the advocate for broadcasters' use of the BAS bands. As we know, the FCC recently has made extensive changes in the Part 74 Rules governing BAS operations. There are also several new proposals that could affect BAS. An example is the recent proposal to move high-power federal government earth stations into the 2 GHz band.

SBE will continue to take a proactive approach in dealing with these issues. We will continue to file written comments on FCC proceedings that could potentially affect BAS services. We also will meet with FCC staffers to reinforce the positions we take in our comments. We are working with other industry groups in order to present a united broadcast industry position to the FCC on BAS issues.

With the constant threats to our BAS spectrum, BAS issues will continue to be a high priority area of concern to the national board and myself.

Education also is going to be an area of concentration. At the present time, more than 100 chapters offer monthly educational programs for local members. SBE at the national level offers management training for broadcast engineers with the Leader-Skills program. In cooperation with the Ennes Educational Foundation Trust, SBE offers regular workshops that cover broadcast technology. SBE co-presents the NAB Broadcast Engineering Conference with NAB at the association's spring convention.

AMBER

SBE has been involved with EAS for many years. We provide the only training available for local engineers. We also assist state and local groups in the formulation of state and local EAS alert plans. Our involvement in EAS has been instrumental in shaping FCC EAS rulemakings for more than 10 years. Many of the changes that happened in the transition from EBS to EAS were the results of suggestions made by the SBE.

We are taking a leadership role in adapting EAS to accommodate the new AMBER Alerts. The EAS Committee has been coordinating closely with AMBER Alert organizations to ensure EAS can provide the needed support for AMBER Alerts.

As well as continuing to provide training and operational support for EAS, we also are planning on taking a broader look at EAS to see how it can be improved. It appears that the current EAS is beginning to evolve into a national warning system. I would like

to see SBE take a leadership role to ensure that the transition involves the knowledge and experience broadcast engineers and the broadcast industry have in this area.

Because of its financial condition, growing membership and industry reputation, the Society of Broadcast Engineers is in an excellent position to continue its leadership role in the broadcast industry. I would like to see the SBE Board and national leadership concentrate on certification, frequency coordination, education and EAS. We need to ensure that the society continues its industry leadership in these areas and that the SBE committees concentrating on these areas do the necessary planning and studies to keep up with current trends and changes in the industry. 🌐

MARKET PLACE

Dialight Has Low-Profile LED Flashing Beacon

The L864 series is a low-profile, LED-based flashing red beacon from Dialight Corp., intended for marking obstacles that pose hazards to aircraft navigation.

It measures a bit less than 20 inches high and designed to replace 300-mm incandescent obstruction lighting fixtures.

The beacon uses high-flux LEDs that the company says use 90 percent less energy and last years longer than incandescent lights.

The light can be operated in flashing or steady-state mode and the company says it creates no troublesome EMI/RFI. It is available in 120 and 240 VAC versions.

For information contact the company in New Jersey at (732) 751-5875 or visit www.dialight.com.

Starlink SL9003T1 Digital T1 STL



STL AND TSL Together on a Single, Low-Cost Digital Link!

TOGETHER AT LAST!

Opt for compatibility and convenience with the Moseley Starlink SL9003T1! The Starlink gives you digital transport of 20 kHz IBOC-ready program audio channels, voice channels for phones or data circuits for Ethernet, plus transmitter control, all over a single low-cost digital link.

Because it uses T1 lines (microwave or spread spectrum radio), its added bi-directional payload capacity saves you money on program line costs.

The Starlink T1 system is perfect for interconnecting remote studios and transmitters over any distance. And it's digital, so your clean, crisp on-air sound will stand out from your competition.

Call us today to plan your system. Moseley can help you put it all together.

- STL/TSL/ICR with no terrain or mileage restrictions
- Bidirectional payload saves on program line costs
- Be IBOC-ready now to ensure future compatibility
- Digital STLs sound great!

Moseley

Corporate Headquarters - (805) 968-9621 East Coast Sales Office - (978) 373-6303
WEB: <http://www.moseleysb.com> EMAIL: Sales@moseleysb.com

◆ MARKETPLACE ◆

Products for the Radio Broadcast Professional

Mail info and photos to: RW Marketplace, P.O. Box 1214, Falls Church, VA 22041

Comrex Ships Wireless Module

Comrex Corp. is accepting orders for its Matrix GSM Module, an addition to its Remote Broadcast System line. It lets broadcasters transmit high-quality remote audio over a wireless network, without a phone line or separate wireless phone. Updated firmware provides up to 7 kHz frequency response.

The company said it ran a successful beta test of the module in 25 states and six continents this summer. The module incorporates a GSM wireless phone and firmware into a compact housing, compatible with portable Matrix units. It adds an external antenna and increased power over standard handheld phones, which the company says results in improved reliability and stability. With an optional battery kit, the Matrix can broadcast in the field for up to four hours.



For information contact the company in Massachusetts at (978) 784-1776 or visit www.comrex.com.

DaletPlus Radio Suite Eases Music, News

Dalet is promoting the DaletPlus Radio Suite for customizable news production and music programming functionality. It manages newsroom workflows and metadata for audio wires, script production, editing, run-down management, broadcast and archiving. Field reporters can use the DaletPlus InterWeb option to participate in the news production process. Templates for importing and creating logs make the program suitable for music stations.

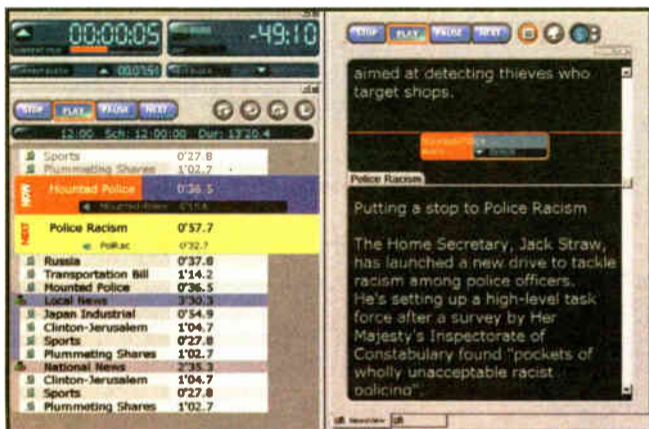

Dalet also supports the Ibiqity HD Radio standard. Broadcasters can adapt their programming to HD Radio, as well as such new media as Internet and Interactive TV, without adding significant resources.

For information, call the company in

New York at (212) 825-3322 or visit www.dalet.com.

Prophet Has PocketGen

PocketGen software is a method of transferring digital files from a remote location to a station, offered by Prophet Systems.

The software with wireless option allows recording to handheld devices and "seamless" transfer to NexGen Digital automation systems. This allows users to send actualities via wireless simply by recording and then hitting "transfer."

Also new: NexGen Digital Version 3 contains enhancements for audio storage and playback. Delivering files via WANcasting is made easier with bulk file feeds and off-peak time delivery. Increased tracking capabilities in the WANcasting module allow the user to distinguish data recordings.

MusicGen, the company's music scheduler, is compatible with most digital automation systems.

For information contact the company in Nebraska at (308) 284-3007 or visit www.prophetsys.com.



Wheatstone Expands Console and Router Lines

Wheatstone Corp. came to the conventions this fall with several new products.

The G-5, a member of the Generation-9 digital audio family, debuted at the NAB Radio Show. The company describes it as a low-profile, through-counter design that provides basic on-air functionality for facilities that don't require EQ or DSP functions. It is compatible with Wheatstone's Bridge Router digital audio network system.



Wheatstone has expanded its Generation-9 family.

Bridge Satellite is an addition to that network audio system. A new design has been implemented for cost-effective remote location expansion.

Audioarts Engineering showcased its D-16 digital on-air radio board, which has a compact footprint and built-in router that assigns any source to any input or monitor. The D-16 controls 16 input channels and two caller phone channels.

The rackable Audioarts ADR-32 is a compact digital audio router with X-Y control and monitor speaker. It is designed to interface with Wheatstone and Audioarts digital console source display strips and can be populated with modular I/O cards for an up to 32 x 32 matrix. An Ethernet and two RS-485 ports facilitate communication with X-Y controllers, consoles and automation systems.

For information contact the company in North Carolina at (252) 638-7000 or visit www.wheatstone.com.

BE Touts AudioVault Updates

Broadcast Electronics this fall has updated its AudioVault digital audio system. Features include file-sharing and ad insertion capabilities, as well as music storage across several stations and studio locations.

BE's FMI-703 transmitter for FM analog and HD Radio also made an appearance at the fall NAB Radio Show. The transmitter can convert FM stations to HD

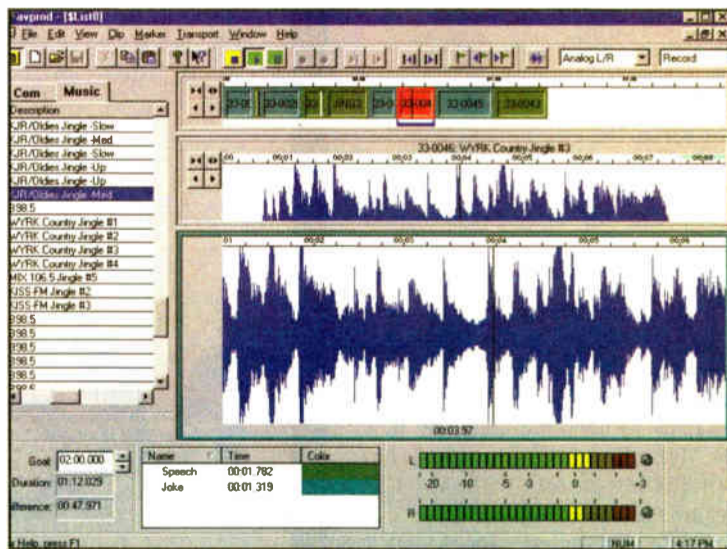

Radio or function as the main transmitter for existing FM analog service until HD Radio is added.

BE also hosted another of its HD Radio seminars in Philadelphia, which took place at the same time broadcasters gathered in the city for NAB. The seminar was conducted by BE's engineering and marketing departments, and covered HD radio implementation, installation, planning criteria and field reports.

For more information, contact the company in Illinois at (217) 224-9600 or visit www.bdcast.com.

What's better than MP3? Broadcasters agree: it's AAC.

Being a technology leader is something we take pretty seriously. When new tech is introduced by a Telos product, you can be confident it's the absolute best – so you shouldn't be surprised to find high-performance MPEG AAC coding in the latest Zephyr products.

Remember the original Zephyr? Its introduction of MP3 coding turned broadcasting upside down, and since then MP3 has become extremely popular for audio distribution, especially on the Internet.

But MP3's compression technology is now over a decade old, and there have been a lot of advances in perceptual audio coding and compression since then. You wouldn't settle for a '386 computer these days – so why be content with compression technology from the same era? What you want is Advanced Audio Coding... MPEG AAC.

MPEG AAC takes advantage of all of the latest advances in compression technology. Compared to MP3, AAC delivers higher quality audio at much lower bit rates, resulting in noticeably better audio even over low-data-rate connections. AAC also cascades better than older codecs – especially important for HD Radio considerations.



Move Over, MP3

AAC was developed by the Fraunhofer Institute for Integrated Circuits (FhG IIS, the inventors of MP3) and a consortium which included Sony, Dolby Labs, Nokia and AT&T. Their goal: to create a codec

that would satisfy the International Telecommunications Union's Recommendation BS.1115, which specified indistinguishable source-to-output quality at 64 kbps per mono channel. They succeeded with AAC, which is a coding algorithm 30% more powerful than MP3.

AAC is, by scientific and subjective analysis, the best-sounding, most efficient pure perceptual codec yet, and has been part of the International MPEG-4 standard (ISO/IEC 14496) since 1999. As a

point of reference, the near-CD quality Layer 2 codec needs a data rate of 192 kbps per channel to deliver high-quality stereo; AAC gives the same quality at just 64 kbps!

"The AAC codec outperforms the rest of the codecs," stated Canada's Communications Research Centre after performing double-blind subjective tests of 17 codecs (including MP3 and Layer 2) to determine which was best.

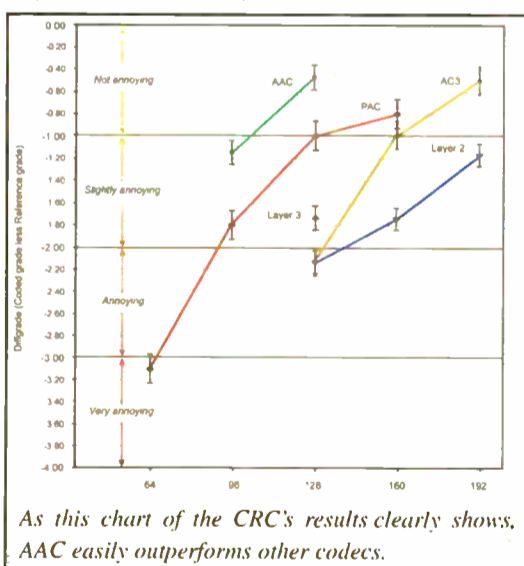

"When compared side-by-side, AAC proves itself worthy of replacing MP3 as the new Internet audio standard," says Apple Computer, which has incorporated AAC into its latest software products.

Better Audio, Less Delay

In addition to "plain" AAC, broadcasters have another tool specifically designed to improve the performance of remote audio transmissions: AAC Low Delay (known as AAC-LD for short).

AAC-LD slashes encoding delay by nearly 70% compared to MP3 – invaluable for real-time two way broadcasts. It also employs new techniques to offer both low delay and high fidelity. Compared to speech coders (such as G.722), AAC-LD handles both speech and music with good quality. Unlike speech coders, however, audio quality scales up with bit rate. With AAC-LD, audio quality is far superior to G.711 or G.722 at the same bit rate, and equal or better to MP3 at the same bit rate.

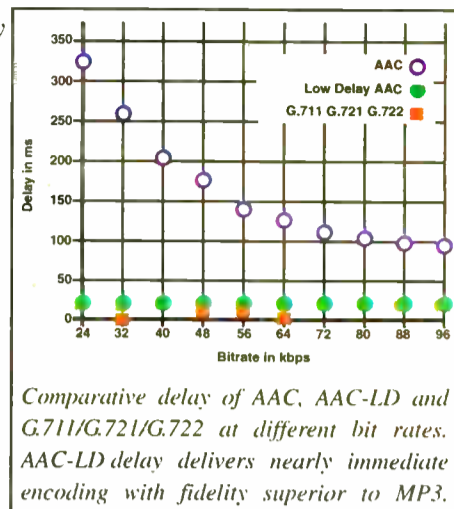

Both AAC and AAC-LD are featured in the Telos Zephyr Xstream rack and portable codecs.

Major personalities such as Rick Dees have come to rely on AAC-LD for better-sounding remotes. Jerry Burnham, KIIS-FM Special Projects Engineer, told us "AAC-LD coding in Zephyr stream is amazing. Low-Delay coding is a tremendous advantage. We get fantastic-sounding remotes, and we can interact with phone callers, traffic reporters and other remote sources without that annoying time lag."

"The Best Low-Bit rate Codec on Earth"

There's one more exciting part of the AAC story: *aacPlus*TM. This extension of AAC melds Spectral Band Replication with MPEG AAC, resulting in truly stunning audio fidelity at bit rates never thought possible before. In tests conducted by the European Broadcasting Union (EBU) which compared a variety of codecs at several bit rates, they declared *aacPlus* as the clear winner, significantly outperforming proprietary competitors and improving over other standards; studies conducted by DRM and MPEG confirmed that *aacPlus* is ideally suited for the low bit rates of AM & FM IBOC. *aacPlus* has been chosen for use by XM Satellite Radio and Digital Radio Mondiale, and will soon be in 2.4G and 3G audio applications deployed by Matsushita and NEC.



Zephyr Xport is the only POTS codec with *aacPlus*. It can send 15 kHz mono audio over analog lines.

Industry experts agree. "AAC Plus is the future... all else is stone knives and bearskins," according to Gary Blau of Jefferson-Pilot Communications. Jeff Johnson of X-Star Radio Network agrees: "It is quite amazing how decent a 32 kbps bitstream can sound."

Telos has chosen *aacPlus* as the algorithm used in the new Zephyr Xport POTS + ISDN codec. Paired with custom modem technology developed by Telos, *aacPlus* enables Xport to send 15 kHz mono audio over ordinary POTS phone lines.

Of course we hope you will purchase Telos equipment. But even if you decide differently, make certain that whatever codec you do purchase – POTS, ISDN, serial or otherwise – takes full advantage of today's advanced audio coding technology. Make certain it has AAC.



telos-systems.com

◆ MARKETPLACE ◆

Products for the Radio Broadcast Professional

Mail info and photos to: RW Marketplace, P.O. Box 1214, Falls Church, VA 22041

ATI Grows Digital DA Line

ATI debuted six Digital Audio Distribution amplifiers this fall. The company expanded its DXA offering to include four models that fit in a 1 RU space, in 1-x-4, 1-x-6, 2-x-6 and 2-x-12 versions, with retail pricing starting at \$499.

Its DDA206-XLR and DDA212-XLR were redesigned, but retain the features of the units they replace.

ATI also recently delivered its RM103 rack-mount option for its System 10K to



ATI Digital Audio DAs

Philadelphia's NBC TV affiliate for service in the Lincoln Financial Field, home of the Philadelphia Eagles.

The RM103 expands upon the System 10K by enabling the use of three more modules in a 1RU space. The user can plug in 10 single- or dual-line or microphone amplifier modules and/or distribution amplifiers and two dual redundant power supplies.

For more information, contact ATI in Pennsylvania at (215) 443-0394 or visit www.atiaudio.com.

OMT Expands Features Of iMediaTouch

New voice-tracking features are among the selling points for iMediaTouch 2.0, OMT's flagship product (shown). The automation system also offers WAN-enhanced capabilities.

iMediaLogger 2.0 is a digital logger that can record up to 1, 2, 4, 8 or 12 audio sources simultaneously in four formats for four purposes per source to multiple hard drives (Logging, Skimming, Best of, Internet).

Users can access files from iMediaLogger's built-in Web browser via the Web.

For information contact the company



in Winnipeg, Canada, at (204) 786-3994 or visit www.omttechnologies.com.

Navigator 100 Is for Field Measurements

Audemat-Aztec offers the Navigator 100 field strength meter and signal monitor, which facilitates a broadcaster's signal measurement survey in the field by combining an RF/stereo/RDS/DARC measurement system with control computer and GPS receiver.

The Navigator measures the signal, stamps the data with the location and commits it to a computer PCMCIA Flash Card. Upon the operator's return, the survey can be loaded into a spreadsheet or database program.

For more information contact the company in Miami at (305) 692-7555 or visit www.audemat-aztec.com.



ERI Completes Working Prototype IBOC Antenna

Electronics Research Inc. said it has developed a working prototype of a dual-input, side-mounted FM antenna for FM IBOC applications.

The antenna can transmit the analog and the digital FM signals without a high-loss combiner or a circulator to attain the required isolation between the digital and analog transmitters, the company said, adding that the prototype's design meets FCC requirement

source code for the operating system, Scott can fine-tune Linux and SS32 to virtually ensure no crashes, blue-screens or lockups," the company said. "Linux works with the same hardware as Windows but with less obsolescence. Linux drives never need defragmenting. Linux does not waste resources on irrelevant functions."

Scott said SS32 for Linux connects well to Windows traffic and music scheduling software. Stations running it can switch to SS32 for Windows free if they aren't satisfied.

For information contact the company in Texas at (972) 620-2211 or visit www.scottstudios.com.

Route-XY Expands Audio Engine Capabilities

Logitek Electronic Systems has introduced the Route-XY, a 1 RU input/output selector for the Logitek Audio Engine digital audio router.



Users plug cards into the Audio Engine for the desired number of analog and digital inputs/outputs, networking with other Audio Engines and DSP audio processing capabilities. Analog inputs to the Audio Engine are converted to digital at a sample rate specified by the user; digital inputs are converted to the desired sample rate. Routing and mixing are done in the digital domain.

The Route-XY permits a user to select any input on the Audio Engine to any output quickly. Source and destination locations are indicated on the LCD panel, along with the unit's mode of operation. Twelve Route-XY units may be connected in series and connected to a port on the Audio Engine.

For information call the company in Texas at (800) 231-5870 or visit www.logitekaudio.com.

for informal notification of IBOC implementation requiring that all the elements in an FM antenna array be excited by both the digital and analog FM signals.

Benefits of the antenna include the savings of using a single antenna while eliminating the combining loss, and the ability to achieve 1.05:1 VSWR for both analog and digital inputs. Because the same elements are used for analog and digital signals, both formats have the same horizontal and vertical patterns and the same gain.

For information contact the company in Indiana at (812) 925-4030 or visit www.eriinc.com.

Scott Has Digital Audio System for Linux

Scott Studios' SS32 audio system is now available for the Linux operating system. President Dave Scott reported strong enthusiasm among booth visitors at the NAB Radio Show this fall.

The company cites improved security, support and safety as reasons for using Linux.

"Because Linux openly includes the

ENCO Updates DADpro32 System

The latest version of ENCO Systems' DADpro32 has new features including support of the ClipShot LCD button interface box, the Phonetica text to speech searching system and enhanced user interfaces.

Also highlighted this fall was continued support for Ibiquty's HD Radio PAD stan-



dard for data broadcasting. The company also has new versions of Qed, the PC-based phone editor from ENCO Systems, and NewsBoss, a newsroom management system that integrates with DADpro32.

For more information contact the company in Michigan at (248) 827-4440 or visit www.enco.com.

The 61st Annual

NATIONAL RELIGIOUS BROADCASTERS

Convention & Exposition

February 13–18, 2004

Charlotte, NC



NRB

Faith and family programming is gaining audience share, and NRB's Annual Convention & Exposition is the best place to meet the foremost producers of quality, faith-based, family friendly programming.



With a new peer-to-peer Innovation Exchange, intensive Boot Camps, crucial Super Sessions on Public Policy and Leadership, and more than 40 Educational Sessions, NRB provides serious communications training.

But the Convention is only half of the attraction. NRB's award-winning Exposition – named one of the **50 Fastest Growing Expositions by *Tradeshow Week Magazine*** – is a vibrant marketplace of nearly 300 vendors. Browse 140,000 square feet of exhibit space to find the vital tools and services to grow your audience.



Don't miss this opportunity to meet the people who can give your audience what it wants: quality, faith-based, family friendly programming.

Register today and grow your audience with NRB 2004!

www.nrb.org • 703-330-7000

Studio Sessions

Radio World

Resource for Radio On-Air, Production and Recording

December 3, 2003

Miami Cluster Gets Studio Upgrade

by Ken R.

In real estate, the rule is "location, location, location." In studio rebuilds, it is "planning, planning, planning."

Gary Blau, director of engineering

Blau got an assist in the rebuilds from Mager Kizziah, president of Mager Systems Inc. of Phoenix, which designs and builds the customized furniture for each production and air studio.

design process begins.

"We want to know if a talk studio will need room for a sidekick, how many additional mic positions will be required and where the keyboards and computers will need to be accessed,"

to keep it cool," said Kizziah. "Then there is also an air release going back out of the room. All of this is designed to match the furniture."

Blau said the rooms are built to last for at least 10 years.

"It's not a matter of just coming up with a box for all our stuff," he said. "The quality of the cabinetry and the



WLYF has a light-rock format.



WAXY Air Studio D, top, and Production Studio

for the Miami cluster of Jefferson-Pilot Communications, knows the drill. Two production rooms and two air studios in his three-station cluster recently were upgraded, with more to come.

"We're in a long process of upgrading all our studios, which were built in the early 1980s," he said. "There are nine studios in the building, and we're converting to all-digital rooms as we go."

Mager help

The stations in the Miami cluster are WAXY(AM), WMXJ(FM) and WLYF(FM). Their formats are talk, oldies and light rock, respectively.

"We have incorporated a number of interesting ideas into these rooms, including pull-out computer shelves which rotate 180 degrees for easy access to wiring," said Kizziah.

"We also built touch switches right into the counter tops. The switches actually shine through the solid surface and can only be triggered by human touch. If you spill something on them, it's no problem because the liquid can't get into the switch. They are rated for 32 years of life."

Blau takes into account the wishes of the people who will be using the rooms. He provides those ideas and the equipment list to Kizziah and the

he said. "We'll usually create two or three designs and Gary can pick the one he likes best. In all cases we strive to eliminate clutter and boxes from the countertops."

HVAC elements are built into each design because of the need to keep the personnel and equipment running efficiently.

"There is a conduit to the equipment

styling are very important to us, and Mager is simply the best in the business."

Blau said his senior engineer and project coordinator John Morris is meticulous in his initial designs, using computer-aided design to double check dimensions before any building starts.

As the rebuilds continue, the rooms

See JEFF-PILOT, page 35 ▶

Soundcraft Celebrates 30 Years of Console Production

Soundcraft crossed the 30-year mark for console production in September, while sister company BSS Audio achieved its silver anniversary of 25 years in signal processing.

Soundcraft and BSS Audio are part of the Soundcraft Group, based in Hertfordshire in the United Kingdom. They are distributed by Harman Pro North America in the United States.

Phil Dudderidge and Graham Blyth formed Soundcraft in 1973. Their first console release was the Series 1. Since then the company has targeted the professional audio market with products from entry-level mixers, with the Spirit family, through large-format recording and live desks, broadcast on-air and production desks like the digital RM1d.

Blyth remains active participant in the company's design process, and was involved with the creation of the MH3 and MH4 touring consoles.

For more information, contact Harman Pro North America in California at (818) 920-3212 or visit www.bss.co.uk for BSS Audio products or www.soundcraft.com for Soundcraft products. ●



Soundcraft founders Phil Dudderidge, left, and Graham Blyth celebrate their Queen's Award for Export Achievement, circa 1985.

are similar but not identical.

"We're only replacing major items," said Blau. "So we're not driving a bulldozer through everything and starting over. We're keeping what works for us."

One of the people working daily in these revitalized rooms is Gary Aybar, director of operations at WAXY.

"All the things I asked for in our production room were incorporated," he said. "These include CD-Rs, additional CD players, our MediaTouch system and even a backup for the MediaTouch. It's an interesting mix of older and new equipment. So far there have been no glitches."

OMT Technologies of Canada is the maker of MediaTouch, now iMediaTouch 2.0, a suite of station software and hardware that performs multiple functions.

With each new room, the consoles are standardized. The common denominator is the new BMXdigital Modular Digital Audio Console by Harris Pacific.



A pull-out computer shelf can rotate 180 degrees for access to wiring.

"Our original consoles were all Ward-Beck analogs, and three still remain in rooms we intend to rebuild in the next year or so," said Blau. "The mics are a mixed bag including ElectroVoice RE20s, Rode condensers and Neumann U-87s. We use Short/cuts and Instant Replays from 360 Systems, three Pro-Tools digital editors, and an Orban Audicy, too."

Even though the rooms were originally built 20 years ago, the physical layout was thought out well. The air and production studios are in the interior of the building, with no outside views; so no additional isolation or acoustics were needed.

"They don't build them like that anymore," said Blau. "It's too expensive!"

Smooth sailing, Captain

So far this long-term renovation project has gone well.

"Little things come up in the designing stages, but if you ask the right questions of the customer, you avoid those big surprises," said Kizziah. "There's no secret other than a lot of planning and hard work. Gary Blau and I have a long working relationship. He knows what he wants, so what we come up with together is magical."

"I can't stress the planning enough," he said. "The secret is all in the preparation." 🌐

So Bad, It's Good: 'Dead Radio'

Each year, agency Oink Ink Radio honors a script that for one reason or another has been rejected by its clients. The 2003 winner is "Babysitter," written by copywriter Adam Greenwood of Albuquerque-based Rick Johnson & Company. Greenwood was awarded a trip for two to the Oink Ink New York studio, where he supervised production of the spot.

Written for Rainbow Foods of Minnesota, the racy 30-second spot begins:

"What is wrong with you?! It was Danny's [bleep] fault! Why don't you ever tell him to go to his [bleep] room?! You're not even my [bleep] mom! You're just the [bleep] babysitter!"

An announcer intones: "Bars of soap. Now two for one at all Rainbow Foods."

The piece was produced onto CD, copies of which were sent to all copywriters who submitted entries; more than 1,000 were received.

"We love to recognize those frustrated copywriters who have to wrestle with the occupational hazard of rejection," said Dan Price, president of Oink Ink. In some cases, Price said, the clients have been known to reconsider their rejections and air the resuscitated spots.

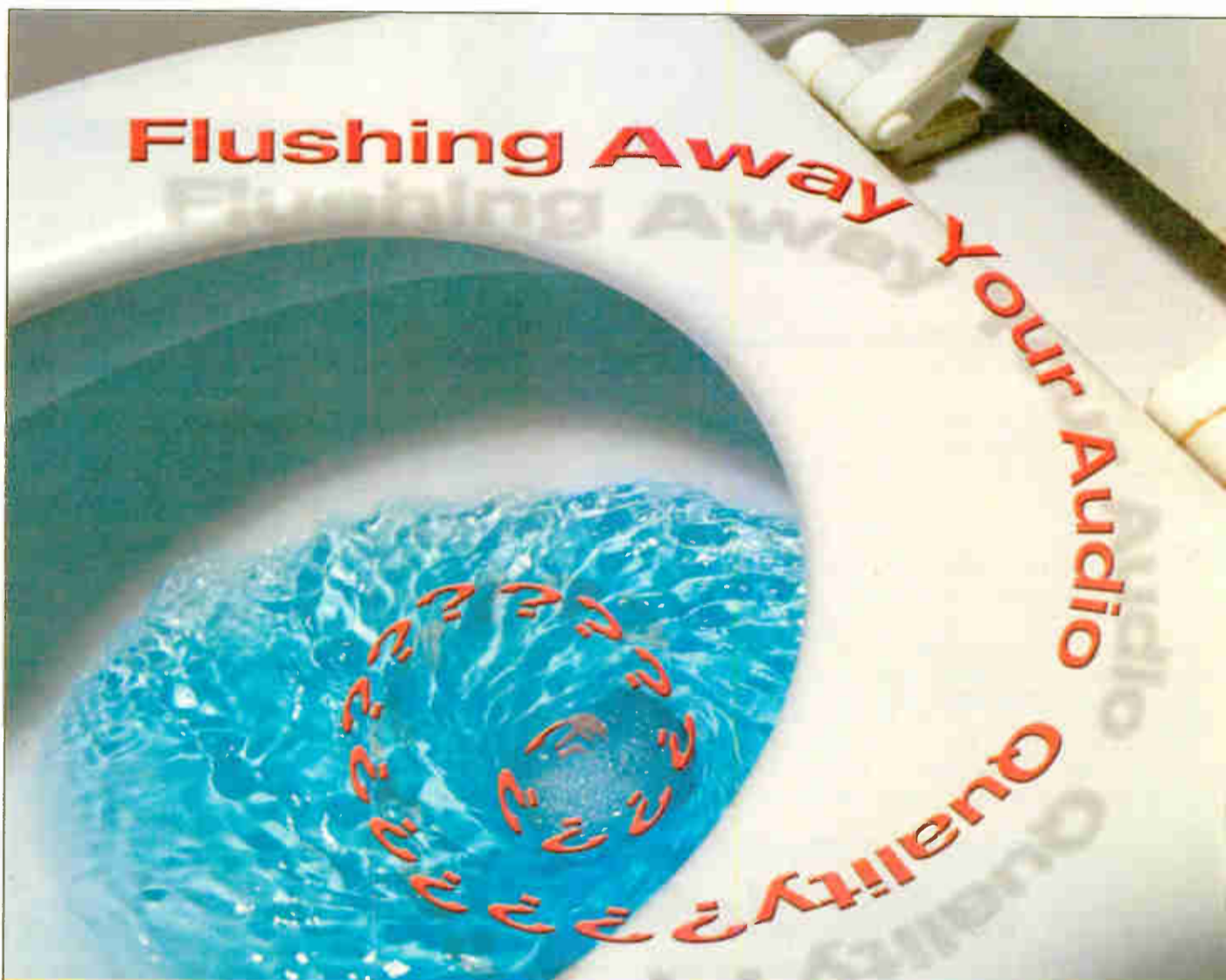

Swishing and swirling audio is the sad result of bit rate reduction combined with the wrong processing. Unless all sources, storage media and transmission systems are linear the audio will be bit rate reduced at least once, probably several times. Each pass generates more artifacts. Lower quality processing, multiband compression, limiting and clipping can make those artifacts even more apparent. But level control is still essential.

Introducing the new Compellor® 320D - the world standard AGC is now available with both digital and analog i/o. For almost two decades the Compellor has sustained its unrivaled reputation for 'invisible' operation. The same cleanliness of circuitry and intelligence of processing algorithms that make it 'invisible' also make it perfect for processing in the digital domain. The Compellor will not 'unmask' the masking from upstream reductions and it will feed a signal that will sail through downstream reductions.

The 320D fits any plant from all digital to all analog and anywhere in between. Perfect for all HD applications, the Compellor 320D will help keep your great audio great at a price that won't wipe you out.



The NEW Aphex Model 320D Compellor - 2 Channel Compressor/Leveler with Digital and Analog I/O

APHEX SYSTEMS *Improving the way the world soundssm*
 11068 Randall Street, Sun Valley, CA 91352 U.S.A.
 818-767-2929 Fax: 818-767-2641 www.aphex.com

Compellor and Aphex are registered trademarks of Aphex Systems

PRODUCT EVALUATION

Diamond Cut Takes a Quantum Leap

by Read G. Burgan

In 1995 I was asked to review a new digital restoration software, Dcart, for Diamond Cut Audio Restoration Tools, from Tracer Technologies. After testing the software for several weeks, I felt the software was not ready for professional

in the more expensive DC Live. This allows the user to string together any of the filters and then preview the incoming signal to the sound card in real time.

A radio station could run its turntables through a computer sound card and play LPs right over the air digitally restored in real time. Rather than taking the time to

Fast Edit. In previous editions, DC software displayed dual files on the screen that required a new file to be created each time a process was applied. This is now called the Classic mode. I always felt it slowed down the work process.

While the Classic editing mode is still available, I suspect that most users will opt for the new Fast Edit mode, which applies a new process directly to a sound file. A complete undo list is provided so that you can readily revert to (or compare) an earlier version.

Surprisingly, it is also possible to go back into the edit history and redo just a portion of the file without changing the subsequent processing that has already been done to the rest of the file. This is a real time-saver.

A new EZ Impulse Noise Filter has

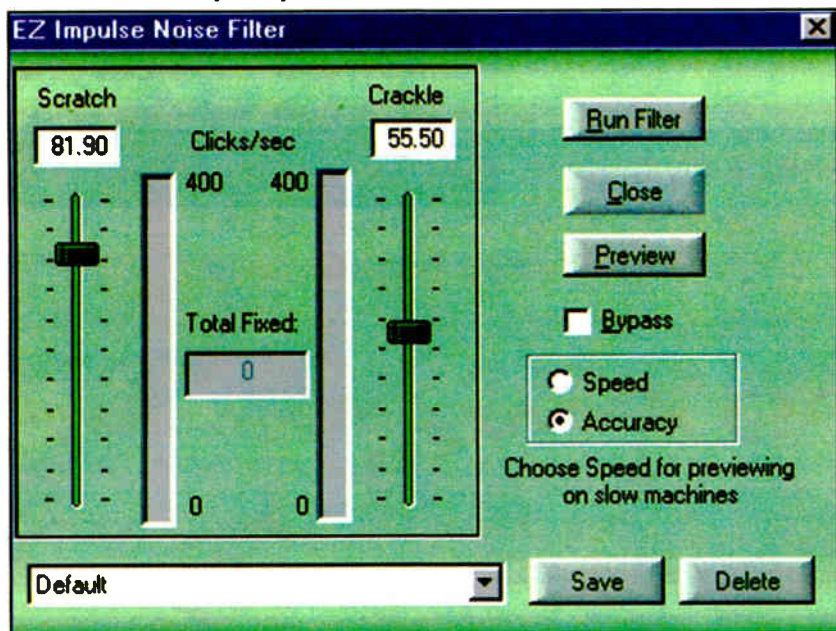

applications.

Since then the DC restoration software has made several quantum leaps. The latest versions are DC Five and DC Live 5.0.

Ready to roll

The main differences between the two products are the price — \$199 for DC Five, \$1,399 for DC Live — and the addition of several forensic tools in DC Live designed for specialized applications such as law enforcement and scientific research.

What is new in these latest versions? For starters, DC Five includes the Live Preview feature previously available only

transfer a vintage record library of thousands of albums to CD and digitally restoring them one at a time, they could just play the original LPs live through the computer using the DC Five software. The pops and clicks and surface noise will be removed as the albums are playing.

How well does this feature work? Very well. Depending on the computer processing power, there may be a slight latency (delay between the original sound and the restored sound). In addition, because of the complexity of the algorithms, the user may not be able to apply the impulse filters as aggressively as when digitally restoring a WAV file.

The feature that I welcome most is

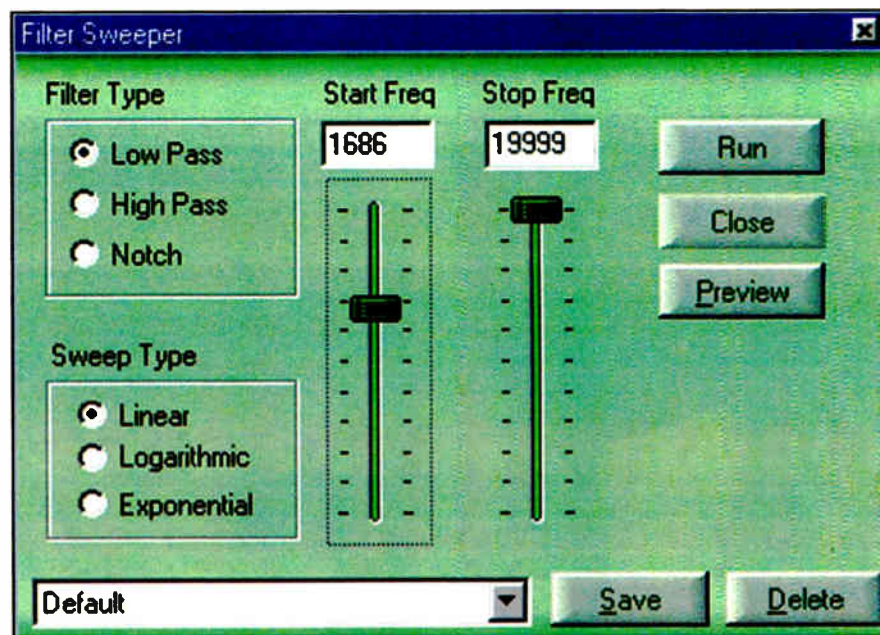

been added. The DC software already had one of the most comprehensive impulse noise filter sets that I have used with special algorithms for 78 rpm, vinyl and even a High Quality mode. These impulse filters are still available under the Expert Impulse Filter.

The EZ Impulse filter has only two sliders: Scratch (for larger pops and clicks) and Crackle (for smaller clicks and crackle). Unlike the Expert Impulse Filter, the EZ Impulse Filter can be set quickly, with a minimum of trial and error. The former is optimized for 44.1 kHz files while the latter is optimized for 96 kHz files.

New as well are Vox and Timer Recording options. One can set the record mode to start and stop automatically based on the level of the input signal to the computer sound card. The software will start recording when it sees a certain level and stop when the sound falls below the prescribed level. Or one can set a timer to start and stop the recording. Either way, one can record audio on an unattended computer. A radio station could use this feature to record feeds coming off a satellite, for instance.

And finally someone has added a feature that I have long been waiting for: A Filter Sweeper. What, you may well ask, is that? And why is it helpful?

The Filter Sweeper allows you to apply either a Low-Pass, High-Pass or Notch filter to a sound file (or portion of a sound file) with differing degrees of frequency attenuation from start to finish.

Here is example of where it might be

used: 16-inch electrical transcriptions (78s, and other records, too) often reduced the high-frequency response of the cutting head as it approached the center of the transcription. This caused a discernible and disconcerting difference in sound quality between the beginning and end of the ET.

With the filter sweeper, you can match the end to the beginning by using a Low-Pass Filter setting that attenuates the sound at the beginning of the file to the same degree that the original recording equalization attenuated it at the end of the recording.

As the Filter Sweeper is applied to the sound file, the attenuation gradually is reduced until eventually there is no attenuation. The result is a recording the sound quality of which is uniform from beginning to end. Until now there was no good way to correct such problems. There are other uses for this unique filter, as well.

Everything I have mentioned is available in both DC Five and DC Live 5.0. But there is at least one filter in DC Live that should be of interest to anyone specializing in restoring very old and noisy recordings.

The Adaptive Normalize Filter has the ability to literally pull sounds out of noise that is as high or higher than the sound you are trying to hear. I tried it on a 1930 direct aluminum ET and was absolutely amazed at how well it was able to reject the noise while preserving the sound. No other filter that I have used

See TRACER, page 37 ▶

Product Capsule:
Tracer Technology DC Five and DC Live 5.0 Digital Audio Restoration Software

Thumbs Up

- ✓ Great manual
- ✓ Lots of Presets
- ✓ Choice of screen editing modes
- ✓ New Impulse Filter
- ✓ Vox/timer recording
- ✓ Lots of digital tools

Thumbs Down

- ✓ DirectX support iffy for some third-party programs

Price: DC Five: \$199; DC Live: \$1,399

Contact Tracer Technologies in York, Pa., at (717) 764 9240 or visit www.tracertek.com.

Radio World
The Newspaper for Radio Managers and Engineers

Our readers have something to say

"I've been a RW reader for years. It's full of great information not only on new products and services, but I especially love the technical articles and tips on station maintenance. RW is the kind of on the job training that I look forward to each time!"

Tom Conroy
Contract Engineer
Owner, CE
Studio 800 Productions
Baltimore, Md.

PRODUCT EVALUATION

Epson Makes Impression for CD-R Printing

by Carl Lindemann

Optical storage has evolved quickly since the first consumer CD recorders appeared around 1997, costing under \$500. With them, distributing CD-Rs instead of cassettes became the standard in radio for sales and talent demos.

Printing on these, however, has been limited — typically stick-on labels that work in standard printers. While better than using a felt pen, these don't match the look of commercially manufactured discs. Printers dedicated to writing directly on discs have been available but are designed with robotic replication units in mind. They deliver terrific results, but are pricey.

Special adapter

Epson has added a special adapter tray for CD/DVDs to some of its consumer inkjet printers to break that price barrier for on-disc printing. The company's 900 and 960 printers are the first mass-market units that will print directly on CDs. These machines fill an important niche in the market for radio sales people and talent looking to make a profes-

sional impression. is obvious under Windows XP Professional. The only thing out of the ordinary here is plugging in all seven ink cartridges (six color shades plus black for color accuracy) and attaching the CD tray.

for discs to save the effort of recalibrating.

Using the application to select images and superimpose text is easy. The print quality at highest resolution is photo-realistic.



Altogether, it is a well-engineered, by-the-numbers setup process. The only trick — and it seems inherent to all such devices — is centering the discs properly so that the ink lands

The only downside to inkjet printing is smearing. The ink takes time to dry, and even when it has fully cured, rubbing the surface will smudge it. Better to send these discs in a plastic jewel case rather than in an envelope to keep the quality pristine.

Another downside for now is that printable discs are not that common. You have to special-order them, and they are not as cheap as regular discs. But the proper price comparison is with the cost of blank media *plus* labels. With that, the premium for printable CDs is negligible. The payback is a more polished, professional look.

At around one-third the price of the specialized CD printers, the Epson 960 is a real bargain, a good investment for radio professionals looking to improve their image.

Carl Lindemann is a free-lance writer specializing in broadcast technology.

For radio salespeople and talent, these machines fill an important niche.

sional impression.

The model 900 is a midline (less than \$200) consumer unit while the 960 is a top-notch printer. Testing the 960 demonstrated both the possibilities and limits for inkjet printing on discs.

The 960 has both a USB and parallel port interface. Either way, installation

where you want it. A special application for designing and printing on discs adjusts the print position. This takes a bit of trial and error. So switching between printing on paper and discs is not instantaneous. Despite the multi-function capabilities, some will just want to keep this as a dedicated device

Product Capsule:
Epson Stylus Photo 900 and 960 CD DVD Printers

Thumbs Up

- ✓ Inexpensive on-disc CD printing
- ✓ Excellent color accuracy
- ✓ Commercial-grade appearance

Thumbs Down

- ✓ Ink prone to smearing
- ✓ Multifunction use requires recalibration

Price: 900: \$199; 960: \$249

Contact Epson in California at (800) 873-7766 or go to www.epson.com.

Tracer

► Continued from page 36 has even come close to producing such results.

I've listed just few of my favorite new features in this amazing software. The bottom line is this: most digital editing software contains some restoration tools; DC Five and DC Live 5.0 are designed for digital restoration and contain just about any conceivable tool that you could ask for or think of to do the job.

Not only is the price of DC Five modest, but so also are the minimum computer requirements: 200 MHz Pentium, Windows 98 SE, 2000, ME or XP, standard RAM and hard disk, as well as a good sound card.

Read Burgan is a free-lance writer and a former public radio station manager specializing in digital audio restoration. Reach him at (906) 296-0652 or e-mail to rgb@chartermi.net.

SH SHOWCASE SE

Products & Services

Looking for a MANUFACTURER, a DISTRIBUTOR, a CONSULTANT?



Look no further...

The 2003 Radio World

Directory Source Book is available for purchase!

To order copies contact: Simone Fewell at sfewell@imaspub.com or fax your request to: 703-671-7409

ONLY \$14.95
(INCLUDES SHIPPING/HANDLING)

There will be no billing, all orders must be pre-paid. We accept VISA, Master Card, and American Express.

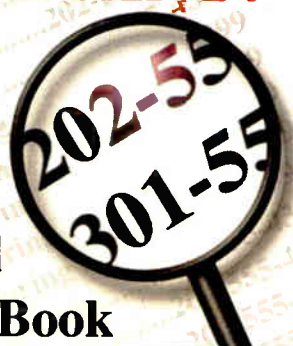

The Simple Cell Phone Interface Solution
FJ-500 FlipJack
CELL PHONE INTERFACE



Connect To Standard Telephone In Event Of Poor Cell Phone Connection



CONEX
ELECTRO-SYSTEMS

Call For More Info
800-645-1061
www.conex-electro.com

Products & Services SHOWCASE

Superior Broadcast Products

FM TRANSLATORS

Frequency Agile Transmit & Receive
In a Wide Range of Power Choices
CALL FOR SPECIAL PRICING

SOLID STATE TELEVISION TRANSMITTERS

From 5 watts to 120 Kw
Starting at \$4990

ANTENNAS

UHF-VHF Panel Antennas
UHF Slot Antennas
Low Power Medium Power High Power
Custom Antenna Patterns

TELEVISION STL's & MICROWAVE CALL FOR PRICING!!

FM TRANSMITTERS & EXCITERS from 20 watts to 30,000 watts

30 watt exciters starting at \$995
250 watt Solid State Transmitter \$2750
1000 watt Solid State Transmitter \$6500
3500 watt FM Transmitter \$14,990

*** Special Pricing ***

10,000w FM Transmitter \$18,990
20,000w FM Transmitter \$35,990

FM ANTENNAS

Low Power Starting at \$495
Custom Designed Patterns
All Power Ranges
Full Wave Length or Half Wave Length

FM AMPLIFIERS

100 watt \$1195
250 watt \$1750

STLs

Complete Transmitters & Receiver
*** Special Pricing ***

\$3500

Superior Broadcast Products

WHERE WE BELIEVE IT IS AS IMPORTANT
WHO YOU BUY FROM AS WHAT YOU BUY!

CONTACTS

Jimmie Joynt Voice (800) 279-3326

Benny Springer

Voice (800) 695-7919
Fax (903) 297-4651
email bennySBP@aol.com
web: www.superiorbroadcast.com

17194 Preston Rd Suite 123-297 Dallas, Tx 75248

Match-Maker™

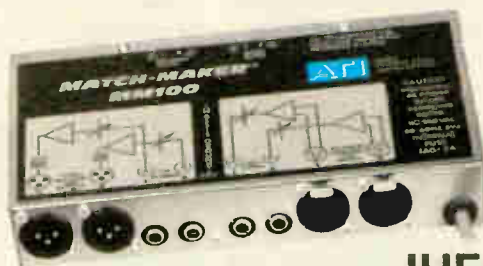

Disc-Patcher™



IHF ↔ PRO

Level and Impedance Converters

BI-DIRECTIONAL FOR

- Digital Workstations
- Equalizers, Recorders and Sound Card
- Audio Effects Processors and Digital Reverb
- Dual Line Amp, DA, Splitter or Combiner

Interface consumer/industrial IHF (-10db) stereo source equipment and signal processing devices into professional studio +4dBm, 600 ohm systems without loading distortion, crosstalk, hum, response roll-off or RF pick-up.

True transformer output isolation, balance and protection with dynamic range better than 18 bit digital! Rugged gold connectors. Adjustable 6dB reserve gain - all channels. • Excellent RF immunity. Distortion 80dB below +22 dBm peaks (20 - 20KHz), under noise at +4dBm. Rack mount kits • Internal 115/230VAC Power • UL and CE markings.

UNI-DIRECTIONAL FOR

- Disc Players and/or DAW
- ENG Cassette Dubbing
- Off-Air Monitor Tuners
- Console Audition Outputs

AUDIO TECHNOLOGIES INCORPORATED

Free Brochure Available Upon Request
<http://www.atiguys.com>

328 W. Maple Avenue, Horsham, PA 19044
800-958-8807 • (215) 441-0330 • Fax: (215) 443-0384

Embedded Control Over Audio

Easily control
network local
inserts
or Internet
streaming!

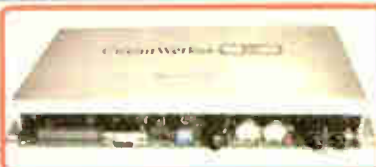

The **SEN-6** is a single channel Subaudible tone encoder with integral audio filtering that can produce 25Hz, 35Hz and combination tones from external closures.

Cool Problem Solver!

- Encodes 25, 35 & 25/35 combination tones (can also generate 50 & 75Hz or 19 & 27Hz).
- Tunable notch filters remove subaudible content from program material prior to tone insertion.
- Jumper-set precise tone duration.
- Model SEN-6 List Price only \$399.00

* 50 & 75 Hz tones may require external input filtering to avoid false tripping.

(352) 335-6555 <http://www.circuitwerkes.com>

CIRCUITWERKES, INC. - SERVING BROADCASTING SINCE 1990

VoxPro PC

\$499

Fast, Simple, Voice-phone
Editing, Network Included

Instantly share files room to room,
user to user and more!



MP3

Import-Edit

WAV WMA AIF TOO

206.842.5202 x204
www.audionlabs.com

Broadcasting to the World

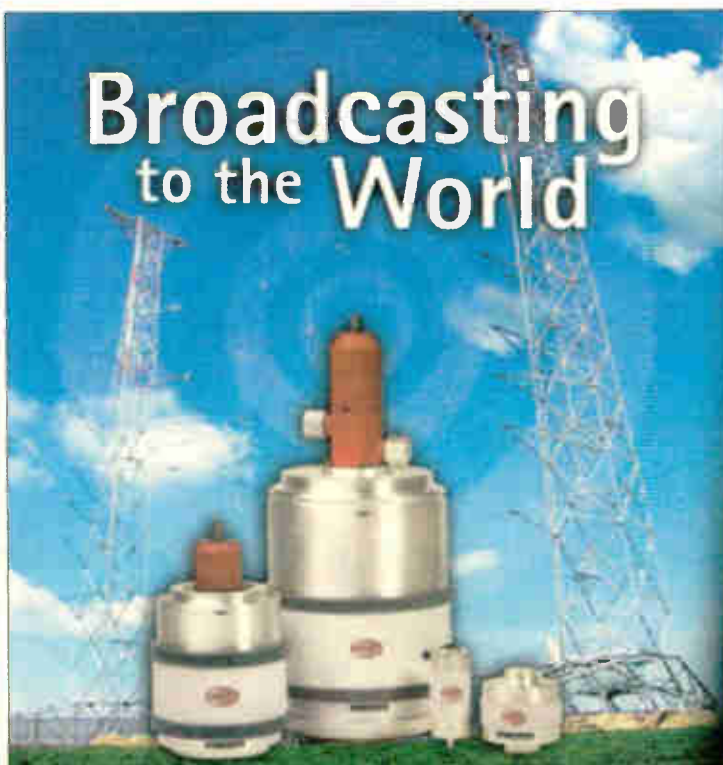

COMET NORTH AMERICA

421 Woods Corner Road
Cincinnati, Ohio 45148
Ph: (513) 831-5000
Fc: (513) 831-7888
www.cometna.com

- 2100 Amps 480VAC 3-Phase 4-Wire
- 1000Watts 240VAC 1-Phase
- 4000Watts 240VAC 1-Phase

- Standard equipment for all types AM & FM transmitters

- Professional HV test equipment for regularly test systems

- Trained in North America with Kirtinac Labs to provide engineering expertise to manufacturers



Kirtinac Labs, Inc.
144 Pk 2244, Dallas Road
Suite 200, TX 75218
Ph: (409) 815-2147
Fax: (409) 815-4024
www.kirtinac.com



Classic Console Comes to Roost

by Alan R. Peterson

I don't mean to dwell on some nostalgia trip.

I mean, two months back I regaled you with that McMurphy/McMartin tale. Many months before that, I related the experience of hacking out an old Executive console to make way for a new mixing board at a Washington-area broadcast school.



Al at WSGO(AM-FM) in 1980. Note the '80s hair, the 77-DX microphone, the Gatesway 80 and Al's inability to keep the meter out of the red.

Before that was when I began to get those gooey, drippy nostalgic feelings for my early days behind the mic and expressed an interest in scaring up an old Gatesway 80 console for my own personal use.

I did not think it would be hard to do so. Stations everywhere were finally beginning to tear out their oldest components to make way for gear better equipped to function in the new digital age.

relay closure to flip an eight-pole toggle switch, you know it is time to upgrade.

There is no assurance that a console made today will still be in service 30 years from now, yet that is what some consoles being removed have experienced. Many hit the air brand-new just before the peak of disco and rode the wave until the digital experience forced the issue of retirement.

I would take a modern mixer over one

given the chance to walk out the door with all the station gear our AMC Pacers could hold, we would, in a second ... with or without the boss's permission.

Take a look at that smiling youth with the thick black hair, not knowing just what a cruel, heartless future awaited him behind the microphone.

That's yours truly doing a "Swap Shop" show on WSGO(AM-FM), Oswego, N.Y., in 1980. Back when local radio stations still aired pet patrols and school lunch menus.

That was the first pro job you've heard me refer to countless times over our 15-year relationship through these pages. That was also my first Gatesway 80. Even after 23 years I can still tell you what each knob did on that eight-pot special. I can still reach out with my eyes shut and hit where each rotary fader was, even today.



Fast-forward 23 years to the present. The hair is a lot greyer but the retired WKXL Gatesway 80 has just arrived, covered with Styrofoam packing crumbs, at the RW offices in November.

of those dinosaurs any day. So why the big Jones for a Gatesway 80?

That's not such a toughie.

The feel-good factor

I suppose it's the same reason that someone goes driving through the hills of Connecticut or Kentucky, hoping to find in some antique barn along the way the same huge console radio they listened to as a kid.

For the same reason lurkers on eBay

When you cannot get a satellite relay closure to flip an eight-pole toggle switch, you know it is time to upgrade.

Even the tiniest of small-market operations have found it necessary to cut the cord to their old Sparta Centurions and install consoles that communicate with digital automation systems.

Crystal-clear

The new gear simply sounds better. Even a \$400 Mackie mixer outclasses the specs on everything made for broadcast prior to 1983.

Noise and THD levels are the lowest ever, frequency response is wide enough to get your dog's attention, digital conversion is done inside a broadcast console on a single chip and you probably don't have to re-cap the entire rig after five years.

Also, the current crop of consoles can GPI to just about everything (never thought you'd see GPI used as a verb, didja?). When you cannot get a satellite

hope to score that G.I. Joe lunchbox they toiled around with back in third grade, or why grown men hit every pawnshop between here and Anchorage, hoping to find the same model guitar they had in their first garage band.

For some of us, it was the feel of that first studio, the one where we made our mark on the ionosphere. The one where the studio equipment did exactly what we wanted it to. We knew Turntable One needed a three-quarter turn to start properly, while Turntable 2 started right away. We knew Cart Deck 1 had a loud slamming noise, so we always used Deck 2 when the mic was open.

The power leapt from our fingertips into that old studio junk and into the waiting ears of millions who hung on our every word, or so we wanted to believe.

Many of us that never wanted to get into the station ownership game, yet if

I would have been happy to toss that old nicotine-caked DX-77 mic and those wretched cart decks into the bushes behind the station, but that GW80 and I got along like Calvin and Hobbes.

Anyway, our two-year bond ended when I headed to New England. Years later, I encountered Gatesway consoles in both the main studio and automation encoding rooms at beautiful-music WRHP(FM) Syracuse, then again in the tiny former main studio of WSBS(AM), Great Barrington, Mass.

Everywhere I went, there was a Gates mixer following me. I suppose it was inevitable that I would finally seek one out.

On the air ... sorta

The perfect excuse to do so came about when I put up my little Part 15 AMer in Annandale, Va., a few years back.

Regular readers will remember "Annandale Terrace Radio 1170," which was fitted with a five-pot Sparta mixer. It sufficed, but just didn't feel right. Eventually, the operation came down when I moved from Annandale, and has yet to be resurrected. Still I kept my desire for a classic GW80 to myself.

It wasn't until I tore up that Harris Executive earlier this year that I mentioned out loud that I was on the lookout

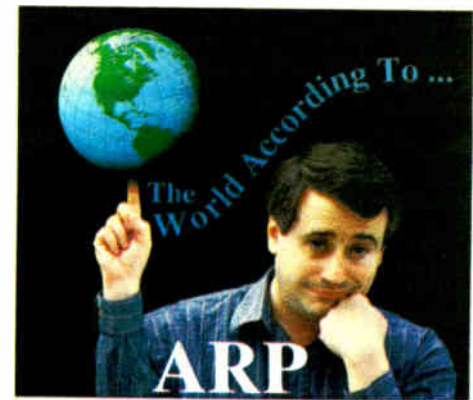

for one. The next thing I knew, there were e-mails from nine Radio World readers, all with GW80s they were ready to retire or already had in their scrap piles and storage bins.

Many proposed I buy theirs, with prices ranging from \$350 to around \$800. When word came from radio engineer Steve Ordinetz in New Hampshire that he'd send me their freshly retired one for \$200 — the cost of shipping only — I happily agreed.

How happily? Look to the left; that's me leaning over my latest acquisition: a prime example of the classic '70s era Gatesway 80, shipped directly to the Radio World editorial office in Falls Church, Va.

This one differs from my first one at WSGO in that the dial inserts are all brushed aluminum, where the old one had color-coded knobs; and the chassis is a military grey, where the WSGO one had that "Harris Blue" paint job typical of the era.

If given the chance, I would have gone back to see if the old WSGO board was still knocking around anywhere in upstate New York, thrown it in the back of my AMC Pacer and laid down rubber in the parking lot. But I am extremely happy with my acquisition.

My thanks to everyone who apprised me of their own GW80s for sale, and a big thank you to Warren Bailey, general manager of WKXL in Concord, N.H., who agreed to part with this console for not much more than a smile and a tip of the old bowler here in these pages.

After some re-capping and a little calibration, this baby should be ready to go back up on the air. Then comes the tough part. No, not connecting it to my existing rig.

Explaining to the missus why I dropped \$200 on a 30-year-old mixer that weighs more than a sofa. ●

BOOK REVIEW

Two New Books Take on Pro Tools

by Alan R. Peterson

With some exception, the conventional choice for digital audio workstations for radio production has been Windows-based rather than Mac-based. Typically, PC hardware is more affordable, parts are more plentiful and there is tons of software out there.

Cool Edit (now Adobe Audition), Xtrack, Vegas, the classic SAW line, ACID and other audio programs have pretty much cemented the lasting popularity of the PC for radio audio production. Even the Orban Audicity uses PC hardware for system housekeeping.

Across the street, the superb Digidesign Pro Tools audio suite has long been the choice of discriminating audio engineers looking for lots of production power, but until recently it was only available for the Mac platform.

With the porting of Pro Tools to Windows, a new galaxy has opened up for production engineers looking to tap new avenues of creativity.

If you are such a producer, whether you run Mac or PC hardware, be aware of two books on Pro Tools that recently rolled off the presses.

"Producing in the Home Studio with Pro Tools" is by David Franz and published by Boston's Berklee Press (\$34.95). "A Professional Guide to Audio Plug-ins and Virtual Instruments" by Mike Collins comes from Focal Press (\$49.95).

At home

Franz's book assumes the reader knows a little about Pro Tools in general, then goes off in a direction best suited to owners and users of "basement" studios.

Admittedly, this book is more appropriate for musicians looking to lay down tracks in Pro Tools to create music. There are pages devoted to the musical ranges of instruments, proper mic technique for recording drums and polar response charts for specific microphones.

The book includes detail on the roles of the producer and the engineer in a music recording session, including some "feel good" ways to draw a good performance out of insecure talent.

Not a lot of this is pertinent to the role of the radio production director, who generally works alone and is not concerned about drum kits. However, Franz

includes a lot of necessary material on the operation of Pro Tools in general.

The obligatory definitions of sampling rate and bit depth are discussed on pages 36 and 37. As more folks would rather make music than do the math associated with 65,536 discrete amplitude levels, Franz keeps this mercifully short.

In clear language, Franz gets the reader acquainted with the basics of sends, returns, busses, edit playlists, signal routing and more of the nuts and bolts of Pro Tools.

While associated with music production, there are some excellent details in Chapter 12, "Mixing" regarding special effects, roughing out a decent three-dimensional mix, plug-ins and Surround Sound.

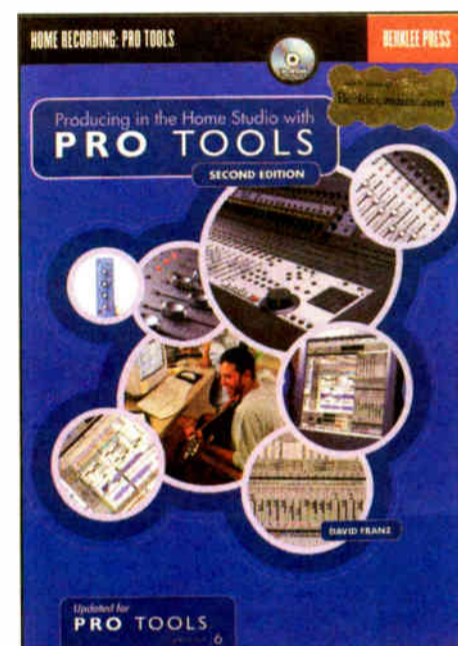

Chapter 13, "Mastering," is somewhat short, lacking some of the depth needed to explain the mastering process fully. Franz does touch upon the problems realized with over-compression, but a glancing mention of multiband compression left me wanting to know a little more.

It is impossible to "hear" a good mix on paper, so author Franz included a CD filled with lots of musical material to listen to, experiment with and generally put Pro Tools through its paces. Naturally, this assumes you have a version of Pro Tools on a Mac or PC already.

If music recording is an interest of yours, "Producing in the Home Studio

with Pro Tools" by David Franz might be a worthwhile consideration. You have to decide if the \$34.95 price tag is right for you, but it does come with that nifty CD.

Plug it in and go

Quite possibly of more value to the producer of audio for radio broadcast is "A Professional Guide to Audio Plug-ins and Virtual Instruments" by Mike Collins (not the moon guy).

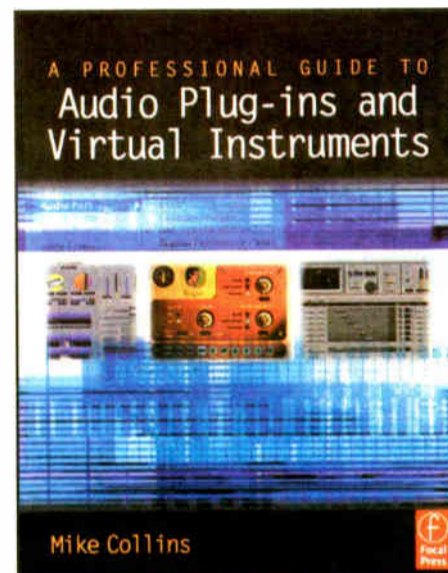

Using Pro Tools as a point of reference, Collins lays down long looks at plug-ins, those tiny software applications that literally "plug in" to host software to create reverbs, vocoders, synthesizers or pretty much whatever you need.

A good portion of the book reads like a long grocery list, examining one format or company at a time; but the read is never dull. Color graphics and screenshots are abundant, and may include programs you never heard of.

Emphasis is given right up front to Digidesign Pro Tools proprietary TDM plug-ins — not just the standard tool box that accompanies the main program, but optional after-market applications such as noise reduction units and retro-sounding lo-fi processors that give audio a gritty old-school sound. Mentions of plug-in music synthesizers are also abundant.

Third-party plug-ins and applications conforming to the Steinberg VST standard are covered in subsequent chapters. While TDM plug-ins are mostly limited to Digidesign products, VSTs can be

used in almost any audio recording and editing program.

The use of a VST "wrapper" (another small application) literally puts a jacket of code around a VST plug-in, allowing it to communicate with an appropriate host program. There is much in this book regarding VST plug-ins, and radio production people love them because many of them can be downloaded for free on the Web.

Attention also is devoted to the MAS line of plug-ins from Mark of the Unicorn, and an entertaining Miscellaneous chapter looks at plug-ins that really do not fit anywhere else in the book.

Chapter 15, "Roll Your Own Plug-ins," tells how you can create some powerful apps of your own using programs such as Reaktor or DUY SynthSpider. Oddly absent is a popular Windows program available for free all over the Web — SynthEdit — that allows nearly anyone with an ear to draw and program their own VST plug-in.

The difficulty with a book such as this is that, after only a year or so, much of what has been written would have been overtaken by newer technologies and newer plug-ins.

Only a couple of years ago, I got to try out and write about the Steinberg Neon software synthesizer — a rudimentary synthesizer emulator completely done in software. Back when I tried it, it was revolutionary. Today, it could only be called quaint. Such is the useful life of plug-ins.

Collins duly notes that fact in his opening, and fortunately keeps the copy moving along at a fairly brisk pace for a reference book.

I do wish this book came with a CD. Sadly, it does not. I would like to have heard samples of some of the plug-ins mentioned in the copy. At least many of the companies that author plug-ins have downloadable MP3 or WMA samples on their Web sites.

Also, you probably won't notice it, but the book is presented in U.K. English, with all of its colours and flavours. I am sure you will manage, however.

So one book tells you how to run Pro Tools in your basement studio, while the other tells you all the cool things to plug into it. If you are a new or intermediate Pro Tools user, these books may be appropriate additions to your shelf.

If you are not, download the free version of Pro Tools from the Digidesign Web site and get busy. Then read these books. 

PRODUCT GUIDE

Additional Coding Increases Xport Flexibility

Telos has a free upgrade available for Zephyr Xport users that adds G.722 coding to ISDN-equipped Xport units.

The coding enables the unit to connect to another Xport or to third-party codecs. G.722 coding allows ISDN calls to be made from one Zephyr to Xport to another while using low-delay MPEG AAC-LD coding.

Features of the version 2.0 software include updated MPEG AAC-LD code from Fraunhofer IIS for improved fidelity for low-delay IFB returns on POTS connections.

The Xport has won several honors since its introduction, including a Radio World "Cool Stuff" Award. The technology permits the establishment of a high-quality audio link between POTS and ISDN phone lines. The company says the combination of a studio-side ISDN link and Spectral Band Replication provides Xport users with 15 kHz audio and solid connections using any available POTS line. Spectral Band Replication also is used by Digital Radio Mondiale and HD Radio.

For more information from Telos Systems, contact the company in Cleveland at (216) 241-7225, or visit www.telos-systems.com.



BROADCAST

Equipment Exchange

"Broadcast Equipment Exchange" accepts no responsibility for the condition of the equipment listed or for the specifics of transactions made between buyers and sellers.

ACOUSTICS

Want to Sell



Full product line for sound control & noise elimination.

www.acousticsfirst.com

ANTENNAS/TOWERS/CABLES

Want to Sell

AM Ground Systems

Reliable, On-time Installation
Quality Workmanship
Ground System Evaluation
and Repair

www.amgroundsystems.com
1-877-766-2999

3" line, 400'. Ken Kuenzie, KRMS, 5715 W Hwy 54, Osage Beach MO 65065. 573-348-2772.

300' of 3" coax; (1) 3-bay Shively antenna tuned to 105.5; (1) 3-bay Dielectric antenna tuned to 103.5. Cale Sharp, WASE, 519 North Miles St, Elizabethtown KY 42701. 270-766-1035.

Central 30" face, 440' guyed tower complete with guys & lighting. On ground & ready to ship. 10 yrs old, like new condition. \$12,000/BO. Pat Delaney, KKRK, 204 So Division, Stuart IA 50250. 608-792-9524.



AUDIO PRODUCTION

Want to Sell

ATI Audio Distribution Amplifier 2016-1. We have about 10 of these as a result of studio renovations. They cost over \$1,100.00 new but will let these go for \$250.00 each plus S&H. Contact Michael Raley at (704)523-5555 for more information or e-mail Mraley@rb.org for a picture.

Audio Arts 8400 Distribution Amplifier. We have about 15 of these as a result of studio renovation. They cost over \$1,100.00 new but will sell "as is" for \$250.00 each plus S&H. Contact Michael Raley at (704) 523-5555 or e-mail Mraley@rb.org for a picture.

Tascam CD 301 (Have two working units) will sell as is for \$225.00 each plus s/h. Email Mraley@rb.org for a picture or call (704) 523-5555.

Tascam Ministudio Porta One Cassette. Four mic lines for remotes This cost \$600.00 new but will sell "as is" for \$95.00 plus s/h. Call Mike Raley at (704) 523-5555 or e-mail mraley@rb.org for a picture.

Two RTS 416 Distribution Amplifiers. Has slight problem pushing +4. Cost \$1,173.00 new but will take \$325.00 for each unit plus S&H. Call Michael Raley at (704) 523-5555 or e-mail Mraley@rb.org for a picture.

Want to Buy

Telcom/ANT C4 noise reduction unit. Gary Wachter, Service Bdctg, 621 NW 6th St, Grand Prairie TX 75050. garyw@k104fm.com or fax 972-558-0007.

SPACE IS AVAILABLE!

To advertise, call
703-998-7600,
ext. 154.

CART MACHINES

Want to Sell

Audio Cord Cart machines. We have about Several "E" series playbacks at \$20.00 each, 10 "DL" series playbacks and two "A" series playbacks at \$20.00 each. Most of them have been refurbished. We also have one "A" series P/R mono, two "E" series p/r mono and two "DL" series stereo p/r at \$100.00 each. Call Michael Raley @ (704) 523-5555 or e-mail Mraley@bbradio.org for more information. No connectors are available. Will sell "as is". Shipping and handling charges apply. Call Michael Raley @ (704) 523-5555 or e-mail Mraley@rb.org for some pictures.

CD PLAYERS

Want to Sell

Denon 650 F CD player. Will sell "as is" for \$225.00 plus s/h. Email Mraley@rb.org for picture or call (704) 523-5555 for more information.

Sony CDK-3600 CD jukebox, 360 disks w/2. play decks. Expand your existing system or keep as spare. Like new condition, 4 left. Gary Wachter, Service Bdctg, 621 NW 6th St, Grand Prairie TX 75050. garyw@k104fm.com or fax 972-558-0007.

COMPLETE FACILITIES



CONSOLES

Want to Sell

BE 10S-150 console in good condition w/spare parts, \$750. Pick up only. Herman Gibbs, WCWS, Box C-3177, Colleg of Wooster, Wooster OH 44691. 330-263-2212.

DISCO-PRO SOUND EQUIP

Want to Sell

Two dozen Sony MDS-JE470 minidisc units. Can record & includes a remote which can record as well. Has PC connection in back as well as a digital optical out. New, never been opened. \$135 which includes shpg w/in lower 48 states. Mike Raley, 704-523-5555 or email: mraley@rb.org for a picture.

LIMITERS/AUDIO PROCESSING

Want to Sell

CRL AM audio SPF 300, SEP 400B, APP-400, PMC 300A, \$850. Ken Kuenzie, KRMS, 5715 W Hwy 54, Osage Beach MO 65065. 573-348-2772.

CRL SMP-850 FM stereo modulation processor. Gary Wachter, Service Bdctg, 621 NW 6th St, Grand Prairie TX 75050. garyw@k104fm.com or fax 972-558-0007.

Orban Optimod FM 8200. Gary Wachter, Service Bdctg, 621 NW 6th St, Grand Prairie TX 75050. garyw@k104fm.com or fax 972-558-0007.

Want to Buy

Teletronix LA-2A's, UREI LA-3A's & LA-4's, Fairchild 66C's & 670's, any Pultec EQ's & any other old tube compressor/limiters, call after 3PM CST, 972-271-7625.

MICROPHONES

Want to Buy

RCA 77-DX's & 44-BX's, any other RCA ribbon mics, on-air lights, call after 3PM CST, 972-271-7625.

MISCELLANEOUS



Want to Sell

K-Y Filter Company
3010 Grinnel Place
Davis, CA 95616



ELIMINATE BROADCAST BAND RFI

Plug-in telephone/modem RFI FILTERS

(530)757-6873

www.ky-filters.com/rw.htm

Enberg BA - 6 Annunciator. Four of them in great condition with no more than eight years of use in them. Original cost was \$359.00 each but we will sell them for \$200.00 each "as is" plus s/h. Call Mike R at (704) 523-5555 or e-mail Mraley@rb.org for more information.

ROTRON BLOWERS AND PLATE BLOCKERS, new & rebuilt for Elcom, Harris, CCA, CSI, McMartin, Goodrich Ent. 11435 Manderson St. Omaha, NE 68164 402 493 1886 FAX 402 493 6821

Henry universal turntable controller. Gary Wachter, Service Bdctg, 621 NW 6th St, Grand Prairie TX 75050. garyw@k104fm.com or fax 972-558-0007.

Honeywell Medium Intensity Strobe System Model K-6 225 TW KVA.6 120 VAC. Lines include Royal electric 12/7 SOW 600v at 132' Royal Electric 12/5 SOW-A 90c and 60c with lengths or 52' and 160'. Good for parts only. Will sell total kit "as is" for \$950.00. Call Michael Raley @ (704) 523-5555 or e-mail Mraley@rb.org

QEI Model ARC - 27 Automatic Remote Control - \$45.00 "as is" plus shipping and handling - Call Michael Raley @ (704) 523-5555 for more information or e-mail Mraley@rb.org for a picture.

Technics SL-D2 record player can let go "as is" for \$125.00 plus s/h. E-mail Mraley@rb.org for a picture or call Mike at (704) 523-5555 for more information .

Ten Nidec motors for Audio-cord "E" series. 117v 6H 3.1w 0.2amp 12p and 600rpms. Will sell "as is" for \$5.00 each. Working condition just somewhat noisy. Call Michael Raley (704) 523-5555 or e-mail Mraley@rb.org for pictures.

www.rwonline.com

BAY COUNTRY BROADCAST EQUIPMENT

BUY - SELL - TRADE
Your #1 Source For Quality Used Radio Broadcast Equipment
View The Latest List On Line At: <http://www.baycountry.com>
Or Call And We Will Fax It To You.
7117 Oliva Rd., Baltimore MD 21220
Toll Free: 877-722-1031 • FAX 786-513-0812 • E-mail: info@baycountry.com
Member of BBB

Inovonics Map II Multiband processor - \$275.00 "as is" plus shipping and handling - Call Michael Raley @ (704) 523-5555 for more information or e-mail Mraley@rb.org for a picture.

Proteck 20 MHZ Spec. analyzer (A-3502). Make a decent offer. Call Michael Raley @ (704) 523-5555 or e-mail Mraley@rb.org.

MONITORS

Want to Sell

TFT 713 AM Frequency and Modulation Monitor. Cost \$3,400.00 new but will sell for \$1500.00 plus S&H. Needs re-calibration. Call Michael Raley at (704) 523-5555 or e-mail Mraley@rb.org for a picture.

ACTION-GRAM

EQUIPMENT LISTINGS
Radio World's Broadcast Equipment Exchange provides a FREE listing service for radio stations only. All other end users will be charged. This FREE service does not apply to Employment Help Wanted ads or Stations For Sale ads. These are published on a paid basis only. Send your listings to us by filling out the form below. Please be aware that it takes one month for listings to appear. The listings run for two consecutive issues and must be resubmitted in order to run again. Thank you.

Please print and include all information:

Are you currently a subscriber to Radio World?
 Yes No

Signature _____ Date _____

Contact Name _____
Title _____
Company/Station _____
Address _____
City/State _____
Zip Code _____
Telephone _____

Brokers, dealers, manufacturers and other organizations who are not legitimate end users can participate in the Broadcast Equipment Exchange on a paid basis. Line ad listings & display advertising are available on a per word or per inch basis.

WTS WTB Category: _____
Make: _____ Model: _____
Brief Description: _____
Price: _____

*Closing for listings is every other Friday for the next month's issue.
All listings are run for 2 issues unless pressed for space or otherwise notified by listee.
Broadcast Equipment Exchange
PO BOX 1214, Falls Church, VA 22041 • Tel: 703-998-7600 • Fax: 703-998-2966



RECEIVERS/ TRANSCIEVERS

Want to Sell

Hammarlund HQ140X, matching speaker, excellent condition in appearance, professionally restored to original factory specifications, warranty, \$400. Troy Spencer, WODY, 3196 Stones Dairy Rd, Bassett VA 24055. 276-629-1161.

RECORDERS

Want to Sell

Revox Reel to Reel Recorders. Good for parts but might be repairable. We've got seven of them and can let them go for \$20.00 each plus s/h. Call Michael Raley @ (704) 523-5555 or e-mail Mraley@rrb.org for pictures.

Two B.E. Record Playback cart machines Two Stereo units "as is" for \$65.00 each and two mono units "as is" for \$50.00 each. Call Michael Raley @ (704) 523-5555 or e-mail Mraley@rrb.org for pictures.

REMOTE & MICROWAVE

Want to Sell

AETA Audio Scoop Reporter II, AETA Audio Scoop II rack mount, AETA Audio Scoop EZ pots ISDN. Ken Kuenzie, KRMS, 5715 W Hwy 54, Osage Beach MO 65065. 573-348-2772.

Bext 2 watt STL transmitter, current model, frequency agile. Ken Kuenzie, KRMS, 5715 W Hwy 54, Osage Beach MO 65065. 573-348-2772.

BE/Marti SMARTI pots line codec/mixer, excel like new condition, one unit RKS-111 in rack mount, one unit RKS-411 in portable bag. Gary Wachter, Service Bdctg, 621 NW 6th St, Grand Prairie TX 75050. garyw@k104fm.com or fax 972-558-0007.

Comrex LX-R Decoder. Gary Wachter, Service Bdctg, 621 NW 6th St, Grand Prairie TX 75050. garyw@k104fm.com or fax 972-558-0007.

WE RENT FOR LESS

| | |
|----------|----------------|
| Hotlines | FM Exciters |
| Zephyrs | STL's |
| Nexus | FM Pwr Amps |
| Audio | Test Equipment |

If we don't have it, we will get it!
SCMS, INC. (800) 435-6040
"You Know We Know Radio"

Gentner GSC3000 I/O 16 unit, excellent condition; Gentner GSC3000 voice unit, excellent condition. Gary Wachter, Service Bdctg, 621 NW 6th St, Grand Prairie TX 75050. garyw@k104fm.com or fax 972-558-0007.

Gentner VRC antenna monitor interface. Gary Wachter, Service Bdctg, 621 NW 6th St, Grand Prairie TX 75050. garyw@k104fm.com or fax 972-558-0007.

Marti SCD-10 subcarrier demodulator. Gary Wachter, Service Bdctg, 621 NW 6th St, Grand Prairie TX 75050. garyw@k104fm.com or fax 972-558-0007.

Potomac Instruments RSA-19 remote switching adapter. Gary Wachter, Service Bdctg, 621 NW 6th St, Grand Prairie TX 75050. garyw@k104fm.com or fax 972-558-0007.

Telos 2x12 digital talk show system for up to 12 pots phone lines, rack mount unit only, does not include telephone sets; Telos 1A2 interface. Gary Wachter, Service Bdctg, 621 NW 6th St, Grand Prairie TX 75050. garyw@k104fm.com or fax 972-558-0007.

SATELLITE EQUIPMENT

Want to Sell

Model 5495 satellite receiver. Ken Kuenzie, KRMS, 5715 W Hwy 54, Osage Beach MO 65065. 573-348-2772.

Starguide II/III 37 pin relay card, never used, \$200. Ken Kuenzie, KRMS, 5715 W Hwy 54, Osage Beach MO 65065. 573-348-2772.

Three Zephyrus Analog Sat Recievers \$20.00 each "as is" and one Digital Zephyrus sat reciever for \$100.00 "as is" plus shipping and handling - Call Michael Raley @ (704) 523-5555 for more information or e-mail Mraley@rrb.org for a picture.

Wegner DN 86 Digital Audio Reciever 3944.1 MHZ - \$170.00 "as is" plus shipping and handling - Call Michael Raley @ (704) 523-5555 for more information or e-mail Mraley@rrb.org for a picture.

SERVICES

Vinyl Records DE-NOISED & DIGITIZED on CD

We specialize in professional sound services, & can clean up all your recordings, from wire to cassette tape to 78's to LP's & transcriptions.

Our lab utilizes a complete 'Cedar' system as well as the Sound Forge computer program.

Audiophonic Corporation
POB 4390, Woodland Park, CO 80866
719-687-6357

STATIONS

Want to Sell

5KW station in upper North East Tennessee for sale due to owners health. Call Jennings at 423-968-5221 or 276-466-2893.

Atlanta Metro 1 KW AM. Profitable, \$750K. 1-239-573-4707 or 1-706-692-4100.

SC AM, \$65K for license, \$100K for land and building. 1-239-573-4707 or 1-706-692-4100.

SYNDICATION COMPANY FOR SALE. Great growth potential, turnkey operation. Owner retiring. Serious inquires only, reply to radiomichael2000@yahoo.com.

Want to Buy

AM's, FM's, non-commercials, translators or CP's, will consider partnerships. Prefer in RI, CT, MA, FL area. Call after 6PM EST 401-942-8341.

Looking for AM's, FM's, non-commercials, translators, or CP's in western US. Please email: Dougs@ihradio.org.

CONSULTANTS

EVANS ASSOCIATES Consulting Communications Engineers

FCC Applications • Design • Field Engineering • Tower Detuning Upgrade & Relocation Studies • AM Directional Array Tuning & Proof

EXPERTS IN:
TV • DTV Transition • FM • Directional Antennas • RF Exposure

210 S. Main St., Thiensville, WI 53092. (262) 242-6000. FAX (262) 242-6045
<http://www.evansassoc.com> Member AFCCE

Consulting Communications Engineers EMC Test Lab

- FCC Applications and Field Engineering
- Frequency Searches and Coordination
- AM-FM-CATV-ITFS-LPTV
- EMC Test Lab-FCC and European (IEC)

OWL ENGINEERING, INC.
E-mail: info@owleng.com 651-784-7445 Fax (651) 784-7541
5844 Hamline Ave. N., Shoreview, MN 55126 Member AFCEE

FASTER... MORE ACCURATE RADIO COVERAGE

- Real Time 3-D Displays
- Interference calculations
- Cost effective mapping
- Fully integrated databases
- Used by the FCC
- Latest standards built-in

RADIO SOFT

Visit us on the web at www.radiosoft.com
109 West Knapp Ave., Edgewater, FL • (386) 428-2521

System One Communications
Broadcast Constructors & Consultants
Houston, Texas
888-625-5649

- AM-FM Site Construction Specialists
- Complete Tower Service
- Antenna & Transmission Line Diagnostics

GRAHAM BROCK, INC.
BROADCAST TECHNICAL CONSULTANTS
Full Service From Allocation to Operation/AM/FM/TV/LPTV Services.
Field Work Antenna and Facilities Design

Over 35 years engineering and consulting experience

912-638-8028
202-393-5133
www.grahambrock.com

M Celenza
Communications Consultants
FM-AM-TV-LPTV-LPFM
Applications, Amendments, Upgrades, Frequency Searches, Directional Antennas
Field Work (Station Inspections)
631-928-0077
Fax: 631-928-1905
41 Kathleen Crescent, Coram N.Y. 11727

MULLANEY ENGINEERING, INC.
Consulting Engineers

- Design & Optimization of AM Directional Arrays
- Analysis for New Allocation, Site Relocation, and Upgrades AM-FM-TV-LPTV
- Wireless Cable (MDS/MMDS/ITFS/OFS)
- Environmental Radiation Analysis
- Field Work
- Expert Testimony

9049 Shady Grove Court
Gaithersburg, MD 20877
Phone: (301) 921-0115
Fax: (301) 590-9757
email: mullengr@aol.com

Communications Technologies, Inc.

Radio Frequency / Broadcast Engineering Consultants
AM FM TV LPTV
Cellular/PCS Site Analysis
P.O. Box 1130 / Marlton, NJ 08053
Tel: 856/985-0077
Fax: 856/985-8124
web: commtechrf.com

Clarence M. Beverage
Laura M. Mizrahi

Doug Vernier
Telecommunication Consultants

Broadcast Engineering Consulting
AM/FM/TV/LPTV/DTV
Custom mapping service
Frequency searches
Propagation prediction
FCC application preparation

V-Soft
SOFTWARE FOR YOUR PC
(800) 743-3684
www.v-soft.com

David C. Schaberg
Allocation Specialist

FM & AM Frequency Searches
Move-ins, upgrades, allocations
Maximization of signals
"If someone else says it can't be done, then we want the opportunity to prove them wrong!"
Since 1989
3105 S. Martin Luther King Jr., Blvd.
Lansing, MI 48910-2939
www.starradio.net
800-393-1037

dataworld

Market Analysis
Engineering Software
Ethnic/Demographic Data
Custom Full-color Mapping
Sales Marketing Packages

www.dataworld.com info@dataworld.com
800-368-5754 fax: 301-656-5341

Structural Analysis

ERI
Electronics Research, Inc.
7777 Gardner Road
Chandler, IN 47610
(812) 925-6000
www.ERInc.com

REGISTERED PROFESSIONAL ENGINEERS
STRUCTURAL ANALYSIS
ERI Incorporated 1943
TOWER REINFORCING

R. MORGAN BURROW, P.E. & ASSOCIATES, P.C.
ALLOCATION STUDIES
(AM, FM, TV, LPTV) New locations, site relocation, FM upgrade studies

FIELD WORK A SPECIALTY

- AM Directional antenna adjustment, measurement & proof
- RADIARZ measure ments, RADAR evaluation
- FM & TV field intensity & other measurements
- Facility inspections for out-base/surround purposes
- CATV coverage testing

ELECTROACOUSTICS
OSHA measurements

304-258-7921 • Fax 304-258-7927

Planck Technical Services, Inc.
Broadcast Construction/Service

909-370-4515
www.plancktech.com

- AM-FM-LPTV-SW Station construction
- Tower Construction
- Transmitter/Antenna Service

RUOnline

To advertise in Radio World e-mail: stewell@imaspub.com

Visit our web site: www.ruonline.com

DISTRIBUTOR DIRECTORY

The following distributors serving the broadcast industry would be glad to help you with any of your requirements.

CORNELL-DUBILIER MICA CAPACITORS
FROM STOCK

JENNINGS VACUUM CAPACITORS
FROM STOCK

JENNINGS VACUUM RELAYS

SURCOM ASSOCIATES
2215 Faraday Ave., Suite A
Carlsbad, California 92008
(760) 438-4420 Fax: (760) 438-4759
e-mail: link@surcom.com web: www.surcom.com

...Some people get hooked on broadcast equipment big time...they think about it...dream about it...talk about it all the time...for example...us...

RADIO! The beat goes on!
CROUSE-KIMZEY OF ANNAPOLIS
tops in broadcast equipment

1-800-955-6800
ask for Kathleen
kkannapolis@worldnet.att.net

Are You a Distributor?
ADVERTISE HERE!
Space is available.
Call 703-998-7600, ext. 154.



POWER TUBES
REBUILT

1/2 THE COST
OF NEW!

ECONCO

TEL: 800-532-6626
INTL: +1-530-662-7553
FAX: +1-530-666-7760
www.econco.com
SE HABLE ESPAÑOL



**TAPES/CARTS/
REELS/CD's**

Want to Sell

ITC record/play, and ITC play, \$250 each. Ken Kuenzie, KRMS, 5715 W Hwy 54, Osage Beach MO 65065. 573-348-2772.

Want to Buy

Drake Chenault news join reels, Contempo 300 reels, time carts. Chuck, 570-434-2782.

**TELEPHONE
EQUIPMENT**

Want to Sell

A non-profit 501(c)(3) Christian Ministry, seeks tax deductible donations of working professional grade live/post radio production equipment of studio automation systems, modulation monitors, DAT, CD players, mikes, turntables, mixing boards, and other radio production equipment. Also, need transmitters, translators, transmission lines, and antennas to be used in our Youth Radio Ministry Training Program. All donations will receive a tax deductible receipt and God's blessings for their donations. Minister Dr. R. Hodges, 916-721-3285 or info@lwcr.org.

TEST EQUIPMENT

Want to Sell

Audio Precision System One. Gary Wachter, Service Bldg, 621 NW 6th St, Grand Prairie TX 75050. garyw@k104fm.com or fax 972-558-0007.

TRANSMITTERS

Want to Sell

(5) Five KW FM's. Continental Communications., 314-664-4497, ContComm@sbcglobal.net.

10 KW AM's (5). Continental Comm., 314-664-4497, contcomm@sbcglobal.net.

BEXT
From the tall to the small
WWW.BEXT.COM
888 239 8462
Transmitters & Antennas

CSI T-25-F 25 KW (GG) FM. Continental Comm., 314-664-4497, contcomm@sbcglobal.net.

Harris MW-5-B, 5 KW AM (5). Continental Comm., 314-664-4497, ContComm@sbcglobal.net.

OFF THE AIR?
Emergency Back-up Rentals
FM Exciters - STLs -
FM Pwr Amps - Antennas -
Studio & Test Equipment
SCMS Inc (800) 438-6040
"You Know We Know Radio"

McMartin BF-5K, 5kW FM. Factory rebuilt in perfect, like new condition, includes new tubes, tested & tuned on your frequency. Guaranteed, fully adjustable from 0 to 5.5 KW. Goodrich Enterprises Inc, 402-493-1886.

RANGEMASTER AM: Legal FCC Part 15 type accepted transmitter, 1-2 miles range possible! 919-367-0607 or go to www.am1000rangemaster.com.

Harris/Gates BC 500H @ 1150, BC1T @ 1530, BC-250-GY1 @ 810, excellent working condition. Ken Kuenzie, KRMS, 5715 W Hwy 54, Osage Beach MO 65065. 573-348-2772.

CCA HELP
▪ Rotron Blowers ▪ Rebuilt Plate Blockers ▪ Tubes
▪ Tube sockets/parts ▪ most all transmitter parts
▪ rebuilt tuning line assemblies
Goodrich Ent. Inc
402-493-1886
www.goodrichenterprises.com cgoodrich@tconl.com

Non-profit (501(c)(3)) broadcasting organization seeks donation of a 1000 watt AM transmitter for our new station in north Alabama. We prefer a solid-state transmitter, but will consider any tube-type model if it is in working condition or needs minor repair. We have two tube type transmitters which need repair, a Gates BC-III and a CCA 1000D, and would consider a donation of a non-working model of either of these for parts. A tax-deductible receipt will be given, and we will arrange pick-up and transportation. Call Ed Smith at 205-384-3461, or fax information to 205-384-3462.

QEI FMQ 10000 transmitter tuned to 100.1 in good working condition and can be returned on the field. This was installed in March of 1994 but will be replaced by another xmitter sometime at the end of the year. This xmitter cost \$30,000.00 new but will let go for \$18,000.00. Call Mike Raley @ (704) 523-5555 or e-mail Mraley@rrb.org.

QEI FMQ series 6.0 to 9.6FM. This xmitter did a tour of duty in Argentina but some goofy laws in this country made it impossible to permit the station to operate at this power. To make a long story short it was only in operation no more than four months. Will let this go for \$20,000.00. Call Mike Raley at (704) 523-5555 or E-mail Mraley@rrb.org for pictures.

RCA BTF-20E1 20 kW FM. Sell complete or will part out, make offer. Joe Davis KLSR, 114 N 7th, Memphis TX 79245. 806-259-3511.

SINGER (remake of CCA) model FM 20,000 E tuned to 89.5FM. Currently in "fairly good" operating condition, with a TPO of 17.1 KW. This can be returned on the field and parts are available through Goodrich Enterprises (402)-493-1886. Call Michael Raley @ (704) 523-5555 or e-mail Mraley@rrb.org for pictures. \$6,750.00 and buyer arranges shipping.

TUBES

Want to Sell

FOR THE BEST PRICE
& 24 Hr service on transmitting tubes & sockets/parts, new & rebuilt call Goodrich Ent. of 402-493-1886 day or night, www.goodrichenterprises.com.

TUBES, Eimac, Svetlana
Fax: 905-844-6263
Phone: 905-844-5772
ams@hard-to-find.net
www.hard-to-find.net

EMPLOYMENT

HELP WANTED

A Chief Engineer is needed in Columbus, Ohio. The applicant must have 3 years experience in professional radio broadcasting and must be able to install, troubleshoot and maintain FM transmission systems, broadcast auxiliary facilities, studios, computer audio delivery and satellite downlinks. Also needed is the ability to lift 50 lbs, stoop, crouch and work on ladders up to 20 feet in height and on rooftops. A college degree in a related technical field and/or certification by the S.B.E. is preferred. Applicants must have a valid driver's license and be insurable. Applicants should respond by e-mail only to: john.marocchi@columbusradiogroup.com. EOE

POSITIONS WANTED

Recent ABS graduate multitalented in all facets of broadcasting. Dedicated, self-motivated, determined, and hardworking female. Seeking sales, marketing, and voice-over position. Jonna, 405-390-2991.

Young and energetic guy looking for positions in sports talk, on-air, or production. Just out of school and willing to relocate. Bobby T, 405-685-1840.

Early 20's hard rock DJ seeking first gig in the radio world. Willing to travel anywhere, will bust tail for position. Greg Spicoli, 972-370-3332.

Friendly, industrious, commercial FCC-1st Class with radar-amateur radio extra licensed, asst CE, seeks FT, PT, contract, with AM/FM, cable, TV, preferred within 75 mile radius of metro NYC area. 718-969-5224 or write: Mitchell Rakoff, 110-64 Queens Blvd, PMB# 494, Forest Hills NY 11375-6347 or email at MitchellRakoff@Yahoo.com.

Highly motivated female rookie willing to relocate for right opportunity. Proficient in promotions, news, programming, on-air, sales. Great voice. Kiki J, 214-718-5620.

I'll make the crowd scream to the top of their lungs. Magnificent voice, laughter, and smile. Shante 405-245-1927.

If you are looking for a bilingual, creative, dependable and responsible broadcaster, you found it! Buscando a alguien bilingue, creativo y responsable? Lo acabas de encontrar! Carlos Aguilar 817-377-3560 or cagu1larj@msn.com

Natural born DJ looking to ride the (radio) waves in your city. Experience with Cool Edit, digital, sports/news. Anthony 214-498-1012.

Recent ABS graduate can do it all. Willing to relocate to put my vast talents to work. Geoff 405-376-4806.

Rookie willing to travel to start a career in broadcasting. DJ, commercial writing, board operator. Angie 405-528-3053.

Seeking position in promotions or advertising. Also interested in DJ, copywriting, production. Have extensive background in marketing. Shanne 405-947-7108.

Buying used equipment?
Selling used equipment?
You're in the right place!
Radio World
Broadcast Equipment Exchange
To advertise, call 703-998-7600, ext. 154

RF PARTS COMPANY • Broadcast • Industrial Communications
• EIMAC • TAYLOR • ECONCO • SVETLANA
Also Motorola • Toshiba • SGS-Thomson & Mitsubishi Semiconductors
Catalog: www.rfparts.com
Se Habla Español • We Export
760-744-0700 • 800-737-2787
Fax: 760-744-1943 E-mail: rfp@rfparts.com

D And C Electronics
An International Distributor of RF Components
Tubes
NEW & REBUILT
TRANSMITTERS, STUDIO EQUIPMENT, STLs, ANTENNAS, RADIO DATA SYSTEM (FOR CAR RADIO DISPLAY) EXCITERS-TRANSMITTERS, TRANSLATORS, MIXERS-CONSOLES, RADIO LINK RPU, MOSFETS, VACUUM CAPACITORS, SOCKETS
Eimac SVETLANA Pro-Tek® OMB EEV
BEST PRICES To Order: 1-800-881-2374 FROM OUR STOCK Outside U.S. (352) 688-2374 Se Habla Español
3089 Deltona Blvd. Spring Hill, FL 34609 BEST SERVICE 352-688-2374 Fax 352-683-9595 Website: www.dandcelectronics.com

TRANSCOM CORP.
Serving the Broadcast Industry Since 1978
Fine Used AM & FM Transmitters and Also New Equipment

| USED FM TRANSMITTERS | | | NEW TV TRANSMITTERS | | |
|----------------------|------|---|--|--|--|
| 2.5kw | 1978 | Collins 831D2 | VHF AND UHF, 10w TO 10kw | | |
| 5kw | 1983 | Harris FM5K | TV Antennas | | |
| 10kw | 1988 | BE FM 10A | TV STL | | |
| 10kw | 1997 | BE FM 10T | Contact us for a quote | | |
| 10kw | 1980 | Harris FM10K | USED MISC. EQUIPMENT | | |
| 10kw | 1999 | Harris Z10 CD (solid state) | BE FX30 Exciter | | |
| 20kw | 1978 | Collins 831G2 | Continental 802B Exciter | | |
| 20kw | 1982 | Harris FM20K | Belar AMM3 Mod. Monitor | | |
| 20kw | 1989 | QEI FMO20.000B | Denon 720R Cassette Recorder | | |
| 25kw | 1980 | CSI T-25-FA (Amplifier Only) | Harris AMS-G1 AM Stereo | | |
| 25kw | 1982 | Harris FM25K | Inovonics AM Stereo Processor, Model 250-01 | | |
| 30kw | 1984 | BE FM30 | Kintronics 50kw AM RF Switch, Model RFC8-1 | | |
| 30kw | 1985 | BE FM30A | Potomac Phase Monitor AM1901, Digital, 2 Tower | | |
| 35kw | 1987 | Harris FM35K | Potomac Phase Monitor AM19, 2 Tower | | |
| 50kw | 1982 | Harris Combiner w/auto exciter-transmitter switcher | Potomac TU-16 Remote Control | | |
| USED AM TRANSMITTERS | | | | | |
| 40kw | 1988 | Nautel P400 (solid state) | | | |
| 5kw | 1995 | Harris "Gates 5" | | | |
| 5kw | 1982 | Harris MW5A | | | |
| 5/10kw | 1982 | Continental 316F | | | |
| 50kw | 1985 | Continental 317C2 | | | |
| 50kw | 1986 | Nautel AMPFET 50 | | | |

2655 Philmont Ave #200, Huntingdon Valley, PA 19006
800-441-8454 • 215-938-7304 • FAX No. 215-938-7361
VISIT OUR NEW INTERNET SITE: www.fmamtv.com
SEND YOUR E-MAIL REQUESTS TO: transcom@fmamtv.com

ENTER TO WIN

Here's your chance to unpack **FREE GEAR** in 2003.
Enter to win one of 26 New Technology prizes.

Over the past two years, **Radio World** and dozens of industry suppliers have joined forces to award more than \$115,000 worth of radio and pro audio gear — from microphones, master clocks and sound cards, to audio processors, routers, CD mastering machines and shopping sprees.

In 2003 you can expect a similar range of cool New Technology products from our great sponsors. It takes only seconds to sign up online. And best of all, there are 26 chances to win in 26 drawings -- one for every issue of **Radio World**. This is our way of saying "thank you" for allowing us to bring you New Technology for the past 27 years.



To enter the sweepstakes you must complete these 3 easy steps:

- 1 Go to our website www.rwonline.com
- 2 Click on the New Technology Sweepstakes icon
- 3 Follow the instructions and fill out the electronic entry form — that's it, you're done!

So what are you waiting for? Don't miss out in '03. Enter to win New Technology products from these fine **Radio World** supporters:



Contest Rules: To enter the drawing, simply register online at www.rwonline.com/sweeps. 26 drawings will be held throughout the year. Contest registration expires Dec. 3, 2003. Final contest prize announcement on Jan. 1, 2004. One prize per winner. All contestants MUST reside in the United States and have a valid mailing address. Winners should receive prizes within 30 days of notification; however, actual delivery time may vary and is not guaranteed by IMAS publishing. Federal, state and local tax/tariffs may apply to prizes and are the sole responsibility of the winner. Employees and affiliates of IMAS Publishing are not eligible.

ADVERTISER INDEX

This listing is provided for the convenience of our readers.
Radio World assumes no liability for inaccuracy.

| PAGE | ADVERTISER | WEB SITE URL |
|--------|--|--|
| 35 | Aphex Systems | www.aphex.com |
| 38 | ATI | www.atiguys.com |
| 38 | Audion Labs | www.voxpro.net |
| 6 | AudioTX Communicator | www.audiotx.com |
| 22 | Autogram Corporation | www.autogramcorp.com |
| 16 | Belar | www.belar.com |
| 21 | Broadcast Software Int'l (BSI) | www.bsiusa.com |
| 24, 25 | BSW | www.bswusa.com |
| 4 | Burk Technology | www.burk.com |
| 22 | Circuit Werkes | www.circuitwerkes.com |
| 38 | Circuit Werkes | www.circuitwerkes.com |
| 18 | CKE/HVCA | www.rectifiers.com |
| 38 | Comet North America | www.cometna.com |
| 7 | Comrex | www.comrex.com |
| 37 | Conex Electric Systems | www.conex-electro.com |
| 12 | dMarc Networks | www.dmarcnetworks.com |
| 23 | Dorrough Electronics | www.dorrough.com |
| 22 | Gorman-Redlich Mfg. Co. | www.gorman-redlich.com |
| 28 | Grace Broadcast Sales | www.gracebroadcast.com |
| 1 | Harris | www.broadcast.harris.com |
| 11 | Harris | www.broadcast.harris.com/network-access |
| 17 | Henry Engineering | www.henryeng.com |
| 22 | LBA Technology | www.lbagroup.com |
| 19 | Logitek | www.logitekaudio.com |
| 22 | Mager Systems | www.magersystems.com |
| 29 | Moseley Associates | www.moseleysb.com |
| 27 | Musicam USA | www.musciamusa.com |
| 9 | Omnia, a Telos Company | www.omniaaudio.com |
| 15 | OMT Technologies | www.omt.net |
| 5 | Radio Systems | www.radiosystems.com |
| 28 | www.radiomall.com | www.radio-mall.com |
| 28 | RF Licensing | www.terrestrialrf.com |
| 3 | S.C.M.S. | www.scmsinc.com |
| 20 | Sine Systems | www.sinesystems.com |
| 38 | Superior Broadcast Products | www.superiorbroadcast.com |
| 13 | Telos Systems | www.telos-systems.com |
| 31 | Telos Systems | www.telos-systems.com |
| 10 | Tieline America | www.tieline.com |
| 2 | Wheatstone | www.audioarts.net |
| 47 | Wheatstone | www.wheatstone.com |
| 48 | Wheatstone | www.wheatstone.com |

Radio World

5827 Columbia Pike, 3rd Floor Falls Church, VA 22041
PHONE: 703-998-7600 • FAX: 703-671-7409

Classified Advertising Rates Effective January 1, 2003

| | 1x | 6x | 13x | 26x |
|---------------------------|-----------------|-----|-----|-----|
| 1-9 col inch (per inch) | \$105 | 100 | 95 | 90 |
| 10-19 col inch (per inch) | \$90 | 80 | 70 | 60 |
| Distributor Directory | \$130 | 125 | 120 | 115 |
| Professional Card | \$100 | 95 | 90 | 85 |
| Station/Studio Services | \$195 | 165 | 140 | 119 |
| Classified Line Ad | \$2/word | | | |
| Blind Box Ad | \$15 additional | | | |

Call Simone Fewell, Ext. 154, Classified Ad Manager,
to reserve space in the next issue. Use your credit card
to pay, we now accept VISA,
MASTERCARD and American Express.

www.rwonline.com

GUEST COMMENTARY

The Engineer-to-Station Ratio System

Quantifying Your Workload: How Many Engineers Does It Take to Keep the Stations Running?

by Dave Obergoenner

Radio has been in a tremendous state of change over the last decade in regards to engineering. Often workload demands have shifted from the programming departments to the engineering departments for much of the broadcast day, which is usually 24/7.

This comes as a result of station automation, voice tracking and satellite delivered programming. A station frequently operates in an automated, voice-tracked mode, and much of the responsibility for keeping things running smoothly is shifted from the programming departments to the engineering departments.

Not all radio stations and markets are equal in their engineering demands and requirements. The workload placed onto radio stations' engineering departments cannot be accurately determined by a simple station-to-engineer ratio.

Therefore, some kind of a system was needed. That is what I have attempted to achieve.

Crunching numbers

A simple music FM station with good equipment, a reliable main transmitter and a back-up transmitter is not nearly as complex to maintain as a news/talk formatted station with a multi-tower, directional antenna system. The format, the reliability of the station's equipment and amount of redundancy must be taken into account when estimating the workload and stress level on the engineering department.

The umbrella of responsibilities of the engineering department now includes several computer networks at every installation, as well as maintenance of non-broadcast-related equipment. In some markets, a member of the engineering department, an IT specialist, spends most of his or her time working on computer-related issues that have little to do with traditional broadcast engineering.

We now have complex office computer networks and systems that are imperative to the smooth operation and efficiency of all departments in the market. In most cases, this adds the workload of another radio station to the engineer's plate.

The nature of the broadcasting business requires immediate repairs to these systems. If the traffic department can't produce tomorrow's logs on their computers, the station won't make any money the next day. When dealing with broadcast automation and computer systems, waiting a few days for a computer-repair person is not an option. If they go down, the station probably will go off the air, losing revenue and listeners every minute.

Reliable back-up systems can lessen

the stress load on the engineering department and decrease the possibilities of lost revenue or FCC rule viola-

mostly live FM station, up to 25,000 watts ERP, and with good equipment, reliable transmitters and back-up transmitter systems. This is a baseline, station equivalency of 1.0.

Determining "station equivalence" involves the establishment of additive

Poplar Bluff Market:

KWOC

(AM, 5kw, 4 tower directional, News/Talk format)

| | | |
|------------------------------------|------|--|
| Baseline | 1.0 | |
| 4 tower directional AM, add | 0.5 | |
| News/Talk format, add | 1.0 | |
| Satellite fed most of the day, add | 0.25 | |

KWOC Station Equivalency Total 2.75 2.75

KKLR

(music FM, 100,00 watts, mostly live, good redundancy)

| | | |
|------------------------|------|--|
| Baseline | 1.0 | |
| Over 25,000 watts, add | 0.25 | |
| Remote intensive, add | 0.25 | |

KKLR Station Equivalency Total 1.5 1.5

KJEZ

(100,000 watt music FM, lots of voice tracking, no back-up transmitter)

| | | |
|-----------------------------|------|--|
| Baseline | 1.0 | |
| Over 25,000 watts, add | 0.25 | |
| Voice tracked a lot, add | 0.25 | |
| No back-up transmitter, add | 0.25 | |
| Remote intensive, add | 0.25 | |

KJEZ Station Equivalency Total 2.0 2.0

Other Market Factors: Three LAN systems, add 3.0

Poplar Bluff Market, Total Station Equivalency: 9.25

tions. Proper preventative maintenance is certainly an important part of this equation.

Station equivalence

An engineering reader may be familiar with the telephone company's use of a "ringer equivalence" figure on a phone. If you connected several phones, and got a ringer equivalence greater than the rating on the phone line, the phones would not ring. I like to think of this ratio system in a similar way. If you pile a greater "station equivalence" on the engineering department than it can carry, the stations will be more likely to spend increased time off the air due to error, and possibly violate FCC rules.

You also will be setting the engineers up for imminent burnout. Qualified, experienced broadcast engineers are in short supply. It can take months to find one, and years for an engineer to get completely familiar with a station's environment. In light of this, running a revolving-door, burnout factory for engineers is not a good way to operate.

In order to set up a proper way to evaluate workload, a baseline had to be established. To simplify the equation, this baseline is set on the predicted workload of a single, music-formatted,

factor guidelines. These additive factors are based on many years of experience by the author, interviews and input from other broadcast engineers with years of experience at a variety of stations. When all is taken into account, this system will provide a guideline for how many stations a broadcast engineering department can handle. It should predict when a market is heading for technical trouble and FCC fines.

While there are probably many others, here are some examples of additive factors. Add all these factors to the single station baseline of 1.0.

- If the station runs a news/talk format, add 1.0
- If the station does not have reliable back-up transmitters and other such systems, add 0.25
- If the station is a multi-tower directional AM (up to four towers) add 0.5
- Multi-tower directional AMs with more than four towers add 0.1/tower
- FM stations 25,000 watts and over, add 0.25
- AM stations over 5,000 watts, add 0.25
- If the station has a second transmitter site to maintain, add 0.25
- If the station runs a music format and

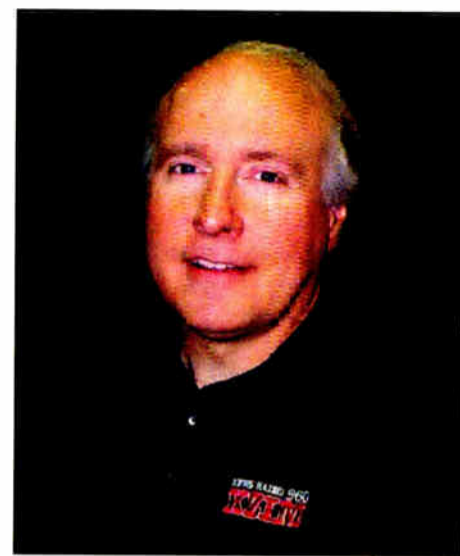

Dave Obergoenner

is voice tracked more than half of the day, add 0.25

- If the station is on satellite-delivered programming most of the day, add 0.25
- If the station is remote-broadcast intensive, add 0.25
- If the market has computer LAN systems, and just about all do, add 1.0 for each LAN

Other factors could be present, such as multi-hop microwave STL systems, excessive travel time to transmitters, etc. These have to be considered on a case-by-case basis, but should be taken into account.

It all adds up

Making the calculation for each station is simple. Add up the factors and get the station total. Next, add the other market factors. Consider the examples shown in the box for the Poplar Bluff, Mo., market.

Experience has shown that a talented, hard-working broadcast engineer working 40 to 50 hours a week can handle a total station equivalency figure of between 8 and 10, with corporate broadcast engineering and IT support. (This figure drops to between 6 and 8 without such support).

Having said that, the examples here show that one good broadcast engineer can take care of the stations listed in the Poplar Bluff market, with some degree of corporate support. Adding another market, or more stations, results in a burned-out engineer. Things may be overlooked due to time limits at the sites, including FCC compliance.

It should be noted that, in any professional position, some sort of planning must be made for vacation and sick days. When the market engineer is out of town or sick with the flu, alternate broadcast engineers must be prepared to handle the problems that arise. This is especially true during storm season (spring and early summer) when most people want to take a vacation.

With a little practice, proper estimations can be made for the adequate number of broadcast engineers that a given market should have for equipment maintenance and FCC compliance.

The author is director of broadcast engineering for the Zimmer Radio Group.

◆ READER'S FORUM ◆

RWBI Seeks Broadcast Partner

Radio Baltic Waves International, a Lithuania-based private AM radio station, has been awarded a license for broadcasting on AM 1386 kHz, using a 1,000 kW transmitter (EIRP=1,600 kW).

RBWI is looking for a United States partner interested in broadcasting on the frequency of 1386 kHz. A skywave coverage area includes most of Europe and European Russia. Currently we operate 100, 150 and 500 kW AM transmitters.

RWBI is ready to negotiate on the issue of installation of a new 1,000 kW AM transmitter and antenna system of our partner. The broadcasting is possible in any language, the daily program duration is unlimited and the power has no reductions.

Interested readers can contact RWBI by e-mail to radio@balticwaves.cjb.net or by calling +370-5-2652532.

Rimantas Pleikys
Project Coordinator
RWBI
Vilnius, Lithuania

Condemning Private Censorship

J. Curtis's Oct. 8 letter, "A Very Dangerous Farce," completely misses the point of Sen. McCain's criticism of the Dixie Chicks ban by Cumulus Chair Lewis Dickey Jr.

McCain repeatedly emphasized during the hearing that the decision itself was not the problem. He said his concern was that the programming decision was made by a distant corporation instead of local licensees in response to their communities of service.

McCain said he had no problem with local management deciding what, and what not, to play. "That's their job," he said. McCain was absolutely right. Stations are licensed to serve their communities of license, not Wall Street.

Curtis's indirect assertion that broad-

cast licensees have a constitutional First Amendment right to censor program material they don't like is wrong, as well. Perhaps he got his idea from FCC Commissioner Abernathy, who testified that, "The First Amendment to the Constitution protects the free speech rights of broadcasters." She also believes FCC Chairman Powell's theory that media consolidation breeds program diversity.

The Bill of Rights is for the protection of "we the people," not the government or its fiduciaries who manage program content over the people's spectrum. Radio and Communication Acts recognized this, and the Supreme Court has consistently reaffirmed it.

For example, in *Associated Press v. United States*, the court said, "It is the purpose of the First Amendment to preserve an uninhibited marketplace of ideas in which truth will ultimately prevail, rather than to countenance monopolization of that market ... There is no sanctuary in the First Amendment for unlimited private censorship operating in a medium not open to all."

Cumulus's Dixie Chicks ban was inappropriate. It was private censorship by a distant entity, not by local stations in response to the interest, convenience or necessity of the communities they were licensed to serve.

Bill Brooks
Bill Brooks Engineering & Design
Sunnyvale, Calif.

In Defense of Provizer

Shame on you, Paul Shinn, for your attack on Stephen Provizer (*Reader's Forum*, Oct. 8). Apparently, your inadequate upbringing failed to include a tutorial on the inappropriateness of judging a person's value or station in society on appearance. I found your assumptions about Mr. Provizer's radio background, political beliefs and personal appearance thoroughly offensive.

And shame on you, Radio World, for publishing Mr. Shinn's libelous, angry tirade. Upon first reading the article about Mr. Provizer's departure from A-B Free Radio ("Provizer Leaves Station He Started," Oct. 13), I also was a bit puzzled as to why your publication was devoting space to an article about such a small broadcaster. I

assumed that you were trying to cover both large and small operations in your pages. How equitable.

Now it appears that you were attempting to "set up" Mr. Provizer in order to attack his character and his person. Shame.

While it's probably too much to expect narrow-minded individuals, such as Mr. Shinn, to contain their contemptuous nature, I expect far better from an international publication such as Radio World. I think that you both owe Mr. Provizer an apology, assuming that he hasn't already initiated legal action in response to your joint indiscretions.

R. Sparks Scott
Broadcast Engineer
Eugene, Ore.

What Branding Means for You

Radio World has received numerous letters regarding the benefits of going digital for AM radio stations. While some readers decry IBOC's interference to adjacent stations and call instead for a galvanization of AM content, others feel an upgrade in audio quality is essential if AM is to compete and survive.

No matter what your position may be, consider the possibility that AM — analog or digital — may fail due to stations' inability to see themselves as brands. And just like any brand, the product must be marketed properly to establish an emotional connection with the public, or risk obsolescence. Kmart, for instance, filed for bankruptcy protection after failing to connect with consumers as a reliable brand amidst an ever-swelling sea of discount stores with images that were more current. Radio stations should evaluate their promotional tactics and switch their focus to resonating with the listener.

The philosophies of cult branding and how they can be applied to the radio industry were featured in a session at the fall NAB Radio Show. Author Matthew Ragas discussed recipes for customer loyalty from his book, "The Power of Cult Branding," and gave Big Radio the truth behind its inability to connect with listeners and keep them tuning in to a particular station — regardless of wattage, gains, formats or any other industry term that matters only to those in the studio.

He suggests "simple things like listener advisory boards for their most hardcore listeners, where they can feel special and stand out from other listeners." He also encourages better utilization of the Web.

Ragas argues that stations still must learn to think more like businesses, seeking to create powerful brands that convey distinctive messages with which listeners can identify, along with the investment of time and money in self-promotion. Listeners don't care about audio quality or ratings, but rather how they feel when they are tuned in to the station. Your emphasis should be on finding a rapport with your audience that compels them to listen to your station or network over any other.

This lesson holds true whether your organization is commercial or not. The late Joan Kroc's \$200 million bequest to NPR is a prime example. Kroc was described as a news junkie, up by dawn every morning combing Internet news stories and listening to her favorite station, NPR affiliate KPBS(FM) in San Diego. In addition to her gift to NPR, she earlier had given KPBS \$3 million for a new studio and included an additional \$5 million in her will.

In a news conference, NPR President Kevin Klose acknowledged Kroc's "vision for NPR," an organization she felt was working to provide a service for her as a listener. Instead of conveying a "We're Number 1!" promotional message to its audience, NPR chose to say, "You're Number 1."

After receiving the largest monetary gift ever bestowed upon an American cultural institution, NPR must be doing something right.

— RW

Kudos From 'Our World'

We receive Radio World here at RFA, and it is often thumb-worn by the time we recycle it. I wanted you to know how much I appreciate the RW Weekly NewsBytes Digest I receive via e-mail.

As you know, we never seem to have enough time in our workdays. The Weekly Digest gives me a chance to catch up on what is going on in "our world." It's a great service. Thanks.

AJ Janitschek
Manager, Production Support
Radio Free Asia

Correction

A byline for a story on page 3 of the Oct. 22 issue misstated the name of the author. His name is R. Sparks Scott.

—EDITORIAL STAFF—

| | | |
|-------------------------|----------|--|
| Paul J. McLane | ext. 117 | Editor |
| Leslie Stimson | ext. 129 | News Editor/Wash. Bureau Chief |
| Michele Kramer Peterson | ext. 149 | Studio Sessions Editor |
| Kelly Brooks | ext. 136 | Buyer's Guide Editor |
| Thomas R. McGinley | — | Technical Adviser |
| Alan Peterson | — | Technical Adviser |
| John Bisset | — | Contributing Editor |
| Skip Pizzi | — | Contributing Editor |
| T. Carter Ross | ext. 120 | Editor-In-Chief (International) |
| Marguerite Clark | — | Editor (International), Milan |
| Rogelio Ocampo | ext. 121 | Latin America Editor in Chief |
| Karina Gerardi | ext. 137 | Latin America Editor |
| Terry Hanley | ext. 130 | Editorial Assistant & Listings Coordinator |
| Peter Finch | — | Editorial Assistant, Milan |

—EDITORIAL CONTRIBUTORS—

W.C. Alexander, Bruce Bartlett, Frank Beacham, Naina N. Chernoff, Harry Cole, Troy Conner, Vince Ditingo, Mark Durenberger, Charles Fitch, Ty Ford, Scott Fybush, Harold Hallikainen, Jeff Johnson, Craig Johnston, Paul Kaminski, Peter King, Mark Lapidus, Mark Persons, Sharon Rae Pettigrew, Michael LeClair, Carl Lindemann, Frank R. Montero, Ted Nahil, Tom Osenkowsky, Ken R., Rich Rarey, Randy Stine, Travis the V/O Guy, Barry Umansky, Tom Vernon.

Radio World

Vol. 27, No. 25 December 3, 2003

Telephone: (703) 998-7600 • Business Fax: (703) 998-2966 • Editorial Fax: (703) 820-3245
E-mail: radioworld@imaspub.com • Web site: www.rwonline.com

—ADVERTISING SALES REPRESENTATIVES—

| | | | |
|---|-------------------|-----------------------|--|
| US East: John Casey | 330-342-8361 | Fax: 330-342-8362 | e-mail: jcasey@imaspub.com |
| US West: Dale Tucker | 916-721-3410 | Fax: 815-352-1698 | e-mail: dtucker@imaspub.com |
| Product Showcase & Classified Ads: Simone Fowell | 703-998-7600 x154 | Fax: 703-671-7409 | e-mail: sfowell@imaspub.com |
| European Sales Mgr., Africa, Middle East: Raffaella Calabrese | +39-02-7030-0310 | Fax: +39-02-7030-0211 | e-mail: rcalabrese.imaspub@tin.it |
| Japan: Eiji Yoshikawa | +81-3-3327-2688 | Fax: +81-3-3327-3010 | e-mail: callem@msn.com |
| Asia/Pacific: Wengong Wang | +86-755-5785161 | Fax: +86-755-5785160 | e-mail: wwg@imaschina.com |
| Latin America: Alan Carter | 703-998-7600 x111 | Fax: 703-671-7409 | e-mail: acarter@imaspub.com |

NEXT ISSUE OF RADIO WORLD DECEMBER 17, 2003

For address changes, send current and new address to RW a month in advance at P.O. Box 1214, Falls Church, VA 22041. Unsolicited manuscripts are welcomed for review: send to the attention of the appropriate editor.

—ADMINISTRATION & PRODUCTION—

| | |
|----------------------|------------------------------------|
| Stevan B. Dana | President/CEO |
| Carmel King | VPI/Group Publisher |
| Marlene Lane | Editorial Director/COO |
| Chuck Inderrieden | CFO |
| Eric Trabb | Sales & Marketing Director |
| John Casey | Associate Publisher |
| Annette Linn | Production Director |
| Melissa SE Robertson | Production Publication Coordinator |
| Kathy Jackson | Ad Traffic Manager |
| Milagros Castañeda | Classified/Product Showcase Layout |
| Robert Green | Circulation Manager |



Radio World (ISSN: 0274-8541) is published bi-weekly by IMAS Publishing (USA), Inc., P.O. Box 1214, Falls Church, VA 22041. Phone: (703) 998-7600, Fax: (703) 998-2966. Periodicals postage rates are paid at Falls Church VA 22046 and additional mailing offices. POSTMASTER: Send address changes to Radio World, P.O. Box 1214, Falls Church VA 22041. REPRINTS: Reprints of all articles in this issue are available. Call or write Joanne Munroe, P.O. Box 1214, Falls Church, VA 22041; (703) 998-7600; Fax: (703) 998-2966. Copyright 2003 by IMAS Publishing (USA), Inc. All rights reserved.

—Printed in the USA—

WHEATSTONE D-4000

DIGITAL AUDIO CONSOLE



Based on the technical architecture of our popular D-5000, this new D-Series console is totally modular, offering features to satisfy the most demanding engineers—but at a lower price point than its predecessors.

- Hot-swap design
- Four stereo mix buses
- Six pointer-style true VU meters
- Any mix of digital and analog inputs
- AES and balanced analog outputs
- Choice of master clock rates
- Up to 4 mix-minus outputs using SPD-4000 phone remote modules
- 24 bit A-to-D conversion on analog inputs,
- A/B source switching with fully independent logic and machine control
- Mode selection on stereo inputs
- Low profile drop-through counter design
- Multiple studio outputs with talkback interrupt

*Wheatstone has more digital audio experience than most of our competition combined. The D-4000 is a truly high performance, reliable console that will make your transition to digital a pleasure. Benefit from our expertise—**CHOOSE WHEATSTONE**—the Digital Audio Leaders!*

 *Wheatstone*



GENERATION 9 DIGITAL CONTROL SURFACE

Designed to integrate flawlessly with the Wheatstone BRIDGE digital audio network router, the Generation 9 control surface allows you to easily create large or small platform-based systems that are exceptionally user-friendly and flexible. Wheatstone BRIDGE network cages house all I/O ports and engine cards, and may be wired in tandems within a single equipment room or interconnected to separate remote locations by means of fiberoptic or CAT-5 cables to provide single wire studio integration schemes.

Once configured, the system operates entirely independently of external computers. Configuration itself is intuitive and carried out onsite by means of user-friendly graphic interfaces provided by Wheatstone desktop software. We have gone to great lengths to make these setups easy for your field engineers, allowing expansions and changes to be achieved painlessly. Naturally, the Generation 9 system also takes full advantage of Wheatstone's exclusive VDIP® configuration

software as well, so that studio functions (like mutes, fader and timer starts, tallies, etc.) are easily accomplished right at your desktop. Once set-up is completed the desktop is disconnected; all settings are retained in nonvolatile storage and the entire system runs standalone. Ethernet protocol is built in, providing interface with automation, scheduling, and hardware controllers as you require.

Whether you're planning a small, centrally located studio network or a large, multiple format build-out, the Generation 9 Digital Control Surface can form the basis for a fully integrated, reliable and user-friendly broadcast system that will handle your most demanding requirements and be able to change with your varying needs as they arise.

At Wheatstone we have more combined digital design expertise than anyone. **Benefit from our hard work!** Choose **WHEATSTONE—the Digital Audio Leader.**

 **Wheatstone Corporation**

600 Industrial Drive, New Bern, North Carolina, USA 28562
www.wheatstone.com / sales@wheatstone.com

copyright © 2003 by Wheatstone Corporation

tel 252-638-7000 / fax 252-635-4857