

\*\*\*\*\*AUTO\*\*3-DIGIT 857  
 S117298 D08 0204  
 TOM MILLER 706  
 ASST CHIEF ENGINEER  
 KTZR  
 2033 S AUGUSTA PL  
 TUCSON AZ 85710 7905

**Voices of World War II**

In Kansas City, a special project recalls KMBC Radio and another era.

Page 12

**AM Believers**

C. Crane says it has the best AM radio available. Audacious? Hell yes.

Page 21



# Radio World

\$2.50

The Newspaper for Radio Managers and Engineers

February 12, 2003

**INSIDE**

**ENGINEERING**

▼ Robert Hammett is remembered for his tower array innovations.  
 Page 10



▼ Wisconsin Public Radio shares a neat ISDN line-switcher it developed for the show 'Whad' Ya Know?'  
 Page 19

**GM JOURNAL**

▼ Spanish radio holds Arbitron to the fire.  
 Page 23

▼ Non-PC devices promise to move Web radio listening to the stereo room at home.  
 Page 23

**BUYER'S GUIDE**



▼ The latest tools for portable audio and news-gathering.  
 Page 33

**LAPTOP POWER**

▼ A Texas chief engineer wins AudioTX Communicator software.  
 Page 4



Sign Up For NewsBytes Weekly Digest at [www.rwonline.com](http://www.rwonline.com)

**NEWS ANALYSIS**

## HD Radio 'Baby' Is Ready to Fly

by Leslie Stimson

**LAS VEGAS** Finally, consumer electronics retailers don't need PowerPoint presentations or product mock-ups to understand the concept of terrestrial digital radio. Proponents say soon, the public will be equally informed.

The receiver partners of Ibiqity Digital Corp. had real products on display at the Consumer Electronics Show, the event where retailers place orders for radios, which traditionally reach store shelves in the spring.

This milestone places the developer  
 See HD RADIO, page 6 ▶



Ibiqity's Mike Lyons (foreground) and Paul Peyla demonstrate in-dash HD Radios from receiver manufacturers Kenwood USA, Visteon, Alpine, Delphi, Jensen, JVC and Sanyo.

**NEWS MAKER**

## NATE Sees 'Tremendous Strides'

**WATERTOWN, S.D.** Craig Snyder began working as a tower hand in 1984. Today he is chairman of the board of the National Association of Tower Erectors, and is president and CEO of Sioux Falls Tower & Communications.

NATE was formed in 1995. Its annual convention takes place Feb. 18-21 in Dallas.

*RW: What has NATE accomplished toward its goals of encouraging uniform safety standards, improved communications and a voice for members?*

**Snyder:** NATE has made tremendous strides ... For example, in 1995, most members looked at the Occupational Safety and Health Administration as the enemy, and often our focus on safety was a combative defense of the status quo.

We now work as partners with OSHA and have helped them in developing a better understanding of our industry and how it differs from others. This understanding has been very beneficial to our members in that, when OSHA does show up on a site, they are not likely to arbitrarily cite tower erectors for rules that

See SNYDER, page 5 ▶

**GREAT COMPANY**  
**EXCELLENT PEOPLE**  
**CELEBRATED PRODUCTS**

**NIB**  
 Booth N2403

**IDT Continental Electronics**  
 INTEGRATED DESIGNER

800.733.5011 [www.contelec.com](http://www.contelec.com)

## ◆ NEWSWATCH ◆

### Radio Show May Morph

**WASHINGTON** Declining attendance at the fall radio show has NAB Radio Board members thinking it's time to pursue alternatives.

Discussion at the winter board meeting on this topic centered on possibly combining the fall show with the annual Radio Advertising Bureau show. RAB staff has been producing sales/marketing sessions at NAB shows for several years.

The NAB board directed its staff to explore that approach, as well as the feasibility of combining the radio show with other industry events.

### Radio One Cable Expected by Mid-Year

**LANHAM, Md.** Radio One and Comcast plan to merge parts of their companies to form a cable channel by mid-year that would be a competitor to

Black Entertainment Television.

While Comcast is based in Philadelphia and Radio One in Lanham, Md., the new company will be based in the Washington area.

The channel provides a way for Radio One to expand into TV. Executives expect the new venture to launch by the middle of the year. Radio One Chief Executive Al Liggins III told The Washington Post he's been trying to expand into TV for four years.

Radio One is to put up \$70 million and provide radio ad time in markets

where Comcast launches the network. Comcast is to put up \$60 million and offer the network to its subscribers. Each company would own 38.5 percent of the new network. Other investor deals had not been finalized at presstime.

### NAB Contemplates Broadcast Lab

**WASHINGTON** The NAB Radio Board supports the concept of launching a broadcast lab to "enhance terrestrial broadcasting," according to a statement released by NAB after the winter board meeting in January. The mission of the lab would be to improve and enhance delivery of over-the-air broadcasting to consumers, stated NAB.

Board approval is contingent upon funding issues being resolved. Maximum Service Television asked NAB to commit \$6 million over three years to the project, with an additional \$6 million expected to come from Consumer Electronics Association member companies. MSTV expected to commit \$3 million.

### Former NCR Exec To Head Harris

**MELBOURNE, Fla.** Howard Lance is the new president and CEO of Harris Corp., effective Feb. 1.

He also was elected to the company's board of directors. Lance previously served as president of NCR Corp. and COO of its retail and financial group. Lance also worked as executive vice president of Emerson Electric Co.

Current chairman, president and CEO of Harris, Phillip W. Farmer, will stay on as chairman of the board and as an employee until the end of the company's fiscal year in late June.

# THE AMAZING LITTLE MIXER



## ALM

### Routes any INPUT to any FADER...

**OR ANY INPUT TO YOUR MONITORS!** The new ALM-12d console from Auditronics combines the benefits of a router and a console—all into one cost effective package. It's got everything you need: twelve faders plus two caller faders, four mic pre-amps and of course control room and studio monitoring, built-in cue and headphone amplifiers, and a concealed headphone jack.

It's got the high end features too, like bright LED dot matrix source displays above faders and monitor pots, and 24 bit A>D and D>A ins and outs. Its AES digital inputs have sample rate convertors so it works

with virtually any digital source gear you have. It can run your source machines too—up to eight of them—all opto-isolated. It even has DSP digital metering that simultaneously displays VU columns and peak hold full scale digital so you can be assured of pristine performance. It has powerful caller tools that generate MXMs automatically, and you can program any of its four MXMs to be pre or post fader.

And because it's **AUDITRONICS**, it's built tough as steel, and will be easy to maintain.

**DIGITAL CAN BE EASY—JUST CALL AUDITRONICS!**



Digital so easy you don't install it—you CONNECT it!

tel 252-638-7000/fax 252-635-4857/sales@wheatstone.com  
600 Industrial Drive, New Bern, North Carolina, USA. 28562

**AUDITRONICS**  
www.auditronics.com

copyright © 2002 by Wheatstone Corporation

### Index

#### NEWS

|  |    |
|--|----|
| HD Radio 'Baby' Is Ready to Fly                          | 1  |
| NATE Sees 'Tremendous Strides'                           | 1  |
| NewsWatch  | 2  |
| Satellite Radio More Entrenched                          | 3  |
| Satellite in Home, Office,<br>Car, Truck or Boat         | 3  |
| IBOC Is Here, for Better or Worse                        | 4  |
| Receiver Companies Build HD Radios                       | 6  |
| 'Tomorrow Radio' Tests Second<br>Digital-Channel Concept | 6  |
| Robert Hammett in Retrospect                             | 10 |

#### FEATURES

|   |    |
|---|----|
| Collaboration Brings<br>History to the Web        | 12 |
| Open Your Eyes and Take a Look<br>Workbench: Hey, | 16 |
| Don't Flip Out — Flipit!                          | 19 |
| C. Crane Loves AM Radio                           | 21 |
| Jeffrey Lalumiere Remembered                      | 21 |

#### GM JOURNAL

|   |    |
|---|----|
| Will Arbitron Walk the Talk?                      | 23 |
| Web Watch: CES Showcases New<br>Web Radio Devices | 23 |
| Web Radio Ratings                                 | 30 |

#### BUYER'S GUIDE

|                                    |    |
|------------------------------------|----|
| Sonifex Courier at BBC London 94.9 | 33 |
| Comrex Codex and a Moving Train    | 33 |
| Rayovac Rechargeable Battery Test  | 34 |
| CellCast Passes 'Manual' Test      | 36 |
| ComPack Connects for Field Work    | 37 |

|         |    |
|---------|----|
| OPINION | 46 |
|---------|----|

# Satellite Radio More Entrenched

by Leslie Stimson

**LAS VEGAS** Satellite radio firms XM and Sirius are maturing, with heftier subscriber bases and more radio models available compared to a year ago.

The companies created the satellite digital radio product category, and it was apparent at the CES show that consumer electronics retailers are enthused to have new features to pitch to the public in the in-dash and aftermarket receiver categories.

XM and Sirius helped subsidize receiver development costs to get product to market faster than normal, particularly for in-car models.

Experts say it can take several years to get a new design in a car, but the satellite radio companies got their radios in the dash quickly. For example, XM launched nationwide in fall 2001 and began to have in-dash radios made by receiver partners as vehicle factory options in available in the fall of '02.

Ibiquity, the newest arrival in the digital radio product category, has said it is not in the same financial position to provide receiver partners funds to supplement development costs. That hasn't seemed to affect its ability to get HD Radios developed for the car. Visteon and Delphi have manufactured HD Radios for in-dash use and displayed them at CES.

## More in-dash

At the show, receiver partners for XM and Sirius showed more radios integrated into the dash and fewer black-box items where the receiver is mounted in the trunk or under a seat. Manufacturers also introduced portables and home radios for satellite digital radio. Antennas for the satellite digital radios are smaller than they were a year ago.

Although both XM and Sirius highlighted their programming and audio quality to differentiate themselves from

terrestrial radio, they differed dramatically in how they presented their respective companies at the convention.

XM President/CEO Hugh Panero said the company signed up more than 360,000 subscribers in 2002, adding 145,000 of those in the fourth quarter.

**We want to be the HBO of radio and we're on the way to making that happen.**

— XM's Hugh Panero

"XM hit these numbers in the face of a weak economy and soft retail environment," said Panero, who said the company is on track to pass 1 million subscribers this year. Reaching that figure, Panero said, would "firmly establish" XM as a mass-market product.

"We want to be the HBO of radio and we're on the way to making that happen."

XM investor General Motors expanded its XM offering as a factory-installed option to 25 vehicle lines for model year 2003, and plans to make XM radios available in 44 vehicle models in model year 2004, cars that will be available this fall. Honda and Nissan plan to expand XM's availability in their vehicles this year.

GM also is pulling more of the financial weight of XM's national advertising in '03 and XM is running ads on ABC Radio and Premiere Radio Networks, Panero told Radio World. XM would not disclose advertising financials.

The Delphi SkyFi "boombox," which can be used in home, office or car, is new. The product has a larger display with

larger text than other XM radios. XM said the unit sold well during the holidays and retailed for \$199.

"If they had had more product in the market, they would have done even better. They set themselves up well for 2003," one analyst said.

XM executives said referrals by friends and family members are helping boost their subscriber numbers. Each subscriber in a household is counted individually and pays separate subscriptions. When asked if the company would offer discounts for such referrals or a household plan, XM executives said it's being discussed within the company but no decision had been made.

Sirius executives, on the other hand, emphasized future concepts more than subscriber numbers.

## Breaking even?

Sirius President/CEO Joe Clayton did say that having 2 million subscribers in 2005 would give the company "a strong balance sheet." At that time, Clayton said, the company would break even.

In the meantime, Sirius expected to have 40,000 subscribers by the end of March and 300,000 by the end of this year, prompting analysts to debate whether Sirius is hitting its subscriber targets.

Sirius Satellite Radio's new slogan is "It's On," and the company is quietly dropping the "Satellite Radio" from its

branding. It wants to be known for more products than satellite radio. That concept is part of its new ad campaign that will include cable, TV, print and, Sirius says, spots on commercial radio. Sirius President Joe Clayton didn't disclose the campaign amount.

The company showed future ways in which its programming could be delivered, other than in radios, such as an exercise bicycle that could receive Sirius programming and mall applications, using a multi-zone receiver that enables stores to play Sirius channels.

But the demo that garnered much of the attention was a live streaming video display of a cartoon over a Kenwood Sirius radio. The idea is to give consumers another viewing option to a built-in VCR or DVD player in the car.

Company executives told Radio World the video would only be engaged in the front seat when the vehicle is parked, with no limit on the back-seat use. Sirius and Kenwood have not agreed when the product would be available.

Sirius said it could devote data bits to the video product without compromising the quality of its audio channels.

"Sirius is the only satellite radio company that features statistical multiplexing technology, which allows us to maximize the utilization of our bits," said Larry Pesce, vice president of product management and strategic planning.

Sirius said its so-called "S-Plex" technology allows it to allocate bandwidth dynamically, giving more bits to channels that need bandwidth and less to those that

See CES SAT, page 10 ▶

AudioTX Communicator Software ISDN and IP Network audio codec for Windows 98/NT/2000 • Uses Standard Sound and ISDN cards  
• Connects to all MPEG 2, MPEG 3 and G.722 codecs  
• Ideal for Studio or On-the-road use in a Laptop

**£500 \$725 €795**

## ISDN &

## IP AUDIO CODEC

AudioTX Communicator is big on audio quality, reliability and ease of use - but low on price

As an ISDN codec, Communicator offers MPEG 2, MPEG 3 and G.722 coding plus G.711 telephony and is compatible with virtually all other manufacturers' units for outside broadcasts, studio links, voice-over work, reporting and news-gathering.

As an IP-based codec, Communicator works over any IP-based network - from Ethernet to ATM or a Satellite link, Leased-line connections or even over the internet using ADSL, DSL, Cable Modem or other high speed connection.

All you need to get connected is a standard Sound card and an ISDN card installed in your PC or Laptop, plus AudioTX Communicator.



**AudioTX**  
Communicator

Download a FREE, fully working trial version today.  
[www.audioTX.com](http://www.audioTX.com)

Tel: +44 121 256 0200 (GMT)  
Email: [sales@audioTX.com](mailto:sales@audioTX.com)

## Satellite in Home, Office, Car, Truck or Boat

Kenwood and Audiovox showed home and portable Sirius radios at the CES convention. Both plan to ship product to retailers by mid-year. Home units can be operated with a wireless remote and include audio presets and RCA left and right audio jacks to enable integration into a home audio system.

Kenwood introduced a portable Sirius tuner used with a slide-in cradle for car, home, office or boat. Available in the second quarter of 2003, the tuner is expected to list for about \$150.

Kenwood is offering a special retailer deal through February. A consumer who buys any head unit in January and February could get a Sirius receiver and one month's service for free.

Audiovox also expects to ship a plug-and-play Sirius portable receiver in mid-year.

Other Sirius plug-and-play models were introduced by Sanyo, Panasonic and Delphi.

Sirius showed a Terk antenna and combiner system that can be added onto an existing satellite TV dish for the home.

Sirius has a new, smaller chipset design, allowing it to introduce integrat-

ed in-dash AM/FM/CD in-dash radios. Sirius has reduced the number of chipsets in each radio from eight to four, consuming less power and allowing radio makers to save on component costs.

Delphi makes OEM radios for both Sirius and XM. Delphi is working with both on radios capable of receiving both services, which are still in development.

Delphi satellite radio antenna subcontractor Fuba is developing antennas that combine functions, so ultimately the same auto antenna could be used for satellite radio, GPS and cell phone. This would eliminate the need for a second antenna for satellite radio.

XM expects some 80,000 Delphi XM SkyFi "boom box" units to ship to retailers in the first half of this year. It has an integrated high-gain antenna and can be powered by an A/C adapter or batteries. The unit can be adapted for car installation.

Alpine, Delphi, Pioneer and Sony showed XM in-dash head units. Showing XM receivers were Alpine, Audiovox, Delphi, Pioneer and Sony.

— Leslie Stimson

# IBOC Is Here, for Better or Worse

First, a quick visual:

Engineering consultant Mike McCarthy sends us the photo shown on this page. Given recent events, such a picture might seem alarming; but all is in order.

Mike snapped it at a station located right under the approach to Chicago O'Hare International Airport, about five miles from the end of the runway, to show how startlingly close the planes seem to come.

"Perfect day — tower is freshly painted," Mike says. "If we tried to build that tower today, forget it."

★ ★ ★

If you had any doubts that IBOC/HD Radio is about to hit in a big way, the recently concluded CES show should put them to rest.

As Leslie Stimson, who was in Las Vegas for the convention, reported last issue, more than 35 radio groups have signed up for HD Radio licensing agreements and placed equipment orders, and stations in at least 40 markets will be on the air with digital in early 2003. HD-R



This tower site offers Mike McCarthy a dramatic view of air traffic near O'Hare.

## From the Editor



### Paul J. McLane

will head north again. Another factor in demand from stations will be whether Ibiquity decides to offer incentives again, such as the now-expired fee waiver.

In the longer term, demand will be driven by availability and the consumer uptake of receivers (or a lack of it).

How long it will take the entire radio industry to go digital is an open question; but the general sense of the Harris managers was that the time frame may well be shorter than the 10 years often quoted in industry projections.

Meantime, the supplier is planning lots of emphasis on HD Radio at the spring NAB. We'll have details on Harris' plans, and those of other HD-R vendors, in upcoming issues.

★ ★ ★

However, one industry veteran who walked the floor at last month's CES show was unabashedly skeptical about IBOC.

"HD Radio. What a joke," he told me, agreeing to share his thoughts here if I did so without naming him. "(HD Radio was) totally lost at this show, and I believe once again a missed opportunity.

"I cannot believe that the average buyer for these large (retail) chains even have a clue to this technology or service, much less care. The Ibiquity booth reminded me of nerdy scientists. They really need PR help and marketing assistance if they are to continue with these types of non-broadcast shows," he said.

See IBOC, page 5

is on the air in several markets. IBOC is about to stand the real test.

Opinions on its prognosis diverge wildly.

One company that stands

to profit is Harris Corp., which has invested a great deal in the technology and in ramping up production of transmitters.

Several Harris managers visited Radio World in January as part of a pre-NAB convention press tour to discuss their plans for the upcoming convention. Most of the discussion focused on IBOC.

Harris had taken approximately 45 orders for HD Radio systems as of mid-January. The Harris folks repeated Ibiquity Digital Corp.'s CES observations that IBOC orders are coming from stations in all sizes of markets, not just the biggest cities.

(This is not surprising to me; smaller markets usually participate in, or lead, radio innovation. Witness our experiences with computer automation and compact discs.)

One Harris executive predicts that after the first rush of early adopters, IBOC's demand curve will flatten or pause as the industry assesses the impact.

Then, as non-digital stations hear competitors trumpeting themselves for being the first, and as clients begin to take notice, the demand for IBOC gear

We're off to a galloping start in the 2003 New Technology Sweepstakes. Did you sign up at [www.rwonline.com](http://www.rwonline.com)? It takes moments and costs nothing to enter.

Andy Hudack, chief engineer with Susquehanna station KRBE(FM) in Houston, is the winner of AudioTX Communicator software, which turns a PC or laptop into an ISDN codec, compatible with most manufacturers' units.

The system offers an alternative to hardware ISDN codecs. The software auto-detects and configures itself for the type of codec on the other end. Only an ISDN card and sound card are required in the PC.

Communicator can connect over IP networks and the Internet, sending compressed or linear audio over LANs, WANs, T1/E1, wireless networks or high-speed Net connections

like DSL/cable modem, for audio transfer or STL-type connections. Multicast functionality allows broadcast-quality streaming to multiple receivers on a network.

Value: \$790. Communicator is distributed by CCS/Musicam USA.

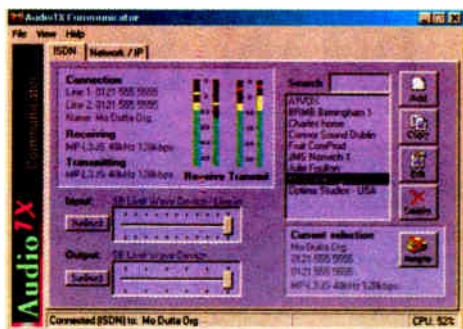

**AutoPilot**

# All-New AutoPilot<sup>®</sup> 2...

## Unleash the Power!

### Broadcast Transmitter Control Software

- Control all sites from one PC
- Wizards for easy setup
- Powerful Scripting

*"AutoPilot 2 has not missed a beat -- which is critical for a high powered AM station. It's very dependable."*  
Paul Reynolds, Chief Engineer  
Cox Radio.

*"AutoPilot 2's open architecture has really expanded our monitoring capabilities. The power of the scripting wizard can't be overstated."*  
Jeff Kuhne, Engineer, WRPI-FM

**Special Offer!!**

Order now and receive free ARC-16 5.4 firmware with your purchase!

5.4 Firmware Features include:

- Adjustable Alarm Delays
- Adjustable Raise/Lower Durations
- Autoload for PC Based ARC-16 Configuration

**BURK**  
TECHNOLOGY

Tel: 800-255-8090  
Web Site: [www.burk.com](http://www.burk.com)  
Email: [sales@burk.com](mailto:sales@burk.com)

# Snyder

► Continued from page 1  
make no sense to our industry.

Furthermore, much of the advances in safety equipment have come through the efforts of the NATE Safety and Education Committee as well as individual members working with the various vendors of this equipment. Tower climbers can now access towers using state-of-the-art personal protective equipment that was not available just five years ago. This has undoubtedly saved lives and (prevented) personal injury.

Finally, NATE has developed numerous safety manuals and videos available to its members that have served to standardize safety practices within the industry. Most of what NATE has done is now accepted as the "standard" for tower workers inside and outside the association.

**RW:** What is the biggest challenge facing this industry when it comes to loss control?

**Snyder:** I see the biggest challenge as one facing our customers rather than the tower erector and service companies themselves.

I have seen a trend toward customers choosing to hire general contracting companies who then in turn hire smaller sub-

contractors who might then actually hire a third company to do the tower work required at the site. Often these smallest companies are not members of NATE and do not use safe practices in performing the required work. Most of the fatal accidents that made the news last year can be traced to this phenomenon.

I think that as more of our customers determine that they will get a better understanding of who is actually doing the work on their towers and make it a requirement that they meet minimum standards of safety, the more likely losses will begin to diminish.

Of course, it is my belief that NATE members are the safest in the industry. It is our job to try to get all tower service companies to join the association. As this continues to happen, a gradual education process will occur.

**RW:** Broadcasters have expressed a lot of interest in the Koor case in New Hampshire, in which that state's highest court overruled a city ordinance limiting the height of new communications towers



Craig Snyder

and stated that, in this case, federal law pre-empts local law. Do you see that case as precedent-setting?

**Snyder:** I would like to believe that the Koor case sets a precedent for other zoning officials to look to in developing (or not developing) similar ordinances in the future. But I fear that each jurisdiction will attempt to hold to the notion that towers are basically undesirable and need to be limited.

I think the more times these cases are won in the higher courts, the better chance that a loosening of similar tight regulations will occur.

**RW:** Characterize your members' relations with OSHA.

**Snyder:** Our members' relations with OSHA have come a long way in the past seven years.

Shortly after NATE came into existence, OSHA formed what they refer to as the "Tower Task Force." The association's OSHA Relations Committee works very closely with this tower task force and has been instrumental in getting an OSHA "directive" allowing workers to access towers by "riding the line" from the ground to the required work location on the tower.

OSHA was adamant against this practice before NATE was started, and even for sometime thereafter, but through the process of gentle persuasion and education, NATE has been successful in bringing OSHA around to see our point of view.

NATE and OSHA also formed a partnership in 2002 in one of the national regions in which partnering companies

agree to voluntarily abide by certain safety practices in exchange for OSHA focusing on only the most important safety matters at the work site and not citing companies for other more frivolous violations. If this partnership is successful, we hope to expand it to a national level.

I could not say that, at this time, there are any major areas of disagreement between OSHA and NATE. However, we continue to work with OSHA to educate them on such issues as "free climbing," which is not allowed under current OSHA rules, but is required in certain circumstances on towers or TV antennas. OSHA has been sympathetic to our efforts and we continue to work toward an agreement.

**RW:** What's the status of industry hoist and gin pole standard efforts?

**Snyder:** The gin pole standard that has been the effort of the TIA/EIA committee and NATE is now before the committee in what is hoped to be its final draft form. Unfortunately, the committee has been dedicating most of its efforts toward the revision of ANSI/TIA/EIA 222-"G" and will not likely present it for balloting until later in 2003 or early 2004. A tremendous amount of work has gone into this draft standard and it will be of great benefit to the industry once it is official and released to the public.

The NATE board of directors currently has the first draft of the Hoist Standard in its hands and it is being reviewed. We hope to have it completed by the end of 2003 as well and available to our members by early 2004.

See SNYDER, page 8 ►

# IBOC

► Continued from page 4

"My opinion to the consumer (about HD Radio (is) that dog won't hunt. Quality of signal is not in question; content of the signal is. A 22-minute stop set of commercials in digital is still 22 minutes of commercials.

"The argument of 'free' isn't going to last much longer," he predicted. "Twenty-two minutes of my time per hour is not free. You want me to suffer through your crappy commercials, pay me. Otherwise I'll insert my MP3 unit in my car radio and listen to six hours of music, uninterrupted."

I might treat these harsh comments more skeptically if this particular individual had not spent most of his life in the business of providing services to radio stations. He is no whacko outsider but a man with deep connections to our business.

MP3, he said, was the only real audio buzz at CES: "MP3s for car. MP3s for jogging. MP3 units retailing for \$99 about the size of a large wristwatch," he said. "USB input. Headphone output. One AA required and included.

"No tuners in these portable units. When I asked someone where the tuner was, the response was, 'Why?'"

Listeners, particularly but not only younger ones, are downloading music to avoid radio, he said.

Personally, I think these are separate issues. The industry should indeed seek to better its service by pursuing technical advancements like HD Radio. If this means having scientists, nerdy or otherwise, in the booth, so be it. And many of those "nerds" are people I know and admire.

The writer's legitimate concern over radio's spot load does not render unnecessary the drive for us to make radio as competitive as possible. However, his comments do remind us that many people who love radio are frustrated with the medium these days.

\*\*\*

What's going to happen to the fall NAB Radio Show?

We've asked that question many times in these pages. Now the NAB Radio Board of Directors has directed the association's staff "to begin reviewing alternative approaches" to presenting the current show. One option specifically included in its instructions: the possibility of combining the event with the annual Radio Advertising Bureau Conference or other industry events.

I wrote here in October that Radio Show attendance had declined from 7,680 in 2000 to 3,983 this past fall, a drop of 48 percent in two years. And that's overall attendance, including journalists, exhibitors and exhibit-only guests. The number of booths also was down.

I said then, and I believe now, that these trends are a reasonably predictable outcome of radio consolidation, and that the convention can remain a useful part of the industry landscape if we reset our expectations and accept it as a session-heavy event with fewer managers, a smaller show floor and a modest budget.

Don't kill the Radio Show. Be willing to reinvent.

The NAB board's action is welcome if overdue.

\*\*\*

Suppliers: Our readers want to know about your new products. To help you get the most out of Radio World's NAB convention coverage this spring, I've compiled a list of tips and answers to common questions from exhibitors.

What's the best day to hold a press conference at NAB? What's the most common marketing error we see in press releases? How can you take full advantage of our existing coverage opportunities? Find out.

For a copy of this list of tips, just e-mail me at [radioworld@imaspub.com](mailto:radioworld@imaspub.com).

# Learn to Adapt



**Discover** the versatile CAT-5 wiring solution that integrates analog, digital and data signals. It's a brilliant system of pre-made cables, adapters and harnesses that will save you time and money on your next digital-ready wiring project.

StudioHub – the new way to connect.



**BY StudioHub**  
Radio Systems

Radio Systems, Inc. 601 Heron Drive, Logan Township, New Jersey 08085  
(856) 467-8000 (856) 467-3044 fax [www.radiosystems.com](http://www.radiosystems.com)

# HD Radio

► Continued from page 1

of in-band, on-channel digital audio broadcasting on a more even playing field with its satellite brethren, whose receiver partners have had at least one satellite digital radio system available to the public since late 2001.

More than 35 radio group owners in 40 U.S. markets said at CES they plan to begin broadcasting in both digital and analog this year, with many stations doing so by the end of March.

After more than 10 years of IBOC development, several things are falling into place so that Ibiquity Digital Corp. can get terrestrial digital radio away from the workbench and to the companies that will take the technology into consumers' homes.

## Baby flies

Ibiquity executives say the company is transitioning from a technology developer into a company that's transferring that information to radio groups and equipment partners.

"Today's the day the baby finally leaves the nest," said Ibiquity



Kenwood showed a car receiver that can be controlled by 17 Kenwood head units. This particular head unit can be modified to be either an HD or Sirius radio. Kenwood has also developed an adapter that can be installed in the trunk so that both types of digital radio services can be controlled with one tuner.

President/CEO Robert Struble to reporters at CES in early January.

Representatives from several facets of the consumer electronics industry and broadcasters joined Ibiquity to proclaim that HD Radio is rolling out. HD Radio is the name by which consumers will know in-band, on-channel digital audio broadcasting.

The Consumer Electronics Association produces the convention. President/CEO Gary Shapiro said, "This show increasingly focuses on the digital lifestyle. Almost every American understands what CD quality is," a reference to the promise that HD Radio delivers CD quality on FM.

Manufacturers displayed HD-R car audio tuner prototypes and two home versions (see sidebar below).

Retailer representatives and NAB joined Ibiquity in praising the rollout.

John Orlando, NAB senior vice president of external relations and acting head

of government relations, said HD Radio will enhance the listener experience. In what is likely a preview of the basic marketing pitch to consumers, he said, "It's all going to be brought to them for free."

Ibiquity originally believed most of the radio groups that agreed to convert early would be in big cities; but the 40 markets with early stations on the air were a mix of sizes. "We exceeded all of our expectations," said Struble. Representatives of transmitter companies taking orders echoed that observation.

Thirty-five radio groups agreed to convert at least some of their stations this year. About 100 stations are converting to digital this quarter. Early adopters received waivers of Ibiquity's technology license fee; that incentive deal ended Dec. 31, 2002. Those groups had to show proof that they had ordered IBOC RF equipment and intended to have it installed as soon as they could this year.

The radio groups also came to terms with Ibiquity on which specific stations would convert this year.

Asked whether Ibiquity is considering renewing the fee waiver or creating another incentive for stations to convert later, Struble said the deal was over and implied that no more are planned. He added, "Never say never."

Ibiquity expects about 300 stations to be transmitting HD-R by the end of this year and an additional 500 to 600 stations to make the switch in '04.

Markets where at least one HD Radio  
See HD RADIO, page 7 ►

## Receiver Companies Build HD Radios

**LAS VEGAS** Kenwood USA and Harman Kardon showed HD Radio receivers for the home at CES, with Kenwood predicting shipments to retailers in April or May.

Kenwood also showed a car receiver that can be controlled by 17 Kenwood head units. The target retail price for the receiver is \$350.

Kenwood USA's Bob Law said the dawning of HD Radio is an opportunity to replace existing product. "The potential we see is astounding."

Some retailers expressed enthusiasm about HD as well. Tweeter representative Bernie Sapienza said terrestrial radio's adoption of a digital format gives receiver manufacturers a chance to talk about the tuner spec and "rejuvenate those price points."

More receiver manufacturers are expected to have HD Radio receivers to sell to retailers by next year as well. At CES, manufacturers showed products that are ready to ship to retailers, as well as radios still in development.

Visteon has manufactured an HD Radio that includes a CD player; it will be offered by an unnamed European automaker as a factory-installed product in 2005 model year autos.

Delphi Automotive Systems has developed an in-dash HD Radio. Delphi said it could make its HD Radios available to auto companies in time for model year 2004. Those automobiles would be in dealerships this fall.

Delphi is testing various in-dash and aftermarket HD Radio prototypes with station WSHW(FM), Frankfurt, Ind., near Delphi's Kokomo plant. Delphi's Bob Schumacher said company engineers are driving cars equipped with HD Radios to test for multipath interference, as well as pops, fades and similar problems. The idea is to test under all conditions and stress the radio to see how it processes the analog and digital signals. Delphi OEM and aftermarket HD Radios are available for automakers now, he said.

Alpine and Jensen showed an in-car HD Radio that may ship by late this year. JVC and Sanyo showed in-dash versions

Alpine promoted the data potential of HD Radio. An Alpine receiver could someday deliver coupons to drivers as they approach certain stores.

of HD product. Both are targeting 2004 for shipping to retailers.

Harman Kardon demoed a home receiver with an integrated HD Radio.

Texas Instruments programmable digital signal processing chips are in the early HD Radios. Philips plans to have a hard-coated ASIC chip ready for HD Radio makers by mid-2003.

Among the many HD Radios displayed in Ibiquity's booth at CES was a portable HD Radio receiver with MP3 or WMA music file playback and FM radio capabilities. The unit by Personal Telecom is detachable from its docking station. The detachable part runs on batteries when it's not docked and plugged into the wall. The docking speakers look like Mickey Mouse ears.

The company displayed a similar Eureka-147 radio in the Texas Instruments booth.

— Leslie Stimson

## Tomorrow Radio' Tests Second Digital-Channel Concept

**LAS VEGAS** National Public Radio wants to test whether it's feasible for non-commercial stations using Ibiquity Digital's HD Radio technology to send two programming streams on each station.

NPR has begun a multi-year, multi-million dollar project called "Tomorrow Radio" to do just that.

Kenwood USA and Harris Corp. have agreed to join the first test team for the project.

NPR Executive Vice President Ken Stern said, "Tomorrow Radio represents our commitment to making HD Radio an important new development in delivering programming and services."

NPR has been working with Ibiquity for a special solution with its IBOC technology. Splitting a station's spectrum into two channels would mean that station could not use Ibiquity's blend-to-analog feature. This, in turn, creates certain issues that receiver makers need to resolve.

Manufacturers would need to build receivers capable of processing a second digital program stream and provide another "digital" button on the head unit. They would also need to resolve how these users would have near-instant tuning, one of the reasons Ibiquity uses the blend-to-analog technology.

Kenwood plans to test the so-called "second audio" concept later this year at KKJZ(FM), Long Beach, Calif. Harris Broadcast will provide the RF equipment.

Asked whether the FCC would need to approve dual-channel HD operation, one NRSC source said that is yet to be determined.

A major question for the companies involved is whether splitting a station's spectrum into two channels would still

allow those streams to be robust enough to withstand a mobile environment. If not, the concept might be limited to at-work or at-home listening.

As part of the Tomorrow Radio tests, Kenwood will try feeding supplemental audio via the second channel using new receiver designs that it intends to accommodate new digital services. These might include supplemental audio channels and customized services such as zoned traffic announcements, weather reports and market quotations.

The receiver maker also will test choices some consumers have told retailers and manufacturers they'd like in a digital radio, such as high-quality text-to-speech announcement and customized graphic displays.

"Kenwood and NPR have been allies in the rollout of the Sirius Satellite Radio service, and we look forward to benchmarking new features into the Kenwood product line as a result of this initiative," said Bob Law, Kenwood USA's senior vice president.

NPR believes it will take about 10 years for all public radio stations to become fully compatible with HD Radio.

Also on the public radio front, WUSF(FM), Tampa, Fla., an NPR affiliate, recently announced a digital upgrade of its transmission system and planned to go HD in early February using Harris RF equipment.

"When the HD Radio conversion is completed, WUSF will use the separate amplification model to broadcast both analog FM and IBOC digital signals and will be one of the first public broadcast radio stations to broadcast HD Radio," Harris stated.

— Leslie Stimson

# HD Radio

► Continued from page 6

station is expected to activate shortly include New York, Los Angeles, Chicago, San Francisco, Dallas, Philadelphia, Houston, Boston, Detroit, Atlanta, Miami, Seattle, Baltimore, Tampa-St. Petersburg, Fla., Cleveland, Cincinnati, San Jose, Calif., Milwaukee, Middlesex-Somerset-Union, N.J., and New Orleans.

Also on the list: Raleigh, N.C., West Palm Beach-Boca Raton, Fla., Monmouth-Ocean, N.J., Louisville, Ky., Richmond, Va., Birmingham, Ala., Greenville-Spartanburg, S.C., Syracuse, N.Y., Ft. Wayne, Ind., Roanoke-Lynchburg, Va., Morristown, N.J., Jackson, Miss., Charleston, W.Va., Morgantown, W.Va., Cedar Rapids, Iowa, and Lafayette, Ind.

At least four unranked markets will have HD Radio services: Forest and Raymond, Va.; Price, Utah; and White Oak, Ga.

Some stations stated during the show that they were the first to begin airing

## Yes, Ibiqity Promote Interactive Services

**LAS VEGAS** Interactive radio company Yes Networks and Ibiqity Digital inked an agreement to develop interactive services compatible with HD Radio technology.

Yes will develop a way for consumers to interact with data they see on the HD Radio displays. The company aggregates data from retail partners, such as Amazon.com and eBay, to show price, name of seller, description, picture and other info to be offered to broadcasters to include in digital broadcasts.

Yes says it correlates and delivers this information to access points, such as phone, Web sites and wireless devices, where listeners can interact with ads or buy music, an example of the so-called "buy" button Ibiqity has said may be on its radios in the future.

Yes is one of several companies with which Ibiqity is working to develop such data services. It has put together a group of related industry experts to develop data standards, so receiver makers build to certain specs and all broadcasters transmit the data in the same way. Ibiqity has planned a public meeting of these groups at NAB this spring.

## Here Comes dMarc Flow

Where is the extra revenue from IBOC going to come from? Expect to hear more about "dMarc Flow." Ibiqity and dMarc Networks, an RF subcarrier management and wireless data distribution firm, will market dMarc Flow for use by AM and FM broadcasters using HD Radio.

Ryan Steelberg, president of dMarc, said his company's technology uses analog RDS to enable text to be broadcast and displayed on HD receivers. HD Radios will receive both analog and digital signals. The first generation HD Radios will have RDS-like text display capabilities.

"The increased bandwidth capacity inherent in digital technology affords dMarc offerings of enhanced value-added content and data services," he said.

HD-R in some capacity — whether the first non-Ibiqity test station, or the first in their market or the first with a particular manufacturer's equipment.

Radio One's WDMK(FM) in Detroit said it was the first FM to go on the air with HD-R using commercial equipment. WJLD(AM), Birmingham, Ala. claimed to be the first AM that was not an Ibiqity test station to go digital.

Capitol Broadcasting's WRAL(FM) in Raleigh, N.C., said it was the first East Coast FM in the nation to provide the service. In late fall, Infinity's WOR(AM) in New York and Susquehanna-owned WGY(FM) in Cincinnati said they were first to go digital. WOR bills itself as "New York's First Digital AM Radio Station."

Struble said they were all correct in the individual claims and said he couldn't be

See HD RADIO, page 8 ►



This portable HD Radio receiver from Personal Telecom comes with an MP3 player and FM tuner. The unit detaches from its docking station and can run on batteries for about an hour. When in the docking station, it can be plugged into the wall. The company showed a similar Eureka-147 version in the Texas Instruments booth.

## Meet Ed McMahon's Loyal Sidekick.

Ed McMahon is back on the air, broadcasting his new show "Lifestyles Live" from the comfort of his own home. Thanks to his Comrex codec, the distinctive quality of Ed's famous voice comes through — even when he's on the road.

Expand your talent pool. Comrex ISDN or POTS codecs can bring in the best voices and the most compelling shows from around the world, without the expense of having to bring the people into your studios.

*"Honey, we need to be in Paris tomorrow! Pack the Comrex and we'll do the show from there!"*  
— Ed McMahon

**Rely on Comrex for your next broadcast. And we'll give you the shirt off our back.**

Mail us the warranty card from the purchase of your next BlueBox, Matrix, Vector or Nexus. We'll send you a handsome Comrex shirt like the one Ed is wearing (retail value \$65) FREE. Plus, we'll extend your warranty to two years. How's that for reliability?

**For a dealer call 800-237-1776**

- BLUEBOX
- MATRIX
- VECTOR
- NEXUS



19 Pine Road, Devens, MA 01432 USA  
Tel: 978-784-1776 • Fax: 978-784-1717 • Email: info@comrex.com • www.comrex.com

# HD Radio

► Continued from page 7  
happier to see the competition.

A Harris Broadcast representative said it was good "to see the competitive juices come out" at the start of the rollout. Harris and Broadcast Electronics have stated publicly they are supplying HD Radio RF equipment to several of the early adopter stations.

A number of radio group engineers attended the show. Several said more radio engineers attended than ever, testifying to the importance of this year in particular at CES.

Keeping in mind that such shows are designed to promote excitement about a concept, engineers who spoke to Radio World were pragmatic in regards to HD Radio. Most said they are transitioning a fraction of their stations at first, to try to minimize potential difficulties in converting.

## 'Competitive juices'

The exception is Greater Media, which intends to transition as many of its 19 stations as it can this year. Milford Smith, vice president of radio engineering, believes his company saved roughly \$1 million due to the licensee fee waiver.

Sterling Davis, vice president of engineering for Cox, which plans to convert nine stations this year, believes once some stations begin transmitting in HD-R, there will be competitive pressures for others in their markets to follow.



These new Sirius roof-mount car antennas from Terk are smaller than the current versions and incorporate an insert that changes the antenna color to match the vehicle's paint or its owner's own color preference.

"It's been announced in Richmond one of our competitors is going digital. It's on our radar screen. If they get any traction, we might look at that more seriously," and move up the Cox Richmond properties in its priority list.

Harris officials said stations in the city of Miami, for one, seem to be particularly interested in HD Radio based on early orders.

Other engineers contacted for this story who attended the show agreed that converting AM remains a challenge due to the nighttime interference questions that remain about the technology.

Depending how the IBOC rules are shaped, one engineer implied, stations that operate on skywaves can go digital at night, or those that transmit over groundwaves can do so; but both cannot be achieved without

potential interference.

One engineer whose company doesn't have stations in the so-called key receiver rollout markets is holding back on committing to HD-R. Equipment cost is a factor, he said.

He said some AM engineers also believe converting their stations will not be easy, especially those that have several tower arrays. He believes the rollout will be slower than Ibiquity would like. "HD will not be here in a year."



Antennas for XM and Sirius are getting smaller. This is a roof-mounted XM antenna.

Early adopters have applied for and received special temporary authorizations from the FCC to transmit both analog and digital signals.

In its initial authorization of IBOC, the FCC has only authorized AM stations to broadcast both the analog and digital signals during the day, using analog-only if the stations remain on the air after sundown. The FCC accepted guidance from the standards-setting National Radio Systems Committee on this point.

The NRSC told the FCC that not enough is known about the potential for IBOC to interfere with neighboring stations, especially those transmitting on skywaves at night.

The signals of high-power clear-channel AM stations relying primarily on skywaves at night travel hundreds of miles, much farther than the signals of stations using groundwaves only. Atmospheric conditions that change nightly can alter

how far skywaves travel and how powerful the signals sound.

Ibiquity completed an additional round of AM nighttime testing requested by the NRSC in mid-December 2002 using WLW in Cincinnati and WOR in New York. Those tests were designed to test the impact of AM IBOC on analog skywave and groundwave signals.

The December tests repeated measurements that were conducted last summer. "By conducting the tests in different seasons —

different weather, shorter days, colder temperatures — we were able to observe the impact of IBOC with different signal propagation conditions," said Ibiquity Vice President and General Counsel Al Shuldiner.

Ibiquity was preparing a report analyzing the additional AM test results that it hoped to deliver to the FCC and an ad-hoc committee of the NRSC by the end of February.

Members of the NRSC also met at CES and have shifted their focus from system testing for IBOC to standards setting. They're beginning the standard-setting process with Ibiquity's FM system, because they have all of that data.

NRSC members have been discussing the scope of whatever standards they develop for IBOC, whether they would be limited to transmission issues or would include receiver and data issues. Receiver makers would need to design radios capable of interpreting the IBOC signal, and include associated data

displays on the radio.

The first-generation HD-R receivers will have simple text displays such as the name of a song and artist. Future generations of HD-R receivers are expected to have bigger graphics and more interactive displays.

Using the Ibiquity system, broadcasters can decide how much of their spectrum they choose to devote to audio programming, and how much to devote to data services.

NRSC members have formed a new subcommittee to design standards for an interface between Ibiquity's system and data offerings, said Smith, the NRSC DAB Subcommittee chairman.

## Who's converting?

The list of groups with at least one station going HD-R this year provided by Ibiquity includes Infinity Broadcasting, Clear Channel Radio, Entercom Communications Corp., Radio One Inc., Hispanic Broadcasting Inc., Susquehanna Radio Corp., Bonneville International Corp., Greater Media, Spanish Broadcasting System, Beasley Broadcast Group, Journal Broadcast Group, Buckley Broadcasting, Capitol Broadcasting Co., Inc., Chicago Public Radio, Cleveland Classical Radio, WCGA(AM) and Cram Communications, Inc.

Also on the list: Crawford Broadcasting Co., Crystal Boynton Beach Inc., Eastern Utah Broadcasting, Elyria-Lorain Broadcasting Co., Federated Media, Fenix Broadcasting Corp., Gee Communications Inc., Hunter Broadcast Group, Kaspar Broadcasting, KZIA Inc., Multicultural Radio Broadcasting Group, New World Broadcasting and OneCom Inc.

Also Perception Media Group Inc., Renaissance Radio Inc., Richardson Broadcasting Co., Sellers Broadcasting-KMRY, South Sound Broadcasting, Spanish Media Broadcasting, WWNO(FM) — University of New Orleans, University of South Florida, W&B Broadcasting Inc., West Virginia Radio Corp., WRHC Management Corp., WOLF Radio, Inc., Wood Broadcasting Co. Inc. and WWOZ Inc. 🌐

# Snyder

► Continued from page 5

**RW:** The U.S. Fish & Wildlife Service recently said it was accelerating its efforts to address so-called "bird kills" at tower sites. Some observers feel there is no solid evidence that towers are a threat to wildlife. Where is NATE on this issue?

**Snyder:** NATE has looked closely at teaming with others in the industry, such as the Site Owners and Managers Association, to study further the bird kill issue. We feel that the studies done by U.S. Fish and Wildlife and others to date are not conclusive. Based on anecdotal evidence of our members, there is no real problem with birds being killed by flying into towers in any significant numbers.

To date, we have not begun the process of formally studying this issue but hope to make it a priority in the near future.

**RW:** In an historic move, the FCC has begun to issue fines to radio broadcasters as well as cellular towers for exceeding RF radiation limits at transmission sites. How does this affect your members?

**Snyder:** NATE, of course, has focused its efforts on worker safety. To this extent we are working on a safety and training video to educate tower workers on risks posed by RF radiation exposure. This video will sup-

plement our "Resource Reference for RF Awareness." OSHA regulates our members in this regard as opposed to the FCC. We have not heard of an inordinate amount of citations from OSHA regarding RF exposure affecting our members.

What we see as the biggest challenge in this regard is multiple broadcasters or users on one structure. Climbers typically are working for only one station at a time on any given structure and other broadcasters or users don't feel inclined to reduce or turn off power to their antennas to allow climbers access to their competition's antennas. This places tower climbers in a difficult position of coordination between multiple users and one that often has no good solution.

**RW:** What can broadcasters and other wireless companies do to make tower companies' jobs easier in maintenance and construction?

**Snyder:** One of the biggest things broadcasters or wireless companies could do to make tower service companies' jobs easier would be to ensure that their towers are brought up to the latest standards of safety.

For example, all towers should now be equipped with a climbing ladder and safety climb cable or similar device. This allows climbers to be in compliance with current OSHA regulations in accessing the tower and can dramatically limit the risk of falling that is inherent without such devices being installed.

Another great help would be for tower

owners to include language in rental contracts with other tenants that allow for simple coordination between the owner and tenants for reducing power during maintenance and other work that requires workers to be in areas where RF radiation exposure is above the allowable threshold.

**RW:** What is the status of standard EIA-222G, a standard for structural analysis of towers (it replaced 222F)? What structural studies does the insurance industry want?

**Snyder:** I serve as the chairman of the committee that writes this standard. The past year has been a challenging one for progress in completing revision "G," mostly due to the incredible downsizing of staffs at the various companies that serve on the committee in key roles with the development of the standard. With smaller staffs the committee volunteers are pressed for time more than ever.

Having said all this, we hope to have the standard out for internal and then public ballot by June 30, and then available for public use by the end of the year. The standard will have major changes over revision F, but will not automatically mean older towers will be rendered obsolete.

Many of the changes will not affect older towers, but will use new approaches in engineering and ... bring the standard in compliance with current standards and use.

For information about the NATE convention, go to [www.natehome.com](http://www.natehome.com). 🌐



## What flamethrowers use for fuel.



You're scanning the AM dial. Everything sounds harsh, bland, weak. Then you find it: an amazing sounding AM station. Loud, smooth, dynamic, exciting. You glance at your radio to make sure you didn't switch bands. This is AM?

Meet the first digital processor designed especially for AM stations who want to breath fire. Omnia 4.5AM. We held nothing back—this is the world's best AM processor. Of course it has all the latest bells and whistles: advanced DSP chips, bright color display, Ethernet and modem connections, PCMCIA expansion slots, and powerful remote control software. But the real breakthrough is the sound.

Our algorithm designers spent countless hours studying the great AM stations, listening and learning. We found that the very best sounding stations were using highly tuned, customized analog processors. Then we set out to reproduce the best analog had to offer. But because we were working in an all digital environment, we had vastly improved precision and flexibility than could ever be achieved in analog. The result is, well, breathtaking.

Talk is clean and clear. Bumpers and ID's have more definition. Callers punch through with force. And music jumps off the dial. Everything sparkles. The stations who have tried the new Omnia won't give it back! Some have even told us their coverage has improved.

Omnia for AM. Fire it up and you'll know why Omnia is the hottest selling radio processor in the world today. Scorch the competition.



o m n i a a u d i o . c o m

# Robert Hammett in Retrospect

*A Consulting Engineer Is Remembered for His AM Tower Array Innovations*

by Steve Jess

**SONOMA, Calif.** Robert L. Hammett is thought of as a generous man whose legacy includes innovations in the way many consulting engineers practice their profession.

Hammett, 82, a co-founder of Hammett & Edison Inc., Consulting Engineers, of Sonoma, Calif., died of lymphoma at his home on Oct. 11, 2002.

A native of Bakersfield, Calif., Hammett graduated from Stanford University with a master's degree in electrical engineering in 1942. During World War II, he served on a research team at Harvard Labs, where he met consulting engineer A. Earl Cullum.

At war's end, Hammett took a job with Cullum's engineering firm in Dallas. Hammett returned to his home state in 1952 to establish his own consulting practice.

It was the dawn of the television era. His son, William F. Hammett, said the firm's first client was KRON(TV), Channel 4 in San Francisco.

"He was instrumental in all sorts of developments in television, including Instructional TV Fixed Service," William

Hammett said. "He did a lot of work with a Catholic TV network around the country."

In the 1960s, the elder Hammett also encouraged AM broadcasters to expand into the relatively new medium of FM.

With partner Edward Edison, who joined the firm in 1956, Hammett & Edison grew to become "probably the engineering firm of choice outside of Washington," according to Roy Russo, managing partner of the Washington law firm Cohn and Marks. Russo said many of Cohn and Marks' clients on the West Coast gravitated to Hammett & Edison when they needed engineering assistance.

Bob Hammett's greatest contribution to broadcast engineering may be in the use of computers. In the 1970s, using remote terminals connected to a time-shared mainframe computer, engineers at Hammett & Edison developed techniques for designing directional AM tower arrays that maximized the station's service area.

"He laid the groundwork that many others followed for designing arrays," said William Hammett. "Many arrays used towers set out in a straight line or a parallelogram. It's easy to analyze. Early on, we developed a method of designing

arrays based on radiation limits. Our arrays tend to have an irregular array of towers of different heights. This way we can maximize the service area."

The new technology allowed engineers to explore more options in designing a directional array. "The computer can move towers around based on rules of optimization that my dad developed," William Hammett said. Scores of stations benefited from the technology, and several other consulting engineers adopted similar analysis methods, he said.

By 1985, Hammett & Edison's use of computers advanced to the point that the firm needed its own mainframe. They bought a used machine previously owned by Wayne University, Hammett said, and the engineers cleared out one of the garage stalls in its building in order to install it.

Today the FCC uses another technology Hammett developed. In the 1970s the firm digitized soil conductivity readings for the entire country. The resulting database enabled computers to calculate how far an AM radio signal was likely to travel.

"The FCC bought the system for their own use, in projecting signal contours," William Hammett said. "It was the first application of this technology to this field."

## Award winner

The NAB recognized the achievements of Robert Hammett and Edward Edison with its 1992 Engineering Achievement Award. William Hammett says the award honored them "in recognition of their distinguished professional careers, and outstanding contribution to



Bob and Luana Hammett in France in 2000

the broadcast industry."

Hammett is remembered for his personality and his service to the community as much as for his engineering expertise. He worked to preserve and expand Stanford Sierra Camp, a retreat for Stanford alumni that lies on Fallen Leaf Lake in the Sierra Nevada range near Lake Tahoe.

"He brought an intelligence, maturity, a wide range of experience," Roy Russo said, "the kinds of things you need, particularly when you're dealing with unusual situations as we found ourselves doing from time to time. ... if you needed waivers of the rules, things like that."

His son William said Hammett "was a very generous man. He left us a great legacy of high-quality work and high ethics in client service. We work hard to fulfill that legacy."

Robert Hammett retired in 1988. Hammett & Edison continues in business under the management of William Hammett.

Besides his son William, Hammett is survived by his wife of 57 years, Luana, two other children and nine grandchildren.

## CES Sat

► Continued from page 3

don't, such as talk channels (Radio World, May 22, 2002, page 3). Statistical multiplexing uses a variable bitrate encoder and only uses what it needs at that moment and places the rest in a common bit pool for other channels, according to Sirius.

Asked for reaction to the announcement, Hugh Panero, president and CEO of competitor XM Satellite Radio, said, "We talk about products that are fully baked."

He also said the concept was not new. "We could do it as well, but what will you sacrifice to do it?" He said the bandwidth needed for video would limit the bandwidth for audio channels, a claim Sirius disputed.

Sources said it was unclear whether the FCC, which approved satcasters' licenses for radio, would need to approve video use.

Both companies also were promoting home receivers. Sirius disputed whether XM's home antennas could actually pick up a satellite signal.

As Pesce described Sirius' new in-home antennas, they could be mounted on a roof, or a deck and pointed straight up to receive Sirius' satellite signal. His competitor's home antenna, he said, referring to XM, would need a southern-facing window to catch those satellites — if there are no trees in the way blocking the signal reception. An XM spokesman said that wasn't true.

As they have since they began their respective services, both satcasters contin-

ued to peck away at the reputation of terrestrial radio to build up their own products.

Sirius Executive Vice President of Marketing Mary Pat Ryan said Sirius could offer "deeper tracks than on radio." She said music choice on radio and on MTV has become narrow. Sirius Vice President of Programming and Market Development Larry Rebich added, "We're programmed as a premium entertainment service, like cable. We're not re-delivering what consumers already hear."

Both satcasters dismissed the idea that consumers might be confused when Ibiquity's receiver partners ship HD Radios this spring. Sirius and XM talked up their national footprints and 100 channels of specialized programming.

Sirius focused much of its press efforts on programming. The company has re-made some channels and introduced others for a total of nine new or significantly changed music channel streams. It added information and talk streams including weather channels zoned for the East, West and Midwest, and political talk channels Sirius Right and Sirius Left. There's also a new gay talk channel and a stream for independent music artists.

Daimler-Chrysler is offering Sirius as a dealer-installed option on most of its 2003 vehicles and as standard equipment in the 2003 Chrysler 300M and Chrysler PT Cruiser. Ford plans to offer Sirius in some of its products this year.

XM and Sirius made headway on their respective financial restructuring efforts shortly after CES. Both companies hoped to finalize those efforts to recapitalize their companies by the end of the first quarter.

**BROADCAST TOOLS® *new***  
**"Rack-Ables"**

SS 2.1 III
SS 4.1 III
SILENCE MONITOR III

SS 8.1 II
RA-1 with FP-II Filler Panel

The upgraded SS 2.1/TERM III & BNC III switcher/routers are improved with new front panel switches. They may be used as a desktop device, and are equipped with mounting holes for wall mount installation or may be installed on the new RA-1 "Rack-Able" 1RU mounting shelf.

The new "Rack-Able" SS 4.1 III switcher replaces the popular SS 3.1 while adding a fourth stereo input channel and front panel control. We've kept the best of the SS 3.1 features and added a few more.

The new Silence Monitor III improves on the features of the original SSM, with front-panel control, removable screw terminals, "Plug & Play" installation, built-in program switcher, restore timing delay, aural alarm and relays for most remote functions. Now rackable!

The new SS 8.1 II switcher replaces the popular 6x1 with the addition of two more stereo input channels and GPI, while keeping the price the same! The SS 8.1 II may be desktop, wall mounted or installed on the new "Rack-Able" mounting shelf.

The new RA-1 (1-RU rack shelf) provides mounting for three tri-rack or two half-rack "Rack-Able" configured products. The RA-1 is pre-drilled for flush and recessed product mounting. The RA-1 is furnished with filler panels and mounting hardware.

*Look for additional  
"Rack-Able" products soon.*

639 Sunset Park Drive • Suite 101  
Sedro-Woolley, WA 98284 USA  
(360) 854-9559 • FAX: (360) 854-9479

**BROADCAST TOOLS**  
*tools* inc.  
www.broadcasttools.com

# Rhapsody in Blue.

.....  
**Digital Core  
Routing System**  
.....

.....  
**Scalable Up to  
4,096 Channels**  
.....

.....  
**Digital & Analog  
24 Bit I/O**  
.....

.....  
**Mix Multiple  
Inputs to  
Any Output**  
.....

.....  
**IFB-Talk to  
Remotes**  
.....

.....  
**Integrated  
Intercom  
Functions**  
.....

Introducing the new 32KD Digital Audio Network from Sierra Automated Systems.

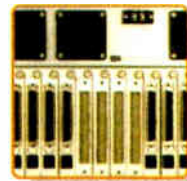

This modular, digital-core routing system processes more audio, routes more signals, and provides more user control than any other system in its class.



Routing, mixing, signal processing, IFB, mix-minus, and more, run simultaneously without conflict. All this functionality is readily accessible via PC, mixing boards, or dedicated control panels. And the performance? Like music to your ears.



For more details about the impressive capabilities of the 32KD, give us a call or visit our web site.

SAS. Doing more for radio. Again.



**SIERRA  
AUTOMATED  
SYSTEMS**

818-840-6749  
sasaudio.com

## ROOTS OF RADIO

# Collaboration Brings History to the Web

by Skip Pizzi

It's not often commercial radio stations and libraries appear in the same sentence, but in Kansas City, Mo., just such collaboration has produced an unusual Web site that presents an interesting, localized perspective on WWII-era history.

The project, titled "Voices of World War II: Experiences from the Front and at Home — KMBC Radio," was based around the contents of 100 16-inch transcription discs from the Arthur B. Church-KMBC Radio Collection.

Arthur Church was a broadcast pioneer who owned and operated the KMBC radio and television stations in Kansas City from the 1920s through the late 1950s. He was one of the first to use radio for advertising purposes. Church also was the creative force behind several popular syndicated radio shows, including "The Texas Rangers" and "Phenomenon."

He built KMBC into a model for major-market radio stations — it was one of the first to incorporate a mobile news unit, a music director and librarian, and a publicity department. It provided training for talent in the burgeoning industry, with many radio stars getting their start there, among them John Cameron Swayze and Walter Cronkite.

Church's institutional attitude toward broadcasting stimulated him to create an archive of the 30-plus years of his career. Besides the sound recordings, the collection includes photos, published sheet music, scrapbooks, advertising brochures, contracts, telegrams and station newsletters from the period.

In 1996, his son, Arthur Church Jr., donated the collection to the Miller Nichols Library at the University of Missouri-Kansas City, where it is held in the Marr Sound Archives.

Although carefully inventoried and maintained there, the archives are part of the library's Department of Special Collections, meaning that they are not open to the public but only accessible to professional researchers. To widen the availability of this material, the department's staff recently obtained funding to develop and host the Web content, which is now running on UMKC's site.

## A joint effort of radio, library, government and academia creates a noteworthy WWII oral history site.

The support came in the form of an \$11,000 Digital Imaging Grant administered by the Missouri State Library, using funds provided through the federal Library Services and Technology Act. This program is aimed at increasing public access to cultural heritage collections and developing new support and sustainability models for such efforts. Its criteria include the development of best practices and standards for selection, digital capture, storage and online delivery of resources.

The "Voices of WWII" project was deemed an excellent candidate.

Another partner in the project is the well-known Harry S. Truman

Presidential Museum and Library, which has contributed public programming and archival research materials for the site. (The Truman Library was the first to be created under the 1955 Presidential Libraries Act, and is one of 10 presidential libraries operated by the federal government.)

The site is available in two forms, text-only and multimedia. The latter is a rich and well-designed experience that includes elements created in dynamic HTML, Javascript, Flash animation and streaming media. The audio quality on the site is surprisingly high, and the numerous images and anima-

tion throughout the site are compelling. Modern metadata formats are used for cataloging and describing the content in standardized fashion.

Audio elements range from speeches and interviews of WWII-era personalities to war-related entertainment, propaganda and advertising. There are examples of USO Shows, Armed Forces Radio, V-Discs and other morale efforts, plus some of the first battlefield recordings and information on how the audio technology of the day worked.

Most of the sound recordings create a sense of how WWII was experienced in Kansas City through the broadcasts of KMBC(AM) radio, then and now a CBS affiliate at 980 kHz (although it is today renamed KMBZ, an Entercom property running a news/talk format).

The content is organized into six historical periods running from 1939 to the post-war. The site also features a

substantial section describing the project itself, plus a hefty set of references and recommended resources for additional study.

For interested professionals, there are Powerpoint presentations describing the technical aspects of the site's development, including the digitizing, processing and encoding of the archival audio. Among the intriguing items noted here are details on the collection's acetate transcription discs, some of which used glass rather than the more common metal substrates due to wartime conservation measures.

### A unique appeal

The site maintains a good balance between an accessible style with broad appeal to the general Web surfer and a resource providing serious value to students, researchers and professional historians. It is the product of an unusual alliance of federal and state government agencies, library scientists and the estate of a pioneering broadcaster.

In addition, the project is noteworthy for having a multimedia Web site as its sole focus. This is not a "companion Web site" to a physical exhibit or show.

The project is uncommon in its description of a global, historic event through the use of localized, day-to-day content. History typically takes on a high-level and disengaged perspective, so it is rare to see it presented through such a regional, real-time lens.

In many respects this brings a greater sense of realism to the historical data, and leaves visitors to the site with a fresh and deepened grasp of the period. It applies the maxim that "all news is local" in a distinctively retroactive way.

And of course, the site's heavy emphasis on media content makes it far more powerful in conveying understanding than one limited to static text and images might be.

Best of all, you can experience the fruits of the project without leaving your desk, at [www.umkc.edu/lib/spec-col/ww2/](http://www.umkc.edu/lib/spec-col/ww2/).

Skip Pizzi is contributing editor of *Radio World*. 

## MARKET PLACE

## LED Flashlight Offered

LEDtronics is on the market with a pocket flashlight that uses three white LED lamps. It retails for \$19.95.

The White Mini-Flash LED is 5 inches long and weighs 2.1 ounces. The light turns on and off by a twist switch or a pulse-only switch.

The light output is 90 end foot candles. It will operate for three to four days on three replaceable E90 N-cell alkaline batteries, which the company says is 20 to 50 times longer than equivalent incandescent-lamped flashlights.

The company also makes LED lamps to replace incandescents, panel-mount LED lamps, circuit board status indicators and other LED products.

For information contact the company in California at (800) 579-4875 or visit [www.ledtronics.com](http://www.ledtronics.com). Ask for datasheet 105.

## Dielectric Software Update Helps With RFR Compliance

Dielectric is offering a new version of its antenna system planning software, DASP 5.0. It includes elevation patterns for Dielectric FM DCR series antennas.

"Of particular interest for broadcasters concerned with RFR compliance, this software includes a selection of special bay spacings designed for minimum downward radiation," the company stated.

Several output formats are available, including PDF for filling FCC applications, as well as V-Soft, EDX and Radiosoft-compatible formats.

DASP 5.0 includes a system summary tool. After selecting an antenna type, elevation and azimuth pattern, the system summary tool provides pull-down menus for selection of standard transmission line types and calculates the transmitter output power requirement.

DASP 5.0 is a free download available on Dielectric's Web site.

For information contact the company in Maine at (866) DIELECT or visit [www.dielectric.com/broadcast/Welcome.asp](http://www.dielectric.com/broadcast/Welcome.asp).

## MARKET PLACE

## Andrew Adds Link Calc Feature

Andrew Corp. has added a design option called Link Calc to its Microwave System Planner software. The option helps users calculate communication system link budgets based on their chosen design parameters and products.

"Once the required fade margin is achieved, Link Calc users can, within seconds, generate a fully itemized bill of materials," Andrew stated. "The (software) automatically checks system components for compatibility."

The feature lets you choose components from Andrew's line of microwave products. The planner is part of the company's free Powertools telecommunications design software line.

For information contact the company in Illinois at (708) 349-5661 or visit [www.andrew.com/downloads](http://www.andrew.com/downloads).

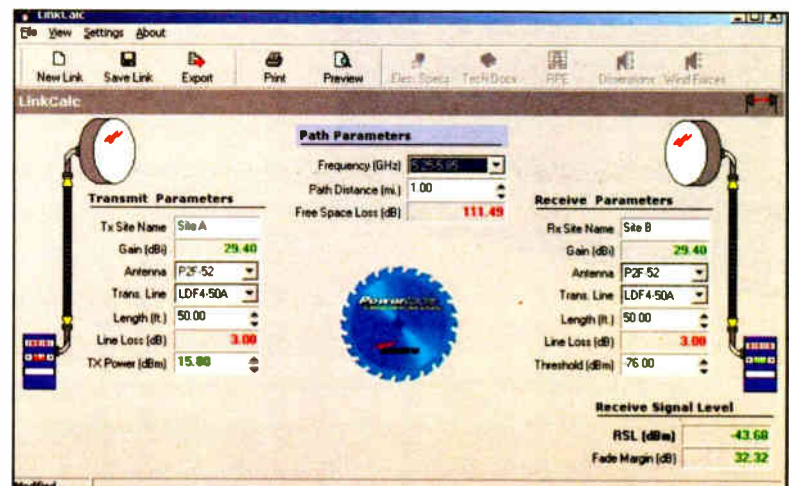

# Instant gratification.

Immediacy is the nature of radio. Remotes, special broadcasts, breaking news... all must be delivered on time, on demand, with no excuses — and no delay.

That's where Low-Delay MPEG AAC comes in. It is the absolute state-of-the-art in coding technology, maintaining studio-quality audio while shrinking delay by as much as 70% compared to Layer 3. And Zephyr Xstream is the first broadcast codec to offer it.

Zephyr Xstream has what it takes to make remotes smooth and trouble-free — like complete Web-based remote control and a graphic user interface so simple and intuitive even an intern can use it. Portable models include a four-input stereo mixer with smooth, effective DSP audio processing by Omnia and easy to use local + mix-minus monitoring capability. The Ethernet port prepares you for IP-based connections.

With thousands of Zephyrs installed around the world, you can count on your new Zephyr Xstream to be The Best Way To Hear From There.

## Pots only?

You can always get ISDN at your remote. The new Zephyr Xport connects to ordinary analog (POTS) phone lines in the field and connects with your Zephyr Xstream back at the studio. Rock-solid connection reliability, built-in mixer and monitor, sweetening by Omnia, Ethernet for a convenient audio connection to your laptop, and more. Updating your Zephyr Xstream to work with Xport is a simple (and free) software update. And an SDX option ensures that you're ready for a rollover on your remotes.

Breathtaking audio quality takes POTS codec performance to a new level.



*Telos*

z e p h y r . c o m



BUSINESS DIGEST

### V-Soft Settles Into New Quarters

V-Soft Communications is in new offices. The engineering software and consulting firm run by Doug Vernier is based in Cedar Falls, Iowa. He recently retired after 30 years as director of broadcasting services at the University of Northern Iowa, where he helped launch its public radio stations. "The V-Soft Communications software business has had my part-time involvement since its inception some 20 years ago. The business literally occupied the lower floor walk-out of my home," he said. "Having retired from the university, I didn't really want to go to work at home, and the wife was ready to see the business move out." The company is leasing space in a building, right,



where it could design the workspace and facilities for its computer LAN and high-speed Internet capabilities. Vernier, a collector of old radios, decorated the offices with several dozen. "We really like our new space," he said. Photos of the facility are at [www.v-soft.com/web/NeweOffices.htm](http://www.v-soft.com/web/NeweOffices.htm).

### Woodline Launches Broadcast Furniture Division



Dave Howland

A familiar name will team with a new one to offer furniture systems for broadcasters. Dave Howland is heading up Designcraft, a new division of Woodline Furniture, based in the Grand Rapids, Mich., area. Howland was with Audio Broadcast Group for 27 years, working his way up from the shipping department through sales, eventually to become part-owner. ABG was sold to Harris Corp. in 1999. Woodline is owned by Rob Smit, who met Howland during the latter's ABG tenure. "Woodline built the furniture for ABG for the last four years we were in business," Howland said. "I found Rob and really liked his work ethic and the way he treated customers. "When we sold (ABG) and I went to Harris, he kept getting jobs, but it really wasn't his focus. (Broadcast) was about 15 percent of what he was doing. This is what I know and what I did at ABG, among other things. It's what I love doing." Howland is coming off of a year's retirement to work as vice president of sales and marketing for Designcraft, which he says will offer three lines of furniture, called Dura Tech, Pro Standard and Premium, with various degrees of customization. Howland's sales office is in Rockford, Mich. For information contact Designcraft in Michigan at (616) 874-2037 or visit [www.woodlinefurniture.com](http://www.woodlinefurniture.com).

**Today's audio requires careful attention to precise level control...**  
 Simultaneous display of Peak & Average. See the actual loudness of program content with the Dorrrough ballistics based on Time and Amplitude. Select from 6 different models including AES/EBU meters.

**Features common to all models:**

- Peak hold functions • Sum/Difference • Alarms for audio loss and full scale
- Scale selection for 14dB and 20dB of headroom
- AES/EBU includes more features

**Remote**

A wired remote for accessing phase from the 280 analog and 280 digital reading meters. Display the functions of L/R, Sum/Diff, Phase, Overs Display/Overs Reset, 3 sec. Peak Hold, Peak Hold Permanent, and Reference Mode. Red alarm status lights for Phase, BSC, and Full Scale.

**Model RW-100**

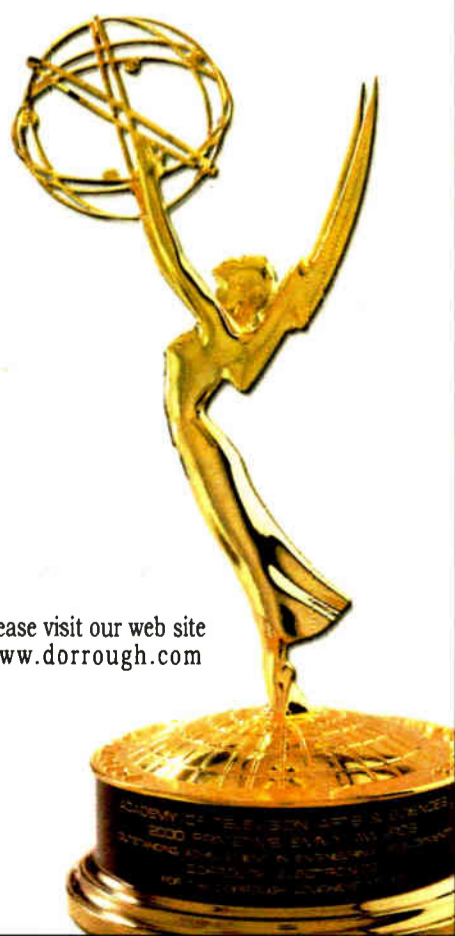

Please visit our web site [www.dorrrough.com](http://www.dorrrough.com)

Dorrrough Electronics Inc. 5221 Collier Place • Woodland Hills CA 91364  
 Tel: (818) 998-2824 Fax: (818) 998-1507



### RadioSoft License Agent

What are the "other guys" up to? A new product from RadioSoft is intended to help your station keep track. The company is offering a service that will permit tracking of FCC license data for AM, FM, TV and other parts of the spectrum. The License Agent service tracks items of competitive interest, including "those that could cause potential interference or allocation problems with the subscriber's facility or location," the company stated. The supplier says this is the first service generally available that covers all activity in FCC Parts 22, 73, 74 and 90 in a single format. "License Agent is a first warning to allow ample time to allow further investigation when necessary. It can be used not only to identify potential interferers but to see the details of what is being proposed and the possible effects on the flagged site." The user enters a latitude, longitude and radius distance for each site he or she wants to flag, or just the call signs of interest. Daily, weekly or monthly e-mails notifications are available. "Any flag will generate an online list of information that pertains to a facility or market the user wishes to monitor. Flags are available for one site or hundreds of sites." Pricing starts at \$39.95 per month and varies based on the number of flags you want. For information call the company in Florida at (386) 426-2521 or visit [www.radiosoft.com](http://www.radiosoft.com).

### Changes

Alert readers will notice a change in the frequency of some features in Radio World. We've added a new column called "Technology for Managers," which will appear in alternating issues. It is intended to help non-technical readers understand the trends that are discussed elsewhere in the paper and in radio stations every day. That column reported on recording and storage media in the Jan. 1 issue and consumer radios in the Feb. 1; we'll feature "digital plumbing" next time. Also, we've consolidated the *Studio Sessions* section into alternating issues, to present that popular content more efficiently; and our Internet Radio coverage now appears within the *GM Journal* section.

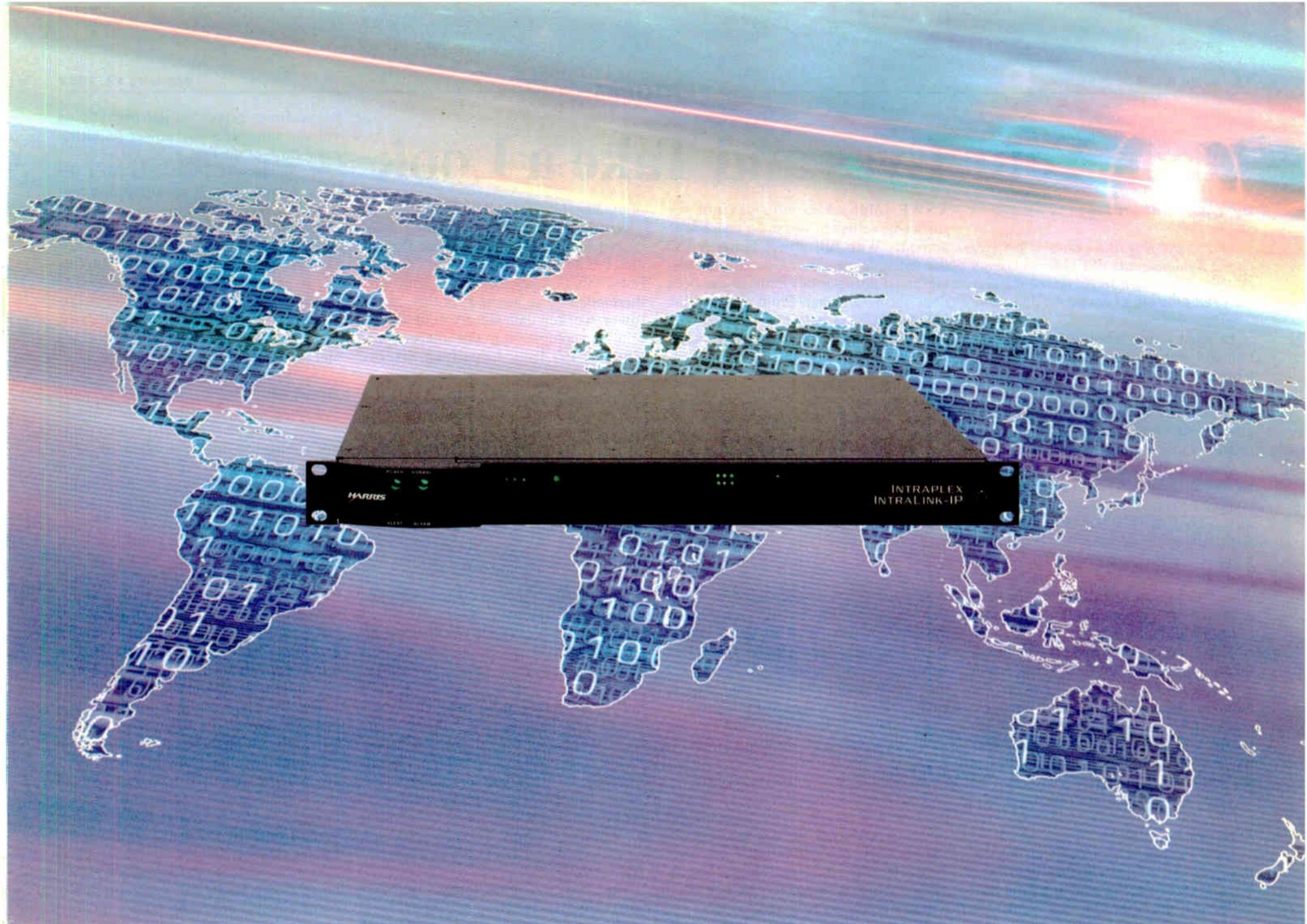

## Reliable Program Audio Over The Internet?

### IntraLink-IP™ Streaming Multiplexer

Create a program audio circuit wherever an Ethernet jack exists with the **IntraLink-IP** streaming multiplexer. The QoS of packet switched networks has improved dramatically signaling the beginning of a new low-cost means of professional audio transport.

**IntraLink-IP** has a Harris exclusive forward correction scheme which takes advantage of these networks. It delivers robust streaming for critical STL/TSL and general purpose broadcast audio transport. Contact your Harris sales representative today.



### Save money on program circuits with IntraLink-IP.

- Make the Internet into your virtual STL
- Turn low-cost public and private packet switched networks into program audio circuits
- Ethernet jacks, DSL and cable modems become instant RPUs

FEED LINE

# Open Your Eyes and Take a Look

by W.C. Alexander

*This is the last in a series of articles on the fundamentals of FM transmission systems. The entire series appears under the Feed Line tab at [www.rwonline.com](http://www.rwonline.com).*

In most cases, once a transmission line and antenna have been installed on a tower, little thought is given them until something goes wrong. That is unfortunate, because they do require a certain amount of maintenance to keep them reliable and operating at peak efficiency.

Regular mechanical maintenance of an FM antenna system should include a complete visual inspection at least annually. This can be done in conjunction with relamping or other tower maintenance to minimize costs. Excitation must be removed from the antenna and other steps taken to ensure that the tower is safe for workers to climb and work in the vicinity of the antenna.

The tower worker making the visual inspection should look at each element in the array for proper installation; for burns or pitting on the element ends; for cracks, carbon traces or defects in insulators; and for any evidence of abnormal mechanical stresses. Weep holes in the antenna elements, if any, must be oriented so that they face down.

## Deicers

If the antenna is equipped with deicers, they should be turned on during the inspection. The tower worker should then verify that the deicer in each element is working by feeling of the element.

One of the most dangerous icing situations for an FM antenna occurs when all the elements' deicers are working except one. All of the elements except that one remain clear of ice, and a serious mismatch occurs in the interbay line.

Because the mismatch is limited to that one element, the transmitter's

VSWR foldback circuit may not see sufficient reflected power to cause it to activate. With full power being fed to the antenna, an arc can occur and sustain itself until serious damage has been done to the antenna. From a protection standpoint, it is better to operate with no deicers than with a partially operating system.

## Maintenance of an FM antenna system should include a complete visual inspection at least once a year.

A good deicer maintenance tool is a permanently-installed AC ammeter on the deicer circuit. With the deicers operating normally (and after a 10-minute warm-up period), mark on the meter face the nominal current. From time to time, the deicers should be turned on and allowed to warm up. The current then can be checked against the mark. If there is a deviation, a tower worker should be dispatched to investigate.

Transmission lines likewise should be inspected visually every year. Inspect the connections at the top and bottom for security, and investigate any evidence of movement. Ground connections should be checked and tightened and any corrosion removed.

In the case of rigid transmission lines, the length of each hanger spring should be checked against the manufacturer's recommendation. If necessary, adjust the springs. Check nylon buttons or bushings in the spring hanger collars. Should these fall out or become damaged, the copper transmission line will chafe against the metal of the hanger. This eventually will wear through the copper

of the line, leading to line failure.

Rigid and semi-flexible lines should be checked for "hot spots" near flanges and connectors. In the case of rigid lines, this is every 20 feet. An infrared thermometer can be used for this, or the tower worker can simply feel of the joint and compare it to the adjacent portions of the line. Localized discoloration in rigid lines is a good indicator of abnormal heating.

The cause of any significant heating should be investigated, as heating at a joint is a precursor to a line failure. Such heating often is caused by a "split bullet" or chafing in the inner conductor where it makes contact with the "bullet." The heating is evidence of  $I^2R$  loss in the joint, which is power not being radiated. In many cases, heating in the joints can quickly produce a thermal runaway situation leading to catastrophic failure of the line.

## Infrared

One tool available today that is of great help in locating hot spots in a transmission line or antenna is infrared photography. Hot spots will show up as a lighter color. The advantages of this method are that it can be done from the ground and it can detect subtler temperature rises. While IR photography has several advantages, it is not a substitute for a good visual inspection.

In some situations where an FM antenna is mounted on an AM tower, the transmission line will be mounted using insulated hangers. Inspect each insulator for cracks and carbon traces. Check the shorting stub, usually located somewhere close to 90 electrical degrees (at the AM frequency) above the tower base, for a good electrical connection at the line and the tower.

Other FM on AM situations employ an isolator to cross the base insulator with the FM transmission line. In these cases, it is important that the transmission line be electrically bonded to the tower frequently along its length. Check each bond for good electrical connection.

In addition, check the entire outer jacket for evidence of arc-through to the tower. If such evidence is present, it likely indicates that more frequent bonding is needed. Such arc-through, if permitted to continue, eventually can penetrate the outer conductor of the line and open the line to the elements.

Grounded-base AM towers, such as folded unipoles and shunt-fed antennas, likewise require the FM transmission line to be bonded frequently to the tower steel along its length. The same checks of the bonding and outer jacket should be made on grounded-base AM towers.

Proper pressurization of air-dielectric lines is critical to their performance. Pressurization with dry air or nitrogen

has a direct effect on the breakdown voltage (and thus the power handling capability) of the line.

If moisture is allowed to enter the line, corrosion will result, producing higher losses, hot-spots and eventual line failure. The pressure integrity of the line and antenna should be checked by closing the air valve feeding the line at the bottom of the run and observing the line pressure over a period of several hours. If the pressure bleeds off, there is a leak and it should be located and repaired.

## Good air

Maintain an adequate nitrogen supply at the site to ensure that the supply is not exhausted before another delivery can be made. If the pressure integrity of the line is maintained, very little nitrogen should be used. Inspect pressurization equipment regularly, at least weekly, and maintain it in good working order. Desiccant should be rotated out and dried or replaced whenever it begins to turn from blue to pink. A dehydrator with a saturated desiccant pumping moist air into a line is almost as bad as having no pressurization at all. Use a self-recharging dehydrator to prevent this from ever happening.

Finally, make a check of the system reflected power during every site visit. A significant change, up or down from the nominal value, should be investigated. A more sensitive indicator of load impedance in some power amplifier designs is the screen current. Higher screen current generally indicates a lighter (higher Z) load. If PA tuning is otherwise correct, an increase in screen current may be an indicator of a developing antenna or line problem.

## Infrared photography is a great help in finding hot spots.

In addition to checking the reflected power, the VSWR foldback and trip circuits in the transmitter or external protection device should be checked from time to time to ensure that they are working. Transmitter manufacturers usually provide a procedure for checking and adjusting the internal protective circuits.

If the directional coupler(s) use removable slugs to detect forward and reflected power, check regularly for proper operation and good connections. A reflected power meter that reads zero all the time may be an indication that the connection, either between the slug and the coupler or between the coupler and the transmitter, is bad. If that is the case, chances are there is no VSWR protection in place, which can lead to a catastrophic failure of the line/antenna and damage to the transmitter.

*Cris Alexander is director of engineering for Crawford Broadcasting. He welcomes questions on this topic and suggestions for future series via e-mail to [crisa@crawfordbroadcasting.com](mailto:crisa@crawfordbroadcasting.com).*

## More innovative solutions...



### Thermal Sentry III

monitors transmitter operating temperature  
analog output for remote monitoring  
programmable alarm output with relay  
front panel adjustments and LED display  
two air temperature sensors included  
indicates failed or clogged ventilation system  
early warning for antenna icing conditions

model tsn-3



### Time • Temperature • ID

time and temperature delivery for automation  
60 seconds of user recordable storage  
automatically varies message delivery  
professional male announcer voice  
temperature in Fahrenheit or Celsius  
battery backed AC synchronized clock  
digital message storage - no moving parts

model tti-2



### Dialup Audio Interface

perform unattended remote broadcasts  
DTMF operated controller with relay outputs  
fully programmable output on any key press  
momentary and/or maintained relay outputs  
four logic inputs with programmable output  
balanced audio input and output with ALC  
seven DPDT relays and one 4PDT relay

model dai-2

innovative solutions

nashville, tennessee • 615.228.3500 voice • 615.227.2393 fax-on-demand • [www.sinesystems.com](http://www.sinesystems.com)

Sine Systems



# KLOTZ DIGITAL

## 4-Faders, Unlimited Inputs...

Combined with KLOTZ DIGITAL's revolutionary VADIS AudioMedia Platform, the DC II minimizes space while maximizing functionality, making it the most powerful digital broadcast console in the world. It's easily configurable from 4 to 24 faders in a single frame.

Call us today to discover the possibilities...

*Bonneville International St. Louis' "News 2" has become the airstaff's favorite for production while doubling as on-air news.*



# The New Face of Digital

KLOTZ DIGITAL AMERICA  
5875 Peachtree Industrial Blvd., Bldg. 340, Norcross, GA 30092 Tel: 678.966.9900  
ussales@klotzdigital.com www.klotzdigital.com/america

# Keep Your Transmitter Cool

by Richard J. Fry

Landscapers say, "A \$50 tree takes a \$100 hole," and that concept is pretty much the case when installing broadcast transmitters.

Inattention to the operating environment of a transmitter can reduce its performance and reliability greatly. Following are some comments that may help understand and plan for this important need.

A little-recognized fact about broadcast transmitters is that their internal air system is designed to move the CFM needed for cooling the transmitter

only when its air interface ports are looking at essentially zero differential in static pressure.

Adding ductwork directly to a transmitter can drastically change the amount of air flowing through it. There have been cases where a transmitter has had ductwork coupled directly to its air outlet to carry that air outside through a narrow, long and twisted path, with no assist fans. The back pressure of such a path will reduce greatly the CFM that the transmitter blower can provide, and the unit will run hot.

Sometimes an installation does not even provide a path for makeup air into

the transmitter room, so the unit is starved for air to begin with. No transmitter is designed to withstand such conditions. This is a recipe for early and frequent failure.

## Heat load

This is not to say that an air system using ductwork coupled directly to a transmitter cannot be made to work, but it needs some careful system engineering by an experienced HVAC designer.

One approach in planning a transmitter room air system is to calculate the solar heat load on the closed building (it depends on building design, location, ori-

entation, insulation, etc.), then add the heat produced by all the equipment in the building when in operation, including standby transmitter, air-cooled RF load, racks, lights and other sources. This number is used to calculate how much air is needed to move through the room to keep its heat rise to 1-2 degrees above outdoor ambient, and/or how many tons of A/C is needed.

There are variations on this, where the transmitter/equipment is isolated by a wall around the fronts of the cabinets and use ambient air cooling, and only the work space in the room has A/C.

**The on-air reliability of even the best transmitter can be improved if it doesn't have to 'fight' its installation environment.**

Most transmitters will run fine and with excellent service life as long as well-filtered air at the specified CFM and inlet air temperature is flowing through them. If this is observed, A/C is not required in many climates. However, using A/C and closing off the room to outside air helps keep the room and transmitter clean — at the expense of the A/C hardware and extra mains power needed, and with some reduction in system reliability (without a backup air system).

In some seasons it may even be necessary to add heat to the room to keep the transmitter air inlet temperature above the minimum value specified by the manufacturer. Often this can be done by recirculating the heated air from the transmitter, in some cases assisted by supplementary heat from an electric element, or other means.

A good air system for the transmitter room tends not to get the attention and budget it needs. But the on-air reliability of even the best transmitter can be improved if it doesn't have to "fight" its installation environment.

*Richard J. Fry, CPBE, is a veteran FM RF system analyst and author of technical papers and software. Reach him via e-mail to rfry@adams.net.*

## How to Submit Letters

Radio World welcomes your point of view on any topic related to the U.S. radio broadcast industry.

Letters should be 100 to 300 words long; the shorter the letter, the better chance it will be published in full. We reserve the right to edit material for space. Longer commentaries are welcome but may not reach print as quickly.

Include your name, address and contact information, as well as your job title and company if appropriate.

Send letters via e-mail to [radioworld@imaspub.com](mailto:radioworld@imaspub.com), with "Letter to the Editor" in the subject field; fax to (703) 820-3245; or mail to Reader's Forum, Radio World, P.O. Box 1214, Falls Church, VA 22041.

## This Broadcaster made a bad decision...

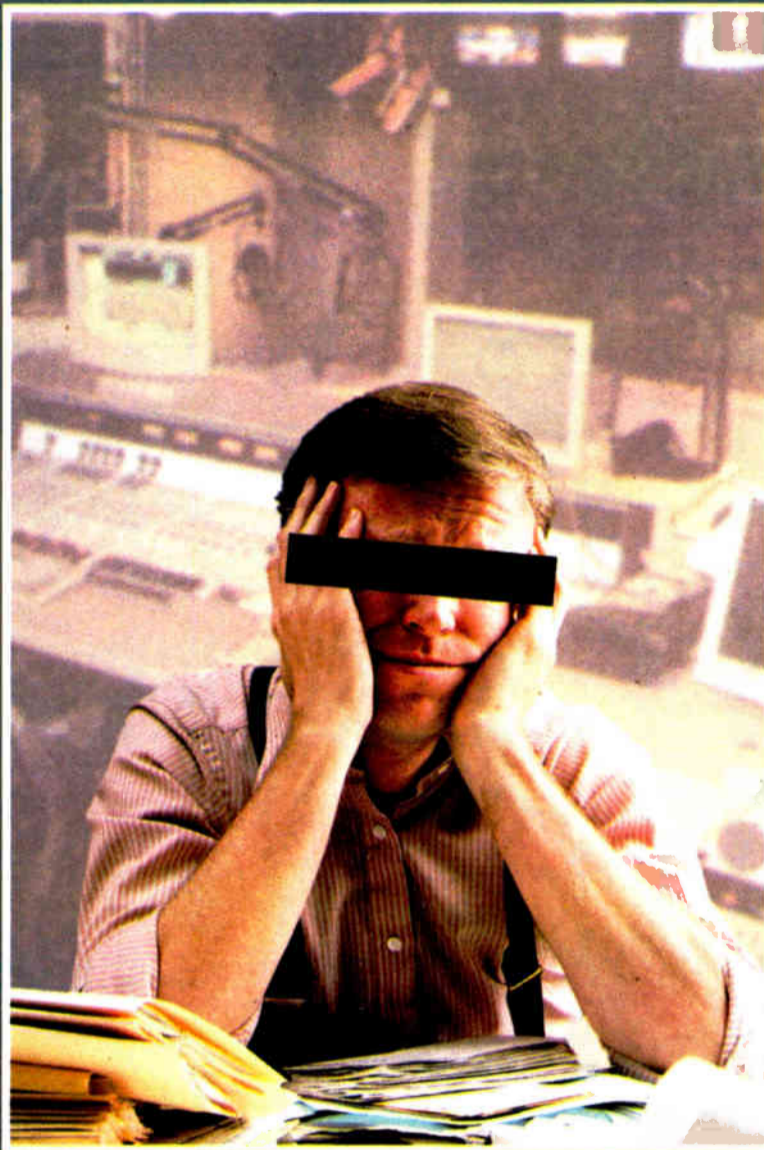

... and now is out of business.

make a good choice in FM Radio or TV equipment.

OMB has a large stock of quality equipment, spare parts and technical support

EUROPE Commercial & TV Factory:  
Avda. San Antonio, 41  
Phone: #976.50.46.96 (6 lines)  
Fax #976.46.31.70  
50410 CUARTE DE HUERVA  
(Zaragoza) • Spain

Radio & Antenna Factory:  
Camino de los Albures, 14, bajos  
Phone: #976.50.35.80 (6 lines)  
Fax #976.50.38.55  
50410 CUARTE DE HUERVA  
(Zaragoza) • Spain  
e-mail: [ombcom@infonegocio.com](mailto:ombcom@infonegocio.com)  
VideoConference(RDSI) 976 46 32 00

INTERNATIONAL 3100 NW 72 nd. Avenue Unit 112  
DIVISION MIAMI, Florida 33122  
Ph.: 305 477-0973 - 305 477-0974 (6 lines)  
Fax: 305 477-0611  
Internet: <http://www.omb.com>  
e-mail: [ombusa@bellsouth.net](mailto:ombusa@bellsouth.net)  
Videoconference: 1 305 5940991  
1 305 5940992



# Workbench

Radio World, February 12, 2003

Past columns are archived at [www.rwonline.com/reference-room](http://www.rwonline.com/reference-room)

## Hey, Don't Flip Out — Flipit!

by John Bisset

ISDN is a mainstay for many stations — so much so that most stations have a backup ISDN line, and even a backup ISDN unit.

Wisconsin Public Radio developed a useful line-switching device to be shared with *Workbench* readers. Called the WYK Flipit Box, it was designed around the program "Whad'Ya Know?"

Two Telos Zephyr ISDN units are used

with this adapter. Both Zephyr units are programmed so that their status outputs (pin 3 of the parallel port DB-15 connector) are activated should lines 1 or 2 (stereo mode) fail. Other programming options are available by referring to the

Telos manual.

Should the main Zephyr fail, Flipit instantly will switch to the backup Zephyr, restoring the audio. Tests on the bench show that simulating a failure of the main audio source will switch instantly to the backup source, with no discernible interruption of the program.

In reality, a failure in the main Zephyr may produce a momentary "hole" in the program, but this is certainly better than the seconds or minutes that it would take to either play with a patch panel, or redial the ISDN connection to restore audio.

### Main and standby

Two simultaneous ISDN feeds are provided for the "Whad'Ya Know" origination. Flipit assumes that ISDN 1 box is the "main" unit. If the main unit fails, Flipit will switch automatically to the ISDN 2 box, and sound an alarm.

Operation of Flipit is straightforward. The dial-up connection is established with ISDN #1 and then ISDN #2. Then the ARM button is set. If a failure occurs, pressing RESET will toggle the audio back to ISDN #1.

The first stage of the Flipit box consists of two level shifters, consisting of Q1, Q2, Q3 and Q4, as seen in Fig. 1. Because the Zephyr's status outputs are open-collector ground logic, and the Flipit is bipolar logic, a conversion is necessary.

The outputs of the two level shifters are combined in AND gates IC7C to produce a RESET command, to restore Flipit to its standby state. The standby state is attained on power-up or by pushing RESET. This closes solid-state switch IC5 and allows Zephyr 1 audio to pass through to your console, uplink, or router.

With both Zephyrs connected (off-hook) their STATUS outputs are at ground LOW. This causes the collectors of Q2 and Q4 to go LOW lighting

See WORKBENCH, page 20 ▶

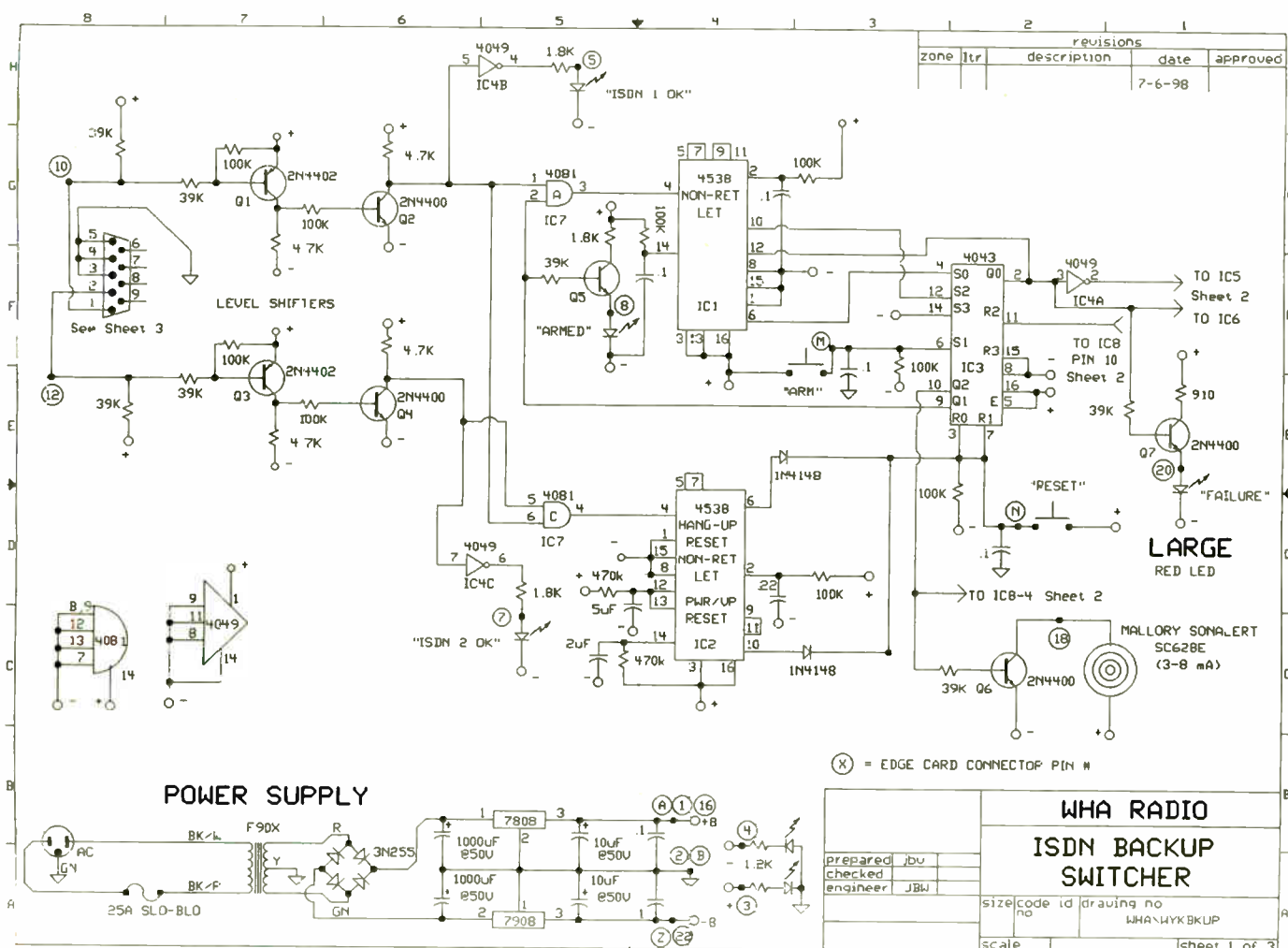

Fig. 1: Schematic for the ISDN Backup Switcher Developed by Wisconsin Public Radio

## Digitally Diverse

### Omega\_FM - \$5880

**NEW!**  
v2 Software

COMPREHENSIVE PROCESSING FOR FM, WITH AN INDEPENDENT AES/EBU OUTPUT THAT CAN FEED A DAB EXCITER AT THE SAME TIME.

Omega\_FM is a 100%-digital, software-based design. New Rev2 software offers a built-in scheduler for dayparting, plus advanced AGC logic, a fourth section of parametric EQ, harmonic bass enhancement and composite output filtering.

While Omega\_FM's composite/MPX output feeds your existing FM exciter, the fully independent AES/EBU digital output can be configured for flat, 20kHz response with programmable delay. This allows a single processing chain to impart a common 'sonic signature' to simultaneous FM and DAB transmissions. The inherent audio quality limitations of FM (15kHz cutoff, plus pre-emphasis and its attendant 'protection' limiting) will not compromise the digital broadcast.

Despite its modest price, Omega\_FM challenges the versatility and performance of any processor on the market. Even if you are delighted with what you're using now, see your preferred equipment supplier for a comparison demo at your station.

**Inovonics**  
1305 Fair Ave • Santa Cruz, CA 95060  
TEL: (631) 458-0552 • FAX: (831) 458-0554  
[www.inovon.com](http://www.inovon.com) • e-mail: [info@inovon.com](mailto:info@inovon.com)

**SEE IT... Hear It...**

Processing doesn't get any better than this.

Retaining for \$199.99, C. Crane Co. says this radio, designed by chief engineer Chris Justice in cooperation with Sangean, is "the best AM radio available."

Audacious, yes. The claim is backed by numerous online testimonials, plus a 30-day money-back guarantee.

"I talked about this wonderful radio on my own radio show 10 days ago," said Tim Carter, broadcaster and nationally

known host of *Crane's Morning Drive* in Silicon Valley, where he worked as a designer, to Fortuna in 1983, "I couldn't get any AM radio stations."

Determined to get talk radio one way or another, Crane eventually tracked down the Select-A-Tenna ([www.selectantenna.com](http://www.selectantenna.com)). A strange-looking device resembling a standing plastic car tire with a tuning knob in its center, the Select-A-Tenna

This said, Bob Crane is prepared to face the IBOC challenge: just as he faced the challenges of distant analog AM reception years ago.

"If and when the IBOC format is consummated, we will have some real technological advances for receivers that use the system," he said. "We will remain a radio performance leader, whatever happens."

learned a lot from you." That was a fine compliment. When Jeff passed on, I lost not only a colleague but a friend.

Jeff is survived by his parents and a daughter, age 11.

Tom Osenkowsky is a consultant and Senior Member of IEEE, SBE and NARTE, based in Brookfield, Conn.

# Workbench

► Continued from page 19  
the "OK" LEDs via IC4. At this point, LOW on the IC7C output

turn on, allowing Zephyr 2 (backup) audio to pass on to your console. At the same time, the FAILURE LED will go on via transistor Q7.

The IC3-2 Q0 output also leading-edge triggers the second half of IC1, which sends a HIGH pulse out to pin 10

With the broadcast concluded, the operator can either push RESET to return Flipit to its standby state, or let the Zephyrs hang up. With the system armed, and both Zephyrs on-hook, both inputs of IC7C are HIGH, output IC7C4 is HIGH, leading-edge trigger-

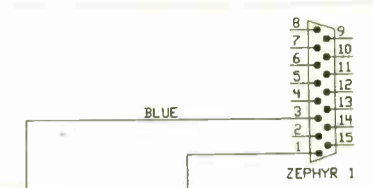

# AEB

## ASSOCIATED BROADCAST GROUP Los Angeles

**Spots From Concept to  
Final Dub**

**Infomercials**

**Station Imaging**

**Agency Or Retail**

**Complete Creative  
In English And in Spanish**

**Syndication Packaging  
And Fulfillment**

# AIRTIME IS MONEY™

*Call for RAB Special Pricing*

### 888-772-8224

[www.associatedbroadcast.com](http://www.associatedbroadcast.com)

**The Company That Advertisers, Radio Stations And Broadcasters  
Turn To When It Comes To The Business Of Radio**

# Workbench

Radio World, February 12, 2003

Past columns are archived at [www.rwonline.com/reference-room](http://www.rwonline.com/reference-room)

## Hey, Don't Flip Out — Flipit!

by John Bisset

ISDN is a mainstay for many stations — so much so that most stations have a backup ISDN line, and even a backup ISDN unit.

Wisconsin Public Radio developed a useful line-switching device to be shared with *Workbench* readers. Called the WYK Flipit Box, it was designed around the program "Whad'Ya Know?"

Two Telos Zephyr ISDN units are used

with this adapter. Both Zephyr units are programmed so that their status outputs (pin 3 of the parallel port DB-15 connector) are activated should lines 1 or 2 (stereo mode) fail. Other programming options are available by referring to the

Telos manual.

Should the main Zephyr fail, Flipit instantly will switch to the backup Zephyr, restoring the audio. Tests on the bench show that simulating a failure of the main audio source will switch instantly to the backup source, with no discernible interruption of the program.

In reality, a failure in the main Zephyr may produce a momentary "hole" in the program, but this is certainly better than the seconds or minutes that it would take to either play with a patch panel, or redial the ISDN connection to restore audio.

### Main and standby

Two simultaneous ISDN feeds are provided for the "Whad'Ya Know" origination. Flipit assumes that ISDN 1 box is the "main" unit. If the main unit fails, Flipit will switch automatically to the ISDN 2 box, and sound an alarm.

Operation of Flipit is straightforward. The dial-up connection is established with ISDN #1 and then ISDN #2. Then the ARM button is set. If a failure occurs, pressing RESET will toggle the audio back to ISDN #1.

The first stage of the Flipit box consists of two level shifters, consisting of Q1, Q2, Q3 and Q4, as seen in Fig. 1. Because the Zephyr's status outputs are open-collector ground logic, and the Flipit is bipolar logic, a conversion is necessary.

The outputs of the two level shifters are combined in AND gates IC7C to produce a RESET command, to restore Flipit to its standby state. The standby state is attained on power-up or by pushing RESET. This closes solid-state switch IC5 and allows Zephyr 1 audio to pass through to your console, uplink, or router.

With both Zephyrs connected (off-hook) their STATUS outputs are at ground LOW. This causes the collectors of Q2 and Q4 to go LOW lighting

See WORKBENCH, page 20 ▶

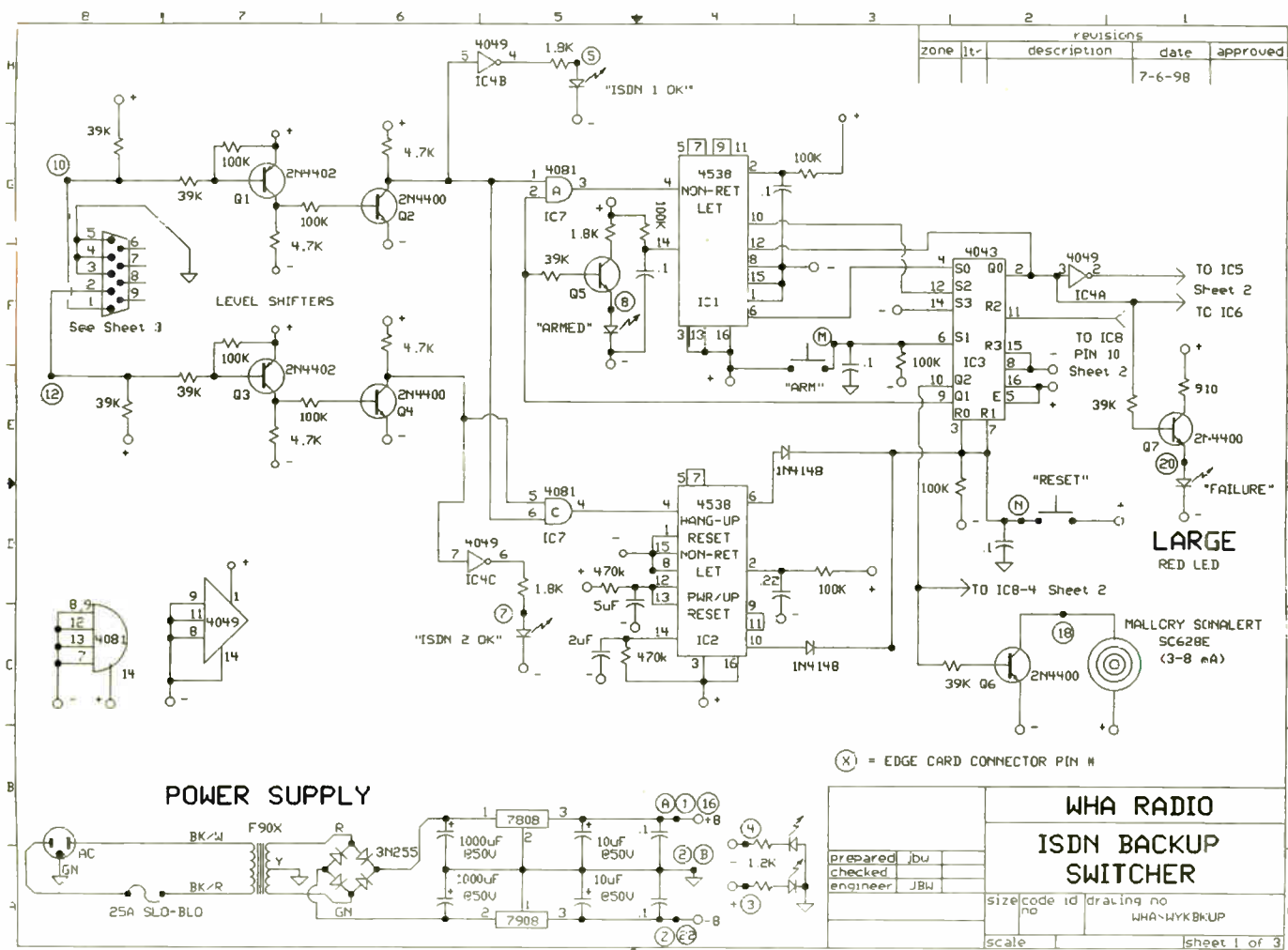

Fig. 1: Schematic for the ISDN Backup Switcher Developed by Wisconsin Public Radio

## Digitally Diverse Omega\_FM - \$5880

**NEW!**  
v2 Software

COMPREHENSIVE PROCESSING FOR FM, WITH AN INDEPENDENT AES/EBU OUTPUT THAT CAN FEED A DAB EXCITER AT THE SAME TIME.

Omega\_FM is a 100%-digital, software-based design. New Rev2 software offers a built-in scheduler for dayparting, plus advanced AGC logic, a fourth section of parametric EQ, harmonic bass enhancement and composite output filtering.

While Omega\_FM's composite/MPX output feeds your existing FM exciter, the fully independent AES/EBU digital output can be configured for flat, 20kHz response with programmable delay. This allows a single processing chain to impart a common 'sonic signature' to simultaneous FM and DAB transmissions. The inherent audio quality limitations of FM (15kHz cutoff, plus pre-emphasis and its attendant 'protection' limiting) will not compromise the digital broadcast.

Despite its modest price, Omega\_FM challenges the versatility and performance of any processor on the market. Even if you are delighted with what you're using now, see your preferred equipment supplier for a comparison demo at your station.

**Inovonics**  
1305 Fair Ave. • Santa Cruz, CA 95060  
TEL: (831) 458-0552 • FAX: (831) 458-0554  
www.inovon.com • e-mail: info@inovon.com

*Hear It...*

Processing doesn't get any better than this.

# Workbench

► Continued from page 19  
the "OK" LEDs via IC4. At this point, there are two LOWs on the IC7C and IC7A inputs, hence their outputs are LOW.

Pressing the ARM button sets the Q output of latch IC3 HIGH, turning on the ARM LED, via transistor Q5, and applying a HIGH to IC7A-2. Now if Zephyr 1 glitches and hangs up, the Zephyr 1 status output will go HIGH via the 39k-ohm pull-up resistor. This forces collector Q2 to go HIGH, placing a HIGH on IC7A-1.

IC7A-3 goes HIGH, leading-edge triggering IC1-4, which produces a HIGH pulse out on pin 6. This pulse latches the Q0 output of IC3-2 HIGH, causing the solid-state switch IC5 to turn off, and solid-state switch IC6 to

turn on, allowing Zephyr 2 (backup) audio to pass on to your console. At the same time, the FAILURE LED will go on via transistor Q7.

The IC3-2 Q0 output also leading-edge triggers the second half of IC1, which sends a HIGH pulse out to pin 10. This pulse latches the Q2 output of IC3 HIGH, causing the alarm to sound via transistor Q6.

The Q2 output of IC3 also leading-edge triggers IC8-4, and after approximately 5 seconds, IC8-6, 11 is trailing-edge triggered. This produces a HIGH pulse out on pin 10, which unlatches the Q2 output of IC3 silencing the alarm.

With Zephyr 2 (backup) audio now online, the operator can re-establish the Zephyr 1 connection, push the RESET button, which puts Zephyr 1 audio back online. When the ARM switch is depressed, the system awaits for another Zephyr 1 failure.

With the broadcast concluded, the operator can either push RESET to return Flipit to its standby state, or let the Zephyrs hang up. With the system armed, and both Zephyrs on-hook, both inputs of IC7C are HIGH, output IC7C4 is HIGH, leading-edge triggering IC2-4, producing a HIGH reset pulse out on pin 6 to IC3-3, 7. This puts Flipit back in its standby state. The alarm will always sound if Flipit is armed, and Zephyr 1 hangs up.

The schematics are shown including the Zephyr interconnect logic cable schematic. The front panel of the Flipit is a standard 19-inch rack plate drilled for the appropriate alarm, lamps and switches.

This is the kind of project that will win you points with your manager and program director. Minimizing down time saves on make-goods, which translates to the bottom line. Make sure you advise them of your initiative.

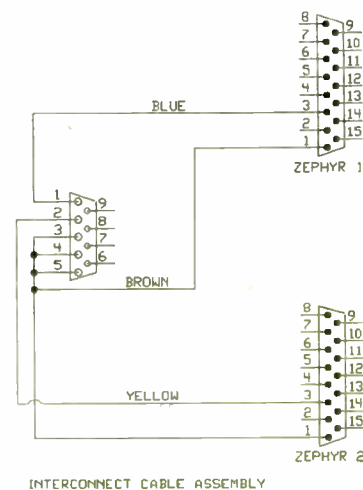

INTERCONNECT CABLE ASSEMBLY

| RIBBON CABLE     | PIN # |
|------------------|-------|
| BN +8U           | 1     |
| BK -8U           | 22    |
| W +8 LED         | 3     |
| GY -8 LED        | 4     |
| V ISDN 1 LED     | 5     |
| BE ISDN 2 LED    | 7     |
| GM ARM LED       | 8     |
| Y ISDN 1 CTRL    | 10    |
| O ISDN 2 CTRL    | 12    |
| R ARM PB         | M     |
| BN(2) RESET PB   | N     |
| Y(2) FAILURE LED | 20    |

Fig. 3

\*\*\*

Ralph Jones of Entravision Radio and Dave Fortenberry of Salem Communications, both in Sacramento, Calif., pass along a Web site that offers ISDN long-distance service 10 ten cents per minute. The site is [www.ISDNlongdistance.com](http://www.ISDNlongdistance.com).

The service is transparent, just dial the 10-10 number and the destination ISDN number.

The phone bill can be reviewed online (with password access), and a paper copy can be sent to the accounts payable manager.

John Bisset has worked as a chief engineer and contract engineer for more than 30 years. He is a district sales manager for Harris Corp. Reach him at (703) 323-8011.

Submissions for this column are encouraged, and qualify for SBE recertification credit. Fax your submission to (703) 323-8044, or send e-mail to [jbisset@harris.com](mailto:jbisset@harris.com).

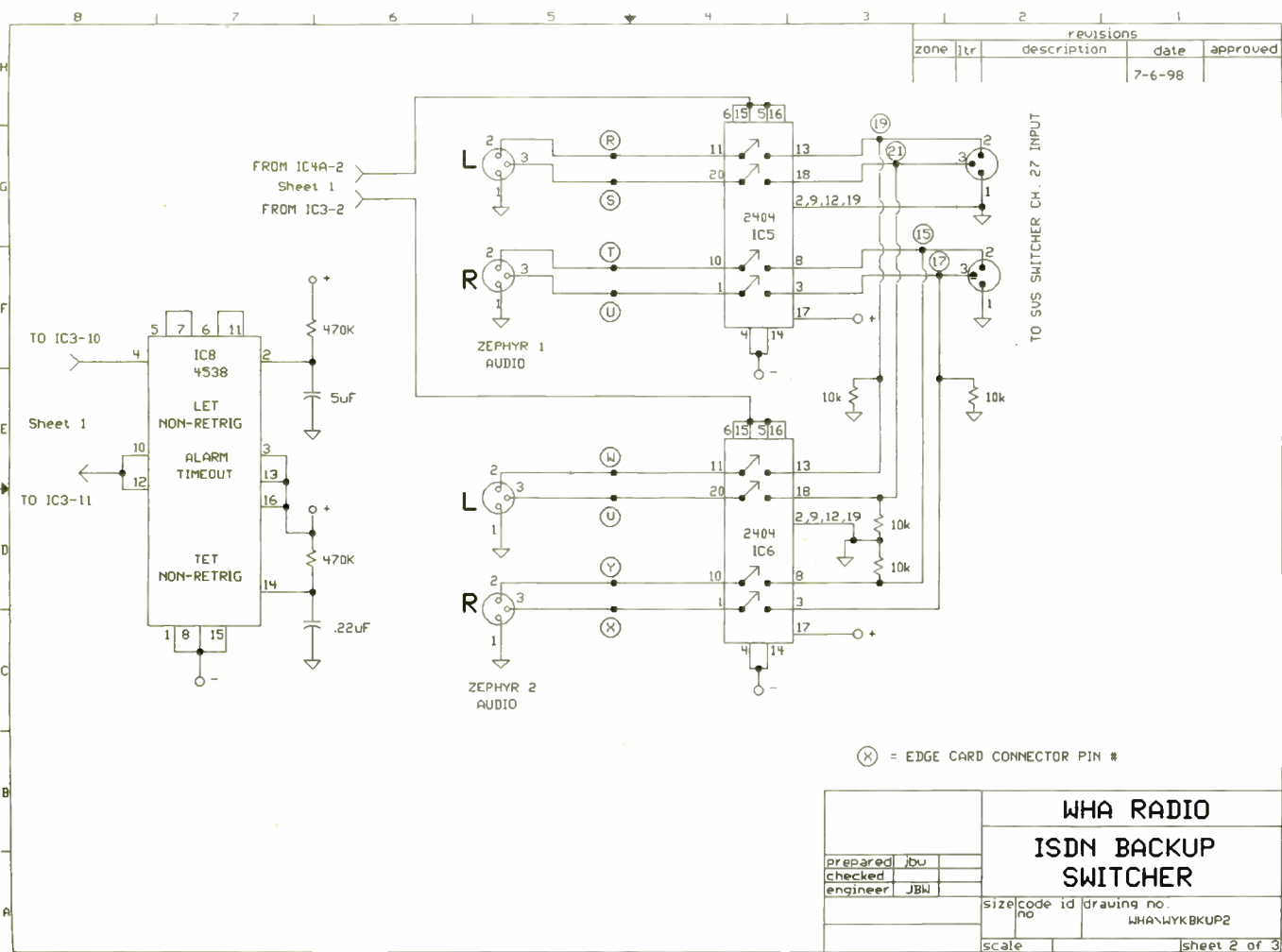

Fig. 2

|                      |                     |
|----------------------|---------------------|
| WHA RADIO            |                     |
| ISDN BACKUP SWITCHER |                     |
| prepared             | Jbw                 |
| checked              | Jbw                 |
| engineer             | Jbw                 |
| size                 | code id drawing no. |
|                      | WHA-WYK BKUP2       |
| scale                | sheet 2 of 3        |



## Simple level setup . . . for a switch.

- Switchable fixed Mic and Line level outputs and inputs make module or audio system gain setting simple
- Combination precision oscillator, visual meter with monitor speaker: PT-AMG2
- Precision oscillator: PT-ASG1
- Benchtop performance, 9V portability
- Rugged construction with test leads and bench stands included, carrying case optional

USA 800 281-2683  
INTL 805 684-5415  
EUR 31 20-6238-983  
<http://rdlnet.com>



# RDL

Radio Design Labs

SPECIALISTS IN PRACTICAL PRECISION ENGINEERING™

# C. Crane Loves AM Radio

by James Careless

Once upon a time, the world's best radios were designed and built in the United States. But times have changed, and today Asian manufacturers dominate the consumer radio market.

syndicated newspaper columnist of "Ask The Builder."

"Within moments I received three phone calls from listeners who own a CCRadioplus. They sang its praises louder than me. The bottom line is this: If you want an awesome portable radio that has

passively adds up to +30 dB signal gain when placed close to a radio's internal AM ferrite antenna.

Bob Crane liked the Select-A-Tenna and started to sell them. Then he added radios — quality radios only, please. Today C. Crane Co. — the C. salutes the middle initials of both Bob and his wife, Susan — is a respected radio designer and retailer.

In the case of the CCRadioplus, he said, "We approached Sangean in 1988 with plans for a top-end AM receiver. However, we didn't have the clout of financing to convince them to do it. Then, when they let us know they were building their own AM receiver a few months later, we replied, 'What's the point of competing, when we can work together?' And that's what happened."

## Coil boost

Since then, C. Crane has developed other AM products. A case in point is the Justice AM Antenna. Also designed by Chris Justice, the \$99.95 Justice is meant to be the "best compact AM antenna available."

The patent-pending Justice Antenna's secret is its use of twin coil on its ferrite bar antennas.

"A conventional ferrite bar antenna naturally has north and south magnetic poles," Crane said. "Chris realized that if you put a second coil on the ferrite bar and combine the signals electronically, you can boost the signal 6 dB."

So does the Justice AM Antenna perform as billed? Yes, says the fan-run Web site Philly Talk Radio Online.

"The Justice antenna is an amazing unit," PTRO says. "C. Crane has come up with some new technology here and they have every right to be proud of it."

In addition, the Justice antenna has been adopted by many cable TV operators, who have connected it to their EAS radio receivers.

"Our product was initially recommended by an EAS radio manufacturer to a cable TV operator," said Justice. "Since then, we've been supplying these antennas to cable TV operators nationwide."

After 26 years in radio design, Bob Crane's enthusiasm shows no sign of waning.

"I love radio, pure and simple," he said. "It's the only addiction I know of without a treatment center. Until they come up with one, I guess I'll keep at it."

"Besides, I like making products for people who appreciate them. The old slogan about 'making life better with technology?' That's what we're all about."

As for the future, Bob Crane is monitoring IBOC's progress; the company's Web site talks extensively about the digital radio technology, and Crane himself wrote to the National Radio Systems Committee in early 2002 with his opinions about it.

"I recommend that the initial rollout tests be watched closely by station owners and the public," Crane said. "This is a real big change, and I believe it will affect broadcast communications for ever more."

This said, Bob Crane is prepared to face the IBOC challenge; just as he faced the challenges of distant analog AM reception years ago.

"If and when the IBOC format is consummated, we will have some real technological advances for receivers that use the system," he said. "We will remain a radio performance leader, whatever happens." 🌐

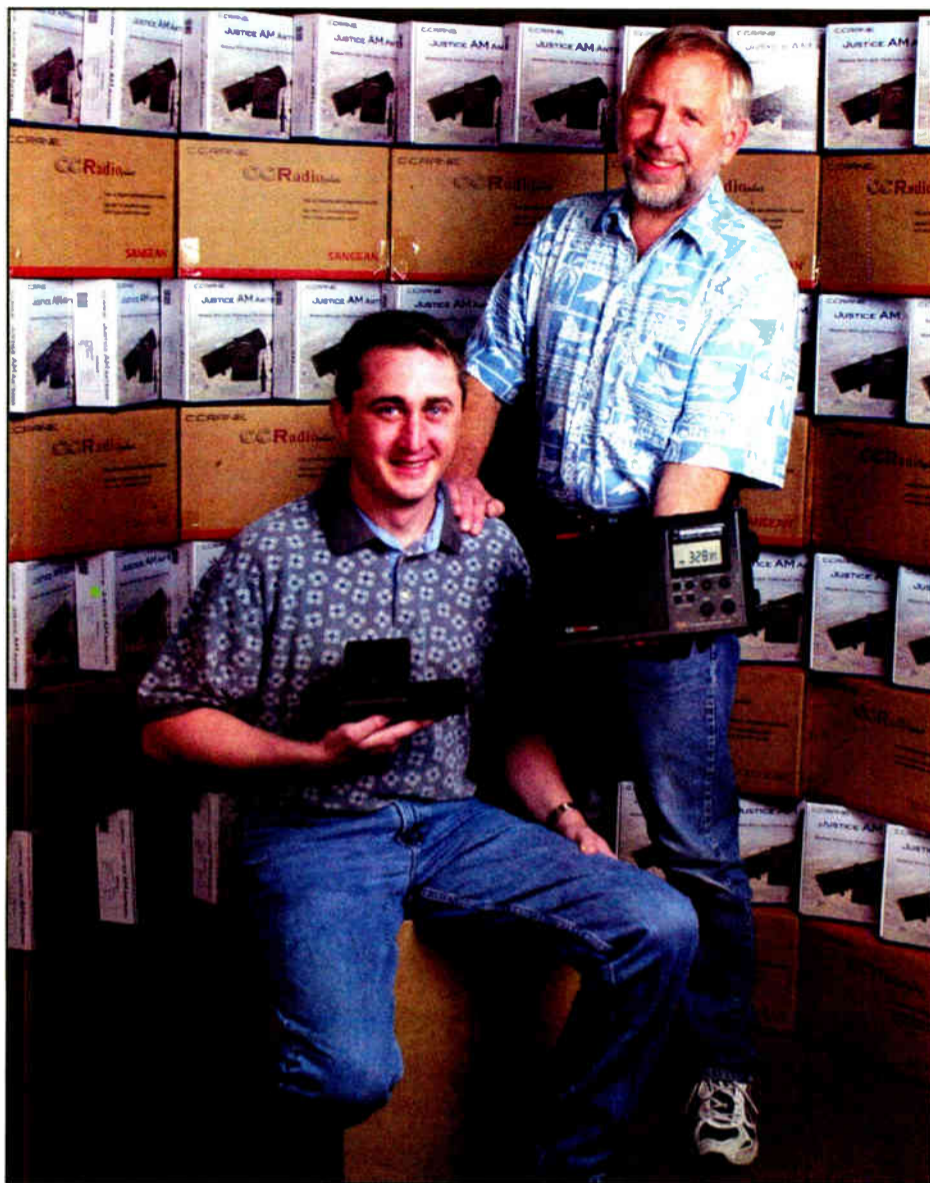

Chris Justice and Bob Crane pose with the CCRadioplus and the Justice AM Antenna. The latter, held by Justice at left, uses twin coils on a ferrite bar antenna to boost signal gain.

However, this doesn't mean America is out of the race. For instance, in the northern California town of Fortuna (population 10,000), stands a rustic two-story farmhouse that's home to the C. Crane Company. For 26 years, it has been an innovative family-owned designer and marketer of leading-edge AM radios and accessories for talk radio fans.

## Why AM?

"Talk radio is the No. 1 format in the U.S., and has been for years," said Bob Crane, the company's president and owner. "However, most radios are designed to reproduce music, rather than voice. In contrast, our products emphasize accurate, full-bodied voice quality; especially on AM."

Today, C. Crane's flagship product is the AM/FM/TV/Weather Alert CCRadioplus. Retailing for \$159.95, C. Crane Co. says this radio, designed by chief engineer Chris Justice in cooperation with Sangean, is "the best AM radio available."

Audacious, yes. The claim is backed by numerous online testimonials, plus a 30-day money-back guarantee.

"I talked about this wonderful radio on my own radio show 10 days ago," said Tim Carter, broadcaster and nationally

unparalleled reception, then you should consider the CCRadioplus."

"A hands-on evaluation confirms that the CCRadio lives up to its promise," wrote Stephen A. Booth, in the January 1999 edition of Popular Science magazine. "It is the best AM radio I've ever had the pleasure of trying," said MSNBC's Gary Krakow.

Okay: so the CCRadioplus is a great AM radio. But still, why would anybody bother to make a great AM radio these days? Especially when the GE Super III, the legendary AM long-distance tuning receiver, is also available — at [www.ccrane.com](http://www.ccrane.com) — for \$64.95?

The answer is that Bob Crane personally loves talk radio.

"You can actually get an education just by listening to some of the shows," he said. "I listen to this format all the time."

However, when Crane moved from Silicon Valley, where he worked as a designer, to Fortuna in 1983, "I couldn't get any AM radio stations."

Determined to get talk radio one way or another, Crane eventually tracked down the Select-A-Tenna ([www.selectantenna.com](http://www.selectantenna.com)). A strange-looking device resembling a standing plastic car tire with a tuning knob in its center, the Select-A-Tenna

## APPRECIATION

# Jeffrey Lalumiere Remembered

by Tom Osenkowsky

On Nov. 29, 2002, Jeffrey Lalumiere, 42, owner of Signal Step Communications in Dayville, Conn., and former director of engineering for Tele-Media Broadcasting Co., died following a brief battle with cancer.

Jeff began his broadcast career in May 1985 while attending the Rhode Island School of Electronics. Robert W. Knott, chief engineer of WSBE(TV), recalls hiring Jeff as a Master Control and camera operator.

"Once he learned operations, Jeff was not one to just sit at the console, but wanted to get into the equipment," Knott recalls. "In a strange twist of fate, I became answerable to him, as we rent space on the WPRO(FM) tower for our TV."

## Teen student

According to Matt Lightner, president of Lightner Electronics, "I started working with Jeff when I was only 16. His nickname for me was Matlock. He would always call me and ask what broadcast engineering mysteries I was solving today."

"Jeff trusted me when I was starting in radio, and helped me learn a lot about engineering. He always was very appreciative of anything I did."

I remember working with Jeff on many field projects for Tele-Media, in Providence, R.I., and State College and York, Pa. I found Jeff to be professional in his attitude and attentive in his work.

I hired Jeff for projects and was extremely satisfied with his performance. I first met him while on a field visit to WINY in Putnam, Conn. Jeff was at the station to observe the adjustments I was making to the station's ATU. Jeff told me he was impressed with my work and taking the time to explain everything I was doing.

While at Tele-Media Jeff hired me to prepare an exhibit as part of its application to purchase WPRO(AM-FM). This was the beginning of an association that lasted through preparation of many exhibits during Tele-Media's acquisition phase until Citadel purchased the Tele-Media properties.

He was an accomplished guitarist and played in the Killingly High School band Pioneer and played with The Drive Band for 21 years.

Ironically, it was at WINY in October of 2002 that I learned that Jeff had cancer. I visited him in the hospital. His parting words were "I learned a lot from you." That was a fine compliment. When Jeff passed on, I lost not only a colleague but a friend.

Jeff is survived by his parents and a daughter, age 11.

Tom Osenkowsky is a consultant and Senior Member of IEEE, SBE and NARTE, based in Brookfield, Conn. 🌐

# AEB

**ASSOCIATED BROADCAST GROUP**  
Los Angeles

**Spots From Concept to  
• Final Dub**

**Infomercials**

**Station Imaging**

**Agency Or Retail**

**Complete Creative  
In English And in Spanish**

**Syndication Packaging  
And Fulfillment**

**AIRTIME  
IS MONEY™**

*Call for **RAB** Special Pricing*

**888-772-8224**

**[www.associatedbroadcast.com](http://www.associatedbroadcast.com)**

**The Company That Advertisers, Radio Stations And Broadcasters  
Turn To When It Comes To The Business Of Radio**



## Will Arbitron Walk the Talk?

*Spanish Radio Holds Arbitron Commitment to the Fire*

by Dee McVicker

Recent attempts by Arbitron to avoid fallout from low Spanish listener turnout in at least one book have only earned it more criticism from Hispanic broadcasters.

Hispanic radio groups lobbed missives the size of Manhattan at the ratings

research company after a November summit meeting, in which Arbitron announced it will begin language-preference weighting but didn't give a timeline when it would do so. In January, the research company indicated it would take at least three years, according to several published reports.

"Arbitron is putting out into the market what amounts to a defective product," said Joaquin Blaya, the chairman/CEO of Radio Unica, Miami, after the November meeting. "In any other industry, if you put a defective product into the market you are forced to recall it."

### Criticism

Arbitron has been the target of criticism by Hispanic Broadcasting Corp., Spanish Broadcasting Systems, Entravision Communications and Radio Unica Communications since its summer Los Angeles book, which under-sampled Spanish-speaking listeners to the detriment of Hispanic stations' ratings in the market.

Language weighting would help repair the relationship between Arbitron and Hispanic broadcasters, who long have

See SPANISH RADIO, page 26 ▶

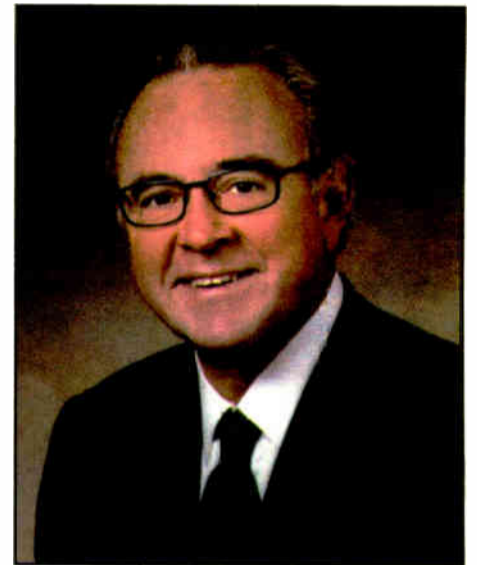

Hispanic broadcasters lose more than \$150 million annually in ad revenue because of current tabulation methods, said Joaquin Blaya, chairman/CEO of Radio Unica, Miami.

## CES Showcases New Web Radio Devices

by Craig Johnston

There is plenty of copyright royalty news to report, some of it really depressing. So Web Watcher was happy to return from January's Consumer Electronics Show with optimism: Manufacturers are making non-PC devices that promise to move Internet radio listening into the stereo room of the house.

Prior to CES, the pickings of Webcast listening devices other than PCs had been slim: Philips Streamium MC-i200 is one of the few that come to mind.

But if imitation is the greatest form of flattery, Philips ought to be flattered by Sony's introduction of its Universal Music System. The device is a stereo component that allows the listener to tune among FM, AM, various other audio component sources and Internet radio.

### Highlights

Another shelf radio device making a debut at CES was the GlobalTuner InTune200 from Promotion and Display Technology of the United Kingdom. A



wireless transceiver plugs into the USB port of a PC connected to the Net. It provides wireless service to the InTune200 within 300 feet of the PC.

Internet stations, as well as FM, can be tuned by the InTune200. The unit is not yet available. PDT is looking to bundle it into broadband Internet access offerings by Internet service providers.

If Internet radio listeners yearn for the freedom the pocket transistor radio gave traditional radio listeners in the '50s, a new Dell Computer Corp. product takes them almost there. Its Axim X5 Pocket PC uses a Compact Flash wireless card to connect to the Net via a WiFi network.

This unharnesses the listener from a wired Internet connection and a bulky

See WEB WATCH, page 28 ▶



GlobalTuner InTune200

## Your Link To The World



**ComPack™ Connects Your Audio Gear To Any Telecom Line – Cell, PBX, Analog, Digital, ISDN, Conventional...**

With the rugged ComPack there's never been a more portable, flexible, cost-effective solution for interfacing audio and telecom gear. ComPack is perfect for remote broadcasts, IFB feeds, or interviews over any phone connection. ComPack also functions as a simple telecom interface for your beltpack intercom system, providing a full duplex, always-on connection to any telephone network.



**JK Audio**  
Toll Free (USA & Canada): 800-552-8346  
Tel: 815-786-2929 • Fax: 815-786-8502  
www.jkaudio.com

# Want the facts about Aphex, CR other processors? Just call Paul...



Order direct from Paul Schweiger by calling 877-564-0559 or emailing him at PaulS@bswusa.com

... Schweiger\* who will probably immediately protest that he's being stereotyped, since he's equally expert at discussing the technical specs of microphones, consoles, CD players or studio monitors.

That's because Paul not only has two college degrees in Communications, but also spent twenty years working for radio stations in Arizona and California.

Call Paul and you're talking to a seasoned broadcast industry pro who has the training to ask the right questions and make the best recommendations to help you find your unique sound.

Along with Tom, Laz, John, Shannon, Gary, Ryan, Ricardo and Steve, Paul Schweiger is another reason why BSW really *is* your best source for professional audio — our friendly folks know how to take care of you whether you need a processor or a whole production studio full of gear.

Call us today.

\*Paul wishes you to know that nepotism isn't as rampant at BSW as it might seem. Paul's last name is spelled Schweiger, unlike, BSW President Tim SchwIEger. The rule is "i before e except when hiring terrific, experienced staff."



Broadcast Supply Worldwide's Sales Order Center looks nothing like this stock photo we found.

All BSW Sales Representatives' cubicles are much larger and have individual jacuzzis and mini-bars.



## Powerhouse Aphex FM Processor

The Aphex Model 2020 MkIII is a complete FM broadcast audio processor contained in a single chassis. All functions are integrated within one interactive, stable, and optimized processing framework. Over 12 Aphex patents in audio signal processing technology are incorporated in the Every stage of processing is crafted to work seamlessly so there is no of competition or "fighting" for control between the leveler, compressor, limiter elements. At every stage, the sonic effect of the process was tuned for the minimum objectionable artifacts and maximum performance. Importantly, no multiband or composite clipping are used, minimizing grunge, listener fatigue and multipath distortion. Aphex developed techniques to gain comparable and even greater loudness while generating far less artifacts.

2020MKIIIWITH03

List 7,995<sup>00</sup>

Call for Price

APHEX SYSTEM

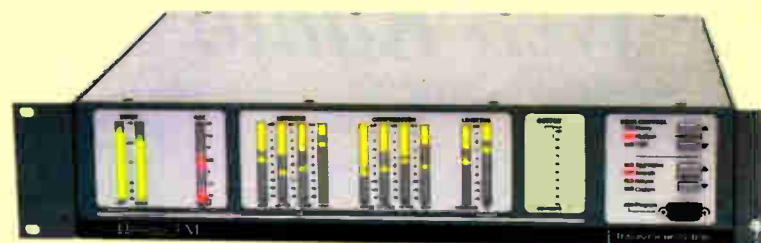

## Smarter, Software-Based Digital Processing

Outstanding design simplicity, and a straightforward product conceals the Omega FM ahead of the competition. Not too mention its affordable price! The Inovonics Omega FM is software-based which provides a clean, audio signal path. This approach avoids relying on application-specific integrated circuits and assures negligible "latency" or audio delay, all traditional, direct "off-air" signal monitoring. **Features:** gated, intelligent "gain-riding" AGC erases unwanted input level variations; multi-band leveling to ensure a consistent tonal balance; wide-range, triple parametric EQ and multi-band compression to help create and define on-air sound; split-spectrum final limiting to provide optimal carrier deviation despite pre-emphasis restrictions; digital inputs and outputs (AES/EBU) balanced XLR; S/PDIF unbalanced BNC.

OMEGAFM

List \$5,880<sup>00</sup>

Call for Price

Inovonics



## RE20 75th Anniversary Special Edition Microphone — Exclusively at BSW

Here is your chance to own a piece of history. Be the first on your block to own the Special 75th Anniversary Edition Electro-Voice RE20 Microphone. This limited edition collector's mic is an RE20 through and through but is painted black and has a special 75th Anniversary Logo. This mic will look and sound great in your studios. It comes complete with a wooden box, serial number certificate and stand clamp. Hurry, once these are gone...there will be no more.

RE20-75SE

List 798<sup>00</sup>

429<sup>00</sup>

# CRL, Inovonics, Omnia, Orban and



## Affordable AM and FM Stereo Processing

The CRL Amigo FM is a complete stereo audio processing system – both flexible and powerful. It has easy-to-understand processing controls to customize your station's sound. A wide range dual band AGC ensures consistent station loudness, by automatically monitoring and adjusting your audio levels. Powerful multi-band limiting system gives your station a natural sound with superior loudness. The Amigo's digitally synthesized multiplex generator provides a flawless stereo signal.

The Amigo AM is a complete audio processing system for AM stereo. A wide range dual band AGC ensures consistent station loudness, by automatically monitoring and adjusting your audio levels. Three-band matrix limiter maximizes your station's coverage area and loudness. Stereo sound enhancement provides additional stereo separation to make your station stand out.



AMIGOFM or AMIGOAM List 2,695<sup>00</sup> **2,495<sup>00</sup>**



## Looking to be #1 in Your Market!

Built to satisfy the most competitive radio markets, Omnia-6fm's rich feature set and advanced DSP algorithms push digital audio processing to new levels. Omnia's 96 kHz sample rate broadcast audio processor, with separate compressor and limiter sections, eliminates intermodulation distortion. **Features:** four-frequency high-pass filter; selectable multi-stage phase rotator; wideband AGC; adjustable stereo enhancement algorithm; five-band crossover network; adjustable five-band AGC; over-sampled six-band limiter; Ethernet port; much more.

Omnia-4.5fm may be exactly the processor your station is craving for, with incredibly big sound at an economical price. Its 96 kHz sampling rate, stereo and bass enhancement features, five-band limiter and smooth, precise AGC, give you maximum control over your sound.

OMNIA6 List 11,590<sup>00</sup> **Call for Price**  
 OMNIA4.5FM List 7,980<sup>00</sup> **Call for Price**



## Trust Orban for Your Station's Unique Sound

The Orban Optimod 8400 offers state-of-the-art five-band and two-band processing structures, but with its supercharged processing power, there is a clearly audible improvement, namely a louder and brighter signal, with the smoothness and pristine clarity needed to hold listeners for extended periods. Recently introduced Version 2.0 software advances the 8400 in two important ways: it reduces input/output delay far enough to make off-air headphone monitoring practical for talent, and DSP improvements have significantly enhanced sound quality.



The Optimod 2200 offers important features you'll find in high-end processors, but in a downsized box. **Features:** 8 factory and 8 user-programmable presets that can be switched from the front or via remote control; 2-band processing structure with HF enhancement to protect against peak over-modulation; non-volatile memory; built-in tone generator; input/output and gain reduction LED meters; balanced analog XLR I/O and two BNC composite outputs. The Optimod 2200 has analog I/O. The 2200D adds digital AES/EBU I/O.

8400 List 10,900<sup>00</sup> **Call for Price**  
 2200 List 4,150<sup>00</sup> **Call for Price**  
 2200D List 4,450<sup>00</sup> **Call for Price**



## Incredible Value Headphone 5-Pack

Five AKG K110M headphones for \$89.00! We're not kidding. These durable, great sounding headphones have sealed ear cushions, a self-adjusting headband and low 32 ohm impedance. A BSW exclusive!

K110MPKG **89<sup>00</sup>**



## BSW Exclusive Microphone 5-Pack

The Audio-Technica ST95MKII is a quality sounding dynamic mic that is perfect for PA and studio recording. **Features:** On/Off switch; XLR output; low impedance; cardioid pick-up pattern. Includes stand adaptor.

ST95MKIIPKG **99<sup>00</sup>**

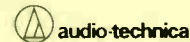

## Don't Forget Stands and Cables

These durable mic stands for less than \$18 each in the 5-pack are an incredible bargain exclusively from BSW.

Also save on quality, low-loss 25 ft. mic cables at a great price. Money saving 5-Pack!

MS200PKG **89<sup>00</sup>**

M25PKG **49<sup>00</sup>**

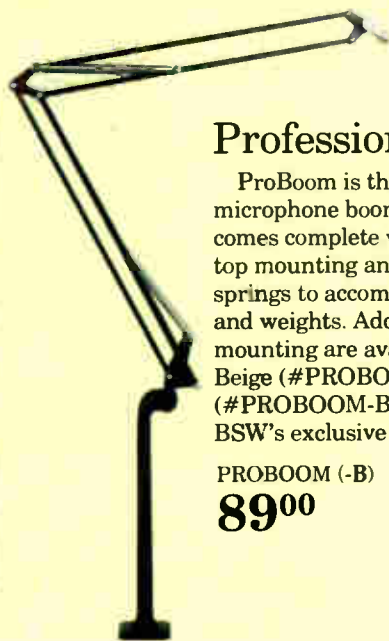

## Professional Mic Boom

ProBoom is the best value in studio microphone booms. This 41" arm comes complete with 12" riser for table top mounting and two sets of upper springs to accommodate all mic sizes and weights. Additional mounts for wall mounting are available as options. Beige (#PROBOOM) or black (#PROBOOM-B). Get it today at BSW's exclusive low price!

PROBOOM (-B) **89<sup>00</sup>**



BSW offers package pricing • Let us save you money on your next quote

**800 • 426 • 8434 or online @ [www.bswusa.com](http://www.bswusa.com)**

Broadcast Supply Worldwide.  
 Your Best Source for Professional Audio Products.



# Spanish Radio

► Continued from page 23

argued that Arbitron short-shrifts them because their Spanish-speaking only listeners are not represented accurately in audience measurements. But without a timeline for implementation, these operators feared that Arbitron was long on promise and short on action.

Jeffery Liberman, president of Entravision Radio in Santa Monica, Calif., suspects Arbitron made the weighting announcement to diffuse tensions during the two-day meeting in which Spanish-language operators voiced their concerns with existing measurement practices. Instead of placating them, the announcement ignited anew Hispanic broadcasters' frustra-

tions with a ratings company that they claim consistently under-rates Hispanic language stations and costs them millions of ad dollars each year.

stated Owen Charlebois, president of U.S. Media Services, Arbitron, New York, after the November meeting. "We told Hispanic broadcasters when we got

## Arbitron is putting out into the market what amounts to a defective product.

— Joaquin Blaya, Radio Unica

The four broadcast groups have banded together to "explore our options," according to Liberman. "We are definitely committed to this."

back an independent analysis ... (that) gave us an indication we may not be collecting quite as many Spanish-dominant diaries as we might need ... we would



Owen Charlebois, president of U.S. Media Services, Arbitron, said the ratings service will add language-preference weighting to its tabulation methods.

commit to language-weighting. We got that indication on Nov. 5. On Nov. 12, we made the commitment.

"We didn't say, 'I don't know how long is it going to take us.' We committed immediately. We lived up to that obligation very quickly, and we're going to live up to this obligation, too."

To make good on that promise, Arbitron will need to update its computer systems. It also will need to get accurate statistics of language preferences in Spanish-speaking markets, which is proving to be more of a challenge.



Media researcher Norman Hecht said language-preference weighting and larger sample sizes would reduce the likelihood of inaccurate ratings of Spanish-speaking stations.

Charlebois said the U.S. Census Bureau doesn't collect the information in sufficient detail. A possible solution might be to plug in figures used by Nielsen Media Research, already widely accepted by advertisers.

"We're looking into that to see if the Nielsen numbers will work. But even if they do work, we need to move on to something bigger. We need to get numbers for all 68 of our Hispanic markets. We have 68 Spanish-controlled markets and Nielsen has about 16," said Charlebois.

He said Arbitron was moving as fast as it can to make the necessary changes.

Yet even as Arbitron announces a new statistical model for Spanish-speaking See SPANISH RADIO, page 31 ►

**YOU GOTTA GO!**

Join us at the **Radio Luncheon** on Tuesday, April 8 for the induction of **Scott Shannon, Air Personality and Program Director, WPLJ**, into the NAB Broadcasting Hall of Fame.

**SEE ONE OF COMEDY'S BEST — LIVE!**  
NAB Opening Celebration with **Bill Cosby** Sunday, April 6, 2003 The Bellagio Hotel and Casino Ticket required.

Register for **NAB2003** today and save! Register by February 28, 2003 and save up to \$200 off the regular price. Packages start at \$395. For details and up-to-the-minute information, visit [www.nab.org/conventions/nab2003](http://www.nab.org/conventions/nab2003)

## You gotta network. You gotta learn. You gotta see. You gotta NAB.

Let's face it, time is money — now more than ever. For the most comprehensive electronic media industry experience available, you'd be wise to invest your time in an event with global returns.

**NAB2003** is the only truly worldwide event for electronic media, offering professional networking opportunities with industry leaders from more than 137 different countries. The **Radio Management Conference** is guaranteed to leave you with the wisdom you need to succeed well into the future. And there's no bigger or more complete showcase of broadcast and multimedia products on the planet.

Make plans to attend **NAB2003**, The World's Largest Electronic Media Show and the Radio Opening Reception on Sunday, April 6. Because if you wanna know, You Gotta Go!

**Conferences: April 5-10, 2003 • Exhibits: April 7-10 • [www.nab.org/conventions/nab2003](http://www.nab.org/conventions/nab2003)**



# Trapped at the station?

# You need iMediaTouch.

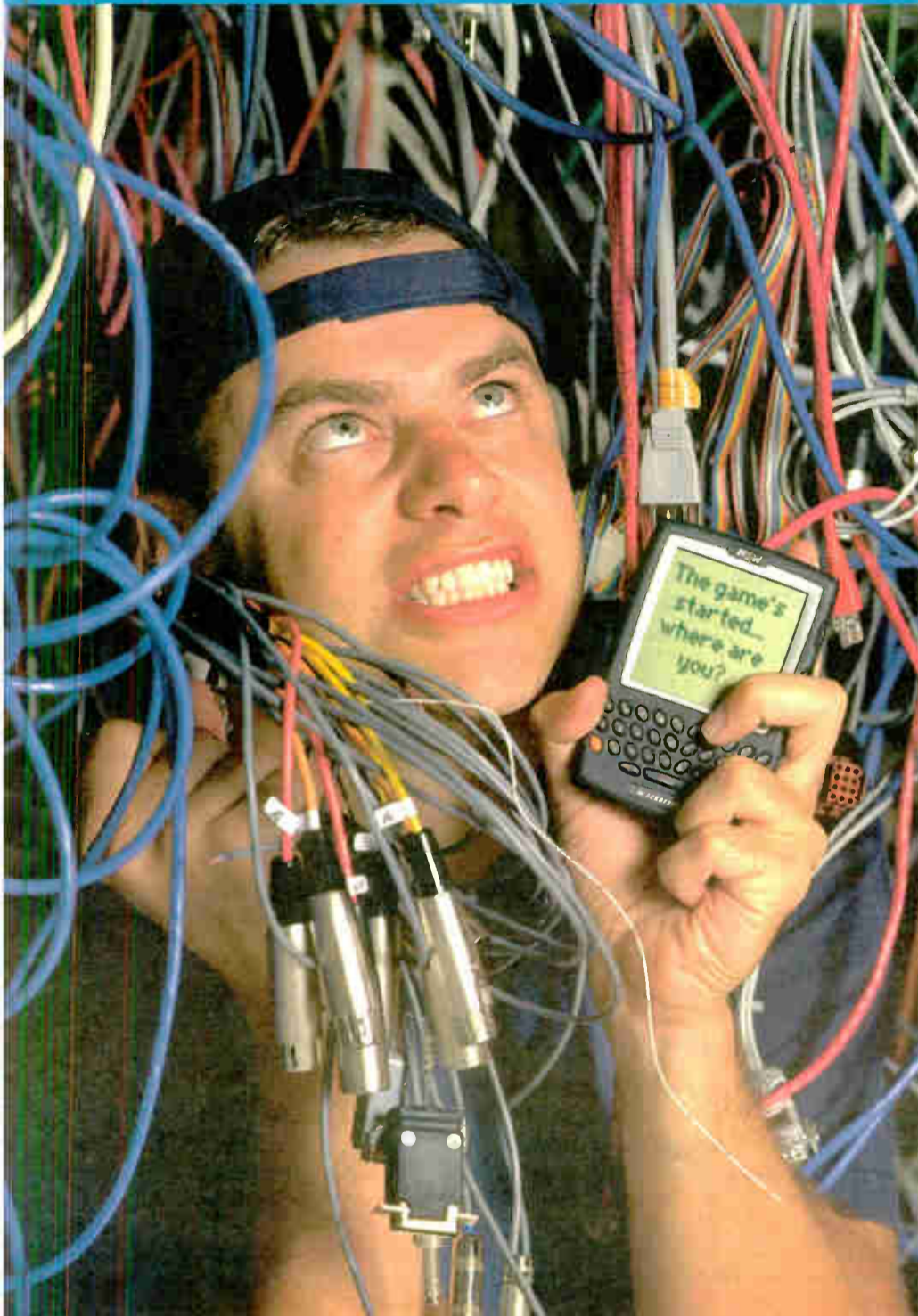

## Is your digital audio delivery system keeping you from the big game?

Since 1984, over 500 radio stations around the world have trusted iMediaTouch broadcast automation software. With a host of award winning features designed to save both time and resources without breaking the bank, the iMediaTouch digital audio delivery system is easy to use and dependable time after time.

**iMediaTouch broadcast automation software.**  
**Big market dependability. Small market affordability.**



To find out more call us  
Toll Free 888 665 0501 or visit [www.omt.net](http://www.omt.net)

**NAB** See us at NAB 2003 - Las Vegas, NV - Booth#N2934

World Radio History



# Web Watch

► Continued from page 23  
PC. Internet stations can be changed on the Pocket PC itself, and sound through headphones is terrific. (A built-in speaker/microphone is unsatisfactory for music listening.)

Because of the need to be within range of a WiFi network, the Axim doesn't offer the ability to listen while walking through the woods. But it could allow listening around the company office or in a person's backyard.

The Axim isn't the first handheld computer to be able to receive Internet radio, but at around \$250 it debuted at half the price of its predecessors. Apparently the public was excited about the unit. Dell customers waited two weeks and longer for their orders to be filled, about triple the normal period.

Web Watcher expects a lot of imitation of the Dell unit.

Web Watcher thinks the confidence of all Webcasters had to be shaken when, the first day of 2003, approximately 150 Clear Channel Communications stations pulled their simulcast streams from the Net.

Prior to Jan. 1, financial responsibility for Clear Channel stations' streaming activities had been covered by corporate. Clear Channel Interactive's VP of Technology Brian Parsons told Web Watcher that in December, the decision was made to move that responsibility to individual stations.

Faced with the choice of adding a possible drain on the bottom line at the 11th hour of the budgeting cycle, all but 55 of the company's stations chose to quit streaming. A week or so later, 45 of the stations that had yanked their streams returned to Webcasting.

"We have a trial agreement with

## The confidence of Webcasters was shaken when numerous Clear Channel stations pulled their simulcast streams in January.

Someone who has been in the Internet radio business a long time cautioned Web Watcher on his enthusiasm for non-PC Web radio listening devices. He noted that even if hundreds of thousands of the devices are sold in the next few years, Internet radio operators need to keep their focus on monetizing the tens of millions of PCs that can listen to them.

Sage advice.

HiWire," said Parson, "that engages some stations that they wanted to run the trials on."

HiWire, the ad-insertion provider, has been bullish on Internet radio sales at both the local and national level. "For over a year, we have been changing our model to provide more services for stations under our all-in-one pricing," HiWire CEO Steve Goldberg told Web Watcher. "What we're doing right

\*\*\*



Dell Axim X5 Pocket PC

now with Clear Channel is a continuation of that attempt to do it."

Parsons said more of the Clear Channel stations can be expected to return to Internet radio operations as they revise their strategies.

"We are going to take successful practices from the stations that are making it work, document and distribute those to other stations," said Parsons.

To gauge how big a blow Clear Channel's announcement was to Webcasting, it bears reminding that before the bulk of the company's streams left the Internet, Clear Channel was the No. 1-ranked Web radio network in Arbitron Inc.'s MeasureCast Ratings. The company delivered a December total of more than 5.5 million hours of Total Time Spent Listening or Aggregate Tuning Hours. (See chart, page 30.)

\*\*\*

While the old saying about the two things you don't want to see get made, sausage and law, may be true, it was still fascinating to Web Watcher to see how H.R. 5469, the Small Webcasters Settlement Act, wound its way through the legislative process.

Legislation that ultimately benefited small commercial and non-commercial Webcasters was shaped by the political power of another Internet-radio group that had only a defensive interest in the language of the bill: religious broadcasters.

Small commercial Webcasters were being heard and served by Congress last fall, but non-commercial Internet radio stations, including college stations, were being left out in the cold. Fortunately for them, as legislation ignoring their plight was racing toward passage in the Senate, religious broadcasters got help from an old friend, the soon-to-retire Sen. Jesse Helms, R-N.C.

The reason religious broadcasters prevailed upon Helms to block the Sensenbrenner bill was that all broadcasters, included religious broadcasters, feared the bill's percentage of revenue formula might be viewed as precedent setting by the next Copyright Arbitration Royalty Panel.

Russ Hauth, National Religious Broadcasters' Music Licensing Committee executive director, told Web Watcher their fear was the percentage of revenue formula

would be applied to their broadcast revenues as well.

"Let's say you're a million-dollar radio station, or thereabouts, and your Webcasting part of that is basically no revenue or very little revenue," said Hauth. "But they're going to calculate your fee based on your total revenue. It would be awful."

By the time Helms' staff and NRB lobbyists finished rewriting the bill during the 2002 general election recess, not only had the potentially precedent-setting language been clarified, but non-commercial Webcasters had their copyright royalty payment obligations suspended until June 30, 2003. (It is expected the non-commercial Webcasters will come to an agreement with the recording industry royalty collection agency, SoundExchange, by that date.)

H.R. 5469 didn't solve all of the religious broadcasters' copyright royalty issues, and the group was expected to discuss these matters when the NRB convention kicked off Feb. 7 in Nashville. But Robby Richardson of the NRB's Internet Committee gave Web Watcher this note of caution:

"Any time, obviously, that you get something through, it's going to be harder to get their attention the second time. If you come back and say 'Wait a minute, that's only half the answer,' (Congress feels like they've) done that, before I listen to you I've got 30 other people hollering at me that I've got to listen to. So there's that danger."

That doesn't mean religious broadcasters or Webcasters in general will get a deaf ear from a group of legislators who pushed the Internet Radio Fairness Act to rewrite the Digital Millennium Copyright Act last session. But when Web Watcher checked in with prime sponsor Rep. Jay Inslee, D-Wash., he found the congressman ready to wait before reintroducing the legislation.

"It makes sense to see how successful the parties are in negotiating new terms on their own before reintroducing the Internet Radio Fairness Act," said Inslee. "I plan to continue talking with members about the issue to gauge their interest in the issue, and to move forward with legislation if appropriate."

Inslee observed that Sensenbrenner continues to have a strong interest in reforming the Copyright Arbitration Royalty Panel in general. As Web Watcher has noted before, it is hard to gauge what direction the new Senate leadership, and particularly Senate Judiciary Committee Chairman Orrin Hatch, R-Utah, will go on this issue.

\*\*\*

Regardless of what may or may not be brewing in Congress, the U.S. Copyright Office is obligated to determine copyright royalty rates for 2003 and beyond. Toward

See WEB WATCH, page 29 ►

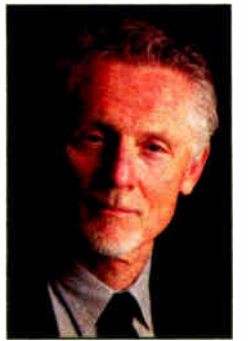

Russ Hauth



Robby Richardson

## STATION/STUDIO SERVICES

Business Boosters from Grace Broadcast Sales • ORDER TOLL-FREE! 1-888-GRACE-88

# "Got Any New Ideas?"



You bet!! Check out these :30-:60-sec. radio features YOU CAN SELL for:  
Nat'l Agriculture Week (3/16-22)  
Easter (4/20) • April Home Improvement Month  
Mother's Day • High School Graduation  
Memorial Day • Lots More!

Visit [www.gracebroadcast.com](http://www.gracebroadcast.com) for FREE DEMOS!

### ATTENTION PROVIDERS!

Promote your services to Radio World's readers. Reach Radio Station and Recording Studio owners/managers and engineers with your message. For information on affordable advertising call Simone at 1-703-998-7600, ext. 154.

## SPACE AVAILABLE

Call Simone For Details  
1-703-998-7600 ext. 154

# Web Watch

► Continued from page 28  
that end the Copyright Office will be empanelling three new CARPs:

- One CARP will recommend royalties for the same non-subscription Webcasters as the prior CARP.
- A second CARP will recommend rates for the pre-existing subscription services, those that were in existence as of the adoption of the DMCA. This will primarily be aimed toward XM Radio and Sirius Radio.
- A third CARP will recommend fees for new subscription services.

“Any of these CARPS could be avoided if there is an industry-wide settlement,” said David Oxenford, attorney at Shaw Pittman LLP. “Whether or not any settlements occur remains to be seen.”



David Oxenford

Oxenford, who is representing some of the parties to the CARP process, told Web Watcher at the beginning of January that the timing of the various CARPs is not yet clear.

It is well to remember that the CARP recommendations are only that: recommendations. Last spring Librarian of Congress James H. Billington made major changes to the CARP's recommendations, including cutting copyright royalty fees to be charged to non-broadcaster Webcasters in half.

★ ★ ★

Several radio group owners and the NAB are expecting in February to hear the decision of the Court of Appeals for the Third Circuit in Philadelphia, where their appeal of a Copyright Office determination was heard in December.

The broadcasters have insisted from the start that the DMCA's instituting sound recording copyright royalties does not include simulcasts of their terrestrially broadcast programming. The Copyright Office ruled they are included, and has denied broadcasters' every appeal on the subject.

★ ★ ★

As this episode of Web Watch is so heavy with copyright royalty material, it is fair to close by noting a small crease in the copyright zone that has emerged.

U.S. copyrights had long extended for 75 years, and in 1998 Congress extended them an additional 20 more years. That means that to find a U.S. sound recording in the public domain (where it wouldn't be subject to copyright royalty fees), you would have to go back to something in the pre-1908 genre. How many pre-1908 sound recordings are there?

Well, Web Watcher doesn't know. But from the “more than you ever wanted to know about something” category, Web Watcher's extensive research has found that the French developed the phonoautograph, a device that recorded sound wave on a rotating cylinder, beating Thomas Edison to the punch by 20 years.

But that's all smokescreen around the

fact that there's not a lot of pre-1908 recordings out there, and probably even less audience to listen to them.

What about the early '50s? There are a lot of recordings from the early '50s and the decade before, recordings from Glenn Miller, Ella Fitzgerald, and (gasp) even Elvis Presley. Now, if the U.S. copyright extends back 95 years, what brings the early '50s into question?

It turns out that European Union copyright protection lasts only 50 years. But you note that Elvis recorded in the United States, for American labels. It turns out that though the recordings were made and released in America, the door is open for any European recording company to release albums that had been owned an individual label.

Selling those physical European CD or cassette recordings of U.S. copyrighted



Thomas Edison and His Early Phonograph

material in the United States might be difficult, but there's a real question as to whether European-based Webcasters can

legally deliver this early '50s and before material via Internet-radio to listeners in the United States copyright royalty-free.

So this year an all-Elvis Europe-based Internet radio station might only be able to play “My Happiness,” but next year they could add “That's All Right, Momma” and “Baby Let's Play House.”

Though Web Watcher makes light of this situation, it's not all that funny for recording companies or U.S.-based Internet radio operators. If the duration of European Union copyrights on American sound recordings are half of that for the United States, how long might they be in an offshore tax haven?

Craig Johnston is a Seattle-based Internet and Multimedia developer who is a frequent contributor to RW. Reach him via e-mail to [craig@johnston.com](mailto:craig@johnston.com).



YOU NEED THE NEW APHEX 2020MKIII AUDIO PROCESSOR



Settling for flabby, undefined bass? Buried, clouded, mids? Shrill, annoying high end that you just can't tune out of your current processor? Is your only comfort that some of your neighbors on the dial sound as bad or worse than you do? Then it's time to step up to the new ApHex 2020MkIII.

Radically new processing algorithms and circuitry bring even greater loudness while maintaining clarity and musicality. The bass is tight, deep and resonant, the mids are detailed and forward, and the highs are open and natural. The 2020MkIII is so powerful, yet so clean, it is the only “broadcast” processor used in world class post production and mastering facilities.

With an extensive range of useful controls you can readily achieve your own unique sonic signature ....a sound that you'll never want to get rid of.

Call us today to audition the new 2020MkIII at your station.

**APHEX**  
SYSTEMS

Improving the way the world sounds<sup>SM</sup>  
11068 Randall Street, Sun Valley, CA 91352 U.S.A.  
818-767-2929 Fax: 818-767-2641 [www.aphex.com](http://www.aphex.com)

ApHex is a registered trademark of ApHex Systems

## Radio Sales Continue to Gain

Money continues to come into station coffers at a faster clip. Radio revenue rose 10 percent in November 2002 compared to the same period a year earlier, back when the industry was in the post-9/11 gloom. This makes nine months of increases in the monthly comparisons issued by the Radio Advertising Bureau, and three in a row of double digits. Breaking down the overall performance, national revenue was up 23 percent and local was up 7 percent in November. Year-to-date, radio was up 6 percent through November over the first 11 months of 2001. "We expect equally strong numbers for December, regardless of what some forecasters have predicted," stated Gary Fries, president and CEO of RAB.

### STATION SERVICES

## WOR, RCS and The Best of Everything'

Will online listeners pay for good, commercial-free radio?

Buckley station WOR in New York is online with a new format called "The Best of Everything," a stream that lets listeners customize what they hear in exchange for a monthly fee. The service uses RCS iSelector, an Internet scheduling engine announced earlier this year.

"It has the blessing of all the major record labels and is 100 percent DMCA-compliant," said RCS President Philippe Generali. "As you start listening and interact with the player, it learns and remembers your musical tastes to create your specific music mix, different from any other listener's stream."

Listeners obtain a personalized online player from the WOR Web site for \$4.95 a month. The monthly fee covers streaming costs, database management, record label and music publishing company fees. Special buttons on the player allow listeners to play specific artists more, less, or not at all. The first 48 hours are free. Listeners also can buy songs.

WOR VP/GM Bob Bruno created the format. "It's targeted to the adults who think that radio has forgotten them. You'll hear everything from Mariah to Motown to Mozart, from Sinatra to Springsteen."

For information visit [www.wor710.com](http://www.wor710.com) and [www.rcsworks.com](http://www.rcsworks.com) or contact RCS in New York at 914-428-4600.

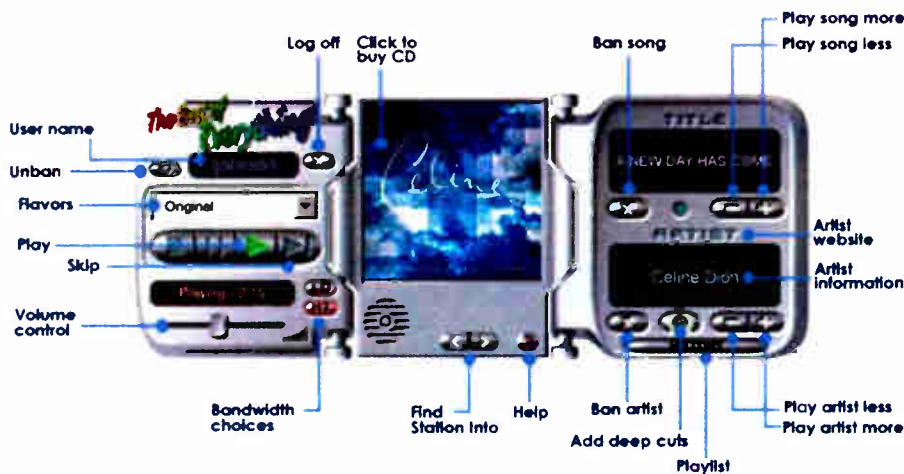

### RADIOIO, MOONTAXI GAIN IN NET RATINGS

The names of the top Internet radio networks are familiar in the new Arbitron MeasureCast ratings for the month of December — although there was some jostling in the lower ranks of the top 10. Clear Channel Worldwide, MusicMatch and StreamAudio were again first, second and third. But the gap between Clear Channel and MusicMatch, as measured by total time spent listening, narrowed. Meanwhile, Warp Radio moved from fifth to fourth in the rankings, switching position with Radio Free Virgin. Internet Radio Inc. held at No. 6. StreamGuys jumped from 10th to 7th, Moontaxi, which wasn't ranked last month, came up to 8th, while SurferNetwork held at 9th and Virgin Radio fell to 10th from 7th. ABC Radio, last month's No. 9, didn't make the top 10 networks this month. MusicMatch Artist Match was the top individual channel with 1.18 million hours of TTSL. Radioio jumped from 4th to the No. 2 position. JazzFM was ranked third.

#### Top 10 Internet Radio Networks (December 2002)

| Rank | Company                 | TTSL      | CUME      |
|------|-------------------------|-----------|-----------|
| 1    | Clear Channel Worldwide | 5,585,467 | 796,330   |
| 2    | MUSICMATCH              | 5,272,302 | 1,361,611 |
| 3    | StreamAudio             | 3,824,927 | 364,724   |
| 4    | Warp Radio              | 2,479,659 | 301,669   |
| 5    | Radio Free Virgin       | 2,318,960 | 276,151   |
| 6    | Internet Radio, Inc.    | 1,915,731 | 518,131   |
| 7    | StreamGuys              | 1,747,059 | 368,083   |
| 8    | Moontaxi                | 1,686,787 | 283,162   |
| 9    | SurferNETWORK           | 1,589,182 | 96,611    |
| 10   | Virgin Radio            | 1,320,181 | 186,055   |

#### Arbitron's MeasureCast Top 20

| Rank | Station   | Format                 | Owner/Network                                      | URL  | TTSL (ATH) <sup>1</sup> (in hours) | Cume Persons <sup>2</sup> |
|------|---|------------------------|--|--|------------------------------------|---------------------------|
| 1    | MUSICMATCH Artist Match (Internet-only)           | Misc.                  | MUSICMATCH   | <a href="http://www.musicmatch.com">www.musicmatch.com</a>             | 1,183,194                          | 459,139                   |
| 2    | RADIOIO (Internet-only)                           | Adult Alternative      | RADIOIO/IO MediaPartners Inc. / LimeLight Networks | <a href="http://www.radioio.com">www.radioio.com</a>                   | 1,012,992                          | 166,092                   |
| 3    | JazzFM/102.2 FM & 100.4 FM (London)               | Jazz                   | Guardian Media Group                               | <a href="http://www.jazzfm.com">www.jazzfm.com</a>                     | 890,620                            | 161,196                   |
| 4    | Virgin Radio/1215 AM & 105.8 FM (London, UK)      | Hot AC                 | Virgin Radio New Media                             | <a href="http://www.virginradio.co.uk">www.virginradio.co.uk</a>       | 846,585                            | 110,652                   |
| 5    | WQXR-FM/96.3 (New York)                           | Classical              | New York Times                                     | <a href="http://www.wqxr.com">www.wqxr.com</a>                         | 787,094                            | 95,949                    |
| 6    | MUSICMATCH Top Hits (Internet-only)               | CHR / Top 40           | MUSICMATCH   | <a href="http://www.musicmatch.com">www.musicmatch.com</a>             | 606,991                            | 322,867                   |
| 7    | K-LOVE Radio (Sacramento)                         | Contemporary Christian | Educational Media Foundation                       | <a href="http://www.klove.com">www.klove.com</a>                       | 495,292                            | 57,721                    |
| 8    | Beethoven.com (Internet-only)                     | Classical              | Beethoven.com                                      | <a href="http://www.beethoven.com">www.beethoven.com</a>               | 426,433                            | 50,451                    |
| 9    | MUSICMATCH Traditional Christmas (Internet-only)  | Holiday Music          | MUSICMATCH   | <a href="http://www.musicmatch.com">www.musicmatch.com</a>             | 409,999                            | 146,635                   |
| 10   | 3WK Undergroundradio (Internet-only)              | Alternative Rock       | 3WK  | <a href="http://www.3wk.com">www.3wk.com</a>                           | 353,350                            | 88,395                    |
| 11   | KPLU-FM/88.5 (Tacoma)                             | Jazz                   | Pacific Lutheran University                        | <a href="http://www.kplu.org">www.kplu.org</a>                         | 324,398                            | 41,816                    |
| 12   | KING-FM/98.1 (Seattle)                            | Classical              | Classic Radio Inc. Real Broadcast Networks         | <a href="http://www.king.org">www.king.org</a>                         | 322,888                            | 42,138                    |
| 13   | MUSICMATCH Contemporary Christmas (Internet-only) | Holiday Music          | MUSICMATCH   | <a href="http://www.musicmatch.com">www.musicmatch.com</a>             | 317,960                            | 117,093                   |
| 14   | WFXZ-FM/93.7 (Wilmington, NC)                     | Classic Rock           | Sea-Comm Media / Warp Radio                        | <a href="http://www.937thebone.com">www.937thebone.com</a>             | 288,964                            | 19,455                    |
| 15   | WBLS-FM/107.5 (New York)                          | Hip Hop                | Inner City Broadcasting BroadcastURBAN.com         | <a href="http://www.wbbs.com">www.wbbs.com</a>                         | 287,692                            | 23,890                    |
| 16   | BlueGrass Country (Internet-only)                 | Country                | American University Warp Radio                     | <a href="http://www.bluegrasscountry.org">www.bluegrasscountry.org</a> | 287,026                            | 56,623                    |
| 17   | MUSICMATCH Artist On Demand (Internet-only)       | Misc.                  | MUSICMATCH   | <a href="http://www.musicmatch.com">www.musicmatch.com</a>             | 280,492                            | 112,515                   |
| 18   | KNAC.COM (Internet-only)                          | Pure Rock              | KNAC.COM   | <a href="http://www.knac.com">www.knac.com</a>                         | 262,603                            | 47,027                    |
| 19   | WSHI-FM/106.3 (Fort Wayne, IN)                    | AC                     | Shine Broadcasting / Warp Radio                    | <a href="http://www.sunny106fm.com">www.sunny106fm.com</a>             | 254,696                            | 38,829                    |
| 20   | MUSICMATCH Soft Hits (Internet-only)              | Soft Hits              | MUSICMATCH   | <a href="http://www.musicmatch.com">www.musicmatch.com</a>             | 214,822                            | 51,663                    |

**Notes:**  
 1. TTSL (Total Time Spent Listening), sometimes referred to as Aggregate Tuning Hours (ATH), is the total number of hours streamed by the broadcaster in the reported time period.  
 2. Cume Persons is an estimate of the total number of unique listeners who had one or more listening sessions lasting five minutes or longer during the reported time period. This estimate is derived using an algorithm that takes into account unique media player GUIDs, unique IP addresses, and other variables during the reported time period.

**About Arbitron**  
 Arbitron Inc. (NYSE: ARB) is an international media and marketing research firm serving radio broadcasters, cable companies, advertisers, advertising agencies and outdoor advertising companies in the United States, Mexico and Europe. Arbitron's core businesses are measuring network and local market radio audiences across the United States; surveying the retail, media and product patterns of local market consumers; and providing application software used for analyzing media audience and marketing information data. Arbitron Webcast Services measures the audiences of audio and video content on the Internet, commonly known as Webcasts. The Company is developing the Portable People Meter, a new technology for radio, TV and cable ratings.  
 Arbitron's marketing and business units are supported by a world-renowned research and technology organization located in Columbia, Maryland. Arbitron has approximately 800 full-time employees; its executive offices are located in New York City.  
 Through its Scarborough Research joint venture with VNU Media Measurement & Information, Arbitron also provides media and marketing research services to the broadcast television, magazine, newspaper, outdoor and online industries.  
 All names are the property of their respective owners.



**BEJAR STEREO MONITOR**

**You can measure...**

with the best monitor and the most accurate test set.

The FMM-2/FMS-3 series monitors provide an even greater degree of precision measurement than ever before... You can measure S/N below 90 dB, You can measure crosstalk below 85 dB, You can measure separations of better than 70 dB, You can measure frequency response to better than 0.25 dB, You can measure distortions to lower than 0.01%, and much more... Our uncluttered panels and autoranging voltmeters make these measurements a dream.

**BEJAR ELECTRONICS LABORATORY, INC.** [www.belar.com](http://www.belar.com) (610) 687-5550  
 LANCASTER AVENUE AT DORSET, DEVON, PENNSYLVANIA 19333  
 Call or write for more information on Belar AM, FM, Stereo, SCA and TV monitors.



# Spanish Radio

► Continued from page 26

markets, it is standing by its existing methods and the resulting audience measurements.

"Just because you can put a side airbag in a car doesn't mean your car isn't safe (without a side airbag)," said Charlebois. "We stand by the estimates we produced."

The company refers to statistical weighting as an enhancement to its methodologies rather than an outright fix, therefore implying that it's not giving out flawed results in the interim. Others, however, disagree.

erences of the market to uncloak those 250,000 listeners plus others obscured by current tabulation methods.

Arbitron committed to language-preference weighting, according to its November press release. It proposes dividing Hispanic survey samples into two language groups, either Spanish-speaking only or partial-Spanish-speaking, and weighting the returned diaries for each group against a predetermined estimate of the language preference of the Hispanic population in the market. It currently weights by age, sex, geography and ethnicity.

Until it acts on that promise, however, it's business as usual, say Hispanic broadcasters, who claim that existing Arbitron measurement methods miss the critical correlation between listeners who speak Spanish only and the

stations that broadcast in Spanish.

Radio Unica's Blaya estimates Spanish radio markets are under-estimated by at least 20 to 25 percent in an Hispanic radio ad market now bringing in \$700 million annually. As a result, Hispanic radio ad sales are down \$150 million annually, he said, with accumulative loss to the value of Spanish broadcast entities.

"We're not only *not* getting the sales, we're not getting the value of the company. Broadcasting entities are sold on a multiple of the cash flow, so this is impacting the whole industry," said Blaya.

"Everybody focuses on Los Angeles. But it happened in San Francisco, it happened in Denver, it happened in Las Vegas. It is happening in every marketplace there is," added Liberman.

Adding insult to injury are the thou-

sands of dollars Spanish-language operators spend on Arbitron fees. "I pay to get less than my fair share," he said.

Still, the news from Arbitron hasn't been all bad for Hispanic broadcasters. The year 2002 will be a watermark year for Spanish radio stations in terms of their total share of radio listening across the United States. Spanish language stations earned a 7.7 percent share of radio listeners across the United States in 2002, compared to a 6.2 percent share in the fall of 1998, according to Arbitron.

Getting Hispanic broadcasters to trust those numbers, however, is a different matter.

Dee McVicker can be reached at (480) 545-7363 or via e-mail to [deemcv@qwest.net](mailto:deemcv@qwest.net).

**We stand by the estimates we produced.**

— Owen Charlebois, Arbitron

"Arbitron doesn't have estimates of the markets' speaking ability, like Nielsen does. Therefore when it sends out its one-week radio-listening diaries where people can make entries, it's as if they get back a smaller percentage of the diaries from Spanish dominance than they should," said Norman Hecht, the CEO of media research firm Norman Hecht Research Inc., Syosset, N.Y.

### Nutty numbers

That missing variable from ratings tabulations could explain the bizarre results of the summer 2002 Los Angeles book, which bucked an upward trend in Spanish radio listenership and surprised analysts with a downturn in the market share of Spanish-language stations.

"It was as if 250,000 Spanish dominant listeners 'vanished' from the market," said Hecht. And, in fact, a sampling representative of that market subset vanished from the raw data.

"The percent of Spanish-dominant Hispanics in our sample did decline. It went from 53 to 47 percent," Charlebois said.

Los Angeles stations whose listeners speak predominantly Spanish were affected the most.

"We have a Spanish pop format that is more apt to be (listened by) bilingual listeners, so we weren't as affected as some other stations. There are stations that dropped a whole share," said Liberman, who estimates a rating point to be worth \$7 million in annual ad revenue in the Los Angeles Hispanic marketplace.

A larger sample would have increased these stations' odds for a higher turnout. But even better, according to Hecht, would be to increase sample size and weight the Spanish-only diarykeepers against the speaking pref-

FREE DEMO!

# Engineers rate Tieline POTS Codecs #1



i-Mix 15kHz POTS Audio Codec

**- Clay Frienwald, Senior Facilities Engineer, Entercom/Seattle**  
*"Where other codecs give problems or won't work, Tielines connect and give no problems when we're on the air".*

**- Mike Rabey, Radio Magazine field report, April 2000**  
*"The Tieline sounds bright and smooth on music, and punchy and crisp on voice - Rock Solid without any unanticipated line drops".*

**- Dave Kittley, Engineer, KGNZ**  
*"We trialled Vector, Scoop Reporter and Tieline. We chose Tieline because they sounded better and made better connections. Now, we always have other stations asking what we're using when they can't get on the air with their remote equipment and we can".*

**Use Tieline 15kHz POTS Audio Codecs**

- Fact - Rock Solid Modems that stay connected
- Fact - Total Remote Control
- Fact - Fully Software Upgradeable

*"There is something about getting 15kHz audio out of a system designed for maximum 3kHz that I find entertaining"*  
 Alan R. Peterson, Radio World Magazine, December 2002



#### Other satisfied Network and Radio Group Tieline Owners

- |                                |   |
|--------------------------------|---|
| ■ Clear Channel                | ■ Tribune Broadcasting                    |
| ■ Entercom                     | ■ University of N. Alabama Sports Network |
| ■ Disney/ABC                   | ■ Simmons Media                           |
| ■ CBS/Infinity                 | ■ Tennessee Titans Radio Network          |
| ■ Sandusky                     |   |
| ■ Jefferson-Pilot Broadcasting |   |
| ■ Westwood One                 |   |

**Ask your favorite dealer for a FREE demo today!**

**Tieline**  
TECHNOLOGY  
[www.tieline.com](http://www.tieline.com)

5555 N. Tacoma Ave., #101, Indianapolis, IN 46220-3547 Toll Free (888) 211-6989 Fax (317) 259-8040 Email: [sales@tieline.com](mailto:sales@tieline.com)

# If you're looking for the best in digital excitement, X MARKS THE SPOT.



**extreme digital...**  
from HARRIS

Harris offers one of the world's first commercial IBOC DAB excitors, DEXSTAR. Industry insiders know that Harris is responsible for most of the innovation in radio transmission products for the last 35 years. So it should be no surprise, that

Harris is also the leader in IBOC DAB products. The DEXSTAR IBOC exciter is designed by Harris engineering, built to exacting standards in the world's largest broadcast transmitter-manufacturing facility and backed by a service department, recognized the world over for quality and commitment. If you're looking for a digital broadcast solution, from beginning to end, that offers the most advanced performance and reliability, stop searching. X marks the spot for Extreme Digital from Harris.

next level solutions

SERVICE

SYSTEMS

AUTOMATION

TRANSMISSION

**HARRIS**

# Buyer's Guide

Rayovac  
Battery Test



Page 34

Radio World

Portable Audio & Newsgathering

February 12, 2003

USER REPORT

## Sonifex Courier at BBC London 94.9

by Ben Wilkins  
Senior Reporter  
BBC London 94.9

**LONDON** Six o'clock in the morning on Jan. 8 and I've just arrived at a dingy flat in North London, the scene of the recent M15 swoop on an Algerian terrorist cell producing deadly ricin poison. I'm there because I'm BBC London 94.9's senior reporter and my job is to do on the spot reports for "The Danny Baker Breakfast Show."

Courier is the on-board editing facility. A proper waveform appears in the screen and you can use a scrub wheel to move the cursor around and put in edit points. It's a simple matter to top and tail clips or turn a string of interviews into a vox.

The final step is to drop all the clips and links into a playlist and put them in the right order. Without a hangover it can be done in around six minutes. This morning it takes me a couple of minutes longer!

It's not a perfect machine. I'd like to be able to mix tracks together and fade

clips in and out. Also it takes a bit too long to boot up for my liking. But it's light enough to run with, can be bashed around and rained on without failing and the loudspeaker is nice and loud.

Also the XLR sockets mean I don't have to carry a bag of leads around with me. When I first started at BBC London 94.9, we were using Uhers. Radiocar reports either had to be live or fed back raw to studio and mixed there. With a Courier, I easily can make three different packages during the show on my own.

The BBC has bought almost 400 in total and we have about 20 in the station. Our sports team use the ISDN facility to send reports back from football grounds, Radiocar reporters use the more complex editing functions, but anyone can pick one up and go out and record something...

"Just turn it on, slide the big red button to the right, point the spongy end of the mic at your face." Like I said, child's play.

For more information, including pricing, contact the company's U.S. distributor, Independent Audio, in Maine at (207) 773-2424 or visit [www.independentaudio.com](http://www.independentaudio.com).

SPECIAL REPORT

## Comrex Codecs and a Moving Train

by Willem Bagchus  
Technical Director and Co-Host  
'Travel World Radio Show'

**ABOARD THE CANADIAN** In an unusual broadcast in November of 2002, Southington, Conn.-based WNTY(AM) aired the syndicated "Travel World Radio Show" live from Via Rail Canada's west-bound transcontinental train.

The wireless capability of the Comrex BlueBox and cellular technology can make exciting, creative remote broadcasting practical at minimal expense.

The first moment I heard the WNTY audio feed coming through the Comrex BlueBox via cell phone, I knew that I could share the excitement of being on a Canadian transcontinental train by doing a live remote of the show.

**Taking a chance**

The "Travel World Radio Show" in its present form was born in 1997 on Montreal's CIQC(AM), formerly CFCF and CXWA, and is hosted by Stephen Pickford and myself.

He's a travel agent; I'm a computer engineer. We've been doing travel broadcasting together since the 1980s. It seems people liked our stories and adventures. Today, CAB Radio syndicates us, and WNTY is our flagship.

We have always enjoyed trains. Via Rail Canada's Canadian is one of the most interesting trains of them all. It captures the imagination. The Canadian is the legendary transcontinental, running on tracks that united Canada in the 1880s. British Columbia's entry into confederation was contingent on the building of the railroad. Pierre Berton wrote about it in "The National Dream."

"Travel World" decided to run a piece on this great train. Of all of the routes of Via Rail Canada, none is more celebrated.

It snakes through Toronto, the Great Lakes, Winnipeg, Manitoba and makes its way northwest through Saskatoon, Saskatchewan to Edmonton, Alberta, crossing the Canadian prairies. Its most

exciting run is through the foothills to the Rocky Mountains.

Stephen and I have covered Via Rail since the beginning of "Travel World." We were beside ourselves with excitement at the idea of riding in The Canadian. In addition to our regular broadcasts, I wondered whether we could actually do a live broadcast from the train.

I know that people have done remotes from trains, but they usually involved some kind of chase vehicle and complicated, costly methods. That made exciting radio remotes prohibitive. We sought a way around this.

for the HotLine warns specifically, "Don't even think about connecting this to a cell phone." So no wireless ... until now.

Comrex recently introduced its BlueBox. Not only is it actually blue, but its land-line audio quality is way better than the company achieved with the HotLine, and it works with cellular phones. For the first time, wireless broadcasting is practical using cell phone technology. But even Comrex didn't have in mind what we wanted to do.

Comrex was supportive of the idea but cautioned that a train remote via cell phone and BlueBox had never been



Ben Wilkins, BBC London 94.9's senior reporter, holds a Sonifex Courier.

On this occasion, I've got about half an hour to look around the scene, find out what's going on from the police, record some interviews with the neighbors and produce a two-minute package. All this has to be done from the field and fed live into the program from the Radiocar. The only thing I need is my Sonifex Courier.

At first sight, it looks like a Fisher Price toy made of plastic, with big colored buttons and knobs. The good news is that compared to a domestic MiniDisc recorder, it's child's play to use. Recording is simply a matter of sliding the red button to the right and setting the record level with a round dial much like that of a Uher, a line of portable recorders popular overseas.

When the recording is finished, the file name pops up and the duration is displayed in the LCD window on the front.

This morning I recorded a couple of minutes with a police spokesman and ran around grabbing a few words from worried neighbors. After roughing out my script and recording three links, I'm ready to start turning it into a package. With eight minutes to go, it shouldn't be a problem.

For me, the best thing about the



Willem Bagchus and Stephen Pickford broadcast on-board across Canada.

Remote broadcasts often present engineering challenges. Usually, an engineer would connect matching audio codec units on either side of some kind of landline.

We already rely heavily on the Comrex HotLine POTS codec. It allows us to broadcast remotely from WNTY from virtually anywhere we can get a plain old phone line and electricity. This makes the show fun and entertaining. You never know where we will be.

But what about cases where a landline just isn't available? Comrex's own manual

done, that this basically was experimenting. Obviously, with anything technical, there are gotchas and snafus, but we were ready.

Armed with cell phones, mics, a mixer and a Comrex BlueBox, "Travel World" boarded Via Rail Canada's train Number One from Toronto Union Station heading west to Vancouver.

The BlueBox allows cell phones to be used in one of two ways. You can connect the codecs if you have a GSM-based

See TRAIN, page 35

## SPECIAL REPORT

# Rayovac Rechargeable Battery Test

by Paul Kaminski  
News Director  
Motor Sports Radio Network

Radio field reporters and producers can tell you many stories about the "one that got away" simply because of batteries going dead in the middle of an interview recording session.

The fear of losing an interview to dead batteries causes some of us to change batteries in our recorders before every major use. That can get expensive if you change out four disposable (single-use) batteries at a time. Rayovac's line of rechargeable batteries makes that practice economical.

When I quit using a cassette deck to get field sound in 1998, I began using Rayovac rechargeable alkaline AA batteries for my MiniDisc recorders, the Sony MZR-37s. Rechargeable alkaline batteries come fully charged and you can put them in a machine right out of the blister pack. I've used the batteries and the portable PS1 charger for years and also have a PS3 charger in the office that can charge eight AA batteries at a time or four C or D cells.

At the 2002 Indianapolis 500, Rayovac sponsored driver Alex Barron in Indy Racing League competition. Its press release contained a boilerplate item about a one-hour battery charger for AA batteries. The batteries used in this new charger, called the PS4, weren't the rechargeable alkalines, but were rechargeable nickel-metal hydride, or NiMH.

Recharging the NiMH batteries wouldn't be a problem, because the MZR-37 has charging circuitry and the PS1 charger, which I carry in my field kit, will charge NiMH batteries, rechargeable alkalines and nickel-cadmium (NiCad) cells. The Rayovac PS4 works on AC and in that mode, four new NiMH AA batteries will come to full charge in an hour.

NiCad cells because I wanted to test the products generally available from Rayovac.

The test consisted of making a stereo recording of 74 minutes, 59 seconds with a microphone and earbuds attached and marking seven to eight tracks while recording.

The criterion was the number of bars in the battery display of the MZR-37 MD recorder after the 74:59 test was complete, with four bars indicating nominally full and a flashing display indicating battery recharge



or replacement. The control set of Rayovac single-use alkaline AA cells displayed four bars throughout the entire 74:59.

The set of rechargeable alkaline Renewal batteries in service for more than a year started to lose power at the 16-minute mark when three bars were displayed. At 21:44, the display went to two bars. At 31:19, the batteries went to one bar in the display until the 45:37 mark, when the single bar started to flash. The flashing continued to 58:55,

42-minute mark, when the display went to three bars, and stayed there until the end of the recording. It took 13 minutes in the PS4 rapid charger for the NiMH batteries to come back to full charge.

## Pricing

The PS4 rapid charger charges both AAA and AA NiCad and NiMH batteries. I found one at retail for \$29.99. Four NiMH AA batteries cost \$10.99 at retail (Walmart, Target, HomeDepot, etc.). The PS4 also charges NiMH and NiCad 9-volt batteries but can't charge C and D cells.

The PS1 charger retails for \$9.99. Rechargeable Renewal alkaline AA batteries were found for \$6.99 for a set of four. The PS1 won't recharge C, D or 9-volt batteries, just AAA and AA batteries. It will only run on AC power. The single-use Rayovac alkaline batteries are sold in four-, eight- and 12-packs. I've seen eight AA cells available for \$3.99 at retail.

So what do I do when I forget to charge up the batteries? In theory, that ought not to happen because my MD

recorders have come with a recharger circuit, and the PS4's charge in a car or with a regular AC plug. The real world doesn't run on theory, though.

For such instances, I have a set of the single-use Rayovac which will get me

through those periods of brain fade, while the rechargeables are getting back up to full power.

If you can develop the habit of putting one set of batteries on charge while you're using the other, like the TV camera folks, you might never need to buy a single-use battery again. The NiMH cells will lose some power in storage (over 30 days), like the NiCads. Rayovac suggests that the rechargeable alkalines can be charged up to 100 times, and the NiMH can be charged up to 1,000 times.

Both alkaline and NiMH systems have no appreciable memory effect as do NiCad batteries. Memory effect is simply the shortening of a discharge cycle, usually caused by recharging NiCad batteries before they are fully discharged.

The chart details the cost for using single-use batteries in two recorders (four AA alkaline cells) vs. the rechargeable NiMH and alkaline systems in the field over a two-year period. I'm assuming 36 weeks on the road each year and that you replace four batteries at least once a week with backup set at all times. I used Rayovac pricing for comparison and sales taxes weren't included.

There may be generic store single-use alkaline brands that are less expensive, but over time, the rechargeable systems will pay for themselves in less than a year when compared to the cost of disposable single-use alkaline batteries. If you replace batteries more frequently, you will see a quicker payback.

Even if you follow my practice and have one set of single-use alkalines as a backup to the rechargeable battery system, you will still save serious money on batteries while not giving up anything in performance.

For more information, contact the company in Wisconsin at (608) 275-3340 or visit [www.rayovac.com](http://www.rayovac.com).

The author is a contributor to Radio World and president of PK Communications Co. 

## Total Savings

| Battery type                          | Cost of charger/batteries                    | Total cost over 72 weeks | Savings  |
|---------------------------------------|--|--------------------------|----------|
| 8 AA                                  | \$3.99 per pack                              | \$143.28                 | \$0      |
| Rechargeable alkaline systems (100 X) | PS1 = \$9.99<br>8 AA recharg. alk. = \$13.98 | \$23.97                  | \$119.31 |
| Rechargeable NiMH system (1000 X)     | PS4 = \$29.99<br>8 AA NiMH recharg = \$21.98 | \$51.97                  | \$91.31  |

It also works on 12-volt power, which need three hours in the car for a full charge. Because I spend a lot of time in a car, I thought the new charger could solve problems and give me no excuse for missing a recording because of dead or low batteries.

The question here was whether the NiMH batteries would work as well for me as the rechargeable alkalines.

That question led to a somewhat unscientific test at the 2002 Indy Racing League season finale at Texas Motor Speedway.

During a lull in action, I tested four sets of AA batteries made by Rayovac. The first was a set of Renewal rechargeable alkalines in service for more than a year, probably closer to two; an almost new (one use) set of Renewal rechargeable alkalines, the NiMH rechargeables, and as a control, a set of Rayovac single use alkalines. I did not test

when the unit shut down. An attempt to recharge these cells failed (although the charger light went out, the cells did not get warm, which they do when charging — it was time to recycle those batteries).

The almost-new rechargeable Renewal alkaline batteries did better on the test. At the 13:39 mark, the display went to three bars. Two bars were displayed at 19:09. At 26:06, the display went to one bar, and stayed there until the 72:19 mark, when the single bar started to flash, and flashed until the 74:59 mark. Those cells showed two bars before recharging in the PS1 charger and became warm, taking 1 hour and 45 minutes to recharge back to the four bar level. This is the usual performance.

The rechargeable NiMH batteries performed almost as well as the single-use alkalines. The display showed four bars until the

## TECH UPDATE

### HHB, Recording on the Move

The HHB Portadrive combines 24-bit/96 kHz multichannel recording with mixing facilities in a portable package, a system for pro location recording.

The Portadrive records audio onto a shock-resistant, removable 2.5-inch hard drive in BWF and SDII formats. For compatibility with Mac- and PC-based digital audio workstations, it connects via a drive docking station. The company says more than two hours of 8-track 24-bit/96 kHz recording, or more than nine hours of 4-track 24-bit/48 kHz, is possible on the supplied hard drive.

A 6-into-2 digital mixer enables the recording of a stereo mix alongside six discrete inputs. Microphone inputs offer increased sensitivity with six high-gain, low-noise balanced XLR mic/line inputs with individual phantom powering, gangable limiters, attenuation, high-pass filter, delay and phase reverse. The two-channel return input and the main and auxiliary analog stereo outputs are balanced.

Digital connectivity includes eight channels of AES I/O, one S/PDIF input and AES and S/PDIF stereo digital outputs.

The Portadrive is equipped to read and generate time code at popular frame rates and will synchronize to word clock, video sync and digital inputs. A SCSI interface is provided for data transfer to and from external storage devices. USB and Ethernet ports are included for control, logging and upgrades. Remote control is facilitated via RS-422 and a parallel remote socket. A keyboard port is available for logging and labeling.

For more information, including pricing, contact the company in California at (805) 579-6490 or visit [www.hhbusa.com](http://www.hhbusa.com).



# Train

► Continued from page 33

cell phone service that supports circuit-switched data — that is, if you can plug your GSM phone into your computer's serial port and dial out to any modem using Hayes-style AT commands. In other words, the BlueBox will see your cell phone and service as if it was an ordinary modem.

The dial-out part is the tricky one because some cell providers switch this feature off in their GSM service and want you to use their GPRS (General Packet Radio Service) instead. This won't work because the GPRS' only application is the Internet. You get Internet connectivity using the cell provider as an "access point." This is not suitable for the BlueBox.

There are two GSM providers in Canada: Microcell, marketed as "Fido," and Rogers AT&T, formerly known as "Cantel." Neither one of these providers allow circuit-switched data. Therefore, we could not use the GSM data service to connect the codecs.

## Armed with cell phones, microphones, a mixer and a Comrex BlueBox, we boarded The Canadian.

Rogers' TDMA service did allow the circuit-switched data, and they connected the codecs this way. Comrex's manual cautions against using TDMA service for this due to data-delivery delays. An interactive show would have been impractical as the delay in getting the audio from one side to the other was rather large, more than 5 seconds.

Even so, we did manage to do some tests for approximately five minutes.

Eventually, we used the second method offered by the BlueBox, its cellular hands-free port. You can still use your professional mikes and mixers to get good audio this way. You connect the hands-free port on the cell phone to the BlueBox using a special patch cable. You might have to make this cable. If you do, Comrex has detailed technical notes to walk you through it. Its service is first-class.

The entire set-up time took less than a half hour. "Travel World" did a one-hour broadcast as The Canadian pulled out of Edmonton station and headed west. The cellular coverage along the highway was great and the views out of the scenic dome where our broadcast was done were spectacular.

The cellular signal within the stainless-steel Budd-made trains was great. This proved that fun remotes like this are not only possible, but also practical.

Yes, it did happen — towards the end, one cell antenna did not hand off the call properly to the other and the show was interrupted briefly. WNTY and Charlie Profit, the station manager, were right there on the ball and he helped fill in the blanks as they reconnected.

"Travel World" did three broadcasts in all. Two were from the train and one was in Vancouver. The BlueBox made this possible. Cellular coverage is only improving and other exciting remote



Via Rail's Canadian

broadcast possibilities await.

For a station contemplating an interesting wireless remote, this is an excellent choice. You do not need a senior technician to run it, and you will get first-class quality and service. Your expenses are minimized.

The performance and versatility of the Comrex BlueBox were amazing. Using landlines, the Blue Box delivered an FM-quality signal (15 kHz), and using cell phones, the sound quality was noticeably better than by just using a cell phone.

Listeners will be in for a treat when stations begin to use their imaginations and do really fun remotes. Imagine the possibilities.

For more information, including pricing, contact the company in Massachusetts at (978) 784-1776 or visit [www.comrex.com](http://www.comrex.com).

## Production Ready.

## ASI5111

- > 4 Stereo PCM Play Streams
- > 2 Stereo PCM record streams
- > Balanced stereo analog I/O
- > AES/EBU or S/PDIF digital I/O
- > Low noise mic input with 48v phantom supply
- > Compressor/Limiter and Parametric Equalizer

### YOU DEMAND SERIOUS AUDIO PRODUCTION.

So take a look at AudioScience's new ASI5111 audio adapter. This PCI card provides stereo analog and digital inputs and outputs, 2 record streams and 4 play streams, plus a mic preamp with phantom power.

MRX Multi-Rate Mixing™ is included, so you can record, play and mix multiple audio streams to a 1Hz precision. And our SoundGuard™ transient voltage suppression protects against lightning and other high voltage surges. Windows 98, NT, 2000 and XP drivers are included—even Linux! And we even throw in the XLR breakout cables.

For features you demand at a breakthrough price, get the ASI5111. Call +1-302-324-5333 or check us out on the web at [www.audioscience.com](http://www.audioscience.com).

16 SOUND GUARD  
MULTI-RATE MIXING

(BUILT FOR BROADCAST)

AUDIOSCIENCE  
Sound Engineering  
Sonic Excellence

USER REPORT

# CellCast Passes 'Manual' Test

by **Andy Disterhaft**  
and **Mike Gannon**  
**Operations Manager**  
and **On-Air Personality**  
**Hometown Broadcast, LLC**

**BERLIN, Wis.** Just turn it on and go.

Plenty of remote units can make the claim, but not all can actually live up to it.

A "manual" test is the best litmus test we know of to find out which ones make the grade and which ones do not. The premise is simple: if the equipment can be set up and used without a field engineer so much as cracking open the manual, then it passes.

Add extra points if the gear in question is set up by a radio announcer in a small market — not that we're all thumbs when it comes to broadcast equipment. We're just simply busy with other remote broadcast duties, so most of us don't like to be bothered with the technology.

works would adapt to the various digital cellular services out there today, however.

But, the unit proved capable in this regard. It can be set up for AT&T's or Cingular's TDMA cellular service as well as for GSM services from providers like VoiceStream. Digital CellCast comes in several variations: TDMA Dual Band, TDMA Tri-Band, GSM 900 MHz, 1900 MHz and even for the European GSM 1800 MHz systems.

We were also impressed that such a small, lightweight unit (weighing only around five pounds) could have mixer and cell phone all rolled into one box. Its four-channel mixer has separate pots for each channel, which can be set up for program or cue, mix or line selectable. This four-channel mixer is especially useful for sportscasts. It has a single-line encoder built in, so we're able to set the frequency response to whatever the event demands. We no

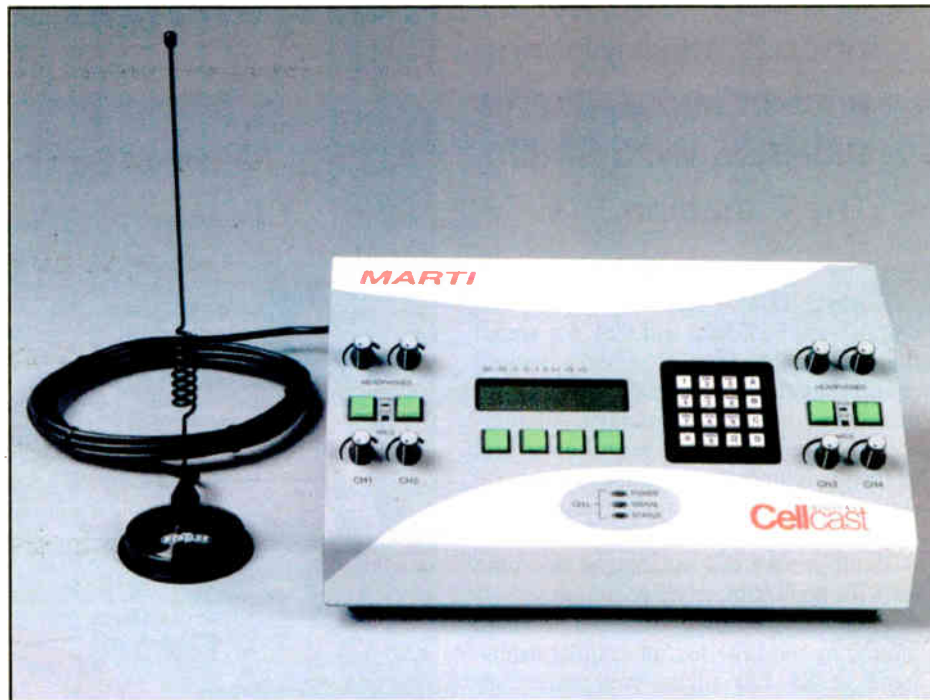

In this respect, and others, we are happy to report that Marti's Digital CellCast passed the litmus test, thumbs up. This mixer and digital cellular phone was so easy and intuitive to use that we learned to use it effectively in a few minutes, without reading the manual. You can't say that about many remote units, or even today's consumer cell phones.

When we purchased the Digital CellCast three months and 15 remote broadcasts ago, we anticipated a steeper learning curve. Our primary concern was ease of use during a variety of remote scenarios. WISS(AM) is a classic country station with heavy involvement in Berlin, Wis., and neighboring communities. Remotes carried on WISS(AM) can take us just about anywhere, from school sporting events to the local car dealership. We need to adapt our remote broadcasts to all those environments.

Fortunately, in our search for a new remote unit, we didn't have to contend with line-of-sight, phone access and antenna issues. Marti had done away with those concerns years ago when it introduced the CellCast for the old AMPS analog cellular networks. We did wonder how Marti's newer unit for digital cellular net-

longer have to lug around equipment; it's just one unit.

Another plus in the adaptability area is the power options that come with CellCast. Just about any remote environment you can imagine (and remote broadcasts have their share of interesting scenarios!), the CellCast can take a power source from: electrical outlet, battery and even a car cigarette lighter, if it came to that. The unit comes with battery pack and AC/DC converter.

And, of course, as radio announcers, we're always sticklers for audio quality. Digital CellCast delivered on that, too. We were able to get good, solid audio through the Digital CellCast during all the remotes we've done so far. We traveled a good 45 minutes from the station for one remote, and the unit still delivered clean audio as if it were coming from the studio next door.

Needless to say, this remote unit proved to be a worthy road companion. It's adaptable, capable and easy to use. We have yet to crack open the manual, but we keep it around just in case.

For more information, including pricing, contact the company in Illinois at (217) 224-9600 or visit [www.martielectronics.com](http://www.martielectronics.com).

## ENTER TO WIN

Here's your chance to unpack **FREE GEAR** in 2003.  
Enter to win one of 26 New Technology prizes.

Over the past two years, Radio World and dozens of industry suppliers have joined forces to award more than \$115,000 worth of radio and pro audio gear — from microphones, master clocks and sound cards, to audio processors, routers, CD mastering machines and shopping sprees.

In 2003 you can expect a similar range of cool New Technology products from our great sponsors. It takes only seconds to sign up online. And best of all, there are 26 chances to win in 26 drawings — one for every issue of Radio World. This is our way of saying "thank you" for allowing us to bring you New Technology for the past 27 years.



To enter the sweepstakes you must complete these 3 easy steps:

- 1 Go to our website [www.rwonline.com](http://www.rwonline.com)
- 2 Click on the New Technology Sweepstakes icon
- 3 Follow the instructions and fill out the electronic entry form — that's it, you're done!

So what are you waiting for? Don't miss out in '03. Enter to win New Technology products from these fine Radio World supporters:



**APT**  
AUDIO PROCESSING  
TECHNOLOGY



**audio-technica**

**Audio  
TX**  
Communicator IBSI & P Codes



**AUTOGRAM**  
CORPORATION

**Audemat  
Aztec**

**BRADLEY**

**BROADCAST  
tools**

**ESW**  
BROADCAST SUPPLY WORLDWIDE

**COMREX**



**ESE**



**JK Audio**

**KLOTZ**  
DIGITAL

**Lynx**  
STUDIO  
TECHNOLOGY

**MAYCOM**  
AUDIO SYSTEMS

**Moseley**

**NAGRA**

**NSD**  
Less noise • More sound

**RAM**

**SCMS INC.**  
YOU KNOW WE KNOW RADIO!

**SONIFEX**

Contest Rules: To enter the drawing, simply register online at [www.rwonline.com/sweeps](http://www.rwonline.com/sweeps). 26 drawings will be held throughout the year. Contest registration expires Dec. 3, 2003. Final contest prize announcement on Jan. 1, 2004. One prize per winner. All contestants MUST reside in the United States and have a valid mailing address. Winners should receive prizes within 30 days of notification; however, actual delivery time may vary and is not guaranteed by IMAS publishing. Federal, state and local tax/tariffs may apply to prizes and are the sole responsibility of the winner. Employees and affiliates of IMAS Publishing are not eligible.

## USER REPORT

# ComPack Connects for Field Work

by Carl Lindemann

With the explosion of cell phones, interfaces that take advantage of the new connectivity are popping up. JK Audio's ComPack lives up to the company's claim of being a "universal telephone audio interface" bringing together everything needed to work with both wired and cell phones.

The ComPack is small enough (8 x 3 x 2.2 inches) to be an easy add to any field kit. The sturdy metal case makes sure that it survives the beating that such duty demands.

For wired applications, the ComPack plugs into standard and digital PBX lines. If there's a phone line handy, this lets you use it.

As you might expect given JK Audio's success in this arena, it earns its keep well as a full-function, clean-sounding hybrid. But the real bonus here is cell phone connectivity. Despite the decidedly "iffy" audio quality of cell phones, the simplicity and ubiquity of the services make it irresistible. Calling in live reports in a pinch via cell beats looking for a land line! But working with a bare cell phone means accepting many limitations besides the sound quality.

What the ComPack offers is the means to conduct interviews with a professional mic, monitor using real headphones and send actualities down the line as needed. It's not just a hybrid; it also integrates a mixer so that there's nothing else needed.

This extended functionality comes from taking advantage of the tiny 2.5 mm jack now included in many cell phones. These are designed to provide "hands-free" operation with headsets that integrate mic and headphone. Extending the capabilities of the 2.5 mm jack takes some doing, especially since these are unbalanced connectors. But the ComPack manages to work around these issues admirably.

I took a ComPack out for a test last election eve covering a gubernatorial campaign inside a local hotel. How well could I work the room with the ComPack? My assignment was to phone in hourly reports and to be set to deliver breaking news live as needed. Typically, the calls were recorded station-side and trimmed. Here, the ComPack offered two options. I could record with my standard MiniDisc setup, then feed the audio via the 1/8-inch line input. Or I could simply conduct interviews on the fly and have them recorded directly.

That, as it turned out, was the preferred method. The MD playback was reserved for clips drawn from speeches taken from the pooled feed.

The full rig consisted of using the ComPack to tie together a beyerdynamic MCE 58 mic, Sennheiser HD 25 headphones and a Motorola V60 cell phone. The mic and headphones just snapped into standard connectors. Bringing the cell phone online required the proprietary 2.5 mm-to-1/4-inch adapter cable.

At first, there was some RF interference. This is an inherent issue; the cell phone transmissions are problematic for the unbalanced connections. Fortunately, the noise only came through the headphones. It was not transmitted to the other end of the line.



It is a minor annoyance that can be minimized by carefully placing the cell phone as far away from the ComPack as possible.

I had it slung on my right side by the shoulder strap with the cable reaching behind me to the cell phone tucked away in a left side pocket. This all but eliminated the interference.

With the headphones on and the newsroom producer tapped in, it was easy getting good sound almost effortlessly, at least as good as the cell phone connection allowed. The unit itself was easy to operate. The only adjustments used were the headphone and mic levels. A third control adjusted the line input when that function was in play.

Newsrooms should find it easy to dispatch reporters with a ComPack and not have to make much effort in the way of training. Operation is virtually self-explanatory.

The beauty of the ComPack was its near-invisibility. It fast faded into the background, allowing me to focus on conducting interviews.

The only thing I had to be mindful of was the hit-or-miss qualities of cell phone audio. I avoided some "dead spots" in the hotel where the signal got sketchy. The beauty here is that if I'd found the cell connect unacceptable, it would have been easy enough to tap into a standard phone line.

With the ComPack, you don't have to worry about bringing separate devices. The single solution takes care of it all. If nothing else, that is enough to commend this for any remote work. Add the well-thought-out design, ease of use and superior sound quality, and you have an irresistible combination. Once you've had a chance to use a ComPack, you won't want to head out on assignment without one.

Carl Lindemann is a frequent contributor to Radio World.

For more information, including pricing, contact the company in Illinois at (815) 786-2929 or visit [www.jkaudio.com](http://www.jkaudio.com).

## TECH UPDATE

## Porter Case Takes Audio on the Go

Porter Case has modified the interior of its larger carry-on, the 1502 AVCS, to help it adapt to a variety of uses.

For mobile applications, the broadcast industry can combine a Porter Case AVCS with a DV laptop notebook, a portable satellite uplink terminal, a portable three-chip digital camera and editing software. Porter Case says the package is being used by major broadcasting companies for field reporters in countries like Afghanistan and Iran.

For more information, including pricing, contact the company in Indiana at (574) 289-2616 or visit [www.porter-case.com](http://www.porter-case.com).



## Experience Exceptional Quality, Reliability and Service! Experience Armstrong Transmitter!



FM 30000 TX

Our single tube high power FM transmitters offer you exceptional quality at affordable prices.

Built for the "real world" environment, these RF workhorses offer long term reliability and features not found in any other single tube transmitter available.

**Features Include:**

1/4 Wave Grounded Grid Tetrode PA

Fiber Optic PA Arc Detection

PA Temperature Protection

Advanced Control System with remote computer interface

More internal status sensors than any other transmitter

CD Quality Audio (AES/EBU optional)

Available from 20 to 35 kW.  
Combined systems to 60 kW

Armstrong Transmitter.. the best RF products, the best around the clock support and the best prices

....because you deserve nothing less!



**ARMSTRONG**  
TRANSMITTER CORPORATION

4835 North Street, Marcellus, NY 13108 (315) 673-1269 Fax 315 673-9972 [www.armstrongtx.com](http://www.armstrongtx.com)

# Products & Services SHOWCASE

## Affordable Custom Broadcast Furniture

Constructed,  
Delivered and  
Installed by

**STUDIO  
TECHNOLOGY**



Now also serving you  
from the West Coast!

Studio Technology West  
310B Coney Island Dr.  
Sparks, NV 89431  
TEL: 775-351-2042  
FAX: 775-351-2082

TEL: 610-640-1229  
FAX: 610-296-3402  
32 Pennsylvania Avenue  
Malvern, PA 19355

e-mail: [sales@studiotechology.com](mailto:sales@studiotechology.com)  
web: [www.studiotechology.com](http://www.studiotechology.com)

**SIX MILLION  
THUNDERSTORMS HIT  
PLANET EARTH EVERY YEAR!  
IT TAKES ONLY ONE TO  
PUT YOU OFF THE AIR!**



The STATI-CAT LIGHTNING PREVENTION SYSTEM provides a continuous, low-resistance discharge path for the static electric charge on tall structures. Dissipation points are 1/8" stainless steel rods.

This affordable and rugged system has proven itself in the field for over 20 years.

**Cortana**  
Corporation Inc.

Write or call for a free brochure and design  
P.O. Box 2548, Farmington, N.M. 87499-2548  
Toll Free: 888-325-5336 • Fax: 505-326-2337 • [www.cortanacorporation.com](http://www.cortanacorporation.com)

## WEATHER RADIO

Model CRW



Price \$540.00

Sensitivity .28 microvolts for 12 dB quieting. All 3 frequencies. Alert tone demutes receiver, closes relay and gates audio to 600 ohm rear terminals. Another set of rear terminals has continuous 600 ohm audio output. Double conversion crystal controlled, crystal filter in first I.F., ceramic filter in second I.F. Dual gate MOS FET front end. 50 ohm coaxial input. Adjacent channel ( $\pm 25$  kHz) down to 70 dB. 19" rack mount, 3.5" H, all metal enclosure. In stock—available for immediate delivery.

**GORMAN REDLICH MFG. CO**

257 W. Union St. • Athens, Ohio 45701  
Phone 740-593-3150 • FAX 740-592-3898  
[www.gorman-redlich.com/jimg@gormanredlich.com](http://www.gorman-redlich.com/jimg@gormanredlich.com)

## Pack, Rack or Stack'em!

Call or  
write for free  
detailed brochure.



## NANOAMP SERIES™

Mono and Stereo Mixers and Expanders

MX100, MX200 & MXS100 Three Input Mic Line Mixers  
XP100 & XPS100 Four Input Companion Expanders



- Low noise MicLine switchable inputs
- Phantom Power • Independent headphone and Balanced line outputs • Bright 3 color LED meter • XLR connectors
- External power or battery operated • UL & CE Markings

**AUDIO TECHNOLOGIES INCORPORATED**

328 W. Maple Avenue, Horsham, PA 19044

Tel: (215) 443-0330 • (800) 959-0307 • Fax: (215) 443-0394 • <http://www.atiguys.com>



## Mix and Match!

Henry Engineering's NEW rack-mountable "blue boxes" are now available in a compact 1/3 rack-width! Mount 3 units in only 1 RU of rack space!

- Mix and match...they're all the same size
- Built-in AC power supply...NO wall warts
- Desk top, wall mount, or rack mount
- Superb specs and performance

**We Build Solutions  
(that mount in your rack!)**

626.355.3656  
[www.henryeng.com](http://www.henryeng.com)  
Blueboxes, Inc.



In stock at all Henry Engineering Dealers



Plug-in installation.



## TECH UPDATES

## Fostex Explores DVD Recording With the PD-6

The PD-6 is Fostex's addition to a line of portable timecode machines, with six audio tracks, timecode-locked DVD-RAM recording and integrated mixing. It uses an 8cm DVD-RAM drive.

Normal DVD-RAM drives have become a recording format of choice but, Fostex says, they are not well equipped for location recording. Fostex says it designed the PD-6 for vibration stability, high-speed access and field reliability. It records to removable 8cm DVD-RAM cartridges; each side provides 1.46 GB or about 126 minutes per disc of four-track recording at 468 kHz/16 bits.

A six-channel mixer accepts microphone level, with T-Power (12 V) and phantom power (48 V) available, or line level. Phase reverse is provided on three even-numbered channels while each channel features adjustable input gain, a defeatable and variable high-pass filter and a digital limiter.

Fostex touts the routing capability of the PD-6 saying it works with each channel's level control mounted on its face. The "Disc Feed" switch allows the recording section to derive its audio feed pre the channel level control, meaning levels are set once with the earlier trim pot.

This leaves the front-level controls for bus mixing, post of the channel level control providing for regular level adjustment on the controls. This also can occur from the Stereo Bus, routed by the PAN switch, which gives stereo mixing of all six channels and using a combination of the modes, parallel mix (guide) tracks can be made while recording of either five tracks (mono guide track) or four tracks (stereo guide track). Fostex calls these "1+5" and "2+4."

The PD-6 is equipped with BWF file format in 2, 4, 5 and 6 track modes and simultaneous two file recording modes of 1 and 5 and 2 and 4 tracks for guide track audio. It records on UDF on DVD-RAM so the disc can be mounted and read on both PCs and Macs.

Retail price: \$9,995.

For more information, including pricing, contact the company in California at (562) 921-1112 or visit [www.fostexdvd.net](http://www.fostexdvd.net).



## Tieline iMix Consolidates Remote Functions

Tieline is on the market with a product intended to reduce clutter in radio remote kit bags, including mixers, codecs and wiring.

It has developed the iMix, an integrated five-input remote mixer with 15 kHz POTS and optional 15 kHz ISDN codecs.

The digital mixer comes with five switchable mic/line inputs. iMix also has intercom talkback switching between each input channel, allowing off-air communications between headsets, channel on/off control, cue buttons, relay/RS-232 control, PA output and PA output level adjustment.

It also has a cellular telephone interface and provisions for an optional plug-and-play ISDN card offering 15 kHz audio over a 64K ISDN B channel.

Tieline targets dropouts and disconnections by using automatic line stabilization and an on-screen visual of link stability. The iMix is equipped with the "Tieline Toolbox," software that enables users to connect the codec to a PC and configure, control, monitor and text chat simultaneously while transmitting audio. iMix software is upgradeable over the Internet.

In addition to the standard 200 bps of raw data, which can be transmitted bi-directionally while broadcasting 15 kHz of bi-directional audio, the iMix will offer optional extra data capabilities. A software upgrade will be available offering up to 9,600 bps of bi-directional RTS/CTS flow controlled data with simultaneous audio.

A recent use of the iMix was a radiothon organized to benefit North Carolina Children's hospital. Six stations in Curtis Media Group set up individual remote broadcast tables at the hospital and raised \$183,000 in 20 hours. Due to the large number of interviewers, hosts and interviewees, many of the stations used iMixes to take the live programming back to their respective studios and broadcast the appeal live.

For more information, including pricing, contact the company in Indiana at (317) 259-8000 or visit [www.tieline.com](http://www.tieline.com).



## Maycom Offers Product Trio

Netherlands-based Maycom Audio Systems, a division of Solid Semecs, has released several portable audio and newsgathering products.

The Easycorder (not shown) is a solid-state MPEG-L2 digital portable recorder. Maycom says it targets reporters by offering reliability, audio quality, editing and real-time ISDN communication. The Easycorder costs around \$3,355.

The HandHeld II builds on the original HandHeld. Due to increasing demand for smaller and lighter devices, Maycom says, it developed a solid-state, MPEG-L2 portable recorder that fits in the palm.

The display comes with an omni-directional microphone situated atop the HandHeld. To use an external mic, Maycom's accessory program has a mono and stereo mic cable to connect with the preferred external mic. External cables like mic cables and a USB connection for laptop or PC fit into the multi input/output connector located on the bottom side of the HandHeld. The price, including docking station, is approximately \$1,047.

Maycom's MP3 ReporterKit / MicTube is its most compact recording product. The kit is a combination MP3 recorder/player and MicTube pre-amplifier, allowing customer to use their own professional XLR dynamic microphones.

The MicTube "clicks" into the microphone and can be connected to a recording device equipped with a line-level input. The MicTube will be available as separate product as well. The Maycom MP3 ReporterKit / MicTube costs about \$418.

Note: U.S. prices quoted here are subject to change based on euro fluctuations.

For more information, including pricing, contact the company's U.S. distributor, Bradley Broadcast & Pro Audio, in Maryland at (301) 682-8700 or visit [www.maycom.nl](http://www.maycom.nl).



Maycom's Mictube 'clicks' into the microphone.



The Handheld II is a solid-state, MPEG-L2 recorder that fits in the palm.

# Products & Services SHOWCASE

## WIN YOUR OWN PORTABLE MINI STUDIO



A Pro Tools Mbox + A Macintosh iBook,  
and you're in business.

Mbox works in tandem with Pro Tools LE 5.3.3 software and your computer to provide you with a high quality, self contained project studio (Pro Tools software included with Mbox)

Register today for The Radio Express Spring Sweepstakes to be eligible for the grand prize drawing. Sign up at [www.radioexpress.com](http://www.radioexpress.com). Or you can email us ([info@radioexpress.com](mailto:info@radioexpress.com)) or fax us (18182955801) your name and company name and we'll forward you an entry form.



#1 in Programming and Products for Radio--Worldwide.

## Control Solutions by CircuitWerkes



### The SEN-6 Subaudible Tone Encoder

The SEN-6 is a single channel Subaudible tone encoder with integral audio filtering that can produce 25Hz, 35Hz and combination tones from external closures.



### The SUB-03 Subaudible Tone decoder

The SUB-03 is a single channel subaudible tone decoder that can detect 25Hz, 35Hz and combination tones on audio channels. Each tone gives a distinct relay closure. Integrated filters strip each tone from the SUB-03's audio output so no one hears it.

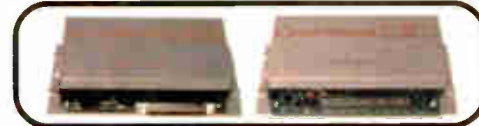

### Control your world with CircuitWerkes DTMF Tone decoders and controls

The DTMF-16 and DS-8 DTMF tone decoders provide economical remote control over audio lines. The DTMF-16 decodes single or dual codes while the programmable DS-8 accepts up to 8 four-digit sequences. Silencer option removes DTMF tones from audio.



### THE DR-10

### Perfect for Studio & Automation Control

**Dial-up** remote control with audio interface lets you control anything over regular phone lines. Interfaces with most studio automation systems. Control it from a dial-up line or external audio path. The DR-10's active, balanced, telco audio output lets you do live remotes, remote announcement recording and...much, much more!

CircuitWerkes - (352) 335-6555 / Fax 380-0230 <http://www.circuitwerkes.com> 2805 NW 6th Street, Gainesville, FL 32609

## AM Antenna Solutions



LBA Tunipole™  
Folded Unipole Systems



RF Components



Antenna Tuning Units



Diplexer, Triplexer and  
Phasor Systems

COMET  
Sold Here!

Reach further –  
sound better!

**LBA Technology, Inc.**

3400 Tupper Drive, Greenville, NC 27834

800-522-4464 / 252-757-0279 / Fax 252-752-9155 / Email [Lbatech@Lbagroup.com](mailto:Lbatech@Lbagroup.com) / [www.Lbagroup.com](http://www.Lbagroup.com)



LBA  
Since 1963

## S.C.M.S., Inc

Charlotte, N.C.



- ✓ Competitive Prices
- ✓ Extensive Rental Fleet (RF Codex Test Equipment, Audio)
- ✓ Experienced Staff
- ✓ Used Trade-Ins Welcomed
- ✓ New and Rebuilt RF and Audio
- ✓ Custom Studio Design and Furniture
- ✓ Representing Over 600 Quality Manufacturers
- ✓ Turnkey Installations Available

**You Know We Know Radio**

800-438-6040 • [www.scmsinc.com](http://www.scmsinc.com) • Fax 704-889-4540

## RAM BROADCAST SYSTEMS, INC.

Building Broadcast Furniture  
for over 35 Years

STARTING AT  
**\$2,484**

PREWIRED  
SYSTEMS  
AVAILABLE



## STANDARD BROADCAST FURNITURE

- SOLID SURFACE OR LAMINATED TOP
- 10 YEAR WARRANTY ON SOLID SURFACES
- RICH STAINED OAK TRIM
- LAMINATED VERTICALS
- REVERSIBLE PUNCH BLOCK PANEL
- 4 3/8" KICK BASE
- 30" HIGH TABLE TOP (38" OPTIONAL)
- 12 RACK UNIT UTILITY HOUSING
- 12 RACK UNIT PEDESTAL BAYS
- POP OUT REAR PANELS
- CABLE WIRE TRAYS
- ASSORTMENT OF COLORS
- GUEST WINGS AVAILABLE
- OVERBRIDGES AVAILABLE



USA  
(847) 487-7575

[www.ramsyscom.com](http://www.ramsyscom.com)

CANADA  
(705) 722-4425



BUYER'S GUIDE

TECH UPDATE

**Marantz Records to PC Cards, CD-R/RW**

Marantz PMD Solid-State Stereo Portable Recorders and its CDR300 CD Recorder are two new choices for broadcasters who need portable audio recording equipment.



The PMD690 (not shown) records digital audio files to removable PC cards, including PCMCIA or compact flash cards.

IBM Microdrives are compatible with the PMD690; it can record 74 hours of MPEG Layer II compressed files on a 1 GB Microdrive. The user inserts the card into the computer's USB card reader and can drag and drop recorded audio files to the hard drive, avoiding real-time delay disadvantages of cassette, MiniDisc or DAT.

Marantz says the PMD690 can use

EDL markers to enable easier searches during playback or for file management and edit with the optional PMD Edit software, which has 48V phantom power, speaker and S/PDIF digital output.

File formats are compatible with third-party software for transcribing digital audio files directly from a computer with the use of a USB transcription foot-pedal system. It comes with a shoulder strap, AC adapter and battery holder.

The PMD680 monaural version has

similar features. It records with an RJ11 telephone jack, XLR and 1/4-inch mic. It does not include 48 V phantom power.

The CDR300 is, according to Marantz, the first device to merge the capabilities of a stand-alone portable professional tape recorder with the ability to record directly to blank CD-R/RW media.

Using the optional RPS300 battery system, users can record four hours in the field or have battery-backup capability in case of power loss to save the recording. The CDR300 is a tabletop design, with a condenser microphone,

internal speaker and two inputs for external mics. These CDs can be played back in standard CD players. The "Minute Track Recording Mode" provides the ability to navigate to a specific minute of a meeting on any CD player.

For more information, including pricing, contact the company in Illinois at (630) 741-0957 or visit [www.marantz.com](http://www.marantz.com).

**Marantz Deck Features At a Glance**

**PMD690:**

- 32, 64, 96, 128 and 192 kbps MP2 files
- Uncompressed PCM .wav format
- 2 second pre-record cache
- Auto record level
- Limiter
- Mic
- Time/date stamp
- XLR mic/line in

**CDR300:**

- Live recording directly to blank CDs
- Transportable, table-top operation
- CD-R/RW compatible
- AC Power or 4-pin DC connection, for use with RPS300 Battery system
- Minute track mode for spoken word recording
- Preamp microphone
- 48 V phantom power
- Pro and consumer disc compatible
- Onboard limiter
- Adjustable digital and analog record level
- Create and display CD-TEXT
- Sample rate converter
- RCA I/O
- Coaxial digital I/O (S/PDIF)

You Read It Here



**Ten Years Ago**

"Seeing an all-digital future for radio broadcasting, Sony Corp. has announced a major new lineup of digital audio equipment especially designed for radio stations.

"At the debut news conference at its New York City headquarters, Sony introduced a digital broadcast console, MiniDisc cart machines, compact disc players and changers and the DATstation, a DAT field editing system built into a laptop computer."

— "Sony Digital Gear Targeted to Radio" by Frank Beacham March 24, 1993

**Fifteen Years Ago**

"Last year, the National Bureau of Standards was tasked by Congress to determine whether a proposed notch at 3840 Hz, placed in digital source material, would harm the sound quality of the material.

"The notch is part of the Copycode system, designed by CBS Records, and would trigger a device proposed for R-DAT recorders, rendering them temporarily inoperative and therefore useless for digital-to-digital copying. Home recording groups have protested this proposal, while its supporters maintain it would be an effective deterrent to copyright infringement.

"Soon the Bureau will release its report on the matter, drawn from exhaustive testing and statistical analysis."

— "What Is the Sound of a Notch?" by Alex Zavistovich March 15, 1988

Products & Services **SHOWCASE**

May we present... **YOUR AD**

**RADIO WORLD'S** Products and Services Showcase provides a perfect medium for marketing your products and services.

For more information, call Simone at 703-998-7600, ext. 154 to request a media kit.

**Call Today!** before \$5,995\* **Introductory Price Expires!**

**SOUND CHOICE FURNITURE**  
High quality stock studio furniture from the manufacturers of The Best Custom Studio Furniture

Starting as low as \$3,295

\*As shown, excluding Console & Guest Top

Introducing "Sound Choice Furniture," new from Mager Systems, Inc. the manufacturer of The Best in Sound Furniture. Sound Choice Furniture is high quality stock studio furniture, featuring the same high quality construction methods and materials found in Mager Systems, Inc. custom furniture. All "Sound Choice Furniture" includes solid surface countertops. The standard color is stormy gray for the solid surface top and a medium speckled gray on the cabinets (see photos). Call today to see how Sound Choice Furniture will benefit your studio.

**Winner NAB 2002**  
**2002 PICK UP!**  
**Radio**  
BE Radio Magazine

**Sound Choice Furniture offer these Fine Standard Features:**

- Solid Surface Tops
- 1-1/2" thick 19-ply plywood cabinet construction
- 13-ply Finland Birch access panels
- No Particle Board or melamine
- 10-year Limited Warranty
- Reversible Punch Block cabinet
- Modular - Many Configurations, add-ons and colors available
- Built in ventilation
- Fast Installation - No cabinet assembly

**MAGER SYSTEMS, INC.**  
The Best in Sound Furniture

TEL: 623-780-0045 • FAX: 623-780-9860  
[www.magersystems.com](http://www.magersystems.com) • [mager@magersystems.com](mailto:mager@magersystems.com)  
Visit our website for more information

# BROADCAST EQUIPMENT EXCHANGE

"Broadcast Equipment Exchange" accepts no responsibility for the condition of the equipment listed or for the specifics of transactions made between buyers and sellers.

**ACOUSTICS**  
**Want to Sell**

**AcousticsFirst™**  
 Toll-Free 888-765-2900  
 Number: 888-765-2900

Full product line for sound control & noise elimination.

www.acousticsfirst.com

**ANTENNAS/  
 TOWERS/CABLES**  
**Want to Sell**

**Superior Broadcast Products**  
**FM Antennas**  
 All Power Levels.  
 Contact Jimmie Joynt  
 Phone 800/279-3326

Pirot SS 80-180'; Utility 340 SR,  
 25 sections. 513-521-1729.

**AM Ground Systems**  
 Reliable, On-time Installation  
 Quality Workmanship  
 Ground System Evaluation  
 and Repair  
 www.amgroundsystems.com  
 1-877-766-2999

Gates/ERI 5 bay horizontal with  
 deicers, \$1500. Brian Larson,  
 WNGN, 65 Kings Rd, Buskirk NY  
 12028. 518-686-0975.

**THE ANTENNA SITE STORE**  
 Tower Registration Signs  
 FCC and OSHA Compliance  
 Tower Leasing Signs  
 Your Wording Added  
 610-458-8418  
 www.antennaid.com  
 Antenna ID Products Glenmoore, PA

Cetec JSCP Series B FM broadcast  
 antenna, 105.3 MHz, 6 bays, 3.2  
 power gain ratio, 5.05 gain in dB, 1.79  
 field gain, 246.0 FS @ 1 mile 1KW,  
 MV/M, 40 KW safe power rating, end  
 input feed point, 498 lbs, new weight  
 w/mounting brackets, 730 lbs  
 windload at 50/33PSF, 112mph, with  
 mounting brackets, \$1950/BO. Rob  
 Kaneta, KNIK, 907-562-8119 or email:  
 rkaneta@ubik.com.

**S.W.R**  
**FM & Television**  
**Antennas**  
 Contact Jimmie Joynt  
 Phone 800/279-3326

**To advertise in**  
**Radio World**  
 e-mail:  
 sfewell@imaspub.com

Visit our web site:  
 www.rwonline.com

www.rwonline.com www.rwonline.com www.rwonline.com

**AUDIO**  
**PRODUCTION**  
**Want to Sell**

Shure FP31 portable 3 channel  
 mixer. AC/DC powered, mint  
 condition, two available, \$400 each.  
 Dean Kannes, KBEV, 103 N Nevada  
 St, Dillon MT 59725. 602-525-7577.

Shure M367 6 channel mixer,  
 AC/DC powered, only used twice,  
 \$500. Dean Kannes, KBEV, 103 N  
 Nevada St, Dillon MT 59725. 602-  
 525-7577.

**AUTOMATION**  
**EQUIPMENT**  
**Want to Sell**

Audisk, complete mail unit with  
 audio cards, SCSI drives, built-in  
 switcher. Call for details, \$1500.  
 Mark Bohach, WRFD, 8101 N High  
 St., Columbus OH 43235. 614-318-  
 0407.

**COMPLETE**  
**FACILITIES**

NEW OR USED  
 COMPLETE PACKAGES  
 STUDIO/STL/TRANSMITTER/ANTENNA  
 OR ANY COMBINATION OF ABOVE.  
 -LEASE OPTIONS-  
 -EMERGENCY RENTALS-  
 -REMOTE BROADCAST RENTALS-  
 SCMS, Inc. (800) 438-6040  
 "You Know We Know Radio"

**CONSOLES**  
**Want to Sell**

McCurdy Penny & Giles slide pots  
 (2), \$2500 ea. Brian Larson,  
 WNGN, 65 Kings Rd, Buskirk NY  
 12028. 518-686-0975.

**Want to Buy**

Western Electric 25B console  
 wanted. Will pay up to \$10,000.  
 Parts also wanted. Call Sumner  
 McDanel, 1-800-251-5454.

**LIMITERS/  
 AUDIO PROCESSING**  
**Want to Sell**

CRL audio preparation processor  
 and spectral energy processor,  
 \$1000. Ken Lane, KVVP, Box 1118,  
 Haskell TX 79521. 940-864-8505.

Optimod 8100A in excellent  
 condition with manuals, \$3000. Ken  
 Lane, KVVP, Box 1118, Haskell TX  
 79521. 940-864-8505.

**Want to Buy**

Teletronix LA-2A's, UREI LA-3A's  
 & LA-4's, Fairchild 660's & 670's,  
 any Pultec EQ's & any other old  
 tube compressor/limiters, call after  
 3PM CST, 972-271-7625.

**MICROPHONES**  
**Want to Sell**

Sennheiser HMD 2501  
 sportscaster headset, best  
 sounding on the market, like new,  
 two available, \$250 each. Dean  
 Kannes, KBEV, 103 N Nevada St,  
 Dillon MT 59725. 602-525-7577.

**Want to Buy**

RCA 77-DX, 44-BX, KU-3A's, WE-  
 639's, On-Air & recording lights  
 wanted, top dollar paid! 615-352-  
 3456, FAX: 615-352-1922. E-mail:  
 billbryantmgmt@yahoo.com.

RCA 77-DX's & 44-BX's, any other  
 RCA ribbon mics, on-air lights, call  
 after 3PM CST, 972-271-7625.

**MISCELLANEOUS**  
**Want to Sell**

1990 General 100 KW 3Q  
 generator, propane, good condition,  
 \$10,000. Barry O'Connor, KDES,  
 2100 Tahquitz Canyon Way, Palm  
 Springs CA 92262. 760-325-2582  
 x237.

Onan 7.5 KW generator, propane  
 with transfer switch, \$3000. Barry  
 O'Connor, KDES, 2100 Tahquitz  
 Canyon Way, Palm Springs CA  
 92262. 760-325-2582 x237.

**ROTRON BLOWERS AND PLATE BLOCKERS,**  
 new & rebuilt for Elcom, Harris, CCA,  
 CSI, McMartin. Goodrich Ent. 11435  
 Manderson St. Omaha, NE 68164  
 402 493 1886 FAX 402 493 6821

SCA Generator/Processor/Monitor  
 set. Includes CRL SCA 300-B SCA  
 generator, CRL AGC-400 audio  
 processor & Belar SCM-1 mod  
 monitor, works with Belar FMM-2 or  
 other FM mod monitor sets. Just  
 removed from service, in very good  
 condition, \$750/all. Jack Taddeo,  
 WKTT, 111 S Washington St, #150,  
 Park Ridge IL 60068. 847-518-0340  
 or email: RadioKT@WKTT.com.

**Want to Buy**

Gates CB 77. Need motor.  
 Turntable 60 Hz model, new or used  
 in working condition. Richard Miller,  
 KUAU, 590 Ulumalu Rd, Haiku,  
 Maui, HI 96708. 808-572-5534.

**MONITORS**  
**Want to Sell**

Used Mod Monitors, McMartin & Belar.  
 Many to choose from, tuned & calibrated  
 on your frequency, full guaranteed.  
 Goodrich Ent. 402-493-1886.

**RECORDERS**  
**Want to Sell**

Scully 280B's with Ruslang  
 consoles, \$500 each. Brian Larson,  
 WNGN, 65 Kings Rd, Buskirk NY  
 12028. 518-686-0975.

**Want to Buy**

Pair of 1.5" hubs for Revox A-77.  
 Wayne, 800-283-2666.

**REMOTE &  
 MICROWAVE**  
**Want to Sell**

**REMOTE**  
**EQUIPMENT**  
**RENTAL**  
 Silver Lake Audio  
 (516) 763-1776  
 silverlakeaudio.com

Comrex Vectors, two rack mount  
 units, one remote mixer unit, \$200  
 ea unit. Bryan Hubert, KCMS,  
 19303 Fremont Ave N., Shoreline  
 WA 98133. 206-546-7371 or email:  
 bdh@crista.org.

**Superior**  
**Broadcast Products**  
**FM STL Transmitter &**  
**Receivers 3,500 for both**  
 Contact Jimmie Joynt  
 Phone 800/279-3326

**SEE**  
**YOUR AD**  
**HERE!**

**Radio World's**  
**Broadcast Equipment**  
**Exchange**  
 To advertise, fax Simone @  
**703-671-7409**

**WE RENT FOR LESS**

|          |                |
|----------|----------------|
| Hotlines | FM Exciters    |
| Zephyrs  | STL's          |
| Nexys    | FM Pow Amps    |
| Audio    | Test Equipment |

If we don't have it, we will get it  
 SCMS, INC. (800) 438-6040  
 "You Know We Know Radio!"

**SATELLITE**  
**EQUIPMENT**  
**Want to Sell**

Harris 6550 satellite receiver, card  
 included, BO. Ken Lane, KVVP, Box  
 1118, Haskell TX 79521. 940-864-8505.

Scientific-Atlanta AD-7550 satellite  
 receiver, card included, BO. Ken Lane,  
 KVVP, Box 1118, Haskell TX 79521. 940-  
 864-8505.

Universal 300C satellite SCPC  
 receiver in working condition, BO.  
 Richard Miller, KUAU, 590 Ulumalu  
 Rd, Kaiku, Maui, HI 96708. 808-  
 572-5534.

**STATIONS**  
**Want to Sell**

Christian radio station in N.  
 California for sale or lease. Call 530-  
 283-4145.

**TEST EQUIPMENT**  
**Want to Sell**

Potomac FIM-41 AM field strength  
 meter, excellent condition, \$4500.  
 Dean Kannes, KBEV, 103 N Nevada  
 St, Dillon MT 59725. 602-525-7577.

**BROADCAST ENGINEERING**  
**CONSULTING SOFTWARE**

Professional software  
 packages for preparing  
 FCC applications and  
 plotting coverage. For  
 Windows and NT.

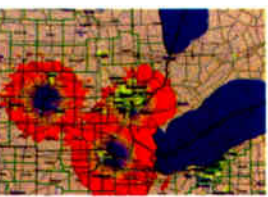

- ✓ Create "real-world" coverage maps with Longley-Rice, TIREM, PTP & other models using polygon map features.
- ✓ Prepare concise FCC model coverage maps and allocation studies using USGS geographic map databases. Census calculations, tower and airport databases.
- ✓ Search for AM, FM, TV, DTV & LPTV channels with graphics oriented programs and FCC databases.
- ✓ Plot STL paths in 3-D using NGDC terrain databases... and more!

**VSoft**  
 Communications  
 800-743-3684  
 www.v-soft.com

**TRANSMITTERS**  
**Want to Sell**

CCA FM-3000-D, 3KW FM. Continental  
 Communications. 314-664-4497, email:  
 contcomm@sbcglobal.net

Harris FM-3-H, 3KW FM. Continental  
 Communications. 314-664-4497, email:  
 contcomm@sbcglobal.net

**BEST**  
 From the tall to the small  
 WWW.BEST.COM  
**888 239 8462**  
 Transmitters  
 & Antennas

**Superior**  
**Broadcast Products**  
**FM Transmitters**  
 20 watts to 30 Kw  
 Contact Jimmie Joynt  
 Phone 800/279-3326

Harris MW-10-B, 10KW AM.  
 Continental Communications. 314-664-  
 4497, email: contcomm@sbcglobal.net.

**Out** with the old...  
 ...**In**  
 with the new!

**NEED TO MAKE ROOM FOR THE NEW**  
**EQUIPMENT YOU ORDERED?**

Sell your used equipment here  
 in the pages of Radio World  
 Broadcast Equipment Exchange.

It's easy... just fill out the Action-Gram in the  
 back of the issue and mail or fax it in. We'll  
 run your listing (s) for two consecutive issues!

**DON'T LET YOUR OLD EQUIPMENT**  
**COLLECT DUST...COLLECT \$ INSTEAD!**

If you have any questions regarding the  
 procedure, you can call Simone Fewell at  
 703-998-7600 ext 154 or email her at  
 sfewell@imaspub.com, for more information.

McMartin BA-1K, 1KW AM. Continental Communications. 314-664-4497, email: contcomm@sbcglobal.net.

Harris 10-H 10 kW FM transmitter, no exciter, \$10,000/BO. Joseph Bahr, Islands FM, POB 6556, San Juan PR 00914. 787-725-4164.

McMartin BF-5K, 5kW FM. Factory rebuilt in perfect, like new condition, includes new tubes, tested & tuned on your frequency. Guaranteed, fully adjustable from 0 to 5.5 kW. Goodrich Enterprises Inc, 402-493-1886.

Harris FM-20K, 20 kW Fm transmitter with all new tubes, just removed from service, BO. Chuck Springer, KANZ, 210 N 7<sup>th</sup>, Garden City KS 67846. 620-275-7444.

**CCA HELP**

- Rotron Blowers ▪ Rebuilt Plate Blockers ▪ Tubes
- Tube sockets/parts ▪ most all transmitter parts
- rebuilt tuning line assemblies

Goodrich Ent. Inc  
402-493-1886

www.goodrichenterprises.com cgoodrich@tconl.com

1975 Harris 20H-K in good condition with manual & spare parts, \$17,000. Barry O'Connor, KDES, 2100 Tahquitz Canyon Way, Palm Springs CA 92262. 760-325-2582 x237.

CCA 1000-D 1 kW FM transmitter, no exciter, \$5,000/BO. Joseph Bahr, Islands FM, POB 6556, San Juan PR 00914. 787-725-4164.

**OFF THE AIR?**  
Emergency Back-up Rentals

FM Exciters - STLS -  
FM Pwr Amps - Antennas -  
Studio & Test Equipment

SCMS Inc (800) 438-6040

"You Know We Know Radio"

Gates 186 1 kW AM for spare or parts, \$2500. Brian Larson, WNGN, 65 Kings Rd, Buskirk NY 12028. 518-686-0975.

**COMET**

**Vacuum and Gas Capacitors**

Standard equipment in all major AM and SW transmitters

513-831-5000  
www.cometna.com

**TRANSCOM CORP.**  
Serving the Broadcast Industry Since 1978

Fine Used AM & FM Transmitters and Also New Equipment

| USED FM TRANSMITTERS |  | NEW TV - VHF                                   |            |
|----------------------|--|--|------------|
| 300w                 | 1988 Harris FM 300K Solid State                          | 10 watt  | 500 watt   |
| 600w                 | "NEW" Amplifier  | 100 watt                                       | 1,000 watt |
| 2.5kw                | 1980 Harris FM 5.5K                                      | 250 watt                                       |            |
| 2.5kw                | 1978 Collins 831D2                                       | NEW TV - UHF                                   |            |
| 25kw                 | 1986 Harris FM25K  | 10 watt  | 500 watt   |
| 25kw                 | 1980 CSI T-25-F  | 100 watt                                       | 1,000 watt |
| 50kw                 | 1982 Harris Combiner w/auto exciter-transmitter switcher | 250 watt                                       |            |
| USED AM TRANSMITTERS |  | USED EXCITERS                                  |            |
| 1kw                  | 1980 Harris MW1A   | BE FX 30                                       |            |
| 5/10kw               | 1982 Continental 316F                                    | New 30 watt synthesized                        |            |
| 10kw                 | 1996 Harris DX 10  | USED MISC. EQUIPMENT                           |            |
| 50kw                 | 1997 Nautil ND50   | Potomac Ins. AA51 Audio Anyl. (new)            |            |
| 50kw                 | 1982 Continental 317C2                                   | Potomac Phase Monitor AM19, 2 Tower & 3 Tower  |            |
| 50kw                 | 1986 Nautil AMPFET 50                                    | Potomac Phase Monitor AM19, 1901 Digital       |            |
|                      |  | Kintronics DL50, 50kw Dummy Load               |            |
|                      |  | Dielectric 4 Port Motorized Switch             |            |
|                      |  | Technics SH9010 Equalizer                      |            |
|                      |  | SCA Generator (MX-15 Module)                   |            |
|                      |  | Optimod 8100A (cards 3 thru 5 only) & 9100B AM |            |
|                      |  | Dummy Load 80 kw air cooled, #DPTU-75K         |            |

2655 Philmont Ave #200, Huntingdon Valley, PA 19006  
800-441-8454 • 215-938-7304 • FAX No. 215-938-7361  
VISIT OUR NEW INTERNET SITE: www.fmamtv.com  
SEND YOUR E-MAIL REQUESTS TO: transcom@fmamtv.com

Harris MX15. Exciter needs new fan & a cleaning, otherwise OK, \$600. Mark Bohach, WRFD, 8101 N High St., Columbus OH 43235. 614-318-0407.

**Want to Buy**  
Pre-war or slightly later Western Electric transmitter, parts, etc. Call Sumner McDanel, 1-800-251-5454.

Continental digital exciter 802D, two years old, \$4800. Bryan Hubert, KCMS, 19303 Fremont Ave N., Shoreline WA 98133. 206-546-7371 or email: bdh@crista.org.

**rwonline**  
www.rwonline.com

**TUBES**  
Want to Sell

**FOR THE BEST PRICE**  
& 24 Hr service on transmitting tubes & sockets/parts, new & rebuilt call Goodrich Ent. at 402-493-1886 day or night, www.goodrichenterprises.com.

EIMAC, AMPEREX, ED-COM, 3CX2500F3, 3CX3000A7, 4CX250B, 4CX300A, 4CX1000A, 4CX1500B, 4CX5000A, 4-400C, 811, 833C, ETC. WESTGATE 800-213-4563.

**D & C Electronics Co.**

**NEW TUBES**  
We have the alternatives for all your needs, at the lowest prices, direct from OUR STOCK!!!

EIMAC, SVETLANA, PRO-TEK®, EEV and many others.  
(352) 688-2374  
PH: (800) 881-2374  
FAX: (352) 683-9595

SE HABLA ESPAÑOL  
WE EXPORT  
VISA/MASTERCARD ACCEPTED

**Radio World**  
Equipment Exchange

**CONSULTANTS**

**EVANS ASSOCIATES**  
Consulting Communications Engineers

FCC Applications • Design • Field Engineering • Tower Detuning Upgrade & Relocation Studies • AM Directional Array Tuning & Proof

EXPERTS IN:  
TV • DTV Transition • FM • Directional Antennas • RF Exposure

210 S. Main St., Thiensville, WI 53092. (262) 242-6000. FAX (262) 242-6045  
http://www.evansassoc.com Member AFCCE

**Consulting Communications Engineers EMC Test Lab**

- FCC Applications and Field Engineering
- Frequency Searches and Coordination
- AM-FM-CATV-ITFS-LPTV
- EMC Test Lab-FCC and European (IEC)

**OWL ENGINEERING, INC.**  
1-800-797-1338 Fax (763) 785-4631

E-mail: info@owleng.com  
8899 Hastings St NE, Minneapolis, MN 55449 (763) 785-4115 Member AFCCE

**GRAHAM BROCK, INC.**  
BROADCAST TECHNICAL CONSULTANTS

Full Service From Allocation to Operation AM/FM/TV/AUX Services; Field Work; Antenna and Facilities Design

Over 35 years engineering and consulting experience

912-638-8028  
202-393-5133  
www.grahambrock.com

**Doug Vernier**  
Telecommunication Consultants

Broadcast Engineering Consulting  
AM/FM/TV/LPTV/DTV  
Custom mapping service  
Frequency searches  
Propagation prediction  
FCC application preparation

**Vsoft**  
Software for your PC  
(800) 743-3684  
www.v-soft.com

**System One Communications**  
Broadcast Constructors & Consultants  
Houston, Texas  
888-625-5649

- AM-FM Site Construction Specialists
- Complete Tower Service
- Antenna & Transmission Line Diagnostics

**FASTER... MORE ACCURATE RADIO COVERAGE**

- Real Time 3-D Displays
- Interference calculations
- Cost effective mapping
- Fully integrated databases
- Used by the FCC
- Latest standards built-in

**RADIO SOFT**

Visit us on the the web at www.radiosoft.com  
109 West Knapp Ave. Edgewater, FL • (386) 426-2521

**Communications Technologies, Inc.**  
Broadcast Engineering Consultants  
AM FM TV LPTV  
Cellular/PCS Site Analysis

P.O. Box 1130, Marlton, NJ 08053  
Phone: (856) 985-0077  
Fax: (856) 985-8124  
Internet: commtechrf.com

Clarence M. Beverage  
Laura M. Mizrahi

**M Celenza**  
Communications Consultants  
TV-\$550; LPTV-\$550; FM-\$250;  
AM Freq Searches-Call for quote

Applications, Amendments & Upgrades  
Antenna Structure Registration.  
Field Work Avail  
631-928-0077  
Fax: 631-928-1905

**MULLANEY ENGINEERING, INC.**  
Consulting Engineers

- Design & Optimization of AM Directional Arrays
- Analysis for New Allocation, Site Relocation, And Upgrades AM-FM TV LPTV
- Wireless Cable (MDS/MMDS/ITFS/OFS)
- Environmental Radiation Analysis
- Field Work
- Expert Testimony

9049 Shady Grove Court  
Gaithersburg, MD 20877  
Phone: (301) 921-0115  
Fax: (301) 590-9757  
email: mullengr@aol.com

**PROMOTE YOUR BUSINESS!**  
**ADVERTISE!**

For more information, call  
Simone Fewell at  
703.998.7600, ext. 154.

**DISTRIBUTOR DIRECTORY**

The following distributors serving the broadcast industry would be glad to help you with any of your requirements.

**CORNELL-DUBILIER MICA CAPACITORS**  
FROM STOCK

**JENNINGS VACUUM CAPACITORS**  
FROM STOCK

**JENNINGS VACUUM RELAYS**

**SURCOM ASSOCIATES**  
2215 Faraday Ave., Suite A  
Carlsbad, California 92008  
(760) 438-4420 Fax: (760) 438-4759  
e-mail: link@surcom.com web: www.surcom.com

...country, top 40, news, urban, talk, jazz, the classics, mixed bag...

RADIO! The beat goes on!

**CROUSE-KIMZEY OF ANNAPOLIS**  
tops in broadcast equipment  
1-800-955-6800  
ask for Kathleen  
kkannapolis@worldnet.att.net

**STUDIO FURNITURE?**

SPACEWISE® is home to the...  
"BUDGET CRUNCHERS"  
QUALITY RADIO STUDIOS FROM \$2450!

- ☆ 1.5" PLYWOOD HARD LAMINATED TOPS!
- ☆ WOOD BULLNOSING, KICKS AND TRIM!
- ☆ STURDY BUILT MODULAR COMPONENTS!
- ☆ VERY AFFORDABLE CUSTOMIZATION!
- ☆ FAST AND EASY ASSEMBLY!

**SPACEWISE**  
800-775-3660 spacewise@qwest.net www.spacewise.com  
"Quality Broadcast Furniture, For Every Budget"

**dataworld**

Market Analysis  
Engineering Software  
Ethnic/Demographic Data  
Custom Full-color Mapping  
Sales Marketing Packages

www.dataworld.com  
800-368-5754

info@dataworld.com  
fax: 301-656-5341

**Structural Analysis**

**ERI**  
Electronics Research, Inc.  
7777 Gardner Road  
Chandler, IN 47610  
(812) 925-6000  
www.ERInc.com

REGISTERED PROFESSIONAL ENGINEERS  
STRUCTURAL ANALYSIS  
ERI Incorporated 1941  
TOWER REINFORCING



**NEW**

## ECONCO NEW TUBES

New tubes are now manufactured by **ECONCO** at our award winning facility in Woodland California! Of course, we continue our 34 year tradition of high quality power tube rebuilding.

TEL: 800-532-6626  
INTL: +1-530-662-7553  
FAX: +1-530-666-7760  
www.econco.com  
SE HABLA ESPAÑOL



Harris MW-1A. 1kW AM transmitter. Marked down to \$3495 or BO. Transmitter was working fine when station went dark. 321-427-3512.

AnaCom ANASAT-C Series C-Band transceiver 10 watt. Just reconditioned, \$7000. For technical info email: [Rmuffley@bbnradio.org](mailto:Rmuffley@bbnradio.org), for purchase call Mike Raley at 704-523-5555 or email: [Mraley@bbnradio.org](mailto:Mraley@bbnradio.org) for pictures.

**RF PARTS COMPANY**

• Broadcast • Industrial Communications

• EIMAC • TAYLOR  
• ECONCO • SVETLANA

Also  
Motorola • Toshiba • SGS-Thomson & Mitsubishi Semiconductors

Catalog: [www.rfparts.com](http://www.rfparts.com)  
Se Habla Español • We Export  
760-744-0700 • 800-737-2787  
Fax: 760-744-1943  
E-mail: [rfp@rfparts.com](mailto:rfp@rfparts.com)

Crown 2000, all solid state 2 kW xmtr, like new, less than 2 yrs old, all manuals, replacing due to upgrade, \$12,000. Roger Wright, WLLX, 1212 N Locust Ave, Lawrenceburg TN 38464. 931-762-2916.

Henry 3000D-95 single phase with bird thru line section, has rheostat for filament mgt, excellent condition, \$12,000. Roger Wright, WLLX, 1212 N Locust Ave, Lawrenceburg TN 38464. 931-762-2916.

Moseley PCL-606 STL xmtr, pulled from service because of bad amplifier & it might be repairable or good for parts, will sell "as is" for \$500. Mike Raley, 704-523-5555 or email: [Mraley@bbnradio.org](mailto:Mraley@bbnradio.org) for a picture.

RCA-FM BTF-10D 10KW xmtr. On air till 2001 at 4.5 kW on 102.3. For donation to non profit organization - you ship. Rick Keefer, KICA, 1000 Sycamore St, Clovis NM 88101. 505-762-6200.

### Want to Buy

AM transmitter must be 20 watts or more, FM exciter must be 10 watts or more, used in working for nonprofit radio station. Michael Cardillo, 151 Morgan St, Cranston RI 02920. 401-942-8341 or email: [mondomikeradio@aol.com](mailto:mondomikeradio@aol.com).

### TURNTABLES

#### Want to Buy

16" turntables with or without tone arms, hopefully in good working order. Write Lynch & Moore Consultants, 2460 Illinois Ave, Modesto CA 95358.

**Radio World**

# EMPLOYMENT

## HELP WANTED

Can you answer "YES" to any of these questions?

Tired of driving a four wheel drive up a mountain in the snow to get to your transmitter in the winter?  
Don't like clearing Wasp nests out of LNB's in the summer?  
Does riding an air conditioned elevator up 83 floors sound like a more civilized way to get to the transmitter?  
Would you like fries with that?!

Then I've got the gig your YOU!

Assistant Chief Engineer or Chief Engineer depending on qualifications:

Join the ClearChannel five station FM cluster in New York City managing the day-to-day engineering operations of WKTU-FM. Extensive practical RF knowledge & component level troubleshooting required. Successful applicant will be an experienced self starter, have an extensive hands-on knowledge of transmitters (Z10's & FM-10B's), be comfortable with large combiner systems, studio & facility maintenance, Prophet Systems, & work well without extensive supervision. IT knowledge helpful but not required. 24/7 on call required. Salary commensurate with experience. Some heavy lifting required, occasional overnight maintenance too. Reply with resume, salary requirements & at least 3 current industry references to: Josh Hadden, DOE & IT, 18<sup>th</sup> FL, c/o WWPB-FM, 1180 Ave of the Americas, NY NY 10036 or via email: [engresume@ktu.com](mailto:engresume@ktu.com).

### WUNC-FM Electronics Technician

This position has the primary responsibility for overseeing complex electronics systems at the station, to include high powered transmitters, audio consoles, audio & digital routing systems, automation, ISDN, satellite uplink, microwave, remote controls, & studio production equipment. Should have a thorough understanding of the FCC Rules & be proficient with Microsoft Office & Visio. Outstanding organizational skills & documentation a must. Position will repair, install & upgrade studio & transmitter facilities. Preferred qualifications include a minimum of 5 yrs of hands-on RF experience. An FCC General Radiotelephone license or equivalent SBE certification is necessary. Assoc. Engineering degree a plus. Should be strong on maintenance & have a desire to achieve excellence. Rotating on-call duties required, as well as some night & weekend maintenance work. Minimum education & experience requirements include graduation from a community college or technical institute with a two-year degree in Electronics & three years of progressive experience in the maintenance & repair of complex electronic systems, including the design of electronic apparatus. Salary Range is \$38,554-56,965. When applying, please specify **Position #0053799, Dept. #5380**. For an application, phone: **919-962-2991**; apply at: **Employment Dept., Office of Human Resources, The Univ. of North Carolina at Chapel Hill, CB #1045, 725 Airport Rd, Chapel Hill NC 27599-1045**; or see our website. The closing date for accepting applications is **2/28/03**. An Equal Opportunity Employer.  
[www.jobs.unc.edu](http://www.jobs.unc.edu)  
**UNC-CH**

## POSITIONS WANTED

**Fresh out of broadcasting school.** Will relocate anywhere. Focused, hard-working, quick learner. Huge desire to be on-air! Brian 972-206-2101.

**I love to learn,** am willing to travel and have no problems with taking orders and taking on responsibilities. Omar, 405-732-3028.

**Multi-talented rookie** seeks an opportunity to shine! Rock or sports format, willing to start anywhere! Prefer Midwest or South. High interest in sportscasting! Brandon, 405-306-6981.

**New ABS graduate** interested in working boards for radio or television as well as production, copy writing, or on-air DJ. Have fresh ideas & always willing to learn. Will relocate. Chawn, 405-672-1296.

**Rookie broadcaster** looking for my first gig. I have the skills, and want to use them to make your station #1. Mark, 903-880-4427.

**Rookie free agent** looking for a place to play. Diligent work ethic & team-oriented explorer full of spirit, passion, and excited to play ball. Adam, 405-943-7443.

**Air personality!** Jay-Diamond one HOT rookie DJ seeking radio gig. On-air or in production. Larry, 918-402-6634.

**Creative radio school grad** with 2 years experience wants to be part of your team. Hard working, dependable. Great on-air and production. Brandy, 918-520-7558.

**Rookie broadcaster** breathing new life into radio. Full of energy & enthusiasm. Great news and copywriting! Jesse, 405-677-3573 or [jclark64@cox.net](mailto:jclark64@cox.net).

**Broadcast graduate** willing to relocate & do whatever it takes to do great radio. Versatile from on-air to production & ready to follow directions. Bill Gardner, 972-253-1969.

**CE position wanted.** Experienced with computers, transmitters, automation, CDS, UDS, digital studios. Robert King, 978-479-4855.

**Creative rookie broadcaster** looking to break into the industry. On-Aid or production position wanted. Vast knowledge of Cool-Edit Pro. Call Jonathan Pyka, 817-488-1785.

### Regional Engineer

**Waitt Radio**, seeks a talented Engineer based in Ft. Dodge, Iowa. Ensure integrity of broadcast signal, technical equipment, build & maintain technical systems to meet long-term objectives. 3 years broadcast engineering experience, FCC General Radiotelephone &/or SBE certification preferred, previous electronics training, ability to travel throughout region, understanding of computer network operations. Competitive salary & excellent benefits. EOE. For more details or to apply, see [www.waittmedia.com](http://www.waittmedia.com). **Online response preferred.** EOE. Waitt Media, Mike Hendrickson, 1125 South 103<sup>rd</sup> St., Ste 200, Omaha, NE 68124. Fax 402-330-2445.

## POSITIONS WANTED

**Engineer in Florida**, willing to relocate to your facility. AM/FM construction or maintenance. NT, IT studios & airchain. Automation a specialty. Currently employed as Chief Engineer. 1<sup>st</sup> Class FCC & other certificates. Contact Chuck @ 904-680-1101 or [mychucky@funport.net](mailto:mychucky@funport.net).

**Friendly, industrious,** commercial FCC-1<sup>st</sup> Class with radar-amateur radio extra licensed, asst CE, seeks FT, PT, contract, with AM/FM, cable, TV, preferred within 75 mile radius of metro NYC area. 718-969-5224 or write: Mitchell Rakoff, 81-12 Roosevelt Ave #702, Jackson Heights NY 11372-6746 or email: [mitchellrakoff@yahoo.com](mailto:mitchellrakoff@yahoo.com).

**Graduated American Broadcasting School**, can do it all! I want to take your station to the top, call Bryan Mills, 817-875-0365.

**Graduated from American Broadcasting School**, seeking opportunity as an On-Air announcer or production talent. Have knowledge of Cool-Edit Pro, willing to relocate & work hard to become an asset to your station, call James, 469-688-9478.

**Have singlewide-will travel** in Texas! Recent grad from American Broadcasting School. Excellent on-air and creative production. Punctual & dependable. Ray Ebee, 972-617-8630.

**Hot new chick needs a job quick!** Energetic rookie DJ great at on-air, newscasting, sportscasting & more! Allow me to help you stay at the top! Call Lakeysha, 405-733-4531 or [ryceqt@sbcglobal.net](mailto:ryceqt@sbcglobal.net).

**Pure attitude** with a pinch of twisted perceptions is the recipe for your cookbook. Heavy on production, announcing, copywriting for your palate. Contact treby, 405-229-1087.

**Rookie DJ ready to go pro!** Creative, dedicated individual seeks announcing/production position, will travel. Joe, 918-293-9100.

**Space cowboy** ready to rock! Radio school grad seeking classic rock, country format. Rip-roaring on-air, production. Oran, 918-293-9100 or [Roberts@yahoo.com](mailto:Roberts@yahoo.com).

## ATTENTION

**ADVERTISE  
YOUR  
EMPLOYMENT  
AD ON  
OUR WEB SITE  
FOR ONLY  
\$2 PER WORD!**

**ADS GET POSTED THE  
NEXT BUSINESS DAY  
AND WILL RUN  
FOR A FULL TWO WEEKS!**

**COMBINE THIS WITH AN  
AD IN OUR RADIO WORLD  
NEWSPAPER  
EMPLOYMENT SECTION  
AND REALLY COVER THE  
BROADCAST INDUSTRY  
AND THEN SOME!**

**RW Online**

[www.rwonline.com](http://www.rwonline.com)

**Call Simone Fewell  
for all the details at**

**703-998-7600  
Ext. 154**

**between 9-5 EST**

# ACTION-GRAM

## EQUIPMENT LISTINGS

Radio World's Broadcast Equipment Exchange provides a FREE listing service for radio stations only. All other end users will be charged. This FREE service does not apply to Employment Help Wanted ads or Stations For Sale ads. These are published on a paid basis only. Send your listings to us by filling out the form below. Please be aware that it takes one month for listings to appear. The listings run for two consecutive issues and must be resubmitted in order to run again. Thank you.

Please print and include all information: \_\_\_\_\_

Are you currently a subscriber to Radio World?  
 Yes  No

Signature \_\_\_\_\_ Date \_\_\_\_\_

Contact Name \_\_\_\_\_  
 Title \_\_\_\_\_  
 Company/Station \_\_\_\_\_  
 Address \_\_\_\_\_  
 City/State \_\_\_\_\_  
 Zip Code \_\_\_\_\_  
 Telephone \_\_\_\_\_

Brokers, dealers, manufacturers and other organizations who are not legitimate end users can participate in the Broadcast Equipment Exchange on a paid basis. Line ad listings & display advertising are available on a per word or per inch basis.

WTS  WTB  Category: \_\_\_\_\_  
 Make: \_\_\_\_\_ Model: \_\_\_\_\_  
 Brief Description: \_\_\_\_\_  
 Price: \_\_\_\_\_

WTS  WTB  Category: \_\_\_\_\_  
 Make: \_\_\_\_\_ Model: \_\_\_\_\_  
 Brief Description: \_\_\_\_\_  
 Price: \_\_\_\_\_

WTS  WTB  Category: \_\_\_\_\_  
 Make: \_\_\_\_\_ Model: \_\_\_\_\_  
 Brief Description: \_\_\_\_\_  
 Price: \_\_\_\_\_

WTS  WTB  Category: \_\_\_\_\_  
 Make: \_\_\_\_\_ Model: \_\_\_\_\_  
 Brief Description: \_\_\_\_\_  
 Price: \_\_\_\_\_

\*Closing for listings is every other Friday for the next month's issue. All listings are run for 2 issues unless pressed for space or otherwise notified by listee.  
**Broadcast Equipment Exchange**  
 PO BOX 1214, Falls Church, VA 22041 • Tel: 703-998-7600 • Fax: 703-998-2966



5827 Columbia Pike, 1st Floor • Falls Church, VA 22041  
 PHONE: 703-998-7600 • FAX: 703-671-7409

### Classified Advertising Rates Effective January 1, 2003

|                           | 1x              | 6x  | 13x | 26x |
|---------------------------|-----------------|-----|-----|-----|
| 1-9 col inch (per inch)   | \$105           | 100 | 95  | 90  |
| 10-19 col inch (per inch) | \$90            | 80  | 70  | 60  |
| Distributor Directory     | \$130           | 125 | 120 | 115 |
| Professional Card         | \$100           | 95  | 90  | 85  |
| Station/Studio Services   | \$195           | 165 | 140 | 119 |
| Classified Line Ad        | \$2/word        |     |     |     |
| Blind Box Ad              | \$15 additional |     |     |     |

Call Simone Fewell, Ext. 154, Classified Ad Manager, to reserve space in the next issue.  
 Use your credit card to pay, we now accept VISA, MASTERCARD and American Express.

# ADVERTISER INDEX

This listing is provided for the convenience of our readers. Radio World assumes no liability for inaccuracy.

| PAGE   | ADVERTISER                  | WEB SITE URL                            |
|--------|-----------------------------|---|
| 29     | Aphex Systems               | www.aphex.com                           |
| 37     | Armstrong Transmitters      | www.armstrongtx.com                     |
| 22     | Associated Broadcast Group  | www.associatedbroadcast.com             |
| 38     | ATI                         | www.atiguys.com                         |
| 35     | AudioScience                | www.audioscience.com                    |
| 3      | audioTX Communicator        | www.audiotx.com                         |
| 2      | Auditronics/Wheatstone      | www.auditronics.com                     |
| 30     | Belar                       | www.belar.com                           |
| 10     | Broadcast Tools             | www.broadcasttools.com                  |
| 24, 25 | BSW                         | www.bswusa.com                          |
| 4      | Burk Technology             | www.burk.com                            |
| 40     | Circuit Werkes              | www.circuitwerkes.com                   |
| 7      | Comrex                      | www.comrex.com                          |
| 1      | Continental Electronics     | www.contelec.com                        |
| 38     | Cortana                     | www.cortanacorporation.com              |
| 14     | Dorrough Electronics        | www.dorrough.com                        |
| 38     | Gorman-Redlich Mfg. Co.     | www.gorman-redlich.com                  |
| 28     | Grace Broadcast Sales       | www.gracebroadcast.com                  |
| 15     | Harris                      | www.broadcast.harris.com/network-access |
| 32     | Harris                      | www.broadcast.harris.com                |
| 38     | Henry Engineering           | www.henryeng.com                        |
| 19     | Inovonics                   | www.inovon.com                          |
| 23     | JK Audio                    | www.jkaudio.com                         |
| 17     | Klotz Digital AG            | www.klotzdigital.com                    |
| 40     | LBA Technology              | www.lbagroup.com                        |
| 41     | Mager Systems               | www.magersystems.com                    |
| 27     | MediaTouch                  | www.omt.net                             |
| 18     | OMB America                 | www.omb.com                             |
| 9      | Omnia, a Telos Company      | www.omniaaudio.com                      |
| 20     | Radio Design Labs (RDL)     | www.rdlnet.com                          |
| 40     | Radio Express               | www.radioexpress.com                    |
| 5      | Radio Systems               | www.radiosystems.com                    |
| 40     | RAM Broadcast Systems, Inc. | www.ramsyscom.com                       |
| 40     | S.C.M.S., Inc.              | www.scmsinc.com                         |
| 11     | Sierra Automated Systems    | www.sasaudio.com                        |
| 16     | Sine Systems                | www.sinesystems.com                     |
| 38     | Studio Technology           | www.studiotechology.com                 |
| 13     | Telos Systems               | www.telos-systems.com                   |
| 31     | Tieline America             | www.tieline.com                         |
| 47     | Wheatstone                  | www.wheatstone.com                      |
| 48     | Wheatstone                  | www.wheatstone.com                      |

## ◆ READER'S FORUM ◆

**SBE handbook**

I was reading the Dec. 18, 2002 issue and want to clarify the title of the Certification Handbook ("Engineer Shortage Worries SBE").

The book that is coming out early in the year is "Certification Handbook for Radio Operators." It is in the second review process, and I'm looking forward to offering this educational tool along with certification in 2003.

Linda Baun  
Certification Director  
Society of Broadcast Engineers  
Indianapolis

**No sexy models needed**

While I may not be quite as offended as John Stortz (Dec. 4, "Sliding into sleaze?") about the StudioHub ad, I, too, am concerned about the slide into sleaze that appears to be happening in RW ads.

I remember the days before radio and TV were split into separate publications, when old man Townsend was advertising his UHF transmitters. One ad had him leaning against one of them, pointing at the reader, with the caption reading something like "You shouldn't need some sexy model to sell you a new Townsend UHF transmitter!"

## Shame on any of us who buys something just because we were enticed by some sexy chick.

— Scott Todd

Shame on any of us who buys something just because we were enticed by some sexy chick. Let the products stand or fall on their own merits.

Scott Todd  
Cambridge, Minn.

**Processing**

As a radio consultant based in California, I read with interest the claims from Omnia and Orban about market dominance (RW Online Special Report, "Omnia, Orban Issue Market Claims," Dec. 11, 2002). Especially interesting is

that both are claiming to have their processor on the same L.A. station.

First Omnia says that KIIS(FM) is using their box. Then Orban claims to have theirs on the top four L.A. stations. But KIIS has been in the top four for as long as I can remember. Is someone lying, or did KIIS fall out of the ratings when I wasn't looking?

You've got to love marketing!

Chris McKay  
Radio Consultant  
MC Broadcast  
San Diego

Paul McLane's editorial about audio processor marketing was well done (Jan. 1, "From the Editor"). Thank you for the comments. I'd like to express that in Frank Foti's eyes, we'll always be No. 2.

I vividly remember conversations we've had over the years about the market position of Omnia, what my goals were, and still are; but in reality, nothing has changed. You see, we're in competition with every processor company ... including ourselves. That actually makes the challenge even more stringent than it was before.

The following is an excerpt from our welcome letter in the Omnia manual.

"1986 seems like just a short time ago! It was that year, in the engineering

shop at Z-100, WHZZ(FM) New York City, that our first product was born ... the Vigilante FM Limiter. Now, 15 years later, along with an incredibly talented team of fellow broadcasters and engineers, we offer you the next progression in broadcast processing: Omnia-6! This processor is not just Frank anymore. It's a complex effort from a tremendous team that has had only one goal in mind ... to raise the bar, yet again, and present you with the best product possible."

I don't have enough space here to thank every one of the Telos/Omnia worldwide team members who have con-

## For the Love Of Radio

Most of us are in this business because we love radio.

For many readers, the love affair began in the years when FM was coming into its own and DJs had more of a voice as well as choices in what was played and said. Over time, market research, demographic studies and computer-aided programming sanitized the experience. Consolidation accelerated the loss of spontaneity.

Today a few formats dominate the music airwaves: pop/rock, hip-hop, a small variety of adult contemporary and country. Quirky niche formats are rare and found mostly in smaller markets not dominated by the supergroups that arose during consolidation.

We wrote here last time about a recent survey that found Americans to be satisfied with radio. We agree but we feel this is true despite, not because of, recent programming and ownership trends.

Standing ready to profit from our errors are XM and Sirius, the satellite radio players, which aim to fill Americans' need for program diversity through paid programming, much as cable TV segments programming to narrower niches than broadcast TV does. While there may not be enough true jazz-fusion fans in Peoria to support a jazz-fusion station, there are enough jazz-fusion lovers nationwide who may be willing to pony up for such a channel.

Whether the satellite companies can survive their debt burdens is unknown. But it's a shame that satellite's best selling point is that it is not FM radio. Too common is the poor opinion of our business reflected in the title of a recent Washington Post article: "Can XM Put Radio Back Together Again?"

Satellite, of course, is not local. The great thing about radio has been the impact we have on our neighbors, conveying local information and fomenting a sense of community. Satellite radio, while catering to special interests, does not provide that localism.

But let us in radio not give lip service to localism while we work behind the scenes to diminish it.

The FCC is considering easing controls on media ownership even further. Opinion differs on how successful those efforts might be; but it's a good time to take a serious look at the effects of deregulation on communities as a whole.

Large segments of the population get news and views from a few large corporations. Fewer creative people can find jobs in an industry that relies more than ever on automation, voicetracking and "group think." These trends literally result in fewer voices on the air.

We don't suggest that radio throw all of its research tools out the window and start letting jocks pick any songs they want. Nor do we blame the tools of automation and voicetracking themselves.

But maybe the pressure brought to the industry by the satellite guys will help us see the obvious: consolidation and an over-reliance on market research have indeed helped make radio less exciting and more homogenous in most markets.

— RW

## —EDITORIAL STAFF—

|                         |          |                                 |
|-------------------------|----------|---------------------------------|
| Paul J. McLane          | ext. 117 | Editor                          |
| Sharon Rae Pettigrew    | ext. 126 | Managing & Business Editor      |
| Leslie Stimson          | ext. 129 | News Editor/Wash. Bureau Chief  |
| Michele Kramer Peterson | ext. 149 | Studio Sessions Editor          |
| Michael Hedrick         | ext. 146 | Associate Editor                |
| Elizabeth Prevatt       | ext. 136 | Buyer's Guide Editor            |
| Thomas R. McGinley      | —        | Technical Adviser               |
| Alan Peterson           | —        | Technical Adviser               |
| John Bisset             | —        | Contributing Editor             |
| Skip Pizzi              | —        | Contributing Editor             |
| T. Carter Ross          | ext. 120 | Editor-in-Chief (International) |
| Marguerite Clark        | —        | Editor (International), Milan   |
| Rogelio Ocampo          | ext. 121 | Latin America Editor in Chief   |
| Karina Gerardi          | ext. 137 | Latin America Editor            |
| Terry Hanley            | ext. 130 | Editorial Assistant             |
| Peter Finch             | —        | Editorial Assistant, Milan      |

## —EDITORIAL CONTRIBUTORS—

W.C. Alexander, Bruce Bartlett, Frank Beacham, Naina N. Chernoff, Harry Cole, Troy Conner, Vince Ditingo, Mark Durenberger, Charles Fitch, Ty Ford, Scott Fybus, Harold Hallikainen, Jeff Johnson, Craig Johnston, Paul Kaminski, Peter King, Mel Lambert, Mark Lapidus, Michael LeClair, Carl Lindemann, Frank R. Montero, Ted Nahil, Tom Osenkowsky, Ken R., Rich Rarey, Randy Stine, Travis the VIO Guy, Barry Umansky, Tom Vernon.

# Radio World

Vol. 27, No. 4 February 12, 2003

Telephone: (703) 998-7600 • Business Fax: (703) 998-2966 • Editorial Fax: (703) 820-3245  
E-mail: radioworld@imaspub.com • Web site: www.rwonline.com

## —ADVERTISING SALES REPRESENTATIVES—

|   |                   |                       |                                  |
|---|-------------------|-----------------------|----------------------------------|
| US East: John Casey   | 330-342-8361      | Fax: 330-342-8362     | e-mail: jcasey@imaspub.com       |
| US West: Dale Tucker  | 916-721-3410      | Fax: 815-352-1698     | e-mail: dtucker@imaspub.com      |
| Product Showcase & Classified Ads: Simone Fewell              | 703-998-7600 x154 | Fax: 703-671-7409     | e-mail: sfewell@imaspub.com      |
| Germany, Austria, Switzerland: Charles Kingston               | +49-69-4908-5785  | Fax: +49-69-4908-5804 | e-mail: chaskingston@t-online.de |
| European Sales Mgr., Africa, Middle East: Raffaella Calabrese | +39-02-7030-0310  | Fax: +39-02-7030-0211 | e-mail: rcalabrese@imaspub.com   |
| Japan: Eiji Yoshikawa   | +81-3-3327-2688   | Fax: +81-3-3327-3010  | e-mail: callems@msn.com          |
| Asia/Pacific: Wengong Wang                                    | +86-755-5785161   | Fax: +86-755-5785160  | e-mail: wwg@imaschina.com        |
| Latin America: Alan Carter                                    | 703-998-7600 x111 | Fax: 703-671-7409     | e-mail: acarter@imaspub.com      |

## NEXT ISSUE OF RADIO WORLD MARCH 1, 2003

For address changes, send current and new address to RW a month in advance at P.O. Box 1214, Falls Church, VA 22041. Unsolicited manuscripts are welcomed for review: send to the attention of the appropriate editor.

## —ADMINISTRATION &amp; PRODUCTION—

|                      |                                    |
|----------------------|------------------------------------|
| Stevan B. Dana       | President/CEO                      |
| Carmel King          | VPI/Group Publisher                |
| Marlene Lane         | Editorial Director/COO             |
| Chuck Inderrieden    | CFO                                |
| Eric Trabb           | Sales & Marketing Director         |
| John Casey           | Associate Publisher                |
| Lisa McIntosh        | Production Director                |
| Annette Linn         | Production Department Manager      |
| Melissa SE Robertson | Production Publication Coordinator |
| Kathy Jackson        | Ad Traffic Manager                 |
| Sheryl Unangst       | Circulation Director               |
| Robert Green         | Circulation Manager                |

Radio World (ISSN: 0274-8541) is published bi-weekly by IMAS Publishing (USA), Inc., P.O. Box 1214, Falls Church, VA 22041. Phone: (703) 998-7600, Fax: (703) 998-2966. Periodicals postage rates are paid at Falls Church VA 22046 and additional mailing offices. POSTMASTER: Send address changes to Radio World, P.O. Box 1214, Falls Church, VA 22041. REPRINTS: Reprints of all articles in this issue are available. Call or write Joanne Munroe, P.O. Box 1214, Falls Church, VA 22041; (703) 998-7600; Fax: (703) 998-2966. Copyright 2003 by IMAS Publishing (USA), Inc. All rights reserved.



—Printed in the USA—



# D-8000

## Digital Radio Console

**ADVANCED TECHNOLOGY!** WHEATSTONE'S fourth generation digital console has what you need: dual-domain input modules that accept both analog and digital sources; built-in router integration with 8-character displays; a choice of features like auxiliary sends, equalization, dynamics control and event memory/recall—all without the aid of an external computer. The D-8000 is an all-modular design with no active components mounted inside. And best of all, it uses Wheatstone's exclusive VDIP® setup software, letting you easily configure individual console modules, logic modes and automatic functions. **Contact Wheatstone—the digital audio people!**



sales@wheatstone.com  
tel 252-638-7000

www.wheatstone.com  
copyright © 2002 by Wheatstone Corporation

# THINK INSIDE THE BOX



## ONE INTERCONNECT DOES IT ALL!

THAT'S RIGHT — ONE DUPLEX FIBEROPTIC LINK OR A SINGLE CAT-5 WIRE = 64 channels of simultaneous bi-directional digital audio, interstage communication, logic signals, X-Y controller commands, plus auxiliary RS-232 data streams. *This single interconnect between your studio and central rackroom can save you thousands — if not TENS of thousands — of feet of wire in a typical installation!*

THE WHEATSTONE BRIDGE DIGITAL AUDIO NETWORK ROUTER can start small with a single cage and only a few cards, or fully populated units can be stacked to form larger systems. Wheatstone's STAR TOPOLOGY ARCHITECTURE lets you connect multiple locations to your central rack room, providing shared resources for all yet still permitting independently functioning studios, each with its own combination of plug-in modules specifically suited for a select set of gear.

SIGNALS ARE ROUTED entirely in the digital domain. sample rate converters on each input, freeing you from sample rates throughout your facility. A family of plug-in makes installation easy, letting you mix varied signal standards all within the same cage. WHEATSTONE'S intuitive setup software handles system configuration, matrix selection sets. All systems interface directly with Wheatstone consoles source selection and display.

All AES cards have worry about varying connector modules technologies and graphic based and salvo pre-for seamless



**THE BRIDGE**

DIGITAL AUDIO  
NETWORK ROUTER

 **Wheatstone**

tel 252-638-7000 / sales@wheatstone.com / www.wheatstone.com

copyright © 2002 by Wheatstone Corporation (this technician not included)

World Radio History

