

\*\*\*\*\*3-DIGIT 857  
 J750737 D11 9007 S512 586  
 BARRY MISHKIND  
 2033 S AUGUSTA PL  
 TUCSON AZ 85718

# Radio World

Repairing Console  
 Power Supplies,  
 see page 23

Vol 17, No 12

Radio's Best Read Newspaper

June 23, 1993

## Compression Standard Not Easy to Implement

by John Gatski

**WASHINGTON** Some manufacturers and digital equipment users have called for a standard to deal with audio compression algorithm "stacking." But actually creating a standard, especially for broadcast equipment, may be difficult, according to members of broadcaster and standards-making groups.

Following the revealing listening test results demonstrated by Herb Squire, chief engineer, WQEW(AM)-WQXR-FM New York, at the National Association of Broadcasters convention (see RW, May 12 and May 26), the issue has become one of the most talked-about in the industry.

Squire's tests showed that running audio through different compression schemes can degrade audio significantly.

Digital audio compression is often used to conserve storage space and to allow reduced bandwidth for transmission. Some use a technique called "perceptual encoding," designed to reconstruct a data-reduced signal to approximate the uncompressed audio, but with fewer digital bits.

### Compression problems

If a station uses multiple digital products using one type of compression scheme, manufacturers claim audio stays relatively intact for a few passes. The more significant problems are created by combining different systems, such as, a workstation using one type of compression that eventually passes audio to another scheme on a digital STL or compression-based cart machine.

Recent discussion has centered on possible interface standards. The Audio Engineering Society (AES), the National Radio Systems Committee (NRSC), comprised of EIA and NAB members, and the international ISO/MPEG and CCIR standards groups have all begun or could

soon begin considering such standards.

CCIR recently completed listening tests of "tandem" passes through the same compression algorithms, but did not test the effects of multiple algorithms. The results are due this summer.

The AES also has subcommittees dealing with multiple compression codecs, but they are targeting performance of the codecs and methods to evaluate the technology.

### Stacking tests

Steve Lyman, a senior technician at the Canadian Broadcasting Corporation (CBC) and a member of CCIR's working group that deals with compression, said the CBC may conduct listening tests and evaluation of different compression encoders in a broadcast chain along with signal processing effects.

Some industry analysts believe a single standard for compression encoding (a standard for decoding the data stream already exists), that would allow interoperability of varying digital devices using compression, would be difficult to achieve since there are so many systems already out there.

Currently, systems now used include MUSICAM, apt-X, Dolby AC-2, Scientific Atlanta's SEDAT and others.

"That (single standard) is certainly desirable, but not very possible," said



Christian Steiner/Courtesy BSO

Broadcasting from Boston Symphony Hall for over 40 years, WGBH - FM recently expanded its space and equipment to include audio processing gear from Benchmark Media Systems. See story, page 41.

Charlie Morgan, NRSC co-chairman and vice president of engineering at Susquehanna Broadcasting."

Morgan said that NRSC could set a broadcast-only standard for compression devices, "but this (compression issue) goes beyond just broadcasting." Other industries, such as

continued on page 7 ▶

## DAR Testing Plans Set for Cleveland Site

by Randy Sukow

**WASHINGTON** The Electronic Industries Association (EIA) characterized its decision to delay the start-up of its digital audio radio (DAR) system testing until this October as "very practical."

According to EIA officials, the new testing schedule will give the association time to coordinate its tests with the National Radio Systems Committee's (NRSC) evaluation of in-band, on-channel (IBOC) systems.

The schedule also gives the EIA time to equip its test facility, the NASA Lewis Research Center in Cleveland, selected last month. (RW, June 9)

### NRSC involvement

Earlier this year, NRSC took over formulation of IBOC test procedures in response to complaints from the National Association of Broadcasters (co-sponsors of the NRSC with EIA) that the EIA test plans were weighted toward new-band systems. NAB and several broadcasters also said the process was being

## CCA Broadcast Transmitters

The Standard for Reliability Throughout the World.

**Available FM Transmitters:**

2.5 KW 20 KW  
 4 KW 25 KW  
 5 KW 27.5 KW  
 8 KW 35 KW  
 10 KW 45 KW  
 12 KW

CCA

CCA Electronics, Inc.

P.O. Box 426 • 360 Bohannon Road  
 Fairburn, Georgia USA 30213  
 (404) 964-3530 • FAX: (404) 964-2222

Studio Sessions

Equipment and Applications for Radio Production and Recording, begins on page 11

Circle (45) On Reader Service Card

World Radio History



# NEWSWATCH

## Cook Withdraws Name From FCC Chair List

**WASHINGTON** Antoinette (Toni) Cook, majority counsel to the Senate Communications Subcommittee surprised many by withdrawing her name from consideration for the FCC chairmanship. Cook, who was instrumental in the passage of the 1992 Cable Television Act, has been considered the leading candidate since early this year.

Cook said she was satisfied with

her current Senate position and that the recent birth of her first child also affected her decision.

Earlier this year questions were raised over Cook's involvement in a mid-1980's partnership that accepted a \$2-million settlement to withdraw its bid for the license of WGMS-FM Washington during the break-up of the RKO station group. However, the settlement did not violate FCC regulations at that time and is not believed to have had an impact on her decision or

the administration's long delay in nominating a chairman.

Among candidates now believed to be under consideration to head the commission, is David Leach, senior staff member of the House Energy and Commerce Committee.

## RDS Tops Schedule During Summer CES

**CHICAGO** Taking a lesson from last winter's Winter Consumer Electronics Show (CES) and the NAB convention in April, both in Las Vegas, Radio Data System (RDS) products were put in front of retailers at the summer CES earlier

this month.

Twelve stations went on the air with RBDS in Chicago to help promote the technology, which enables radio receivers to: receive text from stations transmitting RBDS (call letters and slogans), scan stations by format, and automatically switch from one translator or transmitter to another. The technology also can provide emergency alerts.

Stations involved in the demo included: WBEZ-FM, WGCI-FM, WLIT-FM, WLS-FM, WLUP-FM, WNUA-FM, WPNT-FM, WUSN-FM, WVAZ-FM, WXRT-FM, WTMX-FM and WWBZ-FM.

Nationwide, more than 50 stations are now on the air transmitting the 57 kHz RDS data stream.

Six manufacturers exhibited products at CES including Access USA, Delco, Denon America, Goldstar, Jensen, Sony and Coupon Radio, an innovative interactive use of RDS for stations and customers.

The Electronic Industries Association said manufacturers, such as Denon, are now starting to ship new RDS receivers to retailers. Some receivers are already available. RDS is considered a logical bridge from analog to digital transmission systems.

## Muzak Using CD-R To Store Music Catalogs

**SEATTLE** Muzak, a major provider of satellite-delivered business music, recently purchased five Yamaha YPDR601 CD recorders.

The network plans to transfer  
continued on next page ▶

# Only AUDIOARTS Has It...

**WHEATSTONE'S STRENGTH!** With Wheatstone's professional experience, engineering know-how, support capability and corporate stability behind it, this AUDIOARTS console design is the right choice.

The A-50 is cost effective through clever engineering and the latest advances in CAD design and electronic assembly procedures. It was developed by the same design team that creates Wheatstone's high end equipment. This console's performance is light years beyond the competition.

Naturally, it has all of the most important features: machine control functions, programmable channel logic, and three busses (Program, Audition, and Telephone). It also has the monitors you need: control room, studio and headphone—each with its own level control. It's designed so you can expand or add accessory modules as your needs grow.

You can benefit from our major market experience. Take advantage of Wheatstone's expertise and reputation; call us today for immediate action.



**AUDIOARTS ENGINEERING**

7305 Park Road, North Hollywood, CA 91605 • Tel: 818-708-4500 / Fax: 818-708-0160

Circle (111) On Reader Service Card

World Radio History

## Index

### FEATURES

#### Don't Let Power Supply Go Out in Blaze

by Andrew Ellis 23

#### Groups Translate to Public Service

by Howard L. Enstrom 24

#### Workbench

by John Bisset 25

#### EEO Report is a Year-Round Project

by Harry Cole 26

#### MJI Reaps Benefits from Leading Audio Architect

by Dee McVicker 28

#### A Few Boxes, a Moose Cure Moving-Day Blues

by Alan Peterson 29

#### Simplex Ready for Next Generation

by Tom Vernon 33

### STUDIO SESSIONS

#### KFI Edits "On-The-Fly" With Akai DD1000s

by Marv Collins 11

#### Removing Noise Using Roland SN-550

by Ty Ford 11

#### Prevent Ground Loop Hum in Audio System

by Bruce & Jenny Bartlett 13

#### Making MIDI Work Using a Sequencer

by Al Peterson 16

#### Transporting Commercials by Telephone

by Ken R. 18

#### Recording Gear For Journalists

by Frank Beacham 19

### BUYERS GUIDE

#### User Reports 36-44

Cutting Edge Technologies, Orban, Dolby, Excalibur Electronics, Sony Professional, Aphex, Broadcast Devices Inc., Benchmark Media, TitusTechnologies Labs and Burk Technologies

#### Technology Updates 46-48

Gentner Communications Corp., UREI, Radio Design Labs, Klark Teknik's, JNS, Yamaha, Audio/Digital, Eventide, FM Systems Inc., Sescom, Audio Technologies Inc. and Modulation Sciences



## NEWSWATCH

► continued from page 3

its extensive tape and other media library to CD. The Music Environmental Music Library, a 5,000 active title blend of contemporary and mainstream styles, will be transferred first—from hard disk to CD, according to Muzak.

### Spectrum Bill Clears Senate Committee

**WASHINGTON** The Senate Commerce Committee reported the Emerging Telecommunications Technologies Act (S. 335) late last month and sent it ahead for a full Senate vote. Along with a transfer of 200 MHz of spectrum from government allocation to the private sector, the bill authorizes a limited, trial auction of 30 MHz for new technologies.

The auction bill, sponsored by Communications Subcommittee Chairman Daniel Inouye (D-Hawaii) and subcommittee member Ted Stevens (R-Alaska), exempts a number of license applicants from the auction process, including broadcasters and public safety licensees. The plan conflicts with a Clinton Administration auction proposal that would open all new spectrum allocations to auctions and would not exempt broadcasters.

S. 335 also differs from a spectrum plan approved by the House Energy and Commerce Committee. The House plan, introduced by Telecommunications Subcommittee Chairman Edward Markey (D-Mass.), limits auctions to frequencies earmarked for pay-per-use services, such as cellular telephone or personal communications services. At press time, the full House had not yet acted on the Markey bill, but was expected to pass it on the suspension calendar.

# Cable Audio Firms Battle in Europe

by Frank Beacham

**NEW YORK** Digital Cable Radio (DCR), flush with an estimated \$20 million investment from new partners Sony and Time Warner, is now challenging its American competitor, Digital Music Express (DMX), for the premium audio market in Europe.

The digital music service, based in Hatboro, Pa., began satellite delivery on Intelsat K of 50 digital audio channels to Europe in late April and was scheduled to begin sales of the service in the United Kingdom, Scandinavia and the Netherlands.

DMX began its satellite feed of 30 channels in early March and is currently selling the service in Denmark. The company plans to launch in the U.K., Norway and the Netherlands before summer, Belgium during the summer and in Sweden and Ireland in the early fall.

Both services deliver multiple channels of commercial-free CD-quality music programming 24 hours a day to subscriber homes and businesses. Subscribers decode the signal with a remote-controlled digital audio tuner connected to the listener's sound system.

### The fast track

DCR's European expansion plans are now on the fast track after the recent announcement that Time Warner Cable, the nation's second largest cable television operator, and a joint venture of Sony Software Corp. and Warner Music Group, have joined the DCR partnership.

The new partners join General Instrument Corp.'s Jerrold Communications Division and a group of the largest cable operators in the United States, including Adelphia Cable Communications, Comcast Cable Communications, Continental Cablevision, Cox Cable Communications and Time Mirror Cable Television.

According to DCR, the partners agreed to contribute additional capital to fund the company's expansion, enabling an increase in program offerings and world-

wide distribution. DCR now is available on many cable systems in the U.S. and Mexico and is seeking regulatory approval to operate in Canada. The company also plans to launch in Latin America this summer and in the Far East next year.

DMX, based in Los Angeles, launched its service earlier this year in Australia. It also is backed by a group of top cable-industry players. DMX's parent company, International Cablecasting Technologies, is in partnership with Telecommunications Inc. (TCI), the largest U.S. cable operator; Scientific-Atlanta; Viacom; KBLCOM; Scripps-Howard; Colony Communications; Crown Media Inc., and Shaw Cablesystems of Canada.

Officials of both services said they will deliver audio programming in Europe by cable, microwave and DBS.

DMX has announced a deal with BSkyB (British Sky Broadcasting) and News Datacom to distribute DMX via direct-to-home satellite in the U.K. and Ireland this year. The service will be offered to BSkyB's 2.8 million homes as a premium option. The DMX tuner/decoder and remote control device will be available through BSkyB's extensive dealer network, made up of nearly 10,000 consumer electronics and satellite equipment dealers.

Of DMX's 30 channels, 21 are from the service's American programming pack-

age. The channels specific to European customers are Dutch, French, Italian, German, Latin Contemporary, European Hottest Hits, U.K. Hits, World Beat and Urban Adult Contemporary R&B. Local DMX operators can add and delete programming in their local communities to further customize the service.

### Target programming

DCR planned to launch with its American feed but gradually switched over to 70 channels of all European programming. "Each major market will have five to 10 channels geared specifically to that market," according to Dave Del Beccaro, president of DCR.

The DCR executive wasted no time in criticizing his competitor, DMX, for its European programming line-up. "We think their programming concept is a non-concept," Del Beccaro charged. "If you can imagine being Dutch and looking at a service that's going to have one channel in your language and being asked to pay \$10 to \$20 a month for it, I think you can imagine what your response is going to be," he said.

According to DMX Managing Director Richard Cohen, up to now DCR has had no presence in Europe. Cohen said he was surprised at the lackluster challenge from such big-name competitors as DCR.

## The MOUSE That Roars . . .

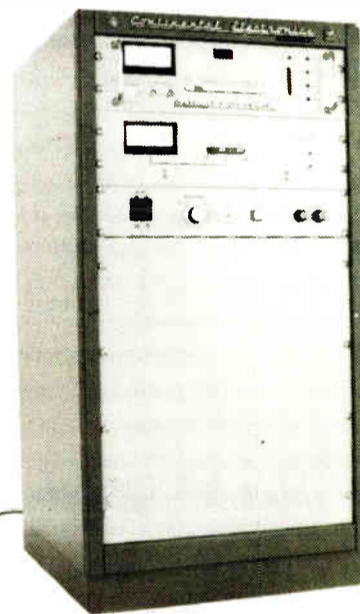

ONLY  
3½ FEET  
TALL

We all know that great things come in small packages. This 1 kilowatt FM transmitter comes complete in a 42" cabinet. Solid-state efficiency with a single phase power source and the ultimate 802A exciter.

FOR MORE INFORMATION, CONTACT



Continental Electronics Corporation

P.O. BOX 270879 DALLAS, TEXAS 75227-0879  
214-381-7161 TELEX: 73-398 FAX: 214-381-4949

## Emph'asize it!



WITH THE

### Emph'asizer™ AUDIO PROCESSOR

- DJ Personality Processor
- Phone Line EQ and Noise Suppressor
- Production Tape Processor
- Room Equalizer and Gated Mike Control
- Gated Recovery Compressor
- Unobtrusive Background Noise Gate
- Four Parametric Equalizers
- Mike and Line Level Inputs and Outputs

Free Detailed Brochure Available



AUDIO TECHNOLOGIES INCORPORATED  
328 Maple Avenue, Horsham, PA 19044 • (215) 443-0330

1-800-959-0307

Fax (215)443-0394

Circle (185) On Reader Service Card

Circle (38) On Reader Service Card



# Pack Your Toothbrush and Computer

It seems that if you don't have a computer these days, you're just out of the loop. Almost every new radio product, no matter how simple or complex, is contained, developed or available on floppy disk.

What is also interesting is that many



products travel between customer and supplier over the phone line, from hard drive to hard drive. Check out the *Studio Sessions* pages—radio commercials can be delivered from the production studio to the on-air studio without anyone having to travel a mile.

Another case in point is the new venture initiated by radio programming consultant, Vallie Consulting, Chantilly, Va., and the well-known Gallup Organization (of the Gallup Poll). The two companies are endeavoring to bring "advanced technology" radio research.

Vallie/Gallup is offering customized ActionPlan Services, allowing a station to select any or all of a wide variety (more than 25) of services, including: download of research data straight to your computer, perception studies with cluster analysis standards, color-coded music/auditorium tests, initial setup of computerized music scheduling, GAP analysis, specially designed plans for duopoly situations, weekly promotion faxes, Vallie's monthly "Radio Focus" newsletter and ongoing consumer lifestyle reports.

★★★

I recently got a letter from Al Hastbacka over at Chatham Research in Oakton, Va., who is introducing a shareware program called FM Gold. It might be of interest to some of RW's more

travel-weary readers.

Al says the FM Gold program that acts like a "smart radio." It allows you to easily find an FM station broadcasting the format you want to hear anywhere in this fine North American continent.

The procedure: 1. Successfully land at one of our fine North American airports. 2. Use your FM Gold-enriched laptop to call up a list stations receivable from that spot.

Hastbacka is making the program available in three versions ranging from \$10 to \$50. The lowest-cost shareware ver-

I know that there have been program guides for radio stations around for years, but maybe this is the kind of product that could help raise awareness.

★★★

Julius Cohen, 79, retired president of Cohen, Dippell and Everist, the Washington-based engineering consulting firm, died of cancer on May 2 at his home in Silver Spring, Md.

Cohen was a past president of the Association of Federal Communications Consulting Engineers and a lifetime

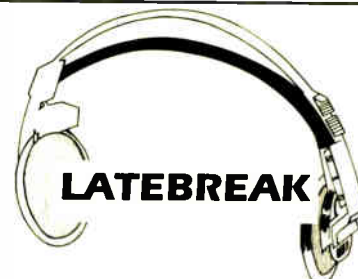

Denon America named Ryusei Takahashi chairman of the board and chief executive officer of its American operation, and elevated Stephen Baker, formerly director of sales, to vice president of sales and marketing. Both will be based in the company's Parsippany, N.J., headquarters.

Takahashi will retain his role as chairman of Denon France, the United Kingdom and Germany. He has worked for Denon's parent company, Nippon Columbia, for more than 30 years, including stints as the general manager of the company's international trade division and director and acting general manager of Nippon Columbia's overseas operations.

Arrakis Systems Inc. has hired Dave Burns and his firm, Radio Networks, to assist the factory with the support of sales, marketing and media for its radio broadcast products and its Digilink product line.

Burns has many years of experience as the sales manager and marketing manager for Harris Allied. He left Harris Allied recently to form Radio Networks.

John Waugaman was named executive vice president of Group W Radio, a newly created, group-wide position. Waugaman will oversee the company's sales force and its relationship with the rep firm, Group W Radio Sales, supervising all development, training and recruitment efforts. He also will be responsible for ensuring that each of the company stations hits its revenue share targets and supervision of the company's annual Super Bowl promotion.

NPR FM Stations Received at BOSTON, MA (c) CR						
Freq.	Call	Format	City	State	Signal	Range
88.1	WMBR	Variety	Cambridge	MA	nnnnnn8	26 W / 16 E
88.9	WERS	Variety	Boston	MA	nnnnnn9	44 W / 38 E
89.7	WGBH	NPR	Boston	MA	nnnnnn9	97 SW / 72 NE
90.1	WMEA	NPR	Portland	ME	n 2	221 NE / 11 SW
90.3	WZBC	Rock	Newton	MA	nnnnn6	30 W / 9 E
90.9	WBUR	NPR	Boston	MA	nnnnnn8	72 W / 45 E
91.5	WMFO	Jazz	Medford	MA	nnn 4	17 NW / 2 SE
91.9	WUMBFM	Variety	Boston	MA	nnnnnn7	25 SW / 10 NE
92.3	WPROFM	Hits	Providence	RI	nnn 4	113 SW / 16 NE
92.5	WLYT	Soft Pop	Haverhill	MA	nnnnnn7	95 N / 37 S
92.9	WBOS	Rock	Brookline	MA	nnnnnn8	78 W / 51 E
93.3	WSNE	Popular	Taunton	MA	nnnn 5	103 SW / 26 NE
93.7	WCGYFM	Rock	Lawrence	MA	nnnnnn8	77N / 45 S
94.1	WHJY	Rock	Providence	RI	nnn 4	105 SW / 19 NE
94.5	WZOU	Hits	Boston	MA	nnnnnn8	80 W / 52 E
95.3	WHRB	Variety	Cambridge	MA	nnnnnn7	25 W / 11 E
96.9	WCDJ	E-Z Listen	Boston	MA	nnnnnn8	80 W / 52 E
97.3	WJFDFM	Variety	New Bedford	MA	nn 3	115 S / 14 N
97.7	WCAV	Country	Brockton	MA	nn 3	49 SW / 5 NE

Press any key to view additional stations . . .

A sample screen of FM Gold database

sions provide all the information for the 31 most-traveled airports. For the few extra bucks you get a full database of lists for 400 airports.

A typical FM Gold screen looks something like the chart on this page which is a sample of stations near Logan Airport, Boston.

As you can see, the display fields are self-explanatory (frequency, calls, format). I found the "signal" category most significant. It tells you the signal strength of the station at the airport. The levels can vary from two to nine, with nine being the best signal rating.

member of the Institute of Electrical and Electronics Engineers. He retired in 1992 after more than 50 years in the business.

Over the years, the firm's clients included CBS, NBC, Post-Newsweek Stations, Cox Broadcasting and Taft Broadcasting.

Cohen was a graduate of George Washington University in Washington in the 1930's and served in the U.S. Army Signal Corps during World War II, first in the Pacific and later at the Massachusetts Institute of Technology, where he participated in the development of radar.



Unattended operation helps you operate your station profitably. All it takes is a satellite or automation program source, a good transmitter control system, and a way to handle EBS.

You take care of the program source... We'll help with the rest.

A transmitter control system from Burk Technology relieves you of the need to keep someone at the station just to take transmitter readings. Add our exclusive Studio I/O and we'll run EBS for you, too.

Burk gives you the flexibility to run your station the way you want, and in full compliance with FCC rules.

Call us now. We'll show you a new way to run a railroad.

TOLL FREE 1-800 255-8090

**BURK**  
TECHNOLOGY

7 Lomar Drive, Pepperell, MA, 01463 (508) 433-8877



## READERS FORUM

If you have comments for Radio World, call us at 800-336-3045 or send a letter to Readers Forum (Radio World, Box 1214, Falls Church, VA 22041 or MCI Mailbox #302-7776). All letters received become the property of Radio World, to be used at our discretion and as space permits.

### What's the rule?

Dear RW,

I appreciated Sam Scott mentioning our first-ever experiment with stereo split broadcast of sports (RW, April 28).

But it seems that the Sullivan, Mo., station made it more complex than necessary. I am just glad it worked for them.

Ours was a simple switch in the middle of one side of the FM stereo to reroute that channel into our production room. We now have fixed it so it is even more simple and use it with complete confidence.

Incidentally, after "Small Market Radio Newsletter" published our story, that publication received a letter from a station in Illinois that said (the split) was illegal.

I wrote back with information from the FCC. They said requirements of maximum and minimum power, and frequency stability were still in place but they have never been asked to rule on what we put on the left or right channel. The district FCC office in Dallas said that may be because no one has ever done it before. As long as they don't get a lot of complaints from citizens they could not imagine ever concerning themselves with it.

Bill Buchanan  
KSHN-FM Liberty, Tex.

Dear RW,

In the April 28 issue of RW there was an article concerning stereo division for the carriage of two separate broadcasts. I find this of particular interest since the FCC denied us permission do just that in December 1986. Have the rules changed, or is KTUI-FM yet to feel the FCC heat?

Few FM radios in today's marketplace are mono-only. However, I have seen nothing indicating the FCC has changed its rules.

C. Curtis Sigmon  
General Manager and Chief Engineer,  
WBZK(AM) York, S.C./WDZK(FM)  
Chester, S.C.

*Editor's note: Bill Hassinger, assistant chief, engineering in the FCC's Mass Media Bureau, said the FM stereo split is "innovative," but that KTUI-FM or any other station "would be well-advised to write the commission and get an opinion in writing" before doing it again.*

*After reading the April 28 article, Hassinger was not prepared to say definitively whether the split is acceptable under the commission's rules. His "initial reading" was that the split might violate Rule 73.310(b), which defines "stereophonic sound" (authorized for FM broadcasting by Rule 73.297) as "a plurality of channels in a range to afford the listener a sense of the spacial distribution of sound sources."*

*Because the KTUI-FM transmission did not provide "spacial distribution," it probably cannot be considered stereo. At the same time, the split would not be considered monophonic transmission either.*

### Mistaken identity

Dear RW,

There is no doubt in my mind that the May 26 issue of RW is the most complete and timely NAB review ever done by any magazine to date. I particularly enjoyed reading the well thought out letter concerning tower safety and gave brief but serious consideration to responding to the section on same-station cancellation (using two flashlights, for example), until I saw that my name was signed to the letter.

I'd be proud to have written that letter, but, unfortunately, I did not write it. Please give the credit to the outstanding author who penned it.

Frederick M. Baumgartner,  
TFT,  
Santa Clara, Calif.

*RW responds: Our deep and sincere apologies go to Fred Baumgartner and the actual author of the May 26 letter, James L. Sorensen, tower manager and chief engineer, TAK Broadcasting Corp., who works out of TAK's WJQY(FM) Fort Lauderdale, Fla. The editors are at a loss to know exactly how they accomplished this particular gaffe in that Mr. Sorensen's name appears clearly on the original letter. Fortunately, it appears to be unanimous that Mr. Sorensen provided RW with an excellent, thought-provoking piece.*

### Corrections:

"STL and EBS Gear Follow FCC Timetables," in RW's May 26 NAB equipment wrap-up cited an incorrect list price for Burk Technology's ES1 interface option to its ACR-16 remote control system. The list price is \$895; the exchange price is \$350.

The May 12 "NAB '93 New Product Sampler" gave the wrong phone number of more information on the Telos Zepher Digital Network Audio Transceiver. Those interested should call Nancy Gidish at 216-241-7225.

## Seven-Day Warning

As of May 29—the approximate midpoint in the FCC's two-month filing window for AM broadcasters willing to migrate to the expanded band—295 stations had responded.

That number appears to be in line with the projected total of 500 applications, based on response to an earlier FCC inquiry.

Any AM owner still wrestling with the question of whether moving to an assignment between 1605 kHz and 1705 kHz is in the station's long-term interest has some time to decide—but not much time.

June 30 (exactly one week after the publication date of this issue) is the day the window closes.

The National Association of Broadcasters and other organizations worked long and hard to convince the FCC that the public interest would be served by taking stations in the overcrowded, established AM band and moving them to the new band (with a reasonable period of simulcasting on both frequencies to give consumers ample time to buy radios receiving 1705 kHz).

RW does not dispute this premise. The interference relief provided by expanded-band migration will be minimal, some critics have complained. But taken with the FCC's 1990 approval of the National Radio Systems Committee's "RF mask" standard and other measures designed to reduce AM interference, the migration could be significant in several markets.

(It is also encouraging that new technical rules will be in place from the beginning on the expanded band and that many of those stations are likely to be broadcasting in stereo.)

But RW's editorial office still receives occasional anecdotes of station owners unaware of the commission's filing window or even that the AM band is expanding. In those few cases, it would be advisable to seek a communications lawyer or engineering consultant and explore the possibilities while there is still time.

No one should assume a similar filing window will open again. The commission will decide where to relocate TIS (Travelers Information Services) stations—perhaps within the expanded band—after the filing window. Minority and public-broadcasting interests are waiting in line for expanded-band assignment preferences.

There will be plenty of takers for expanded-band slots that existing broadcasters do not apply for today. —RW

### Curious about C-QUAM support

Dear RW,

I would suggest that the headline "Groups Support C-QUAM" (RW, May 12) perhaps overstates the situation slightly. The thing that I observe (and I will admit that I am not without prejudice) is that the equipment manufacturers support C-QUAM but the poor devils that have to buy, install, operate, and live with the thing do not want a quadrature system, especially a wide bandwidth one.

I believe that RW would do the industry a service by surveying its readers to see why people choose the system they did and how made the decision. Are they still operating the system and are they satisfied with it? I am ready to learn from the answers.

Lee S. Parr  
Monroe, Va.

### U.S. behind royalty times

Dear RW,

I am an international music copyright consultant, replying to your article, "Performance Royalties Addressed" (RW, April 28). I would like to mention that the U.S. is a member of the Universal Copyright Convention (1952) and revised (1971), the Berne Convention for protection of literary and artistic works (1971) and as amended in 1979, and the Berne Implementation Act of 1988, the Geneva (Phonogrammes) Convention (1971) and the Bruxelles (Satellites Convention, 1974).

Oddly enough, the U.S. is not a member of the Rome (neighboring rights) Convention (1961)—protection for performers, producers of phonogrammes and broadcast organizations.

Secondly, as stated in the European Community's "Green Paper," (1988, 1990 and just updated in December 1992), and the International Federation

of Phonogram and Videogram Producers Incorporated (IFPI) Reports, there are many European nations that already have a royalty tax on blank audio/video tapes plus a royalty tax on analog audio cassette recorders.

Thirdly, in my opinion, if DAB becomes a reality in the U.S. the Registrar of Copyrights should and shall mandate a royalty tax on DAB receivers, administered by BMI.

Germany will probably have this mandated soon. The U.S.A. is behind the times.

David S. Pulwers  
Alexandria, Va.

I sure wish I could get paid for advertising my product. My overhead would be much lower and I could get the jump on my competitors. Perhaps I could force the government to impose strict rules on magazines, newspapers and broadcasters (including cable systems) to pay me what I think my ads are worth.

The complaints brought forth in "Performance Royalties Addressed" in the April 28 RW remind me of this mentality.

Mike Seaver  
Quincy, Ill.

### solution to June 9 puzzle

R	T		P	M	T	E	S	T	S				
S	H	A	M		P	R	Y	O	M	C	S		
	A	R	C		R	E	A	C	T	I	O	N	
A	L	P	I	N	E		T	O		P	O	P	
I	L		E	S	E		M	O	D	E	M		
D	I	V	A		S		P	A	T		S	A	X
	K	U		I	P	A	R	A	S		D	X	
	A	U	D	I	O	M	E	T	R	I	C	S	
H	I		I	W		C	I	N		S			
	N		O	D	E		I	S	K	I	M	P	
	E	S	P		R		S	P		T	A	U	
O	N		A	B		D	I	G	I	S	T	O	R
U		K		L	E	O		F	O				
I	B	I	S		O	W	N	E	R	S	H	I	P

**Radio World**  
Vol. 17, No 12 June 23, 1993

Editor .....Lucia Cobo  
Managing Editor .....Randy Sukow  
News/Studio Sessions Editor .....John Gatski  
Assistant Editor .....Mary Ann Dorsie  
Contributors .....Frank Beacham/N.Y.

Bruce Ingram, Pamela Watkins, Nancy Reist  
Technical Editor .....John Bisset  
Technical Advisor .....Tom McGinley  
Editor (International) .....Alan Carter  
Managing Editor (International) .....Charles Taylor

Radio World (ISSN 0274-8541) is published semi-monthly by Industrial Marketing Advisory Services, Inc., 5827 Columbia Pike, Suite 310, Falls Church, VA 22041. Phone: 703-998-7600, Fax: 703-998-2966. Second-class postage rates are paid at Falls Church VA 22046 and additional mailing offices. POSTMASTER: Send 3579 forms and address changes to Radio World, P.O. Box 1214, Falls Church VA 22041. Copyright 1993 by Industrial Marketing Advisory Services, Inc. All rights reserved.

—PRINTED IN THE USA—

**Next Issue of  
Radio World  
July 14, 1993**



# The Heavyweight Player At A Lightweight Price.

The Audio-Metrics CD 10 Compact Disc Cartridge Machine is *the* heavyweight player. But, the price ain't heavy. Just \$1,049— for a limited time.

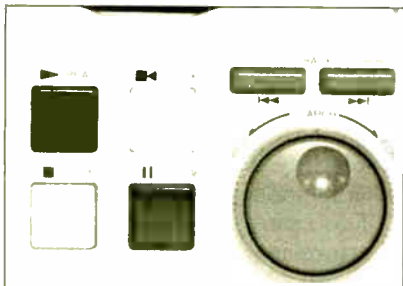

The CD 10 features cartridge autolock, programmable EOM indicator, instant start with music, and true broadcast standard construction. It's the only cartridge tape player with a STOP function to reduce maintenance.

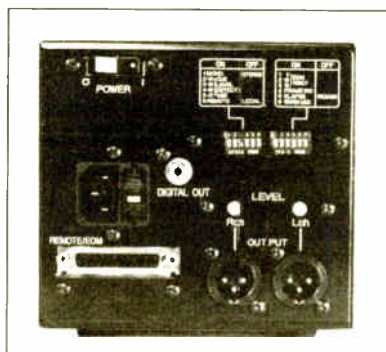

Designed and built for easy configuration and remote interface, it accepts open collector or dry contact control. Dubbing to DAT in the digital domain is as easy as running a cable with appropriate connectors from the CD 10 to the DAT machine. An optional rack mount lets you install three units side-by-side.

Vertically slotted plug-in cards permit easy access and service. Superior phase characteristics were achieved by using eight times over-sampling and an FDNR

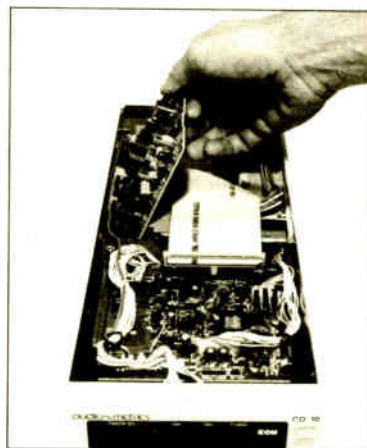

analog filter. For convenience and better control, the in-built remote port supplies a 'ready'

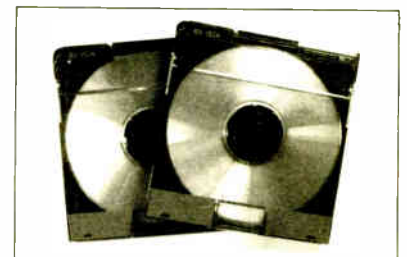

signal when a disc cartridge is inserted.

You'll find the CD 10 a friendly, likeable programming tool that will encourage you to take compact discs direct-to-air.

Order soon and get the lightweight price.

8:00 a.m. to 8:00 p.m. EST  
1-800-622-0022  
Fax 317-966-0623

**HARRIS  
ALLIED**



## Not Easy to Standardize Compression

► continued from page 1  
recording and production, are involved, he said.

The CBC's Lyman said any future action from the CCIR on data compression would be in the form of "guidelines and recommendations" for broadcasters to follow, not a standard recommendation for manufacturers.

"It would (likely) be a recommendation of the type of codec to use and the appropriate bit rates," Lyman said. A rigid standard might not allow manufacturers to make improvements to their compression technologies, he said.

Ken Springer, an NAB engineer who focuses on digital technology issues, agreed that a single standard would be difficult to mandate, calling the current compression technology market very "fluid." The market already has a number of compression technologies in use, and the companies are not likely to abandon them, he said.

"I think it's very unlikely that a standard is going to be put in place for broadcast equipment," Springer said. But, he said, a de facto standard may emerge once a U.S. DAB system is chosen.

Most of the proposed DAB systems use a form of compression. But choosing a U.S. DAB standard is at least a year away. "I think DAB has cast a shadow over this particular issue," Springer said.

### DAB's effect

One of the leading candidates for U.S. implementation as a DAB standard is USA Digital's in-band, on-channel AM/FM systems, which uses MUSICAM compression.

Springer said a more realistic solution would be to educate broadcasters on when to use compression-based equipment and when not to use it.

Barring a universally accepted standard, "that's an excellent suggestion," Morgan said.

However, Morgan said that until broadcasters know more about how to deal with multiple compression schemes to minimize audio degradation, or until a consensus is reached on a standard, "I see a wisdom in a radio station not using any compression."

A standard is unnecessary, said Robert Finger of Panasonic, a member of the AES Digital Audio Subcommittee. "What we have here is a fact of life, if you don't take precautions," Finger said, referring to Squire's NAB presentation.

He said there are variety of incompatibilities that can occur in a radio station or recording studio that have to be addressed daily. "That's what an engineer is for."

As for engineers who may decide to avoid compression-based equipment in the studio, Finger asked: "Is that a reasonable position?...How are you going to avoid it?"

## Europeans Tackle Pro Audio Standards

**LONDON** European manufacturers and standards organizations are grappling with the issue of mixing different digital compression schemes.

The groups are exploring ways to minimize audio degradation when using compression schemes in the audio chain, and make various types of digital equipment work well with each other.

### Understanding codecs

Company consortiums supporting a given coding system say they advise minimizing the number of different codecs a signal must pass from source to transmitter.

Mixing different digital compression codecs through the chain can introduce serious distortions. Developers are looking at how their systems work with signals that already have been processed with a competitor's codecs.

This problem of "dueling algorithms" was put under the spotlight during the recent National Association of Broadcasters convention in April when radio engineer Herb Squire released the results of tests based on several manufacturers' products. (See RW, May 26 and June 9).

Absent a definitive compression world standard, some industry analysts speculate that less "powerful" systems, or those like APT's apt-X that do not use "psycho-acoustic"-based codecs, may be recommended because they are considered more "transparent."

During the NAB convention, APT announced establishment of an apt-X user group that will let OEMs (original equipment manufacturers) discuss how various elements in the broadcast chain can be brought together with a minimum of A/D, D/A conversions.

"Our user group consists of the whole broadcast chain: the cart machine, the hard-disk storage systems, STLs, satellite, etc.," APT's Steve Cheung said. "We want to explore the whole possibility on how you can go through the complete broadcast chain without repeatedly going to and from analog."

Cheung said that the compression element also has been a key issue. "This is also something we have been able to discuss in the user group," Cheung said. "Manufacturers are sharing information about the way their systems work through different algorithms. (But) in our discussions, we have had no reports of these problems occurring (with apt-X)."

In an ideal world, the establishment of a single industry-wide standard for data reduction stands would be an attractive solution. European DAB may end up standardizing MUSICAM, but Cheung believes the market will adopt different systems to meet specific needs rather than to fit in with one standard.

### Evaluating needs

"For distribution, contribution, hard disk storage and point-to-point links, apt-X has its position for its robustness and quality," he said. "Professional people want to use the most appropriate or the best system they can find; they seldom listen to standards claims."

In Europe, Digigram of France and the CAR (Computer Aided Radio) group of Germany published their standard audio file format proposal, "MusiFile," which would standardize a file structure encoded according to ISO/MPEG 11172. This measure allows equipment from different

manufacturers to create, process and playback audio files without degradation, the companies said.

### File data

The new development is said to allow a straightforward exchange between the widely used Digigram PCX cards and the BEDAS system from Barco-EMT, which is a member of the CAR group along with David, GTC and Management Data.

Currently, ISO/MPEG only defines the data bitstream, but not the arrangement within a file. This can be achieved by defining the arrangements of all bits and embedding them between a file header and a file trailer.

Within the header, numbers are reserved for the definition of a file type, which assigns a specific company product and version. These numbers identify the file exactly by other equipment. Both file header and trailer contain additional data, such as extended file name and reproduction mode, which are not necessarily required for the reproduction of the audio.

This ensures that the audio part of a file may be reproduced by a target system, even if the actual header type is not yet known to the system or does not yet exist.

All the details of the file header are not yet defined in this first step. That task will be completed in accordance with broadcasting corporations.

## THE RUGGEDNESS OF OUR CD PLAYERS ISN'T A RETROFIT.

From the get-go, we designed our Industrial Strength CD players to stand up to the kind of heavy-duty use that typical consumer CD players can't handle.

That's why every TASCAM CD player is rack-mountable. And why both the CD-301 and CD-401 feature balanced XLR and unbalanced RCA outputs for added flexibility.

The economy-minded CD-301 (\$549\* including hardwired remote) offers the high reliability required for heavy-use applications, plus precision playback capability. The CD-301 also features a single-play function to automatically stop playback at the end of a song, allowing DJs to concentrate on voice-overs or to make a clean start for the next track. And a link function to permit hookup of multiple CD-301s for automatic back-and-forth sequential play.

The high-performance CD-401 (\$849\*) incorporates TASCAM's award-winning ZD circuit to eliminate low level distortion and ensure sound quality that meets the most demanding standards. The CD-401's fader-start feature allows play to start automatically on fade-in and stop at the completion of a fade-out. The CD-401 is available with optional hardwired or wireless remote.

For more information, call or write TASCAM, the company whose Industrial Strength product line also includes cassette decks and mixers.

## TASCAM.



©1992 TEAC America, Inc., 7733 Telegraph Road, Montebello, CA 90640. 213/726-0303. \*Suggested retail price.

Circle (200) On Reader Service Card



# World Evaluates German DAB Decision

by John Gatski

**WASHINGTON** The fallout from the decision by the German public radio authority, ARD, to delay consideration of the Eureka-147 DAB system from 1995 to 1997, is still being evaluated.

In the U.S., the National Association of Broadcasters said, it is too early to tell what type of impact the delay of Eureka service in Germany will have on the rest of the world. But the impact probably will be minimal, said NAB Executive Vice President John Abel: "My impression is that there is more being read into this than there should be."

Other countries supporting Eureka said they want to keep development moving toward a 1995 implementation. The U.K., Canada, France and Sweden all appear to be moving forward with their Eureka-147 development plans.

Mexico, however, seems to be re-evaluating its previously planned use of Eureka, according to sources.

## Looking at in-band

In-band proponents, favored by U.S. broadcasters, may have a potential opening for their systems in Europe as a result of the ARD's decision to delay. In-band, if it works, addresses the parity

issue between AM and FM stations and would answer the spectrum availability question in Europe.

Dieter Hoff of ARD said the organization is not opposed to looking at the in-band systems. They have the added advantage, he said, of no political arguments over new frequencies.

If it is proven that the U.S. in-band systems can deliver quality equal to that of Eureka-147 in the more crowded European context, then it might be an option. Hoff, however, does not believe in-band development has progressed that far.

Egon Meier-Engelen of the German Aerospace Research Establishment, a key developer of Eureka-147, said that "for whatever reason," an in-band DAB demonstration of USA Digital Radio at the NAB show in Las Vegas, did not work properly, and that Eureka-147 is the only system which meets all the demands put on it.

Developers of USA Digital Radio have said its in-band FM system at NAB was damaged by a power surge that destroyed chips.

USA Digital's Paul Donahue said Germany's delay of Eureka is significant to the state of worldwide DAB plans, and that numerous European communications officials visited the USA Digital in-band demonstration booth at NAB 1993.

ARD's delay will have an effect on Germany's commercial stations. Without the clout of ARD behind Eureka 147, the small (and young) German commercial stations have no resources to continue the research, officials said. The stations do not have the money or the research facilities to lead the way.

## Commercial stations

The ARD is the most powerful force in German radio, and if the organization says it is not ready to implement DAB, there are no other organizations strong enough to introduce the service, officials said.

ARD delayed a decision on Eureka for economic and spectrum-availability reasons.

Money is not available for the development of a new network and the parallel analog broadcasting that will be necessary, until DAB has a permanent frequency on the radio dial. The ARD estimated the cost of conversion to the Eureka 147 system at 500 million Deutsche marks.

A second reason is that ARD wants to be sure that all its programs—four or five in each radio authority area plus some local stations—will be available on DAB. Questions exist on spectrum availability in all of the ARD coverage area.

Because of manufacturers' vested interest in Eureka-147, ARD will likely come under pressure to change its decision.

□□□

Alan Carter and Michael Lawton of RWI also contributed to this report.

## EIA Sets DAR Test Schedule

► continued from page 1  
receiver-manufacturer interests.

The EIA tests have been postponed twice, in part because of the IBOC controversy. EIA originally intended to begin the trials on April 1 and later delayed start-up until July 1. With a site now selected and IBOC test plans approaching completion, the current scheduled appears to be more realistic.

Under the new plan, EIA will direct the testing of in-band and new-band systems at NASA's Lewis Research Center in Cleveland this fall. (At press time a lease with NASA had not been signed, but an agreement was anticipated by mid-June.)

Testing of IBOC systems will follow test criteria mapped out by NRSC, which are expected to be completed in August. EIA has already approved procedures for new-band systems.

## Test schedule set

The tests are projected to last approximately nine months, after which NRSC and EIA are expected to release separate reports and recommendations—NRSC's report dealing with IBOC systems only and EIA's on all other systems.

Some signal propagation tests of digital transmissions began earlier this spring in Charlotte, N.C.

"We'll try to keep everything as unified (among NRSC and EIA) as possible in the actual conducting of the tests so we can save a lot of expense and trouble," said Ken Springer, NAB staff engineer for digital communications.

The final price tag for the entire testing project is estimated at \$500,000. Systems proponents are being asked to pick up half the cost and the rest is to be paid by NAB, EIA and various equipment manufacturers and other parties with an interest in digital radio development.

Use of the Cleveland facilities will likely be treated as an in-kind contribution toward NASA's share of the costs. NASA/Voice of America are among the participating system developers.

## New equipment

About \$280,000 of the test budget is earmarked for new-equipment purchases, most of which is to be spent on test and simulation equipment. The majority of the equipment used in the tests, however, is expected to be loaned to EIA by interested companies.

Like the Advanced Television Test Center (ATTC), the Alexandria, Va., lab now testing proposed digital high definition television transmission systems, the special circumstances of the DAR tests will require the development of some customized systems, especially in the area of subjective assessment.

Otherwise, EIA and NRSC are purposely avoiding the ATTC model, an EIA official said. Systems will be tested simultaneously rather than the ATTC one-at-a-time procedure. Also, a greater level of flexibility is being written into the DAR test procedures to allow for changes in the middle of the test process.

A final list of the proponents to be tested had not yet been released at deadline, but those considered most likely to submit systems are: U.S.A. Digital and AT&T/Amati (IBOC systems); Eureka 147 (new-band system), and NASA/VOA (S-band satellite system).

System developers were given until June 18 to declare their intentions to participate in the testing.

"We're looking for people who have developed systems, not people to go out and start developing systems," Springer said. "We're ready to begin a standards process."

## CONSIDERING VSAT DIGITAL AUDIO?

# 1-800-345-VSAT

8 7 2 8



**It's been our phone number for 5 years**

### •First VSAT data network serving broadcasters

*NSN's National Off-Premise Control via Satellite, 1988.*

### •ComStream® VSAT products distributor since 1990

### •First digital MUSICAM® audio/data network in the USA

*Rocky Mountain Radio, 1992.*

### •First MUSICAM® digital conversion of an existing analog satellite audio distribution system

*Colorado Public Radio on NPR satellite service, 1992.*

**No one in broadcasting has more VSAT experience than NSN.** No one has more digital audio VSAT networks up and running. Why? Service. Only NSN provides 24-hour, toll-free technical support, and same-day, overnight shipping from our warehouse stock, should disaster strike.

We'll help you put together your own fully integrated VSAT system to centralize programming and production for your radio group or network. Call us for network design, equipment, installation, spacetime, and superior customer service. Leasing available for qualified clients.

Share our **VISION** for your broadcast group or network. Call today.

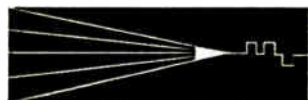

**NATIONAL  
SUPERVISORY  
NETWORK**

Avon, Colorado  
(303) 949-7774

VISION

**VSAT Intelligent Satellite Integrated Operations Networks**



# KGO Offers Dial-Up Information Service

by Nancy Reist

**SAN FRANCISCO** Pacific Bell has teamed up with San Francisco's top-rated radio station, KGO(AM), and with the Dow Jones Voice Information Network to provide the Daily Reporter, a voice-mail delivered information service.

The experimental service is available to Pacific Bell's voice mail subscribers in some California area codes. Messages are typically about a minute long. The service is subscriber-supported and does not include any advertising.

Subscribers receive information briefs in their mailboxes on up to seven different topics, including weather, a morning financial outlook, an afternoon financial recap, sports, world news, movie reviews and Bay Area Minutes, a "round table" of local information including fitness, gardening, politics, consumer tips, and upcoming events.

The first six topics are provided by the Dow Jones Voice Information Network; Bay Area Minutes is produced by KGO.

"Dow Jones represents a very good variety of information that's available on a national basis," said Jean E. Graham, manager of business development for Pacific Bell's Information Services Group. Dow Jones can cover some local news, such as sports which it can handle through its Sports Ticker service.

But as far as news of California communities, "that's something that a national provider has a more difficult time doing. KGO basically represents the local community," Graham said.

KGO News Director Ken Beck oversees the radio station's contributions. It's too early to predict the benefits the station may get from the partnership, he said.

"It's like packaging your product in several different packages, rather than depending solely on a broadcast delivery. In this case, since it's experimental for us, it will have to be evaluated as to its worth as it goes along," Beck said.

KGO is not charging Pacific Bell for its programming during the experimental stage. "We're not putting a broadcast line in there, since they can't deliver a wide-band signal to a Message Center customer anyway. They don't have the capability to do that yet," he said.

The station's costs are minimal, Beck said. KGO sends programming to Pacific Bell over regular phone lines. The Bay Area Minutes programming comes either directly or indirectly from KGO's regular air schedule.

"In some cases, they spin off a product that's on the air already. For example, Joanie Greggins does a talk show on Saturday morning involving fitness and diet and other issues," Beck said. "She offers what you might call a

spin off of that show in a sixty second capsule that's part of the service."

Both Graham and Beck agree that during this preliminary phase, control of the content of Bay Area Minutes should be given to KGO and its talent. Graham said the two organizations worked together to develop general guidelines for Bay Area Minutes, but now Pacific Bell leaves the programming to KGO. Beck confirmed that currently the Bay Area Minutes programmers work independently.

"During this experimental period they've let us put on basically anything we want to. Like any product, that will be refined," he said.

"This thing is just starting to creep into the marketplace. Knowing the phone company, I think they'll probably research this very heavily and have a pretty focused kind of product before the whole thing is over."

Graham said the feedback on the Northern California Daily Reporter so far has been very positive, particularly for the Bay Area Minutes, weather and movie

review services. Formal research is scheduled to begin this month (June), before offering the service more extensively.

Graham anticipates that once the preliminary research is completed, Bay Area Minutes will expand its offerings to financial information and sports.

Most of the programming for the expanded service probably will come from the sources Pacific Bell has already developed, although if there is a need for other topics outside current providers' expertise (religious

programming, for example), they might work with another radio station, Graham said. Pacific Bell's Southern California service might also wish to develop an arrangement with a local station.

Graham is very enthusiastic about the growth of the Daily Reporter, but does not believe it could develop into a competitive threat for radio.

"We're not in any way shape or form a radio replacement, we're a radio complement," she said. "Bay Area Minutes just says, you can listen to KGO on the radio and by the way, here are snippets of information from our talent and personalities and programming that may be of interest."

## THE DIFFERENCE IN SPECTRAL PURITY IS UNCANNY.

*Skip Como, Group Engineer, WRZE, Hyannis, MA*

*I wouldn't even consider any of the others.*

*Jim Bender, Chief Engineer, KZLO, Bozeman, MT*

Both systems were a breeze to install and they work great on our paths.

*Craig Bowman, Director of Engineering, Liggett Broadcasting, WLHT, Grand Rapids, MI; WLQT, Dayton, OH*

**The management says they can't believe how much better it sounds.**

*Mario Hieb, Chief Engineer, KXRR, Salt Lake City, UT*

**THE SONIC CLARITY OF THIS DSTL IS UNBELIEVABLE.**

*Grady Moates, Consulting Engineer, WWKX, Providence, RI*

*It's perfection!*

*Lyle Henry, Director of Engineering, KUSC, Los Angeles, CA*

**YOUR BOX IS A BOLT-IN CURE-ALL.**

*Ed Trombley, Chief Engineer, WSAE, Spring Arbor, MI*

**It's the most transparent STL we've ever used.**

*Don Ford, Director of Engineering, KACY, Amarillo, TX*

**We were able to do our**

**46.5 mile link in one hop**

**with the added bonus of**

**the best stereo separation**

**and sound we've ever had.**

*Michael Bradford, Consulting Engineer, WUPS, Mt. Pleasant/Houghton Lake, MI*

**We'll also be glad to quote you on a new STL.**

Dolby DSTL users are awed by the difference it has made to their stations. It has not only improved their RF performance, but its punchy, dynamic sound has grabbed the ear of management and programming alike. No wonder the Dolby DSTL Digital Studio-to-Transmitter Link has become the new standard in STL quality.

Dolby Laboratories Inc. • 100 Potrero Avenue, San Francisco, CA 94103-4813 • Telephone 415-558-0200 • Facsimile 415-863-1373 • Telex 34409  
Dolby Laboratories Inc. • Wootton Bassett • Wiltshire SN4 8QJ • England • Telephone 0793 842100 • Facsimile 0793 842101 • Telex 44849  
Dolby, Dolby Stereo and the double-D symbol are trademarks of Dolby Laboratories Licensing Corporation © 1993 Dolby Laboratories Inc. S93/9842

**Dolby**  
Broadcast Quality



# RAB Debates New Arbitron System

by Randy Sukow

**DEARBORN, Mich.** The Radio Advertising Bureau (RAB) board of directors, meeting last month in the Detroit area, gave Arbitron executives mixed reviews on the company's proposed redesign of its radio ratings services.

Most agreed Arbitron is moving in the right direction with computer upgrades and new methods for analyzing data. But proposed methods for changing sample size and the frequency of its reports drew considerable fire.

Arbitron is committed to significant change, said company President Steve Morris. "The current system is badly

flawed and the negatives are simply going to get worse and worse as we move forward into a world of electronic information," he said.

But, said RAB President Gary Fries, who sits on the Arbitron Radio Advisory Council, which participated in developing the redesign proposal, a system to please every radio station as well as Arbitron's other clients is probably not possible.

"We're at least moving instead of standing here stagnant, bitching about the whole thing," Fries said. "Somewhere, this (radio) industry has to give this company some guidance."

The redesign proposal, hammered out

by Arbitron and the council during an April day-long meeting in Chicago, seeks to achieve three major goals: increase the value of the ratings data, increase sample size and keep the cost to the subscriber down.

## The plan

"It's to be expected that there will be incremental costs in changing the data collection and processing," Morris said. "We at Arbitron will pay that price. That will not be passed on."

Questions remain over details of the new system and when it can be implemented. Arbitron is currently in the process of informing groups like RAB, the National

Association of Broadcasters and advertising trade industries of the plan and seeking feedback. It hopes to have enough information by September to finalize the plan for implementation in fall 1994.

Several elements of the redesign were well-received by RAB, such as the plan to switch to "block group coding," a system based on units of 250 households in a geographic area.

"When you get geographic data that small you can start stringing them together for very strong lifestyle characteristics, very strong purchasing habits and all kinds of information," said Jay Guyther, Arbitron vice president, sales and marketing, radio station services.

Current Arbitron reports are based on 12 weeks worth of measurement. Rather than increase the number of households reporting, Arbitron is proposing 18-week reports, based on six-week updates. Eighteen-week reports represent a 70 percent increase in sample size over the old 12-week reports.

In addition, every six weeks, Arbitron is tentatively planning to send a 50-page "Buyers Guide" report, which would include the latest "rolling" 18-week summary as well as several other new data not offered before.

Many board members complained that six weeks will in fact become the standard. Ad agencies and other Arbitron customers will be able to extrapolate the latest six-week data from the Buyers Guide and use numbers based on a sample 25 percent smaller than the current 12-week reports.

Guyther agreed: "It's very important that 18 weeks becomes the standard, not the six-week phase because the six-week phase takes it a step backwards."

Other board members, however, protested the idea of sending the buyer's guide out at 18-week intervals because a station would have to wait six weeks longer to redeem itself after a bad book.

Morris and Guyther assured the board that final decisions on the Buyers Guide contents and the frequency of its delivery have not yet been decided.

## Other business

Besides Arbitron, the main concern of the May RAB board meeting was a series of meetings set up with about 20 major Detroit-area advertisers that do not use radio. The goal of the meetings is to educate advertisers on the strength of radio advertising and learn why some advertisers do not find radio useful.

The most common complaint RAB board members heard after a similar series of meetings in Los Angeles last October was that radio ads often tend to be uncreative. RAB is attempting to battle that perception with its Radio Mercury Awards program, created to honor the year's most ear-catching radio ads. This year's Radio Mercury Awards ceremony was held June 9 before a sold-out crowd at the Waldorf Astoria Hotel in New York.

RAB membership is up to 3,230 stations as of early May, "which I believe is an all-time high," said Ron Ruth, executive vice president of RAB's stations division. That figure is up from a low point of 2,341 in early 1992. But, Ruth warned, the association is still experiencing "a tremendous amount of churn" among small-market stations.

One reason for the churn, he said, is the increase in duopolies and local management agreements. "Broadcasters are asking themselves: 'Do I have to pay RAB and NAB four times?' if they have the max of four stations (in a market)," Ruth said.



**Perfect tools for professionals: CD and CD-R players from STUDER**

The new professional D730 and D731 CD players hold several trump cards. The operating concept is identical on both the desktop and rack-mount version. Not only are the RED book standards implemented, but also important parts of the ORANGE book standard. A special scan function allows the user to play CD-Rs on which the TOC has not yet been written: Once the TOC has been created, coded skips are correctly processed. In addition, the remaining time is displayed with great accuracy. This is of special benefit in the intro mode with its high-precision count down.

Safety features are an integral part of both models: The status preservation which guarantees that even after a «power down», the laser is repositioned exactly on the last address; a quality indicator that provides information on the CD playability; program-controlled customization of all operating procedures, comprehensive remote facilities, integrated optional interfaces for special functions, and, what is more, access to all CD sub-code information via the AES/EBU output for advanced data processing.

**STUDER**  
PROFESSIONAL AUDIO EQUIPMENT

STUDER REVOX AMERICA, INC.  
1865 AirLanc Drive, #12  
Nashville, Tennessee 37210  
(615) 391-3399/Fax (615) 391-5974  
New York (212) 626-6734  
Los Angeles (818) 780-4234

STUDER REVOX CANADA  
1947 Leslie Street  
Toronto, Ont M3B 2M3  
(416) 510-1347/Fax (416) 510-1294

Circle (49) On Reader Service Card

World Radio History



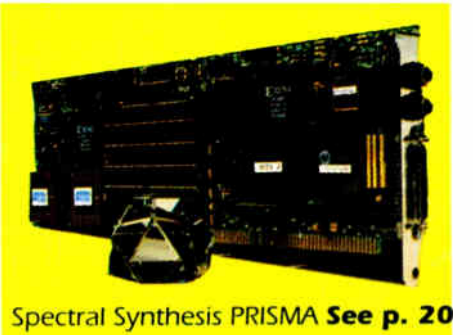

Spectral Synthesis PRISMA See p. 20

Equipment and Applications for Radio Production and Recording

## USER REPORT

# KFI Edits 'On-The-Fly' with Akai DD1000

by Marv Collins

**LOS ANGELES** When KFI(AM)'s fast-paced talk shows needed their many jingles and sound effects cued up and ready to air at a moment's notice, we began to investigate several digital workstations for the solution. We looked for gear that

would be simple to use, rugged and reliable.

Purchased in 1990, the AKAI DD1000 magneto optical disk recorder/player has proven itself to be the ideal radio production and on-air tool for KFI(AM)-KOST(FM). It is self-contained and compact, occupying only five rack-units of

space. We have found it to be solid and well-constructed, versatile and easy to use.

The workstation's first clear distinction is that it uses no internal hard drive. Its media is 5 1/4-inch double sided magneto-optical disks capable of recording up to 80 minutes per side at 32 kHz mono; at 44.1 kHz stereo, 29 minutes per side. That's

full 16-bit PCM, non-compressed audio.

With removable media instead of a fixed hard drive, we benefit from virtually unlimited storage capacity. It's perfect for radio. Each show records and maintains its own disks, and when the shifts change, the operator simply inserts his or her disk with its accumulation of recorded audio.

## PRODUCT EVALUATION

# Removing Noise Using Roland SN-550

by Ty Ford

**BALTIMORE** Nasty sounding source audio, when not due to an overdriven amp or impedance mismatch, is usually the result of circuit noise, tape hiss and hums. If you're not in a position to correct the problems that caused the noise before the recording begins, you're left with having to figure out how to minimize the problem.

Although it's not capable of the performance level of the CEDAR and Sonic Solutions noise reduction systems, the Roland SN-550 Digital Noise Eliminator does a respectable job and costs many times less. It is a single-ended filter and it works in real time. List price is currently \$2095.

Each channel of the SN-550 is equipped with separately adjustable Noise Cancelling (high frequency) and Hum Cancelling (low frequency) sections. The three things the SN-550 does best are reducing 40 Hz-80 Hz hum, tape hiss and circuit noise. This includes the various buzzes that emanate from effects boxes and MIDI synthesizers, tape hiss from improperly adjusted analog recorders and circuit noise from amp stages that are pushed past their ideal operating parameters.

### Setup and operation

Roland has provided both balanced XLR and 1/4-inch TRS inputs and outputs. The 1/4-inch jacks also work with unbalanced 1/4-inch TS plugs, but the unprocessed throughput of the SN-550 is 5 dB hotter than when the filters are in the circuit during unbalanced operation. This makes comparison and level setting more difficult if you're running an unbalanced system.

Setup and operation of the SN-550 are very straightforward. Just insert it into your system, adjust the input to the filters with the internal level control, activate the noise cancelling or hum cancel modes (or both) and adjust the thresholds of each until you get what you want.

The front panel LED display shows internal levels for each channel, and whether the noise and hum cancelling circuits are operating. According to the manual, the noise cancelling circuits split the audio into five bands, each one centered at 350 Hz, 700 Hz, 1.4 kHz, 2.8 kHz and 5.6 kHz. Each band has its own

Roland's SN-550 is effective in reducing hum, hiss and circuit noise.



noise canceller, however, they can't be manually tuned. I tried to null out a series of tones from 200 Hz to 20 Hz using the noise cancellers threshold controls, but the individual frequencies were unaffected.

Like the hum cancellers, the noise cancellers also can be chained, although most of my testing showed that one trip through was all that was needed.

I had some interview material that had been recorded on analog cassette. It was moderately hissy. The SN-550, while not perfect, did remove a major amount of the tape hiss. There was a small diminishing trail of noise after each phrase that was the result of the expander closing down. While it was possible to adjust the threshold to completely eliminate the noise between phrases, I found hearing the noise during phrases and during the trail to be distracting. I readjusted the threshold so that a small amount of noise remained between phrases.

After I reduced the tape hiss, I was able to hear an air handler fan motor growling in the background. As it turned out, the AC motor, which was running on 60 Hz, was causing the air handler housing to vibrate. I kicked in the manual frequency adjust mode of the Hum Cancel section first and began tuning for the frequency which, you guessed it, turned out to be 60 Hz.

Either from the "manual" mode adjusted to 60 Hz, or from the automatic "line frequency" mode, the results were the same; the hum of the housing dropped noticeably. If you do a lot of recording in buildings where you can't turn off the HVAC blower motors, and if they're 60 Hz motors, this feature will definitely

improve your audio.

The SN-550 also effectively reduced the synth whine and hiss from the output of my Roland U-20 keyboard. It also took some of the buzz out of my MXR stereo chorus stomp box. However, as with most of these kinds of devices, success is a question of balance. Use too much cancellation and the top end of your audio loses its sparkle. In addition, the expanders will also close down on your reverb ring outs.

### On Music

I ran some basic rock and roll music and a series of sine waves from 20 Hz to 20 kHz through the system and found that the circuit was just not sophisticated enough to remove or noticeably reduce the single tones from the music. I also noticed a reduction in the lower frequencies of the music (kick drum and bass) when using the hum cancelling circuit.

In a more controlled test, I fed a 50 Hz tone to the SN-550 and manually adjusted the hum cancel section to null the tone. At 50 Hz, I was able to drop the level 10 dB. At 75 Hz, it dropped 9 dB. If I was out to improve on this feature, I'd make the range a bit wider, like 20 Hz to 120 Hz to catch those ultra low tones and the 60 Hz harmonics.

The Roland SN-550 may not be the kind of box you use on everything, unless you deal with a lot of really bad sounding audio all the time, but it can elevate horrible sounding audio to the passable level.

□ □ □

For more information on the Roland SN-550, call Al Dugas at Roland at 213-685-5141 ext. 333; or circle Reader Service 109.

### Easy to operate

The AKAI DD1000's human interface, a logically organized panel of switches, knobs, and LCD display, allows the many different operators at KFI-KOST to quickly and easily accomplish their work. We discovered that a computer-based system—with its bulky hardware, monitor, keyboard and mouse, requiring "clicks" and "drags" to navigate through screens—was too complex and time consuming to meet the demands of our hectic stations.

AKAI combined the best of two design concepts: traditional hardware control and software engineering. Most of the work is completed by selecting menu choices from six function keys below the LCD display. Their purpose changes with each screen that is in use.

Edit features include the very accurate jog and shuttle wheel, the waveform editing, and assembling "takes" and their associated "cuts" into "Qlists," for four-channel playback.

To record a "take," press the record button. The LCD screen presents the user with a menu of options. Here the sampling rate is selected, mono or stereo mode, digital or analog inputs, and the take's name is entered. Function key "6" starts and stops the recording. It is all very logical.

To edit the recording, press the edit key. The waveform is immediately displayed on the screen. In this mode, the user sets in and out points for up to 50 cuts per take. Press the "detail" function key and the scrub wheel becomes operative. You can instantly zoom in and magnify to see and hear a small section of the waveform, even a few hundred samples.

Everything about the AKAI is quick; there's no software "overhead" needed to redraw screens, or read and write files. In fact, the entire operating system and editing software is contained in two EPROMS. There is no boot up time required; the unit is ready to go in two or three seconds after power-up.

### "Playsheet" function

One of the most impressive capabilities of the DD1000 is its cart machine function. As the "Playsheet" was demonstrated to us, we knew it was the perfect tool for our application. The Playsheet feature is the DD1000's rapid-fire, cart machine style of playing takes and cuts "on-the-fly."

Using the DD1000, up to nine cuts may be programmed into a group, and

continued on page 14 ►





Starting  
under \$3,100

# Cost-Effective Quality

## The New Dynamax MX Series

### Modular Audio Console

- True modular design
- Ultra-reliable motherboard construction
- VCA mixer and monitor control
- Active balanced line inputs, transformer isolated mic inputs
- Active balanced main and monitor outputs
- Full monitoring/cueing facilities with VCA level control and active source selection
- Built-in cue amp with speaker and amplified stereo 8-ohm headphone output
- Remote start logic
- Count-up event timer
- Two input expansion switches standard
- Two inputs per module, mic/line or line/line - line inputs may be mono or stereo, consumer or professional format
- Four assignable outputs - two stereo plus two mono
- Available in 6, 8, 10 or 12 channel models
- Rotary or linear faders
- Separate audio and logic power supplies
- Sturdy, all-steel construction
- Durable Lexan overlay control surfaces
- All inputs/output connection via compact, captive screw barrier strips - no soldering, crimping or spade connectors necessary
- Excellent RF immunity

8:00 a.m. to 8:00 p.m. EST • 1-800-622-0022 • Fax 317-966-0623  
Canada 1-800-268-6817 • Toronto 416-731-3687

 **HARRIS  
ALLIED**

Circle (155) On Reader Service Card  
World Radio History



# Prevent Ground Loop Hum in Audio System

by **Bruce Bartlett**  
with **Jenny Bartlett**

**Part II of IV**

**ELKHART, Ind.** Here are more tips on hum prevention for your audio production system. Let's start by reviewing balanced and unbalanced lines.

Hum fields are rejected better by balanced lines than by unbalanced lines. A balanced line is a cable that uses two conductors to carry the signal, surrounded by a shield. The shield does not carry the signal; it is connected to ground and keeps electrostatic fields out of the conductors. Balanced cables and equipment use three-pin pro audio connectors (XLR-type connectors). Professional audio equipment uses balanced connectors.

In a balanced line, each of the two conductors is at an equal impedance to ground. Consequently, the conductors pick up equal amounts of hum interference. The cable plugs into a balanced input, which is sensitive to the voltage difference between the two conductors. Since there is little or no difference in hum voltage between the two conductors, hum picked up by the cable is not amplified.

Twisted-pair cable creates less magnetically induced hum than non-twisted pair cable. This is because twisted conductor pairs occupy the same point in space on the average, so they are the same distance from the hum source, and receive equal hum interference.

An unbalanced line is a cable that uses a single conductor surrounded by a shield. An unbalanced cable has either an RCA phono plug or a 1/4-inch phone plug. Unbalanced equipment has RCA phono jacks, or has 1/4-inch phone jacks. Home stereos and semi-pro recording equipment use unbalanced connectors.

Both the conductor and the shield carry the audio signal, thus, so the shield isn't as effective in blocking electrostatic hum as it is in a balanced line. Also, the inner conductor and outer shield are at different impedances to ground, so they pick up different amounts of hum interference. This difference in induced hum voltage is amplified by the equipment the cable is plugged into. In spite of these drawbacks, unbalanced lines under 10-feet long usually provide adequate hum rejection.

When connecting balanced equipment to unbalanced equipment, you may want to add a 1:1 audio isolation transformer at the unbalanced input or output. This allows most of the interconnecting cable to be balanced.

**Preventing ground loops**

A major cause of hum is the ground loop. This is a circuit formed out of ground leads. It is the circuit loop that is formed when equipment is connected to ground through more than one path. It occurs when two pieces of audio gear are connected to each other through a shield and also through the AC safety ground.

A ground loop also can be created between two cable shields connected to the same piece of equipment. How does a ground loop create hum? In two ways:

First, the ground loop acts like a big coil of wire or antenna that is sensitive to "hum

fields" radiated by power wiring in the walls. The bigger the area of the loop, the more hum interference it picks up. Second, if the voltage on each chassis is not the same (that is, if the safety grounds are different), a 60 Hz current flows between the two chassis, causing a hum signal.

You can get rid of ground loops in several ways. The following measures reduce the area of a ground loop, which reduces hum pickup.

- If possible, keep your equipment close together and use short audio cables.
- When running send-and-return cables to a signal processor, tape these cables together.
- When running separate left-channel and right-channel cables for a stereo hookup, tape these cables together. Better yet, use a stereo cable, which combines both channel pairs in a single cable.

**Connect to same ground**

If you do this, all chassis are at the same ground voltage, so no hum current can flow between them when they are connected by cables.

Suppose you're trying to record a synth by connecting it to your mixer. The synth is plugged into a wall outlet in one room, and the mixer is plugged into a wall outlet in another room. When you connect them with a guitar cord, you hear hum. What's going on?

Chances are that the outlets are fed from different circuit breakers. So the outlets are at different ground voltages. When you plug your synth and mixer into these separated outlets, and connect the equipment together with a guitar cord, the difference in ground voltages makes a 60 Hz hum current flow between the synth and mixer. That's a ground loop.

One solution is to plug all your equipment into one or more outlet strips fed from the same circuit breaker. That way, the ground voltage for all the equipment is the same. Plug the electric musical instruments and recording equipment into the same strips. Use long, thick extension cords if necessary for distant equipment. However, make sure that the current requirement of the system (the sum of the equipment fuse ratings) doesn't exceed the amperage rating for that circuit.

Another solution is to use a transformer-isolated direct box between the synth and your mixer. Unlike a guitar cord, the transformer passes the signal without connecting the two chassis together.

The orientation of two-prong AC cords makes a difference, too. For each piece of audio gear, rotate the two-prong power cord in its outlet to find the minimum-hum position. If you have a small semi-pro audio system with 2-prong power cords and short unbalanced cables, you should have no hum problems if you followed these suggestions.

Portions of this article were excerpted from the authors' book, "Practical Recording Techniques," published by Howard W. Sams. More on hum prevention next time.

□ □ □  
*Bruce Bartlett is a microphone engineer and technical writer for Crown International. Jenny Bartlett is a technical writer. Bruce can be reached at 219-294-8388.*

## Overnite Hits\*

**EV RE-20**

The world-standard broadcast microphone. Only Broadcast Services buys in bulk to save you more!  
BSC PRICE \$338



**Marantz PMD-201**

Portable mono cassette recorder features two heads and has an optional carry case and battery pack.  
BSC PRICE \$230

**Comrex TCB-2**

This auto-answer coupler connects your caller to your listen line. Also useful for dial-up networks, remote sites, etc.  
Optional AC supply powers up to 4 units. BSC PRICE \$275



**Comrex LX-T & LX-R**

Want frequency expansion on a budget? These units are ideal for networks, remotes, sporting events. Optional rack mount available.  
BSC PRICE \$699

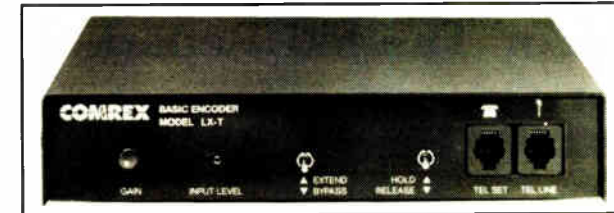

**Tascam DA-30**

This is a proven RDAT two-track digital master recorder built to withstand broadcast use.  
BSC PRICE \$1080



**Tascam 112B**

A rugged 2-head, two-channel cassette recorder complete with rack ears and balanced XLR in & out. BSC PRICE \$575

\* All items are in stock and available for overnite shipment if approved order is entered by 5 pm Eastern time. Quantities may be limited.

Eastern & Central VOICE 800/525-1037 FAX 919/934-1537

**BROADCAST SERVICES CO.**

The Davis Communications Group, Inc.

**The Preferred Source**

Mountain & Pacific VOICE 800/523-1037 FAX 619/277-6319





# 'On-The-Fly' Editing

► continued from page 11

300 groups may reside on a disk. The cuts are played by pressing the AKAI's numeric keypad, or using the KS500 remote.

After takes and cuts are made, they need to be assembled in a list for playback. Either the "Qlist" or "Song" will do this. The Qlist is familiar to anyone who's worked with video style edit decision lists; it's SMPTE timecode based.

Time	Take	Cut
00:00:01:00.0	RADIO SPOT	CUT 1
00:00:13:24.5	RADIO SPOT	CUT 2
00:00:51:18.8	RADIO SPOT	CUT 3

The "Song" mode is an even simpler method of accomplishing the same thing. Timecode isn't used, just numbers in a sequence.

No.	Take	Cut	Rep
1	SPOTMUSIC	CUT 1	1
2	SPOTMUSIC	CUT 2	4
3	SPOTMUSIC	CUT 3	1

In the above example, the Song mode's repeat function is used to loop "cut 2" four times before advancing to "cut 3."

Two other modes, "Set-up," and "Disk" allow the operator to select from dozens of options: master sampling rate, internal or

external reference clock, footswitch mapping, file directory maintenance, deleting, renaming, tagging, and much more.

After our original goal of on-line, on-air multiple cuts, on-air, was met, we began to enjoy more of what the DD1000 had to offer in the production studio. We installed it in Studio A, where much of the commercial voice-over work is done.

KFI-KOST Production Director Ken Davis has a library of disks that has grown to over a dozen, and they contain often used agency donuts, work elements, and local tags. Davis is pleased with the many ways in which the unit replaces the analog 8-track reel-to-reel tape machine.

**"We have found the DD1000 to be solid and well-constructed, versatile and easy to use."**

— Marv Collins, KFI/KOST

Multiple voice spots, parts recorded at different times, are easily assembled in the Qlist. Audio overlaps and crossfades are possible, because the DD1000 will play two cuts at the same time.

Also built into the unit are other valuable production tools, including time compression and expansion, pitch shift, and digital EQ. The algorithms that accomplish these feats sound great, and the techniques are based on AKAI's sampler technology.

#### Talkshow recording

At KFI, we also employ the DD1000 to replace the open-reel taping of selected KFI talk shows used for replay overnight. All of

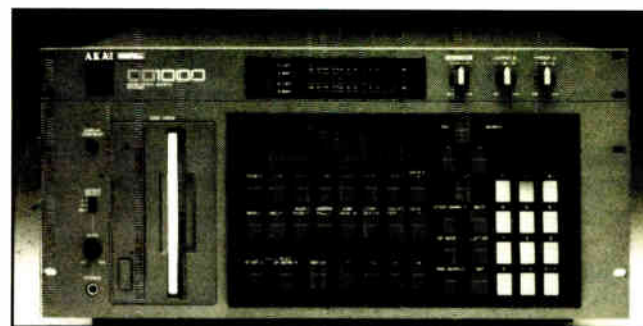

KFI/KOST uses five Akai DD1000s in its on-air and production facilities.

the recording and editing is performed on optical disks. We are no longer editing by cutting expensive reels of tape. We are saving thousand of dollars in tape cost every year with the five AKAI DD1000 machines in use in the various KFI-KOST studios.

Playback can be remote controlled using the DL500 Playsheet desktop remote control unit. Also available is the DL1000 remote control that provides remote access to the DD1000's record/playback and editing functions. It also connects up to seven units and controls them under the SCSI ID management system.

The DL1000 remote control is equipped with an LCD display that may be tilted to give the user the best view, and a SMPTE code generator. In the KFI-KOST studios a simple mounting was fabricated that permits the KL1000 remote control to rest on the audio console for convenient access. The DL500 "Playsheet" desktop remote control has been installed in the conference studio so that talk show hosts can remotely start sound effects and jingles if desired.

The DD1000 will connect to a wide array of devices: additional SCSI optical drives, a parallel printer, digital inputs and outputs, timecode input, MIDI input, output and loop through, two assignable footswitch or contact closure inputs.

□ □ □

For more information, contact Mike McRoberts at Akai; 817-336-5114, or circle Reader Service 83.

Marv Collins is chief engineer for KFI(AM)-KOST(FM), and a contributing writer to RW.



**Press 1 For Today's Weather.  
Press 2 For The Ski Report.  
Press 3 For Concert Information.  
Press 4 For . . .**

Now you can provide multiple listener information services with one phone line!

The new Telephone Information System (TIS) from Henry Engineering stores up to ten separate messages for instant playback via touch-tone.

With just one "info hot-line" phone number, your listeners can get the specific info they want just by pushing the right buttons on their phone.

Digital audio memory means messages never wear out. When the unit is called, a "Menu" message plays,

telling your caller which messages are available. The caller may then select any message(s) for instant playback. Messages are easily updated by re-recording. And, over eight minutes of information can be stored in the TIS digital memory.

Henry's TIS . . . Telephone Information System . . . from Harris Allied. It's quick. It's easy. It's profitable. And, it's in stock now.

8:00 a.m. to 8:00 p.m. EST  
1-800-622-0022  
Fax 317-966-0623  
Canada 1-800-268-6817  
Toronto 416-731-3697

**HARRIS  
ALLIED**

## WANT TO KNOW THE BEST KEPT SECRETS IN DIGITAL AUDIO STORAGE?

- What the Dow Jones, CBC, NBC and Westwood/Mutual Radio Networks and many other broadcasters all know about CA products, and why **you** should know, too?
- Why the HDS-1000 was designed from the start **without** any audio compression?
- Why the HDS-1000 **wasn't** designed around a PC?
- Why the HDS-1000 allows front panel access to all cards, and why the system is **fully expandable?**
- Why anyone who's been looking to replace cart machines, reel-to-reels, and even Go-Cart/InstaCart systems, without reinventing the wheel, should look at the HDS-1000?

Then call (309) 837-2244 or fax (309) 833-5175 and get the answers!

CLARK & ASSOCIATES, LTD.  
318 E. CALHOUN  
MACOMB, IL 61455





**DAT-to-D2 44.056-to-44.1**  
**CD-to-DAW DAW-to-DAT**  
**32-to-48 CD-to-DAT**  
**DAT-to-1630 44.1-to-48**  
**DAW-to-Digital Console**  
**48-to-44.056 Varispeed-to-44.1**  
**DAW-to-Digital Multitrack**  
**DAT-to-DAT DAW-to-D2**

**Finally! Solve your digital audio copy problems for just \$2595...**

Your customers want "all digital." Now you can give it to them with Roland's new SRC-2 Dual Sample Rate Converter. It's getting rave reviews from customers. "It sounds great!" "Very innovative--a remarkable design." "I can crossfade and mix with the two digital inputs--fantastic!" "I intend to buy at least three of these units; every room will need one..."

Roland's ASIC chip set, two years in development, is what made this "leapfrog" sample rate converter design possible. So now the A/D, D/A signal degradation you've had to put up with is gone. And your "all digital studio" can really be...all digital!



For the solution to all your digital copy problems, call Roland at (213) 685-5141 ext. 337 or FAX (213) 722-0911.

© 1993 Roland Corporation US

**Roland**  
**ProAudioVideo**



# Making MIDI Work Using a Sequencer

by Al Peterson

Part III of IV

**HARRISBURG, Pa.** In our last two sessions, you saw how MIDI controls your DSP, sampler and synth. You may also recognize it would take an octopus to run it all in real time. Not to mention trying to lay a drum groove, hot bass, piano and horns onto the multitrack. If MIDI is so "fandamntastic," shouldn't there be a machine that can do all of this nonsense for you? It's called a Sequencer, and it's the topic this time out.

A MIDI sequencer does not record audio but "performance data." Every time a key

on a MIDI board is hit, the sequencer records the event rather than the actual sound. Think of a player-piano; it doesn't make any sound of its own, but contains the events the piano can convert into music. So it is with a MIDI sequencer.

## Sequenced data can be manipulated in many ways.

Sequencers can be hardware or software. Alesis, Yamaha, Roland and others manufacture very fine hardware sequencers set up to emulate the workings of a multi-track recorder. A good many companies also write sequencing software for computers (see accompanying article). Either way, MIDI performance can now come under automated control. Here's how.

### Multiple manipulations

Sequenced data can be manipulated in many ways including time. The "Tempo" feature changes performance speed, and can effectively "time-slip" a sampled event. Say you need a stuttered "Win Cash!" promo effect exactly 22 seconds into your work track (with no hands left to fire the sampler).

Set the tempo to 60 beats-per-minute, and record several "Note On" events to occur on the 22nd beat. Roll tape and sequencer together and at 22 seconds, "Wi-wi-wi-Win Cash."

For finer control, sequencers allow you to nudge bits of time called "sub-beats" with resolution finer than 96 slices of that second.

The sequencer can automatically change programs on your DSP. Figure out when changes occur in the copy, then record Program Change information into the sequencer. Roll tape and sequencer simultaneously then watch your effects box jump from reverb to flanging, doubling to

pitch transposition, ending with a small slapback echo. Look Ma, no hands!

Some sequencers like the Alesis MMT-8 allow you to sync to tape by laying a tone on one track. On playback, the sequencer begins rolling when tone hits it. Doing this frees you from having to start cart, reel and MIDI all at once.

Ambitious types can sequence a complete mix of music, processing and effect fly-ins (requiring some degree of musicianship). Assume you've composed a fantastic MIDI jingle for a car dealer. Sequencer tracks one through six are directed to the multi-timbral sound module. Track seven triggers car effects and audience "ooh-aahs" off the sampler. Track eight manipulates DSP reverb or alters the panning of your voice as you're going to tape, all in one pass.

### Not a recorder

It's worth mentioning again that a sequencer does not record audio at all. We use it to generate a jingle mix with effects; audio still is directed to reel, cart, DAT or some manner of digital archiving. However, it is possible to save the sequence to floppy disc for future use. Doing this (rather than archiving the music track) allows the luxury of experimentation: Horns and strings can swap parts. Make the bass player a singing duck. Eliminate a sampled effect. Remove the "middle 16" to make a :30 version or even transpose it so the dealer's daughter can sing lame lyrics in a key comfortable for her. Since all information is digital data, it is yours to manipulate and store to achieve a creative end.

At last, we've got a way to control all this cool gear we had the boss buy us. Next time out, we'll tie it all together into one complete package, including a look at my own MIDI rig for inspiration.

□ □ □

Al Peterson is production director for WINK(FM) Harrisburg, Pa. He can be reached in care of RW.

## A User Guide to MIDI Programs

by Al Peterson

**HARRISBURG, Pa.** Good news. You've been given the old computer from the storage closet for a sequencer. Bummer—it's an XT. How do you coax MIDI production brilliance out of one of these fossils?

No sweat. MIDI software companies have programs that will cook in XT Turbo mode (a whole 10 MHz). Call the computer manufacturer for the BIOS chip to handle DOS 5.0, and drop in new RAM chips to bring it to 640KB. Then check out the following software:

"Cakewalk 4.0" from Twelve Tone Systems. 256 tracks to sequence on. Minimum requirements are 512K RAM and at least one floppy. A hard drive is recommended, otherwise you'll be swapping discs back and forth—a serious deadline killer (800-234-1171).

Voyetra's "SP Classic", "SP Jr." and "SP Gold." Inexpensive and remarkably versatile. Use these programs on a 286 machine or higher; anything slower may "choke" the MIDI data stream (914-738-4500).

"Cadenza" from Big Noise. Runs on laughably-meager machines with 512K RAM and two floppy drives. Cadenza depends heavily on graphics, so CGA or Hercules capability is a necessity (904-730-0754).

Dr. T's Music Software (617-455-1460) and Opcode Systems (415-369-8131) have immensely powerful programs, and run on proportionally powerful frames.

You'll require a MIDI interface to connect the computer to your gear.

## At Your Fingertips!

Find the information you need in Radio World's 1993 Directory.

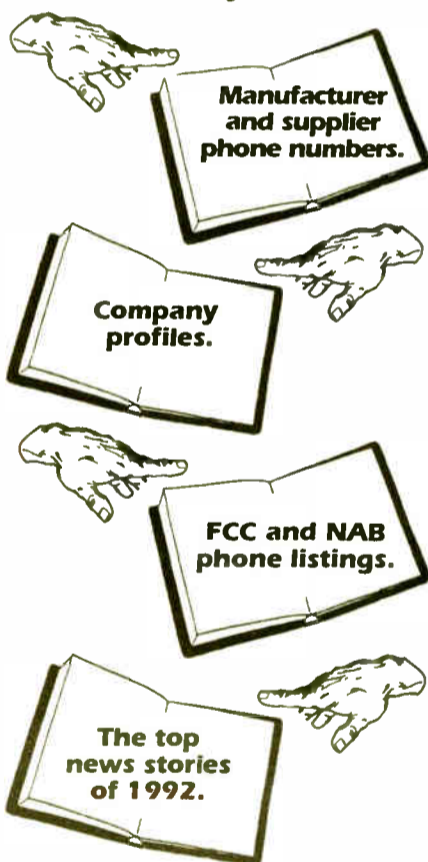

...And more.

We have a limited number available at \$14.95 each.

To order, call



1-800-336-3045



A Whole New Concept With A Fresh Set Of Parameters...

The next generation of dynamics control from Valley Audio! Bridging the gap between high fidelity analog and modern digital innovation comes a breakthrough professional audio tool — the Model 730 Digital Dynamics Processor.

More than just a digital version of an analog stereo compressor, limiter, expander, sibilance controller or keyed gate, the Model 730 allows complex, easily programmable multi-threshold, multi-ratio dynamic transfer curves to be combined for total control of demanding audio signals. There's nothing like it, anywhere!

The Model 730 features zero-attack detection for distortionless broadband limiting, simultaneous multi-ratio compression and expansion, externally keyable gating and selectable high frequency limiting. An optional dual linear fader

remote control allows assignable "in-hand" parameter and volume control, great for remote zipper-free digital fade-ins and fade-outs on DAT to DAT transfers!

The Model 730 speaks every common signal and control protocol, from analog -10 to +4; digital 30 kHz to 50 kHz AES/EBU, S/PDIF, SDIF-2; TOSLINK optical, MIDI, RS-232, and RS-422.

Internal 24 bit architecture with 18 bit I/O conversion insures the utmost in high fidelity, and ROM resident software, flexible Aux connectors and daughter board modular expansion provide lots of room for future growth.

The options and functions could fill a brochure, which we'd be happy to send you. Or contact your favorite pro audio dealer for a test-listen of the Model 730.



Valley Audio Products Inc.

9020 West 51st Terrace, Merriam, Kansas 66203  
Phone (800) 800-4345 FAX (913) 432-9412

Circle (143) On Reader Service Card



# YOU DON'T KNOW WHAT YOU'RE MISSING



**If** you don't have an Eventide® VR240 Digital Broadcast Logger, you're missing the easiest, most efficient way to keep track of everything that goes out on your air, and more. There's no bulky, high maintenance, hard-to-use hardware, because Eventide has compressed a complete 8-to-24 channel digital broadcast logging system into one easy-to-use three-rack-space device. There's no need for a tape warehouse, either—the VR240 records up to ten days worth of audio on a single ultra-compact DAT cassette. With the dual-drive option, total unattended logging time stretches up to three weeks. And yes, you can search and play a tape on one deck while simultaneously recording audio on the other.

Without an easy, practical, multi-channel logging system, you're missing what's going on with your crosstown competitors, what your talent (and call-ins) *really* said on the air, when that commercial *actually* ran, who called your contest lines, what the police and fire

dispatchers said. The VR240 even records modem, fax, and transmitter remote control telemetry transmissions. The advantages of logging have always been clear. Now the Eventide Digital Broadcast Logger gets rid of the disadvantages.

There's no broadcast logging system as advanced as the VR240. And with hundreds of Eventide-built digital loggers already in service worldwide, there's no other digital logger with our track record of reliable service. So don't miss out—call Eventide or your broadcast distributor for full information on the logger that makes full-time logging practical: The Eventide VR240 Digital Broadcast Logger.

## Eventide

One Alsan Way • Little Ferry, New Jersey 07643 USA  
Tel: 201-641-1200 • Fax: 201-641-1640



ON-THE-SPOT

# Transporting Commercials by Telephone

by Ken R.

**TOLEDO, Ohio** Your radio station spends a fortune just picking up spots at other stations and recording studios. Don't believe it? Take the average salary of a sales person, and divide it by 40 (the number of hours he/she is supposed to work).

Let's just make up a number. Let's say the sales person makes \$400 a week. That's about \$10 an hour. How many hours does that person spend picking up spots? Maybe 5? That's \$50 per week, per sales person. If your station has five sales people, that's about \$13,000 per year.

Now add mileage costs into the equation. Let's be conservative and say \$10 per week per sales person. That's another \$2600 per year your station spends.

Well, you could buy a whole other employee for your station if you could figure a way to get that commercial from the source to your production board without using a car.

Good news. The technology is now available to do it. Here's how it works.

Say station "A" records a commercial, converts it to digital information using an A/D converter (a DAT machine will do just fine). The production director

then "encodes" it using ISO/MPEG MUSICAM compression and sends it down a phone line to station "B." The production person at station "B" receives it via a modem into a computer or digital workstation, "decodes it," and *Voila*. Just add water (just kidding) and you have instant audio.

### Never leave the station

No wear and tear on the tires, no unproductive driving time for the sales person. That sales person may still decide to stop off and waste an hour or two at the doughnut shop, but that's another problem.

The point is that commercials no longer need to be "dubbed off" onto analog tape, put in boxes and shipped all over town. One such piece of equipment that makes this possible currently is in use in the United Kingdom. English recording studios are able to "transmit" commercials and production to stations in distant areas (and in fact sometimes across oceans) using the CCS CDQ-2000.

It allows them to select from several digital transmission rates, depending on the bandwidth required. At a data rate of 112Kbps or greater, the CDQ-2000 delivers CD quality stereo audio at 20 kHz bandwidth. AES/EBU interface is provided as an option. (Other products from companies such as APT, Comrex and by the end of the year, Telos, also can be used for spot delivery.)

Ken R. Inc., produces jingle packages for radio stations, commercial jingles for agencies and plain old radio spots for everyone. We spend about \$3000 a year on overnight shipping, and our clients probably spend about \$6000 each year on their end when they want our stuff in a big hurry.

**The point is that commercials no longer need to be "dubbed off" onto analog tape, put in boxes and shipped all over town. . . . No wear and tear on the tires, no unproductive driving time for the sales person.**

We're looking closely at getting such a system, but the only drawback is you need folks with the right equipment on both ends of the phone line for it to work. And right now, the technology is too new for many radio stations to have picked up on it.

### Waiting for equipment

Granted, radio stations are just beginning to go digital because prior to the past year or so, the prices of workstations were too high for most to afford. But little by little it's happening. First CDs replaced records. Then the DAT machine arrived in your production room. Trust me, soon the old technology, those machines that you've had since the '60s, will go away.

So eventually will the razor blades, the turntables and those scratchy old production libraries on vinyl. And using a modem transmission system for commercials will make sense to your GM because it will save money and man-hours for the station every year.

Each year, I watch the price of various pieces of digital equipment plummet, memory capabilities expand and software get more flexible. Save this article and in a couple of years you can look back and say, "Hey remember when we had to drive all over town to pick up commercials?" Right now I'm on my way out for a doughnut.

□ □ □  
Ken R. is president of Ken R. Inc., a 15-year old audio production business in Toledo, Ohio. He can be reached by phone at 419-243-1000, or by fax: 419-241-KENR.

**Quality That Inspires Confidence!**

**REMOTE CONTROL**      **AUDIO PROCESSING**

**DIGITAL STORAGE**

**AUDIO ROUTING AND DISTRIBUTION**

**FREQUENCY EXTENSION**

**TELEPHONE INTERFACE**

**AUDISK's proven digital storage technology streamlines your station's operations. Feel the confidence that comes from owning a system that's easy to use and built to last.**

**Gentner**  
Gentner Communications Corporation  
Professional Audio Products  
1825 Research Way / Salt Lake City, Utah 84119 / (801) 975-7200 / FAX (801) 977-0087

Circle (125) On Reader Service Card



SIGNAL-TO-NOISE

# Recording Gear for Journalists

by Frank Beacham

**NEW YORK** Whether I'm wearing the hat of a writer or that of an audio producer, I depend on tape recorders.

For years I've fumbled with recording devices on interviews, trying to piece together a lightweight portable system that I can operate alone but that will provide consistently high quality recordings.

The task has not been easy. In fact, I've searched for that perfect system for more than 25 years. I've lost track of how many portable reel-to-reel and cassette recorders, mixers and microphones I've used over the years.

My requirements for the ideal personal recording system are really very simple. First, the entire system has to be extremely light in weight. Preferably no more than

sounds much better than its specs: 10 Hz-14,500 Hz (+1, -3 dB) with a S/N of more than 80 dB. The tiny machine, designed for voice recording, uses postage-stamp size tapes with recordings times of 60, 90 and 120 minutes.

With the Scoopman system portability reigns supreme. The recorder weighs 5.2 ounces with the single AA battery that powers it for about seven hours. In addition to the manual recording mode, Scoopman employs a digital AGC circuit that leaves no audible artifacts when recording normal speech.

Sony also includes a feature on this recorder called "Plug In Power," a phantom power system for consumer mics. What Sony doesn't tell you is that the 2.71 volts delivered at this connector can power a pair of professional quality, lava-

ASC made up a special Y-cable adapter so I could use a mic on each channel with full recorder powering. The male mic cable connectors were wired so that if I chose to use only one mic, it could be plugged directly into the recorder and would deliver sound to both channels.

Now, for the first time, a standard DAT

## The D-7 offers all the features of the NT-1 Scoopman.

recorder duplicates the key features of the Scoopman and integrates perfectly into my system. Sony's new TCD-D7 (\$629.95 list) weighs just over a pound with four AA batteries installed. This is a real breakthrough since power consumption has been cut drastically from previous portable models. No more of those heavy, expensive nicads to lug around.

The D-7 offers all the features of the NT-1 Scoopman including "Plug In Power" and, for the first time on a Sony portable DAT machine, there are two types of AGC (music and speech).

The D-7 also offers a significant feature not found of the Scoopman: a long play mode that allows four uninterrupted hours of recording on a single 120 DAT cassette. This is a great feature for conferences and meetings when you want to set it and forget it.

Most people won't need both recorders, but I bought a D-7 as a companion to my Scoopman. As I see it, each has its place. When I want an ultra lightweight system, you can't beat the Scoopman. When you want or need the extra audio quality of DAT or four hours of uninterrupted recording time, the D-7 fits the bill.

With one of these machines and a few well-matched accessories, the day of the ideal personal recording system for journalists has arrived.

□ □ □

Frank Beacham is a writer, director, producer and consultant. His address is 163 Amsterdam Ave. #361, New York, NY 10023.

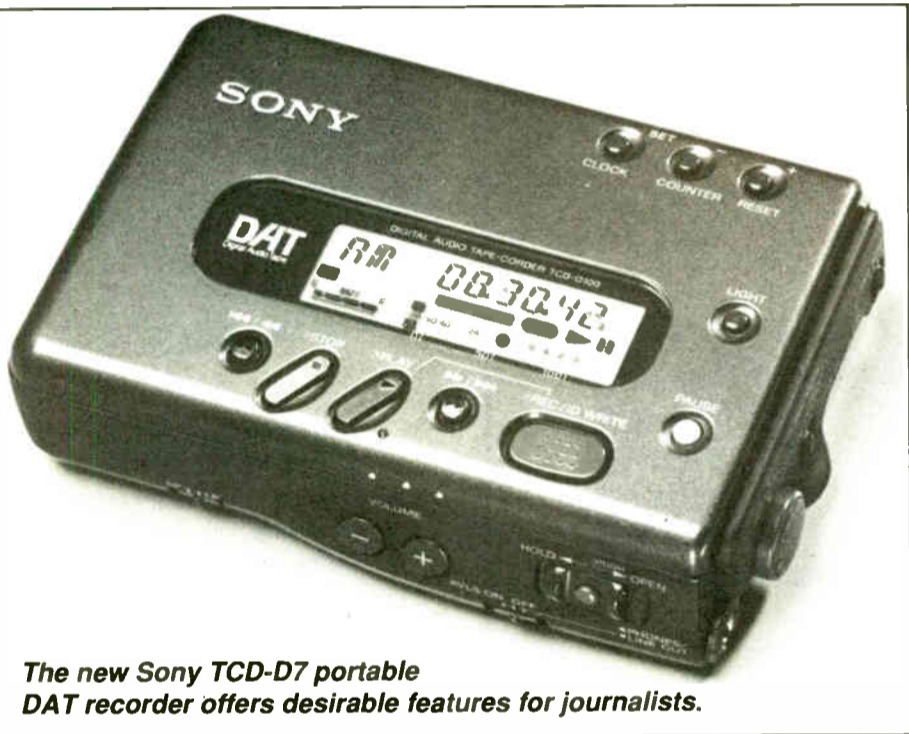

The new Sony TCD-D7 portable DAT recorder offers desirable features for journalists.

two or three pounds total. Most analog cassette or DAT gear, when packaged with extra batteries, tapes, mics, headphones etc., can quickly get heavy and bulky.

The system must run all day on a very few, easily-found batteries. I don't even want to think about AC power sources on location. The recording system should use small cassettes with long running time. In most cases, I don't want to change a cassette in less than an hour.

As the interviewer, I want my voice on a separate audio track from the person I'm interviewing. This simplifies any editing I have to do later. I also want the recorder to ride gain automatically so I can concentrate on content and not technology. (I know what you are thinking, but with the new digital AGC systems now available, this function has dramatically improved and certainly beats a fried DAT recording.)

And, as icing on the cake, I want great sound. I reject those cheap tinny-sounding mics that come with many portable recorders. I want to use professional-quality microphones but without bulky in-line phantom power supplies.

I found the perfect system about a year ago and have been using it ever since without a hitch. Last month, thanks to the introduction of a revolutionary new tape recorder, my personal system has acquired even greater capability.

Last summer, I achieved recording "nirvana" with Sony's NT-1 Scoopman digital microcassette recorder (\$999.95 list). It

liere condenser microphones as well.

With the help of Mike Riner at Audio Services Corp. (ASC), North Hollywood, Calif., I paired the Scoopman with two Millimics, tiny condensers manufactured by ASCU's sister company, Professional Sound Corp. These mics, as well as several other brands now available, need only 0.9 volts each to operate.

## AFFORDABLE FM1C

1 kW SOLID STATE FM STEREO TRANSMITTER

- Industry acclaimed FX50 Exciter.
- Reliable solid state design.
- 2 RF Power Modules for soft failure.
- Broadband design-no tuning.
- Internal Low Pass Filter.
- Reliable CMOS Controller.
- Compact, easy to install, rack mountable.
- Self protected RF Modules.
- Integral Reject Load.
- Two year warranty.
- Meets IEC-215 safety requirements.
- Low cost of \$16,500 includes FX50 Exciter.



**BROADCAST ELECTRONICS INC.**  
4100 N. 24TH ST. P.O. BOX 3606  
QUINCY, IL 62305-3606 U.S.A.  
PHONE (217) 224-9600  
FAX (217) 224-9607  
TELEX 250142

## TAG 2020

TELEPHONE AUTOMATIC GAIN



### A PROCESSOR FOR ALL SEASONS

- ★ BASEBALL SEASON
- ★ BASKETBALL SEASON
- ★ FOOTBALL SEASON
- ★ HOCKEY SEASON

**FEATURES:** BROADBAND OR BANDPASS FILTERED MIC OR LINE INPUT (SELECTABLE)  
OPTIONAL AUTO-ANSWER BOARD  
DIFFERENTIAL LINE OUT

**HINAT HINDES Inc**

42 ELAINE ST. THOMPSON, CT 06277 TEL203-935-9066/9242/9919FAX

Circle (51) On Reader Service Card

World Radio History

Circle (25) On Reader Service Card



# PRODUCT GUIDE

Companies with new product announcements for Studio Sessions Product Guide should send them to Radio World, C/O Studio Sessions Editor, 5827 Columbia Pike, Suite 310, Falls Church, Va. 22041



## Arrakis Trak\*Star Multitrack Recorder

The Arrakis Trak\*Star is a multitrack digital audio recorder, mixer, and editor

designed specifically for the radio broadcast professional. Trak\*Star also offers a family of task-specific software products designed to run on the basic Arrakis digital audio workstations.

Trak\*Star comes in two configurations: the Trak\*Star-2 and the Trak\*Star-8. The two-track editing software operates on the Trak\*Star or the Arrakis DigiLink workstations. The eight-track version is a sophisticated multitrack, mixing and editing software package.

For more information, contact Arrakis Systems at 303-224-2248; or circle **Reader Service 81**.

## Spectral Synthesis PRISMA Production System

Spectral Synthesis has introduced the low-cost PRISMA, a random access, multi-channel digital audio production system card that works with any ISA bus-compatible computer. The PRISMATICA software also is available for Windows users.

The PRISMA plays, records and mixes twelve simultaneous digital audio segments on 64 virtual tracks. It also includes multi-band parametric EQ on active channels and can connect to a

variety of external products via AES/EBU, S/PDIF or SPECTRAL Multi-I/O protocols.

For more information, contact Spectral Synthesis at 206-487-2931; or circle **Reader Service 138**.



## Peavey PRM Line of Monitors

Peavey offers a line of near-field monitors that are compatible with in-house radio production studio and independent studio use.

The PRM-308Si is a three-way, ported monitor with an eight-inch treated paper woofer, five-inch midrange and one-inch soft dome tweeter. The 28i (eight-inch treated paper bass driver) and 26i (six-inch treated paper bass driver) are sealed boxes with one-inch soft dome tweeters.

For more information, contact Peavey at 601-483-5376; or circle **Reader Service 208**.



# Clearly Digital.

Moseley's DSP 6000 Digital Transmission System... the clear solution to your STL problems is now a reality.

- ▼ Convey up to four 15 kHz audio channels with CD quality specifications over a single STL.
- ▼ 25 dB system gain improvement over analog STLs reduces new antenna & transmission line costs.
- ▼ Fade and co-channel intermod problems have no effect on SNR, so even quiet passages remain crystal clear and noise free.
- ▼ AES/EBU digital I/O allows direct digital interface to other digital hardware.
- ▼ Interface to any composite STL, preserving the capital investment of your existing STLs.
- ▼ Low coding delay of 3.8 ms keeps the air talent happy.
- ▼ A built-in V.35/RS-422 interface opens the door for utilizing the DSP 6000 with Fractional T1 digital Telco circuits.

To learn more about the digital transmission advantage, call today for our free color brochure.

**Moseley**

MOSELEY ASSOCIATES INC. • 111 CASTILIAN DRIVE • SANTA BARBARA, CA 93117 • (805) 968-9621 • FAX (805) 685-9638



## Tube-Tech LCA-2A Stereo Compressor/Limiter

The Tube-Tech LCA-2A compressor/limiter is entirely tube-based except for the power supply and sideband circuit. The compressor features six att./rel. presets as well as manual control. The limiter has variable threshold and LED indicator. Other features include input gain control and clickless relay bypass.

Frequency response performance is rated from 5 Hz to 50 kHz (minus 3dB) with a -85 dB S/N ratio.

For more information, contact David Schecterson at AudioTechniques, 212-586-5989; or circle **Reader Service 151**.



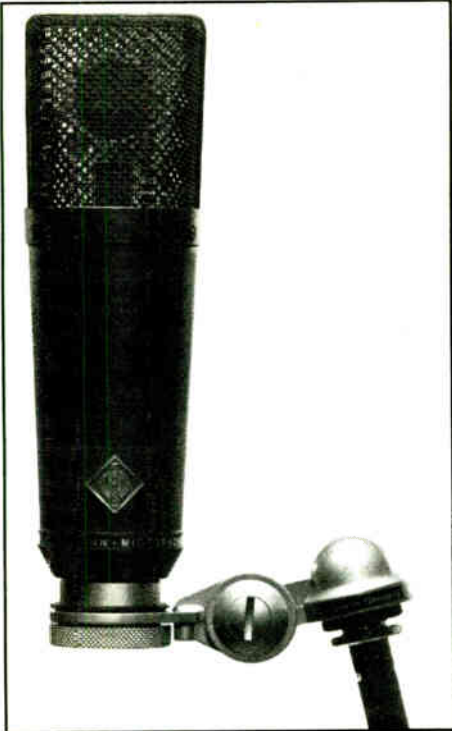

**Neumann TLM 193  
Large Diaphragm  
Microphone**

Neumann's new TLM 193 large diaphragm condenser microphone is slated for delivery in September. Cost is \$1,295.

The microphone is designed for critical recording, broadcast and live sound applications. Performance parameters include low self noise (10 dB on A-weighted scale) 140 dB maximum SPL (less than 0.5 percent THD) with 130 dB dynamic range, -73 dB S/N ratio, and 20 Hz to 20 kHz frequency response.

For more information contact Jeff Alexander at Neumann USA, 203-434-5220; or circle **Reader Service 28**.



**Genelec Monitors  
From Finland**

Genelec professional monitors are distributed in the U.S. by QMI in Hopkinton, Mass.

The Genelec 1019A, 1031A and the 1032A are considered good choices in studio applications. The 1019A is a two-way ( five-inch bass driver, one-inch tweeter) with bi-amp system. The 1031A also is a compact near-field monitor with bi-amp system and has an eight-inch driver. The 1032A is similar to the 1031A except with a 10-inch bass driver.

For more information, contact Barry Fox at QMI, 508-650-9444; or circle **Reader Service 114**.

**Wes Dooley Audio's  
New Headphone Amp,  
Stereo Decoder**

Wes Dooley Audio Applications has introduced two new products: the MS38 Lite stereo headphone amp/decoder (\$300) and the MS38 Mark II MS stereo decoder (\$585).

The MS38 Lite is a battery powered stereo headphone amp/decoder for field use with portable DAT recorders and VCRs. The unit is said to provide flexible stereo monitoring, even when recording component MS direct to DAT.

The MS38 Mark II is a MS stereo decoder in a half-rack package that is optimized for post production. Sum and difference points are said to allow additional reverb to be added to a stereo mix without affecting mono compatibility.

For more information, contact Wes Dooley Audio at 818-798-9128; or circle **Reader Service 167**.



**DIC Digital AR-4000  
DAT Drive Cleaner Tape**

DIC Digital's new dry, non-abrasive AR-4000 DAT Drive cleaning tape is good for 24 cleanings without any head damage.

The unit has raised cleaning nodules that are said to lift debris from the tape path and remove it from the machine without damaging the heads. DIC Digital said the AR-4000 is compatible with all DAT drive mechanisms in the industry.

For more information, contact DIC Digital at 1-800-DAT-1-DIC; or circle **Reader Service 42**.

**ART MDC-2001  
Master Dynamic Controller**

The ART MDC-2001 is a comprehensive controller for audio production that includes

stereo compressor, expander, noise gate, de-esser, exciter, peak limiter and clipper.

The unit features 21 LED gain control metering, balanced inputs/outputs, full stereo processing. Frequency response is listed at 16 Hz to 28 kHz (+0, -5 dB) with a S/N ratio of -110 dB.

For more information, contact ART (Applied Research and Technology, Inc.) at 716-436-2720; or circle **Reader Service 209**.

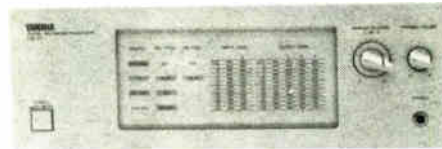

**Yamaha CBX-D5  
Hard Disk Recorder**

Yamaha's CBX-D5 hard disk, stand alone multitrack digital recorder can work with almost any computer systems including Macintosh and PCs using Windows.

Utilizing a four-track system with two simultaneous recording and four-track CD quality playback, the CBX-D5 has an on-board co-processor that allows it to be used with low-cost computers such as the Macintosh Classic II, SE 30, Atari ST and any Windows 3.1 compatible computer.

The unit also provides on-board DSP and DEQ, as well as four-band parametric equalizer for each channel. Used with a 100 megabyte hard drive, the CBX-D5 can record about 10 minutes of stereo audio. Time can be increased by adding extra hard drives to the SCSI chain or larger capacity drives.

For more information, contact Yamaha of America at 714-522-9011; or circle **Reader Service 193**.

What happens when you don't Advertise . . .

. . . NOTHING

Advertise in  
**Radio World Today!**

**STUDIO SERVICES**

**SOUNDQUEST MEDIA PRODUCTIONS**

FEATURING  
**Mark Driscoll and Daniel John**

\* ID's, Sweepers, Promos  
\* Radio Formatting \* Professional Consulting

Raise Your ARBS... Increase Your Sales...  
And Make The Competition Sweat...

Call the Worldwide Headquarters of Soundquest Media Productions...

**(908) 627-0376**

*Soundquest...The Competition Exterminators*

**427 SOUND EFFECTS \$89.00**

For a 5-CD set with a 30-day money-back guarantee.

*Take an extra \$10 off if you mention this ad!*

Send \$79 to Ghostwriters  
2412 Unity Ave. N., Dept. RW  
Minneapolis, MN 55422

For credit card orders call  
**(612) 522-6256**

**ATTENTION PROVIDERS!**

Promote your services to **Radio World's** 21,000+ readers. Reach Radio Station and Recording Studio owners/managers and engineers with your message. For information on affordable advertising call **Simone at 1-800-336-3045**.

**EFFICIENT  
AM LINE  
SOLID STATE  
STEREO TRANSMITTERS**

**AM5  
BROADCAST ELECTRONICS**

- **C-QUAM™ AM stereo included**
- **Patented high efficiency Class E power modules**
- **5 separate power levels meet all license requirements**
- **Redundant switching power supplies**
- **1, 2.5, 5 and 10 kW models available**
- **Star Combiner network provides uninterrupted operation**
- **Built-in output matching network**

**BROADCAST ELECTRONICS INC.**

4100 N. 24TH ST. P.O. BOX 3606  
QUINCY, IL 62305-3606 U.S.A.  
PHONE (217) 224-9600  
FAX (217) 224-9607  
TELEX 250142



OVER  
5 MINUTES  
OF 15KHZ STEREO AUDIO  
ON EACH 13MB FLOPPY DISC



## The Dynamax DCR1000 with New Version 2.0 Software

**SPECIAL PACKAGE PRICE: FOUR MASTER PLAYERS AND ONE RECORD MODULE  
\$ 9,995 UNTIL JULY 30, 1993**

### The Recorder

- Selectable sampling rates
- Secondary and Tertiary cues
- AES/EBU digital input
- Start on audio
- Direct digital dubbing from CD
- PC keyboard for titling
- Cut & paste editing
- New* • Variable length beds
- New* • Kill date checking
- New* • Disk label printing

### The Reproducer

- Simple cart-like operation
- No on-air personality training
- Just three front panel buttons
- Instant start and cue
- Maintenance-free design
- Awesome audio quality
- New* • Rotation & chaining
- New* • Replay lockout
- New* • Count-up/count-down timer
- New* • RS232 logging/remote control

### The Media

- 13MB stores over 5 minutes stereo audio with 15kHz bandwidth and 15 minutes mono with 10kHz
- Standard low-cost 2MB floppy disk holds 60-second commercials
- New* • Non destructive media diagnostic test

8:00 a.m. to 8:00 p.m. EST • 1-800-622-0022 • Fax 317-966-0623  
Canada 1-800-268-6817 • Toronto 416-731-3687

 **HARRIS  
ALLIED**

**Special Offer  
Ends Soon!**



# Don't Let Power Supply Go Out in Blaze

by Andrew Ellis

**SAN FRANCISCO** Power supplies have replaced vacuum tubes as the least reliable electronic equipment.

Many console manufacturers use OEM open-frame power supplies and package them in a single rack-mount unit. This is less expensive than engineering a power supply in house.

Most OEM-regulated supplies have current limiting. Some include "fold-back" limiting, which reduces current to a low value after a short or other over-current. Others, sadly, use current limiting which delivers the full-rated supply current (at reduced voltage) into a short circuit.

## Case in point

Recently, we had a large production console go up in various kinds of smoke due to a power supply failure.

There were three supplies. Two 18V at 3A supplies ran the analog sections, while lamps, relays and logic ran from a 12V at 6.8A unit. We believe that the initial failure was in the +18V supply. This caused the direct-coupled output amplifiers to slam against the -18V rail and reverse-volt their output capacitors, which failed in entertaining and showy ways.

We have since installed a modification to add protection to the power supply and shut down all three outputs if any one of them goes over or under rated voltages.

Approach such projects with caution. It is easy to degrade the overall reliability of any system by adding new parts. In this case we tried to make the monitor extremely reliable. Even more importantly, we made sure that the protection circuit was fail-safe by shutting off the console and by making the failure mode (all supplies off) safer than the original design.

The circuit checks the output voltage of all three supplies against high and low limits. A relay connects the power supplies to the console only if all three pass the test. Otherwise, all power supplies are disconnected from the load until the voltages are correct.

## Circuit description

Operation of the +18V supply monitor is typical of all three. The OEM supply output line to the console connector is broken, and normally open relay contacts K1A are inserted in it. The output of the supply is divided by R1/R2. (This allows use of a ±12V supply to operate the monitor.)

If the divided sample is above 8.5V, the output of U1A is cut off. Should it fall below that value, the open-collector output of U1A saturates. U1B operates in the opposite direction. It is cut off when the sample is below 9.5V, and saturates above that value.

The effect is that both outputs are cut off (indicating OK power) only when the sample is between 8.5 and 9.5 volts (corresponding to supply values of 17 through 19 volts).

The other two monitors operate the same way. If one or more comparator outputs are low, associated LEDs light to show which test is failing. Otherwise, R4 pulls the LED anodes to +12V. This

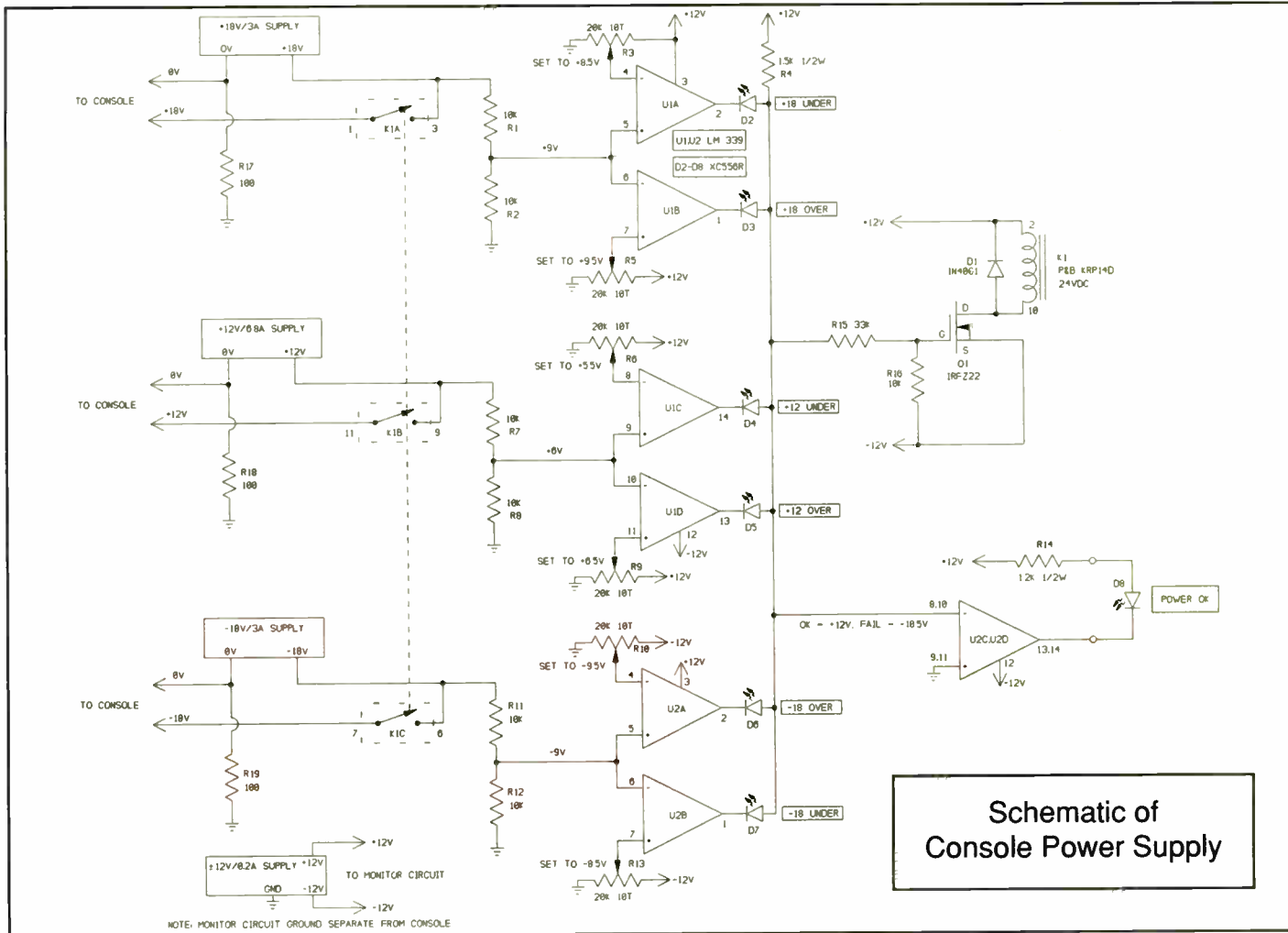

lights a "Power OK" LED on the front panel and pulls in relay K1 to connect all three supplies to the load. K1 is driven by VMOSFET Q1. Since it operates in switching mode, no heat sink for Q1 is needed.

Six 10-turn potentiometers set the limit voltages. The balance in setting them is between nuisance shutdowns if the limits are too tight, versus failing to shut down on a real fault if they are too loose. We found supply tolerances of ±1 volt work well.

We used a small OEM ±12 VDC at 200 mA supply for the monitor. Since the regulation of this supply controls the reference voltages, we felt this wiser than using the supplies being monitored. Using normally open relay contacts power supply will shut down the console, rather than leaving it operating without protection.

R17-R19 are used to prevent ground loops. The supply's common outputs are connected in the console, and these resistors force circulating currents through the single-point ground. Because of the 20K ohm input to the monitor, they do not affect the voltage samples.

Power supplies are troublesome beasts. They require regular checking. Careful design can ensure that when a power supply does fail, it does not damage other equipment as well.

Andrew Ellis is assistant technical director of CBS's KCBS(AM)-KRQR(FM) San Francisco. He holds a BA in communications (1972) from Stanford University, Palo Alto, Calif., and has been on staff at KCBS since 1973, where he has engineered radio coverage for two Super Bowls. Ellis has designed much of the remote equipment for KCBS/KRQR.

## For the world's strongest AM transmitters, look to Nautel

**Totally solid state AMPFET ND 10 10kW AM**

**Removable AM Power Module**

**Make a strong transmitter choice. Call us today for all the facts on our totally solid state AM and FM transmitters.**

**Nautel Maine Inc.**  
201 Target Industrial Circle  
Bangor, Maine 04401 USA  
Phone: (902) 823-2233

**Nautel**  
(Nautel Electronic Laboratories Limited)  
R.R. #1, Tantallon, Halifax County,  
Nova Scotia, Canada B0J 3J0  
Fax: (902) 823-3183

**Low cost of ownership** – with typical efficiency ratings up to 80 percent, a totally solid state Nautel transmitter pays for itself in tube replacement and utility

**Superior audio transparency** – Nautel AM transmitters utilize inherently linear digital Pulse Duration Modulation for the cleanest sound you can broadcast. Audio is ruler-flat throughout the range and distortion is typically less than 0.5%

**Field-proven reliability** – Nautel transmitters give you multiple protection systems for both power line and lighting transients, VSWR protection, soft failure design, reserve cooling and safe on-air servicing



## LOW POWER LOWDOWN

# Groups Translate to Public Service

by Howard L. Enstrom

**MOUNT DORA, Fla.** Engineering consultants work with engineers, but often with non-technical types as well, such as laymen starting up translator stations.

Independent translator groups seek to import a missing dimension of broadcast service to their community or area. A spark-plug leader who inspires such an effort is often buying into a lot of hard work and sweat. Many in a translator group are either lukewarm supporters or armchair critics. Small wonder group leaders look to a consultant for more than engineering service.

I marvel over the courage and tenacity of purpose many such leaders display. One case is Bill Young of Bitterroot Christian Radio Satellite, Inc. (BCRS).

### How it happened

Bill Young is a rural mail carrier in the Bitterroot Valley of Montana. Bill liked listening to a Christian radio station as he drove his route every day. The signal he picked up was translated from Missoula, 40 miles north of Corvallis, where Bill and his wife Glenda live.

In Corvallis reception is poor and riddled with interference. Bill and Glenda met with the translator people in

Missoula to discuss the problem, but learned that the translator was already operating at maximum legal power.

The Youngs then tried to form a group to build a translator to relay the Missoula translator signal, but found few people interested in such a project. Bill and Glenda's idea was to gather a multi-denominational group.

One day a cross-country truck driver told them about KILA(FM), a Las Vegas station with "Satellators." KILA was mentioned to them again, by a couple returning from a trip through Idaho and Nevada, KILA satellator country. The group debated and decided to go the

satellator route. They chose the name Bitterroot Christian Radio Satellite Inc.

### Green light from KILA

BCRS contacted KILA President Jack French, who provided written permission to rebroadcast the signal. The next step was to send out some 10,700 flyers to publicize the project. The cost was close to \$500, the very amount of the group's first contribution, donated by The Galileah Christian Book Store in Hamilton.

The "Ravalli Republic" newspaper inserted the flyers, and felt confident that they had reached most of the families in the valley. All the contributions were to be mailed to a special BCRS post office box.

The response to the flyers was a disappointment for the group and they began a search for other, more effective fund raising methods.

They raised \$226 from ticket sales at the county fair to raffle off a child's bicycle. But that was a long way from the needed \$12,000. BCRS then organized an auction, which turned out to be a lot of work. The BCRS account, however was raised by \$1,407.50.

Some gave half-heartedly in direct financial gifts. The group carefully kept records of all gifts for refunding the money later, in case the project didn't fly.

Advice came more freely than funds. Says Bill: "Frankly, we went through some very discouraging periods. But each time we really felt down, it was like the Lord sent someone with a donation and, even more importantly, a word of encouragement.

"We began thinking about putting on a benefit concert featuring some well known personality, such as Glen Campbell. Why not? Glenda and I visited with numerous church pastors in the area, to seek their thoughts and support of the idea for BCRS fund-raising."

### Involve the locals

Allen Maki, the pastor of the Baptist church in the south valley's very small community of Darby, told them it would cost a great deal to bring in big-name talent. He suggested they look to all the local talent to produce a concert. That did it.

The first "Evening of Praise" concert drew 400 people, a big success. Adds Bill: "We've now had six and they have become our biggest source of income." (Pastor Maki is master of ceremonies.)

I was hired by the group to design the equipment for the project. I studied topographical maps of the Bitterroot, and came up with my plans. The group had some trouble with equipment, mainly the result of not having technicians familiar with satellite dish antennas and their low-noise amplifiers.

Anyway, two years after their first efforts, the KILA satellator station became operational at 2 p.m. on Feb. 10, 1992. It certainly was a happy day for BCRS and a lot of people.

Many are not prone to just give, unless they get something, right now. I hope sharing the BCRS story helps other groups to work harder to seek public support for a community translator. It's a privilege for me to help such groups.

□ □ □

Howard L. Enstrom is an engineering consultant and president of FM Technology Associates Inc., specializing in engineering design and sale of FM translator services and equipment. He can be reached at 904-383-3682; by fax at 904-383-4077, or by mail at 30925 Vista View, Mount Dora, Fla. 32757.

## AUTOMATION BREAKTHROUGH!

# Music on Computer ROM is BETTER than Compact Discs!

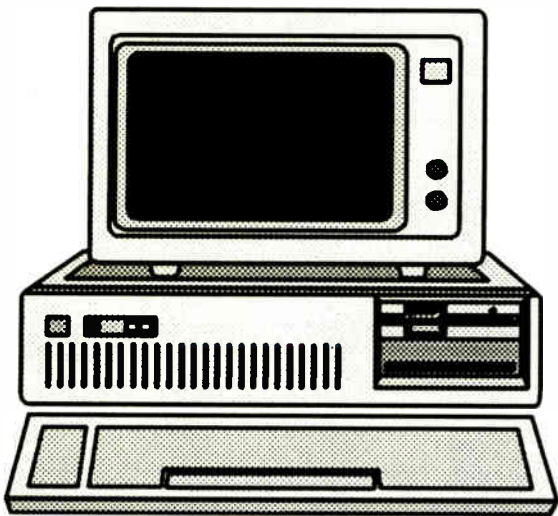

It's a fact: Scott Studios' new computer ROM is your best source of music! Here are four reasons why:

1. Computer ROM holds AT LEAST FOUR TIMES AS MANY SONGS on each disk as you get on any Compact Disc.
2. You'll SAVE THOUSANDS OF DOLLARS because you DON'T need a room full of consumer CD decks or expensive juke boxes! Simply dub current hits to our multi-studio digital audio hard

drive. Two computer ROM 6-pack players hold 800 songs and cost \$1,995!

3. ROM music quality is UNSURPASSED! Dave Scott uses 100% DIGITAL breakthrough technology to deliver the sonic enhancements of the highest priced CD libraries--in less space, and a fraction of the cost!

4. 500 SAFE-LIST SONGS ARE FREE on ROM with purchase of Scott Studios' new \$19,995 automation! Includes 2.9 hours of stereo hard disk digital audio for current hits and spots (5.8 mono)--with true overlap, recording while playing, and week-long automation walkaway. More storage available at extra cost. Music libraries include AC, Soft AC, Oldies, CHR, Country, and others.

This month, complete hardware AND 500 researched songs, only \$19,995! Call Dave Scott Studios toll-free at (800) 330-3004.

# Scott Studios

4125 Keller Springs, Suite 122  
Dallas, Texas 75244  
(214) 221-3100 FAX: (214) 931-0707  
**(800) 330-3004**



# WORKBENCH

## Maintaining Connections, Rolling Cleaner

by John Bisset

**FALLS CHURCH, Va.** Dirk Neal from Prestige Audio Visual, Cincinnati, wrote in with a way to do the impossible: feed a larger-than-normal cable through the rubber boot of a Switchcraft XLR plug. Put away the needle nose pliers, which only chew up the boot anyway, and grab a tube of lubriplate. Spreading a thin coating on the outer sheath of the wire reduces friction and ends the frustration.

Dirk's procedure is to completely remove the screws that form the clamp of the Switchcraft XLR. After the wire is inserted through the boot and soldered, reassembly of the clamp/boot is simple. Dirk Neal can be reached at 513-784-1711.

Speaking of Switchcraft, are you aware of their T3F Connector? This connector combines a three-conductor female XLR with an extended barrel that houses an "on/off" switch. The connector plugs straight into the mike, and the switch provides slide-switch on/off operation.

For remote PA applications, where the jock has to talk to the crowd and mix his PA mike levels, and where the standard studio mike is used (which has no on/off switch) this connector is an ideal choice. Circle Reader Service 121 for a Switchcraft Catalog.

Since we're on the topic of XLR mike connectors, here's a little trivia. No, I'm not going to ask you which pin is wired to be "hot." The question is, do you know how to determine which sex plug is used for custom-wiring applications on inputs or outputs? For years this puzzled me.

Here's a real easy way to remember. The three prongs of the male connector point to the direction the signal flows. Therefore, on a mike, the connector you will find opposite the windscreen or

diaphragm is a male, since the prongs point out, or away from the mike (and signal travels out of the mike through that connector).

At the mike mixer, the input of the mixer will have female inputs, since as you look at the other end of the mike cable, the male prongs point to the mixer, which, again, is the direction the signal will flow.

The same is true for the mixer output. A chassis-mounted male connector is found at the output, since the signal flows out of the mixer at that point. A silly little analogy, but one that should help your intern (or you at 2 a.m.) avoid making same-sex connectorized cables.

★ ★ ★

I know that after the "all-digital" NAB, few of us will remember what a cart machine is, but those of us still using them will recall that the heads and pinch rollers need routine cleaning. A few wooden cotton-tipped applicators fastened to a bottle of isopropyl alcohol with a rubber band is the usual fare—that is until the bottle gets knocked over.

A company called Techni-Tool markets a solution to spilled alcohol called a Menda Dispenser. Used primarily in laboratories, this little container combines a small plastic bottle/reservoir with a stainless steel pump. The pump is activated by lightly pressing down on the dispensing dish with your cotton swab.

The dispensing dish screws onto the plastic bottle and contains a flip up cap to keep the bottle contents from spilling. As you press the dish with the swab, a small amount of alcohol is squirted up into the dispensing dish, where it is quickly absorbed.

You'd expect something that does all this to cost a bundle, but the dispensers are just \$9.95, and have a lifetime guaran-

tee. You'll find them listed on page 104 of the new Techni-Tool catalog. If you'd like a copy, circle Reader Service 13.

★ ★ ★

Jon Banks of CBS's WLTT(FM) Washington shared a solution for burned out lamps in Auditronics consoles. The company, LEDTRONICS, manufactures LED replacement bulbs. The part number for the Auditronics console is W206-CR6-24V/20. The LEDs aren't cheap (about \$4 each), but if you've bought a box of miniature bulbs lately, you'll realize nothing's getting cheaper, and the long life provided by an LED makes good economic sense.

Conversion to the LEDTRONICS LED bulbs does require a little surgery on the console modules. To lengthen incandescent bulb life, Auditronics runs a small idling current through the bulb contacts when the switch is off, the idea being that the shock of electrons to a cold filament is reduced, lengthening bulb life. This trickle current will cause the LEDTRONICS replacements to illuminate dimly, which could be confusing for the air talent. Snip the two idling current resistors, located near the switches on the board, and the problem goes away.

One caution before you buy—on consoles using subminiature bayonet-style bulbs, check to see which end is positive polarity. These bulbs are LED's and will not work if the wrong polarity voltage is applied. This poses no problem on the bi-pin bulbs used in the Auditronics boards. Simply remove the bulb, turn it around, and re-insert.

On bayonet style bulbs like the #387, however, you must get the polarity right. Ask for a sample before you buy a large quantity. For more information on the LEDTRONICS replacements, circle Reader Service 73.

John Bisset is a principal with Multiphase Consulting, a contract engineering and projects company in Falls Church Va. He can be reached at 703-764-0751. You can fax tips to his attention by dialing 703-998-2966, or write in care of Radio World. Published submissions qualify for SBE re-certification credit.



### LMA/DUOPOLY CONTOUR MAPS

The DATAWORLD LMA/DUOPOLY Market Survey Contour maps present a precise electronic verification of overlapping and intersecting contours.

AM 5 mV/m and FM 3.16 mV/m City Grade contours are shown in full color, including transmitter site indicator. The map is supported with a printout showing all of the stations which appear on the map.

Daily updating of DATAWORLD'S AM and FM databases protects against errors and omissions.

#### OTHER MAP OPTIONS

- SHADOWING (TERRAIN SHIELDING)
- CONTOUR COVERAGE
- POPULATION DENSITY
- ZIP CODE BOUNDARIES
- RECEIVED SIGNAL LEVEL
- SPECIAL REQUIREMENTS

### 1990 CENSUS

#### WHO ARE YOUR LISTENERS?

#### 1990 BUREAU OF CENSUS POPULATION COUNTING

- Comprehensive Ethnic and Demographic Data
- Ethnic/Demographic Data Available for Each Zip Code Within Coverage Area
- Age Analysis Reflected in Ethnic Breakout
- Resolution Increased to Block Level
- Percent of County Coverage Shown

#### ETHNIC PIE-CHART DISPLAY

- Projects Ethnic Population in Multi-Color Pie Chart Form

dataworld®

800-368-5754 FAX: 301-656-5341

## THE SIMPLE SOLUTION FOR DIGITAL AUDIO TRANSPORTATION

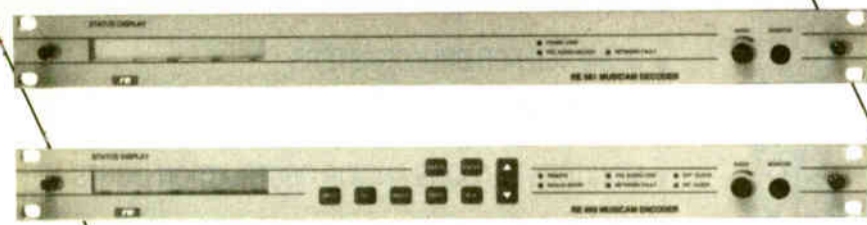

- ▲ MUSICAM ISO/MPEG Layer 2, 2A
- ▲ Switched 56, 64 kbit/s, ISDN, Fractional T-1
- ▲ User data channel from 300-9600 baud
- ▲ Easiest set-up locks to network or internal clock
- ▲ Fully automatic decoder reduces operator set up

- ▲ Multiplex or redundant two times 56/64 for 112/128 kbit/s
- ▲ Mono, Dual Mono, Stereo, Joint Stereo operation
- ▲ AES/EBU and SPDIF digital interface *included*
- ▲ Two-times V.35, X.21 or RS 422 interface *included*
- ▲ Headphone monitor *included*

The RE 660/661 MUSICAM Digital Audio Codec was developed to enhance MUSICAM technology, providing up to 20 kHz of audio bandwidth. From satellite networks to switched

56 telephone lines, the full-featured RE 660/661 is completely bit rate flexible up to 384 kbit/s.

Applications range from network program distribution to remote pick-ups for sports, concerts, special events, news gathering, STL back-up, audio backhaul, recording and post production studios.

When it comes to digital audio transportation, nothing comes close to the RE 660/661 for providing quality audio with hassle free set up. Backed by 55 years of experience in analog and digital audio products, the RE 660/661 is the simple MUSICAM solution for all your digital audio transmission needs.

Available through Harris Allied and Broadcasters General Store



RE AMERICA, INC.  
31029 Center Ridge Rd. ▲ Westlake, Ohio 44145  
Phone: (216) 871-7617 ▲ Fax: (216) 871-4303



## COLE'S LAW

# EEO Report is a Year-Round Project

by Harry Cole

**WASHINGTON** If you're a good and faithful licensee, you have probably just filed your 1993 Annual Employment Report (FCC Form 395).

Accurate preparation of this report hardly ranks up there with brain surgery or rocket science, but its actual importance is likely underestimated by many. With that in mind, here are a couple of tips for you to consider in connection with your next 395.

It is true that the preparation of the form itself ought to be a piece of cake. All you

have to do is pick a pay period (generally, the same pay period you used last year) during the first three months of 1993, pull your employment records for that period, and transcribe the raw numbers from those records into the appropriate rows and columns on the FCC form.

No sweat, as long as you have easily retrievable records that reflect not only the names and genders of your employees, but also their racial and/or ethnic characteristics. It would also help if your records from year to year consistently reflect the FCC job category assigned to each position. That way you won't have

to worry about trying to figure out whether to classify, say, your traffic director as an "administrative" employee or as an "official or manager."

Okay, let's assume for the moment that your records are in apple-pie order, that you filled out the form and shipped it in to the commission by the May 31 deadline, and that you put a copy in the station's local public inspection file right away. Is your job done for the year?

Technically yes, but that is a very short-sighted view which can easily come back to haunt you at renewal time. When you file your renewal application, of course, you have to prepare and submit an EEO report which is considerably more detailed than the annual 395. And when the commission's staff reviews your renewal, it can (and is likely to) pull out your 395s for the preceding license term, just to see if any trends appear.

### More information

If, for example, the staff notices a chronic lack of females or minorities in your employment (whether overall or only in the upper-four job categories), it is very possible that you will receive a letter of inquiry asking for more detailed information about your employment practices. Responding to such an inquiry can take a considerable amount of time and energy. An inquiry will almost certainly mean delay (possibly years) in grant of your

renewal, even if you come up clean.

All of this can be avoided in most cases by taking some reasonably low-impact precautions. The most sensible time to take those precautions is when you have all your employment records out anyway for the preparation of your annual 395.

First, make sure that you do have a good handle on the job categories of your employees and their ethnic/racial identifications. You should have this information just to fill out the 395 form, but it's good to go back over your files to make sure.

Second, compare your answers on this year's form to your answers on the reports you filed for the last two or three years. Are there any significant changes in total number of employees, total number of minorities or females, number of women or minorities in the "upper-four" positions? If from this comparison you can see that there has been a noticeable decrease in minority or female employment, you can safely assume that the FCC's staff will see the same thing, and may very well ask you about it.

Third, if you do notice a decrease, you should review your files to make sure that you can demonstrate that trend did not arise from any discriminatory practices on your part. This is not an easy thing to do. If employees (particularly minority or female employees) have left your employment, you should have some record of the reasons for the departures.

### Good record keeping

If positions have become available and non-minority males have been hired to fill them, you should doublecheck to

continued on page 33 ►

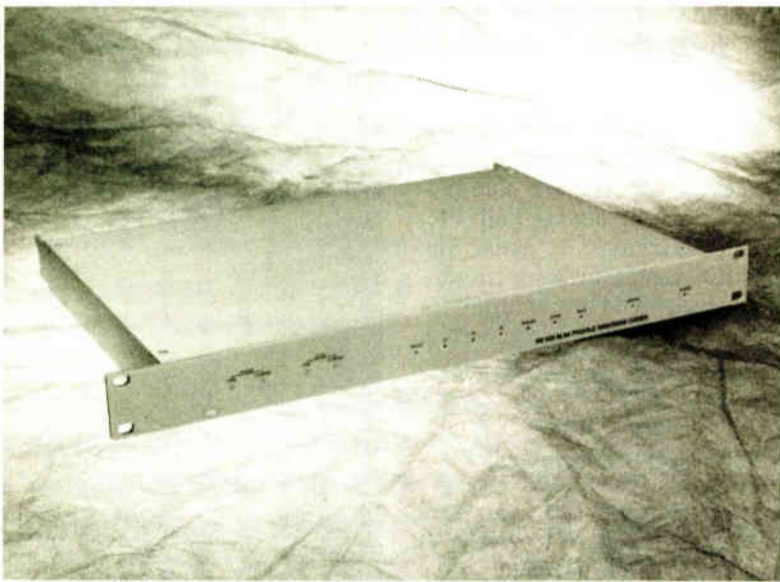

## "Smart Radios" Are Here!

Unlock the revenue potential of RDS/RBDS with RE America's model 533 Slim Profile Coder. In just minutes, your station can be on line, talking to the "smart radios."

Years of experience and input gained from broadcasters in the development of RDS equipment is revealed in this RE533 compact RDS coder.

The RE533 Coder gives broadcasters instant gratification on the "smart radio" dial by transmitting call letters and providing format seek.

Designed to meet the rigors of all FM broadcast environments, the RE533 is capable of storing 16 different RDS records.

Broadcast engineers know that flexibility is the key when locating spare auxiliary channel input capacity for subcarrier signals. The RE533 will adapt to studio or transmitter placement, inline with composite signal or as an RDS/RBDS subcarrier source.

The RE533 PC control software is very user friendly making data programming a snap.

We've got all the details on RDS/RBDS and the RE533 Coder.

8:00 a.m. to 8:00 p.m. EST

1-800-622-0022

Fax 317-966-0623

**HARRIS ALLIED**

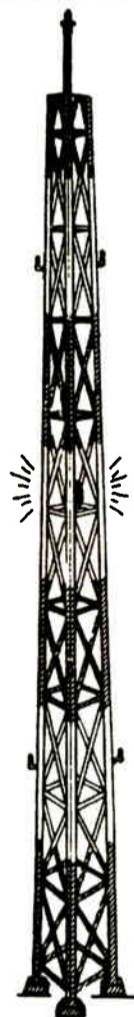

## Are Your Tower Lights On?

With the 1750-TLM  
You'd know for sure!

- FOUR INPUTS
- AC LINE TRACKING
- PHOTOCCELL INHIBIT INPUT
- LOGIC SUMMARY "ON" CARD
- DAISY CHAIN FOR MULTI-TOWER APPLICATIONS
- CAN HELP YOU MEET FAA/FCC REQUIREMENTS
- DESIGNED FOR BROADCASTERS
- ALARMS FOR SINGLE BULB FAILURES
- MONITORS BEACONS AND/OR OBSTRUCTION LIGHTS
- STATUS OUTPUTS FOR REMOTE CONTROL APPLICATIONS

CONTACT US NOW FOR COMPLETE DETAILS & DESCRIPTIVE LITERATURE

**POTOMAC INSTRUMENTS**

932 PHILADELPHIA AVE., SILVER SPRING, MD 20910

(301)589-2662 FAX: (301)589-2665





**BUYING YOUR FIRST HARD DISK SYSTEM?  
ASK DCS USERS WHO'VE BOUGHT THEIR  
2ND, OR 3RD OR 4TH...**



*"We needed a one-button operation to fire commands at each of our four simulcast stations and the DCS was the only system reliable and smart enough to trust with our spot load."*

MARK ROLLINGS,  
PRESIDENT, ROLLINGS  
COMMUNICATIONS,  
CHAMPAIGN/URBANA, IL



*"I have installed a half dozen DCS systems here and in other stations, and I think it's the most functional, flexible and complete system on the market."*

DENNIS EVERSOLL,  
VP ENGINEERING,  
WRHQ, SAVANNAH, GA



*"Computer Concepts leads the way, in my opinion. Our next system was delivered right after Radio '92... that says it all!"*

MARK VAIL,  
STATION MANAGER,  
KSJQ & KFEQ,  
ST. JOSEPH, MO



*"We are very pleased with the Computer Concepts hard disk system for both our stations, but I am most pleased with the support, especially the pleasant, knowledgeable and fast help from your staff."*

DAVE ANTHONY,  
STATION MANAGER,  
WCED/WOWQ DuBois, PA

**apt-X** DIGITAL  
COMPRESSION

**Computer Concepts**  
CORPORATION

**PROFIT FROM OUR EXPERIENCE. CALL 800-255-6350**

COMPUTER CONCEPTS CORPORATION • 8375 MELROSE DRIVE, LENEXA, KS 66214 • TEL: 913-541-0900 • FAX: 913-541-0169

Circle (177) On Reader Service Card



QEI QEI QEI QEI QEI QEI QEI QEI QEI QEI

## Bring your station into the 90's with CAT-LINK—the digital STL/TSL.

"It's a dream system—we get specs like the microwave wasn't even there. CAT-LINK has completely eliminated the STL delay."

Jeff Andrew, WGCI-FM, Chicago

"CAT-LINK solved all our problems in 4 minutes—2 minutes to install each end. Performance has been impeccable."

Paul Christensen, WIVY-FM, Jacksonville, FL

"CAT-LINK makes money for us, and it improves the sound of the station."

Mike Callaghan, KIIS-FM, Los Angeles CA

"CAT-LINK has held up through extreme heat, a hostile RF environment and nasty summer lightning storms."

Dick Byrd, WZGC-FM, Atlanta GA

### Two-way multi-channel communications

CAT-LINK digitizes the entire composite signal with no data compression, so you can run the stereo generator and processing at the studio, where they really belong. At the same time, CAT-LINK sends and receives up to four customized auxiliary channels with no crosstalk—SCAs, control channels, voice communications, RS232 data, AM audio, transmitter readings and satellite or remote program feeds. What's more, CAT-LINK gives you extra capabilities like transmitter building surveillance via closed circuit TV and an analog telemetry channel.

### Transparent digital transmission

CAT-LINK encodes the fully processed composite signal, then decodes it at the transmitter. You always get full stereo separation, without the phase or amplitude variations that plague two-channel STLs. Dynamic range is up to 84 dB, and your processed composite signal can use virtually all of it. You hear clear, clean, undistorted audio—all the time.

### No audible delays

CAT-LINK's real-time digital encode/decode process doesn't introduce audible delays as data compression can. Jocks can monitor on-air without problems.

### Flexible signal path options

#### • 23 GHz

Stations across the country are avoiding 950 MHz problems by using 23 GHz with CAT-LINK. They've stopped worrying about frequency congestion and interference, repeater-induced signal degradation, and fresnel zone clearance fading. 23 GHz dish sizes also reduce wind loading and tower space requirements.

#### • DS1 (T1) Data Line

CAT-LINK is cutting phone bills for stations that don't have a clear microwave path. With CAT-LINK, a single bidirectional DS1 line replaces multiple Class A telco lines, providing multi-channel STL and TSL over the same link. Already available virtually anywhere, DS1 service is getting cheaper every day.

#### • Fiber Optic

CAT-LINK and its optional fiber optic modem provide direct connection to discrete fiber.

#### • Twisted Pair

CAT-LINK will drive up to 5000 feet of twisted pair wire without repeaters. Four wires provide full two-way multi-channel capabilities.

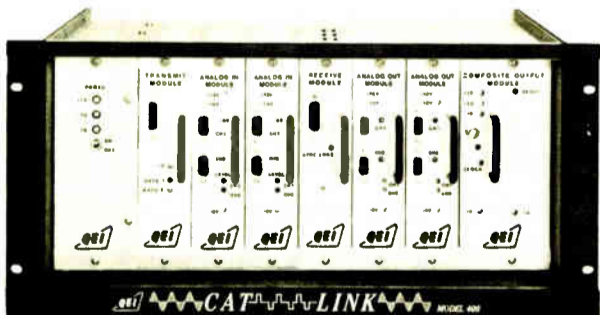

### Turn the weak link in your signal chain into one of the strongest.

Call QEI toll-free at 800-334-9154 for more information on CAT-LINK—the digital STL/TSL for the 90's...and beyond.

QEI CORPORATION  
ONE AIRPORT DRIVE • P.O. BOX 805 • WILLIAMSTOWN, N.J. 08094

24 HOUR SERVICE HOTLINE (609) 728-2020  
TEL (800) 334-9154 • FAX (609) 629-1751

**Q**UALITY • **E**NGINEERING • **I**NNOVATION

Circle (131) On Reader Service Card

## FACILITIES SHOWCASE

# MJI Reaps Benefits from Leading Audio Architect

by Dee McVicker

**NEW YORK** John Storyk has built over 500 world-class recording studios during his 20-plus years as an architect—the Frank Lloyd Wright of the audio world.

Over the years, some of the more impressive names on his client list have included Jimi Hendrix, Atlantic Records, Def-Jam Records, Sony, and Whitney Houston.

More recently he has completed a studio design for MJI Broadcasting, the nation's second largest radio syndicator with 2,000 affiliate stations and 20 million listeners. The facility, built on New York City's

Sixth Avenue, employs all the design principles of a Storyk studio: acoustical sound design, ergonomic layout and occupant personality.

Space and money were still very much finite resources, as they were when Storyk built the former MJI Broadcasting studios 10 years ago. But this time around he was given ample room to work his craft.

Like 500 or so studios before, Storyk and his New York architecture firm, Walters-Storyk Design Group Inc., started with the basics. He spent the first year assessing potential buildings with MJI's founder and President Joshua Feigenbaum.

Feigenbaum had specific real estate requirements. After location, foremost on his list was increasing the number of production studios for MJI programming, which includes specials like The Rock 'n' Roll Hall of Fame induction ceremonies, The Country Music Association Awards, and, most recently, VH-1's "Center Stage" concert series.

Storyk, meanwhile, had physical and acoustical goals for the ideal building. "It does pay to put in the extra effort to get the right space," said Storyk, who suggests at least a 10-foot clearance from the underside of any overhead beam and no less than 22 feet between columns.

Storyk also suggests adjacency and program studios, which he did for MJI "to see exactly how big of a space we should be looking for," he said.

It took a year of searching before Storyk and Feigenbaum found a vacancy at 1290 Avenue of the Americas (Sixth Avenue's other name), an address shared by the Rolling Stones and other big-name music acts. MJI signed a lease to occupy 15,000 square feet on the sixth floor.

### Layout challenge

Next came facility layout, which proved to be Storyk's biggest challenge given the sixth floor's oblong shape. "The idea was to get everybody to enter into the middle and to split off to the three basic categories of business. That was the biggest single trick," he said.

It took over 14 sketches, but finally Storyk and Feigenbaum created a layout that was technically sound and made good use of space for traffic flow into the three main areas of MJI's business: executive, sales and audio production.

The final layout solved another problem: where to put the two interview rooms that would be used by guest personalities on their public-relations junkets to New York. The two interview rooms, said Storyk, "needed to be close to the reception area and sort of integrated into the office, but they had to be isolated also."

Storyk was able to physically integrate both the business and the production functions of the interview rooms by placing the rooms between the studio wing and business wing of the facility. The two rooms also are near the entrance and reception area, another requisite of the design.

After final layout was settled, the project went to bid. Nine general contractors competed for the project, which comprised a production facility of two interview rooms, a large pre-production studio and five production studios, two of which include vocal booths.

Sound specifications for the studios were within moderate professional audio standards. Said Storyk: "Josh's sound transmission requirements are moderate, they don't really monitor at extremely loud levels."

### NC and STC requirements

The noise criteria (NC) for the main studios were specified at NC 25, which required walls and doors with a standard transmission criteria (STC) at around the mid-50s.

Wall partitions between studios are STC 56, and between vocal booths and the studios, STC 54. Doors are specified at STC 49, and the entrance to studios from their vocal booths is through a sound-lock chamber to buffer against noise.

Moreover, said Storyk: "The production rooms are complete room-within-room construction. They're totally floating, as well as the interview rooms." The two interview rooms were more lightly specified for sound isolation than the main studios.

Overall, said Storyk, the studios and interview rooms are "pretty quiet, certainly more than sufficient." Just as important, he said, the studios are "ergonomically set up to accommodate the way Josh works."

Within the studios, Storyk employed several pro audio techniques he's learned over the years. "Basically we had to introduce into this office complex pretty much standard pro audio recording conditions," he said.

All studios have sloped ceilings higher at the back and lower at the front. They have an isolated transformer to eliminate copier noise or computer hum from coming over the electrical lines, and a large conduit for cabling and wiring of an anticipated computer workstation.

The studios were completed within 11 weeks, after which Storyk went on to start another of his many studio designs.

□ □ □

Dee McVicker is a freelance writer who regularly contributes to RW. She can be reached at 602-545-7363.



# A Few Boxes, a Moose Cure Moving-Day Blues

Dear Luci,

Sorry you never got to hear from me last month. It's movin'-on-up time again.

After three productive years at WLAD(AM)-WDAQ(FM) Danbury, Conn., I'm now production director for WINK 104 Harrisburg Pa.—multitrack MIDI production, no air work and designs on digital via Roland gear. (Warn Ty Ford to expect calls from me when I hit snags.) All told, a very good choice.

You know the secret to landing desirable jobs? Get as busy as possible in as many things as possible, thereby making any departure an utter personal catastrophe. Once you're committed to the point there just aren't enough numbers on the clock, along will come that dream gig that forces the order of the universe into absolute ruin.

No kidding. Only days ago, I was acting in a production of "Beyond Therapy" (how fitting for a jock), planning with my local cable TV company to do comic voiceovers, working on my next epic MIDI planetarium music score and prepping for summer's commercial load. I also had to break the bad news to some delightful ladies I'd been seeing.... \*sigh\*...

Then—joy of joys—came dealing with movers, utilities, lease loopholes and the like. I think of how much simpler my life would have been to just pull a Mrs. O'Leary and burn down my condo during milking time.

## Moving made easy

Consultant Dan O'Day's marvelous handbook for broadcast personality development (available through the *Whole O* catalog—you're welcome, Dan) devotes only two or three lines on moving from gig to gig. To any broadcaster on a budget, I offer the following suggestions:

- Check the classifieds for some Rent-A-Moose operation. Since the former Mrs. Peterson got all the light, easy-to-move stuff, I've found this service quite valuable. Three big strong guys lug your Sauder Woodworking bolt-together furniture right up the Ryder ramp for a fair price. And since Sauders weigh as much as Steinways, it's money well spent.

Can't find this service? Negotiate free chiropractic sessions into your new contract. You'll find out why.

- The U-Haul people suggest about 35 boxes for a one-bedroom apartment. I've found the same way you pack laundromat machines when low on quarters works very well for moves too...ten boxes, max.

- If you actually took that last bit of advice, find an apartment close to a mess of family restaurants. It'll take you a week to find your cookware, so you may as well get to know the folks behind the counter at Denny's or Stuckey's.

- Find out who your replacement is. Just before deadline I heard the guy replacing me (at least for a week) is the same guy I replaced back in 1990, effectively making my contributions to the community filler between his appearances. I may be overreacting, but then again show me any performer who's self-confidence isn't easily rattled.

- Finally, if making a move during this time of year, skip the cable subscription. The pool at the condo complex is cheaper and better for you. I've grown to like that

summery look, subtle tan and chlorine-green hair. Besides, it's a hoot hearing your station on every radio around the pool.

I'll check in again next month, Luci. I'm still trying to find which box has my home studio in it. It's either in with my glassware or roped inside the fridge. Both are behind the Sauder furniture.

This could take a while.

—Al

□ □ □

*Al Peterson is the new production director at WINK-FM Harrisburg, Pa. Reach him at 717-238-1041. If he's not there, try Denny's or Stuckey's.*

## FROM THE TRENCHES

by Alan Peterson



cold cool



stale fresh

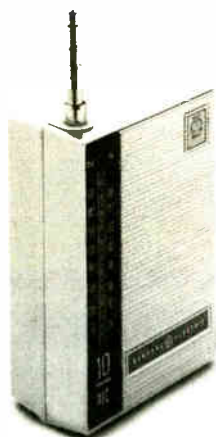

then now



in



**the unity 2000i**

the world's best sounding fm processor



CUTTINGEDGE

2101 SUPERIOR AVENUE, CLEVELAND, OHIO 44114 • TEL: (216) 241-3343 • FAX: (216) 241-4103

Circle (92) On Reader Service Card

World Radio History







# ULTIMATE DIGITAL STUDIO®

**MUSIC IS FROM COMPACT DISC (TM CENTURY GOLD DISC MUSIC LIBRARIES ARE AVAILABLE IN ALL POPULAR FORMATS)**

**COMMERCIALS, JINGLES AND LINERS ARE FROM HARD DISK.**

The SOURCE is clearly displayed AT ALL TIMES

The screenshot displays the following information:

- Header:** T M C I 8 58 ULTIMATE DIGITAL STUDIO 3.925 Tuesday 06/22/93
- ON THE AIR (1:23):**
  - PINK HOUSES** (CD JUKEBOX #1, Slot:35 Cut:02)
  - MELLENCAMP, JOHN COUGAR** (CD ID:129, Sked at:09:05, Sked on:05/25)
  - Time: 3:13 Intro:16 End:C
- READY TO AIR:**
  - BEST OF MY LOVE** (CD JUKEBOX #3, Slot:19 Cut:12)
  - EAGLES** (CD ID:510, Sked at:09:13)
  - Time: 4:16
- NEXT TO AIR:**
  - DREAM WEAVER**
  - WRIGHT, GARY**
  - Time: 3:07
- VIEW EVENTS (ESC to Exit):**

8:54	3	I NEED YOU	AMERICA
8:57	4	MIX_105_1	JINGLES
ON AIR		<b>PINK HOUSES</b>	<b>MELLENCAMP, JOHN COU</b>
09:13	:15	BEST OF MY LOVE	EAGLES
09:21	:11	DREAM WEAVER	WRIGHT, GARY
09:24	:02	IF YOU BELIEVE	LOGGINS, KENNY
- System AUTO-SEGUE** and **LOGGING: ON TIME UPDATE** are also visible.
- Copyright 1990 - 1993 TM Century, Inc. Dallas, Texas** is at the bottom.

UDS clearly shows you WHAT'S ON THE AIR, WHAT EVENT IS READY TO AIR NEXT, AND WHAT IS NEXT TO FOLLOW.

USER FRIENDLY WINDOWS POP UP WITH ONE KEY STROKE

View what has played and what is coming up without access to schedule

**TM CENTURY HAS DELIVERED OVER 300 ULTIMATE DIGITAL STUDIO SYSTEMS WORLDWIDE. THE SOFTWARE AND HARDWARE COMPONENTS THAT COMPRISE THE UDS ARE HIGHLY RELIABLE AND PROVEN.**

**CALL YOUR SALES REPRESENTATIVE FOR INFORMATION ABOUT THE MANY OTHER FEATURES THAT ARE INCORPORATED INTO THE ULTIMATE DIGITAL STUDIO.**

**(800) TM CENTURY**

Circle (90) On Reader Service Card  
World Radio History



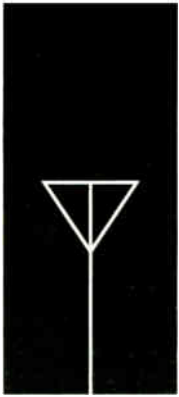

# DIGITAL STL BREAKTHROUGH

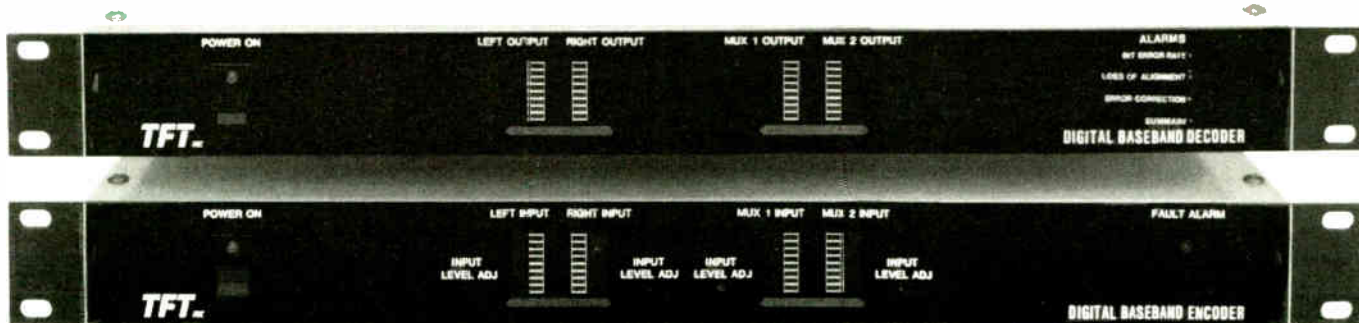

## *Introducing the TFT DMM92: The Better Digital STL System*

**W**ould you like to extend the fade margin of your existing analog STL by 20 dB or more? Extend Signal-to-Noise Ratio by at least 10db? Extend STL distance by miles? All with the bandwidth efficiency of 15-level duobinary modulation? There's just one digital STL system that lets you do it all— TFT's new DMM92. It works with your existing composite STL to give you vastly extended performance, and a whole lot more:

### ◆ **More Channels —**

- ◆ Six audio channels, 4 program and 2 voice
- ◆ Co-exists with FM SCA/MUX channels
- ◆ AES/EBU and 32 kbps data channel available

### ◆ **More Flexibility —**

- ◆ Internal, or external **apt-X** DIGITAL COMPRESSION, MUSICAM & Dolby audio codecs
- ◆ Instant plug-in installation with virtually **any** STL
- ◆ Useable for LMA's and duopoly applications

### ◆ **More Useable RF Spectrum —**

- ◆ Six audio channels in a 250kHz RF slot
- ◆ Perfect for highly congested markets
- ◆ Tolerant to co-channel interference

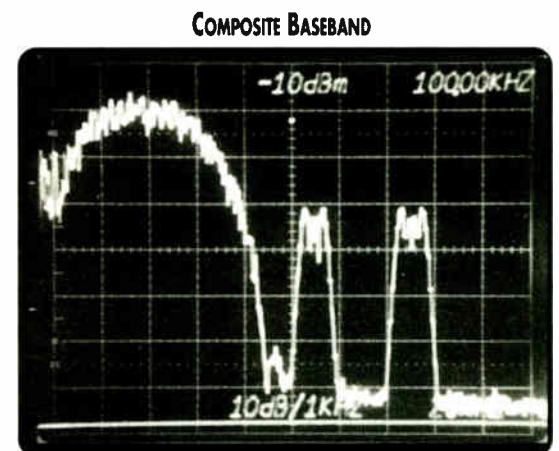

2 x 15 kHz, 2 x 7.5 kHz, 1 x 9600 baud RS232, 110 kHz and 152 kHz Subcarriers.

*to complete the system:*

### **New TFT 9100 Composite STL**

- ◆ Ideal for use with DMM92
- ◆ Frequency-synthesized, field-programmable Tx and Rx
- ◆ Patented IF Modulation for superior performance
- ◆ Very sharp cavity RF filter, phase linear IF SAW filter

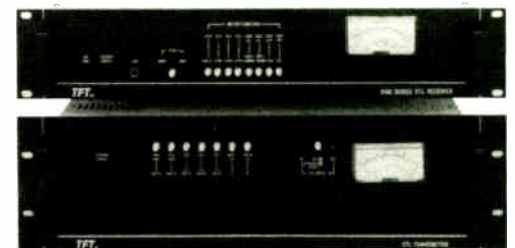

TFT 9100/9107 STL Tx and Rx.

### *Sound Quality for over 20 Years*

3090 Oakmead Village Drive • Santa Clara • California 95051  
Toll Free: 1-800-347-3383 • Tel: 408-727-7272 • Fax: 408-727-5942



Circle (67) On Reader Service Card



STATION SKETCHES

# Simplex Ready for Next Generation

by Tom Vernon

**HARRISBURG, Pa.** Sometimes supposedly new techniques have actually been around for decades, waiting to be found by the next generation of engineers. Simplex control is such a case. Perhaps you'll be able to discover some uses for this "new" technique around your station.

Simplexing, developed in the 1930s by the telephone company, is a technique for controlling and metering circuits via a balanced audio line. It is widely used by college carrier-current broadcasters to

remotely control and meter transmitters in dormitories scattered across campus. It's also the technique for master/slave control of clocks and bells in most school buildings.

The technique can be used for a number of applications around the station. Permanent remotes may be equipped with remote 'on air' lights to cue talent in locations where reception is poor and off-air monitoring is not possible. Automatic alarm circuits may be devised to alert station personnel to disconnection of remote lines or telemetering circuits.

Other uses depend on your imagination

and creativity.

As long as the power supply on the control side of a basic simplex circuit (shown in Figure 1) is energized, the relay at the remote end will pull in. It may be inconvenient to supply continuous DC down the lines. A slightly more elaborate system allows simplex latching control (shown in Figure 2).

Here's how the circuit works. Minus 24 volts is momentarily applied from the power supply to the phone line through the 'on' pushbutton. Current flows through the relay coil to ground via

continued on page 34 ►

## EEO Report Is Year-Round Station Effort

► continued from page 26

make sure that, in recruiting to fill those slots, you made appropriate efforts to encourage minority and female applicants. Such efforts could include job availability announcements sent to minority employment firms or other minority-oriented organizations or schools.

If minority or female applicants do apply for available positions, you should be sure that your records reflect that fact. The same is true if those applicants are offered the job and decline to accept it. If a non-minority male is given the job, your records should certainly provide some indication of why that person was deemed preferable to other candidates.

If minority or female applicants do not apply (despite your reasonable affirmative recruiting efforts), your records should also reflect that. Perhaps more importantly, you should be sensitive to such an apparent lack of success and you should take steps to expand your recruitment efforts. Document any such expansion efforts.

As you may have guessed by now, a crucial element of complying with the commission's EEO rules is maintaining documentation of your efforts. It is probably not enough to just not discriminate; you have to *demonstrate* to the commission—through employment records, recruitment notices and the like—that you did not discriminate. Lack of adequate documentation can constitute a violation itself.

So when you're preparing your annual 395 and you have (at least theoretically) your employment records out on the desk, it would be prudent to make sure that those records are complete and accurately demonstrate your employment practices. In this case a little annual prevention is well worth the time.

★ ★ ★

On a completely unrelated topic, we received a pleasant call the other day from a representative of a firm that has designed and is promoting Emergency Broadcast System equipment along the lines proposed by the commission. He gently pointed out that, contrary to an impression we may have created in this space recently, the EBS equipment industry is ahead of the curve in developing the next generation of hardware and will be ready, willing and able to supply broadcasters with gear satisfying the standards.

□ □ □

Harry Cole is a partner in the Washington-based law firm of Bechtel & Cole, Chartered. He can be reached at 202-833-4190.



2101 Superior Avenue  
Cleveland, Ohio 44114  
216.241.7225 · FAX: 216.241.4103

The Telos 100 Delta works like magic to produce the most natural sounding, full-duplex conversation. The secret? It's the only telephone hybrid that uses advanced digital signal processing (DSP) to automatically adapt to the phone line, adjust levels, and equalize the caller audio. Our exclusive digital dynamic equalization is so advanced you won't find it in any other broadcast audio product. All functions are quick as a blink. Once installed, the 100 Delta requires no further adjustment. And you can monitor callers through open speakers without feedback. The Telos 100 Delta. It's the easiest way for you to experience the pleasure of great phones.



# Simple Simplex Circuits

► continued from page 33

diode D1. The relay contacts close, turning on power to the device. Once this happens, the current path reverses.

Now 24 volts flows from the device back to the control end through a current-limiting resistor and normally closed contacts of the 'off' switch to ground. Pressing the 'off' switch breaks this path and the relay contacts open, turning the device off. Note that the pushbuttons must be held down long enough for the power supply to energize and discharge, typically two-three seconds. You can remotely check power supply voltage by measuring current across the N.O. contacts of the 'off' button.

Perhaps you have more complex needs, like controlling two circuits or control and metering simultaneously.

No problem. Figure 3 shows how this is accomplished using simplex techniques. Note the need for transformers with split windings and good quality 4µf non-polarized capacitors. The capacitors provide an open circuit to audio, while isolating DC from the two lines. Ohm's law and a little experimenting will give you the proper meter range and shunt value to use. Carrier-current broadcasters use the metering side to send back demodulated RF to insure that remote

transmitters are operating properly.

One brief aside on repeat coils. If you're using telco coils such as the 111C, be sure the line and drop sides are appropriately wired. The line side has precision windings to insure an absolute balance between halves. This is necessary for minimum noise and crosstalk. The drop side windings are less precise.

## More complex simplex

The use of simplex control assumes DC continuity over the audio line. If you're using unequalized lines from the phone company or your own pair, this is not a problem. Equalized lines, however, have equalizers and amps at the telco end that will break the DC path. If this is the case, you'll have to inform the phone company of your special needs. They can usually provide a DC path around their equalizers, although there may be an additional charge.

Control currents should be kept fairly low. A large DC imbalance on the lines is undesirable as it can result in noise and electrolytic corrosion of ground rods. Sensitive relays are normally employed at the receiving end. The P & B LM 5 has always been a popular choice and many more can be had through the usual surplus catalogues.

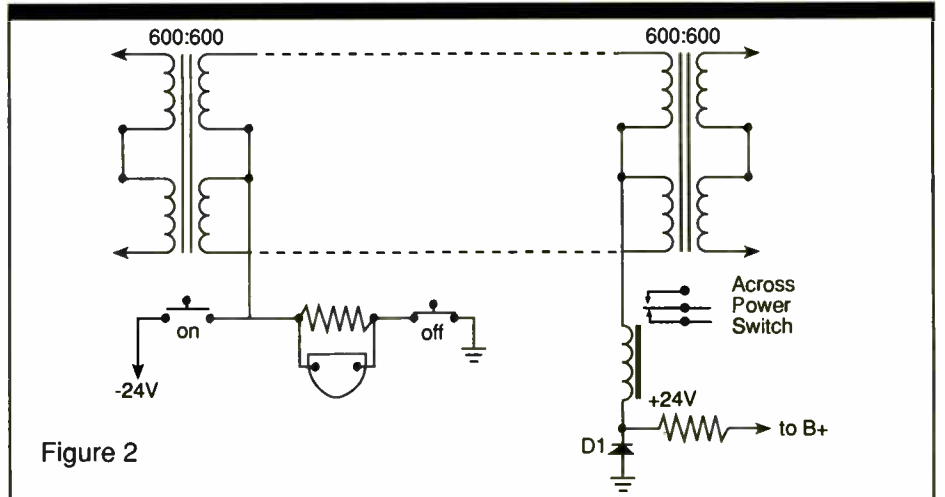

Figure 2

More elaborate control schemes are possible. Four circuits can be controlled over one pair with polarity-sensitive relays. By using relays with different coil resistances, two or three relays can be controlled by increasing the DC control voltage.

A word of caution: the phone company sometimes has maximum voltage and current specifications for simplex control over their lines. Typically these are 50 volts at 350 mA. Check with them while your planning is in the early stages.

Additional voice channels may be added through simplexing and a related

technique, phantom circuits. These may only be used on your own pairs and there's a price to pay in increased crosstalk into the main channel.

□ □ □

Tom Vernon divides his time between consulting and completion of a Ph.D. He can be reached at 717-367-5595.

Observant readers of Tom Vernon's column will recognize the three figures shown here as the same figures that inadvertently ran with Tom's April 28 column on another topic. RW regrets the error and any inconvenience to the reader.

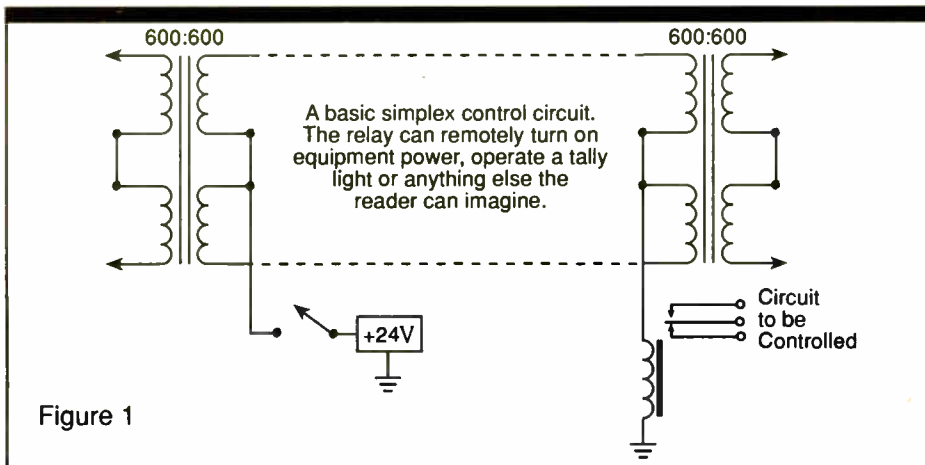

Figure 1

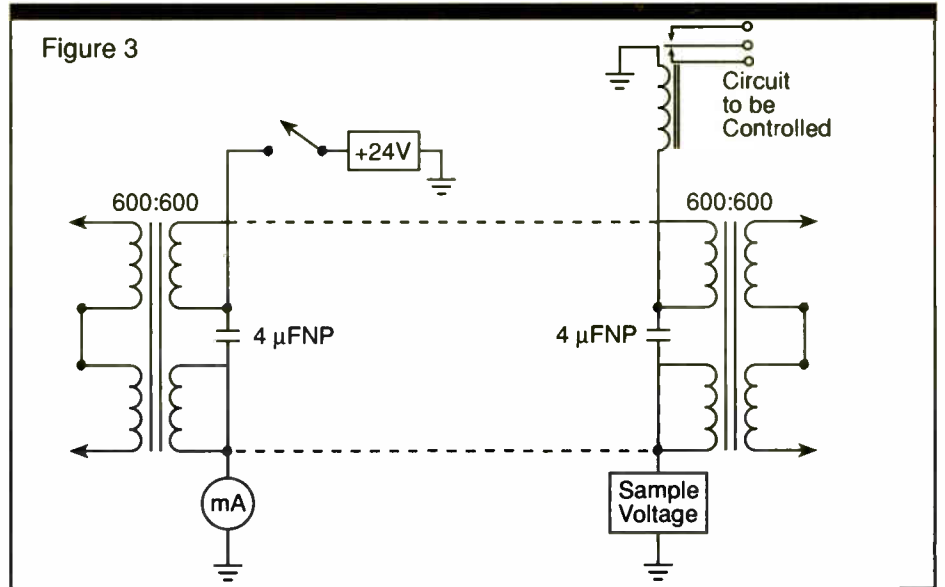

Figure 3

## Products & Services Showcase

For more information on the products shown below, circle the appropriate Reader Service No.(s) on the enclosed Subscription/Reader Service card or contact the advertiser directly.

NEW FROM TITUS TECH LABS

### THE SIMPLE TRUTH

**COMPOSITE AUDIO MONITOR**

Very Fast—Wideband—Precision  
Baseband FM Stereo Level Measurements

- Accurately measures audio limiting and composite clipping levels
- Pilot and SCA injection levels
- Balanced, bridging, floating inputs
- scope, freq counter, peak hold outputs

AND MUCH MORE... CALL FOR DETAILS

**TITUS TECHNOLOGICAL LABORATORIES**

77 Kreiger Lane Glastonbury, CT 06033  
(203) 633-5472

READER SERVICE NO. 20

## Shape Up!

Coverage. Saturation. DBk contours. In FM broadcasting, the "bottom line" is always based on your pattern.

More than any other manufacturer, Shively has the experience and reputation for providing crucial pattern solutions for critical propagation problems. On any tower. At any power level. Remember, *it pays to be heard.*

A good pattern. The shape you need. Talk to your consultant. And contact us.

### Shively Labs

A Division of Howell Laboratories, Inc.

19 Harrison Road, Bridgton, ME 04009  
207-647-3327 FAX 207-647-8273

READER SERVICE NO. 215

### AD2100 Audio Synchronizer

The AD2100 provides from 0 to 5.4 seconds of stereo audio delay (10.8 sec. monaural) for talk show censoring, lip-sync error correction, or to compensate for video processing delays. Delay can be set manually, or controlled by a frame sync, standards converter or other device for automatic delay tracking.

Pressing the "Dump" button causes an instant zero delay (censoring any offensive audio in memory) and then auto-increments to restore the required delay. Advanced processing reduces or eliminates audible pitch variations when the delay changes.

The AD2100 uses 16 bit sampling at 48 kHz for maximum transparency (custom sampling/delays available).

For more information, call Pixel Instruments today.

**PIXEL INSTRUMENTS CORP.**

718 University Ave., Suite 210 • Los Gatos, CA 95030  
Phone: 408-354-9122 • Fax: 408-354-0122

READER SERVICE NO. 159



# Full function RDS for only \$1750

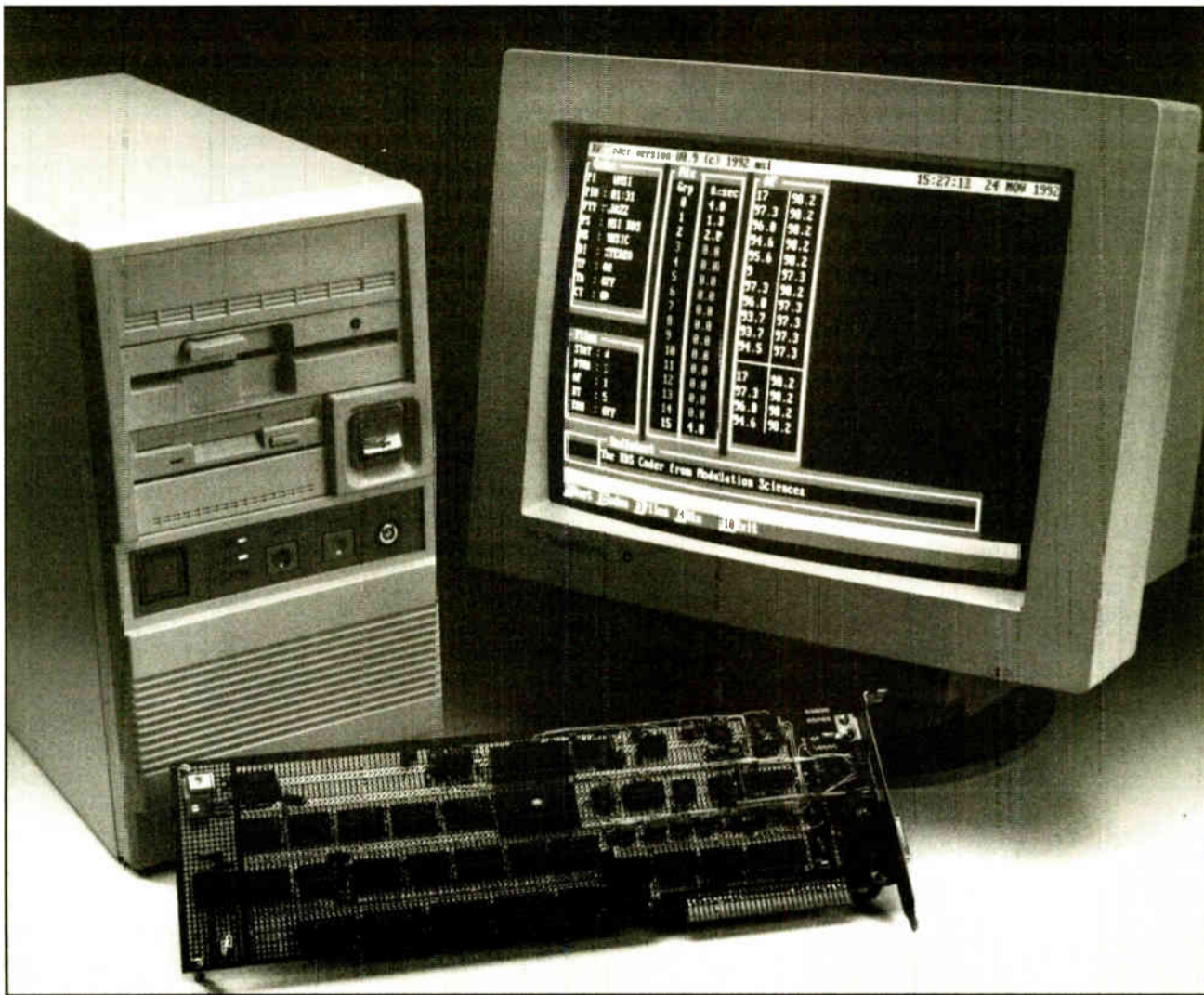

When you're ready for RDS, Modulation Sciences is ready for you. You already know us as the world's largest supplier of subcarrier equipment for radio and TV, with more Sidekick® SCA generators in use worldwide than all other brands combined.

Now we've made it easy and affordable for you to enjoy *all* the

benefits of broadcasting an RDS signal. Our RDS generator plugs right into your PC. And our included software gives you access to the entire CENELEC or U.S. RDS or RBDS Standard feature set.

So why buy an RDS coder offering only part of the RDS standard when, for even less money, you can have the whole thing?

*Modulation Sciences is a worldwide supplier of ModMinder® FM modulation monitors, StereoMaxx™ spatial image enlargers, composite audio processors and distribution amplifiers, Sidekick® subcarrier generators and receivers for FM and TV, Wired STL™ line drivers & receivers, TV stereo generators, SAP and PRO channel generators, and the remarkable new PROceiver™*

*For details on the RDS-1 System or any MSI product, contact your MSI dealer or*

**modulation sciences, inc.**

12 A World's Fair Drive • Somerset, NJ 08873 USA

Toll Free (800) 826-2603 • FAX (908) 302-0206 • Outside USA (908) 302-3090



USER REPORT

## Unity 2000i Puts WNEW on Cutting Edge

by John J. Rosso  
Chief Engineer  
WNEW-FM

**NEW YORK** I used to call the rack containing WNEW-FM's audio processing "The Wall of Sound." It seemed like we had at least one of every processor on the market; enough audio processing power to make the station very loud.

The downside of using all of these different devices was the difficulty in getting them matched up and working in their desired operating ranges. A lack of consistency meant we spent a lot of time "massaging" the audio chain.

This consistency problem caused us to look for a one-box solution; a unit in which all of the stages are matched and designed to work together. After thorough on-air testing of many different devices, we chose the Unity 2000i from Cutting Edge Technologies.

The Unity contains an extensive complement of processing "tools" (see

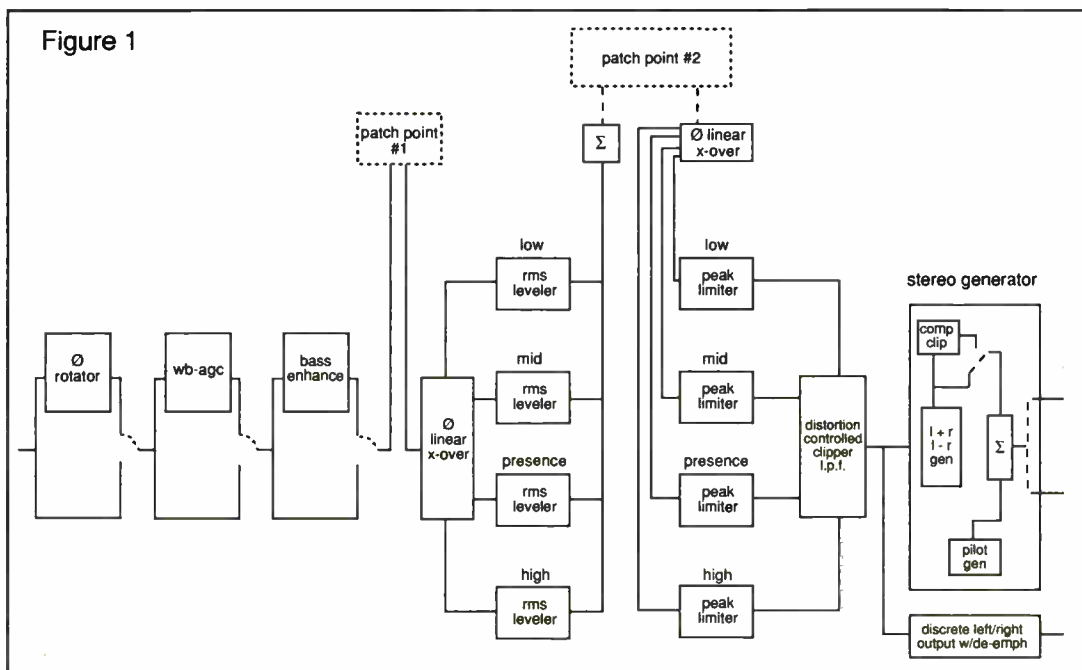

Figure 1). The front end consists of a selectable phase rotator, wide band AGC and bass enhance circuitry. A phase lin-

ear crossover then splits the audio into four bands for compression and peak limiting.

The four bands of audio recombine in a distortion-controlled, band-limited clipper. This clipper produces an incredible amount of loudness without introducing significant distortion.

There's an advantage in integrating a composite clipper into the design of a stereo generator. In the Unity, the 19 kHz pilot is injected downstream of the composite clipper.

This means you can work the clipper very hard (if that's what you want) without "bouncing" the pilot. The integrated

design of the clipper also alleviates problems caused by the composite level fluctuations found in many STL systems.

### Making a difference

There are a number of audio processing systems that provide all these building blocks. However, one thing really sets the Unity apart from the others: the use of feed-forward control circuitry.

By using feed-forward control, the Unity always operates at the same processing ratio regardless of the amount of gain reduction employed.

This is critical. Other processors using feed-back control tend to sound more dense as the amount of gain reduction increases. This is largely due to an increasing ratio as the gain cell is driven deeper and deeper into compression. The Unity always sounds very open, no matter how much you try to abuse it.

### Accessing levels

Another advantage of the Unity is its user interface. All of the Unity's parameters are controlled via software and accessed through the front panel or via an RS-232 interface.

There are multiple levels of security permitting different levels of access to different people. For instance, you might want to make all of the operating controls available to the program director with the exception of pilot injection and composite level. These two adjustments could be reserved for adjustment by the chief engineer only.

The amount of flexibility available in the Unity software is also a main advantage over competing systems. Attack and release times, gating levels, equalization, crossover points, input and output levels, pilot injection, clipper drive and more are all adjustable through the Unity software.

Additionally, a number of great sounding presets are preprogrammed at the factory. You'll probably be happy running one of the presets, but if not, they can be custom tailored.

At WNEW-FM, we replaced a complex, high maintenance, processing chain with the Unity. I was skeptical that any one device could perform all of the various audio processing tasks necessary to compete, particularly in New York City. Now I couldn't be more convinced.

□ □ □

For information, contact Frank Foti or Nancy Gadish in Ohio at 216-241-3343; fax: 216-621-2801; or circle Reader Service 55.

A Broadcast Industry

# BEST KEPT SECRET

Mono Record Play

**\$1290**

Stereo Record Play

**\$1480**

F.O.B. Factory

Reliable / Rugged / Professional Design

- All Metal Housing with Cast Aluminum Front Panel
- Half Inch Thick Aluminum Deck with Stainless Steel Overlay
- Air-Damped Solenoid with Telfon™-Coated Plunger
- Direct-Drive Capstan Motor
- Three-Point Adjustable Head Mounts
- Input & Output Transformers
- CMOS Logic
- Straightforward / Serviceable Design
- Available as Dual Record/Play for Simultaneous Record or Cartridge Copy
- 30-Day Guarantee of Satisfaction / 1-Year Warranty



DL Series

## AUDI-CORD CORPORATION

1845 West Hovey Avenue, Normal, Illinois 61761 USA  
Phone 309-452-9461 - Fax 309-452-0893

Available Through Your Regular Distributor

Circle (199) On Reader Service Card

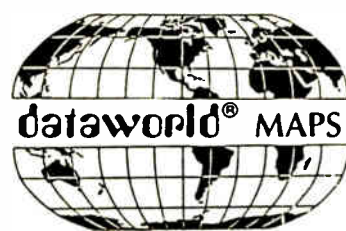

### DO YOU KNOW YOUR MARKET? YOUR COMPETITION DOES!

#### DATAWORLD MAPS CAN

- Depict your coverage!
- Market orient your sales people!
- Target your ethnic/demographic markets!
- Identify marginal signal areas!
- Plot any special requirements!

#### MAP OPTIONS

- SHADOWING (TERRAIN SHIELDING)
- CONTOUR COVERAGE
- POPULATION DENSITY
- ZIP CODE BOUNDARIES
- RECEIVED SIGNAL LEVEL
- SPECIAL REQUIREMENTS

**dataworld®**  
A Service of DW, INC.

(301) 652-8822

(800) 368-5754

Circle (188) On Reader Service Card



USER REPORT

# Orban Provides KEGL With Optimod Sound

by Chris Hudgins  
Chief Engineer  
KEGL(FM)

**IRVING, Texas** In the first quarter of 1992, we budgeted to purchase a new audio processing system. Being a contemporary rock station in the seventh market meant we had to make the right decision. With everything on the market these days, it would be foolish not to demo all the processing choices available.

After many long nights and a lot of unpacking and packing, we discovered that today's processors range from terrible to pretty good. One unit claimed to be totally digital when it wasn't. Several of them came from the factory in non-working condition, and it wasn't the result of any shipping damage. One of the units, after three trips to the factory and back, still never worked properly.

It wasn't difficult to decide that Orban's all digital OPTIMOD-FM 8200 was by far the best choice. The unit worked the first time right out of the box, which was clearly a good sign. The setup was simple and took about 30 minutes. But most important, the sound we obtain from this unit is outstanding.

**Easy upgrades**

The 8200 uses Motorola DSP 56001 24-bit processors. The DSP uses algorithms stored in PROMs, which determine the processing structure. The PROMs are contained in a module that is easily changed for future software upgrades.

The 8200 comes from the factory with factory-programmed presets for virtually all formats. The presets specify both a processor structure and control settings.

The processing structure consists of a two-band processor, which is an improved version of the 8100, or an optional five-band structure that provides more presence and brightness, without

The unit also can be controlled via a modem and software. This is very useful if the unit is located at the transmitter, or if you have a cellular modem and laptop computer.

**Highs and lows**

If you're looking for a unit with incredible bass characteristics and crystal clean highs, this is the unit. The bass can be adjusted for a very loud, deep "tubby" sound, which some stations try hard to achieve.

The stereo generator is one of the best,

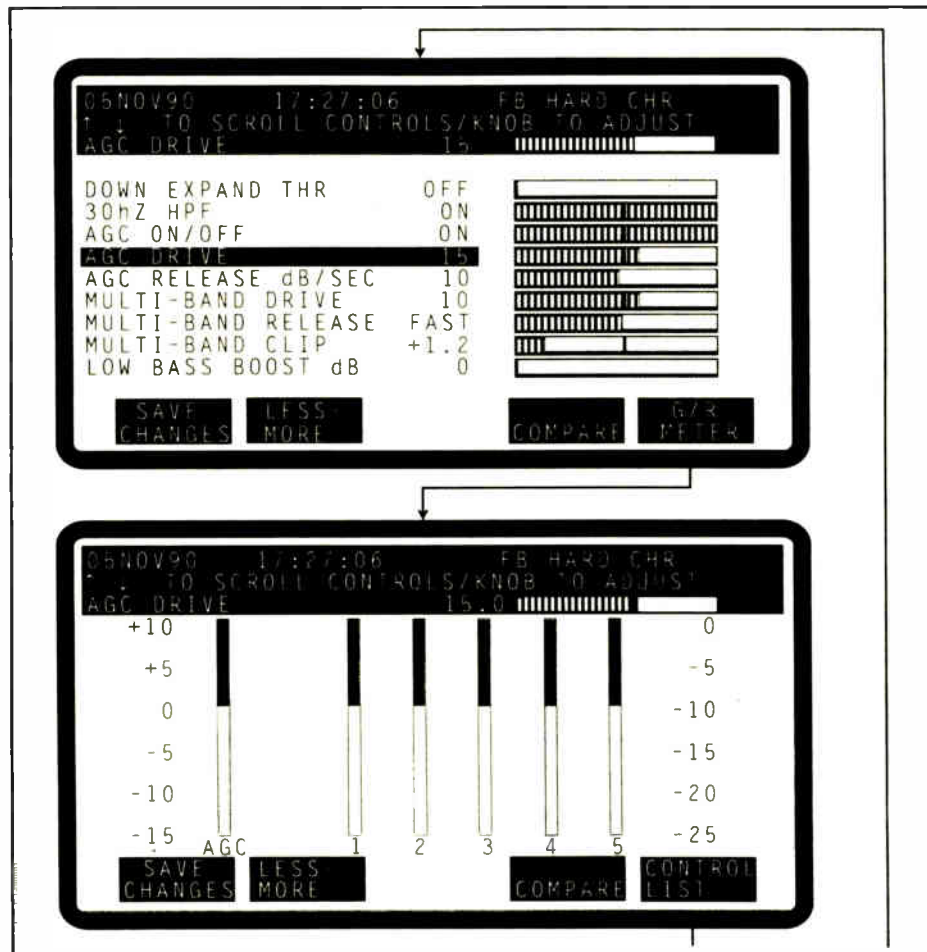

pumping or unwanted artifacts.

With the five-band structure, the processing can be set at an almost unlimited number of combinations. This is very advantageous for "customizing."

with average separation at 70 dB. The generator has two outputs with independent level controls, each capable of driving 75 ohms in parallel with 47,000pf (100 feet of coax).

The 8200 can be configured for analog and/or digital inputs and outputs. The digital I/O is AES/EBU running at 32 kHz.

The rest of the unit's specifications speak for themselves. The total de-emphasized harmonic distortion is 0.008 percent with the noise floor 90 dB down. The crosstalk, main to sub and sub to main, is 90 dB down with 75 dB 38 kHz subcarrier suppression. The overshoot is limited to less than 0.3 dB, which is outstanding.

If you are really interested in a new audio processor, demo the 8200 to see what you think. The PD will probably tell you not to give the demo back.

□ □ □

For information, contact Phil Moore in California at 510-351-3500; fax: 510-351-0500; or circle Reader Service 173.

**AM ANTENNA SYSTEMS**



50 KW AM TUNING UNIT

**Antenna Tuning Units  
Transmitter Combiners  
Folded Unipole Antennas  
Diplexers, Triplexers  
RF Components**

Call LBA Technology for RF systems and excellent technical service. Products for AM, FM, Shortwave and TV are designed and built to international standards. LBA antenna systems will improve your efficiency, performance and reliability.

LBA is the world leader in single and multiple station folded unipole antenna systems for high efficiency, wide-band AM transmissions at all power levels. LBA systems are found from Alaska to Argentina, Kuwait to Saipan.

Our capabilities include the design and fabrication of RF equipment, complete system integration with products of other leading suppliers, project management, on-site installation, and commissioning. Consult LBA for fast response to your RF needs.

919-757-0279

919-752-9155 FAX

or Contact Our Representatives  
Worldwide



**LBA TECHNOLOGY, INC.**  
P.O. Box 8026 Greenville, NC 27835 USA

30 YEARS OF  
WORLDWIDE ENGINEERING  
SERVICES

**COMPLETE LINE OF RF  
PRODUCTS**

An LBA Group Company

© 1993

# What do you do with a twenty-year-old STL?

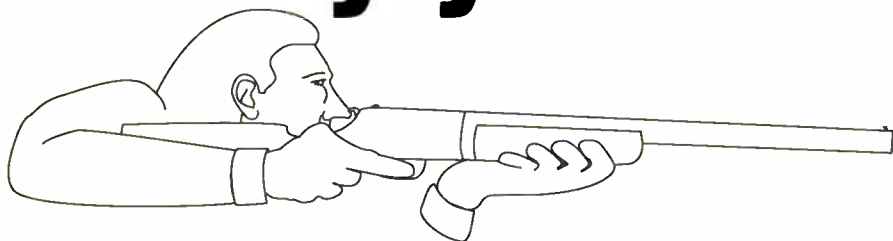

They make lousy planters. As boat anchors, they perform poorly. Too big to be good paperweights, they are too small to provide inner-city housing.

But after years of service, they deserve to retire with style. And while you may have trouble giving them their final exit the way we would, release them you must.

After July 1, 1993, All STL's in service must be FCC type approved. That means that no matter how loyal your old unit has been, it has to go. We hope it also means you'll call BEXT for the pricing and availability of our products.

BEXT STL's actually outperform our more expensive

competitors, and have become exceedingly popular with stations large and small. Both the high value LC Series and the high performance SD Series offer front-panel frequency programmability, which makes delivery immediate in most cases.

So, if your old STL is missing that all-important FCC number, please give us a shot at your business. Call us today and we'll fire back a product catalog and a list of present users, eager to tell you of their experience with BEXT.

**Transmitters start at \$1,985!**

739 Fifth Avenue  
San Diego, CA 92101  
619-239-8462



Circle (78) On Reader Service Card

World Radio History

Circle (27) On Reader Service Card



## USER REPORT

# Dolby Performs Audio Magic at CMBE

by **Chip Morgan**  
President  
CMBE

**EL DORADO HILLS, Calif.** When Tom Daily of Dolby Laboratories and Eric Lane of Cancomm asked us to review the new Dolby model 740 Spectral Processor, we immediately saw an application for the unit.

It's a good, low-cost solution as an "electronic EQ" in front of almost any audio processor. We suggest it in place of a parametric or graphic EQ normally used to "tailor" the sound of a station.

## Signal magic

The unit is designed to "bring out low-level detail without affecting louder signals or transients." I have to admit I thought it was hype until I understood what the Dolby wizards were up to.

All the magic happens in a sidechain, and the processed signal is added to the original untreated signal at the output of the unit. This allows all the original transients and nuances to come through, and lets you tune the sidechain for the effects you want.

The way it works is complicated, but the unit is very user friendly. Each channel of the processing side chain works in

four pairs consisting of a fixed band and a "sliding" band.

Each band automatically changes its

linear relation to the input, while the sidechain output continues to diminish. When combined, we get a smooth tran-

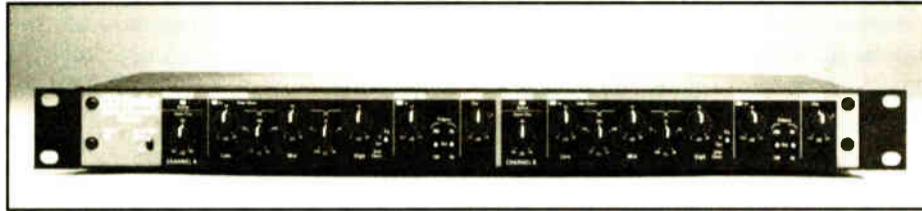

The Dolby 740 Spectral Processor

characteristics depending on input level and frequency. Here's the twist: the sliding bands have constant boost, but automatic corner frequency. The fixed bands have automatic boost only.

The magic happens when the bands are combined. Two of the four pairs are for high frequencies and two are for low frequencies first.

An adjustable threshold sets the point at which compression begins to occur. One of the pairs works from threshold levels to 20 dB above the threshold.

The other pair works on levels above 20 dB over threshold. (The low frequencies work the same way.) At high input levels (40 dB over threshold), the main signal path continues to rise in

sition in levels from a gain of more than 20 dB at low levels to unity gain at high levels.

## Adjustable frequencies

But there's more. After this multi-band processing takes place, a three-band equalization section similar to a three-way crossover allows adjustable output of low, mid and high frequencies.

While this seems basic, it actually gives full control of most of the parameters

## USER REPORT

# Excalibur's CD-1 Interfaces Help KCRW(FM) Work Like a Pro

by **John C. Huntley**  
Chief Engineer  
KCRW(FM)

**SANTA MONICA, Calif.** KCRW(FM) integrated a few pieces of "semi-pro" or "consumer equipment" into its broadcast and production operation. We nearly always use some type of unbalanced to balanced interface amplifier with this equipment.

We have used many of the brands available for these interfaces, but I give high marks to the Excalibur Electronics CD-1 family.

In broad strokes, there are two types of equipment in use at broadcast facilities. The professional equipment is usually characterized by a rugged mechanical design and a balanced, professional level (+4 dBm) output. It's designed to operate for at least five years, and is priced concomitant with rugged design.

A CD player "consumer model" has the advantages of being readily and inexpensively available (dare I use the term "trade-out"?). It's used continuously until it fails, usually between one and two years from installation.

It is then replaced with "this year's model." It is less rugged and has IHF standard inputs and outputs. The IHF standard uses RCA connectors, which are unbalanced, high impedance at -10 dBV.

The choice of whether to purchase the professional model or the consumer model is often argued. There are partisans for both types of equipment.

The use of consumer equipment, particularly CD players, at broadcast stations has become commonplace. With the demise of LP records, an increasing portion of the program material on many stations is directly from CD. Thankfully, the "state of the art" in connecting consumer equipment into a broadcast studio has changed over the last few years.

Professional level to IHF level interface

normally associated with a complex compressor. Two crossover controls set the limits of the bands in the EQ section. This only affects the compressed signal.

After all that, a single-ended noise reduction system is included to reduce noise in the signal by up to 12 dB.

The unit is 1RU high and provides stereo processing. Input levels are switch selectable +4 dBu or -6 dBu. Maximum output levels are switch selectable +26 dBu or +20 dBu.

Controls include adjustable crossovers with the low-mid section adjustable from 75 Hz to 1 kHz. The mid-high section is adjustable from 500 Hz to 8 kHz. Maximum boost in each section is greater than 20 dB. Dynamic range is 108 dB, including 20 dB of headroom.

Don't expect this unit to give you that "processed" sound. They've designed it so you can't get in serious trouble. The effects are smooth and pleasing.

As you put in that hot new overall processing system, try this unit right after the console. I think you'll like it.

□ □ □

For information, contact Nancy Byers in California at 415-558-0200; fax: 415-863-1373; or circle Reader Service 211.

## What is this man doing?



... he is optimizing his audio processing!

You no longer have to compromise your station's sound. Format changes, audience profile variations and cut-to-cut music inconsistencies present challenges that no ordinary processor can hope to deal with. That's why Inovonics pioneered the Programmable Processor.

Our Model 250 behaves just like five independent audio processing chains. The AGC action, Compression, Equalization and Limiting of each of these chains can be custom-tailored to any specific audio feed or to any station format. This gives precisely the proper processing to make any program source or format sound its very best. No compromise.

Controlled by station automation, a time clock, or simple manual selection, the 250 provides processing which can change with your programming throughout the broadcast day. What's more, our RS-232 Interface Option can put the 250 under continuous computer control with almost endless processing possibilities.

Has the Inovonics 250 proved to be ahead of its time, or haven't you been keeping up?



MODEL 250 - PROGRAMMABLE BROADCAST AUDIO PROCESSING

**Inovonics, Inc.**

1305 Fair Avenue  
Santa Cruz, CA 95060 U.S.A.

TEL: (408) 458-0552  
FAX: (408) 458-0554



Circle (11) On Reader Service Card



# To Make Money in Radio Advertising, You've Got to Push the Right Buttons.

Since 1990, radio stations in every music market have been more creative, more efficient and more profitable with the



DSE 7000. In order to increase profits in the competitive

radio environment of the '90s, general managers have been asking more from their production directors, who in turn have had to do things faster and cheaper. Clearly, the trusty 8-track recorder wasn't going to lead radio stations through this new era.

Since it was impossible to become more efficient at tape splicing, astute production types contemplated digital technology. They found out

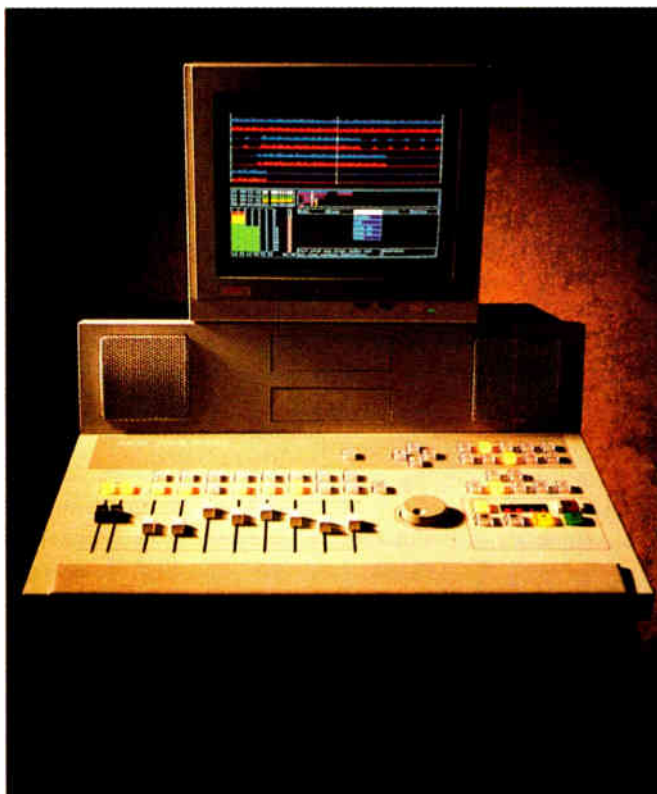

about a company with over 40 years experience manufacturing professional audio products, who was already shipping a digital sound editor for radio production. Not coincidentally, this system had many of the same controls and functions they were used to.

They tried a demo of the DSE 7000 and realized they



could produce spots in one-third the time. Which meant they had time for a certain luxury called creativity.



The DSE's UNDO button gave them room to experiment. And its audio quality raised their standards to an entirely new level.

Today, hundreds of radio stations are making more money producing radio commercials, because they're pushing buttons on the DSE. Now it's time to push some buttons on your telephone and call AKG.



**DSE 7000 • THE NEW SPEED OF SOUND™**



**AKG Acoustics, Inc.** 1525 Alvarado Street, San Leandro, California 94577, USA, Tel: (510) 351-3500, Fax: (510) 351-0500

AKG is a registered trademark of Akustische u. Kino-Geräte Ges.m.b.H., Austria. ©1993 AKG Acoustics, Inc.



## USER REPORT

# Sony DPS-M7: a One-Unit Modulator

by Dave Straub  
Production Director  
WFMS(FM)

**INDIANAPOLIS** Recording on-air promos in a fast, professional manner in today's radio environment requires equipment that can integrate with a variety of components.

Products eliminating the need for multiple effects processors, signal processors and other pieces of digital gear are greatly desired, but very hard to find. One tool that has been invaluable in the production of on-air promos for WFMS(FM), a number one country station in the Indianapolis market, is the Sony DPS-M7.

The DPS-M7 is a 2-channel digital effects modulator that literally takes the place of several different units.

In the three years I've been with WFMS(FM), and in my 10 years of promo production, I've never had such an easy time recording promos. The DPS-M7 combines the best of the industry's top-quality harmonizer, flanger, echo unit and other effects.

The DPS-M7 is much like the SPX-90, but much more advanced. We have it rack-mounted and placed on one of the return busses.

The sound quality my promos gained since the installation of the DPS-M7 in August 1992, is immeasurable—I use it for a number of harmonizing effects.

My chief engineer, Max Turner, did a great deal of scouting to find the perfect rack-mount unit for promo production. We were confident that the DPS-M7's 18-bit oversampling A/D and one-bit pulse D/A converter system would pro-

vide a high quality modulator.

Because the DPS-M7's pre-set memory stores 100 effects, with up to 256 effects stored in memory, we decided to directly hook the unit to our board.

The station's promos represent our strength in live concert sponsorship, so we want the spots to have an extra dimension to them. With the DPS-M7, you can really get the feel of

what you are producing.

Even though I haven't tapped the DPS-M7 to its full potential, I know the machine so well that it doesn't take any more time to call up an effect than on an eight-track.

The edit modes can help you manipulate the sound, which can be adjusted in a variety of ways. Because the DPS-M7 is a high-speed digital effects processor,

## USER REPORT

## Aphex Air Chain Connects with WTCX for Competitive Coverage

by Tom Lijewski  
Owner, General Manager  
WTCX-FM

**ROSEMOUNT, Minn.** As a brand new suburban Class A station just south of Minneapolis-St. Paul, WTCX-FM needed a way to compete with a market full of Class C FMs. This meant keeping an eye on the bottom line, but not sacrificing anything in on-air quality.

From the start, we were straddling the fence between bringing local service to just the southern tier communities, and serving the entire metro area. One of the first things we did was install a part-live, part-automated hot adult contemporary format.

A second thing we did was improve our on-air sound by putting in the Aphex Audiophile Air Chain.

When we went on the air in February, we used a different brand of processing as part of a turn-key build. I found the

other brand didn't allow us to compete head-to-head with the other stations in town, and it didn't maintain our quality standards.

We adjusted it for loudness, depth and fullness, and we were especially concerned about the lows. But no matter what we did, we couldn't get our desired sound.

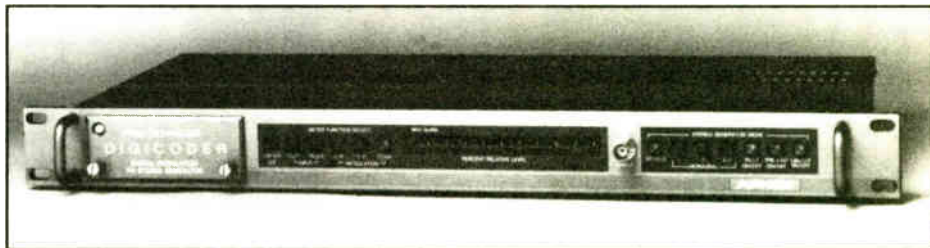

The Aphex Digicoder Stereo Generator is the last link in the Audiophile Air Chain.

We were up against the wealthy Class C stations with racks full of various processors to get the competitive sound. So I knew we needed to find some kind of processing that would give us their big sound without sacrificing audio quality.

The chain is a series of four products manufactured by Aphex, designed to work together for a quality sound.

The Aphex Compellor Model 320 rides gain on the entire audio bandwidth without changing the original dynamic feel of the audio that goes into it.

The Aural Exciter with Big Bottom Model 104 brings up the low end I was

my editing sessions have been more productive than ever before.

Promo production before the era of the DPS-M7 was a complicated job.

I produce an average of five promos per week for WFMS(FM), not including updates. Everything that can be done to maintain the interest of our listeners is a major advantage.

We hope the station's success, and the DPS-M7's part in it, continues.

□ □ □

For more information on the Sony DPS-M7, call Sony's Business and Professional Group at 201-358-4197.

so concerned about. It also restores brightness to the highs and adds presence and details.

Next is the Dominator II Model 720 multiband peak limiter, which provides an absolute brick wall without sounding "crunched."

The last link in the chain is the Digicoder. It's a high frequency limiter, low pass filter and analog stereo generator with digital control.

Now we have depth, fullness, clarity and the ability to discern individual instruments in the music. We are actually truer to the purity of the original recording, but with a fuller sound making us more competitive with other sta-

tions.

From listening around our service area, I also think the Digicoder helped improve reception in areas where multipath used to be a problem.

Of course, our air staff also is pleased with our improved sound. But the big satisfaction comes from the reaction of our competitors: even they've admitted we perform extremely well.

□ □ □

For information on the Audiophile Air Chain, contact Chrissie McDaniel in California at 818-767-2929; fax: 818-767-2641; or circle Reader Service 139.

**You can measure... with the best monitor and the most accurate test set.**

The FMM-2/FMS-2 series monitors provide an even greater degree of precision measurement than ever before... **You can measure S/N below 90 dB, You can measure crosstalk below 85 dB, You can measure separations of better than 70 dB, You can measure frequency response to better than 0.25 dB, You can measure distortions to lower than 0.01%, and much more...** Our uncluttered panels and autoranging voltmeters make these measurements a dream.

**BELAR ELECTRONICS LABORATORY, INC.** (215)687-5550  
LANCASTER AVENUE AT DORSET, DEVON, PENNSYLVANIA 19333  
Call or write for more information on Belar AM, FM, Stereo, SCA and TV monitors.

Circle (30) On Reader Service Card

**ARE YOU LOOKING FOR  
A COST EFFECTIVE  
ALTERNATIVE TO  
MANUFACTURER SERVICE?**

**IN CASE OF  
EMERGENCY**

We can help get you back on the air with our STL Loaner Program. We have STL's available that will be set to your frequency prior to shipping.

We also provide over-the-phone technical assistance.

**SERVICE, REPAIR  
& CALIBRATION**

› STL's › RPU's › TSL's › Exciters  
› AM/FM Broadcast Monitors  
› Remote Control Systems

**SPECIALIZING  
IN EQUIPMENT BY**

› Belar › Marti › Moseley  
› McMartin › TFT › And others...

An authorized TFT service center

**T** SQUARED  
TECHNICAL SERVICE  
2198 Hubbard Lane  
Grants Pass, OR 97527  
**(503) 471-2262**

Circle (137) On Reader Service Card



## USER REPORT

# WBLS Shifts Gears to the Right Track

by David Schwartz  
Engineer  
WBLS(FM)

**NEW YORK** Have you listened to that great processing on your station, switched to mono, and had it come out sounding dull and lifeless?

If out-of-phase source material is the culprit, then the Right Track, an audio phase corrector from Broadcast Devices Inc. may be what you need in your production room.

Phase error can come from many sources. The Right Track is capable of correcting all of these problems.

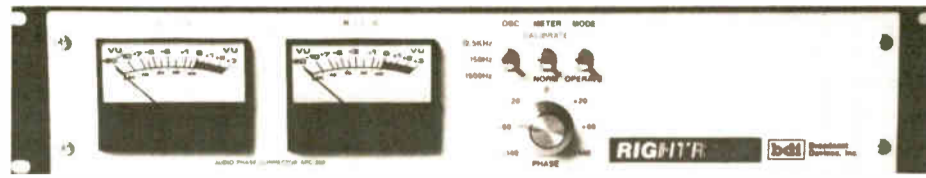

Broadcast Device's Right Track helps correct phase problems.

There are two standard configurations for the Right Track. The first assumes that the recording device, such as a cart machine, is aligned properly. In this setup, the Right Track corrects phase errors on any source material used.

The second configuration corrects for phase errors in an individual cart tape or recording cart machine. It doesn't correct for out-of-phase source material in this mode.

At WBLS(FM), most of our music and all the commercials are on cart. Material comes in on a wide variety of formats, such as CD, vinyl (what's that?), DAT, digital downlinks, and tape. Because we use ITC 99Bs for all recording, we use the Right Track to correct any audio source coming into the console.

Installation of the Right Track for this purpose is very simple. All in, out and metering connections are made on the back panel to Phoenix connector strips. The main outputs of the console connect to the left and right Right Track inputs.

The Right Track left and right outputs are connected to a DA that feeds all the recording machines in the studio.

Connecting the Right Track to correct for cart machine phase error is accomplished in much the same way. Console output goes to the Right Track input. Right Track output connects to the cart machine input. Cart out goes to metering in, and metering out goes to the console input from the cart machine.

Once connected to the rest of the production room, electronic alignment of the unit is very simple. Remove four screws on the front panel and the whole panel flips down, exposing three cards with edge connectors.

Each card has two 10-turn pots on it—one for left channel, and one for right. The right hand card controls the input levels, the middle card controls the output levels and the left hand card adjusts the meter sensitivity.

Using the Right Track to compensate for cart machine errors involves selecting the 12.5 k tone on the built-in, 3-tone generator. Flip the other two switches to calibrate and start recording.

You can monitor the sum and difference signals on the front panel VU meters. Now, null the difference (L-R) meter using the phase adjust control. Once this is done, return all switches to the operate mode and start recording your source material onto a clean cart.

It is even easier to use the Right Track the way we have it set up at WBLS(FM). Flip the center switch to calibrate, and start playing whatever it is you want to record.

Using the phase adjust control, null the L-R meter. On some enhanced stereo material, it may be difficult to get a meter null. In that case, listen to the Right Track playback in mono, and adjust the phase control for best mono sound. When that is done, return the switch to operate and start recording.

Also, many manufacturers still haven't figured out whether pin 2 or pin 3 is "hot." Just because the box says "digital," it doesn't mean all your audio problems will be solved magically.

The Right Track is not a panacea. It will not improve poor fidelity or cure distortion. What it will do is provide proper phase relationship between channels and excellent mono compatibility of recorded material.

□ □ □

For information, contact Robert Tarsio in New York at 914-737-5032; fax: 914-736-6916; or circle Reader Service 120.

## WGBH Moves With MDA-102

by Jim Donahue  
Recording Engineer/Producer  
WGBH(FM)

**BOSTON** WGBH-FM has broadcast from Boston Symphony Hall since the station's inception some 42 years ago. Recently, we had the opportunity to expand our operation at Symphony Hall into a second control area and studio, one floor above our original space.

We found ourselves wondering how to deal with yet another set of long microphone lines, how to distribute signal to both control rooms without any signal degradation and how to do this in a hall renowned for both its acoustics and high RFI.

The solution arrived in a few boxes shipped from Allen Burdick and Rory Rall at Benchmark Media Systems. One box contained five MDA 102 stereo microphone pre-amplifier/DA cards and the card frame. The other contained the robust PS-202ph dual power supply.

Our first task was to wire it all together, and for this we hired Walter Lenk of LA Design in Cambridge, Mass. Walter soon had the unit packaged into a Future Case road case, and added a few modifications to ease operation from 300 feet away (we placed this unit in the Symphony Hall loft).

We added a local/remote system for Phantom power, the 20 dB pad and the level/overload indicators. The first test of the system was with Boston's Handel and Haydn Society. This performance was under the direction of Christopher Hogwood, and featured soprano Lorain Hunt.

The results were stunning. We were especially impressed by the clarity of the MDA-102s and their ability to handle the wide dynamic range of a full orchestra with soprano. It's nice to be able to install a product and have it work flawlessly and sound wonderful.

□ □ □

For information on the Benchmark products, contact Rory Rall in New York at 315-437-6300; fax: 315-437-8119; or circle Reader Service 218.

# DIGITAL EVOLUTION

Technology evolves. The market develops.  
DIC Digital excels.



As one of the original suppliers of DAT tape to the professional, DIC Digital recognized industry demands. As a result, we were the first DAT supplier to offer a truly professional DAT cassette.



Once again DIC Digital is leading the way by introducing recordable CD's. Our discs are fully compatible and bear the "compact disc" logo. DIC Digital's CD-R's are readily available in 18, 63 and 74 minute lengths. Call today for the name of your nearest DIC Digital dealer.

THE ULTIMATE IN SOUND

# DIC DIGITAL™

222 Bridge Plaza South, Fort Lee, NJ 07024  
Phone: 201-224-9344 or 1-800-328-1342, Fax: 201-224-9363

Circle (34) On Reader Service Card



# THIS CONSOLE



**LED A REVOLUTION**  
by proving that a low-priced console  
could offer major market features, rugged  
construction, and superb audio specifications.

**IS AVAILABLE** in 6, 12, 18 and 24 channel models for  
any size studio.

**FEATURES AS STANDARD EQUIPMENT** a mix-minus buss,  
full remote control, full metering, talk-back, two stereo outputs, P&G faders, cue and  
headphone amps, mic through line level on any input, timer, and much more.

**IS WELL SUPPORTED** by a caring factory staff via a toll-free service line, and a super next-day  
delivery no-charge warranty.

**IS HIGHLY REGARDED** by the 600+ owners who have purchased RS-Series consoles since  
their introduction. Over 90% rated their boards a "superior value". Over 250 owners bought another  
RS-Series console when they built another studio.

**HAS A COMPLETE RANGE** of available options including copy stand, distribution  
amplifier card, special application remote interface cards, input extender card, 4 and 2 buss mix-minus  
cards, squawk box card, and more. And even with all these standard and optional features, the factory  
is happy to modify the board when special user applications call for something different.

**IS THE BEST VALUE** available today in broadcast consoles, and is now available from select  
distributors. Call today for more information and the name of a dealer in your area.

**RADIO SYSTEMS INC.**

110 High Hill Road • P.O. Box 458 • Bridgeport, NJ 08014-0458 • 609/467-8000 • 800/523-2133 • FAX 609/467-3044

Circle (23) On Reader Service Card  
World Radio History



USER REPORT

# Titus Helps Put WHCN in Control

by Richard T. Walsh  
Vice President/Chief Engineer  
WHCN(FM)

**HARTFORD, Conn.** The Composite Audio Monitor, a unique test and measurement device by Titus Technologies Labs, can come in handy at FM broadcast facilities.

High resolution bargraph LED meters determine total modulation within one percent, while pilot and SCA injections are observed in 0.1 percent increments.

I found the Composite Audio Monitor to be a useful tool in the maintenance of WHCN(FM). I use it anywhere composite signals are present, such as the output of redundant stereo generators, the dual

unlike traditional stereo modulation monitors.

I found three features of the monitor particularly noteworthy. First, the peak hold meter indication for levels 100 percent or greater allows easy viewing of transient modulation peaks while one is adjusting processing or transmission levels.

Second, the front-panel "MONITOR" output (BNC) jack facilitates the viewing of composite waveforms on an oscilloscope by folding both positive and negative halves into the same quadrant on the scope face.

This helps one observe asymmetrical or clipped signals. The front-panel input switch for two composite inputs (front and rear) allows rapid comparison of the effects of composite processing by monitoring the input and output of the device under observation.

The third feature, the "MAGNIFY" mode, lets one zoom in by a factor of five on the area of greatest concern—that region immediately above and below 100 percent modulation.

The Titus Composite Audio Monitor offers a number of additional features that warrant your closer attention to this handy device.

□ □ □

For information, contact Larry Titus in Connecticut at 203-633-5472; fax: 203-633-8244; or circle Reader Service 52.



The Composite Audio Monitor is useful in WHCN's signal maintenance.

The compact unit makes accurate measurements of composite baseband signals, including total modulation and both pilot and (optional) SCA injections.

hop redundant composite STL system, the redundant STL receivers and at the two FM transmitters.

The half-rack width unit travels readily.

INDUSTRY ROUNDUP

## Fast, Efficient Products Mark Sign of New Times

by Mary Ann Dorsie

**WASHINGTON** The audio signal processing gear of today, which covers everything from harmonizers to amplifiers to actual processors, helps make radio sound better and do more than ever before, according to various manufacturers.

"I think the trend in broadcasting is in trying to improve the sound of radio," said Frank Foti, president of Cutting Edge Technologies. "We hear more and more that they're beginning to be compared to other mediums."

He said products are becoming more user friendly, something he thinks will continue in the future. And the power coming from the latest processing equipment, including the company's Unity 2000, is increasing.

"You can dial up over a modem from the other part of the world and control it," he said. "This was not here a couple years ago."

**Subtle vs. obvious**

Gil Griffith, sales manager for Eventide, said he sees many trends with audio processing, including more specialized effects.

"I see a trend for more subtle enhanced effects to increase the dynamics of the voice over and to give more presence to the individual talent's voice," Griffith said.

Phil Moore, Orban product manager, said automating processing gear for the different dayparts is a fairly new technique.

For example, if a station's morning show is high impact, the processing may be heavier, he said. At night, stations

may want a tamer sound

Griffith said the move to digital, from 16- to 18-bit, is helping to make products much more user friendly. In addition, one box performs tasks that several boxes used to accomplish just a few years ago.

"They are offering more bang for the buck," Griffith said.

The Orban OPTIMOD-FM 8200 is one processor Moore thinks is setting the pace with its all-digital system.

"It offers you several possibilities as far as expansion and upgrade abilities go," Moore said.

**A different class**

The digital trend will most likely introduce a new class of engineers—ones who aren't afraid of MIDI or computers, Griffith said.

"There are a lot of complex productions happening using computers, with sequences and MIDI automation," Griffith said.

But Foti said he thinks the industry's technology has become diluted within the last 10 years, and the ability to understand it is decreasing. He said this is true even of engineers in large markets.

"It's the chicken vs. the egg problem," Foti said. "The problem is that if you make it too simple, there's not enough power. If there's too much [power], it's easier to crash and burn."

Foti said he thinks potential buyers need to spend more time researching and testing equipment before purchasing.

"Don't open the box and throw it in the rack," Foti said. "See what the manufacturer is trying to achieve with the product. People are all too quick to give a yea or nay."

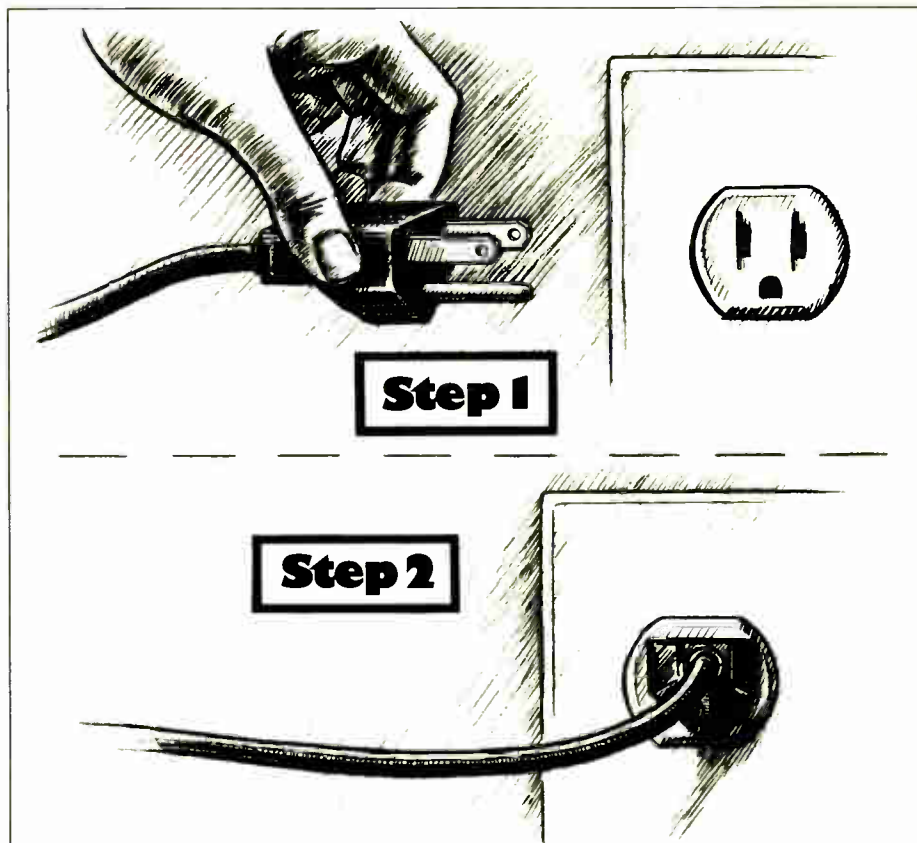

## How To Install Your Gates AM Transmitter.

Easy now, we know we're exaggerating. Barely. Because installing our Gates AM transmitter actually requires little more than connecting the antenna, AC power, and audio feed, and pressing the start button.

This field-proven, 100% solid state, low-maintenance transmitter delivers a strong, clean, reliable signal, thanks to our patented PPDM technology. The transmitter is available in mono or stereo, and in power

levels of 1, 2.5, and 5 kW.

The Gates AM transmitter's high performance shouldn't be a surprise. After all, it's a Harris, the leader in AM technology. We've been involved in AM longer than our domestic competition combined. Which makes Harris the easy solution for your next AM transmitter.

**217-222-8200**  
**Fax 217-224-1439**  
**Canada 800-268-6817**  
**Toronto 416-731-3697**



©1993 Harris Corp.

"Call me, I'm interested." Circle (61)

"Send me literature." Circle (150)



# MARKETPLACE

A compendium of new and recently introduced radio broadcast products

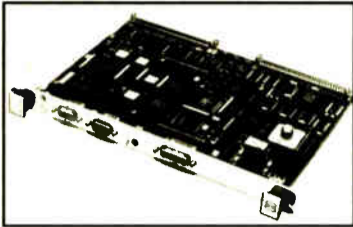

## VME Serial Modem Card

Harris RF Communications introduced a high-performance modem card for data communications over HF radio channels.

The RF-5730 is a serial data modem mounted on a single-slot VMEbus card. The modem provides full-duplex or half-duplex data communications at rates of 75 to 4800 bps using the MIL-STD-188-110A serial single-tone waveform.

The modem card uses a data-directed equalizer (DDE) for reliable operation on channels with high fade rates and large multipath delay spread.

The RF-5730 modem is controlled from the VMEbus controller.

For information, contact Harris Corporation, RF Communications Group, 716-244-5830, or circle **Reader Service 175**.

## Three-Phase Voltage Monitors

The WVM Series is the latest addition to the line of three-phase Voltage Monitors by SSAC Inc.

The series continuously monitors the phase-to-phase voltages. It protects motors and other three-phase loads from premature failure and downtime caused by phase loss, phase reversal, low and high voltages, unbalanced voltages and short cycling.

It features microcomputer based circuitry, with a 10 fault non-volatile memory. Each time the WVM's output relay de-energizes.

The WVM Series is available

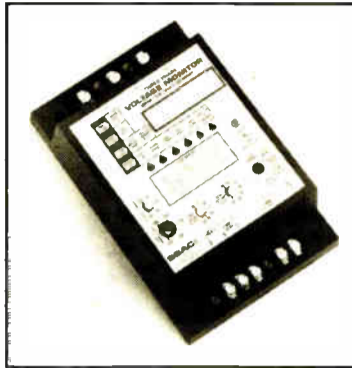

for line voltages of 208/240, 380/415, 440/480 and 550/600 volts, 50/60 Hz AC.

For information, contact Gary L. Weeks in New York at 315-638-1300; fax: 315-638-0333; or circle **Reader Service 104**.



## Cue System

The Comrex Cue System relays both program and instructions from a transmitter installed in a van, studio, press box, stadium, etc., to a pocket-sized receiver.

The 1 W, rack-mount CTA Cue Transmitter combines program and cue audio.

The compact LPQRA Receiver provides 6 MHz audio response so field personnel can accurately monitor program broadcast quality.

For information, contact Lynn E. Distler in Massachusetts at 508-263-1800; fax: 508-635-0401; or circle **Reader Service 206**.

## Vacuum Tube Microphone Preamplifier

The VT-1 Vacuum Tube Microphone Preamplifier from D.W. Fearn provides audio recording studios a new tool to enhance the sound of their microphones.

The preamplifier helps recreate the sound of the classic tube mic preamps of the 1960s, but with modern components and computer-optimized circuitry.

It is available directly from the manufacturer for \$2,000.

For information, contact D.W. Fearn in Pennsylvania at 215-793-2526; or circle **Reader Service 47**.

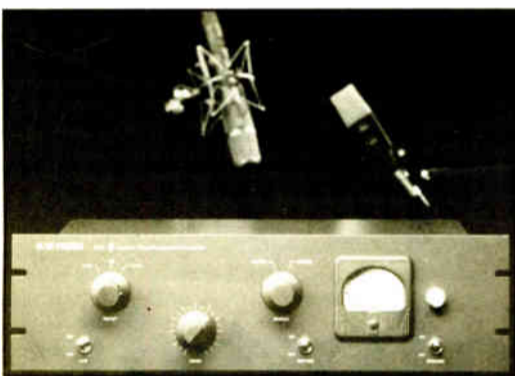

## Clark Listens...

Clark listens to its customers and designs its complete line of audio/video cable accordingly. Now you can listen to Clark's new 700 Series snakes that are designed, as usual, with the customer in mind.

Why not give Clark a listen?



Cables available cut to length and terminated to your specs.

**CLARK** WIRE & CABLE

1-800-CABLE-IT!

1801 Holste Road • Northbrook, IL 60062

**Listen to Clark!**

Circle (112) On Reader Service Card

## USER REPORT

# Burk's LX-1 Aids In Station Upgrade

by Jon Frank  
Engineer  
WGBH-FM

**BOSTON** We're involved in an ongoing project at WGBH-FM to upgrade our technical facilities. We're currently concentrating on our master control.

At this point, incoming sources are routed to various control rooms. The output of the control rooms are routed to air, our NPR satellite uplink, another control room or our co-located television station.

WGBH-FM maintains a very strong commitment to producing the highest quality audio possible. The majority of our recording is mastered on either DAT or analog with Dolby SR. Major projects are edited on our digital workstation, and our link to the FM transmitter is through a digital STL.

We typically look for signal-to-noise ratios in excess of 80 dB and distortion of 0.01 percent or better.

Most of our existing audio switchers are of the relay variety. Being mechanical, they're obviously of a passive nature and introduce no significant noise or distortion. However, they're bulky and offer no features.

## Test taking time

Our original intention was to build a new mechanical air chain switcher. We planned to add a resistive combining net-

work and a distribution amplifier, allowing multiple control rooms to be on the air simultaneously.

I was just about to start ordering the necessary parts for this project when the Burk LX-1 came to my attention. I called Burk, and we decided that running an LX-1 through our test gear would be the only way to determine if it passed our stringent requirements. A loaner unit arrived two days later.

The first of our trials tested isolation between inputs. We were concerned that the solid state switches in the LX-1 might leak an off-line control room onto the air under extreme circumstances.

We cranked our test generator up to maximum output (a little over +30 dbm, unloaded) and connected it to input number one of the LX-1. When the input was switched off line, we could see isolation in the neighborhood of 105 dB.

Speaking of +30 dBm, headroom is another factor we consider very seriously. Ideally we look for a figure of +26 dBm before clipping. At +26 we observed no clipping, with distortion in the 0.001 percent region.

It's difficult to be precise about the results of our tests on the LX-1, because the results challenged the limits of our test equipment in many cases.

## Remote beauty

Once past all the audio specs on the LX-1, we really began to appreciate the beauty of its design.

The LX-1 allows on-line switching of up to six stereo sources, either individually or summed. This means several control rooms can be on the air simultaneously.

The LX-1 offers two fully isolated outputs and a feature called Loop, which allows you to insert an audio processor into the output of the switcher. It then may be bypassed with the Loop function.

Everything on the LX-1 is designed for remote control and remote tally. Momentary start and stop contacts are also available to automatically start or stop an audio source as a channel is switched on line.

All in all, the Burk LX-1 is an extremely affordable audio switcher with superb specs and features.

□□□

For information, contact Phil Halter in Massachusetts at 508-433-8877; fax: 508-433-8981; or circle **Reader Service 169**.

COST-EFFECTIVE PROGRAMMABLE PATCHING

## Replace 16 Patchcords in a Single Keystroke

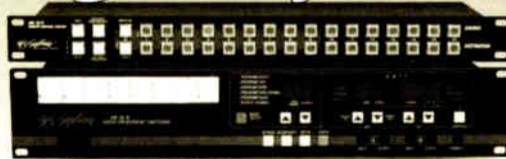

### AM-16 SERIES PROGRAMMABLE AUDIO SWITCHER

- 16x16 switching matrix, balanced inputs & outputs
- Non-volatile storage of 100 programs
- Serial interface ■ Expandable to 5 levels deep
- Multi-station remote control ■ Level adjustment for each input ■ Exceptional audio performance

Routing multi-channel audio and time code signals electronically outperforms patch bays for speed and reliability. The AM-16 allows for a variety of system configurations in small to medium size applications and is priced far less than any other alternative — a complete 16 x 16 matrix for only \$1,495.

*360 Systems*

PROFESSIONAL AUDIO

18740 OXNARD STREET, TARZANA, CALIFORNIA 91356  
PHONE 818-342-3127 FAX 818-342-4372

Circle (16) On Reader Service Card



# PRODUCTS & SERVICES SHOWCASE

For more information on the products shown below, circle the appropriate Reader Service No.(s) on the enclosed Subscription/Reader Service card or contact the advertiser directly.

## WEATHER RADIO

Model CRW



Price \$540.00

Sensitivity .28 microvolts for 12 dB quieting. All 3 frequencies. Alert tone demutes receiver, closes relay and gates audio to 600 ohm rear terminals. Another set of rear terminals has continuous 600 ohm audio output. Double conversion crystal controlled, crystal filter in first I.F., ceramic filter in second I.F. Dual gate MOS FET front end. 50 ohm coaxial input. Adjacent channel (j25 kHz) down to 70 dB. 19" rack mount, 3 1/2" H, all metal enclosure. In stock—available for immediate delivery.

**GORMAN REDLICH MFG. CO**

257 W. Union St. • Athens, Ohio 45701  
Phone 614-593-3150 • FAX 614-592-3898

READER SERVICE NO. 98

## AUTO-ANSWER TELEPHONE COUPLER

Ideal for unattended situations such as listen lines, IFB feeds, dial-up networks, remote transmitter sites & satellite links.

- Clean connection to phone line
- Easy to install
- Send or receive program
- F.C.C. registered



**COMREX®**

Comrex Corp., 65 Nonset Path, Acton MA 01720  
Tel: 1-800-237-1776 Fax: 508 635-0401

READER SERVICE NO. 70

Don't let their size fool you.

## STEREO HEADPHONE AMPLIFIERS



### HD-1000 MASTER

- Drives Four Independent Headsets
- High Output for 8 to 600 ohm Headsets
- Stereo Balanced Line Inputs
- Panned Microphone Input for Announcements
- Stereo or Left Only-Mono Output
- Balanced Line Out to HD-100
- Half Rack or Desk Mount

### HD-100

- Drives Single Headset
- High Output for 8 to 600 ohm Headsets
- Stereo Balanced Line Inputs
- Loop-thru Inputs Feed Multiple Positions
- AC Powered, Compact
- Ideal for Offices and Study Carrels

CALL OR WRITE NOW FOR FREE DETAILED BROCHURE.

**ATI AUDIO TECHNOLOGIES INCORPORATED**

328 Maple Ave. Horsham, PA 19044, USA  
(215) 443-0330 • FAX: (215) 443-0394

READER SERVICE NO. 89

## RECORDABLE CD and DAT

## MEDIA and MACHINES

## LOWEST PRICES!

Your New Digital Headquarters

**LPB®**

28 Bacton Hill Rd. Frazer PA 19355  
215-644-1123 Tel. 215-644-8651 Fax

READER SERVICE NO. 53

### Central to:

- Customer Needs
- Engineering
- Quality
- Fabrication
- Installation
- Specialized Services



CENTRAL TOWER INC.

### Central to All Your Tower Needs

2855 Hwy. 261 • Newburgh, IN 47630-8642  
800-264-0595 • FAX 812-853-6652

READER SERVICE NO. 116

## Greetings... from the FCC

Get a friendly greeting from the FCC during your next inspection.

Harold Hallikainen (author of Radio World's INSIGHT ON RULES) will inspect your station for compliance with the FCC's technical rules and prepare a report discussing areas that need attention. Chief operators, get an outside opinion confirming your excellent work! Station managers, get an outside opinion, just to make sure! A single low price includes the inspection, report, travel and lodging. A multi-station discount is available, so get together with your competitors!

This is a limited time offer, so call today!

**805-541-0200**

**Hallikainen & Friends, Inc.**

141 Suburban Road, San Luis Obispo, CA 93401-7590  
fax +1-805-544-6715  
email ap621@cleveland.freenet.edu

READER SERVICE NO. 135

## Simple-CD \$4,995.00!



New CD based storage & hard disk automation system  
New Simple-CD is a powerful digital hard disk system for basic CD music formats. Full live assist, sweep, overnight, weekend or full walk-away CD automation at an economy price.

- ❑ Interface for up to 32 Pioneer™ PD-M501 or PD-TM/2 CD playbacks in any combination.
- ❑ Simple-CD sounds great! CD-CD and CD to digital overlap, tight production and real time control included.
- ❑ Superb stereo digital sound from the premium apt-X™ digital audio card which is included.
- ❑ Computers are cheap! You supply 386 SX-25 or better computer, color monitor and the hard disk and we supply the intelligent Simple-CD software and audio cards.
- ❑ Cards & software install in your computer with no hassle. Just plug into your mixer or console.
- ❑ Interfaces available to CD-Music Log, EZ Log, Simple Log and Super Log and other Traffic and Billing and Music selector systems.

**The Management**

1-800-334-7823 1-817-625-9761 FAX: 817-624-9741  
P.O. Box 1-36457 Ft. Worth, TX 76136  
1600+ Stations - Our 13th Year

READER SERVICE NO. 10



## Econco REBUILT POWER TUBES



Approximately One Half the Cost of New

3,000 Hour Unconditional Guarantee  
Call for Our Price List

Econco 1318 Commerce Ave. Woodland, CA 95695  
Phone: 916-662-7553 Fax: 916-666-7760 Telex: 176756  
Toll Free: 800-532-6626 From Canada: 800-848-8841

READER SERVICE NO. 63



- Custom Broadcast Furniture
- Delivery and Installation
- Leasing Now Available

Contact Vince Fiola at:

Tel: (215) 640-1229  
FAX: (215) 640-5880



**STUDIO TECHNOLOGY**

4 Pennsylvania Ave., Malvern, PA 19355

READER SERVICE NO. 84



# TECHNOLOGY UPDATES

## GENTNER

### Lazer DSP Digital Limiter/Stereo Generator Combines Push-Button Control, Precision

**SALT LAKE CITY** Lazer, by Gentner Communications Corporation, is a 100 percent DSP digital limiter/stereo generator. The unit's digital nature combines push-button control, digital precision and repeatability to your station's audio chain.

Lazer also provides a high signal-to-noise ratio and low distortion.

Its three-band limiting independently limits spectral peaks without affecting the overall level of program material. The unit's digital process, known as waveform shaping, instantaneously modifies the signal to meet modulation requirements. This ability to generate loudness through digital waveform modification means no clipping.

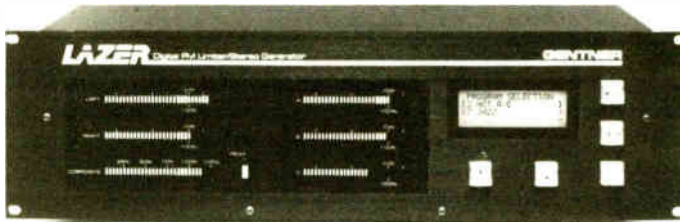

When a signal doesn't need to be limited, the Lazer leaves it alone. It offers complete control over 20 adjustable parameters and eight separate preset processing programs.

You can fine-tune the sound, compare a variety of alternative settings, and then either implement the change or return to where you started.

For information, contact Elaine Jones in Utah at 801-975-7200; fax: 801-977-0087; or circle Reader Service 128.

## UREI

### PLATFORM Series Offers Signal Chain Electronics

**NORTHRIDGE, Calif.** The UREI PLATFORM™, a new modular line of signal processing units, includes a series of signal chain electronics "cards" offering flexibility, compact size and remote control capabilities.

Dubbed the PLATFORM because of its flexible "building block" characteristic, the unit fits into a range of applications, including remote truck installations, conference/AV rooms, post production facilities, home studios, professional recording studios and broadcast applications.

A unique design aspect of the PLATFORM is a bus that allows summing and intermodule communications. Communication between modules is coordinated by a single computer module, which can be programmed to recall 100 memory settings of primary functions.

Parameters such as volume, mutes, bypass and threshold can be controlled via a serial connection or switch closure.

The rackmountable 3u RACK card-cage can hold up to 11 stand-alone or computer controlled modules. Six module units are available initially.

For information on the UREI Platform, contact David Kimm in California at 818-893-8411; Flash Fax: 818-895-8190; or circle Reader Service 119.

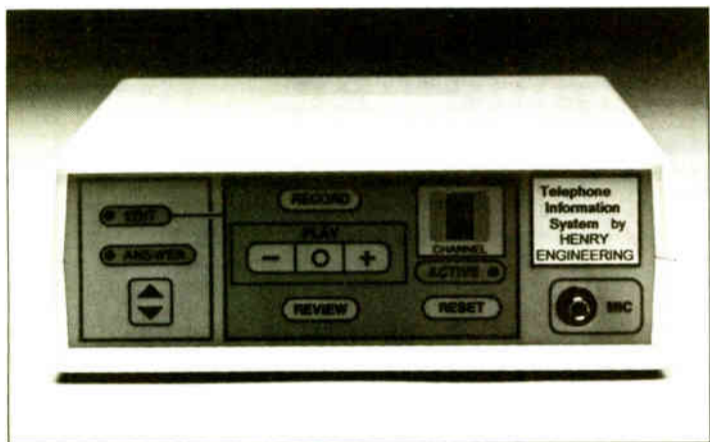

**Press 1 For Today's Weather.  
Press 2 For The Ski Report.  
Press 3 For Concert Information.  
Press 4 For . . .**

Now you can provide multiple listener information services with one phone line!

The new Telephone Information System (TIS) from Henry Engineering stores up to ten separate messages for instant playback via touch-tone.

With just one "info hot-line" phone number, your listeners can get the specific info they want just by pushing the right buttons on their phone.

Digital audio memory means messages never wear out. When the unit is called, a "Menu" message plays,

telling your caller which messages are available. The caller may then select any message(s) for instant playback. Messages are easily updated by re-recording. And, over eight minutes of information can be stored in the TIS digital memory.

Henry's TIS . . . Telephone Information System . . . from Harris Allied. It's quick. It's easy. It's profitable. And, it's in stock now.

**8:00 a.m. to 8:00 p.m. EST  
1-800-622-0022  
Fax 317-966-0623  
Canada 1-800-268-6817  
Toronto 416-731-3697**

**HARRIS ALLIED**



## RADIO DESIGN LABS

### ST-CL1 Compressor/Limiter Provides Processing and Improved Gain Reduction

**CARPINTERIA, Calif.** The ST-CL1 by Radio Design Labs provides advanced wideband processing characteristics in a small package.

Features such as "soft-knee" compression, variable compression ratios and "transparent" audio form the basis of the ST-CL1. Audio circuits are direct-coupled, producing audio clarity and low noise.

To maintain audio transparency and tight audio control, RDL developed incremental gain reduction. Multiple detectors continuously sample the audio at different rates and levels, causing separate control loops to precondition the audio for the next gain reduction detector.

Tailoring the audio for each subsequent increment of gain reduction, together with interactive release-time circuitry, help produce nearly inaudible operation.

Compression ratios and attack/release times automatically adjust to the program

material, eliminating the need for installer settings other than input and output.

The input gain determines the threshold and compression levels, and is set using the LED indicators covering the incremental ranges of compression.

ST-CL1s may be strapped together for stereo operation, or average compression may be restricted by the user for versatility.

For information, contact Jerry Clements in California at 805-684-5415; fax: 805-684-9316; or circle Reader Service 105.

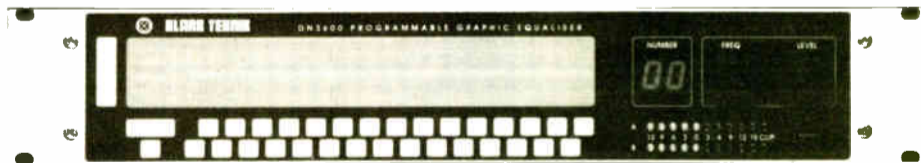

## KLARK TEKNIK

### DN3600 Allows Alteration of Gain Within 24 dB Range

**BUCHANAN, Mich.** Klark Teknik's new DN3600 is a fully programmable digitally-controlled analog graphic equalizer designed for studio signal processing applications.

The DN3600 includes two special function keys for alternating between an EQ curve, relative fader position for channel A or B, or a combination of both. In the stereo mode, the two channels can be linked together to provide identical curves to two signal paths from one set of fader controls. In dual mode, these can be adjusted independently.

The DN3600 also offers 30 individual selection keys that correspond to each of the frequency bands. Each channel includes two notch filters and sweepable low/high pass filters. All important information is shown on a large, illuminated LCD display in a two-rack-space chassis.

Other features include a special function key allowing the user to instantly alter the gain within a 24 dB range (+6 to -18); an "auto make-up" gain function and a total of 66 memory locations for storing equalization curves under a user-defined name.

For information, contact Allan Nichols at 800-695-1010; fax: 616-695-0470; or circle Reader Service 191.



JNS

**Hum, Noise and Distortion from Signal Chain Kept to a Minimum with LA.8103 Line Amplifier**

**SAN JOSE, Calif.** Every broadcaster experiences hum, noise and distortion in an audio signal chain. This is becoming more common with the numerous audio interfaces occurring.

Both internal and remote broadcasts present new AC and DC challenges, including poor common mode rejection,

impedance mismatches and balanced to unbalanced. Sometimes remotes have the biggest challenge.

The design of the JNS LA.8103 Line Amplifier targets a number of these. AC and DC isolation to 1 kV is obtained with transformers. Each LA.8103 has two line transformer inputs to active balanced outputs and two active balanced inputs to transformer outputs.

The distortion normally associated with transformer interfaces is reduced to below 0.007 percent (1 kHz, +18 dBm) by using active transformer drive stages, and remains below 0.01 percent at 100 Hz, 0.2 percent at 20 Hz.

The input stages are all high impedance greater than 20k $\Omega$  (600 $\Omega$  user selectable) and the outputs are 35 $\Omega$  (with 600 $\Omega$  user selectable). Fractional dB audio response exceeds the goal of 20 kHz.

For information, contact John Leonard in California at 408-729-3838; fax: 408-926-1003; or circle Reader Service 220.

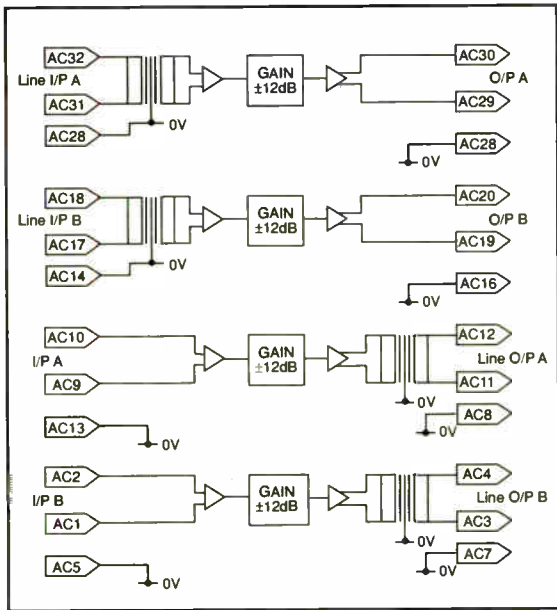

YAMAHA

**SPX900 Simul-Effect Processor Offers 20-Bit A/D and D/A Conversion**

**BUENA PARK, Calif.** The new Yamaha SPX900 Simul-Effect Processor is a multi-effect processor offering high quality effects and programming versatility for radio production applications.

The SPX900 represents the latest advances in Yamaha processor technology, offering more features than its predecessor, the SPX90. The unit contains a data entry wheel and six additional function keys on the front panel.

The SPX900 allows the user to add compression, EQ and additional processing before and after the main effect.

The SPX900's 20-bit A/D and D/A conversion helps provide the effects without digital noise or distortion. In addition to the 50 preset and 100 user memory locations contained internally, the SPX900 offers RAM card memory expansion that allows storage of up to

100 user-modified effect programs on a single data card.

The data cards allow you to organize your customized effects by project or effect type. Balanced +4/-20 dBm inputs and outputs, and XLR and TRS phone jack connectors allow compatibility with a wide range of equipment.

Delay time parameters on the Yamaha SPX900 can be programmed in terms of tempo or note length, and can also be entered via MIDI clock data or by footswitch. Algorithms and internal reverb parameters have been refined to deliver a natural reverb sound.

Pitch change precision is improved through a new dynamic waveform analysis technique. The SPX900 features a pitch change program in which the appropriate harmony is created based on a specified key and scale type. Price of the Yamaha SPX900 is \$1,099.

For more information, contact Yamaha Corporation of America, Professional Audio Products in California at 714-522-9011; fax: 714-739-2680; or circle Reader Service 88.



AUDIO/DIGITAL

**TC-4 Features Profanity Delay of 6.5 Seconds**

**NORTHRIDGE, Calif.** The TC-4 Broadcast Digital Processor by Audio/Digital features a delay time of 6.5 seconds, with an 18 kHz bandwidth and 85 dB dynamic range.

The auxiliary card allows memory dump in less than one second, and a delay time buildout feature that allows an inaudible gradual return to full delay

following a memory dump.

It also permits starting programs in near real time. Affordable stereo operation is achieved using two TC-4s.

For information on the Audio/Digital TC-4 Broadcast Digital Processor, contact David Kimm in California at 818-893-8411; Fax: 818-895-8190; or circle Reader Service 66.

**110%.  
25 HOURS  
A DAY.  
366 DAYS  
A YEAR.**



TASCAM's industry-standard 122MKII has a lot to live up to.

Starting with its own reputation as the hardest working professional cassette deck in broadcasting.

No problem.

Because the 122MKII was designed from Day One to withstand the ravages of people who detest dead air as much as you do.

Its FG servo, direct-drive capstan motor was designed to handle the kind of round-the-clock cueing and rewinding that burns most other motors out fast.

The unique Hysteresis Tension Servo Control actually lets you adjust take-up, back-tension and torque with open-reel precision. So you maintain the same back-tension throughout the entire cassette, significantly reducing wow and flutter and distortion.

And while relentless play tends to take its toll on conventional tape heads, the 122MKII's three cobalt amorphous heads are built for the long run, delivering crisp, clean sound that's enhanced even more by a choice of Dolby® B, C and HX-PRO.

But even all that's not all. Because the 122MKII also features front-panel bias and EQ, +4 dBm XLR-balanced Ins and Outs and a suggested retail price of just \$1,149.

For more on the broadcast deck built to work like there's no tomorrow, every day, call or write TASCAM.

**TASCAM.**

© 1992 TEAC America, Inc., 7733 Telegraph Road, Montebello, CA 90640. 213/726-0303. \*Dolby B, C and HX-PRO are registered trademarks of Dolby Laboratories Licensing Corporation.





**EVENTIDE**

**Broad Ultra-Harmonizer Has 484 Factory Presets**

**LITTLE FERRY, N.J.** Eventide's H3500B, the broadcast version of the H3500 Ultra-Harmonizer, features 484 factory presets, digital sampling up to 95 seconds and digital TimeSqueeze® time compression/expansion.

The H3500B incorporates all the features of the H3500, with effects such as pitch shifting, reverb, delay effects and sampling.

And like the H3500, the H3500B has DFX Dynamic Effects algorithms with control over effects such as ducking, gating and compression.

Each of the new DFX algorithms in the

H3500B also has a full set of independent processing modules, from delays and filters or pitch shifters to envelopes, modulators and mixers. The modules can be patched together in virtually any combination.

The H3500B also gives you Ultra-Sampling, with an internal sampling board and Eventide sampling software. The company's pitch change technology allows you to change playback length on the fly—without changing pitch.

The H3500B also includes other Harmonizer audio effects, including delays, rich flanges, choruses, trick voices, 1,000 voices in a box, reverb and a recreation of the classic Instant Phasor®.

For more information contact Gil Griffith at Eventide Inc. at 201-641-1200 or fax: 201-641-1640; or circle Reader Service 133.

**SESCOM**

**Field-Pro Series: Interface Boxes for Field Use Powered with 9-Volt Battery**

**HENDERSON, Nev.** The world of audio is continually changing. At one time, audio was an inside job only, and the audio professional hardly ever did a remote.

Matching and mixing various brands of equipment with pro and semi-pro causes problems for most people. Sescom has developed a line of interface boxes, the "Field-Pro Series," for the audio person in the field with these problems.

There are 11 boxes designed for field use. They are housed in a rugged extruded aluminum enclosure with the end panels recessed to prevent the knobs, jacks, switches and controls from accidental breakage.

The units are powered with a single nine-volt battery with a slide lock case for field servicing and custom wound transformers for protection.

The series includes FP-MS Mic-Splitter, FP-MC Mic-Combiner, FP-DB

**FM SYSTEMS**

**SPM-1 Performance Meter Gauges Stereo Separation**

**SANTA ANA, Calif.** The SPM-1 meter by FM Systems Inc. measures the degree of stereo separation present in a stereo signal. The meter displays the stereo content of any program audio signal in 1 dB steps, and up to 50 dB on a bar graph.

This enables the production of the desired stereo separation (spreading or focusing of sound) for each instrument and performer.

The recording engineer can create a specific stereo environment that can be repeated in subsequent cuts.

The SPM-1 also measures the degree of loss of stereo due to application of compressors and limiters. While heavy-duty compression and limiting increases the loudness of the recorded or broadcast music, it also suppresses stereo separation.

For information, contact Frank McClatchie in California at 714-979-3355; fax: 714-979-0913; or circle Reader Service 172.



**ATI**

**Emph'a Sizer Accentuates Audio Functions**

**HORSHAM, Pa.** The Emph'a Sizer by Audio Technologies Inc. (ATI) is a combination of audio processing functions designed for easy "on-air" use in the studio or on remotes.

The Emph'a Sizer includes a program controlled Input Gate, four switch selectable parametric equalizer sections and a low distortion Compressor-Limiter.

The Input Gate helps reduce undesirable background pickup or crowd noise on remotes. It also helps eliminate microphone crossfeed or reverberation pickup in the studio and quiet noisy phone line inputs on telephone talk shows.

The Emph'a Sizer Compressor-Limiter is designed around a professional grade, low noise VCA (Voltage Controlled Amplifier).

The heart of the Emph'a Sizer is a four-band personality equalizer. Each of the four parametric equalizer sections has separate, protected, internal adjustments for frequency, bandwidth and up to 20 dB of boost and cut.

For information, contact Sam Wenzel or Edward Mullin in Pennsylvania at 215-443-0330; fax: 215-443-0394; or circle Reader Service 145.

**MODULATION SCIENCES**

**CP-803 Gives Up to 6 dB Of Additional Loudness**

**SOMERSET, N.J.** The CP-803 Composite Processor by Modulation Sciences enhances an audio chain by offering up to 6 dB of additional loudness, depending on the existing level

of processing. The CP-803 eliminates the brief electrical overshoots in audio limiters and stereo generators. The processor also eliminates the acoustically insignificant high-frequency peaks present in program material, making greater average modulation possible.

The CP-803 works with the stereo composite signal out of a stereo generator or composite STL receiver. The absence of

variable gain elements eliminates pumping, swishing and breathing effects found in processors. The CP-803 won't clip a 19 kHz pilot.

Some composite STLs have as much as 2 dB of overshoot, which can reduce modulation by as much as 20 percent. The CP-803 helps eliminate the problem.

For information, contact Art Constantine at 800-826-2603; fax: 908-302-0206 or circle Reader Service 57.

**SENNHEISER**  
**marantz**  
*30 Systems*  
**SHURE**  
**Panasonic**  
**OTARI**  
**TASCAM**  
**EV**  
**JBL**  
**SONY**  
**Technics**  
**CROWN**

**1-800-356-5844 — CALL!**  
**THE BEST FOR LESS. EVERY DAY DISCOUNTS**

**FULL COMPASS**

Over 350 Product Lines — Audio, Video, Lights  
Consultation: (608)271-1100 — Fax (608)273-6336  
5618 Odana Road, Madison, WI 53719

**HEAVY DEALS!**

**The right stuff at the right price!**



of processing. The CP-803 eliminates the brief electrical overshoots in audio limiters and stereo generators. The processor also eliminates the acoustically insignificant high-frequency peaks present in program material, making greater average modulation possible.

The CP-803 works with the stereo composite signal out of a stereo generator or composite STL receiver. The absence of

variable gain elements eliminates pumping, swishing and breathing effects found in processors. The CP-803 won't clip a 19 kHz pilot.

Some composite STLs have as much as 2 dB of overshoot, which can reduce modulation by as much as 20 percent. The CP-803 helps eliminate the problem.

For information, contact Art Constantine at 800-826-2603; fax: 908-302-0206 or circle Reader Service 57.

**SUBSCRIPTION/READER SERVICE FORM**

**Radio World**

**FREE Subscription/Renewal Card**

I would like to receive or continue receiving Radio World FREE each month.  Yes  No

Signature \_\_\_\_\_ Date \_\_\_\_\_

Please print and include all information:

Name \_\_\_\_\_ Title \_\_\_\_\_

Company/Station \_\_\_\_\_

Address \_\_\_\_\_

City \_\_\_\_\_ State \_\_\_\_\_ ZIP \_\_\_\_\_

Business Telephone ( ) \_\_\_\_\_

Please circle only one entry for each category:

**I. Type of Firm**

D. Combination AM/FM station F. Recording Studio  
A. Commercial AM station G. TV station/teleprod facility  
B. Commercial FM station H. Consultant/ind engineer  
C. Educational FM station I. Mfg, distributor or dealer  
E. Network/group owner J. Other \_\_\_\_\_

**II. Job Function**

A. Ownership G. Sales manager  
B. General management E. News operations  
C. Engineering F. Other (specify) \_\_\_\_\_  
D. Programming/production \_\_\_\_\_

**Reader Service**

June 23, 1993 Issue Use Until September 23, 1993  
Please first fill out contact information at left. Then check each advertisement for corresponding number and circle below.

**Purchasing Authority**  
1. Recommend 2. Specify 3. Approve

001	023	045	067	089	111	133	155	177	199
002	024	046	068	090	112	134	156	178	200
003	025	047	069	091	113	135	157	179	201
004	026	048	070	092	114	136	158	180	202
005	027	049	071	093	115	137	159	181	203
006	028	050	072	094	116	138	160	182	204
007	029	051	073	095	117	139	161	183	205
008	030	052	074	096	118	140	162	184	206
009	031	053	075	097	119	141	163	185	207
010	032	054	076	098	120	142	164	186	208
011	033	055	077	099	121	143	165	187	209
012	034	056	078	100	122	144	166	188	210
013	035	057	079	101	123	145	167	189	211
014	036	058	080	102	124	146	168	190	212
015	037	059	081	103	125	147	169	191	213
016	038	060	082	104	126	148	170	192	214
017	039	061	083	105	127	149	171	193	215
018	040	062	084	106	128	150	172	194	216
019	041	063	085	107	129	151	173	195	217
020	042	064	086	108	130	152	174	196	218
021	043	065	087	109	131	153	175	197	219
022	044	066	088	110	132	154	176	198	220

Copy & Mail to: Radio World, PO Box 1214, Falls Church, VA 22041, or FAX to: 703-998-2966



# Surprise Yourself.



## Why settle for less?

Radiomixer is the most affordable high-performance console in radio with configurations starting at under \$10,000.

Stations with the most stringent budgets can now have major market PR&E quality. Isn't that a nice surprise? Call today for more information.

Add multitrack production power to the on-air features of a Radiomixer and you have Productionmixer, the most affordable production console in broadcasting.



Pacific Recorders & Engineering Corporation  
2070 Las Palmas Drive  
Carlsbad, CA 92009  
Tel: 619-438-3911 Fax: 619-438-9277

**DESIGNS THAT MAKE THE DIFFERENCE**



# Who's running the ship?

**U**nattended operation is one way to keep your station profitable, but you still have to mind the store.

The acclaimed Burk Technology ARC-16 Remote Control System is the first step. You can control transmitter and studio from any phone.

But wait. There's more!



**I**ntroducing AutoPilot™ from Burk Technology.

AutoPilot is break-through computer software that makes automatic operation of your studio/transmitter facility a dream come true.

Automatic power changes  
Automatic pattern changes  
Automatic site changes  
Automatic power trim  
Automatic fault recovery  
Automatic logging

Now your imagination is the only limit.

The new FCC fine schedule is imposing. Why risk a big penalty when AutoPilot can help you stay within the rules?

Call us at 508-433-8877  
or toll free at  
1-800 255-8090  
for more information  
and a FREE DEMO.

**BURK**  
TECHNOLOGY

Circle (140) On Reader Service Card

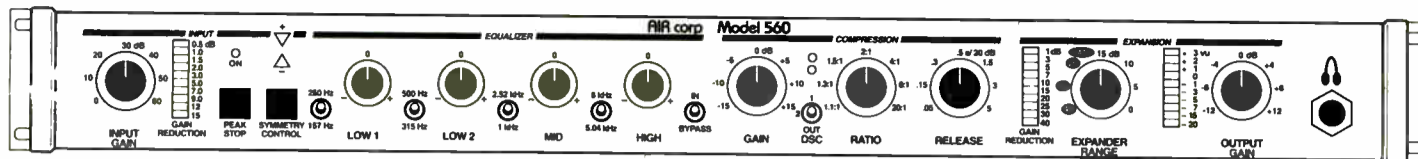

## AIR CORP.

### Mic Processor Designed To Record Directly From the Microphone

**IRVING, Texas** The AIR Corp. Model 560 is designed to provide the recording engineer the processing needed to record a clean, well-controlled vocal or instrumental track directly from the microphone.

The Model 560 features a low-noise, autoranging and voltage controlled pre-amplifier with an interactive peak stop

feature. It's coupled to a dynamic symmetry control, a type of baseline corrector that helps compensate for waveform asymmetry at its input.

A four section bandpass equalizer with selectable ISO 3rd octave center frequencies is included, with phase compensation to help enhance clarity of the equalized signal.

The Model 560 also incorporates a feed-forward compressor with variable ratio and release and variable input level.

For information, contact Jim Loupas at AIR Corp. in Texas at 214-255-0550; fax: 214-252-0020; or circle Reader Service 60.

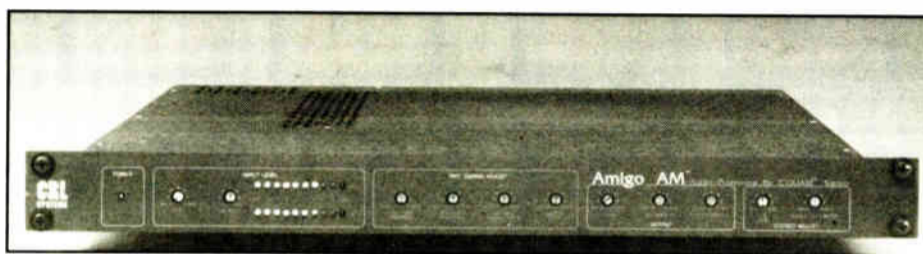

## CRL

### Amigo AM: A Single Unit Processing System

**TEMPE, Ariz.** During the last year, Circuit Research Labs received a number of inquiries from small to medium market size stations wanting to convert to AM Stereo within their budgets, while still producing a full, on-air sound.

Our answer to these stations is the Amigo AM, a single unit matrix processing system for AM Stereo. The unit includes a wide range Dual Band AGC, triband matrix limiter and NRSC filtering.

The controls are separated into four functional groups: Input Level, Processing Adjust, Output, Stereo Adjust. Most of these controls are calibrated to produce the best sound setting at the 12 o'clock position.



## FM STUDIES

- **SPACING/INTERFERENCE SEARCHES** to locate a channel
- **DETAILED INTERFERENCE STUDIES** optimizing site location and directional antenna designs (calculates allowed ERP on all 360 bearings)
- **TERRAIN ELEVATION RETRIEVAL** determines HAAT for 8 or more radials
- **DISTANCE TO CONTOURS** plots projected coverage
- **POPULATION COUNTING** to determine potential listening audience
- **COVERAGE MAPS AND OVERLAYS** depicts signal coverage, zip code boundaries, received signal level, terrain shadowing and more

**dataworld**  
A Service of DW, Inc.

(301) 652-8822 (800) 368-5754

Circle (37) On Reader Service Card

World Radio History

## RADIO SYSTEMS

### Dolby S Audio System Helps Improve Cart S/N

**BRIDGEPORT, N.J.** In the excited rush to digital, many broadcasters were left with a substantial investment in a very good, reliable, old format—cart machines. Carts are, from a user standpoint, still the most convenient playback format, but they suffer from relatively poor S/N ratios.

That's why Radio Systems licensed the Dolby S technology, which can lower cart noise floors by up to 24 dB.

Originally developed for consumer applications, Dolby S is a close derivative of the world-standard Dolby SR.

The Radio Systems package customizes Dolby S for professional applications by including balanced audio I/O and stereo phase correction circuitry for up to 90 degrees of phase correction at 1 kHz.

For information, contact Radio Systems in New Jersey at 609-467-8000; fax: 609-467-3044; or circle Reader Service 76.



## SYMETRIX

### Digital Voice Processor Allows On-the-Fly Editing

**SEATTLE** The 601 Digital Voice Processor by Symetrix offers a user interface integrating the Alpha wheel and large numeric display, allowing on-the-fly editing of its parametric EQ, compression, AGC, limiting, de-essing, dynamic filtering noise reduction, gating, downward expansion and stereo delay functions.

The mic pre-amp of the voice processor is analog based to retain warmth. Through internal building blocks containing additional parameter features, functions such as preset crossfade are accomplished.

There are 256 presets, 128 factory and 128 user defined. Two levels of front panel security protect these patches and all parameter settings when you need the 601 to be tamper-proof.

Medium security leaves only the preset load button active, while high security makes all front panel functions inoperative.

Both digital and analog inputs and outputs are included, accommodating line and mic levels in, AES/EBU and S/PDIF I/O and stereo XLR line outputs. MIDI connections allow a number of external interfaces for controlling or programming the 601. A/D-D/A conversion is 18-bit design, while all internal digital processing is 24-bit.

For information, contact Jon Bosaw in Washington at 206-282-2555; fax: 206-283-5504; or circle Reader Service 171.

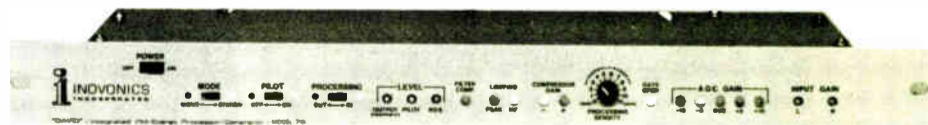

## INOVONICS

### DAVID Joins Digital Synthesis and Analog Processing

**SANTA CRUZ, Calif.** The DAVID by Inovonics Inc. was developed to meet the FM broadcaster's need for a basic audio processor/stereo generator package. It combines digital synthesis of the FM composite baseband signal with simple analog processing.

Pilot and subcarrier are generated with digital logic not much more complex than

sequential turn signals from a '70s Ford Thunderbird. Audio processing features a short program audio signal path with a minimum number of circuit stages.

Processing is comprehensive with gated AGC and dynamic range compression.

For information, contact Inovonics in California at 408-458-0552; fax: 408-458-0554; or circle Reader Service 75.



# PRODUCTS & SERVICES SHOWCASE

For more information on the products shown below, circle the appropriate Reader Service No.(s) on the enclosed Subscription/Reader Service card or contact the advertiser directly.

## Obstruction Lighting That's Not Sky High

### ElectroFlash™ Aviation Lighting Systems

- Medium and High Intensity Obstruction Strobe Lighting
- ETL Certified. FAA, Transport Canada and ICAO Approved
- Compatible with Dual Installations—Auto Restart
- Available with AC, DC, or AC/DC Combo Input Voltage
- Installation and Service Maintenance Available
- Equipment Warranted for 24 Months—Includes Flash Tube

P.O. Box 329  
Nashua, NH 03060  
Phone: (603) 883-6500  
Fax: (603) 883-0205



READER SERVICE NO. 29

## ARE YOUR LIGHTS ON?

The FCC requires that towers be lighted in accordance with the provisions of the station license. The Commission specifies (Section 17.47) that licensees shall make an observation of the tower lights at least once every 24 hours either visually or by observing an automatic and properly maintained indicator. The indicator should register any failure or malfunction of the tower lights.

Obstruction Lamp Alarm Relay  
SCR490D

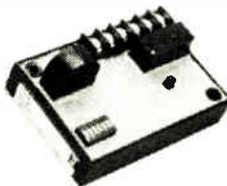

**SSAC inc**  
SOLID STATE TOWER LIGHTING CONTROLS

Senses Failed Obstruction Lights  
2 to 9 Steadily Burning Lamps can be Monitored

**\$86.49**

Universal Light Alarm Relay  
SCR430T



**\$86.49**

Senses Flashing Beacon or Obstruction Lights  
Switch Selectable Number, Voltage, and Wattage of Lamps

Shorted Flasher Alarm Relay  
SFA430T



**\$74.89**

Senses a Constantly ON Beacon  
Operates with SCR430T to Provide Complete Beacon Monitoring

Main Sales Office  
2342 S. Division Avenue  
Grand Rapids, Michigan 49507



**AUDIO BROADCAST GROUP**

**1-800-999-9281**

Southeastern Sales Office  
200 Fareway Drive, Suite 2  
Smithfield, North Carolina 27577

**1-800-369-7623**

READER SERVICE NO. 201

## CONSOLE UPGRADE WITHOUT THE BIG EXPENSE

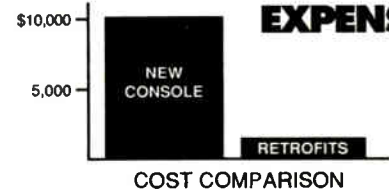

Approach digital quality with your yesteryear audio console by using BDI plug-in retrofit electronics. If the cost of a new console is depriving you of a competitive air sound then BDI electronics are the answer. Better headroom, lower noise, lower distortion, dynamic range approaching 90dB and improved reliability are just some of the advantages of our easy to install upgrades. Call us today direct for a competitive air sound tomorrow!

Our retrofit electronics currently support most:

Gates/Harris Consoles  
RCA Consoles  
McMartin Consoles  
McCurdy Consoles



**Broadcast Devices, Inc.**

5 Crestview Avenue  
Peekskill, NY 10566

**(914) 737-5032**

READER SERVICE NO. 109

## DIELECTRIC... your "RF Source."

- \* Antennas (TV & FM)
- \* Transmission Line & Waveguide
- \* Switches
- \* Filters
- \* Combiners
- \* Loads

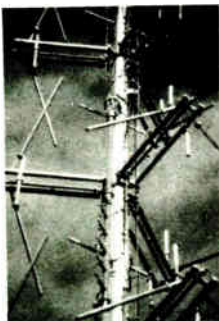

With over 40 years of engineering and manufacturing excellence, Dielectric supplies standard and custom RF products *built to last*. Call and let us help...

**DIELECTRIC COMMUNICATIONS GS**

207-655-4555  
Fax 207-655-7120

P.O. Box 949  
Raymond, Maine USA 04071

READER SERVICE NO. 24

## Take Control...

The Jr. Audio Director provides output source selection between **Left Only, Right Only, Mono, Stereo, and Stereo Reverse**. Installation is easy, using the plug-in Euro-style barrier strip.



**\$390.00**

**BENCHMARK MEDIA SYSTEMS, INC.**

315/437-6300 800/262-4675 FAX 315/437-8119

### Features/Functions

- Stereo (normal)
- Mono
- Left Only
- Right Only
- Stereo Reversed
- Right Channel Polarity Inversion
- Rackmountable
- Built in mono mode gain reduction
- LED Indicators
- Balanced I/O's

*Benchmark*  
...the measure of excellence!™

READER SERVICE NO. 46

**Cellcast**

REMOTE BROADCAST STUDIO

The CELLCAST RBS-400 1.8 offers complete portability and flexibility for remotes. Complete with a 4-channel mixer, frequency extender, cellular transceiver and landline capabilities, 600 ohm line out, and Vu meter. It is powered by 10 Ni-Cad rechargeable batteries, 12v adaptor, and AC power supply. 24 hour product support standard.

Call Bridget Taylor today for our \$195.00 2 week trial at



**1-800-852-1333**

READER SERVICE NO. 9

## Manufacturers

Is your company or product featured in our pages? Distribute extra copies of **Radio World** articles to your customers with **Radio World's** reprint service.

Print as many copies as you want for **one low price.**

For information, call Simone Mullins at

**1-800-336-3045**



# RadioWorld

## Broadcast Equipment Exchange

"Broadcast Equipment Exchange" accepts no responsibility for the condition of the equipment listed or for the specifics of transactions made between buyers and sellers.

### RADIO RESOURCES

1201 S. Sharp St.  
Baltimore, MD 21230

DO YOU HAVE EXCESS  
EQUIPMENT TO SELL?

Mail or fax us a list of what you have for sale, and we will help you turn your excess equipment into CASH

Some of the equipment items we need are:

- POTOMAC FIELD STRENGTH METERS
- MARTI VHF/UHF RPU EQUIPMENT
- MARTI STL EQUIPMENT
- MOSELEY STL EQUIPMENT
- ORBAN 8100A OPTIMOD

If there is a piece of pre-owned equipment you are looking for give us a call, we can probably help you

THE INDUSTRY'S BEST NEW &  
PRE-OWNED EQUIPMENT DEALER

Ask for Bill, Steve or Chuck  
Voice: 1-800-54-RADIO  
FAX: 1-410-783-4635

Circle (115) On Reader Service Card

### ACOUSTICS

**STUDIOFOAM**  
SOUND ABSORBENT WEDGES  
TESTS 18% BETTER THAN SONEX!  
COSTS LESS! BETTER COLORS!  
**1-800-95-WEDGE**

### AMPLIFIERS

Want to Sell

Dynaco Stereo 70 tube power amp 35W/chnl, works, \$20. P Russell, Bowdoin College, Sills Hall, Brunswick ME 04011. 207-725-3066.

Leak stereo 50 point one preamp through line II FM tuner, all tubes near mint, \$3000. P Robillard, WYLD, 2228 Gravier St, New Orleans LA 70119. 504-581-1280.

McIntosh Mc240 tube power amp, chrome & blk w/manual, gd cond, \$700. R Glenn, WJGR, 1718 Shannadoa, Wimauma FL 33598. 813-634-1940.

Crown D-300A Series II, mint, 300 W convection cooled, w/rack case, \$700. L Just, Auditech, POB 2426, Secaucus NJ 07096.

Lafayette Stereo 224, all tube pre-amp/amp, very quiet when w/o signal, (4) new output tubes 6GW8, \$125. H Jeschke, The Fellowship Press, 5820 Overbrook Ave, Philadelphia PA 19131. 215-879-6300.

Crown Micro-Tech 600LX stereo power amp, \$550; Crown DC 300A power amp, \$400; South West Tech power amp, \$175; Haller P-230 power amp, \$400. D Lundy, Lundy Tape Duplicators, POB 408, Heidrick KY 40949. 609-546-6650.

Dynaco stereo 70 fact built; McIntosh MC-40 pwr amp, all documentation. L Lindstrom, WJEZ, 315 Mill, Pontiac IL 61764. 815-844-6101.

LPB DA 1 16 distribution amp, new. J Gelo, 813-642-6899.

Want to Buy

McIntosh, Marantz, Harmon-Kardon, Fisher tube amps, preamps, tuners, manuals, tubes, etc. R Glenn, WJGR, 1718 Shannadoa, Wimauma FL 33598. 813-634-1940.

### ANTENNAS & TOWERS

Want to Sell

268' solid galvanized steel FM or two-way tower, 18" face w/tops to 13", light kit, turn buckler, will hold ERI 3-bay or equiv, BO. M Casey, WKSX, Drawer I, Johnston SC 29832. 803-275-4444.

Utility towers, (6) 400' w/antenna coupling units & six tower phasor, priced standing or on the ground, BO. G Proctor, WCRJ, 980 FM 1746, Woodville TX 75979. 409-429-3679.

### FM - ANTENNAS

Designed and built for your frequency. Choose from 1 to 12 bays and five power levels. Financing available. Call Jimmie Joynt at S.W.R. **214-335-3425**

Patch bay, 24 position patch bay, pre wired terminal strips, BO G Johnson, WLDY, POB 351, Ladysmith WI 54848. 715-532-5588.

Shively A6810 2-bay high powered mtl tuned to 100.7, great cond, \$2500. M Bitner, WGWD, POB 919, Quincy FL 32353.

Gates phasor 2 tower plus ATU's 5 kW 1480 DA-2. K Kuenzie, KFXE, 13E 11th, Washington MO 63090. 314-239-0209.

Kintronics FMC-30 iso-coupler, 107.3 MHz, BO. G Proctor, WCRJ, 980 FM 1746, Woodville TX 75979. 409-429-3679.

### GELECO

Coils, Ribbon & Tube Contactors & Parts  
Hotline Jacks, Toroids, Capacitors & Flanges, Lighting & Static Chokes  
Parabolic Microphones  
Stock Items; Fast Service  
—since 1957—

ph: 416-421-5631  
fax: 416-421-3880

Andrew A 10R 50507 coax, 1-5/8", (2) 275' rolls, \$8.75/ft. S Ross, WQFE, 733 N Green St, Brownsburg IN 46112. 317-852-9119.

Dielectric DCVS6B 6-bay FM CP antenna w/radomes, 8 yrs old, excel cond, tuned to 93.1 MHz, BO. R Cleveland, Radio One Ltd, 206 Rockwood Ave, Frederickton NB E3P 2M2, Canada.

Misc RF parts: (3) 15 A light chokes, (3) Delta TCT-2 xlms, (5) shunt assys w/shunts, (15) 100 mld@20 kv vacuum caps, (3) M-24-20 inductors, (1) M-23-15 inductors. M Martindale, KVON, 1124 Foster Rd, Napa CA 94558. 707-252-1440.

Transmission line parts, many Dielectric hard line reducers & elbows from 4-1/16" system. C Murray, KMGE, 925 Country Club Rd #200, Eugene OR 97401. 503-484-9400.

ERI FML-3E 3-bay, \$3K. R Miller, Miller Media Group, POB 169, Taylorville IL 62568. 217-824-3395.

Phelps-Dodge FMC-2-LP 2 bay circ pol FM tuned to 98.3 MHz, gd cond. M Rice, Contemporary Media, 222 Indacom Dr, St Peters MO 63376. 314-928-6589.

Shively 6813 2-bay w/radomes tuned to 96.1, BO. D Magnum, WBOG, 1021 N Superior Ave, Tomah WI 54660. 800-736-WBOG.

Collins phasor for DA-2, 10 kW in 2 cabinets & components for ATU's. E Hoehn, KFMZ, 1101 Walnut, Columbia MO 65201. 314-874-3000.

Tower Comm Co G8KDP 7 GHz parabolic antenna w/passive reflector & mounting hardware, \$600. E Black, 405-524-3770.

Kintronics 7.5 kW isocoupler at 103.1. L Lindstrom, WJEZ, 315 Mill, Pontiac IL 61764. 815-844-6101.

Andrew Heliax 700' 1-5/8" line, in service only 6 yrs on a reel ready to ship, \$5/ft; ERI 10 bay antenna FMH-10AC circular polarized tuned to 98.9, \$22000. M Wodlinger, WIXI FM, 813-262-1000.

ERI 403 isocoupler, \$250 plus shipping. J Hughey, WIZK, POB 548, Bay Springs MS 39422. 601-764-3151.

Cooper strap, 150', 0.020 thick, 4" wide, never used, \$150/BO; 60' Cablewave 50 ohm, air, 1-5/8, never used, \$400/BO. C Scherer, WDOK, One Radio Ln, Cleveland OH 44114. 216-696-0123.

800' of Andrews 3" heliax with gas pass and gas barrier connectors, hoisting grips and grounding kits. Some hangars available also. 3 yrs old, only in service 18 months. Pressurized and sealed on spool. Excellent condition. Free delivery up to 300 miles. \$21,000. **512-847-2449.**

Kintronics Labs PS-1 AM PSA/PSSA pwr reduction unit, from 1 kW to PSA/PSSA power input; CCA Watchdog II VSWR transmission line monitor, like new w/instructions. M Rice, Contemporary Media, 222 Indacom Dr, St Peters MO 63376. 314-928-6569.

Jampro clr polar 4 bay on 103.1. L Lindstrom, WJEZ, 315 Mill, Pontiac IL 61764. 815-844-6101.

Dielectric 3-1/8" rigid line reflectometer, type 122-245-24 ser #103, \$300; Bird Thru-line wattmeter 4110 type AN/URM-182 ser #852, in case w/1990 test data, \$100. A Olean, WMFG, 96 Falmouth St, Portland ME 04103. 207-780-4424.

Scala HDCA10 10 element yagi on 102.3 MHz, \$150; 500 point stainless lightning dissipator, \$350. D Rose, KAAA, 2534 Hualapai Mtn Rd, Kingman AZ 86402. 602-753-2537.

Andrew 1-5/8" Heliax flange connector, unused, \$50. E Black, 405-524-3770.

722' TV tower, 8' face, 43% guy radius, new Central w/warranty. Original price \$321,000, available for \$150,000. Scott or Ray (812) 853-0595.

## STUDIO EQUIPMENT IMMEDIATE DELIVERY

- SIERRA AUTO SYS Audio Routing Switch
- BENCHMARK SYSTEM 1000
- YAMAHA YPDR 601 CD Recorder
- RANE SM82 / SP-15 / SM-26
- TASCAM 2 & 8 Trk Rcdr, CD & Cass Player
- SATELLITE DISHES . . . and MUCH MORE!

Call 617/267-8600 for complete configurations

Like New! • Sale or Lease

EQUIPMENT REMARKETING COMPANY • Boston, MA

Want to Buy

Phasor, 5 tower, 5 kW. G McClintock, WNQM, 1300 WWCR Ave, Nashville TN 37218. 615-255-1300.

Lapp 9863 insulator for AM tower. K Broeffle, KUPL, 6400 SW Canyon Ct, Portland OR 97221. 503-297-3311.

Rohn 45G, need 5 sections. R Sewell, WORQ, 1075 Brookwood Dr, Green Bay WI 54304. 414-494-9010.

Band pass cavity filter, 10 kW or more. R Murphy, 602-855-1051.

8-bay FM, low power on 103.3 & high power 8-bay, low freq. R Murphy, 602-855-1051.

Dielectric or Delta 4 port 3-1/8" coax switch in gd working cond; also need 3-1/8" to 1-5/8" EIA adaptor. H Kneller, WKII, 3151 Cooper St #56, Punta Gorda FL 33950. 813-639-1112.

Self-supporting tower, 180'. E Prendergast, KAOK, 801 Columbia Southern Rd, Westlake LA 70669. 318-882-0243.

### AUDIO PRODUCTION

Want to Sell

Sparta TPA 7-1 (3), 25 W audio modules, new, \$45/ea or 3/\$100. D Peluso, KJUL, 2880 E Flamingo #E, Las Vegas NV 89121. 702-732-2200.

Rane SP15 5-band studio parametric EQ, \$330; Rane DC 24 2-chnl or stereo ganged dynamics simultaneous limit, compress & expand, \$330; Symetrix 511A single ended NR, \$395; Howetech phase Chaser, unused, BO; Sound Ideas sound effects libraries on CDs, BO; Acoustic System 6' x 6' broadcast booth, \$5500. W Dooley, 818-798-9128.

SAVE \$300 ON T T  
144 POINT PATCH BAYS  
brokers of fine and coarse used equipment  
audio village 619/320-0728

Audio Digital TC-2 digital delay unit, new, no manual, \$790 prepaid UPS. D Peluso, KJUL, 2880 E Flamingo #E, Las Vegas NV 89121. 702-732-2200.

Used audio equipment including: Auditronics console, Orban 245 stereo synth, dbx 463X (2), 3M mincom 1/4" FT in console, Scully 280, Dynac 240, Orban 526A & 622B, Aphex 602, Auditronics PEQ 82, Scully 280 FT in console, 360 Systems programmable EQ, Lexicon 1200, UREI 964, Burwyn DNF 1500A, Kepex rack w/5 Gates & 1 limiter, Scully 280 4 trk 1/2", call for details, \$5950 takes all. N Funk, Rodel Audio, 1028 33rd St NW, Washington DC 20007. 202-338-0770.

## FM Transmitters have never offered this much for so little!

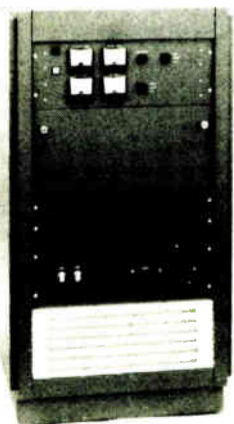

### HENRY RADIO FM AMPLIFIERS offer these standard features:

- Single tube grounded grid output with solid state IPA
- Modular construction using quality standard components
- CD quality audio
- Power levels from 100 watts to 15 kW
- Full 1 year warranty

We at Hall Electronics understand RF however large or small the need.

We'll be glad to help with all your RF needs!

(804) 974-6466 • FAX: (804) 974-6450  
1305-F Seminole Trail  
Charlottesville, VA 22901



### COMARK Antennas

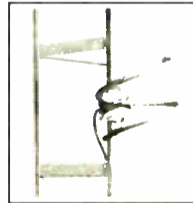

FM Broadcast Antennas  
Circularly & Horizontally Polarized antennas available  
Multiple bays available

### Marti STL 15-C Composite STL System



Composite FM Stereo with 2 subcarriers  
140 - 960 Mhz freq. range available  
Digital Stereo Audio (with external Modems)

### SINE SYSTEMS



RFC 1-B Dial Up Remote Control  
Automatic Transmitter power control  
Alarm dial out for 6 numbers  
Timed functions for day/night power levels etc.  
Optional RS-232 computer interface  
Up to 64 channels of control and metering

### SINE SYSTEMS DAI-1 Dial up Audio Interface



Aviod Heavy Fines for EBS Non-Compliance  
Easily handles EBS requirements for "walk away" Operations  
Allows direct access to the air chain  
Remote Broadcasts (no one at the station)

Circle (26) On Reader Service Card

World Radio History



### AUDIO PRODUCTION...WTS

SAE 5000A impulse NR system, \$100/BO; Fisher space expander, \$50. B Ladd, WNRR, 108-1/2 E Main, Bellevue OH 44811. 419-483-2511.

Telex PH93 (2) sportscaster headsets, new in box, \$125 ea; Telex CS-91 sportscaster headset, \$30. J Sidole, WELC, POB 949, Welch WV 24801. 304-436-2131.

**Correlation / Phase Indicator**

A compact alternative to X/Y displays for Stereo / Mono Compatibility Checks  
Tape Head Azimuth Adjustment  
Transmission Path Evaluation  
Stereo / Mono Identification  
Signal Polarity Testing  
CPI-300 — \$ 265

**recording studio services**  
PO Box 3004  
Hendersonville, TN 37077  
615-824-9300 Fax: 824-9303  
CompuServe: 75366.311

**Circle (12) On Reader Service Card**

Furman PB 40 patch bay, front 1/4" tip-sleeve jack, rear RCA, \$35; dbx 400X route switch to switch in/out processing & NR, gear in rcrdg chain, stereo, RCA conn, \$150; Sony PCM 501 ES pulse code mod to record digital audio & PB on any video tape rcrdr, mint cond, no digital output, \$450. H Jeschke, The Fellowship Press, 5820 Overbrook Ave, Philadelphia PA 19131. 215-879-6300.

Orban 412A compressor/lmtr, mono, exc cond, \$200. Howe 2300A, Phase Chaser, exc cond, \$1250. G Faltus, WZMX, 10 Executive Dr, Farmington CT 06032.

Orban 622-B stereo 4-way parametric EQ, new w/warranty card, \$375. L Just, Auditech Inc, POB 2426, Secaucus NJ 07096. 201-867-5158.

Phase Linear 1000 auto correlator NR system in good condition, \$100. R Glenn, WJGR, 1718 Shannadoa, Wimauma FL 33598. 813-634-1940.

Shure M-267 4 channel mixer, tone osc, line or mic inputs & outputs, AC or DC, \$175 ea. L Just, Auditech, POB 2426, Secaucus NJ 07096.

ADC 144 Pt TT patchbays, exc cond, 1 rack space, 3 rows of 48, top 2 rows normalled, \$129 (you remove old wiring) or \$199, we totally refurbish w/new front panel, ready to install. TT cords at cost w/purchase! Also 1/4" PB's. Audio Village, POB 2902, Palm Springs CA 92262. 619-320-0728, or Fax 619-320-2454.

### Want to Buy

**MERCENARY AUDIO**

**WANTS TO BUY YOUR:**

NEVE-SSL-TRIDENT-AMEK  
UREI-TELETRONIX-FAIRCHILD  
PULTEC-LANG-LEXICON  
UNIVERSAL AUDIO-NEUMANN  
AKG-TELEFUNKEN-AMS

**ANYTHING THAT IS OF EXCEPTIONAL AUDIO QUALITY!**

"this is not a problem"  
**(508)543-0069 TEL**  
**(508)543-9670 FAX**

Fairchild 600 conac or 602 Conex high freq limiters. J Gangwer, 942 32nd St, Richmond CA 94804. 415-644-2363.

### AUTOMATION EQUIP

#### Want to Sell

SMC 350 Carousels (3), \$350 ea/BO. D Quinlan, KSYC, 316 Lawrence Ln, Eureka CA 96097. 916-842-4158.

SMC 350 series, stereo in wood laminated cabinet, works gd, \$450. D Koehn, KKPR, Box 130, Kearney NE 68848. 308-237-9333.

IGM & EC w/3 24 tray Go-Carts, great cond, \$3995; IGM, EC w/4 24 tray SMC Carousel units that were factory refurbished, \$2995. C Murray, KMGE, 925 Country Club Rd #200, Eugene OR 97401. 503-484-9400.

Cetec 7000 Level 2, 5046 event, 4 audio files, 2 wking 2 for pts, \$2500; various Cetec 7000 source cards & pts, \$100 ea. E Moody, KJEM, 216 N Main, Bentonville AK 72712. 501-273-9039.

Soundmag DPS-1, (3) 350 Carousels, (4) tone sensors, (2) dbl deck cart machines, stereo R/PB cart deck, new motor-hands, remote keyboard, local keyboard, Brain, (4) R-R PB, \$2000. M Casey, WKSX, Drawer 1, Johnson SC 29832. 803-275-4444.

Cetec 7000 Brain only, controlled R-R PB & Audiophile cart stacks, \$1600. C Knerr, KCNA, 139 SE J St, Grants Pass OR 97526. 503-474-7564.

Schafer 901 w/901 control unit, (4) R-R's, 902 switch unit, (3) random select Carousels, cart PB, (4) racks, \$4500/BO. P Coates, KBZZ, POB 485, La Junta CO 81050. 719-384-5456.

Automated Broadcast Controls tone generator, for automation, \$150. C Scherer, WDOK, One Radio Ln, Cleveland OH 44114. 216-696-0123.

SMC ESP1 automation w/(4) TS25 tone sensors, (2) 350 RSB Carousels, Xtel printer, remote control, \$2000; SMC IC1 instacart interface, \$50; encode center, \$50. D Rose, KAAA, 2534 Hualapai Mtn Rd, Kingman AZ 86402. 602-753-2537.

SMC 350 random select Carousels (3), \$450 ea. R Ness, WCSJ, 1802 N Division, Morris IL 60450. 815-942-0022.

Harris SC-90 w/(2) consoles, memory load dump feature, alphanumeric encode decode, etc, w/(2) SMC Carousels, sell complete or by piece. P Willey, WMNB, 466 Curran Hiway, N Adams MA 01247. 413-663-3419.

SMC MSF-12 w/(4) Otari ARS-1000 decks, (3) 350 random select Carousels, ITC 3D cart, \$7000. R Ness, WCSJ, 1802 N Division, Morris IL 60450. 815-942-0022.

#### Want to Buy

Reels, carts, Brain's w/schematics, reasonably priced. R Bell, WRVB, 4314 Cherry Ct, Evansville IN 47714. 812-479-3377.

### BUSINESS OPPORTUNITIES

#### Want to Sell

### MANUFACTURING BUSINESS FOR SALE

Manufacturer of AM components & systems since 1963. Large stock of components & raw materials on hand: RF coils, contactors, hot line jacks, toroidal transformers. We also have one of the largest stocks of mica and vacuum capacitors on the continent. Builder of over 100 tuning & matching systems for arrays from 2-12 towers, 1-50kW, in Canada, US, South America, Mexico, Lebanon. OWNER WISHES TO RETIRE...

Fax or write to:  
Radio World  
POB 1214, Falls Church, VA 22041 Attn Box #

Two top quality music formats ready for partnership or sell outright, potential unlimited. J Gelo, 813-642-6899.

### CART MACHINES

#### Want to Sell

Fidelipac CTR 90 good condition, stereo, all tones, timer, etc, \$1200 or trade for prod equipment. R Wells, KSRO, 1410 Neotomas Ave, Santa Rosa CA 95405. 707-545-3313.

Fidelipac CTR-112, clean, good condition, stereo PB units (2), \$800 ea or \$1500/pair. P Bammerlin, WRQK, 4111 Martindale Rd, Canton OH 44705. 216-492-5630.

ITC 30 stereo with single tone detector cue cards, good condition, heads recently replaced, \$750 ea. C Alexander, Crawford Bdcgt, POB 561307, Dallas TX 75356. 214-445-1713.

ITC triple deck, 2 mono machines, one w/automation tones, gd cond, \$750, one needs motor/bearing, \$500. E Moody, KJEM, 216 N Main, Bentonville AK 72712. 501-273-9039.

Many Premium line SP & WP players & recorders, call for info. C Murray, KMGE, 925 Country Club Rd #200, Eugene OR 97401. 503-484-9400.

**No matter how you stack it...**

**Nobody reconditions tape heads like JRF.**

- Heads restored to new performance spec at a fraction of new cost
- Cart machines and all open reel formats
- Full line of replacement heads for all manufacturers

Experience the difference experience makes. Ask around. Nobody treats you or your heads better than JRF.

**JRF MAGNETIC SCIENCES**

249 Kennedy Rd., Greendell, NJ 07839  
**(201) 579-5773 Fax (201) 579-6021**

BE 1070RPS stereo R/P fast forward w/service manual, \$500. P Ferrand, Ferrand Comm, 65 Atherton Ave, Nashua NH 03060. 603-889-1067.

Audicord R/P mono 100 Series, \$400. D Rose, KAAA, 2534 Hualapai Mtn Rd, Kingman AZ 86402. 602-753-2537.

Tapecaster 700 RP stereo electronics, needs repair, transport fine, w/replacement transistors, \$65/BO. J Rudisill, Audio Independence, POB 746, Aptos CA 95001. 408-684-0605.

ITC Delta I stereo cart machines, working. E Trevino, KBOR, POB 3407, Brownsville TX 78523. 210-544-1600.

Fidelipac Dynamax CTR112 stereo (5), perfect cond, \$1300 ea plus shipping. B Lord, Lord Bdcgt, 13313 SE 208th, Kent WA 98042. 206-631-2374.

Great Prices on original equipment tape heads for ITC, BE, Fidelipac, Otari, Tascam & others!

**HE HALL Electronics**  
(804) 974-6466 • FAX 6450

ATC stereo R/P cart machines. A Zand, Villanova Univ, Villanova PA 19085. 215-645-4285.

Nortronics CH3-R sensor type tape heads (8), \$10/ea or 8/\$80 pre paid. D Peluso, KJUL, 2880 E Flamingo #E, Las Vegas NV 89121. 702-732-2200.

Fidelipac Dynamax CTR12PB (3), CTR14 R/PB (1), rack shelves (2), great cond, \$400 for set. S Bulman, First Take Recording, 16128 Orchard Grove Rd, Gaithersburg MD 20878. 301-963-7758.

Harris CCII stereo play, new motor bearings, excel cond, \$675. P Willey, WMNB, 466 Curran Hiway, N Adams MA 01247. 413-663-3419.

ITC ESL IV splice finders/erasers (2), \$350/BO. C Scherer, WDOK, One Radio Ln, Cleveland OH 44114. 216-696-0123.

ITC 99B new in '87, in excellent condition with manual, \$3500/BO; ITC 3-deck, 15 years old, good hands, play only, \$850/BO. C Mellon, WLI AM/FM, 720 Main St, Willimantic CT 06226. 203-456-1111.

BE5300B 3 deck cart machine, BO; Audi-Cord 121 cart rcdcr/reproducer, BO. 504-657-5249.

Harris Gates Criterion 80 stereo cart player with manual, works, BO. Dave, Allmake Productions, 517-652-6863, leave msg.

ITC Delta stereo play, like new, \$850; Audi-Cord E-16 stereo PB, factory recond, \$695. C Spencer, CS Prod, 10032 Hillgreen Circle, Cockeysville MD 21030. 410-783-0737.

ITC Delta I stereo PB, new heads, excellent condition, low use, \$2500/both. C Guglielmetti, Edgewater Co, 232 C St, S San Francisco CA 94080. 415-589-3313.

Spotmaster stereo delay machine, \$100/BO. B Ladd, WNRR, 108-1/2 E Main, Bellevue OH 44811. 419-483-2511.

BE 5300C tripledeck, stereo, PB, mint less than 50 hrs, BO. R Kaufman, Pams Prods, POB 462247, Garland TX 75046. 214-271-7625, after 3PM CDT.

#### Want to Buy

ITC RPD 3 tones, rk mnt ears. DJ Williams, Lincoln County Bdcrt, 1103 Utah Ave, Libby MT 59923. 406-293-6234.

### CASSETTE & REEL-TO-REEL RECORDERS

**STUDER SERVICE SPECIALIST**

Thousands Served • Unbeatable Rates  
Precision Capstan Resurfacing

**Audio Advantage**

Tel (615)742-3834 FAX (615)254-8826  
**PRICE-QUALITY-SERVICE**  
*Let Us Prove It*

#### Want to Sell

Otari ARS1000 play decks (6), \$250 ea. M Ripley, KOZE, Box 936, Lewiston ID 83501. 208-743-2502.

## EMPLOYMENT

To place ads in this section, use the ActionGram form. To respond to box numbers write Radio World, PO Box 1214, Falls Church, VA 22041. Attn: \_\_\_\_\_

### POSITIONS WANTED

**Voice/Production talent** avail for small market stations, low, low rates, spots, sweepers & liners. Call or write for demo package. B Simonson, Box 206, Oshlema MI 49077. 616-363-8561.

**Experienced AT** seeks FT airshift, currently on air in Milwaukee, gd voice & prod, credible, reliable & dependable. Prefer midwest, but all offers considered. Jack 414-242-4357.

**Would like to get back into sports**, currently working at station in Illinois, May '92 grad, 3 yrs of play-by-play experience, 5 yrs total radio experience, will relocate. Derek, 618-667-6169.

**Exper air-personality** avail for FT airshift, prefer oldies, AC, Country formats, anywhere in USA, gd voice & prod, poss assist PD/PD duties, currently on air in Milwaukee. J Reynolds, 414-242-4357.

**Radio production & announcing** experienced under graduate degree in business & economics, plus mgmt & sales exper. Kevin, 515-432-1741.

**Sales-oriented, computer-literate**, prod/promo director with own equip seeks permanent home, will relocate, 15 yrs exper, call for demo tape. 208-467-6799.

**Radio announcer** looking for pos in top 40 or A/C format, also exper in talk radio. John, 904-683-9059.

**Experienced air personality** seeks overnight shift at Midwest Top 100, oldies/classic, rock/hot, AC/country /AOR/AC. Jack, 414-242-4357.

**Corp Engrg/Operations** director & station manager w/25 yrs successful experience seeks new career opp. 513-621-9292.

**Ready to work hard** in news/sports/talk radio, college station GM w/expert in news, play-by-play, production, sales. Andy, 205-870-2877.

**Sales, mgmt, progrmg, mktg** and engrgr, expertise to successfully achieve turnaround for any station w/good signal in decent mkt. 813-849-3477.

**Exp Bdcrt Engrg/Prod** voice w/18 yrs exper, prefer SE but will discuss other, AM/FM preferred. R Watts, Rt 1 Box 91-C, Carrollton AL 35447. 205-367-2113.

**Construction/fix it engineer**, will go anywhere, anytime, avail day/week/project, excel credentials, US or foreign, call 24 hrs, 813-849-3477.

**CE w/Big Prod Voice & over 15 yrs** hands-on engineering exper seeks CE pos w/production or air shift in a competitive top 100 mkt. G Morgan, 704-563-8676.

**Gen Manager** for Florida medium or large market, 29 years experience in sales, programming & engineering, turnarounds or start ups, avail immed. 813-849-3477.

**Nationally-quoted** film critic will customize movie reviews for your station or network, get 'The Movie Guy' working for you. Call Paul Chambers, 214-352-3232.

**Experienced:** strong background in sales, management, engineering, operation, construction & ownership seeks challenge in small to medium market. Resume/voice mail box: 803-430-3005.

**Talented AT** seeks 25-54 demo station for FT air shift, prefer Midwest Top 100 but will consider all offers, specialize in PM drive. Jack, 414-242-4357.

**The popular John Benson Hillbilly** Hayride, the sounds that rocked the cradle of C&W Music is searching for a new weekend late/overnite home, Hudson Valley, North Jersey, SW CT mkt. 914-342-1930.

**Mama's Dead!** David F. Diamond, major mkt talk show host. "Diamond in the Rough"...a poor man's Rush Limbaugh, is ready to move now. 1-800-844-1841.

Revox PR-99 MK II 1/2 trk stereo play units with 25 Hz sensor (4), new still in factory boxes, \$950 ea/FOB. D Peluso, KJUL, 2880 E Flamingo #E, Las Vegas NV 89121. 702-732-2200.

**Uher 5000 5"** reel transcriber, spare parts, service manuals of Uher products, \$50/all plus UPS. E Davison, POB 7167, Springfield IL 62971-7167.

**Radio Systems DTC-1000** DAT recorder, cosmetic ding on one corner, 6 mos old, \$995 plus shipping. B Lord, Lord Bdcgt, 13313 SE 208th, Kent WA 98042. 206-631-2374.

**HEAD RELAPPING/REPLACEMENT**

All tape and film formats  
30 years experience

350 N. Eric Drive  
Palatine, IL 60067  
708-358-4622

**Pentagon mono duplicator**, makes 1-3 copies from master VU meters. \$150. P Russell, Bowdoin College, Sills Hall, Brunswick ME 04011. 207-725-3066.

**Ampex 350 mono R-R's (2)** w/Inovonics electr, solid state rack-mount units, \$300 ea; Ampex AG-350 mono R-R w/solid state electr from Ampex, rackmount unit also, \$500. A Baker, Bdcrt Prod of America, 804 E 38th, Indianapolis IN 46205. 317-925-7371 or fax 317-924-5293.

**Scully 280 14"** stereo machine & electronics, no console. K Kuenzie, KFEX, 139 11th, Washington MO 63090. 314-239-0209.

**MCI JH-110-B-2 (4)** R-R play only, BO; MCI JH-110-B-2 R-R R/P, BO; Otari MX5050BQII, 4 track, 1/4". \$2500. C Scherer, WDOK, One Radio Ln, Cleveland OH 44114. 216-696-0123.

### HELP WANTED

**Salesman**, aggressive for new talk AM station. Send resume to 34D MacArthur Drive, Alexandria LA 71303.

**Gen Mgr** heavy exper in sales to operate 3 new FM AC stas in central Georgia. Send resume to D.L. Jones, 3017 Piedmont Rd #200, Atlanta GA 30305.

**Production person** needed for satellite automation syst, new Hot AC FM station. Skill in using Digilink a plus. Located in middle Georgia mkt. Send resume, photo & air-check to D.L. Jones, 3017 Piedmont Rd #200, Atlanta GA 30305.

**CE for AM/FM** in small mkt No. Ca. Digital automation, satellite receivers, xmtr move soon. Great livability! Call Gary Hawke, 916-842-4158. Yreka CA.

**Assistant to C.E.** start Oct. 1, 1993. A Gannett station. Must be A-1 on bench work & studio repair w/proven exper. Send resume to: Jack Rabell, Chief Engineer, KSDO-KCLX FM, Ste 200, 5050 Murphy Canyon Rd, San Diego, CA 92123.

### CCA ELECTRONICS

Manufacturer of AM, FM and Shortwave broadcast transmitters is once again expanding and looking for Sales Engineers with a good RF background preferably in a broadcast environment, must be able to communicate effectively and must really love working in radio. A successful sales background is a plus. Must be willing to relocate to Metro Atlanta, Georgia area. Send resume in confidence to:

**Mr. Steve McElroy,**  
VP Sales  
**CCA Electronics Inc.**  
PO Box 426  
Fairburn, GA 30213

## ABOUT OUR EMPLOYMENT SECTION

**HELP WANTED:** Any company or station can run "Help Wanted" ads for \$1.50/word or buy a display box for \$55/column inch. Payment must accompany insert, use your MasterCard or VISA; there will be no invoicing. Blind box numbers will be provided at an extra charge of \$10. Responses will be forwarded to listee, unopened, upon receipt. Call 800-336-3045 for details.

**POSITIONS WANTED:** Any individual can run a "Position Wanted" ad, FREE of charge (25 words max), and it will appear in the following 2 issues of Radio World. Contact information will be provided, but if a blind box number is required, there is a \$10 fee which must be paid with the listing (there will be no invoicing). Responses will be forwarded to the listee, unopened.

Mail to: **BROADCAST EQUIPMENT EXCHANGE**  
PO Box 1214, Falls Church, VA 22041  
Attn: Simone Mullins



## CASSETTE &amp; R-R...WTS

Fostex 80-8 8-trk w/NR, new Ampex tape & metal reels, remote control & foot switch, punch in remote w/original box & manual, nice cond, \$2300/BO. W Dougherty Jr, WLD Recording Std, Music Valley, Rt 1, Mill Spring MO 63952. 314-998-2681.

Nakamichi 550 stereo recorder w/pwr supply, \$250; Tandberg 11, 3 speed, 7" reel, battery operated, \$100; Ampex 600/620 7.5 ips recorder, gd cond, BO. R Woolf, Audio & Recording Systems, 3986 Eddin Dr, Jacksonville FL 32211. 904-744-1661.

3M M-79 Professional 2-trk mastering machine in roll-around console, above meter bridge/NAB metal reels & hard-cover manual, excel cond, \$1250. W Dougherty Jr, WLD Recording Std, Music Valley, Rt 1, Mill Spring MO 63952. 314-998-2681.

## EXPERT REVOX REPAIRS

Fast Turnarounds—Competitive Rates  
Rebuilt A77s, \$800  
Capstan shaft resurfacing, \$35.  
JM TECHNICAL ARTS  
30 Music Sq. W. #5  
Nashville, TN 37203 (615) 244-6892

Teac 22-4 4-chnl 1/4" w/factory tech manual, \$500. J Hunter, KBRE, Box 858, Cedar City UT 84720. 801-590-1277.

Sony stereo cassette, belt broke but works good, \$20. W Dougherty Jr, WLD Recording Std, Music Valley, Rt 1, Mill Spring MO 63952. 314-998-2681.

Ampex Pro R-R, (1) 350 & (3) 440. A Zand, Villanova Univ, Villanova PA 19085. 215-645-4285.

Ampex 350/440 transport & electronics parts some new, most used, in superb condition, motors, headstacks, guides etc; parts for Scully 280s and complete Inovonics electronics for 350s & 440s, all reasonably priced. M Gore, 54 Ney St, San Francisco CA 94112. 415-469-0136 noon to 5PM West Coast time.

Ampex MM 1100 16 track 15/30 ips in superb condition, heads almost unused cond, all electronics have been checked out, has updates, counter, MDA fans, AC stabilizer card, mods, \$6000. M Gore, 54 Ney St, San Francisco CA 94112. 415-469-0136.

Telex copier 1 & 2, mono cassette duplicator workhorse, factory refurbished, 1-3 copies, \$150. P Russell, Bowdoin College, Sills Hall, Brunswick ME 04011. 207-725-3066.

ITC 750 with tone detector (2), good condition, \$250 each. F Willis, WKXH, POB K, Alma GA 31510. 912-632-0104.

Tascam ATR-60-4HS 4 track, 1/2" R-R, 15/30 ips, 2 yeaitons old in mint cond, \$2500. D Shaw, De Koch Music, 900 S Fifth St, Milwaukee WI 53201. 414-645-4464.

MCI JH-110 2 track with new head stack, excellent condition, \$1500. K Harvey, KISC, E 300 Third Ave, Spokane WA 99202. 509-459-9800.

Otari MX5050 in good condition with remote, manual, reels, \$850/BO. J Rudisill, Audio Independence, POB 746, Aptos CA 95001. 408-684-0605.  
Tascam ATR-16-60 16 track with auto locator, no more than 100 hours use, excellent condition, \$10,000. A Mauro, 972 E 88th St #002, Brooklyn NY 11236. 718-927-0926.

Studer 807 2-track, 2 years old, 3 speed shuttle wheel, \$2695. D Matyis, KLTR, 10533 Richmond Ave #6937, Houston TX 77042. 713-780-0937.

Lipps 8 track head stock, very little use, some cables shortened, \$100. T Boddie, Boddie Recording, 12202 Union Ave, Cleveland OH 44105.

Ampex 440 in good condition, spare motors, heads in good condition with Ampex electronics, \$750/BO. J Schloss, KICD, 2600 N Hiway Blvd, Spencer IA 51301. 712-262-1240.

Tascam 38 1/2" 8 track with 8-channels of dbx NR, \$1500/all, with out dbx, \$1200. P Cibley, Cibley Music, 138 E 38th St, NY NY 10016. 212-986-2219.

Tascam MS-16 1" 16-track with factory dbx, excellent condition, factory rack, full remote with stand, will separately or as package with Yamaha RM-1608 studio console, \$7000/package. J Block, Production Block, 906 E 5th St, Austin TX 78702. 512-472-7875.

## STUDER/REVOX

Factory Authorized Service

"Superlative Service"

Over 14,000 units serviced! Fast turnaround w/War. Huge parts inventory. New/Used Equip., Capstan shaft resurfacing.

STUDIO-SONICS  
450 W. Rand Road  
Mt. Prospect, IL 60056  
708-670-0025

Otari 5050 BII (2), \$700 ea; Otari 5050B, \$650; (2) QUAD ESL 63, factory updates, \$1500; GAS Grandson amp (2), \$125 ea. Bob, India Navigation, 177 Franklin St, NY NY 10013. 212-219-3670.

Magnecord RP, \$75 plus shipping; Scully RP, no case, \$75 plus shipping. J Hughey, WIZK, POB 548, Bay Springs MS 39422. 601-764-3151.

Tascam 52 with optional rack mount, excellent condition with low hrs, \$895. C Spencer, CS Prod, 10032 Hillgreen Circle, Cockeysville MD 21030. 410-783-0737.

Ampex ATR-800 4 track, needs repair, BO. T Rusk/J Harvill, KSSN, POB 96, Little Rock AR 72203. 501-227-9696.

SCULLY  
TAPE  
RECORDERS  
PARTS AND  
SERVICE

SEQUOIA  
ELECTRONICS  
4646 Houndshaven Way  
San Jose, CA 95111  
(408) 363-1646

ITC 750/770 (4) 750 R/R stereo PB gd cond, \$300/ea or BO; (2) ITC 770 R/R stereo PB gd cond, \$400/ea or BO. D Fortenberry, Brown Broadcasting, 280 Commerce Circ, Sacramento CA 95815. 916-923-6828.

Fostex 80 8 track 1/4", low hours, excellent condition, \$875; Tascam 40-4 4 track 1/4", new heads, spare new heads, spare amp board, excellent condition, \$750. W Ahlberg, Davis & Glick Productions, 11846 Ventura Bl #306, Studio City CA 91604. 818-509-9100.

ITC 750 R-R stereo recorder, excellent, \$350; Ampex AG 440-B FT console, \$350; Ampex AG 600-B stereo, \$100. D Lundy, Lundy Tape Duplicators, POB 408, Heidrick KY 40949. 609-546-6650.

Ampex ATR700 good condition, low hours, \$700; Teac A3340s, like new, \$800; Pioneer RT1020L, low usage, \$300; Teac A3300SX, new in box, \$450; Teac X1000R, recondition clean, \$400. J Parsons, Parsons Sound Service, 2781 Fayson Circ, Deltona FL 32738. 904-532-0192.

Otari ARS 1000 stereo PB decks (4), \$500 ea. R Ness, WCSJ, 1802 N Division, Morris IL 60450. 815-942-0022.

Infonics 200 series duplicator, reel master, mono, excellent condition, 7 or 10" reels, 1/4" tape, \$500. T Boddie, Boddie Recording, 12202 Union Ave, Cleveland OH 44105.

Recorder heads, used Scully mono & 2 trk, \$25-50. ATR100's, 3M M79-16 & 8's, Otari 1/2" 8 trks, \$495. W Gunn, 619-320-0728.

Technics RS1500 2 track, excel cond. J Gelo, 813-642-6899.

Technics 1500US (2) 2-trk, cherry wood sides, fair cond, \$350 ea; Technics 1520, gd cond, \$450, or \$1050/all. J Block, Production Block, 906 E 5th St, Austin TX 78702. 512-472-7875.

Ampex 440-C/7.5 15" per sec (2), 5-15 ips 1/4" with Ampex roll around cabinets & remote controls, new erase, ercord & playback heads, excellent condition, \$1395 ea. Bill 313-242-2319, 8-4 in MI.

Revox PR 99 (4), PB decks, great cond, automation ready. E Gross, KEYZ, 410 E 6th St, Willston ND 58801. 701-572-5371.

Tascam 644 4 trk, 8 chnl cassette only, 4 hrs use, \$800. D Ott Jr, Otter Bdc, POB 314, Bath OH 44216. 216-836-3896.

Tape-a-thon, Channel Caster 6, 10" 702 bi-directional p/b system, gd cond, many extras, playing when taken out of serv, \$1000/BO. R Swafford, 417-883-5488.

MCI JHS solid state electronics with built-in sync (8) with cables, power supply, etc for mounting on Ampex 300 deck, \$100 ea. T Boddie, Boddie Recdg, 12202 Union Ave, Cleveland OH 44105.

Otari MX 5050 R/R in gd cond, \$1600/BO. K Stevens, 14241 Ventura Blvd #204, Sherman Oaks CA 91422. 818-981-8255.

16 trk 2", \$3450; Otari 1" 8 trk, \$2450; 5050 III-8, \$1950; Ampex ATR800 mono, \$750; Tascam 25-2, \$750; Tascam 52 mint, \$1200; MCI Locator III, \$1195; Ampex AG350 solid st electr, \$100/ch. W Gunn, 619-320-0728.

Otari Mark II-IV 1/2" 4-trk, multi-track, mint, less than 50 hours, BO. R Kaufman, Pams Prods, POB 462247, Garland TX 75046. 214-271-7625, after 3PM CDT.

## Want to Buy

Tascam MU-40 meter bridge. D Green, KTCU, POB 30793, Ft Worth TX 76129. 817-921-7630.

Schematic/manual for Pioneer CTF-950 cassette deck, call with asking price. CR Lease, WTBO, POB 1644, Cumberland MD 21502. 301-722-6666.

Low-priced R/R Rec/PB compact, portables, suitable for splicing/production projects, possible quantity if suitable. H McDonald, KKJV, POB 807, Veradale WA 99037. 509-535-7535.

Schematic for Scully 280B w/constant tension circuitry. B Bordeaux, KSLY, POB 1400, San Luis Obispo CA 93406. 805-543-6855.

Need heads, cables & additional electronics to convert Scully 280, Ampex 351's to 2-track stereo & upgrade tube electronics to solid state; 10-1/2" stereo machines also needed, donations accepted by new non-commercial FM. M Sophos, WDFH, 21 Brookside Ln, Dobbs Ferry NY 10522. 914-693-3963.

Dual dubbing cassette deck in good condition, RCA in/out OK, prefer used unit. P Kaminski, Sportcom, 82 Zevan Rd, Johnson City NY 13790. 607-770-9165.

Ampex ATR100 taperecorders for parts. Circuit cards, heads, motors, machine parts, or electronic parts. Call 818-907-5161.

Scully '100' recorders, record/play amplifiers, 8, 16, 24 track heads. Sequoia Electronics, 4646 Houndshaven Way, San Jose CA 95111. 408-363-1646.

## CD'S/PLAYERS

## Want to Sell

Studer A725 (3), \$250 ea. K Rider, Unistar Radio Networks, 1675 Broadway, NY NY 10019. 212-373-4947.

Denon DN-950FA CD cart player, 6 mos old, \$725 plus shipping. B Lord, Lord Bdcg, 13313 SE 208th, Kent WA 98042. 206-631-2374.

Denon 950FA CD players, working. E Trevino, KBOR, POB 3407, Brownsville TX 78523. 210-544-1600.

## Want to Buy

CD library, EZ listening or beautiful music, no reel or carts. R Potyka, KRXS, 1730 E Indigo, Mesa AZ 85203. 602-969-7707.

Gd used CD player w/rack mount, RCA out OK. P Kaminski, Sportcom, 82 Zevan Rd, Johnson City NY 13790. 607-770-9165.

Sony CDP-3000 CD players in working condition vintage 1988 or later. Call Bill or John at CD Associates, 714-733-8580 or FAX 714-786-1486.

## COMPUTERS

## Want to Sell

Superior Electric Stabaline computer power conditioner, handles up to 4 computers, \$135 plus shipping. B Lord, Lord Bdcg, 13313 SE 208th, Kent WA 98042. 206-631-2374.

Tandy 1000HD computer w/monochrome monitor & printer, \$300. J Hunter, KBRE, Box 858, Cedar City UT 84720. 801-590-1277.

Amstrad PCW-9512 (2) word processors, \$150/ea. G Arroyo, 407-830-0800.

## CONSOLES

## Want to Sell

Spotmaster 4 chnl, 8 input, gd cond, \$200 plus shipping. F Willis, WKXH, POB K, Alma GA 31510. 912-632-0104.

McCurdy Custom 8700 Series, 20 inputs, 8 trk, fully functional when removed, many spare parts, \$10,000/BO. B Vellner, WCSX, One Radio Plaza, Ferndale MI 48220. 313-398-7600.

Cetec Centurian 12 channel consoles, one good, one for parts, many extra parts & modules also available, \$1750. E Moody, KJEM, 216 N Main, Bentonville AR 72712. 501-273-9039.

Autogram IC-10 10 chnl stereo w/all mods & some active-balanced input modules, excel cond, \$2500. C Alexander, Crawford Bdcg, POB 561307, Dallas TX 75356. 214-445-1713.

Gately 16 x 8 custom audio board with EQ on every channel, 4 effects buss, quad monitoring, Canon connectors for line & mic inputs & outputs, \$1000. A Baker, Broadcast Productions of America, 804 E 38th, Indianapolis IN 46205. 317-925-7371 or fax 317-924-5293.

Spotmaster 5 BM 100 5 chnl dual mono, vgc, \$700. J Arzuaga, WREI, Rd 2 KM 102.5, Quebradillas PR 00678. 809-895-2725.

## Daven • SHALLCO

Rotary Step Attenuators for Console Upgrades

Gates	Langevin
Harris	Continental
Autogram	LPB
Collins	RCA
Cetec	McMartin
Broadcast Electronics	
Sparta and others	

## Shalloco, Inc.

308 Components Drive  
PO Box 1089, Smithfield, NC 27577  
919-934-3135 info  
800-876-3135 orders  
VISA and Mastercard Accepted

Ramko XL41S 4 channel stereo in very good condition, wired to punch blocks, with power supply & manual. M Martindale, KVON, 1124 Foster Rd, Napa CA 94558. 707-252-1440.

RCA BC7A in good condition, 10 channel stereo, BO. R Scott, GMN Inc, 1831 N Ft Thomas Ave, Ft Thomas KY 41076. 606-781-3323.

Ampro AC8DSB stereo, 8 channel, \$650; Ampro 10 channel stereo, both approx 15 years old with wooden ends, no books or schematics, \$800/both. J Hughey, WIZK, POB 548, Bay Springs MS 39422. 601-764-3151.

Ramko DC5AR 5-channel mono recondition, \$350; Altac 1592B, 5 channel mono clean with plugins, \$250; Grommes Precision M5, 5 channel mono new in box, \$275. J Parsons, Parsons Sound Service, 2781 Fayson Circ, Deltona FL 32738. 904-532-0192.

Tascam M-35 8x4 mixer, good condition, \$700/BO. W Ahlberg, Davis & Glick Productions, 11846 Ventura Bl #306, Studio City CA 91604. 818-509-9100.

Harris Medalist 10 chnl stereo, needs work, cosmetically good, \$1200. G Arroyo, 407-830-0800.

Yamaha RM-1608 in excellent condition, one owner, 16x8, 48V, 3-band parametric, separate power supply, available separately or as package with Tascam MS-16 16 track, \$2200 or \$7000/package. J Block, Production Block, 906 E 5th St, Austin TX 78702. 512-472-8972.

Ramko DC-5RA 5-channel mono, dual outputs, LED, VU meters, like new, have several available, including manual, \$250. D Fortenberry, Brown Broadcasting, 280 Commerce Circle, Sacramento CA 95815. 916-923-6828.

Sparta 20C 8-chnl mono in gd cond, new pots & rebuilt, \$850/BO. E Prendergast, KAOK, 801 Columbia Southern Rd, Westlake LA 70669. 318-882-0243.

PHONE: 703-998-7600 FAX: 703-998-2966



Call Simone Mullins, Classified Ad Manager, to reserve space in the next issue. Use your credit card to pay, we now accept VISA and MASTERCARD.

RadioWorld

5827 Columbia Pike, Ste 310  
Falls Church, VA 22041

## Select from these categories for best ad positioning:

Acoustics  
Amplifiers  
Antennas & Towers & Cables  
Audio Production (Other)  
Automation Equip.  
Brokers  
Cameras (Video)  
Cart Machines  
Cassette & R-R Recorders  
CATV-MATV Equip.  
CD's  
CD Players  
Computers

Consoles  
Disco-Pro Sound Equip.  
Financial Services  
Limiters  
Microphones  
Miscellaneous  
Monitors  
Movie Production Equip.  
Receivers & Transceivers  
Remote & Microwave Equip.  
Satellite  
Software  
Stations

Stereo Generators  
Switchers (Video)  
Tapes, Carts & Reels  
Tax Deductible Equip  
Test Equipment  
Transmitters/Exciters  
Tubes  
Turntables  
TV Film Equip.  
Video Production Equip.  
Video Tape Recorders  
Positions Wanted  
Help Wanted

## Display Rates for Classified Advertising Effective January 1, 1991

	1x	3x	6x	12x
1-9 col inch (per inch)	\$55	53	50	45
10-19 col inch (per inch)	50	48	45	40
Distributor Directory	90	85	80	75
Professional Card	60	55	50	45
Classified Line Ad		\$1.50 per word		
Blind Box Ad		\$10 additional		

To compute ad costs: Multiply the number of ad inches (columns x inches) by the desired rate schedule for your per unit cost. Example: a 3" ad at the 1x rate is \$165, at the 3x rate \$159, at the 6x rate \$150, at the 12x rate \$147, etc.

## DISTRIBUTOR DIRECTORY

The following distributors serving the broadcast industry would be glad to help you with any of your requirements.

... Canada, Alaska, Hawaii, Puerto Rico, Virgin Islands, Ye Ol' Forty-Eight ...

RADIO! The beat goes on!

CROUSE-KIMZEY  
OF ANNAPOLIS

tops in broadcast equipment

1-800-955-6800

ask for Kathleen

CORNELL-DUBILIER  
MICA CAPACITORS

FROM STOCK

JENNINGS VACUUM  
CAPACITORS

FROM STOCK

JENNINGS VACUUM  
RELAYS

SURCOM ASSOCIATES

2215 Faraday Ave., Suite A  
Carlsbad, California 92008  
(619) 438-4420



### CONSOLES...WTS

LPB Monogram II 5 chnl, 2 input, gd cond, \$800. C Hicks, WEAX-FM, W Park Ave, Angola IN 46703.

Ramsa 8816 16.4 in vgc, 6 different effects, returns, 4 sub-mix channels, \$950 plus shipping. Ken R, 1806 Madison Ave, Toledo OH 43624. 800-451-5367.

Shure PE 68 M mixer, 5-channel mic mixer, \$25; Interface Electronics 300 mixer, 16-channel, 16x8x2 with book, works but needs work, \$300. A Olean, WMPG, 96 Falmouth St, Portland ME 04103. 207-780-4424.

Electro-Voice BK-2432 24-chnl mixer, vgc, \$1200. G Arroyo, 407-830-0800.

Sony MX16 for parts, \$50. B Ladd, WNRR, 108-1/2 E Main, Bellevue OH 44811. 419-483-2511.

Ramko Research DC 8MS 8 channel stereo, \$1200; Shure M-67 mixer, \$100; Sony MX-6S, stereo mixer, \$45. D Lundy, Lundy Tape Duplicators, POB 408, Heidrick KY 40949. 609-546-6650.

Gates 4-channel mixer with power supply, XLR inputs, Dynamote 70, \$100; Gates Dualux II, stereo 8-channel, many spare knobs, pots, spare amp modules, external power supply, vgc sound, \$1000. A Olean, WMPG, 96 Falmouth St, Portland ME 04103. 207-780-4424.

Pacific Recorders CI-2, TI-2, TT-3 console interface units; stereo cart, (2) 3 inputs ea; stereo reel (2) one input ea; TT 2 inputs, \$150 ea/\$600 all. C Guglielmetti, Edgewater Co, 232 C St, S San Francisco CA 94080. 415-589-3313.

Neve 5303 in vgc, avail 6-93, \$1000/BO. J Schloss, KICD, 2600 N Hiway Blvd, Spencer IA 51301. 712-262-1240.

### Want to Buy

Manual, schematic or information regarding Quantum Audio QM-8A audio console. H Reinders, 228 E Lowes Circle Rd, Eau Claire WI 54701. 715-839-0109.

Book or schematic or instruction manual for Ampro AC8DSB 8 chnl stereo console & 10 chnl stereo console by Ampro, need urgently. J Hughey, WIZK, POB 548, Bay Springs MS 39422. 601-764-3151.

Stereo board, 12 or more inputs. D Royer Sr, POB 3384, Kinston NC 28501. 919-523-5151.

### DISCO & SOUND EQUIPMENT

#### Want to Sell

Realistic stereo 12 band EQ with expander, very clean, \$50/Best Offer. W Dougherty Jr, WLD Recording Studio, Music Valley, Rt 1, Mill Spring MO 63952. 314-998-2681.

Fostex 80-8 & 812 8-track & 12x8x2 recording console, remotes, phantom power, peak hold, new Ampex tape & metal reel, manuals, all in original boxes, excellent condition, \$3950/Best Offer. W Dougherty Jr, WLD Recording Studio, Music Valley, Rt 1, Mill Spring MO 63952. 314-998-2681.

JBL 4311 (2), \$500/pair. J Diamond, Blue Diamond, Box 102C Chubbic Rd RD 1, Cannonsburg PA 15317. 412-746-3455.

Orban 674A stereo graphic parametric EQ, \$750; UREI 539 1/3 oct EQ (4), \$395 ea; dbx 20/20 RTA/EQ as new, \$595. R McMillen, Super Duper Audio Duplicating, 1634 SW Alder St, Portland OR 97205. 503-228-2222.

Lexicon 224 reverb ver 4.4, \$1900; Sennheiser infrared headphones & xmr, \$225. R McMillen, Super Duper Audio Duplicating, 1634 SW Alder St, Portland OR 97205. 503-228-2222.

Eventide DDL 1745A digital delay, three separate outs with manual, \$125/BO. J Rudisill, Audio Independence, POB 746, Aptos CA 95001. 408-684-0605.

Cerwin-Vega DM-1 disco mixer, high quality classic, no bells or whistles, \$125/BO. J Rudisill, Audio Independence, POB 746, Aptos CA 95001. 408-684-0605.

Burwen/KLH TNE7000A transient noise eliminator, excellent condition, rack mount, \$315; SAE 5000 transient noise eliminator, excellent condition, \$125; UREI 560 parametric EQ, mic/line in, line out (2) in rackmount, vgc, \$250. S Hofmann, Cameron Univ Theatre, 2800 W Gore Blvd, Lawton OK 73505. 405-581-2428.

AKG R-25 remote control with cable for AKG BX-25 reverb unit, \$50/trade. E O'Brien, Imperial Sound, 383 N Studio St, Terre Haute IN 47803.

Yamaha QX-5 MDF-1 MIDI sequencer, \$125, MDF-1 disk drive also, \$100 or both/\$200; dbx 155 4-channel Type 1 NR (2), \$200 each or \$325/both. P Cibley, Cibley Music, 138 E 38th St, Nyny 10016. 212-986-2219.

JBL D16R2405 16 ohm replacement diaphragm, JBL 2405 tweeter new in box, \$50. E O'Brien, Imperial Sound, 383 N Studio St, Terre Haute IN 47803.

TOA SM25A powered speakers, clamp mounts, \$125 ea. L Just, Auditech, POB 2426, Secaucus NJ 07096.

JBL 4312 control monitors (2), \$600; JBL 4311-B control monitors (2), \$600. D Lundy, Lundy Tape Duplicators, POB 408, Heidrick KY 40949. 606-546-6650.

Sony C-37a mic, \$1250; (2) API 550a modules w/P.S., \$1500; EMT 140 ST reverb, \$3000; 2 ch Massenberg pre-amp, \$2000. Tony Campana. 313-553-4044.

### Want to Buy

Spectral processor, used, in excellent condition with manual; used Eventide effects generator in excellent condition with manual. Send info/price to: Heritage, POB 16, Boston MA 02167.

### FINANCIAL SERVICES

EQUIPMENT Financing, Lease Purchase Option. Need equipment for your radio, television or cable operation? New or Used. No down payment. Carpenter & Associates, Voice 501-868-5023 Fax 501-868-5401.

**FINANCING** ON ALL

**RADIO EQUIPMENT**

- Easy to qualify
- Fixed-rate, long-term leases
- Any new or used equipment & computers
- 100% financing, no down payment
- No financials required under \$50,000
- References available

**IMMEDIATE**

**Call Mark Wilson (800) 275-0185**

**ENF EXCHANGE NATIONAL FUNDING**

Use Our Experience For Your Business

### LIMITERS

#### Want to Sell

Aphex Dominator II 723. BO. R Scott, GMN Inc, 1831 N Ft Thomas Ave, Ft Thomas KY 41076. 606-781-3323.

Harris/Gates M-6543 FM mono with manual, \$75. T Rosen, KBCC, 1229 Alacia Ave, Bakersfield CA 93305. 805-671-6094.

Orban 222A stereo spatial enhancer, new, \$500. C Kner, KCNA, 139 SE J St, Grants Pass OR 97526. 503-474-7564.

Orban 424A, as new, black stereo compressor/limiter, \$500. P Christensen, WIVY, 3101 University South, Jacksonville FL 32216. 904-646-0129.

CBS Volumax 400; CBS Audimax III; UREI BL40 Modulimiter, BO. G Johnson, WLDY, POB 351, Ladysmith WI 54848. 715-532-5588.

UREI LA-3A (3), excel cond, \$425 ea. C Lawson, WXBQ, POB 1389, Bristol VA 24203. 703-669-8112.

UREI BL-40 modulimiter, \$75; Moseley TFL-250, \$100; Moseley TGR-340 AGC, \$100. D Rose, KAAA, 2534 Hualapai Mtn Rd, Kingman AZ 86402. 602-753-2537.

Aphex Type C aural exciter stereo processor, vgc, \$150. B Harwell, Compact Disc Jockeys, 1861 Brown Blvd #630, Arlington TX 76006. 214-407-7347.

Gates Solid Statesman limiter, \$100/BO. C Scherer, WDOK, One Radio Ln, Cleveland OH 44114. 216-696-0123.

CRL SGC-800 audio processor, \$950. C Fletcher, WLJE, 2755 Sager Rd, Valparaiso IN 46383. 214-462-8125.

Audiomax IIIs stereo, \$200/BO. B Ladd, WNRR, 108-1/2 E Main, Bellevue OH 44811. 419-483-2511.

Orban 422 A/V compressor/limiter, new never installed, \$550; Gentner Prisms (pair), excel cond, \$1900/pr. C Spencer, CS Prod, 10032 Hillgreen Circle, Cockeysville MD 21030. 410-783-0737.

Inovonics 222 NRSC AM processor, 2 yrs old. L Lindstrom, WJEC, 315 Mill, Pontiac IL 61764. 815-844-6101.

Texar Audio Prisms (2), gd cond, C Tarkenton, WCOH, 154 Boone Dr, Newnan GA 30263. 404-253-4636.

Orban 8200/U3S new digital Optimod w/multiband option in pristine cond, \$7995. P Christensen, 11142 Paley Creek, Jacksonville FL 32225. 904-725-6099.

CBS Labs Audimax 4440A, \$150/BO; CBS Labs dynamic presence EQ 4500, \$150/BO; (2) UREI 537 graphic EQ, \$200/BO. C Scherer, WDOK, One Radio Ln, Cleveland OH 44114. 216-696-0123.

### Want to Buy

Orban 8100AXT2 6-band compressor chassis for Optimod FM. H Kneller, WKII, 3151 Cooper St #56, Punta Gorda FL 33950. 813-639-1112.

**BUY-SELL-TRADE**

**OPTIMOD 8000 & 8100**

**414-482-2638**

Orban 8000 reasonably priced. R Bell, WRVB, 4314 Cherry Ct, Evansville IN 47714. 812-479-3377.

Orban Optimod 8100 card cage w/pwr supply plus 19 khz card only, damaged OK. K Kuenzie, KFXE, 13E 11th, Washington MO 63090. 314-239-0209.

CBS Labs stereo AGC in gd cond. P Hons, Mainline Comm, Poplar St, Portage PA 15946. 814-736-3883.

### MICROPHONES

#### Want to Sell

EV RE55 (2), excel cond in boxes & metal case, no clamps, \$340/pr. R Schneider, POB 80795, Springfield MA 01138.

Sennheiser M2002 binaural system w/dummy head, windscreens & JVC BN-5 binaural processor, \$350/BO. J Rudisill, Audio Independence, POB 746, Aptos CA 95001. 408-684-0605.

WE & Altec 639A mics, ea w/11A yoke, 442 jack, 24A stand & zipper case, excel cond, WE mdl \$450, Altec mdl \$350. R Woolf, Audio & Recording Systems, 3986 Edidin Dr, Jacksonville FL 32211. 904-744-1661.

# CONSULTANTS

**W. LEE SIMMONS & ASSOC., INC.**

**BROADCAST TELECOMMUNICATIONS CONSULTANTS**

5 Gracefield Road  
Hilton Head Is., SC 29928

1-800-277-5417  
803-785-4445  
FAX: 803-842-3371

**Consulting Communications Engineers**

- FCC Data Bases
- FCC Applications and Field Engineering
- Frequency Searches and Coordination
- AM-FM-CATV-ITFS-LPTV

**OWL ENGINEERING, INC.**

1306 W. County Road. F,  
St. Paul, MN 55112  
(612)631-1338 \*Member AFCCE\*

**MLJ**

**Moffet, Larson & Johnson, Inc.**

Consulting Telecommunications Engineers

Two Skyline Place, Suite 800  
5203 Leesburg Pike  
Falls Church VA 22041

(703) 824-5660  
FAX: 703-824-5672

Member AFCCE

**MULLANEY ENGINEERING, INC.**

Consulting Engineers

- Design & Optimization of AM Directional Arrays
- Analysis for New Allocation, Site Relocation, and Upgrades
- AM-FM TV LPTV Wireless Cable (MDS/MMDS/ITFS/OFS)
- Environmental Radiation Analysis
- Field Work
- Expert Testimony

9049 Shady Grove Court  
Gaitersburg, MD 20877  
Phone: (301) 921-0115  
Fax: (301) 590-9757

# SERVICES

**REMOTE EQUIPMENT RENTALS**

**COMREX and GENTNER**  
1, 2 & 3-Line Extender Systems

**MARTI and TFT**  
450, 455 & 161 MHz RPU Systems

**SWITCHED-56 SYSTEMS**  
Call or FAX Dwight Weller  
WELLER AUDIO-VISUAL ENGINEERING

Phone: 410-252-8351 FAX: 252-4261

**ROHN.**

**Broadcast Towers**  
Furnished & Installed

Guyed or Self-Supporting  
Solid or Tubular

**20 Year Warranty!**

Call Mike Fleissner toll free

**1-800-225-ROHN**

**Where In The World Are You?**

Reach radio professionals worldwide by advertising in *Radio World's* international edition. Call Simone for more information.

**1-800-336-3045**

**T. Z. Sawyer**

**Technical Consultants**

**1-800-255-2632**

- FCC Applications & Exhibits
- Frequency Studies - Class Upgrades
- Directional Antennas - AM/FM/TV
- High Power Antenna Arrays

Telefax: (301) 913-5799

6204 Highland Dr. Chevy Chase, MD 20815

**Teletech, Inc.**

**BROADCAST CONSULTANTS AND ENGINEERS**

- FCC Applications & Field Engineering
- Frequency Searches & Coordination
- Tower Erection & Maintenance
- Facility Design & Construction

CONTACT:  
**Kenneth W. Hoehn**  
23400 Michigan Ave  
Dearborn, MI 48124  
**(313) 562-6873**

**PC - SOFTWARE**

AM FM TV Search Programs  
Contour Mapping-STL Paths  
RF HAZ-1990 POP Count  
FAA Tower-Draw Tower

**Doug Vernier**  
Broadcast Consultant  
1600 Picturesque Dr  
Cedar Falls, IA 50613

**800-743-DOUG**

**E.T.S.**

Strobe Installation & Repair  
6 Mo. Labor & Parts Warranty  
Complete Tower Erection & Maint.

"Our Business is Climbing to New Heights"

**419-424-0020**  
FLASHTECH • E.G.G. • T.W.R.

**UNITED STATES TOWER SERVICES, LTD.**

5263 Agro Drive  
Frederick, Maryland 21701  
301-874-5885

Quality Construction, Installations, Sales, and Maintenance since 1970.

**EVANS ASSOCIATES**

Consulting Communications Engineers

TV • FM • AM • ITFS • Satellite  
FCC Applications, Design and Field Engineering

Video/Data/Voice • Light Fiber & Microwave • Wide-Area Networks & STL's

216 N. Green Bay Road  
Thiensville, WI 53092  
(414) 242-6000 • FAX (414) 242-6045  
Member AFCCE

North America RF & Audio

**Mirkwood Engineering Services**

Broadcast and Telecommunications Consultants

Multidiscipline Engineering and Planning Firm including • Application & Allocation Services

- Project, Engineering & Construction Management • Site Acquisition
- Rural & Remote Site Installations
- Field Service • Studio Design & Installation

50 Park Ave. Claremont, NH 03743  
(603) 542-6784

**Don't Gamble with your advertising dollars.**

Advertise in Radio World and reach 22,000+ subscribers.

**Call Simone at 1-800-336-3045 today!**

**Contact Radio World Newspaper for availabilities**

**P.O. Box 1214 Falls Church VA 22041**

**1-800-336-3045**





## MICROPHONES...WTS

AKG D-900 (2) dynamic shotgun mics, \$125 ea or \$225/both; (1) AKG N46E 2 mic AC power supply, \$50; Lectrosonic quad box, new, \$1175. E Toline, Audio Etc, 525 W Stratford Pl, Chicago IL 60657.

RCA DX77 on original floor stand w/3 wheels; RCA 4095A antique table-top mic stand; heavy duty accordion style mic arm w/base, BO. G Johnson, WLDY, POB 351, Ladysmith WI 54848. 715-532-5588.

B&K type 2801 mic pwr sply for B&K tube-type mic systems, \$50/trade for Sony CP-3 mic sply. E O'Brien, Imperial Sound, 383 N Studio St, Terre Haute IN 47803.

AKG 414's, \$695, original D12 like the Beatles used, \$295. Sony ECM54, \$150, Beyer M500 lk new, \$300, Demeter 4-ch tube DI rack mt lk new, \$875. W Gunn, 619-320-0728.

Gefell Neumann UM57 tube mics, New capsules for SM2 & many others, New AC701 tubes for Neumann mics, \$275. W Gunn, 619-320-0728.

## Want to Buy

Sennheiser K2U or K3U condenser mic power unit. E Davison, POB 7167, Springfield IL 62971-7167.

Any microphone processors (2), Symetrix, Valley, etc. B Dickerson, WEAG, 1421 S Water, Starke FL. 904-964-5001.

CBS/NBC call-ltr plate & antique floor mic stand for RCA 44 mic, M Harrington, POB 7619, Little Rock AR 72217. 501-223-9056.

Sennheiser 441 or Shure SM-81's in gd cond. W Dougherty Jr, WLD Recording Std, Music Valley, Rt 1, Mill Spring MO 63952. 314-998-2681.

Shure SM-5 or SM-7, Sennheiser MD-421 or EV RE-20/FL-20 or equiv, gd used mdls desired. P Kaminski, Sportcom, 82 Zevan Rd, Johnson City NY 13790. 607-770-9165.

RCA 77DXs/44BXs ribbon, chrome/TV grey, good condition, BO. R Kaufman, Pams Productions, POB 462247, Garland TX 75046. 214-271-7625, after 3PM CDT.

77-DX's, 44-BX's, KU-3A's On-Air lights. Top price paid. Fast response. Bill Bryant Mgmt, 2601 Hillsboro Rd, G12, Nashville TN 37212. 615-269-6131.

## MISCELLANEOUS

## Want to Sell

WE SSA telephone speaker phone, \$50/BO plus UPS. E Davison, POB 7167, Springfield IL 62971-7167.

New up timers (2), 2" readouts, counts to 9:59 and resets, momentary closure resets unit to 0:00, \$65 postpaid. D Peluso, KJUL, 2880 E Flamingo #E, Las Vegas NV 89121. 702-732-2200.

Onan 12.5JC-18R 12.5 kW standby generator, propane powered w/60 amp 3 phase transfer panel & all access, \$5000. J Hunter, KBRE, Box 858, Cedar City UT 84720. 801-590-1277.

Anvil cases in various sizes w/rack rails. J Hunter, KBRE, Box 858, Cedar city UT 84720. 801-590-1277.

JBL ceiling speakers, housing & volume controls (2), \$35 ea; Lil Miss Moffat 48V phantom power supply (2), \$22 each; Broadcast Supply 6' equipment mounting rails (2), \$20 each, all items plus shipping. B Lord, Lord Bdcgt, 13313 SE 208th, Kent WA 98042. 206-631-2374.

Dummy loads, Bird air-cooled, oil filled 5 kW, 2.5 kW, 1 kW, 500 W. Goodrich Ent, 11435 Manderson St, Omaha NE 68164. 402-493-1886.

Lazy Susan wire cart racks, floor/table mdls, several TT's w/preamp, tonearms, cartridges, Gates Stereo Statesman board (parts), BO. M Casey, WKXS, Drawer I, Johnston SC 29832. 803-275-4444.

RTS Intercom PS-31 power supply, \$300; ADC audio patch bays, new, \$75. K O'Malley, WTAR/WLTY, 804-446-2731.

Audio & RF tech manuals for Sparta equip, write for list. D Peluso, KJUL, 2880 E Flamingo #E, Las Vegas NV 89121. 702-732-2200.

CLOSING UP SHOP. SELLING CHEAP!! Exc decks, amps, mixers, music & EFX libraries, 16" TT and 30" programs on 16" etc. Call for list: 708-739-0044.

Radio Sales training tapes on 16 VHS cassetts, 30 topics covered, station going non-profit, \$2000. R Trumbo, KNLF, POB 117, Quincy CA 95971. 1-800-397-4146.

Puregas 4200 air dryer, hi capacity, transmission line or cable drying use, \$700. E Black, 405-524-3770.

Teledyne Thermolectric 50 W LPG fuel generator, \$2000/BO. D Quinlan, KSYC, 316 Lawrence Ln, Yreka CA 96097. 916-842-4158.

## Want to Buy

Bdct equip catalogs, literature, manuals, esp Collins Radio Company equipment catalogs. J Stitzinger, 23800 Via Iрана, Valencia CA 91355. 805-259-2011.

Table rack mount for ancillary equip, will pay shipping. P Kaminski, Sportcom, 82 Zevan Rd, Johnson City NY 13790. 607-770-9165.

Looking for all kinds of crystals. E Prendergast, KAOK, 801 Columbia Southern Rd, Westlake LA 70669. 318-882-0243.

Sperry Rand 104 E-14 weather radar. H Hoeflicker, KRFS, RR 2 Box 149, Superior NE 68978. 402-879-4741.

Jazz record collections, 10" LP/12" LP be-bop, swing, dixie, highest prices paid. B Rose, Program Recordings, 228 East 10th, NNYN 10003. 212-674-3060.

Radio transformers by Chicago, UTC, Triad, Peerless, Freed, Sola, send list. J Gangwer, 942 32nd St, Richmond CA 94804. 415-644-2363.

Ampex tube recorders and mixers. W Gunn, 619-320-0728.

## MONITORS

## Want to Sell

Belar FMM-1 & FMS-2 monitor, good condition, \$2995/pair. C Murray, KMGE, 925 Country Club Rd #200, Eugene OR 97401. 503-484-9400.

Rust SFM-19 deviation monitor, BO; Indesys mod mon, BO; Collins mod mon, BO. C Scherer, WDOK, One Radio Ln, Cleveland OH 44114. 216-696-0123.

Ramko ARA-1612 (2) switcher/routers, BO; (4) Ramko ARA-1612CP-2 remote selectors, BO; Ramko ARA-1612PS power supply, BO. C Scherer, WDOK, One Radio Ln, Cleveland OH 44114. 216-696-0123.

## Want to Buy

Belar AMM2/3 mod monitors or others. G McClintock, WWCR/WNQM, 615-255-1377/1300.

EBS system, encoder, decoder & AM rcvr, TFT or McMartin preferred. R Wells, KSRO, 1410 Neotomas Ave, Santa Rosa CA 95405. 707-545-3313.

FM & stereo monitors, remote meter panels, RF amp, EBS rcvr/enc/decoder, donations accepted by new non-comm FM. M Sophos, WDFH, 21 Brookside Ln, Dobbs Ferry NY 10522. 914-693-3963.

McMartin (buy & sell) any model. C Goodrich, 11435 Manderson, Omaha NE 68164. 402-493-1886 or fax 402-493-6821.

## RECEIVERS &amp; TRANSCEIVERS

## Want to Sell

Sony SRF-A1 AM stereo walkman, new, quantities avail, \$89. C Fox, WOLF, 4853 Manor Hill Dr, Syracuse NY 13215. 315-468-0908.

Marti SCG-10 67 kHz subcarrier generator, SCG-10 39 kHz subcarrier generator, SCG-10 39 kHz sub carrier demod; AFI-55 67 kHz receiver, 1 year old; Marti CLA-40A amp. D Sorenson, SBC, 604 N Kiwanis, Sioux Falls SD 57104. 505-334-1117.

**AM STEREO RECEIVERS**  
From \$34.95 Portable, Home, Auto  
**RRADCO**  
Phone/FAX 708-513-1386

Altec 711A FM rcvr, early SS, selective, \$75 plus UPS. E Davison, POB 7167, Springfield IL 62971-7167.

GE MPI 5 W VHF 2 channel handheld, 136-150 MHz for meters no charger, \$50. P Russell, Bowdoin College, Sills Hall, Brunswick ME 04011. 207-725-3066.

Gorman Redlich CEB EBS decoder/encoder, \$100. B Ladd, WNRN, 108-1/2 E Main, Bellevue OH 44811. 419-463-2511.

## REMOTE &amp; MICROWAVE EQUIP

## Want to Sell

Marti STL-10 mono STL xmt & rcvr on 948.5 MHz, \$2000. J Callow, WAGN, 413 10th Ave, Menominee MI 49858. 906-863-1340.

## COMREX RENTALS

1, 2 and 3-Line Extenders  
Switched 56 Systems  
Call Steve Kirsch for details  
Silver Lake Audio  
(516) 623-6114 FAX: 377-4423

Burk Technology TC8, 3 yrs old, excel cond, \$1500. B Anderson, WTYG, POB 9, Charleston MS 38921. 601-647-5600.

Moseley 303 (2) trans/ (2) receive. K Kuenzie, KFEX, 13E 11th, Washington MO 63090. 314-239-0209.

Moseley TPT-2 STL transfer panel, gd cond, \$425. D Peluso, KJUL, 2880 E Flamingo #E, Las Vegas NV 89121. 702-732-2200.

Gentner EFT-3000 telephone line frequency extender (2), \$8250. D Becvar, KTIS, 3003 N Snelling Ave, St Paul MN 55113. 612-631-5047.

Gentner SPH3A telephone interface, \$400. J Hunter, KBRE, Box 858, Cedar City UT 84720. 801-590-1277.

Moseley TRC 15, 15 chnl remote control unit, gd working cond, no book, \$500/BO. L Nixon, Classic City Prod, 1094 Baxter St, Athens GA 30606. 706-613-6724.

1986 Winnebago LaSharo radio bdctg remote truck, ready to roll, cabinetry new, track lights, chairs, etc, \$12,000/BO. R Clark, WYNF, 9720 Executive Ctr Dr, St Petersburg FL 33702. 813-576-6090.

**RENTALS**  
**RENTALS**  
**RENTALS**  
**COMREX**  
3-line extender  
Frank Grundstein 215-642-0978  
Audio/Video

Anixter-Mark 10' & 6' STL dishes grid style w/950 MHz feeds, call for price. J Hunter, KBRE, Box 858, Cedar City UT 84720. 801-590-1277.

Moseley PCL-505 2 split-chnl xmtrs, (2) rcvrs & Decibel Products DB-8061-2B transmit combiner, working cond, \$2850. J Shadle, KPSN, 3719 N 32nd Ave, Phoenix AZ 85017. 602-279-5577.

TFT 8600 STL, excel cond, spare, 2 RX, 2 TX w/TX combiner, meets 1993 specs, \$3500. R Potyka, KRXS, 1730 E Indigo, Mesa AZ 85203. 602-969-7707.

Complete broadcast facility, set up for talk, news & music, all late, high quality equip, 14' x 30', 2-axle mobile studio, less than 5 yrs old w/air-cond & restroom, ideal for emergency or export in any market. Nationwide Talk Radio, POB 68088, Oak Grove OR 97268. 503-774-0459.

Marti RMC-30 w/30 functions, \$750. G Proctor, WCRJ, 980 FM 1746, Woodstar TX 75979. 409-429-3679.

QEI Cat-Link w/T1 modems w/manuals, \$5000. Dave/Mick, Brown Bdctg, 280 Commerce Circle, Sacramento CA 95815. 916-923-6800.

Micro Controls 9-chnl linear remote control, \$600/BO. R Swan, WROY, POB 400, Carmi IL 62621. 618-382-4161.

Marti CR-10/RPT-15 TRL link with Racom ID, good shape, \$1500; Moseley TRC-15 R/C setup for sub-carrier, \$500/BO. D Fcrttenberry, Brown Broadcasting, 280 Commerce Circle, Sacramento CA 95815. 916-923-6828.

Comrex PLXII & RTLX II late mdl 2-line freq extenders w/TCB-3 couplers, excel cond, \$3995. C Spencer, CS Prod, 10032 Hillgreen Circle, Cockeysville MD 21030. 410-763-0737.

Symetrix TI-101 telephone interface (2), \$250 ea. C Fletcher, WLJE, 2755 Sager Rd, Valparaiso IN 46383. 214-462-8125.

TFT 8610/8611 (4), working in good condition with manuals, \$1200 ea; Moseley MRC-1600 (2) working good condition with manuals, \$1400 ea; Moseley TRC-15AR with Hallikainen & Friends TEL 171 digital telemetry remote terminal adapter, \$700. Jefferson Public Radio, 1250 Siskiyou Blvd, Ashland OR 97520. 503-552-6301.

Marti transmitters (2), Marti receivers (2), Marti 4' dish antenna, Mark 8' transmitting dish and many other misc STL items, package price \$9,000. J Baer, ZL-91 FM, 381 E Ramsey, San Antonio TX 78216. 210-430-9052 or fax 210-340-7729.

TFT 7700 dual mono or stereo in good condition, for use outside of US. M Rice, Contemporary Media, 222 Indacom Dr, St Peters MO 63376. 314-928-6569.

Moseley MR1600 transmitter site unit only, \$500. S Minshall, KJSN, 3600 Sisk Rd, 2B, Modesto CA 95356. 209-545-5585.

TFT 7700 STL xmtrs on 950.5 MHz (2), BO; TFT 7771 dual STL rcvr on 950.5 MHz, BO. C Scherer, WDOK, One Radio Ln, Cleveland OH 44114. 216-696-0123.

## Want to Buy

Moseley, Marti, TFT, need STL xmt & rcvr reasonably priced. R Bell, WRVB, 4314 Cherry Ct, Evansville IN 47714. 812-479-3377.

Marti old tube remote pick-up xmt & newer solid state xmt & rcvr. G McClintock, WWCR/WNQM, 615-255-1377/1300.

Scala 960 mini-flectors STL antenna. K Kuenzie, KFEX, 13E 11th, Washington MO 63090. 314-239-0209.

Comrex TCB-1 telephone voice coupler. S Kirsch, Silver Lake Audio. 516-623-6114.

Telephone hybrid, Comrex TLX xmt, Comrex PLX-II xmt, Comrex RLX rcvr or gd used Comrex THX. P Kaminski, Sportcom, 82 Zevan Rd, Johnson City NY 13790. 607-770-9165.

Marti STL8 or 10 mono with transmitter & receiver in excellent condition with manuals. B Olson, WMPL, 326 Quincy St, Hancock MI 49930. 906-482-3700.

## SATELLITE EQUIPMENT

## Want to Sell

Wegener 1606-II sat receiver, needs some work, BO. C Knerr, KCNA, 139 SE J St, Grants Pass OR 97526. 503-474-7564.

Harris 6529 satellite rcvr (2), working, stereo, \$200 ea or \$400/all. Bud K, W4OAK, 4237 Airline Rd, Musk MI 49444. 616-733-4040.

7300 wideband BPSK rcvr, 7300 digital processing unit complete w/satellite dish, \$7000 cash. H Morgan, WHJM, 802 S Central Knoxville TN 37902. 615-546-4653.

Wegener satellite rcvr 1601-50 main-frame w/all cards needed to rcve Unistar oldies chnl in excel cond, just taken out of service for format chng, will also work w/other Unistar/Jones formats, \$2500. J Kimel, WLFE Radio, 102 Swanton Road, St Albans VT 05478. 802-524-2133.

Adcom 7550 Unistar ACII rcvr, \$2800. C Tarkenton, WCOH, 154 Boone Dr, Newman GA 30263. 404-253-4636.

Wegener 1601-24 LNB Wegener receiver with card for CNN, news, ready for Unistar country format with CNN, excellent condition, \$1875/shpg. C Walmer, WTHU-AM, 10 Radio Ln, Thurmont MD 21788.

Wegener 1601 mainframe with all cards for Unistar format 4.1, with Microdyne 4120 down converter, 1 year old, \$4200. A Baxa, WAVV, 11800 Tamiami Tr E, Naples FL 33962. 813-775-9288.

Microdyne 1100-CSR (2) prof sat video receivers, dual 4 GHz inputs, \$200 each. S Minshall, KJSN, 3600 Sisk Rd 2B, Modesto CA 95356. 209-545-5585.

Raytheon color weather radar system mdl 4804C, 6' antenna, 50 mile range, VRM, EBL, plus many other features, \$3500. K Casey, 602-582-6550.

## Want to Buy

SEDAT 7.5 or 15 kHz satellite receiver card for DAYNET. H Sell, KTRR, Box 727, Rolla MO 65401. 314-364-2525.

Harris 6550 satellite rcvr. H Hoeflicker, KRFS, RR2 Box 149, Superior NE 68978. 402-879-4741.

## STATIONS

## Want to Sell

AMs in Northern Maine (2), unique set-up, great first ownership for the right person, \$140,000. T Beardsley, WSJR, 6 10th Ave, Madawaska ME 04756. 207-728-4000.

FM 99.1 commercial license avail, small Caribbean island, full studio & xmt, package & manager/investor needed to start-up. Lou, Box 269, Anguilla WI. FAX 1-809-497-3770.

## MUST SELL

**AM 500 Watt full time**  
**in central Ohio. Some terms,**  
**offers considered.**  
For info write to:  
**Chamberlain, PO Box 69**  
**Bellefontaine, OH 43311**

1 kW FT AM in small single station market in South Central Virginia, \$125,000 includes building, serious cash inquiries only. WODI, 1230 Radio Rd, Brookneal VA 24528. 804-376-2288.

FM 90.5 Educ, 700 W/W/7, \$75K. D Parsons, KLUH, POB 1313, Poplar Bluff MO 63901. 314-606-1663.

Central Virginia small market fulltime 1 kW AM with real estate, \$125K/OBO cash. G Jones, WODI, 1230 Radio Road, Brookneal VA 24528. 804-376-2288.

5kW day/29W nite w/new tower/ground system, w/4 acres in Jacksonville, FL metro market. Beautiful historic beach town. Best cash offer over \$200,000. Bill, 205-238-0281 or Mark, 205-236-6484.

## Want to Buy

Station in Southeast U.S., prefer SC, NC, GA, FL or TN, will consider all, down payment w/owner financing, reply in conf to: Radio, 104 Pearson Rd, Easley SC 29642.

FM or AM/FM combo in North Central Iowa or South Central Minnesota. G Hawley, 3708 240th St, Clear Lake IA 50428. 515-357-7870.

## STEREO GENERATORS

## Want to Sell

McMartin BFM 1521 tested & guaranteed, also mono & stereo audio processors. Goodrich Ent, 11435 Manderson St, Omaha NE 68164. 402-493-1886.

## TRANSCOM CORP.

Serving the Broadcast Industry Since 1978

Fine Used AM & FM Transmitters  
and Also New Equipment

For the best deals on Celwave products,  
Andrew cable and Shively antennas.

1 kW FM 1978 Collins 831C2	2.5 kW AM 1982 CCA 2500D
2.5 kW FM 1978 CCA 2500R	2.5 kW AM 1976 McMartin BA2.5K
3 kW FM 1975 CCA 3000D	5 kW AM 1977 RCA BTA 5L
3 kW FM 1974 Harris FM3H	
3.5 kW FM 1979 Syntronics SI-F-3	50 kW AM 1977 CCA AM50,000D
10 kW FM 1970 Collins 830F2	50 kW AM 1979 Harris MW50B
15 kW FM 1971 AEL 15KG	
25 kW FM 1981 Harris FM25K	
30 kW FM BE FM30	

1077 Rydal Road #101  
Rydal PA 19046

800-441-8454 • 215-884-0888 • FAX No. 215-884-0738



### STEREO GENERATORS...WTS

**CRL SG-800** in excel cond, \$800; Moseley SCD-9 stereo demodulator, \$400. S Minshall, KJSN, 3600 Sisk Rd, 2B, Modesto CA 95356. 209-545-5585.

**Modulation Science** Sidekick SCA generator, excel cond, \$2200. R Swafford, IAM Inc, POB 2501, Springfield MO 65801. 417-883-5488.

**Kahn AM stereo system**, mint cond w/manuals, \$875. P Willey, WMNB, 466 Curran Hiway, N Adams MA 01247. 413-663-3419.

### Want to Buy

**CCA SG-1E** composite stereo gen for CCA FM-40E exciter, working or serviceable cond OK, documentation required. C Dunnam, Linear Research Assoc, 5244 Perry City Rd, Trumansburg NY 14886. 607-387-3411 or fax 607-387-7806.

### TAPES/CARTS & REELS

#### Want to Sell

**Fidelipac Master carts**, most 4 min long w/country songs recorded, \$300/all or \$.50 ea. KD Austin, KFXI, 1101 Hwy 81N, Marlow OK 73055. 405-658-9292.

**Fidelipac Gold Mastercarts**, music lengths, \$1 ea; Gray, 300 carts, \$.25 ea, you pay shipping. E Moody, KJEM, 216 N Main, Bentonville AK 72712. 501-273-9039.

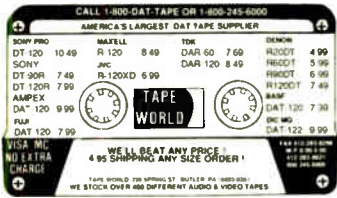

**Oldies/A.C.** music library, approx 80 reels w/tones, \$350 plus shipping. F Willis, WKXH, POB K, Alma GA 31501. 912-632-0104.

**Transcriptions**, 16" incl armed-forces radio shows & Hawaii Calling shows, trade for other transcriptions or equipment. R Wells, KSRO, 1410 Neotomas Ave, Santa Rosa CA 95405. 707-545-3313.

**Mix format on Scotchcart II's**, 3274 songs, 6 months old, \$8950; Scotchcart II's, music sizes, some new, others 6 months old, \$2-2.50 each; Abco & Fidelipac wire cart racks, hold 50 & 25 carts each, \$20 & 15 each plus shipping. B Lord, Lord Broadcasting, 13313 SE 208th, Kent WA 98042. 206-631-2374.

**Collection of Jazz 7" reels & LPs** from 1920-1980, \$100 or will trade for Tascam or Teac 2-channel cassette deck. D Pulwers, Dave's Price Audio Productions, 310 N Howard St #103, Alexandria VA 22304. 703-751-9346.

**Audiopak** in various lengths, \$1, rebuildable \$.75. D Koehn, KKPR, Box 130, Keamey NE 68848. 308-237-9333.

**3M Scotchcart II** qty 300, mostly 3.5 & 4.5 min, like new, \$3.25/ea or \$700/all; Aristocart qty 100, assorted lengths & 10 plastic modular 20 position cart holders. BO. Dave, Allmake Prod, 517-652-6863, leave msg.

**200 carts**, various lengths, 200-7" plastic reels w/tape, BO. 504-657-5249.

**Pams Jingles** ref tapes, 1951-1976, BO. R Kaufman, Pams Prods, POB 462247, Garland TX 75046. 214-271-7625.

### Want to Buy

**Century 21, TM, Bonneville** or other syndicated reel tapes, all formats, will consider CDs, complete sets only. R Simonson, Box 206, Oshemo MI 49077. 616-363-8561.

**Gold Discs** 1 or all, radio CDs of all kinds. K Kuenzie, KFXE, 13E 11th, Washington MO 63090. 314-239-0209.

**Library desperately needs** music from 40's-50's-60's-70's, records & tapes, ASAP. S Stevenson, POB 1288, Blaine WA 98231. 604-531-4576, leave message.

### TAX DEDUCT EQUIP

#### Want to Sell

**Non-profit student broadcast** program seeks old/used equipment, any condition, will pay S&H. L Jackson, 616-445-8093.

**Educational radio** needs broadcast & studio equipment, legal & IRS recognized, will pay s/h & give receipt. Dr Newcomb, GRRN, 19130 Nelson-Parkman Rd, Garrettsville OH 44231. 216-643-4125.

### TEST EQUIPMENT

#### Want to Sell

**General Radio 1606A** RF bridge, excellent condition, late serial No., \$400 plus shipping. Fred Spaulding, P.E., Mtn View, CA 94043. 415-961-5018.

**Wavetek 907AF**, all mode signal generators (2), cover 7.0-12.4 GHz. Excellent condition, with manual, \$1200 each. Douglas RF Devices, 916-688-5647.

**Crown RTA-2** analyzer, \$1400; Klark-Teknik DN60 real time analyzer, \$1850. R McMillen, Super Duper Audio Duplicating, 1634 SW Alder St, Portland OR 97205. 503-228-2222.

**ITT 1735D 17"** oscilloscope with manual, needs work but clean, BO. R Meyers, Benchmark Comm Corp, 4700 SW 75th Ave, Miami FL 33155. 305-264-2357.

**Westcom Hameg HM103-3** oscilloscope, \$270 plus shipping. B Lord, Lord Bdcg, 13313 SE 208th, Kent WA 98042. 206-631-2374.

**Potomac AG-51/AA-51** test set in A-1 cond, \$2700 plus UPS. J Fernandez, Box 3047, Bayamon, P.R. 00960. 809-798-7281.

**Potomac AT-51** w/matching transformers, vgc, \$2995. J McPhearson, Blue Ridge Bdcg Assoc, 14926 Ampstead St, Centreville VA 22020. 703-968-7492.

### We Have RENTAL EQUIPMENT available to SAVE YOU MONEY

**Spectrum Analyzer  
Potomac Field Strength Meters  
Impedance Bridges  
Receiver/Generator  
Audio Test Set**  
**ALSO**  
**Other Equipment Available**  
**RADIO RESOURCES**  
Ask for **STEVE, BILL** or **Chuck**  
**1-800-54-RADIO**

**Hewlett Packard** vector impedance meter, needs probe, excellent condition, \$800. G Arroyo, 407-830-0800.

### Want to Buy

**Audio Precision**, HP, Neutrik, Tek, Sound Tech or similar decent audio test gear. W Dooley 818-798-9128.

**Manke M-1** wow & flutter meter in good condition, top dollar paid. E Davison, POB 7167, Springfield IL 62791-7167.

**Potomac FIM-41** AM field strength meter in good condition. C Spencer, CS Productions, 10032 C Hillsgreen Circle, Cockeysville MD 21030. 410-783-0737.

### TRANSMITTERS

#### Want to Sell

**Collins 20V3**, 1290 kHz, for use or parts, BO. G Erway, KKSB, POB 40309, Santa Barbara CA 93140. 805-560-1290.

**Harris IG 1 kW** AM, good condition, \$4500; Harris Vanguard I, 1 kW AM, good condition, \$2900; Robert Jones J-318 FM booster, 10 W, \$2500. J Arzuaga, WREI, Rd 2 KM 102.5, Quebradillas PR 00678. 809-895-2725.

**Bendix TDD-5 30 W** AM, new government surplus, modified to cover your frequency, tube type, 62 LBS, plate modulation, \$300. J Cunningham, KHKC, Rt 2 Box 113B, Stonewall OK 74871. 405-265-4496.

**Collins 30K-4** dual channel 2-30 MHz AM voice or key 300 W, good condition, police or aviation transmitter, trade for stereo exciter/TE-3 or equivalent. J Cunningham, KHKC, Rt 2 Box 113B, Stonewall OK 74871. 405-265-4496.

**Gates BC-10P** AM, used only as stand-by, \$10,000. G Proctor, WCRJ, 980 FM 1746, Woodville TX 75979. 409-429-3679.

**Gates BC-5P/2**, 5 kW AM, excel cond, \$5,000. G Proctor, WCRJ, 980 FM 1746, Woodville TX 75979. 409-429-3679.

**Gates TE-3** FM exciter, stereo, SCA on 95.1 MHz, excel cond, \$350/BO plus UPS. L Van Prooyen, WGRD, 8330 Myers Lk, Rockford MI 49341. 616-874-9242.

**Harris MS15** technical manuals; MS15 exciter & modules, Vol 1 & 2, \$25 FOB USA Continent. E Davison, POB 7167, Springfield IL 62971-7167.

**Moseley 505-C** transmitter/receiver, factory type accepted, unit at Moseley, will ship recalibrated to your frequency. C Murray, KMGE, 925 Country Club Rd #200, Eugene OR 97401. 503-484-9400.

**McMartin BF-25K** 10-25 kW FM transmitter, completely refurbished & tuned & tested to your frequency, guaranteed; 1 kW AM transmitter. Goodrich Enterprises, 11435 Manderson St, Omaha NE 68164. 402-493-1886.

**CSI T-3-F1** with harmonic filter at 99.5 with spare tubes, excellent condition, \$7000/BO. R Hays, KRLL, 5800 Quick, Lubbock TX 79405. 806-745-5800.

**Continental 816R-2B** 21.5 kW FM with 802A exciter tuned to 107.5 MHz, 2 years old, cash and/or cash plus trade for 2.5-5 kW FM transmitter. S Wallington, K-Love Radio, 2290 Airport Blvd, Santa Rosa CA 95403. 707-528-9238.

**Continental/Bauer** 1 kW AM, minor repairs, \$2500. F Willis, WKXH, POB K, Alma GA 31510. 912-632-0104.

**RCA BTF-1E2** 1000 W FM w/stereo exciter type BTE-15A, solid state. John, 405-672-2593.

**Gates FM5H** 5 kW FM, rebuilt w/McMartin BFM8000 exciter, package \$16K. R Miller, Miller Media Group, POB 169, Taylorville IL 62568. 217-824-3395.

**CSI exciter** FM synthesized tuned from 88 to 108 10 with good condition, same QEI 675, a few spare boards, \$550. J Arzuaga, WREI, Rd 2 KM 102.5, Quebradillas PR 00678. 809-895-2725.

**Harris MW1A** 1 kW solid state, good condition, \$8500. B King, 1809 Lightsey, Austin TX 78704. 512-832-4061.

**Wanted  
Dead or Alive  
FM Transmitters  
Any Age or Power  
414-482-2638**

**Harris FM 2.5K 2500 W**, one owner, w/spare tube, spare blower, MS-15 exciter, \$10K. R Miller, Miller Media Group, POB 169, Taylorville IL 62568. 217-824-3395.

**RCA BT-1D** 1 kW FM tuned to 104.3 MHz, w/Harris MX-15 exciter, record but never used, \$8000 FOB Las Vegas NV, Harris exciter alone, \$2500 prepaid UPS. D Peluso, KJUL, 2880 E Flamingo #E, Las Vegas NV 89121. 702-732-2200.

**CCA AM5000DX** 1970 mdl, needs some work, BO; 50' 3-1/2" coax, new, \$500; 75' & 15' 7/8" coax, \$150 & \$30; used 7/8" on spool, BO. D Koehn, KKPR, Box 130, Kearney NE 68848. 308-237-9333.

**Circuit cards (4)** for TTC XL10FM translator; (2) TVK code keyer ID, (2) mod cards for 30 sec spot with timer, \$200 ea. D Rose, KAAA, 2534 Hualapai Mtn Rd, Kingman AZ 86402. 602-753-2537.

**DEMOED EQUIPMENT**  
BEXT Inc. has a few demoed exciters, amplifiers and STL's for sale. All demoed systems are sold first come first served and have the same 2-year warranty as BEXT's new equipment. For information:  
**619-239-8462**

**CCA AM-1000D** 1 kW xmtr, tuned to 1190 kHz, vgc, presently on air, \$3000. G Arroyo, 407-830-0800.

**RCA BTF-50** 5 kW FM, in service, \$5000/BO. C Binder, WZOS, 33-48 E Bridge St, Oswego NY 13126. 315-342-9600.

**Harris FM20H3** late 70s mdl (2), one with QEI exciter, one with TE-3, available now, \$16,995 each. C Spencer, CS Productions, 10032 C Hillsgreen Circle, Cockeysville MD 21030. 410-763-0737.

**RCA 5 kW AM** dummy load; CCA 10DS FM exciter with stereo generator; ITA 5000C FM, 5000 W in good condition tuned to 98.3 MHz with spare parts; Collins A830-2 direct FM exciter with Collins 786-1 stereo generator. M Rice, Contemporary Media, 222 Indacom Dr, St Peters MO 63376. 314-928-6569.

**Gates FM 20 H3** w/exciter, good condition, \$13500; Harris HT 3.5 kW, excellent condition, \$15000. M Wodlinger, WIXI FM, 813-262-1000.

**TTC UST-106** on ch 61, recently rebuilt, tuneable, \$14,000/BO; Bext NS1000 1 kW amp on ch 61, tuneable, 2 years old, very clean, solid, \$24,000. S Kalka, K62CO-TV, 945 S 12 #4, Lincoln NE 68508. 402-477-2813.

**RCA 10 kW** AM mdl BTA-1002, tuned to 1030 kHz, needs modulation transformer, vgc, workhorse, \$10K. G Arroyo, 407-830-0800.

**Nautel AMPFET 10**, 10 kW solid state, almost new. E Hoehn, KFMZ, 1101 Walnut, Columbia MO 65201. 314-874-3000.

**NEW 3 kW  
FM transmitters  
for under \$14,000.  
Call for details  
Bill Hoffman  
518-583-9490**

**Continental 816R-1A** well maintained, great condition, 10 kW tuned to 102.5 MHz, BO. M Murphy, KMSO, 725 Strand, Missoula MT 59801. 406-542-1025.

**FM - TRANSMITTERS**  
Factory new not used. Why buy a used Transmitter when you can own a new FM Transmitter for about the same cost? Call JIMMIE JOYNT at 214-335-3425.

**Used & New Transmission Line**, many sizes & lengths, many like new. 816-635-5959.

### Want to Buy

**Harris MX-15** FM exciter, must be in good condition. G Sapiano, WLNG, POB 2000, Sag Harbor NY 11963. 516-725-0803.

**Any FM 3 kW**, needing repair OK. R Bell, WRVB, 4314 Cherry Ct, Evansville IN 47714. 812-479-3377.

**Collins 820 F1** or other gd 10 kW AM xmtr. G McClintock, WNQM, 1300 WWCOR Ave, Nashville TN 37218. 615-255-1300.

**5 kW stereo FM** in good working condition with exciter. D Royer Sr, POB 3384, Kinston NC 28501. 919-523-5151.

**Used 20 kW FM**, 1980 or newer. W Wilson, KJTY, 1005 SW 10th Ave, Topeka KS 66604. 913-357-8888.

**Collins 30K-4** or 30K-5, 20-30 MHz transmitter. J Stitzinger, 23800 Via Irena, Valencia CA 91355. 805-259-2011.

**Schematics of any tube type** cathode modulation AM broadcast transmitters from late '50s through '70s, up to \$30. J Cunningham, KHKC, Rt 2 Box 113B, Stonewall OK 74871. 405-265-4496.

**CCA 10A DS** 10 W exciter, send info/description/price to Heritage, POB 16, Boston MA 02167.

**15-20 kW FM** transmitter. G Bonet, WIOB, POB 3822, Mayaguez PR 00681. 809-834-0760.

**AM xmtrs including:** Collins 20V Series, 300J, 500J & RCA BTA-500 or BTA-1, will arrange shipping for operational restorable units. G Lee, POB 5786, Beverly Hills CA 90209. 310-696-0177.

**Any 250 W AM**, no PCB's, on or near 1360 kHz, small stature & foot print desired, will consider all except junkers. C Rohde, KNRB, 121 NE Loop 820, Hurst TX 76053. 817-589-1100.

**10 W AM** for travelers info stations. AJ Anello, 1915 W Waters #1, Tampa FL 33604. 813-933-6009.

**1 kW transmitter** in good condition, translator or FM booster, harmonic filter for older Wilkinson. B Wolf, WMMR, RT 4, Woodstock VT 05091. 802-457-9494.

**250-500 W FM** w/wo exciter, tunable to 90.3, donations accepted by new non-comm FM. M Sophos, WDFH, 21 Brookside Ln, Dobbs Ferry NY 10522. 914-693-3963.

**Collins 20V 1-2** or 3 buffer & driver tank canisters, meter banks for these units also; 250 W AM transmitter that operates on 120 V like Gates BC-250A and RCA 250M. E Prendergast, KAOK, 801 Columbia Southern Rd, Westlake LA 70669. 318-882-0243.

**McMartin AM/FM** transmitter, any model, exciter or stereo modules. Goodrich Enterprises, 11435 Manderson, Omaha NE 68164. 402-493-1886.

### TUBES

#### Want to Sell

**New RCA 5762 tubes.** Distributors surplus inventory. 305-757-9207.

**ARMSTRONG TRANSMITTER**  
**World Leaders in rebuilt transmitters!**  
**AM-FM-TV Transmitters, FM Antennas, STLs**  
Transmitters are available:  
• Tuned & Tested on YOUR Frequency  
• Guaranteed  
• Parts and Technical Support with Every Purchase  
• Expedited Service Available  
**-TRADE INS GLADLY ACCEPTED-**  
**See Your Transmitter WORKING in Our Showroom BEFORE You Take it Home!**

**OVER 500 CUSTOMERS IN 30 COUNTRIES**

**Corporate Office**  
5046 Smoral Rd.  
Syracuse, NY 13031  
Phone 315-488-1269  
FAX 315-488-1365

**International Hablo Español**  
Phone 305-471-1175  
FAX 305-471-1182  
Miami, FL

**Armstrong Southeast**  
Phone 615-822-0256  
FAX 615-826-0082  
Hendersonville, TN

**NO ONE ELSE OFFERS YOU MORE**

**MADE IN THE USA**

**1 kW FM Solid State Transmitter \$13,200 list includes Exciter!**

**LEGEND 1000 Features**

- Automatic Power Output Control
- VSWR Foldback and Protection
- Remote Control Ready
- Full System and Individual Module Metering
- Motorola MRF151G MOSFETS

**PLUS MANY MORE FEATURES**

**"The Transmitter People"**

**Energy-Onix**

752 Warren Street, Hudson, New York 12534  
(518)828-1690 FAX(518) 828-8476

**MADE IN THE USA**

Circle (96) On Reader Service Card



**TUBES...WTS**

Gates BC1G (2) 900 kHz vacuum crystals to plug-in octal socket, \$100 ea. R DuFault, Chesapeake Engineering, 1308 White Way, Laurel MD 20707. 410-792-0851.

**ECONCO**

Quality Rebuilt Tubes

Approximately 1/2 the Cost of New

Call for Our Price List

800-532-6626

916-662-7553

FAX 916-666-7760

Circle (77) On Reader Service Card

National 4CX1000A1816B, new never used, \$200/BO. T Peterson, WPZX, 220 1/2 S Michigan, Big Rapids MI 49307. 616-796-7000.

4-1000A, 8877, 4CX250B, 4CX1500B, 4CX3000A & more. We carry large inventory all major brands, Eimac, Ampere, RCA, etc. Call Stew 1-800-842-1489.

**Want to Buy**

**WANTED!**  
Transmitting Tubes

We BUY & SELL all types of transmitting/receiving tubes.

C&N Electronics  
Harold Bramstedt  
6104 Egg Lake Road  
Hugo, MN 55038

(612) 429-9397 ext.23  
(800) 421-9397 ext. 23  
FAX (612) 429-0292

Circle (58) On Reader Service Card

KT 88 Gold Lion, Genelex, American, British output tubes, new or used. R Glenn, WJGR, 1718 Shannadoa, Wimauma FL 33598. 813-634-1940.

**TURNTABLES**

**Want to Sell**

Technics SP-10 good condition, with out base, \$500. G Faltus, WZMX, 10 Executive Dr, Farmington CT 06032.

RTS-405 stereo TT preamp (2), \$190 ea plus shipping. B Lord, Lord Bdcg, 13313 SE 208th, Kent WA 98042. 206-631-2374.

JVC 4-DD-5 quadrophonic disc demodulator, never used, \$125/BO, will trade for Teac or Tascam 2-channel cassette deck. D Pulwers, Dave's Price Audio Productions, 310 N Howard St #103, Alexandria VA 22304. 703-751-9346.

Technics SP-25 (2), tonearms, Stanton 310 preamps & Henry Universal controller, \$500. K Surgeon, KLIK, POB 414, Jefferson City MO 65102. 314-893-5696.

Keith Monks record cleaner, \$650; Keith Monks anti-static Lp sleeves, never opened, \$24/box of 300. R McMillen, Super Duper Audio Duplicating, 1634 SW Alder St, Portland OR 97205. 503-228-2222.

Technics SL1200 MKII, very good with cartridge, \$325/BO. J Rudisill, Audio Independence, POB 746, Aptos CA 95001. 408-684-0605.

Technics SP-25 with tonearm, good condition, \$150/BO. R McDaniel, KJRG/KOEZ, Box 567, Newton KS 67114. 316-263-5150.

RCA MI-11833B 16" transcription disc TT & cabinet, 16" Gray tonearm & Stanton 680EL cartridge, \$300. A Olean, WMPG, 96 Falmouth St, Portland ME 04103. 207-780-4424.

Russco Cue Master (3) with Micro-trak tonearms & Stanton heads, \$100 each; Henry Engineering Universal TT controller, \$75. D Rose, KAAA, 2534 Hualapai Mountain Rd, Kingman AZ 86402. 602-753-2537.

**Want to Buy**

Need tonearm & head shell for Gates CB-500. B Abel, KOSE, 509 S Walnut, Osceola AR 72370. 501-563-2641.

**VIDEO TAPE RECORDERS**

**Want to Sell**

Sony VO-2610, 3/4" U-matic VTR, 2 audio chnl's, auto repeat, vgc, \$250. C Yengst, WAWZ, Zarephath NJ 08890. 908-469-0991.

**Space Available!**  
Call  
**1-703-998-7600**  
for information

**Efficient & Economical**

Radio World's Products & Services Showcase reaches over 20,000+ radio station owners, managers, engineers and consultants every month.

To advertise your product or service, contact your sales representative or Simone Mullins at  
**1-703-998-7600**

## ADVERTISER INDEX

This listing is provided for the convenience of our readers. Radio World assumes no liability for inaccuracy.

Page No.	Advertiser	Reader Service No.	Page No.	Advertiser	Reader Service No.
44	360 Systems	16	45	Hallikainen & Friends	135
3	ATI	185	6	Harris-Allied Broadcast Equip.	15,118
45	ATI	89	14	Harris-Allied Broadcast Equip.	79,154
36	Audi-Cord	199	26	Harris-Allied Broadcast Equip.	94,161
51	Audio Broadcast Group	201	46	Harris-Allied Broadcast Equip.	48,164
2	Audioarts/Div. of Wheatstone Corp.	111	43	Harris-Allied Radio RF Products	61,150
40	Belar	30	19	Hnat-Hindes	51
51	Benchmark Media Systems	46	38	Inovoric	11
37	Bext	78	40	J Squared Technical Service	137
51	Broadcast Devices	74	37	LBA	27
19	Broadcast Electronics	25	45	LPB	53
21	Broadcast Electronics	32	35	Modulation Sciences	68
13	Broadcast Services	5	20	Moseley	8
4	Burk Technology	99	8	National Supervisory Network	71
50	Burk Technology	140	23	Nautel	72
58	C & N Electronics	58	39	Orban/akg/DBX	101
1	CCA Electronics	45	49	Pacific Recorders	40
51	Celcast Communication Product	9	34	Pixel Instruments	159
45	Central Tower	116	26	Potomac Instruments	54
14	Clark & Associates	85	28	OEI	131
44	Clark Wire and Cable	112	25	RE America	162
27	Computer Concepts Corp.	177	52	Radio Resources	115
45	Comrex	70	42	Radio Systems	23
3	Continental Electronics	38	53	Recording Studio Services	12
29	Cutting Edge	92	15	Roland Corp. U.S.	97
41	DIC Digital	34	24	Scott Studios Corp.	22
25	Dataworld	14	34	Shively Labs	215
36	Dataworld	188	10	Studer	49
50	Dataworld	37	45	Studio Technology	84
51	Dielectrc Communications	24	32	TFT	67
9	Dolby	134	30,31	TM Century	90
45	Econco	63	7	Tascam	200
58	Econco	77	47	Tascam	148
57	Energy-Onix	96	33	Telos Systems	141
17	Eventide	31	45	The Management	10
12	Fidelipac	155	34	Titus Technology Labs	20
22	Fidelipac	56	56	Transcom	50
51	Flash Technology	29	16	Valley Audio Products	143
48	Full Compass	202	59	Wheatstone	100
18	Gentner	125	60	Wheatstone	178
45	Gorman Redlich	98			
52	Hall Electronics	26			

Publisher .....	Stevan B. Dana	Production .....	Vicky Baron, Lisa Lyons, Lisa Mamo
Associate Publisher .....	Carmel King	Ad Coordinator .....	Regan Deatherage
Marketing Consultant .....	Al Leon	Ad Coordination Manager .....	Simone Mullins
Marketing Assistant .....	Annette Deutscher	Circulation Director .....	Tiana Hickman
Production Director .....	Kim Lowe	Circulation Manager .....	Rebecca Seaborg
Production Manager .....	Julianne Stone	Accounts Receivable .....	Steve Berto

**Advertising Sales Representatives**

U.S. East: Skip Tash ..... 703-998-7600 Fax: 703-998-2966  
 U.S. West: Dale Tucker ..... 916-721-3410 Fax: 916-729-0810  
 International: Stevan B. Dana ..... +1-703-998-7600 Fax: +1-998-2966  
 Europe: Dario Calabrese ..... +39-2-753-0274 Fax: +39-2-753-2697  
 Japan: Eiji Yoshikawa ..... +81-3-3327-2688 Fax: +81-3-3327-3010

Free Subscriptions are available upon request to professional broadcasting and audiovisual equipment users. For address changes, send current and new address to RW a month in advance at P.O. Box 1214, Falls Church, VA 22041. Unsolicited manuscripts are welcomed for review: send to the attention of the appropriate editor.

## ACTION-GRAM

**Equipment Listings**

Radio World's Broadcast Equipment Exchange provides a FREE listing service for radio stations and recording studios only. All other end users will be charged. Simply send your listings to us, following the example below. Please indicate in which category you would like your listing to appear. Mail your listings to the address below. Thank you.

Please print and include all information:

Contact Name \_\_\_\_\_  
 Title \_\_\_\_\_  
 Company/Station \_\_\_\_\_  
 Address \_\_\_\_\_  
 City/State \_\_\_\_\_  
 Zip Code \_\_\_\_\_  
 Telephone: \_\_\_\_\_

I would like to receive or continue receiving Radio World FREE each month.  
 Yes  No

Signature \_\_\_\_\_ Date \_\_\_\_\_

Please Circle only one entry for each category:

**I. Type of Firm**

- D. Combination AM/FM station
- A. Commercial AM station
- B. Commercial FM station
- C. Educational FM station
- E. Network/group owner
- F. Recording studio
- G. TV station/teleprod facility
- H. Consultant/ind engineer
- I. Mfg. distributor or dealer
- J. Other \_\_\_\_\_

**II. Job Function**

- A. Ownership
- B. General management
- C. Engineering
- D. Programming/production
- G. Sales Manager
- E. News operations
- F. Other (specify) \_\_\_\_\_

Brokers, dealers, manufacturers and other organizations who are not legitimate end users can participate in the Broadcast Equipment Exchange on a paid basis. Line ad listings & display advertising are available on a per word or per inch basis.

WTS  WTB  Category: \_\_\_\_\_

Make: \_\_\_\_\_ Model: \_\_\_\_\_

Brief Description: \_\_\_\_\_

Price: \_\_\_\_\_

WTS  WTB  Category: \_\_\_\_\_

Make: \_\_\_\_\_ Model: \_\_\_\_\_

Brief Description: \_\_\_\_\_

Price: \_\_\_\_\_

WTS  WTB  Category: \_\_\_\_\_

Make: \_\_\_\_\_ Model: \_\_\_\_\_

Brief Description: \_\_\_\_\_

Price: \_\_\_\_\_

\*Closing for listings is the first and third Fridays for the next month's issue.

All listings are run for 2 issues unless pressed for space or otherwise notified by listee.

### Broadcast Equipment Exchange

Phone: 703-998-7600 PO Box 1214, Falls Church, VA USA 22041 FAX: 703-998-2966



# Give Your Production People Some POWER!

**THE SP-6 IS LOADED WITH FEATURES!** Like a powerful equalizer section that gives your talent greater creative freedom; four auxiliary sends that can be used for special effects, headphone feeds, or IFB mixes; both 8-track and stereo bus assigns for multi-track and dubbing work; plus a choice of mono mic/line or stereo input channels. And, to keep things fast and productive, it even includes full machine control logic, control room and studio mutes, plus tally systems—just like you'd expect on an on-air console. The SP-6 provides independent headphone, control room and multiple studio monitors, and (of course) an automatic stereo cue/solo

system. Our unique track monitor section will speed your production pace, allowing simultaneous stereo mixdown during the multi-track bed session.

A powerful group of accessory modules will increase your production control, like a 7-station intercom module that links this console with other Wheatstone consoles and talent stations throughout your complex; a full-function tape recorder control panel; an 8-position source selector to enhance input capability; additional studio modules to accommodate multi-studio installations; and finally, a digital event timer and a precision clock.

So contact Wheatstone, the company with the integrity and experience you can count on.



 Wheatstone® Corporation

6720 V.I.P. Parkway, Syosset, NY 11791 (tel 315-455-7740 fax 315-454-8104)

Circle 1001 on Reader Service Card  
World Radio History

SP-6



# Wheatstone Has It!

## Super Performance – Great Price!

**OUR NEW A-300 CONSOLE HAS ALL THE RIGHT STUFF:** Performance right at the limits of technology, the features you want, and a fresh clean look your clients will admire. It's got all the busses you'll need. It's got the crosstalk and bus off isolation you HAVE to have for LMAs and FM/AM combos. Its small footprint and low profile let you conserve valuable studio real estate. Its virtual audio bus™ architecture lets you place any module anywhere in the console—no dedicated slots!

Talent will love our easy-to-learn superphone module and the automated cue system that makes monitoring confusion-free. Our integrated intercom system lets them communicate with any other Wheatstone console or talent location—handsfree.

Your program director will really like the sound of this console: no VCA distortion—just flawless specs. And, because of its ultra-flexible architecture, it can be easily adapted to any format, anytime.

The A-300 has what engineers want: first class documentation, gold switches, gold connectors, a hinged meterbridge for easy re-lamping, straight-forward reliable logic technology, and the best I/O connection and tooling system in the industry.

The A-300 is the console that has followed the evolution of radio. Benefit from Wheatstone's experience and total commitment to your satisfaction. Contact us.



 Wheatstone® Corporation

**A-300**

7305 Performance Drive, Syracuse, NY, 13212 (tel 315-452-5000 / fax 315-452-0160)

Circle (178) On Reader Service Card

World Radio History