

*****3-DIGIT 857
J750737 D11 9007 5873 973
BARRY MISHKIND
2033 S AUGUSTA PL
TUCSON AZ 85718

SBE '91 SHOW PREVIEW
See Our Special Section, pp 16-19.

Radio World®

Vol 15, No 18

Radio's Best Read Newspaper

September 25, 1991

The Party's Over

World Band Radio Played Vital Role During Failed Soviet Coup

by Frank Beacham

MOSCOW With all the high technology communications available in the world today, the venerable short-wave frequencies have proven several times the most useful and reliable in a time of international political crisis.

During the recent coup in the Soviet Union, short-wave again had its shining moment.

Soviet President Mikhail Gorbachev was isolated and under house arrest in his vacation home in the Crimea. His phone lines had been cut and television disconnected. So he eavesdropped on the outside world through a dusty old shortwave radio found abandoned in a maintenance room. The BBC, Voice of America and Radio Liberty became the Soviet president's only window to the world.

Radio White House

Meanwhile, in Moscow, where most media was controlled by coup leaders, Russian President Boris Yeltsin



Radio White House:

ABC's Diane Sawyer (left) located Yeltsin's shortwave base—an ICOM transceiver and DAIWA DC power supply.

PHOTO: ABC News

sin braced for an expected attack of the Russian Parliament building, nicknamed "White House." He informed the Russian people of his defiance of the coup attempt through "Radio White House"—an amateur

(continued on page 7)

SBE Predicts Solid Houston Show

by Alex Zavistovich

HOUSTON Society of Broadcast Engineers (SBE) executives remain optimistic about the success of their coming convention, to be held Oct. 2-5 at the George Brown Convention Center here.

This optimism, however, has been tempered by the realities of the economic problems experienced throughout the country. Exhibit booth sales are down from last year at this time, and some

manufacturers continue to express concern over the show's move from last year's successful St. Louis venue.

Still, the SBE is looking to Houston as a chance to bring the show to a different segment of its membership. What's more, an agreement with a regional show will add more still to the convention's attendance numbers, the association hopes.

"I think we're doing really well, given the economy," said SBE Executive Director Stephen Ingram. "We have a chance

of beating last year's attendance," he added.

Ingram estimated that

(continued on page 17)



Heart of Texas:

The SBE '91 convention will be held at the George R. Brown Center in Houston.

NAB Requests Eureka In-Band

by Judith Gross

WASHINGTON In a surprise move, the NAB has asked Eureka 147 researchers to develop an in-band DAB system for AM and FM—on the FM band.

The request came during the most recent talks between NAB and Eureka over a possible licensing agreement, NAB Executive Director of Operations, John Abel explained. He said a written request was sent to Eureka engineer Daniel Pommer as well.

The aim, according to Abel, is to develop a system with a bandwidth narrower than the current Eureka 147, which puts four channels in 6 MHz.

Eureka engineers have said repeatedly that an on-channel in-band DAB system would not reduce multipath and would interfere with the analog signal. But Abel said in-band Eureka would not necessarily be on-channel.

"Narrowband would be a better description," Abel noted. But he said, "We are looking to accommodate all AM and FM stations in the FM first adjacent."

When asked about possible objections of FM stations to such a system, Abel said, "We'd face the same objections that some other in-band DAB systems face. But I don't think the industry will accept an inferior quality signal for AM. And I don't think the FCC will abandon AM."

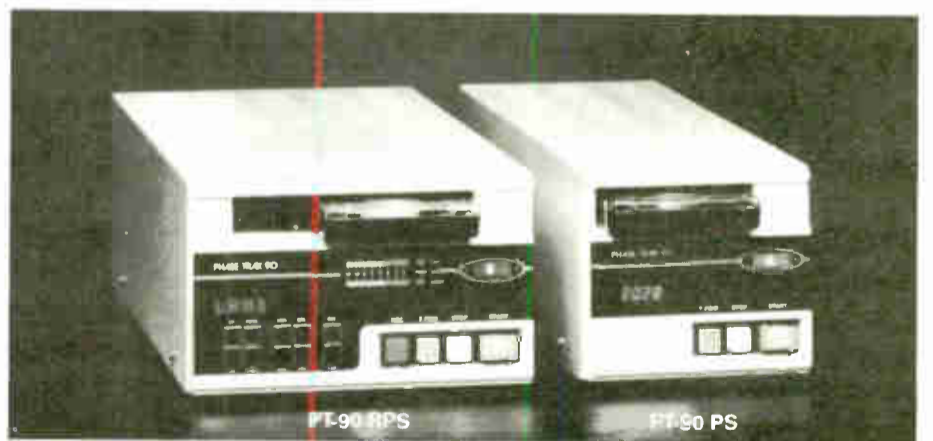

Superior Production and Playback Quality

The Phase Trak 90 Cart Machines from Broadcast Electronics guarantee you superior production and playback quality... no matter what brand of tape you use.

With such exclusive features as Tape Analysis with a "Learn" mode and Continuous, Electronic Phase Correction, Phase Trak 90 is raising the on-air standards of the industry.

For more information contact your Broadcast Electronics' Distributor or call Bob Arnold at 217-224-9600.

BE BROADCAST ELECTRONICS INC.

4100 N. 24th ST., PO. BOX 3604, QUINCY, IL 62305 (217) 224-9600. TELEX 250142. FAX (217) 224-9607

World Radio History

See Us At SBE Booth 420

Circle 98 On Reader Service Card

NEWS BRIEFS

Moseley Buys Back Moseley

SANTA BARBARA, Calif. A group of investors including senior management officials and company founder Jack Moseley have bought Moseley Associates from General Research Corp. (GRC) International.

According to Moseley Executive VP/CEO Jamal Hamdani the

ownership change should "strengthen Moseley Associates' position in the broadcast industry" domestically and overseas.

Facsimile Signatures Nixed by the FCC

WASHINGTON The FCC has upheld a Mass Media Bureau decision to dismiss four FM appli-

cations because the applications were found to have been "signed" electronically, a violation of the Commission's "hard look" rules.

The "hard look" approach was instituted to reduce the large volume of "carelessly prepared, abusive and speculative FM applications" being filed at the Commission. The FCC advised applicants that sections of the applications are "crucial for tenderability" and would not be subject to amendment at the close of the filing window if they were not filled out correctly.

In upholding the Mass Media's

decision, the Commission noted that "the original signature requirement provides assurance that the applicant has personally reviewed the applications and can be held responsible for the truthfulness and the accuracy of the statements."

Updated FCC Laws Publication Available

WASHINGTON Update of the Communications Act of 1934, including recent legislation enacted by the 101st Congress, is now available through the U.S. Gov-

ernment Printing Office.

Entitled "Compilation of Selected Acts Within the Jurisdiction of the Committee on Energy and Commerce-Communications Law," the 456-page publication includes the latest fee and fine schedules and various other laws affecting radio and television.

To order, send \$13 (check or money order) to Superintendent of Documents, Government Printing Office, Washington, DC 20402. To order by credit card, call 202-275-3030. The publication number is 052-070-06759-4.

NAB Names "Future" Committees

WASHINGTON The NAB has named radio and television committees that will examine the future of broadcasting including future technologies, public policy and business strategies.

The NAB announced its intention to create the committees in June, and indicated that the committees could make recommendations that could result in long term technology research via a permanently funded center, or funding for private research.

NewCity Communications Senior VP Richard Ferguson will chair the radio committee. Other members include: Charles Banta, VP of radio for Greater Media; Mark Bench, VP/GM for WSNR; Bill Clark, president of Shamrock Broadcasting; Jack Clements, VP of operations, Westwood One; William Fignshu, Senior VP of Broadcasting/Radio Division President for Viacom Broadcasting; Skip Finley, president of WKYS; William McElveen, president/GM of WTCB; Jim Thompson, president of Group W Radio; and Nancy Widman, president of CBS Radio.

Give Your Production People Some POWER!

THE SP-6 IS LOADED WITH FEATURES! Like a powerful equalizer section that gives your talent greater creative freedom; four auxiliary sends that can be used for special effects, headphone feeds, or IFB mixes; both 8-track and stereo bus assigns for multi-track and dubbing work; plus a choice of mono mic/line or stereo input channels. And, to keep things fast and productive, it even includes full machine control logic, control room and studio mutes, plus tally systems—just like you'd expect on an on-air console. The SP-6 provides independent headphone, control room and multiple studio monitors, and (of course) an automatic stereo cue/solo

system. Our unique track monitor section will speed your production pace, allowing simultaneous stereo mixdown during the multi-track bed session.

A powerful group of accessory modules will increase your production control, like a 7-station intercom module that links this console with other Wheatstone consoles and talent stations throughout your complex; a full-function tape recorder control panel; an 8-position source selector to enhance input capability; additional studio modules to accommodate multi-studio installations; and finally, a digital event timer and a precision clock.

So contact Wheatstone, the company with the integrity and experience you can count on.



INDEX

SBE '91 Show Preview	16
FCC Refines Its Fines by Harry Cole	20
Can I Put a Translator There? by Howard Enstrom	21
Shure Solves Open Mic Woes by Ty Ford	24
Recession Stops Short of KJZS by Dee McVicker	25
KinTel Initiates In-Band DAB by Steve Crowley	26
The Right Advertising Media by John Cummuta	28
Reliving the Radio Memories of Youth by Al Peterson	29
Workbench by John Bisset	31
Fax Modems Connect the World by Barry Mishkind	32
Appreciating Gold Dip Meters by Tom Vernon	39

Wheatstone Corporation

5720 Wilburton Road, Synovate, NC 27217 (Tel 315-255-7142 fax 315-434-6124)

Circle 60 On Reader Service Card

NAB Gears Up for Eureka L-Band Tests

Research Planned for Late October; May Go Longer Than Expected

by Judith Gross

WASHINGTON The NAB and its DAB Task Force have set aside two days in October to conduct tests of Eureka 147 at L-band frequencies, but the tests may go on longer than that to gather sufficient technical data, according to NAB Senior VP for Science and Technology Michael Rau.

Rau said L-band tests are slated to take place Oct. 20-21, in Washington D.C. As of late August, he said the NAB had not yet filed a request for the experimental frequency, but that it planned to do so in the weeks just prior to the Radio 1991 convention.

He said the tests would probably take place mostly in Washington, and that he had offers from several D.C. radio stations to let NAB use their towers.

Eureka modifies equipment

Werner Kohnert, a representative of Eureka 147, told RW that Eureka researchers were working on the equipment in anticipation of the L-band tests. Rau noted that currently, the Eureka 147 DAB prototype transmitter and receiver only operate up to 1 GHz.

While a final test plan has not been completed, Rau said that the DAB Task Force has looked at a preliminary plan and that he hoped the task force's Technical Advisory Group could design the test programs.

"We will have both stationary and mobile testing and look at both power levels and building and foliage attenuation,"

Rau said. "We may continue testing beyond the two days to obtain additional information," he added.

According to Rau, one of the problems is that few tests with criteria applicable to broadcasters have been done at the higher frequencies. Also, other propagation studies do not account for Eureka's method of using signal reflections.

"We can't use the CCIR 370-5 propagation curves for Eureka, because they don't take multipath into account. So we have to gather data and infer the propagation curves," he said.

Multipath may help

Rau said there is reason to believe that Eureka's way of making use of multipath signal reflections to strengthen the overall signal may actually result in less power needed than when broadcasting by conventional methods.

He said that feature may dispel the claims of L-band critics who claim that the power needed to broadcast at 1.5 GHz may be too high to be feasible. But, Rau acknowledged, even these L-band tests may not answer all the questions.

"We'll have much more accurate information, but I don't know that we'll absolutely answer them," he said. "It will be a first step toward designing an allocation system for Eureka at L-band."

According to Rau, no budget has yet been approved for the tests. He said the NAB's Executive Committee will consider funding at its next meeting.

The October L-band tests will be the first time Eureka 147, or any terrestrial DAB system, is tested at L-band. The quest for L-band remains up in the air while the FCC and the National Telecommunications and Information

EMCEE to Debut DAB

by Judith Gross

WHITE HAVEN, Pa. One of the DAB systems proponents scheduled to make a presentation to the NAB's DAB Task Force at the Radio 1991 convention declined the invitation because its equipment was to debut at the same time—south of the border.

EmCee Broadcast Products Inc., based in White Haven, Pa., is a manufacturer of transmitters for "wireless cable" TV systems, which use microwave distribution in the S-band region, at 2.5-2.7 GHz.

The company's VP, Perry Spooner, said General Instruments Digital Cable Radio service was set to begin experimental digital audio broadcasts in mid-September in Mexico City using EmCee transmitters.

He said the same transmitters used for wireless cable video can be altered for digital audio.

"The transmitter can accommodate about 20 video channels. If you take two of these channels and modify them, you can get up to 20 audio channels, ten per channel," Spooner said.

Spooner said General Instruments would supply the special receivers needed to decode the signal on the listener end.

"It's been licensed and approved by the Mexican equivalent to the FCC and the plan is to broadcast for three months. We supplied the transmitters," Spooner said.

He noted that the timing of the experimental service made it impossible for him to discuss it with the DAB Task Force. "I preferred to wait until the experimental service had begun," Spooner said.

Spooner added that he became interested in DAB when the FCC's World Administrative Radio Conference (WARC) advisory group first suggested S-band as a possible spectrum allocation for DAB.

Agency (NTIA) continue to discuss their differences.

The FCC has recommended that some L-band be allocated for DAB, but the

NTIA sides with the military in opposition to relinquishing the spectrum. The issue may remain in doubt until next year's WARC meeting.

Satellite Quality Audio...

COMREX, the leader in remote audio broadcast transmission via standard telephone lines, now sets the pace with satellite-quality audio transmission using standard dial phones or digital circuits. Since 1961, Comrex has been consistently delivering the most reliable equipment and personalized response to broadcasters world-wide.

COMREX gives you a choice of options:

- 1, 2 or 3 line frequency extenders with up to 8 KHz bandwidth on dial telephone service
- Digital Audio Codec systems for ISDN
- Plus . . . a full range of telephone interface products including couplers, hybrids and portable mixers

Performance so good, we invite you to try it before you buy it. Hear the difference for yourself.

by Telephone.

COMREX

Specialists in Remote Broadcast Audio Transmission

Comrex Ltd.
75 The Grove, Ealing, London, W5 5LL, UK
081-579-2743 / FAX: 081-840-0018

Comrex Corporation
65 Nonsset Path, Acton, MA 01720 USA
(508) 263-1800 / FAX: (508) 635-0401

The MOUSE That Roars . . .

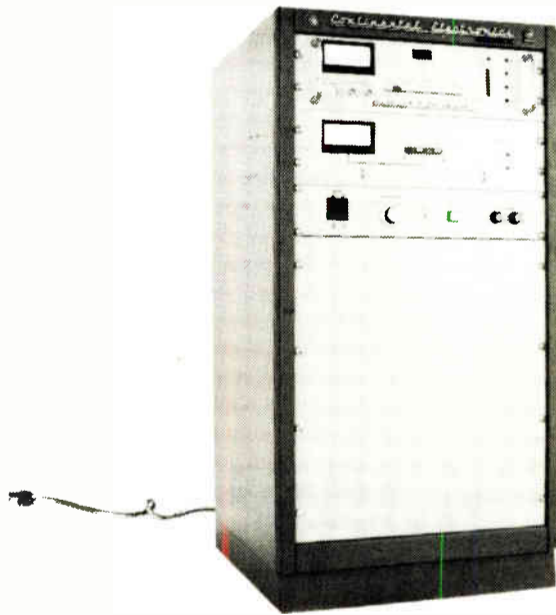

ONLY
3½ FEET
TALL

We all know that great things come in small packages. This 1 kilowatt FM transmitter comes complete in a 42" cabinet. Solid-state efficiency with a single phase power source and the ultimate 802A exciter.

FOR MORE INFORMATION, CONTACT



Continental Electronics Corporation

P.O. BOX 270879 DALLAS, TEXAS 75227-0879
214-381-7161 TELEX: 73-398 FAX: 214-381-4949

Surviving the DAB Tilt-A-Whirl

by Judith Gross

FALLS CHURCH, Va. Like *Buffalo Springfield* said: "There's something happening here . . . What it is ain't exactly clear . . ." Every time you turn around, the DAB scene goes topsy-turvy on you.

So first the NAB looks around, sees the hardware constructed by Eureka 147 and their eyes grow wide with wonder. Then they get this letter from Eureka that sounds like Monty Hall saying, "Let's make a deal."



But not so fast, royalty-face. Just about the time they get their Radio Board all hopping and jumping about how great this DAB stuff is—and let's face it, it's pretty great, you don't have to be an atomic scientist to figure that out—some rather large U.S. radio owners begin working on a digital system of their own.

These U.S.-developed systems use West Coast military technology, give digital signals to stations and, lo and behold, you don't need any new spectrum for it, unlike Eureka, which, despite its many benefits, is somewhat of a spectrum glutton.

But all this doesn't stop the NAB from jumping feet first into the great big DAB pool (which, as anybody who's been swimming in it lately knows, is chock-full of alligators).

They figure an ounce of hardware you can license is better than a pound of systems that aren't built yet, so next thing you know we got the Radio Board endorsing a European technology, a scant one year before the NAB plants permanent roots into Europe with a radio convention, not coincidentally.

But hold the phone, we're not finished

yet. In fact, we're just getting warmed up. Next comes a very credible showing from Project Acorn, and although it may not be moving along as soon as some techno-rats desire, it opens the door to a new concept: Anything you can do I can do better.

Next we got in-band systems coming out our ears: for FM but not AM, for AM but not the same quality as FM, for AM and FM but on the FM band. You name it, it's in there.

At the same time, that all-precious and scant commodity, the spectrum pie, is being sliced into more and more and nobody wants to give up the piece already on their plate. So the possibility of getting the extra spectrum Eureka gobbles down begins to seem more and more like a remote dream.

But this doesn't stop the NAB from pushing Eureka, negotiating a licensing agreement, going after L-band spectrum and continuing to pooh-pooh the idea of in-band systems, which Eureka engineers say point blank won't work.

What does make NAB kinda stop and think, however, is its own members writing letters to the FCC opposing their DAB policies.

That, and some pointed criticism during a Radio Operator's Caucus meeting finally makes good ole NAB take a deep breath and do what a lot of folks think they shoulda done all along—open the doors to equal consideration of all systems. Or do they?

Now all wounds are healed and everybody is cozy, because everybody tells you it's that way and so it must be so. But wait a minute. NAB is still going after L-band. Hmmm. They're still negotiating an agreement with Eureka. Hmmm.

Now they get Canada and Mexico in on the licensing deal. Hmmm. And NAB funded the Eureka demo at Radio 1991 and is doing L-band tests of Eureka. Hmmm.

And finally, we come full circle, because, NAB now asks Eureka to go develop an in-band DAB system to put both AM and FM stations on the FM first adjacent, in effect, supporting a European company's technology over the same U.S.-

developed technology. Hmmm.

What about all the declarations from Eureka that in-band won't work? Well, NAB says, "Oh, did we say in-band? No, we meant narrow-band. Yes, that's it."

"But what band will you put it on?"

"FM, in the first adjacent, for AM and FM stations."

"So you do mean in-band, right?"

You figure it out.

I'd like to bring you some reaction to all this from industry insiders and other in-band folks, but—I'm not making this up—everybody I called for a quote was too stunned to give me one.

The best I can say is that some nostalgic souls among us pine for the days when we could look to our industry-

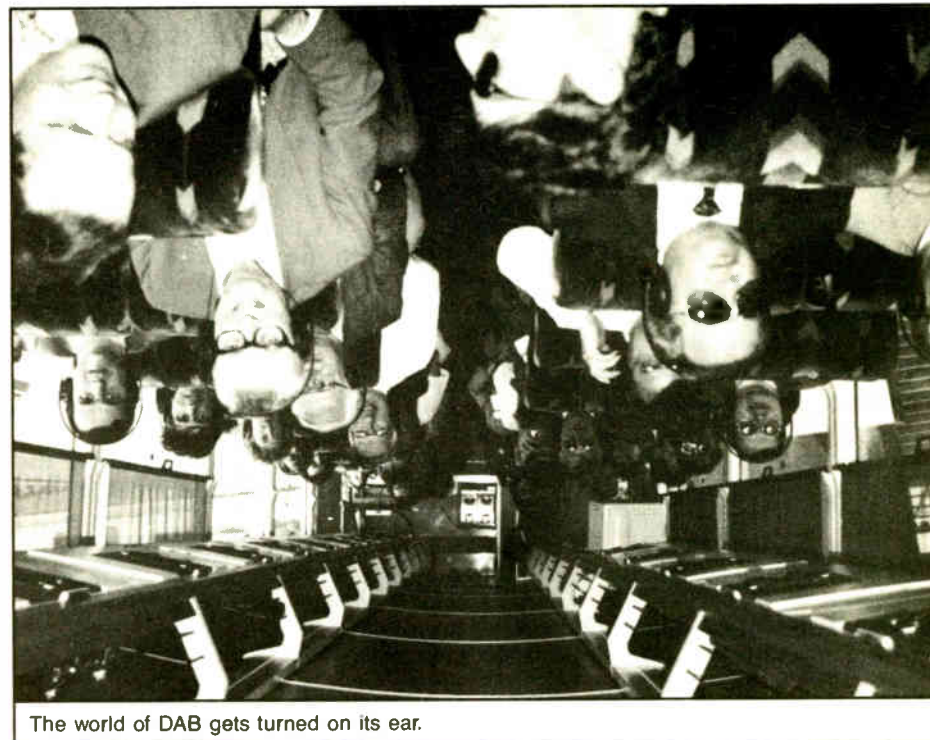

The world of DAB gets turned on its ear.

"Oh well, if you want to be a stickler for details . . ."

Course, I don't know why these new wrinkles never fail to astound me. After all, I do remember back before the NAB spring convention, at the Annenberg seminar on DAB, when Acorn first revealed its system.

Mere moments later, the Eureka folks got up and started talking about narrowing their bandwidth by increasing the error correction, etc. Now who's zooming who? Did they learn a few tricks from their American counterparts, if only that there's a way to: "Promise 'em anything, but give them Eureka?"

funded institutions for some impartiality.

Yes, everyone admires a bold, aggressive leadership stand. But if you take that stand out on a limb, I hope you've tested the strength of that bough and taken a good look at the critters lingering beneath. And better pray that nobody comes along with a chain saw, while you're at it.

■ ■ ■

Have a juicy tidbit, wisecrack, rumor, innuendo or something silly to say? Spill those guts out to Earwaves by faxing JG at 703-998-2966, writing to P.O. Box 1214, Falls Church, Va. 22041, calling 703-998-7600, or whispering to the wind. Maybe there's an RW mug in your future.



Get on the right track...

Unattended operation helps you operate your station profitably. All it takes is a satellite or automation program source, a good transmitter control system, and a way to handle EBS.

You take care of the program source... We'll help with the rest.

A transmitter control system from Burk Technology relieves you of the need to keep someone at the station just to take transmitter readings. Add our exclusive Studio I/O and we'll run EBS for you, too.

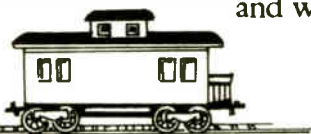

Burk gives you the flexibility to run your station the way you want, and in full compliance with FCC rules.

Call us now. We'll show you a new way to run a railroad.

TOLL FREE 1-800 255-8090

BURK

TECHNOLOGY

7 Lomar Drive, Pepperell, MA, 01463 (508) 433-8877

READERS FORUM

If you have comments for *Radio World*, call us at 800-336-3045 or send a letter to Readers' Forum (Radio World, Box 1214, Falls Church VA 22041 or MCI Mailbox #302-7776). All letters received become the property of Radio World, to be used at our discretion and as space permits.

More on Fessenden

Dear RW,

I was pleased to read about the work of Mr. Reginald A. Fessenden (RW, Aug. 7, 1991). The only "error" noted is the reference to Morse Code operating at under 100 cycles per second. This may have been meant to read 100,000 cycles per second. During the 1906 period, Morse Code was being sent by "non-continuous" arc transmitters. Each spark excited an oscillation in the antenna and related components. This resonance would decay quite rapidly while awaiting the next excitation spark. The resonant frequency used varied widely. Today "experts" cannot even agree on who used what frequency when!

Had Mr. Fessenden received quick delivery on his initial order for a 100,000 cycles per second alternator in 1900, history would have been quite different. He would have had very few, if any, listeners capable of hearing the voice and music. Many ship and shore stations were operating in 1900, but the detector in use would not demodulate a voice signal. The coherer which was widely used at that time would

respond to a signal by becoming conductive. It would stay in a conductive state until mechanically vibrated, "tapping back."

The coherer was discovered in 1878 by David E. Hughes, in 1889 by Oliver Lodge, and in 1890 by Edouard Branly. In 1894 Mr. Lodge demonstrated a wireless system to the British Associations for the Advancement of Science, using an improved coherer. Mr. Lodge claimed to have been successful for a distance of one-half mile with this system. In 1896 Guglielmo Marconi patented another improvement in the coherer.

It was Mr. Fessenden in 1902 who developed the "electrolytic detector," which was capable of demodulating a voice signal. This device, which was patented May 26, 1903, resembles the "electrolytic rectifier" discovered in 1899 by Michael Pupin. Similar devices were invented by W. Schloemlich in Germany and G.A. Ferrie in France.

The crystal detector was also discovered: carborundum by General Henry H.C. Dunwoody in 1906, silicon by G.W. Pickard at about the same time. Galena and iron pyrites were also discovered to function as detectors. All of these detectors offered improved sensitivity over the coherer and made demodulation of the voice signal possible.

Mr. Fessenden's slow receipt of his order not only allowed more receiving stations to be built, but it also enabled them to have detectors that would demodulate the signal.

The prior notification to others and the availability of "modern detectors" caused the 1906 test to become a "scheduled broadcast" instead of a "private test."

Larry Albert
Murray State University
Murray, Ky.

Support for rotating SBE venues

Dear RW,

After reading the article in the August 7 RW entitled "SBE Site-Hopping Opposed," I have to speak my mind.

Keeping the convention site in the same location each year, as some of the manufacturers appear to be demanding, will result in the same people coming every year. These people will consist of mostly major market and corporate engineers, and medium market engineers within driving distance. By locating the convention in equal rotation from east to central to west, more engineers—hence more manufacturers—will be served. To the "big guys" there is no additional cost with the rotating schedule because the higher cost for the most distant convention will be offset by the reduced cost of the nearest convention. The "little" and "medium" guys will be able to attend at least once every three years.

Another thought for the manufacturers who appear to be throwing their

The SBE has worked hard this year to bring a solid schedule to Houston for its annual convention. SBE '91 will be a worthwhile event, and engineers should show their support by attending.

Still, a tough question needs to be asked. Past SBEs have been marked by attendance more in line with a regional than a national show, and exhibitors are wary about the effects of moving the event to cities not on the top of anyone's list.

As one company noted, "Success is the best way to lure us to a show." With conventions, success is measured by attendance.

So what can the SBE do to entice more of its members to the show?

It seems that a full slate of sessions, scheduled so as not to conflict with exhibit hours, hasn't been enough. Perhaps the SBE should consider moving the convention once more—this time, from one season to another. Say, the late summer.

New Move For SBE?

Why? Let's look at the facts.

The fall (especially September and October) has turned into "Gathering Time." Every special interest group in broadcasting has a convention, seminar or symposium, and most have exhibits as well.

Exhibitors, thus, are spread pretty thin in the fall—not to mention how grueling it is for companies to tie these events together in an endless autumn chain.

What's more, many of these shows expect to draw from the same pool of potential visitors. A year hasn't gone by recently when one of these shows hasn't conflicted with some other, similar event.

Attendees, in turn, are forced to create a budget item that they sit on most of the year, then spend in two big bursts—and they really get hit hard in the fall. That's not good management of *time*, let alone money.

With the convention in the summer, competition would be minimized. Also, if it were staged at a venue with a more resort-like setting, and more social events were scheduled, SBE members might include the Convention as part of their vacation plans.

The SBE convention deserves support no matter when or where it's held, but it needs more than education alone as a hook to attract attendees. It needs less competition and more pizzazz.

By moving the show to a place people want to go to, and by changing the mix of events to add more fun and camaraderie, the SBE could see improved attendance and more exhibitor interest.

—RW

Radio World

Vol 15, No 18 September 25, 1991

Editor, Alex Zavistovich
Editorial Consultant, Judith Gross
International Editor, Alan Carter
Associate Editor, Charles Taylor
News Editor, John Gatski
Assistant Editor, Debra Green
Reporter, Frank Beacham/N.Y.
Technical Editor, John Bisset
Technical Advisor, Tom McGinley

Production Director, Kim Lowe
Julianne Stone, Lisa Roach, Lisa Stafford
Ad Production Coordinator,
Regan Deatherage

Publisher, Stevan B. Dana
Associate Publishers, Arthur Constantine
Carmel King
Marketing Consultant, Albert Leon

Ad Coordination Manager, Simone Mullins
Circulation Director, Tiana Hickman
Circulation Manager, Rebecca Seaborg
Accounts Receivable, Valerie Mason

Advertising Sales Managers:
Eastern U.S., Art Constantine
800-336-3045, Fax: 703-998-2966
West & Midwest U.S., Jack Ducart
916-962-2240, Fax: 916-962-2194

Radio World (ISSN: 0274-8541) is published semimonthly by Industrial Marketing Advisory Services, Inc., 5827 Columbia Pike, Suite 310, Falls Church, VA 22041. Phone: 703-998-7600, Fax: 703-998-2966.

Second-class postage rates are paid at Falls Church VA 22041 and additional mailing offices. POSTMASTER: Send 3579 forms and address changes to Radio World, P.O. Box 1214, Falls Church VA 22041. Copyright 1991 by Industrial Marketing Advisory Services, Inc. All rights reserved.

Free subscriptions are available upon request to professional broadcasting and audiovisual equipment users. For address changes, send current and new address to RW a month in advance at the above address. Unsolicited manuscripts are welcomed for review; send to the attention of the appropriate editor.

Next Issue
Radio World
October 9, 1991

weight around is that many engineers may be left with a bad taste in their mouth regarding those manufacturers' opposition to the engineers' organization's attempt to better serve the membership. Compound that with the lack of presence at the show, and I don't see how they (the manufacturers) can expect anything but reduced sales.

Michael E. Settles, CE
WJQI-FM/AM
Virginia Beach, Va.

AM stereo report card

Dear RW,

In going through some old clippings recently, I found an article from RW which had featured our station's conversion to AM stereo in your edition of April 6, 1986.

Perhaps by sharing our station's report card since that time we may be of benefit to some fellow broadcaster who has not yet made the transition.

Since beginning AM stereo in February 1986, WZKY has continued a constant promotion of the stereo. All our station ID material identifies us as AM Stereo 1580 WZKY. All print ads and visual materials are done the same way. We've continued to recruit and utilize car dealers in pointing out our stereo broadcasts. Listeners have given testimonials about how good it sounds. In brief, AM stereo has become as much a part of what we do as anything.

The end result has been most gratifying. Research shows that people in our marketplace perceive us as an AM station with a superior technical quality. Even listeners with existing mono radios say they can tell a difference in our audio compared to other stations. (This of course is due to audio processing, but it doesn't hurt a thing.) Recently a lady came driving into our

parking lot. She was a listener who bought a new car and was listening to WZKY on the way home. She heard us play a Mamas and Papas song and was so thrilled by the separation and quality of her Chrysler AM stereo that she had to have us come out to the parking lot to hear the receiver!

While your success as an AM broadcaster is certainly going to be dependent on all that you do, I can tell you that AM stereo has enough penetration today to be an important factor. For WZKY, it has been a profitable investment that I would easily do again!

WZKY utilizes the C-QUAM system with an Optimod audio processor coupled to a new Harris Gates One transmitter. By the way, we began with a converted 1940s Raytheon RA-1000 that also sounded great! Our total investment in converting to stereo in 1986 was about \$30,000. Costs included the BE AX-10 exciter, Motorola mod monitor, BE stereo consoles and other related items.

To sum up our report card . . . yes, it works! Excusing me for remaining a little bit of a dreamer, but if all my fellow broadcasters would get AM stereo on the air, I believe we would see more demand for home and portable receivers. And, after all, isn't it better to control your own destiny than to wait for others to exercise control?

We at WZKY don't know all the answers or even all the questions, but we do know that AM stereo in combination with good programming, a good sales effort, and heavy involvement in one's community is a formula that works. We will be happy to share information we've learned with anyone who would like to know more.

Bill Norman, President and GM
Radio Station WZKY
P.O. Box 550
Albemarle, N.C. 28002-0550
Phone: 704-983-1580
Fax: 704-983-1436



FINANCIAL AID

OTHER SOURCES MAY HAVE DRIED UP. THAT'S WHY WE'VE BEEN WORKING WITH OUR FUNDING INSTITUTIONS TO LINE UP LEASE FINANCING FOR YOU TOTALING

\$37.6 MILLION*

WE'VE GOT THE EQUIPMENT

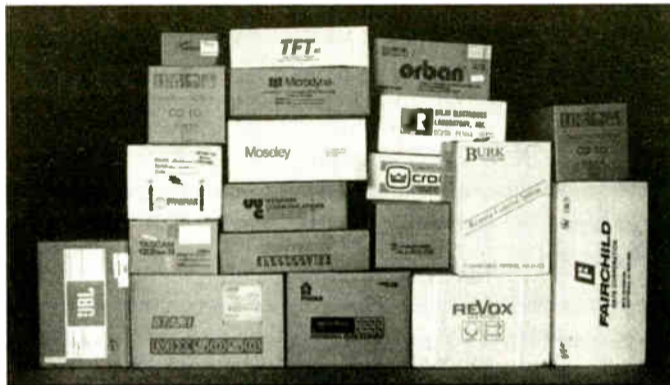

AND

THE MEANS FOR YOU TO HAVE IT



MAKE SURE YOU GET YOUR SHARE!

*AVAILABLE TO QUALIFIED APPLICANTS THRU 3/31/92



FAX 317-966-0623

800-622-0022

IN CANADA 800-268-6817

Plans for Radio 7 Continue

by Alan Carter

GILLETTE, Wyo. The political upheaval in the U.S.S.R. is not stopping a Wyoming businessman from continuing his plans to put a contemporary commercial FM station on the air in Moscow this year.

Instead, Ben Doud, president of Top 40 KGWY-FM, said he is more optimistic about the long term for the operation, which will be called Radio 7.

In May, Doud finalized a 50-50 partnership with the Soviet government to build and operate Radio 7 from Moscow, with the option to establish another station in Leningrad (or St. Petersburg, as its citizens have begun calling the town).

Radio 7 will broadcast at 60 kW around the clock and is scheduled to begin operations Oct. 1. The deal was initiated when a video company Doud also owns was in the U.S.S.R. filming for Rand McNally.

"We were constantly reassured by our Soviet counterparts that the coup would have no effect on what we are doing," Doud said. "We believe it bodes well for us. We are looking forward to more open relations."

The only effect Doud suggested was how the events may have slowed production of the Russian-built transmitters.

While not revealing any names, Doud said he has signed contracts with international advertisers, none of whom wanted to cancel immediately after the attempted coup.

Doud said he believes that no matter who is in control in the Soviet Union, they will want to conduct business with the West to help the nation's economy. The benefit to that nation from Radio 7 is that advertising will be purchased in U.S. dollars, giving the government money to trade on the international market. The Russian Ruble is not exchangeable.

"It's a gamble any time you make a business investment," Doud said. "Without any question, the rewards are equal to the risk. We're walking into a market of 16 million people with the only 24-hour-a-day independent frequency in existence there."

Doud said an operational policy will be in place for the staff if there is a political uprising once Radio 7 is on the air.

"I think the key element is we don't intend for our people to be in danger," he said. "We will not become a puppet. Our people will be instructed not to put themselves at risk."

"I guess I would be curious to know what would have happened to us if we had been on the air at this time," he added.

World Band Plays Role in Coup

(continued from page 1)

radio transmitter located in his office.

The transmissions were picked up by outside news agencies and beamed into the Soviet Union through Russian language broadcasts.

Even newly independent Soviet broadcasters got into the act. Moscow Echo, a radio voice the Kremlin coup leaders tried to silence, went on and off the air repeatedly during the crisis. On the first day of the coup, KGB agents took control of the station's studio. Within a day the station was back on the air, broadcasting from the Russian Parliament building.

Then the phone line to its remote transmitter was cut. After the line was restored, paratroopers supporting the coup confiscated the transmitter. An impostor station, claiming to be Moscow Echo, went on the air with propaganda supporting the coup. But within hours, the real Moscow Echo was back on the air, this time to report that the coup had collapsed.

When President Bush was finally able to reach President Gorbachev by telephone, a news photo showed the American president in the bedroom of his Kennebunkport, Maine, vacation home. Beside him was a Sony ICF-2003 portable world band radio. "The president listens to the radio all the time," a White House press spokesperson said.

An unexpected endorsement

In a news conference after release by his captors, Gorbachev told the world the role radio played in his days of captivity. "Everything was down, but we found some type of old receivers in the maintenance rooms, and we fixed the antennas—there were some smart guys (among his personal guards) who know something about this—and we began to get whatever we could from there," he said. "We got the BBC best of all."

The BBC Russian Service that Gorbachev heard in the southern part of the Soviet Union originated in London and

was transmitted in Cyprus.

"It was a tremendous feeling of recognition for all the hard work," said David Morton, director of BBC Russian Services. The service has a staff of 55 Russian natives based in London and was supplemented by stringers in the U.S.S.R. and BBC correspondents.

The recognition could not have come at a better time for shortwave services, when some governments are considering curtailing the operations as the Cold War ends. But Morton has a word of advice: "They are extremely expensive insurance policies. And until someone finds a better way, it is an insurance premium we will have to pay."

While direct broadcast satellite (DBS) radio could be a replacement, Morton stressed that the new technology is at least 10 years away from implementation.

The role outlined

Shortwave broadcasters, both stations and amateurs, played a vital part in the failure of the coup attempt, said Stephen F. Cohen, a professor of politics and director of Russian studies at Princeton University.

"Yeltsin and the Russian Parliament had a problem of communicating with the people of the country because the coup makers were taking over the airwaves and the newspapers. It was through shortwave that the foreign correspondents in Russia were broadcasting out and it was being broadcast back in on shortwave," Cohen said.

"Almost everybody (in the Soviet Union) has shortwave receivers, certainly in the cities," Cohen continued. "They used shortwave before 1985—before *glasnost*—to pick up more information from abroad because of censorship. Everybody was listening to their shortwave radio."

Some models of shortwave receivers, now commonly termed "world band" radios, can receive both broadcast services and amateur communications, said Jock

Elliott, associate editor of "Passport to World Band Radio," a yearly publication for world band listeners.

"An AM signal is a carrier and two sidebands. The broadcasters use the carrier and the amateurs just send on a sideband. So if a radio can receive sideband signals, it can receive both world band and amateur broadcasts," Elliot said.

World band receivers can be purchased for as little as \$29, Elliot said, and are common throughout the world, especially in countries where censorship is prevalent. "This is reminiscent of the old deep, dark days of the Cold War when they tried to tightly control what the local populace heard and to jam what was coming in from the outside," he said. "In most coups, the first thing they try to do is seize control of the media to keep the people in the dark."

Renewed interest

Since the Persian Gulf war, sales of world band radios have exploded, Elliot said, noting that many now want to hear more diverse opinions concerning world events.

"If you have Americans reporting world events you are getting things through the American filter," he said. "When you hear an event reported through Radio Netherlands or another service you heard it through another kind of filter. In a sense, you can say everybody is broadcasting propaganda but it's their propaganda. By listening to diverse sources you can make your own decision about what is true or not."

Elliott noted that, even with all the high technology communications available in the world today, world band broadcasting has proven its value in still another international crisis.

"Despite all the satellite technology," he said, "when it gets right down to the crush the ability to send a signal out and bounce it across the ionosphere is what people rely on in a tough situation."

Your Problem Solvers

from **ATI**



- Mike
- Line
- Phono
- Mixing
- Matching
- Metering
- Monitoring
- Processing
- Distribution
- Rack Mounting

AUDIO TECHNOLOGIES, INC.

328 W. Maple Ave., Horsham, PA 19044 • (215) 443-0330 • FAX (215) 443-0394



SCI Creates DATA Group for DAB

by Judith Gross

HAMMOND, La. Strother Communications Inc., which entered the DAB arena last year as a DAB systems proponent, may be poised to move from a neutral position and become a backer of an in-band system.

SCI President Ron Strother announced that he has formed a technical alliance to investigate in-band DAB technology and develop a system that meets certain implementation and technical criteria. The team's name is the Digital Audio Technical Alliance—or DATA group.

"The problem with in-band technol-

ogy to date is that it's not being developed as quickly as I thought it would," Strother said.

To investigate the technology, Strother has enlisted the resources of three broadcast firms: transmitter manufacturer Broadcast Electronics (BE); LDL, a member of the LeBlanc group which manufactures towers and antennas; and the engineering consulting firm du Treil, Lundin & Rackley.

But the three were hesitant to characterize their involvement in the DATA Group.

Just exploring

"We're not really a part of the alliance," said BE President Jack Nevins. "What

we're willing to do is provide technical assistance and resources to investigate DAB technology."

"We're neutral on DAB; we're collecting information on DAB because we want to stay on top of developments," the company's VP of Engineering Geoffrey Mendenhall added.

LDL officials said the company is participating in the alliance at this point. "We're part of the alliance while it's in the investigative mode," noted Jim Wilson, president of LDL. "We're in it to keep abreast of what's going on. We're prepared to participate with equipment if necessary."

Ron Rackley, a partner in du Treil, Lundin & Rackley, pointed out that SCI has been a client of the firm in matters pertaining to DAB. "Right now, we're in this for the good of the industry. We also think it serves the interests of our clients," Rackley said.

Strother has designed an in-band DAB approach that he says would accommodate both FM and AM stations—on the FM band. He has set up technical criteria for such an in-band system, including the successful mitigation of multipath, meeting existing separation criteria, tolerating on-channel boosters and providing similar coverage as existing contours.

He called these tasks "formidable," especially the elimination of multipath, which he does not believe can be done

on the existing AM band. He said putting both AM and FM on an in-band system using the FM band is the solution, despite the opposition that may arise from FM broadcasters.

"Any system that does not provide AM with a true digital signal is not acceptable. How can you relegate AM stations just to the AM band when the alternatives haven't been explored?" Strother added.

In search of technology

Strother said he hopes to have something ready to show to the industry, in prototype form, at next year's spring NAB convention. "If you don't have a prototype by April of next year and a booth demonstration by next September then you aren't a player," he said.

But if Strother becomes a DAB system proponent again, it may put the companies providing resources for the DATA group in an awkward position.

"We're customer- and needs-driven; if a system is embraced by our customers, then our job will be to provide the equipment to implement it," Mendenhall added.

"We're not sure what will happen if Strother backs a DAB system," LDL's Wilson said. "We just want to go through the investigative process for now."

Rackley pointed out that du Treil, Lundin & Rackley is hired by many radio groups, some of whom may be involved in systems already being proposed. "We certainly have no intention of going into competition against our own clients," he added.

**TAKE
THE
LEAD**
WITH HARRIS ALLIED

**IT'S A COMPLETE
DUBBING FACILITY
IN A BOX!**



FAST TRAC lets you make dubs without tying up your production studio. It's a "one-pot board" with the input selection, gain control, and monitoring functions of a console. Connect a CD player, R-DAT, turntable, and cart recorder to dub carts with one-button ease. Automatic recorder timing produces tightly cued carts every time with no guesswork! Built-in test oscillator, multi-mode recording, processor insert ability. It's like adding another studio for a fraction of the cost! In Stock.

**HARRIS
ALLIED**
BROADCAST EQUIPMENT

FAX 317-962-8961

800-622-0022 IN CANADA 800-268-3817

With expanded staff and services... our lead keeps on growing!

HARRIS ALLIED ©1991

"Call me, I'm interested." Circle 25.

"Send me literature." Circle 81. See Us At SBE Booth 822

World Radio History

Circle 50 On Reader Service Card

PROOFS IMPROVED

FM and TV-BTSC AUDIO PROOF TESTING is reduced from hours to minutes with System One from Audio Precision... Automatic proofs run properly at constant deviation, plotting the required generator amplitude... and when finished, the results are stored in graphic form for your records.

SPLIT SITE proofs are simple with System One's available separate generator and analyzer configuration. With immediate capability to view and control both instruments, it's like being in two places at once.

THE REST OF THE TIME System One is the universal audio test set for maintaining any audio device or channel... STLs, consoles, carts, cassettes and RDATs, digital recorders and workstations... System One is the only product that can completely test both your analog and digital audio.

Call 800/231-7350 for our 36 page color catalog... and when you're ready our representative will arrange for an on-site demonstration.



**Audio
precision**

P.O. Box 2209, Beaverton, OR 97075
503/627-0832, 800/231-7350
FAX: 503/641-9806
TELEX: 283957 AUDIO UR

FCC Tries Inspections by Mail

by Alex Zavistovich

WASHINGTON Someday soon your station may get a surprising package from the FCC—a do-it-yourself inspection by mail.

The FCC's Field Operations Bureau (FOB) is looking into whether such self-inspections are useful in determining broadcasters' compliance with Commission regulations. Preliminary test results have been encouraging, according to the bureau.

FOB Chief Richard Smith said inspections by mail—which have already been tested on the West Coast—are a response to the FCC's decreased general operating budget, which has affected the FOB.

"We used to send inspectors to stations

and lighting), certifications and additional information.

One of the things the FCC concentrated on most in the test survey was to "get across believable assurances that you wouldn't get your name on a list and be targeted for inspections just because you sent back the results," Smith said.

Broadcasters were assured that in reviewing the results the FCC was only interested in achieving compliance, he added. Stations would not be penalized, and no notices or fines would result from the self-inspection. Stations were expected to correct any out-of-compliance situation.

"Most broadcasters are responsible people," Smith added, noting that the FOB still intends to do "a few" random field inspections. If stations are still found to be out of compliance, "appropriate sanctions" would be imposed at that time.

Small survey sample

Only nine surveys were sent out as a test, according to Smith, because the government has regulations on sending out "survey instruments." The rules apply to surveys of 10 or more, which accounts for the small test sample.

Still, based on results of the test, Smith said the FOB intends to pursue the concept of self-inspections. "We received favorable responses," Smith said. A number of stations called or wrote letters to the FOB, indicating that the idea was "well-accepted."

Marvin Collins, CE of KFI-AM in Los Angeles, said he received his survey booklet in early May. He commented that the self-inspection was "a good idea, because it forced us to go and find things we don't always have at our fingertips."

The survey took six or seven hours to complete, Collins said. He pointed out, however, that KFI is a 50 kW clear-channel non-directional, so he was able simply to cross out sections pertaining to directional stations.

"If we were a directional, the whole thing would have taken a lot longer to fill out," Collins added.

Richard Rudman, CE for KFWB in Los Angeles, agreed, noting that "the first time through is time-consuming," but he added that "once that's done, the work for any future inspections has also been done."

Rudman cautioned that while self-inspections are "an excellent way for the FOB to address its problems," there is the possibility that contract engineers who work with several stations "may not

have the time" to fill out the questionnaire properly.

As to implementation of future inspections, the FOB still is trying to satisfy the federal statute on surveys, according to Smith. He estimated that nationwide self-inspections may begin as early as the "fall or the early part of the next

calendar year (1992)."

Inspections by mail will help the FOB do its job the way it prefers to, Smith noted. "We've been known as the enforcement branch, but compliance is what we're really after," he said. "We'd rather achieve compliance through education than by imposing fines."

FCC inspections by mail are a result of the FCC's decreased operating budget.

at least once every three years. But as our resources have gotten slimmer, we've shifted much of our focus to running down interference to safety services," Smith said.

"Over the years as resources have dwindled, and with no expectations of having the resources renewed, we've had to come up with other ways to assure compliance, determine levels and provide enforcement and education," he noted.

A West Coast idea

Smith said the idea to have stations inspect themselves came from one of the West Coast offices (inspection materials credit the Los Angeles office in Cerritos, Calif.). The FCC developed a draft inspection booklet that was sent to nine broadcasters on the West Coast.

FCC Public Affairs Specialist Michael Ritter of the Los Angeles Field Office helped compile the survey results. Ritter said five booklets were sent to stations in Los Angeles; the others went to broadcasters in San Diego, San Francisco and Douglas, Ariz.

The inspection booklet is divided into eight parts: station documents, station records, the Emergency Broadcast System, technical requirements, operating parameters, antenna structures (painting

THE BIGGEST PENNY PINCHER IN RADIO SINCE JACK BENNY.

Mr. Benny certainly knew a great bargain when he made one. And we think he'd appreciate the brilliance of the bargain-priced Tascam BR-20 Broadcast Production Recorder.

The BR-20 is built to do one thing—broadcast production—and to do it exceedingly well. It's a rugged, reliable 2-track with features that make every job easier and more efficient. Like independent reel-size selection. Splice block. Built-in monitor speaker. Independent L/R record for monitoring on one track while recording in sync on the other for overdubs and voiceovers. Fader start. And Quick Cue with Auto-Repeat.

The \$2,299* BR-20. It's got everything you need in a broadcast production recorder. Including a price even your station manager can live with.

Come see it today at your nearest Tascam dealer.

TASCAM®



© 1990 TEAC America, Inc., 7733 Telegraph Road
Montebello, CA 90640 213/726-0303.
*Manufacturer's Suggested Retail Price.

FM & TV RF Transmission Products

We manufacture solutions for your RF component requirements

- Hybrids/Combiners
- Directional couplers
- Power dividers
- Coaxial line
- Filters
- Constant impedance or branched transmitter combiners
- FM & TV duplexers
- Dummy loads
- Harmonic filters
- Bandpass filters
- Notch filters
- Antennas
- Waveguide
- Transitions
- Impedance matchers
- Coaxial switches
- Power couplers

Expert Field Engineering Services

Call, write or circle our Reader Service number for further information on complete RF systems

-RFT- RF TECHNOLOGIES CORPORATION

238 Goddard Road • Lewiston, ME 04240
1-800-634-4075 207-777-7778 FAX: 207-777-7784

Circle 69 On Reader Service Card

Circle 5 On Reader Service Card

Simon Concert Uses Digital Link

by Frank Beacham

NEW YORK As Paul Simon sang, "These are the days of miracles and wonder" to the sea of humanity in Central Park Aug. 15, he might well have been referring to the awesome arsenal of technology that beamed his music to millions of radio and television receivers throughout America.

On Westwood One's 200 station radio network, the music from Central Park traveled a path so complex—and so seemingly risky—that even some of the backstage engineers were in awe as they tried to explain it.

Through the maze of 750,000-plus spectators, 500 policemen, 160 portable toilets and dozens of television cameras snaked miles of cable, each critical to some piece of a giant technological puzzle.

Tons of equipment

Just as some concert-goers made new friends, several technologies also met for the first time in Central Park. Dolby Surround met apt-X 100 compression technology for the first time and seemed to hit it off.

Digital audio microwave had an encounter with New York's forbidding sky-

line of skyscrapers and struck up an instant friendship.

Backing Paul Simon on the towering 60'x40' stage at the end of the Great Lawn were 17 musicians with instruments ranging from an Akai EWI Wind Synthesizer to clay pots and the jawbone of a mule. Each of the 96 stage microphones were split three ways: sound reinforcement in the park, stage monitoring (20 discrete stage mixes—a new record) and recording/broadcast.

The recording/broadcast feed was routed into Effanel Music's 45-foot mobile mixing suite parked behind the stage. Using a Solid State Logic console and four Sony 12-channel auxiliary boards, the music was mixed and sent to two Sony 48-track digital tape machines and into a second mixing truck owned by Unitel Video.

In the Unitel truck the signal was encoded with Dolby Surround (four channels: left, right, center-front and rear folded into two-channel stereo) and fed to HBO for the television audio feed and to a third mixing truck behind the stage for the production of Westwood One's radio feed. Announcer commentary and

commercials were mixed with the feed by Westwood One in Central Park.

At this point another new—and still experimental—technology came into play. Westwood One rented a new mobile production truck that transmits digital audio with a conventional microwave remote pickup system.

Designed as a collaborative project between New York's WQCD Radio and LNR Communications, a Long Island-based terrestrial and satellite communi-



Paul Simon backstage prior to his August concert in New York's Central Park.

cations company, the mobile unit was constructed and is operated under an experimental license from the FCC.

Compressing Rhymini' Simon

Operating as a microwave link on C-band frequency (6.4 to 6.5 GHz), WQCD's remote truck uses LNR's DAV-SAT terrestrial modulation hardware with a 4-to-1 data compression system developed by Audio Processing Technology (APT), a subsidiary of Solid State

(continued on page 15)

**TAKE
THE
LEAD**
WITH HARRIS ALLIED

SOLUTIONS



TO
SKIPPING
DISCS



TO
SKIPPING
DISCS

The combination above solves CD-Direct-to-Air problems. Your CD is permanently housed in a carrier that keeps out all those things that damage your library. Fingerprints, peanut butter, hair, spike heels and chair casters don't stand a chance!

The CD remains in new condition which allows our new AudioMetrics CD-10 to play flawless digital music to your listeners.

The AudioMetrics CD-10 is available NOW. It's a generation better.

THE SKIP ELIMINATORS

**HARRIS
ALLIED**
BROADCAST EQUIPMENT

FAX 317-966-0623

800-622-0022

IN CANADA 800-268-6817

HARRIS ALLIED ©1991

"Call me, I'm interested." Circle 7.

"Let's Talk Radio & TV One to One at Houston SBE Booth 916"

"Send me literature." Circle 38.

World Radio History

Ellason E250 Color Radar

Real-time local radar coverage for your entire audience.



- Detects snowfall as well as rain and thunderstorms.
- Five selectable ranges up to 200 miles.
- Operator selection of antenna tilt, receiver gain, two separate graphic overlays, and automatic operations.
- Optional larger antenna to provide better snow detection.
- Picture storage to determine weather changes.

For complete information, call 314/532-3031, or write Ellason Weather Radar, 747 Spirit of St. Louis Blvd. Chesterfield, MO 63005.

1-800-727-2327



ELLASON WEATHER RADAR

Circle 118 On Reader Service Card

THE LINEAGE CONTINUES...

Today's **1900 Series** Antenna Monitors

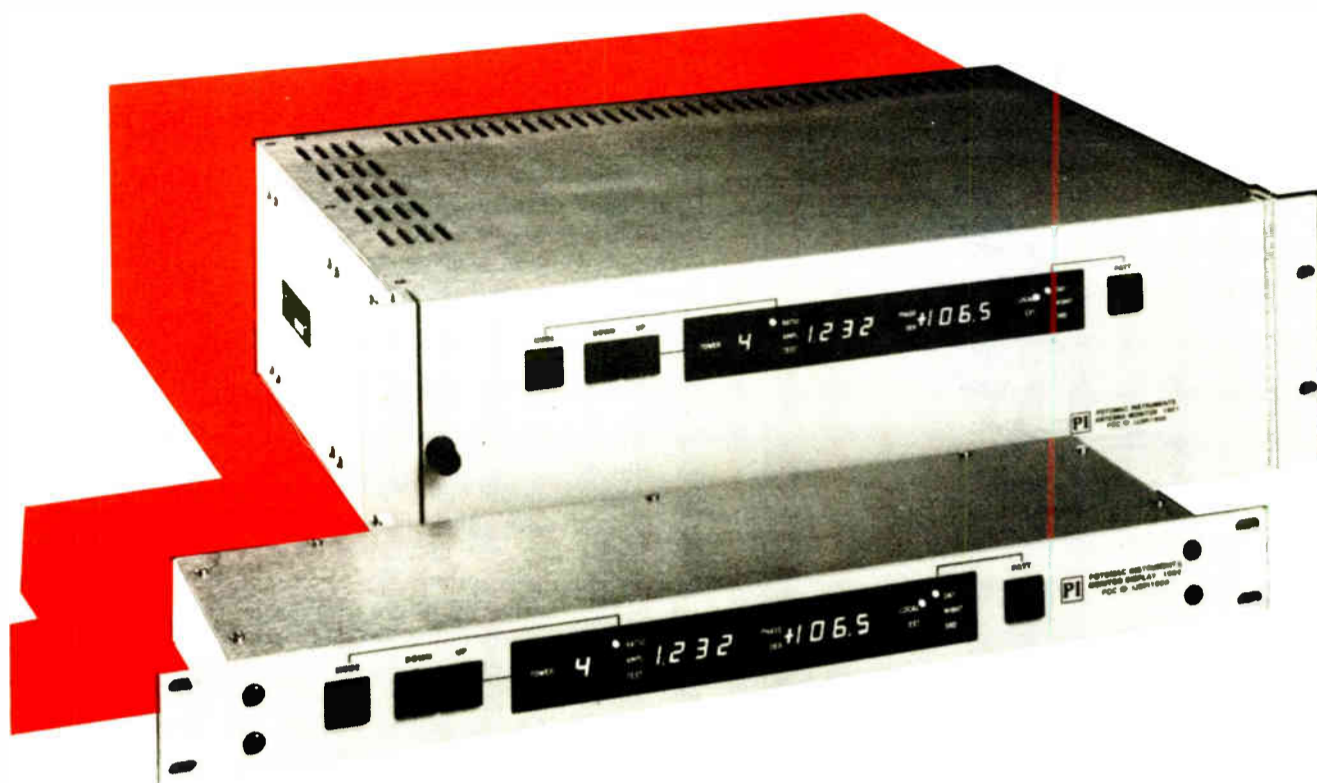

FEATURES

- 2 to 12 towers—Modular construction
- Fully Compatible with AM Stereo
 - Suited to duplexed arrays
 - Moveable Control & Display Panel option
- Jitter-free "True Ratio" Display
 - Unambiguous positive or negative angle sign display
 - Continuous remote outputs of all phase and ratio measurements
 - Microprocessor remote control system compatibility
- From the world's leading antenna monitor manufacturer

For complete information, contact your authorized Potomac distributor, or

P
POTOMAC
INSTRUMENTS

932 Philadelphia Avenue • Silver Spring, MD 20910
Phone: (301)589-2662 • FAX: (301)589-2665

...THE STANDARD FOR THE NEXT GENERATION

Circle 137 On Reader Service Card
World Radio History

TRUE BLUE FOR THE NEWS.

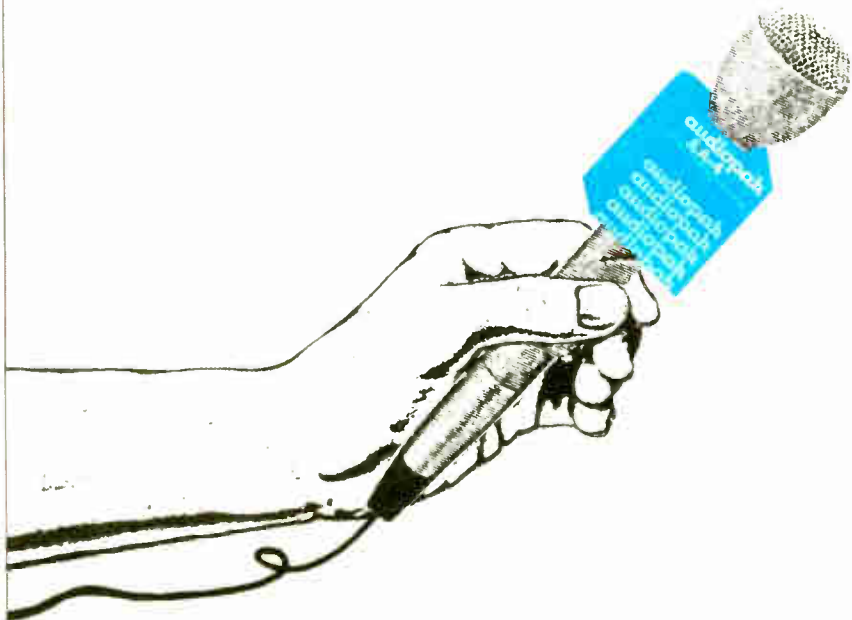

For top reliability, put your news cuts on the cart more stations count on.

audiopak
BROADCAST CARTRIDGES

P.O. Box 3100 • Winchester, VA 22601
Tel: (800) 522-CART or (703) 667-8125
Fax: (703) 667-6379



More stations play their music on the world's best-selling tape carts.

audiopak
BROADCAST CARTRIDGES

P.O. Box 3100 • Winchester, VA 22601
Tel: (800) 522-CART or (703) 667-8125
Fax: (703) 667-6379

Circle 91 On Reader Service Card

AES '91 Slated for N.Y.

Audio Fact and Fantasy Is Convention Theme

by John Gatski

NEW YORK The 1991 Audio Engineering Society (AES) convention, slated for Oct. 4-8, promises to be a comprehensive show, covering everything from digital audio broadcasting to audio cables to recordable CDs.

The convention will be held at the New York Hilton and Towers at 53rd and Sixth Streets in midtown Manhattan. The exhibits will be spread out on six floors.

This year's AES theme will be "Audio Fact and Fantasy: Reckoning with Reality" and will include sessions on the effectiveness of double-blind A/B testing, speaker design and other audio processes that may or may not affect actual listening perception.

Exhibits will highlight several products and newer audio designs, and sessions will spotlight new technologies such as Philips' Digital Compact Cassette (DCC).

Sessions, which have been extended through the five days of the show, are based on 142 submitted papers and will include: fiber optic connection considerations for professional audio, low cost

high quality digital dynamic range processors, an update on the AES/EBU 199X digital interface standard, cleaner production for improved on-air radio sound, audio fact and fantasy, and two sessions on hearing damage and loud noise.

Paper presenters will represent more than 10 countries, including England, Hungary, Japan, Poland, Italy and Canada. Besides the sessions, there will be more than 12 seminars and workshops including DAB, recordable CDs, new audio media for the 1990s, digital audio compression and digital audio workstations. Also, tours will be given of several New York broadcast and recording facilities.

The paper sessions will be categorized under: Digital Electronics I and II, Digital Technology I and II, Measurements I and II, Signal Processing, Architectural Acoustics I and II, Listening Tests I and II, Loudspeakers I and II, Psychoacoustics, Transmission, Recording I and II, Microphones, Auralization, Electronic Music, Audio Production, and Music Sound Levels.

The AES awards banquet will be held on Oct. 7 at 6:00 p.m.

For additional information, contact AES Convention Chairman Jerry Bruck at 212-229-1991 or AES Executive Director Donald Plunkett at 212-661-8528.

OPTIMUM PERFORMANCE BROADCAST QUALITY CABLES FOR THE PROFESSIONAL

LATEST NEC COMPLIANCE,
UL LISTED, INDUSTRY PROVEN

Audio Cables • Video Cables • Composite Video and Audio Cables • Studio Set Lighting Cable • Portable Cordage • Portable Power Cables • Control Cables • Fiber Optic Cables • Telecommunications Cables • Local Area Network Cables • Custom Marked Pre-Cut Shrink Tubing & Sleeving • Custom Cable Assemblies • Breakout Boxes • Custom Panels • Rack Rails • Cable Reelers • Gep-Pak—Reeless One-Man Payout System

CABLE PRODUCTS DESIGNED, DEVELOPED, AND PROVEN FOR THE PROFESSIONAL TECHNICIAN:

Corporate Headquarters

2225 West Hubbard St., Chicago, IL 60612
Tel: (312) 733-9555 Fax (312) 733-6416 (800) 966-0069

Eastern Regional Sales Office

Ocala, FL
Tel: (904) 732-4123 Fax (904) 732-5799

Western Regional Sales Office

Pacific, CA
Tel: (415) 355-0890 Fax (415) 359-6298

Exhibiting at: SBE—Houston TX, Oct. 4-5
Booth #921
SMPTE—Los Angeles, CA, Oct. 26-29
Booth #2208



Gepco International Inc.
COMING THROUGH LOUD AND CLEAR™

Circle 32 On Reader Service Card

Auditronics 800. Not just a new state-of-the-art.



A new state of mind.

To really understand the thinking that created the Auditronics 800 series, you'll need more than a new appreciation for the state-of-the-art. You'll need a different state of mind – an open one.

Begin with an ideal: Perfection. Because when Auditronics design engineers began development of the 800, there was only one rule – no shortcuts.

To their credit, they took this opportunity to create an entirely new console whose appearance is more suggestive of high-performance stealth technology than the flight deck of a vintage B-52.

And, the beauty of our new 800 is much more than skin deep. Because beneath its subdued charcoal exterior you'll find uncompromising compo-

nent quality, and superior circuit design that clearly indicates a "no guts, no glory" mentality on the part of our design team.

In short, the Auditronics 800 is designed and built to incorporate the best of everything broadcasters say they need in on-air consoles today, while omitting needless bells and whistles. The results are astonishing – a high-performance console that clearly reflects not only a new state-of-the-art, but a new state of mind.

If this sounds like your idea of the perfect console for your station, we invite you to find out more about the Auditronics 800. Call 901-362-1350 today for complete information.

 **auditronics, inc.**

3750 Old Getwell Road, Memphis, TN 38118 • Tel: 901-362-1350 • FAX: 901-365-8629

Quality with Reliability...Service with Integrity

Circle 140 On Reader Service Card
World Radio History



**A HEADSET
THAT TOOK THIS
MANY YEARS TO
PERFECT, WILL
BE A CLASSIC
FOR YEARS
TO COME.**

**Get this *new* classic today
and avoid the rush.**

No one knows exactly what makes a product a classic but everyone knows which products qualify. We do know that "standards" of the industry always excel in technical performance, comfort, durability and appearance, so with these as our criteria the V Series was designed to be superior to any headset on the market. By all accounts, after years of development, we succeeded.



Earcup fits any head shape or size.

Technically, the V Series specs are a cut above the rest.

But classics are created over time by the people who use them, not by manufacturers' claims, so let your own ears confirm our data. The revolutionary floating earcup conforms to any head shape or size for a more comfortable fit. But, of course, you'll realize that after one of those long, grueling production days. We know the materials and workmanship are second to none, but only time can tell about its durability. However, when enough time has passed to be a fair test, the V Series will already be a classic.

For complete details about the unique V Series modular ordering concept, outstanding specs and the comfortable



Model V220 with
MB-11 Dynamic
Mic option.

new earcup design write to Telex Communications, 9600 Aldrich Av. So., Minneapolis, MN 55420, (612) 887-5550.

©1991 Telex Communications, Inc.

TELEX®

World Radio History

Simon Concert Uses Digital Link

(continued from page 10)

Logic. The apt-X 100 system offers real-time compression and retrieval of audio data and delivers CD-quality fidelity, according to APT.

The new remote truck is breakthrough technology which dramatically reduces the cost of high quality remotes in crowded urban environments like New York City, WQCD Technical Director Andy Bater said.

"Traditional remote broadcast methods have become problematic in larger cities," Bater said, citing over-allocation of frequencies for existing systems, the high cost of stereo telephone lines and interference problems with satellite transmission.

"The ruggedness of the digital signal and its immunity to multipath allowed the microwave to bounce off two buildings before hitting the receiver on the roof of 1700 Broadway," the distribution point for Westwood One's feed, Bater said. "We did not have line of sight from Central Park and this system succeeded where others have failed in the past," he said.

At 1700 Broadway, Westwood One's audio feed passed through a digital delay so

broadcast rights to the concert.)

All primary systems worked well during the concert, though the prototype LNR digital microwave receiver on the roof at 1700 Broadway overheated during pre-show coverage and the 15 kHz land lines were used while the receiver was cooled down with a fan, WQCD's Bater said. Downtime was about an hour.

How did the concert sound to America's radio audience? Because listeners throughout the country heard the feed through different delivery systems and eventually through more than 200 individual station processing schemes, a universal assessment was hard to establish.

With an estimated four million Dolby Surround processors now in U.S. homes, the concert gave the surround sound process a rugged broadcast test.

Dolby Surround analysis

In New York, RW taped the Westwood One feed off WXRK-FM (K-Rock 92.3) and asked some professional listeners familiar with Dolby Surround to evaluate the production from the perspective of surround sound. The tape was played in a listening room equipped with a Dolby Pro-Logic Surround decoder at Lyric High Fidelity, a high-end Manhattan consumer audio dealer.

"I definitely get the effect of the Dolby

Surround over the FM. I get more of a feel that I'm actually at the concert... more involved with the crowd in the open outdoor theatre," said Leonard Bellezza, who is general manager of Lyric's three New York stores. "I would definitely prefer to listen to it in surround sound than in straight stereo."

However, Bellezza, who had viewed the concert on HBO, said the FM signal was poorer in audio quality than the television feed and not in the league with a laser disc or CD concert recording. "The FM does limit the quality of the signal. I am aware of a higher noise floor. I am aware of some pumping in the low frequencies, possibly due to compression," he said as he listened to the concert tape. "But I think in a live concert like this the Dolby encoding really adds another dimension to the radio sound."

For ten dollars more,*



more STL is what you'll have.



NEW!

FREQUENCY SYNTHESIZED

The 9200/9205 Monaural STL

More Features

- Frequency synthesized
- Monaural program
- Two subcarriers (optional)
- High SNR/low distortion

More Company

- 21 years of broadcast equipment
- 15 years experience in STL's
- 24-hour emergency service
- Patented design

More Serviceability

- Frequency agility means better delivery
- Field frequency change

More Performance

- 75 db SNR
- 7.5 watts (900-960 MHz)
- 20 watts (other bands)
- 25µv sensitivity for 60 db SNR

More Versatility

- Covers all bands
900-960 MHz 200-230 MHz
450-470 MHz 140-190 MHz
300-330 MHz
- ± 25 kHz deviation

More Value

- Transmitter/Receiver \$3,300
- Includes 2-year warranty

*Based on latest available price information

TFT inc

TFT Inc.
3090 Oakmead Village Drive, P.O. Box 58088
Santa Clara, CA 95052-8088
Tel 408-727-7272, FAX 408-727-5942, 1-800-347-3383

Sound Quality for 20 Years

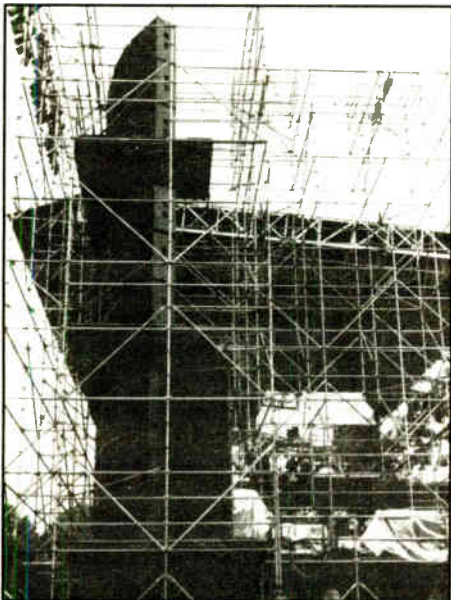

Concert-goers heard the Paul Simon show via a mammoth sound system while radio listeners were treated to a digitally linked simulcast.

that the concert audio could be synchronized with the HBO video feed. From there it was sent to a DATS multiplexer for the trip to the satellite uplink in Vernon Valley, N.J. and the live feed to stations.

West Coast radio listeners hearing the delayed broadcast got the concert feed through a different route. HBO recorded Westwood One's radio feed along with its own stereo audio and video feed onto a single digital videotape. The radio audio, in sync with the television feed, was fed to Westwood One's affiliates for time-delayed broadcast.

Everywhere a backup

Every transmission path had a backup, Westwood One Director of Technical Operations Bob Demuth said. At the concert site, a PA sub-mix was routed into the Unitel mixing truck in case the main mix from the Effanel truck failed and 15 kHz stereo telephone lines backed up the digital microwave feed from WQCD's mobile unit.

"Distribution-wise this is one of our most complex remotes ever," Demuth said. "Our production and transmission costs are about \$45,000." (Westwood One paid another \$100,000 for the American

SBE '91 CONVENTION PREVIEW

SBE '91 Sessions Look at Latest Radio Technology

by Alex Zavistovich

HOUSTON "It's a golden opportunity to learn about equipment," said Richard Farquhar of the Society of Broadcast Engineers (SBE) about the group's annual convention and trade show, to be held here Oct. 2-5.

Indeed, the convention's technical sessions—most notably, the Ennes Foundation workshops offered on Wednesday, Oct. 2—give engineers a taste of the latest broadcasting technology from RF systems to digital audio broadcasting.

The Ennes workshops are open to paid registrants for the conference portion of the convention. Workshop attendees will be awarded credits through John Wood Community College.

Sessions included in the workshops are "How to Become a Contract Engineer" by Terry Baun, "Frequency Coordination" with Richard Rudman, Paul Lentz and Gerry Dalton, and "RF—From the Ground Up" by William Decormier and Joseph Zuba of Delectric Communications."

Also included in the sessions are "RF for the Engineer," a full-day workshop by

Harris-Allied and "Antenna Selections and Systems Design for AM/FM and TV" by Don Markley.

The remainder of the convention's technical sessions are devoted to a variety of subjects in the FM, AM and digital fields. Following is a schedule of the sessions, arranged by day and date.

Thursday, Oct. 3, 1991

8:00 a.m. SBE Membership Meeting
Morning Session: State of Broadcast Industry

Coordinator: John Battison

8:50 a.m. Reality Check: Broadcasting Today

Technical writer Jerry Whitaker assesses the state of the industry.

9:30 a.m. NAB Looks Toward the Future

NAB Senior VP Michael Rau summarizes work being done by the association on behalf of radio and TV stations.

10:10 a.m. WARC-92 and Other International Activities: What They Mean to You

John Reiser of the FCC reports on the upcoming World Administrative Radio Conference.

10:50 a.m. Digital Cable Radio: No

Spectrum Required

National Public Radio's Don Lockett gives a technical overview of cable radio.
11:30 a.m. Digital Audio Transmission System for Backhaul of Network Traffic
Keith Angstadt of Westwood One reports on the design of a new digital backhaul system.

Afternoon Session: The Regulation Front

Coordinator: Jerry Whitaker

1:50 p.m. Bureau Check: AM Radio

John Sadler of the FCC's AM division discusses filing requirements for stations with directional antennas.

2:30 p.m. Bureau Check: FM Radio

Bob Greenberg of the FCC's FM division provides a status report on FM band regulation issues.

3:10 p.m. Bureau Check: Field Enforcement

An overview of FCC enforcement activities is provided by Lloyd Perry of the FCC Field Enforcement Bureau.

4:30 p.m. FCC Roundtable

8:00 p.m. Night Owl Session: Audio Processing in the Digital Age

Teleport Minnesota's Mark Durenberger moderates this session.

Friday, Oct. 4, 1991

Morning Radio Session: RF Technology

Coordinator: John Battison

8:00 a.m. Multiple Station Operation with a Single Folded Unipole Antenna System

George Grills of Lawrence Behr Associates explains how AM stations can enjoy the same tower-sharing arrangements now available to FM and TV stations.

8:40 a.m. Using Isolation Transformers to Lease AM Tower Space

KinTronic Laboratories' Tom King shows how your present tower could be a source of additional income from cellular and paging system operators.

9:20 a.m. De-Tuning Reradiating Struc-

tures

Ron Nott of Nott, Ltd. solves the problem of reradiation from nearby power poles, storage tanks and large buildings.
10:00 a.m.- 4:00 p.m.: Exhibit Floor Open

Afternoon Radio Session: Digital Radio Broadcasting

Coordinator: Skip Pizzi

4:00 p.m. Digital Radio Update

Skip Pizzi provides an overview of digital radio issues.

4:20 p.m. The Regulatory Picture

CDRB Co-chairman Michael Starling assesses possible transitions to digital radio and potential effects on broadcasting.

4:40 p.m. Digital Audio Compression

Larry Hinderks of Corporate Computer Systems explains the relative strengths of various data compression schemes used for DAB source coders.

5:10 p.m. Project Acorn DAB

USA Digital's Paul Donahue updates attendees on this in-band DAB system.

5:30 p.m. Digital Radio Format Testing Communications

SCI's Ron Strother outlines on-air testing of various DAB systems.

5:50 p.m. Panel Discussion

Saturday, October 5, 1991

Morning Radio Session: New Technology Come of Age

Coordinator: Alex Zavistovich, RW

8:00 a.m. The Digital Radio Station

Gentner's Kelly Hannig provides an overview of the capabilities of digital technology for today's radio stations.

8:40 a.m. Design Considerations for Digital STL Applications

Kevin Tam and Louis Fielder of Dolby Labs discuss digital STLs.

9:20 a.m. Case History: Synchronous Broadcasting

KSSA Radio's George Whitaker, Sr., gives a report on synchronous AM from a hands-on perspective.

(continued on page 18)

SIMPLY THE BEST

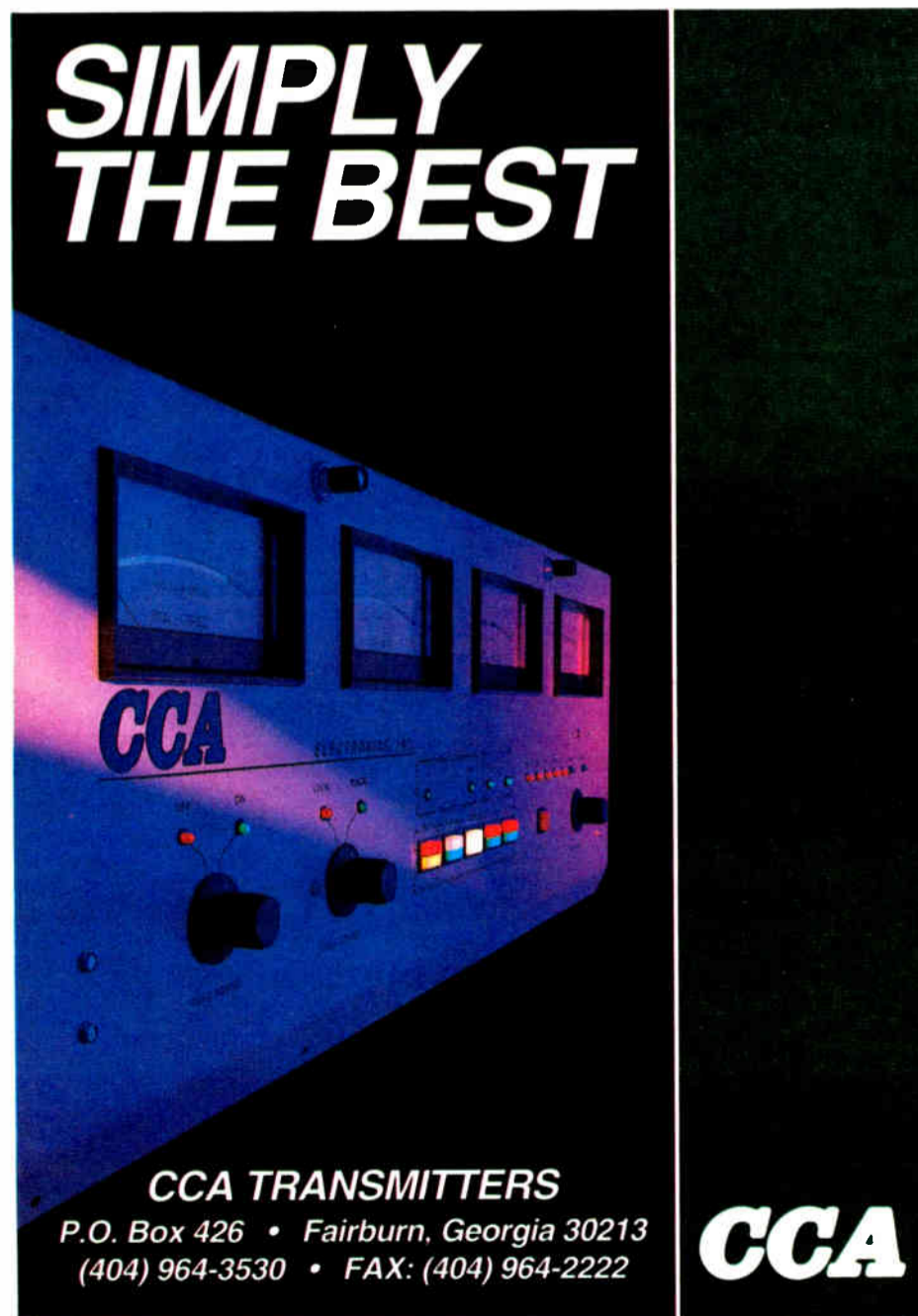

CCA TRANSMITTERS
P.O. Box 426 • Fairburn, Georgia 30213
(404) 964-3530 • FAX: (404) 964-2222

CCA

ITC CART II



- Patented Dynamic Tensioning System
- Stationary Hub Design
- Passive Tape Guidance
- 100% Laser Inspected High Output Tape

Only ITC Cart II assures consistent audio quality, excellent phase stability, and low flutter, play after play.

Want more information on the ITC Cart II? Call us.

International Tapetronics Corporation
P.O. Box 241
Bloomington, IL 61702-0241
TEL: (800)447-0414; (309)828-1381
FAX: (309)828-1386



Convention Planners Predict a Solid Show

(continued from page 1)

last year's SBE convention drew a combined 3,700 in paid attendees, exhibitors and guests. This year, he credits a diverse program of technical sessions and the convention's connection with the regional Texas Association of Broadcasters (TAB) show for the expected increase in attendance.

"I'd say about one hundred-plus will attend the TAB show," said Ingram. The TAB gathering has its own slate of technical sessions, he said, which are separate from the SBE's schedule of workshops, seminars and other presentations.

For its part, the SBE will be providing a full slate of such presentations for registrants. The Ennes workshops scheduled for Wednesday, Oct. 2, will give attendees hands-on experience in a variety of areas. Continuing education college credit will be awarded for completion of the workshops.

Besides the Ennes agenda, the SBE has scheduled morning and afternoon sessions Thursday through Saturday. These sessions address such disparate topics as regulatory issues, frequency coordination, digital technology and RF theory. The sessions have also been planned around the 10:00 a.m. to 4:00 p.m. time frame each day during which the exhibit hall will be open.

Among the special events that the SBE has planned for its 1991 convention are tours of the National Aeronautics and Space Administration (NASA) and Mission Control on Wednesday, Oct. 2 and Thursday, Oct. 3 from 1:00 p.m. until 4:00 p.m.

Concurrent with the NASA tours, the association will hold tours of the Senior Road Tower site. This site is the only one of its kind, running nine Class C FM's a full 100 kW ERP each into a single antenna system. The tours are co-sponsored by Spectrum Engineering Co.

The SBE is also providing a spouse program that will offer attendee spouses or guests a look at the attractions of Houston while the attendees are taking in the sessions and exhibits. On Thursday will be a tour of Sam Houston Park and the Galleria shopping complex. On Friday, a trip to the Museum of Fine Arts, Museum of Natural Science and the IMAX Theatre. Shuttle buses for the program depart each day from the Dallas Street side of the Houston Hyatt Regency Hotel.

Transportation to and from the convention will be provided at the Hyatt, Four Seasons and Days Inn, throughout the event. A shuttle bus will also be provided Thursday, October 3, between the Four Seasons and Days Inn to the Hyatt for an attendee reception.

A dial-up remote control for *how much?*

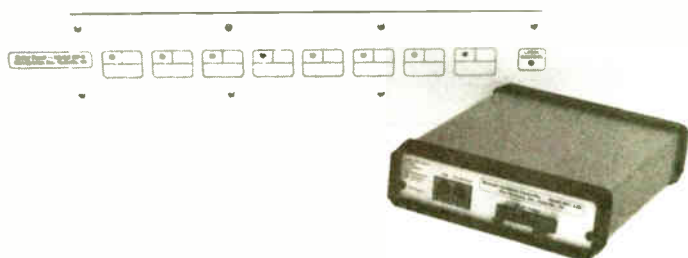

You would probably expect to pay \$2,500 or more for what the Sine Systems RFC-1 remote control offers for just **\$1,498 complete.**

(That leaves \$1,002 for something else!)

Crouse-Kimzey
C O M P A N Y

800/433-2105 Main Office
800/955-6800 Annapolis Office

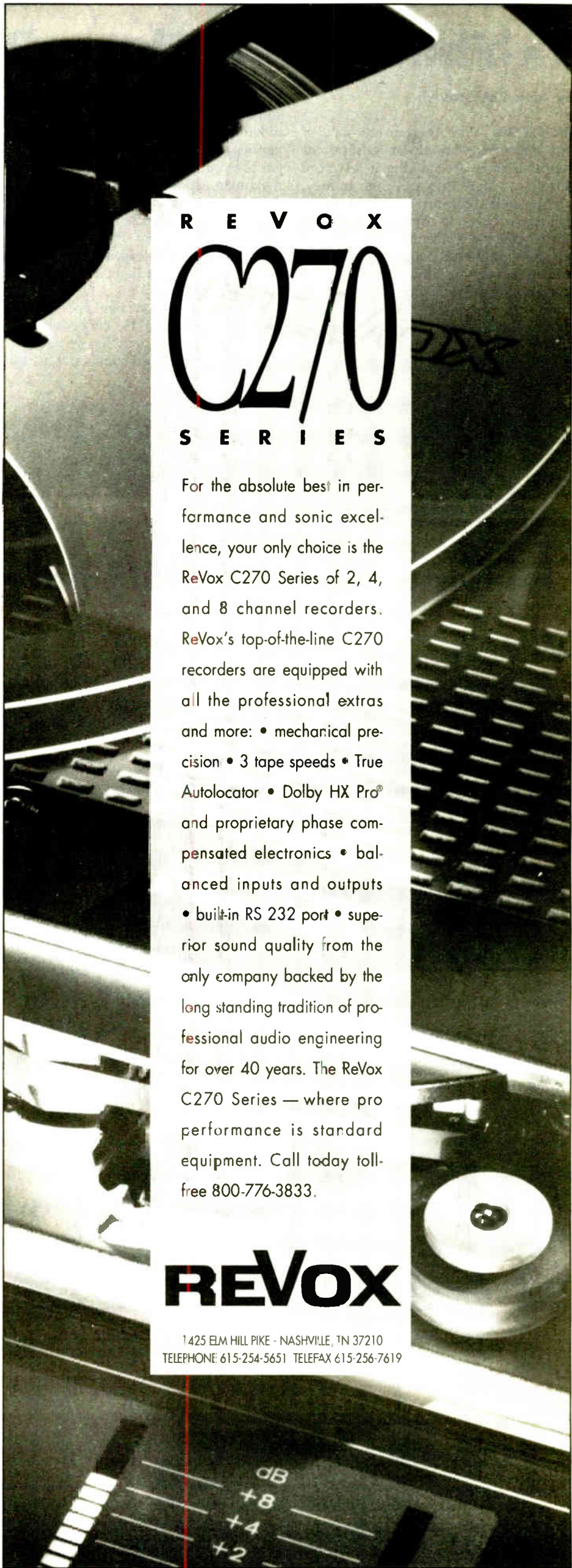

R E V O X
C270
S E R I E S

For the absolute best in performance and sonic excellence, your only choice is the ReVox C270 Series of 2, 4, and 8 channel recorders. ReVox's top-of-the-line C270 recorders are equipped with all the professional extras and more: • mechanical precision • 3 tape speeds • True Autolocator • Dolby HX Pro® and proprietary phase compensated electronics • balanced inputs and outputs • built-in RS 232 port • superior sound quality from the only company backed by the long standing tradition of professional audio engineering for over 40 years. The ReVox C270 Series — where pro performance is standard equipment. Call today toll-free 800-776-3833.

REVOX

1425 ELM HILL PIKE - NASHVILLE, TN 37210
TELEPHONE 615-254-5651 TELEFAX 615-256-7619

Exhibitors Eye Show Performance

by Alex Zavistovich

HOUSTON With the current state of the economy, broadcast equipment manufacturers are looking a lot more closely at where they put their money.

This belt-tightening attitude has spilled over even to company participation in national conventions. The NAB's fall show only held pace with last year, and the forecast for SBE '91, the national convention of the Society of Broadcast Engineers, also is status quo.

At the SBE, however, people remain upbeat about space sales for the show, to be held Oct. 2-5 here at the George

Brown Convention Center. Although some manufacturers have questioned moving the show from St. Louis to other venues around the country, SBE organizers maintain such rotation will maximize exposure for the event.

Eddie Barker and Associates of Dallas, Texas, is organizing the SBE show again this year. Company President Eddie Barker said he is "pleased with the way things are going in light of the overall economy."

Barker said the show has booked more than 115 exhibitors. He conceded that the number is "short of what we had last year at this time," and considerably less

than the "more than 250 exhibits" alluded to in convention registration materials. Still, Barker said he is comfortable with the show.

"The exhibits are holding up," Barker said. He noted that, "on a show like this, a lot of selling is done in the 30 to 60 days before the show."

SBE '91 also will get a boost from its pairing this year with the regional Texas Association of Broadcasters (TAB) show, Barker said, noting that the TAB add-on will bring 30 to 40 exhibitors for its portion (of the show).

The enthusiasm displayed by Barker is not matched by all equipment manufacturers, however. Some have chosen not to attend SBE '91, and even those who will be on hand acknowledge that the economy has caused them to watch shows more closely.

Tim Bealor, trade show manager for Broadcast Electronics, believes a trend

has emerged among shows this year.

"Overall, people are reducing booth size, and not all space is taken," Bealor said. "That's the general trade show climate for this fall." While Bealor thinks SBE '91 will have "good luck" being paired with the TAB convention, he admitted he has some reservations.

"But I don't see it as a bust. I think it could be as good as or better than past shows," he added.

Broadcast Electronics will not be introducing new products at this show, although at press time they were expecting to do so at Radio 1991, the NAB's fall show in San Francisco. The decision was based on the timing of the two shows, Bealor said, adding that the NAB fall radio show is "considered to be the second most attended show of its kind each year."

As to the issue of shifting venues from one location to another each year, Bealor said he wasn't "crazy" about SBE moving to California next year (the 1992 SBE show is slated to be held in San Jose.)

(continued on next page)



1st Class Console Bargain!

We have a \$41,000 WARD-BECK TV audio production console — used about ten years and waiting for a new owner! Call today for the content details and shocking low price (which is open to negotiation).

We have lots of other great bargains on our shelves in used radio equipment. **BUY, SELL, or TRADE** with the broadcast industry leader. Call Harris Allied today.

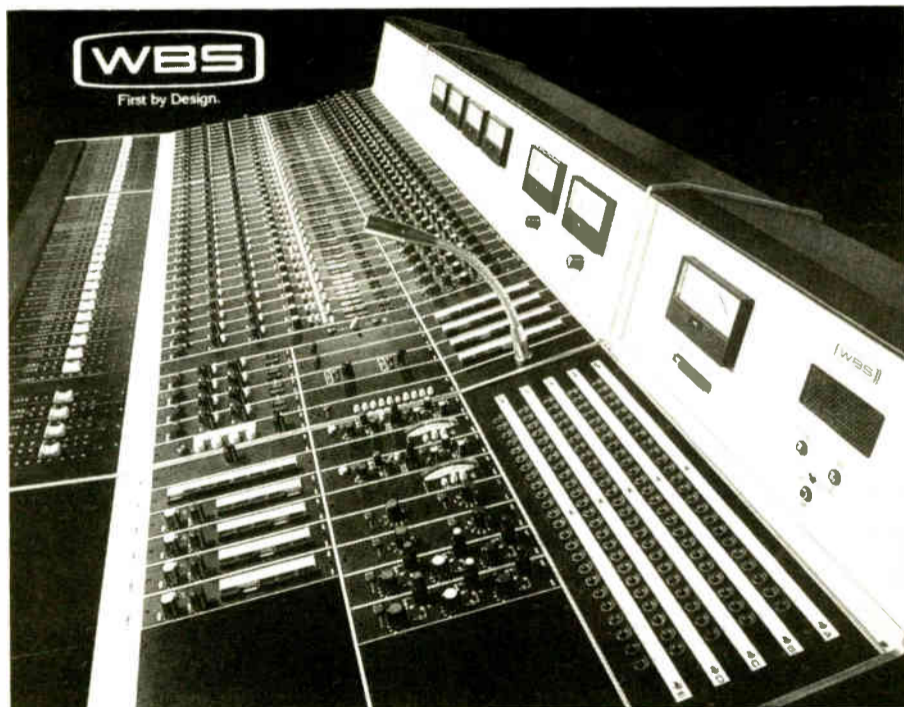

WARD-BECK Modified Type L3242A TV Audio Console

HARRIS ALLIED
EQUIPMENT EXCHANGE

FAX 317-966-6321

317-962-1471

BUY—SELL—TRADE

HARRIS ALLIED ©1991

See Us At SBE Booth 916

Sessions Examine Trends

(continued from page 16)

10:00 a.m.-4:00 p.m. Exhibit Floor Open

★ ★ ★

Afternoon Radio Session: New Technology for Radio

Coordinator: Mark Durenberger

4:00 p.m. Digital VSAT Technology

National Supervisory Network's Bill Sepmeier looks at digital VSATs.

4:40 p.m. Inside LANs

Gerry Dalton, WTS Services, provides an overview of networking topologies and products for radio.

5:20 p.m. Bidirectional Radio Links

Marti Electronics' Dan Rau explains how new technology can be applied to solve programming problems.

6:00 p.m. FM Translators and Boosters

Engineering consultant Doug Vernier updates FM translator licensing policies.

★ ★ ★

Sessions close at 6:40 p.m. At 6:00 p.m. the annual SBE reception is slated to commence, with a banquet to take place at 7:30. Congressman Don Ritter (R-Pa.) will be the guest speaker at the event

Get Control of Time ..



Real Time Event Sequencer

CRL is proud to introduce our new **Real Time Event Sequencer**. This one rack height unit is a seven day programmable event sequencer. Any combination of eight or one of 255 outputs can be controlled via a rear panel connector. The unit can store up to 200 events. The outputs are selectable either to latch on or provide half or one second contact closures. Programming is done via a simple key pad, and is displayed on a back-lit LCD. Security keylock and battery backup included. To control time more easily, write, FAX, or phone:



Circuit Research Labs, Inc.

2522 West Geneva Drive

Tempe, Arizona 85282-3192 U.S.A.

(800) 535-7648 (602) 438-0888 FAX 438-8227

Bulletin Board System (602) 438-0459 Telex: 350464

SBE '91 Exhibitor Directory

Editor's note: Following is a list of radio exhibitors to be on hand at the the SBE '91 Convention; booth numbers are also provided. This information was accurate as of press time, but is subject to revision. For more information, contact the SBE.

Company Booth Number

3M	912
Acrodyne Industries	830
ADC Telecommunications	225
Allied Tower Company	537
Altronic Research	626
Ampex Corporation	1021
Andrew Corporation	803
ATI-Audio Technologies	731
Audio Animation	331
Audio Precision	822
Avid Technology	1022
BE-Broadcast Electronics	420
Broadcasters General Store	421
CCA Electronics	326
Cel Broadcast	624
CRL-Circuit Research Labs	216
Coaxial Dynamics	627
Comark Communications	526
Comrex Corporation	416
Continental Electronics	810
Control Concepts Corp.	902
Crouse-Kimzey Company	430
Current Technology	634

Cycle Sat	629	Nautel Maine	218
Dataworld	723	Nemal Electronics	910
Delta Electronics	611	Northern Technologies	222
Dielectric Communications	622	NPR Satellite Services	730
Dolby Laboratories	729	NSI	904
Econco	524	Nucomm	431
EEV	631	Panasonic Communications	616
Electronic Components Dist.	630	Pesa America	335
Electronics Research	907	Phasetek	931
Electrotex	320	Polyphaser Corporation	1016
Energy-Onix	734	Potomac Instruments	913
Fidelipac Corporation	816	Radiation Systems	324
Flash Technology	613	Radio Systems	628
Gentner Electronics Corp.	417	RF Technology	425
Gepco International	921	Riser-Bond Instruments	636
Harris-Allied	916	Rohde & Schwarz	523
Hedco	606	Rohn	325
Holiday Industries	625	Scala Electronic Corporation	811
Hughey & Phillips	906	Sennheiser	831
Intraplex	337	Setcom Corporation	531
Jampro Antennas	727	Shively Labs	610
Kavouras, Inc.	716	Society of Broadcast Engineers	334
Kintronic Labs	623	Sony Business & Prof. Group	217
LDL Communications	1018	Sony Magnetic Products	221
Mark IV Broadcast Group	520	Tektronix	823
Marti Electronics	836	TTC-Television	
Microtime	608	Technology Corp.	933
Microwave Networks	529	Telex Communications	528
Microwave Radio Corporation	424	TFT	236
Mitchell Tech Institute	427	TM Century	905
Moseley Associates	935	Wheatstone Corporation	915
Myat	725	Winsted Corporation	530
National Assoc. of Broadcasters	224	Wohler Technologies	834

Firms Eye Show

(continued from previous page)

Bealor acknowledged that BE likes the concept of the SBE show and said "the SBE is a worthwhile organization and we want to support it." Still, he explained that the "pressure is on us all to examine each show."

Performance is the name of the game at Bradley Broadcast Sales, which has chosen not to participate in SBE '91. Neil Glassman, sales manager for the broadcast equipment distributor, linked Bradley's decision to pass on SBE '91 with the show's rotation among venue cities.

"Our observation has been that by rotating the show, the attendance has suffered," Glassman said. "Of the several national shows we participate in, we haven't seen the numbers (from the SBE) that would warrant our attendance."

Glassman did not rule out Bradley's participation in future SBE gatherings, but noted that "success is the best way to lure us to a show."

SBE executives and show organizers continue to defend rotating the show.

"If you've got a national show, you move it around some," Barker said. He added, "The George Brown Center in Houston ranks in the top five percent of convention centers in the nation."

Another point in Houston's favor is what Barker calls its "good climate, labor-wise." Exhibitors have long complained about union labor at some conventions, which Barker said would not be an issue at SBE '91 in Houston.

"Texas is a right-to-work state," he explained.

SBE Executive Director Stephen Ingram said demographic research shows "70 percent of SBE's members live and work on one coast or the other."

Moving the venues allows more of the SBE's membership—which has "tremendous drive-in attendance" of shows—to come to the convention, Ingram explained.

He added that moving the show from one location to another "doesn't mean we won't come back to the midwest. But we have numbers to support moving it around."

On Voices It's Perfection. On Everything Else, It's Merely Superb.

A Symetrix 528 Voice Processor can also:

- clean up news activations
- eliminate monitor feedback
- punch up wimpy sound effects
- tighten and brighten mushy agency dubs
- bring dull samples to life

It's no secret that many of radio's 'perfect' voices rely on the Symetrix 528 Voice Processor. After all, even the top broadcast consoles can't offer the 528's combination of unmatched processing power and uncompromising signal quality. With its mic pre-amp, switchable phantom power, de-esser, expander, compressor/limiter, and three bands of fully parametric EQ, the 528 gives you the control you need to handle any on-air situation.

But don't let the name mislead you: This 'voice processor' is just as helpful in the production studio, the newsroom or on live remotes.

Your voice may not be perfect. And with the hectic pace of radio, your productions may occasionally fall short as well. But who says anyone else has to hear about it? Call your broadcast distributor for more information on radio's most versatile 'audio tool kit,' the Symetrix 528 Voice Processor.

Symetrix

4211 24th Avenue West • Seattle WA 98199 • USA
Toll Free (800) 288-8855 • Tel (206) 282-2555
Fax (206) 283-5504

FCC Refines Its Fines

by Harry Cole

WASHINGTON Let's take our cue today from the Chiffons' "One Fine Day," with the emphasis on "fine."

We're talking about the FCC's new method of meting out fines and forfeitures. That new method was announced in early August and became effective Aug. 8. Whether our lives are better for the change is not entirely clear.

Historically, there was no easy way to determine how much the Commission

COLE'S LAW

would fine a broadcaster for any particular transgression. You could obtain listings of the various fines that the FCC had doled out and the violations for which they were assessed, but that would give you at most the general range of potential fines. There did not seem to be any well-publicized, uniform set of standards governing the fining process.

This problem was complicated when the Commission delegated to its FOB staff the authority to assess fines. Up to that point, virtually all fining decisions came out of one office in Washington, so there was at least a reasonable chance that fining determinations might be consistent. But when fining authority was handed

out to each of the various, geographically distant field offices, the possibility of markedly different fines increased.

Increased fining authority

Even greater problems arose in 1989 when Congress vastly increased the Commission's fining authority. As a result, the FCC can fine broadcasters up to \$25,000 for each violation or each day of a continuing violation, up to a maximum of \$250,000. Ouch.

This increase obviously raised broadcasters' possible exposure, and it also introduced still further potential disparities in fines for common offenses that might be issued by the various fining authorities.

Enter the new fining method, supposedly designed to provide uniformity in the fining process. That method begins with a list of "base" fines for certain types of violations. If a licensee is determined to be guilty of such a violation, the fine starts off at that "base" amount. Then the Commission will examine whether the fine should be adjusted upward or downward in light of 11 separate criteria.

The "upward adjustment criteria" include whether: the misconduct was considered egregious; the licensee's ability to pay is such that a small fine would not constitute a sufficient incentive to proper conduct; the violation was intentional; the violation caused substantial harm; the licensee has previously been guilty of the same or other misconduct; the licensee

Here is the Commission's published list of violations and the base fines. In considering these base fines, you should be sure to understand that these are "per day" fines.:

BASE FINE	VIOLATIONS
\$20,000	Misrepresentation/lack of candor; failure to mark and light towers as required; unauthorized construction; unauthorized substantial transfer of control; violations of rules relating to distress and safety frequencies (including false distress communications)
\$18,750	Failure to permit inspection
\$17,500	Malicious interference; failure to respond to FCC communications
\$15,000	Exceeding authorized antenna height
\$12,500	Exceeding power limits; unauthorized emissions; unauthorized frequency; EBS equipment not installed or operational; transmission of obscene/indecent material; violation of EEO rules; violation of political broadcast rules
\$10,000	Unauthorized discontinuance of service; use of unauthorized equipment; violation of children's television rules; violation of main studio rule; construction/operation at unauthorized location; failure to engage in required frequency coordination
\$7,500	Failure to file required forms or information; violation of public file rule
\$6,250	Violation of sponsorship ID rule; violation of lottery/contest rules
\$5,000	Violation of technical logs/time brokerage agreements file requirements; unauthorized broadcast of telephone conversations
\$2,500	Failure to make required readings or conduct required monitoring; violation of enhanced underwriting requirements (noncommercial licensees); failure to provide station ID; unauthorized pro form transfer of control; failure to maintain required records
\$1,250	Miscellaneous violations

realized substantial economic gain from the misconduct; and whether the violation was repeated or continuous.

The "downward adjustment criteria" (of which—surprise, surprise—there are significantly fewer than their "upward" counterparts) include whether: the violation is "minor" (which the FCC ex-

plains is at a low level of seriousness within the violation category—"the opposite of egregious misconduct"); the licensee has acted in good faith and has voluntarily disclosed the violation; the licensee has a history of overall compliance; and the licensee is unable to pay.

(continued on page 42)

MASTER AUDIO ROUTING



- ▶ Modular expandability from 16 x16 to 512 x 512
- ▶ 7 x 99 event/salvo capability with embedded controls
- ▶ Supports up to 124 remotes
- ▶ Non-volatile memory with data cartridge archiving
- ▶ RS-232 and logging printer interface
- ▶ User programmable with security and alarms
- ▶ Built-in metering and monitoring

Want to know more about the ITC Audio Switcher?
Call us at (800)447-0414 or (309)828-1381. FAX: (309)828-1386

Only the ITC Audio Switcher provides complete and cost effective facility routing control, design flexibility and maintains professional audio performance specifications.

International Tapetronics Corporation
P.O. Box 241
Bloomington, IL 61702-0241



Can I Put a Translator There?

by Howard L. Enstrom

MOUNT DORA, Fla. A spiral note pad, always next to my business telephone, is used for logging all calls in my own shorthand-like style. A small square check-off box means a commitment was made to do something.

Question marks signify a promise to answer questions the caller has about translators. This month I'll paraphrase some of the questions, along with my answers.

Q (from a station owner): I'd sure like our signal to reach the Louisville market. Can I put a translator there?

A: Not as a licensee of a full-service commercial station and not as a fill-in translator, since that community is well beyond your station's protected contour. Part 74.1232(d)(e) of the rules are explicit about who may not be authorized for such a translator.

If another entity proceeds in this, you may not directly or indirectly support any stage of application, construction or operation, other than to provide technical assistance. Of question: Whether a useful commercial channel could be found for a translator to serve such a large metro area.

Q: I was told a translator can be 250 W, but now I'm not sure. What's the deal?

A: Under the new translator rules, operating power is expressed as the ERP. Yes, up to 250 W may be used under conditions that pertain to the antenna's effective height above average terrain in any direction (radial HAAT). It may not exceed 32 meters for systems east of the Mississippi River and Zone I-A, or 107 meters in all other areas.

The intent of the rules is to limit distance of the predicted 1 mV/m coverage contour to seven or 13 kilometers, respectively, for those geographic areas of the U.S. The rules provide what ERPs are allowed for other antenna heights, in order to limit distance to the coverage contour, which is why it seems confusing.

Q: That doesn't make any sense, Howard. Remember the time we took a four wheel drive up to our mountain site? It's the only site we can get for the primary station, and it's 45 miles from town. So now we're illegal.

A: No problem. To begin with, the translator is grandfathered. The FCC knows about such circumstances and since this is a NCE translator and your community is not served by a full-service public radio station, the Commission can be expected to issue a waiver.

I'll help you. But there's more about this ERP and antenna height thing—possible interference. A translator might radiate a signal strong enough to interfere with another station on the same channel or even up to three channels higher or lower.

FCC rules deal with the amount of tolerated interference, which can have the effect of further lowering the ERP, to avoid overlapping another station's protected contour. So you see, under certain conditions, a translator might radiate up to 250 W in most directions, but not all.

Q: That translator we ordered from your firm, now we wish it was a model for making local announcements. But we hate to take it off the air and send it back

for modification. Can we get a loaner? **A:** There's a better way. We can send you a module your technician can easily install, with a sketch showing how to assemble a simple control unit/microphone

LOWPOWER LOWDOWN

amplifier connected to the rear terminals of the translator. Your office is in the same building as the translator, so you could manually do local live announcements.

Q: I wouldn't want to get into that. Can't we use recorded announcements?
A: Sure. Here four ways:

(1) Local-manual operation, where you interrupt regular programming at a strategic moment, play the announcement from a cassette unit, switch back to regular programming and rewind the tape.

(2) Remote control manual operation using two circuits, control and audio. If hard-wired, one pair of conductors will do for audio and control, using a "phantom" circuit. But you have to use playback equipment, such as a cartridge machine, that resets for the next use. Or

perhaps, a carefully operated continuous loop cassette player.

(3) Local control-automatic operation, using a time switch and cartridge machine that resets after each playback.

(4) Remote control by the primary station, where a sub-audible cue tone is impressed on programs to actuate the studio or translator-located playback equipment. Involvement with any of these methods calls for technical expertise for setup.

I think automatic time switches are a problem because they do not respect
(continued on page 24)

MICROWAVE MONSTER EATING YOUR DISH?

You Probably Need Our EXCLUSIVE Block Band TI Filters!

Used by over 3000 commercial TVRO installers and operators:

- SMATV builders such as Spectradyne.
- CATV MSO's such as Warner, TCI, ATC, Viacom and others.
- Program providers such as HBO, TBC and others.
- TV/FM Broadcasters such as NBC.
- Motels/Universities/Government/Industry.

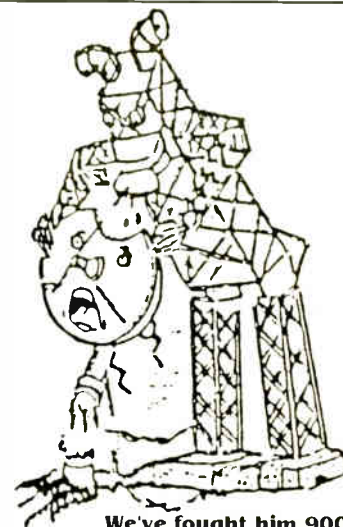

We've fought him 9000 times and never lost!

Most TVRO systems are now block downconverted, with LNB and no 70 MHz loop-out on the receiver. Neither microwave (4GHz) notches or 70 MHz filters are applicable. Block band filters can ALWAYS be installed in the coax cable, to suppress the TI before it hits the receiver. Their batting average is over 90% - we know, because we sell them MONEY BACK!

But, in the rare case they don't tame the monster, our FREE in-house consultants know ALL the Monster's tricks - and have a solution for each one of them - most of them available OVERNIGHT if necessary:

- Telephone Microwave
- Coastal Navigation Radar
- VHF Ingress
- Aircraft Altimeter Signals
- Railroad Microwave
- False TI (Low Signal)
- Airport Radar
- Common Carrier

Having A Problem NOW? Up Against A DEADLINE? Call Your FREE TI Consultant TODAY - And Sleep Tonight!



Before



After



Before



After

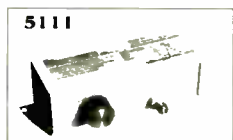

Single Receiver

Block band TI notchers: tunable single receiver or multiple carrier models for CATV/SMATV. Models for all blocks.

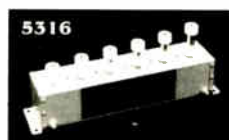

Multiple Receiver

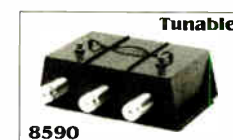

Tunable 8590

Tunable or single channel block bandpass filter clears up pictures due to weak transponder signal. (Single channel 8730)

Ask for your TI First Aid Handbook and Filter Catalog MTV/87.



- TI Sources/Symptoms
- Cures For 500 Receivers
- Exclusive Block Filters
- Exclusive 4 GHz Filters
- Notches For 70 MHz or Any IF
- Side Lobe Reducers
- TI Site Test Equipment

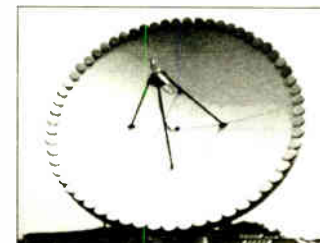

"Stick-on Absorber Kit, reduces side lobes - the gateway to all microwave TI"

MICROWAVE FILTER COMPANY, INC. • 6743 KINNE STREET • EAST SYRACUSE, NY 13057

Toll Free (US/Can): 1-800-448-1666 • Collect (NY/AK/HI): 315-437-3953 • FAX: 315-463-1467 • Telex: 249-613

PRODUCT & SERVICES SHOWCASE

For more information on the products shown below, circle the appropriate Reader Service No.(s) on the enclosed Subscription/Reader Service card or contact the advertiser directly.

LOOK

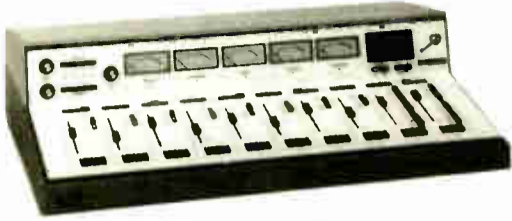

PACEMAKER 1032
BUILT WITH INTENSIVE CARE

AUTOGRAM CORPORATION

1500 Capital Ave. (214) 424-8585
Plano, Texas 75074-8118 1-800-327-6901

See Us At SBE Booth #17

READER SERVICE NO. 6

CONSOLE UPGRADE WITHOUT THE BIG EXPENSE



If you own one of these Harris Executive, Diplomat, Ambassador, President, Stereo Statesman, Gatesway II and Dualux II Consoles RCA Consoles McMartin Consoles McCurdy Consoles today's best!

If your console isn't listed - call us, we may be able to help. Most retrofits are plug-in and ready to go with no hassle. A typical console can be upgraded for as little as \$1,000! Call today for details!



Broadcast Devices, Inc.

5 Crestview Avenue
Peekskill, NY 10566
(914) 737-5032

READER SERVICE NO. 117

NEW PRODUCT

Micro Mic 28

Our Mighty Miniature Microphone Cable
Just over 1/10" diameter.

Clark	Weight per 1000'	Center Conductor	Insulation	Nom. O.D.	Shielding	Jacket	Nom. Cap.	D.C. Resist.	Color Code
MM28	6 lbs.	28g (19x40) SCC	008 PP PE	.107	95% B.C. braid + bonded foil	.015 Black PVC 80°	24 p/ft	310 per 1000'	red/black

1000'... \$325.00 250'..... \$110.00
500'..... \$185.00 100'..... \$60.00

Super thin microphone cable for tight places. Silver coated copper conductors for low capacitance. Highly flexible.



CLARK WIRE & CABLE

1801 Holste
Northbrook, IL 60062
708-272-9889
FAX: 708-272-9564

To Order or for Further Information Call 708-272-9889
READER SERVICE NO. 66

"AUTOMATE WITH CD'S"



Lee Hurley, Sentry Systems

Whether you are live or automated, FORMAT SENTRY makes it simple to play back your CD's with ease!

- Never touch a CD again. FORMAT SENTRY interfaces with multiple CD systems and most ALL other audio devices.
- Interface with many music and traffic software systems.
- Three modes: LIVE ASSIST, FULLY AUTOMATED and SATELLITE.
- Find out why over 200 broadcasters worldwide have chosen FORMAT SENTRY. See us at SBE Booth #5.

Call Mike Bettelli at BP for more information:

1-800-426-9082 Fax: 206-441-6582

SENTRY SYSTEMS
Seattle, Washington

READER SERVICE NO. 20

CHECK OUT THESE ENERGY - ONIX TRANSMITTER FEATURES!

- Automatic power level control
- Automatic VSWR foldback & protection
- "User Friendly" controller with manual override panel*
- 8X automatic fault recycling*
- Solid state IPA (with "E" patch)
- Solid state exciter
- Remote control interface panel with opto-isolated circuits
- Built-in line surge protection*
- No neutralizer required!
- No proprietary parts!

*Available only on Energy-Onix transmitters.
(Allows emergency on air patching)



Energy-Onix

752 Warren Street, Hudson, NY 12534
(518) 828-1690 Fax (518) 828-8476

See Us At SBE Booth #734
READER SERVICE NO. 42

IS YOUR FURNITURE READY TO BE PUT OUT TO PASTURE?

WE'RE OUTSTANDING IN THE FIELD...

· High Quality Studio Furniture.

· Modification & Repair of Existing Studio Furniture.

· Installation.

For Additional Information Call:
VINCE FIOLA
215-640-1229



STUDIO TECHNOLOGY

4 Pennsylvania Ave.
Malvern, PA 19355
215-640-1229
FAX: 215-640-5880

READER SERVICE NO. 121

Digital DJ™

TAB-SBE Booth # 11
Houston, Tx. - Oct 4 & 5

SMN - DRAKE - UNISTAR - Moody - Etc
Digital DJ replaces all your old audio Cart sources with high quality digital audio from a computer hard disk.

Complete Satellite Systems From \$250.00 / Mo
Multi-day Satellite programming is a snap. Full ID, Jingle, Magic Call & Liner rotation and live assist options. Auto spot Set fill, Subs for illegal spots. Real Time operation. Easy operation. Eliminate your paper Log. It's all on the screen including live rotating tags & copy, news and lists. Call for new Demo disk.

Traffic & Billing System Special (Limited Time)
New Low Prices: Special Original

EZ Log: \$ 695.00 \$ 995.00
Simple Log: 1,295.00 1,995.00
Super Log: 1,995.00 2,995.00

All Traffic systems interface to Digital DJ
Call for 60 page brochure - Our 11th Year

1000+ Stations

The Management

1-800-334-7823 - 1-817-625-9761 - Fax 817-624-9741
P.O. Box 1-36457 Ft. Worth, Tx. 76136

READER SERVICE NO. 3

LDL COMMUNICATIONS INC

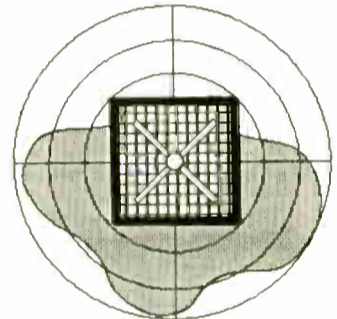

For your full turn-key or individual component needs...LDL supplies a full range of product and services for the FM broadcaster. RF transmission products include low power, side-mount antennas as well as high power, broadband, multi-channel antennas and combiners.

CONTACT:

LDL COMMUNICATIONS INC
14440 CHERRY LANE CT, #201
LAUREL, MD 20707
Telephone: 301-498-2200
Fax: 301-498-7952
See Us At SBE Booth #1018
READER SERVICE NO. 95

FCC PROBLEMS?

Copyright/Trademark Dilemmas?

Contact
MIDLEN & GUILLOT
First!

Quality Legal Services at Competitive Rates

Phone: 202-333-1500
FAX: 202-333-6852

READER SERVICE NO. 8

PRODUCT & SERVICES SHOWCASE

For more information on the products shown below, circle the appropriate Reader Service No.(s) on the enclosed Subscription/Reader Service card or contact the advertiser directly.

ALPHA PORTABLE SOUND BOOTH

- On-location isolation booth
- Quick and easy assembly
- High acoustical ratings STC-29 NRC.75



ACOUSTICAL SOLUTIONS, INC.

licensee Alpha Audio Acoustics

1-800-782-5742

READER SERVICE NO. 11

PRECISION BROADCAST CABLES NEC CL2

NEMAL ELECTRONICS

AUDIO

- One pair, 22-gauge
- Available in 7 colors
- Flexible jacket
- One-step stripping

NEMAL ELECTRONICS

VIDEO

- Low loss .7 db @ 10 MHz
- Same size as RG-59
- Flexible jacket

NEMAL ELECTRONICS

SNAKE

- 2-24 pair
- Each pair numbered

Complete line of broadcast interconnect products, connectors, custom panels and cable preparation tools.

NEMAL ELECTRONICS, INC.

12240 N.E. 14 AVE., NO. MIAMI, FL 33161

OFFICES IN NEW YORK & FLORIDA

Please call or fax for your copy of our 44-page Cable & Connector Selection Guide
US:(800)52-CABLE (522-2253) • Fax:(305)895-8178 • Intl.:(305)899-0900

See Us At SBE Booth #910

READER SERVICE NO. 79

UNLEASH YOUR ITC DELTA

The Audio Dynamics retrofit card can upgrade your Delta to an unprecedented level of cartridge audio performance.

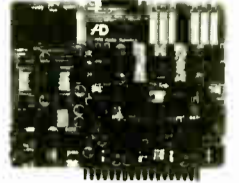

- DNR® Dynamic Noise Reduction provides up to 14dB of non-encoded noise reduction.
- An exclusive equalization trim network design provides a frequency response of 32Hz—16KHz ±0.7dB.
- The on-board three-tone cue detector is based on an asynchronous programmable logic device for quieter audio.
- Full compatibility is assured—just plug in and go!

Call for complete specifications
(804) 296-4111

AD Audio Dynamics

137 W. Buckingham Circle, Suite B
Charlottesville, VA 22901

DNR® is a registered trademark of National Semiconductor Corporation.

READER SERVICE NO. 138



Econco

REBUILT POWER TUBES



Approximately One Half
the Cost of New

3,000 Hour Unconditional Guarantee

Call for Our Price List

Econco 131A Commerce Ave. Woodland, CA 95695
Phone: 916-662-7553 Fax: 916-666-7760 Telex: 176756
Toll Free: 800-532-6626 From Canada: 800-848-8841

See Us At SBE Booth #524

READER SERVICE NO. 141

ANDREW HELIAX®

Cable & connectors

Cable up to 2-1/4", connectors up to 6".
Cable cut to length, pressurized, connectors attached. Cable hardware too!

In Stock....Ships Next Day!

Call for our FREE 96 page pricebook



CARTWRIGHT
COMMUNICATIONS COMPANY

7812 Red Sky Drive
Cincinnati, Ohio 45249

800-543-8614

READER SERVICE NO. 58

Books

Focal  Press

Opens the Door
to

New Skills

Books published specifically for
broadcast professionals and students.

Check out our new series of succinct, topical
handbooks: *The Electronic Media Guides*

Managing Electronic Media *The Federal Communications Commission*
Broadcast Writing *Full Service Radio*
Sportscasting *Radio Music Directing*

...And Many, Many Other Books ...

Call or Write today for our free catalog:
Professional & Technical Books on Operations & Techniques

FOCAL PRESS, Office #2

80 Montvale Avenue

Stonham, MA 02180

1-800-366-2665

READER SERVICE NO. 31

STILL RIPPING THE WIRE?

YOU'RE SPENDING \$75 - \$150/mo. ON PAPER AND RIBBONS FOR YOUR WIRE SERVICE BECAUSE YOU PRINT EVERYTHING ALL THE TIME

WireReady Newsroom Software™ lets you plug your wire service(s) directly into any IBM compatible XT/AT computer without the high costs associated with other systems. WireReady automatically prints just what your staff needs. Imagine the savings alone during nights and weekends. WireReady tracks all the news and lets your staff read and edit stories right on the screen and print only the ones they need. In fact, WireReady lets your staff type local news on the same computer with full split screen access. Too many other features to mention.

- No Weekly Fees! Own the basic system for only \$549
- 24/hr toll-free support and upgrades for only \$99/yr
- Multiple user and custom systems available for Radio & TV
- Compatible with AP, UPI, NOAA weather, Learfield Data
- Compatible with ABC, NBC, CBS and many others
- Soon to offer audio automation and cart features on same PC!
- In use all over the U.S.A. from the Virgin Islands to Alaska

800 833-4459

GERSTMANN SOFTWARE TECHNOLOGIES
FRAMINGHAM, MASSACHUSETTS (508) 820-7284

READER SERVICE NO. 52

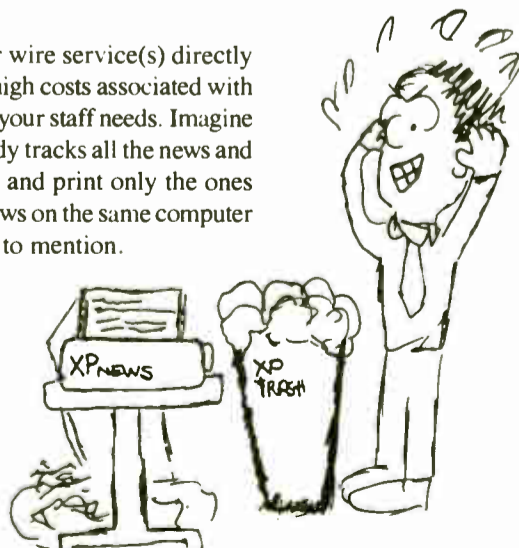

WHY LEAVE THEM IN THE DARK...

...when you can reach over
18,000 radio professionals
with your product showcase
ad? Gain valuable exposure
for your products or services
at minimal cost.

For more information
Call Simone at

1-800-336-3045

or

FAX 1-703-998-2966

Shure Solves Open Mic Woes

by Ty Ford

BALTIMORE Several years ago, Shure put out its Smart Mic System, a multiple mic system that used logic control circuits to allow the user to reduce the number of open mics in multiple mic situations like churches, courtrooms, conferences and talk shows.

The proprietary double-capsuled mics were designed so that if a source came from more than 60 degrees to either side of the center of the mic pattern, the mic would not open.

The logic was accessible enough to trigger other circuits. For example, upon receipt of the correct audio signal, a video camera could be switched to the appropriate video monitor. Although these and other features qualified the system as a major breakthrough, the fact that the user was limited to the use of four differently designed Shure proprietary AMS mics dimmed some of the enthusiasm.

Lather and mic ideas

In the company's continuing effort to bring useful products to the market, Shure showed the FP-410 earlier this year at the NAB show in Las Vegas. Director of mixer

The activation threshold of each input is continuously updated so that only sounds louder than the background level will "turn on" the mic.

With MaxBus, even if multiple mics are picking up that person's voice, as long as there is at least a 6 dB difference in level between the mics, the FP-410 shuts down the quieter mic, even if the front panel LEDs show both mics are receiving signals.

Last mic lock-on, as the name implies,



Shure's groundbreaking FP410



keeps the last mic spoken into "turned on." This ensures a constant room tone until the next person speaks.

Overall gain

The NOMA feature regulates the overall gain of the output as the number of open microphones increases. This keeps the gain from getting out of control as more microphones are "opened." When the number of open microphones doubles (one to two, two to four, four to eight), the level goes down 3 dB.

In addition to these "IntelliMix" features, the FP-410 also includes a defeatable fast acting peak limiter with a 3 msec attack time and a 350 msec recovery time that keeps overly loud passages from distorting the output.

Limiter threshold can be set to 0, +4, +8 or +16. This is not the simple limiter you've heard in earlier Shure products. It's a totally new design and sounds very good.

Each of the four channels is back panel switchable to accept mic or line inputs. The line inputs come in handy when using telephone hybrids and wireless mics that operate at line level.

The main output LEDs are front panel switchable to peak or VU. There are separate monitor input and aux output jacks.

The headphone output jack and volume control also are on the front panel. Pulling out on the headphone volume control switches the headphone feed from source to monitor. The built-in 1 kHz oscillator is activated when the main gain control is pulled out.

There are two balanced XLR outputs and one unbalanced 3.5 mm phone jack "tape" output on the back panel. All are overload- and short-protected, isolated

and each of the balanced outputs can be switched to mic or line level.

A total of 100

If you need more than four inputs, up to 25 FP-410s can be linked for a total of 100 inputs. The link mode is notably different than the simple links used in earlier Shure mixers like the M267.

Say you're using three FP-410s for a total of 12 inputs. The combined audio from all 12 inputs comes out of all three mixers,

which comes in handy if you're doing multiple feeds. You can even change the output levels of each of the units as needed.

In effect, you're getting a very versatile distribution amp. The manual/auto switch, when placed in auto mode, only affects the inputs of that mixer, regardless if it's the first, second or third mixer in a linked system.

With the older M267, which is a passive system, loading occurs when mixers are linked, which lowers the output level of linked mixers. When the FP-410 is in link operation, that does not occur.

The manual states that the IntelliMix features of the FP-410 can be used in conjunction with any existing console with inserts. In this configuration, you would run your mics through the console input, feed the insert outputs to the FP-410 and feed the single output of the FP-410 to a sub-master fader on the console. If the console insert jacks are after any EQ or dynamics processing on the console, you could process each mic separately before combining it into the FP-410.

Phantom power is switchable from 14V to 48V. Pettersen points out that phantom-powered mics running on 30V can be powered by the 48V supply. T-powered mics (which run pin two positive and pin three negative) and Nagra "red dot" (pin three positive, pin two negative) are not compatible.

The FP-410 will run on 80-132 VAC, 160-264 VAC or by two 9VDC batteries. Pettersen says the batteries provide up to eight hours of operation; less if phantom power is used.

Although the battery operation implies portable use, there are several considera-

tions that should be observed. The FP-410 is single space rack mountable, making it more cumbersome than Shure's FP31 and FP32.

The dip switches that allow modification of the limiter threshold, off mic attenuation, hold time, last mic lock-on and phantom power are not accessible once the unit is rack mounted. Also the battery case must be unplugged to allow access to the dip switches, which means you have to power down to get to them.

In addition to the stock configuration and those variable by the dip switches inside the battery compartment, the FP-410 has a number of engineer-modifiable functions, including the ability to customize the monitor input sensitivity, tape out level, off-attenuation value, low-cut filter frequency, peak meter attack and decay time constants, meter calibration, limiter threshold and hold time values.

You also can modify the lock-on circuit to permanently lock on or off one or more microphones, change the Monitor In jack to an Aux In for cascading mixers or creating a mix-minus, or reduce the program level feed in the headphones when the Pull For Monitor switch is activated.

That's a lot of versatility for a list price of \$1,595. For information, call Michael Pettersen or John Phelan at 708-866-2523.

■ ■ ■
Ty Ford helps people with their production woes. Find a comfortable couch, lie down and call him to unburden yourself before he puts in a 900 number. Until then, try 301-889-6201 or MCI mail, 347-6635.

PRODUCER'S FILE

products Michael Pettersen came up with the idea in the shower one morning.

Although the FP-410 can be operated manually, and uses any low impedance mics, its noise-adaptive threshold, "MaxBus," last mic lock-on and number of open mics attenuator—"NOMA"—make it a very useful device in controlling feedback and the hollow sound that multiple mics often create.

The noise-adaptive threshold "monitors" the input from each source. If the input becomes too constant, as in air conditioner noise, the mic will be "turned off."

FM TRANSLATORS

- **INTERFERENCE SEARCHES** based on NEW rules to locate a channel
- **DETAILED INTERFERENCE** studies optimizing Site Location and Directional Antenna designs. Calculates allowed ERP on all 360 bearings
- **TERRAIN ELEVATION RETRIEVAL** determines HAAT for 12 bearings (every 30 degrees)
- **DISTANCE TO CONTOURS** plots projected coverage
- **COVERAGE MAPS AND OVERLAYS** depicts signal coverage and other desired data
- **POPULATION COUNTING** to determine potential listening audience

dataworld[®]
A Service of DW, Inc.

P.O. Box 30730, Bethesda, Maryland 20814

FAX (301) 656-5341

(301) 652-8822 (800) 368-5754

Translator

(continued from page 21)

program material and therefore impose a certain rudeness toward listeners. And, AC operated time switches can get out of sync with real time, due to power dropouts.

Q: What happens to a translator application filed with the FCC?

A: All too briefly, the three sets get checked for fees and go to the Mass Media mailroom for examination. One set goes to the public reference room, another to the database staff.

The third flows through a file system for study about tenderability, after which the applicant is notified of acceptance. Minor changes are studied and acted upon in 30 days.

Otherwise, the application flows to an engineering and legal study. If, following a final engineering review, a hearing is not scheduled, it then goes to a computer-generated authorization point, and the proposal is granted.

■ ■ ■
Howard L. Enstrom is a broadcast consultant. He can be reached at 904-383-3682.

The Complete RF Exposure Measurement System from Holaday Industries

Measure Both E and H fields

ANSI RF exposure standard requires measurement of both the electric and magnetic field.

Automatic Self-zero

Completely automatic self-zeroing eliminates drift, improves accuracy of readings.

Recognized by Federal Agencies

Evaluated and used by NIOSH, OSHA, EPA and CDRH, as well as state, local health departments and consulting engineers.

Call or write for more information on these reasonably priced systems. Rental systems also available.



HOLADAY INDUSTRIES, INC.
14825 Martin Drive
Eden Prairie, MN 55344
Telephone: (612) 934-4920
Telex: 29-0922 FAX: 612/934-3604

NBS Probe Design

Isotropic probe design originated by National Bureau of Standards.

Displays Time Average Reading

Real-Time display of the current six minute relates directly to the ANSI RF average exposure standard.



Recession Stops Short of KJZS

by Dee McVicker

HOUSTON While some stations have tightened their belts at the mere mention of the "R" word, with a few even buckling under the weight of the publicized economic downturn, it is business as usual for other stations.

Such is the case with KJZS, an FM licensed to Conroe, Texas. The recession, by all appearances, had stopped short of the station when, during the latter months of 1990, its new owners master-minded the financing to upgrade the tower, change format, change call letters and move the station to a new studio facility on the 11th floor of a Houston highrise.

Everything—from tightening the nuts and bolts on the station's new tower to placing the billboard announcements of its new jazz format—was done first class.

The new studios were no exception. Said Harold Riley, KJZS-FM CE, "Our goal here from the beginning was to build a first-class facility." The result: KJZS-FM's

FACILITIES SHOWCASE

new studio complex in west Houston, which includes an on-air master control studio, two production studios and a news studio.

Transmigration of audio

Riley started the studio project with the obvious concerns of any engineer faced with stacking radio studios into a busy metropolitan highrise. His immediate worry was the transmigration of audio between floors.

Fortunately, he noted, "The way the building is built, there's about two feet or so between the ceiling and the next floor." With the concrete floor thick enough to isolate the studio complex from inter-floor noise, Riley was able to forego extensive isolation techniques and costs.

In addition, he said, "We're high enough up that the outside noise has not been a problem."

Riley did, however, take extensive precautions to quarantine stray noise from an office situated next to the new on-air control studio. On the end of the studio that joins with the office, Riley installed three floor-to-floor walls, each independently suspended from each other.

After preparing the studio complex for radio, Riley then began signal and studio layout and equipment selection. For signal routing, Riley elected to centralize access with punch blocks and to route signals through studio conduits. Everything, he said, comes back to the engineering room.

Enlisting the help of The Express Group, a firm specializing in top-line modular furniture for broadcasters, Riley was able to individualize each studio with module groups from two of the company's furniture lines.

New Wheatstone consoles

Riley also enlisted the help of Wheatstone to outfit three of the four studios with new consoles. "If you're going to build a top-of-the-line facility," commented Riley, "you start with a top-of-the-line console." In the station's eight-track production studio, a new Wheatstone SP-

5 is in use. In the new on-air control room and new two-track production studio, the station is using new Wheatstone A-500 consoles.

For the source of the station's new jazz format, or what Riley calls "smooth jazz" to distinguish the format from the more traditional New Orleans jazz, four new Denon DN 950FA compact disc players were purchased for the on-air control studio. Six ITC Delta cart machines, one Otari MX5050B recorder and a Technics SP-15 turntable also were purchased for the studio, as well as the Telos 100 telephone system.

Similar to on-air control, the two-track

production studio was designed to double as production and on-air backup. With similar equipment to the on-air, the studio "is readily switchable to air through a Gentner switcher," Riley said.

For the news studio, Riley elected to purchase a new ATI eight-channel Vanguard BC8DSR/L console. "I saw it advertised a lot, and was rather impressed with it," commented Riley, adding that he is even more impressed with the new board now that he's had a chance to use it.

Support gear surrounding the ATI board include an Otari MX5050B reel-to-reel, Tascam 122 MKII and a ITC 99B record/playback cart machine. A Gentner

SPH-5E telephone interface also is used in the newsroom, as well as a CRL Dynafex noise reduction unit.

Microphones used by the news studio and elsewhere in the facility are AKGs, each of which has a dbx 160X compressor and a Yamaha equalizer. The only exception to this, said Riley, is in the eight-track production studio, which has mic EQ off of the Wheatstone board to feed the AKG microphones and dbx compressor.

Heart of the facility

The new eight-track studio, the station's main production room with one four-track and two two-track Studer A807 reel-to-reels feeding the Wheatstone, is at the heart of the facility. Equipped with similar equipment as the two-track studio, as well as an Eventide H3000B Harmonizer,

(continued on page 26)

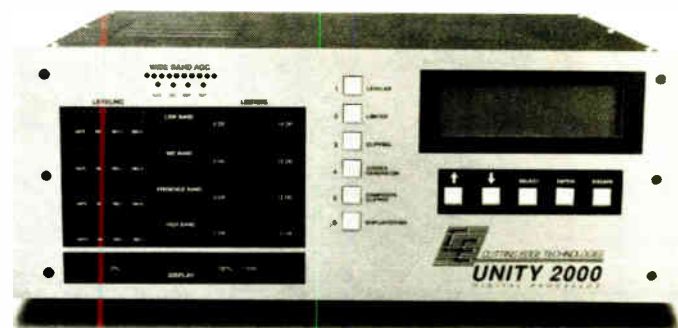
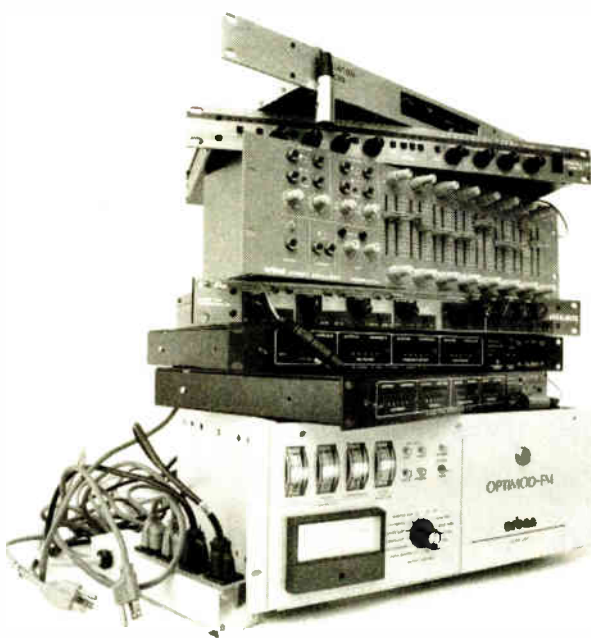

Sounds
Like
Radio

Sounds
Like
Music

The UNITY 2000 Digital Audio Processor
from Cutting Edge Technologies

Replaces an entire FM broadcast audio processing chain,
making your sound more open and musical than ever,
while maintaining the loudness you need.



CUTTING EDGE TECHNOLOGIES

2501 West Third Street • Cleveland, OH 44113 • TEL: 216.241.3343 • FAX: 216.621.2801

KinTel Initiates In-Band DAB

by Steve Crowley

WASHINGTON Late last year, when attention was focused on the Eureka 147 and Stanford Telecom DAB systems, a California company began circulating a proposal for an FM in-band DAB system. Since, five other companies have come forth with in-band DAB proposals.

The company that started much of the in-band DAB interest is Kintel Technologies, Inc., out of San Jose, Calif. Heading up this firm are Dr. Glen Myers, an electrical engineer who is now an associate professor with the Naval Postgraduate School in Monterey, Calif., and John

E. Leonard, Jr., president of JNS Electronics, a manufacturer of broadcast equipment.

CONSULTANTS CORNER

Leonard is familiar to many broadcasters through his previous association with Gentner Electronics; TFT; Moseley Associates; and Gates/Harris Corp.

Since Kintel's system is intended to not disrupt the existing FM service, it's called compatible digital audio broad-

casting, or CDAB. Using a technique it calls Power Multiplexing (a trademark), or PMx, it would occupy no more than 200 kHz of bandwidth on the same frequency as the associated FM station.

Most engineers have heard about time division multiplexing or frequency division multiplexing. Power Multiplexing works in the power domain, relying on the capture effect of FM receivers. A strong FM signal tends to suppress the effect of a weaker signal if the power levels are sufficiently different.

Kintel concludes that the reduction

in FM stereo broadcast coverage will be negligible if the digital signal is at least 10 dB below the main FM signal.

Keeping the digital signal at lower power is intended to minimize impact to FM. To extract the lower-power digital signal, PMx uses a Myers' demodulator incorporating a phase tracking circuit. This demodulator creates a replica of the FM signal, shifts it in phase 180 degrees, and adds it back to the original, attenuating it to the point where the digital signal can be recovered without interference.

In a paper presented at last April's NAB Engineering Conference in Las Vegas, Kintel noted three considerations in the selection of a waveform to carry the digital audio signal: the relation of the probability of bit errors to signal-to-noise ratio, the impact on existing FM receivers and the effect of multipath interference.

Candidates for waveforms include those that can reliably carry more than one bit per hertz of bandwidth, including multiple carrier modulation such as employed by the Eureka 147 system.

Another way to combat multipath interference is redundancy, interleaving and error correction of data in the DAB signal. These techniques require the transmission of more information, but Kintel says that extra capacity might be had by extending the PMx concept to more than one digital carrier—a digital signal would be underneath a digital signal, doubling the bandwidth available for DAB.

■ ■ ■

Steve Crowley is a consulting engineer with the Washington firm of du Treil, Lunden & Rackley, Inc. He can be reached at 202-223-6700 or by fax at 202-466-2042.

Thanks

Julian!

June 6, 1991
Pete Charlton
The Management
PO Box 1-36457
Fort Worth, TX 76136

WYER 104.5 FM
ATRA EASY RADIO

Dear Pete:

THANKS for making radio FUN AGAIN! Your Digital DJ system is fantastic. WYER went on the air at 12:00 noon on June 1, 1991 with the complete Digital DJ System you recommended including the on air system, production system, Super Log and Lantastic Network to tie them all together. We are on the air 24 hours a day with Unistar Special Blend and SOUND GREAT, thanks to you. People are calling to buy time. I've been in radio here for 33 years. It's never happened before!

I looked at all the systems out there including Smartcaster, Shaeffer, Systemation and support staff on your logging system and the features of the Digital DJ made the decision. Incidentally, I found your system was priced lower than any of the others for more features and hardware.

The System was easy to install, just as easy to understand and works flawlessly. WYER is a brand new FM in the area and after an experience with an AM Daytime stand-alone I decided this was going to be different! No more 14 plus employee staff to keep things going. Well, the Digital DJ came along just at the right time. We are on the air 24 hours a day and Sunday we have someone come in to update the weather. That's it! Staff now is me and three others. And ALL of us sell including my secretary who does telemarketing. (I may have to add another salesperson, the rest of us are getting very busy and can't handle all the sales calls.)

Alan Freeman, Dana Roach, Lawrence Miller and the rest of your staff been a real joy to work with. Have there been some problems? Of, course, but your people usually fixed them over the phone or with overnight software updates and fixes. Now it just runs all day. And some of your future plans for additional features and hardware sound really exciting. I can hardly wait.

Thanks for the fantastic system.

Sincerely,
Julian E. Jeltzer
President

Do It Right the First Time

We thought you might be interested in reading just one of the many letters we have received from our Digital DJ stations. Our installation at WYER is very typical: Digital DJ™ is running the Unistar Special Blend format with dual mono/stereo spot playback capability. A full production (DJ Log) system is interconnected through a low cost LAN network to the On-Air (Sky Pilot) DJ system. Also interconnected through the LAN network is the Super Log traffic system (Julian has been a Traffic system customer since 1982!). Spots are produced on the DJ production system and transferred at high speed via the LAN to the Sky Pilot system. The Super Log traffic system produces the Logs, Billing and a complete ready-to-run DJ Log that is automatically loaded into the system. In addition, the Traffic system computer is also used to update the Cut Indexes of the DJ system to keep everything up to date and to display and print a number of DJ Reports that are invaluable in keeping up with the activity in a busy station.

WYER has several periods of Live operation daily. Live Assist capability is standard on Digital DJ. The complete broadcast Log is accessible by the operator and no printed Log is necessary. WYER will be adding our DJPBR option to record and automatically time shift his CNN Network news and our DJRAR Remote Audio Recording feature to allow remote updating of his weather forecasts on weekends and overnight.

The entire WYER system above leases for about \$550.00 per month, complete. Single, standalone Satellite systems could cost as little as \$240.00 per month.

Digital DJ

Scrap Your Cart Machines: Record all your Spots and features on the Digital DJ computer hard disk. Instant Access. Super sound.

Satellite Programming: Digital DJ has built in control for any Satellite programming service. SMN, Drake, Unistar, Moody. You name it, DJ will do it. 24 hours per day, 7 days per week. For as long as you have current programming material loaded: Features matched Jock ID's., Liners, Jingles and Magic Calls. On-air dead breaks with automatic Sat fill. Auto Sub for automatic Spot substitution. Real-Time updating and event handling. Multi-network options. Full live assist included.

Automation Replacement: Replace your cranky Carousels™, Go-Carts™, InstaCarts™ and AudioFiles™ and worn out cart machines with Digital DJ. Unlimited capacity, instant access and long walk away. Works with any Automation controller of any kind. Easy plug in operation.

CD Automation: A special interface to Digital DJ programs stacks of the popular CD "6-pack" players. Use a Playlist interface to our low cost Music Log music selector program to get automatic download of the daily Playlist selections to Digital DJ. Can be used standalone or in combination with reels, live or Satellite programming.

Traffic & Billing: Over 1000 stations in North America are using our SuperLog, Simple Log or EZ Log Traffic & Billing. Direct interface to Digital DJ. Prices start as low as \$695 for single stations.

The Management Box 1-36457 Ft. Worth, TX 76136

800-334-7823 817-625-9761 Fax: 817-624-9741

KJZS Beats Recession

(continued from page 25)

CRL Dynafex noise reduction, Yamaha reverb, Yamaha SPX-900 audio effects unit and dbx 166 compressor/limiter, the eight-track is in high demand by the station's production personnel.

To keep eight-track functions accessible, Riley said, "(production) will go through the eight-track (to mix a spot) and have it laid on reel-to-reel and then someone else—a production assistant—will take it over to Production 2 (the two-track studio) and lay it on cart so as not to tie up the facilities in the main production studio."

This plan, he said, has enabled the station to maximize the use of eight-track equipment and keep the studio accessible for all needs.

With the station's esoteric format and its emphasis on production, Riley expects to put a new digital editor on-line at KJZS-FM in the near future. This studio addition, he suspects, will lessen the production burden on the eight-track studio and enable more to be accomplished in less time.

Riley also expects to be able to take advantage of a new model of production compact disc players when his budget permits. As a first-class facility, insisted Riley, KJZS-FM will need to change with the technology.

■ ■ ■

Dee McVicker is a free-lance writer and regular contributor to RW. She can be reached at 602-899-8916.

RADIOMIXER.[®] For everyone who thought a PR&E console was out of reach.

You've tried, but your console budget just can't accommodate a Pacific Recorders BMX—not this time. So you're probably thinking about settling for a copy, even though it won't have the standard-setting features, performance and long-term reliability that have made our BMX consoles so successful.

Fortunately, you don't have to settle. Radiomixer is genuine PR&E. All the way from its high quality components to its efficient BMX-style layout, comprehensive telephone mix system and unique Off Line Mix Matrix. Yet its manufacturer-direct price is no higher than the "clones."

How did the PR&E engineering team build a less expensive console without lowering our standards? Let's start with what we didn't do:

We didn't compromise on quality. Radiomixer uses the highest caliber components throughout, including our standard professional-spec meters, faders, and switches. Plus the best-sounding VCA technology in the industry. To keep Radiomixer's cost down, we've limited the number of different module types and mainframe sizes, and simplified the construction of the card frame, mainframe and modules.

The final result? In less than a year, Radiomixer has quietly become one of our most popular consoles. In fact, it's now one of the best-selling boards in broadcasting. Our color brochure will tell you more of the reasons why, and help you configure a Radiomixer for your particular application. To get your copy, call PR&E direct at 619-438-3911.



PACIFIC RECORDERS & ENGINEERING CORPORATION
2070 Las Palmas Drive • Carlsbad, CA 92009 • Tel 619-438-3911 • Fax 619-438-9277



The Right Advertising Media

by John Cummuta

DOWNERS GROVE, Ill. I wondered whether a column on selecting advertising media was relevant to contract or freelance engineers. I mean, it would be easy to assume that their potential market is relatively small, so they would be able to make personal calls on each prospect.

But over the past week as I was writing this, the entire world has changed. Communism is practically against the law in Russia. The member republics of the Soviet Union may have all quit by the time you read this, and entrepreneurialism is running wild where it was once banned.

All these things considered, I figured that many engineers may decide to see if they can pick up a few new clients in the

holds: The more targeted you get in your media selection and execution, the higher the cost per contact, but the more productive the results per contact will be.

Experienced marketers know that, in many cases, the optimum media selection is a combination of several media, each intended to do a different part of the job.

If you remember, a few issues back I mentioned the basic marketing acronym: AIDA. It stands for Awareness, Interest, Desire and Action. Those are the stages that you must bring each of your prospects through before they will reach a buying decision. Here's how you might

use interated media to work your prospects through AIDA.

Suppose you maintain a regular ad in *RW* and other trades read by target prospects. They will see the ad from time to time and it will make an impression.

You then do a direct mailing that says, "Perhaps you've seen my ad in *RW*. Well, there's something really important that I couldn't fit in that ad, and it could mean a lot of profit for you and your station..."

Your direct mail letter will cause your reader's brain to recall the ad, gaining additional impact for your message. The fact that you had an ad in print also gives

you imputed credibility as a legitimate, professional business.

Then, a day or so after you're sure your prospect has your mailing package, you give them a phone call. Your ad created Awareness, your letter created Interest, now your call can move them to Desire and potentially Action.

See how an integrated use of various media, with increasing targeting, can produce a net result that any one medium by itself would be hard pressed to accomplish?

By the way, good luck building your client list in the Soviet Union. Remember, when you write your ads and direct mail letters, their alphabet has more letter than ours.

■ ■ ■

John Cummuta can be reached at 708-960-5999.

ENGINEERING MANAGER

Baltic States or Eastern Europe, so advertising might be useful.

Target market selectability is the main determining factor in the choice of media, and specific options within a medium. Simply stated, target market selectability means how precisely you can reach *only* people who are likely to want what you're selling.

For example, you can more precisely communicate to potential clients by advertising in a broadcasting magazine than you could with the same ad in "People" magazine. The reason: The former's readership is more densely populated with prospects for what you're selling than is the latter's.

However, many of the readers of some of the broadcasting trades are not station owners or managers, so even though it is more targeted than a general interest magazine, you might be able to augment your "reach" with other means. So how could you assure yourself of thoroughly covering your intended marketplace?

Well, you could rent a mailing list of radio stations and do a mailing to the managers. To be even more targeted than that, you could mail only to the stations within your trade area.

If you use the direct mail option, you could pay as much as a dollar or two to actually reach a person. Believe it or not, some people will actually throw your letter in the trash unopened. You can reduce this by addressing the letter to a real person, by name.

If you choose to just mail to those stations within reasonable travel distance from your location, you have effectively reduced the size of your mailing even more.

So, you can see that each time you tighten the focus of your advertising efforts, you increase the cost per contact. But you overcome that by producing a higher number of positive responses per number of contacts made.

We could take our focusing another step by using telemarketing instead of direct mail. With telemarketing, by its very nature, you'll invest more time in each contact (so you'll get fewer done), but you'll be able to make more in-depth and usually more response-producing presentations.

And of course, telemarketing is more expensive than direct mail. So the rule

DIGITAL AUDIO.

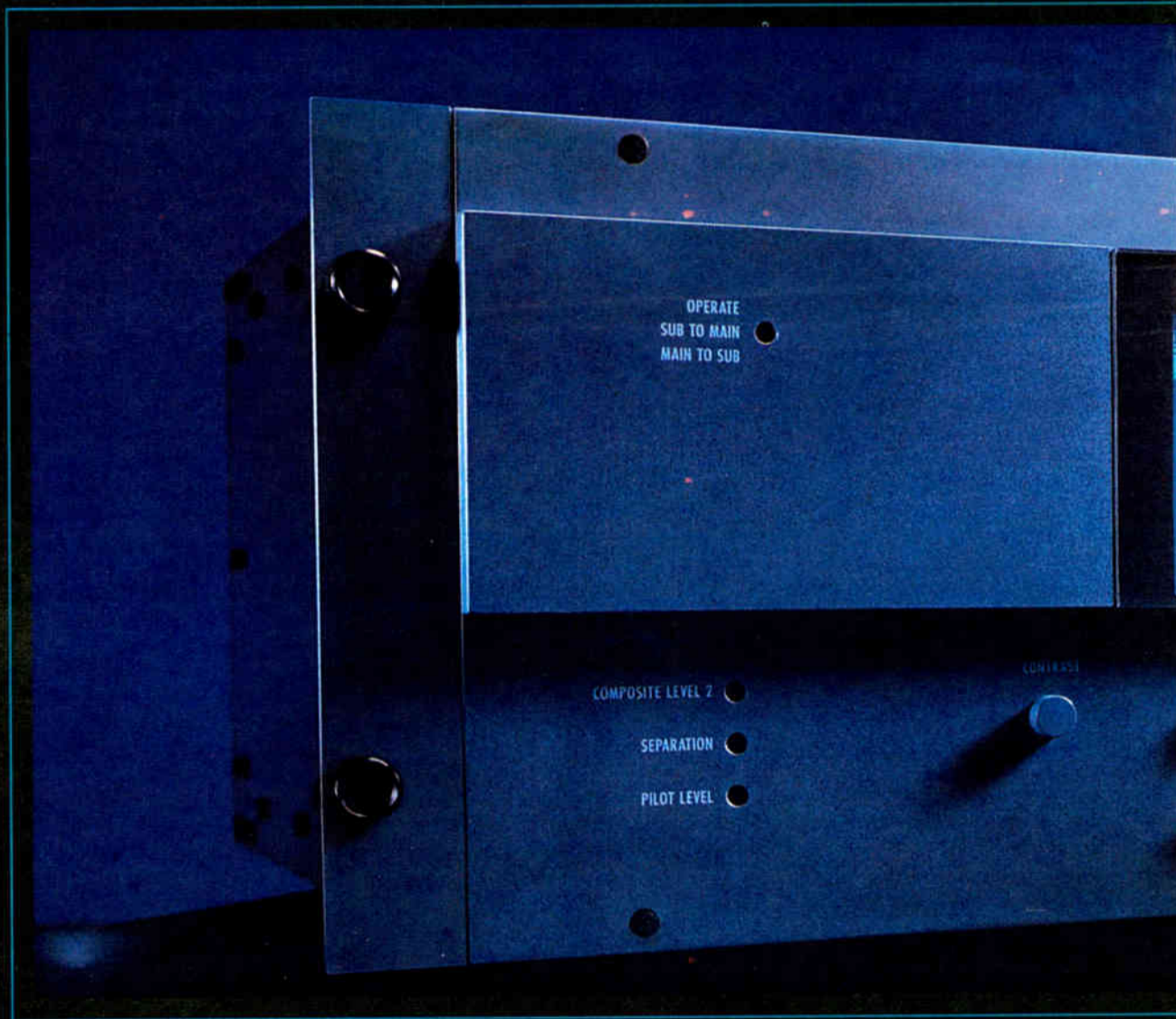

OPTIMOD-FM DIGITAL

The power of digital propels the 8200 to new levels of performance and functionality. OPTIMOD-FM 8200 is a true digital audio processor—the audio is digitized and all control functions are digital.

In addition to true digital audio processing,

which improves upon the successful "OPTIMOD sound," the 8200's digital control permits:

- ▶ **Changeable Processing Structures**—Modular Variable Processing (MVP) structures, the software equivalents of different traditional hardware configurations, allow the 8200 to change its sound with the push of a button.
- ▶ **Programmability**—The automatic preset switching feature changes the 8200's processing on

Reliving the Radio Memories of Youth

Dear Alex,

At this writing, I am mulling over an offer to join K-92 (WXLK-FM) in Roanoke as their midday man and resident production nut. You'll know more by next month.

Realistically speaking, I consider myself a little too young to be nostalgic about very much (although I still miss Freedomland Amusement Park, which folded some 30 years back), but only recently did I come across something

which really pushed the Memory Rewind key.

It was my old portable three-inch reel deck I toyed around with as a kid—I must have been all of eight years old when it came home from Arrow Electronics in Mineola, N.Y. More than anything else, this horrible little import machine had to be what got me hooked on recording technology and eventually, broadcasting.

For endless hours, my brother and

FROM THE TRENCHES

by Alan Peterson



I would pretend we were 77-ABC disk jockeys, playing our 45s under a three-pound Webcor phono tonearm, right into the "precision" crystal mic the recorder came with. The "WABC Chime Time" was provided by a well-placed pencil smack on a metal desk lamp.

You wouldn't find any delta sigma

64x oversampling on that junker and real-time EQ was accomplished by putting a hanky over the mic. It was noisy, hissy and ugly, with more wow and flutter than a rusty gramophone. Even the pressure pad holding the tape in place was a piece of Muppet fuzz on a bent spring. And I thought it was the best sounding audio device ever designed. I wouldn't have traded it for the top Nagra made at the time.

It finally croaked in my early 'teens when I tried to add an extra head to make it into an echo machine. Even though I completely ruined it, I didn't have the heart to pitch it. I am presently up to my hips in synths, the newest digital signal proc toys, my sequencer Linda and my Syracuse Burp Mug . . . all the "now" junk designed to make noise and I can't wrestle a broken no-name tape deck out of my own fingers.

Staring at that crummy little machine, I recall how much help I had along the way in learning about what I do now—a letter from Les Paul packed with tips ("In recording, start out flat with no peaks or dips . . ."). Herb Deutsch of Hofstra University, who let a 12-year-old Future Razor Rat of America make noise on one of the early big Moog systems. Trips to WTAE-AM in the Roosevelt Field Mall ("Don't bang on the glass") . . .

I also couldn't help but recall some of the real goinky gear my little deck prepared me for encountering. Tell me if any of these sound familiar.

That 1960 Bell & Howell reel machine with the "piano keys"—this was one unit best left forgotten by most of the guys I worked with. It was unstable, hummed when too hot and just had that "A-V Club" smell to it. In all fairness to the company, it was a consumer deck, but that didn't stop one jock from editorializing by relabeling it "Hell & Bowl."

I really enjoyed using WHPC's Uher ENG deck. My first real interviews ever with Henny Youngman and Rocky Graziano went to tape on this baby. I can hardly blame Station Manager Jim Green for retiring it when he told me a motor would cost 900 bucks to replace. *Nine hundred.* Two extra weeks of allowance on top of that and Jim can score a DAT machine.

And show me anyone who's never used a Magnecorder. Terrific versatile little decks that I still see in use. I really like these machines, but in 1983 ours began to suffer from what I call "staplethump." A leather drivebelt was held together by a metal cleat that would put a little flutter onto tape every time it rolled over the flywheel pulley. Two or three overdubs down, a 1 kHz test tone would have more vibrato than Perry Como.

How about a recordable medium that you tied a knot in to make a splice? I didn't buy it either until station owner Bob Gessner of WGES/WSGO showed

(continued on page 43)

DIGITAL CONTROL.

Bob Orban and his engineering staff worked tirelessly for more than half a decade to design a true successor to the worldwide, industry-standard OPTIMOD-FM 8100A.

The result. The OPTIMOD-FM 8200 Digital Audio Processor.



a programmed schedule, which is ideal for dayparting or for stations with multiple formats.

► **Expandability and Upgradability**—DSP cards can be added as needed when future software upgrades and additional processing structures require more processing power.

► **User-friendly Interface**—A large Liquid Crystal Display makes setup, adjustment and programming easy.

► **PC Interface**—With a standard computer modem, the 8200 can be controlled from a computer in your studio, home or car.

Call your dealer now to hear the power of OPTIMOD—in pure digital.

orban

A Division of AKG Acoustics, Inc.
1525 Alvarado Street
San Leandro, CA 94577 USA
Tel: (1) 510/351-3500
Fax: (1) 510/351-0500

© 1991 AKG Acoustics, Inc. Orban and Optimod are registered trademarks of AKG Acoustics, Inc. AKG is a registered trademark of Akustische U. Kino-Geräte Ges.m.b.H. Austria.



SYSTEM 12



SYSTEM 16



SYSTEM 20



SYSTEM 24



SYSTEM 8

Broadcast Audio Series VI Dependable, Affordable, Practical

Broadcast Audio consoles sound great, are easy to use and employ proven reliable electronics for absolute dependability. What's more, they offer blue chip value at new economical list prices with an extended warranty.

Top quality construction is a hard and fast rule. Double-sided ground plane motherboards assure minimum noise and cross-talk as well as superior RFI immunity. Premium Penny & Giles faders are standard. VCA's are not used. Ribbon cables aren't used for audio signal paths. The no-nonsense design doesn't cut corners.

All mixer modules can be interchanged freely

because console logic is not programmed on the module and each module is switchable between mic and line levels. Mixers and output amplifiers can be removed or inserted with power on. Additional flexibility is provided by three stereo busses and a mono mix-minus bus which are standard in all units. In short, high-grade construction and audio performance are uncompromising.

Broadcast Audio consoles are installed in every one of the 50 states in the USA. During the past 13 years, over 1,400 consoles have been delivered and virtually every one remains in use today. A 5-year warranty is provided on all new units.

Call Fidelipac for the name of your authorized Broadcast Audio dealer.



**SPECIAL OFFER
AT SBE HOUSTON
See Us In Booth 816**

Fidelipac Corporation □ P.O. Box 808 □ Moorestown, NJ 08057 U.S.A. □ TEL 609-235-3900 □ FAX 609-235-7779

WORKBENCH

Hangers on a Budget

by John Bisset

FAIRFAX, Va. In talking with manufacturers and distributors, I've been surprised at how many capital improvement projects have been pushed into the fourth quarter.

For many, it seems the improvement in the economy has freed up capital monies. For others, simple necessity has dictated that projects commence.

Whatever the case, the engineer is most

you can ensure that the chain will pass through it. Using chain as a support system saves money, and the "S" links used to secure the chain make height adjustments (to get the line level) very simple. Joe Davis can be reached at 703-998-2765.

Barry Thomas, CE at WPHR in Cleveland used all-thread when his budget was drying up. All-thread (threaded stock or threaded rod) is like a long bolt, with no head—hence the name "all thread."

Barry combined the all-thread with six-inch pieces of Kindorf channel to form a sturdy yet cost-effective support structure. By using channel nuts, the channel was easily adjusted to the required height. With the money Barry saved, he was able to buy a spare 20-foot section of rigid line.

I remember seeing a variation on the threaded rod tip not so long ago. In this case, the rod was bent to form a crook

the diameter of which was the same as the rigid line. The rod was supported in the same manner, using nuts and washers; the crook portion was covered with heat-shrink to prevent scratching the line. Barry Thomas can be reached at 216-348-0108.

If you own a Potomac Instruments Audio Analyzer (Model AA-51), you'll want to pick up the following Radio Shack accessory: Catalog #277-1008C, better known as an Archer mini-amplifier/speaker. Often the proof equipment must be used where

there is no convenient way to monitor the signals you are measuring.

The Archer mini-amplifier with built-in speaker solves that problem. What's more, the soft plastic case can be easily drilled to permit the mounting of a dual banana plug on the rear.

The finished product permits the amplifier/speaker assembly to be plugged into

place, these clips make the job a cinch.

Got a better way of doing something, perhaps a simple circuit that makes your job easier? Share it with your broadcast brothers and sisters in the pages of *Workbench*. Not only will you receive financial remuneration for your efforts, but being published in a national trade publication counts toward your SBE Certification credits. Fax your suggestion to me at 703-998-2966.

■ ■ ■

John Bisset is a principal with Multiphase Consulting, a contract engineering and projects company. He can be reached at 703-379-1665.

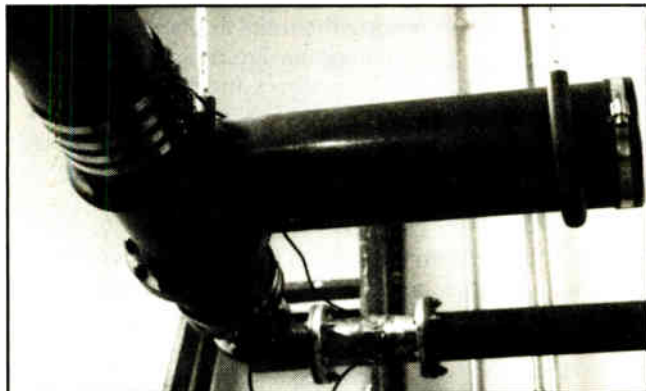

Common hardware store chain and heater hose makes for an inexpensive alternative when hanging harmonic filters or rigid line indoors.

certainly strapped by trying to do more with less. If your capital project involves the hanging of transmission line, you might want to consider several efficient, yet inexpensive alternatives.

Our first submission comes from Joe Davis, CE at WETA-FM in Washington. It involves trips to the hardware and auto parts store. Shown in Figure 1, Joe's alternative hanger system involves chain and rubber heater hose.

It's best to buy the heater hose first, so



the "scope" banana jacks on the front of the AA-51. Now, as you measure noise, for example, you can hear what you see on the analyzer meter. Listening to the distortion products you measure is equally enlightening.

Next time your phone man comes around, ask if he has any Dracon magnetic cable clips. Shown in Figure 2, these clips are the latest in routing cables along steel beams. The U-shaped clips have a pretty strong magnet, which makes for a more or less permanent installation. For routing cables in a suspended ceiling or in a building where there is no easy way to wire-tie wires in

**Air Cooled
Dummy Loads
now in power
ratings of
5kW, 10kW,
15kW, 25kW,
35kW, 50kW,
and 75kW
with low VSWR
that is stable
under power
with a
frequency range
of 60hz to
240Mhz.**

**QUIET
COMPACT
PORTABLE**



**ALTRONIC
RESEARCH
INC.**

For (OMEGALINE) RF
Coaxial Load Resistors

WATER AND AIR COOLED
MODELS FROM 5 to 200KW

CALL TOLL FREE
1-800-482-LOAD

P.O. Box 249
Yellville, AR 72687
(501)449-4093

ElectroFlash FTB 301

Obstruction Lighting That's Not Sky High.

Single Unit Flash Tube

Life is full of surprises, but when it comes to radio towers and aircraft, you don't need any surprises. Strobe lighting for tall structures is the most effective method of alerting air traffic to the location of obstructions. Why sacrifice visibility and waste money on the old-fashioned method of painting and repainting when the **ElectroFlash FTB 301** offers a much better method for marking structures 500 feet or less AGL?

The **ElectroFlash FTB 301** is an ETL tested, FAA approved medium intensity white flashing beacon that's simple to install. The fixture itself is affordable and operates reliably 24-hours a day with very low power consumption. The **FTB 301** is primarily used in AC applications, but can be ordered for DC compatibility if no electricity is available.

If obstruction lighting sounds like a tall order, let Flash Technology show you how inexpensive it can be to make your tower shine.

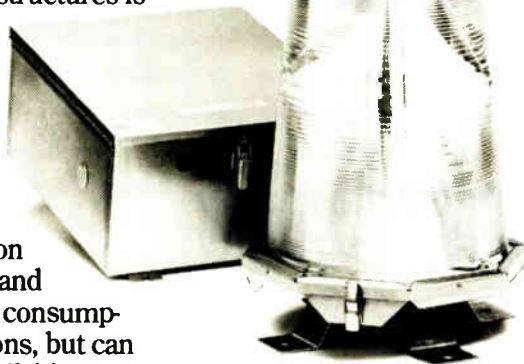

**FLASH
TECHNOLOGY**

Meeting the World's Safety Needs in a Flash

Flash Technology Corporation of America • P.O. Box 329 • Nashua, NH 03060 • (603) 883-6500 or FAX: (603) 883-0205

ElectroFlash FTB 301

Fax Modems Connect the World

by Barry Mishkind

TUCSON, Ariz. There are some of you out there that have never had your computer connected to anything except your

KEYBOARD CONNECTION

printer. If so, you need to know you're missing some of the best advantages of having a computer.

For example, would you like to send a message to someone thousands of miles

away? Or locate co-op money for one of your advertisers? Or, perhaps you are in great need of a schematic to fix a problem with a piece of equipment.

It might take several long distance phone calls to reach someone, and even more time to get a question answered or have a reply mailed to you. On the other hand, you can often make contact and get what you need to be more productive in a few minutes.

To get this speed of communication, all you need is a modem or a fax/modem in your computer. You can then leave a message for someone, interrogate a remote computer database for needed in-

formation, or receive a faxed schematic to fix the equipment problem.

Is your interest aroused? Modems have dramatically dropped in price over the past year. My local computer shop has several 2,400 baud internal modems at \$69 to \$79 each. Telecommunications programs run from simple ones included free with a modem, to sophisticated products like Crosstalk 4™ from DCA.

Fax/modems add fax send and receive,

BBS Update

As we've noted recently, Ray Vaughan has started a nationwide SBE echo, emphasizing the technical side of broadcasting. He invites local SBE chapters and other BBSs to hook into the discussions. Some more of the BBSs that have now joined this echo are:

Broadcaster's BBS	Phoenix	602-872-9148
StarScan	Montgomery Ala.	205-279-7313
CBFCC	Denver	303-341-0129
"The Black Hole"	Lima, Ohio	419-228-7236
Private Line	Austin, Texas	512-323-9383

and several are available at well under \$200. That's a lot less than the \$500 to \$800 most fax machines cost. Using your computer, you not only avoid slimy fax paper, but can view the faxes on screen, deciding which ones you want to print.

Among the units available, two of the fax/modems that I recommend come from Zoom Telephonics and Image Communications. These U.S.-made cards balance good performance with quite reasonable prices by combining both modem and fax on one card.

The Zoom FaxModem FC 96/24 (the numbers mean the fax speed is 9,600, the modem runs at 2,400) was installed quickly and easily. It comes with a seven-year warranty. I've used it to send faxes over to Europe and dial into BBSs (Bulletin Board Systems) all over the U.S. without any problems.

Installing these units is quite easy. All you need to do is set the jumpers for the COM port desired (COM1 or COM2 in 99 percent of all cases), open the case of your computer, insert the modem in an empty slot and plug in the phone line.

Setting up the software is nearly as easy. Most telecom packages run install scripts to customize the program for your setup. You'll be up and running in just a few minutes.

While the fax program included with the Zoom FC 96/24 was free, it was difficult

(continued on page 43)



The World Prefers Nautel Transmitters

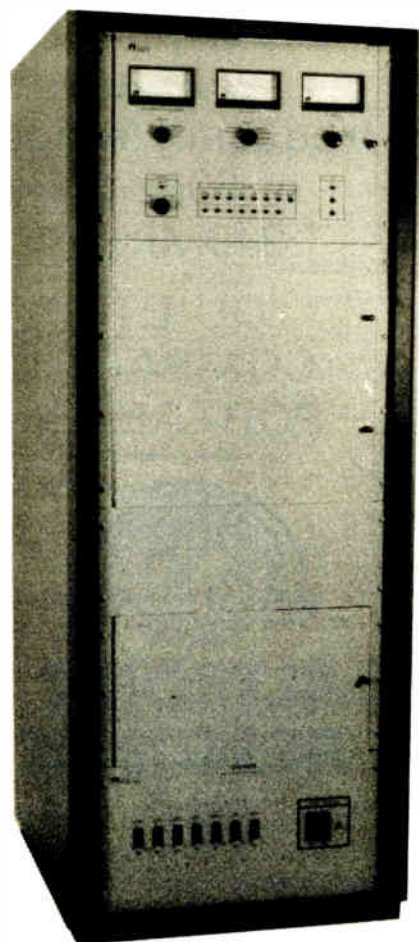

AM and now also FM Solid State Transmitters.

FM Broadcasters witnessed the introduction of the Nautel solid state modular 7kW FM transmitter at NAB '91.

This new product brings to FM the benefits of performance serviceability and economy enjoyed by our many friends now broadcasting with Nautel solid state AM transmitters.

AMPFET ND series second generation solid state AM transmitters from 400W to 100kW and more.

AMPFET FM4, 4kW
AMPFET FM7, 7kW

Phone: (902) 823-2233 Canada • Fax: (902) 823-3183 • Telex: 019-22552

Nautel
(Nautel Electronic Laboratories Limited)
R.R. #1, Tantallon, Halifax County,
Nova Scotia, Canada B0J 3J0

Nautel Maine Inc.
201 Target Industrial Circle
Bangor, Maine 04401 U.S.A.



Measure Up With Coaxial Dynamics Model 81070 WATTCHMAN Transmitter Protection System.



WATTCHMAN—protects your transmitter and transmission line system. A permanent 19 inch rack installation used with any dual socket line section 7/8", 1-5/8", 3-1/8" and elements (additional) to monitor CW, TV, and FM power. Model 81070 features two easily read meters to monitor both forward and reflected power. The reflected meter provides a front panel adjustable set point which controls the trip level for fast transmitter shut down and alarm. Abnormal load conditions quickly cause transmitter shut down in less than 15 milliseconds including control relay. Both visual and audible alarms indicate system malfunction. Contacts provided for remote alarm and reset switching.

Contact us for your nearest authorized Coaxial Dynamics Representative or Distributor in our World Wide Sales Network.

COAXIAL DYNAMICS, INC.

15210 Industrial Parkway • Cleveland, Ohio 44135
(216) 267-2233 or 1-800-COAXIAL
Fax: (216) 267-3142
Service and Dependability...
A Part of Every Product



RadioWorld®

Broadcast Equipment Exchange®

"Broadcast Equipment Exchange" accepts no responsibility for the condition of the equipment listed or for the specifics of transactions made between buyers and sellers.

ACOUSTICS

Want to Sell

ROSATI Acoustics
Acoustic Design • Consultation
Architectural, Engineering &
Analysis Services, Since 1976.
Solutions for Audio Monitoring
Anomalies, Vibration, Isolation
& HVAC Noise Control Problems.
Select Booth's Aural Contributions
"Isn't it about sound?"
617-423-5546 • Boston, MA

Circle 77 On Reader Service Card

AMPLIFIERS

Want to Sell

Crown MT1200 pwr amp, 1200 W, bridge mono, excel cond, \$750 ea+shipping. Philip, Big Red Sound, 172-28 Henley Rd, Jamaica NY 11432. 718-523-2815.

Langevin AM138G tube amp, \$150; (2) AM2138 amp, \$125 ea; Altec 1568 tube amp, \$200; RCA BA-33A, \$75; BA-74C, \$100. M Helelak, Milwaukee Sound, 610 N Water St, Milwaukee WI 53202. 414-272-7085.

Bogen Challenger 6-chnl amp, gd cond, \$75; Gates M6108 mon amp, gd cond, \$50; Henry Eng Match Box, excel cond, \$100; Lauderdale DA-8 4x2x2 dist amp, vgc, \$175. B Williamson, WWWK/WELV, Ellenville, NY. 914-858-2941.

Dyna SF70, pair, w/tube preamp PAT-2, \$400; all mint NAD 2140, as new, \$225. R Nelson, Tropical Brdcstg, 14093 SW 142 St, Miami, FL 33186.

CBS Labs 1602 stereo DA, 8 outputs/chnl, \$150. P Cibley, Cibley Music, 138 E 38th St, NY NY 10016. 212-986-2219.

Bogen AP35 stereo tube amp, \$50. M Saady, First City Rec, 141-60 84 Rd #3E, Briarwood NY 11435. 718-846-2062.

Marti PGM-20 line amp, \$40. P Wells, KJQY San Diego, 619-238-1037. FAX: 619-238-6157.

Tascam 1 headphone amp, 200 hrs; (2) Tascam LA-8 line amp, like new; call for prices. D Curtis, Creative Sound, 2810 W 4th St, Appleton WI 54914. 414-733-2299.

CBS Labs 1602 dist amp, dual 1x8, \$150. P Cibley, Cibley Music, 138 E 38 St, NY NY 10016. 212-986-2219.

Halco PB-2T R/PB amp, BO; Altec 1589-A 75 W amp tube, like new, BO. F Virtue, Virtue Studios, 8809-11 Rising Sun Ave, Philadelphia PA 19115. 215-763-2825.

Auditronics 1100DAGLC dist amp (20), in (2) Auditronics 1100MF 10-input mainframes, w/Auditronics PS60 RM external pwr supply, used 6 mnths, \$1500/all. B Lord, Lord Brdcstg, 13313 SE 208th St, Kent WA 98042. 206-631-2374.

Carvin FET900 200 W/chnl stereo pwr amp, fan cooled w/variable compressor, subsonic filter, ultrasonic filter, bridge switch, 3 space, 10" deep, 35 lbs, as new cond, \$400. B Fisher, KPOK, Box 477, Bowman ND 58623. 701-523-3883.

Perma Power S-102 amp w/S1420 batt holder, mobile/portable PA unit, 12 W out, SS, excel cond, \$100; Altec 1591A compressor amp w/15095 & 1578A matching xformers, all SS, mint cond, \$125. R Sumner, CAJU Corp, 3322 Applegate Ct, Annandale VA 22003. 703-560-0233.

WE 16575-L1 (2), made by McIntosh Lab, grt shape, rack mount, \$200; Auditronics 0.3, 100 W/chnl, rack mount, silver & black, excel cond, \$125; Sherwood AD260 100 W/chnl integrated amp, black & gold, new in box w/manual, \$115. R Glenn, WJGR, 1718 Shannoa, Wimauma FL 33598. 813-634-1940.

Dynakit PASII pre-amp, new & used cable w/Canons 3 prong; manuals for Ampex 351/350/601 & mixer MX-35; Pultec EQP1A; Univox headsets, new, stereo or mono guitar; monitor panel for 8 trk recorder through speakers to stepdown to 2 trk, or whatever. Mr. Oliver, 212-874-7660.

Want to Buy

Altec 287-F/287-W, any cond; also, WE amps, Marantz & Ampro vacuum tube audio amps, Westrex cutter amps. D deForrest, 7441 Wayne Ave #10-D, Miami Beach FL 33141. 305-866-5401.

Mono feedback amp for cutting vinyl records, must work on Gramphin cutter head. H Sewell, Oakridge Music Rcrdng, 2001 Elton Rd, Ft Worth TX 76117. 817-838-8001.

Harmon, Kardon, Marantz, Dynaco tube hi-fi gear, working or not. R Glenn, WJGR, 1718 Shannoa, Wimauma FL 33598. 813-634-1940.

Westrex RA-1474 line amp modules. J Roberts, ENCORE, Box 19302, Alexandria VA 22320. 703-683-2955.

ANTENNAS & TOWERS

Want to Sell

Belden cable: 8449, 8790, 8422, 9750, 8448, 8663, 8627, various lengths, new, \$1100/all or will sell separately, you ship; (4) Andrew 78ARF, 3" heliax connectors, never used, \$300 ea/\$1100 all. R Kerbawy, WTNJ FM, Box 1127, Beckley WV 25802. 304-877-5592.

Celwave CP-1000 2-bay, 2 kW antenna, missing harness, tuned to 107.1, can sell sep as (2) 1 kW single bays, BO. J Galanes, WAVI, POB 25016, St Croix VI 00824. 809-773-3693.

Celwave CFM-LP-3 FM antenna, 3 bay wideceers, tuned to 104.5, excel cond, \$2000. J Jetzer, WXR, 414-893-1045.

Utility G-480 440' tower, 30" face, (2) sections less than 5 yrs old, new guys & insulators, side lights, beacons, base insulator, all but (2) 20' sections in gd cond, on ground, please call. C Loughry, WFRB, RD2 Box 373, Frostburg MD 21532. 301-689-8871.

Stainless Tower GST-500, 500', 6' face, tradeout for dismantling. W Baxter, WFRM FM, POB 212, Suring WI 54174. 414-842-2839.

ERI 4-bay circ polarized high pwr antenna, tuned to 105.3, gd cond, bullets should be replaced, please call. C Loughry, WFRB, RD2 Box 373, Frostburg MD 21532. 301-689-8871.

Bendix Radio, 24" x 6" diameter, loading coil w/5" diameter variometer inside, unused, made for US govt, \$70. J Cunningham, YS-DA, Rt 2 Box 113B, Stonewall OK 74871. 405-265-4496.

Cablewave HF 4-1/8", 250'; CUZY Flexwell cable; 6-1/8" gas pass; 6-1/8" gas barrier connector; \$3000/all. B Weiss, KLSI, 3101 Broadway #460, Kansas City MO 64111. 816-753-0933.

Cablewave splice for 1-5/8" coax, \$195; Cablewave gas blocking end connector for 1-5/8" line, w/EIA flange, \$145; Phelps-Dodge CFM-LP-4 4-bay FM antenna, 94.3 MHz w/randoms, circ, excel cond, ready to ship, \$1500. B Brewer, KOKL, 410 W 6th, Okinlgee OK 74447. 918-756-3646.

Andrew 1-5/8" splice kit, new; used 1-5/8" splice kit; 3-1/8" to 1-5/8" reducer; BO. D Tabor, WLCK-WVLE, Box 158, Scottsville KY 42124. 502-237-3148.

ERI FML 3-bay tuned to 92.5 FM, used 2 yrs, packed in orig boxes w/all parts, like new, changed freq, \$2900. H Thompson, WLYU FM, POB 111, Lyons GA 30436. 912-526-8122.

Angular guyed tower, 120', on the ground, \$500. J Stromquist, WNCB, 2828 Piedmont Ave, Duluth MN 55811. 218-722-3017.

Cablewave FLC-7850J solid conductor AM line, 100', 7/8", BO. B Graham, WYMK/WEMR, RR#3 Box 1460, Tunkhannock PA 18657. 717-836-1460.

Jampro JHPC 5 bay antenna, tuned for 104.3 MHz, unused, \$6000 FOB. D Peluso, KJUL FM, 2880 E Flamingo Rd Ste E, Las Vegas NV 89121. 702-732-2200.

EZ Way 350', 16" face at bottom, 12" at top, all lights, you disassemble & move, BO. C Jones, WQBS, 2525 Dio Nona Ave, Macon GA 31206. 912-781-1063.

Celwave 6-bay FM, 10,000 W bay, 105.1 MHz, \$4000. R Murphy, 602-855-1051.

Andrew 194' antenna, 1-5/8" semi flex w/connectors, you ship, BO. J Harper, KQMC-FM, Box 44, Brinkley AR 72021. 501-734-1570.

Andrew ADF7-80A 1-5/8" foam dielectric xmission line, 197'; \$6/ft. S King, KATP-FM, I-40 W, Amarillo TX 79110. 806-355-9777.

Beam antenna (2), 160 MHz. T Noordyk, 616-924-4700.

Want to Buy

ERI rototiller antenna, 6 or more bay, on or near 93.3 & 95.5; tower, 500' taller, standing on ground; feedline also needed. R Wachter, KNSX, FAX: 314-921-2122.

Cablewave/Celwave 150-160' 1-5/8" air dielectric xmission line in gd used cond. K Diebel, KTJC-FM, 1207 Louisa St, Rayville LA 71269. 318-728-5852.

Cablewave HFM LP-4 antenna, 4-bay horiz only, tuned on or near 95.9 MHz; Also, any Class A antenna, horiz only, 4-8 bays, tuned to 95.9 or 96.7 MHz, incl Phelps Dodge, RCA, Collins, etc. T English, 70 Middle St, Bridgeport CT 06604. 203-366-9321.

Tall towers & antennas, 1 10-bay 107.1, 1 10-bay 98.3 or tunable; also, xmission line. B Zellmer, Colorado Farm Net, Box 2475, Greeley CO 80632. 303-330-1342.

Circular 6-7 bay, lw pwr tuned to 103.3 MHz. R Murphy, 602-855-1051.

High pwr FM antenna, 10 bay, 94.7. T Noordyk, 616-924-4700.

Grid dishes, 6', 8' & 10' for 95.0 MHz STL systems, reasonably priced; (6) pieces 7/8 heliax in at least 300' lengths w/connectors, reasonably priced. K Austin, Austin Brdcst, 1101 Hwy 81 N, Marlow OK 73055. 405-658-3330.

AUDIO PRODUCTION

Want to Sell

Eventide BD980 stereo delay, 15 kHz, excel cond, \$3500; Orban 222A stereo enhancer, excel cond, \$500; Tascam RS20 spring reverb, excel cond, \$100. B Williamson, WWWK/WELV, Ellenville, NY. 914-858-2941.

AUDIO
ANNOUNCING
TWO NEW OFFICES
COMPLETE RF
SYSTEMS

ROSCOM GENERAL

Featuring
ENERGY ONIX TRANSMITTERS

Bob Stewart—East
(404) 992-2230

Tom Butler—Midwest
(501) 253-8127

John Shideler—Rocky Mtn.
303-482-9254

Circle 123 On Reader Service Card

Dolby 361 SR & A type NR stereo pair w/cards for SR & A, work fine, \$2200/pair; BSR/dbx stereo tape hiss reducer, RCA inputs, variable low pass filter dynamically dependent on program content, \$49. R McMillen, 503-239-6070.

dbx 128 Type II NR w/comp & expander, \$150+shipping. Philip, Big Red Sound, 172-28 Henley Rd, Jamaica NY 11432. 718-523-2815.

Lexicon 224, 404 reverb, excel cond, BO; UREI 529 EQ, excel cond, BO. F Virtue, Virtue Studios, 8809-11 Rising Sun Ave, Philadelphia PA 19115. 215-763-2825.

dbx 140X NR in orig box, not used, \$100. S Cassidy, Radio Prog Services, Box 472, Manitou CO 80829. 719-661-1744.

Radio Design Labs pods to make (2) control boards, modular design, new, unused, request list, \$10,000 all FOB. D Peluso, KJUL-FM, 2880 E Flamingo Rd #E, Las Vegas NV 89121. 702-732-2200.

Yamaha SPX-90 Series II digital audio effects processor, vgc, \$285+shipping. B DeFelice, DeFelice Prod, 93-2R Fowler St, New Haven CT 06515. 203-397-2595.

Universal Audio 175 tube limiting amp, vgc, \$600; dbx K-9-22 card for Dolby A-360 mainframe (2), BO. J Guillebeau, Deer Tree Grp, 2165 E Clairborne St, Springfield MO 65804. 417-883-0120.

Lang PEQ-2 EQ, \$500; Organ 672A, \$500; Gates Sta-Level, \$300; dbx 160, \$350; dbx 166, \$350; Yamaha GC2020 2-chnl compressor, \$150; Yamaha R1000 dig reverb, \$125. M Helelak, Milwaukee Sound, 610 N Water St, Milwaukee WI 53202. 414-272-7085.

Digital LED up timer (5), 2", resets to 0 when 9:59 is reached or momentary closure made, self-pwr, \$57.50 ea, prepaid UPS. D Peluso, KJUL FM, 2880 E Flamingo Rd Ste E, Las Vegas NV 89121. 702-732-2200.

Want to Buy

Burwen TNE7000A or comparable. T Young, Bible Brdcstng Network, 1300 N Battlefield Blvd, Chesapeake VA 23320. 804-547-9421.

dbx Type 1 audio processing equip incl CD players & EQs. S Wood, Modern Syst Res, 12648 La Crosta Ct, Los Altos CA 94022. 415-941-8000.

RCA, WE, Altec & other tube amps; also, tube mixers, consoles, EQs, compressors & recorders. R Van Dyke, Caffrey House, 2 Squires Ave, E Quogue NY 11942. 516-728-9835.

Yamaha/Eventide harmonizer/effects unit. T Noordyk, 616-924-4700.

Ham radio operators looking for surplus audio processors, mixers & mics, as well as other inexpensive gear that could help bdcet engrs play radio at home among enthusiasts for vintage AM. Please write w/offerings. WA3VJB, Box 73, West Friendship MD 21794-0073.

AUTOMATION EQUIP

Want to Sell

MEI Satmaster 1000 event satellite programmer & (2) SMC 452 stereo Carousels, manuals, cables, recently removed, \$6000+shipping. R Kerbawy, WTNJ FM, Box 1127, Beckley WV 25802. 304-877-5592.

Conex CG25 tone encoder, excel cond, \$200; Conex CG25-R tone encoder, excel cond, \$225; Gates time pulse module, gd cond, \$100; Gates ATC logging encoder, gd cond, \$125; Schafer 903 automation system incl (4) R-R, (3) Carousels, used, \$4000; (3) Sonomag 250 cart Carousels, gd cond, \$200 ea; (2) Sonomag TS-25 tone decoder, vgc, \$200 ea. B Williamson, WWWK/WELV, Ellenville, NY. 914-858-2941.

SMC 450 Carousel (3), gd cond; triple deck cart player; MSP-1 programmer & control head; 350 Carousel for parts; SMC tone gen. J Galanes, WAVI, POB 25016, St Croix VI 00824. 609-773-3693.

SMC DAS 6/12 digital audio switcher, (2) SMC chnl 4 programmers, (2) Magnavox computer mon 80, SMC MSP-12, (3) mono SMC Carousels, racks, cables, etc. BO. P Berger, WNAM/WUSW, POB 707, Neenah WI 54957. 414-727-2040.

Sonomag 350RS Carousel (2), used but operate, \$1000 ea/BO; (3) standard equip racks, used, \$300 ea/BO; BE automation rack, used, \$400/BO; Gates 5-chnl stereo Statesman board, needs work, BO. S Willett, WAYI/WBZA, Glen Falls NY, 518-792-2151.

Schafer/Cetec 7000 brain; also, (1) Audiofile & (2) SMC 248 Carousels, pick-up only, BO. D Doughty, H&D Brdcst Group, POB 781, Utica NY 13503. 315-797-1330.

IGM Go-Cart 24, used 1 yr, w/manual, gd cond, \$3000/BO; Systemation Superswitch, 6 closures, w/manuals, like J Pescatello, WMMW-AM, 900 E Main St, Meriden CT 06450. 203-634-1470.

IGM Go-Cart 24 (2), 2.5 yrs old, on air, mint cond, must sell quickly, BO. J Amburn, KTUE/KJMX, POB 1260, Tulia TX 79088. 806-995-3531.

SMC/MSP 12, w/(3) 450 Carousel, (2) rack, set up for Unistar Adult Contemp, in use, removed when sold, BO. C Veirs, 901-772-3700.

Otari ARS-1000DC (4), PB only w/brackets, tone sensor & auto rewind, excel cond. \$900 ea. B Christie, Grande Radio, POB 907, LaGrande OR 97850. 503-963-4121.

Tone detectors from diff mfrs (8), 25 Hz, some spare units for parts, \$50 ea/trade all. S Callahan, WCEG, 1120 Pinellas Bayway, St Pete FL 33713. 813-821-9549.

Schafer 903E, complete in fair cond, (3) wrking Audiofiles, (3) Audiofiles need repair, keyboard, RAS cards updated, new PS battery, \$5000, you haul/pay shipping. M Hoffman, KNCK/KCKS, RRI 11th, Concorde KS 66901. 913-243-1414.

SMC TS-25 tone sensor, new, w/spare chips & manual, \$300/BO/trade; Gates FA-25 25 Hz tone filter, passive, gd cond, no manual, \$100/BO/trade. D Willey, Life Brdcstg, POB 96, John Day OR 97845. 503-575-1840.

SMC 250RS 24-tray cart Carousel (3), w/front panels, mounting hardware & full doc, wrking for parts, you ship, \$400 ea/\$1000 all. A LoPresti, AJL Soundwave, 21 Carter Rd, Geneva NY 14456. 315-789-4019.

Otari ARS-1000 R-R tape transport (2), \$675 ea. S King, KATP-FM, I-40 W, Amarillo TX 79110. 806-355-9777.

Harris 9000 w/R-R, 48-tray Go-Cart, (2) 24-tray Go-Cart, (6) other source cards, spare boards, you ship, \$2600. G Faluts, WZMX, 100 Executive Dr, Farmington CT 06032. 203-677-6700.

SMC system, (4) 350 RSB mono Carousel, (2) double cart transport, PDC-5 clock, DS-20 switcher, DP-2 programmer & racks, will part out, BO. D Blankenship, WTKT AM/FM, 2600 Iron Works Rd, Georgetown KY 40324. 502-863-1580.

Harris System 9000, complete wall assoc equip incl (4) Otari PB, (2) Go-Cart Carousel, data terminal, keyboard, printer, gd wrking cond, \$7000/BO. R Crossman, WJMA, POB 271, Orange VA 22960. 703-672-1000.

IGM Rampart Satellite System, brain, controller cards, 72-tray Go-Cart, 48-tray Instacart, Carousel Plus/parts, SMN controller & clock system, complete manual set, mono but capable of stereo, in service & working, \$6500/BO. M Johnson, 2745 Alexander Ln, NE Albany OR 97321. 503-926-3994.

BUSINESS OPPORTUNITIES

Want to Sell

Prior owner/operator w/22 yrs exper will build your AM/FM station, facility construct to hiring/training staff, upgrades, turnarounds, will consider equity. R Ritchey, 512-828-9252.

CAMERAS (VIDEO)

Want to Sell

Ikegami 730A w/Canon J12X9 BIE lens, plate, case, excel cond, \$4200. M Veselich, Walden Group, POB 10451, Marina Del Rey CA 90295. 213-871-0392.

Hitachi FP-10 industrial color ENG camera w/pwr supply, shotgun mic, road case, manual, \$1800. D Bailey, Rock Shoppe Prod, 3422 Beech St, Rowlett TX 75088. 214-475-9796.

CART MACHINES

Want to Sell

Misc cart players incl: ATC, BE, Collins, Gates, Harris, Spotmaster, Tapecaster, some for parts, call for details. B Williamson, WWWK/WELV, Ellenville, NY. 914-858-2941.

Sharp XC-A1 camera control unit & multi-core cable. K Knowles, Knowles Video, POB 12127, Tallahassee FL 32317. 904-878-2298.

BE Cartwinder w/over 200 Fidelity carts for parts, gd cond, BO. M Ring, WTNJ AM/FM, 134 Mallin St, Watertown NY 13601. 315-288-0790.

BE eraser/splice finder, Audicord DL stereo recorder, Otari CTM10 stereo R/P, never used, BO, like new equip, used only in limited lab testing. S Martin, 609-235-3900.

BE 3203 stereo R/P w/3 tones, mint cond, used vly little, \$1495; BE 3102 stereo P w/3 tones, mint, \$995; BE 3300 mono R/P w/3 tones, \$795. B Mounjoy, WITM-AM, POB 1240, Elizabeth TN 37644. 615-543-5849.

IT PDII (2), w/remote start, fair cond, \$100 ea. J Pescatello, WMMW-AM, 900 E Main St, Meriden CT 06450. 203-634-1470.

Spotmaster 500, plays but needs work, you pay shipping, \$150. B Davis, BDMZ Prod, 408 N 11 St, St Joe MO 64501. 816-279-6851.

UMC 11-113 mono repro, 3 tones, \$325; set LEL alignment gauges for Ampro cart decks, \$15. P Wells, KJQY San Diego, 619-238-1037. FAX: 619-238-6157.

Nortronics cart machine R/P heads, singledual trk, \$10 ea. M Jones, WIVK, 6711 Kingston Pk, Knoxville TN 37939. 615-588-6511.

Keycart mono cart R/P w/extra belts, 3 yrs old, \$300. R Ness, WGEN, 1003 S Oakwood Box 67, Geneseo IL 61254. 309-944-4633.

CART . . . WTS

Spotmaster 505, (2) R/P, (1) P only, gd cond, \$200 ea; Sparta cart delay, like new, \$500. R Meyer, Benchmark Comm, 4700 SW 75 Ave, Miami FL 33155. 305-262-5963.

Spotmaster 2000 RPS stereo R/P, needs minor cue tone adjust, \$195. Davis, MCP, POB 521, Newberry SC 29108. 803-276-0639.

ITC Delta I stereo (2), in use, w/manual, \$1250 ea. D Donovan, KCGR FM, 1620 American Bank, Corpus Christi TX 76226. 512-888-8555.

ITC SP stereo PB, gd cond, no manual, \$450. S Kowalski, 407-695-5553.

ITC sngl play (5), mint cond; (3) ITC sngl R/P, mint cond; (2) ITC 3-shelf machine; (2) ITC BE-2100 R/P mono; (4) Criterion sngl P, gd cond; (2) ESL bulk splice finder eraser. T Noordyk, 616-924-4700.

Tapecasters incl: X700RPS, gd cond, \$695; X700PS2, gd cond, \$495; 700RP, gd cond, \$450; 700P, \$195. A Ishkhanian, 9723 Riggs Rd, Adelphi MD 20733. 301-439-7222.

Sono Mag 352 Carousel (3); (5) Sono Mag 350 Carousel; (2) Audicord 101R cart machine. G Gilbert, CSRG, POB 50539, Denton TX 76206. 817-380-0229.

Want to Buy

Tapecaster 700 RB & RP, poor-gd cond. A Ishkhanian, 9723 Riggs Rd, Adelphi MD 20733. 301-439-7222.

CASSETTE & REEL-TO-REEL RECORDERS

Want to Sell

Misc R-Rs incl: Ampex, B&H, Omnilib, Revox, Scully, Teac, call for models & prices; Goldstar port cassette recorders, vgc, \$15. B Williamson, WWWK/WELV, Ellenville, NY. 914-858-2941.

HEAD RELAPPING/REPLACEMENT
All tape and film formats
30 years experience



350 N. Eric Drive
Palatine, IL 60067
708-358-4622

Ampex 602 FT mon, portable case, ave cond, \$60 UPS paid; Ampex AG500 FT mono, portable case, gd cond, \$150 UPS paid. W Arnett, WBAT, Box 839, Marion IN 46952. 317-664-6239.

Denon DRM2 (4), (3) w/new motor & idler arm, mic inputs, gd cond, all working, \$75 ea/BO or \$250/all+shipping; Uher R-R, DKN I/Os, cables, \$100/BO. B Strapko, 708-830-0701.

Sony TC105-A (3), (2) wrkg, (1) for parts, \$50/all+shipping; Marantz PMD 200, for parts, \$10+shipping. P Mueller, KUTA-AM, N Hwy 191 G-1, Blanding UT 84511. 801-678-2261.

Teac/Tascam 35-2 & 35-2B R-R 2-trk rcrdrs, (1) w/dlx, recently refurb, w/attractive, custom, side-by-side console, excel cond, \$1700/BO+shipping. W Ahlberg, Davis Glick Prod, 11846 Ventura Blvd #306, Studio City CA 91604. 818-509-9100.

MCI JH-110B FT stereo for 14" reels, in metal roll-around cabinet, \$1875/trade for computer, etc. P Wells, KJQY San Diego, 619-238-1037. FAX: 619-238-6157.

Otari MX5050 1/4" 4-trk; Teac 32-2B 1/4" 2-trk. J Edman, Results Brdcsng, 7732 Tampa Way, Shreveport LA 71105. 318-797-3211.

Otari ARS1000-DC R-R PB tape deck (2), w/none sensors, excel cond, \$600 ea. B Brewer, KOKL, 410 W 6th, Okinukeing OK 74447. 918-756-3646.

Ampex AG440 1/2" 4-trk w/console & dbx Type II NR, \$650. R Correns, Madison Park Prod, 700 W Pete Rose Way, Cincinnati OH 45203. 513-651-5375.

EXPERT REVOX REPAIRS
Fast Turnarounds — Competitive Rates
15 ips mod. for A&B77's \$350
Capstan shaft resurfacing, \$35.
JM TECHNICAL ARTS
30 Music Sq., W. #5
Nashville, TN. 37203 (615) 244-6892

Dictaphone 10 chnl logger, 1/2" tape, dual transport, fail-safe, time code gen/reader, metal cabinet, \$1000. Mel Crosby, Sequoia Electronics, 408-866-8434.

Electrosond 200 Series cassette splicer head, very low mileage, \$50. Mel Crosby, Sequoia Electronics, 408-866-8434.

Magnecord PF-6, (2) stereo, (3) FT mono, amps, cases, parts, manuals, all/part, fair-gd cond, BO; RCA 2" tape transport components, (1) capstan motor, (2) reel motor w/platforms, brakes, guides, pinch rollers, gd cond, BO; Shafer logging recorder, 10-1/2 reels, 3/6 ips, 1/4-trk, 2-chnl, gd cond, \$200. R Meyer, Benchmark Comm, 4700 SW 75 Ave, Miami FL 33155. 305-262-5963.

Tascam Mini Studio Porta II, like new, w/all papers & instruct, \$399. Dan, 206-546-1498.

Tascam 22-2, 1/4", 1/2-trk, 7.5/15 ips, clean, just tweaked, \$400. J Kreines, DeMott/Kreines Films, 5330 Kennedy Ave, Millbrook AL 36054. 205-285-6179.

Otari 8-chnl rcrdr w/remote, less than 200 hrs; Otari 2-chnl rcrdr, like new cond; Master Cassette Deck MCS-3590 w/NR & dbx; (12) Cassette Deck MCS-3556 for dupl cassettes; port case for Ampex AG-440B & case for electronics; call for prices. D Curtis, Creative Sound, 2810 W 4th St, Appleton WI 54914. 414-733-2299.

Studer 820 2-trk master rcrdr, latest mods & software, mint cond, \$9000+shipping. R Canaia, Cantrax Recorders, 2119 Fidler Ave, Long Beach CA 90815. 213-498-6492.

ITC 750 reel deck (2), (1) w/recrd amp & extra parts box, \$700/all; (2) Magnecord mono R/P, (1) rebuilt, (1) unknown cond, BO; Rollaround adj tape deck rack, gd cond, \$50+you pick up. R Ness, WGEN, 1003 S Oakwood Box 67, Geneseo IL 61254. 309-944-4633.

Ampex 440-C 4-trk w/servo capstan, heads manual, \$500. C Benner, WUSL-FM, 440 Domino Ln, Philadelphia PA. 215-483-8900.

Ampex 300 ('53) w/tube elec, w/new spare pinch roller & manual, drive motor may not operate, \$75+shipping. J Morinelli, Morinelli Entertainment, 901 Fairfax Rd, Drexel Hill PA 19026. 800-666-2641.

Otari MX-5050B 2-trk stereo, gd cond, \$995; Otari MX-5050 2-trk stereo, gd cond, \$795; Otari MX-5050 FT rec/stereo play, \$595. B Mountjoy, WITM-AM, POB 1240, Elizabeth TN 37644. 615-543-5849.

Otari 5050B, new capstan motor w/PC board, \$100; Panasonic SV3500 DAT demo, checked by mfr, \$850/BO. R Rhodes, Rhodes Music, POB 1550, NY NY 10101. 212-245-5045.

Ampex torque motors, new, AG440, \$50; AG440 w/brakes, \$80; 350/351 Series w/brakes, \$80. Mel Crosby, Sequoia Electronics, 408-866-8434.

Scully torque motors, new, Elinco brand, all speeds, \$200/each. Mel Crosby, Sequoia Electronics, 408-866-8434.

Dictaphone 20 chnl logger, 1" tape, dual transport, fail-safe, time code gen/reader, metal cabinet, \$1500. Mel Crosby, Sequoia Electronics, 408-866-8434.

Scully 280 4-trk, in console cab, gd cond, BO; Scully 280 2-trk, w/portable cases, gd cond, BO. F Virtue, Virtue Studios, 8809-11 Rising Sun Ave, Philadelphia PA 19115. 215-763-2825.

Audiotronics AV123-4TS 1/4-trk; Infonics RR-1, 73M, FT; Infonics RR-2, 74M, 2-trk; all gd cond, all/part, \$200 ea. R Meyer, Benchmark Comm, 4700 SW 75 Ave, Miami FL 33155. 305-262-5963.

Tascam Mini Studio Porta II, 4-chnl, like new, w/all papers & instructions, \$399. Dan, 206-546-1498.

Ampex PR-10 stereo rack mounted R-R, w/some spare parts & manual, excel cond, \$250/trade. S Callahan, WCEG, 1120 Pinellas Bayway, St Pete FL 33713. 813-821-9549.

Tascam RC-71 wired 12-pin remote for model 38 & similar equip, \$55. B DeFelice, DeFelice Prod, 93-2R Fowler St, New Haven CT 06515. 203-397-2595.

Ampex 300, 350, 351, 440 NAB spring-type hold down adapters (6), as new, \$20 ea. M Saady, 1st City Rec, 141-60 84 Rd 3E, Briarwood NY 11435. 718-876-2062.

Ampex 601, w/out cover, many spare parts & manual, excel cond, \$150. S Callahan, WCEG, 1120 Pinellas Bayway, St Pete FL 33713. 813-821-9549.

Tascam 38 8-trk R-R, brand new, w/(4) reels Ampex tape, all manuals, in box, new cond, must sell, \$1700. B LeCato, WKRE, POB 220, Exmore VA 23350. 804-442-5000.

Ampex AG-440C stereo, fair cond, \$400. G Falut, WZMX, 100 Executive Dr, Farmington CT 06032. 203-677-6700.

Revox PR-99 MK II 1/2-trk stereo P (5), \$1200/each FOB. D Peluso, KJUL FM, 2880 E Flamingo Rd Ste E, Las Vegas NV 89121. 702-732-2200.

MCI 110B, several; also, 110As, Otari 50/50Bs; all gd wrkg cond, plus many spare parts; \$500-1500+shipping. M Shea, Precision, POB 723, NY NY 10276. 212-989-2684.

Telefunken M15A 1/4" stereo in console w/meters, 15/30 NAB, w/manual, \$4000/BO; Otari 5050B rebuilt capstan motor w/PC board, \$125/BO. R Rhodes, Rhodes Music, POB 1550, NY NY 10101. 212-245-5045.

Ampex AG-440 2-trk stereo, console mounted, w/manual & all cables, gd cond, \$750. D Harbour, KISI, 212 S Main, Malvern AR 72104. 501-337-9000.

Atari R-R PB (3), G Gilbert, CSRG, POB 50539, Denton TX 76206. 817-380-0229.

Want to Buy

Otari 4-trk in gd cond. J Laprad, Sunspots Prod, Box 403 W Side Station, Worcester MA 01602. 508-755-0732.

Ampex 351 stereo headstack, fair-excel cond. D MacKenzie, WJBR AM-FM, 2617 Ebright Rd, Wilmington DE 19810. 302-475-4000.

Uher recorders, all conds; also, access, manuals, new parts stock, promo items & ads; mini R-R recorders, esp 2" reel capacity; also, empty 2" & colored reels up to 5"; plus, vintage open reel access from '60s. J Morinelli, Morinelli Entertainment, 901 Fairfax Rd, Drexel Hill PA 19026. 800-666-2641.

Ampex MR-70, gd cond. D deForrest, 7441 Wayne Ave #10-D, Miami Beach FL 33141. 305-666-5401.

Stellavox SP7 stereo; ABR lrg reel adaptor for SP7; Stellavox TD88. R Cummins, 212-219-3670.

MCI/Sony capstan & reel motors, any cond., recd/gd heads, most mfgs, machines, new, used. Relapped then sold. Amp Services, 224 Datura St No 614, W Palm Beach FL 33401. 800-826-0601, in FL 305-659-4805.

Ampex ATR100 taperecorders for parts. Circuit cards, heads, motors, machine parts, or electronic parts. Call 818-907-5161.

Scully '100' recorders, record/play amplifiers, 8, 16, 24 track heads. Sequoia Electronics, 1131 Virginia Ave, Campbell CA 95008. 408-866-8434.

CD's

Want to Sell

Studer A727 studio CD player w/balanced XLR outputs, rack mount & complete doc, excel cond, \$1175+shipping. B DeFelice, DeFelice Prod, 93-2R Fowler St, New Haven CT 06515. 203-397-2595.

COMPUTERS

Want to Sell

Wang 2200 PC Business System for use w/Computer Concepts Broadcast System, BO. M Ring, WTNV AM/FM, 134 Mallin St, Watertown NY 13601. 315-288-0790.

IBM Proprinter dot matrix, \$40; Proprinter II for parts, \$15; (4) TAB 132/15 editing terminals, 15" screen, \$25 ea. P Russell, Bowdoin Coll, Sills Hall, Brunswick ME 04011. 207-725-3066.

CONSOLES

Want to Sell

Radio Systems ESA-10 w/manuals & copy stand, \$4500; BE 5S150 w/manual, \$1500. T Pless, WHYY, 112 Main, Annapolis MD 21401. 301-626-0103.

Russco 505S stereo 5-chnl board w/10 inputs, cue & mon systems, \$600. J Laprad, Sunspots Prod, Box 403 W Side Station, Worcester MA 01602. 508-755-0732.

Collins 8081-1 portable console w/TT, all transistor, never used, like new, BO. J Anderson, WKCU/WXPZ, 2192 Hwy 72 E, Corinth MS 38834.

Pyramid PR8900 mixers (2), grt cond, \$300/BO. J Galanses, WAVI, POB 25016, St Croix VI 00824. 809-773-3693.

Gates Ambassador 5-chnl w/(4) xtra chnlis, used, \$300; Gates Yard II mono 8-chnl, vgc, \$500; Prokit audio mixer, 6-chnl, used, \$75; Shure, M68 mixer, vgc, \$100; Sony MX14 6-chnl mixer, gd cond, \$30; Sony MX650 8-chnl mixer, gd cond, \$50; Sparta S-15 mixer, used, \$25. B Williamson, WWWK/WELV, Ellenville, NY. 914-858-2941.

RCA 6B6 tube-type 2-chnl, functions wrkg, grt old board, \$800+shipping/BO. T Heathwood, Heritage Radio Classics, POB 16, Boston MA 02167. 617-969-9966.

ADM S/TV-24, 24-input w/4 subs, subs have EQ, 4 yrs old, excel cond w/dcc & records, \$20,000. B Covey, WATL-TV, 1 Monroe Pl, Atlanta GA 30324. 404-881-3600.

Audio Arts Engineering 8X recording console, factory patch bay, 24 x 8 x 24 trk mon, brand new cond, \$7800. D Koche, Digital Sound Makers, 1901 Hanover Ave, Allentown PA 18103.

Tascam 5-A mixing boards (2), 200 hrs; call for price. D Curtis, Creative Sound, 2810 W 4th St, Appleton WI 54914. 414-733-2299.

McMartin 1082V 8-chnl stereo console w/slide faders, 20 inputs, gd cond w/pwr supply, spare parts & manual, \$1000; Harris Medalist-10 10-chnl stereo console w/rotary faders, excel cond w/spare parts & manual, \$2000; Harris Medalist-8 8-chnl stereo console w/slide faders, excel cond w/spare parts & manual, \$1800. B Mountjoy, WITM-AM, POB 1240, Elizabeth TN 37644. 615-543-5849.

Roland CompuEditor automated fader system (2), locks to SMPTE, \$700 ea; Trident Series 80, spare chnl & misc parts, \$200. B Seifried, Eclair Eng, 101 Prospect St, Northampton MA 01060. 413-584-6767.

Henry Fast Trac dubbing system, \$400. B Lord, Lord Brdcsng, 13313 SE 208th St, Kent WA 98042. 206-631-2374.

LPB Signature II. G Gilbert, CSRG, POB 50539, Denton TX 76206. 817-380-0229.

Shure M267 mic mixer, vgc, \$250; Shure M268 mic mixer, new, used once, \$150. A Smothers, 803-365-9268.

Ramsa WR-8210A, 10x4, XLR mic-ins, RCA line-ins, 3-band EQ/chnl, effects I/O, like new, \$995. M Friend, WTJU, 804-924-0885.

CCA Ultimate 10 10-chnl dual mono console, \$400+shipping/BO; Ramko DC-5M 5-chnl mono console w/touch control, BO. B Graham, WYMK/WEMR, RR#3 Box 1460, Tunkhannock PA 18657. 717-836-1460.

Audix MXT1000 8x2 mix down board; Yamaha PM700 12x2x2 PA board; Shure 8x1 rack mount mixer; UREI Cooper time cube delay line & MXR flanger doubler; all BO. J Krepol, RNDL, 7 Dustin Dr, Wilmington DE 19703. 302-798-4076.

Shure M67 & M675 mic mixer & prod master, excel cond, \$300. M Saady, 1st City Rec, 141-60 84 Rd 3E, Briarwood NY 11435. 718-876-2062.

Harris Medalist 12, gd cond, recently removed, \$2900. G Falut, WZMX, 100 Executive Dr, Farmington CT 06032. 203-677-6700.

Shure SR101 Series 2 portable audio mixer, SS, 8 chnl mixer/preamp w/reverb, rack mount in port case, excel cond w/manual, \$395; Collins 212T-1 audio control system, 28 inputs, 2 wrkg chnl out, 2 aux, 2 mon, mint cond w/manual, \$595. R Sumner, CAVU Corp, 3322 Applegate Ct, Annandale VA 22003. 703-560-0233.

RCA 8-chnl stereo, circa '65, SS, wrkg when removed, \$1500/BO. Don, KCKN-KBCQ, POB 670, Roswell NM 88202. 505-622-6450.

Want to Buy

API or Neve consoles; esp API 550A & 550B; also API & Neve EQ & other modules; anything considered. J Kreines, DeMott/Kreines Films, 5330 Kennedy Ave, Millbrook AL 36054. 205-285-6179.

RCA BC3, BC5 & 76B2 spare parts. L Scott, POD 1449, Highland City FL 33836. 813-533-4654 eve.

Langevin AM4A w/documents. J Gangwer, 942 32nd St, Richmond CA 94804. 415-644-2363.

DISCO & SOUND EQUIPMENT

Want to Sell

Furman RV-1, 1-space rack mount spring-type reverb w/limiter, tone controls, unbal 1/4" I/O, excel cond w/manual, \$110. S Hofmann, Cameron Univ Theatre, 2800 W Gore Blvd, Lawton OK 73505. 405-581-2428.

RCF/Altec 3-way PA system, all horn loaded, 18" bass, 15" mid compression horns, sell separately, \$800; BES 255 Mark II 3-way bipolar home mons, 4" x 22" x 32", orig box, \$400+shipping. Philip, Big Red Sound, 172-28 Henley Rd, Jamaica NY 11432. 718-523-2815.

JBL 4350 w/crossover 5234A, new cones, \$2100; JBL 4343, new cones, \$1500; Altec 60AA w/time align crossover, \$750. R Nelson, Tropical Brdcsng, 14093 SW 142 St, Miami, FL 33186.

Shure M67 remote audio mixer, balanced terminal post output, adjustable metering & Shure M68 4-chnl 1-aux mixer w/balanced I/O, (2) QRK 3-speed TT w/none arm & cartridge, \$250. J Brown, CAV Corp, POB 3471, Charlottesville VA 22903. 804-979-0402.

JBL 4312 (2), latest version of L-100, 4311, etc, deluxe studio 3-way mon, new, under warranty, will ship UPS, \$550/pair; Yamaha NS-104 2-way studio mons, pair avail, will ship UPS, \$280/both. C Keith, ALI, POB 313, Keane NH 03431. 603-352-8960.

Dolby A301 2-chnl NR, \$300/BO. R Rhodes, Rhodes Music, POB 1550, NY NY 10101. 212-245-5045.

Comm Light & Sound RS440 4-way spkrs (2), w/Community VB790 bass bins, Arvil cases, excel cond, \$1250+shipping. J Kreines, DeMott/Kreines Films, 5330 Kennedy Ave, Millbrook AL 36054. 205-285-6179.

AKG BX-10 reverb wrack mount panel, like new; call for price. D Curtis, Creative Sound, 2810 W 4th St, Appleton WI 54914. 414-733-2299.

Urei 813B studio mons, \$1600. R Tiegen, Plum Sound, 335 Merrimac St, Newburyport MA 01950. 508-465-5653.

JVC NR-1020 NR (3); call for prices. D Curtis, Creative Sound, 2810 W 4th St, Appleton WI 54914. 414-733-2299.

EMU Emulator II+ sampling keyboard, \$1000; Fostex 4030/4035 sync system, w/remote & cables, \$1000; Fostex 4010 SMPTE reader/gen, \$500. B Seifried, Eclair Eng, 101 Prospect St, Northampton MA 01060. 413-584-6767.

API 553 EQ (10), 3-band proj, \$175; API 559 graphic EQ, \$325; Langevin AM-16 discrete mic preamps, \$150 ea; Universal Audio 100B tube mic preamps, \$200. M Linett, Your Place or Mine, 818-244-1909.

dlbx 21 Type II NR decoder, \$25. D Bailey, Rock Shoppe Prod, 3422 Beech St, Rowlett TX 75088. 214-475-9796.

Dyma Engineering Resonator 2 audio reverb, \$50. Don, KCKN-KBCQ, POB 670, Roswell NM 88202. 505-622-6450.

DISTRIBUTOR DIRECTORY

The following distributors serving the broadcast industry would be glad to help you with any of your requirements.

THE SOURCE
CALL US FOR ALL YOUR NEW BROADCAST EQUIPMENT NEEDS
Toll free: 800-HOT-AMFM (800-468-2636)
305-651-5752
FAX: 305-654-1386
18620 N.E. 2nd Ave. Miami FL 33179



. . . Canada, Alaska, Hawaii, Puerto Rico, Virgin Islands, Ye Ol' Forty-Eight . . .
RADIO! The beat goes on!
CROUSE-KIMZEY OF ANNAPOLIS
tops in broadcast equipment
1-800-955-6800
ask for Kathleen

PHONE: 703-998-7600 FAX: 703-998-2966



Call Simone Mullins, Classified Ad Manager, to reserve space in the next issue. Use your credit card to pay, we now accept VISA and MASTERCARD.

Radio World
5827 Columbia Pike, Ste 310 Falls Church, VA 22041

Select from these categories for best ad positioning:

Acoustics	Consoles	Stereo Generators
Amplifiers	Disco-Pro Sound Equip.	Switchers (Video)
Antennas &		

DISCO . . . WTS

Peavey 19-10 Flite case (2), 6-space rack case w/ front & rear removable covers, laminated 3/4" construction w/ steel corners & handles, vgc, \$125 ea/BO; Apex Type C aural exciter, 1-rack-space unit in excel cond, \$150/BO. B Fisher, KPOK, Box 477, Bowman ND 58623. 701-523-3883.

Phase Linear 1000 Series II NR, removes tape hiss, \$150; Burwen DNF 1201-A dynamic noise filter, removes record/tape noise, \$200. D Bailey, Rock Shoppe Prod, 3422 Beech St, Rowlett TX 75088. 214-475-9796.

Ramsa WS-A 200 & WS-A 240 portable hi pwr bi-amp PA speaker system w/WS-SP2A subwoofer processor, pair 2-way 12" WS-A200 full-range cabinets & pair 12" WS-A240 subwoofers, as new cond, \$1500/BO. B Fisher, KPOK, Box 477, Bowman ND 58623. 701-523-3883.

Auratone Super Sound Cubes, trade industry stand sm ref mon, like new, \$75/pair. Davis, MCP, POB 521, Newberry SC 29108. 803-276-0639.

SAE 5000 impulse NR, removes clicks & pops, excel cond, \$125. R Glenn, WJGR, 1718 Shannoa, Wimauma FL 33598. 813-634-1940.

Want to Buy

Rane MT-6 multi-chnl 70/25 V xformer system. M Nardella, Nards Inc, 1446 Emerson Ave, McLean VA 22101. 703-821-8629.

FINANCIAL SERVICES

LEASING AVAILABLE ON USED TRANSMITTERS
AMERICAN BROADCAST FINANCIAL CORPORATION
414-482-2638

LIMITERS

Want to Sell

CBS 411 Stereo Volumax, vgc, \$300; CRL PMC300 AM limiter, vgc, \$400; (2) Dorrough DAP-610 triband processor, vgc, \$1250; Elcom Bauer Level Guard AGC gain controller, gd cond, \$150; Harris MSP-90 AGC/limiter, gd cond, \$500; Inovonics 705 stereo gen w/FMX, excel cond, \$1000; many more, call for details. B Williamson, WWWK/WELV, Ellenville, NY. 914-858-2941.

Gregg Labs FM stereo processor, extremely rare, mint cond, serious inq only, \$8600. P Christensen, WXXL-FM, 337 S Northlake, Altamonte Springs FL 32701. 904-721-9111.

Optimod 8000A
\$1495 & UP
414-482-2638

API 525, vgc, \$375; (2) Audionics 201, excel cond, \$500 ea. M Linett, Your Place or Mine, 818-244-1909.

Gates Solid Statesman limiter, \$275. P Wells, KJQY, San Diego, 619-238-1037. FAX: 619-238-6157.

Moseley TFL-280 audio limiter (2), \$300/both. R Ness, WGEN, 1003 S Oakwood Box 67, Geneseo IL 61254. 309-944-4633.

Century D-70 limiter (2); call for price. D Curtis, Creative Sound, 2810 W 4th St, Appleton WI 54914. 414-733-2299.

CBS Stereo Volumax peak controller, older creme-colored unit, no front covers, manual, \$150. S Callahan, WCEG, 1120 Pinellas Bayway, St Pete FL 33713. 813-821-9549.

Spotmaster CLA 20/40A compressor/limiter (2), w/manual, \$275/both. K Gutzke, 7134 15th Ave S, Minneapolis MN 55423. 612-866-6183.

Durrough DAP-310 tri-band audio processor (2), for AM/FM brdcst use, vgc, \$325 ea + shipping. B DeFolice, DeFolice Prod, 93-29 Fowler St, New Haven CT 06515. 203-397-2595.

Audio Design Transdynamic stereo brdcst limiter, can control up to 6 add'l limiters for 3-band limiting, never used, w/user-service manual, \$650 + shipping. M Shea, Precision, POB 723, NY NY 10276. 212-989-2684.

Howe Phasechaser Series 2000, corrects phasing probs in stereo tape sys & phone lines used in EQ prog lines & STLs. BO. D Donovan, KCGR FM, 1620 American Bank, Corpus Christi TX 76226. 512-888-8555.

Want to Buy

Tube limiters, compressors & EQs: Fairchild 660/670; Teletronix/UREI LA2A, LA3A; Pultec; MAVEC; Lang; API; etc.; also, other tube signal processing gear. J Kreines, DeMott/Kreines Films, 5330 Kennedy Ave, Millbrook AL 36054. 205-285-6179.

Urei LA-3A/LA-2A compressor/limiter, prefer operating cond, need (2). R Kaufman, Pams Prod, POB 462247, Garland TX 75046. After 3PM: 214-271-7625.

Gentner Audio Prisms stereo pair, late generation pref. P Christensen, WIVY-FM, 3101 University S, Jacksonville FL 32216. 904-721-9111.

Optimod 8000A, will pay cash, leave message at 703-276-0125.

MICROPHONES

Want to Sell

Neumann TLM 170 mics, rare pair of consecutively serial numbered mics, \$3350/pair. R McMillen, 503-239-6070.

EV 635A (6), mint, \$75.00 each. G Mundkowsky, 12918 Smalley, Grandview MO 64030. 816-966-0731.

Saba stereo mic, vgc, \$10; Shure 565SD, vgc, \$50. B Williamson, WWWK/WELV, Ellenville, NY. 914-858-2941.

Sony ECM-50 lavalier mic, \$50. P Cibley, Cibley Music, 138 E 38th St, NY NY 10016. 212-966-2219.

Electro Voice 644 shotgun mic, \$140; Electro Voice 664A variable D dynamic, indust standard, \$100; AKG D-310 dynamic, \$100; all like new, complete, no blms. C Keith, ALI, POB 313, Keane NH 03431. 603-352-8960.

Altec 639B, vgc w/bag, \$400. C Bucy, Cisco Sound, POB 16583, Lubbock TX 79490. 806-792-1662.

Neumann M-250 w/cable & pwr supply, vgc, \$4500. M Linett, Your Place or Mine, 818-244-1909.

Altec 639 classic ribbon/dynamic (2), w/boxes & straight mount, \$450 ea. L Beigel, On Cue Rordng, POB 85032, Iowa CA 90072. 800-726-9813.

Sony ECM-22P condenser mic (5); Sycon S-10 condenser mic for pipe organ only; (4) Atlas mic stand & misc cable; call for prices. D Curtis, Creative Sound, 2810 W 4th St, Appleton WI 54914. 414-733-2299.

Electro Voice 666 variable D cardioid dynamic, '60s type, gd cond, \$65/BO; Electro Voice 666 variable D dynamic, '50s type, fair cond, \$50/BO; Electro Voice 635A dynamic omnidirectional, fair cond, \$40. M Saady, First City Rec, 141-60 84 Rd #3E, Briarwood NY 11435. 718-846-2062.

Sony ECM-50 lavalier mic, \$50. P Cibley, Cibley Music, 138 E 38 St, NY NY 10016. 212-966-2219.

Shure 51 (41) & 555W (51) antique mics, \$300/both + shipping. D Besler, 207 Fort St Rm 312, Winnipeg Manitoba CN R3C-1E2.

RCA 77DX vintage ribbon mic, excel cond, BO. R Kaufman, Pams Prod, POB 462247, Garland TX 75046. After 3PM: 214-271-7625.

RCA 44 vintage ribbon mic, late 50s model, works well, \$375/BO; Shure SM-7, used few hrs, like new, in case, \$350. Davis, MCP, POB 521, Newberry SC 29108. 803-276-0639.

AKG D190ES dynamic cardioid, on/off switch, new cond, complete, \$100; (4) Altec C71 omni condenser, flat response, excel for recording, 0-30 db attenuator selector, vgc, \$125. A Allegra, Calvary Baptist Church, 1380 Valley Forge, Lansdale PA 19446. 215-368-4444.

Neumann U67 (5), various cond, \$1500-2400; also, U87, \$1250; SM2, \$2400; accessories. M Helelak, Milwaukee Sound, 610 N Water St, Milwaukee WI 53202. 414-272-7085.

Arrakis MK-5 5 mic amp to 5 line-level 600 R outputs, will mix to sngl 600 R out, requires ± 15 VDC. M Friend, WTJU, 804-924-0885.

Presto 45 rpm adapter sleeve for 6N disc cutter, new; manuals: Sencore tube conductance analyzer, Sams transistor sub book #8 & #6, RCA tube manual. Mr. Oliver, 212-874-7660.

EV 630/635 w/cable; RE10 EV-desk mics, EV & Shure all very reasonable; baby booms (3). Mr. Oliver, 212-874-7660.

RCA/Altec/Telefunken: RCA 44-BX, 77-D, BK-5, KU3A 100001, SK-46, WE 639, Altec M-11 system, Altec M30 tube mic, Altec M49 & M50, (2) absolutely mint Telefunken U47's, will trade for other high quality mics & equipment. Tracy Eaves, 615-821-6099 (evenings).

Want to Buy

Desk mount flex mic arm, heavy duty, & shock mount for heavy RCA mic. T Heathwood, Heritage Radio Classics, POB 16, Boston MA 02167. 617-969-9966.

Neumann U-67 pwr supply, cable connectors, shockmount, will pay cash/trade other vintage mics. W Kremer, 301 SW 16th St, Ft Lauderdale FL 33315. 305-524-5652.

Tube condenser mics: Telefunken ELAM 250/251; AKG C12/C24; Neumann U47, M49, KM54, U64, U67, SM2, SM69; also, other pro condenser mics, wrecked mics, any cond. J Kreines, DeMott/Kreines Films, 5330 Kennedy Ave, Millbrook AL 36054. 205-285-6179.

RCA 44BX/77DX; WE & RCA velocity mics. D deForrest, 7441 Wayne Ave #10-D, Miami Beach FL 33141. 305-866-5401.

HP 15109, 15108, 15119, 15118 laboratory reference mics, any cond. S Dorsey, WCWM, 173-7 Merrimac, Williamsburg VA 23185. 804-864-4056.

RCA, Neumann, WE & other vintage mics; also, parts, flags & stands. R Van Dyke, Caffrey House, 2 Squires Ave, E Quogue NY 11942. 516-728-9835.

RCA 44 & 77 mics, prefer chrome, will consider TV grey; also, 77DX desk stand. R Kaufman, Pams Prod, POB 462247, Garland TX 75046. After 3PM: 214-271-7625.

AKG C-12412/414, tubular/diamond-shaped body; Synchro AU7A; Fairchild F-22; RCA KU3A. M Helelak, Milwaukee Sound, 610 N Water St, Milwaukee WI 53202. 414-272-7085.

MISCELLANEOUS

Want to Sell

AM dummy load, 1 kW, typical of those inside Gates BC-1G & H series xmtrs, BO + shipping. D Kelley, KISZ-FM, POB 740, Cortez CO 81321. 303-565-1212.

COMREX RENTALS
1, 2 and 3-Line Systems
Call Steve for details
Silver Lake Audio
(516) 623-6114

Telex Audiocom IF-1 interface unit, interfaces headset intercom system w/2, 3 or 4 wire communications systems, excel cond w/manual, \$150. S Hofmann, Cameron Univ Theatre, 2800 W Gore Blvd, Lawton OK 73505. 405-581-2428.

Blackbourn 1200 (363), black vinyl page for 3-ring binder holds 4 cassettes w/o boxes, compl sale preferred, \$250 + shipping. B Strapko, 708-830-0701.

Symatrix T-101 telephone interface, \$250; Audio Digital TC4 digital delay unit, \$800. T Pless, WHVY, 112 Main, Annapolis MD 21401. 301-626-0103.

McMartin TG-2 EBS encoder, vgc, \$125; Ford mono AM/FM car radio, vgc, \$15; Gates on-air light, gd cond, \$40; Spotmaster cart winder, gd cond, \$100; (2) WE KS19645-L2 recorder coupler, gd cond, \$50; various racks; call for details. B Williamson, WWWK/WELV, Ellenville, NY. 914-858-2941.

WE patch panel (12), TR/S normalized, 6 rows, 24 jacks/row, 19" x 7", wire wrap or solder connections, \$35/ea + shipping. R Kerbaw, WTNJ FM, Box 1127, Beckley WV 25802. 304-877-5592.

M-Print Central, manual pad printer, used to print directly onto audio cassettes & other items, w/instruct video, \$900. F Scheidt, Frank Scheidt Audio, 15 Charlotte St, Rochester NY 14607. 716-232-5210.

Orban ACC11 1-34" security cover (6), \$15 ea; Pitney Bowes A-120 postage scale, 6200 postage meter & A215 printer, \$1500/alt; Broadcast Supply 6' mounting rail (5), \$30 ea; (3) 3-1/2" rail, \$20 ea. B Lord, Lord Brdcstg, 13313 SE 208th St, Kent WA 98042. 206-631-2374.

Gentner FBTRB prewire bay (8), \$225 ea; Gentner GEC-FB-100 Flexiblock (50), SIE-MF2250, \$10 ea; Gentner GEC-50DR pre-wired patch bay, 52DR w/TRS jacks #8 & approx 15' wire, \$90. B Lord, Lord Brdcstg, 13313 SE 208th St, Kent WA 98042. 206-631-2374.

TMC deluxe pushbutton switches, 31 new, w/hardware, \$30/lot. Mel Crosby, Sequoia Electronics, 408-866-8434.

Bird 4600/460 Thru-line 3-1/8 line section w/25 W slug, Thru-line wattmeter, 25 kW full scale, \$600. C Benner, WUSL-FM, 440 Domino Ln, Philadelphia PA. 215-483-8900.

IGM Silent Sensor; IGM keypad controller w/battery back-up; Auto Gram SG14 sequence drawer; Auto Gram SG256 memory drawer; Auto Gram AS14 audio switcher; Auto Gram RT-5 network join clock. G Gilbert, CSRG, POB 50539, Denton TX 76206. 817-380-0229.

Zercum MAX-Z, brand new, never used, must sell, \$450; Telex headset, vgc, \$100. A Smothers, 803-365-9268.

Phasemaster T7500 3-phase converter, \$2000. R Murphy, 602-855-1051.

UTC HA-108X multi-tap mic/line/matching xmr (20); (12) A39; (10) A20; (2) Langevin PS4800 48 V supply; (2) Kepco PAR24 24 V supply; (25) Daven 600 ohm ladder attenuator. M Helelak, Milwaukee Sound, 610 N Water St, Milwaukee WI 53202. 414-272-7085.

Sparta Corp audio & RF tech manuals, call/write for list. D Peluso, KJUL FM, 2880 E Flamingo Rd Ste E, Las Vegas NV 89121. 702-732-2200.

Money maker/PR. Telephone based time/temperature/weather announcer. Starting at \$3495. Demo: 605-343-7300. Info: FAX 605-892-2669.

Want to Buy

Western Union Naval Observ clock. T Heathwood, Heritage Radio Classics, POB 16, Boston MA 02167. 617-969-9966.

Alden C-2000-R & C-2000-M weather radar receiver, leave name, number & asking price. S Voros, Voros Ent, 1537 S 81, Milwaukee WI 53214. 414-475-6200.

Longframe patch cords, sngl plug, 3-conductor, 1/4" TRS (18"-36"); also, Xmas tree terminal blocks, 120 terminals. F Badesaux, Musik Faktory, 1812 Procter St, Pt Arthur TX 77640. 409-982-7121 5-8PM CDT.

Records from 50s & 60s, 45 & 33 rpm, esp obscure non-chart items, \$50-\$1 ea, references avail. B Berry, Karavan Brdcstg, 13 Montgomery Pl, Conroe TX 77384. 409-273-2801.

Jazz record collections, 10" LP/12" LP be-bop, swing, dixie, highest prices paid. B Rose, Program Recdgs, 228 East 10th, Nyny 10003. 212-674-3060.

MONITORS

Want to Sell

General Radio 1931-A AM mon, wrkg when removed, \$45 + shipping; Motorola DS9660 Conalrad mon, as is, you ship, \$30. P Mueller, KUTAM, N Hwy 191 G-1, Blanding UT 84511. 801-678-2261.

HP 500A freq mon, used, \$100; McMartin 3005 freq mon, gd cond, \$200; McMartin AMR1 AM fixed freq tuner, gd cond, \$125; HP 335B FM mod/freq mon, gd cond, \$275; Belar RFA-1 FM RF amp, new, \$400; many more, call for details. B Williamson, WWWK/WELV, Ellenville, NY. 914-858-2941.

Complete FM monitor package, stereo, mono & SCA. Will sell all or part tuned & tested on your frequency; also have several extra SCA's priced low. Goodrich Enterprises Inc, 11435 Mander-son St, Omaha NE 68164. 402-493-1886 or fax 402-493-6821.

EMPLOYMENT

To place ads in this section, use the ActionGram form. To respond to box numbers, write Radio World, PO Box 1214, Falls Church, VA 22041, Attn:

POSITIONS WANTED

Attention getting talk radio, full spectrum personality. H Friedman, 512-445-5453.

Broadcaster w/2 yrs non-commercial exper seeks PT/FT commercial pos in SE PA, NJ or N DE. Mit, 215-533-3773.

Recent grad, announcing since '87, wants to begin career, work anywhere, pay not important. T Morrow, 2353 Nebraska, Blair NE 68008. 402-533-2821.

Station manager w/hwys & prog exper, also, computer billing, collections, automation & strong sales background, very willing to relocate, young & highly motivated. Stan, 404-884-6531.

New DJ wants to break into TX market, any format, strong in commercial & news prod, any shift, tape & resume avail. S Bradshaw, 7727 Nimrod, San Antonio TX 78240. 512-523-2035.

IDs, sweepers, spots, billboards, etc, for sm market budget minded station. 803-457-4556.

Chief eng, former tech dir of 26 stations, seeking eng mngr pos, SBE certified, FCC license, 13 yrs exper w/FM & AM directional. D Nelson, 206-387-3558.

Announcer w/5 yrs exper, esp in major market Baltimore, seeks FT shift in S-central PA, W MD or MD Eastern Shore, prod skills are excel, write for T/R: 8432 Pleasant Plains Rd, Baltimore MD 21204.

Aggressive, tireless, company-minded 31 yr old PD/OM seeks turnaround situation w/limitless opportunity, 11 yrs exper, ACA/OR/urban, SE location. James, 601-841-6815 nights.

Engineer w/5 yrs exper, studio construct. TX site construct, all levels maint & planning, anywhere in Mid-Atlantic. Engineer, Rt 1 Box 179, Callaway VA 24067.

15 yr vet, On Air & PD, top 40, oldies, rock, hot AC, please no dance station, SE only. 803-457-4556.

11 yrs radio exper, PD, prod, DJ, traffic & news, seeking PD & On Air pos in Albuquerque/Farmington, NM. John, 503-267-2249.

Exper eng accepting temp/PT assignments, anywhere, projects, construction, restoration, gen mgt. T Low, 2946 Amanecer Pl, Escondido CA 92027. 619-741-1054.

McMartin 4500A FM stereo mon. G Gilbert, CSRG, POB 50539, Denton TX 76206. 817-380-0229.

TFT 723 AM mod mon w/presselector, \$600/BO. S King, KATP-FM, I-40 W, Amarillo TX 79110. 806-355-9777.

Want to Buy

Gates & RCA 1950 AM mod freq mon service manuals. L Scott, POD 1449, Highland City FL 33836. Eve: 813-533-4654.

Belar AMM2/3 or Harris AM90. George, WINCM, 4647 Old Hydes Ferry Pk, Nashville TN 37218. 615-255-1300.

FM mod mon, D Van Zandt, WJLU, 2596 SR 44, New Smyrna FL 32168. 904-427-9000.

FM mod mon, late model, tuned to 93.5, reasonably priced. B Crane, WLIL, POB 340, Lenoir City TN 37771. 615-986-7536.

Any older McMartin mod monitors. C Goodrich, 11435 Mander-son, Omaha NE 68164. 402-493-1886.

MOVIE PROD EQUIP

Want to Sell

Nagra III, internal xtal, rolloff filter, Sennheiser 805 w/KAT 15, leather case, ATN pwr supply, excel cond, \$1425; B&H 70 DR w/Arvil case, 1" Cornat, instructions, brand new, \$325. J Kreines, DeMott/Kreines Films, 5330 Kennedy Ave, Millbrook AL 36054. 205-285-6179.

Cinema Products GSMO, 16mm reflex, Ang 15-150 zoom, batts, chargers, 2 mags, hand-grip & shoulder pod, Zero case, excel cond w/manual, \$4995. R Sumner, CAVU Corp, 3322 Applegate Ct, Annandale VA 22003. 703-560-0233.

Want to Buy

Arriflex, Bolex, CP, Eclair & Mitchell cameras, lenses & access; film sound equip, esp Stellavox rcrdrs & access; old film magazines, literature, etc; SMPTE Journals; old copies ACS & others like The Filmmaker. H Biller, 108 Hamilton Ave, Silver Spring MD 20901. 301-565-2798.

Javelin sm night vision device, or equiv, prefer 2nd generation C-mount, anything considered. J Kreines, DeMott/Kreines Films, 5330 Kennedy Ave, Millbrook AL 36054. 205-285-6179.

Mitchell 16/35mm, other pro 16/35mm incl Arri,

CONSULTANTS

W. LEE SIMMONS & ASSOC., INC.
BROADCAST TELECOMMUNICATIONS CONSULTANTS
 1036 William Hilton Pkwy Ste 200F
 Hilton Head Is., SC 29928
(803) 785-4445

Moffet, Larson & Johnson, Inc.
 Consulting Telecommunications Engineers
Two Skyline Place
5203 Leesburg Pike # 800
Falls Church VA 22041
703-824-5660
800-523-3117
 Member AFCEE

EVANS ASSOCIATES
 Consulting Communications Engineers
FCC Applications, Design & Field Engineering
Broadcast Engineering Software
216 N. Green Bay Rd.
Thiensville, WI 53092
(414) 242-6000
 Member AFCEE

Consulting Communications Engineers
 • FCC Data Bases
 • FCC Applications and Field Engineering
 • Frequency Searches and Coordination
 • AM-FM-CATV-ITFS-LPTV
OWL ENGINEERING, INC.
1306 W. County Road. F.
St. Paul, MN 55112
(612)631-1338 "Member AFCEE"

SOFTWARE
FM CHANNEL SEARCH
FM Database pool
MSDOS
EGA Graphics-Color
Broadcast Technical Consulting
Doug Vernier
Broadcast Consultant
 1600 Picturesque Drive
 Cedar Falls, IA 50613
319-266-8402

MULLANEY ENGINEERING, INC.
 Consulting Engineers
 • Design & Optimization of AM Directional Arrays
 • Analysis for New Allocation, Site Relocation, and Upgrades
 • AM FM TV LPTV Wireless Cable (MDS/MMDS/ITFS/OFS)
 • Environmental Radiation Analysis
 • Field Work
 • Expert Testimony
9049 Shady Grove Court
Gaithersburg, MD 20877
Phone: (301) 921-0115
Fax: (301) 590-9757

Teletech, Inc.
 BROADCAST CONSULTANTS AND ENGINEERS
 • FCC Applications & Field Engineering
 • Frequency Searches & Coordination
 • Tower Erection & Maintenance
 • Facility Design & Construction
CONTACT:
Kenneth W. Hoehn
 23400 Michigan Ave
 Dearborn, MI 48124
(313) 562-6873

T.Z. Sawyer
Technical Consultants
1-800-255-AMDA
 AM Directional Antenna Proofs
 AM-FM-TV-LPTV
 FCC Applications & Exhibits
 Station Inspections
 6204 Highland Drive
 Chevy Chase, MD 20815-6610
 Telefax 301-913-5799

Lahm, Suffa & Cavell, Inc.
 Consulting Engineers
 • Interference Resolution
 • Coverage Improvement
 • RF Hazard Studies
 • Custom Software
 • AM Antenna Improvement
 • Former Chief Engineers
 • Suburban Washington Based
 3975 University Dr., Suite #450
 Fairfax, Virginia 22030
 Phone 703-591-0110
 Fax 703-591-0115

Without Advertising a Terrible Thing Happens...

...NOTHING

Huntsville Antenna Engineering
 There is hope for AM radio! AM station unipole antennas with circular polarization & beam tilt. Broadband your present AM tower Series R shunt fed.
 205-353-6747
Kenneth Casey
 Consulting Radio Engineer

SERVICES

1990 POPULATION COUNT for PC
 Our 1990 POPULATION COUNT for PC program utilizes the most recently published census data required for FCC filings for the next decade. Call today for more information. We also offer:
 • Real World Propagation™ Studies
 • On-Line Services
 • 3 Second Terrain Data on CD-ROM
 • FCC's AM, FM & TV Databases
 Richard L. & Richard P. Biby, Principals
Communications Data Services, Inc.
 6105-E Arlington Blvd. • Falls Church, VA 22044 • (800) 441-0034

MIRKWOOD ENGINEERING
 Rural & Remote Site Field Engineering
 50 Park Ave.
 Claremont, NH 03743
603/542-6784

PHASETEK INC.
 • High Quality RF Components
 • Custom Antenna Tuning Units
 • Custom Directional Feeder Systems
 • Field Installation Services
 • Replacement Parts for CSP Inc. and Vector Technology Inc. Components and Systems
 • Limited Supply of VTI FM Transmitters and Accessories
PHASETEK INC.
 P.O. Box 193 Fountainville, PA 18923
 Phone: 215-249-1977
YOUR NUMBER ONE SOURCE!

Eastern Tower Erector
 "We climb anywhere, anytime!"
 P.O. Box 007
 Sharptown
 Maryland 21861
Erection Maintenance
 1-800-832-2366 or 1-301-883-2030

RENTALS
 For your next remote event rent the:
GENTNER EFT-3000
 — or —
COMREX 3XP/3XR
 3-line frequency extender package w/Shure SM-7 studio mics.
 Dwight Weller
WELLER AUDIO-VISUAL ENGINEERING
 Baltimore, Maryland
301-252-8351

Where In The World Are You?
 Reach radio professionals worldwide by advertising in *Radio World's* international edition. Call Simone for more information.
1-800-336-3045

RADIO & TV
 Painting, Lighting, Maintenance & Repair
INTERSTATE TOWER SERVICE
 Todd Callahan
 5913 Bermuda Dr.
 Boise ID 83709
 208-385-0896

RECEIVERS & TRANSCEIVERS

Want to Sell
 High quality micro-miniature 67 kHz SCA decoder, about 1" square, prewired and ready to install, \$15. D Jackway, Background Music Eng, 5742 Fair oak, Springfield MO 65810. 417-881-1846.
Drake ESR2240 satellite rcvr, tunable over 24 chris, w/subcarrier audio, adjustable AV outputs, meter tuning, \$500; Arunta SSP-312 satellite audio, stereo processor, \$200; CA Amplifier CFK-100 dual hybrid feedhorn w/polarizer, Gardner C Band LNB, Norsat Ku Band LNB, \$250. J Brown, CAV Corp, POB 3471, Charlottesville VA 22903. 804-979-0402.

AM STEREO RECEIVERS
Portable, Home/Studio, Auto
RRADCO GROUP
708-513-1386

Motorola Pagecom & Director pagers (18), on 154.25 MHz, w/(3) spares, parts, chargers, reeds, & batteries, xmtr & pager manual incl, \$400; Yaesu FT-4 touch tone pads for handheld FT-23, FT-73, FTH2005, FTH7005, FTH2008, FTH7008, \$10 ea. P Russell, Bowdoin Coll, Sills Hall, Brunswick ME 04011. 207-725-3066.
 Fairchild Dart-384 digital audio rcvr, Satcom 1-R cards, \$5000. WKTIT, 414-693-3103.
 Marti AR-10 receiver (4); (3) 2-way radio at 161.64 w/base. T Noordyk, 616-924-4700.

Want to Buy
 Technics ST9030 FM tuner. J Ramsey, WUUH, Univ of Hartford, W Hartford CT 06117. 203-243-4703.
 Sony SRF-A100 AM stereo radio. Ralph, 55 K-USA, St Louis MO. 314-997-5594.

REMOTE & MICROWAVE EQUIP

Want to Sell
 Mark P-972 6' parabolic grid for 944-952 MHz STL, (2) avail 10/91, BO+shipping. D Kelley, KISZ-FM, POB 740, Cortez CO 81321. 303-565-1212.
 Moseley TRC-15AR 15-chnl remote control, 110 kHz/67 kHz w/spare board, gd cond, must sell, \$450/BO. J Ramsey, WUUH, Univ of Hartford, W Hartford CT 06117. 203-243-4703.
 Wegener 1602 & 1601 mainframes w/these cards: 1621, 1645, 1646, 1606-21, 1683-08 & 1605-12, used for SMN; also, TFT 7610 xmtr remote w/relay panel, needs some work. J Galanses, WAVI, POB 25016, St Croix VI 00824. 809-773-3693.
 Micro Controls RCR-9/RCT-9 9-chnl remote control, 6 yrs old, gd cond, \$1500. R Swan, WROY/WRUL, POB 400, Carmil IL 62821.

Want to Buy
 Fairchild Dart 384 receiver w/down converter. M Rollings, Rollings Comm, POB 882, St Louis MO 63006. 314-726-9595.

SOFTWARE

Want to Sell
 Wire service capture and news editor. Save on paper! Computer and software: lease \$60 month, purchase \$1495. Software only, \$495. Info: FAX 605-892-2669.

STATIONS

Want to Sell
 AM & FM radio stations for sales in Central Arkansas, selling or part, some financing. 501-376-0880 week days, 501-470-1525 nights/weekends.
Class A, WIST 94.3 FM, Lobelville TN w/50 kW CP on hand is once again being offered at a reasonable price of \$150,000. We will consider \$80,000 down, balance on easy terms w/references required. Located 1/2 way between Jackson & Nashville TN, just 10 miles south of I40 & the famous Loretta Lynn's Dude Ranch. Call for appointment today & inspect this nice facility. Bill Coleman Jr, 615-593-2294.
FT C&W station, to 1850 W, new automation, in VA, on air since '60, owner anxious to retire, financing avail after sm down payment. A Terry, WODY, POB 545, Basset VA 24055. 703-629-2509.
AM, 1 kW, 1480 kHz, w/PSSA, covers city plus eq equip, gd terms, \$139,000. B Ludwig, KRFR, 4211 N Elizabeth, Pueblo CO 81008. 719-542-2121.
Radio/TV combo: old dependable AM & new LPTV in gd market in E NC, nice buildings & acreage, new twr & new TV studios, \$450,000 w/\$100,000 down, owner financing. 919-965-5328 after 7PM.
Want to Buy
 10 yr+ broadcaster seeking to take over FM station in KY, OH, WV, looking for no money down/debt assumption, any pwr OK. Mike, Star-Comm, 8078 Sun Circle #103, Manassas VA 22110. 703-368-2955.

HOT AUDIO
DOES YOUR STATION SOUND COMPETITIVE? DO YOU WANT IT TO SOUND FULLER, & DYNAMIC? DO YOU WANT YOUR LISTENERS TO "FEEL IT"?
 We do "stem to stem" audio consulting and we will make your audio tops! —ROCK—COUNTRY—CHR— PETER'S TECHNICAL SERVICE, JAY, MAINE Call the "HOT" LINE 207-645-3019. We go coast-to-coast.

Telephone equip: ADC 109D & 109H repeat coils, 4 primary & secondary terminals, 600/900 ohm, use bridged/terminated, \$10 ea; Wescom 2/4 wire balanced hybrids, gd null features, make grt talk show phone syst, \$50 ea. R Weaver, WHEVAM, Creech Rd, Garner NC 27529. 919-552-9357.
 TFT 7601 digital remote w/SCA gen for control via STL/wire line (any voice-grade chnl from 300 Hz-3 kHz), w/manual, BO. D Donovan, KCGR FM, 1620 American Bank, Corpus Christi TX 76226. 512-868-8555.

Want to Buy
 Marti RMC-2AX 25-chnl, gd cond, manuals, \$500/BO/trade. D Willey, Life Brcdstng, POB 96, John Day OR 97845. 503-575-1840.

Want to Buy
 Marti tube-type xmtrs, freq: 161.67, gd working order. C Webster, WCLD, 1101 S Davis, Cleveland MS 38732. 601-843-4091.

Want to Buy
 Moseley PCL 505C, Marti or TTF 950 MHz STL equip for export, priced right. K Austin, Austin Brcdst, 1101 Hwy 81 N, Marlow OK 73055. 405-658-3330.

Want to Buy
 Moseley STL system for FM. T Noordyk, 616-924-4700.

Want to Buy
 Marti STL 8 stereo STL system, reasonable. J Ingram, WBLE, Hwy 6 W, Batesville MS 38606. 601-563-4664.

SATELLITE EQUIPMENT

Want to Sell
 Fairchild, 15 kHz dual chnl audio card & one voice cue card for a Dart 384 downlink, \$900/both/BO. M Rogers, 504-626-7305.

Want to Sell
 Scientific Atlanta DAT-32 receiver, 15 kHz stereo audio card for use w/all major networks, like new cond, \$1000/BO. Chip, KCPS, pOB 946, Burlington IA 52601. 319-754-6693.

Want to Sell
 Scientific Atlanta DAT-32 system, w/7300 & 7325 modules, w/(2) 15 kHz stereo demod cards, voice cue card, etc, need to sell now at \$3500. A Morris, KSWM, Aurora MO. 417-678-0416.

Want to Sell
 Scientific Atlanta 7300/7325 wideband BPSC rcvr & digital processing unit, (2) 15 kHz decoder cards, 75 kHz card, excel cond, \$4500. Tom/Harry, KTMC, POB 848, McAlester OK 74502. 918-426-5300.

Want to Buy
 Fairchild Dart 384 receiver w/down converter. M Rollings, Rollings Comm, POB 882, St Louis MO 63006. 314-726-9595.

Want to Buy
 Moseley TRC-15AR 15-chnl remote control, 110 kHz/67 kHz w/spare board, gd cond, must sell, \$450/BO. J Ramsey, WUUH, Univ of Hartford, W Hartford CT 06117. 203-243-4703.

Want to Sell
 Wire service capture and news editor. Save on paper! Computer and software: lease \$60 month, purchase \$1495. Software only, \$495. Info: FAX 605-892-2669.

STATIONS

Want to Sell
 AM & FM radio stations for sales in Central Arkansas, selling or part, some financing. 501-376-0880 week days, 501-470-1525 nights/weekends.

Want to Buy
 Class A, WIST 94.3 FM, Lobelville TN w/50 kW CP on hand is once again being offered at a reasonable price of \$150,000. We will consider \$80,000 down, balance on easy terms w/references required. Located 1/2 way between Jackson & Nashville TN, just 10 miles south of I40 & the famous Loretta Lynn's Dude Ranch. Call for appointment today & inspect this nice facility. Bill Coleman Jr, 615-593-2294.

Want to Buy
 FT C&W station, to 1850 W, new automation, in VA, on air since '60, owner anxious to retire, financing avail after sm down payment. A Terry, WODY, POB 545, Basset VA 24055. 703-629-2509.

Want to Buy
 AM, 1 kW, 1480 kHz, w/PSSA, covers city plus eq equip, gd terms, \$139,000. B Ludwig, KRFR, 4211 N Elizabeth, Pueblo CO 81008. 719-542-2121.

Want to Buy
 Radio/TV combo: old dependable AM & new LPTV in gd market in E NC, nice buildings & acreage, new twr & new TV studios, \$450,000 w/\$100,000 down, owner financing. 919-965-5328 after 7PM.

Want to Buy
 10 yr+ broadcaster seeking to take over FM station in KY, OH, WV, looking for no money down/debt assumption, any pwr OK. Mike, Star-Comm, 8078 Sun Circle #103, Manassas VA 22110. 703-368-2955.

STEREO GENERATORS

Want to Sell
 AEL 2213, gd cond, no manual, \$100/BO/trade. D Willey, Life Brcdstng, POB 96, John Day OR 97845. 503-575-1840.

Want to Buy
 Optimod 8000A, will pay cash, leave message at 703-276-0125.

SWITCHERS (VIDEO)

Want to Sell
 American Data Corp 553 wonboard digital spec effects gen w/(9) effects, colorizer, (7) inputs w/TBC ports, excel cond, \$850. Pinetuck-et Rcrding, 747 Wire Rd, Auburn AL 36830. 205-826-0390.

TAPES/CARTS & REELS

Want to Sell
 Adult contemporary library w/2200 songs on CD & cart, incl 93 Goldiscs & 230 misc CDs, add'l 170 songs dubbed on Scotchcart IIs, \$6500; country library w/1500 songs on 66 CD Goldiscs & 500 add'l Scotchcart IIs, \$5000; (380) 3.5 min Scotchcart IIs w/country songs, \$2 ea; all used 6 mnths. B Lord, Lord Brcdstg, 13313 SE 208th St, Kent WA 98042. 206-631-2374.

Want to Sell
 Scotch 176 (34), 14" x 2500', used once, \$125/BO. D Pulwers, 703-751-9346.

Want to Sell
 C&W & Gospel albums (3000 ea), '60-'91, some never used, special price if buy all of 1 category. A Terry, WODY, POB 545, Basset VA 24055. 703-629-2509.

Want to Sell
 Fidelipac 300 carts, various lengths, some vgc, \$1 ea. B Davis, BDMZ Prod, 408 N 11 St, St Joe MO 64501. 816-279-6851.

Want to Sell
 Audiopak AAA (1000), 2.5-5.5 min carts, loaded w/new tape, \$4 ea lots of 100, \$325/lot, incl shipping. S Cassidy, Radio Program Services, Box 472, Manitou CO 80829. 719-661-1744.

Want to Sell
 Dynamax, Gold Master, & Red Master carts (135), 100s-5.5s, some Reeds unused rebuilt, \$250 as-is/\$325 cleaned, bulked & splice-found. M Friend, WJLU Radio, Box 711 Newcomb Hall St, Charlottesville VA 22901. 804-924-0885.

Want to Sell
 Pepper-Tanner & TM Prod library records (2007), variety avail. P Wells, KJOY San Diego, 619-238-1037. FAX: 619-238-6157.

Want to Sell
 Plastic tape reels, 1/4", all regular hub, excel cond, incl: (49) 105", (106) 5" fat hub, (66) 5" sm hub, (8) 4", (64) 3", \$85/lot postpaid. D Ember-ton, Clarence Brown Theatre, 1714 Andy Holt Ave, Knoxville TN 37996. 615-974-3256.

Want to Sell
 7" reels (125), 1 mil tape, played once, in boxes, you ship, \$300/lot. A LoPresti, AJL Sound-wave, 21 Carter Rd, Geneva NY 14456. 315-789-4019.

Want to Sell
 Scotchcarts (500) & (60) Scotchcart II, 3.5-5.5 min, vgc, little use, all/part, \$1 ea. R Young, KSNi, Santa Maria CA. 805-925-2582.

Want to Sell
 Reels w/NAB hubs, 10", many avail, come w/box, \$1 ea & you ship. J Harper, KOMC-FM, Box 44, Brinkley AR 72021. 501-734-1570.

Want to Sell
 Grey & Blue carts (500), various lengths, \$1 ea. T Noordyk, 616-924-4700.

TAX DEDUCT EQUIP

Want to Buy
 American Top 40 shows w/Casey Kasem, 4-record set or 3-piece set, no finders fees, must be gd cond, will pay \$25. B Davis, BDMZ Prod, 408 N 11 St, St Joe MO 64501. 816-279-6851.

Want to Buy
 Old 457" station collections, promotional. S Groff, Yesterday & Today Records, 1327 Rockville Pike, Rockville MD 20852. 301-279-7007.

Want to Buy
 AM xmtrs, carrier current/twr LPB type, wanted to wire Spanish-speaking neighborhood; also, FM exciter or cable TV FM modulator for same reason; will pay shipping. B Diener-derfer, Morning Star Ministries, 590 Main St, Slatington PA 18080. 215-767-5985.

Want to Buy
 Youth radio station in public housing seeking donations of radio brcdstng equip, tax deductible. Frank/Julie, ARHA, Alexandria VA. 703-549-7115.

Want to Buy
 Monte Vista Christian School, would appreciate any donations of used TV broadcast equipment. T Quinn, 408-475-0423.

Want to Buy
 Eng student desiring donation of old bcdt equip (anything) in repairable cond, will pay all shipping charges, EE student at Purdue. C Gill, POB 371, Indianapolis IN 46206. 317-923-2800.

TEST EQUIPMENT

Want to Sell
 B&K 1250 NTSC gen; B&K 1035 wow & flutter meter; B&K 1045 telephone product tester; B&K 530 lab semi-conductor tester; B&K TP-28 temperature probe; HP 645A test oscillator; Leader LDM-170 distortion meter/ACVTVM; Tektronix RM-529 waveform analyzer; call for price & compl details. E Wilkie, 602-547-0227.

Contact Radio World Newspaper for availabilities.
 P.O. Box 1214 • Falls Church VA • 22041

TEST . . . WTS

Potomac FIM-72 field strength meter for UHF-TV & Hi-band STL measurements, quality pre-owned equip from our rental inventory. Call Steve or Chuck, Radio Resources, 1-800-547-2346.

Potomac FIM-41 field strength meter for AM station antenna proofs, quality pre-owned equip from our rental inventory. Call Steve or Chuck, Radio Resources, 1-800-547-2346.

Fluke 4085 412B high V pwr supply, 2 kV's DC max, rack mount; Boonton Elec 93A, true RMS voltmeter, portable; HP 5201L scaler/timer, rack mount; Princeton Applied Research 120 lock in amp; Radio Freq Labs 459A crystal impedance meter; all gd cond; BO/trade motion picture equip. H Biller, 108 Hamilton Ave, Silver Spring MD 20901. 301-565-2798.

Sencore FC45 freq counter, range 30 Hz-230 MHz, w/Sencore PR47 UH7 prescaler, extends counter to 600 MHz, \$350. L Stone, Semo Eng, 843 Wilcox Rd, Poplar Bluff MO 63901. 314-785-1956.

Tektronix 575 transistor curve tracer, \$500. B Seifried, Eclair Eng, 101 Prospect St, Northampton MA 01060. 413-584-6767.

Leader LPM880 RF wattmeter, 3 scales: 0-5 W, 0-20 W & 0-120 W, new, \$150; several audio xformers: Triad, Ampex, Hycon, VTC, WE, \$150 ea. S Lawson, KAK Prod, 928 Hyland Dr, Santa Rosa CA 95404. 707-528-4055.

Telco 88 EBS encoder/decoder, new w/warranty, \$388. M Jones, WIVK, 6711 Kingston Pk, Knoxville TN 37939. 615-588-6511.

B&B AM2B phascope, checks headroom, used 6 mnths, \$900. B Lord, Lord Brcdst, 13313 SE 208th St, Kent WA 98042. 206-631-2374.

Tektronix 529 188D TV waveform mon, response to 8 MHz, multi-standard version, PAL frame selector, excel cond w/manual, \$525; Philips PM3266 oscilloscope, portable transfer storage, 100 MHz, dual trace, excel cond, \$1995; HP 200CD audio gen, 5 Hz-600 kHz, at 600 ohms, excel cond w/manual, \$295. R Sumner, CAVU Corp, 3322 Applegate Ct, Annandale VA 22003. 703-560-0233.

Tektronix 323 oscilloscope, portable, SS, 4 MHz single trace, AC/linead pwr, 7 lbs, mint cond, w/manual & probe, \$450; Bruel & Kjaer 2033 high res signal analyzer, FFT sound & vibration analyzer, 0-20 kHz, 11 baseband ranges, ampl of 40 db, 80 db & linear, excel cond w/manual, \$4995. R Sumner, CAVU Corp, 3322 Applegate Ct, Annandale VA 22003. 703-560-0233.

Bird 6154 dummy load/wattmeter, 150 W, 25-1000 MHz, excel cond w/manual, \$335; Bird 434275-100 RF wattmeter/variable sampler, 20-1000 MHz, 1 kW, requires element, excel cond w/manual, \$225. R Sumner, CAVU Corp, 3322 Applegate Ct, Annandale VA 22003. 703-560-0233.

Patchbays (4), 24 single inputs, also patch cords; Editorial splicing block, 1" tape, audiohead alignment tape for Ampex 7.5-15 ips, 14" tape. Mr. Oliver, 212-874-7660.

Want to Buy

Freq counter to measure AM & FM freqs. gd cond & cheap. B Crane, WLIL, POB 340, Lenoir City TN 37771. 615-986-7536.

AM field strength meter. D Van Zandt, WJLU, 2596 SR 44, New Smyrna FL 32168. 904-427-9000.

TRANSMITTERS

Want to Sell

Gates 994-4703-003 & 994-5066-001 motor drive for older AM xmt, as is, BO+shipping. R Kerbawy, WTNJ FM, Box 1127, Beckley WV 25802. 304-877-5592.

Bird 8926 5 kW dummy load for transmitter testing, quality pre-owned equip from our rental inventory. Call Steve or Chuck, Radio Resources, 1-800-547-2346.

OFF AIR?
FM EMERGENCY TRANSMITTER SERVICE
Same-Day • Major Cities
Next Day by 10 am Everywhere
414-482-2638

Molded replacement rectifiers for most transmitters. Upgrade kits for older equipment. Reasonable prices, any quantities. DEALERS WELCOME. Call Plastics Technology Inc. with your requirements. 205-633-6277.

Collins filament xformer for 830F xmitter, part #662-0213-000, new in box, \$250. C Leasure, WTBO-WKGO, 350 Byrd Ave, Cumberland MD 21502. 301-722-6666.

CAPACITORS OVERNIGHT

- Power Supply computer grade: up to 450 VDC
- Transmitting-MICA Sangamo, Cornell-Dubilier
- Oil Filled Non-PCB Oval, Rectangular

1-800-323-0460
FAX 1-802-425-3664
Kellner Electronics, Inc.
Charlotte, VT 05445

Sparta 701A 1 kW AM xmt, tuned to 1190 kHz, vgc, \$6000; CSI T-25A1 25 kW AM, 200 hrs, tuned to 1200 kHz, like new, \$30,000/trade for Nautel 10 kW KC, Collins 20V AM, 1 kW, tuned to 1090 kHz, gd cond, \$1000. G Arroyo, WONQ, 2483 John Young Pkwy, Orlando FL 32804. 407-293-0000.

CCA 10-D 10 W mono exciter, 99.3 w/pwr supply, BO. D Tabor, WLCK-WVLE, Box 158, Scottsville KY 42124. 502-237-3148.

Continental 315R-1 5 kW AM xmt w/1 kW cut-back, 29,000 orig 1-owner hrs, new in '81, tuned to 1090 KC, spare parts & manual, excel clean cond, \$18,000+freight. B Mountjoy, WITM-AM, POB 1240, Elizabeth TN 37644. 615-543-5849.

RCA S-H, dismantling, all parts for sale. R Humphrey, WLTJ, 7 Parkway Ctr, Pittsburgh PA 25220. 412-922-9290.

Kahn STR-84 Power Side adapter & mon on 1420 kHz, BO. D Doughty, H&D Brcdst Group, POB 781, Ulica NY 13503. 315-797-1330.

Used McMartin BF-25K, 275 kW tuned & tested on your frequency. Goodrich Enterprises Inc., 11435 Manderson St, Omaha NE 68164. 402-493-1886 or fax 402-493-6821.

Alcon-Bauer 690-B, programmable, in use, w/manual, \$1200; Harris MS-15 revision D, programmable, in use, \$1200. D Donovan, KCGR FM, 1620 American Bank, Corpus Christi TX 76226. 512-988-8555.

Broadcast BTF20E1 FM xmt, 20 kW output rating using 208 V 3-phase pwr & Broadcast BFC-12B FM antenna, for sale by sealed bid, closes 10/28/91, call/write for more info. D Schroeder, KOSU, Stillwater, OK 74078. 405-744-6352.

Marti xmt's: (2) 2 W, (2) 40 W. T Noordyk, 616-924-4700.

CHECK OUT THESE ENERGY - ONIX TRANSMITTER FEATURES!

- Automatic power level control
- Automatic VSWR foldback & protection
- "User Friendly" controller with manual override panel*
- 4X automatic fault recycling*
- Solid state IPA (with "E" patch)
- Solid state exciter
- Remote control interface panel with opto-isolated circuits
- Built-in line surge protection*
- No neutralization required!
- No proprietary parts!

*Available only on Energy-Onix transmitters. (Allows emergency on air patching)



Energy-Onix

752 Warren Street, Hudson, NY 12534
(518) 828-1690 Fax (518) 828-8476

Circle 94 On Reader Service Card

Henry 4.5 amp DC filter choke (3), mfr'd by Peter Dahl Co, new in shipping crate, \$525+shipping. D Dodd, KKTZ, 107 W 9th St, Mountain Home AZ 72653. 501-425-5104.

Brand New Crated
53.5KVA Electro Transformer
Collins #664-0232-00
Type: E13858 s/n 88
Primary: 200-250 V.A.C., 3ph., 50/60 HZ.
Secondary: T-1 5200 VAC @ 5.3 Amp. CCS
T-2 550 VAC @ 6.1 Amp. CCS
Built By: Electro Engineering Works
San Leandro, CA
\$1100, Plus Shipping, Call 503-884-3778

Eimac 4CX15.000A, Econco Tested, 100% Emission, 154 Total Filament Hrs. \$900 plus Shipping. 503-884-3778

Collins 831-G 20 kW FM, all new capacitors in pwr supply, no PCBs, parts to convert to 25 kW, vgc, \$25,500. D Dayton, Dayton Brcdst, 1907 Lincoln Ave, Mendota IL 61342. 815-534-4681.

RCA BTF 3A, wrking when removed, \$500; Karen, KYKA, 509-453-6296.

Collins 820 hybrid exciter & stereo gen, \$200. S King, KATP-FM, I-40 W, Amarillo TX 79110. 806-355-9777.

CSI 25 kW AM xmt, tuned to 1200 kHz, like new, 200 hrs, can be modified for HF, avail immed, \$30,000, you ship. G Arroyo, WOEC, W Palm Beach. 407-687-9350.

Bird 3128 Wattcher, alarm/RF pwr mon, up to 10 kW, 450 kHz-2300 MHz, requires line section, mint cond w/manual, \$350. R Sumner, CAVU Corp, 3322 Applegate Ct, Annandale VA 22003. 703-560-0233.

Gates/Harris FM-2.5H3, gd cond, 1975 mdl w/spares. 816-635-5959

Harris FM-35K, 3 years, like new. 816-635-5959.

Used Transmission Line, many sizes & lengths, many like new. 816-635-5959.

Harris FM-3.5K only 3.2 years, better than new, many spares. 816-635-5959.

FM TRANSMITTERS

300 W QEI 675T
2.0 kW Collins 831-D1
10 kW Harris 10K
10 kW Collins 830-F

FM EXCITERS

QEI 675
BE FX 30

PMA MARKETING, INC
"Transmitting Savings To You"
414-482-2638



FIRST FOR ALL YOUR FM NEEDS:

- Exceptional FM Exciter Performance
- Advanced Line of 1kW to 8kW Total Solid State FM Transmitters
- Full Line of FM Transmitters from 150 Watt to 50kW to Meet All Your FM Needs
- Excellent Financing Available

TTC

303-665-8000

ARMSTRONG TRANSMITTER

FINEST REBUILT TRANSMITTERS

We're the leading re-manufacturer of transmitters worldwide.

Transmitters are available:

- Tuned & Tested on YOUR Frequency
- Guaranteed and Installed
- Completely Re-manufactured
- Expedited Service Available

Trade-Ins gladly accepted - **WE DELIVER!**
See your choice in transmitters **WORKING** in our huge new showroom **BEFORE** you take it home!



NO ONE ELSE OFFERS YOU THIS!
SEE & TEST IT ALL YOU WANT!

ARMSTRONG TRANSMITTER CORP.

5046 Smoral Road Syracuse NY 13031
Phone 315-488-1269 FAX 315-488-1365

RADIO RESOURCES

We can save you \$\$\$ on your next equipment or supply purchase.

Ask for our current list of quality pre-owned equipment.

Equipment available to rent for a day or a month...

Field strength meters
Audio test system
Impedance bridge
Telephone frequency extender
Spectrum analyzer

Call: 1-800-54-RADIO
1-800-547-2346
Fax: 1-301-783-4635

Ask for Steve or Chuck

Circle 26 On Reader Service Card

B&W 210 tone oscillator, gd cond, \$75; B&W 410 distortion analyzer, gd cond, \$100; Gates M3625 gain set, vgc, \$100; Heath 1G-72 audio gen, gd cond, \$30; Heath V7A VTVM, gd cond, \$25; Leader 3060D storage oscilloscope, new, \$3000; many more, call for details. B Williamson, WWWK/WELV, Ellenville, NY. 914-858-2941.

General Radio 1932A distortion analyzer, like new, w/case, \$150/BO; Vu-Data portable oscilloscope, 25 MHz BW, dual trace, gd cond, \$200. S Wood, Modern Syst Res, 12648 La Crosta Ct, Los Altos CA 84022. 415-941-8000.

B&W 410 distortion meter; B&W 210 audio oscillator; Leader Elec LBO-53B oscilloscope; BO ea. R Ness, WGEN, 1003 S Oakwood Box 67, Geneseo IL 61254. 309-944-4633.

Leader LFR-5600 audio response test unit w/recorder, \$1500. C Bucy, Cisco Sound, POB 16583, Lubbock TX 79490. 806-792-1662.

TRANSCOM CORP.

Fine Used AM & FM Transmitters and Also New Equipment

For the best deals on Celwave products, Andrew cable and Shively antennas.

1 kW FM 1976 Harris FM1H3	1 kW AM 1986 Continental 314R1	
2.5 kW FM 1978 CCA 2500R	1 kW AM 1974 Harris BC1H1	
10 kW FM 1990 BE FM10B w/FX-50	2.5 kW AM 1982 CCA 2500	
10 kW FM 1972 Collins 830F-1	5 kW AM 1980 McMartin BA5K	
10 kW FM 1975 RCA BTF 10ES1	5 kW AM 1972 CCA AM5000D	
20 kW FM 1975 Collins 831G2	5 kW AM 1977 RCA BTA 5L	
20 kW FM 1973 RCA BTF 20E1	10 kW AM 1972 Harris BC10H	
30 kW FM 1990 BE FM30 w/ factory warranty	10 kW AM 1972 RCA BTA 10U	
30 kW FM 1981 BE FM30	50 kW AM 1977 CCA AM50000D	

201 Old York Rd. • York Plaza Ste 207
Jenkintown PA 19046

800-441-8454 • 215-884-0888 • FAX No. 215-884-0738

TRANSMITTERS . . . WTS
 Best has some show units at sale price. Full 2 yr warranty, like new. Exciters, amplifiers, STL's. First come first served only. Call for details. Best, 619-239-8462.

Want to Buy

CCA, Harris, BE, 4-5 KW FM, '86 or newer. J David, KMPL/KSTC, POB 907, Sikestol MO 63801. 314-471-7520.

FM xmtr, 4 KW-5 KW, prefer late model in excel cond. T Pelowset, Wolverine Radio, POB 1844, Midland MI 48640. 517-631-5583.

10 KW FM, 20-25 KW FM & 10 KW AM, older OK but must be vgc. B Zellmer, Colorado Farm Net, Box 2475, Greeley CO 80632. 303-330-1342.

Gates 6095 FM exciter, working; Gates 5534 FM exciter, working; Gates 6146 stereo modulator. J Richardson, KXIO-FM, POB 37, Clarksville AR 72830. 501-754-2076.

Robt A Jones/Tepeco snlgl or dual 10 W trans-lator. J Stromquist, WNCB, 2828 Piedmont Ave, Duluth MN 55811. 218-722-3017.

WE BUY
 MOSELEY PCL-303 & 606's
 414-482-2638

Continental for 10 KW TPO, might consider clean 10 KW Harris in gd cond. D Dayton, Dayton Brcdst, 1907 Lincoln Ave, Mendota IL 61342. 815-538-4681.

Low pwr, 3-10 W. J Benjamin, JC Enterprises, 3923 E Thunderbird Box 139, Phoenix AZ 85032. 602-493-5312.

FM xmtr, 25 KW. T Noordyk, 616-924-4700.

Late model FM xmtr, 500 & 1000 W, stereo gen. R Murphy, 602-855-1051.

McMartin AM/FM xmtr, any model, exciter or stereo modules. Goodrich Ent., 11435 Manderson, Omaha NE 68164. 402-493-1886.

TUBES

Want to Sell

Johnson Capacitor 124-0113-001, several, new & in box, BO; 8122 driver tubes & (2) sockets, BO. D Tabor, WLCK-WVLE, Box 158, Scottsville KY 42124. 502-237-3148.

3CX1500A7, 4CX5000A, 6146B, 4CX250B, 4CX3000A & more. We carry large inventory all major brands, Eimac, Amperex, RCA, etc. Call Stew 1-800-842-1489.

RCA/SYL/GE, 32 pieces, also carbon resistors; Canon plugs, 3 prog male & female, new; Lafayette TE22 audio gen; Sencore transistor & diode tester. Mr. Oliver, 212-874-7660.

PETER DAHL CO.

Save \$\$

Heavy Duty Replacement Transformers, DC Filter chokes and capacitors for AM & FM transmitters manufactured by: AEL, CCA, CSI, COLLINS, CONTEL, CONTINENTAL, BAUER, GATES, GE, HARRIS, ITA, McMARTIN, RAYTHEON, RCA, SINGER, SINTRONIX, WILKINSON. Many other models also available.



FAST Delivery and FREE Technical Support.



—Write For Free List—
 5869 WAYCROSS AVENUE, EL PASO, TEXAS 79924
 (915) 751-2300 FAX: (915) 751-0768

Circle 56 On Reader Service Card

ECONCO

Quality Rebuilt Tubes

Approximately 1/2 the Cost of New

Call for Our Price List

800-532-6626

916-662-7553

FAX 916-666-7760

Circle 18 On Reader Service Card

Tubes, Transformers, filter capacitors, receiving tubes, \$5.00+up; 500 watt modulation transformer, \$50.00. Madison Electronics, 1-800-231-3057.

Want to Buy

Telefunken VF14 & AC701, used OK, must work. J Kreines, DeMott/Kreines Films, 5330 Kennedy Ave, Millbrook AL 36054. 205-285-6179.

TURNTABLES

Want to Sell

Technics SL-1200 w/Audio Technica cartridge, like new cond, \$250. B Weiss, KLSI, 3101 Broadway #460, Kansas City MO 64111. 816-753-0933.

Technics SP10, SH10 ps, w/16" Rek-O-Kut tone arm & Stanton 500 cart, spare shell, no base. \$450. L Beigel, On Cue Rcrdng, POB 85032, Iowa CA 90072. 800-726-9813.

Empire 1000ZEX cartridge, any cond; Weathers ML1 & ML234; Rek-O-Kut B-12 & B-12GH w/ white deck plate; Grey 33H; components PBT; Pickering 800; Scott 710; Empire 698; auto-lift add-on device for manual tonearms, any brand. W Laughlin, 753 Ruth Ln, Hurst TX 76053. 817-282-9033.

QRT rim drive TT, used, \$100, call for details. B Williamson, WWWK/WELV, Ellen-ville, NY. 914-858-2941.

Russco Cue Master TT pair, incl tone arms & cart, \$245/both. Davis, MCP, POB 521, Newberry SC 29108. 803-276-0639.

Want to Buy

Rabco SL-8E straight-trking tone arm in gd cond. R Meyer, Benchmark Comm, 4700 SW 75 Ave, Miami FL 33155. 305-262-5963.

Fairchild disc rcrding equip, #740 & similar, Presto, Rek-O-Kut, RCA, etc; also, accessories incl amps, limiters, heads, manuals, needles. K Gutzke, 7134 15th Ave S, Minneapolis MN 55423. 612-866-6183.

Fairchild disc rcrding equip, #740 & similar, Grampian/Gotham, Neumann, Presto, Rek-O-Kut, RCA; also, accessories incl amps, limiters, heads, manuals, needles; also, disc cutting equip by same mfrs. K Gutzke, 7134 15th Ave S, Minneapolis MN 55423. 612-866-6183.

Micro-Trak 303 tone arm in wrking cond. J Kimple, WMCO, Stormont St, New Concord OH 43762. 614-826-8376.

RCA 70-D spare parts & service manual; Gates CB-11 floor cabinet; RCA BQ2A 76 & Gates CB11 spare parts & manuals; Gray SP-600 tone arms. L Scott, POD 1449, Highland City FL 33836. 813-533-4654 eve.

TV FILM EQUIP

Want to Sell

RCA FR35 35mm film proj, variable speed, gd cond, \$7500. J Kiss, Multi Video Grp, 50 E 42 St, NY NY 10017. 212-986-1577.

Want to Buy

ND Filter Wheel assembly for automatic light control on telecine film chain, must reference to video output of film chain for level control & have optional manual override. K Knowles, Knowles Video, POB 12127, Tallahassee FL 32317. 904-878-2298.

VIDEO PROD EQUIP

Want to Sell

COHU, color bar gen, sync gen, rack mount, gd cond, BO. S Wood, Modern Syst Res, 12648 La Crosta Ct, Los Altos CA 84022. 415-941-8000.

Panasonic NV8500 VHS editor (2), w/NV500 controller, all cables, covers, vj hw hrs, \$3500; (2) JVC TM-13U color mon, \$500. Duane, Safair Prods, 7984 E Boojum St, Tucson AZ 85730. 602-721-0550.

Sony BVP507 Beta SP package, incl BVP7 camera, BVV5 recorder, Fujinon 8.5x superwide 5.5-47.5 zoom, (5) batts, case, rain cover, mint, \$21,000/BO; also, Sachtler Video 20 II w/legs, case, nice, \$3200. J Kreines, DeMott/Kreines Films, 5330 Kennedy Ave, Millbrook AL 36054. 205-285-6179.

Sony CUM1250 12" color video mon w/UHF-VHF tuner, AV I&O, excel cond, \$300/BO. R Glenn, WJGR, 1718 Shannoa, Wimauma FL 33598. 813-634-1940.

VIP Hybrid-8 SEG, video dup-proc w/hybrid digital video effects, A/B, split screen, wipes, dissolves, 6 spec effects, auto fades, enhance, more, \$395. Davis, MCP, POB 521, Newberry SC 29108. 803-276-0639.

VIDEO TAPE RECORDERS (VTR's)

Want to Sell

Panasonic NV9300A 3/4", gd cond, \$300/BO; JVC CR61000 3/4", gd except rewind, \$850/BO; (2) Sony VP1000, parts only, \$25 ea+shipping. B Strapko, 708-830-0701.

Ampex 7900A 1" video proc recorder, flying erase, horz lock, high band color, like new, \$1500; Ampex 7800A 1" video prod recorder, color, vertical lock, gd cond, \$500. S Wood, Modern Syst Res, 12648 La Crosta Ct, Los Altos CA 84022. 415-941-8000.

Sony VO-5600 3/4" U-matic R/P, excel cond w/manual, \$900. R Sumner, CAVU Corp, 3322 Applegate Ct, Annandale VA 22003. 703-560-0233.

Sony LDP-1000A indust laser video disk player for CAV & CLV disks, RS232C serial port for computer interface, w/remote & flight case, excel cond, \$500. J Krepol, RNDL, 7 Dustin Dr, Wilmington DE 19703. 302-798-4076.

Sony 3/4" U-matic top loaders: VP-1000, VP-1200, VP-2000, VO-2630, VO-2800; editing controllers BVE 500, BVE 500A (AVB roll); (6) 1/2" EIAJ recorders & players; Ampex Quad VR1200B parts inventory; all BO. J Krepol, RNDL, 7 Dustin Dr, Wilmington DE 19703. 302-798-4076.

JVC CR-4400-LU portable 3/4" U-matic, \$600; Sony SLO-340 portable industrial beta w/pwr supply & soft case, hw hrs, \$500. D Bailey, Rock Shoppe Prod, 3422 Beech St, Rowlett TX 75088. 214-475-9796.

ACTION-GRAM

Equipment Listings

Radio World's Broadcast Equipment Exchange provides a FREE listing service for all broadcast and pro-sound end users. Simply send your listings to us, following the example below. Please indicate in which category you would like your listing to appear. Mail your listings to the address below. Thank you.

Please print and include all information:
 Contact Name: _____
 Title _____
 Company/Station _____
 Address: _____
 City _____ State _____ Zip _____
 Phone Number: _____

I would like to receive or continue receiving Radio World FREE each month. YES NO

Signature _____ Date _____

Please circle only one entry for each category:

I. Type of Firm

D. Combination AM/FM station F. Recording studio
 A. Commercial AM station G. TV station/teleprod facility
 B. Commercial FM station H. Consultant/ind engineer
 C. Educational FM station I. Mfg, distributor or dealer
 E. Network/group owner J. Other _____

II. Job Function

A. Ownership D. Programming/production
 B. General management E. News operations
 C. Engineering F. Other _____

WTS: WTB: Category: _____
 Make: _____ Model #: _____
 Brief Description: _____

 _____ Price: _____

WTS: WTB: Category: _____
 Make: _____ Model #: _____
 Brief Description: _____

 _____ Price: _____

Broadcast Equipment Exchange

PO Box 1214 • Falls Church VA • 22041 • 703-998-7600 • FAX: 703-998-2966

Visit Our New 13,000 Sq. Ft. Used Transmitter Supermarket World's Largest



Our Centrally located Low-Overhead showroom location means BIG SAVINGS to you!

Available:

- ALL TRANSMITTERS Tuned & Installed ONLY by FCC Licensed Licensed Technicians, each with 15 years MINIMUM experience in RF.
- INSTALLATION & FIELD SERVICE by Former FCC Bureau Chief & Field Inspector.
- Expedited Service
- TRADE-INS ACCEPTED
 - We tune & test units purchased from others—including units they say they've tuned.
- 3 OFFICES TO BETTER SERVE YOU:
 McCook, NE • Dallas, TX • Miami, FL

Phone: 308-345-7633

FAX: 308-345-7650

Hablamos Español Phone: 305-448-5066 FAX: 305-448-5127

Imperial Transmitter
Worldwide

Appreciating Grid Dip Meters

by Tom Vernon

HARRISBURG, Pa. In these days of expensive, microprocessor-based test equipment, it's easy to overlook simple instruments that have been around for a while. Such a device is the grid dip meter.

Grid dip oscillators, or GDOs, are very simple devices. They're basically oscillators with a meter for measuring grid (or base) current. Typically, GDOs are battery-powered with several plug-in coils for overlapping frequency bands. The dial of the variable capacitor is calibrated in kHz or MHz, with bands that match the range of the plug-in coils.

The principle of operation also is quite simple. Oscillator current dips when the

One of the most common applications of grid dip meters is to determine the resonant frequency of tuned circuits in transmitters and other RF devices. The coil of the GDO is placed close to the circuit being evaluated, and the tuning dial is adjusted for a dip in the meter. The frequency then is read off the calibrated dial.

STATION SKETCHES

Care must be exercised when using this technique to get just enough coupling between the GDO and the circuit under test to see a dip on the meter. Too much coupling will cause the oscillator to be pulled off frequency, resulting in measurement errors.

The electrical length of transmission lines may be determined by opening the far end and putting a loop of wire on the other end. Now tune the grid dip meter to the lowest frequency where a dip is located. This dip is the point where the transmission line is a quarter-wavelength long.

In a similar manner, the resonant frequency of antennas may be determined. Simply connect a loop from the antenna to ground, couple in the grid dip meter and tune for a null on the meter.

A GDO also may be used to check the resonant frequency of RF components. To check coils, simply place the unit close to the meter and tune for a dip. It's that simple. Capacitors are a little more

involved. Connect the unknown capacitor across a coil of known inductance. Measure the resonant frequency of the circuit and solve for Cx in the formula:

$$Cx = 25,400 / (F^2L)$$

where C is in picofarads, L is in microhenries, and F is in MHz.

You can find the inductance of a coil using the same procedure, but with a known capacitor value. In this case solve the above formula for L instead of C.

Applications at the station and around the shop are numerous. A GDO can be used to align a communications receiver with no power applied. You begin by coupling the meter to the last transformer and adjusting the slugs for a dip at the IF frequency.

Gradually work your way back to the antenna in this manner. To tune up the local oscillator, set the receiver for 1500 kHz. The meter is tuned to this frequency minus the IF frequency, in this case 1045 kHz. With the meter coupled to the oscillator coil, adjust for a null at 1045.

Since the GDO radiates RF, it also can be used as a signal generator, as well as a BFO and Q multiplier for a communications receiver.

By noting dips at places other than the resonant frequency, the grid dip meter is useful for tracking down spurious radiation. Checks of crystals and filters also are possible with this device.

Grid dip meters are also inexpensive. These units frequently show up in government surplus catalogs for very reasonable prices. Hamfests are yet an-

other source. Just make sure the batteries are still available for older units and that all plug-in coils come with the meter.

If you don't mind a few evenings with a drill and soldering iron, The Radio Amateur's Handbook contains complete plans for building GDOs.

Although the grid dip meter gives an accurate indication of resonant frequency, it's not as razor sharp as a fre-

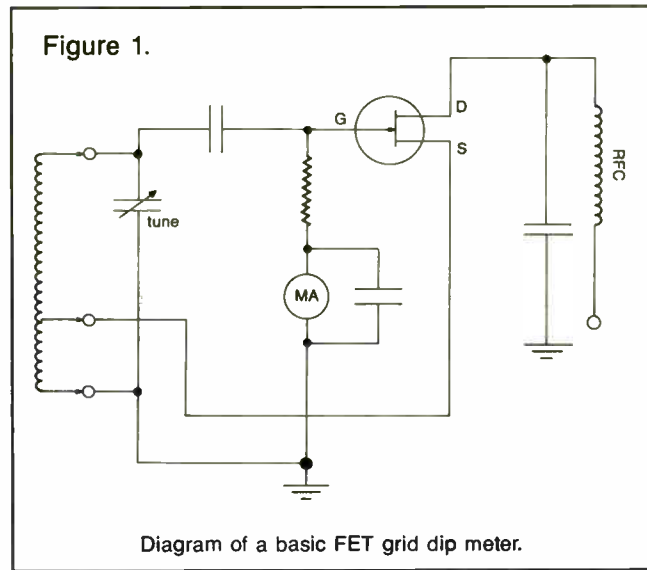
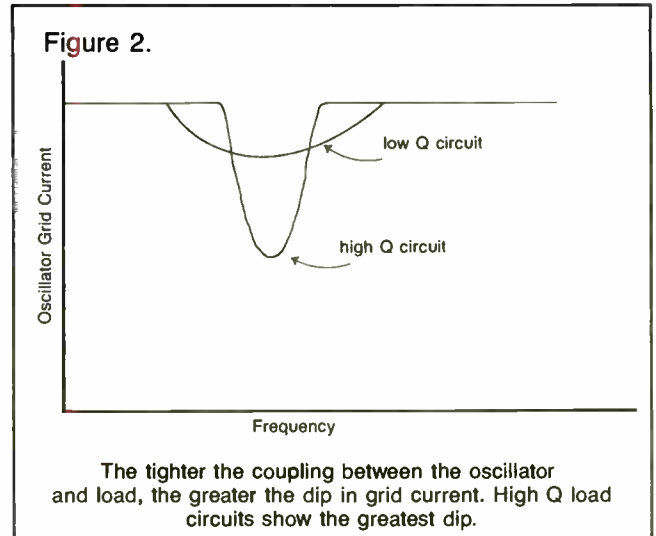

Diagram of a basic FET grid dip meter.

coil is in the presence of an external resonant circuit at the oscillator's frequency. This is because a certain amount of the oscillator's energy is absorbed by an external resonant circuit. The sharpness of the meter's dip depends on the tightness of coupling to the external circuit as well as the Q of that circuit. The relationship is illustrated in Figure 2.



quency counter and should not be used for FCC required measurements. Its real advantage is that it can give you information that cannot be easily obtained in any other way.

Tom Vernon, a regular RW columnist, divides his time between broadcast consulting, computers and instructional technology. He can be reached at 717-367-5595.

What happens when you buy a "high performance" product from a low performance company?

If electronics lasted forever, it wouldn't matter where you bought your next exciter, amplifier, STL, translator or transmitter. Track records of customer frustration would be of no concern as you simply chose the box which suited you.

Since failures not only occur, they usually take place at the worst possible time, it's a good idea to go into the purchase knowing exactly what the manufacturer will do if you need help. Will they handle your need themselves? Will they take action? Will they follow up to see if you're okay?



At BEXT, customer service is a way of life. We freely share our reference list so that those whose experience with other companies leads them to doubt our claim can hear what a difference BEXT has made in our customers' lives. Beside our service, you'll hear about the technical superiority and reliability that have made our products the growing choice of the engi-

neering community.

To find out what it's like to have a relationship with BEXT, unchain that high tech telephone system and call 619-239-8462, or rev up the fax machine and aim it at 619-239-8474. We'll promptly return the complete BEXT catalog of FM, UHF and VHF equipment, with reference list.

And don't be surprised if we call to be sure you got it.



739 Fifth Avenue
San Diego, California 92101 USA
619-239-8462 FAX: 619-239-8474

LOW FAT CARTS

audionax™
MODEL 4000 BROADCAST CARTRIDGE

AA-4 Compatible
for Bias and Phase

- Lower Noise / expanded headroom
- Lower Wow and Flutter / better phase stability
- Lower abrasiveness / longer life tape
- Lower breakage / sturdier shell
- Lower calorie / Save up to \$2⁰⁰ cart

Satisfaction fully
Guaranteed by



Fidelipac Corporation • PO Box 808
Moorestown, NJ 08057
Tel: 609-235-3900 • Fax: 609-235-7779

Broadcast Standard Remote Control Stop, Start, Record, and Drawer Open controls are all brought out to standard pull-to-ground contacts. Lamp drivers are also provided for these and other functions.

Wired Remote Control All front panel functions are available on an optional hand-held remote controller with 15' of cable provided.

Balanced Inputs and Outputs on XLR Connectors High slew rate and low distortion audio circuitry insure the integrity of the audio signal.

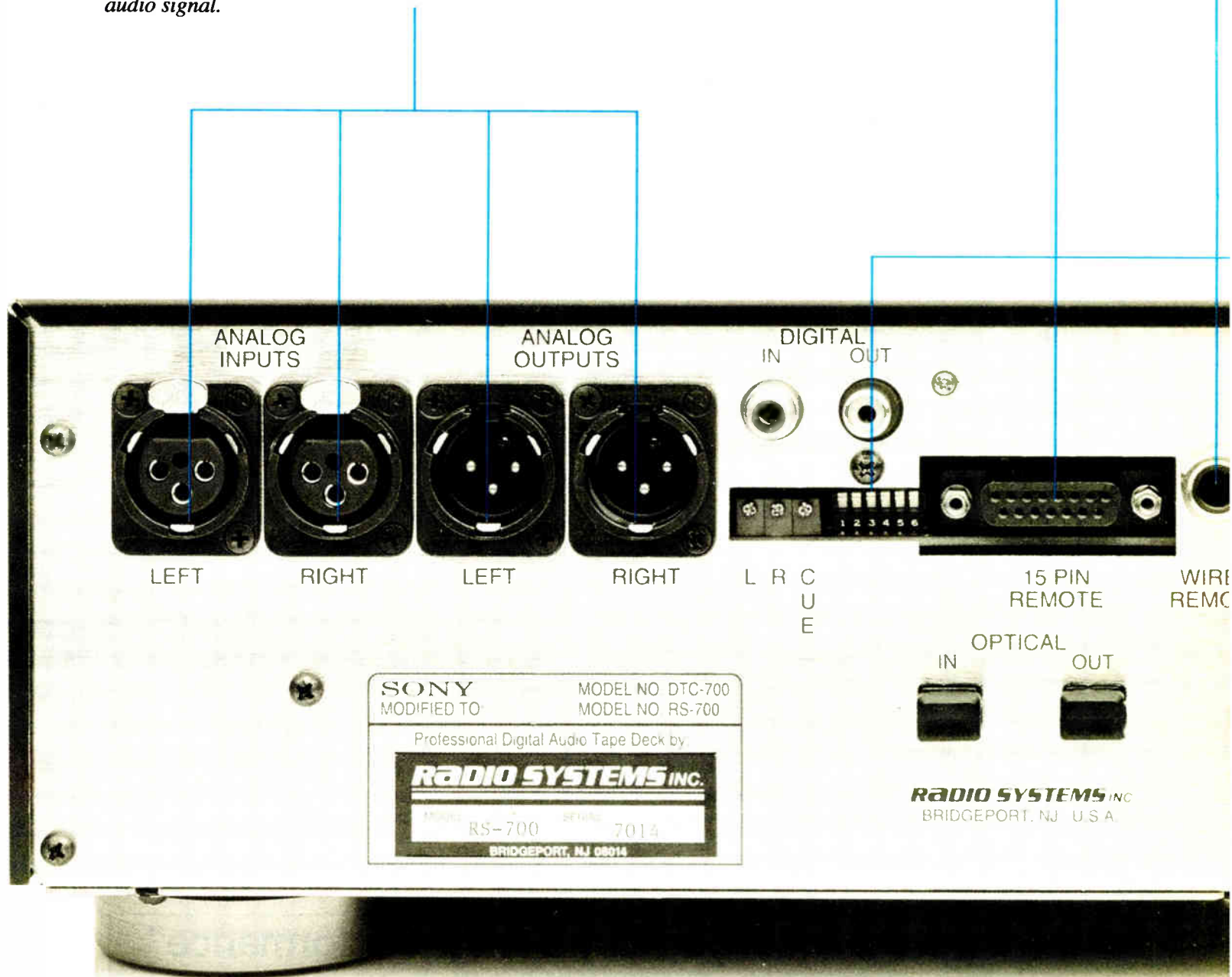

RS-DAT 700...Backed up

All DAT machines look about the same viewed from the front panel. But the business end of the RS-700 is around back. That's where it has been extensively factory modified to connect and

perform like a professional studio machine. Built around the superb sounding SONY DTC-700, the RS DAT-700 includes a large circuit board housed just under the lid, with

User-Programmable Logic Functions:

End-of-Cut Relay Closure RS-DAT machines are the only DAT machines to provide user-positioned end-of-message closures for automatic next event sequencing.

Tape Auto-Cue on Insertion Tapes cue up to the beginning of cut start-ins and park in pause-play automatically after insertion.

Drawer Open On Cut End Dip switch settings allow the drawer to open automatically on cut completion, signaling the operator to change tapes.

Cue to Next Cut on Cut End The RS-700 can be programmed for multiple end-of-cut functions. The next cut option automatically fast forwards the tape to the next cut and parks in pause play, and awaits the next start command.

Re-Cue to Cut Beginning Programming allows tapes to automatically rewind on cut end, and re-cue to the beginning of the cut to facilitate special one-cut-per-tape applications.

One Button Network Record The RS-700 is perfect for auto-record functions because it easily interfaces with network formats. One closure to the remote connectors puts the RS-700 into record/play.

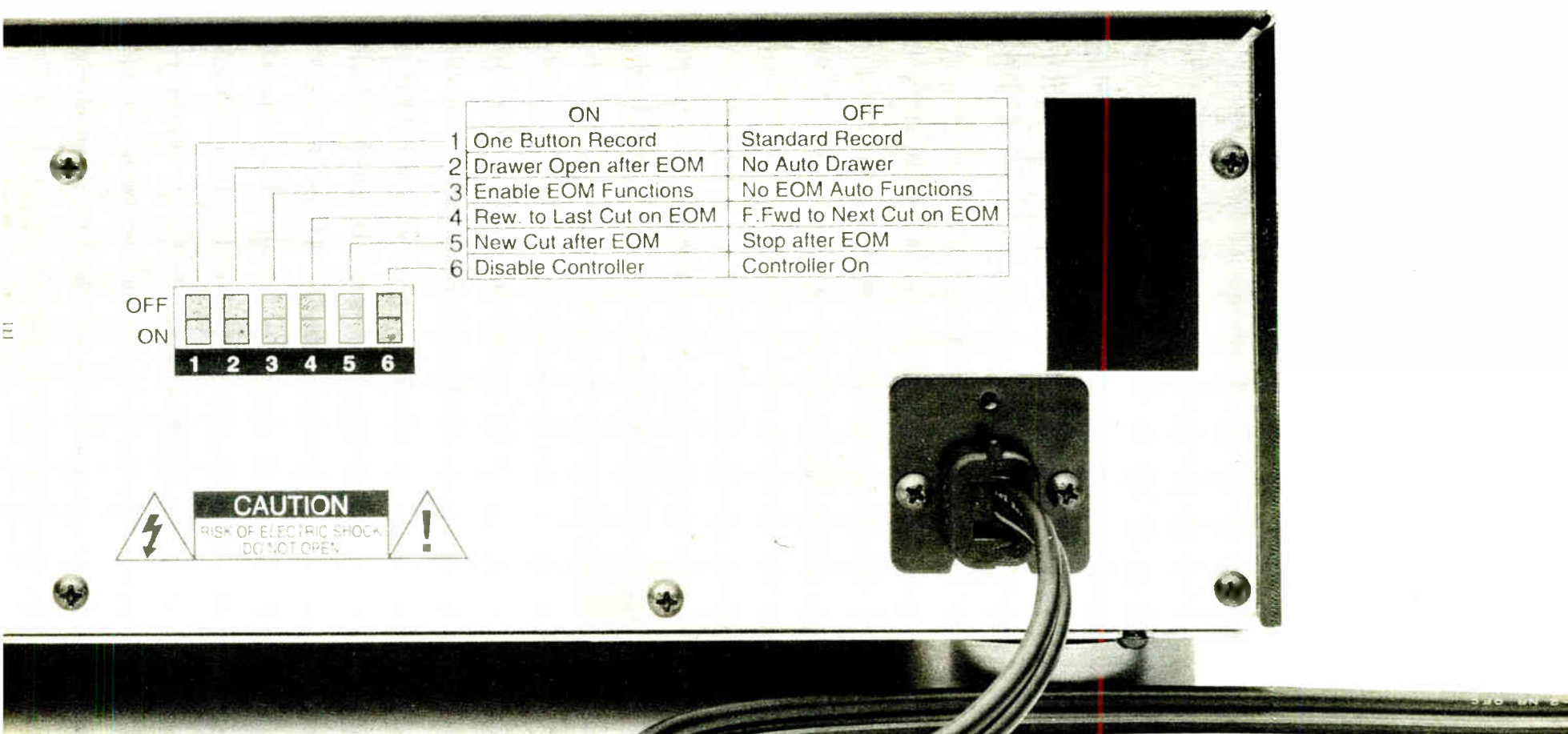

with professional features.

connectors and controls accessible on the rear panel. Extensively inter-wired to the DAT machine's logic and audio sections, this special RS-700 circuitry delivers true professional performance.

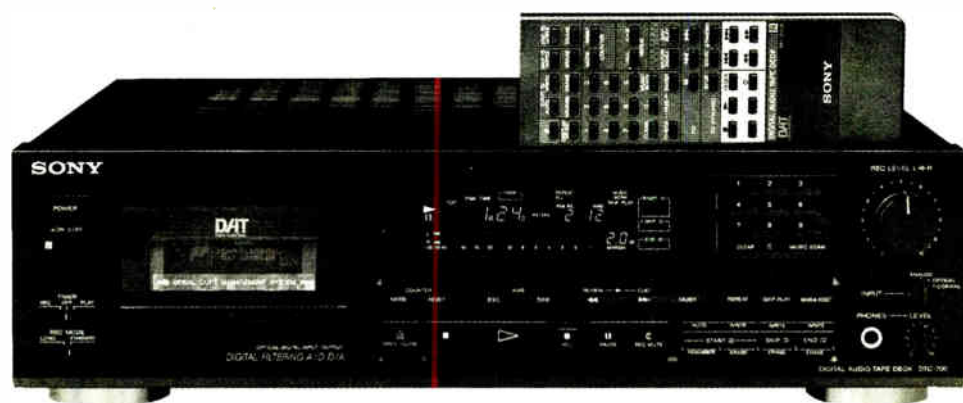

RADIO SYSTEMS INC.

110 High Hill Road • P.O. Box 458 • Bridgeport, NJ 08014-0458
(609)467-8000 • (800)523-2133 • FAX (609)467-3044

Circle 103 On Reader Service Card

World Radio History

QEI QEI QEI QEI QEI QEI QEI QEI QEI QEI

WHY QEI?

24 Hours.



Our 24 hour service hotline number is 609-728-2020.

Call us toll free at 800-334-9154 for all the facts on QEI

"New Reliables" FM transmitters from 1kw to 30 kw.

Power Up.



With our FMQ 3.5/5/10 kW or 20/30 kW FM transmitters, you can upgrade power in the field.

Call us toll free at 800-334-9154 for all the

facts on QEI "New Reliables" FM transmitters from 1kw to 30 kw.

No Extras.



We never charge you extra for single phase power. Not on our FMQ 10000 or our FMQ 20000B—not even on our 30 k FMQ 30000B.

Call us toll free at 800-334-9154 for all the facts on QEI "New Reliables"

FM transmitters from 1kw to 30 kw.

Less is More.



All of QEI's FM transmitters have no plate blockers or sliding contacts.

Call us toll free at 800-334-9154 for all the facts on QEI

"New Reliables" FM transmitters from 1kw to 30 kw.

Free.



Our FREE spares kits include every solid state component of the transmitter, exciter and remote control.

Call us toll free at 800-334-9154 for all the

facts on QEI "New Reliables" FM transmitters from 1kw to 30 kw.

The Longest.



Our PA tube warranty is the longest in the business — 15,000 hours.

Call us toll free at 800-334-9154 for all the

facts on QEI "New Reliables" FM transmitters from 1kw to 30 kw.

Single Phase 30 kW.



Our new FMQ 30000B is the only 30 kW transmitter available with a single phase power supply.

Call us toll free at 800-334-9154 for

all the facts on QEI "New Reliables" FM transmitters from 1kw to 30 kw.

Built-in Backup.



QEI's constant 50 Ohm interstage impedance lets you bypass the IPA or PA in the unlikely event of a problem.

Call us toll free at 800-334-9154 for all the

facts on QEI "New Reliables" FM transmitters from 1kw to 30 kw.

QEI CORPORATION
ONE AIRPORT DRIVE • P.O. BOX D • WILLIAMSTOWN, N.J. 08094
TEL (800) 334-9154 • (609) 728-2020 • FAX (609) 629-1751

QUANTITY • **E**NGINEERING • **I**NNOVATION

FCC Refines Its Fines

(continued from page 20)

Each of these adjustment criteria is assigned an effective range, measured in percents. For example, the "egregious" criterion could increase the fine by a factor of anywhere from 50 percent to 90 percent, depending on how egregious the misconduct is found to have been.

Quintupled to the max

These adjustment criteria are cumulative, which means that a base fine of, say, \$10,000, could end up being quintupled if all of the upward criteria are found to be applicable to the max and none of the downward criteria are.

How would this work in practice? Let's say that you get caught using unauthorized equipment for one single day. Bingo: You start off with a \$10,000 base fine. It turns out that it was an intentional violation—so much so that the Commission decides a 70 percent upward adjustment is warranted. Tack on an extra \$7,000 (that is, 70 percent of the \$10,000 base).

But wait, there's more. It also turns out that the violation caused substantial harm, enough to warrant another 40 percent increase—add an extra \$4,000 (40 percent of \$10,000). We're up to \$21,000.

But let's say you have a history of overall compliance with the rules. For keeping your nose clean, the FCC gives you a 30 percent downward adjustment—subtract \$3,000 (30 percent of \$10,000). Bottom line—a fine of \$18,000.

The trouble with all of this is that, when

the dust settles, there is still about as much uncertainty as there was before the new regulations in how much you might get fined.

Despite such an apparently simple example, the fine could end up being anywhere from \$0 to \$25,000. With so great a potential swing, you can't really say that the new approach provides much definite predictability, or that it is likely to lead to effective uniformity, particularly when the swing will depend on case-by-case judgment calls such as how egregious any particular misconduct might be.

And the potential swing just gets bigger when you realize that most violations are not one-time-only, one-day-only affairs.

While we applaud the FCC's apparent desire to provide predictability and uniformity in the fining process, the new system is unfortunately not likely to result in either. Probably the most useful aspect of the Commission's new approach is the fact that the Commission has established base amounts for particular violations.

That at least gives broadcasters an idea of how serious certain types of violations are in the FCC's eyes. If your usual inclination to do things by the book is not enough to convince you to steer clear of misconduct, the potential industrial-strength monetary penalties evident in the list may do the trick.

Harry Cole is a partner in the Washington-based law firm of Bechtel & Cole, Chartered. He can be reached at 202-833-4190.

SCALA

SCALA now offers a complete line of antennas for aural STL/ICR links in the 940-960 MHz band. Since 1954 broadcasters have appreciated the unequalled performance and reliability of the Scala

Paraflector™ and Miniflector™ antennas. Now the same Scala quality is available in full parabolic grid antennas from 4 to 12 ft. diameter!

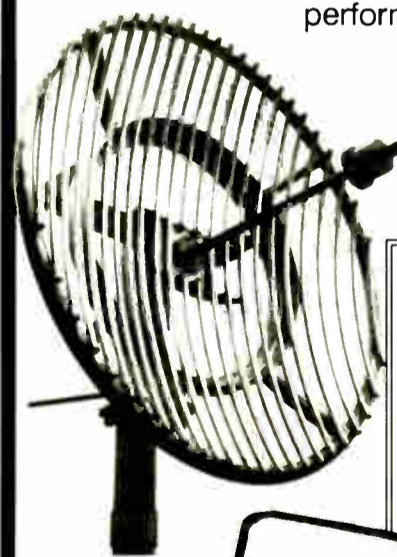

MODEL	GAIN (dBI)	F/B Ratio	FCC Category
PR-450U	20.15	20	B*
PR-450CU	20.15	25	A*
MF-960	16.15	23	B*
GLF4-940	18.5	24	B
GLF6-940	21.9	26	A
GLF8-940	24.5	28	A
GLF10-940	26.5	30	A
GLF12-940	28.1	30	A

*when vertically polarized.

NOW!
PR-450U and PR-450CU
PARAFLECTORS™
PACKAGED FOR SHIPMENT VIA
UPS or FEDERAL EXPRESS

SCALA ELECTRONIC CORPORATION

P.O. Box 4580, Medford, Oregon 97501 (USA)
Phone: (503) 779-6500 Fax: (503) 779-3991

Fax Modems Link World

(continued from page 32)

to obtain good results from it. A fax to its customer service went unanswered for almost a month.

In fact, I was so annoyed with the program that I got hold of WinFaxPro™, Version 2.0, from Delrina Technology. This program runs under Windows 3 and does a fine job of sending and receiving faxes. Just select WinFax as the printer and the output of your word processor, graphics, a scanner program or all three at once go right to a fax.

WinFaxPro will store phone numbers for you to call up as needed. Another nice feature allows you to select the time and date of transmission, so faxes can be set for overnight transmission.

With WinFaxPro, you can have incoming faxes print out immediately, or go to disk storage. At 200×200 dpi, the output of text and illustrations is close to anything you can create locally. You can even paste an incoming fax into a Windows application.

I've found the combination of the Zoom FC 96/24 and WinFaxPro work well for me.

Another fax/modem you may want to consider is the Image Communications TWINCOM 24/96 (the numbers are reversed from the Zoom, but they mean the same specs). Like the Zoom

FaxModem, this unit from the Target Tuning people uses the Rockwell fax chipset, found in the majority of fax machines.

The TWINCOM 24/96 setup could hardly be easier: a dip switch selects the desired COM port and you insert the card into the computer. Included in the package is Quick Link II fax™, a DOS-based program that allows background operation.

TWINCOM also works well with WinFaxPro. My only real

complaint with the TWINCOM is that when installed in the computer, I could barely hear the speaker.

The other half of fax/modems is the modem itself, the part that connects you to databases, conferences and electronic mail.

If your need is instant communication: MCI Mail, CompuServe, Prodigy, Genie and the worldspanning Internet all provide ways of sending messages to another user's electronic mail-

box instantly.

From time to time, RW highlights broadcast-oriented BBSs around the country (see box). There, you can connect with other broadcasters that will share experience, locate parts and manuals for old equipment, discuss transmitter safety or chat about why and how stations received their original call signs.

If that isn't enough to interest you, BBSs feature hundreds of different areas of interest: software reviews and support, current events, science fiction, etc.

Thanks to many thousands of hobbyists, these echo conferences, as they are called, are of-

ten no more than a local phone call away with no time charges for these services. Look for them and if you don't see any broadcast areas, often local SYSOPS (system operators) will add them on your request.

Zoom Telephonics can be reached at 800-631-3116, and Image Communications at 800-666-2496. Delrina Technology is at 800-268-6082.

■ ■ ■
Barry Mishkind, aka RW's "Eclectic Engineer," is a consultant in Tucson, Ariz. He can be reached at 602-296-3797, or 1:300/11 on FidoNet, or "barry@coyote.data-log.com" on Internet.

Reliving The Past

(continued from page 29)

me his Webster-Chicago wire recorder. Most broadcasters under 30 would think you were blowin' sunshine up their skirt when describing one of these jobbies. It was a good bet that "Bobs" owned it all way up the valley while putting stations on-air throughout N.Y.'s resort areas. He won't pitch his machine, either.

As I said up front, it's a little silly to be nostalgic at only 34. But when I see where WaveFrame's got its next upgrades in place, that AKG is lopping nine grand off my dream machine DSE-7000 and Motorola debuting the "Media Engine" (send for the fact sheet on the DSP96002 chip—scary!), it's tough not to smile at my wretched little import tape deck.

So, back in the box it goes for another day . . . right next to a badly beaten piece of metal sculpture on a gooseneck. I think it was a senior art project.

Holy, geez, it's my desk lamp. Quick, find me a pencil!

-Al

■ ■ ■
Al has written for RW since July 1989 and still doesn't know what these three little black squares are for.



When you need extra hands mixing audio, Shure's AMS can help.

Until recently, you needed outstanding hand-eye coordination to mix audio in multiple-microphone broadcast situations.

Now there's a system that gives you broadcast-quality audio when you can't cover all the faders at once. It's the Shure Automatic Microphone System (AMS), featuring patented direction-sensitive gating.

The Shure AMS continuously compares audio signal levels from two matched unidirectional condenser microphone cartridges located back-to-back in each AMS microphone. The rear-facing cartridge monitors ambient sound, while the front-facing cartridge handles sound from the desired source. When the front cartridge output exceeds the rear cartridge output by 9 dB, the AMS mic channel gates on automatically in .004 seconds.

Because of this unique gating concept, an AMS microphone channel will *only* gate on

when addressed from within a 120-degree "window of acceptance" centered at the front of the microphone. AMS mics not addressed from within this angle remain off. So the number of open microphones is kept to a minimum automatically, with no need for manual control.

Since the Shure AMS automatically keeps track of the number of open microphones and adjusts the overall gain to compensate, your broadcast level stays constant as mics open and close, without troublesome gain-riding.

Direction-sensitive gating makes the

Shure AMS the best system to use in multiple-mic situations, from panel talk shows to game shows to hearings on Capitol Hill. More and more broadcast engineers are discovering the advantages of having broadcast-quality multiple-microphone



audio without the headaches of manual mixing or the time-consuming setup of so-called automatic mixers.

With AMS you not only get all the advantages of a truly automatic microphone system, you also get the broadcast-quality audio and reliability of Shure microphones.

For a comprehensive AMS literature packet, call us at 1-800-257-4873. For AMS technical support, call Michael Pettersen at 1-708-866-2512.



SHURE®

The Sound of the Professionals...Worldwide.

Circle 139 On Reader Service Card

World Radio History

SMARTCASTER

DIGITAL AUDIO

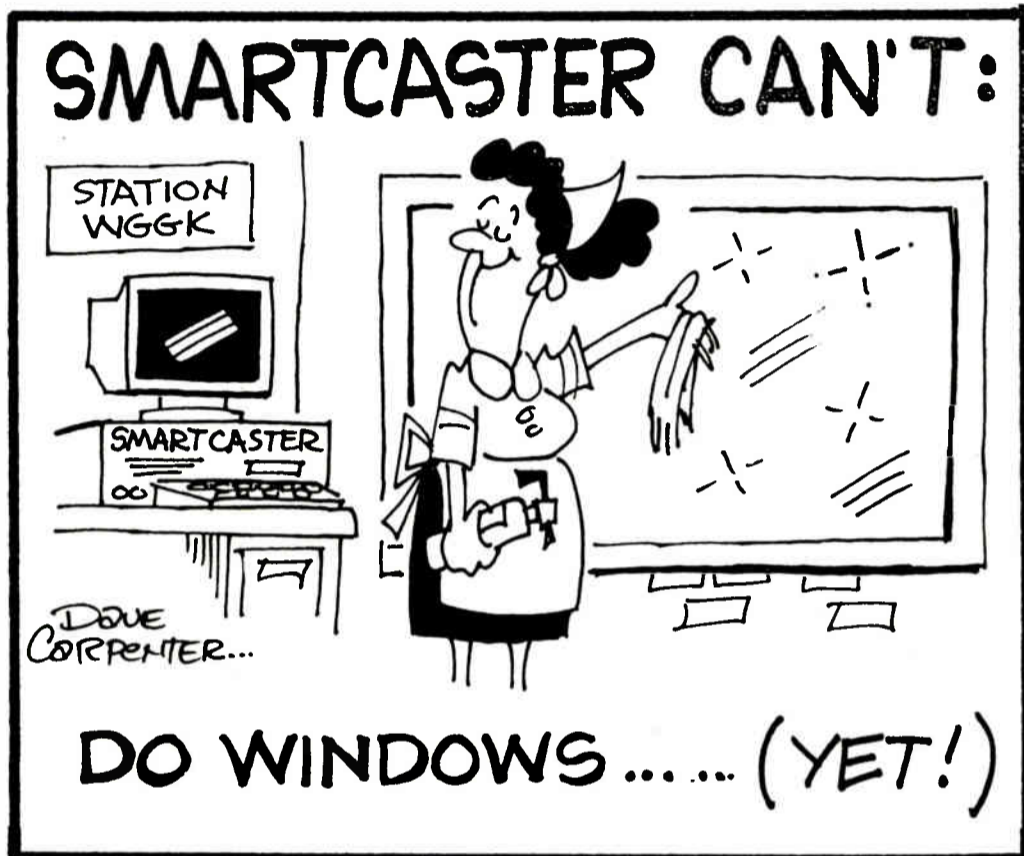

BUT LOOK AT EVERYTHING THAT SMARTCASTER CAN DO

SMARTCASTER replaces a room full of conventional automation equipment, storing all your commercials, promos, psa's, and other material directly on the hard drive of a computer...

BEST OF ALL, SMARTCASTER now offers enhanced audio. Sparkling clear sound that rivals any audio source in your station, in stereo or mono configuration, without gobbling more disk space.

NOW, SMARTCASTER goes a step further, with a host of new features.

** CD to Open Reel automations interfaces - to allow the SMARTCASTER to work with stations not on a satellite network.

** Ability to record audio while playing back at the same time. Use the same unit to be doing production, while it is playing spots on the air.

** Unattended recording. You never miss a network feed again. Record on relay cue, real time or both.

** Time based event switching. Bring in networks and other outside sources based on real time.

** Automatic clock updates, virtually eliminates clock drift by updating to the network every hour.

** Log printing: A full log of the date and time that every spot ran on the system; printed on demand on a dedicated printer or on a printer in your front office.

** Discrepancy sheets: Printed as above, indicating every spot that did not run as scheduled.

** Automatic break updates: If your satellite or automation system misses a break SMARTCASTER will jump to the correct break and give you a discrepancy report.

** Opto-Isolated control lines to help eliminate ground loops, transient currents and RF induced signals and provide for positive control.

** Modem control: You can run the SMARTCASTER from any PC computer.

** Touch tone control: Control SMARTCASTER from any touch tone telephone.

Call for a **FREE VIDEO TAPE** and
Information Packet About SMARTCASTER

(800) 747-6278 (712) 852-4047

FAX (712) 852-3061

BUYERS GUIDE

DAT and Reel-to-Reel Recorders

DAT Jazzes Up European Cable

by Garry M. Greth
CE, KLON-FM

LONG BEACH, Calif. KLON-FM houses one of the most extensive jazz libraries in the United States. In February 1991, we were contacted by a group of European entrepreneurs who were familiar with KLON and liked our mainstream jazz format.

They were interested in developing Euro-jazz, a cable radio network, and they asked what it would take to emulate KLON's jazz programming in Western Europe.

For the initial start-up, the cost of going directly via satellite from Long Beach was prohibitive (although this may be a future option). Hardware and tape shipping costs for an analog-based automation system also were too expensive.

DAT via courier

We decided that the most cost-effective option was to produce programming on DAT here at KLON and ship it via air courier to a satellite uplink facility in

automated network. Using four SV-3900s on-line loaded with 120-minute tapes each, we get eight hours of uninterrupted programming. When it stops at the end of the eight-hour run, the operator has to be there to reinitiate the program, or "dead air" will result.

As soon as we get a computer program developed and customized with Panasonic's SV-3900 Software Developer's "ToolKit," Eurojazz will have the ability to make the programming 100 percent automated.

When continuous programming is desired, (and if you look at the professional DAT machines on the market right now, there are only a few choices), the Panasonic SV-3900 is the only one that gives us serial remote control and the reliability and performance of a fully professional machine.

little or no instructions. They were able to program and operate the machines successfully with minimal assistance.



Garry Greth, CE at KLON-FM, utilized Panasonic's SV-3700 and SV-3900 DAT machines for Europe's first DAT-based broadcast automation system.

replace one. CDs are not DJ-proof. Neither are DATs.

Once we acquired the Panasonic DATs at KLON, we tried them, liked them and decided to purchase more. They are used for day-to-day operations, including satellite feeds, news production and remote music recordings. KLON's news department also uses DATs to produce Calnet, a daily state-wide news show heard on 20 California public radio stations.

Currently, we are transferring all of our analog archives to DAT. For continuous programming, we've found DAT to be the method of choice.

Garry M. Greth recently traveled to Europe to incorporate a DAT-based tape automation system. He utilized Panasonic SV-3700 and SV-3900 DAT machines to complete the project. For information on the products, call Chris Foreman, Panasonic/Ramsa marketing manager at 714-373-7278; fax: 714-373-7903; or circle Reader Service 17.

USER REPORT

Usingen, West Germany. We've constructed a "Eurojazz studio" at KLON strictly for this purpose.

We utilize 13 Panasonic SV-3700s at KLON for DAT production and six SV-3900s at the Eurojazz facility in West Germany. The SV-3900s are most suited to our needs because they can be addressed via a serial control interface for bidirectional remote control of all transport and programming functions. We link them together and control them with a Panasonic SH-MK390 remote controller.

With the SH-MK390, we have a semi-

More cost effective

In the beginning, Eurojazz program hosts wanted to produce on two-track analog tape, and I insisted that we look into DAT technology for cost-effectiveness and quality. Tape is less expensive, machines are more cost-effective and they sound better than any analog system on the market right now.

In the Eurojazz studio, I was able to train program hosts on the SV-3700 with

WIRELESS CABLE

- WIRELESS WITHIN STUDIES
- EARLY WARNING (FLAG) DATA
- TERRAIN SHADOWING PLOTS
- POPULATION COUNTING-1990 CENSUS (With Ethnic and Demographics)
- FULL CONTACT DATA (Name, Address & Telephone Number)
- TRANSMITTER-ANTENNA (Manufacturer and Model Number)
- DIRECTORIES-STATE AND REGIONAL
- ON-LINE REMOTE ACCESS

dataworld[®]
A Service of DW, Inc.

P.O. Box 30730, Bethesda, Maryland 20814

FAX (301) 656-5341

(301) 652-8822 (800) 368-5754

Join the LPB Signature Console Crowd



Over 1000 licensed U.S. radio stations
Hundreds of international stations
Hundreds of college stations

Discover *why* the LPB Signature may be radio's most popular console:

- an unparalleled record of reliability and longevity
- clearly labelled screw-terminal connections for painless installation
- modular electronics for easy maintenance
- superior RFI immunity

Signature's standard features set new standards of flexibility:

- 3 inputs per channel
- 2 identical output buses
- remote starts
- tape outputs for each bus
- internal monitor, headphone and cue speaker amps
- mono/stereo input switches (on stereo consoles)

Signature options add even more versatility:

- mix-minus plug-in module (mounting kit for mono consoles)
- mono mixdown plug-in module for stereo consoles

Signature is available in a size to fit your station and your budget:

- stereo 6, 8, 10 or 12 channel
- mono 6, 8 or 10 channel

It's easy to join the LPB Signature Console Crowd—just call your broadcast distributor. For full information and specifications, contact LPB.

LPB[®]

28 Bacton Hill Road • Frazer, PA 19355 USA • Tel: 215-644-1123 • Fax: 215-644-8651

BUYERS GUIDE INDEX

USER REPORTS

Panasonic SV-3700/SV-3900

DAT recorders

by Garry M. Greth, KLON-FM **45**

Studer A-807

reel-to-reel recorder

by Harold Beer,
Michigan State University **48**

JVC DS-DT900N DAT recorder

by Gary Chang,
Film Music Composer **54**

TECHNOLOGY UPDATES

Radio Systems RS-700

DAT recorder

46

Sony PCM-7000 Series/

PCM-2700 DAT recorders

50

RS-700 Ideal for Live Formats

by Paul J. McLane
Sales Manager
Radio Systems Inc.

BRIDGEPORT, N.J. Radio Systems Inc. entered the DAT marketplace with the RS-1000 three years ago. The machine was designed to bring the quality

TECHNOLOGY UPDATE

of digital audio tape to the broadcast studio, so it incorporated features such as EOM logic, fast and accurate cueing, cart machine-style buttons and special random cut access and memory.

The RS-1000's widespread applications now include live playback, network recording, high-quality archiving and automation; the RS-1000 can be used as an audio source in any automation system.

But to answer the demand for a more affordable alternative, Radio Systems has introduced the RS-700. It's well-suited for cut playback, network recording and program archiving.

Modification of Sony

The RS-700, like the RS-1000, is a modification of a Sony DAT machine. Sony products were selected for their exceptional track record: good head life, solid drawer mechanism, durable

switches, easy access to parts and superb audio specs.

The process of upgrading the Sony 700 involves installation of an internal circuit board that allows the unit to perform a number of broadcast functions. Also, the entire back panel of the Sony DTC-700 is replaced at the factory.

Part of the upgrade is the installation of XLR connectors providing balanced, line level audio inputs and outputs (digital I/O in the S/PDIF format also is available). A rear-panel 15-pin connector allows remote start, stop and record, and also offers "one-button" record for unattended downloading of network feeds. Open-collector lamp drivers are provided.

When a tape is inserted for playback, the RS-700 will cue up to the beginning of the first cut automatically. Start-up time is comparable to a cart machine.

The DAT's Skip ID is used to mark the end of the cut and to close a relay. End-of-cut functions are pre-determined by the user. Dip switches on the rear panel allow you to program the RS-700 in one of several modes: continue to play after the end of cut; stop immediately after a cut and wait in the Ready mode; fast forward to the next cut and wait in the Ready mode; and rewind and re-cue to the beginning of the cut just played.

The last option is helpful if your station chooses to put only one song on each DAT tape to reduce the chance for

operator error. The RS-700 also can be programmed to open the drawer automatically after each cut.

Front panel programming

Cut programming, start/skip ID write and all other important functions can be done on the front panel (unlike some DAT machines that can only be programmed through a remote). The Sony

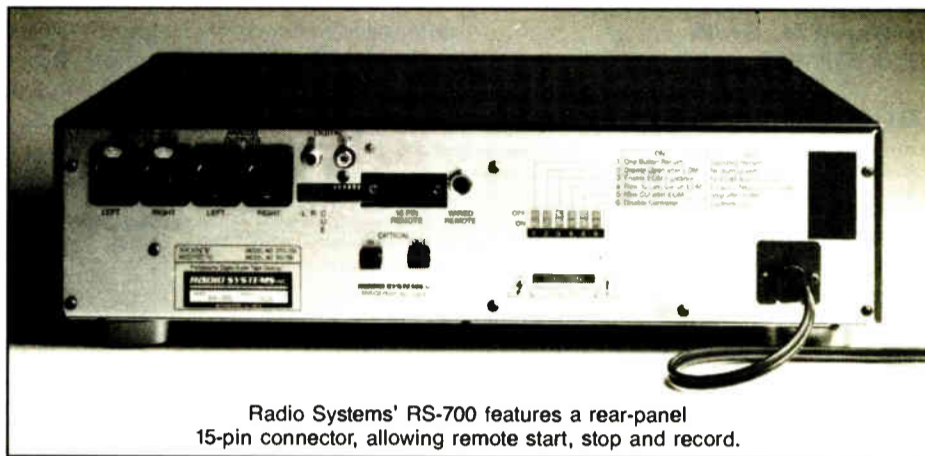

Radio Systems' RS-700 features a rear-panel 15-pin connector, allowing remote start, stop and record.

hand-held infra-red remote normally is not used on the RS-700, but it can be ordered as a hard-wired option.

A switch on the front panel allows four-hour recording at 32 kHz sampling.

Users of the established RS-1000 are familiar with its special lower chassis, which contains a microprocessor. By contrast, the modifications to the new

RS-700 are entirely within its original Sony chassis.

The RS-1000 is a perfect audio source in an automation system, we think. It has special serial connectors that allow status confirmation and random cut access. The new RS-700 can be interfaced to sequential automation controllers only.

The RS-700 incorporates the SCMS copy-protect system. The RS-1000 does not.

Except as noted above, most important functions of the successful RS-1000 are maintained. With fast cueing, quick start-up time, one-button record and re-

mote start-up, the RS-700 is ideal for use in live formats.

Radio Systems Inc. manufactures DAT machines, cart machines, mixing consoles and other studio products. For information, contact Paul McLane or Gerrett Conover at 800-523-2133; fax: 609-467-3044; or circle Reader Service 10.

CD Quality Stereo Audio In 128Kbps...

CCS Makes MUSICAM™ Reality

In 1989 **CCS Audio Products** set new standards for 7.5kHz digital audio CODECs with the Micro56. Now CCS is proud to introduce CDQ-2000, the world's first commercially available CD quality stereo MUSICAM CODEC. CDQ-2000 delivers high quality audio yet requires only 128 Kbps of digital facility. This means stereo music can be transmitted using as little as half the digital bandwidth of other competing systems. Furthermore, only CDQ-2000 offers you multi-rate flexibility between 384 Kbps to 128 Kbps, permitting connectivity between satellite services and terrestrial digital telephone networks such as ISDN, switched 56 or fractional T1.

For stereo remotes, STLs or symphonic concerts, CDQ-2000 gives you *Crystal Clear Digital Audio™* with **12 to 1** digital Compression. Another first from **CCS Audio Products**.

Hear us at Radio 1991 Booth 240.

 **CCS Audio Products**
Crystal Clear Digital Audio™

A Division of Corporate Computer Systems
33 West Main Street Holmdel, NJ USA
908-946-3800 Fax:908-946-7167



BUYERS BRIEFS

Innovations in DAT and Reel-to-Reel Recorders



LITTLE FERRY, N.J. Eventide's VR240 digital logging recorder uses DAT tapes to record more than 180 hours of audio divided among from one to 24 channels.

The machine is suited for applications such as recording 911 emergency calls, air traffic control, telephoned brokerage transactions and broadcast station logging. The unit's 180+ hours of audio capacity are fully utilized, regardless of the number of channels recorded. Silent periods on any track are not recorded and therefore do not count against the elapsed recording time.

A full range of search functions are provided for precise retrieval by date and time. The unit is available with either one or two DAT decks and with eight, 16 or 24 simultaneous channel capacity. Telephone and other audio interfaces are available. Eventide also offers a play-only version.

For information on the VR240, contact Richard Factor at Eventide: 201-641-1200; fax: 201-641-1640; or circle Reader Service 126.

LYNDHURST, N.J. Plastic Reel Corp. of America offers a complete line of audio reels, storage and shipping boxes, and reusable shipping containers.

Its quarter-inch audio tape reels are molded with crystal high-impact styrene and all reels are precision balanced for flutter-free operation. In addition, all reels have an anti-static inhibitor added prior to molding for reduced drop-outs and dust problems.

For information, contact VP Pat Baccarella at 201-933-5100; fax: 201-933-9468; or circle Reader Service 102.



FORT LEE, N.J. DIC Digital has introduced its Master Quality (MQ) Series of DAT tape, DIC///DAT.

Features of the tape include a new formulation finish to reduce friction and provide more efficient tape-to-head contact; DIC MicroFinity metal particle technology, known for its extremely high magnetic density; and a new dust-inhibiting cassette design that virtually eliminates recording errors and tape jamming due to environmental contamination.

DIC, with this product, will continue to market the industry's only 15- to 30-minute DAT cassettes for small programs, demos and test tapes.

For information, contact Kevin Kennedy at 201-224-9344; or circle Reader Service 45.

MAHWAH, N.J. Aiwa America has entered the professional marketplace with the HD-X3000 DAT recorder, which the company calls "the world's smallest and lightest broadcast professional DAT recorder."

The HD-X3000 features an AES/EBU-type digital in/out interface, the inclusion of a cannon connector and three hours, 40 minutes of operation through



the combination of 10 AA alkaline batteries and a built-in rechargeable lead acid battery.

The unit weighs 31 ounces and will function equally well as a high-quality portable studio recorder with true 16-bit linear digital recording performance.

For information, contact Rusty Bennett at Aiwa: 201-512-3600; fax: 201-512-3702; or circle Reader Service 34.

Telephone Interface Products

Finally, just what you've been looking for, a really important phone message.

Have you been playing telephone tag trying to solve your telephone interfacing problems? Well, have we got an important message for you. Every telephone interface you could possibly need is available with a single call.

Only Gentner Has A Hybrid For Every Application.

Rapidly growing needs for sophisticated special purpose telephone interfaces have driven our engineers to develop quite a range of products. Here are just a few for you to consider.

If you're looking for an inexpensive, fully automatic 2-way interface for your "listen line," sports line or weather phone, you're looking for our Auto Coupler. Maybe your field reporters need an auto-answer line that triggers a recorder so they can dump their story and run. That's our TC-100. If you need a telephone hybrid for on-air interviews or recording calls in the production studio and newsroom, you can rely on our SPH-3. It's a full blown hybrid that's been the workhorse of many stations for years.

Gentner telephone interfaces give you the on-air presence you need to dominate your market. That's because they're designed to make callers sound like they're right in the studio with you.

New Solutions To Old Problems.

The latest additions to our growing line of hybrids, the DH-2 and SPH-5, take proven Gentner technology to new heights.

Thanks to some real design and manufacturing innovations, we've packed a lot more features into higher performing packages. With 16 bit processing and 2X oversampling, the DH-2 Digital Hybrid gives you auto-nulling, full digital separation of "send" and "receive" signals and a sound quality that rivals analog. The new SPH-5 Analog Hybrid with its "dual coil" hybrid system will give you a great sound at a great price.

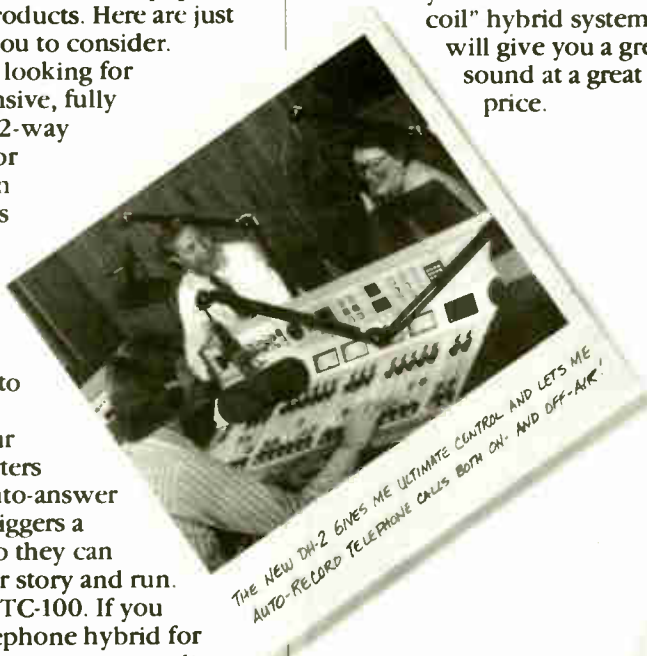

Both the DH-2 and SPH-5 give you a CUE button to toggle send audio between the console and the announcer's mic. This allows your announcer to easily use the hybrid like a speakerphone before putting a caller on-air. And a RECORD button lets you automatically record calls, both on- and off-air, for later playback. Finally, telephone hybrids designed to work the way you work.

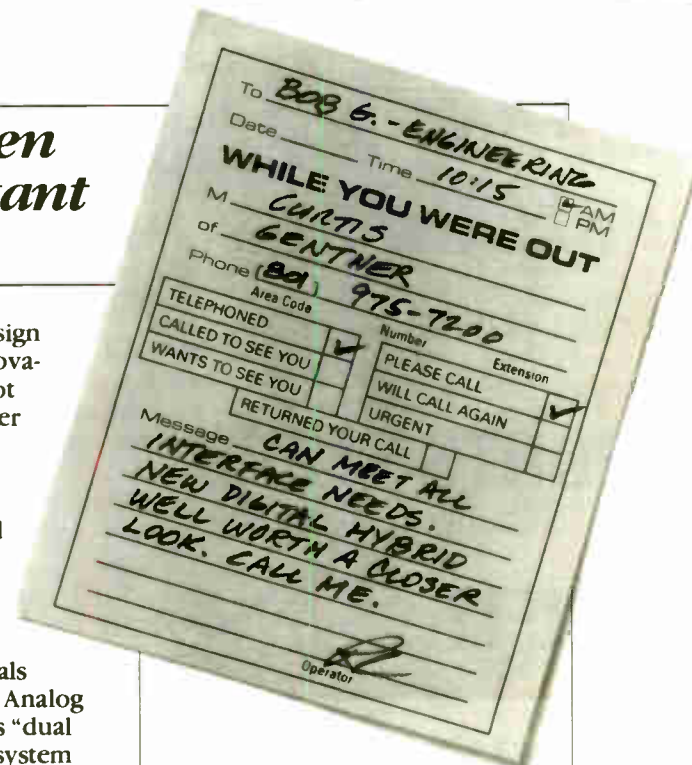

Get The Message?

Your single source, for every telephone interface you could possibly need, is Gentner. Give us a call for the name of your authorized dealer. Our operators are standing by. Hello, you're on the air...



GENTNER

Gentner Electronics Corporation
1825 Research Way
Salt Lake City, UT 84119
(801) 975-7200
Fax: (801) 977-0087

MSU Station Sold on Studer

Michigan State Employs 10 Studer Reel-to-Reels For On-Air, Music Production and Satellite Use

by **Harold Beer**
Head Technical Operations
Radio Broadcasting Services
Michigan State University

EAST LANSING, Mich. Studer has long had a reputation for high quality, high reliability—and high prices. In spite of the prices, you can't get better value for your money from anyone else. At WKAR, we have 32 reel-

to-reel audio tape recorders. Of the 32, 10 are Studers.

We use Studers in our on-air control rooms, music production room and satellite uplink room. These are the critical functions for which we require uncompromising quality and reliability. Dating back in some cases to 10 years ago, the older B67s look, sound and behave like new machines. We have two Studer A807s, which

still are in production.

Our need for a three-speed transport led us back to Studer the last time we were shopping for reel-to-reel machines. Other machines can provide a pair of speed selections from three choices, but only the Studer has true three-speed operation.

Any common speeds

The machines will handle any of the common speeds used by broadcasters. Our machines also are used to high speed dub 3.75 ips programs at 15 ips. The quality of these transfers is more than adequate for our SCA-borne radio reading service.

Maintenance of our Studers has been easy. We have changed a couple of switches, some spooling motor bearings and a few heads. Speaking of heads, Studer makes the most solid head stack I have ever seen. You really don't need to adjust azimuth more than once every other year—it's that solid.

Alignment of the B67 is the usual "green tweaker" affair, but you can leave it in your tool drawer for the A807s. The A807s adjust with front panel buttons. In fact, if you have an Audio Precision System One, you have only azimuth to adjust—the System One can "talk" to the A807 and make the adjustments through the RS-232 port. That's the life.

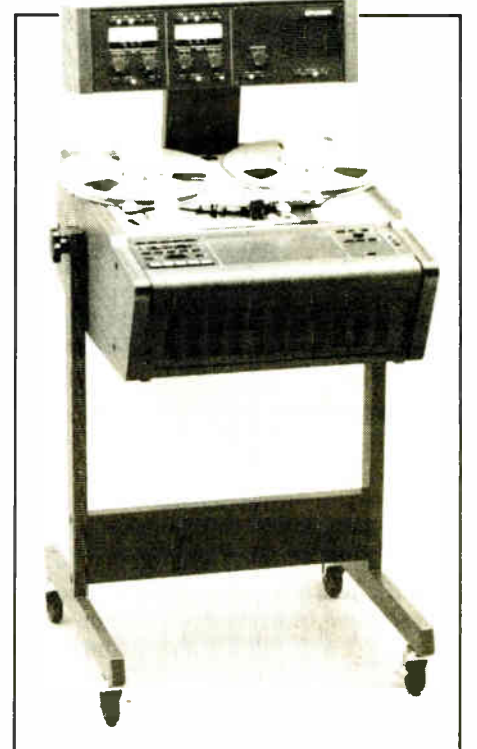

Studer's A807 two-track pro recorders are used throughout the broadcast facilities of Michigan State University.

the tape reels and a library wind, a faster-than-real-time, but slower-than-fast-wind function that gently packs the tape for storage.

Wow and flutter

Tape handling is something all the Studers do well. Nice clean tape packs and really low wow and flutter are things we are accustomed to from our Studers. When the wow and flutter numbers get up to spec (0.07 percent or 0.08 percent peak weighted DIN), I usually look for bad bearings. The wow and flutter typically is down around 0.04 percent at 7.5 ips.

I know the Studers are expensive, but they are consistent performers, rarely failing in their duty. I'm glad we have a bunch of them. As we add DATs in our studios, they sit alongside the Studers; they won't replace them.

When the 21st century arrives, our Studers will be twenty-something and they'll likely still be on the job.

For information on Studer reel-to-reel machines, contact President Tore Nordahl at 615-254-5651; fax: 615-256-7619; or circle Reader Service 109.



SPORTS
PROFIT
GENERATOR

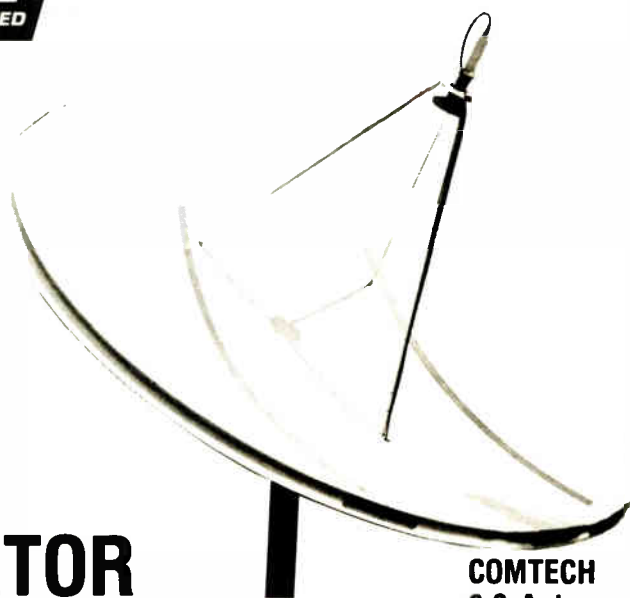

COMTECH
3.8 Antenna



1100-FFC-X1 RDC(L) Downlink Receiver



1100 PCDR-5 SCPC Demodulator

Lease your "generator" package for \$189 a month: Microdyne (L) Downconverter, Microdyne PCDR-5 SCPC Demodulator, and Comtech 3.8 Antenna (*world's finest!*) — plus LNA and 100' of cable.

Call today for details that will save you money and *make* you money!



FAX 317-962-8961

317-962-8596

IN CANADA 800-268-6817

HARRIS ALLIED ©1991

"Call me, I'm interested." Circle 16.

"Send me literature." Circle 85.

WorldRadioHistory

USER REPORT

Other advanced features of the A807 include a spiffy real-time tape timer with return to zero, and a locator that will wind the tape to a setable or store-taped time location. One super feature of the A807's timer is that when you switch tape speeds, the tape time is corrected for that speed; for example, if you're at 10 minutes at 15 ips, and you switch to 7.5 ips, the timer will indicate 20 minutes.

Other features include a shuttle wheel for hands-off "rock 'n' roll" of

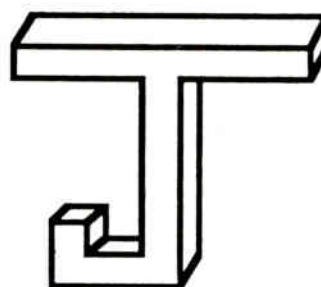

SQUARED
TECHNICAL SERVICE

2198 HUBBARD LANE
Grants Pass, OR 97527

503-471-2262

Equipment Repair and Calibration

We service most AM/FM broadcast monitors, remote control systems, exciters, STL's, TSL's RPU's, Etc.

Give Us A Call
Check Our Rates
STL Loaner Program

Circle 99 On Reader Service Card

Now Available:

Modulation Readings You Can Trust.

With its new internal DeModulator, ModMinder is calibrated at our factory and certified accurate for two years.

ModMinder's advanced digital circuitry makes it the most accurate, temperature-stable modulation monitor ever made. Now it has a front end that maintains the same level of precision, reliability and stability.

When you order a ModMinder™ with the internal DeMod Board, or have Modulation Sciences upgrade your ModMinder, we actually seal the modulation calibration control. We also send you a certificate of calibration valid for the next 24 months.

How can we do that? DeMod™ is the first and only demodulator whose calibration is traceable to an NBS (NIST) reference. Modulation calibration is totally stable from freezing to 122° F. It's also immune to mechanical shocks, so we certify calibration not only at our factory, but at your station. In addition, DeMod works with an exceptionally wide range of RF levels – from 10 mW to 1 W, without any user adjustment.

ModMinder and DeMod eliminate the uncertainties that have plagued modulation measurement. There's no calibration drift due to temperature fluctuations. No need to calibrate for modulation and RF level before each measurement. No meaningless moving pointers. Instead, you get high-resolution, instantly readable, totally reliable numerical readouts. You can get those readouts anywhere there's a modem-equipped PC, too – with ModMinder Remote software. It's free with every ModMinder, and it includes a unique Modulation Histogram that gives you important insights into your station's modulation.

ModMinder has revolutionized the way hundreds of stations measure modulation. Now the optional internal DeMod card turns it into a standalone dynamic modulation measurement and analysis system – the most accurate ever made. Of course, for precision, convenience and reliability, ModMinder has been standing alone from the very beginning.



modulation sciences, inc.

12A World's Fair Drive • Somerset, NJ 08873
Tel (908) 302-3090 • Toll Free (800) 826-2603
Fax (908) 302-0206

©1991 modulation sciences, inc.

Circle 134 On Reader Service Card

World Radio History

Sony's New DAT Series Answer More Pro Needs

by Ron Remschel
Marketing Manager Audio Products
Sony Business and Pro Group

MONTVALE, N.J. The PCM-7000 Series time code DAT and PCM-2700 professional DAT recorder are the newest additions to the Sony line of professional DAT products.

The PCM-7000 is designed to meet requirements essential to a variety of applications, including audio post production, and is targeted as a replacement for quarter-inch, analog reel-to-reel time code machines. The PCM-2700 answers the demands of recording studios, broadcasting stations and other professional audio users.

TECHNOLOGY UPDATE

Currently, there is no single dominant two-channel digital format to address the full spectrum of audio production and post-production requirements. Professional DAT with time code supporting the proposed I.E.C. format for time code recording in the DAT format subcode area is ideally positioned to become the medium of choice.

The PCM-7000 Series machines' four-head design permits confidence monitoring during recording. Editing can be performed with a PCM-7000 Series DAT editing system comprised of the PCM-7050, the PCM-7030 and the RM-D7300 DAT editing controller. The system provides one microsecond accuracy in electronic editing with crossfade.

The PCM-7000 Series exhibits the superior specifications associated with digital audio performance, including a dynamic range exceeding 90 dB; frequency response extending from 20 Hz to 20 kHz; and wow and flutter below measurable limits.

Parallel control interfaces are included on all models to facilitate external synchronization, remote control units and fader-start. The series also is compatible with consumer DAT recorders. Tapes from consumer DAT recorders can be post-stripped to enable SMPTE time code compatibility.

The PCM-7000 offers a variety of advantages over quarter-inch, most notably fast forward, rewind and search at 150 to 200 times playback speed; optional instant start using 4 Mbit RAM to store audio information for instant access; as well as convenience and ease-of-storage due to the small size of the DAT cassette.

The series also features two hours of



recording time; automatic track finding to ensure accurate tracking; a high-grade rugged transport for stability and reliability and built-in "chase synchronization" capability.

Other advantages of the PCM-7000 Series include the relatively low cost of DAT tape, the compact size of the equipment (rack-mountable), and a variety of flexible configuration options to meet many diverse production and post-production needs.

At the past NAB, Sony introduced the replacement for the popular PCM-2500. The PCM-2700 studio DAT recorder takes advantage of the latest devices developed through Sony innovations in digital technology, such as one-bit pulse digital-to-analog conversion and ad-

vanced LSI circuitry.

The recorder features a 48 kHz/44.1 kHz sampling frequency option, while its IEC-958 format digital input/output interface enables digital-to-digital recording at 44.1 kHz from consumer digital equipment.

The PCM-2700 is equipped with four-head construction for confidence monitoring. In addition, the unit features precise ID recording, digital fader, high speed auto location, a four direct-drive motor mechanism for stable and accurate tape transport, convenient date function and versatile time display. The recorder is rack mountable.

For information on Sony DAT machines, call Ron Remschel at 201-833-5745; fax: 201-833-9645; or circle Reader Service 106.



...because you can't always trust your ears.

The Sentinel is a Station Monitor Receiver with all-mode reception: NRSC AM/AM-Stereo, FM/FMX™-Stereo and SCA. But what's more important, The Sentinel has built-in diagnostics that measure and display 12 separate parameters of the program audio signal.

With 24 station presets and well-defined readouts, even non-technical personnel can instantly compare their audio with anyone else on the dial for Peak Modulation, Relative Loudness, Dynamic Range, Spectral Profile and Stereo Image.

The Sentinel: see what your ears have been missing!

Inovonics Audio Recording,
Signal Processing and Instrumentation
1305 Fair Ave., Santa Cruz, CA 95060—CALL (408) 458-0552 FAX 458-0554

WHAT'S NEW?

We Are!

Always the leader in Quality...
Always the leader in Engineering
Always the leader in Galvanizing and Warranty

and now...

The New Leader In Affordable Pricing!

for towers and equipment shelters
direct to the end user on turnkey
installations

Including the ROHN 20 year warranty!

ROHN®

Division of UNR Industries, Inc.
6718 W. Plank Road, P. O. Box 2000
Peoria, Illinois 61656 USA
Phone: 309-697-4400 FAX: 309-697-5612

43 years of service to broadcasters

BUYERS BRIEFS

Innovations in DAT and Reel-to-Reel Recorders

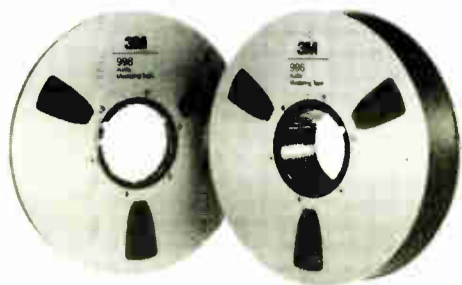

ST. PAUL, Minn. 3M Magnetic Media Division has introduced three recording tapes.

The 3M 275 digital audio mastering tape was engineered with 3M Posi-Trak backside treatment to reduce static build-up and head wear. Designed for high-density digital recording, it has a low CRC rate and precision reels for finer alignment. The 275 is compatible with DASH, DMS and PD formats.

The 3M professional DAT cassette is available in standard playing times of 120, 90, 60 and 46 minutes. The DAT cassette uses a high-coercivity ultra-fine metal particle coating on a smooth base film to deliver the high output and wide bandwidth needed for digital recording. A durable binder handles the stresses imposed by 2,000 RPM rotary head scanning and searching at up to 200 times play speed.

The 3M 966 analog mastering tape has an operating level of +9, with minimal distortion. The signal-to-noise ratio is 79.5. Output levels are 14.0 dB. The 966 also is bias-compatible with 3M's 266 and other industry products.

For information, contact Jim Hoskins at 3M at 612-737-4218; fax: 612-737-5583; or circle **Reader Service 71**.

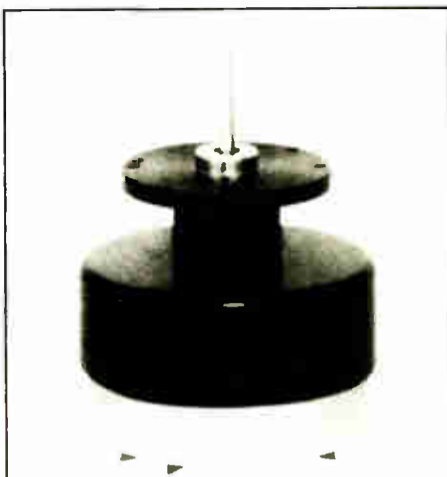

BETHANY, Conn. The Beau Motors division of Manger Engineering Inc. is continuing to manufacture the entire line of Beau Motors. These include reel-to-reel and cart capstan motors, torque motors and DC brushless units.

The company said it can repair or replace any Beau Motor, regardless of age, and can repair or replace most foreign and domestic made products as well.

Beau was the originator of the external rotor motor for the broadcast and tape reproduction industries.

For information, contact Paul Manger at 203-735-7881; fax: 203-735-4543; or circle **Reader Service 41**.



NEW YORK Digital Domain's FCN-1 format converter addresses the difficulty of transferring material to and from DATs and other machines carrying incompatible formats. It avoids converting between balanced and unbalanced signals, and converting the channel status bits in the serial digital bitstream to a format that the recorder will accept.

The FCN-1 offers input switchable between a 110 ohm XLR and a 75 ohm RCA jack. Its internal four-output distribution amplifier simultaneously feeds three RCA jacks and one XLR male, so you can make a master and safety, or DAT copies for all your studios at once.

All inputs and outputs are floating, transformer-coupled, keeping hum and interference from entering your analog domain. An eight-position DIP switch sets the important channel status bits that allow compatibility between machines, including pro/consumer, emphasis, sampling frequency, copy, generation and category code.

For information, contact Bob Katz, president of Digital Domain, at 212-369-2932; or circle **Reader Service 111**.

REDWOOD CITY, Calif. Ampex manufactures and markets a complete line of professional audio and data storage tapes for entertainment, education and government applications.

Ampex's R-DAT is an advanced formulation of metal particle tape. The new product features Ampex's new "DATpak" DAT mastering storage system, a user-friendly packaging/labeling system designed specifically for use by audio professionals.

The new DATpak mastering system includes a two-cassette storage tray for cassette with or without the album box; a documentation storage area for storing track sheets, recording information and/or duplicating instructions; and a professional labeling system with check-off boxes, track sheets, cassette labels and extended J-cards, designed to meet the documentation needs of the professional user.

Ampex 467 DAT digital audio tape products are available in a range of length configurations: 30, 60, 90 and 120 minutes—and utilize a small tape-view window that allows for a larger labeling area.

For information, contact Phil Ritte at 415-367-2580; fax: 415-367-4132; or circle **Reader Service 29**.

We are pleased to announce
a solution to your
capital budget problems
with the

BROADCAST SERVICES/EME
Priority Lease Plan

a nationwide offering with
\$25,000,000
in available funding

Funds up to \$50,000 available on credit application only — no financial statements required in most cases.

Convert capital expenditures into fully deductible operating expense by leasing. Leasing does not affect your borrowing power, and leaves your capital free for investment. Terms and payments can be structured to fit your cash flow situation, and you get the equipment you need immediately. Our leasing program accommodates amounts from \$5,000 up to the largest facility packages.

Another reason why people are calling us...

The Preferred Source
for audio and video equipment

Here are just a few of our product lines:

- | | | |
|-----------------------|---------------------|--------------------|
| Abco | EFXX | Otari |
| Adams-Smith | Electro-Impulse | Priority Leasing |
| ADC | Electro-Voice | Pro Products |
| AIR Corp. | Enberg | QEI |
| AKG | ESE | Radio Design Labs |
| A-Line Furniture | Eventide | Radix |
| Alps Furniture | Express Group | Ramko |
| Andrew | Fidelipac | Rane |
| Aphex | Gentner | Revox |
| ATI | Gepco Wire | Ruslang |
| Atlas | Hedco | Russco |
| Audi-Cord | Henry Engineering | Samson |
| Audio Animation | Hnat-Hindes | Scala |
| Audio-Digital | HOME Racks | Sennheiser |
| Audiometrics | Inovonics | Shure |
| Audio-Technica | ITC | Siemon |
| Audiopak | JBL | Somich Engineering |
| Auditronics | Kintronics | Stanton |
| Autogram | Klark-Teknik | Sonex |
| Azonic | Koss | Sony Pro Audio |
| B & B Systems | Lexicon | Soundcraft |
| Belar | Logitek | STL |
| Beyer Dynamic | Luxo | Symetrix |
| Broadcast Audio | Marantz | Tapecaster |
| Broadcast Electronics | Mark Products | Tascam |
| Burke Technology | Marti | Technics |
| Cablewave | Middle Atlantic | Telex |
| Celwave | Modulation Sciences | Telfax |
| Comark | Monroe | TFT |
| Compu-Temp | MTS | 360 Systems |
| Comrex | MTU | 3M/Scotch |
| CRL | Murphy Studio | Titus |
| Crown | Furniture | TMD/Will-Burt |
| DAC | Nakamichi | Valley Intl. |
| dbx | NEC | Vega |
| Di-electric | Neutrik | Viking |
| Denon | O. C. White | Wegener Comms. |
| Dictaphone | Omni-Mount | West Penn Wire |
| Dorrough | Orban | Zercom |

BROADCAST SERVICES/EME

The Davis Communications Group, Inc.

Mid Atlantic 800/345-7112
Southeast 800/525-1037
West Coast 800/523-1037
Video Sales 800/942-6005



MARKETPLACE

Radio World's Marketplace, a compendium of new and recently introduced radio broadcast products, appears monthly in Buyers Guide.



Portable Sound Booths

Alpha Audio Acoustics' Audio Seal Portable Sound Booths are made of flexible panels constructed from the audio seal barrier and quilted fiberglass absorber combination blankets.

This system provides for maximum sound absorption within the booth and reduction of unwanted outside noise transmitted into the booth. The booths have a steel frame and are assembled using component parts and velcro fasteners.

For information, contact Michael Binns at Alpha: 804-358-3852; fax: 804-358-9496; or circle Reader Service 116.

Microphone Cable

Clark Wire & Cable has introduced Micro Mic 28, a miniature microphone cable, just over 1/10-inch in diameter.

It is available in lengths of 1,000 feet, 500 feet, 250 feet and 100 feet. This super thin cable is ideal for tight places and features silver coated copper conductors for low capacitance. It is highly flexible.

For information, contact Susan Clark at Clark Wire & Cable at 708-272-9889; fax: 708-272-9564; or circle Reader Service 96.



DJ Express 400

Univenture Inc.'s DJ Express 400 portable case holds 400 compact discs and was designed to be used in conjunction with Univenture's patented CD-Viewpacks, featuring the Safety-Sleeve.

Its design allows for lightweight port-



Dynamite 2

Valley International announces its multi-function audio signal processor, the Dynamite 2.

The piece offers its operator the ability to simultaneously compress, gate or expand, and peak limit the audio signal. Each processing mode can be used independently, thanks to a full complement of user-adjustable controls.

Dynamite 2 employs Linear Integration Detection in its compressor section; the circuitry is designed to respond to vocals, music and speech in the same manner as the human ear.

Audio inputs and outputs of each channel are balanced to deliver professional performance for live sound, recording, broadcast or fixed sound installations.

For information, contact Tammy Webb at Valley at 615-370-5901; fax: 615-370-5907; or circle Reader Service 22.

ability and ultimate protection of CDs. It measures 17 3/4" x 17 1/4" x 6" and features a removable hinged lid, which can be used as a base; individual dividers to organize the CDs; and two key locks.

For information, contact Rich Williams at Univenture: 800-992-8262; fax: 614-793-0202; or circle Reader Service 151.

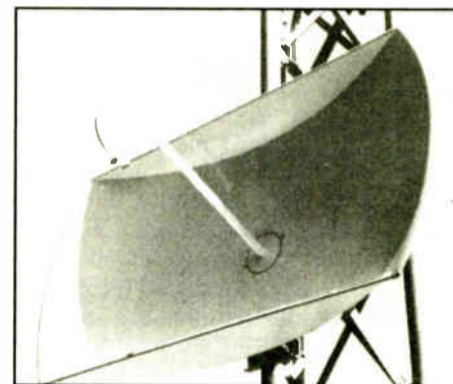

Category "A" Antenna

With Mark Antennas' introduction of an affordable truncated eight-foot antenna, broadcast companies now can cost-effectively upgrade systems from six-foot Category B to Category A performance.

The truncated design of the PT-65A96 is an industry first, according to Mark.

The PT-65A96 provides the half-power beamwidth of an eight-foot antenna, with the gain of a six-footer (29.5 dBi at 7.0 GHz). It also is available in 2 GHz and dual frequency 7 and 13 GHz versions. All models meet FCC Part 74 Category A specifications in both the horizontal and vertical polarizations.

For information, contact Radiation Systems, Mark Antennas Division, at 708-298-9420; fax: 708-635-7946; or circle Reader Service 132.

GETTING SOAKED? GET A MARINER!

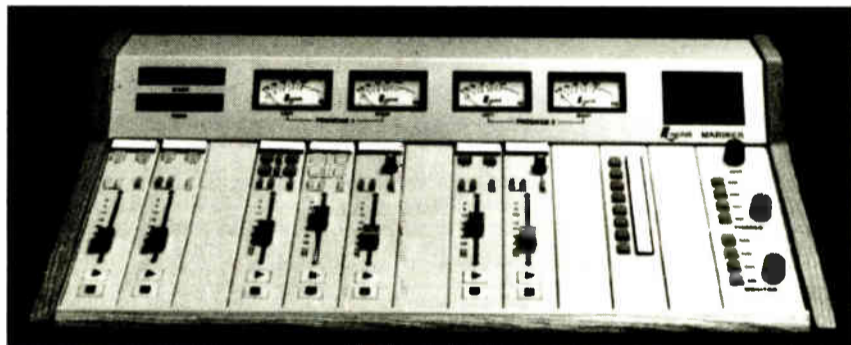

The MARINER On-Air Console

- Waterproof Switches & Pots
- Works While Dripping Wet
- 6, 12 or 22 Modular Mixer Frames
- 3 Styles of Mixers
- 6-Button Integrated Machine Controls
- Connections via QCP® Terminal Posts
- Optional Clock, Timer & Backup Supply
- Built for Reliability & Low Service
- Prices from \$4,400 to \$13,500

Logitek

When it has to
work right!

Call 800-231-5870 for your nearest Logitek Dealer.
(Alaska, Hawaii, Canada : 713-782-4592)

Peak Weighting Module

Belar Electronics Laboratory announces the availability of the PWM-1 Peak Weighting Module for the company's Model FMM-2 FM Modulation Monitor.

The PWM-1 adds the ability to select five time constants of peak weighting to the peak indicators of the FMM-2. A sixth position is a bypass mode.

The module is available as an option on new FMM-2 monitors and as a field-installable kit for existing units.

In addition to peak weighting, the PWM-1 adds a wideband 75 ohm buffered composite output to the FMM-2 for driving low-impedance loads.

The product is priced at \$395. For information, contact David Hirsch at Belar: 215-687-5550; or circle Reader Service 15.

WEATHER RADIO

Model CRW

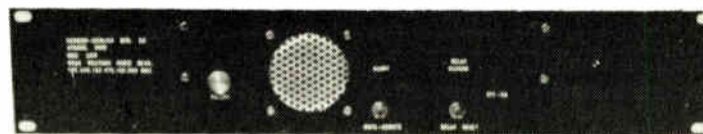

Price \$540.00

Sensitivity .28 microvolts for 12 dB quieting. All 3 frequencies. Alert tone demutes receiver, closes relay and gates audio to 600 ohm rear terminals. Another set of rear terminals has continuous 600 ohm audio output. Double conversion crystal controlled, crystal filter in first I.F., ceramic filter in second I.F. Dual gate MOS FET front end. 50 ohm coaxial input. Adjacent channel (j25 kHz) down to 70 dB. 19" rack mount, 3 1/2" H, all metal enclosure. In stock—available for immediate delivery.

GORMAN REDLICH MFG. CO

FAX 614-592-3898 • 257 W. Union St. • Athens OH 45701 • 614-593-3150

STOP AT THIS SPOT..

...and take advantage of this sensational new program that will save your station hundreds to thousands of dollars!

RAMKO RESEARCH is introducing a new product line and marketing strategy that will enable you to enjoy new station equipment of uncompromised quality at amazingly low cost.

Examples: An 8 mixer stereo/mono on air console for only \$2,204; or a 12 mixer console for only \$84/month; or a dual 1 x 4 audio DA at an unheard of \$171! And there are 91 different broadcast products (over 600 variations) in our line from preamps to audio DAs thru full switching systems: all available with super discounts and/or monthly mini financing.

What microprocessors did for computers, RAMKO's doing for broadcast.

Over three years ago we led a trend that told us broadcasting was headed for some very rough times. With this premise, we set out to develop a product line that capitalized on all the latest technology to provide performance & quality exceeding any broadcast requirements and, deliver a dramatic cost advantage. The xL SERIES is the result of this intensive product development program with pricing, performance & quality that will put all other manufacturers on the spot and get you off of it.

☛ **27 1/2% DISCOUNT**
PAYMENT WITH ORDER

☛ **25% DISCOUNT**
NET 30 DAYS

☛ **20% DISCOUNT**
LEASING FROM 1 TO 5 YEARS

☛ **20% REBATE**
LEASING FROM 1 TO 5 YEARS

**OFFER EXTENDED
TO NOVEMBER 24, 1991 !!**

With 91 products you're bound to find many other items to improve your stations performance & your bottom line

MIXERS --- Portable, battery operated **CONSOLES** --- Mini production/news room **CONSOLES** --- Studio 4,6,8,12 channels **AMPLIFIERS** --- Audio interfacing/consumer matching **AMPLIFIERS** --- Audio power **SWITCHERS** --- Audio switching, routing, & mixing **PREAMPLIFIERS** --- Turntable **AMPLIFIERS** --- Line level **AMPLIFIERS** --- Microphone **AMPLIFIERS** --- Modular distribution/special function **AMPLIFIERS** --- Audio distribution **MIXERS** --- Studio & sound systems

Put us on the spot. Call TOLL free today (800) 678-1357, for your free information package & product literature.

Then compare prices, features and performance with anything else on the market. And, we are so confident of our products quality, everything is offered with a 2 year warranty, 2 week free trial period plus, we'll spot you UPS ground charges both ways if you are not wholly satisfied for any reason!

Don't delay as this is the only spot where you will see this offer advertised and is for a limited time only.

This is part of a world wide marketing test and, although RAMKO reserves the right to extend this offer, the discounts and financing options outlined herein are for a limited time.

EXAMPLE #1

MODEL: xL4S/8M: Dual 1 x 4 audio DA. XLR in & barrier strip out. Balanced in & out.

● Payment with order	● 3 year lease w/20% discount
LIST PRICE \$.....\$236	LIST PRICE \$.....\$236
YOUR COST.....\$171.10	MONTHLY PAYMENT.....\$6.87
	(Minimum \$1,500 package required)



EXAMPLE #2

MODEL: xL12/1S: Twelve mixer, 31 input, stereo/mono broadcast console.

● Payment with order	● 5 year lease w/20% discount
LIST PRICE \$.....\$4,043	LIST PRICE \$.....\$4,043
YOUR COST.....\$2,931.18	MONTHLY PAYMENT.....\$84.09



EXAMPLE #3

MODEL: DC38-10S: Ten mixer, 40 input, dual channel out, stereo/mono broadcast console w/ alpha numeric & custom backlighted readouts.

● Payment with order	● 5 year lease w/20% discount
LIST PRICE \$.....\$6,831	LIST PRICE \$.....\$6,831
YOUR COST.....\$4,952.48	MONTHLY PAYMENT.....\$142.08



EXAMPLE #4

MODEL: RS-1616FP (8 stereo in by 16 out): Audio switching, mixing system expandable from 8 in 2 out to 250 by 250, stereo/mono. Remote, computer & front panel controls.

● Payment with order	● 5 year lease w/20% discount
LIST PRICE \$.....\$3,850	LIST PRICE \$.....\$3,850
YOUR COST.....\$2,791.25	MONTHLY PAYMENT.....\$80.08

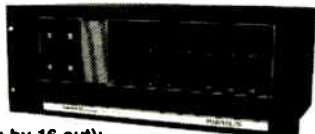

**TOLL FREE (800) 678-1357
FOR ADDITIONAL INFORMATION
& LEASE QUOTES.**

OR FAX: (916) 635-0907

3501-4 SUNRISE BLVD.,
RANCHO CORDOVA, CA 95742



Winner of the 1990 Arthur Anderson fast track 25 award for the 25 fastest growing companies in Northern Calif.

RAMKO RESEARCH

JVC SMPTE DAT Fills Niche

by Gary Chang
Film Music Composer

NEWHALL, Calif. Although DAT hasn't replaced analog two-track tape recorders, it does fill a valuable niche in the audio chain these days.

Record/playback speed stability has made it ideal not only for broadcast production, but also for film and video sync. While specific applications may differ, the across-the-board advantages of DAT can be clearly seen.

Its compatibility to professional digital audio gear allows digital copies that

you can play back in your living room. Since the introduction of the DAT format, however, I have wanted SMPTE compatibility.

Worth the wait

In May, I purchased JVC Professional Products Co.'s DS-DT900N R-DAT machine and have found it to be well worth the wait.

As a film music composer who does a substantial amount of production at home, I was delighted to find a SMPTE DAT for about half the price of other existing time code DAT machines

on the market.

Price, as ugly as it is, was a factor for me when I considered buying a SMPTE DAT. The DS-DT900N has a suggested list price of \$4,500, while the other machines were nearly double that. The other DAT machines featured a four-head design, as opposed to the JVC two-head design, which accounted for the added expense.

This difference results in two additional features not found on the JVC: Read After Write—monitoring a recording off the tape while recording, such as a three-head analog recorder; and post-striping SMPTE time code after recording program.

Read After Write, also called confidence recording, is very important for production recording and other remote applications. What not having the feature means to me is that I must play back my DAT tapes after recording in order to check for flaws.

As for post-striping SMPTE time code on existing DAT tapes, most experienced engineers will recommend that you make a safety copy of the DAT tape you intend to stripe.

Integrated onto DAT

Unlike analog two tracks that have discrete tracks, the two digital audio tracks and time code track are integrated on the DAT tape. In other words, you can't record just the code track; you must re-record the audio as well. Machines that post-stripe carry this out by playing back the audio from the DAT into a buffer memory and then re-record those audio tracks from the buffer while adding the SMPTE time code to it.

Although these machines are designed to do this flawlessly, not backing up the master in case of an act of God (power outage, earthquake, etc.) is like playing chess with death.

The funny thing is that if you need

two machines to make the safety for the four-head DAT in order to post-stripe SMPTE, then why not buy the two-head DS-DT900N and simply stripe SMPTE while making the copy? So I play back after recording in order to check for flaws and save \$3,000.

The time code DAT machine now functions in my studio for sample recording; producing a code-matching

USER REPORT

safety copy of all masters; an extra two tracks synced to multi-track; and two-track recording that can synchronize with my Synclavier for demo purposes.

The one feature that no one seems to mention about the machine is how good the converters sound. Although most DAT machines can bypass their own converters in favor of the user's preference, it is nice to see that JVC attended to this detail.

Inside the machine, there is plenty of room to access most anything for cleaning, ROM replacements, jumper setting changes, etc. I have some other JVC professional VCRs, which are similarly packaged, so the DS-DT900's assimilation to my studio environment was very natural.

So now I have a SMPTE DAT machine. The JVC DS-DT900N meets my expectations in video/multitrack synchronization and surpasses my expectations in sonic quality construction, all at a relatively reasonable price. Although DAT isn't the next "audio toaster," there is a legitimate function for it now. The JVC meets a real need at a value that makes good business sense.

Gary Chang is a graduate of Carnegie-Mellon University and California Institute of the Arts. His credits include "Miami Blues," "Shock to the System," "52 Pickup" and "The Breakfast Club." For information on the JVC DS-DT900N DAT machine, call Matthew Weiner at 201-794-3900; fax: 201-523-2077; or circle Reader Service 88.



TAKE THE LEAD
WITH HARRIS ALLIED

GATES
HARRIS GATES AM

DURABILITY SIMPLICITY RELIABILITY PERFORMANCE

Traditional value,
today's technology.

Affordable Gates Series 1, 2.5, 5 kW solid state AM transmitters.

AM broadcasters know the Gates name stands for durability, simplicity, reliability and performance. We knew those traditional values are still popular. But even we couldn't have guessed *how* popular. Since its introduction, the Gates Series has become the first choice of AM stations from 1 to 5 kW. Here are some of the reasons:

- Reliable 100% solid state design
- Simple IC logic control
- Built-in analog multimeter
- Six adjustable power levels
- Output matching network
- Bandpass output network
- 130% positive peaks w/patented Polyphase Pulse Duration Modulation
- ColorStat™ front panel diagnostics
- Open collector and dry contact remote control compatibility
- Short and long term VSWR protection with power cutback
- AC restart and fault memory
- Low maintenance "chimney" air handling

Call Harris Allied today at 800-622-0022 for more information on the transmitters than bring one of radio's proudest traditions up to date—the affordable Gates Series.



P.O. Box 4290 • Quincy, IL USA 62305-4290
Fax (217) 224-1439

800-622-0022

ADVERTISER INDEX

This listing is provided solely for the convenience of our readers. Radio World assumes no liability for inaccuracy.

Page No.	Advertiser	Reader Service No.	Page No.	Advertiser	Reader Service No.	Page No.	Advertiser	Reader Service No.
23	Acoustical Solutions	11	30	Fidelipac	70	49	Modulation Sciences	134
31	Altronic Research	122	39	Fidelipac	119	32	Nautel	21
7	ATI	67	31	Flash Technology	40	23	Nemal Electronics International	79
23	Audio Dynamics	138	23	Focal Press	31	28,29	Orban/AKG/dab	148
8	Audio Precision	50	47	Gentner Electronics	129	32	Pacific Recorders & Engineering	—
12	Audiopak	91	12	Gepco International	52	11	Potomac Instruments	137
13	Audiotronics	140	22	Gerstman Software	52	42	QEI	4
22	Autogram Corp.	6	52	Gorman Redlich	53	40,41	Radio Systems	103
39	Bext	144	6	Harris Allied Broadcast Equipment	—	53	Ramko Research	120
1	Broadcast Electronics	98	8	Harris Allied Broadcast Equipment/Henry	25,81	9	RF Technologies Corp.	69
22	Broadcast Devices	117	10	Harris Allied Broadcast Equipment	7,38	50	Rohn Towers	33
51	Broadcast Services	2	18	Harris Allied Broadcast Equipment	—	42	Scala Antenna	43
4	Burk Technology	90	48	Harris Allied Broadcast Equipment	16,85	22	Sentry Systems	20
23	Cartwright Communications	58	54	Harris Allied Radio RF Products	83	43	Shure	139
16	CCA Electronics	51	24	Holiday Industries	37	44	SMARTS Broadcast Systems	86
22	Clark Wire & Cable	66	50	Inovonics	49	17	Studer Revox	35
32	Coaxial Dynamics	93	16	ITC	63	22	Studio Technology	121
3	Comrex	68	20	ITC	135	19	Symetrix	54
3	Continental Electronics	12	48	J Squared Technical Service	99	9	Tascam	5
46	Corporate Computer Systems	46	22	LDL Communications	95	14	Telex Communications	73
18	CRL	114	52	Logitek	89	15	TFT	133
17	Crouse-Kimzey	112	45	LPB	9	26	The Management	3
25	Cutting Edge	92	21	Microwave Filter	27	2	The Management	115
24	Dataworld	1	22	Milden & Gullot	8	55	Wheatstone	60
45	Dataworld	14	52	Energy-Onix	42	27	Wheatstone	30
23	Econco	141	22			56	Wheatstone	142
10	Elkason Weather Radar	118						

Advertising Sales Representatives:

Eastern U.S., Art Constantine: 800-336-3045 Fax: 703-998-2966
West & Midwest U.S., Jack Ducart: 916-962-2240 Fax: 916-962-2194

The Closer You Get...

WE MEAN IT—we really DO provide the quality, performance, technical support, and innovation we promise!

Our model A-500 is a thoroughly engineered on-air console: it delivers the level of performance your clients now expect, and DAB demands. All components are selected for long life—gold bus connectors, gold I/O connectors, all gold contact switches, gas-filled relays, triple burned-in integrated circuits, solid state ON/OFF lamps, and precision laminated Lexan control surfaces for a lasting, wearproof finish. And we back that up with a 3-year parts and labor warranty, complete with

factory support from a technically competent and responsive staff.

We've also handled your special requirements as well with a super family of accessories, including a choice of three different telephone modules, an intercom module, an off-line mixer module for your remote feeds, talent control stations, accessory panels, failsafe power supplies, and auto cart and CD sequencing options.

So take a close look: we've got the quality, we've got the innovations, and you've got our commitment to top-notch support.



The Better We Look!

A-500

The New Wheatstone Production – Air Console



In Fact, a Whole New Console Family...

These consoles give you full multitrack production capability while at the same time providing familiar program and audition busing so your production room can double as a back-up on-air facility. They free up your primary Air studio for routine calibration and maintenance sessions. They are a perfect solution for complex talk or news formats.

Beyond its on-air capability the SP-4 is a powerful production console offered in 2, 4 and 8-track formats. Production crews will love the smooth sounding equalization, the auxiliary send buses, and, of course, the full on-air type machine and console logic. There's also plenty of room for those special functions: like a phone module that can handle multiple callers, yet

doesn't tie up your line inputs; an intercom module that lets you communicate with other Wheatstone consoles and rackmount locations throughout your facility; plus a studio control module, line preselectors, tape controllers, and automatic timers.

And, of course, there's the componentry: all gold contact switches for the ultimate in reliability, gold bus connectors, gold I/O connectors, solid state on/off lamps, and triple burned-in ICs. Naturally, each console is also triple-tested.

The fact is, Wheatstone's got the features, the componentry, the reliability, the performance and the reputation you can depend on.

Call us.

SP-44/4-Track