

RW Visits Canada's
DAB Tests (Page 8)

Radio World®

Vol 14, No 15

Radio's Best Read Newspaper

August 8, 1990

FCC Launches NRSC Sweep

by Alan Carter

Washington DC In a move that sent some stations scrambling to buy equipment, the FCC launched a nationwide sweep of surprise inspections in early July to make sure AM stations were complying with the NRSC standard.

Some stations—as many as a third, some reports said—had threatened not to implement the standard, which cuts a station's occupied bandwidth back to

10 kHz, unless forced to by the FCC.

But the FCC showed that the matter would not be treated lightly when it sent inspectors to stations in the far reaches of the country with the sole purpose to check for NRSC compliance.

Reports flooded into RW when inspectors began showing up at stations 10 July—only 10 days after the NRSC deadline—from Washington, DC, to Seattle, Detroit to Houston and New York to as far away as Honolulu. The

NAB also reported getting hordes of calls.

The FCC approved a two-step implementation of NRSC limitations in April 1989. By 30 June, stations were to have installed processing filters to reduce occupied bandwidth to 10 kHz under NRSC-1.

In turn, until 30 June 1994, the Com-

mission is assuming compliance to the NRSC-2 rule that defines a station's transmission parameters and reduced occupied bandwidth from 15 kHz to 10 kHz—provided the station has installed NRSC-1 processing.

Initial results on the first-phase of inspections showed compliance was (continued on page 10)

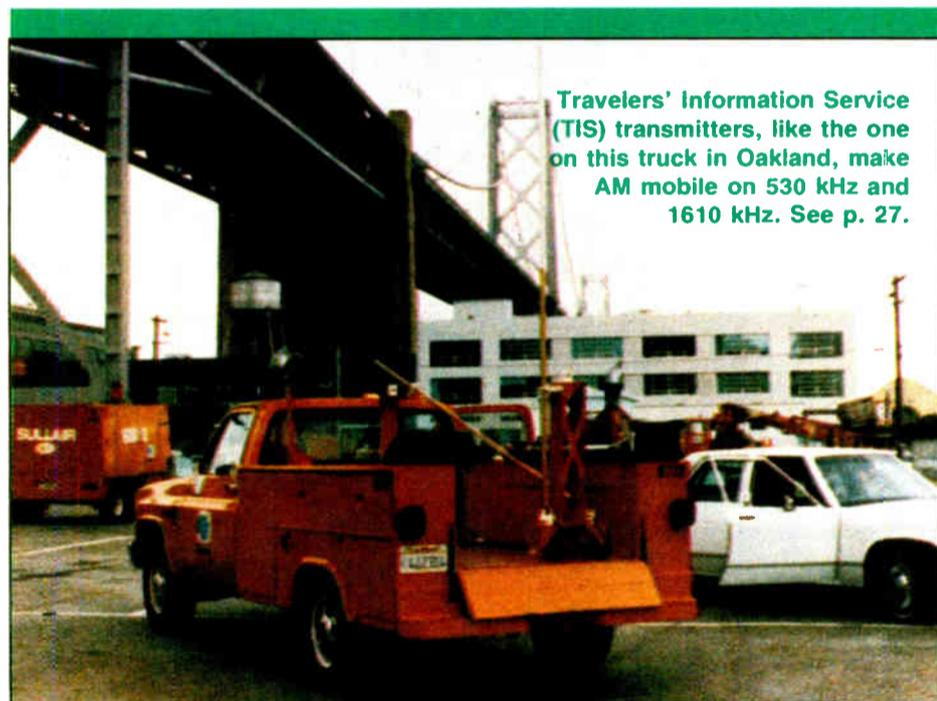

Travelers' Information Service (TIS) transmitters, like the one on this truck in Oakland, make AM mobile on 530 kHz and 1610 kHz. See p. 27.

DAB Task Force Is Off to a Fast Start

by Charles Taylor

Washington DC In response to explosive industry interest in digital audio broadcasting, the NAB's recently formed DAB task force is wasting no time getting a practical look at the hot new technology.

In early August, the eight-member group, established last month to formulate NAB's policies regarding DAB, will convene in Montreal, Canada, for a demonstration of the Eureka 147 DAB system, which began testing in Ottawa in July.

"We thought it was important to see this demonstration early in the game," said Alan Box, task force chairman and president of EZ Communications. The Canadian DAB system is being sponsored by the Canadian Association of Broadcasters, the Canadian Broadcasting Corp. and the federal Department of Communications.

A number of accomplishments

The decision was among a number of accomplishments at the group's initial meeting 10 July. It was attended by six (continued on page 10)

RDS to Replace EBS?

by John Gatski

Stamford CT Proponents of the Radio Data System (RDS) digital display technology believe that it could eventually replace the Emergency Broadcast System (EBS) as the national disaster warning system.

Sage Alerting Systems of Stamford, CT, which is promoting the technology for emergency and commercial use by radio stations, recently signed a "multimillion" dollar contract with the emergency authority in Jefferson County, TX, to install RDS.

Also, Sage Alerting is preparing a national emergency alert plan using ADS for review by the FCC, according to President Gerry Lebow.

Rule making in the works

Commission approval is unnecessary for stations to use RDS to supplement EBS, but Lebow said a proposed rule

making acknowledging the emerging technology could "facilitate" its eventual acceptance as a national system.

Lebow said he envisioned a two-phase adoption process for an RDS-utilized national emergency alert system. The first phase would consist of automating stations with an RDS decoder to supplement EBS. The second phase would eventually lead to a complete conversion to RDS.

Sage Alerting hopes to start the RDS ball rolling by installing RDS decoders at six FMs, three AMs, three TV stations and three cable headends serving Jefferson County, which is in the vicinity of 18 petroleum/chemical plants, Lebow said.

Because the FCC requires broadcasters to use an EBS two-tone system, RDS will augment EBS in Jefferson County, Lebow noted.

First developed for use in Europe, RDS (continued on page 11)

SIMPLY BETTER



TRY IT — SATISFACTION GUARANTEED

MAXIMUM PERFORMANCE and Type AA-4 COMPATIBILITY

TRUER HIGHS TOUGHER SHELL
LESS SHEDDING LOW ABRASION

CALL YOUR FIDELIPAC DEALER FOR SPECIAL INTRODUCTORY PRICING

Fidelipac Corporation • PO Box 808 • Moorestown, NJ 08057 USA • Tel: 609-235-3900 • Fax: 609-235-7779

Circle 60 On Reader Service Card

Sony Sued Over Consumer DAT

Music Publishers Demand that Royalty Compensation for Artists Be Addressed

by John Gatski

New York NY The fight over DAT recorders has intensified with a suit against Sony Corp. by several music publishers. The publishers had threatened legal action against any manufacturers that sold consumer DAT recorders in the US that can digitally record CDs.

Noted song writer Sammy Kahn and four music publishers filed suit here against Sony, the first manufacturer to sell consumer DAT recorders in the US with the capability to digitally record CDs.

In late June, Sony began a marketing blitz with its under \$1000 DAT recorders that contain the recently developed

Serial Copy Management System (SCMS). SCMS allows a DAT recorder to digitally record CDs onto a blank tape, but that copy cannot be copied.

International agreement

The SCMS technology was approved by foreign manufacturers, the Electronic Industries Association and the Recording Industry Association of America in an international agreement last year. It was believed to be a way to reduce the tension between songwriter

groups and manufacturers over DAT.

However, song publisher groups denounced SCMS-equipped DAT machines, maintaining that the technology did not address royalty compensation to artists.

In their suit, publishers said that before consumer DAT machines capable of digitally recording CDs are allowed to be sold, a royalty system, perhaps a levy on blank tapes, must be worked out to compensate artists for lost royal-

ties from illegal taping.

SCMS-equipped DAT machines allow the potential for illegally circulated, "perfect" DAT copies of copyrighted CDs, a scenario not possible with conventional analog cassette recorders, the publishers contend.

Sony and EIA said the legal challenge could be withstood, based on a similar suit against the company when it introduced consumer video recorders in the 1970s.

The US Supreme Court eventually decided that the consumer had a right to tape copyrighted material off the air for private use, a precedent Sony and other DAT manufacturers are likely to use in their fight against the publishers, legal experts said.

Music publishers have countered that DAT's quality is a new factor to be considered by the courts.

Limited DAT market

The litigation cloud hanging over DAT has hurt the consumer units' market penetration since introduction in 1987.

Manufacturers had pinned their hopes on SCMS as way to finally overcome the litigation issue and allow consumer DAT to rebound. Many companies announced at spring audio shows their plans for summer or fall introduction of new consumer DAT equipment.

DAT opponents have never opposed professional equipment, most of which has never been able to digitally copy CDs either. According to audio analysts, however, the professional market could benefit from a successful consumer market in the form of lower prices for software.

We Re-invented the Wheel AND IT'S SQUARE!

Naturally, with all of Wheatstone's experience at building and interfacing consoles, it was inevitable that we would take on the design and manufacture of suitable furniture for our audio installations. First we listened to engineers and their requests, then we went to work. The result is a significant improvement over previous designs.

Consider the advantages of double-sided equipment cabinets with fully interchangeable door panels, with each side able to accommodate 19 inches of rackmount equipment. Consider the convenience of hinged twin drop-down punchblock panels for easy installation and maintenance. Consider the advantage of hard chrome plated steel mounting rails that eliminate the stripping problems associated with lesser aluminum designs. Simply consider the strength we've achieved with full inch and a half thick side panels and hybrid inch and a half thick countertops.

We have re-invented cabinet technology. We've wedded the latest precision NC metal componentry to hybrid plywood high density, high resin pressure-laminated substrates. Our construction and bonding techniques have been optimized to eliminate stress related laminate problems. We've handled wire management: there are generous pathways between each enclosure, as well as an integral channel punchblock housing under the console counter to keep everything neat, concealed and away from unauthorized hands. And, since cabinet faces can accept either equipment or door panels, systems can easily be configured to fit virtually any room. Doors can even be placed on cabinets intended for future electronics installation.

This cabinetry is very clever, unbelievably strong, and (of course) square--*precisely*. It has that Wheatstone major market look. So contact Wheatstone for furniture, consoles, or prewires.



 Wheatstone Corporation

6720 V.I.P. Parkway, Syracuse, NY 13211

TEL 315-455-7740/FAX 315-454-8104

INDEX

Putting the DSE 7000 to the Test	
by Mark Windsor	15
How To Bring Zest To Stereo	
by John "Q" Shepler	17
Audisk Assists UK Independents	
by Mel Lambert	18
Workbench	20
Miking a Roundtable Discussion	
by Bruce Bartlett	21
AM Radio Mobilizes with TIS	
by Dee McVicker	27
Sharing Thoughts with Veterans	
by George Riggins	29
Hearing Yourself Think Again	
by Barry Mishkind	30
Digital Radio Nearly Reality	
by Lex Felker	31
A History of Remote Control	
by Harold Hallikainen	33

FCC to Scrutinize Booster Policy

by John Gatski

Washington DC Confusion and complaints from stations have prompted the FCC to consider clarifying a policy regarding the use of FM boosters.

The confusion began when the Commission recently started sending out letters notifying broadcast license applicants who sought to use boosters

boosters and translators and that has led to confusion over whether stations can go on the air without a new type acceptance.

Part 74 for under 10 W

The Commission first authorized use of boosters with more than 10 W in 1987, but requiring type acceptance for those higher power boosters under Part 74 was

was already covered by Part 74 because it contained a section that said boosters over 10 W must meet Part 73 type acceptance technical specifications.

Equipment already purchased

KSOL-FM in San Mateo, CA is one station that complained to the FCC about the futility of type accepting or notifying high power boosters twice.

Under the Commission's current Part 74 rule interpretation, KSOL cannot use its Broadcast Electronics FM 250-B 180W booster until it files a copy of the station's Part 74 acceptance/notification request to the company with the FCC, according to CE Kevin Douglass.

But the booster is already type accepted under Part 73, Douglass said.

In addition, other stations that had the Part 74 type acceptance/notification condition included in their CPs must wait until the manufacturer completes the process before going on the air with their boosters, Douglass said.

Why require both?

Hammet and Edison, Inc.'s Senior Engineer Dane Erikson said he does not understand why the Commission now also requires Part 74 type acceptance/notification for high powered boosters.

"As the rules are written, as soon as you go over 10 W, their own rules refer

you back to Part 73. I think the rules are real clear that you don't need separate type acceptances," he said.

Based on the FCC's action, companies manufacturing booster transmitters said they will comply with Part 74 type acceptance notification requests unless the rule is clarified differently.

But the confusions and concerns have prompted the FCC into taking a second look at its latest interpretation of Part 74, according to FCC Auxiliary Service Branch Chief Alan Schneider.

"The FCC may need to reexamine its position to determine whether equipment that has been type accepted under Part 73, may also be used for Part 74 booster stations," Schneider said.

The Commission may also consider reexamining its policy for high-powered translators, which also require separate Part 74 type acceptance/notification, Schneider added.

Schneider noted that the Commission may clarify any new rules adopted as part of its inquiry into role of translator stations or such other rule makings that may be forthcoming.

For more information about the booster rule, contact Kevin Douglass at KSOL, at 415-341-8777; Dane Erikson at Hammet and Edison, 415-342-5200; or Alan Schneider at the FCC's Auxiliary Service Branch at 202-634-6307.

"The FCC may need to reexamine its position to determine whether equipment that has been type accepted under Part 73, may also be used for Part 74 booster stations,"

in excess of 10 W that they would have to be type accepted/notified under Part 74 usage.

This requirement meant that stations that had already purchased a high power booster transmitter that was type accepted/notified under Part 73 of the Commission rules also had to be type accepted/notified under Part 74.

Part 73 deals with full service AM and FM equipment.

Now the FCC has decided to reexamine its interpretation of its Part 74 rules regarding type acceptance of FM

not done until this year, according to the FCC.

Part 74 specifically governs boosters and translators and has since 1970. Boosters originally were limited to 10 W or less and these were required to be type accepted under Part 74.

When the Commission began sending out letters to stations stating they could not use the higher-powered boosters until they were also type approved under Part 74, many stations were confused.

They believed booster type acceptance

The Sky's The Limit



ComStream satellite equipment is ideal for point-to-point transmissions such as remote broadcasts. The reason is that ComStream's innovative digital audio compression techniques yield CD quality audio while using less satellite bandwidth than other methods. The use of new technologies also provides economical two-way transmission between sites.

Satellite time is simple and economical to lease, and an easily transported ComStream earth station can allow your broadcasts to originate from virtually anywhere. Some station groups are purchasing systems to share so that costs are even lower. Additionally, many radio program distributors are now selecting ComStream's unique system.

Call or fax your Bradley professional today for details. ComStream equipment is another way Bradley will help you go digital in the 1990's.

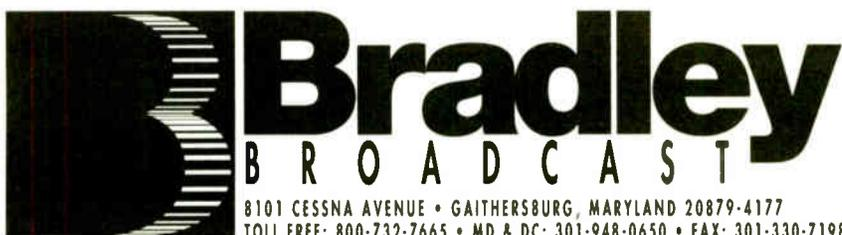

Where Service and Engineering Make the Difference

Circle 31 On Reader Service Card

ADVANCED TECHNOLOGY...

Broadcast Electronics' FM 20B 20 KW FM Transmitter

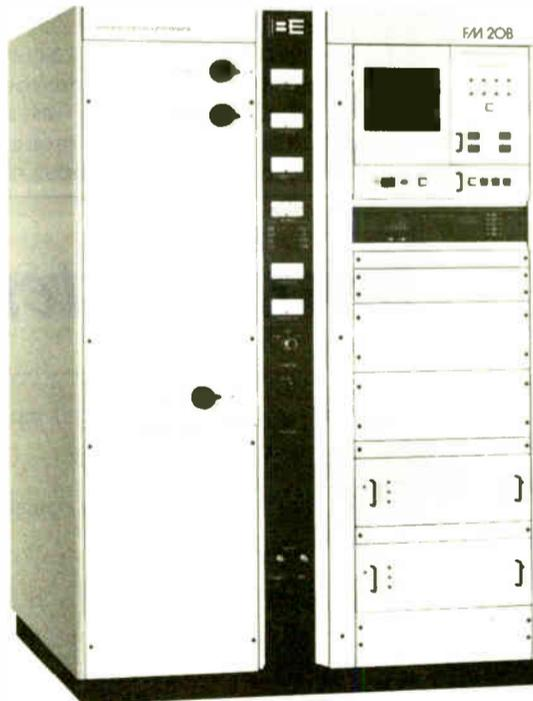

- Digital quality transmission.
- New world standard FX 50 Exciter.
- Highest overall efficiency available.
- Typical THD and IMD 0.009%, 90 dB FM S/N.
- Built in synchronous AM noise test port.
- Patented folded half-wave cavity eliminates plate blocking capacitor and sliding contacts.
- Self Contained solid state broadband IPA in slide out drawer.
- Emergency 450 watt RF patching.
- Automatic Power control that maintains constant output power with proportional VSWR foldback protection.
- Optional self-diagnostic system (MVDS).
- Optional MVDS based remote control.

For information on the FM 20B Transmitter and on Broadcast Electronics' NEW FX 50 Exciter, call Bill Harland or Russ Erickson at 217-224-9600.



4100 N. 24th ST., PO. BOX 3606, QUINCY, IL 62305, (217) 224-9600, TELEX: 250142, FAX: (217) 224-9607

Circle 129 On Reader Service Card

Strong Medicine For AM's Ills

by Judith Gross

Falls Church VA Anybody paying attention to what's going on in radio these days ends up in an interesting position: smack dab, or is it smack DAB, between efforts to pump life back into radio's oldest service and curiosity about a future which seems to be increasingly digital.

I was no sooner back from a visit to the **Digital Radio Project** in Toronto when bang! the FCC finally released its **NPRM on AM**. It only took them two months. If you've heard that it's over a hundred pages long, that's not exactly true, unless you count the appendices and all.

But the writing sure is tiny and it will take awhile to digest the **massive changes** being proposed to bring AM back into a competitive position.

There's a definite **tone** coming from the Commission and it's clearly diverging from the path the FCC has tread previously. They're saying: **Broadcasters** told us **interference and congestion** was the problem. We intend to get rid of interference first and foremost.



If that means interference actions **take preference** over our past concerns, over special interests, over more and more stations, even over the issues facing **minorities and daytimers**, so be it.

Underlying the whole notice is a sense that only the **strong** may survive on the AM band.

Stay tuned and we'll give you more details about the NPRM next time. But ya gotta wonder . . . have we finally come to that **crucial crossroad** in AM's history when there's nothing left to do but grit



Ascending to radio's future

our teeth, swallow hard and do **whatever it takes** to help AM, no matter how painful?

☆☆☆

Then there's the **future**. Despite lots of fear and loathing from some quarters, you can't help but feel energized when you're surrounded by **Canadian broadcasters**.

The first hand look/listen to the **Eureka 147 DAB system** in action was worth the trip (even the plane change in Cincinnati) to **Toronto**, where they brew Molson, among other beers.

First there was the "digital" **mini-bus** with its crimson and yellow logo; over there were lots of **helpful engineers** to explain the set-up; then there are the private and public broadcasters, pushing harder and harder to let the world generally, and their **neighbors to the south** specifically, know that this is the best thing to happen to radio since Marconi.

And how did it **sound** when they threw the switch and the station on the air went from 99.1 on the FM dial to a **digital signal**? Well, like a CD. Really. The noise went down, the signal filled out dynamically and spatially. It was right up there, in your face.

But that wasn't the **best of it**. I was on my way out of the building where the project was headquartered. It was a beautiful evening in downtown Toronto and I was hoping to catch a glimpse of

the lake before it got dark.

I happened to pass by the **AES studio** that's been set up as a stationary listening room to compare digital and analog signals and my ears were greeted by beautiful, full fidelity, stereo, CD-quality music. Of course it was the **digital feed**, but it was originating from an **AM station**.

Imagine it: **AM sounding as good** as a

compact disc. All right, you say it wasn't **really AM**, and technically it wasn't. But it was an AM station whose over-the-air signal couldn't even get into the steel-structured building clearly. The scope showed a very fuzzy snowball.

Then the same station's feed was switched to **digital transmission/reception**

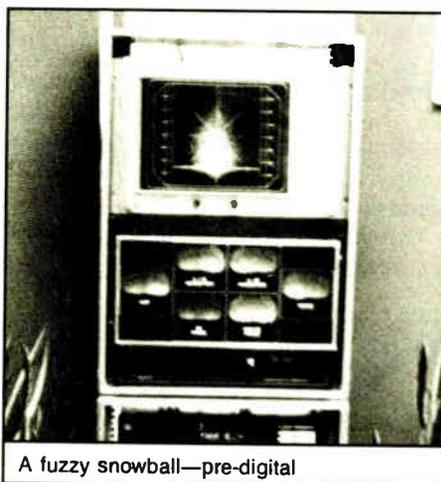

A fuzzy snowball—pre-digital

and there it was, just like a CD. And looking very clean, stereo and full fidelity on the scope screen.

If **every AM station owner** could hear his/her station coming through sounding like that, I think the entire industry would be **screaming loudly**, "Let us have it. Now." This is the **parity** AMers have wished for against their

FM sisters. Yup. A level playing field at last.

No wonder some see it all as a **competitive threat**. Fortunately, the NAB's **task force** on DAB has jumped right in and taken the initiative. They're going up to Canada to hear for themselves. Maybe some of that **Canadian enthusiasm** will be contagious.

By the way, the **European developers** are about to take the system back into the shop for some revisions. The word is that instead of getting 16 stations on 7 MHz there will be 20 stations on 4 MHz. How's that for **efficiency**?

☆☆☆

Now that **AM's problems** seem to be back in the limelight, it's only fitting that the **NRSC standard** has come full circle.

My phone was ringing **off the hook** on 10 July when the FCC sent out the troops to check for NRSC compliance. **RW Central** tracked the cities as the sweep moved from the early time zones to the later ones, although **Seattle** called me pretty early—they were conscientious there.

Some engineers came to work to find the **inspector waiting**, clipboard in hand. We haven't heard about any **finest** yet, but anybody who thought it was smart to wait because "I'll never get caught" found out otherwise.

Of course there was a **mad scramble** for products and phones were busy at the distributor houses, too. Interestingly, some accounts of inspections hinted that the troops sent out on the street weren't just the **hierarchy**, but may have included some of the FCC's **clerical staff**. All hands on deck.

So now, let's see **those radios** out there on the market, OK?

Hard to believe it, but the **summer** is half gone. You know what that means. **Fall showtime**. We'll start with **Beantown** next time. Then it'll be a whirlwind September.

Heard a juicy tidbit? Spill your guts to Earwaves by faxing JG at 703-998-2966, writing to PO Box 1214, Falls Church VA 22041, or calling 703-998-7600. Who knows, you could win a coveted RW mug.

Transmitter Control can be a Bear

You need to make sure you can stay on the air and stay legal. At the same time, you need to keep operating costs under control.

Choosing the right remote control system is the first step.

The ARC-16SA* from Burk Technology lets you control your transmitter from any phone. You can establish off-premises control points for unattended operation, or supervise non-technical operators by phone.

The annual savings can be thousands of dollars.

The ARC-16SA is part of a modular system. For full-time control, add a studio unit. Multi-site options make it easy to control several transmitter sites or even control studio equipment such as program automation.

Call now for your copy of our new catalog, then ask us to show you how we can improve your operation and your bottom line.

Call TOLL FREE
1-800 255-8090

BURK
TECHNOLOGY

7 Lomar Drive, Pepperell, MA, 01463 (508) 433-8877

*bear telephone not included

READERS FORUM

If you have comments for *Radio World*, call us at 800-336-3045 or send a letter to Readers' Forum (Radio World, Box 1214, Falls Church VA 22041 or MCI Mailbox #302-7776). All letters received become the property of Radio World, to be used at our discretion and as space permits.

Market move won't work

Dear RW:

In reply to the article in the 27 June *Radio World* on the proposed move of WHMA-FM from Anniston, AL to Sandy Springs, GA, let me say this: *It can't be done!*

Presently, WMBW (FM) in Chattanooga, TN, owned by the Moody Bible Institute, already has a translator on 100.5 MHz in Conyers, GA, with its transmitter atop Stone Mountain. In addition, such a move would cause interference to the signal of WUSY (FM) Cleveland, TN, at 100.7 MHz, which has a strong signal all the way to Interstate 285 near Atlanta.

WHMA-FM presently programs a country and western music format, which is currently being offered by five radio stations in the Atlanta market (WKHX-AM/FM, WCHK-FM, WYAI-FM and WYAY-FM). Plus people in much of metro Atlanta can receive WTSH-FM, based in Rockmart, GA.

The proposed city of license for Emerald's new 100.5 operation, Sandy Springs, is presently unincorporated, bordered by the Chattahoochee River in the north, Cobb County in the west, the City of Atlanta in the south and DeKalb

County in the east. Did they (Emerald) ever think of moving it to a place lacking FM service, such as Douglasville, Lithia Springs, Austell, Powder Springs, Hiram or Tallapoosa? These are communities in Georgia, near Atlanta, without FM radio service or having no radio service at the present time.

I think that Emerald Broadcasting should keep WHMA-FM in Anniston. My group tried unsuccessfully to purchase an AM daytimer in the St. Louis area to move it to an unserved northern St. Louis County municipality and gain fulltime status. The Atlanta market doesn't need another FM station, and certainly doesn't need another country and western station.

By contrast, the Anniston/Gadsden market needs a country and western music FM station, to compete with WAAX (AM) and WJXL (AM). WHMA-FM cannot successfully compete in the Atlanta market with the same format that Kicks 101.5 (WKHX), K-Country (WCHK-FM) and Y-106 & Y-104 (WYAY/WYAI) are already programming.

If they did move to Atlanta, a set number of jobs should be set aside for entry level (on-air) and disabled (off-air) applicants, two of the most discriminated-against groups that seek employment in the broadcast industry at the present time. That was one of the purposes White Birch Communications had in pursuing the St. Louis AM daytimer.

Eric Bueneman, President
White Birch Communications
Woodstock, GA

It's still the receivers

Dear RW:

I want to state at the start of this letter that I am an avid AM radio buff. I have worked in radio off and on for over 20 years and have a general class license. I see one of the major causes in the decline in AM radio today is the near impossibility to find even a *fair* AM radio. I can agree: Who wants to listen to 2 or 3 kHz distorted audio on a radio that has such poor sensitivity you have to stand near the tower to have the radio perform satisfactorily?

When I saw in the current *RW* that General Motors was balking about making an NRSC "IQ"-certified radio (*RW* 9 May), I was *not* surprised. GM has balked for years in making a radio that had even an acceptable AM section. GM has expressed more interest in making money than a good product. That's one reason GM has had such a dismal quality control rating.

But the Japanese car makers and stereo makers take the cake. I had read that the new car radios from the Orient had AM sections that basically don't work unless you are at the transmitter site. A friend of mine had just bought one of the new Mazda 323/Protege models with a rather fancy looking radio and the FM sounded fair. The AM was just awful. It wouldn't even pick up *anything* but the local stations at night, not even the strong stations on skywave!

With the advances in technology in the

The NAB's task force on DAB is off to a fast and commendable beginning. With industry interest in digital radio rising rapidly, and with WARC '92 fast approaching, the task force has wasted no time in holding the first in a series of meetings and making some quick decisions.

The six-point mission statement, with its focus on exploration and investigation of the technology, sets specific directions for future task force work.

And the interest in raising the industry's awareness, defining new spectrum requirements and monitoring other countries' efforts helps establish NAB's leadership role as the new technology emerges.

Especially encouraging is the task force's awareness that engineering input is critical to help meet the challenges that DAB poses. The decision to appoint an engineering advisory group will insure that decisions will not be made in a vacuum.

A Strong First Step

The task force also shows good judgment in planning a trip to Canada during demonstrations of the Eureka 147 system. Since this is the first hands-on over-the-air experience with the system in this part of the world, a first-hand look will provide much-needed information in a practical setting.

It will also help forge the ties with neighboring broadcasters which may prove valuable when spectrum allocation questions take center stage.

Finally, the decision to add a seminar on DAB to the Radio '90 agenda will help educate other radio broadcasters and generate the healthy discussion which is necessary if all of the industry's interests are to be served.

It will take a wholehearted and concentrated effort to overcome the new challenges and dissolve the misunderstanding and apprehension that a new, potentially competitive technology brings.

Whatever the ultimate policy decisions are, the NAB through its DAB task force has taken a very good step in that direction.

—RW

last 40 (50???) years we ought to be able to simply make a good AM radio at a reasonable cost, shouldn't we? Why do all the current radios except one (the Sony shortwave ICF 2010) *still* have diode detection? The Sony has synchronous detection and I have actually handled one in a ham radio store in Atlanta and it is a good radio—both AM and FM.

If I want to listen to AM on the road, the radio in my 1988 Ford is OK, and I'd accept a tad more selectivity and sensitivity. That radio was the reason I got the Ford over the Chevy as I liked them both (hear that, GM?). If I really want to hear good radio in the car, I get in my '56 Studebaker. By the way the '56 and up Studebakers used Delco radios . . . and it sounds good. The old '67 Chevy radio was just grand.

In the house I listen to a mid '60s big Fisher console (22 tubes or so) and the AM on it is almost as good as the FM! So I'm sick and tired of these manufacturers whining about they can't do this and they can't do that. If they would quit whining and stop worrying about the

next fad in styling and technology, we might see some better quality products on the market.

And while I am at it I want to make a comment about the FCC. They haven't helped the AM band either. Thinking that cramming other stations on clear channels and allowing nighttime low power authority on regionals and some clear channels doesn't hurt is a delusion. At night I can hear (when the Cuban isn't too strong) the new WGST on 640 in Atlanta, as well as the Fayetteville, NC station.

These stations are *only* running 1000 W at night with a directional pattern. In fact I am hearing WGST off of the side of their pattern. I think that all of this nighttime low power for daytimers ought to be cancelled *post haste* with the advent of the opening of the expanded band. Some of these crammed in stations should be moved too.

And as a close, does anyone know how to modify the Ford radios to tune the expanded band?

Powell F. Way III
Columbia, SC

Radio World

Vol 14, No 15 August 8, 1990

Editor, Judith Gross

Associate Editor, Alex Zavistovich

News Editor, Alan Carter

Reporters, Charles Taylor, John Gatski

Benn Kobb, Frank Beacham/L.A.

Editorial Assistant, Marissa Friedman

Technical Advisor, Tom McGinley

Production Director, Kim Lowe

Chris Freter, Lisa Roach, Bill Spencer

Ad Production Coordinator, Jeanne Pearson

Publisher, Stevan B. Dana

Associate Publishers, Arthur Constantine
Carmel King

Ad Coordination Manager, Simone Mullins

Circulation Manager, Tiana Hickman

Accounts Receivable, Valerie Mason

Advertising Sales Representatives:

East & Midwest, Art Constantine

800-336-3045, Fax: 703-998-2966

West Coast, Pat Macsata

415-786-2198, Fax: 415-786-2754

Radio World (ISSN: 0274-8541) is published semimonthly (except February, which has 3 issues) by Industrial Marketing Advisory Services, Inc., 5827 Columbia Pike, Suite 310, Falls Church, VA 22041. Phone: 703-998-7600, Fax: 703-998-2966. Second-class postage rates is paid at Falls Church VA 22041 and additional mailing offices. POSTMASTER: Send 3579 forms and address changes to Radio World, P.O. Box 1214, Falls Church VA 22041. Copyright 1990 by Industrial Marketing Advisory Services, Inc. All rights reserved.

Free subscriptions are available upon request to professional broadcasting and audiovisual equipment users. For address changes, send current and new address to *RW* a month in advance at the above address. Unsolicited manuscripts are welcomed for review; send to the attention of the appropriate editor.

Next Issue
Radio World
August 22, 1990

by Brad Gebhart



Radio's Top Ten! *Eleven!*

Many of our customers understand that this is more than a hollow boast. They know that when a distributor offers them a broad choice of products, it means money in their pockets.

How? Simple. You can select *exactly* the right equipment for your specific application. And when you're not forced to make compromises in features or performance,

MKIII/4, MKIII/8, or the MX-70 with 8 or 16 tracks.

Need a 2-track? How about Otari's famous

"workhorse" MX5050 BII, or the MKIII/2, or the MX-55NM with gapless, seamless, punch-in, punch-out and HX-Pro*.

And don't forget the MX-50, perhaps the most affordable professional 2-track on the market.

We also offer three models of the CTM-10 cart machine. And if yours is an automated radio station, the ARS-1000 reproducer is the most popular machine in the world.

You could say we have

a broad cast for broadcast.

But as we've pointed out, it can mean a

lot more to you than just a phrase.

11? . . . The 10 Otari machines here PLUS the ONE radio distributor that supplies more Otari than anybody else.

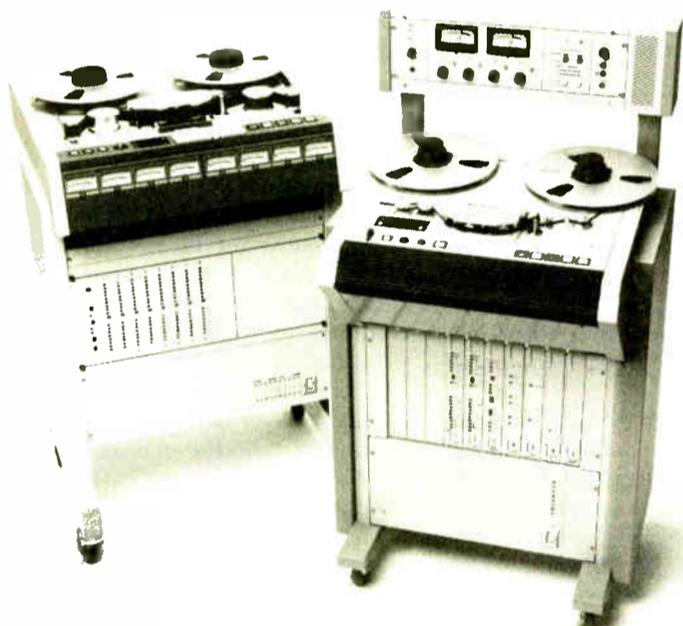

your station not only sounds better to your listeners, it is also much more efficient in its day-to-day operation.

Otari and Allied have machines for news editing, on-air, and production with features to fit any application or budget.

To make a point, let's say you are in the market for a multitrack.

You can choose from the top of the line MTR-10 that gives you all the features you'll ever need, or the BQII,

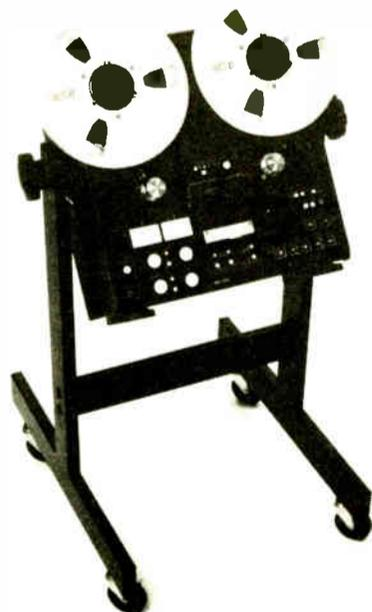

*HX-Pro is a trademark of Dolby Laboratories Licensing Corporation.

FOR
OTARI®

IT'S

**HARRIS
ALLIED**

BROADCAST EQUIPMENT

800-622-0022

CAB's Tremblay Discusses DAB

Michel Tremblay, radio senior VP for the Canadian Association of Broadcasters (CAB), was instrumental in the digital audio broadcasting (DAB) tests in Canada, first working as chairman of the CAB Advanced Radio Working Group that initiated the project. He talked with *Radio World News Editor Alan Carter* about the work underway and the future of DAB broadcasting there.

RW: What has initial DAB testing shown?

Tremblay: The equipment has more than met our expectations delivering technical quality. We knew it worked after seeing it in Europe, but we wondered if it would deliver all the goods, like reduction of multipath, absence of interference and sound quality equal to CDs.

In fact, it is delivering all of that and it has proved to be very reliable.

RW: How is it being received by Canadian broadcasters?

Tremblay: They have been astonished by the quality. . . . They are extremely impressed. I haven't heard of anybody who has indicated they were deceived or really felt only so-so about what they heard.

RW: How would DAB be implemented in Canada—terrestrially, by satellite or a through a combination?

Tremblay: Very early in the game we jumped on the bandwagon when we realized the potential of DAB and we tried to map out our own future. In our (CAB) view, we saw digital radio evolving in the context of a hybrid system in Canada, which would be terrestrial but include some satellite use for national users such as the Canadian Broadcasters and regional satellite use for educational broadcasts.

We also felt that it would be uneconomical to run the AM and FM bands plus digital. We clearly didn't see digital as a new band but as a gradual and orderly replacement for AM and FM sta-

tions over the next 10 to 20 years. These are the views that we have presented to the Canadian government.

I guess that one of our top priorities was to ensure that terrestrial digital allocations would be on the agenda of WARC '92, and we were quite pleased when we heard it has been added to the agenda.

RW: Will Canada use the Eureka system technology?

Tremblay: It's quite simple. At this point it is the only technology of that caliber that is available anywhere in the world. But I don't think we are married to this technology. We would be open to testing other

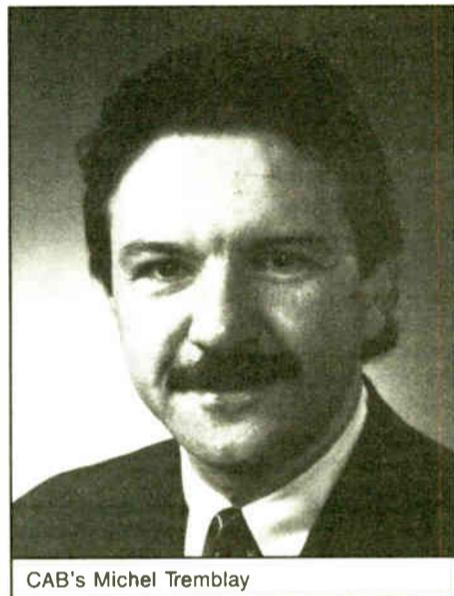

CAB's Michel Tremblay

technology, but in my view the Europeans are at least two to three years ahead of anybody else.

RW: What is the scenario for implementing DAB in Canada?

Tremblay: Looking at the fact that WARC is going to rule on spectrum in 1992, spectrum may become available in 1993 and a standard will be set for transmission and receivers. We think there might be some initial commercial use of terrestrial DAB by

1995 increasing toward the year 2000.

As we are favoring a very orderly transition, we think it may take as long as 10 to 20 years after that point to really make the switch. Receiver penetration will really drive the move.

RW: Is there any indication when the first receiver may be on the market?

Tremblay: If the standards are set parallel to the WARC decision, we may see some receivers on the market anywhere between 1993 and 1995. I think some of the Eureka partners are working on receivers; we're not that far from it.

RW: How will Canadian broadcasters obtain the spectrum needed for digital broadcasting?

Tremblay: We are going to be continuing discussions with the Department of Communications here, which is responsible for frequency allocation and with the CRTC which allocates the licenses. I guess we're going to have to establish a clear plan. I guess this is one of our next priorities and both government regulatory agencies are very aware and involved in this project.

RW: How closely will Canadian broadcasters have to work with US broadcasters to settle the spectrum issue?

Tremblay: We've been in close relationship with the US and the NAB in these discussions. We agree that the priority must be given to terrestrial allocation. They (the NAB) have a different view about satellite, but we're pretty much on line that this service should primarily be offered to existing broadcasters; that's what we're fighting for.

RW: What is the difference between Canadian and US radio broadcasters that has generated such enthusiasm in Canada for DAB versus traces of panic or fear of competition in the US?

Tremblay: With the differences in the regulatory agencies, entrance into the

market here is very tightly controlled based on economic conditions. We have been advocating priority for existing broadcasters. New entrants would have to justify that their entrance into the market would not create chaos.

We also have to keep in mind that really not everybody—even in Canada—is fully up to speed about DAB, and people don't know what they're facing in terms of technology. It raises some concern, but once people become aware of the potential, and what it can do to improve signal transmission by allowing stations to compete with CDs and DAT, then I guess that's when people are falling in line.

In North America, we're still in the educational process that this can work for us, rather than being a technology to be solely feared.

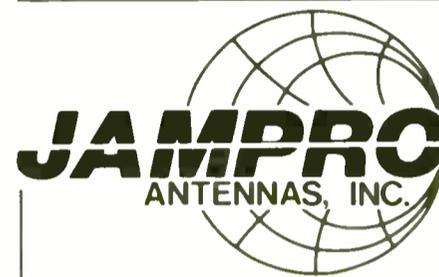

For Excellence In Antennas

- A complete line of TV and FM Broadcast Antennas
- Modern 7,000 ft. test range facilities
- Innovative Engineering Careful construction
- Two Year Warranty on Product and Workmanship



With over 1500 delivered, we've helped more stations penetrate their market.

FCC Directionals
Pattern Studies
Multi-Station Arrays
Full Scale Measurement

JAMPRO ANTENNAS, Inc.
6939 Power Inn Road
Sacramento, CA 95828
(916) 383-1177 TELEX 377321

Vanguard Series™

Stereo Broadcast Consoles

Performance, Value and Reliability through Innovative Technology

- Full Featured On-Air Performance
- Reliable VCA Faders and Electronic Switching
- Serviceable Plug-in Circuit Boards
- Quick Punch Block Installation
- RF Protection that Works!

BC12DSL
12 Mixers • 24 Inputs
Dual Stereo Outputs
\$4995

BC8DSR/L
8 Mixers • 12 Inputs
Dual Stereo Outputs
\$3395

Call or write NOW for free detailed color brochure.

AUDIO TECHNOLOGIES, INC.
328 Maple Avenue, Horsham, PA 19044 • (215) 443-0330

Digital Tests Move To Toronto

by Judith Gross

Toronto CANADA Canada's digital radio demonstration, using the Eureka 147 DAB system, moved to Toronto in mid-July before traveling to Montreal and Vancouver.

was even a digital broadcast of a Toronto Blue Jays baseball game.

Participating stations sent a 15 kHz stereo feed to the CBC's Advanced Audio Production Facility—a digital experimental studio—in downtown Toronto over equalized phone lines. These were fed

(receiver).

The other signal went into a D/A converter and was sent through an FM transmitter on 99.1 MHz so the digital and analog comparison could be made between the two—from the same signal.

During the tests it was possible to listen simultaneously to a station on its own frequency, on 99.1 on the FM dial or as a digital signal through the prototype receivers placed in the mini-bus and the stationary room.

Each seat in the bus had a pair of headphones hooked up to the receivers. It was possible to adjust the L and R volume independently and an overhead light indicated whether the signal coming through the headphones was analog or digital.

The switch from analog to digital brought a dramatic increase in dynamic range and decrease in SNR. Background noise virtually disappeared and what had been a typical sounding "radio" signal sounded like a compact disc.

While the time afforded RW for listening was brief, some multipath effects were audible in the FM analog signal which disappeared when the signal was switched to digital.

A second dramatic demo in the stationary listening room at Telemedia's facilities showed the improvement when comparing over-the-air AM to the digital signal. In the steel-structured building CFTR's AM signal was inaudible, but the switch to digital gave CFTR a clear and full 15 kHz stereo signal complete with CD-quality dynamic range.

Both private and public Canadian broadcasters are working together on the digital radio project. Walter Unger, Director of Network Radio Resources for the CBC said private and public radio has never worked so closely.



The CBC Building, a former school, housed the digital studio where feeds originated.



Walter Unger (CBC), Duff Roman (CHUM), David Dobbs (CBC), and Fred Benedikt (CBC), ponder spectrum needs for DAB.

The demos are a joint project between the Canadian Association of Broadcasters (CAB), the Canadian Broadcasting Corp. (CBC) and Communications Canada (DOC) and brought the European-developed system to its first North American tryout starting in Ottawa (see 11 July RW).

In Toronto, considered by Canadian broadcasters to have "the best radio service in the world," the tests lasted from 5-15 July. They were headquartered in Telemedia offices and the digital mini-bus again took to the road to demonstrate the CD-quality audio and multipath-cancelling properties of the system.

In addition, there was a stationary listening room constructed by AES members which allowed comparisons of over-the-air AM and FM with digital radio, DAT, CD and analog tape.

A total of 18 Toronto stations, both AM and FM, provided programming for the demo during the 10-day tests and there

into Yamaha DMP7D digital mixers and then into a sample rate converter to produce 48 kHz sampling.

The digital signal then traveled to the 1800' CN Tower and was split into two.



Canada's digital mini-bus let visitors compare digital and analog radio.

One signal was fed into the MUSICAM data reduction system which has been part of the European system for the purposes of the test. This digital signal was then sent over UHF channel 68 to be picked up by a special digital decoder



Both digital and analog signals were transmitted from the CN tower in downtown Toronto.

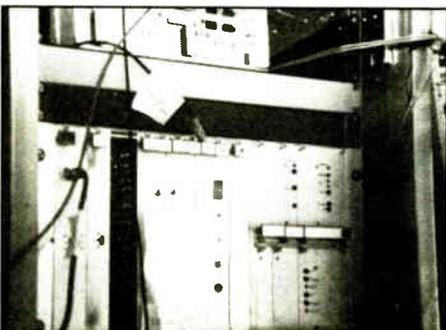

DAB listening tests used Eureka 147 equipment.

"We're getting a very solid common front between private and public broadcasters . . . the most solid front we've ever had in our history," Unger said. He explained that Canada will need that unity when it joins other countries in deciding the future of digital radio at the 1992 World Administrative Radio Conference.

Duff Roman, VP of Industry Affairs for CHUM, represented private broad

casters. He said the tests helped publicize the potential of digital radio and gave some hands-on experience to Canadian broadcasters.

Roman also pointed out that the future of DAB suggests that stations in a given market will be working more closely together. Currently, the Eureka 147 system allows for 16 stations on 7 MHz of band. But the European developers are expected to upgrade the system to accommodate 20 stations on 4 MHz.

Because many stations will share a single transmitter, there will be a cost savings—but also the need for cooperation, Roman said. He also pointed to the need for certain tradeoffs—giving up AM's skywave reach in favor of high fidelity, for example.

And he noted that stations will have a "level playing field" coverage-wise and will need to sharpen their programming skills to remain competitive. But he said he believes the trade-offs are worth it.

"We now have something that says 'Welcome to the 20th century.' People who listen to a CD player are going to

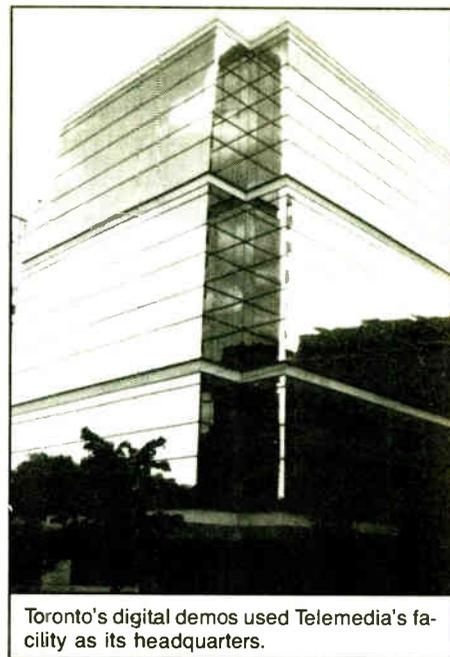

Toronto's digital demos used Telemedia's facility as its headquarters.

be able to take that quality into their autos and their Walkmans. We'll no longer have that 'this is radio' stigma."

While US broadcasters, via the NAB, have decided to oppose satellite forms of DAB in favor of terrestrial methods, Canadian broadcasters see a hybrid system developing. "We are locally driven, we sell 85% local advertising. Private stations are interested in the terrestrial part of this system whereas the national broadcasters, who are mandated to serve the entire country, are interested in the satellite possibilities," Roman said.

(continued on page 12)

NEW Mini D.A. from HENRY!
Combines & splits audio signals for distribution

For the **FULL** picture...

Call toll free...



5618 Odana Road Madison, WI 53719-1208

Audio & Video Equipment & Supplies

(800) 356-5844

Consultation

(608) 271-1100

Filings Support Pioneer Plan

by Charles Taylor

Washington DC The FCC's proposal to grant preferential treatment to parties that apply for innovative uses for spectrum was exalted by the vast majority of those filing comments in late June.

In fact, among the 54 groups or individuals responding to the Commission's query on its "pioneer preference," only the NAB and the Association for Maximum Service Television (MSTV) cast doubt on the concept.

The proposal, inspired by a petition for rulemaking submitted in July 1989 by the Washington Center for Public Policy, is aimed at insuring that those who request spectrum allocation rule changes associated with the development of new

communications services are rewarded for their initiative.

"If some party comes in with a truly imaginative idea and the Commission adopts it, the way it is now, he competes with it like everyone else and gets no reward from it," said FCC Mass Media Assistant Chief for Engineering, Bill Haslinger.

"We wondered if there was a way the Commission could reward them for their creativity. What we were asking is if there were a practical way to even do something like this," he said.

According to Washington Center's proposal, innovators of a new service often lose out because larger companies with greater resources, under current rules, can compete for a license at the same

time as the original petitioner.

"The governmental process thus undermines the competitive edge that would normally accrue to the innovator," the Center said.

In its notice, released in April, the Commission compared the policy to the protection granted to inventors, writers and artists.

"Under the constitutionally-enabled patent system of the United States, inventors are granted, to the exclusion of all others, the right to produce, use or sell their invention for a specific period of time as a reward for their endeavors," it said. The Commission proposed a head-start period of six months.

The consulting engineering firm of du Treil, Lundin & Rackley agreed. "An inventor is protected under patent law. A writer is protected under copyright law," it wrote in its comments. "The basic concept of awarding a preference to an innovator has traditionally been the American way of doing business."

But the Commission must be cautious about the guidelines by which it defines a new service, warned Motorola, who was otherwise supportive of the idea.

First, preferences should not be awarded to proposals that copy services and technologies that have already been adopted in other parts of the world, Motorola advised. Also, it questioned whether a shallow, relatively superficial but innovative proposal would receive

preference over a more thoughtful, better developed version that comes later.

One of the supportive filings came from Satellite CD Radio, which recently petitioned the Commission to create an allocation for a new digital audio broadcasting service. Using itself as an example, the company said that the pioneer preference is a "good and useful idea," and, not surprisingly, suggested that its proposal before the FCC should qualify for a pioneer's preference.

MSTV generally approved of the concept; however, not for broadcast services. It is more difficult, more time-consuming and more expensive for broadcasters to implement industry changes based on new or altered spectrum allocations, thus a pioneer's preference is not likely to be a significant incentive to seek allocation changes, MSTV said.

The NAB, in its filings, opposed pioneer preference which it said would award spectrum to possibly less qualified applicants or to less desired services, while increasing the number of unsubstantiated or premature requests for spectrum allocation.

In protection of its member radio and TV stations, NAB said that newer technologies encouraged by the pioneer preference "should not be encouraged to simply supplant or inhibit existing over-the-air broadcasting."

It also pointed out that technologies such as color TV, FM radio, radar, satellite and microwave communications, mobile phone service and others "have been routinely accommodated under existing policy."

AM Antenna Data Is In

by John Gatski

College Park MD The NAB has completed field testing of its experimental anti-skywave antenna project and is now analyzing the results, which will be released at the NAB's Radio show next month.

The tests were conducted 20-23 June using the 290' base-fed antenna designed by consultant Ogden Prestholdt. With its tunable vertical radiator/matching circuitry, the antenna theoretically can tune out unwanted skywave in any particular direction.

NAB Science and Technology staff engineer Kelly Williams did not elaborate specifically on how well the antenna performed because the raw data had not been analyzed, but he said preliminary results indicated some "appreciable suppression" in the desired directions.

On each of the nights a 400 W test broadcast signal was beamed toward a monitoring site in Plaineville, NJ, which was manned by Prestholdt, and another site in Brownsville, PA.

The tests ran into some problems including failure of the final output amplifier on the transmitter during the first night and atmospheric noise because of thunderstorm activity north of the Washington, DC area, Williams said.

The NAB had an auxiliary transmitter on hand and engineers at the College Park site were able to get the 1660 kHz test signal on the air, William added.

Approved in 1989, the \$100,000 anti-skywave project took longer than expected to get the tests underway due to weather-forced delays and bureaucratic snags getting local government zoning approval.

The NAB and Prestholdt will present complete findings from the anti-skywave test during an engineering session at the Radio Show, which will be held in Boston, 12-15 September.

For more information about the anti-skywave antenna, contact Kelly Williams at 202-429-5346.

Computer Automation

A-Bus Low Cost Data Acquisition and Control

Measuring, Sensing, Switching and Governing.

A-Bus is a system for connecting equipment and sensors to a computer. From measuring voltage levels, to sensing switch closure, to activating relays, to controlling position, you can have complete computer control. A-Bus is designed to help you automate, whether it's an extensive remote application, or a simple repetitive chore.

When nothing else will do.

Sometimes you're presented with a unique problem, where the normal solution just doesn't fit. The A-Bus system was designed to be adaptable to whatever computer you have, expandable beyond your needs, and modular to fit your project exactly. This was required by a major radio station in San Francisco. Their remote transmitters were blocked by hills. A-Bus devices were connected to the repeaters atop the hills. The main studio could test and adjust the antennas for optimum performance.

The bottom line.

When budgets are tight, it's nice to know that the A-Bus was designed carefully to keep it affordable. This was very important to a small college radio station. They couldn't afford an expensive automation system, but inexperienced announcers required careful supervision to ensure FCC compliance. With the low-cost A-Bus system installed, the station manager had more time to spend on important tasks.

Support.

Alpha Products has produced thousands of systems, and they are being used by customers all over the world. Our recent customers include KSFO, KFRC, KBIA, WMJX, WBNX-TV, KETA-TV, and the Sun Radio Network. We are committed to reliability and customer satisfaction; our team of engineers stands ready to help you with any questions you might have. A-Bus components are stocked and available for immediate delivery.

A Sampling.

Relay Card, 8 SPST, 3A @120VAC: \$142. Fast 12-bit A/D, 8 analog inputs, 0-5V, 10µS conversion: \$179. Digital Input, 8 opto isolated: \$65. Touch-Tone decoder: \$87. TTL I/O, 24 lines: \$65. Also: Latched Input, Serial Multiplexing, D/A, Clock, Stepper Motor Control, etc.

Call for our Catalog
(800) 221-0916

ALPHA Products

242-Q West Avenue, Darien CT 06820 (203) 656-1806 (fax 203 656 0756)

Live! . . . in concert! ALL the Time

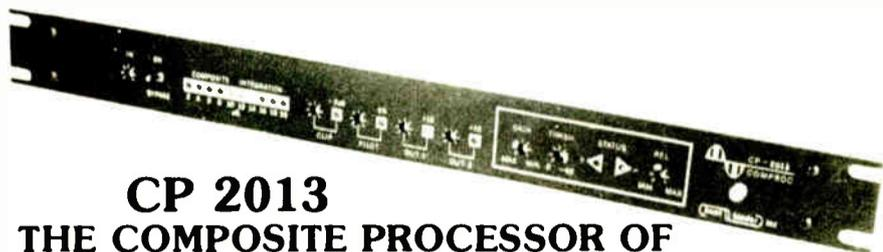

CP 2013 THE COMPOSITE PROCESSOR OF THE FUTURE HERE TODAY

- ★ Low second harmonic clipper — flat to 420KHz!
- ★ Separation exceeding 60 dB
- ★ Ultra smooth, fast acting AGC, builds stereo image without the grunge!
- ★ 1½ dB louder than any other composite clipper
- ★ Multiple outputs plus remote control

AVOID THE RUSH — CALL NOW

hnat hinders inc

42 Elaine Street • R.R. 1 • Thompson, Connecticut 06277 • (203) 935-9066 • (203) 935-9242

Circle 35 On Reader Service Card

World Radio History

Circle 88 On Reader Service Card

FCC Checks NRSC Compliance

(continued from page 1)

"pretty high," said Jeff Young, an electrical engineer in Field Operations Bureau inspections and investigations. Inspectors visited more than 300 stations, he said.

The second phase of inspections, slated to begin the following week, were to involve monitoring.

Engineers contacted were generally pleased with the FCC action.

"Everything was just fine," said WQXR-AM CE Herb Squire in New York after the inspector left. The station went with NRSC in 1988.

He supported the FCC action, main-

taining that stations that do not comply with the stopband limit hurt the overall purpose of the rule. "It's got to be universal," he said.

In Richmond, VA, WRVA-AM/WRVQ-FM DE Jon Bennett said he showed the inspector documentation that the gear had been in place for a year, along with spectrum analyzer photos. "I think he was surprised we had so much documentation so early," Bennett said.

At KMPS-AM in Seattle, CE George Bisso said the inspector found his station on line with equipment installed in 1987. "We run a clean ship," he said.

Bisso, however, advised stations that

have not installed the filters to make the move. "They (the FCC) mean business," he said.

WSUN-AM CE David Solinske in St. Petersburg, FL, said the inspector found his station in compliance, but he noted that the FCC found some stations without equipment performance measurements on file.

No hesitation, now

Once word spread that inspectors were making rounds, manufacturers and distributors of NRSC filters received calls—from some desperately trying to buy the equipment that now has a delivery time of three to six weeks.

"We're getting a lot of people calling and begging for delivery yesterday," said CRL TV and Radio Products Manager Bill Ammons. "We've had some really panicked people call."

Bradley Broadcast sales rep Bill Ashley noted some real desperation in callers' voices. "They're not asking the price," he said, "they're asking what we have in stock."

That is exactly the reaction the FCC wanted, with Mass Media and Field Operations officials taking no pity on stations in violation.

"We're waving the flag, and we're serious about this regulation," said Young. "If they're in violation, they're going to be fined."

Not so strict

But Young noted that mitigating circumstances could affect an inspector's determination. In fact, reports indicated some inspectors were lenient with stations who could prove they made a good faith effort to comply.

If the FCC levied maximum fines, totals could be \$25,000 a day up to \$250,000 overall.

Young said the rule and the effective date was no surprise to anyone. "There has been quite a bit of publicity about it."

The inspections came as a result of reports to the Mass Media Bureau that some stations would not comply unless forced to.

"That didn't make us happy," said Jim McNally, CE in the MMB Policy Branch. Noting that NRSC is one of numerous steps the FCC is taking in AM, he said, "We are going to make the best effort to make AM competitive."

DAB Task Force Acts Fast

(continued from page 1)

of the eight members of the task force, as well as officials of each NAB division and members of the executive committee.

The group also resolved to add a session on DAB at the NAB Radio 1990 show in Boston in September. The session will be held Wednesday, 12 September at 4:45 PM and repeated on Saturday, 15 September at 2:30 PM.

In addition, the task force reacted to concerns that it lacked engineering presence. NAB Science and Technology Senior VP Michael Rau, who attended the meeting, announced the establishment of a team of DAB technical advisors for the task force, which will be used to field technical ideas regarding applications of DAB.

"I gathered a list of 30 to 40 interested radio engineers, mostly corporate, who have called in and asked to be kept informed on DAB. There are also some that I'd like to keep informed," Rau said. "I suggested the idea and (the task force) approved it."

A mission statement

Members also decided on a set of formal goals, which were expressed in a press release, along with a quote from

Box: "Recognizing the historic and revolutionary nature of DAB technology, our task force will fully investigate the challenges and opportunities a potential terrestrial service would have on the nation's 12,000 radio stations and their listening audience."

"Keeping in mind the value of our community-based system of local broadcasting, we will need to make prudent decisions about any satellite-based DAB proposals that would threaten radio localism," Box added. "But we shall remain open to the opportunities DAB terrestrial service presents to the US and the world."

The mission statement listed the following goals: to advise the NAB board of directors on the development of NAB policies regarding DAB technology; to develop recommended strategies for NAB to implement and achieve the board policies; and to analyze legal, technical, political and practical implications for DAB technology in the existing US radio broadcast industry.

Also, the group vowed to determine what elements may be needed to identify new spectrum, if appropriate; raise the awareness of the broadcasting industry on the challenges and opportunities of DAB, promote and coordinate radio broadcast industry consensus; and to monitor domestic and international DAB broadcasting activities.

Briefing the industry

According to Box, the group intends to give the industry a brief update on its discussions at the NAB Radio 1990 show in Boston in September. A thorough report will be given to the executive board in January and to the industry at the NAB show in Las Vegas next spring.

"I think Las Vegas will shape up as a digital radio convention," he said. "Things are happening so quickly."

The task force also intends to meet again just prior to the NAB Radio 1990 show in Boston in September.

For information on the task force, contact Alan Box at EZ Communications at 703-591-1000.

GET IT RIGHT
GET IT FROM ALLIED

On Target...



with
DART
384
by
Fairchild

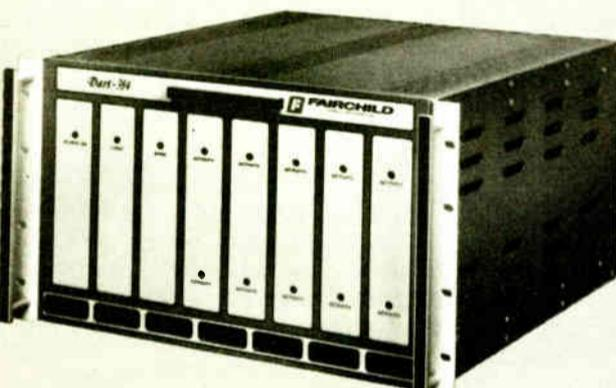

**SWITCHABLE
DIGITAL
AUDIO
RECEIVER
FOR
PROGRAM
MATERIAL
BROADCAST
VIA
SATELLITE
USING
DIGITAL
TECHNIQUES**

EXCLUSIVELY from



Complete system packages are available and include the antenna, mount, feed, LNA, all cables and all electronics. Let HARRIS ALLIED put the best system together for you!

**SOUNDS GREAT
...like digital should!**



FAX 317-962-8961
317-962-8596

3712 NATIONAL RD. WEST • P.O. BOX 1487 • RICHMOND, IN 47375

©HARRIS/ALLIED 1990



orban

Listen to the Difference

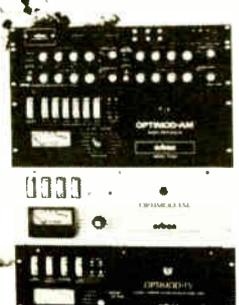

No Safe Harbor for Indecency

by Charles Taylor

Washington DC Despite consistent criticism from broadcasters, the FCC has followed a lead established by Congress in late 1988 by adopting a report that enforces the banning of indecency over the airwaves 24 hours a day.

But the action, passed in a 5 to 0 vote at a Commission meeting 12 July, raises questions of constitutionality, leading many in the industry to believe that the issue's ultimate outcome may lie with the

Supreme Court.

The move, which is stayed until it meets approval by the courts, strikes at what is now known as the "safe harbor," a period between midnight and 6 AM, when it was presumed children were not in the audience.

The FCC now has determined that children are in the broadcast audience at all times of the day and night and that alternatives to prohibition are insufficient to "protect them from exposure to harmful indecent programming."

However, Timothy Dyk, an attorney with Jones, Day, Reavis & Pogue, representing a consortium of broadcasters including the NAB, CBS, NBC and ABC, argued, "Our view has been all along that the decision of what children should see and hear is up to the parents. A blanket ban cannot be justified."

The NAB also was quick to respond. In a statement following the meeting, President and CEO Eddie Fritts commented, "The courts have made it clear that a 24-hour ban on constitutionally protected speech is contrary to the First Amendment. We are disappointed that the FCC ignores this judicial precedent."

The Commission, however, said the ban conforms with the constitution, citing a Supreme Court case that dealt with indecent telephone transmissions. That case concluded that indecent speech may be regulated if doing so promotes a "compelling" government interest and is "narrowly tailored" to serve that interest.

In taking the action, Commission Chairman Al Sikes cited 88,000 letters from the public in favor of a ban versus 4500 against it.

"It seems the public strongly supports the action we will take today," he said at the meeting.

But Commissioner Andrew Barrett al-

luded to less-than-wholehearted support for the 24-hour ban, despite the fact he voted for it. When given the opportunity to comment, Barrett passed, saying that because the issue will ultimately end up in court, "it doesn't make a great deal of difference what I think."

The action is rooted in the September 1988 passage of congressional legislation mandating the Commission to enforce a 24-hour indecency ban. The FCC complied by adopting such a rule in December 1989.

But in January 1989, following an outcry from broadcasters, the US Court of Appeals postponed the effective date of the 24-hour ban, pending a review of the rule's constitutionality. The FCC, meanwhile, requested that it be allowed to compile a record supporting the 24-hour prohibition. In October, it adopted a Notice of Inquiry to initiate a formal proceeding for this purpose.

Comments on the notice panned the ban. The broadcast consortium represented by Dyk, in a joint filing, asserted that the law is unconstitutional because it reduces the adult population to seeing or hearing only what is fit for children.

For information on Docket MM 89-494, contact David Siddall at the FCC at 202-632-7792.

RDS Alert Plan in Works

(continued from page 1)

is a 57 kHz digital subcarrier that is transmitted from a station's main carrier. Along with emergency alert potential, broadcasters are also looking at RDS for its ability to scroll station call letters and messages to listeners with RDS decoder-equipped radios.

Lebow said RDS is a better technology than the 30-year old EBS because it eliminates the need for a station operator to activate it.

"This is a new technology that will get the job done better," Lebow said.

Weak links

With EBS, Lebow explained, a local or state alert is initiated from a designated AM or FM station, which is fed to the other stations in the local system. Personnel at the station then decide whether the alert applies to their area or not.

If they decide, for example, a tornado warning is pertinent to the listening area, they are supposed to switch on the EBS tones and then read the appropriate over-the-air instructions.

However, Lebow said that personnel designated to activate EBS at the stations are often part-time DJs and weekend personnel. They may be trained in EBS procedures, but are the "weak link" in the system, Lebow added.

"You are putting a guy in charge (of EBS) who plays records," Lebow said. "He or she is not a management level person, but ends up making life or death decisions."

Lebow said an RDS system will eliminate the chance of a mistake because the emergency authority officials will be the primary decision-makers and then the automation takes over.

An RDS emergency alert system is similar to EBS in that there must be an initiating station from which the other

stations receive, but with an important difference, Lebow said.

Instead of manual activation, the emergency alert system will automatically be activated at each station by the RDS encoder at the main station.

The individual stations would have several seconds advance warning about the emergency and could manually override the automatic activation if it is not germane to their listeners, Lebow noted.

One FM station within the Jefferson County system, which has not yet been chosen, will initiate the RDS alert based on emergency information provided by a trained operator, Lebow said. That station will have an encoder, which will feed the information to the other stations' decoders.

One of many

FCC EBS Engineer Frank Lucia said RDS is just one of several EBS augmentation systems being proposed or tested as alternatives to EBS. A digital EBS system has been proposed for San Francisco and another modified EBS system may be tested in Colorado.

Lucia noted that RDS' claimed advantage of being automatic and out of station personnel's hands is not totally true.

"It may be automatic at the down-line stations, but somebody has to make the decision to get the thing going at the initiating station," Lucia pointed out.

The FCC is likely to evaluate RDS, or any other system, as a possible replacement for traditional EBS, based on industry acceptance, Lucia noted.

"At this point in time, I think we will take a wait-and-see attitude," he said.

For more information about RDS and emergency alerting, contact Gerry Lebow at Sage Alerting Systems, 203-357-1464; or Frank Lucia at the FCC EBS office, 202-632-3906.

AS-101 Audio Switcher

- Illuminated and legendable control buttons
- Instant or overlap switching
- Front panel accessible level controls
- Options include: RS-232 interface, remote control, relay-follow-switch outputs
- Network proven quality and reliability!

P.O. Box 1342 Bellingham, WA 98227
(206) 734-4323 (206) 676-4822 (FAX) **Conax Electro-Systems, Inc**

Circle 102 On Reader Service Card

It's Not Just A Phase We're Going Through.

The tremendous success of the Tannoy PBM series of reference monitors is by no means coincidental. Since the introduction of the world renowned NFM-8 nearfield monitor, much time and effort has been spent on discerning the needs of the mixing engineer and the applied requirements of "playback monitors". The PBM Line exemplifies this commitment to excellence in reference studio monitoring. These compact loudspeakers sport robust poly cone mid-bass transducers utilizing efficient long-throw, high power voice coils. The low frequencies are carefully controlled by optimally tuned ports located on the rear of the loudspeakers. Hi frequencies are provided by Hi Power ferro fluid cooled polyamide dome tweeters which extend H.F. bandwidth beyond 20KHZ. The driver accomplishment is knitted

together by means of a precision hardwired crossover unit, utilizing robust low loss components, and heavy-duty input terminals which will accept standard 3/4" spaced banana plugs and the majority of high quality, specialist audio cables. Transducers and crossover assemblies are neatly housed in a stylish, high density, partical wrap cabinet, specially designed to minimize unwanted cabinet resonance, and high frequency reflection. In summarizing, we have left the best feature of all for last "price versus performance."

TANNOY
Professional Products



TEC AWARD WINNER

TANNOY

Tannoy North America, Inc. 300 Gage Ave., Unit 1, Kitchener, Ont., Canada, N2M 2C6
Telephone (519) 745-1158 Telex 069-55328 Fax (519) 745-2384

Circle 146 On Reader Service Card

Ingram Named SBE Director

by Marissa Friedman

Indianapolis IN The Society of Broadcast Engineers (SBE) has hired its first on-staff executive director, Stephen Ingram, who started work here 1 June.

In making the announcement, SBE President Brad Dick said Ingram's management background will be instrumental in the society's strategic planning.

Dick said the hiring of Ingram brings the SBE a step closer to its long term goal, which is to have a Washington, DC-based full-time executive director.

Ingram, who is a Certified Association Executive (CAE), has been a professional association manager for the past eight years. He serves on the Indiana Society of Association Executives board of directors and the membership development committee of the American Society of Association Executives.

ious programs to increase membership. Other objectives, he noted, include coordinating public relations and convention activities and identifying new marketing



SBE Executive Director Stephen Ingram

Not full time position

Although the position is not "full time," Dick said Ingram's responsibilities are far too important to classify the job as "part time." Dick said that Ingram's hours will be contingent upon the workload.

"I have specific job functions and duties," Ingram said. "It doesn't matter how long it takes; I must complete them. The amount of hours is irrelevant."

Ingram said he will concentrate on var-

opportunities.

In addition, Ingram said he wants to develop strategies to support the Ennes Foundation, an educational endowment, so it will be self-supporting.

The board of directors will get involved with the plans in July through the mail, Ingram explained, because no summer meetings are scheduled.

"What the association is in need of is associate management issues. There must be a focus on membership recruitment/retention while keeping dues at a

regular rate," Ingram said.

"We need to look for an alternative way to finance the organization through non-dues revenue. One way is to increase profitability through effective marketing," Ingram continued.

Director's duties

Promoting SBE's national convention to membership is key on Ingram's list of ways to improve the society's finances, he said.

Ingram's duties will also include determining future convention management

with Dick. A three-year contract with Eddie Barker and Associates to run the annual convention expires after this year's show. Dick said the SBE will look at other bids for future exhibits.

Dick maintained that Ingram will not serve as an SBE lobbyist. "A lobbyist is the absolute last thing the SBE needs," he said. "We have an effective lobbying program now."

Asked if his position was equivalent to a national director, Ingram said, "In my mind, the term 'national director' is inappropriate, because we are an international society."

Ingram is enthusiastic about his new position. "My job is to make the association better," he said, "and you can count on it."

DAB Moves To Toronto

(continued from page 8)

Roman and Unger explained that Canadian broadcasters see a rapid timetable to the implementation of DAB, with an initial period of simulcasting on AM, FM and digital until a "critical mass" of receiver penetration is reached.

They noted that companies are already working on receiver designs, with the hope of developing an affordable digital receiver—perhaps one smart enough to switch automatically between terrestrial and satellite reception.

After this summer's tests, the next step in the process is to define a request for appropriate spectrum to take to WARC '92. Unger noted that several options are possible, but that the likeliest focus will be in the UHF band. Both he and Roman emphasized that Canada will need to work closely with the US in developing a spectrum request.

And Unger noted that "We're going to have to generate a spirit of understanding and cooperation" to overcome any short term or negative thinking that might cause initial resistance from existing broadcasters.

He said, however, that he thinks the DAB demos will help fuel the en-



Inside Telemedia's offices, the AES set up a digital listening room.

thusiasm needed to move forward. "We're not going to have to generate excitement . . . this is going to generate its own excitement. All you have to do is put on the headphones and listen."

For more information contact Canada's digital radio project at 416-926-4117.

Ease of Carts, Quality of CD?

Rugged CD Cartridge, instant cueing, full remote & EOM connections and Digital Display make the DENON 950FA easy to use.

Real time D/A conversion, four times oversampling and active balanced outputs provide unparalleled CD performance.

YES!!

DENON 950-FA CD CART PLAYER™

NORTHEAST BROADCAST LAB, INC.
"Serving The Broadcast Industry Since 1961"

Main Office
P.O. Box 1179 • S. Glens Falls, NY 12803
Tel: 518-793-2181

Mid-Atlantic New England Southwest
Tel: 215-322-2227 Tel: 603-483-1002 Tel: 214-612-2053

For friendly service, fast delivery and great value contact your nearest Northeast sales office. They have all the details.

fm TRANSMITTERS FROM CONTINENTAL

- COMPACT AND EFFICIENT
- SOLID-STATE DRIVER
- EXCLUSIVE SOFT START™
- AUTOMATIC POWER CONTROL
- TOTALLY SELF CONTAINED
- TRANSTAT™ READY

varian **continental electronics division**

P.O. Box 270879 Dallas, Texas 75227 • (214) 381-7161 FAX: (214) 381-4949

WHY YOU SHOULD PAY MORE FOR LESS.

**New Name-
Same Great Cart!**
The ITC Cart II Cartridge, formerly ScotchCart® II

Less phase jitter caused by poorly tracking tape, because the naturally lubricated concave guides gently position the tape and allow the cartridge machine to perform critical guidance.

Less tape noise and signal loss with our 100% laser-inspected, high output, low noise tape which delivers better frequency response and keeps signal-to-noise ratio high, harmonic distortion low.

Less wow and flutter or stop cue overshoot, because there's no rotating hub to wear out, warp or rattle.

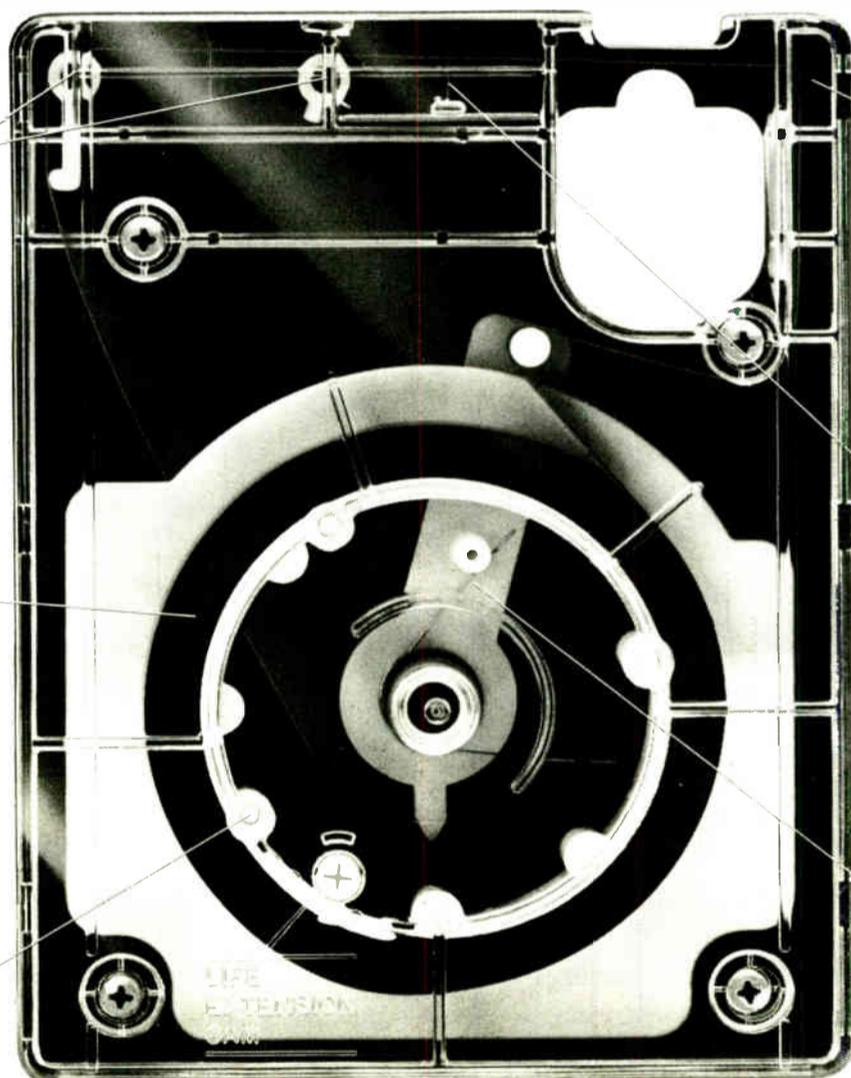

Less chance of the cartridge cracking or breaking, because the tough polycarbonate cover withstands repeated use and abuse.

Less head wear, tape steering and modulation noise, because there aren't any pressure pads to add friction.

Less chance of tape destruction, because our patented dynamic tension control system ensures proper tape-to-head contact, and provides constant tension to control looping and prevent twisting.

The ITC Cart II Cartridge, formerly ScotchCart® II

With broadcast cartridges, like everything else, you get what you pay for. With ITC Cart II cartridges, you get a revolutionary design that delivers trouble-free operation, superb sound quality and a life expectancy that's second to none.

We have renamed the cartridge due to trademark considerations, but only the name has changed, the cartridge and tape are the

same. New name, same great cartridge and performance.

For a complete listing of ITC Cart II dealers, call ITC toll-free at 800-447-0414 (in Illinois, call collect 309-828-1381.) Or write to ITC at P. O. Box 241, Bloomington, IL 61702-0241.

Because a cheaper cartridge may be more trouble than you can afford.

ScotchCart® II is a registered trademark of 3M

Circle 100 On Reader Service Card

World Radio History

C270

C274

C278

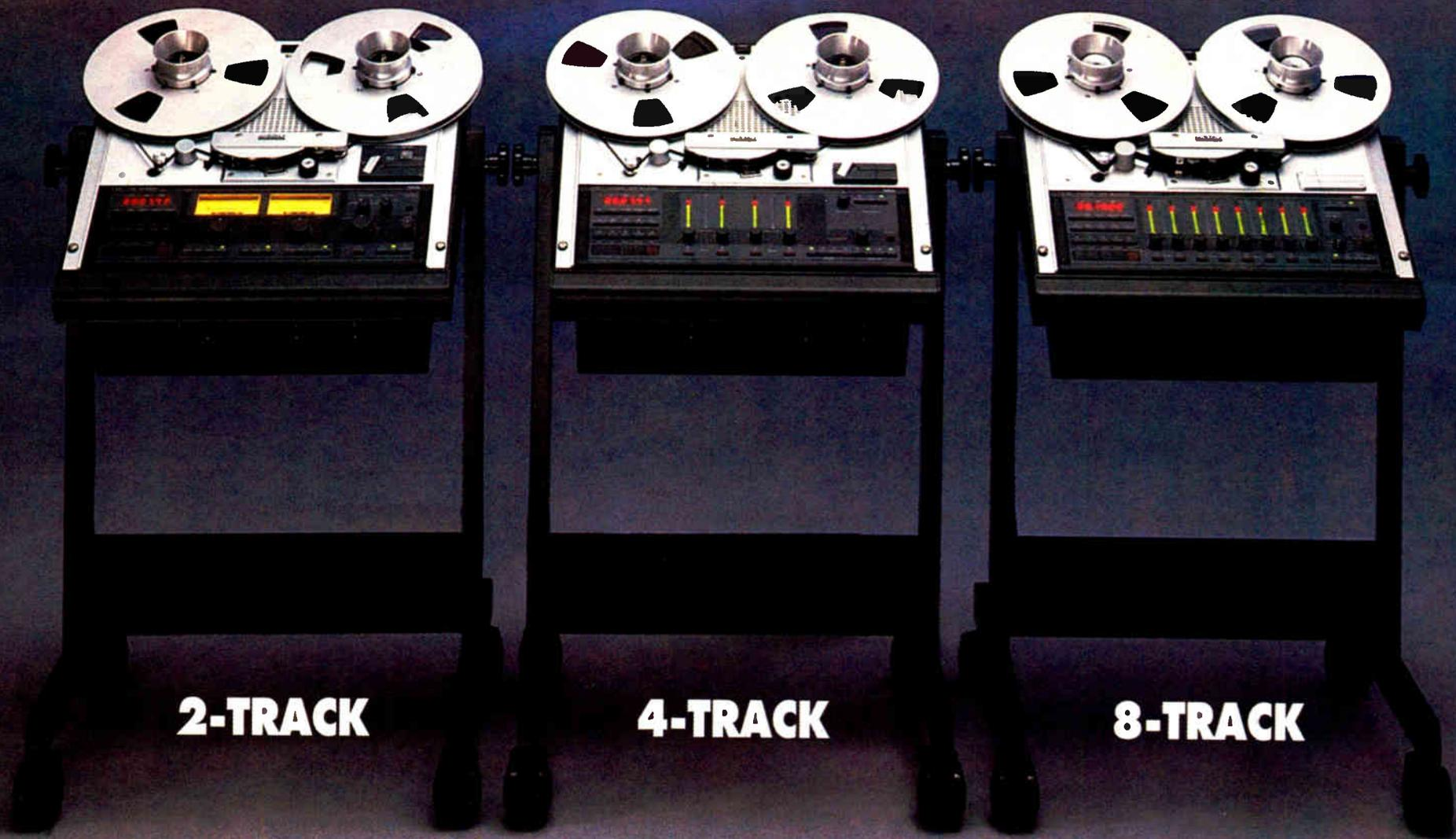

2-TRACK

4-TRACK

8-TRACK

REVOX OPEN REEL RECORDERS. YOU'RE ON THE RIGHT TRACK.

THE C270 SERIES This exciting new line of recorders provides you with all the traditional Studer Revox benefits—mechanical precision, electronic sophistication, supreme sound quality and superior support—adding up to state-of-the-art analog recording technology. The C270 is available in 2, 4 and 8-track versions with or without remote/autolocator.

BEST BUY Compare the performance of any C270 Series machine with the competition, and you'll find there is no competition. The die-cast deck plate and head block, the precision mechanics and a host of powerful features tell you any C270 Series machine will last as long as you need a reel-to-reel in this emerging era of digital workstations. And in the digital future, you'll need analog recorders that will sound good—for a long time. That's why your last reel-to-reel should be from Studer Revox.

TIME CODE . . . OR NOT The C270 2-track version offers optional center track time code for effortless synchronization to picture or sound. The C274 4-track and C278 8-track are both equally adaptable to production or post. The optional remote/autolocator stores 18 start/stop addresses and provides full transport and channel remote control to fit into any professional studio environment.

LOGGING TOO For station logging applications, special super low speed versions of the C274 and C278 are available with built-in time/date code generator and reader with search capabilities, providing up to 25 hours of continuous audio on one reel of tape.

Call your Studer Revox Professional Products Dealer—or Studer Revox direct—to discuss all the details. Or simply call **800-366-4900** to receive our C270 series color booklet.



C270 Remote/Autolocator

STUDER REVOX

Studer Revox America, Inc. • 1425 Elm Hill Pike • Nashville, TN 37210 • (615) 254-5651
New York (212) 255-4462 • Los Angeles (818) 780-4234
Studer Revox Canada Ltd., Toronto (416) 423-2831

© 1990 Studer Revox America, Inc.

Circle 109 On Reader Service Card
World Radio History

Putting the DSE 7000 to the Test

by Mark Windsor

Atlanta GA Back this spring, a few weeks before NAB '90, Atlanta-area production directors were contacted by AKG Digital Products with a challenging invitation. AKG wanted to know if we were interested in putting a production model of their new DSE 7000 Digital Sound Editor to the ultimate test: real work.

The plan was for us to attend one of AKG's product demos, then head over to the Harris/Allied booth, where a second DSE 7000 was on display. We would then record, edit and mix an actual spot scheduled for broadcast on our respective stations.

The Harris/Allied demonstrator would be standing by to give assistance, but we'd essentially be on our own. One demo, a quick briefing, then get to work!

Neither myself nor Power 99's Kevin Hayes, the other area production director who was able to take advantage of this opportunity, had any prior experience with the DSE 7000.

Even more surprising was the fact that although both of us were working on the DSE 7000 for the first time, we completed complex productions faster than would have been possible using analog equipment.

Longer promos

The station where I work, WFOX, often sponsors oldies concerts (FOX-97 is the Gold-format radio leader in the Atlanta market). That gives us a little extra leeway in working on promos for these multi-artist shows. Some of them are as long as 90 seconds, in fact. I thought one of these would give the DSE 7000 a real workout.

The raw material I brought with me to the NAB convention included the copy (in a couple of separate sections), a music bed, a few effects, and slices of each performer's big hit. Since this was my first digital audio production, I was a little nervous about using a brand new machine. But Harris/Allied's demonstrator Mick McCabe, an experienced radio production director himself, quickly helped me get my bearings.

In the few minutes it took to load my reel on the Otari two-track Allied had standing by, I already understood how to record material into the DSE 7000. It's exactly like dubbing from one deck to another, right down to the Play and Record buttons and Input level faders.

Within a few minutes we had voice-over, music segments and effects roughly laid out in the order they would follow and spread over all eight tracks. Once my raw material was in the DSE 7000's RAM memory, I started assembling the spot. After a short time, working on the PC-based system felt very natural.

While I was cleaning up the voice track, I discovered that disk-based editing has its advantages over tape and blades. Using the jog/shuttle wheel to rock the reels digitally, I could mark breaths and pauses on the voice track, then cut them out instantly.

Seeing the audio on the PC screen gave me the confidence to do very fine edits I'd never try with a razor blade. If I cut off the beginning or ending of a word, I just hit Undo and redid the edit.

I never had to abandon the work I'd already done. It gave me a 'safety net' to work with.

Once I had a tight, well-paced voice track, it was time to edit the music segments to fit.

Instant music

The procedure was easier to learn than it is to describe; I'd just hit Play, tap an edit marker button on the beat, then mark the next section in the same way. Hit Execute, and the cut is made. If I was a little off the beat, I could Undo it and fix it.

After the show I spoke with another area production director Kevin Hayes from WAPW-FM, Atlanta's top CHR. He'd brought in a standard 60-second doughnut music bed and a voice track with several takes.

"I didn't get too artistic with this spot," Kevin told me, "because I wanted to evaluate
(continued on page 17)



The author concentrates on a tricky edit at NAB '90.

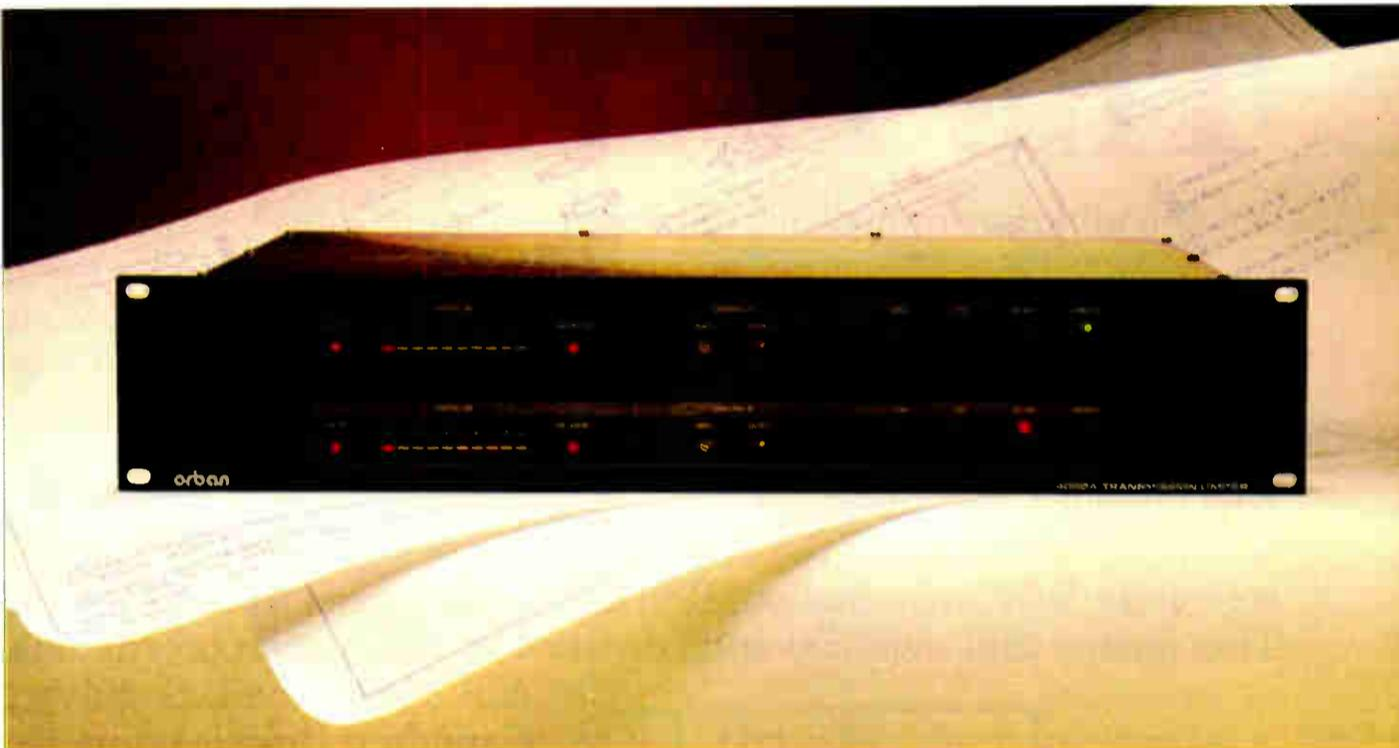

We aimed for undetectable transmission limiting . . .

And we reached our goal.

We designed this product to meet a challenge offered by one of the world's largest broadcasting organizations. In a series of independent listening tests, their panels agreed that the sound of the 4000A was virtually indistinguishable from the original source, when below threshold, when in maximum (15dB) gain reduction, when processing voice, or when processing dynamic symphonic music.

Sophisticated peak control.

The 4000A provides absolute peak level control with no overshoots. And with no audible artifacts, or unnatural gain changes, a common problem with delay-line type designs.

Our proprietary-design high-frequency limiter prevents overload due to the pre-emphasis found in most transmission systems, without causing any high-frequency dulling! It's selectable for 25µs, 50µs, 75µs, 150µs, NICAM's J.17 pre-emphasis, or OFF.

You set your limits.

Setup is very easy. The only operating controls are INPUT LEVEL and OUTPUT LEVEL.

Remote-controllable switching supplies a calibrated TONE at 100% modulation; just adjust the 4000A's OUTPUT LEVEL to match the overload point of your transmission system. Then switch to OPERATE, and adjust the INPUT LEVEL for the desired drive level (or unity gain). And you're ready to go on-the-air.

Unbeatable product reliability and technical support.

The new 4000A Transmission limiter is from Orban, the company that manufactures the world-famous OPTIMOD Audio Processors for AM, MW, FM/VHF, TV, and HF used by tens of thousands of broadcasters all over the world.

Orban products are known for their high standard of construction and reliability. We're proud of our products and stand behind them with technical support from broadcast engineers who understand your needs. Contact your Orban agent or dealer for more information or a demonstration.

orban

LISTEN TO THE DIFFERENCE.

a division of AKG Acoustics, Inc.
1525 Alvarado Street, San Leandro, California 94577 USA
Telephone (1) 415/351-3500 Fax (1) 415/351-0500

Circle 85 On Reader Service Card

World Radio History



The DAT Standard.

We all know it: broadcasters are a cautious lot.



So, despite DAT's great promise, at first most Radio stations, TV stations, and production houses took a wait-and-see attitude toward the new format.

But today, five years after the format was unveiled, two years after the RS-1000 was developed, and on the brink of a consumer DAT introduction, RS-DAT has emerged as the Pro DAT Machine. This means that over 300 units are now in use at such prestigious institutions as



ABC, CBS, the U.S. Navy, BBC, Muzak, Canadian Broadcasting Corporation, KIIS in LA, WQCD in NY, Greater Media, and hundreds of others.

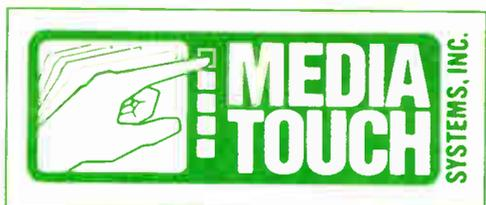

RS-DAT is the perfect automation machine. Because it's the only one with end-of-message cues and broadcast standard remote control, it easily connects to all existing systems. And random cut access adds a whole new creative dimension to automation programming.



In fact, all of the prestigious automation companies whose logos appear on this page have integrated RS-DAT into their automation systems and recommend it to their customers for the best DAT performance.



RS-DAT is tested and ready for

automation, or as a live source in your air studio, or for DAT archiving.



The world is going DAT—RS-DAT—the one that works. Call today, or contact these fine companies directly about RS-DAT for automation.

RADIO SYSTEMS INC.

110 High Hill Road • P.O. Box 458 • Bridgeport, NJ 08014-0458
609/467-8000 • 800/523-2133 • FAX 609/467-3044

How To Bring Zest To Stereo

by John "Q" Shepler

Part II of II

Rockford II A sound with sparkle is a sound that will hold an audience. Are those long-term listeners important to your format? OK, then polish your audio chain until your sound radiates from the dial.

Getting the signal to the transmitter means running another gauntlet. Remember that once the signal leaves the studio, it can only get worse, not better. Your challenge is to preserve the quality of the studio output until the transmitter processing can add the final touches.

low the upper limit. Don't just clip the peaks. You'll want them for later processing. Instead, ride gain and perhaps compress the audio with a wideband or multiband compressor/limiter.

Allow 10 to 20 dB of headroom for the peaks. Safety clipping above this limit is OK to prevent overmodulation of the link.

Noise is often a problem, especially with older equipment. Clean up as much as you can by bringing the components up to factory specs. If you can't afford the latest composite STL or T-1 phone link, consider a noise gate at the transmitter end as a temporary measure.

Most low level hiss will be masked by your programming. When the programming stops, the noise gate suppresses any remaining background hiss.

Phase distortion destroys the timing relationship of the signal harmonics with the fundamental and causes the signal to lose clarity. Check for this with a scope at many audio frequencies. The left and right channels should remain in phase over the 50 Hz to 15 kHz spectrum. Also, check for audio response flatness and low distortion. These are important qualities in maintaining audio sparkle.

Final processing must be done at the transmitter. Processing is adjusted to taste, of course.

Easy on limiting

If sparkle is your goal, rather than a solid wall of sound, then go easy on compression and limiting. Heavy wideband compression and limiting are almost guaranteed to destroy the signal's definition. Get your sparkle with reasonable gain riding, gentle multiband compression, and a touch of clipping to keep the peak flasher off.

(continued on page 18)

Q-TIPS

A major problem with any studio to transmitter link is preservation of the dynamic range. You must keep the signal between the noise floor and the clipping level.

Digital links are even worse than analog at handling overloads. When the A/D converter hits full range, it stops abruptly and clips any higher signals. An analog STL might at least round off the last dB or two.

It is important to keep the peaks be-

Testing the DSE 7000

(continued from page 15)

things of a more technical nature: how easy it was to clean up a voice track, how the system allows you to take things out of a track and put them in, things like that."

He said he was able to cut a piece out of Track 2 and fit it into a hole in Track 1. "That's something you could never do with analog tape. With any new production tool, you've got to get used to where things are." My own experience agreed with Kevin's.

The learning curve on the DSE 7000 is very short; anybody who's worked with multitrack already has the theory down. I've seen other systems, but they all seem to be designed primarily for other markets. One thing you're always lacking in radio is time and the DSE 7000's familiar layout really expedites our work.

The people at AKG emphasized in their demo that the DSE 7000 is designed from the inside out and the bottom up for radio production. After working with it, I believe them.

Cost is always a concern, so it helped that AKG also took the time to point out that the DSE 7000 costs no more than the eight-track recorder, ten-input mixer and two-track mixdown deck it's designed to replace.

Now that I know how the DSE 7000 speeds up my production time, the next time our production room is due for an upgrade, I'm going to make sure my engineer and station management are well aware of the bottom line.

Mark Windsor is Production Director at WFOX-FM in Atlanta.



Enhance
Intelligently

STEREO MODULATION OPTIMIZER™

(JEFF KEITH - Design Engineer)

MODEL SMO 900 by HIT DESIGN™

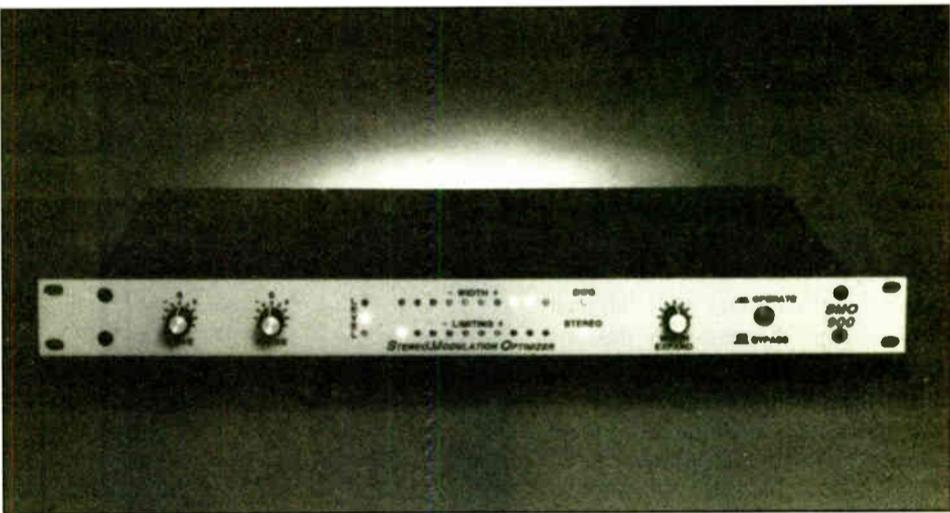

SMO 900 enhances audio intelligently by analyzing your stations program content.

The secret to our success lies in the Dynamic Width Computer (DWC) and smart Stereo Detector designed for the SMO 900. Together they decide WHEN or WHEN NOT to enhance, and by how much, keeping your signal loud, smooth, and pleasing to listen to, but definitely HIGH IMPACT. Your competition will hate you for it!

BROADCASTERS GENERAL STORE

HOME OFFICE
2480 S.E. 52nd Street
Ocala, FL 32671
(904) 622-9058

REGIONAL OFFICES

Illinois (708) 231-7120
Georgia (404) 425-0630
Texas (817) 275-1380



Audisk Assists UK Independents

by Mel Lambert

Studio City CA Recently, I came across a new hard disk system that might be plain vanilla in its implementation of digital technology, but one that presents an elegant solution to a problem common throughout the radio community.

A consortium of independents

The UK radio marketplace is divided into several BBC-operated national networks for pop/rock, AOR, classical and talk/documentary; a series of BBC-operated local radio stations; and several dozen Independent Local Radio (ILR) stations that, unlike the BBC outlets, carry commercials.

located in Swindon.

The consortium has decided to behave for most of the programming day as if it were a single radio station serving a large community—and hence be able to attract national advertisers.

GWR also has decided to produce a service that appears to its regional audiences as if it were originating from five individual stations serving their local community, with local time checks, station IDs, and all the rest.

Because of this regional "narrowcast-

ing," so to speak, it will be easy to sell the audience to local advertisers at a reasonable cost-per-thousand, without reaching listeners for whom their products and services are inappropriate.

Satellite-style network

GWR intends to place the main DJs and programming sources at a central studio complex and beam the service over dedicated landlines to a series of FM and AM transmitters servicing each of the five urban and rural communities.

In essence, The GWR Group is looking to establish the equivalent of a hard-wired "satellite-style" network. Sections of the hour could be available to local stations or filled from the master studio on a regionally-specific basis.

Several hardware alternatives presented themselves to the system's designers, headed by Quentin Howard, chief engineer of The GWR Group.

Initially, a system of dedicated analog landlines was contemplated. Remote-

(continued on next page)

Adding Sparkle To Station's Stereo

(continued from page 17)

You will have to listen carefully to tell when the adjustments are right. One way to do this is to locate the main processor at the studio or in a monitoring room away from the transmitters. This leaves only a final clipper at the transmitter site. With this arrangement, you can tweak and compare with other stations over studio monitors or headphones.

One tip for good stereo imaging is to keep the stereo processors coupled. This is only a problem if you have two separate boxes. They need a coupling strap between them to synchronize their gain reductions. If you neglect this step, the left and right channels will process independently and the stereo image will wander back and forth.

The setup of the stereo generator is critical to good stereo and the sparkle that accompanies it. Plan on aligning your stereo generator to the book quarterly.

The stereo generator and mod monitor are a dynamic duo for high performance audio. You need the monitor to align and test the generator and the rest of your system. Your ability to align is only as good as the accuracy and resolution of the test equipment.

Antennas affect sound

You may think that once the left and right channels have become composite stereo that there is nothing else to go wrong. This is false security. It has been proven that transmitters and antennas can have a drastic negative effect on your signal.

FM and AM transmitters add distortion and hum. There are also subtle effects like phase distortion caused by misaligned tuned circuits. FM transmitter tuning even affects transmitted noise. This says you are not out of the woods until you tune your transmitter for best performance.

The mod monitor is also a help here. Many AM transmitters have a hum balance pot. Monitor for hum and noise as you tune the transmitter. Sometimes small adjustments that barely show on the meters will gain you an extra 3 to 6 dB of dynamic range.

How can an antenna affect your sound? Some directional AM arrays are

so narrow in bandwidth that they actually filter out the higher frequencies of the sidebands.

FM antennas either work or they don't. The effect of a degrading antenna is reduction of your coverage area, causing additional noise in the receivers. If you have an oldie, it is probably worth your while to take a few field strength measurements. Otherwise, simply monitor the VSWR or reflected power to make sure the antenna and feedline are still intact. Keep the output stage of the transmitter tuned and loaded properly.

A complete systems check

The old but wise saying is that the chain is no stronger than its weakest link. This is true of audio chains, too. Proof the system from the mic preamp through the modulation monitor and you'll see how true that is.

The noisiest component sets the noise floor for the chain.

The final check, of course, is the listening check. The sparkle of your station is perceived in comparison to other stations and to tapes, records and compact discs. CDs are a formidable competitor. However, a carefully aligned station with competitive processing as an enhancement will ensure that you are always a contender.

...

John Shepler is an engineering manager, broadcast consultant, writer and regular RW columnist. He can be reached at 815-654-0145.

DIGITAL DOMAIN

ILR stations are widely successful in the larger metropolitan markets. In scattered rural areas, the potential listening audience is sometimes too small to support even a bare-bones station.

In the west of England, however, there now exists a consortium of five ILR stations, known collectively as The GWR Group. These stations comprise the flagship GWR-FM, based in Swindon, about 65 miles west of London; Radio 210 in Reading; 2CR-FM in Bournemouth; Plymouth Sound and Brunel-AM, also

CCA

Evolution.

CCA has delivered more than 3,000 Broadcast Transmitters over the past 25 years. For 25 years our designs have been refined and improved. The result is the Evolution of the world's most perfected, most tested, most reliable, Radio Transmitter.

- * Grounded Grid Triode
- * Longest Tube Life
- * Auto Power Control
- * VSWR Power Foldback
- * Single Phase Optional

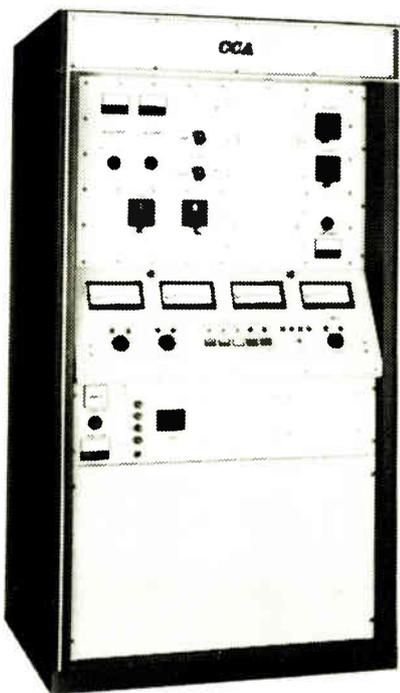

CCA Electronics, Inc.
P.O. Box 426
Fairburn, GA 30213
(404)964-3530 FAX (404)964-2222

Circle 111 On Reader Service Card

Get ready for Fall sports MARTI

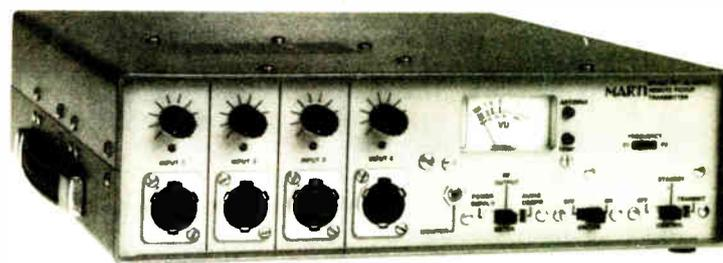

We've been bringing back live remotes for over 30 years.

Systems in stock and ready to ship!

MARTI *The performance-value leader in Broadcast Equipment.*
Marti Electronics, Inc., P.O. Box 661, Cleburne, Texas 76033-0661
(817) 645-9163 TELEX #794835 "Marti CLBN" FAX (817) 641-3869

Circle 20 On Reader Service Card

Audisk Automation

(continued from previous page)

controlled NAB cart machines would be used to play out individual commercials, IDs and other materials to each of the outgoing lines feeding the network's 10 FM and six AM transmitters scattered around the hilly region. Replay of the appropriate audio segments via cart would be controlled via serial commands from the central studio.

The walk-away time for single- and triple-stack cart machines is barely minutes; an automated multicart system might run unattended for several hours. In either case, an operator would be needed to rotate and replace the commercials, IDs, promos and other material on a regular basis. Any last-minute changes would require the sending of replacement carts by road or landline to the relevant station(s).

Maintenance costs are also high. All in all, such a cart-based system would have been expensive, complex to operate and reasonably inflexible to last-minute changes in running order.

To cut a somewhat long story short, it was decided early on while planning the GWR system to implement an all-digital system, based upon hard-disk recorders.

Audisk gets the nod

After analyzing current hardware, The GWR Group opted for a series of networked MacroMedia Audisk systems. At the recent APRS Exhibition in London, MacroMedia's UK dealer, Audio Systems Components, announced an initial order for six systems, which will be installed during the next several months; others will follow later.

The Audisk MM-Series system comprises a serially-controlled hard disk recorder and editor supplied with an interlinked series of software utilities for setting up data entry, replay sequences, logging functions and a host of other tasks.

Standard configurations are available with up to 360 minutes of stereo storage capacity (two 766-megabyte drives), with or without secondary "mirror" hard drives that automatically back up all material and take over virtually instantly if there is a problem with the main drive(s). Larger (or additional) SCSI-equipped drives can also be used within Audisk.

Sampling frequency of the 16-bit system can be set to 22.05 kHz (10 kHz bandwidth for mono AM applications), 32 kHz or 44.1 kHz. A sophisticated four-band adaptive PCM data compression circuit developed by Audio Processing Technology, Ltd. enhances the storage capacity by a factor of 4:1. This reduces the system costs and improves access speeds without affecting audio quality.

Front-end controller software runs on a standard IBM AT clone with a black and white/color monitor. Two basic versions of software are available: one to augment an existing tightly-formatted music/news service and the other for operator assist, in which the majority of replay functions are initiated by a DJ or engineer. The GWR system will be configured as a combination of these two formats.

Master control functions

At "Network Central," the master controller is configured to allow a single keypress to initiate local commands such as the replay of a commercial to the lo-

cal transmitter chain. It also outputs a series of command pulses that can be carried via standard 2400/9600-baud modem links to remote Audisk systems.

Alternatively, the programming might be more tightly sequenced to the clock, with breaks occurring at preset times throughout the hour and the system software automatically replaying pre-selected commercials and ID sequences.

At the remote sites, software in unattended mode intercepts these commands and selects the appropriate audio segment for replay from hard disk. A set of sensor probes and ancillary software will even allow local temperatures to be announced from each transmitter location.

A series of intros, bridges, outros and temperature readings will be pre-recorded into Audisk by various station personalities, and then sequenced according to the local conditions. Other functions, such as local weather forecasts or traffic conditions, might also be added and triggered from the central studios via suitable setup commands.

Recording while playing

Because of the Audisk system architecture, it is possible to record onto hard disk at the same time material is being replayed to air. Several possibilities present themselves.

At each site, The GWR Group will be installing ancillary data lines that carry data-compressed audio material in either real time or half speed; this allows last-minute commercials or promos to be loaded directly into the system from the central controller.

In addition, remote systems could be set up to automatically record news feeds as they occur at the top and/or bottom of each hour, then relay them to air at the end of a local music segment, or after a locally programmed stop set.

In fact, the combinations of remote and locally-controlled sequencing available from the GWR format is almost infinite. By simply switching to a new page of software commands, each local Audisk system, which normally will handle all automatic record/replay functions, could be set up for local live-assist.

Each local system could also be used during the day as a digital production suite, for recording and editing local commercials, station IDs, promos and PSAs to hard disk, while it simultaneously takes care of other business.

As an added bonus, Audisk can also be interfaced with most computer-based automated billing systems, thereby reducing operator workload in logging commercials and station IDs. It will even automatically replace date-sensitive material as necessary.

While conditions faced by The GWR Group in England are very specific to the local market and operational parameters, something tells me that several US stations could benefit from finding out more about digital hard disk systems such as Audisk.

■ ■ ■

Mel Lambert has been intimately involved with the production and broadcast industries on both sides of the Atlantic for the past dozen years. Now principal of Media & Marketing, a consulting service for the professional audio industry, he can be reached at 818-753-9510.

The Cart You Can Count On



From The Supplier You Can Count On

It only makes sense to stick with something if it's working for you. That's why, year after year, broadcasters keep buying Audiopak cartridges from BSW. Audiopak carts are designed and manufactured for consistency, durability, and exceptional audio performance. The industry standard A-2 with 605 tape offers "workhorse" performance and outstanding longevity. The A-3, with revolutionary "neutral-design" casing and high-performance 613 is perfect for stereo recording and playback. And the A-4 goes a step further with advanced 614 tape that delivers a crisp, clean sound which rivals CD quality. No matter what your requirements, Audiopak carts give you the longevity, consistency and performance you need. And when you buy them from BSW you'll get the same prompt delivery, great pricing and professional service that thousands of broadcasters have come to depend upon.

BSW[®]

BROADCAST SUPPLY WEST

America's Full-Time Broadcast Supplier

1-800-426-8434

ORDERS • INFORMATION • SPECIFICATIONS

BSW • 7012 27th Street W • Tacoma, WA 98466 • FAX 206-565-8114

Circle 54 On Reader Service Card

WORKBENCH

Tee Network Methods

by **Vernon Boyce**
Broadcast Technical Consultant

Dallas TX Using an audio Tee pad for matching different audio impedances can be done using the following formulas.

Equation 1.

$$r = \text{antilog} \left(\frac{\text{dB}}{10} \right)$$

Power ratio formula

Equation 2.

$$R_3 = \frac{2 \sqrt{Z_1 Z_2}}{\sqrt{r} - \sqrt{\frac{1}{r}}}$$

Shunt leg resistance formula

Equation 3.

$$R_1 = Z_1 \left(\frac{r+1}{r-1} \right) - R_3$$

Input leg resistance formula

Equation 4.

$$R_2 = Z_2 \left(\frac{r+1}{r-1} \right) - R_3$$

Output leg resistance formula

mula in Equation 2. Substituting r , (Z_1) and (Z_2) with values mentioned in the first paragraph, we have a calculated shunt leg resistance of 464 ohms.

Next solve for the input leg and output leg resistances using the formulas in Equations 3 and 4.

The values calculated are: input leg resistance (R_1), 552 ohms; output leg resistance (R_2), 92 ohms and shunt leg resistance (R_3), 61 ohms.

For a balanced "H" pad use one half of (R_1) for each input leg and use one half of (R_2) for each output leg.

Vernon Boyce has a BASIC program that can calculate the audio Tee pad described in this article and can be reached at 214-328-7501.

Consult Table 1 for the correct terminology.

First let's assume that the load resistance (Z_2) is 150 ohms and the input resistance (Z_1) is 600 ohms and a 20 dB attenuation is needed.

First we need to change the 20 dB attenuation to a power ratio. The formula for this is Equation 1. For 20 dB the ratio (r) is 100.

Since (R_3) is used to determine the resistance of the input and output leg resistance, the next step is to solve for the shunt leg resistance (R_3) using the for-

Table 1.

r = Power ratio	R_1 = Input leg resistance
Z_1 = Input resistance	R_2 = Output leg resistance
Z_2 = Output load resistance	R_3 = Shunt leg resistance



You can measure...
with the best monitor and the most accurate test set.

The FMM-2/FMS-2 series monitors provide an even greater degree of precision measurement than ever before... You can measure S/N below 90 dB, You can measure crosstalk below 85 dB, You can measure separations of better than 70 dB, You can measure frequency response to better than 0.25 dB, You can measure distortions to lower than 0.01%, and much more... Our uncluttered panels and autoranging voltmeters make these measurements a dream.

BELAR CALL ARNO MEYER (215) 687-5550
ELECTRONICS LABORATORY, INC.
LANCASTER AVENUE AT DORSET, DEVON, PENNSYLVANIA 19333
Call or write for more information on Belar AM, FM, Stereo, SCA and TV monitors.

Maintenance Tips for ICs

by **Fred Allen**
IDC Communications

New Hope MN Here are two tech tips that may be helpful. Both should help you work better when dealing with ICs.

First: After removing an electronic component from a circuit board with solder wick or by other means, clean the rosin left behind from the circuit board with a cotton swab and some denatured alcohol.

This will help prevent the copper land patterns from lifting from the circuit board. It is also suggested that the board be cleaned in the same manner after the new component is installed

so you will finish with a clean, neat and professional looking repair.

Second: Removing defective ICs from a double sided circuit board can be hard to do without damaging the copper patterns on the circuit board. To remedy this, with a small sharp diagonal cutters, cut the IC pins at the chip close by its body.

Do this to every pin, then remove the legless body of the IC. Now with a small needlenose plier, grasp a pin at the top and heat the solder holding the pin in at the circuit board; remove the pin when the solder is melted. Do this for all pins.

Clean the solder out of all patterns with solder wick and clean the patterns with denatured alcohol and the circuit board is now ready for insertion of the new IC.

Fred Allen can be reached at 2745 Winnetka Ave. N, Suite 205, New Hope MN 55427.

A Cheap Effects Library

by **Richard Scott**
Menorah Productions

Canby CA Want to build a great sound effects library that is easy to use and cheap?

I went to the public library and found a three record set (put out by someone) that had printed on it "public domain." I took this album cover and focused my camera on the part that lists each sound effect and with the built-in character generator created a dotted line through the scene.

I used this to scroll down the album cover while simultaneously playing the record onto my Hi-Fi VCR. This not only provides a rapid visual search but also provides what other information is printed on the jacket like length of each effect.

Also if you zero your meter before you start you will be able to keep a log for faster access.

Richard Scott can be reached at Box 35, Canby, CA, 96015.

We Need Your Tech Tips!

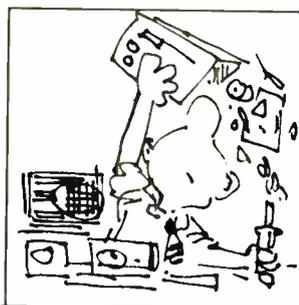

RW's new *Workbench* page needs your quick fixes, short build-it projects and favorite tech tips. You've spent those late nights perfecting them; now let us know.

Send it on 5 1/4" floppy in WordPerfect or ASCII or MCI mail to:302-7776. Or FAX us at 703-998-2966 or mail it to PO Box 1214, Falls Church VA 22041.

Share your expertise with your engineering colleagues by getting your tech tips published in *Radio World* and get paid while you help others.

In the 12 September issue of RW, Ed Montgomery will begin a 12-part course on Amplifier Fundamentals.

Amplifier Fundamentals is an overview of how amplifiers function. It will review audio and RF amplifiers, small-signal and power amps and cover terminology, decibels and circuit analysis.

The cost of registering for the course is \$35 and all who register will be mailed an exam at its completion. The course is good for 1.2 CEUs of credit and can also count toward SBE certifications. To register use coupon below.

NORTHERN VIRGINIA COMMUNITY COLLEGE Social Security No. _____
 Director of Continuing Education, Annandale Campus
 8333 Little River Turnpike, Annandale, Virginia 22003
 (703) 323-3159

Please enroll me in the Community Service Program listed below:

Name _____
FIRST NAME MIDDLE INITIAL LAST NAME

Address _____

City _____ State _____

Course Title Amplifier Fundamentals

Course Code BCST91601 Course Date(s) and time _____

Home Phone _____ Business Phone _____

Zip Code _____ Fee \$ 35.00

How did you learn about this course? Received brochure in mail, Newspaper advertisement,
 Library, Referral Radio/TV announcement Other _____

Enclosed is my check payable to Northern Virginia Community College. I understand that enrollment may be limited and if the course is cancelled for any reason, my check will be refunded in full.

For office use: SA 91 RU 97 SD 91 RU 98

Miking a Roundtable Discussion

by Bruce Bartlett

Elkhart IN Imagine you have a group of people in your studio seated around a table, ready for a talk show or interview. What are some microphone placements that will pick up the discussion clearly?

"Clearly" means "without room reverberation." We want to minimize the pickup of room reverberation, or achieve a high speech-to-reverb ratio. That's because sound reflections from room surfaces cause a time-smear of the original signal. This time-smear adds a "muddy," "hollow" sound to speech and hampers intelligibility by slurring syllables together.

LINE OUT

How should we choose and place microphones to reduce pickup of room reverberation? This installment of *Line Out* presents a scientific approach to solving this problem.

Pickup parameters

First, we need to know what microphone parameters affect reverb pickup. These parameters are:

- Microphone polar pattern (omnidirectional, cardioid, hemispherical, etc.)
- Microphone-to-source distance.
- Number of open microphones (NOM).
- Angle of each sound source relative to the microphone axis.

The polar pattern of a microphone is a plot of the microphone's sensitivity to sounds arriving from various angles. An omnidirectional mic is equally sensitive to sounds arriving from all directions. A unidirectional mic is most sensitive to sounds arriving from one direction in front of the microphone. The most common type of unidirectional pattern is the cardioid pattern.

In general, as the microphone polar pattern becomes more directional, reverberation pickup decreases. The random energy efficiency of a polar pattern is its reverb rejection compared to an omnidirectional pattern.

Random energy efficiencies of various polar patterns are shown in Table 1. As the table shows, an ideal cardioid microphone picks up 4.78 dB less reverb than an omnidirectional microphone, when both mics are placed the same distance from the sound source.

If a microphone is mounted on a large surface (such as a conference table), the mic picks up 3 dB less reverb than it does when mounted in open space.

Here's why: Reverberation is a pattern of reflected sounds which approach the microphone randomly from all directions. The surface blocks half of the incoming sound, reducing its power by 3 dB.

A surface-mounted microphone (such as a Crown Pressure Zone Microphone or PZM®) takes advantage of this effect by mounting the mic capsule very near a hard reflective surface. The PZM has a hemispherical polar pattern, which is an omnidirectional pattern cut in half by the mounting surface (table top).

Also available are

unidirectional surface-mounted mics such as the Shure SM91, Shure AMS22, Audio-Technica 871, and Crown PCC® - 160. Each of these combines the benefits of the unidirectional pattern and the hemispherical pattern, so the reverb pickup of each microphone is quite low. Mic-to-source distance is another fac-

tor affecting the amount of reverb in your broadcast. The closer the talker is to the mic, the less the reverb pickup. That's because the talker's voice is loud close to the mouth and quiet far from the mouth.

But the level of reverb in the room is constant no matter what the miking distance is. Consequently, the speech-to-reverb ratio increases as miking distance decreases.

Mathematical relationship

This relation is expressed in the equation $\text{dB} = 20 \log(D)$, where D is the mic-to-source distance in feet, and dB is the

(continued on page 22)

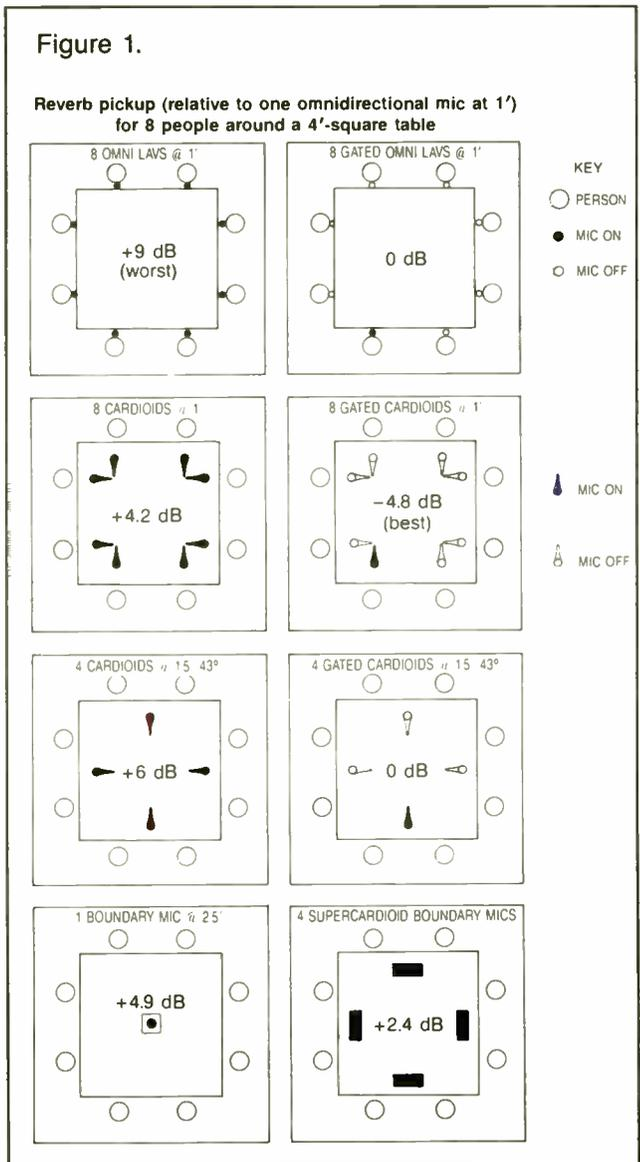

Fishing For A Phone Number?

Catch it in the
1990 Radio World Annual

—The Industry Source for Manufacturer, Supplier, NAB and FCC Phone Listings, as well as Product Information, Company Profiles, Buyers Guide Reprints, RW's 1989 Editorial Index, Reference Material, and More...

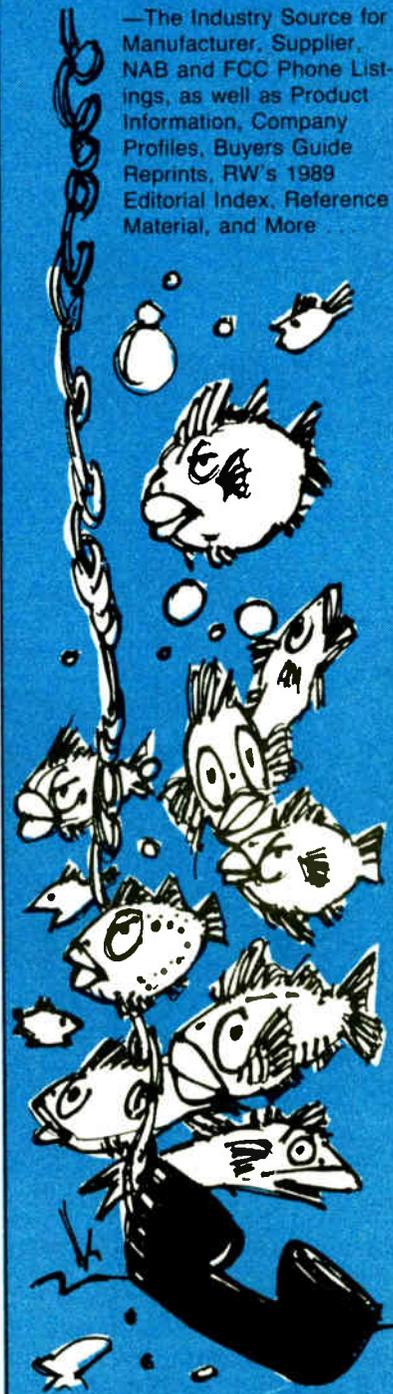

Send \$14.95 for each Annual to:

RW 1990 Annual
P.O. Box 1214
Falls Church, VA 22041

The Natural.

Finally a multiband limiter that's brilliant, open, natural sounding and LOUD with no audio fatigue. These are the qualities that make the **VIGILANTE Multiband Limiter** from **Cutting Edge Technologies** the processor of choice for the hottest stations in New York, Los Angeles, Philadelphia, Baltimore, and Cleveland...just to name a few.

The VIGILANTE'S unique clipper/filter circuitry utilizes distortion eliminating techniques which allow you to control the loudness versus quality tradeoff. Through a combination of multiband high frequency limiting and user-controlled threshold levels, you can limit the shrill of a crashing cymbal without losing the clarity, brightness, or impact of mid-range vocals.

CUTTING EDGE TECHNOLOGIES, INC.
2501 West Third St. Cleveland, OH 44113

216-241-EDGE
FAX: 216-621-2801

Mic Placement at Table Talks

(continued from page 21)

reverb rejection compared to the same microphone at one foot.

For example, if you double the distance to the mic, the speech level at the mic drops 6 dB. So the speech-to-reverb ratio drops 6 dB and the speech starts to sound distant or muzzy.

Number of open microphones

Another factor to consider is the number of microphones you have "open" or "on" at any one time. As the number of open microphones increases, the reverb pickup increases.

Specifically, the reverb increases 3 dB

every time the number of mics is doubled. Two mics pick up 3 dB more reverb than 1 mic, and 4 mics pick up 3 dB more reverb than 2 mics. In other words, the more mics you turn on, the muddier the sound.

... as the microphone polar pattern becomes more directional, reverberation pickup decreases.

The equation in this case is $\text{dB} = 10 \log(\text{NOM})$, where NOM is the number of open microphones and dB is the reverb rejection of the microphones relative to one open microphone.

For the clearest sound, try to turn down microphones not in use by at least 9 dB. Or use an automatic mixer (i.e. Shure AMS22) or gated microphone, which does the same thing automatically.

Angle of the sound source

This is our final parameter. The farther off-axis a person is speaking into a directional microphone (up to a point), the less the output of the microphone. The less the output of the mic, the lower the speech-to-reverb ratio. Thus, best reverb rejection for directional mics occurs when the talker is on-axis to the mic (directly in front of it).

If several people share a microphone, some of them are at a wide angle off-axis

the center of the table to pick up everyone, or should you use several mics—one per person?

If you use several mics, the number of open microphones is high (so reverb pickup is high), but the mic-to-source distance is small (reducing reverb pickup). If you use fewer mics—say, one mic to cover every three people—the number of open microphones is small (less reverb) but some talkers are far off-axis (more reverb). We see that many of the mic-array parameters conflict with each other.

Finding the best compromise

To sort out these conflicts and determine the best compromise, I calculated the reverb pickup of various miking arrangements, based on the equations given before.

Figure 1 shows several microphone setups on a 4' square conference table with eight people around it. In the center of each table, you see the reverb pickup of that setup relative to one omnidirectional mic at one foot from a talker.

As the figure shows, an effective, inexpensive arrangement is a single boundary microphone in the center of the table. Surprisingly, this single mic picks up about the same reverb (4.9 dB) as eight close-placed cardioid mics (4.2 dB). The advantage of multiple mics is that you can match the voice levels of all the participants with your mixer. But all these extra inputs add noise.

The muddiest-sounding setup is an omni lavalier mic on each person. Here, the reverb pickup is 9 dB more than a single omni mic at one foot.

Table 1.

Random Energy Efficiencies Of Various Polar Patterns

Omnidirectional	0.00 dB
Hemispherical	-3.00 dB
Cardioid	-4.78 dB
Bidirectional	-4.78 dB
Supercardioid	-5.72 dB
Hypercardioid	-6.02 dB

and so are picked up with a lower speech-to-reverb ratio.

The amount of off-axis level loss depends on the polar pattern of the microphone. As an example, suppose a person is speaking 45° off-axis to a supercardioid microphone. Calculations show that the voice level is reduced 1.78 dB. So the relative reverb pickup is 1.78 dB higher than it would be if the talker were on-axis to the mic.

Armed with these facts, let's compare the reverb pickup of several miking arrangements. Should you use one mic in

Gated systems

A gated-microphone system provides the least reverb pickup (the most clarity) because it turns off microphones not in use at any one time. This reduces the number of open microphones.

Some gated systems include a group of conventional mics plugged into an automatic (gated) mixer, a group of gated microphones (such as the Crown PCC® - 200), and a gated microphone/mixer system, such as Shure's Automatic Microphone System™.

For example, the PCC-200 is a gated supercardioid boundary microphone. When placed on the table at arm's length from a talker, it picks up 7.3 dB less reverb than a PZM in the center of the table. Reverb pickup is very low, so the talker sounds "on-mic" or "close-up," and speech sounds clear—even though the mic is not in the user's face.

One final suggestion to reduce reverberation: add wideband acoustical absorbers to your studio walls, such as 4" thick foam panels made by Sonex™ or Cutting Wedge™.

Bruce Bartlett is a microphone project engineer and technical writer with Crown International. He can be reached at 219-294-8000.

GET IT RIGHT
GET IT FROM ALLIED

YESTERDAY, TODAY, TOMORROW.

**We BUY—
SELL—
TRADE—
Broadcast Equipment.**

At Harris Allied Equipment Exchange, we accept TRADE-INS, SELL NEW and USED gear and selectively BUY used radio equipment. Call us today. Let us help you, economically!

HARRIS ALLIED
EQUIPMENT EXCHANGE
FAX 317-966-6321
317-962-1471
635 SOUTH E ST. • P.O. BOX 1487 • RICHMOND, IN 47374
©HARRIS/ALLIED 1990

DATAWORLD MAPS®

**DO YOU KNOW YOUR MARKET?
YOUR COMPETITION DOES!**

DATAWORLD MAPS CAN

- Depict your coverage!
- Market orient your sales people!
- Target your ethnic/demographic markets!
- Identify marginal signal areas!
- Plot any special requirements!

MAP OPTIONS

- SHADOWING (TERRAIN SHIELDING)
- POPULATION DENSITY
- CONTOUR COVERAGE
- SPECIALS

dataworld®
A Service of DW, Inc.

Fax (301) 656-5341
(301) 652-8822 (800) 368-5754

The Industry's Top Hat

orban

New

FX 50 Exciter

Audio Performance That Rivals CD's

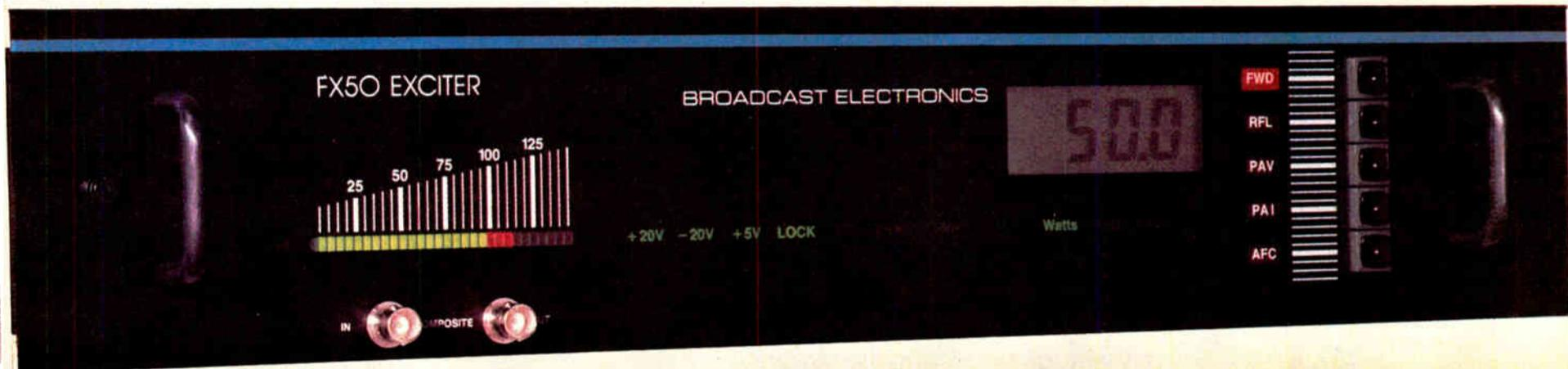

THD and IMD 0.003%, 93 dB S/N, 50 Watts



Broadcast Electronics introduces the ultimate FM Exciter - the new FX50 - with performance even superior to the world standard FX30.

CD Sound

The new FX 50 Exciter has the lowest distortion of any exciter available with THD and IMD of 0.003%.*

Move Up To CD Standards

Every new "B" Series FM Transmitter incorporates the FX 50 for true CD transparency. And, the FX 50 is the ideal retrofit for your present exciter.

*Typical

CD Dynamic Range

With a signal to noise ratio (S/N) of 93 dB* the FX 50 can handle all of the nuances and power of compact discs.

Set It And Forget It — 50 Watts

Sophisticated automatic control systems assure stable and reliable 50 watt MOSFET power output even under mismatch conditions.

For information on the FX 50 Exciter and on Broadcast Electronics' new "B" Series FM Transmitters which incorporate the new FX 50 Exciter, call Bill Harland or Russ Erickson at 217-224-9600.

BE® **BROADCAST ELECTRONICS INC.**

4100 N. 24th ST., P.O. BOX 3606, QUINCY, IL 62305-3606 U.S.A., PHONE (217) 224-9600, TELEX 250142, FAX (217) 224-9607

Circle 41 On Reader Service Card

World Radio History

NEW NEW NEW

SERIES CONSOLES

S – \$6,499 /18 CHANNELS – \$8,893

FEATURES

- Totally Modular Console-Input modules, Output modules, Option modules
 - Ease of Service
 - Ease of Installation
 - Ease of Expansion
- Three Mainframe Sizes—8 channels, 18 channels, 28 channels
 - Full Metering
 - Timer on All models
 - Talkback to "2" studios
- Ultrahigh Quality Construction and design
 - Penny and Giles 3000 Series slide faders
 - VCA's
 - ITT Schadow switches
 - Gold connectors—IC's socketed—regulated power supply
- 3 Stereo Output Buses
- 2 Internal Mix-minus Buses for 'Telephone'
- Option Modules-D.A.'s, Mono Mixes, Remote Selectors, Etc.
- Comprehensive Logic system
 - Start and stop sources by isolated internal reed relays
 - Remote channel On and Off control with Tally lamps for turrets
 - Flashing OFF switches for cart machine status
 - Three muting buses for Control room and two studios
 - Timer reset selectable on each module
 - Monitor DIM function during cue and talkback

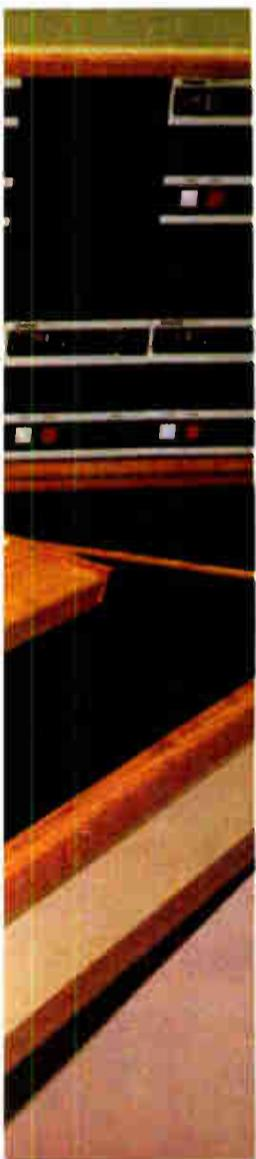

24-2248



arrakis
SYSTEMS, INC.

**NEW
NEW
NEW
NEW
NEW
NEW**

NEW NEW NEW

HE SAID,



“You can write almost anything you want about this machine and put my name under it.” SO WE DID.

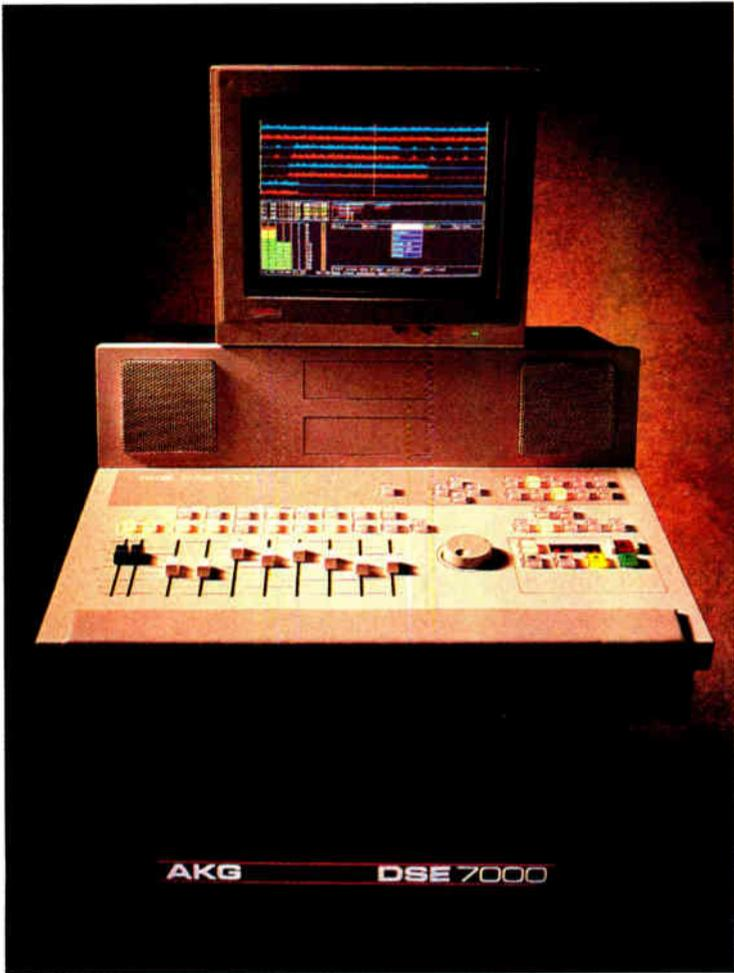

THE DIGITAL SOUND EDITOR. STATIONS FROM BOSTON TO SAN DIEGO ARE MAKING IT THE HOTTEST BOX IN RADIO.

Dan McCoy was the first production director in radio to use the DSE 7000, and he saw it revolutionize the way production is done at

WZOU-FM,



one of the top stations

in Boston. A spot that used to take an hour to produce now takes 20 minutes. Without tape.

Without razors. Without a single dB of generation loss. Even agency dubs now go right to the

DSE for levels, sound enhancement



and tags; then onto carts. Creativity has exploded, too. With the DSE's instant UNDO feature, the fear of trying new things is gone. You simply try another take, assemble a different edit, or test a new effect. If you don't like the results, UNDO it instantly. No wonder WZOU has

designed their production facility around the DSE.



And no wonder Dan McCoy calls

this machine “the most impressive thing that's ever happened to radio.” His words, not ours.



1525 ALVARADO STREET, SAN LEANDRO, CALIFORNIA 94577, USA. (415) 351-3500. FAX: (415) 351-0500



DSE 7000 • THE NEW SPEED OF SOUND



AM Radio Mobilizes with TIS

by Dee McVicker

Tempe AZ AM has been called a lot of things, but seldom is it called a medium on the move. And yet, one brochure describes broadcasting on the AM band as anything but stagnant. In fact, according to this source, some AM stations are quite mobile.

Reading on, it becomes apparent that the brochure isn't referring to just any AM station, least of all one with call signs. The frequencies, which are 530 kHz and 1610 kHz, are suspect. As is the power: only 10 watts.

Hardly the AM that broadcasters know and love, these dissimilar AM stations are called Travelers' Information Stations, or TIS. And it seems just about everyone has one, including departments of transportation, chambers of commerce, airports and universities.

On the road again

Where are these stations on the move going? Those who dispatch them will tell you that they go to places such as roadside emergencies, natural disasters and wherever they can alert listeners to local travel conditions.

Complete transmission and antenna systems are mobilized, typically mounted on the flatbed of a pickup truck or attached to the push bumper of a highway patrol car (the antenna folds out!). Some are powered by generators, and others are powered by automobile batteries, where an energy efficient transmitter can operate for days without the engine running.

In some cases, a mobile unit can be dispatched to broadcast on both 530 kHz and 1610 kHz—one frequency informs listeners heading southbound and another frequency informs northbound listeners. But usually, mobile TIS units broadcast on the frequency that is the most isolated and free from adjacent channel interference.

In some states, such as California, where commercial stations dominate 540 kHz on one end of the state and 1600 kHz on the other, TIS mobile units usually can be found opposite commercial broadcasts—on the other end of the band, where adjacent channel interference isn't likely to be a problem.

Mobility, however, hasn't been without its challenges. Grounding, for one, is a continuing problem. But once the antenna is properly installed, mobile units can expect to cover approximately two to two and a half miles.

TIS service can vary from a few hours to days, even months. The earthquake that rocked California on 17 October, 1989, for instance, is still receiving a great deal of broadcast coverage from one mobile TIS unit parked near the Oakland Bridge.

The California Department of Transportation dispatched this unit soon after the quake, and expects to keep it on site until travel conditions return to normal on and near the bridge.

Going places

Not all TIS stations are mobilized; in fact, most aren't. But those that don't dispatch them—such as airports, which use TIS as stationary broadcasts that listeners tune into to find terminals and so

forth—will tell you that their stations are going places, too. TIS, as it turns out, is using one of the best inventions in recorded audio.

Virgil Duncan, the vice president of research and development at Digital Recorders, Inc., and the man behind the brochure, couldn't agree more. Said to be the grandfather of TIS, Duncan is a veteran broadcaster who got his start in radio and television following World War II.

In some cases, a mobile unit can be dispatched to broadcast on both 530 kHz and 1610 kHz . . .

"When I left the military, I had an opportunity to go to work for a broadcast station," recalled Duncan. "I was in it for almost 25 years. Went from a 250 W AM radio station to an FM, to TV."

In 1969, Duncan left broadcasting for a brief time to work with digital technology in a peripheral telecommunications field. "We did a lot of work for roadside emergency terminals and multichannel telephone communications systems. We were the forerunner of cellular telephones," he said.

Then, in the late '70s, some news came down from the FCC that interested Duncan. "I heard through the grapevine that the Commission was going to make 530 and 1610 available for travelers information stations, or highway advisory radio. So, I designed a transmitter," he said.

Educating the uninitiated

According to Duncan, one of the biggest problems of the time was educating non-broadcasters on a system that was unlike anything they had used before. Said Duncan, "They were familiar with two-way communications, but when it got into the groundwaves of AM broadcasting, they were a bit lost."

Another more pressing problem, how-

ever, was the continuous feed of cartridge tape. TIS stations typically broadcast a continuous recording usually one to two minutes in length; broadcasting carts could not hold up to the wear and tear of TIS use.

"They (cartridges) would not run 24 hours a day, seven days a week for more than just two to three months," said Duncan. "The tape wore out."

As one of the members of an NAB advisory committee to set the standard on cart machines years ago, Duncan's new challenge held an interesting twist of fate: He set out to replace the cartridge tape that he had so painstakingly helped standardize in his early radio career.

Borrowing from the digital technology he had learned during his hiatus from broadcasting, Duncan developed one of the first TIS record/playback units using solid state technology.

Just record and play

"There are no mechanical parts other than the push buttons on the front that say 'record' and 'play,'" said Duncan. "We record into a solid state memory, usually a CMOS static RAM. Consequently, with a small lithium battery, the program will stay in there for ten years—you can change it 10,000 times and it still won't wear out!"

The going record on a Digital Recorders recorder is four years of continuous playback, playing seven days a week, 24 hours a day.

Travelers' information stations are band limited by the FCC to 3.5 kHz, making storage of two to three or even four minute messages possible. Storage on the company's digital recorder, according to Duncan, is approximately a minute per megabit.

"We stack memory boards up," informed Duncan, referring to circuit boards that come eight 256 K memory chips per board and are random accessed according to bus address.

The first recorder, patent approved only two years ago, allowed up to 15 minutes of record/play time. The recorder to follow, which is up for patent approval in September, will grant up to 37 hours of playback time. Duncan admits, however, that this unit involves quite a bit of memory.

Not yet practical for commercial broadcast use, Digital Recorders' units have gained notoriety in peripheral markets where continuous feed audio makes storage onto memory chips feasible. Zoos, parks, and transit systems are just a few of the organizations benefiting from the technology.

Duncan suspects that his solid state technology will eventually make its way to commercial broadcast, but until then, he plans to continue mobilizing AM on 530 kHz and 1610 kHz.

■ ■ ■

Dee McVicker is a free-lance writer and regular contributor to RW. To inquire about her writing service, call 602-899-8916.

Oh-Oh!

Call
CORTANA

STATI-GAT The Affordable Lightning Prevention System

- Charge dissipation with 1/8", type 304, sharpened stainless steel rods
- Won't bend from ice/severe weather
- Provide a continuous low-resistance discharge path for static electricity

Cortana Corporation

Write for a Free Brochure.
P.O. Box 2548, Farmington, N. M. 87499
Call (505) 325-5336

Circle 67 On Reader Service Card

World Radio History

- A. RF Specialties of Washington, Inc.**
19237 Aurora Avenue N.
Seattle, WA 98133
Phone (206) 546-6546
FAX (206) 546-2633
John Schneider & James Kaplan
- B. RF Specialties of California**
3463 State Street, Suite 229
Santa Barbara, CA 93105
Phone (805) 682-9429
FAX (805) 682-5170
Sam Lane
- C. RF Specialties of Missouri**
R.R. #2, Box 152H
Kearney, MO 64060
Phone (816) 635-5959
FAX (816) 635-4508
Chris Kreger
- D. RF Specialties of Texas**
P.O. Box 7630
Amarillo, TX 79114
Phone (806) 372-4518
FAX (806) 373-8036
Don Jones & Tim Hawks
- E. RF Specialties of Pennsylvania, Inc.**
121 Conneaut Drive
Pittsburgh, PA 15239
Phone (412) 733-1994
FAX (412) 327-9336
Tom Monahan
- F. RF Specialties of Florida**
P.O. Box 397
Niceville, FL 32578
Phone (904) 678-8943
FAX (904) 729-2744
Bill Turney
- Each Office is Independently Owned and Operated

RF SPECIALTIES GROUP

LEADERS IN RF SYSTEMS FROM COAST TO COAST

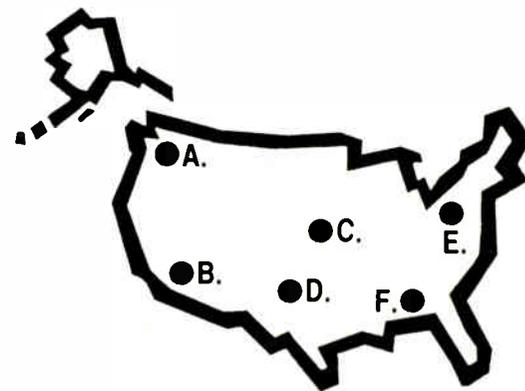

FOR ALL YOUR BROADCAST EQUIPMENT NEEDS, CALL THE SPECIALIST NEAR YOU

SYSTEM DESIGN COMPETITIVE PRICING

RF Specialties® Group

Circle 133 On Reader Service Card

**GET IT
RIGHT**
GET IT FROM **ALLIED**

2 TRANSPORTS, NO WAITING!



Finally, here's one CD player that makes everybody happy. The chief loves the *reliability* and the *redundancy*. The PD's *happy* because his on-air staff is working *smarter* than ever before. All this is possible because Numark put two transports in one chassis. So now, with a Numark CD6020, CDs can be handled with the same ease as you used to mix LPs.

A CD6020 TOMORROW?



GETS IT THERE!

The CD6020 system consists of two rack-mountable components... a control unit (2RU) and a dual-transport module (3RU).

The control unit features pitch controls for each player which allow 8% increase or decrease from recorded speed. Large start/stop buttons and a full complement of remaining time readout per deck, search, repeat, and memory functions provide total control. Numark's patented "Integrate" function permits the host to set up a playlist of up to 48 selections, in any order, from the discs in the two transports. (24 per disc.)

- Remaining time readout per transport per cut.
- Mono/stereo switch.
- + or -8% speed control.
- Front panel level controls.
- Remote start option.

The CD6020 transport cues to music, of course. Call us today. We can deliver by FedX® tomorrow.

HARRIS
ALLIED
BROADCAST EQUIPMENT

800-622-0022

CANADA 800-268-6817

STUDIO EQUIPMENT • HARRIS RF PRODUCTS • SATELLITE GEAR • TRADE-INS • TURNKEY SYSTEMS

© 1990 HARRIS/ALLIED

"Call me, I'm interested." Circle 11.

World Radio History

"Send me literature." Circle 90.

Sharing Thoughts with Veterans

by George Riggins

Long Beach CA I mentioned some of the sponsors of 1927 programs in the last installment of *Old Timer*. What I did not mention, however, were the names of the programs.

According to *History of Broadcasting: Radio to Television*, by Harrison B. Summers, Eveready sponsored the Eveready Hour; Atwater Kent had The Atwater Kent Hour. The Boston Symphony Orchestra, The Capitol Theater Concert and the Midweek Hymn Sing were listed as "Sustaining."



Other early programs and their sponsors included: Brunswick—Chicago Civic Opera; La France—La France Orchestra; and Baulkrite—National Symphony Orchestra, conducted by Walter Damrosch. Maxwell House had the Maxwell House Hour. And this is the listing for just one category, "Concert Music."

Other categories listed were Light Music, News-Commentary, Religious Talk Programs, Miscellaneous Talk Programs and Daytime Homemakers' Talk. As for ratings, none appear until the 1930-1931 season.

KMJ and WNEW

Jim Hilliker, news director at KOCN, Pacific Grove-Monterey, CA has been researching stations in the West—and Southern California specifically—for several years. He has kindly shared some of his data for our use.

As he reports, "San Joaquin Valley Light and Power of Fresno, CA sold KMJ to the McClatchy interests between the time the station was put on the air in 1923 and 1926." Jim sends along a report that the sale was published in the 28 June 1925 issue of *Radio Doings*.

This indicates that the official transfer of ownership probably took place during the preceding 60 to 90 days. In all likelihood the sale was consummated in either April or early May of 1925.

Synchronized transmission

Some readers have asked how WBZ, Boston and WBZA, Springfield accomplished their synchronous transmissions.

WBZ went on the air 19 September 1921 at Springfield, MA, according to the *Broadcasting Yearbook*. (The oldest listing in my possession is corrected to 1 September 1922.) WBZA, Boston went on the air sometime between the listings of 1923 and 1926.

In 1926, WBZA was listed as licensed to Boston with a power of 250 W on a wavelength of 242 meters. WBZ was authorized 2000 W on a wavelength of 331.1 meters. By 1928, both WBZ and WBZA were on 333 meters—WBZ with 15,000 W; WBZA authorized 500 W.

By 1929, the wavelength had changed to 302.8 meters, or 990 kilocycles. The cit-

ies of license remained unchanged.

Sometime between 1929 and 1937, Westinghouse switched the licenses between Springfield and Boston. I was informed the change was made in anticipation of selling the Springfield property in order to purchase a station in the Pacific Northwest. Whether the purchase in the Northwest never materialized, or was one of minimal duration, my informant did not state.

It was after the sale of WBZA and the caper in the Northwest that Westinghouse purchased KFWB in Los Angeles from Warner Brothers.

As reported to me by Don Parker, who recently retired from KFWB, a Group W station, the frequencies of WBZ and WBZA were synchronized by use of an audio signal of approximately 600 Hz fed from WBZ to WBZA by phone line. Don said he transferred to WBZ at about the time the practice of synchronizing the two transmitters was discontinued.

Don states that he did see the entire synchronizing set-up as it was originally installed. Reportedly, there was an area of about a mile where there was some interference, but the spot was "out in the country."

Al Smith reports that WBBM, Chicago and KFAB, Lincoln, NE did the same thing, using the phone lines to keep the frequency of each station locked to the other. Al did not indicate what sort of signal was sent down the phone line to accomplish the synchronous transmissions. The stations broadcast separate formats during the day, and resorted to the synchronous transmissions at night so each station could have a broader coverage area.

Touring AM by auto

It's that time of year again. We, the XYL and I, recently returned from several weeks in the Midwest and South. During our travels, we listened to probably 80% of the AM stations between Los Angeles; Laurel, MS; Birmingham, AL and Peoria, IL.

The most noticeable difference between 1989 and 1990 was an overall improvement in the audio quality of the programming. The reason? More stations now are connected to some program network and their signals are being delivered to the local stations by satellite.

It is very easy to discern between the local mic, cart machines, local TT, live remote or local tag. The audio quality of most stations still goes down when the source of the audio is local.

A conversation with a programmer in Los Angeles confirmed my thoughts that much of the program audio has improved. In fact, the programmer referred to his recently purchased Midwest station and said that he could recognize each cart machine or turntable by the difference in audio quality.

His first reaction? Get new cart machines and install a satellite downlink for more consistent audio quality.

I use an "out in the boonies" station in my travels as a control. Between the time we passed the station on the way to South Central Kentucky and the return by Laurel and Peoria, a satellite receiver had been installed and the audio

quality was much improved.

Yes, Matilda, we have come full circle and have network radio again! There are more networks now than in the heyday of the big networks and there is more diversity of entertainment. On an overall basis, we probably have a more consistent audio quality (I did not say better programming) by way of satellite distribution than when we used the telco lines.

Thoughts from a seasoned veteran

As space has permitted, we have been featuring comments from Al Smith, WOPEX, a true old timer in the radio business. In the following, Al relates how he spent several years doing part time work while servicing radios in the Midwest.

OT: You mentioned that you converted many of the early receivers to 6 V tubes so only a 6 V battery was required. What other service did the early sets require?

Smith: "While servicing radios, I sold a lot of Ray-O-Vac 'B' batteries. In operating a service shop in a small town, I had to go out to get the business. When I didn't have work, I would load up my car with 'B' batteries and tubes and go out into the rural areas selling. At one time I sold more 'B' batteries than any other Ray-O-Vac dealer in Nebraska."

OT: Did you do more than change tubes and batteries when you were out in the country?

Smith: "I would pick up radios for repair on these trips. I rather enjoyed these trips and servicing, but my goal was to get a good job in a broadcast station."

OT: When and where did you get your first regular position in broadcasting?

Smith: "In 1936 I received a call from KMMJ in Clay Center, NE asking me to come to work. I asked for how long. The chief engineer said that I had a full time job. I married my girl friend Helen, whom I had been courting for many years, after being employed for several months.

"This was an interesting job. All programming was live including dance bands that would play once or twice a week for free to get publicity and line up dance dates in the listening area. These dates would be announced during the program. People would drive for several hundred miles to watch live talent in the studio, which had a big glass window between it and the auditorium.

"I used to hope that I would be able to play a record due to someone not showing up in time."

We will continue with more reminiscences from Al in our next installment.

George Riggins has experience in radio and electronics dating back to the 1930s. He is also a licensed ham operator and has had his own broadcast sales and service company, Riggins Electronic Sales, for over 20 years. He can be reached at 213-598-7007.



CRL SPOTLIGHT

Upgrade Your
FM Stereo Generator
... with the CRL SG-800A



Your stereo generator is an important part of your overall on the air quality. Older generators can often color your audio because they can not handle dynamically processed audio very well. The digitally synthesized CRL SG-800A produces a flawless composite baseband signal. Our unique low distortion pulse amplitude modulator ensures maximum stereo separation (60 dB typical). The SG-800A is also available with two low-pass filter options, including the new CRL DSP-1 digital low-pass filter. The price of the SG-800A starts at \$1795. Our two week trial program will let the SG-800A prove itself to you. Call or write us for details.



CRL Systems
2522 West Geneva Drive
Tempe, Arizona 85282 U.S.A.
(800) 535-7648 (602) 438-0888
TELEX: 350464

Hearing Yourself Think Again

by Barry Mishkind

Tucson AZ A lot of radio engineers in this country are dealing with a true dilemma. Ironically, it comes as the result of good planning.

ECLECTIC ENGINEER

In many well-designed facilities the engineering office is located close to the control room. This accomplishes a number of objectives, depending on the station.

By having the engineering office close to the air studio, wiring can be looped through or terminated there for ease of patching or testing circuits.

And it's much easier and quicker to respond to problems in the air studio if your office is located right there.

On the other hand, such convenient proximity to the control room often adds this little irritation to the engineer's life: He can't hear anything while the control room is open.

Hello, hello?

As soon as the DJ opens the door to the control room, anyone in the hall can

forget finishing their sentence. Similarly, forget listening for that slight audio hum in the cart machine on the bench.

You may even have observed the futility of putting pots on the monitor level in many stations. The monitor seems to run at only two levels: off (when the DJ is talking on the phone) or full level. An on/off switch is all they seem to need!

Worse, some DJs seem to feel isolated in the control room and prefer to roam the halls during records, with the monitor up high so they can hear when the record is ending.

But the part that really drives me up the nearest wall is when I'm on the telephone and suddenly can't continue the conversation because of the audio assault.

Battling the invading sound

An automatic door closer would seem to be a perfect answer to the problem. Some sound does come out when the door is opened, but it rapidly goes away.

You might even make a mental note that the station is, in fact, still on the air.

Unfortunately, DJs are resourceful beings. In their attempt to ensure that the station has no other pursuits than their show, DJs have found an amazing number of items to use to prop the door open.

Wastepaper baskets, chairs, phone books, pens, shoes, piles of record al-

Figure 1.

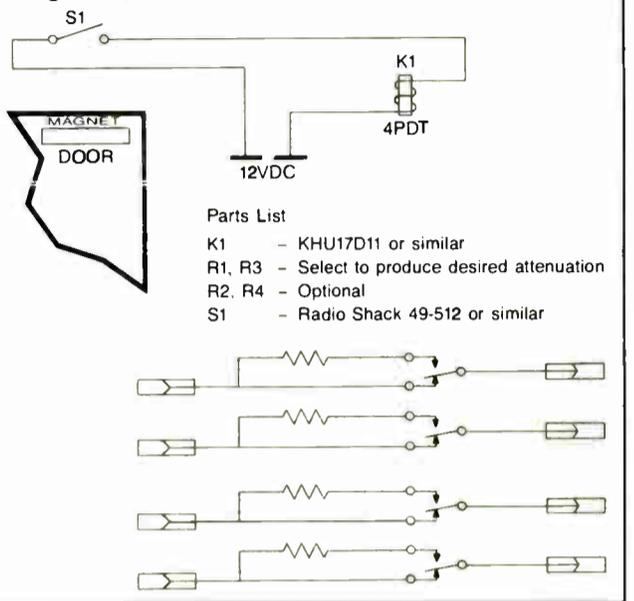

bums, cartridges and telephone cords are just a few of the things used to prop a door open, despite the existence of an automatic door closer.

Adjusting the monitor level to a lower maximum would seem to be the solution. However, as we discussed last month, DJs seem to believe that not

(continued on next page)

One source for your total

DESIGN

RENOVATION

CONSTRUCTION

EQUIPMENT

ENGINEERING

MANAGEMENT

SERVICE

INSTALLATION

GET IT RIGHT
GET IT FROM ALLIED

HARRIS ALLIED SYSTEMS

217-222-8200
FAX 217-224-2764

P.O. BOX 4290 • QUINCY, IL 62305-4290

©HARRIS/ALLIED 1990

FM Harmonic Low Pass Filters

500 - 50,000 Watts

Delivery: 30 Days (Faster For Your Emergencies)

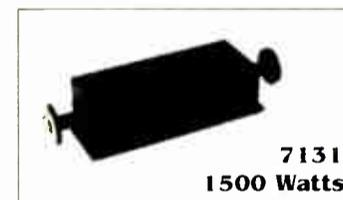
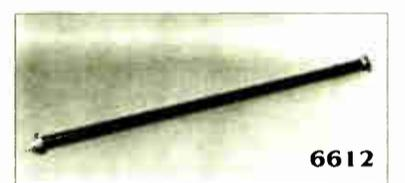
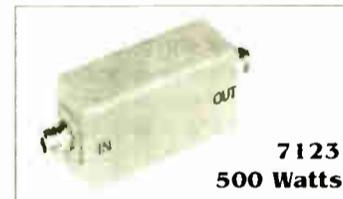

Model #	Watts
6612	6,000
6516	15,000
7772	30,000
7455	50,000

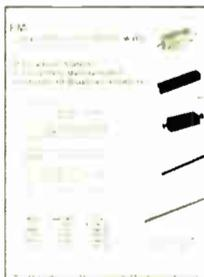

Bulletin #14

Full Details In Bulletin #14!

Also, request BTV/87 which describes TV/FM/MMDS Broadcast Filters & Combiners for service radio bands.



Catalog BTV/87

Need A Special Filter? Call Us Today!

"We make Filters In A Hurry For Customers In Trouble!"

Microwave Filter Company, Inc.
 6743 Kinne St. • E. Syracuse, NY 13057
 Toll Free(US/Can.): 1-800-448-1666 • Collect(NY/AK/HI): 315-437-3953
 FAX: 315-463-1467 • Telex: 249-613

Digital Radio Nearly Reality

by Lex Felker

Washington DC Four months ago, when it was displayed at the NAB show in Atlanta, digital radio broadcasting was a curiosity. It fascinated technical buffs, but not many others.

Over the past couple of months, however, digital radio has made a significant move toward becoming a reality. In this month's column, we again check the status of what may well be the next generation in radio broadcasting.

European beginnings

As has been reported extensively in this publication, work on a digital broadcast radio system has been going on in Europe for several years.

The system was displayed at the NAB convention this year in taped demonstrations and its performance appears most impressive. Its proponents claim that the system provides both a sound quality indistinguishable from compact discs and an immunity to the multipath distortion that plagues FM broadcasts in urban areas.

Although the European system was originally conceived for satellite broadcasts, it would also appear to be suitable for broadcasting from terrestrial facilities.

FELKER'S FORUM

As has been indicated in earlier articles describing the European system, however, it employs a form of "spread spectrum" modulation in which several stereo audio pairs "share" a single radio frequency carrier. This approach is significantly different from the conventional "single channel per carrier" (SCPC) scheme which broadcasters employ.

US applications

Two sets of events now promise to quickly move the concept of digital radio from the laboratory to the marketplace. One is the emergence of three cable-based digital radio services.

The first of these systems, Digital Cable Radio, is already available commercially on a few CATV systems. The other two systems (Digital Music Express and Digital Planet) are expected to begin commercial operations this year.

Then in May, two digital radio proposals were filed with the FCC. One, contained in a satellite earth station application filed by Radio Satellite Corporation (RSC), proposes a pure satellite broadcast system using the mobile satellite being launched by the American

Mobile Satellite Corporation. RSC anticipates offering ten less-than-CD-quality stereo audio channels.

The second proposal, filed by Satellite CD Radio, envisions a more ambitious undertaking. As is evident from its name, Satellite CD Radio proposes a 66 channel, satellite-based, CD-quality broadcast audio service.

It also proposes, however, a complementary 34-channel terrestrial allocation that would be available only to existing local broadcasters. Satellite CD Radio suggests that the proposed services share the 1460 MHz-1530 MHz frequency band with flight test operations.

In contrast to the European approach, Satellite CD Radio proposes to employ a SCPC modulation scheme. This method is much more compatible with existing broadcast operations and would provide terrestrial broadcasters substantial flexibility in choosing the location

and coverage, of their digital transmission facilities.

The FCC, apparently intrigued by the concept and anxious to obtain more information to factor into its preparation for the 1992 World Administrative Radio Conference, has placed the Satellite CD Radio proposal on public notice.

NAB position

What appeared as late as this spring to be a technological development that might be five to ten years off is now very much an emerging broadcast service. The matter has, therefore, become an important public policy issue, and as such was addressed by the NAB Board at its June meeting in Washington.

The NAB Board adopted a resolution supporting further study of terrestrial-based digital broadcast services but opposing satellite-based systems, including the two proposals pending at the FCC.

The Board also established a task force to consider means of both providing existing broadcasters with adequate competitive protection and minimizing the economic and other dislocative effects of digital services to broadcasters and listeners.

At this point, it is not clear what effect, if any, the NAB Board's position will have at the FCC. The word on the street is that there is substantial interest in the topic at the agency and some kind of action may be on a relatively fast track.

Regardless of the FCC's immediate response to the developments in digital radio, however, the benefits of this technology may be so significant that a question may no longer exist as to whether it will be employed by the broadcast media; only a question of when and how.

Lex Felker is a technology/engineering consultant with the law firm of Wiley, Rein & Fielding in Washington, DC.

Limiting Control Room Volume

(continued from previous page)

being able to "feel" the audio means it is too soft.

Threats don't work, and put the engineer in an adversarial position. Earplugs are not practical. I understand now why the GM's office is as far from the control room as is physically possible.

Finally, I developed a solution that seems to have worked in a number of facilities. You may want to make this a part of your aural defense system.

And the best part is that it's not expensive. All it takes is a few parts and some time.

The solution

What I did was go to the local parts shop and get some of those burglar alarm switches that go on doors.

By running the switch contacts to a 4PDT wired with a couple of resistors, I was able to drop the monitor level about 20 dB while the door was open. I could hear on the phone again!

As you'll note in Figure 1, installation is simple. Perhaps the hardest part is deciding where to insert the pad.

Some like to cut the audio at the output of the monitor amplifier. Others prefer it ahead of the amplifier, which obviates the need for load resistors to keep some amplifiers happy.

With an IC-10, for example, it is relatively easy to insert the pad across the monitor pot itself. Choose padding resistors to your preference. Voltage to run the relay is easily available inside the console, or a simple AC/DC converter can be used.

You'll probably wish to wire the relay so the non-energized position is the "normal" level and the energized position the "attenuated" level.

This prevents a relay, switch, or wiring failure from locking the audio in the attenuated mode at 3 AM, something sure to result in an annoying call or an even more annoying trip to the studio.

An "optional" extra might be to run a wire to the engineering office for manual activation of the pad in case one of your DJs reads this and figures out how to bypass the door relay!

Barry Mishkind, aka RW's "Eclectic Engineer," is a consultant and contract engineer in Tucson. He can be reached at 602-296-3797, or on FidoNet 1:300/11.

Splatter matters.

And any unbelievers should discuss it with Uncle Charlie! A new AM emission standard is now law, and Delta provides the inexpensive means to verify compliance. Accurate, cost-effective spectrum measurements can now be made with the in-stock, built-to-last, field-proven Splatter Monitor.

Designed for AM Broadcast applications, the Splatter Monitor can help you evaluate FCC spectral compliance (NRSC-2), verify proper operation of your NRSC-1 processor, and even assist with processor and transmitter adjustments, all at a fraction of the cost of a lab-type swept spectrum analyzer.

Add the optional AWA-1 Active Whip Antenna and Delta's rugged Splatter Monitor can be used in the field to either

monitor your own signal or that of a competitor. The Splatter Monitor's portability makes it ideal for consultants, contract engineers, or group stations.

Now, more than ever, Splatter Matters! Call us toll free (1-800-8-DELTA-8) for a data sheet, applications notes, and a free spectrum compliance chart showing the new emissions standard. Delta Electronics, Inc., 5730 General Washington Drive, Alexandria, VA 22312.

The Above Standard Industry Standard.

DELTA ELECTRONICS



1990 Delta Electronics, Inc.



"Call me, I'm interested." Circle 112.

World Radio History

"Send me literature." Circle 81.

**GET IT
RIGHT**
FROM HARRIS ALLIED

TRIPLE YOUR PRODUCTION ROOM'S OUTPUT FOR LESS THAN

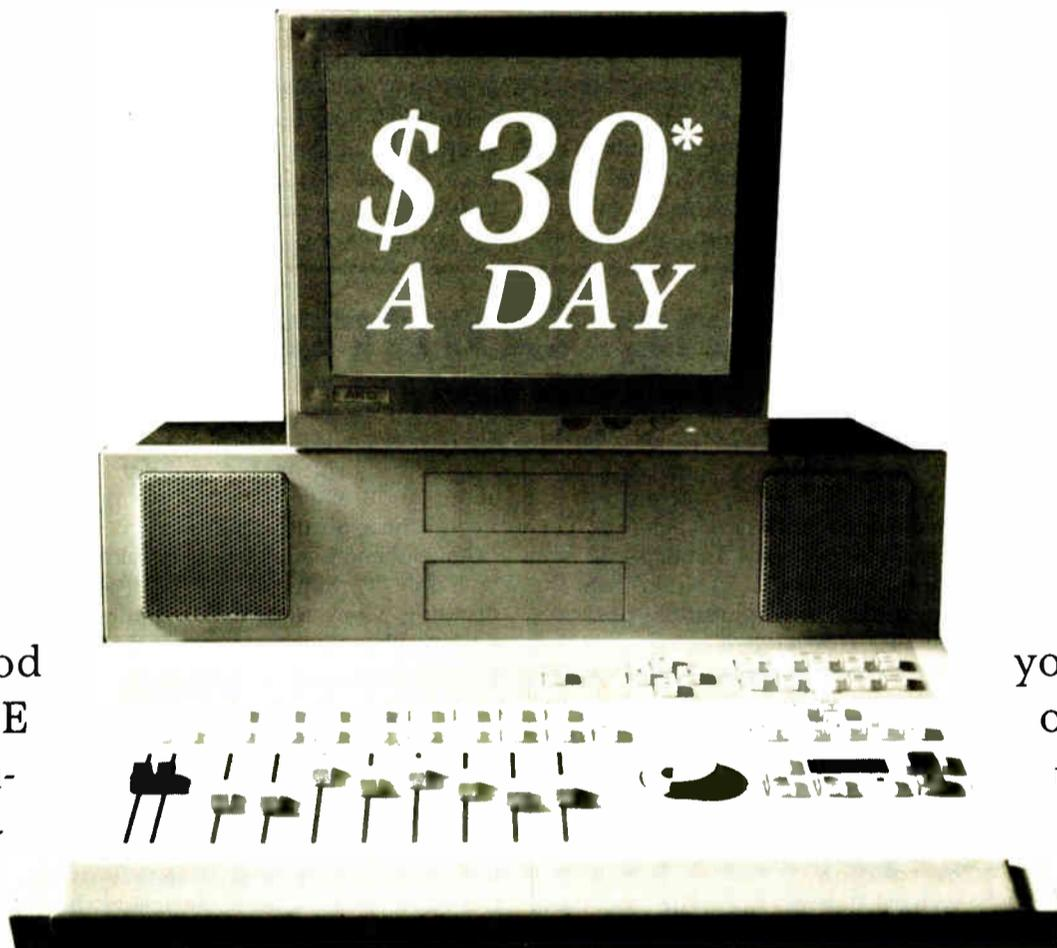

LEASE AKG'S DSE 7000 DIGITAL SOUND EDITOR FROM ALLIED.

First the good news. The DSE 7000 is revolutionizing production at stations from Boston to San Diego.

Production directors already know how to use the Digital Sound Editor's tape transport-style controls, real faders and on-screen "grease pencil." They sit right down and start turning out the tightest, cleanest, punchiest spots, promos, and news actualities they've ever done—three times as fast as they could with analog tape.

Now the even better news. With Allied's leasing program, the DSE 7000 can triple

your production output for less than \$30 a day. You can arm your sales staff with "killer" spec spots.

Change copy every day, if the client wants to. And still have time left over for outside production that can generate extra income.

The future of radio production is here now. And at less than \$30 a day, you can't afford not to be part of it. For more information on the DSE 7000 and details on our leasing plan, call your Allied representative toll free at 800-622-0022. It's the new speed of sound!

*60 month lease with one payment in advance, 10% purchase option, sales tax not included. Prior credit approval required.

 **HARRIS
ALLIED**
BROADCAST EQUIPMENT

800-622-0022
IN CANADA 800-268-6817

STUDIO EQUIPMENT • HARRIS RF PRODUCTS • SATELLITE GEAR • TRADE-INS • TURNKEY SYSTEMS

© 1990 HARRIS/ALLIED

"Call me, I'm interested." Circle 89.

World Radio History

"Send me literature." Circle 30.

A History of Remote Control

by Harold Hallikainen

San Luis Obispo CA I'm sure that there are some stations that did not meet the 30 June deadline to install NRSC-1 audio processing. What now?

The new AM occupied bandwidth rules (which went into effect 30 June) do not require stations to use an NRSC-1 preemphasis/filter network. Instead, the rules have reduced the -25 dB bandwidth from 15 kHz to 10.2 kHz.

A transmitter that is not overmodulated, has low audio distortion and low IPM and is driven by audio with few components above 10 kHz should meet the new requirement.

You can check the last annual equipment performance measurements (required by 73.1590) on file to see if the station was complying with the new specifications at that time. If so, the station probably still complies (unless something's changed in the transmitter or the audio).

Stations that had NRSC-1 in place by the deadline are waived from having to make the equipment performance measurements required by 73.1590 until 30 June 1994. However, stations with or without NRSC-1 are required to comply with the new occupied bandwidth specifications.

INSIGHT ON RULES

NRSC-2 (the limitation on RF bandwidth) limits interference to second adjacent channel stations. Stations using NRSC-1 audio into a properly operating transmitter should meet the NRSC-2 specifications, again limiting interference.

Remote control clarification?

The most recent FCC Regulatory Agenda (55 Federal Register 17093) indicates the FCC is planning to issue another Notice of Proposed Rule Making to further clarify the remote control rules.

The agenda item says, "Proceeding will clarify transmitter remote control and monitoring responsibilities. The Commission will consider the rule pertaining to the distance a transmitter must be from the duty operator." The NPRM was scheduled to be released in June, but no further information was available as this was written.

I recently spent a couple weeks reading through forty years of the *Federal Register*, checking the regulatory history of remote control. There's a lot of background there that is not evident in the current rules.

I had forgotten that the rules never did specify what transmitter parameters had to be remotely indicated. Instead, the rules required only that operators be able to fulfill their duties from the remote control point. Since the rules then specified parameters that had to be logged at least every half hour, it was clear what parameters had to be telemetered.

The first stations authorized to use remote control were the old "class D" NCE-FM stations. These stations had to have a method of turning the transmitter on and off, an indication of modula-

tion or audio level and an air monitor. Faults in the control circuit causing loss of control had to shut down the transmitter. This, from 1950, was the origin of the "fail safe" requirement.

When I showed up at Cal Poly, San Luis Obispo in 1969, KCPR was still using this sort of remote control to run a 2.5 W "Phasatron" transmitter.

In 1952, remote control was authorized for non-directional AM stations and FM (and NCE-FM) stations 10 kW and under. Operator requirements for these stations were reduced to the restricted permit (first class radiotelephone had been required). The new rules included a con-

trol fail safe requirement.

In the notice of proposed rule making, some consideration was made as to whether the proposed rules should require stations to have the capability to remotely change to the Conelrad frequency. No such requirement was adopted. Sufficient telemetry and control was required to allow the operator to perform the required duties.

Conelrad requirement

In 1957, the FCC authorized remote control of AM and FM stations over 10 kW and DA stations. AM stations over 10 kW had to have the capability of re-

motely changing to the Conelrad frequency with 5 kW or 50% of authorized power (whichever was less).

This Conelrad power requirement was reduced in 1960 to whatever the Conelrad Field Supervisor required. DA stations had to submit an analysis of the DA parameter logs for the past year demonstrating array stability.

This was necessary because most antenna monitors could not be remotely, so they'd be read only once a day. They were also required to run a skeleton proof once a year. DA stations were required to remote base current indications.

In 1961, the FCC proposed authorizing remote control of UHF-TV stations. Remote control of VHF-TV was not proposed. This was an attempt to improve

(continued on page 34)



Chuck Steak - Our overzealous food critic. EQ Number: 72.



Doggie Demento - Always a dot off center. EQ Number: 7.



Earl E. Bird - Awake only with headphones on. EQ Number: 19.



Woof-man Jack - One howling party dude. EQ Number: 49.

We make everyone sound great, day, after day, after day.

The span between the basso growl of your morning talent and the punch demanded by your evening party animal is measured in seconds and digits—two seconds and two digits, to be exact.

Every talent on the station has worked out the optimum combination of parametric EQ, compression and de-essing for their personal requirements, and we've given them a number between 00 and 99—their personal number—to achieve this combination at the touch of a

button. They just punch in the number when they sit down, and all of their processing is reset instantly, exactly, repeatably.

We keep all that processing safely out of harm's way; no need to twist any dials because when their number's on the readout, they know they'll sound their doggoned best.

Call the folks at Orban for more information about their 787 multi-processor. It brings a whole lot of mike processing under control.



The Orban 787A Programmable Multi-Processor

orban

a division of AKG Acoustics, Inc.

1525 Alvarado Street
San Leandro, CA 94577 USA
Telephone 415/351-3500
FAX 415/351-0500

LISTEN TO THE DIFFERENCE.

Circle 136 On Reader Service Card

World Radio History

Remote Control Chronicle

(continued from page 33)

the economics of UHF broadcasting.

Further, the FCC argued, because UHF stations are in an uncrowded spectrum allocated entirely to broadcasting, little harm would be caused by a malfunctioning UHF transmitter. VHF stations, however, are surrounded by public safety spectrum. Rules were finally adopted to allow the remote

control of UHF stations in 1963.

The FCC proposed authorizing automatic logging in 1962. These automatic logs were based on chart recorders. I installed a couple of these about 1972. Because operators are not continuously watching the automatic logging equipment, it was to include tolerance alarms. These rules were finally adopted in 1963.

The rules also instituted a

five-day-a-week transmitter site inspection requirement. At the same time, the FCC also increased the operator requirements for ND-AM and FM stations up to 10 kW to the broadcast endorsed third. Stations had to have at least one first class radiotelephone license holder as an employee or contractor.

In 1965, the FCC proposed authorizing the remote control

of VHF-TV transmitters. A unique provision of the proposed rules was a requirement that the transmitter automatically shut down if out of band emissions were generated (or the control point would include a monitor that would allow the operator to check such emissions). In 1967, the FCC decided against authorizing remote control of VHF-TV's.

The Commission proposed in 1966 to authorize subaudible telemetry return on AM stations. After considerable discussion (especially as to whether the telemetry would

be audible on high fidelity AM receivers), the FCC authorized its use in 1969.

Telemetry fail safe

Remote control of VHF-TV stations was again proposed by the FCC in 1969. The proposal included a requirement for telemetry fail safe. In addition, tolerance alarms were to be required if the operator was employed for other duties that might distract her/him from continuous attendance to the transmitter. These rules were finally adopted in 1971.

At the control point, stations were required to have an aural modulation monitor, a waveform monitor, and a vector scope. Stations were also required to insert Vertical Interval Test Signals (VITS) at the control point and monitor the radiated VITS.

Stations without a standby transmitter were required to inspect the transmitter site five days a week. Those with a standby transmitter (at least 20% of authorized power) were allowed to inspect only once per week. The standby transmitter requirement was eliminated in 1974; the VITS requirement was eliminated in 1982.

The five-day-per-week transmitter site inspection requirement was reduced in 1972 to once per week. The logging of transmitter readings was reduced from once every half hour to once every three hours.

Remote indicators

In 1973, directional stations were authorized to log remote indications of the newly approved antenna monitors instead of logging remote base current indications.

In 1974, the FCC proposed and adopted rules authorizing extension metering.

A Notice of Inquiry regarding ATS was issued by the Commission in 1975. A Notice of Proposed Rulemaking issued in 1976 proposed extensive requirements for ATS of AM (including directional), FM and TV stations. ATS rules for non-directional AM and FM stations were adopted in 1977. These detailed rules were not as strict as those proposed, but still were quite detailed.

In 1984, the FCC adopted the current remote control rules. The new rules eliminated the fail safe requirement (dating back to 1950), allowing continued operation without a continuous control link. This made "dial up" remote control possible.

Finally, in 1988, the FCC released a clarification of the remote control rules, explaining its policies regarding dial up.

■ ■ ■

Harold Hallikainen is president of Hallikainen & Friends, a broadcast equipment design, manufacture, sales and installation firm. He can be reached at 805-541-0200.

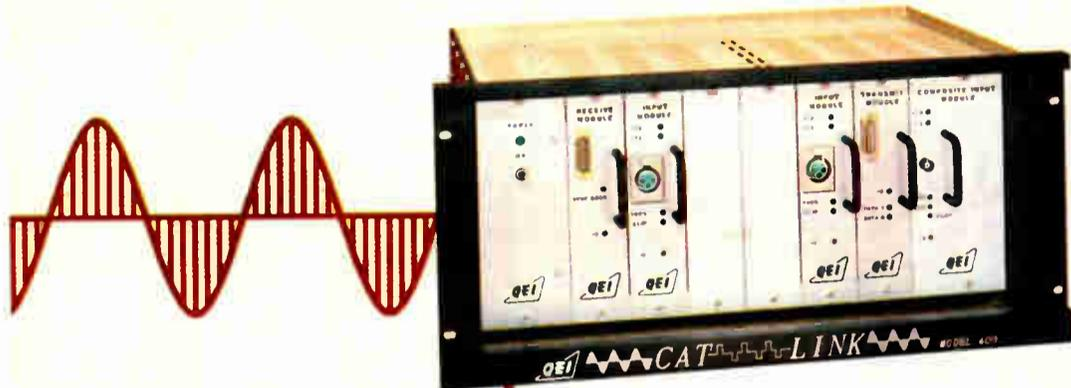

The
STL/TSL
for the
90s is
here now.
And not a
moment
too soon.

- Two Way Multi-Channel Communications
- Transparent Digital Audio
- Multiple Signal Path Options

It's time for a new kind of STL. Drastic cost increases are just one sign that the phone company is tired of balanced equalized lines and is ready to pull the Class A plug. Meanwhile, microwave spectrum is scarce—in some areas, channels are unavailable.

QEI's new CATLink Composite Audio Transmission Link is the *digital* STL alternative. It transmits composite and other signals over a single telco T1 data line*. T1 service costs less than Class A, and it's so reliable that the big banks use it for their vital financial data.

CATLink encodes the fully processed *composite* signal and decodes it at your transmitter, so you can run the stereo generator and processing at the studio. At the same time, CATLink configurations can send and receive SCAs, control channels, voice communications, RS232 data, AM audio, transmitter readings, and satellite or remote programs.

With CATLink, you always get full stereo separation: There are none of the phase or amplitude fluctuations that plague dual-channel STLs. Dynamic range is up to 84 dB, and your processed composite signal can use virtually all of it. So the only thing you'll hear is clear, clean, undistorted audio.

Worried about replacing Class A lines, getting a microwave channel, or sight-line infringement? Call QEI toll-free at 800-334-9154 for full info on CATLink, the bidirectional, digital, *easy-wired* STL. And turn the weak link in your signal chain into one of the strongest.

* CATLink will also drive over a mile of twisted pair wire, nearly two miles of fiber optic cable, or a 23 GHz STL.

Quality • Engineering • Innovation
P.O. Box D • One Airport Drive
Williamstown, New Jersey 08094
24 Hr. Service Hotline 609-728-2020 • Fax 609-629-1751



Circle 83 On Reader Service Card

Built for Business.



The Revox PR99 MKIII Professional Recorder

The **PR99** means business and in today's high-pressure, competitive environment, your station can't settle for anything but the very best. Featuring advanced audio electronics, the PR99 MKIII professional recorder outlasts and outperforms all others. With its superior construction, this recorder was built for long-term dependability, easy maintenance and the highest quality audio. And our reputation for service and technical support remains unsurpassed in the industry.

Take note of these PR99 features: • a solid die-cast aluminum transport chassis and head block • record and playback heads built to the same tolerances as the heads for Studer multitracks

- easily accessible modular electronics for tough, reliable performance
- an Autolocator with digital counter in hours, minutes and seconds
- rack mounts standard.

With ease and versatility, this no-nonsense machine stands up to the rigors of daily station operations. Whether taping news call-ins, downlinking or uplinking satellite feeds, producing commercial spots or remote recording—whatever your station needs, the PR99 delivers!

For value and performance over the long haul, Play a Pro. The one built for business.

STUDER REVOX

Studer Revox America, Inc.
1425 Elm Hill Pike • Nashville, TN 37210 (615) 254-5651
New York (212) 255-4462 • Los Angeles (818) 780-4234
Studer Revox Ltd., Toronto (416) 423-2831

Call your Studer Revox Professional Products Dealer for more information about the complete line of Studer Revox Professional Products.

Circle 57 On Reader Service Card

World Radio History

INTRODUCING

RS CART 2000.

A great *new* cart machine.

With so many good cart machines on the market today, how do you make a new one better?

Begin by including every important cart machine feature: 3 cue tones, fast forward, XLR connectors, active phase correction, front panel azimuth adjust, LED VU and phase meters, full logic, remote control, and more. You'd have to buy every other machine available to assemble all these features.

Next, build it to last. That means long life heads, 1/2" thick deck plate, direct drive Nidec motor, massive toroidal power supply, newly designed positive cart hold-down and guidance systems, and precision head-block assembly.

Finally, distinguish it with features no other unit has. The RS-2000 is the first cart machine to offer flutter correction, splice finder, and timer on all models.

But features aren't important if the engineering isn't top-notch. The RS-2000 was created by industry-renowned design engineer Mike Sirkis. So this "new" machine carries more than a decade of cart machine experience.

One last note: since the RS-2000 is built, sold and supported exclusively by Radio Systems, it carries one more trademark—VALUE. Every RS-2000 model is very affordable.

Call toll-free today for details.

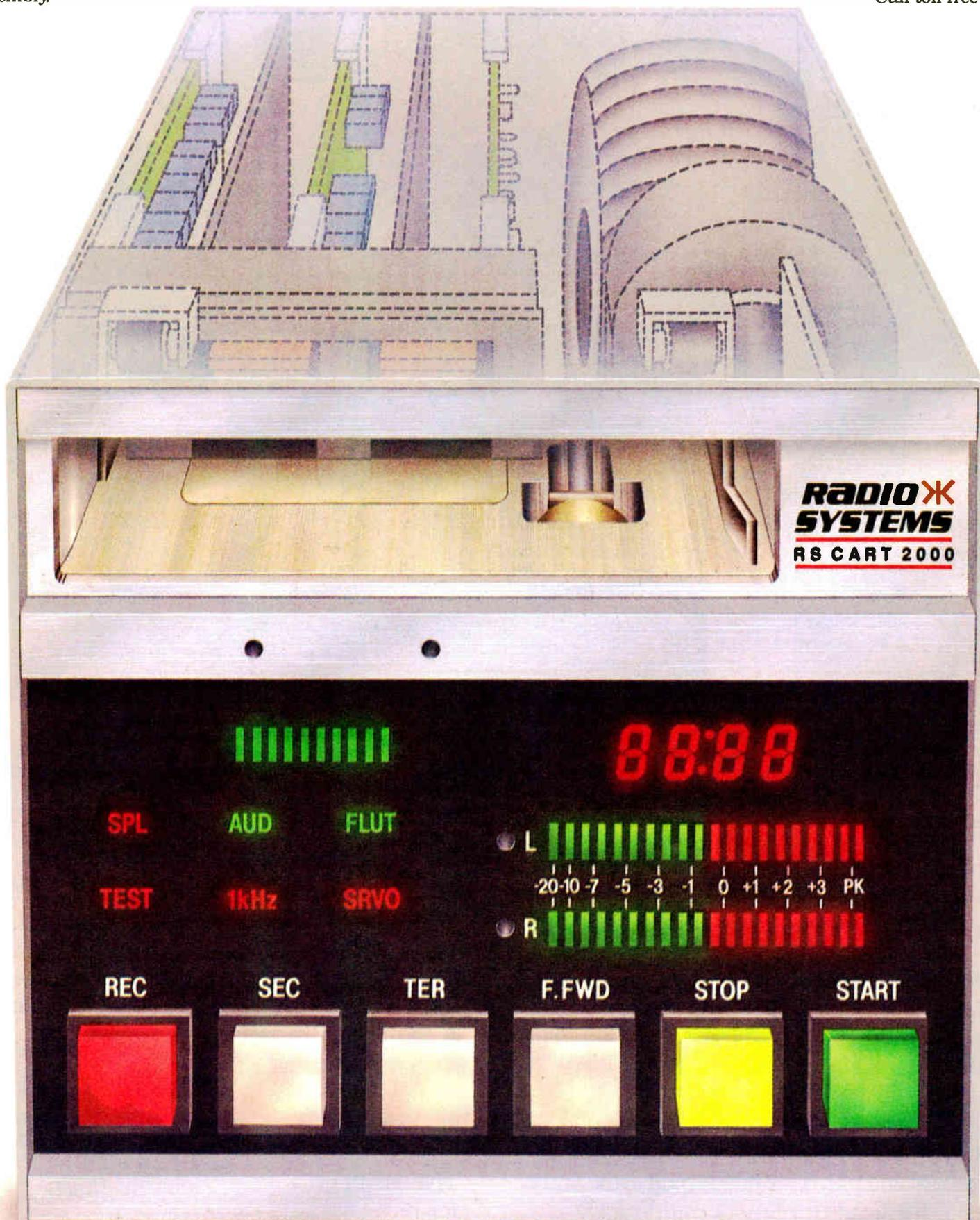

Broadcast Equipment Exchange®

"Broadcast Equipment Exchange" accepts no responsibility for the condition of the equipment listed or for the specifics of transactions made between buyers and sellers.

AMPLIFIERS

Want to Sell

McIntosh MC-2500, sealed, BO; MC-240 (2), \$1175; MC-40 (4), MC-225 (2), \$575 ea. R Katz, Allegro Snd, 15015 Ventura, Sherman Oaks CA 91403. 818-377-5264.

Crest P3500 power amp, 400 W/ohm at 4 ohms, 2 spaces, \$675. R McMillen, 3235 SE 39th, Portland OR 97202. 503-239-6070.

Crown power amps DC-300 (2), \$450; DC-300 II (2), \$490; PS-400 (2), \$650, all in excel cond. P Mobley, 300 Main St, Brookings SD 57006. 605-697-5326.

Bogen 30 W stereo tube type integrated amp, w/case, \$75. M Saady, First City Recd, 141-60 84 Rd, 3E, Briarwood NY 11435. 718-846-2062.

McIntosh C-4 mono tube preamp in gd working cond, w/D-8A power supply, \$250 plus shpg. L Hoover, L.A.S. 325 Saude, Essington PA 19029. 215-521-2933.

MacIntosh MC40 (2), 40 W classic tube amps, new tubes, excel cond, \$1000/pair. J Zelinger, Z Productions, 847 Twelfth St, Santa Monica CA 90403. 213-395-9636.

ITA RCFMA-1A tube type FM RF amp, \$40; McMartin TBM 2500A tube type FM RF amp, \$20. B Umberger, WNL, 813-446-0957.

Nikko Alpha 230 120 W/C, stereo rack mount, pro power amp, black, like new, \$250. C Keith, ALI, 9 Roxbury, Keene NH 03431. 603-352-8560.

QSC 1400 stereo pwr amp, 200 W/ohm at 8 ohms, 300 W/ohm at 4 ohms, 600 W mono, fan cooling, balanced/unbalanced inputs, \$400. R Ross, AP Lab, 88 Sherman 2nd Fl, Brooklyn NY 11218. 718-965-2420.

AIWA MX-100U, 55 W/ohm, 4 inputs & mic input for mic mixing, LED pwr output meter, vgc, \$175. L Hoover, Logical Audio Solutions, 325 Saude, Essington PA 19029. 215-521-2933.

Edcor HA-400 headphone amp, \$75. C Hall, WZOU, 235 Bear Hill, Waltham MA 01254. 617-290-0009.

Want to Buy

WE, Marantz, Fairchild, Westrex, etc, amps, preamps, signal processors w/vacuum tube elect. D deForrest, 7441 Wayne, Ste 10-0, Miami Bch FL 33141. 305-866-5401.

WE, Westrex, Marantz amps, preamps & other vacuum-tube electronics. D deForrest, Insight Prod, 7441 Wayne Ste 10-D, Miami Bch FL 33141. 305-866-5401.

Dick Smith Electr Cat K-3442, 100 W high pwr amp PCB kit, prefer kit but will buy completed unit w/pwr supply or enclosure. R Jordan, Southland Rec, 812 Young, Selma AL 36701. 205-874-8009.

Tube amps & remote mixers incl RCA OP-6, OP-7, BN series, BA & 80 series amps. B Davies, 5548 Elmer, N Hollywood CA 91601. 818-761-9831.

FM RF amp 250-500 W output, 10 W input on 10 W drive w/schematics. F Magloire, POB 370681, Miami FL 33137.

WE amps in working cond. D deForrest, 7441 Wayne Ste 10-D, Miami Bch FL 33141.

Scully '100' recorders, record/play amplifiers, 8, 16, 24 track heads. Sequoia Electronics, 1131 Virginia Ave, Campbell CA 95008. 408-866-8434.

ANTENNAS & TOWERS

Want to Sell

FM-ANTENNAS ALL POWER LEVELS 1 TO 12 BAYS 1-800/279-3326 J & L ASSOCIATES P.O. BOX 25966 Colorado Springs, CO 80936

ERI/Harris FMH6AE 6-bay high pwr FM Rototiller tuned to 94.9 MHz, \$6000. W Boller, WGIL, 154 E Simmons, Galesburg IL 61401. 309-342-5131.

Andrew 7/8" foam LFD5-50A, 175/\$450, 275/\$750; Andrew 1/2" foam LFD4-50A, 300/\$300, 330/\$325. E Burkhardt, WLEE, 121 Wyck, Ste 300, Richmond VA 23225. 804-232-0300.

Antenna 92.1; 1-5/8" coax. R Whitlock, 512-792-4560.

Harris/ERI FML-3E 3 bay CP FM on 99.3 MHz; 370' Andrew HJ7-50A 1-5/8" transmission line, both less than 3 yrs old, avail in June. T Stine, KTXI, 106 Farrar, Cape Girardeau MO 63701. 314-335-9099.

1 5/8" line 90 degree elbow, w/EIA flanges, \$75. N Beaty, 2116 Osman Lane, Greenfield IN 46140. 317-326-3620.

Scala FMO-4 4-bay, plus pwr divider & coax cables, \$550. S Lawson, KAK Prod, 928 Hyland, Santa Rosa CA 95404. 707-528-4055.

Swap 500' of Rohn 45 tower for 500' of Rohn 80 tower or other tower that will stack 500' high, BO, will pay cash for difference. K Diebel, KTJC, 1207 Louise St, Raysville VA 21269.

FM ANTENNAS

1 BAY	\$1,500
2 BAY	2,300
3 BAY	3,150
4 BAY	4,000

MORE BAYS AVAILABLE
All warranted, tuned
and tested

ARMSTRONG TRANSMITTER CORP.
5046 Smoral Road (315) 488-1269
Syracuse, NY FAX (315) 488-1365

Comark 4-bay horizontal, tuned to edc band, gain 3.8, power input up to 1 kW, gd cond, \$1800. R Franklin, Super Snd Stds, 211 Virginia, Norristown PA 19401. 215-277-7112.

Magnum 24" x 150" w/guys & (3) fiberglass insulators, BO. S Hess, KDUC, 29000 Radio Rd, Barstow CA. 619-256-2121.

Jampro 7 bay FM, JLCP-71063 MHz, pwr gain 3.65, documentation, 200' of 1-5/8" Prodelin Spiroline w/EIA connectors, \$4900/all. B Dickerson, WEAG, Starke FL 32091. 904-964-5001.

Phelps Dodge 3 bay CP FM tuned to 99.3 MHz, \$1200 plus shpg; Jampro single bay CP tuned to 99.3 MHz, \$400 plus shpg. B Downs, KISX, Box 131869, Tyler TX 75713. 214-593-4444.

Phelps Dodge ECFM-2 w/radomes 92.1, BO; Phelps Dodge ECFM-2 94.3, BO; Phelps Dodge ECFM-2 98.3, BO. Howells Audio, POB 6184, Kingman AZ 86402. 602-753-4915.

Gates/ERI Cycloid 3-bay, circularly-polarized winput & interbay sections & de-icers, tuned to 95.3 MHz, BO. F Weller, KVNU, POB 267, Logan UT 84321. 801-752-5141.

RCA TFU 30J Pylon antennas, one for ch 19, one for ch 46, both are down & ready to go, \$25,000 ea or will consider exchange for production equipment or up & running used 60K on ch 19; need TBCs, VTRs & more powerful xmt, are small market Christian UHF TV station. J McFarland, WLCN, 27 Grapevine, Madisonville KY 42331. 502-821-5433.

Phelps-Dodge 3-bay Class A, 107.1 MHz, gd cond, \$1500; Helix 1-5/8" approx 90' w/flange connectors. B King, KLBV, 500 Leland, Austin TX 78704. 512-832-4061.

ERI G4CPH-10, 10 bay CP tuned to 96.1 MHz; Jampro Penetrator 10 bay CP tuned to 93.1 MHz, both in gd cond & avail now in Eugene OR, call for price on both systems. C Murray, KMGE, 503-484-9400 or R Sparks Scott, KSND, 503-686-9125.

ERI 4 bay CP FM w/deicers, rebuilt recently by ERI on 95.3, for sale due to upgrade, \$2500. E Moody, KJEM, 216 N Main, Bentonville AR 72712. 501-273-9039.

ERI FMC-3E 3 bays on 95.9, working when removed for pwr increase, \$1000. R LaFore, WOPW, POB 1327, Valdosta GA 31603. 912-244-8642.

AM Utility tower, 300', 26", all accessories, including beacon, side lights, flasher unit, guy wires & jony balls, plus hardware, dismantled & ready to load, located in the Pacific Northwest. M-R-S, 110 North 2nd Ave #39, Chula Vista CA 92010.

Harris/ERI FML-3E, 92.1 M, gain 1.5588, 3 bay circular, tower mounts, end feed, on ground, excel cond, \$2150. L Halstead, KPNY, #2 Elmwood Grove, Gering NE 69341. 308-635-1996.

Phelps Dodge 300' of 7/8" air dielectric Helix w/flanges, gd cond; ERI 402 isocoupler, 10 kW; (3) ERI sample loops & isolation coils for AM directional monitoring, gd cond; Kintronics 3 wire lighting choke, new; Gates 2 wire lighting choke, in gd cond. C Gennaro, WJMT, 1018-A E Main, Merrill WI 54452. 715-536-6262.

Phelps Dodge CPFM-12 12-bay high power antenna on 101.9, \$3500. D Miller, KATP, 810 N Pierce, Amarillo TX 79107. 806-373-6777.

Collins remote meter/control panel 831 series, \$100; Potomac remote meter panel RMP-19, \$150; ERI Isocoupler 3-1/8" flanges, tunable, \$500. W Blackwelder, KNUE, POB 7935, Tyler TX 75711. 214-581-0606.

PIR0D 60, 110' tower complete w/4 level strobe system, \$130,000. A Warmus, 216-659-4440.

Gates ERI cycloid 3 bay, circuitry pwr winput, interbay sections & de-icer, tuned to 95.3 MHz, BO. F Weller, POB 267, Logan UT 84321. 801-752-5141.

ERI 2 bay 1-5/8" 92.7 M. J Phillips, WZOM, 408-1/2 Clinton, Defiance OH 43512. 419-782-8591.

Gates/ERI FMA-8B 8 bay horizontal on 94.5 M, complete, BO. F Hellon, GNB Inc, Rt 1 Box 72, Plymouth IL 62367. 217-392-2340.

Collins 2-bay dual polarized face mount FM antenna on 102.3, \$1200; Electronic Research Type 402 isocoupler on 102.3, \$600. W Christensen, KLOH, Box 456 West Hwy 30, Pipestone MN 56164. 507-825-4282.

Gates FMA-4 4-bay hor 10 kW tuned to 103.1, changes in adj up to 1 MHz plus or minus, BO over \$2000. A Branch, KYAY, Box 1979, Decatur GA 30031. 404-325-7847.

Fort Worth 300' CATV tower, on ground, in Plover WI, fair cond, \$500. R Kotas, WSFP, 10934 Bird Song La, Bokeelia FL 33922. 813-489-9580.

Dielectric 6-bay, 1-5/8" FM antenna line tuned to 93.5 MHz; 10 kW isocoupler 1-5/8" line; 300' 1-5/8" helix transmission line; Scala CL-FM yagi antenna for translator tuned to 93.5 M, new; 40 & 50' Andrews LDF-50A coax line. E Nearman, KUMU, 411 N Nimitz Hwy, Honolulu HI 96817. 808-531-4511.

Broadcast Transmission Systems

Sells and Erects
Tower/Antennas, Too

In Stock Now:

300' Utility 460 tower
260' Rohn 55G tower
300' Rohn 45G tower

(512) 448-0058

Phelps Dodge CFM-LP2 2-bay circular polarization w/radomes tuned 100.9. J Eck, KSAJ, POB 69, Abilene KS 67410. 913-263-1263.

Andrew LDF4 50A coaxial 1/2 line, 125', \$200. C Haynes, WJMT, 1850 Lynch, Jackson MS 39203. 601-948-1515.

H57-50A 1-5/8" Helix, 250'. J Carroll, 523 Meadow Rd, Towas MI 48764. 517-362-3417.

90' 3-1/8" end sections, \$150; UHF harmonic filter & directional coupler on channel 49, BO; 3 bay antenna on 95.1 MHz, \$1000. C Haynes, 1850 Lynch St, Jackson MS 39203. 601-948-1515.

Prodelin 3 1/8" rigid line EIA flanges, 19.5' length, 12 yrs old, gd cond, on ground & avail now, BO. M Doyal, 3625 N Hall St #1300, Dallas TX 75219. 214-522-0979.

Phelps Dodge 3 bay antenna system 103.9 w/deicers. J Carroll, 523 Meadow Rd, Towas MI 48764. 517-362-3417.

Scala paraflector, \$100; dbx 142 & 140 NR, \$150 ea; Orban Optimod 8100A/ST studio chassis, \$500; Tripp Lite SB-8C-2000 AC inverter, \$200. C Hall, WZOU, 235 Bear Hill, Waltham MA 01254. 617-290-0009.

Dielectric 6 bay 1-5/8" FM tuned to 93.5 MHz; 10 kW isocoupler 1-5/8" line; 300' 1-5/8" Helix transmission line. E Nearman, KUMU, 441 N Nimitz Hwy, Honolulu HI 96817. 808-531-4511.

Potomac Instruments AM-10 two tower, gd cond. B Bie, 80 N Tillman St, Memphis TN 38111. 901-458-5818.

LDF 5-50 Helix, 250'. J Carroll, 523 Meadow Rd, Towas MI 48764. 517-362-3417.

50 kW AM antenna tuning unit, (2) ITT 25 kV CVFP-2000-255 variable caps, CFED-1000-255 fixed cap, 0-50 amp RF base meter w/TC & switch, BO. T Jordan, Cape Fear Bdct, POB 35297, Fayetteville NC 28303. 919-864-5222.

RCA 4 bay FM antenna BFC-4B w/radomes on 94.5 MHz, \$500. C Hall, WZOU, 235 Bear Hill, Waltham MA 01254. 617-290-0009.

Scala CL-FM yagi antenna for translator tuned to 93.5 MHz, new; Kay Industries T-12000A rotary phase converter, 2 hrs of srv; Andrews LDF-50A coax line, 40' & 30'. E Nearman, KUMU, 441 N Nimitz Hwy, Honolulu HI 96817. 808-531-4511.

Dielectric A50000-203 3-1/8 motorized coax switch, vgc, BO; MCI 61103 1-5/8 coax switch, solenoid control, gd cond, BO. B Webster, WLIT, 150 N Michigan, Chicago IL 60601. 312-329-9002.

Harmonic filter, 1-5/8", \$250. M Guidotti, KKLK, 143 Fifth St, Ste 5, Colusa CA 95932. 916-458-5585.

Comark CSW-318 3-1/8" 4 port motorized coaxial switch, never used, \$2700; Electro Impulse DPTC-25 KFM forced air cooled dry dummy load, never used, \$3450. D Eressy, WFCB, POB 1308, W Chatham MA 02609. 508-945-4855.

ERI 8 bay, Class C FM, 98.5. Regina Dean, KUAR, Univ of Ark at LR, Little Rock AR 72204. 501-569-8485.

Andrew LDF5-50A, 250', 7/8" foam helix, new, still on reel, connectors & hosting kit, \$4,655 plus shpg. B Brown, WMINI, 1458 Dublin, Columbus OH 43215.

Want to Buy

Rigid transmission line, 400' of 3.125". J Courseille, WGGG, 414-324-4441.

24" face, 400' tower, also need coax. E Moody, KJEM, 216 N Main, Bentonville AR 72712. 501-273-9039.

Coaxial switch, 4 port 1-5/8" EIA flange, needs to be automatic type in gd working order; also need any type 87R 1-5/8" flange or equiv. JP Connor, WSBY, Salisbury MD 21801. 301-742-5191.

Air-dielectric cable, (2) 200' sections of 1-5/8", 500' of 7/8" used Helix or other low loss cable. K Diebel, KTJC, 1207 Louise St, Raysville VA 71269.

2 or 3 Bay tuneable to 96.3, radomes. L Maierhofer, 101 Armory Blvd, Lewisburg PA 17837. 717-523-3271.

High power circular 8 bay FM antenna at or near 107.7 MHz, also 3" line & fittings. T Smith, KXSM, Box 340, Pendhston OR 97801. 503-276-1511.

Need 3-1/8" to TYPE N female reducer that's reasonably priced & in working order. K Browall, Box 808, Riverton WY 82501. 307-856-2922.

ERI FML type, pre-1984 FML bays on or near 92.1 M, must be in gd cond. J Fellows, KCMA, 2021 S Lewis, Ste 760, Tulsa OK 74104. 918-747-9999.

AUDIO PRODUCTION

Want to Sell

Klark-Teknik DN 405 EQ 5 band studio EQ, new cond, never rack mounted, \$300. R Hull, 918-254-0464.

dbx 140A NR units (2), \$300 ea or \$550/both. T Cochran, KNOM, Box 988, Nome AK 99762. 907-443-5221.

Sony PCM 701, \$1000; Lexicon 200, \$2000; Scully 280B, \$1300; Shure EQ's & room analyzers. D Kocher, DLK Snd Std, 1901 Hanover, Allentown PA 18103. 215-432-0520.

Studio Sound S-305 passive filter sets (2), matched pair, rack mount, very rare, \$250/BO/ea. R Katz, Allegro Snd, 15015 Ventura, Sherman Oaks CA 91403. 818-377-5264.

Tascam M-30 mixer, one intermittent chnl, otherwise gd cond, \$495/BO; Delta Labs DL-4 effect processor, mint cond, \$200/BO. C Fries, KSQY, 666 Main, Ste D, Deadwood SD 57732. 605-578-3533.

UREI 575A 1/3 octave mono, \$350; AKG 1291E1 stereo echo, \$300; Inovonics 375 mono electronics, \$200; ITC 854 mono electronics, \$150; ESE 112LS slaves, \$40/ea. E Burkhardt, WLEE, 121 Wyck, Ste 300, Richmond VA 23225. 804-232-0300.

Optimod 8100A exciter. R Whitlock, 512-792-4560.

Conex AS101 10x1 routing switch (2), never used, as new, \$590; Conex AS401 remote control boxes for AS101 routing switch, new, (6), \$99. D Eressy, WFCB, POB 1308, W Chatham MA 02609. 508-945-4855.

THE HALL Electronics

THE BEST DEALS ON QUALITY REBUILT & BRAND NEW BROADCAST EQUIPMENT

We BUY & TRADE equipment too!
Please phone or send for our latest flyer.

10:00AM-6:00PM EST
804-974-6466 1305-F Seminole Trail
FAX 804-974-6450 Charlottesville, VA 22901

Audio Digital TC 2 DDL digital delay/effects, 18K bandwidth, 2.25 second extended memory, 2 outputs, \$575/BO; Dolby 361 A type NR SR ready, \$1475/pr; Scamp mini rack, studio outboard gear w/F300S expander/gate, S01 compressor, S04 parametric EQ, S23 stereo autopanner, Anvil case, pwr supply, TT patch-bay, \$800/BO. R McMillen, 3235 SE 39th, Portland OR 97202. 503-239-6070.

Used equip inventory incl Texar Audio Prism w/Phoenix AM upgrade, \$1500; Carousel 248-II & Carousel elect for parts, \$350/BO; IMP-3 tri-band AM audio processor, needs work, \$350/BO; Ampex 600 w/rack mount & Ampex 600 transport for parts, \$400/BO; Magnecorder 1021 transport/elect in gd shape, & one for parts, \$450/BO. M Johnson, KGAL, POB 745, Albany OR 47321. 503-451-5425.

Lexicon 1200 mono time compressor/expander interface to ATR's & VTR's, \$700. J Zelinger, Z Productions, 847 Twelfth St, Santa Monica CA 90403. 213-395-9636.

Do you have an upcoming remote? We now have available for rental:

2-LINE COMREX
WIRELESS MIC • PORTABLE DAT
plus much more, at reasonable rates!

Silver Lake Audio
2590 Hillside Ct. Baldwin, NY 11510
(516) 623-6114

McMartin audio processor & McMartin stereo gen, \$250 ea or \$400/both. G Gaskey, KWHQ, 261 Main, Ste 6, Weed CA 96094. 916-938-3828.

Audio Design 1500 EQ's (3), 4 band, 14 frequencies, \$40/ea. R Humphrey, WLJ, 7 Parkway Cir, Pittsburgh PA 15220. 412-922-9290.

Pultec EQH-2 EQ. D Smith, WFCB, Box 94, Chillicothe OH 45601. 614-773-3000.

Eventide BD955 digital delay w/15 kHz bandwidth, 6.4 sec delay, \$2500. J Littlejohn, WYSY, POB 2010, Aurora IL 60507. 708-851-4600.

Shure M267, excel cond, (2), \$390; Gentner EFT9000, excel cond, \$640; Henry UTC control, never used, \$350. D Eressy, WFCB, POB 1308, W Chatham MA 02609. 508-945-4855.

Lexicon digital delay processor, \$300. C Hall, WZOU, 235 Bear Hill, Waltham MA 01254. 617-290-0009.

Orban 222A stereo spatial enhancer, mint cond, \$400. R Ross, AP Lab, 88 Sherman, 2nd Fl, Brooklyn NY 11218. 718-965-2420.

Sequential Prophet 600 MIDI synthesizer w/softwear upgrade, \$350. P Cibley, Cibley Music, 138 E 38 St, NYNY 10016. 212-986-2219.

MEI Digisound, 2 hard drives, remote keyboard, configured for 10 kHz, 175 minutes mono, 86 minutes stereo, \$8000. D Greer, WDDZ, Genesee Towers, Ste 1830, Flint MI 48502. 313-767-0130.

J & I AUDIO/VIDEO

A wholesaler in the Radio and Television market.

Now running SPECIALS on audio and video:

BASF CASSETTES - AMPEX R-R'S AUDIOPAK, FIDELIPAC & 3M CARTS

For more information call person-to-person collect:
Kris Elliot at 818-992-4288
or write to: J&I Audio/Video
20899 Kelvin Pl., Woodland Hills, CA 91367

Circle 25 on Reader Service Card

Henry Engineering Synchrostart TT/CD recorder synchronizer, new & still in box, \$225/BO. K Conner, KAMO, 4001 W Walnut, Rogers AR 72756. 501-636-4611 (9-3).

Want to Buy

AUTOMATION EQUIP . . . WTS

Shafer 903 w/(3) Carousels, dual cart machine, network card for satellite, plus extras, \$5000. Tom, 509-522-5412.

Satellite automation unit, complete in roll around rack, w/(3) Carousels, 1000 event Satmaster programmer, wired into 19" rack 84" high, in use now, \$7500/BO. B Tolby, WMKO, Box 1129, Millen GA 30442. 912-982-5695.

Shafer 903E, & other equip for new KITE FM in Kerrville TX. R Whitlock, 512-792-4560.

Otari ARS-1000 DC (4), \$800/ea, Persons programmer 3A, \$425, Conex CG-25 25 Hz tone generator, \$200, entire package for \$3500. S Speheger, WCFY, 108 Beck Ln, Lafayette IN 47905. 317-474-4436.

MSP-1 10 chnl switcher/programmer for satellite, \$2500/BO; interface, \$2500/BO. J Hansen, KKSX, POB 699, St Cloud MN 56302. 612-253-9600.

SMC ESP2 w/remote controller, (4) Carousel 350's & (4) reels, \$7000/BO. J Flynt, WSGY, 200 John Howard Way, Titon GA 31794. 912-382-1101.

IGM 78 tray Go-Cart stereo bi-directional, BO. Howells Audio, POB 6184, Kingman AZ 86402. 602-753-5352.

SMC 20 chnl (2) rack automation unit w/(3) 350 Carousels, twin cart unit & set up for satellite automation including DP-1 Brain, \$4500/BO. J Hansen, KKSX, POB 699, St Cloud MN 56302. 612-253-9600.

IGM Instacarts, one mono & one stereo, both 48 trays, \$300/both; Otari ARS-1000 R-R reproducer, near mint, w/25 Hz sensor, \$1000; Schafer Blue equip rack, \$100; IGM 12 tray Instacart, \$750. G Gaskey, KWHO, 261 Main, Ste 6, Weed CA 96094. 916-926-5946.

SMC 352 RS Carousels (6), \$800 ea/BO plus shpg. B Downs, KISX, Box 131869, Tyler TX 75713. 214-593-4444.

IGM 90 Cart 42 tray, \$1200/BO. R Maxwell, 114 S 4th St, Yakima WA 98901. 509-457-8115.

SMC Carousels (2) 250's, (1) 350, \$800/BO. R Maxwell, 114 S 4th St, Yakima WA 98901. 509-457-8115.

Harris 9002, (2) CRT terminals, racks, (4) Otari ARS-1000 R-R's, (2) IGM Go-Cart 24, spare parts, fully loaded, super clean, \$7500. G Gaskey, KWHO, 261 Main, Ste 6, Weed CA 96094. 916-938-3828.

Schafer 8000 automation controller, minicomputer w/CRT terminal, loggers, 3 rack cabinets, complete extra system for backup, \$1500/both plus spare parts; SMC Carousels if purchased w/Schafer 8000 (4), \$500 ea. G Gaskey, KWHO, 261 Main, Ste 6, Weed CA 96094. 916-926-5946.

IGM Instacarts, one mono, one stereo, both 48 trays, \$3000/both; Otari ARS-1000 R-R reproducer, near mint cond, w/25Hz sensor, \$1000; Schafer blue equip rack, \$100; IGM 12 tray instacart, \$750; IGM Go-Cart 24, \$1500. G Gaskey, KWHO, 261 Main Ste 6, Weed CA 96094. 916-938-3828.

Auto-Jock for automation, the economical & simple way. C Mandel, KAMP, POB 1018, El Centro CA 92244. 619-352-2277.

Schafer 8000 automation controller, minicomputer w/CRT terminal, loggers, 3 rack cabinets, complete extra system for backup, \$1500/both plus spare parts; SMC Carousels if purchased w/Schafer 8000 (4), \$500 ea. G Gaskey, KWHO, 261 Main, Ste 6, Weed CA 96094. 916-938-3828.

Complete automation system including CD28M, CD12C, CD28A, CD28P, (5) CD25S, (5) Revox A-77, (3) CD24R, IGM Instacart, Perma Power UPS, Pioneer Centrex monitors, 4-bay rack w/rear doors, cabling, manuals & schematics, spare parts & source cards, \$15000. G Elmer, Slew Tech, 1617 N Poinsetta Pl Ste 205, Hollywood CA 90046. 213-851-0870.

SMC ESP2, 2 yrs old and on air, includes (4) Carousels, (9) Otari R-R's w/25 Hz sensors, (2) cart PB units, (6) racks, (2) Amdek video monitors & studio remote unit, \$30K. L James, KWKL, POB 650, Wichita KS 67201. 316-265-1065.

Schafer 901-902 automation system w/(6) Teac/Schaferdeck R-R's & I/O cards, (6) cart I/O cards, (3) rack cabinets. E Neaman, KUMU, 441 N Nimitz Hwy, Honolulu HI 96817. 808-531-4511.

DS-20 audio switcher; RP-1000 brain; time clock (4); 350-RSB Carousels; racks w/drs, pwr sup, wiring, etc (2); spare cards for Carousels, switcher & brain, extender card, all manuals, wiring charts, schematics, etc. \$8000/all. Call C Ferguson, 701-852-4646.

Cetec Series 7000, 2x48 carts, (4) reels, (2) terminals. B Wilson, WLSM, POB 111, Louisville MS 39339. 601-773-3481.

Sentry controller w/PC card, (2) IGM Go-Carts 78 tray, IGM Go-Cart 24 tray, (3) IGM racks, software included, \$12,500. T Noordyk, WSHN, 517 N Beebe, Fremont MI 49412. 616-924-4700.

SMC MSP-1 for live assist, satellite, or RTR automation, 4 yrs old, perfect cond, \$3400. Can include Otari ARS-1000's & ITC 3-D & SP cart machines. D Doelitzsch, WDDD, 1 Bdct Cir, Marion IL 62959. 618-997-8123.

Live-Assist Tape System including (4) IT 750 Series PB only, stereo 25 Hz tone detect card, M.W. Persons mini-mixer includes count-up clock, cabling & hardware interfacing, \$2300. G Elmer, Slew Tech, 1617 N Poinsetta Pl Ste 205, Hollywood CA 90046. 213-851-0870.

Satcue 400 switchers (2) for Unistar formats, mint cond, \$500 ea. D Igou, KGNB, 1540 Loop 337 N, New Braunfels TX 78130. 512-625-7311.

Otari ARS-1000 w/25 Hz decoder (4), \$1000; IGM Go-cart 24, \$2500; SMC RP-1000 Brain w/DS-20 switcher & clock & TAC-1 time announce, \$2700; (2) SMC 250 Carousel, one w/electr random select, one w/Schafer random access, \$350; SMC 721 dual cart PB in drawer, \$500; SMC 710 single cart PB in drawer, \$250. J Wenstrom, Wynne Bdctg, 503-882-4656.

SMC RP-1000 brain, DS-20 switcher, PDC-3A clock, pwr supply, TS-25 tone sensor, (4) Otari ARS-1000DC, (4) BE auto rewinds, (4) SMC 352-RSB Carousels, (3) SMC racks w/doors, manuals, parts, SMC remote control, unlimited walkaway w/auto rewind units. E Nichols, KMCR, POB 189, Montgomery MO 63361.

ESP-1 automation system including (5) SMC 350 series Carousels; (2) SMC 721 dual play decks, (4) Revox A-77, Extel printer, AL-1 cassette memory loader, PDC-4A superclock, PSB-3 pwr supply, DS-20A switcher, ESP-1 programmer, RAC-31 remote control, (4) equip racks, (2) TS-25 tone sensor units, was operational when removed from service in 3/90, \$11,000 plus shipping. J Hartmeyer, WCLT, POB 880, Newark OH 43055. 614-345-4004.

SMC MSP full feature 2000 event for satellite format, tape service, or live assist, remote control, 4 yrs old, like new cond, \$3200. D Doelitzsch, WDDD, 1 Broadcast Ctr, Marion IL 62959. 618-997-8123.

Conex DS25B, dual 25 Hz sensor, never used, \$350. D Eressy, WFCC, POB 1308, W Chatham MA 02609. 508-945-4855.

Complete automation system including CD28M, CD12C, CD28A, CD28P, (5) CD25S, (5) Revox A-77, (3) CD24R, IGM Instacart, Perma Power UPS, Pioneer Centrex monitors (pr), 4-bay rack w/rear doors, cabling, manuals & schematics, spare parts & source cards, \$15,000 (equip in St Cloud MN) G Hoppe, WHMH, 1617 N Poinsetta Pl Ste 205, Hollywood CA 90048. 213-851-0870.

Automated Broadcast Controls complete automation system w/(5) Otari R-R's, (3) ABC Carousels, will sell all or parts; SMC 581 time announce dual cart machine. D Smith, WFCB, POB 94, Chillicothe OH 45601. 614-773-3000.

Complete IGM EC System instacart 48-mono, black rack, uninterruptible pwr sup, Isaltron, cables, exc cond, \$7000. D Klahr, 609-692-8888.

McCurdy Cue System satellite decoded for Fairchild application w/time zone switcher, 2 mos old, \$1500. J Michaels, WJOD, POB 276, Galena IL 61038. 815-777-2555.

Live-Assist tape system including (4) ITC 750 series, PB only, stereo, 25 Hz tone detect card, M.W. Persons mini-mixer w/count-up clock, cabling & hardware interfacing, \$3000 (equip in St Cloud MN) G Hoppe, WHMH, 1617 N Poinsetta Pl Ste 205, Hollywood CA 90048. 213-851-0870.

Harris 9000 automation system w/CRT-70X keyboard, (2) new style & (2) old style Instacarts, (2) 42 slot Go-Carts, (4) ITC 750 R-R's, Sony remote video monitor, (2) Criterion large cart machines, play only, Extel printer w/5 cases of paper, (4) racks, all cables & interfaces & manuals, presently in service, \$37,000. D Greer, WDZZ, Genesee Towers, Ste 1830, Flint MI 48502. 313-767-0130.

SMC MSP automation system w/(4) Otari R-R's, (3) SMC 350 Carousels, SMC 721 dual cart PB's, (3) SMC equip racks, all clean, on air now, avail now, \$16,500. J Wenstrom, Wynne Bdctg, 1338 Oregon, Klamath Falls OR 97601. 503-882-4656.

Schafer 901-902 automation system w/(6) Teac/Schafer deck R-R's & I/O cards, (6) cart I/O cards, (3) rack cabinets. E Neaman, KUMU, 441 N Nimitz Hwy, Honolulu HI 96817. 808-531-4511.

Schafer automation system, older style, working, \$400. E Moody, KJEM, 216 N Main, Bentonville AR 72712. 501-273-9039.

Satcue 400 switchers for Unistar formats by Colorado Magnetics (2), \$500 ea. H Widsten, KGNB, 1540 Loop 337 North, New Braunfels TX 78130. 512-625-7311.

Systemation X7 full system w/Nakamichi MR-1 & MR-2 decks, excel cond, BO. L Wheeler, 4350 Johnson Dr, Fairway KS 66205. 816-531-2535.

Robot Jock CD600 60 CD player (4), Toshiba drive, will interface w/BM. C Keith, ALI, Box 313, Keene NH 03431. 603-352-8460.

Want to Buy

25 Hz tone generator & R-R easy listening music library. E Moody, KJEM, 216 N Main, Bentonville AK 72712. 501-273-9039.

Insta-carts or Go-carts or Carousels. C Mandel, KAMP, POB 1018, El Centro CA 92244. 619-352-2777.

Schafer 800 manuals & clock for 800 Series. E Stanley, Standey Bdctg, Box 161X, Jeffersonville NY 12748. 914-482-3158.

IGM 48 tray Instacart, call or write, prefer seller within 200 miles driving distance. C Leaseure, WTBO, POB 1644, Cumberland MD 21502. 301-722-6666.

Insta-Carts or Go-Carts or Carousels. C Mandel, KAMP, POB 1018, El Centro CA 92244. 619-352-2777.

Controller cards for Automated Bdct Controls, automation system, maybe interested in other parts for same. B Stevenson, KCRT, 100 Fisher, Trinidad CO 81082. 719 846-3355.

CAMERAS (VIDEO)

Want to Sell

RCA TK44B studio cameras (3) w/full CCU, \$3500/all. C Almasian, Tri-Core, 27503 Five Mile Rd, Livonia MI 48154. 313-427-8784.

Hitachi FP10 cables, AC pwr supply, 10:1 zoom hard shell case, manual, \$1500/BO. D Garcia, 69 Pine, Waterberry CT 06710. 203-574-4857.

Sharp XC-800 3-tube broadcast color camera, Fuji 12x lens w/2x ext, 2L image enhancer, road case, etc, excel cond, \$3600/BO. R Jensen, 5812 21st St, Racine WI 53406. 414-632-3131.

Want to Buy

Old tube type RCA, Dumont, GE, Marconi, etc, & tripods. A Weiner, 14 Prospect, Yonkers NY 10705. 914-423-6638.

GE B&W studio camera; RCA TK-42/43. B Gentry, KA21VY, 622 Plymouth, Mattydale NY 13211. 315-455-7257.

Collecting old IQ, Icoscope b&w & color cameras. RCA, Dumont, GE. Also looking for early portable TV cameras, CBS, Bendix, Ikegami, etc. A Weiner, 14 Prospect, Yonkers NY 10705. 914-423-6638.

TK-86, TK-76 & HL-79 camera cases, (3/4) needed for reworking into remote kits for air travel, will pay freight, donation preferred but can pay a reasonable price. J Hart, 502-782-2052.

CART MACHINES

Want to Sell

ITC RP cart recorder, \$850; ITC cart machine rack mounts, will work w/Premium series cart machine such as RP, WP, etc, \$20. G Gaskey, KWHO, 261 Main, Ste 6, Weed CA 96094. 916-926-5946.

ITC Delta record unit, new, record elect only, \$650. R Thomson, KDKB, 1167 W Javelina, Mesa AZ 85202. 602-897-9300.

Broadcast Electronics 2100 RPS stereo R/P, \$1650; BE 2100 PS stereo PB (3), \$950/ea; BE 3200 R/P/DL mono R/P w/optional delay, \$1250, all very low hrs, like new. G Jones, POB 229, Uvalde TX 78802. 512-278-1545.

RCA 4-Spot cart decks (2), \$400 both/BO; Spotmaster Model 500 GRP (3); one Model 500C play only; Teacaster Model 700 (2); one RP, one play only, BO. L Maierhofer, 101 Army Blvd, Lewisburg PA 17837. 717-523-3271.

Dynamax CTR10, new, BO. Howells Audio, POB 6184, Kingman AZ 86402. 602-753-4915.

ITC Delta record unit new, \$650. R Thomson, 1167 W Javelina, Mesa AZ 85202. 602-897-9300.

Teacaster X-700 mono RP in gd cond, \$200. T Stine, KGIR, 106 Ferrar, Cape Girardeau MO 63701. 314-335-9099.

Spotmaster 505, \$250; Sparta delay, \$150; Gates Criterion, needs work, \$75; (2) BE 2000 RP, \$750. J Phillips, WZOM, 408 1/2 Clinton St, Defiance OH 43512. 419-784-1059.

ITC 3 deck stereo, excel cond. J Arzuaga, POB 980, Quebradillas PR 00742. 809-895-4198.

Harris Criterion (2) triple deck repro, 10 yrs old, gd cond, \$700/both. T Stine, KGIR, 106 Ferrar, Cape Girardeau MO 63701. 314-335-9099.

Teacaster 700-P in gd cond, \$100; Gates R/P (2) in gd cond, \$175/ea plus shpg; Spotmaster PB, gd cond, \$100. J Lee, BCI, 2139 10th Ave N, Lake Worth FL 33461. 407-547-0600.

ITC PDII mono play excel cond. G Beeker, 4110 W Bank Ave, Tampa FL 33624. 813-960-8153.

ITC RP Series cart machine wall tones, \$845. P Willey, POB 560, Bennington VT 05201. 413-663-3419.

ITC R/P 3 tone, \$700. J Wenstrom, Wynne Bdctg, 503-882-4656.

BE cart winder w/imer, \$125. W Blackwelder, KNUE, POB 7935, Tyler TX 75711. 214-581-0606.

ITC Premium RP rack mount, mono, excel cond w/low hrs & manual, \$1150; ITC late mdl premium SP mono, less than 5 yrs old w/low hrs, rack mount w/manuals (4), \$875. D Doelitzsch, WDDD, 1 Bdct Ctr, Marion IL 62959. 618-997-8123.

BE 5301 mono triple-deck cart machine, working cond but needs top motor bearing, \$500. B Bicoy, POB 65, Medford MA 02153. 617-629-8476.

ITC RP Premium stereo; RP Premium mono; SP high speed cue mono; (2) BE 2000 RP mono; Sparta RP mono & delay; Spotmaster 505; Gates Criterion. J Phillips, WZOM, 408-1/2 Clinton, Defiance OH 43512. 419-782-8591.

ITC RP cart recorder, \$850; ITC cart rack mounts, will work w/Premium series cart machines, \$20. G Gaskey, KWHO, 261 Main, Ste 6, Weed CA 96094. 916-938-3828.

Sparta MC 104 PB's (4) plus spare in cabinet w/spare pwr supply, 150 Hz & 8 kHz Q-tones, \$700. L Beigel, On-Cue Record, POB 85042, Los Angeles CA 90072. 213-466-3595.

SMC 570 PB unit. E Neaman, KUMU, 441 N Nimitz Hwy, Honolulu HI 96817. 808-531-4511.

Teacaster RP 700, gd cond, \$295. A Ishkhanian, Advent Duplication, 9725 Riggs Rd, Adelphi MD 20763. 301-439-7222.

Gates Criterion 80 mono PB only, desktop cabinet, gd cond, \$450/BO. J Stack, WMPO Radio, 614-992-6485.

Harris Criterion 3 deck stereo play, excel cond, w/150 Hz tone, \$900. R Statham, WESTU, 1000 Alice Ave, Stuart FL 34994. 407-692-1000.

Entire inventory of tape cartridge equip including approx 600 Fidelipac 300 gray carts, 75¢ ea; Spotmaster 5301-A, \$600; wire cart rack, \$75; ITC triple play cart deck, \$600; (2) BE Series 3000, \$800 and much more, call for more information. E Moody, KJEM, 216 N Main, Bentonville AR 72712. 501-273-9039.

SMC 570 cart PB unit. E Neaman, KUMU, 441 N Nimitz Hwy, Honolulu HI 96817. 808-531-4511.

Otari ARS-1000 stereo PB w/25 Hz tone sensor, low hrs in excel cond, \$1000 ea. D Doelitzsch, WDDD, 1 Broadcast Ctr, Marion IL 62959. 618-997-8123.

DENON

DENON's Successor to the CD CART PLAYER™, the new DN-950FA



Call for Quote
In Stock at

NORTHEAST BROADCAST LAB
(518)-793-2181/(215)-322-2227
(603)-483-1002/(214)-612-2053

UMC/Beau mono PB (2); UMC/Beau mono R/P (2); ITC SP mono (2). D Smith, WFCB, Box 94, Chillicothe OH 45601. 614-773-3000.

ITC stereo R-P, mint, mono high speed cue, mono R-P Premium, needs work, BO; BE RP 2000 mono (2), \$150. Gates Criterion, Sparta, Spotmaster, \$750 ea. J Phillips, WZOM, 408 Clinton, Defiance OH 43512.

SMC 721 dual, \$600 & 710 single, \$300, cart PB's; SMC 250 Carousel w/random select elect, \$350; ITC RP 3 tone cart recorder, \$700. J Wenstrom, Wynne Bdctg, 1338 Oregon, Klamath Falls OR 97601. 503-882-4656.

ITC Premium series record amp, mono, \$300. J Littlejohn, WYSY, POB 2010, Aurora IL 60507. 708-851-4600.

Audicord DL-RS stereo R/P, new, remote control connections, plugs, \$1100. D Stubbs, The Sound Saloon, 1611 E Charleston Ste 1, Las Vegas NV 89104. 702-366-1696.

Gates Criterion 80 mono R/P, 2 cue tones, new p/roller & lamps, total mech & elect alignment, desktop cabinet, excel cond, \$650/BO. J Stack, WMPO Radio, 614-992-6485.

ITC Premium R/P mono, rack mount, gd cond, \$1150 3 tone; (4) Premium SP, mono rack mount, 3 tone, \$800 ea; Premium 3-D triple deck, mono, 3 tone, rack mount, gd cond, \$1000, all have manuals. D Doelitzsch, WDDD, 1 Broadcast Ctr, Marion IL 62959. 618-997-8123.

Want to Buy

Erase/splice finder should be in gd cond, will consider unit in repair. B O'Connor, 4001 Brandywine St NW, Washington DC 20016. 202-364-3982.

ITC PB & record. S Jeffries, Hwy 14 East, Mankato MN 56001. 507-345-4537.

ITC-SP & RP, must be in gd cond. E Stanley, Standey Bdctg, Box 161X, Jeffersonville NY 12748. 914-482-3158.

ITC 3-deck working cond, mono, all tones. R Yaw, Box 7000, Havre MT 59501. 406-265-7841.

CASSETTE & REEL-TO-REEL RECORDERS

Want to Sell

Revox PR 99's (2) reproduce only; automation controller, all used only a few months, excel cond, BO. K Diebel, KJJC, 1207-1/2 Louisa, Rayville LA 71269. 318-728-4915.

Otari 5050 B II 2, rack mounted, \$1775; Panasonic SV 250 mini DAT, 1 yr old, low hrs, perfect cond, \$1800. R McMillen, 3235 SE 39th, Portland OR 97202. 503-239-6070.

Crown & Ampex CR tube decks (2); (2) Ampex AG-500 solid state; Ampex 350 stereo tube, \$200 ea. C Elmiasian, Tri-Core, 27503 Five Mile Rd, Livonia MI 48154. 313-427-8784.

Teac Syncaset 124, \$200 plus \$10/UPS. N Mishan, POB 335, Lynbrook NY 11563. 516-582-1338.

Otari ARS1000 7.5/15 ips w/tone detect, clean & complete, \$900/BO. B Webster, WLIT, 150 N Michigan, Chicago IL 60601. 312-329-9002.

A

RECORDERS . . . WTS

Otari MX-5050 Mark III-8 trk w/xt control input, excel cond. L Runge, WOI-TV, Communications Bldg, Ames IA 50011. 515-294-3880.

Ampex 440 deck w/Schafer stereo solid state PB electr, \$250; Teac/Tascam 32-2 trk, stereo, dual capstan recorders, factory rack mounts, (4), virtual new cond, \$750 ea. G Gaskey, KWHO, 261 Main, Ste 6, Weed CA 96094. 916-926-5946.

Revox A77 (2), one rack mount, one not, \$350/ea or \$500/both. E Moody, KJEM, 216 N Main, Bentonville AR 72712. 501-273-9039.

Studer A80 1" 8 trk, 7.5/15 ips, 1100 hrs use, \$8000. 212-645-6319 & leave message or B Mason at 212-242-2100.

Studer Revox HS-77 Mk IV special fact order FT mono, 15/7.5 ips, only 10 hrs use, wood case, mint cond, \$575/BO. R Katz, Allegro Snd, 15015 Ventura, Sherman Oaks CA 91403. 818-377-5264.

Ampex AG 350 mono R/R w/solid state electronics rack mount, \$800. A Baker, 804 E 38th, Indianapolis IN 46205. 317-925-7371.

Studer Revox port case for A77 w/mn spkrs & pwr amos, excel cond, \$275/BO. R Katz, Allegro Snd, 15015 Ventura, Sherman Oaks CA 91403. 818-377-5264.

Scully 270S (5) used very little, BO for one or all. L Maierhofer, 101 Armory Blvd, Lewisburg PA 17837. 717-523-3271.

Ampex 350 mono R/R w/Inovonics solid state rack mount, \$500. A Baker, 804 E 38th, Indianapolis IN 46205. 317-925-7371.

Scully 255 reproducer 1/2 trk stereo, BO. Howells Audio, POB 6184, Kingman AZ 86402. 602-753-4915.

PERPETUAL MOTION
Your old reliable Ampex or Scully deck will probably run forever. Get new machine performance with our plug-compatible electronics. Several models - record/play - play-only.



Thousands in use!
Inovonics
SANTA CRUZ, CA (408) 458-0552

TEAC 90-16 16 trk in excel cond, \$7000/BO. B Kaplan, POB 644, St Cloud FL 56302. 612-253-9600.

Otari ARS 1000 (2) in excel cond, \$1500/both. M McAnally, WEKC, Williamsburg KY 40769. 606-549-3000.

Otari MX5050 MK III 2 trk w/roll around stand, manual & remote, less than 60 hrs use, mint cond, C.O.D. pick-up only, \$1400. G Finerman, Fintronics, 18 W Maple, Suffern NY 10901. 914-357-5419.

Fostex 250 porta studio replacement motor, \$50 or trade for Revox A77 remote. E O'Brien, Imperial Sound, RR 31 Box 405, Terre Haute IN 47803. 812-877-2663.

Ampex 440-C R/P, mono, Ampex electr, recently removed from srvs, gd cond, \$650. B Norman, KFLI, 3200 N Willow Creek, Prescott AZ 86301. 602-776-3785.

HEAD RECONDITIONING

Restore your worn heads to original (new) performance specifications at a fraction of the replacement cost. Our laboratory services include:

- Digital/Optical & Electrical inspection
- Precision recontouring of heads
- Complete digital/optical alignment of assembly
- Exclusive "Audio Magnetic Head Test Report™" & Data Sheets

We also carry a full line of replacement heads and parts. Our 25 years of experience and reputation are unmatched in the industry.

GMP MAGNETIC SCIENCES
249 Kennedy Road
P.O. Box 121 • Greendell, NJ 07839
Tel (201) 579-5773
Fax (201) 579-6021

Ampex 440-B R/P in Russlang cabinet, gd cond, \$375. J Lee, BCI, 2139 10th Ave N, Lake Worth FL 33461. 407-547-0600.

3M M79 1/2" 4 trk in excel cond w/synch resolver, \$750. G Zelinger, KCET, 4401 Sunset Blvd, Los Angeles CA 90027. 213-667-9310.

Teac X-300 1/4 trk, 3 motor transport, 3 head, mic/line mix, record mute, tape/source monitor select, new cond, \$625. B McCue, WEXL, 317 E Eleven Mile, Royal Oak MI 48067. 313-544-2200.

Revox A-77 3.75-7.5 ips, has record amps (3), \$700/ea plus shpg. B Downs, KISX, Box 131869, Tyler TX 75713. 214-593-4444.

Tascam 44 4 trk 1/4", excel cond, \$650. C.O.D. pick-up. G Finerman, Fintronics, 18 W Maple, Suffern NY 10901. 914-357-5419.

Inovonics 375 (4) & a mdl 370 w/Ampex R-R electronics; (3) Ampex 350's & one 354 R-R transports; (2) Teac R720 R-R transport. E Nearman, KUMU, 441 N Nimitz Hwy, Honolulu HI 96817. 808-531-4511.

Ampex AG 350 mono w/solid state rack mount, \$800. A Baker, 804 E 38th St, Indianapolis IN 46205. 317-925-7371.

Revox A77, \$350. J Wenstrom, Wynne Bdctg, 503-882-4656.

Otari MX5050 MKIII 2 trk, less than 60 hrs use w/roll-around stand, remote & manual, cash & carry, pick-up only, \$1400. G Finerman, Fintronics, 18 W Maple, Suffern NY 10901. 914-357-5419.

Magnecord 1022 stereo (2), transports for parts, electr OK; (2) Magnecord 1021 mono, transports for parts, electr OK; Magnecord 1021 mono, in port case, gd cond; Ampex AG-600, mono, in port case, gd cond; (4) Scully 270's for parts, BO on all items. D Joug, KGNB, 1540 Loop 337 N, New Braunfels TX 78130. 512-625-7311.

Inovonics 375 (2) w/R/P electr, like new w/interconnect cables, ZTR R/P head stacks avail, \$400; Inovonics tension control for Ampex 351-354-440 tape recorders, all installation, wiring & sensors & manual, \$300; Ampex 440-C R/P electrs w/spare VU meter, cards avail w/75-15 or 15-30 ips EQ cards, \$225. W Helander, MFT Recdg, 4311 Miranda, Palo Alto CA 94306. 415-948-0972.

STUDER REVOX

FACTORY AUTHORIZED SERVICE CENTER
"SUPERLATIVE SERVICE"
Swiss trained in servicing all open reel & cassette tape recorders, CD players, & other Studer/Revox equipment. Over 12,000 units serviced Nationwide since 1978. Fast 48-72 hour service w/90 day warranty. Huge parts inventory. Capstan shaft resurfacing & head relapping service. New & used machines available w/warranty. Visa/MC.

STUDIO-SONICS CORP.
2246 N. Palmer Dr., #100
Schaumburg, IL 60173
Phone: (708) 843-7400
FAX: (708) 843-7493

Ampex 440 FT recorder in roll around console, \$1250. B Blynder, TVA Inc, 11024 SW 112 Ave, Miami FL 33176. 305-595-9898.

Ampex 350 mono, w/Inovonics solid state rack mount, \$500. A Baker, 804 E 38th St, Indianapolis IN 46205. 317-925-7371.

Scully 280B (6), gd cond, rack mountable, \$1800; Scully 280B (2) sets R/P electronics, BO. T Ray, WTC, 1 Financial Plaza, HTFD CT 06103. 203-522-1080.

ITC 770 Series PB units, gd cond, one for \$600, (2) for \$1000, plus shpg. L Jones, Mediarworks, POB 625, Columbia SC 29202. 803-765-1133.

Studer B-77 1/4 trk, excel cond, recently checked out, \$500/BO. R Herman, Frontier Radio Network, POB 9292, Austin TX 78766. 512-280-5691.

Tascam 22-2 w/manual, needs some repair, \$375. W Blackwelder, KNUE, POB 7935, Tyler TX 75711. 214-581-0606.

Ampex 440 deck w/Schafer stereo solid state PB electrs, \$250; Teac/Tascam 32-2, 2 trk, stereo, dual capstan recorders, factory rack mounts (4), new cond, \$750 ea. G Gaskey, KWHO, 261 Main, Ste 6, Weed CA 96094. 916-938-3828.

Otari MX 5050-II (2), 7.5-15 1/2 trk, one w/rack mounting & one in wood case, both excel cond, \$1500 ea. R Rhodes, Roger Rhodes Music, POB 1550, NYNY 10101.

MCI R/P console R-R (2), complete w/mic/line meter bridge, pwr supply, tape drive elec, one unit is less capstan, \$350/BO. C Woodrome, KVLL, 100 Spring Valley, Woodville TX 75797. 409-283-3734.

Scully 280B-2 recorder/reproducers, gd cond (2), \$750/both. G Nelson, KSYM, 1300 San Pedro, San Antonio TX 78284. 512-733-2793.

Otari ARS1000 w/tone detect, clean & complete, \$900/BO. B Webster, WLIT, 150 N Michigan, Chicago IL 60601. 312-329-9002.

Otari 5050BII R/P decks (2), \$1800 ea; (2) Otari 5050B2HD R/P decks, \$1300 ea; (2) Otari remote control units, \$75 ea; (4) Scully 270 PB decks, \$400 ea; (2) Crown 800 R-R's, \$300 ea; ITC 850 mono R/P deck, \$550; M.W. Persons 25 Hz tone detector, \$75. E Moody, KJEM, 216 N Main, Bentonville AR 72712. 501-273-9039.

Ampex 350 R-R transports (3); Ampex 354 R-R transport; (2) Teac R720 R-R transports. E Neaman, KUMU, 441 N Nimitz Hwy, Honolulu HI 96817. 808-531-4511.

Stereo audio cassette duplication equip, over \$250,000 worth including (2) cassette loaders, (3) master bin loop players, 20 pancake tape recorders which interface w/bin loop players & much more. CC II On-Spot Prod, 460 Country Club Dr, Colby KS 67701. 913-672-3428/3117.

CLEAN PATCH BAYS
NO DOWN TIME



VERTIGO BURNISHERS AND INJECTORS RESTORE ORIGINAL PERFORMANCE TO YOUR PATCH BAYS
\$34.95 Ea.
VERTIGO RECORDING SERVICES
12115 Magnolia Blvd. #116 818-907-5161
North Hollywood, CA 91607 Fax 818-784-3763

Dokorder 7050 7" auto-reverse, built in amp & pair of speakers, gd cond, \$150. L Hoover, Logical Audio Solutions, 325 Saude, Essington PA 19029. 512-521-2933.

Otari MX 5050-8SD 1/2" 8 trk, low hrs, mint cond, calibration tape & xtrs, \$2700. C Volpe, 540 Stemmens Run Rd, Baltimore MD 21221. 301-391-6927.

Scully 280 14" R-R, \$250. C Hall, WZOU, 235 Bear Hill, Waltham MA 01254. 617-290-0009.

Dokorder 7050 7" auto-reverse, built in amp & pair of speakers, gd cond, \$150. L Hoover, Logical Audio Solutions, 325 Saude, Essington PA 19029. 512-521-2933.

Otari MX 5050-8SD 1/2" 8 trk, low hrs, mint cond, calibration tape & xtrs, \$2700. C Volpe, 540 Stemmens Run Rd, Baltimore MD 21221. 301-391-6927.

VIF INTERNATIONAL
PO Box 1555
Mtn View CA
94042
Direct order line (800) 848-4428
in area code 408
dial 739-9740
Telex 62922869 ESL UD
FAX: 1-408-739-0809

Inovonics 375 (4) & 370 w/Ampex R-R electronics. E Neaman, KUMU, 441 N Nimitz Hwy, Honolulu HI 96817. 808-531-4511.

Nagra 4.2 7" lid, xtal sync, internal resolver, phantom-T power preamps, A/C supply, extras incl Senn preamp, headsets, PDM leather case, hi impact vinyl carrying case, \$4800. G Lombardo, 61 Stephenville Pkwy, Edison NJ 08820. 201-549-8078.

Magnecord 1022 stereo (2); (2) Magnecord 1021 mono, transports for parts on both these pairs, electronics OK; Magnecord 1021 mono in portable case, gd cond; Ampex AG-600 mono in portable case, gd cond; (4) Scully 270's for parts only, BO on any items. H Widsten, KGNB, 1540 Loop 337 North, New Braunfels TX 78130. 512-625-7311.

METROTECH DICTAPHONE LOGGERS
—PARTS—
and Service

SEQUOIA ELECTRONICS
1131 Virginia Ave
Campbell CA 95008
(408) 866-8434

Technics RS-631 w/Dolby timer, LED peak indicators & mic line mixing, wooden side panels, gd cond, \$150. L Hoover, Logical Audio Solutions, 325 Saude, Essington PA 19029. 215-521-2922.

MCI JH110-B 1/4" 2-trk, excel cond, lw hrs; 7-1/2, 15/30 ips in roll around stand, \$2650/BO. T Keenan, 11105 Knott Ave, Cypress CA 90630. 714-892-9469.

Scully 280 2 trk, portable cases, vgc, \$900. F Virtue, Virtue Studios, 1618 N Broad, Philadelphia PA 19131.

Audiometrics AMCDs-1000 multiplay CD players w/SMC automation controller, live assist CD playing system, gd cond wall schematics & manuals, BO. J Glass, WZOK, POB 6186, Rockford IL 61125. 815-399-2233.

Ampex 440 B mono R/P (4); (2) Ampex 440 B stereo R/P; (2) Metrotech 500 PB; (5) Otari PG; Ampex 351 electronics. D Smith, WFCB, POB 94, Chillicothe OH 45601. 614-773-3000.

ITC 750 R/P 2 trk, fair cond, \$250. A McCarty, 600 E Main, Valaville CA 95660. 707-446-0200.

Ampex 601 (3), mono, 7.5, portable case, also 623 speaker amp, \$100 ea. S Cislser, 728 Zorn Ste 10, Louisville KY 40206. 502-895-5596.

Scully 280B mono R/P, excel cond, w/manuals, \$500. R Statham, WSTU, 1000 Alice Ave, Stuart FL 34994. 407-692-1000.

ITC 750 (2), play only, stereo, \$500 ea. J Littlejohn, WYSS, POB 2010, Aurora IL 60507. 708-851-4600.

Otari ARS-1000 (4) w/25 Hz detectors, excel cond, \$750 ea. T Jordan, Cape Fear Bdct, POB 35297, Fayetteville NC 28303. 919-864-5222.

Want to Buy
Ampex MR-70 working 2 trk in original cond. D deForrest, 7441 Wayne 10-D, Miami Beach FL 33141. 305-866-5401.

ITC 750 PB-only decks for standby use, parts (2) K Brown, Box 808, Riverton WY 82501. 307-856-2922.

Instructions/manual for Eumig FL-1000 cassette recorder, also interested in buying used FL-1000. B Harwell, Compact Disc Jockey, 2409 Wynncrest Crs, Ste 6104, Arlington TX 76006. 817-633-8462.

Revox A77 remote control. B Berry, Karavan Bdct Srvs, 13 Montgometry Pl, Conroe TX 77384. 409-273-2801.

ITC 850 service manual. K Scheffel, 9 Cougar Rd, Edwardsville IL 62025. 618-692-9798.

Otari 4 or 8 trk. S Jeffries, Hwy 14 East, Mankato MN 56001. 507-345-4537.

Tascam 32 1/4" 2 trk in new or reconditioned reel motors, reasonable, will consider cash &/or trade AT&T Comkey 416 phone system, complete w/cables, punch block & box. H Hart, Media Prod, 9440 Montego, Shreveport LA 71118. 318-687-8745.

Revox A-77 remote control, rack mounting housing & roll-around/titling rack. B Harwell, Compact Disc Jockey, 2409 Wynncrest Crs, Ste 6104, Arlington TX 76006. 817-633-8462.

ITC-750 stereo PB deck for spare, fair-gd working cond. K Brown, Box 808, Riverton WY 82501. 307-856-2922.

ITC 3D & low price reel. E Nichols, KMCR, POB 189, Montgomery MO 63361.

Ampex MR-70 2 trk in gd working cond. D deForrest, 7441 Wayne Ste 10-D, Miami Bch FL 33141. 305-866-5401.

Scully 250-2 1/4" 1/2 trk erase & record heads, w/service manual or schematics. M Sokol, 121 E Baltimore St, Hagerstown MD 21740. 301-791-2562.

WANTED
Nortronics QM707
"handylap"
lapping block
HALL ELECTRONICS
804-974-6466

Marantz or Sony PMD 201, 221 or Walkman Pro portable in gd cond. M Markiewicz, 415 Pawnee, Flagstaff AZ 86001. 602-525-1514.

MCI/Sony capstan & reel motors, any cond., recdg heads, most mfgs, machines, new, used. Relapped then sold. Amp Services, 224 Datura St No 614, W Palm Beach FL 33401. 800-826-0601, in FL 305-659-4805.

Ampex ATR100 taperecorders for parts. Circuil cards, heads, motors, machine parts, or electronic parts. Call 818-907-5161.

CONSOLES
Want to Sell

Gates Gateway 80 in gd cond, \$700 plus shpg. J Lee, BCI, 2139 10th Ave N, Lake Worth FL 33461. 407-547-0600.

Ampro AC-10 dual mono board, mint cond, low use, \$950. J Kreines, 5330 Kennedy Ave, Millbrook AL 36054. 205-285-6179.

ARCOR

2 Channel—Red and Green

DZ2202
Zip Stereo™ 2-Channel Shielded
Pair Audio Cable

IN STOCK
\$199.00 /M

NORTHEAST BROADCAST LAB
(518)-793-2181/(215)-322-2227
(603)-483-1002/(214)-612-2053

Gates Diplomat M5700 program amps (3); M-6034 pre amps (3); M-6035 cue amps, misc parts (3). BO. D Dorwart, 570 N Plymouth Blvd, Los Angeles CA 90004. 213-468-8883.

Sound Workshop Logex 8 20 chnl board w/complete EQ controls, console desk w/heavy metal stand, \$2500. D Coffman, WSOB, 940 Tarpon, Ft Myers FL 33916. 813-334-1393.

Gately 16x8 w/EQ 4 effects buss, quad monitoring Canon connector for line & Mic inputs & Canon connectors for outputs, \$2800. A Baker, 804 E 38th, Indianapolis IN 46205. 317-925-7371.

Quantum QM-8, 8 inputs, 4 busses, quad & stereo mon, etc, excel cond, \$775/BO; Speck 16 inputs, 8 busses, etc, excel cond, \$775/BO; Snake, 16 phantom-pwr inputs w/xt ps, 250' Belden 19-pair cable w/mil connectors & stainless-steel strain reliefs, etc, excel cond, \$750/BO. R Katz, Allegro Snd, 15015 Ventura, Sherman Oaks CA 91403. 818-377-5264.

Teac/Tascam 2, slide pot, 6 chnl, \$150. G Gaskey, KWHO, 261 Main, Ste 6, Weed CA 96094. 916-926-5946.

Broadcast Electronics 4 BEM 50 4 channel console, BO. J Sidote, POB 949, Welch WV 24801. 304-436-2131.

Ampro AC 85 8 chnl stereo dual, \$1800; BE 150A 8 chnl, new, \$1750. J Phillips, WZOM, 408 1/2 Clinton St, Defiance OH 43512. 419-784-1059.

CCA FM-AM 10 chnl radio studio board, \$150. Roger, Master Promotions, 5792 E Edison, Tucson AZ 85712. 602-886-1853.

Harris Stereo 5 3 mic inputs & a multiple line level inputs, gd cond. BO. R LaFlore, WOPW, POB 1327, Valdosta GA 31603. 912-244-8642.

CCA/QRK Futura Six slide pots fair to good, still in service, BO. L Maierhofer, 101 Armory Blvd, Lewisburg PA 17837. 717-523-3271.

Wheatstone Audioarts 8X recording prod console, factory patch bay, excel cond, \$11,500. D Kocher, DLK Snd Std, 1901 Hanover, Allentown PA 18103. 215-432-0520.

Bi-Amp 1642 16 chnl, 4 sub masters, 2 masters, parametric EQ, stereo pans, phantom mic pwr, rack mountable, pwr supply, flight case, \$650. B Hurley, Audio Chicago, 100 E Ohio Ste 618, Chicago IL 60611. 312-467-0170.

BE 4550 4 chnl stereo refurbished & ready to go, \$455. R Bronte, WWNT, POB 1828, Dothan AL 36302. 205-792-2161.

Gates II consoles (2); (4) Ampex 440 C recorders; (2) Metrotech 500 PB & one for parts; QRK TT warm & control; (2) UMC/Beau cart machine; UMC/Beau R/P, large quantity of spare parts for all this equip, \$1150/all, FOB Ft Pierce. F Sherwood, WDKC, POB 1330, Ft Pierce FL 34954. 407-464-1330 or Fax: 407-464-8578.

Micro-Trak 6444B stereo, new; Ampro AC85; BE 150A 8 chnl prod, new; Ramas WR-130; Heathkit mic mixer. J Phillips, WZOM, 408-1/2 Clinton, Defiance OH 43512. 419-782-8591.

Gately 16x8 w/EQ 4 effects buss quad monitoring cannon connectors for line & mic inputs and outputs. \$2800. A Baker, 804 E 38th St, Indianapolis IN 46205. 317-925-7371.

Quantum QM-8 8 chnl, quad output, \$900. W Blackwelder, KNUE, POB 7935, Tyler TX 75711. 214-581-0606.

Collins 121M-1 w/8 pots mono console. B Umberger, WNLT, 813-446-0957.

BE 4M50 mono 4 chnl mixer, little use, \$400. P Russell, Bowdoin College, Sills Hall, Brunswick ME 04011. 207-725-3066.

Russco 505-S stereo 5 chnl, \$700; Gates Producer 4 chnl mono, needs work, \$75. W Blackwelder, KNUE, POB 7935, Tyler TX 75711. 214-581-0606.

Harris Stereo 5 console, vg cond, \$695. P Willey, POB 560, Bennington VT 05201. 413-663-3419.

Harris Criterion 90 stereo play all tones, mint cond, \$995. P Willey, POB 560, Bennington VT 05201. 413-663-3419.

MOTORS REBUILT
All CART & MCI

We guarantee quiet, flutter free performance when we meticulously rebuild your motor.

Single Decks \$150.00
Triple Decks \$175.00
MCI CAPSTAN \$400.00
MCI REEL \$200.00

Metal shaft resurfacing on other motors available.

Audio Magnetic / Professionals

AMP SERVICES INC
224 Datura Street, Suite 614
West Palm Beach, FL 33401
1 (800) 826-0601
In Florida (407) 659-4805

Authorized
OTARI, SONY, TEAC Parts Dealers

CONSOLES . . . WTS

Harris Medalist 10 10 chnl, stereo, excel cond, \$1800. D Miller, KATP, 810 N Pierce, Amarillo TX 79107. 806-373-6777.

Sparta A15 5-pot news console. E Nearman, KUMU, 441 N Nimitz Hwy, Honolulu HI 96817. 808-531-4511.

BE 8M20, mono 8 chnl, gd cond, \$600. D Igou, KGNB, 1540 Loop 337 N, New Braunfels TX 78130. 512-625-7311.

Ramko DC8MS, 8 chnl 20 input stereo board, excel cond, \$3850.00. R Trumbo, KNLF, POB 117, Quincy CA 95971. 916-283-4144.

Teac/Tascam 2, slide pot, 6 chnl, \$150. G Gaskey, KWHO, 261 Main, Ste 6, Weed CA 96094. 916-938-3828.

Gates Producer w/new replacement pots, dual chnl w/q switch, not installed, 4 ch mono, could modify for stereo or mix minus, \$150. L Beigel, On-Cue Record, POB 85042, Los Angeles CA 90072. 213-466-3595.

Gates II 8 chnl mono solid state (2); Collins/Autogram IC-10 10 chnl stereo; Ramko 8 chnl stereo DC-38-8S; Teac 3 chnl 4 out; lg qty modules & parts for RCA BC 7 & 8 consoles; RCA BC 2 console shell. D Smith, WFCB, POB 94, Chillicothe OH 45601. 614-773-3000.

Tapco C-12 portable, stereo, 12 in & 4 out w/manuals, \$1000/BO; K LH Burwen TNE 7000A & DNF 1201A transient noise eliminator & dynamic noise filter w/manuals, \$600/BO. D Christian, Pacific Lutheran Univ, 121st & Park Ave South, Tacoma WA 98447. 206-535-7265.

Wheatstone Audio Arts 24 input 8 buss factory patch bay, mint cond, trades considered, \$10,000. D Kocher, DKL Snd Std, 1901 Hanover, Allentown PA 18103.

Cetec remote console, (2) TT's, 5 chnl mixer & cabinets, old Gates remote mixer/TT's/cabinets, \$200; (2) BE 5M250 mono consoles, excel cond, \$900 ea; Shure M67 mixer, \$75; Gates Dualux 12 chnl console, \$250; Gates stereo 80 console w/pwr supply, \$1000. E Moody, KJEM, 216 N Main, Bentonville AR 72712. 501-273-9039.

BE 8M20, 8 chnl mono, gd cond, \$600. H Widsten, KGNB, 1540 Loop 337 North, New Braunfels TX 78130. 512-625-7311.

Sound Workshop 1280 12 chnl board w/parametric EQ, excel cond. 12x8x2, complete monitoring section. C Volpe, 540 Stemmens Run Rd, Baltimore MD 21221. 301-391-6927.

Peavey MK3-16 portable, stereo, \$100/BO; Quantum Audio Labs QM 1010 16/8 w/some documentation, avail in 10/90, \$2000/BO; Quantum Audio Labs QM 8 portable, stereo, w/manuals, \$500/BO. D Christian, Pacific Lutheran Univ, 121st & Park Ave South, Tacoma WA 98447. 206-535-7265.

BE stereo 8 chnl w/Daven pots, \$1000; BE mono 8 chnl, \$850; BE mono 4 chnl, \$300; Collins stereo 8 chnl, \$1250; Gates stereo Yard, \$300; McCurdy stereo 8 chnl, \$900. C Haynes, WJMI, 1850 Lynch, Jackson MS 39203. 601-948-1515.

Sparta A15 5 pot news console. E Nearman, KUMU, 441 N Nimitz Hwy, Honolulu HI 96817. 808-531-4511.

BE 150A 8 chnl dual mono prod & air board, new in box; Ampco AC-8S 8 chnl stereo board, original box & manual, BO; Micro-trak 6444B stereo mixer board, new, \$400; Ramsa 8 chnl stereo board WR-130, J Phillips, WZOM, 408 Clinton, Defiance OH 43512. 419-792-8591.

Auditronics 300 series 4 trk, \$8000; Autogram R-TV 20 chnl stereo, \$7500. C Hall, WZOU, 235 Bear Hill, Waltham MA 02154. 617-290-0009.

Want to Buy

Tube limiters, compressors & EQ's, Fairchild 660 & 670, Teletronix LA2A, LA3; any Pultec EQ's, Lang EQs, etc; Fairchild 660 & 670, Teletronix LA2A, any Pultec EQs or MAVEC, Lang EQs, etc. J Kreines, 5330 Kennedy Ave, Millbrook AL 36054. 205-285-6179.

Schematic for Tascam 2A & Tascam Portastudio 05; also need meter bridge for Tascam 2A mixer. R Mize, KZMK, 3514 Kings Court Way, Sierra Vista AZ 85635. 602-458-9631.

DISCO & SOUND EQUIPMENT

Want to Sell

Fostex 765 studio reference monitors, like new, \$225/pr. K Thomas, Rebel Recdg, POB 207, Atlantic Bch FL 32233. 904-388-7711.

JBL 4695, 4622 & 2445J 3 way Cabaret series PA system, excel cond, \$2400. P Mobley, 300 Main St, Brookings SD 57006. 605-697-5326.

dbx Boom Box subharmonic synth, regenerates super low bass, \$125; JBL K140 15" speakers (2), \$225. R McMillen, 3235 SE 39th, Portland OR 97202. 503-239-6070.

Peterson strobe tuner mdl 400, new cond, \$250; Yamaha electronic piano mdl CP30, new cond, \$795, formerly Gospeltrax recdg std, out of business. Twila Stoller, 2320 Eade, Ft Wayne IN 46805. 219-484-7390.

Community Light & Sound RS440 (1 pr) 4-way speakers w/Community VB790 bass bins, in Anvil cases, excel cond, \$1600. J Kreines, 5330 Kennedy Ave, Millbrook AL 36054. 205-285-6179.

JBL 4350 (2) 15", (1) mid, (1) horn, (1) tweeter w/electronic crossover for biamp application, vgc, \$2400/BO. R Nelson, 14093 SW 142 St, Miami FL 33186. 305-253-9240.

UREI 529 room EQ's (2), excel cond, \$250. F Virtue, Virtue Studios, 1618 N Broad, Philadelphia PA 19131.

Lexicon 224-4.4 echo unit, excel cond, \$3200. F Virtue, Virtue Studios, 1618 N Broad, Philadelphia PA 19131.

Altec co-axial speakers, 604 series, gd cond w/x-overs, send price & details. D deForrest, 7441 Wayne Ste 10-D, Miami Bch FL 33141.

FINANCIAL SERVICES

EQUIPMENT FINANCING "LOANS BY PHONE"

- NO FINANCIALS REQUIRED FOR TRANSACTIONS UNDER \$35,000
- NEW OR USED EQUIPMENT
- \$2,000 to \$200,000
- NO DOWN PAYMENT
- SALE-LEASEBACK EQUIPMENT FOR WORKING CAPITAL

TO APPLY OR REQUEST ADDITIONAL INFORMATION CONTACT MARK WILSON

ENF EXCHANGE NATIONAL FINANCING (800) 342-2093 FAX: (214) 235-5452

LIMITERS

Want to Sell

Aphex Type II aural exciter, BO. J Stanford, WYLD, 2228 Gravier, New Orleans LA 70119. 504-822-1945.

Modulation Sciences CP-803 Composite Clipper, \$500/trade. G Liebisch, POB 29521, Raleigh NC 27626. 919-876-0674.

RCA BA-147 FM mono limiter, \$200. G Liebisch, POB 29521, Raleigh NC 27626. 919-876-0674.

Texar/Gentner Audio Prism latest Model w/PR-1, new cond, never rack mounted, \$1300. R Hull, 918-254-0464.

McMartin audio processor & McMartin stereo gen, \$250 ea or \$400/both. G Gaskey, KWHO, 261 Main, Ste 6, Weed CA 96094. 916-926-5946.

CRL SEP-400B/PMC-300A, excel cond, both only 3-1/2 yrs old, \$1100. T Stine, KGIR, 106 Farrar, Cape Girardeau MO 63701. 314-335-9099.

Harris/Gates AGC-994-6629-002 & M6631 Solid Statesman mono AGC & Solid Statesman mono FM limiter, both working when removed, w/manuals, \$400/BO. J Durall, WJNZ, POB 494, Greencastle IN 46135. 317-653-9717.

Optimod 8000A, BO. Howells Audio, POB 6184, Kingman AZ 86402. 602-753-4915.

Dual UREI LA-4 limiters in rack mount, \$300. G Liebisch, POB 29521, Raleigh NC 27626. 919-876-0674.

UREI BL-40, \$295; Comex bleepmate 675, \$499; Lake patch bay, \$79. C Dube, WSPR, POB 1270, Springfield MA 01102. 413-732-4182.

Spectra Sonics Compilimter, mono compressor/limiter, gd for dialogue, \$150. G Zelingor, KCET, 4401 Sunset Blvd, Los Angeles CA 90027. 213-667-9310.

CBS Audimax 4450, BO; CRL APP-300, BO; (2) CBS Volumax 411, BO. Howells Audio, POB 6184, Kingman AZ 86402. 602-753-4915.

CBS Audimax 3 compressor, \$100; CBS Audimax 3S stereo chasis compressor, \$200; CBS Volumax 410 limiter, \$100; CBS DPE 450 dynamic presence EQ, \$100; Kahn SP58-1A Symmetra Peak, \$50. B Umberger, WNLT, 813-446-0957.

Harris MSP-90 tri-band AGC & AM limiter, mono, excel cond, new in '84 out of serv in '86, \$500/both. R Hines, 250 W Court, Cincinnati OH 45202. 513-241-9500.

Orban 8000-A gd cond, factory test results avail, \$1500. D Karns, 915 E Broadway, Columbia MO 65201. 314-874-5676.

Allison Research Gain Brain 700, single chnl, rack mount, Kepex 500, BO; Dorrough 310 DAP AGC peak limiter, update card, BO; Inovonics 230 multiband audio processor, update card, BO. T Liston, WOBL, Box 277, Oberlin OH 44074. 216-774-1320.

CRL AM4 mono (4), 3-1/2 yrs old, excel cond, purchase one or all, BO. M McNeil, Guardian Comm, 800 Compton, Ste 33, Cincinnati OH 45231. 513-931-8080.

Orban 8000A, \$1600; CBS Volumax 400, \$150; CBS Audimax III, \$150; DAP 310 tri-band, \$250; (2) Harris/Gates 944 Solid Statesman, \$300, all in mint/excel cond. D Igou, KGNB, 1540 Loop 337 N, New Braunfels TX 78130. 512-625-7311.

CBS stereo Audimax 4450A. E Nearman, KUMU, 441 N Nimitz Hwy, Honolulu HI 96817. 808-531-4511.

CBS FM stereo level control; Optimod 8000; CBS Audimax; CBS Volumax; CRL AC 400. J Phillips, WZOM, 408-1/2 Clinton, Defiance OH 43512. 419-782-8591.

Orban 9000A w/manual, \$1200. R Ingram, KMY, POB 4076, Beaumont TX 77704. 409-833-4400.

UREI LA4, \$300; Audimax 4440 auto level, \$150; Marti CLA-40H, \$200; Gates Sta-Level, \$75. C Haynes, WJMI, 1850 Lynch, Jackson MS 39203. 601-948-1515.

Harris AM limiter, \$500; Harris ME-1 mod enhancer, \$150; Harris AM tri band AGC, mdl MSP 90, \$1250; Gates Sta Level, \$85. E Moody, KJEM, 216 N Main, Bentonville AR 72712. 501-273-9039.

PR&E Multimax processors (3), \$200 ea; (2) PR&E multimiters, \$200 ea; Hnat-Hindes 104 peak limiter, \$50. C Hall, WZOU, 235 Bear Hill, Waltham MA 02154. 617-290-0009.

Orban 8000A, mint cond, \$1600; CBS Volumax/CBS Audimax III, rebuilt, \$150 ea; DAP 310 tri-band, \$250; Gates Solid Statesman limiters (2), \$300/pr. H Widsten, KGNB, 1540 Loop 337 North, New Braunfels TX 78130. 512-625-7311.

CRL Systems FM4G consisting of SPP-800 Stereo Prep Processor, (2) SEP-400B Spectral Energy Processors, SMP-800 Stereo Modulation Processor & SG-800 Stereo Generator, excel cond, \$4500. B Dickerson, WEAG-FM, 904-964-5001.

Optimod 8000A
\$1495 & UP
414-482-2638

Dorrough DAP 610 (2), set up for AM, may be converted, \$1000 ea/BO. J Littlejohn, WYSY, POB 2010, Aurora IL 60507. 708-851-4600.

Orban Optimod 8000A, just rebuilt, like new, \$1750. K Krueger, KGTS, 204 S College, College Place WA 99324. 509-527-2991.

Dorrough DAP 310 AM processor. D Smith, WFCB, Box 94, Chillicothe OH 45601. 614-773-3000.

Want to Buy

Texar Audio Prisms wanted pair plus RCF-5 audio card for Orban 8100-A. J Bahr, 154 Guajajata St, Crown Hills, Rio Piedras PR 00924.

Fairchild 660 or 670, Teletronix LA2A, LA3, other tube compressors & limiters; & other vintage tube signal processing equip. J Kreines, 5330 Kennedy Ave, Millbrook AL 36054. 205-285-6179.

Altec 436 A, B, C, cheap. J Ganguer, 415-644-2363.

Altec 436 A, B or C & Altec 438 A, B or C cheap. J Ganguer, 942 32nd St, Richmond CA 94804. 415-644-2363.

MICROPHONES

Want to Sell

RCA 44-A velocity bi-directional diamond shaped ribbon mic, a classic, yoke & shock mount intact, \$550. R Franklin, Super Snd Stds, 211 Virginia, Norristown PA 19401. 215-277-7112.

EV 1957 collectors edition 667 w/adjustable EQ preamp system, gold plated head & fittings, custom cables & mahogany case, documentation, new cond, \$395. D Miller, Airborne Audio Prod, 11847 W 83rd Terr, Lenexa KS 66214. 913-492-8822.

Neumann KM-88, rare 3-pattern w/nickel capsule, hot-setup percussion mic, mint cond w/orig case, \$875/BO; Neumann KM-86 3-pattern, mint cond, \$675/BO. R Katz, Allegro Snd, 15015 Ventura, Sherman Oaks CA 91403. 818-377-5264.

Bruel & Kjaer 4007 high intensity, omni mic, phantom power, never used, still in wood box, ruler flat, \$750/firm. B Ford, Spunk Prod, Box 1052, El Granada CA 94018. 415-726-4786.

Telefunken tube CM-61, very rare, uses std plug-in tube, mint cond w/custom ps, BO. R Katz, Allegro Snd, 15015 Ventura, Sherman Oaks CA 91403. 818-377-5264.

Sennheiser 2003 diversity UHF wireless receiver, new, \$2500. B Blynder, TVA Inc, 11024 SW 112 Ave, Miami FL 33176. 305-595-9898.

RCA Classic ribbon mics, send for list. B Davies, 5548 Elmer, N Hollywood CA 91601. 818-761-9831.

Sennheizer 421's (2) in metal boxes. J Phillips, WZOM, 408-1/2 Clinton, Defiance OH 43512. 419-782-8591.

Neuman U87 w/shock mount, mint cond, \$1300. D Kocher, DKL Snd Std, 1901 Hanover, Allentown PA 18103.

RCA 77DX ribbon mic, gd cond, complete w/shock mount, works, BO. E Duellman, WOMT, POB 1385, Manitowoc WI 54221. 414-682-0351.

RCA ribbon mics including (1) 44-BX; (1) 77-D; KU3A10,0001; BK-11; BK-5; SK-46; WE639A, will trade for other high quality condenser, dynamic, ribbon mics & audio equip. Tracy Eaves, 615-821-6099 (evenings).

Want to Buy

Vintage tube condenser mics, Neumann, Telefunken, Schoeps, AKG & classic ribbon mics, RCA 77s, 44s; Telefunken ELAM 250s or 251s, any cond; AKG C12s & C24s, any cond; Neumann U47, U48, M249B, KM56, U67, etc, any cond. J Kreines, Demott/Kreines Films, 5330 Kennedy Ave, Millbrook AL 36054. 205-285-6179.

Altec M-20, M11 mics, capsules, windscreens shock mounts; Ampex ATR100 & AC-500 tape recorder field engr bulletin sets, booklets/ads. D Bisbee, 685 S Roys, Columbus OH 43204. 614-279-6163.

RCA top dollar and/or trade old RCA movie mikes for RCA (pre-4AA) ribbon-field coil mikes such as PB-17 or PB-31 etc. J Webb, 15117 Hamlin, Van Nuys CA 91411. 818-769-6738.

RCA 77DX/44BX non-working cond is ok. M Brooks, POB 106, Toccoa GA 30577. 404-886-2191.

RCA 44s, 77s & other ribbon mics, working or not, also WE. B Davies, 5548 Elmer, N Hollywood CA 91601. 818-761-9831.

Schematic for Altec 21B mics. R Robinson, 203-269-4465.

Fairchild F22 power supplies (2) or AUI condenser mics, buy or trade, also schematics on these. J Edwards, WRET, POB 4069, Spartanburg SC 29305. 603-599-0201.

Vintage mic for antique radio display, all types. D Koehn, KNEN, Box 937, Norfolk NE 68701. 402-379-3300.

Will buy or trade for RCA 4 AA condenser mike no major missing parts please. J Webb, 15117 Hamlin, Van Nuys CA 91411. 818-769-6738.

MISCELLANEOUS

Want to Sell

Hammond REFK19035-24 rack cabinets (2) w/locking solid front door & louvered rear door w/lock, dual squirrel cage blowers w/filter for clean cabinet pressurization, Hammond RAVB-290 blowers, 35" vertical panel space & threaded rails in racks, gd cond, \$350/ea. TX Valley Translator, 6903 Spring Garden, San Antonio TX 78249. 512-696-5615.

Data Signal MTI-700 modular telephone interface, BO; (3) RCA Tactec programmable trunking mobile telephone radios, BO; 3M fax machine, BO. Howells Audio, POB 6184, Kingman AZ 86402. 602-753-4915.

Jingles that sing K-95 FM & 3-40,000 bumper stickers that say I LOVE K95FM, BO. E Moody, KJEM, 216 N Main, Bentonville AR 72712. 501-273-9039.

Standard rack cabinets (3) 6' military spec, \$75/all. G Gaskey, KWHO, 261 Main, Ste 6, Weed CA 96094. 916-926-5946.

AT&T Comkey 416 telephone system, one base unit, 2 extension units, 2 incoming lines & 1 intercom path, expandable to 5 lines w/icom & total of 16 stations, w/cables, punch terminal & box, \$321.27 or trade for Tascam 32 reel motors. H Hart, Media Prod, 9440 Montego, Shreveport LA 71118. 318-687-8745.

Radio Systems TM-2R new, in original boxes, studio timers, \$125/ea. K Thomas, Rebel Recdgs, POB 207, ATL Bch FL 32233. 904-388-7711.

Alden Electronics C2000R weather radar, 16 pgs of memory, telephone access to site, full color graphics, composite video or RGB interface to monitor. W Rossini, WLQR, 125 S Superior, Toledo OH 43602. 419-244-8321.

Equipment inventory including Commodore 64 w/monitor & FSD-1 floppy disk drive, \$150/BO; stereo monitor amp, gd cond, 30 W tube type, \$75; Gra-Lab photo electric timer, \$25; part of Gatesway manual & schematics, BO; Miralot Conelrad rcvr, BO. M Johnson, KGAL, POB 749, Albany OR 47321. 503-451-5425.

Tellabs 4008 equalizer modules (2) w/Tel-lab 1911 single card housing & transformers, \$100/ea. N Beaty, 2116 Osman Lane, Greenfield IN 48140. 317-326-3620.

OTARI MTR12-I
1/2" 4 Track
Demo, like new



One Only
List \$13,525.
SPEC. \$9,999.
CWO

NORTHEAST BROADCAST LAB
(518)-793-2181/(215)-322-2227
(603)-483-1002/(214)-612-2053

Elgar HIT-7.5 7.5 kW isolation transformer, perfect cond, 120/240 V, \$2600/firm. A Reis, TNL Resources, 308 Eastgate Court, New Lenox IL 60451. 815-485-7388.

Trompeter original gold J13-75 patch jacks, PN2BE-75 paralleling, PNS3/625 & PNS4/625, TPC-9.75 O Berliner. SoundDesign, Box 921, Beverly Hills CA 90213. 213-276-2726.

Misc equip inventory including several hundred feet of RG-8U coaxial cable on reel (2), new, \$50/roll; Gates 14425 audio transformer, BO; 4000' of #10 bare copper wire, 1000' rolls, \$125/roll. M Johnson, KGAL, POB 749, Albany OR 47321. 503-451-5425.

LEL SF101 splice finder, poor shape, motor works, not finding splice now, \$40. B Umberger, WNLT, 813-446-0957.

RCA, Presto Etc, 16" disc recorders & other equip including blanks, needles & pre-recorded discs. B Davies, 5548 Elmer, N Hollywood CA 91601. 818-761-9831.

Dale SPA 2000 power arrester (2) for 3 phase wiring systems, new, BO. C Phillips, WVVO, POB 987, Clinton TN 37717. 615-457-2697.

Bird 100 W load, 43. 2-slugs; ESE 301AE timer; McKay base & head. J Phillips, WZOM, 408-1/2 Clinton, Defiance OH 43512. 419-782-8591.

Military rack cabinets (3) 6", 19", \$75/all. G Gaskey, KWHO, 261 Main, Ste 6, Weed CA 96094. 916-938-3828.

Tandy computers, mdl 600HD & mdl #2, in excel working cond, also (2) Tandy printers, sold together or separate, BO. F Fess II, WLRB, 1199 Carroll, Macomb IL 61455. 304-833-5561.

Video radio sales training tapes, 30 topics on 16 VHS tapes, \$1500. R Trumbo, KNLF,

MISCELLANEOUS . . . WTS

Harmon-Kardon mixers, new DPR7; Meissner mixer five inputs-battery; Cannon plugs, 3 prong, male & female; 40 new tubes & resistors cheap; Lafayette TE22 audio generator; Sencore transistor & diode tester; manuals for Ampex, Pultec, Altec & others. Mr. Oliver, 212-874-7660 in afternoons.

Rotron Blowers for Elcom, CCA, CSI, McMartin, rebuilt & new. Goodrich Enterprises Inc. 11435 Manderson St., Omaha, NE 68164 402 493 1886 FAX 402 331 0638

Executone 'Encore' telephone system recently removed from computer store. 12 phone, punch blocks, options, cords, installation jacks, etc. priced low. Goodrich Ent, 11435 Manderson St, Omaha NE 68164. 402-493-1886, Fax: 402-493-1886.

Attention: Government seized vehicles from \$100. Fords, Mercedes, Corvettes, Chevys. Surplus Buyers Guide. 1-602-838-8885, Ext A-12079.

Attention: Government Homes from \$1 (U-repair)! Delinquent tax property. Repossessions. Call 1-602-838-8885, Ext GH-12079.

Want to Buy

Telos 100 System, complete system which would include (3) Telos digital hybrids & switch console. H Reinders, WWDB, 5558 Hallie, Chippawa Falls WI 54729. 715-723-1037.

Manuals/catalogs for RCA, Dumont, GE sales. A Weiner, 14 Prospect, Yonkers NY 10705. 914-423-6638.

RCA On Air light old style in gd cond, cash or trade. F Beacham, 6201 Sunset Blvd #29, Los Angeles CA 90028. 213-462-2908.

Manuals to convert Pioneer multi-play home units CD players to interface w/automation equip for music source of automated radio stations. 703-935-4541 (days); 703-935-9230 (aft 7PM EST).

50's & 60's style radio station clock, naval observatory time w/red light that illuminated on the hour, would like to know mdl number if it had one. B Berry, Karavan Bdct Svcs, 13 Montgomery Pl, Conroe TX 77384. 409-273-2801.

WE any mdl amps, mixers, speakers, literature, Altec amps, speakers, top \$ pd for WE amps. D deForrest, 7441 Wayne 10-D, Miami Beach FL 33141. 305-866-5401.

Maxitel 82 or any model telephone mixing unit remote bdct system. S Hess, KDUC, 29000 Radio Rd, Barstow CA. 619-256-2121.

Lafayette radio catalogs, any yr before 1978. A Peterson, 117 Park Ln Ste 84, New Milford CT 06776.

Western Union studio clock, wall clock wired light, brown case, cream color face, red hands. T Heathwood, Heritage Radio, POB 16, Boston MA 02167.

Schematic & service info for Olivetti electronic typewriter w/TV screen Mdl ETV-240; main flat drive belt for Pioneer RT-909 R-R. Q Morrison, KHLO, 913 Kanoehueha, Hilo HI 96720. 808-961-0651.

NBC Hotline decoder unit. J Haynes, Haynes Bdct Svcs, 81 Knox, Millinocket ME 04462. 207-723-9190.

Jazz record collections, 10" LP/12" LP bebop, swing, dixie, highest prices paid. B Rose, Program Recdgs, 228 East 10th, NUNY 10003. 212-674-3060.

MONITORS

Want to Sell

Belar RFA-2 AM RF on 1220 kHz, less than 1 yr old, mint cond, \$400. T Stine, KGIR, 106 Farrar, Cape Girardeau MO 63701. 314-335-9099.

Delta amplitude mod controller, closed loop, w/optional Delta monitor board, excel cond, \$1800. T Cochran, KNOM, Box 988, Nome AK 99762. 907-443-5221.

Gates M5774 tube type AM mod mon, \$30; Gates 88F FM freq mon, \$30; McMartin TBM 3500 tube type FM mon, \$30; Collins 900 F1 FM SCA mon, \$100; Collins 900 C2 FM stereo mon, \$500. B Umberger, WNLTI, 813-446-0957.

Ball Miratel 7-007-0200 AM air monitor. BO T Liston WOB, Box 277, Oberlin OH 44074. 216-774-1320.

TFT 760 AM EBS rcvr/decoder/gen, BO. B Webster, WLIT, 150 N Michigan, Chicago IL 60601. 312-329-9002.

McMartin TBM 2000A SCA monitor for 67 kHz, \$400. J Littlejohn, WYSY, POB 2010, Aurora IL 60507. 708-851-4600.

McMartin tuner mdl TR-55 SCA, \$50; Marti PGM 20H program line amp, \$65; RCA AM mod mon, \$100; TFT 713 AM freq & mod mon, \$750; TFT EBS rcvr w/FM rcvr, \$325; TFT 704A remote meter, \$50; Plectron FM rcvr 155.49 MHz, \$35. E Moody, KJEM, 216 N Main, Bentonville AR 72712. 501-273-9039.

McMartin TBM3500B base band monitor w/low level card tuned & calibrated. Goodrich Ent., 11435 Manderson, Omaha NE 68164. 402-493-1886.

McMartin B-910 stereo FM exciter, tuned & calibrated to your freq, like new. Goodrich Ent, 11435 Manderson St, Omaha NE 68164. 402-493-1886. Fax: 402-331-0638.

CONSULTANTS

EVANS ASSOCIATES
Consulting Communications Engineers

FCC Applications, Design & Field Engineering
Broadcast Engineering Software

216 N. Green Bay Rd.
Thiensville, WI 53092

(414) 242-6000
Member AFCCCE

W. LEE SIMMONS & ASSOC., INC.

BROADCAST TELECOMMUNICATIONS CONSULTANTS

1036 William Hilton Pkwy
Ste 200F
Hilton Head Is., SC 29928

(803) 785-4445

SOFTWARE
FM CHANNEL SEARCH

FM Database pool
MSDOS
EGA Graphics-Color
Broadcast Technical Consulting

Doug Vernier
Broadcast Consultant
1600 Picturesque Drive
Cedar Falls, IA 50613
319-266-8402

MAGRILL ENGINEERING
Radio Engineering Consultants

FCC Applications - Upgrades
Pre-purchase evaluations
Station planning & Design
Turnkey systems - Field service

Experienced, Economical & Fast

(904) 591-3005

Barry Magrill P.O. Box 1010
President Fairfield, FL 32634
Member IEEE

AM-FM Transmitter: Installation, maintenance, frequency change and field service

VERNON BOYCE
broodcast technical consultant

10433 Cayuga
Dallas, Texas 75228

214-328-7501

MEYER GOTTESMAN
Broadcast consultant/engineer

FM, TV and LPTV applications. Frequency studies, transmitter field service, etc. We go anywhere! Former CE Boston, Houston, Miami and Ft. Lauderdale. Former HARRIS transmitter field engineer.

3377 Solano Ave., #312
Napa, CA 94558

Tel: (415) 221-2000 (anytime)
FAX (415) 387-2425 (days)

Consulting Communications Engineers

- FCC Data Bases
- FCC Applications and Field Engineering
- Frequency Searches and Coordination
- AM-FM-CATV-ITFS-LPTV

OWL ENGINEERING, INC.

1306 W. County Road. F,
St. Paul, MN 55112
(612)631-1338 "Member AFCCCE"

Looking for a position in radio or television?
Looking for personnel for your station?
I can help! Reasonable rates. Free information.

Full Service Consulting

Bill Elliott
48 Imperial Avenue
Pittsfield, MA 01201
413-442-1283

Huntsville Antenna Engineering

There is hope for AM radio! AM station unipole antennas with circular polarization & beam tilt. Broadband your present AM tower Series R shunt fed.

205-353-9232 205-353-6747

Kenneth Casey
Consulting Radio Engineer

new station construction field service AM directionals

RON KROB
broadcast technical consultant

4910 Four Star Court
Fort Collins, CO 80524 303 484 2704

RADIO SYSTEMS ENGINEERING

FCC Applications • Design • Installation • Field Service

Experienced & Affordable

4289 Roanridge
Las Vegas, Nevada 89120

24 Hr: (702) 454-2085
FAX: 702-458-2787

Moffet, Larson & Johnson, Inc.
Consulting Telecommunications Engineers

Two Skyline Place
5203 Leesburg Pike # 800
Falls Church VA 22041
703-824-5660
800-523-3117
Member AFCCCE

DISPLAY YOUR CONSULTANT'S CARD HERE AND BE SEEN BY OVER 21,000 READERS

SERVICES

BRENTLINGER BROADCAST ENGINEERING, INC.

Charles Jayson Brentlinger
President

COMPUTERIZED REPORTS
ALLOCATION STUDIES • AM • FM
AM DIRECTIONALS • AUDIO • STL
SATELLITE COMMUNICATIONS

4338 East Acoma Drive
Phoenix, Arizona 85032
(602)867-0181

HARMON'S TOWER SERVICE, INC.

Maintenance, Painting, Antenna & Equipment Installation, Winch Services

435 B Broadway
Columbus, GA. 31901
(404) 327-1074

FCC's Engineering
AM, FM and TV Data Bases for your PC

Call today to request a free sample

Communications Data Services

6105 E Arlington Blvd
Falls Church VA 22044
(703) 534-0034

R.F. Systems

Installation Checkout
Optimization

Donald "Donny" Millar
President

916-644-7055
5874 Rose Court
Pollock Pines, CA 95726

BROADCAST COMPUTER DATABASE BBS

300 to 19200 Baud
N-8-1
Multi-Node System
(713) 937-9097

FCC Information
On-Line Call Sign Search
On-Line Engineering Formulas
Messages, Conferences, Files, Doors

BROADCASTING & ELECTRONIC SERVICES LABS

PO BOX 178
NEWTON, UT 84327
801-563-3088

BROADCAST EQUIPMENT
REFURBISHED & REPAIRED
AUDIO, VIDEO, RF, DIGITAL
15 YRS EXPERIENCE

TOWER SERVICES
Light Replacement
Routine Maintenance
Ground Systems
Painting
20 years Experience

John Nix

PO Box 13244 Salem, OR 97309
503-581-4056
1-800-321-4056

SPECIALIZING IN ERECTION, REPAIRING, PAINTING AND MAINTENANCE RADIO, TWO-WAY, TV, TOWERS AND FLAG POLES

A STEEPLEJACK CO.
PAINTING AND STEEPLEJACK CONTRACTORS

FULLY INSURED FOR YOUR PROTECTION

DON HIGLEY 3722 ROMA
713-462-6105 HOUSTON, TEXAS 77080

MIRKWOOD ENGINEERING

Rural & Remote Site
Field Engineering

50 Park Ave.
Claremont, NH 03743

603/542-6784

T & W

Tower/Antenna
Erection • Maintenance

* 24 Hr. Emergency Service *

Hurlock, MD
301-376-3555

TENCO TOWER

Lic. No. 357096

Installation & Maintenance of
Broadcast & Communications
Towers & Antennas

Donald J. Tenny

(916) 362-6846
(916) 638-8833
9723 Folsom Blvd. Suite A
Sacramento, CA, U.S.A. 95827
FAX: (916) 638-8858

PARAMOUNT COMMUNICATION SYSTEMS

INSTALLATION AND SERVICE OF BROADCAST ANTENNA SYSTEMS/TOWER MAINTENANCE & ERECTION

WESTMONT, NJ (609) 869-0222

WIDEST & FINEST CHOICE OF PRODUCTION MUSIC & SFX

PROMUSIC

Call For Our Free Demo & Information On
BROADCAST Plus
Annual Rates.

1-800-322-7879

RF Components
Field phasing modifications and installation

Call Dave Gorman
215-249-9662
POB 401
Dublin PA 18917

THIS SPACE AVAILABLE

Call Simone Mullins
at 1-800-336-3045

Contact Radio World Newspaper for availabilities: P.O. Box 1214 • Falls Church VA • 22041

EMPLOYMENT

To place ads in this section, use the ActionGram form. To respond to box numbers, write Radio World, PO Box 1214, Falls Church, VA 22041, Attn: _____

HELP WANTED

WJMI/WOAD Jackson MS seeking engineer w/exp in RF & studio maintenance, start \$20,000/yr. C Haynes, 601-948-1515.

Chief Engineer needed in high level small market with 24 hr operation for both 1 kW AM and full class C 100,000 watt FM. Knowledge of mobile radio and mobile telephone helpful. Much better compensation and fringes than normal. Write Jerrell Shepherd, Box 619, Moberly MO 65270, or call 816-263-5800. Highly prefer someone within 500 mile radius of Moberly so personal interview can be made. If you are not making \$30,000, give me a call.

Chief Engineer for Premier Boston Stations WRKO, WROR-FM. Five years experience. Strength in transmitters and management. Resumes to: Susan Theye, 3 Fenway Plaza, Boston, MA 02215. An EOE M/F/H/V.

Sales/marketing/PR professional with track record and initiative for a new, lucrative challenge. To sell, market and promote a new line of radio programs to small market stations. Someone from Nashville, Pittsburgh or able to work from current location. Profit participation to right party. This is a ground floor opportunity. Send information to:
West Hills Studios/WHS
Radio Network
827 Meridian Street
Nashville, TN. 37207

Quality Transmitter Mfg Co. Now Hiring Production Manager, Production Assistant, Parts Manager, Exciter Technician, Sales Engineer. Send Resume to: Radio World, PO Box 1214, Falls Church, VA 22041. Attn: 90-08-05RW.

Chief Engineer for top-rated Midwest combo. 100 kW FM & 1 kW non-directional AM. Previous broadcast engineering required. Will maintain transmitters, STL, satellite receivers, all studio equipment. Must have knowledge of FCC guidelines. Create & adhere to engineering budgets. Well-maintained & modern facilities in a great family city. Competitive pay & benefits package. Contact: Roger Larson, KFOR/KFRX, POB 80209, Lincoln NE 68501. EOE.

Assistant CE for Washington, D.C.'s #1 station. Successful candidate will become CE within 1 yr. Excellent trouble shooting, construction & people skills required, 5 yrs experience & SBE certification required. Superb opportunity! Send resume to: T McGinley, WPGC FM, POB 10239, Washington DC 20018. EOE

Project Engineers, Satellites (two positions). Radio network seeks electrical engineers w/three or more years hands-on satellite operations or maintenance experience. Familiarity w/radio or TV station operations helpful. Become part of a team designing & implementing national satellite network improvements, including new control facility & enhancements to local radio station satellite equipment. BSEE, FCC license & SBE certification desirable, gd communication skills, some travel required. Familiarity w/standard spreadsheet, database or project management software desirable. Fixed term position through December 1993. Salary commensurate w/experience. Applicants should include salary history. Submit resumes to Personnel, National Public Radio, 2025 M St., NW, Washington DC 20036. EOE.

Attention: Postal Jobs! Start \$11.41/hour! For application info call 1-602-838-8885, Ext M-12079, 6AM-10PM, 7 days.

Warm water, sand, sun, palm trees, take charge engineer, 3 powerful FM's in Virgin Islands, re-location assistance, salary, tremendous benefits, commensurate w/exp. Fax 809-775-6063.

Prominent Washington, D.C. consulting electronics engineering firm specializing in telecommunications has an immediate opening for a bright, eager person. Send Resume to: Radio World, POB 1214, Falls Church VA 22041. Attn: Box 90-08-03RW.

POSITIONS WANTED

Gen Op Dir w/top prod skills seeks bigger market/challenge in N England, MIDI & automation familiar. C Keach, 252 Union St, Littleton NH 03561. 603-444-0659.

Design engineering position w/broadcast equip mfg looking ahead to a digital future. Digital logic/systems and/or firmware/software development. A Melnyk, POB 127, Kanona NY 14856. 607-583-4117.

Morning man/PD w/great leadership skills & 8 yrs exper seeks small/medium market oldies/AC AM/FM, prefer NE PA or Southern NJ. Mike, 814-676-3077.

NAC PD with digital library considering a format change, serious inquiries only please. B Hallihan, Box 3125, Turlock CA 95381. 209-634-0318.

Production wiz up for grabs 14 year vet prefers NY area but will relocate for killer offer. Call B Ranes, 718-526-6501.

On-Air production pro w/4 yrs exper seeks new opportunities, very strong on-air/prod presentation & great attitude. R Ray, 404 S Wisconsin, Ste 5, Gunnison CO 81230. 303-641-1258.

Engineer/Businessman engineering, technical sales, communications sales/service, regional manager, teacher, need new challenge, presently DOE for nine station radio group. M Beasley, 1319 Heritage Place, Moberly MO 65270. 816-263-5800 or 5605.

FCC Gen/RT lic, 30 yrs exper AM/FM all phases, strong construction, studio & xmr maint, FCC R7R, will relocate. D Walrod, 1245 Tower Dr, Logansport IN 46947. 219-722-1695.

Programmer/Engineer, 4 yrs exper as Chief, willing to relocate. P Jensen, 905B 46th, Niceville FL 32578. 904-678-6765.

Producer/Writer/Engineer w/14 yrs syndication & broadcasting exper, available for any area, will relocate for good offer. B Ranes, 718-526-6501.

Production director w/14 yrs writing/producing/engr exper avail for your station or network. B Ranes, 718-526-6501.

CE, FCC General Class Lic, 30 yrs exper AM/FM bdsting, strong on FCC R&R, construction, RF & studio/xmitter maintenance. D Walrod, 1245 Tower Dr, Logansport IN 46947. 219-722-1695.

Graduating 5/20 w/(2) B.A. degrees, business admin & accounting, plus 15 yrs of bdst exper, seeking mgmt position, relocate anywhere. L Witt, 319-242-0400.

General or station mgr/operations director quality announcer avail, seeking job with quality owner, intending to stay around and serve comm, small medium large mkt background. J Banks, POB 2031, Sylvania GA 30467. 912-564-2922.

Entry level position in LI NY area wanted for college freshman, 1 yr exper in announcing, engineering, post-prod, seeking challenging/creative opportunity. D Rothstein, 516-431-2928.

Energetic, young, fast-learning DJ w/2 yrs on-air exper wants to improve himself & you, southeast FM AOR preferred, but all accepted. B Fredette, POB 642, Newport TN 37821.

Looking for Music Director, programming or engineering position, wide music knowledge from Classical to Modern Rock, exper in LA & SF. Bruce, 415-388-8368.

Engineer 20 yrs AM, FM, satellite, automation, bubble gum, baling wire. P Morton, POB 57, Rupert VT 05768. 802-394-2858.

Experienced announcer/degreed eng/SBE w/great top market voice seeks small/medium AC/CHR/Oldies station in New England area needing prof, reliable, mature announcer at reasonable rate. G.P. Brefini, 508-543-4213.

Bell System RF engineer w/28 yrs exper, PE, 1st phone. w/Mt Washington exper seeks mountain-top station engineering position. G Pugh, 89 Trumbull Rd, Manhasset NY 11030. 516-627-2153.

Humble on-air, great voice, production, timing, charisma, excel study, sports background, news, seeks South Carolina FT midlands position. AC, Urban, CHR, Herb, 803-534-8285.

Personality w/4 yrs exper seeks on-air position in small or medium mkt. MD & background in AOR, CHR & AC formats, will relocate. N Adams, 97 N 100 W #4, Logan UT 84321. 801-752-1907.

Enthusiastic female seeking on-air position, music programs, news, traffic, also comfortable w/production, music research & programming. Tracey, 708-852-1049 or 309-792-3956.

Chief engineer w/big production voice & over 15 yrs of hands-on engineering exper, seeks CE pos w/production in a competitive top 100 mkt. G Morgan, 704-563-8676.

Chief Engineer/Assistant chief seeks pos w/major Southeast radio station, FCC generalist/class license, SBE certification, amateur EXTRA license, 14 yrs of radio & TV bdst engineering exper, excel ref, quality workmanship, hardworking & hands-on, exper in all aspects of AM/FM radio engineering. H Ginsberg, 12 Beech St, Essex Junction VT 95452. 802-878-8796.

Operations/Production Mgr currently employed, seeks challenging new pos, will relocate, extensive travel ok. D Smith, POB 11902, Baltimore MD 21207. 301-591-2128.

30 yr veteran in radio engineering & equipment sales seeks agreement w/organization to provide field sales &/or engineering support on an expense plus basis. L Darrigo, 803-650-3466.

Tampa contract temporary w/22 yrs bdst, audio, RF, telco includes Power Pig construction & AM remotes, also Sony trained editor, Bosch 3-D DVE, self employed MATV. AJ Anello, 813-933-6009.

Producer/Engineer w/radio prod/prog exp, former recording studio owner, seeks program/engineer position. Z Nicall, 6404 Hollywood Blvd 4th flr, Hollywood CA 90028. 213-464-2145.

Award winning sports director needs bigger challenge, college/pro PBP, 11 yrs exper. Chip, 409-846-5474.

DOE, CE, 29 yrs exper in station, corporate, contract & consulting firm partner positions. Texas, Louisiana, Oklahoma preferred. Right offer other areas possible. Reply to Radio World, POB 1214, Falls Church VA 22041. Attn: Box 90-08-04RW.

27 yr bdst looking for mgmt/buy in option. Owner/mgr, sales, announcing, production, CE experience, great turnaround record, prefer NC-SC-VA areas. B Hull, POB 741, Mt Airy NC 27030. 919-786-4675.

CE/Asst CE, SBE, FCC, Asst CE in LA for 2 yrs, seeks position on West Coast but will consider all. T Brooks, 7201 Haven Ave, Ste E-333, Rancho Cucamonga CA 91701. 818-574-7053.

MONITORS . . . WTB

Want to Buy

TFT 763 mono FM mod monitor, working or repairable. N Herbot, KBEN, POB 335, Carizo Springs TX 78834. 512-876-2210.

BE/C-QUAM AM10K prefer 1982 or later. R Payne, 774 Roswell St, Marietta GA 30060. 404-424-9850.

Any older McMartin mod monitors. C Goodrich, 11435 Manderson, Omaha NE 68164. 402-493-1886.

MOVIE PROD EQUIP

Want to Sell

Eiki ST-OH 16mm sound movie projector, excel cond, \$100; Schneider 360mm C-mount telephoto lens, marks on barrel, otherwise excel cond, \$29. G Ormrod, GFO Prod, 432 East X St, Tumwater WA 98601. 206-352-8028.

Nagra III internal xtal, rolloff filter, Sennheiser 805 w/KAT 15, leather case, ATN pwr supply, excel cond, \$1450; & new Bell & Howell 70 DR w/Anvil case, 1" Comat, instructions, \$325. J Kreines, 5330 Kennedy Ave, Millbrook AL 36054. 205-285-6179.

Want to Buy

Mitchell 35 & 16mm cameras & accessories, other professional 16/35mm cameras, incl Arriflex, Aaton, CP, etc; optical printers, Research Products 1000, 1001, & Acme & Osberry; cine lab equipment; upright Moviolas, especially 35mm. Westrex 35mm; optical recorders, & RCA & Maurer optical recorders; CP16s any condition; good cine optics (Zeiss, Ultra-T, Angenieux, Cooke, etc); also need Zeiss 9.5mm Distagon, reasonable, need not be mechanically mint. J Kreines, DeMott/Kreines Films, 5330 Kennedy Ave, Millbrook AL 36054. 205-285-6179.

RECEIVERS & TRANSCEIVERS

Want to Sell

ICOM R-7000 25 MHz-2 GHz all mode AM/FM/NB/WB/SSB communications rcvr, rack mount panel w/built in speaker, \$1100 pls shpg (firm). B Coleman Jr, WIST, POB 460, Lobelville TN 37097. 615-593-2978.

ICOM R-71A 100 kHz-30 MHz all mode AM/FM/SSB long wave, medium wave & shortwave communications rcvr, w/rack mount panel & monitor speaker, \$1100 pls shpg (firm). B Coleman Jr, WIST, POB 460, Lobelville TN 37097. 615-593-2978.

Motorola Micor FM 2-way radio less access, mdl T43RXA1900AA, 162-174 MHz, 12 VDC. \$150. B Dickerson, WEAG, Starke FL 32091. 904-964-5001.

Moseley RPL-2 RPU rcvr tuned to 161.67 & 161.76. E Nearman, KUMU, 441 N Nimitz Hwy, Honolulu HI 96817. 808-531-4511.

Fairchild Dart 384 digital audio receiver terminal, in service less than 1 yr, \$4300. E Sears, WXLW, POB 22300, Indianapolis IN 46222. 317-925-6494.

Moseley RPL-2 RPU rcvr tuned to 161.67 & 161.76; McMartin EBS AM rcvr tuned to 760, tone gen & tone decoder. E Neaman, KUMU, 441 N Nimitz Hwy, Honolulu HI 96817. 808-531-4511.

McMartin EBS system w/AM-R1 AM rcvr, EBS-2 monitor & TG-2 EBS 2 tone gen, as is, \$200. C Haynes, WJMI, 1850 Lynch, Jackson MS 39203. 601-948-1515.

Heathkit HW 100 10-80 M SSB xcvr 100 W, \$125. A McCartney, 600 E Main, Valaville CA 95660. 707-446-0200.

Want to Buy

TFT 760 or newer EBS rcvr-decoder & generator; Scientific Atlanta DAT 32 system satellite receiver & dish or Fairchild Dart system. S Hess, KDUC, 29000 Radio Rd, Barstow CA 619-256-2121.

Schematic for Avcom 100 EBS encoder/decoder, will pay reasonable copying & shipping. D Grant, WLAV, 50 Louis NW, Grand Rapids MI 49503. 616-456-5461.

REMOTE & MICROWAVE EQUIP

Want to Sell

Potomac remote meter panel for ant monitor, BO; Moseley TRC-15AW xmr unit only, BO. J Stanford, WYLD, 2228 Gravier, New Orleans LA 70119. 504-822-1945.

Harris/Gates M5862 RDC-10C w/manual, works, but better used for parts or rebuilding, \$100/BO. J Durall, WJNZ, POB 494, Greencastle IN 46135. 317-653-9717.

Wegener Panda II & satellite switcher. B Hearst, WWCH, POB 688, Clarion PA 16218. 814-226-8600.

Marti RPT 15 dual freq UHF xmr; Marti CR-10-2 dual freq UHF rcvr, 450.700 & 450.925 MHz, used on only a few remotes, like new, \$1700/both plus UPS. G Jones, POB 229, Uvalde TX 78802. 512-278-1545.

Gates RDC-10 remote control unit in gd cond, spare Gates RDC-10 for parts, w/plenty documentation, \$250/both. N Beaty, 2116 Osman Lane, Greenfield IN 46140. 317-326-3620.

Sine Systems RFC-1/B "DIAL UP"

Remote Control Complete systems starting at less than \$1,400.00!

HE HALL Electronics
804-974-6466

Moseley MRC-1600, like new, latest software, \$3700. C Leavens, 412-241-2985.

Moseley PCL 505 STL stereo system, w/manual, excel cond. J Arzuaga, POB 980, Quebradillas PR 00742. 809-895-4198.

Moseley MRC 1600 remote control, just back from Moseley for calibration, in factory cartons w/manuals, warranty, excel cond, \$2500/BO. J Salov, 3431 W Houghton Lake, Houghton Lake MI 48629. 517-366-5364.

Moseley MRC-1600 digital remote control, \$1995.
804-974-6466

Moseley PCL-505C STL system on 947.00 MHz, \$3750. C Leavens, 412-241-2985.

MCI remote control 9 chnl digital, 450 MHz xmr, studio-line, SCA cards, 1/2 price; Moseley RPU 161.67 & 166.25 xmr & rcvr. BO. J Phillips, WZOM, 408 1/2 Clinton St, Defiance OH 43512. 419-784-1059.

Gentner VRC 1000 3 yrs old, exc cond, complete pkg incl relay panel, terminal strip, battery backup, qume computer terminal, TC 100 hybrid interface and printer, \$1500/0r trade for Moseley MRC 1. T Teagarden, 710 W 14th St, San Angelo TX 76902. 915-655-9879.

Moseley TRC-15, CRL audio processing APP-300A & PMC-300A, Pacific Recorders Multimax MX/AM audio compressor/limiter, Belar AM-2 mod mon. C Mandel, KAMP, POB 1018, El Centro CA 92244. 619-352-2277.

Moseley 1600, like new, \$1950/BO. T Cranford, KMTY, POB 1465, Grand Island NE 68802. 308-381-3697.

Complete RPU system, Marti dual-freq xmr & rcvr for 160 MHz band, w/(2) Scala Yagis w/interbay stacking, ASP whip, omni antenna, all in gd working cond w/manuals, \$1050. T Spaight, WLRZ, POB 73, Peru IL 61354. 815-224-2100.

Inventory Clearance

ELECTRO VOICE
Sentry 100 Studio Monitor

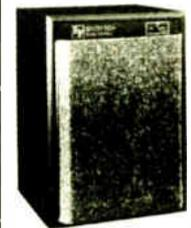

Spec. \$195. CWO

While they last

NORTHEAST BROADCAST LAB
(518)-793-2181/(215)-322-2227
(603)-483-1002/(214)-612-2053

Modulation Associates complete SCPC rcvr shell incl pwr supply downconverter & demod, suitable for use on Westar 4 transponder 2D or 2X. \$995/trade. G Liebisch, POB 29521, Raleigh NC 27626. 919-876-0674.

Harris SCA gen card for MX-15 exciter, BO; Moseley SCG-4T subcarrier gen, BO; Moseley MRC-1600 remote control, BO; Moseley SCG-8 subcarrier gen, BO; Moseley SCR-8 subcarrier receiver, BO. Howells Audio, POB 6184, Kingman AZ 86402. 602-753-4915.

TFT 8600 narrow bandwidth on 951.5 MHz, excel cond, w/built-in subcarrier, \$2000/both; Moseley subcarrier gen & demodulator, SCG-8/SCD-8 on 39 kHz w/conversion kit for 67 KHz, excel cond, \$1700/both. T Cochran, KNOM, Box 988, Nome AK 99762. 907-443-5221.

Wegener SCPC satellite rcvr for use w/SMN's The Heat format, avail 7/1/90. J Coursolle, WGGQ. 414-324-4441.

Comtech Transtar AC format system w/Colorado Magnetics network switcher, \$1800. B King, KLBUI, 500 Leland, Austin TX 78704. 512-832-4061.

Wegener 1601 mainframe cards for SMN formats rock & star station 1621, 1645, 1646, 1605-03, 1646, 1610-01, 1610, 1689-05, \$300/ea. D Crisp, 302-629-6636.

Moseley TRC-15; CRL audio processing APP-300A & PMC-300A; Pacific Recorders Multimax MX/AM audio compressor/limiter; Belar AM-2 mod mon. C Mandel, KAMP, POB 1018, El Centro CA 92244. 619-352-2277.

Subcarrier gen card 67 kHz for MRC-1600, \$150; 6 kHz subcarrier demod card for MRC-1600, \$150; 2 pole 100 A manual pwr transfer switcher, \$50; Comex Bleepmate 6 second digital delay, \$600. W Blackwelder, KNUE, POB 7935, Tyler TX 75711. 214-581-0606.

MCI digital remote control; MCI 450 M, 10 W, return link. J Phillips, WZOM, 408-1/2 Clinton, Defiance OH 43512. 419-782-8591.

Marti RMC-2 remote control system, \$950. C Haynes, WJMI, 1850 Lynch, Jackson MS 39203. 601-948-1515.

WE'RE BUYING!

INTERESTED???

Then call Jim or Chuck
@ 317-962-1471 @
ALLIED EQUIPMENT EXCHANGE

BUY We selectively buy used radio equipment
SELL We sell used and new radio equipment
TRADE We take trade-ins for used and new radio equipment

Allied has served broadcaster needs since the 60s! Our veteran broadcasting salesmen will "horse trade" with you—give them a try today!

HARRIS ALLIED EQUIPMENT EXCHANGE

317-962-1471

EMPLOYMENT SECTION

HELP WANTED: Any company or station can run "Help Wanted" ads at the flat rate of \$25 per listing per month (25 words max). Payment must accompany insert; there will be no invoicing. Blind box numbers will be provided at an extra charge of \$5. Responses will be forwarded to listee, unopened, upon receipt. Call 800-336-3045 for display rates.

POSITIONS WANTED: Any individual can run a "Position Wanted" ad, FREE of charge (25 words max), and it will appear in the following 3 issues of Radio World. Contact information will be provided, but if a box number is required, there is a \$5 fee which must be paid with the listing (there will be no invoicing). Responses will be forwarded to the listee, unopened.

Mail To: BROADCAST EQUIPMENT EXCHANGE
PO Box 1214, Falls Church, VA 22041

REMOTE & MICRO . . . WTS

Harris 6550 satellite receiver chassis w/PS & down-converter, no demod cards, mint cond. \$400. D Igou, KGNB, 1540 Loop 337 N, New Braunfels TX 78130. 512-625-7311.

Harris 70-L upconverter mdl 8220; L-Ku up-converter mdl 8221; LNC pwr supply mdl 6312; (2) Ku-band LNC mdl 6312; (2) IF conditioning panels, one for parts; ITT amp; travelling wave tube mfg 20948; PTS 160 freq synth mdl 160-54010, \$15,000/all. E. Welch, Welch Media, POB 1455, Moncks Corner SC 29461. 803-761-7585.

Macom 23 GHz audio/video link w/Macom MA-2300 xmtr w/dish, Macom MA-2300 rcvr w/dish, dbx digital audio processor system, \$6000 package. C Hall, WZOU, 235 Bear Hill, Waltham MA 01254. 617-290-0009.

Scientific Atlanta 7.5 kHz dual audio decoder card for CBS, NBC, ABC mainframe rcvr/demod, excel cond, \$500. H Ginsberg, Communications Eng Inc, 12 Beech St, Essex Junction VT 05452. 802-878-8796.

Moseley MRC-1600 in excel cond, \$2500. B Williamson, WALL, One Broadcast Pl, Middletown NY 10940. 914-343-7400.

Harris 6550 satellite rcvr chassis w/PS & down converter, no demod cards, mint cond, \$400. H Widsten, KGNB, 1540 Loop 337 North, New Braunfels TX 78130. 512-625-7311.

TFT 7601-C & 7601-R digital remote control for AM, FM & TV xmtrs w/10 chnl of raise/lower or off control & display of telemetry from a remote site w/manual, \$1500/BO. J Strong, WXF, 120 Wildwood Dr, Mt Zion IL 62549. 217-864-4141.

Henry Network Commander currently configured for Drake Chenault, 6 mos old, new cond, \$700. B Downs, KTSR, Box 3248, Bryan TX 77805. 409-846-1150.

Moseley MRC 1600 4 yrs old, includes cards for both subcarrier or telephone line operation, \$2200. R Watson, WXCOC, POB 778, Wausau WI 54401. 715-645-8218.

Moseley TR-55A telemetry rcvr, \$50. C Hall, WZOU, 235 Bear Hill, Waltham MA 02154. 617-290-0009.

Wegener 1806-24 stereo rcvr w/tone decoder, 6 mos old, comes w/Henry Eng NetCommander set for Drake Chenault, avail as package or separate, \$1900. B Downs, KTSR, Box 3248, Bryan TX 77805. 409-846-1150.

Stationmaster PD-455 450 MHz fiberglass co-linear, new, in original carton, \$465. D Eressy, WFCO, POB 1308, W Chatham MA 02609. 508-945-4855.

Want to Buy

Marti RPT 30 or RPT 15 15 W or greater, must be in 455 MHz band, solid state, balanced input. K Scheffel, 9 Cougar Rd, Edwardsville IL 62025. 618-692-9798.

Satellite receiver for Transtar's Niche 29 format. B Hearst, WMCH, POB 688, Clarion PA 16218. 814-226-8600.

Marti RPT 2540, BR10/150 RPU remote pick-up xmtr & rcvr on 161 MHz. S Hess, KDUC, 29000 Radio Rd, Barstow CA. 619-256-2121.

Marti remote equipment 160 or 450 band rcvr & tran. S Jeffries, Hwy 14 East, Mankato MN 56001. 507-345-4537.

Television satellite uplink, C-band or K-band, fixed or mobile, incl exciter, HPA, dish, etc. Ugly George Satellite TV, 314 W 52nd St, NY NY 10019. 212-677-2200.

STL electronics, dishes, hardware & Marti RPU xmtrs, receivers, antenna, repeaters on 161 & 450 bands. L Maierhofer, 101 Armory Blvd, Lewisburg PA 17837. 717-523-3271.

Marti STL-8 or 10. J Stanford, WYLD, 2228 Gravier, New Orleans LA 70119. 504-822-1945.

STATIONS

Want to Sell

Class A soon to be C3 in Pacific Northwest, signal in large market, for info call Larry at 404-460-6159.

AM/FM combo in mountain area, 580 kHz, 2.3 kW day, 310 W night, ND, Class A FM, C1 applied for, 17 acres, 2 story building, positive cash flow, owner financing avail, would consider aircraft in trade, \$260K/BO. Tracy, 605-745-3797 (evenings).

Distressed, failing or dark station. Low cash price, take over or little cash down. AM or FM anywhere. Must have real estate included. Answers confidential. Private buyer for own operation and ownership.

B. Bridges, 827 Meridian St. Nashville, TN. 37207
615-226-1122, FAX #615-227-1268

AM & or FM radio station in Central Arkansas, good area, excellent potential. Ask for Vivian, 501-470-1525 or 501-568-5448.

Partner/Investor for licensed FM start-up, Class C2 radio station for Taos & northern New Mexico. Scheduled November on air date. Francis, 505-377-6450.

Southern California daytime in high growth area, \$1.5 mil/negotiable. M Sadacca, POB 1317, Crestline CA 92325. 714-882-2575.

Receiver's sale: KESP Santa Barbara accepting offers cash or terms to qualified 1/3 down, 1988 gross \$411,000, 1989 gross \$508,000, for information call G Erway, 407-283-6871.

AM daytimer, early sign on, 1000 W, bldg & residence & 4.59 acres. LaVerne McBeath, KJBC, 1903 S Lamesa Rd, Midland TX 79701. 915-684-5152.

WE CAN SELL YOUR AM STATION FOR MORE!

We have buyers looking for small to medium market stations with or without owner financing. Call us before you sell.

THE JESSE NEAL BROWDER CO.
202 Whistlewood Ct.
Woodstock, GA 30188
1-404-928-7906

Financing needed for 10 kW AM, 50 kW FM, located between major Montana markets, take lien or corporate shares, excel opportunity. M-R-S, 110 N 2nd Ave #39, Chula Vista CA 92010.

AM construction permit 880 kHz at Moneta, Smith Mountain Lake VA, tower site firm, studios avail, great area potential, will work w/buyer to build. L Williams, Rt 1 Box 314, Wirtz VA 24184. 703-647-1530.

FM CP for college town, no other radio station in city or county, price includes engineering for C-3 upgrade, \$25,000. D Ballard, KLF, 4410 10th, Lubbock TX 79416. 806-791-1747.

AM/FM station, 10,000 W AM, Class A approved for Class C FM, western resort area, gd market, popular program & community reception, priced to sell, terms & information on request. J Gayer, West Engineering, 815 Reed St, Lakewood CO 80215. 303-233-8433.

LPTV 1000 W Goleta, Santa Barbara CA, trade, sell, or take partner, BO G Erway, 3450 SE Martinique, Stuart FL 34997. 407-283-6871.

APPRAISALS based on value of equipment, revenues & real property in a format lenders will understand. Reasonable fees.

THE JESSE NEAL BROWDER CO.
1-404-928-7906

Class B FM, northern California, gd revenue, 3 large county coverage area. R Trumbo, KNLF, POB 117, Quincy CA 95971. 916-283-4144.

Make More Money At Night. Offer our books on per-inquiry basis. 1-800-562-4381.

WISCONSIN

Class A, C/3 Possible
\$395,000
414-482-2638

Want to Buy

FM or AM/FM, gd terms, financially qualified, in NY, PA, Ohio, MD or IL or KY. E Stanley, Standey Bdcg, Box 161X, Jeffersonville IN 12748. 914-482-3158.

LPTV CP's & troubled stations, buy or trade or joint venture, send details w/prce & terms. J Worrall, 537 Ridgewood, Louisville KY 40207. 502-896-4513.

Seeking existing AM or CP in eastern or central North Carolina. L Afferbach, CTC Media, 5550 Sterrett Pl, Columbia MD 21044. 301-621-5045.

AM fulltime near metro or AM daytimer in small town or LPTV. B Turner, 1000E 3rd, Del Rio TX 78840.

First time buyer looking for small market AM or FM w/little or nothing down & owner financing in NJ, PA, OH & DE. M Gehring, 7 Crestview Dr, Oil City PA 16301. 814-676-3077.

AM/FM/LPTV, owner financing, monthly note plus percentage of gross. Norm, 904-892-4038.

AM or FM East of the Mississippi w/nothing down & owner financing, will consider small cities. Rev P Fleming, POB 1792, Torrington CT 06790. 203-482-9355.

STEREO GENERATORS

Want to Sell

Harris STX-1B & STM-1B AM stereo gen & monitor, both modified for Motorola C-Quam, excel cond, \$7500/BO. B Bailey, KJEF, POB 1248, Jennings LA 70546. 318-824-2934.

MARATHON PRODUCTS COMPANY

Audio Cartridge Rebuilding Division

Rebuilding/reloading, like new, all brands, any length up to & including 2.5 minutes, \$1.50 ea. FOB our plant, 48 hrs delivery.

New NAB Marathon cartridges prices on request.

35 Years professional experience!

Lifetime member AES R.D.MYERS Sr.

Manufacturers of Audio Devices, Continuous Tape Mag.

69 Sandersdale Rd.,
Charlton, MA 01507

1-508-248-3157 or 1-508-853-0988

Moseley 20A234 26 kHz subcarrier gen, \$30; Moseley 20A2345 26 kHz sub-carrier demod, \$30, cards only in an aluminum box on both. B Umberger, WNLT, 813-446-0957.

Harris MS-15R digital stereo gen w/overshoot control, \$800; BE FC-30 SCA gen on 67 kHz, \$350. J Littlejohn, WYSY, POB 2010, Aurora IL 60507. 708-851-4600.

CCA FM 10DS working when removed from service, \$300/BO. J Stack, WMPO Radio, 614-992-6485.

SWITCHERS (VIDEO)

Want to Sell

3M 1174 w/4 busses, mix to wipe, direct buss, take bar, ext. int keys, \$850. R Jensen, Telecab Corp, 5812 21st, Racine WI 53406. 414-632-3131.

CEL Model P169V 4x8 routing switcher, local or remote control, full instructions, mint cond, \$1475. Chief Engr, Vidcom Consultants, 412-327-1333.

CoHu 9501 w/manual & broadcast sync generator model TSG3000 GL, \$1000. D Garcia, 69 Pine, Waterbury CT 06710. 203-574-4857.

Sigma Electronics VSS-120 (4) like new, 12x1 w/stereo audio follow, \$100 ea. P Russell, Bowdoin College, Sills Hall, Brunswick ME 04011. 207-725-3066.

Arrakis router switcher, 16 stereo in, 8 stereo out, rack mount, includes power supply & connectors. 5 yrs old, \$600. D Doelitzsch, WDDD, 1 Broadcast Ctr, Marion IL 62959. 618-997-8123.

Want to Buy

Bdct school needs non-working Vital 114 switcher &/or Vital Squeezeezoo for parts to keep existing system running, partial systems OK, can give tax receipt if donated. B Hodges, OSV Journalism Bdcg, 206 Paul Miller, Stillwater OK 74078. 405-744-8273.

TAPES, CARTS & REELS

Want to Sell

Tascam 32, 7.5-15 ips stereo up to 10" reels, very little use, \$1200 pls shpg (firm). B Coleman Jr, WIST, POB 460, Lobelville TN 37097. 615-593-2978.

Ampex 406 10 1/2 " metal reels (10), new in sealed factory shpg carton, \$100 + UPS. G Jones, POB 229, Uvalde TX 78802. 512-278-1545.

Audiopak AA-2, AA-3 & AA-4, like new, 70 sec lengths & music lengths. BO. R Thomson, KDKR, 1167 W Javelina, Mesa AZ. 602-897-9300.

Audiopak AA-4 hundreds of music lengths, like new, \$2.25/ea. R Thomson, 1167 W Javelina, Mesa AZ 85202. 602-897-9300.

Twelve hours of music & life of Elvis, gd cond, 7" reels, BO. G Erway, 3450 SE Martinique, Stuart FL 34997. 407-283-6871.

Beta & 3/4" cassettes, sometimes 1", both large & field size avail, 1/2" s are BC(T)5s. 5 min commercial or 1 hr at Beta 3 speed. P Dowie, Good Sound, 171 Drexel, Lnsdn PA 19050. 215-626-9322.

A&D Cartridge Rebuilding Service

We clean, load & pack. Serviced within 10 work days! Work guaranteed!
3380 Bakely Ave., Eau Claire, WI 54701
(715) 835-7347

Audiopak AA-4, music lengths, like new, \$2.25 ea. R Thomson, KDKB, 1167 W Javelina, Mesa AZ 85202. 602-897-9300.

Easy listening music reels, 10.5", no dupes, all in vgc w/play sheets (250), \$10 ea. J Wenstrom, Wynne Bdcg, 503-882-4656.

Fidelipac carts (530), brown/clear shell, \$500; Audiopak AA-3 carts (300), blue/clear shell, \$450. W Blackwelder, KNUE, POB 7935, Tyler TX 75711. 214-581-0606.

Sound Ideas Series 1000 sound effects pkg on reels, 7 1/2" ips, excel cond, \$550/BO. T Keenan, 11105 Knott Ave, Cypress CA 90630. 714-892-9469.

Metal reels 10" (60), \$60. J King, POB 2308, Roswell NM 88201.

Easy listening music, 250 reels, all vgc, no duplicates, \$10/reel or BO. J Wenstrom, Wynne Bdcg, 1338 Oregon, Klamath Falls OR 97601. 503-882-4656.

Want to Buy

Scotch/Ampex/Agfa 1" wide audio tape used once & bulk erased, either reels or hubs, boxed or un-boxed. T Houston, Custom Audio Recording, 929 California Ave, Bakersfield CA 93304. 805-324-0736.

Classical record library on 78 rpm classical records, pre-recorded R-R tapes, airchecks, etc. D deForrest, 7441 Wayne Ste 10-D, Miami Bch FL 33141.

TAX DEDUCT EQUIP

UPS/Battery back-up generators needed by university amateur radio club, willing to pay shipping for working/useable gear. J Bondon, 10318 Missouri, Los Angeles CA 90025. 213-338-3556.

Alabama A&M Univ seeks donation of radio equip for starting a non-commercial FM station, will issue tax deductible receipt. C Haygood, POB 324, Normal AL 35762. 205-851-5227.

VHF/UHF/HF/CB amateur & comm equip desired, also packet controller, remote based antennas/tower, etc. J Bondon, 10318 Missouri, Los Angeles CA 90025. 213-338-7356.

Educational station seeks donation of automation equip for training program, will pick up & provide tax letter, need Brain, racks & accessories, repairable's OK. H Espravnik, WYCP, 1360 Nashville Pk, Gallatin TN 37066. 615-451-1640.

Need mics, cart machines & consoles. C Riddle, World For Christ Radio, 6046 Greenway Ct, Manassas VA 22111. 703-670-7764.

Front line Christian TV station on US-Mexico border needs all types of video/audio equip. S Frahm, KSCE, 614 E Yandell, El Paso TX 79902. 915-542-0038.

High school station in need of cart machines, consoles, R/R, TT's, etc. J Kelly, SCS High School, Ovid NY 14521. 607-869-9636.

Ohio University campus station seeks audio equip of any kind for use in studio & prod room, will pay shipping & send tax deductible receipt. D Harlett, WNWG, West Green Office, Athens OH 45701. 614-597-5885.

R-R tape decks, 10" tapes, VCR's, stereos, TV's. H Saina, Elderly & Disabled, 1213 Pine, Chester PA 19013. 215-497-3990.

Eng student desiring donation of old bdct equip (anything) in repairable cond, will pay all shipping charges, EE student at Purdue. C Gill, POB 371, Indianapolis IN 46206. 317-923-2800.

Monte Vista Christian School, would appreciate any donations of used TV broadcast equipment. T Quinn, 408-475-0423.

TEST EQUIPMENT

Want to Sell

Leader LDM 171, highly accurate, AC volt-meter/dist analyzer, brand new cond, less than 4 hrs use w/manual, \$695. G Finerman, Fintronics, 18 W Maple, Suffern NY 10901. 914-357-5419.

Potomac FIM-21, \$1800; Potomac AM-19 4 tower, \$2300; Delta RG-3, \$2900; (2) ITC 3 deck mono w/tones, \$500-700; Belar AMM-1, \$450; Belar AMM-3, \$550; GR 1931A mod mon, \$400. E Burkhardt, WLEE, 121 Wyck, Ste 300, Richmond VA 23225. 804-232-0300.

B&W 410 tube type dist meter, \$25. B Umberger, WNLT, 813-446-0957.

HP 205AG audio signal gen, BO; International Instrument 600 ohm T network analyzer, BO; HP 325B noise dist analyzer, BO. T Liston, WOBL, Box 277, Oberlin OH 44074. 216-774-1320.

RCA WO-91B oscilloscope; Hickok 600A tube tester. E Neaman, KUMU, 441 N Nimitz Hwy, Honolulu HI 96817. 808-531-4511.

TFT 760-04, 01, 03, very little use, tone generator/decoder, AM rcvr, works perfectly, \$700. T Coucke, KNLS, POB 475, Anchor Point AK 99556. 907-235-8262.

RCA WO-91B oscilloscope; Hickok 600A tube tester. E Neaman, KUMU, 441 N Nimitz Hwy, Honolulu HI 96817. 808-531-4511.

Potomac Instruments SD-31 RF synthesizer/detector, excel cond, \$1750; Potomac Instruments FIM-21 AM field intensity meter, excel cond, \$1800. H Ginsberg, Communications Eng Inc, 12 Beech St, Essex Junction VT 05452. 802-878-8796.

Leader LBO 524, complete w/manuals, probes, needs no calibration, 40 MHz, hardly used, \$600. D Eressy, WFCO, POB 1308, W Chatham MA 02609. 508-945-4855.

TEST EQUIPMENT

Why Buy When You Can Rent?
POTOMAC, DELTA, BIRD.

Other Equipment Available
Call For Rates and Availability

RADIO RESOURCES

1-800-54-RADIO
1-800-547-2346
301-859-1500

HP antenna VSWR test equip incl HP608C signal gen, \$350; HP 415B VSWR meter, like new, \$325; directional couplers, \$100-\$450, slotted line, prices incl packing & UPS within continental US. P Onnigan, 1236 40th Ave, Sacramento CA 95822. 916-381-4469.

Want to Buy

GR Telephone CG-3 service instructions/schematic for counter-generator, buy or pay for copy. M Kaplan, Puget Snd, Naval Shipyard, Bremerton WA 98314. 206-476-7419.

Bird 4712 in-line wattmeter, 5 kW element, 1 5/8" line, L Maierhofer, 101 Armory Blvd, Lewisburg PA 17837. 717-523-3271.

Used field intensity meter; Nems Clark 120 series or RCA WX series; Potomac FIM-21 or 41; used Delta Electronics Operating Impedance Bridge, OIB-1 or OIB-3. N Beaty, 2116 Osman Lane, Greenfield IN 46140. 317-326-3620.

McCurdy 14023 extended range audio meter, will consider other devices. J Beahn, 4001 Brandywine St NW, Washington DC 20016. 202-364-3868.

Tektronix 520 vectorscope, working or not. B Gentry, KA21VY, 622 Plymouth, Mattytale NY 13211. 315-455-7257.

Complete board A3, reciprocal amp for HP 8690B sweeper; also want 8698B & 8699B plug-ins. Herb, CFQC TV, 216 First Ave N, Saskatoon, Sask S7K 3W3, Canada. 306-373-7919.

TRANSMITTERS

Want to Sell

Used McMartin FM Exciter, B-910. Goodrich Ent., 11435 Manderson St., Omaha, NE 68164. 402-493-1886.

TRANSMITTERS
FM - AM - LPTV
ALL POWER LEVELS
1-800/279-3326
J & L ASSOCIATES
P.O. BOX 25966
Colorado Springs, CO 80936

Collins 830-D 1000 W, in service w/spare parts, stereo gen to be replaced this month due to pwr increase, \$4500. J Anderson, WKCU, 2192 Hwy 72 East, Corinth MS 38834. 601-286-8451.

LEASING AVAILABLE ON USED TRANSMITTERS

AMERICAN BROADCAST FINANCIAL CORPORATION
414-482-2638

TRANSMITTERS! TRANSMITTERS! TRANSMITTERS!

AT LAST!

Quality Rebuilt AM & FM Transmitters Delivered, Matched To Your Antenna, and Placed On The Air. And, For No More Than You'd Pay For a Transmitter In Pieces From The Other Guys.

When you buy a BTS transmitter, we deliver it on our company truck. We place it in your transmitter building. And, the *very best* transmitter engineer in America places it on the air for you. When we're finished, you know how it will sound because it's On the Air. No other way of buying a used transmitter makes sense. Overseas and Alaskan/Hawaiian services are available, too!

We'll take your old transmitter and other broadcast gear in trade!
Complete turnkey station construction available!

Broadcast Transmission Systems
7008 Lock Lommand Austin, Texas 78749
(512) 448 - 0058

TRANSMITTERS ... WTS

Elcom Bauer 605C 5 kW FM, one tube, single phase, brand new, minor shipping damage, \$27,000/BO. V Michael, WHTO, 575A Montgomery Pike, S Williamsport PA 17701. 717-323-8200.



High performance at affordable prices.

- New front panel programmable composite STL's.
- New directly programmable FM composite receivers
- New options for synchronous boosters and translators
- New FM exciters, transmitters, amplifiers: 2W to 30kW
- Same old price, quality service and reliability

Bext, Inc.
739 Fifth Avenue
San Diego, CA 92101
619-239-8462
Telex 229882 Fax 619-239-8474

Energy-Onix MK 15 FM, 15000 W, single phase pwr, 2 yrs old w/CSI EX 20F exciter tuned to your freq, \$20,000/BO. P Moore, KXFX, POB 2158, Santa Rosa CA 95405. 707-523-1389.

RCA 10 kW BTA-10H PCB free, completely rewired, \$11,000. C Stone, 234 E Meadow, Eden NC 27288. 919-623-9966.

Sintronc SI-F-5 5 kW FM w/10 W Sintronc exciter, used 5 yrs, exciter gd, xmtr PA cavity needs work, on 103.5 MHz, you ship, BO. G Savoldi, WCQL, 195 E Broad, Columbus OH 43215. 614-221-7811.

Harris MW5A 10 yr old AM xmtr, new spare final, mint cond, tuned to 1420 kHz, \$21000. H Connellan, WACT Radio, 3900 11th Ave, Tuscalousa AL 35402. 205-349-3200.

CAPACITORS OVERNIGHT

- Power Supply computer grade: up to 450VDC
- Transmitting - MICA Sangamo, Cornell-Dubilier
- Oil Filled Non-PCB Oval, Rectangular

Relays - Filters - Transistors
Any Parts starting with 1N or 2N

1-800-323-0460
FAX 1-802-425-3664
Kellner Electronics, Inc.
Charlotte, VT 05445

GE 50 kW AM, small size, 3 cabinets mdl BTC-50-C in super clean cond, 1510 kHz, well maintained. J Perez, 315-673-1070.

210/240 V Pri-3000 V 1 A sec plate transformer, \$250/BO; 240 V Pri-3000V sec George Sturley plate transformer, BO. M Johnson, KGAL, POB 749, Albany OR 47321. 503-451-5425.

CCA 10,000D AM 10 kW, gd cond on 1210, BO. J Stanford, WYLD, 2228 Gravier, New Orleans LA 70119. 504-822-1945.

FOR SALE

Shively 6810 8 bay ant. with heaters. Only one year old. like new. 101-mhz. 1060' 6-1/8" Andrew rigid line, vgc. 5+20/Section

ERI antenna, 2-Bay, 200-Series Rototiller, like new.

Moseley STL PCL-606/C, excel., 325' coax, 1-5/8" air line, like new.

Moseley MRC-1600 remote control, new w/full warranty.

PRICED TO SELL
(816)-635-5959

RCA BTA-50H 3-plate transformers & complete set of schematics, you pick-up at site, non-PCB. D Niccum, KCKN, POB 670, Roswell NM 88202. 505-622-6450.

Sparta 680 FM exciter w/681 meter panel, not working, \$200. B Umberger, WNLT, 813-446-0957.

Homebrew 50 W AM, 19" rack mount style, 8-3/4" by 11", 32 lbs, \$700. J Cunningham, KHKC, Rt 2 Box 113B, Stonewall OK 74871. 405-265-4496.

Harris MS-15 exciter, \$2500; TTC Mdl X exciter, new, \$4500; TTC FM-300J solid state 300W FM xmtr, new, \$7500; Sintronc 10W solid state FM exciter, \$850. G Gaskey, KWHO, 261 Main, Ste 6, Weed CA 96094. 916-938-3828.

Gates AM BC1G, excel cond, \$2500/BO. WRDN, Box 208, Durand WI 54736.

Collins 20V-2 completely rebuilt solid state lower deck. Dale, 503-774-0459.

Harris FM-40K (2), center cabinet, (2) MS-15 exciters, combiner, reject load, etc, on air now at 101.3 MHz, avail late June, will split into (2) 20 kW's, \$60,000 complete/BO. J Buckham, KIOI, 700 Montgomery, San Francisco CA 94111. 415-956-5101.

Elcom Bauer 605C 5 kW FM single phase, one tube w/exciter, new, \$25,000/BO. V Michael, 575A Montromery Pike, Williamsport PA 17701. 717-323-8200.

RCA BTE-15 w/SCA gen & stereo gen w/crystal. Dale, 503-774-0459.

RCA-50H 50 kW in great cond, \$15,000. V Stone, WWMO, POB 81, Cascade VA 24069. 804-685-3128.

Harris MW 1 in excel cond on 1340, \$9000; Bauer 1 kW AM, gd cond, \$4000. E Moody, KJEM, 216 N Main, Bentonville AR 72712. 501-273-9039.

A&B EST-300, 300 W, solid state RF amp, new. C Springer, KLMR, POB 890, Lamar CO 81052. 719-336-2206.

LPB AM-30/TCU-30 30 W carrier on 830 MHz, excel cond, \$700/BO. Neu-Comm, 1240 Riverbreeze, Ormond Bch FL 32176. 904-441-6956.

RCA TTU-60 UHF xtmr/dioplexer system w/Townsend exciter operating on ch 19 currently, avail Spring 1991, BO. D Roden, 1701 Monte Sand Blvd, Huntsville AL 35801. 205-533-3676.

Gates FM1B, 1 kW, clean, vgc, just removed from service, \$2500. M Guidotti, KKLK, 143 Fifth St, Ste 5, Colusa CA 95932. 916-458-5558.

RCA BTF-3B 3 kW FM on 98.5 MHz, for parts, BO. D Hancock, POB 234, Hanover PA 17331. 717-637-3831.

Collins 830 FM, xmtr, exciter, 4 bay antenna & 165' feedline, all tuned to 95.3 MHz; Gates 250 AM xmtr on 1520 kHz, all working fine when removed, BO. C Veirs, WBHT, POB 198, Brownsville TN 38012. 901-772-3700.

FM 3 kW transformer, never used. D Smith, WFCB, Box 94, Chillicothe OH 45601. 614-773-3000.

Radio Systems TR-20/CP-15 20 W carrier on 820 MHz/530 MHz, excel cond, \$600/BO. Neu-Comm, 1240 Riverbreeze, Ormond Bch FL 32176. 904-441-6956.

CSI EX-20F 20 W freq programmed, excel cond w/instruction manual, \$1995. T Scott, WWIQ, 5658 143rd Ave, Holland MI 49423. 616-394-1260.

Bext has some show units at sale price. Full 2 yr warranty, like new. Exciters, amplifiers, STL's. First come first served only. Call for details. Bext, 619-239-8462.

Upgrade your McMartin BF-35KM to a BF5KM in the field (5500W). Goodrich Ent, 11435 Manderson St, Omaha NE 68164. 402-493-1886. Fax: 402-331-0638.

Want to Buy

FM 500-1000 W w/wo exciter, stereo solid state preferred. L Maierhofer, 101 Armory Blvd, Lewisburg PA 17837. 717-523-3271.

3K or 6K xmtr for Class A station, STL link, remote control, other related equipment. A Stevenson, 312-975-9882.

TOP DOLLAR
For Your Old Transmitter, STL or Exciter!
Call for a quote
We arrange quick dismantling & removal
PCB's? No Problem Call Us.

ARMSTRONG TRANSMITTER CORP.
5046 Smoral Rd
Syracuse, NY
(315) 488-1269
FAX (315) 488-1365

Wanted late model 1 kW UHF LPTV xmtr, close to VHS channel 43. J Bahr, 154 Guajataca St Crown Hills, Rio Piedra PR 00924.

RCA BTA-1R or equiv AM 1 kW xmtr. L Afflerbach, CTC Media, 5550 Sterrett Pl, Columbia MD 21044. 301-621-5045.

WANTED

AM and FM Transmitters, all powers. Finders fee for locators. **DON'T** take the chance of not being paid, sell to the oldest broadcast supply house in Latin America.

GUARANTEE RADIO SUPPLY CO.
1314 Iturbide
LAREDO, TX 78040
(512) 722-3233
(512) 727-8458 (fax)

Spare parts for Gates BC-1T xmtr & parts for Rust model OC and IC remote control units. Jim or Dale, WXEE, 304-436-4191.

1 kW FM, complete, 103.7 M or near, call or write. V Danielson, HRVC Honduras, RR2 Box 2791, Arlington MN 55307. 612-964-2838.

ARMSTRONG TRANSMITTER

FINEST REBUILT TRANSMITTERS

We're the leading re-manufacturer of transmitters worldwide.

Transmitters are available:

- * Tuned & Tested on YOUR Frequency
- * Guaranteed and Installed
- * Completely Re-manufactured
- * Expedited Service Available

Trade-Ins gladly accepted - **WE DELIVER!**
See your choice in transmitters *WORKING* in our huge new showroom *BEFORE* you take it home!



**NO ONE ELSE OFFERS YOU THIS!
SEE & TEST IT ALL YOU WANT!**

ARMSTRONG TRANSMITTER CORP.

5046 Smoral Road Syracuse NY 13031
Phone 315-488-1269 FAX 315-488-1365
Hablamos Español: 305-471-1180



On parle français—Hablamos espanol—Turkçe konuşabiliriz

250-500 W FM xmtr or pwr amp for auxilliary, have exciter, hi miles ok if in gd wrking cond. K Browell, Box 808, Riverton WY 82501. 307-856-2922.

Collins 1965 21M, 10/5 kW AM, new tubes. B Bie, 80 N Tillman, Memphis TN 3811. 901-323-2679.

Any FM model & equip related to put up new 88.9 FM station in Lorain OH including 300' tower, ss or guyed. C Arroyo, Box 436, Arecibo PR 00720. 809-878-0070.

Harris, Continental 1982 or later, AM 10K. R Payne, 774 Roswell St, Marietta GA 30060. 404-424-9850.

1 kW FM looking for good, used, reliable, any or all. Ken, POB 617, Cuba MO 65453. 314-239-6800.

WANT TO BUY: TV Transmitter CH 9 5/10 kW, Visual Power, Ext. Duplx. Antenna & Tx. Line Complete. 1980 or newer. TV Studio Equipment in Gd Working Condition. International Broadcast Supply, Inc. 1771 N. Powerline Rd. Pompano Beach FL 33069 TEL (305) 977-9111 FAX (305) 977-0488

McMartin AM/FM xmtr, any model, exciter or stereo modules. Goodrich Ent., 11435 Manderson, Omaha NE 68164. 402-493-1886.

McMartin older B-910 FM exciter. C Goodrich, 11435 Manderson, Omaha NE 68164. 402-493-1886.

TUBES

Want to Sell

For the Best Prices
& 24 Hr service on transmitting tubes call 402 493 1886 day or night. FAX 402 331 0638. TELEX 940103 WU PUB TLX B5N

TRANSCOM CORP.

Fine Used AM & FM Transmitters and Also New Equipment
For the best deals on Celwave products, Andrew cable, Shively & Comark antennas.

1978 CCA 2500R 2.5 FM	1981 McMartin BA 2.5K 2.5 AM
1981 CSI T3F 3 FM	1966 Continental 315B 5 AM
1975 RCA BTF 10ES1 10 FM	1978 Collins 5 kW AM Power Rock. 828 E-1
1976 RCA BTF 20E1	1974 Harris BC 1H1
1972 CCA 20,000DS 20 FM	1980 McMartin BA5K 5 AM
1986 Continental 314R1 1 AM	1967 Gates BC5P2 5 AM
1974 Harris BC1H1 1 AM	1976 CCA AM 50,000D. 50 kW AM

201 Old York Rd.
York Plaza Ste 207
Jenkintown PA 19046
215-884-0888
FAX No. 215-884-0738

PETER DAHL CO.

Save \$\$

Heavy Duty Replacement Transformers, DC Filter chokes and capacitors for AM & FM transmitters manufactured by: AEL, CCA, CSI, COLLINS, CONTEL, CONTINENTAL, BAUER, GATES, GE, HARRIS, ITA, McMARTIN, RAYTHEON, RCA, SINGER, SINTRONIX, WILKINSON.

Many other models also available.

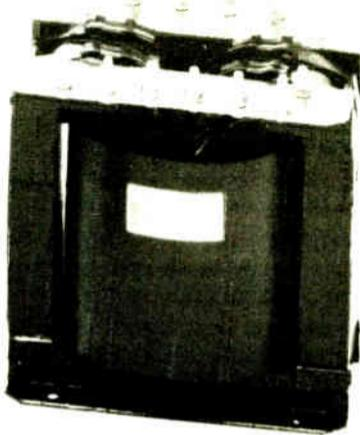

FAST Delivery and FREE Technical Support.

5869 WAYCROSS AVENUE EL PASO, TEXAS 79924
(915) 751-2300 TELEX: 76-3861 PWDCO
FAX: (915) 751-0768



Circle 27 on Reader Service Card

TUBES . . . WTS
Penta Labs Super Premium output tubes w/increased plate dissipation, new w/warr, individually tested, KT88, \$18; EL34, \$9, quantity discounts avail. R Katz, Allegro Snd, 15015 Ventura, Cherman Oaks CA 91403. 818-377-5264.

Information on a 5736 power tube, maximum ratings, pin out, etc. D Karl, WHHI, 3319 W Bellline Hwy, Madison WI 53713. 608-273-6919.

Thorens TT plays 33, 45 & 78's, w/cart. J Gangwer, 942 32nd St, Richmond CA 94804. 415-644-2363.

Dual 1218, need a hard shell. A McCartney, 600 E Main, Valaville CA 95660. 707-446-0200

ECONCO

Quality Rebuilt Tubes

Approximately 1/2 the Cost of New

Call for Our Price List

800-532-6626

916-662-7553

FAX 916-666-7760

Various inventory of electron tubes including (2) 813; 845; OD3; (2) 1R5; (4) 1T4; 885; (3) 6J7; 5R4; (5) 5AR4; (2) 5V4; (2) 6J5 & many more, \$2/ea. M Johnson, KGAL, POB 749, Albany OR 47321. 503-451-5425.

ELECTRON TUBES

Partial List: 6623, 23791, 7H150, 6425F, 5604, 6696, 6697, 5681, 5682, 5671, 7804, 3CX10, 000H3, 3CX20, 000H3, 4CX5000A, 4CX35, 000C

Vacuum Tube Industries, Inc.

1-800-528-5014

EIMAC 4-400A, (2), approx 1000 hrs, \$125 ea. M Guidotti, KKLJ, 143 Fifth St, Ste 5, Colusa CA 95932. 916-458-5558.

3CX3000A7 power tube, just rebuilt, BO. C Springer, KLMR, POB 890, Lamar CO 81052. 719-336-2206.

3CX1500A7, 4CX5000A, 6146B, 4CX2508, 4CX3000A & more. We carry large inventory all major brands, Eimac, Ampere, RCA, etc. Call Stew 1-800-842-1489.

Want to Buy

Tubes wanted, 6072/6072A, no RCA, need 1000 pieces. R Katz, Allegro Snd, 15015 Ventura, Sherman Oaks CA 91403. 818-377-5264.

We buy electron tubes.

Contact us if you have any for sale.

BETHPAGE ASSOC.

507 Superior Ave.
Newport Beach CA 92663
714-722-6733

TUBE REBUILDING

FREELAND PRODUCTS

Since 1940
SAVE ABOUT 50%
—We buy dud tubes—

800-624-7626

504-893-1243

FAX 504-892-7323

REBUILT ELECTRON TUBES

Partial List: 6623, 23791, 7H150, 6425F, 5604, 6696, 6697, 5681, 5682, 5671, 7804, 3CX10, 000H3, 3CX20, 000H3, 4CX5000A, 4CX35, 000C

Vacuum Tube Industries, Inc.

1-800-528-5014

TURNTABLES

Want to Sell

Technics SL-1200MK2 (2) stereo TT's w/needles/carts, perfect cond, \$600/both. B Coleman, POB 460, Lobelville TN 37087. 615-593-2978.

Gates 16" TT w/16" Micro-Tract tone-arm; BO. J Sidote, POB 949, Welch WV 24801. 304-436-2131.

Technics SH 10B3 TT base, \$150. B Umberger, WNLT, 813-446-0957.

Russco Cue-Master (2), 3345/78 TT's, BO. T Liston, WOBL, Box 277, Oberlin OH 44074. 216-774-1320.

Russco Studio-Pro TT's w/warms, \$225. W Blackwelder, KNUE, POB 7935, Tyler TX 75711. 214-581-0606.

Gemini 1500 II (2), clone of Technics 12001, new w/AT cartridge w/boxes, etc, \$229 ea. C Keith, ALI, 9 Roxbury, Keene NH 03431. 603-352-8460.

Ramko TT preamp, \$25. C Hall, WZOU, 235 Bear Hill, Waltham MA 01254. 617-290-0009.

Technics SP10MKII (2) in working cond complete w/SP10MKII, IV bases. \$800 ea; Audio Technica APT12T tonearms (2) in working cond, \$250 ea. M Lashutka, WOBC, Oberlin College, Oberlin OH 44074. 216-775-8107.

Want to Buy

Presto 6N cutter. A Weiner, 14 Prospect. Yonkers NY 10705. 914-423-6638.

TV FILM EQUIP

Want to Sell

B&H JAN 614 EVMS lightweight pedestal mount 16mm magnetic & optical sound telecine projector, complete w/manuals, vgc, \$425. G Ormrod, GFO Prod, 432 East X St, Turmwater WA 98801. 206-352-8028.

Collectable/usable film snd recording equip including Pro 600 mag head, MA-11, orig mic, PS, cables & book; Auricon NR optical snd amp; Magnesync DR-1 monitor panel only w/book; Neumade film measuring machine mtd DS16D w/circular dial; plus traditional footage counter; Frezzi pwr pack; Siemens interlock proj, BO P Dowie, Good Sound, 171 Drexel, Lnsdr PA 19050. 215-626-9322.

Want to Buy

VIDEO PROD EQUIP

Want to Sell

Quanta Microgen-100B-SIO video titler w/256 colors, 50 pg memory, 9 speed rolls, crawls, RS-232 I/O port, character edging & more. like new, \$1195/BC. B Hines, Rd 1 Box 413A, Export PA 15632.

Panasonic AG-A750 editing controller w/cables & instructions, mint cond, used 5 hrs, \$575. Chief Engr, Vidcom Consultants. 412-327-1333.

VTA Wiz color correction computer for Bosch FDL-60 B2 telecine, BC; Nagra/Ampex VPR-5 1" portable VTR, new \$13,000; Stuart 8" floppy drive for Boxx/Alpha audio system, never used, \$2000. D Schlegel, SSI, 7155 Santa Monica, Los Angeles CA 90046. 213-874-9344.

CBS 5500A color corrector chroma keyer 7000, image enhancer 8000 MK III, plus 5500 sensor, BO. J Phillips, WZOM, 408 1/2 Clinton St, Defiance OH 43512. 419-784-1059.

Panasonic Model WJ-810 time/date generator plus stop watch function, excel cond, \$250. Chief Engr, Vidcom Consultants. 412-327-1333.

Convergence Model CI-90 time code reader & burn in unit, excel cond, \$382. Chief Engr, Vidcom Consultants. 412-327-1333.

Zenith video projector w/10" motorized screen, Panasonic WV-F2 remote camera, \$5500. B Hull, WDX, POB 741, Mt Airy NC 27030. 919-786-4675.

Chyron IIIB w/all avail fonts, many discs, gd cond, in service, \$2000/BO. T Turk, Travis Turk Prod, 518 Macfie Ct, Madison TN 37115. 615-255-7787.

Microtime 1020 TBC, w/manual, \$1500. Dave, 17094 McGuffie, Salinas CA 93901.

CBS NTSC 5500A; CBS chroma keyer 7000; CBS image enhancer; CBS sensor-RC. J Phillips, WZOM, 408-1/2 Clinton, Defiance OH 43512. 419-782-4591.

VIDEO TAPE RECORDERS

Want to Sell

JVC CR4400U 3/4" port recorders (4) w/access, \$800 ea/BO; (3) Sony RM-430 edit controllers, \$500/BO; JVC BR-6400U VHS recorder, \$1500/BO. T Quinn, Monte Vista St, 208 Cherry, Capitola CA 95010. 408-475-0423

WORLDWIDE DIGITAL CONVERSION

ALL FORMATS BROADCAST QUALITY

Pal Multi-dupe/Hi-Band/1"

TK VIDEO 12300 Coppola Drive Potomac, MD 20854 301-762-2786

Sony VO-2600 3/4" R/P, audio dub, excel cond, \$550. R Jensen, 5812 21st St, Racine WI 53406. 414-632-3131.

Sony BVU-110, gd cond, \$1000 ea; BVU-50, gd cond, \$600/ea; BK-112 time code generators, \$400/ea; blank tapes, all formats; Beta breakaway cables. Ugly George Satellite TV, 314 W 52nd St, Nyny 10019. 212-677-2200.

Sony VO-2610 3/4" R/P, audio dub, excel cond, BNC I/O, still adj, \$550. R Jensen, 5812 21st St, Racine WI 53406. 414-632-3131.

Video production editing, ENG or the entire bus, we will buy, sale, trade or consign. Call 301-840-0296.

JVC CR6600U 3/4" recorder, feeder deck for JVC edit system, low hrs, nice shape, new drum, \$950. J Kreines, 5330 Kennedy Ave, Millbrook AL 36054. 205-285-6179.

Sony VO-2610 3/4" R/P, w/RF pack \$500; Panasonic NV9100A 3/4" player, \$350; (2) Sony VO-2600 3/4" R/P, \$450/ea, plus \$25 shipping for ea item. N Mishaan, POB 335, Lynbrook NY 11563. 516-582-1338.

JVC CR-850U (3) 3/4" broadcast recorders w/address trk time code have time code readers for machines but not in machines, \$6000/ea. A Baker, 804 E 38th St, Indianapolis IN 46205. 317-925-7371.

JVC CR-850U 3/4" w/address trk time code, \$6000/ea. A Baker, 804 E 38th St, Indianapolis IN 46205. 317-925-7371.

Sony VP700 3/4" video player, vg cond, BO; NSS-4 channel share switcher & 1 ill' money-maker used for cable ad insertion, BO. D Staats, POB 1346, Parkersburg WN 26102. 304-863-3319.

Sony VO-5600 (3), \$1200; Sony VP 7000 source player, \$1000; Panasonic BT-1900N underscan monitor, \$350; Tek 528A waveform, \$1500, all like new. B Dorsey, 212-675-0477.

Panasonic AU300 B M1, bdct quality 1M editor decks w/TBC, (5) almost new, \$595/ea. C Wiegand, 7758 Lafayette Rd, Newark OH 43055. 614-967-0059.

Sony SLO-340 portable Betamax; JVC HR4100AU portable VHS, both w/AC adaptor, \$200 ea. S Cister, 728 Zorn Ste 10, Louisville KY 40206.

Want to Buy

Panasonic AG-2200 in gd cond. W Datzell, 3033 Locust St, St Louis MO 63103. 314-531-3555.

ACTION-GRAM

Equipment Listings

Radio World's Broadcast Equipment Exchange provides a FREE listing service for all broadcast and pro-sound end users. Simply send your listings to us, following the example below. Please indicate in which category you would like your listing to appear. Mail your listings to the address below. Thank you.

Please print and include all information:

Contact Name: _____

Title _____

Company/Station _____

Address: _____

City _____ State _____ Zip _____

Phone Number: _____

Brokers, dealers, manufacturers and other organizations who are not legitimate end users can participate in the Broadcast Equipment Exchange on a paid basis. Listings are available on a \$25/25 word basis. Call 1-800-336-3045 for details and complete display rates.

I would like to receive or continue receiving Radio World FREE each month. YES NO

Signature _____ Date _____

Please circle only one entry for each category:

I. Type of Firm

- | | |
|------------------------------|---------------------------------|
| D. Combination AM/FM station | F. Recording studio |
| A. Commercial AM station | G. TV station/teleprod facility |
| B. Commercial FM station | H. Consultant/ind engineer |
| C. Educational FM station | I. Mfg, distributor or dealer |
| E. Network/group owner | J. Other _____ |

II. Job Function

- | | |
|-----------------------|---------------------------|
| A. Ownership | D. Programming/production |
| B. General management | E. News operations |
| C. Engineering | F. Other _____ |

WTS: WTB: Category: _____

Make: _____ Model #: _____

Brief Description: _____

Price: _____

WTS: WTB: Category: _____

Make: _____ Model #: _____

Brief Description: _____

Price: _____

*Closing for listings is the first Friday of the previous month. All listings are run for 3 months unless otherwise notified.

Broadcast Equipment Exchange

703-998-7600 PO Box 1214 • Falls Church VA • 22041 FAX: 703-998-2966

MARKETPLACE

Send us your new product info. Be sure to include a black and white photo. Send all submissions to Radio World Marketplace, P.O. Box 1214, Falls Church, VA 22041



Voltage suppressor

The Protector AC from Energy Control Systems is able to withstand over 20,000 transients with no performance deterioration.

For information, call Robert Lamkin at Energy Control Systems: 817-483-8497 or circle Reader Service 21.



Power amp

Furman Sound, Inc., announces the SP-20 half rack 20 W per channel stereo power amplifier.

The SP-20 is equipped with a stereo input level control, and signal present and overload LEDs for each channel.

The unit also features a headphone output with its own volume control and speaker mute switch, and may be used as a multistation headphone amp by connecting a chain of HR-2 headphone remote stations.

For information, call Joe Desmond at Furman Sound: 415-927-1225, ext. 23 or circle Reader Service 55.



Access set

The T-BERD 224 PCM analyzer from Telecommunications Techniques Corp. (TTC) is a full-duplex T1 channel access set which tests voice and data circuits within interoffice trunks, digital loop carrier systems and leased T1 circuits.

The unit can monitor or test any channelized VF or DSO traffic.

For information, call Susanne Hale at TTC: 301-353-1550 or circle Reader Service 117.



Automatic dehydrator

The ADH-2 automatic dehydrator from Environmental Technology, Inc., can pressurize waveguide, air-dielectric coaxial cable, feed horns and similar applications with dry air.

Features include built-in test and fault diagnostic capability along with an alarm relay.

For information, call Steve Leykauf at Environmental Technology: 219-233-1202 or circle Reader Service 48.



AM transmitter

Omnitronix introduces the OMNI 1000 solid-state AM broadcast transmitter.

Selectable 9 kHz or 10 kHz filter rolloff is available.

Frequency changes are implemented quickly due to the broad band design of the amplifier modules and the frequency synthesizer.

The Omni 1000's specified VSWR at full modulation is 1.2:1.

For information, call John Solt at Omnitronix: 215-542-9580 or circle Reader Service 93.



Data acquisition processor

Ariel's DSP-16 DSP-based data acquisition-processing board SDI permits direct-to-disk recording/playback of 16-bit audio at sample rates of up to 50 kHz on two channels simultaneously.

Recorded signals can be viewed graphically and edited, and parts of the signal can be marked, zoomed, moved or deleted.

All the signal processing power of the DSP-16 is available to the user, including a program development system for specific Texas Instruments processors.

For information, call Leslie Listwa at Ariel Corporation: 201-249-2900 or circle Reader Service 80.

SUBSCRIPTION/READER SERVICE FORM

Radio World

August 8, 1990 Issue Use until November 7, 1990

FREE Subscription/Renewal Card

I would like to receive or continue receiving Radio World FREE each month. YES NO

Signature _____ Date _____

Please print and include all information:

Name _____ Title _____

Company/Station _____

Address _____

City _____ State _____ ZIP _____

Business Telephone () _____

Please circle only one entry for each category:

I. Type of Firm

- D. Combination AM/FM station
- A. Commercial AM station
- B. Commercial FM station
- C. Educational FM station
- E. Network/group owner
- F. Recording studio
- G. TV station/teleprod facility
- H. Consultant/ind engineer
- I. Mfg, distributor or dealer
- J. Other _____

II. Job Function

- A. Ownership
- B. General management
- C. Engineering
- D. Programming/production
- E. News operations
- F. Other (specify) _____

III. Purchasing Authority

- 1. Recommend
- 2. Specify
- 3. Approve

Reader Service

Please first fill out contact information at left. Then check each advertisement for corresponding number and circle below. NOTE: Circle no more than 15 numbers, otherwise card will not be processed.

- 001 023 045 067 089 111 133
- 002 024 046 068 090 112 134
- 003 025 047 069 091 113 135
- 004 026 048 070 092 114 136
- 005 027 049 071 093 115 137
- 006 028 050 072 094 116 138
- 007 029 051 073 095 117 139
- 008 030 052 074 096 118 140
- 009 031 053 075 097 119 141
- 010 032 054 076 098 120 142
- 011 033 055 077 099 121 143
- 012 034 056 078 100 122 144
- 013 035 057 079 101 123 145
- 014 036 058 080 102 124 146
- 015 037 059 081 103 125 147
- 016 038 060 082 104 126 148
- 017 039 061 083 105 127 149
- 018 040 062 084 106 128 150
- 019 041 063 085 107 129 151
- 020 042 064 086 108 130 152
- 021 043 065 087 109 131 153
- 022 044 066 088 110 132 154

ADVERTISER INDEX

This listing is provided solely for the convenience of our readers. Radio World assumes no liability for inaccuracy.

Page No.	Advertiser	Reader Service No.	Page No.	Advertiser	Reader Service No.	Page No.	Advertiser	Reader Service No.
26	AKG/Orban	-	19	BSW	54	18	Marti Electronics	20
22	Allied Broadcast	97 & 148	4	Burk Technology	66	30	Microwave Filter Co.	6
30	Allied Broadcast	46 & 69	18	CCA Electronics	111	12	Northeast Broadcast	125
32	Allied Broadcast	30 & 89	11	Conex	102	15	Orban	85
10	Allied/Fairchild	37 & 122	12	Continental Electronics	9	33	Orban	136
28	Allied/Numark	11 & 90	27	Cortana	67	45	Peter Dahl	27
6	Allied/Otari	14 & 79	29	CRL	140	34	QEI	83
9	Alpha Products	88	21	Cutting Edge	95	16	Radio Systems	75
24-25	Arrakis Systems	110	22	Dataworld	16	36	Radio Systems	153
7	ATI	105	31	Delta	81 & 112	27	RF Specialties	133
38	Barrett & Associates	39	1	Fidelipac	60	14	Studer Revox	109
20	Belar	150	8	Full Compass	144	35	Studer Revox	57
3	Bradley Broadcast	31	9	Hnat Hines	35	11	Tannoy	146
3	Broadcast Electronics	129	13	ITC	100	44	Transcom	71
23	Broadcast Electronics	41	37	J&I Audio	25	2	Wheatstone	120
17	Broadcasters General Store	50	7	Jampro	116	47	Wheatstone	44
						48	Wheatstone	74

Advertising Sales Representatives:

East Coast, Art Constantine: 800-336-3045 Fax: 703-998-2966
 Midwest, Art Constantine: 800-336-3045 Fax: 703-998-2966
 West Coast, Pat Macsata: 415-786-2198 Fax: 415-786-2754

WE SURPRISED OURSELVES!

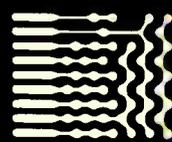

AUDIOARTS[®] A-50 RADIO CONSOLE!

We wanted to know if it really was possible to build a high quality low-cost radio console. We found the answer to be quite exciting! We've come out with the A-50 console and even given it its own trade name: AUDIOARTS. This console comes complete with machine control functions; individually programmable channel logic; program, audition and telephone outputs; control room and studio monitors; as well as headphone and cue power amplifiers. It's also designed so you can expand or add accessory modules as your needs grow.

The A-50 is cost effective through clever engineering and the latest advances in electronic assembly procedures. It was developed by the same design team that creates our other high end equipment. Its performance is light years beyond the competition.

Imagine the benefit that our major market experience can bring to your station. Take advantage of Wheatstone's expertise and reputation. Call us today for immediate action!

 Wheatstone[®] Corporation

6720 V.I.P. Parkway, Syracuse, NY, 13211 (TEL 315-455-7740 / FAX 315-454-8104)

Circle 44 On Reader Service Card
World Radio History



"Many of the headaches associated with building a new studio were eliminated with the WHEATSTONE pre-wire package. Set up and wiring of WAZU was a breeze. The furniture is solid and good looking, quick and easy to assemble—many hours were saved. Our jocks love the easy straight-forward layout of the new A-500 air console... and after a quick and easy production room installation, little time was needed teaching the staff how to use the new multi-track studio; operators familiar with an on-air console adapt themselves easily to the SP-6 stereo console and the easy ways to insert special effects and audio processing—operation is so simple!"

John Soller, chief engineer at WAZU

Radio is Starting to Experience a Shortage: *Technical Experts*

Let our experts supply your prewired studio, consoles, studio furniture and audio system engineering. We'll help with your design, then build, wire, test and document your whole studio furniture installation—all at our factory. This takes a *major* load off your technical people and ensures project completion on time.

When Osborn Communications decided to upgrade member station WAZU in Dayton, Ohio, they chose WHEATSTONE for the job. With 12 rooms of Wheatstone consoles already installed, the Osborn people are well qualified to vouch for our commitment to client satisfaction.

Draw on our experience and reputation. Get a great looking studio with cutting edge performance. Contact WHEATSTONE—the experts!

 Wheatstone® Corporation

6720 V.I.P. Parkway, Syracuse, NY, 13211 (TEL 315-455-7740 / FAX 315-454-8104)

Circle 74 On Reader Service Card

World Radio History