

BULK RATE
US POSTAGE
PAID IN
DES PLAINES IL
PERMIT NO 321

Radio World®

Broadcast
Equipment
Exchange
see pages 25-30

PO Box 1214, Falls Church VA 22041
ADDRESS CORRECTION REQUESTED

July 1, 1987

Volume 11, Number 13

Radio Moscow Hits Florida

by David Hughes

Washington DC ... "This is Radio Moscow," can be heard at 1040 kHz on the AM band in South Florida on weekends.

Since mid-May, the Soviet Union's international service in English has been beamed on the AM band from Cuba.

Despite the fact that the broadcasts have, so far, been confined to daylight hours on weekends only, they have been interfering with at least two Florida stations.

Owing to the good propagation characteristics of salt water, the signal, estimated by US authorities to be at about 300 kW, has caught the ire of officials of WYFX, a 10 kW daytimer in Boynton Beach (near West Palm Beach) and WHBO, a 5 kW daytimer in Pinellas Park (near Tampa). Both stations are on 1040 kHz.

While Cuban interference to AM broadcasters in Florida is nothing new,

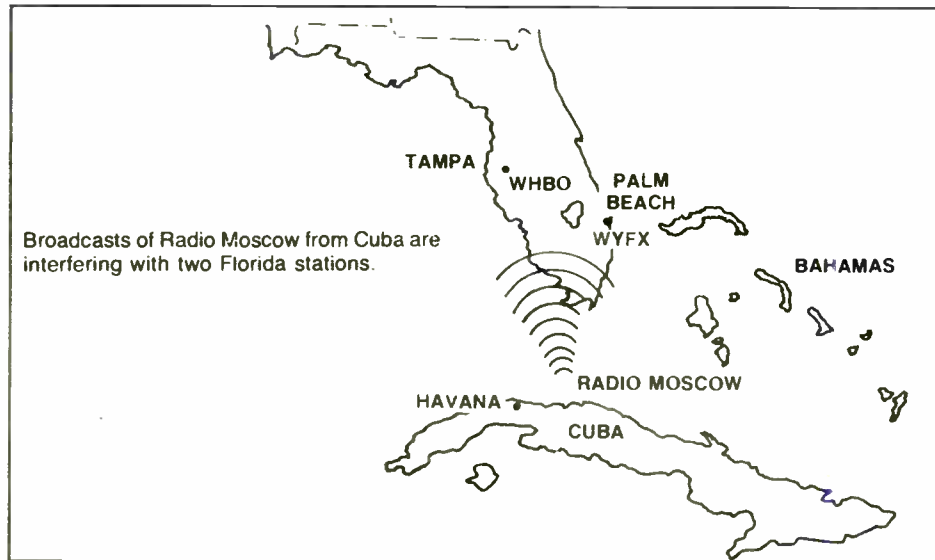

the relay of Radio Moscow in English is. However, this is not the first time Cuba has provided an AM band relay of service, which is widely available on shortwave.

In the early 1980s, Radio Moscow was relayed, including at night, on 600 kHz, causing skywave interference with many US stations. However, that Radio Moscow ceased as mysteriously as

it began.

The new relay of Radio Moscow is said to be difficult to hear clearly outside the Florida Keys. The signal has been heard Sundays and alternate Saturdays from 8 AM to 6 PM. The broadcast was heard as early as 23 May.

The broadcasts, which feature a variety of music, cultural programs and "news," come after word that the USSR has ceased its attempts to jam the Voice of America's (VOA) Russian and other Soviet language programs beamed to the USSR on shortwave.

However, sources say that US-backed Radio Liberty and Radio Free Europe transmissions are still jammed.

The US State Department has informed Soviet and Cuban officials about its displeasure with the new relay.

Wilson LaFollette, head of the FCC's international staff, confirmed that the issue is being handled by the State Department.

He added that in addition to direct complaints to the Soviet and Cuba governments, the US can also file a complaint with the International Telecommunications Union (ITU).

The FCC's monitoring stations have heard no evidence that the 1040 kHz operation may start operating at night, LaFollette said.

NAB Counsel Barry Umansky echoed what many other broadcasters said their reaction would be if the 300 kW Radio Moscow relay began operating at night: "It would be terrible."

Twenty stations, mostly daytimers, are licensed to operate on 1040 kHz.

Ft. Lauderdale-based Glenn Hauser indicated in his publication, *Review of International Broadcasting*, that the current daytime only schedule "insures that (the relay) will be heard only in the southern tip of Florida—why bother?"

He adds, "Is tokenism that important? The fuse has been lit, but the bomb of high-power nighttime broadcasting has not yet exploded."

As of early June, the FCC had received one formal complaint about the problem—it came from WYFX. WHBO GM and President Jonathan Pinch said his station had also filed a complaint.

Pinch told RW that WHBO received "over 100 calls" from listeners complaining that they could hear the Radio Moscow relay underneath the station.

He said that because of the conductivity of salt water, the interference to WHBO is more severe the nearer the listener is to the Gulf Coast.

"For our listeners in our main coverage area, the interference is largely an annoyance. But it gets rather heavy in our peripheral coverage area," Pinch maintained.

For more information on the Cuban interference situation, contact Wilson LaFollette at the FCC: 202-632-5414.

McKinney Mum on Job Switch

by Alex Zavistovich

Washington DC ... Industry sources indicate FCC Mass Media Bureau Chief Jim McKinney will leave the Commission to take a telecommunications position at the White House.

At *Radio World's* press time 15 June, McKinney refused to comment on the rumored departure, which comes on the heels of speculation that the bureau chief was being considered for the Commission seat vacated by the promotion of Dennis Patrick to chairman.

However, McKinney, who has headed the Mass Media Bureau since 1983 and spent a total of 24 years at the FCC, did not deny the White House rumor outright. "I won't confirm or deny it—no comment," he said.

The bureau chief was equally closed-mouthed about talk that he may be in contention for the open Commis-

sioner's seat.

He was reported to have been recommended for the slot by Drew Lewis, former chairman of Warner Amex Cable and now president of Union Pacific Corp.

Before the latest rumor surfaced, McKinney maintained: "I have received no calls from the White House concern-

ing the vacant Commissioner's job, and my assumption is I am not under consideration for the position."

"All the cards are in the hands of the White House," he said. "It's their (the White House's) call. It is up to them to make an initiative, and they have not done so."



FCC Mass Media Bureau Chief
Jim McKinney

Fidelipac introduces a brand new cartridge
and a brilliant new tape

DYNAMAX®

COBALT TAPE BROADCAST CARTRIDGE

- Expanded high frequency headroom
- Superior phase uniformity
- Inaudible wow and flutter
- Greatly extended cartridge life

Get complete information and your free sample of
DYNAMAX Cobalt. Call toll free: 800-468-8273



Fidelipac Corporation □ P.O. Box 808, Moorestown, NJ 08057 □ U.S.A.
609-235-3900 □ TELEX 710-897-0254 □ Toll Free 800-HOT TAPE
Dynamax is a trademark of Fidelipac Corporation.

Regulatory News

FCC Amends Hearing Policies

by Alex Zavistovich

Washington DC ... Broadcast license and construction permit (CP) holders are no longer entitled to an automatic hearing contesting FCC modifications to channel allotments, because of an amendment to the Commission's rules in the matter.

The FCC in mid-May announced its

FCC's Table of Allotments for television and FM.

Rulemaking mandatory

A rulemaking proceeding is instituted each time there is a change in the channel of any allotment, either to another channel or to another class, if that allotment was occupied.

Further, new channels allotted to a

offered to deny the proposed modification, no hearing would be required to deny it.

However, Hayne added, if the station has insufficient reasons to deny the modification, or does not raise substantial and material questions of fact, the proposal could be adopted without benefit of a hearing.

"Without a substantial and material question of fact, we (the FCC) would just go out with a Report and Order modifying the license or permit," Hayne stated.

Although the entitlement to an automatic hearing has been "somewhat eroded" by Congressional action, Hayne commented, written notification by the FCC before any modification has been retained in the amended rules.

For additional information, contact Robert Hayne at 202-634-6530.

In some cases ... modification issues may be settled without a hearing.

amendment to rules pertaining to such modifications.

The full text of the Commission's decision was released earlier the same month.

The amendment was made, the FCC said, to allow for greater conformity of the Commission's rules with Section 316 of the Communications Act, which provides procedures for modifications.

Automatic hearing eliminated

In place of the automatic hearing for stations whose permits or licenses must be modified, the FCC will require the station to submit a "substantial and material question of fact" contesting the modification.

The automatic hearing provision for changes in channel allotments has been eliminated by Public Law 98-214, said FCC Mass Media Bureau spokesperson Robert Hayne.

According to FCC practice, channels designated for use in communities throughout the US are maintained in the

community often require substitution of an occupied channel.

Existing licenses or CPs must be modified to specify the new channel.

As part of the rulemaking proceeding, the FCC is required to accompany any modification intentions with written notification to the licensee or permittee.

The notification must give the recipient the opportunity to explain why the modifying action should not take place, and inform the permittee or licensee of his right to a hearing.

Question of fact

Hayne explained that a hearing before the Commission, previously granted automatically, is now dependent on whether the licensee or permittee can give sufficient and satisfactory reasons for holding one.

In some cases, based on the reasons offered by the stations in question, modification issues may be settled without a hearing, he commented.

If, for example, enough reasons are

FCC Clips

Daytimers comment deadline

A comment deadline of 17 July has been set for a proposal by the FCC, which would allow all "qualifying" AM daytimers, including those on domestic clear and regional channels, to add nighttime operations.

Reply comments on the proposal will be accepted until 3 August. The full text of the proposal was released by the FCC 26 May.

For more information, see the 1 June issue of RW, or contact Louis Stephens at the FCC: 202-254-3394.

"Cross-interest" policy examined

A review and clarification of the FCC's cross-interest policy was announced by the Commission in mid-May. The policy restricts individuals from having "meaningful cross-interests" in two broadcast stations serving the same area.

Other combinations, such as a daily newspaper and a broadcast station, or a television station and a cable TV system in the same basic area, are also proscribed by the policy, the FCC maintained.

According to the Commission, many aspects of the cross-interest policy are out of date because new ownership rules prohibit such relationships.

FCC docket is MM 87-188. For more information, contact Andrew Rhodes at 202-632-7792.

US/Mexican Border FM changes

Non-commercial FM stations within 199 miles of the US/Mexican border may soon be allowed to submit applications based on non-overlapping signal contours of domestic stations.

The FCC, in a Notice of Proposed Rulemaking in May, suggested using the contour method for all such station assignments, while keeping minimum distance separations between US and Mexican stations, as set out in an agreement between the two nations.

Presently, applications for station assignments with the 199 mile limit are based on the FCC's table of allocations, rather than the contour method.

FCC docket is MM 87-140. Contact Hank Van Deursen at 202-632-9660.

Fowler joins law firm

Former FCC Commission Chairman Mark Fowler, on 1 June, joined the Washington office of Latham & Watkins, a Los Angeles-based law firm. Fowler will take on the role of senior communications counsel.

Earlier, Fowler had stated his intention to become involved in "entrepreneurial" ventures with Albert Halprin, formerly chief of the FCC's Common Carrier Bureau. Although no further details have been announced, Latham & Watkins have given Fowler freedom to develop such ventures, in addition to his responsibilities to the firm.

Fowler left the FCC in April.

INDEX

Going "Giga" with New 23 GHz STLs <i>By Tim McCartney</i>	11
Teamwork Lets Station Sparkle <i>by John Shepler</i>	13
Building a Production Room On a Budget <i>by W.C. Alexander</i>	14
Installing a New Transmitter At a New Station <i>by Kirk Harnack</i>	15
Build An Emergency Controller <i>by Fred Baumgartner</i>	17
Coping With Lightning Strikes <i>by Ron Balonis</i>	19
Contract Engineering	20

Vanguard Series™

Broadcast Audio Consoles

Performance, Value and Reliability through Innovative Technology

- Raised, tactile feel, lighted membrane switch panel-digitally scanned
- 12 stereo inputs plus optional expander
- VCA controls, rotary and linear
- Analog and fluorescent meters
- Modular, plug in electronics
- Easy punch block installation
- Effective RF protection

**BC8DS
8 Mixer
Dual Stereo**

only \$3,195

AUDIO TECHNOLOGIES INCORPORATED



328 Maple Avenue, Horsham, PA 19044 • (215) 443-0330



BULK RATE
US POSTAGE
PAID IN
DES PLAINES IL
PERMIT NO 321

Radio World[®]

Broadcast
Equipment
Exchange
see pages 25-30PO Box 1214, Falls Church VA 22041
ADDRESS CORRECTION REQUESTED

July 1, 1987

Volume 11, Number 13

Radio Moscow Hits Florida

by David Hughes

Washington DC ... "This is Radio Moscow," can be heard at 1040 kHz on the AM band in South Florida on weekends.

Since mid-May, the Soviet Union's international service in English has been beamed on the AM band from Cuba.

Despite the fact that the broadcasts have, so far, been confined to daylight hours on weekends only, they have been interfering with at least two Florida stations.

Owing to the good propagation characteristics of salt water, the signal, estimated by US authorities to be at about 300 kW, has caught the ire of officials of WYFX, a 10 kW daytimer in Boynton Beach (near West Palm Beach) and WHBO, a 5 kW daytimer in Pinellas Park (near Tampa). Both stations are on 1040 kHz.

While Cuban interference to AM broadcasters in Florida is nothing new,

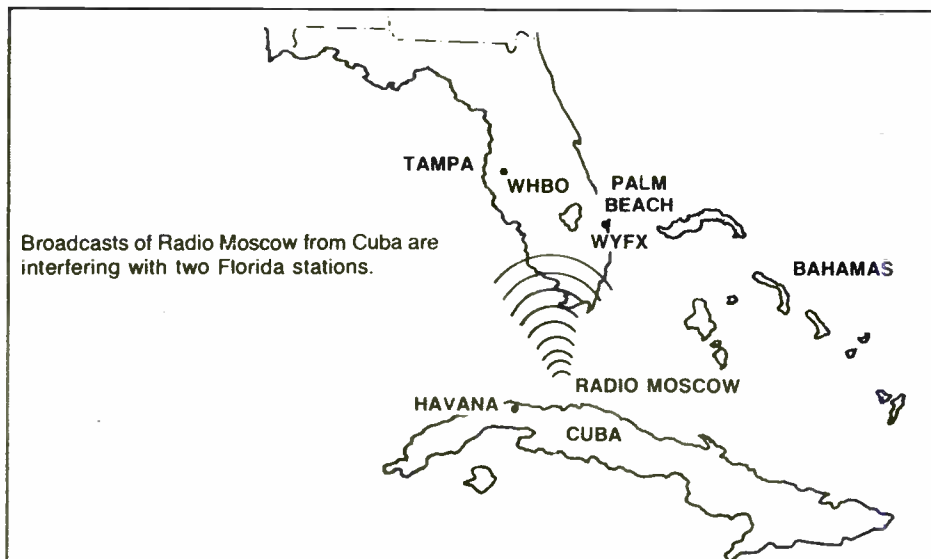

the relay of Radio Moscow in English is. However, this is not the first time Cuba has provided an AM band relay of service, which is widely available on shortwave.

In the early 1980s, Radio Moscow was relayed, including at night, on 600 kHz, causing skywave interference with many US stations. However, that Radio Moscow ceased as mysteriously as

it began.

The new relay of Radio Moscow is said to be difficult to hear clearly outside the Florida Keys. The signal has been heard Sundays and alternate Saturdays from 8 AM to 6 PM. The broadcast was heard as early as 23 May.

The broadcasts, which feature a variety of music, cultural programs and "news," come after word that the USSR has ceased its attempts to jam the Voice of America's (VOA) Russian and other Soviet language programs beamed to the USSR on shortwave.

However, sources say that US-backed Radio Liberty and Radio Free Europe transmissions are still jammed.

The US State Department has informed Soviet and Cuban officials about its displeasure with the new relay.

Wilson LaFollette, head of the FCC's international staff, confirmed that the issue is being handled by the State Department.

He added that in addition to direct complaints to the Soviet and Cuba governments, the US can also file a complaint with the International Telecommunications Union (ITU).

The FCC's monitoring stations have heard no evidence that the 1040 kHz operation may start operating at night, LaFollette said.

NAB Counsel Barry Umansky echoed what many other broadcasters said their reaction would be if the 300 kW Radio Moscow relay began operating at night: "It would be terrible."

Twenty stations, mostly daytimers, are licensed to operate on 1040 kHz.

Ft. Lauderdale-based Glenn Hauser indicated in his publication, *Review of International Broadcasting*, that the current daytime only schedule "insures that (the relay) will be heard only in the southern tip of Florida—why bother?"

He adds, "Is tokenism that important? The fuse has been lit, but the bomb of high-power nighttime broadcasting has not yet exploded."

As of early June, the FCC had received one formal complaint about the problem—it came from WYFX. WHBO GM and President Jonathan Pinch said his station had also filed a complaint.

Pinch told RW that WHBO received "over 100 calls" from listeners complaining that they could hear the Radio Moscow relay underneath the station.

He said that because of the conductivity of salt water, the interference to WHBO is more severe the nearer the listener is to the Gulf Coast.

"For our listeners in our main coverage area, the interference is largely an annoyance. But it gets rather heavy in our peripheral coverage area," Pinch maintained.

For more information on the Cuban interference situation, contact Wilson LaFollette at the FCC: 202-632-5414.

McKinney Mum on Job Switch

by Alex Zavistovich

Washington DC ... Industry sources indicate FCC Mass Media Bureau Chief Jim McKinney will leave the Commission to take a telecommunications position at the White House.

At Radio World's press time 15 June, McKinney refused to comment on the rumored departure, which comes on the heels of speculation that the bureau chief was being considered for the Commission seat vacated by the promotion of Dennis Patrick to chairman.

However, McKinney, who has headed the Mass Media Bureau since 1983 and spent a total of 24 years at the FCC, did not deny the White House rumor outright. "I won't confirm or deny it—no comment," he said.

The bureau chief was equally closed-mouthed about talk that he may be in contention for the open Commis-

sioner's seat.

He was reported to have been recommended for the slot by Drew Lewis, former chairman of Warner Amex Cable and now president of Union Pacific Corp.

Before the latest rumor surfaced, McKinney maintained: "I have received no calls from the White House concern-

ing the vacant Commissioner's job, and my assumption is I am not under consideration for the position."

"All the cards are in the hands of the White House," he said. "It's their (the White House's) call. It is up to them to make an initiative, and they have not done so."

Fidelipac introduces a brand new cartridge
and a brilliant new tape

DYNAMAX[®]

COBALT TAPE BROADCAST CARTRIDGE

- Expanded high frequency headroom
- Superior phase uniformity
- Inaudible wow and flutter
- Greatly extended cartridge life

Get complete information and your free sample of
DYNAMAX Cobalt. Call toll free: 800-468-8273



DYNAMAX[®]
BROADCAST PRODUCTS BY FIDELIPAC[®]

Fidelipac Corporation □ P.O. Box 808, Moorestown, NJ 08057 □ U.S.A.
609-235-3900 □ TELEX 710-897-0254 □ Toll Free 800-HOT TAPE
Dynamax is a trademark of Fidelipac Corporation.

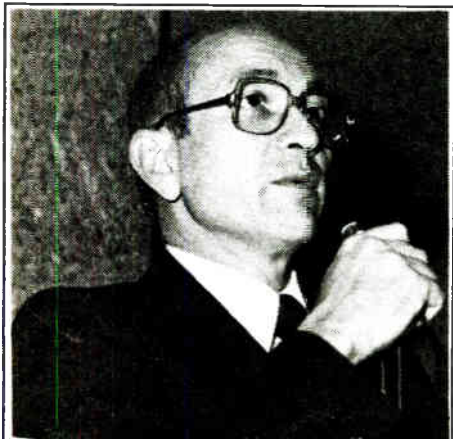

FCC Mass Media Bureau Chief
Jim McKinney

Regulatory News

FCC Amends Hearing Policies

by Alex Zavistovich

Washington DC ... Broadcast license and construction permit (CP) holders are no longer entitled to an automatic hearing contesting FCC modifications to channel allotments, because of an amendment to the Commission's rules in the matter.

The FCC in mid-May announced its

FCC's Table of Allotments for television and FM.

Rulemaking mandatory

A rulemaking proceeding is instituted each time there is a change in the channel of any allotment, either to another channel or to another class, if that allotment was occupied.

Further, new channels allotted to a

community often require substitution of an occupied channel.

However, Hayne added, if the station has insufficient reasons to deny the modification, or does not raise substantial and material questions of fact, the proposal could be adopted without benefit of a hearing.

"Without a substantial and material question of fact, we (the FCC) would just go out with a Report and Order modifying the license or permit," Hayne stated.

Although the entitlement to an automatic hearing has been "somewhat eroded" by Congressional action, Hayne commented, written notification by the FCC before any modification has been retained in the amended rules.

For additional information, contact Robert Hayne at 202-634-6530.

In some cases ... modification issues may be settled without a hearing.

amendment to rules pertaining to such modifications.

The full text of the Commission's decision was released earlier the same month.

The amendment was made, the FCC said, to allow for greater conformity of the Commission's rules with Section 316 of the Communications Act, which provides procedures for modifications.

Automatic hearing eliminated

In place of the automatic hearing for stations whose permits or licenses must be modified, the FCC will require the station to submit a "substantial and material question of fact" contesting the modification.

The automatic hearing provision for changes in channel allotments has been eliminated by Public Law 98-214, said FCC Mass Media Bureau spokesperson Robert Hayne.

According to FCC practice, channels designated for use in communities throughout the US are maintained in the

community often require substitution of an occupied channel.

Existing licenses or CPs must be modified to specify the new channel.

As part of the rulemaking proceeding, the FCC is required to accompany any modification intentions with written notification to the licensee or permittee.

The notification must give the recipient the opportunity to explain why the modifying action should not take place, and inform the permittee or licensee of his right to a hearing.

Question of fact

Hayne explained that a hearing before the Commission, previously granted automatically, is now dependent on whether the licensee or permittee can give sufficient and satisfactory reasons for holding one.

In some cases, based on the reasons offered by the stations in question, modification issues may be settled without a hearing, he commented.

If, for example, enough reasons are

INDEX

Going "Giga" with New 23 GHz STLs <i>By Tim McCartney</i>	11
Teamwork Lets Station Sparkle <i>by John Shepler</i>	13
Building a Production Room On a Budget <i>by W.C. Alexander</i>	14
Installing a New Transmitter At a New Station <i>by Kirk Harnack</i>	15
Build An Emergency Controller <i>by Fred Baumgartner</i>	17
Coping With Lightning Strikes <i>by Ron Balonis</i>	19
Contract Engineering	20

FCC Clips

Daytimers comment deadline

A comment deadline of 17 July has been set for a proposal by the FCC, which would allow all "qualifying" AM daytimers, including those on domestic clear and regional channels, to add nighttime operations.

Reply comments on the proposal will be accepted until 3 August. The full text of the proposal was released by the FCC 26 May.

For more information, see the 1 June issue of RW, or contact Louis Stephens at the FCC: 202-254-3394.

"Cross-interest" policy examined

A review and clarification of the FCC's cross-interest policy was announced by the Commission in mid-May. The policy restricts individuals from having "meaningful cross-interests" in two broadcast stations serving the same area.

Other combinations, such as a daily newspaper and a broadcast station, or a television station and a cable TV system in the same basic area, are also proscribed by the policy, the FCC maintained.

According to the Commission, many aspects of the cross-interest policy are out of date because new ownership rules prohibit such relationships.

FCC docket is MM 87-188. For more information, contact Andrew Rhodes at 202-632-7792.

US/Mexican Border FM changes

Non-commercial FM stations within 199 miles of the US/Mexican border may soon be allowed to submit applications based on non-overlapping signal contours of domestic stations.

The FCC, in a Notice of Proposed Rulemaking in May, suggested using the contour method for all such station assignments, while keeping minimum distance separations between US and Mexican stations, as set out in an agreement between the two nations.

Presently, applications for station assignments with the 199 mile limit are based on the FCC's table of allocations, rather than the contour method.

FCC docket is MM 87-140. Contact Hank Van Deursen at 202-632-9660.

Fowler joins law firm

Former FCC Commission Chairman Mark Fowler, on 1 June, joined the Washington office of Latham & Watkins, a Los Angeles-based law firm. Fowler will take on the role of senior communications counsel.

Earlier, Fowler had stated his intention to become involved in "entrepreneurial" ventures with Albert Halprin, formerly chief of the FCC's Common Carrier Bureau. Although no further details have been announced, Latham & Watkins have given Fowler freedom to develop such ventures, in addition to his responsibilities to the firm.

Fowler left the FCC in April.

Vanguard Series™

Broadcast Audio Consoles

Performance, Value and Reliability through Innovative Technology

- Raised, tactile feel, lighted membrane switch panel—digitally scanned
- 12 stereo inputs plus optional expander
- VCA controls, rotary and linear
- Analog and fluorescent meters
- Modular, plug in electronics
- Easy punch block installation
- Effective RF protection

BC8DS
8 Mixer
Dual Stereo

only \$3,195

AUDIO TECHNOLOGIES INCORPORATED



328 Maple Avenue, Horsham, PA 19044 • (215) 443-0330



FM2 Band Proposal Still Alive

by David Hughes

Hackettstown NJ . . . Despite a previous rejection from the FCC, Radio New Jersey (RNJ) is continuing its efforts to create a second FM broadcast band—dubbed "FM2."

The plan to create a second FM band, to be used by daytimers and AM stations facing interference, is still alive, says Larry Tighe, president of RNJ, which owns a daytime AM station in Hackettstown, NJ.

While RNJ has filed a petition to ask the FCC to reconsider its rejection, the firm is also planning a campaign to get broadcasters to write to the Commission in support of the plan.

FCC rejection

In a March decision, the FCC rejected any reallocation of the 225-230 MHz band. The Commission indicated that those frequencies had already been reserved for military uses and could not be reallocated for broadcasters.

Thomas Stanley, head of the FCC's Office of Engineering and Technology (OET) told RNJ that the plan to use 225-230 MHz would "displace government operations" that are "vital to national security interests." However, no one at the FCC would say specifically what the band was used for.

Tighe, who has formally petitioned the FCC to reconsider its decision, said he has asked several Congressional representatives to determine if the frequencies are actually needed for security

interests or are just being reserved by the government. He said he has monitored the frequencies and has never heard any use of them.

If it is determined that the 225-230 MHz frequencies are still out of bounds, Tighe indicated that he may resubmit his FM2 plan but instead ask for reallocation of the 220-225 MHz band.

RNJ unveiled the FM2 plan last November. It calls for daytimers and fulltime AMers with poor nighttime signals to move to the an FM2-type band.

Eventually, according to the plan, the AM operations would be discontinued and not replaced, thereby allowing the remaining AM stations to face less clutter and be able to upgrade.

Campaign planned

RNJ's Washington DC-based attorney, Larry Roberts, added that the firm plans to implement an advertising campaign to rally support for FM2 from the broadcasting community.

While Roberts said RNJ has received support for the plan from broadcasters, he maintains a letter writing campaign must be started to let the FCC know the apparent depth of that support.

For more information about the FM2 plan, contact Larry Tighe at 201-850-1000, or Larry Roberts at 202-659-4700.

Engineering Team to Tour China

by Alex Zavistovich

Indianapolis IN . . . A delegation of broadcast engineering professionals from around the world will travel to the People's Republic of China this fall, at the request of the Chinese Radio and Television Broadcasting Society.

The team is being selected by the Citizen

“ This will be an excellent chance to meet with our professional counterparts. ”

zen Ambassador Program of People to People International, a private enterprise founded by President Eisenhower in 1956 to further international understanding.

SBE VP/Engineering Jack McKain has been appointed leader of the delegation, which is slated to convene in China 20 September, returning 11 October.

According to an 18 May letter from McKain to prospective candidates, "The delegation will exchange ideas and experiences with Chinese broadcast en-

gineering professionals about current practices, trends and needs in broadcast engineering technology."

The group, McKain continued, will take part in the 1987 International Symposium on Broadcasting Technology in Beijing, afterwards visiting Chengu, Hefei, Guangzhou and Hong Kong.

John Luppert, director of Science and Technology Projects for the Citizen Ambassador Program, detailed in another letter to candidates some of the topics likely to be discussed during the visit to China.

These topics include on-line facility operations, such as programming, production and traffic. Other areas may include development and management of technical standards, and use of computer assistance in systems control, traffic, budgeting and facility design.

Each delegate must pay \$4700, which covers transportation, accommodations and other costs connected with the trip. A separate spouse program is also available.

McKain stressed the trip "is designed to comply with Section 162" of the new US tax code, and may be deducted as a business or educational expense.

Participation in the China trip was encouraged by McKain. "This will be an ex-

cellent chance to meet with our professional counterparts and, at the same time, observe firsthand a completely different system of handling broadcasting concerns."

McKain said representatives of all broadcast-related disciplines will be invited to take part.

At press time, McKain was the only SBE officer confirmed for the trip, although he said some SBE members, as well as members of other professional associations including SMPTE and IEEE had expressed interest.

For additional information, contact Jack McKain at 316-265-2815.

A. RF Specialties of Washington
11721 15th Ave. N.E.
Seattle, Washington 98125
(206)363-7730
John Schneider & Bob Arnold

B. RF Specialties of California
3463 State St. #229
Santa Barbara, CA 93105
(805)682-9429 Sam Lane

C. RF Specialties of Nebraska
2003 Brewster Road
Bellevue, Nebraska 68005
(402)734-5521 Don Denver

D. RF Specialties of Texas
P.O. Box 8316
Amarillo, Texas 79114
(806)372-4518
Don Jones & Tim Hawks

E. RF Specialties of Florida
P.O. Box 397
Niceville, Florida 32578
(904)678-8943 Bill Turney

F. RF Specialties Pennsylvania
121 Conneaut Drive
Pittsburgh, Penn 15239
(412)733-1994 Tom Monahan

Each Office is Independently Owned and Operated

RF SPECIALTIES GROUP

LEADERS IN RF SYSTEMS FROM COAST TO COAST

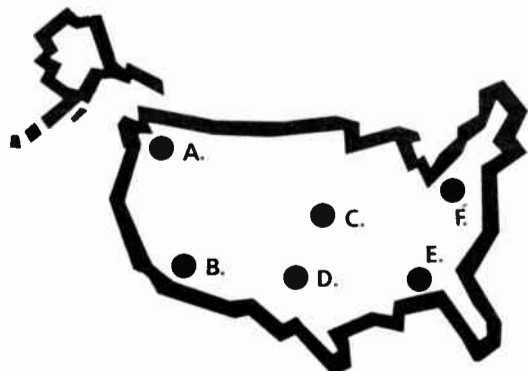

FOR ALL YOUR RF NEEDS, CALL THE SPECIALIST NEAR YOU

SYSTEM DESIGN COMPETITIVE PRICING



RF Specialties Group

FM-3.5A 3500 Reliable FM Watts



- Patented folded half-wave cavity eliminates plate blocking capacitor and sliding contacts.
- Solid state broadband IPA in slide out drawer.
- Synthesized FX-30 exciter.
- Single phase AC power.
- Emergency 250 watt patching.
- Automatic power control maintains constant output power with proportional VSWR foldback protection.
- Ten meters.
- Optional microprocessor video display system (MVDS) with diagnostics.

The Model FM-3.5A single tube FM transmitter is the first choice for optimum Class A service. Over sixty on the air in the United States, Canada and overseas.



BROADCAST ELECTRONICS INC.

4100 N. 24th ST., P. O. BOX 3606, QUINCY, IL 62305-3606. (217) 224-9600. TELEX 250142

NRSC Continues RF Mask Work

by Alex Zavistovich

Washington DC ... The National Radio Systems Committee (NRSC), fresh from apparent success in setting a voluntary standard for AM preemphasis and deemphasis, has turned its focus to researching an RF mask—a proposed RF emission standard.

The proposed RF mask was discussed during the last meeting of the NRSC AM Technical Subgroup, held 3 June in Chicago, following the Consumer Electronics Show.

On the next day, a full meeting of the NRSC was also held, at which the progress of implementation of the NRSC preemphasis standard was discussed.

At RW's mid-June press time, Subgroup Co-chairman John Marino, VP/engineering for NewCity Communications, said that discussion of RF mask details was "premature," but stressed it was based on real-world data, "not something we just pulled out of the air."

The mask is based on spectrum analysis of actual transmitted RF bandwidth from various radio stations, Marino said.

Further substantiation of the mask, he added, came from research in Europe conducted by the International Radio Consultative Conference (CCIR), an international standard-setting organization.

Discussion of the mask during the last subgroup meeting involved such factors as rolloff beyond a certain point, and whether the level should be relaxed for older model transmitters still in operation.

Marino explained that some facilities built in the 1940s may still use the aging transmitters, which may have trouble meeting RF mask specifications.

"We (the NRSC) want to make sure that most stations, even older ones, will still fall within the RF emission mask. Or, if they can't, at least be able to get advice on what they can do for their old transmitters—lower rolloff, use less high frequency boost."

The subgroup is also concerned with

tying the RF mask specs in with the 75 μ S preemphasis guide first proposed at an NRSC meeting before the Radio '86 convention in New Orleans last September.

"We're trying to get the mask as close to the audio standard as we can," said Marino.

"The audio standard is an ideal—with it, you have 10 kHz bandwidth and no second adjacent channel interference," Marino explained. As long as the RF mask comes close to the standard, he said, "we can still say there won't be any second adjacency interference."

Other action proposed by the NRSC subgroup includes theoretical modeling of the AM system, which would enable the group to examine the modulation artifacts produced by the transmitter.

Marino also credited the work of Canada's Department of Communications (DOC), which establishes technical regulations for that country's broadcasting industry.

DOC representatives have been on

hand at the last two subgroup meetings, Marino said, and have also examined RF emission data from a number of stations.

According to Marino, the data brought in by the DOC "closely matches" the subgroup's current RF mask proposal. "It looks like everything is falling into place for the mask," he said.

The NRSC AM Technical Subgroup will continue its examination of the RF mask proposal through its next meeting, to be held 15 July in Denver, Marino said.

If all goes well, he speculated, a completed RF mask will be established by the NAB's Radio '87 convention, slated for September in Anaheim, CA. A 90 day comment period will follow any mask proposal.

The full NRSC meeting was held in Chicago on 4 June, at which the subgroup presented a report on its progress in resolving the RF mask issue.

Also presented during the meeting was a status report from processor manufacturer Circuit Research Labs

(CRL), Marino said. CRL has reportedly shipped over 150 NRSC processors since the preemphasis standard was approved.

NAB has been receiving a steady flow of response cards from a direct mail survey of radio stations' reactions to the NRSC audio standard and its implementation, Marino commented.

Marino said the mailing has seen a "good return" so far; most comments regarding the standard have been positive, he noted.

NAB Engineer Mike Rau, a member of the NRSC, added that other action during the meeting included discussion of continuous tuning radios and upcoming FCC regulatory proceedings.

Of particular interest to the NRSC is the Commission's forthcoming proceeding on AM technical standards, Rau said. (See related story, this issue.)

He maintained that the AM Technical subgroup will "want to play a part in developing higher quality AM standards, for the expanded band and, ultimately, the existing band."

For additional information, contact John Marino at 203-333-4800. Contact Mike Rau at 202-429-5340.

FCC to Examine AM Standards

by David Hughes

Washington DC ... The FCC is planning to begin a major, long term examination of a number of its AM technical standards.

By early summer, according to Wilson LaFollette, head of the FCC's International Branch, the Commission will begin a formal inquiry to reexamine AM technical rules pertaining to protection ratios, protected contours, RF bandwidth limitations and calculation methodologies.

The inquiry, which could take a year or more to complete, was hinted at in January, when the Commission released a time table for its AM improvement campaign, which began with the *Report on the Status of AM Broadcasting Rules*,

released in April 1986.

FCC Mass Media Bureau Chief Jim McKinney told RW that the "broad rulemaking" inquiry will concentrate on a number of issues discussed in the April 1986 report.

That 106-page document highlighted AM "assignment principles," including protection ratios and antenna systems, as well as "engineering standards," which covered groundwave and sky-wave propagation.

"The criteria that we are using now we have been using for the last 50 years," McKinney said. "We have much more information today on the propagation of AM radio and ground conductivity."

He added: "Now that we have much better information and much better tools to work with, we think it is appropriate to have an inquiry as to whether those old, existing criteria that have been in use for many, many years are correct. Should they be strengthened or relaxed?"

At BDRW's press time in mid-June, LaFollette, who is organizing the inquiry, said that "no exact date" was available as to when the inquiry will be released, but it should be available "by summer." He declined to go into greater detail.

"It will be a long term Notice of Inquiry that will review the technical criteria used in making (AM) assignments," he said.

Ron Rackley, a Washington DC-based

consultant, said that he heard the inquiry notice will also examine AM antenna requirements and their relationship to local zoning rules.

NAB Counsel Barry Umansky added that the FCC will also take a look at its "50% exclusion rule." He said the inquiry will be "on track before the (FCC's) August recess."

"The FCC is beginning to realize that the AM band is mature," Rackley said. "They have heard complaints from the NRSC (National Radio Systems Committee) that the band is too crowded, and that there's limited frequency response."

Rackley added that with the recent freeze on new AM daytimers, the FCC apparently wants to "step back and take a look" at the band.

The Commission recently implemented another "long term" AM improvement issue to give nighttime powers to as many daytimers as possible, including some on clear channels.

Some "short term" AM improvement issues that are or have been examined by the FCC include allowing synchronous AM transmitters, eliminating the main studio and program origination rules, relaxing the AM duopoly regulations and considering new RF lighting interference limits.

For more information on the latest FCC activities on AM improvement, contact Wilson LaFollette at 202-632-5414, or Steve Selwyn at 202-254-3394.

PAS and MARANTZ TEAM UP TO SAVE YOU \$\$\$ ON THE MOST USED CASSETTE MACHINES IN THE BUSINESS

PAS

is dedicated to SAVING you money. Call for pricing on our over 200 Lines of Equipment and Supplies!



PMD 221	- Deluxe Portable Three-Head Two Speed Cassette Recorder	\$ 245.00
PMD 201	- Portable Two-Head Two-Speed Cassette Recorder	\$ 210.00
CLC-221	- Vinyl Carrying Case	\$ 29.95
RB-430	- Rechargeable Nicad Battery Pack	\$ 49.95



A RETEX INTERNATIONAL COMPANY
5700 East Loop 820 South
Fort Worth, Texas 76119-7050
Order Desk 1-800-433-7668
Consultation 1-817-483-7474

NEW!

INSTALLING A "CONCERT LINE"?? YOU NEED TELECARD!

TELECARD is the *best* way to interface your cart machine to automatically answer phone calls... *perfect* for info lines!

- DIGITAL CALL COUNTER
- WORKS WITH ANY CART MACHINE
- NO AUX TONES OR RELAYS NEEDED
- EASY INSTALLATION

RADIO RESOURCES
1-800-547-2346



In Stock \$195.00

Readers' Forum

Got something to say about *Radio World*? Any comments on articles? Call us at 800-336-3045 or send a letter to Readers' Forum (*Radio World*, Box 1214, Falls Church VA 22041 or MCI Mailbox #302-7776).

Composite processing for AM

Dear RW:

In order to drag AM stereo down the pathway to success, I have a suggestion to make.

With the availability of used Orban 8000 processors, etc., wouldn't it be a great idea to have AM stereo generators with a composite input port?

While this would cost little in manufacturing, it would allow stations to process their AM stereo signal like the FM counterparts do.

A typical chain would then include console to Optimod (or similar) to composite STL, and STL receiver directly into the AM stereo exciter.

No ringing, no overshoot, you get the idea.

This would boost STL sales, and I think, make AM stereo look more favorable to combo stations, because they could then use their downgraded FM equipment for a good cause.

Bob Mayben, C.E.
WCNN
Atlanta, GA

In case you are wondering, the frequency is the only thing shared by the stations. Each station maintains and operates its own transmitter, tower and studios.

Dan Voss, Chief Operator
KADR/KCTN
Elkader, IA

Honoring Steinmetz

Dear RW:

Radio World's Old Timer extolled the work of Steinmetz in the 15 May issue.

It is indeed lamentable that few engineers know the importance of the work of that undisputed genius.

Several years ago, however, there was an attempt by a writer for a radio publication to enshrine Steinmetz's name so that it would be forever remembered.

When the standard unit for frequency was changed to Hertz in honor of Heinrich Hertz, there was, of course, a great uproar from the ranks evidenced by many letters to the editor and other out-

(continued on page 8)

Everyone loves a bargain, and radio CEs, GMs and others who handle station equipment purchases are no exception.

A market where there is healthy competition ultimately benefits the buyer with a diversity of choices and competitive pricing, and that is certainly the case in the radio equipment industry today.

But cutthroat competition and price-shaving taken to its extreme leads to a marketplace where it's impossible for vendors to survive.

If pricing gets driven down too low, vendors are forced out of business, causing a situation where sources for equipment dry up and prices soar.

An attempt to always get the best bargain by pitting one vendor against another might make for an impressive bottom line, but it may backfire in the long run.

Really buying smart doesn't mean going just for the cheapest price. Other factors besides cost should be taken into account.

An example of extreme price competition has shown up in recent government contracts such as the

VOA modernization, where the process for keeping costs low may lead to trade-offs in quality or reliability.

Service, deliverability, a company's reputation and relationship with its customers are considerations which have to be weighed along with costs to decide what constitutes a good buy.

Buyers should be just as concerned with having a continuing source for parts, or a second source, than with getting the cheapest price.

Realistically, a marketplace has to allow its vendors a reasonable profit margin or risk putting them out of business.

No buyer wants to be "taken to the cleaners" on a deal. Yet if radio equipment purchasers do the same to the industry's vendors, they add to a situation where they end up hurting themselves.

Buying cheap and buying smart do not mean the same thing.

—RW

Buying Smart

More time-sharing

Dear RW:

Just a note to let you know there is at least one instance of "shared time" stations still in existence in the US.

One of the stations up the road, KDEC-AM in Decorah, IA shares time with KWLC-AM. KDEC operates on 1240 kHz Monday thru Saturday as a commercial station from 6 AM to 9 AM and 11:45 AM to 10 PM.

KWLC, operated by Luther College in Decorah, is on the air Monday thru Saturday from 9 AM to 11:45 AM and 10 PM to midnight. KWLC also operates on Sunday from 7:15 AM to midnight.

Dial-Up Gear Can Meet Rules

By James Sorensen

Fort Lauderdale FL ... I read with interest the first part of the four part discussion on dial-up remote control devices for transmitter systems.

About a year ago, our company purchased a Gentner VRC-1000 with its attendant relay and power back-up equipment with the specific purpose of using it as a transmitter error alarm and as an automatic controller for some transmitter functions.

Keeping in mind our interpretation of the FCC rules on automatic transmitter controllers, we decided not to use the unit as the means of taking formal (log grade) readings and making changes in the power levels of the transmitters.

We left the functions that are of interest to the Commission in place on the existing wire-line remcon ... those of plate control, power level adjustments, and PA parameters.

We added equipment to the two PAs which will allow us to monitor three additional functions of the PA tube ... filament voltage at the tube socket (using a low loss wire scheme, 2% iron vane meters), filament current in the filament loop itself, not input current to the filament transformer, and tube body temperature at the ceramic/anode seal.

The Gentner box is set up to monitor these three parameters and to offer corrective action through its automatic features in this loop.

We have found that the Gentner box works very well for the applications we have chosen, and offers us the big plus of being able to call the duty operator in

James L. Sorensen is CE of WJQY-FM. He can be reached at 305-484-8107.

the event of difficulty it can't solve automatically.

In addition to the filament management program, we use this device to monitor the status of various RF switches in the transmitter plant, some coupler body temperatures, the status of the tower lighting plant, the security of the building, and the status of the air-handlers and HVAC system.

Guest Editorial

In essence, the Gentner box is programmed to call the duty operator if *anything* in the facility deviates from the normal parameters we have described for its operation.

I think it is important to note that in the case of the PA parameters of the transmitters, the Gentner VRC-1000 does *not* make any adjustments—it only blows the whistle on the deviant rig.

This was done not because we doubt the ability of the unit to respond properly to the needs of the system, but for reasons based upon our interpretation of the FCC's rule in these matters.

There is one thing of additional concern in the matter of dial-up control of transmitters and that is the idea of "hackers" breaking into the system.

In our transmitter plant the phone is attached to the VRC-1000 ring.

When it rings and we answer it, we either get asked if someone is there, or we get silence and a hang-up.

Certainly in major markets, and in many smaller markets it is impossible to get a "clean" phone number that has never been assigned before and is not listed in any book.

In our case, the machine answers by telling the caller that he is now connected to the WJQY Transmitter Control Computer and is asked for an access code.

It seems that a person who now knows that this is a radio transmitter site could eventually come to the conclusion that this thing speaks DTMF and could feed in random numbers in such a way that would eventually break the access code.

There are certainly ways around this problem, but the simple fact that this could happen gives me chills when it comes to putting important control functions on the box.

My interpretation of the rule governing these devices is that the purpose in the first place is to prevent persons who are not in the employ of the station and who are not properly authorized and trained by the station from having access to the control system at all.

This is hardly served by having them blocked out of the control loop by a simple-to-crack number string.

I would not hesitate to recommend to stations that they explore the use of units of this type for these kinds of applications.

But I continue to urge caution where public access to the unit through the phone system cannot be absolutely controlled.

The phone networks being what they are makes me think that the industry cannot satisfy the requirements of the rules and of self-protection by allowing full control of their transmitter plants by dial-up equipment at this time.

A relaxation of the standards by the Commission and a station's willingness to "stick its neck out" does not make sense to me.

Radio World

Vol 11 July 1, 1987 No 13



Radio World (ISSN: 0274-8541) is published twice a month by Industrial Marketing Advisory Services, Inc., 5827 Columbia Pike, Suite 310, Falls Church, VA 22041. Phone (703) 998-7600. Copyright 1987 by Industrial Marketing Advisory Services, Inc. All rights reserved.

Publisher, Ad Sales Manager: Stevan B. Dana; East Coast, Ernie Robitel (516-671-2502); West Coast, Pat Macsata (415-786-2198); Simone Leeser *Advertising Co-ordinator*; **Editor:** Judith Gross; **News Dept:** David Hughes/*Manager*; Alex Zavistovich; **Buyer's Guide:** Marlene Petska Lane/*Editor*; **Technical Consultant:** John Bisset; **Circulation Manager:** Marion Alsup; **Production Department:** Jean Barnes/*Manager*; Gina R. Rosario, Kelly Quill/*Graphic Artists*.

Free subscriptions are available to professional broadcasting and audiovisual equipment users. For address changes, send current and new address to RW a month in advance at the above address. Unsolicited manuscripts are welcomed for review; send to the attention of the appropriate editor.

Remote Dial-Ups Are A Boon to Networks

Editor's note: In the fourth segment of our multi-part series on transmitter remote control systems using dial-up telephone lines, we focus on the use of the technology by radio station networks—both microwave and satellite.

by David Hughes

Washington DC ... South Dakota is a big state, and South Dakota Public Broadcasting does not have the personnel or the time to send someone to read

the meters at an FM station at locations hundreds of miles from the network's control center in Vermillion.

The network of six radio stations (five FMs and one AM), as well as eight TV stations, depends on a new dial-up remote control system to not only read the meters at its widely spaced stations, but also to monitor a wide range of transmitter and other parameters.

Tony Dock, engineer and studio supervisor for the non-commercial network, says the dial-up technology, which utilizes telephone line links to the network's two control centers—one in Vermillion

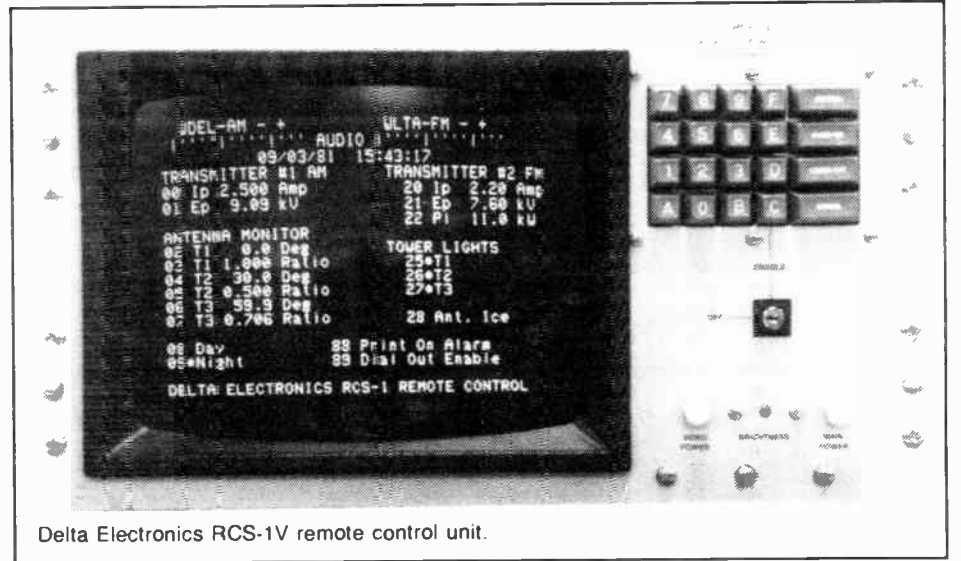

Delta Electronics RCS-1V remote control unit.

and the other in Rapid City—is more reliable than a remote control system via microwave links, which are used to supply the program feed to the stations.

"In many kinds of weather conditions or in a power outage, the microwave link is the first thing to go," Dock said. "The phones very rarely ever go down."

"Big difference"

The dial-up remote system "makes a big difference," Dock said. "Here in South Dakota, there is such a big area to cover with such a few people (on his engineering staff). It could take an all-day drive just to visit a transmitter site to take a few readings."

Special Report

The educational network is currently installing—as fast as its budget will allow—Gentner VRC-1000s at all its transmission sites, which will be monitored from Vermillion and Rapid City.

The dial-up remote gear provides continuous monitoring that alerts a control point operator if something is out of kilter, he said. If something goes out of tolerance, an alarm will go off. The system even monitors security, temperature extremes and fire hazards.

He says the network is converting from the "manual remote" microwave link-based system to the "automatic remote" phone line system.

Dock said he also plans to feed the large amount of data accumulated by the remote gear into a computer database to do long term analysis. "We will be able to plot data such as power output efficiency, and we'll be able to do it on a weekly, monthly or yearly basis."

"Even with the dial-up gear, there is still a human there who decides what should be done," he added. Dock main-

tains that the system does not replace ultimate human control.

Dock added that the system has several failsafe features. Besides the built-in internal failsafe system in the VRC-1000, the system's transmitters will shut down if they loose their program feed.

Regulatory questions

While, right now, remote monitoring is confined to the Vermillion and Rapid City control points, Dock said that his engineers will soon have equipment to allow them to monitor any of the transmitters via "the cellular phone in their car."

However, he stressed that FCC rules still prohibit transmitter changes from sites other than specified remote control points.

Even though many of the Commission's rules regarding dial-up remotes have been labeled by some in the industry as being vague, the FCC does stress

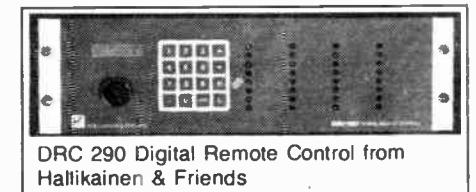

DRC 290 Digital Remote Control from Hallikainen & Friends

that the technology cannot be used to bypass a designated control point.

While monitoring of transmitter parameters is considered to be within the rules, the FCC has said that dial-up changes to transmitter operation can only be made with the full knowledge and ultimate control of the specified control point operator.

The same FCC regulations that apply to dial-up gear at a lone station also apply to network control of a series of stations, according to John Reiser of the Commission's Engineering Policy *(continued on page 8)*

HOLD THE PHONE!

New Low-Cost Option Adds Dial-Up Capability To Advanced Micro-Dynamics TC-8 Transmitter Remote Control.

And It's 100% FCC-Legal.

Now Advanced Micro-Dynamics puts it all together—The simplicity, reliability and convenience that's made our TC-8 today's fastest selling transmitter control package. PLUS the added flexibility of dial-up remote control. All at a price you'll scarcely believe.

Our new dial-up option gives you full access to all TC-8 features from any touch-tone telephone. Its on-board speech synthesizer announces all readings, and a user-selectable password protects against unauthorized access.

And this is one dial-up remote that's unquestionably legal. FCC regulations require a designated positive control point, and that's what the TC-8 studio unit gives you — even when the dial-up remote is in use.

So now there's no need to choose between full-time remote control and dial-up. You get both with the TC-8.

How much? That's the most amazing part. The TC-8 dial-up option is just **\$395!** The TC-8 studio/transmitter system is just **\$2495.**

For value, no other transmitter control system comes remotely close to Advanced Micro-Dynamics' TC-8. Add it up for yourself. TC-8 now gives you full-time studio remote control PLUS dial-up features for LESS than others charge for a dial-up remote control alone!

Your next move? Call your favorite distributor, or call Advanced Micro-Dynamics Toll-Free at **1 (800) 255-8090.** And if you're already among the hundreds of TC-8 users, call us for information on adding the dial-up option.



Advanced
micro-dynamics inc.

7 Lomar Drive, Pepperell, MA 01463 (617) 433-8877

NEW!

INSTALLING A HYBRID??

YOU NEED MIX-MINUS PLUS!

MIX-MINUS PLUS adds a mix-minus output to a console that lacks one! Provides 40db of caller attenuation so your hybrid works its best.

- Easy connection to most consoles
- NULL adjustment never needs re-tweaking
- Self contained power supply



HENRY ENGINEERING
(818) 355-3656

In Stock **\$195⁰⁰**

FOR STATIONS WHO CARE HOW THEY SOUND

This Cart's For You!

AUDIOPAK AA-4

by **Capitol**

Available from "Capitol Distributor of the Year"

ALLIED

The best sounding and most
reliable broadcast cartridge
no matter how you
"stack 'em!"

When you need
carts fast
Allied delivers.

Call us up today,
cart 'em up
tomorrow.

ATLANTA, GA
(404) 964-1464

LOS ANGELES, CA
(818) 843-5052

CHICAGO, IL
(312) 470-0303

RICHMOND, IN
(317) 962-8596

DALLAS, TX
(214) 423-8667

SEATTLE, WA
(206) 838-2705

RICHMOND HILL, ONTARIO (416) 731-3697

ALLIED
Broadcast Equipment

P.O. BOX 1487 • RICHMOND, IN 47375

Networks Thrive With Dial-Up

(continued from page 6)
Branch.

He said that the rules indicate that regardless of whether the transmitter changes are made from a remote control point at the local station's offices or at a network control center hundreds of miles away, the Commission must be notified of and be able to contact the specific point.

In addition to the specified control point, the network control must also have the ability to shut down station transmitters should a malfunction in the dial-up circuit occur, as well as to monitor the Emergency Broadcasting System (EBS).

To the east of South Dakota, in neigh-

boring Minnesota, the St. Paul-based Skylight Network satellite delivers its religious-oriented programming to five stations using the Hallikainen and Friends DRC-190 remote control system with dial-up capability.

According to Dick Becvar, technical director of the network, the network's master control in St. Paul monitors, via telephone lines, the transmitter parameters and the national EBS for the network's five owned stations, which are all in the upper midwest.

Even in network remote control cases, the FCC requires that remote monitoring points have access to the EBS. However, in some cases the FCC has been willing to bend the rules slightly.

According to Hallikainen and Friends, the Skylight Network operates with a waiver from the FCC which allows the network to monitor the national EBS, which is mandatory.

But individual stations are not required to monitor local and state EBS lines; they can participate in local and state EBS emergencies if they establish a local on-call person and "if the station wishes to participate," Hallikainen indicated.

The Skylight Network control can turn any of the stations' transmitters on or off, raise or lower power and perform other modifications via dial-up, Becvar said.

He added that the system also has a

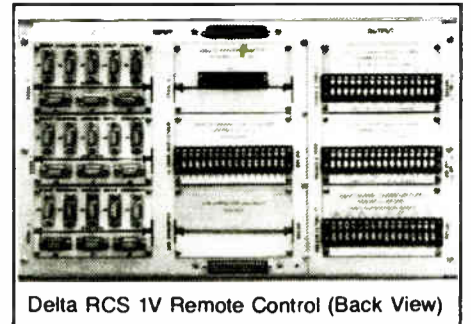

failsafe provision, with a password, that would operate to turn off the transmitters should the network system fail.

FCC informed

Becvar said he informed the FCC about the design of the Skylight remote system before it became operational to make sure it conformed with the Commission's remote control regulations. "They gave it a clean bill of health."

He stressed that the system meets an important FCC criteria—it operates with a specific, notified control point—the St. Paul network control. In fact, the dial-up system features a call-back system that prohibits any dial-up access to be made from any remote point other than the network control center.

If operations at a local station malfunction, the network control point operator in St. Paul is immediately notified by the system. In some cases, the system will also notify a local engineer.

Becvar added that when stations on the network are doing their own programming, the ultimate transmitter monitoring and control are transferred to the local station.

Skylight plans to add stations in Montana, Illinois and Alaska to its network.

For more information on the network uses of dial-up technology, contact Tony Dock at 605-677-5861, Dick Becvar at 515-753-4151, or any of the manufacturers listed in previous installments.

RADIO Classics

What makes a *Radio Classic*? Timeless design, flawless performance, outstanding value, and above all — bullet-proof reliability. Because, in radio, we don't coddle our classics.

The RCA 77DX is one such product. It set new standards in microphone performance. Even now, decades later, its quality still endures. Arrakis Systems' SC audio consoles are *Radio Classics* too. Introduced in 1980, the SC series set new standards in design, performance and value. Today, Arrakis SC consoles are the choice of more radio stations worldwide than any competitive unit in their class. Shown below is the 2000SC, an outstanding value at \$4695. Like all Arrakis audio consoles, the 2000SC is ultra-reliable. And it will continue to deliver outstanding performance as the years go by. After all, that's what it takes to be a *Radio Classic*.



Call (303) 224-2248

RCA 77DX MICROPHONE

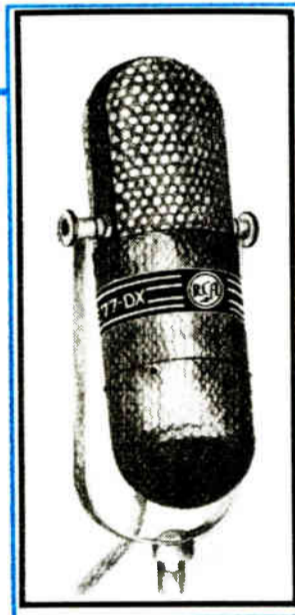

ARRAKIS 2000 SC AUDIO CONSOLE

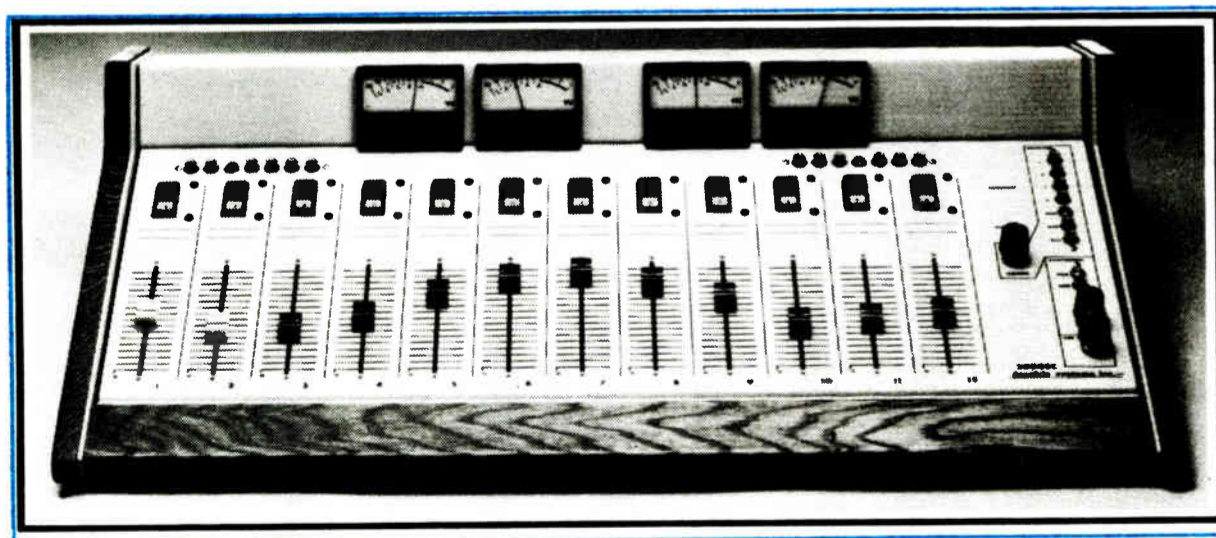

2000SC FEATURES:

- 12 Stereo Channels, 24 Inputs Total.
- Program, Audition, and Mono Mixdown Balanced Outputs.
- Telephone Mix-minus Buss.
- Full Monitoring Facilities.
- Remote Equipment Start.

For features,
performance,
price and
reliability,

2000SC RELIABILITY:

- DC Controlled — No Audio On Pots Or Switches.
- Rugged Motherboard Construction
- Penny & Giles Slide Faders.
- ITT Shadow Switches.
- Only 3 IC types employed, all plug-in.

NOBODY BUILDS CONSOLES LIKE ARRAKIS.

Arrakis Systems Inc. 2609 Riverbend Court Fort Collins, CO 80525

Circle Reader Service 11 on Page 22

World Radio History

Readers' Forum

(continued from page 5)

pourings in the press.

One writer suggested perhaps the most practical way to take care of the matter.

He reasoned that the use of a man's name might be inevitable but that it might be more palatable to the American engineer if the name were that of one who achieved his fame in this country.

He recounted some of the achievements of Steinmetz, as did the Old Timer.

Then he proposed that the unit of frequency be named not for Heinrich Hertz, but for Charles Proteus Steinmetz, and hereafter to be known as CPS!

Richard Houston
High Country Engineering
Durango, CO

RADIO EQUIPMENT SALES OPPORTUNITY

Bradley Broadcast seeks sales personnel to complement our rapid growth. We require experienced broadcasters with proven ability to sell studio and radio RF gear, emphasizing engineering and service support to our clients. Excellent salary and benefits. Send resume with salary history, in confidence to

Personnel Department
BRADLEY BROADCAST SALES
8101 Cessna Avenue
Gaithersburg, MD 20879
No Telephone Inquiries. EOE M/F

US-Japan Trade Focus of Talk

by Mary C. Gruszka

New York NY ... Both the US and Japan must be willing to take the initiative to alleviate the trade problems which have led to recent tariffs on Japanese imports, according to Akio Morita, chairman and CEO of Sony Corporation.

Morita noted that the US should not be quick to blame Japan for all its problems while Japan should be more willing to develop methods to encourage imports.

"Trade should not be simply a one-way street," he said, noting Sony's San Diego plant which now ships large screen TVs back to Japan as an example of Japanese commitment to investing in the US.

Morita spoke to a capacity crowd of about 400 people in the United Engineering Building in New York City in May as part of the Japan Society's distinguished lecture series.

Morita's speech, "Doing Business Without Blame," focused on relations between the US and Japan, especially in the areas of communication and trade. He expressed concern about Congress-

Mary Gruszka is a New York-based broadcast engineer who writes a regular engineering column for RW's sister publication TV Technology.

sional antagonism towards Japan.

Morita also voiced his concern about two economic problems—the "destructive money game" and the fluctuating exchange rate.

He noted that in the US, "the best talent and the most energy are being drawn off into a kind of money game, in which

“ ————— ”

Trade should not simply be a one-way street.

” ————— ”

the buying and selling of companies have become more important than the buying of materials and making of saleable products."

"For me," Morita said, "the wealth of a company is its employees, and the unity which exists among them. Without these, the company cannot produce quality products."

He added that in the US, there seems to be a growing attitude that employee allegiance can be bought and sold, like any other commodity.

"In too many cases, companies with proud work forces and solid bodies of

technology fall completely apart after they are taken over by another company," he said.

Pressure on the dollar

Mergers and acquisitions cause another problem, according to Morita. They are "sapping the basic strength of the US economy and reducing foreign confidence. This puts a downward pressure on the dollar," he said.

Morita said a strong dollar is important for both the US and Japan.

However, he added that "the protectionist measures the US has taken against Japan in the last two months have resulted in continued weakening, rather than the hoped-for strengthening, of the dollar."

As a solution to the trade problem, Morita proposed that businessmen stop playing the money game and "take a long-range look at where we want to be and where we are going."

"We must invest our resources and energy in research on new technology and in new facilities. We must invest in our engineers and scientists and create an atmosphere in which they can work with enthusiasm and a sense of real commitment," he said.

"The world economy is founded on industry, not on speculation in the swings of the exchange rate. We must avoid allowing money, which is only a measur-

ing stick for industries, to become an end in itself," he added.

Business should take lead

Morita suggested that the business community "take the initiative in setting the stage for the solutions of our problems."

"Successful businessmen do not have time to blame each other if business is bad," he said.

"The answer to a business problem must be found from within—increasing the competitiveness of our companies, reducing costs, improving quality or developing new products," he added.

On the issue of trade, Morita acknowledged that the trade imbalance has grown and that "Japanese attempts to open the market have been called 'too little, too late.'"

Morita said that all too often, misunderstandings between the two countries occur, even as the means of communications improve.

He said the US and Japan should listen to each other to better understand "the basic structure of each others' societies, political processes, business practices and cultures."

Morita added, "there has never been a long-term vision of how our two nations should relate to each other." He proposed that such communication now take place.

"The US-Japan relationship has matured to a point where the two nations are clearly interdependent. Without the US, Japan could not survive," he said.

ALL CD BY THE END OF THE YEAR!

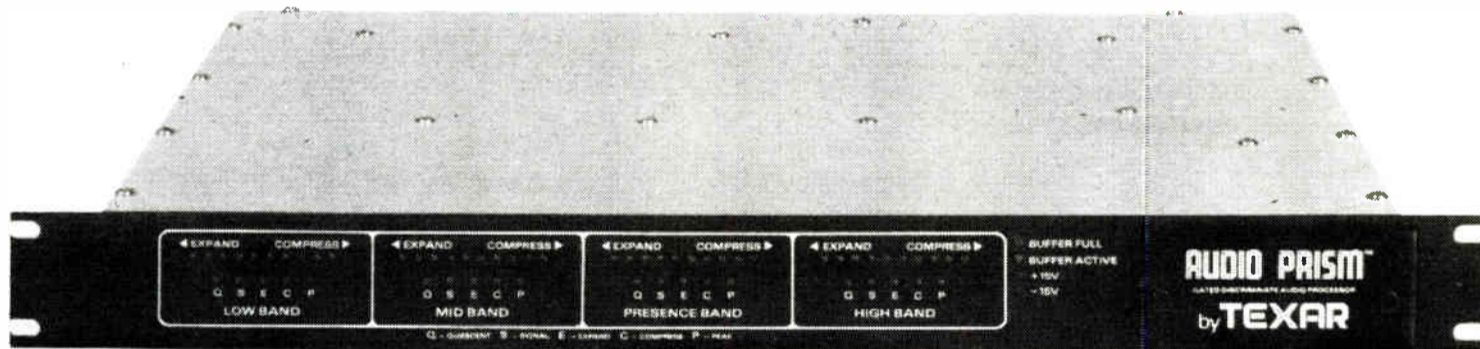

That's the goal that many stations have set for themselves: to generate 100% of their music programming from CDs by the end of 1987. Using copyrighted station identifiers like "Lazer 104," broadcasters are able to position themselves in the listeners' minds as the high-quality music source. One promoted slogan is "Declare your independence from vinyl on July 4th 1987!" Surprisingly, it's not necessarily the big chain stations in major markets that are leading the charge. Medium and small market stations have shown themselves just as likely, if not more likely, to become leaders in their market.

Many of the early hurdles to on-air use of CDs have been removed. While early CD players were difficult to cue to music, making it impossible to run a tight air show, and were user-unfriendly, this has changed. Today's CD players (such as the Technics SLP-1200 and the Studer A725) feature instant start and incremental cueing, making it possible to cue exactly to any desired point in the music.

Many stations also questioned whether sufficient material, both oldies and current, existed on CD format to support all-CD operations. Oldies have come a very long way in the past few months. Several of the Beatles' albums have been released in CD format in just the past

few weeks, with more to follow shortly. And literally thousands of oldies titles are available on CD from Century 21 Programming in Dallas, Texas (214/934-2121). Each disc contains cuts from many different artists, so you don't pay for the album cuts that weren't hits. Each cut is a hit.

And more and more of the new release hits are being made available as a single-title CD. Under intense pressure from stations and also from influential program consulting firms like Burkhart/Abrahms/Douglas/Elliott, record firms are putting new emphasis on making hit releases immediately available on CD. Some record companies are getting the message slower than others, and are also finding themselves at a disadvantage when trying to get airplay for their new releases. Some stations simply won't add a title that is not on CD.

Why the big deal over CDs? Because today's listener has better equipment and is more quality-conscious than ever before. A higher-quality air product can translate into higher ratings and higher station revenues.

If you do or will originate a significant portion of your music from CDs, you should also consider the quality of your audio processing equipment. CDs deliver crisp, clear audio, but not all audio processors can preserve that quality. The digitally controlled TEXAR AUDIO

PRISM delivers the cleanest, powerful audio money can buy. All three networks have made multiple purchases of the AUDIO PRISM for their Owned and Operated radio stations. And the AUDIO PRISM has been the audio processor of choice for the top three rated FM stations in America's number one market, New York City, for seven Arbitrons in a row!

The secret? Digital control. Using digital technology allows the AUDIO PRISM to preserve the brilliance and quality of CD source material. On FM, the plug-in TEXAR Replacement Card Five (RCF-1) can add even MORE signal punch with no loss in quality.

For the complete story of how digital control can make you the quality leader in your market, contact your favorite distributor of high quality audio equipment, or call Barry Honel at (412) 85-MICRO.

TEXAR

616 Beatty Road, Monroeville, PA 15146-1502
(412) 856-4276
(412)85-MICRO

*Summer and Fall '85, Winter, Spring, Summer and Fall '86, and Winter '87 ARBITRON Ratings. Total Persons 12+ Share, Mon-Sun, 6AM-12M. (Used with permission.)

NO KITCHEN CABINETS!

Introducing Radio Systems' Broadcast Only Furniture Woodshop

We're Specialists

Our cabinetmakers are never out installing someone's kitchen. All they do is build professional broadcast studio furniture — all day long.

That's important because it takes an experienced cabinetmaker and a company that understands broadcasting to make *studio furniture that performs properly*.

Performance Furniture

The quality construction, and appearance of your cabinetry *does* impact on your air sound in a *big* way. Furniture must be fabricated with your format, equipment and operation in mind to allow efficient operation.

Custom Built

Don't let the word "custom" scare you. Because we're always building studios, it's just as fast and inexpensive for us to build furniture in your size and color as it is to build standard pieces that never quite fit in your studio.

That means that instead of "catalogue compromises" you can get custom furniture built to your dimensions, finish, counter-top color, and with all the built-in options your operation demands for a hectic broadcast environment.

Buy Furniture from a Broadcast Company

Our woodshop was started to build furniture for our in-house broadcast installation group. Over the years, we refined construction techniques that work in the real world.

When you take advantage of our experience — your console cutouts will fit perfectly, rack rails will space right, and wiring areas will be pre-planned — because we've been where you are.

Start with a Design



Call us today and we'll draft a blueprint exactly to your specifications, or we'll suggest a layout based on your equipment and room size.

We take broadcast furniture very seriously.

Broadcast Furniture from Radio Systems

- Console Tables
- Equipment Racks
- Turntable Pedestals
- Reel-to-Reel Mounts
- Equipment Terrets
- Record Storage Units
- Cart Racks
- CD Racks

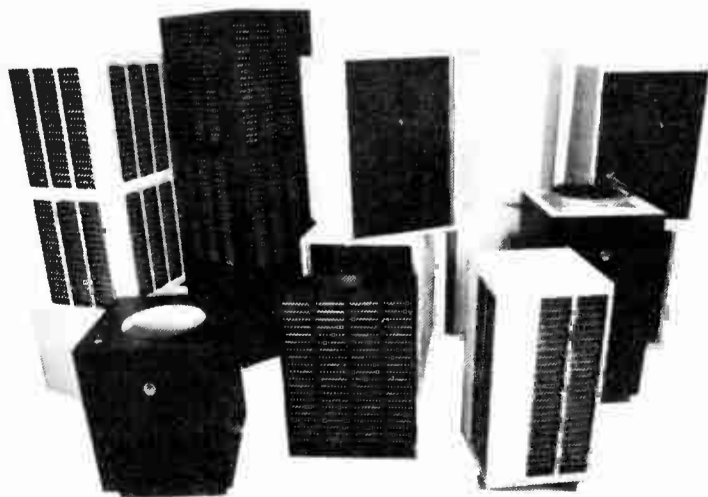

RADIO SYSTEMS INC.

5113 WEST CHESTER PIKE • EDMONT, PA 19028 • 215/356-4700
800/523-2133 (IN PA 800/423-2133)

Going "Giga" With New STLs

by Tim McCartney

Boise ID . . . At this year's NAB show, the 23 GHz STL option was all the rage. The interest is prompted not only by necessity, but also by a variety of interesting advantages.

The spectrum, traditionally used by non-broadcast businesses, is particularly attractive to radio broadcasters in areas of dry climate with large population density.

With congestion in the 944-951 MHz range, the problem is most clearly exemplified in the Los Angeles market where all TVs and FMs want to be on Mt. Wilson.

On a smaller scale, it's the same in Boise where Deer Point Mountain is the desired location because of its clear shot to the metro areas some 4700' down.

Tim McCartney is CE of KBSU, Boise State University, Boise, ID. He is a regular contributor to RW, is an SBE Broadcast Engineer, has a masters degree in human resources development, and is a former GM. He can be reached at (208) 385-3760.

The standard 10 MHz baseband bandwidth (12 MHz minimum with roll-out to 20 MHz) allows digital audio processor encoding.

Thus full digital disc stereo audio quality is available for an STL link, with no measurable degradation of stereo separation, frequency response, noise or distortion.

If that mix is not enough, toss in 110 dB of dynamic range!

The use of the video channel for digital audio alone is reason enough for serious consideration of this technology. But, additional high-quality SCA channels allow a variety of options.

One manufacturer is working with KBSU in designing its equipment so that four additional analog audio channels can provide a flat frequency response ± 1 dB over the 50-15 kHz range with a SNR of at least 60 dB. See Figure 1 for this use of the baseband.

Stations with line-of-sight paths less than 15 miles can take advantage of the technology provided certain considerations are made.

A 1' dish is recommended for dis-

tances up to three miles. The maximum distance of 10-15 miles requires a 6' dish. In the middle are 2' and 4' sizes.

The 23 GHz path design is similar to that of lower frequencies with the added consideration of rain attenuation.

Although rainfall is a prime consideration in determining path reliability, the

“ “ —————
Thus full digital disc stereo audio quality is available for an STL link.
 ————— ” ”

result of heavy rainfall has been found in the field to be slightly perceptible noise, most of which is eliminated by digitally modulating the video channel.

Depending on factors such as local rainfall and distance, a reliability factor is predicted.

For example, a seven-mile hop in Chicago would be 99.585% reliable. That means about 80 minutes per year would not be considered reliable.

Some stations have used the STL system directly from their studios in downtown high-rise office buildings. Shooting through glass does, however, pose

additional concerns.

One manufacturer sells a basic 1' system for \$6,600. This includes the transmit and receive dish assemblies, related rack-mounted equipment, and two SCA cards.

Sony manufactures pulse-code-modulated (PCM) systems which run anywhere from \$1,300 to \$2,000 each. Two systems are needed: one to encode at the transmit end and the other to decode at the receive end.

The FCC classifies 23 GHz STLs in its Private Fixed Microwave Service (Part 94 of the rules), unlike 950 MHz applications (Part 74) which are handled in the Auxiliary Radio Broadcast Services.

So it may be that your consulting engineer does not have much experience dealing with a different branch of the Commission.

Expertise is, however, available from frequency search firms which routinely conduct spectrum searches from available data bases and prepare FCC Form 402.

The search, like others, reports who else is using the spectrum in your area. In Boise, the users include the corporate headquarters of Boise Cascade, a hospital, state government and a theatre.

One firm charges \$300 for each of the two services: frequency search and license application preparation. In addition, the FCC now requires a \$135 fee to accompany each filing with an exception made for governmental entities.

The FCC application needs to be filed **(continued on page 12)**

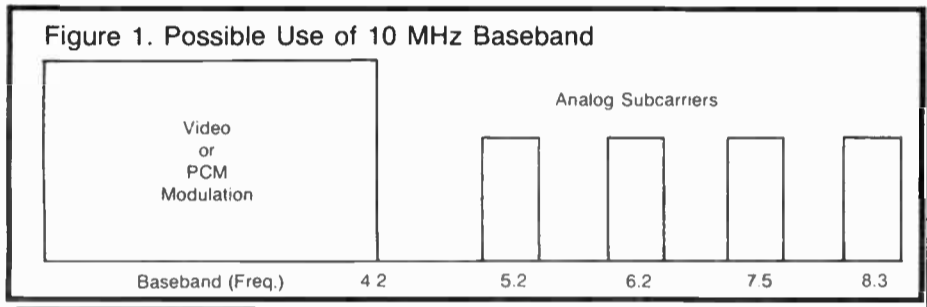

RADIX
 Distribution Amplifier

STERLING PERFORMANCE

DA-1600
 Sterling performance is the result of exceptional engineering design and careful selection of high quality components. If sterling performance is your preference then Radix is your product.
 Mfg. list \$435.00
CALL FOR BSW PRICE

- 8 stereo or 16 mono outputs with individual level control
- Exceptional low noise circuitry
- Selectable pads to accommodate a wide range of input levels
- THD .01% max @ +20 dBm out
- Noise 90 dB with respect to dBm out
- Output separation 90 dB

Toll Free 1-800-426-8434
 Broadcast Supply West • 7012 - 27th St. W. • Tacoma, WA 98466

Are you serious about CD programming?

If you understand the full potential of the Compact Disc in broadcasting, then Philips has the player you need. The LHH 2000 provides features and capabilities you'll never find in a consumer player, including:

- Balanced outputs
- Precise cueing
- Access time under 2 seconds with accuracy of 13.3 milliseconds.
- Search wheel with 3 time/turn ratios
- Indication of real music time remaining
- Fader start
- Status indication for each player (edit, ready, on line, on-air)
- Solid, professional-grade construction

Perhaps most important, the LHH 2000 is easy to use. Basic on-air operation can be learned in a matter of minutes.

Large LED displays are programmed to lead the operator through the sequence, step by step. Also, the control buttons are widely spread and clearly labelled to prevent errors, miscues, and dead air.

Finally, with the LHH 2000 you can be assured of knowledgeable service support because, in the USA, Philips professional CD systems are sold and serviced by authorized Studer Revox Professional Products dealers.

If you're serious about the CD, please call or write: Studer Revox America, 1425 Elm Hill Pike, Nashville, TN 37210; (615) 254-5651.

STUDER REVOX

23 GHz STL Popular

(continued from page 11)

quickly after the frequency search due to rapidly changing microwave environments.

In fact, the date of the frequency study and the application date must be no more than six months apart.

The FCC typically takes about two months to approve the application. But, the Commission now rejects the entire application if any errors are found.

Typical errors are:

- miscalculation of the height to center of the antenna radiating element
- valid engineering analyses and necessary attachments not included

(such as the required statement of use)

• technical information on the frequency analysis not the same as that contained on the application form

Without any of these problems, the FCC generally approves such applications.

The transmit and receive antenna assemblies are designed for outdoor use and consist of weather-resistant integrated antenna/RF assemblies.

Rack mountable indoor baseband processing units contain the power supply and baseband circuits.

Interconnection between the indoor and outdoor units is via coax cable and

power cable.

The 1' unit's transmit power is 62 MW (+18 dBm), antenna gain is 33 dB, and beamwidth is 3.5°. Its weight is 12 lbs.

KBSU makes maximum use of this technology. The station needs a bi-directional hop between two buildings on the Boise State University campus.

The tie interconnects KBSU and the local public TV station.

In addition, the system provides the first of two hops in linking KBSU's studio audio to the transmitter site on Deer Point Mountain.

The 23 GHz hop for KBSU in semi-arid Boise is only a few hundred feet. So, the station gets to take advantage of the short hop and the small amount of rainfall.

It's a perfect match for the our needs!

ARRS Holds Annual Meet

by Alex Zavistovich

Washington DC ... Fox Technology, Johnson Electronics, Radio Systems, V-Tek and Modulation Sciences exhibited equipment and services at the annual conference of the Association of Radio Reading Services (ARRS), held 28-30 May at the Mayflower Hotel in Washington, DC.

This year's conference featured an increase in registrants over last year's, according to Kathy Kielich, executive director of the Washington Ear, the Washington DC-based reading service which hosted the gathering.

Approximately 115 attendees, many from radio stations and associated services, came from as far as Alaska to take part in the event, which this year focused on fund raising and featured a number of panels and workshops devoted to the subject.

Technological sessions at the conference covered topics such as maintenance and automation, computers, and small staff operations.

FCC Mass Media Bureau Chief Jim McKinney took part in a panel discussion entitled "Words from Washington," a question-and-answer session.

Modulation Science VP/Engineering Eric Small led another question and answer session, touching on topics such as receive antennas for reading services.

In addition to the technological information available at the conference, rumors spread about the possibility of Panasonic withdrawing from the subcarrier tuner market.

The company has an original equipment manufacturer (OEM) arrangement to produce the radios for other companies, which are marketed under various names, such as Uni-band.

The rumor was squelched, however, by Matsushita Electric Industrial Corporation spokesperson Justin Camerlengo. Matsushita is Panasonic's parent company.

For additional information, contact Kathy Kielich at 301-681-6636. Contact Justin Camerlengo at 201-392-4437.

AM stereo and C-QUAM® Superior performance is the Delta difference

Like more than 40 dB of channel separation for a purer, cleaner sound your listeners can hear. But we didn't stop there. We engineered our improved C-QUAM® system for all around excellence:

The Delta Difference is applied technology:

- More than 45 dB* channel separation for a purer stereo sound, guaranteed 43 dB* at 1 kHz and 40 dB* at 5 kHz.
- Transformer-less, active balanced input/output circuits for excellent frequency response, distortion, and modulation peak control characteristics.
- Dual high level RF adjustable and dual logic level (TTL) circuits and dual L + R audio circuits for faster installation and versatility in transmitter interfacing.
- Day/night and stereo/mono capability remotely controllable.
- Dual transmitter interlock protection circuits.

The Delta Difference is longer life:

- Chassis mounted heat sinks at critical points.
- Improved high-efficiency power transformer for cooler operation.
- Multi-board construction for simplified maintenance and trouble-shooting.
- Zero insertion force card edge connectors assure longer contact life.

The Delta Difference is economy:

- Day/night or main/auxiliary audio equalization is a no-cost option.

The Delta Difference is experience and commitment to your industry:

- More than 23 years serving the broadcast industry.
- More than 60 operating installations of Delta C-QUAM AM stereo systems in the U.S., Canada, Australia and Africa. (And the number continues to grow.)

- A highly experienced installation team ready to serve your needs.

When you're ready to bring AM stereo to your listeners, check on the Delta Difference.

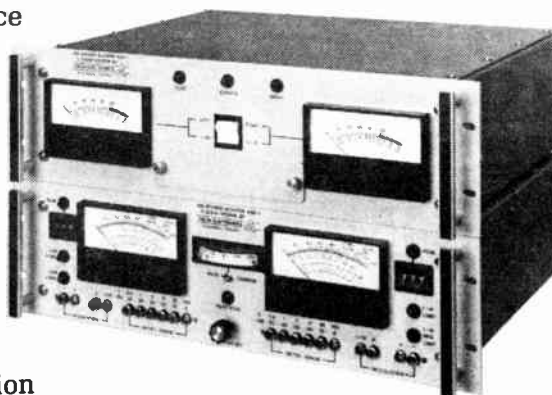

For complete information on ASE-1 AM Stereo Exciters and ASM-1 AM Stereo Modulation Monitors, contact Delta at (703) 354-3350.

Delta Electronics, Inc.
5730 General Washington Drive
P.O. Box 11268
Alexandria, Virginia 22312
(703) 354-3350
Telex: 90-1963

* C-QUAM is a registered trademark of Motorola, Inc. Manufactured under license from Motorola, Inc.

* 50% single channel, closed loop exciter monitor

DELTA ELECTRONICS



Circle Reader Service 28 on Page 22

World Radio History

CUSTOMER SERVICE MANAGER

TEXAR, maker of the digitally-controlled AUDIO PRISM, is looking for a Customer Service Manager. Knowledge of modern audio processing techniques and equipment is necessary, but the abilities to work with people, communicate well over the telephone, and to write a well-organized letter are equally important. A sincere desire to work with customers and to assist them with their installation and maintenance questions will be valued highest of all. Opportunities also exist to expand into other areas.

TEXAR offers a modern, air-conditioned working environment with the most modern equipment and computers available. We are located less than 20 miles from three professional sports franchises and three major universities, but in a tree-shrouded rural setting. Compensation for the right applicant includes incentives, medical insurance and educational reimbursement. Want to use the skills you've learned, but tired of the phone calls at 3 AM. Please send your current resume to:

Larry Honel, Operations and Sales Manager
TEXAR Inc.
616 Beatty Road
Monroeville, PA 15146-1502

TEXAR

TEXAR is an equal opportunity employer

Teamwork Lets Station Sparkle

by John "Q" Shepler

Rockford IL ... Steve and Don are excited. For months they have been planning the big switchover. Tonight they'll add the final touches.

QQ-100 Stereo Rock is typical of a lot of stations. The last major format change was five years ago.

At that time the management bought a couple more cart machines, but most of the equipment has been collected on and off since the '60s. It all works. That's thanks to Don staying on top of problems.

Even so, the sound lacks that certain sizzle that identifies the top stations in any market.

Steve came on board six months ago as program director. Shortly after arriving, Steve and Don sat down to see what they could think of to zip up the station's air sound.

They made a giant wish list of everything they could possibly make good use of.

Then reality took over and they made a smaller list of a dozen key items.

When Steve and Don sat down with the GM they were ready. Steve talked programming changes and Don talked equipment.

Both pushed the concept of higher ratings and more revenue if the station could spring for these improvements.

The GM swallowed hard at the price.

John Shepler is a broadcast teacher, writer, former CE and regular RW columnist. He can be reached after 8 PM at 815-654-0145.

Even so, he knew the operation hadn't moved ahead for a lot of years. Yes, it was time. Steve and Don got the go-ahead.

Slow burn-in

The first major change was to retrofit the control studio with a new board. The present one had taken a beating from DJs and lightning strikes over the past 15 years.

Q-Tips

It was noisy and unreliable. A lot of the wiring had been cobbled up over the years. It had to go.

Don readied the new board in the shop. He did a "burn-in" for several weeks which simply involved plugging the board in and letting it cook.

This would show up any weak parts that would otherwise quit when the board was on the air.

After a couple of days of cooking, he fed program audio into one of the line inputs and set the levels to 0 VU output. This gave the electronics a bit more of a workout for the rest of the burn-in period.

Meanwhile, Don made wiring harnesses approximately the right length. He put the right connectors on for cart machines.

He also added the remote control buttons and their wiring.

Don worked the rest of the installation a bit at a time. During network shows,

he pulled new audio cables from the transmitter room to the studio and dressed them neatly through the existing furniture.

The trusty staple gun with rounded staples made quick work of tacking the shielded pairs to the wood furniture.

Masking tape that identified each wire would later be replaced with cable tie labels as the wires were connected within the new board.

Good-bye to old faithful

The whole crew was anxious to get the new equipment in service. Don had no trouble gathering volunteers for a Sunday night work session.

Early in the evening they switched to network and patched the production studio in for local breaks.

Then the demolition team pulled the plug on the old board and dragged it back to the shop.

"Old faithful" had served them well and would later be refurbished and used as the starting point for another production studio.

Meanwhile, Don and Steve carried the new console gently into the studio and jockeyed it into position.

The first connections were power and ground. Everybody smiled as the meters lit up.

While the happy crew headed for the

pop machine, Don hooked up his audio generator and audio analyzer to the board.

The noise level was right where it should be and response and distortion met specs. They had the foundation in place.

The rest of the night was spent hooking up inputs one by one.

Step by step

They worked from left to right: studio mic, news mic, cart machines, CD player, turntables, satellite receiver, automation, and so on.

As each input was installed, the levels were carefully balanced and tests were run for noise and distortion.

The CD player was wired through an impedance matching amplifier that also converted the unbalanced outputs to balanced in order to drive the board.

At about 2 AM, Don connected the processor lines to the board output and ran some quick checks.

He realigned the levels and checked the noise via the mod monitor. He also upped the input levels by 10 dB and then 20 dB to check headroom.

Satisfied, he put the new board on the air for the first time.

The excitement of a new piece of equipment might have made it sound **(continued on page 16)**

TALK ABOUT SEX

Or drugs. Or personal finances. Or politics. Or anything of interest to your listeners. Because when you use the Telos 10 digital hybrid, you'll have the best sounding call-in segments on the dial.



THE TELOS 10 It Works!

Call Toll Free 800-732-7665



**BRADLEY
BROADCAST
SALES**

Where Service and Engineering Make the Difference

8101 Cessna Avenue • Gaithersburg, Maryland • 20879
MD & DC: 301-948-0650 • FAX: 301-330-7198

Circle Reader Service 34 on Page 22

It's time to think again about Automation.

If you had previously dismissed program automation as too expensive, now is the time to reconsider. If you considered automating the overnight, but didn't think that it was economically feasible, IGM has the system for you. If you are using Satellite Music Network, Transtar, or any of the satellite services and have not automated because of the expense, IGM provides a cost-effective system today.

With systems starting at less than \$20,000, IGM thinks it's time for you to re-consider automation. The IGM-EC is an economical automation controller for use in your station. We developed a computer program to turn your IBM-PC or compatible computer into a program automation system, using the IGM-EC as the audio/machine controller.

The IGM-EC is already equipped with 12 audio channels. These can be used for satellite and studio inputs. You may also use the IGM GoCart or Instacart for random-accessed commercials or announcements. To meet your other requirements, we can add Studer-Revox PR-99 Reel-to-Reel machines and Fidelipac cart machines.

IGM has over 20 years of program automation experience and will help you design a system to meet your operational and financial requirements. For more information on the IGM-EC, use the attached coupon or call 800-628-2828, Ext. 578

IGM COMMUNICATIONS

OK, I thought about it. Send me information on automating with the IGM-EC.

Name _____ Title _____

Station _____ Phone _____

Address _____

City _____ State _____ Zip _____

or Call 800-628-2828, Ext. 578

IGM COMMUNICATIONS

282 W. Kellogg Road, Bellingham, WA 98226, 206-733-4567

*

Circle Reader Service 42 on Page 22

Production Room On a Budget

by W.C. Alexander

Part I of III

Dallas TX ... The broadcast production room is perhaps the least understood part of most radio stations.

In many stations, an on-air tape console is used, and together with turntables, cart machines and reel-to-reel tape decks, production is possible but it is cumbersome at best.

The advent of the economical multitrack recorder and inexpensive recording studio type consoles has made these facilities obsolete, and at the same time has opened the doors to much more creative and flexible production.

This first in a series of articles on how to successfully construct a state-of-the-art radio production room without spending a fortune will discuss the various parts that make up such a facility, their features and drawbacks, and cost.

Consoles

At the heart of any production room is the audio console or mixer. For production use, the broadcast type console with program and audition outputs are generally inflexible and therefore not suitable for production use.

There is, however, a wide variety of new generation recording studio consoles, complete with electronically balanced inputs and outputs, equalization

W.C. Alexander is Director of Engineering for Crawford Broadcasting Company, and an aspiring horror-fiction novelist. He can be reached at 214-445-1713.

and gain trim on each input channel, multiple effects and send busses, and four or more outputs.

The console should be chosen for the specific level of features and flexibility that is required for a particular application.

Prices on such consoles can range from around \$2,000 to upwards of \$20,000, depending on features, so it is

“

A good multitrack recorder is a must for radio production in the '80s.

”

important to select the right console for your particular application, leaving some room for expansion without going overboard.

Recorders

A good multitrack recorder is a must for radio production in the '80s.

While four tracks might be enough for a mono AM station that is certain that stereo broadcasting will never be in its future, eight tracks are needed for any good stereo production.

Some stations opt for 16 tracks, but this is probably excessive for all but the largest operations where complex program production or jingle recording takes place routinely.

There are two types of economical

eight-track recorders: half-inch and quarter-inch format.

While the quarter-inch format machines are considerably less expensive than the half-inch, there are certainly drawbacks as well.

With the tracks on the quarter-inch spaced so closely together, crosstalk is not usually as good as with the larger format machines.

In addition, sel-rep playback (recording on one or more tracks while listening to playback of the adjacent track or tracks through the record head) can be difficult on quarter-inch because of heavy crosstalk, especially as the machine ages and the heads wear down.

Half-inch format machines fair considerably better in these departments, and are not prohibitively expensive. A typical half-inch eight track recorder lists for less than \$5,000.

In addition to the multitrack machine, a good two-track reel tape deck is also critical to successful production. A number of excellent decks are available for under \$2,000.

Care should be used in selecting the two-track recorder, and special attention should be paid to head accessibility (for cleaning and edit marking), ease of threading and operation, and tape timer accuracy (electronic digital real-time counters are preferable over the old mechanical types).

Cart machines

In the production room, the only function of the cart machine should be final mix dubbing for air play.

With multitrack production, there is

little or no reason to use carted material in the production process, and use of such material detracts considerably from the quality of the finished product.

Many stations opt for cart machines with some sort of phase correction built in.

While this type of correction usually works quite well, these machines are expensive and require considerably more maintenance than fixed azimuth recorders.

The current state-of-the-art has permitted development of low-cost downstream phase correctors that can be placed in the audio chain prior to the audio processing equipment, thereby correcting phase errors on all source material, regardless of source.

Such units list for less than \$1,000 and considerably lessen the cost of the overall facility without noticeable sound degradation.

Turntables

In the past, most stations used rim-drive turntables, where the motor, running at 1800 rpm, drove a puck against the turntable rim.

This system had its advantages in that a small, low torque motor could be used and still achieve rapid starts, and it was simple.

Wow and flutter of such turntables, however, is quite high by today's standards, and the special care and adjustment that such systems require make these turntables unacceptable in many state of the art installations.

The new, consumer type direct drive turntables seem to fit into the production picture much better.

While many of the less expensive models are somewhat slower to start,

(continued on page 18)

The PREMIUM Plug-In Replacement For The PREMIUM® LINE

audio~metrics®

by **INDY AUDIO**

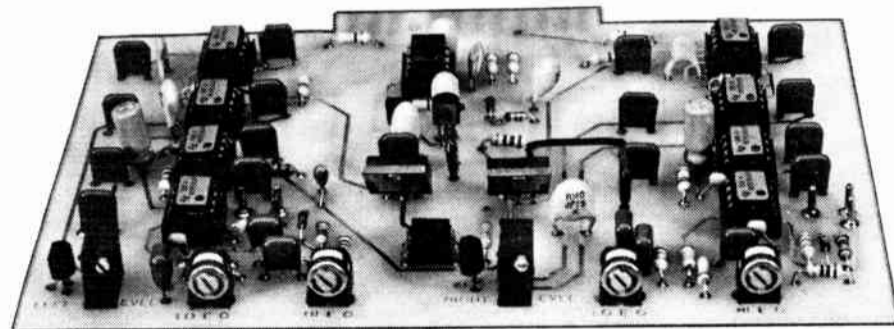
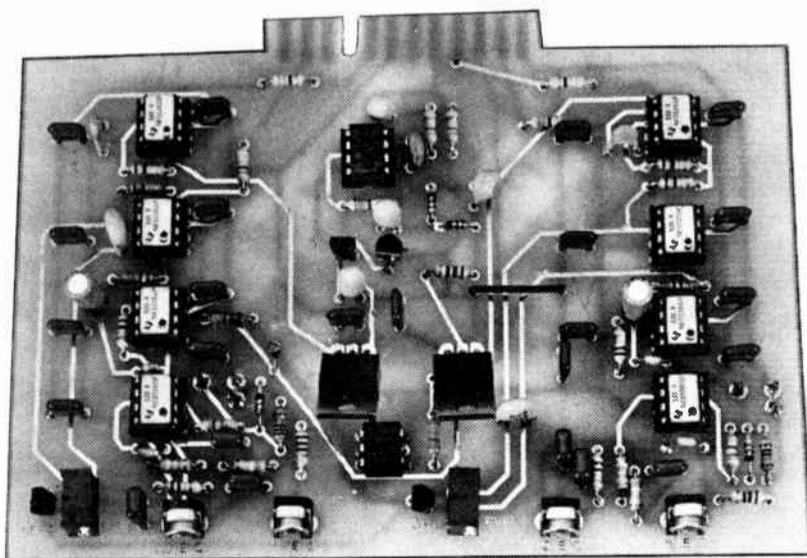

Upgrade your faithful ITC's with technology of the 1990's. Direct plug-in — NO modifications. Slew rate, rise time, noise, distortion . . . All state-of-the-art.

ONLY \$229 + frt.

STEREO READY — MONO OK — PLAY BACK ONLY

ITC is a registered trademark of 3/M Corp.

ATLANTA, GA
(404) 964-1464
LOS ANGELES, CA
(818) 843-5052

CHICAGO, IL
(312) 470-0303
RICHMOND, IN
(317) 962-8596

DALLAS, TX
(214) 423-8667
SEATTLE, WA
(206) 838-2705

RICHMOND HILL, ONTARIO (416) 731-3697

ALLIED
Broadcast Equipment
P.O. BOX 1487 • RICHMOND, IN 47375

New Transmitter for New FM

by Kirk Harnack

Memphis TN . . . When we last looked at KWLN-FM, a new 700 foot tower had just been erected in Frenchman's Bayou, AR and we were awaiting the transmitter and antenna.

Since we weren't positive our STL shot would work properly (who ever is?), we wanted to try it out ahead of time.

To free-up a pair of dishes for the path test, we combined all three Marti STL-8 transmitters (2 for FM, 1 for AM) into one dish. (AM and FM had been on separate antenna systems, although their paths were identical.)

At the current AM/FM transmitter site, we split one antenna three ways into the three STL receivers. This left the dishes we needed free for the test.

Before we could test the path, however, the CSI 25 kW FM transmitter arrived—and boy, did it arrive!

Steel brute transmitter

The truck driver who brought us this gargantuan brass and steel brute of an RF amplifier was friendly, but he had no intention of setting it in place or even putting it on the doorstep.

In fact, he wouldn't even back it into the driveway!

So, with a great deal of bribery and promise of rewards unimaginable, we persuaded the tower crew to help out.

Here was their task: convey the transmitter (two cabinets, plus several trans-

Kirk Harnack is president of Kirk Harnack Engineering, Richmond, KY. He can be reached at 606-624-2181.

formers) onto a pickup truck, drive it up to the doorstep, unload it, and shove it into place in the building—all in pouring rain—and without dropping anything.

Well, somehow it was accomplished, the transmitter was set about six inches off the floor on 2x4's, and just as we were wiping the sweat from our brows the rain stopped.

Pulling it all together

The next two days were frenzied with activity—all focused on getting the Shively 10-bay antenna on the tower and getting the transmitter connected to AC power and the coax.

The CSI 25 kW transmitter's low-pass filter is external to the transmitter (it's about eight feet long) and must be well supported to avoid straining the EIA flange on the transmitter.

Our building contractor provided a simple, effective "sling" to hold the filter, then installed plumbing straps to hold the 3/8" coax.

AC power mains, remote control wiring, modulation monitor feed line, and the exciter coax were pulled through conduits already laid into our poured concrete floor.

I've always found it good to locate an FM transmitter's exciter outside the transmitter itself, usually in a nearby equipment rack.

Removing the exciter from the transmitter gets it away from the large magnetic field of the plate transformer, and away from the vibration of large blower motors.

If you remove your transmitter's ex-

citer, be sure to cover the hole left with a blank 19" rack panel (to maintain proper airflow).

Also, some transmitters require every ounce of power their exciter offers, so placing 20 or 30 feet of coax between them may reduce the drive to an unacceptably low level; it might be wise to check with the manufacturer first.

I had to be sure the coax is 50 ohm. Once I hooked-up an exciter to a transmitter with RG-59 and I just couldn't get much grid current into the IPA tube.

It took several days of head scratching before I realized this stupid error. Replacing the coax with RG-58 immediately made it work fine.

Now back to the installation. Luckily,

I had a spare STL transmitter and receiver which was on one of our assigned STL frequencies.

We connected the transmitter to the spare dish at the studio (remember, the other dish was carrying AM and FM audio to our old AM/FM transmitter site).

Much to my amazement the STL signal was wonderful.

Success with the STL path was due in large part to careful planning and figuring. I had previously plotted the 21-mile path on a topographical map and on a 4/3 True Earth graph.

Also, the system losses and gains were figured and a 15 dB "fade margin" was determined.

Obviously, the more fade margin, the better, but 15 dB would be enough for us until I built the new studios in Memphis.

(continued on page 18)

OUR FM MONITOR DESERVES A SECOND GLANCE.

BUT IT DOESN'T NEED IT.

Engineers look twice when they first see our 691 Stereo and SCA Monitor. But when they start to use it, they find the 691's meters are easily tracked in a single glance. Like everything else about the 691, its measurement displays are very well thought out.

A color-coded system ties together the associated displays, switches, and jacks for a particular function or test. Select your test by pushing a color-coded button and simply read the results on *all* of the indicators. It's as easy as it sounds.

Other benefits of the 691 include over 40 proof-of-performance and signal quality measurements. Add a scope and use the 691 as a spectrum analyzer . . . or get a vector display of L/R phasing. Perform a Bessel-Null calibration in minutes. Measure clipped composite accurately and quickly.

The 691 can now be optionally ordered to measure two SCAs. There are many other features . . . write or call for complete information.



QEI CORPORATION
One Airport Drive □ Box D
Williamstown, NJ 08094
Phone 609-728-2020
Toll Free 800-334-9154

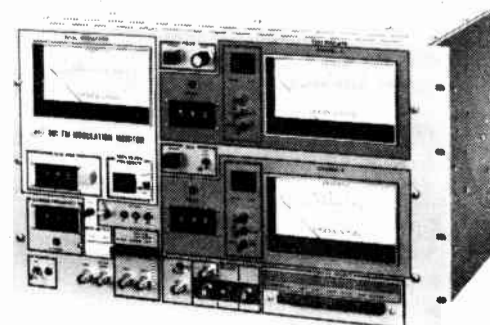

AUDIO CONTROL INDUSTRIAL SA-3050P REAL TIME ANALYZER



An exciting and cost effective new audio tool, the SA-3050P features 30 one-third octave bands, precision fourth order tuned filters, six non-volatile memories, pink noise source, SPL display and three inputs (XLR, BNC, 1/4"). Manufacturer's list of \$850.00 includes calibrated mic.

Call 800-732-7665 for Details and Introductory Pricing.

BBS
BRADLEY BROADCAST SALES

Where Service and Engineering Make the Difference

8101 Cessna Avenue • Gaithersburg, Maryland • 20879
MD & DC: 301-948-0650 • FAX: 301-330-7198

Team Effort Improves Sound

(continued from page 13)

better than it really was. However, the lower levels of amplifier hiss were clearly noticeable.

The sonic improvement of reduced distortion and flatter response were a matter of opinion, but everyone seemed to think the sound was much "clearer."

Processing debate

The next couple of weeks were spent changing out microphones, turntable preamps, and monitor speakers. The station was sounding better every day.

The last big piece of the changeover was being set up in the shop. The new

audio processor had arrived.

Processing is one of those emotional subjects that everyone has an opinion on and is willing to defend to death.

Half of the opinions are based on such flimsy notions as what a friend of a friend of a guy who works at a major market station thinks is installed at the transmitter site.

Other people are sure that the station they heard three months ago on the other side of the country definitely sounds louder and better than anything on the dial here.

Moving past all the hoopla, one can reasonably say that big advances have

been made in audio processing equipment over the years.

It's also a fact that a lot of great sounding stations owe some of their success to the Optimods, Dorrroughs, CRLs and Texars cooking away in the back room.

The processors are the superchargers of audio. Once the rest of the equipment is tuned for maximum performance, the right processor will enhance the energy of the program audio and produce that extra magic in the air-sound.

Installing the processor

A couple of Sundays went by before Don was ready for the last big event.

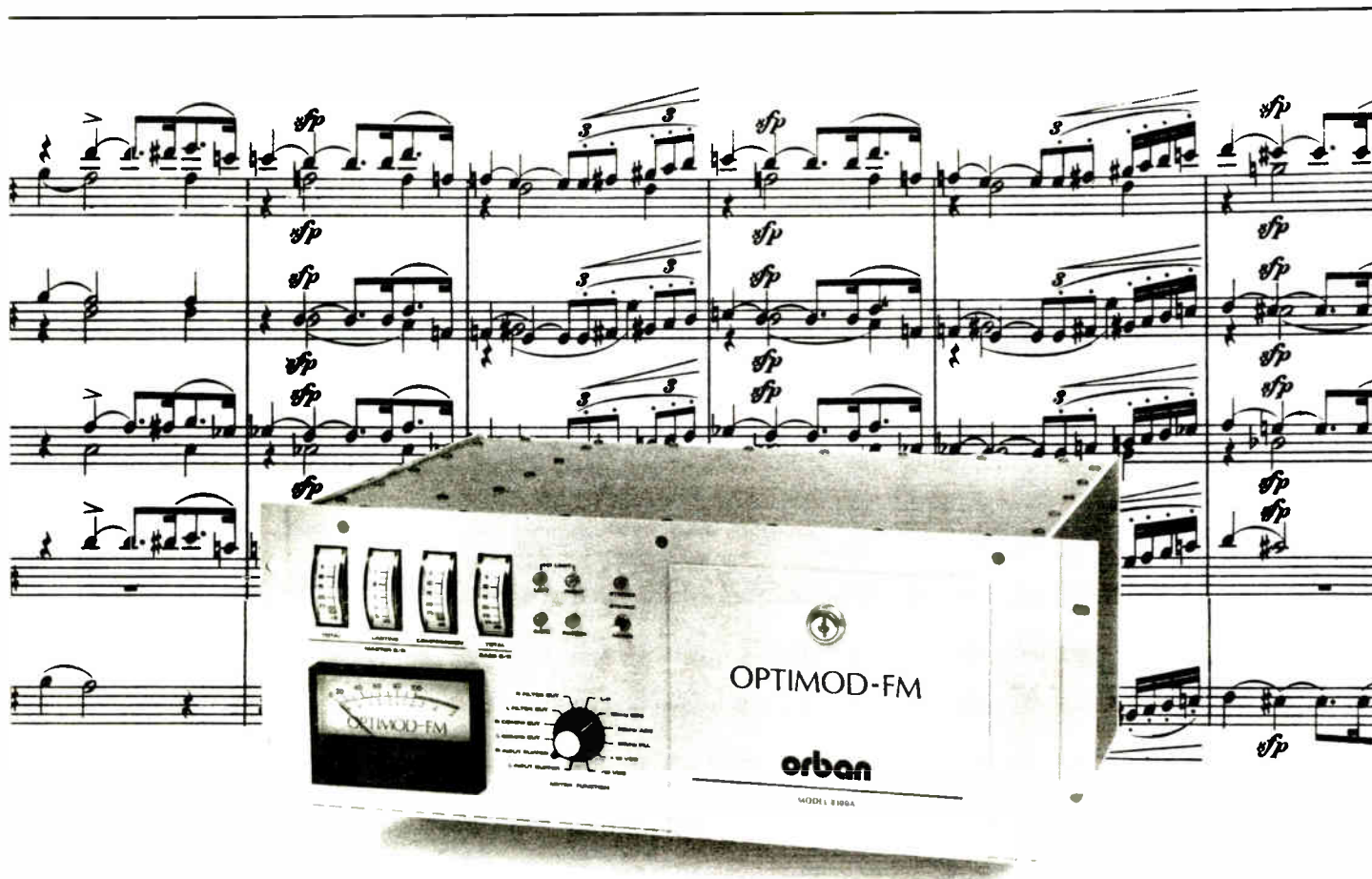

Even though loudness was considered of vital importance in the design of OPTIMOD-FM Model 8100A/1, something else had even higher priority.

Music. Because music is what your listeners care about passionately.

OPTIMOD-FM was designed and built by people who have worked professionally in the recording industry. People with educated ears who *know* natural, musical sound—and who aren't satisfied with anything less. And people who are also skilled in the art of sophisticated, mathematical design techniques.

In OPTIMOD-FM, the math and the music come together in perfect harmony.

There are no bells and whistles. The few flashing lights are functional, not cosmetic. The sophistication is on the inside, where it belongs—assuring *listener satisfaction* by never mangling the music.

**OPTIMOD-FM:
BECAUSE
MUSIC MATTERS.**

That's why OPTIMOD-FM is the best-selling FM processor ever. Use it alone, or adapt it to special needs with its optional Six-Band Limiter (for the more aggressive sound demanded by certain formats) and/or Studio Accessory Chassis (for dual STLs). OPTIMOD's versatility makes it the right choice for *your* station, regardless of format.

If you believe that music matters to your listeners, why wait any longer to bring them the best? Call your favorite Orban Broadcast Dealer, or contact us direct.

Orban Associates Inc.

645 Bryant Street, San Francisco, CA 94107
(800) 227-4498 or (415) 957-1067 Telex: 17-1480

orban

Circle Reader Service 18 on Page 22

World Radio History

Early in the evening, he slipped into the shop and moved the processor into the transmitter room. He had already prepared an empty spot in the rack by removing some old gear that was just plugging holes anyway.

Once Don had the processing gear mounted firmly in the rack and plugged-in, he turned the power back on so the equipment could get back up to temperature and stabilize.

He hooked up the audio inputs in parallel with the present processor. Both would remain in the rack, the old equipment there for emergency use only.

Levels set, Don relaxed with a can of pop and the equipment manuals.

At about 11:30, Steve and Tom, the overnight guy, showed up with pizzas.

Don finished hooking his scope to the mod monitor and joined them. They finished at sign-off and Don headed back to the transmitter room.

When the transmitter plates were off, Don disconnected the outputs from the old processing and connected the new gear to the exciter.

The old stereo generator and limiters were quiet now. Don turned the output of the processing to minimum and clicked the transmitter back on.

Listening test

Steve started a record and Don brought the levels up to 85% on the mod monitor. Then they cut the music and listened for noise.

The mod monitor read -85 dB. Things were looking up. Steve made a brief announcement before they started tone tests.

Don balanced the inputs of the processor with the null meter and then shut off the pilot. He had Steve switch the generator to the left input only.

Don then adjusted the baseline of the scope waveform as flat as it could be. One adjustment completed.

With the tone back in both channels, Don used a patch cord to flip the phase of the right channel.

Carefully, he adjusted the scope so the two points were facing each other in the middle of the screen.

Don tweaked the pilot phase adjustment on the stereo generator just a hair so that the points were exactly across from each other. Phase was set.

Don pulled the patch cord and the tone generator and Steve loaded a compact disc. They picked a tune with a lot of brass to make the modulation adjustments.

First set the levels, then the pilot injection. Then tweak the levels again.

Convincing results

The new processor was great in that the peaks were carefully controlled so that the flasher was blinking at 98% modulation but not 100%.

Steve was off duty for the next hour while Don ran a host of tests on crosstalk, noise, response, and distortion.

Don ran the test equipment with one hand and wrote the results in his engineering notebook with the other. Don smacked his lips.

Separation was nearly 60 dB.

It only took a couple of days for the GM to realize that the guys had made a good decision.

Several of his top accounts stopped him on the street to say how good the station sounded. Had he boosted the station's power?

"Not exactly," he smiled, as he brought up the subject of a new ad campaign.

Controller Handles Emergency Backup

by Fred Baumgartner

Part I of II

Englewood CO ... Unless you consider it necessary or exciting to race into the station everytime the power dumps or a transmitter burps, an Emergency Controller is for you.

What it does is put you back on the air should you ever go off, by switching in backup systems when a failure occurs.

In this device, the controller can switch in a backup power supply, a backup AM transmission system or a backup FM plant.

Now that operators do not have to know to turn on the filaments first for their FCC exam, the controller can remember that and lots more for them.

The controller also works quickly, often before the operator has figured out how to turn on the flashlight.

Every emergency controller is really an instrumentation system, which means it is composed of process control, feedback and logic.

Each brings to mind some special concerns as this device sits above all others and has nothing (save the key lock I will

Frederick Baumgartner, assistant CE at KWGN-TV and former CE of WIBA, Madison, WI, is a frequent contributor to RW. He can be reached at 303-740-2883.

talk about) to monitor and control its performance.

In the case of the logic, it must survive situations such as power loss, extreme power surges, stray fields and the like. It is important that it be very simple. It cannot have "disallowed" states.

The feedback (the information to the logic) must be reliable and redundant. Two independent sources of information must agree that the problem does exist.

It is better for the controller to miss an opportunity than it is for it to correct a fault that does not exist.

The process control must not hinder the normal operation of equipment and it must not be allowed to damage it. It must safely put to rest the equipment that it has put off line.

My emergency controller has three parts. The first is the power supply control.

In most stations there are two sources of power. In most places the power source is the most likely part of the chain to fail.

When the utility goes away the generator is run or business ceases. Most generators installed over the years make a couple of assumptions not suitable for broadcasting.

Most have a changeover relay that swaps to the generator on the order of 1/3 of a second after the power goes away, and then sends a start command to the

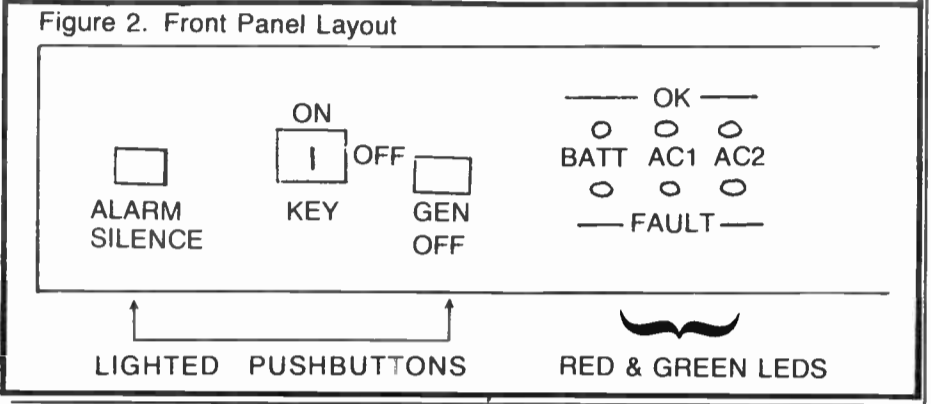
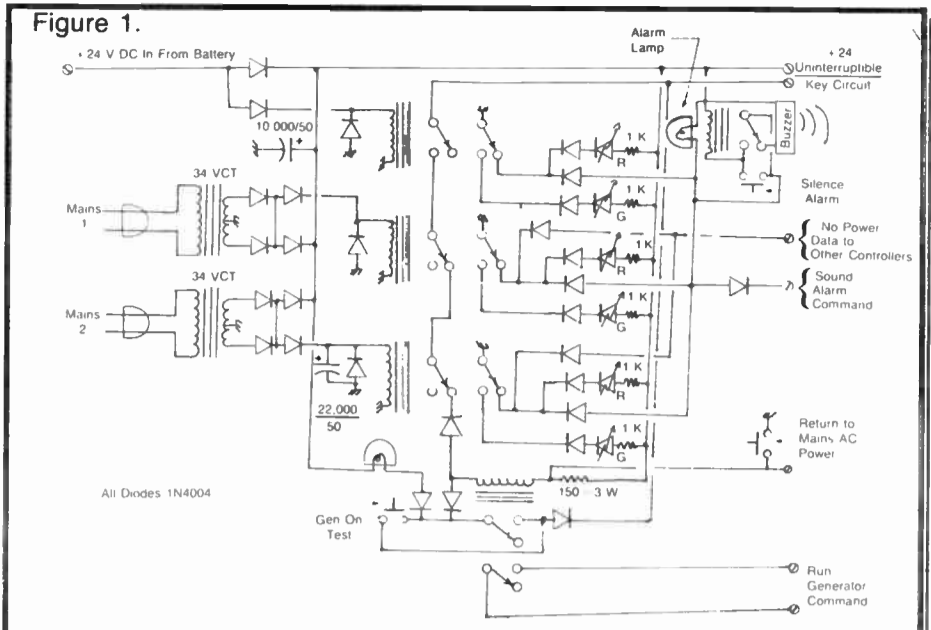

generator.

When the utility power returns the changeover relay returns to utility and the generator is either shut down or (better yet) waits out a time delay before shutting down.

What is wrong with this is that power outages seldom are simple "power off, wait some reasonable portion of an hour or more, power on" types.

In cases where outages are of the half-
(continued on page 22)

It's 3:55 a.m. Do you know what your transmitter is doing?

Now your transmitter can alert you to problems by phone—anywhere, anytime with the VRC-1000 Remote Control. A preprogrammed, synthesized voice quotes parameters; you make adjustments right on your Touch Tone® phone. Or you can dial from any

where with complete remote control capabilities.

- VDT and printer options
- Full automatic commands
- Fully secure
- Automatic alarm reporting and correction.

Patent Pending

GENTNER
SOUND THINKING



Gentner RF Products • P.O. Box 32550 • San Jose, California, 95152 • (408) 926-3400 • Telex II 510-600-1445 Gentner RF PRDT © Gentner 1987

Essentials for Cost Cutting Production

(continued from page 14)

their cleanness and speed stability, along with low maintenance requirements, make these turntables very attractive for production rooms.

Cassette decks and CD players

There are more models of cassette decks to choose from than perhaps any other piece of equipment in the production room.

Generally, the solenoid activated,

quartz lock drive decks are better for production use, and other features such as Dolby, dbx, metal tape, and adjustable bias should be selected according to your needs.

More bells and whistles doesn't always mean a better deck, just a more complicated one.

Any state-of-the-art production studio will have to take into consideration the latest digital offerings.

While disk storage of any kind is still

too new or costly to take seriously, CDs have made inroads into many studios. With production libraries now offered on CD, stations might find it useful to incorporate a CD player into the production layout.

There are several professional players on the market, and while the cost is still high for many stations, they do feature cueing and speed of play changes that make for quality production.

Many stations are buying consumer CD players these days, because their cost is generally low, and even without the special features desired for direct air play, consumer models become a convenient way to reap the benefits of digital audio.

In the next installment, we'll take a look at studio wiring and layout.

Installing New Gear

(continued from page 15)

The STL path and fade margins were figured using a well-designed kit and forms from Moseley Associates, which is happy to send you one free for the asking.

That night, after the STL path was confirmed, the time came to try our new 25 kW CSI transmitter.

It would be great fun to give you a horror story of smoke, fire and brimstone, but I can't—the transmitter came up just fine.

No pops, cracks, or fizzles—just a loud whirr and three clicks as it step-started up to 25 kW.

Success story

Bill Pollack, the station's owner and GM, wanted to know as soon as possible how our coverage of Memphis would be from the new transmitter site, so for the next three hours (from midnight until 3 AM) I played music from the transmitter site while he drove all over Memphis.

Once an hour, I would disconnect the CD player from the Optimod input and hook-up mic and Shure M-67 mixer to give the legal ID. Then it was back to music.

The next night we moved the FM STL receivers from our old AM FM transmitter site to the new transmitter and went on-the-air, covering Memphis with 100 kW.

Have some fun one night when the PD isn't listening (I mean really late) and hook-up a CD player directly to your audio processing input. Then drive around listening.

If your processing isn't ridiculously heavy, you should be pleasantly surprised as to how good your station can sound.

If it does sound better, make it your goal to clean up the rest of your audio chain. Remember, in broadcast audio, "less is more".



The new 8600 Aural STL System

MORE FEATURES

Designed for either single channel or dual monaural operation, our new 8600 STL system is loaded with features: a built-in subcarrier generator and demodulator for voice and data linking; spurious-free power amplifier; front panel mic input (transmitter) and headphone jacks (receiver) and built-in capability to properly match phase and gain between dual links for either AM or FM stereo applications.

MORE PERFORMANCE

From our extensive experience with STL's we have used the latest design techniques and components to create a superlative sounding system. Because the design is derived from our respected 8300 Composite STL, you can also expect the same caliber of stable performance.

MORE COMPANY

Because TFT is behind the new 8600, so is a full two year limited warranty with service if you need it: 24 hours a day, 7 days a week.

Photo shows 8600 STL System (Model 8600 Transmitter) as a single link with redundant receivers (Model 8601 x 2). *Based on available price information 6/86

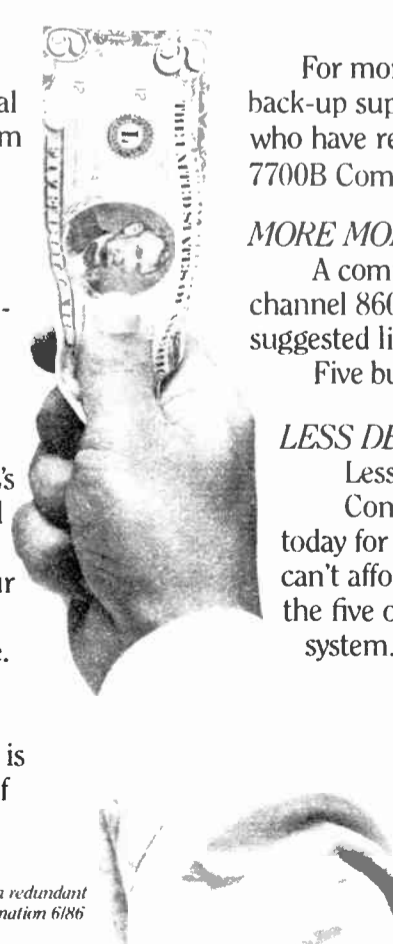

For more than 10 years, this is the kind of back-up support we've provided to broadcasters who have relied on our legendary 8300 and 7700B Composite STL's.

MORE MONEY

A compact, single rack-space, single channel 8600 system is an affordable \$3,195 suggested list (1 Receiver & 1 Transmitter). Five bucks more than the Marti STL-10.*

LESS DELIVERY

Less than 4 weeks. Contact us or your favorite TFT dealer today for full technical information. If you can't afford to call, then go ahead and save the five on our competitor's less expensive system. We understand.



... Where New Things Are Happening!!!
3090 Oakmead Village Drive
Santa Clara, California 95051
Tel: (408) 727-7272
Telex: 910 338-0594 © 1986, TFT, Inc.



FCC Database

ONLINE SERVICES

- 24-hour Remote Access
- AM, FM, FMTX, NCE-FM, TV, LPTV, ITFS Studies/Searches
- Terrain/Population FAA & FCC Tower Databases
- Predicted Contours
- DATAFLEX – user-specified sort/retrieval programs
- FLAGSM SERVICE – Broadcast site monitoring report

dataworld®

A Service of DW, Inc.
P.O. Box 30730
4827 Rugby Avenue, Suite 200
Bethesda, Maryland 20814
(800) 368-5754 (301) 652-8822

Circle Reader Service 35 on Page 22

Circle Reader Service 17 on Page 22

Coping With Lightning Strikes

by R.F. Balonis

Wilkes-Barre PA . . . Theory is nice, and sometimes it's a necessary evil for understanding things in the world of radio.

But this column deals with lightning protection and prevention as you find it in practice at radio stations.

The stroke of lightning originates in the cloud and moves in steps or spurts as a highly conductive arc, surrounded by a corona, towards ground.

When the potential gradient between the lower end of this arc and the ground exceeds the breakdown potential of the intervening air, arcs move from the ground to meet it to complete an ionized column from cloud to ground.

Then the return stroke moves upward along this low conduction path at about one-third the speed of light.

The overall time duration is short, generally less than a second, and the lightning stroke currents vary from 5,000 to 50,000 amps, with some rare ones exceeding 300,000 amps.

Even though the lightning stroke process appears to be erratic and probabilistic, it is a very deterministic phenomenon.

Once started, its enormous electrostatic charge always finds some place to be dissipated, directly in the ground or indirectly at points along the current's path.

And, damage at these points results from the voltage developed which fol-

lows Ohm's Law: current times the "surge" impedance at the point.

This means that to minimize lightning damage good ground connections, ones that not only have minimum resistance but also minimum inductance too, are essential.

For small cables and transmission lines to, from, and on a tower, the cables should generally be grounded wherever and as often as possible. They should also follow a path parallel to one with a lower resistance that can carry the lightning currents.

For inside the tuning houses, matching network cabinets, and all the equipment in the transmitter building it is important to have common grounds so that the components and equipment cannot move away from each other in potential during a direct hit—Ohm's Law again.

Based on a general consensus of lightning experience, the components most likely to see lightning damage are: capacitors, insulators, transmission lines and inductors.

The damage to inductors is usually abrupt and obvious—they melt. However the damage to the other components can be in their dielectric and that can result, sometimes, in an insidious kind of fault: dielectric puncture.

Dielectric puncture is cumulative, even though it may have made it through a strike. Partial puncture from one strike renders puncture (and total failure) more likely for succeeding strikes.

The first level of traditional and customary lightning protection is a direct electrical path from tower to ground through a spark gap at the base of the

tower.

If properly designed, spaced and connected to ground, the gap presents the path-of-least-resistance at the instant of the discharge and shunts the bulk of the current directly to ground.

To insure that the gap is, indeed, the path of least resistance, it is customary practice to put small amounts of inductive impedance (one or two turn loops) in series with connections to the tower.

Depending on the design engineer's preference, the spark gaps can be ball gaps, points, or self-extinguishing horn gaps.

There is no uniform way to set gaps. Some recommend setting them so that they almost arc on maximum modulation.

Obviously, the one that works for you is the best one.

Another level of lightning protection is a static drain path.

Certain atmospheric conditions, while not completely favorable to the formation of thunderstorms, will cause high static potentials to build up on a tower.

If the tower is not grounded, then there should be a resistive path to ground through the networks, or an RF choke, or a 100,000 to 200,000 ohm G-load resistor connected from tower to ground.

The next level of lightning protection is in some type of transient protection on the transmitter.

In the early days of radio it was in the form of a relay connected to protect the transmitter from damage due to transient surges such as arcs and static discharges in the transmitting an-

tenna system.

The relay was wired so that the arc completed the circuit and turned off the high voltage to interrupt the arc, preventing overloads because of the short it presents to the transmitter's output.

These days it's some sort of VSWR circuit or device to protect the antenna system and the transmitter from the arcs that result from a lightning hit or static discharges.

The last levels of lightning damage prevention comes from EMP (Electromagnetic Pulse) protection efforts. EMP is the magnetic pulse that is generated by nuclear detonations.

It's a huge RF wave of enormous proportions which behaves, to some extent, like a lightning strike. But instead of the surges originating at one or two points, everything metal and conductive can have surges trying to find ground.

In addition to traditional lightning protection

(continued on page 22)

Lightning Survey

A company known as Lightning Technologies is conducting a survey to gather data on lightning caused incidents and outages, and is interested in having radio stations participate.

Interested stations can obtain a copy of the survey, called the "Lightning Strike Incident Report" and return it to the company for inclusion into a national database.

Write: Lightning Technologies, 10 Downing Parkway, Pittsfield, MA 01201. Or call them at 413-499-2135.

WWV Clock - Laboratory Precision

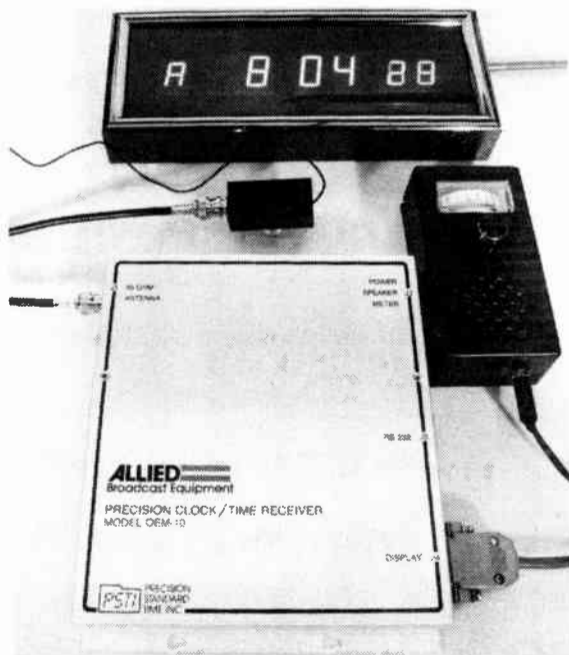

— MODEL OEM-10 —

\$695 complete with simple antenna & digital readout as shown

The Precision Clock/Time Receiver is ideally suited for applications that require ACCURATE, TRACEABLE, UNATTENDED and/or RELIABLE time.

ACCURATE TIME: The OEM-10 provides precise time automatically. It gives the user accuracy to within 10 milliseconds of the worldwide standard (Coordinated Universal Time), transmitted by the National Bureau of Standards (NBS).

TRACEABLE TIME: The product synchronizes with and is traceable to the NBS atomic clock.

UNATTENDED TIME: The OEM-10 eliminates the need to ever set or adjust the clock. The user can just plug it in and forget it. The time out-put automatically includes corrections for daylight-savings and leap year.

RELIABLE TIME: In the event of a power failure, the OEM-10 quickly locks on to the WWV broadcast when power is restored.

The OEM-10 acquires the NBS time in less than three minutes under favorable radio reception conditions. And, once it has synchronized with the NBS atomic time standard, it needs to receive reasonable signal integrity for only a few minutes per day to remain within 10 milliseconds accuracy. (Slave units may be added.)

Prices and specifications subject to change without notice.

ATLANTA, GA
(404) 964-1464
LOS ANGELES, CA
(818) 843-5052

CHICAGO, IL
(312) 470-0303
RICHMOND, IN
(317) 962-8596

DALLAS, TX
(214) 423-8667
SEATTLE, WA
(206) 838-2705

RICHMOND HILL, ONTARIO (416) 731-3697

ALLIED
Broadcast Equipment
P.O. BOX 1487 • RICHMOND, IN 47375

Contract Engineering

Bismarck AMs Thrive in Stereo

by Mark Persons

Brainerd MN . . . All three AM stations in the capitol city of North Dakota are now broadcasting in AM stereo. All are Motorola C-QUAM and all sound *great*.

As a note of further explanation, Bismarck has a population of about 40,000 and that's why they have only three AM stations.

One of the stations is KFYZ which recently converted from the Harris AM stereo system to Motorola C-QUAM. The change was dramatic.

Stereo separation increased, distortion decreased, and the sound became much more open. Chief engineer Herb Leupp said he was extremely pleased.

KFYZ has a colorful history that goes back to the year 1925. The North Dakota Bureau of Department of Commerce Bureau of Navigation Radio Division issued a license to Hoskins-Meyer Inc. to operate with 10 W on 1210 kHz.

The KFYZ call letters were issued sequentially, probably without input from the station as to what they would prefer. "K-Fire" is an excellent call and I can see why they have never switched away from it.

A power increase to 500 W day and 250 W night was authorized in 1927. At that time, two lattice towers were con-

Mark Persons is president of M.W. Persons and Associates engineering consultants. He can be reached at 218-829-1326.

structed on the roof of the studio building to support the antenna system.

It's a good thing they didn't have transistorized equipment at that time or they probably would have had real problems getting rid of RF pickup.

The national frequency re-allocations plan for all radio stations moved KFYZ to 550 kHz in 1928. However, the station shared airtime with two non-commercial school-owned radio stations.

One of them moved to another frequency two months later. KFYZ paid all expenses to move the other (KFDY Brookings, South Dakota) to 780 kHz in 1934.

During this transition to full-time on 550 kHz, the KFYZ transmitter site was moved to a rural location six miles from Bismarck.

Power was increased to 1000 W day and night. A new RCA 5B Transmitter was installed in 1934 and day power was increased to 2500 W and then 5000 W.

That RCA transmitter must have been a marvel of engineering at the time. It was water cooled via a heat exchanger cooled by well water. Tube filaments were DC, getting their power from a motor/generator.

Second tower site

In 1937 a 704' Truscon self-supporting tower was built at a new transmitter site several miles away. The tower still stands with a shorter self-supporting tower nearby to form the 5 kW night pattern.

I was there recently to do the AM stereo installation. The tall tower and site are awesome.

Getting back to the history though, can you believe KFYZ operated 24 hours a day during World War II as a navigational beacon?

Operators at the transmitter site wore sidearms as a precaution against enemy sabotage.

There must have been a lot of money

in radio back then because KFYZ spent \$400,000 in 1949 to build a 110 seat auditorium/studio and three other new studios.

Great coverage

The ground conductivity of North Dakota is so good that KFYZ's 5 kW signal on 550 kHz covers the largest number of square miles of any station in the US during the day.

KFYZ joined the National Broadcasting Company "Chain" in 1931 and broadcast the network programs that we associate with radio's Golden Age.

Favorite shows included *Jack Benny*, *Fibber McGee and Molly*, *Henry Aldrich*, and *Ma Perkins*. Soap operas were big then as well.

KFYZ and radio have come a long way in 60 plus years. Who would have thought in 1925 that KFYZ's adult contemporary format in 1987 would be broadcast in beautiful AM Stereo?

Sleep May Be Best Strategy

by David P. Hebert

Pasco WA . . . It's a feeling that can strike terror into the heart of anyone. The clock says 3 AM and you've been working on that transmitter for seven hours and getting absolutely nowhere.

The station has to sign on in two hours

and the program director is getting more upset by the minute.

To make matters worse, you're physically tired, mentally exhausted and feel generally overwhelmed by the situation. It's lonely at the top and you've finally arrived. Will this ever end?

Fortunately it will, and you will be the better for having weathered it.

Every step forward involves effort, and even now you are developing into a better engineer.

The problem has become more than electronic—it has evolved into a personal challenge that you cannot walk away from.

Aside from the many tricks we can describe to circumvent a given problem, ul-

timately one must approach this situation with some basic "housekeeping" attitudes that can be most helpful in dealing with a seemingly impossible challenge.

In the case of this, the worst type of midnight engineering, you can prevail.

Generally we get too close to the problem to see it for what it is.

Our minds transform loss of drive, shorted bias supplies, lack of high voltage and all the other related symptoms into an impossible order that prevents finding a clue as to what's really wrong. At best it's confusing.

to say "Get away from it for awhile!"

You have entered a mode where you
(continued on next page)

STEREO HEADPHONES ANYWHERE!

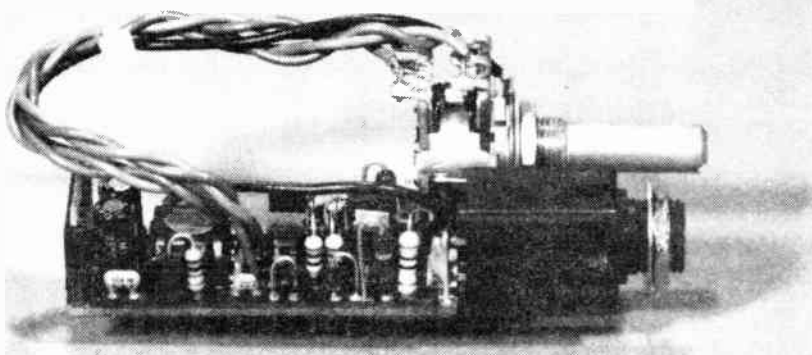

The Benchmark jack mounted amplifier series has been called brilliant. We call them practical. We have a recognized commitment to excellence, and the new HPA-1 stereo headphone amplifier follows the tradition.

As with our differential input and output devices, the HPA-1 can be used anywhere. Use them in consoles, at the patch bay, in telephone talkshow roundtables and in test sets, wherever you need individual level control. Use them in studio monitor boxes, with belt-pack mic preamps, and as unbalanced line

drivers. You can even use them to drive speakers to moderate levels.

The HPA-1 features a current boosted NE5532 with a 60 kHz bandwidth at full gain, a gain range of Off to +18 dB and a noise floor of -90 dBu, again at full gain. The HPA-1 is ideal for the "Studio Series" headphones in the 200 to 600 ohm range but will work with 8 ohm devices as well.

NOW you can put headphones where you've always wanted them. HPA-1s are available off the shelf, direct or through your favorite dealer.

Benchmark MEDIA SYSTEMS INC. 3817 Brewerton Rd. N. Syracuse, NY 13212
Call 1-800-BNCHMRK (262-4675) In New York (315) 452-0400

Audio Processing for Position

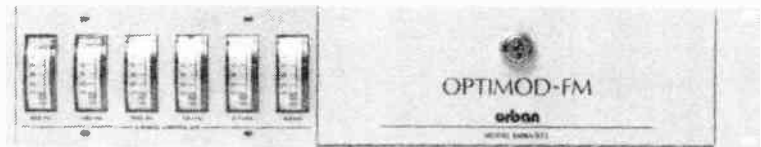

XT2 Six-Band OPTIMOD-FM

The surprisingly affordable new XT2 accessory chassis plugs into any 8100A OPTIMOD-FM. It retains all of the benefits of its XT predecessor, and adds two new user controls—PRESENCE and BRILLIANCE. Together with the XT2's BASS EQ, DENSITY, and CLIPPING controls, they let you precisely adjust bass and treble sound texture, program density and program dynamics.



NORTHEAST BROADCAST LAB, INC.
P.O. Box 1179
S. Glens Falls, NY 12803
518-793-2181

P.O. Box 565
Southampton, PA 18966
215-322-2227

Contract Engineering

In Crisis . . . Sleep Is Necessary

(continued from previous page)
 mind is playing tricks on you, and you are rapidly becoming your own worst enemy. Fatigue, frustration and a little loss of confidence are taking their toll.

Reversing the process

The first thing to do is stop dead in your tracks. Time to hang it up and get some sleep.

When you're tired and backed into a corner, the only thing that's easy to do is make matters worse.

So many times I have been brought in to repair a transmitter that someone else has spent untold hours trying to repair, and the first thing I had to do was fix the damage he caused by his mistakes.

I have to get it back to the state it was in when it went off the air, which can be no easy task.

One's pride can exact a heavy price when it comes to fighting this kind of transmitter problem. Sometimes the cost is simply not justified.

Sure, it's hard to walk away from a dead transmitter and leave the station off

It's also helpful to call the factory, another engineer or even the program director for help.

The important thing to remember at a time like this is to take your problem anywhere and everywhere you might get some help. Don't overlook even the simplest source for reinforcement.

Once when I was wrestling with an almost impossible problem involving a cranky transmitter, I found that taking a shower and letting my mind go blank produced an answer to my dilemma.

Many times I can simply wake up af-

ter a restful sleep with a solution to my problem.

Successful engineering must involve assuming responsibility to "see through" a problem to its eventual conclusion.

Part of this responsibility is evaluating when we are beyond our own capacity to deal with a difficulty, and knowing when to divorce ourselves from it.

Separating ourselves might mean calling other engineers (including the factory if necessary) or simply just knowing when to walk away and recharge our own systems.

Things have a way of working out for the better if we give them a chance, and knowing that a solution will, in fact, be found can be comforting.

Rest assured that any engineer worth his or her salt will admit to these same feelings at some point in a long career.

Now, let's get that thing back on the air . . .

Dave Hebert is president of Dave Hebert Engineering. He is an occasional contributor to RW and can be reached at 509-545-9672.



“
A body cannot function without sleep; and like it or not yours is no exception.
 ”

the air. But this must be done, sometimes, if a solution is to be found.

A body cannot function without sleep; and like it or not yours is no exception. A station that is off the air is still preferable to an electrocuted engineer, or even an overly exhausted one.

Fresh start

When you pull out of the sack, reflect on what has happened. I have found several good ways of doing this.

The first way is to simply read over the instruction manual and study the schematic.

What is the transmitter trying to tell you? What was the last stage that seemed to be working properly?

You might make up a list of cause and effect steps you have already taken and look for any common denominator.

A second way is to reconstruct the events by explaining them to a layperson—the talent, your spouse or even your dog.

They might look at you as if you are crazy, but suddenly you will start to hear your own voice explaining it and it may begin to make sense.

AUDIOPAK AA-4
 Broadcast Cartridges by Capitol
NUMBER ONE IN SALES

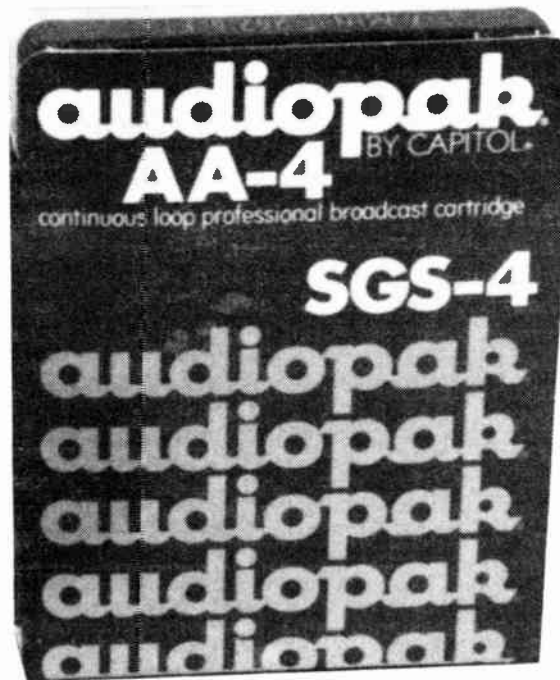
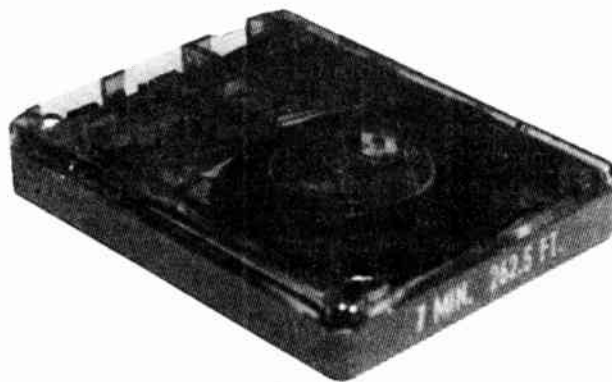

The key feature of the AA-4 is the SGS-4 broadcast mastering tape. When recorded on a high quality cartridge recorder, the SGS-4 tape can produce virtually identical copies of the best analog or digital master tapes.

**For Stations Who Care How They Sound
 In Stock - Fast Delivery - Lowest Prices**

Toll Free Order Number
 1-800-426-8434



BSW • 7012 - 27th St. West • Tacoma, WA 98466

VELCRO CABLE WRAPS
 Quick, safe, neat, never lost
 Use them in Studio, Remote & Mtce Shop
 Call or write for sample
 VIDEO PARTS CO.
 POB 13, CROTON NY 10520
 914 271 3969

Build an Emergency Controller

(continued from page 17)

minute or more variety, the power returns in fits, maybe clean for 10 minutes and then drops again. The old style generator just shuts down and it is needed again.

With this in mind, the emergency controller must decide what is a real power outage and once committed to the generator, leave it there until a more intelligent source determines that utility power is again stable.

Figure 1 is a schematic of one approach to an emergency controller. The device provides the outside world with alarm information.

Even if part of the device has a problem, it notifies you to fix it or at least evaluate and disable it before it makes a mistake.

Second, it provides information to the other parts of the controller. It tells them not to worry that the transmitter is down, there is not any power.

This is important as it makes little sense for an emergency controller to insist that a transmitter is faulty if it has no power.

Third, an interlock chain is provided to tell the controller that you really want to take the station off the air.

The design of this and the remaining sections is rather devoid of TTL and microprocessors—though they are a whole bunch neater and impressive.

The reasons are twofold. First and most important, a design around relays and power steering diodes is very secure.

Second, it allows for simple and easily repaired construction. There will be a group who question this approach. But relays have improved greatly and do provide millions of repeated operations without fault.

Further the design is such that the traditional relay problems (switching non current or high current paths, frequent switching and higher than rated coil currents) are avoided.

The benefits of microprocessor-based design really are in the realm of speed

and complex logic and are not needed here.

If anything, the emergency controller is "reptilian" and the spinal cord upon which the rest of the devices are built.

The schematic shows three 24 VDC power supplies. One comes from a battery bank source, the others from separate AC power drops.

A fault of any of the three is enough to require some maintenance and thus the device calls on its alarm if any does fail. To turn the generator on, it is required that both AC sources fail.

A mistake that blows a fuse in one place, or a fault in the circuit of one of the AC supplies is not enough to decide that the utility is gone and the generator is required.

If both supplies are gone, one of these for the time period determined by its hold capacitor and relay, it is enough to believe that the utility is lost and even if it bounces back occasionally is not worth staying on.

This is the sum total of the logic. If I have control power and if two separate sources of power say I have no utility power, and if at least five seconds pass, it is time to switch to the generator and wait for a command to return.

The key logic OK circuit verifies that this is an approved sequence. If the key logic goes away, then so does the controller.

I use a set of key lock switches in series to ground. Without the path to ground the device will not function.

The +24 VDC supply is a station standard. It is the same supply that holds up the computers, controls and clocks. If the +24 VDC battery supply does go away, it is not worth it to come back. It is also rather easy to build.

If a battery supported bus is not available, then it is time to consider a "topical" supply to run the emergency controller.

The "topical" supply is enough to supply commands to start the generator. It is of course assumed that the generator has a battery supply available to supply

"cranking" power to start.

In short, the controller will have power when those around it do not and every piece of data is supported by sources removed and independent from the first.

The circuit around the buzzer allows the sound to be silenced but the lamp remains lit as long as a fault is detected. Other parts of the controller will also set this off.

Each relay on the power mains and battery supply has contacts that light either a green or red LED (OK or FAULT).

One mains relay has a large capacitor that with the relay coil forms the five-second time delay to allow small power glitches to occur without starting the generator.

The relay that provides closed contacts to the generator is wired to latch, and a "test" switch and a "return to normal"

switch are provided.

In most generators and changeover switches there is a "test" switch that this relay can parallel to put the generator on line regardless of the mains state.

Values indicated assume "sugar cube relays" and a 24 V system, but others can be used.

Figure 2 is a front panel layout. While all three units fit nicely into one two rack slot box, having three boxes makes maintenance easier.

As always, look to the design and if you design to build, do it with what you have access to and modify to meet your needs.

In summary, the emergency controller for the power portion of the circuit provides power no matter what, provides data when no power exists and thus ignores the fact that the transmitter doesn't work.

It reinforces the decision to change to a generator until it is sure that broadcast grade power has returned.

Avert Lightning Damage

(continued from page 19)

tection measures, EMP measures aim to prevent damage to all equipment from the surge currents—Ohm's Law again—by shunting them to ground.

Basically, EMP practice is the application of good and multiple grounding techniques wherever possible, the installation of MOV (Metal Oxide Varistors) surge protectors across most all AC lines and equipment cables, and the use of "Gas-Gaps" across surge sensitive equipment components—transmission lines and network capacitors.

Gas-gaps are hermetically sealed spark gaps with a controlled gas mixture and pressure. They have a precise arc-over voltage, and protect by shunting over-voltage surges directly to ground.

At WILK, AC and control circuit surge protection was installed the last time lightning-induced line surges got into the building, and into the equipment.

It has been 12 years since GE MDL 9L15DCB001 surge arrestors were installed at points on the AC distribution panel and on the bottom sides of the tower lighting chokes in each tower.

They have worked too, the lightning devil hasn't been inside WILK's transmitter building since.

If the customary and the traditional lightning protection efforts are not enough to tame lightning at your transmitter plant, you can try prevention—by using charge dissipation systems and techniques.

The charge dissipation methods of lightning prevention are based on the concept of draining the static charges from the cloud, and thereby preventing or minimizing the possibility of the charge building up to lightning discharge potentials.

In theory and in practice a sharp point in a strong voltage (potential) gradient in air has the ability to start a current across the gradient.

The charge dissipation techniques involve specifically designed configurations of numerous "sharp-points" to leak and drain the static charges from the clouds passing over the charge dissipation system.

The real basic problem with all lightning prevention or protection efforts is that the need for them is not constant: thunderstorms are seasonal and cyclical.

But, regardless of immediate results, lightning fault protection or prevention efforts and activities should be a part of a station's on-going maintenance.

Emph'asize it!



WITH THE **Emph'asizer™ AUDIO PROCESSOR**

- DJ Personality Processor
- Production Tape Processor
- Gated Recovery Compressor
- Four Parametric Equalizers
- Phone Line EQ and Noise Suppressor
- Room Equalizer and Gated Mike Control
- Unobtrusive Background Noise Gate
- Mike and Line Level Inputs and Outputs

Free Detailed Brochure Available

ATJ AUDIO TECHNOLOGIES INCORPORATED
328 Maple Avenue, Horsham, PA 19044 • (215) 443-0330

Subscription/Reader Service Forms

Radio World
July 1, 1987 Issue Use until October 1, 1987

FREE Subscription/Renewal Form

I would like to receive or continue receiving **Radio World** FREE each month. YES NO

Signature _____ Date _____

Please print and include all information:

Name _____ Title _____

Company/Station _____

Address _____

City _____ State _____ ZIP _____

Business Telephone () _____

Please circle only one entry for each category:

I. Type of Firm

A. Commercial AM station	F. Recording studio
B. Commercial FM station	G. TV station/teleprod facility
C. Educational FM station	H. Consultant/ind engineer
D. Combination AM/FM station	I. Mfg, distributor or dealer
E. Network/group owner	J. Other _____

II. Job Function

A. Ownership	D. Programming/production
B. General management	E. News operations
C. Engineering	F. Other (specify) _____

III. Purchasing Authority

1. Recommend 2. Specify 3. Approve

Reader Service

Please first fill out contact information at left. Then check each advertisement for corresponding number and circle below.
NOTE: Circle no more than 10 numbers, otherwise card will not be processed.

001	021	041	061	081
002	022	042	062	082
003	023	043	063	083
004	024	044	064	084
005	025	045	065	085
006	026	046	066	086
007	027	047	067	087
008	028	048	068	088
009	029	049	069	089
010	030	050	070	090
011	031	051	071	091
012	032	052	072	092
013	033	053	073	093
014	034	054	074	094
015	035	055	075	095
016	036	056	076	096
017	037	057	077	097
018	038	058	078	098
019	039	059	079	099
020	040	060	080	100

Sales Call Service

Please have a salesperson contact me about these items (list numbers):

Clip & Mail to: Radio World, PO Box 1214, Falls Church VA 22041

Save this Ad!

It may save your Station.

INTRODUCING THE
RICHARDSON RESCUE
TEAM

1 SPEED

OVER
90%
Same Day Shipment

Richardson gives
you fast shipment

2 COURTESY



We make that extra
effort when you
have an emergency.

3 DEPENDABILITY



All our products carry
full manufacturer
warranties.

4 CONVENIENCE

#1-800-

Phone or write for our full
catalogue. In the meantime,
use the attached line card for
quick reference.



Richardson Electronics, Ltd.

BROADCAST COMPONENT SPECIALISTS

Products/Major Manufacturers

BROADCAST POWER TUBES BY:

Amperex	Cetron
EIMAC	G.E.
ITT	Machlett
Mullard	National
RCA	Siemens
Thomson-CSF	Varian
Westinghouse	

CAMERA TUBES BY:

Amperex	Hitachi
G.E.	National
Panasonic	RCA
Toshiba	

RF TRANSISTORS BY:

Acrian	Amperex/Philips
CTC	Motorola
TRW	Thomson-Mostek

UHF TV LINEAR AMPLIFIERS BY:

Acrian

SOLID STATE TUBE REPLACEMENTS BY:

National

CATHODE RAY TUBES BY:

Clinton National

FM AMPLIFIERS BY:

EIMAC

KLYSTRONS BY:

ITT Varian

VACUUM CAPACITORS BY:

Jennings

RECTIFIER STACKS BY:

Amperex National

RF POWER AMPLIFIERS BY:

(For STL and Remote Pickup links)

RF Gain

SOCKET AND ACCESSORIES BY:

EIMAC E.F. Johnson
National

CALL US FOR SERVICE, QUALITY & OFF-THE-SHELF DELIVERY

SALES OFFICES

EASTERN/BROADCAST DIVISION

Ceco Communications, Inc.
Brooklyn, NY 11235
Phone: 800/221-0860
718/646-6300

WESTERN DIVISION

Richardson Electronics, Ltd.
Woodland Hills, CA 91364
Phone: 800/348-5580
818/347-5580

CENTRAL/CORPORATE OFFICE

Richardson Electronics, Ltd.
LaFox, IL 60147
Phone: 800/323-1770
312/232-6400

CANADIAN OFFICE

Richardson Electronics, Ltd.
Brampton, Ontario L6T 3T4
Phone: 800/387-2344
416/454-5950

Congratulations Allied!

"Imitation is the Sincerest Form of Flattery"!

BARRETT ASSOCIATES INC.
Welcomes You to the World of Used Equipment

NOW CATCH THE LEADER, B.A.I.

With 7 Years of Experience

Creating our own Laboratory to **RECONDITION** and
Test All Broadcast Equipment - Even the cosmetics,
issuing a **Six Month Guarantee** with all units.

Transmitters & Turntables

Sound Processors & STL's

Reel Recorders & Remote Controls

Consoles & Cart Machines

Racks & RPU's

Carousels & Cassette Machines

Sensor's & SCA's

Phone Units & Power Supplies

Amplifiers & Automation

Patch Bays & Pre-Amps

EBS & Exciters

Limiters & Monitors

Generators & Boosters

No "Scratches"

No "Dents"

Just the Best Price & Quality!

ALL GUARANTEED in Top Make Brands:

Moseley, Harris, Gates, Ampex, Revox, TFT, Otari, Technics, Orban,
Continental, RCA, Collins, Marti, Audicord, UMC, Belar, Russco

**TRADE IN YOUR EQUIPMENT AS CASH
FOR ANY ITEM IN 204 TOP LINES
of NEW EQUIPMENT**

Barrett Associates Inc. is one distributor run by a broadcaster - a "Broadcast Pioneer" concerned for getting and keeping you "On The Air". Experience counts when you need help.

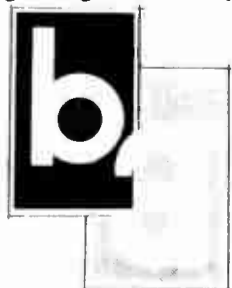

barrett associates, inc. (619) 433-5600
BROADCAST • AUDIO EQUIPMENT

3205 Production Ave.
Oceanside, California 92054

RadioWorld Broadcast Equipment Exchange®

"Broadcast Equipment Exchange" accepts no responsibility for the condition of the equipment listed or for the specifics of transactions made between buyers and sellers.

AMPLIFIERS

Want to Sell

Altec 1569A pwr amps, mono, 80-100 W (15), \$125 ea; Ampex 3200/custom PB 3200 transports, handle 1/4 & 1/2" tape, 4/3/2/1 trk heads, customized Ampex PB cards, \$500 ea; RCA BA21A(21), BA23A(3), BA33A(4) preamps, line amps, etc. plug-in trays, etc, \$750. W Slaten, 424 Grant Ave, Scotch Plains NJ 07076. 201-322-7269.

Pulse Com 1671-4L1 switch gain amp, vgc, \$50. J Schloss, KICD, 2600 Hiway Blvd, Spencer IA 51301. 712-262-1240.

McIntosh 222 stereo tube, \$200; MC 110 FM/AM tuner, \$150; MC 2105 stereo, \$500. SA Cisler, 2405 Hermitage Way, Louisville KY 40222. 502-458-7420 aft 11 AM.

Dynaco PAT 5 stereo preamp w/assoc Dynaco stereo 120 power amp, assembled from kit by station personnel w/manuals. B Mins, WTSU, Troy St Univ, Troy AL 36082. 205-566-3000.

RCA MI-9377 rack mt, theatre amp, 50 W, working, gd cond, (6), \$75 ea; Dukane 100 W rack mt, tube PA amp, working, gd cond, (3), \$45; HH Scott LK-72 stereo tube amp, \$40. N Carlson, Mobile Snd Group, 721 W Melrose, Chicago IL 60657. 312-871-7459.

McMartin MS-75 (2), great cond, \$100 ea. M Dailey, 311 S Gloster, Tupelo MS 38801. 601-841-1506.

Ampex speaker amp, matches Ampex 601 style, not working, \$50. K Retzer, KGRZ, POB 4106, Missoula MT 59806. 406-728-1450.

Mirage D-24 RF power amp, brand new, ham type, \$150. K Retzer, KGRZ, POB 4106, Missoula MT 59806. 406-728-1450.

Home brew in Vector cage D/A, 1 in 6 out each card (6) w/power supply, \$600. D Abdo, WTRY, WTRY Rd, Schenectady NY 12309. 518-785-9061.

Marantz 140 \$190/BO. B Van Prooyen, 2111 Shangri-la Dr SE, Grand Rapids MI 49508. 616-243-2026.

Gray Research 602C phono preamp, mono. A Bendix, KGWY, POB 1179, Gillette WY 82716. 307-686-2242.

Pioneer SA-5200 power amp, \$75. K Retzer, KGRZ, POB 4106, Missoula MT 59806. 406-728-1450.

Radio Shack MPA-20 AC/DC 20 W audio power amp, \$35. K Retzer, KGRZ, POB 4106, Missoula MT 59806. 406-728-1450.

Gates 994-6690-001 solid state mono TT amps (2), \$80/pair. K Retzer, KGRZ, POB 4106, Missoula MT 59806. 406-728-1450.

Radio Shack PA amp, 35 W w/priority page, \$50. R Kerbaway, WTNJ, Box 1127, Beckley WV 25802. 304-877-5592.

Elec Navigation Indus 310L w/meter, 250 kHz, 110 MHz, 50 dB RF power amp, 10 W output, \$600. M Rakoff, WQVM, 114-41 Queens Blvd #148, Forest Hills NY 11375. 718-591-0002.

Collins 356H-1 TT preamps & phone EQ. L Wilson, 409 Hillaire Dr, Hopkinsville KY 42240. 502-886-1678.

Gates Courier 70 2 chan remote amps w/power supply & schematics, needs work, less VU meters. L Wilson, 409 Hillaire Dr, Hopkinsville KY 42240. 502-886-1678.

RCA TT preamps (4), J Lies, WTRC, POB 699, Elkhart IN 46515. 219-293-5611.

Want to Buy

McIntosh C4 preamp w/EQ switches, any cond. SA Cisler, 2405 Hermitage Way, Louisville KY 40222. 502-458-7420 aft 11 AM.

McIntosh, Marantz, Dynaco Quad, Audio Research, etc, amps; WE, Tannoy, Altec, EV, JBL, Hartfield, Olympus, Harness, Laguna speakers; Thorens, Fairchild turntables; WE tubes & microphones. Lapine, 10919 Oasis, Houston TX 77096. 713-723-5281.

Ampex AA620 speaker amp in case. SA Cisler, 2405 Hermitage Way, Louisville KY 40222. 502-458-7420 aft 11 AM.

ANTENNAS & TOWERS

Want to Sell

Scala FMVH-4 CP 4 bay w/divider network & all cables, excel cond, \$700 plus ship. S Lawson, KAK-FM, 928 Hyland Dr, Santa Rosa CA 95404. 707-528-4055 aft 6 PM PST.

Strobes: Brighter Idea, medium/low intensity. Retrofit your existing 300mm beacon. Self-contained unit, no extra wiring or rigging of tower required. Broadcast Communications, 6 Round Hill Circle, Madison WI 53717. 608-833-3977.

Bird 8572-115-6 dummy load, air cooled 25 kW, 5 hrs daily use, \$3000. J Keyes, WA1TKG, POB 645, Yelville AR 72687. 501-449-4147.

Rohn 65 370', w/many access, \$13,000. A Crain, Box 157, Collierville TN 38017. 601-895-6483.

Tower, 370', 4' face, Windcharger type, guy wires, dismantled, you ship, \$19,000. A Crain, WVEE, POB 157, Collierville TN 38017. 901-853-4735.

Rohn 65G 370' incl guy wires, dismantled, you ship, \$13,000. A Crain, WVEE, POB 157, Collierville TN 38017.

Windcharger, 370', \$19,000/BO or may take 1 kW AM xmtr trade & 2 tower phaser. A Crain, Box 157, Collierville TN 38017. 601-895-6483.

Gates/ERI FMS-2A, 2 bay CP antenna w/factory de-ice & tower-leg stand-off mounting brackets, 1-5/8" interbay, tuned to 103.9 MHz, \$1200/BO. L Ayer, KRPL, POB 8849, Moscow ID 83843. 208-882-2551.

Tower, 960' solid leg, zone A, w/guy wire on ground, call for price. L Dupree, KQID, POB 7057, Alexandria LA 71301. 318-445-1234.

Kintronics 7.5 isocoupler, like new, \$750. C Haynes, Haynes Comm, POB 31235, Jackson MS 39206. 601-948-1515.

Continental/ERI 12 bay, CP, 93.1 MHz. L Dupree, KQID, POB 7057, Alexandria LA 71301. 318-445-1234.

Dielectric BFH 2 bay, CP, never used, pole mt hardware, 99.9 MHz, \$1200. R Lane, KYTD, 5360 Hellister, Santa Barbara CA 93111. 805-967-4511.

Scala 2CA5-150HV yaqi HP, 98.7 MHz, new in box, \$440. D Abdo, WTRY, WTRY Rd, Schenectady NY 12309. 518-785-9061.

RCA 6-1/2" transmission line, 75 ohm, 900', \$600/20' section. B Richert, WPCB, Signal Hill Dr, Wall PA 15148. 412-824-3930.

TFU 30J chan 48 RCA antenna, \$40,000. B Richert, WPCB, Signal Hill Dr, Wall PA 15148. 412-824-3930.

ERI 6 bay HP antenna, 104.3 MHz, BO. C Schipper, KOKS, 9191 Sheridan #205, Westminster CO 80030. 303-427-7700.

Steel guy cable, 5/16", (3) 200' sections, BO; (2) 50' sections 3/8" Phyllystran guy cable w/connectors, \$100; (2) new Andrew 1062-3 90° mitre elbows, \$75 ea; Bird 51.5 ohm in-line wattmeter w/25 kW element, BO over \$50; Andrew 6710 coaxial switch, 3PST for parts, w/drawings, BO. R Kerbaway, WTNJ, Box 1127, Beckley WV 25802. 304-877-5592.

Jampro JSCP-12 12 bay FM, 94.5 MHz, rebuilt, still in crates incl leg mt brackets. J Wagner, KFMX, 5613 Villa Dr, Lubbock TX 79412. 806-747-1224.

Andrew air dist manifold w/4 valves & 4 gauges, \$160. S Hasskamt, KDLH, 425 W Superior St, Duluth MN 55820. 218-527-8911.

Cablewave FLC78-50J, 7/8" foam, 250' unused on spool, \$795 & frt. G Thomas, KELI, POB 3834, San Angelo TX 76902. 915-655-9679.

Fisher AM towers, (3), 330' high, 2' face, insulated, guyed, vgc, take all three & we'll dismantle, \$5000 ea, you transport. B Glasser, WHBC, POB 9917, Canton OH 44702. 216-456-7166.

Cablewave FLC158-50J 1-5/8" foam, 110' unused, not on spool, \$875 & frt. G Thomas, KELI, POB 3834, San Angelo TX 76902. 915-655-9679.

Collins 37CP 8 bay, 97.9 MHz, mounted on tower, BO. J Banoczi, KNOB, POB 3159, Anaheim CA 92803. 714-772-5662.

Collins 637D-1 HF antenna, high power broadband, 2-30 MHz w/50-650 Ohm balun, termination resistors & paperwork, new in large box, 120' x 120' when erected, installation avail, serious offers. Z Smith, Airwaves Comm's, 4801 Lamar Ave, Paris TX 75460. 214-785-8881.

Stainless tower, 370', 320' Windcharger, 320' solid leg tower, last to be taken down, BO. J Tidwell, WAFB, Box 338, Valdosta GA 31603. 912-244-5180.

Collins (ERI) G5CPS 4 bay antenna, \$2000. B Harlan, WFAH/WDUJ, 393 Smyth Ave NE, Alliance OH 44601. 216-821-1112.

ERI 403 isocoupler, 10 kW, 102.3 MHz. B Statham, WSTU, 1000 Alice, Stuart FL 33494. 305-692-1000.

Tower, used, heavy duty galvanized, on ground, will ship, you pay frt. J Pickett, ABC Ent, Rt 1, Sturgeon MO 65284. 314-687-3932.

Andrew LDF5-50, 120', 7/8" helix trans cable, brand new never used, \$250 plus ship. B Mountjoy, Custom AV Svcs, Box G1240, Elizabeth TN 37644. 615-543-5849.

Bare copper wire, #No10, 150,000' ft, 4'ct/ft. W Blackwelder, KTTB, Box 7935, Tyler TX 75711. 214-581-0606.

Andrew 1920A air dehydrator, gd cond, \$700. S Hasskamt, KDLH, 425 W Superior St, Duluth MN 55820. 218-527-8911.

Andrew RG322 355', brand new on spool, flanged on both ends, \$4-5/ft. B Husband, 215 Taylorsville Rd, Yardley PA 19067. 215-493-4467.

Want to Buy

Helix 1-5/8" or 3" line, also need matching connectors. J Powley, WIIM, 1536 Logan Ave, Altoona PA 16602. 814-944-8571.

Bogner UHF TV antenna, B4U, B8U, B16U, any chan incl old translator band 70-83, low to medium power input series. J Powley, WIIM, 1536 Logan Ave, Altoona PA 16602. 814-944-8571.

ATU & base insulator for 1 kW AM 1400 & 1490 kHz stations. B Dodge, WTUJ, POB 1818, Brattleboro VT 05301. 802-254-2560.

Tower sections (4), either Rohn #80 or Stainless G-36, new or used. J Powley, WIIM, 1536 Logan Ave, Altoona PA 16602. 814-944-8571.

Diplexer for FM station, send details. R Gold, Suwebe Bdcig, 19355 NE 36th Ct Ste 11J, Miami FL 33180.

FM antennas, 2-4 bay, 1-10 kW tuned to 91.7. E Goetsch, WXPB, 303 W Prospect, Rhineclander WI 54501. 715-362-6000.

Tower light beacon, R Wright, WLLX, Box 156, Lawrenceburg TN 38464. 615-762-2916.

Any 4 bay FM antenna, 107.1 MHz; also any 360' tower. E Kazmark, KAZZ, Box 1369, Deerpark WA 99006. 509-276-8816.

AUDIO PRODUCTION OTHER

Want to Sell

dbx 142 NR unit (2) encoder/decoder. J Aasen, KFJM, Box 8116 Univ Station, Grand Forks ND 58202. 701-777-2577.

dbx 150X, new in box, \$195 free ship. J Sheperd, Globe Prod, 539 Westminster Ln, Salem VA 24153. 703-389-1670.

Shure 610 feedback controller, mint, \$90; Shure SE30 compressor mixer, \$100; EV XEQ2 crossover (2), \$120 ea; Accesit Noise Gates 3 chans w/PS, mint, \$175. D Kocher, 1901 Hanover Ave, Allentown PA 18103. 215-776-1455.

Panasonic SE-405H CD-4 system disc demodulator, w/cartridge, test disc, etc, \$100. W Slaten, 424 Grant Ave, Scotch Plains NJ 07076. 201-322-7269.

Comex Bleepmate 675 3 or 6 sec digital delay, \$700. S Bush, KTKK, 3595 S 1300 West, Salt Lake City UT 84119. 801-264-8250.

Telefunken C4D Telcom NR cards (8), \$300 ea; (2) dbx K9-22 NR cards, \$250 ea; BTX 4100, 4500 & 4010 SMPTE gen & reader, \$2000 package. E Sanders, 7th St Snd, 688 S Santa Fe #105, LA CA 90021. 213-627-5392.

Eventide BD955 digital delay, \$1300/BO. Sluder telephone hybrid, dual, \$995/BO. A Soroka, WJRO, POB 159, Glen Burnie MD 21061. 301-761-9220.

Sparta-Cetec AS3013 push button style, 2 tables, Stanton cart, remote console w/legs, Spotmaster mono R/P cart machine, low hrs, \$1500. J Gardner, The Way, 2 Maria Hotchkiss Rd, Prospect CT 06712. 203-758-4769.

Gentner VRC-1000 w/failsafe, punch B/K, service manual, extra connector, all access, BO. T Berry, WKRR, POB 36070, Greensboro NC 27416. 919-274-8042.

Orban Stereo synthesizer, \$175. B Kramer, WQXO, Box 3176, Longwood FL 32779. 305-682-5463.

Northern Electric R5461C 4-input portable mic mixer, accepts internal batteries or AC line power, carrying case, vgc, \$95. M Byrnes, WAMU, 4400 Mass Ave NW, Wash DC 20016. 202-865-1030.

Melcor GME-20 console mount parametric EQ's, gd cond, (2), \$25 ea; Haeco CSG-2 compatible stereo gens, perf, no center chan build up for stereo to mono conversion (3), gd cond, \$75 ea. T Steele, Frankford/Wayne Mastering Labs, 1697 Broadway, NY NY 10019. 212-265-5563.

Gates GE-3, working in 1/87 when removed, \$700. BJ Hunsinger, WNTB, Box 84 South Hall, Mansfield Univ, Mansfield PA 16933. 717-662-4650.

Telex CS91 sports bdctrs headsets w/boom mic (5) in need of repair, \$195/all. CJ Pringle, Trinity Entrp, Box 831, Webster City IA 50595. 515-832-1263.

Eventide RD 780 (2) Monstemat matrix encode-decode, \$200 ea. R Dietterich, WAMO, 411 7th Ave, Pittsburgh PA 15219. 412-471-2181.

Conex Systems 675 bleep mute; (2) BE TG-2 dual tone gen; UREI 535 dual graphic EQ; Orban 424A dual graphic EQ; Ramko ARA 1612 audio router; SAE impulse NR; CN Rood stereo decoder SM0203. A Bendix, KGWY, POB 1179, Gillette WY 82716. 307-686-2242.

Inovonics 355 w/power supplies (900 Series), BO. T Low, Foster Communications, 115 W First, San Angelo TX 76903. 915-653-3387.

Shure M267 mixer, near new cond, \$260. CJ Pringle, Trinity Entrp, Box 831, Webster City IA 50595. 515-832-1263.

Shure M63 audio master EQ's (2), gd cond, \$75 ea; Orban 526A de-esser, vgc, \$125. M Byrnes, WAMU, 4400 Mass Ave NW, Wash DC 20016. 202-865-1030.

Shure M-625 Voicegate, \$100. W Brown, KVNI, Coeur d'Alene ID. 208-664-9271.

Studio Tech AN-2 stereo simulator, 1 yr old, just taken out of service. L Davis, WKOV, 287 E Main, Jackson OH 45640. 614-286-3023.

Studio package: 16 input console, 2 trk Scully, 8 trk cart machines, D150 Crown amp, Rusco turntable, 2 Altec limiters, 1 Fairchild limiter, 2 Mix down speakers, 8 mic booms, cassette recorder, Sony & AKG mics, all for \$7000. B Burchett, Bur-K Inc, 842 Bellefont Princess Rd, Ashland KY 41101. 606-324-8812.

Fostex 3180 2 chan spring reverb, new cond. BO. R Schumacher, KENO, 4660 S Decatur Blvd, Las Vegas NV 89103. 702-363-1808.

Want to Buy

Sontec, Pultec or API EQ's. D Kocher, 1901 Hanover Ave, Allentown PA 18103. 215-776-1455.

SAE 5000A impulse NR, will pay up to \$200 & would like 2 ea. T Hall, Radio Program Svcs, 3615 E Unidah #10, Colorado Springs CO 80909. 303-574-8628.

Color weather radar weather system, hard or software. S Voros, WLZR, 1537 S 81st, Milwaukee WI 53214. 414-475-6200.

Grey Research EQ, mdl 603 or 602C. J Burdeau, WBEE, 15700 Campbell, Harvey IL 60426. 312-933-1570.

Sennheiser HD224 headphones, gd to excel cond. B Sheridan, WFAS, Box 551, White Plains NY 10602. 914-693-2400.

AUTOMATION EQUIP.

Want to Sell

BE Control 16 Automation System: (4) Otan ARS1000DC decks, (2) ITC 770 decks, (4) IGM Go-Carts, ITC 3D cart deck, (2) ITC RP decks, (5) racks, (3) CRTs, (2) control stations, battery backup & charger, auto logging, cart encoder. D White, WYBR, Box 7180, Rockford IL 61126. 815-874-7861.

Cetec-Schafer owners, add 48 trays of random access multicart to your automation system, Audiofile IIA's, \$2250 ea. JD Belt, Com-Tech Inc., POB 1622, Bluefield WV 24701. 304-327-0090.

SMC satellite automation MSP 10 channel w/3 stereo Carousels, 4 stereo singles plays, Brain, rack, wired, mint cond, bargain at \$10,000. B Kramer, WQXO, Box 3176, Longwood FL 32779. 305-682-5463.

BROADCAST AUTOMATION, INC.

THINKING ABOUT AUTOMATING?
Think of what BAI offers ...

- New and remanufactured control units
- Multi-cart playbacks
 - SMC Carousels
 - IGM Go-Carts
 - IGM Instacarts
 - Cetec Audiofiles
- New Otari & Revox reel playbacks
- Remanufactured reel playbacks
- New and remanufactured single cart playbacks
- Cassette playbacks (live or automated)
- Compact Disc players (live or automated)
- Complete systems from very small to very large
- Installation, Training, Technical support
- New studio equipment
- CRL audio processing
- We accept limited trade-ins
- Affordable prices

We include warranty and technical support on all our remanufactured equipment...

QUALITY • VALUE
REPUTATION
ASK US ABOUT LEASING

BROADCAST AUTOMATION, INC.

4125 Keller Springs, Suite 122
Dallas, Texas 75244
(214) 380-6800

The BIG MIC SALE

BIGGER, BETTER, CHEAPER

AKG
Audio-Technica
Beyer-Dynamic
Crown
Countryman
Electro-Voice
HME
Nady
Ramco
Samsen
Sennheiser
Shure
Sony
Stewart
Teac
Telex
Tram
Toa
Vega
Williams

PRICES SO LOW
WE PROMISED NOT
TO PRINT THEM!

BACK
by Popular Demand

TOLL FREE in 50 States
(800)356-5844

AMPLIFIERS • CASSETTES • HEADPHONES • INTERCOMS • LIGHTING • MICS • MIXERS • PARTS
SIGNAL PROCESSING • SPEAKERS • TAPE • TAPE RECORDERS • TEST EQUIPMENT • TURNTABLES

FULL COMPASS SYSTEMS

6729 SEYBOLD RD., MADISON, WI 53719-1393

In Wisconsin:
(800)362-5445
Consultation:
608)271-1100



Broadcast Equipment Exchange

AUTO . . . WTS

SMC DP1 digital programmer w/5 Carousels, several single play deck encoder/decoder & other misc automation equip. call for price. D Mackenzie, WJBR, 2617 Ebright Rd, Wilmington DE 19810. 302-475-4000.

Model 20A (250) Carousels, (4), \$600 plus fr. M Ripley, KOZE, POB 936, Lewiston ID 83501. 208-743-2502.

Harris System 90, (4) R-R's, IGM Go-Cart 48, (2) cart decks w/logger, \$7600. D Tarum, KRZ, 2402 E 37th No, Wichita KS 67219. 316-832-9600.

Schafer 800F complete system, call for details, complete or components, \$10,500/BO. B Van Prooyen, WYGR, 1055 28th St SW, Wyoming MI 49509. 616-532-1168.

Control Design Corp. CD-28AS w/12 source stereo switcher, sequential programmer & 8 event clock & manuals, BO, J Aasen, KFJM, Box 8116 Univ Station, Grand Forks ND 58202. 701-777-2577.

Control Design Corp CD-24R stereo random access cart Carousel w/manual, J Aasen, KFJM, Box 8116 Univ Station, Grand Forks ND 58202. 701-777-2577.

IGM Instacart new heads, new pinch rollers, BO D Haworth, KFGO, 1020 S 25th, Fargo ND 58108. 701-237-5346.

Systemation 9 deck & 2 deck prod system, w/RVCY316 Fairchild satellite receiver & down converter, set up for Translar, \$8500. S Karmann, KCMJ, 490 S Farrell St C202, Palm Springs CA 92262. 619-320-6818.

Gates random access automation control unit, Gates automation timer; Gates SSA-3 silence sense, Gates FA-25 25 Hz tone filter; Gates STC source transfer control; (2) Gates 900-0206-0C1 Carousel interfaces; Gates TG 25, 25 Hz tone gen. A Bendix, KGWY, POB 1179, Gillette WY 82716. 307-686-2242.

Schafer 901 system w/IGM 48 cart stereo Insta-Cart, (2) Sono-mag 250 Carousels, Sono-mag 350 Carousel, Extel printer. A Bendix, KGWY, POB 1179, Gillette WY 82716. 307-686-2242.

SMC w/DP1 digital programmer w/fixed 24 cart Carousels, 3 Scully SLJ10 R-R's, you take out, ready now, \$8000 cash. T Graham, WKAA, 106 4th St, Ocala GA 31774. 912-468-9898.

BE Control 16 system, auto logging, cart encoder, (3) CRTs, (2) control stations, battery backup & charger, (5) racks, (4) IGM Go-Carts, ITC 3D cart deck, (2) ITC 770 open reel decks, all stereo & operational when removed from service. G Capogna, WYBR, POB 7180, Rockford IL 61125. 815-874-7861.

SMC 521 mono dual play on pull out drawer wiaux cards, solid state, \$400. W Hoisington, WTCG, Andalusia AL 36420. 205-222-8849.

Harris w/4 Sonomag Carousels, 4 Ampex R-R's, misc parts, call for details, BO, R Hugler, WSUL, 250 Broadway, Monticello NY 1701. 914-794-0242.

Basic A complete 3K system, w/everything, P Sorio, WBAZ, Box 1200, Southold NY 11971. 516-765-1017.

Microprobe Elec 100 programmer, rarely used, remote 8 machines, 24 events, \$2500. J Yinger, WBCM, 301 The Davidson Bldg, Boy City MI 48708. 517-894-4543.

IGM Instacart, 48 tray stereo, working when removed from service, \$3500. M Meyer, KLQP, POB 70, Madison MN 56256. 612-598-7301.

SMC TAC-1 time announce controller w/book & cables, cards all check, \$350. W Hoisington, WTCG, Andalusia AL 36420. 205-222-8849.

Schafer 8000 automation control system w/4 stacks of memory, BO B Harlan, WFAH/WDJQ, 393 Smyth Ave NE, Alliance OH 44601. 216-821-1112.

Schafer 7000 48 tray Audifile, 2 Otari R-R, 2 Carousels, 1 yr use, \$14,000. D Monce, WDNV, 129 Main, Dansville NY 14437. 716-335-2273.

Capital SMC TS25 dual tone sensor, never used, mint cond, \$400. A Weiner, WREM, Monticello MA 04760. 207-764-8300.

SMC ESP1, comp system inc brain, 4 Carousels, 2 PB R-R, 4 single plays, backtime unit, time announce, ADC-5 time update clock, Extel printer, RAC-30 remote control, wiring, manuals, excel cond, must sell. L Ellis, WAKE, 2755 Sager Rd, Valparaiso IN 46383. 219-462-6111.

Want to Buy

IGM 364J program logger-printer, for parts L Ayer, KRPL, POB 8849, Moscow ID 83843. 208-882-2551.

Tone gen/encoder 25 Hz & service manual for Schafer 800. B Van Prooyen, 2111 Shangiia, Grand Rapids MI 49508. 616-243-2026.

IGM 392 network switcher, w/all the relays, an earlier model, J Robinson, KOMW, Box 151, Omak WA 98841. 509-826-0100.

CAMERAS (VIDEO)

Want to Sell

JVC KY1900, w/AC adapter-charger, battery & case, excel cond, \$3000. R Larsen, Metropolis Video, 316 S Maple, Oak Park IL 60302. 312-848-3172.

Norelco PC 70 cameras (7), most need lenses, \$5000 for package, Nigel, Technichrome, 701 Desert Ln, Las Vegas NV 89106. 702-386-2844.

Hitachi GP7U single tube w/AC power, \$600. G Sive, Your Video Connection, POB 239, Bonsall CA 92003. 619-729-7662.

Houston Fearless PD-3 pedestals (2): GE 400 camera heads, CCU's, PS & cables. K Knowles, Knowles Video Prod, Box 12127, Tallahassee FL 32317. 904-575-6689.

ITE P-5 w/H-2 head, perfect cond, T Smith, CCI Comm, 192 Lancaster Ave, Frazier PA 19185. 215-289-1725.

RCA TK76 spare parts & assbly, also parts for TK86, TK760, TK761, TK781, TK86. T Smith, CCI Comm, 192 Lancaster Ave, Frazier PA 19355. 215-289-1725.

RCA lenses, TK-76-86-781-760 Fujinon, Schneider 17:1, 20:1, 30:1, 14:1, zoom lenses, BO, T Smith, CCI Comm, 192 Lancaster Ave, Frazier PA 19355. 215-289-1725.

Hitachi SK70 3 tube w/CCU, AC power supply, battery patch w/2 battery, 300' camera cable & shipping case, \$4500. J Workman, Maritz Comm, 600 W Layette Blvd, Detroit MI 48226. 313-963-1200 ext 501.

Hitachi FP40 3 tube saticon w/access, BO or trade, M Glaser, MRG Assoc, 679 Nassau Rd, Uniondale NY 11553. 516-489-1071.

Philips LDH-20 (2) w/CCU's, cable, hand controls, 12:1 Canon lenses, 1" plumb, ITE T10 tripod head & dolly, \$6000 for both. T Smith, CCI Comm, 192 Lancaster Ave, Frazier PA 19185. 215-289-1725.

Want to Buy

Panasonic Recam B-100 system cameras; AK-100, extension board, AC adaptor, batteries & chargers, power supply & any/all access. B Briggs, KCAM, 827 Meridian St, Nashville TN 37207. 615-226-1122.

Sony SVP330 video camera. M Glaser, MRG Assoc, 679 Nassau Rd MS 25A, Uniondale NY 11553. 516-489-1071.

Viewfinder & trinicon tube for Sony DXC1210 camera. C Lunde, Cycle Sound & Video, 167 Madison St, Waterbury CT 06706. 203-756-7751.

Philips LDH1 & LDH20 w/ or w/o tubes, in any cond as long as complete. G Odell, TFG, Box 9, Wethersfield CT 06109. 203-527-2972.

CART MACHINES

Want to Sell

Sparta Sparkomatic, gd cond, \$100/BO. Gates ATC, fair cond, \$125/BO. J Schloss, KICD, 2600 Hiway Blvd, Spencer IA 51301. 712-262-1240.

Spotmaster BE 5300B 3 deck, gd cond, \$1200. M Daley, Daley & Assoc, 311 S Clauster, Tupelo MS 38801. 601-841-1506.

ITC 3D triple stack machine w/rec amp & heads, 3 tones, 1 yr old, \$3400. V White, 4600 E Herndon #244, Clovis CA 93612. 209-298-2373.

Hams R/P, R Sanchez, KUCV, Lincoln NE. 402-486-2520.

ITC Premium stereo play w/SWA elec, BO, B Van Prooyen, WYJR, 1055 28th St SW, Wyoming MI 49509. 616-532-1168.

BE 4300RPS R/P stereo, excel cond, \$895. B Anthony, Anthony Assoc, Rt 3 Box 185, Cornelius OR 97113. 503-357-6120.

ITC RP (2), one excel, one cracked VU & missing case, works, \$850/both. G Sive, Your Video Connection, POB 239, Bonsall CA 92003. 619-729-7662.

Gates Criterion, R/P, stereo, \$500/BO. B Van Prooyen, WYJR, 1055 28th St SW, Wyoming MI 49509. 616-532-1168.

Revox PR99 (2) w/tones, PB only, mint cond, \$850/BO. B Van Prooyen, WYJR, 1055 28th St SW, Wyoming MI 49509. 616-532-1168.

Tepecaster PB, \$200. C Mandel, KAMP, Box 1018, El Centro CA 92244. 619-352-2277.

Tepecaster 700RP (2) 2 tones on ea, gd cond, \$250 ea. S Bush, KTKK, 3595 S 1300 West, Salt Lake City UT 84119. 801-264-8250.

ITC Premium line, new stereo PB elec, new motor, 3 tone, \$2000. J Rosso, WCZE, 869 Church Rd, Elmhurst IL 60126. 312-834-6474.

Gates R/P, works well, \$350. S Angrum, WTMX. 317-545-8100.

Tepecaster 700P (6) well maintained/gd cond, \$200 ea. S Bush, KTKK, 3595 S 1300 West, Salt Lake City UT 84119. 801-264-8250.

ITC ESLY eraser splice locator, \$400. J Rosso, WCZE, 869 Church Rd, Elmhurst IL 60126. 312-834-8474.

RCA mono PB (3) all work, \$200 ea; RCA mono reproduce, gd working cond, \$300. M Dailey, 311 S Gloster, Tupelo MS 38801. 601-841-1506.

BE 200PS w/30 blank cartridges, \$250. S Angrum, WTMX. 317-545-8100.

Spotmaster 400A record/play mono, works, \$95. Spotmaster 405A play only mono, needs pullup solenoid, \$40. Tepecaster 700P (2) mono playback, working, \$60 ea. M Byrnes, WAMU, 4400 Mass Ave NW, Wash DC 20016. 202-885-1030.

Lauderdale Labs Splicemaster MK2 splicing/finder, fair cond, \$75. K Retzer, KGRZ, POB 4106, Missoula MT 59806. 406-728-1450.

BE 3000, excel cond, just off air, play, mono, \$500. P Remaker, WQHS, 3905 Spruce St, Phila PA 19104. 215-898-9553.

Tepecaster 700RP, \$350; Tepecaster 600 RP, \$300; (2) Tepecaster 700P, record, \$225; Tepecaster used start, stop & record buttons, \$1; Spotmaster 500 rackmount RP (2), \$200 ea; Spotmaster 400 RP, \$250. AD Ishkani, 9521 Riggs Rd, Adelphi MD 20783. 301-439-7222.

Spotmaster 5304 stereo 3-spot PB deck, complete w/all three cue tones & manual, spare motor, vgc, \$725. M Byrnes, WAMU, 4400 Mass Ave NW, Wash DC 20016. 202-885-1030.

Tepecaster 700 R/P fair cond, \$250. K Retzer, KGRZ, POB 4106, Missoula MT 59806. 406-728-1450.

Spotmaster 505 mono cart deck, BE cart re-winder. A Bendix, KGWY, POB 1179, Gillette WY 82716. 307-686-2242.

McCarta 510 cart machines (2), BO, L Olsen, Koss Comm, 4824 Fir Ln NW, Gig Harbor WA 98335. 206-858-7312.

ITC RP excel cond, 3 tones, like new, \$2000. H Buttermore, WHYT, 2100 Fisher Bldg, Detroit MI 48202. 313-435-3932.

ITC mono PB (2) w/130 carts, excel cond, BO, J Griffin, Comm Services, 2900 E 6th St #75, Stillwater OK 74074. 405-377-3666.

Spotmaster 500 Series, \$325, Spotmaster 500 Series, \$200. J Emmel, Emke Media, POB 401, Olyphant PA 18447. 717-383-1118.

Scully 270 PB decks (3), \$700 ea. Gates Criterion R/P deck, \$350; Gates Criterion decks (2), \$200. B Harlan, WFAH/WDJQ, 393 Smyth Ave NE, Alliance OH 44601. 216-821-1112.

Ampro CT2500B PB stereo, 3 tone FF (2), \$400 ea. D Stebbins, KELK, 1800 Idaho, Elko NV 89801. 702-738-7118.

Ampro CT3500B R/P stereo, 3 tone FF, \$500. D Stebbins, KELK, 1800 Idaho, Elko NV 89801. 702-738-7118.

Want to Buy

ITC or Criterion, G Miller, PA Network, 260 S Broad, Phila PA 19102. 215-732-7100.

BE 3000 & 2100 cart machines wanted. Exporter needs 90 used machines, working cond, not more than 6 yrs old, reasonable price avail. Send particulars to: RW, POB 1214, Falls Church VA 22041. Attn: Box 1-1.

Rapid Cue, any cond, mono PB, J Breitter, Breitter Assoc, 7 S Monroe St, Monroe MI 48161. 313-242-6600.

WRA record amp for ITC triple decker. J Viekeich, Metro Recdg, 4551 Flag Ave N, Minneapolis MN 55428. 612-537-1431.

ITC triple deck stereo play in working cond, R Lane, KTYD, 5360 Hellister, Santa Barbara CA 93111. 805-967-4511.

RCA RT-27 mono cart decks, or version w/4 decks, will consider other brands. F Vobbe, 706 MacKenzie, Lima OH 45805. 419-224-1335.

CASSETTE & REEL-TO-REEL RECORDERS

Want to Sell

Ampex 601-2, \$185; Ampex AG350, \$2500; Ampex 4 trk, \$1000, 3 trk \$750, or both \$1700; Ampex 2 trk (2), \$725 & \$775 or both \$1400; Ampex 350 FT console cab, \$550; Ampex 8 trk AG350, \$3500. L Oliver, 212-874-0274/7660 (PM).

Scully 10" PB great cond, \$400. M Dailey, 311 S Gloster, Tupelo MS 38801. 601-841-1506.

REVOX
FACTORY AUTHORIZED REPAIR SERVICE
Swiss trained in servicing all A77, D77, A700, PR99, A67, D67, A810 tape recorders. Typical 48-72 hour service. 90 day warranty. Huge parts inventory, factory boxes, new and used machines for sale.
VISA & MASTERCARD ACCEPTED
Call Studio-Sonics for all your audio equipment needs...
STUDIO-SONICS CORP.
1165 Tower Road
Schouburg, IL 60195
(312) 843-7400

Ampex 351 2 trk, \$250. E Luciani, Natl Recdg, 460 W 42nd, NY NY 10036. 212-279-2000.

Sony ACG1 power supply for TCD5 & TCM5000, \$15. P Cibley, Cibley Music, 138 E 38th St, NY NY 10016. 212-986-2219.

Teac 7030SL (2) w/remotes, overhauled, excel cond, \$600 ea or \$1100/both. R Ashmore, S Front Range Bldg, POB 421, Colorado City CO 81019. 303-676-3588 eves.

Tepecaster X700P, (2) just overhauled, excel cond, \$275 ea or both \$500. R Ashmore, S Front Range Bldg, POB 421, Colorado City CO 81019. 303-676-3588 eves.

Magnecord 1021 mono (3), 2 still in use, all working, \$250 ea. M Dailey, 311 S Gloster, Tupelo MS 38801. 601-841-1506.

Nagra III R-R, w/sync-pilot hd, 3-3/4 7-1/2:15 IPS, 5 or 7" reels, excel oper & phys cons, w/manual, \$1100 ea/BO. JG Von Vleck, Vtech, 2844 Beechtree La, Woodbridge VA 22191. 703-221-6984.

Ampex AD-15, \$4500; Concertone CR-90L, \$250; ElectroSound 100-48/200, \$750; Ampex 3200/custom PB, \$500 ea. W Slaten, 424 Grant Ave, Scotch Plains NJ 07076. 201-322-7269.

Ampex AG500 mono, mint, \$499 in case. (4) no case \$300 ea; Logging recorder, Magna Sync TR 720, 24 hrs on 1/2" tape, rack cabinet, time code controller, manual, w/24 reels tape, \$500 plus ship. SA Cislser, 2405 Hermitage Way, Louisville KY 40222. 502-458-7420 alt 11 AM.

Revox PR99 (2) play only w/tone detect. set for automation, \$850 ea. B Van Prooyen, WYJR, 1055 28th St SW, Wyoming MI 49509. 616-532-1168.

Scully 280-B 1" 8 trk w/remote, \$2900. L Fried, West Bank Sound, 1413 Washing Ave S, Minneapolis MN 55454. 612-370-0098.

Revox A-77 decks (4), \$25 ea. SMC Mini-Pro complete for small automation system, \$2000. M Ripley, KOZE, POB 936, Lewiston ID 83501. 208-743-2502.

ITC 750 PB only, R/R, \$500. J Rosso, WCZE, 869 Church Rd, Elmhurst IL 60126. 312-834-6474.

Courrier 720 portable 1/4" deck, \$50. J Schloss, KICD, 2600 Hiway Blvd, Spencer IA 51301. 712-262-1240.

Magnecord 1028-2 stereo, vgc, \$300ea/BO. J Schloss, KICD, 2600 Hiway Blvd, Spencer IA 51301. 712-262-1240.

Crown 700 FT R-R, like new, \$300. K Peckham, WMTV, 615 Forward Dr, Madison WI 53711. 608-274-1515.

3M Series 500, 16 trk 2", 15-30 ips, totally re-built, \$10,000/BO. N Jameson, Jameson Assoc, 1254 Hopkins Terr, Atlanta GA 30324. 404-633-4308.

MCI JH1120B (6) w/cabinets in gd cond, \$2500 ea. M Drayton, WPFV, 700 H St NW, Wash DC 20001. 202-783-3100.

Sony TC-SK tabletop cassette R/P, \$50. K Retzer, KGRZ, POB 4106, Missoula MT 59806. 406-728-1450.

3M M64 2 trk stereo, 15/30 ips, console mounted, excel cond, \$650/BO. Ampex 350-2 2 trk stereo, rack mount, gd cond, \$300. Ampex 351-2 (2), \$350. T Steele, Frankford-Wayne Mastering, 1697 Broadway, NY NY 10019. 212-582-5473.

Magnecord PT-6, w/loptions PT6-AH, amp & record sections PT6-J, PT6-M, R Elm, WWWJC, 1120 E McCuen St, Duluth MN 55808. 218-626-2738.

3M Mincom, one 2 trk & one 2 or 4 trk, old, big, but restorable, call for info. M Wiist, WAUS, Andrews Univ, Berrien Springs MI 49104. 616-471-3400.

Infonics cassette dup equip, (2) systems avail w/open reel masters, 1 w/cassette master, also, 8 slaves ea, call for info. M Wiist, WAUS, Andrews Univ, Berrien Springs MI 49104. 616-471-3400.

Teac 3300S 1/4 trk stereo, rack mounted, vgc, \$150/BO. Ampex 350-2 elect only master & slave, R/P elects for Ampex 350, power supply, gd cond, rack mount, \$400; Technics 676 stereo cassette, rack mount, gd cond, \$75; Akai GX-6300 1/4 trk stereo, \$400. T Steele, Frankford/Wayne Mastering Labs, 1697 Broadway, NY NY 10019. 212-265-5563.

Otari MKII-4 excel cond, 1/2" 4 trk, BO, Nalamichi 550 batt oper, excel cond, BO; Eumig FL-1000 cass deck, excel cond, BO. R Kaufman, Solid Gold Time Machine, POB 29804, Atlanta GA 30359. 404-636-9911.

Otari ARS-1000 10" R-R w/25 Hz detector, 7.5-15 ips, \$800, you ship. R Keraway, WTNJ, Box 1127, Berkeley WV 25802. 304-877-5592.

Ampex 350-2 2 trk stereo, 10.5" reels, rack mount, gd cond, \$275; Ampex 351-2 2 trk stereo, 10.5" reels, Inovonics Tentrail Constant tension controller, rack mount, vgc, \$350; Ampex 375 Vari-speed control unit/oscillator for Vari-speed of 300 or 350/351 series recorders, gd cond, rack mount, \$60. T Steele, Frankford/Wayne Mastering Labs, 1697



Broadcast Equipment Exchange

CASSETTES . . . WTS

MCI JH10 16 trk w/opt 8 trk head stack & rollers, \$6000 or will trade for mixer. G Bishop, Reel Time Recording, 3205 E Bessemer, Greensboro NC 27405. 919-378-1034.

3M M23 4 trk, \$1250; Ampex transports, power supplies, top plates, parts, etc, also Scully parts. J Price, Price's Rcdg Svcs, 2651 Globe Ave, Dallas TX 75228. 214-321-6576.

Dictaphone 5042 4 trk logger, 2 transports, time code unit, audio controller, \$4500. E Turner, British Bdct, 630 5th Ave, NY NY 10111. 212-581-7100.

Teac A3300SX 2 trk 7.5-15 ips, \$400 plus frt. J Shepard, Globe Prod, 539 Westminister Ln, Salem VA 24153. 703-389-1670.

Teac 80-8 w/dbx 8 NR, \$1850. G Bishop, Reel Time Recording, 3205 E Bessemer, Greensboro NC 27405. 919-378-1034.

Telex Magnecord 1022 1/2 trk R-R, owners manual, schematics, recently totally serviced, \$450. S Campbell, Sound Crafters, 105 Cool View Dr, Seneca SC 29678. 803-882-2762.

Tascam Pro Series 70, 1/2" 4 trk w/dbx in Scully roll-around, \$2000/BO. P Dickson, 3011 211th Ave NE, Redmond WA 98052. 206-868-4942.

Ampex 440C 2 trk has 2 new head stacks, excel cond, \$1750. P Dickson, 3011 211th Ave NE, Redmond WA 98052. 206-868-4942.

Otari 7800 1" 8 trk, less than 300 hrs, \$5K/BO. P Dickson, 3011 211th Ave NE, Redmond WA 98052. 206-868-4942.

Tascam 80-8 1981 w/dbx, low hrs. M Baykian, Granny's Kitchen, 4261 Iverness, Orchard Lake MI 48033. 313-626-4075.

Ampex AG600 (2), gd cond, \$300 ea. M McAnally, WEKC, POB 1071, Williamsburg KY 40769. 404-943-3437.

Tascam 38 8 trk R-R, 1 yr old, low hrs, \$1800. R Visel, Super Sound, 6300 Weddington Ct, Mobile AL 36609. 205-660-1400.

Scully 280-8 1" 8 trk, \$3750. C Neilson, West Bank Sound, 1413 Washington Ave S, Minneapolis MN 55454. 612-370-0098.

Ampex PR10, \$100/BO. L Houck, Rollin Recdg, 210 Altgelt, San Antonio TX 78201. 512-736-5483.

Otari MX5050 2 trk, \$1050. S Bogart, Bogart Prods, 9 Twin Lakes Court, Arlington TX 76016. 817-467-0158.

Ampex AG350 2 trk, gd cond, \$600/BO. L Houck, Rollin Recdg, 210 Altgelt, San Antonio TX 78201. 512-736-5483.

Want to Buy

8/16/24 trk recorder, any cond, also mixer 8/16/24 lines out, any cond. J Price, Price Recdg Sld, 2651 Globe, Dallas TX 75228. 214-321-6576.

Teac A-3300SX-2T or similar, units needing repairs will be considered, will also consider Revox A-77, prefer 7.5/3.75 ips versions, pay or trade. F Vobbe, 706 MacKenzie, Lima OH 45805.

RCA RT21 manual or photo copy, also parts & pieces, units working or not. M Salvaggio, MFS Prod Svcs, 417 Lauback St, Hellertown PA 18055. 215-838-9274.

Revox A-77 R-R's, don't mind one that needs repairs. F Vobbe, 706 MacKenzie, Lima OH 45805. 419-224-1335.

Pioneer RT707 1/4 trk reversible. J Vieklich, Metro Recdg, 4551 Flag Ave N, Minneapolis MN 55428. 612-537-1431.

Ampex 3200 custom duplicator. 10 slave 1 master, 8-1 dup system, all solid state, Saki heads, reel time quality copies, call for more info. P Hogan, TM Comm, 1349 Regal Row, Dallas TX 75247. 214-634-8511.

Capstan motor for Tascam 7030SL. C Lunde, Cycle Sound & Video, 167 Madison St, Waterbury CT 06706. 203-756-7751.

CATV-MATV EQUIP.

Want to Sell

Catel FMS cable modulator, like new, \$1000. W Vos, KYJR, POB 79, Wenatchee WA 98801. 509-663-5186.

CONSOLES

Want to Sell

Ampex MX35 (3), \$275 ea; Sigma 4 chan (3), \$100 ea; Altec portable mixers/meter 4 chan/master con 1567A (2), \$275 ea/both \$525. L Oliver, 212-874-0274/7660 (PM).

Ramko 8 chan stereo console, new pots, \$999. B Kramer, WQXO, Box 3176, Longwood FL 32779. 305-682-5463.

RCA BC-7 wired for stereo, gd cond, \$2000/BO. S Streitenberger, WFCB, 45 W Main, Chillicothe OH 45601. 614-773-3000.

Bogan LOM-5 mic mixer, gd cond, \$75/BO/trade. J Schloss, KICD, 2600 Hiway Blvd, Spencer IA 51301. 712-262-1240.

Yamaha PM1000 32 input, \$6000 FOB. J Damien, Sheraton Wash Hotel, 2660 Woodley Rd NW, Wash DC 20008. 202-328-2000 X2693.

Teac 15 16 in 8 out tape remotes, \$3000/BO. D Marcum, Thin Man Prod, 3204 Bruce, Austin TX 78735. 512-892-4433.

Sunn audio control board, 24-chan, like new w/custom Nashville road case, \$1800. S Steele, Platinum Prod, 815 W Hollow Rd, Greenup KY 41144. 606-473-7279.

Gates Yard power supplies & monitor amps (4), two rebuilt & in excel cond w/tubes, \$75 ea plus ship & two need minor work w/o tubes, \$30 ea plus ship. G Heidenfeldt, 2880 Lake Rd, Wilson NY 14172. 716-751-6187.

Harris Micromac 16 ch, 32 input, stereo, 3 mixdown busses, \$3200. D Tarum, KRZ, 2402 E 37th No, Wichita KS 67219. 316-832-9600.

GE BC-1A power supply, gd cond but needs minor work, \$30 plus ship. G Heidenfeldt, 2880 Lake Rd, Wilson NY 14172. 716-751-6187.

BE 55150 5-chan stereo, gd cond, \$1300. S Angrum, WTMX. 317-545-8100.

Gates Yard misc parts, some new, some used, call for details. G Heidenfeldt, 2880 Lake Rd, Wilson NY 14172. 716-751-6187.

LPB 8 chan stereo, gd cond, \$1000; UREI 1/3 octave mono EQ, needs work, \$100. C Ocean, WIZD, POB 1047, Daphne AL 36526. 205-826-9600.

BE 85150 8 chan stereo, 1 yr old, used for prod only, \$2000. V White, 4600 E Herndon #244, Clovis CA 93612. 209-298-2373.

MCI JH416, 16 chan, \$3K/BO. M Fiedler, Mahoney Fiedler Prods, 5346 Dupont Ave S, Minneapolis MN 55419. 612-822-0018.

Collins 212J-1 PA mixer, Gates Studioette mixer, tube type; Howe 7012 stereo 12 chan mixer rotary; Howe 7512 stereo, 12 chan slide; Ampro Microtouch 5 chan stereo mixer. A Bendix, KGWY, POB 1179, Gillette WY 82716. 307-686-2242.

Ramko BC8-M mono, 8 chan, full docs, needs work, \$400 plus ship. P Remaker, WQHF, 3905 Spruce St, Phila PA 19104. 215-898-9553.

Collins, 50's vintage tube type console, \$200. C Raliffe, WADE, POB 1210, Wadesboro NC 28170. 704-694-2175.

Custom recording console, 16 x 16, w/Spectronics components, Orban 111B w/dual reverb, 2 Gates 3-speed TT's & EV Sentry 100, \$1500/all. G Bender, Commercial Features, 3650 Washington, Indianapolis IN 46705. 317-926-5570.

Gates Working 80 w/manual, missing 1 meter, working when removed, \$800. R Lane, KYTD, 5360 Hellister, Santa Barbara CA 93111. 805-967-4511.

Gates M-6540-C Stereo Statesman (in storage), \$950. K Retzer, KGRZ, POB 4106, Missoula MT 59806. 406-728-1450.

Electrodyn 16 in 16 out, 144 patch, full 16 trk monitor, includes 16 trk Scully M-100 R/P 2" machine w/remote, excel cond, \$12K for both. Mr. York, Jewel Recdg, POB 31078, Cincinnati OH 45231. 513-522-9336.

McMartin B502 mint cond, custom snake & breakout box, \$1000. B Mounjoy, Custom AV Svcs, POB G1240, Elizabethton TN 37644. 615-543-5849.

QRK Futura 10S Stereo w/10 pots complete w/back-up console, circuit cards & new pots, BO; Harris Stereo 5, 5 pot, BO. T Low, Foster Comm, 115 W First Ave, San Angelo TX 76903. 911-653-3387.

Gates M-5526 Yard, mono w/pwr supply, gd cond, in service, \$225. D Sparano, WVCR, Rt 9, Louconville NY 12211. 518-783-2990, call & leave message.

BE 8M 200 mono dual buss console, mint cond, Daven step attenuators, \$2500. B Mounjoy, Custom AV Svcs, POB G1240, Elizabethton TN 37644. 615-543-5849.

Collins 212T-1 audio control system, mint cond, w/manual, \$1200. R Sumner, CAVU Corp, 331-1 Contessa Ct, Annandale VA 22003. 703-560-0233.

Tascam M-35 studio console, 8 inputs, talk-back, slate, cue, slate tone, 8 band EQ, separate controls for control room, studio, headphones, ideal for prod room or 8 trk facility, \$1250/BO. Mr. York, Jewel Recdg, POB 31078, Cincinnati OH 45231. 513-522-9336.

McMartin B502 stereo, 5 chan, \$575. J Griffin, Comm Services, 2900 E 6th St #75, Stillwater OK 74074. 405-377-3666.

GE 4BC1A1, BO. B Harlan, WFAH/WDJQ, 393 Smyth Ave NE, Alliance OH 44601. 216-821-1112.

Sparta A-16R rack mountable console, 5 chan, 15 input, 2 chan output, \$850. W Brown, KVNI, Coeur d'Alene ID 208-664-9271.

Harris Medalist 10 w/P&G linear faders, in service, fully operational, \$1750. M Golchert, WVBR, Box 298, Russelville KY 42276. 502-726-3555.

Harris Executive 10 chan w/integrated outboard elec, fully operational when taken out of service 12/86, \$1800/BO. K Gordon, Key Comm, 10622 SW 100th St, Miami FL 33176. 305-271-1671.

Quantum 128, 12 in 8 out w/144 position tiny telephone patch bay, housed in walnut cabinet, vgc, \$4100. B Castner, Castners Ltd, 747 W Maple, Birmingham MI 313-433-3530.

RCA BC18-8, gd cond, \$800. P Nicholson, Hollis Bldg, POB 7008, Columbus GA 31908. 404-322-2220.

Tascam 8 x 4 mixer, \$800. D Weeks, Sharpe Bdct, 515 E Park Dr, Monroe NC 28110. 704-283-7015.

Gates Yard 8 ch mono, \$400 & frt. M McAnally, WEKC, POB 1071, Williamsburg KY 40769. 404-943-3437.

MCI JH618, fully automated, less than 200 hrs, w/#12 phase meter, #no9, #7, #13, #21 options, phantom power, \$19,000. J Simons, EVS Fleetwood Stds, 321 Revere St, Revere MA 02151. 617-289-6305.

Apache 100 mono, gd for news, \$300. K Trimble, Elizabethton Bdct, Box L, Elizabethton KY 42701. 502-769-1400.

RCA BC7A w/7 extra chan, \$500. J Lies, WTRC, POB 699, Elkhart IN 46515. 219-293-5611.

Want to Buy

Gates President, Executive or Diplomat. J Alexander, KARV, Box 190, Russellville AR 72801. 501-968-1184.

DISCO & SOUND EQUIP.

Want to Sell

Masterroom reverbs mdl MR II, MR III, excel cond, \$250 & \$350. J Von Vleck, Vtech, 2833 Beechtree La, Woodbridge VA 22191. 703-221-6984.

BGW 10, mono 2-way electronic crossover, rack mount, EC w/manual, \$150. S Hofmann, Cameron Univ Theatre, 2800 W Gore, Lawton OK 73505. 405-581-2428.

ARP Odyssey keyboard synthesizer, recently removed from service in gd cond, BO or trade. F Vobbe, 706 MacKenzie, Lima OH 45805.

Mobile disco w/Superscope mixer, BSR TTs, 800 W Heathkit amp, custom corner speakers, mirrored ball, black light, pin spots & color wheel, \$1500. J Lipski, Ind Engr, P 1456, Lompoc CA 93438. 805-733-2726.

DX-8 mint, \$500; dbx 155 mint, \$300; Mx digital delay, \$250; Urso Major digital reverb & echo, mint, \$850; Delta Lab DL-2 stereo delay & effects, mint, \$600. D Kocher, 1901 Hanover Ave, Allentown PA 18103. 215-776-1455.

Tapco amp, 260 W, Tapco 4400 reverb, Enter Sound PRV1 reverb, 6' equip rack on rollers, cheap, BO. D Marcum, Thin Man Prod, 3204 Bruce, Austin TX 78735. 512-892-4433.

6-chan snakes, 100' (2), \$150/both. S Steele, Platinum Prod, 815 W Hollow Rd, Greenup KY 41144. 606-473-7279.

Lang PEQ 2 EQ's (2), \$1000 ea. A Polhemus, Excalibur Snd, 750 8th Ave, NY NY 10036. 212-302-9010.

Deltalab 1024 ADM digital delay, \$175. S Steele, Platinum Prod, 815 W Hollow Rd, Greenup KY 41144. 606-473-7279.

dbx 150 NR unit, rack mounted, \$100. S Steele, Platinum Prod, 815 W Hollow Rd, Greenup KY 41144. 606-473-7279.

EMT 140 plate reverb system, solid-state w/on-board mdl 262 amps, w/manual, excel cond, \$1750/BO. JG Von Vleck, Vtech, 2844 Beechtree La, Woodbridge VA 22191. 703-221-6984.

Pultec EQP1A, \$2250. L Oliver, 212-874-0274/7660 (PM).

Quantec room simulator, like new, \$8000. N Jameson, Jameson Assoc, 1254 Hopkins Terr, Atlanta GA 30324. 404-633-4308.

Lexicon M93 Prime Time digital delay, \$350/BO. M Fiedler, Mahoney Fiedler Prods, 5346 Dupont Ave S, Minneapolis MN 55419. 612-822-0018.

EMT 140 stereo tube plate, \$3000/BO. N Jameson, Jameson Assoc, 1254 Hopkins Terr, Atlanta GA 30324. 404-633-4308.

AKG BX20E reverb, mint cond plus second unit for parts, \$990 firm. K Heyne, German Masterworks, 1301 45 Ave, San Fran CA 94122. 415-664-0163.

JBL N1200 crossovers, 1200 Hz, vgc (4), \$30 ea. T Steele, Frankford/Wayne Mastering Labs, 1697 Broadway, NY NY 10019. 212-265-5563.

EMT 240 plate reverb system, 0.7-5 sec delay w/ch board model 262 amps, mint cond, w/manual, \$1850/BO. J VonVleck, V-Tech, 2844 Beechtree Ln, Woodbridge VA 22191. 703-221-6984.

EV Sentry II's, \$400/pr. W Preist, Classic Sound & Recd, 1249 Bayshore Blvd, Dunedin FL 33528. 813-736-4474.

Soundcraftsman 20-12-600 stereo full octave graphic EQ's, 600 ohm output, vgc, rack mountable (3), \$65 ea; dbx 187 4-chan R/P type 1 prof NR unit, rack mount, vgc, \$350/BO; Dolby A301 stereo type A NR unit, switchable R or PB, rack mount, vgc (2), \$280 ea; Dolby A301 stereo type A NR unit w/au-to R/P changeover unit, latest mods, rack mount, vgc, \$350. T Steele, Frankford/Wayne Mastering Labs, 1697 Broadway, NY NY 10019. 212-265-5563.

Quantum QM12P mixer; MicMix Super C, BO. L Olsen, Koss Comm, 4824 Fir Ln NW, Gig Harbor WA 98335. 206-858-7312.

MXR pitch & digital display transposer, like new, \$550. J Price, Price's Rcdg Svcs, 2651 Globe Ave, Dallas TX 75228. 214-321-6576.

Master Room reverb units (2), one MR II, \$225 & one MR III, \$325. J VonVleck, V-Tech, 2844 Beechtree Ln, Woodbridge VA 22191. 703-221-6984.

Orban 245F stereo synthesizer (2), new, \$340 ea. B Salzman, Stevens Comm, 2600 Lupino St, Unit F-5, Vail CO 81657. 303-476-6786 alt 6 PM MT.

Travel rack case w/angled top & space below, 30 space, flash hardware, \$250. M Baykian, Granny's Kitchen, 4261 Iverness, Orchard Lake MI 48033. 313-626-4075.

Audio gear inc: Eventide 1745A, 2830; Urso Major 323, SST282; Yamaha R1000; UREI 920-16, 964; Urso Major 8X32; Lexicon 224, 1200B; Roland RE201; Lexicon 93, 95, 1025; Eventide PA101A, FL201A, 910-06; Countryman 968; dbx 216; EMT 251, call for details & prices. R Burton, Audio Rents Inc, 7237 Santa Monica Blvd, LA CA. 213-874-1000.

Distributor Directory

The following distributors serving the broadcast industry would be glad to help you with any of your requirements.

HY JAMES
The audio professionals
Aphex
Broadcast Electronics
dbx
Eventide
Gentner JBL
Nakamichi Pro Orban
Otari
Straight Wire Audio
Tascam UREI
And a whole lot more!
Call Paul Grzeblak:
313/471-0027
in Michigan: 800/482-2291
24166 Haggerty Road
Farmington Hills, MI 48024

One Source the best prices
CALL:
SPENCER BROADCAST
1-800-221-6941
P O Box 26899 • Phoenix Arizona 85068

CeCo
communications, inc
A Richardson Company
Contact the #1 distributor of broadcast tubes & components and get the best price available on:
• RCA • AMPEREX • GE
• RAYTHEON • SYLVANIA
• EIMAC • NATIONAL
Anthony Ianna
Broadcast Sales Representative
800-221-0860
718-646-6300

Call for availabilities. Phone 800-336-3045

SANGAMO-ACUSHNET MICA CAPACITORS
PLASTIC CORP.—NON-PCB OIL FILLED CAPACITORS
RF-ANTENNA AMMETERS
RCA-RAYTHEON-AEL TRANSMITTER PARTS
TRANSFORMERS & CHOKES 250 WATT THRU 50 KW
COMMERCIAL RADIO COMPANY
BOX 43, CAVENDISH VT 05142
802-226-7582

CORNELL-DUBILIER MICA CAPACITORS
FROM STOCK
JENNINGS VACUUM CAPACITORS
FROM STOCK
JENNINGS VACUUM RELAYS
SURCOM ASSOCIATES
305 Wisconsin Avenue
Oceanside, California 92054
(619) 722-6162

STAR SYSTEMS
Audio Solutions
Otari, Tascam ATR, Nakamichi Pro, JBL/UREI, dbx 700, Valley People, Studer/Revox, Fidelipac And much much more!
Call for a current quote
(617) 794-9399
462 Merrimack Street
Methuen, MA 01844

SUPERIOR LINES SUPER PRICES
ADC • Andrew • Audio Technica • Audio Cable • AudioPak • Belar • Beyer • Cable-wave • Canare • Clear-Com • Crown • Electro-Voice • Farrtronics Fidelipac • Gentner RF • Henry • JBL • Jampro • Leader • Luxo • Moseley • Stantron • TFT • Tascam • Telex • UREI
!!!! AND MORE !!!!
CALL 800-531-5143 NATIONAL BROADCAST SYSTEMS
2113 Wells Branch, Bldg. 6-100 Austin, TX 78728

KINTRONIC LABS
YOUR SOURCE FOR ALL:
□ AM / MF Directional Antenna Systems and Components
□ Antenna Tuning Units
□ AM / MF Dummy Loads
□ RF Power Attenuator
□ Broadband Baluns
□ Isocouplers
□ Fixed & Variable Inductors
□ Thermocouple Ammeters
□ Sangamo Capacitors
□ RF Contactors
□ AM / FM Combiners, Filters
P.O. BOX 645
BRISTOL, TENN 37621 USA
PHONE: 615-878-3141
TLX: 557416

THE SOURCE
CALL US FOR ALL YOUR EQUIPMENT NEEDS
Toll free: 800-223-8202
In Florida: 305-651-5752
ELECTREX COMPANY

CART'EM UP ON AUDIOPAK AA-4
Call for best price Sales—Service
Broadcast Cartridge Service
(714)898-7224

Can't Find It? Call 1-800-426-8434 For Immediate Action! Want To Sell It?



Broadcast Equipment Exchange

DISCO . . . WTS

EMT 140-T plate reverb, mono, \$1500. D Flynn, Continental Recds, 102 South St, Boston MA 02111. 617-426-3131.

Want to Buy

Klark Teknik DM360, any outdoor equip. J Price, Price Recdg Std, 2651 Globe, Dallas TX 75228. 214-321-6576.

Lyrec timer or other 1/4" tape timer, 7.5 or 15 ips OK. A Tucker, Foothill Prod, 70 W 83rd St, NY NY 10024. 212-877-0973.

LIMITERS

Want to Sell

Valley People rack w/(3) Gain Brains II, (1) Maxi Q parametric, mint, \$1000. D Kocher, 1901 Hanover Ave, Allentown PA 18103. 215-776-1455.

Collins 26U-2 comp-lim, excel cond, \$300/BO/trade. J Schloss, KICD, 2600 Highway Blvd, Spencer IA 51301. 712-262-1240.

VERY TWEAKABLE

You call the shots with this 3-band stereo-FM processor. A wide range of user controls lets you burn a hole in the dial or back it off to totally mellow. Many unusual features - call for blurp.

Inovonics
(408) 458-0552

CBS 4000A AM Volumax, \$200. R Lane, Mtn Prod, POB 460294, Aurora CO 80015. 303-699-7482.

Orban Optimod 9000A, \$2500/BO. R Fritsch, KOOK, POB 6340, Tyler TX 75711. 214-593-2519.

Dorrough 310 (3), \$900 ea. T Pless, PCA Comm Corp, Dundalk Prof Bldg #407, Baltimore MD 21222. 301-522-6710.

CRL SMC600A stereo/limiter w/manual, \$200; Shure MG2V Levelock, new w/manual, \$75. B Spitzer, KKLS, POB 460, Rapid City SD 57701. 605-343-6161.

CBS 411 FM Volumax tested, fully operational, excel cond, w/manual, \$300 plus ship. G Heidenfeldt, 2880 Lake Rd, Wilson NY 14172. 716-751-6187.

EMT PDM 156 limiter, compressor, expander, \$2500. E Sanders, 7th St Snd, 688 S Santa Fe #105, LA CA 90021. 213-627-5392.

UREI LA-4 compressor/limiter, gd cond, \$450. S Angram, WTMX, 317-545-8100.

Gates dual limiters, \$150 ea. B Van Prooyen, WYJR, 1055 28th St SW, Wyoming WI 49509. 616-532-1168.

EASY NRSC

A "post-processor" for REAL AM improvement! Simply connect it between your existing limiter and the transmitter for "protected" pre-emphasis and overshoot-controlled lowpass filtering to NRSC specs.

Inovonics
SANTA CRUZ, CA (408) 458-0552

Inovonics MAP II, mint cond, \$650. B Kramer, WQXO, Box 3176, Longwood FL 32779. 305-682-5463.

CBS Audiomax limiter, works fine, \$200; CBS 4450A stereo Audiomax, works fine, \$400. M Dailey, 311 S Gloster, Tupelo MS 38801. 601-841-1506.

Altec 438A/436C compressor line amps, (2) 438A, (1) 436C, mike in, \$125 ea. W Staten, 424 Grant Ave, Scotch Plains NJ 07076. 201-322-7269.

Dorrough 610 digital tri-band processor, \$2100/BO. A Soroka, WJRO, POB 159, Glen Burnie MD 21061. 301-761-9220.

RCA BA6A tube limiter, \$500. N Jameson, Jameson Assoc, 1254 Hopkins Terr, Atlanta GA 30324. 404-633-4308.

CBS 445 stereophonic level controller, Collins Level Devil; (2) Harris Solid Statesman AGG units; (2) Harris Solid Statesman limiters. A Bendix, KGWY, POB 1179, Gillette WY 82716. 307-686-2242.

Optimod 9100 stereo, in service, 2 yrs old, works fine, \$5000. Eng Dept, POB 3131, Modesto CA 95353. 209-523-7756.

Fairchild Conax 600 mono, \$275; Gates Stay-Well M5167, \$250. L Oliver, 212-874-0274/7660 (PM).

Audiomax 2RZ AGC, \$150. B Van Prooyen, WYJR, 1055 28th St SW, Wyoming WI 49509. 616-532-1168.

Inovonics MAPII, \$500. W Vos, KYJR, POB 79, Wenatchee WA 98801. 509-663-5186.

CBS Labs 400 stereo Volumax limiter amp, latest mods, gd cond, (2), \$250 ea; Neumann HK-66 dual chan high freq only limiter w/PS, rack mounted, perf for disk cutting or FM bdct, vgc, \$290. T Steele, Frankford/Wayne Mastering Labs, 1697 Broadway, NY NY 10019. 212-265-5563.

Gates M6629 Solid Statesman AGC (3), \$100 ea plus ship. J Shepard, Globe Prod, 539 Westminister Ln, Salem VA 24153. 703-389-1670.

CBS Labs 410 FM Volumax & 444 FM Audiomax w/manuals, \$125 ea or \$225 for both, you ship. R Kerbaway, WTNJ, Box 1127, Beckley WV 25802. 304-877-5592.

UREI LA3A (2), excel cond, BO. R Kaufman, Solid Gold Time Machine, POB 29804, Atlanta GA 30359. 404-636-9911.

Gates Solid Statesman AGC, mono, \$150; CBS Volumax 410 FM limiter, mono, \$200. R Dietterich, WAMO, 411 7th Ave, Pittsburgh PA 15219. 412-471-2181.

CBS Model 444 Audiomax III, gd cond, \$125. R Sumner, CAVU Corp, 3351 Contessa Ct, Annandale VA 22003. 703-560-0233.

Want to Buy

Audiomax CBS 4450, stereo. D Proctor, WCPE, POB 828, Wake Forest NC 27587. 919-556-5178.

RCA BA45 & BA43 manual for both units. M Salvaggio, MFS Prod Svcs, 417 Lauback St, Hellertown PA 18055. 215-838-9274.

GIVE IT A CALL

This stereo processor can be pre-programmed with 5 different presets to "call up" for format changes, etc. Unit has slow-AGC, 5-band compressor, and either an AM or FM peak limiter. Computer/modem control option available.

Inovonics
(408) 458-0552

Orban Optimod AM mono, must be bargain. A Caswell, C&G Bldg, POB 171, Linden MI 48451. 313-735-4545.

MICROPHONES

Want to Sell

Neumann U47 power supply & stand, \$3250. L Oliver, 212-874-0274/7660 (PM).

E-V CO90 (5) lavaliers, BO. C Springer, KLMR, POB 890, Lamar CO 81052. 303-336-2206.

Senn Binaural mic. R Sanchez, KUCV, Lincoln NE. 402-486-2520.

RCA 77-DX (3) in superb cond, restored to excel orig cond both cosmetically & in performance, \$375 ea plus ship. P Talerico, WWAX, POB 750, Olyphant PA 18447. 717-489-1370.

Altec (WE) lip stick condensers (3) w/cable & holder & amp, \$150 ea. SA Cisler, 2405 Hermitage Way, Louisville KY 40222. 502-458-7420 alt 11 AM.

Altec 21B Coke Bottle tube mic w/elect complete, gd cond, not working, \$150. N Carlson, Mobile Snd Group, 721 W Melrose, Chicago IL 60657. 312-871-7459.

Neumann U67 w/PS, new tube & capsule, immaculate, \$1500. N Jameson, Jameson Assoc, 1254 Hopkins Terr, Atlanta GA 30324. 404-633-4308.

AKG C414EB, \$450. P Cibley, Cibley Music, 138 E 38th St, NY NY 10016. 212-986-2219.

E-V 635 w/stand clamp, gd cond, \$50. S Hofmann, Cameron Univ Theatre, 2800 W Gore, Lawton OK 73505. 405-581-2428.

Sennheiser binaural rec system, new, BO. R Sanchez, Lincoln Fine Arts Radio, 3800 S 48th St, Lincoln NE 68506. 402-486-2520.

Turner 4500 mobile (2) never used, \$40 ea. M Dailey, 311 S Gloster, Tupelo MS 38801. 601-841-1506.

RCA 44DX collectors item, \$200. D Gurdy, Sound Concepts, 1113 Jackson St, Alexandria LA 71301. 318-473-4170.

Audio-Technica ATM41 new, white finish, uni-directional w/20" cable & connectors, \$165. CJ Pringle, Trinity Entrp, Box 831, Webster City IA 50595. 515-832-1263.

Sennheiser binaural rec system, new, BO. R Sanchez, Lincoln Fine Arts Radio, 3800 S 48th St, Lincoln NE 68506. 402-426-2520

HME 252 wireless mic xmtr (3), sell or trade for HME rcvr; (2) Com-Tek MR72 rcvrs, one M72 xmtr, BO; Vega AV72 rcvr, Vega AV71 xmtr, \$595; Telex WT200 xmtr, Telex WT50 xmtr, BO; TOA WT402-311U rcvr, (2) handheld WM140-2 xmtr, BO. J Price, Price's Recdg Svcs, 2651 Globe Ave, Dallas TX 75228. 214-321-6576.

Want to Buy

Bdct mics w/stand call letters or network insignia, does not have to be in working cond. N Carlson, Mobile Snd Group, 721 W Melrose, Chicago IL 60657. 312-871-7459.

Sennheiser MZA-16-P48U shotgun, plus MKH816-P48U. G Warren, Warren Tech Svcs, 3715 N Lakewood, Chicago IL 60613. 312-327-4785.

RCA 77D mic, gd cond, please call. B Landrum, Allison Gas Turbine/GM, Indianapolis IN. 317-242-7559.

RCA 88A, working or not, need chassis parts. B Robinson, WTKO, POB 2988, Meridian MS 39302. 601-693-1441.

Shure SM5B mic or RE-20 in gd cond, reasonable. J Emmel, Emke Media, POB 401, Olyphant PA 16447. 717-383-1118.

Sennheiser MD421, 2 ea wanted. G Stafford, Capital Magnetics, 1030 E Hruard Rd, Burbank CA 91501. 818-843-7987.

MISCELLANEOUS

Want to Sell

Extel AL weather reporter w/stand, Nat'l WX Svc over phone-lines, \$1200. B Surratt, Charlottesville Bdct Corp, 501 E Main, Charlottesville VA 22901. 804-977-3030.

Equip cabinet, 22" x 24" x 83" w/19" rack, rails in front & rear, complete w/rear door, \$100. R Elm, WWJC, 1120 E McCuen, Duluth MN 55808. 218-626-2585.

Elgin ERC-1952-2 telco answering unit, for PD listen line or for use w/cart machine PB, BO or trade. F Vobbe, 706 MacKenzie, Lima OH 45805.

Amertran 5 VAC CT transformer, 12 kV test, single phase, 230 VAC primary, \$25 ea. R Elm, WWJC, 1120 E McCuen, Duluth MN 55808. 218-626-2585.

EF Johnson 50 W xmtr sockets, all gd cond, \$2 ea. R Elm, WWJC, 1120 E McCuen, Duluth MN 55808. 218-626-2585.

RCA transformers used to power filament to 892R xmt tubes, \$75. R Elm, WWJC, 1120 E McCuen, Duluth MN 55808. 218-626-2585.

Metroltel MT-911G telco repairman's handset, tone or pulse, new, \$150. B Spitzer, KKLS, POB 460, Rapid City SD 57701. 605-343-6161.

Tape-A-Thon Librarian background music player, w/(2) 10.5" decks, intersperser & 40 W line/monitor amp. R Wiles, 9421 Ballentine, Overland Park KS 66214. 913-541-9674.

Ampex 9500, heavy duty bulk tape eraser, handles up to 2" video, \$100 ea (2); Plastic 16mm film shipping cases in colors, \$1 for 12" or \$75 for 10" in lots of 10; Antique rare WE 3 stage audio, circa 1922, one tube, excel, \$200. SA Cisler, 2405 Hermitage Way, Louisville KY 40222. 502-458-7420 alt 11 AM.

Rainbow equip case. R Sanchez, KUCV, Lincoln NE. 402-486-2520.

Otari 5050B MR5A021 capstan motor, w/PC board, rebuilt by Otari, \$125; Ampex 440 No. 020274-01 4 trk power supply, BO. R Rhodes, Rhodes Music, Box 1550 Radio City Sta, NY NY 10101. 212-245-5045.

Star, misc sizes of Star equip/shipping cases. BO. J Johnson, Interand Corp, 3200 W Peterson, Chicago IL 60659. 312-478-1700.

Rainbow case 2'9" x 2' x 2' insert rack mount incl, \$300/BO. R Sanchez, Lincoln Fine Arts Radio, 3800 S 48th St, Lincoln NE 68506. 402-428-2520.

Recortec tape evaluators, 1", 2" & 3/4", several of ea. H Casteel, Technichrome, 701 Desert Ln Ste 4, Las Vegas NV 89106. 702-386-2844.

Soundolier 300-61 relay racks, (2), white, \$175 ea. K Rietzer, KGRZ, POB 4106, Missoula MT 59806. 406-728-1450.

Standard Electric 60S 60-min elec timers w/mech & elect reset (2), \$30 ea; Lyrec TIM-4 high speed rewind or fast forward tape timers for Ampex or Scully recorders, gd cond (2), \$50 ea; API 361 3.5" VU meters (4), \$30 ea. T Steele, Frankford/Wayne Mastering Labs, 1697 Broadway, NY NY 10019. 212-265-5563.

Bird 3128 Wattcher RF power monitor (2), up to 10 kW, 450 kHz to 2300 MHz, mint cond w/manual, \$350 ea. R Sumner, CAVU Corp, 3351 Contessa Ct, Annandale VA 22003. 703-560-0233

CBS network alert receiver, \$450. B Mountjoy, Custom A/V Svcs, POB G1240, Elizabethton TN 37644. 615-543-5849.

Sonex 3" natural blue, 96 sq ft per box, 6 shts, each 4 ft sq, 3 boxes, BO. G Vanderwerf, Record-A-Song, 746 W Roanoke Cir, Murray UT 84123. 801-265-9501.

Sola Model 28-2128-1 constant voltage DC power supply, 28 VDC output at 15 A, vgc, \$45. M Byrnes, WAMU, 4400 Mass Ave NW, Wash DC 20016. 202-885-1030.

Quick-Set QHT-1 Hercules tripods, w/QHD-1 dolly, no heads, 150 lb cap, \$250 ea. R Sumner, CAVU Corp, 3351 Contessa Ct, Annandale VA 22003. 703-560-0233.

Teletype ASR 33 w/tape reader, \$75; Centronic 588 parallel dot matrix printer w/serial interface, \$100; Hitachi FM-T44 AM/FM tuner, \$150; Cobra telephone answering machine, \$50; Square-D 3 phase dbl pole 100 A safety switch, \$150; HSC-1 video hum stop coil, \$75; Heathkit HD-10 dist anal., \$10; Radio Shack 64K color computer & 40 col. printer, \$150. R Kerbaway, WTNJ, Box 1127, Beckley WV 25802. 304-877-5592.

Want to Buy

Vacuum caps for Raytheon RA 1000, GE VC-100-10, 100 pF at 10 kW. B Dodge, WTIJ, POB 1818, Brattleboro VT 05301. 802-254-2560.

Gates BC1T 1240 kHz crystals, need ASAP & Gates 9131850002. C Ewing, WGRM, POB 555, Greenwood MS 38930. 601-453-1240.

Elect wanted, shortwave/hi-fi/radio, tubes, parts, etc. M Disch, 427 W Capital Dr, Hartland WI 53029. 414-367-5719.

MONITORS

Want to Sell

McMartin 2000B, gd cond, (3), \$500 ea, McMartin TBM-3000 gd cond, \$100. M Dailey, 311 S Gloster, Tupelo MS 38801. 601-841-1506.

McMartin TBM4500A FM, stereo mod mon, recently taken out of svcs, needs calib, tuned 102.5 MHz, \$500/BO. D Woodcock, WNWV, 5606 Medical Circle, Madison WI 53719. 608-271-1025.

Consultants

BROADCAST TECHNIQUES

Applications & FIELD ENGINEERING SERVICES

P.O. Box 26899
Phoenix, AZ. 85068
602-242-2211

R.L. HOOVER
Consulting Telecommunications Engineer

11704 Seven Locks Road
Potomac MD 20854
301-983-0054

Member AFCCCE

TOWER DESIGN AND FABRICATION, INC.

TOWERS, ANTENNAS, STRUCTURES
New Tall Towers, Existing Towers
Studies, Analysis, Design Modification,
Inspections, Erection, Etc

Rt. 1, Box 33AA
Sturgeon, MO 65284
(314) 687-3932

Robert M. Lund
Broadcast Consultants
Auburn, Massachusetts

Applications -
Field Engineering

617 832-2611

W. LEE SIMMONS & ASSOC., INC.

BROADCAST TELECOMMUNICATIONS CONSULTANTS

14 Archer Road
Hilton Head Is., SC 29928
(803) 785-4445

Moffett, Larson & Johnson, Inc.
Consulting Telecommunications Engineers

1925 North Lynn Street
Arlington, VA 22209
(703) 841-0500
800-523-3117

Member AFCCCE

R.J. GRANDMAISON, P.E.
CONSULTING ENGINEER
Applications and Rulemakings

11213 Split Rail Lane
Fairfax Station, VA 22039
(703) 764-0513
Member AFCCCE

EVANS ASSOCIATES
Consulting Communications Engineers

FCC Applications, Design & Field Engineering
Broadcast Engineering Software

216 N. Green Bay Rd.
Thiensville, WI 53092
(414) 242-6000

Member AFCCCE

MIRKWOOD ENGINEERING

Rural & Remote Site
Field Engineering

50 Park Ave.
Claremont, NH 03743
603/542-9634

Contact
Radio World
Newspaper
P.O. Box 1214,
Falls Church VA 22041
for availabilities.
Phone
800-336-3045

Employment

To place ads in this section, use the Action-Gram form. To respond to box numbers, write Radio World, Box 1214, Falls Church VA 22041, Attn: ____.

POSITIONS WANTED

Former CE has motor home, will travel to your location for vacation relief, construction completion, field strength surveys, etc. B Fargo, POB 24946, Denver CO 80224-0946.

Dedicated, hard working, 10 yrs in P3, MD, OM, PD exp, degree, refs, super prod, AOR, AC, CHR, want to move up. J Turley, KDXR, Box 1478, Borger TX 79007. 806-273-7576.

CE seeks work, eng 2 college stations, NBN, HBO MDS CE NYC, CET, FCC licensed & certified, NABER, NARTE & ISJET member. M Rakoff, 114-41 Queens Blvd Ste 148, Forest Hills NY 11375. 718-591-0002.

Desire position maintaining mostly xmtrs. V or U, microwave & translators, well exper, prefer West. Paul, 916-674-3532.

Good Radio CE seeks gd people to work for, NC or SC, exp w/installations, gd audio, dependable. Write: RW, POB 1214, Falls Church VA 22041. Attn: Box 7-1.

Eng, 7 yrs AM/FM, certified, West Coast only. Write to: Radio World, POB 1214, Falls Church VA 22041. Attn: Box 6-1.

Disc Jockey, exper, 30's-60's music, will furnish. Amanda Schauberg, 2003 Aldrich Ave S, #304, Minneapolis MN 55405. 612-872-9376.

Tech oriented person seeks bdct engr position, ISJET, CET, Genl Amateur License, HBO MDS exper, NBN CE, exper studio repair & maint. M Rakoff, 114-41 Queens Blvd Ste 148, Forest Hills NY 11375. 718-591-0002.

Radio CE, FCC genrl, former CE in Boston, Houston, Miami, Ft Lauderdale, non-drinker, non-smoker. M Gottesman, 3377 Solano Ave #312, Napa CA 94558. 619-352-5688.

Corp CE, hard working, self-starter, wanting FT position w/single or group owner stations, 10 yrs hands-on exper in AM/FM, for KS, CO, MO, NE, OK, TX, IA, IL, avail immed. L Timmons, RR 2 Box 41, Stockton KS 67669. 913-425-6509.

Hard working, dedicated exp (18 yrs) morning man/news/prod/admin, married, stable, avail, gd voice, warm climates, medium/larger markets. L Kay, 203 Harvestview N, Mount Joy PA 17552. 717-653-2500.

Chief position, 30 yrs in radio-TV bdct maint, prefer West. Rick, 916-674-3532.

Seeking asst or CE position in central US, major market asst & CE exper, FM/AM/DA, studio/TX repair & maint exp. TS, N143 W6175 Pioneer Rd, Cedarburg WI 53012.

HELP WANTED

Assistant CE, minimum 5 yrs radio maintenance exper, studio & xmtr. FCC general & SBE certification preferred. Send resume, salary requirements. EOE. WHBC, POB 9917, Canton OH 44711.

Chief Engineer, good-sized market, in North-west, gd maintenance skills required w/studio, directional AM stereo, Class C FM, E.O.E. Send resume to: Radio World, POB 1214, Falls Church VA 22041. Attn: Box 5-1.

Can't Find It?

Call 1-800-426-8434 For Immediate Action!

Want To Sell It?



Broadcast Equipment Exchange

MONITORS . . . WTS

Belar RFA-1 FM RF amp, excel cond, \$350/BO. B Mishkind, KFX, 3222 S Richey Ave, Tucson AZ 85713. 602-296-3797.

H-P 335B FM monitor, tuned to 99.9 MHz, w/manual & all tubes, \$75 plus ship. G Heidenfeldt, 2880 Lake Rd, Wilson NY 14172. 716-751-6187.

G-R Type II AM, freq monitor, 1010 kHz, w/manual & all tubes, \$30 plus ship. G Heidenfeldt, 2880 Lake Rd, Wilson NY 14172. 716-751-6187.

McMartin TBM 4500A FM stereo monitor, vgc, \$300. K Peckham, WMTV, 615 Forward Dr, Madison WI 53711. 608-274-1515.

RCA BW66E AM mod mon, \$150 plus frt. S Bartkowski, WEDC, 4923 W 28th, Cicero IL 60650. 312-863-3090.

Nems-Clarke 1671 FM monitor, 50-260 MHz, \$125. M Disch, 427 W Capital Dr, Hartland WI 53029. 414-367-5719.

Want to Buy

GTA 6741 Gates SCA monitor. B Van Prooyen, WYJR, 1055 28th St SW, Wyoming MI 49509. 616-532-1168.

Gates GTA6741, SCA monitor; also Gates FM RF amp, GTM 88R. B Van Prooyen, 2111 Shangri-la Dr SE, Grand Rapids MI 49508. 616-243-2026.

Gates GTM 88F FM freq monitors. B Van Prooyen, 2111 Shangri-la Dr SE, Grand Rapids MI 49508. 616-243-2026.

MOVIE PROD. EQUIP.

Want to Sell

Auricon Pro 600 16mm film w/Angenieux 1:10 zoom lens, portable case, mint, \$750. SA Cister, 2405 Hermitage Way, Louisville KY 40222. 502-458-7420 aft 11 AM.

Beaulieu R16 camera w/Ang 12-120 zoom lens, 4 gang, synch, rewinds, snd readers, viewers, B&H 816 hot splicer, B&H 202 optical magprojector, w/sync motor, B&H 385 projector, recd gamps, light meter, reels, other misc access & equip, Polecat lighting mounts, BO. B Howard, Academy Film Prod, 3918 W Estes Ave, Lincolnwood IL 60645. 312-674-2122.

Want to Buy

Auricon EIF-20 Finder #. automatic parallax viewfinder for Auricon 16mm pro camera. H Deans, Deans Prods, 170 Gran St, White Plains NY 10601. 914-949-5920 aft 6 PM EST.

RECEIVERS & TRANSCEIVERS

Want to Sell

Realistic DX-160 w/speaker, rack mounted, w/mods for audio demod & IF carrier, 150 kHz to 30 MHz. BO or trade. F Vobbe, 706 MacKenzie, Lima OH 45805.

Halicrafter 115 receiver, 32A xmtr in spotless cond, BO. G Popdavid, WHBC, 1255 Shadyside, Canton OH 44710. 216-452-2710.

Kenwood KR6170 stereo amp/receiver, \$100. C Mandel, KAMP, Box 1018, El Centro CA 92244. 619-352-2277.

Cushman CE-3 FM comm monitor w/#301 scope, 305B, 360D, 304B, fused pad & misc cable, \$1000. Patty, Gabriel Engr, 833 W Main, Mesa AZ 85201. 602-969-8663.

Want to Buy

VHF 161 MHz RPU downconverter to FM band, desire receive RPU freqs on FM rcvr, proven RF converter designs, RF converter component kits or assembled. R Malone, WCRN, Box 6336, E Rochester NH 03867. 603-335-2005.

REMOTE & MICROWAVE EQUIP.

Want to Sell

Moseley PCL505C composite STL, excel cond, \$4000. B Mishkind, KFX, 3222 S Richey Ave, Tucson AZ 85713. 602-296-3797.

Antenna Specialist 7 element yagi, set for 450.650 MHz, BO or trade. F Vobbe, 706 MacKenzie, Lima OH 45805.

GEC microwave rcvrs & xmtrs, C-band. H Casteel, Technichrome, 701 Desert Ln Ste 4, Las Vegas NV 89106. 702-386-2844.

Moseley PCL 505C STL, 951 MHz transfer panel, like new w/factory update, BO. S Calahan, WFTI, 1120 Pinellas Bay Way #103, Tierra Verde FL 33715. 813-866-2478.

Moseley PCL505C w/latest Moseley updates on 947.5 MHz, \$5000. E Stoltz, KWOD, 777 Campus Commons Dr, Sacramento CA 95825. 916-929-5000.

McMartin 2000B SCA mon (3), \$500 ea; Moseley SCG4T SCA mon, \$500; McMartin SCA gen, \$750. M Daily, Daily Assoc, 311 S Gloucester, Topelo MS 38801. 601-841-1506.

Sitex CR 1011 color radar, complete, all cabling, BO. D Haworth, KFGO, 1020 S 25th, Fargo ND 58108. 701-237-5346.

Marti RMC 2AXT RC stepping relay coil, brand new, \$48 ea. C Smith, KREK, POB 1280, Bristow OK 74010. 918-367-5501.

Moseley PCL101 trans-rec, factory aligned as brand new, never used, \$3000. M Bradford, WKHM, 1873 Crouch Rd, Jackson MI 49201. 517-278-7339.

Western Paging AO3JVC2468A pager w/charging stand, freq 152.240 MHz, BO. T Low, Foster Comm, 115 W First Ave, San Angelo TX 76903. 915-653-3387.

Gates xmtr remote control terminal. A Bendix, KGWY, POB 1179, Gillette WY 82716. 307-686-2242.

LAUX analog audio terminal, BO; LAUX analog audio terminal w/dynamic NR, BO; Microwave Assoc 1808300-2 VR-3X satellite rcvr, BO. T Low, Foster Communications, 115 W First, San Angelo TX 76903. 915-653-3387.

Want to Buy

Marti RMC 2AX RC for parts or rebuild. C Smith, KREK, POB 1280, Bristow OK 74010. 918-367-5501.

Moseley TRC15 in gd cond, w/manuals pref, negotiable. F Kavenik, WLMV, Box 187, Vernon Hill IL 60061. 312-680-7557.

STATIONS

Want to Sell

Radio station, 1 kW, 1170 AM, near major market, operation at one location, real estate, \$75,000 down pmt. A Crain, Box 157, Collierville TN 38017. 601-895-6483.

Oklahoma Class A, single station market, beautiful town, new equip, new bldg, valuable real estate, low down to qualifier, long term payoff, retiring, \$199,000. G Erway, KBOG, Rte 2 Box 26B, Cordell OK 73632. 405-832-5332/5432 aft 5 PM.

Class A FM, Cordell OK 73632, beautiful city, single station market, new bldg & new equip, \$195,000, low, low down, will finance to responsible party. G Erway, KBOG. 405-832-5332.

North Carolina FT AM station in large coastal city, \$450,000, will finance; FT AM station in large western NC city, \$350,000, will finance. G Whittle, 8304 Druids Ln, Raleigh NC 27612. 919-848-3596.

Want to Buy

Got an FM CP, about to run out of time to build, we may be interested, call or write. F Morton, KMGZ, POB 7953, Lawton OK 73506. 405-536-7953.

STEREO GENERATORS

Want to Sell

Versa-Count V322 FM exciter w/built in stereo gen, excel cond, \$1800. S Angrum, WTMX. 317-545-8100.

RCA BTS-1A stereo gen, \$35/BO. A Soroka, WJRO, POB 159, Glen Burnie MD 21061. 301-761-9220.

Moseley SCG4T gd cond, \$600; Orban Optomod 8000A stereo gen, works, \$1500. M Dailey, 311 S Gloster, Tupelo MS 38801. 601-841-1506.

CSI SG-1E rack mount stereo gen, \$250. K Retzer, KGRZ, POB 4106, Missoula MT 59806. 406-728-1450.

BE FS30 stereo gen. A Bendix, KGWY, POB 1179, Gillette WY 82716. 307-686-2242.

SWITCHER (VIDEO)

Want to Buy

Grass Valley 900SE-1 special effects for 1400 production switcher. B Briggs, KCAM, 827 Meridian St, Nashville TN 37207. 615-226-1122.

TAPES, CARTS REELS

Want to Sell

Audiopak AA3 (650) near new, excel cond, all music lengths, \$1.50 ea. B Anthony, Anthony Assoc, Rt 3 Box 185, Cornelius OR 97113. 503-357-6120.

3M-Scotch 206, 208 & Ampex 632 1/4" on 5", 7" & 1 1/2" reels-repro. Also available Ampex 406, 456, 3M 250 & Agfa 469 2" audio tape w/ho splices & with one splice. Also available Ampex 406 & 456 1" audio tape with no splices. Call for prices. Burlington Audio Tapes: 106 Mott St, Oceanside, NY 11572. 1-800-331-3191 or in NYS 516-678-4414.

Scotch 1" video tape, 2100' reels, only one pass, \$3/reel. C Potorti, Potorti Video, 10005 Lacy Ave, Morrisville PA 19067. 215-945-3990.

Audio carts, Size A, various mtgs, cond useable to like new, 30" ea. R Elm, WWJC, 1120 E McCuer, Duluth MN 55808. 218-626-2585.

Fidelipa: grey carts, (4) boxes 28" x 14" x 14", most gd cond; also (1) box of 14" x 14" x 14" of C&W songs, oldies, BO or trade for Teac/Revox decks. F Vobbe, 706 MacKenzie, Lima OH 45805.

Fidelipac(100) 40 sec to 7.5 min, gd cond, \$1 ea. R Ashmore, S Front Range Bldg, POB 421, Colorado City CO 81019. 303-676-3588 eves.

Scotch 800 (38) 2" instrumentation tape, (4) 5000' reels of Ampex 456 Grand Master 2", unused, K Knowles, Knowles Video Prod, Box 12127, Tallahassee FL 32317. 904-575-6689.

Audio-Pak, almost like new, various lengths, \$1.25 ea. T Abrego, KVLV, Box 850, Edinburg TX 78540. 512-383-7478.

Ampex 641, 1800' on 7" reels (1000 avail), \$1.25 per reel. D Price, Radio Arts, 210 N Pass Ave Burbank CA 91505. 800-423-2840.

Want to Buy

Old musical ET libraries, 16" arms, RCA or WE universal pickup cartridges. SA Cister, 2405 Hermitage Way, Louisville KY 40222. 502-458-7420 aft 11 AM.

Music library from the 50's. JB Ingram, WBLE, Box 73, Batesville MS 38606. 601-563-4664.

Oldies automation tapes esp those w/Wolffman Jack material. M Salvaggio, MFS Prod Svcs, 417 Lauback St, Hellertown PA 18055. 215-838-9274.

TAX DEDUCT. EQUIP

Heliar or hard line, 400', 1/2" or 7/8" 50 ohm for 2 meter amateur repeater. D Pichard, Oakdale Rd, McComb MS 39648. 601-684-3654.

Tax exempt foundation requires video prod equip, especially 3/4" editors, cameras, lights. Wholesome Prod, 314 W 52nd St, NY NY 10019.

Non profit college station needs bdct gear & test equip. S Walter, WMMR, 328 Coffman Union, 300 Washington Ave SE, Minneapolis MN 55455. 612-625-5926.

Non-profit religious station, new CP request donation FM xmtr, 10 kW or less, audio console, STL, recorders, etc. J Ranch, Fairfield Christian Academy, 1330 E Main, Lancaster OH 43130. 614-654-5550.

TEST EQUIPMENT

Want to Sell

Datapulse 120 pulse gen, HP-3340A DVM, Eico 470 scope, BO. J Schloss, KICD, 2600 Hiway Blvd, Spencer IA 51301. 712-262-1240.

Tek 535 scope, needs minor repair, \$150. D Gurdry, Sound Concepts, 1113 Jackson St, Alexandria LA 71301. 318-473-4170.

Vero FL-3D flutter meter, excel cond, \$350. W Slaten, 424 Grant Ave, Scotch Plains NJ 07076. 201-322-7269.

Scorec BAG2, VCG3, NT64, like new, \$2500. L Clinton, Snider Corp, 4021 W 8th, Little Rock AR 72204. 501-661-7500.

Tek 555 dual beam scope, (3) type Q vertical amps, three time base plug-ins, extra PS, w/manuals, \$350. J Lipski, Ind Engr, POB 1456, Lompoc CA 93438. 805-733-2726.

Tek 214, dual-trace storage scope, 500 kHz, excel cond, w/manuals, \$1400/BO. JG Von Vleck, Vtech, 2833 Beechtree La, Woodbridge VA 22191. 703-221-6984.

HP 1415A TDR; HP 140A scope, accepts TDR plug-in; HP 1416A swept freq indicator, plug-in, all items in excel cond w/manuals, \$1150. W Garrison, Garrison Assoc, POB 2760, Greenville SC 29602. 803-298-4401.

Tek 465 scope w/sync trigger option, cal 115/85, \$1000. G Ricciarelli, WICZ, 4600 Vestal Pkwy E, Binghamton NY 13902. 607-770-4040.

GR-1607 transfer, function & emittance bridge, new, w/optional standards, in orig mahogany case, \$4000. R Meyers, Sound Masters, 4700 SW 75 Ave, Miami FL 33155. 305-376-2126.



FOR FREE LISTINGS IN BROADCAST EQUIPMENT EXCHANGE



CALL TOLL FREE
1-800-426-8434
15 LINES TO SERVE YOU

Free listings in Broadcast equipment exchange are offered to all United States Broadcasters AM/FM/TV and all Pro-Sound end users. BSW will accept up to three listings by telephone. For more than three listings BSW will send you an ad order sheet for your convenience. BSW will list each ad for a period of three full months.

PACIFIC MOUNTAIN CENTRAL EASTERN
6:00 AM to 6:00 PM 7:00 AM to 7:00 PM 8:00 AM to 8:00 PM 9:00 AM to 9:00 PM

Open For Business When You Are
12 Hours Daily - In Your Time Zone



BSW • 7012 - 27th ST. WEST • TACOMA, WASHINGTON 98466

ACTION-GRAM

EQUIPMENT LISTINGS:

Radio World's Broadcast Equipment Exchange provides a FREE listing service for all broadcast and pro-sound end users. Simply call 1-800-426-8434 to place your listings courtesy of Broadcast Supply West. Brokers, dealers, manufacturers and other organizations who are not legitimate end users can participate in the Broadcast Equipment Exchange on a paid basis. Listings are available on an \$18/25 word basis. Call 800-336-3045 for details and complete display rates.

EMPLOYMENT SECTION:

Help Wanted

Any company or station can run "Help Wanted" ads at the flat rate of \$18 per listing per month (25 words max). Payment must accompany insert; there will be no invoicing. Blind box numbers will be provided at an extra charge of \$2. Responses will be forwarded to listee, unopened, upon receipt. Call 800-336-3045 for display rates.

Positions Wanted

Any individual can run a "Position Wanted" ad, FREE of charge (25 words max.), and it will appear in the following 3 issues of Radio World. Contact information will be provided, but if a box number is required, there is a \$2 fee which must be paid with the listing (there will be NO invoicing). Responses will be forwarded to the listee, unopened.

Check as appropriate: Help Wanted With Box Number
 Positions Wanted Without Box Number

Text (25 words maximum): _____

Name _____ Title _____

Company/Station _____

Address _____

City _____ State _____ Zip _____

Telephone _____

BROADCAST EQUIPMENT EXCHANGE
PO BOX 1214
FALLS CHURCH VA 22041

Rw

Broadcast Equipment Exchange

TEST EQUIP... WTS

Telegquipment JD-D53 dual trace scope, industrial type, gd cond, needs alignment, \$75; Heath IM-16 solid state multimeter, needs minor repair & alignment, \$35; HP 410B VTVM, fair cond, \$35. T Steele, Frankford/Wayne Mastering Labs, 1697 Broadway, NY NY 10019. 212-265-5563.

Rane spectrum analyser pink noise gen & cal mike, \$350. W Preist, Classic Sound & Recd, 1249 Bayshore Blvd, Dunedin FL 33528. 813-726-4474.

HP 7010B X-Y plotter w/UREI 2010 level & freq detect module; UREI 2000 freq & response module; RCA AM phase display; TFT 7630 20 chan telemetry expander. A Bendix, KGWY, POB 1179, Gillette WY 82716. 307-686-2242.

Gold Line ASA-10B audio spectrum analyzer & PN-2 pink noise gen, like new, \$175/both. R Kerbaway, WTNJ, Box 1127, Beckley WV 25802. 304-877-5592.

Tek 465 scope, \$1095; Ithaco 4302 dual 24DB octave filter, \$725; Non-Linear MS230 mini scope, \$295; Waveforms sensitive AC volt meter -60 to +50 dB or -0.001-300 V, 4 MHz, \$175; HP 10529A logic comparator, \$475; HP volt meter 403B, \$275. J Price, Price's Rcdg Svcs, 2651 Globe Ave, Dallas TX 75228. 214-321-6576.

Heathkit IO104 15 meg triggered sweep scope, needs a little work, \$200/BO. R Wells, KREO, POB 1598, Santa Rosa CA 95402. 707-433-4895.

Tek RM529 waveform monitor, new tube, \$450. H Donnell, Creative Video Prod, 211 Windsor St, Reading PA 19601. 215-378-0994.

Tek 7704A scope, incl: 7A26, 7A13, 7B85, 7B80, scope cart, excel cond, new CRT in 1985, \$8400/BO. T McConville, Complete Post, 6087 Sunset Blvd, Hollywood CA 90028. 213-467-1244.

Want to Buy

HP-331A dist analyser. S Bartkowski, WEDC, 4923 W 28th, Cicero IL 60650. 312-863-3090.

Sencore capacitor/inductor 2 meter & Sencore super cricket. J Price, Price Recdng Std, 2651 Globe, Dallas TX 75228. 214-321-6576.

TEF 10/ or 12 analyser. P Westendorf, Gabriel Eng, 333 W Main, Mesa AZ 85201. 602-969-8663.

TRANSMITTERS

Want to Sell

RCA BTA 50F, excel cond, recently out of service, you remove & ship, \$18,000. G Heidenfeldt, 2880 Lake Rd, Wilson NY 14172. 716-751-6187.

BE FM30A nearly new, 93.3 MHz, BO. C Springer, KLMR, POB 890, Lamar CO 81052. 303-336-2206.

Stellartron FX2 stereo, 200 mW output, \$150. J Titus, Titus Assoc, 566 Briarcliff Rd, Pittsburgh PA 15221. 412-243-1674.

RCA BTE-10C FM exciter, \$75/BO. A Soroka, WJRO, POB 159, Glen Burnie MD 21061. 301-761-9220.

Gates/Harris BT-100H; M-6652 chan 8 100 W TV xmt (2), clean repairable, \$6500/both. M Murphy, 11621 Valle Vista Rd, Lakeside CA 92040. 619-561-2726.

Gates BC-250GY-1 1520 kHz, gd standby xmt, BO. P Stage, WKVI, Box 12, Knox IN 46534. 219-772-6241.

Sintronix SI-F-25 27.5 kW FM, remove from svc late June w/spare parts, BO over \$12K. G Brandenburg, WKQQ, POB 100, Lexington KY 40590. 606-252-6694.

Harris BC1H 1 kW 1450 AM, excel cond, BO. B Mishkind, KFXX, 3222 S Richey Ave, Tucson AZ 85713. 602-296-3797.

RCA BTA 5F 5 kW AM, excel cond, recently out of service, you ship & remove, \$10,000. G Heidenfeldt, 2880 Lake Rd, Wilson NY 14172. 716-751-6187.

GE BF2A 3 kW FM, new CSI exciter, vgc, lots of spares, BO. S Callahan, WFTI, 1120 Pinehills Bay Way #103, Tierra Verde FL 33715. 813-866-2478.

RCA BTA-5F mod transformer, new in crate, \$600 plus ship. G Heidenfeldt, 2880 Lake Rd, Wilson NY 14172. 716-751-6187.

OVER 100 AM AND FM TRANSMITTERS

AMs: 50kw, 10kw, 5kw, 2.5kw, 1kw. FMs: 40kw, 25kw, 20kw, 10kw, 5kw, 1kw. All Manufacturers, All powers, All working, All spares, All inst. books.

ALL IN OUR INVENTORY.

World leader in AM and FM transmitters.

BESCO INTERNACIONAL
5946 Club Oaks Drive
Dallas, TX 75248

214-630-3600
214-276-9725

RCA BTE-15A tuned to 88.5 MHz w/stereo gen, 42 kHz SCA gen & 67 kHz SCA gen, vgc, fully operational, can be retuned, w/manual, \$875. M Byrnes, WAMU, 4400 Mass Ave NW, Wash DC 20016. 202-885-1030.

GE plate transformer primary 208-242, sec 1090-1890 KVA 13.89. R Elm, WWJC, 1120 E McCuen St, Duluth MN 55808. 218-626-2738.



High performance at affordable prices.

15, 30 and 80 W exciters, 100, 200, 250, 400, 500 and 1000 W solid state amplifiers. All front panel programmable, broadband.

2, 10 and 20 W STLs. 24 Hr. technical support on call.

Credit/Leasing options available.

BEXT Inc.
739 Fifth Ave.
San Diego, CA 92101
619-239-8462
Telex 229882LJMJUR

LPB crystals, 990 kHz & 880 kHz, BO. A Caswell, C&G Bdcg, POB 171, Linden MI 48451. 313-735-4545.

FM xmt, 10 kW, not too old, also diplexer for FM. R Gold, Suwebe Bdcg, 19355 NE 36th Ct Ste 11J, Miami FL 33180.

FM & AM stereo exciter, from 2-10 W, pass all FCC regs, prod room prods, from \$750. L James, Rock 108, 975 S Florida Ave, Tarpon Springs FL 33589. 813-937-3429.

CCA FM20000-DS, 97.1 MHz, w/exciter, recond, no PCB's, \$10,000. R Mullinax, WFOX, 2000 River Edge Pkwy, Atlanta GA 30328. 404-953-9369.

TEX-20, new PLL exciter, slight cosmetic damage from shipping, 15 watt FM, \$1200. D Pieri, Bext Inc., 739 5th Ave #7A, San Diego CA 92101. 619-239-8462.

Amertran plate transformer, 3-phase, primary 208-230, sec 3810-4210 KVA 24. R Elm, WWJC, 1120 E McCuen St, Duluth MN 55808. 218-626-2738.

Gates FM5H w/TE3 exciter, needs work, \$2000. C Schipper, KQKS, 919 Sheridan # 205, Westminster CO 80030. 303-427-7700.

Andrew 3-1/8" air helix 100' on reel, never used, BO. C Schipper, KQKS, 919 Sheridan # 205, Westminster CO 80030. 303-427-7700.

McMartin BA 2.5K 2500 W AM xmt, 1080 kHz, in service, needs new tubes. D Dart, KPRX, POB 1076, Price UT 84501. 801-637-4666.

FM exciter, 10 W, fully programmable, excel cond, \$750. L James, The Prod Room, 975 S Florida Ave, Tarpon Springs FL 33589. 813-937-3429.

Versa Count V322 FM exciter, 10 W stereo, 87.9 MHz, fully programmable, \$850. M Rakoff, WQVM, 114-41 Queens Blvd #148, Forest Hills NY 11375. 718-591-0002.

Want to Buy

Harris MW10 AM xmt or similar. H McDonald, KKMT, Box 710, Ennis MT 59729. 406-682-7171.

AM 1 kW prefer RCA 1MX or Collins 20V2 or 20V3, fixer uppers OK. B Dodge, WTJ, POB 1818, Brattleboro VT 05301. 802-254-2560.

Xmt, 1 kW, preferably use 4-400 & 5-500 tubes. R Lopez, RF Specialty Prod, 4214 San Pedro, San Antonio TX 78212. 512-736-6116.

Operating manual for a AEL 10 kW xmt. C Haynes, Haynes Comm, POB 31235, Jackson MS 39206. 601-948-1515.

High band VHF, 100 W to 5 kW, any make or model, driver to higher powered xmt OK. J Powley, WIIM, 1536 Logan Ave, Altoona PA 16602. 814-944-8571.

RCA TTU-2A or TTU-10A UHF, need parts of every kind for re-build of damaged xmt; Adler or TTC UHF TV translators, old 70-83 units OK, 10-20-100 W. J Powley, WIIM, 1536 Logan Ave, Altoona PA 16602. 814-944-8571.

Collins 20V2 (2) in gd cond for amateur radio collectors. R Smith, 2245 Falspar St, San Diego CA 92109. 619-483-9331.

AM xmt, 3-4 tower antenna, phaser & phase monitor. B Barry, WAMB, 1617 Lebanon Rd, Nashville TN 37210. 615-889-1960.

Audio driver xmt T5 or T6 for Gates DC500K. L Weatherford, WSQR, Box 249, Sycamore IL 60178. 815-895-3636.

FM xmt, 25 kW in gd cond. E Kazmark, KAZZ, Box 1369, Deerpark WA 99006. 509-276-8816.

FM xmt, 1-5 kW. E Goetsch, WXPB, 303 W Prospect, Rhinelander WI 54501. 715-362-6000.

TUBES

Want to Sell

RCA 8976 new cond, BO. T Smith, CCI Comm, 192 Lancaster Ave, Frazier PA 19355. 215-289-1725.

Hundreds of new old stock receiving tubes & ballast tubes, call or SASE for list. N Carlson, Mobile Sound Group, 721 W Melrose, Chicago IL 60657. 312-871-7459.

Want to Buy

Image Orthicon 5820 tube, 7TP4 CRT (TK31 viewfinder). C Harper, WBGK, 520 W Capitol Dr, Milwaukee WI 53212. 414-964-8300.

TURNTABLES

Want to Sell

Shure M64 phono preamp, \$50. P Cibley, Cibley Music, 138 E 38th St, NY NY 10016. 212-986-2219.

Russco Studio Pro w/phono cartridges, gd cond, w/(2) Micro-Trak 303 tonearms, \$450. S Anglum, WTMX, 317-545-8100.

Technics SP10 MKII w/base & manual (2), \$500 ea. S Bartkowski, WEDC, 4923 W 28th, Cicero IL 60650. 312-863-3090.

Gates Solid Statesman II preamps (2) in operating cond w/manual, \$50 ea plus ship. G Heidenfeldt, 2880 Lake Rd, Wilson NY 14172. 716-751-6187.

Technics SP15 base, Audio Technica tone arm, \$450. A Soroka, WJRO, POB 159, Glen Burnie MD 21061. 301-761-9220.

Presto Disc-cutter lead screws for cutting, 224/104/106 lines, \$50 ea/all for \$135; Flek-O-Kut CVS12 speed variance w/settings. L Oliver, 212-874-0274/7880 (PM).

QRK 12C TTs w/Micro-Trak 303 tonearms (2), \$100 ea. M Ripley, KOZE, POB 936, Lewiston ID 83501. 208-743-2502.

Shure M64 preamp, \$50. P Cibley, Cibley Music, 138 E 38th, NY NY 10016. 212-986-2219.

RCA 16" transcription TTs 33, 45, 78 vertical lateral heads & carts, you pickup, \$375/both. R Bellavia, WSBC, 4949 W Belmont, Chicago IL 60641. 312-777-1700.

Micro-Trak 303 tonearms (2), \$25 ea. M Ripley, KOZE, POB 936, Lewiston ID 83501. 208-743-2502.

Ramko SP-8E Stereo II preamp w/manual, less than 200 hrs, like new, \$100 plus ship. G Heidenfeldt, 2880 Lake Rd, Wilson NY 14172. 716-751-6187.

Haeco PB2TX stereo TT preamp, variable EQ & level, like new cond (2), \$25 ea; Ramko TT preamp, stereo, fair cond, \$25; disk cutting systems avail, complete turnkey disk mastering rooms, Scully Westrex systems, complete w/EQ, limiters, monitors, variable pitch & depth, call for info; Thorens TD-160C unit w/dust cover, \$35/BO. T Steele, Frankford/Wayne Mastering Labs, 1697 Broadway, NY NY 10019. 212-265-5563.

Technics SL-1100A quartz lock direct drive TT, needs minor repair, vgc, \$40; Dual 601 automatic TT, gd cond, \$35; Scully Lathe, complete w/Westrex 3DII cutterhead & driver amps, vgc, \$7500; Sony PS-5550 belt drive TT, needs minor repairs, gd cond, \$25. T Steele, Frankford/Wayne Mastering Labs, 1697 Broadway, NY NY 10019. 212-265-5563.

Gates direct drive TTs (4) plus 2 wooden tonearm sets included, all work but are ancient, desperate to move, \$75 for all 4. D Sparano, WVCB, R9, Loudonville NY 12211. 518-783-2990, call & leave message.

Collins 200 TTs (2). A Bendix, KGWY, POB 1179, Gillette WY 82716. 307-686-2242.

Russco Cue Master w/Micro-Trak 303 arm, excel cond, \$250 plus ship. R Kerbaway, WTNJ, Box 1127, Beckley WV 25802. 304-877-5592.

Sparta GT w/peDESTAL cabinet, \$150 plus ship. J Emmel, Emke Media, POB 401, Olyphart PA 18447. 717-383-1118.

RCA 12" TTs, 33/45 (3), \$75 ea. B Harlan, WFAH/WDJJ, 393 Smyth Ave NE, Alliance OH 44601. 216-821-1112.

AR turntable, circa 1972, hole cut for SME arm, original arm reinstalled, \$25 plus ship. J Martin, Box 160326, Mobile AL 36616. 205-460-2395.

Presto 16" transcription TT, EQ, tone arm, BO. R Nelson, Lutheran Gospel Hr, Box 1, Flaxton ND 58737. 701-596-3565.

RCA transcription player, 78/33 rpm, \$500. R Bellarva, WSBC, 4949 W Belmont, Chicago IL 60641. 312-777-1700.

QRK 3 speed TTs w/QRK tonearms, no cartridge heads (4), \$200 ea. W Brown, KVNI, Coeur d'Alene ID. 208-664-9271.

QRK 3 sp, w/Micro-Trak 303 arms, gd cond, \$135 ea. E Martin, Maxwell Prod, 220B Terrace View Rd, Louisville TN 3777. 615-970-2192.

Metron 12" TTs (2), 2 speed, \$50 ea. D Ibel, KICD, 2600 N Hwy Blvd, Spencer IA 51301. 712-262-1240.

Want to Buy

Gates M5202 tone arm for Gates 16" transcription TT, negotiable. R Nelson, Lutheran Gospel Hr, Box 1, Flaxton ND 58737.

TV FILM EQUIP.

Want to Sell

RCA film chain (2) TP66 16mm projectors, TP55 film island control motorized mirror box, TP7 slide projector, TK27 color cam unit, \$9500/all, will separate. J Rubenstein, MD Pub Bdcg, 7913 Yarnwood Ct, Springfield VA 22153. 703-451-1994.

RCA TP66 projectors 16mm for RCA TV film islands, very clean, \$6000 ea or \$10,000/both. S Shumatt, WVIR-TV, 503 E Market St, Charlottesville VA 22902. 804-977-7082.

Want to Buy

Philco Cinescanner TV bdcg projector. DMT A/V, Box 9064-RW, Newark NJ 07104. 201-484-5291.

VIDEO PRODUCTION EQUIP.

Want to Sell

Telestrator 600, effects gen, operational other than cracked grid plate, gd for parts or refurb, w/manuals, \$600/BO. JG Von Vleck, Vtech, 2833 Beechtree La, Woodbridge VA 22191. 703-221-6984.

Grass Valley 900 series rack w/940A vid proc, 962 color lock, 950W sync gen, 906A AGC video amp, 900 dual power, \$500. SA Cislser, 2405 Hermitage Way, Louisville KY 40222. 502-458-7420 alt 11 AM.

Chyron 3 character gen, complete w/key-board, all cards, disk drive, colorizer, manuals & 8 font discs w/many fonts, working gd when removed, quick sale, \$4500 as is, will ship freight COD; second unit as above w/o disk drive, \$4000, both \$8000. B Briggs, KCAM, 827 Meridian St, Nashville TN 37207. 615-226-1122.

CMX I squares for VR1200, VPR2, Sony 28 600, MM1200, Grass Valley 1600, etc, BO. N Macrae, Technichrome, 701 Desert Ln Ste 4, Las Vegas NV 89106. 702-386-2844.

KTV KCT-5003 4" color TV, \$125. K Retzer, KGRZ, POB 4106, Missoula MT 59806. 406-728-1450.

JVC 2GX700U cams, (2) gen lockable, 2 BR62000 portable recorders, KM1200 special effects gen, (2) B9W monitors & various acces, \$6200. M Mortimore, Mister Mike Prods, 535 Broadway, Thermopolis WY 82443. 307-864-9444.

Ampex Mark 10X video tape head newly refurbished, \$500. B Richert, WPCB, Signal Hill Dr, Wall PA 15148. 412-824-3930.

Knox 128B/Mod 8 char gen, blink, roll, crawl, multiple fonts & sizes w/manual, perfect, recent factory recond, \$1500. RPC, 827 Meridian St, Nashville TN 37207. 615-226-1122.

WORLD VIDEO STANDARDS CONVERSION
Digital PAL/SECAM/NTSC Chroma, Luminance, Error Correction given careful set-up for broadcast quality at budget price. VHS, BETA, 3/4", \$45/hr. Quantity discount

TK VIDEO
12300 Coppola Drive,
Potomac, MD 20854
301-762-2786

Want to Buy

Transfer service for old A-format 1" video reel to VHS, originally recorded on Ampex 7000. W Watrous, Watrous Prod, 1038 Citrus Ave, Sarasota FL 33577. 813-955-4000.

Editing sys with 3/4 to 1" capa., prefer computerized but not nec. J Harsh, On Spot Prod, 170 Hwy 83, Oakly KS 67748. 913-672-3428.

Panasonic Recam B-100 sys, any & all equip, cameras, recorders, edit controllers, cables, access, manuals, etc. B Briggs, KCAM, 827 Meridian St, Nashville TN 37207. 615-226-1122.

VIDEO TAPE RECORDERS

Want to Sell

Sony VO 3800 3/4" port, \$350; JVC, Panasonic, Sony 3/4" for repairs, \$150 ea. SA Cislser, 2405 Hermitage Way, Louisville KY 40222. 502-458-7420 alt 11 AM.

Panasonic NV9500 & NVA9500 editor & controller, \$2000. R Larsen, Metropolis Video, 316 S Maple, Oakpark IL 60302. 312-848-3172.

Sony 3800 portable R/P, 3/4" w/AC color adaptor & manuals, \$500 G Sive, Your Video Connection, POB 239, Bonsall CA 92003. 619-729-7662.

JVC CR4400L-J 3/4" portable VCR, AC power adaptor, gd working cond, \$1000. J Snavely, Alternative Cable TV, RD 3 Box 255, Boyertown PA 19512. 215-689-9447.

Tascam Series 30 reel motor, new, trade for Sony 850 Series headblock. E O'Brien, Out-house Recdgs, 3041 Crawford St, Terre Haute IN 47803. 812-238-9312.

Want to Buy

Panasonic Recam B-100 system recorders: AU-220, AU-300, AU-100, access, cables, etc. B Briggs, KCAM, 827 Meridian St, Nashville TN 37207. 615-226-1122.

VCR rec/play, 1" C format, prefer external edit capabilities. J Harsh, On Spot Prod, 170 Hwy 83, Oakly KS 67748. 913-672-3428.

TRANSCOM CORP.

Fine Used AM & FM Transmitters
and Also New Equipment

For the best deals on Cablewave cable,
Rohn towers
and Celwave antennas.

Special on Revox PR-99
and B-225 CD Player
Call for Super Low Prices!

201 Old York Rd, York Plaza Ste 207
Jenkintown PA 19046
215-884-0888

Telex No. 910-240-3856 (TRANSCOM CORP. UQ)

UNDER NEW MANAGEMENT
MCMARTIN INDUSTRIES
Sales & Service of McMartin Products
402-331-7515

Can't Find It?

Call 1-800-426-8434 For Immediate Action!

Want To Sell It?

Once Your Station Gets *StereoMaxx*'ed,

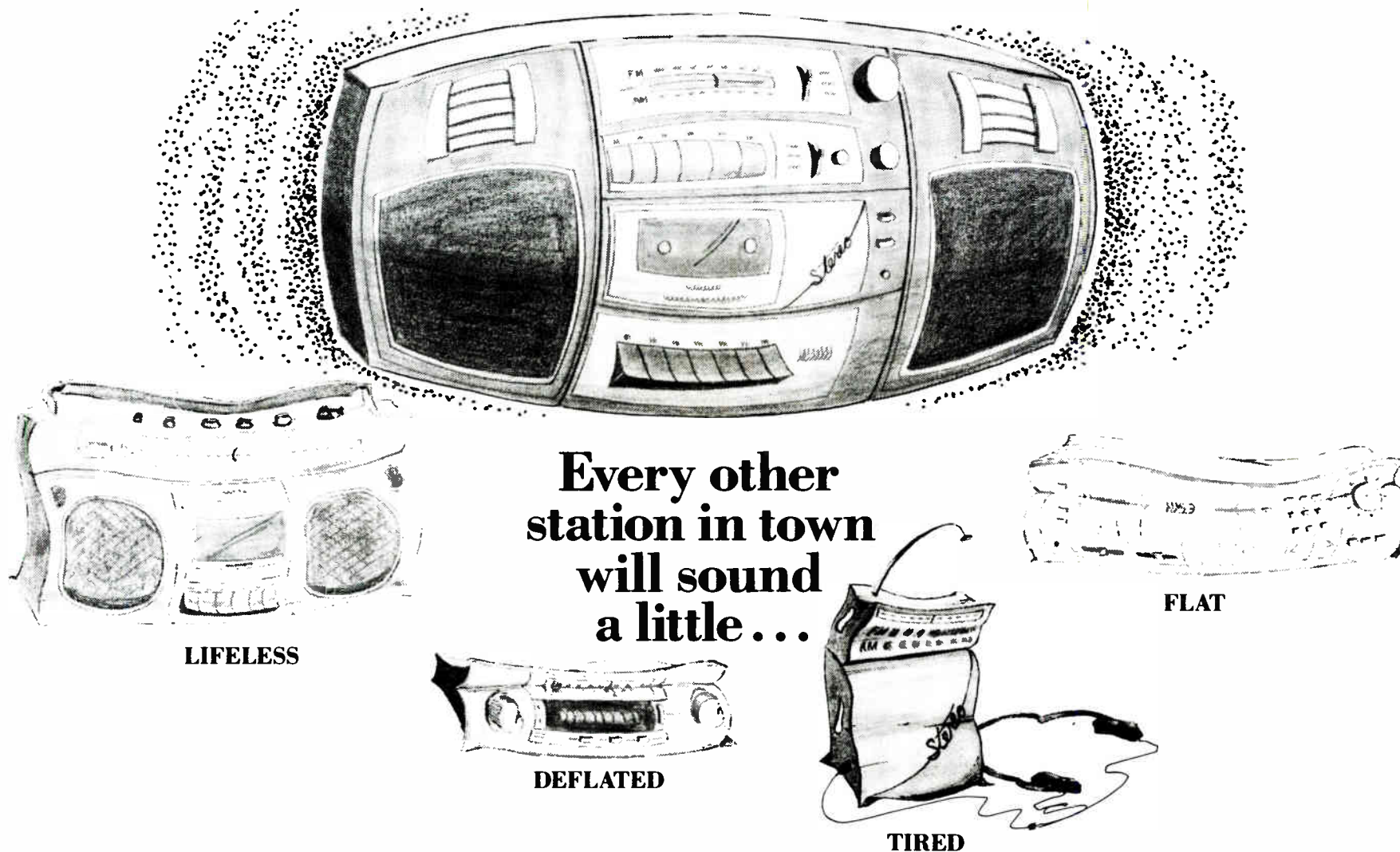

Every other station in town will sound a little...

LIFELESS

DEFLATED

TIRED

FLAT

***StereoMaxx*, The Spatial Image Enlarger From Modulation Sciences, Gives Your Station An Extra Edge ...Without Extra Problems.**

- ***StereoMaxx* Makes You Bigger, Not Just Louder.**

StereoMaxx[™] enhances and enlarges your music's stereo image, for a dramatically Bigger, Fuller sound. It works *with* any loudness processor you use — Optimod, Texar Audio Prism, CRL, you name it. The spatial image enlargement impact of *StereoMaxx* is compatible with — but completely different from — loudness processing. From Rock to Easy Listening, *StereoMaxx* adds punch and excitement to *any* AM or FM stereo music format. *StereoMaxx* makes your station *stand out* on every kind of stereo radio — from large hi-fi systems to portable boom boxes and headphone radios, and in the car . . . WOW!

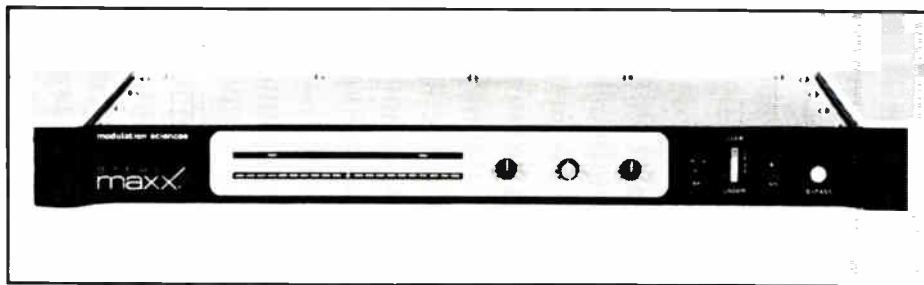

- **Many Have Tried. *StereoMaxx* Succeeded.**

With *StereoMaxx*, you get the added punch and impact of stereo image enlargement with No phase problems, No increased multipath problems, No problems for mono listeners, in fact, no problems at all. Radio professionals know Modulation Sciences is a company that keeps its promises: Our CP-803 Composite Clipper is on the air at over 1200 stations, keeping them loud, clean and legal. And our Sidekick is *the* industry-standard SCA generator. So when we say *StereoMaxx* enlarges your stereo image, with no problems or side-effects, you can believe it.

- **There's No Downside Risk With *StereoMaxx*.**

The idea of making a station stand out by enhancing and widening the stereo image is certainly not new. Enterprising engineers at competitive stations have tried a number of schemes. Everything from simple matrixes to consumer hi-fi ambience gadgets. Unfortunately, these attempts have always yielded unacceptable side effects: No-no's such as mono incompatibility, increases in multipath, and jet-streaming D.J. voices. But the potential benefits of stereo image enlargement are too good to ignore, so Eric Small and the Modulation Sciences design team went to work. And we succeeded!

- **Call Now For More Info And Free Demo Cassette.**

Once your station starts broadcasting with *StereoMaxx*, all the "ordinary" stereo stations in town will sound like just that . . . ordinary! Of course, since *StereoMaxx* is brand new, no one else in your market has it — yet. So now's the perfect time to check it out. Call Modulation Sciences for your **FREE** demo cassette and more details about *StereoMaxx*. Our Toll-Free number is **(800) 826-2603**
[in NY: (718) 625-7333].

Why not call for your demo cassette right now!

modulation sciences, inc.

115 Myrtle Avenue • Brooklyn, New York 11201 • Tel. 718-625-7333 • Toll Free 800-826-2603

Optimod, Texar Audio Prism and CRL are trademarks of Orban Associates Inc.; Texar Incorporated; and Circuit Research Labs, Inc.; respectively.

Circle Reader Service 22 on Page 22



A SUCCESS STORY

THE OBJECTIVE was no small task: design a radio console that would become the new standard.

THE METHOD involved listening to veteran broadcast engineers and installers. After all, they're the people who have seen and experienced all the ideas that came before. From this research we learned of the problems that had to be solved and the features that broadcasters required. We then added ten years of console building experience and innovation, and created the A-500α console.

THE RESULT: An unsurpassed console that exceeds prior broadcast standards. Its module/mainframe interface borrows from the computer industry, utilizing all-gold contact insulation displacement technology. The logic system is based on programming the module slot, allowing full module interchangeability. It also provides for separate programming of the module's "B" input selection, thus avoiding embarrassing false starts and mutes. Full console-to-machine control is supported without extensive use of interface boxes and cables. Three audio busses are provided to enhance talkshows and remote functions. There are separate processing loops for the speech and music paths, as well as individual channel insert points. A complete line of microphone and line inputs, remote selectors, and machine control modules is offered in virtually any combination, configuration or mainframe size you desire. The A-500α also features a full family of studio turret and turret components to ease facility design.

THE PERFORMANCE: Needless to say, it's a new age for audio, and the A-500α is a step ahead. While specifications don't say it all, ruler flat frequency response, 0.03% distortion, crisp square wave response and a noise spec that's unheard of deserve merit. Couple such performance, reliability and innovation together, and a new broadcast standard is set.

THE SUCCESS: WHEATSTONE broadcast consoles are installed in major markets all over the country, from frontline independents to national networks. They are in use right now at some of the world's largest institutions.

THE POSSIBILITIES: The possibilities are up to you.

 Wheatstone Corporation

6720 V.I.P. Parkway, Syracuse, N.Y. 13211 315-455-7740