

Radio Guide

www.radio-guide.com

Digital Issue Now On-Line

September-October 2020 – Vol. 28, No. 5

A New Way to Run Coax



5394

K.M. RICHARDS
K.M. RICHARDS PROGRAMMING SVC.
PO BOX 7427
VAN NUYS CA 91409-7427

*****AUTO**ALL FOR ADC 913
S70 P1

PRSRT STD
U.S. POSTAGE
PAID
PERMIT NO. 410
BEAVER DAM WI

AARON 650

FM REBROADCAST RECEIVER



For Challenging Reception Scenarios.

NEW! FAILSAFE POWER FROM YOUR UPS

BackUPS™ bypasses your UPS when things go wrong!

It instantly switches to Direct Line AC if the UPS output fails or becomes unstable, keeping critical equipment on-line.

- Safely replace UPS batteries
- Restart Timer prevents harmful power cycling
- Easy UPS maintenance without shutting off the load
- Remote-Bypass can disable a failed UPS at a remote site



NEW! SuperLight Controls LED Tally Lights!

Simple interface to your networked studio or console.
Directly powers 12V lights, built-in flasher,
plus relays for speaker muting, etc.

In stock at all Henry Engineering dealers,
visit www.henryeng.com for details Tel: 562-493-3589



Accuracy, Peace of Mind and Reliability

These are at Least Three Reasons Why the DPS-100D Series Power Meter has Become the Choice of Broadcasters Worldwide



No other power meter on the market meets the stringent and changing requirements like BDI's DPS-100D Series True RMS Power Meters. FM broadcasters, television broadcasters and now AM all digital broadcasters can take advantage of the DPS-100D Series feature set including 40 dB dynamic range, measurement of analog FM and IBOC simultaneously, measurement of multiple carriers simultaneously for master antenna applications and much more. With BDI's exclusive 3-Strike™ VSWR protection algorithm your system is protected from damage. The DPS-100D interfaces directly to our SWP-200 series motorized switch controllers, SWP-300 remote controls and our SWP-206 master antenna monitor system. Email alerts, SNMP IP interface and a host of other features make the DPS-100D series unmatched in flexibility and ease of use.

bdi ... Serving the Broadcast Industry for 35 years

Tel. (914) 737-5032 www.broadcast-devices.com

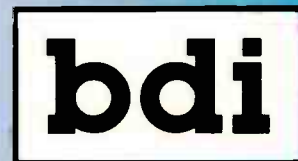

Radio Guide

Contents

September-October 2020

Chief Engineer	6
<i>A New Way to Run Coax and a Satellite Dish Fix</i>	
Studio Site	8
<i>Reconnecting in More Ways Than One</i>	
Tower Topics	10
<i>Greasy Fingers</i>	
FCC Focus	12
<i>New Public Notice Rules Coming Soon</i>	
Maintenance Guide	14
<i>What Flavor Maintenance Do You Want?</i>	
Survival Guide	16
<i>2020: The Year of COVID</i>	
Transmitter Site	18
<i>High Voltage is Not Your Friend</i>	
Radio Stories	20
<i>The World of Short Wave Broadcasting</i>	
Radio Report	22
<i>Advancing HD Radio™ Technology Through Existing Standards</i>	
Engineering Perspective	26
<i>Is It Good – Good Enough – or Great?</i>	
Facility Focus	30
<i>Baptism by Fire: Becoming a Project Manager</i>	

Shop Talk	34
<i>Misc. Tech-Tips and Thoughts</i>	
Small Market Guide	38
<i>How a Small Market Station Cured Its STL Reception Problems</i>	
Transmitter Topics	40
<i>Capacitors in Solid-State Transmitters</i>	
Service Guide	44 & 45
<i>Radio Equipment, Products, and Services</i>	
The Final Word	46
<i>Low Power AM</i>	
Final Stage	47
<i>Convention, and Event Register and Advertiser Information</i>	

Radio Guide

Volume 28 – Issue 5

Radio Guide Website: www.radio-guide.com
 Classified Ads: www.radio-classifieds.com

PO Box 20975, Sedona, AZ 86341
 Phone: 928-284-3700 • Fax: 866-728-5764

Ray Topp (publisher & editor) – radio@rconnect.com

Radio Guide, ISSN 1061-7027, is published bi-monthly, six times a year, by Media Magazines Inc., PO Box 20975, Sedona, AZ 86341. Radio Guide is copyright 2020, Media Magazines Inc., and may not be copied, reproduced, or stored in any format, without the written permission of the publisher.

In This Issue

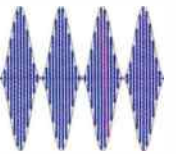

Critical Content for Radio

Chief Engineer – by Scott Schmeling (page 6)

New Way to Run Coax: “We debated various methods for pulling those two runs of 7/8 Heliax through the underground pipe. The pull was horizontal, not vertical, so gravity wouldn’t be working against us. But the pull would be about 146 feet. I’m strong, but I don’t know if I’m that strong! We discussed tying a pull-rope to the hitch of a pickup. But ultimately, we decided I would pull the cables carefully through the pipe.”

Tower Topics – by Gary Minker (page 10)

Greasy Fingers: “This photo is an example of everything that can possibly go wrong, right up to the point where fire starts. Excessive “O” ring grease is everywhere. Nothing is cleaned. If it were not for the fact that there was only 1,200 Watts in this bay connection, the fire would have started sooner and been spectacular. The grease had started to burn and boil, expelling the molten goo everywhere.”

FCC Focus – by Gregg Skall (page 12)

New Public Notice Rules Coming Soon: “Broadcasters have complained for many years that FCC public notice requirements are outdated, expensive and unnecessary. Newspaper publication, it is argued, generally goes unnoticed while broadcast notices are sufficient and better at reaching listeners who have views on station performance. In May of this year, the Commission finally acted on its proposals to eliminate the newspaper public notice. After the effective date, it will require that applicants provide on-line public notice with links directly to the station’s FCC-hosted on-line public inspection file or its application databases, or through on-air announcements ...”

Coaxial Dynamics

A CDI INDUSTRIES, INC. COMPANY
 SPECIALISTS IN RF TEST EQUIPMENT & COMPONENTS

COAXIAL DYNAMICS has been a leading manufacturer of precision equipment for the measurement and termination of RF Power since 1969. Our equipment is used by engineers in a wide variety of applications throughout the world.

Our products include:

- Directional Wattmeters for both Analog & Digital applications from 1 W to 100 kW and from 2 MHz to 2.3 GHz.
- Watchman RF Monitor/Alarm Systems.
- Line Sections & Plug-In Elements.
- RF Loads - Dry, Oil, Water, and Air designs up to 200 kW.
- Low Pass Filters & Power Sensors.

6800 Lake Abram Drive, Middleburg Hts., Ohio 44130, USA
 440-243-1100 • Toll Free: 1-800-COAXIAL • Fax: 440-243-1101
 E-Mail: sales@coaxial.com • Web Site: www.coaxial.com

- **Broadcast Equipment** •
 Watchman - High Power Wattmeters - Elements
- **Line Sections & Meters** •
- **Termination Loads** •
 Dry - Oil - Water - Air



Radio Air-Chain INNOVATION



1st

Cloud-Based Air-Chain
with Time-Locked FM +
HD Radio™



1st

To Eliminate **HD Radio™**
Time Alignment
Drift

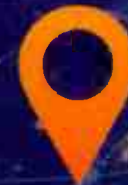

Find your path to innovation

Nautel and Telos Alliance are bringing exciting, innovative approaches to the radio air-chain. We've demonstrated a practical application of cloud and software approaches, using existing "Made for Radio" standards, to create flexible and easy to deploy solutions for long-standing issues such as HD Radio™ time alignment drift.

Learn about these disruptive new approaches which can bring your station future opportunities at: nautel.com/radio-air-chain

Chief Engineer

A New Way to Run Coax and a Satellite Dish Fix

by Scott Schmeling

We had a very interesting project this past summer. The project itself was pretty straight forward, but one of the processes was something I'd never been involved with before and was really very cool.

Working with Rod Thannum, Director of Radio Engineering for Northwestern University in St. Paul, Minnesota, the project was to install two translators with a combiner feeding into one antenna. So far ... easy stuff. But I didn't mention the translator antenna would be mounted on a hot AM tower. That means we also have a ground system to contend with since we did not want to run the lines (yes, plural – I'm also installing an STL antenna) above ground.

This station is new to our group. Travis (a very tall young man with an equally *long* last name – which I will not attempt to spell or pronounce), has been with the station for a few years and has been doing On-Air and quite a bit of the “tech stuff,” worked with us and found much of the documentation we needed. You might say he knew where a lot of things were buried!

Rod's suggestion was to get a directional boring company to bore a tunnel, of sorts, under the ground system and insert some 4-inch, thick-wall tubing. We planned on 4-inch because we have two runs of 7/8 line and we didn't want it to be tight at all.



We picked a spot near the base of Tower #1 and dug a hole where we wanted the tubing to come up – being careful to not damage any of the ground radials. Then the boring company went to work. (It's difficult, but I will resist the temptation to call this a ... *boring job!*) They set up on the other side of the tower fence, again being careful to not damage any ground radials. A hole was also dug near the building, where we wanted the tubing to surface.



During the process, one man would follow the head of their device under ground (the device, not the man) with a sensor showing him where the head was. Then the machine operator was able to make adjustments to keep the head on

course. It poked through *exactly* where we wanted it! To me, it was really pretty amazing.

Their next step was to pull that thick-walled tubing through the underground “tunnel.” For that, they put something very similar to a coaxial cable hoisting grip over the end of the tubing and connected it with a chain to the head of the boring device. I'm not going into great detail because I honestly don't know specifically how every phase and piece work. What I do know is they were able to pull that tubing into the hole near the transmitter building and it came out through the hole near the base of Tower #1!



This tubing (also called PIPE) is a High Density Polyethylene resin (HDPE). I've mentioned that it was thick walled. It mated well with 4-inch plumbing PVC pieces – *except* – the cement we normally use on PVC doesn't bond the same. We found that the pieces we had glued together were not fused at all. Ultimately, we assembled the pieces, then applied “Black Jack,” a roofing repair product, to the joints. We figured that since they would not be flexing at all and would be under ground, the Black Jack should work just fine.

We also dug a hole near the Tower #1 base for a 4x4 post for mounting the two isocouplers. One was for the translator and one for my STL. It was while we were mounting them to the post that Travis (remember him, tall kid – very long last name?) asked if the FM and the Marti needed isocouplers too. Rod and I said yes and explained why ... when we noticed *no isocouplers* for neither the FM nor the Marti receiver! Rod and I looked at each other in a “head-scratching” moment and said, almost in unison, *bazooka!* A bazooka is a method for mounting a line to a hot AM tower in such a way that an isocoupler is not necessary ... more on that another time.

We debated various methods for pulling those two runs of 7/8 Heliac through the underground pipe. The pull was horizontal, not vertical, so gravity wouldn't be working against us. But the pull would be about 146 feet. I'm strong, but I don't know if I'm *that* strong! We discussed tying a pull-rope to the hitch of a pickup. But ultimately, we decided I would pull the cables carefully through the pipe. Of course, Travis was *pushing* the line in at the other end, and Rod was making sure it came off the spool alright. By coordinating, I could easily pull when Travis was pushing and it actually worked very well.

Let me digress for just a minute. I had asked Travis previously to build some kind of a spool stand so we could pull the line somewhat easily. I had some designs in mind but there wasn't enough material on hand. Travis is a farm boy and, as such, has the great ability to solve a problem

with what we have available. What he *did* come up with was rather brilliant – two metal rails laying on 2x4's. There's a metal rod between them (spaced for the width of the spool) with a bearing on each end and a conduit clamp around the bearing holding them in place on the metal rails. It looks crazy, but it worked fairly well. Way to go, Travis!



The next step was for the tower crew to mount the Translator and the STL antennas and lines, and connect them to their respective isocouplers. That step was fairly uneventful – everything went smoothly.

We had taken readings and measurements before starting anything so we knew what our starting point was and where we wanted to return to. As was expected, after adding the two antennas and two lines, some of the antenna readings had changed a bit. But it didn't take too terribly much to bring everything back in to where they should be.

Like any project, this one had its *snafu's*. Rod's translator was to be satellite fed. We had picked a spot and “planted” a pipe in cement ahead of time. When he arrived with the dish, the pipe was too big for the mount! He just happened to have another dish with him. This one had a mount the right size for the pipe – but the dish was too small! Sadly, we could not move the “good” mount to the “good” dish. So we did a little in-field modification. We fastened two 4-foot pieces of Super Strut to the cross-arm pieces on the back of the “good” dish, spaced so that the mount from the “other” dish could be bolted to the strut. It maintained the same geometry and is nice and solid.

After we lifted the *slightly modified* dish up onto its pipe we were able to align the dish and pick up a nice solid signal.

And did I mention the *sheep*? We have sheep grazing in the grass in the tower field. We always had to be sure the gates were closed so they couldn't escape. (A couple of them *did* get out once!) I noticed that

the sheep had numbers on their backs. The hardest part of the whole project was staying awake. With the sheep there, I could only count to about 11 before falling asleep! (Sorry – it was just sitting there. I *had* to tee it up and take a swing!)

I hope you've all had a good summer and that you are staying healthy. Remember, stay positive – test *negative!*

And until next time ... Keep it between 90 and 105!

Scott Schmeling is the Chief Engineer for Minnesota Valley Broadcasting. He can be reached via email at scottschmeling@radiomankato.com



We can help on air talent work remotely

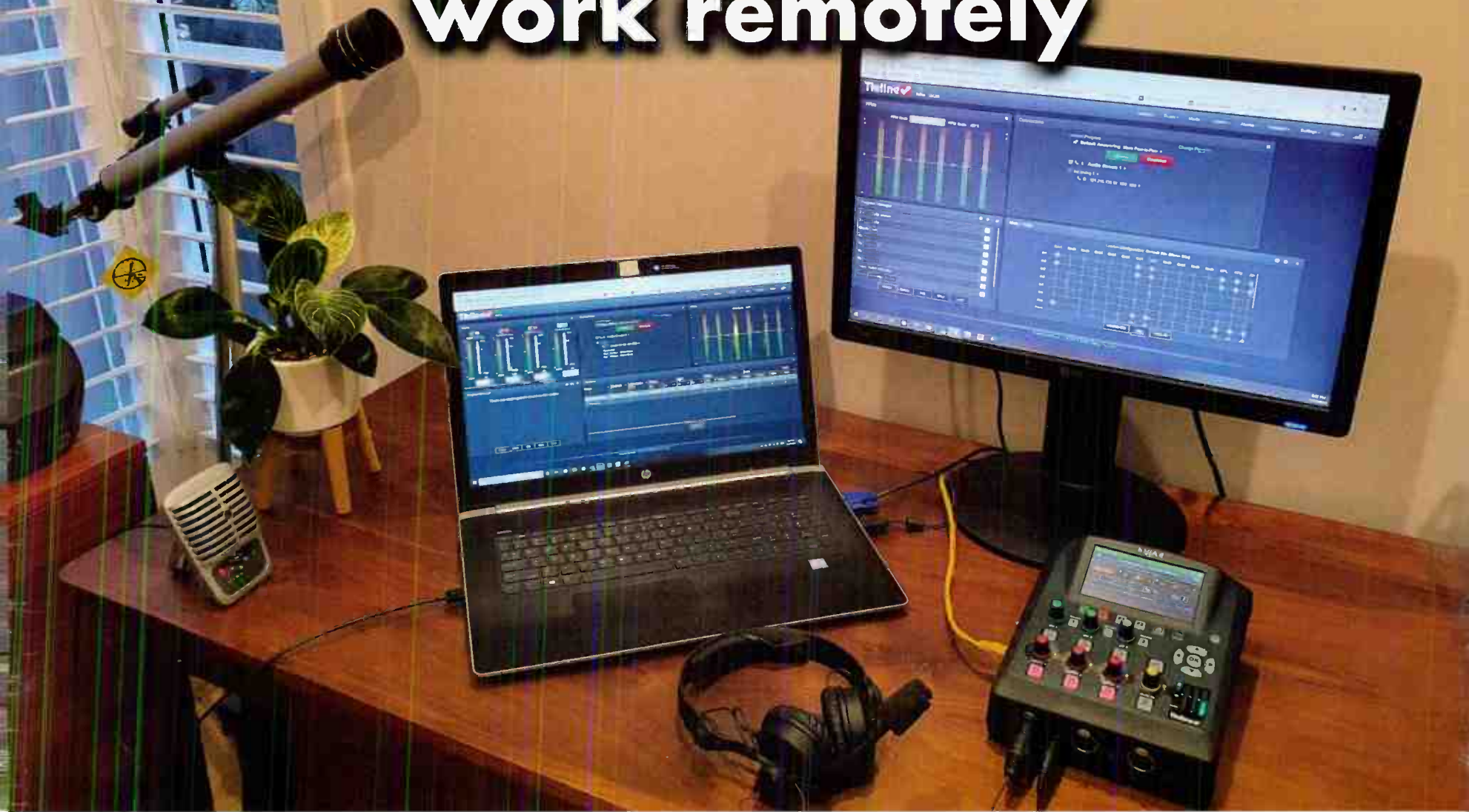

We have the solutions to keep you on-air.

Via



Go live with record, playback, podcast and FTP capability

Bridge-IT



Our cost effective Bridge-IT Pro and Bridge-IT XTRA

Report-IT



Our Smartphone Solution

Tieline ✓
The Codec Company

317-845-8000 | sales@tieline.com | tieline.com

World Radio History

Reconnecting in More Ways Than One

Beating Covid with Comrex

by George Zahn

In this column, over the last few issues, we've been discussing using new, and sometimes older, technology to enhance communication and efficiency during the Covid pandemic. Normally we discuss the "nuts and bolts" of studio equipment, but I'd like to share a story brought on by the pandemic and my station's need to create a critical connection for our on-air use. Reviving an older means of CODEC phone equipment created something even more rewarding than just the on-air link we badly needed.

Many of us can look back on mentors who have helped to guide our careers and provide inspiration. As in my article on "Engineer X" a few years ago, sometimes we lose those people who have a significant effect on our lives, and we don't always savor the moments we have with them. This is a story of recycling technology, rejuvenating our station, and continuing a relationship despite Covid-19.

Here's the dilemma my station was facing. As a public radio entity, we have fund drives throughout the year. One of our fund drive volunteers and "pitchers" is Dr. Jim King, retired after decades of building a radio network with Xavier University and a champion for the programming that my current station, WMKV, provides. He also happens to be a former General Manager under whom I served for more than twenty years earlier in my career.

Dr. King would normally drive to our station a few times throughout September to help us fundraise, but in this day of social distancing, vulnerable populations, and limited station income, we were facing the loss of his involvement, unless we wanted him pitching over Zoom or phone, both of which we considered less than ideal for a fund drive. As we were planning our drive schedule, our building was only open to staff, with no volunteers allowed to enter.

"I knew I wasn't allowed in the station at the time, but I wanted to help the best I could from a distance," said King. "I thought we could have a precedent that no other public station would be trying."

Always the mentor, King suggested we haul out some older technology, and he invested in two older version Comrex Matrix CODEC units. I opened his e-mail proposing an attempt at this and remember thinking, "This might just work!"



The Comrex Matrix CODEC rack unit.

The Comrex Matrix was a staple of remote broadcasting in the days of POTS (Plain Old Telephone Service). If you had a copper phone line at each end of the connection, the bidirectional Matrix CODEC unit

would compress the frequency range on each side of the line, and squeeze it to fit through the limitation of a dial up phone line. On the other end, the signal would be decoded and, depending on the connect rate, you could achieve near studio quality sound with little latency.



Mike Martini in studio and Dr. King on the monitor.

The POTS CODEC units were an affordable and portable alternative to fixed ISDN circuits or dedicated phone lines that were available usually only on a local basis and only from one fixed point to the studio. When Dr. King and I worked together at a previous station, we used POTS CODEC units for sports broadcasting as we were the only public station I know to ever broadcast a professional team's live game broadcasts (Cincinnati *Might Ducks* of the American Hockey League), which we did for several seasons.

Today's limitation to the older POTS CODEC was the availability to POTS, a basic copper phone circuit installed on each end. POTS CODEC units do not play well with VOIP or digital phone lines. The newest Comrex CODEC units are designed to work with digital lines and even cell phones. In this instance, our station was extremely lucky that we still had one copper line extant, despite an earlier conversion of most of our communications to Voice Over Internet Protocol. Dr. King had a standard line added at his home.

As you might imagine, as all this was going into place, some restrictions in our building (also a medical facility) loosened, and we were able to have limited volunteers come to the station. We stayed the course since we had the equipment available. Trying to do our project on a shoestring, we needed a simple Mix Minus connection from our console to the Comrex. It turns out Dr. King had actually worked on the board we're using today. earlier when he and it were at WXXU.

Here's the human reconnection part. Given some leeway to have a volunteer in for a short while, we arranged to have Dr. King come in at a time when there would be minimal contact with staff to protect his exposure and adhere to the strict building access at our facility. I spent a short stint on a Sunday afternoon with my mentor, discussing the technology, audio strategies for our drive, and engineering.

Even though the wiring process lasted all of about thirty to forty minutes, I was pleasantly thrilled to see the glint in his eye as this retired manager and engineer set up the Mix-Minus feed circuitry for the Comrex Matrix unit. I had to wonder how many retired engineers would love the chance to "tinker" on a meaningful project. I honestly believe we both "reverse aged" by about twenty years as we relived some great memories and I learned more from a man who is like my second father. After the short stop, Dr. King was on his way.

"I was astonished at the ease of transition to this older technology," adds King, "If stations have the right older phone capability, they can likely find the Comrex pair (remote and rack units) in the \$500-\$550 range, and save some money by stepping back in time."

The results: Instead of just having Dr. King on our drive, maybe four times in the drive with him having to drive a long round trip and risk exposure during a pandemic, we were able to do six productive on-air shifts (more than twelve hours total) with Dr. King, keeping him safe and having him help WMKV with a successful drive. Even those listening who knew of the technical setup were positively impressed with the "studio quality sound." We did use a Zoom connection simply for visual contact of Dr. King with our host at the station, which added to the "in studio" feel of the conversation.



Dr. King on the Zoom visual connection.

We also have developed a useful system for other remote broadcasting post-pandemic, and it opened up new concepts for us even looking at some of the newer digital CODEC equipment. Through some creative guidance, thinking, and tenacity, we revived some old technology to help our station survive, but personally, and maybe even more importantly, it was a significant reconnection to work with a valued colleague and to allow him to be a vital participant in our on-air sound for the drive and for the future!

As for the "remote" experience, King adds, "It was wonderful. I felt more comfortable and less distracted. In addition to being able to participate safely, I felt I was more effective, and it was a tremendous way to use technology to make a difference!"

George Zahn is a Peabody Award winning radio producer and Station Manager for WMKV-FM at Maple Knoll Communities in Springdale, Ohio. He is a regular contributor to Radio Guide and welcomes your feedback. Share your stories with others by sending ideas and comments to: gzahn@mkcommunities.org

50 ENGINEERING THE FUTURE.



CASE STUDY

Astro Radio

<https://j.mp/3dc1bcH>



Virtual mixers. Real radio.

Virtual mixing and remote production are today's hottest topics. But not every company has the knowledge and experience to make them work — and live on-air is no time to try and straighten out the kinks.

Professional radio demands professional solutions. Expert engineering, feature-rich software and workflows that adapt to work the way you do. These are the reasons Astro Radio chose virtual mixers built with Lawo VisTool, the most capable touchscreen mixing software in the business. Ultra-customizable and ultra-reliable, with hundreds of installations around the world. And backed by a network of broadcast technology experts throughout Europe, Asia and North America. Ready to go virtual? So are we. Let's do this.



Lawo Lounge Webinars. Tech Talk, Insights, Tips & Tricks...
Now streaming on demand. More to come. Stay tuned!



www.lawo.com

Greasy Fingers

by Gary Minker

To stress the importance of clean, tight mechanical connections in any type of electrical work should seem redundant. Clean connections, while having only a marginal connection to Godliness, offer better conductivity, lower heat generation, less possibility of spurious or Intermodulation issues, and certainly will live a lot longer in the intended class of service. If just these items are insufficient to keep you on the proper path, another line of work may be indicated. Good mechanical integrity is similarly important. Good mechanical connections, where electricity is involved, should be only too obvious. Lower heat, less chance of spurs and certainly once again ... that longer life thingy.

In my articles I pose some constant themes. In this vein, I mention that the factories who make these RF and other electrical related parts do exactly this – they *make* the parts. They *do not* clean them. They make them in a hostile, dirty environment, bag em, tag em, and ship em to you. They don't care if you are dumb enough to yank em out of their bag or container and put em in, as is, because they seem to look shiny.

Perhaps one of the best photos running around is of this ground bar. This is not my photo (and I don't know whose it is) but certainly, other than the horrific ground fault current running through this cable, the loose nut on the terminal is a problem.

Similar problems can arise from dirty rigid line bullets. A dirty bullet is often the source of extreme heat. Yes, a high V.S.W.R. condition or lightning can contribute to this kind of over heating but I find that from station records, and annual Line Sweeping, systems with no sign of tuning or V.S.W.R. faults can often just cook off dirty bullets.

The factory just makes this stuff. They don't clean this stuff. Copper tarnishes. Silver tarnishes. There are multiple dissimilar metals in Rigid Line. These metals do not play well together in the Galvanic Table, when subjected to high humidity for any period of time.

If Galvanic corrosion is not bad enough, introduce the tarnish on the copper surfaces and the all time winner is the patina that appears on the fine German Silver plating of the bullet anchor connectors. What is an oxide? Other than containing some extra oxygen, oxides are a crystalline substance. Think about sand paper, and grinding wheels. The silver patina is a crystalline abrasive that, through thermal cycling, grinds away,

twice or more a day at the mated surface that it is connected to. This grinding action creates arcing and pitting.

The explosive action of the arcing in a bullet connection ejects carbon everywhere. Whether it is a Nickel plated bullet, Silver plated bullet, or a Brass bullet, the surfaces of the bullet and the inside of the inner must be clean. Once the carbon has a conductive path, the show begins.

Greasy Kid Stuff

The mechanical connections are not the only thing that have to be extremely clean. Insulators are very susceptible to greasy fingers. While it may seem like a broken record (skipping CD for the younger of us), greasy finger mung on insulators is a primary cause for that initial carbon track to bark across an insulator and Yippee Zippee, you have a fire on your hands.



Notice if you will the pristine condition of the above bullet. Notice how clean and shiny the fingers are. This bullet has only been in service for two years. This line section was assembled by a crew who did not use any cleaning protocol at all. Lucky enough that the bullet survived and was relatively clean when installed, but the insulator did not fare so well.

I know that there will be those who might suggest that this is a bolted half bullet and the bolt was loose. There are those who will suggest that this was not greasy fingers but a high V.S.W.R. point node that *only* cooked the Teflon and not the bullet ... and to those I wish a Merry Christmas.



This photo above is an example of everything that can possibly go wrong, right up to the point where fire starts. Excessive "O" ring grease is everywhere. Nothing is cleaned. If it were not for the fact that there was only 1,200 Watts in this bay connection, the fire would have started sooner and been spectacular. The grease had started to burn and boil, expelling the molten goo everywhere.

Clean is Good

Having a discussion about cleaning R.F. parts is almost as bad as discussing religion or politics. There are Ford Fans, Chevy Fans, and there is always a Dodge Fan out there. Cleaning parts meant going over the item once with any old clean or dirty rag and some Denatured Alcohol. I am both thrilled and regretful to say that It Is *not* 1927 – no longer. Alcohol has issues as certain as a dirty rag. Alcohol is very slow to evaporate, and denatured alcohol often contains water. This deadly combination leaves a residue on the parts and in the cracks that does not want to evaporate. Worse yet, it does not displace water, remove dirt, manage carbon, clean the part, or leave it shiny and bright. Yup, alcohol and water vapor can accumulate inside of your lineand, though it is rare, flame outs have happened because of the low volatility of both of these liquids prior to assembly. Here we are a hundred years later and they are *still* in use. The dirty rag part should be self explanatory. If you would not wipe your face with a dirty rag (well some of you), then don't wipe the parts with one either.

Members of the military and other governmental concerns might have had run-ins with MEK or Freon as cleaning agents. Both of these are banned these days and for about 30 good reasons. While they did their job very well, these chemicals needed to go away.

Today, the ideal choice for a cleaner is a liquid, that after it is applied and it has done its thing, quickly and completely evaporates as a fully volatile chemical. You want a 100 percent volatile nasty chemical that cleans, whitens, brightens, solves dirt, grease, grime and manages carbon, all the while sucking these evil contaminants in to the "clean" terry cloth or cotton rag.

This highly volatile chemical that I refer to is generically called Brake Cleaner. There is chlorinated and, for the copper purists, non-chlorinated. This nasty chemical is truly nasty and has a 37 page hazardous materials data sheet. While it is more flammable than most aerosols in the presence of a flame, it fills the bill precisely as the cleaning chemical Du-Jour. Contact with this stuff should be kept to a minimum. Nitrile gloves might be recommended as are cotton gloves over top of the Nitrile to keep finger prints off of the target cleaned surfaces. Remember, clean parts are happy parts. Aside from the fact that your fingers will be bright and shiny, if you do not wear the rubber gloves, most of the moisture will be pulled from your skin – you get my drift that this 100% nasty chemical is just what the doctor ordered for cleaning RF parts after you have done your thing. If you are sitting there gritting your teeth, thinking that Lectroclean or some other electrical solvent is good, think what you will, but that does not evaporate well either. Just keep all of these away from plastics unless you want a gooey mess.

Your Thing

Cleaning parts is often a mechanical venture. This venture typically involves Green or Red Scotch Brite. Many of the learned out there would be shocked to learn that there are actually ten (10) grades of this magnificent product. www.3m.com/3M/en_US/metalworking-us/products/flat-stock/hand-pads/

This product can be as damaging to the fine Silver plating as it can be effective in cleaning both the silver and copper. It takes practice with the different grades of abrasive pad to properly clean and polish away the gunk and tarnish. All abrasive cleaning activities should be followed up with a good dousing of the aforementioned nasty chemical and dried off with the dampened terry cloth or cotton, lint free rags. I know that this strikes a nerve with those of you who are addicted to the ways of the forefathers but get with it guys (and girls) there are better tools and methods to insure that your new antenna lives a happy and long life.

Gary Minker owns Radio Works R.F. Consulting Email him at: gary@RadioWorksRFConsulting.com or call 561-346-8494. Find Gary on the web at www.RadioWorksRFConsulting.com

Skylla

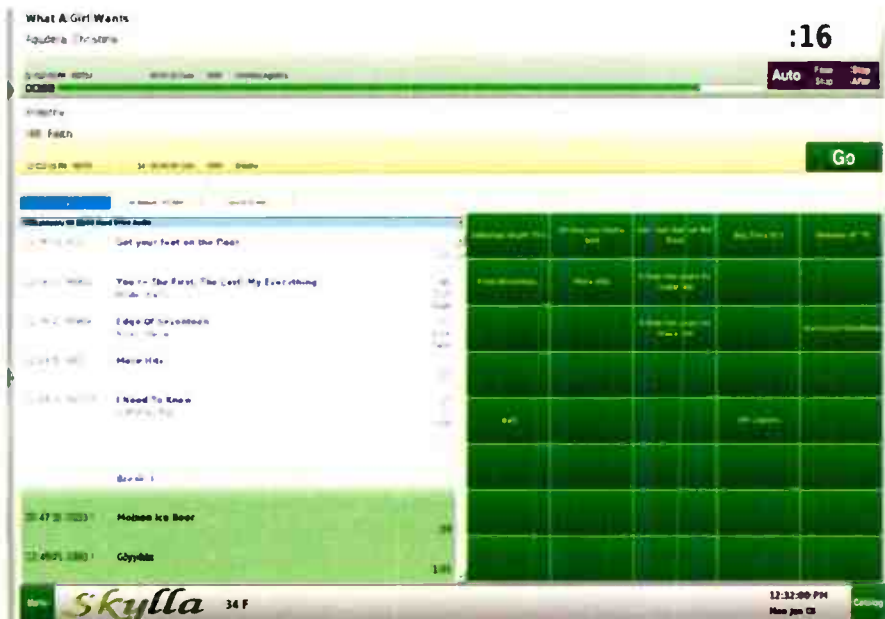

Skylla's Smart Features:

Smart Special Events like ballgames, national and local.

Smart Satellite support, complete with incoming RBDS data, announcers, clocks, break-tracking, and automatic break fill.

Smart Automatic Downloads of audio from the Internet.

Smart Automatic Unattended Recording by time, closure, or both.

Smart Voice Tracking allowing people to voice track at the same time to the same log, both at the station and remotely. Also allows voice tracking to future yet-to-be-merged playlists.

Smart Design. For uptime and reliability: Linux. For data safety: RAID and machine-to-machine backups of audio and data.

SkyllaPad



Simplify local sports broadcasts.

With features found only on SkyllaPad, broadcasting remote sporting events has never been easier.

You supply audio, SkyllaPad supplies control. With the touch of a button on a Smartphone, tablet, or laptop, you're on the air and in charge of your remote.

SecGen

Traffic & billing software designed for you.



SecGen, the second generation of our original Smarts program, lets you define the setup by matching the program to your station's formats and breaks. Combined with the ability for single user, multi user, and remote user, SecGen can be customized to fit your needs.



New Public Notice Rules Coming Soon

by Gregg P. Skall, Member – Telecommunications Law Professionals PLLC

It looks like the Commission has finally gotten the word: Newspapers are out – broadcast and the Internet are in. So, get ready for a big change in the FCC public notice requirements.

Broadcasters have complained for many years that FCC public notice requirements are outdated, expensive and unnecessary. Newspaper publication, it is argued, generally goes unnoticed while broadcast notices are sufficient and better at reaching listeners who have views on station performance. In May of this year, the Commission finally acted on its proposals to eliminate the newspaper public notice. After the effective date, it will require that applicants provide on-line public notice with links directly to the station's FCC-hosted on-line public inspection file or its application databases, or through on-air announcements that direct viewers and listeners to those application resources.

Effective Date

For now, the new rules have not yet become effective. While they await approval from sister government agencies, the old rules remain in effect with one exception: The Commission has waived the license renewal pre-filing announcement requirement for all license renewals filed since June of 2020 until the effective date.

Background

Section 311 of the Communications Act requires applicants to give notice of application filings in the principal area served or to be served by the station. The Commission implements this mandate in Section 73.3580 of its Rules. Agreeing with broadcasters that the rule "has become increasingly complex, creating compliance difficulties," it has revised on-air public notice announcements to make them simpler, less frequent, and more effective at referring viewers and listeners to the Commission-hosted on-line public inspection file (OPIF) where they can make their views known.

Under the new rule, public notices in newspapers are no longer required, replaced by on-line public notices. Each notice must be posted on a publicly accessible website for 30 days, but there is a rub. The notice period must begin within five days of FCC acceptance of the application for filing, instead of with the filing date. This poses a problem for broadcasters. Careful monitoring of the FCC daily public notices will be needed to determine the date of acceptance, which is not always a predictable number of days from filing. While some new service may make that task easier in the future, for now it will require scouring FCC releases for a period following the filing of an application.

The requirement to post the notice text on a station's homepage has also been changed. Broadcasters will now be required to include a conspicuous "FCC Applications" link or tab on the website home page. The link must lead to a separate page containing the full notice text.

The proposed on-line notice text has also been changed to mirror the on-air announcements and to indicate where members of the public may obtain information to file comments on the applications. The Commission has committed to provide links on its OPIF and LMS Landing pages to a new fcc.gov page detailing how members of the public can comment on an application.

Since some broadcasters have multiple websites and some do not have even one, the Commission adopted a posting priority system, in the order of availability. That website priority postings, in order, is as follows: (1) the applicant station; (2) the station licensee; (3) the parent entity or, if there is no applicant-affiliated website (4) on a locally targeted website that is publicly accessible and free to access without charge or exposing personal details. Examples of the fourth priority include a local government website, local

community bulletin board website, local newspaper website or a state broadcasters' association website. The licensee applicant must also post a tab or link on its home page conspicuously labeled "FCC applications," that will link to a separate page containing the text of the notices.

As it did with the contest rules, the Commission is requiring that the link or tab must be "conspicuous," defining that to mean that the link or tab must be displayed in such size, color, contrast, and/or location on the home page so that it is readily readable, understandable, and locatable by visitors to that page. Even if there are no pending applications requiring on-line public notice, the station must still have the link and it should direct to a page that indicates there are no pending applications subject to the posting requirement. The page must also indicate when it was last updated.

Despite the growing use of "APPS" by stations, the Commission specifically retained the World Wide Web as the locus of the on-line public notice.

The Revised Broadcast Public Notice

The public notice order also adopted a new standardized and simplified on-air announcement it characterized as "streamlined." The new script directs viewers and listeners to the application On-line Public File or the Commission database. Broadcasters may now air the notice anytime from 7:00 AM to 11:00 PM local time, Monday through Friday, rather than in specific dayparts. The total number of required on-air announcements is increased from 4 to 6, and they must be aired at least once per week for four consecutive weeks. As noted above, they must commence no later than five days after release of the public notice announcing the acceptance for filing. Since six announcements in four weeks will require that some weeks have more than one announcement, announcements broadcast in the same week may not be aired on the same day. Notably, all pre-filing announcements have been eliminated. Since the commencement period was changed from five "calendar" to five "business" days following the notice of acceptance, notices will not be aired on weekends.

Requiring that the announcements air at any time 7:00 AM to 11:00 PM local time, brings uniformity to the current rule, which has different announcement requirements based on the applicant, type of application and service.

The Announcement Script

Here is the new FCC-required announcement script:

On [DATE], [APPLICANT NAME], licensee of [STATION CALL SIGN], [STATION FREQUENCY], [STATION COMMUNITY OF LICENSE], filed an application with the Federal Communications Commission for [TYPE OF APPLICATION]. Members of the public wishing to view this application or obtain information about how to file comments and petitions on the application can visit publicfiles.fcc.gov and search in [STATION CALL SIGN'S] public file.

For stations without an OPIF:

On [DATE], [APPLICANT NAME], licensee of [STATION CALL SIGN], [STATION FREQUENCY], [STATION COMMUNITY OF LICENSE], filed an application with the Federal Communications Commission for [TYPE OF APPLICATION]. Members of the public wishing to view this application or obtain information about how to file comments and petitions can visit www.fcc.gov/searchlms, and search in the list of [STATION CALL SIGN'S] filed applications.

The On-line Public Notice

The text for the on-line public notices is slightly different: **For authorized stations (with a granted construction permit or license):**

On [DATE], [APPLICANT NAME], [PERMITEE / LICENSEE] of [STATION CALL SIGN], [STATION FREQUENCY], [STATION COMMUNITY OF LICENSE OR, FOR INTERNA-

TIONAL BROADCAST STATIONS, COMMUNITY WHERE THE STATION'S TRANSMISSION FACILITIES ARE LOCATED], filed an application with the Federal Communications Commission for [TYPE OF APPLICATION]. Members of the public wishing to view this application or obtain information about how to file comments and petitions on the application can visit [INSERT HYPERLINK TO APPLICATION LINK IN APPLICANT'S ONLINE PUBLIC INSPECTION FILE (OPIF) OR, IF THE STATION HAS NO OPIF, TO APPLICATION LOCATION IN THE MEDIA BUREAU'S LICENSING AND MANAGEMENT SYSTEM; IF AN INTERNATIONAL BROADCAST STATION, TO APPLICATION LOCATION IN THE INTERNATIONAL BUREAU'S MYIBFS DATABASE].

For proposed stations that have not yet been authorized:

On [DATE], [APPLICANT NAME], [APPLICANT FOR] A NEW (STATION TYPE) STATION ON [STATION FREQUENCY], [STATION COMMUNITY OF LICENSE OR, FOR INTERNATIONAL BROADCAST STATIONS, COMMUNITY WHERE THE STATION'S TRANSMISSION FACILITIES ARE TO BE LOCATED], filed an application with the Federal Communications Commission for [TYPE OF APPLICATION]. Members of the public wishing to view this application or obtain information about how to file comments and petitions on the application can visit [INSERT HYPERLINK TO APPLICATION LOCATION IN THE MEDIA BUREAU'S LICENSING AND MANAGEMENT SYSTEM; IF AN INTERNATIONAL BROADCAST STATION, TO APPLICATION LOCATION IN THE INTERNATIONAL BUREAU'S MYIBFS DATABASE].

The online notice must be posted for thirty continuous days, beginning no earlier than five business days after application acceptance.

NCE Stations

NCE stations may continue to fulfill their local notice requirements solely through on-air announcements, where possible, unless they are not broadcasting during the part of the year when on-air announcements are required. Applicants for initial NCE construction permits need only to comply only with the online notice requirements, as they are unable to broadcast on-air announcements.

Only Station Exemption

Where the applicant is the only operating station in its broadcast service in the community the current rule exempts it from the written notice requirement. This exemption is revoked in the new rule. The Commission concluded that the proliferation of outlets in today's media landscape no longer guarantees that a notice will be viewed or heard merely because it airs over the only station licensed at a given community.

Silent Stations

When a station is not broadcasting during the period when the on-air announcements are required, it must then comply with the online notice requirements during the period when it is not broadcasting. Once the silent station returns to the air, the station must resume on-air announcements.

Channel Sharing and Multicasting

Television broadcasters will now be required to display on screen the full text of the on-air announcement during the verbal broadcast of the announcement. The rule does not require visual text beyond the announcement nor television text crawls containing the text of the on-air notice.

Each television station in a channel sharing arrangement must broadcast appropriate on-air announcements on its own program stream. In multicasting situations, however, the Commission said it will interpret Section 311 of the Act to require on-air notice only on the digital TV or digital radio station's primary over-the-air programming stream.

This column is provided for general information purposes only and should not be relied upon as legal advice pertaining to any specific factual situation. Legal decisions should be made only after proper consultation with a legal professional of your choosing.

Gregg Skall is a member of the law firm of Telecommunications Law Professionals PLLC. He frequently lectures on FCC rules and regulations, represents several state broadcaster associations and individual broadcasters and other parties before the FCC.

ARC-talk-Blue

5 Mic channels with dual Conferencing Bluetooth Phone interfaces

- Eight channels
- Stereo Program output
- 5 mic, 1 stereo line, 1 PC, & 2 Bluetooth inputs
- USB interface for play and record from a PC
- 2 Bluetooth interfaces for Two Cell Phone callers
- ...or... stream audio from any Bluetooth Audio device



Easy access connectors for Fast installation...



- Fast, easy installation:
- RCAs for unbalanced IO,
 - Cat5s for balanced inputs,
 - XLRs for mics & Program output

NO Hybrids needed

list price **\$1,149**

Mic Mixers Reinvented !!!

Powerful, compact, portable and not needing a land line to take incoming calls, the 'ARC-talk-Blue' is ideal for applications that require a mic mixer with bluetooth sources or bluetooth telephone caller interface. The revolutionary console features 5 high quality mic channels plus phantom power. Channels 6 & 7 on the console can be paired to any Bluetooth enabled audio device such as your Cell phone, MP3 player, MP3 recorder-editor, and more. Each 'Blue' channel features a button you push to connect an incoming caller and push again to disconnect from the caller. The channel One mic features 'Talk' buttons to talk to each Blue caller off line. No external hybrids are needed. OR... you can pair any Bluetooth enabled audio device such as an Ipad, Tablet device, or MP3 player and stream full bandwidth, high quality stereo (A2DP) audio into the console. The 'ARC-talk-Blue' also features a built in USB PC sound card on channel 8 so that you can play audio from your PC while recording the console Program output with your favorite software. Once again, Arrakis is 'The Leader' in Radio console evolution. Follow the Leader and visit our website today.

...the Bluetooth phone interfaces work with BOTH cell phones and Bluetooth headset enabled land lines.

www.arrakis-systems.com

970.461.0730

ARC-15 advanced Radio console

1 Mic, 4 Mic-line, 10 line channels with optional Bluetooth Phone interface



CAT 5 cables included



Easy access connectors for Fast installation...



- BOTH balanced and unbalanced Outputs
- RJ45 balanced inputs WITH cables supplied
- XLR connectors for ALL mic inputs

NO compromise, take no prisoners design !

Our ARC-15 (Advanced.Radio.Console) is called advanced for many reasons: 15 input channels, 5 assignable mic preamps with optional phantom power, Telco interface, PC USB sound card built in with free Radio software, analog VU meters for high resolution and ease on the eyes, socketed ICs for ease of repair, RJ45 connectors with cables included for fast wiring, electronic switching of all audio for crystal clear performance, LED lamps for highest reliability, optional Bluetooth interface and much more.

list price **\$3,999**

...the Bluetooth phone interfaces work with BOTH cell phones and Bluetooth headset enabled land lines.

www.arrakis-systems.com

World Radio History

970.461.0730

What Flavor Maintenance Do You Want?

by Michael Bradford

It may be strange to talk about a “flavor” of maintenance but it seems as if different descriptions or styles of maintenance are becoming more prevalent as the Covid-19 pandemic works its way into every-day life around the work place. What might have been routine in 2019 may now be difficult because of staff reduction, income disparity, or management decision to eliminate maintenance, unless and until a failure causes an off-air situation.

Let’s face it; if your lawn mower runs out of fuel in the middle of the job, it’s no big issue, unless you’re getting ready for an outdoor wedding in 24 hours. If your generator runs out of fuel, it may not be a big deal right then, but if the weather turns ugly and you lose power, then it could be a big deal. If the sump-pump in the basement at your location fails it could be a big deal, especially if it goes wheels-up during an intense rain storm.

Before the Covid-19 interfered with every day life, you could travel to your various work sites with little concern and perform your proactive maintenance work. Checking on the LPG tank level, checking the radiator fluid level, the battery condition, fuel level, and the warning lights on a monitor panel could be easily accomplished and often at your leisure. With the travel restrictions in place these days of staff reduction, your travel might be impacted. If your station is operating on reduced or no staff, thanks to C-19, regular maintenance could be placed on the back-burner. This may not be a big concern to management because if you have been performing a good maintenance job for a long time, management may take reliable operation for granted. They may not even consider maintenance until the machines you have been responsible for fail and all of a sudden they become vital to every-day operation.

“Proactive” maintenance, in my opinion, means there are failures you know will occur and you plan for them. You know the fan belt will fail at some time, so you have one on-site. You know the radiator hoses and thermostat will eventually fail, causing your generator to die, so you have a hose-set and new thermostat on-site. You know the battery has a finite life so any unit older than 3 years is running on borrowed time. Of course, storing a spare battery on-site presents some other issues, like keeping a trickle-charge on it, keeping it in a clean environment and not too cold or too warm. Most modern generator sets provide a battery charger built into the system. But what happens if the

charger fails and the battery self-discharges over a period of time.

My definition of “Predictive” maintenance means some problem has been detected by a sensor or circuit of some type and a warning of an impending or present danger is sent in real-time so you can respond. “Proactive” means some live person made regular observations of the various components of a system and reacted prior to an actual failure. For instance, you notice the radiator level is down from the last inspection, so you run the machine and look for a leak or overheating. You check the open-circuit voltage on your battery and finds it’s below 11.5 VDC and either the battery is in “end-of-life” mode or your charger has failed. Most generator monitor panels can provide an

indication when there is a “fail to start” condition. If you don’t have this alarm sent via some sort of monitoring system, and on-site visits have been restricted or eliminated all together, you won’t know there is trouble until the generator is needed. Then a simple battery swap isn’t simple any more. “Predictive” maintenance is becoming more important as a

single person may now have to inspect so many generators, because of staff reductions, that the luxury of “Proactive” maintenance doesn’t exist.

More and more generator manufacturers are touting their own monitor systems (at extra cost of course) to send various alarm conditions to you via an I-Net connection. My experience with wired systems connected to the building I-Net LAN in some fashion, is that they are doomed to fail at the most important time. If your ISP at a remote site is not 99.9% reliable with sufficient bandwidth, then you could be in trouble. If you have an otherwise good generator without the extra alarm contacts available, how can you monitor the unit and be “Proactive?”

I have been recommending a wireless system from Ayantra, Inc. of Fremont, California that uses tried and tested cell-phone capability to send a text alert and an email alert for any of several alarm input conditions. If you have cell-phone service at a site, you have wireless alarm capability. The inputs to the monitor module can be open collector types or a simple dry contact. Many generator manufacturers have on-board auxiliary relays you can program to send closures to such an outboard device. The Ayantra system offers an auxiliary relay that disconnects the battery charger for a moment to give a “true” indication of battery charge

level. A simple float switch can be installed in the diesel fuel tank to confirm level. This same type of float switch could be used to monitor that basement sump-pump if you have one at your location. Third-party vendors can provide pressure switches for your LPG tank to confirm level. The Ayantra monitor provides constant confirmation of the presence of primary power, generator output power and length of run-time. The unit monitors actual generator output voltage so you know the generator is functioning and not just the engine. You will know each time the weekly test-run is underway. You can enter the engine hours upon installation and program the system to alert you when normal maintenance is due.

You can label the numerous inputs to your liking to give a clear indication of the source, so when you get an alert at 3:00 a.m. you can quickly determine your next move. If the generator has been running for 9 hours and you get a “low fuel level” alert, perhaps you should call for an emergency fuel delivery. If the battery charge drops below the predetermined level, should you launch right then or wait until morning?

The Ayantra units are weather resistant and include a built-in battery backup. I have installed several in outdoor enclosures with an input terminal strip and the “hockey puck” antenna mounted on top. The actual monitor module seen in **Figure-1** is small enough to mount inside the generator control panel if you choose and the antenna includes a 12 foot cable for easy mounting at a distance. You can power the units with anywhere from 12 to 48 VDC. You can connect to the generator battery or I like to get power from the outlet used for the battery charger using an ordinary plug-in power supply module – a good way to confirm a breaker hasn’t popped in that auxiliary outlet circuit. I have found that the text alerts and email alerts arrive in less than 30 seconds from the alarm closure. You customize the web-page to your liking and it gives a complete indication of all parameters in real-time. You can print the entries as a good backup for your regular maintenance log.

As the RCA-870 unit has six (6) alarm inputs plus the primary power and battery condition indications, you could connect a generator enclosure tamper circuit, building entry alarm circuit, or interface with the building’s existing fire alarm for redundancy. Check out the RCA-870 monitor module and other Ayantra units at www.Ayantra.com.

Michael Bradford began his career at WCCW in 1962, A CPBE since 1984, and currently a contract engineer. You may reach him at: mbradford@triton.net



Open the door to *your* possibilities!



ON THE AIR

Powerful, state-of-the-art automation with the flexibility to grow with you...

- The power of OPX in one stand-alone computer
- Easy to learn
- The power to handle the largest audio libraries
- Satellite and live programming
- Additional stations
- Remote voicetracking
- Remote control

OPX ONE



Call (888) 274-8721
(888) BSI-USA-1
or email us at sales@bsiusa.com

Survival Guide

2020: The Year of COVID

What have we learned and where do we go from here?

by Shane Toven, Senior Broadcast Engineer
Educational Media Foundation (K-LOVE/Air1)

As we watched the calendar roll over to 2020, I don't think any of us could have predicted what this year had in store. I doubt that anyone expected to see a global pandemic explode and most economic activity in the world essentially grind to a halt for three months while businesses were shuttered, and everyone was told to stay at home to "flatten the curve." Eventually, as summer arrived, things started to look slightly better. Restrictions were eased, only in many cases to see them put back in place shortly thereafter as the numbers deteriorated once again and the risks increased.

Challenges

We as broadcasters still have a job to do as an essential service, so engineering and IT departments quickly scrambled to find creative ways to equip their on-air and office staff to work from home. This included implementing automation improvements or changes such as remote voice tracking, remote access and control of AoIP systems, setting up on-air and production staff with "studios" at home, codec links from those home locations back to the main studios (software or hardware based) – on top of the work required to ensure the rest of the station staff could work from home. VPN links needed to be established, laptops needed to be equipped with the proper software – all of this in a very short period of time, without knowing how long we might need to work under these conditions.

These challenges of quickly adapting to an entirely new way of working were on a scale unlike anything we had faced before. Most of us have done remote broadcasts at some point in our career, but this took the idea of "remote broadcasting" to a whole new level. Thankfully, some broadcasters already had groups of staff working remotely, so the impact was minimal in those cases. Many broadcasters also had some form of business continuity plans in place, but some of those plans likely never accounted for something of this magnitude, or they had not been kept up to date as various needs and available resources changed. This was not a simple temporary evacuation of the studios due to a natural disaster or other localized emergency with a defined timeline – it ultimately became a public health issue of unprecedented scope with no defined end date. This sort of uncertainty isn't easy for any company to deal with, let alone broadcasters.

Broadcasters suddenly found themselves forced to answer some important questions. Who stays at the studios (if anyone)? How do we keep our staff safe, and keep the public informed with the latest information about the pandemic? How do we work from home to maintain normal on-air and business operations if we can't access the studios at all? What about the financial implications? Do the spots or imaging we are running need to be adjusted? Will the businesses that support us survive being shut down for an extended period of time? Can we get critical supplies and equipment that we need? Will staff that needs to travel for purposes of keeping the station on the air actually be allowed to do so?

Ripple Effects

As the pandemic started to ramp up in earnest, we saw shortages of any number of items (besides the inexplicable

lack of toilet paper on the shelves early on). Webcams were nearly impossible to come by, as were laptops, and many other pieces of networking, broadcast, and production equipment. PPE (Personal Protective Equipment) for staff such as masks, gloves, and sanitizer were also in short supply initially. This wasn't so much because there was a shortage as it was extremely high demand in a very short window of time. The supply chain simply could not keep up. In addition to supply chain issues, we started to see unprecedented cancellations of major trade events such as the NAB Show. Tragically, we have also seen many people lose their jobs and businesses close their doors permanently due to the downturn in revenue.

Creative Solutions

Challenging times require creative solutions, and we as an industry have stepped up to the plate. One of the first things to be addressed for most stations was getting the air staff set up remotely. This took any number of forms, but many broadcasters chose to use remote voice tracking. Most automation vendors already offered this feature, so it was a pretty straightforward addition for those stations. Even broadcasters without this capability from their automation vendor could use remote access software such as TeamViewer and some form of audio codec link, or simply record voicetracks locally and then place them in a secure folder for retrieval by the automation system.

This worked fine for single hosts on a shift. For broadcasters with teams hosting various dayparts, however, it presented another set of challenges. Live may not have been the most desirable option due to the possibility of a connection dropping out at the worst possible time with nobody as a backstop at the studios to switch to an alternate source. In those cases, teams were often set up with some form of "behind the scenes" link between them such as Zoom so they could see and hear each other.



Rodecaster Pro

Another popular solution for these remote teams and hosts was the RODEcaster Pro (<https://www.rote.com/rodecasterpro>) paired with broadcast quality microphones such as an RE27 or SM7. Many hosts improvised room treatments such as comforters hung from walls or worked from inside a closet. Studio quality audio could then be transported between the hosts and the studios via websites such as CleanFeed (<https://cleanfeed.net/>) or ipDTL (<https://ipdtl.com/>).

Dedicated hardware codecs were also an option. These teams could then record their breaks in near realtime as voicetracks in the automation system. The end result was mostly seamless to listeners.

As for the shortage of webcams? Wyze, a popular manufacturer of inexpensive WiFi cameras, quickly developed firmware for their cameras to allow usage as a USB webcam. Although it requires an oddball USB A to USB A cable, this lash up works remarkably well and the cameras are in abundant supply (<https://support.wysecam.com/hc/en-us/articles/360041605111>).

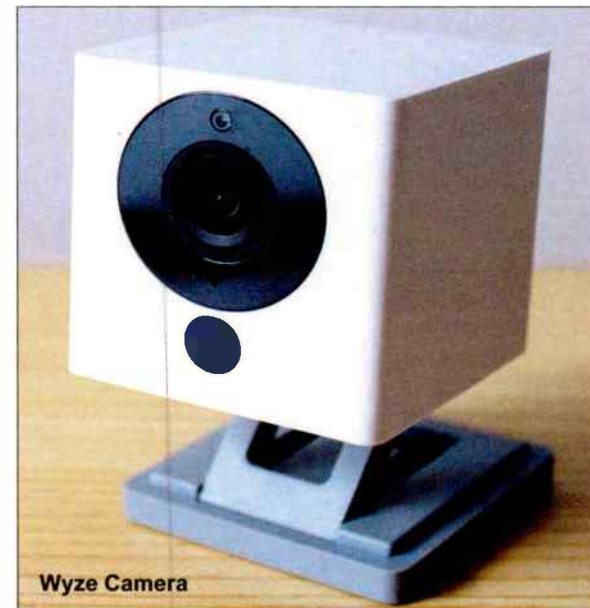

Wyze Camera

Despite the cancellation of the NAB Show and other major gatherings, broadcast equipment manufacturers and other professional groups have readily made the shift to virtual gatherings. Nautel successfully held their very well attended annual NUG conference virtually and continues to host their Tech Talk Tuesday webinars. Other manufacturers such as Telos are also producing regular webinars for the industry. The SBE has a large archive of webinars available to its membership as well.

Lessons Learned

While we are still learning as we navigate this ever-changing situation, there are a few basic lessons to take away from our response thus far...

Lesson 1: Ensure your contingency plans are kept up to date and test them regularly. If you don't have a contingency plan, make one and incorporate steps that you have taken during the pandemic so far. As part of this, ensure you have any identification or documentation that might be required for mobility during emergency conditions, such as the CISA letters issued earlier this year.

Lesson 2: Expect the unexpected and stay flexible. We as engineers like things neat, tidy, and well defined – but sometimes you need to roll with the punches.

Lesson 3: Use whatever resources are available to you. Don't be afraid to even reach out to (gasp) a competitor to share resources or see if they need any resources if you are in a position to do so. We are stronger together.

Lesson 4: Make sure you take care of your own needs before anything else. You know how, during the airline safety announcements, they tell you to put your own mask on before assisting others? The reason is because you will be in no position to help others if you aren't ensuring your own well-being first. Burnout is a very real issue. Learn to recognize the signs and respond appropriately *before* reaching that point.

Stay safe, stay healthy, stay flexible. Life may look different, but we will get through this. – Radio Guide –

One Receiver to Tune Them All

**Powerful, Versatile,
Rock Solid
Dependability!**



- **AM / FM / NOAA Weather Receiver & Real-Time RDS Decoder**
- **Industrial Grade: Built to be used 24/7/365**
- **Unbalanced Headphone Output**
- **Balanced Speaker Output**
 - **Analog Standard, AES3 Optional**
- **Extensive Monitoring & Alarm System**
- **User API Makes Automation Easy**
- **Modular Design for easy reconfiguration**
- **Tamper Resistant Settings**

For Full Information Visit

www.rfengineers.com

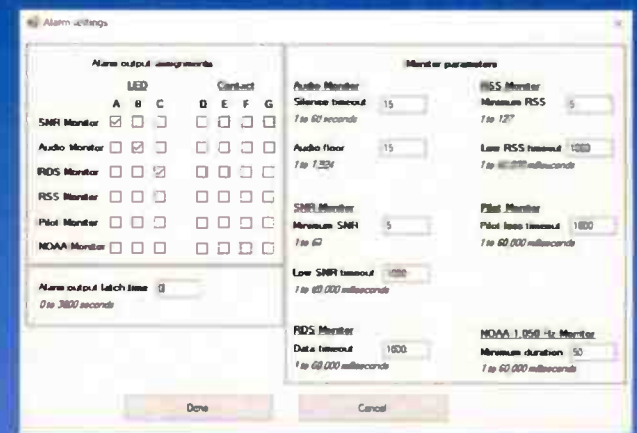

**Contact your favorite
dealer to order today!**



High Voltage is Not Your Friend

by Dave Dunsmoor

When working with equipment utilizing high voltage, it is a given that we stay clear of energized elements. But what constitutes “high” voltage? And how far away is safe? How can we determine both what is safe for us and safe for our equipment?

Forty volts seems to be the threshold that activates the “HV” annunciator on many DVMs today. I never used to consider this seemingly low voltage to be a problem. However, manufacturers (or their attorneys) presumably have done the research indicating anything over 40 Volts is potentially hazardous.

Current is the dependent variable here; its value is the result of the applied voltage and skin resistance. Very low currents – way less than 1/10 of an Amp – can bring severe pain, loss of breathing and/or muscular control, and even heart fibrillation. As little as 50 mA can be fatal. This is why the “One Hand in the Pocket” Rule is a good one – it has saved me at least once.

Since I personally prefer to avoid such empirical research into the subject, I will use 40 Volts as the point where I do not poke about with my bare hands.

Now that I have defined 40 Volts as “high voltage,” just how do we go about safely troubleshooting equipment that generally has far more potential in it than this? After all, it seems like many feel it is just “common knowledge” that you have to do some “fingerpoken” to get the job done.

Know the Circuit

Probing equipment with a voltmeter can usually be done safely if you are very careful to keep in mind where your hands are and where the energized parts are located. This rule works well until you get distracted, or are tired – situations that can easily occur during a callout to make repairs.

Older audio boards, new audio boards’ power supplies, older transmitters, newer transmitters, receivers, and computers all have high enough voltages in them to be truly hazardous. If you treat them all with the required care and respect, you will reap the benefits of (1) keeping your life and good health, (2) keeping your repair time to a minimum, by not having to run out for more repair parts or test equipment, and (3) keeping your self respect and professional status with your clients intact.

Few things will make you seem to be the dull-witted, nerdy stereotypical engineer quicker than a “snap!, flash!, and a puff of smoke.” Someone will always notice the event.

Danger Comes Quickly

Consider this: the override of your nervous system when you contact a high voltage source is instantaneous. You have no control over the muscles involved. Just like the FM capture effect, the strongest signal prevails. Your fist will clench, your arm will jerk, chest muscles contract, and your heart may stop.

Even if you do not receive a severe enough shock to do permanent damage, you may suffer substantial cuts as a result of this involuntary reaction. Worse, while your hand is busy impaling itself onto some hardware, that open wound now provides an even better electrical path, and the damage could become even more life threatening. This is an immediate effect – you simply cannot pull your hand out before the electricity has done its work.

I have managed to arrive at a ripe old age, relatively unhurt – partially by luck in my earlier years and mostly by being careful in the later years. Troubleshooting or adjusting

transmitters often requires the determination of high voltage levels and comparing these values to either published specifications, or to theoretical or logical values. The only safe way to do this is to power the equipment down, carefully connect your test equipment, then power everything back up and interpret the metering indications.

Truthfully, I (almost) always do this for anything over 24 Volts. And I when I say power down, I mean for you to give it time to discharge completely. Use the shorting stick – after all, it is there to protect you.

Take Your Time

Sure, I have poked around in live service panels checking for an open fuse, as I am sure all of you have. I just no longer think it is worth the time saved. First, it is just too easy to contact live parts, and secondly, the test leads and probes can fail to provide the insulation protection as designed. You do not need any information so immediately as to chance being hurt or killed while doing your work

I was nearly knocked off the chair at the bench some years ago by “only” 500 Volts in a two-way radio. I felt it clear into my chest even though I did have one hand in my pocket.

Mentally reviewing the event later on, I guessed that the shock I received was similar to the charging of a capacitor – me being one plate, the carpeted floor the insulator and the concrete being the other plate. I do not know for certain what the actual dynamics are. But it was intense, and I do not ever want to experience that again.

An acquaintance of mine was troubleshooting a 2 kV power supply problem some years ago by probing it “hot” with a voltmeter. He was nearly killed, and suffered some severe burns across his chest. Possibly the probes were dirty, cracked, or maybe his hand slipped. No matter, if he had powered down, connected the meter, then powered up when he was outside of the equipment, he would have not have spent time in the ER and ICU.

True, 2 kV does not seem like much when compared to the 10 kV or more usually associated with some tube style transmitters. but it is a dangerous and potentially lethal voltage. I will submit to you that contact with the 5-10 kV B+ inside tube transmitters will likely kill you before you even hit the floor.

Keeping the Equipment Safe

Earlier, I mentioned “safe for the equipment.” This refers to how you dress your test leads outside the cabinet before you power it back up. I usually bypass interlocks with their built-in mechanical override, then continue. However, if the door or access point you have open, does not want to stay open, please be sure to block it open.

Although a set of test leads may fit under the door without being completely pinched off, they can still arc through – or worse, be cut by the door’s edge. Then you have at least one more problem to solve before you get back to troubleshooting. And the evidence of you having been there is left forever.

Next, consider test equipment placement. Just because your meter has a plastic or rubber case is no guarantee it will not flash over when you do re-apply the power. Whether it is sitting on the chassis or on the concrete, relying on the case to provide sufficient insulation can be risky.

Insulating matting (or electrical switchboard matting) is cheap enough, and available from many suppliers. It is sold in various lengths and thicknesses, and rated from 20 to 50 kV, with suggested working voltages from 3.5 kV up to 17 kV.

Check your favorite parts and equipment supplier, and if they do not carry it, there is always the Internet. I did a Google search and found several. For the extra \$100 or so, I think this is good protection for you and your test equipment. It is also more comfortable than walking or kneeling on concrete.

Problems From Loose Connections

Another aspect of working with electrical equipment is the open or loose neutral. This most commonly is exhibited by either dimmed or overly bright building lighting. What happens is this: the neutral connection from the utility power transformer becomes loose, which in turn causes the 240 VAC to the building to lose its center tap neutral reference.

The phase-to-phase voltage still reads 240, but measuring from the breakers to the panel neutral will show anything from very low to very high. I have had voltages from 65 to 185 Volts at the 120 Volt connection. The equipment on the low leg will run poorly or not at all, on the high leg it will probably run OK (for a while) but its power supply will be over-stressed and will probably fail early. A third problem associated with this is the offending connection will run hot, and could even start a fire.

This applies to all connections from the utility power to the last bullet in your FM antenna, or the connector to your AM tower. If it is not tight, it is taking power from its intended purpose and generating heat instead. It is a good idea to go through your entire plant annually and check and retighten as necessary all connections – not just the high current/high voltage ones.

A new method to check connections is the non-contact, Infrared (IR) thermometers that are generally available for under \$100 (Another Franklin well spent!). They make quick checks easy to do, but I still like doing an occasional physical “back off and re-tighten” as connectors not drawing much current will not heat up much, and thus will not show up on the IR thermometer.

RF Voltage

The last item I want to discuss is an issue for many who maintain transmitter sites, and that is the RF voltages on the AM towers, on the output connectors of the transmitter, or the exposed portions of the ATU components. There is a real problem of RF burns.

I have had RF burns at power levels as low as five Watts – so how much worse will 5,000 Watts feel? Lots. As I said: I was more lucky than smart in my earlier years.

Five kilowatts into 79 Ohms results in about 680 Volts RMS at the feedpoint – and with full modulation, it rises to over twice that (if you are running your processing hard). RF voltages will be even higher in the ATU, as the impedances are greater at some points in the tuned circuits.

Contact with exposed parts burns – and it burns deep. Quite often RF burns take a long time to heal as it seems like the wound goes clear to the bone, and heals from the outside in.

My “Elmer” once showed me “the wooden pencil drawing an arc from the tower trick,” warning me: “Dave, don’t ever do this!” Understanding the physics, I will *not* do that. Yet, some years later I started pulling the metering panel off an ATU while the tower was hot.

The metering cable was about a quarter-wavelength long back to the transmitter building. After the last panel screw was removed, what do you suppose I had in my hand? Yes, a very expensive, very RF hot meter panel. I must have gotten a half dozen good RF burns before I got it put back into place.

Take It Slow and Easy

The lesson is clear: think about what you are going to do and how you are going to go about it. Take your time. Thinking a problem through and developing a careful course of action will likely lead you more quickly to an answer – and may also keep you alive.

Dave is mostly retired, and does backup engineering for Air-1 and I-heart Media as requested. He can be reached at: mrfixit@min.midco.net



OLD SCHOOL.

Flexiva™ FMXi 4g



HIGHER EDUCATION.

Flexiva™ FMXi 4g

HD Radio® Embedded
Exporter/Importer

- Integrated Diversity Delay
- Dynamic Time & Audio Correction
- Integrated Audio & PAD Monitoring
- No Fans or Moving Parts
- Full Support of SFN
- Fast Bootup Time
- Simplified Artist Experience Setup
- No Windows Operating System

gatesair.com/fmxi4g

gatesair.com/v-events



No one delivers greater performance and network analytics for your IP audio and data streams



Intraplex® IP Link 100 · 100c · 100e · 100p · 200 · MPXp

- Multi-stream encoding lowers channel costs
- Rock-solid, reliable Intraplex connectivity
- Real-time network diagnostics with LiveLook

Highly integrated codecs for next-generation, multichannel radio networks



NEW

Intraplex Ascent platform for scalable, multichannel SRT audio/video over IP, available as either a 1RU server or a software-only solution

The World of Short Wave Broadcasting

by Steve Callahan

I'm a *huge* fan of shortwave broadcasts. I've enjoyed listening to international broadcasts since I was in grade school and I thought that I was spying on the Russians by listening in to Radio Moscow. In the days before the Internet and cable, when there were only three local TV stations in my area, listening to shortwave signals brought the world to my little Panasonic shortwave receiver. In the good old days, the BBC was an easy catch along with Radio Tirana from Albania. I'd stay up late and sweep up and down the dial listening for different voices and accents.

I wondered what the continuous electronic noise was on some channels and years later found out that it was radio facsimile or teletype being distributed over a large area via shortwave. My hometown was home to an international shortwave station and even though it wasn't much of a "catch" for me, it was fascinating to hear what they were sending out to the world. I also learned very quickly how to rid a turntable or telephone of RF induced by living near a large transmitter. I was fascinated by the red and white towers behind my grade school and the guy wire that almost reached our playground. While my friends took the shortwave station for granted, or couldn't care less about it, I was fascinated. Years later, I had the pleasure of meeting and talking on many occasions with Jim Howard, who had been the Chief Engineer at the shortwave station when I was a little kid.

Shortwave stations operate much like an AM station, but they depend on signal propagation and intended skip to help it reach its intended listenership. Shortwave communications are not intended for domestic use but are licensed for international reception so they often are located at the shore and use some sophisticated antennas that are pointed toward the area they hope to serve. The FCC licenses specific times and frequencies to maximize coverage for specific service locations.



Brown Boveri SK 55, 500 kW Short-Wave Transmitter

I once was interviewing for the position of Chief Engineer at the Christian Science Monitor's shortwave station on Saipan in the Northern Marianas in the Pacific. The folks at the Monitor had three shortwave stations at the time – in Saipan, South Carolina and Maine. Initially they sent me to take a look at their facility in South Carolina and I was more than impressed. I thought I had died and gone to radio heaven. Shortwave antenna arrays are always big and plentiful and this one did not disappoint. Shortwave facilities

always run lots of power and this one certainly did. Everything, even the door frames, were grounded. It's the first time I saw their two Brown-Boveri 100,000 Watt shortwave transmitters that were so big you could walk through them.

The Monitor then sent me to take a look at their Saipan station and, after a two-hop plane ride via Dallas and Honolulu and a commuter flight from Guam, I found myself in Garapan, the capital of the Northern Mariana Islands. The first day I was there, I went to the station which was a well-built concrete block building on the end of the island.



Ampegon Antenna Systems Curtain Antenna

This station had two curtain antennas which were made of a metallic mesh and was supported by towers on both sides with one antenna pointed toward Asia and the other one pointed toward Australia. The antennas were also capable of being lowered quickly in the event of a hurricane. There was another shortwave station on the other side of the island which was, at that time, operated by a religious entity.



Ampegon Antenna Support Detail

When I got to the station, I saw two brand new Continental 50,000 Watt shortwave transmitters which you could change frequency "on the fly." It was mid-morning and the building was practically empty until a couple of minutes before the hour when the staff came flooding in and turned on the transmitter filaments and selected the right frequency and the curtain antenna for Asia. On came the transmitter, the lights in the building dimmed, and they played the Christian Science Monitor's identifier which was two minutes of

a trumpet sound called *The Herald*. Shortwave stations use unique audio at the beginning of their broadcast so that listeners can find them and that the program is ready to start.

The program ran for just one hour and then they turned the transmitter off and the building was once again empty. The station used that frequency and that direction for just one hour, and later in the day the staff would re-appear to change frequency and antenna and turn it on again to serve another area. At the time there wasn't enough commercial power on the island to operate both of the Continental transmitters at the same time so they used the very large diesel generator just outside the concrete block building to supplement the island power grid. I was offered the Saipan chief engineer's job but unfortunately had to decline the offer, and I still wonder what it would have been like to be in charge of such an impressive operation in paradise.

Years later, I found myself working for Harold Camping's *Family Radio* and I had the opportunity to visit their huge shortwave facility in Okeechobee, Florida. By the time I drove out of town several miles and got to the station, I saw the largest antenna array I have ever seen. There were antennas pointed in every direction and when I entered the squeaky clean transmitter building, there were two rows of Continental shortwave transmitters ready to feed the world. Coincidentally, the shortwave station in my hometown had been sold to Family Stations and two of their transmitters, a couple of Gates 50,000 Watt boxes, had been relocated to Okeechobee and were in use there.

The staff at Okeechobee was remarkable as they bought the RF cavities from Continental and then used their on-site engineering staff and in-house machine shop to build the new transmitters. Mr. Camping told me that the shortwave service was expensive but had to be paid for by domestic donations as the international donations didn't come close to operating a shortwave facility of that magnitude. I couldn't help but notice that the Okeechobee station's Western Canada service had to beam across most of the U.S. to reach western Canada. *Family Radio* later sold the Okeechobee facility to another well-established shortwave operator, Radio Miami International.

Recently, I was looking around to see what the state of Shortwave was today. The BBC has discontinued some of its languages in their world service and some older shortwave facilities have given way to program delivery via the Internet. One shortwave facility that is absolutely fascinating is *WBCQ*, "*The Planet*," broadcasting from little Monticello, Maine. Alan Weiner is the driving force behind what has to be the most unique radio station in the country. He has a local AM and FM along with a shortwave facility that operates a very full and very eclectic schedule of programs. I had the pleasure of meeting his most excellent chief engineer, Tim Smith, years ago in Portland, Maine. Alan's days as a pirate broadcaster in Yonkers, NY are well documented, but his most recent acquisition of another shortwave operator, World Harvest Radio International, has led him to build a single-mast Ampegon rotatable curtain antenna capable of 500,000 Watts. Pull out your shortwave receiver and give it a listen.

Steve Callahan, CBRE, AMD, is a member of the engineering staff at Entercom Boston. Email at: wvbf1530@yahoo.com

mixIT

The Affordable Touchscreen Console

- AES67, Ravenna, Livewire™ AoIP built in
- Optional Dante® AoIP now available
- Mic In, Analog & Digital I/O
- EQ, Dynamics and Mix-Minus

6 Faders - \$4800

12 Faders - \$5800



Logitek

Networked Audio Consoles

Learn more at logitekaudio.com or call 800.231.5870

Radio Report

Advancing HD Radio™ Technology Through Existing Standards

by Elaine Jones

In the mid 1960s, FM Stereo operation was introduced as the new way to attract and keep radio listeners – and adoption of this new standard became critical to success. It can be argued that HD Radio™ operation is the new critical tool for attracting and keeping listeners; it not only gives stations important “eye candy” for listeners – the user experience – but the opportunities available via the HD1, 2, 3 and 4 channels give stations the ability to increase their outreach and even their revenue through channel leasing or monetizing data services such as traffic and new IoT (Internet of Things) applications.

A huge hurdle in adoption has been the complexity and cost of implementation, even for many broadcasters who have a modern broadcast transmitter ready for HD operation today. The additional equipment needed to ensure time alignment of the FM and HD1 signals is also an issue. Nautel and Telos Alliance are looking at ways to leverage existing standards already in use by thousands of broadcasters to simplify the HD air-chain.

The first “proof of concept” was presented last month when the two companies demonstrated a standards-based method of precisely locking the FM and HD1 signals to completely eliminate time alignment drift issues. With locked FM and HD1 signals HD equipment installation can occur anywhere, which allowed a second concept demonstration two weeks later where the HD equipment was hosted as software components in the cloud. More on this shortly.

HD Radio uses separate but identical streams of audio on the analog and first digital channel (HD1). Since the HD1 has a longer delay through the broadcast air chain and modulation, the FM has to be delayed in order for these streams to be broadcast at the same time when the HD Radio receiver blends from FM to HD1 or back to FM. This delay is termed the diversity delay, typically 8-10 seconds depending on equipment and installation. The goal in the time alignment is to be “within 3 samples” – 68 microseconds. Minor errors in this time alignment can create audible artifacts, and excessive errors can cause content to be repeated or skipped entirely as the receiver blends.

When HD Radio was first introduced, the HD equipment was required to be located with the transmitter. The third generation of HD Radio equipment attempted to move the HD equipment back to the studio for most efficient use of STL bandwidth plus equipment management and reliability reasons. Time-locking the HD1 and FM signals has now become a significant challenge especially when using separate STL paths or separate audio processors. Thus, the NRSC has recommended placing the HD equipment and audio processor at the transmitter site. Although a superior solution, specialized receivers/GPS synchronization are needed at the site for reactive time alignment control. The STL capacity must also be increased to accommodate the HD side channels.

The first Nautel-Telos Alliance demonstration addressed this problem. It showed a single transmission stream, over a TCP/IP network, interleaving HD Radio content via E2X (Exgine to Exporter) packets with FM content via composite stereo MPX over IP, in which the FM and HD1 signals were perfectly time-locked. This new protocol definition, along with a Nautel synchronous exciter design and Nautel synchronous HD equip-

ment, combined with the new Telos Alliance Omnia Enterprise 9s, a software implementation of the Omnia 9 processor, make this possible.

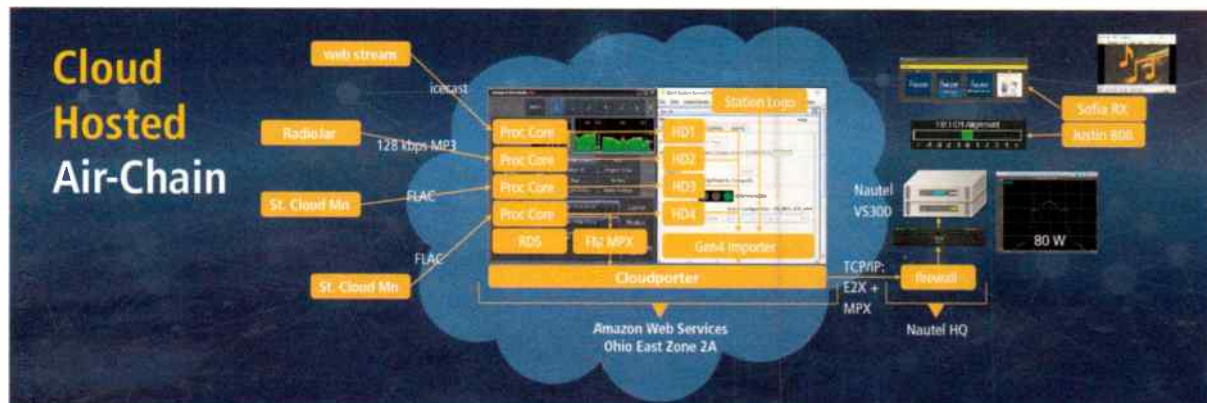

A Deeper Dive

Xperi's Gen4 code is a defacto standard in common use among HD broadcasters; it allows the importer and exporter to be combined and also allows remote capture clients for alternate programming on the HD2, 3 and 4 channels. When the processor and importer/exporter are located at the transmitter site, as per the NRSC's recommendation, this requires broadcasters to find a way to bring RDS/data services and HD2/3/4 out to the site as well.

Nautel and Telos Alliance propose that an ideal solution is to combine all of these signals into a single stream via a software radio server. The Omnia Enterprise 9s provides the processing for the FM and all HD channels (using a shared processing structure up to the final output stages), and a Gen4 software implementation from Nautel provides the importer/exporter. FM/HD1 time lock is achieved by synchronously splitting the audio in the audio processor, transmitting E2X and MPX in a single IP stream, and joining the modulated FM and IBOC in the exciter. This synchronous audio processor, combined analog/digital transmission method, and synchronous modulator are rate-and ratio-locked; the HD1 uses a 44.1 kHz sample rate and the MPX output is an exact 4X multiple at 176.4 kHz.

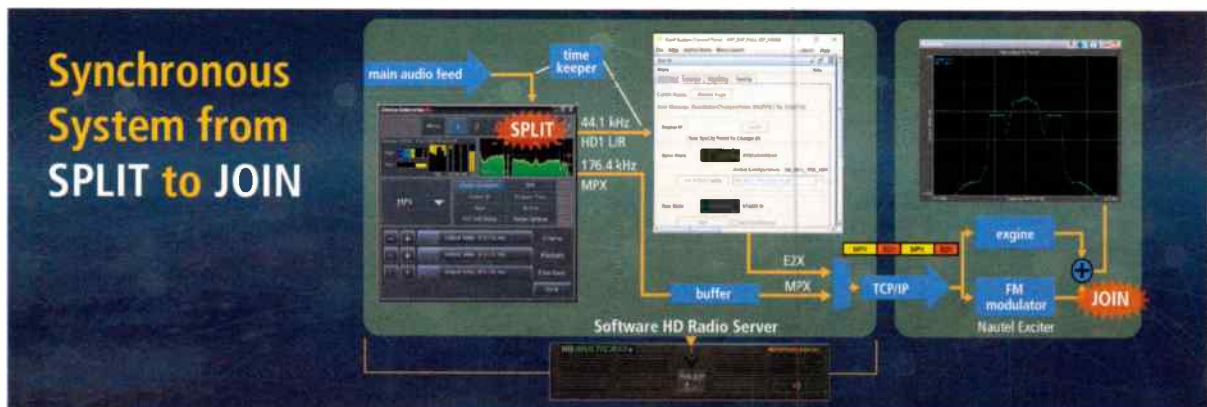

This method makes the audio processor and E2X location-agnostic rather than requiring their placement at the transmitter site.

The companies' first demonstration showed the concept of sending this combined signal via a long distance over the public Internet, using a path from Minnesota to Nautel's headquarters. Perfect time alignment within 3

samples was maintained throughout. The second demonstration hosted this air-chain on the cloud, using the Amazon Web Services platform.

An important aspect of any virtual network is failover – the system's ability to switch to backup paths should something happen to the primary path. The companies' demonstration included multiple failover events, switching from servers in Ohio to Oregon and then to Sao Paulo, Brazil, and finally to Nautel's HD MultiCast+ acting as a physical resilient node co-located with the transmitter. In all cases, the program flow was only briefly interrupted as the path changed.

So Why Do This?

The broadcast industry has been moving toward virtualization for quite some time. Even before COVID-19, radio stations were utilizing virtualization for simplified workflows. Moving operations to the cloud reduces the amount of physical equipment needed (along with energy needs and floor space), and the combination of AoIP, networkable products, and servers make it possible to operate regular programming from almost anywhere. HD programming can also be initiated from almost anywhere, reducing its equipment requirements as well as complexity of implementation.

Finally, survival is an issue. Radio has a lot of competition, even in the car. Younger listeners are particularly keyed in to the visual aspects of their entertainment and a radio station has a hard time competing with attractive logos presented by streaming and satellite services. The improved “user experience” of HD Radio can help to level the playing field for broadcasters. There are also extra revenue opportunities as mentioned earlier. This concept further simplifies the implementation of these opportunities.

It's important to note that at present, this is still just a concept. As with other transmission concepts introduced in the past, considerable testing is yet to be completed and

industry feedback is required to define interoperable solutions for 3rd party and legacy equipment. Additional development is underway by both companies which will further solidify this technology and address IT security issues.

Elaine Jones operates a technology marketing and PR firm based in Tucson, Arizona, and is Nautel's publicist.

MONITOR REMOTELY FROM
HUNDREDS OF MILES AWAY
using just your smartphone.

SOFIA 568

HD Radio SiteStreamer+™



ALSO AVAILABLE



SOFIA 565 FM SiteStreamer+



SOFIA 567 AM SiteStreamer+

The new SOFIA 568 HD Radio SiteStreamer+ takes it up a notch combining remote off-air monitoring with a host of features to ensure that you are the first to know when there is a problem. You've got the tool to listen to the off-air programming and confirm that Artist Experience graphics are displaying correctly.

It's a SiteStreamer PLUS.

The elite SOFIA SiteStreamer+™ (plus) adds new features to the SiteStreamer product line.

- Internet listening stream for up to 10 listeners
- Displays HD Radio Artist Experience graphics and station graphics on Web interface
- Adjustable Audio Outputs in L/R Analog, AES digital, and Dante AES67 AoIP
- Monitor multiple transmissions sequentially with StationRotation™
- Alarms & notifications sent via email or SMS messaging
- Remotely monitor fulltime off-air FM and HD Radio signals
- Easy set up and operation; full SNMP support



i INOVONICS
BROADCAST

WHY INOVONICS?

- Quality Solutions. Competitive Prices.
- Quick to install. Easy to Program
- Three-year Factory Warranty.
- Quality after sales service.

www.inovonicsbroadcast.com
sales@inovonicsbroadcast.com

831-458-0552

PTEK

FM Transmitters

YOUR MESSAGE MATTERS

PTEK DELIVERS



ALL PTEK TRANSMITTERS FEATURE:

- Wide range input 88 to 264 VAC
- Frequency agile from 87.7 to 108 MHz
- True proportional (VSWR) fold back
- Direct Digital Synthesis exciter with great sonic performance
- Built-in stereo generator (includes composite & SCA inputs)
- Built-in programmable FSK ID
- Front panel metering
- Remote control interface with analog and serial I/O
- Compact, Rack mountable Chassis
- Designed, manufactured & supported in the USA

FEATURING:

ES SERIES

300 Watt
500 Watt
1200 Watt

PS SERIES

2 kW
2.5 kW
3 kW
3.5 kW
4 kW
4.5 kW



ES Series 300-1050 Watt



PS Series 2-3.5 kW



PS Series 4-4.5 kW

ES Series Transmitters range from 300W to 1.2kW

The FM300ES is FCC type certified for use on LPFM stations. The ES Series is conveniently designed to be used as an exciter or a stand alone, low power transmitter. Optional internal Webserver available for the ES300 & ES500. Other models supported soon.

PS Series Transmitters range from 2kW to 5kW

PS SERIES KEY FEATURES:

- Very low cost to purchase
- Low operating cost (reduced power consumption)
- Super High efficiency (80%) LDMOS technology power amplifiers
- Reduced cooling requirements
- Compact and lightweight for ease of installation
- Digital front panel metering & controls
- Spacious design with major components accessible by removing top cover
- 1,500 Watt Hot Pluggable Switching Power Supplies



FM BROADCAST TRANSMITTERS

www.ptekpower.com

Ph: 888.889.2958

111 N Vista Rd, Suite 3E, Spokane Valley WA 99212

World Radio History

Sicon-8 Internet & Voice Remote Control

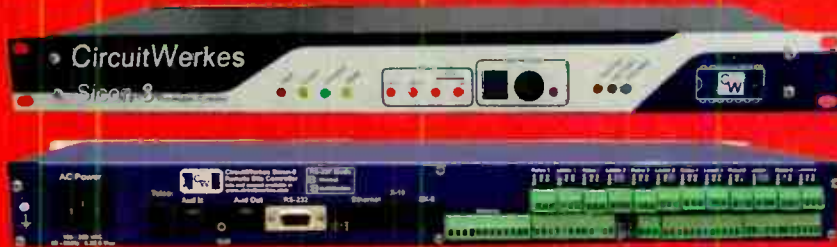

The CircuitWerkes Sicon-8 Remote Monitor & Control

- Uses Dial-up, Internet Web server or free Sicon-troller Software!
- 8 channels of metering, status and control (expandable to 32) and up to 5 alarms per channel.
- No accessories necessary to control your site right out of the box.
- Auto-ranging, auto-calibrating meters make setup a snap.
- Includes: Function scheduler, auto-logging & alarm reporting.



Internal Web Server



Free Sicon-troller Software

The Sicon-8 lets you control your site via Internet with its internal Web server, via telephone, auto-answering cell phone or with our free software. Setup is a breeze using the Sicon-troller software that also includes scripting, e-mail alerts, multi-site management, virtual metering & much more!

Web-Based Remote Controls w/Streaming Audio Option

Introducing the SiteSentry4 (4 channel remote control), SiteSentry2 (2 channel remote control) & WAM-2 audio monitor

- Web enabled remote controls with 6 relay outputs & 2 status inputs on all units.
- All units detect Stereo or Dual Mono Silence (independantly adjustable channels).
- User-programmed relays (DPDT) close automatically or via Web control
- All products include onboard temperature sensor
- Internal logging with onboard e-mailing.
- Supports DDNS services and Netbios names
- Upgradable firmware. Keep your product current with downloadable updates!
- Streaming audio option encodes Ogg-Vorbis & decodes mp3 or Ogg-Vorbis.

SiteSentry4



SiteSentry2



WAM-2

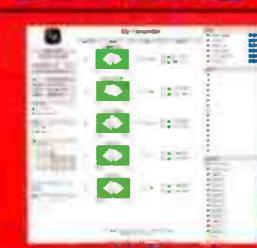

Remote Broadcasting Solutions

Discover more online at www.circuitwerkes.com



MicTel Mic/Line to Telephone Interface

- Outputs & inputs for telephone handset, cellular phone or balanced line level at up to +10dBm.
- Operates up to 36+ hours on two 9V alkaline batteries.
- High quality, user-switchable, internal limiter prevents clipping.
- External power input with silent, auto-switching battery backup.
- Individual gain controls for send, receive & headphones levels.

Unattended Dial-Up Broadcasts with the DR-10

- The DR-10 is a Dial-Up remote control with balanced, telephone audio input & output that can control many automation systems or your audio console for unattended remote broadcasts.
- Our Silencer™ option removes control tones from the audio path.
- Use the DPDT relays to insert the phone audio directly into the program path when necessary, especially for emergencies.

TelTap Pocket-Sized Manual Telephone Coupler

- Can be used as a phone tap or a passive manual telephone coupler.
- Send or receive telephone audio.
- Compact size & low cost makes the TelTap a great addition to your remote kit for main or backup capabilities.



Lots More CircuitWerkes Problem Solvers

- Transcon-16 - Move up to 16 contact closures from room to room over an audio cable
- DT-232 - Turns DTMF sequences into user-programmed serial outputs & act on steps.
- FSK Encoders, decoders, transceivers and contact-to-FSK encoders/decoders.
- SUB-03 Subaudible tone decoder and SEN-6 Subaudible encoder.
- HC-3 telephone autocoupler and AC-12 rack of autocouplers
- DTMF-16 and DS-8 DTMF tone decoders.

Find Full product info & downloadable manuals online at www.circuitwerkes.com. 352-335-6555

Engineering Perspective

Is It Good – Good Enough – or Great?

by Jim Turvaville

It's been an interesting – to say the least – several months, as the nation and the world has been dealing with the change of lifestyles because of the Coronavirus Pandemic situation. While I have the luxury of living in an area which has only been very mildly affected by the medical and social repercussions of it, this has certainly been a time of reflection. With many people staying home more, traveling less, and tightening up that close-knit community we all share, this has been an opportunity to reassess some of the things we do and why we do them.

I've heard many sessions of sales training and management classes argue about "good" being the enemy of "great." Too often we want to settle for something that is "good" when the extra effort to make something "great" is not at all demanding. I know, we are all really busy; most of us are wearing many hats and there are people trying to get a piece of you every minute of the day – I get that. Not only is this a trying time in our nation, this radio business we are in has been newly realized to be *essential*, which has made all of us still working in it even that much more in demand. But we also have to balance that demand with remaining conscious of the *quality* of what we can do, not just the *quantity*. A wise man once noted, "Every time you find work to do, do it the best you can." (Ecclesiastes 9:10 ERV)

I'm reminded of the story when a young man married into a large family that still kept multi-generational family get-together times and holiday celebrations. The first Thanksgiving, his new bride was in the kitchen helping with the meal preparation, and she went to place the whole ham in the pan for baking. She promptly took a large knife and sliced the end off of the ham. Being curious, the new member of the family asked why she cut the end off of the ham before placing it in the oven. Puzzled, the girl just said, "I don't really know, that's what Mom always did." So her Mom was found and asked the same question on ham preparation; only to also reply, "I don't really know, that's what Mom always did." Fortunately Grandmother was still around and she was summoned to answer the now very pressing family question. Laughing, the Grandmother simply said, "because Grandpa and I were quite poor, and I only had one baking pan – and the whole ham would not fit in it unless I cut off the end first." And that simple act of necessity had shaped the culinary skills of three generations of cooks, only because it was what Grandmother had done.

I'm certain that no one who reads this column has ever fallen into the trap of doing something just because it's what has always been done – right? After all, it's





always worked before, so there's no reason to believe we can't just keep doing it the same way – right? No, I do not have to remind you of one definition of insanity is to, "Believe you can keep doing the same thing and expect different results."

During my corporate career, I always welcomed the changes in viewpoint that came about by the addition of new staff. During the orientation period, I made it clear that there were no "dumb questions," and invited inquiry into not only *how* we did things, but an understanding of *why* it was done that way. On many occasions, the simple act of training new personnel would bring to light some policy or procedure which was being done only because we'd always done it that way, not because it was the easiest or best way to accomplish the task. I made many changes in policy and procedures after such an inquiry. Interestingly, after I retired and my successor came on board, he also found many things that even I had kept doing, only because we had always done it that way before. I have enjoyed seeing many things in that organization grow and advance since I left, and new leadership above my old position has brought even more questioning of, "why do you do that?" to the table and it has been a great strength to their growth.

I am the Media Director at our church and, while we are a small body in a very small town (population 1,700), being a center of commerce for a rather large area means our church reflects that diverse demographic. Prior to this recent Pandemic time, we regularly had 250-300 people in attendance at our weekly services, with 450-500 at special events. So the Media outreach has been strong for a long time, and we were very well prepared

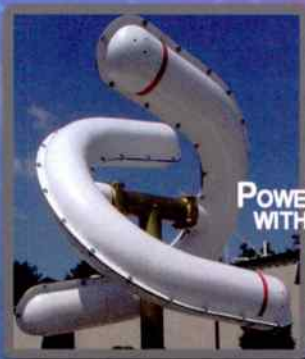
(Continued on Page 28)

Quality FM & TV Antenna Systems



SLANT-V DIRECTIONAL

FM PANEL

POWER-TILLER

POWER-TILLER WITH RADOME

PSI is dedicated to designing and manufacturing the highest quality product. Working diligently with station engineers, consultants and outside vendors ensures that each project is completed to the customer's satisfaction.

Wide range of antenna models are available at all power levels, directional and non-directional, multi-station and more.

Additional products include..

- Transmission Line
- Combiners
- Filters
- Turnkey Systems



Propagation Systems, Inc.

Phone: (814) 472 - 5540 Fax: (814) 472 - 5676
Email: sales@psibroadcast.com www.psibroadcast.com

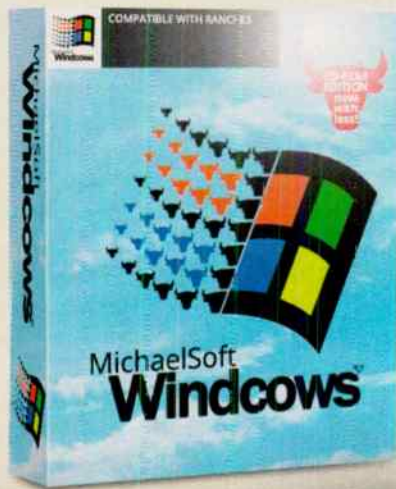

“...but I saved money!”

GET REAL!

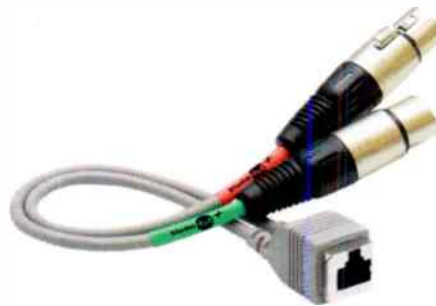

This is the iconic StudioHub adapter. Proven in thousands of radio studios all over the world. That kind of success is sure to bring out imitators. Hey, we're flattered.

But let's face it, if you could get real StudioHub adapters for the same price as the copies, you wouldn't even blink at those knockoffs.

Well, here's some great news! For a limited time, StudioHub products are on sale for 20% off. That makes genuine StudioHub adapters about the same price as those cheap knockoffs. You don't need to compromise just to save money.



Adapters



Cables



Dongles



Hubs/DAs



Matchjacks



Mounts



Panels



Power

And that's not all. StudioHub offers far more than adapters. We make a complete line of panels, power inserters, cabling systems, breakouts, matchjacks and everything else you need to wire the modern radio studio.

And now it's all on sale for 20% off! So call your favorite dealer and ask for StudioHub by name. If he tries to sell you a knockoff, tell him you want the real deal. The real genuine StudioHub deal.

Use promo code GETREAL20 to receive 20% off all genuine StudioHub products.

Is It Good – Good Enough – or Great?

– Continued from Page 26 –

for the sudden changes in attendance and the need to maintain communication with the congregation. Facebook Live was nothing new – since 2018 we have been streaming the Sunday morning services on-line – it's just that that a couple of dozen regular viewers has most recently been multiplied by 10 or 20. Suddenly it became more important to have the highest quality of video and audio possible for that rapidly growing audience. The system in use was "okay" – we used the MEVO camera controlled by a tablet, to which I had wired an interface from the sound mixer for "good" audio. I say it was "good," but probably "acceptable" was more accurate – dry talk material was very good, but the complex audio of live music very often could be best described as "fatiguing" or downright "bad" at times. It was not a technical problem on our end, it was a limitation in the audio coding capabilities from the hardware manufacturer, but we chose to accept it and live with the results. However now, with an exponentially larger viewing audience, that "good" was not really "good enough." The decision was made to actually buy a "real" video camera, which has stereo line audio inputs, and HDMI output. While before we had simply streamed the video to Facebook live, now that HDMI output is now being fed to a quality video encoding hardware box and to a cloud-based streaming

provider, which not only provides simultaneous video feed to multiple on-line sources (Facebook, You Tube, etc.) but archives that high quality video for on-demand playback via the church webpage and mobile app. Suddenly, not only were large numbers of people seeing a vast improvement in the video presentation, the demand for new video content also skyrocketed. A couple of permanent sets were built in extra rooms in the back of the building – after all, the building was mostly unused on a regular basis these days – and nearly every department of the church found an outlet to reach, via new video production.

In a similar vein, the church has had a presence on local radio for four years, but it was a pre-recorded and "edited for broadcast" version that was used to bring what was thought to be the best audio product for the radio audience. The Senior Pastor quickly realized that not only was current and immediate communication more vital to reaching the vastly growing listening audience, but what we were producing in the auditorium was really good quality stuff – so that pre-recorded message got switched to a live broadcast. The impact for the church was quickly realized and what was thought to have been "good enough" with a pre-recorded and edited program for broadcast was found to be lacking in the impact that live radio can have on the community.

That one change in radio broadcast style, by one church, suddenly caught on elsewhere – another church which was also doing the pre-recorded and edited playback method changed their service time so they could also switch to a live broadcast; a third church came on board with their live service and a fourth decided that

radio outreach was important and began a pre-recorded message. Since I own the local radio stations in both towns in the county, I can air multiple pre-recorded and can actually have up to four live services each Sunday morning (two "early" services and two "late" services) and it was no difficulty to set up the hardware and software at the churches to feed live Internet audio to the radio station and to get things rolling with them all to expand their local community outreach. My local pastors have found the value of both radio in general, and instant and timely live communication with their congregations by live radio. What was "good" for them in having a radio presence in the community, suddenly was found to be "not good enough" in being effective for their outreach.

So make a concerted effort to examine what you do on a regular basis, and see if it's "good" – or could it be "great" with little more effort. One way that I use to self-examine is to write an instruction manual on how to do my regular tasks. Though I have been actually physically doing that lately, I don't always actually write it down, but at least verbalize the details of your task in my head, as if I were training someone to take over the duty themselves. Describe exactly how to do each step of the process, and then pause and see if that is really the best way to do it, or are you just cutting off the end of the ham?

Jim "Turbo" Turvaville is semi-retired from 42 years in full-time Radio Engineering and lives in Rural Wheeler County Texas in a "tiny house" where he maintains a small clientele of stations under his Turbo Technical Services (www.jimturbo.net) operation providing FCC application preparation and field work.

AES Switching Made Easy



AES Switcher Sentinel® 2+1

The AES Switcher Sentinel 2+1 is a web-enabled three channel AES/EBU silence monitor combined with an integrated 3x1 AES switcher. It is designed to monitor two AES audio sources and one analog to digital (ADC) audio source. When silence is detected on the primary AES input it can automatically switch to the back-up

AES input or the backup ADC input via mechanical latching relays. The AES Switcher Sentinel 2+1 can be configured and monitored locally and/or remotely over any IP network, including private networks, IP-based industrial control networks, and the Internet. Supports SMTP (Gmail, etc.) and SNMP.



Broadcast Tools is a Veteran Owned Business
Designed, Assembled and Supported
in WA State, USA.
www.broadcasttools.com



BROADCAST
t o o l s
PROBLEM SOLVED

**“I’ll never leave
your pizza
burnin’”**



**Make misheard lyrics a thing of the past.
Process with Omnia.**



Baptism by Fire: Becoming a Project Manager

by Chris Ark (CBT)

As Engineer or IT Manager, chances are good that you will be crowned Project Manager for build outs at your facility. As Project Manager, it's your responsibility to leave no stone unturned, from pre-planning to final walk through. This can be stressful, as a young professional with zero project management experience. Most Project Management strategies and principals apply, no matter the project type – whether it be a studio, transmitter, or a business office. Concepts and ideas mentioned in this article will require further education and research as this is a broad overview to get you familiar with terminology and processes.

If you have never been a Project Manager, the biggest question is, "where do I start?" My first suggestion would be to consult with a mentor or fellow engineer. Pick their brains on past projects (the good, bad, and the ugly). Find out what methods worked and didn't work for them. My second recommendation would be to take an introductory Project Management course on *LinkedIn Learning* to learn strategies, models, and industry terminology. Thirdly, be comfortable with the fact that you will not have all the answers to every question. That's OK, but you need to know where to get the answers.

Pre-Planning with Stakeholders

Before breaking ground on a project, you need to identify **Project Stakeholders**. A stakeholder is someone who could impact or be impacted by the project. There are primary and secondary stakeholders. You can place each stakeholder into their respective categories based on what influences they have on the outcome of the project. Conduct a **Stakeholder Analy-**

sis to place each stakeholder into the proper category.

• **Potential Stakeholders:** Shareholders, CEO, CFO, GM, PD, GSM, Controller, Legal, On-Air, General Employees and the Public.

Once identified, meet with each stakeholder to understand their objectives, thoughts, and ideas.

• **Key Objectives:** Identify Location, Budget, Time Frame, Key Functionalities, and New Business Processes.

• **Project Charter:** Once information is collected from the stakeholders, it's time to input all of that data into a Project Charter. A Project Charter, as defined by PMBOK® Guide, 3rd Edition, is "a document issued by the project initiator or sponsor that formally authorizes the existence of a project, and provides the project manager with the authority to apply organizational resources to project activities."

This task is arduous but is entirely necessary for the success of any professional project. A Project Charter should include the projects objective, requirements, budget, project assumptions and constraints, summary schedule, and deliverables. This document is what gets all stakeholders on the same page and makes a project real.

Once this document is created, it's time to schedule an internal project kick-off meeting to review the document. If all primary stakeholders are in agreement on the information contained within the Project Charter, have each high-level / primary stakeholder sign off on the document. Don't ever start a project without primary stakeholders signing off on the Project Charter, even if they tell you "just go ahead and start." This is an insurance policy for your career.

Selecting Architects, Contractors & Vendors

Depending on the ownership and management of the space your project is taking place in, you may have to use pre-authorized contractors, architects, and/or vendors – just something to be aware of. I'm currently wrapping up a business office build out for a station in a building managed by CBRE. I had to use their architect and general contractors. Let us assume you're building at a site where you can use whatever vendors you wish. And for the sake of this article, we're going to generalize and say that the architect, GC (general contractor), low voltage, security companies, etc. are all "Vendors."

Established Vendors

Does your company have an established relationship with a vendor that already services your sites? If so:

- This is great because they are already familiar with the facility and/or the way your company conducts business.
- Communication is a bit easier because you're not learning new personalities.
- Easier for your accounting department as they don't have to set them up as a new vendor - W9, ACH, etc.

New Vendors

If you must source a new vendor, consider the following:

- Call other station engineers to see if they have recommendations. Station brass may view other stations as the enemy. Not the case with engineers – they usually work together.
- Call a handful of vendors to review the project scope. You can usually gauge their competency in a few minutes.
- Ask for references. If they're hesitant on providing a list, look elsewhere because they might have something to hide.
- Contact BBB (Better Business Bureau) to see if they have any grievances against them.
- Don't ever go with a vendor because they're a buddy or someone "knows a guy." No good can come of it.

(Continued on Page 32)

ALTRONIC RESEARCH INC.

Performance By Design

RF DUMMY LOADS for ALL YOUR APPLICATIONS

- AIR-COOLED
- HDTV
- HD
- WATER-COOLED



ALTRONIC RESEARCH INC.

P.O. Box 249 Yellville, Arkansas 72687 870-449-4093 Fax: 870-449-6000

E-mail: info@altronic.com Web Site: <http://www.altronic.com>



Broadcasters General Store

Family Owned & Operated Since 1979

352-622-7700

www.BGS.cc

INOVONICS BROADCAST

Brand Your Station



RDS MESSAGING

RDS ENCODING, DECODING, RECEIVERS, & SIGN DRIVERS

- Advanced Dynamic RDS Encoding
- Supports automated playout systems
- Monitor & log your FM/RDS broadcast
- Decode & display RDS data
- RDS Receiver & Sign Driver
- Remote scheduler

EASY as SNMP!



Interfere to SNMP Remote Controls with a Single CAT 5 Connection

SWP-200 Series RF Switch Controllers and SWP-300 Site Controllers with Direct Interface to all RF Switches on the Market and BDI's DPS-100D Series RF Power Meters

ALL NOW WITH SNMP CAPABILITY!



The DPS-100D Series RF Power Meters and Companion RMD-100

Rack Mount Remote Meter Display

Tel. (914) 737-5032

sales@broadcast-devices.com

www.broadcast-devices.com



Guest Interviews Don't have to be Complicated.

Quality Interviews, Simple Setup.



COMREX

PODCAST PRO[™] BY ACCU-LITE[®]



Broadcast quality for a podcaster's budget!

*Includes: mic boom, c-clamp, cable with male & female XLR connectors. Microphone not included.

PN: ALMBP1

www.accu-lite.com
www.ocwhite.com



Facility Focus

– Continued from Page 30 –

Vendor Diversity

Try to have as few vendors / contractors involved as possible.

- This will help reduce miscommunication for ownership of project responsibilities.
- Less invoices to keep track of.
- Some contractors charge extra to have collaborative meetings with other contractors.

Vendor Contracts and Considerations

It is critical to the success of your projects timeline and budget that you specify, in painstaking detail, the vendors scope of work and deliverables. Leave nothing to interpretation. A contract should include:

- Main Scope of Work.
- Cost for additional planning for work that was not included in the original scope.
- Cost associated with having weekly project meetings / calls with other vendors for planning purpose.
- Who is responsible for submitting permits to the city (Electrical, Mechanical, Construction)
- Service guarantee after completion of install (Not additional service coverage)
- Cost of S.L.A (Service Level Agreement)

Vendor Insurance

Never work with a vendor with no insurance! Any reputable vendor will be able to provide you with a COI (Certificate of Insurance). A COI is usually a one-page document showing the level of insurance coverage a vendor has, in the event they damage your property or are injured on-site. If you are a tenant in a building, building ownership may have a specific set of insurance requirements that must be met based on the type of contractor performing the work. Ask for a

sample COI or COI requirement one-sheet from ownership and pass it along to the vendor.

Other Vendor Considerations

Most vendors require a percentage of the project total paid up front to cover equipment procurement, planning, and permits. If you're working with a vendor that you have a good working relationship with, a percentage up front may not be required. No matter your relationship, get it in writing.

Electrical Requirements

Have a firm understanding of how many circuits you need, their locations, and whether they need to be dedicated circuits. Depending on the existing service and your needs, you may need to have a larger service brought in. This could make the cost of the project go up significantly. Have a good idea on this before budgets are finalized. Look at equipment spec sheets to perform an amperage load calculation yourself. Do not leave it solely to the electrical contractor to determine. Here are some locations and appliances to keep in mind when planning your electrical needs.

- Studio, Server Room / TOC, Transmitter, Kitchenettes, Offices, Cubicles, HVAC
- Printers, Coffee Makers, Microwaves, Fridge, Hair Dryers
- Only load a circuit up to 80% of its amperage capacity.

HVAC Requirements

Before meeting with the HVAC contractor, perform a rough BTU load calculation for your server rooms, studios and production rooms. Most equipment has a BTU spec on its product sheet. If not, you may have to perform a manual calculation based off the power supplies power consumption. This isn't the most accurate but its better than nothing at all.

Note: the HVAC changes require a MEP (Mechanical Engineering Permit) which is different than the construction permit.

Construction Documents Review & Submissions

Before the GC (General Contractor) bid and permit submittal process begins, you will review the preliminary CD Set (Construction Documents) provided by the architect. Scrutinize every line and its wording. Once the local municipality issues permits and the project has been awarded to the GC, a change order could cost you more money, may require another permit review, and will push back your project's timeline.













One small example: On my current build out project, I told the architect that I needed backer board in the walls so the Contractor could hang the TV mounts. Within the CD set, the architect noted that backer boards need to be placed within the walls so TVs could be mounted throughout the facility. Did you catch that? It didn't say is that backer board was needed so the General Contractor could hang the TV mounts. That little difference in phrasing made it so this action item was outside the scope of work. This cost me nearly \$1,000 even though I specifically requested the GC install the mounts. Keep in mind that you should have an overage percentage built into the project budget, however, that is not the way you want to spend it.

Be aware that every municipality has different lead times on permit applications and approvals. Ask the architect or GC if they have a general pulse on the typical turnaround time. This will help you manage stakeholder expectations and overall project timeline.

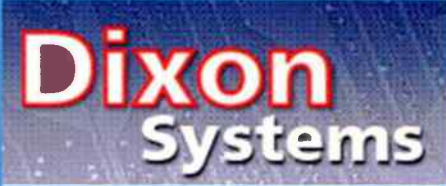
Conclusion

The topics mentioned above are in no way totally inclusive but should provide a novice Project Manager with some food for thought. Project Management takes a lot of education, forward thinking, attention to detail, large amounts of patience, and being OK with making mistakes. If you never make mistakes, you'll never grow. But when you do make mistakes, you hope they don't cost too much.

– Radio Guide –

 <p>Studio Items Inc</p>   <p>Mic Booms On-Air Lights Speaker Mounts www.studioitems.com</p>	 <p>(The Good Time People)</p>   <p>Clocks Up/Down Timers www.ram68.com</p>	   <p>News Mixers Line Matchers www.ram68.com</p>	 <p>RAM Systems</p>   <p>Broadcast Furniture Sound Absorption Panels www.ram68.com</p>
--	---	--	--

Control Your AoIP Universe



QUASAR

by AXIA

Application-specific controls. Customizable Source profiles. Metering where you need it. User-assignable buttons. All cosmically connecting with networked sources near and far.

Finally, you have the power to create the most brilliant content in the AoIP universe. Harness It.

To experience
limitless production
possibilities,
contact us today.

 Telos
Alliance®

TelosAlliance.com | inquiry@telosalliance.com | +1.216.241.7225

World Radio History



Misc. Tech-Tips and Thoughts

I always enjoy getting emails from my readers. Some of you have made some very interesting and helpful comments. If you have something positive to contribute, I would love to hear from you. If you have some helpful technical advice or words of wisdom, please contact me at stuzeneu@sbe.org. Your help will be appreciated by the readers, and I would appreciate it as well.

Letters from Readers

I recently received an email from Mike Rice, Vice President of the Connecticut Broadcasters Association. Mike mentioned that some smart phones are not equipped to receive FM signals, and he is right. However, if you download an app that is designed to receive FM, your headphones act as an antenna and you are ready to go. With my smart phone, which is an Android, I am able to use this feature. Not all phones will be capable of utilizing the FM Radio app, but if you choose your phone carefully, you can monitor your station on your smart phone.

Engineering is a lot like being a teacher in high school or college. You often must keep up with what is new and take an exam to keep your SBE certification. If you do not want to get left behind and you take your profession seriously, education is a never-ending process.

Whether you are a relatively new engineer or someone who has been in this business a long time, there are

publications and websites you want to be reading often. One of those sources is the publication you are reading right now. *Radio Guide* column writers have already done many of the things you may soon be doing. I look forward to each issue and always find something of interest in each one. Sometimes I even clip out an article or two and place them in a file for later reference. One of the things *Radio Guide* does that I really like is that Ray Topp comes out with an electronic copy of the paper publication. I can go on the Internet from anywhere and read the latest issue, and often read a copy from many weeks ago. You can find an electronic copy of this publication here: www.radio-guide.com

A while ago, *Radio Guide* began a partnership with an on-line publication that I enjoy visiting. The BDR.net, or also known as the *Broadcast Desktop Resource*, is a great place to visit, whatever your level of expertise. I could spend all day reading the articles there. Barry Mishkind is the editor, and he does a great job of bringing together a huge assortment of knowledge from all over the planet. In addition to the on-line publication, Barry hosts a Thursday afternoon, virtual get-together. I have been to a number of these gatherings and always come away with some useful knowledge. If that's something you are interested in, visit his website and ask to be put on his mailing list. You will

receive a weekly newsletter with a lot of great information and a notice of the virtual meetings. www.thebdr.net

As a member of the Society of Broadcast Engineers (SBE), I have a wealth of information available whenever I want it. At the beginning of this year I signed up for the member plus program. It was worth every penny. I have access to all of the previous webinars, and new webinars are free, as long as I maintain my member plus status. Another benefit of belonging to the SBE is the mentor program. New or young engineers can request someone to be your engineering mentor, and senior engineers can sign up to help those who are less experienced. I will go into mentoring in more detail a little later in this column. In addition to the mentoring and webinars, the SBE also produces a publication with a lot of useful information to those of us in the engineering community. You can also take advantage of the great fellowship at SBE chapter meetings. Attending these meetings is both enjoyable and educational.

You Tube is another place I like to visit. You can learn or refresh yourself on almost any topic you can think of. I have found, however, that some of the videos on RF theory are presented by individuals with rather thick accents that are difficult to understand. There does not appear to be as extensive a list of educational videos on radio broadcast engineering. At the time I searched for instructional videos



(Continued on Page 36)

DIGITAL AUDIO SWITCHING

TITUS TECHNOLOGICAL LABORATORIES
3-DRX
AUTOMATIC
THREE CHANNEL DIGITAL REPEATER / ADC SWITCHER



THE LOGICAL WAY **3-DRX**

Automatically switches between two AES digital audio signals or a stereo analog signal. Analyzes digital signal errors (CRC, bit, framing, etc.) and checks for loss of audio on the digital signal. User programmable.

TITUS TECHNOLOGICAL LABORATORIES

860-633-5472

WWW.TITUSLABS.COM

AM WORKS!

Orban's XPN-AM processor makes

GREAT AM!

"I don't know what magic Bob Orban developed for AM processing, but it IS magical."

-Tom Read, Owner, ACN, KTBI, KTRW, KYAK

Call SCMS to Schedule an

XPN-AM Demo

TODAY!



www.scmsinc.com

1-800-438-6040 | sales@scmsinc.com

Broadcast Equipment Solutions | 19 reps across the U.S. and Latin America

World Radio History



Misc. Tech-Tips and Thoughts

– Continued from Page 34 –

on how to use a Field Intensity Meter (FIM), there were maybe two. For new engineers, it would be good to see a video on how to use a FIM for AM, and a separate video on how to use a FIM for FM. Perhaps this article will prompt someone with a little time on his or her hands to produce such a video.



I enjoy watching as many webinars as I have time to watch, and one of my favorites is one sponsored by the Telos Alliance called *This Week In Radio Tech* (TWIRT). TWIRT is hosted by Kirk Harnack. I love Kirk's down-to-earth style, and most every edition of TWIRT contains something I want to hear about. If you have about an hour to spend watching the live broadcast, or the on-demand recording, you will get a great education on a variety of radio engineering topics. Kirk makes learning fun, and I hope to meet this guy someday. www.thisweekinradiotech.com

For those of you who want or need something a bit more on the academic side, you can enroll in a course from the Cleveland Institute of Electronics. I have taken a course through them, and I enjoyed it very much. You can take a course that touches mostly on the radio engineering side, with little on the mathematics side, or you can take an electrical engineering course and earn an Associates Degree in Electrical Engineering.

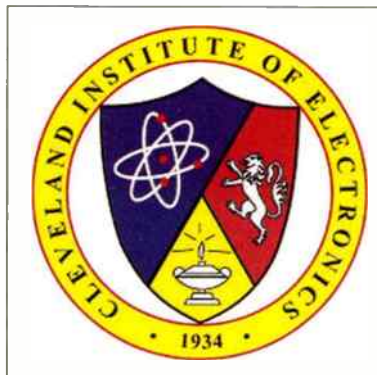

I mentioned mentoring earlier when talking about the SBE. One of the biggest advantages of having a mentor is being able to learn one-on-one from an engineer that has already done it. You can also ask questions that you might think are "stupid." Mentors don't consider questions "stupid." The only "stupid" questions are those that don't get asked. I appreciate the gracious attitude of fellow engineers who love to teach. As you know, good engineers are always learning.

By the way, if you are an experienced engineer with some time to spare, consider contacting the SBE and volunteering as a mentor. If you are a new engineer and would like a mentor, I would encourage you to contact the SBE, too. To become a part of the mentoring program, please contact Cathy Orosz, Education Director with the Society of Broadcast Engineers, at this email address: corosz@sbe.org You may also reach Cathy at 317-846-9000. Cathy is a gracious and helpful person

and you will enjoy speaking with her. I got to meet her at the South Carolina Broadcasters Association Convention and she is a delightful gal with a passion for education. Thanks, Cathy, for helping us engineers keep our knowledge current.

Another place where you can get help and mentoring is from social media. I belong to a few engineering-related Facebook groups. There is a wealth of knowledge on Facebook. You can join groups that talk about RF, groups that talk about broadcast automation, and a lot more. When you are on Facebook, go to the search bar and enter some key words like "engineering" and join the groups that appeal to you.

Last, but not least, is Amateur Radio. In my studies to get my Extra Class license, I noticed a lot of what I learned in Amateur Radio applies to radio broadcast engineering. Not only is "Ham" radio a fun hobby, it is a way to learn the RF side of radio broadcasting. There are a lot of great websites about Ham radio, as well as Facebook groups. You can also locate a local "Elmer," which is Ham jargon for a mentor who will help you learn a lot.

I am about out of space, but I hope I have covered enough for the young, somewhat inexperienced engineer to get a good education on all things engineering, at least from the radio side of things. If you have some great educational resources I didn't mention, please let me know.

The thoughts, ideas, and opinions in this column are my own, and do not necessarily reflect the views of *Radio Guide* or its publisher.

Steve Tuzeneu, CBT, is the general manager and chief engineer for WIHS 104.9 FM in Middletown, Connecticut. He is a member of the SBE, and an extra class radio amateur.



SERIES CORTEX

Take Your Remote Site Intelligence to the Next Level

Monitor, Control and Automate Your Transmitter Site

- Completely Customizable HTML 5 GUI
- Powerful SNMP Manager & Modbus Master
- Smartphone Application Dav2You

Working remotely has never been easier with a remote site management system

cortex.davicom.com



T. 1 877 282-3380 | dvsales@davicom.com



WALLTIME

NTP Clock & Notification System

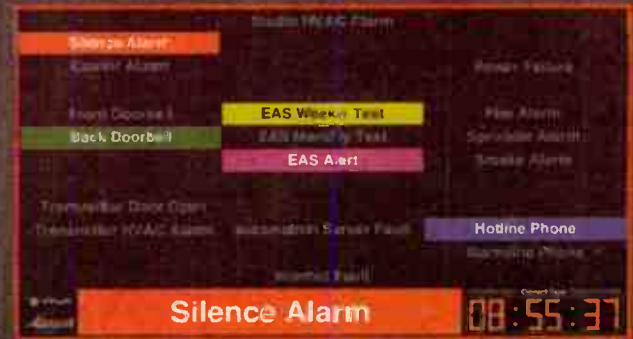

\$295

- Display Styles with Analog and Digital Clocks, Multiple Time Zones, Notifications & Alerts
- Built-in NTP Client & Server
- Widgets for On Air Light, Segment Counters, Status Notifications, Livewire Audio Meters and More
- Customize with Your Logos
- Supports Livewire, WheatNet & Ethernet GPIO Interfaces

www.paravelsystems.com

(877) 44-PARAVEL
(877) 447-2728



Antenna Sizes Available
.6m to 5.0m

DH Sectional C/Ku Band Antennas Available:

1.8m ~ 2.4m ~ 2.7m ~ 3.0m
3.7m ~ 4.2m ~ 4.5m ~ 5.0m

Mount Options:

Fixed Az-El, Polar Tracking, Horizon to Horizon,
Fixed & Dual-Powered Gibraltar Az-El
Dual-Powered Gemini Az-El

Options:

Hot Dip Galvanizing, Electronics, Cabling, Filters, De-icing,
Non-Penetrating Roof Mounts & Concrete Template Kits

For More Information: dhsat@mhtc.net

DH Satellite Leading the Industry

Outperforming the rest for over 35 years!
Our 3.7m 4-piece sectional antenna with computer
generated ribs has been the industry standard
FOR DECADES!

Superior Quality Quick Delivery
Inexpensive Shipping & Simple Installation
Low Maintenance 10,000's Installed Globally



**Prepare for the
Upcoming
5G Transition**

DHSatellite.com ~ 800-627-9443

Small Market Guide

How One Small Market Station Cured Its STL Reception Problems

by Roger Paskvan

Just about every year, in the spring and fall, our small market stations experienced one or more audio outages, usually early in the morning and sometimes around sunset. Part of our problem is that the STL path skims a lake for several miles. Usually this fade occurs in fog or radical temperature changes. When this condition happens, the on-air signal just mutes and it appears like the transmitter failed even though it is still on the air. The outage can last from several minutes to half an hour then, like magic, everything just starts to work as if nothing ever happened. The effect is similar to sun outages on your satellite dish. After putting up with these outages for several years, we decided enough – let's fix this problem.

The thought occurred to me that "two is better than one." Two Kathrein PR950 antennas, the longtime standard for STLs, were ordered for the job. These half-moon dish antennas coupled together could provide a 3dB signal improvement. (That's double the signal.)

The wavelength at 950 MHz is only a foot, so the 0.68 phasing rule is out the window. That's not all bad since greater spacing would open the door to a property called diversity reception. In theory, the received signal could be picked up on the top dish or the bottom dish – or both. We chose to position the PR950 dishes at six (6) feet apart on the receiver end. This is the vertical spacing between the two antennas on the tower. (Measured feed point to feed

point.) The combiner also provides 30 dB of reverse isolation to help with diversity reception.

The phasing harness can be made up made up of coax cable and a handful of connectors. Since the frequency is so high, the dimensions get real critical. A homemade coaxial splitter would have been a challenge at this frequency and offers no isolation between ports. Even 1/8" off, can make a large difference, therefore we chose the commercial power combiner by Telewave which would preserve "N" connectors in the whole system. The combiner consists of manufactured rigid coax that is exactly one quarter wavelength. Its magic property is that it will double the 50 Ohms at the opposite end. The combiner utilizes this property to match the two dish antennas by converting them both to 100 Ohms and combining them together at a tee connector. (Two 100 Ohms in parallel will get us back to 50 Ohms). (See figure 1)

This combiner allows the use of any equal lengths of coax between the dishes. Half inch Heliac was ordered to exact four foot equal lengths and connected to each dish feed point, then to the combiner. The output of the combiner is connected to the original Heliac going to the STL receiver. The layout of the combiner system is shown in the illustration. (See figure 2)

Since the installation of the two dish diversity STL receive system, we have not had any problems with signal

fading to date. Either the 3dB signal increase or the diversity reception fixed the problem.

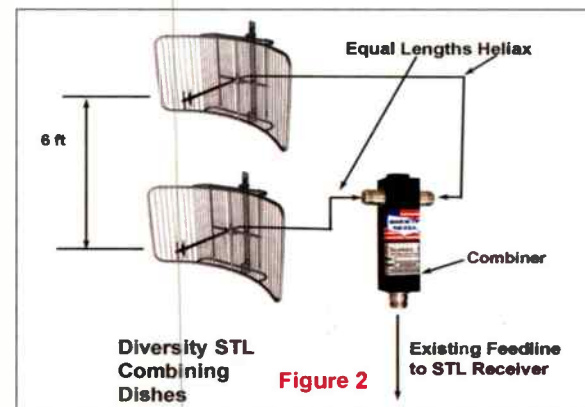
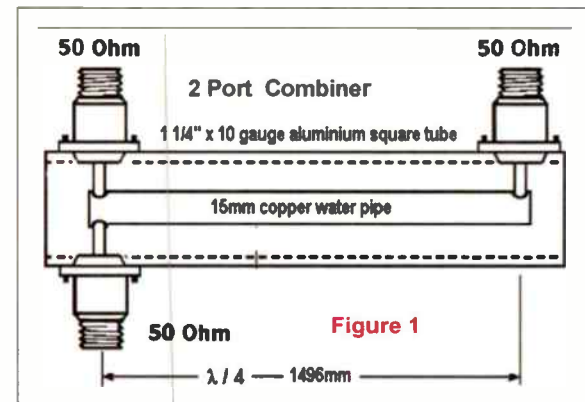

If your station is having STL reception problems, this may be worth looking into for an easy solution to an age old problem.

Roger Paskvan is a Professor of Mass Communications at Bemidji State University, Bemidji, MN. You may contact him at: rpaskvan@bemidjistate.edu

Your constant in a changing world.

chaotic

Engineered solutions

Timely delivery

Emergency support

Directional pattern leader

Shively Labs®

FM Antennas - Filters - Combiners - Coax

www.shively.com

888-744-8359

WebDAD

Native-level access to
your automation system
from anywhere.



ENCO.com/VirtualDemo

800-ENCO-SYS

sales@enco.com

Why Not Switch to



Complete FM / TV Product Line

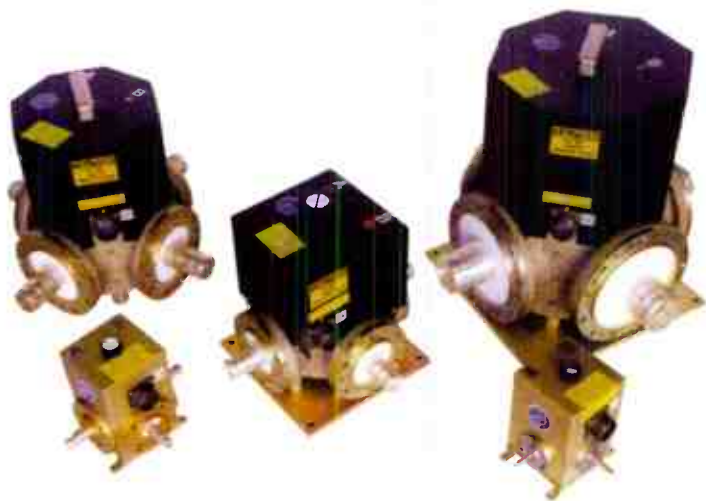

Coax switches available in
Type-N and 7/16 DIN and
7/8" through 6-1/8"

- Antennas
- Splitters
- Notch Filters
- Harmonic Filters
- Power combiners
- Channel combiners
- N +1 Switching Matrix

Control panels available.

A subsidiary of **MEGA** RF Solutions

www.megaind.com

Toll Free: 800-545-0608 | www.mcibroadcast.com

Capacitors in Solid-State Transmitters

by John L. Marcon, CBRE CBTE 8VSB Specialist

Station engineers are well aware that their equipment can sometimes breakdown because of a relatively inexpensive component like a capacitor. Capacitors are found just about everywhere in a transmitter: control system, power supply, amplifier system and so on. Whether your transmitter is tube or solid state, AM or FM, one has to deal with this device. It comes in all sizes too: from as small as a grain of rice or as big as your office trash can. This reminds me years ago when I worked on a station with a 100 kW AM transmitter. The aluminum blocking capacitor was so big, I could not wrap my hands around it. Nowadays, we deal with much smaller capacitors, especially in our solid-state transmitters.

Not too long ago, the transmitter PA modules of our flagship station started failing due to shorted gate to source junction of the Field Effect Transistors (FETs). This was always accompanied by a faulty surface-mount electrolytic capacitor on the input side of the amplifier and on the gate DC supply circuit. The failure also happens randomly – it occurs on any of the modules and not only in one cabinet, it happens on all the cabinets. A power module consists of four pallets and each pallet has two transistors and four surface-mounted 220 uF electrolytic capacitors. The 4 pallets sit directly on top of a big heatsink. The heatsink, of course, is what absorbs all the heat coming from the flange of the transistors and, as heat energy goes, the heatsink temperature is always less than the flange temperature. An inlet airflow temperature of 59°F (15°C) would yield a heatsink temperature of 104°F (40°C) and a flange temperature of 162°F (72°C).

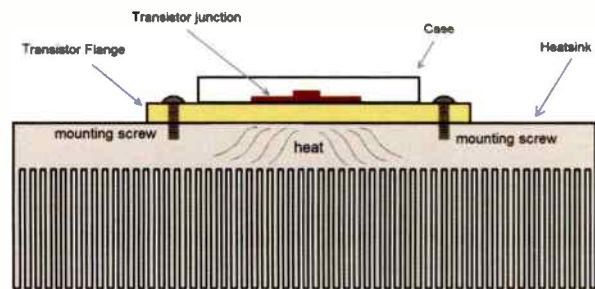

RF Transistor heat dissipation. The flange is the source of all the wasted heat and any passive device close by such as surface mount capacitors will absorb some of the heat, increasing its temperature.

I have suspected for some time that the flange temperature was a little higher than it should be and this was affecting the surface mount capacitors nearby. Capacitor life in an energized circuit is directly affected by the ambient temperature. See Figure 2.

As we can see from the chart, the higher the temperature, the lower is the lifespan of the capacitor. Let's look at some values from the chart. If the ambient temperature is 65°C, the life span would be about 85,000 hours. If the ambient temperature increased to 85°C, the lifespan would be about 21,000. If your transmitter is running 24x7 and had this increase in temperature, the lifespan went down from 9.7 years to 2.4 years.

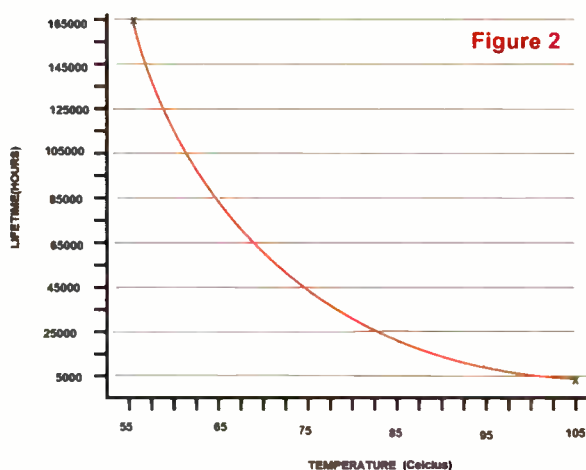

A sample lifespan vs temperature chart of an Electrolytic capacitor.

If you look at the trend in the chart, it does not look linear. Manufacturers actually provide an equation for this phenomenon. It is based on Arrhenius equation for temperature dependence of reaction rates.

The equation is:

$$L_f = L_r \times 2^{\left(\frac{T_{max} - T_a}{10}\right)}$$

L_f = Estimated life (hrs)

L_r = Life at rated temperature (hrs)

T_{max} = Rated temperature, °C

T_a = Ambient temperature, °C

The formula looks to be non-linear but if the difference between ($T_{max} - T_a$) is 10°C, the estimated life L_f will be $L_r \times 2^1 = 2 \times L_r$. In other words, the Life span doubles for every 10°C decrease in working temperature. In a sense, this is somewhat of a linear relationship. I saw this effect of heat on a capacitor first hand with a high-power SCR controller. The firing circuit for the SCR has an electrolytic capacitor mounted very close to a TO-220 transistor heatsink. The heat quickly dried up the capacitors resulting in faulty firing pulses.

In the case of the modules in our transmitter, the capacitors used are 220uF/35V surface mount Panasonic VKF series. There are 16 of these caps per module and there are 24 modules – in total there are 384 pieces. Also remember that whenever one fails, it also damages the transistor. The first question I asked then was: how long should these capacitors last under normal conditions? The transmitter was installed in 2008 and failures started occurring in 2015, or a total of 7 years, that is equivalent to 61,320 hours.

Now based on the capacitor data, the Panasonic capacitor was rated 2,000 to 5,000 hours at 105°C. I saw flange temperature back then reaching 185°F (85°C). If I based the ambient temperature at 85°C and

use the equation, the Life span only ranges from 8,000 to 20,000 hours total. The max value of 20,000 hours is obviously much less than 7 years of operation (61,320 hours). It seems to show that the capacitors were, on average, not really having abnormally high temperatures. However, back in 2014 there were a number of breakdowns with the air-conditioning and capacitor failure in the modules began to increase as well.

The air-conditioning was replaced with a new one but the caps were still failing so I decided to replace all of them. I first ordered a proper soldering station and other accessories for the job. A de-soldering station was added later. I also cleared up the working table and re-arranged all the parts and tool placements so that it would be more efficient to work on all 384 capacitors. The hardest part was removing the surface mount capacitors. There was barely enough wiggle room for the tip of the soldering iron.



All the old surface-mount capacitors were replaced with a higher voltage rated capacitor. The bunch on the left are 35V rated while the 50V ones are on the right side.

We always thought that a higher voltage rated device was always better, so the new capacitors I ordered had a higher 50V rating. The new capacitors were physically larger but still fit the space where the old ones were. It took a few weeks to replace all of the capacitors and it was a great satisfaction that this job was accomplished. The change seemed to work because there were no more failures on any of the capacitors and FETs.

However, much to my surprise, after only 3 years, some of the new 50V capacitors started failing. The “bigger is better” idea is not true in this case. It was quite a work replacing all those capacitors and it was looking like I had to do it all over again. “The engineer’s path is littered with mistakes,” as they say. Fortunately, these are relatively inexpensive devices. The big question was, what caused the failure this time? They were supposed to last longer because their voltage rating was higher. I wondered whether this was just infant mortality, due to a bad batch of capacitors from the vendors, or maybe the soldering iron was too hot. The other thing was that the DC supply may also have increased in its ripple voltage.

To check the ripple, I had to look at the supply while it was on full load. The main DC supply was a high-power linear circuit using a transformer, diodes and capacitors. No inductor on the DC. There was one power supply per four modules so it uses a big transformer and really hefty diodes.

The power supply capacitors are 22,000 uF each and there are eight of them, for a total of 176 mF. I looked at the DC with an oscilloscope but the ripple was very low – almost nonexistent.

(Continued on Page 42)

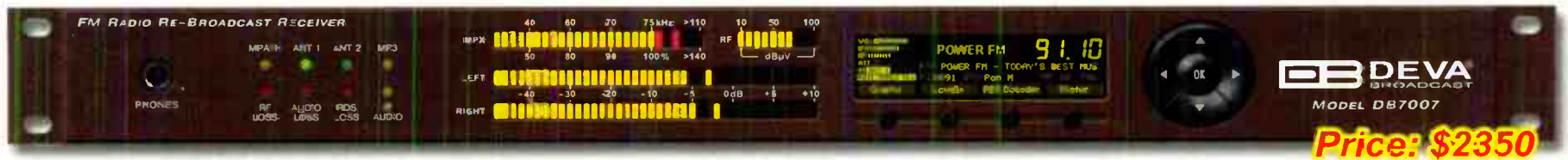
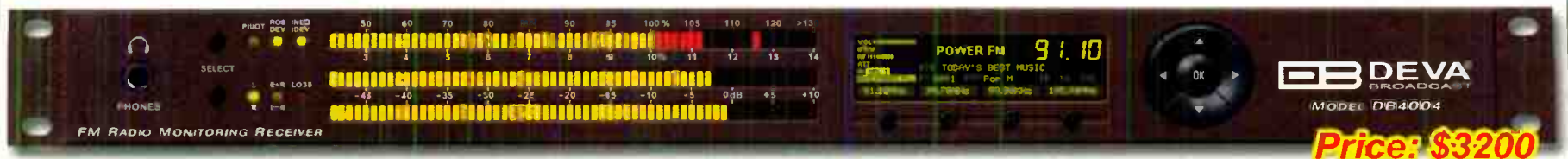

Modulation Monitors • Rebroadcast Receivers • RBDS Encoders • Broadcast Tools



**RF Contactor
Repairs & Spare Parts**

- Solenoids
- Fingerstock
- Insulator Bar



**Mica & Vacuum
Capacitors**

Available for overnight
shipment



Kintronic Labs[™]
An ISO 9001 registered company
Kintronic is a trademark of Kintronic Labs Inc.



LAB4.50 Dehydrator

- 6 Air Outlets,
- 300 l/hour flow rate



**Climate-Controlled
Weatherproof
Equipment Racks**

Model: WPR-26-24-29



**FM Isocouplers &
Broadband Isocoils**

Email: ktl@kintronic.com

Tel: 1-423-878-3141

Web: www.kintronic.com

Capacitors in Solid-State Transmitters

– Continued from Page 40 –

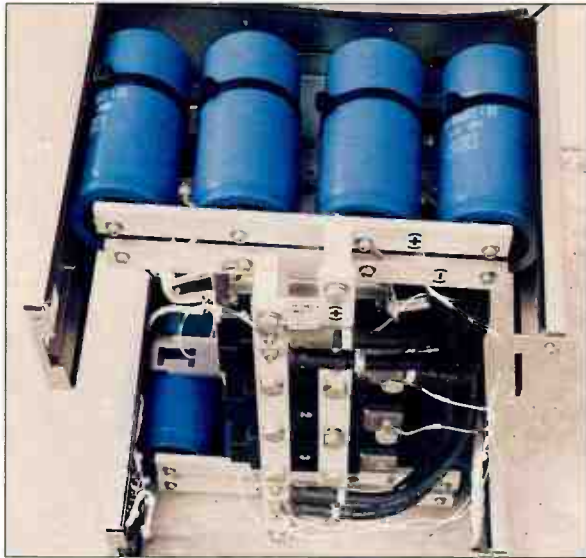

The 32V power supply for four power modules. These big capacitors, unlike their small surface mount cousins, seem to last forever. One possible reason is that the air from the blower hits this unit first before going into the other parts of the transmitter.

At any rate, I called the vendor and asked them about the capacitors we bought and they assured us that they were all from a good batch and that they would replace them if we asked for it. I thought of

doing over-voltage or over-temperature tests on the 50V capacitors. However, a number of them failed again. So, I just decided to replace them all with the original 35-volt rated capacitor.

I bought a new batch of the 35V type and it took a few weeks again to replace all of them. This time I made sure that the soldering iron temperature was not too hot. I was using a higher temperature the last time I changed them, so it might have affected some of the capacitors as well. There is somewhat of a tradeoff in the soldering because soldering the ground side of the capacitors required more heat because of the heatsink. The heatsink is huge so it really draws most of the heat. However, if you lessen the heat, it may result in a cold solder joint. Soldering the positive side of the capacitor is no problem at all. Hopefully this time, it will last a little longer until we can replace the whole transmitter with a new one.

Capacitors are actually always in the news and you are not to be blamed if you did not notice it. The issue of a bad batch of capacitors from manufacturers was news from 1999 to 2005 and they called it the “capacitor plague.” A large number of aluminum electrolytic capacitors were failing prematurely and the culprit was determined to be a manufacturing defect. This high failure rate occurred in motherboards and power supplies of computers.

Many computer and electronic manufacturers were affected by this problem. In fact, Dell spent \$420 million replacing computer parts and other related actions. It was suspected that the bad capacitors were made in Taiwan. Then in 2018, I got a 4-page letter from a law firm asking us to join a class action lawsuit

against capacitor manufacturers (e.g. Chemicon, Panasonic, Nichicon, etc) and this time for price fixing. We did buy hundreds of surface mounted capacitors to be used for our transmitter. But the cost was not much, just a few hundred dollars. The GM decided to just ignore the letter. The manufacturers are trying to reach a settlement, that was the last I heard on this issue.

It seems the saga on this passive device will not end soon. But as long as we keep our equipment cool, and the capacitors are not of the bad batch, they will surely last for a long time.

Source: <https://www.xppower.com/resources/blog/electrolytic-capacitor-lifetime-in-power-supplies>

John L. Marcon, CBTE CBRE 8VSB Specialist, is the Chief Engineer for Victory Television Network (VTN) in Arkansas, with international experience in both Radio and Television Broadcast, and has an Electronics Teaching background.

TRANSMITTING CAPACITORS

MICA-VACUUM-CERAMIC

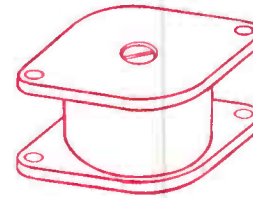

SURCOM ASSOCIATES, INC.
(760) 438-4420
LINK@SURCOM.COM



HELPING YOU SEND CLEAR SIGNALS SINCE 1997

AMERICAN



MADE



FM & TV TRANSMITTERS



STL SYSTEMS



FM & TV ANTENNAS

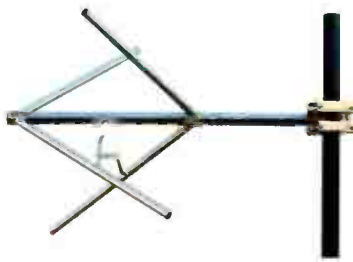

TRANSCOM CORPORATION

Serving the Broadcast Industry Since 1978

Visit Our Website – www.fmamtv.com

Send your e-mail requests to: transcom@fmamtv.com

Fine Used AM & FM Transmitters & New Equipment

AM	1 kW	2005	Nautel J1000
	5 kW	2015	GateAir DAX5
	5 kW	2004	GateAir DAX5
	6 kW	2016	Nautel XR6
	12 kW	2001	Nautel XL12
	50 kW	1999	Harris DX50
	50 kW	2006	Harris 3DX50

Please see our current listings on our website.

FM	55 W	2000	Harris DIGIT™ CD
	3.5 kW	1985	BE FM3.5A
	10.0 kW	2005	Harris Z10CD
	20.0 kW	2005	BE 20T
	25.0 kW	2004	Harris HT25CD

Please see our current listings on our website.

Special	10.0 kW	1995	CCA AM10000HF
	1 kW	2018	Radio Partes 1000

Used Misc. Equipment:

Bird Model 8932, 10kW Air-Cooled RF Load

Exciters:

Harris DIGIT™ – New 30W Synthesized



Please go to our website for updated listings. Retuning and testing available – call for quote!

OMB STL systems for radio, complete with antenna and cable for under \$5,000!

PO Box 26744, Elkins Park, PA 19027
800-441-8454 • 215-938-7304 • Fax: 215-938-7361

619.671.9500

NICOMUSA.COM

The HIGH EFFICIENCY BROADBAND ANTENNA



(877) HEBA-4-US (781) 275-1147
www.worldwideantennasystems.com

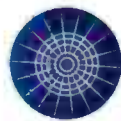

WORLD WIDE
ANTENNA SYSTEMS

THE FUTURE OF BROADCASTING IS

BRIGHT WHITE



All the features
you want in the new line of
transmitters from the company you can trust

Call Bext today to learn more about the many
built-in features of the new XD White Line of Transmitters

BEXT

888 239 8462

bext.com

ECONCO

Rebuilt Power Tubes



Approximately One Half the Cost of New
3,000 Hour Unconditional Guarantee
Call for Your Quotation



Phone: 530-662-7553 • Fax: 530-666-7760
Toll Free: 800-532-6626

www.econco.com

1318 Commerce Ave, Woodland, CA 95776



**RF Specialties®
Group**

The most trusted Nautel
dealer for 35 years

Contact your local RF Specialties office
for more information

rfspecialties.com



nautel

Bay Country Broadcast Equipment

Buy • Sell • Trade

Your #1 Source for Quality Used Radio Broadcast Equipment

View our latest list of equipment on-line at:

www.baycountry.com

(Website Updated Daily)

All equipment sold with a 15 day return guarantee.

Turn Your Excess Gear Into Cash

Send your list to us and we will respond with our offer promptly.

We only buy good working equipment with traceable serial numbers.

Send Your List Today – sales@baycountry.com -or- Fax 443-596-0212



E-mail: sales@baycountry.com

877-722-1031 (Toll Free) 443-596-0212 (Fax)

7117 Olivia Rd, Baltimore, MD 21220

TLM-2 TOWER LIGHT MONITOR

Total Monitoring for Older Lighting Systems



A microprocessor based system designed to monitor the status of FAA type A incandescent tower lights.

- Individual alarms for photocell, flasher, beacon & marker.
- Status outputs for lights on/off and beacon on/off.
- LED indicators for each alarm and status output.
- Opto-isolated fail-safe outputs for each alarm.
- Easy setup – one button calibration.
- Installs at the circuit breaker panel.
- Available through broadcast distributors.

FM Services

www.towermonitor.com • 336-667-7091

RF ENGINEERS, INC.

- Tower Grounding & Lightning Protection
- Coverage Modeling & Maps
- RF Exposure Studies
- FCC Applications

Call us to discuss your project needs.

352-367-1725

rfengineers.com/services

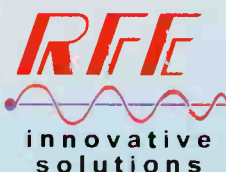

A Professional Engineering Company

ICE KRACKERS®

The Solution Since 1979

NEED ICE DAMAGE PROTECTION FOR YOUR TOWER?

With the higher levels of atmospheric moisture, we may have very high snow and ice levels this year. Be prepared with Ice Krackers®.

Protect your tower site investment by protecting your anchor hardware and dampers with an inexpensive Ice Kracker.

Ice Krackers are galvanized and supplied with all mounting hardware and can be installed within minutes.

The average cost for equipping Ice Krackers at the tower is about \$500.



Contact us for a quote:
icekrackers@comcast.net
icekrackers.com

800-747-8921

Doug Vernier

Telecommunications Consultants

- FCC Applications for AM, FM, TV, DTV, LPTV, STL
- Upgrade and Due Diligence Analysis
- Frequency Searches
- Site Relocations
- Propagation Prediction with Custom Mapping
- Demographic Analysis
- Directional Antenna Design



We use V-Soft Software!

www.v-soft.com consulting@v-soft.com 800-743-3684

TRANSMITTING CAPACITORS

MICA-VACUUM-CERAMIC

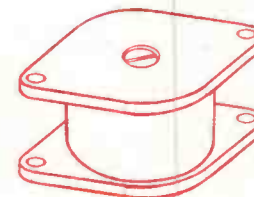

SURCOM ASSOCIATES, INC.
(760) 438-4420
LINK@SURCOM.COM



The Leader in Broadcast Engineering Software!

• Create stunning "real-world" coverage maps, interference studies, and population reports with Probe 5™

• AM Pro 2™, used daily by FCC engineers, performs skywave and groundwave allocation studies and AM coverage mapping

• Find STL broadcast auxiliary and Part 101 microwave frequencies and generate PCN letters with Microwave Pro™

• Map FM stations and find upgrade possibilities using FCC minimum separations and contour-to-contour methods with FMCommander™

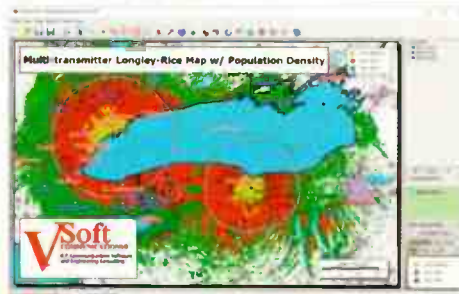

www.V-Soft.com - info@v-soft.com - 1-800-743-3684



AM-FM Transmitters

Pre-Owned – Tuned and Tested to Your Frequency

www.Besco-Int.com

Rob Malany – Owner

321-960-4001 • sales@Besco-Int.com

YOUR ULTIMATE SUPPLY & SERVICE SOLUTION



From our Facility to yours



Design & Integration

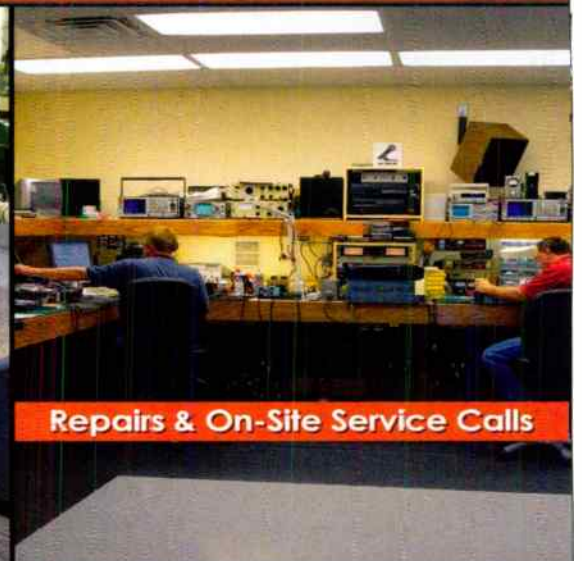

Repairs & On-Site Service Calls

LIGHTNER ELECTRONICS www.lightnerelectronics.com
 Toll Free 1-866-239-3888 | Shop online www.broadcastavsales.com

Simple. Easy.

Your life and your processing should be that way.



Complete FM broadcast processor with NO DIGITAL LATENCY.

- Simple, easy, and cost-effective audio processing solution.
- Rapid and simple installation, setup, and operation.
- Compressor out for audio streaming feed.
- Optional frequency-agile PLL FM signal generator for in-house modulation monitoring.

Even the price is easy: MSRP \$1094.95 | \$1249.95 with FM signal generator

Designed and built in the USA by:

SEPsoniX
Simple. Easy Processing

JT Communications, LLC
Ocala, FL USA
352-236-0744
www.sepsonix.com



LOW POWER AM

by Ron Erickson

Before LPFM came into existence, I often wished for a legal way to broadcast a few miles around town on AM. I thought that Part 15 rules should be modified to allow Low Power on AM for purposes of super-serving small markets and of course for hobby radio. As it turns out, other people were thinking similar thoughts. At least one petition in the past was submitted to the FCC. The petition asked for things like: no restriction on antennas, eliminating the field strength threshold of 15.209, allowing 1710 kHz to be exclusively used by one Watt broadcasters and bringing back AMAX standards for receiver manufacturers. I have mentioned in previous articles that many of us in commercial radio today started with Part 15 AM transmitters.

On that note, If you had a "Knight Kit" back in the day, you may enjoy this Ebay store I found: <https://www.ebay.com/str/piratepeteelectronics>

I was inspired to look more closely at various gear used in Low Power AM Broadcasting when I recently read that One Watt AM Transmitters were being licensed on 1485 kHz in the Netherlands. I found a transmitter called the "Swordfish" that is being built and sold for that purpose. Then I discovered the same box with a different name is being sold in Scandinavian countries; it's called the "Mosquito." But this "little buzzer" is frequency agile from 1000 kHz to 1710 kHz. This company offers a 100 milliwatt Part 15 AM transmitter sold under the name of "Spitfire." I don't believe this one is actually FCC approved, but there are many low power AM transmitters sold commercially that do adhere to the FCC Part 15 requirements:

Section 15.219 Operation in the band 510 - 1705 kHz. (Excerpt)(a) The total input power to the final radio frequency stage (exclusive of filament or heaterpower) shall not exceed 100 milliwatts.(b) The total length of the transmission line, antenna and ground lead (if used) shall not exceed 3 meters.(c) All emissions below 510 kHz or above 1705 kHz shall be attenuated at least 20 dB below the level of the unmodulated carrier.

(Simple answer to "(c)" – don't use your 100 mW transmitter above or below the broadcast band.)

For many years my company, Erickson Broadcast Sales, sold broadcast equipment and performed engineering services. Included in our sales portfolio were hobby broadcast transmitters like the Rangemaster 1000 transmitters. The Rangemaster 1000 was the choice of LPAM broadcasters

because it seemed to have more range than other similar transmitters.

But hang on friends, there is a new Part 15 AM transmitter being designed and built in Grants Pass Oregon. Radio Design Group Inc., led by Mr. Jim Hendershot, President/Chief Technology Officer, is designing a new FCC-legal, low power AM transmitter with cutting edge technology. Imagine an automatic, no-tune match to the FCC limited 10' antenna. A circuit that keeps the input power at a constant 100 milli-watts regardless of external temperatures or other challenges. It sports a super efficient antenna output of 60 milliwatts, and is designed to operate well, regardless of placement, mounting or grounding. The advent of this new, as of yet unnamed transmitter, is very exciting. It has a built-in audio limiter which can be disabled allowing for the use of an external AM Audio processor.



Radio Design Group LPAM Tx

The company will soon seek certification from the FCC and then the unit will go into production and be available to purchase.

That brings me to what I feel is the best AM Processor for the price, available today.

Jim Wood, retired CEO of Inovonics, designed and built a compact, low cost AM audio processor with a funny name; The Schlockwood AM 200. Its functions include gated-AGC, variable pre-emphasis, multiband compression/limiting, program equalization, asymmetrical peak control and a sharp cutoff filter. Designed to enhance AM better than commercially built units and at a very affordable price.



There's more Part 15 AM radio as described in the FCC rules. Perhaps the oldest form of un-licensed broadcasting is something called Carrier-Current radio. The "art" of using power lines as an antenna for AM transmitters. The AC power

grid is very un-friendly to radio signals. Special couplers were developed in the 1960's to make the transition more effective. "Wired-Wireless" as it was called when U.S. Major General George Owen Squire was experimenting with this form of radio. In fact, according to Wikipedia, Squire was the first person to attempt to use Wired-Wireless radio in a commercial application. The technology had to catch up with the invention of the vacuum tube, but in 1922, he created a company called *Wired Radio*, a service which piped music to businesses and subscribers over wires. In 1934, he changed the service's name to *Muzak*. *Muzak* gave up electrical wires for other methods of piping background music into elevators and stores. In fact, *Muzak* is still around today, but now it's called *Mood Media* and they do song testing and targeted audience research to get you in the mood to buy goods and services..



Carrier current radio went to school and became very popular for student operated college radio stations. So popular that a new organization, the *Intercollegiate Broadcasting System*, was formed in 1940 to represent the growing interest in school operated stations. The FCC modified Part 15 to include *Free Radiating AM* signals on college campus property and also summer camps. The restrictions include non-interference in commercial stations and a set field strength measurement at the property line.

Two companies built up to 30 Watt commercially available Carrier-Current transmitters and equipment. LPB, which started in 1960 and Radio Systems, which was founded in 1976, but didn't start building transmitters until 1980. They both built similar transmitters and AC couplers and both companies' products have faded from existence.

This photo shows an early LPB tube style transmitter. This one was the model RC-6A. Drive in theatres used these types of transmitters to offer better quality sound that you received on your cars AM radio.



So, let's review: The FCC has allowed field strength measured, Free Radiating AM on College Campuses without power restrictions, Free Radiating signals out in the woods at summer camps, carrier-current practically anywhere you can load onto a power line, and a bunch of 100 milliwatt transmitters to be sold in the USA. Like the Rangemaster, that new one from Radio Design Group will have actually have no limits on range, according to Part 15.219.

Perhaps it is time the Commission allows hobby LPAM to be developed with some modifications. What do you think?

Ron Erickson can be reached at ronerickson@gmx.com or at 541-460-0249.



OWL ENGINEERING, INC.

Consulting Communications Engineers
5844 Hamline Ave. N., Shoreview, MN 55126

651-784-7445

- AM/FM/NCE Applications
- Allocation and Upgrade Studies
- Pre-Purchase Inspections
- ANSI and NRSC Measurements
- AM Directional Array, Design, Tuning and Proof using Method of Moments
- Tower Detuning
- Intermodulation Studies
- Radiation Hazard Evaluation and Measurements

Fax (651) 784-7541 E-mail: info@owleng.com "Member AFCCE"

Remote Reboot of AC Powered Devices

**Stackley
Devices
LLC**

**(609)
647
9677**



**RemOutlet
Reboot
Mini
\$179**

**Adjustable
Power
OFF Time**

www.RemOutlet.com

FINAL STAGE



RADIO ROUNDUP

The Radio Guide Event Register

Email your dates and info to: radio@rconnect.com

WBA Broadcasters Clinic **CANCELLED**

October 13-15, 2020

Madison Marriot West – Madison, Wisconsin

www.wi-broadcasters.org/events/broadcasters-clinic-2/

Midwest Broadcast & Technology Conf **CANCELLED**

November 17, 2020

Columbus Convention Center – Columbus, Ohio

mbmtc.oab.org

2020 Nebraska Broadcasters Assn. Convention

CANCELLED

2020 Ohio Broadcast & Technology Conference

CANCELLED

2021 CES Conference **CANCELLED**

January, 2021

Convention Center – Las Vegas, Nevada

<https://ces.tech>

2021 NRB Convention

March 15-18, 2021

Grapevine, Texas

www.nrbconvention.org

NAB Show 2021

April 10-14, 2021

Las Vegas, Nevada

www.nabshow.com

Radio Guide Advertiser Info – September-October 2020

Advertiser - Page

Altronic - 30

Angry Audio - 27

Arrakis - 13

Bay Country - 44

Besco - 44

BEXT - 43

Broadcast Devices - 3

Broadcasters General Store - 31

Broadcast Software Intl. - 15

Broadcast Tools - 28, 47

CircuitWerkes - 25

Coaxial Dynamics - 4

Davicom/Comlab - 36

Deva - 41

D&H Satellite - 37

Econco Tubes - 43

Enco - 39

ESE - 47

FM Services - 44

GatesAir - 19

Graham Studios - 47

Henry Engineering - 2

Inovonics - 1, 23

Kintronic Labs - 41

Lawo - 9

Lightner Electronics - 45

Website

www.altronic.com

www.angryaudio.com

www.arrakis-systems.com

www.baycountry.com

www.besco-int.com

www.bext.com

www.broadcast-devices.com

www.bgs.cc

www.bsiusa.com

www.broadcasttools.com

www.circuitwerkes.com

www.coaxial.com

www.davicom.com

www.devabroadcast.com

www.dhsatellite.com

www.enco.com

www.eso-web.com

www.eso-web.com

www.eso-web.com

www.eso-web.com

www.eso-web.com

www.eso-web.com

www.eso-web.com

www.eso-web.com

www.eso-web.com

www.eso-web.com

Advertiser - Page

Logitek - 21

Mega Industries/MCI - 39

Nautel - 5

Nicom - 42

Owl Engineering - 46

Paravel - 37

Phasetek - 47

PTEK - 24

ProAudio.com - 48

Propagation Systems (PSI) - 26

RF Engineers - 17

RF Specialties/Nautel - 43

SCMS - 35

Sepsonix - 45

Shively - 38

Smarts Broadcast Systems - 11

Stackley Devices - 46

Studio Items - 32

Surcom - 44

Telos Axia - 33

Telos Omnia - 29

Tieline - 7

Titus Labs - 34

Transcom - 42

V-Soft Communications - 44

Worldwide Antenna Systems - 43

Website

www.logitekaudio.com

www.mcibroadcast.com

www.nautel.com

www.nicomusa.com

www.owleng.com

www.paravelsystems.com

www.phasetekinc.com

www.ptekpower.com

www.proaudio.com

www.psibroadcast.com

www.rfengineers.com

www.rfspecialties.com

www.scmsinc.com

www.sepsonix.com

www.shively.com

www.smartsbroadcast.com

www.stackleydevices.com

www.studioitems.com

www.surcom.com

www.telosalliance.com

www.telosalliance.com

www.tieline.com

www.tituslabs.com

www.framtv.com

www.v-soft.com

www.worldwideantennasystems.com

Plug & Play Distribution



2x16 DA/RJ Analog Distribution Amplifier

The new Broadcast Tools 2x16 DA/RJ is the perfect choice for analog audio distribution. Standard pinout RJ45 audio jacks for easy installation with Cat5 cables. Configurable stereo (2x8) or monaural (1x16) outputs. Balanced RJ45 and unbalanced RCA input jacks eliminate the need for external input level conversion.



Broadcast Tools is a Veteran Owned Business
Designed, Assembled and Supported
in WA State, USA.
www.broadcasttools.com



PHASETEK INC.

Custom Phasing Systems

Phasetek, Inc. is dedicated to provide the broadcast industry high quality AM Phasing and Branching systems, Antenna Tuning units, Multiplexers, and RF components.

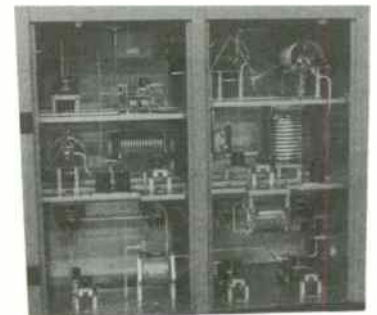

Phone: 215-536-6648
sales@phasetekinc.com
www.phasetekinc.com

Precision | Innovation | Proven



RADIUS XP

MODULUX

BIRCHLINE TALK TABLE

GRAHAM STUDIOS

Broadcast Furniture



815-222-3556
www.supportradio.com

866-481-6696 | www.graham-studios.com

TIME TO SYNCHRONIZE



ES-185E/NTP6 GPS Master Clock

Accurately generate time code with ESE's Master Clock via the 12-channel GPS receiver and output multiple types of Time Code, SMPTE-LTC/EBU, ESE, IRIG-B, ASCII (RS-232 & USB), and an extremely accurate 1PPS signal. Further reliability with dual battery back-up, and new control panel software. ESE's NTP6 feature provides an NTP server compatible with the latest version of Internet Protocol, IPv6. You can also easily interface with new or existing computers, automation and clock systems. Visit www.eso-web.com for all your time synchronization needs.



www.eso-web.com
+1-310-322-2136

SHURE

WIRELESS EXCELLENCE, WHEREVER REQUIRED.



SLX-D Digital Wireless Systems

SLX-D delivers transparent, 24-bit digital audio and rock solid RF performance with easy setup and rechargeability options in a suite of versatile system configurations.



SM7B Vocal Mic

Popular radio and TV mic featuring excellent shielding against electromagnetic hum.

Twin:Plex™ Subminiature Lavaliers

Stands up to the toughest conditions to make every word a clear statement of quality.

*New! Twin:Plex™ TH53
Subminiature Headset*

SONG + SPEECH



Learn more at proaudio.com
or call us at (800) 433-2105 for more information.

PROAUDIO
com
smart sound solutions

World Radio History