

Radio Guide

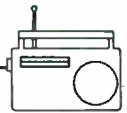

Radio's Technology Forum

February 1995

A 100% Increase

I've always felt that **Radio Guide** has been a bit on the skinny side. While we don't publish by the pound, we do, however, try to give you as much technical information as possible in each issue.

Between our paid subscriptions, strong renewals, and steady advertiser support, we have been able to increase the **Radio Guide** to 16 pages. This has allowed us to double the pages of technical content, and add a few other features to help you find the equipment you're looking for.

The INFO-FAX Form

On the back page, we've added the new **Radio Guide Info-Fax** form. You'll find Info-Fax numbers next to each advertisement in the **Radio Guide**. Circle as many as you like, and we'll do the rest. You'll receive additional product information from each advertiser you select.

If you're looking for equipment information for your next studio or transmitter project, the Info-Fax can help with that too. Just circle as many of the pieces of equipment about which you need more info, then we'll contact our contacts, and tell them to send you detailed equipment information. It's a new **Radio Guide** service that we hope you'll use often.

The Radio Guide BBS

We've modified the **Radio Guide BBS**. You no longer have to be a paid subscriber to join the BBS. Just call the BBS number, at 507-280-4045, and you can sign up on-line immediately.

Tech-Tips Wanted

With the addition of more pages, I'd like to be able to publish even more tech tips. We can only print 'em if we get 'em, so it's up to you, how many appear in each month's **Radio Guide**.

Ray Topp (editor/publisher)

Radio Guide (ISSN 1061-7027) is published monthly, 12 times a year, by Media Magazines Inc., 511 18th Street SE, Rochester, MN 55904.

All material contained in Radio Guide is copyright 1995 by Media Magazines Inc., and may not be reproduced in any form without the written permission of the publisher.

FEATURE OF THE MONTH

The Hum Eliminator™ from Ebtch & ABG breaks the ground-loops that cause AC hum, quick and easy. Just plug it into the signal lines between offending pieces of equipment and you're done.

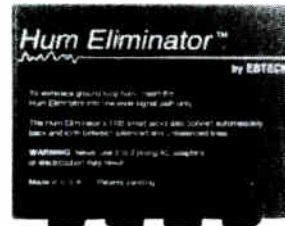

So get the Hum Eliminator™ today, and silence AC hum forever.

2 Channel Unit Just **\$55⁹⁵_{ea}**

Please call today!

MAIN SALES OFFICE
2342 S. Division Avenue
Grand Rapids, Michigan 49507
Phone: 800-999-9281
Fax: 616-452-1652

SOUTHEASTERN SALES OFFICE
200 Fareway Drive, Suite 2
Smithfield, North Carolina 27577
Phone: 800-369-7623
Fax: 919-834-8120

WESTERN SALES OFFICE
P.O. Box 1638
Palmdale, California 93550
Phone: 800-858-9008
Fax: 805-273-3321

For 35 years
AUDIO
broadcast group inc.

YOU MAY ALSO REACH US ANYTIME VIA ELECTRONIC MAIL
75371.144@compuserve.com

Info-Fax #108

Inside This Issue

Telco RFI (editorial)	2
Coupling Cap Kills Audio	3
Curing Delay Spasms	3
Tuning Tee Networks	3
Audio Pads and Attenuators	4
A Cheap Wireless Mike	6
Anomalous Nuts	7
Remote Transducers	7
The New EAS: An Overview	8
The New EAS: A Detailed Look	10
Continental 317-C Dougherty Hump	12

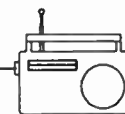

Radio Guide Publication

Raymond Topp (*editor and publisher*)

511 18th Street SE, Rochester, MN 55904

Phone: 507-280-9668

Fax: 507-280-9143

Our Contributing Technical Writers

George Whitaker - Arlington, TX

3505 Daniel, Arlington, TX 76014

Phone: 817-468-2586

John Bredesen - KLCC, Eugene, OR

3120 Nob Court, Eugene, OR 97405

Phone: 503-485-6869

Gordon Carter - WFMT, Chicago, IL

34 North Madison Ave., LaGrange, IL 60525

Phone: 312-565-5032

Andy Butler - Broadcast Electronics Inc.

P.O. Box 3606, Quincy, IL 62305

Phone: 217-224-9662

Frank Berry Ph.D.

190 112th Ave. N, #708

St. Petersburg, FL 33716

Phone: 813-577-0041

How to Submit Tech Tips

By BBS: Call our BBS at 507-280-4045, and leave your tech tips, info and articles.

By Disk: Send your tech tips and information on a 3.5" or 5.25" double, or high density floppy disk, in ASCII format.

By Compuserve: Leave E-Mail files to Radio Guide at Compuserve ID [71203,2341].

By Letter: We also accept clean, typewritten or printed manuscripts mailed to our address.

Telco RFI

The more I study the problem of RF in studios and telephones, the more intrigued I become. There seem to be some patterns, and yet, there are some completely anomalous happenings.

One thing I have concluded from my, admittedly unscientific, research is that shunt fed antennas seem to cause considerably more problems than series fed. And I have, as yet, been unable to determine exactly what frequencies are causing the problems. Sometime in the near future I hope to have the time to take my spectrum analyzer and see if I can learn anything with it. It is about a two hour drive to the station I am using as my study sample, and it is difficult to take off from trying to make a living, to go and do experiments.

However, because one of my sons and I own a company that manufactures RF filters for telephones, I find out real fast where the stations are, that nothing seems to work. They buy my filters, install them, and either nothing happens or the RF actually gets worse in the phone. Fortunately, this has not happened too often. But, it has identified for me some characteristics of the real problem stations.

At the present time, I am working with a couple of stations in Texas and in Washington. All of the problem stations have one thing in common: they all have shunt fed antennas.

The filter we sell is designed to have a deep null in the AM broadcast band and, in the vast majority of cases, will clear up a telephone. However, in the problem cases, it doesn't. In an effort to learn more about this, I designed a two-part filter with a deep null in the center of the broadcast band and a deep null in the middle of the second harmonics. The first place we tried this was in Tacoma at a house where every filter on the market (ATT, GTE, RF1400, and ours) had already been tried. Nothing changed. There are four phones in the house: a couple of Radio Shack cheapies, a good ATT desk set, and a reputable brand cordless. All of them have radio in them. On the test bench, anyway, the prototype filter removed the fundamental and the harmonic. What is out there that is still causing the interference? Ghosts of broadcasts past?

In Stephenville, removing the fundamental cleared most of the phones. However, there are a couple in the building, as well as some studio equipment, that seem to have something other than the fundamental as interference. I have not yet had time to do anything else there, except lose a little more of my hair, and some sleep, trying to come up with a solution for them.

I am still seeking information on RF interference. If you can add to my experiences, please do. You can send them to the address in the masthead, or fax them to me at (817) 472-5094.

George

Coupling Cap Kills Audio

George Whitaker — Arlington, Texas

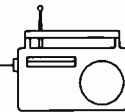

Recently I had occasion to go back to the basics in dealing with a 30 year old, ten-kilowatt Continental AM. The solution to my problem was so simple it took me several nights of trying things before seeing it.

The problem was that the station sounded thin, with no bass at all. Since the station's format is almost all talk, it really did not become apparent until the loss was really severe. It finally became noticeable when they did play something with music in it.

This particular station is also operating non-directional under an STA, with an antenna that is not really matched at all. The DA has been disassembled, and there are loose ends everywhere. I knew that the mismatch should cause loss of highs rather than lows. However, this transmitter is the first one I had ever been around (other than transistorized units) that used low level modulation, and I wasn't sure what was going on back down in the lower sections, or whether a mismatch at the output could cause weird stuff in the lower levels.

I, of course, started my search for the missing lows at the Optimod. Everything was fine leaving there. After considerable head-scratching and tweaking on the transmitter, I finally got the bright idea to take my scope and trace a tone through the audio section, which consists of two 6CA7's and three 4CX250's. Sure enough, at one

coupling cap I found that 1 kHz on up would pass, but below 1k just disappeared.

This only started the fun. Try to find an electrolytic that is 0.05 mFd at 600 volts. I went all over Dallas to every place I knew of that sold capacitors and could not even come close. Technology has changed too much in the last 30 years and voltages have gone down as capacitance has gone up.

Finally, I took two 1 mFd, 400 volt capacitors, and put them in series. This gave me 0.5 mFd at 800 volts. Not very pretty, but it got my audio back to normal. There probably is a better solution; however, at the time, I couldn't come up with it. If anyone out there has some ideas for dealing with this, I would be happy to learn something.

Tuning Tee Networks

Guy Hutcheson — Arlington, Texas



When tuning up RF networks, (especially antenna base units, directional antenna, or phasing networks), here is a tip that might make the job easier.

If you have fairly *large* coils with many *un-used* turns, you can get a small and smooth vernier action for changing the reaction of the coil, when one complete turn is too much for the main tap. Be sure to add the vernier tap on the *un-used* end of the coil. It's hard to make work if the coil is too small, especially on directionals.

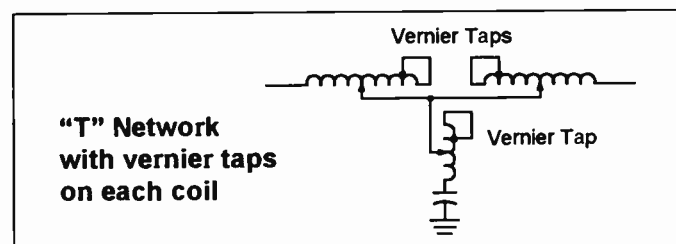

Also, there is a small power loss in the shorted turns which some directionals can't afford to lose, but most single towers wouldn't notice the loss.

If the capacitor is of the correct value, a coil is not needed in series. But, I have wished for a capacitor of a different value many times about 2 a.m. when no substitute was readily available. If a coil is used in series with the capacitor, even if it is not the correct value, the reactance of the total shunt path to ground can be varied, within limits, just as if it were a variable capacitor.

Curing Delay Spasms

George Whitaker — Arlington, Texas

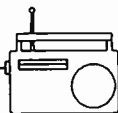

At KSKY in Dallas, we had a strange situation The AUDIO DIGITAL TC-4 delay unit would speed up and then slow down every time we changed phone lines on the talk shows. It sounded like a tape recorder that would speed up and then return to normal, even though the unit is all solid state.

The phone line selector switches and the delay on-off switch are located in the same box on the console desk. However, they are theoretically isolated. The actual phone line switching is done by relays located back in the phone room, and the box contains nothing but the DC control.

The only thing I could think of that might cause a blip in the delay unit was switching transients. So, playing a hunch, I put a couple of 2,000 mFd capacitors across the delay “on” and “off” remote control lines to absorb any transients. Sure enough, the unit became stable.

Audio Pads and Attenuators

Gordon S. Carter — Chief Engineer, WFMT, and Owner, Professional Audio Services

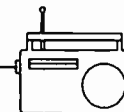

In one of our previous articles on impedance we mentioned using pads and attenuators to match impedances and adjust levels between two pieces of audio equipment. We thought some additional exposition on the subject may be useful.

In the “good old days” of mostly 600 ohm circuits and matched impedances, it was not uncommon to have to do something to adjust the levels between two pieces of equipment while maintaining the proper impedance(s). This sounds easy enough until you look at it a bit closer. The problem becomes even more complicated when you have to match two pieces of equipment with unequal impedances. The math required to calculate the correct resistors for these pads is even more complicated, requiring either the use of hyperbolic trig functions or calculating current ratios through the pad.

Of course, the big need for this was mostly in the days BC (before calculators), when all you had to work with was paper, pencil, your brain, and a slide rule. If you don’t know what a slide rule is, check with an “old-timer.” He may still have his and be able to show it to you. A good engineer never went anywhere without one. Of course, the accuracy was limited in comparison to a calculator, but it didn’t need batteries. To help with this problem, the major broadcast manufacturers of the time (RCA and Gates were the biggies) had large reference sections at the rear of their catalogs with some shortcuts for calculating pads. These shortcuts were tables for the most commonly used pads and special factors for calculating the odd ones.

There are a number of types of pads that are used, each one named for the shape of the components on the schematic. There are T, H, L, U, Pi, and O pads. The drawing on page 5, shows the schematic of each one. The top figures in each group are all unbalanced pads, while the bottom figures are all balanced. You will most commonly encounter the L, T, and H pads in real situations, but it helps to know a bit about the others as well.

If you look at the schematics on page 5, you will notice that the series elements of the balanced pads are all half the value of the series elements of the unbalanced pads. Z_1 and Z_2 are the impedance presented to the source device and the impedance presented to the load device, respectively. We will use these values in the calculations.

Think of a situation where you have an equalized phone line, but the level is too high for the amplifier you are using. The phone line requires a 600 ohm termination for the equalization to be correct, and the amplifier has a 600 ohm

input impedance. In most cases you would connect the line to the amplifier and all would be well, but in this situation doing so would overdrive the input stage of the amplifier. If the source impedance were significantly lower, such as a solid state output, or the input impedance were higher you would have no problem, but you have 600 ohms for each. You have measured the level coming from the phone line and it is only about 4 dB hotter than what the amplifier can handle. The solution is a simple 4 dB, 600 ohm pad. Since the phone line is balanced, you will need to use a balanced pad, such as an O or H pad.

Although there are formulas to calculate the values of the individual pad resistors, another way is to look at a chart and apply some simple math. The chart on page 5, was taken from an old (1963) edition of the Allied Electronics Data Handbook, edited by Nelson M. Cooke. This was an 88 page booklet that sold for \$.50 and contained all sorts of electronics information — well worth the investment, at the time. I am not aware of any similar book on the market today. If you ever find one at a flea market, grab it!

Just look up the dB loss in the left column of the chart, and then look across to the proper values to fill in the various simple formulas, shown beside each pad. Plug the numbers into the formulas and you have your answers.

Another use for pads is to match impedances where you don’t have a proper transformer. You can match from a higher impedance to a lower one, or the other way around. However, you will have a certain amount of loss, depending on the ratio of the impedances being matched. This is called a minimum loss, or taper pad. For instance, a pad matching 600 ohms to 150 ohms would have 11.4 dB of loss. *(We’ll cover these, and other types of special-purpose pads, in a future article . . . editor)*

Fortunately, you don’t need these impedance matching pads very often today. With the low source impedances and high input impedances that you have in typical modern equipment, you can make much simpler pads. First determine the input impedance (Z) of the second device. Then find a convenient resistor that is about 1/10 the input impedance (Z), and make that your shunt resistor (R_1).

Calculate the voltage ratio, E_2/E_1 (E_r), or find the value from the table, representing a specific dB loss. Enter the value of R_1 and the voltage ratio E_r into the formula, and you have your series resistor (R_2). As long as the total of all the resistors is larger than the minimum load on your source, all is fine. This type of pad is shown in Figure 1, on page 5.

(continued on page 5)

Audio Pads and Attenuators

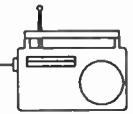

Continued from page 4

Pad Configurations and Formulas

(Z1 = Z2 in all pads, and is the value for Z)

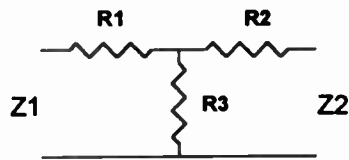

T pad
(unbalanced)

$$R1 = R2 = ZD$$

$$R3 = ZE$$

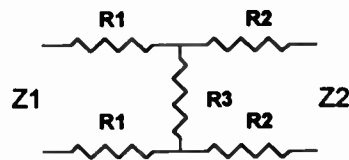

H pad
(balanced)

$$R1 = R2 = \frac{1}{2}ZD$$

$$R3 = ZE$$

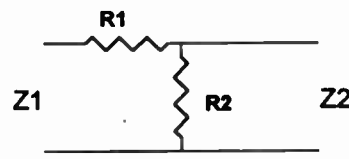

L pad
(unbalanced)

$$R1 = ZB$$

$$R2 = ZC$$

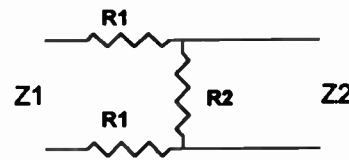

U pad
(balanced)

$$R1 = \frac{1}{2}ZB$$

$$R2 = ZC$$

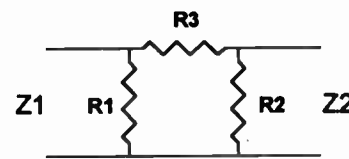

Pi pad
(unbalanced)

$$R1 = R2 = Z / D$$

$$R3 = Z / E$$

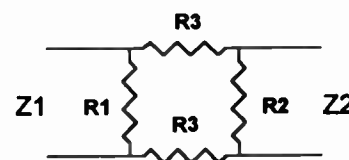

O pad
(balanced)

$$R1 = R2 = Z / D$$

$$R3 = \frac{1}{2}(Z / E)$$

Table for Attenuator Network Formulas

dB	Voltage Ratio E_r	B	C	D	E
0.1	.98855	.011447	86.360	.005756	86.857
0.2	.97724	.022763	42.931	.011512	43.426
0.3	.96605	.034046	28.456	.017268	28.947
0.4	.95499	.045008	21.219	.023022	21.707
0.5	.94406	.055939	16.876	.028774	17.362
0.6	.93325	.066745	13.982	.034525	14.428
0.7	.92257	.077429	11.915	.040274	12.395
0.8	.91201	.087989	10.365	.046019	10.842
0.9	.90157	.098429	9.1596	.051762	9.6337
1.0	.89125	.10875	8.1955	.057501	8.6667
2.0	.79433	.20567	3.8621	.11462	4.3048
3.0	.70795	.29205	2.4240	.17100	2.8385
4.0	.63096	.36904	1.7097	.22627	2.0966
5.0	.56234	.43766	1.2849	.28013	1.6448
6.0	.50119	.49881	1.0048	.33228	1.3386
7.0	.44668	.55332	.80728	.38247	1.1160
8.0	.39811	.60189	.66143	.43051	.94617
9.0	.35481	.64519	.54994	.47622	.81183
10.0	.31623	.68377	.46248	.51949	.70273
11.0	.28184	.71816	.39244	.56026	.61231
12.0	.25119	.74881	.33545	.59848	.53621
13.0	.22387	.77613	.28845	.63416	.47137
14.0	.19953	.80047	.24926	.66732	.41560
15.0	.17783	.82217	.21629	.69804	.36727
16.0	.15849	.84151	.18834	.72639	.32515
17.0	.14125	.85875	.16449	.75246	.28826
18.0	.12589	.87411	.14402	.77637	.25584
19.0	.11220	.88780	.12638	.79823	.22726
20.0	.10000	.90000	.11111	.81818	.20202
22.0	.079433	.92057	.086287	.85282	.15987
24.0	.063096	.93690	.067345	.88130	.12670
26.0	.050119	.94988	.052763	.90455	.10049
28.0	.039811	.96019	.041461	.92343	.079748
30.0	.031623	.96838	.032655	.93869	.063309
32.0	.025119	.97488	.025766	.95099	.050269
34.0	.019953	.98005	.020359	.96088	.039921
36.0	.015849	.98415	.016104	.96880	.031706
38.0	.012589	.98741	.012750	.97513	.025183
40.0	.010000	.99000	.010101	.98020	.020002
45.0	.0056234	.99438	.0056552	.98882	.011247
50.0	.0031623	.99684	.0031723	.99370	.0063246
55.0	.0017783	.99822	.0017815	.99645	.0035566
60.0	.0010000	.99900	.00100100	.99800	.0020000
65.0	.00056234	.99944	.00056266	.99888	.0011247
70.0	.00031623	.99968	.00031633	.99937	.0006325
75.0	.00017783	.99982	.00017786	.99964	.0003557
80.0	.00010000	.99990	.00010000	.99980	.0002000
90.0	.00003162	.99997	.00003162	.99994	.00006325

Figure 1 — Simplified Loss Pad

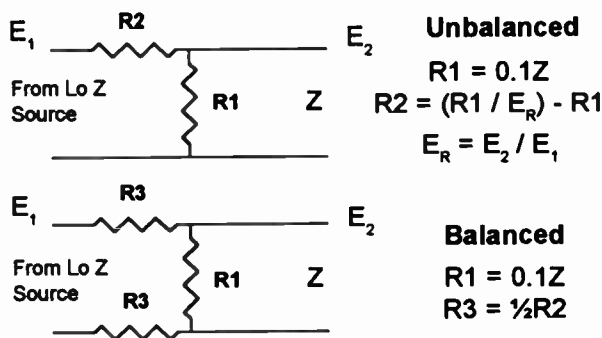

A Cheap Wireless Mike

Dave Hallow — DAG Communications, Dallas, Texas

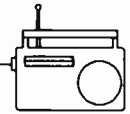

Quite often in the world of remote broadcasting, it becomes necessary to link an audio signal from the remote van to the actual remote site (usually inside a store), or from the remote site back out to the remote van. There are two ways of doing this. One is to run cables between the van and the remote site, and the other is to use a radio link. Cables aren't especially handy when the only route is through a high-traffic area, such as the client's main entrance, and they're even less welcome during the winter when they let all those freezing drafts in.

A radio link, while much easier to set up, has usually meant using an RPU on one of our scarce-and-getting-scarcer RPU frequencies. But not always. Here's something I've used before, and it might just be what the doctor ordered for you. Radio Shack makes a neat little FM cordless room monitor (catalog number 43-487) which is very easy to modify for our needs and costs less than \$50. I got mine for \$30, but it was on sale. Look around. See what you can find. The audio performance is roughly equivalent to most RPUs. Both the transmitter and the receiver run on 9 VDC and come with suitable AC adapters, so their use is very flexible.

Here's all you need to do to modify them for broadcast use. Open the transmitter, and remove the condenser mic. We won't be needing it for our project, but you're not going to pitch it, are you? Put it in your junk box; it doesn't eat anything!

Next, install a 1/8" phone jack (274-248A) where the mic was. This will require a tiny bit of plastic surgery, but I swear this is the hardest part of the mod.

Now remove C5 from the circuit board, and run a wire from the tip of the jack you just installed and connect it to the negative (-) side of where C5 was. Run another wire from the sleeve of the jack to circuit board ground (where the green mic wire was connected will do just fine). The photos show both sides of the board showing how I did it.

That's it! Your transmitter is now ready to test. I did this by taking the line level audio from an AM/FM tuner and running it into the jack on the transmitter and listening to it on the room monitor's receiver. Provided you don't drive the bejeebers out of the transmitter, it should sound quite good.

All you have to do to modify the receiver is to install the other of those 1/8" jacks (they come in pairs) somewhere on the radio. There's a lot of room in the upper part of the receiver for this, so that's where I suggest you install it. The lower part is taken up with the battery compartment. Installation of this is so elementary, I won't go into details.

If you're successful, you should be able to listen on an earphone while cutting off the internal speaker.

Now, what can you do with this setup? Well, I've used it to link program from the van into a store when, due to the building's construction, the station's signal couldn't be heard inside. You could also use it to link audio back to the van if that's where your RPU transmitter is, similar to a wireless mic. You could even plug the station's two-way receiver into your new system to allow cues to be fed to the remote talent. I've seen occasions where the two-way in the van could copy master control, while an HT with a rubber duck inside couldn't.

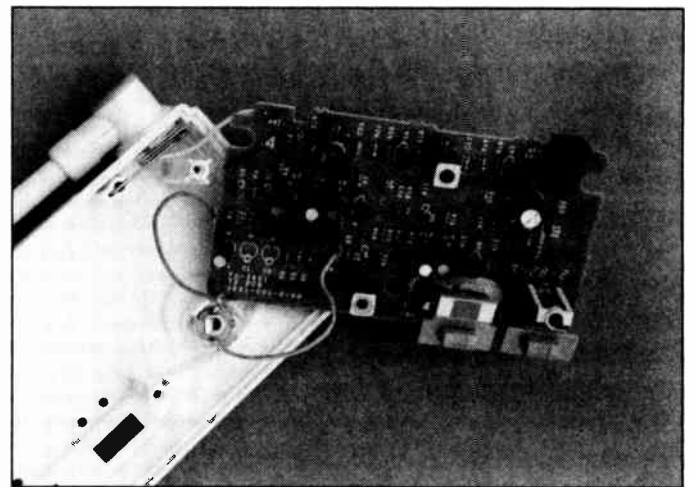

The Front Side

The system uses little flex antennas on both the transmitter and the receiver, and this seems to be quite adequate for up to about 50 feet of coverage. If you need more range, you might try experimenting with other antennas. Remember that a 5/8 wavelength, 160 mHz whip is just about a quarter wavelength at 49 mHz. It also doesn't hurt to place your transmitter on the van's roof, thereby giving it a better ground plane to work with.

One word of warning: even though the system has two channels (49.86 mHz and 49.89 mHz), it is susceptible to interference from cordless phones and other 49 mHz equipment. Still, unless you're in a high population density area such as an apartment complex, this shouldn't be a problem.

Is this intended to replace your existing RPU system? Of course not. It's little more than a modulated oscillator connected to an inefficient antenna. But if you can live with the shorter range, give it a try. I've found it's an unbeatable addition to any station's bag of remote tricks!

(continued on page 7)

Wireless Mike

Continued from page 6

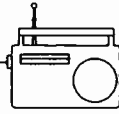

Editor's Note:

George Whitaker modified a couple of these units when at KRVA. His report follows:

Radio Shack used to sell a different version of this monitor, and it came with a schematic. We modified a couple of these for use when I was with KRVA.

Unfortunately, the current model does not come with a schematic and Tandy headquarters in Ft. Worth told us that there was not one available, even from their home office repair dept. Dave just used his experience and a signal injector to find the right place to go into the transmit end.

What we have done is bypass the first couple of audio stages. The monitor comes with a condenser mike installed. This means the input to the printed circuit card was looking for a signal in the -65 dB range. We want to come out of a mixer at about a +4 dB. Therefore, we skip down to C-5. If your mixer seems to overdrive the unit, a 10 dB pad on the output of the mixer should bring it into range.

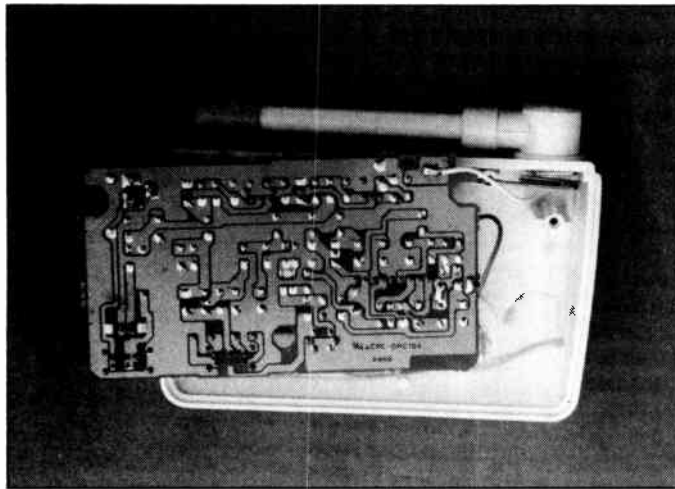

The Back Side

If I had been doing the conversion, I would have used an 8 ohm to line speaker matching transformer in the receiver. Radio Shack has one (273-1380) with 8 ohms on one side and a 1,000 ohm, center tapped winding on the other, for \$1.69.

If you disconnect the speaker, connect the 8 ohm side in its place, then connect the center tap and one side of the other winding to the jack, you will have a better match into your RPU gear, or whatever you are feeding.

This gives the receiver a 500 ohm output, which will match 600 ohm inputs quite well enough for good power transfer and reasonable quality.

Anomalous Nuts

Guy Hutcheson — Arlington, Texas

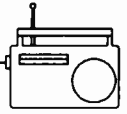

One night I was having difficulty tuning up a new transmitter, fresh from the factory. The trouble was traced to an RF coil in the output network. It was the usual edgewise mounting with the end terminated to a binding post on the insulated strip supporting the turns. The locking nut, supposedly holding the coil end tight against the strip was loose, even though the outside connection to the terminal on top was tight against the locking nut.

Tightening the locking nut against the strip, then making the terminal tight against the locking nut, corrected the trouble. Always remember, RF connections must be clean and tight.

Remote Transducers

Richard Walsh — WHCN, Hartford, CT

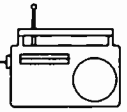

I recently became aware of a company that makes sensing transducers for various remote monitoring purposes. Their products are intended for the HVAC market, but can have definite applications at broadcast facilities.

I discovered their products when I needed a way to monitor the AC line current of our FM antenna's de-icing heaters, by remote. Kele and Associates, of Memphis Tennessee, manufacturers a model 4CTV, current transducer, that provides a DC voltage in proportion to the AC current flowing through its integral transformer core.

The transducer can directly monitor up to 20 amps of current (max 600 VAC), and provide a 0-5 VDC sample. For currents under 10 amps, multiple turns through the current transformer will yield better scaling.

The unit does not require any power supply to generate the sample voltage. For currents greater than 20 amps, an external current transformer can be employed. For three-phase power sources, the output of three model 4CTV transducers can be wired in series, yielding a single sample that is proportional to the total current. This would be useful for monitoring the AC input power to a transmitter.

Kele makes a complete three-phase power monitor (the WT series) that will provide real-time telemetry of power demand in kilowatts, and energy consumption in kilowatt-hours. Other products allow numerous variables like temperature, humidity, AC line voltage, phase rotation, etc., to be monitored by a broadcast remote control system.

Ask Kele for their catalog "20/20 Interface Products." They can be reached at 901-382-4300.

The New EAS: An Overview

John Bredesen — KLCC, Eugene, Oregon

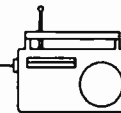

On November 9, 1994, the FCC adopted a Report and Order (R&O) dealing with the long-awaited replacement of the EBS system. The article I wrote for a recent issue of **Radio Guide** presented some preliminary information. Other publications have covered the technical aspects of the new Emergency Alert System. I'll attempt to cover some of the topics in the R&O which fall in the cracks between "why it is being replaced" and out-and-out technical descriptions of digital and operational protocol.

Broadcast stations, as in the past with EBS, will continue to play a significant role in the new EAS. All station licensees, including noncommercial educational Class D FM stations and low power TV stations, will be required to have EAS decoders. All stations (except non-commercial educational Class D FM stations and low power TV stations) will be required to have equipment capable of encoding the EAS codes installed in the broadcast station programming chain, such as at the transmitter, studio or control locations. Where broadcast stations are co-owned and co-located with a combined studio or control facility, only one set of EAS equipment will be required for the combined facility.

A curious aspect of the RM is that while there was significant discussion of using Radio Broadcast Data Systems (RBDS) capabilities in the EAS, it was not mandated. Many respondents to the original NPRM argued against it for a variety of reasons. However, when the R&O was issued, strong encouragement was given for "key" FM stations to install RBDS, or to incorporate the EAS data into it if it was already installed. The FCC notes that RBDS devices can be easily integrated with EAS equipment because both employ common RS-232 data connections and protocols.

One of the great attractions of RBDS is that it's possible to incorporate a system of "automatic turn-on" or other alerting signals into consumer equipment, including TV sets and radios, car radios, pagers, smoke detectors, CD players, cassette players, and strobe lights. For years, radios have been available which receive National Weather Service broadcasts in the U.S. Many have the requisite tone decoders to un-mute the receiver if an alert is transmitted by the Weather Bureau. RBDS is capable of doing that and more, when manufacturers start building appropriate circuitry into consumer equipment.

It's interesting to note that weather related emergencies represent over 80 percent of the total number of EBS activations. (A TV station with which I was associated in Dallas, Texas, originated three separate EBS alerts in one

day in 1982 because of tornado sightings in the area.) These warnings are initiated by the National Weather Service and are dispatched over local National Weather Radio (NWR) transmitters. NWR services are being upgraded to preface all forecasts and warnings from all transmitter sites with intelligent digital codes. These codes are created by a device called the Weather Radio Specific Area Message Encoder (WRSAME) that is part of the NWR programming equipment at the local weather bureau.

In the new system, any EAS decoder can directly monitor for and decode WRSAME codes. EAS participants can be immediately and reliably informed of weather related emergencies with the addition of any ordinary weather radio receiver and off-the-shelf connections to the EAS decoder.

The following is directly from the R&O. I include it because it provides a good description of how the system will work. During the East and West coast field test and during the NPRM comment period, the request for one standard protocol was repeated time and again. For something as fundamental and important to protecting lives, nobody wanted to see anything like the AM Stereo standards debacle repeated.

"We agree with the commenters and have adopted mandatory EAS codes and protocol that must be used to construct an EAS message. The EAS message consists of a digital header, an attention signal, an audio or text message and an End Of Message (EOM) code. The digital codes use audio frequency shift keying tones similar to the National Weather Radio WRSAME system. The digital codes and protocol will be used to activate the EAS for national messages and state or local emergencies. Because the codes are predefined, anyone receiving them can quickly determine their meaning. The codes define who originated the emergency message, the nature of the emergency, the location of the emergency, and the valid time period of the emergency. Also, the codes are within the audio bandpass of radio and television receivers and, therefore, are immediately available to the public. The codes have a unique transmission rate, which provides a measure of security because off-the-shelf equipment cannot be used to replicate the codes. This aids in identifying equipment that may have been used to transmit the codes illegally. Also, the code structure is very short and contains just three or four key elements. This enables EAS message originators to quickly develop warning messages for injection into the communications system."

(continued on page 9)

The New EAS: An Overview

Continued from page 8

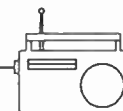

"The location parameters can be for events affecting a whole state, a whole county, or a portion (down to 1/9th) of a county. If a city or area has its own Federal Information Processing System (FIPS) number, it can also be distinguished. An individual EAS message can contain 31 location codes. There can be unique codes for alerting specific locales such as schools, hospitals, neighborhoods, a single block within a neighborhood, or individual homes. All EAS messages will be Universal Coordinated Time (UTC) based time so that EAS messages originating in areas near the border of two different time zones and during time changes for Standard and Daylight time will be compared using the same base time standard. Additional emergency-specific codes can be developed to interface with the EAS equipment. All codes will be cataloged by the FCC. The FCC and NWS will keep records of all of the codes in use. This will prevent the same Event code from being used for different emergencies and aid manufacturers and the public in programming their equipment."

"The EAS header codes, attention signal, emergency program (audio or text) and EOM code must be transmitted in sequence in the main audio channel of all radio and television broadcast stations for EAS national emergency and required test messages . . . For state and local emergencies, EAS participants are permitted to transmit the EAS message codes and the EOM code without the audio message in the main audio channel."

"The attention signal, which is what the public will hear, must precede any emergency audio message. Although the two-tone EBS attention signal will continue to activate the EBS system, after July 1, 1997, that signal will only be used to alert the public and not to activate the new EAS."

The present system relies upon a daisy chain structure where any given station monitors *one* other station higher up the chain, etc. A failure at any point along the way effectively breaks the chain of notification.

The new system will be more in the form of a web because it's designed to allow multiple inputs to the EAS decoder. As a matter of fact, after July 1, 1996, stations will be required to monitor at least two stations designated by State Emergency Communications Committees. Other inputs would be allowed as well. For example, a given station might monitor, simultaneously, two other stations and the local WRSAME equipped weather station.

Another significant problem with the current EBS is the necessity of human intervention in all levels of relay.

The EAS will allow either automatic or manual operation according to the situation and desire of station management. Again from the R&O:

"We have, therefore, adopted rules requiring EAS encoders and decoders to provide both automatic and manual operation and will permit each EAS participant to determine whether to use automatic or manual operation to send or receive EAS alerts. Additionally, in a companion item adopted concurrently with this Order, the Commission is proposing rules to permit the unattended operation of broadcast stations. [Author's note: see the December, 1994 issue of Radio Guide.] Unattended operation of a broadcast station requires automatic operation of EAS equipment."

Let's review the time-line for the implementation of the EAS, because at the time of the adoption of this R&O, the clock began running. These dates are for the broadcast industry.

1. From now until July 1, 1996, new EAS equipment will be optional or broadcasters.
2. After July 1, 1995, the length of the two-tone EBS signal may be shortened to 8 seconds for the weekly tests. The FCC encourages broadcasters to retain the present 20-25 second tone length in case of an emergency alert.
3. By July 1, 1995, EBS decoders must be modified to respond within 3-4 seconds. You may modify your decoder anytime between now and July 1st.
4. After July 1, 1996, operational EAS equipment is required for broadcasters. There will be a one year overlap of the two systems, until July 1, 1997, to assure that the EAS system is operating properly. EBS equipment must be kept operational during this period.
5. After July 1, 1997 the two-tone signal is to be used only as an alerting signal, and will not be used for testing. EBS decoders will no longer be required.

You can reach me via Internet e-mail at jab@efn.org.

Radio Guide BBS

Technical Information and Services

The BBS is now free to all callers.

Phone: 507-280-4045

The New EAS: A Detailed Look

Andy Bulter — Broadcast Electronics, Quincy, Illinois

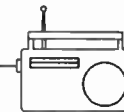

There has been a great deal of excitement about the “New EBS” or EAS system, since the rules were announced by the Commission in late November. Unlike many rulings, this decision affects every radio, television and cable operator in the United States. We will discuss the actions that radio stations must take to comply with the new rules later in this article, but many of those changes are much easier to understand with a minor amount of background material.

Five years ago a young woman named Helena Mitchell moved from the N.T.I.A. to the FCC. Ms. Mitchell had been a highly effective person at NTIA and the Republican administration believed she could help revitalize the commission. At the FCC she was appointed to lead the attempt to improve the performance of the Emergency Broadcasting System. Rather than plunge in blind, she began talking to a number of experienced broadcasters. This group included those who had long supported EBS, as well as those who were highly critical of the existing system. As she continued the fact-finding process, Ms. Mitchell began to realize that the challenge was not to repair a broken system but to build a replacement for a system that was taxed beyond its basic capabilities. Once again, she called on experienced broadcasters to help determine the needs for a replacement system. The process of gathering testimony and then field testing various alternatives has been well covered during the past three years so I won't repeat it here. The main point is, that while the process was conceived and managed by a government entity, the real expertise came from broadcasters with vast experience in the day-to-day needs of broadcasters and the public.

The “secret” of the new system is the highly robust WRSAME [Weather Radio Specific Area Message Encoder] packet signaling technology. This protocol was developed under contract to the National Weather Service to provide a versatile, highly reliable dissemination vehicle for weather advisories. The resulting technology was placed in limited public release by NOAA so it can be used without a licensing fee for any purpose that supports public safety.

The structure of a WRSAME packet is highly interesting. A typical message takes the form, shown in Figure 1. Each portion of the message serves a distinct purpose. The **PREAMBLE** is a consecutive string of bits sent to clear the system, set the receiver AGC and set the asynchronous decoder clocking cycles. The preamble must be transmitted before each header and End Of Message code. **ZCZC** is the identifier sent as ASCII characters to indicate the start of ASCII code. **ORG** is the Originator code to indicate who originally initiated the EAS message. These codes include EAN (Emergency Action Network), PEP (Primary Entry Point), WXR (National Weather Service), CIV (Civilian Authorities) and EAS (Another Broadcaster or a cable operator). **EEE** is the Event code that indicates the nature of the activation. There are thirty-one approved event codes ranging from an Emergency Action Notification (National only) to a Required Monthly Test to a Winter Storm Warning. If some of these sound familiar it is because the commission has specified that the Event codes must be fully compatible with the codes used by the National Weather Service in their current alert system. **PSSCCC** is the Location code. Up to 31 different location codes may be included in a single EAS alert. The Location

Figure 1

(continued on page 11)

[PREAMBLE]ZCZC-ORG-EEE-PSSCCC+TTTT-JJJHHMM-LLLLLLLLL-(one second pause)
[PREAMBLE]ZCZC-ORG-EEE-PSSCCC+TTTT-JJJHHMM-LLLLLLLLL-(one second pause)
[PREAMBLE]ZCZC-ORG-EEE-PSSCCC+TTTT-JJJHHMM-LLLLLLLLL-(at least a one second pause)
(transmission of 8 to 25 seconds of Attention Signal)
(transmission of audio, video or text messages)
(at least a one second pause)
[PREAMBLE]NNNN
(one second pause)
[PREAMBLE]NNNN
(one second pause)
[PREAMBLE]NNNN
(at least one second pause)

**A Typical
WRSAME Message Code**

EAS: A Detailed Look

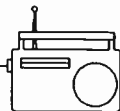

Continued from page 10

code uses the Federal Information Processing System (FIPS) numbers assigned by the U.S. Department of Commerce. Each state is assigned an SS number. Each county is assigned a CCC number. A CCC number of 000 refers to an entire State or Territory. P defines county subdivisions as follows: 0=all or an unspecified portion of a county, 1=Northwest, 2=North Central, 3=Northeast, 4=West Central, 5=Central, 6=East Central, 7=Southwest, 8=South Central, 9=Southeast. You will notice that this allows an alert to be specified for an area as small as 1/9 of a county. There is also provision for additional special p codes for critical installations such as a major nuclear plant.

For the first time officials will be able to direct an alert to a very small area so that broadcasters don't have to trigger a statewide EBS to announce something that only affects a limited area. TTTT indicates the valid time period of a message in 15 minute segments up to one hour and then in 30 minute segments beyond one hour; i.e., +0015, +0030, +0045, +0100, +0430 and +0600. JJJHHMM is the day in Julian Calendar days (JJJ) of the year and the time in hours and minutes (HHMM) when the message was initially released by the originator using 24 hour Universal Coordinated Time (UTC).

These codes must remain unchanged for retransmitted messages. LLLLLLLL is the call sign or other identification of the broadcast station, or NWS office transmitting or retransmitting the message. These codes will be automatically affixed to all outgoing messages by the EAS encoder. NNNN is the End of Message (EOM) code sent as a string of four ASCII N characters.

The primary advantage of the WRSAME message packet is the flexibility it allows a broadcaster. Manufacturers will be able to supply "smart" EAS systems that can be pre-programmed to determine the nature of each alert message and automatically deal with it in an appropriate manner. This will remove the final barrier to fully unattended operation since the systems will be able to automatically pass a message on without human intervention. This same capability will guard against inattentive or poorly trained operators, by triggering the appropriate actions or notifying the appropriate people, even if the person on duty has no idea what actions to take.

All of this capability comes at a price. Every radio station in the country will have to buy new EAS equipment in the next two years. The exact timetable for implementing the new system is as follows:

EAS Timetable for Broadcast Stations				
Requirement	Until 7/1/95	7/1/95	7/1/96	7/1/97
Two-tone encoder timing.	20-25 sec	8-25 sec	8-25 sec	8-25 sec
Two-tone decoder timing.	8-16 sec required. 3-4 sec optional.	All decoders at 3-4 sec.	All decoders at 3-4 sec.	Two-tone decoder no longer used.
Digital decoder and encoder.	Optional	Optional	Required	Required

As you can see, some immediate action is necessary. If you haven't done so, now is the time to determine how to shorten both the send and detect timing for your current EBS receiver. No programmer is going to be happy if the station is still transmitting a 20 second tone a minute longer than necessary.

The next step is more complex, but very important. One of the great strengths of the new EAS is its flexibility. Since the WRSAME message packet can successfully pass through any voice grade circuit, it will be possible to create an almost unlimited number of variations to deal with the specific needs of states and local communities. These options include statewide satellite networks, dedicated two-way systems, direct dial telephone systems and a number of others. Broadcasters will be allowed to migrate to the new technologies and qualify for unattended operation, as soon as the local digital system is in place. This is where the strength may become a burden. The new rules require the creation or revitalization of an Emergency Communications Committee for each state. This committee must plan the new EAS implementation for their state. The new plans must be on file before any broadcaster in the state can implement the new system. This is an opportunity for you as a broadcaster to make sure you don't get stuck with another system that burdens your operation without producing the best benefit for your listeners. Find out who runs your state committee, then volunteer to help configure the new system. If you don't get involved, we'll all be sorry.

The new EAS promises to be a great benefit to both broadcasters and the public, but you have to get involved. If you need help locating your state committee or have other questions on the new systems you can contact:

Helena Mitchell - FCC Compliance and Information
Room 720, 1919 M Street, N.W., 20554
202-418-1220.

Continental 317-C and the Dougherty Hump

Frank Berry — St. Petersburg, Florida

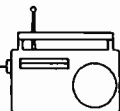

From March, 1987 until December, 1994, I was the Chief Engineer for Infinity's WQYK-AM and WQYK-FM in Tampa/St. Petersburg, Florida.

WQYK-AM operates a Continental 317-C transmitter (S.N. 32, formerly owned by WFNC, Fayetteville, North Carolina). Over nearly eight years, and through a nearly complete rebuild of the transmitter, I have come to know the old, reliable beast well.

The 317-C is a well-built unit. It performs its intended function, producing a good-sounding amplitude modulated signal with a minimum of downtime. It does, however, have one teeny tiny little flaw . . . it splatters like hell!

Most, if not all, Continental model 317 50kW AM transmitters fail the NRSC-2 occupied bandwidth tests because of the "Dougherty Hump."

To understand the Dougherty Hump, and my correction circuit, you must first understand the process of modulating the 317. Briefly, the transmitter applies modulating voltage to the screen grids of two 4CX35000C power amplifier tubes; the carrier tube and the peak tube. As the names imply, the carrier tube is biased so as to provide about 95% of the R.F. power under conditions of zero modulation. The peak tube is biased to provide the remaining 5%.

When you apply a sine wave to the input of the transmitter, two things happen. During the negative portion of the sine wave, the power output of the carrier tube decreases, and the output of the peak tube cuts off. During the positive portion of the sine wave, the carrier tube saturates to full power and the peak tube adds the required additional output power. At peak positive modulation, both tubes produce full R.F. power. At 100% negative modulation, both tubes are cut off.

What is the Dougherty Hump?

The "Hump" is a phenomenon that occurs at all depths and audio frequencies of modulation in many transmitters that use the Dougherty modulation method. The Continental 317 series of AM transmitters are in this general class. In the process of modulating the Carrier and Peak tubes, there is a crossover point . . . a point at which, in theory, the Carrier tube ceases to produce more power, and the Peak tube begins to contribute power. In the design of the 317, Continental "softened" the crossover point by requiring the Peak tube to produce a small amount of output power under static (zero modulation) carrier conditions. Continental's "soft-knee" approach eliminated the possibility of a crossover notch and the excessive harmonic distortion that the notch would produce. Unfortunately, their method didn't provide a way to accurately limit the output of the carrier tube to match the turn-on characteristics of the peak tube. In most 317's, depending on the particular tubes, the carrier tube will continue to increase in power . . . ever so

slightly, as modulating voltage is applied to the screen of the tube. The result, when viewing the RF output of the transmitter on an oscilloscope, is an audio "hump" at the crossover point . . . the Dougherty Hump.

What's the Fix?

To correct the problem, you must do two things:

1. Introduce a series resistance at the screen of the carrier tube to gain control of the softness-hardness of the tube's clip point. The resistance will force the tube to clip as positive modulating voltage drives the screen into saturation. Try two 250 ohm adjustable resistors in series. Each resistor should be rated at 225 watts. Begin by adjusting them to near 200 ohms each.

2. Use four series-connected, reverse-biased high speed 50 amp/1kV diodes across the series resistors; so that the modulators can more easily pull the carrier screen to cutoff during negative modulation troughs. The cathode of the diodes must point towards the modulator tubes, with the anode pointing towards the carrier screen grid.

Adjust the 250 ohm resistors for minimum splatter at ± 80 kHz from your carrier frequency.

NOTE: This modification may introduce some negative carrier shift. You can minimize it by adjusting the control grid bias resistors on one or both of the PA tubes. Adjust the resistors for minimum carrier shift at all depths of modulation.

Using this correction network, I was able to reduce ± 80 kHz splatter at the transmitter's modulation monitor sample point from -65dB, to better than -82dB.

Inverse Feedback and Splatter

I have had some additional success at reducing splatter by adjusting the level of the transmitter's inverse feedback loop. In WQYK's case, I reduced the feedback to near zero. It's important that the 1N661 feedback diode has not changed characteristics. It's a good idea at this point to replace the diode and to try several of them. Some diodes, even new ones of the same type and manufacturer, perform better than others. In this respect, the 317-C is fussy!

Some Other Things That Have Contributed to Excessive Splatter

On occasion, I have experienced some modulation anomalies in the 317-C. They have caused excessive sideband splatter. Often, the splatter was the only clue that something was wrong. Some of the causes have been:

1. Loose PA filament connections or poor crimps on the filament connectors.
2. Loose connections to the plate transformer.
3. Low RF drive to one or both of the PA tubes.
4. Loose or corroded connections from the modulators to the carrier or peak tube sockets.
5. Corroded or burned fingers (especially the screen) on the PA tube sockets.

If you would like some specific or more in-depth information, please feel free to give me a call at 813-577-0041.

The *Radio Guide Product Pages*

New Equipment Reports, Products, and Services for the Radio Industry

The Equipment Report

The TIC Ring Rotor **Info-Fax #100**

Tower shadow has long been a problem for broadcasters, distorting the antenna radiation pattern for their primary antenna system, and limiting their coverage for RPU and ENG systems.

Realistically, the most advantageous mounting location on a support structure has been the top, forcing all other users on the tower to accept less than optimum performance using solutions that often cause excessive loading to the tower itself.

The TIC Ringrotor solves all of these problems with a unique and rugged device specifically designed for the broadcaster's environment.

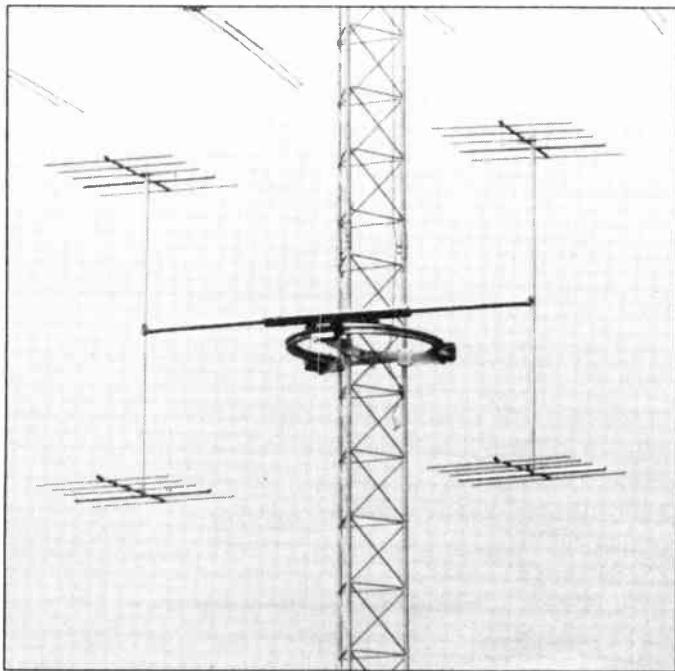

Instead of the commonly-used sidearm assembly, which produces an unbalanced load to the tower and significant tower shadow, the TIC Ringrotor uses a rugged steel mounting ring which completely encircles the tower. The TIC Ringrotor rides on a sturdy drive bracket assembly that permits the ring to rotate a full 360 degrees around the tower.

The unique properties of the ring itself help to transfer the tremendous environmental forces cause by wind, to all three faces of the supporting structure simultaneously. This helps to balance the load to the tower and prevent the excessive torque caused by conventional sidearm assemblies.

In addition, most wind-induced forces are canceled in the ring itself. In a balanced array, the wind will tend to produce approximately equal, but opposite, torque to the ring "halves."

This reduces the principle environmental strain on the tower, to lateral pressure rather than the destructive torsional forces that tend to bring a tower down.

Antenna systems mounted to the ring encounter no tower shadow because the array rotates around the tower rather than at the end of a sidearm or other assembly. This fact alone allows the broadcaster to utilize, within tower load limits, the full vertical height of the support system. Rotatable antennas may now be mounted at any location on the tower system without loss of performance.

The applications are obvious. Broadcasters have long utilized VHF/UHF equipment for their RPU/ENG systems in an attempt to circumvent costly telco charges and provide the flexibility needed for rapidly changing situations. Range has often been limited, however, by the relatively low receive antenna height at the studio. This has been especially exasperating because most broadcasters have remote transmitter locations with towers that have more than enough height to provide excellent RPU/ENG receiver coverage.

The RPU/ENG array can be mounted at the transmitter site on the TIC Ringrotor, and controlled through any remote control system having RAISE/LOWER contacts. Now the broadcaster can achieve top-of-the-tower performance at any mounting location on the tower. Program audio may be returned to the studio though a single leased line, rather than the multiple connect/disconnects required for a typical sports season. Or telco facilities may be circumvented altogether, through a simple TSL link or an SCA channel on the main carrier. The TIC Ringrotor has an RS-232 interface for complete control and position feedback.

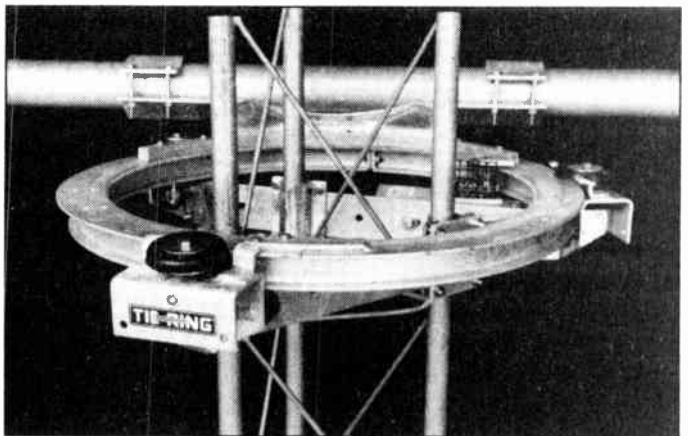

For information on the Ringrotor, circle **Info-Fax #100**, on the Radio Guide INFO-FAX form and fax it back. Or, for more information you can contact:

TIC General Inc.
P.O. Box 1., 302 Third St. East
Thief River Falls, MN 56701
Phone 800-842-7464
Fax 218-681-8509

Radio Guide Page 13



WHY is HALL Electronics for YOU?

You'll like our GREAT PRICES on NEW & REBUILT EQUIPMENT. WE CARRY MOST BRANDS

You'll LIKE HALL's personal SERVICE - for one piece or an ENTIRE STATION. You are not a number to us; rather someone who needs a problem SOLVED.

We have an IN-HOUSE TECHNICAL SUPPORT TEAM. Our THREE full-time technicians give support after the sale and are always available to help with ALL your rebuilding or repair needs. WE STAND BEHIND OUR WORK. We are an authorized service center for Tascam and Otari.

Contact Rick or Jon . . . today!

WHEN YOU NEED GOOD PRICES & SERVICE,
Call Hall!

Phone 804-984-4255 Fax 804-984-3299

Info-Fax #101
Info-Fax #102

Need more information? Circle the Info-Fax numbers on Page 16

Info-Fax #103
Info-Fax #104

UNIVERSAL SCPC

NEW Receiver!

XE-1000



SCPC BROADCAST AUDIO RECEIVER

New, affordable, frequency-agile receiver, direct channel entry by keyboard, selectable companding 1:1, 2:1, 3:1, wide/narrow bandwidth, de-emphasis selectable, 950-1450 MHz, line output 600 ohms, muting, transponder agile, LNB power supply, 50-channel memory, full baseband output, high-quality audio. Every needed feature at a sensible price (lowest in the industry). Write or call for full information on this quality receiver—the answer for your station. Networks call for prices.

Phone: (614) 866-4605 Fax: (614) 866-1201

UNIVERSAL ELECTRONICS, INC.
Communications Specialists
4555 Groves Road, Suite 12 Columbus, OH 43232

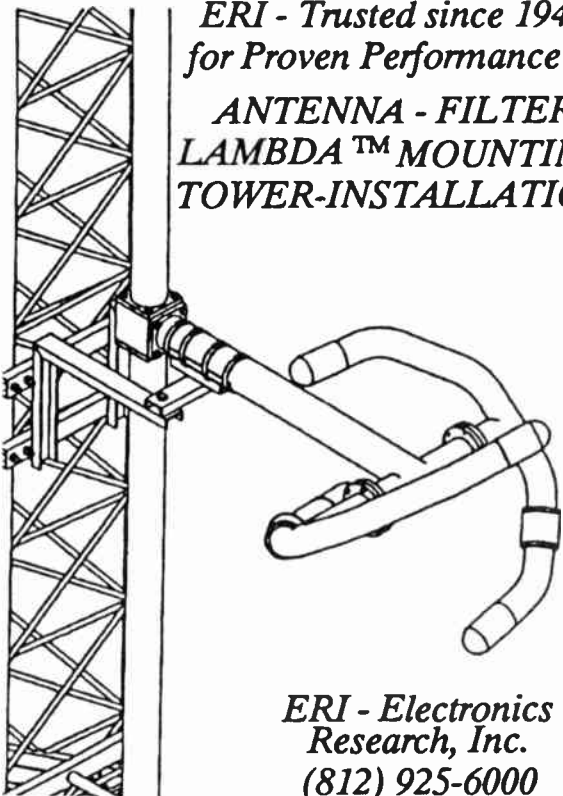

ERI - Trusted since 1943 for Proven Performance in

ANTENNA - FILTER LAMBDA™ MOUNTING TOWER-INSTALLATION

ERI - Electronics Research, Inc.
(812) 925-6000

Commercial Radio Company

Duttonsville School Dr., Cavendish, VT 05142
Phone 802-226-7582 Fax 802-226-7738



Transmitter Parts
RCA - Gates
Collins/Continental



Mica Transmitting Capacitors: Sangamo, CD, Sprague, Aerovox, Acushnet types: CM-15, CM-20, CM-25, CM-30, HT, HK, AT, AK, F1, F2, F3, 30B, E, 1996, 291, 292, 293, 294 & G5.

Fixed and Variable Vacuum Capacitors: Jennings, Dolinko & Wilkins, Mounting brackets and flanges. Vacuum relays.

Oil Filled Filter Capacitors: Plastic Capacitor Corp., 600 to 40 kV, 1 mFd to 30 mFd with special mounting brackets. Non-PCB oil capacitor replacements are available for most transmitters.

Ceramic RF Capacitors: Centralab, Jennings, Sprague, High Energy, 5 kV to 40 kV.

Variable Transmitting Capacitors: E.F. Johnson Co., Cardwell Condenser Co., insulated shaft couplings as used in phasors, variable transmitting capacitors.

Weschler-Westinghouse: RF ammeters, 0-0.5 amps through 0-50 amps, internal and external thermocouples, expanded and linear or square-law scales. Sizes are 3 & 4 inch, round and square. Special meters are available.

RCA: Transmitter, phasor and antenna tuning unit parts.

ULTRAMOD® . . UM2000

FM STEREO MODULATION SYSTEM

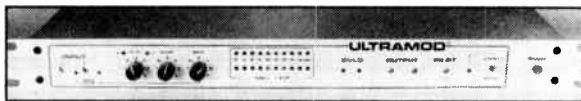

- The UM2000 is a complete FM processing and stereo generating system featuring:
- Dual band, stereo AGC and peak processors of exceptional clarity.
- Digitally synthesized stereo generator with separation exceeding 60dB at 1kHz, and typically 55dB at 15kHz.
- Dual composite outputs for feeding main and auxiliary transmitters or STL's. Very affordable.

WHY PAY MORE ... AND GET LESS?

HNAT HINDES inc

42 Elaine Street, RR1, Thompson, CT 06277
203-935-9066 203-935-9242

Info-Fax #105

Need more information? Circle the Info-Fax numbers on Page 16

Info-Fax #106

Info-Fax #107

Econco

Rebuilt Power Tubes



Approximately
One Half the Cost of New

Call for Our Price List

Econco

1318 Commerce Ave., Woodland, CA 95695
800-532-6626 Canada 800-848-8841

FCC Rules on Kahn POWER-side™

Motorola tried to deny broadcasters the right to increase coverage by using SSB — Kahn POWER-side™ equipment. But the FCC specifically ruled that the "Kahn POWER-side system ... may continue to be operated ..." as a mono improvement system. So you can now use POWER-side with Kahn independent sideband exciters to immediately increase coverage to listeners using any and all type of AM receivers.

Federal Communications Commission FCC 93-485:

21. Kahn "POWER-side" Operation. Several parties express concern over the continued acceptability under our rules of operating using the Kahn POWER-side AM single-sideband system. POWER-side operation, as distinct from Kahn stereo operation, involves an AM transmitter with two independent sidebands, containing identical program material, but with intentional level and frequency response differences. This system is implemented with a Kahn independent sideband stereo exciter and is claimed to have certain advantages for reception with monophonic receivers, particularly in adjacent-channel interference situations. CTI and Furr argue that adoption of the proposed standard would prohibit such an implementation. Motorola maintains that the Kahn POWER-side mode of operation is not stereophonic and questions its legality under the present rules.

22. Our AM rules do not include a definition of the term "stereophonic." However, generally accepted definitions of stereo service infer two or more channels of audio information designed to produce an audio "image" when demodulated by an appropriate receiver. On this basis, we find that stations employing the Kahn POWER-side system are not subject to the provisions of the stereophonic transmitting standard adopted herein and may continue to be operated, provided that the program material fed to both channels of the exciter is identical in content.

POWER-side™

PROBLEMS

Adjacent Channel Interference
Antenna Null Distortion
Co-Channel Interference
Power-Line Re-Radiation
Building Re-Radiation
Receiver Tuning
Low Fidelity Home Radios
Co-Channel Beat
Selective Fading

SOLUTION!

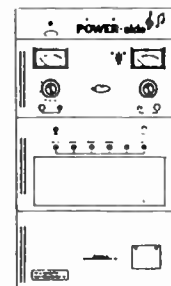

(516) 222-2221

POWER-side™

The solution to many of
AM radio's most serious
technical problems.

*From the developers of the AM STEREO system
that isn't afraid of the dark, and will let you drive right past FM Stereo.*

Kahn Communications, Inc.

222 Westbury Avenue, Carle Place, NY 11514

The Radio Guide

INFO-FAX

Free Product Information

1. Enter personal information.
2. Circle the names of all the manufacturers and suppliers from which you need more info.
3. Fax this form to us.

Free Product Service

1. Enter personal information.
2. Circle the names of all the gear that you'll be buying within the next 90 days.
3. Fax this form to us.

Fax it Today!



(507) 280-9143

Personal Information:

Please change my subscription mailing address.

Name: _____ Station: _____

Address: _____

City: _____ State: _____ Zip: _____

Phone: _____ Fax: _____

Free Product Information

Check out the product information on page 1 and pages 13-15 of this Radio Guide. Then circle each one from which you need more information, below.

- | | | |
|-------------------------|------------------------------|------------------------------|
| #100 - TIC Ringrotor | #103 - Universal Electronics | #106 - Econco |
| #101 - Hall Electronics | #104 - Commercial Radio | #107 - Kahn Communications |
| #102 - ERI | #105 - Hnat Hindes | #108 - Audio Broadcast Group |

Free Product Service

If you plan to buy any of the following pieces of equipment in the next 90 days, circle each one. We will send your name to our contacts and they will send you free information on the products you have selected.

- | | | | |
|-------------------------|----------------------|---------------------|----------------------------|
| Antenna - FM | Cart Decks - Tape | Remote Control | Transmission Line |
| Audio Power Amps | DAT Decks | RPU Equipment | Transmitters - AM |
| Audio Distribution Amps | Digital Workstations | Satellite Equipment | Transmitters/Exciters - FM |
| Audio Processing | EBS/EAS Equipment | SCARDS | Tubes |
| Automation/Live-Assist | Microphones | Speakers | OTHER PRODUCTS: |
| Cassette Decks | Modulation Monitors | STL Equipment | _____ |
| Consoles & Mixers | PA/DJ Equipment | Studio Furniture | _____ |
| CD Players/Recorders | Phasors/ATUs/DA | Telephone Interface | _____ |
| Cart Decks - Digital | Reel Tape Decks | Towers | _____ |



Fax This Form to 507-280-9143

Feb-95

Copy and Use This Form as Many Times as You Like

Page 16

Radio Guide

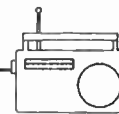

Radio's Technology Forum

March 1995

Tech Tips Wanted

We've increased the **Radio Guide** from 8 to 16 pages. We'd like to keep heading in that direction, but we can only do it with your tech tips.

It's time, once again, to shake the tree and see what comes out. I have to admit I feel like Public Radio during pledge drive. But as long as it works, I'll keep on pestering you.

Radio Guide has over 500 paid subscribers. That tells me the value of this publication is worth your money. But is it worth your time? That is the question we need to face, if the **Radio Guide** is to continue to grow.

Radio Guide exists to help promote and educate the radio engineering community. You can help, by submitting your tech tips for publication. There is nothing easier than leaving it to someone else, and the last thing you may want to do is to relive your latest problem in print.

However, your problems, and their solutions, are important. If it's happened once, you can bet it's going to happen again. Unfortunately, it is going to affect someone else, and they probably won't have the advantage of your solution, unless they can read about it in the **Radio Guide**. You can submit your tech tips in a variety of ways:

Radio Guide BBS

Call the BBS at 507-280-4045, can leave your tech tips on-line. The BBS has been changed. You can now sign up on-line immediately, without verification.

Compuserve

You can leave your tech tips for us on Compuserve. Just leave them as E-Mail for Compuserve ID [71203,2341].

Floppy Disk

Send your tech tips on single or double density 5.25 or 3.5 floppy disks, in ASCII text format, to the address on page 2 of this **Radio Guide**.

Ray Topp (editor)

Radio Guide (ISSN 1061-7027) is published monthly, 12 times a year, by Media Magazines Inc., 511 18th Street SE, Rochester, MN 55904.

All material contained in Radio Guide is copyright 1995 by Media Magazines Inc., and may not be reproduced in any form without the written permission of the publisher.

FEATURE OF THE MONTH

The Hum Eliminator™ from Ebtech & ABG breaks the ground-loops that cause AC hum. quick and easy. Just plug it into the signal lines between offending pieces of equipment and you're done.

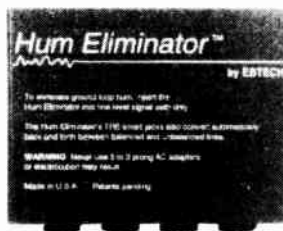

So get the Hum

Eliminator™ today, and silence AC hum forever.

2 Channel Unit Just **\$55⁹⁵_{ea}**

Please call today!

MAIN SALES OFFICE
2342 S. Division Avenue
Grand Rapids, Michigan 49507
Phone: 800-999-9281
Fax: 616-452-1652

SOUTHEASTERN SALES OFFICE
200 Fareway Drive, Suite 2
Smithfield, North Carolina 27577
Phone: 800-369-7623
Fax: 919-934-8120

WESTERN SALES OFFICE
P.O. Box 1638
Palmdale, California 93550
Phone: 800-858-9008
Fax: 805-273-3321

For 35 years
AUDIO
broadcast group inc.

YOU MAY ALSO REACH US ANYTIME VIA ELECTRONIC MAIL
75371.144@compuserve.com

Info-Fax #108

Inside This Issue

Are You Protected? (editorial)	2
Remote Tascam Plug	3
Bext PTX-30 Pot Fix	3
STL Ground Loops	3
Cable Capacitance Effects	4
Power Tube Life Extension	6
FCC Forms Via Fax	7
Transmitter Site Surge Protection	8
8 Second STL Conversions	10
Quick "T" Network Values	11
The Equipment Report	13

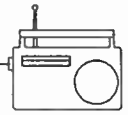

Radio Guide Publication

Raymond Topp (*editor and publisher*)

511 18th Street SE, Rochester, MN 55904

Phone: 507-280-9668

Fax: 507-280-9143

Our Contributing Technical Writers

George Whitaker - Arlington, TX

3505 Daniel, Arlington, TX 76014

Phone: 817-468-2586

John Bredesen - KLCC, Eugene, OR

3120 Nob Court, Eugene, OR 97405

Phone: 503-485-6869

Gordon Carter - WFMT, Chicago, IL

34 North Madison Ave., LaGrange, IL 60525

Phone: 312-565-5032

Andy Butler - Broadcast Electronics Inc.

P.O. Box 3606, Quincy, IL 62305

Phone: 217-224-9662

Frank Berry Ph.D.

190 112th Ave. N, #708

St. Petersburg, FL 33716

Phone: 813-577-0041

How to Submit Tech Tips

By BBS: Call our BBS at 507-280-4045, and leave your tech tips, info and articles.

By Disk: Send your tech tips and information on a 3.5" or 5.25" double, or high density floppy disk, in ASCII format.

By Compuserve: Leave E-Mail files to Radio Guide at Compuserve ID [71203,2341].

By Letter: We also accept clean, typewritten or printed manuscripts mailed to our address.

Are You Protected?

On page 8 of this issue, Andy Butler reports on ground systems and surge protection, that can go a long way towards helping you get a good night's sleep.

Why is it always the late night thunderstorm that seems to cause the most damage? I'm not aware of any statistics on this, but I swear that daytime storms just don't pack the punch of their evening counterparts.

The real question is — are your sites protected? The effectiveness of lightning protection devices can be reduced by a poor installation. You can pay a couple thousand dollars for a good, high capacity surge protector, but it can be rendered useless by installing it too far from the AC panel. AC wiring does have inductance, and the reactance of the connecting wires can prevent the surge suppressor from doing its job.

Just grounding the chassis or cabinet of a piece of gear doesn't do much good if you are forcing surge currents through the device; the surge must be allowed to pass around the equipment. I've seen installations where all equipment was bonded together with a massive copper strap. The problem was that the strap wasn't connected directly to a solid station ground. The ground was "found" through the chassis of the equipment and through its associated AC wiring. Once inside the gear, surge currents tend to do a lot of damage.

It's easy to overestimate the cost of lightning protection. Once we sit down and start to figure, there's a tendency to get carried away with fancy, high cost protection schemes. Of course, many times the budget won't allow for it, and we end up doing nothing. Lightning/surge protection is much more a matter of proper installation, rather than high cost. Yes, good protection is going to cost a few hundred, at least, but there's no excuse for you not to insure your site with a few well-placed MOVs, and good physical bonding to a solid station ground.

The smaller MOV protection devices will sometimes self-destruct, giving their lives for the cause. When you install them, try to find a location where they will be easy to replace, if they do blow.

You may be surprised at how effective a dozen or so well-placed MOVs can be.

Ray Topp

Remote Tascam Plug

John Stortz — CE, WKES

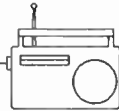

Just had a problem. I couldn't find a custom remote control plug for a Tascam cassette deck. They sell for the exorbitant price of about \$35 each. Aside from the price, I needed it *now*.

It turns out that a very good substitute for odd-ball plugs can be made with a few pins taken from a "surplus" plug, whose pins fit the socket, and hot melt sealer. In this case, I had to make a plug with male pins.

Place a piece of masking tape over the socket and insert the pins through the tape. Fill in around the pins with the hot melt product of your choice, in small layers at a time. Allow each layer to cool enough so that it does not move, before adding more hot melt.

I have successfully made several plugs this way and am fairly partial to the hot melt sealer. Hot melt glue works, but is more difficult to contain where you want it. A soft plumber's epoxy works too.

When working with female pins, I usually cover them with shrink tubing before the filler to be sure the filler does not wander into the void area of the pin, and to allow some room for the pin to expand. It's best to keep female pins filled with male pins while filling the void area, to be sure there is enough room for expansion.

Bext PTX-30 Pot Fix

David Young — Tooele, Utah

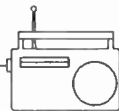

The power control on our Bext model PTX-30 exciter has the habit of being destroyed by heavy-handed operators. I decided to replace the panel-mount Helitrim pot with one that had a shaft and knob.

As space for the control was at a premium, I couldn't find a pot, with a shaft, small enough to fit. Thanks to the good people at Bourns Trimpot, I was directed to one of their new products — a 9mm square, panel mount, miniature pot (3310 series). While I don't have the resolution a 10-turn pot would give me, the control is very smooth and is plenty adequate for the job.

Radio Guide Quick-Tip

Make sure that you have installed telephones or jacks in each location at your transmitter site: behind the transmitter, and even in the doghouses. It beats having to stretch a cord.

STL Ground Loops

William Miller — San Louis Obispo, CA

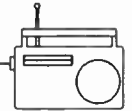

Lighting is rare here on the central coast of California, but a recent mid-winter storm brought lightning that struck the local CATV and telephone companies. Our transmitter is co-located with the CATV company. While there was no evidence that our equipment was damaged by the lightning, the CATV company did suffer some damage.

Our FM equipment was on the air after the storm and operating normally, with one exception: there was a large 60 Hz hum on the air audio. Disconnecting the audio input and output of the STL system, showed that the hum was in that system.

I first replaced the STL receiver with a spare, but there was no change in the hum level. I then replaced the STL transmitter, and there was still no change. Even though I had isolated the hum to the STL system, replacing the components of that system did not cure the problem.

The solution came when I realized that disconnecting and re-connecting the shield of the STL receiver antenna would cause a change in the hum level. An experimental connection of the STL receiver antenna cable, with only the center pin connected, resulted in a quiet signal. Unfortunately, I could not maintain this temporary connection.

I found some scrap 2-inch PVC conduit on site. I sawed about 18 inches of the conduit, in half, lengthwise. I took these two half pipes, and cut them into four 9-inch lengths. I climbed onto the roof and un-bolted the top bracket of the STL dish. I inserted two of the plastic sleeves around the STL mast and tightened the bracket. I repeated the operation on the bottom bracket, electrically isolating the STL dish from the tower mast. The problem was gone!

The tower on which our STL dish is mounted, is shared by the CATV companies. I suspect, but have not proven, that somewhere in one of the CATV systems, a MOV spike protector connected between the power line, ground, and neutral, may have shorted. Connecting the power ground and neutral together in this way, could certainly cause a change in the grounding scheme of the entire site. I don't like not knowing the cause of this problem, but at least I found a cure, if only temporary.

Radio Guide Quick-Tip

Always carry a variety of cable tie-wraps, duct tape, and electrical tape in your tool kit. None of us likes a temporary fix, but there's nothing like tie-wrap or tape to hold something together in a bind. Electrical putty can also come in handy, as well.

Cable Capacitance Effects

Gordon S. Carter — Chief Engineer, WFMT, and Owner, Professional Audio Services

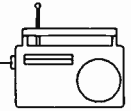

Sometimes when you are writing, you are so busy thinking about what you are trying to say that you don't say it well. You think you explained it thoroughly, but when you have a chance to clear your mind, and come back to it later, you find that you weren't as clear as you thought. This happened in the December issue of Radio Guide (Impedances and Audio — Part 2). Let's try it again.

I was talking about the problems of driving long lengths of audio cable with modern amplifiers, and mentioned that you would get high-frequency roll-off under certain circumstances. Unfortunately, I was not clear on those circumstances.

Any amplifier will have a finite output source impedance. Most solid state amplifiers (including integrated circuits) have a low output impedance, typically in the order of only a few ohms. However, due to the high gain-bandwidth product of most IC amplifiers, the capacitance of longer lengths of cable will create a phase shift in the feedback, that may create a high-frequency oscillation in the circuit. The length of the cable required for this to happen may be quite critical, and you may not run across this in most instances. However, if you happen to get just the right conditions, the results could be very disturbing if not catastrophic.

To reduce the effect of cable capacitance the designers will often place a small amount of resistance in series between the amplifier output and the load. This will tame the oscillation and instability from the cable capacitance, but creates other ill effects. The equivalent circuit of an amplifier with a series resistor and a long length of cable is shown below:

Equivalent Circuit

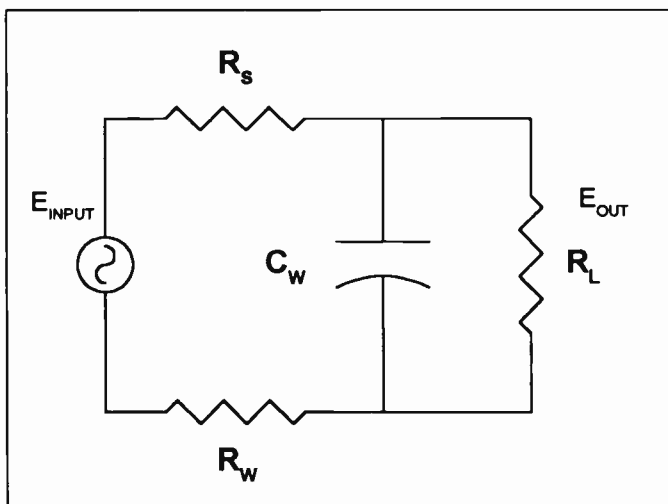

R_s is the source impedance of the driving amplifier. R_w is the series resistance of the wire. C_w is the total capacitance of the wire, and R_L is the load resistance. Normally the series resistance of the wire is quite low, only a few ohms.

Let's look at an actual example. We have about 750 feet of Belden 8723, which is a two-pair shielded cable. The specifications of the wire are 15 ohms/1000', 35 pF/foot from conductor to conductor, and 62 pF/foot from any conductor to the shield. In our example we measured a total loop resistance of 23.6 ohms. This translates to about 786 feet of cable. If we measure the capacitance we see 25,000 pF from conductor to conductor in the same pair, which translates to about 714 feet. The differences can be attributed to inaccuracies in the measuring equipment. We will put a 10K load on the end of the wire, which is typical of most modern bridging inputs. If we drive this wire with a plain op-amp circuit (NE5534), a frequency response check shows a slight rise at 20 kHz, which indicates the possibility of an instability in the circuit. If we insert only 100 ohms of series resistance, the response drops by about 1.5 dB. If we increase the value of the load resistance, the roll-off will decrease a bit. Raising the resistance in series with the amplifier output will increase the roll-off.

If we know all the parameters of the circuit, we can predict the amount of roll-off we will have at any frequency. The circuit reduces to a simple three resistor voltage divider with a capacitor across the center resistor. The voltage is applied across the entire divider and the output is measured across the center resistor. If the capacitance did not exist, the formula to determine the output voltage would be:

$$E_{OUT} = E_{INPUT} \times \frac{R_L}{R_s + R_L + R_w}$$

To get the loss in dB, the formula would be:

$$LOSS(dB) = 20 \log \frac{E_{OUT}}{E_{INPUT}}$$

To account for the capacitor, the center resistor (R_L) would be replaced by the parallel combination of the capacitive reactance and the resistor. The capacitive reactance is:

$$X_c = \frac{1}{2 \pi f C}$$

Cable Capacitance Effects

Continued from page 4

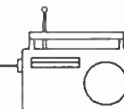

The parallel combination of the capacitive reactance and the resistor is:

$$Z = \frac{X_c R_L}{X_c + R_L}$$

We could work through all of this to give you the complete equation in one, but I will leave that up to you.

If you look at the original equation you will note a few things:

1. The lower the source resistance the less the roll-off.
2. The lower the load resistance the less the roll-off, but the lower the output level.
3. The lower the capacitance (shorter cable lengths) the less the roll-off.

Unfortunately you do not always have control over some or all of these parameters.

There are a number of ways to get around these problems, and some are more effective than others. One method is to use a small power amplifier as a line driver. This type of circuit will provide relatively large amounts of current to the load while still maintaining stability. The disadvantage to this technique is more complexity and perhaps more cost to the circuit. Keep in mind that for an amplifier to deliver large amounts of current to the load, its internal impedance must be very low. That is the real trick to making this method work.

Another technique is simple and low in cost, but very effective. This technique takes the feedback for the op-amp from the point where the series resistor joins the line. Doing this, effectively lowers the output impedance of the circuit to almost zero while maintaining stability for the op-amp. Until recently you had to build this type of circuit from discrete op-amps and resistors, but now Analog Devices has the SSM-2142 available. This circuit provides proper drive for most realistic lengths of cable, while maintaining stability. It also drives either balanced or unbalanced loads with virtually no change in performance.

This brings us to the subject of balanced lines. A balanced line is one in which neither side of the line is grounded. Both sides of a balanced line must be at the same potential and fed with an out-of-phase signal. The circuitry at the receiving end of the line responds to the difference between the two sides of the line. Since most interfering signals that would be induced on the line would be in phase with each other (common-mode), they are canceled at the receiving end.

In the real world, there are a few problems with balanced lines. If anything happens to upset the balance of the circuit, the rejection of the interfering signals will be compromised. Typically this would be caused by unequal wire resistance on the two sides (bad connections or an open side) or unequal impedances to ground from either side of the line (short to ground or an inadvertent load). Another problem that can happen is a mis-match in the gain from the two sides of the line to the point where they are combined. This most commonly occurs with a transformerless circuit. To build a common-mode receiver from discrete op-amps and resistors requires resistor matching better than 1% for good operation. Also, the common-mode characteristics of most op-amps deteriorates with increasing frequency, so you have less rejection of unwanted signals where it is most important.

Again, Analog Devices has a circuit to solve this problem. It is their SSM-2141, and solves the above problems with laser trimming of the resistors on the chip. Simply plug it in and it works!

These IC's from Analog Devices are just some of the many audio circuits they have available. If you would like to get more information on their audio circuits, contact Analog Devices at One Technology Way, P.O. Box 9106, Norwood, MA 02062-9106. They have a data book for audio and a very good book of applications for audio. Their phone number is (617) 329-4700.

One good application of these circuits is to convert unbalanced hi-fi equipment inputs and outputs to balanced lines for broadcast use. A number of companies have similar circuits available but they are made with discrete op-amps and resistors. These IC's make it simpler and less subject to inaccuracies from resistor tolerances. Professional Audio Services has a kit available made with the Analog Devices chips. For more information contact Professional Audio Services, 34 North Madison Ave., LaGrange, IL 60525. The phone number is (708) 482-4142. As you use the circuits and look at the books you will probably come up with other uses. As you do, you may want to share the ideas with other Radio Guide readers, as Tech Tips.

Radio Guide Quick-Tip

CB Radio is not dead! It's an excellent substitute for cellular phone, and a heck of a lot cheaper. It's great for extended work, the air time is free, and it's easy to have multiple units on line, for DA work.

Power Tube Life Extension

John Bredesen — KLCC, Eugene, Oregon

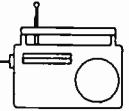

I sometimes (but not often) lament the passing of vacuum tube equipment: burned fingers from pulling tubes from operating equipment to get them into the tube checker (!) with the filaments hot to save time, slipped scope probes resulting in nasty shocks, unstable circuits. Ah, the good 'ole days; I remember them well. Most modern equipment has such low operating voltages that you can get right into an operating chassis with almost no concern for physical safety, as long as you stay away from the area where the 120V enters the box. Genuine component level troubleshooting became easier in some ways, at least until large scale integrated circuits began to make "troubleshooting" a matter of changing modules. On the whole, however, solid state circuitry has become the preferred way of life for a variety of reasons.

I'll ignore the fact that *new* equipment with tubes is being manufactured in ever greater quantities for the professional audio recording and sound reinforcement field! It boggles my mind that people will pay big bucks for amplifiers and microphones with performance good enough to satisfy NASA, then pay for equipment to intentionally introduce distortion. Hang on to those old 12AT7s; they're probably valuable. Actually, I've got a box of 5U4s and 5Y3s in the basement, and if I can just convince the industry that the real cause of whatever dissatisfaction is running rampant is the rectifier and not the amplifier stages, I'll have it made. Will wonders never cease?

With all this, it's sometimes easy to forget that vacuum tubes remain the primary source of high power RF energy in our transmitters.

Transistors, FETs and ICs have become the way of life in almost all broadcast equipment, in most cases replacing tubes in studio equipment decades ago. Solid state devices are making significant inroads in providing higher power at FM and TV frequencies. 50 kW AM transmitters are available. In spite of that, vacuum tubes remain the primary source of RF energy in high power, high frequency transmitters, and will continue to do so for years to come.

High power RF tubes are expensive to replace, and so it makes sense to do what ever is practical to prolong the life of the tube as much as possible. It's important to make sure the tube is running within manufacturers' specifications and that protective devices like overload relays are properly calibrated and tested occasionally. Adequate cooling is very important; make sure that cooling fins are clean and filters aren't clogged. Tubes with glass in their construction should be rotated into service at least annually because

of potential gassing problems. (Tubes with totally ceramic construction probably can be stored indefinitely without danger of becoming gassy.) It's also crucial to handle transmitting tubes gently because the filament structure is very brittle.

All of these points are known to experienced broadcast engineers. There is, however, one life-extending technique that isn't as well known. It has the capability of prolonging tube life, in certain tubes with directly heated cathodes, by 50 percent or more compared to "normal" operating conditions. This is known as filament voltage management. I should caution you that this is only applicable to directly heated cathodes; not tubes that contain indirectly heated cathodes. Operating such tubes at other than rated filament voltage can actually shorten their life.

During the manufacturing process, carbon is burned into the pure thoriated tungsten filament. Electron emission is dependent upon the presence of this carbon. Operation of the tube causes the carbon to "boil" off, and when the residual carbon reaches a certain minimum level, the cathode won't be capable of emitting enough electrons to make power. The operating temperature of the filament is an important factor in the rate of decarburization, and so in the interest of greatest life, filament temperatures should be kept as low as possible by lowering filament voltage, while at the same time assuring that the reduced temperature isn't an emission limiting factor. In using this technique of filament voltage management, the filament voltage is operated just above the point where emission limitation occurs. Primary voltage variations must be taken into account when determining the minimum filament voltage, so that emission limitation doesn't occur when the commercial voltage goes to it's lowest point. This is done by running the filament enough above the "knee" of emission to provide enough reserve filament voltage when the primary goes low.

If your primary voltage varies much, consider a regulated filament supply. Probably the best regulator is a constant voltage transformer installed ahead of the filament transformer. Our transmitter used an automatic voltage control circuit operating a motor driven autotransformer. I'm leery of electromechanical operations of this type because I've had them fail simply because they wear out, as mechanical things tend to do. In one case, the sliding brush wore itself out from constant correction, began arcing and took the transformer out with it.

(continued on page 7)

Power Tube Life

Continued from page 6

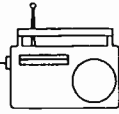

The process of extending tube life begins with the installation of a new tube. It's important to make sure that you know, accurately, the filament voltage at the base of the tube. Using appropriate safety precautions, apply only filament voltage, and measure the RMS voltage at the tube socket, using an iron vane voltmeter or an RMS responding digital meter. Use this reading to calibrate the filament meter built into the transmitter.

With the new tube installed and full rated filament voltage applied, tune the tube and then continue to operate it for the first 100 to 200 hours at full rated filament voltage. Full voltage is crucial to make sure that the built-in getter can finish the job of removing residual gas.

After this initial period, and after ascertaining that the tube is properly tuned, gradually reduce the filament voltage until you notice a decrease in plate current or other sign of departure from normal operation. Note the filament voltage reading at the point where a change of operation is observed, and then raise the voltage one or two tenths of a volt above that point. This is the point where you want to operate the tube. As the tube ages, however, it will be necessary to check the emission-limiting point occasionally, and make sure the operating voltage remains that same one to two tenths of a volt above that point. It will change as the tube ages.

This procedure is quite straight forward with FM transmitters, because the current flow in the tube(s) remain constant with modulation. AM transmitters are different in that the tube(s) must be able to supply peak current during times of peak modulation. Check with your transmitter manufacturer for the proper procedure for your AM transmitter.

Whenever you wish to check the tuning, return the filament supply to full rated voltage because various tuning combinations can result in higher than normal plate current. If tuning is attempted with reduced filament voltage, the current limiting nature of that reduced voltage can cause confusing results. Reduce the voltage again when the tuning procedure is finished.

As testimony of the effectiveness of this procedure, we've just passed the 27,000 hour mark on the Econco rebuilt 4CX15,000A in the KLCC Continental rig. (The 27.5 kW transmitter is operating at about 24 kW.) We're operating the tube with a filament voltage of 5.3 which is still considerably less than the rated 6.0 volts. According to our records, the longest tube life we had gotten before filament voltage management was instituted was just under 21,000 hours.

At about the time we installed the present tube, we also installed a 2 KVA, single phase Sola constant voltage transformer to regulate filament voltage. When I performed the calculations to determine the size of transformer needed, I was surprised to find the filament on a 4CX15,000 can draw 1600 watts of power! If you choose to follow this path, do your calculations well. A transformer of that size is quite expensive if purchased new (well over \$1,000), but we found a new one on the surplus market for just over \$300. We also modified the filament voltage control module in the transmitter to remove the automatic adjustment feature. The motor driven autotransformer was retained to allow manual adjustment of the filament voltage.

Based on a tube cost of 6.2 cents per hour of operation, before we began filament voltage management (\$1300 for a tube from Econco and 21,000 hours), the extra approximately 6000 hours we've gotten so far has saved us more than the cost of the transformer, and we're well on the way toward paying for the electrical installation. And that's just with the first tube!

FCC Forms Via Fax

The FCC has instituted a new procedure which will allow retrieval of certain FCC forms via FAX as well as through the mail. The FCC's Forms Distribution Center has a toll-free number for persons outside the Washington DC area: 1-800-418-3676. Individuals in the Washington, DC area should call 202-418-3676.

This number connects to an automated response system which will allow you to order FCC forms and get a listing of the most commonly requested forms. It also provides phone numbers for additional FCC services.

In addition to providing these services, callers may obtain an index of FCC forms available via FAX. By choosing option-1 during the toll-free automated response, you can have this index sent to a FAX machine. You can order the FAX copies of the forms listed on the index by contacting 202-418-0177 from the handset of your FAX machine. *You must be calling from a fax machine to retrieve a form.* If you don't see the form you need listed on the FAX index, it is not yet available via FAX and you should contact the forms distribution center as enumerated above. One tip — listen carefully to instructions before you punch any touch-tone buttons on the FAX machine. The system works; I know because I've used it. *John Bredesen, KLCC*

Transmitter Site Surge Suppression

Andy Butler — Broadcast Electronics, Quincy, Illinois

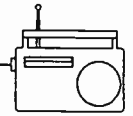

A truth in life is that the basics usually screw you up. That is particularly true when you upgrade from an older tube transmitter to a new solid state rig.

I was amused to see it pop up as the topic of a paper presented by L. Rogers, General Manager of Telstra Broadcasting at the Asia-Pacific Broadcasting Union's Conference at the Kyoto International Conference Hall last fall. With the help of Mr. Rodger's paper and some installation documentation from Broadcast Electronics, let's review the precautions you need to take to make sure your new box is as happy as it's predecessor.

The Antenna System

This is the most obvious point of entry for damage, but it is often overlooked. A typical lightning discharge has a peak current of approximately 50kA over a rise time of one micro-second. A good earth ground system with carefully planned attachments is essential to insure that this energy finds a destination other than transmitter components. Specific items to be checked include the following:

Static Drain Chokes — each tower should have its own, connected directly to a hefty piece of copper strap that is bonded to the tower's radial grounds.

Tower Guy Wires — each insulator should have a drain coil or resistor across it.

Ball Gaps (or Horn Gaps) — each tower in the system should be equipped with a gap type lightning arrestor. The gap on each arrestor should be carefully set so they don't arc under peak modulation. Don't forget, the new transmitter probably has better peak modulation capability than the old — if the gaps are too close it'll put some real funky rhythm in your programming!

Ferrite Coils — install on the transmitter RF output, power lines, and audio input and control lines.

Inductive Loop — call it a 'drip-loop' if you must, but be sure you put at least one full loop in the feed tube between the ATU and the tower. The RF won't notice the inductance, but that fast rise time lightning pulse sure will!

ATU Spark Gap — each antenna tuning unit should be equipped with either a horn gap, lightning gap or a gas discharge tube.

The Ground System

It might seem that the radials under the tower are more than enough ground system. Unfortunately, the path from the equipment or antenna system elements to these radials is often quite long with a fairly high impedance. In order to effectively discharge static or drain off a direct lightning

strike, the path to ground must present a low impedance. International codes suggest 10 ohms or less, but experience has shown that something on the order of an ohm or so is necessary for full protection. This is most easily accomplished by using the 'building ground ring' illustrated in the drawings on page 9. Be sure that even the "doghouses" have this protection in place. The radials from the tower should be bonded to this "ring" whenever they approach a structure. A hefty copper strap should interconnect each "ring" on a site, and all of the equipment in each structure should be attached to the ring at a single point.

Surge Protection

Once a good ground is in place, you have to make sure unwanted energy spikes go directly to ground rather than finding that path through the transmitter. This protection includes MOV devices to shunt energy to ground and ferrite chokes to reduce the magnitude of short rise time pulses. These devices should be installed as follows:

Transmitter AC Power — An MOV from each leg of the power to ground, as close as possible to the transmitter power connection. A single ferrite core should be placed around the main power cable bundle.

Audio Input — An MOV from each audio line to ground, and ferrite cores around the entire audio cable.

Control Lines — An MOV from each line to ground. A ferrite core around the whole control bundle (or one around each cable, if they come from different places).

Antenna Tuning

The output loading and tuning on a tube type transmitter compensated for impedance variations in antennas. Many solid state rigs use broadband output amplifiers without these adjustments. While most of these amplifiers will operate into VSWR as high as 3:1, they are most efficient when operating into a 50 ohm, non-inductive load. A little time with a bridge will insure that you get the performance the AM transmitter is really capable of delivering. An FM antenna problem is a little tougher to fix, but if you see VSWR over about 1.1:1, finding the problem will be worth the cost.

Audio input level

Newer transmitters tend to modulate more efficiently. Be sure to turn your audio levels down before you fire up the new rig. Lots of things can go wrong very quickly when the new transmitter proves it can deliver 150% positive modulation!

Transmitter Site Surge Suppression

Continued from page 8

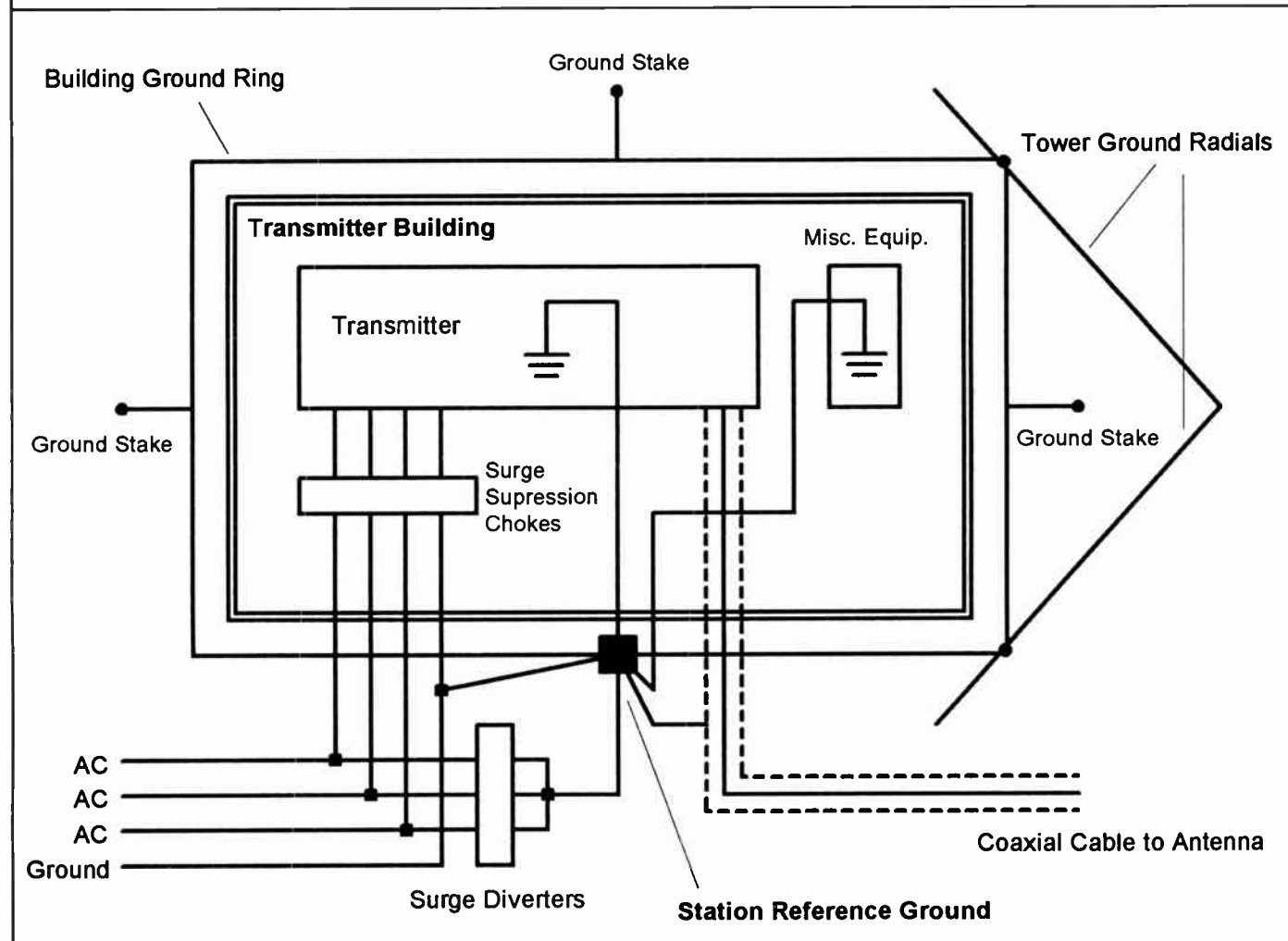
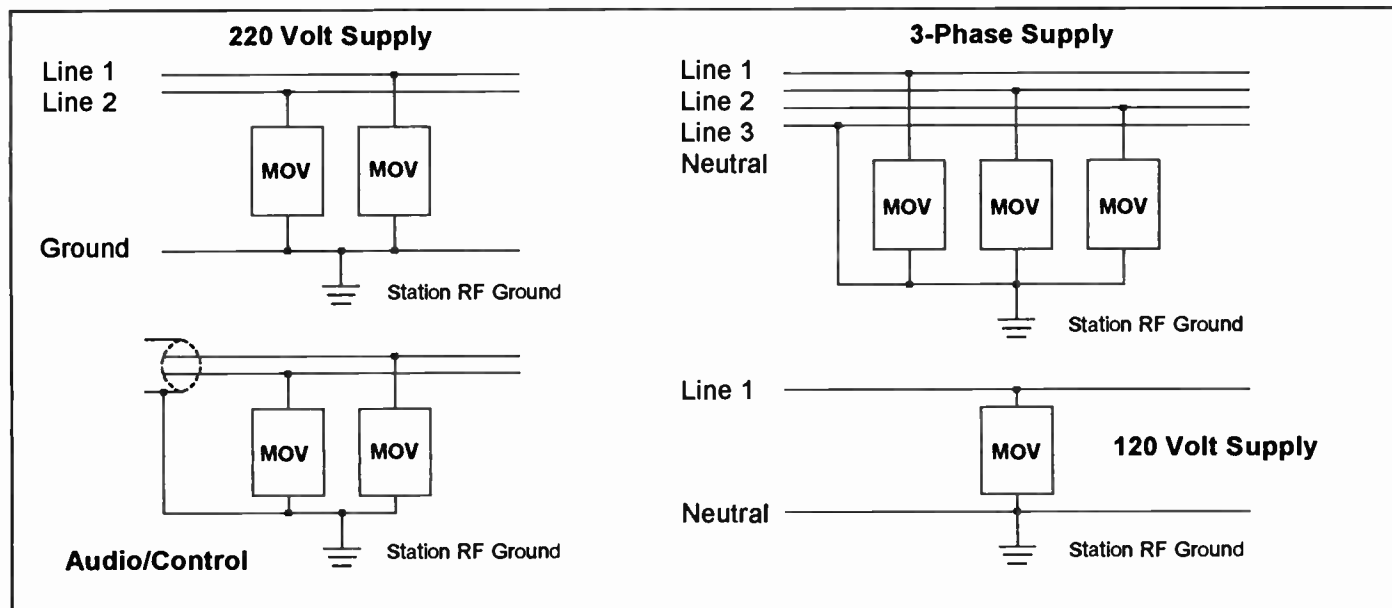
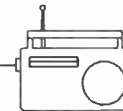

8 Second EBS Conversions

Dave Biondi — Houston, Texas

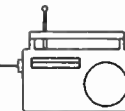

Editor's Note: I just received the following information from Dave Biondi, owner of The Broadcast Service Company in Houston, Texas. The last two issues of Radio Guide have dealt, in large part, with the new EAS changes. Now that you know the when and why, in this article we're going to show you how. Dave can be reached at 800-350-4964.

All broadcaster *must* make this conversion by June 30, 1995. As soon as all decoders in an area are capable of DECODING (receiving) EBS tones in less than 8 seconds, all stations and the primary alerting station can commence ENCODING (sending) the 8 second tone. This will cut the EBS test program interruption time, considerably.

To assist you in converting your present EBS equipment to the new 8 second tone standard, I have gathered the technical modifications to Gorman-Redlich, TFT and McMartin type EBS encoder/decoders.

Remember, only the DECODE function can be modified, until all the broadcasters in your EBS Broadcast Area have decided to switch to the new standard. Do not make the ENCODE modification until this happens.

Gorman-Redlich — All Models

DECODER - The outputs of the 107 Hz filters for the two tone decoders go into a diode, a parallel RC circuit, another diode, and combine into a voltage divider. Where these two diodes tie together, there is a 47 uF Tantalum capacitor. Change this to a 22 uF @ 16-25 volt Tantalum. The decoder will now activate at about 6-7 seconds.

ENCODER - On the encoder, turn the 1 megohm Activate Internal Adjust pot counter clockwise, until the tone is at 9-10 seconds (recommended). This modification may require a slightly longer closure of the activate switch to allow the timing capacitor to fully charge.

TFT — 760 Series

DECODER - On the decoder board, replace C13 with a 22 uF, 25 volt Tantalum capacitor. Replace R26 with a 182K, 1/4-watt, 1% resistor. This will cause the decoder to activate in approximately 4 seconds.

ENCODER - On the encoder board, cut the trace at Z3, pin 1. Then jumper from Z3, pin 1, to Z4, pin 9. This will give 8.5-9 seconds of tone.

If you want to put in a 8.5/23 second, encode select switch, install a SPDT switch on the back panel of the chassis, with the common on Z3, pin 1 and the other switch terminals on Z4, pins 9 and 11, respectively, to select the tone times.

McMartin - EBS-2/TG-2

DECODER - In the EBS-2 decoder, parallel R37 with a 500K, 1/4-watt, 1% resistor. This unit should now should decode in 5.5-7 seconds.

ENCODER - In the TG-2 encoder, adjust the trimpot near the NE555 chip, clockwise to 9 seconds.

Quick "T" Network Values

Lawrence Behr — LBA Technology Inc., Greenville, NC [919-757-0279]

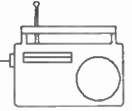

Is it often helpful to know approximate values of reactances in "T" networks, without resorting to mathematics. The table below has been developed as a quick reference to get network components close enough so that an empirical adjustment may be made with an RF bridge.

When using this method, bear in mind that actual components must be properly rated in current and voltage, to guard against failure. The table also lists some typical voltages and currents for 1,000 watts. These can be adjusted to actual operating power by multiplying by the square-root of the power ratio. Voltages and currents include a 3.5 voltage, and a 1.3 current safety factor, adequate for normal 125% modulated AM.

The values provided are for a network feeding pure resistance loads. If the antenna is reactive, that value must be added algebraically to the value given for Z2. The current through Z2 will not change, but the voltage across the component will, and must be computed. Also, note that the voltages across components assume a single component per leg. Series or parallel combinations, to achieve these values of Z, must be individually examined for component voltages and currents. The 1,000 watt voltage to ground, at the input for 50 ohms, should be assumed to be about 800 volts, with safety factor.

"T" Network Diagram

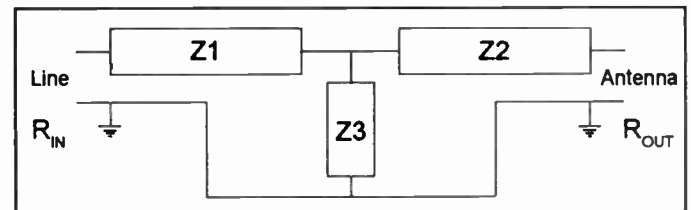

"T" Network Value Table

(All values are for 50 ohm line impedance)

Antenna Resistance (ohms)	Voltage/current values shown, are for 1kW power.									
	+90 Degree Net Impedances			-90 Degree Net Impedances			1kW Network Voltages/Currents (kV/A)			
	Z1	Z2	Z3	Z1	Z2	Z3	Z1	Z2	Z3	Antenna Terminal
15	+j27	+j27	-j27	-j27	-j27	+j27	0.5/5.8	0.8/10.6	0.9/12.1	0.4/10.6
30	+j39	+j39	-j39	-j39	-j39	+j39	0.6/5.8	0.8/7.5	1.0/9.5	0.6/7.5
50	+j50	+j50	-j50	-j50	-j50	+j50	0.8/5.8	0.8/5.8	1.1/8.2	0.8/5.8
75	+j61	+j61	-j61	-j61	-j61	+j61	1.0/5.8	0.8/4.7	1.2/7.5	1.0/4.7
100	+j70	+j70	-j70	-j70	-j70	+j70	1.1/5.8	0.8/4.1	1.4/7.1	1.1/4.1
150	+j87	+j87	-j87	-j87	-j87	+j87	1.4/5.8	0.8/3.4	1.6/6.7	1.4/3.4
200	+j100	+j100	-j100	-j100	-j100	+j100	1.6/5.8	0.8/3.0	1.8/6.5	1.6/3.0
300	+j123	+j123	-j123	-j123	-j123	+j123	1.9/5.8	0.8/2.4	2.1/6.3	2.1/2.4
450	+j150	+j150	-j150	-j150	-j150	+j150	2.3/5.8	0.8/1.9	2.5/6.1	2.5/1.9
600	+j173	+j173	-j173	-j173	-j173	+j173	2.7/5.8	0.8/1.7	2.8/6.0	2.8/1.7

just released
with complete Guide Section

TUNE TO SATELLITE RADIO® ON YOUR SATELLITE SYSTEM

"Satellite Radio" is the first complete, up-to-date book dealing with the non-video (audio) services carried on many domestic C and Ku Band satellites.

These interesting audio services can be received by most home satellite systems (TVRO) in very simple ways, sometimes without the use of additional equipment. These systems are easy to understand and place into use. The additional equipment is usually low in cost.

The audio programming is high quality in transmission and in content. All types of programming, music, talk shows, radio programming, radio networks, all news services, business services, weather services, all major sports are available on "Satellite Radio." Hundreds of services are "up there" if you know how to receive them. "Satellite Radio" shows you how to do it.

"Satellite Radio" has the most novel form of inclosed satellite audio services guide of any book or service. The Satellite Radio Guide is not bound in the book itself, and this guide

section is updated every three months. Each issue of "Satellite Radio" includes the latest Satellite Radio Guide Section no matter when the book is purchased. This is the most complete satellite audio guide in the industry.

Another feature of "Satellite Radio" is the yearly Satellite Radio Guide subscription option. A one year subscription is available at a nominal cost with the purchase of this book. The Satellite Radio Guide Section of "Satellite Radio" is updated and published four times each year, once every three months. It contains the latest changes in all four sections of the guide. This feature is important because there are major changes in programming on a monthly basis. These changes take place due to the retirement of aging satellites, the changes that take place as new satellites are placed in service and programming is changed, plus new services that come on line at a regular pace. The Satellite Radio Guide feature gives you all the needed information to enjoy "Satellite Radio."



★ ★ PARTIAL CONTENTS of "SATELLITE RADIO"® ★ ★

CHAPTER 1
WHAT SERVICES ARE ON THE SATELLITES?
RADIO STATION PROGRAMMING
TALK SHOWS, MUSIC
SPORTS AND SPORTS SHOWS
NEWS AND INFORMATION
STANDARD AUDIO SUBCARRIERS, 5.0 TO 8.0 MHz
BASIC STEREO FORMATS, HOW TO TUNE THEM
TUNING AUDIO SUBCARRIERS WITH AN IRD

CHAPTER 2
FM² - FM/FM - SUBCARRIERS BELOW VIDEO
HOW TO RECEIVE FM² CHANNELS
HOW TO LOCATE FM² SERVICES
EQUIPMENT NEEDED TO RECEIVE FM²
HOOKUP OF FM² EQUIPMENT
SERVICES CARRIED ON FM²
GUIDE TO FM² PROGRAMMING

CHAPTER 3
WHAT IS SCPC? WHAT DOES SCPC MEAN?
COMPANDING OF SCPC SIGNALS
BANDWIDTH OF SCPC SIGNALS
WHAT SERVICES WILL WE FIND ON SCPC?
HOW TO TUNE SCPC SERVICES ON YOUR SYSTEM
AFFORDABLE RECEIVERS, SCPC-100

FULLY AGILE SCPC 300-C RECEIVER
USING A SCANNER FOR SCPC
SCANNER HOOKUP FOR SCPC
FULL GUIDE TO SCPC SERVICES

CHAPTER 4
OTHER INTERESTING SERVICES ON THE SATELLITES
HOW TO RECEIVE WEATHER PHOTOS ON YOUR SYSTEM
WEATHER FAX PHOTOS, SYSTEM ONE
HOOKUP FOR WEATHER FAX, SYSTEM ONE
SYSTEM TWO FOR WEATHER FAX
METEOROLOGICAL SATELLITE SYSTEMS
LOCATIONS GUIDE TO WEATHER FAX PHOTOS

CHAPTER 5
RECEIVE WORLD PRESS PHOTOS ON YOUR SYSTEM
SATELLITE PRESS SERVICES WITH YOUR PC AND DISH
LOCATIONS OF WORLD PRESS GUIDE
HOW TO HOOK UP FOUR SYSTEMS TO ONE DISH

CHAPTER 6
ATIS, Automatic Transponder Identification System
WHAT IS ATIS?
LOCATIONS OF ATIS SIGNALS
HOW TO RECEIVE ATIS
EQUIPMENT AND HOOKUP FOR ATIS

CHAPTER 7
SATELLITE RADIO EQUIPMENT AND PARTS SOURCES
SATELLITE STEREO PROCESSOR SOURCES
GENERAL COVERAGE RECEIVERS FOR SATELLITE USE
CONSUMER SCPC RECEIVERS
COMMERCIAL SCPC RECEIVERS
SCANNERS FOR SATELLITE USE
COMMUNICATIONS TERMINALS
SATELLITE PARTS SOURCES

CHAPTER 8
UP-TO-DATE SATELLITE RADIO GUIDE (NOT BOUND)
SECTION A - AUDIO SUBCARRIER SERVICES
(5.0 MHz TO 8.0 MHz)
SECTION B - SATELLITE RADIO - FM²
(100 kHz TO 5.0 MHz)
SECTION C - COMPLETE, UP-TO-DATE SCPC CHANNEL LIST
SECTION D - OTHER SATELLITE SERVICES, WEATHER, PRESS, ATIS

THE ENTIRE SATELLITE RADIO GUIDE SECTION IS UPDATED EVERY 3 MONTHS IN EACH "SATELLITE RADIO" BOOK.
PLUS MORE

UNIVERSAL ELECTRONICS, INC.
4555 Groves Road, Suite 12
Columbus, OH 43232

NEW EDITION
Dealer Inquiries Invited

\$16⁹⁵ plus \$3.00 Shipping and Handling
Two Day Priority Mail

Please send _____ copies of the New "Satellite Radio"® book and "Satellite Radio Guide"®

Name _____

Address _____

City _____ State _____ Zip _____

Mastercard Visa Number _____ Exp. Date _____

Enclosed is \$16.95 plus \$3.00 Shipping and Handling, \$19.95 TOTAL _____

UNIVERSAL ELECTRONICS, INC. 4555 GROVES ROAD, SUITE 12 COLUMBUS, OH 43232 (614) 866-4605 FAX (614) 866-1201

The **Radio Guide Product Pages**

New Equipment Reports, Products, and Services for the Radio Industry

The Equipment Report

LP-3 Loop Antenna

Info-Fax
#100

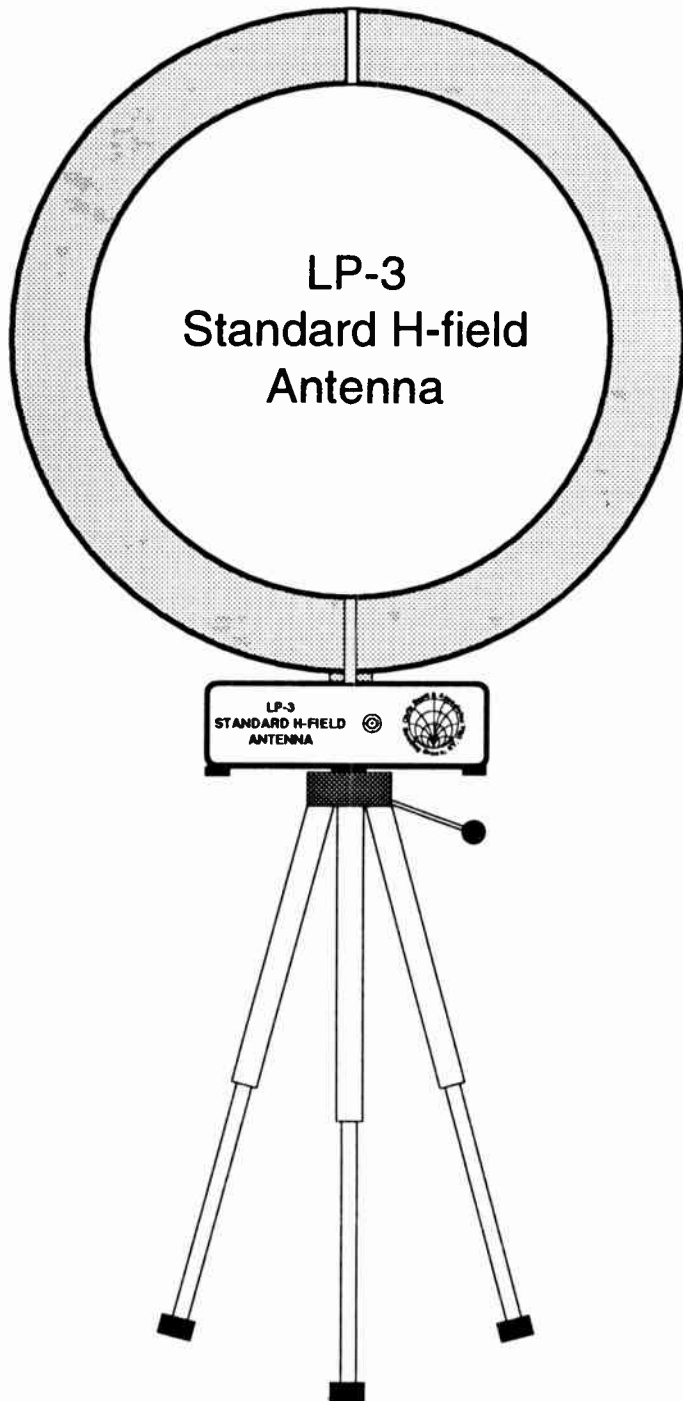

Chris Scott and Associates has introduced two new instruments designed to improve accuracy when making NRSC (AM Bandwidth), as well as harmonic measurement.

The LP-3 series Standard H-Field antenna is specifically designed to facilitate emission measurements of AM broadcast stations, using a spectrum analyzer or other calibrated receiver. The electrostatically shielded loop provides un-matched E-Field rejection, greatly reducing electrical noise pickup, normally associated with real-world measurement environments.

A good 50 ohm match is provided across the band. The bi-directional null pattern permits greater than 20 dB reduction in interference from other carriers, as well as verification of subject emissions.

Proprietary design allows accurate bandwidth and harmonic measurement. NIST-traceable antenna factor calibration, produced and documented in accordance with MIL-STD-45662A, is supplied standard from 0.5-5 MHz. An optional tripod is recommended for all but the most casual work. Highly selective resonant versions are available for dedicated monitoring applications.

MF Notch Filter

Info-Fax
#100

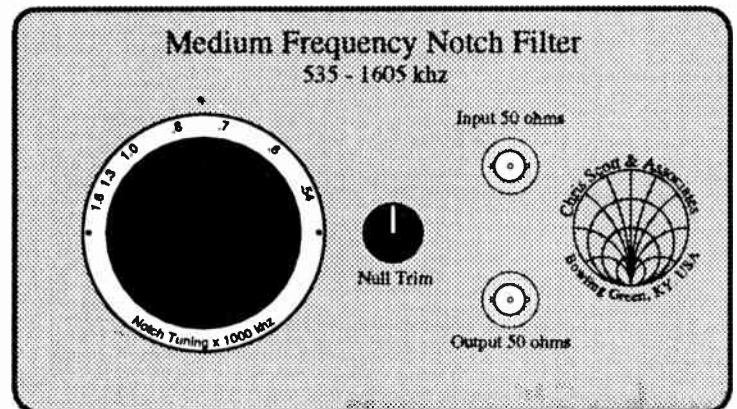

Actual size 7.5 x 4.25 x 2.5 inches

The Medium-Frequency Notch Filter is an accessory, allowing accurate measurement of harmonic or other out-of-band spurious emissions in the presence of strong fundamental or interfering signals.

Optimal High-Q design makes this possible with negligible insertion loss at harmonic frequencies, while preventing the artificially high harmonic syndrome, caused by front-end intermodulation. Typical notch depth is 32 dB at 1000 kHz.

For information on the LP-3 Shielded Loop Antenna or the MW Notch Filter, circle Info-Fax #100, on the Radio Guide INFO-FAX form. Or, for more information you can contact:

Chris Scott and Associates
Bowling Green, KY

Phone 502-781-5301 Fax 502-781-1232

HE HALL Electronics

WHY is HALL Electronics for YOU?

You'll like our GREAT PRICES on NEW & REBUILT EQUIPMENT. WE CARRY MOST BRANDS

You'll LIKE HALL's personal SERVICE - for one piece or an ENTIRE STATION. You are not a number to us; rather someone who needs a problem SOLVED.

We have an IN-HOUSE TECHNICAL SUPPORT TEAM. Our THREE full-time technicians give support after the sale and are always available to help with ALL your rebuilding or repair needs. WE STAND BEHIND OUR WORK. We are an authorized service center for Tascam and Otari.

Contact Rick or Jon . . . today!

WHEN YOU NEED GOOD PRICES & SERVICE,

Call Hall!

Phone 804-984-4255 Fax 804-984-3299

Info-Fax #101

Info-Fax #102

Need more information? Circle the Info-Fax numbers on Page 16

Info-Fax #103

Info-Fax #104

UNIVERSAL SCPC

NEW Receiver!

XE-1000



SCPC BROADCAST AUDIO RECEIVER

New, affordable, frequency-agile receiver, direct channel entry by keyboard, selectable companding 1:1, 2:1, 3:1, wide/narrow bandwidth, de-emphasis selectable, 950-1450 MHz, line output 600 ohms, muting, transponder agile, LNB power supply, 50-channel memory, full baseband output, high-quality audio. Every needed feature at a sensible price (lowest in the industry). Write or call for full information on this quality receiver—the answer for your station. Networks call for prices.

Phone: (614) 866-4605 Fax: (614) 866-1201

UNIVERSAL ELECTRONICS, INC.
Communications Specialists
4555 Groves Road, Suite 12 Columbus, OH 43232

*ERI - Trusted since 1943
for Proven Performance in
ANTENNA - FILTER
LAMBDA™ MOUNTING
TOWER-INSTALLATION*

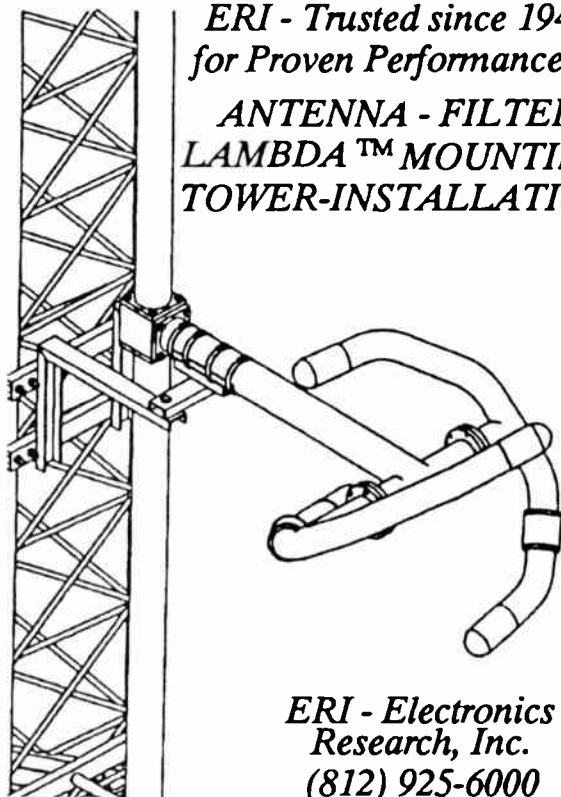

*ERI - Electronics
Research, Inc.
(812) 925-6000*

Commercial Radio Company

Duttonsville School Dr., Cavendish, VT 05142
Phone 802-226-7582 Fax 802-226-7738



Transmitter Parts
RCA - Gates
Collins/Continental



Mica Transmitting Capacitors: Sangamo, CD, Sprague, Aerovox, Acushnet types: CM-15, CM-20, CM-25, CM-30, HT, HK, AT, AK, F1, F2, F3, 30B, E, 1996, 291, 292, 293, 294 & G5.

Fixed and Variable Vacuum Capacitors: Jennings, Dolinko & Wilkins, Mounting brackets and flanges. Vacuum relays.

Oil Filled Filter Capacitors: Plastic Capacitor Corp., 600 to 40 kV, 1 mFd to 30 mFd with special mounting brackets. Non-PCB oil capacitor replacements are available for most transmitters.

Ceramic RF Capacitors: Centralab, Jennings, Sprague, High Energy, 5 kV to 40 kV.

Variable Transmitting Capacitors: E.F. Johnson Co., Cardwell Condenser Co., insulated shaft couplings as used in phasors, variable transmitting capacitors.

Weschler-Westinghouse: RF ammeters, 0-0.5 amps through 0-50 amps, internal and external thermocouples, expanded and linear or square-law scales. Sizes are 3 & 4 inch, round and square. Special meters are available.

RCA: Transmitter, phasor and antenna tuning unit parts.

ULTRAMOD® .UM2000

FM STEREO MODULATION SYSTEM



- The UM2000 is a complete FM processing and stereo generating system featuring:
- Dual band, stereo AGC and peak processors of exceptional clarity.
- Digitally synthesized stereo generator with separation exceeding 60dB at 1kHz, and typically 55dB at 15kHz.
- Dual composite outputs for feeding main and auxiliary transmitters or STL's. Very affordable.

WHY PAY MORE ... AND GET LESS?

HNAT HINDES Inc

42 Elaine Street, RR1, Thompson, CT 06277
203-935-9066 203-935-9242

Econco

Rebuilt Power Tubes

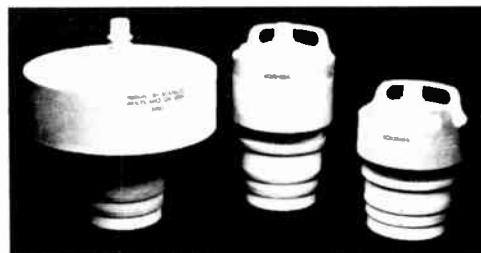

Approximately
One Half the Cost of New

Call for Our Price List

Econco

1318 Commerce Ave., Woodland, CA 95695
800-532-6626 Canada 800-848-8841

Info-Fax #105

Need more information? Circle the Info-Fax numbers on Page 16

Info-Fax #106

Info-Fax #107

FCC Rules on Kahn POWER-side™

Motorola tried to deny broadcasters the right to increase coverage by using SSB — Kahn POWER-side™ equipment. But the FCC specifically ruled that the "Kahn POWER-side system ... may continue to be operated ..." as a mono improvement system. So you can now use POWER-side with Kahn independent sideband exciters to immediately increase coverage to listeners using any and all type of AM receivers.

Federal Communications Commission FCC 93-485:

21. Kahn "POWER-side" Operation. Several parties express concern over the continued acceptability under our rules of operating using the Kahn POWER-side AM single-sideband system. POWER-side operation, as distinct from Kahn stereo operation, involves an AM transmitter with two independent sidebands, containing identical program material, but with intentional level and frequency response differences. This system is implemented with a Kahn independent sideband stereo exciter and is claimed to have certain advantages for reception with monophonic receivers, particularly in adjacent-channel interference situations. CTI and Furr argue that adoption of the proposed standard would prohibit such an implementation. Motorola maintains that the Kahn POWER-side mode of operation is not stereophonic and questions its legality under the present rules.

22. Our AM rules do not include a definition of the term "stereophonic." However, generally accepted definitions of stereo service infer two or more channels of audio information designed to produce an audio "image" when demodulated by an appropriate receiver. On this basis, we find that stations employing the Kahn POWER-side system are not subject to the provisions of the stereophonic transmitting standard adopted herein and may continue to be operated, provided that the program material fed to both channels of the exciter is identical in content.

POWER-side™

PROBLEMS

Adjacent Channel Interference
Antenna Null Distortion
Co-Channel Interference
Power-Line Re-Radiation
Building Re-Radiation
Receiver Tuning
Low Fidelity Home Radios
Co-Channel Beat
Selective Fading

SOLUTION!

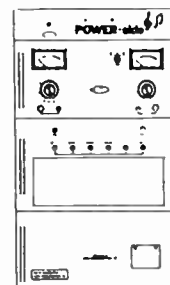

(516) 222-2221

POWER-side™

The solution to many of
AM radio's most serious
technical problems.

*From the developers of the AM STEREO system
that isn't afraid of the dark, and will let you drive right past FM Stereo.*

Kahn Communications, Inc.
222 Westbury Avenue, Carle Place, NY 11514

The Radio Guide

INFO-FAX

Free Product Information

1. Enter personal information.
2. Circle the names of all the manufacturers and suppliers from which you need more info.
3. Fax this form to us.

Free Product Service

1. Enter personal information.
2. Circle the names of all the gear that you'll be buying within the next 90 days.
3. Fax this form to us.

Fax it Today!



(507) 280-9143

Personal Information:

Please change my subscription mailing address.

Name: _____ Station: _____

Address: _____

City: _____ State: _____ Zip: _____

Phone: _____ Fax: _____

Free Product Information

Check out the product information on page 1 and pages 13-15 of this Radio Guide. Then circle each one from which you need more information, below.

#100 - Chris Scott

#103 - Universal Electronics

#106 - Econco

#101 - Hall Electronics

#104 - Commercial Radio

#107 - Kahn Communications

#102 - ERI

#105 - Hnat Hindes

#108 - Audio Broadcast Group

Free Product Service

If you plan to buy any of the following pieces of equipment in the next 90 days, circle each one. We will send your name to our contacts and they will send you free information on the products you have selected.

Antenna - FM

Cart Decks - Tape

Remote Control

Transmission Line

Audio Power Amps

DAT Decks

RPU Equipment

Transmitters - AM

Audio Distribution Amps

Digital Workstations

Satellite Equipment

Transmitters/Exciters - FM

Audio Processing

EBS/EAS Equipment

SCARDS

Tubes

Automation/Live-Assist

Microphones

Speakers

OTHER PRODUCTS:

Cassette Decks

Modulation Monitors

STL Equipment

Consoles & Mixers

PA/DJ Equipment

Studio Furniture

CD Players/Recorders

Phasors/ATUs/DA

Telephone Interface

Cart Decks - Digital

Reel Tape Decks

Towers

Fax This Form to 507-280-9143

MAR-95

Copy and Use This Form as Many Times as You Like

Page 16