



ROCHESTER

# RADIO GUIDE

CHIEF ENGINEER  
KBNA AM/FM  
5710 TROWBRIDGE  
EL PASO

TX 79925

BULK RATE  
U.S. POSTAGE  
PAID  
ROCHESTER, MN.  
PERMIT 445

July 1988 511 18th Street Southeast Rochester, Minnesota 55904 (507) 280-9668

For as long as I can remember, there has been no forum for the exchange of real-world radio technical information. There have been many attempts to get the job done, but somehow they all end up with a disproportionate amount of advertising, want-ads and news; very little that can be used on the hard technical level.

The other trade magazines are not bad, it's just that they have a different focus. I have always felt there's a need for a nuts & bolts forum for radio engineers. My purpose here, is to offer an alternative with a new perspective.

## WHERE IS ALL THE INFORMATION?

Radio has been around for quite a few years. By now there should be quite a bit of technical information available to radio engineers. Unfortunately, most of that information is in the heads of various engineers and not on paper.

I don't expect everyone to be a publisher or a writer, but I would hope that most engineers would be willing to supply technical information, if asked.

Well - I'm asking!

The goal of Rochester Radio Guide is to simply provide a forum for the exchange of radio technical information between all of us. There will be no specific format here. If it can help engineers do their job, then it will be published.

## THE NEED IS REAL

I need large or small articles (even a paragraph), hints & kinks, your special maintenance or test procedures, schematics and anything else that you've found out about, over the years, that could be of use to your peers.

Please don't feel that someone else will do the job. It's really up to you to help us all.

I can't do it myself; in fact, I simply wouldn't want to. I don't need anything formal - just some notes on a legal pad will do. This is your forum - please treat it as such.

You've heard my pitch. Will you help? There is no backlog of technical information to be printed. If you would like to see the Radio Guide next month, you will have send that information in.

Send to:

Rochester Radio  
511 18th St. SE  
Rochester, MN 55904  
(507) 280-9668  
Attn. Ray Topp - Editor

## HOW IT BEGAN

I've been involved in radio engineering for around 15 years now and I've loved every minute. Yes, I looked forward every day to getting a call at 3:00

AM, rushing to a transmitter, finding a complete set of test equipment & spare parts along with the station manager waiting with a blank check.

The 3:00 AM call always happens. Usually when I get to the TX site, there's a Simpson 260 with dead batteries, and a tackle-box of old tools. Spare parts? You're kidding! Station manager? He doesn't even know where the transmitter site is! The blank check? You're right! It was usually 2 months before I saw anything.

Still, those problems are part of the job. They always have been and always will be; there are very few ideal stations out there. You're being paid to solve problems, and problems aren't always technical.

What has bothered me most in my career has not been the lack of tools or parts, but the lack of real-world technical and maintenance information.

It took ten years for me to figure out how to really test a modulation transformer (next issue). There had been many occasions where I know I could have saved a lot of time and headaches. If only I'd known how . . .

My point? There's a lot of "common knowledge" that is not so common. We're just charged with fixing things when they break, and the more each one of us can learn about the technical side of our jobs, the less un-productive and sometimes dangerous on-the-job training we'll need.

Here is a forum to share what we have learned and to help those of us, who for various reasons, have not had the opportunity to develop or learn those tech-tips that make an engineer's life easier.

## WE NEED TO COMMUNICATE

Those of us in this communications medium, need to communicate on a technical level. I will provide the space; you'll have to provide the information.

No matter how the industry changes, there will still be a need for new station engineers. Many of these engineers will not have as much knowledge as they should. I think we were all in that position at one time. Let's help them out, and at the same time help ourselves.

Much of what appears in the Radio Guide will at first seem to be basic technical information. You won't find out how to design 9-tower DAs here. What you will find, is the information needed to maintain that array. You will probably find that if you don't learn something new, you will at least have reinforced what you already knew. I have a feeling that each article will contain a bit of both.

Thanks for listening to my ramblings. The Radio Guide will be published next month - but only if you help me out. -Thanks-

Ray Topp  
Editor-Publisher

## ROCHESTER RADIO GUIDE

Volume 1, Number 1  
July 1988

Rochester Radio Guide is published monthly by Rochester Radio Publications, 511 18th Street Southeast, Rochester, Minnesota 55904 Phone (507) 280-9668.

Copyright 1988, Rochester Radio Publications. All rights reserved.

Rochester Radio Guide is mailed free to all radio station technical personnel each month. Unsolicited articles are welcome.

### CONTENTS

- Page 2 CCA 1000-D AM TRANSMITTER  
Power Supply Repair  
Dave Stewart KBNA El Paso, Texas
- Page 3 NBS TIME SERVICE ON-LINE  
Denver PC Board Watch  
Littleton, Colorado (303) 973-6038
- Page 4/5 NFR (NOISE FREE RADIO)  
George Yazell Lakeland, Florida
- Page 6/7 CLEANING & INSPECTING YOUR XMTR.  
Dana Meyers Field Service Engineer  
Harris Broadcast Corporation
- Page 8 WHEN 115 VOLTS IS NOT  
Steve Sandlin SBE Chapter 99  
Bryan, Texas

## MAIL LABELS

### AM, FM & TV BROADCAST STATIONS

FAST SERVICE  
100% ACCURACY GUARANTEED

SELECT BY TYPE OF STATION, TRANSMITTER  
POWER, GEOGRAPHICAL AREA, MARKET SIZE,  
COMMERCIAL/EDUCATIONAL, ETC.

CHESHIRE OR PRESSURE SENSITIVE LABELS.

TOTAL COST: \$55.00 PER THOUSAND LABELS.

PHONE (800) 338-3264

**BROADCAST MAILING SERVICE**

## CCA 1000-D AM TRANSMITTER

Power Supply Repair

Dave Stewart KBNA El Paso, Texas

The KBNA(AM) main transmitter went off the air and couldn't be brought back to life with the studio remote control. Finally the chief was called and he placed the auxiliary transmitter on the air at the transmitter site.

The first thing he tried, was to place the main transmitter into the dummy load at low power. The transmitter kicked off each time he tried and the overload light lit. The overload relay covers were removed and, during the next attempt to bring it up, it was noted that the high voltage supply overload relay was kicking out.

### DIVIDE AND CONQUER

1. Removed all power and disconnected power transformer from high voltage rectifiers. The plate supply was turned back on and there was no overload indication.
2. Removed all power and connected transformer back to rectifiers. Removed connection from rectifiers to filter choke. The plate supply was turned back on and there still was no overload.
3. Removed all power and restored connection between rectifiers and filter choke. Removed connection between filter choke and filter capacitors. Plate supply was energized, transmitter hummed, but did not kick off.

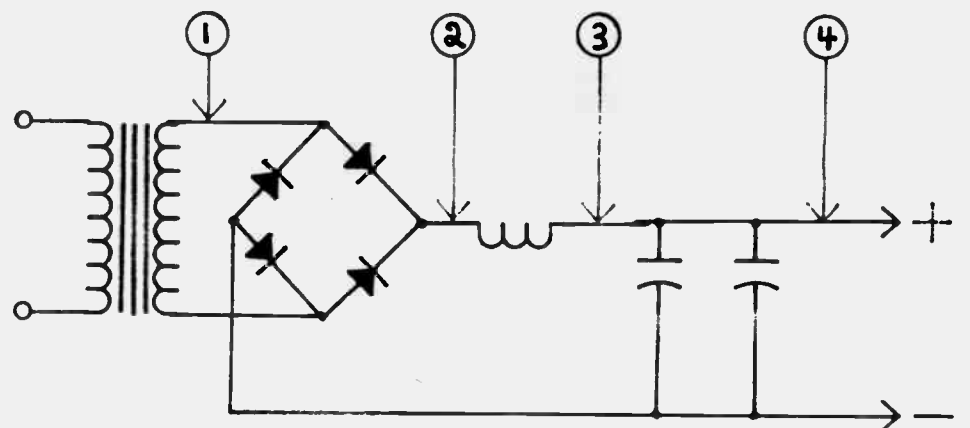

4. Finally, removed all power and restored connection between filter choke and capacitors. Removed high voltage connection from filter capacitors to rest of transmitter. Turned supply back on and found that transmitter kicked off.

The problem had been localized to one or both of the two 8uf filter capacitors. Each capacitor was tested with a Sencore Z-Meter and it was found that the first one read 3.4uf and the second one read 0uf. Both capacitors were replaced because of age and the distinct possibility of PCBs.

Many stations don't have access to a Z-Meter, but any testing of high voltage capacitors should be done with a voltage as near to the capacitor's voltage rating as possible. The couple of volts in a DVM just won't do the job. That old B+ supply in the attic may be of some use after all.

Make sure that you check the noise floor and carrier shift after replacing the filters. New capacitors aren't always good capacitors.

### A TIP TO MAKE LIFE SAFER

1. Be careful and assume nothing. Personally assure that your grounding stick is at ground and is capable of carrying current. Using a VOM or DVM to test the continuity, may not be the best idea. Use 120VAC and a light bulb to check that the grounding stick is really grounded.

## NBS TIME SERVICE ON-LINE

Denver PC Board Watch Littleton, Colorado  
(303) 973-6038 for subscription information

The National Bureau of Standards (NBS) in Boulder Colorado has a new time service that allows personal computer owners with a modem, to dial up NBS by phone and connect their PCs to the Master Clock in Boulder, allowing retrieval of the correct Universal Coordinated Time (UTC) in ASCII text format.

The new data service operates at 1200 baud, using 8 data, no parity and 1 stop bits (8N1). It's available at (303) 494-4774/4775 and 4776. Each number has its own time code generator tied to the NBS-9 Cesium beam atomic standard used as a time base at NBS. This "atomic clock" has an accuracy of one second in 300,000 years. Users who dial the service via modem will receive an ASCII text string every second with an asterisk time mark.

The string is repeated for at least ten seconds with automatic disconnect at 55 seconds. The string contains a wealth of information including modified Julian date, daylight savings time countdown, leap second status, a DUT1 factor and a telephone line delay correction factor.

= = = = =

### ASCII TEXT STRING EXAMPLE

47096 88-10-28 16:28:13 00 1 0.4 0007.9 UTC(NBS) \*

47096 is the Julian date  
88-10-28 is year-day-month  
16:28:13 is hour:minute:second, military time  
00 is daylight savings time countdown flag  
1 is leap-second status  
0.4 is DUT1 correction factor  
0007.9 is telephone delay factor, in milliseconds  
UTC(NBS) is NBS identifier  
\* occurs at the actual time mark

= = = = =

The daylight savings flag is 00 when no change is imminent. At 49 days prior to the Spring change, the countdown goes from 99 to 50, with the actual change occurring at 50. The flag remains at 50 until 49 days prior to the Autumn change, when it will count down from 50 to 00.

The leap-second status indicator can be 0, 1 or 2. A 1 indicates that a leap-second will be added to UTC at the end of the current month and a 2 indicates that a leap-second will be subtracted from UTC at the end of the current month. A 0 indicates no leap-second activity. Historically, a leap-second has been added to the last month of each year to coordinate the atomic based UTC with the astronomically based UT1.

The asterisk (\*) marks the exact instant when all the information in the ASCII text string is correct. Unfortunately, the string itself is delayed in transmission through the telephone network. This line delay can vary between 20 milliseconds for a local call to around 250-300 milliseconds for long distance calls routed via satellite.

Dick Davis and Mark Weiss, who wrote the software, have devised a clever solution. A delay algorithm is built into the system. To use it, simply echo the asterisk (\*) back to NBS immediately upon receipt. When at least four of these echoes have been received, the service will use these characters to correct for telco delay factors.

The next ASCII string transmitted after correction will contain a (+) in place of the asterisk (\*). The actual telephone system delay is printed, in milliseconds, just before the UTC(NBS) characters.

# THE Brains BEHIND OUR Brain

At The Systemation Company, we are proud of our people: radio people manufacturing random-access automation systems for other radio people... like you.

Five of our top people have been chief engineers. Three have been general managers and three have been program directors. Like you, they've learned first-hand what a radio station needs from an automation system.

To build the "brain" that drives our systems, our radio people are backed by some of the best computer people around—twelve of them, headed by a guy who holds advanced degrees in computer technology and who cut his teeth programming medical computers at the University of Chicago.

With brains like that on our team, it's no wonder that in the past seven years Systemation has installed over three hundred random-access automation systems world-wide.

And it's no wonder that today Systemation is leading the field in random-access digital, with over twenty systems already in operation in radio stations just like yours. (Our people are doing digital while others are just promising it.)

Whether you need a simple satellite interface or a complete random-access digital system with all the bells and whistles, talk to the people at Systemation first. You'll be talking to people who talk your language. People who've been there.

After all, it's hard to lead the field unless you've been in it.



337 North Water, Decatur, Illinois 62523 • (217) 428-7101

## POWER-side™

The solution to many of AM radio's most serious technical problems

From the developers of the AM STEREO system "that isn't afraid of the dark"



425 Merrick Avenue  
Westbury, N.Y. 11590  
(516) 222-2221

# NFR (NOISE-FREE RADIO)

George Yazell Lakeland, Florida

This discussion is for the reader interested in improving the Standard Broadcast Band so AM stations can compete on equal footing with FM stations.

I retired in 1987 after 48 years of day and night participation in broadcasting. I planned to devote time and energy to fishing, photography, travel, hamming and to improve my social skills dancing, bridge, ect. I've done some of those things, and still found time to ponder the problems of AM. No, I am not a die-hard AM fanatic. In fact, I suffered through 20 years of nurturing the underdog FM stations, and was very pleased when FM became viable. Even more so when it became the dominant medium.

I don't need to outline the decline of AM for you. In spite of all the AM "improvements" introduced in the past 10 years the value of an AM station in any given market has declined. Most AM stations on the market sell for the actual value of the inventory and real estate, sometimes less. FM stations in major markets are changing hands for prices that are 100 times the actual value of the real estate and inventory.

Why? More people listen to FM! Why? FM sounds better! Certainly not because of superior programming. Tuning across the FM band reveals 95% of the stations are no more than glorified music boxes.

Why does FM sound better? The secret of FM's superior performance is the characteristics of the de-modulator in the FM receiver.

In an FM receiver the de-modulator responds only to frequency modulated signals and ignores any amplitude modulated signals. This means that it's not going to produce the pops, cracks, sizzles and other noises produced by lightning, sputtering fluorescent lights, electric shavers, and many other noise makers that spoil AM radio's reception.

The FM de-modulator has another even more important characteristic. When you tune in a station on your FM radio, the de-modulator "locks on" to that signal and ignores other weaker signals on that channel or adjacent channels. This is commonly known as the "capture effect". This is demonstrated when you are driving down the highway about halfway between two FM stations on the same frequency. You are listening to station "A", a clear signal without interference from station "B". As you move away from "A" and get closer to "B", your radio will flip from "A" to "B".

On the other hand, if you are driving midway between two AM stations, "X" and "Y", on the same frequency with equal power, you will hear both of them simultaneously on your AM radio. As you move away from "X" toward "Y", "Y" will gradually become louder and "X" will fade down. When you are about 3/4 of the way from "X" to "Y", you will no longer hear "X" in the background. So, along a path from "X" to "Y", at least half the distance will be subject to "co-channel" interference - 1/4 of the way you will hear "X" clearly and 1/4 of the way you will hear "Y".

On most AM radios, the desired signal must be at least 20 times as strong as the interference before the "cross-talk" or interference is reduced to an acceptable level. On most FM radios, an RF signal ratio of 1.5 to 1 is adequate to prevent co-channel interference.

## AM RECEIVER BANDWIDTH RESTRICTED

Another important characteristic of FM is the ability to transmit and receive a much wider audio frequency band, normally from 30 Hz to 15 kHz. While the AM transmitter could well handle such a signal, the AM receiver bandwidth is restricted to reduce noise and interference. Nominal bandwidth of most AM receivers limits the audio high-frequency response to about 3.5 kHz.

With the deck stacked so much in favor of FM, it's hard to understand why it took so long for FM to become dominant, and why the demise of AM has taken so long.

Up to this point in our discussion I don't think I have encountered any serious opposition to what I've said. From here on, I think we may stir up a bit, perhaps quite a bit, of controversy.

The first step in solving any problem is to define to problem. That has been outlined above. The effort put forth so far to solve the problem include increase transmitter power to override noise and interference, process the audio so we maintain a higher modulation level, limit frequency response, increase frequency response, pre-emphasize the higher audio frequencies, reduce sky-wave radiation, add stereo, ect. None of these have had a significant effect on the problem. I often hear the comment that the many audio processor designs introduced in the past 10 years may have actually contributed to the problem rather than eliminate or reduce it.

The time has come to face the music! There is only one way to make AM radio stations sound as good as FM. Replace AM with NFR, a special type of FM! I'll bet that will stir up some controversy.

### Rochester Radio Report

FCC Daily Radio Broadcast Proceedings



FCC Policy and Rule Changes ?  
You are expected to have the answers !

FCC information found in magazines ?  
Too late and too short !

Paying good money for a "newsletter" ?  
Still not getting it straight !



Our job is to provide precise information on all FCC daily Radio Broadcast text, notices and releases.  
You will have the right information at the right time all of the time !

Each week you will receive . . .

<p><i>Proposed Rules (NPRM)</i></p> <p><i>Rule Changes (ORDERS)</i></p> <p><i>Public Notices and News Releases</i></p> <p><i>Station Call Assignment and Changes</i></p> <p><i>AM-FM-STL-RPU Applications and CP's</i></p>	<p><i>AM-FM-STL-RPU Assignments and Changes</i></p> <p><i>AM and FM Allocations - Cutoff Dates - Etc.</i></p> <p><i>Station Transfers and Ownership Changes</i></p> <p><i>Docket 80-90 Information and Windows</i></p> <p><i>Translator Information</i></p>
--	---

FCC rule changes DO affect you !  
The FCC requires you to . . .  
Implement rule changes at your station.

Don't Wait !  
Changes are happening daily.

Rochester Radio Report - First Class Mail - Every Week

Mail to: Rochester Radio  
511 18th Street S.E.  
Rochester, Mn. 55904  
1-507-280-9568

\$19.50 for one month     \$199.00 for one year (get 11 weeks free)  
 \$58.50 for three months     Bill me

Name \_\_\_\_\_ Phone \_\_\_\_\_

Address \_\_\_\_\_

City \_\_\_\_\_ State \_\_\_\_\_ Zip \_\_\_\_\_

## "IT CAN'T BE DONE"

Make that proposal to twenty good engineers and you'll get 20 good reasons why it can't be done. My reply is, it can be and has been done. I have developed a simple inexpensive method of transmitting full-fidelity FM with all the important characteristics of FM in the medium-wave band and receiving it on a current model AM/FM receiver with simple inexpensive modifications.

No, I'm not going to describe the design in this article. The reason is simple, I've found a way and there may be other ways - even better. I'd like to answer enough of the obvious objections to encourage others to put their creative efforts into their own distinctive solution to the basic problem.

For example: "You can't modulate a 1000 kHz carrier with a 50 Hz to 15 kHz audio signal and hold the bandwidth within the present FCC specifications." Reply: Early FM transmitters employed very low frequency phase-modulated oscillators. Gates Serrasoid Exciter started out with crystal oscillator around 100 kHz, modulated by 50 Hz to 15 kHz audio with a frequency swing of about 87 Hz. Remember, the total spectrum bandwidth of an FM signal depends on the modulation index. And the modulation index at 15 kHz with an 87 Hz maximum deviation is less than 0.006. Get out your Bessel function tables and check it out.

## CAPTURE RATIO IMPORTANT

Next: "The capture ratio of an FM receiver improves with the modulation index. You need a modulation index of at least 5.0 to achieve normal FM broadcast quality." Reply: Remember, the capture ratio in an FM receiver depends on the modulation index of the I.F. signal at the FM demodulator, not what is received at the antenna.

Also: "If I switch over to FM, what do I do for revenue until the FM receivers are in the hands of listeners." Reply: Just what you have been doing. You see, your transmitter can handle both AM and FM simultaneously. That's how Motorola's C-QUAM works. L+R is on AM and the L-R signal is transmitted by phase modulation, a form of frequency modulation.

But enough of the technical discussion. Please give me the benefit of the doubt that it can be, and has been, done. Whether it is my model or someone else's, nothing will have been accomplished unless we find ways to implement the change. Believe me, the technical solution is the small part of the problem. Look at AM Stereo. We've waited at least 5 years on it and are still far from universal acceptance.

## DIRECTIONAL ARRAYS ELIMINATED

The people who have the most to gain by the success of NFR are the AM broadcasters. Just think how wonderful it would be if your transmitter had FM's advantages. No summertime static, full fidelity audio, no monkey chatter in the early afternoon. Probably 75% of the directional antenna arrays could be reduced to a single tower non-directional system. Much improved night-time coverage. Full-time operation for most of the day-timers, ect.

The FCC reports 4,908 AM licenses and 170 CPs are presently in effect. That's a total of 5078 authorized stations. 262 AM stations are off the air for various reasons. That leaves 4796 active AMs.

I have neither the dollars nor the years left to launch NFR. A lot of work remains. We need engineers to work on development, a committee of top

level engineers to prepare final operating specifications. Another committee would be required to handle the legal/lobbying function. Then there would be a coordinating committee to handle relations with receiver and transmitter manufacturers

## GRASS ROOTS SUPPORT

There doesn't appear to be an association in existence that could or would give this project the all out and undivided attention it requires for prompt development. That support must come primarily from AM broadcasters, with some very important assistance from equipment manufacturers.

Right now all we need is an indication of your interest. A brief letter to that effect will suffice. It will be even more helpful if you would give us your suggestions and/or questions. Be sure to identify yourself and your organization.

Mail to:

Noise Free Radio  
P.O. Box 8086  
Lakeland, FL 33802-8086

Rochester Radio Guide has been kind enough to provide space for this essay, and will provide future space if your interest is aroused. If you would like to talk about it, my phone number is (813) 682-2270. If I'm not available when you call, leave a message on my answering machine. You can talk up to three minutes. Thanks.

George W. Yazell, P.E. (Retired)

(I find this proposal very interesting. I'll stick my neck out and say that AM will never sound as good as FM, as things stand - Editor)

## Introducing The most innovative STLs on the market.



### PCL 6000 Series STLs

- Frequency agility
- Switchable monaural or composite operation
- 100 to 500 kHz channel spacing for receiver IF bandwidth
- Built-in receiver transfer circuitry
- Comprehensive front-panel metering
- Dual conversion 6020 Receiver
- Triple conversion 6030 Receiver

**Moseley**

111 Castilian Drive  
Santa Barbara, CA 93117  
(805) 968-9621 FAX: (805) 685-9638

## CLEANING & INSPECTING YOUR XMTR.

Dana Myers Senior Field Service Engineer  
Harris Broadcast Corporation

The old expression that an ounce of prevention is worth a pound of cure is especially true when it comes to transmitter maintenance. A good preventative maintenance program should include periodic inspection and cleaning of the equipment.

### DUST REMOVAL

A vacuum cleaner is preferred for dust removal over use of compressed air, since compressed air will simply blow the dirt into the air and let it fall on something else. Meter cases should be cleaned with Glass-Wax or another non-static cleaner.

A paint brush may be used to dislodge dust from delicate circuit boards. Avoid using a nylon bristle brush with a plastic handle, since the static charge may damage C-MOS or other static-sensitive components. Instead we recommend a natural bristle brush with wooden handle and metal binding.

### HIGH VOLTAGE WIRES & INSULATORS

High voltage wires and insulators must be cleaned with de-natured alcohol or another cleaner, capable of removing dirt without leaving any residue.

### AIR FILTERS AND BLOWERS

Air filters should be replaced or cleaned as necessary to provide adequate air flow to the equipment. If your station is using a single transmitter in critical service, a second set of washable filters on hand will save time by enabling you to quickly switch to the clean filters and wash the dirty ones later.

Blowers should be inspected to ensure that the curved fins are not filled with any debris that would reduce air flow. Motor windings may collect a layer of dirt which would interfere with the cooling of the motor itself.

The fins of the high-power tubes also must be cleared of any obstructions which may have gotten past the air filters.

Monitoring the blower motor current on a routine basis is a good indication of the CFM of air flow. The work or pounds of air moved is a close function of blower current. If the current goes down, then one can assume the blower is doing less work and moving less air.

Bearings should be lubricated and checked for excessive noise.

### SILVER-PLATED CAVITY PARTS

Silver-plated cavity parts should be inspected for color change - which can be a sign of over-heating and may require the disassembly of the cavity to check for obstructed air passages or loose connections.

A color change in silver-plated parts also can result as a natural reaction of silver to chemicals in the atmosphere. When there is a question of possible overheating, the part should be cleaned with a chemical silver cleaner such as Tarnex. If it cleans to a silver color, it is normal. If the cleaned part is blackened or exhibits blue or purple-colored areas, the over-heating is suspect. As in any chemical reaction, higher temperatures will cause the silver to react to chemicals in the air at a faster rate.

## The Complete RF Exposure Measurement System from Holaday Industries

### Measure Both E and H Fields

ANSI RF exposure standard requires measurement of both the electric and magnetic field.

### Automatic Self-zero

Completely automatic self-zeroing eliminates drift, improves accuracy of readings.

### Recognized by Federal Agencies

Evaluated and used by NIOSH, OSHA, EPA and CDRH, as well as state, local health departments and consulting engineers.

### NBS Probe Design

Isotropic probe design originated by National Bureau of Standards.

### Displays Time Average Reading

Real-Time display of the current six minute average relates directly to the ANSI RF exposure standard. Also calculates average of user-selected test intervals. This feature is also useful for doing spatial averaging by programming appropriately timed test intervals and using constant probe velocity over a prescribed area.

Exclusive from Holaday Industries, Inc.



Model HI 5000SX

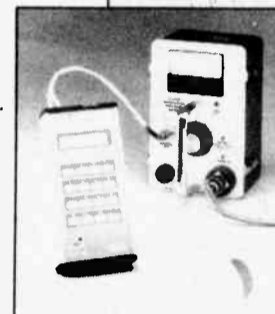

For more information, please call or write:

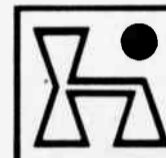

HOLADAY INDUSTRIES, INC.

14825 Martin Drive  
Eden Prairie, MN 55344  
Telephone: (612) 934-4920  
Telex: 29-0922 FAX: (612) 934-3604

## Blank Audio Cassettes at Great Prices!

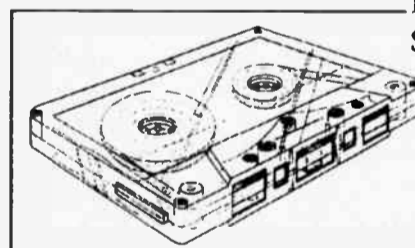

BASF Pure Chrome  
Shape Precision see-thru shell

as low as

C-90	\$1.06 ea.
C-60	\$ .75 ea.
C-30	\$ .55 ea.

Custom Lengths available to fit your needs!

AGFA PE649/949 Normal Bias  
Michelex German made shells

as low as:

C-90	\$.99 ea.
C-60	\$.55 ea.
C-30	\$.43 ea.



PHONE: (507) 288-7711

Tom Jones Recording Studios  
220 South Broadway  
Rochester, Minnesota 55904

Set-screws in the gear and chain drive tuning mechanisms should be checked for tightness. Black silver oxide is a good conductor and need not be removed.

Be sure to flush the parts after cleaning to remove any residue! Scotch-Brite is a good non-metallic cleaning pad for silver plated parts. Remember, you do not want to remove the plating while cleaning these parts!

#### HIGH CURRENT WIRES

High current wires may move during turn-on surges. They can suffer abrasions which eventually may cause an arc if the wires are not properly dressed away from any sharp edges. Additionally, wiring on terminal boards may loosen through thermal cycling and vibration.

All connections must be checked to ensure they remain tight. If wires do need to be replaced, it is important to select the correct gauge, voltage rating and temperature rating when choosing the replacement.

#### EDGE CONNECTORS

Edge connectors on printed circuit boards should be cleaned with Cramolin or a similar cleaner. A small amount of this cleaner is applied to the edge of the connector and then removed with a lint free cloth. Do not use pencil erasers since this will remove the gold or silver plating from the edge of the traces and could degrade the connection or create an intermittent later, as the sulfur in the eraser causes chemical reaction to the edge connector material.

#### BACK-UP SYSTEM

Any back-up system or emergency mode of operation should be checked periodically. Sometimes, relay contacts only need a little exercise to keep their contacts polished and in working order.

#### TRANSMITTER SITE

Transmitter site cleaning should also include building inspection for such things as leaks in the roof or insects and small animals that can play havoc by wandering into unwanted areas.

Intake blowers with filters capable of creating positive pressure in the room can minimize the need for cleaning by keeping much of the dust out.

#### MAINTAINING RECORDS

A careful log must be maintained for future reference. A log should include a description of what was done, when it was done, and the name of the person who performed the work.

When people ask, "How often must I clean the transmitter?", the only answer is, "How often does it need cleaning?" Such seasonal events as harvesting, severe weather or construction projects can necessitate special action, but usually a pattern emerges that allows maintenance to be scheduled on a somewhat regular basis.

A complete set of meter readings taken when the equipment is working properly and updated weekly or monthly will greatly assist the engineer when trying to diagnose a problem.

Create a maintenance program spreading weekly, monthly, quarterly, bi-annual and annual tasks evenly throughout the year. By choosing when to do what needs to be done and not waiting until any task is so urgently needed that it must be completed to keep the equipment operating, you can win the war against dirt and stay on the air.

## ACCURATE SOUND CORP

Studio Condenser Microphone Model CR-3A

*For today's demanding digital recording needs:  
studio quality at a reasonable price...  
only \$795.00 plus \$5.00 shipping and handling.*

Try it for 10 days, you'll like it! If not, just return it.

#### Features Include:

- -10 dB pad switch
- Cardioid polar pattern
- High pass filter switch
- Classic European styling
- 3-pin "Cannon" type connector
- Gold coated polyester membrane

#### All accessories Included:

Fixed mount            Operator manuals  
Suspension mount    Calibration tape  
Foam windscreen     Carrying case

#### Optional: @ \$179.00

DJ-601 Power Supply (good for two microphones)  
Microphone Cables (5m, 10m, 20m)



1/2 Actual Size



Accurate Sound Corporation  
3515-A Edison Way  
Menlo Park, CA 94025  
(415) 365-2843 Telex: 34 8327

## PROGRAM ABILITY

### Programmable Digital Remote Control.

What others promise, Hallikainen & Friends delivers to your exact specs with the DRC190. With its extended BASIC language, the DRC190 can control, alarm, display and log measured and calculated system parameters. Typical installations also generate a daily report showing the minimum, maximum and average of each parameter, simplifying oversight of the system. For true flexibility of user control over evolving equipment demands, get with the program, get the DRC190.



## HALLIKAINEN & FRIENDS

141 SUBURBAN E4 805 / 541-0200  
SAN LUIS OBISPO, CALIFORNIA 93401-7590 USA

## WHEN 115 VOLTS IS NOT

Steve Sandlin SBE Chapter No. 99 Bryan, Texas

There are times when what you see is not what you get. I was at my AM transmitter site - a 5 kW directional - when the transmitter went off and the generator cranked. I was a bit suprised because the lights in the building never went out.

I checked the status panel and one leg of the three-phase power showed out. I didn't think much about it, but after an hour or so with the generator running (this, all on a sunny spring afternoon), I called the power company. They had no reports of trouble in the area, but they would send a truck.

The possibility of a malfunction in the generator control circuitry was looking very real, so I got out my Simpson 260 VOM and checked the power line. The high leg of the 3-phase looked good and the low legs showed 115 VAC to ground. About the time I was measuring the first leg we had a transmitter overload; the line voltage dropped to zero on the Simpson. As the transmitter came back on, the line voltage returned to normal.

I was really puzzled. To do some more checking, I turned the transmitter off and the line voltage disappeared from that leg. Now I didn't trust my meter, so I got light bulb in a test socket. The lamp did not light on the leg that was going on and off with the transmitter. It took more head scratching, but I finally realized that the Simpson was rectifying the RF and it happened that the reading on the meter was close to 115 VAC.

I guess that shows you can't blindly follow your test gear. What caused the power failure? The splice at the building weather-head had come disconnected from incoming power.

## NORTHERN MAGNETICS

CERTIFIED TAPE HEAD SERVICES

Northern Magnetics is an industry leader in the supply and service of tape heads and tape head products.

P.O. Box 16409  
Minneapolis, MN 55416

Phone: (612) 333-3071  
Telex: 1561238 MPS UT  
FAA Repair Station # C14-57

## ADVANCED BROADCAST CONSULTANTS

JOSEPH S. SHERMAN

IHOR "SLIM" SULYMA

APPLICATIONS & FIELD SERVICES

204-B CROSS KEYS RD. ■ BERLIN, NEW JERSEY  
(609) 767-7070 08009

## The Dorrrough Console Model 700

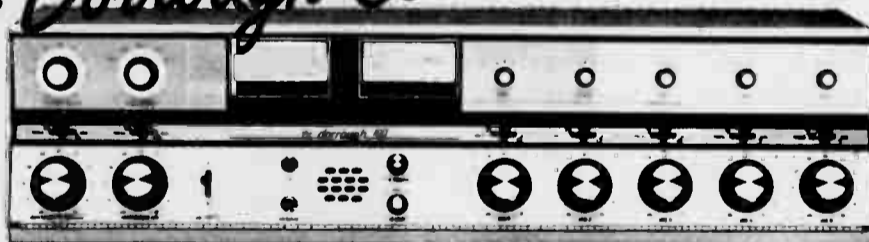

### Dual Channel Mono Console

#### Features

- Seven mixing positions
- Two microphone positions with switchable third
- Five line level positions with three inputs each
- Two balanced program busses
- Three external monitor inputs
- Fifteen watt monitor amplifier
- Shallco stepped attenuators
- Telephone type key switches
- Plug-in IC circuits
- Metal cabinet construction

Trim pots on all line inputs allow professional and consumer products to be preset to a desirable point of mixer rotation. Easy installation, as microphones are on XLR connectors, line inputs and outputs are barrier strip type, and located on a recessed rear panel.

A HIGH QUALITY CONSOLE AT A REASONABLE PRICE—\$2825.00

#### Block Diagram

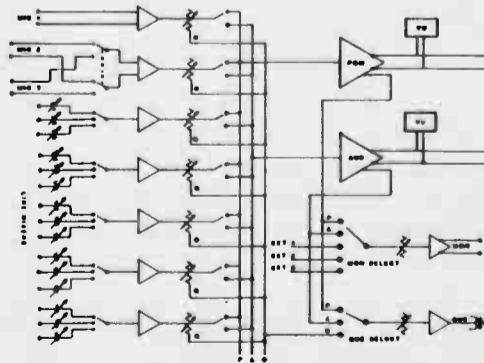

*the dorrrough 700*

Dorrrough Electronics • 5221 Collier Place • Woodland Hills, CA 91364 • (818) 999-1132