

SPEAKER BUILDER

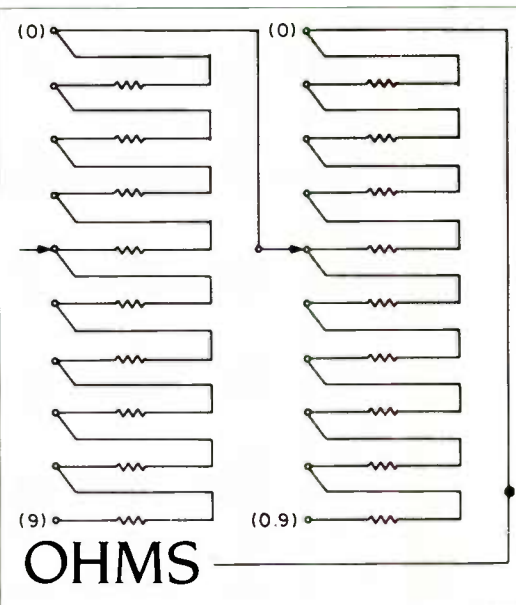

Good News

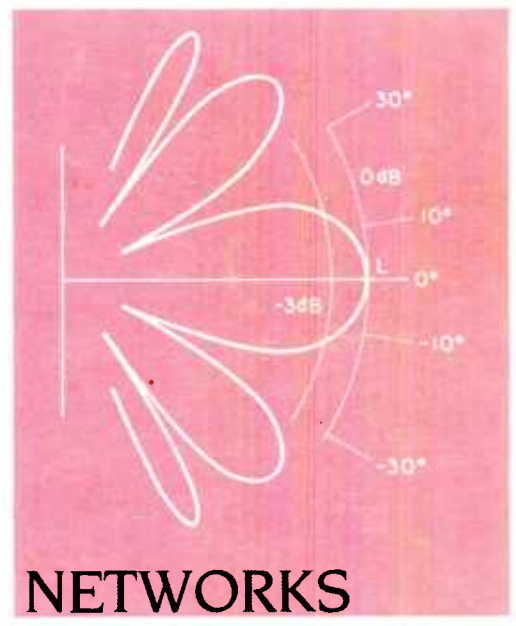
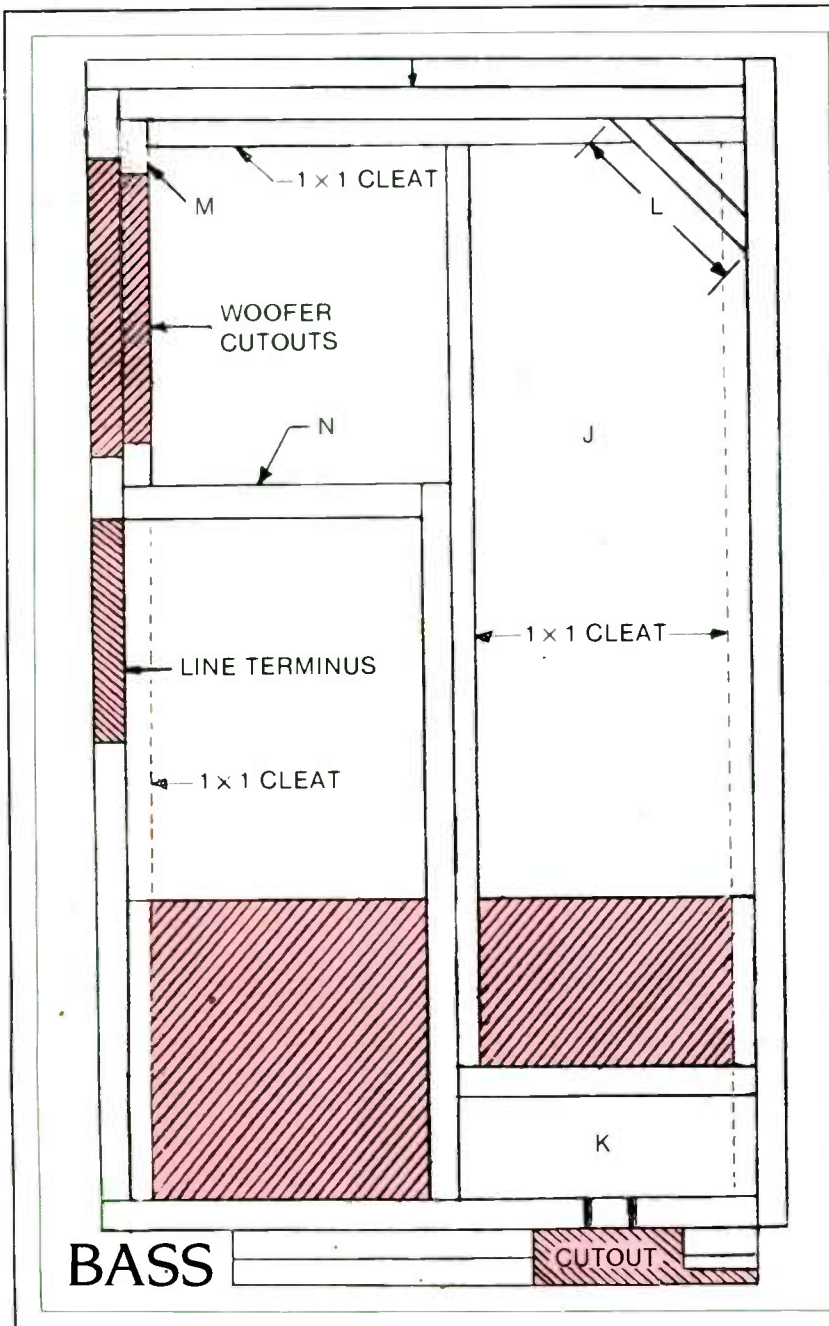

A wedge-shaped speaker system is **BANG & OLUFSEN's** latest entry in the home loudspeaker market.

The Red Line (RL) 60's low-distortion cabinet design, integrated with twin woofers and a dome tweeter, produces a neutral yet active sound suitable for all types of music. It is only 21 inches wide, 16 inches high and less than 7 inches deep, yet achieves high output capability without compromising sound quality. The interior surfaces of the RL 60's cabinet are curved, like the interior of a concert hall. Because conventional wood materials could not be used for the curved surfaces, B&O engineers used ABS, a thermoplastic material of high structural integrity. Compared to conventional designs, this design reduces distortion-producing cabinet sound radiation by 10dB.

The RL 60 has a sensitivity of 93dB and

needs only 8W of amplifier power to produce a sound pressure of 102dB, equivalent to very loud classical music. With additional power input, the speakers can produce up to 115dB of sound pressure. The system handles a continuous load of 60W and a peak load of 90W at 8 ohms. To handle high-quality digital source materials, the RL 60 provides a frequency response of 45Hz to 20kHz (+4, -8dB). Its dual 5-inch woofers contain lengthened voice coils and special large magnets to improve sensitivity. Crossover is at 2,500Hz to a 1-inch dome tweeter.

The RL 60 speakers may be placed vertically or horizontally on the floor or attached to a wall with optional stationary or swivel-type brackets. For more information about the RL 60, contact Bang & Olufsen of America, 1150 Feehanville Drive, Mount Prospect, IL 60056.

FAST REPLY #FH535

The 250Ti four-way speaker system is the top of **JBL's** latest loudspeaker line. The system features the company's new 044Ti titanium dome tweeter, whose mass and stiffness translate into instantaneous response, added strength and precise control of resonances. This results in a high-frequency response that is flat to 27kHz and a smooth, neutral sound through the 3 to 20kHz range. The 250Ti also includes the Model 104H midrange, the first JBL driver constructed of polypropylene. Low-frequency reproduction is provided by 12 and 14-inch drivers made of a fiber and aquaplas cone laminate.

The 250Ti's asymmetrical pyramid enclosure, constructed of ¾-inch extra-high-density compressed wood and a teak veneer, is designed to be free-standing. Internally, connections are made with heavy-gauge cable, hard-wired for better current transfer and lower distortion. The unit also features bus-bar selection of mid and high-frequency levels. It crosses over at 400Hz, 1.4kHz and 5.2kHz and has a maximum recommended amplifier power of 400W/channel. Nominal impedance is 8 ohms, while sensitivity is 90dB at an SPL of 2.83V at 1 meter.

To find out more about the Ti Series, contact JBL, 8500 Balboa Blvd., PO Box 2200, Northridge, CA 91329.

FAST REPLY #FH366

The Sparkomatic ASK 3000 is a bi-amplified door-mount car stereo speaker set with 4-inch polypropylene woofers and 2-inch satellite tweeters. The tweeters are designed to be mounted independently for improved high-frequency reproduction. All components are housed in a resilient polymer material called Thermo TestTM and the complete speaker unit is enclosed in a Thermo Test cover, making it resistant to dust, dirt, moisture and temperature. Slide

tone controls are built into the housing. Audio output is 45W per pair and frequency response 80Hz to 20kHz.

The ASK 3000 may be combined with either the 3010 deck-mount or 3015 surface-mount set and the ASK 3030 sub-woofer to make a complete system. For information on the ASK 3000 and other ASK units, write to **SPARKOMATIC CORPORATION**, Milford, PA 18337.

FAST REPLY #FH781

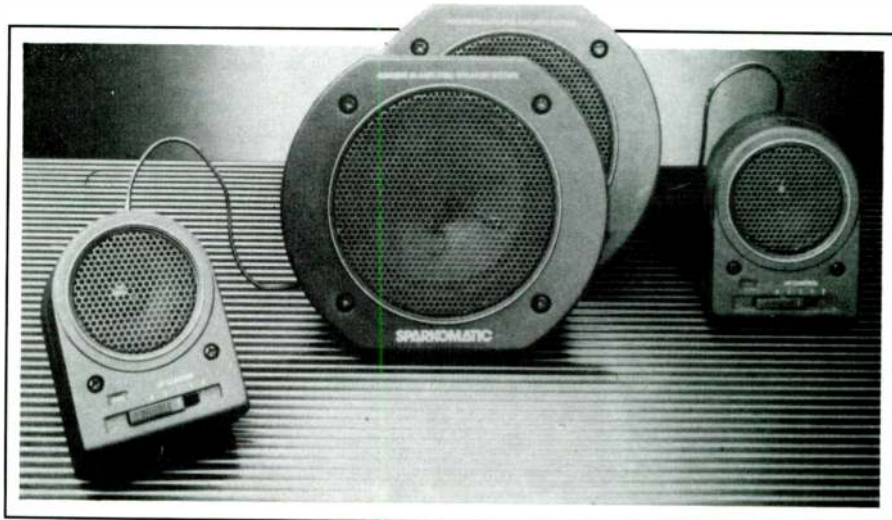



MADISOUND SPEAKER COMPONENTS
 8982 TABLE BLUFF ROAD
 BOX 4283
 MADISON, WISCONSIN 53711
 PHONE (608) 767-2673

We have in stock 800 pieces of the VIFA three inch dome midrange DM 75 MX-4. The manufacturer describes it as "a very high quality midrange soft dome. The diaphragm is formed from a special plastic with high internal damping, which ensures a very smooth frequency response. The driving system is very efficient due to an internal ferrite magnet. This allows a special venting leading to a very linear impedance characteristic." It is identical to the standard model DM 75 X, except that the flange is tinted gold. The units were made for a well known manufacturer who experienced financial difficulties and is no longer in production. While the supply lasts, you can purchase them for a cost significantly below wholesale prices. **Special Price: \$10.**

TECHNICAL DATA

Nominal impedance	8 ohms
Frequency range (DIN 45500)	350-5000 Hz
Free air resonance	300Hz
Operating power (DIN 45500)	3.2 W
Characteristic sensitivity (1W, 1m)	91 dB
Nominal power (DIN 45573) (fo: 500 Hz, 12 dB/oct)	80W
Force Factor (B1 product)	4.7 Tm
Voice coil diameter	75 mm
Voice coil height	3 mm
Air gap height	2 mm
Voice coil resistance	7.2 ohms
Effective diaphragm area	55 cm ²
Moving mass (incl. air)	3.6 g
Weight	0.65 kg



Aktieselskabet
 Videbæk Højtalerfabrik

**3" MIDRANGE DOME
 DM 75 MX-4**

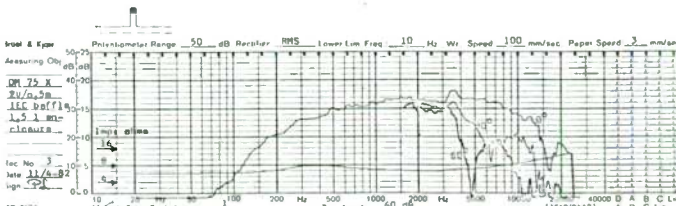
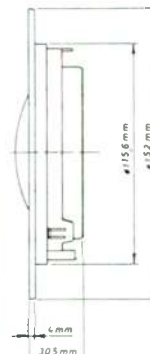

TANNOY has introduced five new speaker systems employing the company's Dual Concentric "two-in-one" drivers. Called the "Surrey" series, the speakers are named after five towns in the English county of Surrey. The series consists of a compact model, two larger bookshelf units and two floor-standing systems with integral stands. The compact unit is notable for its 8-inch driver, Tannoy's first use of such a small Dual Concentric unit.

All the models are very efficient, measuring at least 90dB/W/m. This, combined with a high power-handling ability, enables them to produce realistic sound pressure levels and the full dynamic range of today's recorded media, particularly digital. The wood veneer cabinets are rigidly constructed and internally damped to minimize resonance and sound coloration.

Write to Tannoy, 97 Victoria St., N. Kitchener, Ontario N2H 5C1, Canada.

FAST REPLY #FH780

NEW POLYPROPYLENE CAPACITORS

We are pleased to announce that we now have in stock METALLIZED POLYPROPYLENE CAPACITORS of exceptional quality and excellent price. This type of dielectric has been characterized by Walter Jung and Richard Marsh as "outstanding" when compared with all other dielectrics in the areas of:

DISSIPATION FACTOR PERCENTAGE DIELECTRIC ABSORPTION PERCENTAGE STABILITY

FEATURES

- Low dissipation factor
- Low dielectric absorption factor
- High insulation resistance
- High frequency and temperature stability
- Good self healing characteristics of polypropylene dielectric
- High Current Capacity
- Excellent Overvoltage and Pulse handling capability
- Low self inductance
- Low equivalent series resistance
- Excellent stability
- Superior high frequency characteristics
- High Ionization level

TECHNICAL SPECIFICATIONS

- Dissipation factor @ 20 degrees C: Less than .01%.
- Dielectric absorption factor @ 20 degrees C: Less than .01%.
- Insulation resistance @ 20 degrees C: More than 100 K megohms/mfd
- Temperature range: - 25 degrees C to +85 degrees C.
- Dielectric: Polypropylene Film.
- Working Voltage: 250 VAC/400 VDC
- Test Voltage: 2.15 times rated voltage.
- Encapsulation: Aluminum Can, Epoxy Closing.
- Leads: Tinned pure copper multistrand insulated sleeves, radial, 4 inches.
- Capacitance tolerance: ± 10%: (grading to 1% available)
- Size examples: 2 mfd: .83" D, 1.9" L; 4 mfd: .98" D, 1.9" L; 8 mfd: .98" D, 2.6" L; 15 mfd: 1.4" D, 2.6" L; 25 mfd: 1.6" D, 2.6" L.

AUDIOPHILE Net prices:

1.0 mfd	\$1.85 each	6.0 mfd	\$3.05 each	15.0 mfd	\$5.30 each
2.0	2.05	7.0	3.25	20.0	6.80
3.0	2.15	8.0	3.50	25.0	7.55
4.0	2.50	10.0	4.20	Matched pairs or grading to 1%: add 10%.	
5.0	2.75	12.0	4.30		

FAST REPLY #FH43

FAST REPLY #FH20

POLYDAX - SEAS - PHILIPS PEERLESS - AUDAX AMPEREX - EV - MOTOROLA

- COMPLETE LINES IN STOCK
- DOME & RIBBON TWEETERS, DOME MIDRANGES, AND BEX-TRENE & POLYPROPYLENE DRIVERS
- KITS AVAILABLE
- EXTENSIVE LIBRARY OF PLANS
- FREE TECHNICAL AND DESIGN ASSISTANCE

Audio Lab

5269 Buford Highway
Atlanta, Georgia 30340

404/455-0572

800/554-9248

FAST REPLY #FH7

SPEAKER BUILDER

MAGAZINE

EDWARD T. DELL, JR. *Editor/Publisher*
Contributing Editors

ROBERT M. BULLOCK BRUCE C. EDGAR
G. R. KOONCE NELSON PASS

BARBARA JATKOLA *Managing Editor*

KAREN HEBERT *Office Manager*

NANCY NUTTER *Circulation Director*

BETTE PAGE *Layout Design*

RUTH S. WILDER *Production Associate*

TECHART ASSOCIATES *Drawings*

Advertising Representative

Chris Smith—Inter Marketing Associates, Inc.
12 West St., Suite 20

Keene, NH 03431 Phone: (603) 352-1725

Editorial and Circulation Offices

Post Office Box 494

Peterborough, New Hampshire 03458 U.S.A.
Speaker Builder is published four times a year by Edward T. Dell, Jr., P.O. Box 494, Peterborough, NH 03458. Copyright © 1985 by Edward T. Dell, Jr. All rights reserved. No part of this publication may be reprinted or otherwise reproduced without written permission of the publisher.

All subscriptions are for the whole year. Each

subscription begins with the first issue of the year and ends with the last issue of the year. A sample issue costs \$3 in the U.S., \$4.00 in Canada.

Subscription rates in the United States and possessions: one year (four issues) \$12, two years (eight issues) \$20.

To subscribe, renew or change address in all areas outside the UK write to Circulation Department, P.O. Box 494, Peterborough, NH 03458. For subscriptions, renewals or changes of address in the UK write to J. L. Lovegrove, Leazings, Leafield, Oxford, OX8 5PG, England. For gift subscriptions please include gift recipient's name and your own, with remittance. Gift card will be sent.

A Note To Contributors

We welcome contributions for possible publication in the form of manuscripts, photographs or drawings, and will be glad to consider them for publication. Please enclose a stamped, addressed return envelope with each submission. While we cannot accept responsibility for loss or damage, all material will be handled with care while in our possession. Receipt of all materials is acknowledged by postcard. Payment is on publication.

Speaker Builder Magazine (US ISSN 0199-7920) is published four times a year (Feb., May, Aug. and Nov.) at \$12 per year; \$20 for two years, by Edward T. Dell, Jr. at 5 Old Jaffrey Road, Peterborough, NH 03458 U.S.A. Second class postage paid at Peterborough, NH.
POSTMASTER: If undeliverable send PS form 3579 to P.O. Box 494, Peterborough, NH 03458.

About This Issue

Three of this issue's four feature article authors are teachers by profession. **Craig Cushing** (p. 6, "A Compact Transmission-Line Subwoofer") teaches English and much else at the Technical Institute in Concord, New Hampshire. His project, revised several times to please the editor, was inspired by Gary Galo's two-part transmission-line series in Issues 1 and 2/82.

Contributing Editor **Bob Bullock** teaches in the applied math department at Miami University in Ohio. His landmark series on passive crossover networks begins on page 13. He also reports on an active crossover kit, the Shadow Engineering MKIVF, on page 36.

Max Knittel teaches in the physics and astronomy department at the University of Western Washington in Bellingham, Washington, and pursues his avocation with great gusto. His article on driver levels (p. 24) offers a short BASIC program for calculations and a practical resistor bank as well. Doubtless no speaker builder will want to leave ohm without it.

Bob White works in the high-tech industry in Dallas, Texas. Since he and Bob Bullock teamed up in SB 1/84 to produce BOXRESPONSE, White has used the program extensively and finds some surprises (p. 28).

Our TT&T submission (p. 33) is a long piece by **Steve Ball** on a quasi-Zobel network he devised from a modified Heath IB-5281 RCL bridge. Mr. Ball's modification details are clear and to the point.

Next time, you'll be seeing a curved line array from **Scott Ellis**, a small powered bass cube from **Philip Todd** and **Bob Bullock's** second article in his passive crossover series. Mr. Bullock will concentrate on new two-way, formula-based designs in this second installment.

SPEAKER BUILDER

VOLUME 6 NUMBER 1

FEBRUARY 1985

FEATURES

6 A COMPACT
TRANSMISSION-LINE SUBWOOFER
BY CRAIG W. CUSHING

13 PASSIVE CROSSOVER NETWORKS:
PART I
BY ROBERT M. BULLOCK III

24 MICROCOMPUTER-AIDED
DRIVER ATTENUATION
BY MAX R. KNITTEL

28 REALIZING THE POTENTIAL
OF BOXRESPONSE
BY BOB WHITE

DEPARTMENTS

- 2 GOOD NEWS
- 33 TOOLS, TIPS & TECHNIQUES
- 36 KIT REPORT BY ROBERT M. BULLOCK III
- 39 MAILBOX
- 44 CLASSIFIED
- 46 AD INDEX

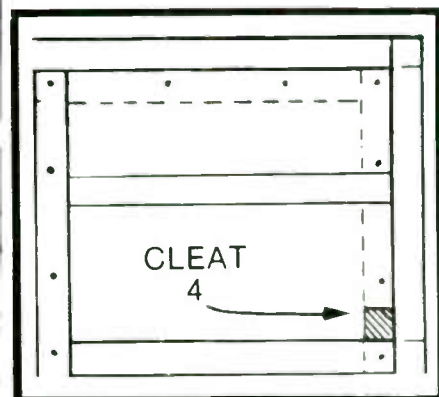
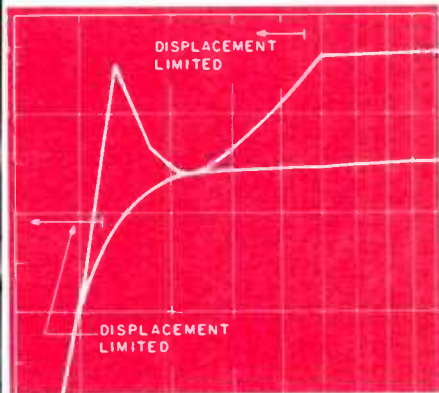

A COMPACT TRANSMISSION-LINE SUBWOOFER

BY CRAIG W. CUSHING



The LFT Mk-IV transmission-line subwoofer is made of $\frac{3}{4}$ -inch particle board and has a Speakerlab W848P driver. The grilles are covered with black cloth and mounted with Velcro.

"Transmission-line designs also make superb subwoofer systems..." Hmmm. This intriguing suggestion in Gary Galo's demystifying article on transmission-line (TL) loudspeaker theory (*SB* 1/82, p. 7; 2/82, p. 24) fascinated me. Early in the article, Mr. Galo speaks of the "boxy colorations" caused by conventional enclosures. As I reattuned my ears to a problem in the bass of my common-woofer system, the boxiness became clear. "Why not experiment?" I thought. After all, I already had a Speakerlab W848P woofer (originally part of my car stereo system), a sheet of $\frac{3}{4}$ -inch particle board and an itch to build my fourth subwoofer. Why not give it a try?

WHAT DID I NEED? Two of my earlier subwoofer systems were an infinite-baffle model with a 12-inch woofer and a huge fourth-order box with a 15-inch driver. My most recent project was a carefully designed and built acoustic suspension "lowboy" subwoofer using a Speakerlab W1208S 12-inch driver and having a system *Q* of 0.9. From the standpoint of compactness and performance, this was the most satisfying system.

Each of these woofer systems, however, left something to be desired—openness and/or true linearity—even though bass extension with the latter two was fine. Additionally, space restrictions in my listening room dictated a bass reproducer that would not occupy more than 4 square feet of floor space or be more than 3 feet tall. To meet these requirements, I conceived the LFT Mk-IV (Low-Frequency Transducer, Fourth Try), an 18 $\frac{1}{4}$ -inch-square column, 32 $\frac{1}{2}$ inches tall, which despite its dimensions, is a 9 $\frac{1}{2}$ -foot, one-quarter wavelength, 30Hz line.

This TL subwoofer system is compact, unlike Mr. Galo's tall, room-dominating tower designs; has a rigid, nonresonant enclosure; is relatively inexpensive; is easy to assemble; and offers an exceptionally linear, powerful, deep uncolored bass performance I did not believe was possible. It deviates from the original Galo postulates on one point: the Speakerlab driver uses a foam surround. I think the driver's assets—huge motor, high efficiency and power-handling capability, polypropylene cone and 23Hz resonant frequency (broken in)—outweigh the surround "problem," and Speakerlab commends its use in TL systems. In an update letter to *SB* (4/82, p. 38), Mr. Galo conditionally recants his earlier position on foam woofer surrounds by praising the polypropylene-cone/foam-surround combination.

Other drivers, some of which cost considerably less than my selection, are also suitable. I tried two drivers that are the sonic equivalent of the Speakerlab—the Audax HD20B25H-4C12 and the Sherman Research 20.3W8. Neither will handle as much power as the W848P. Although I have not tested them, other potentially successful drivers for the LFT Mk-IV con-

figuration include the Dalesford D100/200, the Focal 8P 501, the KEF B200 SP1039 and the Peerless TD205R. The "sleeper" for budget-conscious builders might be the little sibling of the Galo-recommended 10-inch Madisound woofer—the Madisound 8154. This 8-inch driver has a polypropylene cone, a four-layer voice coil, low *Q*, a low resonant frequency and a low price (less than \$23 at this writing).

STUFFING CONSIDERATIONS.

When I built the first version of the LFT Mk-IV, I stuffed it with three pounds of Dacron polyester fluff packed tightly behind the woofer and progressively more loosely farther down the line. This is known as a constant-impedance format. I chose Dacron for its easy availability, low cost and reputation for not settling. The second version has a removable top, which allows ready access to the entire line, except the chamber below the woofer, which is accessible through the terminus opening. This accessibility encourages considerable experimentation with damping materials.

I have tried stuffing the line with Dacron fluff and long-fiber wool in variable and constant-impedance for-

mat and with varying amounts of both substances. Subjectively, my experiments confirm A.R. Bailey's objective results,^{1,2} which he obtained by impulse testing. Specifically, he found that long-fiber wool is the best available sound-absorbent stuffing material. (Two and one-quarter pounds of wool is roughly equal to three pounds of Dacron in absorbency and rear-wave time delay.) Roger Sanders suggested that stuffing the line in a constant-impedance mode would achieve the deepest possible bass, and my listening tests have confirmed that.

To summarize, these are the important stuffing considerations:

- The best damping (and the best sound) results from stuffing the LFT Mk-IV with 36 ounces of long-fiber wool.
- Good but acoustically less-efficient damping results from stuffing the LFT Mk-IV with 48 ounces of Dacron polyester fluff.
- With either material, greatest bass extension results from stuffing the line with as even a density of damping material as possible, then adding several compressed fistfuls of damping material to the area immediately behind the woofer. While

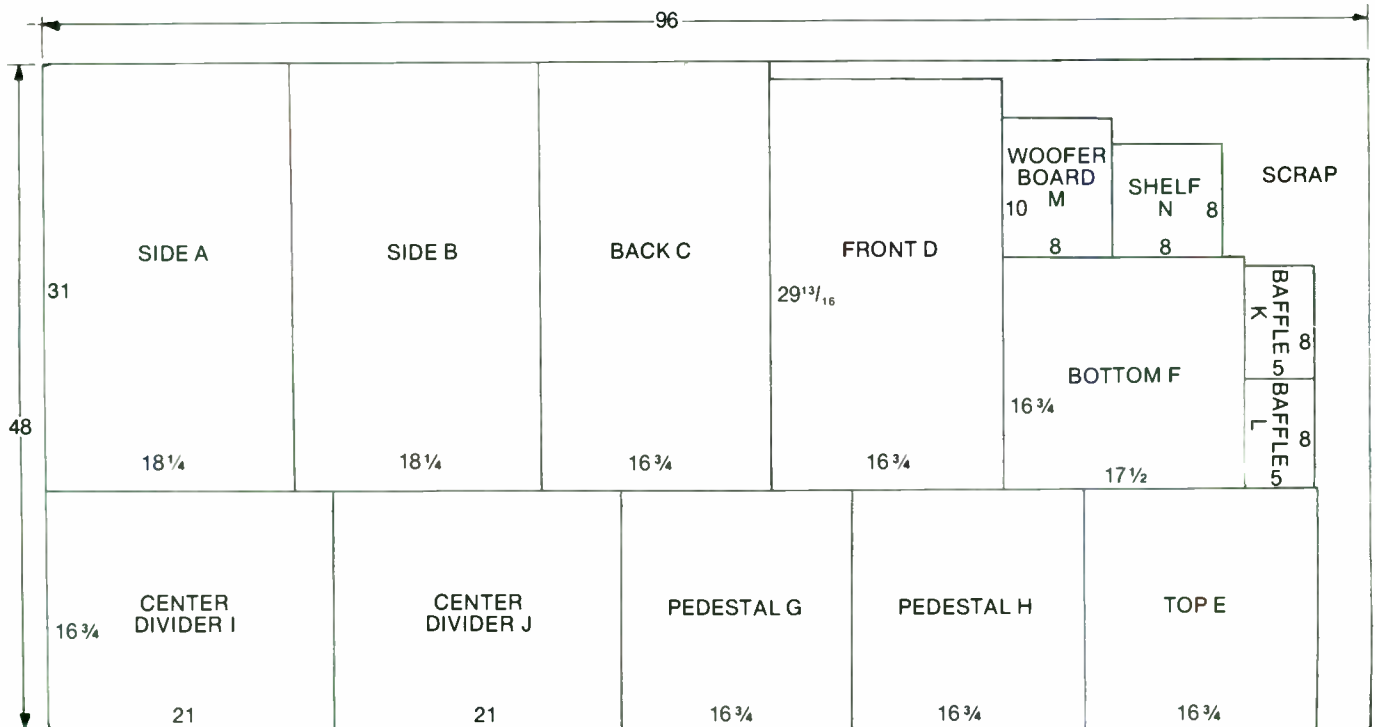

* ALL DIMENSIONS IN INCHES.

FIGURE 1: Cut all the pieces from one sheet of 8-foot by 4-foot by 3/4-inch cabinet-grade particle board.

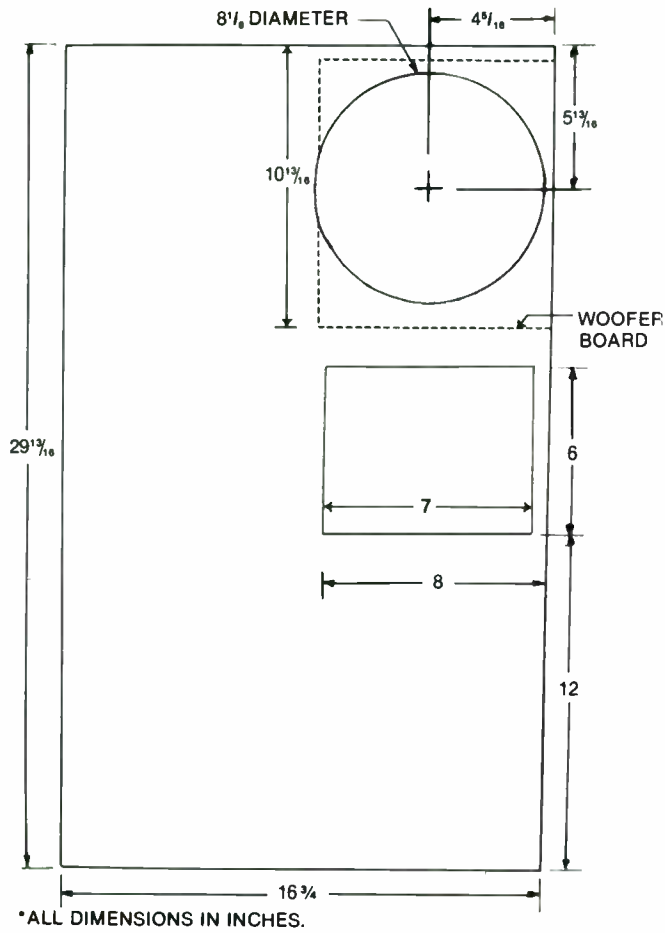

FIGURE 2: Front baffle panel (D).

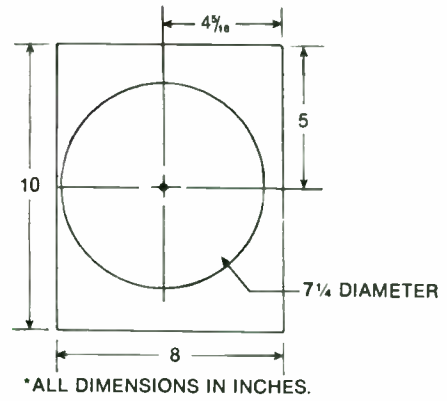

FIGURE 3: Woofer mounting board (M).

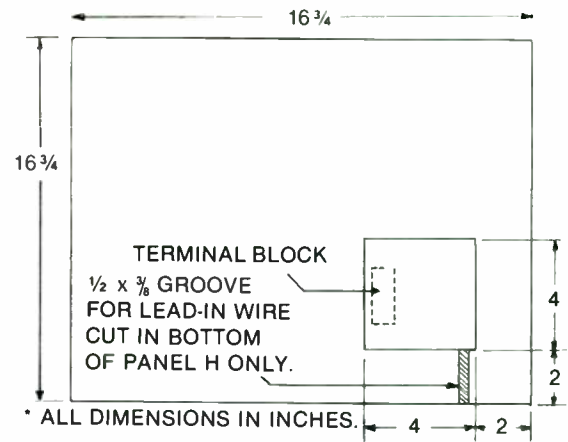

FIGURE 4: Pedestal, with cutout (G and H). Not to scale.

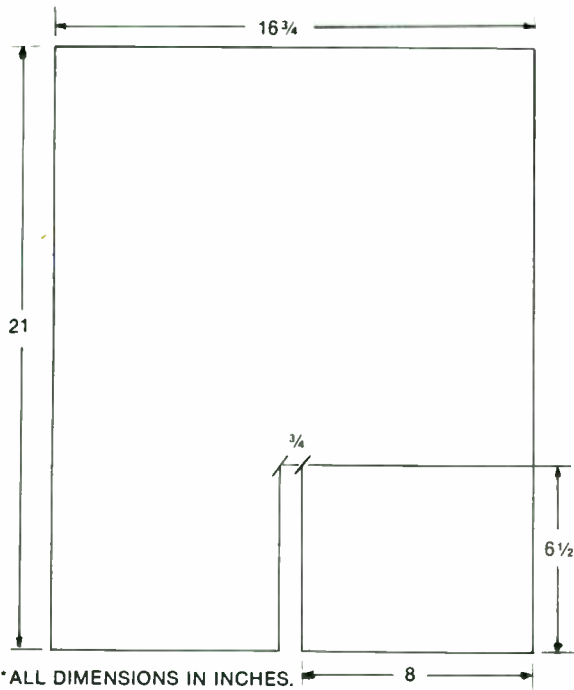

FIGURE 5: Front/rear center divider (J).

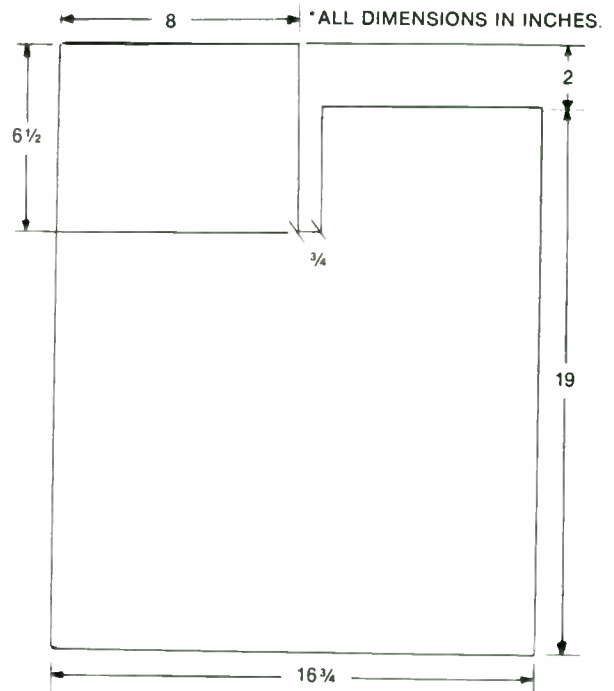

FIGURE 6: Left/right center divider (I).

this does not fulfill the Sanders ideal of constant impedance, it is an easy stuffing technique and is consistently repeatable. Variable stuffing (constant impedance) is not. Additionally, if you use less line stuffing toward the terminus, you might sacrifice some very deep bass.³ If you choose a driver other than the Speakerlab W848P, you will probably have to modify the amount of stuffing material to match that driver's specific characteristics. It should, however, be within a few ounces of the numbers given here.

The problem of stuffing a line properly, coupled with the need to minimize settling of the damping material, has vexed TL system builders for some years. The most clever and easiest answer I have found appeared in *SB 2/84* (p. 32). In his "Tools, Tips & Techniques" submission, Andreas Schubert suggests spreading the preferred damping substance evenly on net curtain material, which you cut to the appropriate size of each line chamber, then roll up to a round or oval cylinder and stitch loosely at the ends to facilitate handling.

The LFT Mk-IV has five chambers—one horizontal (behind the woofer) and four vertical (two short and two long). The woofer chamber requires 6½ ounces of wool (8½ ounces of Dacron), each long vertical chamber 9 ounces of wool (12 ounces of Dacron) and each short chamber 5¾ ounces of wool (7¾ ounces of Dacron). I will discuss the actual stuffing technique later in the article.

SIMPLE CONSTRUCTION. As noted earlier, the LFT Mk-IV is relatively simple to build. Butt joints are used throughout, and all parts may be cut from one sheet of 8-foot by 4-foot by ¾-inch particle board (Fig. 1). After cutting out the panels (or having your local lumberyard do it for you), cut the necessary openings in the front baffle for the driver and line terminus (Fig. 2), the baffle for the woofer mounting (Fig. 3), and the recess openings for the terminal connector (Fig. 4). You may eliminate this step if you elect to mount the terminal block on the rear panel of the cabinet. Make the indicated cutout on center divider I and cut the necessary 6½-by-¾-inch notches in center dividers I and J (Figs. 5 and 6), which form the internal baffling of the loudspeaker system.

Fasten the woofer mounting panel

(M) to the back of the front baffle (D) with #8 1¼-inch wood screws and glue along the dotted lines in Fig. 2. Next, affix the pedestal panels (G and H) together with glue and 1¼-inch screws, keeping the panels aligned. Cut a groove from the terminal cutout to the back of the pedestal to accommodate the lead-in wire (Fig. 4).

Using 1¼-inch screws, attach the 28¼-inch vertical cleats (1, 2 and 3) to the rear (C), left (A) and front (D) panels respectively (Figs. 7, 8 and 9). Finally, add the 25½-inch cleat (4) to side panel B.

Assembly from this point is with 2-inch #8 flat-head wood screws and glue, except for installing the top cleats, which require 1¼-inch screws. I spaced the screws 4 inches apart because I prefer tight construction. As Mr. Galo notes, a variable-speed electric drill with a flat-blade screwdriver

bit, used in tandem with a Stanley Screwmate to drill, counterbore and countersink screw holes, will make assembly much easier.

Start with the left side (A), attach the back (C) and bottom (F), then install the right side (B). Next, attach the left-right center divider (I), using plenty of glue on all mating surfaces. Install the front panel (D). Thoroughly glue the center notches of the two center dividers (I and J), then slide the front/rear center divider (J) into place and fasten. Install the shelf (N) and invert the cabinet. Add the completed pedestal, using lots of glue and 2-inch screws. Make sure the pedestal is centered on the bottom of the cabinet.

While the cabinet is inverted, drill two ⅜-inch holes for the 16-gauge (or larger) internal wiring in the bottom (F), then push sufficient wire through the holes from the inside of the box to

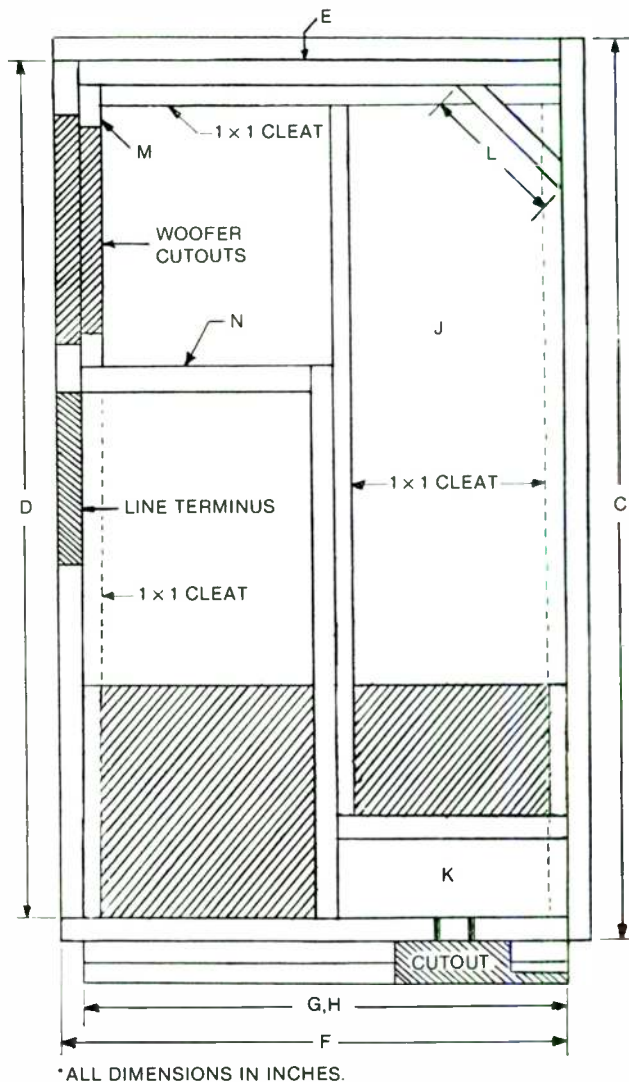

FIGURE 7: Side view of the cabinet with the left panel removed.

facilitate soldering the leads to the terminals on a Radio Shack spring-loaded connector. Attach the connector, caulking the wire-lead holes thoroughly before screwing the assembly into place. Run the wire out through the woofer opening and tape it temporarily to the front of the baffle so that it will not get lost in the shuffle.

After righting the assembly, install the lower angle baffle (K) and upper angle baffle (L). At this time, cut the horizontal top cleats to length and install them (Figs. 9 and 10). These cleats will support the removable top panel (E). Caulk all joints thoroughly to prevent any possible leakage between chambers and allow the caulking time to cure. Staple a 1-inch-thick layer of Radio Shack fiberglass to one side, the top of the shelf, and the right angle and back of the woofer chamber.

Put the top (E) into place temporarily, and drill, counterbore and counter-sink screw holes every 4 inches around the periphery and along the front/rear center divider. This will prepare it for later removal if necessary.

FINISHING TOUCHES. Stuffing the transmission lines is usually a worrisome and fussy task, but the Schubert method outlined earlier offers a reliable means of distributing damping material and easily changing the volume of that material. Although you will probably want to experiment, my experience with Schubert's method might be helpful.

The horizontal chamber behind the woofer is approximately 8 by 10 by 17 inches. Cut a piece of net curtain material 18 inches wide by 4 or 5 feet long, then weigh out the required amount of damping material as noted earlier. Spread the netting on a table or floor and evenly distribute a carefully fluffed layer of the stuffing along the full length of the netting. Now, beginning at one short end, *gently* roll the strip into a spiral shape. You might have to reroll it several times until you get the correct diameter. You are attempting to form a roll of stuffing that fits its chamber snugly, filling the entire cross-section. Avoid winding the roll too tightly and overcompressing the stuffing material.

With a needle and thread, loosely whip-switch the netting at either end and along its length where the netting meets. Measure each chamber in turn and repeat the process. If you use long-fiber wool as your stuffing mate-

rial, sprinkle it with mothproofing crystals or use moth spray before you roll the stuffing.

After the chambers are stuffed, install ¼-inch-square foam weather stripping on the top of the horizontal cleats, the front/rear center divider and the top of angle baffle L. Put the top in place and install the 1¼-inch screws, compressing the weather stripping evenly until the top is even with the top edge of the front panel and the three-sided well formed is level and equidistant from the top edges of the sides and back.

Fill imperfections in the completed cabinet with a wood filler, such as Plastic Wood, sand the assembly smooth and finish as desired. I used walnut-grain, matte-finish Formica on the front baffle, top edges and sides of my cabinet. (If you save some sawdust

and mix it with Duco cement, you will have a cheap version of Plastic Wood.—Ed.) I painted the back, base and top well area with several coats of flat black latex. A less-expensive method that I have used on other speakers is an "antiquing" kit, available from a number of suppliers in a wide range of colors.

I made the grilles in the photograph on p. 6 from ¾-inch scrap particle board, with a ⅜-inch, 45-degree chamfer on the outer edges. I covered them with black Radio Shack grille cloth and mounted them with Velcro. For the line-terminus mounting surfaces, I used ½-inch-square scrap stock, recessed ½ inch into the opening. The woofer grille mounts directly on the face edge of the driver frame. Although they are visually interesting, both grilles are easily removable for

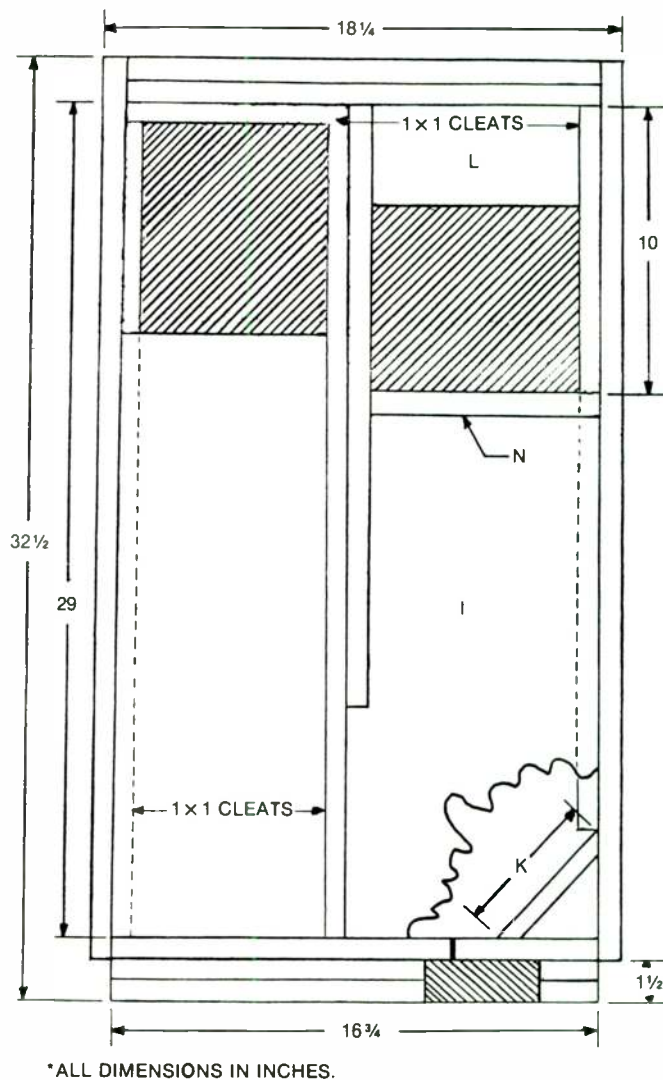

FIGURE 8: Front view of the cabinet with the front baffle removed.

serious listening. If you do not use a grille, apply black latex to the edges of the woofer opening and the line terminus. For a final touch, try a piece of $\frac{1}{8}$ or $\frac{1}{4}$ -inch smoked glass cut to fit the well at the top of the cabinet.

To minimize edge diffraction, cut a ring of scrap material to go between the woofer frame and the mounting board. In the case of the W848P woofer, a $\frac{3}{8}$ -inch-thick spacer ring is

necessary to mount the woofer flush with the cabinet face. Secure the ring with short wood screws and glue prior to mounting the woofer.

Lay the cabinet on its back, solder the speaker-wire leads to the woofer terminals (observing polarity), put the additional stuffing immediately behind the woofer, and mount the woofer with a $\frac{1}{4}$ -inch bead of GE silicone rubber glue. Fasten with machine

head screws and washers if you are skeptical about the "glue-only" method or if you want to try your new toy immediately. Otherwise, let the glue cure for 24 hours.

HOW DOES IT SOUND? My stereo system, while by no means "state of the art," offers fine performance. It is biamplified, with a Pioneer 100W/channel integrated amplifier to power

MATERIALS LIST

- (1) Speakerlab W848P 8Ω polypropylene woofer or equivalent (see text)
- (1) 8-by-4-foot sheet of $\frac{3}{4}$ -inch particle board, cabinet grade
- (90) 2-inch #8 flat-head wood screws
- (60) $1\frac{1}{4}$ -inch #8 flat-head wood screws
- (1) large bottle of Elmer's carpenter's glue or equivalent
- (1) small caulking tube of GE clear silicone rubber glue
- (1) caulking tube of latex caulking compound
- 2¼ pounds of long-fiber wool or 3 pounds of Dacron polyester fluff
- (1) package of Radio Shack speaker fiberglass #42-1092
- (1) Radio Shack terminal block #274-621 or equivalent
- (1) $\frac{1}{8}$ or $\frac{1}{4}$ -inch smoked glass top, $16\frac{1}{8}$ by $17\frac{1}{2}$ inches (optional)
- 16 linear feet of $\frac{3}{4}$ -by- $\frac{3}{4}$ -inch hard pine cleat material
- (1) small roll of $\frac{1}{4}$ -inch-square polyfoam insulating weather stripping
- 7 yards of loose-weave curtain material
- 4 feet 16-gauge (or larger) internal wiring

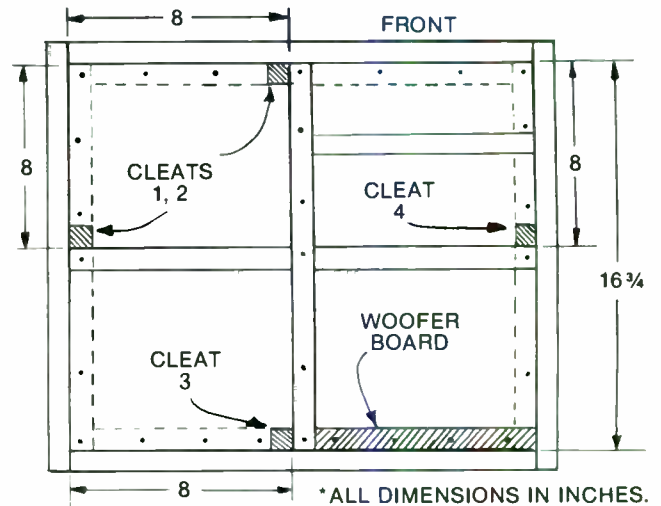

FIGURE 9: Vertical cleats (top view with the top removed). Cleats 1-3 are $\frac{1}{4}$ inch square and $28\frac{1}{4}$ inches long, while cleat 4 is $\frac{1}{4}$ inch square and $25\frac{1}{2}$ inches long. The dotted lines indicate the horizontal cleats for mounting the top. Not to scale.

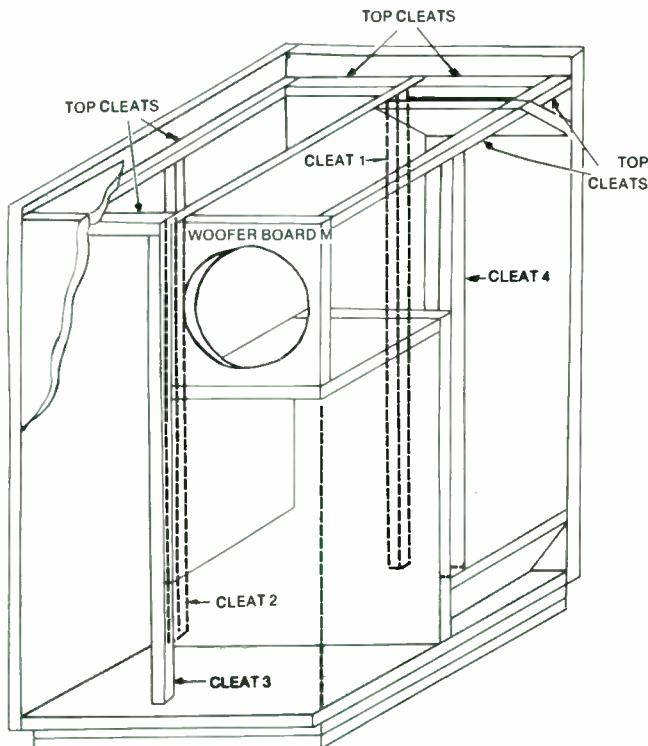

FIGURE 10: Cutaway showing the vertical and horizontal cleats.

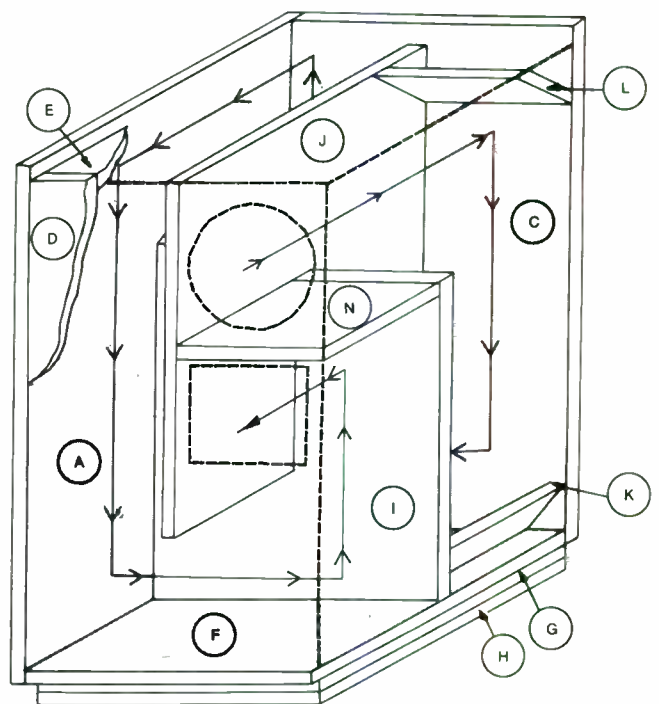

FIGURE 11: Cutaway showing the panels, with side B removed.

OC SOFTWARE BOXRESPONSE

Robert Bullock & Bob White

Model-based performance data for either closed box or vented box loudspeakers with or without a first or second order electrical high pass filter as an active equalizer.

The program disk also contains seven additional programs as follows:

Air Core: This program was written as a quick way of evaluating the resistance effects of different gauge wire on a given value inductor. The basis for the program is an article in *Speaker Builder* (1/83, pp. 13-14) by Max Knittel. The program asks for the inductor value in millihenries (mH) and the gauge wire to be used. (NOTE: only gauges 16 through 38.)

Series Notch: Developed to study the effects of notch filters in the schematics of some manufacturers. Enter the components of the network in whole numbers (i.e., 10 for 10 μ F and 1.5 for 1.5mH) and indicate whether you want one or two octaves on either side of resonance. Output is frequency, phase angle and dB loss.

Stabilizer I: Calculates the resistor-capacitor values needed to compensate for a known voice coil inductance and driver DC resistance.

Optimum Box: A quick program based on Thiele/Small to predict the proper vented box size, tuning and -3dB down point. It is only based on small signal parameters, therefore, it is only an estimate of the response at low power (i.e., limited excursion).

Response Function: Calculates the small signal response curve of a given box/driver combination after inputting the free-air resonance of the driver (f_s), the overall "Q" of the driver (Q_{TFS}), the equivalent volume of air equal to the suspension (V_{AS}), the box tuning frequency (f_B), and the box volume (V_B). Output is the frequency and relative output at that frequency.

L-Pad Program by Glenn Phillips: Appeared in *Speaker Builder* (2/83, pp. 20-22). It is useful for padding down a tweeter or midrange while still retaining the same load as the driver itself.

Vent Computation by Glenn Phillips: Calculates the needed vent length for 1, 2 or 4 ports of the same diameter. Input box volume in cubic feet and required tuning frequency (f_B), output is vent length and vent area for each case.

Medium: 5 1/4 SS/DD Disk. Price: \$25.00 postpaid USA (Canada add \$4.00; overseas add \$6.00) Air to other points on request.

Specify:

AppleSBK-E3A
Commodore 64-Disk.....SBK-E3CD
Commodore 64-Cass.....SBK-E3CC

OLD COLONY SOUND LAB

PO Box 243

Peterborough, NH 03458

(603) 924-6371 8-4 Mon.-Fri.

a pair of two-way TL systems using Philips fabric dome tweeters and Audax 5 1/4-inch Bextrene cone woofers. These satellites are slender, floor-standing columns based on the Galo TL-5 design, but with a bass cutoff of 40Hz when operated independently of the subwoofer. The subwoofer system is powered by 120W from a bridged Aiwa P50 power amp. Crossover is 100Hz via an active 18dB/octave Ace Audio subwoofer electronic crossover (a fine kit-based unit, easily built in several hours). My turntable is "old reliable," a Philips 212 on a Netronics sprung sub-base. The cartridge is a Shure V15 type IIIHE. A home-brewed outboard device provides infrasonic filtering with a 12dB/octave cut below 20Hz.

A second dedicated amplifier and an active electronic crossover provide what I consider to be the only reliable way to integrate a common subwoofer (or separate subwoofers) successfully into a stereo system. Passive crossovers that operate below 200Hz are difficult to design and build properly, especially without extensive test gear. In addition, the inductors are expensive to buy or build, and there is a limited change of design success in either case.

How does the LFT Mk-IV sound in the system outlined above? Organ recordings with deep fundamentals are reproduced with stunning sonority. Telarc's digitally recorded *Encores a la francaise* (Michael Murray playing the Aeolian-Skinner organ in Boston's Symphony Hall) demonstrates that the power of the 32Hz pipes is reproduced in full measure, but without the bass colorations and boxiness common in my earlier systems. Sharp bass transients are also handled

exceptionally well, although slight attenuation of power is necessary when you are playing the Telarc *1812 Overture* loudly. Otherwise, the cannon shots can mechanically bottom the woofer, the sole reminder that you are, indeed, using just one 8-inch driver. In sum, the bottom-end sound is exemplary—open, detailed and as powerful as you might wish.

Wired into your system, this subwoofer will provide honest deep-bass performance. Should you be one of those who abhors the "common-woofer" concept, simply build a pair of the LFT Mk-IVs. In either case, you will be most satisfied. ▶

ABOUT THE AUTHOR

Craig Cushing is chairman of the English/Social Science Department at New Hampshire Technical Institute in Concord, NH. Along with his supervisory duties, he teaches composition, a variety of literature courses, and technical and engineering communications.

REFERENCES

1. Bailey, A.R., "A Non-Resonant Loudspeaker Enclosure Design," *Wireless World*, October 1965.
2. Bailey, A.R., "The Transmission Line Loudspeaker Enclosure, A Re-Examination...," *Wireless World*, May 1972.
3. Jastak, J. Theodore, "Transmission Line Speaker," *TAA* 1/73.
4. Jastak, J. Theodore, "A Jolly Transmission Line Giant," *TAA* 4/73.
5. Ruether, David, "The Big Bass Box," *TAA* 2/78.
6. Sanders, Roger, "An Electrostatic Speaker System, Part III," *SB* 4/80.
7. Snyder, Pat, "Notes on Transmission Line Speaker Theory," *Speakerlab Inc.*
8. Webb, B.J., "A Proven Transmission Line Loudspeaker," *TAA* 1/75.
9. Weems, David B., *How to Design, Build and Test Complete Speaker Systems*, Tab Books, 1978.

SUPPLIERS

J. Ebbert
431 Old Eagle School Rd.
Strafford, PA 19087
(long-fiber wool)

Madisound Speaker Components
8982 Table Bluff Rd.
Box 4283
Madison, WI 53711
(Audax, Focal, KEF, Madisound and Peerless drivers)

Radio Shack Stores
(speaker terminals, wire, fiberglass, grille cloth, small components)

Speakerlab Inc.
735 N. Northlake Way
Seattle, WA 98103
(Speakerlab drivers)

SRC Audio
3238 Towerwood Dr.
Dallas, TX 73234
(Sherman Research drivers)

Universal Sound
22353 Ringling Blvd.
Sarasota, FL 33577
(Dalesford drivers)

PASSIVE CROSSOVER NETWORKS

BY ROBERT M. BULLOCK III
Contributing Editor

Finding the right crossover circuits and formulas is a tedious task. Consequently, speaker builders are usually restricted to using standard, ladder-circuit, formula-based passive crossover networks. More involved topologies and/or optimization beyond formula values require extensive test equipment and a computer to perform sophisticated trial-and-error procedures. Only commercial manufacturers can afford such an investment. It is, therefore, extremely important for us to have a thorough understanding of the standard crossover configurations and the means for providing the operating environment in which they can best do their job.

Over several years, I have accumulated circuit designs, formulas, performance information and some tips on crossover capabilities and limitations. In this article, I will talk about crossover networks that can be passively realized. Although "going active" improved my speakers' performance more than anything else I have done, all my active networks could have been passively realized. I have included active implementations and hope this information will encourage you to try one someday.

CONFIGURATIONS & FILTERS.

A two-way crossover network consists of a low-pass and a high-pass electrical filter connected in parallel, as in Fig. 1. For multiple-channel crossovers, you can add bandpass filters in the obvious way. You can also form crossovers by connecting filters in series, as in Fig. 2, but this configuration is less common. When viewed as an active crossover, the amplifier in Fig. 1 becomes the preamplifier, and the woofer and tweeter become the low and high amplifiers. Figure 3 shows a parallel-connected three-way

crossover. I will discuss two-way passive crossovers in this article and leave the problem of more channels and active realizations to a later installment.

An electrical filter is a circuit that passes certain bands of frequencies and rejects—or at least attenuates—

crossover is formed by connecting a low-pass and a high-pass filter with a common corner frequency in parallel. The common corner frequency is the crossover frequency.

Ideally, a filter's response curve (output voltage in decibels for a 1V input plotted against frequency) would have a sharp corner at the corner frequency, as in Fig. 4. In practice, electrical circuits provide rounded corners, as in Fig. 5. It is possible, however, to make the transition from passband to stopband as sharp as desired by increasing the complexity of the circuits used to realize the filter.

The filters comprising standard passive two-way crossovers are invariably realized by a circuit topology called a resistance-terminated LC ladder. A typical configuration is shown in Fig. 6, where each block on a parallel arm (rung) or a series arm (support) is either a capacitor or an inductor. A low-pass filter circuit results when all series arms contain inductors and all parallel arms capacitors. The inductor and capacitor positions are interchanged in a high-pass circuit.

When a low or high-pass filter is realized by such a ladder, the total number of inductors and capacitors in the ladder is a measure of how fast the transition from passband to stopband will be. This is called the order of the filter. A first-order filter has the slowest transition, a second-order is somewhat faster, and so on. More precisely, the order determines the ultimate roll-off rate of the filter in its stopband, which is 6ndB/octave for a filter of order n. Crossover filters are generally limited to order four or less to keep the component count reasonable and still allow the possibility of roll-off rates as high as 24dB/octave.

It is assumed that the filter load is a resistor and that there is no input re-

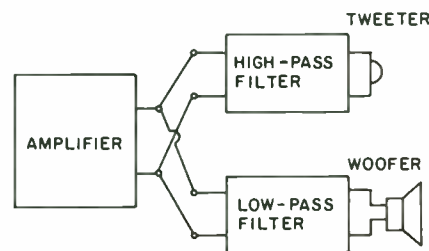

FIGURE 1: Parallel-connected, two-way passive crossover network.

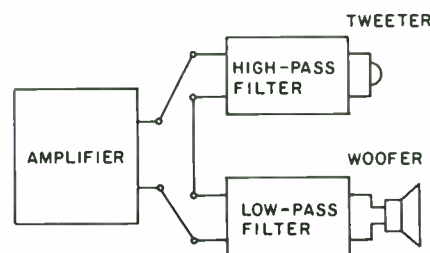

FIGURE 2: Series-connected, two-way passive crossover network.

others. The frequencies passed constitute the filter passband and those rejected the stopband. A low-pass filter is one whose passband consists of all frequencies below a specified corner frequency, while a high-pass filter passes all those frequencies above a given corner frequency. A

sistance. The actual sizes of the inductors (L) and capacitors (C), in conjunction with the load resistance, determine both the corner frequency and the shape of the filter response curve. For such a ladder circuit, it is possible to derive formulas for the LC values that will produce the desired corner frequency and response shape. If the load is not a resistor, or if the circuit is not a ladder, it is generally not possible to obtain such formulas. This is the reason for the widespread use of this topology.

CROSSOVER TYPES. Two types of standard passive crossover are most often recommended for loudspeaker applications. The all-pass crossover (APC) introduced by Garde¹ seems to be the current favorite. When a two-way APC's low-pass and high-pass outputs are combined, the resultant has the same magnitude as the input at all frequencies. Thus, if V_I is the input voltage, and V_L and V_H are the low-pass and high-pass output voltages, respectively, then the following relationship (1) results:

$$|V_L + V_H| = |V_I|$$

This means that the crossover passes all frequencies with unchanged magnitude, although the signal phase is altered. Generally, it is not possible to pass a signal with both magnitude and phase unchanged using ladder circuits. APCs are desirable in loudspeaker applications because they do not directly introduce any variations into the loudspeaker's overall acoustic response magnitude.

The second recommended type of crossover is the constant-power crossover (CPC). Its application in loudspeakers predates the APC by many years.² With the voltage notation above, the CPC is characterized by the condition (2):

$$|V_L|^2 + |V_H|^2 = |V_I|^2$$

In other words, the combined output power of the crossover is equal to the input power at all frequencies. Thus, a CPC does not directly alter a loudspeaker system's overall acoustic output power. CPCs are often called Butterworth crossovers because they are formed from Butterworth filters. I won't use this terminology because APCs also involve Butterworth filters, and it could be confusing.

It turns out that an odd-order stan-

dard crossover is both an APC and a CPC. This would seem to make it the best choice in all circumstances, but as you will see, it has certain limitations that might make an even-order choice preferable. The individual filter response curves of these odd-order crossovers are 3dB down at the crossover frequency.

In even-order networks, you must choose between an APC and a CPC. Even-order APCs—also known as Linkwitz-Riley crossovers—seem to be the current favorite. Their individual filter responses are 6dB down at crossover. Even-order CPCs seem to be the *least* popular crossovers because property (1) is more important than property (2) in this application. Their individual filter responses are 3dB down at the crossover frequency.

SPEAKER CROSSOVERS. When a standard crossover is used in a loudspeaker system, the individual filters are terminated by loudspeakers as their loads and not the resistors for which they were designed. This gives rise to one of the more serious objections to their use. Ideally, crossovers should be designed to work into the loads they will actually encounter. The only way to do this, however, is to use sophisticated computer-aided design techniques not available to the

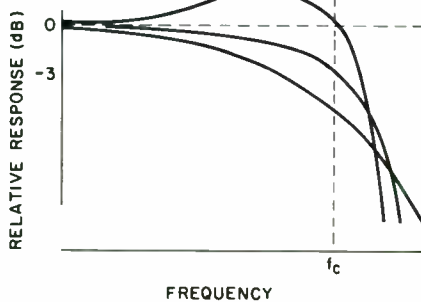

Figure 5: Three typical response curves of realizable low-pass filters, all with corner frequency f_c .

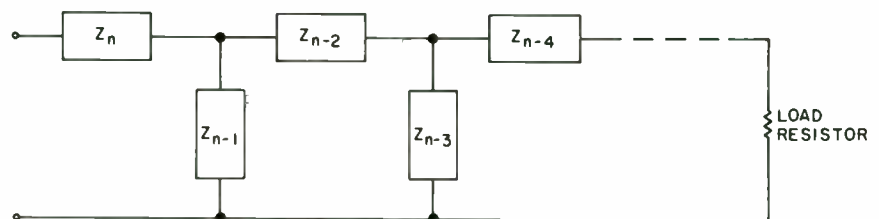

Figure 6: A general resistance terminated LC ladder circuit. Each block (Z_k) is a two-terminal circuit composed of inductors and capacitors.

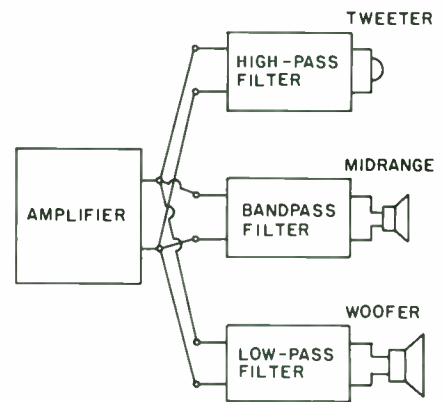

Figure 3: Parallel-connected, three-way passive crossover network.

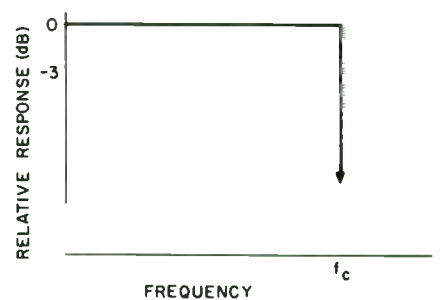
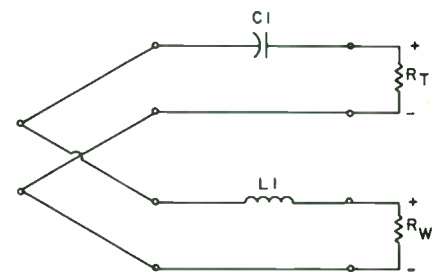

Figure 4: Response curve of a perfect low-pass filter with corner frequency f_c .



$$C1 = 1/(2\pi f_c R_T)$$

$$L1 = R_W/(2\pi f_c)$$

$$(\pi = 3.14159)$$

Figure 7: Circuit and design formulas for a passive first-order crossover network. It is both an APC and a CPC. Values are in farads, henries and ohms.

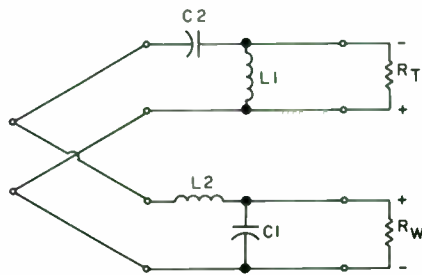

$$C1 = 1/(AR_W 2\pi f_c)$$

$$L1 = (R_T A)/(2\pi f_c)$$

$$L2 = (R_W A)/(2\pi f_c)$$

$$C2 = 1/(AR_T 2\pi f_c)$$

$$(\pi = 3.14159)$$

APC: $A = 2$

CPC: $A = \sqrt{2}$

Comp: $A = 2K$, K from equation (3)

FIGURE 8: Circuit and design formulas for a passive second-order crossover network. An APC is obtained with A equal to 2, a CPC with A equal to $\sqrt{2}$, and a compromise with A equal to $2K$. (K is found from equation (3) in the text). Values are in farads, henries and ohms.

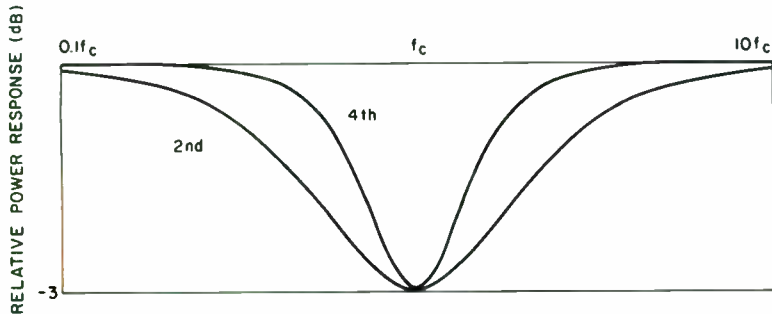

FIGURE 9: Combined power response of even-order APCs, also known as Linkwitz-Riley crossover networks.

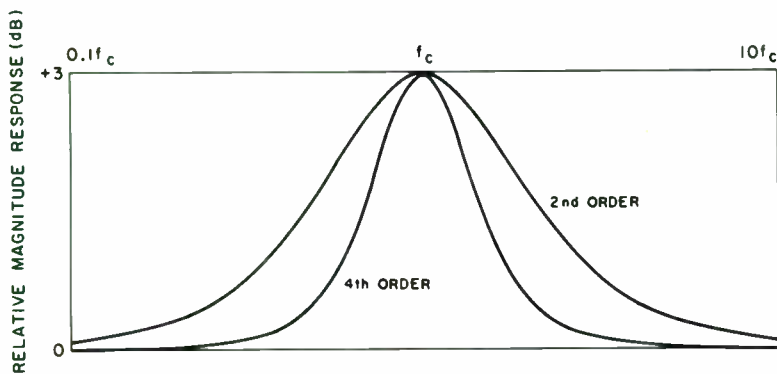

FIGURE 10: Combined voltage magnitude response of even-order CPCs using recommended tweeter polarity.

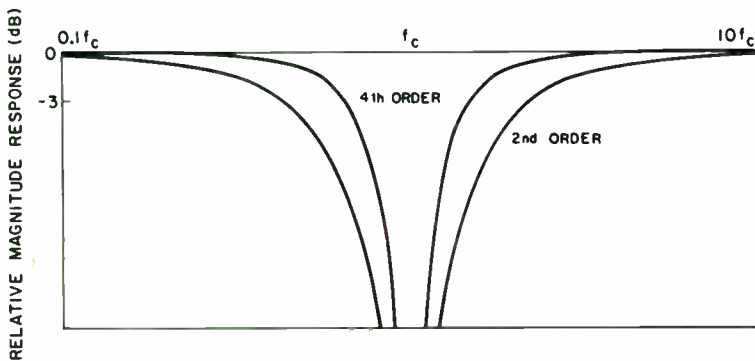

FIGURE 11: Combined voltage magnitude of even-order CPCs if recommended tweeter polarity is reversed.

home builder. I believe that with careful load equalization, standard crossovers can perform quite well.

I will use f_c to denote the crossover frequency of a two-way crossover. The terminating resistors of the low-pass and high-pass sections are denoted R_W and R_T , respectively. For loudspeaker crossovers, you can take their values to be the DC resistance of the woofer and tweeter, respectively. All component value formulas are given in farads, henries and ohms.

FIRST ORDER. Figure 7 shows the circuit and design formulas for the first-order, two-way crossover. Since it is an odd-order network, it is both an APC and a CPC, regardless of which polarity is observed in connecting the loudspeakers. Using the polarity in the figure, this crossover has a much stronger property than (1) or (2). It is a constant-voltage crossover as defined by Small.³ This means that the recombinated output of the crossover has not only the same magnitude as the input, but also the same phase.

In this sense, the output is an exact replica of the input. However, the acoustic response of a loudspeaker system with a first-order crossover can be far from flat because the crossover is very sensitive to system phase relationships. In addition, both drivers contribute substantially to the output over an extremely wide band of frequencies. Factors such as inter-driver spacing, interdriver phase difference and location of the crossover frequency can cause wide response variations.⁴⁻⁵⁻⁶

Designing a good system with a first-order network requires that you use extremely wide bandwidth drivers, pay very careful attention to relative driver positioning and make sure that the tweeter has sufficient excursion capability to handle the slow roll-off in its stopband. As a home builder, I don't use first-order networks because I don't think I can meet all these requirements.

SECOND ORDER. The circuits and design formulas for second-order, two-way crossovers are shown in Fig. 8. Here, the APC and CPC are distinct networks. As I described earlier, they are distinguishable by their individual filter outputs at the crossover frequency and the fact that different component values are required in the circuits.

Second-order networks still have

the advantage of a low component count. In contrast to odd-order crossovers, they are quite insensitive to system phase relationships.⁶ Some people also believe this is the lowest-order network that can adequately control the tweeter's excursion. You must, however, decide whether you want to preserve a flat voltage response or a flat power response, since you cannot do both. If you choose the APC for flat voltage response, then the power response will be 3dB down at the crossover frequency. If you opt for the flat combined power response of a CPC, then the voltage response will have a 3dB peak at the crossover frequency. See Figs. 9 and 10.

Note that the tweeter polarity must be reversed in a second-order crossover (Fig. 8). Otherwise, the APC will not give a flat magnitude response. The CPC would still give a flat power response, but its magnitude response would have a null at the crossover frequency, as in Fig. 11. Some builders find polarity reversal unsettling. For instance, the attack of a bass drum will be transmitted as a rarefaction by the tweeter, while the fundamental will be transmitted as a compression by the woofer—i.e., the tweeter will move backward and the woofer forward. This has never bothered me, but you should investigate to see whether you find it objectionable.

A second-order APC is also known as a Linkwitz-Riley (L-R) crossover. Linkwitz was one of the first to advocate its use as a way of obtaining a symmetric vertical radiation pattern from a two-way loudspeaker system.⁵ For standard odd-order crossovers, this pattern usually has the shape of Fig. 12, at least for frequencies near the crossover point, where both drivers are active. L is the listening position giving overall flat response. The main lobe in the figure can point above or below the main listening axis, depending on the polarity observed in connecting the loudspeakers. It is clear, though, that a small movement above or below L will cause a substantial variation in sound-pressure level (SPL).

The radiation pattern of an even-order standard crossover is shown in Fig. 13, where a slight up or down movement about L will cause little change in SPL. Rather than using an even-order CPC, Linkwitz introduced the APC to achieve this pattern and to produce a flat combined magnitude response as well. The symmetry of the

vertical radiation pattern is most important at high crossover frequencies, where the lobe becomes quite narrow regardless of the crossover type. This is seen in Fig. 12, where the crossover frequency is 3,000Hz and the drivers are 4.5 inches apart. The same crossover type with a 300Hz crossover point and 15 inches between the driv-

ers is shown in Fig. 14. Here the variation in SPL should be no problem.

THIRD ORDER. The third-order network and design formulas appear in Fig. 15. Being of odd-order, this network is both an APC and a CPC, regardless of whether tweeter polarity is observed or reversed. It is popular

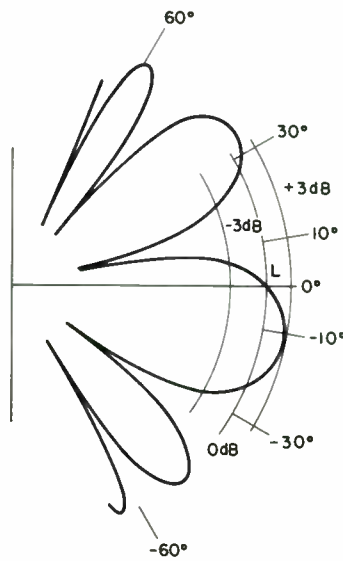

FIGURE 12: Vertical radiation pattern of a standard two-way loudspeaker system at the crossover frequency using an odd-order crossover, where f_c equals 3,000Hz and the driver centers are 4.5 inches apart. If the recommended tweeter polarity is reversed, the graph is reflected in the 0-degree axis. L is the reference listening position.

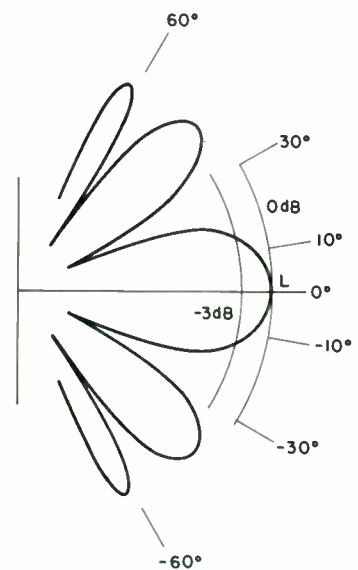

FIGURE 13: The symmetric vertical radiation pattern of a standard two-way loudspeaker system at the crossover frequency using an even-order crossover, where f_c equals 3,000Hz and the driver centers are 4.5 inches apart. If a CPC is used, the level at L becomes +3dB, and the -3dB level becomes 0dB.

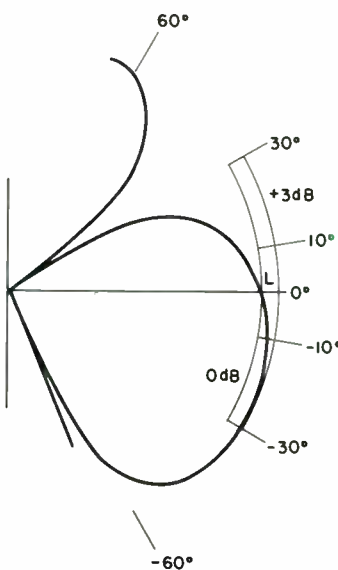
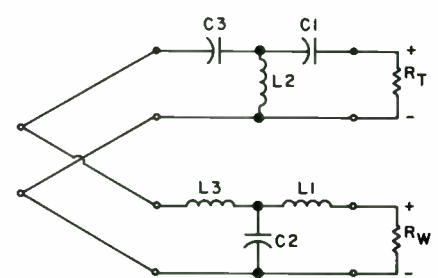

FIGURE 14: This graph is for the same conditions described in Fig. 12, except f_c equals 300Hz and driver separation is 15 inches.



$$L1 = R_W / (4\pi f_c)$$

$$C1 = 2 / (2R_T \pi f_c)$$

$$C2 = 4 / (6R_W \pi f_c)$$

$$L2 = (3R_T) / (8\pi f_c)$$

$$L3 = (3R_W) / (4\pi f_c)$$

$$C3 = 2 / (6R_T \pi f_c)$$

$$(\pi = 3.14159)$$

FIGURE 15: Circuit and design formulas for a passive third-order crossover network. It is both an APC and a CPC. Values are in farads, henries and ohms.

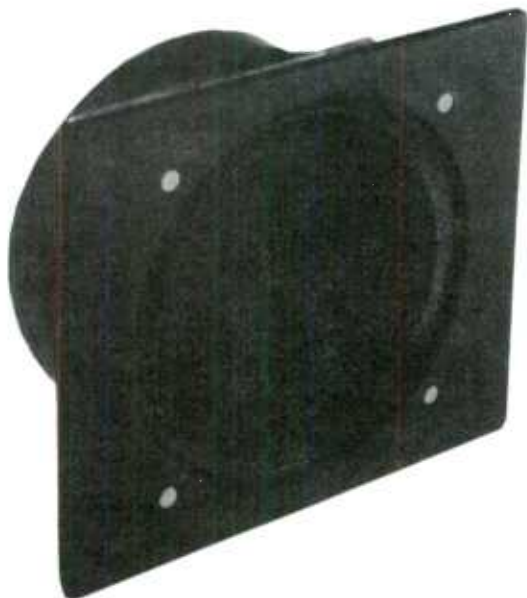

JORDAN 50mm MODULE

Sidereal Akustic is now stocking the JORDAN 50mm MODULE for immediate delivery to distributors and OEM buyers.

DISTRIBUTED BY:

JUST SPEAKERS, INC.
233 Whitney St.
San Francisco, CA 94131
(415) 641-9228

A & S SPEAKERS
2371 Dahlia St.
Denver, CO 80207
(303) 399-8609

CANASON AUDIO MARKETING
2756 Yonge St.
Toronto, ONT. M4N2J2
Canada
(416) 488-2199



Sidereal Akustic..
Audio Systems Inc.

4035 Oceanside Blvd.
Unit G57 Oceanside Ca. 92054
(619) 726-3150

EXCLUSIVE NORTH AMERICAN IMPORTERS

SiderealKaps

PREMIUM AUDIO GRADE CAPACITORS

- Metalized Polypropylene
- Extremely low DA, DF and ESR
- Multi-gauge stranded, high purity copper leads
- Hand soldered lead termination
- Comprehensive objective and subjective evaluation techniques used throughout research and development phases
- 100% quality testing plus high reliability design
- High immunity to microphonic and self modulation effects.
- Competitive O.E.M. and Distributor based pricing



DISTRIBUTED BY:

JUST SPEAKERS, INC.
233 Whitney St.
San Francisco, CA 94131
(415) 641-9228

A & S SPEAKERS
2371 Dahlia St.
Denver, CO 80207
(303) 399-8609

CANASON AUDIO MARKETING
2756 Yonge St.
Toronto, ONT. M4N2J2
Canada
(416) 488-2199



Sidereal Akustic..
Audio Systems Inc.

4035 Oceanside Blvd.
Unit G57 Oceanside Ca. 92054 (619) 726-3150

FAST REPLY #FH778

not only by virtue of its dual properties, but also because it offers what some consider to be the lowest adequate roll-off rate—18dB/octave.

Otherwise, it has the same advantages and disadvantages as a first-order network. The response variations caused by system phase relationships might be less objectionable,

though, because the region over which both drivers contribute to the output is much smaller due to the higher roll-off rate. Some designers recommend reversing the tweeter polarity to improve transient response. I suggest you decide which polarity arrangement sounds best to you, as I cannot hear any difference.

In a conventional two-way system, the vertical radiation pattern of the third-order crossover is similar to Figs. 12 and 14. D'Appolito has found an ingenious way to use any odd-order standard crossover to produce an approximately spherical radiation pattern.⁷ It requires two woofers flanking the tweeter in the vertical direction, as in Fig. 16. The crossover's low-pass section feeds both woofers. With this configuration, the vertical radiation pattern will be within 3dB of spherical, regardless of the crossover frequency or any reasonable driver separation. A typical pattern is shown in Fig. 17. For any listening position, it is better than that offered by the L-R crossovers. Using an L-R crossover in the D'Appolito configuration will not improve the radiation pattern.

If you decide to use the D'Appolito configuration and choose to connect the woofers parallel to the crossover, they must each have 6dB less sensitivity than the tweeter. This does not seem to be a limitation, considering the nominal 85 to 90dB sensitivity of typical small woofers versus the 90 to 95dB sensitivity of many tweeters.

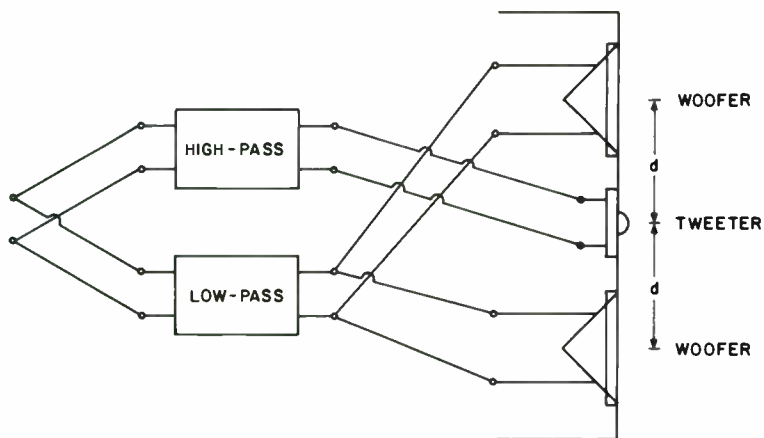

FIGURE 16: A two-way loudspeaker system in the D'Appolito configuration. The two woofers are identical, and both are fed from the low-pass section of a two-way crossover.

FOURTH ORDER. The schematic and design formulas for the fourth-order crossovers are shown in Fig. 18. My comments about the second-order networks' insensitivity to system phase relationships and the symmetry of their vertical radiation patterns also apply to fourth-order networks.

The advantages of a fourth-order APC (an L-R crossover) over a second-order one are that polarity is observed and that the roll-off is a very rapid 24dB/octave. The latter property means that the frequency range over which both drivers contribute significantly to the overall output is very narrow, thus minimizing acoustic interactions. Also, the steeper roll-off often allows a lower crossover frequency, which widens the vertical radiation pattern without overdriving the tweeter.

The major drawback of fourth-order networks is that they require larger capacitors and inductors than do the lower orders. This can cause substantial inductor losses at lower crossover frequencies and complicate the problem of sensitivity matching.

Whereas tweeter polarity was reversed in the second-order network, you must observe it in the fourth-order APC. Nevertheless, the combined power response has the same

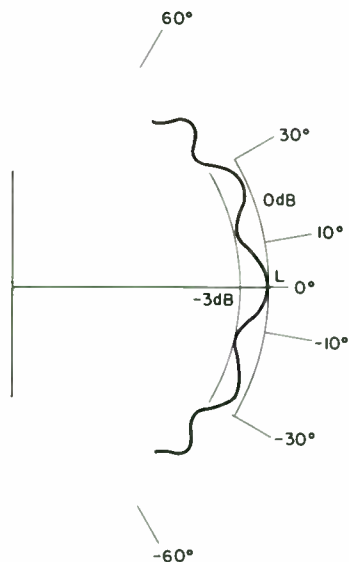
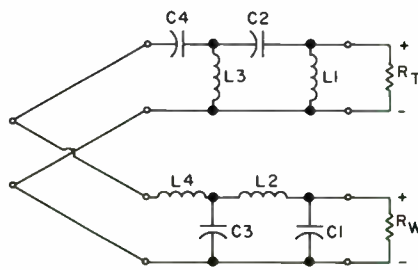

FIGURE 17: Vertical radiation pattern of a D'Appolito-configured two-way loudspeaker system using an odd-order crossover network, where f_c equals 3,000Hz and the tweeter center and each woofer center are 4.5 inches apart.



$$C1 = 1/(AR_W 2\pi f_c) \quad L4 = (ER_W)/(2\pi f_c)$$

$$C3 = D/(ER_W 2\pi f_c) \quad C2 = D/(AR_T 2\pi f_c)$$

$$L1 = (AR_T)/(2\pi f_c) \quad C4 = 1/(ER_T 2\pi f_c)$$

$$L3 = (ER_T)/(D 2\pi f_c) \quad (\pi = 3.14159)$$

$$L2 = (AR_W)/(D 2\pi f_c)$$

$$E = A(1 - 1/D)$$

where $D = B - 1$, $E = A(1 - 1/B)$, and

APC: $A = 2\sqrt{2}$, $B = 4$

CPC: $A = (4 + 2\sqrt{2})^{1/2}$, $B = 2 + \sqrt{2}$

Comp: $A = 2\sqrt{1 + K}$, $B = 2(1 + K)$

FIGURE 18: Circuit and design formulas for a passive fourth-order crossover network. An APC is obtained if A equals $2\sqrt{2}$ and B equals 4, a CPC if A equals $(4 + 2\sqrt{2})^{1/2}$ and B equals $2 + \sqrt{2}$, and a compromise crossover if A equals $2\sqrt{1 + K}$ and B equals $2(1 + K)$. (K is found from equation (3) in the text.)

3dB dip at the crossover frequency as in Fig. 9. If you observe the CPC's tweeter polarity, the voltage magnitude response will have a 3dB peak. If the polarity is reversed, there will be a null. These effects are illustrated in Figs. 10 and 11.

EVEN-ORDER COMPROMISE. As you have seen, if you choose an even-order crossover, you must decide whether you want a flat combined voltage magnitude response (APC) or a flat combined power response (CPC). In my *JAES* article,⁸ I showed how to design an even-order crossover that is a compromise between these two types. It will have neither a flat combined voltage magnitude response nor a flat power response, but the variation in each response will be less than 3dB. As a matter of fact, the sum of the total variations in each response will equal 3dB. For example, a compromise crossover with a 1dB peak in its combined voltage magnitude response will have a 2dB dip in its combined power response.

Schematics and design formulas for the compromise crossovers are shown in Fig. 8 for the second-order network and in Fig. 18 for the fourth-order network. To use the formulas, decide how much peaking (P) in decibels you want in the voltage magnitude response. Remember, $0 < P < 3$. Then calculate K (a constant) as follows (3):

$$K = \frac{1}{10^{(P/20)}}$$

and use it in the formulas to find the component sizes.

If you plan to use an even-order crossover, but have no overwhelming preference for either an APC or a CPC, you can use my compromise to find convenient crossover component sizes by juggling the crossover frequency and P slightly. You will be safe in knowing that the combined variation in both the power and voltage magnitudes of the resulting crossover will not exceed 3dB.

IMPEDANCE EQUALIZATION.

When you use a standard crossover in a loudspeaker system, it might not perform as it should because real loudspeaker loads replace its theoretical resistive loads. The only way a home builder can deal with this problem is to equalize the loudspeaker impedance so that it looks like a resistor to the crossover, at least approximately.

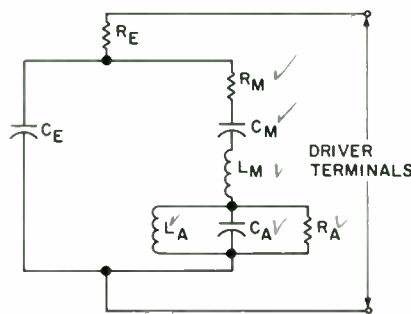

$$C_E = L_E / R_E^2$$

$$C_M = 1 / (R_E Q_{ES} 2\pi f_s)$$

$$R_M = (Q_{ES} R_E) / Q_{MS}$$

$$L_A = (\alpha Q_{ES} R_E) / (h^2 2\pi f_s)$$

$$L_M = (Q_{ES} R_E) / (2\pi f_s)$$

$$C_A = 1 / (\alpha R_E Q_{ES} 2\pi f_s)$$

$$R_A = (\alpha R_E Q_{ES} Q_L) / h$$

FIGURE 19: Circuit and design formulas for a vented-box impedance equalizer. By deleting certain A-subscripted components as described in the text, you can also equalize a closed box or a loudspeaker with no enclosure. Component values are in farads, henries and ohms.

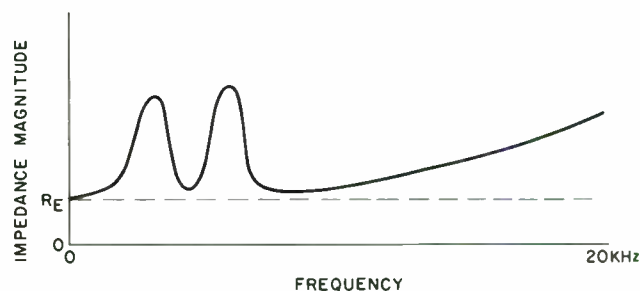

FIGURE 20: Impedance magnitude versus frequency plot of a vented loudspeaker system.

If you accept the Thiele/Small speaker models, you can equalize your speaker with the circuit in Fig. 19. The formulas for the equalizer are in farads, henries and ohms, and are expressed in terms of the Thiele/Small parameters of the driver and its enclosure. These are the driver voice-coil resistance (R_E), driver resonant frequency (f_s), driver electrical Q (Q_{ES}), driver mechanical Q (Q_{MS}), driver/box compliance ratio (α), ratio of vent resonant frequency to driver resonance frequency (h) and box leakage loss Q (Q_L). It is also necessary to know the voice-coil inductance (L_E).

Circuit components C_M , L_M and R_M are related to the driver mechanical parameters, while components L_A , R_A and C_A are related to the system acoustic parameters. The full schematic is for a vented-box loudspeaker. If you use a closed box, you can delete R_A and L_A , then combine the two capacitors into one, C_A , whose size equals

$$C_A C_M / (C_A + C_M).$$

If there is no enclosure, such as with a tweeter, then you can also delete C_A and connect the three components in series directly to ground.

The Thiele/Small models are not exact, so the results of this equalization will not be exact either. The question is, how well does it work? Even more basically, when is it really necessary? I will try to answer these questions for a woofer and tweeter separately.

Figure 20 shows the frequency versus impedance magnitude curve for a vented-box loudspeaker. If the box is closed, then the two peaks at the low-frequency end of the graph coalesce into a single peak. The peak(s) are caused by the system mechanical and acoustical resonances and are tamed by the elements C_M , L_M , R_M , C_A , L_A and R_A in the equalizer. The rise in impedance at high frequencies is caused primarily by the voice-coil inductance and is equalized by C_E . For a crossover to behave as expected, the impedance curve should be the horizontal line in Fig. 20, representing the voice-coil DC resistance (R_E), or at least an approximation of it.

In practice, if the crossover frequency is far removed from the low-frequency impedance peaks, they will have a negligible effect on overall crossover response and need not be equalized. In other words, if the crossover frequency is more than a few hundred hertz, you can delete C_M , L_M ,

R_M , C_A , L_A and R_A without noticeable effect.

It is unlikely that you would consider a lower crossover point with a two-way system, but the equalization problem also arises in crossovers with more than two channels where crossover frequencies less than 300Hz are common. In such a case, the mechanical/acoustical equalization might be crucial in obtaining acceptable performance. Because of the component size requirements, it is best to avoid equalization if at all possible.

Consider, for example, a vented woofer with the following parameters: $R_E = 6\Omega$, $f_S = 35\text{Hz}$, $Q_{ES} = 0.4$, $Q_{MS} = 3$, $h = 1.2$, $\alpha = 1.8$ and $Q_L = 7$.

As you can verify from the formulas, $C_M = 1,895\mu\text{F}$, $L_M = 10.9\text{mH}$, $C_A = 1,053\mu\text{F}$ and $L_A = 13.6\text{mH}$. Components of this size are not only quite expensive, but the inductors will have significant losses, which are not accounted for and which can limit the equalizer's effectiveness.

Woofer voice-coil inductance (L_E) can usually be equalized without component size problems. Deciding which value to use for L_E is often difficult, however. Even when the value is supplied in the driver specifications, it does not always yield the best equalization. This is probably due to model inadequacy. I have found that you can often determine a satisfactory value

by measuring the driver impedance magnitude (M) at some frequency (f_M) between 10 and 20kHz. You can then calculate L_E with the following formula (4):

$$L_E = \frac{\sqrt{M^2 - R_E^2}}{2\pi f_M}$$

I usually set f_M equal to 10kHz.

In practice, you may vary the exact formula values for the equalized components within the usual 20 percent component tolerance range. Because of the inexactness of the loudspeaker models, it is sometimes possible to improve the equalization by doing so. When you equalize impedance, al-

```

100 REM COMPONENT VALUES FOR
110 REM 2-WAY APC'S, CPC'S
120 REM AND COMPROMISE XOVERS
130 REM OF ORDERS 1 THROUGH 4
140 REM CONSTANTS, STRINGS
150 P1=2*3.141593
160 RT=SQR(2)
170 A$="A"
180 B$="P"
190 C$="C"
200 E$="MH"
210 F$="UF"
220 G$="OHMS"
230 H$="C1="
240 I$="L2="
250 J$="C3="
260 K$="L4="
270 L$="L1="
280 M$="C2="
290 N$="L3="
300 O$="C4="
310 P3=1000
320 P6=1000000
330 INPUT "XOVER FREQ ?":FC
340 W=P1*FC
350 INPUT "DRVR. IMPS. ?":R1,R2
360 INPUT "CROSSOVER ORDER?(1-4)":O
370 IF O=1 THEN GOTO 630
380 IF O=3 THEN A=2
390 IF O=3 THEN GOTO 630
400 INPUT "A=APC,P=CPC,C=COMP?":D$
410 IF D$=A$ THEN GOTO 520
420 IF D$=B$ THEN GOTO 580
430 REM COMPROMISE PARAMETERS"
440 INPUT "MAG. PK. IN DB=":P
450 K=1/10^(P/20)
460 IF O=2 THEN A=2*K
470 IF O=2 THEN GOTO 630
480 IF O=4 THEN A=2*SQR(1+K)
490 IF O=4 THEN B=2*(1+K)
500 IF O=4 THEN GOTO 630
510 REM APC PARAMETERS
520 IF O=2 THEN A=2
530 IF O=2 THEN GOTO 630
540 A=2*RT
550 B=4
560 GOTO 630
570 REM CPC PARAMETERS
580 IF O=2 THEN A=RT
590 IF O=2 THEN GOTO 630
600 A=SQR(4+2*RT)
610 B=2+RT
620 REM COMPONENT CALCULATIONS
630 IF O=2 THEN GOTO 740
640 IF O=3 THEN GOTO 860
650 IF O=4 THEN GOTO 1030
660 REM 1ST ORDER
670 L1=P3*R1/W
680 C1=P6/W/R2
690 PRINT "VALUES FOR FIG. 7:"
700 PRINT L$;L1;E$
710 PRINT H$;C1;F$
720 END
730 REM 2ND ORDER
740 C1=P6/A/R1/W
750 L2=P3*A*R1/W
760 L1=P3*A*R2/W
770 C2=P6/A/R2/W
780 PRINT "VALUES FOR FIG. 8:"
790 PRINT H$;C1;F$
800 PRINT I$;L2;E$
810 PRINT L$;L1;E$
820 PRINT M$;C2;F$
830 PRINT "REVERSE TWTR PLRTY."
840 END
850 REM 3RD ORDER
860 E=3/2
870 L1=P3*R1/A/W
880 C2=P6*A/E/W/R1
890 L3=P3*E*R1/W
900 C1=P6*A/R2/W
910 L2=P3*E*R2/W/A
920 C3=P6/E/R2/W
930 PRINT "VALUES FOR FIG. 15:"
940 PRINT L$;L1;E$
950 PRINT M$;C2;F$
960 PRINT N$;L3;E$
970 PRINT H$;C1;F$
980 PRINT I$;L2;E$
990 PRINT J$;C3;F$
1000 PRINT "EITHER TWTR PLRTY O.K."
1010 END
1020 REM 4TH ORDER
1030 E=B-1
1040 F=A*(1-1/E)
1050 C1=P6/A/R1/W
1060 L2=P3*A*R1/W/E
1070 C3=P6*E/F/R1/W
1080 L4=P3*F*R1/W
1090 L1=P3*A*R2/W
1100 C2=P6*E/A/R2/W
1110 L3=P3*F*R2/E/W
1120 C4=P6/F/R2/W
1130 PRINT "VALUES FOR FIG. 18:"
1140 PRINT H$;C1;F$
1150 PRINT I$;L2;E$
1160 PRINT J$;C3;F$
1170 PRINT K$;L4;E$
1180 PRINT L$;L1;E$
1190 PRINT M$;C2;F$
1200 PRINT N$;L3;E$
1210 PRINT O$;C4;F$
1220 PRINT "OBSERVE TWTR PLRTY."
1230 END

```

LISTING 1: Crossover component values.

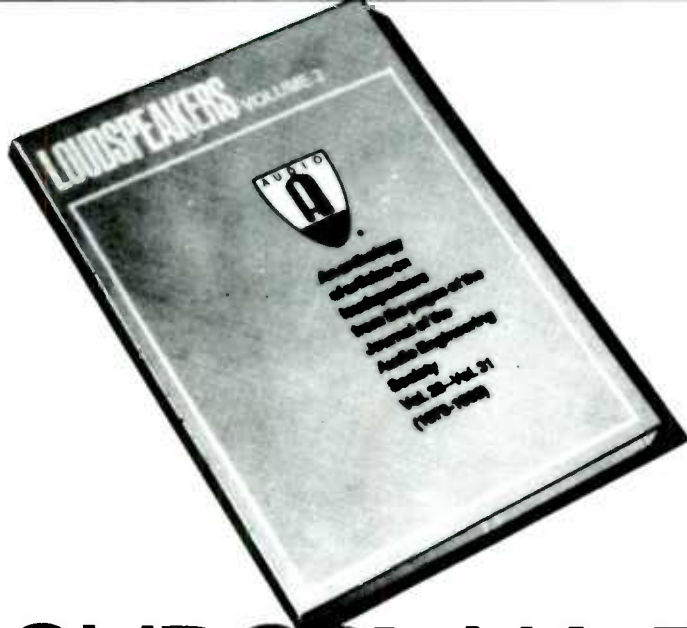

JUST PUBLISHED

**NEW
from the
AES**

LOUDSPEAKERS VOLUME 2

A comprehensive collection of papers on loudspeaker technology from 1978 to 1983... latest addition to anthology series

Announcing the publication of LOUDSPEAKERS Volume 2, a new anthology of papers by distinguished experts in loudspeaker theory and practice collected from the *Journal of the Audio Engineering Society*. This most recent anthology covers the significant papers in this vital field published from 1978 to 1983 and extends the work initiated in the well-received LOUDSPEAKERS Volume 1, which included the years 1953 to 1977.

The AES, an international organization devoted exclusively to audio technology, publishes its *Journal* to bring professional audio engineers the latest developments in all aspects of audio. LOUDSPEAKERS Volume 2 reproduces forty-nine papers, exactly as they appeared in the *Journal*, authored by international experts on design, construction, and operation of loudspeakers. Computer-aided measurement and testing, crossover systems design, component materials, equalization, and radiation patterns are among the many topics discussed. Editor

Raymond E. Cooke, who also edited LOUDSPEAKERS Volume 1 and is a noted authority in the field of transducers, has written a concise and timely foreword to a publication that offers a comprehensive overview of loudspeaker state of the art.

LOUDSPEAKERS Volume 2 is 464 pages, with the editor's foreword, a table of contents, and a bibliography for further reading listing papers of historical importance from other publications. The book measures 8 1/4 inches (209.6 mm) by 11 1/4 (285.8 mm); it is bound in durable covers and is shrink-wrapped for safety in shipping.

To order this special anthology and its companion book LOUDSPEAKERS Volume 1, please use the order form below. Write Special Publications, Audio Engineering Society, 60 East 42nd Street, Rm. 2520, New York, New York 10165. Or telephone 212-661-2355.

ORDER FORM To order, please complete and return with payment to: **Audio Engineering Society
60 East 42nd Street, Rm. 2520
New York, New York 10165**

Single copies of LOUDSPEAKERS Volume 2 cost \$27 each to members, \$30 each to nonmembers. LOUDSPEAKERS Volume 1 is also available for \$27 to members and \$30 to nonmembers. Combination price for LOUDSPEAKERS Volumes 1 & 2 is \$49 per set to members, \$55 per set to nonmembers.

Please make checks payable to Audio Engineering Society.

Mark appropriate box (es):

- LOUDSPEAKERS Volume 1
- LOUDSPEAKERS Volume 2
- LOUDSPEAKERS Volumes 1 & 2

Name _____ AES Member No. _____

Address _____

Check enclosed for \$ _____ Zip _____

EUROPE ORDERING ADDRESS: Ms. T. K. S. Bakker, Polygram B.V., P.O. Box 23, NL-3740AA Baarn, The Netherlands. Prices for single copies: 1570 BEF each to members, 1735 BEF each to nonmembers. Combination price: 2825 BEF per set to members, 3095 BEF per set to nonmembers. (All orders will be invoiced. Invoices will give the amount due in BEF and your local currency, and will indicate a selection of payment methods suitable for various European countries.)

FAST REPLY #FH43

ways make an impedance plot to check how well the equalizer works. You can measure impedance by the techniques described in my *SB* article? The impedance magnitude should be as flat as possible, especially in a wide band of frequencies on either side of the crossover frequency. At least two octaves on either side is best, although anything over an octave should be adequate.

Tweeter systems do not usually include a separate enclosure, so the A-subscripted components are not required. Since their voice-coil inductance is usually negligible, you can also delete C_E . Whether or not the remaining components are necessary seems to depend most strongly on how close the tweeter resonant frequency is to the crossover frequency. If well over an octave separates them, equalization is probably not necessary, although it will not hurt. If an octave or less separates them, I think the tweeter should be equalized.

CROSSOVER FREQUENCY. The precise crossover frequency is not crucial, but its relative position is quite important. You have seen this already in connection with impedance equalization decisions. There are also other, often-conflicting considerations. The crossover frequency must be set high enough so that the tweeter is not driven beyond its capabilities. A higher crossover frequency means

```
(1)
XOVER ORDER 1 AT 2300 HZ
DRVR IMPS= 6.5 . 5.5
1ST ORD. VALS. FOR FIG. 7
L1= .4497856591 MH
C1= 12.58141704 UF
```

```
(2)
XOVER ORDER 2 AT 2300 HZ
DRVR IMPS= 6.5 . 5.5
TYPE APC.
2ND ORD. VALS. FOR FIG. 8
C1= 5.322907209 UF
L2= .8995713183 MH
L1= .7611757309 MH
C2= 6.290708519 UF
REVERSE TWTR PLRTY.
```

```
(3)
XOVER ORDER 2 AT 2300 HZ
DRVR IMPS= 6.5 . 5.5
TYPE CPC.
2ND ORD. VALS. FOR FIG. 8
C1= 7.527727566 UF
L2= .4360929793 MH
L1= .538232521 MH
C2= 8.896405305 UF
REVERSE TWTR PLRTY.
```

```
(4)
XOVER ORDER 2 AT 2300 HZ
DRVR IMPS= 6.5 . 5.5
TYPE COMP WITH P= 1 DB
2ND ORD. VALS. FOR FIG. 8
C1= 5.972400119 UF
L2= .8017437813 MH
L1= .6783985842 MH
C2= 7.058291049 UF
REVERSE TWTR PLRTY.
```

```
(5)
XOVER ORDER 3 AT 2300 HZ
DRVR IMPS= 6.5 . 5.5
3RD ORD. VALS. FOR FIG. 15
L1= .2248928296 MH
```

Sample output for Listing 1.

```
C2= 14.19441922 UF
L3= .6746784887 MH
C1= 25.16283408 UF
L2= .2854408991 MH
C3= 8.387611359 UF
EITHER TWTR PLRTY OK.
```

```
(6)
XOVER ORDER 4 AT 2300 HZ
DRVR IMPS= 6.5 . 5.5
TYPE APC.
4TH ORD. VALS. FOR FIG. 18
C1= 3.763863783 UF
L2= .4240619862 MH
C3= 16.93738702 UF
L4= .8481239724 MH
L1= 1.076465042 MH
C2= 13.34460796 UF
L3= .2392144538 MH
C4= 6.672303979 UF
OBSERVE TWTR PLRTY.
```

```
(7)
XOVER ORDER 4 AT 2300 HZ
DRVR IMPS= 6.5 . 5.5
TYPE CPC.
4TH ORD. VALS. FOR FIG. 18
C1= 4.073976802 UF
L2= .4868444893 MH
C3= 16.79016347 UF
L4= .6885020795 MH
L1= .9945240197 MH
C2= 11.62371369 UF
L3= .2413119915 MH
C4= 8.219206774 UF
OBSERVE TWTR PLRTY.
```

```
(8)
XOVER ORDER 4 AT 2300 HZ
DRVR IMPS= 6.5 . 5.5
TYPE COMP WITH P= 1 DB
4TH ORD. VALS. FOR FIG. 18
C1= 3.870564573 UF
L2= .4446053788 MH
C3= 16.8118402 UF
L4= .7925099218 MH
L1= 1.04678987 MH
C2= 12.72800831 UF
L3= .2410008504 MH
C4= 7.140530105 UF
OBSERVE TWTR PLRTY
```

```
100 REM THIS PROGRAM COMPUTES
110 REM 1. WOOFER INDUCTANCE
120 REM 2. CROSSOVER LOSSES
130 REM 3. IMPEDANCE EQUALIZER
140 P1=2*3.141593
150 C$="UF"
160 O$="OHMS"
170 D$="MH"
180 INPUT "DRVR DC RES=" :RE
190 INPUT "DRVR IND.?(1=YES,0=NO)":O1
200 INPUT "LO-PASS LOSSES?":O2
210 INPUT "IMP. EQ.?" :O3
220 REM DRIVER INDUCTANCE
230 IF O1=0 THEN GOTO 300
240 INPUT "FREQ. OF IMP. MEAS.":F
250 INPUT "MEAS.IMP.MAG.":M
260 LE=SQR(M*M-RE*RE)/P1/F
270 LE=LE*1000
280 PRINT "LE=" :LE :D$
290 REM LO-PASS LOSSES
300 IF O2=0 THEN GOTO 380
310 INPUT "NOM. DRVR. IMP.":NR
320 INPUT "AMP. DMPG. FCTR.":DF
330 INPUT "TOT. LO-PASS IND. R'S":IR
340 AR=NR/DF
350 LO=20*LOG(RE/(RE+AR+IR))/LOG(10)
360 PRINT "LOSSES=" :LO : "DB"
370 REM IMPEDANCE EQUALIZER
380 IF O3=0 THEN END
390 INPUT "DRVR FS.QES.QMS=" :FS.QE.QM
400 W=P1*FS
410 INPUT "1=VNTD,2=CLSD,3=NO BOX=" :O4
420 IF O4=3 THEN GOTO 470
430 IF O4=1 THEN GOTO 460
440 INPUT "BOX ALPHA=" :AL
450 GOTO 470
460 INPUT "H. ALPHA. QL=" :H.AL.QL
470 INPUT "DRVR. IND(MH)=" :LE
480 LE=LE/1000
490 CE=LE/RE/RE*1000000
500 CM=1/RE/QE/W*1000000
510 LM=QE*RE/W*1000
520 RM=QE*RE/QM
530 PRINT "CE=" :CE :C$
540 PRINT "CM=" :CM :C$
550 PRINT "RM=" :RM :O$
560 PRINT "LM=" :LM :D$
570 IF O4=3 THEN END
580 CA=1/AL/RE/QE/W*1000000
590 IF O4=1 THEN GOTO 630
600 CC=CM*CA/(CM+CA)
610 PRINT "CMA=" :CC :C$
620 END
630 LA=AL*QE*RE/H/H/W*1000
640 RA=AL*RE*QE*QL/H
650 PRINT "CA=" :CA :C$
660 PRINT "LA=" :LA :D$
670 PRINT "RA=" :RA :O$
680 END
```

LISTING 2: Impedance equalizer, inductance estimate and losses.

that the principal vertical radiation lobe will be narrower, so you must trade off possible tweeter distortion for a highly variable vertical-response pattern. The distance between the woofer and tweeter acoustic centers also helps determine the lobe width. If the drivers are far apart, the crossover frequency should be kept low so that the lobe width is reasonably wide. I try to keep the crossover frequency low enough so that its wavelength is at least as large as the driver separation. To allow the greatest latitude in crossover frequency placement, you should make every effort to position the drivers as close together as possible.

Driver bandwidth also imposes an obvious placement limitation. Do not cross over a woofer at 3,000Hz if its high-frequency roll-off starts at 2,000Hz. Try to choose drivers that have a reasonably flat response for at least an octave on either side of the intended crossover frequency. This is not always possible, but at least try to avoid using a driver up to the edge of its flat-response region.

SOURCE & INDUCTOR LOSSES. Standard crossovers are designed under the assumption that the amplifier is a perfect voltage source and that crossover inductors have no resistance. The former assumption is quite reasonable if you use an amplifier with a high damping factor (greater than 50).

Inductor resistance can be a problem, though, especially with third and fourth-order crossovers. It causes not only a flat loss in the low-pass section, but also a shift in corner frequency and a change in response shape in both sections. Try to keep these resistances small, even if it means giving up your air-core inductors or raising the crossover frequency. It is impossible for home builders to deal with the corner-frequency shift or response change in any other way. Luckily, it does not seem to be much of a problem in the crossover frequency range commonly used in two-way systems.

The flat loss crossovers cause in the low-pass section can be considered part of the drivers' sensitivity matching. Suppose, for example, you use a woofer with an 8Ω nominal impedance and a 6Ω DC resistance in a system with a fourth-order crossover. If the amplifier damping factor is 50, then the approximate source resistance will be 8 divided by 50, or approximately 0.2Ω. If the crossover inductors have resistances of 0.2 and 0.4Ω, then the overall resistive losses will be determined by the following equation (5):

$$20\log\left(\frac{R_E}{R_E+0.2+0.2+0.4}\right) =$$

$$20\log\left(\frac{6}{6.8}\right) = -1.09\text{dB}$$

Thus, the effective sensitivity of the woofer will be 1dB less than the nominal sensitivity of the driver.

COMPUTER PROGRAMS. For those of you who have your own computer, I have written two BASIC programs (*Listings 1 and 2*) to take care of the calculations for crossover and equalizer component sizes. In *Listing 2*, I have also included options for estimating driver inductance using formula (4) and finding low-section losses as in equation (5). The component values are labeled the same as in the relevant figures in the article. The programs are short, and I have included some sample runs to help in debugging.

If you have any questions or comments, please send them to me care of SB with a stamped, self-addressed envelope. I will be happy to tell you what I know, even if I cannot answer your specific question. Such input might help uncover further topics of general interest for future articles.

Next time, Mr. Bullock will discuss three-way networks and active realizations of standard crossovers using Jung's 30Hz rumble filter (Old Colony Kit KF-6).

REFERENCES

1. Garde, P., "All-Pass Crossover Systems," *JAES* (Volume 28), September 1980, pp. 575-584.
2. Hilliard, J.K., "Loudspeaker Networks for Frequency Division," *Electronics* (Volume 14), January 1941, pp. 26-29.
3. Small, R.H., "Constant-Voltage Crossover Network Design," *Proc. IREE Aust.* (Volume 31), March 1970, pp. 66-73. Reprinted in *JAES* (Volume 19), January 1971, pp. 12-19.
4. Leach, W.M. Jr., "Loudspeaker Driver Phase Response: The Neglected Factor in Crossover Network Design," *JAES* (Volume 28), June 1980, pp. 410-421.
5. Linkwitz, S.H., "Active Crossover Networks for Noncoincident Drivers," *JAES* (Volume 24), January/February 1976, p. 2.
6. Bullock, R.M., "Loudspeaker-Crossover Systems: An Optimal Crossover Choice," *JAES* (Volume 30), July/August 1982, pp. 486-495.
7. D'Appolito, J.A., "A Geometric Approach to Eliminating Lobing Error in Multiway Loudspeakers," *Preprint No. 2000 (F-2)*, 74th Convention of the AES, New York, October 8-12, 1983.
8. Bullock, R.M., "Satisfying Loudspeaker Crossover Constraints with Conventional Networks—Old and New Designs," *JAES* (Volume 31), July/August 1983, pp. 489-499.
9. Bullock, R.M., "How You Can Determine Design Parameters for Your Loudspeaker," *SB* 1/81, p. 12.

```
(1)
RE= 6
DRIVER INDUCTANCE
FREQ. IMP. MEAS= 20000 HZ
MEASURED IMP. MAG= 50
LE = .395012137 MH
LO-PASS LOSSES:
NOM. DRVR. IMP= 8 OHMS
AMP DMPG FCTR= 50
TOT. LO-PASS IND. R'S= .6 OHMS
LO-PASS LOSSES=-1.035908911 DB
IMPEDANCE EQ.
FS= 53 HZ
QES= 5
QMS= 3
VENTED
H= 1
ALPHA= .67
QL= 7
LE= .4 MH
CE = 11.11111111 UF
CM = 1000.974374 UF
RM = 1 OHMS
LM = 9.00876937 MH
CA = 1493.991604 UF
LA = 6.035875478 MH
RA = 14.07 OHMS
```

```
(2)
RE= 6
IMPEDANCE EQ.
FS= 40 HZ
QES= 4
QMS= 3
CLOSED
ALPHA= 3
LE= .5 MH
CE = 13.88888889 UF
CM = 1657.863808 UF
RM = .8 OHMS
LM = 9.549295533 MH
CMA = 414.4659519 UF
(3)
RE= 5.6
IMPEDANCE EQ.
FS= 900 HZ
QES= 2
QMS= 2
NO BOX
LE= .05 MH
CE = 1.594387755 UF
CM = 15.78917912 UF
RM = 5.6 OHMS
LM = 1.980594629 MH
```

Sample output for Listing 2.

MICROCOMPUTER-AIDED DRIVER ATTENUATION

BY MAX R. KNITTEL

Once you have finished building your loudspeaker enclosures, perhaps the greatest and most exasperating task lies ahead—designing and modifying the crossover. First, you must tame the driver impedance,¹ then you can select the crossover order and frequencies. The next step is calculating initial inductor and capacitor values based on the driver impedances at the appropriate frequencies.

If all this goes well, you are still faced with the fact that the midrange and tweeter output levels are going to be incompatible with the woofer output level. With luck, the former will be greater than the latter, so they must be attenuated. Matching an efficient woofer to a midrange can be a problem. Normally, you cannot use a series resistance with the woofer to reduce its output level because this also raises the woofer Q , which in turn changes the woofer box requirements, frequency response and transient response.

MATCHING OUTPUTS. The usual way to attenuate the output of a midrange or tweeter is with some type of voltage-divider network consisting of a series and a parallel resistor between the crossover components and the driver, with its attached impedance-taming network? You could, for example, use the circuit in *Fig. 1* to attenuate the output of an 8Ω tweeter by 6dB. Equation 1 provides the circuit's new equivalent impedance (Z_{eq}). With a resistor (R_P) in parallel with the driver impedance and another (R_S) in series with this combination,

$$Z_{eq} = \frac{1}{(1/R_P) + (1/Z_D)} + R_S$$

where Z_D is the impedance-tamed driver impedance. The attenuation (A) of this circuit is found with equation 2:

$$A = 20 \log \left[\frac{1}{(1/R_P) + (1/Z_D)} \right]$$

For the 8Ω tweeter, you could use an 8Ω resistor for R_P and a 4Ω resistor for R_S . The equivalent impedance from equation 1 turns out to be 8Ω. These choices for R_S and R_P are fortunate because the impedance (and the cross-

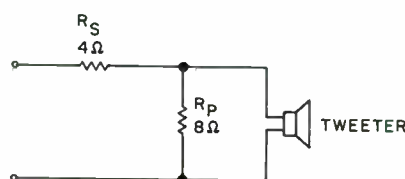

FIGURE 1: You can use this circuit to attenuate the output of an 8Ω tweeter by 6dB.

over capacitor) can remain the same. The series resistor provides attenuation, and the parallel resistor maintains the impedance at the original value. If Z_{eq} takes on a different value, the crossover frequency will inadvertently change or you must change crossover components every time you choose a different attenuation. You must change both the series and parallel resistors to alter attenuation, while keeping the equivalent driver impedance constant.

Special variable attenuators called

L-pads are really two variable resistors on one shaft—one resistance goes up while the other goes down. In the above example, if you adjusted the L-pad from -6dB to -3dB, R_S would decrease from 4 to 2.3Ω and R_P would increase from 8 to 19.4Ω. Such an attenuator, if of sufficiently high quality, can work satisfactorily if your driver impedance is 8Ω. If a different impedance is presented to it, R_S and R_P will not be correct for any attenuation. As you rotate the L-pad knob, not only does the output from the driver change level, but the crossover frequency also moves up and down.

Using the example again, if the driver impedance is really 6Ω at a crossover frequency of 3,500Hz, setting the standard L-pad to -6dB would give an R_P of 8 and an R_S of 4 just as before. But now from equation 1, Z_{eq} equals 7.4Ω and from equation 2, A equals -6.7dB. With this new equivalent impedance, which the original crossover capacitor "sees," the crossover frequency moves down to 2,838Hz. Thus, in most cases, you cannot use a standard L-pad as a midrange or tweeter attenuator. Instead, you must use fixed resistors of appropriate values for R_S and R_P . Finding and then unsoldering and soldering resistors is time consuming, and it does not make for very speedy changes in driver attenuation when you are trying to adjust the frequency balance of your most recently built speakers.

SPEEDY ATTENUATION. To solve this problem, I built two decade resistance boxes (*Fig. 2*), each with six ten-position rotary switches. Using 10, 1 and 0.1Ω, 5W power resistors,³ I can

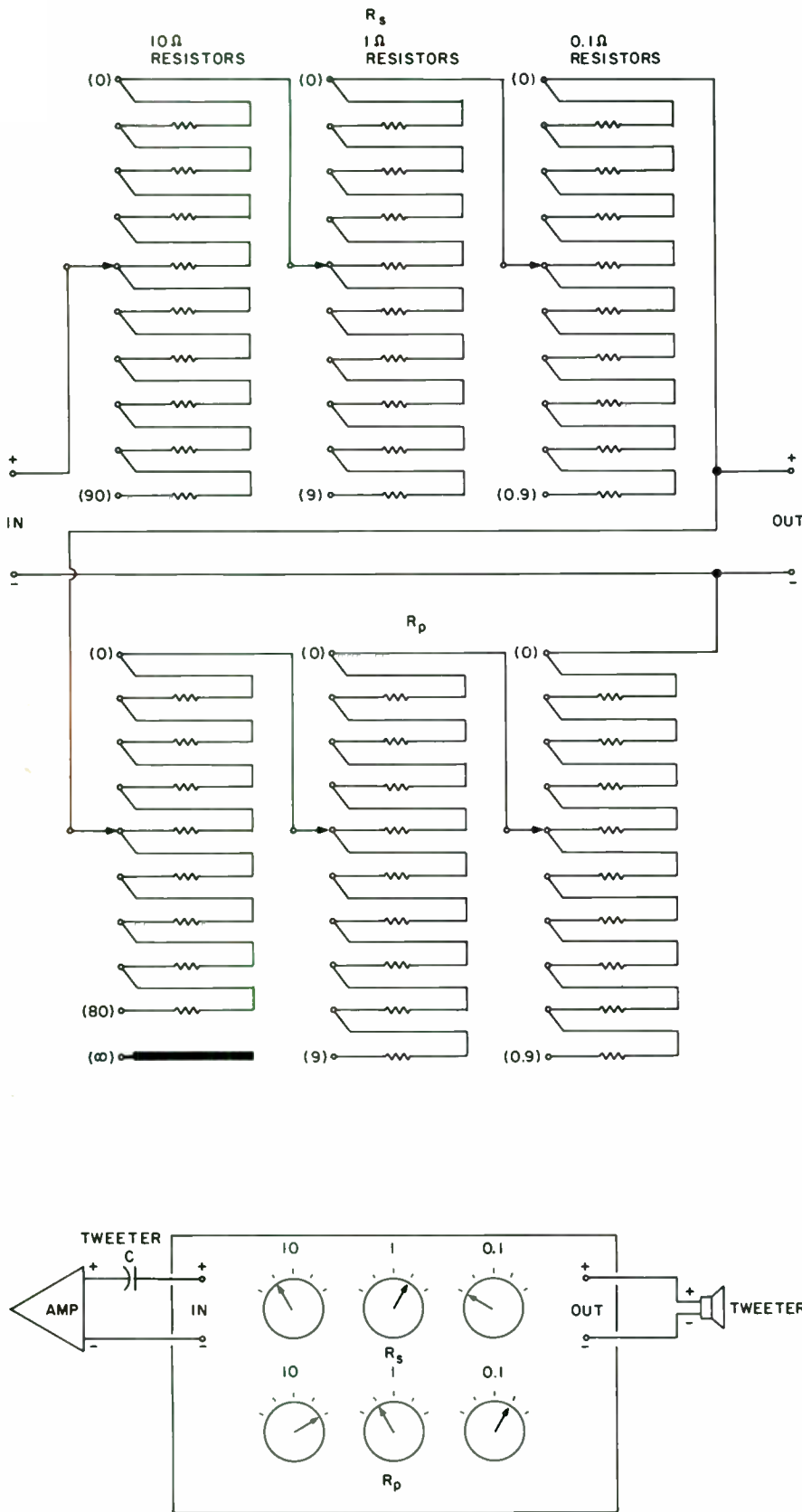

FIGURE 2: The author used the attenuator circuit in Fig. 1 to design his own attenuator decade box.

set R_S from 0 to 99.9Ω in steps of 0.1Ω and R_P from 0 to 99.9Ω (and also infinity) in steps of 0.1Ω. I can now dial in rapid changes in attenuation and have no shifts in crossover frequency. To make the overall box resistance as accurate as possible, you should measure each resistor. By carefully choosing sets of resistors, you can get overall sums that are quite accurate.

At this point, you might be wondering how you can find the appropriate resistance values as quickly as you can dial them up on the resistance decade boxes. Finding the appropriate values for R_S and R_P is not a speedy process, even with a programmable calculator. Setting Z_{eq} equal to Z_D and solving equations 1 and 2 for R_P and R_S yields equations 3 and 4:

$$R_P = \frac{10^{(A/20)} Z_D}{1 - 10^{(A/20)}}$$

$$R_S = Z_D - \frac{1}{(1/R_P) + (1/Z_D)}$$

where A must be in negative decibels (e.g., -6dB).

An alternative to solving these equations each time you wish to change attenuation is to set up a table that immediately shows R_S and R_P for the desired attenuation at a given driver impedance. Listing 1 is a simple BASIC program for calculating and printing R_S and R_P tables for a variety of driver impedances and attenuations. The program is written in IBM PC Advanced BASIC, a version of Microsoft BASIC. Listing 2 is a typical page of output.

For each driver impedance, the program prints a page of values for R_S and R_P for attenuations of -0.1dB to -15dB in steps of 0.1dB. Driver impedance starts at 4Ω and runs to 16Ω in steps of 0.1Ω. This generates more than 130 pages of output, one page for each impedance. The resulting "book" can be bound and kept next to your decade resistance attenuator boxes.

Lines 60-100 include the parameters that you can change to yield a smaller volume of output more suited to individual needs. (The computer does not know about subscripts, so ZD is the computer equivalent of Z_D .) The parameters are defined as follows:

ZD=the starting driver impedance for your tables.

AZD=the increment in driver impedance to be added to ZD each time.

NZD=the number of driver impedances to use.

ASTEP=the increment in attenuation.
 NSTEP=the number of attenuation steps.

For example, if you wanted to print tables for impedances from 6 to 10Ω in steps of 0.2Ω and for attenuations from -0.2 to -30dB in steps of 0.2dB, you would change lines 60-100 to read as follows:

```
60 ZD=6
70 AZD=0.2
80 NZD=21
90 ASTEP=-0.2
100 NSTEP=150
```

The program will print the tables using an Epson FX-80 dot-matrix printer. You might have to alter the LPRINT lines somewhat to use other printers' control codes. Line 130 prints the title on only the first page in enlarged, double-struck type. Line 150 prints the driver impedance on the top of each page. Line 230 prints the column headers. Lines 310-330 print the actual data in three columns.

THE MICRO ADVANTAGE. Using a microcomputer program such as this one or BOXRESPONSE⁴ allows you to see patterns develop, decide when

some quantity is getting out of bounds and trade off one quantity for another. All this is done interactively and nearly instantaneously at the terminal. When you have finalized your parameters, you can then print them. These microcomputer capabilities are particularly exciting for speaker builders because you can write programs to design loudspeaker enclosures interactively.

Starting with the basic Thiele/Small driver parameters, you can investigate the effects of system Q, series resistance, closed vs. vented vs. passive-radiator boxes, frequency response,

```
10 REM *****
20 REM *** LOUDSPEAKER CROSSOVER ATTENUATORS ***
30 REM *** ATTEN.BAS ***
40 REM *** PROGRAMMED BY MAX KNITTEL ***
50 REM *****
60 ZD = 8 : REM BEGINNING DRIVER IMPEDANCE
70 AZD = .1 : REM DRIVER IMPEDANCE INCREMENT
80 NZD = 1 : REM NUMBER OF DRIVER IMPEDANCE STEPS
90 ASTEP = -.1 : REM ATTENUATION STEP INCREMENT
100 NSTEP = 150 : REM NUMBER OF ATTENUATION STEPS
110 DIM RP(NSTEP),RS(NSTEP)
120 ZSTOP = ZD + (NZD-1)*AZD
130 LPRINT CHR$(27);"!";CHR$(56);TAB(11)"CROSSOVER ATTENUATORS"
140 LPRINT
150 LPRINT CHR$(27);"!";CHR$(0);TAB(27) USING "DRIVER IMPEDANCE = ##.# OHMS";ZD
160 LPRINT : LPRINT
170 FOR N=1 TO NSTEP
180 X=N*ASTEP
190 Z=(10)^(X/20)
200 RP(N)=(Z*ZD)/(1-Z)
210 RS(N)=ZD-1/(1/RP(N)+1/ZD)
220 NEXT N
230 LPRINT TAB(13) "DB";TAB(20)"RS";TAB(27)"RP";TAB(37)"DB";TAB(44)"RS";TAB(51)"
RP";TAB(61)"DB";TAB(68)"RS";TAB(75)"RP
240 LPRINT
250 N2 = NSTEP/3
260 N3 = 2*NSTEP/3
270 FOR N=1 TO N2
280 A1=N*ASTEP
290 A2=(N+N2)*ASTEP
300 A3=(N+N3)*ASTEP
310 LPRINT TAB(11) USING "+##.#";A1; : LPRINT TAB(18) USING "###.#";RS(N); : LPR
INT TAB(25) USING "###.#";RP(N);
320 LPRINT TAB(35) USING "+##.#";A2; : LPRINT TAB(42) USING "###.#";RS(N + N2);
: LPRINT TAB(49) USING "###.#";RP(N + N2);
330 LPRINT TAB(59) USING "+##.#";A3; : LPRINT TAB(66) USING "###.#";RS(N + N3);
: LPRINT TAB(73) USING "###.#";RP(N + N3)
340 NEXT N
350 LPRINT CHR$(12);
360 ZD=ZD + AZD
370 IF ZD > ZSTOP GOTO 390
380 GOTO 150
390 END
```

LISTING 1: BASIC program used to generate tables of attenuators.

efficiency, box volume and box proportions. You can also produce comparison tables, graphs and even three-dimensional, hidden-line plots of proposed enclosures.

Although programmable calculators can work miracles in comparison to what we were able to accomplish only a decade ago, they have limitations in input and output (particularly when a large amount of printed output is necessary) and in "what if" analysis. Microcomputers are opening a whole new world for speaker builders that will let you design speakers more quickly and with more predictable results. I hope

more speaker builders will take advantage of this opportunity. 

REFERENCES

1. Knittel, M.R., "Impedance Compensating Crossover," *SB* 1/83, p. 11.
2. Knittel, M.R., "Leveling Balancing Pads," *SB* 2/84, p. 39.
3. These 5W, 5% power resistors cost approximately 40¢ each from Mouser Electronics, 1143 Woodside Ave., Santee, CA 92071.
4. Bullock, R.M. and B. White, "BOX-RESPONSE," *SB* 1/84, p. 13.

CROSSOVER ATTENUATORS

DRIVER IMPEDANCE = 8.0 OHMS

DB	RS	RF	DB	RS	RF	DB	RS	RF
-0.1	0.1	690.9	-5.1	3.6	10.0	-10.1	5.5	3.6
-0.2	0.2	343.5	-5.2	3.6	9.8	-10.2	5.5	3.6
-0.3	0.3	227.6	-5.3	3.7	9.5	-10.3	5.6	3.5
-0.4	0.4	169.7	-5.4	3.7	9.3	-10.4	5.6	3.5
-0.5	0.4	135.0	-5.5	3.8	9.1	-10.5	5.6	3.4
-0.6	0.5	111.9	-5.6	3.8	8.8	-10.6	5.6	3.3
-0.7	0.6	95.3	-5.7	3.8	8.6	-10.7	5.7	3.3
-0.8	0.7	82.9	-5.8	3.9	8.4	-10.8	5.7	3.2
-0.9	0.8	73.3	-5.9	3.9	8.2	-10.9	5.7	3.2
-1.0	0.9	65.6	-6.0	4.0	8.0	-11.0	5.7	3.1
-1.1	1.0	59.3	-6.1	4.0	7.9	-11.1	5.8	3.1
-1.2	1.0	54.0	-6.2	4.1	7.7	-11.2	5.8	3.0
-1.3	1.1	49.6	-6.3	4.1	7.5	-11.3	5.8	3.0
-1.4	1.2	45.7	-6.4	4.2	7.3	-11.4	5.8	2.9
-1.5	1.3	42.4	-6.5	4.2	7.2	-11.5	5.9	2.9
-1.6	1.3	39.6	-6.6	4.3	7.0	-11.6	5.9	2.9
-1.7	1.4	37.0	-6.7	4.3	6.9	-11.7	5.9	2.8
-1.8	1.5	34.7	-6.8	4.3	6.7	-11.8	5.9	2.8
-1.9	1.6	32.7	-6.9	4.4	6.6	-11.9	6.0	2.7
-2.0	1.6	30.9	-7.0	4.4	6.5	-12.0	6.0	2.7
-2.1	1.7	29.3	-7.1	4.5	6.3	-12.1	6.0	2.6
-2.2	1.8	27.8	-7.2	4.5	6.2	-12.2	6.0	2.6
-2.3	1.9	26.4	-7.3	4.5	6.1	-12.3	6.1	2.6
-2.4	1.9	25.1	-7.4	4.6	6.0	-12.4	6.1	2.5
-2.5	2.0	24.0	-7.5	4.6	5.8	-12.5	6.1	2.5
-2.6	2.1	22.9	-7.6	4.7	5.7	-12.6	6.1	2.4
-2.7	2.1	21.9	-7.7	4.7	5.6	-12.7	6.1	2.4
-2.8	2.2	21.0	-7.8	4.7	5.5	-12.8	6.2	2.4
-2.9	2.3	20.2	-7.9	4.8	5.4	-12.9	6.2	2.3
-3.0	2.3	19.4	-8.0	4.8	5.3	-13.0	6.2	2.3
-3.1	2.4	18.7	-8.1	4.9	5.2	-13.1	6.2	2.3
-3.2	2.5	18.0	-8.2	4.9	5.1	-13.2	6.2	2.2
-3.3	2.5	17.3	-8.3	4.9	5.0	-13.3	6.3	2.2
-3.4	2.6	16.7	-8.4	5.0	4.9	-13.4	6.3	2.2
-3.5	2.7	16.1	-8.5	5.0	4.8	-13.5	6.3	2.1
-3.6	2.7	15.6	-8.6	5.0	4.7	-13.6	6.3	2.1
-3.7	2.8	15.1	-8.7	5.1	4.6	-13.7	6.3	2.1
-3.8	2.8	14.6	-8.8	5.1	4.6	-13.8	6.4	2.1
-3.9	2.9	14.1	-8.9	5.1	4.5	-13.9	6.4	2.0
-4.0	3.0	13.7	-9.0	5.2	4.4	-14.0	6.4	2.0
-4.1	3.0	13.3	-9.1	5.2	4.3	-14.1	6.4	2.0
-4.2	3.1	12.9	-9.2	5.2	4.2	-14.2	6.4	1.9
-4.3	3.1	12.5	-9.3	5.3	4.2	-14.3	6.5	1.9
-4.4	3.2	12.1	-9.4	5.3	4.1	-14.4	6.5	1.9
-4.5	3.2	11.8	-9.5	5.3	4.0	-14.5	6.5	1.9
-4.6	3.3	11.5	-9.6	5.4	4.0	-14.6	6.5	1.8
-4.7	3.3	11.1	-9.7	5.4	3.9	-14.7	6.5	1.8
-4.8	3.4	10.8	-9.8	5.4	3.8	-14.8	6.5	1.8
-4.9	3.4	10.6	-9.9	5.4	3.8	-14.9	6.6	1.8
-5.0	3.5	10.3	-10.0	5.5	3.7	-15.0	6.6	1.7

LISTING 2: Typical program output.

JOIN AN AUDIO CLUB



Expand your horizons. Improve your system. Learn about the latest equipment and techniques. Share viewpoints and experiences. Don't miss out on the fun and value of belonging to an audio society.

Typical activities include:

- **Guest Speakers.** Here's your chance to listen to and meet "superstars" of circuit design, prominent manufacturers, acoustical consultants, and recording engineers.
- **Tours.** Get a behind the scenes look at the equipment and talk with the people who operate it at local TV and radio stations, universities, research labs, recording studios, and factories.
- **Newsletters.** These publications are often of high technical quality and are full of worthwhile information even if you don't attend many meetings. Ads and reviews help you find the right equipment, the latest records, and the dealers who carry them.
- **Evaluation and Testing.** Frequently clubs sponsor clinics so you can bring in your equipment for checkups on test equipment most individuals don't own.
- **Group Buying.** This can be an effective way to obtain obscure items from abroad, including audiophile disks.

No club in your area?

Start one—with a free classified ad in *Audio Amateur* or *Speaker Builder*.

For more information, see the club listings in the Classified Ads of this issue.

REALIZING THE POTENTIAL OF BOXRESPONSE

BY BOB WHITE

Even the sagest speaker builder might have overlooked an important feature of the BOXRESPONSE program that appeared in *SB 1/84* (p. 13). With it, you can determine whether a particular driver is capable of delivering the desired target alignment (TA) at the sound-pressure level (SPL) that the thermal limit says it will. Let's back up a bit to see how this is possible.

Most of you are familiar with the frequency response of a particular alignment. The frequency-response curve is generated with the driver's

small-signal parameters (F_s , Q_M , Q_{ES} and V_{AS}) and represents the TA for a given driver/box combination. It does not take into account the driver's large-signal parameters, such as piston diameter, linear excursion capability and thermal capacity. All of these play a very important role in achieving the TA at any power level above a few watts.

TA is represented in the BOXRESPONSE sample runs (*SB 1/84*, pp. 17-18) by the response in decibels (column 2), which is relative to a 0dB reference. Columns 3 and 4 of the

sample runs take into account the driver's large-signal capabilities in its proposed box and with its proposed loading characteristics.

The most important information is contained in column 4 (maximum infinite baffle response in decibels). This column, when graphed against the TA (column 2) tells you whether or not the driver is capable of delivering the TA at the SPL the thermal limit predicts.

Before going any further, I would like to point out that the information from which the curves are generated is based on a mathematical model. Although certain assumptions are made in modeling, they should not affect the accuracy of the results. (*Keep in mind, however, that the model may or may not correspond to an actual driver. —Ed.*)

One of the more important parameters the program requires is the peak linear excursion (x_{max}). This information is sometimes difficult to obtain because not all manufacturers provide it and some, such as Dynaudio and Peerless, require that you calculate it. Mark Gander of JBL ("Moving-Coil Loudspeaker Topology as an Indicator of Linear Excursion Capability," *JAES*, January/February 1981, p. 14) provides the following equation for overhung voice coils:

$$x_{max} = \frac{\text{voice coil height} - \text{gap height}}{2}$$

I am using this equation as an example because it is the one you will most likely encounter.

DYNAUDIO 30W54. As an example, let's look at a popular woofer, the Dynaudio 30W54. Its specifications are as follows:

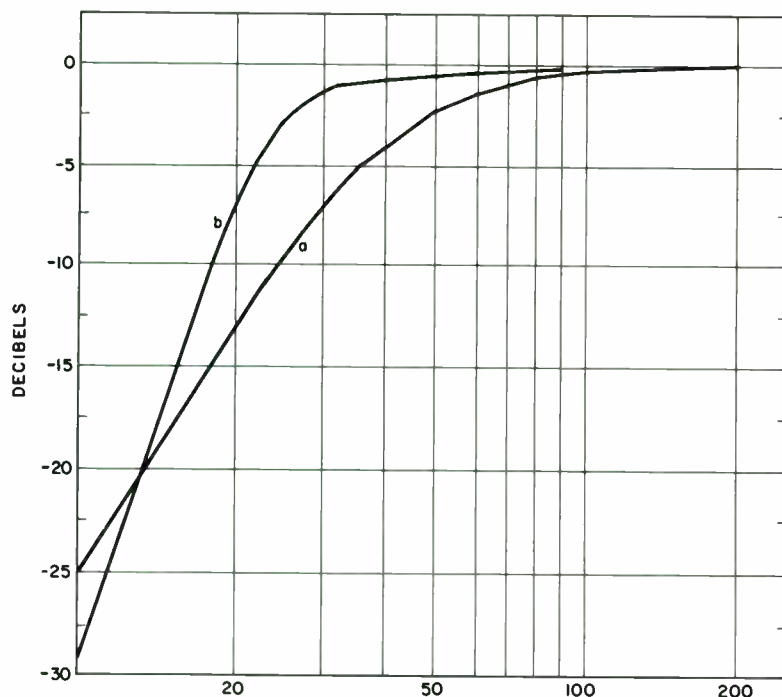

FIGURE 1: Relative small-signal response of the Dynaudio 30W54. Curve a represents the sealed box ($V_B = 3.39$ cubic feet), while Curve b represents the vented box ($V_B = 7.08$ cubic feet).

$f_s = 22\text{Hz}$
 $Q_{MS} = 2.39$
 $Q_{ES} = 0.42$
 $Q_{TS} = 0.357$
 $V_{AS} = 257 \text{ liters } (9.07\text{ft}^3)$
 $\text{power} = 210\text{W}$
 $r_E = 6.25\Omega$
 $\text{diameter} = 8.885 \text{ inches}$
 $\text{voice coil ht.} = 17\text{mm}$
 $\text{gap height} = 10\text{mm}$
 $\text{piston area} = 62\text{in}^2$

Plugging these values into the formula, you get:

$$x_{max} = \frac{17\text{mm} - 10\text{mm}}{2} = 3.5\text{mm}$$

$$x_{max} = \frac{3.5\text{mm}}{25.4\text{mm/in.}} = 0.1378 \text{ in.}$$

The manufacturer recommends an infinite-baffle enclosure of 96 liters (3.39 cubic feet), which gives you an alpha of 2.68. Figure 1 (Curve a) represents the TA for the 30W54/96-liter-box combination. I have ignored the 30W54's two variovents in this analysis because the literature discounts any resemblance to a vented box and I believe the vents have no bearing on the results.

For the sake of discussion, let's also include an optimum Thiele/Small box alignment for this driver. From the equations printed in David Weems' book *How to Design, Build & Test Complete Speaker Systems* (p. 171), you can determine the following parameters:

$$V_B = 15(Q_{TS})^{2.87} V_{AS} = 7.08\text{ft}^3$$

$$f_3 = 0.26(Q_{TS})^{-1.4} f_s = 24.2\text{Hz}$$

$$f_B = 0.42(Q_{TS})^{-0.9} f_s = 23.35\text{Hz}$$

$$H = \frac{f_B}{F_s} = 1.06$$

$$\alpha = \frac{V_{AS}}{V_B} = 1.28$$

Figure 1 (Curve b) represents the TA of the above alignment.

If you were to expect full power input (210W) for the infinite-baffle version, it would be displacement limited to 100Hz and would put out 113.25dB, which is its reference efficiency output. (See Curve a in Fig. 2.) The curve generated from column 4 (maximum infinite-baffle response in decibels) bears no resemblance to the TA for this combination (Figs. 1 and 2). To achieve an acceptable approximation of the TA, I chose the -3dB point (45Hz) as the displacement-limited

thermal-power bandwidth. The infinite-baffle/driver combination is displacement limited to 20W if the -3dB point and displacement limit coincide (Fig. 2, Curve b). Notice that at frequencies below the displacement-limited frequency (45Hz), the roll-off is much faster than the TA predicts.

This is true of all driver/box combinations. Column 3 (maximum power input in watts) shows that the driver is displacement limited at any frequency where it will not take the full thermal rating.

Now let's look at an optimum Thiele/Small vented box for the same

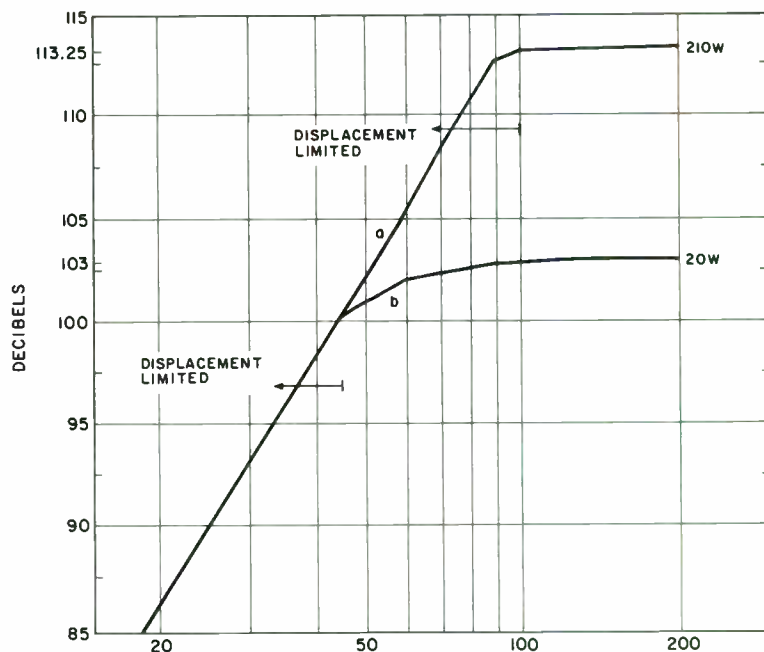

FIGURE 2: Sealed-box response of the 30W54 ($V_B = 3.39$ cubic feet, $x_{max} = 0.1378$ inch). Curve a represents a full 210W input and Curve b a 20W input.

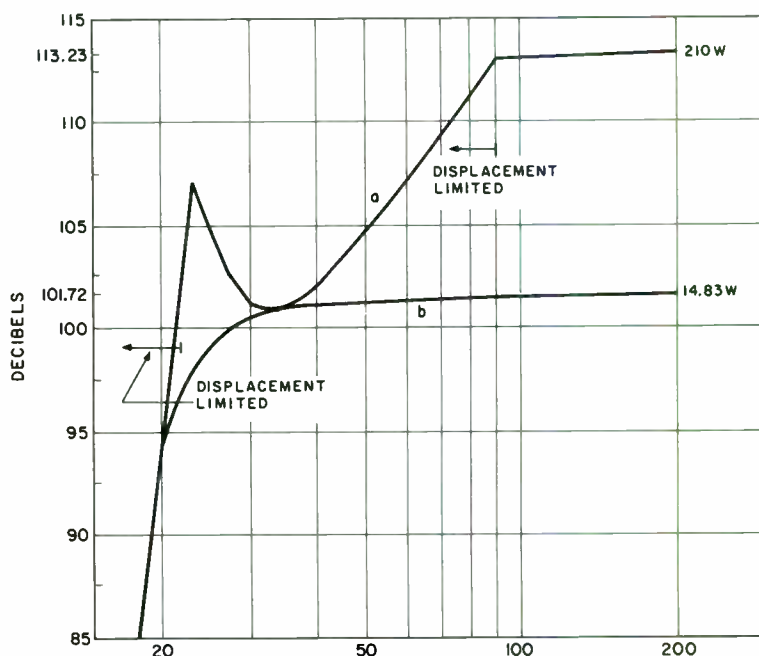

FIGURE 3: Vented-box response of the 30W54 ($V_B = 7.08$ cubic feet, $f_B = 23.35\text{Hz}$, $x_{max} = 0.1378$ inch). Curve a represents a full 210W input and Curve b a 14.83W input.

driver. You can derive the following values from the equations above:

$$V_B = 7.08 \text{ cubic feet}$$

$$f_3 = 24.2\text{Hz}$$

$$f_B = 23.35\text{Hz}$$

The TA is Curve b in Fig. 1. If you ap-

ply the full 210W, you get Curve a in Fig. 3. Note the port's effect on the maximum SPL and on power handling. If you plot the power-handling curve, you will find a minimum value between two maxima. In this case, it is 14.85W. If you rerun the program using 14.83W, you will find that the TA

has been achieved at all frequencies except those below the displacement limit (22Hz). See Curve b in Fig. 3.

This all means that the thermal rating of a driver alone is not a good basis for driver selection. You have seen that in its recommended enclosure, the Dynaudio can accept only 20W while achieving the TA at a maximum SPL of 103dB (Fig. 2, Curve b). You have also seen an optimum alignment of the same driver in a vented box limited to 14.83W at 101.72dB (Fig. 3, Curve b).

Let's suppose I used an incorrect number for x_{max} . As an experiment, I doubled x_{max} to see what would happen. Curve a in Fig. 4 is the same sealed box as before with the same parameters, except x_{max} is now 0.2756 inch instead of 0.1378 inch. Notice that the TA is still not met at the 210W input and that I have lowered the displacement-limited frequency from 100Hz to 65Hz. If you compare the TA to Curve a in Fig. 4, you find they cross at 45Hz, with a power rating of 82W. You could play this system with four times the power and gain 6dB in output, bringing it to 109.2dB (Fig. 4, Curve b).

The same type of thing occurs with the vented-box alignment (Fig. 5). The double x_{max} gains 6dB in output and four times as much input power at 59W and 107.71dB. By doubling x_{max} and leaving everything else the same, the driver can also handle four times as much power and deliver 6dB more output in the passband. The driver magnet structure would have to be beefed up to make up for the loss of sensitivity due to an extension of the overhung voice coil.

PEERLESS POLYPROPYLENE.

Now that you have mastered this concept, let's experiment a little. I have selected the Peerless TP-165F 6½-inch polypropylene woofer for a demonstration. The driver has a thermal rating of 80W and an x_{max} of 0.13 inch. It does not sound promising, does it? In an optimum Thiele/Small alignment (where $V_B=0.7$ cubic foot, $f_3 = 46.42\text{Hz}$, and $f_B=48.6\text{Hz}$), this driver is displacement limited to 30.27W at 103.45dB (Fig. 6). One of these drivers is all right for an extension speaker or background listening, but not for a high-powered SPL.

Let's try four of them in one box, wiring them series-parallel to remain at 6Ω. The result is a loudspeaker that has almost 10 inches of piston diame-

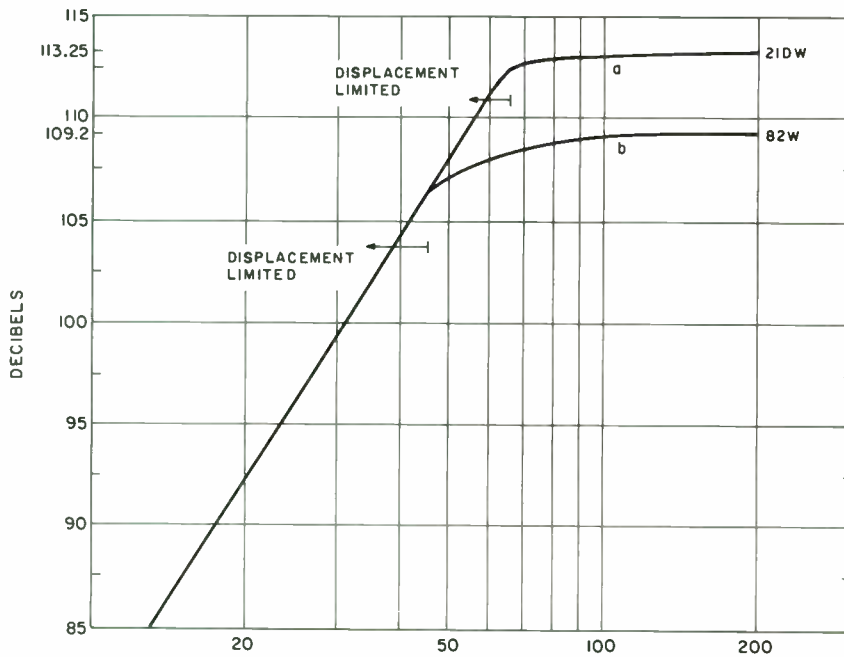

FIGURE 4: Sealed-box response of the 30W54 ($V_B = 3.39$ cubic feet, x_{max} (doubled) = 0.2756 inch). Curve a represents a 210W input and Curve b an 82W input.

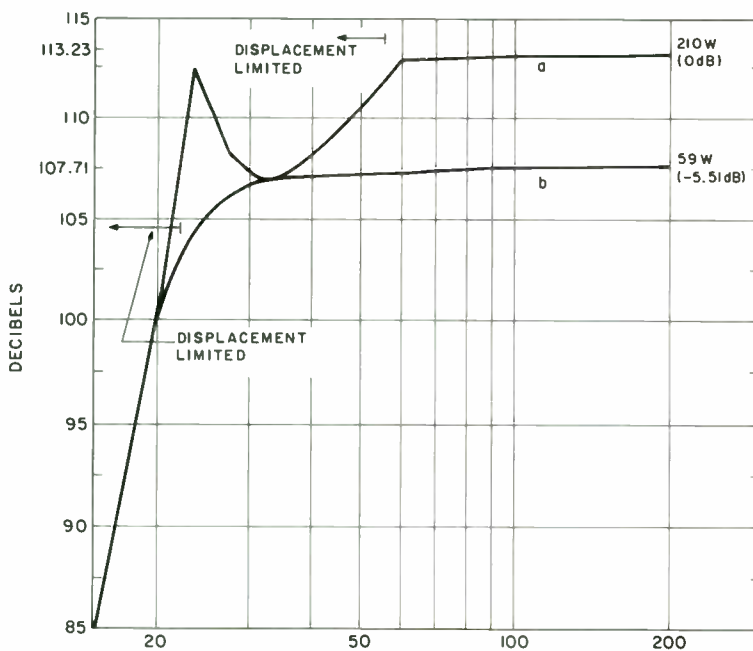

FIGURE 5: Vented-box response of the 30W54 ($V_B = 7.08$ cubic feet, $f_B = 23.35\text{Hz}$, x_{max} (doubled) = 0.2756 inch). Curve a represents a 210W (0dB) input and Curve b a 59W (-5.51dB) input.

KITS

from OLD COLONY

Post Office Box 243 • Peterborough, NH 03458-0243

ORDERING INFORMATION Prices, except as noted, are prepaid in the USA and insured. We prefer to ship via UPS, which requires a street address. If you cannot receive UPS delivery, please include an extra \$2 for insured service via Parcel Post. We cannot accept responsibility for safety or delivery of uninsured Parcel Post shipments. Charge card orders under \$10 please add \$1 service charge.

PRICES SUBJECT TO CHANGE WITHOUT NOTICE.

CHARGE CARD PHONE ORDER SERVICE M-F 9am-4pm EDT (603) 924-6371
MasterCard/Visa Cards Welcome. UPS next day and 2nd day air are available to some areas.

FILTERS & SPEAKER SAVER

- KF-6: 30Hz RUMBLE FILTER.** [4:75] 2 channel universal filter card, 1% metal film resistors and 5% capacitors for operation as 18dB/octave; 30Hz, 0dB gain only. Each \$19.75
- KH-2A: SPEAKER SAVER.** [3:77] Turn on/off protection & fast opto-coupler circuitry to prevent damage to your system. 4PDT relay & socket for 2 channels. Each \$35.00
- KH-2B: OUTPUT FAULT OPTION.** Additional board mounted components for speaker protection in case of amplifier failure. Each \$6.75
- KH-2C: COMPLETE SPEAKER SAVER KIT.** Includes KH-2A & KH-2B. Each \$40.00
- KL-5 WILLIAMSON BANDPASS FILTER.** [2:80] 2 channel, plug-in board and all parts for 24dB/octave 20Hz-15kHz with precision cap/resistor pairs. TL075 IC's. Each \$31.00

CROSSOVERS

- KC-4A: ELECTRONIC CROSSOVER, KIT A.** [2:72] Single channel, 2-way. All parts including C-4 board and LF351 IC's. Choose frequency of 60, 120, 240, 480, 1k, 2k, 5k or 10k. Each \$8.00
- KC-4B: ELECTRONIC CROSSOVER, KIT B.** [2:72] Single channel, 3-way. All parts including C-4 board & LF351 IC's. Choose frequency of 60, 120, 240, 480, 1k, 2k, 5k or 10k. Each \$11.00
- **KF-7: CROSSOVER FOR WEBB TLS.** [1:75] Passive 4-way x-over, in pairs, assembled. Components are included for both STC and Celestion tweeters. Made by Falcon of England. CLOSEOUT Pair \$50.00
- KK-6L: WALDRON TUBE CROSSOVER LOW PASS:** Single channel, 18dB/octave, Butterworth, [3:79] includes Bourns 3-gang pot. Choose 1: 19-210; 43-465; 88-960; 190-2100; 430-4650; 880-9600; 1900-21,000 Hz. Each \$43.00
- KK-6H: WALDRON TUBE CROSSOVER HIGH PASS:** Single channel, 18dB/octave, Butterworth, [3:79] includes Bourns 3-gang pot. Please specify 1 of the frequencies in KK-6L. No other can be supplied. Each \$45.00
- KK-6S: SWITCH OPTION.** 6-pole, 5-pos. rotary switch, shorting, for up to 5 frequency choices per single channel. Each \$8.00; ordered with 2 kits above, Each \$7.00
- KK-7: WALDRON TUBE CROSSOVER POWER SUPPLY.** [3:79] Includes board, x-fmr, fuse, semiconductors, line cord, capacitors to power 4 tube x-over boards (8 tubes), 1 stereo biamped circuit. Each \$88.00
- SBK-A1: LINKWITZ CROSSOVER/FILTER.** [SB 4:80] 3-way x-over/filter/delay. 24dB/octave at 100Hz and 1.5kHz and 12dB/octave below 30Hz, with delayed woofer turn-on. Use the Sulzer supply KL-4A with KL-4B or KL-4C. Per channel \$64.00
Two channels \$120.00 SBK Board only \$14.00
- SBK-CIA: JUNG ELECTRONIC 2-WAY CROSSOVER.** [SB 3:82] 30Hz filter with WJ-3 board & 4136 IC adapted as 1 channel x-over. Can be 6, 12 or 18dB/octave. Choose frequency of 60, 120, 250, 500, 1k, 2k, 5k or 10k. Each \$24.75
- SBK-C1B: THREE WAY, SINGLE CHANNEL CROSSOVER.** [SB 3:82] Contains 2 each SBK-C1A. Choose high & low frequency. Each \$49.70
- SBK-C1C: TWO CHANNEL, COMMON BASS CROSSOVER.** [SB 3:82] Contains 2 each SBK-C1A. Choose 1 frequency. Each \$49.70
- SBK-C2: BALLARD ACTIVE CROSSOVER.** [SB 3:82 & 4:82] 3-way x-over with variable phase correction for precise alignment. Kit includes PC board (5 3/8 x 9 1/2"), precision resistors, polystyrene & polypropylene caps. Requires ±15V DC power supply—not included. Can use KL-4A with KL-4B or C. Two channel \$134.00
- **CLOSEOUT: KITS NOT AVAILABLE AFTER PRESENT STOCK IS GONE.**

AIDS & TEST EQUIPMENT

- KH-7: GLOECKLER PRECISION 101dB ATTENUATOR.** [4:77] All switches, 1% metal film and 5% carbon film resistors to build prototype. Chassis, input/output jacks are not included. Each \$50.00
- KL-3C: INVERSE RIAA NETWORK COMPLETE.** [1:80] 1 KL-3R and 1 KL-3H with 1% polystyrene capacitors. Alternate 600 ohm or 900 ohm R₂/C₂' components for 2 channels. Each \$35.00
- KL-3R: INVERSE RIAA.** [1:80] Resistor/capacitor package complete. Contains stereo R₂/C₂' alternates. Each 25.00
- KL-3H: INVERSE RIAA HARDWARE.** [1:80] Box, terminals, gold jacks, and all hardware in KL-3C. No resistors or caps. Each \$13.50
- KF-4: SINE-SQUARE AUDIO GENERATOR.** [4:75] Morrey's MOD kit for Heath IG-18 (1G5218). 2 boards and parts to modify the unit to distortion levels of parts per million range. Each \$35.00
- **KG-2: WHITE NOISE/PINK FILTER.** [3:76] All parts, circuit board, IC sockets, 1% resistors, ±5% capacitors. No batteries, power supply or filter switch. CLOSEOUT Each \$11.50
- KJ-6: CAPACITOR CHECKER.** [4:78] All switches, IC's, resistors, 4 1/2" D'Arsonval meter, x-fmr and PC board to measure capacitance, leakage and insulation. Each \$78.00
- KK-3: THE WARBLER OSCILLATOR.** [1:79] Switches, IC's, x-fmr and PC board for checking room resonance and speaker performance w/o anechoic chamber. Each \$56.00
- KL-6: MASTEL TIMERLESS TONE BURST GENERATOR.** [2:80] All parts with circuit board. No power supply. Each \$19.00
- KM-1: CARLSTROM-MULLER SORCERER'S APPRENTICE** [2:81] 4 boards and all parts for construction of the first half of a swept function generator with power supply. No knobs or chassis. Each \$145.00
- KM-2: CARLSTROM-MULLER PAUL BUNYAN.** [3:81] All parts except knobs, chassis, output connectors and wire. Includes 2 circuit boards and power supply. Each \$85.00
- KM-3: CARLSTROM-MULLER SORCERER'S APPRENTICE/PAUL BUNYAN** [2:81, 3:81] All parts in KM-1 and KM-2. Each \$225.00
- SBK-D2 WITTENBREDER AUDIO PULSE GENERATOR.** [SB 2:83] All parts, board, pots, power cord, switches and power supply included. Each \$70.00
- SBK-E4: MUELLER PINK NOISE GENERATOR.** [SB 4:84] All parts, board, 1% MF resistors, capacitors, IC's, and toggle switches included. No battery or enclosure. Each \$27.50

SYSTEM ACCESSORIES

- KH-8: MORREY SUPER BUFFER.** [4:77] All parts, 1% metal film resistors, NE531 IC's, and PC board for 2 channel output buffer. Each \$14.00
- KJ-3: TV SOUND TAKEOFF.** [2:78] Circuit board, vol. control, coils, IC, co-ax cable (1 ft.) and all parts including power x-fmr. Each \$21.50
- **KJ-4: AUDIO ACTIVATED POWER SWITCH.** [3:78] Turn your power amps on and off with the sound feed from your preamp. Includes all parts except box and input/output jacks. CLOSEOUT Each \$35.00
- **KK-14A: MacARTHUR LED POWER METER.** [4:79] 2-channel, 2-sided board and all parts except switches, knobs, and mounting clips for LEDs. LEDs are included. No chassis or panel. CLOSEOUT Each \$60.00
- **KK-14B: MacARTHUR LED POWER METER.** [4:79] As above but complete with all parts except chassis or panel. CLOSEOUT Each \$70.00
- SBK-D1: NEWCOMB PEAK POWER INDICATOR.** [SB 1:83] All parts & board. No power supply required. Two for \$10.00 Each \$6.00
- SBK-E2: NEWCOMB NEW PEAK POWER INDICATOR.** [SB 2:84] All parts & board, new multicolor bar graph display; red, green & yellow LED's for 1 channel. No power supply needed. Two for \$15.00 Each \$9.00
- KC-5: GLOECKLER 23 POSITION LEVEL CONTROL.** [2:72] All metal film resistors, shorting rotary switch & 2 boards for a 2 channel, 2dB per step attenuator. Choose 10k or 250k ohms. Each \$36.75
- KR-1: GLOECKLER STEPUP MOVING COIL TRANSFORMER.** [2:83] X-fmrs., Bud Box, gold connectors, & interconnect cable for stereo. Each \$335.00
- KL-2: WHITE DYNAMIC RANGE & CLIPPING INDICATOR.** [1:80] 1 channel, including board, with 12 indicators for preamp or x-over output indicators. Requires ±15V power supply @ 63 mils. Single channel. Each \$49.00 Two channels. \$95.00
Four channels. \$180.00
- KS-7: SCOTCHCAL® PANEL KIT.** [2:84] One 10 x 12" sheet each of 4 types of pressure sensitive panel material (blk on aluminum, blk on transparent poly, blk on white poly, matte clear overlay), one pint of developer plus pads, and instructions. Requires a simple frame and a light source: ultraviolet, photofloods or the sun, plus your own press-on lettering materials. Postpaid. Each \$34.50

What's Included? Kits include all the parts needed to make a functioning circuit, such as circuit boards, semiconductors, resistors and capacitors. Power supplies are not included in most cases. Unlike kits by Heath, Dyna and others, the enclosure, face plate, knobs, hookup wire, line cord, patch cords and similar parts are not included. Step by step instructions usually are not included, but the articles in *Audio Amateur* and *Speaker Builder* are helpful guides. Article reprints are included with the kits. Our aim is to get you started with the basic parts—some of which are often difficult to find—and let you have the satisfaction and pride of finishing your unit in your own way.

ter, a 0.13-inch excursion and a thermal potential of 320W. It appears to have plenty of thermal capacity, but what about displacement-limited thermal capacity? You were right if you guessed it would not handle 320W without displacement limiting before achieving the TA. It will, however, handle 121W and put out an incredible 115.5dB (Fig. 7, Curve a). Remember, this is coming out of a 2.8-cubic-foot box and is -3dB at 46Hz.

I do not need 115dB, but I could use a little lower bass. This is where class I, sixth-order alignments really shine. Let's trade some displacement-limited thermal capacity for some bandwidth. Taking a tip from Don Keele of JBL ["A New Set of Sixth-Order Vented-Box Loudspeaker System Alignments," *JAES* (Volume 23, Number 5), June 1975, p. 356], I tuned the box one-half octave lower to 36.5Hz and added a 6dB boost at 39Hz, which is 7 percent higher than the new f_B . I now have a system that is limited to 29W, puts out 109.3dB and is -3dB at 35Hz (Fig. 7, Curve b). As you can see, I have achieved +6dB on the SPL with the same amplifier power and have lowered the -3dB point a half octave.

CONCLUSION. Informed use of BOXRESPONSE can save time and materials when you are designing a system within certain limitations. Make sure you always graph the results because the effects do not hit

home until you do. Add more frequency points to your data statements in program line 550 and try to find long voice coils. But remember, you pay for bandwidth with efficiency. ▶

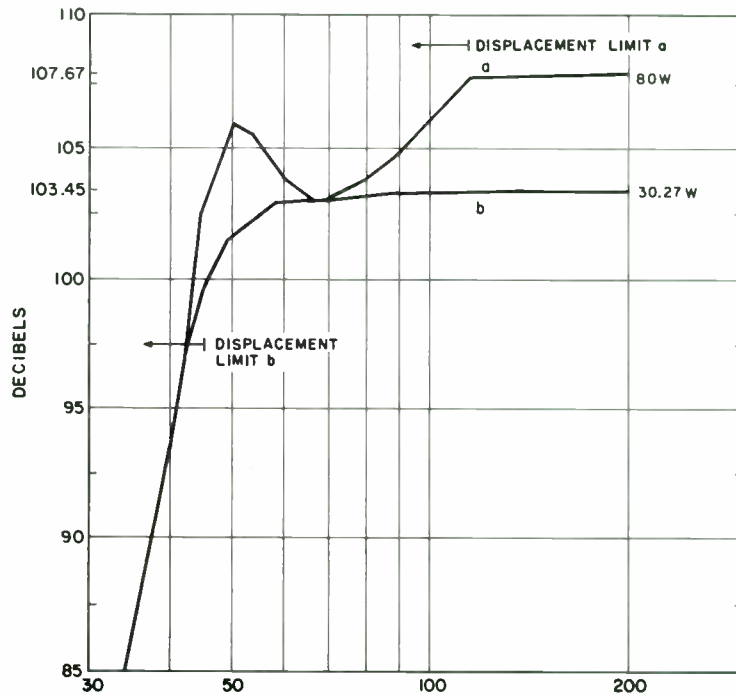

FIGURE 6: Response of the Peerless TP-165F ($V_B = 0.7$ cubic foot, $f_3 = 46.42$ Hz, $f_B = 48.6$ Hz). Curve a represents an 80W input and Curve b a 30.27W input.

SOMETHING NEW

Lots of magazines—most of them, in fact—offer readers special information services for products mentioned in news columns and advertisements. Usually only large magazines offer such services. We think we are one of the first small publishers to do so—and on our own computer.

But we need your help to make it all work. Remember to write your subscriber number (what we are calling your "magic number") on the **FAST REPLY** cards you mail in—and on any other correspondence about your subscription or orders for other items. That "magic number" is actually your record number on our computer. We have designed our little system to use that number in addition to the number of the vendor or vendors from which you wish to hear. Our clerk will enter only the numbers from your returned card, and our computer will do the rest.

If you have a friend who wishes to use the second **FAST REPLY** card, that's fine with us, even though your friend is not a subscriber. Just ask the person to check the non-subscriber box at the top, and we will take care of the rest.

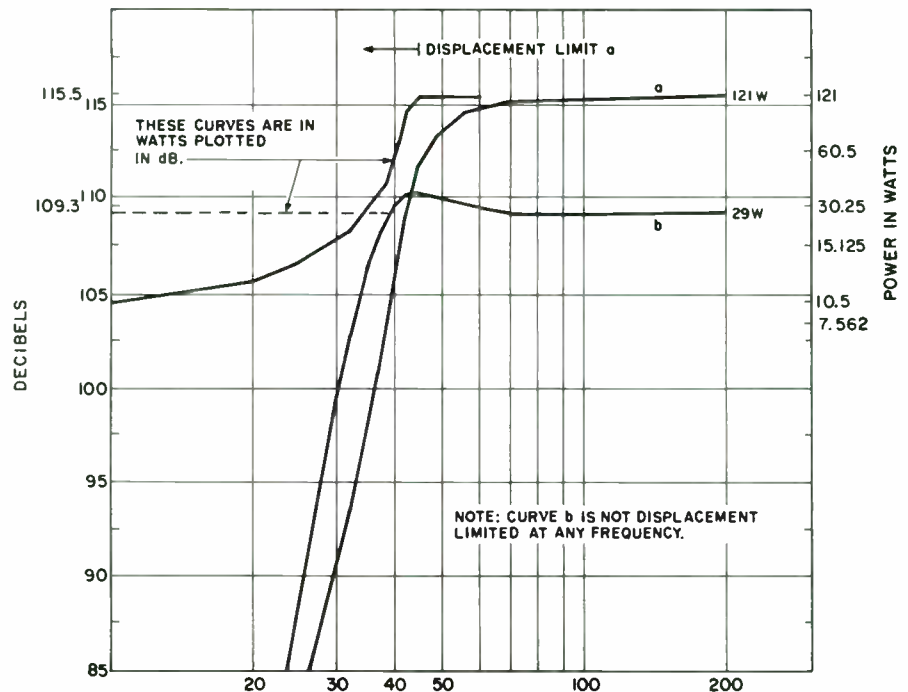

FIGURE 7: Curve a represents the fourth-order vented-box response of the TP-165F at 121W. Curve b is the sixth-order vented-box response at 29W. ($V_B = 2.79$ cubic feet)

Tools, Tips & Techniques

Quasi-Zobel Network

Perhaps you would like to take advantage of the benefits of a Zobel network, but do not have access to an audio oscillator or an oscilloscope. If you own a Heath IB-5281 RCL bridge, you can modify that bridge to obtain a quasi-Zobel network. The IB-5281 uses a Wien oscillator with three fixed frequencies—1,000Hz for high values of C and L as indicated on the range switch, 10kHz for medium values and 100kHz for low values.

All values of R are 1,000Hz. Thus, the 10 μ H to 1mH range will use 100kHz, 1mH to 0.1H will use 10kHz, and 0.1H to 10H will use 1,000Hz. Unfortunately, the external standard position (Zs) on the range switch provides 1,000Hz regardless of the external standard actually used. A 5mH standard coil plugged into the Zs terminals would be used to measure an unknown inductance (Zx) with a 1,000Hz frequency instead of the 10kHz frequency that the range switch would automatically select if you were using the internal standards. The result of this frequency mismatch shows up on the null meter. For example, a maximum null of 5 obtained with 10kHz and internal standards would produce only an 8 or 9 when using an external standard and its accompanying 1,000Hz frequency.

One way to avoid this is to add a two-pole, four-way, nonshorting rotary switch as shown in Fig. 1. Remove R1 and R4 from SW2 and resolder them (or 1 percent resistors) in positions 3a and 3b of switch X. Solder two 43k and two 4.3k resistors as shown, and run four wires from switch X to the appropriate lugs on SW2. Two lugs on switch X are not used for the time being. The high-value position of switch X (430k) will now provide 1,000Hz on range-switch position Zs and will allow normal operation on the remaining nine range-switch positions. The medium-value position (43k) will provide 10kHz on range-switch position Zs, and the low-value position (4.3k) will provide 100kHz.

Now the quasi-Zobel network comes into play. If you are Zobelizing an 8 Ω driver, place an appropriate 1 percent resistor, 6

to 10 Ω , in the Zs terminals. Connect the driver's terminals to the Zx terminals, set the range switch to Zs and set switch X to normal operation. The driver is now producing a 1,000Hz tone, and its impedance might be nowhere near 8 Ω .

Turn switch X to medium values (10kHz) and observe the impedance at that frequency. Turn switch X to normal.

Now use alligator clips to connect one lead of an 8 Ω , noninductive resistor to one speaker terminal. Connect one lead of a small (8 μ F) nonpolarized electrolytic capacitor to the other speaker terminal and then connect the two loose leads. Observe the new impedance measurement at both frequencies. Then vary the value of the capacitor (and possibly also

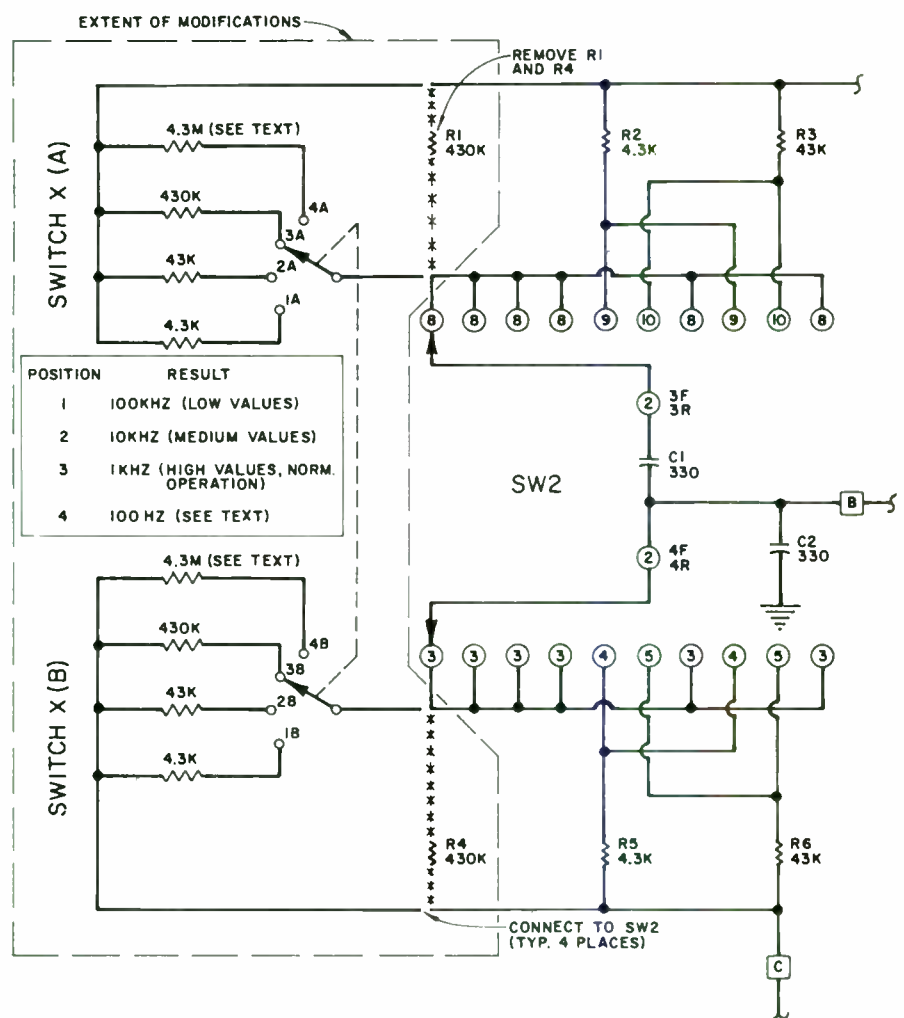
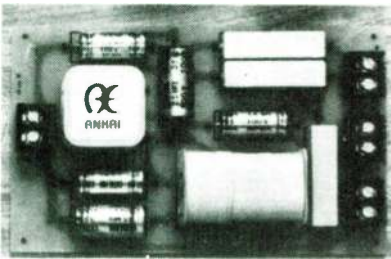

FIGURE 1: Adding this two-pole, four-way, nonshorting rotary switch cures the frequency-mismatch problem.

ANKAI High Quality Crossover Networks



Custom built for professional, home, and automotive speaker systems.

Available in:

2 way, 3 way, 4 way, and separate networks for Subwoofer, Midrange, and Tweeter. Impedance: 4, 8, 16 ohms

Features:

- Printed circuit board design
- Impedance equalizing circuits
- Attenuating circuits
- Simplified L-Pad connection
- Color coded connecting leads
- 12 db/oct slope

Networks may be obtained with the desired crossover points. For more information, write to:

ANKAI ELECTRONICS
6085 Venice Blvd., Unit #84
Los Angeles, Ca. 90034
Tel. (213) 937-6854

FAST REPLY #FH57

6000.6 phase correct

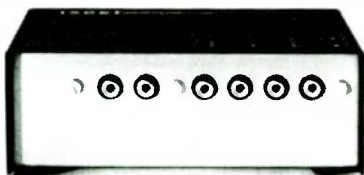

electronic crossover

The new 6000-6 is designed to improve your system by eliminating crossover errors and passing perfect square waves. A plug-in module allows convenient frequency change (from 40-16,000 Hz). Level controls on rear, 1% components used. Model 6000-6 \$175 PPD. Other models from \$16.25. Free folder/reviews. **ACE AUDIO CO.**, 532-5th St., East Northport, NY 11731-2399. (516) 757-8990.

FAST REPLY #FH53

the resistor) to get as close as possible to an 8Ω impedance figure for both 1,000Hz and 10kHz. Chances are that frequencies between these two points will also be close to 8Ω. Finally, bypass the electrolytic capacitor with a small (0.01μF) film capacitor. You might want to solder all connections for a final check.

Some disadvantages of this system are fairly obvious. A tweeter with a resonant frequency near 1,000Hz will never approach 8Ω at that frequency. A woofer with a low voice-coil DC resistance (say 5Ω) might exhibit an 8Ω impedance at 1,000Hz, but the range of impedance from that point down to resonance might vary from 8 to 6Ω or less. (For example, you might get values of 8.5Ω at 1,000Hz and 6Ω at 150Hz for a 10-inch CTS woofer.)

You cannot determine the exact impedance at a particular crossover point unless that point occurs at 1,000Hz or 10kHz. I used this technique on a three-way system's woofer and cone midrange, but not on its dome tweeter. I later obtained an audio oscillator and modified my IB-5281 as Vern Mastel suggested in *SB 1/82* ("Adapting Heath's RCL to Measure Z," p. 31). Measurement of the entire system's impedance (using a passive parallel first-order crossover at 700Hz and 5kHz) yielded 8Ω, ±1Ω, from 200Hz to 30kHz. While this is not perfect, it is certainly a good ball-park figure that provides a nice nonreactive load to an amplifier.

Just for fun, I added two 4.3M resistors to positions 4a and 4b of switch X. The Wien oscillator failed to produce a 100Hz tone, however. Perhaps another *SB* reader could explain why this is so. Enterprising readers might also want to replace switch X with a rotary switch that has more positions, providing a wider choice of frequencies. Even a decade arrangement is possible, but a frequency counter would

be necessary to check this modification.

I also grew tired of trying to read the blue-on-black face of the null meter. A cure for this involves a pair of 12V grain-of-wheat bulbs. Wire them in parallel, then wrap enough 1/16-inch-wide graphic tape around the base of each bulb to space the bulb about 1/16 inch away from the back of the null meter. Place the bulbs upside down and tape them to the back of the meter. Make sure that the filament part of the bulb is not covered when taping the base of the bulbs to the back of the meter.

Next, cut a piece of duct tape 1 1/4 inches wide by 4 1/4 inches long. Place a piece of aluminum foil 1 1/4 inches wide by 2 inches long in the center of the duct tape (shiny side out), bend the foil part of the tape into a rough semicircle and attach the remaining sticky part of the tape to the sides of the meter and the back of the front panel. The foil will now reflect most of the light back through the meter, and the semicircular shape will allow air to enter from the bottom and exit through the top, thus cooling the bulbs.

There is space in the case for two spare 9V batteries, wired in parallel. The bottom rear corners of the case are a perfect fit for two "C" cells, with some thin foam rubber and duct tape holding them in place. I used switch Y, a single-pole, five-position, nonshorting rotary switch, for a choice of OFF/9V/10.5V/12V/OFF to suit variable light conditions. A simple SPST toggle switch would work as well. The current drain is fairly heavy, especially on the 9V batteries, so use the light only when taking readings. *Figure 2* shows the null light wiring schematic and *Fig. 3* the locations of switch X and switch Y on the front panel.

Steve Ball
Austin, TX 78745

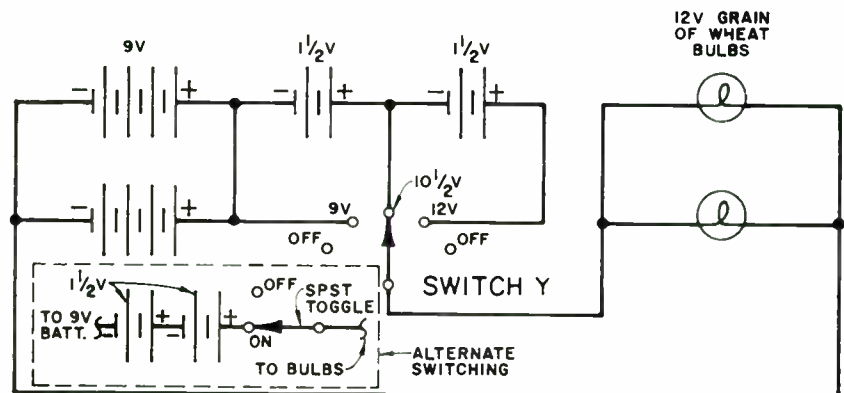

FIGURE 2: Schematic for the null light wiring.

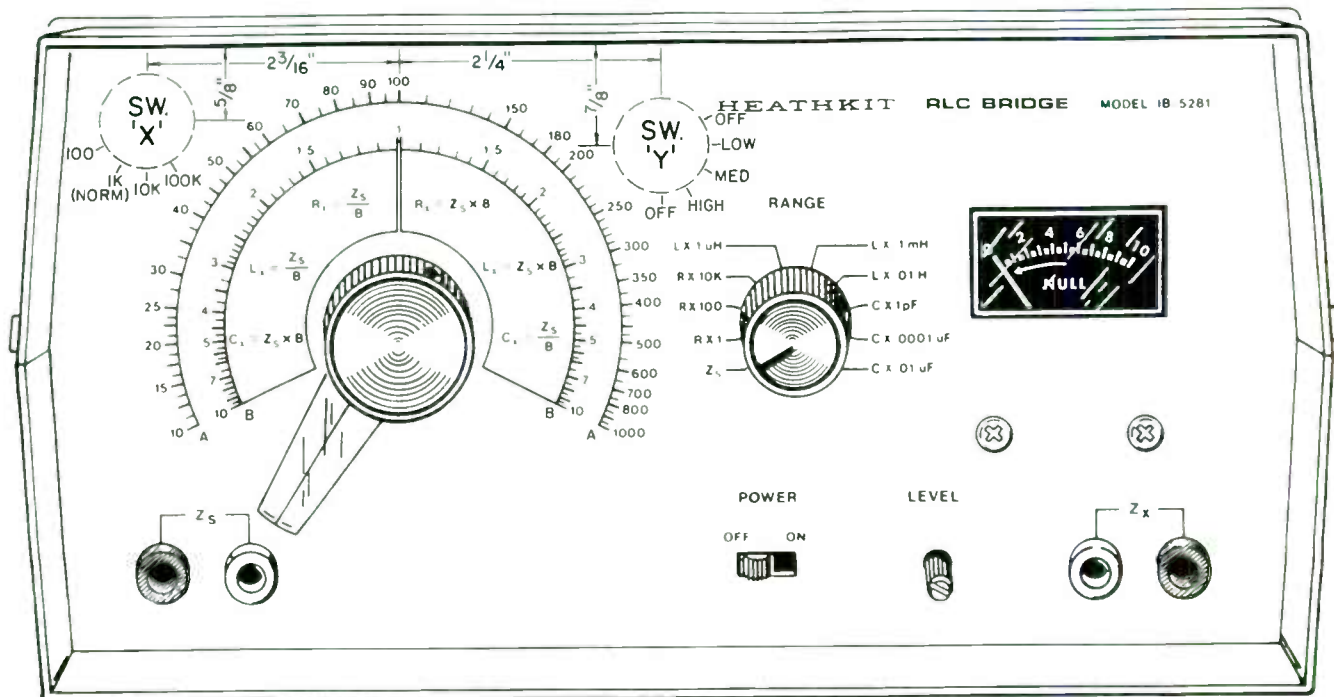

FIGURE 3: Note the locations of switch X and switch Y on the front panel.
Reprinted from the Heath IB-5281 RCL bridge manual.

Order by number or name
Polydax speaker corporation
Polydax speaker corporation

Subsidiary of AUDAX France



Our PR 130 P 20 HR is truly a state of the art Bullet Tweeter which is designed to fit into the most demanding professional applications. It's ring shaped diaphragm of a specially developed aluminum alloy is coupled to an aluminum former which is suspended in a cooling bath of magnetic fluid. A powerful magnetic structure is employed to insure high acceleration factors and sensitivity while keeping transient distortion very low.

If you would like more detailed information on this driver and a copy of our NEW PRODUCTS catalog, please respond to the fast reply number listed below.

PR 130 P 20 HR
19mm-3/4"
BULLET TWEETER

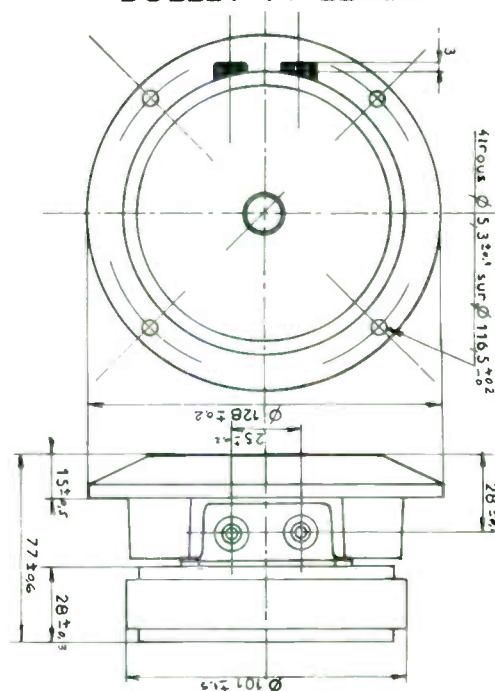

2 Park Avenue, New York, N.Y. 10016 Telephone (212) 684-4442, Telex 237608 Pldx

Kit Report

Shadow MKIVF Crossover

Active crossover networks are a boon to home speaker builders because they allow us to sidestep the problems of driver impedance equalization and inductor losses, greatly simplify system sensitivity matching, are usually very accurate, and are portable from system to system. If these facts convince you to go active, then the Shadow MKIVF electronic crossover kit from Shadow Engineering (PO Box 580, Lilburn, GA 30247) might interest you.



PHOTO 1: The Shadow MKIVF kit is easy to assemble and is characterized by high-quality construction and workmanship.

This kit is a two-way, third-order, all-pass crossover network, commonly called a Butterworth crossover, which can be ordered with any crossover frequency you choose and can be expanded to three-way operation with a second filter board. The basic two-way unit is a little expensive (\$249), but it is very well designed and uses audio-grade components throughout. It is available from Audio Concepts (1631 Caldonia St., LaCrosse, WI 54601).

Kit Assembly

The kit comes with prestuffed power supply and filter circuit boards, so assembly consists of mounting the hardware and installing input/output and power supply wiring. Even a beginner should be able to complete the job in one afternoon following the accurately detailed instructions. It took me about two hours. You can also buy the power supply and filter circuit boards separately (see Audio Concepts' comments for prices), and the unit can be converted to 6dB/octave or 12dB/octave with instructions supplied by Audio Concepts.

Before putting the crossover (Fig. 1) into my system, I decided to make a simple check to see whether things were in order. Knowing that the left and right channel outputs should be the same at a given frequency, I applied a signal at the 100Hz crossover frequency, where all outputs should be at a respectable level. As ex-

pected, the left and right low-pass outputs were the same. Unfortunately, the left high-pass output read about 1V higher than the right. Rather than track down the problem myself, I used a reviewer's perquisite and returned the unit to the manufacturer, after calling and explaining the problem. He had it repaired and returned to me within two weeks. The cause of the malfunction was a solder bridge on the foil side of the filter board, probably caused by my sloppy soldering technique. The repaired crossover measured and worked fine.

I have only one small complaint. The top and bottom covers are held on by allen-head screws, which are extremely hard to turn and tighten. I ruined the wrench supplied with the kit before I got the job done. It would be nice if the screws turned more easily or if slot-head screws were used instead. The latter would make it easier to apply the necessary torque. In all other respects, I was impressed by the high-quality construction and workmanship.

MKIVF Performance

When I returned the unit for repair, I had them change the crossover frequency to 150Hz, which is what I use in my system. In spite of extensive listening to both the MKIVF and my own active network, I was unable to distinguish any difference between the two. My conclusion is that the MKIVF performs its function excellently.

For the record, my crossover is a sixth-order, all-pass network built with four of Jung's 30Hz rumble filter cards and using TL074 op amps instead of the stock 4136s.

The MKIVF circuit design is very clever in crossover frequency selection. I expected to see each filter realized by a third-order, Sallen-Key type circuit, but instead each one is realized by cascading a first and second-order Sallen-Key. This requires a second op amp for each filter and is not as

economical, but the benefits in terms of tuning and accuracy are worth the extra cost.

The second-order stage uses a gain-of-two realization, which can be done quite accurately and allows all the capacitors to be of equal value. Because the filter is a Butterworth, it turns out that all the resistors are also equal, and the same resistor and capacitor values can be used in the first-order stage. Thus, all the filter-shaping resistors, as well as all the capacitors, have the same value. By fixing the value of all the capacitors (at $0.047\mu\text{F}$ for the MKIVF), the crossover frequency is then completely determined by the common value of the 12 filter resistors. Thus, the MKIVF's "frequency module" is simply a resistor array of the value needed to provide the desired crossover frequency.

The output of the MKIVF high-pass section is attenuated so that it is approximately unity gain (depending on the input impedance of the amplifier). The output of the low-pass section passes through a variable attenuator, so its gain can be set anywhere between zero and two (i.e., ∞dB to $+6\text{dB}$). This should allow accurate sensitivity matching in most loudspeaker systems.

Application Notes

Third-order, all-pass crossovers have two weaknesses. First, they are quite sensitive to the phase difference between the drivers at the crossover frequency, and second,

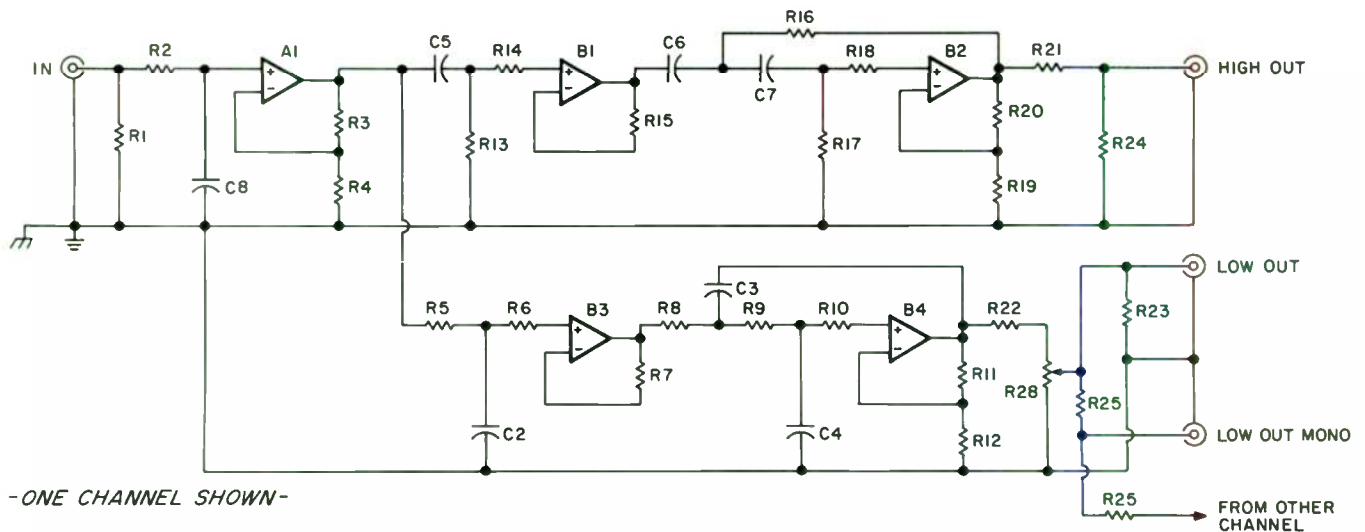

FIGURE 1: The MKIVF is a two-way, third-order, all-pass crossover network from Shadow Engineering. Audio-grade components are used throughout.

they produce a nonsymmetric vertical radiation pattern.

The first weakness can usually be overcome by careful placement of the crossover frequency. In particular, if it is two octaves or more above the resonant frequency of the system's high-frequency driver,

the response ripple caused by the phase effects is less than 1dB. In a conventional two-way system, it is advisable to use a low-resonant-frequency tweeter so that the crossover frequency can be high enough to minimize these phase effects but low enough so that the vertical radiation lobe is

not unduly narrow. When using the third-order network as a subwoofer crossover, a crossover frequency of at least 150Hz is usually necessary to minimize phase-induced response variations.^{1,2}

The nonsymmetric vertical radiation pattern caused by an odd-order network is

A&S SPEAKERS

has the widest selection of high-end speaker kits, raw drivers and custom mobile speaker systems. We specialize in kits from the finest European and American manufacturers such as Dynaudio, Fried, Audax, Falcon-Acoustics and the Jack Caldwell, Avery Dark, Jay Adamson and Bill Reed Signature kits.

Our raw driver selection includes the Jordan 50mm Module, Dalesford/Cambridge, SEAS, Siare, Peerless, Becker and others.

Ask about our expanded selection of high-end separates for mobile applications.

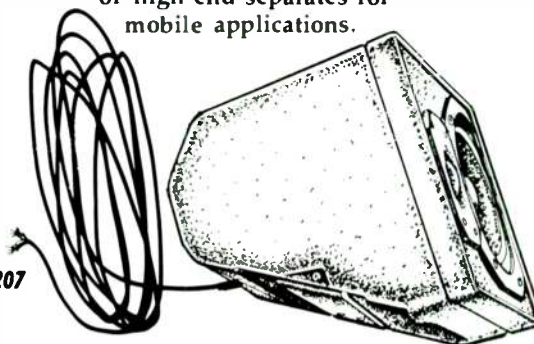
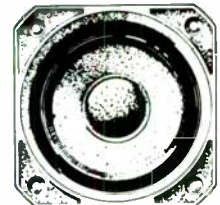
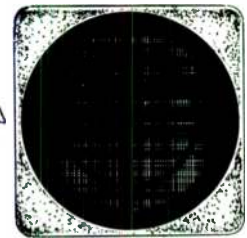
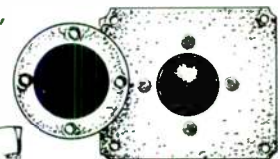
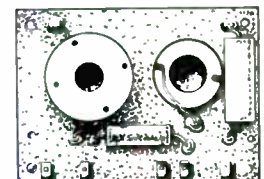
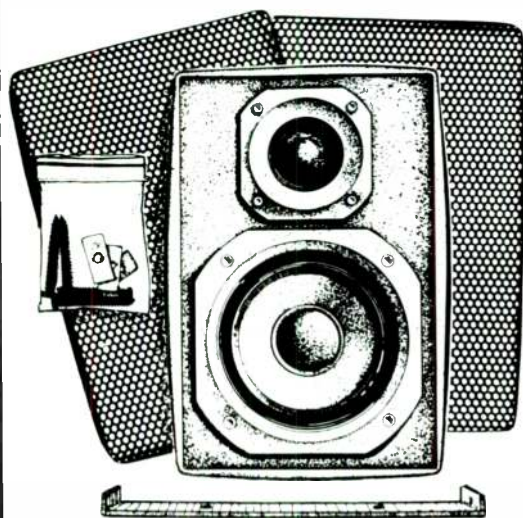

A&S SPEAKERS

Free price list.

Box 7462B, Denver, CO 80207
(303) 399-8609

Specifications

- Equal component value VCVS topology.
- Adjustable frequencies via plug-in frequency-change modules.
- Third-order (18dB/octave) symmetrical Butterworth filtering.
- Symmetrical biasing at every stage for minimum offset.
- DC coupling.
- Single spectral balance control (external).
- Power supply bypass and RF decoupling.
- Mono subwoofer output.
- Triamp capability (two boards required).
- Regulated $\pm 15V$ DC power supply.
- Optional gain, user adjustable (internal).
- Slope and Q , user adjustable (internal).

Hum and noise: Negligible.

Standard gain: 6dB low-pass (adjustable);

0 to -3dB high-pass (internally adjustable).

Power requirements: Less than 5W, 120V AC, 60Hz.

Chassis dimensions: 17 by 1 $\frac{3}{4}$ by 5 $\frac{1}{2}$ inches with a 19-inch rackmount front.

Black baked epoxy enamel. Front is lacquered aluminum.

the main reason Linkwitz introduced even-order, all-pass networks.³ The details of the problem are spelled out in my article on crossover networks beginning in this issue on p. 13. Recently, D'Appolito has shown how to eliminate the problem completely by using dual woofers with odd-order networks.⁴ His article in *SB 4/84* (p. 7) details the construction of such a system.

As I mentioned earlier, the MKIVF can be expanded to three-way operation. The

resulting cascade crossover is no longer an all-pass network, and the amount of ripple it produces depends on how far apart the crossover frequencies are. To keep it under 1dB, the crossover frequency separation should be a decade or more.

With due attention to overcoming its shortcomings, the third-order crossover can produce outstanding results. In particular, the MKIVF is a minimum compromise realization that should contribute to the transparency of the sound produced by any well-designed system.

Robert M. Bullock III
Contributing Editor

Shadow Engineering comments:

I am grateful to Speaker Builder and to Mr. Bullock for his review of the Shadow Engineering MKIVF electronic crossover.

Mr. Bullock mentions that the unit is a bit expensive. We could have made the unit a little more cheaply, but not without unacceptably compromising it. We could also have made it more expensive by using wonderful capacitors and fancy cosmetics. Instead we chose to make all major components available separately for those who wish to invest more money in a custom installation or for those concerned about cutting costs. Further customization is possible for builders who wish to use something other than the standard Butterworth filter. These may be special ordered from Shadow at no extra charge.

The MKIVF was optimized for subwoofer biamp applications between about 40 and 200Hz, although it is certainly viable for other frequencies and applications. At frequencies this low, its phase differences are inaudible in every application we have encountered. The use of higher frequencies requires the use of proportionately more precautions in system

setup, as Mr. Bullock mentions. A surprising number of customers have sought to avoid these problems by using the first-order version. Where this shallow attenuation rate is compatible with the driver complement, we endorse this option. We no longer recommend or supply the second-order version mentioned because of the unacceptable compromises it requires.

We regret the problem Mr. Bullock had with the cover mounting screws. In a few of the chassis from a recent production batch, the threaded inserts were distorted when pressed into place. This is not a typical condition. Normal 6-32 by $\frac{1}{4}$ inch machine screws may be substituted if desired.

Although Audio Concepts stocks the entire assortment of kits and accessories, inquiries and special orders should be sent directly to Shadow. A new limited production, limited application version of this crossover with an altogether different circuit topology is due for a spring 1985 release, as is a high-current, low-impedance power supply. Contact Audio Concepts or Shadow for further details.

Audio Concepts comments:

Thank you for a comprehensive, accurate review of the Shadow MKIVF. We have taken a few of Mr. Bullock's suggestions and have used them to improve the product. The tight screw holes are now being tapped cleaner so that the screws will fit as they should.

We now offer a new crossover called the Limited Edition, which features an asymmetrical configuration with a first-order filter on one pass band and a third-order Bessel on the other pass band for total phase coherence. Frequency for this version must be specified when ordering, and should you wish to change the frequency later, you must return the unit to Shadow and pay a \$50 service charge. The Limited Edition also uses the new HCLZ power supply, which has approximately 0.5A current capability and lower impedance than the stock unit. Full kit price for the Limited Edition is \$289.

As mentioned in the review, all Shadow components can be purchased separately at the following prices: MKIVF circuit board, assembled, \$125; MKIVF power supply, \$32; MKIVF frequency modules, \$10; transient perfect circuit board, assembled, \$150; HCLZ power supply, \$55.

REFERENCES

1. Leach, W.M. Jr., "Loudspeaker Driver Phase Response: The Neglected Factor in Crossover Network Design," *JAES* (Volume 28), pp. 410-421.
2. Bullock, R.M. III, "Loudspeaker-Crossover Systems: An Optimal Crossover Choice," *JAES* (Volume 30), pp. 486-495.
3. Linkwitz, S.H., "Active Crossover Networks for Noncoincident Drivers," *JAES* (Volume 24), pp. 2-8.
4. D'Appolito, J.A., "A Geometric Approach to Eliminating Lobing Error in Multiway Loudspeakers," presented at the 74th Convention of the AES, October 8-12, 1983.

PARTS LIST

Resistors*

R1	100k
R2	1k
R3	gain dependent 6dB-15k 10dB-32.4k 16dB-78.7k
R4, 25	15.4k
R5, 8, 9,	
13, 16, 17	frequency dependent
R6, 10, 14, 18	100 Ω
R7, 15	34k
R11, 12	121k
R19, 20	68.1k
R21	9.09k
R22	221 Ω
R23	475k
R24	10k
R26, 27	not used
R28	10k dual pot, audio taper

Capacitors

C1	not used
C2-7	0.047 μ F polypropylene
C8	1,000pF polystyrene
C9-14	0.01 μ F polystyrene (not shown)
C15, 16	0.1 μ F polypropylene (not shown)

Active Devices

A1, 2	$\frac{1}{2}$ TL072
B1-4	$\frac{1}{4}$ TL074

*All resistors 1% tolerance metal film RN55.

SB Mailbox

SHAHINIAN SUBWOOFER INFO

I am responding to Stephen E. Katz's request for information on the "Wegerman Pro" loudspeaker used by Shahinian for his subwoofer (SB 2/84, p. 42). The speaker was the *Hegeman* subwoofer, designed by Stewart Hegeman, who also designed the original Citations, among other things. I am not sure whether the Hegeman Pro was the subwoofer or a full-range model, but I suspect it was the latter. If the subwoofer was constructed the same way as the full-range Hegemans of the same era, prospective home constructors will have quite a job ahead of them, as the design of the enclosure was very complex.

Ivan Berger
Technical Editor, *Audio*
New York, NY 10036

DRIVER DISTRESS

From a practical viewpoint, Robert Bullock's articles on vented speaker system design are the only good summation of the subject I have seen. I have just begun my first design project and have gotten some off-the-wall results right off the bat. I do not believe they are wrong, but I would like to get some feedback on my findings.

The driver in question is an old Bozak B-207B woofer. It has a rather small magnet and a pretty thick cone. The interesting thing about it, though, is that it is very well damped: if you hit the cone with your finger, it barely moves and does not ring very much. Because of this, I believe, the resonant point of the bare driver does not resonate that much. The highest resistance measured at the driver's resonance is only 22 ohms. This brings my Q_T in at around 1.16, well off Mr. Bullock's design charts.

Might I assume, then, that when I am nosing around speaker shops and surplus outlets, I want a somewhat boingy

suspension in a driver for a vented system? I realize that you can go off court in the other direction, as some will ring for minutes after being whacked, but I can see how all this came about. We want our transducers to be nonresonant, but a reasonable-sized enclosure apparently functions on the basis of that ring. Before I buy a driver and measure it, I have to hold it to my ear, thump it and make a judgment from the approximate ring frequency and duration. Perhaps if someone could add his or her experience to mine, we might find an in-store quick check of the many available drivers.

Hilary Paprocki
Rochester, NY 14607

Mr. Bullock replies:

Your proposed "boingy suspension" test will probably give you some indication of driver compliance. Long vibration duration means high compliance. It will not help you decide whether the driver is appropriate for vented boxes because both low and high-compliance drivers can have acceptable Q_{TS} values.

The best physical evidence of low Q_{TS} is a large magnet assembly and a light cone. Even so, such evidence is relative and undependable. The only sure test of driver acceptability is to measure Q_{TS} . For this reason, I buy only drivers for which specifications are available either from the vendor or the manufacturer. The figures are usually in the right ballpark, and so far I have purchased only one unusable unit.

COOKBOOK APPROACH TO CROSSOVERS

I have observed a polarization of speaker-building enthusiasts. Clearly, I am of the "cookbook" variety looked down upon by some readers. I enjoy building speakers. My skill lies primarily in woodworking, not electronics or crossover design. While I understand the basics of why and how a crossover works, I have very little desire and no time to experiment in this area. Just give

me a recipe, and I will build the speaker. I don't think there is anything wrong with that approach.

My first project was a pair of Webb transmission line loudspeakers, which I have since dismantled (after several years of fine service) and reassembled as a pair of LS3/5A mini-monitors. That leaves me with two KEF B-139s, which are begging to be made into a subwoofer that I could use with my monitors. Someday, I also hope to build some electrostatics and would like to be able to use the bass for them, too.

Multiamping with active crossovers is the purist's delight, but I need a less elaborate alternative. Perhaps some cookbook author can prepare a passive crossover that will blend with the LS3/5As. A purist can always progress to active crossovers and multiamping as finances allow.

I would appreciate any assistance in this area. Please don't forget that some of us enjoy building and listening despite our lack of experience in theoretical physics.

Neil Disney
Marshall, MI 49068

THE BBC DIP

The Falcon mini-monitor article in SB 4/81 (p. 32) inspired me to write and shed some light on certain design features of the LS3/5A that contribute to its particular sound characteristics.

The LS3/5A was originally designed by the BBC as a mini-monitor for use on location in their portable recording vans. Hence, its original purpose was for "close-up" monitoring in a confined area. BBC engineers noted that in this "close-up" situation, a flat mid-band response made the instruments sound too close and unnatural. To alleviate this problem, the engineers added the famous "BBC dip" and found that this slight trough (a few decibels) in the 1 to 3kHz region gave way to a more natural overall effect when the speakers were used as intended. This would account in part for Charles Lyle's trough in the 1 to

Mailbox

4kHz region (SB 1/82, p. 38). This "quirk" also, I believe, accounts for different reviews of the design. It would appear that the LS3/5A is more dependent on placement than many other designs.

Another interesting feature is the BBC's choice of 1/2-inch timber for the cabinets. This thickness was chosen so the cabinet walls would actually resonate at low frequencies (below 100Hz), allowing the use of internal damping to "tune" the cabinets for natural mid-band response.

I hope this information will help readers understand more about the LS3/5A. I would welcome correspondence about this topic or any other aspect of audio.

Joseph P. Kmetz
9861 Good Luck Rd. #10
Lanham, MD 20706

SATELLITES, SUBWOOFERS & STUFFING

I enjoyed Thomas Clarke's article on Thiele/Small alignments in SB 3/83 (p. 26). Nomograms and graphs are a much more efficient way to review prospective drivers than complex formulas. Unfortunately, I am afraid my current project will require me to renew my battle with the old TI.

I am trying to design a low-cost satellite system using a ported subwoofer. I have two satellites with Philips 7066 8-ohm speakers in 400-cubic-inch boxes. The manufacturer's parameters ($V_{AS} = 21.7$ liters, $Q_T = 4.5$) suggest that this size closed box will be adequate. My original intention was to use a simple low-pass filter on the subwoofer and let the 7066s operate "full range." That would, however, unpredictably alter the system impedance. Second and third-order crossovers at 120Hz are very expensive, so I would prefer to build my own low-pass filter.

My questions are as follows. First, is it possible to calculate alignments accurately for speakers in parallel using manufacturer specifications? Second, can anyone recommend a suitable subwoofer? I am currently looking at drivers by Madisound and Sherwood. Finally, I recall reading an article about the effect of stuffing on the apparent size of loud-speaker enclosures. It said that you can increase the apparent size by approxi-

mately 40 percent. Does Fig. 2 in Mr. Clarke's article take that into account? If not, would it cause any major remodifications?

Robert M. Birley II
Goleta, CA 93117

Mr. Clarke replies:

Provided the drivers are located physically close to each other (much less than a wavelength of sound), two identical drivers in parallel will behave acoustically and electrically like one larger driver. This "double driver" will have the same Q as either of the original drivers, the same resonance and twice the acoustic volume. You will find no real surprises here, but efficiency will be 3dB greater due to mutual acoustic coupling between the drivers. If the drivers are not identical, one might tend to "hog" the power near resonance. At higher frequencies, interference between the drivers will produce directivity, and the 3dB boost will vanish, but this should not be important with a subwoofer.

I cannot recommend a specific driver for your subwoofer, but to avoid matching problems, choose one of nearly the same efficiency as your satellite. I am partial to vented-box subwoofers, but my favorite is a design based on my augmented passive-radiator system that hides part of the volume in a closet (or wherever). I am publishing an article on this in Sound and Video Contractor (SVC) and possibly in Speaker Builder. By hiding the volume, you can obtain high efficiency without undue (apparent) size.

My Fig. 2 does not take into account the effects of stuffing. If you measure the speaker using the stuffed enclosure, you can allow for the effect of adiabatic (the air gets hotter when compressed) to isothermal (the air stays the same temperature because of the stuffing's thermal inertia) expansion conversion. The 40 percent apparent volume increase is a theoretical value. Practically, you can obtain only about a 25 percent increase.

Good luck with your project!

PEAK POWER PROPOSITIONS

I have a few suggestions regarding Art Newcomb's SB 1/83 article, "An Easy Peak Power Indicator" (p. 26). First, replace R3 with either a junction FET connected as a current source (Fig. 1a) or paralleled FET diodes (Fig. 1b). You would have to select the transistor for I_{DSS} at the current limit of interest (e.g., 10mA). The two paralleled diodes at 4.7mA will perform the same function. Either option will produce very little voltage drop.

Second, replace the bridge diodes with Schottky types. This reduces the barrier

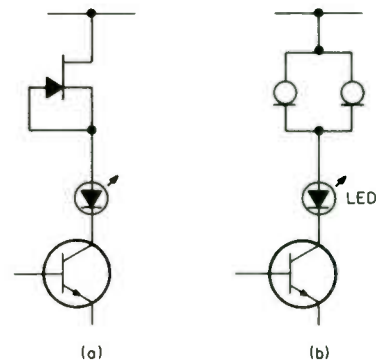

FIGURE 1: Mr. Garner suggests that you may replace R3 in Mr. Newcomb's original circuit with either a junction FET (a) or paralleled FET diodes (b).

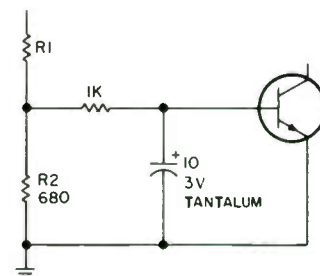

FIGURE 2: This proposed circuit change allows you to lengthen current persistence.

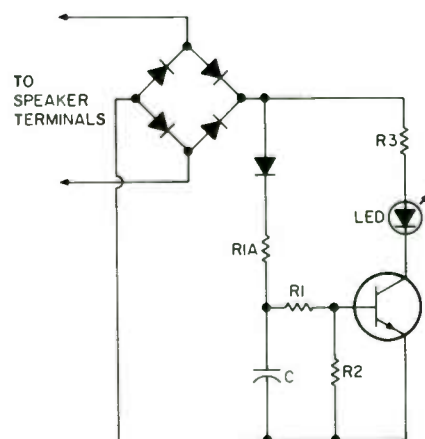

FIGURE 3: Mr. Newcomb's modification shows the capacitor isolated and closer to the bridge output.

TABLE 1

R1 VALUES

P_{IN} (W peak)	R1 for 8Ω
1	1.64
3	3.8
10	8.01
30	14.8
100	28.2

voltage from ~650mV to ~250mV, enabling the circuit to indicate power levels reliably as low as 1W. Table 1 gives values for R1 with the revised diodes.

Finally, since the input current to the transistor is ~100 μ A or less, you can lengthen the persistence with Fig. 2, albeit with some signal delay (~10msec as shown). Under these conditions, the transistor would act as a capacitance multiplier and permit peak LED viewing for a much longer time.

Lou Garner
Torrance, CA 90503

Mr. Newcomb replies:

The current sources Mr. Garner suggests would make acceptable alternates for the fixed-current source, although both would require either more expense or component selection.

In my article, I mentioned energy storage for "peak-holding" capability. Mr. Garner's circuit has two problems. First, the capacitor is placed at a point where the voltage is constrained by V_{BE} . Therefore, no significant delay can be achieved, even with a very large capacitor. The capacitor must be placed where it can charge and hold the voltage long enough to be of use.

Second, simple RC integration will also change peak reading to averaging. Fast charge and slow discharge are required for success. The capacitor must, therefore, be placed nearer to the bridge output and isolated, as shown in Fig. 3. The calculation for R1 should now include the additional diode drop (which will not affect the low-end capability). I recommend that R1A be equal to R1 divided by 100.

Also note that to achieve a one-second discharge delay, C must be about 100 to 200 μ F and will reflect some reactance to the load through the bridge. This reflected reactance might offend purists. There is also some attenuation of high frequencies, but this will probably not be noticeable.

The Schottky diode substitution in the bridge circuit does allow operation at lower levels, but be sure you observe the voltage rating. The reactance of the circuit in Fig 3 might double the diodes' PIV requirements.

See my follow-up article in SB 2/84 (p. 17) for additional information.

WHERE'S THE BEEF?

I am looking for any information or plans on wiring my Dynaco 400 power amplifier for monophonic operation. The amp has 200W/channel, but the manual says it can be wired for 600W mono. I need some beefy power for my JBL subwoofer and would appreciate any help.

Scott Potosky
Fort Wayne, IN 46815

HEAR YE, HEAR YE

Speaker building can be fruitful, but it can also be permanently crippling. The noise generated throughout the process can make you deaf—and deafness is irreversible. Think of all the noise generated from this hobby—visiting noisy lumberyards, cutting wood, hammering, stapling, sawing, and so on. Unprotected ears will soon fail.

The trouble with hearing loss is that it is gradual, be it from sonic shock or other causes. People tend to interpret hearing trouble as a temporary indisposition, subject to recovery after resting. But hearing loss is permanent. If loud noises no longer bother you or you have difficulty understanding conversations when many people are talking at the same time, you might have a hearing loss. If you go for a checkup, resist your doctor's suggestion of an ear operation until you get as many independent opinions as you feel necessary.

Protective devices are sold for wearing outside or inside your ears. Check with your doctor, hardware store or gun shop. Some audiophiles wear cotton plugs in their ears regardless of time, place or activity. Cotton is not the best protector, but it certainly helps in daily encounters

with jet planes, motorcycles, and the like. *Prevention* magazine published an article discussing another aspect of hearing protection—diet. In controlled tests, scientists have found that good hearing is directly related to a low-fat diet.

If you cannot hear the sonic improvements you work so hard to produce, what's the use of trying? It's in your best interest to protect your ears and your listening ability.

Carlos E. Bauza
San Juan, PR 00936-1220

The Editor replies:

As I mentioned in my 3/84 editorial, during a recent checkup, my doctor spent ten minutes removing impacted wax from one of my ears. Although this problem had gone undetected for months, it was amazing how much better my stereo system sounded afterward.

SATISFACTION GUARANTEED

Although I am a charter subscriber to *SB* and an enthusiastic supporter of *TAA*, I am ashamed to admit that I never actual-

SHADOW ENGINEERING ELECTRONIC CROSSOVERS

SHADOW ENGINEERING offers a comprehensive line of high performance electronic crossover to suit any application. Any combination of first and third order filters are available. Crossovers may be purchased as full kits, or purchased individually for use with one of two available Shadow power supplies, or your own supply.

The new Transient Perfect Limited Edition unit uses a third order Bessel on one pass band, and a first order filter on the other pass band for zero phase error. Frequency is set at factory. High current low Z power supply is standard. The MKIVF crossover offers flexibility with its plug in frequency modules and optional passive high pass section.

Either SHADOW crossover is designed for sonic purity. Only the finest materials are used, and the design maximizes musical capabilities as well as ease of construction and flexibility.

Call us today or write
for more information.



Exclusively by:
Audio Concepts

1631 CALEDONIA ST., LA CROSSE, WI 54602 (608) 781-2110

FAST REPLY #FH45

Speaker Builder / 1/85

41

NEW

IN STOCK

10 μ F at 160V. \pm 10% Polypropylene Capacitors

Lead length: 1/4"

Radial Leads: spaced 1 1/2" apart
Body:

1 1/16" W x 1 5/8" L x 1 3/16" H.

1-9 \$17.00 Each

10 and up \$14.35 Each

Orders totalling \$25-\$75 receive a 10% discount. Orders totalling over \$75 receive a 15% discount.

May be combined with parts orders only for discount.

OLD COLONY SOUND LAB

BOX 243, Peterborough, NH 03458

MC or VISA charge orders by phone
(603) 924-6371 9-4 M-F EDT

SPEAKER BUILDER BINDERS

Rich blue, heavy vinyl binders imprinted in white with *Speaker Builder's* logo. Spaces for twelve issues on loose wires will store your valuable *SB* data in a readily accessible format.

Each	\$7.00
Two binders, ea.	6.50
Three or more, ea.	6.00

Ppd. in USA. Outside USA please add \$2. per binder for shipping. Canada must add \$4 for one and \$2 for each additional binder.

ORDER BLANK
Speaker Builder
PO Box 494, Peterborough NH 03458

Send _____ binder(s) @ \$ _____ ea.

Total \$ _____ check; M.O.; MCard; Visa

Charge card no. _____

Charge card expiration date _____

Signature _____

Name _____

Street & No. _____

Town _____ St. _____ Zip _____

SB Mailbox

ly built any of the projects until recently. After years of scheming and planning to build speakers that I hoped would be better than anything I could afford to buy, I settled on the Jordan System 5. Nearly two years ago, I began buying drivers and particle board, selling my faithful Bozaks and trying not to be daunted by the prospect of cabinetmaking. After all, I had never built so much as a birdhouse.

Going at it by fits and starts, I was finally ready to finish the project when the first two Jordan articles appeared in *SB* 2/84. I finished the speakers before the second part of the Jordan interview came out in *SB* 3/84, and much to my surprise, they worked. After a week or two of astonishment, I am now in a period of growing appreciation of their performance. I am also experiencing a growing itch for better electronics. You are right—this stuff grows on you, and there is no satisfaction like doing it yourself, particularly when you are an all-thumbs beginner who has chosen a pretty complicated first project. Thank you for keeping after me all these years.

John C. Farris
Dumfries, VA 22026

MINI-HORN MYSTERY

When I began to consider building Bruce Edgar's 70Hz mini-horn (*SB* 2/83, p. 7), I discovered that the W6C200F is no longer available. Can anyone recommend a replacement speaker? I have also considered using a Klipsch horn (or one of the imitations) for a subwoofer, perhaps with other horns carrying 100Hz and up. Speakerlab has Klipsch-type plans and good drivers, although their prices exceed Mr. Edgar's \$30 per speaker. Does anyone have any advice?

In another vein, I would like to build the Lister Little Big Horn featured in *Audio Amateur* 3/78 (p. 12). Can anyone suggest a speaker? Finally, when is Mr. Edgar's midrange horn article going to appear? I need encouragement to renew my subscription.

Clyde Bostier
New Lebanon, OH 45345

Mr. Edgar replies:

According to my latest *Universal Sound* catalog (2253 Ringling Blvd., Sarasota, FL 33577), the W65C200F is still available. (Perhaps some confusion arose because the number listed in the article was

W6C200F.—Ed.) Pyle also has a new polypropylene cone version of this speaker called the WP65C200F. To my amazement, Pyle has actually improved the *Q* characteristics in the poly cone version. The advertised values ($f_s=51\text{Hz}$, $Q_{TS}=0.25$) give a mass cutoff frequency of 400Hz. I have tried one out on a horn, and the measured mass cutoff is well above 400Hz. This is an improvement over the paper cone model, which began to roll off above 300Hz. Another virtue of the 6-inch poly cone is that it has an 8 Ω voice coil versus the 4 Ω value for the paper cone.

In regard to a suitable subwoofer to go with the 70Hz mini-horns, I have found that only bass horns will match the efficiency of the mini-horns. If you use another type of subwoofer, you must either attenuate the mini-horns with *L*-pads or biamp to match levels.

As I have stated in a reply to Jim Eldridge (*SB* 4/84, p. 40), the *Speakerlab K-horn* uses the wrong driver. Unfortunately, I have not run across any inexpensive 15-inch drivers that will make the *Speakerlab K* an efficient horn. As an alternative, you could try a 12-inch driver in the *K-horn*. This could excite the *Speakerlab K's* 13-by-39-inch throat if you seal the gaps properly. A Pyle MHW12C700CR ($f_s=48\text{Hz}$, $Q_{TS}=0.36$, $V_{AS}=3.1$ cubic feet) has an upper mass cutoff of 266Hz and an optimum throat of 48 square inches. Although I have not tried it, it should work even though there is a mismatch at the throat. As you can see, it is sometimes easier to design a new horn enclosure about a specified driver than to revamp an old design. The new design route may take longer to accomplish, but it yields more satisfying results.

As for the Little Big Horn, the Pyle 6-inch speaker should work, although I have not tried it.

Finally, I must apologize to *SB* readers who have been waiting for my midrange horn article. I designed one that used a *JBL*

Red Alert

We are looking for more articles from speaker builders, either scratch projects or kit building reports. We need volunteers to do kit reports from several suppliers. Please reply to the editor with a letter stating your interests and phone number(s).

driver, but then JBL stopped selling raw drivers from its consumer lines. I have since found other candidates and am now preparing a manuscript.

SRC SUBWOOFER CONFUSION

Several months ago, I purchased a Sherman Research Company (SRC) 12SW20PP4 12-inch, dual-voice-coil subwoofer. The advertised specifications are as follows:

$$\begin{aligned} Q_{TS} &= 0.48 \\ V_{AS} &= 7.9 \text{ cubic feet} \\ f_s &= 19\text{Hz} \end{aligned}$$

I was going to use this driver in a 6.5-cubic-foot closed and stuffed enclosure. For my preliminary calculations, I assumed that the effective enclosure volume would be about 8.1 cubic feet (increase of a factor of 1.25 due to the stuffing). This would result in an f_c of 26.7, an f_3 of 28 and a Q_{TC} of 0.675. I was planning to cross over to my main speakers (Magnepan MG-11As) at about 52Hz, where the Magnepan dies a natural death. I was looking for a fairly low Q_{TC} and the corresponding greater damping that I thought would match the MG-11As better.

After receiving and testing the speaker, I obtained the following results for the driver using one voice coil:

$$\begin{aligned} f_s &= 20.6 \\ Q_{MS} &= 6.14 \\ Q_{ES} &= 0.94 \\ Q_T &= 0.82. \end{aligned}$$

When I mounted the driver in the enclosure, I found an f_c of 29, a Q_{MS} of 4.8, a Q_{ES} of 1.63 and a Q_T of 1.22. The sound was like thunder: it rolled on and on.

I wrote to SRC Audio questioning my results. They responded that "the Q_{TS} should be measured with the voice coils connected in series, and the Q_{TS} should then be 0.46 ± 10 percent; that only 1 inch of damping material should be used on three nonopposing sides (any more will change the Q_{TC} by as much as 40 percent, while making the overall re-

sponse dead); and that the Q_{TC} in the system (6.5 cubic feet) should be about 1.1 or so."

I went back to the bench and obtained the results in Table 1. Sure enough, when I measured the parameters with both voice coils operating, the values were quite different. I do not know how to drive the voice coils in series from a common-ground amplifier, however. Does anyone know why the speaker parameters should be measured with the voice coils connected in series instead of in parallel as the speakers are actually operated? It is easier to make the measurements with the coils in series because the degree of change is more sensitive to frequency.

When I applied the design equation for predicting second-order systems using the advertised parameters and the parameters measured when both voice coils were driven, I found the following:

$$\begin{aligned} \frac{Q_{TC}}{Q_{TS}} &= \sqrt{\frac{V_{AS} + 1}{V_{AB}}} = \frac{Q_{TC}}{0.48} = \\ &= \sqrt{\frac{7.9}{6.5}} + 1 = 0.71 \end{aligned}$$

On the other hand, when I used the 0.82 Q_{TS} value (measured with a single voice coil), the calculated Q_{TC} for a 6.5-cubic-foot enclosure was 1.2, which is fairly close to 1.1 or so. The problem is that I do not know how to design or measure the parameters for a dual-voice-coil system. I have not seen this subject addressed in the literature. Can anyone comment on the subject?

David E. James
Barberton, OH 44203

Thomas L. Clarke replies:

In theory, there is no difference between measuring the driver parameters of a dual-voice-coil subwoofer driver with the voice coils in series or in parallel. The electrical damping (Q_{ES}) is determined by the electrical resistance divided by the square of the voice-coil wire length. For two identical coils, the parallel connection halves the resistance and leaves the length constant, whereas series doubles both resistance and length. In either case, Q_{ES} is halved, Q_{MS} is

unchanged, and Q_{TS} is nearly halved.

Practical considerations such as a smaller signal for parallel measurement and possible mismatches between the two coils might make the series connection more accurate, as SRC suggests. The near equality of the series and parallel values in Mr. James' table shows that his measurement technique is good. I think that for most speaker systems, 5 percent accuracy in driver parameter measurement is plenty. The change of temperature from winter to summer produces a 5 percent variation in sound speed with corresponding changes in enclosure tuning. The effort spent on adjusting beyond the 5 percent level is probably better spent on building a tighter, more rigid enclosure.

The design of a dual-voice-coil system is just like that of a single-voice-coil system. The Q_{TS} for both voice coils must be used to reflect the damping that will be caused by the combined action of the two amplifier channels. In a closed box, the driver acts like a different driver mounted in an infinite baffle, with parameters f_c and Q_{TC} . Mr. James' comment about the sound rolling on

LETTER WRITERS AHOY...

We need your cooperation in the matter of your welcome letters to authors and other readers. Please enclose a stamped and addressed envelope if you expect a reply. If the author/reader lives outside the USA, please include two International Postage Reply coupons (available at your post office) instead of stamps on your envelope.

Please leave room in your letter for replies. Your questions should relate to the article, be framed clearly, and written legibly. Please do not ask for design advice or for equipment evaluations.

Letters to authors or other readers cannot be acknowledged, unfortunately. Any letter which does not comply with the requests above will not be answered.

like thunder seems to indicate that he drove only one voice coil when testing the enclosure, so the Q_{TC} was effectively the underdamped value of 1.22. SRC's Q_{TC} value of 1.1 is mystifying. Perhaps, as Mr. James suggests, they used the single-voice-coil Q_{TS} when calculating the system Q_{TC} . While stuffing the enclosure to increase the effective volume will increase the damping (through Q_{MS}) and decrease Q_{TC} , Mr. James' comments seem to indicate that this might be the sound he is seeking.

Be careful about using a passive crossover between the Magnepan and the subwoofer. Excessive (more than 1Ω) series resistance in the coil will increase the Q_{TS} and cause underdamping. If a separate amplifier is used for the subwoofer, the voice coils can be wired in parallel or series (amplifier to positive, negative to positive, then negative to common).

TABLE 1

SRC 12SW20PP4 TEST RESULTS

	Single Coil	Coils in Series	Coils in Parallel
f_s	20.6	20.6	20.6
Q_{MS}	6.14	5.92	6.38
Q_{ES}	0.94	0.47	0.50
Q_{TS}	0.82	0.43	0.46

Classified Advertising

TRADE

OPEN REEL TAPES from studio masters. Philips, Argo, Telefunken, Vanguard, Unicorn. Catalog \$1.00. **BARCLAY-CROCKER**, Room 1470-L, 11 Broadway, New York, NY 10004. TTF

GOLD LION, "INDIA," TELEFUNKEN tubes. Cramolin, Furman Sound, Hartley, Kimber Kable, Precision Fidelity, Sheffield, Sonex, VPI. Visa, MC, AE. **VECTOR ELECTRONICS**, 2030 NW Marshall, #104, Portland, OR 97209, (503) 227-5641. T1/85

TESLA TWEETER: Very efficient 8 ohm, 40W Round Horn Tweeter, \$39.95. NEOPRENE SPEAKER GASKETS, 10 sizes, 3½" to 15", \$1.30 to \$2.50 each. Free brochure. **TESLA ELECTRIC COMPANY**, 1029 Marles Drive, Santa Ana, CA 92706. T1/85

LONG HAIR WOOL carded, cleaned for stuffing speakers. \$13.50/lb. including shipping. **J. EBBERT**, 431 Old Eagle School Rd., Strabford, PA 19087, (215) 687-3609. TTF

"**YOUR CATALOG IS** the best I've read," writes R. Bullock, contributing editor, *Speaker Builder*. More than 30 proven designs for home, car, subwoofer and professional applications. JBL, Audax, EV, SEAS, Hafler, polypropylene drivers and crossovers. Thousands of parts in stock! Send \$2 to **GOLD SOUND**, Box 141SB, Englewood, CO 80151. T4/85

WONDER-CAP®, **REL-CAP** & Siemens audio grade capacitors, OFHC wire and silver solder for the discriminating audiophile. Available from **PRECISION AUDIO SUPPLY**, PO Box 96, Downey, CA 90241. T1/85

GOLD PLATED phono jacks \$1.20, plugs 90¢ ea., \$1.00 handling. Also custom 1% capacitors, 0.5% resistors. Details SASE. **REFERENCE AUDIO**, Box 368M, Rindge, NH 03461. T2/85

FINALLY THE HELP YOU NEED to build a speaker as good or better than the big boys. Custom crossovers to your specifications or we design for you. Drivers and crossovers for all popular projects. Full line of caps, coils, terminals, woofers, tweeters, grille fasteners, etc. Own a KEF speaker or LS/35A? Upgrade kit for T-27 to A/B standard, \$29.95 plus \$2 postage (Canadian). We have plans and crossovers to match LS/35A to our custom subwoofers (increases handling by 100%). All designs tried and tested. Write or phone for price list, information or free advice. **ATLANTIC IMPORTS**, 58 Gray Ave., Toronto, Ontario M6N 4S8 Canada, (416) 769-1039. Visa or Mastercard accepted. T1/85



**Madisound
Speaker
Components**

8982 Table Bluff Road
Box 4283
Madison, Wisconsin 53711
(608) 767-2673

**Audax, Dynaudio, KEF,
Philips Loudspeakers**

MOST ELECTRIC CROSSOVERS are designed without regard to waveform fidelity. Did you know that even passive designs like the Dahlquist cannot be phase correct? Did you know that buzzwords like "transient perfect" do not mean phase correct? Our X-1 crossover will pass a perfect square wave because it is totally phase coherent. It features purely passive filtering, full regulation and performance best described as remarkable. A 20¢ stamp gets our "Off-White Paper." **GSI**, PO Box 158, Station A, Flushing, NY 11358, (212) 357-5859. Soon to be reviewed by *Stereophile*. T1/85

"**IN PHASE**" 24dB/octave electronic crossover minimizes irregularity in radiation pattern through crossover region. 0.0008% distortion, 5 year warranty. Single frequency with power supply (specify) \$523. **DB SYSTEMS**, Main St., Rindge, NH 03461. TTF

CLUBS

Space in this section is available to audio clubs and societies everywhere free of charge to aid the work of the organization. Copy must be provided by a designated officer of the club or society who will be responsible for keeping it current. Send notices marked Audio Clubs in care of the magazine.

SAINT LOUIS AUDIO SOCIETY meets monthly for discussion and equipment audition. For information sheet send a stamped, self-addressed envelope to SLAS, 7435 Cornell, Saint Louis, MO 63130.

SERIOUS AUDIOPHILES interested in a central Colorado group (Denver, Boulder, Ft. Collins, Greeley area) contact James S. Upton, 2631 17th Ave., Greeley, CO 80631.

THE ESOTERIC AUDIO RATING SOCIETY (usually known as EARS) is San Antonio's premier audio club. Its members consist of audiophiles and music lovers who share a mutual interest in enhancing their enjoyment of recorded music. EARS meets bimonthly and has been fortunate to offer interesting presentations on audio, recordings and music. The club also has an on-going project of recording local concert activities for radio broadcasts or other purposes. Additionally, EARS is currently trying to launch a club newsletter. Anyone interested in finding out more about EARS should write to the following address to obtain information on the next meeting date and location: EARS, PO Box 27621, San Antonio, TX 78227.

HI-FI CLUB OF CAPE TOWN, South Africa issues newsletter monthly for its members and subscribers. Since our audio problems are the same as yours, we'd like to hear from you. Send 2 I.R.C.s for next newsletter (\$16/year) to PO Box 6685, Roggebaai 8012 South Africa.

SAN FRANCISCO BAY AREA AUDIOPHILES. Audio constructors society for the active, serious music lover. We are dedicated, inventive and competent. Join us in sharing energy, interest, expertise and resources. Send self-addressed stamped envelope to S. Marovich, 300 E. O'Keefe St., Palo Alto, CA 94303 for newsletter.

PRIVATE CLASSIFIED ADVERTISING SPACE up to 50 words in length is open to Speaker Builder's subscribers without charge for personal, non-commercial sales and for seeking information or assistance. The publishers reserve the right to omit any ad. Any words beyond 50 are 20 cents per word. Please type or neatly print ad copy on a separate sheet or card with your full name and address.

TRADE CLASSIFIED ADVERTISING RATES: 45 cents per word including name, address and zip code—prepaid only. 10% discount for four insertions. Speaker Builder cannot accept responsibility for the claims of either the buyer or the seller.

THE BOSTON AUDIO SOCIETY INVITES you to join and receive the monthly B.A.S. SPEAKER with reviews, debates, scientific analyses, summaries of lectures by major engineers. The BAS was the first to publish info on TIM, effects of capacitors, tonearm damping, tuner IM distortion, Holman's and Carver's designs, etc. Sample issue \$1, subscription, \$16/yr. P.O. Box 7, Boston, MA 02215.

THE VANCOUVER AUDIO SOCIETY publishes a monthly newsletter with technical articles, humor and news of interest to those who share our disease. We have 50 members and meet twice every month. Dues are \$15/year, which includes 12 newsletters (\$15 US outside Canada). Call (604) 874-3225 or write Dave Mann, VAS, Box 4265, Vancouver, BC, Canada V6B 3Z7. We would like to be put on your mailing list.

SOUTHEASTERN MICHIGAN WOOFER AND TWEETER MARCHING SOCIETY (SMWTMS). Detroit area audio construction club. Meetings every two months featuring serious lectures, recording studio visits, design analyses, digital audio, AB listening tests, equipment clinics, annual picnic and audio fun. Club publication, *LC, The SMWTMS Network*, journals the club's activities and members' thoughts on audio. To join or subscribe call (313) 544-8453 or write SMWTMS, PO Box 1464, Berkley, MI 48072-0464.

THE COLORADO AUDIO SOCIETY is a group of audio enthusiasts dedicated to the pursuit of music and audiophile arts in the Rocky Mountain region. We offer a comprehensive quarterly journal plus participation in meetings and lectures. Membership fee is \$10 per year. For more information, send SASE to: CAS, 4506 Osceola St., Denver, CO 80212.

AUDIOPHILE ACCESSORIES

- DBP-2J (5) SWITCH BOX**..\$9.95, **AU (5) gold jacks**..\$9.95
Selects between up to 5 phono inputs. Used with DBP-6 or 6MC, allows for selectable loading of cartridges
- DBP-6 PHONO EQUALIZATION KIT**.....\$34.95
Allows adjusting the input capacitance of the phono input of every preamp and receiver with low loss Polystyrene Capacitors
- OBP-6MC RESISTIVE LOADING KIT**..... \$34.95
Allows adjusting load resistance from 10 to 200 Ohms for moving coil cartridges. Gold plated phono plugs in both kits.
- OBP-9AU BANANA PLUGS** Eight gold plated, solderless...14.95
DBP-9H BANANA HANOLES Four red, four blk..... 5.50
DBP-9P GOLD PLATED DUAL BANANA PLUGS 2 pk....17.95
DBP-9J GOLD PLATED DUAL BANANA JACKS 2 pk....15.95
OBP-10 PHONO ALIGNMENT PROTRACTOR.....21.95
Allows adjusting the lateral tracking error of a mounted cartridge to within 1/4 of one degree. Non-technical instructions & case included.
- OBP-12 AUDIO CABLE 10 meter (33 ft)**.....\$65.95
Low capacitance (400pF) stereo interconnect cable, terminated with rugged gold plated phono connectors. Custom lengths available.
- OBP-12X AUDIO CABLE 10 meter (933 ft)**.....90.95
Low capacitance (400pF) stereo interconnect cable, terminated with premium DBP-13PX phono connectors. Custom lengths available.
- DBP-13J GOLD PLATED PHONO JACKS (1/4") 8 pk.**.....12.95
OBP-13JR GOLD PLATED PHONO JACKS (3/8") 8 pk......15.95
OBP-13P GOLD PLATED PHONO PLUGS 8 pk......8.95
OBP-13PM GOLD PLATED PHONO PLUGS, 4 red, 4 blk.21.95
OBP-13PX GOLD PLATED PHONO PLUGS 2 pk......14.95
OBP-14 GOLD PLATED SPADE LUGS 8 pk......5.95
OBP-15 GOLD PLATED "Y" ADAPTORS 2 pk......11.95
OBP-CK CRAMOLIN AUDIO KIT contact treatment.....14.95
OBP-SC SOUTHER RECORD CLAMP.....10.00
- ELECTRONIC CROSSOVERS**..6, 12, 18, 24db.....Inquire

At your dealer or direct. Orders under \$45, add \$2.50 Handling MC/VISA

DB SYSTEMS

Main St., Rindge, NH 03461 (603)899-5121

THE NEW YORK AUDIO SOCIETY meets monthly with prominent guest speakers, discussions and demonstrations of the latest equipment. Its \$20 annual membership dues include a subscription to S/N, the society's quarterly publication. For a free invitation to our next meeting, call (212) 544-1222, (212) 289-2788 or (201) 647-2788 or write us at PO Box 125, Whitestone, NY 11357.

ACTIVE ELECTRONIC CROSSOVERS

NEW DESIGN! MODEL 120
NOW AVAILABLE

Plug-in Butterworth (maximally flat) filters 6 db., 12 db., or 18 db. per octave slopes, any specified frequency. Filters flat beyond 100 Khz. New instrument style case with all terminations and regulated power supply.

Made in monaural or stereo bi-amp, tri-amp, or quad-amp with optional level controls, subsonic filters supplied with or without bass boost, and summers for "single woofer" systems.

Also available. 500 Series filters, plug-in filters, regulated power supplies.

Free catalog and price sheet

DeCoursey Eng. Lab.

11828 Jefferson Bl. Culver City, CA 90230
PHONE (213) 397-9668

SARASOTA AUDIOPHILES interested in forming a club—write to Mark Woodruff, 5700 N. Tamiami, Box 539, Sarasota, FL 33580.

AUDIOPHILES INTERESTED IN FORMING an audio club in the Washington, D.C., area please contact: Joseph Kmetz, 9861 Goodluck Rd., Apt. #10, Lanham, Maryland 20706 or call days (301) 794-7296, eves. (301) 585-3186.

NEW JERSEY AUDIO SOCIETY meets monthly with the emphasis on construction and modification of electronics and speakers. Individuals at any level of electronics expertise are invited to join. Contact Bill Donnally, (201) 334-9412, or Bob Young, (201) 381-6269, 116 Cleveland Ave., Colonia, NJ 07067.

AUDIOPHILES IN THE NEW JERSEY and Staten Island areas interested in forming a club please contact Joe at PO Box 1588, Staten Island, NY 10314, (212) 698-2280.

WANTED: Audiophiles in the Riverside-San Bernardino areas to form an audio club. Frank J. Manrique, 1219 Fulbright Ave., Redlands, CA 92373.

LONG ISLAND AUDIOPHILES: The Audio Syndrome is a Nassau/Suffolk county club dedicated to the pursuit of sonic excellence. Monthly meetings. Fred Masters, (516) 589-4260 or (516) 271-4408.

CONNECTICUT AUDIO SOCIETY WANTED. Serious audiophiles in Conn., or Putnam or Dutchess Co., NY, contact John J. McBride, 33 Perry Dr., New Milford, CT 06776, (203) 355-2032.

MINNESOTA AUDIO SOCIETY. Monthly programs, newsletter, special events, yearly equipment sale. Write: PO Box 3341, Traffic Station, Minneapolis, MN 55402.

A CLUB FOR FM AND TV DXers, offering antenna, equipment and technique discussions, plus updates from FCC on new station data. Monthly publication "VHF—UHF Digest." Annual convention in August. For more info: Worldwide TV-FM DX Association, PO Box 97, Calumet City, IL 60409.

PACIFIC NORTHWEST AUDIO SOCIETY (PAS) consists of 50 audio enthusiasts meeting monthly, second Wednesdays, 7:30 to 9:30 p.m. at 4545 Island Crest Way, Mercer Island, WA. Be our guest, write Box 435, Mercer Island, WA 98040 or call Bob McDonald (206) 232-8130.

THE AUDIO SOCIETY OF HONOLULU cordially invites you to attend one of our monthly meetings and meet others like yourself who are interested in the how's and why's of audio. Each meeting consists of a lively discussion topic and equipment demonstrations. For information on meeting dates and location contact Bob Keaulani at 1902 South King Street, Honolulu, HI 96826, (808) 941-1060.

FOR SALE

Electronic parts for sale. Crossover parts—TRW 5µF, 100V DC, \$5 each; heavy duty 5-way binding posts, red, black, white, blue, green and yellow, 75¢ each; TRW 1µF, 50V DC, \$2 each; TRW 3µF, 50V DC, \$2 each. Prices include shipping. M.R. Savage, (507) 285-9451. Prices negotiable.

Crown SS-822 professional tape deck in portable case. Includes DBX 154, technical manuals, MRL alignment tape, over 50 10 1/2 reels of symphonic master tapes (best of 15 years' work). Immaculate condition. \$2800. Roger Sanders, (209) 358-1427.

Macintosh MC 240, \$150; Audax 25cm HD24B45, \$40 pair, never used. Tektronix 435A oscilloscope with probes, \$350. All in excellent condition. C. Asher, No. Five Inman Ave., Kentfield, CA 94904, (415) 454-0519.

Focal 5N302/5 1/4 midrange, nine months old, PVC/rubber surround doesn't deteriorate. Neoflex cone, sim. Bextrene sound/polypropylene sensitivity, 20 oz. magnet, \$30/pair; Audax HD13B25H4C9 Bextrene high power/low midrange, short 9mm voice coil, high output plus 0.15 Q_s for transients, 26 oz./PVC, \$32/pair. Both with data. G. Helman, (718) 858-1587.

Pair Celestion SL6s, perfect condition, with original cartons and packing, nine months old, \$300/pair. Patrick Hughes, 7095 Baxter Grade, Auburn, CA 95603, (916) 885-3163.

Conrad-Johnson Premier 4 amplifier, \$1800; Audio Research D110 amplifier, \$795; ReVox A-700 recorder, \$1400; Dyna Stereo 70 in mint condition, \$150; Magneplanar bass panels, \$500; Pyramid T-1 tweeter, \$500. Douglas S. Robinson, 104 Lincoln Ave., Waterloo, NE 68069, (402) 779-2589.

CIRCUIT BOARDS

Old Colony's Boards are made of top quality epoxy glass, 2 oz. copper, reflowed solder coated material for ease of constructing projects which have appeared in **Audio Amateur** and **Speaker Builder** magazines. The builder needs the original article (indicated by the date in brackets, i.e. 3:79 for articles in **Audio Amateur** and SB 4:80 for those in **Speaker Builder**) to construct the projects.

C-4: ELECTRONIC CROSSOVER (DG-13R) New 2 x 3 1/2" board takes 8 pin DIPs, Ten eyelets for variable components. (2:72) Each **\$4.50**

D-1: HERMEYER ELECTROSTATIC AMPLIFIER II. (3:73) Two sided with shields and gold plated fingers. **Closeout.** Each **\$5.00** Pair **\$9.00**

F-6: JUNG 30Hz FILTER/CROSSOVER (WJ-3) 3 x 3" (4:75) High pass or universal filter or crossover. Each **\$5.50**

G-2: PETZOLD WHITE NOISE GENERATOR & PINK FILTER. (JP-1) 2 1/2 x 3 1/2" (3:76) Each **\$5.00**

H-2: JUNG SPEAKER SAVER. (WJ-4) 3 1/4 x 5 1/4" (3:77) Each **\$7.00**

H-3: HERMEYER ELECTROSTATIC AMP BOARDS. (ESA-3) Set of three boards with plug-in edges for one channel. (3:77) Set **\$19.00**

J-6: SCHROEDER CAPACITOR CHECKER. (CT-10) (4:78) 3 1/4 x 6" Each **\$7.25**

K-3: CRAWFORD WARBLER 3 1/4 x 3 3/8" (1:79) Each **\$6.00**

K-6: TUBE CROSSOVER. 2 x 4 1/2" (3:79) Two needed per 2-way channel. Each **\$4.25** Four **\$13.00**

K-7: TUBE X-OVER POWER SUPPLY. 5 x 5 1/8" (3:79) Each **\$7.00**

K-12: MACARTHUR LED POWER METER. 5 1/2 x 8 1/4" (4:79) Two sided, two channel. Each **\$16.00**

L-2: WHITE LED OVERLOAD & PEAK METER. 3 x 6" (1:80) One channel. Each **\$10.50**

L-6: MASTEL TONE BURST GENERATOR. 3 1/2 x 6 5/8" (2:80). Each **\$8.50**

L-9: MASTEL PHASE METER 6 5/8 x 2 3/8" (4:80) Each **\$8.00**

SB-A1: LINKWITZ CROSSOVER BOARD 5 1/2 x 8 1/2" (4:80) Each **\$14.00**

SB-C2: BALLARD CROSSOVER BOARD 5 1/2 x 10" (3:82 & 4:82) Each **\$14.00**

SB-D1: NEWCOMB PEAK POWER INDICATOR 1/4 x 2" (SB 1:83) Each **\$2.50**

SB-D2: WITTENBREDER AUDIO PULSE GENERATOR 3 1/2 x 5" (SB 2:83) Each **\$7.50**

SB-E2: NEWCOMB NEW PEAK POWER INDICATOR 1 x 2" (SB 2:84) Each **\$2.50**

SB-E4: MULLER PINK NOISE GENERATOR 4 1/8 x 2 1/16" (4:84) Each **\$8.50**

Old Colony Sound Lab

PO Box 243, Dept. SB, Peterborough NH 03458

To order, please write each board's number below with quantity of each and price. Total the amounts and remit by check, money order, MasterCard or Visa. U.S. orders are postpaid. For charge card orders under \$10 please add \$1 service charge. Canadians please add 10%, other countries 15% for postage. All overseas remittances must be in U.S. funds. Please use clear block capitals.

Name _____
Street & No. _____
Town _____
State _____ ZIP _____

No. Bds.	Price
... Board No.	\$
... Board No.	\$
... Board No.	\$
Total	\$

Classified Advertising

ReVox A77 with Dolby B, stainless faceplate and smoked dust cover, (50) 7" reels of tape, (40 unopened), less than 40 hours, like new, \$500 plus shipping. R.G. Camp, 31998 Winona Rd., Winona, OH 44493, (216) 222-1601 anytime.

Four Alps 21 step stereo pots, 100k with metal film resistors, silver contacts, new \$15 each. D. Jensen, 12655 W. Brookview Dr. Circle, Grass Valley, CA 95945.

Nakamichi variable (65-7kHz) electronic crossover and power supply, \$100; Beyer dynamic M500 ribbon microphone, \$100. Both like new. Paul Stangeby, 1700 Edgefield, #1062, Garland, TX 75040, (214) 271-9179.

Hewlett Packard 3580A spectrum analyzer, excellent condition, low hours, with manual, \$3500; Hewlett Packard 410C multifunction voltmeter with AC probe and manual, 15mV, 1.5µA, FS, dcv., excellent for offset, bias, etc., \$295; Simpson 360-2 digital meter with analog scale, boxed with AC adapter charger and manual, \$390 retail, first \$175, (bought two). Nick Palladino, (516) 661-0510.

Twelve used Mallory CGS263U075XR 26,000µF, 75V-95SV caps from cap bank projects, \$12.50 each ppd.; four used Dynaudio 30W54 poly woofers, \$60 each. Jim Katchis, 3016 N.E. Oregon St., Portland, OR 97232, (503) 232-6982 evenings.

Advertising Index

FAST REPLY NO.		PAGE NO.
FH572	A & S SPEAKERS	37
FH53	ACE AUDIO	34
FH57	ANKAI	34
	AUDIO CLUBS	27
FH45	AUDIO CONCEPTS	41
FH43	AUDIO ENGINEERING SOCIETY	21
FH7	AUDIO LAB	4
	DB SYSTEMS	45
	DECOURSEY	45
FH20	MADISOUND	3, 44
	OLD COLONY BOOKS. (Cover IV)	
	OLD COLONY CIRCUIT BOARDS	46
	OLD COLONY KITS	31
	OLD COLONY POLY CAPS	42
	OLD COLONY SOFTWARE	12
FH668	POLYDAX SPEAKER CORP.	35
FH778	SIDEREAL AKUSTICS	17
	SPEAKER BUILDER BINDERS	42
	SPEAKER CLINIC	46
FH12	SRC	(Cover III)



The Speaker Clinic

One S.E. 47th.
Portland, Oregon 97215

Specialty Loudspeaker Services
Computerized Lab Providing:
Acoustical, Parameter/Systems Analysis
Precision Air Coils, 1% tol.
Catalog \$1.00

Pioneer SF850 active crossover, EC, \$190; Dynaco ST120 power amp, EC, \$100; AR integrated amp, VG, \$100; Monarch ST50 FM/stereo tuner, EC, \$50; Heath AJ1219 AM/FM tuner, mint, \$130; SWTP 2AS/A analog delay, EC, \$140. Prices include shipping. Ben Poehland, 14 Carol Lane, Malvern, PA 19355, (216) 644-3677 after 7 p.m. EST.

Nakamichi 70011 3-head deck, \$525; ReVox B790 turntable with Shure IV or Stanton 8815, \$400; SME Series III arm with either cartridge, \$150; Harman-Kardon Citation Eleven preamp, 5-band equalizer and wood cabinet, \$120; Pioneer TX8100 tuner, \$75. Ronald Burk, 938 Westwood, Ann Arbor, MI 48103, (313) 994-0468 anytime.

Differential BIFET stereo crossover (Audio 8/82), set now 230Hz, 1% resistors, polypropylene remote regulated power supply, \$70; Two Alnico 15" JBL bass speakers, 4" voice coil, D140, in boxes, \$225; Nikko 70W stereo power amp, \$90; all \$350. Audax HD13D34H new domes, \$25/pair. Daniel Coyle, 11502 Ice Cave, Grants, NM 87020.

WANTED

One mono version Acrosound Ultra-Linear II amplifier. Terry Painter, 4748 El Camino Real, Los Altos, CA 94022, (415) 941-5737.

Smaller Advent speaker system. Any data sheet, manual, information and suggested replacement for blown-out woofer. Bill Schweber, Jaffa Eng., PO Box 543, Sharon, MA 02067.

STATEMENT OF OWNERSHIP, MANAGEMENT AND CIRCULATION (Required by 39 U.S.C. 3685) Date of Filing Sept. 28, 1984. Title of Publication: SPEAKER BUILDER. Frequency of issue: Four times a year.

Annual subscription price \$10.00. Location of the headquarters or general business offices of the publishers: Old Jaffrey Road, Peterborough NH. Publisher: Edward T. Dell, Jr., Old Jaffrey Road, Peterborough NH 03458, Editor: same. Owner: Edward T. Dell, Jr., Carol Carr Dell, Old Jaffrey Road, Peterborough, NH. Known bondholders, Mortgagees, and other security holders owning 1 percent or more of total amount of bonds, mortgages or other securities: None.

	Average # copies	
	each issue during preceding 12 months	Single issue nearest to filing date
Total # copies printed	10,878	10,265
Newsdealer sales	18	17
Mail Subscriptions	4,333	4,021
Total paid circulation	4,351	4,038
Free Distribution		
Complimentary	114	122
Total Distribution	4,465	4,160
Office use, leftover	6,413	6,105
Return from news agents	0	0
Total	10,878	10,265

I certify that the statements made by me above are correct and complete.
Publication No. 01997920 Edward T. Dell, Jr., Editor

FOR SPEAKER BUILDERS ONLY

Sherman Research is building a new type of loudspeaker. A speaker for you, the home builder. No more do you have to put up with production line speakers built with production costs in mind. Finally someone has the guts to build a great speaker for a decent price and make sure each one is exactly the same as the rest. No other manufacturer, domestic or foreign takes the time and care to do it right. Consider these facts:

- We are the only manufacturer to "burn in" every speaker for 8 hours to allow parameters to settle.
- We are the only manufacturer to give Fast Fourier frequency responses on each individual speaker.
- We are the only manufacturer to give individual Thiele-Small parameters and offer to match pairs and fours.
- We are the only manufacturer to offer a limited LIFETIME warranty.

The two speakers shown on this page are the first in the new line of speakers from Sherman Research. For the next month they will be on sale through SRC AUDIO to Speaker Builder subscribers only. This sale will end February 28, 1985. If you want the best speaker, the best technical information, the best warranty, and THE BEST PRICE, you can't pass up this offer.

20.3W8 8" POLYPROPYLENE WOOFER

The 20.3W8 features the perfect balance of a highly damped cone and a minimum reactance butyl surround. This coupled with extremely accurate manufacturing tolerances, that assure perfect centering, gives a phenomenally flat frequency response. Every aspect of the 20.3W8 has been optimized for smooth low distortion speaker systems. The slightly rising frequency response symptomises low third harmonic distortion content. The perfect second order Bessel roll-off at 2800 Hz allows seamless crossovers with minimum elements. Even the adhesives have been optimized to give resonance free coupling between cone and voice coil former. The 20.3W8 has truly advanced the state of the art in loudspeakers.

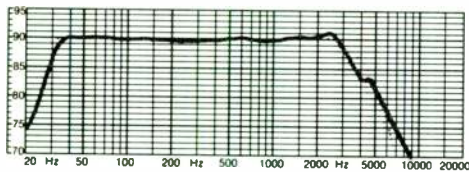

Thiele-Small Parameters

$F_s = 33.75 \text{ Hz}$	$BL = 8.3$
$V_{as} = 64.3 \text{ liters (2.27 cubic ft.)}$	$M_{md} = .025 \text{ Kg}$
$Q_e = .51$	$Acc = 314.56$
$Q_m = 2.124$	$X_{max} = 5.1 \text{ mm}$
$Q_t = .41$	$V.C. = 38 \text{ mm}$
$C_{ms} = .0008755 \text{ m/N}$	$M_{gt.} = .795 \text{ Kg}$
$S_d = .02139 \text{ m}^2$	$P_{wr} = 180 \text{ watts RMS}$
$Re = 5.27 \text{ ohms}$	$L_{vc} = .98 \text{ mH}$
	$eff = 89.0 \text{ dB}$

SALE PRICE SUBSCRIBERS ONLY

\$23 EACH or \$54

for hand matched pairs.

SRC PART #1312 or 1312HMP

8" DVC SUBWOOFER

The Sherman Research 8" subwoofer is a perfect solution for those rooms that just won't allow two large monoliths or even one large subwoofer. If you crave bass and have such a room that you can't pass this offer up. In a small box of just over a cubic foot this speaker is capable of producing incredible low bass down to 40 Hz. Hide it away next to your bed or your easy chair. Build it into a coffee table or a bookcase. Even the smallest room has a nook or cranny big enough for this subwoofer. We recommend using a satellite with a 4-5 inch midbass for the best results although it can keep up with larger speakers. Full cabinet plans and crossovers are also available to take all the guess work out of your system. Experienced system builders should notice that the frequency response on this speaker is much the same as the single voice coil 8". This extended response should give some interesting possibilities such as adjusted response alignments and feedback systems. (Stay tuned to the SRC newsletter for more on these technologies.)

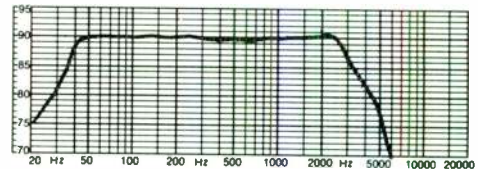

Thiele-Small Parameters

$F_s = 30.5 \text{ Hz}$	$Re = 3.2 \text{ (per coil)}$
$V_{as} = 64.3 \text{ liters or 2.27 cubic ft.}$	$BL = 10.3$
$Q_e = .393$	$M_{md} = .031 \text{ Kg}$
$Q_m = 3.19$	$Acc = 332.6$
$Q_t = .35$	$X_{max} = 5 \text{ mm}$
$C_{ms} = .0008755 \text{ m/N}$	$V.C. = 38 \text{ mm}$
$S_d = .02139 \text{ m}^2$	$M_{gt.} = .795 \text{ Kg}$
	$P_{WR} = 80 \text{ Watts RMS}$
	$eff. = 88.9 \text{ dB}$

SALE PRICE SUBSCRIBERS ONLY

\$27 EACH \$79

for kit with crossover and accessories

SRC PART #1153 or 1327

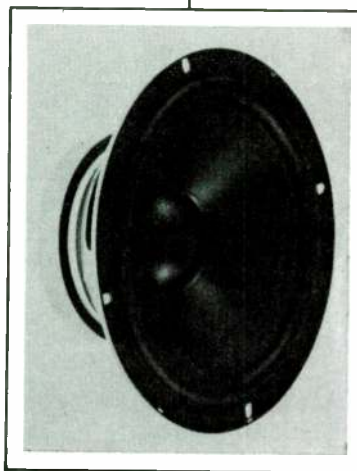

SRC AUDIO TOLL FREE ORDER LINE 1 (800) 922-2188

FAST REPLY #FH12

or SRC AUDIO • 3331 Towerwood Dr. #302 • Dallas, TX. 75234

Old Colony Sound Lab's **BOOK SERVICE**

PENGUINS

P-1 THE COMPLETE PENGUIN STEREO RECORD & CASSETTE GUIDE (3RD ED.) by Edward Greenfield, Robert Layton, and Ivan March. Drawing on profound technical knowledge and on vast musical and historical learning, this newly revised and updated guide to recorded classical music deals with more than 4,000 disks, cassettes, and compact discs, giving details of title, performers, record number, label and price range. 1387pp., softbound. Please add \$1.00 for shipping.
Each \$12.95

P-2 A NEW DICTIONARY OF ELECTRONICS by E. C. Young. This remarkably compact reference covers electronics from A-Battery to Z-parameters with succinct, concise definitions and illustrations. A quick reference completely revised and updated with lots of added charts and reference data. 618pp., softbound.
Each \$5.95

P-3 A NEW DICTIONARY OF MUSIC (THIRD ED., 1973; FIRST PUB. 1958) by Arthur Jacobs. Alphabetically arranged entries covering composers, individual musical works, orchestras, performers, conductors, musical instruments, and technical terms. 458pp., softbound.
Each \$5.95

P-8 INTRODUCING MUSIC by Otto Karolyi. Even if you've listened to music for years, you may be surprised at how little you know about its fundamentals. A beautifully basic and spare introduction to the grammar and vocabulary of music—enough to understand the language without speaking it. It will deepen almost any non-musician music lover's pleasure in listening. 174pp., softbound.
Each \$4.95

McGRAW-HILL

MH-1 HANDBOOK FOR ELECTRONICS ENGINEERING TECHNICIANS (2ND ED.) by M. Kaufman and A.H. Seidman. A comprehensive compendium of electronic facts. Component selection, circuit analysis, power supplies, IC uses and characteristics, op amps, transistors, batteries and tubes. A one-volume encyclopedia on how components work and how to choose the best of them for your application. Includes seven new chapters on such topics as logic analysis, fiber optics, active filters, digital test gear and microprocessors. 752pp., hardbound.
Each \$39.50

MH-2 HOW TO MAKE PRINTED CIRCUIT BOARDS by Joel Goldberg. All the topics on making your own circuit boards are covered both in theory and in practical advice: design and layout, artwork preparation, photo layout, silk screening and etching.
Each \$6.50

HOWARD W. SAMS

S-11 HOW TO BUILD SPEAKER ENCLOSURES by Alexis Badmaieff and Don Davis. The "whys" and "hows" of speaker enclosures. Drawings and instructions cover infinite baffle, bass reflex and horn types plus combinations. 144pp., softbound.
Each \$6.95

S-19 SOUND SYSTEM ENGINEERING by Don and Carolyn Davis. A thorough introduction to sound systems for halls, studios, outdoor locations and much else. 245pp., hardbound, 8½x11.
Each \$21.95

DOVER BOOKS

D-1 REPRODUCTION OF SOUND by Edgar Villchur. An elegantly simple 92-page paperbound primer on the subject by the man who invented the bookshelf speaker. Loan or give it to friends who want to build a system as good as yours.
Each \$2.50

D-3 MUSIC, PHYSICS AND ENGINEERING by Harry F. Olson. A thorough introduction to the physical characteristics of sound and the relationship of sound to musical instruments by the former head of staff at RCA's lab for acoustical and electromechanical research at Princeton, NJ. A classic by one of the giants in the audio field. Good, easy to read chapters on acoustics, mikes and recording, recording and playback systems, as well as an electronic music chapter. 2nd. Ed. (1967) 460pp., softbound.
Each \$6.95

TAB BOOKS

T-4 DESIGNING, BUILDING AND TESTING YOUR OWN SPEAKER SYSTEM (2ND ED.) by David Weems. A cookbook approach to speaker design with 10 tests for performance. Individual drivers are specified for actual building projects. Weems likes closed box and reflex enclosures, but is skeptical of transmission lines. Includes a BASIC program for Thiele/Small parameters. 190pp., softbound.
Each \$9.95

WILEY BOOKS

W-1 HIGH PERFORMANCE LOUDSPEAKERS (3RD ED.) by Martin Colloms. A thorough revision of the 2ND ED. (1980) updates and expands this authoritative volume. The author surveys new developments in the four-year interim and adds some highly original proposals for low frequency alignments, listening tests and much else. For the speaker builder, Colloms' book is one of three indispensable volumes. Hardbound.
Each \$29.95

Old Colony's **BOOK SERVICE**

To order from Old Colony Sound Lab, please write each book's number below with quantity of each and price. Total the amounts and remit by check, money order, MasterCard, or Visa. For charge card orders under \$10 add \$1 service charge. Please add 50¢ for postage on the first book; 25¢ per additional book. Canadians please add 10% for postage. All remittances must be in U.S. funds. Please use clear block capitals. NOTE: Prices are subject to change without notice.

Name _____
Street & No. _____
City _____
State _____ ZIP _____

Number of Books	Price
..... Book No.	\$
..... Book No.	\$
..... Book No.	\$
..... Book No.	\$
	Postage \$
	TOTAL \$

PO BOX 243 • PETERBOROUGH, NH 03458 • CHARGE ORDERS (603) 924-6371 • 9-4 M-F EDT