

Bernie Grundman • The Return of Ribbon Mics • Steve Lukather

U.S. \$4.00 CANADA \$5.00 **DECEMBER 1987**

MIX

TEC Award Winners!

**Directory: Mastering,
Pressing and
Duplication Facilities**

THE RECORDING INDUSTRY MAGAZINE

**CD Production Guide
& Mastering Tips**

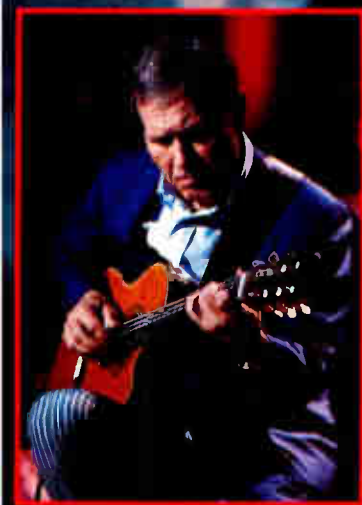
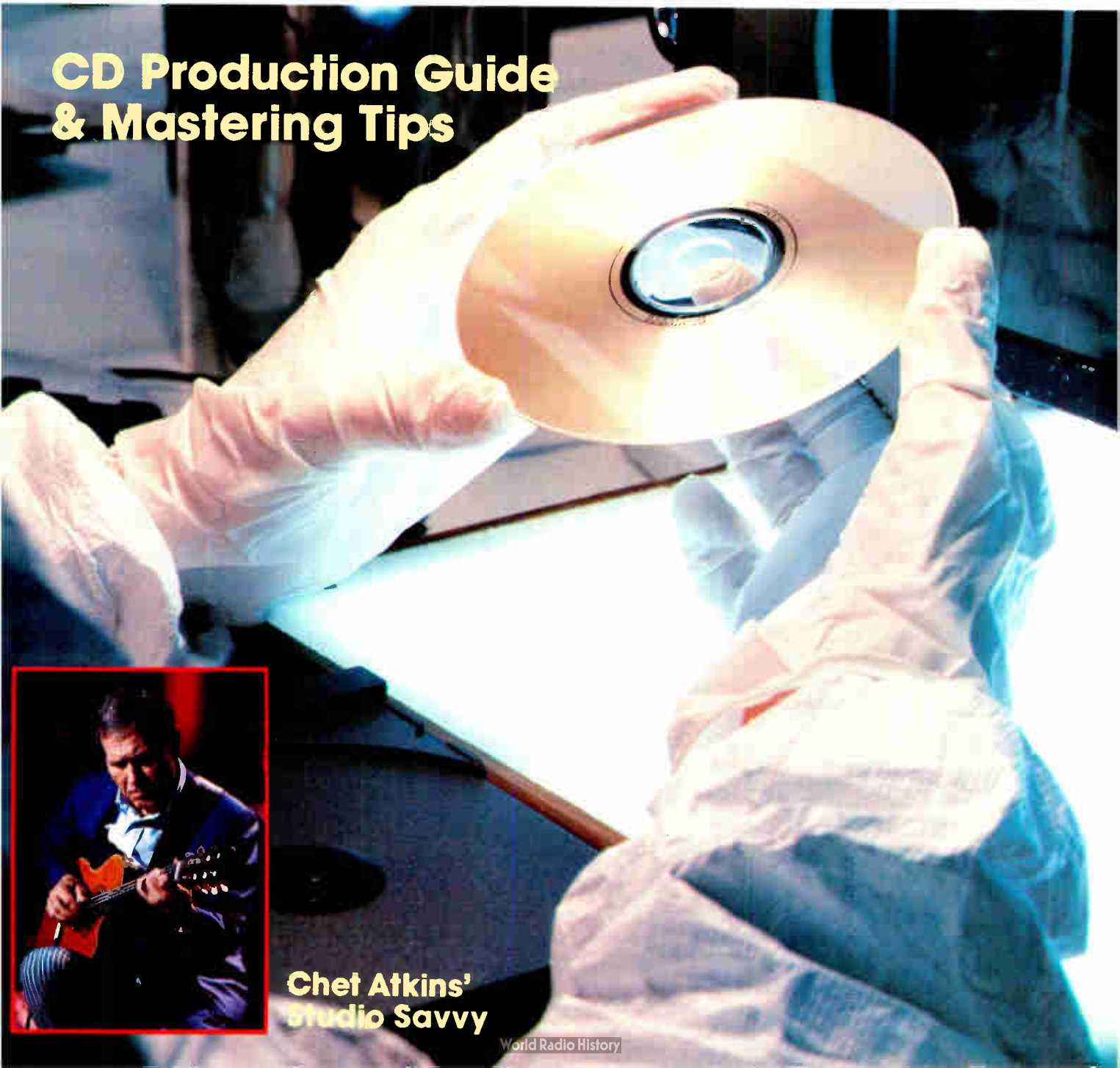

**Chet Atkins'
Studio Savvy**

COMPUMIX IV

The Fourth Generation Console Automation System is here. Compumix IV advances dynamic automation technology far beyond the capabilities of other systems, to a level of sophistication and accuracy demanded by tomorrow's digital recording techniques.

The FORTH realtime software running in a 32-bit 68000 computer provides 4 simultaneous mixes on-line as well as write command recall accuracy of 1/10 frame. SMPTE time code driven, Compumix IV stores *every frame* (not only changes) making it possible to perform editing functions on-line. This requires an 80 Mbyte hard disk storage system designed for fast access in both read and write modes.

Compumix IV is designed to control up to 256 IDF fader functions in realtime through easy to operate touch-sensitive plasma control panels. An optional Graphics Display System is available.

INTELLIGENT DIGITAL FADER

The IDF is a microprocessor-based module that utilizes the most advanced technology available. The super smooth fader is a 10-bit digital encoder that supplies 0.25 dB resolution and 119 dB of dynamic range. The grouping functions are the most extensive ever supplied in a music recording console. 16 groups are assignable with 4 levels of operation: slave, group master, submaster, and grand master.

Up to 256 IDFs run independently through a revolutionary "back door control bus" without the need for external computer automation. Realtime display of dB level, groupings, status, fader position and mutes are available at all times. 9 membrane switches allow for selection of up to 160 software defined functions.

CENTRAL ASSIGNMENT

This electronic output assignment cross-point switching system assures fast and reliable connections from the console to your tape machines with full routing or mixing capability. 64 output busses are assigned from each input module by a central touch control plasma display panel controlling up to a 96 by 64 electronic switching matrix. Completely software driven, the panel allows instant selection and display of the bus assignment with 10 presets in local memory. Optional unlimited storage to disk is provided. Easy to use, the system prompts for bus assignments and provides help through informative menu displays.

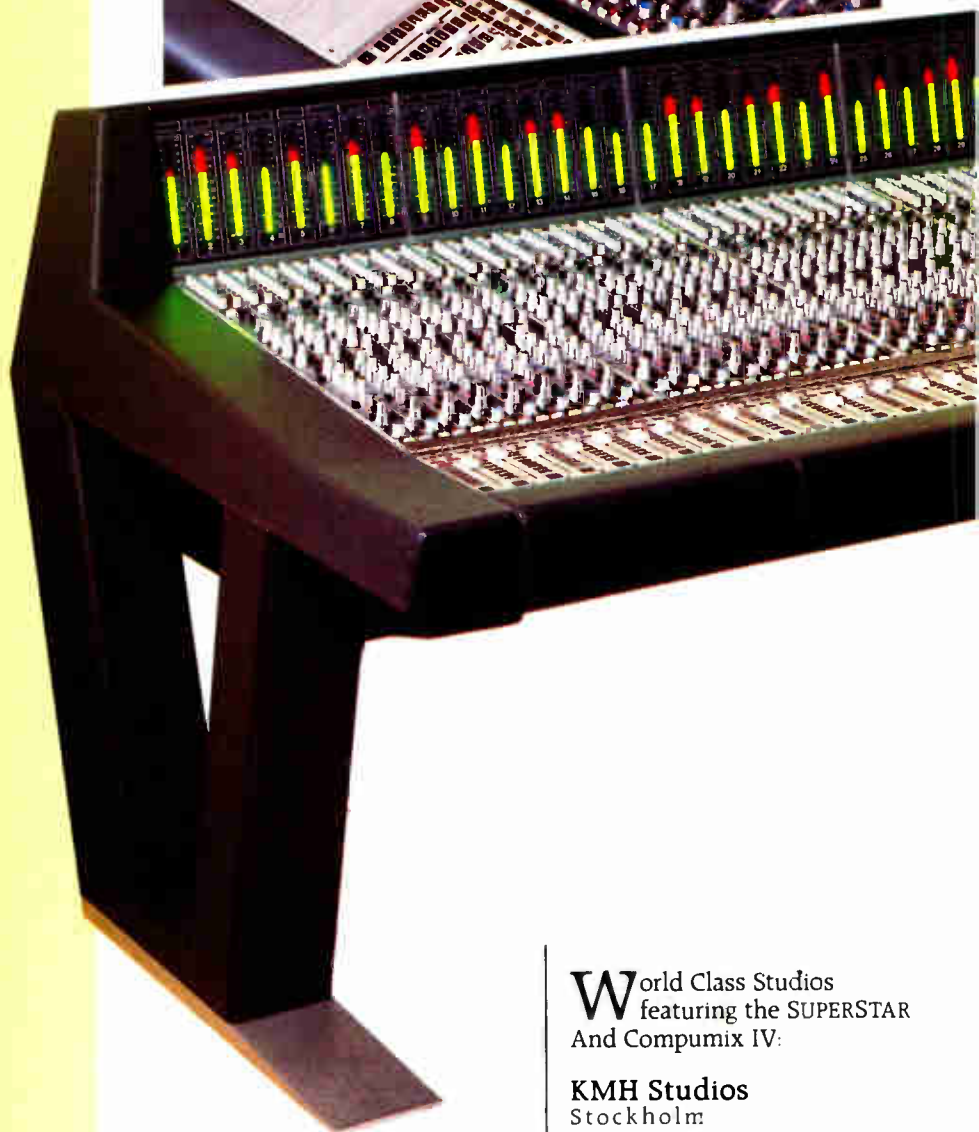
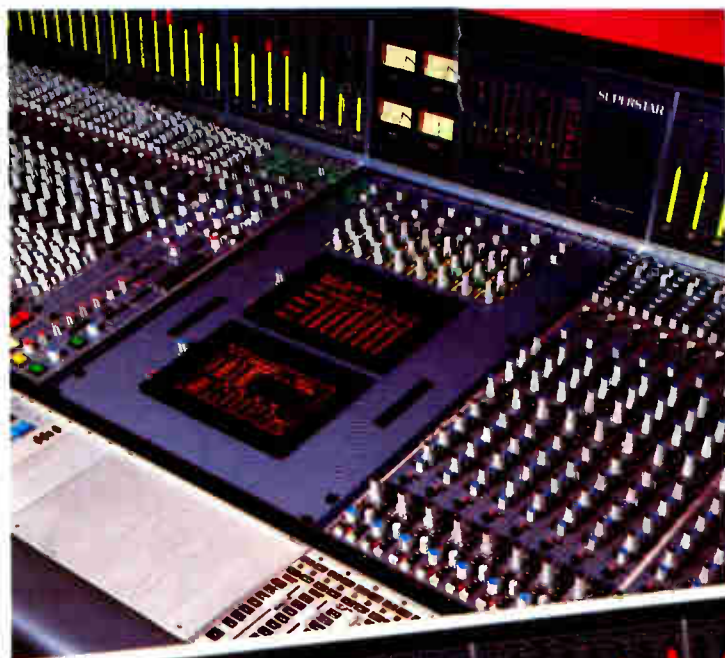

World Class Studios
featuring the SUPERSTAR
And Compumix IV:

KMH Studios
Stockholm

Salzburger Festspiele
Salzburg

Bosanova Hotel
Los Angeles

Sigma Sound Studios
Philadelphia

SUPERSTAR

Advanced technology and unparalleled flexibility come together in the SUPERSTAR music recording console. Development of this console centered around the requirement for high definition sound, improving that most important quality as necessary for digital recording.

No other single console offers the combination of desirable sound, size, and flexibility with an

affordable price. Field expandable, the SUPERSTAR provides ergonomical positioning of the console modules, allowing you to satisfy your own configuration needs. High resolution meters, central bus assignment, Intelligent Digital Faders, and the most comprehensive automation system all add up to SUPERSTAR—your next console.

*Be a Leader,
Not a Follower.*



- Superb Sound
- 36, 44, 52, 60 or 68 I/Os
- Fully Parametric 4-Band EQ
- 32 or 64 Bus Outputs
- 16 Auxiliary Sends
- Intelligent Digital Faders
- Automation Accuracy 1/3 Frame
- 4 Automated Mixes On-line



INTELLIGENT
DIGITAL
FADER



MITSUBISHI PRO AUDIO GROUP

DIGITAL ENTERTAINMENT CORPORATION

Headquarters: 225 Parkside Drive, San Fernando, CA 91340 • Phone (818) 898-2341 • FAX (818) 365-8310

New York: Suite 1321, 555 W. 57th Street, New York, N.Y. 10019 • Phone (212) 713-1600

Tennessee: 104 Eastpark Drive, Suite 306, Brentwood, TN 37027 • Phone (615) 371-6602 • FAX (615) 371-6644

Canada: 260 The Esplanade, Toronto, ONT. M5A 1J2 • Phone (416) 365-3363 • FAX (416) 365-1044

United Kingdom: Unit 13, Alban Park, Hatfield Road, St. Albans, Hertfordshire AL4 0JJ • Phone 0727-40584 • FAX 0727-67684

Circle #001 on Reader Service Card

**Diamond Leasing
AVAILABLE**

MIX

DECEMBER 1987

THE RECORDING INDUSTRY MAGAZINE

VOL. 11, NO. 12



PAGE 126 ALF CLAUSEN



PAGE 16 SHAPE OPTIMEDIA



PAGE 24 CD MYSTERIES



PAGE 48 BERNIE GRUNDMAN

FEATURES

- 24 DIGITAL & CD: Mastering the Mysteries** by Barry Diament
- 29 DOMESTIC CD PLANTS** by George Petersen
- 32 THE INDEPENDENT'S GUIDE TO CD PRODUCTION** by John Barilla
- 53 CELLO SYSTEMS' ULTIMATE STEREO** by Dan Daley
- 90 TRENDS IN FILM SOUND, PART TWO** by Nicholas Pasquariello
- 102 TEC AWARDS WINNERS & HIGHLIGHTS**
- 126 SCORING FOR TV WITH ALF CLAUSEN** by Pauline Rodgers
- 134 MICROPHONES AND DIGITAL RECORDING** by Mike Solomon
- 145 THE HAL BLAINE STORY: Working with John Denver** by Hal Blaine with David Goggin
- 166 COMDISC'S PTT CDs** by Philip De Lancie

COLUMNS

- 16 INSIDER AUDIO: The Shape of Things to Come** by Ken Pohlmann
- 21 JUXTAPOSITIONS: Time & Machines** by Mel Lambert
- 48 STUDIO VIEW: Bernie Grundman on Mastering** by Tony Thomas
- 58 PRODUCER'S DESK: Mannheim Steamroller's Chip Davis** by Linda Jacobson
- 72 FIELD TEST: Barcus-Berry Electronics' 802 Processor** by George Petersen
- 74 LUNCHING WITH BONZAI: Steve Lukather** by Mr. Bonzai
- 86 POST-SCRIPT: The SMPTE-MIDI Connection** by Leslie Fradkin & Elizabeth Rose
- 109 SOUND ON STAGE: Sound Reinforcement News & Tour Update** by Mark Herman
- 112 MUSIC NOTES: Chet Atkins, Inside NAIRD, Digital Music Center, The Far Side**
- 150 PLAYBACK: New Grass Revival's *Hold to a Dream*** by Robyn Flans
- 156 VIDEO NEWS: Desktop Video** by Lou CasaBianca
- 172 AFTER-MIX: Otari's TMD System** by Philip De Lancie

FROM THE EDITOR



Cover: Visual inspection of the completed disc is the final step of the CD pressing process at Nimbus Records. The company operates two manufacturing plants in the United Kingdom, and their U.S. CD facility in Charlottesville, Virginia opened in September. Photo by Jim Lowe, J&S Professional Photography. Chet Atkins photo: Melodie Gimple

DEPARTMENTS

- 6 CURRENT
- 8 INDUSTRY NOTES
- 10 SESSIONS/STUDIO NEWS
- 69 PREVIEW
- 204 FEEDBACK
- 205 MIXWORDS
- 206 CLASSIFIEDS
- 210 AD INDEX

DIRECTORY

- 177 MASTERING, PRESSING & DUPLICATION FACILITIES



Circulation independently audited and verified by Business Publications Audit of Circulation since 1986.

Mix magazine is published at 2608 Ninth St., Berkeley, CA 94710 and is © 1987 by Mix Publications, Inc. This is Volume Eleven, Number Twelve, December 1987. *Mix* (ISSN 0164 9957) is published monthly. Subscriptions are available for \$38.00 per year. Subscriptions outside U.S.A. are \$50.00 per year. Single copy price is \$4.00, back issues \$5.00. Send subscription applications, subscription inquiries and changes of address to *Mix* magazine, PO Box 3714, Escondido, CA 92025 3714 or call one of these toll free numbers: in CA, 1 (800) 255 3302; outside CA, 1 (800) 334 8152. Address all other correspondence to *Mix* magazine, 2608 Ninth St., Berkeley, CA 94710, (415) 843 7901, Fax: (415) 843 9540. Second Class postage paid at Berkeley, CA and additional mailing offices. *Mix* magazine is distributed in pro audio stores, music stores and other related businesses. If you have a recording or music related business and would like to distribute *Mix* please give us a call. Display advertising rates, specs and closing dates are available upon request. This publication may not be reproduced or quoted in whole or in part by mimeograph or any other printed means, without written permission of the publishers.

Back in the summer of 1981, at a SPARS/Sony demo session at L.A.'s United Western Recorders, U.S. recording engineers got their first look at the compact disc. At that time—long before the hardware, software and promo material were in place—those in attendance looked and listened, and contemplated the effects of this new device on the music industry. Those who sang early praises of the CD have seen their belief realized in a new healthy and viable CD market. With all indicators showing that CDs will surpass LPs like LPs surpassed 78s, the CD is the new common denominator.

In this issue on Tape and Disc Technology, we take an intimate look at the CD, its production processes and its special considerations. While in recent issues we have promoted the advanced applications of the compact disc as a multi-media storage device, this time we return to the "traditional" or music-oriented CD. Today we sit in a window of time in which the technology is driving the industry, and much of the energy once put by record companies into new talent development is now put into regenerating catalog material in this exciting, profitable new format. This may be a short-term phenomenon; however, it poses engineering challenges and production demands as intense as any encountered in the recording of new material.

Controversy is also ripe in the CD world—especially as it relates to what's considered by many as "master quality" material in the hands of the consumer. A couple of months ago we asked for your recommendations on the DAT issue, the year's major audio witch hunt. Should we curtail a useful new technology (such as a miniaturized digital audio recorder) because of our fear that it will be used to undermine the sale of legitimate CD product, once again cutting into the artists' fragile claim on income for their creative work?

While the CBS copycode is being considered as a piracy preventative measure, our readers are hard at work coming up with alternatives. Next month, we will publish some of the best ideas we receive on the topic of keeping the world safe for high fidelity.

Keep reading,

David Schwartz
Editor/Publisher

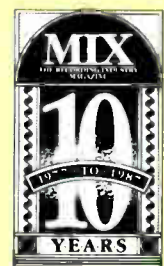

CURRENT

SPARS Names New Director

Shirley Kaye has been named the new executive director of the Society of Professional Audio Recording Services (SPARS). Kaye, an active member since 1982, has served as regional vice president and treasurer. For the past ten years she owned and managed Coconuts Recording Company in Miami, Florida, which she recently sold in order to devote her time exclusively to SPARS.

"During the next year we'll see considerable change in SPARS," says Kaye. "Our first goal is to expand the membership to include the rapidly growing number of personal-use recording studios and the smaller, independent audio facilities."

Nick Collieran is now SPARS chairman of the board, and the national offices have relocated from California to Florida. For more information, contact Shirley Kaye, SPARS, 4300 Tenth Avenue North, Suite 2, Lake Worth, FL 33461, (305) 641-6648.

Technology Center for HDTV

Edward Fritts, president of the National Association of Broadcasters (NAB), recently announced the formation of the Broadcast Technology Center to make high-definition television (HDTV) a reality for terrestrial broadcasters.

"Once or twice in a generation, there arises a challenge that takes vision and industry-wide cooperation to seize control of events to the greatest extent possible—to assure a sound future for the broadcast industry and our future ability to serve the public interest. This is one of those times," says Fritts.

The Center's parent organization is NAB Technologies, Inc., a

subsidiary of NAB formed earlier this year. The Center will be headed by Thomas Keller, now senior vice president of NAB's Science and Technology Department. Some funding will come from the \$700,000 already allocated by NAB for HDTV research. The remainder will come from broadcasters, through direct investment as limited partners and through earmarked contributions. NAB will soon mount a major industry campaign to provide sufficient financing with an expected annual budget of \$2 million.

Phillips and TMS Agreement

Philips Industries of Eindhoven (The Netherlands) and Time Management Software (TMS) of Stillwater, OK have entered into a mutually exclusive agreement on TMS's CD Data Formatters. TMS, designers and builders of the CD Data Formatter, will provide the formatters to Philips on an exclusive basis. Philips, who will provide maintenance and after-sale service, will resell the product to organizations throughout the world.

"We chose TMS's CD Data Formatter after carefully reviewing all the alternatives and coming to the conclusion that TMS offered the most sophisticated and cost-effective solution," says Bill Verkaik, Philips product group manager, optical disc mastering.

The TMS CD Data Formatter is a high-speed system that provides the required processing of any type of data for manufacture of CD-ROM and CD-I discs. It is designed for disc mastering facilities, as well as data publishers and providers.

New England Digital Enters Technology Agreement

New England Digital (NED) Corpo-

ration, designer, manufacturer and marketer of the Synclavier, has entered into a joint technology development agreement with ANALOGIC Corporation, Peabody, MA, a leading designer and marketer of advanced analog-to-digital converters, signal processing equipment and medical products.

Under the agreement, the two companies will work together to develop a new generation of extremely fast analog-to-digital converters and signal processing products that will be incorporated into the Synclavier system. ANALOGIC's founder and president, Bernard M. Gordon, invented and developed the first high-speed, high-precision A/D converter in 1953.

"Since its formation in 1969, ANALOGIC has led the data conversion and signal processing marketplace with one major breakthrough after another," says Sydney Alonso, NED co-founder and chairman. "The alliance of NED and ANALOGIC promises to produce the next wave of technology that will take the Synclavier Digital Audio workstation into the next century."

Soundstage '87: The Exposition

Over 3,000 attendees participated in the Minneapolis area's first trade expo, held at Paisley Park Studio which is owned by recording star Prince. Sponsored by Knut-Koupee Music Stores and AVC Systems, the expo focused on the tools of the music trade, featuring recording equipment, musical instruments, sound reinforcement and video equipment. Seventy-five manufacturers displayed their products, while 14 seminars had standing-room-only attendance. ■

OPPORTUNITY KNOCKS.

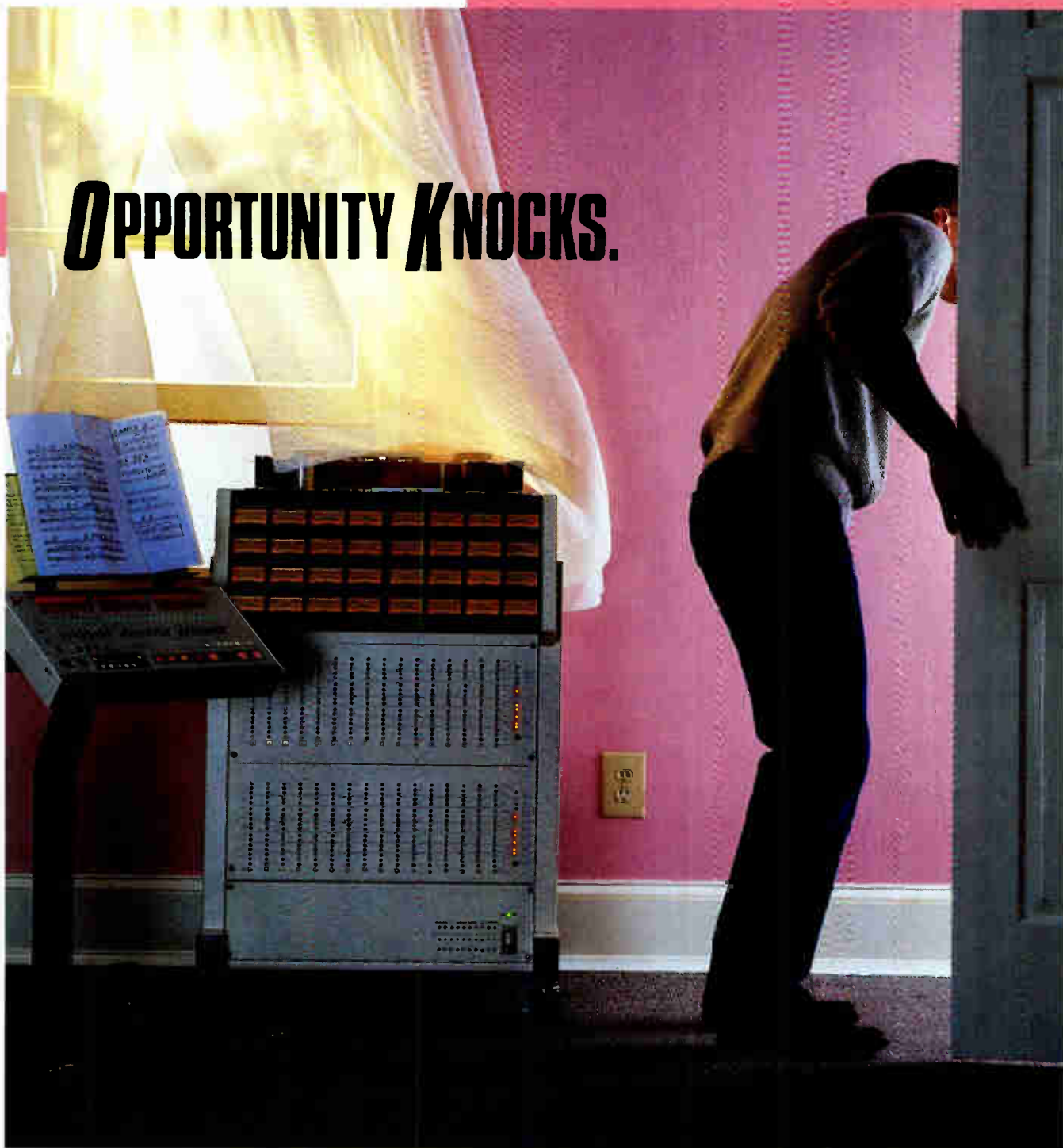

© Otari 1986

32 Tracks; ■ constant tension tape transport; ■ built-in autlocator; ■ noiseless and gapless punch-in/punch-out, and HX-Pro—at a price you can afford. ■ We call it "opportunity". You'll call it "a killer".

We know getting started in the music business can't mean an MTR-90 in the first month, even when your talent warrants it. ■ So we've given you the next best thing—the MX-80. ■ Now you have room for the band, the back-ups, the strings and the horns—with some bucks left over for that new console you've been looking at. ■ And there's a 24 channel version too! ■ From Otari: Technology You Can Trust.

Contact your nearest Otari dealer, or call Otari (415) 592-8311.

■ Otari Corporation, 2 Davis Dr., Belmont, CA 94002

OTARI

INDUSTRY NOTES

Kevin Dauphinee, formerly of Dolby Laboratories in San Francisco, has joined **Digital Audio Research Limited**, England's manufacturer of advanced digital audio products, as director of worldwide marketing and sales. Dauphinee is overseeing the opening of the Digital Audio Research office in the San Francisco area. . . **Tom Oberheim**, founder of **Oberheim Electronics**, has formed **Marion Systems Corporation** to design, develop and market products for the musical instrument electronic industry. . . California's **Todd-AO Corp.** has purchased Trans Audio, Inc., a New York City post-production facility. Besides renaming it **Todd-AO Studios East**, the company plans to convert the facility to high-speed audio post-production by acquiring computer-controlled ADR/Foley equipment and an SSL re-recording console. . . **Larry Lamoray** was named **Amek/TAC's** general manager of sales and support for the U.S., **Arnold Toshner** was named national sales manager for TAC products and **Tim Wilson** was named Amek national sales manager. . . **Rank Cintel, Inc.** has moved to expanded national headquarters at 704 Executive Blvd., Valley Cottage, NY 10989, (914) 268-8911. They also opened a Midwest sales office at 33 West Higgins Rd., South Barrington, IL 60010, (312) 426-2450. . . **SHAPE Optimedia, Inc.**, a full-service replicator of compact discs, has entered the CD-ROM information storage market. SHAPE offers complete CD-ROM services from data tapes to disc, with additional plans for premastering capability and a data encoding and disc simulation system. . . **Discovery Systems**, the Dublin, OH compact disc manufacturer, has formed a national marketing group headed by **Dick Meixner** and **Cliff Tant**. The two will take responsibility for Discovery's sales and marketing to major record companies. . . **Fuji Photo Film USA** has promoted **Joseph Visslailli** to the post of national sales manager, professional videotape products, for the company's

magnetic products division. . . **Sony Communications Products Company** promoted **James Hansen** to vice president of sales, professional video division, and named **Lon Mass** to that division's post of Northeast regional manager. **Bill Heath** was appointed field service engineer for the central region of **Mitsubishi Pro Audio Group**. . . **Otari Corporation** named **David Ruttenberg** central regional sales specialist. He is slated to open an Otari regional office in Chicago next spring. . . **Lew Goldstein** joined **Creative Audio Recording Services (CARS)** as an engineer/audio consultant. CARS owner **Shelton Leigh Palmer** also hired **Lisa Tesoro** and **Lee Katzman** as sales reps for his music production company SLP & Co. Palmer recently signed on with **New England Digital** as a software consultant, where he will work on the development of software for commercial production and film/video post-production applications. . . **Gary Rosen** was named director of sales and marketing of **Time-Line** in New York City. . . **Redwood Records**, a 15-year-old independent record label, has moved from its Oakland office to a larger building at 6400 Hollis Street, Emeryville, CA, (415) 428-9191. The move caused postponement of the annual **Redwood Festival**, sponsored by the company. . . **Dale Rochon** was appointed western regional sales manager of **Lyon Lamb Video Animation Systems, Inc.** . . **CETEK, Inc.** has been named East Coast distributor for **Sony Audio Visual Products**, which designs audio/visual "Learning Systems" for high schools and universities. . . **Jim Gillespie** has been appointed to the post of vice president and national sales manager of NYC's **Interface Technologies Inc.** . . **Michael Lamm** joined **J.W. Davis & Co.** in Dallas as chief engineer. . . **Pat Caster** joined San Francisco's **Pacific Video Resources** as staff editor. . .

STAFF

EDITOR/PUBLISHER
David M. Schwartz
ASSOCIATE PUBLISHER
Penny Riker Jacob
ASSOCIATE PUBLISHER/MARKETING DIRECTOR
Hillel Resner

MANAGING EDITOR
Blair Jackson
TECHNICAL EDITOR
Ken Pohlmann
MUSIC EDITOR
David Gans

ASSOCIATE EDITOR
George Petersen
SENIOR EDITOR
John Woram
EDITOR-AT-LARGE
Mr. Bonzai

ASSISTANT EDITORS
Karen Margroff Dunn Linda Jacobson
EDITORIAL ASSISTANT
Josh Gressel

CONTRIBUTING EDITORS
Iain Blair Lou CasaBianca Dan Daley
Philip Delancie Bruce Nazarian
Larry Oppenheimer Bruce Pilato Tony Thomas

ART DIRECTOR
Tim Gleason
ASSISTANT ART DIRECTOR
Dave Marrs
DESIGN AND PRODUCTION
Patsy Law Messerer Deborah Villa
TYPOGRAPHY
Linda Dierking Connie Wiggins
PRODUCTION DIRECTOR
Anne Letsch
PRODUCTION ASSISTANT
Kathy Badentscher
ADVERTISING TRAFFIC COORDINATOR
Donna Burreston

ADVERTISING DIRECTOR
Ron Taff
ASSISTANT ADVERTISING DIRECTOR
EASTERN AD MANAGER
Jeffrey Turner
SOUTHERN CALIFORNIA/SOUTHWEST AD MGR
Ken Rose
ADVERTISING REPRESENTATIVE
Dennis Gray
NORTHWEST/NORTH CENTRAL AD MGR.
Harton Firmin
SALES ASSISTANTS
Randy Alberts Carol McMurray
MARKETING ASSISTANT
Jane Byer
SALES ADMINISTRATOR
Neil McKamey
DIRECTORIES/CLASSIFIEDS MANAGER
Lauri Newman
DIRECTORIES/CLASSIFIEDS ASSISTANTS
Athena Craig Jeanne Hasan
Robin Boyce
CIRCULATION MANAGER
Nick Clements
CIRCULATION ASSISTANT
Cindy Lukk

GENERAL MANAGER
Mark Gunther
CONTROLLER
Craig Kennedy
ASSISTANT CONTROLLER
Linda Louper
ACCOUNTS PAYABLE
Cathy Boyum
ACCOUNTS RECEIVABLE
Lisa Jensen
CREDIT MANAGER
Ann Cuadra

BOOK DIVISION GENERAL MANAGER
Craig Wingate
OPERATIONS MANAGER
Camille Coyne
CUSTOMER SERVICE
George Keres Brad Smith
FULFILLMENT SERVICES
Todd Souvignier

OFFICE MANAGER
Rachel McBeth
RECEPTIONIST
Lea Lewis

MIX PUBLICATIONS INC.
Chairman/CEO Rudy Hurwich
President Penny Riker Jacob
Executive Vice-President David M. Schwartz
Vice-President, Marketing Hillel Resner
Treasurer Mark Gunther

NATIONAL EDITORIAL, ADVERTISING
and BUSINESS OFFICES
2608 Ninth St., Berkeley, CA 94710
(415) 843-7901
SOUTHERN CALIFORNIA ADVERTISING OFFICES
19725 Sherman Way, Suite 160, Canoga Park, CA 91306
(818) 709-4662

Neve—for the digital experience.

Preparation of master tapes for Compact Disc is a highly exacting process, requiring precise and repeatable control of levels, filtering and equalisation without degrading the original quality.

To achieve these requirements when compiling from digital recordings it is essential to keep the processing in the digital domain, so that the signal remains digital

throughout the whole recording and reproduction chain.

The Neve Digital Transfer Console – designed by the world leaders in digital audio processing – provides a digital stereo mixing and processing chain developed from proven Neve DSP technology, with the unique facility of 'snap shot' automation of all parameters under either manual or SMPTE time code control.

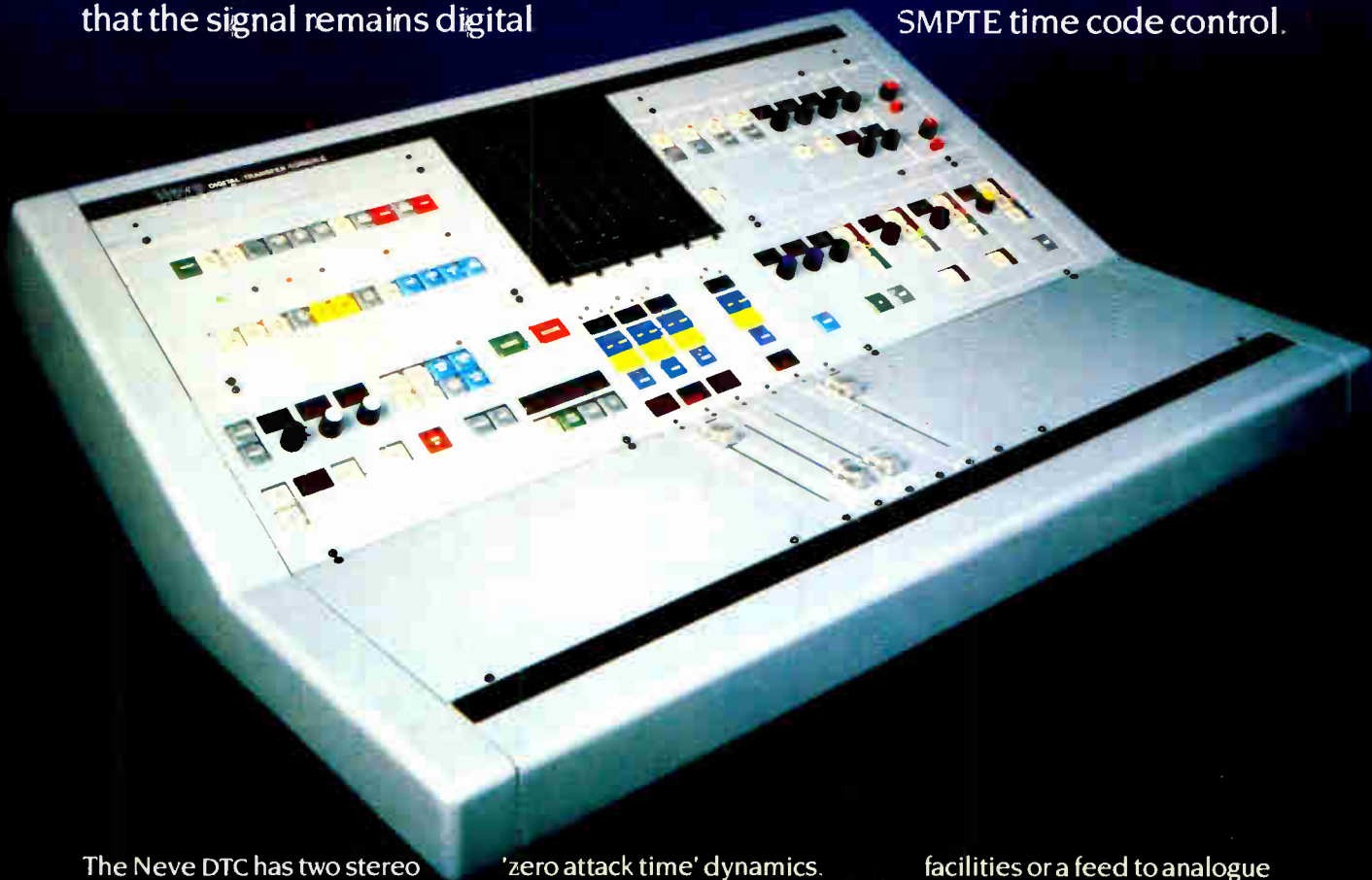

The Neve DTC has two stereo digital inputs accepting either Sony PCM 1610/30 or AES/EBU formats with automatic sensing of pre-emphasis, and one stereo analogue input, all with individual gain and balance trim.

The mixed signal may be processed by the comprehensive Neve Dynamic Range Control and the unique Neve Formant Spectrum equaliser with peaking/shelving selection and variable Q; the EQ may also be used in the Dynamics side chain, and a delay facility is available to give

'zero attack time' dynamics.

Second-order high-pass and low pass filters are structured before the processing section.

Digital output metering is by high-resolution instantaneous-reading bargraphs; a separate digital bargraph provides metering of analogue signal levels and dynamics.

The stereo digital output may be either Sony PCM 1610/30 or AES/EBU, but at the same frequency as the input, with or without pre-emphasis.

A separate stereo analogue output provides monitoring

facilities or a feed to analogue effects units etc.

The console is capable of automated operation of all parameters from SMPTE time-code using up to 200 'memories' which may also be manually accessed; the integral floppy disc system may be used for permanent storage of these 'snap shot' configurations.

Neve

A Siemens Company

PROCESSING SOUND AT ITS PUREST

Circle #015 on Reader Service Card

NEVE ELECTRONICS INTERNATIONAL LIMITED, CAMBRIDGE HOUSE, MELBOURN, ROYSTON, HERTS. SG8 6AU.

TELEPHONE: 0763 60776. TELEX: 81381. FACSIMILE: 0763 61886. CABLES: NEVE CAMBRIDGE.

RUPERT NEVE INC, BERKSHIRE INDUSTRIAL PARK, BETHEL, CONNECTICUT 06801.

SESSIONS AND STUDIO NEWS

SOUTHEAST

Christian metal group **Apostle** finished recording their fourth album, *Chariots of Iron*, at **Key Recording Studio** in Jacksonville, FL, with **John Key** engineering, **Matt Harding** producing. . . Guitarist **David Grier** completed mixing his debut solo album with producer **Jim Rooney** and engineer **Rich Adler** at the **Cowboy Arms Hotel & Recording Spa** in Nashville. . . The **Jay Patten Band** worked on their latest project at **Bennett House Studios** in Franklin, TN. **Greg Humphrey** produced, with **Eric Paul** engineering. . . **Whitney Houston** spent some time at **Reflection Sound Studios** in Charlotte, NC, adding her vocals for a track on a charity Christmas LP. **Jimmy Iovine** produced, **Thom Panunzio** engineered. . . At **Haley's Lightning Sound Studio** in Pensacola, FL, a local favorite, **Everyone's Daughter**, finished mixing their new project for Warner Bros. with the band producing and **Bobby DeVito** engineering, assisted by **Josef Laabs**. . . At **Air Studios** in Hendersonville, TN, producers **Rick Durrett**, **Mike Daniel** and **Susan Hodge** worked with **Ben Vereen** on a theme song for the film *Buy & Cell*. Engineering was **Mike Daniel**, assisted by **Eric Daniel**. . . **Century III Audio** in Orlando, FL had **Jesse** and **Evelyn Stone** in to record some tunes with the popular local jazz group **Rhythm Method**. **Rob Hill** engineered. . . **Emmylou Harris** did some overdubs at Nashville's **Sound Emporium** for a project sponsored by the Smithsonian. **Danavon Cowart** engineered. . . **Mark Five/Sandcastle** in Greenville, SC was busy with **The Singing Americans**, working with producer **Eddie Howard**. . . **New Age Sight & Sound** in Atlanta had the North Carolina Symphony Orchestra in cutting live-to-2-track digital for a new album on the fledgling American Orchestras label. **Peter Kermani** produced,

Bill Allgood engineered, assisted by **Jon Lawry**. . . **Jerry Reed** was in Memphis' **Cotton Row Recording** working on an advertising spot produced by **Dana Lillick**. **Nikos Lyras** engineered, assisted by **Eric Patrick**. . . At Atlanta's new **Musiplex**, the local band **Rockin' Bones** was in cutting with producer **Tim Nielsen** and engineer **George Pappas**. . . At **Cheshire Sound** in Atlanta, **Liking the Idea** put down tracks for their new LP with **Charlie Singleton** producing, **Lewis Turner Padgett** at the console and **Barry Leff** assisting. . . **George Jones** was in at the **Soundshop** in Nashville working on an album with producer **Billy Sherrill** with **Pat McMakin** engineering.

NORTHEAST

At **Evergreen Recording** in New York City, **Charlie Midnight** was in producing tracks for **Southside Johnny**, with **Dave Dachinger** and **Jeff Levine** sharing the engineering duties, while **Gary Clugston** and **Bill Rankin** assisted. . . **John Mahoney** has been working on musical orchestrations and sound design for the upcoming Universal picture release, *Serpent and the Rainbow* at the **Hit Factory** in New York, with **Jim Boyer** producing. . . At **Electric Lady Studios** in NYC, **Keith Richards** was in producing Chuck Berry's project for the movie *Hail Hail Rock and Roll!* Engineering the project was **Michael Frondelli**, assisted by **Bridget Daly**. . . At **Z Studios** in Brooklyn, **Paul Simpson** was in remixing **Aurra** for Virgin Records. Fred Zarr played keyboards. **Don Feinberg** engineered. . . New York-based **Efanel Music**'s live remotes included **Peter Gabriel**'s East Coast concert dates for a live single and video, **David Bowie**'s coast-to-coast satellite radio broadcast from New York, and the **Doobie Bros.**, **James**

Taylor and **Santana** live from the USSR for Showtime. All dates were engineered by **Randy Ezratty**, assisted by **Mark Shane** and **John Harris** with the exception of the Peter Gabriel project which was engineered and produced by **Kevin Killen**. . . At **Iris Recording** in Royersford, PA, **David Ivory** produced sessions for **Shelley Dickinson**. The record was mixed at Philadelphia's **Sigma Sound**. . . The popular Japanese band **Look** was in at **Cove City Sound Studios** (Glen Cove, NY) recording basic tracks for their new album, with **Alan Brewer** producing, **Kevin Kelly** at the board and **Tom Yezzi** assisting. . . At **The Barge** in Wayne, NJ, hard rockers **Trik Blue** worked on an album project produced and engineered by **Jim Barg**. . . **Michael Mugrage** produced **James Mee** for Cashwest Productions at **SounTec Studios** in Norwalk, CT. . . Producer **Jack Douglas** finished mixing the debut album of **Lauren Smokin** at **Island Media Services** in West Babylon, Long Island. . . Producer **John Wicks** was at **Third Story Recording** in Philadelphia completing mixes on **Cage**'s rap tune "Igor at Midnight". . . At **Roar Productions** in Columbia, MD, **Junior Prophet & the Logics** just recorded a new 45, produced by **Lenny Richards** and engineered by **Andrea Weatherhead**. . . Mr. Goodvibes himself, **Wavy Gravy**, was in at **Glasswing Studios** in Hyattsville, MD, recording an album for the studio's own label. . . At **Quantum Sound** in Jersey City, the **Weather Girls** finished mixing three cuts for their new album with producer **Reggie Lucas**, engineer **Doc Dougherty**, and assistant engineers **Abdu Malahi** and **Mark Pawlowski**. . . At **Long View Farm** in North Brookfield, MA, **Larry Marshall** and **Andy Smith** of Joe Cocker's band completed a demo project with producer **Cliff Goodwin** and engineer **Jesse Henderson**. . . At **Power Play Studios** in Long Island City, NY, **Keith Sweat** was in



Our latest release

Ampex hits the top of the charts with its newest release, Ampex 467 digital mastering tape.

We not only pioneered digital audio tape, we also refined it. The result is Ampex 467, a tape that sets the highest standards for all digital audio applications. And it's available in all open reel and cassette formats, including the new 80-minute cassette length.

More top performers record their hits on Ampex tape than any other tape in the world. While opinion may vary on what it takes to make a hit, there's no argument on what it takes to master one.

AMPEX

Ampex Corporation, Magnetic Tape Division,
401 Broadway, Redwood City, CA 94063, 415/367-3800.

Circle #003 on Reader Service Card



At Elumba Studios in L.A. the production team of Jerry Knight (L) and Aaron Zigman (R) worked with Stacy Lattisaw.

working on a new song with producer **Patrick Adams**. That one's for Vintertainment, distributed by Elektra. . . **Little Louie Vega** and **Guy Vaughn** were in NYC's **I.N.S. Recording** working with new artist **Pam Russo** for Island Records. **Steve Griffin** was at the board. . . **AT&T** recorded music for a new campaign of theirs at **The Edison** in NYC with engineer **Gary Chester**. . . **D&D Recording** in Manhattan had the band **Morgan Heritage** completing vocals and mixing for an upcoming project. **Denroy Morgan** produced and **Dennis Thompson** engineered, assisted by **Kieran Walsh**. . . At **Chung King House of Metal** in NYC, **The Boogie Boys** completed mixes for their Capitol LP, *Romeo Knight*. **Ted Currier** produced, **Bob Brockman** engineered. . .

NORTHWEST

At **Triad Studios** in Redmond, WA, **Jim Valley & Rainbow Planet** continued working on their third children's album; **Kelly Kunz** co-producing and **Lary Nefzger** engineering. . . **Coupe Studios**, Boulder, CO, completed a three-jingle campaign for the *Denver Post* through Schenkein/Associates of Denver, Colorado. . . Elektra heavy metal artists **Metal Church** were in at Seattle's **Steve Lawson Productions** with engineer **Terry Date** mixing a live EP recorded in Dallas. . . **Color Zone** worked on an album for Toshiba-EMI at **Studio D** in Sausalito. **Elissa Alford** and **Peter Gilford** co-produced. **Rick Sanchez** engineered with **Jim Vereecke** and **Red Davidson** assisting. . . **KBC Band** members **Slick Aguilar**, **Tim Gorman**,

Marty Balin and **Darryl Verducco** were in at **Prairie Sun Recording** in Cotati, CA, working on a track slated for KBC's second Arista album. **Allen Sudduth** engineered. . . Rock/reggae artists **RAM** have been in **Jungle Studios** in Santa Cruz cutting demos for their next album. The group is producing with assistance from engineer **Pete Carlson**. . . **Stevie Wonder** and **B.B. King** used San Francisco's **Different Fur Recording** to lay some guitar tracks for Stevie's new album. **Gary Olazabal** engineered the SSL/Sony 3324 project, with **Mark Slagle** assisting. . .

NORTH CENTRAL

Producers **Michael J. Powell** and **Sir Dean Gant** were in Detroit's **Sound Suite** laying tracks with **Cindy Mizelle** for a CBS Records album. . . At **Seagrape Studios** in Chicago, **Iron Cross** completed their album project with **Mike Konopka** producing and **Harry Brotman** engineering. . . At **ARS Studios** in Alsip, IL, the rock band **Lixx** recorded their debut LP for an independent label. The project was engineered by **Gary Cobb**. . .

SO. CALIFORNIA

At **Soundcastle** in L.A. Columbia artist **Weather Update** (formerly Weather Report) has been working on an album with Richard Page (Mr. Mister) singing lead vocals; produced by **Joe Zawinul**, engineered by **Paul Erickson**, with **Liz Cluse** assist-

ing. . . At L.A.'s **Hit City West, Little America** was in with producer **Joe Regis** and engineer **Kevin O'Connor** working on tracks for an upcoming film soundtrack. . . Recording at **Studio Masters** in L.A. were **The Pointer Sisters** with producer **Richard Perry**, for RCA Records. Engineering the project was **Michael Brooks**, with **Richard Platt** assisting. . . **Stacy Lattisaw** and **Howard Hewett** made sweet music together at L.A.'s **Elumba Recording Studios**. The hot duo was produced by **Jerry Knight** and **Aaron Zigman**. . . In **Sunset Sound Factory** (Hollywood), **David Kahne** has been producing an album for new CBS recording artist **Spookie**. **David Leonard** was at the controls with Dave "The Blade" **Knigh**t assisting. . . At **Kren Studios** in Hollywood, **Olivia Newton-John** finished vocal work on her new album with producer **Davitt Sigeron**, engineer **Beverly Jones** and assistant **Russell Bracher**. . . Ex-Motels chief **Martha Davis** cut tracks with producer **Richie Zito** at **One on One Recording** in Los Angeles. **Phil Kaffel** engineered, assisted by **Bernard Frings**. . . At **Take One Recording** in Burbank, engineer **Ken Caillat** recorded digitally with **Chicago** for a Westwood One radio show. **Micajah Ryan** assisted. . . **Bernard Edwards** produced three songs for **John Staehley & Matt Hirte** at **Airdrome Studio** in L.A. **Michael Hutchinson** engineered, assisted by **Fred Koch**. . . **The Bell Jar** was in at **Headway Studios** in Orange working on a new record with co-producers **J.B. Lawrence** and **Catherine Enny**, and engineer **Steve Kempster**. . . At **Preferred Sound** in Woodland Hills, **Cory Lerios** has been writing, recording and overdubbing music for the *Ohara TV* series. . . **Los Lobos** checked into **The Enterprise** in Burbank to work on some *La Bamba* remixes with **Steve Berlin** producing; while producer **Richie Zito** finished up mixes there on the forthcoming **New Frontier** LP. . . At the West Hollywood **Summa Music** group studio, producer **Paul Fox** cut a **Boy George** single for a new film, *Hiding Out*. . . Brothers **Reggie** and **Vincent Calloway** returned to L.A.'s **Larrabee Studios** to mix tracks for **Gladys Knight & the Pips**. . .

SOUTHWEST

Latin recording star **Juan Gabriel** and producer/engineer **Ryan Ulyate** have been busy cutting Gabriel's first all-digital album at **Albert's Home Studio**, an El Paso facil-

—CONTINUED ON PAGE 203

NEW Studer A820: Back to the Future



The future of multi-track mastering was commonly assumed to be 100% digital. But now Studer has built a multi-track for the future...by going back to thoroughly refine and update analog technology.

For the best possible combination of reliability, production capabilities, format compatibility, and sonic performance, the Studer A820 challenges *all* competitors. Analog *and* digital. No matter the price.

First, the A820 is fast and flexible. With total microprocessor control, it starts smoother, locks quicker, locates faster, and shuttles tape better than anything the competition has yet to offer. The tougher the job and the tighter the deadline, the more you'll love the A820.

The A820 is also fully user programmable. An extensive software menu lets you choose the operating features you

want, and audio alignment is automatic with all parameters (including NR levels) set and stored digitally.

Finally, the A820 shakes the "sound assumptions." With new amorphous metal heads, advanced phase compensation circuits, and fully integrated NR systems (Dolby A, SR or telcom c4) as an option, the A820 boldly challenges the costliest digital machines for overall sonic performance. Let your ears be the judge.

Some other manufacturers apparently assumed analog could not get significantly better. With the arrival of the A820, that's now a questionable assumption. Call your nearest Studer office for detailed directions back to the future. Studer Revox America, Inc., 1425 Elm Hill Pike, Nashville, TN 37210, (615) 254-5651

Offices: Los Angeles (818)780-4234 New York (212)255-462 Chicago (312)526-1660
Dallas (214)943-2239 San Francisco (415)930-9866

STUDER REVOX

Circle #004 on Reader Service Card



**BECAUSE
MASTERING CD'S
MEANS A LOT
MORE THAN JUST
PRESSING
THEM:**

MASTERED
BY NIMBUS



At Nimbus we've done more than anybody to master CD manufacturing, simply because we want our own recordings to sound as good as they sound when we make them.

We've fine-tuned and improved every step of the CD replication process and backed that up with absolute 100% quality control — so we can guarantee 100% satisfaction. And now, with our new plant in Virginia, we can offer you this same extraordinary service for all kinds of CD's, from the basic disc to a complete printed package, for any quantity. What's more, we meet our deadlines.

Mastered by Nimbus. When that appears on your CD's, it says you're as particular about who manufactures them as you are about what goes on them.

FULL-SERVICE CUSTOM PRESSING:

Mass CD replication — CD-Audio (includes CD Singles), CD-ROM, CD-V, CD-I.

Flawless digital and analog mastering.

Fast turn around — on-time delivery.

Full range printing and packaging services available, plus drop shipping and warehousing.

Now — your graphic design laser-mastered on CD singles. Only from Nimbus.



New York Sales Office:

200 West 57th Street New York, NY 10019 Telephone (212) 262-5400 Telex 239406 NMBS UR Telefax (212) 262-5409

Charlottesville Manufacturing Facility:

P.O. Box 7305 Charlottesville, VA 22906 Telephone (804) 985-1100 Telex 9102408303 Telefax (804) 985-4692

by Ken Pohlmann

COMPACT DISCS

THE SHAPE OF THINGS TO COME

Was it my obligation to speak at the LaserActive Conference in Boston, the chance to drive through the autumnal forests of New England, the prospect of eating Maine lobster fresh off the boat, or the invitation to tour Shape's Optimedia CD pressing plant that persuaded me to jet northward and (I cannot stress this too heavily) tearfully miss occupying my goal line seat at the University of Miami/Florida State game?

As it turned out, Shape's contribution to my itinerary alone made the trip well worthwhile. Many CD manufacturers jealously guard their secrets, for example, refusing to divulge which brand of polycarbonate they use, and other life-and-death issues. But the folks at Optimedia proved to be re-

freshingly forthright and candid regarding both technical details of their operation, and the economic scope of their future plans. Thus supplied with bunny suit and booties I conducted a full review of Optimedia.

Shape Optimedia is a CD pressing plant in Sanford, Maine. It is one of several wholly owned subsidiaries of Shape Inc., which in turn is owned by president and CEO Anthony Gelardi, and his brother Paul. The Gelardis started Shape 14 years ago in an abandoned car wash in Biddeford, molding 8-track tape shells and loading them with tape. Observing the downtrend in 8-tracks, the company moved into audio cassettes, again molding and loading them for OEM purchasers. The

An ongoing quality control program is a vital step in the CD manufacturing process. Here, two Shape Optimedia technicians test samples from a production run.

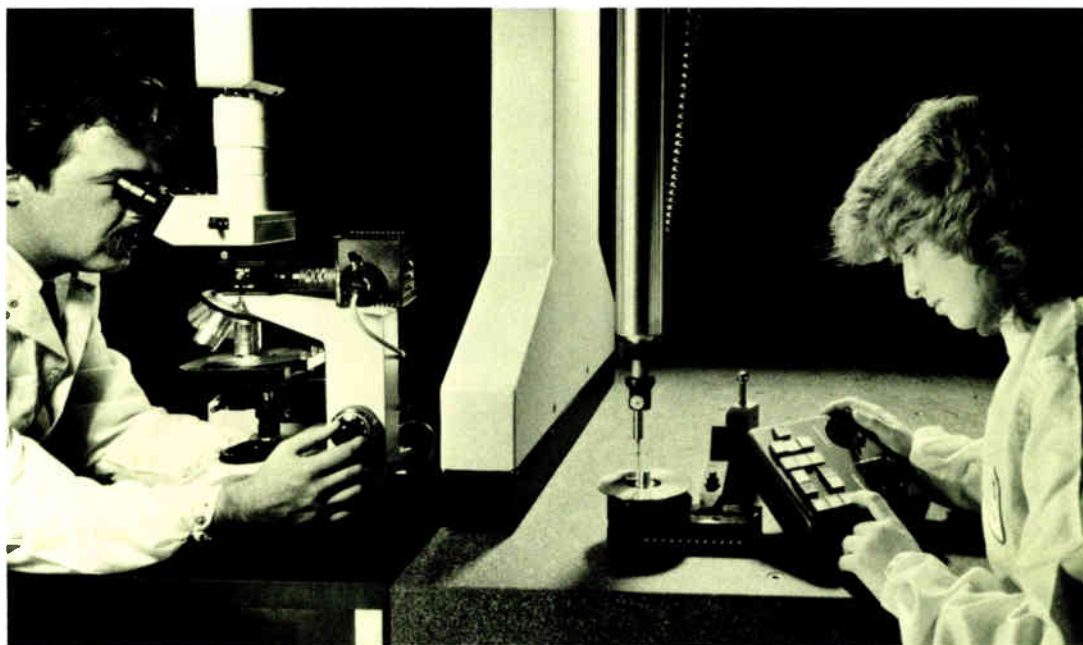

Behind Every Synclavier[®] There's a Success Story



Profile: **André Perry**

C.E.O. and Chairman of the Board of **The André Perry Group** and **Le Studio**

Visionary producer André Perry heads one of the most sophisticated music and video production facilities in the world. Located in a beautiful and secluded Quebec setting, LE STUDIO and THE ANDRÉ PERRY GROUP have proven that, with the right personnel and equipment, a studio doesn't have to be in a major urban center to stay on top. With his facility constantly booked, it's clear that André's philosophy of total service has paid off. Recent projects range from network TV series to records and videos by such leading artists as Chicago, The Bee Gees, David Bowie, and The Police.

He comments on the success of his first Synclavier Digital Audio System and his future plans: "The Synclavier was so simple to learn and use that two weeks after installing the system we did the music and sound effects for a major network Movie of the Week. It's been so cost-effective that we're already ordering a second system for our new Washington, D.C. facility."

Circle #007 on Reader Service Card



RACKMAX

FOR HIGH PERFORMANCE APPLICATIONS REQUIRING UP TO 16 INPUTS, STUDIO CONSOLE SPECIFICATIONS, IN A PORTABLE, RACK MOUNT DESIGN... THERE IS ONLY ONE RACKMAX

- 16 input channels in a 19-inch rack.
- Velvet-glide 100mm faders
- 48 volt phantom power — switchable each channel.
- Complete solo system.
- 3 auxiliary sends per channel — all jumperable. Pre EQ Post EQ/pre fader Post fader
- EIN: < -128 dBv THD: 0.05% any input to any output Frequency response: ± 0.5 dB 20 Hz to 20 KHz

RACKMAX is now available for your review at your favorite Biamp dealer.

biamp AMERICAN SOUND CRAFTSMANSHIP
Biamp Systems, P.O. Box 2160, Portland, Oregon 97208 (503) 641-7287

company's efficiency, and willingness to invest resources in technical innovation, paid off. Shape is now the largest independent producer of cassette shells in the U.S., selling approximately 3 million cassettes per week, heading for 4 million weekly early in 1988.

Their proprietary floating bridge design minimizes the importance of the shell's alignment in the cassette deck, and instead conforms the pressure pad to the head itself, thus helping tape track across the playback head. Their C-0 (empty) shells are widely popular with duplicators, and are available as both screw and sonic welded shells. The trick of developing a better product, often using proprietary manufacturing processes to enhance productivity, proved to be the key to Shape's success.

Shape Video was created to manufacture VHS cassettes for OEM customers, as well as the retail Shape Gold tape available regionally. In addition, computer ribbon cartridges for computer printers are manufactured for OEM sale, a facility in Tucson, Arizona makes 3½-inch floppies, and Shape South in Dadeville, Alabama custom molds CD jewel boxes. Shape is 80 percent owner of Wabash, manufacturer of DataTech 5¼-inch floppies, and has a joint venture with the Penobscott Indian tribe in Maine to manufacture audio cassettes. Shape has joint-ventured Newport Classics, a record label, in the belief that their replication business is intrinsically intertwined with the content of their products; with Newport they can experience first-hand the label side of the business. Finally, there is a Shape sales office in Japan. In all, Shape employs over 2,700 people, and enjoys an annual revenue in excess of \$200 million.

Shape Optimedia was founded in October, 1985 to capitalize on the growth of the CD market. The company was in production by May, 1986, and today manufactures 100,000 CDs per week, with production ramping up toward 300,000 weekly by early 1988. It occupies a 100,000-square-foot facility, on a 23-acre site. The move from audio cassettes into CDs was a natural extension particularly because it offered Shape an opportunity to exercise its ability to develop unique solutions to manufacturing problems. Thus numerous pieces of equipment were

developed by Shape Systems, the in-house engineering division. They specialize in factory automation equipment—high technology solutions for high-volume production products.

As with any CD pressing plant, the replication process begins with disc mastering, followed by electroforming. A Philips master disc cutter is used for glass disc mastering. Optimedia engineers have observed that it is better not to optimize the specifications of the glass master itself, but rather control its specifications to optimize those of the pressed discs. For example, the polycarbonate's response to the stamper's formations will introduce differences in specifications. By allowing for this, discs with low error rates are produced.

Audio Optic equipment is used for electroforming. As with any galvanic processing, cleanliness is essential; for example, de-silvering procedures must be carefully worked out. CD production places new demands in this respect; for example, stainless steel tanks and pipes may be adequate for LP matrixing, but minute contaminant migration into the plating solutions will affect CD work, necessitating use of fiberglass or even polypropylene material.

Disc replication at Optimedia utilizes a continuous, controllable CD manufacturing process housed in a class 10,000 clean room, with individual processes taking place under class 100 HEPA hoods. The disc is transferred from process to process via robotics; no operator touches the disc until it is finished. The process is thus highly predictable from disc to disc, day to day; because of this stability, it is relatively easy to monitor the quality of the product.

The disc starts life as polycarbonate pellets (usually Mobay), then is molded into a disc with a Netstal injection molding machine fitted with Philips dies. An arm transfers the still-warm substrate to a proprietary sputtering machine for metalization. Discs are pumped down and metalized one at a time. Because each disc sees exactly the same conditions each time (versus differing disc-to-disc conditions in a batch process), consistency is enhanced.

Another arm transfers the disc to a turntable for spin coating, labeling, and UV curing. The spin coater is a

—CONTINUED ON PAGE 101



WHAT YOU DO WITH THE M-600 MIXER IS YOUR BUSINESS.

That's why we've designed it to meet or exceed your most demanding requirements. And made it the easiest, most flexible professional mixing console you'll ever work with.

The M-600 is modular. Which means you can custom configure the console to *your* audio or video production needs. The M-600 lets you choose up to 32 input channels, or you can start with 16 or 24 input channels and expand the board as your needs change. Optional stereo modules can also be added to provide even more line inputs for MIDI instruments and video production convenience.

Installation and wiring is exceptionally easy. The M-600 is the only modular mixer that's available with all the necessary finished cables and installation hardware. And that can eliminate a lot of installation hassles and expense. At the same time, no other mixer at its price gives you multi-pin, computer-type connectors for quieter, more secure connections.

But the real pleasures of the M-600 will only be evident after it's in your studio. Up to 64 stereo or 128 mono inputs can be accessed directly from the top panel. A patch bay can be added for fast, flexible routing. That's convenience.

The M-600 has all the features you'd expect in a professional mixing console. Like balanced insert patch points on all inputs, PGM busses as well as the stereo master buss for increased signal processing capability. Plus sweep-type parametric EQ, balanced inputs and outputs, phantom power, talkback/slate channel and all the audio performance you'll ever need. Without the exorbitant price you don't need.

So check out the M-600 modular mixing console. It's ready for fame when you are.



TASCAM

© 1987 TEAC Corporation of America, 7733 Telegraph Road, Montebello, CA 90640 213 726-0303

Circle #034 on Reader Service Card

YOU MAY NOT BELIEVE THIS, BUT I LOVE MUSIC!

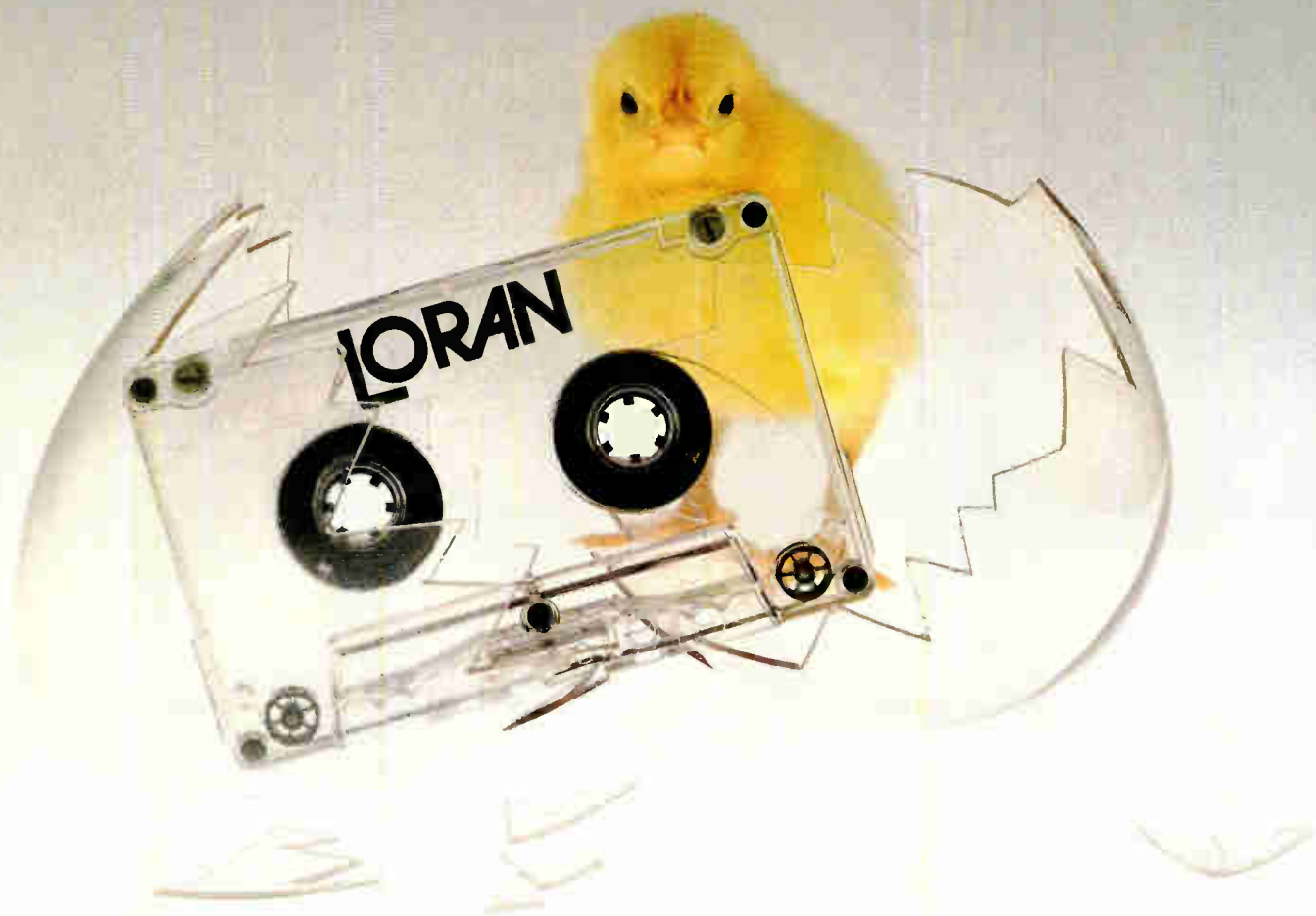

AS A MATTER OF FACT, I'M THE ONLY AUDIOPHILE I KNOW!

When I look for High Quality Duplicated Cassettes,
I look for those manufactured by LORAN Audio.
Now I don't know which came first, the chicken or the egg.
But one thing I do know, LORAN Cassettes are finally here
and I'm sure glad of it!

HIGH QUALITY CASSETTES AND AUDIO PRODUCTS

FOR INFORMATION REGARDING CASSETTES, COMPACT DISCS
AND RECORD MANUFACTURING CONTACT:
SANDY RICHMAN 818-955-8577

by Mel Lambert

TIME & MACHINES

Time present and time past
*Are both perhaps present in time future,
 And time future contained in time past.*"
 —T.S. Eliot, from "Four Quartets."

Time can be a tricky thing. There's never enough of the elusive commodity when you most need it—such as when a client is about to come storming into your studio demanding to know what became of that urgent 4-track transfer/video layback you promised 16 hours ago. And when you don't want to be aware of the passage of time—such as during an achingly slow summer period—you end up with too much of it on your hands. Yes, time really is an odd concept.

We humans are more used to encountering time in reasonably large quanta; usually in second increments. When we drop the time interval into the millisecond range, we begin to lose our ability to discern one discrete event from another. (In the not too distant future, I hope to find space within the hallowed pages of this magazine to examine the fascinating intricacies of the Haas Effect, a phenomenon that has a myriad of psychoacoustical applications.)

Of course, our ability to discriminate one event from another does not mean that a complex piece of music or a complicated soundtrack, for example, should only consist of a sequence of single sounds separated by an interval of around ten to 30 milliseconds. Apart from sounding bizarre, such a composition or soundtrack fails to acknowledge that the human brain can assimilate a broad texture of simultaneous events of which it has prior experience. (And here is another area rich in psychoacoustics discussions: the pri-

mordial effect that certain auditory cues can have on us all—even without our conscious understanding of exactly why we feel uncomfortable; for example, upon hearing a noise not unlike that of long extinct dinosaur.)

Aesthetics aside, we as organic life-forms prefer discrete events that we plan to label as such to occur at a slow pace, chronologically speaking. Micro-

High-speed control is, I'm convinced, the key to the future of recording and production facilities.

processor-controlled noise-producing devices, on the other hand, need to be relied upon to produce their respective sonic gestures at a more rapid tempo. Just how fast one expects the most staccato of sounds or musical notes to occur will determine the clock speed of the system in question.

Just how fast should such a clock be run, we might ponder? And, just as appropriate, how quickly should the timing system used to connect together items that are all contributing sonic events to the master soundtrack—the artifact for which we are to be paid the big bucks—be prepared in the studio? We all live in a cooperative world, don't forget, where a Mac Plus, for ex-

ample, running a breathtaking MIDI sequence into a bank of FM synthesis modules, also needs to enable a reverb modification or, for that matter, an EQ change, at precisely the right moment in time.

Should we base our sync system on musical time frames, or on the timing references of the master microprocessor which, by necessity, must be lurking somewhere in the system? Obviously, the constraints of tasteful composition will dictate that our music events will occur at the accepted notation intervals, such as on 32nd, 64th or 132nd notes. Just so long as we base our timing system on the most flamboyant and speedy composition we are ever likely to encounter, our sequencing computer and its communications system should be able to uniquely label and initiate every discrete event likely to occur.

The problems with such reasoning, however, begin when we need to initiate a complex sequence of events at a particular point in time. Consider the following example: at the start of bar 56 in a 6/8 signature underscore for a high-energy network drama series, we want to effect a stunning change in reverb and ambience that will be used as an adjunct to the visuals. We can set up the master sequencer running on an Amiga to initiate the MIDI command sequence, but time after time we discover that the reverb change is either too late or a heartbeat too early. Eventually we happen upon a realistic compromise that seems to work, spool off the tape for the client, and hope for the best.

What was going wrong, we might ponder, during a postmortem of the session? It was easy to determine that the timing anomalies weren't being produced by the digital effects unit; manually triggering the device resulted in the correct ambience change. To make a long story short, the problem was eventually attributed to the fact that the particular sequencer was only capable of tagging events to a low resolution level (or pulses per quarter note, to use the jargon).

What we seem to be observing is a failure of users and manufacturers to agree on a universal interval of time in which it seems reasonable for a microprocessor-based device to perform the task we are asking of it. (I stress the

use of the word "reasonable" here because the processing speed of outboard processors and effects units is doubling every handful of months; what was the most happening in terms of speed a few weeks ago now seems slow and sluggish.)

It's a two-edged sword: we can run devices faster, which means that they need less time to effect the changes; at the same time, however, because we have the speed available we want to

What we seem to be observing is a failure of users and manufacturers to agree on a universal interval of time in which it seems reasonable for a microprocessor-based device to perform a task.

make the device in question perform processing gymnastics every 0.1 microseconds—simply because, like everything we come to terms with these days, it's there and ready for us to use.

The bottom line is that we should be careful in advocating the use of a basic timing interval or clock speed without looking at the time it takes these devices to perform the desired change. If it so happens that on the receipt of, for example, a 6-byte MIDI command sequence the QuadraPleen 760XL takes "X" nanoseconds to interrogate the command, respond to it and reconfigure itself to become something else, then you had better make sure that you can send that MIDI command sequence precisely X nanoseconds ahead of the cue point.

Sure, we could come up with a control scheme that sends the commands ahead of time, and then causes the pre-programmed change to be enabled at the selected cue point. To my mind, that particular scheme only makes sense if we really do insist on working with slower-speed devices that are of a previous generation, but for which we have a soft spot in our processing hearts. (Not unlike retrofitting MIDI Ins and Outs to an old minimoog because it's the only keyboard capable of producing that amazing

lead sound we just have to have for a new composition.)

High-speed control is, I'm convinced, the key to the future of recording and production facilities. We now have a virtual arsenal of timing and synchronization schemes, including SMPTE time code, MIDI time code, FSK sync, as well as various proprietary control protocols from synth and sequencer manufacturers. On the more traditional recording hardware front, we have RS-232C, RS-422 and the new E-Bus available for time code synchronizers, tape machines, automation systems and outboard processors.

I am reminded of a conversation I had almost a decade ago with a leading engineer/producer who was speculating about the future of console automation systems. What sort of control systems would be most appropriate, he pondered, to enhance our creativity in the control room? He concluded that to really speed up a tracking, overdub or remix session it would be handy to have access to a computer that could automatically recognize music tempos, and could thus work out the location of every bar and measure in the piece. (And, if the audio consisted primarily of sound elements, at least locate them to the nearest video subframe, and wait for the operator to provide a brief script outline to explain their associated visuals.)

That way, he concluded, with a far-away look in his eyes, it would be possible to issue a spoken command, such as "Go to the beginning of the bridge and play the basic tracks plus the take three synth solos. Hold the vocals muted until bar 192, and then unmute as the visuals come up to a medium long shot of the car explosion. Give me a gated reverb with a 196-millisecond pre-delay on the snare track, and an overall wash of room ambience 12B from library bank 37B."

It's a dream that will be reality any day now. Just so long as we realize that time is an illusion that can be manipulated for our entertainment. ■

Mel Lambert has been intimately involved in the pro audio industry—on both sides of the Atlantic—for the past decade. Formerly editor of Recording Engineer/Producer magazine, he currently is a partner in the Marcus Lambert PR firm, and the president of Media & Marketing, a consultancy service for the pro audio industry.*

Need More Inputs? No Problem!

- Up To 80 Inputs In Less Than 8½ Feet
- 30 mm Module Width Equals Unparalleled Compactness
- Inline, Split I/O, Or Monitor Modules With F.S.S. (Floating Subgroup System) Allow Unlimited Expandability And Flexibility
- LED Metering On Individual Channels
- Welded Steel Chassis

Need Digital Quality? No Problem!

- Discrete Mic Preamps And Proprietary Circuit Design Yields Unmeasurable Distortion Figures And Inaudible Crosstalk
- 8 Aux Send Busses Per Module
- Musical Sounding 4 Band Equalizer With Sweepable Mids
- Dual Level (+4/-10) Interface For Easy Installation

D&R Electronica b.v.
Rijnkade 15B,
1382 GS Weesp,
Holland

D&R USA
1720 Chip N Dale Dr.
Arlington, TX 76012
(817) 548-1677

Dayner Series

by:

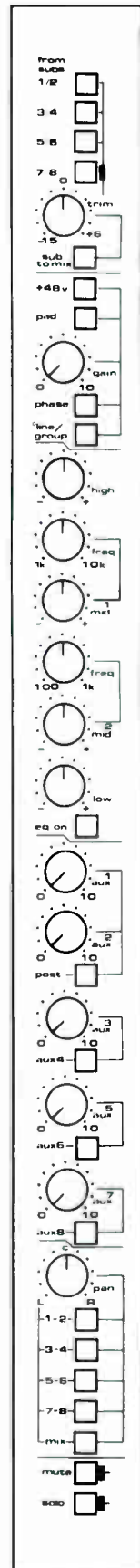

Circle #030 on Reader Service Card

DIGITAL & CD

MASTERING THE MYSTERIES

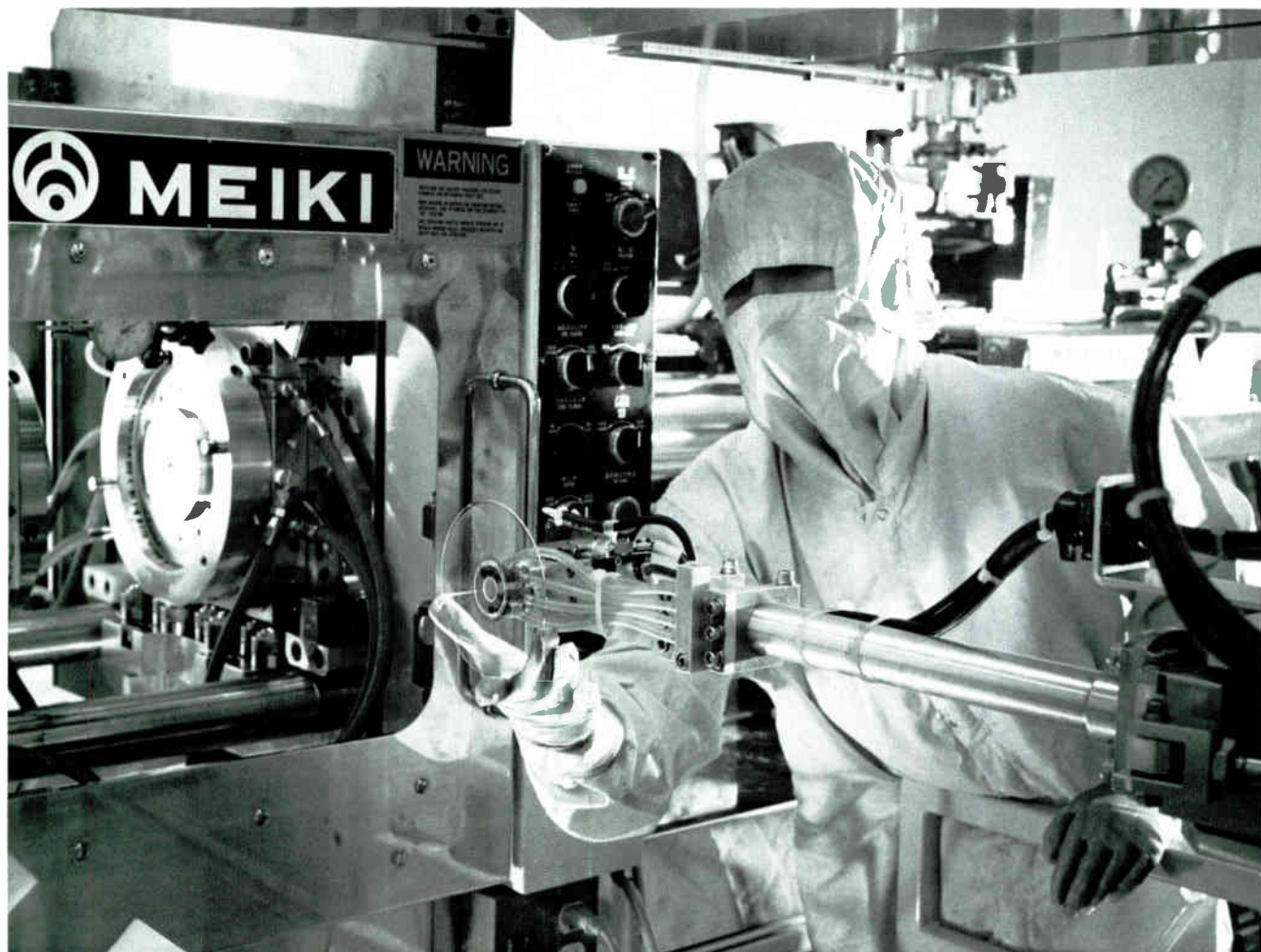

by
**Barry
Diament**

As one of the first CD mastering engineers in the U.S., I've had the opportunity to closely witness the evolution of several aspects of CD production, manufacturing and playback. I've heard the "crunchiness" of early digital recorders and CD players give way to a promising new state-of-the-art. I've heard the flubs and fluffs of early mastering techniques evolve into some of the clearest, most dynamic sounds short of a live performance.

Over the course of several years, there have been a number of questions put to me by clients, colleagues and friends. Several of these questions crop up repeatedly as more and more people become interested in digital and the compact disc as a vehicle for presenting their music or as a means of enjoying music in their homes.

In this article I will address some of the more frequently asked questions and try to shed some light on just what is involved in the production stages of a digital tape and compact disc.

Since the largest number of recordings currently available were made

Technician removes pre-metalized CD from robotic arm after injection molding at Discronics CD plant, near Melbourne, Australia.

*Affordable
Quality*

PC Midi SERIES

SOUNDTRACS

A British company dedicated to the design and manufacture of one of the broadest ranges of mixing consoles in the World. We offer ten individual models in over fifty versions to suit your specific requirements.

The choice is yours.

Exclusive U.S. distributor:

AKG ACOUSTICS, INC.
77 Selleck Street, Stamford, CT 06902
Telephone: (203) 348-2121



Applications: 8, 16 & 24 Track Recording;
Keyboard Workshops;
Keyboard Mixing.

using analog equipment, it seems fitting to begin with the transfer of these to the digital domain.

Transferring an Analog Recording to Digital

The first step in a successful transfer is an analytical evaluation of the master. The first parameters to get attention are the average recorded level, peak recorded level, the music's utilization of dynamics and spectral distribution. These, together with a knowledge of your playback amplifiers, will point to an optimal playback level from the analog machine. It isn't always a question of setting playback levels according to the reference tones on a tape. The primary function of those tones is to provide a reference for the situation during the recording of that tape. I have worked with master tapes which, when set to the playback levels indicated by the reference tones, yielded grossly overloaded, clipped program as a result. Conversely, I've encountered situations where setting playback levels by reference tones yielded peaks several decibels below what modern playback electronics are capable of. An exception to

Much as proper mastering of a vinyl record often involves more than a simple transfer to disc, proper mastering for CD involves more than a simple transfer to digital.

these situations would be a Dolby or similarly encoded master. Double-ended systems like Dolby or dbx require a relatively strict adherence to reference tones in order for the decode sections to perform properly. Under these circumstances levels must be adjusted after the decoder output.

And of course there are those occasional tapes that come without tones. In these instances, as in all the others, a bit of common sense combined with knowledge of your equipment

and a sensitivity to music and sound will produce the best results.

One of the most frequently overlooked aspects of the transfer system (and of most audio chains in general) is the cabling used to connect the various components involved. A lack of understanding combined with a simplistic approach ("resistance and capacitance are all that count") has produced many "professional" cables whose performance is optimized for carrying simple sine waves. While these are fine for connecting a 60Hz source to a light bulb, they cannot adequately deal with the complex, transient nature of a music signal.

Interconnects such as Monster Cable's Pro-Link series or Music Interface Technology's MI-500 are quite successful in preserving musical dynamics, bandwidth and phase relationships often diminished by other cables. Multiple gauge conductors, sophisticated winding techniques and low absorption dielectrics are some of the factors contributing to these achievements.

Continuing along the chain from optimized analog playback through high-quality interconnect cables, the



Think of it as a REV7

For the past few years, audio professionals have been praising Yamaha's REV7 digital reverb to the skies. So there was incredible pressure to make its successor even better than expected.

Introducing the REV5. Representing a breakthrough in the sound barrier for reverb. And a collective sigh of satisfaction from the overachieving design engineers at Yamaha.

Because not only is the REV5 matured in

capabilities, it's improved in sonic quality as well.

We added more DSP chips to boost the REV5's processing power, creating smoother reverb sounds and multi-effect combinations. Full bandwidth extends reverb to 20 KHz.

In addition to master analog EQ, the REV5 has three-band parametric, programmable digital EQ. So when you make individual EQ settings, they're recalled with each program.

next step is digital input level.

Because distortion in the digital domain decreases as more headroom is used (as opposed to analog where *increased* headroom yields lower distortion), it is important to maximize level. Optimum analog playback levels often do not coincide with optimum digital record levels. All too often CD masters and analog-to-digital transfers are made using VU meters or the peak meters on a vinyl mastering console as a reference. Depending on the nature of the program's dynamics, digital input level can frequently be increased to take full advantage of the medium.

It is a widely held misconception that a digital transfer of an analog master can be considered a CD master. While usable as such (assuming the digital format is the U-matic videocassette and SMPTE time code is present), much more can be accomplished with the digital transfer to create a CD master of higher quality.

Much as proper mastering of a vinyl record often involves more than a simple transfer to disc, proper mastering for CD involves more than a simple transfer to digital. Many programs re-



Author Barry Diamant

quire some level and EQ changes midstream to sound their best on the final CD. Also, the digital medium allows a new level of "cleaning up" of masters.

Noises and Hiss Between Cuts on a CD

In addition to the hiss, thumps and noises caused by tape, paper or plastic leaders, several sources can contribute noise to a program. Mixing consoles and outboard electronics can add noise. While taken individually

these components may have noise specs even lower than a digital recorder, there is a cumulative effect that can become quite audible. This is exacerbated by the use of compression which, by its nature, elevates low-level signals to achieve a higher average level.

The elimination of all these noises is a time-consuming process that cannot be achieved with the one-pass, real-time methods of vinyl mastering or the volume-conscious approach of manufacturing.

The removal of clicks, thumps, hiss and other assorted noises involves a continuation of the analytical evaluation of the master as described. Exact (SMPTE) addresses must be noted for band starts and endings and the incidences of clicks or other undesirable noises.

With this information, recording of the digital master can be halted to allow the insertion of total silence (sometimes referred to as "video black" or "digital zeroes") between bands. At the same time, the "spirals" (the spacing between the bands) can be kept exactly as long as on the original master, keeping with the inten-

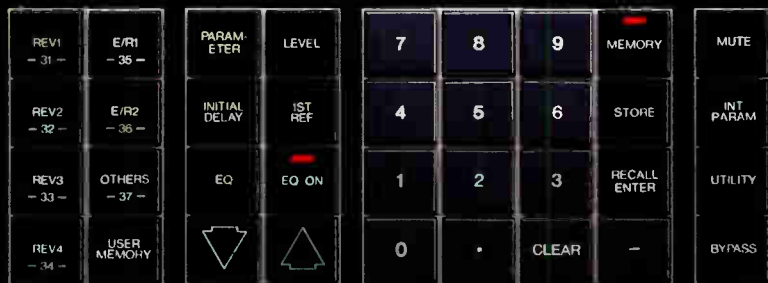

with a sonic boom.

And when you don't have the time to make many decisions, there are 30 preset programs, plus nine unique preset combination programs. Sixty user-memory slots let you save your custom effects.

And even though a lot of the features are new, using the REV5 won't be. Because the format is the same as the REV7 you're used to using.

Check with your friendly Yamaha Professional Audio dealer about the new REV5. Once you hear

it, you may find it difficult to come back down to earth. Yamaha Music Corporation, Professional Audio Division, P.O. Box 6600, Buena Park, CA 90622. In Canada, Yamaha Canada Music Ltd., 135 Milner Avenue, Scarborough, Ontario M1S 3R1.



YAMAHA[®]
Engineering Imagination™

Circle #037 on Reader Service Card

World Radio History

PERFORMANCE

Style

It is the unique mix of sonic excellence and individual styling that identifies a Studiomaster mixing console, and we pride ourselves knowing they sound as good as they look. Each time you switch on your Studiomaster (and you'll only know it's on by looking at the power light), its clear control layout will give you the inspiration to mix a masterpiece. This is the beginning of a Studiomaster sound experience.

Mixers pictured: 16.16.2 SII, 16.4.2 SIII, 16.8.2 S5



16.14.2/16.8.2/16.16.2 frame sizes. 4 band EQ with sweep mids, 6 auxs, phase reverse, MIDI controlled muting of aux returns and inputs, 100mm ALPS master faders, external rack mount PSU, plus much more. Expandable inputs and tape returns to maximum 40.16.24. Coming soon: retro-fit MIDI update kit.



The custom console system, from 8.2 to 40.8.16.2, and constantly expandable to suit your needs. 13 different modules including mono and stereo inputs, two types of master output, tape return module, aux master subgroup, 3 band EQ with sweep mid and bass, 6 auxs, switchable RIAA EQ on stereo inputs, 100mm ALPS master faders, external PSU, plus much more.



16.4.2/16.8.2. An extensive update based on the best-selling Studiomaster 12.2c, 16.4.2, 16.8.2, 16.16.2 range. 3 band EQ with sweep mid and bass, 5 auxs, EQ on L/R outputs, switchable to aux returns, 100mm faders. Expandable inputs up to 32.



For detailed information and technical specifications on the entire Studiomaster range, contact Peter Reeve or Tony Allen at: Studiomaster Inc. 1340-G Dynamics Street, Anaheim, CA 92801. Telephone: (714) 524 2227 Facsimile: (714) 524 5096

STUDIOMASTER

the sound experience

World Radio History

STUDIOMASTER IN CANADA:
CALGARY Mothers Music (403) 245 3785 / EDMONTON Mothers Music (403) 439 0007 / HALIFAX Music Stop (902) 422 5671 / MONTREAL Stereo Music Store (514) 878 2216 / OTTAWA Steves Music Store (613) 232 1111 / QUEBEC Musique Richard Gendreau Inc (418) 522 3877 / ST JEAN Steves Music Store (416) 593 8888 / VANCOUVER Mothers Music (604) 433 3341

Circle #039 on Reader Service Card

tions of the artist and producer when they assembled the final tape. This stop and go procedure also allows for the removal of spurious clicks and thumps occurring in the program.

Some will not agree that time consumption is the reason these noises are left in the program. They argue that the insertion of video black causes program hiss (particularly in older recordings) to stand out even more when juxtaposed with the silent spirals. Careful listening will show this is the case only when an abrupt "cut" to silence is made. Judicious use of gain offset and long ramp times (slow crossfades to black) can offer a much more pleasing result where fades actually disappear into complete silence. To hear this properly achieved is to realize one of the promises of the CD medium: older recordings can actually sound quieter, and without paying the price of additional phase distortion and loss of "air" exacted by dynamic noise filters.

Some engineers mistakenly use the gain offset control as a "fader" to achieve a gradual transition to black. This often results in the *addition* of a noise unique to the digital medium. "Quantizing noise" is the raspy distortion evident at the end of bands on many CDs.

The compact disc is purported to allow the consumer an experience equivalent to listening to the master tape. The technology now exists to improve upon the original masters: to renew older recordings as well. The masters used for CD production become, in effect, the new masters of the original recordings. The evolution of new mastering techniques and the willingness to take the time to implement them will advance the art of music reproduction.

How Long Will the Digital Tape Last?

Analog and digital masters have one thing in common—both represent information stored by arranging magnetic particles of what is essentially powdered rust stuck to a plastic ribbon. Depending on how smooth the surface of the tape is and how well the "rust" is bonded to the base material, both have a finite lifetime. In normal use, the base material will shed some of its magnetic coating (and consequently some information) due to friction with heads and tape guides.

NORTH AMERICAN CD PLANTS

Compiled by George Petersen

The race is on, and the manufacturing capacity of domestic CD plants is now at an all-time high, with several new facilities planned for the coming year and existing CD makers expanding and upgrading for higher output. At the same time, an increasing number of offshore companies—such as Daio Corp., (Camarillo, CA); Sunkyong SKC, (Rutherford, NJ); and Tzuru Tech, (Cerritos, CA)—have established U.S. offices to expedite local pressing business. The following is a list of plants offering onshore CD production.

AMERIC DISC INC.
2525 Canadian St., Drummondville, QUE,
Canada J2B 6V4
(819) 474-2655
Contact: Andy Nagy or Reggie Rutherford
On-Line: February, 1987

CAPITOL EMI
#3 Capitol Way, Jacksonville, IL 62650
(217) 245-9631
On-Line: November, 1986
Annual Capacity: 7M (expanding to 18M during 1988)
Notes: Currently pressing CDs for in-house (Capitol/EMI) projects only

CINRAM LTD.
2255 Markham Road, Scarborough, ONT,
Canada M1B 2W3
(416) 298-8190
Contact: Wendy Anderson or Kim Zenga
On-Line: Spring, 1987
Annual Capacity: 12M

DENON DIGITAL INDUSTRIES, INC.
1380 Montecello Road, Madison, GA 30650
(404) 342-3425
Contact: Eric Fossum
On-Line: April, 1987
Annual Capacity: 18M

DISCOVERY SYSTEMS INC.
7001 Discovery Blvd., Dublin, OH 43017
(614) 761-2000
Contact: Mike Ward, VP Sales
On-Line: August, 1986
Annual Capacity: 10M

COMDISC
1510 Cotner, Los Angeles, CA 90025
(213) 479-0899
Contact: Michael Wanlass or Terry Conway
On-Line: Full production April, 1988
Annual Capacity: 30M (projected)

DIGITAL AUDIO DISC CORP.
1800 N. Fruitridge, Terre Haute, IN 47804
(812) 466-6821
Contact: Scott Bartlett
On-Line: September, 1984
Annual Capacity: Approximately 60M

DISC TRONICS
8439 Sunset Blvd. #401, Hollywood, CA 90069
(213) 654-5550
Contact: Jeannie Brinkman
Notes: Disc Tronics, with one plant in Australia and another in the UK, plans to open a U.S. facility in 1988

JVC DISC AMERICA
#2 JVC, Tuscaloosa, AL 35405
(206) 556-7111
Contact: JVC Disc Sales: (213) 466-4212, (212) 704-9267
On-Line: March, 1987
Annual Capacity: Expanding to 20-25M by year-end

LASERVIDEO
1120 Cosby Way, Anaheim, CA 92806
(714) 630-6700
Contact: Sales Office: (818) 953-7790
On-Line: Anaheim, CA—1984; Huntsville, AL—October, 1986
Annual Capacity: 3M in Anaheim, 17M in Huntsville (now being upgraded to 40-60M capacity)

MEMORY-TECH
5800 Summit, Plano, TX 75074
(214) 881-8800
Contact: Scott Rose or Shinobu Toyota
On-Line: October, 1987
Annual Capacity: 15M
Notes: Memory-Tech's U.S. CD plant is a joint venture by Mitsubishi and Electro-Sound

NIMBUS RECORDS
Box 7305, Charlottesville, VA 22906
(804) 985-1100
Contact: Peter Miller
On-Line: September, 1987
Annual Capacity: 6.5M currently, to 30M within 18 months

PHILIPS/DUPONT OPTICAL
Box 400, Grover, NC 28073
(704) 937-7941
Contact: John Kiernan, (212) 764-4040
On-Line: November, 1986
Annual Capacity: 30M

PRAXIS TECHNOLOGIES
950 Verbena Road, Mississauga, ONT Canada L5T 1T6
(416) 673-9544
Contact: Alun Elias
On-Line: September, 1986
Annual Capacity: 18M

SANYO LASER PRODUCTS
1767 Sheridan, Richmond, IN 47374
(317) 935-7574

SHAPE OPTIMEDIA
Route 109 and Eagle Drive, Sanford, ME 04073
(207) 324-1124
Contact: Dennis Hannon
On-Line: May, 1986
Annual Capacity: 15M (to 20M in 1988)

TECHNETRONICS
Box 496, Matlack Industrial Park, 201 Carter Drive, West Chester, PA 19381
(615) 430-6800
Contact: Dave McQuade
On-Line: May, 1987
Annual Capacity: 10M (to 50M in 1988)

TECHNIDISC
2250 Meijer, Troy, MI 48084
(313) 435-7430
Contact: George Giankulis
On-Line: September, 1986 (CD Audio)
Annual Capacity: 6M

3M OPTICAL DISC PROJECT
1425 Parkway Drive, Menomonie, WI 54751
(715) 235-5541
On-Line: October, 1985 (CD-Audio and CD-ROM)

WEA MANUFACTURING
Box 321 Olyphant, PA 18447
(717) 383-2471

An analog master will reveal incipient oxide loss as diminished high-frequency energy. This is a prime reason why many artists will make a copy of their basic tracks onto a second multi-track machine and use the copy as their reference for overdubs. By avoiding the numerous replays of the original tracks that overdubbing necessitates, and then using the original tracks for the final mixdown, transient response can be preserved, lending that extra sparkle to drums and other percussive instruments.

While digital masters are not subject to loss of high frequencies with

repeated playings, they are nonetheless still subject to oxide loss. And like analog masters, even in storage certain losses will occur due to some of the magnetic particles "forgetting" their orientation. The result for a digital master is an increase in the amount of error correction required during playback. The good news here is that error correction is in the vast majority of cases inaudible. The potential bad news is that as error incidence rises, so does the probability of an uncorrectable (i.e. audible) error.

Fortunately, the designers of the widely used digital formats have in-

corporated a digital encoding scheme involving redundancy. By combining this with a reasonable amount of user maintenance (shuttling stored tapes at least once a year) the lifetime of a digital master can be longer than its analog equivalent.

A further advantage digital masters have over their analog counterparts is that digital masters can be "cloned" to yield not only a virtually exact replica of themselves, but what is essentially a "new" master.

While digital masters are subject to the same physical hazards as analog masters, the possibility of making renewed copies means that unlike analog masters, digital masters can "last" indefinitely.

Digital Error Correction

Anyone who has watched the error correction LED on either a high-end CD player or on the Sony 1630 can tell that most of the time, error corrections are not audible.

In the case of CD playback however, the threshold of audibility is a vague one and often it is crossed. I am referring to laser tracking errors brought about by vibrations of the playback mechanism and by the discs themselves.

A few years ago, upon noticing that discs of the same album made at different manufacturing plants sound different, I experimented with something I'd read about—namely that a weight placed upon a CD will make it sound better. Since both of the CDs I was comparing were made from the same master tape, the sonic discrepancies had to result from some physical difference between the discs themselves.

As it turned out, placing a second CD on top of the one being played did change the sound; hardness decreased, low-end information and dynamics seemed punchier, more like the master. Many engineers with whom I discussed this said the change was imaginary—"Impossible. It's just reading numbers." But what if it can't see the numbers clearly? This in fact was the case and is easy to verify if you put an oscilloscope on the vertical focusing (or lateral tracking) servo loop; you'll see constant correction. This isn't the digital process error correction but is error correction nonetheless, caused by servo loop alignment. In addition, most CD players

—CONTINUED ON PAGE 162

Nothing Else Comes Close



Beyond question, Cetec Gauss produces the finest high-speed audio tape duplicating systems in the world. The Gauss name is synonymous with leadership in equipment technology and quality, and assures a long-term, reliable and cost-effective investment.

The Gauss Series 2400 tape duplicator represents a new dimension in quality duplicators. A combined master and loop bin in a single unit is designed to operate reliably and efficiently at speeds up to 480 ips. This joined with the Gauss salve recorder makes the Series 2400 the ultimate system.

Like the Gauss duplicator, a new Gauss Tape Test System is your only choice to verify the performance of your equipment. It's industry compatible with most duplicating systems from 1:1 through 1:128.



If you demand quality duplicating, the Gauss Series 2400 is your only choice.

Nothing Else Comes Close.

Cetec Gauss

9130 Glenoaks Boulevard
Sun Valley, CA 91352
(213) 875-1900
Telex: 194 989

Circle #096 on Reader Service Card

SAVE UP TO \$20

ON THE WORLD'S BEST SELLING MICROPHONES!



Save \$20 on Shure's popular SM58 mic, \$15 on the unique Shure SM57 and \$5 on other selected Shure microphones if you buy between November 1 and December 31, 1987. Just fill out the coupon below and send it to us with the necessary proof of purchase before January 31, 1988.

Get up to \$20 back during Shure's "World Tour Rebate"

To receive your rebate on selected Shure microphones, send: (1) A copy of your dated sales receipt (non-returnable), (2) The model number label from the end of the outer carton, and (3) this completed coupon to: Shure Microphone Rebate Offer, 222 Hartrey Ave., Evanston, IL 60202-3696.

Name _____
(Please Print Clearly)

Address _____

City _____ State _____ Zip _____

Phone (Area Code) _____

Number of Mics purchased: SM57 _____ SM58 _____

Other _____
(model & qty.)

Offer valid on purchases of all microphones (except Prologue and communications models) made between November 1, 1987 and December 31, 1987. All requests must be post-marked by January 31, 1988. This is a consumer rebate offer only. Shure dealers, distributors and retailers are not eligible. This offer may not be used in conjunction with any other rebate from Shure. Shure is not responsible for late, lost or misdirected mail. Offer good only on purchases made in U.S.A. and open to U.S. residents only. Offer is limited to (6) microphones per individual or company. Void where taxed or prohibited by law. Rebate requests not including proper documentation will be returned as incomplete. Rebate eligibility as determined by Shure is final. Allow 6-8 weeks for delivery of check.

SHURE

THE SOUND OF THE PROFESSIONALS...WORLDWIDE.

MIX-12/87

THE INDEPENDENT'S GUIDE TO CD PRODUCTION

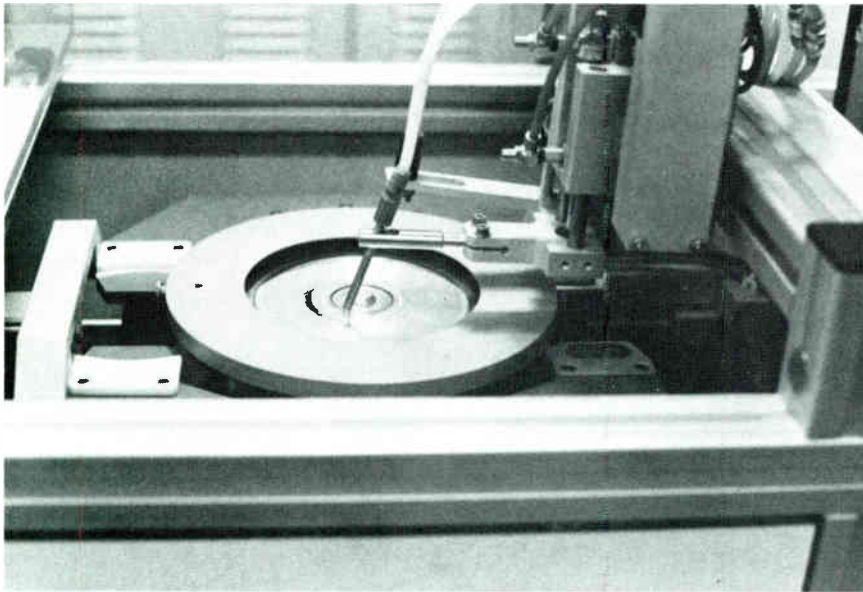

Acrylic sealer being applied to CD at Technetronics.

by John Barilla

PRE-MASTERING

If you are an independent producer or owner of an independent record company, you probably have been watching the CD market lately. You've seen the CD player go from a mere consumer curiosity to a staple component in the home stereo system. Amidst declining vinyl sales, industry prophets are projecting a record year for the compact disc. The writing is truly on the wall: CD is profitable. CD is inevitable. The only question is when will you get on board?

I have been toying with this idea for some months now, and preparing my catalog for that maiden voyage on CD. Every track has been recorded with extra care and most of my mixes have been done in the digital domain using the Nakamichi DMP 100 digital processor and a Sony SL-HF 400 Beta video

deck. Any one of several other "consumer" oriented processors (similar to the classic Sony F1) are currently being utilized for low-cost digital mix-down. As my interest in doing a release on CD peaked, I decided to get some straight talk from some experienced hands and share it with the readers of this magazine.

There was no better person to start with than a man whose exploits in the audio industry have spanned three decades and whose experience has made him a veritable guru of new technology. I wanted an insider's perspective on the pre-mastering and manufacturing of CDs, so I called on Harry Hirsch. (Hirsch is currently director of marketing for Technetronics, a truly unique compact disc company located just outside Philadelphia in West Chester, Pennsylvania.)

To provide an accelerated course on pre-mastering (also called "CD prep"),

he arranged for me to spend an afternoon at Soundtrack in New York City—a multi-studio recording facility that offers CD prep as one of its services. At Soundtrack we met with producer/engineer John Kiehl. Having earned degrees in both music and engineering from MIT, and developed the CD prep operation for Soundtrack, Kiehl was the perfect person to answer questions on the technology and what it all might mean to a producer.

Reflecting on how Soundtrack became involved in the pre-mastering phase of CD manufacturing, Kiehl says: "A year ago, making CDs seemed like a horror show. You couldn't get any plant to quote a delivery time. There was bad press everywhere about rejection rates and how difficult it was to get a good product." Concerned about quality control and fueled by the need to place 20 albums of his Aircraft Music Library on CD, Kiehl and his partners decided to invest \$170,000 to buy their own pre-mastering equipment.

The situation is considerably different today in the CD industry than a year ago, when Kiehl first put his prep facility on-line. The entire CD process, while no less demanding than before, is now operating more like a well-oiled machine. The "horror stories" largely were due to the lack of communication between prep house and pressing plant. Today, although some grey areas still remain, most of the procedures have been ironed out. With well-informed, client-oriented people like Kiehl at the helm, the expectation now is that every client should be able to receive a satisfactory end-product delivered in a reasonable amount of time.

The one proviso of course, is that the production master—your original mixdown tape—is acceptable for the

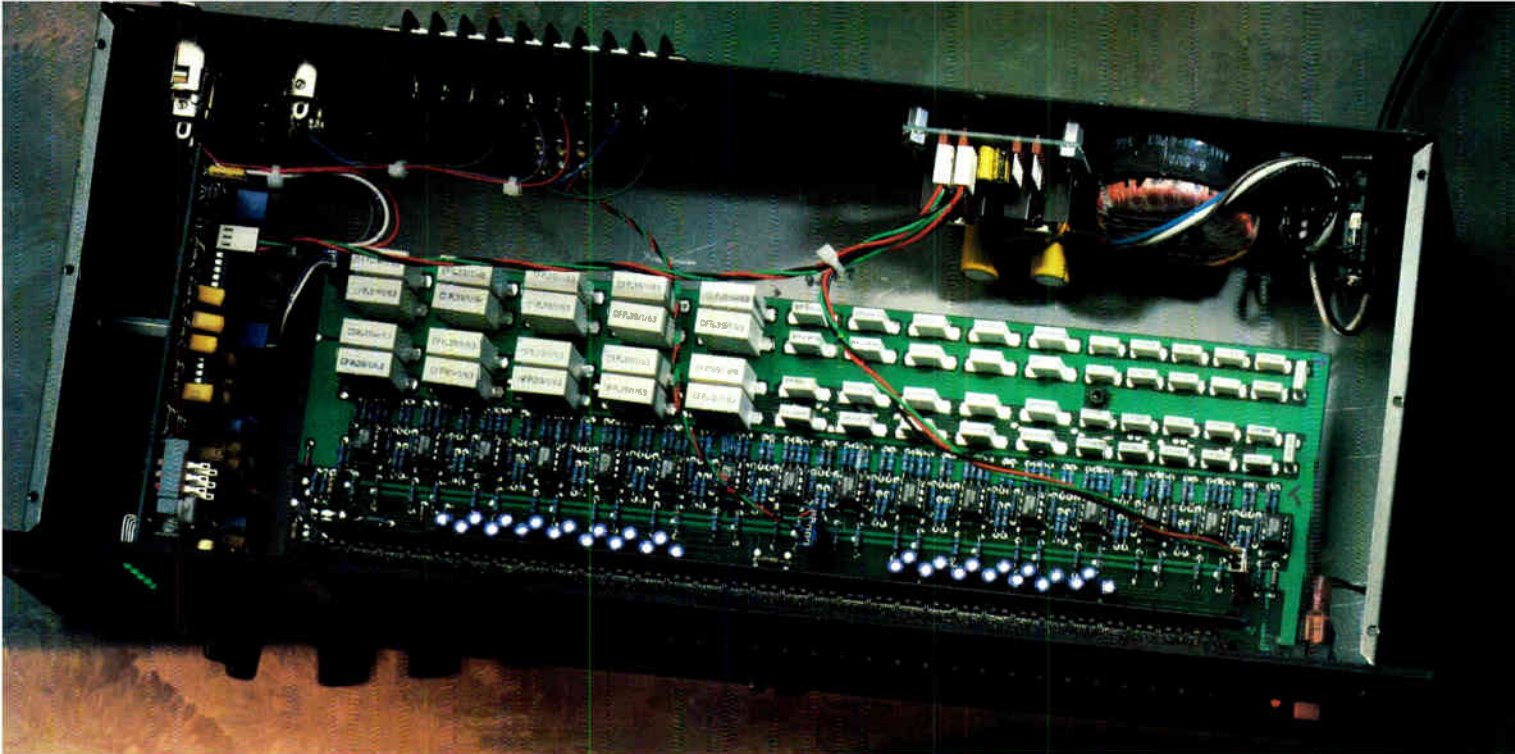

THE COMPETITION HATES OUR GUTS.

It takes a lot of guts to compare yourself to some of the biggest names in professional audio.

Of course, when you offer the quality and features found inside the Audio Logic SC31

Graphic Equalizer, it's easy to display more than a little extra intestinal fortitude.

The SC31 is a powerful signal processing tool designed for professional use. It features 31- $\frac{1}{3}$ octave centered bands of equalization with selectable 6 dB or 12 dB of boost and cut. But that's just for starters.

Take a look at the chart. It shows how the SC31 stacks up against the competition in the specs most important to audio engineers and sound contractors.

Maximum output. Dynamic Range.



	<i>Audio Logic SC 31</i>	<i>RANE GE 30</i>	<i>JBL/Urre 5547A</i>	<i>Klark-Teknik DN 300</i>
Noise	Less than -90 dBm	Less than -90 dBm	Less than -90 dBm	Less than -90 dBm
Maximum Output	+27 dBm	+24 dBm	+22 dBm	+22 dBm
Dynamic Range	+117 dBm	+114 dBm	+112 dBm	+112 dBm
Frequency Response	18 Hz to 30 kHz +/-0.5 dB	10 Hz to 40 kHz +0/-3 dB	20 Hz to 20 kHz +1/-2 dB	20 Hz to 20 kHz +/-0.5 dB
Number of Bands	31	30	30	30
THD plus noise	Less than .005% @ +22 dBm @ 1 kHz	Less than .01% @ +4 dBm	Less than .5% @ +22 dBm	Less than .01% @ +4 @ 1 kHz
Suggested Retail Price	\$550.00	\$699.00	\$849.00	\$995.00

Frequency response. Number of bands. Total Harmonic Distortion plus noise. In every category, the SC31 comes out even or on top.

In every category, that is, except price. Because the SC31 gives you all that capability, plus

incomparable sound quality, for considerably less than any other professional graphic equalizer. And that's what galls the competition most of all.

For a hands-on demonstration of the SC31, visit your professional audio dealer or sound contractor. Or write for additional information:

Audio Logic, 5639 So. Riley Lane, Salt Lake City, Utah 84107.

Or call (801) 268-8400.

*All specifications taken from manufacturer's published literature.

AL
AUDIO LOGIC

© 1987 DOD Electronics Corporation

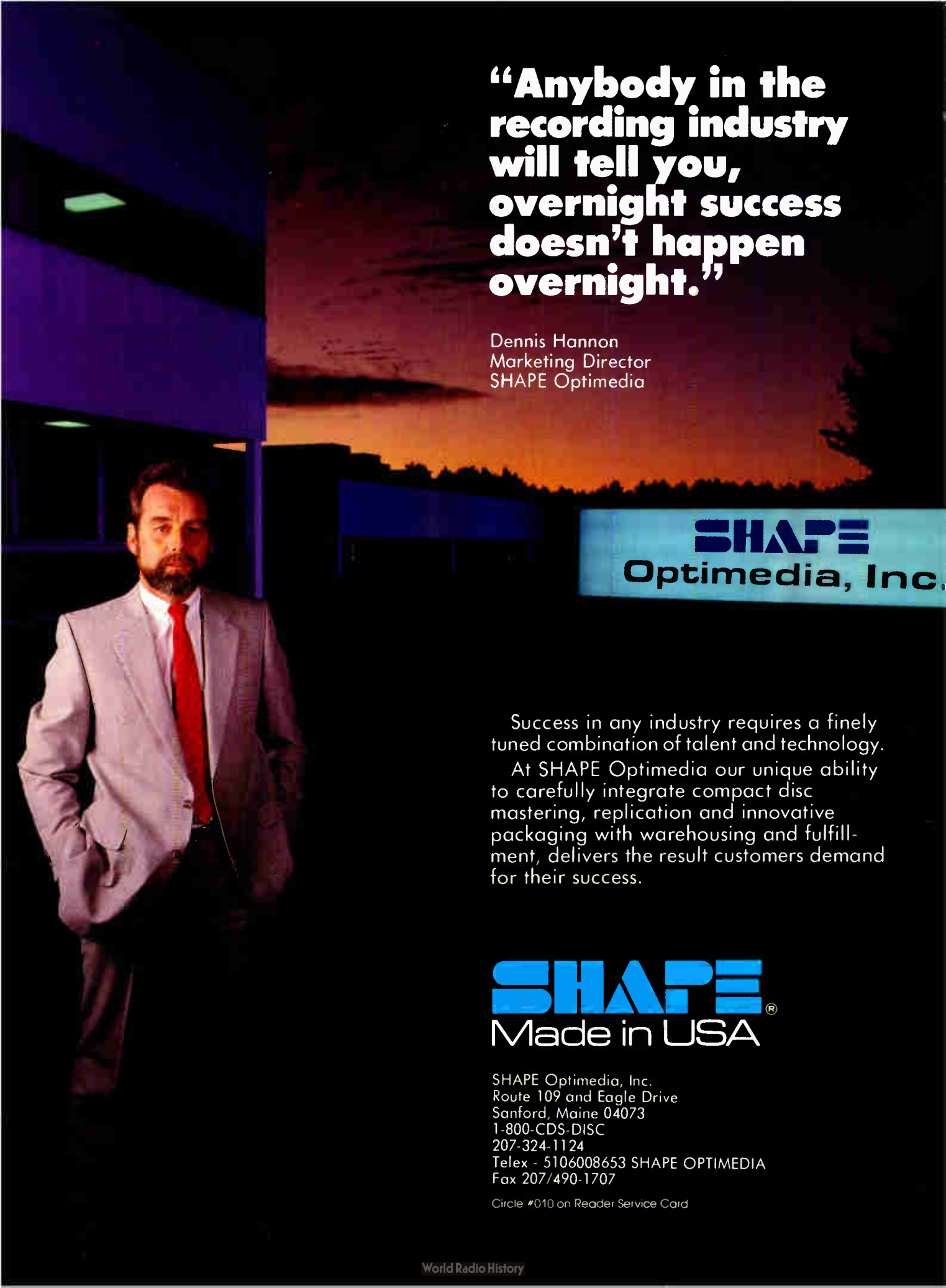
A man with a beard, wearing a light-colored suit jacket, a white shirt, and a red tie, stands with his hands in his pockets in front of a modern building at dusk. The sky is a mix of orange and purple, and the building's interior lights are visible through the windows.

“Anybody in the recording industry will tell you, overnight success doesn’t happen overnight.”

Dennis Hannon
Marketing Director
SHAPE Optimedia

SHAPE
Optimedia, Inc.

Success in any industry requires a finely tuned combination of talent and technology.

At SHAPE Optimedia our unique ability to carefully integrate compact disc mastering, replication and innovative packaging with warehousing and fulfillment, delivers the result customers demand for their success.

SHAPE[®]
Made in USA

SHAPE Optimedia, Inc.
Route 109 and Eagle Drive
Sanford, Maine 04073
1-800-CDS-DISC
207-324-1124
Telex - 5106008653 SHAPE OPTIMEDIA
Fax 207/490-1707

Circle #010 on Reader Service Card

medium. That is where the pre-mastering engineer begins his task. The old computer adage figures well here: garbage in, garbage out. So if the production master has any audible anomalies in it—noise, hum, ticks, pops, dropouts; anything which might cast an unfavorable shadow on the sonic purity of the digital medium—the master will be rejected. If a product is unsuitable for digital, the engineer will let you know up front. Assuming the product is suitable, this kind of quality control has to be implemented at *every* stage of the chain in making a CD.

The importance of this point is driven home by Harry Hirsch: "The whole process between pre-mastering and pressing is a team effort. The presiding engineer has an obligation to protect the integrity of his client's product. It cannot be overstated how important this person's role is. CD does not have proofs. [There is no counterpart to the "reference" lacquer of vinyl disc mastering.] If the initial order is for 25,000, your client could end up eating 25,000 CDs if the engineer has not done the proper sonic evaluation. This is also why you have a DTA 2000 [digital tape analyzer] at the plant and other engineers checking your product. The more ears you have on the case, the better off you are going to be."

This point underscores how important it is for a producer to be informed about the entire CD process, to choose carefully the pre-mastering facility and pressing plant based on evidence of integrity and reputation, and to be *personally* involved at every critical stage. Kiehl notes, "The trend in CD pre-mastering is to give more control to the client; to have the client participate in every decision that has to be made." This is a pleasant departure from the former days of analog mastering where the engineer much preferred to practice his magic art in privacy, and clients had to pay extra even to be present at the session. At Soundtrack, it is thought to be much more efficient for the client to be present; CD prep proceeds at the same hourly rate with or without the client.

These new attitudes are worth noting not only because they are good news, but most importantly because they demand a response from the producer. While the purely technical requirements are most appropriately left to the engineer, being a producer in the digital world demands a commitment beyond the mix. In order to



John Kiehl prepares an analog production master for transfer to 1630.

make informed decisions, the producer needs to have a familiarity with the overall flow of events in the process of making a CD. As an independent, there is probably no budgetary "fat" to fall back on, so options have to be exercised to save money, and to assure that the product flies the first time around.

The Basics of CD Prep

No matter what format your original production master, for the purposes of CD manufacturing it will have to be transferred to the Sony PCM 1610/1630 format which has been adopted as the industry standard. (The 1610 is an earlier model of the same processor, which is now sold as the 1630.) The essential

thing about this 16-bit digital processor is that it clocks information in and out at the sampling frequency of 44.1 kHz and stores that information on Sony ¾-inch U-matic cassettes as video signal. Audio track two ends up with continuous SMPTE time code (for location and synchronization purposes), while audio track one is reserved for the so-called PQ subcode (used in addressing the program on the CD itself).

Provided it passes the initial sonic inspection, the production master will now be transferred. If it's an analog master or the analog output of an F1 type digital processor, it will be a simple matter of re-recording it on the 1630. While the more expensive digi-

tal processors have digital outputs, the F1 family (never meant to be a professional item) does not. Some wise wizards however, have developed a modification which will give a direct digital output. Soundtrack has had this mod done to a Sony PCM 501 (the F1's cousin) which makes it *almost* compatible with the 1630. I say "almost" because it will make a pretty acceptable transfer, but there are a few areas of difference that may annoy you. Fortunately most of these are correctable.

The correctable differences amount to an inaudible DC offset which may cause some editing difficulties, a high-frequency emphasis curve which is

stuck in the "on" position, and a slight (11.34 microsecond) delay between the left and right channels. Maybe it's not a big deal, but if it bothers you there are devices which will correct it. John Kiehl bought the Harmonia Mundi hw 102 system for Soundtrack which will doctor up almost all anomalies in the F1 digital output. (It is also useful in converting digital data originally recorded at the 48K sampling rate on other types of digital processors.)

There is one little bit of weirdness (when we tap into the digital output of F1 type devices) which cannot be rectified by the Harmonia Mundi or any other box presently available. Since

your digital data was probably recorded on a consumer video deck (Beta or VHS)—and consumer decks operate on the time base of color video (29.97 frames per second) while the 1630 clocks in at the black-and-white standard (30 frames per second)—the sampling frequency will appear to be slow: 44.056 kHz instead of the expected 44.1 kHz. (You got that?) The bottom line is that playback from the 1630 will be faster (and hence higher pitched) than normal by .1%. If you are a classical violinist with perfect pitch, my sympathies are with you. Otherwise, most people agree, it's a discrepancy that's rather easy to live with. Considering the fact that you have gotten a full-bandwidth, 16-bit digital master at deliriously little cost, it's not a bad compromise at all.

Creating a Work Master

We are just about ready to start compiling an intermediate tape—our first transfer to the 1630 format. This is not the final product used for mastering the CD; it is simply used to get the original production master into the prep house system where it can be further manipulated; hence the term "work master." (Note that exact terminology varies from engineer to engineer, but the phenomenon is identical.)

The original production master, having been recorded through our F1 clone, is now being played back through Kiehl's modified 501. The digital outputs are patched into the Harmonia Mundi and then into the 1630 (to be recorded on the 3/4-inch U-matic cassette). As part of the process, the engineer seeks out the dynamic peaks of each song, and adjusts the input to the 1630 so that peaks achieve full deflection. This is done in order to take maximum advantage of the 90 dB signal-to-noise ratio CDs are capable of. If there are level differences between songs on the original production master, now is the time to iron these out also. This having been done for the entire program, it is time to make a sonic evaluation of the 1630's playback. Ideally, it should sound identical to the original.

Creating the CD Master Tape

Having recorded all relevant material in the 1630 format, we now use the Sony DAE 1100 digital audio editor to take the tracks on the work master, manipulate them as necessary, and lay them down on the CD master tape.

WE CAN TRANSFORM YOUR PROJECT FROM THIS



...ndr...
NORTHEASTERN DIGITAL RECORDING, INC.

- **Services:** Transfers from 1/4" and 1/2" analog to Sony PCM-1610/30 for archiving and LP or CD mastering.
 Digital transfers to PCM-1610/30 from other digital formats: PCM-F1, 701, or 501, DASH 1/4" (Sony PCM-3202), others.
 Digital Editing and Compact Disc tape mastering with the Sony DAE-1100 Digital Editor.
 Complete Compact Disc Services.
 Rentals.
- **Credits:** Frank Zappa, Arlo Guthrie, Rubber Rodeo, Ritchie Havens, Swimming Pool Q's, Matt Glaser, Lucio Dalla Soundtrack to Diva, A & M, Polygram, Rounder, Rykodisc, Musical Heritage Society, Centaur, Second Hearing, Titanic, Bose, CompuSonics, Polaroid, Wang
 All editing performed by Dr. Toby Mountain, PhD. Music.

Call: 617-753-1192
for information, prices and our PR package.

BRYSTON



BRYSTON POWER AMPLIFIERS CONTINUE TO DEFINE THE STATE-OF-THE-ART IN MUSICAL ACCURACY, LONG TERM RELIABILITY AND PRODUCT INTEGRITY.

Bryston design philosophy incorporates three general concepts.

1. Musical accuracy
2. Long term reliability
3. Product integrity

MUSICAL ACCURACY

Musical accuracy is reflected throughout all Bryston power amplifiers and includes the necessity for wide-band transient accuracy, open loop linearity ahead of closed loop specifications, and power supply design as an integral part of the overall sonic and electrical performance of a power amplifier.

We have found that a simple carbon film resistor can contribute more static distortion to a signal than the entire remainder of the amplifiers circuitry combined.

We discovered that some parameters of transistors must be controlled as much as 1000 times more closely before their contribution to audible distortion is rendered negligible.

We discovered that under certain actual conditions of speaker loading amplifiers were incapable of yielding high-power transients without distortion.

Each of the various steps or stages in every Bryston amplifier, from

the input section to the output section, without exception, are designed to optimize the musical experience.

STANDARDS OF RELIABILITY

We consider this criterion to be exceedingly important. We have applied techniques and materials in our everyday construction of electronic equipment more typically utilized in the military and aerospace industries.

All components used in Bryston power amplifiers are specified for continuous duty at maximum power, with typical safety margins of 250%.

The power transistors used in all Bryston amplifiers are 100% tested for safe operating area, both before and after installation in the circuit. They are then taken to a "burn-in" table when they are given a capacitor load, a square-wave input signal, and set at slightly under clipping for a period of 100 hours. During this time, the input signal is cycled three hours on to one hour off, to exert additional thermal stress.

Following the burn-in period, the amplifiers are monitored for DC bias stability for approximately

another full day. At this point, they are returned to the test bench for another complete checkout of all operating parameters and functions, at which time a test sheet is made, and included in the packing with the unit.

As may be seen, Bryston takes very seriously the correct functioning and long term reliability of its products.

INTEGRITY

Bryston contends that the term 'best' should apply to the honesty, pride and courage with which we conduct our business, as well as to the performance of our products.

For this reason, you will not find Bryston's products being cosmetically "updated" on a regular basis merely in order to keep the customer's interest, in something 'new'. If we make a change in the circuitry, it will be because, and only because, it yields a worthwhile performance or reliability improvement.

We feel that regular sweeping revisions to basic circuit design (accompanied by revised jargon) to be cynical marketing on the part of the manufacturer and insulting to the discerning customer.

In the United States:

BRYSTON VERMONT

RFD #4, Berlin, Montpelier, Vermont 05602
(802) 223-6159

Circle #011 on Reader Service Card

World Radio History

In Canada:

BRYSTON MARKETING LTD.

57 Westmore Dr., Rexdale, Ontario, Canada M9V 3Y6
(416) 746-3300

RECORD PRESSING • TAPE DUPLICATION

TOLL FREE
NUMBER

1-
800-
527-
3472

MAJOR
IN-HOUSE
U.S. RECORD
PRESSING
FACILITY

- Custom Albums
- 45 RPM Singles
- Mastering with Neumann VMS70 Lathe & SX74 Cutter
- Digital Mastering Available
- Plating with Europa Film Equipment

TAPE
DUPLICATION

- Custom Packaging
- Demo tapes (real time copies)
- Blank tapes —

SPECIAL!!

1000 7" 45 RPM
Record Package **\$469.**
1000 1 Color 12"
Album Package **\$1372**

To receive this special price, this ad must accompany order.



A+R RECORD &
TAPE MFG. CO.
902 North Industrial Blvd.
Dallas, Texas 75207
214-741-2027



Harry Hirsch at Soundtrack's DAE 1100 editor.

(Continuous 30 frame/second SMPTE time code is also recorded alongside the tracks.) The kind of manipulation we do with the editor may be simple or complex, depending on the need. It may just be a matter of transferring the tape as is, or simply re-ordering the sequence of tracks, but sometimes a tune will have to be cut, stretched, or pieced together from various takes. This can all be done with the 1100 editor, but not as glibly as with razor blade editing. The "cut it out and sew it up" procedures of deletion editing simply cannot be done with the sequential nature of videotape as a digital audio storage medium.

John Kiehl offers some insight here: With the 1630, "if I want to pull two measures out from the middle, I have to re-build my entire tape from that point to the end. When you go into a 1630 editing session, your frame of mind has to be sequential. You should have all your decisions made about what piece goes where and where it's coming from, so the editor can just start at the top of the reel and assemble the tape."

Once the CD master tape has been assembled, it will be subjected to a sonic evaluation by engineer and producer, as well as a technical evaluation through the Sony DTA 2000 digital tape

analyzer. The DTA will give us a description of the kinds of discrepancies in the data coming off tape, and also their exact location by SMPTE time code numbers. Depending on the severity of the error and whether it is audible or not, certain sections of the program may have to be recorded over again. (Since we have sonically evaluated the previous sources—i.e., production master and work master—we can be reasonably sure that the disparity occurred in this last transfer.)

The cause of these errors is usually related to the instability of tape as a digital storage medium. For this reason, there is a redundancy of data on tape. Even if some of it gets lost in the shuffle, usually some digital emissary will get through to deliver the message. When this fails, the processor will look at the available information and draw a conclusion. As Kiehl puts it, "What's on the tape is both the 'real' digital material, plus some mathematical gamesmanship about that material."

If the DTA reports a "CRC (cyclic redundancy check) error," we can be sure the missing or erroneous data has been perfectly reconstructed; hence, CRCs are inaudible and therefore no cause for concern. Other levels of error are more severe and may or may not be audible.

The report of an "average error" indicates that the system cannot recalculate the data in question, so based on the previous and subsequent information it makes a very intelligent guess. This interpolation between neighboring points is not really correcting the error, but rather attempting to conceal it. Sometimes it is an acceptable attempt, sometimes not. It's up to your ears to decide.

A "hold" is a more severe level of error. In this case, no suitable neighboring points can be found, so the last available point is "held" until the next reliable piece of information comes along. It is output as a moment of DC in an otherwise variable waveform. This is the beginning of discontinuity in the audio and is usually quite noticeable.

"Mutes" are by far the most radical error to be found by the DTA. According to Kiehl, "Mutes occur when there is just a catastrophic amount of data missing, so that the machine says, 'I'm gonna shut down and be quiet, 'cause there's nothing here.'" Since the processor will output two seconds of digital silence instead of music, one could never overlook a mute!

If there are any severe errors, they will have to be fixed or tape will be rejected by the plant. Unless the tape itself bears some defect, usually recording over the offending section will solve the problem. If averages are inaudible, it's usually sufficient to note them on the CD master log, noting the time code numbers and the subjective evaluation, "no sonic deterioration."

One last step before shipping the finished CD master tape on to the pressing plant. Although it's an optional step, no producer should be foolish enough to neglect it. Make a safety copy—an identical CD master that has also been run through the DTA and found to be thoroughly readable. Although it takes some time (about twice the running time of the program—once to record, once for analysis) and extra charges to do this, it is worth it all in peace of mind.

MASTERING, MANUFACTURING, & MARKETING

The final stage in getting your product on CD occurs at the manufacturing facility. To get an inside look at this critical process and some perspective on the activity of independent labels in the CD marketplace, I took a drive to the Technetronics plant in West

EXTRAORDINARY AUDIO

Studio Consultants specializes in a select group of exceptionally fine professional audio products, including:

- **AMS AudioFile**—hard disk-based digital recording and editing system
- **API**—all-discrete equalizers and microphone preamplifiers, distribution amps, and other audio modules
- **Bryston**—professional power amplifiers, preamplifiers, and crossovers
- **T.C. Electronic**—digital delay/sampler, automated equalizers, and effects
- **Westlake**—monitor speakers

Also: **Aphex, Audio Digital, Audio Kinetics, Fostex Professional, Rane, Valley International, White Instruments**

Spec sheets, prices, and in-studio demos are available on request. And for short-term needs, **Studio Consultants** rents **API** and **Bryston**.

studio consultants, inc.

321 West 44th Street New York, NY 10036 (212) 586-7376

Equipment, support, and design services for professional audio facilities and broadcasters.

Circle #094 on Reader Service Card

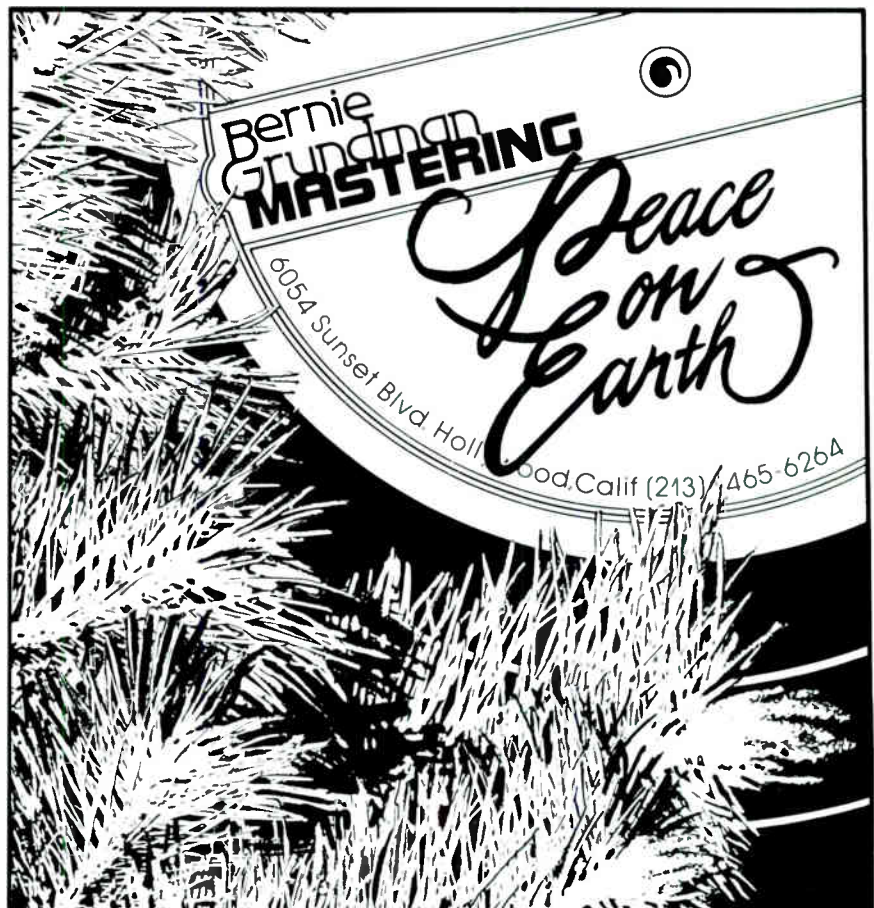

Circle #095 on Reader Service Card

Chester, PA. Upon arrival I was introduced to Dave McQuaid, a company executive who is knowledgeable about both the manufacturing and marketing of CDs. In the course of an afternoon we explored the issues of most concern to the independent producer who plans to release on CD.

"The CD market is really a lot less intimidating than people perceive it to be," says McQuaid. "Until now it's been intimidating for the independent in terms of technology and price, but as technology stabilizes and price gets down to parity with the LP, more and more independents will be issuing CD releases."

We were to return to this subject—the viability of CD releases for independents—several times throughout the course of the day, but at this point I wanted to gain an insight into the CD manufacturing process. I was also curious about Technetronics' newly developed manufacturing system which has created quite a buzz in the industry.

First, let's take a look at the general flow of events—the processes that must occur at all facilities in order to generate a compact disc. Then we will briefly examine the unique aspects of the Technetronics system, and the impact it is having on the industry.

Recipe for a CD

The shiny, 4¼-inch disc is nothing more than a flattened three-layer cake. The first layer, called the substrate, is composed of highly refined polycarbonate plastic, quite similar to plexiglass. The plastic becomes a digital storage medium when it is molded with pits that represent the digital data of the program. So that the laser beam in your CD player (which "reads" the pits) can get a better reflection, the substrate is fogged or sputtered with an aluminum alloy that helps reflect light from the laser. (Believe it or not, fogging and sputtering are technical terms, but let's not get into it.) The third and last layer is simply a clear lacquer sealer to protect the other two layers. In some ways, it's the essence of simplicity.

Actually, it's the pits. Literally. How do you keep the pits from contamination? Even dust is bigger than those microscopic pits. Since any contaminant can wreak havoc with the tracking of the laser beam, the whole notion of the clean room has become central to CD manufacturing. These

STERLING SOUND: AT THE CUTTING EDGE OF TECHNOLOGY

With five cutting rooms producing product that consistently appears in *Billboard's* Top 100 album charts, three consecutive *Mix* TEC Award nominations (1985-86-87) for Outstanding Mastering Studio, and a staff of top notch engineers, New York City's Sterling Sound is regarded as one of the world's premier mastering facilities. However, achieving excellence in the audio industry is a continuing process and one recent example of this is Sterling's commitment to incorporate digital control into the mastering environment. The company installed the first Neve DTC-1 (Digital Transfer Console) just about a year ago, and has already placed their second DTC-1 on line.

Unveiled at last year's AES Convention in Los Angeles, the Neve DTC-1 is designed specifically for compact disc pre-mastering with three stereo inputs (two digital and one analog) and offers real time crossfading, 44.1 or 48 kHz sampling rates, four-band digital EQ, digital dynamics controls and instant reset moving fader automation—a SMPTE-controlled memory system capable of storing 200 snapshots per program. Interest in the prototype Neve transfer console operating at London's Tape One studio brought Sterling's chief engineer Ted Jensen to England to investigate the system, and he eventually wound up assisting Neve in the design of the production models.

"Several years ago, I went over to see the board they developed for Tape One," explains Jensen, whose recent LP credits include Earth, Wind & Fire, Billy Joel and Steve Winwood. "It was a simple transfer console, mainly for doing digital

EQ on CDs. It had no automation, a little equalizer similar to what they were using on their DSP boards and the same compressor they were using on their larger console. At first, we wanted something along those lines, but we started thinking about automation and the number of snapshots we could use. They incorporated some of their own ideas with ours and some from Masterdisk, and it evolved into this slick little unit."

One of the DTC-1's advantages wasn't apparent until after it was installed at Sterling. Maintenance engineer Mark Goode designed a central remote system so all the facility's digital equipment—including the console electronics, Sony PCM-1630s and BVU transports, and DASH machines—can be remotely operated from any of the five cutting rooms; the console's control panel can float from room to room as needed. However Jensen is quick to add that the sonic and creative improvements offered by the DTC-1 are what interest him most. "The obvious advantage is you don't have to go back to the analog [domain] for your moves. That alone—saving two conversion steps—makes a world of difference: the result is a more open, clear, less harsh sound. Another advantage for us is the complete automation: we only have to pop a diskette into the board's memory to do a project again. Also, if you have very complicated EQ moves—say, in some very quick passages—you can set things up off-line, and do moves that would be impossible in real time. You could never do that on an analog console."

—George Petersen

Sterling's chief engineer Ted Jensen (right, flanked by Neve representatives) auditions the DTC-1 console at Neve's U.K. facility.





BAD

The MASTER



When it comes to record mastering, Bernie Grundman wrote the book.

Over the years Bernie has cut the masters for many of the world's best selling albums, including the phenomenally successful 'BAD' by Michael Jackson. What loudspeakers does Bernie rely on to monitor the quality of his output?

“ I've mastered successfully on Tannoy for 17 years. For my new facility I chose Tannoy again. ”

Bernie Grundman

Bernie Grundman
MASTERING

054 Sunset Blvd. Hollywood, California 90028

(213) 465-6264

Rely on TANNOY®

The Name for Loudspeakers

Tannoy North America, Inc., 300 Gage Ave., Unit 1, Kitchener, Ont., Canada, N2M 2C8 (519) 745-1158 Telex 069-55328

Circle #050 on Reader Service Card

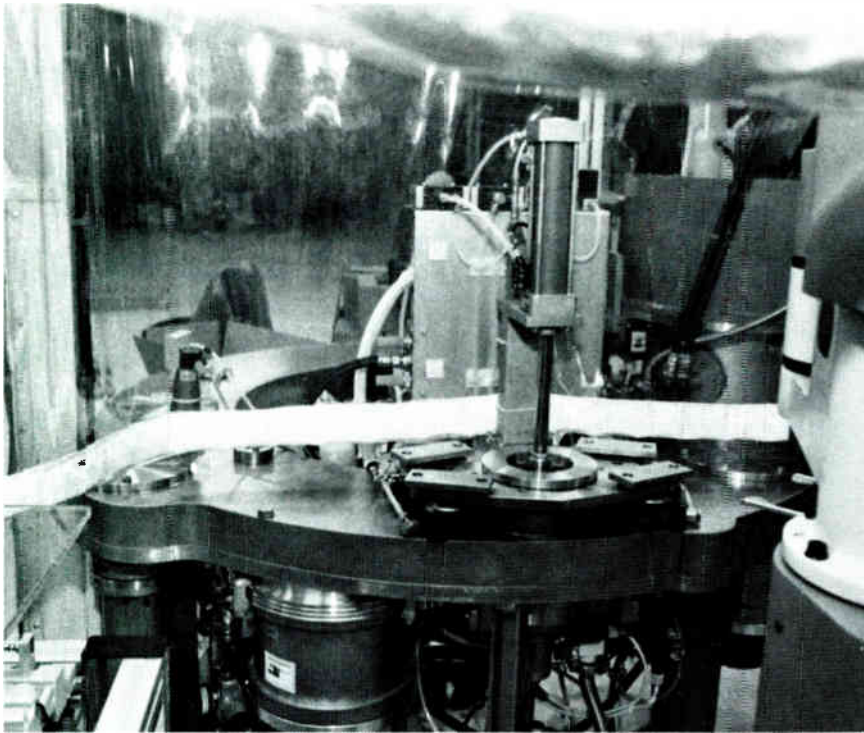

Metalization under "clean shroud" at Technetronics.

are scrupulously particle-free environments, with technicians in caps, gowns and masks and air showers for everybody. This scene has become synonymous with CD manufacturing.

The general flow of events goes something like this: the CD master tape arrives from the prep house. It is run through a digital tape analyzer. Assuming it is found technically acceptable, the P-Q coding is added (if it hasn't already been done by the prep house) and it is sent off to a clean room for glass mastering.

An extremely pure, flat piece of optical grade glass is chosen, and it is coated first with an adhesive and then a material (called a photoresist) that is maximally sensitive to certain wavelengths of light and rather insensitive to others.

The prepared glass master is spun while the laser shoots at it with a beam of light that is tuned to that maximally sensitive wavelength. The inspiration for these pyrotechnics is, of course, your master tape. Played back through the glass mastering system, the data is re-encoded in a language that lasers understand and burned into the photoresist by the laser. Finally, the glass master is washed in a solution which etches only the portions of the photoresist that were exposed to the laser. Voila, the pits!

From this finished glass master disc,

metal stampers are prepared by conventional electroforming techniques—much like the vinyl LP. What is different is that once the father and mothers have been generated, a virtually unlimited number of stampers can be cloned. This means that glass mastering, once done, never has to be done again.

The actual manufacturing of the CDs follows three basic steps: injection molding, metalization, and lacquer coating. Usually, the CDs are processed in batches under stringent clean room conditions, being transported from one site to another by surgically robed technicians.

Technetronics has a whole new angle on the manufacturing process. By placing all machinery in an on-line configuration, discs are moved from one process to another robotically. They are never touched by human hands until they are ready to be packaged. Rather than creating a clean room atmosphere, only the critical working area is covered by a 3-foot-by-8-foot clean shroud. Each of these complete production units, called Monoline cells by Technetronics, is manned by only one technician and capable of turning out 2.5 million discs per year. Technetronics presently is operating with two cells, but since they take up only 600 square feet, the company has room for 18 more.

While the CD is still more expensive to manufacture than the LP, packaging costs for the CD are totally disproportionate. Whereas packaging for the LP may run 25% beyond the pressing cost, for the CD, packaging is usually 50 to 75% beyond the pressing cost. This tradition of prodigal spending on packaging evolved as major record companies sought novel ways of marketing the new digital medium. Such a tradition is by no means obligatory, and clever independents can utilize various non-standard alternatives that result in substantial cost reductions.

Dave McQuaid notes, "As the CD market becomes more competitive, you are going to see different kinds of packaging. One of the cost-prohibitive factors is the 'long box' which really is an unnecessary piece of packaging. In Europe, they don't use long boxes. They strictly shrink wrap the jewel box itself, and that's their packaging." McQuaid goes on to say that even the jewel box can be eliminated. "Using simply the teabag [soft inner sleeve] and the card stock [hard outer sleeve], cost can be cut in half over the conventional jewel box."

The CD is vast uncharted territory as far as marketing is concerned. It's really anybody's ballgame. New avenues for marketing keep on cropping up: direct mail, video, book and health food stores, and heavily discounted point-of-purchase displays. McQuaid believes that price-slashed CDs are being readied by some aggressive independents. "I maintain that if you are doing some of the distributing yourself and watching the packaging costs, you could market a CD for \$5.95 and still make money on it."

As independents find innovative ways to push the price of CDs down, the majors will have to follow. Independents are a force to be reckoned with in the CD market. McQuaid adds, "Internationally, major record companies only make up about 50% of the annual volume of CD sales. The rest of the CD sales come from smaller independent labels and producers." It certainly is time for independents, who have looked at the CD market and wondered, to give it some serious consideration. ■

John Barilla's major passions are writing and producing music. He is president of Hip Records International, a company dedicated to making multi-lingual techno-pop music.

What Makes Sony The Leader In Digital Audio?

Our trac

Before you leap into digital recording, look and listen first. You'll find that only Sony can take you every step of the way.

It all begins with the PCM-3324 digital multi-track recorder. Over 370 are already in use and that number keeps growing. Here's why: The PCM-3324 is more than a proven sonic performer, it's the heart of an unparalleled creative recording system. With the RM-3310 remote unit it offers auto-locate of 100 cue points. Automatic punch in/punch out timing precise enough for spot erasure. And the gateway to a perfect marriage with a second PCM-3324.

With two machines you get 48 perfectly synchronized channels plus added flexibility. Such as the ability to make pure digital-to-digital safeties, the freedom to do digital fly-ins, and full electronic editing capabilities.

And if you want to go beyond music recording to video or film post-production the PCM-3324 system can go with you. Because Sony offers all the peripherals you need to make the right connections.

For mixdown, the perfect companion for the PCM-3324 is the PCM-3402



k record.

2-speed electronic editing recorder: the new generation of Sony DASH 2-channel digital machines.

Advanced digital technology and thoughtful input from Sony customers were combined to create the PCM-3402. You can hear and feel the difference. Over-sampling of the playback circuitry allows super-smooth audio phase response. And new balance and level controls operate completely in the digital domain.

But what really sets the PCM-3402 apart is the incredible control it offers for virtually any recording situation. It features 12 seconds of 16-bit stereo RAM-based memory for electronic editing, insert recording on any track, PCM-1630 style metering, and selectable 48kHz/44.056kHz/44.1kHz sampling frequencies.

And if you need to merge digital audio with video, the PCM-3402 makes it easy. It gen-locks, chase-locks, performs time code based auto-cuing and auto-time fit, and time code triggered audio sampling.

Best of all the PCM-3402 and the PCM-3324 are digital links to an even bigger system. For that story, advance to the next page.

SONY

Professional Audio

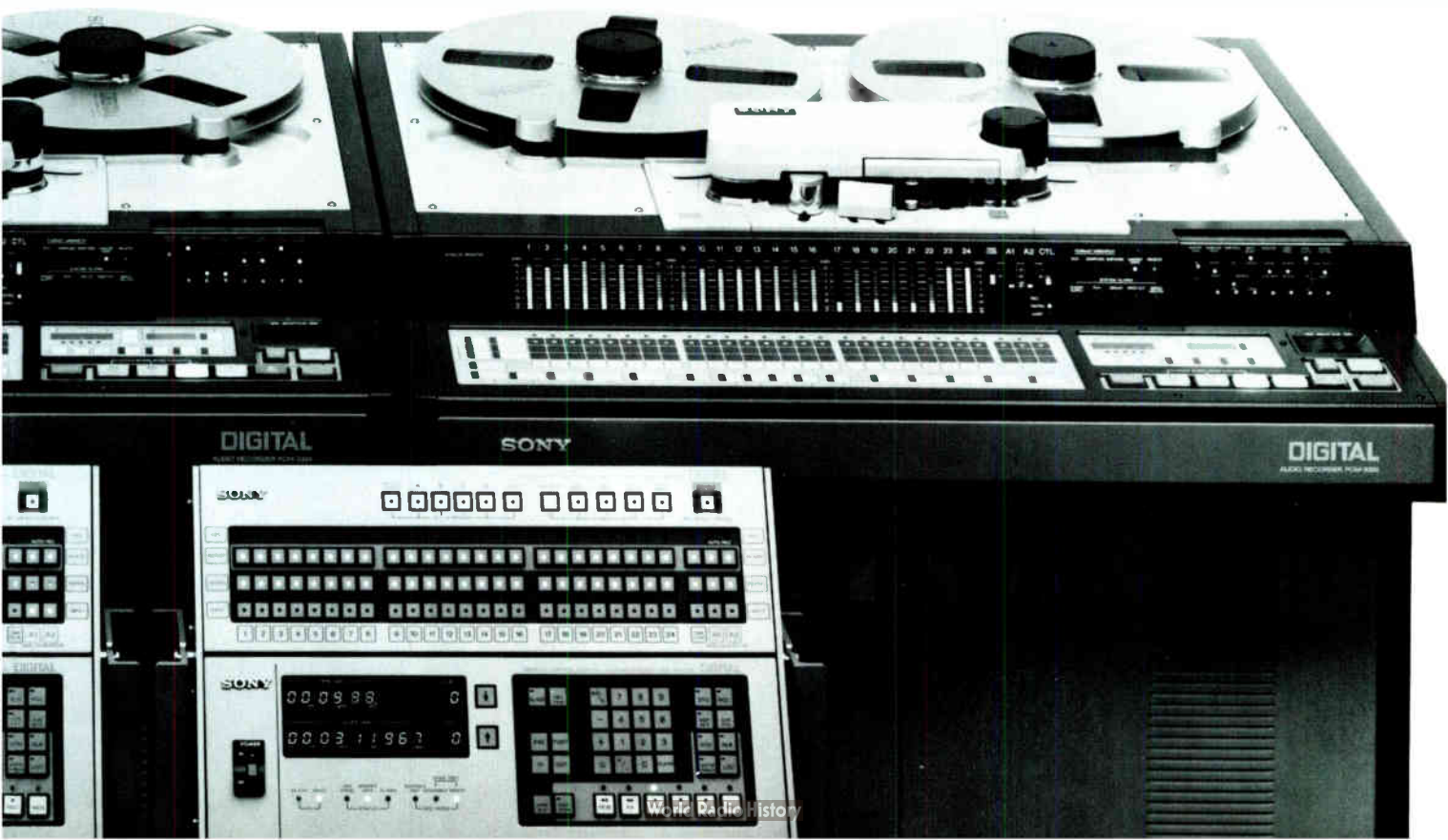

How we've

Walk into practically any compact disc mastering studio and you'll hear the same song: Sony, Sony, and more Sony. The explanation is simple: Our mastering system is the standard for recording studios and CD manufacturers throughout the world. In fact, virtually all of the compact discs ever made have been mastered with Sony digital equipment.

We stay the leader in mastering systems because we constantly refine and expand them for even higher performance and ease of use. You can hear and see our commitment at the heart of the system: the PCM-1630 digital audio processor.

New analog filtering and digital oversampling contribute to dramatically improved tonal quality. It has adjustable digital peak meters with AUTO or HOLD modes and OVER indicator. And with an optional circuit card, the PCM-1630 is capable of both RAR (Read After Read) and RAW (Read After Write) functions. The DMR-4000 master recorder also features RAR and RAW.

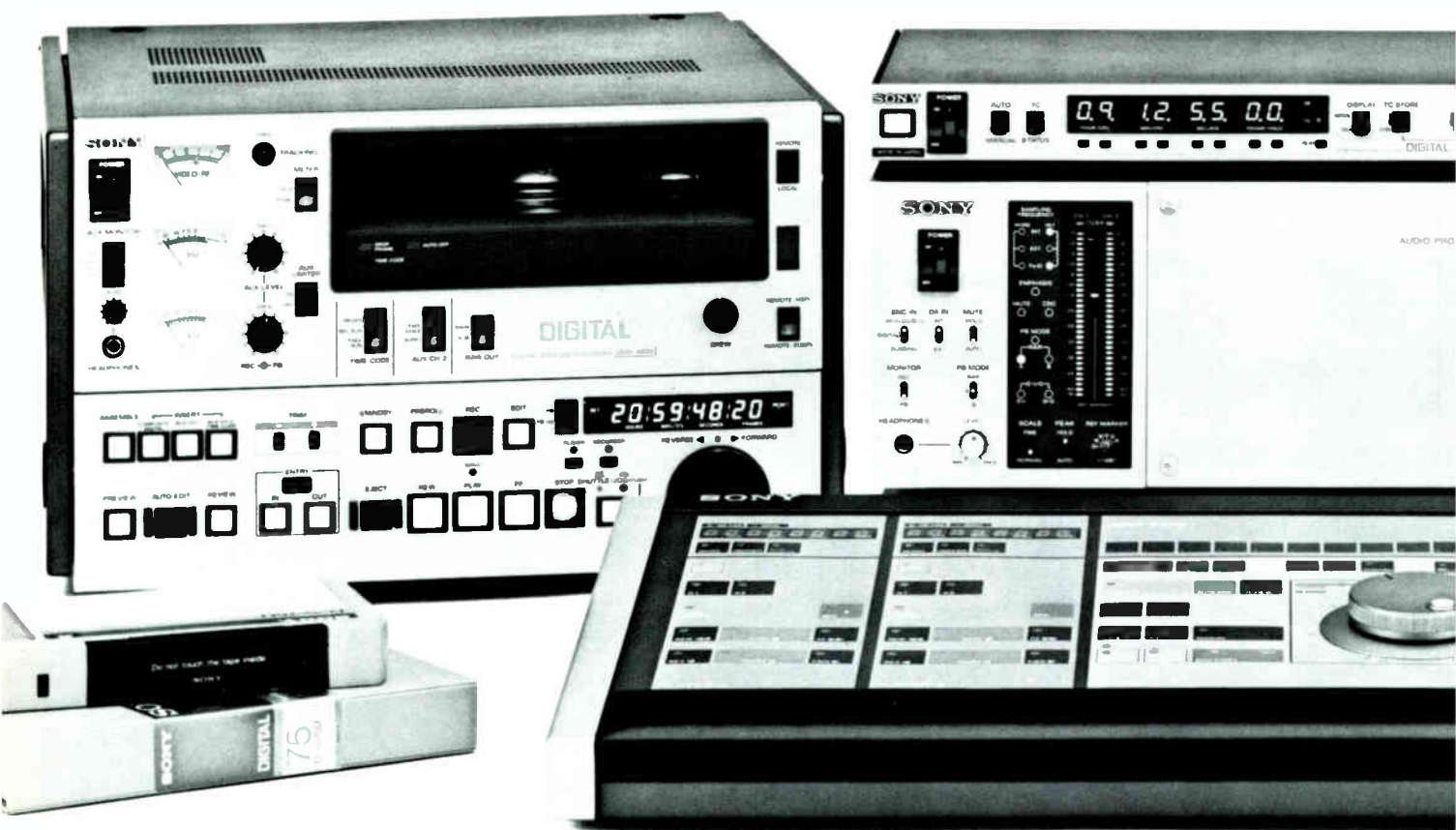

mastered it.

Of course, no mastering system is complete without insurance. You get it with the DTA-2000 digital tape analyzer. When attached to the PCM-1630 and an optional printer, it measures and prints out any code errors in the master tape.

For editing, there's the DAE-1100A digital audio editor and the DAQ-1000 cue editor, the most advanced digital audio tools of their kind. The DAE-1100A delivers seamless electronic crossfades and RAM-based cueing for the most precise electronic editing. The DAQ-1000 gives you the utmost flexibility for generating, recording and checking music track and index numbers as well as the necessary P Q subcodes for CD disc cutting.

Sony also makes digital recording tape, remote metering systems, and a full line of accessories. So if you're about to go digital, or want to get further into it, talk to the company that goes the whole route. Call The Leader In Digital Audio™ at 800-635-SONY.

SONY

Professional Audio



Circle #012 on Reader Service Card

by Tony Thomas

BERNIE GRUNDMAN

MASTERING THE MASTERING BUSINESS

Disc mastering isn't what it used to be. In fact, more and more often, the "disc" involved isn't a conventional disc at all. It's either a "disc" (as in the compact variety) or a cassette tape, both of which are quickly replacing black vinyl as the reproduction medium of choice. As a result, the art of lacquer cutting is being supplanted by the new art of digital manipulation.

Because of this metamorphosis, the economics of the mastering business have also changed. To remain competitive, mastering facilities have had to install costly digital tape transports, sampling rate converters, and even digital consoles. Those facilities that can't afford to keep up technologically have been watching their business slowly dwindle, as vinyl is being squeezed out of existence. As a result, there is very little safety any more in the middle ground. And with the emergence of DAT (Digital Audio Tape), the final nail in vinyl's coffin may be imminent.

Bernie Grundman is a survivor in the mastering business who has been able to roll with the changes. A mastering legend during his tenure at A&M Records' mastering facility, Grundman started his own facility nearly four years ago—just when the cassette and compact disc were beginning to jeopardize the future of the phonograph record. His mastering studios are quickly becoming digital workstations—complete with a wide range of PCM converters, sampling rate manipulators, and even a digital console which is being installed on an experimental basis—all purchased at no small cost to his company. (These costs, of course,

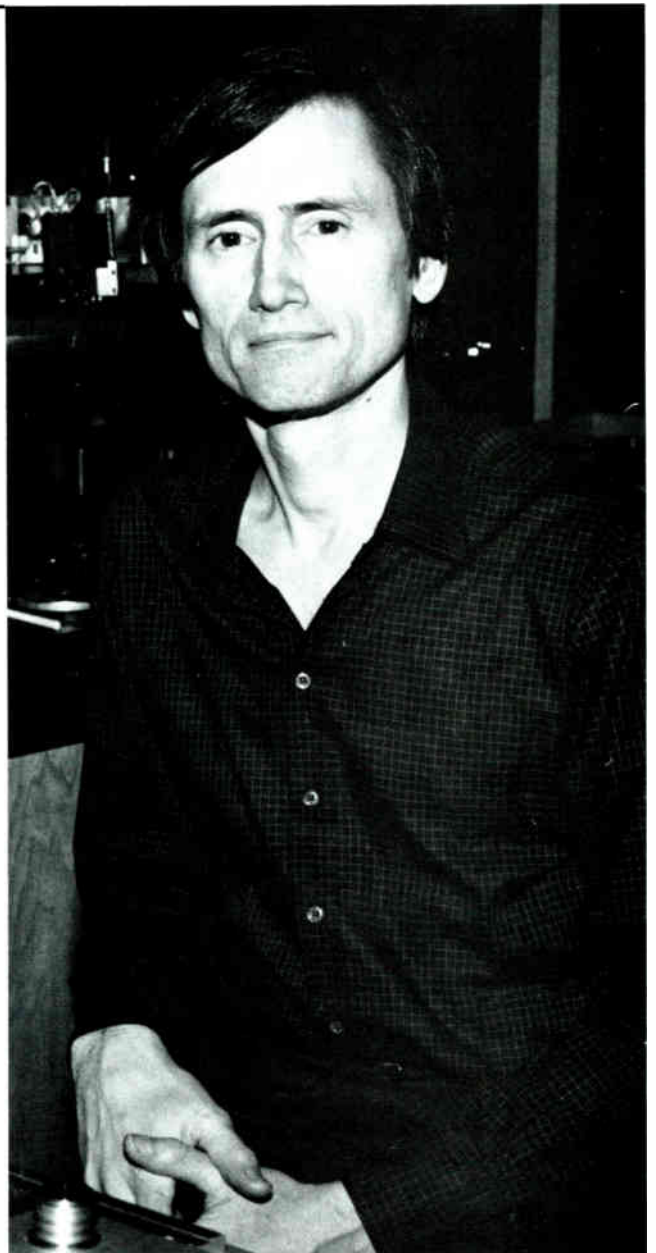

must be passed on to the client, resulting in higher mastering costs.)

Even with these changes, Grundman remains a master of the mastering business. At the time we spoke, Grundman's projects included mastering both the Number One album and single in the country (by Michael Jackson and Whitney Houston, respectively). We caught up with Grundman at his studio early one morning, before his daily onslaught of mastering activity began.

Mix: What is the present economic climate of the mastering industry, with the ascension in popularity of the cassette and compact disc?

Grundman: Everyone you talk to in the mastering field is going to give you the same answer: it's expensive to do this changeover because now it's possible to have all digital equipment in the mastering studio. This still isn't the case in the recording studio—they are still all-analog as far as their consoles go. But in terms of mastering, there are a number of digital boards that will handle two channels, which is all we are concerned with in mastering. They will allow a studio to stay totally in the digital domain, except for monitoring, from the digital source to the master. Everything, including limiting and EQ, can be done digitally. The only problem is that these boards cost about \$140,000, which is very expensive.

Another problem in mastering is purchasing digital tape machines, because we have to be able to accommodate all of the different digital formats. Then, there are the boxes that will convert between the different formats—for example, between the Mitsubishi and the Sony; they cost almost \$30,000. Practically every mastering studio had to invest in the 1600 series Sony system (either the 1610 or 1630), because that is the system that all compact disc facilities have chosen for their masters. The same goes for the Sony F-1 type systems. Almost every cassette duplication house has gone to that format. Even though you're not always mastering from those formats, you need them to make tape copies.

As a result, I think that most of the

mastering studios have noticed that there is a lot of investing going on. Accordingly, records cost a little bit more money to make, because you have to charge so much per hour for all this expensive equipment. So, for the client there are going to be higher costs, and for the studio, a very high initial investment in all of this digital gear.

Mix: Has this changed the way that you view your operation from a busi-

ness standpoint? also because we have to make a lot of digital copies for the foreign affiliate labels. About eight years ago, when LPs were the dominant format, it cost about a quarter of what it cost today. But on a lot of our projects these days, we only cut about one or two sets of discs because records aren't selling as well.

Mix: With the emergence of digital technology, do you think that mastering facilities will become an endan-

“Practically every mastering studio had to invest in the 1600 series Sony system because that is the system that all compact disc facilities have chosen for their masters.”

ness standpoint?

Grundman: Yes, because we have had to absorb the cost of the new gear to some extent. You have to draw the line somewhere. Part of the cost is just the price of doing business. In the past, if a company came out with a new analog machine and you bought one, you couldn't charge the client extra just because you had a new tape machine. That was just part of the mastering process. Even if the studio put in a new board, they might be able to raise the rate a little bit, but they couldn't tack on a huge surcharge just because they had a new board. Unless it's something really unique or extra-expensive, you can't get that much more for it.

Mix: How much has this new digital technology increased the cost of mastering?

Grundman: I would say for a major release it costs about \$1,500 more, which is about double the cost. This is

gered species, since a recording studio can easily produce the digital tape copies?

Grundman: No, I don't see that happening at all because artists and producers have been living with a project for such a long period, by the time it's completed, they want to go to a place that specializes in going back over it, rethink it and make sure it's flowing properly. They want the opinion of an experienced mastering engineer who has a good idea of what is happening in the industry, because he or she is listening to a wide variety of things every day and knows what is going to sound good on the radio or the average sound system. I have always called mastering “the sobering experience.”

Mix: Do you have any advice for the average mastering facility as far as the business end of mastering is concerned?

Grundman: One of the biggest eye openers I had when I opened my own

Use your head

Quality recording head relapping for the most discriminating professionals.

When you send your worn heads to AMP Services, you get the highest quality refurbishing available anywhere. We service OTARI, STUDER, MCI/SONY, AMPEX, 3M, TEAC and others. Take advantage of our downtime-cutting services like weekend work, loaner assemblies and same-day turnaround. All at competitive prices. Now that's using your head!

Our newest services:

- MCI 24 tk loaner assemblies
- MCI motors remanufactured

AUDIO MAGNETIC PROFESSIONAL SERVICES INC.

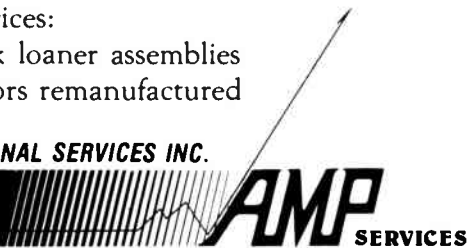

800-826-0601 • in FL (305) 659-4805
224 Datura St., Suite 614 • West Palm Beach, FL 33401

Circle #139 on Reader Service Card

One Stop Service Quality Products Timely Deliveries



Let the quality of your graphics reflect the excellence they can expect to find in your music.

Stoughton Printing can provide all your record and video related printing and packaging. Direct board record jackets, 7 and 12 inch sleeves, labels. The finest in UV Coatings. All done in house. CD booklets and inlay cards, posters, box wraps and any other graphic material you may need to promote your products.

If it's worth doing, it's worth doing right. Come to the source. . . . We're there when you need us.

stoughton printing co.

130 N. Sunset Avenue, City of Industry, CA 91744
From Los Angeles: (213) 686-2753
(818) 961-3678

Quality Printing For The Record Industry Since 1965

© 1986 Stoughton Printing Co.

Circle #140 on Reader Service Card

studio was the amount of work required to run a business. I came from A&M where I just had to do my work, and the billing and everything else was handled upstairs. If I would have thought about it, I would have remembered that they had 26 people upstairs handling it, plus all the other A&M business. When you're on your own, you find out that your office personnel

“There's a lot of investing going on. Accordingly, records cost a little more to make.”

requires a great deal of supervision and you have to have a fair amount of interaction with accountants and lawyers. It would have been impossible for me to start my own studio had it not been for my wife, who handles the administrative end of the business, and my partner, Carl Bischof, who does some of the managerial things. There is no way you can be behind the console all day and have your business run right, unless it's just one room, one engineer and one secretary. But we have two rooms, five engineers, three secretaries, my wife and my partner. You've got to have those people there or else you're going to be a total slave to the business.

Mix: Well, you've done very well. Your work certainly speaks for itself.

Grundman: That's because I've been able to stay out of the office. ■

Tony Thomas has been involved in broadcasting, recording and publishing for over a decade. He is managing director of Target Communications International, a full-service ad agency, broadcast production firm, and MIDI-based recording studio based in Southern Cal.

This is the mixing console that will cause a revolution in 24 track studios.

The world's first Dual Mode mixing console.

With the advanced features and performance of a desk you'd expect to cost a great deal more than it actually does, it's a remarkable achievement. Take Dual Mode.

When you record with the TS12, its in-line monitoring means you create a control room mix on the main faders.

In mixdown this becomes the basis for your master mix. Saving time and helping you keep a train of thought as to how the final mix will sound.

Unlike other in-line desks, though, the TS12 also allows true stereo subgrouping on long-throw group faders.

In this mode the routing matrix offers either six stereo groups or four extra auxiliary sends – totalling ten sends – plus four stereo groups.

No other console in the world provides such versatility.

The TS12 is an open-ended investment, with optional disc-based SMPTE automation for faders, mutes, EQ in/out and auxiliary on/off. Again, at the price it's unique.

And fittingly, audio performance is superb.

Recent Soundcraft advances in summing amp technology, and in grounding and decoupling systems, make the TS12 one of the cleanest and quietest consoles ever.

The mic amplifiers, a critical factor in console quality, create less than 0.01% distortion at 10kHz at 70dB of gain. (Easily exceeding 16-bit digital specifications.)

Standard features are impressive, to say the least. Six auxiliary sends, seven stereo line inputs or effects returns, a 'musician friendly' headphone mix, an extensive 19" metal frame patchbay – and the option to create a massive total of 102 inputs.

Quite a line-up.

Attention to detail is equally stringent with modular PCBs, no dual concentrics and a clear, logical layout that belies the sophistication inside.

But the most remarkable feature of the new TS12 is without doubt the price.

We suggest you call us today to find out just how remarkable.

ALL THE FEATURES YOU'D EXPECT IN A \$50,000 CONSOLE, EXCEPT ONE. THE PRICE.



Soundcraft
TS12

PAUL YOUNG DOESN'T ENDORSE BEYER MICS.



Paul Young shown using the Beyer MCE 81 Tourgroup Series mic.

HE USES THEM.

Paul Young's singing achieves a rare blend of classic soulfulness and modern energy. Matched to an explosive and unusually mobile stage presence, this exciting combination has won the hearts of fans and critics all over the world. Young's passion for excellence on stage places unusual demands on his microphone. That's why he depends on Beyer Tourgroup Series mics. Their unmatched accuracy and transparent natural sound bring out the subtle nuances that form the distinctive character of his sound like no other mics could. And their solid, road-proof construction withstands any kind of punishment.

If performance means more to you than "endorsements," as it does to Paul, choose Beyer.

beyerdynamic U.S., 5-05 Burns Avenue, Hicksville, New York 11801 Tel: (516) 935-8000

TourGroup

beyerdynamic 

*Canada: ELNOVA Ltd. 4190 Rue Sere, St. Laurent, Quebec H4T 1A6
Tel. (514) 3 41 69 33 Telex 5824086*

*Great Britain: beyerdynamic, Ltd., Unit 14, Cliffe Industrial Estate
Lewes, Sussex BN86JL Tel. 273 479 411*

*Australia: Hi-Phon Distributors Pty, Ltd. 356 A-358 Eastern Valley Way
Chatswood N.S.W. 2067 Tel. (02) 417 7088*

*Germany: Eugen Beyer Elektrotechnische Fabrik GmbH & Co., Theresienstrasse 8,
Postfach 13 20, D-7100 Heilbronn Tel: (07131) 617-0 Telex: 728771*

ULTIMATE STEREO

Cello Stereo Systems Don't Fool Around With Playbacks

by Dan Daley

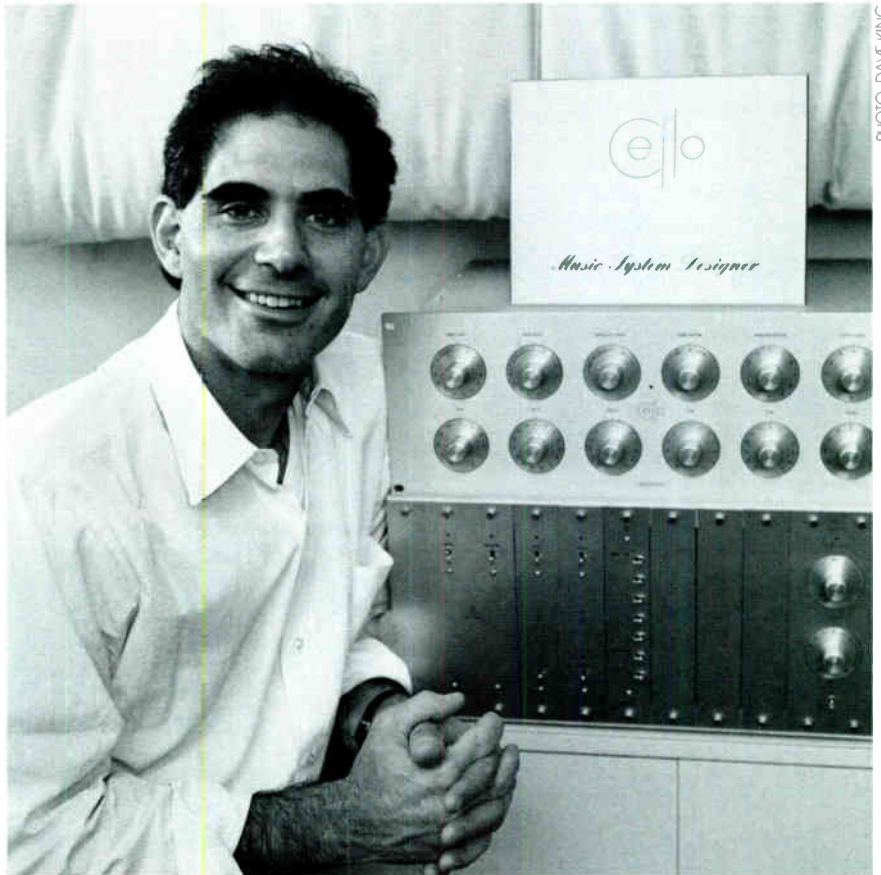

Cello's Mark Levinson with his company's Audio Palette (top) and Audio Suite.

Mark Levinson sits in his newly opened Manhattan showroom contemplating the array of sound gear that occupied the beige-on-white room in a midtown Manhattan apartment hotel. The demonstration system he has in place there runs around \$50,000—not exactly your basic dorm setup. Levinson's New Haven, Connecticut-based company, Cello, Ltd., has done installations that have ranged up to \$400,000. These are for the most part home listening systems we're talking about here, priced at levels that many professional recording studios are budgeted at. But before even one note comes out of the speakers which squat on

either side of the room, the first question which comes to the mind of someone who has squeaked by most of life listening to Metallica over bookshelf two-ways powered by the ubiquitous Technics receiver is, who buys this?

"People are always putting expensive paintings and rugs in their homes," says the bearded 40-year-old Levinson, by way of reply. "It's just that no one ever thought of a music system that way before. Everybody understands that it takes hundreds of

thousands of dollars to make a record, but everyone wants to be able to play it back for \$100. There's a lot of energy in a record that was created by expensive musical instruments and equipment; how much of that energy do you want to retrieve? There's a place for equipment of all levels. We're saying if you want to go for it we have a way that is simple, reliable, compact, elegant, easy to operate and relatively cost-effective."

Cost-effective? Actually, yes, when viewed from the perspective that for people who take music very, very seriously, stereos like those designed and manufactured by Cello are not only tools but investments, much the same as a Jaguar or an Alfa-Romeo, a Matisse or a Renoir. Working on the assumption that it takes one to know one, it seems fitting, even logical, that sonic works of art should be played back over something that at least approximates the technology and effort that went into their creation.

This mindset is reflected succinctly by Levinson when asked who his competition is at such stratospheric levels. Bang & Olufsen? Studer? "We have lots of competition," he dead-

pans, "Porsches, swimming pools, European vacations, boats."

The list of Cello equipment owners, provided by Levinson, includes ringing endorsements from an array of sonic epicureans, including Masterdisk's Bob Ludwig; Tom Jung, president of Digital Music Products; Dennis Drake, the director of studio and technical operations at PolyGram Records and at least one art dealer and one neurologist.

The Cello system is divided along two series of lines: the Basic Module and Premium Module series, which fit into the mainframe Audio Suite. Basic is what Levinson calls low cost, starting at \$600 per module. All the modules, which are at present primarily preamp-related but which will include CD electronics, an FM tuner, headphone amp and programmable crossovers, use active circuitry. The bus bars are screw-on type. "The idea of the mainframe is that everyone wants something different and why not make it possible? Make a chassis and a supply. We have an open-architecture format to come out with the features that people want."

The twin heart of the Cello system

is the Audio Suite and the Audio Palette, a modular grouping of hand-made components whose construction Levinson likens to the finest musical instruments. "We have here the tools to take people from the very basic world of playing a compact disc to the world of making a compact disc," says Levinson. Bob Ludwig uses Cello Audio Suite with a P603 module connected to the playback head of Studer A80, using it in a monitoring application. Other record companies have used Cello equipment in professional applications, according to Levinson and his Manhattan showroom manager, Dave King. The Audio Suite accepts up to ten modular sections. The design utilizes circuits and parts which would not fit into a conventional chassis, providing what Cello's literature refers to as "electronic real estate."

Power is supplied by the Performance Amplifier, a configuration of stereo amplifiers that comes in four pieces: two mono power supplies and two audio amplifiers. A dual-choke input supply and a 40-device audio output section allow what is rated a conservative 200 watts at 8 ohms. The system on display in Manhattan is rated at 3 kilowatts. "The amplifier has a very unusual design," Levinson points out proudly. "It's the world's only dual choke input supply; it's not a normal amp circuit. Most power supplies are capacitor input: transformers go to a bridge and the bridge is filtered by some caps and that drives your audio amplifiers. The thing that drives the amp basically is a signal coming from the capacitors. In this system you have a custom-designed transformer feeding a custom-designed dual choke. This essentially acts like a waveform-shaping filter which optimizes the performance of the power supply in such a way that the DC characteristics are much more stable in respect to grounding and loading. The power supply runs very cool because it's so efficient. It has all this incredible reserve because it has 40 output devices per channel. Most amplifiers have two or four or eight." The chassis also contains custom-made transformers, fan-cooled heatsink tunnels and several thousand individual customized parts. The entire power end of the system weighs in at around 250 pounds.

Cello's speaker system, the Amati, is reminiscent in design to the Klipsch of the 1950s. The speakers are de-

MASTER A FULLERSOUND

Complete Mastering Services for:

- Compact Disc
- Records
- Cassette

Sony PCM 1630/DMR-4000
Sony PCM 3202, Sony PCM 601
Mitsubishi X-80

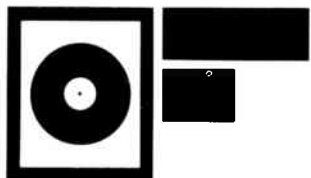

FULLERSOUND, INC.

1755 N.E. 149 STREET / MIAMI, FLORIDA 33181 / (305) 945-6697

ENG: Michael Fuller

Eric Clapton
Rod Stewart
Kenny Rogers
Judas Priest
The Romantics
Company B
Barry Manilow
Expose
Julio Iglesias
Eddie Money
Dionne Warwick
Braulio
Bee Gees
Bellamy Brothers
Kenny Loggins
George Clinton

signed with both home and studio settings in mind, says Levinson.

To say that the Audio Palette is a super equalizer is to oversimplify. Levinson refers to it as a "tone control system" using neither bi-amping nor tri-amping techniques and which is capable of correcting tonal imbalance in records, tapes and other software media with absolutely no sonic coloration. The range of rotary controls, from 15 Hz to 25 kHz, goes beyond simple EQ or room tuning. In a rather graphic demonstration, Levinson showed how manipulating the Audio Palette can dial out the coloration and distortions of older, worn records and tune in lost frequencies on a very selective, precise basis. In fact, several record companies have used the Audio Palette in just this way to refine old recordings for reissue in compact disc format. "It's a music restoration system," says Levinson. "It's a way of correcting for the kinds of aberrations that creep into the recording process. You're correcting for what I call 'bad sound'; sound that doesn't sound natural. It can be caused by the response of the microphones, by EQ during the recording, the techniques that were used during the recording, by processes used in the manufacture of the software; it can creep in as a result of deficiencies in the recording as well as the playback equipment or because of the room. What if they EQ it for the monitors they use and they hear no resemblance to the speakers you're using? *Ad infinitum*. Then there's also a thing called personal taste.

"Till now there's been no way for the music lover or the professional to deal with these kinds of problems in a completely sonically transparent fashion. We're giving the listener a lot more control, but it's done in a very ergonomic way. You don't need any musical training; you just have to have a sense of what music is."

The Audio Palette sells for \$7,500, though a Hewlett-Packard engineer once told Levinson it would cost them between \$30,000 and \$40,000 to duplicate its components and construction.

Levinson has basically rebuilt the concept of a stereo system from the ground up by addressing the myriad aspects of sonic reproduction that over the years have reached a certain point that has been regarded as "good enough" by an industry—specifically the consumer electronics industry—whose main focus has been staying

on top of changing software formats. "The difference with Cello is that we have paid special attention to many old problems which have never gone away, such as signal transmission," explains Levinson. "Cello systems are all balanced line. They're completely compatible with single-ended systems but we're using push/pull balanced cable throughout, articulated with the finest quality custom-made Swiss cables. We have our own cable called Cello Strings which drastically improve the sound of the system and we also use Swiss connectors made by Fisher and we also have XLR available. I'm not saying balanced lines make them sound good, but balanced lines are a big advantage and no one has ever used them in residential equipment before. What makes the sound quality better is new topology [the configuration of the circuit].

"Also, they are expressed with a new kind of packaging which pays special attention to grounding techniques. The power supply systems are designed to enable circuits to function as autonomously as possible without cross-feeding and cross-modulating. Also we're using selected grades of components. But it's not one thing or another thing; it's like, what makes a great meal? Just great wine or bread? No. It's putting it all together that's important, at every single aspect of product design."

Levinson decided right from the start to develop his own components rather than use existing materials; for instance, Cello is the only company he knows of that makes its own volume controls. "It's an approach that covers areas like repeatability, reliability, ergonomics," he says. "If you look in here you won't see anything that you'll find in any other product."

The company does not divide its product between consumer and professional lines. "This level of technology is beyond what's previously been available for either residential or professional and we've designed a product line that's perfectly suited to both," Levinson says. "That's the trick. Basically, we're selling the same products to everyone, except as far as custom plug-in is concerned—you won't have too many residential customers needing tape mastering electronics to connect to Studer A80 machines."

The techno-entrepreneur's background in electronics came as an outgrowth of his musical inclinations.

The BEST DEALS in TAPE, Cassettes, Duplicators, & Video Equipment ... Can be found at FULL COMPASS SYSTEMS...



Panasonic
VIDEO

Otari Telex Sony
DUPLICATORS



Buy a duplicator from us
and for its life, get **BEST**
cassette prices!

We do all our duplication on
OTARI DP4050 and TELEX 6120EXP

**CLONE
TONE**
CASSETTES

Scotch



Ampex

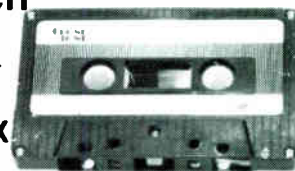

...where you can **BUY**
for **LESS** than **DIRECT!**

200 Product Lines for the Pro

Amplifiers • Cassettes • Headphones • Intercoms
Lighting • Mics • Mixers • Parts • Signal
Processing • Speakers • Tape • Recorders • Test
Equipment • Turntables • Video

Toll Free 50 States
800-356-5844

Wisconsin: 800-362-5445
Consultation: 608-271-1100



6729 Seybold Road Madison, WI 53719-1393

Circle #081 on Reader Service Card

"My main interest as a musician has been to recreate musical events," Levinson says. "I'm a jazz player [string bass and flugelhorn]. To me, there was always a discrepancy between what the instrument sounded like and what it sounded like through the speakers. I was interested in narrowing the gap. I was never interested in making records sound good. By that I mean a record is a piece of plastic. Putting music into grooves is totally different from recording a musical event and playing it back and getting it to sound like it should."

In 1971, Levinson began making custom microphone preamps and mixers. But he came early to the realization that would eventually result in Cello, Ltd.: "The pros didn't want to pay the price for quality whereas the people in residential audio did. And that's because they weren't interested. Nobody cared about sound quality then. In the early 1970s, the most advanced amplifier in terms of consumer stuff was a McIntosh for about \$400, and they had their counterparts for the studio and that was what was available at that time. My idea was to take the highest quality

circuits and parts previously applied to fields like aviation and aerospace instruments and apply them to audio. We're talking about the complexion of circuitry and topology and attention to detail that had never been used in audio before. It's not, however, beneficial to talk about that era."

[That last remark refers to the early incarnation of his gadget-building career. Levinson is no longer connected to the company which bears his trademarked name. Levinson did indicate that there had been a resolution to the litigation that brought this situation about. However, he refused to divulge any details about it, except to say, "My relationship to Mark Levinson Audio Systems ceased sometime in 1982."]

But his nascent awareness of the very high-end market tweaked his interest and he began exploring it. "I start paying attention to both ends then—what was going in on the pro side and what was coming out on the residential side and I saw that nobody was really bridging it," he remembers. "What Cello is doing now is radically different from what I was doing earlier in my career in that we are creat-

ing new models of equipment designed to make possible certain kinds of improvements in sound quality that would not be possible otherwise, and to make improvements on both the recording and the playback side. For example, no company in the last 30 years to my knowledge has done much in the way of tape head electronics. Now they're trying to remaster these great tapes and they're playing them back through circuitry that was developed 30 years ago. Now with the Audio Suite we can make tremendous improvements in sound quality."

Levinson founded Cello in July, 1984, with engineer Tom Colangelo, and later former Timex president Robert Weltzien joined them. Cello has gone from zero to the \$2.5 million level in sales in just two years of shipments, according to Levinson. The company occupies 8,000 square feet of space in a building in New Haven, CT, that once housed the Erector Set company. The building's assortment of artists using the other parts of the 1.5 million square feet beneath its roof attracted him, as did the hard maple floors. Cello currently has a staff of about 35 people building the systems.

His approach to market research was more Down East philosophy than Madison Avenue pragmatism: "We just built the equipment to see what would happen. We're not out to follow the trends; we're out to set the trends. We have a relationship to music, to technology and to business which enables us to do that. The best musical instruments are made by hand by people who are building to a standard, not a price, and they have something in mind and they hope somebody will want to buy it. And that's what we're doing."

With 150 Audio Palettes, over 230 Audio Suites and more than 40 amplifier systems already sold, Levinson projects sales orders totalling in excess of \$3 million for 1988. And if the price tag doesn't intimidate you, Levinson promises that the technology won't, either: "That's the point—to redefine the music system." ■

*Dan Daley's one man show, Mel Tor-
me: The Man and the Concept, will
be appearing at moderately priced
dinner theaters through February.
Outside his rich fantasy life he owns
Pyramid Recording in Manhattan.*

Nobody gives you more sound for less than Sam Ash.

You'll find everything you need to make music at Sam Ash at consistently low prices. It's a fact that Sam Ash has been filling America's playing and recording needs for more than 60 years. So whatever your needs may be, you'll find that the helpful and expert people at Sam Ash will bring music to your ears.

YOUR SOURCE FOR MUSIC AND SOUND

**Call Toll Free: 1-800-4-SAM-ASH
OR 1-718-347-7757**

Sam Ash®

124 FULTON AVENUE HEMPSTEAD, N.Y. 11550

MUSIC STORES

Circle #082 on Reader Service Card

The method now commonly used to connect and distribute the input and output signals of audio and video equipment is to insert patch cables into a jack board. This patch cable type patch bay is a well established connector and distributor of signal lines, but it poses various inconveniences. Changing the connections is time consuming, and to remember a certain patching system it is necessary to record everything on tables. Furthermore, such problems as dirt or rust of the jacks and plugs resulting in poor contacts and damaged patch cables disconnecting the lines occur frequently. The Akai Digital Matrix Patch Bay System has been developed to eliminate all these problems. For the exchange of input and output signals of professional audio equipment, this system uses balanced type/line level inputs and outputs for the audio signals and 75Ω BNC/composite line inputs and outputs for the video signals. To find out more, send for a brochure or see your AKAI dealer.

AUTOMATE YOUR MANUAL PATCH BAY SYSTEM ELIMINATE POOR CONNECTIONS AND TANGLES

*The Akai Digital Programmable
Matrix Patch Bay System*

AKAI
DIGITAL



AKAI
DIGITAL

P.O. Box 2344 Fort Worth,
TX 76113
Phone: 817 336-5114

Send us \$1.00 to cover postage and handling and we'll send you the AKAI patch bay brochure.

Circle #014 on Reader Service Card

World Radio History

Enclosed is \$1.00 for your AKAI digital patch bay brochure.

Name _____
Address _____
City _____ State _____ Zip _____
Tel. (_____) _____

MIX 1287

by Linda Jacobson

CHIP DAVIS

18TH CENTURY THINKING 20TH CENTURY TOOLS

Hear the ocean beating against rocks that ring the islands of Greece... soaring vocal choruses and funky bass lines... horse wings flapping and dolphins singing... ancient musical instruments dancing with symphony orchestras and choral groups... and classical-rock hybrid Mannheim Steamroller.

Not quite new age, this. It's the sound of *Fresh Aire*, the thematic series of musical epics produced by American Gramophone Records. Mannheim Steamroller, American Gramophone, and *Fresh Aire* share the same source of creativity: composer, musician and producer Chip Davis. His music has provided dramatic backdrops for many PBS and National Public Radio specials, the '84 Olympics TV coverage, the NBC Radio Network and *NBC Nightly News*. His band Mannheim Steamroller has recorded nine albums including the popular *Fresh Aire* series (six so far), and has toured the country performing a concert complete with film animation, dance, slides, computerized lighting and music matched to visuals.

Davis is a third-generation, classically trained musician from Nebraska who, by age 11, was taking music dictation. An oboeist and choir singer, he majored in bassoon in college, and afterwards joined the Toledo Ohio Symphony. So he could gig between symphony sessions, at 24 he learned to play rock drums. A few years later, Davis started working for an Omaha recording studio, writing and produc-

ing jingles. One day in 1974 he was asked to write a tune—country & western style—for *Old Home Bread*.

Davis admits C&W music didn't whet his musical appetite. Nonethe-



Fostex Presents a Series of Timely Investments:

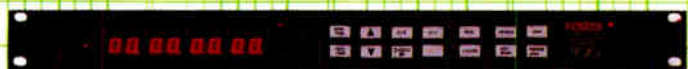

4010

4010 SMPTE Time Code Generator/Reader has all the functions you'll ever need because it's completely software based. As in all high tech digital electronics today, there's a switching power supply. And socketed EPROMs mean your hardware will never be obsolete. Plus, the 4010 has a serial data port on the rear panel which allows communication with (and control by) computers.



4030

4030 Synchronizer with switching power supply



4035

and **4035** Controller for all major brands and models of tape recorders—both audio and video. Control up to one master and three slaves, or slave as many transports as you wish, just by adding a 4030 for each slave. A serial interface port allows communication with personal computers to run F.A.M.E., Fostex Automated Media Editing. SMPTE time code based, it works with 24, 25, 30 fps and drop frame, and features resolution to 1/100 of a frame, selectable pre-roll up to 99 seconds, 10 position auto-locate and **programmable, automatic punch in/out with rehearse function.**



4050

4050 Auto Locator is a full function remote control unit for Fostex Models 80, 20 and all E-Series recorders. In addition to tempo control, you can locate to the measure bar and beat, thus the 4050 is the first autolocator to think musically. Up to ten cue points can be programmed and you can punch in and out automatically. The 4050 is also a MIDI Synchronizer, featuring a SMPTE/EBU Time Code generator/reader—all four formats. Any MIDI instrument can be synchronized to this most accurate timing reference. You can also simulate the running of the recorder in order to have the SMPTE/EBU code run MIDI instruments only. There's even a serial communication port which lets you use a personal computer.

Merging Technologies

Fostex

15431 Blackburn Ave., Norwalk, CA 90650
(213) 921-1112

©1987 Fostex Corporation of America

"One layup console, cream & sugar, please."

Even in your high-speed world of ADR, Foley, and effects layup, it might seem that needs are simple.

A good cup of coffee. A comfortable chair. And a console with just a few basic features.

It's a safe bet, though, that your console can be a major headache. Noisy mic preamps, maybe. Or lame EQ that makes you reach for external. A machine interface that's a collection of add-ons and compromises.

We've designed the Essence to put an end to all that. Its a workstation for multitrack effects layup that you'll think you designed yourself.

We know that the quality of your assembly rooms sets the stage for your mix theater. So we gave the Essence the same powerful parametric equalizers and ultra quiet mic amps as our top of the line Elite.

Now you can have all the monitor inputs you want, 32 if you use a digital multitrack. Each with slide fader and SMPTE automated mutes.

Essence gives you a variety of solo functions on inputs and monitors. Even the headphone feed has its own solo system.

Our logic puts tracks into record ready from the console and you can route audio to any track you select. A sophisticated communication system knows the machines are in rewind and still lets you chat with the talent.

Best of all, we've put the Essence system, with its comprehensive master section and patch bay, into a package that fits Neotek sonic performance into your smallest assembly room. With enough desk space for your scripts and synchronizer keyboard. You can even add an Audiofile.

So sit back in your comfy chair and imagine what you could do without the compromises of a semi-pro console. Think how the quality and efficiency of your work will improve.

We can't do anything about that cup of coffee, but now at least your console won't leave a bad taste in your mouth.



NEOTEK

Neotek Corporation 1154 West Belmont Avenue Chicago, Illinois 60657 (312) 929-6699

Circle #036 on Reader Service Card

World Radio History

PRODUCERS · DESK

less, the resulting soap opera-style commercial delighted people throughout the Midwest and soon became a series of commercials based on the character, truck driver C.W. McCall. It was such a hit that Davis and C.W. (songwriter Bill Fries) released a three-jingle record on American Gramophone, a label Davis set up just for that. In two weeks 20,000 people bought the record. Davis and Fries followed that with 13 big-selling singles, including the still-selling, triple platinum "Convoy." The novelty song earned Davis the title of Country Music Writer of 1976, and a gig scoring the '77 movie *Convoy*.

C.W. McCall's back-up band, unbeknownst to millions of bread buyers, were rock and roll-loving symphonic musicians—who became the core of Mannheim Steamroller. In between jingle sessions, composer, percussionist and recorder player Davis and his partner, keyboardist Jackson Berkey, developed the Fresh Aire concept.

"Fresh Aire began as an experiment in using existing forms of classical music, like Renaissance dance forms such as the sarabande or the fugue, then plugging in notes and rhythms from our present time period. Our first Fresh Aire album, for example, has the four-voice blues/rock fugue, 'Prelude to Chocolate Fudge,'" explains Davis. "The only rule for Fresh Aire is that it work with a classical form in terms of superstructure. *Fresh Aire I* is baroque oriented; *Fresh Aire II* has medieval and Renaissance influences. *Fresh Aire VI* is involved in French impressionism. The thing is time travel through music history—that's what Fresh Aire is all about."

Diverse arts and cultures have influenced Davis' self-described baroque rock style, and he numbers among his favorites Mozart, SuperTramp and Vangelis, so it's natural that Fresh Aire is something quite out of the ordinary. Mannheim Steamroller goes beyond Fresh Aire, and has recorded three other LPs, including the ever-popular, Far East-flavored *Mannheim Steamroller Christmas* (750,000 copies sold since '84, Number Two on *Billboard* Christmas charts, and nominated for a Grammy).

Today, American Gramophone is hugely successful. Annual sales top \$5 million, with virtually no radio play

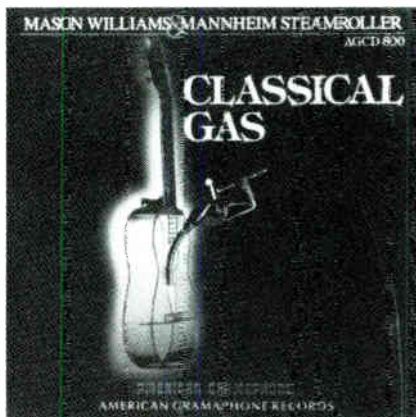

Mason Williams' 1968 hit "Classical Gas" gets updated, Mannheim Steamroller-style.

and little press coverage. Odds are, your local hi-fi store plays American Gramophone fare to show off their finest systems. Renowned for its unpretentious, eclectic content—synth-layered rondos, solo jazz guitar, choir-sung madrigals, rockin' toccatas, and much more—the label is equally noted for superb quality recording/mastering, top grade vinyl and CDs, lush packaging, and a great sense of humor.

Along with running the business, Davis is the A&R department, premier composer and arranger, head producer, and even designs re-creations of musical instruments from the Middle Ages. He also oversees packaging. The *Fresh Aire V* and *VI* CDs, for example, contain his specially commissioned story booklets. The booklet in *Fresh Aire VI*, a film score-style epic based on Greek mythology, contains original English translations of Greek myths. He commissioned visionary artist Gilbert Williams to paint a Grecian harbor that incorporates all the myths. The results enhance the listening experience, providing a visual backdrop for the aural images created by Mannheim Steamroller, the London Symphony Orchestra and the Cambridge Singers.

When he composes, Davis first develops the album's "conceptual visualization" (mythology, the moon, etc.). Then he creates graphs (by hand or computer) that become the foundation of his score—one graph shows the energy flow (things that are repetitive within a section), another is a determination of tempo. Or a graph might show color flow (instrumenta-

FUTURE DISC SYSTEMS

COMPLETE ANALOGUE & DIGITAL MASTERING SERVICES

FOR COMPACT DISC, RECORD & CASSETTE MANUFACTURING

3475 CAHUENGA BLVD WEST, HOLLYWOOD, CALIFORNIA 90068
(213) 876-8733

tion), and another, rhythm. He often doesn't write the melody until late in the score.

"Music has to have feeling and inspiration, but it also has to have its intellectual side. Just like a human being," muses Davis: "You have to think and you have to feel, and I like to have both elements in all pieces. The melody, rhythm, and harmony are second nature to me; the thinking part is harder. So first I figure out the superstructure, and then execute it. I write it all out beforehand, but if I discover a sound in the studio, I'll go off on a tangent."

Davis now is planning *Fresh Aire VII*, and considering a new Mannheim Steamroller series ("There were only supposed to be eight Fresh Aires—how many composers do we know who made it past their ninth symphony?"). His label just released Mason Williams' *Classical Gas*, which contains a Fresh Aire-style version of the original "Classical Gas," one of the late

'60s' most popular and memorable instrumentals. "Producing *Classical Gas* was like producing one of my things," says Davis. "That piece was an inspiration to me when it first came out."

"Classical Gas" was rearranged, recorded and released on this album by guitarist Williams and Mannheim Steamroller (Davis, Berkey, Eric Hansen on bass, and Ron Cooley on rhythm and electric guitar). Davis arranged and produced the "new" tune and 13 other Williams compositions, which stylistically cover pop, "film score," jazz and country, including "Doot-Doot" ("a play-along fantasy for broadcast signal and truck horn") and a Davis arrangement of "Greensleeves" with classical guitar and 5-string banjo. The album was recorded at Sound Recorders in Omaha, by studio owner and veteran engineer John Boyd.

Davis works almost exclusively at Sound Recorders (which also has a studio in Kansas City). The studio's enormous dimensions and Boyd's combination of tight and ambient miking results in an extraordinarily dynam-

ic sound. Masters are cut there too, using the least amount of sound compression possible. In the production plant, stampers are replaced after every 15,000 pressings. Davis also records in London, as he did for *Classical Gas*, working with the London Symphony Orchestra at CTS Studios. Or he'll execute large-scale remotes with BBC's remote unit, like going to echo-laden Ely Cathedral near Cambridge to record the Cambridge Singers.

We contacted Davis to discuss *Classical Gas* and other American Gramophone records, and his use of acoustic and electronic instruments. He notes, "I started on synthesizers back in the days of the P series Moog, and I've been fooling around with MIDI since *Fresh Aire V* four years ago. But *Classical Gas* is the first full album I did completely on the Mac."

Mix: How did you use the Macintosh?
Chip Davis: The Mac Plus is the foundation of the arrangement, using a 20 Meg disk drive, a Kurzweil, two TX7s,

—CONTINUED ON PAGE 64



FRESH SOUNDS

Camel bells, dry ice, and a pencil are but a few of the "instruments" used in Chip Davis productions. Glorious sounding CD-based sound effects may be readily available, but Davis goes to great lengths to capture sounds of the environment and nature. He'll spend an hour snapping a bed sheet, or spend \$3,000 recording the sounds of a rented stud quarterhorse. Anything to achieve *exactly* the right effect, and more importantly, feeling.

One hallmark of Mannheim Steamroller music is its combination of old and new instruments. Davis and his father Louis carefully and lovingly re-create authentic period instruments, such as an eight-foot, 17th century-style harpsichord and a 12th century-style clavichord. We asked Davis if there were others.

"The booklet that comes with *Fresh Aire VI* contains an onion skin drawing of a band. That band was pictured on a Grecian vase from the 5th century BC. We copied it from a photo of the vase. 'Night Festival at

Rhodes' features all their instruments.

"One instrument is a barbitone, which is like a bass lyre. The heart shape at the bottom is a tortoise shell, over which they stretched animal hide, for a soundboard. There's also a double flute, called an 'aulof.' The guys playing 'clappers,' those sticks bound together, are the rhythm section. The other lyre is a 'kit-hara,' a six-string lyre. We used walnut for the curved outer part and the soundbox, and straight grain spruce for the soundboard. For the neck we used zebra wood, extremely hard, brittle wood from Africa. It's so dense it conducts sound really well.

"After building the instruments, I programmed the sounds of each one into the Kurzweil, then in the studio we recorded them live. I played them using a 14-note scale, a Dorian mode of the 5th century BC. Then I added rock and roll rhythms.

"The *Mannheim Steamroller Christmas* album is also interesting. On 'We Three Kings' I played a soprano dulcian, which sounds like a combination of sax and English horn, and was the 16th century forerunner of the bassoon. I also played an oak-wood hammered dulcimer,

which was the name for 15th century zither-type instruments with more than one string but without a keyboard. In 'Renaissance Sweet' I play a crumhorn, which sounds like wax paper and comb. It's a woodwind with a double reed enclosed in a cap."

The aforementioned *Fresh Aire VI* is also spiced with the sounds of nature, such as dolphins singing in "Come Home to the Sea." The liner notes for the three-movement "Rhodes" describe the "Sunrise" portion taking place "... while the drunken band sleeps in (typical musicians). The god, Helios, readies his chariot to take up the sun from the crystal gates on the horizon of the ocean. The wings flap, the horses whinny in the clouds as the ocean disappears below."

Davis explains, "that's about a myth concerning Helios, who lived on the island of Rhodes and who took up the sun each morning with his winged horses, flying over the ocean. I wanted to capture that feeling.

"We knew we wanted a natural pan from left to right when the horse went by. We didn't want to do it with knobs. To do it in a certain amount of time and space—the stereo field was 40 feet long, with two Sennheiser 421s—we got a high-performance stud quarterhorse, which Sharon, my fiancée, rode. We mounted a Nagra on the saddle and tight-miked the hooves with the little Sony ECM-50 under the cinch. Then we found the right road, a dirt road with enough gravel to give some high end to the hooves. Regular dirt isn't punchy enough. We ran the Nagra in mono and got a 2-track with the 40-foot stereo spread. The horse is snorting and Sharon's riding around in circles as if the chariot were getting ready. Later in the studio I added another sound effect that I call 'heartbeat of the sun,' using the Lexicon stereo delay unit and the Prophet. That helps to start to create energy.

"So we got the horse up to speed in that 40-foot span, and then he goes off into the distance, so you

hear the accurate stereo image as the winged horse takes off. The whinny at the end happened when the horse was a half-mile down the road. In the studio I stuck it in a delay so it would sound like it was coming through mountainous caverns, which were in the rocks off the island of Rhodes.

"We took the chariot off a sound effects record in mono and panned it from left to right. As for the wings—when a bird flaps its wings, the sound has a high end, a flutter sound, but it also has a low end. So we used a bed sheet and a large foam baffle. We snapped the sheet and recorded the waft and crack. We put a click track right ahead of one wing flap, with eight clicks as count-off. Then we dropped the baffle and recorded the thud. So we snapped the sheet and dropped the baffle, over and over. We recorded them each one at a time on 24-track and made the sounds closer and closer and closer, to make it sound like it's wings, coming up to speed."

—L.J.

SHOW US A BETTER CASSETTE...

AND WE'LL EAT IT!

We're so confident here at MUSIC ANNEX DUPLICATION, that if you'll bring us a sample duplicated cassette that's better than our own high speed OTARI/DOLBY HX PRO™ product, we'll eat it.

Better, by the way, means better sounding, a better price than you're now paying, and better because we can get the run done faster. Much faster.

If you think we're ready to eat these words too, pick up the phone and give us a shot.

With the money we'll save you on a better, more consistent product, who knows - you might even want to buy us lunch.



Music Annex Duplication

970 O'BRIEN DRIVE • MENLO PARK, CA 94025 (415) 328-8338

—FROM PAGE 62

two DX7s, TX81Z, Prophet 5, and a little Casio CZ230S. And Mark of the Unicorn Performer sequencer software. *Classical Gas* also has 25 strings, percussion [himself], brass, harpsichord, and of course Mason's guitar lead solo. People are using a lot of MIDI stuff, and people are doing a lot of acoustic stuff, but one thing different about *Classical Gas* is the comingling of everything. It starts off with an acoustic front end that has no time, no meter or click track. After it

gets in a ways, the rhythm starts, then different things happen as the piece develops.

The keyboard parts are the most difficult to write out, because they're so time-consuming. So I loaded most of those onto the Performer program. The strings, brass, and other acoustic parts were scored traditionally on a full score, but I wanted to hear my complete arrangement. So after I put down all the synthetic keyboard parts in the Mac, I took my full arranged score and assigned another Performer track for the strings, another for the horns, etc., and had the Kurzweil play those on

top of the keyboard parts. By the time I went to the studio I had my complete arrangement on the computer. But in recording I didn't use the synthetic strings, brass, etc., they were all done acoustically.

Mix: What happens after composing and arranging?

Davis: When I develop a Fresh Aire album, I lay out all the tracking before I go in the studio. Then when I do, I produce audio using video techniques. I lay out blocks based on the way you cut video, where you use A and B rolls, only I use two 24-track machines. If I'm using the London Symphony, the Cambridge Singers and Mannheim Steamroller, we eat up tracks like crazy. I put rhythm on one 24-track, and use two tracks for SMPTE and two for automation, then on the other machine I have 12 or 15 orchestra tracks and another four for the choir. Then we connect the machines with a Shadow synchronizer and mix the 44 tracks live, straight to digital.

Mix: So you record on analog and mix down to digital?

Davis: On *Classical Gas*, for instance, we had the acoustic stuff—strings, brass, percussion, all that—going onto the analog 24-track, and the sync tone on track 24. The sync tone then drove the synthesizers live, and we did a two mix to stereo, live, of all the synths, straight to the Sony 1610, while we mixed the acoustic.

Mix: MIDI must help a lot, especially with all your electronic instrumentation.

Davis: I'm able to compile colors in advance, which is great. But we have a lot of layered keyboard texture sounds and I still do that acoustically. Before MIDI, I used acoustic and synthetic instruments to create sounds that didn't exist. For instance, combining the attack of a harpsichord with the decay of a piano, then muting it with a sine wave-oriented, flutey type sound from the synthesizer. I use synthesizers as synthesizers, not as substitutes for violins or violin players. I'll sample something like hammered dulcimer to put in the sequencer to do something with the instrument that it can't do on its own. But I don't sample an instrument so I don't have to use the player. I'd rather do it live, for the spontaneity and the player's style.

WHY LAKE...



...because this is a people business, and at LAKE I get personal attention, professional service and competitive prices. What else can I say...they're the pro's in New England.

*Jon Russell, Presence Studio,
New Haven, CT*



...when it came to us wanting our component video post production suite to talk to audio, LAKE SYSTEMS provided all the hardware, service, design and support necessary for success.

*Dave Berenson, Chedd Angier Productions,
Boston, MA*



...when we were looking to upgrade our studio, LAKE had a fresh creative approach to our acoustic design needs, our equipment requirements, and our business strategy. They've done everything they said they were going to do and that's helped us tremendously. I would recommend them above anyone else.

*Richard Carr, Blackbeard Studios Inc.,
Lincoln, RI*

LAKE
THE AUDIO COMPANY
287 Grove Street
Newton, MA 02466, U.S.A.
(617) 244-6881
in N.E., PA, NJ and NY
1-800-848-4890

Today's tougher audio requirements demand a new choice

Telex *Pro Series* 6120 XLP

A new duplicator with 8X speed and tougher specs.

Improved frequency response plus less distortion and crosstalk are just a few of the technical gains achieved in the new Telex Pro Series duplicator. This means that you'll make duplicates that are **true to the master** than with any comparable tape duplicator on the market today.

Yes, here's a system with all the advantages of the famous 6120 high speed duplicator plus enhanced specifications. Features that made the 6120 popular such as compact size, unlimited expandability, track select, audio

level monitors and easy one-button operation remain distinct Telex advantages. But, by developing the 6120XLP with 8X speed, Telex gives you the advantage of improvements in many **important professional specifications** such as distortion, frequency response, speed accuracy and crosstalk. And, the new cassette transport speed allows you to duplicate directly from 15 ips open reel masters for the ultimate in quality and convenience.

The Pro Series 6120 uses a newly developed, highly effi-

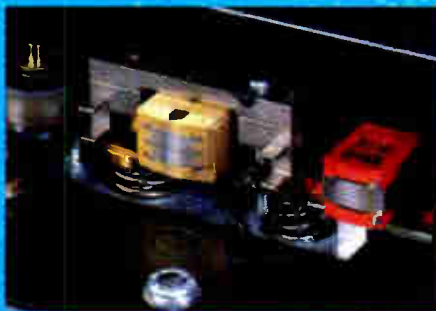

New XL LIFE cassette head.

cient **XL LIFE™** cassette head featuring ultra-hard physical characteristics for **extra long life (10X normal)** plus a satin smooth surface that resists excessive oxide build-up preventing the need for frequent maintenance. Its advanced engineering, precision design and painstaking manufacturing techniques contribute immensely to the Pro Series improved specs including an **unmatched frequency range** of 50 to 13KHz. For further technical details and the name of your nearest 6120 dealer, call or write Telex Commu-

nications, Inc., 9600 Aldrich Ave. So., Minneapolis, MN 55420.

Up to 12 months to pay with no interest!

The entire Telex 6120 duplicator series is available with special **NO INTEREST** financing through participating Telex dealers. Yes, with only 10% down and up to 12 months to pay, you could be eligible for special **NO INTEREST** financing. Think of it! You could pay for your 6120 out of the savings or income generated.



TELEX®

Call Toll Free in U.S. 800-828-6107 • In Minnesota Call (612) 887-5531

Circle #017 on Reader Service Card

Mix: You've been said to have "a pure view of production." Can you elaborate?

Davis: We try not to junk stuff up, we don't use a bunch of outboard gear, don't use a bunch of limiters. John [Boyd] has a real skill in choosing the right mic for the right instrument, so we don't have to worry about EQing the stuff later.

Mix: Do you get technically involved in the control room?

Davis: I don't twist knobs at all. But I get carried away with silly devices that I like using to create certain effects. I love effects, and I don't mean a lot of outboard junk. I love sound effects in nature. I just got back from recording sounds in the Grand Canyon.

Mix: Which other American Gramophone artists do you produce?

Davis: I'm involved with everything on American Gramophone at one point or another, though I don't necessarily produce. For instance, the new Checkfield album [*Distant Thunder*]

is produced and engineered by John Archer, one of the members of Checkfield. On the other hand, I was re-mix producer on Ric Swanson's *Urban Surrender* [which hit the *Billboard* jazz charts]. I've produced and orchestrated a few classical albums, such as *Ballade* by Jackson Berkey. I produced John Rutter's first two albums [*Olde English Madrigals & Folk Songs* and the popular *Mozart Collection*]. John is an English composer and the Cambridge Singers' choral master; his third album comes out soon.

Mix: How do you work when you

produce artists other than Mannheim Steamroller?

Davis: For any album, I start out with choice of repertoire and concept. Each album must be unique and yet fit the criteria of what our audience likes. I try to bring them something eclectic with classical, jazz, or new age roots. I think I have a real good handle on our audience. We still do stuff for our audiophile base, to break their speakers.

The main thing in the studio is to get the sound right, working with the engineer. American Gramophone is known for a real clear sound; we don't have much ambient junk floating around. After the sound portion is handled, then the concern is performance—adjusting tempos, getting the most out of the artist or orchestra. I'm a real stickler for intonation. I have to know the repertoire real well, especially if we're doing something like a live 2-track mix of Mozart, because I like to include inside lines and stuff you don't hear on other recordings. I'll try to dig those out, even if it means putting a mic real tight on it and at the right time, bring up that pot; just to bring out that line and help the overall mix of the 2-track.

Mix: How do you like running a record label in the Midwest?

Davis: In Omaha, Nebraska, we have great engineers and great musicians. We're not around the regular record business and as a result, it doesn't rub off on us. I don't think my thinking gets colored, living out there in the woods, in terms of people thinking there are certain ways to make records. So we just make it up as we go. ■

Linda Jacobson is the assistant editor of Mix magazine. She also runs Wordswork, a creative technical writing service in San Francisco.

“...time travel through music history is what Fresh Aire is all about.”



STEP UP TO THE FUTURE

10 Vol. CD Sound Effects Library

10 Vol. CD Music Library

FOR A FREE COMPACT DISC SAMPLE

CONTACT:

27TH DIMENSION, INC., P.O. BOX 1561, JUPITER, FLORIDA 33468
FLORIDA COLLECT — 305/746-2222 OUTSIDE FLORIDA — 800/634-0091

HOLOPHONICS IS A TRADEMARK OF ZUCARELLI HOLOPHONICS, INC.

Circle #085 on Reader Service Card

World Radio History

Large scale concert sound reinforcement has a smaller future.

**Manifold Technology™
delivers...twice the output
in half the space!**

Concert sound is getting smaller. System size, that is, not tour dollars! In fact, the high-level sound market is stronger than ever. But high transportation and setup costs are forcing lighter, smaller and more efficient speaker systems. While audiences demand better fidelity.

That's why we've made Manifold Technology *systems twice as loud in half the space*. The two-box, 4-way active MT-4 uses 4 (four!) drivers in each bandpass for unequalled acoustic output. Now, your system can be one quarter the size or four times as loud compared to other designs.

The MTA-42 Manifold Technology adapter combines four compression drivers without added distortion. And without the phase cancellations of Y-adapters! That's 4 supertweeter and 4 upper-midrange compression drivers on identical 60° x 40° constant-directivity horns. To complete the MTH-4 "high" box, four DL10X woofers use proprietary phase plugs to provide seamless vocals from 160-1600 Hz. The result is flawless 138-dB midbass at 1 meter!

The MTL-4 "low" box combines four 18-inch woofers in an ultra compact 36" x 36" x 30" cabinet. More efficient than horn-loaded subwoofers, Manifold Technology design prevents woofer "bottoming" even at 40 Hz with 1,600 watts input!

MT-4

Concert Sound System
50,000-Watt Array

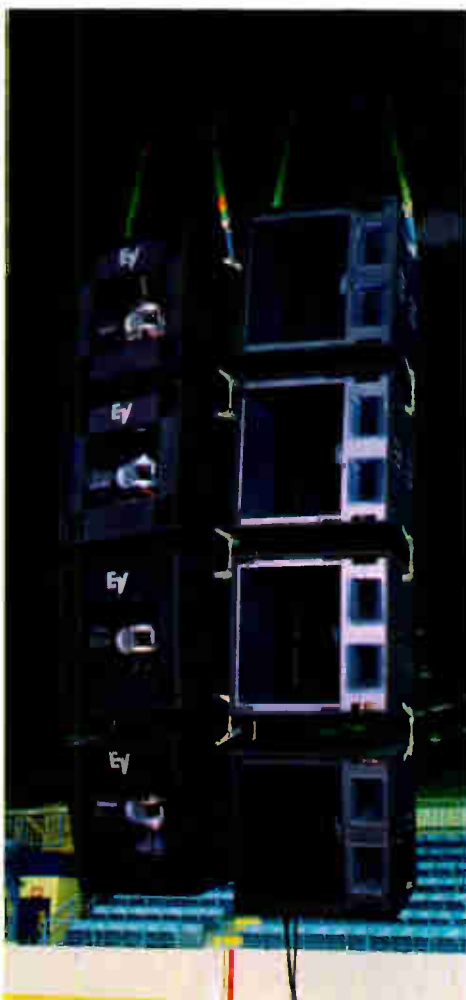

**High output plus high
fidelity**

To produce high-level sound, most concert systems aim many horns at the same seating area. Unfortunately, this approach causes peaky frequency response, decreased sensitivity and ragged coverage patterns. With four drivers on each horn, a large-scale MT-4 system has fewer independent sources. For fewer phase-cancellation problems. Frequency response is smoother, sensitivity increased, and coverage perfectly constant.

**A flying system that's
second to none**

MT-4 cabinets are optionally equipped with a unique two-point flying system that allows true point-source arrays. Tilt angle adjustment is easy because track positions are pre-engineered for popular array configurations. Trial-and-error guesswork is a thing of the past. Nothing is as easy as an MT-4.

You don't have to wait for the system of the future. It's here now! For a free MT-4 brochure, see your EV Professional Audio Dealer or write: Electro-Voice, Inc., Dept. MIX-4, 600 Cecil St., Buchanan, MI 49107.

Electro-Voice®

a MARK IV company

**"ASTOUNDING PERFORMANCE
AT AN ASTONISHING PRICE!"**

MICRO

FROM VALLEY INTERNATIONAL.

FX



NOISE GATE

To eliminate unwanted noise in musical program, instrument amplifier hum and buzz.



COMPRESSOR

To afford complete control of dynamic range, with an automatic downward expander to remove undesirable noise level recovery.



DE-ESSER

To remove excessive "ess" sounds commonly called sibilance.



NOISE REDUCTION

One-way noise reduction unit to eliminate unwanted noise from audio signals, while improving signal-to-noise ratios.



ATTENUATOR

Reduces +4 professional standard operating level signals to -20 musical instrument/amplifier levels or -10 operating levels, while properly matching all impedances.



BOOSTER

Amplifies and impedance-matches musical instrument/amplifier levels and -10 operating levels to +4 professional standard operating levels to ensure proper interface and low noise, low distortion performance.

*** SUGGESTED RETAIL LIST PRICE:
\$149.00 EACH.**



**BEFORE YOU PAY
THE SAME PRICE FOR A PRODUCT
THAT OFFERS LESS, TRY MICRO FX.**



P.O. Box 40306 • 2817 Erica Place
Nashville, TN 37204 • (615) 383-4737

Circle #020 on Reader Service Card

Inexpensive signal processors are not new. But, inexpensive processors capable of delivering truly professional sound quality were practically nonexistent prior to the introduction of Micro FX. Each Micro FX product is designed and manufactured to the same exacting standards which have made Valley International an industry leader in the field of analog signal processing. The time-proven proprietary processing circuitry found in our more expensive processing products is also designed into every Micro FX unit. You will find the same high quality components in each Micro FX unit that you find in the rest of the Valley line, so you can be assured of years of trouble-free operation. And, all of the Micro FX products are made in the U.S.A.

NEW PRODUCTS

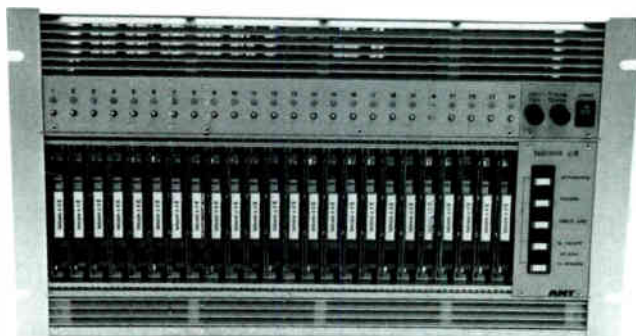

ANT E413 Noise Reduction

The latest member of ANT's (Gaithersburg, MD) noise reduction line is the E413 multi-track NR system. The 24-channel unit is easy to install and use, requiring no alignment. Providing an overall dynamic range of 118 dB, the E413 design is based

positive or negative voltage. The E413 can be used in any analog or digital multi-track machine, for it connects via a screw terminal with balanced inputs and outputs. When used with a 16-bit digital recorder, the E413 achieves 20-bit performance.

Circle #069 on Reader Service Card

Akai PEQ6 MIDI EQ

Akai Professional (Ft. Worth, TX) has released the PEQ6, a rack mount, seven-band device with six independently programmable equalizers. Each of the 32 banks stores all settings of the six equalizers. The PEQ6 provides 12 dB cut/boost at 63, 160, 400, 1k, 2.4k, 6.3k and 10k Hz. The 32 programs can be switched via MIDI program change command, the program-up footswitch, or the unit's front panel switches. Designed for keyboard, bass, guitar, or drum set equalization, the PEQ6 goes for \$449.95 retail.

Circle #066 on Reader Service Card

frequency, amplitude, sample rate, distortion, signal-to-noise and also accesses single samples. The Analyzer displays the subcode information in a decoded, readable format. Both the Generator and Analyzer operate together or independently on sampling frequencies from 28k to 53k Hz. An RS-232 interface allows control by personal computer, with up- and down-loading of waveforms.

Circle #067 on Reader Service Card



TC AES/EBU Interface Test

TC Electronics aims the TC8201, their new AES/EBU Interface Test Generator/Analyzer, at testing of digital audio inputs and outputs on equipment conforming to AES/EBU and IEC specs. The TC8201 provides easy, detailed access to both the digital audio information and the subcode associating the audio information. The Generator section can send waveforms, up to 24 bits resolution and up to 100 msec. in length, selectable via menu and single-sample access. The Analyzer measures audio input

Turbosound Monitors

New York City's Turbosound presents their new TFM-2 High-Projection Floor Monitor, a 3-way bi-amped speaker rated at 450 watts. It employs the Turboconcentric™ loading device and a specially designed bass section featuring front- and down-firing double 15-inch woofers to reproduce high SPLs with clarity and definition.

Circle #068 on Reader Service Card

on a single-channel compander card containing 70 op-amps, eight VCA transistors, and 350 SMDs. This technology eliminates the need for cooling fans. Each card has remote control capability for record and playback, controllable by

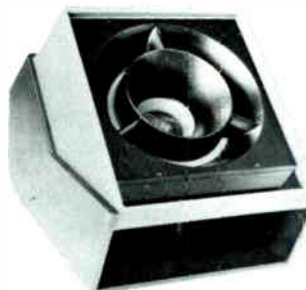

IDM Studio Time

Studio Time is the name of a new software program for controlling the studio's day-to-day business. The program, by International Data Management, Inc. (Newhall, CA), features powerful, easy operation—even for those new to computers. It creates and runs reports on inventory control, aging, invoicing, engineer's hours, clients & artists, quarterly tax reports, and more. The user can cross-index entries into four industry classifications, six professional categories, and four industry support groups. The separate client index provides an 800-character text area for background info, and optional account number entry for instant retrieval. Use the program to do studio invoicing and inventory, including on-screen math functions and auto inventory management. Studio Time auto-



matically generates mailing labels, creates file cards and company or custom labels, and interfaces with word processors. IDM customizes Studio Time for your facility, at no additional cost. Hardware required is an IBM XT/AT computer or compatible, with hard disk.

Circle #070 on Reader Service Card

Soundcraft FAME for TS12

FAME Automation is now available in all Soundcraft TS12 consoles, from the factory or as a retrofit. The SMPTE time code- and disk-based system allows full automation of fader and mute settings as well as channel aux send switching and EQ in/out switching. FAME also sup-

ports nine VCA subgroups with any channel assignable as master. Programming is handled from the TS12, with the help of a small keypad. External hardware is a 2U rack unit that houses the processor and 3.5-inch disk drive. One disk stores up to ten complete mixes (any length). An optional high-resolution color monitor displays current mix info, switch and group status, fader positions, VCR positions, system status and time code. The system synchronizes to the multi-tracks via time code, enabling storage and repeat of console fader movements, mutes, aux send and EQ switching. Settings can be updated, merged with other mix sections, stored indefinitely or transferred

to another studio with a compatible system. An indefinite number of passes may happen, and results in no cumulative timing errors.

Circle #071 on Reader Service Card

Leonardo Music/FX Library

Leonardo Software (Venice, CA) debuts Professional Librarian, a series of programs for IBM and compatible computers for cataloging, search, and playback of music and sound effects in production libraries. Users can define searches by category, description, tempo, length, instrumentation, sound types, key or mode. To help speed up the sorting process, Leonardo can provide databases of effects and music libraries that are pre-sorted and cross-referenced in a variety of categories. The program also prints a report detailing library usage for royalty and client billing purposes. Professional Librarian's custom interface unit controls the Sony CDK-006 multi-disc player (which holds 60 CDs) to allow playback, and synchronization system. Professional

Librarian's price is \$750.

The company also offers the Library Catalog Printing Module, and a multi-user upgrade to allow four (or more) computers to simultaneously use the programs and data files. Other Leonardo software programs are Sound Supervisor, to simplify sound effects editing; CuePrinter, to print mixing cue sheets; and SpotMaker, to organize dialog replacement sessions.

Circle #072 on Reader Service Card

Klark-Teknik Parametric EQs

The DN 405 and DN 410 parametric equalizers are the latest from Klark-Teknik (Farmingdale, NY). The five-band DN 405 features separate variable high- and low-pass filters, individual EQ In/Out switches for each band as well as an overall EQ In/Out, and a three-position range switch for each filter. This allows total overlap between 20 and 20k Hz while maintaining accurate resolution with a 10:1 sweep range. The filters' "Notch" mode enables suppression of feedback frequencies with negligible effect on the



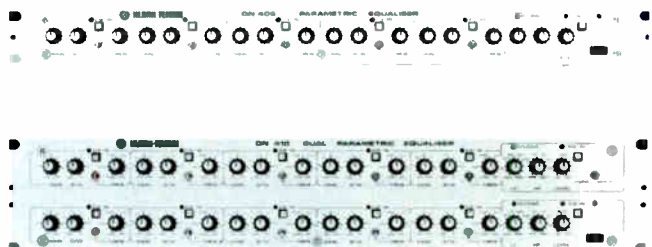

adjacent spectrum. The DN 410 is a dual five-band EQ similar to the DN 405. It offers ten parametric filters, for 2 by 5 dual-channel EQ or 10-band mono use. Both rack mount units are available with security covers.

Circle #073 on Reader Service Card

Free Synchronization Book

Tascam, a leading manufacturer of professional audio equipment, has released *Understanding Synchronization*, offering a wealth of information designed to demystify the intricacies of the synchronization process. The book simply explains topics such as different sync protocols (i.e. SMPTE codes, control track, click track, FSK, MIDI and DIN sync), as well as presents a wide variety of user applications and flow charts detailing different combinations of audio, video and music synchronization cases. For a free copy, write to: *Understanding Synchronization*, Tascam, 7733 Telegraph Road, Montebello, CA 90640.

Circle #074 on Reader Service Card

Soundtracs ERIC Console

The ERIC production console from Soundtracs provides 24 buses in a split configuration, available in 32-, 40- and 48-input main-

frames. In addition to high-level analog audio specs, ERIC features programmable digital switching and automation. The console has 24 identical line inputs on remix. The monitor sections each have two line inputs for two 24-track tape

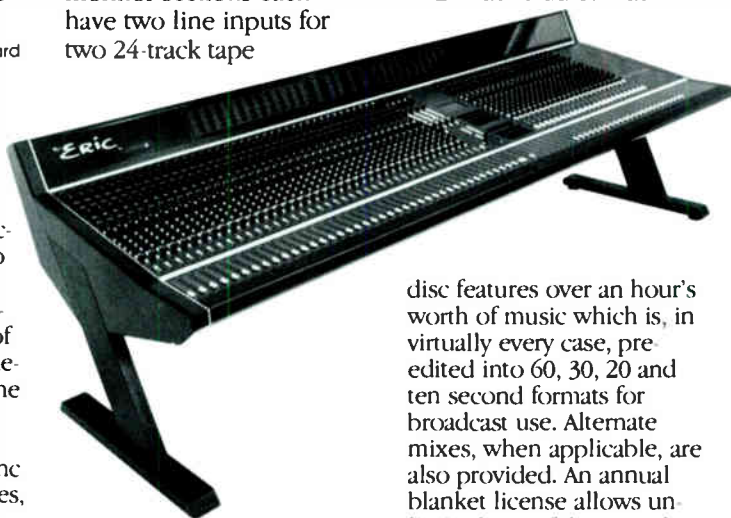

machines; the inputs can then be used to select up to 24 individual tracks from the 48 available. For stereo subgrouping, a post group fader signal can be fed to the LR mix, "odd" to left and "even" to right. The user can assemble a rough mix off tape and send it as a cue feed via any of eight group auxiliaries. Mic/line input switching, solo functions, muting and routing are microprocessor-controlled, and the console stores up to 100 routing patches (unlimited patches can be stored and recalled from disk).

Circle #075 on Reader Service Card

Manhattan CD Library Expands

Manhattan Production Music of New York City recently released its latest Digital Master Series New Music Library disc, extending the library's releases to 11 high-density compact discs, equivalent to 24 standard albums. The Series—composed by eminent composers in symphonic, jazz, pop and commercial scoring—offers a diverse collection of original music ranging from classical to bluegrass, recorded by top-notch studio musicians in 24-track studios. Each

disc features over an hour's worth of music which is, in virtually every case, pre-edited into 60, 30, 20 and ten second formats for broadcast use. Alternate mixes, when applicable, are also provided. An annual blanket license allows unlimited use of the complete library for one year. A needle-drop order, on a production basis, is ideal for more limited use.

Circle #076 on Reader Service Card

SPARS Studio Business Cassettes

SPARS, the Society of Professional Audio Recording Services, is now offering a comprehensive series of 90-minute cassettes and a planning notebook from a recent Studio Business Conference held at the UCLA School of Business. The conference covered a number of topics essential to financial success in the current marketplace. Topics include: "Constructing a Business Plan," Guy Costa, Motown Recording Corp.; "Opening a New Studio," Bruce Merley, Clinton Recording; "Evolution of the Multi-Studio Operation," Wilber Caldwell, Doppler Studios; "Adding a New Location," Dave Porter, Music Annex; "Entry into Video," Fred Jones, Fred Jones Recording; "Adding a Synthesizer Room," Murray Allen, Universal Recording; and "Getting into the Rental Business," Chris Stone, Record Plant.

The price for each cassette is \$15 for members and \$18 for non-members. The seminar notebook is \$30 for members and \$40 for non-members. The entire cassette series and notebook is \$120 for members and \$150 for non-members. ■

Circle #077 on Reader Service Card



by George Petersen

BBE MODEL 802

Since the introduction of the original Barcus-Berry Electronics Model 202R differential load reactance compensators in 1984, these processors have met with favor from many top professionals, including leading producers and engineers in the fields of broadcasting, recording and sound reinforcement. The unit's proprietary circuitry, referred to as "unprocessing" in BBE's literature, splits each input channel into three bands, with cross-overs at 150 Hz and 1,200 Hz, and automatically applies phase correction to each band as needed, based on changes in the input program material. The BBE 802 is the second-generation version of the original Model 202R, but is built into a single rack space unit, and at \$499, is nearly \$1,000 less than the 202R's \$1,495 price tag.

Operationally, the BBE 802 is similar to its predecessor: front panel controls are provided on each channel for processing level, line gain trim, and low frequency gain adjustment. Multi-colored LEDs indicate relative processing level, clipping, and process in/out (a hardwired bypass). One nice touch is the line gain trim pots—recessed on the front panel, they allow the user to balance levels be-

tween the processed and bypassed signals, so comparisons can be fairly assessed. Whether A/B-ing speakers or an equalization change, dealing with perceived loudness differences is frequently a problem when making evaluations of audio equipment, and Barcus-Berry gets my accolades for incorporating this feature into the Model 802.

The unit arrived on the same day that I was producing a video sweetening project, and I didn't have time to read through its information manual before using it. Fortunately, the 802's logical design allows the operator to begin using the processor right away, with a minimum of bother. The concise eight-page manual supplied with the unit is well written and to the point, although no signal flow charts or schematics are included. The manual does supply a calibration procedure, which is *not* standard maintenance, but would only be performed after repairing the unit or replacing parts. The 802 is covered by a one-year warranty, parts and labor.

Rear panel connections are made with either ¼-inch (tip-ring-sleeve) phono jacks, or XLR-type connectors for both inputs and outputs. Inputs are active balanced-bridge, while out-



puts are transformer coupled. Since the outputs are transformer-type, the 802 can be used in balanced or unbalanced systems without special precautions. With the wide variety of applications—studio, live sound, duplication chains, broadcast, etc.—suited for BBE processing, the availability of both balanced and unbalanced connections makes good sense.

I used the 802 over a period of several months on a number of projects—digital and analog recording, sound reinforcement, video post and tape duplication—and found that the unit did live up to its advertised claims that it increases intelligibility, restores harmonics and improves clarity. However, I found there was a very fine line between adding enough processing and experiencing the harshness of an overprocessed signal. While the unit's meters indicate the relative amounts of processing occurring, it is best to rely on your own ears to determine the actual amount of processing required for any specific application. Once set, the 802 did its job admirably.

I was most impressed with the 802's effect on instrumental tracks of all sorts, especially snare drum, cymbals, hi-hat, drum machines, analog synthesizers, and fretted string instruments. In each case, the processed tracks recaptured the natural sparkle and punch I heard when listening to the instruments play in the recording room. In most cases, completed mixes were greatly improved with a dose of the 802's magic. The blanket application of processing over an entire mix resulted in improved instrumental clarity, but sometimes at a cost of some vocal harshness. To avoid this problem when using the BBE in a multi-track mixdown (or with live mixing), I got best results by using stereo effects sends, and then returning the processed signal through two console faders. When working in mono sound reinforcement, the 802's inputs could be divided with instrumental processing in one input and vocals going into the other side, offering a great deal of control.

Before hearing the unit, I was somewhat skeptical about its claims, but after extensive listening tests, I must admit I was impressed. At \$499, the BBE 802 is a cost-effective solution to a number of studio problems, and its versatility in other applications makes it an indispensable tool for the audio professional. ■



...with our New Family of Controllers from Cipher Digital.

Making superior results easier than ever

SHADOWPAD-MINI (Offset/Entry Keyboard)

- Controls offset information for one SHADOW II™ synchronizer or PHANTOM VTR Emulator
- Displays master, slave, user bits, time code and more

SHADOWPAD-MAXI (Edit/Controller)

- Allows full control of one SHADOW II synchronizer
- Allows independent transport control for both master and slave transports

SOFTOUCH™ (Edit/Controller)

- Allows independent autolocation for up to 4 transports via 3 SHADOW II synchronizers
- Offers additional "scratch-pad" memory
- Enables single key execution of intricate or repetitive pre- and post-production routines via 16 programmable SOFTKEYS™

SOFTOUCH-PC (Edit/Controller with PC type Interface)

- Incorporates the versatility of the SOFTOUCH with the power of a PC type computer
- Will interface up to 4 transports
- Provides EDL display and hard copy capabilities

To get your system under control, contact Cipher Digital today. Call (800) 331-9066.



cipher digital, inc.

P. O. BOX 170-FREDERICK, MD 21701
(301) 695-0200 TELEX: 272065

Timely today, consistent with tomorrow.

Circle #086 on Reader Service Card

Mr. Bonzai

STEVE LUKATHER

PICASSO THE HUN OF GUITAR

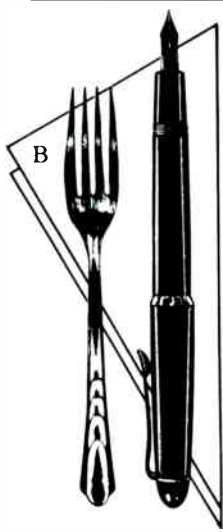

In my lunching with guitar sharpshooter Danny Kortchmar, I asked him to name the Picasso of guitar. He immediately shot back: Steve Lukather. When I asked Kortchmar who the Attila the Hun of guitar was, he said that was Lukather as well. He described him as a conqueror, a destroyer. "He will run you around; he can hurt you in so many ways—he's like a prize fighter. He's got so much going for him as a musician, along with a soul and an integrity and a real joy in his playing." We agreed that Lukather must be the Picasso the Hun of guitar.

As lead guitarist, songwriter and vocalist with Toto, Lukather enjoys mighty international acclaim. The bandmembers' mantelpieces are groaning under the weight of Grammys, Crystal Globes and other souvenirs. As a session legend, Lukather has recorded with such artists as Michael Jackson, Lionel Richie, Don Henley, Quincy Jones, Chicago, George Benson, Elton John and Paul McCartney. These days, he is concentrating on his writing and singing, as well as pushing the guitar where it's never gone before.

Our meeting was arranged by the

Below: Steve serves up some tasty licks at the Suntory Beer Sound Market in Japan. The concert featured an all-star jam with Lukather, Jeff Beck, Carlos Santana, Jan Hammer and Simon Phillips.



PHOTO MR. BONZAI

RENO ROCKS... at GRANNY'S HOUSE



What does CBS, MCA, Warner Bros., I.R.S. and Motown Records think is so great about Reno? They've discovered Granny's House. Come see for yourself what all the excitement is about!

We start with superior technical capabilities... an SSL 6000 fully automated console, Studer mastering machines, plenty of synthesizers, Midi samplers and a large selection of outboard gear, all of which is surrounded by a Chips Davis designed control room.

Warm hospitality from our professional staff, quiet Victorian bedrooms and an incredible cook will make your session at Granny's House a delightful and creative experience.

Call us at (702) 786-2622 for a complete brochure.



The Writer's Lair Our new 3rd floor lairs, for more time during sessions when you want to get away for some new creative work. ARAI MG 12K computer zased MIDI keyboard and a variety of outboard.

World Radio History



AMEK AND GML... THE FORMULA

AMEK/GML... the marriage of two of the most creative forces in audio engineering today. AMEK is renowned for its equalisation, operational flexibility and build quality. The GML Moving Fader Automation System is proven in prestigious studio installations in LA, New York, Nashville, Tokyo and London to be the world's most advanced computer-assisted mixdown system. It is now available on three AMEK console ranges – APC1000, G2520 and CLASSIC – manufactured by AMEK under licence from GML, Inc.

George Massenburg, one of America's most respected recording engineers, designed his system from the engineer's point of view, aiming to enhance professional audio master recording with a unique and innovative approach which more or less transparently follows the engineer's natural workflow. The GML System facilitates the use of today's most complex and sophisticated mixdown techniques, giving total control of the mix data through powerful easy-to-use data processing methods and remarkable off-line fader and mute mix editing operations.

The GML System is purpose designed for multitrack and audio video post production applications, offering an intelligently advanced 'visual-mixing' environment with versatile automatic timecode recognition and programmable timecode 'off set value' commandability in each mix.

GM L programmes are divided into two sections. The outer shell is used in normal mixing operations to enable the various write and read modes for each fader, and for initial storage of mixes. The inner shell contains the 'mix editor', which is the command centre for the editing of all data. The GML mix edit

utility provides the engineer with the capability of advanced mix editing. The user can selectively modify mix data, merging, splicing, copying, swapping, erasing, inserting and deleting as required. Additionally, data for individual tracks or for a whole mix can be shifted back and forwards in SMPTE-time.

GM L also has a simple and flexible subgrouping facility, using 6 dedicated faders as submasters.

The GML System uses two Motorola 68000 series microprocessors clocked at 12.5 MHz with the Idris software operating system, 100% compatible with Unix V6 from Bell Labs, residing on a 40 Megabyte Winchester hard disk. A 1-Megabyte Dynamic RAM memory is provided for the 'mix in progress', with finished mixes stored on the hard disk and later, archived to floppy diskette. Provision is made for the structuring of mixes into directories and subdirectories, so that where a number of producers, engineers or clients use the system their mixes can be kept entirely separate and password-protected.

The system is slaved to SMPTE code and has an internal resolution of 8.33 mS (quarter frame) and can control up to 128 faders and 7 switches per channel to that accuracy. Necam and Solid State Logic fader and Mute data can be converted to the GML format by way of the floppy disk drive input.

Ongoing software development will continue to hone the edge of the GML System, enabling it to remain at the forefront of technical excellence for the foreseeable future.

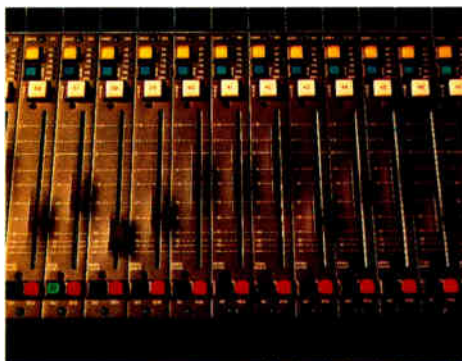

PHOTOGRAPHS OF
GML SYSTEM INSTALLED
ON AMEK APC 1000
CONSOLE COURTESY OF
STUDIO JIVE, TOKYO.



AMEK
GML
GEORGE MASSENBURG LABS

Head Office, Factory and Sales: AMEK Systems and Controls Ltd.
New Islington Mill, Regent Trading Estate, Oldfield Road, Salford M5 4SX, England.
Telephone: 061-834 6747. Telex: 668127. Fax: 061-834 0593.

In the USA: AMEK Controls Inc.
10815 Burbank Blvd, North Hollywood, CA91601.
Telephone: 818/508 9788. Telex: 662526.
AMEK USA E-MAIL: AMEK US. Fax: 818/508 8619.



LUNCHING · WITH · BONZAI

enduring skinsman Jim Keltner, whose history just keeps expanding—he recently added his touch to records by Pink Floyd, George Harrison and Ry Cooder. Keltner suggested that Lukather would bring a welcome food-fight-for-thought to the lunching hall of fame. Keltner is a trusted soul throughout the music world, and I'm in debt to him for opening so many doors in my search for the good rap.

Since Lukather lives in the San Fernando Valley, and grew up there, I suggested that we meet at DuPar's, a coffee shop filled with the aroma of fresh bagels and the vigorous chatting of film producers, car salesmen and actors. The waitresses wear those '50s outfits with the starched aprons and the little nurse hats. I staked out a booth upholstered in pink vinyl tuck and roll, as a man in mirror sunglasses and a volcanic haircut strode in.

Bonzai: How far back do you and Jim Keltner go?

Lukather: I was in awe of him long ago—I followed his career when he was doing his work with George Harrison and Mad Dogs & Englishmen. When we [Toto] were doing our first album he came down to the studio, before I'd ever done a session with him. And he was so positive, encouraging. He drops in a lot and we're always glad to see him.

Bonzai: When's the new Toto album coming out?

Lukather: It'll be out in January. We've put a deadline on ourselves—it's working out much better that way.

Bonzai: And this is the first time you've had some outside producer help?

Lukather: Yeah, we felt it was time. Just somebody to stop us from going too far or to push us when we needed it. Somebody to give us some fresh ideas. When you're in a band for ten years, you develop a formula. Sometimes it works and sometimes it doesn't. You can get a little too used to working with each other and this way you have a middleman to take the edge off if someone gets pissed off at someone else. Plus, George Massenburg as producer/engineer is a wizard sonically. This is our first digital album. And Billy Payne is very

Invite The Flintstones to Your Next Party!

Television's Greatest Hits Volume I, II and now Volume III

Be a looney tune! Liven up your holidays with *Television's Greatest Hits Volume I, II and III*.

The only authorized complete encyclopaedic collection of all your favorite TV themes.

Four decades of the best music to ever come through your TV set. 195 titles in all.

Volume I includes: *The Flintstones, The Jetsons, Bonanza, Green Acres, Addams Family, Mr. Ed, Star Trek, Batman and I Love Lucy*.
Volume II includes: *Pink Panther, Peter Gunn, The Saint, Mary Tyler Moore, Rawhide, Bullwinkle, Tarzan, Road Runner and The Three Stooges*.
Volume III includes: *Miami Vice, All in the Family, Taxi, Dallas, The Muppet Show, Kojak, Love Boat, Taxi, Cheers, Mr. Magoo, and Hill Street Blues*.

Each volume, on two records or one long-play cassette, \$16.95 (CD \$21.95)
or order all three in this specially priced gift set. 6 albums or 3 cassettes, \$39.95
CD set \$59.95

Available on record, cassette and CD at better record stores everywhere.

Television's Greatest Hits The Perfect Gift for the Couch Potato in Your Life.

Circle #087 on Reader Service Card

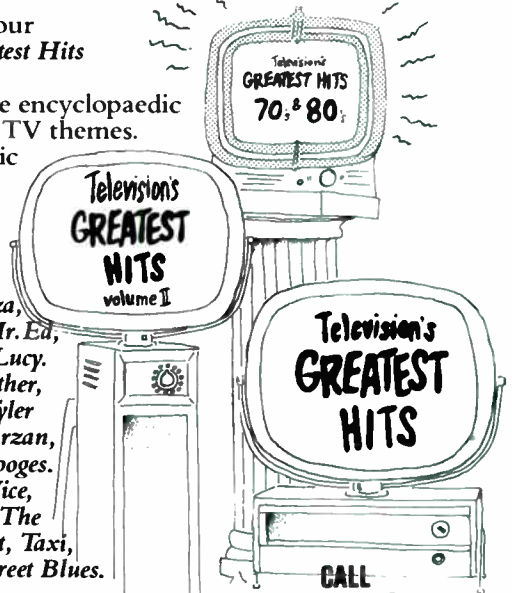

1-800-445-3299

Visa and Master Card accepted.
Mail order customers add \$3.00 for postage and handling.

AUTOMATION ... NATURALLY

Adding automation to a mixing console has never been easier.
Using automation has never been more natural.



Simply patch proMIX in series with the audio path of your existing console and connect it to your MIDI sequencer. No computer is needed.

proMIX™

editing can be done on any or all channels simultaneously

proMIX is a modular system that can grow with you. The basic system can be expanded up to 64 channels in any multiple of 8. Prices start under \$2000.

There is much more to the proMIX story. Call or write today for more information on the most comprehensive, easiest to use automation system you can add to your mixer.

Now do your mixdown using the proMIX panel in MANUAL mode — just as you would use your existing board. Because proMIX is recording every subtle movement of faders and mutes, you are hearing your mix just as it will sound when you play it back in the AUTO mode. With proMIX, what you hear is what you get.

If changes are needed, the EDIT mode allows you to either modify or replace fader moves using the unique proMIX Auto Splice system. And with a fader dedicated to each channel,

Microsystems, Inc.
2500 E. Foothill Blvd., Suite 102
Pasadena, CA 91107 • (818) 577-1471

Circle #088 on Reader Service Card

CASE AND CABINET HARDWARE

OVER 300 DIFFERENT PRODUCTS IN STOCK

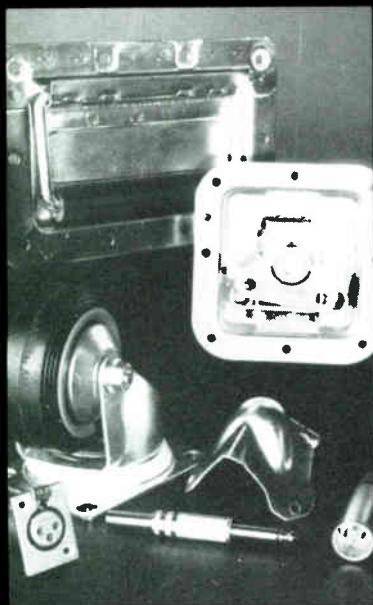

3 DEPOTS

NEW JERSEY:

29 B. Ethel Avenue
Hawthorne, New Jersey 07506
Telephone: (201) 423-4404

DETROIT:

2144 Woodbridge Avenue
Detroit, Michigan 48207
Telephone: (313) 961-9111

LOS ANGELES:

1111 Rancho Conejo Blvd.,
Unit 303
Newbury Park, California 91320
Telephone: (805) 499-5932

PENN FABRICATION (USA) INC.

LUNCHING · WITH · BONZAI

interesting—he came along with the package because George suggested it. When we heard that Billy would be involved we got very enthusiastic. He's not a "Hollywood" producer—we don't need that, somebody to sit around and jive, tell us how to play. Billy has a musical integrity that we all respect. He only says something when it's relevant.

George and Billy are a great team, and working with us has worked out incredibly. We're moving along faster than we ever have before.

Bonzai: Any changes in direction with this new album?

Lukather: Well, we're always trying to write better songs. It's hard to say, because we're still working, but some tunes will be simpler than you might expect. Some tunes will have the mondo production, but we're contrasting that with songs that just sound like five guys playing in a room. It's a very diversified album, but we always like to have a broad range of material.

Bonzai: You guys did the soundtrack to *Dune*.

Lukather: [Laughs] Well, the best thing about doing that film was working with David Lynch. I'm a big fan of his, and he's a crazy mother. He looks real normal and straight-ahead, but what goes on in his mind—it was a bizarre experience. It's a tough business, and it's unusual to have five guys sitting around writing film cues.

Bonzai: You're well known as a session player who circulates heavily. Any recent projects that you're excited about?

Lukather: You know what? I've really calmed down with my studio work, by choice. I did it real hard for a long time and I was beginning to lose perspective on why I was playing music. You do so many sessions and you do some great stuff, but there's also some bullshit. It started to suck the life out of me. I've also been writing a lot and wanted to put energy into that. [David] Paich is very encouraging, as he's always been. I still do sessions once in a while, but I'm being more selective.

Bonzai: Can you remember the first music you made?

Lukather: I must have been about 9

years old. I had a band and we used to play Grand Funk Railroad and Beatles tunes. We'd set up at this apartment building down by the pool and just blast. I started playing when I was really young. I wasn't that great—but I kept at it and I always loved music. My father bought me the *Meet the Beatles* album when I was about 7 years old, and I was sold. Then he bought me a guitar and people showed me a couple of chords and it's something I never grew out of. I was always playing in bands of some kind or another.

Bonzai: Is there one person who gave you special instruction or inspiration?

Lukather: Not really any one person. I was like a sponge and hung out with anyone who could play. I'd learn what I could from them and then find someone else who was better. This was before I was good enough to pick stuff off records.

Bonzai: What catapulted you into your professional career?

Lukather: The one person who turned me on to a lot of stuff was Steve Porcaro, and then his brothers. I went to school with him at Grant High School in the Valley. He showed me different kinds of music and we had a great band in high school—players that have gone on to do some great things. The band was called Still Life. Before that, David Paich and Jeff Porcaro had a band called Rural Still Life. Steve Porcaro took that band over when Jeff graduated and left to go on the road with Sonny & Cher. We reformed the band—Mike Landau playing guitar, Carlos Vega played drums, Steve Porcaro, John Pierce on bass.

This was when I started taking lessons and studying. I realized that I needed to learn more. I had learned all I could by myself. I became aware of the studio players and learned to read music. It intrigued me to begin playing with all kinds of artists. I got turned on to a whole new set of players and it was a big changing period for me.

Bonzai: Is there any project that you are terribly embarrassed by?

Lukather: Yes. Someone called me up to do a session and didn't mention who it was for. I showed up and it was for Richard Simmons, the exercise guy. I was so humiliated, because



— SINCE 1939 —

WORK DIRECTLY WITH THE WEST'S LARGEST
INDEPENDENT RECORD AND CASSETTE DUPLICATING
FACILITY FOR MAJOR LABEL QUALITY AND SERVICE.

RAINBO RECORDS & CASSETTES

1738 Berkeley Street, Santa Monica, CA 90404

BRAND NEW ★ PACKAGE SPECIALS

* 1000 12" FULL-COLOR PACKAGE \$1599

Lacquer mastering — 3-step metal plating — 8 test pressings — 2-color labels (including type) — full-color jackets — white sleeve — shrink wrap — test within 5 working days — completion 10-15 working days

Does not include composite negatives

REORDER AS ABOVE: 10 Days \$1299

* 1000 12" ONE-COLOR PACKAGE \$1399

REORDER AS ABOVE: 10 Days \$999

Does not include composite negatives

1000 7" 45's \$595

Lacquer mastering — 3-step metal plating — 8 test pressings — 2-color labels (including type) — white sleeve — completion 10 working days.

REORDER AS ABOVE: 7-10 Days \$320

500 7" 45's \$475

REORDER AS ABOVE: 7-10 Days \$185

* 1000 FULL-COLOR CASSETTES \$850

Cassette mastering test cassette — Apex printing direct on cassette — label plate — full-color inserts* — 1000 additional inserts for reorder — Norelco box — cellophane wrapped

Does not include composite negatives

REORDER AS ABOVE: 7-10 Days \$750

500 Cassettes \$555

Complete

(Including)

- Composite Negatives from your Camera Ready Artwork
- Cassette Running Master
- Test Cassette-Label Plate
- Apex Printing on Cassette
- 1000 One-Color Inserts (500 for Reorder)
- Norelco Box-Cello Wrapped
- 10-12 Working Days

REORDER ANYTIME

\$333

Compact Disc Packaging Available

Lacquer Mastering by: EMI America, Capitol Records, Inc.

Pressed with: KEYSOR 588 Translucent Select Quality Vinyl.

Tape: BASF-LHD Audiophile Music Quality—State-of-the-Art Bin Loop—HX PRO

Pressing Credits: Capitol Records for the Beatle Releases in the early 1960's, Enigma, Rhino, CBS, RSO, Casablanca, Twin Tone, Tommy Boy, SST, United Artists, Greenworld, Frontier, Pausa, Palo Alto, Celluloid, Metal Blade, Shrapnel, Warner Bros., Elektra, and many, many more including the recently completed MCAs Beverly Hills Cop and we're still pressing Richie Valens' La Bamba, as we did decades ago when this great Latino star made his debut on Del-Fi Records for Bob Keene.

(213) 829-3476 (213) 829-0355

SMALLER QUANTITIES AVAILABLE

there were some really hip sessions going on in other rooms at the studio. It was the jivest thing—I left the session and didn't come back for the rest of the week. It wasn't music, it was just bullshit—making an aerobics album. I take my playing seriously and that's when I realized I was doing too much session work. I was becoming a whore, and didn't need the money that bad. I had to stop.

Bonzai: Who's the angriest guitarist in the world?

Lukather: That's hard to say, these days. I'd have to say Hendrix was probably the angriest guitar player. He had a tremendous influence on me.

Bonzai: Why is he so important?

Lukather: He was doing stuff before synths and sampling. He was making his guitar talk. I don't mean wah-wah pedal stuff, and all the bogus albums that have come out since his death. I'm talking about the records where he had creative control. The first four studio albums had something. There was a magic, an aura that hasn't been matched. There are guys who can play fast now, but he had a soulfulness.

The techniques today—everybody wants to be the fastest player in the world without knowing how to play rhythm guitar first. Running scales up and down the neck. I practice those techniques too, to stay competitive, and whenever I hear something new I want to learn it. But I keep coming back to the blues and Hendrix, and Clapton and Beck. I had a great time last year playing with Jeff Beck in Japan—he's been a hero since I was a kid. Those are the players I grew up listening to, and they still hold true for me. Jimmy Page, too. If you go back and listen to the records now, they're not real flashy, but they hold up.

There are some great players today, though. Edward Van Halen is one of my favorites, and he comes from that school too, but he started new techniques for the '80s. He's spawned a generation of people who misinter-

pret what he is trying to say. You walk into a music store and there's a 13-year-old kid doing the finger-tap thing and he can't even tune the guitar. It cracks me up.

I keep going back. On the last album, I did a solo on "Without Your Love," which was recorded at Jeff Porcaro's house. He had a big picture of Hendrix on the wall and just at the right point during the session he pointed at the picture. The timing was



perfect—I did my best.

Bonzai: What are some of your favorite guitars?

Lukather: Well, right now I'm using a custom Stratocaster-type guitar, a Valley Arts model made by Mike McGuire. I've known him since I was about 8 years old.

Bonzai: How do you stay inspired?

Lukather: I just keep listening for good work. I hear Top 40 radio and it's so formatted; they only play stuff that sounds like Madonna. Madonna's cool, but if everyone tries to sound like that—it sounds like the same person is making every record. For instance, I listen to Miles Davis—we

worked with him on the last album. You hear this guy's stories—this is the real stuff, paying some serious dues and creating music that's never been heard before. That's what I like.

Radio is afraid of music that is a little different. How can original music come through if they won't play it on the radio? I listen to lots of different kinds of music. I'm not saying I'm better than everybody else, because sometimes I'm part of the formula that everybody hates. To be inspired, I go back to things that inspired me to play in the first place. To remind myself why I'm doing this—because I love music. That's why I started playing, before there were girls and money.

Bonzai: Danny Kortchmar said you were the Picasso of guitar—who do you think is the Picasso of guitar?

Lukather: I'm really flattered that Danny would say that about me. He's a good friend, and he's a musician who is really underrated, both as a player and a songwriter. He's brilliant. But the question is almost unanswerable, unless I could weld four or five players together and there would be the Picasso. But Hendrix comes closest. He was painting pictures with sound and he wasn't copying anybody. Everybody is copying today, including me sometimes. He came from another planet. Listen to "Third Stone from the Sun"—1967. Where did he come up with

that? It's moody, dark and scary, but he can also be very happy. I wish I could have seen him play live, but my parents said I was too young to go. I don't mean to dwell on it, but he got to me when I was very young.

The Beatles kicked me too. And then to work with McCartney and George Martin on Paul's movie. Two weeks on a soundstage, playing live with Paul. Weird to grow up with an influence like that and then be playing 20 years later with him.

Bonzai: What music would you like played at your funeral?

Lukather: God, what a morbid question. Let's see—"I Gotta Be Me." And I'd like to have some whoopee cush-

INTRODUCING



The Smart Switcher

Meet our electronically-programmable, digital-audio quality routing switcher that can handle mixing and eliminate time-consuming patchbay set-up – all at a price more affordable than you'd expect.

Control

Had enough with time-consuming patchbay set-up? Tired of reconfiguring each time? With the touch of a button, you can route/mix through local, single or multi-level remote control panels. Store commonly used routing/mixing configurations in standard, non-volatile matrices. Use the RS-232/C port for Terminal/PC control interface. Non-volatile pre-set matrices are standard.

Digital Audio Quality

The Smart Switcher routes your signal with 100 dB SNR, .004% THD, and a 0.1 dB frequency response for transparent, high quality sound.

Expansion

The Smart Switcher can be configured in multi-levels such as stereo, SAP, time codes, etc. Start with an 8 x 8 matrix and expand to 128 inputs or outputs. The units are easily stacked with no limit to expansion.

The Smart Switcher – a smart buy.

Dealer inquiries welcome.

Moseley

The trusted name in communications.

111 Castilian Drive
Santa Barbara, CA
93117-3093

a
Flow General
Company

Phone 805 968 9621
Telex 658448
FAX: 805 685 9638

THE FORCE

Technetronics introduces a totally computerized on-line compact disc manufacturing system.

RESULTS? Cleaner, Faster and more Economical Full Service Production to meet your increasingly demanding run schedules.

**SIMPLY THE FINEST
COMPACT DISC IN THE UNIVERSE...
GUARANTEED.**

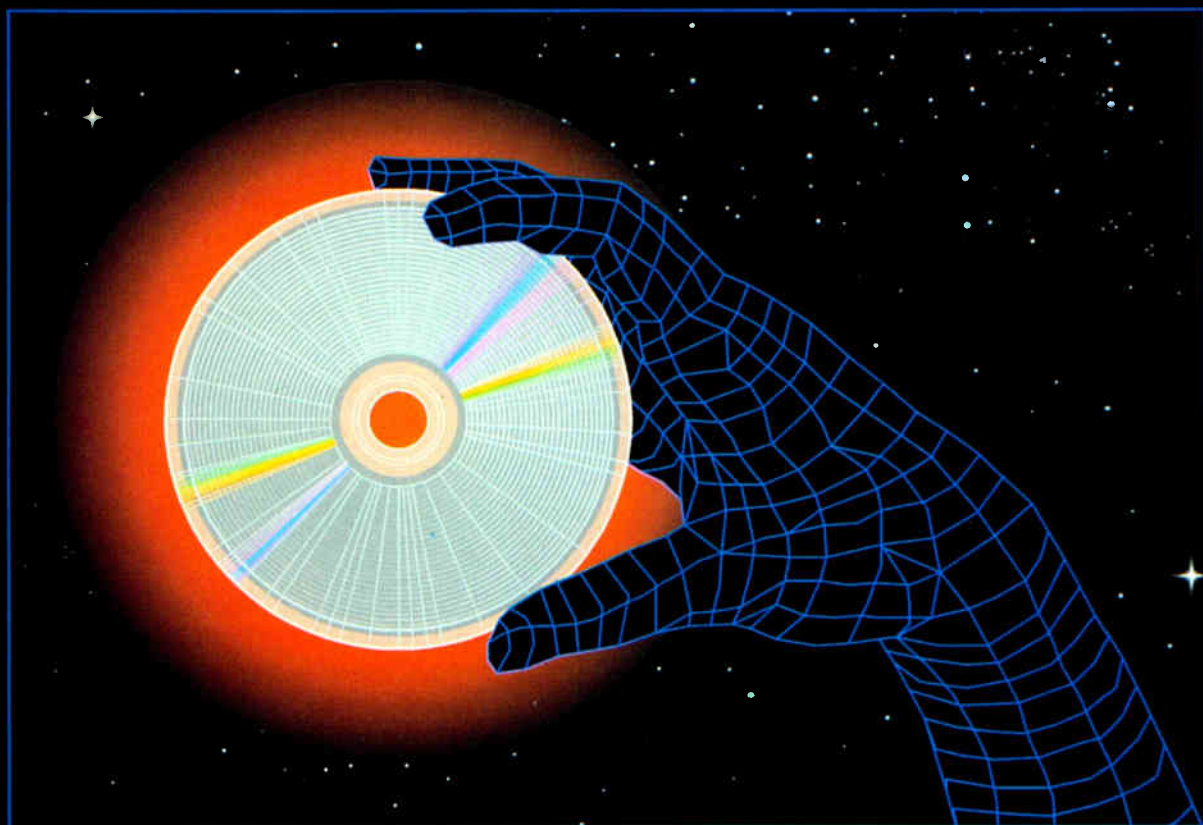

Technetronics

**The Standard of Excellence in Compact Disc Manufacturing
CD/CDV/CD-ROM**

P.O. Box 496, Matlack Industrial Park,
Suite 300, 201 Carter Drive,
West Chester, Pennsylvania 19381-0496 • 215/430-6800
Telex: 255614/TECH UR Fax: 215/430-6804

Circle #024 on Reader Service Card

LUNCHING WITH BONZAI

ions so when they sat down after the eulogy there'd be a chorus of raspberries.

Bonzai: If you could be any animal, not that you aren't already, what would you be?

Lukather: A wild boar, and I'm glad you qualified the question. I like to chase people around and scare 'em.

Bonzai: Who's your best musical friend?

Lukather: David Paich, as a songwriter and someone who thinks like I do. I've spent so much time writing with him. Actually, Jeff Porcaro and all the guys in the band, but Dave and I have a special rapport.

Bonzai: What's your favorite movie?

Lukather: I like the demented stuff. I find humor in some movies that no one else finds funny. Now, having kids, I can't watch movies with ax murderers and things like that. I used to think that was funny, but not so much now. As you get older, you change. I took my wife to see *Pink Flamingos* on our second date and I thought she was gonna cut out on me. The guys in the band still can't believe that I did it. It was the fourth time I'd seen it, and she was just repulsed. I like Rodney Dangerfield, the Three Stooges.

Bonzai: So you go out on the road soon?

Lukather: Yeah, the world tour starts in February—five weeks in Europe, then Japan, Australia, the States, Canada. You know, we do better outside this country.

Bonzai: Why is that?

Lukather: They're more loyal, I guess. Once they like you, they'll buy your albums and come see you play. Also, radio is more restricted, so they're hungry for it. Here, it's different—we're bombarded with things like MTV. It makes it hard for new bands to get started. If you're in between Top 40 and heavy metal, airplay is difficult.

Bonzai: Do you know any interesting business tricks?

Lukather: Yeah, my old accountant pulled one—stole all my money. I

made the mistake of giving him power of attorney and the money just disappeared. My advice is to sign all your own checks and don't trust anybody.

Bonzai: Any advice for aspiring musicians?

Lukather: My advice is don't be caught up with copying others. Learn from the people you like, but apply it to yourself. There's already one Eddie Van Halen—be an innovator and not a follower. Don't be afraid to step away from what everybody else is doing. Satisfy yourself.

Bonzai: How did Toto get its name? When I was in Japan I saw the name in every bathroom because it's the name of the biggest Japanese toilet manufacturer. Is that where it came from?

Lukather: No, we didn't even know about that. Do you think we'd name ourselves after a toilet seat? Although, they'll never forget us in Japan. No, it happened by accident when we were getting our demos together to get a record deal. Dave and Jeff had watched *The Wizard of Oz* and thought it would be great to have a name like

TRIDENT



THE PRODUCERS' CHOICE

Take One Recording Studios
Burbank, CA (818) 841-8697

PROFESSIONAL
AUDIO SERVICES
AND
SUPPLY CO.

619 South Glenwood Place
Burbank, CA 91506 • (818) 843-6320

Circle #091 on Reader Service Card

LUNCHING · WITH · BONZAI

Toto, something simple that means different things in different languages, easy to pronounce, recognizable. We were using it to label demo tapes and the next thing we knew, we had a deal and couldn't come up with anything better.

Bonzai: If you had a record company, what would you call it?

Lukather: Bend Over and Cough Records.

Bonzai: What do you like the best—

the studio or the stage?

Lukather: I like them both. When you go on stage, you immediately get a feedback—it's inspiring when people are digging what you're doing. It allows for a margin of error, because of the energy and rawness of playing live. I love the studio for the art of making records; that's satisfying too. It can be tedious in the studio, because you want it to be great—the ultimate version of what's in your heart. Sometimes you tend to buff it out a little too much.

Bonzai: I understand you play with a

group called Los Lobotomies?

Lukather: Yeah, it's a little jam band. We play at a jazz club, The Baked Potato. It's all instrumental—anti-pop music. The group changes from time to time. It's me, David Garfield, Carlos Vega, Jeff Porcaro or Chester Thompson on drums, Chad Wackermann, Jimmy Johnson on bass or Nathan East, John Pena, Brandon Fields on sax, Lenny Castro on percussion. It's freak-out music, free music. Like bizarre versions of Herbie Hancock tunes, and tunes we cook up together. We try to do it every week but everybody's been touring or making records lately. It's an excuse for us to get together and play both tasteful and

REFINED MOTION... THE 1500 SERIES

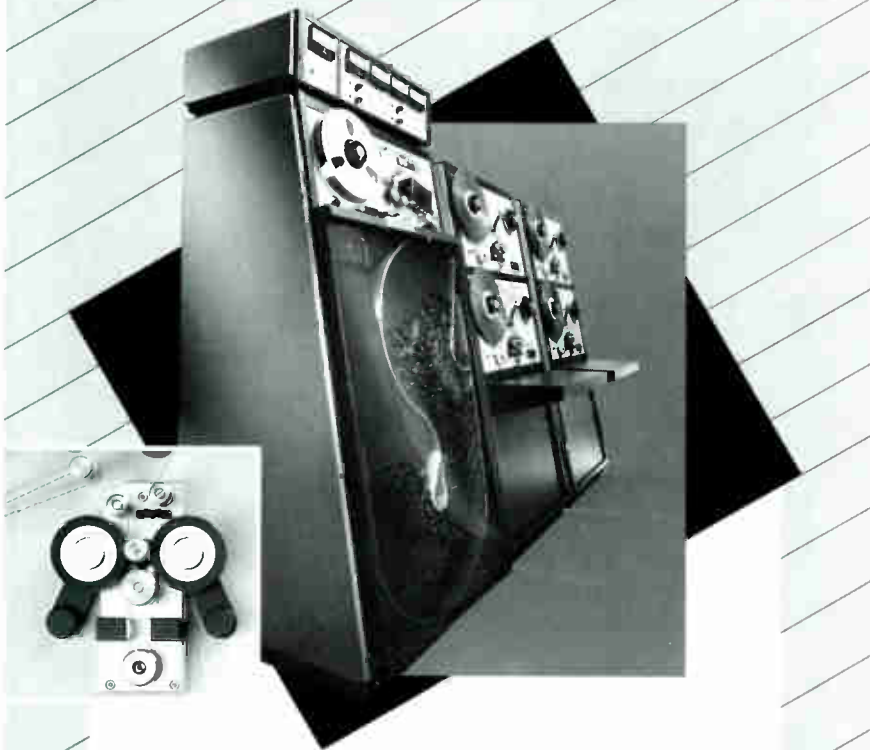

The 1500 Series... the world's smoothest running, most dependable high speed tape duplicating system, ever! Definitely a step beyond state-of-the-art.

The 1500 Series... within its compact, production oriented design are found features such as 32:1 & 64:1 duplication ratios, HFE (high frequency record enhancement), record level expander and a loop-bin that will hold up to 2,000 feet of 1.5 mil tape!

Versadyne

504-C Vandell Way, Campbell, CA 95008
(800) 233-9370 (408) 379-0900 Telex: 172-230

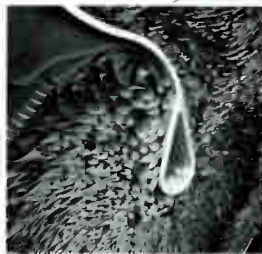

When you go on stage, you immediately get feedback—it's inspiring when people are digging what you're doing.

distasteful music. We just go for it. There are no wrong notes.

Bonzai: Is there any old saying that you really hate?

Lukather: "This is just a rough mix." ■

Mr. Bonzai, a 15-year veteran of the music industry, is former manager of a major Southern Cal recording studio, and author of Studio Life: The Other Side of the Tracks (Mix Publications).

Circle #092 on Reader Service Card



Third in a Series

A Session with John and Paul

Milwaukee-based **Jenson Publications** is one of the leading suppliers of educational music in the country. Their principal marketing tool to schools and colleges is demonstration recordings of their printed catalog. John Higgins and Paul Lavender are not only top executives of the company, but composers, arrangers, and music producers as well. About two years ago, the small writing studio in John's home was converted to a combination writing/recording facility. Here's their report on how things worked out:

On equipping the studio

Paul: "John started out with a piano and a couple of synthesizers. He was testing the waters to become a one-man writer/producer/recording engineer."

John: "16-track was right down the middle for what we needed because of budget limitations. Also, it was a learning time and we really didn't know what we needed until we tried this."

On the importance of the synthesizer

Paul: "It's a major tool in the creative process. We use it to simulate instruments or produce an electronic sound. It provides the synthesizer part that choral groups can use as a background sound if they like."

John: "With the synthesizer, you're constantly discovering new ways you can utilize it. I'm just scratching the surface on what it could do for me. It's given me the feedback that's enabled me to take more chances as a writer."

On technology

John: "Today's technology makes it less important that we work with a technical person. It makes the equipment more available to people with different backgrounds. A musician or writer can learn to function in a small studio environment and utilize the equipment."

On the benefits of an in-home studio

John: "It was a chance to do more experimentation. By having a reasonable representation of the music with synthesizer on tape, more control was possible and more changes could be made at an earlier time."

Paul: "We've educated ourselves in the detail work so that when we act as record producers in a commercial facility, we're more on top of the situation and can make creative suggestions that will save us time and money and improve our end product."

John: "Our in-home studio has provided us with a workshop that has helped us become better producers."

On the role of AudioLine

Paul: "We came from the musician side of it, not the technical side, so we relied on AudioLine to set the course for us. They educated us as to what was available and suitable for our needs. And they keep us abreast of what's new."

John: "They helped us pick out our first equipment, designed the package of what we needed from top to bottom, and helped us develop criteria in terms of the quality we wanted, the budget parameters, and the available room."

On what they've learned

Paul: "The use of contemporary equipment available in small packages has allowed us to invest in a small studio where years ago that wouldn't have been possible. You can get a lot more for your money today than you could ten years ago."

John: "We think the digital revolution is going to make it easier for someone with a restricted budget to provide top quality, impressive sound. But it's important to define your goals and have someone translate these goals into what gives you the best results for the least money."

Our business is expertise

AudioLine
AUDIOLINE, INC.

2323J Bluemound Road

Waukesha, WI 53186

414/785-9166 or 312/449-9166

World Radio History

Circle #041 on Reader Service Card

by Leslie Fradkin
& Elizabeth Rose

THE SMPTE-MIDI CONNECTION ANATOMY OF A SESSION

When the brains at NASA invented SMPTE to log events broadcast from outer space, they could hardly have foreseen that SMPTE time code would make it possible for a jazz ensemble to play live to tape using a combination of computers, acoustic and electric instruments.

Recently, we at Metropolis Music Studios in NYC had the opportunity to record a live jazz ensemble using a

combination of MIDI sequencers, sampling and tape locked through SMPTE. James Morrison, one of Australia's top brass players, brought his combo to our studios. The players included James' brother John on drums; keyboardist Gary Dial; and Mark Egan on bass. Fascinated with the new technology, Morrison decided to record with sequencers so that he could use digital editing. Egan's bass did not



Leslie Fradkin
and Elizabeth
Rose in the control
room of Me-
tropolis Music
Studios in NYC.

have a MIDI interface so we had to put his part directly on tape; the same for Morrison's trumpet. The drums and keyboard were recorded into two sequencers which were driven by the MIDI clock in the Roland SBX-80, a SMPTE-to-MIDI converter box.

First we striped SMPTE from the SBX-80 (30 non-drop frame) to track 24 of the multi-track at the start of the session. We estimated the length of the piece and dropped 30 extra seconds of code to the tape. Once striped, the SMPTE from the 24-track was sent to the SMPTE In of the SBX-80. We then created a beat map in the SBX-80 to drive the two sequencers needed on the session.

Why did we need two sequencers to accomplish this recording? Since both the drums and the keyboard were playing over MIDI, it was necessary to assign each of them to individual MIDI channels to record them. Aside from the sequencer built into the Synclavier, we are an IBM-based studio. Unfortunately there is only one IBM sequencer, Texture, that can

record more than one MIDI channel at a time. (Don't be confused, lots of sequencers can record on multiple tracks simultaneously, not on multiple MIDI channels.) Even the Synclavier's sequencer can record only one MIDI channel at a time. So we assigned the drums to MIDI channel 16 and the Synclavier keyboard to MIDI channel 9, playing the Bosendorfer piano patch. (See chart below.)

CONFIGURATION:

KX-88—Octapad In—Octapad
Out—PMC-1 In—
PMC-1 Out—SBX-80 In—SBX-80
Out—MEP-4 In—
MEP-4 Out #1—IBM (Texture)
In—IBM Out—RX-5 In (ch. 16)
MEP-4 Out #2—Synclavier In (ch. 9)
Bass Guitar—tape
Trumpet—tape

Even though Texture could record the drums on channel 16 and the Synclavier's Bosendorfer on channel 9 simultaneously, we ran into another limitation: Texture only has 64K of memory in its input buffer. The song we were doing, a jazz version of the

Australian national anthem "Advance Australia Fair," required more memory than this, so we needed to use the Synclavier's sequencer to take the load off Texture. To get the MIDI notes corresponding to the drum strokes on the Yamaha PMC-1 drum pads and Roland Octapads, a Yamaha MEP-4 MIDI event processor was placed between the Out of the SBX-80 and the In of the IBM Texture sequencer. Since the drums were transmitting on MIDI channel 16, the MEP-4 filtered out all the channel data except for channel 16 data. Hence Texture ignored the keyboard data and only recorded the drums. The Synclavier's sequencer, in the same way, only saw incoming MIDI channel 9.

Basically, the KX-88 controller was playing the Bosendorfer piano on the Synclavier, the drums were playing the RX-5 kit (plus the Synclavier crash) and the SBX-80 sent MIDI clocks to drive the sequencers. The MEP-4 filtered out unneeded channels before the data arrived at the respective sequencer input. Enough setup. It was time to record.

Tape began to roll. With the SMPTE



3M AUDIO

All Lengths & Widths
3M 250, 226, 227,
806, 807, 808, 809
XSII, AVX and
IRC Cassettes
DIGITAL MASTERING
TAPE &
LOGGING TAPE

Call For Free Catalog



3M VIDEO

All Lengths & Widths
3M 480, 479, Color Plus
1/2 inch, PB, PV. New
MBR Umatics and 3/4
inch Color Plus
Umatics

B Burlington

Audio/Video Tapes Inc.
106 Mott St. Oceanside, N.Y. 11572

Toll Free 1-800-331-3191
In N.Y. (516) 678-4414

- Hard to get related items
- Custom loaded cassettes
- Empty reels and boxes
- 3M Leaders & Trailers
- 3M Splicing Tapes
- 3M Holdown Tapes
- 3M Reels, Boxes & Flanges

**ALL SHIPPED FROM
STOCK—PRICED RIGHT!
IMMEDIATE DELIVERY**

ScotchTM
MAGNETIC MEDIA

NUMBER ONE IN THE WORLD OF THE PRO





Custom pressing, tape duplication and packaging.

1,000

7"-45^S

including mastering, metal parts and processing, white sleeves, labels, pressing.

12" Albums with jackets

including mastering, metal parts and processing, poly dust sleeves, labels, pressing and printing of full colour ultra high gloss board jackets from customer supplied process film.

\$439.00

\$1,390.00

(F.O.B. DETROIT)

- 2 - 3 WEEK SERVICE
- VIRGIN VINYL
- HIGH GLOSS BOARD JACKETS
- CrO₂ CASSETTES
- CUSTOM 7" SLEEVES
- INHOUSE ART & TYPESETTING

Call Toll Free Continental U.S.A.

1-800-263-7798

Canada's Largest Custom Producers



WORLD RECORDS

BASELINE ROAD WEST, BOWMANVILLE, ONTARIO L1C 3Z3

Circle #098 on Reader Service Card

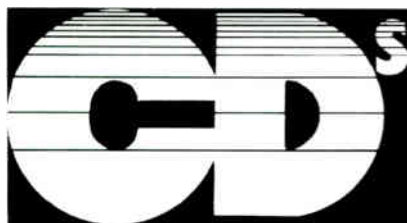

CUSTOM COMPACT DISC MANUFACTURING NOW AVAILABLE!



TRUTONE RECORDS

163 Terrace St., Haworth, NJ 07641 (201) 385-0940

Circle #099 on Reader Service Card

POST · SCRIPT

code from tape heading into the SBX-80, the count-off started when the offset was reached (7 seconds). After two bars, the musicians started to play.

But here's a twist. This particular song had two sections: rubato and "time." The introduction was the rubato section in which Morrison needed to play his trumpet against Dial's Bosendorfer without being confined by hearing a click. For this section, we had to create a beat map of a constant 80-beats-per-minute click in the SBX-80 in order to establish the exact measure location of the "time" section which came right after the rubato. We let them hear the 80 bpm count off, then muted the click and let them play their "free" duo. Morrison's trumpet went to tape, Dial's keyboard was recorded into the Synclavier. Texture was recording bars of rest. They finished the rubato and we located the beginning of the "time" section on the SBX-80.

Now they were ready to add the drums and bass to the trumpet and keyboard for the "time" section. But that section, they decided, was to be played to a 76 bpm click which they wanted to hear in their cans. Now the problem was: how do they get a count-off in 76 bpm for the "time" section when the rubato section was in 80 bpm? This time the musical arrangement helped us out. The rubato section ended with a long chord, sustained over time. We changed the last four beats of the original (silent) click track to 76 bpm. The tape was rewound slightly to the end of the rubato section, the musicians heard the click track count in (at 76 bpm) and came in at the new offset (or downbeat). This new offset represented the SMPTE address which correlated to the downbeat of the "time" section. The two sequencers received song position pointer commands from the SBX-80 enabling them to auto-locate to the new offset.

The quartet then played through the "time" section listening to the 76 bpm click. After playing the basic track, they added some sweetening overdubs into the Synclavier's sequencer: vocal choir and additional strings. Upon playback, they felt that the groove in the "time" section wasn't "human" enough because they'd been playing to a click. They had a dilem-

ma: they wanted a very warm, groovin' rhythm feel and they wanted to take advantage of the editing abilities of the machines. Could we, they wondered, move the data around so it would sit better in the groove? Or could they play the rhythm section again without hearing the click and still be able to use the machine overdubs which they liked? And while they were at it, could they change the rubato section too? Instead of starting the "time" section after the rubato section had ended, could they crossfade the two sections together as follows?

Version 1: Rubato Time

Version 2: Rubato Time

(preferred crossfade)

It was 20 years ago that George Martin faced a similar problem when he was putting "Strawberry Fields" together. He had to combine different takes of the song which had been recorded at markedly different speeds. Without SMPTE, he had to use tape machines to speed up the slow takes and razor blade cut the different sections together. We still used his logic: join the two tempos together, but do it with SMPTE and the Synclavier.

The beauty of SMPTE code is that you can slide the sequenced data anywhere you want relative to the code. (Remember the end of the rubato section was a sustained chord, or else this trick couldn't have been done.) We moved the rubato section forward four beats (one bar) in the Synclavier. Therefore, the keyboard started to play at beat 5 instead of beat 1. In Texture, we added four additional beats of rest to the rubato tracks.

Now the keyboard sequence and Texture's bars of rest were ready to roll at beat 5. But what about the tape recording of Morrison's trumpet in the rubato section? If only the trumpet could be slid forward four beats, it would be in the right place. How to do it?

Bring on the Synclavier! We could sample his trumpet performance into the Synclavier in sync with the original SMPTE code, a tremendous feature of the sampler. We proceeded to make a 79-second, 16-bit (50K) digital sample of his entire trumpet performance straight off the multi-track. No loss of generation, no interruptions, no razor

blades. The trumpet was in the Synclavier in exact sync with where it was on tape. Then we track-slid the trumpet to four beats later—PRESTO!—the trumpet was in sync with the second rubato section playing along perfectly to the sequenced Bosendorfer piano.

(It was crucial that we used a constant 80 bpm for the rubato section. Had we constructed a “rubato” click to the changing tempo of the band, we could never have slid that trumpet to the right place.)

At this time, satisfied with the rubato section, the sequenced rubato parts were dropped to tape. But there were more changes to be made. They were still unhappy with the mechanical feel of their rhythm playing to the click. They still wanted to re-do the rhythm “time” section, not playing to a click. And they still wanted to be able to lock their sequences of overdubs to this new “clickless” rhythm section with no sync code present.

First they recorded a new “time” section pass with which they were happy. But this time, they played it faster than their first take so the old beat map (which had been constructed at 76 bpm) was now useless. However, they played to the old count-in (at 76) so their SMPTE offset was the same as before. After they played the “time” section with their own feel and without a click, we tapped a click track into the SBX-80 following the time of their performance. The SBX-80 “memorized” the musician’s feel and time. So, whenever the SBX-80 was started, it triggered the sequenced overdubs while following the musicians’ feel. They finally had what they wanted: a lively, “human” take with sequenced overdubs.

The monotony of a click does not have to create slaves of musicians; and the need for players to communicate with each other and establish their own groove doesn’t mean that they can’t take advantage of machines. On this session, SMPTE made it possible to eliminate compromises and get the music out, the way it was meant to be heard. ■

Leslie Fradkin and Elizabeth Rose are co-owners of Metropolis Music Recording Studios in Manhattan. They are married to each other. Leslie spends most of his time solving digital problems. Elizabeth spends most of hers telling one-liners.

IMPERIAL TAPE COMPANY
SERVICE • QUALITY • INTEGRITY
 MEMBER OF INTERNATIONAL TAPE ASSOCIATION

MANUFACTURERS OF CUSTOM LENGTH
 BLANK AUDIO & VIDEO CASSETTES
 SEMINAR RECORDING
 AUDIO/VIDEO

PRIVATE LABELING & PACKAGING
 TOP QUALITY AUDIO & VIDEO CASSETTE DUPLICATION
 NATION'S LEADING AUTHORIZED DISTRIBUTOR
 CARRYING FULL LINE OF

AMPEX
Scotch
 PROFESSIONAL AUDIO & VIDEO
 RECORDING TAPES

SHIPMENTS WITHIN 24 HOURS • SAME DAY L.A. SERVICE
 HIGH SPEED CASSETTE DUPLICATOR DEALER

CALL HOWARD
 PERSON-TO-PERSON COLLECT (213) 393-7131
 1014 BROADWAY
 SANTA MONICA, CA 90401

Circle #100 on Reader Service Card

AT LAST!

An affordable high quality bulk cassette duplicator for small production runs! The Magnefax 3802 offers a yield of 125 C-60's per hour while providing high quality and the legendary Magnefax reliability!

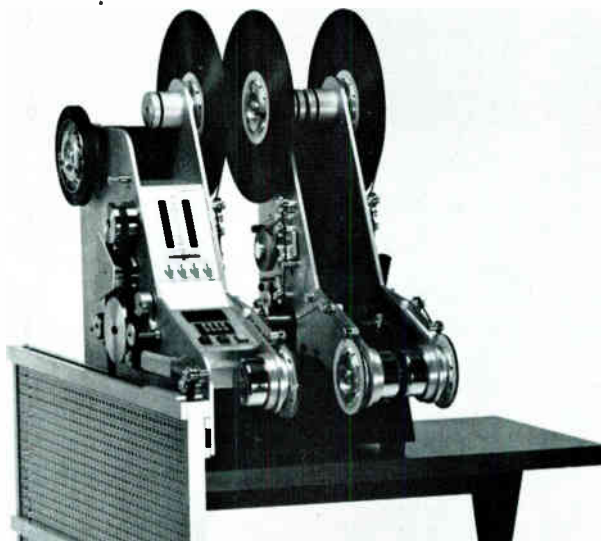

For more information on model 3802 and on the rest of the Magnefax line of duplicators write to: Magnefax International Inc., Route 1, Box 764, Rogers AR 72756 USA, or call (501) 925-1818. Telex: 21588G-AIDC-UR

Circle #101 on Reader Service Card

TRENDS IN FILM SOUND

PART TWO

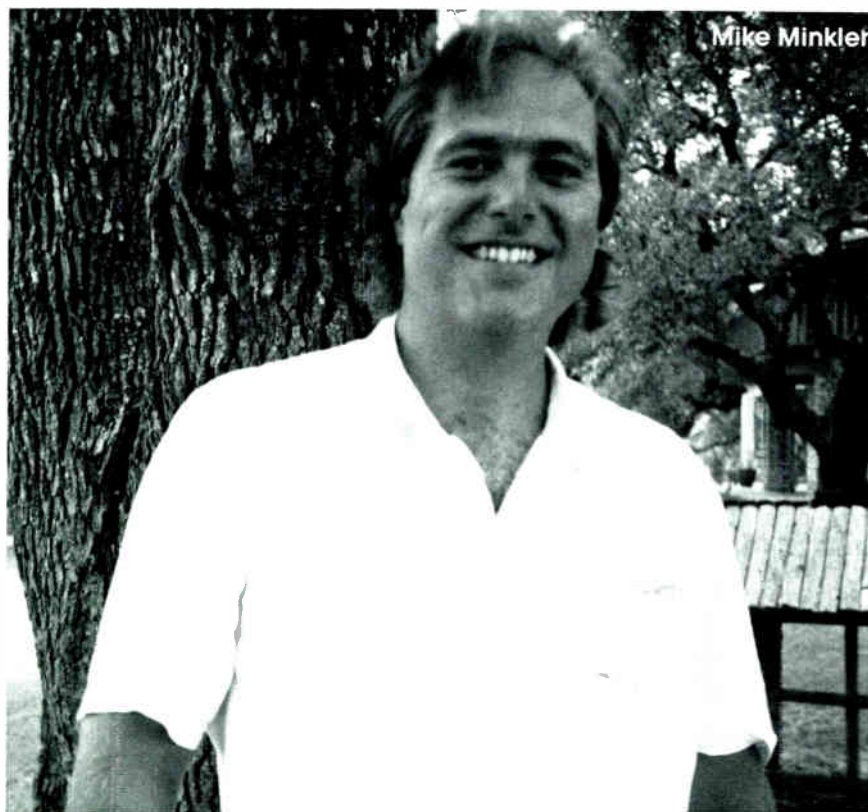

by Nicholas Pasquariello

We continue our interviews with top film sound professionals.

MIKE MINKLER

As a teenager, Mike Minkler swept floors at his father's Hollywood Independent Sound Service company. After a seven-year apprenticeship there, he was promoted to studio work at Warner Bros. Later, he became part owner of Lion's Gate, where during the '70s he experimented a good deal in designing film soundtracks. "I love just playing," he comments. "I was also developing my own creative tastes. There were times when I'd have over 50 pieces of outboard equipment going all at the same time for processing—using, for example, flanges and delay lines. That was fun but I have found

that I get better tracks these days given to me by the sound editor. Also, my tastes have gone back to a tighter, more precise, simpler mix than the wild crazy gimmicky type mix."

Minkler has won the British Academy Award for Best Sound for his work as rerecording mixer on *Star Wars* (1977) and the MPSE award for Best Sound Effects for *Wolfen* (1981; supervising rerecording mixer). He has also been nominated for four American Academy Awards for Best Sound: *The Electric Horseman* (1979; effects rerecording mixer), *Altered States* (1980; effects rerecording mixer), *Tron* (1982; supervising rerecording mixer) and *Chorus Line* (1985; music rerecording mixer). In his 17 years in filmmaking he has participated in the mixing of 87 feature films. Among his most recent were Willie Nelson's *Red*

Headed Stranger and the comedy sci-fi film *Explorers*.

Mix: How has your hardware changed during the past five years?

Minkler: It's changed a little bit. What I use these days more than anything else is a Lexicon 224XL Lark, which I feel is the finest digital reverb device made. It's just amazing what you can do with it; a lot of people who have made them just use them for one or two functions.

Mix: What was your most impressive use of that hardware in recent times?

Minkler: Probably on *Explorers*, where kids met aliens and went up into a spaceship. We had to create different acoustic environments for the different rooms of the ship. I had to create dozens of effects with the Lexicon. For example, the kids went flying through a tube for which we wanted to create the sound of the squealing of their shoes and their clothing. Since we didn't know what material the tube was made out of we could do anything we wanted. We came up with some unbelievable kinds of squeals and rubbing and moaning and groaning, all from that one device. And when they get to the end of the tube—what they're hearing down at the bottom of that tube were these strange kinds of echoes with slight bits of rubbing and pinging going on in the background. That was all done with the Lark.

Mix: What does the Lark do that other hardware can't do?

Minkler: It has a sound that's more distinct; and it's also more versatile. You can manipulate their programs or create your own programs; there must be a half-million to a million variables.

Mix: For the squealing effect what did you start with?

Minkler: Footstep sounds or belt buckle sounds; organic original material.

I also find the Apex compressor/expanders very useful because of the transparency of the compression they render. They work and you cannot hear them working; and you can use them extremely subtly or very heavily and you never hear them working. You never hear the sound change or be colored at all. That's in contrast to all the other similar devices I work with which you can hear very distinctly; yet these other devices claim to be transparent also.

I use it for dialog; it can take care of extremely fast, rapid transient-type sounds like dialog. The Aphex smoothes it out extremely well.

Mix: Give me an example of a problem it helped you solve.

Minkler: All dialog is a problem because it's usually recorded under very adverse conditions and location recordists often don't record a second take just because it may not have sounded that great or because someone jumped on a line. The mixer is mixing it and he doesn't know that the actors didn't do it similar to how they rehearsed it; it may be up too loud or down too soft. Well, we have to live with whatever it is we get because they're not going to reshoot just for sound.

So the Aphex smoothes out the raw, rugged production track like nothing else I've ever heard. It does the same thing for ADR. It takes all of those peaks and rough edges off of the track without coloring the sound.

Another significant change that's come along in the last five years is digital recording. I've done a couple of pictures digitally, though not every

element on the picture was recorded digitally. We did as much as we had control of. It was a great experience.

Mix: Which elements were recorded digitally?

Minkler: The production track was not because it's a risk. It was done analog. The rest of the tracks were digitally recorded. The most fully digital picture I did was *Red Headed Stranger*.

Mix: How were you able to convince them to go digital for post-production?

Minkler: It was their idea. It was a Willie Nelson picture and he does all of his recordings digitally. There was a good deal of music in the film.

The great thing for me was that we didn't have the kinds of problems you normally have with analog, such as generation loss. I usually have to go through four or five generations before they're out the door. You also don't have a headroom problem, you don't have wow and flutter problems, you don't have signal-to-noise problems or crosstalk or intermodulation distortion. All of those are tremendous advantages. They're subtle but if you

add those up—wow!

Mix: Do those efficiencies show up in the budget?

Minkler: Probably not. If you could rent a digital setup for the same price as an analog setup, I'd say it could show up in the budget because you never have to go back and do anything over again because, for example, the track's fallen apart, which happens on analog.

Mix: If you had to place a percentage number on the increased efficiency digital allowed you, what would it be?

Minkler: Five to 10% in time savings. In normal analog recording, I've at times had to make mixes from scratch again because we'll go through material so many times that oxide was wearing off the tape and falling on the floor or we'd polished it down so far we were losing all of our frequency response. With digital I didn't have to worry about the mix not coming back exactly the way I put it down.

Mix: Do you consider 5 to 10% a significant increase in efficiency?

Minkler: Five to 10% is quite a few

MidiMation

The affordable solution to AUTOMATION.

Finally there is an inexpensive, simple-to-operate, modular, full featured Automation System to retrofit any console at any budget. MidiMation, from JLC Cooper, gives your console all the power and all the features previously only available as built-in features on a few megabuck consoles. MAGI (Mixer Automation Gain Interface), MAGI VCA (dbx® VCAs), SAM (SMPTE AUTOMATION MANAGER), SAMDisk 3.5" floppy sub-system, and MIDI MUTE truly constitute a breakthrough in console automation.

Now, you can automate your studio starting for as little as \$549. And, like all JLC Cooper products, these grow with you — up to 56 channels! Buy only the features you need, as you need them, and add to your MidiMation system as your needs change. Best of all, MAGI, MAGI VCA, SAM, SAMDisk, and MIDI MUTE require no modification of your console.

* dbx is a registered trademark of the dbx Corp.

MidiMation, affordable state-of-the-art automation.

JL COOPER ELECTRONICS

1931 Pontius Avenue • West Los Angeles, CA 90025 • (213) 473-8771 • TLX: 5100110679 JL COOPER

The art of shaping sound.

SONEX is a high-performance acoustical foam that upgrades your studio inexpensively. Ideal for a temporary isolation booth, it can also eliminate slap echo and harsh resonances in the main room or silence noisy tape equipment in the control booth.

Write for our color brochure today.



Alpha Audio

2049 West Broad St.
Richmond, VA 23220 (804) 358-3852

Circle #103 on Reader Service Card

Masters
of
Duplication.

CASSETTE WORKS
Audio & Video Duplication

Call or Write for Free Services Kit
P.O. Box 158 Pasadena, CA 91102
1-800-425-TAPE & 1-800-972-TAPE

Circle #104 on Reader Service Card

thousand dollars to the producer. To me it's 40% to 50% of a better sounding track technically because that release print is five generations away from my original mix and it sounds exactly the same as the original. And it sounds fresh and new and bright, instead of having deteriorated.

Mix: What kind of hardware did you use on *Explorers*?

Minkler: A 3M 32-track machine.

Mix: Was that the only way your setup was different from your normal analog setup?

Minkler: Yes. It was just a matter of changing the recorder and playback machine. Some of the masters were on Sony 24-track so we had to swap them over to the 32-track 3M system.

Mix: Is there any hardware not now on the market that you would like to see available that would help improve your efficiency as a mixer?

Minkler: I think the hardware out there almost has everything covered for right now: anything that you can think of doing there's something out there that will do it for you.

MARK MANGINI

Early this year Mark Mangini was nominated for an Academy Award for Best Sound Effects Editing (as distinguished from Best Sound) for his work on *Star Trek IV*.

His other major credits include: *Star Trek—The Motion Picture* (1979), *Raiders of the Lost Ark* (1981), *Under Fire* (1983), the *Amazing Stories* TV series (1985-86) and *Innerspace* (1987).

In this interview the 11-year veteran of feature sound work discusses how he mixed synthetic sound sources with those produced by a live improvisational jazz musician to produce the complex, otherworldly "probe" sound around which so much of the *Star Trek IV* action revolves.

Mix: What effect, if any, has digital technology had on your work?

Mangini: Almost none. That's a very long topic. We record most of our sounds with a stereo Nagra recording at 15 ips, 2-channel, mostly in stereo. If it's a conventional film, I like to use field recordings as they are as an organic element for an exotic effect—for example, we might use a dumpster as a space ship door. But I first do a lot of gathering of elements at the beginning

by recording them on a Nagra. Portable digital machines available today are processors like the Sony RM-F1, which records on a consumer VCR. This setup is hard to use; for example, the batteries go out on you quickly and you can't see the meters in the sunlight. They're impractical to use in the field.

Mix: What technology trends do you see occurring in post-production sound in the near future?

Mangini: It's an incredibly hairy time right now because nobody knows quite what to do, there are so many forms of digital storage being considered: R-DAT, CD, Laserdisc, WORM, DRAW disk drives, even RAM. This doesn't even include the standard DASH and 1610 digital recording formats. Everybody's afraid to jump into equipment, because it's not standardized and the film industry is incredibly staid and archaic in the way it works. It wants everything to be one way.

The next wave for my field is getting sound effects recorded digitally and, more importantly, stored digitally so that we can access them in a random access fashion. Right now, if I want a sound effect for any given scene in a picture I have to find a ¼-inch roll, wind down the cue, review it, rewind it and put it back in its box. I spend five weeks on every film reviewing sound effects to pick the right effects to go in, and that's a huge, long, laborious process with analog tape. Immediate access to a large effects library is the only way to go.

Mix: How soon will that happen?

Mangini: It's hard to say. Memory storage costs are coming down as access time is getting faster. A number of attempts have been made to make systems—Synclavier, Fairlight—that are supposed to replace the Moviola, where you can store all of your sound effects, call them up digitally, review them, edit them, store that as an EDL, split them out onto whatever format you want so you can mix them. There are a number of companies who make digital audio editors, but the problem is a Moviola costs \$10,000 and many digital fully equipped audio editing systems can cost \$300,000.

Mix: Would you describe how you created the whale sounds in *Star Trek IV*?

Mangini: The probe vocalizations all started from whale song, which was

my first instinct and [the film's director] Leonard Nimoy's first instinct. It seemed awfully literal at first and we tried it and didn't like our first test. We threw it out and then started using things like saxophones and didjeridus [a primitive aborigine horn] which Leonard didn't like. We ended up using whale song that was sped up, then layered and severely gated so that we could remove scrimp noise. It was a rather complicated process. In order to get a good whale recording you have to usually record it while it's feeding and it usually feeds on krill, which like scrimp makes a noise like a castinet, a snapping noise, that ruins just about every whale recording ever made except for two or three which Roger Paine [pre-eminent whale sound recordist] has gotten. Roger had a couple which sounded as if he had brought a humpback whale onto an ADR stage.

After it was gated, we double-notch filtered it with one of those UREI Little Dippers. In between the vocalizations we could clean out all the crud, then during the vocalizations we had the UREI's working to try to notch filter out the krill. Then it went into an AMS pitch changer and on a multi-track recorder we would layer harmonic intervals of the original whale vocalization.

So let's say on track one of the multi-track was the whale vocalization at its normal pitch. On track two we would pitch it up, let's say, a minor third, on track three we would pitch it yet again a major fifth, all the way up to eight channels of pitch change. So we had eight voices generated from the one recording on top of each other so it was a multi-phonic—if you will—vocalization.

That 8-channel element was then mixed down to a 2-channel stereo master. Then, on top of that, we had this fellow Vinnie Golia, who's this bizarre, jazz saxophonist, woodwind performer, come in and listen to the material that we had made from whale vocalizations. And with contra bass saxophones and bass saxophones and all these bizarre instruments that he's got, we had him perform his version of whale song; looping the whale with these instruments. He even got a pretty darn good whale song right out of his sax, which blended very nicely with what we were doing.

So we added Vinnie's elements to the whale song. A lot of it was like squeaking and squawking—it wasn't musical; he was trying to make a sound

effect. Then we harmonized that again with another layer of upper harmonics, then passed it through a graphic equalizer to tone it down—it got very screechy and shrill. And that was pretty much the probe vocalizations: the questions [asked of the whales].

Mix: How did Golia get involved?

Mangini: That was my idea. John Postisl [another of the sound effects editors] and I were sitting around the studio one day—this was before Leonard showed up—struggling to come up with an idea for the probe sound. We were thinking of using musical instruments for the sound and asked ourselves what kinds of instruments could be evocative and sound vocal and have a certain depth, or bass, to them. The probe is supposed to be huge, the size of a planet. We decided that a saxophone might be an interesting place to start. We experimented with some tracks produced by an amateur saxophonist; we slowed them down, then sped them up. They were interesting and that got us thinking that if we would get an accomplished saxophonist who had a good deal of control, we'd have something to work with.

We turned up Vinnie Golia, who told us about this approach he uses to playing called multi-phonic, where he can get two or even three notes out of a sax at one time. He can get three pitches out of one blow without using his fingers. We sent Vinnie some tapes of whale songs so he could practice imitating them. He also brought in a didjeridu, which is a giant long pipe made out of a hollowed out branch. It takes a very well defined blowing technique to get any sound out of it at all because the aperture you blow in is about three inches wide. It makes this weird fog horn like sound. We used the didjeridu at the end of the picture when the probe is chatting with the whales. We added that to the layered sound I talked about before.

LEE DICHTER

Perhaps the 30-plus year career of re-recording engineer Lee Dichter can best be explained by describing the proud family tradition of which he is firmly a part:

His grandfather, Joseph Seiden, began in show business as a pioneer director of Yiddish feature films for New York's new immigrant population. Lee's engineer father followed by starting Dichter Sound Studios. It was there



NO NEED TO JUGGLE

**RECORDER PARTS
REPLACEMENT
HEADS
REFURBISHMENT**

**AMPEX/MCI/SONY/3M
OTARI/REVOX/SCULLY
TEAC/TELEX**

SPRAGUE MAGNETICS INC.

15720 STAGG ST., VAN NUYS, CA 91406
818-994-6602 TEL: 754239

800-553-8712

800-325-4243 N. CA

**WE'VE GOT IT ALL
IN ONE CALL**

Circle #105 on Reader Service Card

B&L SALES, INC.

10640 Magnolia Blvd.
North Hollywood, CA 91601

**AUDIO TAPE
DUPLICATING PRODUCTS**

- Bulk audio duplicating cassettes (Maxell, TDK, 3M)
- Music quality cassettes (Maxell, TDK)
- Cassette duplicating equipment (Sony, Pentagon, Otari)
- Tape recorders & accessories (Marantz, Superscope, Califorme)
- Recorder care products (Nortronics, Robins, Audio Technica, Allsop, Maxell, TDK)
- Blank cassette labels, cassette boxes, cassette storage racks

(818) 985-1792

Circle #106 on Reader Service Card

that Lee worked for more than 20 years on documentaries, TV spots and sitcoms (such as *Car 54, Where Are You?* and *You'll Never Get Rich*). He believes this was an excellent training ground for his later film work. In 1975 Lee graduated to feature work and (often) Academy Award-winning documentaries (which he still enjoys working on).

For the past three years he's been Woody Allen's favorite rerecording engineer, having posted *Hannah and Her Sisters* (1986), *Radio Days* (1987) and the forthcoming *September*.

Dichter's other major credits include: *Making Mr. Right* (1987), *Cotton Club* (1984), *The Verdict* (1982), *Sophie's Choice* (1982), *The Times of Harvey Milk* (1984), *The Seduction of Joe Tynan* (1979), *From Mao to Mozart* (1979) and *Harlan County, USA* (1977). Since 1979 alone he has engineered over 48 feature films.

Mix: How have your working methods changed in the last five years?

Dichter: Not a great deal. It's important to point out that in New York there's one mixer who mixes music, dialog and effects. The reason New York only has one is because in the early days of filmmaking—such as the 1940s—New York hardly did any feature films; mixing in New York was very simple, enough for one person to do. Major mixing of feature films began in California, and they needed more than one person because of the complexity of the soundtrack. Here, most mixing consisted of commercials and smaller film projects.

In the last five years we've been doing more stereo work and pre-dubbing because directors are getting more sophisticated and are coming in with more tracks.

Mix: When did you first notice this trend?

Dichter: Probably ten years ago in conjunction with stereo sound and 70mm, about the time *Star Wars* came out.

Mix: How has the change in the technology during that period affected your work?

Dichter: Not much. The film business has always been very, very slow in bringing new technology into it. Theater owners, for one, dictate how much you can do in the post-production area. You can't keep telling the theater owners every three years they have to keep changing their sound systems—pro-



Lee Dichter

jectors and amplifiers.

Mix: Do you mix onto 24-track?

Dichter: No. Right now there are too many conformations happening: when we mix and cut a reel we still want the film, not tape. But that's not the reason for holding back; we've not made any inroads into 24-track.

Mix: So you do all of your mixes onto 35mm full coat?

Dichter: Yes.

Mix: What changes do you foresee occurring in film sound technology in the next five years?

Dichter: Probably moving into some type of digital. But I don't know if it's going to be five years. It might be longer than that, because we're discussing digital right now as a possible storage medium; for the type of work we do we still have to be hands-on. Digital for me is still more of a storage medium. You could probably have the final mix on a digital format but to have all the bits and pieces coming in digitally and still not having a locked soundtrack—to have all the editing equipment suddenly be digital might be mind boggling.

If all of a sudden all the equipment you've been working with becomes obsolete: it's a big problem you have whenever new technology comes in. It's not an easy financial pill to swallow. Sometimes because the technology is there it becomes so expensive that it becomes not feasible to use except on special projects.

Mix: Have you used any digital hardware in your work?

Dichter: Just some outboard equipment: digital delay and digital reverb. We use it all the time and have been

using it for about four years. Of course that's only used for special effects. We might in the future end up recording digitally and transferring it to analog—working with it the way we work now—and then mastering it digitally; but changing all the editorial equipment—such as the dubbers—I'm not sure that's going to be feasible.

Mix: So you can foresee some of the process going digital in the future?

Dichter: Probably, it could be going into background effects. Since we haven't done any amount of research—and nothing on the scale of some place like Lucasfilm and other California companies—New York is really, and always has been, two to three years behind California as far as innovation in this technology is concerned. And this is so because we're only doing 10% of the movies that California does. About 15% of all features shot in New York are posted here. We do a different type of movie also, we don't do the *Star Wars* or *Raiders of the Lost Ark*. We do movies here that are not as dependent on special effects.

Mix: Do you see any difficulties in the way films are generally presented in commercial theaters in this country?

Dichter: Some mixers tend not to use enough equalization for dialog; they tend not to emphasize the upper mid-range enough. I feel this is necessary to overcome the deficiencies in the atrial presentation caused by the uneven quality in the way films are projected. In other words make the dialog a little brighter. But it's a fine line because what happens, for example, if your film gets shown in a perfect theater, the dialog might be too bright. It's a *Catch 22*, what do you do, do you mix for the perfect situation or do you mix for the average theater? Or we could all make the dialog sound perfect for the mixing room that we're in. It's a compromise: do you make it perfect for the mix room you're in, hoping that it's going to play in the perfect theater or do you go a little further with your equalization? I tend to go a little further figuring that 80% of the theaters out there are not going to be up to par.

I try to spot-check every picture that I mix in at least one commercial theater just to see what kind of quality control they're doing on the outside.

Mix: What is the value of these visits

AS SEEN IN
MUSIC STORES

AMAZING NEW MIDI BREAKTHROUGH FROM ENSONIQ!

LOSE UP TO 66 POUNDS WITHOUT GIVING UP ANYTHING*!

NO STRENUOUS EXERCISE!

Now there's a way to trim pounds and inches from your MIDI setup — permanently! If you're currently using multiple keyboards, Ensoniq MIDI Modules can add up to 26 voices and dozens of features, at the same time reducing weight and space.

NO DANGEROUS SIDE EFFECTS!

If you want to add sampled sounds to your setup, you don't have to add another complete keyboard. At just 11 pounds, the Mirage Digital Multi-Sampler gives you all the sound and features of the Mirage Digital Sampling Keyboard — without the keyboard.

The fast-loading Mirage Multi-Sampler can deliver up to 16 distinct sounds at any time, controllable from your keyboard or sequencer. From drums and percussion to pipe organ and special effects, the Mirage is already in over 24,000 studios and setups around the globe. The Mirage even comes with the most popular sampled sounds on diskette.

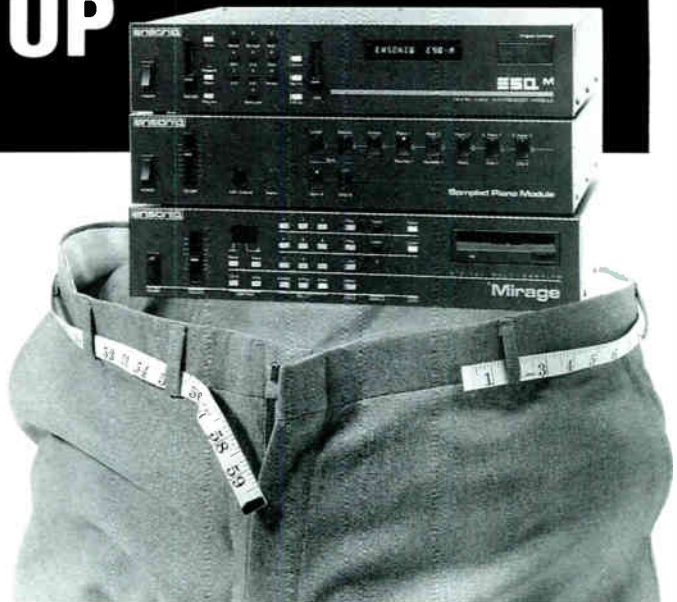

ENSONIQ MIDI MODULES WORK WONDERS

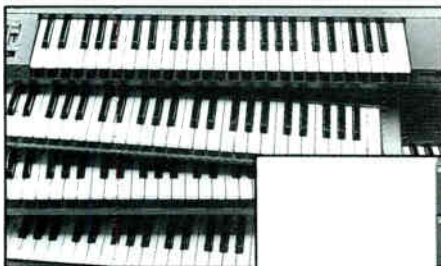

Before - 129 lbs.

"For years my keyboard setup was overweight and unhealthy. Now I'm using Ensoniq MIDI Modules. And because I'm using an Ensoniq ESQ-1 as a controller, I can save ESQ-1 sounds and sequences on diskette, using the disk drive in my Mirage Multi-Sampler. The Sampled Piano Module gives me access to the entire 88-note range of the piano. But best of all, I can use the ESQ-1 and ESQ-M together in the MIDI Overflow Mode and get the performance of a 16-voice synth." —
V. Savage, Milford, PA

LABORATORY TESTS PROVE PIANO LOSES 500 POUNDS

Now you can take a grand piano wherever you play. The Ensoniq Sampled Piano Module uses concert grand multi-samples to create a completely realistic piano sound. In addition to three different acoustic piano sounds, the module features sampled electric piano, marimba, vibes, clav, upright and electric bass.

After - 63 lbs.

can even 'soft split' the bass sounds to the lower portion of your controller keyboard.

PATENTED ACTIVE INGREDIENT — ESQ-M

The Ensoniq ESQ-1 Digital Wave Synthesizer is one of the most in-demand keyboards on the market. The new ESQ-M Module has all the voicing and programming features of the ESQ-1 in a ready-to-rack-mount MIDI package.

In fact, it's in the MIDI environment that the ESQ-M really shines. The ESQ-M is completely multi-timbral — each of its 9 simultaneous MIDI channels can play a completely different sound. Combined with the Ensoniq exclusive 'dynamic voice allocation', the ESQ-M can behave like 9 separate polyphonic MIDI synths — a real plus when sequencing.

Getting started with Ensoniq MIDI Modules is easier than you might think. With a MIDI synth and a few MIDI cables, you can be making better sounding music in minutes.

SEND NO MONEY!

My MIDI setup is too big and too heavy. Show me how the Ensoniq MIDI Module Diet Plan can save space and weight while adding to the quality of my sound.

NAME _____

ADDRESS _____

CITY _____

STATE _____

ZIP _____

For more information write: Department X.

ENSONIQ Corp. 155 Great Valley Parkway, Malvern, PA 19355 □ Canada
6969 Trans Canada Hwy Suite 123, St. Laurent, Que H4T 1V8 □
ENSONIQ Europe BV, Domplein 1, 3512 JC Utrecht, Holland □ Australia:
Electric Factory, 188 Plenty Rd., Preston, Vic. 3072 □ Japan: Hammond
Suzuki, Ltd., 1135 Koike-cho, Hamamatsu

ensoniq

GUARANTEED!

Ensoniq MIDI Modules are guaranteed to reduce the weight of your keyboard setup only. The Mirage Digital Multi-Sampler retails for \$1195 US — the Ensoniq Sampled Piano Module for \$895 US and the ESQ-M Digital Wave Synthesizer Module for \$995 US. Ensoniq, Mirage, ESQ-1 and ESQ-M are trademarks of Ensoniq Corp.

DIGITAL SOUND EFFECTS FOR "THE SOURCE OF POWER"

With the advent of low-cost digital recording and sampling, new methods and opportunities exist for filmmakers and video producers interested in high quality post-production sound. One project using digital technology extensively is *The Source of Power*, an independent French-American feature film by See-God productions. Director Dan Godzich and cinematographer John Seetoo are also designing the sound for the film using the Sony PCM-501 processor and the Korg DSS-1 sampling keyboard.

Most 35mm films have sound effects created by a Foley artist, which are then dubbed onto mag-track along with ambient sound and dialog. See-God productions has chosen to digitally record their sound effects, which are then transferred to the sampling keyboard, where an effect can be truncated, manipulated and changed in pitch. Using this low-cost digital technology, sound effects are digitally recorded with the Sony PCM-501 and then manipulated on the sampler, saving studio time and allowing the filmmakers to fine tune the sounds before entering the studio. This allows the filmmakers great flexibility and control in designing the sound of the film, as footsteps, doors slamming and other effects can be sampled many times, greatly increasing their options when it comes time to record the effects. In addition, the savings in studio and Foley artist fees outweigh the cost of the sampler and the PCM processor, greatly increasing the cost efficiency of the production. Once in the recording studio, sound effects are being triggered from the Korg DSS-1, with the keyboard player actually taking the place of the Foley artist.

The sound for *The Source of Power* is being recorded on a 24-track machine running at 30 ips. Since film reels usually run 20 minutes, and 10.5-inch reels only offer 16 minutes of recording time at 30 ips, a machine with 14-inch reel capacity had to be found in order to record a

full film reel worth of sound. The decision to record at 30 ips was made by Godzich and Seetoo "for reasons of quality," according to Seetoo. "Since we are bypassing initial recording and rerecording on mag-track, the higher speed highlights the clarity of the digitally recorded ambient sound and effects."

Rather than creating the sound in sync using expensive mag-track machines and time, See-God decided to sync the 24-track machines to SMPTE-striped transfers of the film. Having 24 tracks enables the producers to record extra effects and dialog takes, allowing some decisions to be made during mixdown, further increasing creative control of the sound of the film. The finished 24-track is being mastered onto 2-track digital and an 8-track analog machine, and facilities permitting, the digital master will be dubbed onto full-coat mag-track for transfer to 35mm optical soundtrack.

Seetoo feels the most exciting thing about this method of audio post-production is quality: "By digitally recording ambient sound and effects and avoiding all the rerecording usually done, we are able to produce high quality sound and at the same time exercise greater personal control over the sound of the film, utilizing what is basically consumer-level technology. The affordability of this technology puts top quality production power in the hands of the filmmaker, and lowers overall production costs."

Recording engineer Dennis Ferrante, whose album credits include LPs by John Lennon, Lou Reed and Wynton Marsalis, is bringing his experience from working on the feature films *Reds* and *China Girl* to bear in mixing the sound for *The Source of Power*.

Post-production on *Source of Power* is being done at Active, a new recording studio in Manhattan designed for scoring to image. Active was chosen in part because it is equipped with a TimeLine Lynx synchronizer and an MCI JH-24 24-track recorder able to handle the larger 14-inch tape reels used.

—Jeffrey Allgeier

you pay to the commercial theaters?

Dichter: Just to remind myself of what the real world sounds like.

Mix: I would think one would get depressed?

Dichter: Yes, I'm very depressed. I think the way films get presented is so haphazard. Dolby has helped. At least it's a standard so that if the theater owners want to maintain standards they are available by just making a call to Dolby.

Mix: How often have you been satisfied with the way your films have been presented in commercial theaters that you've personally checked on?

Dichter: Fifty percent. I've been checking on my pictures for about the last seven years in this way.

Mix: Do you talk to theater managers about the quality of their presentations?

Dichter: Yes, and they all say they have a planned maintenance program but I know they don't follow it. I usually talk to them when the sound isn't right and what they usually say is: "Well, it doesn't hurt the box office."

LESLIE SHATZ

Sound designer Leslie Shatz has distinguished himself among film mixers by making a commitment to work in a multi-track post production format whenever possible. Thus far he has successfully employed the 24 track, 2-inch audio tape format on two theatrical features, *True Stories* and the recently completed *Tough Guys Don't Dance*. Until the 1970s, the universal practice for sound post was to use sprocketed (16 mm or 35 mm) magnetic film. In recent years, film mixers have often used multi-track for effects work sans dialogue and Foley. But Shatz is one of the few to work all aspects of film sound post (dialogue, effects and Foley) on a multi-track system.

In the interview that follows, Shatz discusses the advantages of the multi-track format, other trends in post-production, and he predicts the eventual demise of mag film as a post-production sound medium.

For his current project, *Tough Guys Don't Dance*, directed by Norman Mailer, the setup at Russian Hill Recording in San Francisco consisted of two half-inch (16-track) Fostex machines plugged into a Soundcraft mixing board, and an Emulator II in con-

junction with a Macintosh computer running Sound Designer software. Their MCI 24-track was run in conjunction with an SSL-4000 mixing board.

Shatz's major credits include: *Apo-calyptosis Now* (1979), *Dune* (1984), *Mishima* (1985), *True Stories* (1986) and *The Journey of Natty Gann* (1986).

Mix: How would you say your working methods have changed in the last five years?

Shatz: Radically. It's gone from being labor-intensive to being hardware-intensive. Now on a job I'll work with two or three other people at the most, whereas on a big film like *The Journey of Natty Gann* you have a crew of five or six sound editors, three or four assistants, a couple of apprentices. And that becomes a management problem—you have to manage people, as well as having to do the sound work. A lot of companies in the Bay Area hire someone separately to manage the people, calling that person supervising sound editor, and someone else to create the sounds, calling him the sound designer. I've never found that to be effective because you have to have a little of both mentalities to do

either job. So it's just been a logical progression for me to deal with the pure creation of sounds and to streamline the process by which those sounds end up in the movie.

Mix: Why has this change occurred?

Shatz: Because of the availability of the equipment. People here at Russian Hill have helped me develop these techniques. A lot of hardware that I've come to rely on heavily was just coming into being five years ago. It's really come around to making a soundtrack for film in a way very similar to the way records are made. It's not an assembly line process anymore. It's a studio process—in the same sense that an artist has a studio. I can operate in my studio and create sounds in conjunction with a director and have a minimum number of steps to go through to make those sounds in sync with the picture and have them end up being the final product. Just like a production designer is responsible for every visual element on the screen, I feel that the sound designer is responsible for every sound element that comes out of the speakers. And I move in that direction by being able to design

sounds, premix the dialog and perform the final mix.

Mix: Is this change in working methods also a function of the size of your budget to an extent?

Shatz: Yes. Since it's less expensive to do the work this way, it naturally attracts producers with lower budgets. And since it's not fully proven in the eyes of many people, films with larger budgets would rather not take a risk, they would rather spend more money and work the conventional way. *Tough Guys Don't Dance* is the second film I've done this way and I think eventually I'll do a big budget film this way.

Mix: What is the risk?

Shatz: The risk is that everybody's doing it another way so that when you're working in film using conventional methods, if your Moviola breaks down you can call all over town and get another Moviola. If your transfer suite is busy you can send your tape out somewhere else to be transferred. These are general examples. The way I'm working, equipment failure could be devastating, although it hasn't happened. The hardware's not as common.

The Jensen Twin Servo™ 990 Mic Preamp



Clearly the World's Finest Microphone Preamplifier

- Winner of Every Listening Test
- 18 to 60 dB Gain
- 0.4Hz to 140kHz
- Phantom Power

Deane Jensen's best mic preamp is now available in half or full rack versions, with 2, 4 or 6 channels. The new standard for audio perfection. Hear it at Audio Rents (LA), The Rental Company (NY) or at your competitor's studio. Write or call for a technical data sheet.

Manufactured for Jensen by Boulder Amplifiers

jensen transformers
INCORPORATED

10735 Burbank Boulevard • North Hollywood, California 91601
FAX (818) 763-4574 • TELEX 6502919207 MCI UW
Phone (213) 876-0059

Closed Fridays, visitors by appointment only

"Twin Servo" is a trademark of Jensen Transformers, Inc.

Telex Autoloader

The Extra Margin In Video Duplicating



With Telex Autoloaders you can increase duplicating production by up to 25%, depending on present capacity. But, there is more. Telex Autoloaders also reduce the man-power required to re-load VCR slaves and significantly reduce the total downtime for loading and unloading per work shift. So, production is up, costs are down. All without additional VCRs, associated electronics or racks.

To install Telex Autoloaders, you don't have to make any VCR modifications. In fact, you don't even need tools. The VCR controls and meters remain accessible. And, Autoloaders are so compact they fit the majority of equipment rack layouts. In most cases there's no need to widen the access aisles or change spacing between slaves.

Microprocessor controlled with built-in diagnostics, the Autoloaders operate off the VCR power supply and interface with the master command station via remote connectors on the VCR slaves. In other words, the operation of the system remains the same.

Telex Autoloader models are available for Panasonic models 6200, 6800 and 6810 or JVC model BR 7000UR video cassette recorders. For complete information, please contact Gary Bosiacki, Pro-Audio Division, Telex Communications Inc., 9600 Aldrich Avenue South, Minneapolis, Minnesota 55420. Phone 612-884-4051.

TELEX®

TELEX COMMUNICATIONS, INC.

Panasonic is a registered trademark of Matsushita Denki Sangyo Kabushiki Kaisha
JVC is a registered trademark of JVC Company of America

Circle #108 on Reader Service Card

We were limited by the fact that we had two of these 16-track [Fostex] machines; we could have worked a lot more efficiently if we had a third one.

Mix: How were you able to work so quickly?

Shatz: Because of the methods we're using: everything has been screened by the director; the sound has been laid down properly and in context; we work on 2,000-foot reels—instead of the smaller conventional reels—so there are half as many reel changes; the thread-up time is nil because all we have to do is put up 2-inch tapes and put up mag. Because of all of this, the mix becomes very efficient.

Mix: Did you find yourself tutoring Norman Mailer, who has never directed a commercial picture before?

Shatz: I always had to be the voice of what was realistic, though I hate being in that position because it's like the renowned physicist J. Robert Oppenheimer said [paraphrasing], "There are children on the streets who can solve my most complicated problems in physics." Just because somebody doesn't know the intimate technology of film doesn't mean that they can't stumble onto an exciting idea. A lot of times Norman would come up with really good ideas—they would sound stupid, they would sound difficult, they would sound impossible, but I would do them and they would turn out to be great.

For example, Norman had a thing about punches and about guns. When we came to create the punching effects for the fight scene he said, "Hey, I'm a fighter, I know what a punch should sound like. Why don't I sit here and hit myself?"

I said, "Norman, you can do that if you want but I have these perfectly good punches that we can use." And he listened to them and he said, "No, those don't sound like what a punch should sound like."

So he ended up sitting here hitting himself and recording it and bit by bit it started to come together and I started to manipulate the sounds a bit and began to think, "Well, maybe we've got something a bit different here," and it worked.

Mix: What future changes do you see occurring in the technology of film sound?

—CONTINUED ON PAGE 142



The Award-Winning Digital MOSFET Amplifiers by Peavey

For two consecutive years, Peavey DECA™ Series power amplifiers have won *Music & Sound Output* and *Music & Sound Retailer* magazines' award for "Most Innovative Product" in the Sound Reinforcement category.

Peavey's digital energy conversion, MOSFET design has made the DECA 724 and DECA 1200 the most popular new amps among sound professionals for 1986 and 1987.

Now, Peavey continues this award-winning series with the DECA 424.

Better than 90% efficient!

Peavey engineers have combined the latest MOSFET designs along with high speed digital computer electronics and electromagnetic energy conversion technology to create an amplifier with efficiency performance

heretofore unmatched in any commercially available units!

These amps also feature a digital version of Peavey's patented DDT™ compression circuit which virtually eliminates the possibility of driving the amplifier into distortion.

No measurable TIM or slew rate induced distortion!

The unique nature of DECA circuitry produces no measurable transient intermodulation or slew rate induced distortion even with complex signals at high concert sound levels.

The DECA Series is another step in Peavey's commitment to produce the most competitive, professional power amplifiers available on a true performance basis.

See your authorized Peavey Dealer for all the details on these award-winning amplifiers. Discover how DECA power amplifiers have redefined power!



PEAVEY ELECTRONICS CORPORATION
711 A Street
Meridian, MS 39301
Telephone: (601) 483-5365/Telex: 504115
Fax: 484-4278

Circle #029 on Reader Service Card

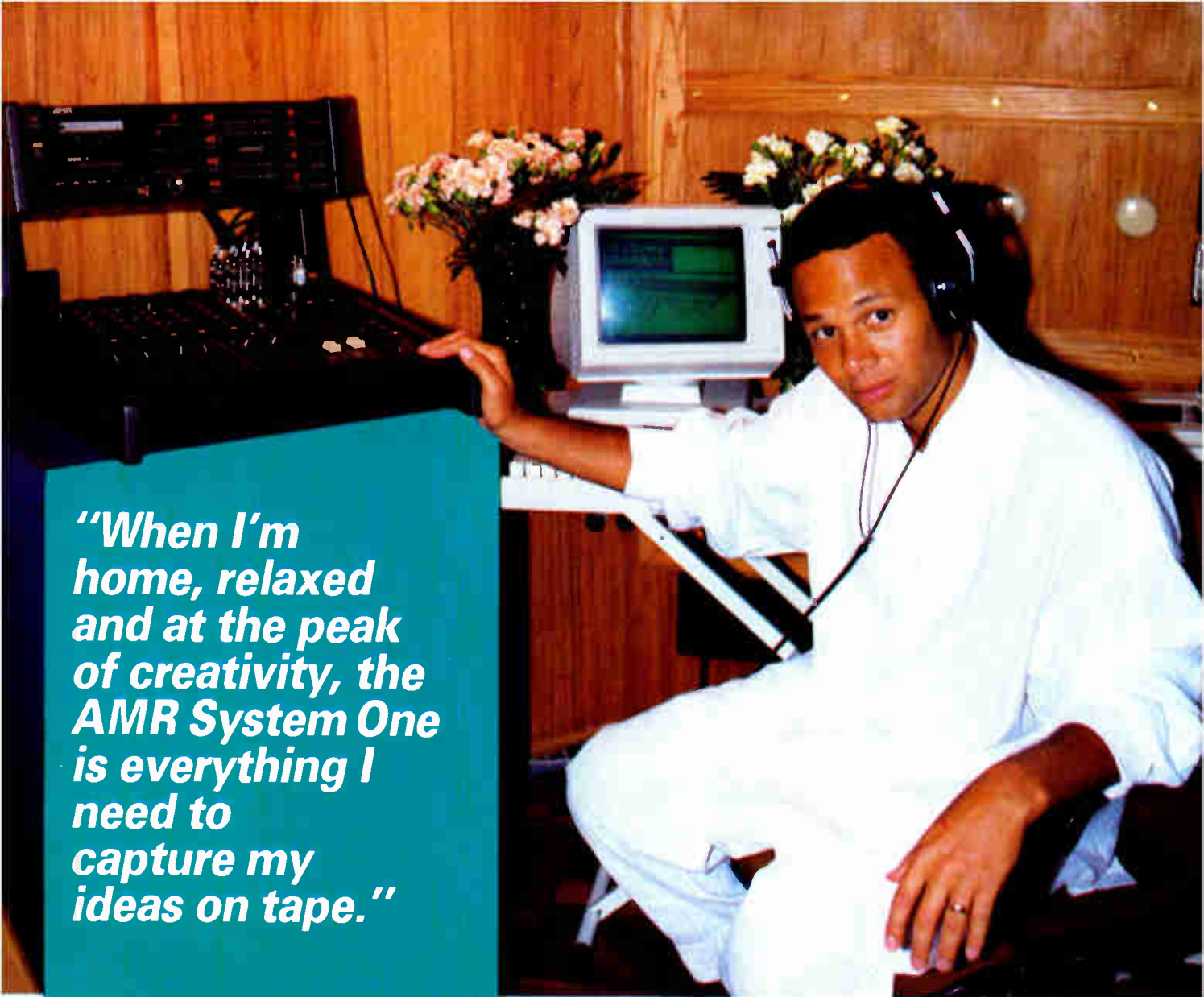
A photograph of Narada Michael Walden in a recording studio. He is wearing a white shirt and headphones, sitting at a desk with a computer monitor and various audio equipment. There are flowers on the desk. A teal text box is overlaid on the left side of the image.

"When I'm home, relaxed and at the peak of creativity, the AMR System One is everything I need to capture my ideas on tape."

NARADA MICHAEL WALDEN

Narada Michael Walden is a world-class drummer, keyboardist, singer, composer and performer. If there's a musical role he can't handle, no one has thought of it yet. As a producer, he's turned out such hits as Aretha Franklin's "Freeway of Love" and Whitney Houston's "How Will I Know" (which he wrote and co-wrote respectively). As a drummer, he's played jazz, fusion, and rock with the likes of John McLaughlin, Jeff Beck, and Weather Report, and R & B with Rick James and Teena Marie.

Narada is an extraordinary musical craftsman. He demands the very best from his music and his equipment. His choice in personal multi-track recording gear is AMR. Naturally.

NARADA MICHAEL WALDEN recent awards:

1986 ASCAP Songwriter of the Year:

"Freeway of Love" Aretha Franklin

1986 ASCAP Song of the Year:

"How Will I Know" Whitney Houston

1986 Billboard's Producer of the Year

1985 Grammy



AMR™ System One

Circle #043 on Reader Service Card ©1987

AMR™

AUDIO MEDIA RESEARCH

P. O. Box 1230/Meridian, MS 39301/Telephone: (601) 483-5372/Fax: 485-7903

—FROM PAGE 18, COMPACT DISCS

proprietary device—another offshoot of existing Shape technology. Two-color silkscreening is used for labeling; Shape feels that this process yields better results over pad printing. A Compu-graphic system accepts client's artwork, and converts it to hardcopy or a camera-ready mechanical. It may be used to enlarge, reduce, manipulate, repair, or create original artwork. In addition, a copy may be faxed to the client for approval.

With a 12-second molding cycle (times of less than nine seconds have been successful), the time from pellet to finished disc is approximately three minutes. The entire line occupies less than 300 square feet, including space for operator access. The operator may request a sample disc from anywhere in the line, for quality analysis. Shape plans to make its production line, dubbed the Unit Disc Manufacturing System (UDMS), available on a limited, turnkey, commercial basis. Presently, Shape is operating seven lines, while two earlier generation lines are available for excess capacity. During my visit one line was devoted to 3-inch CDs; it can be switched to 5-inch in about three hours. Optimedia was the first to commercially ship 3-inch CDs, to Delos, in early September. Presently, inspection is done manually; however, in-house work is progressing on an automated system.

Packaging is accomplished with a combination of commercially available and in-house automation equipment. It also is commercially available as the Shape Econoflex CD packaging machine. The bulk of orders require final packaging, whether long boxes, jewel boxes, blister packages, etc. Packages themselves have drawn Optimedia's attention and they have developed several innovative packages. Their Lift-Lock jewel box raises the disc when the cover is opened, and locks the disc in place when it is closed. It is comparably priced to regular jewel boxes, for Optimedia customers.

Optimedia also has developed a 6-by-12-inch plastic box as an alternative to the long cardboard box. The latter has proved troublesome in some stores because customers can easily slit the box and remove the jewel box. The plastic box provides greater security, and reduces cost of packaging. A

flip file also has been developed; it holds two jewel boxes as well as artwork as a presentation medium, or holds 20 jewel boxes as a storage system. Optimedia also has tackled the problem of a 5-inch adaptor ring for 3-inch CDs, and is developing both squeeze and jewel boxes for the 3-inch CD. For now, 3-inch CDs are being shipped in bulk.

Shape's Anton Labs, a division of Shape Systems, has used its expertise in computer control systems to develop a CD analyzer system. It uses a TI microcomputer and Studer A725 QC CD player to provide a complete check of disc specifications. Bob Collins, manager of quality assurance at Optimedia, and Art Leblanc, director of Anton Labs, designed this system. As implemented in Optimedia, it employs eight Studers interfaced to the TI, with hardcopy output. Thus, eight discs can be checked simultaneously and the results tabulated. The CD analyzer is commercially available.

The first discs produced after each stamper change are carefully scrutinized. A series of tests including birefringence, BER, 100% disc listening, label check, and other physical and process parameters are carried out, and checked by supervisors. Because of the stability of the manufacturing process, a run is usually easily accomplished after these initial checks. The biggest challenge, as one might expect, is prevention of simple mistakes, particularly when the plant is busy.

Shape's audio clientele is fairly evenly balanced between major and independent labels. Of course, considerable capacity is required to accommodate the larger production runs of major labels, and Optimedia's expansion plans will increasingly permit this. A major label may order 5,000 or 10,000 pieces to evaluate a plant's abilities, then order ten times those amounts after they are satisfied with performance. Optimedia's typical turnaround is seven to ten days; larger orders may require 14 to 18 days. On the other hand, some business expects and receives 48-hour turnaround.

Optimedia's current and next objective is CD-ROM replication. CD-ROM premastering capability was introduced last fall, with full data encoding and simulation slated for the beginning of 1988. A separate area is being prepared for CD-ROM, with a closed loop security system, and every mold-

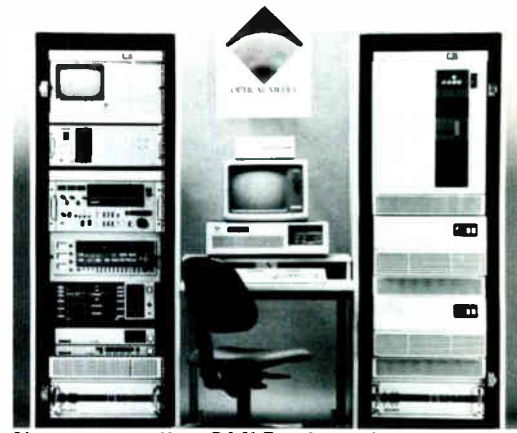

Shape uses the OMI Topix system for CD premastering & encoding.

ed disc will be accounted for. An automated process will automatically destroy every rejected disc.

A Topix CD-ROM premastering system has been selected; it will receive tapes and simulate the operating system the disc is intended for. In addition, the first of every production discs will be compared to the source tape, for bit-by-bit verification. Other standard tests such as BER and process control will ensure disc accuracy. At the end of every production run, identical checks will be performed to verify that no defects have been introduced in the course of the run. In short, Optimedia will guarantee that discs will work in their intended application. Tom Brown is manager of CD-ROM development.

The technical side of CD-ROM will be balanced by customer support, suited to CD-ROM concerns, which differ considerably from those of the audio industry. Optimedia views CD-ROM as an important future business, but not a high-volume part of their overall operation.

Expansion into CD-ROM, and other disc types such as CD-video, will require application of the formula that Optimedia has already demonstrated in CD-audio: a technically innovative, service-oriented approach. As with any successful business, Optimedia delivers what the customer needs, and when he needs it—without mistakes or errors. In this case, on the disc, or otherwise.

Canes 26, Seminoles 25. Piece of cake. ■

Ken Pohlmann is an associate professor of music and heads the music engineering program at the University of Miami in Coral Gables. He is author of Principles of Digital Audio and The Compact Disc Handbook, and a consultant to the digital audio industry.

THE 1987 TEC AWARDS

The 1987 TEC Awards, where *Mix* readers salute the behind-the-scenes superstars, were held October 16 before a sell-out crowd at New York's Manhattan Center Ballroom. Awards were given in three major categories: Institutional, Technical and Creative Achievement, divided into 22 sub-categories. The third annual event attracted 500 of the industry's biggest and brightest names, raising approximately \$20,000 in ticket sale revenues to be divided among the House Ear Institute (50%), a Los Angeles-based, private, nonprofit center for research into ear disorders; Berklee College of Music (25%), winners of the Recording School/Program category; and the Audio Engineering Society Educational Foundation (25%).



Master of Ceremonies Ray Hanna welcomes master guitarist Les Paul.

Presenters Jeff Baxter (left) and Elliott Randall, shortly before launching into an air guitar jam.





Tony Bongiovi and Bob Walters, co-owners of New York's Power Station, accept the award for Recording Studio of the Year.



John Woram and Mel Lambert present Console Technology of the Year trophy to Neve president Barry Roche, for their V Series.



Don Slepian provides a MIDfied dinner serenade.



Bob Clearmountain receives Best Recording Engineer for the third consecutive year.



Jerry Jacob accepts the award for Acoustics/ Studio Design Co. for his partner, Chips Davis.

Les Paul presents Signal Processing Technology of the Year trophy to Yamaha's John Gatts, for their SPX90 Digital Multi-Effects Processor.



FRANCESCO CARLINO

THE 1987 TEC AWARD WINNERS

*Congratulations one and all from
Mix Publications.*

OUTSTANDING TECHNICAL ACHIEVEMENT

Tape/Disc Manufacturing Technology

Teldec DMM CD Mastering System

Signal Processing Technology

Yamaha International SPX90
Digital Multi-Effects Processor

Recording Devices/Storage Technology

New England Digital
Direct-to-Disk

Automation/Control Systems

Solid State Logic Advanced Total
Recall with Autoscan

Ancillary Equipment Technology

Monster Cable ProLink Series 1
Tube Microphone Cable

Musical Technology

Yamaha International DX7IIFD
Digital Synthesizer

Transducer Technology

AKG C-414B-ULS Microphone

Console Technology

Rupert Neve V Series Console

Computer Hardware/Software

Mark of the Unicorn Performer
Version 1.22

OUTSTANDING CREATIVE ACHIEVEMENT

Recording Engineer

Bob Clearmountain

Mastering Engineer

Bob Ludwig

Sound Reinforcement Engineer

Craig Schertz

Record Producer

Russ Titelman/Steve Winwood

Film/Video/Broadcast Production Engineer

David Hewitt

Film/Video/Broadcast Post- Production Engineer

Steve Maslow

OUTSTANDING INSTITU- TIONAL ACHIEVEMENT

Acoustics/Studio Design Company

Chips Davis LEDE Designs, Inc.

Recording Studio

Power Station

Sound Reinforcement Company

Clair Brothers

Recording School/Program

Berklee School of Music

Mastering Facility

Masterdisk

Remote Recording Facility

Le Mobile

Record Company

Island Records

PROFESSIONAL audio



**Learn the techniques and technology of the
professional recording studio.**

- Recording and Mixing ■ Editing Techniques ■ Signal Processing ■ Disc Recording ■ Console & Outboard Gear
- Digital Logic ■ Audio Systems Design ■ Professional Studio Internships ■

Classes filling now – Call Today:
(212) 777-8550



Established 1969

Institute of Audio Research

64 University Place, Greenwich Village, New York, N.Y. 10003

Licensed by N.Y. State Dept. Education

Approved for Veterans Training

Financial aid for those who qualify

Circle #109 on Reader Service Card

SAMPLE THE POWER OF THE ROLAND S-50

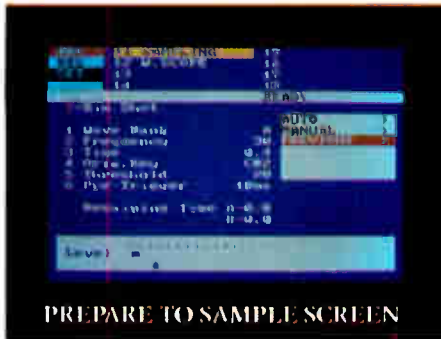

PREPARE TO SAMPLE SCREEN



EDIT LOOP SCREEN

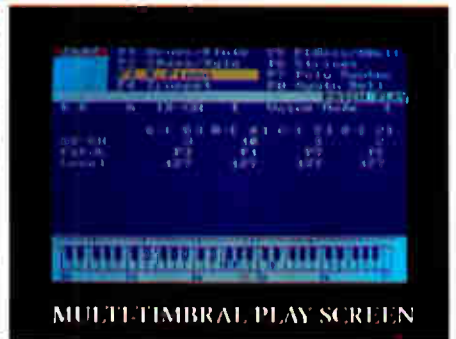

MULTI-TIMBRAL PLAY SCREEN

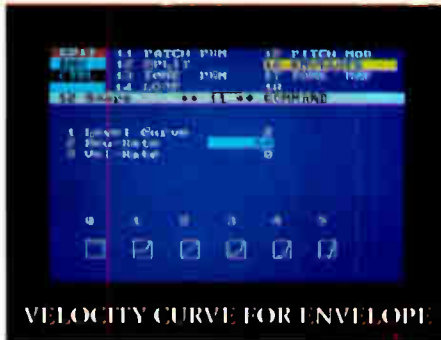

VELOCITY CURVE FOR ENVELOPE



EIGHT STAGE ENVELOPE EDIT



TONE MAP GROUP EDIT

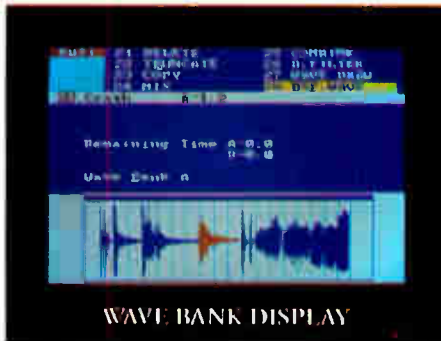

WAVE BANK DISPLAY



WAVE DRAW SCREEN



TRUNCATE WAVE DATA



SYS 503 SONG PLAY



SYS 503 PATTERN WRITE



SYS 503 MIDI AND INFO SCREEN

THE SAMPLER THAT DOES MORE TODAY



World Pacific History

THE SAMPLER THAT DOES MORE TOMORROW

The Benefits of Open Architecture

There's no question, digital sampling is one of the most rapidly developing technologies in music today. So when you buy a sampler today, you don't want it to be made obsolete by some new development tomorrow. That's why there's one line of samplers that not only provides top quality today, but allows for future developments tomorrow. Naturally, they're from Roland, the company who always has one eye on the future.

Roland samplers are based around a "clean computer" design of open architecture. This means that the main performance data

of Roland samplers is resident in software — software that can be updated with new

features and performance just by loading a new disk. Neat trick? That's exactly what our customers think. They've already benefitted from one software update, giving their samplers loads of new features. And more updates will follow.

Professional Performance Sampling

But before we get too far into the future, let's talk about today. The Roland S-50 Digital Sampling Keyboard and S-550 Digital Sampler Module deliver the professional-quality sound and extensive editing capabilities found only in instruments costing many times as much, all thanks to Roland's breakthroughs in proprietary VLSI Sampling technology. The S-50 offers a wave oscillator, amplifier, LFO, and an eight-stage envelope generator for each of its sixteen voices. Although the S-50's features list is far too extensive to be listed here, among its chief attributes are a 512k word of Wave Memory and 16-bit processing, sampling time up to 14.4 seconds at 30kHz, multi-timbral capabilities, and four polyphonic voice outputs.

The S-550 provides all of the S-50's performance with the addition of a 1.5M Byte memory (for up to 64 tone memories and 16 patch memory banks), and expands upon the S-50 by providing eight polyphonic voice outputs.



Quality Sound in the Roland Bank

But we think the best way to judge a sampler is with your ears. That's where the Roland Samplers really shine. Play any Roland Sampler and you'll hear a warm and full sound, with a better bandwidth and greater headroom that especially shows up in dynamic instrument samples. You'll experience an evenness of sound across the entire keyboard without the problems other samplers have of obvious split points. And you'll never run out of sounds, because the purchase of a Roland Sampler gives you access to the Roland Sound Bank — a continuously growing library of great sound samples. Plus, the S-50 is

already enjoying one of the fastest-growing bases of third party software support.

Quality In Means Quality Out

When it comes to user interface, Roland Samplers are simply unrivalled. Both the S-50 and S-550 allow the connection of a video monitor to greatly facilitate sampling process and use such new features as Wave Draw. The S-550 even allows the flexibility of mouse-style input by connecting the new DT-100 Digitizing Tablet. This kind of interface makes the experience of sampling sounds as fun as it is productive.

Today's Updates

The new 2.0 Software Update (available to all owners for a small handling charge) can now add in loads of new features — including twice as many tones, Automatic Loop Search, combined Wave Data, Polyphonic Multi-timbral performance, and much more. Not just new sounds, entirely new performance. Another new software program — the SYS-503 Director-S — can turn the S-50 or S-550 into a sixteen-channel MIDI sequencer, playing its own sounds as well as those of other MIDI instruments.

Put all this together and you can see why Roland Samplers are the choice of so many top pros. And why shouldn't they be? Because if Roland Samplers do this much today, imagine what they'll do tomorrow.

RolandCorp US, 7200 Dominion Circle, Los Angeles, CA 90040 (213) 685-5141.

by Mark Herman

SOUND REINFORCEMENT NEWS

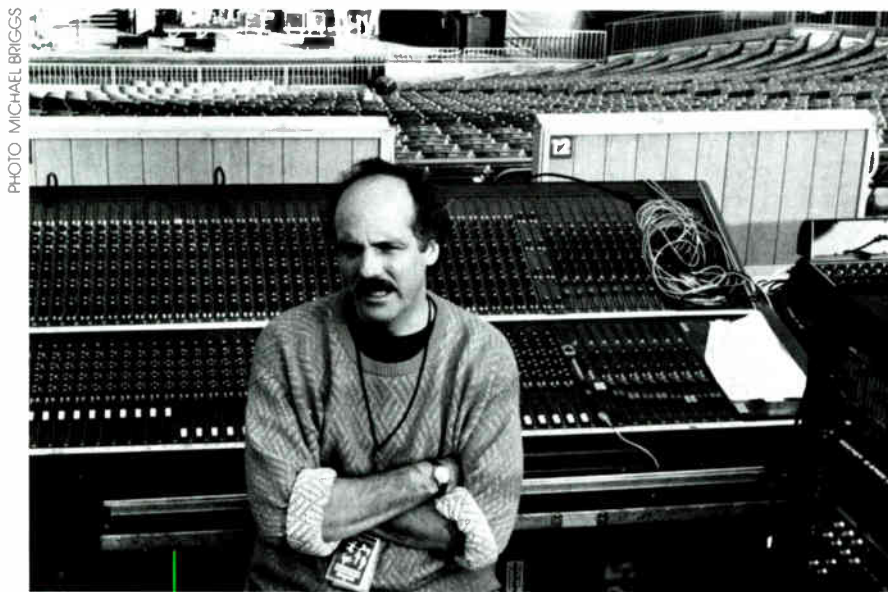

PHOTO: MICHAEL BRIGGS

Happy Holidays! . . . And it ought to be with the general upswing in fall and winter touring. Many of the major sound companies are reporting no winter slowdown with their touring clients. Clair Brothers, Showco, Maryland Sound Industries, Audio Analysts, and Electrotec are examples of sound reinforcement companies that have all, or most, of their numerous touring systems working. The smaller companies don't see the big tour money as often, so this trend won't affect them quite as much. Generally, companies expect a slowdown because of decreased outdoor events. Apparently this past year has been profitable for many because the general mood of most sound reinforcement companies is one of optimism and expansion.

Recently I caught one night of **Heart** headlining Bill Graham's Shoreline Amphitheater. Sound reinforcement for the tour was furnished by **Audio Analysts**. **Richard Erwin** mixed house on a Soundcraft 40 x 16 x 2 Series 4 console. Erwin is a veteran with many years spent touring with the likes of The Eagles, Stevie Nicks, ELO, and Boz Scaggs. Monitor mixer **Thomas**

Above: Heart tour house mixer Richard Erwin

Below: Heart tour monitor mixer Thomas Holmes

Holmes utilized a matching Soundcraft 40 x 16 Series 4 stage console along with Audio Analysts' QSC 3800 powered custom 2 x 15 monitors and sidefills. System engineers for the tour were **Roger Binette**, **Bobby Huckaba**, and **Mark Jay**. The eight-sub, 56-main cabinet PA system powered by Phase Linear amps provided excellent audio quality. A tremendous amount of punch was developed by only eight subwoofers. Head system engineer Binette attributed some of the low end to his placement of the subs down in a partially enclosed concrete area by both sides of the stage. The entire production was very good and a surprise guest appearance by wildman **Ted Nugent** juiced it up even more. Crew, equipment, sound and production were all very professional. I say four stars.

Hard-rocking **Def Leppard** is out touring North America with **Electrotec** from October through next March. Plans are for the tour to continue in Europe after March and then return again to the U.S. The stage is set in the center of the arena with what is basically two PAs; one normally positioned

—CONTINUED ON PAGE 110



PHOTO: MICHAEL BRIGGS

SOUND · ON · STAGE

by Mark Herman

ON THE ROAD

SOUND COMPANIES, EQUIPMENT, ARTISTS & PERSONNEL ON TOUR

Artist Sound Company Tour Dates & Region	House Console #1 House Console #2 Monitor Console #1 Monitor Console #2 Crossovers	Main Speakers Other Speakers Subwoofers Monitor Speakers	Main Amplifiers Other Amplifiers Sub Amplifiers Monitor Amplifiers	House Engineers Monitor Engineers System Engineers (B) = band engineer
John Cougar-Mellencamp Audio Analysts Oct 29-Dec 23 USA	Soundcraft Series 4 40x16x2 ---- Soundcraft Series 4 40x16 ---- JBL 5234	60 AA Arena ---- 8 AA SW AA 2x15, 1x15 & AA SF	QSC 3800 ---- Crown Macro-Tech 10k QSC 3800	Ed Wynn Rocky Holman Dick Offeringa Brian Reese Sean Webb
Def Leppard Electrotec Oct 1-March '88 N. America	Soundcraft Series 4 40x16x2 ---- Soundcraft Series 4 40x24 ---- BBS	132 Lab Q ---- 16 Lab Q low-bass 36 ET Floor	JBL 6233, UREI 6400 ---- JBL 6233, UREI 6400 JBL 6233, UREI 6400	Robert Scovill Phil Wilkey Ted Leany Russel Fischer Brad Madix, Marc Renault
Fleetwood Mac Clair Brothers Sept 29-Dec 18 N. America	Clair 32x12x4 Clair 32x12x4 Harrison SM-5 32x16 ---- Clair custom 4-way	72 Clair S-4 ---- ---- Clair Custom	Carver 1.5 ---- ---- SAE 2600	Bruce Jackson (B) Jim Devenney Bob Bickelman Chris Fulton Robert Miller
Dan Fogelberg Maryland Sound Ind. Sept 10-Nov 25 N. America	Yamaha PM3000 40x8x2 Yamaha PM2000 32x8x4 Yamaha PM2000 32x12 Yamaha PM2000 32x12 Yamaha F 1040	40 MSI/NW2 ---- 8 MSI/NW2B MSI 2x12, 2x15	Crest ---- Ramsa Crest	Dave "Snake" Reynolds George Strakis Greg Salmon Mark Bradley
Lynyrd Skynyrd Showco Sept 23-Nov 1 USA	Harrison HM-5 32x16x4 ---- Harrison SM-5 32x16 ---- Showco	48 Showco AX 8 SS front fill 8 AX subs Showco 100, 450	Crown 1000 Crown PSA2 Crown PSA2 Crown MT1200	Pat Farrell David Conyers Bill Larmour Ron Reeves
Eddie Murphy See Factor Sept-Dec USA	Midas Pro 5 18x4x2 ---- AudioArts M10 24x10 ---- Meyer	26 Meyer MSL3 8 Meyer UPA 4 Meyer 650 Martin LE 200	Crest 4001 Crest 4001 Crest 4001 Crest 3501	Bill Fertig Robert Nelson
Night Ranger Sound On Stage June-Dec N. America Dec-Japan	Yamaha PM3000 40x8x2 ---- Gamble SC 32x16 ---- SOS	12 stacks PP 543 12 PP 422 8 Meyer 650 Meyer UM-1, & Meyer UPA	Crest 4001, 2501 Crest 4001, 2501 Crown MT 1200 Crown MT 1200 & Phase Linear 700A	Louis Barrere Mike Benedetti Dave Muzzini
Oak Ridge Boys Carlos Sound July-Dec USA March-Dec '88 USA	Harrison Alive 32x8x8 ---- Soundcraft 800B 32x10 ---- EAW MX800 4-way fixed	24 EAW 850 ---- 12 EAW 850 sub EAW 222, 600, 155, 152	PhaseLinear 400 ---- PhaseLinear 700 PhaseLinear 400, 700	John Mir Marco Hunt Jim Krueger Joe Falk
Tina Turner Clair Brothers March-July Europe Aug-Dec N. America conf.—Aust, Jp, S.A.	Clair 32x12x4 Clair 32x12x4 Harrison SM-5 32x16 ---- Clair custom 4-way	64 Clair S-4 ---- ---- Clair custom	Carver 2.0 ---- ---- SAE 2600	Dave Natle Rory Madden (B) Randy Weitzel Pete Pelland Cliff Atchison

—FROM PAGE 108

PA array and another duplicate facing out 180 degrees. The monitor system is much more extensive than usual. According to **Pierre D'Astuges**, "In addition to the two PAs used, because the band plays in full 360 degree coverage—the monitor set-up is enormous because they have two monitor systems in effect, with 36 floor monitors concealed beneath the stage. The 24-output monitor mix comes in very handy because there are so many different locations on the stage." . . . **Alabama** has been touring the entire year (Jan.-Dec.) and plans to finish in time for the holidays. After a short rest, they will be hitting the road again starting in February. . . Shock rocker **Alice Cooper** is back. Alice went into rehearsals October 8th before beginning his tour that will continue into January. . . . October also saw **The Cars** warming up their touring engines with rehearsals before departing on a five-month road trip ending in February. . . Electrotec's UK division was out on tour with **Bob Dylan/Tom Petty** and finished off the tour with four dates at **Wembley Arena** ending October 17. . . **Barry Manilow** began his rehearsals in late October in anticipation of his tour that extends to March of next year . . . Hot country western star **Randy Travis** went out at the end of November and continues into the next year. . . As you can see, Electrotec isn't letting the traditional slow winter season affect them. D'Astuges added, "We have *all* our equipment working and committed" . . . In addition to providing sound reinforcement Electrotec also provides the lighting for Alice Cooper, Barry Manilow and Randy Travis.

From the Lone Star state. . . **Showco's** Wil Sharpe reports a brisk fall and winter itinerary. . . In mid-October rock veteran **Eric Clapton's** pre-holiday tour started off down under in Australia and continues to New Zealand and Japan. 1988 will see Clapton celebrate his long career with a **25th Anniversary** tour throughout the U.S. Many special guest stars are expected to drop in at various stops along the way . . . **Lynyrd Skynyrd** was out with a 64-cabinet 360-degree Showco AX system. An eerie emotional opening night September 23 at the Concord Pavilion (Concord, CA) kicked off the five-week USA tour. . . **James Taylor** runs through the rest of this year completing his U.S. trek. . . **Bon Jovi** carried a Showco monitor system while traveling through Australia, New Zealand and Japan. The tour ended with several dates in Hawaii. . . Roaming throughout North

America additional artists **Willie Nelson, R.E.M., the Beach Boys, Aerosmith** with **Dokken** opening, **Kiss, Barbara Mandrell, and Boston** continued to keep Showco's touring schedule full.

This ain't no joke. . . Funny guy **Eddie Murphy** brings his comedy show out on the road with a Crest-powered 38-cabinet Meyer main PA supplied by **See Factor**. Other equipment includes a Midas Pro 5, Wheatstone/AudioArts monitor console, and a Martin monitor system. . . With over 75 MSLS and 30 650 subs, See Factor has one of the largest Meyer systems available. Other equipment includes a complete 48-bin Martin main system, Meyer and Martin monitors, and several Midas consoles. . . See Factor had a Martin rig on tour in Europe till mid-November with speed-metalists **Anthrax**. The U.S. tour leg begins this month. . . They had a Meyer house and monitor system out with **The Cult** on their North American solo tour. . . Locally, in New York a Meyer system was provided for the National Urban League benefit at Lincoln Center's Avery Fisher Hall. The NUL is a charitable organization that helps underprivileged people. Headlining was **Smokely Robinson**, with **Ben Vereen** and **Mary Wilson**.

A rehearsal hall for major artists just opened up in North Hollywood. The new air-conditioned **Power Plant** rehearsal facility has 10,000 square feet and two totally isolated rooms, one 2,000 square feet and the other 1,000 square feet. The equipment features Gamble consoles, bi-amped JBL wedges powered by Carver amplifiers, Schubert Systems processors, high-quality microphones and direct boxes. The Power Plant is also set up for live recording with a Gamble Series EX 56 x 30 and the isolated rooms. The first scheduled clients are **Oingo Boingo** and **Martha Davis**.

Clair Brothers report. . . The opening leg of **Michael Jackson's** latest tour began in Japan the first week in September and ended mid-October. After a break, the tour resumed mid-November with the Bad boy playing Australia into December. A trek across America is very probable beginning in February or March. . . The **Tina Turner** tour keeps on humming. Europe saw Tina from March through July and she has since been performing in North America. After ending the current leg late this month, there are plans for her to continue again internationally in Australia and Japan, with South America remaining a distinct possibility. . . **France Gall** and **Johnny Halliday** remain a hot item in France. . . **Fleetwood Mac** began touring North America in late September and plan to con-

tinue until mid-December. Europe, Australia, and Japan are being considered for upcoming tours.

Check it out. . . One of the hottest selling amplifiers this year is the new **Crest 8001**. With 1,200W/ch. continuous power at 4 ohms, 2,000W peak and 1,400W/ch. continuous power at 2 ohms, 2,000W peak, it has more than enough power for most applications. Other features include impedance sensing, clip limiter and audio-ramp signal control. According to sound company division manager **Craig Hannabury**, "We have over 400 already in the field with national and regional touring sound companies. One unique thing about Crest is that over half our sales to sound companies are, in fact, lease to purchase agreements through our 'Power Leasing' program."

Harry Belafonte picked **Sound On Stage** to supply sound for a short swing through the West. Belafonte's first album in 16 years is due out in January and another tour is planned for early '88. House mixer **Bob Burnham** was pleased to be behind a Gamble Series EX 56-channel console. Main PA was comprised of SOS' Power Physics Cutlass and 422 cabinets. The monitor system utilized a Gamble SC 32 x 16 stage console and 17 wedges plus additional side fills. . . **Audio Yuletides** . . . Around the holidays Sound On Stage gets in the holiday spirit by treating the entire city of Brisbane to some Christmas holiday tunes. Just south of San Francisco, the town is set in a natural amphitheater with SOS located in a great place to set up a PA. **Bob Walker** says "Once every year we bring out some equipment, face the speakers toward the city, and play Christmas carols. The sound quality is fairly loud and amazingly clear throughout the whole city area. Our Christmas concert has become quite a tradition around here."

Heavy metal madness. . . With **Tasco** providing sound reinforcement, **Whitesnake** headlines an eight-month tour after being the opening act for **Motley Crue's** June-October USA tour. . . Ireland's soulful **Simply Red** was out on a small venue/club tour and hired Tasco for sound and lights.

In the latter half of this year, **Speeda Sound** has been keeping busy doing sound for around a dozen California county fairs. Based out of Fresno, Speeda Sound is the largest sound reinforcement company in California's 500-mile long Central Valley. Many national acts perform at these fairs. A recent example was the Farmer's Fair of Riverside held near Palm Springs October 12th through 17th, where **Air Supply, Miami Sound Machine, and Kenny Log-**

gins had their sound provided by Speeda . . . According to owner **Mike King**, recent new equipment purchases include a dozen EAW 550 cabinets and EAW SB 550 subwoofers, 24 EAW dual 12-inch monitor cabinets and a Wheatstone/Audio Arts M16 32 x 16 monitor console. Crest 8001 amplifiers were purchased to power the subs. Speeda has several other Wheatstone/Audio Arts consoles and a large Eastern Acoustics Works inventory.

Monkees at the Zoo . . . On October 24th a fundraising concert at the Lowery Park Zoo in Florida featuring the **Monkees** was slated to attract a large outdoor crowd of around 40,000. **Turn of the Century Productions** provided 32 cabinets and full sound reinforcement for the event . . . A city-sponsored free show with **Tim Weisburg** drew approximately 25,000 people to a downtown park for a large outdoor show October 3rd in St. Petersburg, Florida. A short three-week mini-tour swinging through the Southeast with the **Gregg Allman Band** and several dates with **Molly Hatchet** have kept Turn of the Century busy . . . During October they also headed west to supply monitors for **Wayne Newton** in Las Vegas . . . TOC provided staging and sound for another large crowd at the Clearwater Seafood Festival with the musical **Beatlemania** held on the beach, and a four-day event at the Florida State Boat Show with **Frankie Valli** as the headliner.

Scheduled to tour until the summer of '88, **Rush** is using a quad (five-cluster) PA system provided by **Audio Analysts** . . . Roger Waters and another quad system went out again with AA for three weeks in November . . . **Heart** is out until the end of December and then on to Europe for a month . . . Globetrotting **Billy Joel** stopped off at the Hula Bowl in Hawaii October 12th before embarking on a tour of Australia and New Zealand.

Hey! Who luv's ya Babe? All you regional sound reinforcement companies—if you want to divulge to the rest of us what you are doing in the way of audio, give me a call. Everyone . . . have a good holiday season. ■

Author Mark Herman operates a sound reinforcement company specializing in console rentals.

Got any news? Call (415)726-2428 or E-Mail Herman. US IMC 2560 or send press releases, photos, etc. to: Sound Reinforcement News, *Mix* magazine, 2608 Ninth Street, Berkeley, CA 94710.

our heads stack up!
exceed original
manufacturer
specs

Your exclusive source for ATR100 timecode heads. Also, get our flyer for over 1,000 used equipment items. Call today for a pleasant surprise.

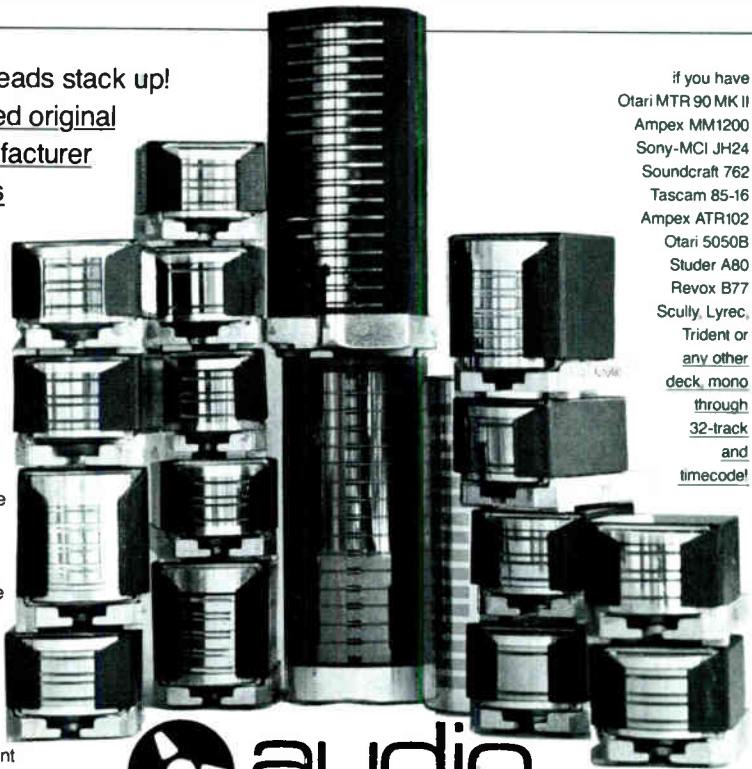

if you have
Otari MTR 90 MK II
Ampex MM1200
Sony-MCI JH24
Soundcraft 762
Tascam 85-16
Ampex ATR102
Otari 5050B
Studer A80
Revox B77
Scully, Lyrec,
Trident or
any other
deck, mono
through
32-track
and
timecode!



audio
village

po box 4692 • palm springs, ca 92263 • 619/320-0728

Circle #110 on Reader Service Card

Midwest Custom Record Pressing Company, Inc.

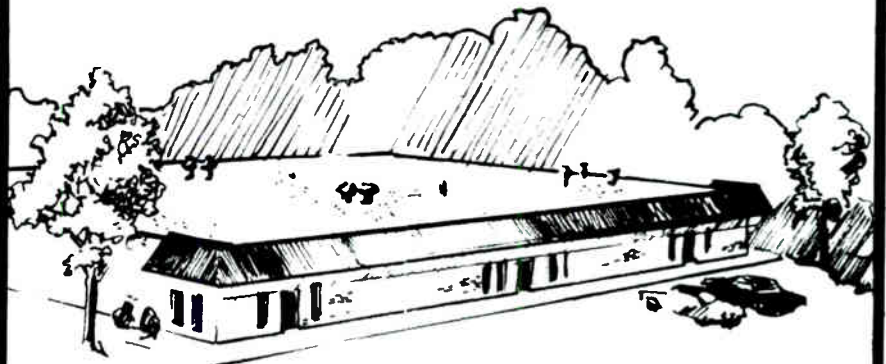

— COMPLETE MANUFACTURING PLANT —

Specializing in Records, Album Jackets & Cassettes. "No order too small!"
Convenient Midwest Location

Write or Call for Free Brochure & Professional Assistance!

#6 Grandview Pk. Dr., P.O. Box 92
Arnold, Missouri 63010 (314) 464-3013



Circle #111 on Reader Service Card

DIGITAL MUSIC CENTER: MIDI DEMYSTIFIED

by Bill Milkowski

A few years ago, entrepreneur Steve Friedman began noticing that many of the musicians who came into his Guitar Man shop on West 48th Street in Manhattan expressed a certain amount of apprehension about the inevitable onslaught of technology. These were mainly purists, more interested in vintage guitars than futuristic hardware: sequencers and software meant absolutely nothing to them, but they could ramble on for hours about the relative merits of a '57 Telecaster or an old Epiphone over the newest guitars on the market.

And yet, these purists were curious about this MIDI stuff. Trouble was, they just didn't know where to begin with it. And some of these stubborn guys, set in their ways after playing most of their lives with their vintage guitars, weren't likely to go back to school and learn it all from scratch.

So Steve Friedman came up with a great idea. "I was watching MIDI technology growing by leaps and bounds. And from being exposed to the response to MIDI from many of my clients, many of whom are very famous musicians, I could only infer that most musicians were staying away from the technology. I mean, for all the people who have been involved with it to this point, there are ten to 20 times more

people who need MIDI technology but have just been so afraid of delving into it that they've stayed away. So I decided to open a business where I would lead these guys by the hand, so to speak, introducing them to MIDI and computers and the whole ball of wax."

Friedman's Digital Music Center (at 155 W. 46th St.) opened just a year ago and has already attracted some notable clientele (Elliott Easton, T.M. Stevens, Carlos Alomar, to name a few). Friedman, himself a professional musician, having recorded with Lou Reed and played in bands with Dan Aykroyd and John Belushi, originally got involved with MIDI for personal reasons. But as the need became apparent, a business was born.

"I took a few courses in computer technology at New York University, thinking that computers might be a way for improving my business efficiency as well as improving my music writing capability. And I later decided that after learning the technology, I'd begin showing people how to use it. So it began primarily for my own projects and then I began introducing it to the musical public."

Perhaps the biggest project to date done at the Digital Music Center was Carlos Alomar's debut album on Private Music, the very orchestral-sounding *Dream Generator*. As Friedman explains, Carlos got his own MIDI education at the DMC.

"Carlos is a good case in point. He knew very little

about MIDI technology before doing this session. But before deciding how he was going to do his album he already realized that conventional means were not going to cut it. So

—CONTINUED ON PAGE 114

NAIRD: OPTIMISM AMONG THE INDIES

by Derk Richardson

CDs and DATs, *Billboard* charts and radio playlists, product configurations and retail breakouts. One thing that was clear at the 15th Annual NAIRD Convention, held at the Holiday Inn Golden Gateway in San Francisco, was that the nation's "indies" speak the same language and share the same concerns as the "big boys." At the panel discussions and workshops, the issues and rhetoric focused on merchandising and promotion: how small entrepreneurs can compete in an industry dominated by giant conglomerates. But the trade show exhibits, the awards banquet, and a few "why we're here in the first place" speeches reminded the business-oriented conventioners that NAIRD exists because its members provide something different when it comes to music.

For the past decade and a half, NAIRD, the National Association of Independent Record Distributors & Manufacturers, has pursued the goal of "perpetuating the independent

THE FAR SIDE

By GARY LARSON

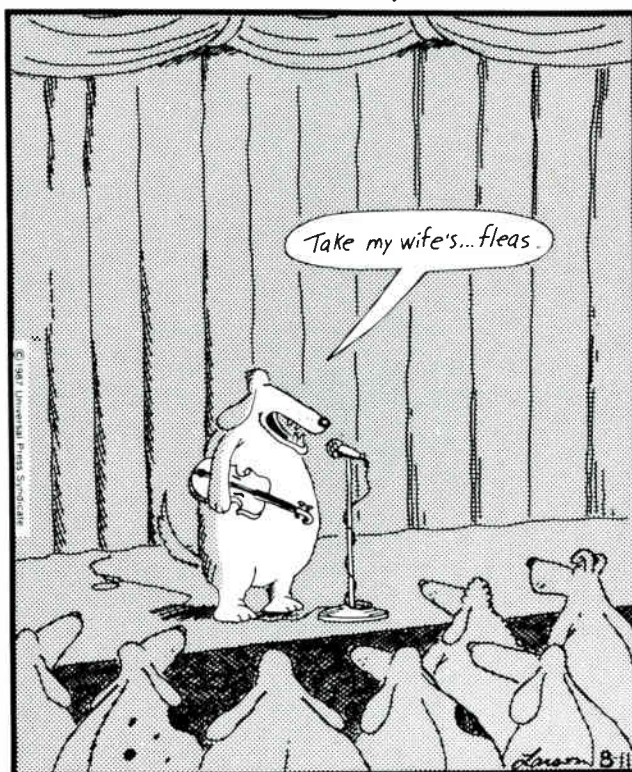

Canine comedians

alternative" in music. It operates like most any other trade association, coordinating activities and communications among its member companies, addressing central business issues, attempting to standardize business practices, and publicizing the independent music industry. In some ways it seems suspended between the mainstream and the underground, operating like a stepchild of the industry's prevailing major labels but sustaining a philosophy of almost righteous independence.

In his keynote address to the convention, Lou Kwiker, CEO of the Wherehouse retail chain, emphasized the central role of evermore rapidly evolving technology. After a long, relatively stable period of "mildly changing configurations," he noted, the industry has seen the explosion of 12-inch singles, compact discs, Beta and VHS, with DAT, CD-V and CD-I on the way. By 1990, Kwiker estimated, Americans will own between 17 and 22 million CD players, DAT will be in full flower, the LP will be relegated to collectors' bins, the 7-inch will be gone, Beta will be dead, VHS will be yielding ground to CD video, and the standard audio cassette will be in decline. He was willing to bet that in 24 months, the LP will account for only 5% of the sales dollar value of the prerecorded music market. To try to save the LP, he warned, would be like trying to catch a falling safe. His message to independents, therefore, was that no one can do well in an

—CONTINUED ON PAGE 118



On his recent television special, Chet Atkins jams with Dire Straits' Mark Knopfler.

CHET ATKINS: THE SUPERPICKER WITH SUPER STUDIO SAVVY

by Robert K. Oermann

Chet Atkins describes himself as "one of those kids that was always fooling around with electronics," and that childhood passion has led him through a career as one of the most renowned producers, guitar players, record executives and instrument inventors in the world.

At 63, he remains one of music's restless innovators and creative fountains. A fall Cinemax TV special showcases him with such admirers as pop king Michael McDonald, ex-Toto mainstay David Hungate and Dire Straits' Mark Knopfler. A critically applauded new LP, *Sails*, continues Atkins' evolution

from country picker to jazz hero.

A forthcoming LP by *Prairie Home Companion* man Garrison Keillor returns Atkins to the record producer's chair. A recently introduced Gibson guitar model that bears Atkins' name and inventor's touch is already a favorite of such renowned players as Sting and Knopfler.

As a picker, his influence extends to the likes of Earl Klugh, George Benson, Larry Carlton, Duane Eddy, Lenny Breau and George Harrison. Atkins' licks have embellished the records of Elvis Presley, Hank Snow, The Everly Brothers, Jerry Reed, Doc Watson and many others. During the 1950s, '60s and '70s he rose to a position as the

most popular and visible country guitarist of all time.

"When I was a kid, I used to sit around and try to play the melody about ten different ways," he says modestly of the genesis of his style. "On my records I've always tried to get in as much finger picking as I can. Because finger picking is me. It's what got me out of Appalachia and got me out here in suburbia with a swimming pool, a swimming pool shaped like a guitar *amplifier*," he adds with a laugh, referring to Nashville's infamous Webb Pierce pool shaped like a guitar.

That suburban house is where almost all of his creativity has taken place. For in its basement is the studio where he created most of his award-winning hits, where he has invented guitars for Gretsch and Gibson, where he has developed the distinctive guitar sounds for the records of others and where he records his current jazz-tinged LPs.

"To have my own studio was a dream all my life," he comments. "I built my own radios when I was a kid. Me and another boy who lived way out in the sticks hooked up telephones between my house and his, which was about a quarter of a mile. We'd run up a wire and talk to each other on battery telephones.

"Then during the war we built a transmitter. But we were afraid to put it on the air because you couldn't in those days because of spies and all. Then in Denver in 1947 I bought a disc recorder and dreamed of making mul-

—CONTINUED ON PAGE 120

MUSIC · NOTES

—FROM PAGE 112, DIGITAL MUSIC

I introduced him to the Photon guitar interface, giving him a conduit for his ideas right from guitar rather than having to communicate his ideas through a keyboard. Because, although Carlos is an adequate keyboard player, [his primary instrument is the] guitar. The voicings of a guitar are completely different. So my job was to fine-tune the Photon so that we could make it as easy as possible for Carlos the guitar player to use the interface, to communicate his ideas as clearly as possible without really altering his technique. So here was someone who would not normally be directly involved with the technology but could suddenly dive right into it and gain significant benefits."

Friedman is particularly hot on the Photon MIDI interface as a means of alleviating the guitar synthesizer blues. "It's the first guitar-to-MIDI interface that really has flexibility written into the software," he says. "The capability of adjustment for all of the parameters necessary to control the MIDI output

signal and triggering . . . it's all there in the Photon. In building this pickup, they did a lot of analysis of what guitar playing is all about. They studied the physics of guitar playing. Most guitar interfaces would not have provided the adjustability that would allow us to trigger the vast array of synthesizers that we used all at once on this project. We routinely used ten and 15 synthesizers at the same time. Being able to fine-tune the Photon to suit Carlos' particular style of playing allowed it to track well.

"We used a technique I call the Digital Method, which we devised especially for Carlos' record. We construct sounds for the guitar that are specifically engineered with the particular kind of triggering of the guitar interface in mind. Using this technique, we can take guitar performance and convert it very easily into orchestral pieces, without any tracking problems.

"Playing a guitar is not closing switches like a keyboard is. The way you trigger the strings has a lot to do with the expression, and we had to devise techniques to balance the way the output of the interface was trigger-

ing various sounds. The great difficulty of recording from any kind of interface to MIDI is that the triggering of the various synthesizers with different sounds is very different one to another. And even within the same synthesizer the triggering can vary greatly. But the Digital Method solved that."

Alomar came to the DMC with seeds for songs in the forms of guitar riffs. Using the Photon guitar interface, Friedman MIDIed him up to whole banks of synthesizers with the Macintosh Plus/Total Music software running the show. After auditioning sounds, the following process ensued:

"Carlos would run through the tune in real time, just to get an idea of how he wanted it to develop. And once he developed it to a secondary stage we would take that tune in the computer and then cut-and-paste, rearranging the tune . . . doubling phrases here, changing a note there, basically making an arrangement out of the parts. We'd do this process for one or two tunes a day. Then Carlos would take home a work copy of the cassette and from there he would develop the idea, build the transitions in and really think

dynafex[®]

Because it's a noisy world.

- Up to 30dB noise reduction (better than many compressor/expander systems)
- Works after the fact – no encoding or decoding required
- Simple, trouble-free operation
- Effective on any audio program material.

Dynafex. The *final* step in post-production.

Call 1(800) 535-7648 or write CRL today for the name of your nearest Dynafex dealer.

2522 West Geneva Drive, Tempe, Arizona 85282
(602) 438-0888
TELEX: 350464
CRL TMPE. UD.



Circle #165 on Reader Service Card

World Radio History

CARVIN's MX2488 for \$4395!

THE AMERICAN-MADE MIXER THAT LEADS IN VALUE!

MX2488 RECORDING FEATURES

- Eight Track Studio Control Center
- Quick Tape Playback and Rough Mix Capability
- Three Band Parametric EQ with Defeat
- Complete Cue Mixing Facilities
- Four Auxiliary Busses with Pre-Post Switching
- Two Effects Returns with Panning and Soloing
- Patch Jacks and Direct Outputs On Each Channel
- Solo and Mute On All Input and Output Channels
- Built-In Talkback System and Monitor Dimming

If you want a transparent sound that fits into today's "digital" recording world, then the MX2488 is worth considering. The CARVIN MX2488 console offers the features and performances you expect from a professional recording console—at a price that's unmatched! CARVIN sells DIRECT, saving you about half the retail price with no commissioned salesmen or store overhead to pay.

The MX2488 is versatile. It handles every recording requirement with ease, from basic tracks to overdubs and mixdowns.

The MX2488 is professional—right down to its modular design and outboard rack power supply. A recent MX1688 test review quoted: "Total harmonic distortion at mid freq. measured only .025% while line inputs measured only 0.01%—very low for a console of this type."

Write for literature and a recent test review, or send \$15 for the complete manual (100 pages) including schematics and circuit layouts.

"Having lived with the Carvin MX1688 for a couple of weeks before reluctantly sending it back to the manufacturer, I can attest to the fact that it is truly targeted at the professional recording engineer or sound reinforcement engineer. It is obvious that the people who designed this unit spent a lot of time in both recording studios and at concerts where sound reinforcement is both critical and complex."

Len Feldman—*db* magazine
September/October—1986



FACTORY PRICES:

	LIST	DIRECT
MX2488 24x8x2.	\$8995	\$4395
MX1688 16x8x2.	\$6950	\$3395
MX1644 16x4x2.	\$4595	\$1895
AN-16 16ch Anvil Case	\$ 395	\$ 269
AN-24 24ch Anvil Case	\$ 469	\$ 299

CARVIN

FACTORY MAIL ORDER:

Dept. MX77, 1155 Industrial Ave.
Escondido, CA 92025
TOLL FREE: 800-854-2235

HOLLYWOOD STORE:

7414 Sunset Blvd.
Hollywood, CA
(213) 851-4200
STORE HOURS: 10 a.m.-8 p.m. M-F
10 a.m.-6 p.m. Sat.

World Radio History

CARVIN 1155 Industrial Ave. Escondido, CA 92025

Free Catalog \$15 Enclosed for MX88 Manual

NAME _____

STREET _____

CITY _____ STATE _____ ZIP _____

Praxis makes perfect

*In a technology where
quality is premier
and subtle differences are
critically important...
Praxis makes perfect.*

*Look to the superior com-
pact disc manufacturer for
service, manufacturing and
competitive pricing.*

*Contact: Loran Cassettes
and Audio Products
(818) 955-8577
In Canada, contact:
Praxis Technologies Inc.
(416) 673-9544*



PRAXIS
TECHNOLOGIES INC.



MUSIC · NOTES

the piece through. So in that respect, the computer was a compositional aid.

"Once the piece finally took some form, we would record Carlos' performance of the new arrangement he decided on. That still would not be the definitive arrangement, but since the data in the sequencer is completely and continuously editable, we kept copying and merging until we had it."

Friedman relied heavily on the Kurzweil 250 throughout the recording of *Dream Generator*, along with the Oberheim Matrix 6R, Akai 612 sampler, Akai S900 sampler, Oberheim expander, Yamaha FB01, PPG Wave 2.3 with Wave Term, Prophet VS, Korg DW8000 and a Casio CZ1, among others. A Yamaha RX-11 drum machine was used in a few spots for drum loop parts and the Kurzweil 250 supplied other percussion parts, triggered by Alomar's guitar. From the orchestral-sounding "Hallucination" to the very ethereal title cut, it's a triumph in technology.

"I believe that it's the first of its kind," Friedman says proudly, "because the intent was not to have the guitar be an accompaniment or solo instrument. It was meant to perform the whole thing. I know there are other guitar players who have used MIDI technology to do albums, such as Allan Holdsworth and Pat Metheny. But in general, their albums have not been orchestral affairs."

Friedman and partner Mark Sterling very carefully programmed the synthesizers to be as natural sounding as possible. And they refrained from quantizing whenever possible.

"Most albums suffer from the artificiality of automatically quantizing to perfect quarter notes so everything is lined up. An orchestral album done that way would sound very artificial. So that put a tremendous burden on us. We would have Carlos and his engineer (Andy Hiernans) sit down with us at the Macintosh and actually redraw the notes in where he intended them to be—not where they would fall if the computer was quantizing them, but where the performing artist himself felt they should be placed. So it was a very long session of painting notes in.

"And, ironically, since the release of the album, Southworth has come out with some new software called MIDI Paint that allows you to automate the process somewhat. It would've been a

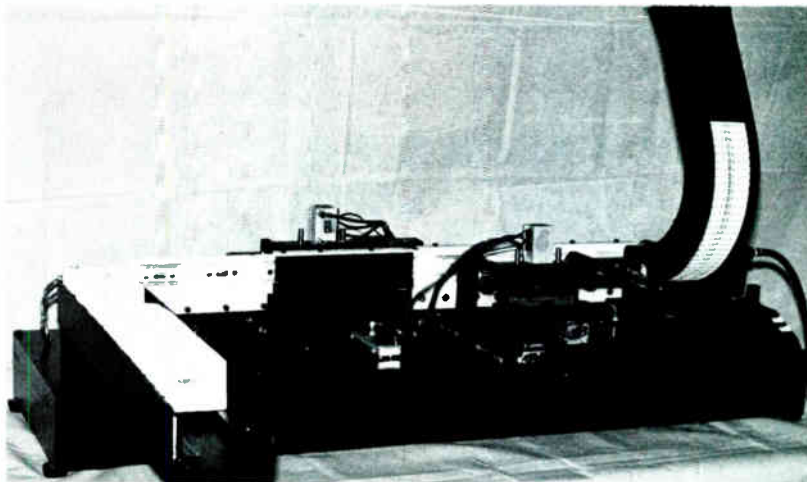

Now You Have A Choice The Auto-Padprint® Imprinter

Print direct on your product, save time and money, versatility to print two or more colors. Compact unit 16" W x 50" Long, weight 125 lbs.

1800-2000 units per hour, both sides printed in one pass, automatic infeed and offloading.

Of course we still manufacture our plain paper labeler and die cutting equipment for paper labels.

Demonstration video available, specify VHS or BETA.

Manufactured and Sold by: **CST Manufacturing & Sales**

6679 Peachtree Industrial Blvd. • Suite J
Norcross, GA 30092 • (404) 449-4903

Call or write for literature
and sample cassette

Circle #166 on Reader Service Card

April 1988 VIDEO FACILITIES

If your company is involved in
any area of

Video Production

and

Video Post-Production,

your directory is coming in

April 1988!

To be included with your **FREE**

listing, call or write:

Mix Directories Dept.
2608 Ninth Street
Berkeley, CA 94710
(415) 843-7901

Deadline: January 2, 1988

QUALITY STANDS THE TEST OF TIME.

RECORD JACKETS & LABELS • 7" SLEEVES • CASSETTE INSERTS & LABELS • POSTERS • PRESSURE SENSITIVE PRODUCTS • A COMPLETE SERVICE TO THE INDUSTRY

... WE STAND THE TEST OF TIME ...

KEYSTONE

GRAPHIC PRODUCTS FOR THE RECORDING INDUSTRY

Printed Specialties | Co., Inc. 1 KEYSTONE PLACE • JESSUP, PA 18434 • 717-383-3280 • FAX: 717-383-2320

MUSIC · NOTES

lot easier using this new software but . . . those are the breaks when you're dealing with technology."

One of Friedman's next projects for the Digital Music Center will combine his current interest in technology with one of his old passions. "We're working on building our gigantic library of sampling discs," he explains. "We're going to be doing some special stereo sampling of vintage electronic guitar sounds through various kinds of amplifiers, which we'll be making available to the public later this year."

So, finally, now all you keyboard players and synth freaks out there who have been dying to get the classic Gretsch Falcon sound or the classic Les Paul TV model sound—just pay a visit to the MIDI doctor at the Digital Music Center and let him lay a sample on you. ■

—FROM PAGE 113, NAIRD

inexorably declining business, and that the small manufacturers and distributors had better keep up with the new technology. Make sure, Kwiker said, that right, growing product, bar-coded of course, is consistently in stock.

Jay Berman, president of the RIAA, followed Kwiker with an equally ominous speech. Arguing that the RIAA, which represents the major powers of the recording industry, should not be seen as the enemy of independents, Berman portrayed his trade association as a "service organization" for all music manufacturers and stated that its primary immediate concern is the elimination of record piracy. "Let me say 'dis about DAT," he joked. Then he turned somber and called DAT the "jaws" of music, posing the "most serious technological threat to prerecorded music" ever conceived.

But after those forboding words from the mogul side of the industry, NAIRD turned to its own, and with increasing frequency, the importance of music shone through. On a panel of "Legends—Past, Present & Future," Gene Norman, for 33 years the president of GNP Crescendo, which he called "the oldest unsuccessful record company," told how he spent \$75,000 on promotion to get the latest Robin

Trower album, *Passion*, to number 100 on the *Billboard* chart. "Royalties," he sighed. "I dream of royalties." Norman's practical advice included, "Own the music, own the masters, own the copyrights. . . Join ASCAP and BMI, they cost you nothing and they send you money!"

On the same panel, Fred Catero, with 38 years of experience as an engineer and producer, and owner of a small label, told fellow indies not to panic over the new configurations. "CD is just another form of storing sound," he said, "and in a few years, any independent will be able to use it." The CD is here to stay, he agreed, while arguing that the potential sound on an analog LP is better than the current compact discs. But DAT, he prognosticated, is doomed before it begins because all tape degenerates. Look for the turntable that reads LPs with laser, he smiled, refusing to talk about the project he's been working on recently.

In other meetings, the independents discussed the value of computers in running small businesses; how to avoid million-dollar mistakes; how to get a break with commercial radio; how to facilitate better relationships between labels and distributors; how to reach retailers; and the meaning and value of the charts. The sessions were cornucopias of complaints and cues, delivered in colorful colloquialisms. New age mavens talked about "trust" and "friendship," Tom Silverman of the hip-hopping Tommy Boy Records cited the importance of "perceived excitement" and slyly alluded to the necessity of good "lube jobs" in getting the right people to pay attention to your record.

In "Special Interest Breakout" sessions, purveyors of different sorts of sounds, such as reggae, jazz, Celtic, folk, dance/R&B, and women's music, put their heads together and tried to come up with practical applications. At the trade show, set up in the early evenings on Thursday and Friday, they displayed their wares. Most tables featured the newest record releases of such independent labels as Redwood, RAS, Green Linnett, Flying Fish, Rounder, Red House, Turquoise and Alligator. But compact disc manufacturers, distributors and cassette tape duplicators were on hand as well.

At the awards banquet on Saturday night, the music and its makers finally got their due. After a rousing set by

stride specialist jazz pianist Mike Lipskin, the organization inducted the late Mo Asch and Kate Wolf into the NAIRD Hall of Fame. Sam Charters gave a moving tribute to Asch's 40 years of pioneering work as the founder and force behind Folkways Records. "Mo's aim," he said, "was to document every form of human expression," and he managed 2,200 LPs' worth before he died. Tom Diamant, of Kaleidoscope Records in El Cerrito, California, accepted on behalf of Kate Wolf, simply acknowledging the deep, humane and loving music the Northern California folksinger left behind.

Wolf's *Poet's Heart* won the 1986 NAIRD "Indie" Award for outstanding folk album. Many of the other categories were dominated by Chicago's Alligator Records (Albert Collins' *Cold Snap* in blues and album design, Dr. John's *Gumbo* for liner notes) and Rounder of Cambridge, Massachusetts (Nanci Griffith's *Last of the True Believers* for country, the Dirty Dozen Brass Band's *Mardi Gras in Montreux* for jazz, Allan Stivell's *Harpes Du Nouvel* for new age and the Klezmer Conservatory Band's *Oy Chanukah* for

Seasonal/Holiday). Other "Indie" winners included the Timex Social Club's "Rumours" (Jay) for best 12-inch single, Robert Cray's *False Accusations* (Hightone) for best compact disc, Tito Puente's *Sensacion* (Concord Picante) for Latin, Hank Williams' *The First Recordings* (CMF) for historical, *Children of a Lesser God* (Crescendo) for soundtracks, Casselberry-Dupree's *City Down* (Iceberg) for reggae, Ladysmith Black Mambazo's *Inala* (Shanachie) for world/ethnic and Robin Trower's *Passion* (Crescendo) for rock.

The victory of a virtual old fogie like Trower, in a category whose other nominees were Teresa Trull and grizzled veterans Commander Cody, Roy Buchanan and Lonnie Mack, underscored the absence of the legions of "underground" rock labels from the NAIRD roster and convention. "I guess we're having a hard time kicking the folkie reputation," said executive director Holly Cass, "but we are trying to reach out." It might be an attitude of staunch independence and a resistance to trade organization that keeps such thriving punk, new wave and garage band labels as SST, Enigma, TwinTone,

Slash, Big Time and Homestead away, although several of those labels already have close links to the majors. If they could be recruited, the "alternative" nature of NAIRD might be both broadened, encompassing a huge chunk of popular but independently produced music, and strengthened by the sheer numbers of indie rock labels.

In the meantime, NAIRD will continue to thrive as a significant network for its members and as a forum where they can air their concerns. As Shelly Lowe of Oakland's Redwood Records noted of the convention, "It's a chance for us to learn about the current issues and the emerging technology affecting this part of the industry." Another, more cynical label executive, wishing to remain anonymous, added, "It's a way to find out if we're paying the right people." Whatever the orientation, it was clear that most of the NAIRD members would be quite happy if they could follow the advice of Crescendo's Gene Norman. "Build a small empire for yourself," he said, "and have a great time doing something you really love: working with music." ■

Kdisc Mastering



**Harmonia Mundi
Digital Interface
Console**



Presents



**Neve
Digital Transfer
Console**

Kdisc mastering

6550 SUNSET BOULEVARD, HOLLYWOOD, CALIFORNIA 90028

(213) 466-1323

—FROM PAGE 113, CHET ATKINS

tiple-track recordings with *two* disc recorders.”

That was the beginning of a remarkable career as a studio builder and manager.

“Les Paul was my inspiration, because I knew all about him. See, my brother [Jim] and Les had a trio, and he would tell me all about Les when I’d talk to him. I admired him a lot, his technical prowess. I emulated him.”

By following in the tracks of one of music’s multi-track recording pioneers, Atkins himself became a trail blazer.

Chester Burton Atkins is almost certainly the world’s most recorded solo instrumentalist. A member of the Country Music Hall of Fame since 1973, he is one of the creators of the famed studio technique known as the Nashville Sound.

He was the head of RCA’s Music City office for 22 years, guiding the star-making recording sessions of Waylon Jennings, Jim Reeves, Bobby Bare, Dottie West, Skeeter Davis, Don Gibson, Eddy Arnold and dozens of others. He signed Willie Nelson, Dolly Parton and other future superstars. He built the company into the most powerful label in Nashville.

His deft instrumental touch, continual studio technical development, quick-study abilities and sharp ear for quality have led to eight Instrumentalist of the Year accolades from the Country Music Association, more Grammy Awards for instrumental work (eight) than any other country picker, 14 consecutive *Cash Box* Top Instrumentalist awards, four *Playboy* jazz and pop guitar poll honors and 118 guitar LPs. In all, more than 40 top music industry accolades line the shelves and walls of his office on Nashville’s Music Row.

It all began for him less than 200 miles east of there, in the small Clinch Mountain community of Luttrell, Tennessee. Born June 20, 1929, Atkins grew up in a musical household. Father James taught piano for a time. Older brother Jim left home at 16 to become a professional guitarist. Although the mountain farm family was poor, Atkins was given first a ukulele and then a fiddle to encourage his musical development.

His parents divorced in 1933. His mother remarried and Atkins’ stepfa-

We've Got You Covered!

If you've got your act together, we can get your master out on Compact Disc in **2 WEEKS!** This includes CD Singles with Laser etched graphics and 4-color printing on the Disc itself. We'll also be producing CD/V by the end of January, so give us a call today and your CDs could be only 2 weeks away!

PRODIGIAL (202) 635-5588



Circle #114 on Reader Service Card

TASCAM • FOSTEX • J.L. COOPER • SOUNDCRAFT • JBL

TAKING MULTITRACK BY STORM—
LIGHTNING MUSIC & SOUND!



TELEPHONE-MAIL ORDERS
SHIPPED ANYWHERE



Huge Selection of Recording Gear & Effects
MIDI/SMPTE Specialists

The Southwest's only Authorized
TASCAM ATR80 24 Track Dealer



4801 Spring Valley #103 A • Dallas, Texas 75244

(214) 387-1198

Circle #115 on Reader Service Card

ther, Willie Strevel, was a blues fan who played a bit of slide guitar. In 1935 Chet went to live with his father in Georgia. By this time the youngster was taking his guitar with him everywhere he went.

His interest in technology was budding, too, for this is the same era during which he began building two-tube radios and tinkering with electronics. The radio broadened his horizons: Les Paul and Jim Atkins' broadcasts over NBC radio from New York weren't Chet's only guitar influences. He also tuned his homemade crystal set in to Cincinnati's WLW where he heard the finger picking of Merle Travis and to Chicago's WLS where he heard the jazz sound of George Barnes.

Hearing Paul, Barnes and Travis led Atkins to invent a homemade way of electronically amplifying his guitar. Then he began looking for ways to hook it up, and this led him to radio studios. At first he played near home over WNOX in Knoxville, Tennessee. Then he began to travel, landing country guitar jobs on stations in North Carolina, Ohio, Illinois, Missouri and places further afield. He made his re-

ording debut in 1946 in Nashville.

A series of radio transcription discs he'd made for KWTO in Springfield, Missouri, caught the ear of RCA's Steve Sholes, who signed him to a recording contract in 1947. As a sideman for Mother Maybelle & The Carter Sisters, Atkins moved to Nashville and a slot on the Grand Ole Opry in spring, 1950.

His faultless execution and technical savvy rapidly attracted attention in Music City, then just beginning to emerge as a recording center. RCA was increasing its presence in the infant country capital. When it began operating its own studio in 1955, Atkins was placed in charge. Two years later when the label opened historic Studio B, now a museum, Atkins was again the guiding force.

During the subsequent three decades the country picker has helped supervise one of the world's major recording centers as it has moved from disc recording to tape, from tape to multi-track tape and from there to digital equipment.

"I think probably the biggest transition was from disc to tape," Atkins recalls. "I wasn't into engineering so

much back in those days. But I remember that at RCA the machines were custom made. They ran at 30 ips on 7-inch reels. We got pretty good quality after a while, but I think the head room on those things was pretty low.

"The engineers in New York told me their first machine had come from Germany. They were the first ones that got it, it had been captured during the war and brought back to RCA. It sat around in the hallways. They went through it and copied down all the specifications and everything, made diagrams and released them to the industry. They didn't make a tape machine themselves because they said disc is better, which of course it actually *was*—when you go direct to disc it is better sound.

"So anyway they said, 'Well tape's not gonna be the thing. It'll be disc.' So Ampex came along and put out the first machine with help from Bing Crosby and some other people. But RCA could have put it out first.

"Of course, after tape got to be the thing, the advantages of editing and all these things became obvious and they got on the bandwagon."

WOLF IN SHEEP'S CLOTHING



Don't let the wool be pulled over your eyes. Today's professional 16 track recording consoles all have similar features, all utilize quality components, all sound good and most come from England. What we don't understand is why they cost so much.

Aries has selected the best of current technology, we only use quality components, we have all the bells & whistles—just like the rest of the flock. So what makes us different? Our price.*

We're not sheepish about our low price—after all it's what's under the clothing that counts.

**CREATIVE
MARKETING
GROUP, INC.**

Professional mixing consoles from Aries.

Imported from England

2720 Monterey St., Suite 403, Torrance, CA 90503 213-533-5112

ARIES 16

*16/8/16 \$5995.00 *24/8/16 \$7499.00

MUSIC · NOTES

Studio B on Music Row was opened in late 1957 with a monaural recording system which could be altered to stereo. It also had a Scully lathe with a feedback cutter for cutting 45 rpm reference lacquers on the spot. In August, 1960, Atkins approved the adding of a tape mastering room, a lacquer mastering lab and additional studio space. In 1964 he added the larger Studio A, still in use, in the basement of the large RCA office building next door.

That still wasn't enough to contain his experimental nature. "All my old records were done live. When we went to 3-track and 4-track and 8-track I bought a machine for my studio at home, so I could cut tracks in the RCA studio and then take 'em home and put my part on. That's really the only way I *could* do it. I was producing between 35 and 40 artists—can you believe that?

"Before we went to 3-track that's what I was doing. When we got into multiple, having to mix down and everything, I began to hire other people to record some of the artists. Anyhow, I

would take the tapes home late at night or put my part on early the next morning at home. And they sound like it, some of them. Some are out of tune, half-assed. But they sold a hell of a lot of records. It was amazing how many records I sold around the world. And they were all done half-assed.

"I think we got into 3-track around 1960 probably, then finally into 8- and 16- and 24-track."

This was around the same time that he, producer/pianist Owen Bradley, guitarist Grady Martin plus producer Don Law, and vocal arranger Anita Kerr began developing the "Nashville Sound" studio method. Atkins mixed the rhythm guitars up front, riding atop the mix to create a steady "jinga-jinga" tone to define the discs as "country." Beneath this he mixed Kerr's creamy harmony vocal group sighing which added a pop flavor. Sometimes strings were added. The lead vocalist was given a slight echo and pushed way out in front of all other sounds.

"The way I made records was we'd take a song and gather 'round the piano and play it awhile and say, 'How about this for an intro?' or 'That's an

interesting sound.' I'd say something or [pianist] Floyd Cramer would or Grady Martin or [guitarist] Hank Garland or somebody. I didn't play too much guitar on records unless the artist asked me to. I played with Don Gibson on his hits or with Jim Reeves because they specifically asked me. But we'd just gang around the piano and my job was to sift the wheat from the chaff and try to make the whole thing sound good on tape.

"I surrounded myself with friends who liked me and would suggest things. We made a hell of a lot of hit records that way. People think that we sat around and invented the Nashville Sound. All we were trying to do was to keep from getting fired! Me and Owen weren't trying to set any trends or anything."

Atkins has kept the technique in use at home for the rehearsal and/or recording of the recent trio of CBS LPs that have brought him new acclaim as a jazz stylist—1985's *Stay Tuned*, 1986's *Street Dreams* and 1987's *Sails*.

"I've had equipment in my home since about 1956 or '57. I started recording some things, solo things, there.

The new master recording process





Cinemax sessions: Chet Atkins & Friends including Waylon Jennings, Emmylou Harris, Ray Stevens, Chet Atkins, The Everly Brothers, Michael McDonald, David Pack, Mark Knopfler and Willie Nelson.

Dolby[®] SR Dolby[®] spectral recording



Dolby Laboratories Inc., 100 Potrero Ave., San Francisco, CA 94103.

'Dolby' the Double-D symbol, and the Dolby Stereo logo are trademarks of Dolby Laboratories Licensing Corporation. S87/784c.

World Radio History

24 TRACK RECORDING FOR LESS THAN \$700 PER TRACK

Akai ML14 Autolocator

Akai MG14D Recorder

ADAMS · SMITH ZETA THREE

Akai MG14D Recorder

Akai ML14 Autolocator

Combine Akai Professional's MG14D/ML14 Multitrack Recorders and an Adams-Smith Zeta Three Synchronizer and you have the ultimate 24 track recording studio.

The MG14D features:

- 12 Audio Tracks
- 1 Time Control Track
- 1 Sync Track
- SN 94 db
- EIN - 128
- Dynamic Range 115 db
- Frequency Response:
19 cm 50Hz to 20KHz
9.5 cm 50Hz to 16KHz

**ADAMS · SMITH
ZETA THREE**

- Audio/Video/MIDI/SMPTE Synchronizer
- 2 full range time code readers
- SMPTE/EBU time code generators
- RS232/422/MIDI communication

AKAI
professional

Creative at Heart

For a complete demonstration, see your locally authorized Akai Professional Dealer or write:
Akai Professional, P.O. Box 2344, Fort Worth, TX 76113 / Ph: (813) 336-5114, Telex: 163203IMCTXUT, Fax: (817) 870-1271



My first equipment was two Magnacorders. Then I got into a better quality Magnacorder that used 10-inch reels. Finally, I had an old RCA console, built for a radio station. I was just mono in those days, like everyone else.

"Then I got an Ampex. I don't remember the model number. Then I got a 3-track Ampex where I could have the band on the outer tracks and put myself in the center. What I have now is an MCI 24-track. My console is a Series II Neotek. It was always just a love of electronics that led me along.

"I recorded *Sails* at home in my studio with David Hungate and [engineer] John Mills always in attendance."

He brought the old Nashville Sound sensibility home with him.

"Most of the tunes for *Sails* were done that same way. They were started with just a trio of us, all contributing ideas, then building on that with synthesizers.

"I think I always keep the quality of the music in mind foremost. But at the same time I realize that there are a heck of a lot of people out there who are changing the record setups and going digital and everything. That's the reason we mixed down to digital. I like that sound.

"The last two projects I've done for other people were mixed down to a VCR with one of those little Sony audio/digital rack jobs. That was an interesting experience because I almost made a couple of mistakes: I almost didn't leave enough room on the front of the tapes for the digital information to lock in when we mastered.

"One of those albums is by Garrison Keillor, which will be out this fall on MPR, the Minnesota Public Radio label, distributed by PolyGram.

"Actually, I quit producing about six years ago. I don't want to do it anymore. But a guy like Garrison, I love him so much. And I didn't have to listen to 100 tunes to find a good one, because he had all of them: just some back-home country-folk type tunes.

"He called me one day and said, 'Let's do an album.' I said, 'Okay.' So he came down to Nashville and we did it in about three days. Then I took the tapes and cleaned 'em up and did some overdubs with some voices and things. It was a very easy album to do.

—CONTINUED ON PAGE 163



LEARN THE ART OF RECORDING



LEARN CREATIVE RECORDING SKILLS ON THE LATEST EQUIPMENT AT THE LEADING SCHOOL FOR SOUND ENGINEERS, PRODUCERS AND STUDIO MUSICIANS. WITH OR WITHOUT PREVIOUS EXPERIENCE, IF YOU'RE SERIOUS ABOUT A CAREER IN RECORDING, OUR 'HANDS-ON' TRAINING PROGRAMS CAN GET YOU STARTED AND PUT YOU AHEAD. FOR FREE BROCHURE, PLEASE CALL OR WRITE TODAY.

THE RECORDING WORKSHOP

455-X MASSIEVILLE ROAD, CHILLICOTHE, OHIO 45601
(800) 848-9900 (614) 663-2544

OHIO STATE BOARD OF SCHOOL AND COLLEGE REGISTRATION #80-67-0696T

Circle #117 on Reader Service Card

2 Ways To Duplicate Your Master Audio Tape For Demos Or Retail Sales

AUDIO CASSETTES:

Eva-Tone is a full-service supplier, offering duplication, labeling, packaging, additional printing and complete mailing services. Write or call for your free copy of "Cassette Talk," our newsletter complete with information, specs, layout sheets and prices.



SOUNDSHEETS:

Use these thin, flexible vinyl recorded discs as audio pages in magazines, as direct mail inserts, as handouts at concerts or trade shows, or even as retail products. Write or call for your free copy of our Soundsheet Idea Kit, complete with information, samples, specs, layout sheets and prices.

PRINTING & MAILING:

Ask your Eva-Tone Representative about our commercial printing and mailing services, too. We just may be the full-service promotional supplier you've been looking for!

EVA-TONE
INCORPORATED

P.O. Box 7020-MX, Clearwater, Florida 33518-7020
Toll-Free 1-800-EVA-TONE (In FL: 813-577-7000)

Circle #118 on Reader Service Card

ALF CLAUSEN & SCORING FOR TV



Composer Clausen's TV credits include "Moonlighting," "Alf" and "Fame."

primarily in television. "But six weeks in the Big Apple playing and hearing music that came from the heart changed everything. When I got back to campus I could detect an immense difference between the technical perfection of a mechanical engineer and the soul of a musician. I guess I had finally figured out where I belonged."

Graduate study at the University of Wisconsin put the starry-eyed young musician in private study with John Barrows, whose French horn was part of recording history on such legendary albums as *Miles Davis Plus Eleven*. "Barrows was terrific and demanding," Clausen says. "I learned a lot about playing from him and also learned how much I loved writing. But I needed something more than what that college's graduate studies could provide. I guess how the music was put together became as important as how it was played. So I started studying arranging and composing by mail. Don't laugh, it was the very beginning of my 'desperation is the mother of invention' theory."

At that point, Boston's Berklee School was the only place where Clausen could pursue his studies by mail and learn the working knowledge of theory that was to get him started on his way to Clio, Emmy and Grammy nominations.

After finishing his correspondence efforts, he moved to Boston to continue his studies. "In those days, the only way a musician could survive in Boston was to do three jobs at once," he remembers. "I ended up teaching at Berklee, playing anywhere they would let me and arranging for local bands and singers."

Soon, the lure of the West Coast took hold and Clausen packed the family and his hopes off to L.A. "It was a completely different town in those days," says Clausen. "A good musician could always find a job with a house band or he could play a party—there were clubs on every corner, and weddings and anniversaries cried out for

Desperation is the Mother of Invention

by Pauline B. Rogers

It was a time of bobby socks and saddle shoes, rolled-up jeans and poodle skirts. Television was in its infancy. It was a time when intelligence tests instead of instinct were telling innocent youths what they were supposed to do with their futures.

In a small North Dakota town, the test scores told a young college-bound student named Alf Clausen that he had a penchant for numbers and that he should pursue a mathematical career. But soon afterward North Dakota State University had a new student in mechanical engineering who seemed far happier with a musical instrument in his hand and an arrangement on his drawing board.

"Everything would probably have gone along as planned if he hadn't gone to New York City one summer to visit a cousin who was a working musician," says Alf Clausen, now one of the most successful composers working

PHOTO: PAULINE ROGERS

A T T E N T I O N

SOUTHEAST RECORDING STUDIOS

The yearly **Mix Directory of Southeast Studios** will be published in March, 1988. Don't miss this **FREE** opportunity to have your message appear in over 44,000 copies of **Mix**. * To receive a questionnaire or more information, call the **Directories Dept.** at (415) 843-7901.

Special 2 for 1! By listing in your regional directory, you'll receive the same listing **FREE** in the **1989 Annual Directory!**

*Source: Publishers' BPA circulation statement for six months ending June 1987. (Average of qualified and non-qualified circulation.) Call or write for statement.

live music. I played bass at night and French horn during the day. It kept food on the table."

But it didn't always feed the musician's soul. Clausen's need to write cried out. He was constantly arranging and composing. "I'd listen to arrangers like Quincy Jones—the way he dealt with the orchestra from a writing standpoint. The combination of instrumental colors fascinated me. He took traditional big band composition techniques and expanded on them and made them contemporary. Unlike many other more traditional composers, he tended to orchestrate across the band from front to back, instead of side to side. He used intriguing combinations of muted trumpets, flutes, tenor sax, etc., in Duke Ellington's style."

Clausen was no stranger to rejection in this time of his life. "Persistence is the only road to success," he tells the young hopefuls who come to him for help. "I knew how many others just like me were out there waiting for the breaks. I also knew how important the virtue of patience would be." Persistence led him to a few jobs for Tony Orlando and other variety performers, and to bits on *The Donny & Marie Show* where, thanks to good friend Tommy Wolf, he got the chance to step in to do a chart here and there. He eventually became the musical director of the show.

"The career progression sounds so easy, but it wasn't," says Clausen. "There were the lean periods, times when all I could get was ghost work. Don't get me wrong; I learned a lot filling in for over-booked orchestrators and composers. There's no substitute for learning the techniques the right way. But it's hard when you have your own way of working and it's so different than the style you're supposed to be doing. Both of you might be right, but with the time pressures, there's only one right—the leader's! If the producer asked for a change, it was done his way. The worst part of it is, you usually can't suggest an alternate way to get to the same effect with your style of music. That's known as dues!"

"The 35 *Donny & Marie* episodes

Unmistakably
wireworks

You know the audio cabling equipment is Wireworks when it's manufactured flawlessly, when it tests perfectly, when you need it today — and get it yesterday (at yesterday's prices), when the quality, service, and warranty are unmistakable...

Wireworks: when you absolutely can't afford to make a mistake.



WIREWORKS CORPORATION
380 Hillside Avenue Hillside, NJ 07205 201/686-7400 TWX: 710-985-4675
800/624-0061 (Nationwide) 800/235-9473 (NJ)
Official Cable Supplier for Opening and Closing Ceremonies of the Pan American Games

Circle #120 on Reader Service Card



Checking his watch, Clausen roughs out a piece for "Moonlighting."

gave me a firm basis for working with an orchestra and for dealing with last-minute choreography changes. Patience was once again a virtue. The 22 episodes of Mary Tyler Moore's variety show that followed taught me even more. From there I learned great organizational sense, how to perform un-

der the gun, and most of all, how to delegate responsibility."

The pace of his career accelerated rapidly from there, to the point where his credits now boast dozens of TV shows, specials, commercials, films and record dates, variously as composer, arranger and/or orchestrator.

Among his film credits are *Dragnet*, *Weird Science*, *Mickie & Maude*, *Splash*, *The Journey of Natty Gann*, *Ferris Bueller's Day Off* and *Into the Night*. His TV credits are too numerous to list, but include shows like *Moonlighting*, *ALF*, *Partners in Crime*, *Remington Steele*, *Little House on the Prairie* and *Fame*.

"The composing began slowly," he says, "a little for *Fame*, then *Wizards & Warriors*, and *Lime Street*, as well as a few others. Then a call came from composer Lee Holdridge, a friend from way back. He'd gotten in touch with my agent and asked for me to work with him on the pilot for the new ABC series called *Moonlighting*. He was going to suggest me as staff composer for the show. Who knew it would turn into this kind of phenomenal hit?"

Two seasons, over 35 episodes and two Emmy nominations later, Alf Clausen's career is now in high gear. He's on a show that often deliberately defies convention, that the whole world watches, and that has changed television. And he gets to create to his heart's content.

"Due to the time pressures, however, I sometimes feel like a traffic cop," Clausen says. "One wrong direction and the whole world could smash up in front of me! Not that it is ever going to happen like that. We've got too good a crew to even come close. *Moonlighting* is unlike any other show on the air. While most shows have some sort of musical consistency to their episodes, there's nothing like moving from A to B with this series. One week I could be doing a hot jazz score, the next an Elizabethan, and the next something from the world of traditional film scoring. It's fresh, it's wonderful and impossible at the same time."

Now that Clausen's fondest dreams are coming true, desperation really is the mother of invention in keeping up with his hit series of *Moonlighting*. He's found producers that love an orchestral sound as much as he does; a show that allows him to experiment, but which doesn't pressure him into using only "new, faddish techniques and hot sounds;" and a pool of talent that is unending. "The smallest orchestra I've used is a solo saxophonist; the largest, 38 musicians with a full choir," he says. "We've done as little as six minutes of original music and as much as 25 in an episode. And I've had as little as 16 hours and as much as six days to com-

MANHATTAN COMPACT DISCS

FOR A FREE DEMO TAPE

call

Toll Free 1-800-227-1954

(NY State) 212-333-5766

or write

Manhattan Production Music

P.O. Box 1268

Radio City Station

New York, NY 10101

★ Our entire music library has been digitally mastered and converted to compact discs including new material never released before ★ Over an hour of music per disc ★ Easy accessing of cuts ★ No more scratches, pops, or ticks ★ Much quieter transfers ★ Easy to edit cuts ★ Cuts are pre edited into 60's, 30's & 10's for quick use ★ All styles of music from high energy industrial music to beautiful pastoral music ★ Accomplished, reknowned composers and arrangers ★ Reasonable needledrop fees ★ Ask about our low cost annual blanket fees ★ Hundreds of satisfied clients ★

MANHATTAN
P R O D U C T I O N • M U S I C

Circle #121 on Reader Service Card

Simple Intelligence

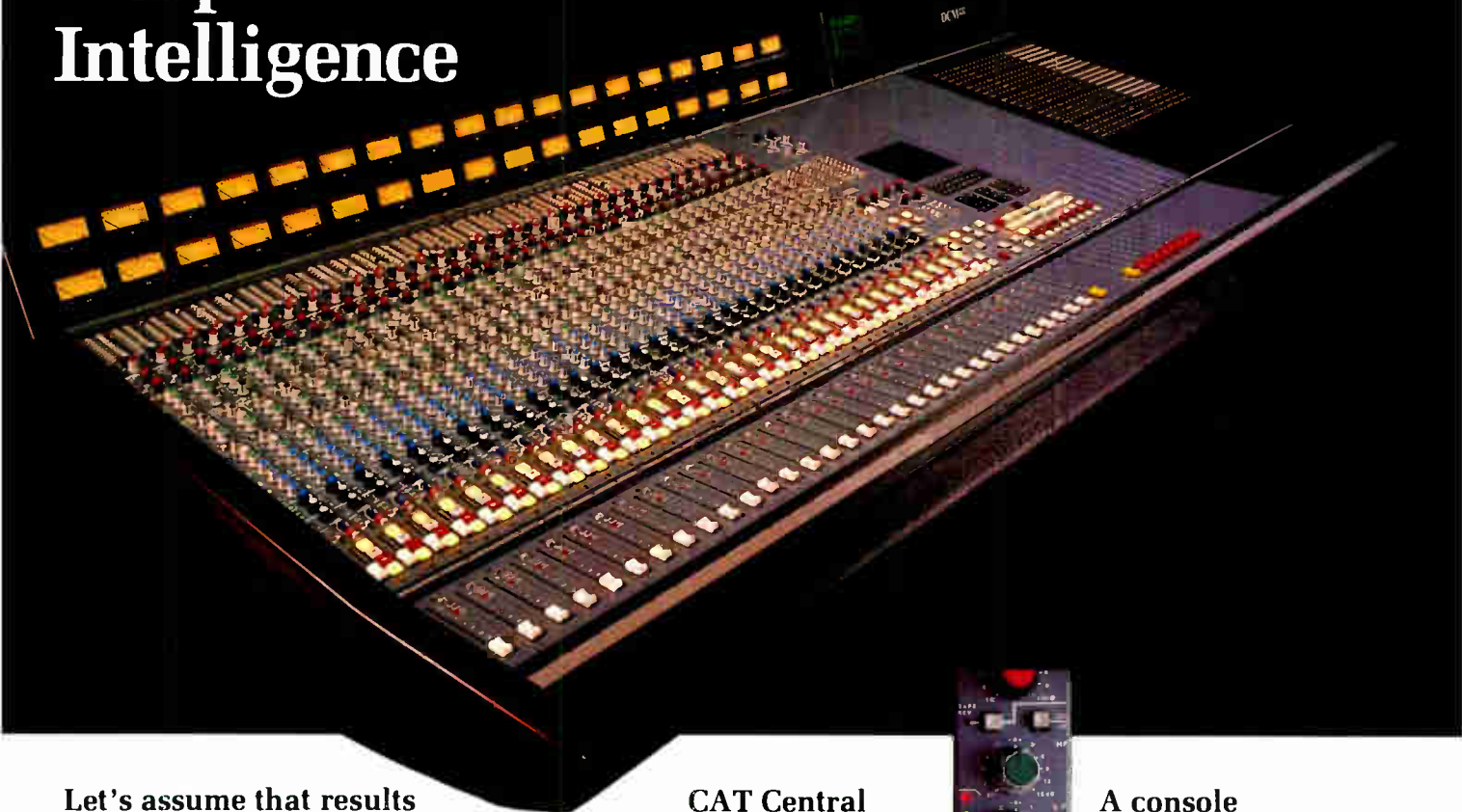

Let's assume that results are what's important, not which tools you use.

Audio production is at least as much art as science; there will always be those who ascribe a magical aura to certain pieces of equipment. But if your client list is built on quality and consistency rather than techno-oodoo, the DCM 232 in-line console with CAT automation can give you more of both.

You need more console, not more headaches.

You're working for more demanding clients, on bigger projects, with tighter deadlines. You need greater flexibility, expanded features, enhanced performance. What you don't need is a "mega-star" console—or the jumbo mortgage that goes along with it.

DDA's AMR 24 has already set new standards of audio performance and versatility in the "classic" split configuration. Now the in-line DCM 232 combines the accuracy of digital-quality audio, the flexibility of digital control and the capacity to handle a pair of synchronized digital 32 tracks.

CAT Central Automation Terminal: engineered to speed your work flow.

The DCM 232's Central Automation Terminal controls one of the most ingenious automation systems ever to shorten a mixing session. Along with the precise fader and muting control you'd expect, the CAT system includes advanced functions like *Channel Copy* that lets you duplicate a channel's signal flow as many times as you need to. The computer will recall a "snapshot" of most console switch settings manually or via SMPTE code.

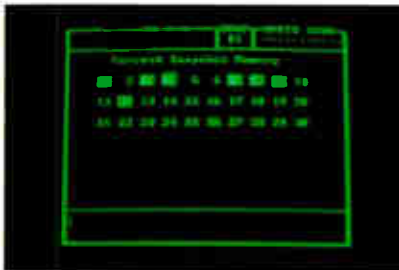

With all of its convenience functions, this CAT won't leave footprints all over your tracks. The DCM 232 maintains an overall dynamic range of 100 dB with at least 22 dB headroom at each stage, thanks to exacting calculation of every circuit component.

A console investment that instantly doubles your returns.

Each of the DCM 232's channels, including the four band EQ section, can be split during mix-down. So a 56 channel frame can handle as many as 112 inputs from samplers, synths and digital storage media. You'll probably run out of control room space before the DCM 232 runs out of inputs.

The advantages of the DCM 232 in-line console with CAT automation are explained more fully in our brochure.

To get a copy, write on your letterhead to the appropriate address below.

Circle #031 on Reader Service Card



Klark-Teknik Electronics Inc., 30B Banfi Plaza North Farmingdale, NY 11735 (516) 249-3660

Unit #1, Inwood Business Pk., Whitton Rd. Hounslow, Middlesex, UK TW3 2EB 01 570 7161

**CLEAN
PATCH BAYS
NO DOWN
TIME**

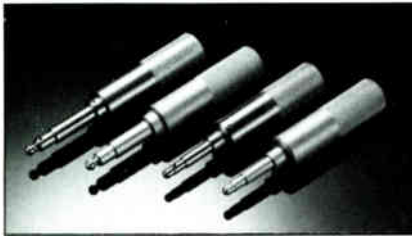

**VERTIGO BURNISHERS AND INJECTORS
RESTORE ORIGINAL PERFORMANCE
TO YOUR PATCH BAYS**

VERTIGO 1/4" TRS AND TT BURNISHERS:
Each used to eliminate noise caused by contamination
of main contacts in normal patching situations

VERTIGO 1/4" TRS AND TT INJECTORS:
Each allows injection of cleaning solvent in breaking
contacts (normals), to eliminate intermittency that
occurs when patch cord has been removed

STILL ONLY \$29.95 Ea. (Cont. USA)
Please write for additional information and order form
Used by Professionals Worldwide Patent Pending

VERTIGO RECORDING SERVICES

12115 Magnolia Blvd. #116
North Hollywood, CA 91607
Telephone: 818/769-5232
Telex: 5106006748 VERTIGO RECRD

Circle #122 on Reader Service Card

FREE WALKMAN!

LET US MAKE A FREE SAMPLE
OF YOUR NEXT AUDIO CASSETTE
DUPLICATING JOB...



...AND WE'LL GIVE YOU A FREE WALKMAN
TO LISTEN TO IT ON.

CALL (516) 242-4646
to arrange pickup of your master.

PROGRESSIVE
TAPE CORPORATION

40-H Corbin Avenue
Bay Shore, New York 11706

Circle #123 on Reader Service Card

“We’ve used synth scores occasionally when the mood of the film calls for them, but I prefer the collective ‘life’ of a live orchestra.”

pose and orchestrate the score for a single episode. It’s never dull.

“One of the biggest advantages is our production staff. When we go in to spot the music for a show, Glenn Caron, Artie Mandelberg and the rest of the nuclear family are right there with direction, invention and suggestion. They really know what they’re doing. It’s the license to create and invent given you by a creative supervisor that makes each episode fresh. Along with dynamite episodes, of course.

“Take this year’s Emmy nomination, ‘Atomic Shakespeare,’ for example. Often a script reads differently than the final product. That’s why I don’t always prefer to read a script prior to seeing the film. But when they sent me this version of *The Taming of the Shrew*, I laughed my way through it. This was one of the funniest scripts I’d ever read. Glenn [Caron] told me he wanted an Elizabethan score, then left me on my own. I centered the orchestra around Elizabethan instruments—recorders, lutes, viola de gamba, Cymbalom, harp, harpsichord, and augmented it with the more traditional orchestral instruments. It was one of the most challenging episodes that I had to score, and in one of the shortest times. And it was the most fun, especially when I had to create a casual band of lutes in the courtyard, playing the period’s version of ‘Close to You’ to set off the David Addison character’s line, ‘I loveth a band that playeth the oldies.’”

Clausen then called on his support system. “We’re lucky in this town,” he says, “that there is such a wealth of talent available. I called my contractor Frank Capp, gave him the specs, and went into my traffic cop mode. Orchestrators had to be dispatched, studio set up, and so forth. The pressure was on.”

Clausen has great confidence in his own staff, whether it’s Capp; his copyist Stan Sheldone; orchestrators Hammie Mann, Don Davis and Don Nemitz; music editors Jim Harrison, Jeff

Carson and Dan Carlin; his engineers Ric Riccio and John Richards at Evergreen; Armin Steiner at Fox and Bobby Fernandez at TBS. “My engineers are exceptional, the best in the business,” Clausen says. “They can change gears and pick up styles at a moment’s notice. They have their finger on what I want when I want it. Second guessing me is so important with this kind of pressure.

“As for the musicians, it’s almost like running a casting agency. I have a great many people to draw from, and I have to think who would be best in what capacity. Part of the success of being in this business for a long time is knowing how to cast a project properly. Sometimes I’m lucky enough to find all of the players I’ve selected available for my sessions; sometimes I use musicians I’ve never met before. There are a great many surprises out there. The depth of players in Los Angeles is truly amazing. Session musicians are a breed unto themselves. They’re quick studies and as versatile as can be. In any given three- or four-hour session, they don’t get ruffled when cues have to be changed, charts redone, themes redirected. They’re the life of the music. We composers couldn’t do without them.”

What keeps top composers in television? Certainly not always the money or the creativity—or the lack thereof. “I think it’s really a combination of factors,” says Clausen. “Although the money in features is ten to 25 times greater and the time to do a project is at least ten times as long, the performance monies in television are nothing to sneeze at, and the recognition is so important. Most important, however, is the chance to practice your craft on a weekly basis. It’s a valuable learning experience. The public’s demand for new product creates a multitude of employment opportunities.

“And, let’s face it—when the producers realize that the music portion of their feature budget can accommo-

The SP-1200 Sampling Percussion System.

Serious Repercussions.



Particularly among serious musicians. Because the new SP-1200™ Sampling Percussion System has more features for serious creative possibilities.

It's the latest refinement of the SP-12™, the sampling percussion system by which all others are measured. Accordingly, the SP-1200 offers a full 10 seconds of sampling time. In a 12-bit linear data format for sounds of unsurpassed brightness and clarity.

Then the SP-1200 adds new features to make programming and performing go even faster and easier. There's an internal 3.5" disk drive that loads sounds and sequences in seconds.

Which could significantly improve the rhythm of an entire performance. There's more flexible segment editing plus MIDI Song Pointer, so when you're running with an idea, you won't have to wait for your hardware to catch up. And there's an abundance of other features, too.

Not the least of which is the formidable and ever-expanding SP-1200 library of sounds. And complete compatibility with all SP-12 sounds, whether from E-mu or anyone else.

To fully appreciate the new SP-1200, you need to play it. You'll discover the SP-1200 has the power to send repercussions through the most important music you may ever hear.

Yours.

For more information, see the SP-1200 at your dealer. Or call E-mu Systems at 408-438-1921.



E-mu Systems, Inc.
1600 Green Hills Road
Scotts Valley, CA 95066

Applied Magic

NEVE V SERIES CONSOLE

WINNER OF THE 1987 TEC AWARD FOR
OUTSTANDING TECHNICAL ACHIEVEMENT IN
CONSOLE TECHNOLOGY

SPECIAL THANKS TO OUR V SERIES CUSTOMERS:



Minnesota Public Radio	St. Paul, MN	V36
Gravity Records	Nogales, AZ	V36
Hi-Lite Studios	Miami, FL	V36/Necam 96
Spectral	New York, NY	V48/Necam 96
PhotoMag 1	New York, NY	V48/Necam 96
PhotoMag 2	New York, NY	V48/Necam 96
Middle Ear Studios	Miami, FL	V60/Necam 96
Conway Recording Studio 1	Hollywood, CA	V60
Conway Recording Studio 2	Hollywood, CA	V60
Hit Factory	New York, NY	V60
Kashif	Hamford, CT	V48/Necam 96
Quadradiad	Miami, FL	V48/Necam 96
Magno Sound	New York, NY	V48/Necam 96
Record Plant	New York, NY	V60/Necam 96
Eleven-Eleven	Nashville, TN	V48
Westlake 1	W. Hollywood, CA	V60/Necam 96
Westlake 2	W. Hollywood, CA	V60/Necam 96
Garden Rake/Jay Graydon	Sherman Oaks, CA	V48/Necam 96
KLRU-TV	Austin, TX	V36/Necam 96
Apollo Theatre	New York, NY	V48/Necam 96
CBS TV	Television City, CA	V48
Facitique	N. Hollywood, CA	V60/Necam 96
Andora Studios	Hollywood, CA	V60
Baby-D Recording	Los Angeles, CA	V60/Necam 96
Cherokee Recording	Hollywood, CA	V60/Necam 96
Chung King House of Metal	New York, NY	V60/Necam 96
Sandra Pope	Nashville, TN	V60/Necam 96
Massey Twins Enterprises	Denver, CO	V36/Necam 96
Sound One 1	New York, NY	Custom V60/Necam 96
Sound One 2	New York, NY	Custom V60/Necam 96
Sonolab	Montreal, Canada	Custom V48/Necam 96



Rupert Neve, Inc.
A Siemens Company

RUPERT NEVE INC., BERKSHIRE INDUSTRIAL PARK, BETHEL, CONNECTICUT 06801, U.S.A.
TELEPHONE: (203) 744-6230. TELEX: 96 9638. FACSIMILE: (203) 792-7863.

NY: TEL. (212) 956-6464 • CA: TEL. (213) 874-8124. FACSIMILE: (213) 874-1406.
TN: TEL. (615) 385-2727. FACSIMILE: (615) 297-5092.

NEVE ELECTRONICS INTERNATIONAL LIMITED, MELBOURN, ROYSTON, HERTS SG8 6AU, ENGLAND
TELEPHONE: ROYSTON (0763) 60776. TELEX: 81381. CABLES: NEVE CAMBRIDGE. FACSIMILE: (0763) 61886

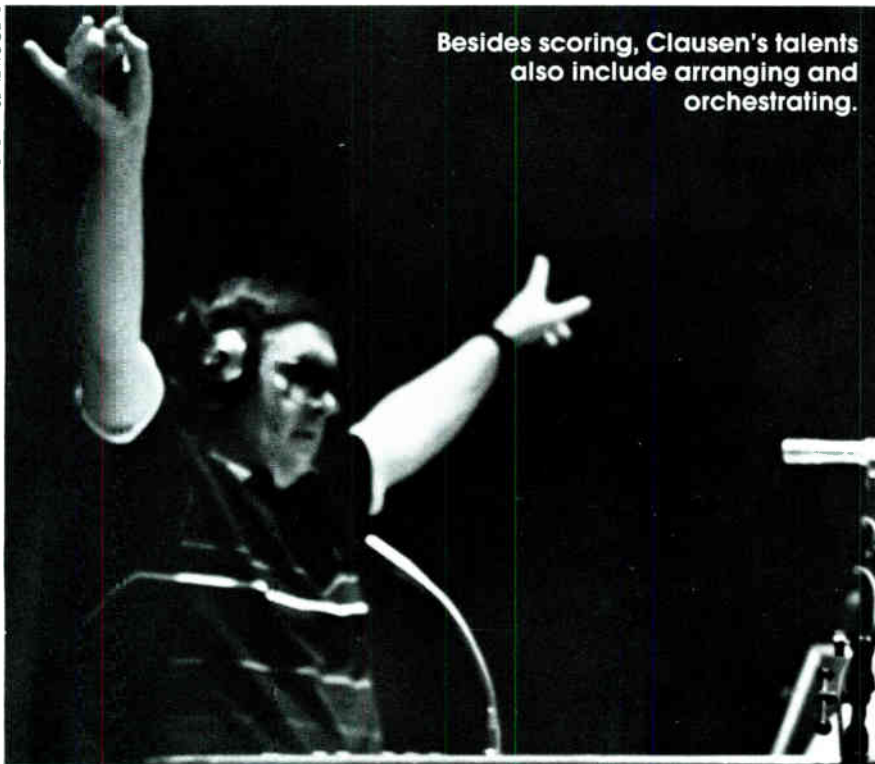

Besides scoring, Clausen's talents also include arranging and orchestrating.

date a Jerry Goldsmith, why not get him! We composers collectively hope that he's not available, so that maybe we'll be the next to get a crack at the next blockbuster feature. I've been lucky, I have done a few features, the last called *Number One With a Bullet*, where we did close to 50 minutes of music in two and a half weeks, with a nine-piece jazz band.

"But the meat and potatoes at this stage of my career is television regardless of the time and creative pressures. And not all of the product is watered down. There is a lot of inventiveness, like on *Moonlighting*.

"We've used synth scores occasionally when the mood of the film calls for them, although I prefer the collective 'life' of a live orchestra. The synth sound works for some shows, and some characters. But I love the beauty of the live score and I don't just mean aesthetically. While the synth composer sits in a little room often by himself or herself, putting on layer after layer of sound on tape with the aid of a computer, with an often panicked producer hanging over his/her shoulder saying that it still doesn't sound quite right, a composer with a full orchestra works everything out before the producer hears it. He may demo the score for the producer, but the pieces are virtually finished before the musicians come in for their three- to four-hour

session. Musicians are great at making quick changes dictated by the composer from the podium. To take a bar out, move a cue, change a tempo is easy when the entire score's in place. Making numerous changes to a synth score can be very time-consuming.

"If innermost thoughts were revealed, most composers would say: 'Give me a full orchestra to work with any time.' Also, the great musicians' sense of humor helps to relieve the stress of the studio pressure cooker. The social part of sessions is part of the joy of recording with a live orchestra. Electronic scoring can be a lonely existence when done on a full-time basis.

"Besides, it's so much easier to write music to fit that character on the screen when you have live, emotional musicians to call on. I can't imagine the depth of emotion in a Dave and Mad-die scene [the main characters on *Moonlighting*] coming from a synthesizer. But, conversely, I can't imagine the tenseness of a *Miami Vice* stalking scene coming from a lush bed of strings and a pretty Fender Rhodes sound. The important concept is being able to come up with the requirements of the picture. It's all music. My preference happens to be the orchestra, and live, warm bodies!" ■

Pauline Rogers is a television, film and magazine writer living in Los Angeles.

Gold & Platinum Recording Careers



Music Video • Recording Engineering
Music Business Management
Studio Maintenance • Sound Reinforcement

Join the successful graduates of this multi-million dollar educational/studio complex in Orlando, Florida.

Learn from well-known professionals and gain hands-on experience in the most comprehensive course available. Internship placement, career guidance and employment assistance included.

Over 19 gold and platinum records awarded to Full Sail alumni. And more than 83% of graduates employed in the music industry.

Full Sail

CENTER for the RECORDING ARTS

For your FREE Career Guide call

800-221-2747

In FL. Call 305-788-2450

or write

658 Douglas Avenue, Altamonte Spr., FL 32714
Accredited by the Accrediting Commission of the National Association of Trade & Technical Schools. Licensed by the Florida State Board of Independent Postsecondary Vocational, Technical, Trade and Business Schools. #414

Circle #124 on Reader Service Card

The DeWolfe Music Library Now Has

30

Compact Discs



DeWolfe Music Library, Inc

Call Collect

(212) 382-0220

25 West 45th Street
New York, NY 10036

Circle #125 on Reader Service Card

MIKING FOR DIGITAL

THE RETURN OF RIBBONS

by Mike Solomon

As digital recording and signal processing become a dominant factor in professional recording, broadcast and production facilities, many engineers assume that the same microphones and recording techniques used for analog can instantly be used for digital. Unfortunately, in the almost unforgivingly accurate digital format, equipment and recording methods designed for analog recording often yield harsh and unnatural sonic results.

Engineers working with digital for the first time often experience an undesirable sound described as a “brittle” or “overly crisp” high end. These engineers are hearing the noise and distortion characteristics of popular microphones and recording equipment, most of which were designed to compensate for the weaknesses of analog performance. What may have been hidden by the analog format is now revealed by digital recording and signal processing equipment.

After experiencing these annoying problems, demanding engineers began to search for microphones and recording methods to maximize digital's low noise floor and wide dynamic range (90+ dB as compared to analog's 60+ dB dynamic range). In a truly strange twist, they've

discovered answers to their problems by looking backwards, to the history of recording.

Minimal Miking

The start of modern high-quality recording can be traced back to the 1920s and '30s when European engineers recorded large symphony orchestras. Using just two ribbon microphones and a record lathe, they produced excellent stereo recordings. One secret to their success was mic placement. The X-Y technique (Fig. 1) and what is now known as the ORTF technique (Fig. 2), from the French Radio & Television Broadcasting Organization, were the most popular. The goal was to accurately capture the sound of the source with an audible level of ambience, an important element in making recordings sound “real.”

The X-Y technique involves the use of two cardioid microphones mounted on the same axis. Their diaphragms are arranged as a coincident pair, spread 135 degrees for maximum response. Since they are mounted on the same axis, arrival time differences between the microphones are minimal. The stereo effect is due to interchannel amplitude differences. The ORTF method

Fig. 1: The X-Y Technique

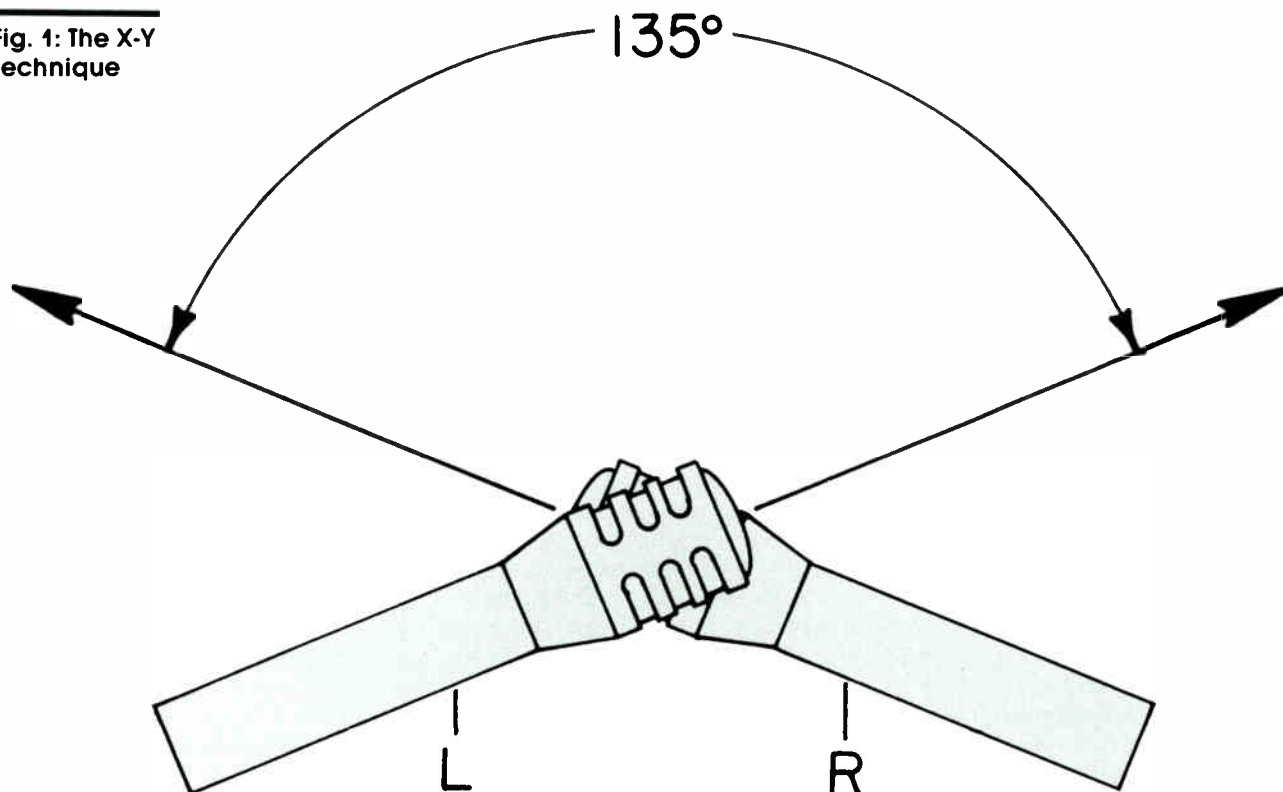

DIAGRAM COURTESY SHURE BROTHERS

How to turn a regular Mac into a bigger Mac

Or how Terry MacDonald substantially increased his client base, business + profit with the AMS AudioFile.

Who, you may ask, is Terry MacDonald?

Well, he's the owner of a small studio in Seattle, Washington.

He's not a Disney or an Editel, but (like Disney and Editel) he does have an AMS AudioFile.

(The hard disc based multitrack recording, editing and playback system).

Which is why MacDonald Recording is now earning more hard cash.

And taking more business from his competitors.

Those who do not have an AMS AudioFile.

Whatever your size of company, AMS has the recipe for turning regular Macs into bigger Macs.

Find out about the AMS AudioFile and find out where your business is going.

"I am a true believer! When we installed the AMS AudioFile in my little 8-track studio, it represented the major cost of my studio build. And it has been everything I dreamt it would be... we have been using AudioFile for radio commercials, pre-production TV audio, video sweetening, industrial film sync work, in short, for everything in sound. And if a small studio like mine can see this system pay off, it has real potential for any studio in the world. AudioFile is paying off and knocking producers off their chairs."

Terry R. MacDonald

**MacDonald Recording Co.
Seattle, Washington.**



Demonstration systems can be booked from:

LOS ANGELES

Harris Sound Inc. (213)
469 3500

NEW YORK

Studio Consultants Inc.
(212) 586 7376

CHICAGO

Doug Ordon & Co Inc.
(312) 440 0500

SEATTLE

Calrec by AMS
(206) 633-1956

TORONTO

Manta Electronics Group
(416) 868 0513

REST OF THE WORLD

AMS Industries Plc, England.
Tel: (0282) 57011 Telex 63108
AMS-G.Fax: (0282) 39542

Circle #04 on Reader Service Card

Fig. 2: The ORTF Technique

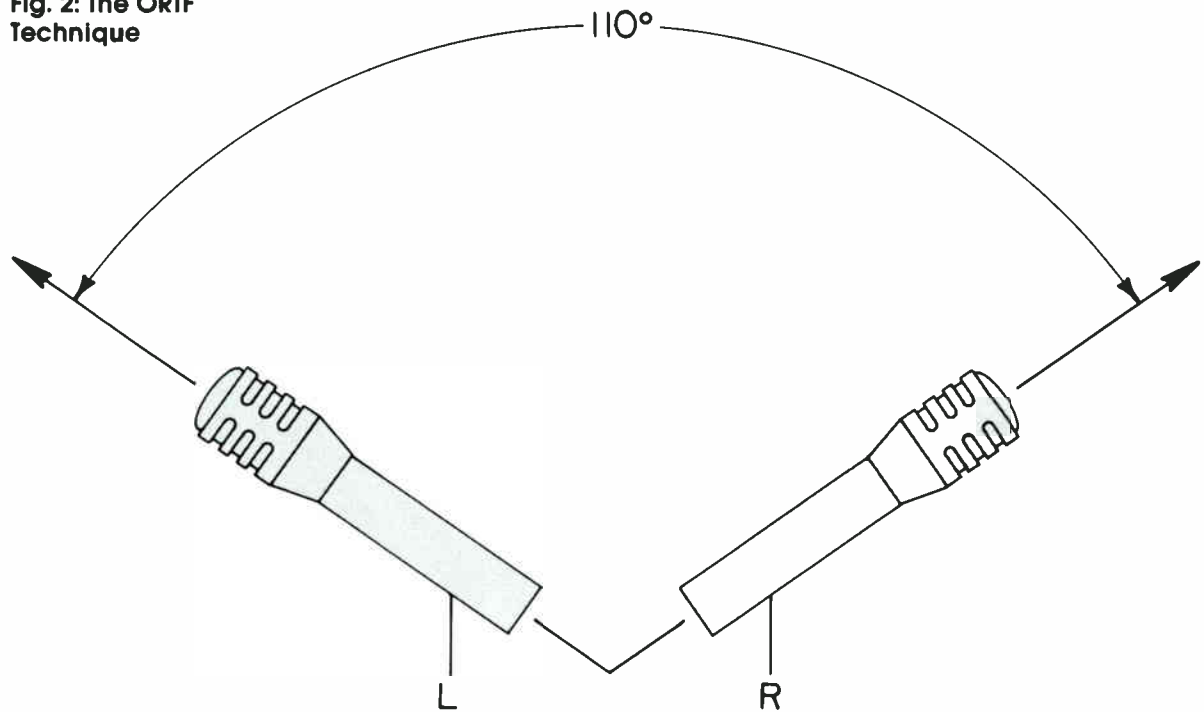

also uses two cardioid microphones, but arranges them as a near-coincident pair with diaphragms spread 110 degrees for maximum response. With this technique, both time and amplitude differences contribute to the stereo effect.

These “minimal miking” techniques (along with a few other less popular versions) were widely employed for many years. American engineers borrowed these European orchestral miking methods to record big band jazz in the '30s and '40s. Slowly, additional microphones crept into the process. A special mic might be used for vocalists or instrumental soloists for instance. This evolved into multi-miking, which eventually sparked an interest in multi-track recording. The only mixers available at the time were simple “volume control only” units designed by RCA for use on film soundstages.

Various refinements to microphones, mixers, tape machines and audio tape itself vastly improved the quality of minimal microphone recordings in the following years. The results were often quite amazing. Recordings from the late '50s and early '60s by Frank Sinatra and Ella Fitzgerald sound as amazing in the digital world of today as they did when first released.

Eventually, the multi-track process

came to dominate the recording world (except in classical music, where it has been attempted but never broadly accepted). Taking advantage of the multi-track's flexibility changed the whole recording process. The ambient sound of minimal miking gave way to the tightly controlled sound of close miking. Additional means of reverberation were invented to recreate the room sound sacrificed in the close miking of the multi-track process. The signal chain between microphone and tape grew to include a multitude of mixer equalization and sub-sections, outboard signal processing, effects and patch cables.

As multi-tracking moved from analog to digital, the noise produced by the complex and expanded recording chain became apparent. Engineers looked for a way to record which best utilized digital's wide dynamic range while eliminating many of the noisy components of the current recording process. Looking backwards, they realized that minimal miking was the cleanest way to get from source to tape machine.

Independent West Coast recording engineer and producer Bob Hodas puts it this way: “I got into the fact that I could bypass the console. With all the chips and garbage being put into consoles, I felt they were getting worse instead of better. Feature-wise, it was

great for mixing, but sound-wise it was going in the wrong direction.

“The whole idea of getting to the tape machine as cleanly as possible got me started with cutting down everything I do. My last record with Windham Hill was done with only a couple of mics direct to the tape machine. No EQ. Microphone choice and placement was how we changed the sound.”

One of the more popular minimal miking methods today is the MS (Mid-Side) technique (Fig. 3). It involves the use of one cardioid microphone to cover the “center” and one bidirectional microphone to capture the left and right sides. They are positioned as a coincident pair facing the same direction. The tape machine records “left” as the cardioid mic plus the bidirectional mic ($L=M+S$) and “right” as the cardioid mic minus the bidirectional mic ($R=M-S$). This provides a strong left/right perception as well as a center with “depth.”

The MS technique requires the use of an MS matrix device to correct the phase problems inherent to the MS technique (remember, there is no pure left and right on tape). Since the device is a decoder as well as an encoder, it's possible to later manipulate the phase relationships of the microphones for control or special effects. “After I record something

PROGRAMMABLE POST PRODUCTION BREAKTHROUGH! WITH THE NEW

AKAI MPX-820

Fully Programmable 8-Channel Mixer!

**AUTOMATION FOR
UNDER \$2,500.00**



AKAI PROFESSIONAL MPX-820 PROGRAMMABLE AUDIO MIXER . . . FINALLY ALLOWS PROGRAMMABLE MIXERS TO BE AFFORDABLE IN POST PRODUCTION

In the demanding world of post production, you need to program your audio as easily as your video. The Akai MPX-820 gives you precise control over level changes and EQ, and then stores this in memory. Your mix can be recalled at the touch of a button, and in sync with your images. Mixing audio for video has never been so easy, and so affordable. For a complete demonstration, see your local Authorized Akai Professional Dealer.

- 99 Programmable Memories
- Programmable Fade Time
40ms - 15 sec.
- Fully MIDI Compatible
- Slave up to 8 Consoles
for 64 Programmable Channels
- Impeccable Audio Performance
- Frequency Response
20Hz-20kHz $\pm 1.0\text{dB}$
- E.I.N. - -128dB Max.
- T.H.D. - 0.04%
- Fader Resolution - 0.03dB

AKAI
professional

Creative at Heart

Circle #042 on Reader Service Card

World Radio History

For complete details write to AKAI, P.O. Box 2344, Fort Worth, Texas 76113
Gentlemen: Send me a data sheet on the new AKAI Professional MPX-820 Programmable Mixer.

Name _____
Firm Name _____
Address _____
City _____ State _____ Zip _____
Tele (____) _____

Westlake Audio Continuing to earn the privilege

of supplying the equipment for your technical creativity!

A partial listing of recent deliveries to customers who received the best products, on time . . . at the fairest prices. Number 2 in the series.

- **MODERN VIDEO/SOUND** (Hollywood) Moshe Barkat: 2 - Trident Series 24 mixing consoles, 5 - Sony JH-24 24-track recorders
- **DUDLEY MOORE**, Designed and equipped complete 24-track studio with Sony JH-24, Soundcraft 1600 and Westlake BBSM-8 monitors
- **ECHO SOUND** (Los Angeles) Josie Siniscal: Trident 80B console, Sony JH-24 and Westlake BBSM-4 monitors
- **WARNER BROTHERS**, (Hollywood) Studio "C" sound stage equipped with JBL Theater Sound System
- **PRINCE, Paisley Park Complex** (Minnesota): Completely equipped recording and production center including Westlake SM-1 monitor system
- **MARK SNOW**, Film/Video Composer (Falconcrest, among others) Complete studio including Trident Model 75 console
- **FRED JONES RECORDING** (Hollywood) Soundcraft Model 600 patchbay version mixing desk, 2 - Sony JH-110C4 four-track recorders
- **O'HENRY STUDIO** (Toluca Lake) Hank Sanicola: 2 - Sony JH-24 recorders
- **DANNY SEMBELLO** (Beverly Hills) Composer/Arranger, Synth Studio: Sony JH-24 recorder
- **TECHNICOLOR**, (Westlake Village) video cassette duplication: Sony PCM 1630 Digital Audio Processor
- **SOUND SERVICES, INC.** Video-Post Film Work: complete out-board package for 2 rooms
- **HLC/KILLER MUSIC** (Hollywood) Ron Hicklin: Outboard gear for four new rooms including Audio-Kinetics Pacer, Sony JH-24 and UREI-813 and -811 monitoring systems
- **ROSS VANELLI** Composer/Producer Sony JH-24 recorder
- **POST GROUP** Video and Film Post Production (Hollywood) UREI monitors, Dolby XP24 and 365 noise reduction
- **WESTWOOD ONE/Mutual Broadcasting Co.** Michael Jordan, Director of Studio Operations, Chief Engineer: equipment for two Mutual PM's LA News Gathering Facilities, three On-Air Production Studios
- **MARK LEONARD**, Composer/Producer Soundcraft 600 24 I/P console and out-board gear.

(213) 851-9800

Westlake Audio Professional Equipment Sales Group

7265 Santa Monica Boulevard
Hollywood, CA 90046

Circle #126 on Reader Service Card

Fig. 3: The M-S Technique

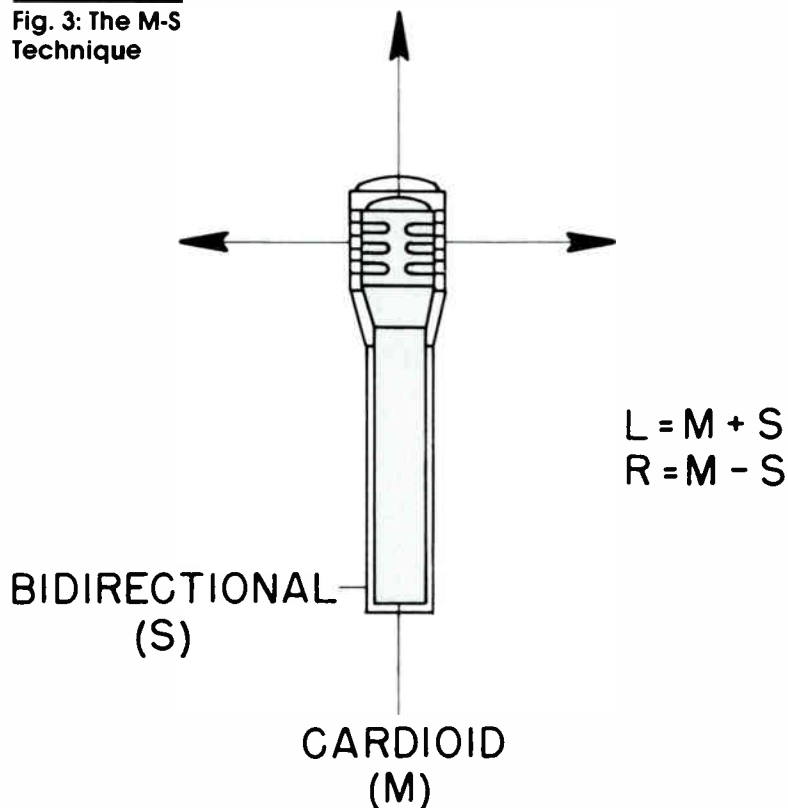

using the MS technique," Hodas reports, "I can go into a studio and actually adjust the stereo spread to the client's liking, in case they want a little more or less room sound. I find it very effective."

The use of minimal miking for digital recording perfectly illustrates the popular and proven adage "less is more." It is not essential to use equipment or equalization when you can do without it. If a performer or group works best in a "live" setting, then minimal miking, or a variation of it, could be the cleanest, most dynamic way to record. This is true for contemporary artists such as Joe Jackson, who digitally recorded his live-to-2-track *Big World* album [spotlighted in the June 1986 *Mix*], as well as for classical and jazz groups.

Although the MS technique is generally thought of as a "live-to-2-track" method, there are many uses for it in multi-track production work. Pianos, drums, horn or orchestra overdubs, percussion and even guitar amps can often be miked with this technique. Paul Simon has employed the MS technique to record his acoustic guitar in a stereo spread. Anything requiring an ambient sound with a deep stereo feel can benefit from MS or

other forms of minimal miking.

Microphone Selection

New miking techniques raise the question: "What mics to use?" The traditional choices don't always apply and engineers are discovering a whole new set of digital rules when choosing and using microphones.

"What I'm learning with the whole digital process is that our brains are a lot more sophisticated than anyone has given us credit for," says Hodas. "We're able to pick out problems that everybody assumed we wouldn't notice, such as phase shift in the high frequency range. It comes across as being a harsh high end. Microphones can help a lot when you want to get smooth, round, natural tones."

"The most important thing I've found with digital is the right mic selection," says Alan Silverman, a New York-based independent recording engineer. "It's vital that you complement the source so if you have to use EQ it's for enhancement rather than correction. A mic's phase linearity is very important. When I A/B newer mics against old familiars, it's almost as if you're switching a phase shifter in and out of the circuit."

—CONTINUED ON PAGE 142

DIAGRAM COURTESY SHURE BROTHERS

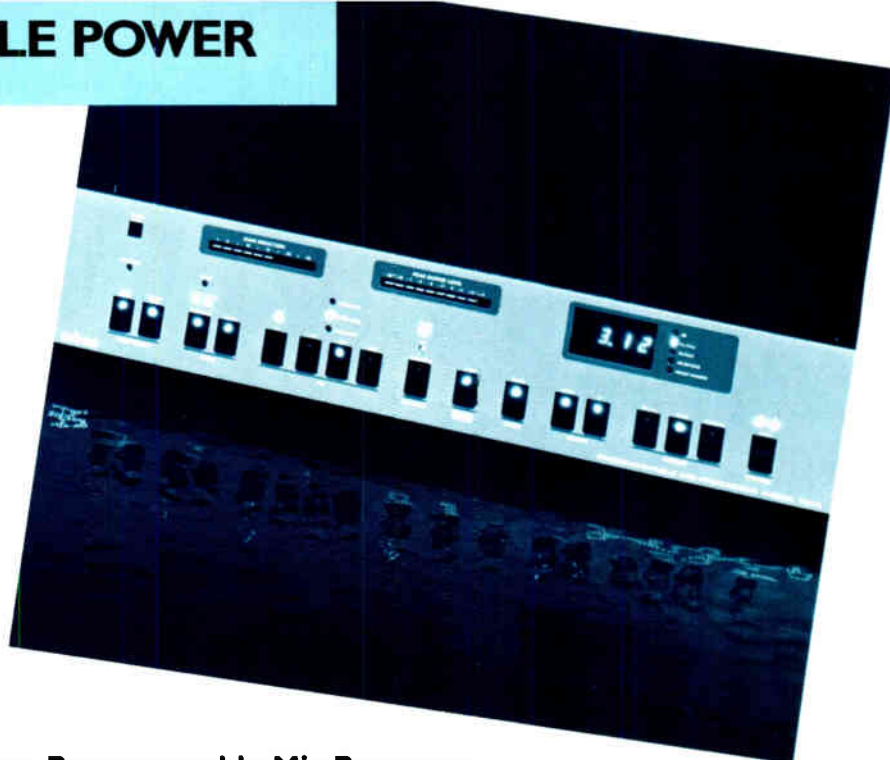

Introducing the new Orban Programmable Mic Processor

- 3-band parametric equalizer with "constant-Q" design and full notch filtering capability
- Smooth, transparent compressor with adjustable release time
- Noise gate (attenuates noise by up to 25dB) and compressor gate (prevents noise rush-ups during pauses)
- De-esser controls excessive sibilance

And it's programmable.

- 32 memory registers store complete control setups for instantaneous recall
- Effects send and return (with programmable return gain) simplifies integration of external reverb or other processors
- Built-in connectors for remote control, MIDI, and future serial interfaces
- Optional second-channel slave for dual-mono or stereo operation (Model 787A/SL)
- Standard line-level input; optional Jensen transformer mic preamp with 48V phantom powering
- Security code prevents unauthorized tampering with presets

Orban's powerful, new 787A Programmable Mic Processor dramatically increases production efficiency so that less of your time is wasted tweaking an array of non-integrated signal processors, and more can be focused on obtaining top performances.

The 787A combines clean-sounding, Orban-quality analog processing with the control and programmability made possible by contemporary digital technology.

The unmatched versatility of the 787A makes it possible to determine the optimum setups for commonly-used announcers, singers, and musicians. These settings can be stored into any of 32 different memory registers for instantaneous recall—the next day, the next week, or in a different studio at some later date.

Call or write today to find out more about Orban's powerful new Programmable Mic Processor, a time-saving, client-pleasing, and money-making addition to your facility.



Orban Associates Inc.

645 Bryant St., San Francisco, CA 94107 (415) 957-1067 Telex: 17-1480 FAX: (415) 957-1070

1988

MIX

ANNUAL
DIRECTORY

OF RECORDING INDUSTRY
FACILITIES & SERVICES

**NEW & ENLARGED!
MORE THAN 7,000
UPDATED LISTINGS!**



**INDUSTRIAL
STRENGTH.**

**LIMITED TIME OFFER
EXPIRES DECEMBER 31!**

50% OFF
Pre-Publication Offer
Only \$12.50!

World Radio History

The Recording Industry's most comprehensive Sourcebook.

Audio/Video Professionals everywhere rely on the regularly updated, monthly MIX Magazine directories for accurate, thorough and *fresh* information about their business. The new **1988 MIX ANNUAL DIRECTORY** is an exhaustive, "nuts 'n' bolts," single-source reference compiled from these detailed directories and expanded with other indispensable industry data.

When you want information fast, the **1988 MIX ANNUAL DIRECTORY** has everything you need right at your fingertips—in one, easy-to-use, definitive reference source. Because the new 1988 edition contains more than *400 pages of new information*, we've added new, heavy-duty, *tabbed Index Pages* which makes sourcing fast and easy.

The totally revised **1988 ANNUAL DIRECTORY** contains more than **7,000** up-to-date listings, arranged by geographic region, in more than a dozen different categories, including:

- Recording Studios of the U.S. & Canada.
- Video Production & Post-production Facilities.
- Facility Designers and Audio/Video Equipment Suppliers.
- Mastering, Pressing and Tape Duplication Facilities.
- "A to Z" listing of Audio, Video and Musical Equipment Manufacturers.
- Enlarged Market Data & Industry Statistics section.

NEW LISTINGS FOR 1988!

Sound Reinforcement companies including lighting, staging and audio/video equipment rentals. Remote Recording Services. Recording Schools, Programs and Seminars. Other essential industry services.

Don't pass-up this opportunity to get your hands on the only industrial strength Recording Industry Directory at the generous pre-publication price of just **\$12.50** each. This limited time offer is 50%-off the February, 1988 cover price of \$25.00 and it expires December 31, 1987—so hurry!

© 1987, MIX Publications, Inc.

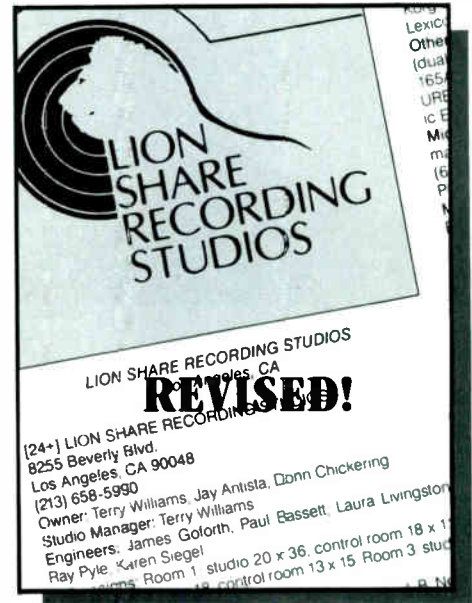

1988 MIX ANNUAL DIRECTORY listings have the detailed and important info industry professionals need to make decisions.

- • • • •
- Please send me _____ copies of the New & Revised 1988 Mix Annual Directory of Recording Industry Facilities & Services as soon as it's off the press. I've also enclosed \$2.00 per copy for postage and handling. If I'm a California resident, I've enclosed 6% for the Duke (sales tax).
- Enclosed is _____ Check Money Order
- Charge to my credit card
- Visa Mastercard American Express M1287
- Card # _____ Exp. Date _____
- Signature _____
- Name/Title _____
- Company _____
- Address _____
- City, State & Zip _____
- Mail this Order Coupon directly to: **ANNUAL DIRECTORY c/o MIX Bookshelf**, 2608 Ninth Street, Berkeley, California 94710. You may also place your order TOLL-FREE at: (800) 233-9604 (In California: 800 641-3349).



COMFORTABLY PROFESSIONAL

SSL 4000E
24-TK. STUDER A-820
2-TK. OTARI MTR 12
UREI 813, 8II MONITORS
NEUMANN, AKG,
SENNHEISER, Etc.. MICS

OUTBOARD EQUIP.
(At no extra charge)

Contact Terri
(212) 228-3063

31 BOND STREET
New York, N.Y. 10012

Circle #127 on Reader Service Card

RCA Test Tapes

A Sound Measure

- Cassettes
- Open Reel up to 1"
- Custom Formats

For a catalogue of standard test tapes or further information contact:

RCA TEST TAPES
DEPT M
108 Monticello Road
Weaverville, NC 28787
(704) 658-2067

Circle #128 on Reader Service Card

—FROM PAGE 138, MIKING FOR DIGITAL

Digital has made leading engineers consider mic selection very carefully, which is something that didn't always occur. When multi-tracking became very popular in the late 1960s and early '70s, microphones often were taken for granted. It was common to find recording studios using the same mics used for PA applications. Many engineers were concerned primarily with a microphone's ability to take high sound pressure levels. The sound would be corrected by all the wonderful new equipment such as multi-tracks, compressors and signal processors.

At the same time, there was a small group of discriminating engineers who understood that a microphone was very important—an instrument in and of itself. Companies such as Neumann and AKG catered to these individuals. Neumann's U87 became enormously popular and for many years was considered the standard large condenser microphone. It is still very popular. AKG's 451 Series combined a high-quality preamp with a modular design allowing the user to choose from a variety of polar capsules. One mic could serve as a cardioid, omni or a figure-8.

As digital became more accepted, microphone manufacturers realized that the noise characteristics of condenser mic preamplifiers were crucial. To produce high-quality results, the signal-to-noise ratio of a microphone has to be at least as good as that of the recorder. Many "popular" microphones fell far short of digital's specifications. In addition, their tailored frequency response led to sonic problems when used with digital. Engineers required a flatter, smoother response. To satisfy this need, microphones such as Beyer's MC 740, Sanken's CU-41 and Neumann's TLM170 were introduced. All of these large diaphragm condenser microphones possess very low self-generated pre-amplifier noise and a smoother high end which makes them sound almost neutral.

Besides these new condenser mics, engineers have found another answer to a digital problem by looking back in time. Often as a result of a listening test where "every mic in the studio was pulled out and set up," engineers have re-discovered *ribbon* microphones. These mics from the '30s and '40s, as well as the handful of new

ribbon mics, are very compatible with the digital format.

Due to their inherently smooth, non-tailored response, ribbon mics produce a pleasing high end which engineers have not gotten from their traditional mic choices. The very design of a ribbon as a transducer, as opposed to the plate used in a condenser and the diaphragms used in a dynamic mic, allows it to respond to the complex waveforms of transients with incredible speed and accuracy. The warm, natural sound of a ribbon mic serves to "humanize" the technically perfect sound of digital.

Some people feel that ribbon microphones are too fragile to be used in many current recording situations. Fragility was one of the initial reasons which led to the design of the more durable dynamic mics.

Fragility is defined by two things: the ability to withstand structural punishment and the ability to handle environmental punishment. Environmental punishment can be defined as extreme heat, humidity, cold, high sound pressure levels and (most important for sound engineers) the movement of extreme amounts of air. Many ribbon mics fail because they're used incorrectly, in applications where they are subjected to excessive air movement. For instance, if you put a ribbon mic inside a kick drum, you'll quickly pop a ribbon diaphragm. It's not because the mic can't handle the sound pressure level, but the shell of the drum restricts air movement. There's no room for the air to move and the ribbon diaphragm cannot handle it. It's the wrong way to use a ribbon mic and that's why it fails in this particular application.

In terms of structural punishment, companies like Beyer (one of the few current ribbon mic manufacturers) have made large strides towards increasing durability. Old ribbon microphones had a very long ribbon with transverse ribs suspended loosely between the magnet's poles. In 1958, Beyer introduced a ribbon microphone with a very short, stiff ribbon, the design currently used in Beyer's M 260 and M 500 microphones. The M 130 and M 160, typically used together in MS recording, are equipped with a double ribbon separated by a 0.5 mm cushion of air. This air cushion smoothes frequency response, pro-

—CONTINUED ON PAGE 164

Shatz: I think that mag film is definitely on its way out. The whole process is archaic: you get grease all over your hands when you cut on film, and it's noisy and it's bulky and it requires a lot of physical labor just to move the materials around. There are so many ways that are a lot better. I think that the method I'm working in [multi-track tape] is a transitional stage: I don't think that tape will be the final medium. I think hard disk storage or some other kind of storage that deals with digital information will be the ultimate medium.

Mix: What concrete, practical changes do you see occurring in this technology in the near term?

Shatz: I believe that sound recording studios will end up doing a lot more sound work in film. It's already become the trend in Los Angeles; using recording studio techniques. And the people who do them will have more of a multi-purpose background. They won't just be the dialog editor or the assistant editor or the Foley editor. There will be more people who can create a little bit of sound, mix a little bit of sound, work on dialog a little bit, thread up tape machines and generally work their way around this equipment.

Mix: Why is that happening?

Shatz: Because there isn't a lot of need for people at the lower skills level of this process. There isn't a lot of room for compartmentalization. The people who work in this process have to know how to mix, how to clean the tape machine, how to select the sound and how it should sync up with the picture. The division of labor is diminishing and gradually disappearing because of the hardware. There is no need for an assistant editor to come around to clean things up, to prepare materials or deal with outside concerns. I think that's going to be a big change and that people who work in film now are going to have to be ready for it.

I think you're also going to see a lot of changes in sound effects libraries because computers are very effective at manipulating databases. And a sound effects library catalog is basically a large database. And there also are more high quality [dense] storage media available than 1/4-inch tape. ■

The Maxcon All the Control You Need On Board

Reinforcement/Keyboard
16x8x2

Stage/Theatre
16x8 Matrix

Studio Recording
16x8x16

Parallel I/O XLRs (splitter) • 8 Aux sends/8 returns • Direct outs
16 Tape Returns • Discreet Send/Returns throughout • Separate Line/Mic
Tape Trim • 3 Band Active Sweep Eq. • LED Status on Most Functions

- Optional Meter Bridge
- Optional Expander
- Optional Patchbay

**It Also Fits in
a 19" Rack**

Manufactured by



CIRCUIT DESIGN TECHNOLOGY, INC.
The Next Logical Step



Distributed by



FORWARD TECHNOLOGIES, INC.
1756 Wilwat Dr. Ste. B, Norcross, GA 30093

404-449-0501

Circle #129 on Reader Service Card

RECORDING EQUIPMENT

—All Major Brands—

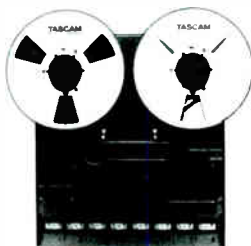

**FOR STUDIOS/HOMES
CHURCHES/CLUBS**

- Reel to Reel Decks (2-4-8-16 Track)
- Cassette Decks • Mixing Boards
- Mikes • Studio Monitor Speakers
- Special Effects Units Accessories

TASCAM
Hi-Fi Production Products

- **VOLUME DEALER**
- **NEW & USED**
- **QUALIFIED LEASING**
- **ALL MAJOR CREDIT CARDS**
- **PROFESSIONAL ADVICE**



RHYTHM CITY

287 East Paces Ferry Road N.E.
Atlanta, Georgia 30305

1-404-237-9552 • 1-404-237-8526

CALL TOLL-FREE IN GA 1-800-282-7995

Circle #130 on Reader Service Card

AEA AND SONY,

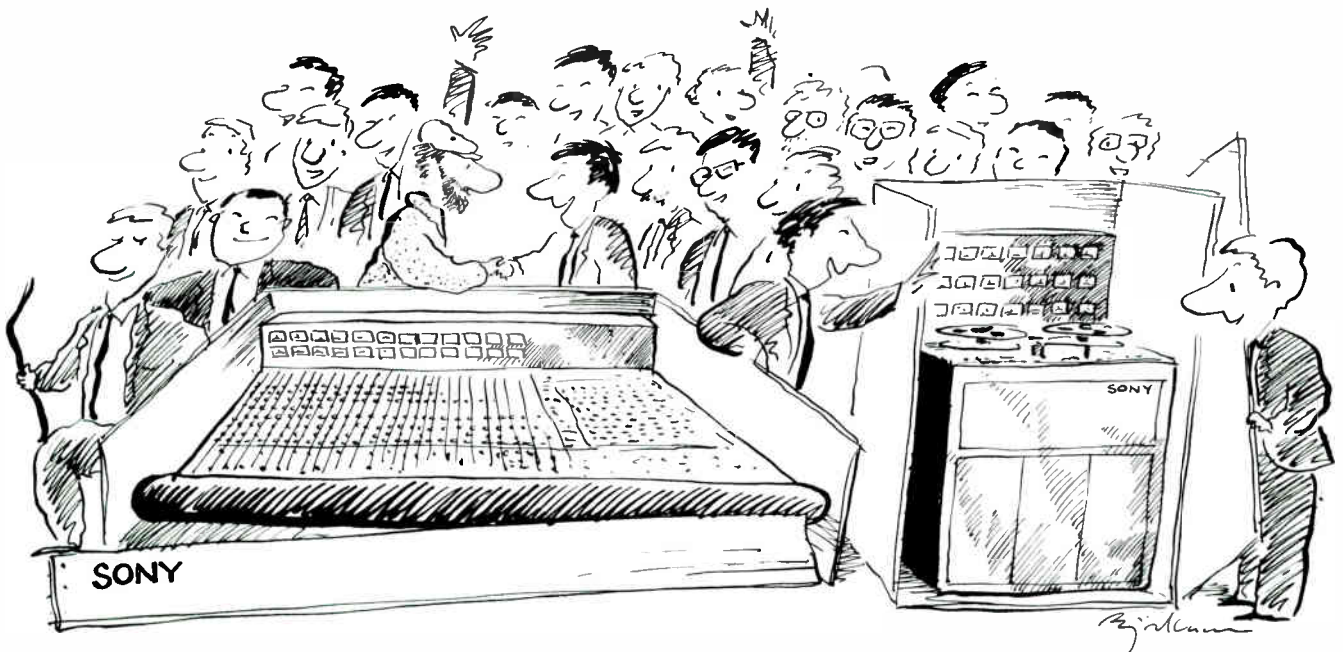

A SOLID COMBINATION.

Are we excited? Absolutely.
And, as we continue to expand, what better way than
for Audio Engineering Associates to join forces
with Sony Professional Audio Products.

Come see the MXP-3000 Series consoles,
JH-24 multi-track recorders,
and join in the excitement.



1029 North Allen Avenue, Pasadena, CA 91104 (213) 684-4461, (818) 798-9127

AROUND THE WORLD WITH

JOHN DENVER



by Hal Blaine & David Goggin

In this fourth installment from his forthcoming autobiography, session drummer extraordinaire Hal Blaine talks about working with John Denver.

On October 29, 1970, I walked into Studio C at A&M and recorded a commercial for Northwest National Bank with a relatively unknown folk singer. I had no idea that less than four years later I would be a part of his group, riding the charts week after week and performing for millions of fans.

On a weekly basis I was doing shows like *Happy Days* and *Alias Smith & Jones*, commercials for sponsors like Coke, Goodyear, Mazda and Budweiser, and films such as *The Harrod Affair*, *Walking Tall* and *Jonathan Livingston Seagull*. I was recording with artists like Johnny Mathis, David Cassidy & The Partridge Family, Dean



Photo above: Johnny & the Sharks (L-R): Herb Pederson, Danny Weetman, Glenn D. Hardin, James Burton, Jim Horn, Renee Armaund (John's ex-wife), John Denver, Emory Gordy, Jr., Hal Blaine and Denny Brooks on roof of the RCA building in Hollywood.

Martin, Barbra Streisand, and on and on. I had become a household word in just about every studio from Burbank to Culver City and was feeling pretty comfortable. I had a beautiful home. My children, David and Michelle, now six and eight years old, were enrolled in the best private

schools. We spent many happy vacations together, sometimes flying to places like Hawaii for a week or two—not a bad existence.

When John Denver's producer Milt Okun called me four years after the commercial date and asked me to record with John, I was flattered that John had remembered me. He was doing his first West Coast album, *Back Home Again*, and it was a dream job. John had grown from a young folkie to a fully blossomed pop singer. He had a special honesty that came across in his songs. It was simply down home—everyone's dream of a happy life. Everyone around John shared the dream and the good feeling radiated everywhere. At the close of his shows, it was common for the audience to stand and start chanting "John Denver for President."

EXPANDING THE SYSTEM

*The 480L Sampling Memory Expander. Accurate sampling in phase-locked stereo:
a Lexicon applications brief.*

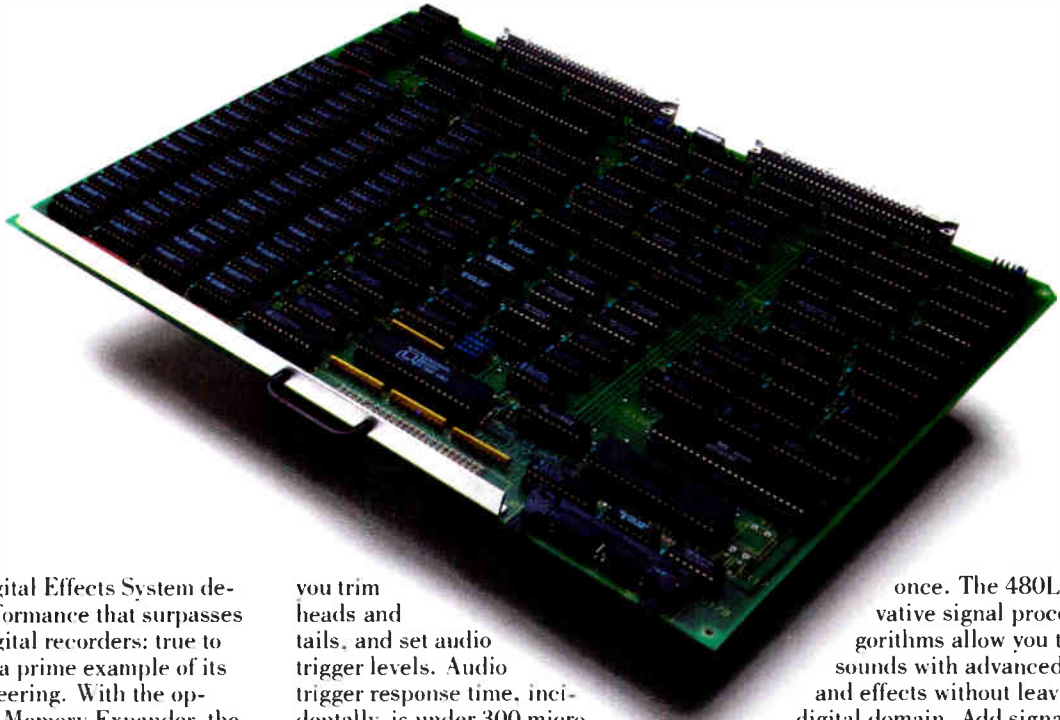

The 480L Digital Effects System delivers audio performance that surpasses conventional digital recorders: true to life sampling is a prime example of its advanced engineering. With the optional Sampling Memory Expander, the 480L becomes an astonishingly practical way to copy or move several seconds of audio from point A to points B and C.

Until now, "flying in" or "slipping" vocal and instrumental overdubs meant tradeoffs. Two-track tape is clumsy and degrades the signal: DDLs with long memories are better, but not by much. Now, with the 480L's optional Sampling Memory Expander, you can digitally record 10 seconds of true phase-locked stereo or 20 seconds of mono at a 48 kHz sampling rate. 18 bit equivalent A/D conversion produces a typical dynamic range of 98 dB, with a bandwidth of 20 – 20,000 Hz: output doesn't get any closer to input.

If you're using a digital recorder that's Sony 1610 compatible, the Sampling Memory Expander and the 480L's digital I/O interface can reproduce the original performance at any location on tape without leaving the digital domain. Slip syncing, copying and time shifting of audio segments is faster and cleaner than ever before.

You control sample recording, editing, processing and triggering from your work position using the 480L LARC. Varying up to six parameters at once,

you trim heads and tails, and set audio trigger levels. Audio trigger response time, incidentally, is under 300 microseconds — virtually instantaneous. Sampling Memory Expander enhancements include Record Trigger to trigger sampling automatically from audio input, Time Variant Record, and sound on sound digital recording in sync with the original sample. Lexicon Dynamic MIDI® lets you assign MIDI controllers to sampling parameters, for new dimensions of real-time or sequenced control.

Sometimes even the most accurate replica isn't exactly what you're looking for: if so, the 480L will take you beyond imitation into creative sampling. Play samples faster or slower (without changing the sampling rate), backwards or forwards, even both at

once. The 480L's innovative signal processing algorithms allow you to enhance sounds with advanced reverbs and effects without leaving the digital domain. Add signal processing as you sample, or process a "dry" sample on playback with digital wet-dry mixing.

The 480L digitally integrates sampling and signal processing because it's designed as a comprehensive audio production tool: a system. And sampling is only the first of many directions in which this Digital Effects System can grow. We're continually examining the possibilities, and as your needs develop we'll implement new tools to meet them. Now is the time to call your Lexicon Advanced Products dealer for a demo of the new production techniques the Sampling Memory Expander makes possible.

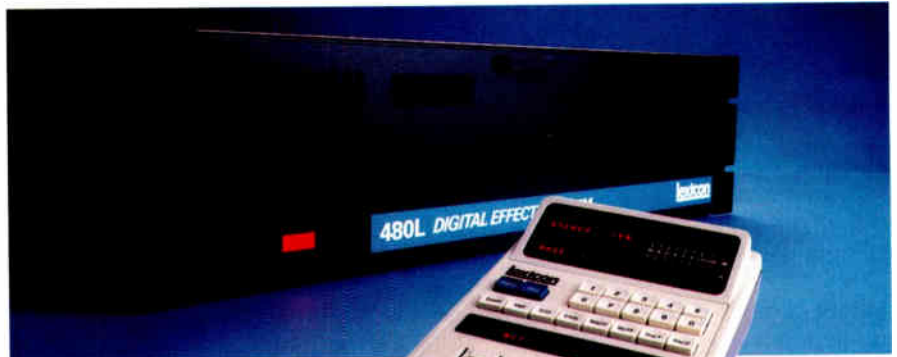

lexicon

Lexicon Inc., 100 Beaver Street, Waltham, MA 02154 (617) 891-6790

Kris O'Connor was road managing and co-producing. John Sommers was playing fiddle, picking banjo and singing backgrounds. (Later on he would write "Thank God I'm a Country Boy" for John.) Steve Weisberg was on rhythm and steel guitar. He was a tall, handsome Texan who sang with a slight lisp that the ladies loved. Dick Kniss, a New Yorker by way of Portland, Oregon, who had toured for years with Peter, Paul and Mary, was on bass.

The first song I recorded with John was "Back Home Again," although the credits were mistakenly given to Jimmy Gordon. When we finished the album, John asked me to play some percussion goodies with him for a concert or two. I'd had similar offers from other artists, but when I told them how busy I was and how much money I'd need to miss work in Hollywood, I usually didn't hear from them until they were ready to record again. John was different, and I was soon headed for St. Paul to augment the John Denver band.

John was a true gentleman and was always considerate of his musicians. It was first class all the way, and it was a great way to get spoiled.

I brought along a set of congas, some assorted shakers and wind chimes, a cymbal tree and some extra cymbals. The dates came off without a hitch. When we finished, John told me that my contribution was exactly what had been missing—no drums, just effects. "Will ya do some more concerts with me, Hal?" he asked. I said yes and John hugged me and welcomed me to the band.

Before long I really felt like a part of the group. My opinions were asked and treated with respect. I was the old man of the group and knew my way around the world of show business. My ideas were usually valid and helped the shows in one way or another. Aside from all the gold records I had worked on, I had done more than my share of concerts, and I was just passing my knowledge on to John and the group. He was grateful and the group was glad to have me as a permanent member. We got along as close friends, and the weekends turned into short tours lasting two or three weeks. I loved every minute of it.

With John I learned to relax and feel good about myself. I learned more about respect and family than I had ever known in the past. John's wife Annie was an absolute dream girl. She

With John I learned to relax and feel good about myself. I learned more about respect and family than I had ever known in the past.

had been his only love since their college days and was his inspiration from their first date. They both had wonderful families, and it was a pleasure to be around these simple, elegant people with their country roots.

1975 was quite a year for me with John Denver. In my first year on the road I played more one-nighters than I had done in my entire career. We crisscrossed the country from Los Angeles to New York and played all the cities in between. We had a crew of 75 taking care of all the backstage work. Everyone from bus drivers to baggage handlers shared in the happiness instilled by John, and we all had a great time being with such a hit show.

During one of our Saturday morning rehearsals in a San Fernando Valley studio, I met my wife to be. (Wife number five, count 'em.) My buddy Rick Verdi had been telling me about a "wonderful" girl who would be perfect for me. When we met she was wearing old Army clothing (she had been an Army nurse), was bundled to the neck and sported an old hat that just showed a curl of blonde hair. I got her number and told her I'd call, but she seemed uninterested, so I decided to pass. Rick wouldn't give up though. He kept after me, and we finally arranged to have a date.

When I walked through the door, I knew I was looking at the woman of my dreams. She was a 6-foot blonde from Texas who looked like a movie star, with silver blonde hair down to her shoulders and a smile that could melt an iceberg. She'd been an Air Force brat and was specializing in intensive care nursing at the UCLA Medical Center. I was ready for marriage, although I'd been single for four years, swearing never to marry again. Here in front of me stood my next six years, nine months and 12 hours of wedded bliss. We were married four months

later in June, 1975.

Just before our marriage, my fiancée called her mother in Abilene, Texas, and told her to watch the John Denver special. She told her mom, "When you see the drummer, take a good look—he'll soon be your son-in-law." Of course, all the family gathered around the TV to see the new relation. Unfortunately, my fiancée had forgotten to mention that I was playing percussion, not drums. Herb Lavelle, a fine looking black man, was on drums for the concert. During the show, the camera zoomed right into the audience for a full-face close-up of my fiancée, and then faded to commercial. I'm sure John arranged it.

The next show after the commercial was of Herb Lavelle drumming with his sticks on a board. It was a country scene, and we were all dressed for the parts. I was playing washboard and Danny Kaye was the special guest. When the show was over, my fiancée called home to see what the family thought. They were paralyzed. Her mother, a real Texan, said, "I guess you know what you're doing, but it'll be a tough life being married to a black man."

John and Annie arranged for our wedding to take place on the top of a mountain in Aspen. The entire band was there with their families. John was best man, Annie was matron of honor and Kris and Bonnie O'Connor's kids were flower children. We all wore the floral arrangements that Annie designed for our hair. John sang "Annie's Song," and the day couldn't have been more beautiful. The reception was held at John's house high in the mountains, and everyone drank champagne and partied. We then gathered for a special dinner at one of John's favorite restaurants.

John took me aside at one point during the reception and, like a father, kissed me on the cheek and said, "Hal, you're not going to be pounding those drums all of your life. When you and your bride are ready to take it easy, come up here and settle down." He pointed out of his picture window and said, "Pick out anything you like—it's yours."

The first six years of my marriage brought perfect domestic happiness. My wife accepted the grind of my work routine and was a gracious hostess with our friends. Everyone fell in love with her. My family adored her. This was the marriage I had been waiting for all of my life.

The show was scheduled to travel to England at one point, and at the last minute Herb Lavelle had to cancel. Kris O'Connor called me and asked if I could possibly play drums as well as percussion. "Hell, yes!" I replied. I had studied independent coordination for so long I sometimes felt like I was schizophrenic. From that day on, I played the sit-down set and the percussion for John.

John's traveling procedure was one of the best I've ever seen with bands, thanks to our do-everything travel planner, John Clark. We always left L.A. in the morning, arrived in the East that afternoon, and spent the first night resting. The flights were always fun and well-planned, and we were able to relax and eat like kings. John called it a sharkfest and later called us the sharks. "Johnny and The Sharks" stuck for a long time.

We generally took over the entire top floor of the hotels we stayed at and had a security officer at the elevator. No one could get off on our floor without the special John Denver Show badge. We also had our own security force led by John's personal security man, Tom Crum, an incredible martial arts instructor from John's Windstar Foundation in Snowmass, Colorado.

The next day we started work for real, if you could call it work. We usually left for the venue at 4 p.m., giving us almost an entire day to sight-see, shop, make calls, etc. The sound check came off about 5 and we finished by 6 or 6:30. As the concert hall doors opened, we would go off to our well-stocked dressing rooms for rest and relaxation. John had a ping-pong table backstage at each hall, and the ping-pong wars would rage as the audience was being seated for the eight o'clock show. Most of the cast and crew were avid ping-pongers, but none of them had the killer instinct like John. No one could beat him except Lowell Norman, and he only did it every once in a great while.

John always saw to it that the handicapped were allowed into the auditorium first and given the best seats in the house. It did my heart good to see some of these folks at ringside clapping and cheering from their wheelchairs. At the end of each show I would jump off the stage and hand my sticks to one of them. It broke my heart more than once, but it made them feel so good.

At the end of each show, a special



PHOTO RICHARD SCHUMACHER

Hal checks out an early electronic percussion system.

backstage section was set up for visiting dignitaries, mayors, governors and presidential families. Record distributors, RCA officials, agents and disc jockeys, and any and all friends of the band were invited. We always had carte blanche as to how many complimentary seats we wanted, and in Texas one night, I had about 15 of the family in. Los Angeles was the only exception, where we were given a limited number of complimentary seats. L.A. was, of course, a madhouse when we played, and the audience was filled with friends of the business, friends of John's personal manager Jerry Weintraub, as well as film stars, producers, directors, etc.

If, on occasion, we had to do two shows on the same evening, there was a catered sit-down dinner served to everyone connected with the show. But generally, we only did one show, and after the dignitary get-together, we would head for the airplane, hop aboard for another sharkfest and fly on to the next date to do it all again.

But times change and people change. Sometimes an outside event can change people's lives. In this case, it was Elvis Presley. When Elvis died, John decided to revamp the band. John Sommers had quit; Steve Weisberg quit after a painful divorce; and Dick Kniss and his wife started a business in New York. To fill out the band, we hired James Burton on guitar, Glen D. Hardin on piano and Emory Gordy on Fender bass—all Presley alumni. Herb Pederson was brought in on banjo and guitar, Danny Weetman on fiddle, Jim Horn on sax and flute, and away we went. It was a terrific band with tremendous energy on stage. John was

playing all kinds of guitars and starting to rock.

I think this was the beginning of the end. The fans loved John for the things he did naturally, the style that set him apart. Although we had a great band, we started sounding more like other pop bands. The special John Denver quality seemed to change, and the fans couldn't identify with him like before.

The new band wanted John to rock more, while the fans wanted "Annie's Song" and the other classics. John used to come to me and say, "Hal, if you see me going too far over to the rock side, grab me and straighten me out." I tried on several occasions, but John had that electric guitar bit clenched in his teeth and there was no stopping him. His marriage began to crumble, along with his popularity.

Although I didn't realize it at the time, I was about to play my final inning with the John Denver Show. In retrospect, it was comical as well as very sad and disillusioning. We were heading for Japan and a beautiful tour. I had requested a sleeper (paid for by me) because I had worked late the night before, and this was going to be a long flight. When we boarded the plane, my berth was taken by one of the brass in our party. At the last minute some of the management people decided to take the same flight, so I was bumped. I was exhausted, but I was booked first class and stretched out there.

When we arrived in Japan, John sent down orders that we were to meet at a certain hour to play baseball with the Tokyo Giants at their stadium. I always acted as the announcer during our games, doing my microphone shtick, prodding the guys on, but this time I just couldn't make it. I was totally wasted from the trip. John felt that my action was a slap in the face to the Japanese fans. I felt bad, because I would never have hurt their feelings intentionally.

Then we did two TV shows from a major TV studio. Since they were nationally advertised specials for Japan, I suggested that we get paid scale for the shows. It was just a few bucks, and it wasn't money out of John's pocket, because the shows were sponsored by JVC (Japanese Victor Company) and NEC (Nippon Electric Company), the corporate equivalents to General Electric in America. I only was asking for what was rightfully ours. The band agreed, but no one backed me up. I was

going over the top alone, rifle in hand, facing the fully armed enemy: the Denver managers. I really didn't mean to upset anyone; this wasn't a labor strike. But it didn't go over very well.

The next bit of friction went back a little farther, but I bring it out now because this is where it fits into the picture. Not long before leaving for Japan we lost Emory Gordy, our beloved bass player, and then the scramble was on to find a replacement. Every guy in the band wanted their own man and every time a bass player came out for a try, the majority would rule. Eventually, a player was chosen. He was a nice guy, but he came from a hard rock group and had no musical finesse whatsoever.

We tried doing an album, but this new guy couldn't even keep a simple time beat going. It was ludicrous. The album just wasn't happening. We had all lost that lovin' feeling, and everyone knew it. I was really hurt when I heard that certain band members had voted to toss me out because the bass player said he couldn't play with me. Fortunately, John vetoed the idea, realizing that my expertise was in recording and the fault wasn't mine. The album was scrapped, and John went to Nashville and recorded with some Nashville cats.

Back to Japan: when we arrived at the TV studio for the show, a new gofer/valet/aspiring-to-producer asked us to listen to John's new album. We all listened and thought it was fine. No big noisemaker, but a nice album. As for the drum parts, they were fine—but for Nashville, it sounded pretty busy. Nashville was just discovering the percussion sounds that most of us on the West Coast were shelving from overuse. John's album was loaded with clicks, bangs, dings and pops at practically every song opening. It sounded a bit silly, but I kept my mouth shut.

Mr. Gofer asked me to particularly listen to the bass drum sound. The band all listened and when the record finished, I said, "What about it?" He said, "This is the sound that we want to get from now on." I said, "That is the exact sound that's coming from my bass drum."

The Denver set that I used on the road was loaded with foam rubber. It had a perfect recording sound with the head off in the studio, but on the road I had a head on the front featuring John's Windstar logo. The American Indian motif was part of the Denver

stage set, designed by John's company, Goshe Graphics. It looked and sounded beautiful.

The gofer persisted: "Well, the drummer in Nashville didn't have a head on the front of his drum, and that's what I want!" Now the band was looking at me, holding back their laughter. I couldn't help but laugh, and it pissed him off. "Go ahead and laugh, but I want that head off of there for this tour." "OK," I said, "but what about all of those funny little things that are holding the head on? How about all of those little things rattling at once? That oughta sound great!"

Now the band was near hysterics, and the argument was getting hot. I looked at Steve Voudouris, our head roadie, and said, "Take it off." John appeared and tried to stop the silliness, but the want-to-be manager really had to show his stuff. "That's right, Steve, take it off!!" shouted the gofer. I said, "Look, if you had ever taken the time to look at my sets—and there are nine of them—you'd have noticed that none of them has a head on the front. I haven't used front heads for years in the studios." Then the gofer said, "Well, don't think I don't know something about music—I used to play trumpet in high school!!" I looked at the band and said, "I rest my case." The band rolled in the aisles.

After the fiascos of the Japanese tour, John went to China for some R&R. He had studied Buddhism and was getting in tune with the old religious scene there. One day I received a wonderful postcard from China. That very night I got a call from the gofer: "Hal, we won't be needing you on the show anymore. We're hiring the Nashville drummer." Click.

The end had come. The gofer had scored. I was heartbroken to say the least and, to top it all off, a few weeks later my wife ran off. Within a year, John's wife filed for divorce.

About a year later, John sent me the nicest trophy in my collection—a gold record to end all gold records. It was a gold-framed, nine gold-record set of all the albums that I did with John. And, although I did lose to the gofer, I still think that somehow, down deep, John knows that I was as loyal to him as a person could be. He was closer than a brother, and I adored him. In the long run, I think that I was the winner. He's found out by now who his real friends are. ■



HIGH QUALITY CASSETTE DUPLICATION

BY THE HUNDREDS OR HUNDRED THOUSANDS STEREO OR MONO MASTERS RECEIVED IN ANY FORM INCLUDING DIGITAL WHITE, GREY OR BLACK 5 SCREW HOUSINGS CUSTOM LABELS & CARD INSERTS POLY OR NORELCO BOXES
Call for Prices & Samples

1-800-331-0405

FORGE RECORDING STUDIOS, INC.
P.O. Box 861
Valley Forge, PA 19481
215-935-1422 or 644-3266



Circle #131 on Reader Service Card

Approved for Foreign Students

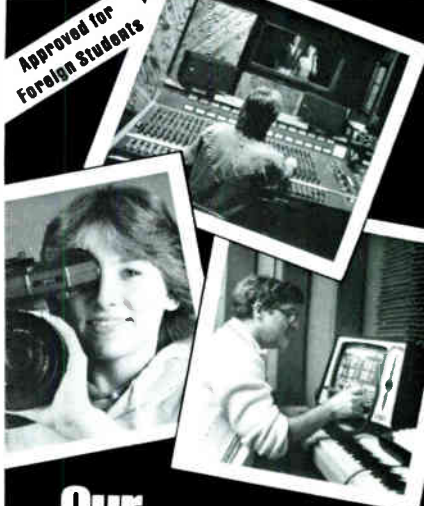

Our Graduates Work
A practical education in audio and video recording arts and sciences for anyone who takes recording seriously.

Institute of Audio-Video Engineering
1831 Hyperion Ave., (MI) Hollywood, CA 90027

Call Toll-Free: National 1-800-551-8877
State 1-800-872-1414 Local (213) 666-2380
Telex 910 240-4388 IAVE HLWD

Circle #132 on Reader Service Card

by Robyn Flans

NEW GRASS REVIVAL TAKES ITS BEST SHOT

Hold To A Dream, the title of the New Grass Revival's new album, pretty much describes this band's commitment. For 14 years there has been a dedication to making music that is innovative, inventive, eclectic and brilliant, words that journalists live to use and radio programmers don't know how to accommodate.

"Everybody we grew up playing with has now made it on their own

like Vince Gill, Ricky Skaggs, Bill Lloyd and Radney Foster," says singer/bassist John Cowan. "Sometimes it's a little nerve-racking to see all your friends succeeding. It's sort of like, 'What's wrong with this picture?'" he laughs.

What's wrong with the picture in radioland is exactly what's right with the picture, artistically. While the fusion of bluegrass, jazz and rock on traditional instruments topped with an



New Grass Revival
(L to R): John Cowan,
Bela Fleck, Pat Flynn,
Sam Bush.

R&B vocal might be considered too off-the-wall to some, to others it is just that eccentricity that creates the magic of the New Grass Revival. Taken out of context those elements might not sound like they would make sense, but the combined approaches of Sam Bush on mandolin and fiddle, Pat Flynn's guitar, the banjo work of Bela Fleck and Cowan on bass, work. But now what?

"We seem to have this dilemma in reverse," ponders Flynn. "The normal new act would say, 'We need to get something on the radio, then we'll create an audience and go out on the road and do shows.' We're already on the road 200 days a year. We play all over the world. There has been a New Grass Revival since the early '70s; and Bela and I have been in the band six years now and we've played for literally millions of people. We've been on major shows, on our own cable TV special, *Austin City Limits*, *Prairie Home Companion*, *Nashville Now*, every festival from the bluegrass to the folk circuit, to the Newport Festival, to the New Orleans Jazz & Heritage Festival, to Telluride, to Louisville, to Winfield, to Yosemite and yet we're a new act in Nashville trying to get credibility. It's an interesting dilemma, but I think the answer is that we've never really attacked the country market."

Certain songs and approaches on *Hold To A Dream* should conquer the problem without compromising the musical vision. In fact, the sparingly used drums—a New Grass rarity—might just aid radio acceptance.

"We don't really know, but we do know that every other song on the radio has drums on it," laughs Bush.

"'Unconditional Love,' our first single, was a gas," Cowan reports. "I love playing with drums. For me, as a bassist, it's such fun and such a relief because I never get to. It's nice to have a new person to communicate with and it takes some of the pressure off me. I'm really used to it since I've done this for 14 years, but if you think about it, whenever there's an ensemble that doesn't have a drummer, most of the responsibility is on the bass to keep the time going."

The title track presented its own set of problems, and Eddie Bayers was asked to lay down drums after the track had been cut.

EXCELLENCE is the result of *uncompromising dedication to quality and service.*

JRF is proud of its reputation as a leader in the field of magnetic heads. Our technical and engineering staff is committed to providing the finest products and services:

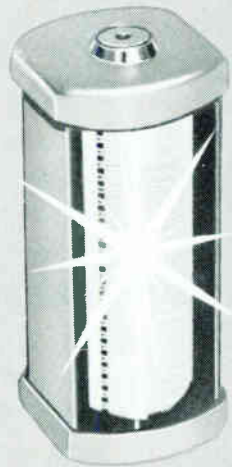

- **Magnetic Head Refurbishing**
- **Optical/Digital Assembly Alignment**
- **Full line of replacement heads IN STOCK**
- **MCI/Sony parts dealer**
- **3M parts dealer**
- **Technical Assistance**
- **Fast, reliable service that's unmatched for quality**



Responsive to the needs of the recording industry, we at JRF feel there can be no substitute for **EXCELLENCE.**



Kennedy Road • P.O. Box 121 • Greendell, NJ 07839
Tel: (201) 579-5773 • Fax (201) 579-6021 • Telex 325-449



Circle #133 on Reader Service Card

Direct from Digital? No problem!

Experience *Ultimate Fidelity*
on the world's largest
Nakamichi real time
cassette duplication system.

Call toll free (800) 323-AAPX
In northern California, call
(800) 327-AAPX or (707) 585-1132

AAPEX™

WE UNDERSTAND SOUND

*"Our Success
is the result of
people caring
about Quality"* ©

**REAL
TIME
CASSETTE
DUPLICATION**

Circle #134 on Reader Service Card

THOROUGHbred MUSIC HAS FREE DELIVERY.

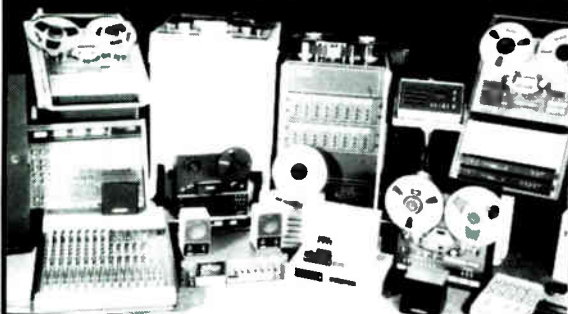

- RECORDERS
- MONITORS
- AMPS
- MICROPHONES
- SIGNAL PROCESSING
- TASCAM
- FOSTEX
- KURZWEIL
- E-MU
- ALESIS
- AKAI
- UREI

20,000 Square Feet Of
State-Of-The-Art Pro Audio
Shipped Daily

THOROUGHbred MUSIC

2204 E. Hillsborough Ave.
Tampa, FL 33610
(813) 237-5597

*Mail orders only
shipped in continental U.S.
via U.P.S.



Circle #135 on Reader Service Card

PLAYBACK

"That song is a fiddle tune with words," explains Bush. "The instrumental parts are almost part of the melody as much as the song and words itself. The first approach was sort of like a string band and then [producer] Garth Fundis suggested we try the trap kit on it. All of the band members were a little wary of that at first, but that's the great thing about the studio. We can try to put them on, but it doesn't mean we have to keep them."

"Records are usually kind of painful for us," Cowan admits. "In a group that's a democratic organization where you have three other guys who have been handlers, deciding what to have on a pizza is a pain in the ass."

"On 'Before The Heartache Rolls In,' the arrangement and licks at the beginning of the song and the vocal ad-libs at the end were all created on the spot," recounts Flynn. "A few of the songs, like 'How About You,' we had been doing on the road for a while, though, so as I was in the studio playing what we always played on stage, I wasn't feeling like it was fresh and spontaneous. We had been doing it in the key of A, so I put a capo on the second fret and played it in G, and by doing that and changing the style of playing, using a lot of open runs and cascading on notes, I came up with a whole different guitar arrangement. I'm glad I was able to do that because had it been a situation where I had to do it very quickly, I wouldn't have chanced it."

The tracks were cut live with a live vocal with as few effects as possible, although they did run directs on the instruments.

"We took directs all the time on Sam, Bela and Pat so we would have the options of using the direct through an effect in the control room or just adding a straight direct sound to add a little edge or get that metallic bottom sometimes," explains Fundis, who relied heavily on engineer Bil VornDick although his background is in engineering as well.

"We're all open to anything that makes our instruments sound unique, but when it gets too effected, we don't like it. We've used harmonizers and delays and all kinds of goofy stuff," says Fleck, who admits to enjoying utilizing the SPX90. "It's one of the most standard things around now because



**You
can't
get
this
catalog...**

...unless you call this number
1-800-223-6278

But if you do, we'll send you right away, and at no charge, the complete **Valentino Compact Disc Production Music and Sound Effects Libraries Catalog** that has everything you need for your productions—the complete listings for both libraries, a **FREE Compact Disc Demo** for both collections, and all ordering information. But, we can't send it to you, unless you call us.

So take the first step. **CALL TODAY!**

VALENTINO...the first Production Music Library on Compact Disc!

VALENTINO...the first and ONLY digitally recorded sound effects library produced in the United States.

In New York call (212) 869-5210

THOMAS J.
Valentino, inc.

151 W. 46th Street, New York, NY 10036

Circle #136 on Reader Service Card

it's reasonably priced and totally great. With that, I can get some odd things and make the banjo sound very different. Basically, chorusing can sound really good on it and reverse gates sometimes are interesting, but it doesn't really work on a fast bluegrass banjo part. I didn't use a reverse gate anywhere on this record.

"But the harmonizing pitch change stuff, where you can have two notes coming out instead of one and they can be in minor thirds or major thirds or fourths or fifths, is a real interesting

"Records are usually kind of painful for us. In a group that's a democratic organization where three guys have been bandleaders, deciding what to have on a pizza is a pain in the ass."

sound on the banjo as well as having two banjos, one that is an octave higher or lower. That's a cool sound, too. The things you can do with this particular device are pretty unlimited."

"On my tune, 'I Can Talk to You,' Bela put his banjo part down and then he had an idea for a high strung part, so he put octave strings on his banjo and finger-picked the part," Flynn recalls. "It's mixed a little bit back, but the banjo part has a sheen to it. It's as if there is a high overtone to what he's doing and I thought it came out real well."

"Our last record [*Boulevard*] was the first time I experimented with certain things," Fleck states. "Like on 'Revival,' I took a little miniature guitar and doubled certain lines and I did things like a stereo banjo break on that song by Holly Dunn, 'Love Someone Like Me.' I did some of that on this record, too. I did a harmony banjo on

Noise Gates Should be Seen & Not Heard

With its unique application of optical switches (rather than the noisier VCA's used conventionally) the Omni Craft offers **very low noise & high performance** – at an affordable price.

Just \$395.00 buys you four noise gates in an AC powered/rack-mounting package, with facilities to "key" the gates from external triggers as well as adjustable Range, Threshold and Release Time.

Also available are plug-ins for most popular rack systems. Studio performance for the budget-conscious! Call us for literature & information.

**Omni Craft - - -
the quiet one!**

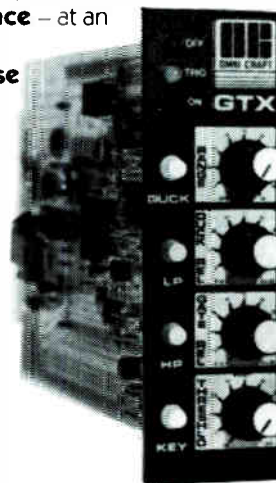

CALL 1-800 CT AUDIO



In Florida Call (305) 738-0622
CT Audio Marketing Inc., 3050 S.W. 14 Place, #3
Boynton Beach, FL 33426

Circle #137 on Reader Service Card



FROM START TO FINISH . . . ian

Audio Cassette & Video Tape Duplication

From 100 - 100,000 copies, the same consistent quality goes into every tape we duplicate.

Computer controlled, state of the art facilities accommodating all formats and budgets.

And there's more . . . with our in-house graphics and printing capabilities, your project will be complimented by great looking packaging, too!

When your reputation depends on it . . .

ian Communications Group, Inc.
10 Upton Drive Wilmington, MA 01887 (617) 658-3700



Circle #138 on Reader Service Card

'How About You' just on the solo and on 'Unconditional Love,' there are a couple of licks I put a second banjo on, playing the same note an octave higher. Then, way in the background, towards the end of the record, I overlapped two banjos on a counterpoint. If you listen to it and know it happened, you might hear it on the repeat chorus. These kinds of things keep me amused in the studio and then nobody ever notices them."

But on "Metric Lips," a Fleck instru-

mental that is probably too much to ask a radio programmer to play, Fleck had his "personal most childlike joy when we turned over the tape to record backwards. All it was was one chord, right at the peak of the song. Also, I brought home an instrument from India, a little drone box that I overdubbed in one spot, just barely in the background.

"Sam was getting a little more into that on this record, too. He got out his fiddle that has octave low strings on it that he calls a Violetra. He plugs it in and gets a real wirey sound, almost

like a cello. He overdubbed that instrument on 'Metric Lips' and we hid it in a couple of other places. I think it's on 'Before The Heartache Rolls In,' on the little bridge sections where you hear this low sustaining sound. He did some harmony stuff with himself on 'I Can Talk To You,' and on 'How About You,' he played rhythm guitar, while Pat did all the fancy licks all the way through it. Sam also added a mandolin, so there's two of him on there. We tried as many ideas as we could, without cluttering the record. Pat doubled some guitars as well."

"On 'Unconditional Love,' the riff that starts the song off is stereo acoustic guitars," Flynn reports. "It has a different sound. I left most of the songs alone. A lot of people double the guitar just as a matter of course, but I use it very sparingly. In my role, I pretty much played acoustic rhythm and acoustic lead. I did use my electrified acoustic guitar as part of the sound, but we miked the guitar normally."

Explaining their double miking technique, Fleck says, "We'll have one mic in a fairly rich, low-ended sounding place on an instrument, like near the sound hole on a guitar or down below the bridge on a banjo, and then we'll put another mic in the most high, bright-sounding part of the instrument, like over the strings, by the end of the finger board on a guitar, banjo or mandolin. Then you can move the faders until you find the place where it's bright and rich. It might be too bright, so you pull back the high-ended one a little. If it's a little too rich, you pull back the low one and use that one for a running point for the whole song. If you turn it up, you turn them both up and keep the relationship the same."

Taking it a step further, Fundis details, "On Bela's banjo we use the B&K pretty close to the top of the fingerboard and then a KM84 down below the bridge. The B&K is a real open, bright, transparent microphone and the 84 picks up the resonance underneath the bridge, so it's the two together that make up the sound. You can get into some phasing problems if you're not careful, but it's trial and error until you find the place that works. With Pat, it's pretty much the same thing, with the B&K on the top and an AKG tube mic on the bottom. Again, it's a crisp, clear top and that gets all the harmonic overtones that



PROSONUS®

Better Than Live

The softness of a sax. The smoke of an electric guitar, the dancing rhythms of a xylophone.

When you're sampling sounds, nothing's as good as live. And nothing's as much trouble.

The new Prosonus Sound Library puts you in control. We offer an on-going series of direct-to-disc recordings on CD that give you the live sounds you need — without the hassles.

Just connect any CD player to any sampler. You get complete and easy access to hundreds of live error-free sounds — each one recorded or designed by professional musicians and engineers.

So sample Prosonus. The professional's sound library.

Because better sounds make better music.

For more information, visit your favorite music store or call Prosonus at 213 463-6191.

S O U N D L I B R A R Y

(formerly known as CSI)

Circle #142 on Reader Service Card

these guys naturally hear themselves, that they want to hear when they come back in the control room. Double miking a mandolin is real hard because the mics are close together. Sam's got a real chunky mandolin sound with a lot of low end to it. We used an AKG on the bottom and a KM84 on top."

"I think this is our best sounding record," says Cowan, who claims he usually doesn't enjoy listening to their albums for pleasure. "I think we're really exciting live, but we're not always able to get that on record. On 'Can't Stop Now,' I really feel like we

"The normal new act would say, 'We need to get something on the radio, then we'll create an audience and go out on the road and do shows.' But we're already on the road 200 shows a year."

captured the live energy of the band.

"We're at a place in our career now where a lot of things are riding on a lot of things," he continues. "To be honest, if we don't have any significant airplay, I can't see how Capitol can justify another record. But I don't look at that as depressing. If we want to, we can do this until we're 70 and people will always be out there who love us." ■

Robyn Flans is a freelance writer who contributes to Mix, Modern Drummer, Pulse, Words & Music and other publications. She's also conducted interviews for radio and TV, and has authored three rock books.

Reliable Music

*is pleased to announce
two additions to our fine*

Professional Sound & Recording Staff



DON KENDRICK

Formerly with PTL Audio Department and DK Acoustic Consultants. Specializing in church and broadcast systems.



TOM FONNER

Formerly with Valley Audio. Experienced in recording and broadcast systems.



Reliable Music

704/375-8662

650 East Stonewall Street • Charlotte, NC 28202

Circle #143 on Reader Service Card

Quality Audio DUPLICATION

CASSETTES

Audiophile Music Quality Materials
State-Of-The-Art Equipment
Dolby A & DBX Masters accepted
Dolby B • HX Pro

COMPACT DISCS

Mastering • Manufacturing •
Packaging

LP & 45 Record Pressing also

All Types of Packaging
Drop Shipping

SOUND IMPRESSIONS, INC.

325 Hill Avenue
Nashville, Tennessee 37210

800-458-7756

615-244-3535

Circle #144 on Reader Service Card

by Lou CasaBianca

DESKTOP TELEVISION

Desktop video is the development, processing and transmission of moving images between microcomputers and video signal devices such as TVs, VCRs and broadcast equipment. Desktop video (DTV) allows a microcomputer user to process video images from artwork, digitized television media or scanned material. The system also permits the operator to run moving images in real time on the microcomputer, edit them, and then export the revised video in a signal that is compatible with VCRs, televisions and broadcast equipment.

Beck-Tech, one of the originators of the DTV concept, has a series of tools which integrate video with microcomputer-based systems to create low-cost, high-resolution graphic productions with the look and feel of studio shows. The Chromatron is an output processing device which converts Macintosh video signals to NTSC/170A television signals. "MacMovies" is a full-screen, real time video processing package which allows the editing, compression and playback of moving pictures at speeds up to 30 frames per second. Current development efforts center around the new IBM microchannel and Macintosh II Nubus architectures. Beck-Tech sees desktop video becoming potentially as large as the burgeoning desktop publishing market.

Animation and Graphics

We will shortly reach the point where business presentations will practically require animation and motion graphics. Overheads, 35mm slides, and charts will be integrated within screen video presentations. This includes video shows with graphics and text that dissolve and fade, titles and logos that

tumble across the screen, and information highlighted with graphic effects. Just a few years ago systems with these capabilities would have been extremely complicated to use and cost hundreds of thousands of dollars.

Microcomputer-based turn-key systems are available for less than \$20,000. These systems will allow anyone, from

Beck-Tech sees desktop video becoming potentially as large as the burgeoning desktop publishing market.

secretary to senior manager, to create media presentations, moving storyboards and training tapes. The master copy is created and stored on a computer disk. The show itself can be run from the computer or laid over to videocassette. These programs can be shown on any monitor, from a computer screen to a large-screen projection TV. The real power of these pre-

JOIN THE WINNING TEAM!

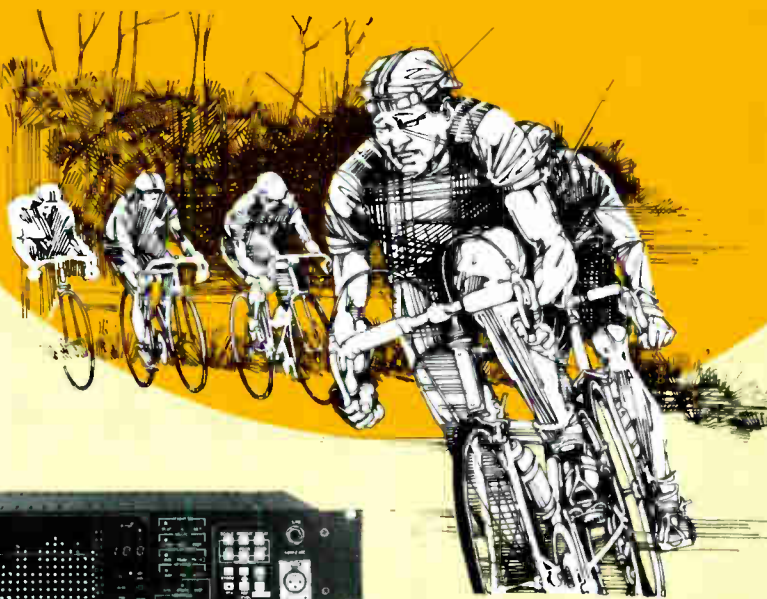

1/3 Octave Spectrum Analyzer (A Growing System)

- Full 30 Bands
- Printer Option with 30 Memories via Parallel Centronics Interface
- Weighted Curves

The Model 30 features 6 memories, line level and microphone inputs, a pink noise generator, summing and averaging ability plus many other features.

Every Model 30 is supplied with 4 expansion ports to allow for growth. Now available for expansion:

- A card to provide 30 non-volatile memories plus printouts on low cost parallel interface printers.

BASIC MODEL 30 \$2150.00
WITH INTERFACE \$2650.00



1/3 Octave Hand Held Real Time Audio Analyzer

The model 30B is a professional 1/3 octave real time audio spectrum analyzer at an affordable price and the ideal machine for:

- **THE STUDIO;** to check room response and monitor the mix.
- **LIVE SOUND;** to eliminate feedback and easily set room EQ.
- **SOUND CONTRACTING;** to analyze rooms, set EQ and SPL levels, eliminate feedback, verify system performance.
- **BROADCAST;** to adjust cart machines and check line quality.

AVAILABLE ACCESSORIES: Carry case & remote instrument microphone with phantom power source.

FEATURES INCLUDE: built-in rechargeable batteries; built-in microphone, aux line input, SPL in A or C weight, Decay settings.
FILTERS: 30 bands on ISO centers to ANSI Class II double tuned specifications.

SUGGESTED RETAIL \$599.95



Loft Model 400B Quad Gate Plus Limiters

4 gates plus 4 limiters complete with 4 key inputs make the 400B the ideal machine for RECORDING, BROADCAST, or SOUND REINFORCEMENT application.

- You can GATE without LIMITING, or LIMIT without GATING. You can GATE and LIMIT at the same time to achieve a wide variety of special effects.

MODEL 400A — Gates only at \$419.95
MODEL 400B — Gates with Limiters at \$599.95



TS-1

Oscillator • Frequency Counter • dB Meter

Three audio test instruments combined in one unit. Features include:

- Low distortion audio oscillator with frequency range 10Hz to 30KHz.
- Frequency counter with response of 1Hz to 99.99 KHz.
- DB meter with range of -50 to 24dB from 20Hz to 20KHz.

MODELS: TS-1 · Balanced In \$299.95
 TS-IRM · Rack Mount Balanced In \$359.95
 TS-IRMX · Rack Mount Balanced In and Out with XLR Connectors \$399.95

CONTRACTOR PRICES



Enclose \$2.00 for postage and handling for full literature line.

P.O. Box 115, West Redding, CT 06896, (203) 938-2583

Circle #038 on Reader Service Card

sentations is that they can easily be customized for different applications. Many of the initial buyers for desktop video are producers in the graphic arts or professional video production market. TV commercial and videotape producers, who use it to create video storyboards, are able to give clients a better idea of what the finished product will look like.

New Technology

There are technological forces acting

on the market that will give desktop video a boost. The new 32-bit microcomputers are more suited for graphics like the IBM Model 80 and Apple's Macintosh II, and will provide the horsepower, high-resolution screens and memory required to do more lengthy real time animation. Lower cost software and hardware peripherals are coming on the market that will complement these more powerful machines, so that soon we will have a true desktop studio for less than \$20,000, instead of the \$50,000 and up for systems now available. Finally, as more

microcomputer users become graphically and visually literate, they will be better able to use the power and versatility of desktop video production.

According to Beck-Tech research, there are several key segments in the \$800 million video graphics and animation market: commercials and advertising (about 50% of the market), broadcast graphics including station IDs, show opens, and news (15%), feature films and entertainment (15%), and scientific/medical/industrial/educational applications (25%).

Beck-Tech is recognized as a leading developer in the desktop video market. For information contact Bob Steele, vice president at Beck-Tech Corporation, 41 Tunnel Road, Berkeley, CA 94705.

New Tools

The AT&T TrueVision family of microcomputer-based video graphics boards and software are extremely powerful elements that fit into the desktop publishing environment. They allow users to capture true-to-life, full-color images from a video source in real time, digitize and manipulate them, and display them on a variety of video monitors or printers. They deliver broadcast-quality graphics at affordable prices. The ability to quickly create, change and save multiple versions of a sketch makes this an invaluable tool in the video studio.

There are several hardware and software elements in the TrueVision product line. The Video Display Adaptor with Digital Enhancement (VDA/D) is a graphics board which creates and displays continuous-tone images at 256 by 240 pixel resolution. The Image Capture Board (ICPB) captures and displays video graphics, featuring 32,768 colors at 256 by 240 pixel resolution. The TARGA series of capture and display video graphics boards feature high spatial-resolution at varying pixel depths. TARGA 8, M8, 16, 24 and 32 boards all display a resolution of 512 by 480, with memory capabilities of 8, 16, 24 and 32 bits/pixel respectively. The varying bit depths allow for color resolutions from 256 grey levels to 16.7 million colors, as well as video overlay and blending. The new VISTA Videographics Adaptor is the most powerful graphics product to date. Not only does it offer the highest spatial resolution, it also is the first adaptor to feature a 32-bit graphics processor on-

NOISE REDUCTION FOR UNDER \$10.

MIXING CONSOLES
SWITCHES
MICROPHONE CONNECTORS
SNAKE CABLES
BATTERY CONTACTS



ALL PLUGS & JACKS
(XLR, PHONE, PHONO, DIN, MIDI, ETC.)
PATCHBAYS
FADERS, POTS
TERMINAL STRIPS
SPEAKER TERMINALS

CRAMOLIN®

Even the finest equipment in the world can't guarantee a noise-free recording. One "dirty" connection anywhere in the electrical path can cause unwanted noise or signal loss.

"MORE THAN A CONTACT CLEANER"

CRAMOLIN® is a fast-acting, anti-oxidizing lubricant that cleans and preserves all metal surfaces, including gold.

When applied to metal contacts and connectors, **CRAMOLIN®** removes resistive oxides as it forms a protective molecular layer that adheres to the metal surfaces and maintains maximum electrical conductivity.

CRAMOLIN® - USED BY THOSE WHO DEMAND THE BEST:

- | | | | |
|-----------------|-----------------|-----------|-------------|
| Bell & Howell | Hewlett Packard | MCI(Sony) | Nakamichi |
| Boeing | John Fluke Mfg. | Motorola | RCA |
| Capitol Records | McIntosh Labs | NASA | Switchcraft |

SINCE 1956

CAIG LABORATORIES INC.

1175-O Industrial Ave., (P.O. Box J) - Escondido, CA 92025-0051 U.S.A. • (619) 743-7143

Circle #145 on Reader Service Card

APM

CONGRATULATES!

Keith Mansfield

on his 25 year association with



*Keith Mansfield, Theme composer for NBC's "Wimbledon,"
PBS's "Nature" and "Innovations" celebrates his Silver Anniversary
with KPM. Congratulations from APM on
more than 75 great albums. **And now...***

writing exclusively

for 

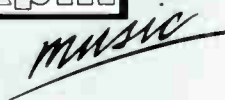

Associated Production Music
888 Seventh Avenue, New York, NY 10106-0201 • (212) 977-5680
6255 Sunset Boulevard, Hollywood, CA 90028-7408 • (213) 461-3211

**AUDIO PROFESSIONALS!
YOU CAN'T AFFORD TO MISS**

**VIDEO
EXPO
San Francisco**

**February 22 - 26, 1988
(Exhibit Hall Open February 23,24,25)
Civic Auditorium
San Francisco, CA**

**Attending will be the wisest
business decision
you make all year!**

**SPECIAL NEW FEATURE
New Power House Seminars
Includes admission into the
exciting exhibit hall**

To make the most of your valuable time, plan to:

Attend one or all of your choice of 6 one-hour "powerhouse" sessions—held each day from 10:00am to 11:00am. These sessions, a new feature this year, will zero in on the most vital issues of concern to video professionals. Topics to be addressed include: "Low Cost Pizzazz," "Video Publishing Update," "New Production Technologies," "Shooting in San Francisco," "Video Management: Issues and Challenges," and "Video Job Clinic."

Then visit the more than 170 companies represented on the exhibit floor to see the latest in products and services, featuring:

Audio for Video	Interactive Systems	Receivers	Video Accessories
Cameras	Lighting Equipment	Rentals	Videodisc Players
Cases	Monitors	Switchers	Video Projectors
Character Generators	Music Libraries	Tapes and Cassettes	VTRs
Duplicators	Production Companies	Time Base Correctors	...and dozens more
Editing Systems	Publications		

**Exhibit Hall Open 11:00am - 5:30pm on February 23 and 24, and
11:00am - 4:00pm on February 25**

PLUS: A complete seminar program

Register for the in-depth seminar program, half-day sessions scheduled each afternoon 3:00pm - 6:00pm. Full day seminars, two-day expanded sessions and a five day basic hands-on production workshop (with one afternoon free to visit the exhibit hall) have been planned to help you make the most of your **VIDEO EXPO SAN FRANCISCO** experience. Seminars will focus on a Basic Track covering, The Script, Audio: The Basics, Editing, Producing Programs, Shooting...a Production Track featuring, Print to Screen, Writing for Video, Corporate Video Applications, Seven Steps to Better Video Graphics, Getting A Grip on Light, How to Operate and Adjust Video Test Equipment, Managing the Video Project...and a Masters Series centering on Mastering Special Effects, Advanced Camera Techniques, Audio Post Production, Advanced Budgeting for Film and Video.

If you are involved in—or about to become involved in—professional non-broadcast television, send for your free Advanced Planning Guide to **VIDEO EXPO SAN FRANCISCO**, or call **(800) 248-KIPI (In NY call (914) 328-9157)**.

Mall to:
Video Expo San Francisco Planning Guide
Knowledge Industry Publications, Inc.
701 Westchester Avenue, White Plains, NY 10604

Co-sponsored by **MIX** MIX-VESF '88
THE INTERNATIONAL VIDEO EXHIBITION ASSOCIATION

- Please send me a free copy of VIDEO EXPO SAN FRANCISCO's Advance Planning Guide with information about events, seminars, exhibitors and registration.
- I may be interested in taking exhibit space, please send me your exhibitor kit with price information.

Name _____
 Title _____
 Organization _____
 Business Address _____
 City _____ State _____ Zip _____
 Telephone _____

board. VISTA is NTSC and PAL compatible, has programmable resolutions at 8, 16, or 32 bits/pixel, and contains 4 Megabytes of video memory on the single-slot board.

The software products include graphic design, visual effects and database management packages. The TIPS Imaging Software is an easy-to-use package for sophisticated image creation, enhancement and manipulation. TIPS is available for all TrueVision video graphics boards, and offers an array of effects, geometric shapes, text fonts and other tools for image processing. TrueVision Slide Presentation Software (SPS) allows users to create PC-based slide shows of images stored in a file by incorporating wipes, dissolves and a timer. Determine the sequence desired, set the effects, and SPS displays a continuous program for training, electronic point-of-sale and other applications. The PicturePower Database Management Software is a powerful package that works in a dBase III environment to create picture-text databases for security, inventory, real estate and other industries.

The TrueVision product line was developed by AT&T's Electronic Photography and Imaging Center (EPICenter) in Indianapolis, IN. Formed in June, 1984, EPICenter is AT&T's first "intrapreneurial" entity. For more information contact: Dennis Collins, Marketing Communications, AT&T EPICenter, 7351 Shadeland Station, Suite 100, Indianapolis, IN 46256; phone: 317/841-0332.

Sony and Hewlett-Packard

DAT moves into data storage. Sony of Japan and Hewlett-Packard (Palo Alto, CA) have announced that they have agreed to jointly develop a range of DAT-based data storage products for the computer market. The two companies say they intend to develop format-compatible data storage products that offer more than 1.2 gigabytes of storage, a fast transfer rate and 20-second average access time, allowing for on-line inquiry. They suggest that DAT's small size will lead to its application in devices for a broad range of systems from personal computers to advanced computer products. H-P and Sony plan to begin product shipments in late 1988, says Raymond A. Smelek, general manager of H-P's computer

peripherals' Bristol, UK division. The division will work with Sony Japan to design and manufacture the new products.

Rock School

Lorimar Home Video has released *Rockschool*, hosted by Grammy award-winner Herbie Hancock. This innovative concept in home video demonstrates the technique, theory and craft behind the scenes. Top British and American recording artists are seen in candid interviews, discussing their musical technique, and are featured in concert scenes.

The series is comprised of six different videos focusing on various aspects of rock. Each cassette combines interviews and concert footage from an assortment of rock legends with step-by-step instruction in the rock-school band: Deidre Cartwright (lead guitar), Henry Thomas (bass guitar) and Geoff Nicholls (drums). The first cassette in the series introduces the basics of rock instruments and techniques, with each successive tape exploring a different aspect of music

from blues to heavy metal, funk, reggae and new wave.

Rockschool was produced in England and features such artists as Duran Duran's John Taylor, John Entwistle of the Who, B.B. King and Nile Rogers.

In addition to interviews with many established musicians there are performances by Genesis, The Police, Elton John, The Everly Brothers, Eurythmics, Bronski Beat, The Pointer Sisters, Depeche Modes, Yes, UltraVox, Thomas Dolby, Japan, Eurasia, Iron Maiden and Jimi Hendrix.

I've seen segments from the series on PBS and recommend it highly. The production value and tone of the productions is very well tuned into the real world and speaks to students in positive and encouraging terms. Each of the six tapes carries a suggested retail price of \$19.95. ■

Lou CasaBianca is involved professionally in advanced music, film, and TV production, interactive authoring and visual design, and computers in media production. He heads the New Media Learning Center in San Francisco.

STUDIO HARDWARE

Equipment Sales.
 Factory Trained Service.
 Studio Design.
 Call us or write for our complete line card.
 (602) 267-0600

CEAR Professional Audio-Video

2641 EAST McDOWELL PHOENIX, ARIZONA 85008

—FROM PAGE 30, DIGITAL & CD

use a common power supply for the servos and the audio circuits. Even if the excessive servo activity did not cause increased incidence of error correction, the effectively diminished power supply available for program would have audible results. Some CD player manufacturers deal with this problem by incorporating separate power supplies for tracking and audio, and at least two companies are manufacturing specially made CD weights for those machines that still do not incorporate an effective means of securing the disc.

Comparing CDs with the Original LP

When you A/B a CD with its corresponding album version, you are not simply comparing the two playback media, you are comparing mastering chains (and techniques) as well.

When a vinyl master is cut, the program passes from the playback machine through the cutting console on the way to the cutter head. The limitations of commercial cutting consoles come from less than state-of-the-art topology combined with long signal

paths that ultimately compromise dynamic integrity and transient response. This is exacerbated by the liberal use of band limiting and compression used to achieve a contemporary "hot" sound.

While CDs do not mind large low-frequency amplitude peaks and unrestricted dynamics, vinyl mastering engineers must worry about overcutting (i.e. "trackability"), available "land" and staying above surface noise. Even if these were not the case, to increase the average level many engineers use some band limiting and compression when making masters for CD. In these instances the LP and CD are quite similar and any audible differences are principally attributable to those between the phone cartridge/preamp and the CD player, except for the CD's lower inherent background noise.

Most of the criticism leveled at the CD medium by some artists, producers, engineers and audiophiles is the result of listening to discs made from master tapes processed as though for prerecorded cassettes. Much of the thin, bright sound these people complain about is not intrinsic to CD but is the result of poor mastering. CDs

can contain dynamic peaks and steep low-frequency transients to an extent not possible with the vinyl disc. The impact of musical fades (both in and out) is dramatically increased when the fades come from, or end in, total silence instead of tape, leader or vinyl surface noise. Adept use of electronic editing makes possible the removal of small (and not so small) clicks present on many masters, resulting in a "copy" that is cleaner and quieter than the original.

It would be a mistake to view the role of the mastering engineer as simply being to effect transfer from one medium to another. Master tapes are the main ingredient of a finished product—be it cassette, vinyl record or compact disc. Mastering engineers are the chefs who prepare the ingredients. The expertise of the chef determines whether the ingredients become fast food or a gourmet delight. ■

Barry Diament is the owner of Barry Diament Audio, a company in New York City that specializes in mastering for compact disc. He was formerly CD mastering engineer for Atlantic Studios in New York.

IMMEDIATE AVAILABILITY FROM STOCK!

1/4" TAPE REELS and BOXES • QUALITY JEWEL BOXES FOR CD'S...
CD STORAGE SYSTEMS...
NORELCO BOXES FOR CASSETTES.

- Soft Poly Boxes
- Ampex Style Boxes
- C-O Cassettes (sonic and screw type)
- Cassette Hub Locks
- Hubs and Cores for Video and Cassette Tapes
- 7-1/2" Reels for Studio Masters
- Cassette Splicing Tape

El Mar Plastics, Inc.

821 E. Artesia Blvd. • Carson • CA 90746

(213) 327-3180



SUPPLYING THE TAPE INDUSTRY SINCE 1966

Circle #146 on Reader Service Card

—FROM PAGE 125, CHET ATKINS

If all albums were that easy, I'd still be in the producing business."

The recent Atkins solo LP *Sails* was somewhat more complicated.

"We brought in a lot of extra equipment when we mixed down. The mix-down engineer was Dave Palmer out of Detroit. He's mixed down my last two albums. He rented a Neve compressor to give the rhythm a little more punch. We rented Pultec equalizer racks that had different EQs; he likes the sound of the old Pultecs.

"On the acoustic guitar we had an old Neumann microphone, a 414. He also rented some UREI Parametrics and a reverberation unit like Lexicon, a Mitsubishi digital recorder, a Calrec Sound Field Microphone system and a Sanken CU-41 microphone that I don't think we used too much.

"Palmer would mix a tune in maybe a day and a half. On one he took two days. And I'm not used to that at all! It took me a long time to get used to that. When he first came in he took two or three hours just getting familiar with the board. And I was thinkin', 'Let's get busy and *mix one* here,' 'cause I'm used to mixing down in 45 minutes."

Weaving in the contributions of Earl Klugh and Mark Knopfler's guitars, David Humphries' and Mark Hammond's drum programming, four keyboardist/synthesizer wizards (Mike Lawler, Darryl Dybka, Clayton Ivey and Randy McCormick), the horns of Mike Haynes and Jim Horn, plus bassist Hungate and a variety of other sessions stars made *Sails* anything but a simple homemade project.

"I played on Earl's second or third album, I guess," says Atkins of his admirer Klugh. "He requested me because he claims he listened to my records a lot when he was a kid. It's been a great association. I love Earl. I think he's one of the most romantic, most beautiful guitar players I've known.

"It's the opposite with Mark. I made the first move. I told my manager, Fred Kewley, 'There's a guy that I like a lot that I'd love to have on my album [1985's *Stay Tuned* as well as *Sails*]. So the next thing I know he said 'Mark Knopfler wants you to call him in London.' Which I did and he said, 'I want to come play on your album.' Since then I've worked with Mark a couple of times. We did an Amnesty Interna-

tional show in England.

"He and all the other people on the TV show are friends of mine."

The Cinemax special, *A Session With Chet Atkins, Certified Guitar Player*, features not only pop star admirers Knopfler, Hungate and Michael McDonald; it also stars people in whose careers Atkins has figured prominently. Waylon Jennings, Willie Nelson and harmonica man Terry McMillan figure from his days at RCA. Emmylou Harris is presently Atkins' banjo pupil. Atkins co-wrote guest Ray Stevens' recent comedy single about TV evangelists,

Would Jesus Wear A Rolex?

And he was the session guitarist on the hits that made the Everly Brothers Rock and Roll Hall of Famers. "Actually, I was never all that pleased with what I played on their records," Atkins reveals. "I just played what [producer] Archie Bleyer wanted me to play. Or sometimes Floyd Cramer would have an idea. And the boys had a lot of ideas, too.

"But working with them was so much fun. They had it going so great. I remember when Don brought in 'Cathy's Clown.' I thought 'My God,

NO MORE DOUBTS.

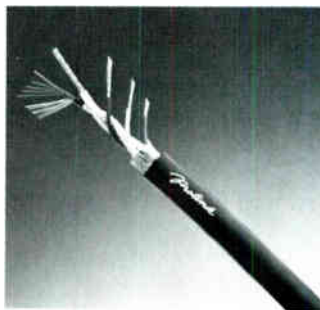

TEC
TECHNICAL EXCELLENCE & CREATIVITY

Monster Cable 1987 TEC Award Winner

Members of a special committee of 85 respected audio industry professionals were convinced. So were many of *Mix* magazine's 35,000 subscribers.

They nominated, voted, and awarded Monster Cable Prolink® Series 1 Tube Mic Cable the 1987 TEC Award for Outstanding Technical Achievement in Ancillary Equipment Technology.

You read that right.

A wire won a TEC Award.

Of course, there were some of you who weren't surprised at all by this award.

Like the growing number of recording studios, mastering rooms, feature film sound effects facilities, and other professionals that currently use Monster Cable products in their work.

They're pioneers. They've discovered the performance difference Monster makes in their work. And they consider Monster Cable to be a milestone achievement in audio engineering.

With good reason, too. Superior cable technology and construction such as "Bandwidth Balanced"™ multiple-gauge "wire networks," "MicroFiber™" dielectric insulation, and "Duraflex"™ jacketing. Extended frequency response and added dimensionality. Exceptional clarity and greater dynamic range.

All that means better sounding recordings. And, ultimately, great music.

This year, discover the powerful difference Monster can make in *your* creative work.

But don't take our word for it. Just ask around.

Some Monster Pioneers: Boddifacations, L.A.; Capitol Mastering Studios, L.A.; Cherokee Recording Studios, L.A.; Chips Davis Lede Designs, Las Vegas; Disc Mastering, Nashville; DMP Records, N.Y.; Eleven-Eleven Sound, Nashville; Garden Rake Recording Studios, L.A.; Georgetown Masters, Nashville; GRP Records, N.Y.; Kdisc Mastering, L.A.; KUSC-FM/Dorothy Chandler Pavilion, L.A.; Le Gonks West, L.A.; Mann Theatres Corp., L.A.; Master Sound Astoria, N.Y.; Masterdisk, N.Y.; Omega Audio & Productions, Dallas; Paisley Park Studios, Minneapolis; Platinum Island Recording Studios, N.Y.; RCA Recording Studios, N.Y.; Record Plant Studios, N.Y.; Right Track Recording, N.Y.; Sterling Sound, N.Y.; Studio D Recording, S.F.; Sunset Sound, L.A.; TAJ Soundworks, L.A.; Tarpan Recording Studios, S.F.; Telarc Digital, Cleveland; The Money Pit, Nashville; The Sound Factory, L.A.; Three Alarm Recording Studios, Memphis; Valley Audio, Nashville; Welk Music Group Studios, Nashville.

© **MONSTER CABLE**® *Advancing the Art of Listening.*

101 Townsend Street • San Francisco, California 94107
Tel: 415 777-1355 Telex: 470584 MCSYUI Fax: 415 896-1745

Circle #147 on Reader Service Card

that's a smash. It's gotta be.' And Boudleaux Bryant brought in these beautiful minuet-type melodies that just changed the whole world. It was a real interesting time to live through."

The TV special, as well as his instructional home video *Get Started On Guitar*, feature him on the Gibson guitar he's played for many years.

"On *Sails* I used a CE Classic with two mics for stereo pickup and a pickup inside the guitar. I like to experiment with other guitars and with guitar sound. I design guitars for Gibson. The CE Classic is a guitar I designed for Gibson that's a solid body with nylon strings. It's been out for three or four years and a lot of rock and roll guys play it, which is a surprise to me.

"See, I designed it for me. I play with my fingernails and I've always had weak nails on my right hand. Steel strings would tear my nails, so I always dreamed of having a guitar with a lot of volume with nylon strings. Gibson went for the idea, and it's been a great selling guitar.

"Nowadays, I play on sessions when

some of my friends want me to play. But I don't let them pay me for it. I get 'em to make a donation to the W.O. Smith Community School of Music. That's where they're doing a lot of good—teaching kids to play music and giving them lessons for 50 cents or so. And you know what? They'll turn out a great one, one of these days."

Perhaps. But probably not one who will leave impact on a musical genre, define an instrument, influence an entire generation of pickers and change the whole recording technology of a music capital. ■

Robert Oermann is the music reporter for The Tennessean (middle Tennessee's largest daily) and a nationally syndicated columnist for the Gannett News Service.

Our apologies to Ebet Roberts in the October issue of *Mix*, page 193. The photo credit for Ebet's shot of Carlos Alomar (from the David Bowie tour) was inadvertently left off.

A CASSETTE LIKE THIS CAN'T BE DUPLICATED

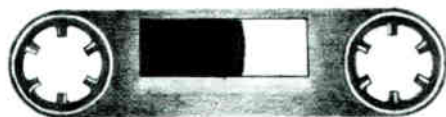

ANYWHERE.

AND HERE'S WHY:

- Sound Recorder's state of the art duplication with Studer mastering.
- In house labeling and direct to cassette printing.
- 40 years experience in the business.
- But here's the real reason Sound Recorders can't be copied *anywhere*: SERVICE. Each order, whether it's for 100 or 100,000 cassettes, is personally handled by owner Miles Muller or production manager Tim Doot. We stay on the job and in touch with you until your order is sealed and delivered.

Hands on service. On our cassettes it's a difference you can plainly hear.

SR
SOUND
RECORDERS, INC.

4031 Guadalupe
Austin, TX. 78751

512-454-8324

—FROM PAGE 142, MIKING FOR DIGITAL

ducing better high-end resolution without lowering sensitivity.

Both of these styles are much sturdier than past designs. Still, you have to be careful with a ribbon mic—just as you have to be careful with a high quality large diaphragm condenser mic. You wouldn't toss a CU-41 or U87 around, would you? Microphones are instruments and the musician who values his prized Stratocaster or Martin D-41 is the same as the engineer who values his ribbon mics.

It's easy to see how ribbon microphones and minimal recording techniques can be applied to digital sampling. Sampling is like taking a snapshot. You're freezing a moment in time. The sampler is like a camera and the mic can be compared to the lens. In certain circumstances, a mic with pronounced sonic characteristics may be desirable, just as fisheye or other lenses may be used for special effects. But in most sampling applications, the mic must be as neutral and free from distortion as the camera lens. It's the same as digital recording.

It may seem strange that one can find solutions for digital problems in the microphones and techniques used 40 and 50 years ago, but it actually makes sense. For every technological advancement, there is a humanized element which balances it. Digital provides us with accurate recordings featuring a wide, natural dynamic range. To balance that, engineers are moving back to more basic recording methods. Performance is becoming increasingly important and a digital recording is often the purest, most exciting way to capture that performance.

Engineer Alan Silverman puts it another way. "It's a funny thing about audio," he says. "You're satisfied about something until something new comes along. As you A/B it, your ears become educated to what you feel is a better sound and it's hard to go backwards. But there's also a process of rediscovery. You may be really turned on by something new and forget all about the old familiar. Years later, you'll come back and re-discover it, probably for the same qualities that attracted you in the first place." ■

Mike Solomon is the marketing manager for broadcast and professional audio products with Beyer Dynamic Inc.

ff

The Mystique continues...

*From Focusrite ISA technology
Another first—ISA 116.*



FOUNDER

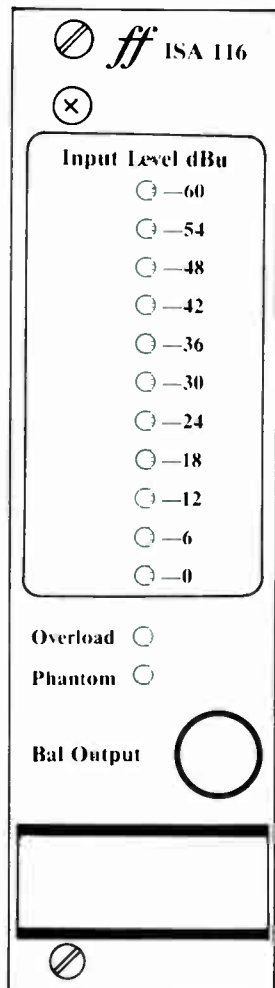

ISA 116

The ISA 116 — A microphone amplifier with a unique addition — remote gain control. The actual module is physically located at the source with the gain adjustment at the control panel. The ISA 116 effectively eliminates signal degradation of traditional microphone lines from relatively short studio installations to extremely long remote recording and video applications, radically improving sonic performance.

Artists, producers, engineers, and studio owners are talking. We've been listening. We will continue to listen and anticipate "market futures" that combine new technology with sonic integrity.

FOCUSRITE LTD — Electro-Acoustic design engineers. Equalizers and microphone amplifiers available in outboard racks and complete custom consoles.

Focusrite

The Sound Alternative.

FOCUSRITE US LTD
1100 Wheaton Oaks Court
Wheaton, IL 60187

(312) 653-4544

FAX: (312) 665-4966

IMC: FOCUSRITE-US



PHOTO-
THERMOGRAPHIC-
TRANSFER
COMPACT
DISCS

COMDISC BETS ON

Given the recent unexpected transition from famine to glut in the CD replication industry, it would seem to be an inauspicious time to consider investment in new manufacturing technologies. Many plants, perhaps especially the newcomers struggling to carve out market share, may be lucky to survive at all unless factory price-cutting translates into a consumer level CD feeding frenzy. Those who had been planning to enter the field, but have yet to actually shell out cash for injection molders and in-line sputterers, are probably blessing themselves for their procrastination and looking into manufacturing widgets instead of CDs. The downward trend in prices may be only temporary, but it has been widely observed that America's current business "leadership" is concerned almost exclusively with the short-term bottom line. Thus, a new CD manufacturing method may be of interest to technophiles, but it has little chance of catching on unless it allows a replicator's costs to fall far below those of the competition.

In Los Angeles, a company named ComDisc Technologies believes it has come up with a replication process that meets the crucial cost-cutting criterion. In a radical departure from conventional injection molding and injection compression techniques, ComDisc uses its proprietary Photo-Thermographic-Transfer (PTT) process to "impress" CD pits onto a continuous ribbon of thin-film polycarbonate. The company expects this continuous pro-

MAKING A GOOD IMPRESSION

duction approach to greatly increase efficiency and cut unit costs by at least 50%. If these projections hold true, replicators using conventional methods will be hard pressed to compete.

ComDisc was founded in 1983 by Mike Foster, James and Michael Wanlass and Terry Conway. Michael Wanlass, marketing vp, describes their background as expertise in "microgeometric surface transfers" and hologram embossing. Working with privately raised capital to guard the secrecy of their ideas, the company founders began transfer experiments using store-bought discs, stripped to their polycarbonate substrate, as masters. Having succeeded with these explorations, the company set about developing the process for commercial manufacturing. Prototypes discs were delivered to potential licensees in February of this year, and licensing negotiations are underway for product delivery commencing this coming April. I spoke with Michael Wanlass from his office in L.A. for details on the applications, advantages and implications of PTT.

Mix: Let's start with an overview of the ComDisc approach to making CDs.

Michael Wanlass: Essentially, rather than make discs one at a time out of hot plastic using the injection molding techniques, we impress them on a ribbon of 6-inch wide, 5-mil polycarbonate. It's a graphics grade polycarbonate film. We do it at high speed, sort of like printing a newspaper. We then put

by Philip De Lancie

TESTED. PROVEN.

The Carver PM-1.5 Magnetic Field Power Amp—For performance, reliability and sound.

On the Road Since the professional debut in 1983 of the Carver PM-1.5 Low Feedback High Headroom Magnetic Field Power Amplifier, the sonic excellence and reliability of this 21-lb., 450 watts per channel* powerhouse has been tested—and proven—on some of the biggest and toughest tours ever to go on the road. 108 Carver PM-1.5's were used by Clair Brothers on the Bruce Springsteen tour, and 180 PM-1.5's on the Michael Jackson "Victory" tour. In both cases the result was purely awesome power.

"Our new Carver amp racks pack twice the number of channels in about the same truck volume as the conventional racks they replace. In addition the average power per channel has increased while the average weight per channel has decreased. In the low end, for example, we now have 1,200 watts per cabinet where 650 watts were previously available. They take less room on the truck, they weigh less and our systems have more headroom than before. The Carver amplifier has allowed us to take a significant step in improving our sound systems." **CLAIR BROTHERS**

And not only a sound industry giant like Clair Brothers tours with Carver.

"We have toured Carvers with the following artists: Softcell, Paul Young, Johnny Mathis, Donna Summers, Howard Jones, Pointer Sisters, Psychedelic Furs, Lee Greenwood, General Public, George Thorogood. This is exclusive of our numerous one-nighters. The consensus of the performers is that the equipment sounds great. They have been amazed by the sound of the amps as well as their size and weight. As for reliability, out of 50 amps we had only one fail in the past year of touring. This is by far the best record we've had with any manufacturer of amplifiers. Sonically, the extra headroom is readily apparent. We, at Manticore unanimously agree that the PM-1.5 is incredible and is the only amp we intend to buy."

Tom Whisner (owner) MANTICORE

In the Laboratory The Carver PM-1.5 was rigorously tested by Len Feldman for MODERN RECORDING (February 1985). His laboratory test results also prove that the PM-1.5 really delivers. The following quotes from the Lab Report are reprinted with permission of MODERN RECORDING & MUSIC:—

"The first thing we noticed when we began to work with the Carver PM-1.5 was the ease with which the amplifier delivered almost limitless power to speaker loads which we had previously considered to be difficult to drive to loud levels. This is the sort of amplifier that just refuses to quit."

"The amplifier delivered a clean 480 watts per channel into 8-ohm loads with both channels driven for its rated harmonic distortion level of 0.5%. Even at the frequency extreme of 20 Hz, power output for rated THD was 470 watts as against 450 claimed by Carver. Furthermore, at rated power output, distortion decreased to an insignificant 0.015% at mid-frequencies and 0.007% at 20 Hz. When connected to 4-ohm loads, the PM-1.5 delivered 750 watts per channel for rated THD of 0.05%—far more than the 600 watts claimed by Carver. Clearly, when it comes to specs for a professional amplifier, Carver has taken a very conservative approach... All (manufacturer's claims) equaled or exceeded published specifications—usually by a wide margin."

"Carver has managed to deliver a tremendous amount of power in a small lightweight package at a very reasonable cost..."

"For the professional audio engineer or technician who has to move a lot of gear around much of the time and who expects total reliability and circuit protection, come what may, the Carver PM-1.5 represents, in our view, a real winning product. We will probably see it used increasingly by professionals in every area of sound reinforcement."

Now—don't you think you owe it to yourself to hurry over to your local Carver Pro Sound Dealer and *test your own PM-1.5?* Whether you run a megawatt sound company, a struggling bar band, or a recording studio gearing up for digital, the Carver PM-1.5 will pay you. In increased portability and reduced freight costs. In freedom from expensive blown drivers. In sheer sonic excellence.

***Power:** 8 ohms, 450 watts/chan. 20 Hz-20 kHz both channels driven with less than 0.5% THD, 4 ohms, 600 watts/chan. rms 20 Hz-20 kHz both channels driven with less than 0.5% THD. 16 ohms, 300 watts/chan. 20 Hz-20 kHz both channels driven with less than 0.5% THD. 2 ohms, 525 watts/chan. at clipping, 1 kHz, with less than 0.5% THD. Note: 2-ohm specification for information purposes only. Operation at 2 ohms is permissible but not recommended. **IM Distortion:** Less than 0.1% SMPTE. **Frequency Response:** -3 dB at 3 Hz, -3 dB at 80 kHz. **Damping:** 200 at 1 kHz. **Gain:** 26 dB. **Noise:** Better than 115 dB below 450W A-weighted. **Input:** Balanced to ground, XLR or phone. **Impedance:** 15k-ohm each leg, balanced to ground. **Bridging:** 1200W into 8 ohms, 1000W into 16 ohms, accessed through rear-panel recessed switch. **Dimensions:** 19 in. wide, 3 1/2 in. high, 10 15/16 in. deep. Weight: 21 lbs.

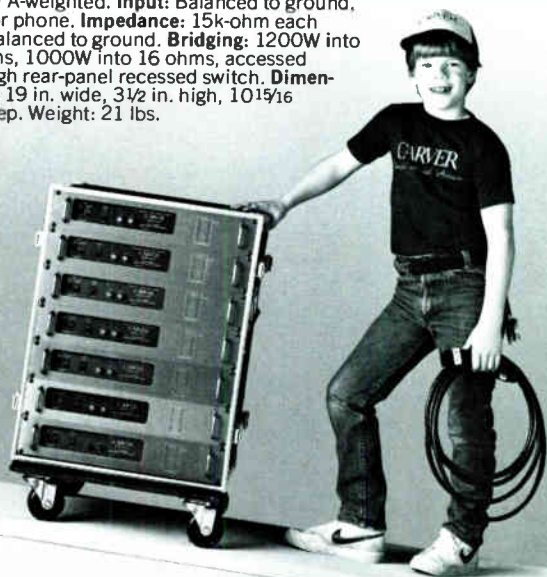

CARVER

POWERFUL

MUSICAL

ACCURATE

Circle #051 on Reader Service Card

the film into a vacuum roll metalizer, rather than metalizing one part at a time. We vacuum metalize with the roll process at 1,000 feet per minute. You take a roll of discs, which may be 4,500 feet long, with a disc spacing of 2.4 per foot. So you have about 10,000 discs per roll. You put that into a vacuum chamber, evacuate the chamber, and then metalize the entire roll. It's similar to what they do in the window film business.

From there the film is laminated to a rigid polycarbonate sheet, making a disc that fits the Philips specifications

of a 47-mil disc. The information is buried between the 5-mil polycarbonate film and the plastic substrate. This makes a better disc because the information is better protected than just being coated on the backside with acrylic. Then they are printed in-line, punched out of the sheet and packaged.

Mix: Much of the discussion about the aluminum oxidization or "laser rot" problem occurring with video discs has focused on the possibility of air being trapped between layers during lamination. How will you avoid this problem in your process?

Wanlass: We have our own theory about why laser rot exists. We think it will eventually show up in every video disc they ever made, except the 3M discs. Not in CDs, but in all injection molded laser video discs that have been laminated together with an actual glue with solvent in it. We concluded that they use an active solvent in their laminating resin. The air spaces are "sinks" where it begins to pull the aluminum off in microscopic pockets.

In our discs we use a 100% solid ultra-violet lamination. There are no solvents in it. UV curing is a big thing in the silkscreen industry. You take a

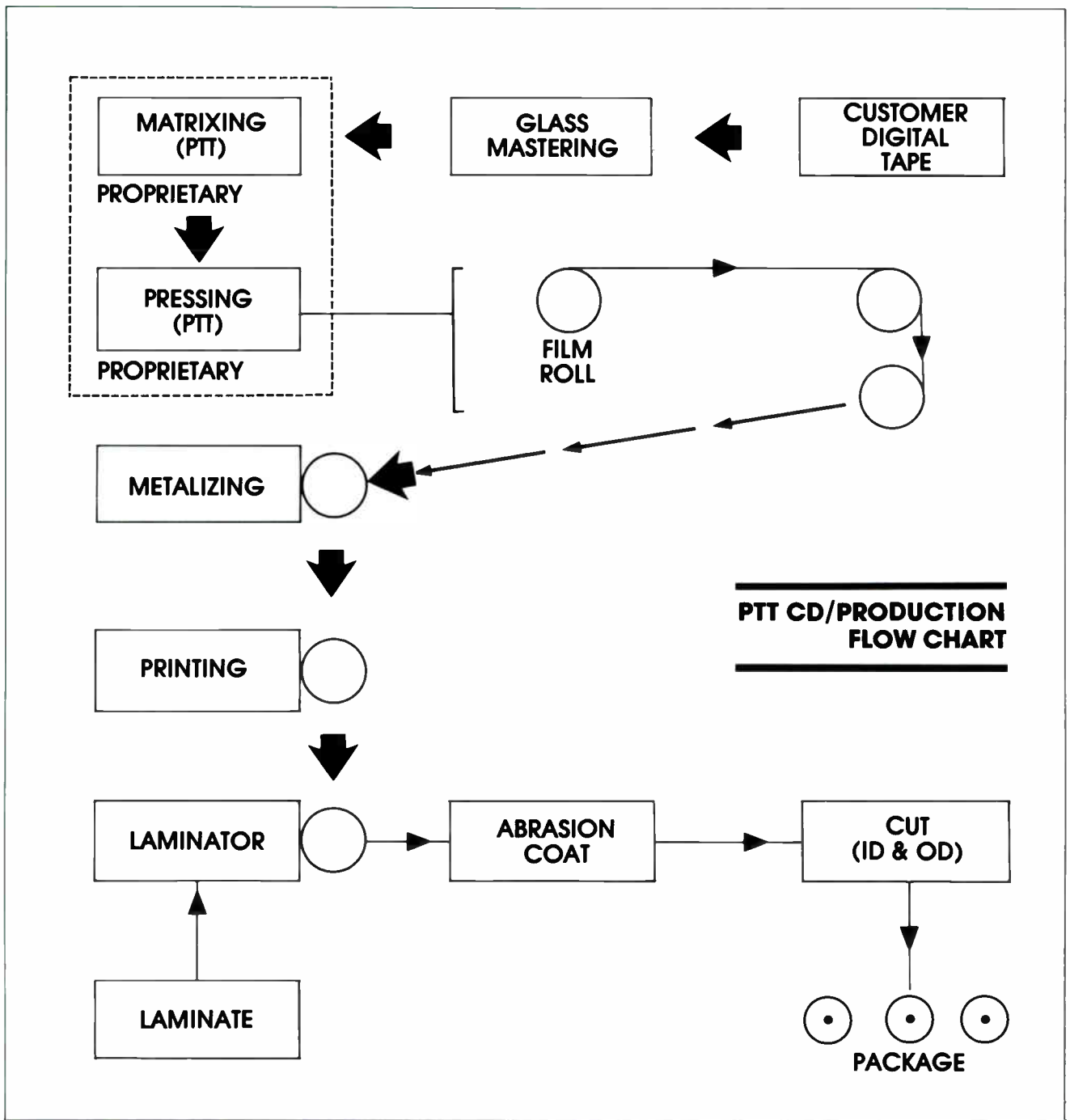

special resin, and when you run it past a real powerful UV light, it turns from a liquid into a solid. It's 100% solid when it sets up, and that's it.

Mix: When the discs are punched out of the plastic sheet, the edge of the metalized layer is presumably exposed to the air. How would you assess the potential for problems with the oxidation of aluminum beginning at those exposed edges?

Wanlass: We've had some discs around for three years without having a problem. The laminating resin is hydrophobic, as are both layers of polycarbonate. It is impervious to water. If you look at a related application, let's say mirrorized acrylic or mylar, they are exposed at the edge also. They are not encapsulated. The reason that most CD manufacturers don't metalize their discs all the way out to the edge is that they have bad adhesion when they sputter-coat the aluminum onto the substrate. So they have to encapsulate it so that the metal layer doesn't start to pull away at the edge, because once it starts to come off the back will just peel right away.

Mix: What do you see as the main advantages of the PTT process over injection molding?

Wanlass: Less people, less space, higher quality discs, faster turnaround. Everyone that is injection molding is really keen on the idea that what they are doing is something high-tech. It's all clean rooms and rubber suits. We consider what we're doing very low-tech, but there is really no way that a batch process can compete with a continuous process like ours, whether you are making steel, automobiles or whatever. The net result is that we don't need clean rooms, our space requirements are far smaller, and the process runs at about 50 feet per minute, so you are talking about 120 discs per minute. With an injection molding machine, even if you take their theoretical perfection, which nobody really achieves, you only get down to a nine- or ten-second cycle time.

We don't need a clean room during the transfer process because common dust in the air has practically the same refractive index as the plastic. If you bury a small dust particle inside the plastic, it is invisible to the laser. The

problem comes if you have one of those pieces of dust on an already formed pit in the disc, and you get pinholes. The problem is that the dust is usually larger than one pit, so you wipe out a lot of pits with one piece of dust. So, if you're dealing with an already fabricated disc with the information on it, and then put coatings and layers down on top of it, you are going to have trouble. In our process, whatever dust was on the film is buried inside it, behind the pits. Once the film has been pressed and rolled up inside the machine, the tension of the roll itself holds the dust out. The film is moved from place to place using portable clean flows, laminar flows like they use in the chip industry. When you put it in the vacuum chamber for metalizing, there is no place for the dust to get in.

Another thing about our process is the pit geometry. The actual pits are far superior to those from injection mold systems. The edge wall is sharper. The closer to a square pit you have where the edge wall starts and stops, the greater contrast you have in the laser pickup. If you have something like an

HOT TRACKS FROM ACES

SECA

24x32 inline
-40 mainframe
8 auxiliary
busses, 4 band
semi-para-
metric eq.,
built in 27
band spectrum
analyser, built
in 160 point
patchbay logic
switched rout-
ing system,
P.&G. faders,
\$21,500.00
also available in
a 60 mainframe



MT-24

24 Track -2"
recorder with
full function,
9 memory
autolocator
30 & 15 i.p.s.,
50% variable -
\$19,800

ACES equipment available - 32 Track recorders to 1/2 - 16 Track recorders. The SECA series to the B 18/16 studio console, a full line of power amps, E.Q.'s, & P.A. consoles.

All ACES professional equipment is covered by a 2 yr. warranty. Leasing available.

For more information on ACES complete line of professional recording equipment, contact the dealer nearest you:

aces
Sound
Professionals
MADE BY
ACES
OF ENGLAND

Power Studio Supply & Dist.
13453 Hollo Oval
Cleveland, Ohio 44136
216-238-9426

Rock Studio Supply
P.O. Box 5997
Norman, Okla. 73070
405-329-8431

Professional Audio & Video Systems
106 Ontario St.
Toronto, Ontario, Canada M5A-2V4
416-364-4848

Circle #149 on Reader Service Card

anthill, where it is a gradual change, then you are going to get confusion in the decoder. In injection molding, you have a certain shrink factor when the polycarbonate solidifies. So you lose a certain amount of resolution. In our case you don't lose anything. So all our discs play on any player, even the inexpensive single-beam trackers, the cheapest possible players.

Also, in the injection process the liquid plastic has to cool against the nickel stamper. If you cool it too fast you get birefringence and stress in the plastic, which makes it a dead disc. In our case, we affect only the first micron of the surface of already made plastic. So we know that everything we put through our process is good before it starts, and we don't have residual heats and pressures to deal with. We start out with polycarbonate that meets the birefringence standard of Philips and Sony, and we don't affect that by going through the process. It is a very low pressure system.

Mix: What are the mastering and processing steps used to arrive at the parts which leave the pit imprint on the

polycarbonate film?

Wanlass: There is not a lot I can tell you, because Philips would love to know and so would Sony. The making of the stamper is one of the two things we have applied for a patent on. The other is the actual method of imprinting.

There are a couple things I can say about the process. You use a standard Sony or Philips master maker. You expose and develop the glass master, and you wind up with pits on the surface. From there on, our entire process is trade secret, to the extent that we don't use anything that is already in existence. We put it into a form that we can then impress into the film, continuously. We have our own type of "stampers," and can make any number we want once we have made the first transfer away from the glass master, without wearing it out. We only have to go to glass once, and we don't need any nickel parts.

Mix: Is PTT an adaptation of a technology that has been applied in some other field to create one surface that resembles another?

Wanlass: No. It is 100% invented and

created here. To our knowledge, there is nothing similar to it anywhere, nor has there been anything even thought up similar to it.

Mix: Aside from the making of the stamper and the printing process itself, are there proprietary technologies involved in the making of the finished disc?

Wanlass: Some of the technologies are marginal. We have developed some things that are not readily available, but if someone had a reason to figure it out, they could.

Mix: What mastering and premastering facilities do you have?

Wanlass: None. All the discs we have done so far have been from glass masters provided by the major record companies.

Mix: How many PTT machines do you currently have in operation?

Wanlass: Two.

Mix: Where does the company stand as far as being ready to produce commercial product?

Wanlass: What we have done so far is to prove the viability of the system. We are in a start-up mode right now. We don't expect to be delivering commercially until April of next year, but we have delivered orders in commercial quantity to prove the process. We said that we could deliver with block error rates under 20 in the thousands of discs, and we did. The lowest block error rate we've done so far was an average of three. I don't think anybody has come close to that.

Mix: Having established that the system works in commercial quantities, do you anticipate keeping the process strictly in-house, or licensing the technology to others?

Wanlass: We will not be selling finished discs, we will be selling impressed thin-film. We have a couple of things we are finalizing right now with some large companies where we will license out the recombining: the laminating, metalizing and die-cutting. We should have a couple of licenses signed within the next 45 days. We will press the film here at ComDisc. They will send us a master; we will send them back film. They will laminate it, punch it, print it and package it.

CD MASTERS

Boston, New York & New York on Broadway

Compact Disc Pre-Mastering/Editing

Sony 1630/DMR 4000

Sony 1100A Editor

P & Q Sub-Code Editing

Digital Mixing & EQ

Inquiries 1-800-343-2514 ♦ Mark Cuddy

Circle #164 on Reader Service Card

Each plant that we license, with one "conversion" line from thin-film to finished product, will have a capacity of 30 million discs per year. So, somewhere around 10 million bucks gets you 30 million discs a year at probably half the cost of injection molding.

Mix: Do you expect the lower costs to be passed on to consumers as lower prices?

Wanlass: Yes, but that would be up to the people we license to. I think they will use price as an advantage to get market share. What it pencils out to is that the cost of making a disc this way for a start-up conversion plant that we would license, without taking some economies of scale into account, would be about the same cost as manufacturing an LP or a cassette, somewhere in the area of 60 to 75 cents. So ultimately, this should wind up being the cheapest way of mass publishing that has ever come up.

Mix: What potential applications of PTT do you foresee in areas other than CD-Audio?

Wanlass: CD-I, CD-ROM, 12-inch video discs, any optical disc. Because it is a roll process, we also envision that it will be far easier to make a write-once (WORM) disc this way. Rather than spin-coat different coatings onto each individual part that you have injection molded, you can doctor-blade various coatings on at high speed. You put a rubber blade across and the film carries the coating under the blade to give you a uniform coat. So your cost of making WORM shouldn't be that much more than making a fixed disc. But if you want to coat an injection molded part, you have to put it in a vacuum, and spin-coat it, avoiding centrifugal forces and making sure it is the right thickness. If you have to put three of four critical coatings on there, you get a very expensive disc.

There is one other thing that PTT would be really good for that no one has considered because you can't make an injection molded optical tape. You can make PTT optical tape. If you had a scanning laser going by a tape, you could pre-track the tape and then record the information on it. You could store vast, vast quantities of information on it because your recording information density would be about the same as CD. Start imagining how much

more surface area you would have on optical tape than on CD. I have never calculated, but I would guess that in an optical tape the size of an audio cassette, you could probably put 50 to 100 CDs.

Mix: Is ComDisc currently devoting any R&D resources in the direction of PTT optical tape?

Wanlass: No, we're not. We know there were a couple other companies that tried, but didn't come up with it. That is where we got the idea that we could do it fairly easily. But there is no

player for it, and right now we are interested in getting into business in the audio market. There are a billion units that will be made in the audio disc market, just for music. That's a pretty big market. ■

Phil De Lancie is one of our resident voices on topics relating to record mastering and manufacturing, tape duplication, CD replication, storage and formats. He's also a mastering engineer at Fantasy Recording Studios in Berkeley, right across the street from the Mix offices.

BACK ISSUES

- | | |
|---|--|
| <ul style="list-style-type: none"> <input type="checkbox"/> 1986 January, Northwest Studios. Equipping Home Studios. Paul Winter. SMPTE-MIDI Connection. Yoko Ono. <input type="checkbox"/> 1986 February, Independent Engineers & Producers. Microphone Special Report. Laurie Spiegel. Budgeting for Sessions. Joni Mitchell. 1986 March — SOLD OUT <input type="checkbox"/> 1986 April, Video Production & Post Production Facilities. Video Supplement. Al Kooper. Wireless Mics. Alan Parsons. <input type="checkbox"/> 1986 May, Northeast Studios. Digital Supplement. Sampling Primer. CD Facilities. Future of Console Design. Steve Lillywhite. <input type="checkbox"/> 1986 June, Remote Recording & Sound Reinforcement Listings. Roadability. Russ Titelman. CD-ROM & CD-I. Ry Cooder. 1986 July — SOLD OUT 1986 August — SOLD OUT <input type="checkbox"/> 1986 September, Southern California Studios. Film Sound. Telecommunications. Production Music Libraries. David Byrne's <i>True Stories</i>. 1986 October — SOLD OUT <input type="checkbox"/> 1986 November, New Products Directory. CD-I Supplement. Kenny Loggins Tour Sound. Daryl Hall. Grounding Primer. Rupert Neve. <input type="checkbox"/> 1986 December, Tape-to-Disc Issue: Mastering, Pressing & Duplication Facilities. CD Manufacturing. Mastering | <ul style="list-style-type: none"> Engineers' Forum. Lee Ritenour's Studio. Casey Kasem. 1987 January — SOLD OUT <input type="checkbox"/> 1987 February, Independent Engineers & Producers. International Recording Supplement. APRS Studio Directory. Bruce Lundvall. DMM for CD. Kitaro. <input type="checkbox"/> 1987 March, Southeast Studios. Digital Recording Supplement. Tom Jung. CD Mastering Forum. Richard Thompson. <input type="checkbox"/> 1987 April, Video Production & Post-Production Facilities. Location Mic Techniques. Adrian Belew. Synchronizer Survey. Pee-wee's Playhouse. <input type="checkbox"/> 1987 May, Northeast Studios. Stevie Wonder & Nile Rodgers Record by Satellite. Programmable Signal Processors. GRP Records. Digital Video Interactive. George Martin. <input type="checkbox"/> 1987 June, Remote Recording & Sound Reinforcement Listings. Touring Consoles. Video's Stephen Johnson. Women in Sound Reinforcement. Paul Simon Live in Zimbabwe. <input type="checkbox"/> 1987 July — SOLD OUT <input type="checkbox"/> 1987 August SOLD OUT <input type="checkbox"/> 1987 September, Southern California Studios. Recording in Hawaii. The Doors. Analog 2-tracks. Phil Spector. <input type="checkbox"/> 1987 October, New Products Directory. Producers' Forum. John Hiatt. Tape Recorder Maintenance. Laurie Anderson. <input type="checkbox"/> 1987 November, North Central and Canadian Studios. George Harrison. Pioneers and Trends in Film Sound. Localization. Maurice Jarre. |
|---|--|

CHECK THE ISSUES YOU'RE INTERESTED IN.

of BACK ISSUES CHECKED ABOVE at \$5.00 each (\$6.00 outside U.S.) _____

CHECK ENCLOSED FOR TOTAL (U.S. Funds)

Payment must accompany order.

\$ _____

NAME _____

ADDRESS _____

CITY _____ STATE _____ ZIP _____

MAIL TO: Mix Back Issues, 2608 Ninth Street, Berkeley, CA 94710
Make checks payable to Mix Publications; allow four weeks for delivery within U.S.

by Philip De Lancie

OTARI'S TMD

HIGH SPEED FOR VIDEO AND DAT

Otari Corporation has announced the forthcoming introduction of a high-speed video duplication system capable of operation at up to 150 times real time. The duplicator, model T-700, is based on Thermal Magnetic Duplication (TMD) technology developed by Du Pont (covered in "After-Mix" in October, 1986). The new machine is an outgrowth of a joint program involving Otari, Du Pont and Bell & Howell/Columbia Paramount Video Services. While Otari will not actually begin selling the systems until the first quarter of 1988, Bell & Howell is already using the new technology for duplication of commercial product.

For those readers who have neglected to archive their back issues of *Mix*, a brief review of TMD is probably in order. Magnetic oxide formulations have a temperature, referred to as their "Curie Point," above which their magnetic particles become thermally excited. The particles rapidly flip back and forth on their magnetic axes, thus erasing any prior magnetic orientation. As the source of thermal stimulation is removed, the orientation of the cooling particles is easily influenced by any magnetic field in their vicinity.

TMD exploits the fact that chromium dioxide has a far lower Curie Point than metal tape. A metal master tape is prepared on a special recorder which writes a track pattern that is a mirror image of the normal pattern for the format to be duplicated (VHS, BETA, etc.). This "mirror master" is run past a "print wheel" where it is pressed against a chromium dioxide copy tape. A laser focused on the oxide layer of the copy tape heats the chrome particles above their Curie Point without affecting the metal oxide of the master. As the tapes move beyond the thermal stimulation, the cooling chrome oxide is oriented by the magnetic field of the metal master's oxide against which it

is pressed. By assuming a mirror image orientation of the mirror master, the copy tape acquires the normal track pattern for its format.

One interesting aspect of this contact print approach to duplication, which is also utilized in the non-TMD Sprinter system from Sony (see "After-Mix," September, 1986), is that the same duplicating machine may be used for all formats based on a given tape width. Thus, present and future half-inch formats, whether of Beta or VHS derivation, all may be duplicated on the T-700. What will be required for each format, however, will be a separate master recorder for the preparation of the metal mirror master tapes.

For video or video-based systems using tape widths other than half-inch, different duplicating hardware will be required. But the applicability of the

**Otari T-700
Thermal Mag-
netic Duplicator**

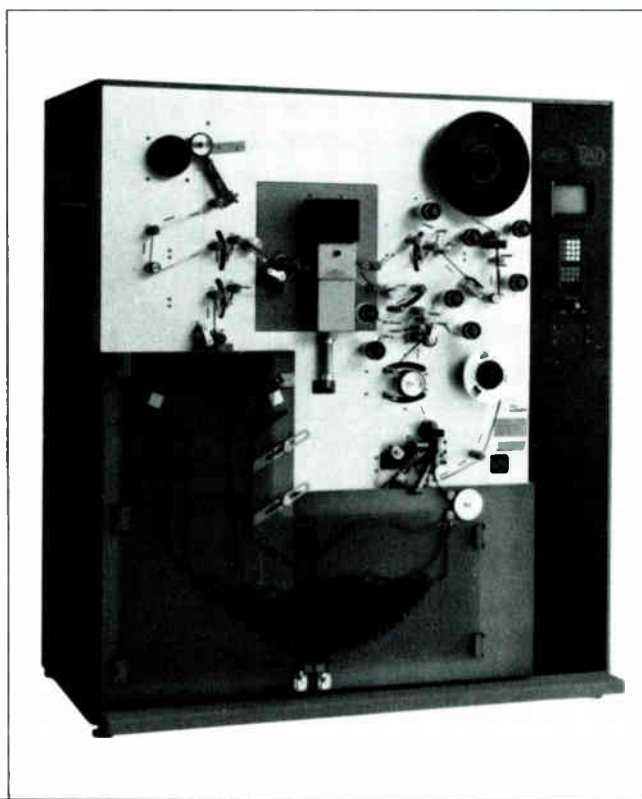

basic design to all video duplication probably means that TMD high-speed duplicators for 8mm and for R-DAT could be introduced as soon as the demand is sufficient. To explore this and other aspects of Otari's plans for TMD, I reached Dave Roudebush, national sales manager, at the company's sales offices in Belmont, CA.

Mix: The two major components of a TMD system would be the duplicator and the mirror master recorder. Your news release covers only the T-700 duplicator. What is the status of the master recorder?

Dave Roudebush: We don't have a model number for it yet, but we have, in fact, produced several of them. They are necessary for the operation of the system, and they are in production.

Mix: What are the projected prices for the components?

Roudebush: We are looking for the T-700 to be in the \$150,000 to \$200,000 range. We don't have pricing set yet on the mirror master recorders.

Mix: Which segments of the video duplication industry do you see as your primary targets as far as initially marketing the new system?

Roudebush: We believe that anyone who is currently running more than 500 1:1 VCRs is a candidate for this system.

Mix: What might be some of the arguments that you will make to convince duplicators to switch over from multiple deck operation to TMD?

Roudebush: We could compare spending \$150,000 on a TMD system with spending the same amount on 150 copy machines. If they were doing a one-hour program on both systems, and they had to run 150 copies, they both would take the same amount of time. But if they were trying to make 175 copies, the TMD system would be faster. As soon as they get away from an even multiple of the number of copy machines they have, they would have to run another full-hour program through the copy machines. Whereas, on the TMD machine, it would take a fraction of the time to run those few extra copies of that same hour program. That's where you start seeing some real differences in throughput.

Further, I think we can effectively make the point that anybody who is

doing high-volume work should move toward doing their own loading of shells. On anything that has variable program lengths, you want to be able to put in just as much tape as the program requires. On a system that is running at the kind of speed that TMD will run, you could put several short programs together on a single master and be turning out really high program output. Then you run it through your loader, automatically cut to length, and you have cassettes produced at very

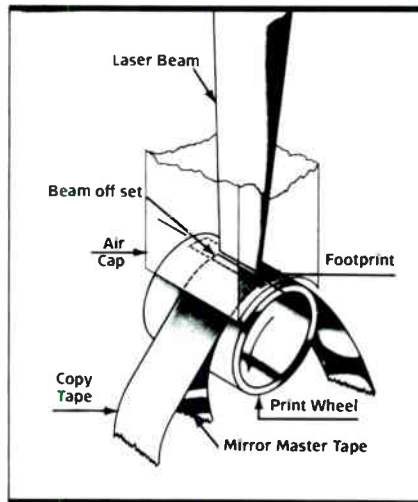

During TMD duplication, the master and copy tapes run oxide-to-oxide while a laser heats the copy, orienting its particles to match the master.

high speed that are all exactly the length they need to be.

Mix: Do you expect any potential customers to be discouraged by the fact that chromium dioxide, which is required for the TMD process, tends to be a higher priced tape formulation?

Roudebush: No, because that is simply one part of the cost of production. If you had two identical systems, and you told people that you were going to charge a penny more per 100 feet of tape, they wouldn't pay it. But if you look at the overall cost of producing products on the two systems, of which tape cost is only one component, and the TMD system is significantly more efficient, then the cost of chromium dioxide is not going to be consequential.

Mix: How many copy passes do you expect to be able to make before having to reload the T-700 bin with a fresh-

ly made mirror master tape?

Roudebush: We don't know that yet. We are still in development. We are hoping to get 3,000 to 5,000 and we don't think there will be any problem with that. But we don't have enough experience yet to really know.

Mix: Given the fact that the system is still in development, and not yet available for commercial sale, is the timing of your press announcement primarily designed to whet the appetite of potential buyers?

Roudebush: Absolutely. Most of the people that we would be selling to aren't going to notice something in the trades and then buy it right away. They are going to look into it, start calling us for information, and see if they know anybody that is using it. They will start thinking about what the implications would be if they have other equipment purchases budgeted, or if they have a budget to build a facility and they want to allocate a certain amount of space for duplication. All that stuff takes a lot longer than six months of lead time. So we need to start letting people know that the TMD systems will be here. We have reached a point in development where we can clearly see that these products are imminent.

Mix: Is development already underway on the application of TMD to high-speed duplication for R-DAT?

Roudebush: Yes.

Mix: What are some of the design considerations in DAT TMD that are different from video?

Roudebush: Of course, there is the tape width. In addition, there is still work to be done on the particle formulation for the chrome tape to conform to the DAT standards. What is of concern is the coercivity of the tape, making sure that it is within the DAT range, and that we can get a chrome tape characteristic that is within the DAT specifications. The spec has changed. There may, in fact, be an official standard which has been promulgated and is fixed, but whether or not that turns out to be the *de facto* standard is probably still open. I was at the ITA (International Tape/Disc Association) conference in Los Angeles this year, and there were three reference coercivities for DAT tape that came up as being proposed or actually being used by

one manufacturer or another. So it hasn't quite settled down.

The work we have been doing up to now at Otari has been on the development of the transport, which is, of course, where we have the background. So, we can produce a machine that will run the tape, once we have a tape that will do the job. The chemical and chrome research, on the other hand, is coming out of Du Pont.

Mix: Does the fact that DAT tape is much narrower than Beta or VHS make it any harder to design a stable, high-speed duping transport?

Roudebush: Yes, but that is not something that we haven't dealt with. We already manufacture and are selling R-DAT loaders. It is harder to control the tape at high speed in a bin than in a loader, but it is certainly something we have worked with. It hasn't proven to be an insurmountable obstacle.

Mix: What are the factors that will determine the timing of the introduction of TMD for DAT?

Roudebush: Well, obviously, people have to be buying DAT machines. We

“We believe that anyone who is currently running more than 500 1:1 VCRs is a candidate for this [TMD] system.”

build to the market. We can't create the market. So the primary consideration will be that there is a market for duplicating the tapes. Our intent is to have a machine available in a timely fashion so that when the people who are doing high-speed audio or video duplication, and are looking into audio in the DAT format, decide that they

really do want to go forward with it, we will be able to offer them the TMD process for that purpose.

Mix: Do you think that widespread knowledge of the fact that a high-speed DAT duping system is waiting in the wings would encourage acceptance of DAT and development of the duping market?

Roudebush: I believe that the market is subject to political forces that are greater than whether or not people can high-speed duplicate.

• • •

Producers Color Service of Southfield, MI has expanded its video duplication facility with the recent addition of 180 VHS machines. PCS also offers Macrovision, an anti-piracy process, as well as in-house PAL-to-NTSC conversions.

• • •

Reference Compact Discs are now available from Digital Intelligence Systems Corporation (DISC) of Santa Ana, CA. The CD refs will allow clients to verify the sound of a disc before it is manufactured. A glass substrate of the



The Best Just Got Better...

We Have Invested In The Future.

audiopak
BY CAPITOL
Broadcast Cartridges

FOR STATIONS WHO CARE HOW THEY SOUND!

Capitol Magnetic Products

CORPORATE AND INTERNATIONAL SALES OFFICES:

6902 Sunset Boulevard Hollywood, CA 90028 (213) 461-2701 Telex: 4720854 Facsimile: 12134676550

EASTERN SALES OFFICE: 2980 Avenue B Lehigh Valley Industrial Park #1 Bethlehem, PA 18017 (215) 868-1401 Telex: 4761180 Facsimile: 12158610878

CENTRAL SALES OFFICE: 1400 Renaissance Drive, Suite 309 Park Ridge, IL 60068 (312) 298-1806

WESTERN SALES OFFICE: 3116 West Avenue 32 Los Angeles, CA 90065 (213) 254-9111 Facsimile: 2132553392

UNITED KINGDOM: 1-3 Uxbridge Road Hayes, Middlesex UB4 0TG United Kingdom 561-0922 Telex: 917029 Facsimile: 15739623

© 1987 Capitol Records, Inc.

Circle #150 on Reader Service Card

World Radio History

same dimensions as a regular CD is "cut," then metalized and coated for protection. Refs are made from Sony PCM 1630 format master tapes, with PQ encoding provided by DISC from clients' cue sheets. Prices range from \$500 to \$750, depending on turn-around time, for program lengths of up to 72 minutes.

• • •

Waring-FDS Mastering Lab has announced the opening of an additional digital mastering room, the second at its Los Angeles facility. The new room features the capability of accessing the Full Dimensional Sound digital mastering computer. The FDS system, based on owner Hank Waring's unique approach to signal processing, will soon be available as well in a third FDS room, which currently is in the planning stage.

FDS is based on the philosophy that high fidelity means recreating what the listener would have heard on the scene when the original recorded sounds were generated. To Waring, the key to this kind of "realism" is to maintain the time relationships between the various overtones of notes as they arrive at the listener's ears. But modern multi-mixing recording techniques, he believes, tend to obscure, cancel or distort these "time constants." The primary goal of FDS is to "restore" the time relationships during the mastering phase of production. Waring says that his clients have been ecstatic with the results.

Development of the FDS system has spanned the last 20 years of Waring's 30-plus-year career in audio engineering, which has included stints with Capitol and Radio Recorders. "I have always been looking for a way," he says, "to reproduce sound like you would hear if you were there in person. I think all of us would like to have that. When a conductor stands in front of the orchestra, everything coming to him has its own time constant. To get the sound he really wants, he will move instruments back and forth to get the blend."

Waring's goal of placing the listener on the conductor's podium has been facilitated by the rapid advances in computing that have been made in recent years. His current system, which represents an investment of roughly \$3.5 million, uses 60 processing cards in two mainframes to evaluate the data stream output of the analog to delta

modulation digital converters. Some of the processing involves comparison of phase relationships in the program material with stored parameters from recordings made by Waring under "ideal" anechoic conditions. Other cards look for unwanted noise to remove from the system, supposedly without any effect on the desired portion of the signal. Waring describes a process of "tuning in" to the various data streams returning from the cards, and listening for the characteristics that provide the greatest clarity and separation between instruments.

Waring is vague on a number of important points when it comes to describing the what and how of the system's operations on the program material. He views his work as a breakthrough, and he definitely wants to keep his secrets secret. But he has prepared a promotional CD to give potential clients an idea of how the system sounds. Waring can be reached at 4007 W. 6th Street, Los Angeles, CA for further information.

• • •

AMS has announced the release of the first CD produced on their AudioFile random access hard-disk based editing system using the new Cut and Splice software. *Cathedral Oceans* by John Foxx was released on Quiet Man Records, and carries the AMS AudioFile logo.

• • •

Monster Cable of San Francisco has revealed that Nashville-based Georgetown Masters is the first mastering facility in the country to purchase an Alpha Genesis 1000 Moving Coil Cartridge. Incorporating a unique coil winding method, the Alpha Genesis 1000 is described by Monster Cable as the first "phase perfect" and "amplitude matching" cartridge, designed to overcome "sound and time domain imbalances" between left and right channels. Its MicroRidge stylus, mounted on a resonance-free boron tube cantilever with a diamond carbon coating, is claimed to be the smallest and most precise stylus ever, offering superior tracking and low distortion. ■

If you have information on products or processes of interest to "After-Mix" readers, send it to: Phil DeLancie, Mix, 2608 Ninth St., Berkeley, CA 94710.

quality and service since 1966



FRANKFORD/WAYNE MASTERING LABS

COMPUTERIZED
disc mastering &
cd preparation

1697 Broadway, New York, NY 10019

(212) 582-5473



Circle #151 on Reader Service Card

AMPEX 3M & AGFA

Professional
Audio and Video
Tapes

Open Reel Audio
Bulk Cassette Tapes
Video Cassettes & 1"
Reels, Boxes & Accessories

AVAILABLE FROM THE NUMBER ONE IN
PROFESSIONAL RECORDING PRODUCTS:

ADVANCE
RECORDING PRODUCTS

7190 CLAIREMONT MESA BOULEVARD
SAN DIEGO, CALIFORNIA 92111
(619) 277-2540

CALL TOLL FREE: (800) 854-1061 IN CALIFORNIA: (800) 858-1061

Please call or write
for our FREE catalog.



Circle #152 on Reader Service Card

EXCEPTIONAL FREQUENCY RESPONSE

AT 1 $\frac{7}{8}$ IPS (REAL TIME)

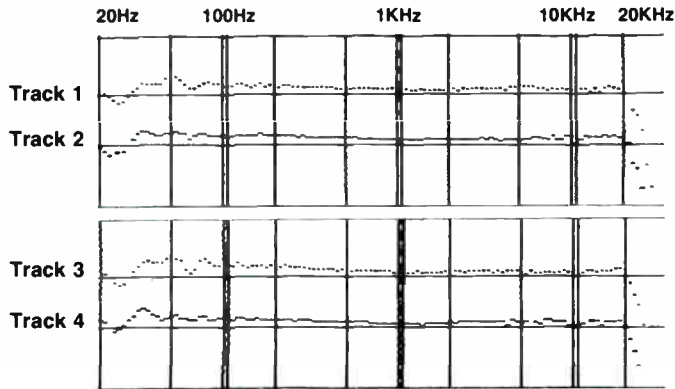

Vertical Scale 10dB/Division

TEST METHOD A 40KHz to 20Hz sweep at -20dB from a Sound Technology 1510-A was recorded at 1 $\frac{7}{8}$ ips in a KABA slave deck on TDK SA tape. The tape was played back at 1 $\frac{7}{8}$ ips in the KABA master control deck and the output displayed on the Sound Technology. The curves represent the **SUM** of the record and playback response of the KABA system at 1 $\frac{7}{8}$ ips.

No. 2 of a series —

Some reasons why KABA, the ultimate in real time and 2X
CASSETTE DUPLICATION
 IS ATTRACTING SO MANY USERS (and customers to those users)



KENNETH A. BACON ASSOCIATES
 Toll Free (800) 231-TAPE

24 Commercial Blvd., Novato, CA 94947
 in CA call (415) 883-5041

EXCEPTIONAL FREQUENCY RESPONSE

AT 3 $\frac{3}{4}$ IPS (DOUBLE TIME)

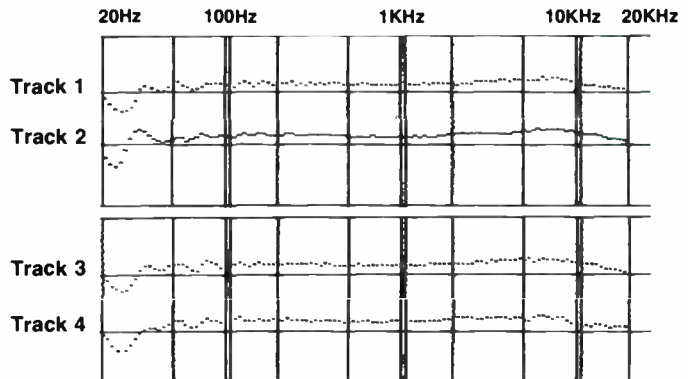

Vertical Scale 10dB/Division

TEST METHOD Same as above except the sweep was recorded at 3 $\frac{3}{4}$ ips on the KABA slave deck and played back at 1 $\frac{7}{8}$ ips on the master control deck. Highest frequency on playback was 20KHz so there is no response beyond 20KHz.

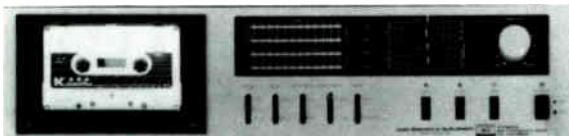

RTDS-4TM MASTER CONTROL DECK



RTDS-4TS DUAL TRANSPORT DECK

FOUR TRACK REAL TIME AND 2X DUPLICATION SYSTEM

TAPE-TO-DISC DIRECTORY

Listings of Mastering, Pressing, Tape Duplication and Compact Disc Facilities

The information in the following directory is based on questionnaires mailed earlier this year, and *Mix* does not take responsibility for the accuracy of the information supplied to us by the companies listed. Personnel, equipment and prices may change, so verify critical information with the companies directly.



Photo: Quality control at Discronics' CD plant in Braeside, Australia (near Melbourne). The company operates another plant in the U.K., and plans to open a U.S. facility sometime during 1988.

CONTENTS

178	EASTERN UNITED STATES
189	CENTRAL UNITED STATES
194	WESTERN UNITED STATES
203	OUTSIDE UNITED STATES

Mix listings procedure: Every month, *Mix* mails questionnaires to recording studios and/or other vital facilities and services for the recording, sound and video production industries. Basic listings (name, address, contact) are provided free of charge. Extended listings (equipment, credits, specialization), and photographs or company logos may be included at a nominal charge. If you would like to be listed in a *Mix* Directory, write or call the *Mix* Directories Department, 2608 Ninth Street, Berkeley, CA 94710, (415) 843-7901.

Upcoming Directory Deadlines:

Southeast U.S. Studios: **December 14, 1987**

Video Production/Post-Production: **January 2, 1988**

Northeast Recording Studios: **February 3, 1988**

Remote Recording/Sound Reinforcement: **March 3, 1988**

TAPE TO DISC

DIRECTORY

Listings of Mastering, Pressing and Tape Duplication Facilities throughout the United States

AAA RECORDING STUDIO
Mastering, Pressing, Tape Duplication
130 W. 42nd St., Room 552
New York, NY 10036
(212) 221-6626
Contact: Fred Vargas

AGFA-GEVAERT, INC.
Mastering, Tape Duplication
100 Challenger Rd.
Ridgefield Park, NJ 07660
(201) 440-2500
Contact: Joe Tibensky

MASTERING

Other Services: Studio mastering tape products PEM 468, PEM 469, PEM 291 D digital, PEM 369 and PEM 526 bin loop tape

TAPE DUPLICATION

Other Services: Bulk audio cassette products PE 649/949/1249, Magnetite 62, PE 6191/9191, PE 677

AIRCRAFT RECORDING AND REAL TIME DUPLICATIONS SERVICE

Tape Duplication

Dormont Square
Pittsburgh, PA 15216
(412) 343-5222
Contact: Jon T. Arnold

TAPE DUPLICATION

Duplicator: Nakamichi MR-2 professional cassette decks
Capacity: 500 album-length tapes per day
Method of Duplication: In cassette
Mastering Equipment: Otari MX-5050, Otari MTR-10 (15 and 30 ips), Beta/Sony PCM 1/2" digital processor
Tape Used: BASF Cr02, ICM 5-screw housing
Duplicating Speed: Real time cassette duplication at 1 7/8 ips.
Loading Equipment: Custom loading to length
Packaging Equipment/Fulfillment Services: Complete custom printing/art/application and insertion/shrinkwrap/packaging
Rates: Call for rates
Other Services: 1/4" reel-to-reel copies

ALPHA RECORDING INC.

Tape Duplication
207 S. Mulberry St.
Elizabethtown, KY 42701
(502) 765-7899
Contact: Con Cottrell

ALPHA RECORDS, INC.

Pressing
1400 NW 65th Ave.
Plantation, FL 33313
(305) 587-6011
Contact: Dick Smith

AMERICAN MULTIMEDIA, INC.

Tape Duplication
Rt. 8, Box 215A
Burlington, NC 27215
(919) 229-5559
Contact: Tim Mallard
MASTERING
Console: Neve 8108
Tape Machines: Otari, Studer
Monitor Speakers: UREI, JBL
Signal Processing: dbx, Dolby A, B and C capabilities, Aphex, Lexicon
Engineers: Richard Clark, Bob Farrow

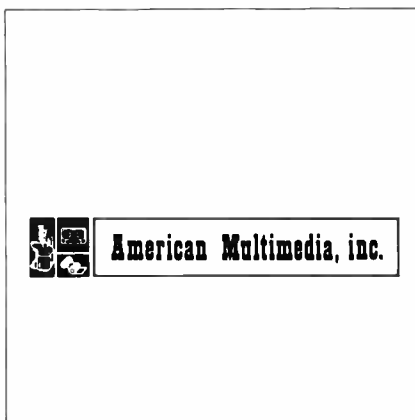

AMERICAN MULTIMEDIA, INC.
Burlington, NC

Other Services: Digital processing Sony 1610, JVC BR-90 and Nakamichi DMP-100, Sony 1630

TAPE DUPLICATION

Duplicator: Concept Design, Electro-Sound, Gauss
Capacity: 100 million annually
Method of Duplication: Bin loop
Mastering Equipment: Studer A80
Tape Used: By customer request
Shell Used: By customer request
Duplicating Speed: 64 1, 32 1, 1:1, AM+ Super 480 process
Loading Equipment: King MK2000, King 790
Packaging Equipment/Fulfillment Services: Apex printing, Ilseman labelers, Scandia wrappers, Sentinel blistering, F-20, HS-3 and A-22 Shanklin
COMPACT DISC
Preparation/Manufacturing: Blister packaging, inlay card printing and collating.

AMPHION ENTERPRISES, INC.

Tape Duplication
PO Box 794
Rockville, CT 06066
(203) 871-1786
Contact: Ed Adams, Ken Carlson

TAPE DUPLICATION

Duplicator: KABA 4-track real time system, KABA RTDS-4TM, 4TS
Method of Duplication: In cassette
Mastering Equipment: Ampex 440B 1/2-track 1/4", TEAC 4-track 1/4"
Tape Used: Agfa, Ampex, MagMedia
Shell Used: IPS, MagMedia
Duplicating Speed: 1X, 2X
Loading Equipment: Superscope Model 1341D
Packaging Equipment/Fulfillment Services: Collating and shrinkwrap available
Rates: Call or write for price list
Other Services: Custom insert and label printing, packaging, fulfillment, blank cassettes, 16-track recording studio, sound reinforcement; we also invite short runs requiring fast turnaround and any runs requiring audiophile quality

APEX MACHINE COMPANY

Tape Duplication
3000 NE 12th Terr.
Ft. Lauderdale, FL 33334

(305) 566-1572
Contact: Bob Coningsby

APEXTON RECORD PRESSING

Mastering, Pressing, Tape Duplication, CD Services
44-27 Purves St.
Long Island City, NY 11101
(718) 937-4038
(212) 944-0002
Contact: Evelyn, Derek, Ledak

PAT APPELSON STUDIOS, INC.

Tape Duplication
1000 NW 159 Dr.
Miami, FL 33169
(305) 625-4435
Contact: Fran Pickens

ASSOCIATED AUDIO SERVICES

Mastering, Tape Duplication
181 Westchester Ave.
Port Chester, NY 10573
(914) 937-5129
Contact: Andy Dolph

ATLANTIC AUDIO VISUAL

Tape Duplication
604 Jackrabbit Rd.
Virginia Beach, VA 23451
(804) 422-5252
Contact: Jody Cox

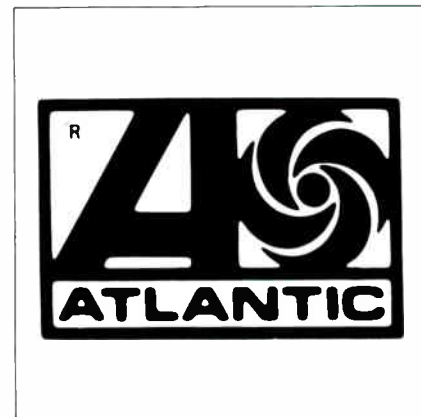

ATLANTIC STUDIOS
New York, NY

ATLANTIC STUDIOS

Mastering, CD Services
1841 Broadway
New York, NY 10023
(212) 484-6093
Contact: Pamela Johnston

MASTERING

Cutting Lathes: Neumann VMS-70, Zuma, SAL-74B
Console: Neumann transformerless
Tape Machines: Studer A80
Monitor Speakers: UREI 838 w/Bryston 4B (bi-amped)
Signal Processing: Sontec parametric, EMT compressor, EMT 252
Engineers: Dennis King, Sam Feldman, Zal Schrewer, Bobby Warner and Steve Innocenzi
Credits: Bruce Springsteen, Led Zeppelin, Genesis, Foreigner, Yes, AC/DC, Rolling Stones, Carly Simon, Ratt, Mike & The Mechanics, The System
Rates: 12" LP, \$135, 12" single, \$85, 7", \$48 \$150/hr. studio; lacquers \$30 and \$60
Other Services: Digital mastering, direct-to-disk
COMPACT DISC
Preparation/Manufacturing: CD mastering and formatting. Sony 1630, DAE 1100, DMR 4000, Harmonia Mundi, Neve console, Mark Levinson Cello Audio Palette, Sony DTA-2000 and CD computer analysis. Engineers: Zal Schrewer, Bobby Warner and Steve Innocenzi

AUDIO ANTICS

Tape Duplication
2 Park Pl.
Bronxville, NY 10708
(914) 779-7000
Contact: Susan Winthrop

UP TO 43% OFF!

▶▶▶ Save \$13
off the ~~\$38~~ basic rate

MIX

THE RECORDING
INDUSTRY MAGAZINE

THE FOLLOWING QUESTIONS MUST BE COMPLETED.

1. Please check your business activities (all that apply):

- A. STUDIO**
A01 2-4 Tracks
A02 8-16 Tracks
A03 24+ Tracks
A04 Digital
A05 Remote Truck
- B. SOUND REINFORCEMENT**
B08 Sound Reinforcement
- C. VIDEO/FILM**
C10 Production Company
C11 Post-Production Company
C12 Remote Truck
C13 Multi-Image Production
C14 Video Tape Duplication
- D. EQUIPMENT MANUFACTURING**
D17 Audio
D18 Music
D19 Video
- E. RECORD/TAPE MANUFACTURING**
E21 Record/Tape/CD
E22 Mastering Only
E23 Other
(Please specify _____)

F. FACILITY

- DESIGN/CONSTRUCTION**
F26 Acoustics/Design/Construction
F27 Sound/Video Contracting
- G. BROADCAST**
G30 Radio Station
G31 TV Station
G32 Other
(Please specify _____)

H. MEDIA

- H35 Ad Agency/PR Firm
H36 Magazines/Newspapers/Books

J. RECORD COMPANY

- J39 Record Company

K. INDEPENDENTS

- K42 Audio Producer
K43 Audio Engineer/Technician
K44 Video Producer/Director
K45 Video Editor/Technician

L. EDUCATIONAL/INSTITUTIONAL

- L48 Music/Recording School/Program
L49 Trade Association
L50 Government

M. RETAIL/RENTAL/MFRS. REP

- M51 Audio/Music
M52 Video/Film

N. INDUSTRY-RELATED

- N55 Musician/Artist/Composer
N56 Artist Management/Booking
N57 Music Publisher
N58 Student
N59 Other
(Please specify _____)

B. Technical & Engineering—

- Chief engineer, engineer, technical director, maintenance engineer, design engineer, engineering director, consultant, production assistant, equipment operator, and other technical and engineering titles

- C. Producer & Director**—Staff producer, executive producer, associate producer, assistant producer, assistant director, creative director, program director and other producer and director titles

- D. Sales & Administrative**—Sales representative, office manager, office assistant, media planner, media buyer, account executive and other sales and administrative titles

- E. Other**
(Please specify _____)

2. Please enter ONE number code from above that best indicates your MAIN business activity:

3. Please check ONE category that best describes your JOB TITLE:

- A. Management**—President, vice president, chairman, owner, general manager, sales manager, marketing manager, operations manager, chief executive and other management titles

Signature _____ Date _____

- YES!** Send me 12 issues of *Mix* for just \$24.95.
- MAXIMIZE MY SAVINGS!** Send me 24 issues (two full years) of *Mix* for just \$42.95—and save me 43%!
- Bill me
 Payment enclosed
(Outside U.S. add \$10 per year)

Name _____
Company Name _____
Address _____
City _____
State _____ Zip _____

D72MA-1

▶▶▶ Save \$13
off the ~~\$38~~ basic rate

MIX

THE RECORDING
INDUSTRY MAGAZINE

THE FOLLOWING QUESTIONS MUST BE COMPLETED.

1. Please check your business activities (all that apply):

- A. STUDIO**
A01 2-4 Tracks
A02 8-16 Tracks
A03 24+ Tracks
A04 Digital
A05 Remote Truck
- B. SOUND REINFORCEMENT**
B08 Sound Reinforcement
- C. VIDEO/FILM**
C10 Production Company
C11 Post-Production Company
C12 Remote Truck
C13 Multi-Image Production
C14 Video Tape Duplication
- D. EQUIPMENT MANUFACTURING**
D17 Audio
D18 Music
D19 Video
- E. RECORD/TAPE MANUFACTURING**
E21 Record/Tape/CD
E22 Mastering Only
E23 Other
(Please specify _____)

F. FACILITY

- DESIGN/CONSTRUCTION**
F26 Acoustics/Design/Construction
F27 Sound/Video Contracting
- G. BROADCAST**
G30 Radio Station
G31 TV Station
G32 Other
(Please specify _____)

H. MEDIA

- H35 Ad Agency/PR Firm
H36 Magazines/Newspapers/Books

J. RECORD COMPANY

- J39 Record Company

K. INDEPENDENTS

- K42 Audio Producer
K43 Audio Engineer/Technician
K44 Video Producer/Director
K45 Video Editor/Technician

L. EDUCATIONAL/INSTITUTIONAL

- L48 Music/Recording School/Program
L49 Trade Association
L50 Government

M. RETAIL/RENTAL/MFRS. REP

- M51 Audio/Music
M52 Video/Film

N. INDUSTRY-RELATED

- N55 Musician/Artist/Composer
N56 Artist Management/Booking
N57 Music Publisher
N58 Student
N59 Other
(Please specify _____)

B. Technical & Engineering—

- Chief engineer, engineer, technical director, maintenance engineer, design engineer, engineering director, consultant, production assistant, equipment operator, and other technical and engineering titles

- C. Producer & Director**—Staff producer, executive producer, associate producer, assistant producer, assistant director, creative director, program director and other producer and director titles

- D. Sales & Administrative**—Sales representative, office manager, office assistant, media planner, media buyer, account executive and other sales and administrative titles

- E. Other**
(Please specify _____)

2. Please enter ONE number code from above that best indicates your MAIN business activity:

3. Please check ONE category that best describes your JOB TITLE:

- A. Management**—President, vice president, chairman, owner, general manager, sales manager, marketing manager, operations manager, chief executive and other management titles

Signature _____ Date _____

- YES!** Send me 12 issues of *Mix* for just \$24.95.
- MAXIMIZE MY SAVINGS!** Send me 24 issues (two full years) of *Mix* for just \$42.95—and save me 43%!
- Bill me
 Payment enclosed
(Outside U.S. add \$10 per year)

Name _____
Company Name _____
Address _____
City _____
State _____ Zip _____

D72MA-1



NO POSTAGE
NECESSARY
IF MAILED
IN THE
UNITED STATES

BUSINESS REPLY MAIL
FIRST CLASS PERMIT NO. 2994 BERKELEY, CA

POSTAGE WILL BE PAID BY ADDRESSEE

MIX

THE RECORDING INDUSTRY MAGAZINE

PO Box 3714
Escondido, CA 92025-9829

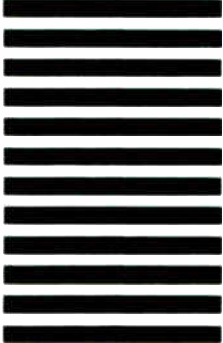

NO POSTAGE
NECESSARY
IF MAILED
IN THE
UNITED STATES

BUSINESS REPLY MAIL
FIRST CLASS PERMIT NO. 2994 BERKELEY, CA

POSTAGE WILL BE PAID BY ADDRESSEE

MIX

THE RECORDING INDUSTRY MAGAZINE

PO Box 3714
Escondido, CA 92025-9829

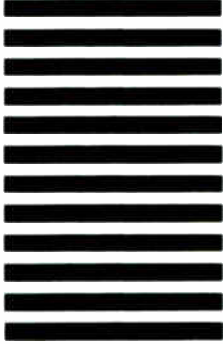

AUDIO CRAFT CO.
Mastering, Tape Duplication
2701 E. Sunrise Blvd. Ste. 406
Ft. Lauderdale, FL 33304
(305) 563-0553, Florida
(800) 432-0405
Contact: Mark Auld

MASTERING

Tape Machines: Sony, MCI, Studer/Revox, Nakamichi, Otari.
Monitor Speakers: E-V
Signal Processing: Lexicon, dbx, EXR, Dolby, UREI, Symetrix.
Rates: Upon request

TAPE DUPLICATION

Duplicator: Studer/Revox and Sony.
Capacity: Constantly growing
Method of Duplication: Real time
Mastering Equipment: Digital
Tape Used: Agfa and BASF.
Shell Used: Shape and ICM
Duplicating Speed: 8-1 and real time
Loading Equipment: TTL
Packaging Equipment/Fulfillment Services: As required.
Rates: Upon request.

AUDIO INTERNATIONAL

Tape Duplication
424 Grant Ave.
Scotch Plains, NJ 07076
(201) 322-4466
Contact: Warren C. Slaten

AUDIO RECORDING AND DUPLICATING

Tape Duplication
323 Santa Villa Dr.
Milton, FL 32571
(904) 994-9297
Contact: Ty Bracken

AUDIO VISION, INC.

Tape Duplication
1102 17th Ave. S., Ste. 200
Nashville, TN 37212
(615) 331-3612
Contact: Jim Reyland

AUDIO VISUAL COMMUNICATIONS INC.

Tape Duplication
435 Crooked Ln.
King Of Prussia, PA 19406
(215) 272-8500
Contact: John Butterworth

AUDIOMATIC/AUDIO MATRIX

Tape Duplication, CD Services
400 Madison Ave.
New York, NY 10017
(212) 308-6888
(212) 308-5817 (FAX)
Contact: Perry Jambor
TAPE DUPLICATION
Duplicator: Electro-Sound
Method of Duplication: Bin loop.
Duplicating Speed: 128:1, 64:1, 32:1
Loading Equipment: Electro-Sound
Other Services: Sale of duplicators, loaders, Apex on-cassette printers, Tapex plate makers, etc
COMPACT DISC
Preparation/Manufacturing: Manufacturer of electro-forming equipment for CD fathers, mothers, stampers

BEBOP PRODUCTIONS

Mastering, Tape Duplication
1006 Brice Rd.
Rockville, MD 20852
(301) 279-0937
Contact: Bob DeWald

BEE VEE SOUND

Tape Duplication
211 E. 43 St.
New York, NY 10017
(212) 949-9170
Contact: Bruno Vinels

BIG OAK DUPLICATING

Tape Duplication
Rt. 2, Box 22-A
Collinsville, MS 39325
(601) 626-8069
Contact: Tim Chesney, Pete Pitts

BOTTOM LINE STUDIO

Tape Duplication
450 NW 69th Ter.
Margate, FL 33063
(305) 974-7345
(305) 755-1868
Contact: Mark R. Nowak

CAPTAIN FIDDLE MUSIC

Tape Duplication
4 Elm Ct.
Newmarket, NH 03857
(603) 659-2658
Contact: Ryan J. Thomson

CASSETTE DUPLICATORS OF BOSTON

Tape Duplication, CD Services
136 Arlington St.
Boston, MA 02116
(617) 423-2542
Contact: Vincent E. Parla Jr.

CASSETTE EXPRESS

(DIV. OF AL. JOLSON ENTERPRISES, INC.)
Tape Duplication
31 Music Square W.
Nashville, TN 37203
(615) 242-1766
Contact: Jim Ramsey

TAPE DUPLICATION

Duplicator: KABA real time duplication system, 40 positions (20 dual)
Capacity: 720 C-45s per shift
Method of Duplication: In cassette
Mastering Equipment: Dolby A, Dolby SR, dbx Type I, Studer A810, Nagra IV-S, Nakamichi DMP-100, Sony Super Beta
Tape Used: Agfa 649/949, BASF Chrome II, Ampex 456.
Shell Used: Michelex, Shape Mark 10, Magnetic Media
Duplicating Speed: Real time, 2:1, 8:1
Rates: Competitive rates, please inquire

CASSETTE PRODUCTIONS, INC.

Tape Duplication
109 Prospect Pl.
Hillsdale, NJ 07642
(201) 666-3300
Contact: Jackie Pavese

CBS RECORDING OPERATIONS (NY STUDIO)

Mastering, Tape Duplication, CD Services
49 E. 52nd St.
New York, NY 10022
(212) 975-2958
Contact: Rob Grabowski

CBS/RECORDS GROUP

Pressing, Tape Duplication, CD Services
CBS Inc., 91 Woodmont Rd.
Milford, CT 06460
(203) 783-4000
Contact: Howard Schwartz

CHANNEL ONE VIDEO

Mastering, Tape Duplication
PO Box 1437
Seabrook, NH 03874
(603) 474-5046
Contact: Bill Channell

DICK CHARLES RECORDING

Mastering, Tape Duplication, CD Services
130 W. 42nd St., #1106
New York, NY 10036
(212) 819-0920
Contact: Dick Charles

CINEMA SOUND LTD.

Mastering, Pressing, Tape Duplication
311 W. 75th St.
New York, NY 10023
(212) 799-4800
Contact: Joan Franklin

CLW CONSUMER PRODUCTS

Tape Duplication
PO Box 22125, 6815 Shallowford Rd.
Chattanooga, TN 37422
(800) 251-6388
Contact: Christy Mundy

COAST TO COAST MUSIC INC.

Tape Duplication, CD Services
1328 Romney St.
Jacksonville, FL 32211
(904) 744-7774
Contact: Fred Frank, Bill Ande

COOK LABORATORIES, INC.

Mastering, Pressing, Tape Duplication
375 Ely Ave.
South Norwalk, CT 06854
(203) 853-3641
Contact: Emory Cook

CRAIG RECORDING STUDIOS

Tape Duplication
Ste. 101, Benjamin Fox Pavilion
Jenkintown, PA 19046
(215) 885-8600
Contact: Michael Gallagher

CREATIVE AUDIO LAB, INC.

Mastering, Pressing, CD Services
6332 Appaloosa Way
Lakeview, NY 14085
(716) 627-4758
Contact: Robert Grotke
MASTERING
Cutting Lathes: Neumann automated w/Compudisk computer. Drive electronics by London/Decca
Console: Custom-built utilizing 990 opamps
Tape Machines: Studer A80 1/4" and 1/2", Sony digital
Monitor Speakers: JBL 250 T1, Westlake BBSM-6, Yamaha NS-10M
Signal Processing: ADR, Barcus-Berry Electronics, dbx, Dolby SR, Dolby A, Lexicon, Polyfusion, Sontec, Yamaha
Engineers: Robert Grotke
Rates: On request
Other Services: Half-speed mastering, reference acetates, cassette duplication masters, format conversions, complete record production services, CD production
PRESSING
Presses: Subcontracted
Capacity: 10M/week
Vinyl Used: Keyser 569, Teldec, JVC
Rates: On request
Other Services: Full graphics from typesetting to design services. Direct-on-board jacket printing
COMPACT DISC
Preparation/Manufacturing: Complete services for CD manufacturing. Master tape preparation from any source, digital editing and sequencing, digital post-production, format conversions, CD pressing, graphics and packaging

CRYSTAL CITY TAPE DUPLICATORS INC.

Tape Duplication
48 Stewart Ave.
Huntington, NY 11743
(516) 421-0222
Contact: Frank Russo
TAPE DUPLICATION
Duplicator: Otari bin loop
Capacity: 12,000 per day
Method of Duplication: In cassette, bin loop
Mastering Equipment: Otari MTR-10, Otari MTR-12
Tape Used: BASF, Magnetic Media, Agfa
Shell Used: Magnetic Media
Duplicating Speed: 64:1
Loading Equipment: Electro-Sound
Packaging Equipment/Fulfillment Services: Apex on cassette print
Rates: On request
Other Services: Video duplication 3/4", 1/2" Panasonic 6810 hi-fi stereo

CUSTOM RECORDING & SOUND, INC.

Tape Duplication
Box 7647-1225 Pendleton St.
Greenville, SC 29610
(803) 269-5018
Contact: Jere Davis

FAX YOUR TRACKS!

If your studio or business has a facsimile (FAX) machine, you can send your press releases for *Current*, *Studio News*, and *Preview to Mix* via our FAX line: (415) 843-9540.

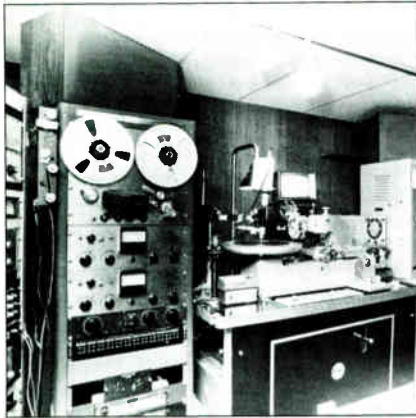

THE CUTTING EDGE
Ferndale, NY

THE CUTTING EDGE
Mastering
PO Box 217
Ferndale, NY 12734
(914) 292-5965
Contact: Paul Gerry

D&G MASTERING
Mastering, Pressing
PO Box 370
Englishtown, NJ 07726
(201) 446-2411
Contact: Don Van Gorden

DANCING BEAR PRODUCTIONS
Tape Duplication
PO Box 239, Brooklyn Heights Stn.
Brooklyn, NY 11201
(718) 875-2156
Contact: Bill Ohashi

DAVIS PRODUCTIONS
Tape Duplication
1208 Elm Ave.
Americus, GA 31709
(912) 924-2521
Contact: King Davis

DB PLUS DIGITAL SERVICES
CD Services
PO Box 694
Lynbrook, NY 11563
(516) 872-2325
Contact: Kathy Campisi

DBF CORPORATION
Tape Duplication
PO Box 900
Waldorf, MD 20601
(301) 843-7110
(301) 645-6110
Contact: Randy Runyon

DEMO-VOX® SOUND STUDIO, INC.
Mastering, Pressing, Tape Duplication
1038 Bay Ridge Ave.
Brooklyn, NY 11219
(718) 680-7234
Contact: Laura B Grassi

BARRY DIAMENT AUDIO
CD Services
2728 Henry Hudson Pkwy. (#C-73)
Riverdale, NY 10463
(212) 543-2079
Contact: Barry Diament, Mary Antonelli
COMPACT DISC
Preparation/Manufacturing: Full CD master preparation, optimized analog to digital transfers, digital editing Machines Sony 1630/1100A/DMR-4000/DTA-2000, Dahquist DQ-20/ MIT and Monster Cables Call for rates Credits include AC/DC, Anita Baker, The Cars, The Coasters, Phil Collins, Jim Croce, Crosby Stills and Nash, The Cult, The Eagles, Kevin Eubanks, Genesis, Guns N' Roses, Led Zeppelin, Julian Lennon, Glenn Miller, Stevie Nicks, Robert Palmer, Robert Plant, The Rascals, Otis Redding, The Rolling Stones, Linda Ronstadt, Simply Red, Steps Ahead, Pete Townshend, U2, Joseph Villa, Yes, Warren Zevon

E A S T E R N
TAPE TO DISC
DIRECTORY

DIAMOND PROD. CORP.
Pressing, Tape Duplication
161 Massachusetts Ave., Ste. 201
Boston, MA 02115
(617) 266-3131
Contact: Raymond Fournier

DIGITAL 1 DUPLICATORS
Tape Duplication
658 Douglas Ave.
Altamonte Springs, FL 32714
(305) 682-7790
Contact: Batt Donovan, Mike Justeniane

DISKMAKERS, INC.
Mastering, Pressing, Tape Duplication, CD Services
153 W. 46th St.
New York, NY 10036
(212) 304-4140
(800) 468-9353
Contact: Regional Sales Rep

DISKMAKERS, INC.
Philadelphia, PA

DISKMAKERS, INC.
Mastering, Pressing, Tape Duplication, CD Services
925 N. 3rd St.
Philadelphia, PA 19123
(215) 627-2277
Contact: Regional Sales Rep
MASTERING
Cutting Lathes: Scully
Tape Machines: Sony Pro Audio, ATR 102-104, Westrex
Engineers: Dave Moysiadias, Glen Fertig
Rates: Call for rate card
PRESSING
Presses: Tracy Val 9
Capacity: 5 million/yr
Vinyl Used: Tenneco
Rates: Call for price list
Other Services: Jacket design and printing, color separations, 7" and 12" sleeve design and printing, stickers, posters and promotional materials
TAPE DUPLICATION
Duplicator: Electro-Sound
Capacity: 6 million/yr
Method of Duplication: Bin loop
Mastering Equipment: Ampex
Tape Used: CBS Premium
Shell Used: Shape
Duplicating Speed: 32 1
Loading Equipment: King
Packaging Equipment/Fulfillment Services: Apex printing, polywrap, alternate packaging
Rates: Call for price list
Other Services: Full color cassette inserts, design, type, printing
COMPACT DISC
Preparation/Manufacturing: All services pre-mastering, graphics, packaging Call for price list

DISTRANS
Tape Duplication
3 Orchard St., Porter Square
Cambridge, MA 02140
(617) 661-7154
Contact: John Pfister, Tracey Pope

DOVE SOUNDS
Mastering, Tape Duplication
1305 Glen Eden Dr.
Raleigh, NC 27612
(919) 782-1095
Contact: Chris Droessler

D.S.M. PRODUCERS
Tape Duplication
161 W. 54th St., #1204
New York, NY 10019
(212) 245-0006
Contact: Suzan Bader

THE DUPLICATOR/BEGEL
Tape Duplication
PO Box 83
New York, NY 10156
(212) 685-2748
Contact: Deborah Begel

EASTERN SKY MEDIA SERVICES
Pressing, Tape Duplication, CD Services
241 Mockingbird Ln.
Winter Springs (Orlando), FL 32708
(305) 327-3720
Contact: David Brown

EASTERN STANDARD PRODUCTIONS INC.
Tape Duplication, CD Services
26 Baxter St.
Buffalo, NY 14207
(716) 876-1454
Contact: Mark S. Mekker

EUROPADISK, LTD.
Mastering, Pressing
75 Varick St.
New York, NY 10013
(212) 226-4401
Contact: Larry Bassman
MASTERING
Cutting Lathes: Neumann VMS-82-DMM direct metal mastering
Console: Neumann SP79B disk mastering console for DMM
Tape Machines: Sony PCM-1610, Sony DMR-2000, Mitsubishi X-80, Studer DAD-16, Nakamichi DMP-100
Monitor Speakers: James B. Lansing 250 T1
Signal Processing: Neumann U473 lim/comp, OE-DUO parametric EQ, VAB vertical lim.
Engineers: Jim Shelton
Credits: Capitol, EMI, Angel, RCA, CBS Records, Warners, MHS, Blue Note
Rates: Call for rate card and brochure
Other Services: High-definition plating, DMM matrix work, DMM copper masters, audiophile quality LP Record Pressing
PRESSING
Presses: Toolex-Alpha, Hamilton Automatics
Capacity: 3 million per year
Vinyl Used: Teldec, imported from Germany exclusively
Rates: Call for rate card and brochure
Other Services: DMM matrix work, high definition plating, DMM copper masters, DMM disk mastering

**WATCH FOR THESE
UPCOMING MIX
DIRECTORIES!**

Northwest Studios

January 1988

Engineers & Producers

February 1988

Southeast Studios

March 1988

A FULL LINE OF RELIABLE OTARI LOADERS

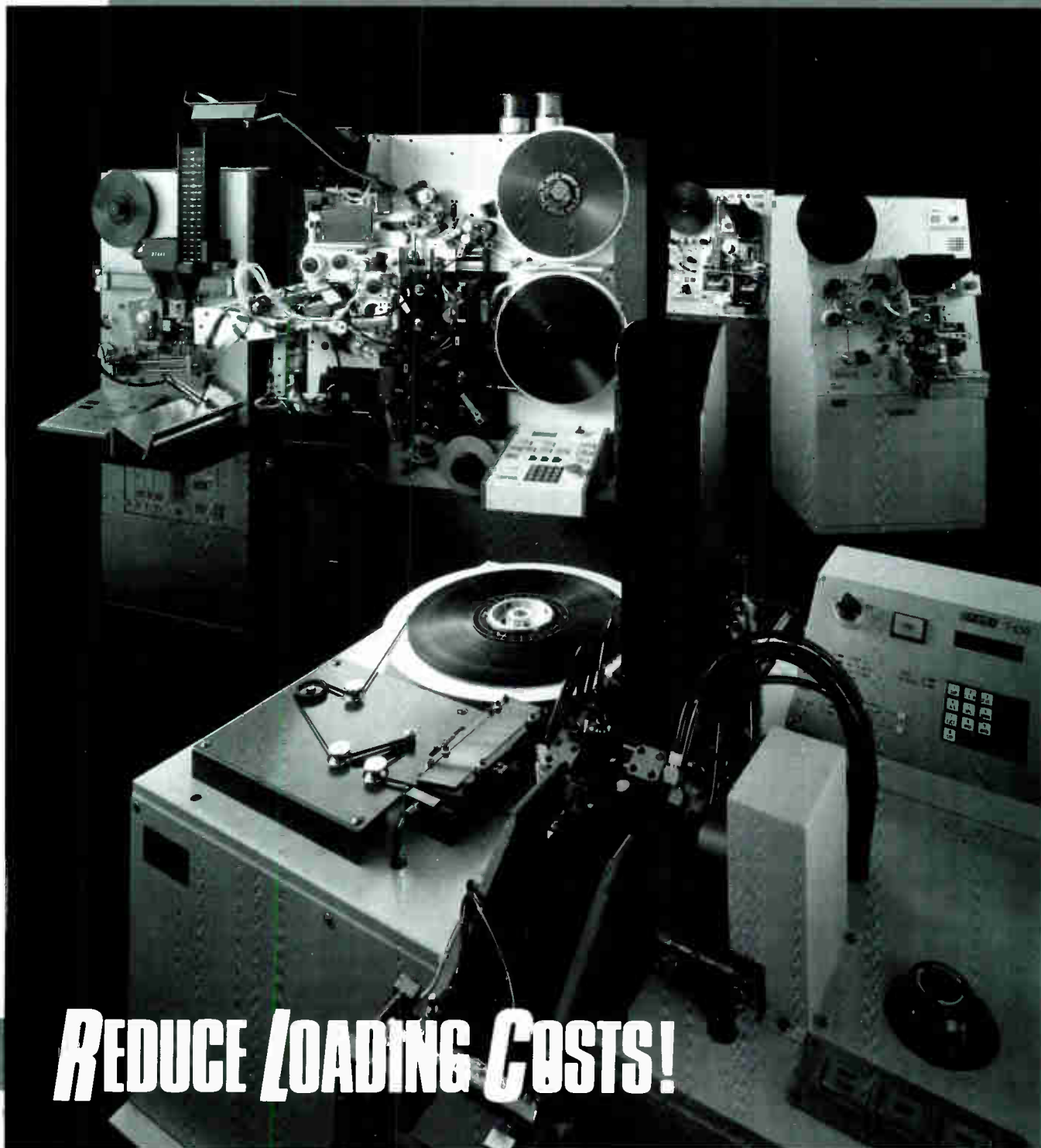

REDUCE LOADING COSTS!

Maximize throughput and minimize equipment down-time with reliable, high quality loaders from Otari.

Otari's re-entry into the U.S. loader market means that you now have access to the industry's broadest line of video, audio, R-DAT, and 8mm loaders, plus a full line of leadering machines.

Our success with all major tape manufacturers and our long-standing commitment to loader customers means you can rely on Otari for technical support, parts, and service.

Contact Otari for specifications and information on our full line.
From Otari, Technology You Can Trust. (415) 592-8311.

OTARI

EVA-TONE

EVA-TONE INCORPORATED
Clearwater, FL

EVA-TONE INCORPORATED
Mastering, Pressing, Tape Duplication
4801 Ulmerton Rd.
Clearwater, FL 34622
(800) EVA-TONE, outside FL
(813) 577-7000
Contact: James M. Dunne

MASTERING

Cutting Lathes: Scully automated and manual
Console: Sony and Eva-Tone customized
Tape Machines: Studer, Revox, Otari, MCI, Nakamichi.
Monitor Speakers: Tannoy, Altec.
Signal Processing: UREI, AMS, Sontec, Aphex, Orban.
Engineers: Michael Newsome, Wayne McElhose, Alan LaVer-
so, Jacques Woodin, Wayne Hampson, Jerry DeClercq
Credits: CBS International.
Rates: On request

PRESSING

Presses: Eva-Tone Design-13
Capacity: 290 million
Rates: On request
Other Services: Printing, packaging, mailing services

TAPE DUPLICATION

Duplicator: Cetec Gauss 2400, 2 masters, 10 slaves.
Capacity: 7,500,000 C-40 per year.
Method of Duplication: Bin loop
Mastering Equipment: MCI, Studer/Revox, Otari
Tape Used: Sunkyong, Capital, BASF, Agfa.
Shell Used: MRS, Magnetic Media, Shape, Unimagnetics
Duplicating Speed: 32:1, 64:1, 128:1.
Loading Equipment: King 790, TTL.
Packaging Equipment/Fulfillment Services: Labeling is Apex
and Stoddard Ilesmann.
Rates: On request
Other Services: Printing, packaging, mailing services

EXECUTIVE RECORDING LTD.

Mastering, Pressing, Tape Duplication
300 W. 55th St.
New York, NY 10019
Contact: Lucille Sayet

FAITH PRODUCTIONS

Tape Duplication
1441 Guthrie Dr.
Cleveland, TN 37311
(615) 478-7251
(800) 251-4024
Contact: Allan Wendt

FALK RECORDING STUDIO

Tape Duplication
7914 Fegenbush Ln.
Louisville, KY 40228

FORGE RECORDING STUDIOS, INC.

Mastering, Tape Duplication
PO Box 861, Valley Forge, PA 19481
119 Great Valley Pkwy.
Malvern, PA 19355
(800) 331-0405
(215) 935-1422
(215) 644-3266
Contact: Warren K. Wilson

TAPE DUPLICATION

Duplicator: MTI and Versadyne 2 x 6 sleeves
Capacity: 10,000/day
Method of Duplication: Bin loop
Mastering Equipment: Ampex, Sony
Tape Used: Agfa, BASF

E A S T E R N

TAPE TO DISC

DIRECTORY

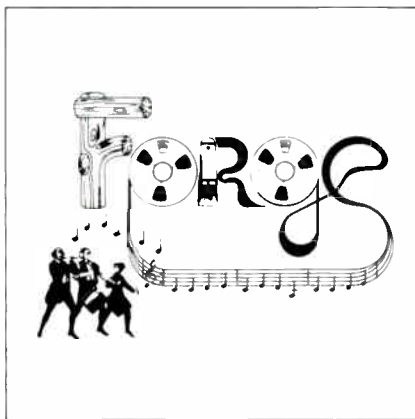

FORGE RECORDING STUDIOS, INC.

Malvern, PA

Shell Used: Magmedia, ICM.
Duplicating Speed: 32:1, 64:1
Loading Equipment: King 790s
Packaging Equipment/Fulfillment Services: Boxing, shrink-
wrapping and album setup
Rates: Call for rate card and samples
Other Services: Drop shipping and syndication services
COMPACT DISC
Preparation/Manufacturing: Master preparation

FRANKFORD/WAYNE MASTERING LABS, INC.

Mastering, CD Services
1697 Broadway, Rm. 1404
New York, NY 10019
(212) 582-5473
Contact: Carol Iacoune

MASTERING

Cutting Lathes: (4) Scully/Ranstele automated quartz locked
lathes w/Block Compudisk computers and Neumann SX-
74/Ranstele cutter drive systems, (2) Neumann lathes
w/Technics quartz drive and Neumann SX-74/SAL-74B driver
rack w/Block-Compudisk, control computer, Scully Westrex
lathe w/Capps computer and Westrex 3DIIAH/1700 cutter-
head drive system.

Console: (5) Ranstele Audio custom/proprietary DC coupled
consoles w/full equalization and processing facilities, analog
and digital capable, transformerless, Ranstele/Harmonia
Mundi full digital transfer console w/digital level, equalization,
compressor/limiter and sample rate conversion to any format.

Tape Machines: (5) Sony/MCI JH-110MB 1/4" and 1/2" play, (3)
Sony/MCI JH-110C 1/4" and 1/2" recorders, (5) Technics RS-
1520 pro 2-track, Scully LJ-12 stereo recorder, (6) Technics
cassette recorders, Sony PCM-3202 Dash reel to reel, Sony
PCM-3402 DASH format reel to reel, Sony PCM-1610 digital
processor, (2) Sony PCM-1630 digital processors, (5) Sony
PCM-10/100 digital F1 compatible processor, (2) Harmonia
Mundi format converters, (2) Sony PCM-F1 digital processors,
(5) Sony DMR-2000 digital U-matic recorders, (2) Sony DMR-
4000 digital U-matic recorders, Sony VO-5850, (2) Sony SL-
2700 Beta recorders, (3) Sony SL-2300 Beta recorders, (3)
Sony DTA-2000 digital analyzers

Monitor Speakers: (6) JBL 3450B biamped, (2) JBL 4343B
biamped, (2) JBL 4330s, (2) JBL 4311s, (2) B&W 701s, (6)
ADS 300s, (4) Auratone 5Cs, (2) Technics 6060s, (2) Altec
604/Mastering Labs, (2) JBL subwoofer systems

Signal Processing: Equalizers: Sontec, UREI, ITI, Pultec, Ran-
stele audio, Orban, Technics, limiters/compressors: Sontec,
CBS Labs, noise reduction: Dolby and dbx, proprietary audio
processing equipment. Ranstele audio, digital processing
AMS, Sony, Lexicon.

Engineers: Tom Steele, Herb "Pump" Powers, Jr., Tom Coyne,
Carlton Batts, Chris Gehringer, Dean Holmes, plus freelance
when applicable

Credits: Sade, Billy Ocean, Thompson Twins, Whodini, The
Eurythmics, Bananarama, ABC, Force MD's, Level 42, Fat
Boys, Alisha, Buster Poindexter, Five Star, Pepsi and Shirley,
Starship, Pseudo Echo, Anita Baker, Shirley Murdoch, Cru-
zados

Rates: Client attendance, \$190/hr.; LP masters, \$140/side; 45
masters, \$50/side, 12" single masters, \$110/side, LP D/F
refs, \$140, 12" D/F refs, \$90; 45 D/F refs, \$60 Other rates,
including custom pressing packages and digital CD prepared
tapes available upon request.

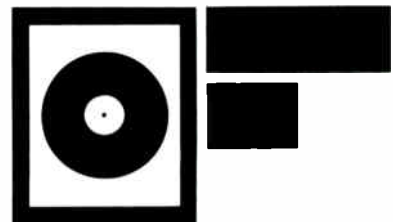

FULLERSOUND, INC.

FULLERSOUND, INC.
Miami, FL

FULLERSOUND, INC.
Mastering, CD Services
1755 NE 149th St.
Miami, FL 33181
(305) 945-6697
Contact: Michael Fuller

MASTERING

Cutting Lathes: Scully LS-76 w/Oroton DSS-821 cutter heads.
Console: Custom Cybersonics automated MC2003E
Tape Machines: Analog: MCI JH-110B 1/2" and 1/4"; digital:
Sony PCM-1630/DMR-4000, Sony PCM-3202, Sony PCM-
601ESD, Mitsubishi X-80.
Monitor Speakers: UREI 813A, Yamaha NS-1000, Auratones
Signal Processing: Sontec MES-430B EQ, Sontec DRC-400,
Ortolon STL-852

Engineers: Michael Fuller
Credits: Eric Clapton, Rod Stewart, Kenny Rogers, Judas
Priest, Romantics, Company B, Barry Manilow, 'Expose', Julio
Iglesias, Eddie Money, Dionne Warwick, Brailio, Bee Gees,
Bellamy Brothers, Kenny Loggins, George Clinton.
Rates: Upon request

Other Services: Pre-mastering for compact disc and cas-
settes.

COMPACT DISC

Preparation/Manufacturing: Compact disc pre-mastering
available with Sony PCM-1630/DMR-4000/DTA-2000. Digi-
tal to digital transfers to and from Sony 1630, Sony 3202, Sony
601esd. Mitsubishi X-80 digital also available.

GALAXY SOUND

Tape Duplication
1508 Harlem
Memphis, TN 38114
(901) 274-2726
Contact: Ed Walker

GEORGIA RECORD PRESSING

Mastering, Pressing, Tape Duplication, CD Services
262 Rio Circle
Decatur, GA 30030
(404) 373-2673
Contact: Kevin Carlson

GROSSINGER PRODUCTIONS/FREELANCE MASTERING

Mastering, CD Services
c/o Trutone Records
163 Terrace St.
Haworth, NJ 07641
(201) 385-0940
(718) 523-2459
Contact: Don Grossinger

HARDMAN EASTMAN STUDIOS, INC.

Mastering, Tape Duplication
1400 E. Carson St.
Pittsburgh, PA 15203
(412) 481-4450
Contact: Barbara Jost

HARRISON AUDIO SERVICES

Tape Duplication
9 Birch Hill Rd.
South Hadley, MA 01075
(413) 536-3830
Contact: Jeff Harrison

HORTON SYSTEMS COMPANY
Tape Duplication
 1268 Chesapeake Dr.
 Lilburn, GA 30247
 (404) 923-5825
 Contact: Fred Horton

HOTTRAX RECORDS
Pressing, Tape Duplication
 1957 Kilburn Dr., Box 13584
 Atlanta, GA 30324
 (404) 661-6662
 Contact: Aleck Janouss

HRM GROUP LTD.
Pressing
 15 Gilpin Ave.
 Hauppauge, NY 11788
 (516) 234-0200
 Contact: Brian Wilson

HUB-SERVALL RECORD MFG. CORP.
Pressing
 Cranbury-S. River Rd.
 Cranbury, NJ 08512
 (609) 655-2166
 Contact: Barry Ruegg
PRESSING
 Presses: (17) 12" Tracy-Val presses w/Hamilton auto
 Capacity: 35,000/day
 Vinyl Used: Tennaco
 Rates: Upon request
 Other Services: Plating, jacketing, labels, DJ services, distributor shipping

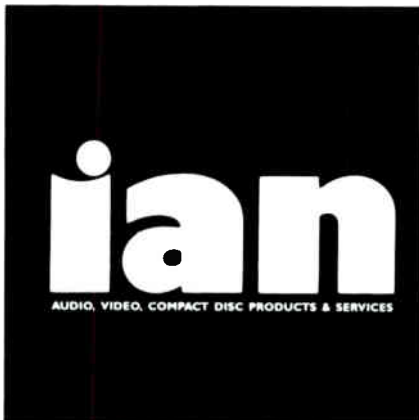

IAN COMMUNICATIONS GROUP, INC.
 Wilmington, MA

IAN COMMUNICATIONS GROUP, INC.
Tape Duplication, CD Services
 10 Upton Dr.
 Wilmington, MA 01887
 (617) 658-3700
 (800) 433-DUPE (out of state)
 Contact: Richard Berberian
TAPE DUPLICATION
 Duplicator: Otari DR-7000, Otari DR-80
 Capacity: 10,000 per shift
 Method of Duplication: Bin loop
 Mastering Equipment: Otari MTR-10 ILX
 Tape Used: Agfa, BASF
 Shell Used: Michelex
 Duplicating Speed: 64 1 or 32 1
 Loading Equipment: AVA 2001
 Packaging Equipment/Fulfillment Services: Tapematic labelers and boxers
 Rates: Rate card for up to 2,000 units. Larger orders on quotation basis
 Other Services: Complete in-house facilities for graphics, typesetting, printing and wrapping. Climate controlled warehouse and order fulfillment
COMPACT DISC
 Preparation/Manufacturing: Editing, mastering and pressing services, printing and packaging.

I.C.C.A.
Tape Duplication
 429 Briabend Dr.
 Charlotte, NC 28209
 (704) 523-7219
 Contact: Harrell Canning, Reg Davies
TAPE DUPLICATION

Duplicator: Electro-Sound ES 8000 (2) masters (10) slaves
 Capacity: 25,000/day
 Method of Duplication: Bin loop
 Mastering Equipment: MCI, Dolby, dbx, F1 digital
 Tape Used: Ampex
 Shell Used: Lenco
 Duplicating Speed: 32-1, 64-1
 Loading Equipment: King 790
 Packaging Equipment/Fulfillment Services: Apex printer, Islemann boxer, Islemann wrapper, Islemann labeler
 Rates: Call or send for brochure and price list
 Other Services: Standard and custom length blank cassettes, graphic art, design and typesetting for label and insert information

INTERNATIONAL CUTTERHEAD REPAIR & CONVERSION CO.
Mastering
 571 Boulevard
 Hasbrouck Heights, NJ 07604
 (201) 833-0152
 Contact: Sharon Rand

INTERNATIONAL TAPE/DISC ASSOCIATION
 10 Columbus Cir., Ste. 2270
 New York, NY 10019
 (212) 956-7110
 Contact: Henry Brief

KENNEDY MUSIC AND RECORDING
Tape Duplication
 5253 Montour St.
 Philadelphia, PA 19124
 (215) 533-2380
 Contact: David Kennedy

KEWALL TAPE DUPLICATION
Tape Duplication
 77 Bayshore Rd.
 Bayshore, NY 11706
 (516) 586-2486
 Contact: Dorothy E. Gutschwager

THE LACQUER PLACE, INC.
Mastering
 116 17th Ave. S.
 Nashville, TN 37203
 (615) 244-5355
 Contact: Ted Fuller
MASTERING
 Cutting Lathes: Scully w/Capps computer and Westrex RA-1700 cutting system
 Console: Custom transformerless
 Tape Machines: MCI 1/2" and 1/4" mastering deck
 Monitor Speakers: Big Reds, Auratones
 Signal Processing: Compressor/limiters, parametric EQ, filters, Dolby A, dbx 187
 Engineers: Doug Lawrence
 Credits: Under new management with seven years experience and over 10,000 records to its credit. The Lacquer Place is prepared to deliver quality product at a reasonable price
 Rates: Call for rates
 Other Services: Tape copies, consultation

LAMON SOUND
Tape Duplication, CD Services
 6870 A Newell, Hickory Grove Rd.
 Charlotte, NC 28229
 (704) 537-9310
 Contact: David Moody

LINDEN, INC.
Mastering, Tape Duplication
 229 N. Henry St.
 Alexandria, VA 22314
 (703) 549-4424
 Contact: Gregg Powers

LION RECORDING SERVICES, INC.
Tape Duplication
 7532 Fullerton Ct.
 Springfield, VA 22153
 (703) 455-5566
 Contact: Richard Lion
TAPE DUPLICATION
 Duplicator: Audio/Tek, 20 slaves, 12 mono, 8 stereo
 Capacity: 20,000 per day
 Method of Duplication: Bin loop
 Mastering Equipment: Studer
 Tape Used: Agfa

—CONTINUED ON NEXT PAGE

Blank Audio/Video Tape

New Digital Audio Tape Available

FOR HARD TO GET ACCESSORY ITEMS
 Reels, Boxes, Custom Cassettes, Leaders and Splicing Tape
 Digital Audio Tape Available
In Stock and Priced Right!
Immediate Delivery

Call for **FREE** Catalog
 Toll Free: 1-800-331-3191
 In N.Y. 516-678-4414

Circle #155 on Reader Service Card

EUROPADISK, LTD.

Direct Metal Mastering
 U.S. Only Complete DMM Facility—

- Disk Mastering Suite
- Hi-Definition Plating
- State-Of-The-Art Pressing

For
*brochure & pricing,
 call or write*

EUROPADISK, LTD.

75 Varick St.
 N.Y. 10013
 (212) 226-4401

Circle #153 on Reader Service Card

Shell Used: Magnetic Media, ICM, Lenco
Duplicating Speed: 32:1
Loading Equipment: TTL
Packaging Equipment/Fulfillment Services: Shrinkwrap.
Other Services: Labeling, boxing, packaging and shipping.
ApeX printing

LIVE SOUND PRODUCTIONS

Tape Duplication
414 Walnut Dr.
Annapolis, MD 21403
(301) 268-3938
Contact: Leslie Lentz

LUNDY RECORDING & TAPE DUP.

Tape Duplication
PO Box 408
Heidrick, KY 40949
(606) 546-6650
Contact: David or Duran Lundy

MAGNETIC TECHNOLOGY

Tape Duplication
50 Music Square W., Ste. 506
Nashville, TN 37203
(615) 329-1875
Contact: Mack Evans
TAPE DUPLICATION
Duplicator: Custom built real time system, (40) Aiwa ADF-660 decks w/HX Pro.
Method of Duplication: In cassette.
Mastering Equipment: Can run 7 1/2, 15 or 30 ips on 1/4" or 1/2" tape and 14- or 16-bit 1/2" digital tapes (Beta or VHS).
Tape Used: Agfa or BASF primary, others on request
Shell Used: Various, customer's choice.
Duplicating Speed: Real time
Rates: Call for quotes
Other Services: Digital (clone) copies to or from Beta or VHS
Limited number of reel-to-reel copies

MAN FROM MARS PRODUCTIONS

Tape Duplication
159 Orange St.
Manchester, NH 03104
(603) 668-0652
Contact: Ed Brouder

MARK CUSTOM RECORDING SERVICE

Mastering, Pressing, Tape Duplication
10815 Bodine Rd.
Clarence, NY 14031
(716) 759-2600
Contact: Vincent S. Morette
MASTERING
Cutting Lathes: Neumann VMS-70/SX-74
Console: Neumann SP272 modified transformerless
Tape Machines: Studer, Ampex, Otari, dbx 700, Sony PCM-F1 Beta or VHS.
Monitor Speakers: UREI 813, Yamaha NS-10, Westlake BBS6, various JBL
Signal Processing: UREI, dbx, EMT, EXR, Dolby, Polyfusion, Lexicon, ADR, Barcus-Berry
Engineers: Vincent S. Morette, Bruce Leek, Tony DiBartolo.
Rates: On request
PRESSING
Presses: Subcontracted
Vinyl Used: Kearsor/Teldec
Rates: On request
Other Services: Graphics, printing
TAPE DUPLICATION
Duplicator: (52) Nakamichi LX-5 Real Time, (50) Nakamichi MR-1.
Capacity: 700 C-60 per 8 hr shift.
Method of Duplication: In cassette.
Mastering Equipment: All formats include dbx 700.
Tape Used: Agfa chrome, Magnetite BASF.
Shell Used: IPS/Shape
Duplicating Speed: Real time 1 1/2 ips
Loading Equipment: King
Packaging Equipment/Fulfillment Services: Complete packaging to shrinkwrap.
Rates: On request
Other Services: Complete graphics and printing.

MARK FIVE/SANDCASTLE

Tape Duplication
10 Michael Dr.
Greenville, SC 29610
(803) 269-3961
Contact: Matt Schwartz

E A S T E R N
TAPE TO DISC
DIRECTORY

MASTER MIX

Mastering, CD Services
1808 Division St.
Nashville, TN 37203
(615) 321-5970
Contact: Chris
MASTERING
Cutting Lathes: Neumann VMS 70 w/Technics quartz direct drive and Zuma audio/preview computer. Neumann SAL 74B cutter rack, Neumann SX-74 cutter head.
Console: Neumann SP77.
Tape Machines: Studer preview machine 1/2" and 1/4", Studer copy machine
Monitor Speakers: John Meyers and Rogers powered by Times, One and Hafler amplifiers.
Signal Processing: Sontec and Neumann equalizers. Sontec and NTP compressors, Dolby and dbx available
Engineers: Hank Williams and Ken Love.
Credits: Lee Greenwood, Eddie Rabbit, Earl Thomas Conley, Statler Bros., Ed Bruce, Sandi Patti, Al Green, Tanya Tucker and Whiteheart.
Rates: Available upon request
Other Services: CD and cassette preparation via Sony 1630, DAE-1100 editing system

MASTER SOUND ASTORIA

Tape Duplication
34-12 36th St.
Astoria, NY 11106
(718) 786-3400

MASTER SOUND STUDIOS, INC.

Mastering, Pressing, Tape Duplication, CD Services
1227 Spring St. NW
Atlanta, GA 30309
(404) 873-6425
Contact: Bob Richardson

MASTERCRAFT ELECTROPLATING INC.

801 Magnolia Ave.
Elizabeth, NJ 07201
(201) 354-4404
(212) 765-7467

MASTERDISK CORP.

Mastering
16 W. 61st St.
New York, NY 10023
(212) 541-5022
MASTERING
Cutting Lathes: Neumann DMM lathe, (4) Neumann VMS70 lathes
Console: Neve digital transfer console and (4) Neumann consoles
Tape Machines: Sony DMR-4000s, Studer, Mitsubishi X-80, Sony Beta, JVC VHS
Monitor Speakers: Sovereign 2001, Altec, Hartley subwoofers, UREI 813, Fournier 8s, Yamaha, JBL
Signal Processing: Sony 1610, Sony 1630, Cello, Sontec EQs, NTP limiters, Lexicon reverb, Aphex, Pultec, Sony 501, Sony 701
Engineers: Bob Ludwig, Howie Weinberg, Bill Kipper, Tony Dawsey, Scott Hull, Alan Moy.
Credits: Bruce Springsteen, David Bowie, Sting, U2, Run DMC, Beastie Boys, Def Leppard, Branford Marsalis and Musical Heritage Society.
Rates: Call for brochure
COMPACT DISC
Preparation/Manufacturing: CD tape masters

MASTERFONICS, INC.

Mastering, Tape Duplication, CD Services
28 Music Square E.
Nashville, TN 37203
(615) 327-4533
Contact: Margaret Meadows
MASTERING
Cutting Lathes: Neumann VMS70, SAL 74B, Zumaudio.
Console: Neumann custom, JVC DM900 digital.
Tape Machines: Studer, JVC VP-900.
Monitor Speakers: Kinoshita/Hidley, Yamaha NS-10, etc.
Signal Processing: JVC digital console, Sontec EQ and DRC, outer ear.



MASTERFONICS, INC.
Nashville, TN

Engineers: Glenn Meadows, Benny Quinn, Jim Loyd, Milan Bogdan, Ric Landers
Rates: On request
Other Services: SSL/Otari DTR-900 equipped re-mix room available. Tom Hidley-designed 20Hz monitor environment must be heard to be appreciated. Real time cassette copies, small-run high quality, premium tapes used
TAPE DUPLICATION
Duplicator: Aiwa F660A
Capacity: 10
Method of Duplication: In cassette
Mastering Equipment: JVC VP-900
Tape Used: TDK SAX, HSX, MAX
Shell Used: TDK
Duplicating Speed: 1:1
Rates: On request, per size of run.
Other Services: Sub master preparation for high speed duplicating. Editing compilation services for sampler cassettes.
COMPACT DISC
Preparation/Manufacturing: Complete CD master tape preparation from any 2-track source (digital or analog). In the past six years, over 470 CD tapes have been prepped for all major record companies. Total digital signal processing including compression, EQ, pre-emphasis removal, crossfades. If you can do it in analog, we can do it digitally

MASTERWORK RECORDING, INC.

Mastering, Pressing, CD Services
1020 N. Delaware Ave.
Philadelphia, PA 19125
(215) 423-1022
Contact: Albert Oon, Peter Humphreys
MASTERING
Cutting Lathes: Scully w/Sontec "Compudisk" digital control computers equipped w/Westrex 3DIAH cutterheads/Ran-steele driver systems.
Console: Custom/proprietary by Masterwork.
Tape Machines: MCI 1/4" and 1/2", Sony digital.
Monitor Speakers: (2) JBL 4343B, (2) JBL 4301B, (2) Yamaha NS-10, (2) JVC mini-monitors, Sontec limiters/compressors, Ampex ADD-1 digital delay systems, equalizers/filters by Sontec, UREI, Soundcraftsman
Engineers: Nimitr "Nim" Sarikananda, Peter Humphreys.
Credits: Grover Washington, Jr., Levert, The O'Jays, Phyllis Hyman, Shirley Jones, Miles Jaye, Third World, Montana Orch. and many others
Rates: Available upon request.
Other Services: Custom pressing orders—LP, 12" singles and 7" 45s, compact disc preparation and manufacturing.

METRO RECORDING STUDIO LTD.

Tape Duplication
1422 Crain Hwy. SW
Glen Burnie, MD 21061
(301) 761-6159
Contact: Joel Jacobs

MIAMI TAPE, INC.

Mastering, Pressing, Tape Duplication, CD Services
8180 NW 103rd St.
Hialeah Gardens, FL 33016
(305) 558-9211
(305) 558-9212
(305) 825-9873 (FAX)
Contact: Carlos Garcia
MASTERING
Cutting Lathes: Haeco computerized
Tape Machines: MCI
Monitor Speakers: JBL.
Signal Processing: Orban EQ, UREI limiters, Burwen NR, Dolby A

Engineers: Jorge Garcia
 Credits: Upon request.
 Rates: Upon request.
 Other Services: Safety's, editing, EQ'd transfers.
PRESSING
 Presses: SMT automatic presses: four LP, two 45.
 Capacity: 3,000 LPs daily.
 Vinyl Used: Keycor.

Rates: Upon request.
 Other Services: Complete packaging services.
TAPE DUPLICATION
 Duplicator: Electro-Sound.
 Capacity: 200,000/month.
 Method of Duplication: Bin loop
 Mastering Equipment: Electro-Sound
 Tape Used: Agfa, BASF.
 Shell Used: Various types available.
 Duplicating Speed: 32:1.
 Loading Equipment: King.
 Packaging Equipment/Fulfillment Services: Complete packaging.
 Rates: Upon request.

Other Services: Editing, Dolby D and C encoding.
COMPACT DISC
 Preparation/Manufacturing: In-house premastering using Sony equipment, complete compact disc packages, digital editing, digital transfers, rates upon request

MULTITAPE
 Tape Duplication
 2112 18th St. NW
 Washington, DC 20009
 (202) 332-1522
 Contact: Bruce F. Moyer

MUSIC & SOUND DESIGN STUDIO
 (MILBRODT COMMUNICATIONS)
 Tape Duplication
 1425 Frontier Rd.
 Bridgewater, NJ 08807
 (201) 560-8444
 Contact: Bill Milbrodt

THE MUSIC CONNECTION INC.
 Pressing, Tape Duplication, CD Services
 166 Madison Ave.
 New York, NY 10016
 (212) 686-9595
 Contact: Fred Levy

MUSTARD SEED MINISTRIES/STUDIO K
 GOSPEL RECORDING
 Tape Duplication
 PO Box 177, 79 Lewiston St.
 Mechanic Falls, ME 02456
 (207) 345-9073
 Contact: Stephen Kilbreth



NASHVILLE RECORD PRODUCTIONS, INC.
 Nashville, TN

NASHVILLE RECORD PRODUCTIONS, INC.
 Mastering, CD Services
 469 Chestnut St.
 Nashville, TN 37203
 (615) 259-4200
 Contact: George Ingram

MASTERING
 Cutting Lathes: Neumann, Zuma and Capps computer two.
 Console: Sphere and Neve
 Tape Machines: Studer and MCI.
 Monitor Speakers: Electro-Voice Sentry 3s, Yamaha NS-10s.

Signal Processing: Parametric and graphic EQ, reverb, compressor/limiter
 Engineers: Glen Bullard, chief engineer, John Eberle, studio manager
 Credits: Ronnie Milsap, Amy Grant, Rick & Janice Carnes, Sha-Na-Na, Tupperware, American Airlines, Drifters, Bill Anderson, Dan Seals, Ray Price, Sammi Smith, Pat Boone, Alabama.
 Rates: \$90/side, 12"; \$35/side, 7"
 Other Services: Digital mastering: 1/2" Sony F1, 501-701; 3/4" Sony 1610 CD preparation, complete record and cassette packaging, LP and 45 pressing, tape duplication, editing, reference acetates

NIMBUS RECORDS INC.
 Mastering, Pressing, Tape Duplication, CD Services
 200 W. 57 St.
 New York, NY 10019
 (212) 262-5400
 Contact: Marc S. Feingold

NIMBUS RECORDS, INC.
 Mastering, Pressing, Tape Duplication, CD Services
 PO Box 7305
 Charlottesville, VA 22906
 (804) 985-1100
 (910) 240-8303 (telex)
 Contact: Jeffrey L. North, Mark Galloway, Marc S. Feingold, Peter Miller

L. NIX & CO. INC.
 Mastering, Tape Duplication
 2000 Madison Ave.
 Memphis, TN 38104
 (901) 725-0855
 Contact: Larry Nix



NORTHEASTERN DIGITAL RECORDING, INC.
 Shrewsbury, MA

NORTHEASTERN DIGITAL RECORDING, INC.
 Mastering, CD Services
 12 Sadler Ave.
 Shrewsbury, MA 01545
 (617) 753-1192
 Contact: Toby Mountain, Tracy Crane

MASTERING
 Console: Troisi SA 200 12 x 4 x 2, full parametric EQ.
 Tape Machines: Sony PCM-1630, PCM-1610 w/Sony BVU-800DB 2-track, digital, Sony APR-5002 2-track analog, Sony PCM-F1, 701, 501
 Monitor Speakers: Snell Type C
 Signal Processing: Lexicon PCM70
 Engineers: Dr. Toby Mountain.
 Credits: Frank Zappa, Arlo Guthrie, Ritchie Havens, Devo, Kingston Trio, Rykodisc, Rounder, A&M, Chrysalis, Bose, Polaroid
 Rates: Digital transfers, editing, CD mastering: \$95/hr., analog to digital transfers: \$100/hr.
COMPACT DISC
 Preparation/Manufacturing: Complete digital editing and pre-mastering for compact disc using the Sony PCM-1610/30 system with the DAE-1100 digital editor. Also complete compact disc replication services.

NU TRAX RECORDING STUDIO
 Mastering, Tape Duplication
 141 W. Ruscomb St.
 Philadelphia, PA 19120
 (215) 456-9141
 Contact: Paul M. Helfrich

Diskmakers

**DISKMAKERS
 MAKES THE
 RECORD
 PRESSING
 BUSINESS
 EASY FOR YOU...**

**DISKMAKERS
 DOES IT ALL!**

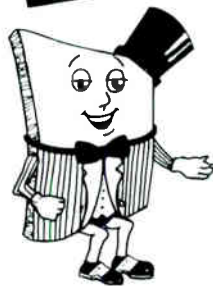

we
 handle
 the
**jacket
 design,
 printing**

and
 color
 seps...



we
 handle the
**pressing
 along with
 mastering,
 plating and**

record
 labels...



we
 handle the
**cassette
 duplication**

**and give
 you the
 complete job...
 it's that easy!**

**CALL TOLL FREE
 1-800-468-9353**

Ask For Our
 Complete Price Package

Diskmakers

**NEW YORK • CHICAGO
 PHILADELPHIA**

Circle #154 on Reader Service Card

P&P STUDIOS INC.
Tape Duplication
 17 Viaduct Rd.
 Stamford, CT 06907
 (203) 359-9292
 (203) 325-8329 (FAX)
 Contact: Dana Anthony

PRC RECORDING INDUSTRIES
Tape Duplication
 422 Madison Ave.
 New York, NY 10017
 (212) 308-2300
 Contact: Laurie Gale, Albert Santoro

PRECISION RECORD PRESSING, INC.
Pressing
 70 Visco Ct.
 Nashville, TN 37210
 (615) 256-8978
 (800) 367-0067
 Contact: Ronnie Yearwood

PRESTIGIOUS AUDIO VIDEO CORP.
Tape Duplication
 11 S. Gold Dr.
 Robbinsville, NJ 08619
 (609) 586-4040
 Contact: Robert Kriss, Edward Joseph

PRODIGITAL, INC.
 3400 Pendleton Dr.
 Wheaton, MD 20902
 (202) 635-5588
 Contact: Bill Burns, Alan Wonneberger

PROGRESSIVE MUSIC STUDIOS
Tape Duplication
 2116 Southview Ave.
 Tampa, FL 33606
 (813) 251-8093
 Contact: Ken Veenstra

PROGRESSIVE TAPE CORPORATION
Tape Duplication
 40-H Corbin Ave.
 Bay Shore, NY 11703
 (516) 242-4646
 Contact: Paul Glantzman



PROJECT 70 AUDIO SERVICES, INC.
 Atlanta, GA

PROJECT 70 AUDIO SERVICES, INC.
Tape Duplication
 777 Lambert Dr. NE
 Atlanta, GA 30324
 (404) 875-7000
 Contact: Jerry L. Connell
TAPE DUPLICATION
 Duplicator: Ampex BLM 200 (new electronics 1987), Electro-Sound 6000
 Capacity: Ampex, 10 slaves, Electro-Sound, 6 slaves
 Method of Duplication: Bin loop
 Mastering Equipment: Otari MTR-10 1/4", Ampex AG-440 1"
 Tape Used: Agfa and Capitol
 Shell Used: Magmedia
 Duplicating Speed: 32 1
 Loading Equipment: King 790s w/AMI splicers and software
 Packaging Equipment/Fulfillment Services: Shape labeller.

E A S T E R N
TAPE TO DISC
 DIRECTORY

Apex printing
 Other Services: Complete fulfillment services from script to finished mailing of product

QTI, INC. (SUBSIDIARY OF BMG MUSIC)
Tape Duplication
 108 Monticello Rd.
 Weaverville, NC 28787
 (704) 658-2000
 Contact: Don Fiscus
TAPE DUPLICATION
 Duplicator: (40) Electro-Sound 8000, (50) 3M, (60) RCA slaves
 Capacity: 300,000 per day
 Method of Duplication: Bin loop
 Mastering Equipment: All formats accepted and transferred to 1" running master
 Tape Used: BASF, Aurex, CBS, Sunkyong, Capitol
 Shell Used: Athenia, Allen, Auriga, Shape, IPS, Supply Dynamics
 Duplicating Speed: 32 1 and 64 1
 Loading Equipment: King 780 and 790
 Packaging Equipment/Fulfillment Services: Apex printers, Scandia inserters/wrappers, Ampak wrappers, automatic 3" x 12" 1/4" x 12" packaging equipment
 Rates: Based on order size and material specified
 Other Services: Full service printing of cassette wraparounds, labels and "O" cards and record labels. Real time duplication and sales of custom alignment tapes (all formats)

QUIK CASSETTE CORP.
Tape Duplication
 250 W. 57th St., Ste. 2101
 New York, NY 10107
 (212) 977-4411
 Contact: Ron Klipstein

RADIO ACTIVE AUDIO
Tape Duplication
 9 W. Grace St.
 Richmond, VA 23220
 (804) 643-2022
 Contact: Victor T. Benschoff

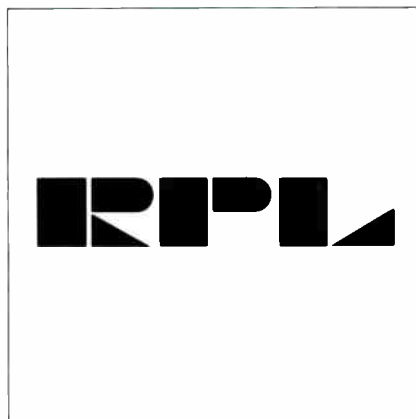

RECORDED PUBLICATIONS LABORATORIES
 Camden, NJ

RECORDED PUBLICATIONS LABORATORIES
Tape Duplication
 1100 State St.
 Camden, NJ 08105
 (609) 871-0840
 Contact: Sidney E. Morton
TAPE DUPLICATION
 Duplicator: Electro-Sound 20 slaves, Ampex 20 slaves
 Capacity: Approx. 50,000 C-60 audio cassettes, approx. 45,000 1,200" reel-to-reel weekly
 Method of Duplication: Bin loop
 Mastering Equipment: Ampex recorders, Pultec, Orban, Para-sound, Universal Audio
 Tape Used: Agfa Gavaert, Ampex, Capitol
 Shell Used: Shape

Duplicating Speed: 64 1, 32 1, 16 1
 Loading Equipment: King instrument
 Packaging Equipment/Fulfillment Services: Individually poly-sealed, Scandia wrapped.
 Rates: Please phone or write for quote
 Other Services: Custom signalling for AV programs, video duplicator 3/4" U-matic, 1/2" VHS, hi-fi stereo, mono 1/2" Beta

RECORDING AT AKINOM
Tape Duplication
 700 Wood St.
 Pittsburgh, PA 15221
 (412) 243-3074
 Contact: Daniel B. Gaydos

REFLECTION SOUND STUDIOS
Tape Duplication
 1018 Central Ave.
 Charlotte, NC 28204
 (704) 377-4596
 Contact: Mark Williams

RESOLUTION, INC.
Tape Duplication
 1 Mill St.
 Burlington, VT 05401
 (802) 862-8881
 (800) 862-8900
 Contact: Linda Citron

ROAR PRODUCTIONS INC.
Mastering, Pressing, Tape Duplication
 6655-H Dobbin Rd.
 Columbia, MD 21045
 (301) 596-2600
 Contact: Steven Rosch

RODEL AUDIO
 1028 33rd St. NW
 Washington, DC 20007
 (202) 338-0770
 Contact: Renee Funk



ROMABA RECORD PRESSING CORP.
 Brooklyn, NY

ROMABA RECORD PRESSING CORP.
Mastering, Pressing, Tape Duplication
 33 34th St., Industry City
 Brooklyn, NY 11232
 (718) 499-3060
 Contact: Ted Kolsky, Vicki Guerra

RON ROSE PRODUCTIONS, INC.
Mastering, Tape Duplication
 3409 W. Lemon St.
 Tampa, FL 33609
 (813) 873-7700
 Contact: Ron Rose, Mike Stram

S&S CUSTOM TAPES, INC.
Mastering, Tape Duplication
 Rte. 4, Box 328A
 Church Hill, TN 37642
 (615) 357-TAPE
 Contact: Mike Shiple, Rose Yonts

SACRED SPIRIT MUSIC
Mastering, Tape Duplication
 Box 1030 D, Shaker Rd.
 New Lebanon, NY 12125
 (518) 794-7860
 Contact: Mikhail Horowitz

Contact: Dennis Hannon, James Roe
COMPACT DISC
 Preparation/Manufacturing: Mastering, electroforming, disc
 replication, full graphic capabilities, packaging, jewel boxes
 and distribution. Prices based upon volume

STAMPER MAKERS, INC.
Mastering, Pressing, Tape Duplication, CD Services
 130 W. 42nd St., Room 911
 New York, NY 10036
 (212) 944-0002
 Contact: Ledak

SELECT SOUND RECORDING STUDIOS
Tape Duplication
 2315 Elmwood Ave.
 Kenmore, NY 14217
 (716) 873-2717
 Contact: William A. Kohen

SOUND MAKERS RECORD MANUFACTURING CO. INC.
Mastering, Pressing, Tape Duplication, CD Services
 1650 Broadway, Ste. 1212
 New York, NY 10019
 (212) 265-6662
 Contact: David Moldauer

STARDISC USA, INC.
Pressing, Tape Duplication
 305 11th Ave. S.
 Nashville, TN 37203
 (615) 256-7827
 (615) 254-6100
 Contact: Tari Storer



SHAPE OPTIMEDIA, INC.
 Sanford, ME

SHAPE OPTIMEDIA, INC.
CD Services
 Rt. 109 and Eagle Dr., PO Box 592
 Sanford, ME 04073
 (800) CDS-DISC
 (207) 324-1124

SOUND STAGE
Tape Duplication
 2042 N. Rio Grande Ave., Ste. F
 Orlando, FL 32804
 (305) 849-9767
 Contact: Bill Fletcher

STARSTRUCK SOUNDLABS
Tape Duplication
 PO Box 161
 Hicksville, NY 11801
 (516) 931-7231
 Contact: Peter Durso

SOUND TECHNIQUE, INC.
Mastering
 130 W. 42nd St.
 New York, NY 10036
 (212) 869-1323
 Contact: Gladys Hopkowitz

E.J. STEWART, INC.
Mastering, Tape Duplication
 525 Mildred Ave.
 Primos, PA 19018
 (215) 626-6500
 Contact: Lou Stricoff

SOUND INVESTMENT CO. INC.
Tape Duplication
 3586 Pierce Dr.
 Chamblee, GA 30341
 (404) 458-1679
 Contact: Lou Simmons

STUDIO B
Pressing, Tape Duplication
 1119 Bell St.
 Montgomery, AL 36104
 (205) 834-6881
 Contact: Jayonn Bearden

SOUNDWAVE RECORDING STUDIOS, INC.
Mastering
 2 W. 45th St.
 New York, NY 10036
 (212) 730-7366
 Contact: Ray Hagerty

STUDIO MAGNETICS CO. INC.
Tape Duplication
 12 Long Island Ave.
 Holtsville, NY 11742
 (516) 289-3400
 (800) 874-2202 (outside NY)
 (212) 797-1660
 Contact: Jim Makowski

HEARD ANY GOOD ONES LATELY ?

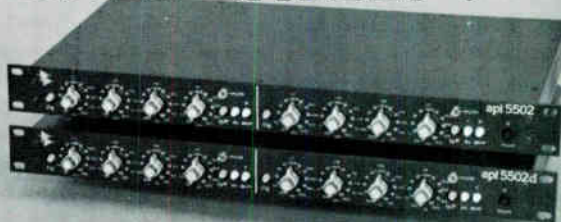

NEW PRODUCTS:

- 3124 Mic pre/direct box
- 3124m Mic pre/direct box/mixer
- 5502 Dual equalizer
- 5502d Disc & CD mastering eq

(all discrete OP-AMPS)

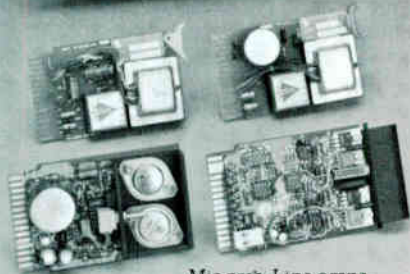

Mic pres, Line amps,
 Power amps & Distribution amps



The famous 550a
 (all discrete)



560b 10 band eq
 (with 252C)

api audio products, inc.

7951 Twist Lane, Springfield, VA 22153
 (703) 455-8188 tlx: 510-600-1898

ea Everything Audio
 2721 W. Burbank Blvd., Burbank, CA 91505 818-842-4171

studio consultants, inc.
 321 West 44th Street, New York, NY 10036 (212) 586-7376

SUNSHINE SOUND, INC
Mastering, Pressing
1650 Broadway
New York, NY 10019
(212) 582-6227
Contact: Frank J. Trimarco

THE TAPE COMPLEX, INC.
Tape Duplication
4 Haviland St.
Boston, MA 02115
(617) 437-9449
Contact: Peter Cecere, Kathryn Torda

TAPE TIME CORP
Pressing, Tape Duplication
161 Mass. Ave.
Boston, MA 02115
(617) 266-3131
Contact: Raymond Fournier



TAPEX CORPORATION
Fort Lauderdale, FL

TAPEX CORPORATION
Tape Duplication
2999 NE 12 Terr.
Fort Lauderdale, FL 33334
(305) 565-1617
Contact: A sales executive

MASTERING
Other Services: Tapex has in stock the new T-8 water soluble plate makers which are used to make the printing plates for the Apex printers
TAPE DUPLICATION
Other Services: Tapex Corp. has in stock high and low grade C-0 cassette shells and Norelco boxes at excellent prices.

TARGET
Tape Duplication
801 Valley Rd.
Newark, DE 19711
(302) 731-4431
Contact: Marc Moss

TFI (TAPE-FILM INDUSTRIES)
Tape Duplication
619 W. 54th St.
New York, NY 10019
(212) 708-0500
Contact: Charlie Ahto

THE TIME MACHINE RECORDING & DUPLICATING
Mastering, Tape Duplication
2852 20th Ave. N., #2
St. Petersburg, FL 33713
(813) 321-7900
Contact: Steve Repetti

TRACY-VAL CORPORATION
201 Linden Ave.
Somerdale, NJ 08083
(609) 627-3000
Contact: James or Joan Miller

E A S T E R N
TAPE TO DISC
DIRECTORY

TRAXX RECORDING PRODUCTS
Mastering, Tape Duplication
24 Crestway Kc
New Fairfield, CT 06812
(203) 746-3561
Contact: Jim Beck

TREY RECORDS
Mastering
PO Box 538
Gordon, GA 31031
(912) 628-2594
Contact: Willie Smith

TROPICAL RECORDING
Tape Duplication
PO Box 3572
Pittsfield, MA 01202
(413) 443-5973
Contact: Mark Aunet

TRUSTY TUNESHOP RECORDING STUDIO
Tape Duplication
Rt. 1, Box 100
Nebo, KY 42441
(502) 249-3194
Contact: Elsie Childers

TRUTONE RECORDS
Mastering, Pressing, Tape Duplication, CD Services
163 Terrace St.
Haworth, NJ 07641
(201) 385-0940
Contact: Adrienne Rowatt
MASTERING
Cutting Lathes: Neumann VMS70 w/Zuma computer, Scully w/Capps, Varipitch II
Console: Neumann, custom and Studer
Tape Machines: Studer A80 MKIII, Studer A810, Studer B67, Ampex ATR-102, MCI JH-110B.
Monitor Speakers: UREI 813, JBL, Yamaha, B&W DM220, Auratone.
Signal Processing: Neumann, Pultec, UREI, Sontec
Engineers: Carl Rowatt, Phil Austin, Steve Robb, Ray Janos, asst. engineer Patti Firrincili.
Credits: Upon request
Rates: Upon request
Other Services: Compact disc masters, high quality short-run pressing and cassette duplication. Sony PCM-1610 and F1 mastering
COMPACT DISC
Preparation/Manufacturing: Assembly and preparation of Sony PCM-1610 tapes for CD

TWELVE OAKS PRODUCTIONS
Tape Duplication
3830 S. Cobb Dr.
Smyrna, GA 30080
(404) 435-2220
Contact: Randy Bugg

UNITED RECORDING LABS
Tape Duplication
681 5th Ave.
New York, NY 10022
(212) 751-4660
Contact: Anita Adams

USC SOUND ENTERPRISES
Tape Duplication
4829 Barfield Rd.
Memphis, TN 38117
(901) 682-7002
Contact: Rodney Peppenhorst

VARIETY RECORDING STUDIO
Mastering, Pressing, Tape Duplication, CD Services
130 W. 42nd St. (Room 551)
New York, NY 10036
(212) 221-6625
Contact: Warren Smith

VIDEO IDEAS, INC.
Tape Duplication
3965 N. Federal Hwy.
FL Lauderdale, FL 33308
(305) 561-1447
Contact: Carleton Chernehoff

VIDEO VISION DUPLICATIONS
Tape Duplication
6851 Yumun St., Ste. 12
Coral Gables, FL 33146
(305) 666-1799
Contact: Charles Ray

VIRGINIA ARTS PRODUCTION STUDIO
Tape Duplication
Box 800
Louisa, VA 23093
(703) 967-2245
Contact: R. Paul Briar

THE WAREHOUSE RECORDING STUDIO
Tape Duplication
2071 Emerson St., Unit #20
Jacksonville, FL 32207
(904) 399-0424
Contact: Roger Peck

WESTCHESTER INTERNATIONAL ENTERTAINMENT LTD.
Mastering, Pressing, Tape Duplication, CD Services
232 Madison Ave., Ste. 510
New York, NY 10016
(212) 684-5634
(212) 684-5636
Contact: Jon H. Starke

WHITE CROW AUDIO
Tape Duplication
19 Marble Ave.
Burlington, VT 05401
(802) 658-6475
Contact: Douglas Jaffe
TAPE DUPLICATION
Duplicator: (30) Nakamichi BX-1 decks
Capacity: 300 C60/day (max order: 500)
Method of Duplication: In cassette
Mastering Equipment: Studer A80, Studer A810, Studer A820, Neve console
Tape Used: TDK AD (norm), TDK SA (chrome).
Shell Used: TDK (preloaded)
Duplicating Speed: Real time 1:1.
Packaging Equipment/Fulfillment Services: Shrinkwrap
Rates: Call or write for rate card.
Other Services: Custom labels, U-card layout/printing.

WK STUDIO
Tape Duplication
611 Broadway, Ste. 529 & 531
New York, NY 10012
(212) 473-1203
Contact: Phyllis Whitehouse, Konstantine Sareyan

The new, updated Fall/Winter Mix Bookshelf Catalog, with the best books, music software, video and audio cassette courses from over 70 publishers, is now available. For your free copy, call (800) 233-9604; in California, dial (800) 641-3349. Local and foreign customers call (415) 843-7901.

CENTRAL

A&F MUSIC SERVICES

Tape Duplication
2834 Otsego
Pontiac, MI 48054
(313) 682-9025
(313) 682-5576
Contact: Frank C. Merwin

A&R RECORD & TAPE MFG. CO.

Mastering, Pressing, Tape Duplication
902 N. Industrial Blvd.
Dallas, TX 75207
(800) 532-3472
(212) 741-2027
Contact: Richard Sobel, Stanley Getz II

A TO Z AUDIO SERVICES, INC.

Tape Duplication
21929 Lorain Rd., PO Box 26087
Fairview Park, OH 44126
(216) 333-0040
Contact: Duane Abarca, Greg Zarnoski

TAPE DUPLICATION

Duplicator: Magnefax stereo, Telex CD stereo, Recordex 330II mono.
Capacity: 2,000 C-60s/day
Method of Duplication: In cassette, bin loop.
Mastering Equipment: Revox, Nakamichi, Tascam
Tape Used: BASF, Ampex
Shell Used: Shape Mark-10, Almac 5-screw
Duplicating Speed: 30 ips, 45 ips.
Loading Equipment: (2) AMI modified, King 780s.
Packaging Equipment/Fulfillment Services: Shrinkwrap, imprinting, 4-color inserts, custom labels.
Rates: Please call.
Other Services: Video duplication, Ampex reel tape, reel supplies, splicing blocks and tabs.

ACME AUDIO & RECORDING CO.

Mastering, Tape Duplication, CD Services
3821 N. Southport
Chicago, IL 60613
(312) 477-7333
Contact: Jim Rasfeld
MASTERING
Console: NEOTEK Series One.
Tape Machines: Ampex ATR-102 1/2" and 1/4", Technics 1520, Technics 1500, Technics 1506, Sony PCM-501ES.
Monitor Speakers: E-V Sentry 100A, E-V Sentry 500.
Signal Processing: Brooke Siren dynamics processor, phase-linear auto-correlator, Orban 422B, Technics SH-9010 EQ, Teletronix and dbx compressors.
Engineers: Mike Rasfeld, Bob Colton, Paul Smith, Sam Fishkin, Al Wittek
Credits: Flying Fish, Blind Pig, Red Beans, Blues R&B, Global Village, Earwig, Ken Nordine, Judy Roberts, National Public Radio.
Rates: \$40/hr. for digital copymasters, \$30/hr. editing & copying.
Other Services: Compilations from any format for CD release, we specialize in digital remastering.

TAPE DUPLICATION

Duplicator: (35) Nakamichi BX-300s customized
Capacity: 1,000 C-45s a day
Method of Duplication: In cassette.
Mastering Equipment: Beta, VHS, Sony PCM-501ES, Technics 1500.
Tape Used: BASF chrome, Ampex 615.
Shell Used: Shape Mark 10, Michelex clear normal.
Duplicating Speed: Real time.
Loading Equipment: King
Packaging Equipment/Fulfillment Services: Insertion and shrinkwrap.

COMPACT DISC

Preparation/Manufacturing: Remastering from any analog format for CD master.

ACME DISTRIBUTORS

Mastering, Tape Duplication
Box 8123
Kansas City, MO 64112
(816) 444-8123
Contact: F.W. Black

ALL AMERICAN PRODUCTIONS

Mastering
7514 Buena Vista
Houston, TX 77087
(713) 644-8916
Contact: Robert Strong

ALTIM PROFESSIONAL SERVICES

Tape Duplication
PO Box 330271
Ft. Worth, TX 76163
(817) 346-1012
Contact: Tim Hood

AMBASSADOR AUDIO

Tape Duplication
PO Box 271
Euless, TX
(817) 451-8967
Contact: Walt Beauvieu

ARC ELECTRONIC SERVICES INC.

Tape Duplication
1737 Division Ave. S.
Grand Rapids, MI 49507
(616) 243-1366
Contact: Ron Harkai

ARS RECORDING STUDIO & TAPE DUPLICATION

Mastering, Tape Duplication
11628 S. Pulaski
Alsip, IL 60658
(312) 371-8424
Contact: Allen Keilman, Kirk Brauch

AT THE TOP CASSETTE/ZIG ZIGLAR CORP.

Tape Duplication
3330 Earhart, Ste. 208
Carrollton, TX 75006
(214) 980-7671
Contact: Chad Witmeyer, Glenn Wilson

AUDIO GRAPHICS SERVICES

Tape Duplication, CD Services
1516 Ferris Ave.
Royal Oak, MI 48067
(313) 544-1793
Contact: Edw. J. Wolfrum

AUDIO MIXERS RECORDING CO., INC.

Tape Duplication
30 E. Huron St.
Chicago, IL 60611
(312) 943-4274
Contact: S. Schwartz

AUDIO TAPE PRODUCTIONS

Tape Duplication
PO Box 428
Pottsville, MI 48876
(517) 645-7561
Contact: Dean Bredwell

AUDIO-VIDEOGRAPHICS

Tape Duplication
13801 E. 35th St.
Independence, MO 64055
(816) 254-0400
Contact: Dennis Kaleikau

AUDIOCRAFT

Tape Duplication
915 W. 8th St.
Cincinnati, OH 45203
(513) 241-4304

AUDITEC OF ST. LOUIS

Tape Duplication
330 Selma Ave.
St. Louis, MO 63119
(314) 962-5890
Contact: William F. Carver

BASF CORPORATION INFORMATION SYSTEMS

5901 N. Poplar Dr.
Kansas City, MO 64118
(617) 271-6642
Contact: Jerry Shields

BENSON SOUND, INC.

Tape Duplication
3707 S. Blackwelder
Oklahoma City, OK 73119
(405) 634-4461
Contact: Larry Benson

W.H. BRADY CO.

Tape Duplication
PO 571, 727 W. Glendale Ave.
Milwaukee, WI 53201
(414) 332-8100
Contact: Jackie Loeder

CAVALIER PRODUCTIONS

Tape Duplication
3412 Erie Ave.
Cincinnati, OH 45208
(513) 871-8818
Contact: Ed Foss

C.D.S. CASSETTE DUPLICATING SERVICE

Tape Duplication
444 Dimmick Ave.
Cincinnati, OH 45246
(513) 851-1956
(513) 742-3677
Contact: Carl J. Burkhardt

CENTURY 21 PROGRAMMING, INC.

CD Services
4340 Beltwood Pkwy.
Dallas, TX 75244
(800) 527-5959 (outside TX)
(214) 934-2121
Contact: Dave Scott

CLAYTON STUDIOS INC.

Tape Duplication
1126 S. Big Bend
St. Louis, MO 63117
(314) 781-6200
Contact: Joe Crawford, Robyn Goffstein

CLOCKWERKE SOUND STUDIO/TAPEWERKES

Tape Duplication
1328 Linda St.
Cleveland, OH 44116
(216) 331-2210
Contact: Greg James

COACHOUSE MUSIC

Mastering, Pressing, Tape Duplication, CD Services
PO Box 1308
Barrington, IL 60010
(312) 382-5295
Contact: Michael Freeman, Theodora Vosnos

CONCEPT PRODUCTIONS, INC.

Tape Duplication
7878 Big Sky Dr.
Madison, WI 53719
(608) 833-8273
Contact: C. Dan Geocariss

CREATIVE SOUND PRODUCTIONS, INC.

Tape Duplication
8383 Commerce Park Dr., #604
Houston, TX 77036
(713) 777-9975
Contact: Edward B. Smith
TAPE DUPLICATION
Duplicator: Otari DP-1010 master/bin loop 5 slaves, Infonics open reel master, 3 slaves.
Capacity: 4,600 per 8-hour shift.
Method of Duplication: In cassette, bin loop.
Mastering Equipment: Otari, Ampex.
Tape Used: Agfa 649/949, Agfa 619/819, Ampex 615/616.
Shell Used: IPS Premium, ICM Premium, Shape MK10.
Duplicating Speed: 16:1, 32:1.
Loading Equipment: Tapematic 2000, King automatics.
Packaging Equipment/Fulfillment Services: Compugraphic typesetting, shrinkwrap, custom labels and full-color case-liners, printing, custom vinyl albums, full graphic design.
Rates: Catalog available upon request.
Other Services: Video duplication and packaging, all formats, custom loaded blank cassettes, studio production and post-production facilities.

CUSTOM RECORDING STUDIOS

Tape Duplication
3829 Scott Ave. N.
Minneapolis, MN 55422
(612) 535-2587
Contact: Jim or LaVern Reynolds

DACE AUDIO
Mastering, Tape Duplication
Ann Arbor, MI
(313) 668-0002
Contact: David B. Anderson

DIGITAL AUDIO DISC CORPORATION

CD Services
1800 N. Fruitridge Ave.
Terre Haute, IN 47804
(812) 466-6821, ext.169
Contact: Michael Ellis

MASTERING

Console: Sony digital mixing console K-1105, -1106, -1107, DAE-1100 digital editor and DAQ-1000 PQ editor
Tape Machines: PCM-1630, DMR-4000 VTRs, DASH 3202, Mitsubishi X-80, Sony JH-110 1/4" and 1/2"
Monitor Speakers: Custom Kinoshita enclosures w/TAD components

Signal Processing: Sony DFX-2400 SFC, Studer SFC-16, Sony DAL-1000 limiter, Dolby A, dbx noise reduction

Rates: On request

COMPACT DISC

Preparation/Manufacturing: Complete compact disc mastering and replication, including PQ encoding; analog to digital conversions, digital to digital conversions, digital equalization and digital editing

DISCOVERY SYSTEMS

CD Services
7001 Discovery Blvd.
Dublin, OH 43017
(614) 761-2000
Contact: Ed Thompson

COMPACT DISC

Preparation/Manufacturing: (2) Sony DAE-1100 editing rooms w/DMR-4000s. P and Q insertion w/DAQ-1000. Sony, JVC, EIAJ format conversion. Sony DASH available (1988). Analog conversion (Studer 810 1/4", A80 1/2"). dbx 700, Sony F1 copies. Call for current rate

DISKMAKERS, INC.

Mastering, Pressing, Tape Duplication, CD Services
1812 N. Halsted St.
Chicago, IL 60614
(312) 642-8525
(800) 468-9353
Contact: Regional Sales Rep.

DOMAIN COMMUNICATIONS, INC.

Tape Duplication
289 Main Pl.
Carol Stream, IL 60188
(312) 668-5300
Contact: Jim Draper

ELECTRONIC ENGINEERING & SUPPLY CO.

EMIR RECORDS
Mastering, Pressing, Tape Duplication
712 North St.
Burlington, IA 52601
(319) 752-0381
Contact: R.E. Melford

FLASH INTERNATIONAL ENTERPRISES

Tape Duplication
PO Box 580058
Houston, TX 77258
(713) 996-8900
Contact: Renel "Flash" Boudreaux

G.O.D.T.E.L. PRODUCTIONS (GP STUDIOS)

Tape Duplication
PO Box 604
Nacogdoches, TX 75963
(409) 560-4282
Contact: Rick Smith

HIGH FIDELITY RECORDING

Tape Duplication
1059 Porter
Wichita, KS 67203
(316) 262-6456
Contact: Jim Strattan

INLAND SEA RECORDING

Tape Duplication
2117 E. 5th St.
Superior, WI 54880
(715) 398-3627
Contact: Dave Hill

C E N T R A L

TAPE TO DISC

DIRECTORY

INTERNATIONAL AUDIO, INC.

Tape Duplication
2934 Malmo Rd.
Arlington Heights, IL 60005
(312) 956-6030
(800) 448-TAPE
Contact: Margaret Googe

INTERNATIONAL CASSETTE CORP.

Tape Duplication
PO Box 1928
Greenville, TX 75401
(214) 454-9164
Contact: Ron Moyer
TAPE DUPLICATION
Duplicator: (9) Magnefax LB-72 mono, (2) Magnefax 7574 stereo
Capacity: 100,000 per day
Method of Duplication: Bin loop
Mastering Equipment: Technics, Ampex, Revox
Tape Used: Varies
Shell Used: Varies
Duplicating Speed: 16:1 stereo, 24:1 and 32:1 mono
Loading Equipment: (6) Tapematic 2000, (4) King 790
Packaging Equipment/Fulfillment Services: Full packaging available.
Rates: Extremely competitive
Other Services: Custom length video cassettes, professional video duplication

JEWEL RECORDING

Mastering, Pressing, Tape Duplication, CD Services
1594 Kinney Ave.
Cincinnati, OH 45231
(513) 522-9336
Contact: Linda York

JOR-DAN, INC.

Tape Duplication
1100 Wheaton Oaks Ct.
Wheaton, IL 60187
(312) 653-1919
Contact: Mark Granzow, Lynn Wallace

JORDAN SOUND PRODUCTIONS

Tape Duplication
200 Green Lane Trail
Whitehouse, TX 75791
(214) 839-6623
Contact: Gary Jordan

KAYRON, INC.

Tape Duplication
641 Madison St.
Oak Park, IL 60302
(312) 386-0464
Contact: Hal Kaitchuck

LARR COMPUTER CORP. OF DEL.

Mastering, Pressing, Tape Duplication, CD Services
KLARR Satellite Radio & TV Div.
Attn: Recording Studio Dept. PO Box 3842
Houston, TX 77253
Contact: Dr. Lawrence Herbst

THE LITTLE WAREHOUSE, INC.

Tape Duplication
4906 Van Epps Rd.
Brooklyn Heights, OH 44131
(216) 398-0022
Contact: Joe Kauffman
TAPE DUPLICATION
Duplicator: Telex 6120XLP CD Series, Magnefax TM81-FI, Magnefax LBC 82-TT, Magnefax LBC 82-QT.
Method of Duplication: In cassette, bin loop
Mastering Equipment: Studer Revox PR99, Otari MX-5050B, Ampex ATR-700, Tascam 35-2 and 3440
Tape Used: Agfa 619, 649, Magnetite, BASF Chrome.
Shell Used: Mag Media 5-screw, Shape Mark 10.
Duplicating Speed: 8:1, 16:1, 24:1.
Loading Equipment: (2) King 790s.
Packaging Equipment/Fulfillment Services: Shrinkwrap

Rates: Quote on request.
Other Services: In-house printing of labels and inserts. Full color foto-sert inserts. Video duplication: 1/4" and 1/2" VHS and Beta w/digital time base correction.

MAGNETIC STUDIOS, INC.

Tape Duplication
4784 N. High St.
Columbus, OH 43214
(614) 262-8607
Contact: John Fippin

MAJESTIC AUDIO DUPLICATION

Tape Duplication
1170 Lancaster Ave., Box 472
Reynoldsburg, OH 43068
(614) 861-6076
Contact: Mark Rentzel

MASTER PRODUCTIONS RECORDING STUDIO

Tape Duplication
407 S. Neb. St.
Weslaco, TX 78596
(512) 968-5777
Contact: Jose A. Leal

MEDIA INTERNATIONAL, INC.

Tape Duplication
247 E. Ontario St.
Chicago, IL 60611
(312) 467-5430
Contact: Duane Lundeen

MIDITRACS/DBA RANMEDIA, INC.

Mastering
3808 Beecham Ct.
Columbus, OH 43220
(614) 451-7955
Contact: Ron Naille

MIDWEST CUSTOM RECORD/TAPE

Pressing, Tape Duplication
PO Box 92
Arnold, MO 63010
(314) 464-3013
Contact: Lisa Weske, Rich Schaumberger

MOSES SOUND ENTERPRISES

Tape Duplication
RR 2, Box 548-A1
Catawissa, MO 63015
(314) 257-2345
Contact: Nelson

MUSICOL, INC.

Mastering, Pressing, Tape Duplication
780 Oakland Park Ave.
Columbus, OH 43224
(614) 267-3133
Contact: John W. Hull

THE MUSIK FAKTORY

Tape Duplication
1812 Procter St.
Port Arthur, TX 77640
(409) 982-7121
Contact: Floyd Badeaux

NIGHTINGALE-CONANT CORPORATION

Tape Duplication
7300 N. Lehigh Ave.
Chicago, IL 60648
(312) 647-0300
Contact: James E. Reising

NORWEST COMMUNICATIONS INC.

Tape Duplication
123 S. Hough St.
Barrington, IL 60010
(312) 381-3271
Contact: Mark Karney

OAKRIDGE MUSIC RECORDING SERVICE

Mastering, Tape Duplication
2001 Elton Rd.
Ft. Worth, TX 76117
(817) 838-8001
Contact: Homer Lee Sewell



OMEGA AUDIO & PRODUCTIONS, INC.
Dallas, TX

OMEGA AUDIO & PRODUCTIONS, INC.
Mastering, Tape Duplication, CD Services

8036 Aviation Pl.
Dallas, TX 75235
(214) 350-9066
Contact: Paul Christensen

MASTERING

Console: Harmonia Mundi Acoustica bw 102 4 x 2.
Tape Machines: Sony PCM-1630, DMR-4000, DMR-2000,
Mitsubishi X-80, Sony PCM-601.
Monitor Speakers: JBL 4435
Signal Processing: HMA bw 102 digital EQ, Amek analog EQ,
Aphex Compellor.
Engineers: Paul Christensen, David Buell, Philip Barrett.
Rates: Call.

Other Services: Digital editing with Sony 1100A editor, Digital
format conversion: 1610, 1630, X-80, X-86, PCM-F1, 501,
701, 601, 44.1kHz, 48kHz, digital audio-for-video, film.

TAPE DUPLICATION

Duplicator: Technics 20.
Capacity: 20 C-60/hr.
Method of Duplication: In cassette.
Mastering Equipment: Mitsubishi X-80, Sony PCM-F1.
Tape Used: BASF Chrome.
Duplicating Speed: 1:1 (real time only).
Rates: Call.

COMPACT DISC

Preparation/Manufacturing: Compact disc premastering, digi-
tal conversions, CD editing—see mastering info.

OPLAND RECORDING

Tape Duplication
Rte. 7, Box 403
Sioux Falls, SD 57103
(605) 335-5940
Contact: Ken Eckert

PETERS SOUND RECORDING SERVICE

Tape Duplication
240 E. 242nd St.
Euclid, OH 44123
(216) 731-4171
Contact: Michael G. Peters

PLAYTOWN SOUND PRODUCTIONS

Mastering, Tape Duplication
625 Connable
Petoskey, MI 49770
(616) 347-0063
Contact: Bob Bollinger

POLYCOM TELEPRODUCTIONS

Mastering, Tape Duplication
142 E. Ontario, 4th Floor
Chicago, IL 60611
(312) 337-6000
Contact: Carmen Trombetta

PRC TAPE COMPANY, INC.

Tape Duplication
1600 Rich Rd.
Richmond, IN 47374
(800) 443-2805

PRECISION AUDIO, INC.

Tape Duplication
18582 US 20
Bristol, IN 46507

(219) 295-7493

Contact: Larry Becker

TAPE DUPLICATION

Duplicator: Versadyne, Infonics, Telex.
Capacity: 20,000 wk.
Method of Duplication: In cassette, bin loop.
Mastering Equipment: Otari MTR-12 ILX.
Tape Used: Ampex, Agfa, BASF.
Shell Used: El Mar, Mag Media, Michelex.
Duplicating Speed: 32:1.
Loading Equipment: King 790.
Packaging Equipment/Fulfillment Services: ITI labeler.

PREMIER FILM VIDEO AND RECORDING CORP.

Mastering, Pressing, Tape Duplication
3033 Locust St.
St. Louis, MO 63103
(314) 531-3555
Contact: Grace Dalzell

PRESCO PRODUCTIONS

Mastering, Tape Duplication
4366 W. 66th St.
Cleveland, OH 44144
(216) 749-7244
Contact: John F. Presby Jr.

THE PRESSING PLANT

Pressing, Tape Duplication
2727 Irving Blvd.
Dallas, TX 75207
(214) 630-6401
Contact: Dewayne Elery

PRESSING

Presses: S.M.T. fully automatic.
Capacity: 7,200 albums daily, 8,400 singles daily.
Vinyl Used: Keycor audiophile virgin (colors in stock).
Other Services: Direct to board jackets, laser color seps.,
posters, shrinkwrap, mailouts, etc.

TAPE DUPLICATION

Duplicator: Min. order 500.
Capacity: 75-90 thousand per day (3 shifts).
Method of Duplication: Bin loop.
Mastering Equipment: Sony PCM-1610, Sony 701-ES, Otari
MTR-10, Electro-Sound 8000 Series.
Tape Used: Ampex, BASF, Capitol.

Duplicating Speed: 64:1.

Loading Equipment: King 760s.

Packaging Equipment/Fulfillment Services: Ampex printing

BUD PRESSNER MUSIC & RECORDING SERV.

Mastering, Pressing, Tape Duplication
4839 S. Broadway
Gary, IN 46409
(219) 884-5214
Contact: Bud Pressner

PRODUCERS TAPE SERVICE, INC.

Mastering, Tape Duplication
395 E. Elmwood Ave.
Troy, MI 48063
(313) 585-TAPE
Contact: "Rockin' Bill" Gutherie

PROGRAMMING TECHNOLOGIES, INC.

Mastering, Tape Duplication
6666 N. Lincoln Ave.
Lincolnwood, IL 60645
(312) 676-9400
(800) REC-ORDI
Contact: William P. Bennett



GET INTO THE MIX!

Let the industry know what's going on at your studio. Send press releases, news, photos, etc. to Mix Sessions Editor, 2608 Ninth Street, Berkeley, CA 94710.



THE CLOSER YOU LOOK THE BETTER WE SOUND

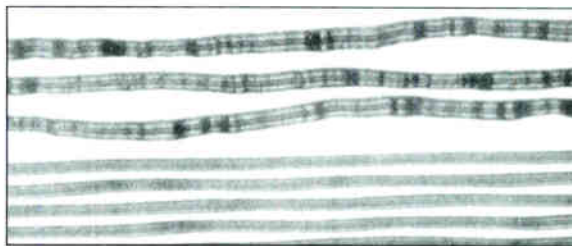

Magnified photo of record grooves

IN YOUR SEARCH FOR HIGH QUALITY RECORDS AND CASSETTES WE
ENCOURAGE YOU TO LOOK MORE CLOSELY AT QCA
YOU'LL LIKE WHAT YOU HEAR.



Manufacturer of high quality records and cassettes.

(513) 681-8400

2832 Spring Grove Avenue • Cincinnati, Ohio 45225

Circle #157 on Reader Service Card

**FROM ONE TAPE
LOVER TO ANOTHER
(313) 585-TAPE**

AMPEX
FORMERLY AEC

SHAPE

RAKS  **TDK** **SONY**

Scotch



SKC

3M

Geneva
FORMERLY FORTRONICS BRAND

MEMOREX

VHS



8 mm VIDEO CASSETTE

1 INCH RECORDING TAPE

**BEST PRICES
SAME DAY SHIPMENT IN MOST CASES**

**PRODUCERS
TAPE
SERVICE, INC.**
395 EAST ELMWOOD
TROY, MICHIGAN 48083
(313) 585-TAPE
(313) 585-8273

Circle #158 on Reader Service Card

ITI

**LABELING MACHINES
AUDIO/VIDEO/FLOPPY
DISKS**

PRESSURE-SENSITIVE LABELS

**Quality,
Performance
&
Service**

Investment Technology, Inc.
1940-124th Ave., N.E., A-107
Bellevue, WA 98005

Telephone (206) 641-8884
Telex 32-89561
BUS SER VUE
FAX (206) 454-4383

Circle #163 on Reader Service Card

C E N T R A L

TAPE TO DISC

DIRECTORY



QCA CUSTOM PRESSING, INC.
Cincinnati, OH

QCA CUSTOM PRESSING, INC.
Mastering, Pressing, Tape Duplication, CD Services
2832 Spring Grove Ave.
Cincinnati, OH 45225

(513) 681-8400
Contact: Dan Dorff, Amber Hines
MASTERING
Cutting Lathes: Neumann VMS66 w/Zurna disc computer
Console: Neumann.
Tape Machines: MCI JH-110M, Otari MTR-10
Monitor Speakers: UREI 811, Eastern Acoustics.
Signal Processing: Sontec parametric EQ, Aphex Compellor,
Aphex Dominator
Engineers: Don Kraft.
Rates: Call sales department.

PRESSING
Presses: (5) SMT automatic 12" presses, (2) SMT automatic
dual 7" presses.
Capacity: 15,000 LPs per day, 15,000 7" per day.
Vinyl Used: Keyser E 588.
Rates: Call sales department.
Other Services: Plating, typesetting, color separation, jacket
and sleeve printing, packaging, shrinkwrap.

TAPE DUPLICATION
Duplicator: Celec Gauss 2400 w/Dolby HX-Pro.
Capacity: 9,000 per day.
Method of Duplication: Bin loop.
Mastering Equipment: MCI JH-110, Neumann console, Otari
MTR-10 4LX.
Tape Used: Agfa 612 Magnetite
Shell Used: Michelex, Shape Mark 10
Duplicating Speed: 32:1, 64:1.
Loading Equipment: King 790.
Packaging Equipment/Fulfillment Services: Apex printing, 4
color insert, printing, packaging and wrap.
Rates: Call sales department.
COMPACT DISC
Preparation/Manufacturing: Q.C.A. handles complete manu-
facturing of CD from pre-mastering to final packaging

**RAINBOW RECORDING STUDIOS, INC./
RAINBOW PRODUCTIONS "OMAHA"**
Mastering, Tape Duplication
2322 S. 64th Ave.
Omaha, NE 68106
(402) 554-0123
Contact: Nils Anders Erickson

REALTIME
Tape Duplication
PO Box 412732
Kansas City, MO 64141
(816) 254-2585
Contact: Royal Scanlon

MASTERING
Console: Amek/TAC Scorpion.
Tape Machines: Tascam 52s, Sony 420-SLO, Panasonic 950.
Monitor Speakers: EAW MS-50s, Yamaha NS-10s, Auratone
Supersound cubes.
Signal Processing: UREI 1178, Lexicon PCM60, Sony PCM-
501.

Engineers: Royal Scanlon.
Rates: \$35 an hour.
Other Services: Basic sweetening.
TAPE DUPLICATION
Capacity: 1,000 C-45s a day.
Method of Duplication: Real time.
Mastering Equipment: 14- or 16-bit digital, U-matic, Beta,
VHS, 1/4" 2-track, 1/2-track or 1/4-track.
Tape Used: BASF Chrome.
Shell Used: Shape.
Duplicating Speed: Real time 1 7/8 ips.
Loading Equipment: King 790s
Packaging Equipment/Fulfillment Services: Shrinkwrapper,
labeler.
Other Services: Labels, J cards, can decode Dolby A and SR
and dbx Type One, can encode with Dolby B or C or dbx Type
II.

RICHARDSON TAPE

Tape Duplication
HC 71, Box 231
Mountain View, AR 72650
(501) 269-3908
Contact: Aubrey Richardson
TAPE DUPLICATION
Duplicator: (51) Nakamichi MR-2
Capacity: 700 C-30s per shift.
Method of Duplication: In cassette.
Mastering Equipment: Otari, Crown, Technics digital, DOD,
UREI, dbx, Aphex.
Tape Used: BASF Chrome, Ampex, Mag Media, Agfa.
Shell Used: Mag Media
Duplicating Speed: 1 7/8 ips real time.
Loading Equipment: King, Audico.
Packaging Equipment/Fulfillment Services: Complete label-
ing and shrinkwrap 1- to 4-color.
Rates: On request. We do small orders (under 1,000).
Other Services: Each cassette is checked for QC before
packaging. Demo copies with letter quality computer labels in
small quantities. Call for prices.

RMS RECORDING & ELECTRONICS

Tape Duplication
PO Box 1075
Ames, IA 50010
(515) 232-7464
Contact: Randall M. Slocum

RSVP, INC.

Tape Duplication
7701 N. Teutonia Ave.
Milwaukee, WI 53209
(414) 354-6400
Contact: Linda Radtke

SOLID SOUND INC.

Tape Duplication
PO Box 7611
Ann Arbor, MI 48107
(313) 662-0667
Contact: Rob Martens, Will Spencer



SONIC SCULPTURES
Cincinnati, OH

SONIC SCULPTURES
Mastering, Pressing, Tape Duplication
636 Northland Blvd.
Cincinnati, OH 45240
(513) 851-0055
Contact: Lan A. Ackley

SOUND IDEAS OF FORT WAYNE

Tape Duplication
6803 Saige Dr.
Fort Wayne, IN 46835
(219) 485-3628
Contact: Jack Flanagan

SOUND IMPRESSIONS, INC.

Tape Duplication
110 River Rd.
Des Plaines, IL 60016
(312) 297-4360
Contact: Bill Holtane

SOUND RECORDERS, INC.

Tape Duplication
4031 Guadalupe
Austin, TX 78751
(512) 454-8324
Contact: Miles Muller, Tim Doot
TAPE DUPLICATION
Duplicator: Electro-Sound 8000, Magnetax
Capacity: Thousands per day.
Method of Duplication: Bin loop.
Mastering Equipment: Studer.
Tape Used: Agfa, Ampex and others.
Shell Used: Various
Duplicating Speed: 64 1, 32:1.
Loading Equipment: King and Tapernatic. All fully automatic.
Packaging Equipment/Fulfillment Services: In-house printing, packaging and shrinkwrapping.
Rates: Nationally competitive.
Other Services: A lot of extra care and quality.

SOUND RECORDERS INC.

Mastering, Tape Duplication, CD Services
206 S. 44th St.
Omaha, NE 68131
(402) 553-1164
Contact: Clete Baker

SOUND RECORDERS, INC.

Mastering, Tape Duplication, CD Services
3947 Stalene Rd.
Kansas City, MO 64111
(816) 931-8642
Contact: Ron Dabbs

SOUND TRAX+

Mastering, Tape Duplication, CD Services
1000 W. 17th St.
Bloomington, IN 47401
(812) 332-7475

THE SOUNDMAKERS

Pressing, Tape Duplication
1000 E. 80th Pl.
Merrillville, IN 46410
(219) 769-1515
Contact: Dick Hutter

STAGE III SOUND PRODUCTIONS

Mastering, Tape Duplication
1901 W. 43rd St.
Kansas City, KS 66103
(913) 384-9111

STUCKY AUDIO SERVICE

Tape Duplication
1412 W. 5th St.
Newton, KS 67114
(316) 283-7597
Contact: Homer Stucky

STUDIO ONE

Tape Duplication
8535 Selendine
San Antonio, TX 78239
(512) 650-0442
Contact: Tim Gressler

THE STUDIO—32 TRACK

Mastering, CD Services
8431 Lydia
Kansas City, MO 64131
(816) 523-8199
Contact: Evan Smalley

SUMA RECORDING STUDIO

Mastering, Pressing, Tape Duplication, CD Services
5706 Vrooman Rd.
Painesville, OH 44077
(216) 951-3955
(216) 352-9802
Contact: Michael Bishop

SUNSET STUDIO

Tape Duplication
117 W. 8th
Hays, KS 67601
(913) 625-9634
Contact: Mark Meckel

SUTTMAN PRODUCTIONS

Tape Duplication
PO Box 72
Dayton, OH 45409
(513) 278-4601
Contact: Eric J. Suttman

TAKE 1 STUDIOS

4900 Euclid Ave.
Cleveland, OH 44103
(216) 431-1444
Contact: Jeff Kassouf

TECHNISONIC STUDIOS

Tape Duplication
1201 S. Brentwood Blvd.
St. Louis, MO 63117
(314) 727-1055
Contact: Linda Schumacher

3G'S INDUSTRIES INC.

Tape Duplication
6016 Troost
Kansas City, MO 64110
(816) 361-8455
Contact: Eugene Gold

TIN MAN ENTERPRISES

Tape Duplication
2800 Yellow Brick Rd.
St. Louis, MO 63129
(314) 487-3735

VIDEO I-D, INC.

Mastering
105 Muller Rd.
Washington, IL 61571
(309) 444-4323
Contact: Sam B. Wagner

WESTMARK PRODUCTIONS

Tape Duplication
8345 Duluth St.
Golden Valley, MN 55427
(612) 544-3050
Contact: DuWayne or Joann Kloos

WORLD CLASS TAPES

PO Box 7611
Ann Arbor, MI 48107
(313) 662-0669
Contact: Sherry Prindle

COMING SOON:

**The Mix Annual Directory of
Recording Industry Facilities
& Services! See page 140 for
complete details.**

**Professional
SOUND recording
& duplicating
SUPPLIES**

POLYLINE

- Blank-loaded audio cassettes
- Empty reels and boxes
- Audio cassette boxes and albums

AUDIO TAPE and CASSETTES from

- Agfa • FUJI
- Ampex • Maxell
- 3M • TDK
- BASF

POST-PRODUCTION and MAINTENANCE SUPPLIES

ASK FOR OUR FREE CATALOG

SHIPPED FROM STOCK WITHIN 24 HOURS under normal circumstances

**Call Polyline
312 / 298-5300
8:30 am - 5 pm Central Time**

Polyline Corp.
1233 Rand Road
Des Plaines, IL 60016

Circle #159 on Reader Service Card

WESTERN

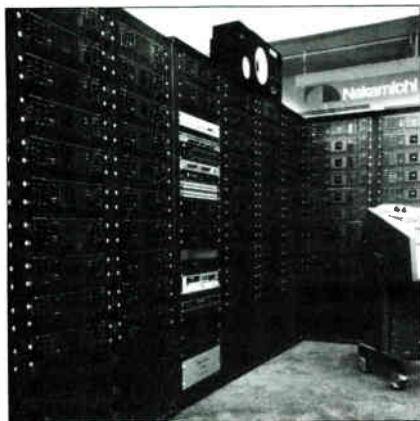

AAPEX TAPE DUPLICATION
Santa Rosa, CA

AAPEX TAPE DUPLICATION

Tape Duplication
350 E. Todd Rd., Ste. A
Santa Rosa, CA 95407
(707) 585-1132
(800) 323-AAPX (outside CA)
(800) 327-AAPX (in Northern CA)
Contact: Theresa Stoops
TAPE DUPLICATION
Duplicator: (103) Nakamichi MR-2B (real time)
Capacity: 1,000-1,500 per day
Method of Duplication: In cassette
Mastering Equipment: Otari MTR-12 2-track (7 1/2, 15 or 30 ips), Sony PCM 501ES digital processor, Sony Super Beta VCF
Tape Used: Mastering Agfa 469, duplication Agfa 649611 normal and BASF chrome
Shell Used: ICM and Shape (upon request)
Duplicating Speed: 1:1 (real time only)
Packaging Equipment/Fulfillment Services: X-Rite shrinkwrap machine and Auto-Labe automatic labeler
Rates: Rates upon request, please call
Other Services: Sonic enhancement, analog-to-digital mastering, full graphic design and printing services offered, full mixing, mastering and recording at our 24-track recording studio, Banquet Sound Studios



AARDVARK RECORDS
Denver, CO

AARDVARK RECORDS

Mastering
4144 Zenobia St.
Denver, CO 80212
(303) 477-2273
(303) IPS-AARD
Contact: Paul Brekus

ABBEY TAPE DUPLICATORS, INC.

Tape Duplication
9525 Vassar Ave.
Chatsworth, CA 91311

W E S T E R N

TAPE TO DISC

DIRECTORY

(818) 882-5210 (in CA)
(800) FIN-ETAP
Contact: Norman Cooke
TAPE DUPLICATION
Duplicator: Dubblings (bin-loop), KABA (real time)
Capacity: 5,000/day
Method of Duplication: In cassette bin loop
Mastering Equipment: MCI, Ampex, Technics, Sony, Yamaha digital reverb
Tape Used: BASF-LHD, BASF chrome
Shell Used: 5-screw white, black or clear, Shape MK10
Duplicating Speed: 36 ips and real time
Loading Equipment: King 790s
Packaging Equipment/Fulfillment Services: ITI labeler shrinkwrapping, albums, individual mailings
Other Services: Complete narration studio and audio production facilities Editing, sequencing, equalizing, mixing Video duplicating

ADVANCE RECORDING PRODUCTS

Tape Duplication
7190 Clairemont Mesa Blvd.
San Diego, CA 92111
(619) 277-2540
(800) 854-1061 (in CA)
Contact: Joyce Wozniak

AMERICAN AUDIO VISUAL CORP.

484 Lighthouse Ave.
Monterey, CA 93940
(408) 373-2125
Contact: Dan Diedrickson

AMERICAN MOTION PICTURES - AUDIO SERVICES

Tape Duplication
7023 15th Ave. NW
Seattle, WA 98117
(206) 789-TAPE
Contact: Ella Bachmann

AMERICAN RECORDER TECHNOLOGIES, INC.

Tape Duplication
4505-2H Industrial St.
Simi Valley, CA 93063
(805) 527-9580
Contact: Alan Adelstein

ARCHON CASSETTE DUPLICATION CO.

Tape Duplication
1831 1/2 Pearl St.
Boulder, CO 80302
(303) 444-5035
Contact: John Arcotta

ARTISAN SOUND RECORDERS

Mastering, CD Services
1600 N. Wilcox Ave.
Hollywood, CA 90028
(213) 461-2751
Contact: Gregory Fulginiti

ARTIST SOUND

Tape Duplication
12311 NE Glisan, #254
Portland, OR 97230
(503) 254-9742

TAPE DUPLICATION

Duplicator: Nakamichi
Capacity: 500/shift
Method of Duplication: In cassette.
Mastering Equipment: Panasonic NV 8200 (VHS), Sony SLO-383, Sony HF-900, Sony HF-500 (Beta), Fostex 20, Pioneer
Tape Used: BASF chrome international Type II reference standard
Shell Used: Shape Mark 10
Duplicating Speed: 1:1
Packaging Equipment/Fulfillment Services: Shrinkwrap, labels, J-cards
Rates: Example C-45 w/tape, box and labor = \$1.75 (from analog)
Other Services: Digital mastering, digital editing (Beta format), remastering, recording and editing services available



AT&T RECORDING/DUPLICATING
Los Angeles, CA

AT&T RECORDING/DUPLICATING

Tape Duplication
501 N. Larchmont Blvd.
Los Angeles, CA 90004
(213) 466-7756
Contact: Lesley Cohen
TAPE DUPLICATION
Duplicator: Ampex (hi-speed), KABA (real time)
Capacity: 1-25,000 (1/4" or cassette)
Mastering Equipment: Studer, Audiotronics, Dynaflex, dbx, etc
Tape Used: Full line of Agfa or BASF
Shell Used: Shape, Data-Pac, Mag-Media
Duplicating Speed: 1:1, 2:1, 8:1, 16:1
Loading Equipment: King
Packaging Equipment/Fulfillment Services: Label printing, application, shrinkwrap
Rates: Vary with quantity, call for quote.
Other Services: 3/4", VHS, Beta video dubs, 8-track recording studio

AUDIO CASSETTE DUPLICATOR CO.

Tape Duplication
12426 1/2 Ventura Blvd.
Studio City, CA 91604
(818) 762-ACDC
Contact: Steve Katz, Steve Mitchell

AUDIO RECORDERS

Tape Duplication
3843 Richmond
San Diego, CA 92103
(619) 296-6355
Contact: John Mullen

AWARD RECORD MFG.

Mastering, Pressing, Tape Duplication
5200 W. 83rd St.
Los Angeles, CA 90045
(213) 645-2281

B&G RECORDING

Mastering, Tape Duplication
5341 W. Banff Ln.
Glendale, AZ 85306
(602) 938-2189
Contact: Bernard or Gordon

BAMCO RECORDS

Pressing
1400 S. Citrus Ave.
Fullerton, CA 92633
(714) 738-4257
Contact: George Baker

BATISH RECORDING ENT.

Tape Duplication
1310 Mission St.
Santa Cruz, CA 95060
(408) 423-1699
Contact: Ashwin or Ravi Batish

BAUER AUDIO

Tape Duplication
10735 Burbank Blvd.
North Hollywood, CA 91601
(818) 763-8606
TAPE DUPLICATION



BAUER AUDIO
North Hollywood, CA

Other Services: Short runs requiring fast turnaround and audiophile quality are our specialty, utilizing state-of-the-art duplication and mastering equipment custom modified by Deane Jensen and Steve Hogan. Personalized service is emphasized to match your requirements to our variety of tapes, C-zeros, packaging, in-cassette or out-of-cassette duplication processes. Complete project management available including location recording.

THE BURBANK SOUND DEPARTMENT

Tape Duplication
3917 Riverside Dr., #9128
Burbank, CA 91505
(818) 848-1004
Contact: Phil A. Yeend

CALIFORNIA MAGNETICS
(FORMERLY DON'S CASSETTES)

7898 Ostrow St., #1
San Diego, CA 92111
(619) 576-0291
Contact: Don Nuzzo

CAPITAL COMMUNICATIONS INDUSTRIES, INC.

Tape Duplication
PO Box 481
Olympia, WA 98507
(206) 943-5378
(800) 426-8664 (in WA)
Contact: Jerry Lamb



CAPITOL RECORDS STUDIOS
Hollywood, CA

CAPITOL RECORDS STUDIOS

Mastering, CD Services
1750 N. Vine St.
Hollywood, CA 90028
(213) 462-6252
Contact: Barbara Hein

MASTERING

Cutting Lathes: (2) Neumann SAL74B w/Zuma computer. Console: Neve console w/Sontec. Neve and NTP computerized equalization.
Tape Machines: Studer A-80 2-track (1/4" and 1/2"). Sony and JVC digital mastering.

Monitor Speakers: JBL custom, Yamaha and Auratone.

Signal Processing: Eight live chambers, digital echo.

Engineers: Wally Traugott, Eddy Schreyer.

Credits: The Beatles, Richard Marx, Lee Ritenour, Jufio Iglesias, The Whispers, Diane Schurr, Kenny Rogers, Juice Newton, Shalamar, The Bangles, Bob Seger, Steve Miller, Crowded House, Dwight Yoakam, Poison, Stryper, David Bowie, Pet Shop Boys and many, many more.

Rates: Call for rates

TAPE DUPLICATION

Other Services: Call for tape duplication info.

COMPACT DISC

Preparation/Manufacturing: CD preparation: analog to digital mastering. Format conversion of all types. JVC to Sony mastering. Digital mastering engineers: Tom Ketterer, Nick Dofflemyer, Bob Norberg and Larry Walsh. Call for prices for preparation and manufacturing.

CASSETTE PRODUCTIONS UNLIMITED

Tape Duplication
5796 Martin Rd.
Irwindale, CA 91706
(818) 969-6881
Contact: Layne Scharton

CASSETTE TECHNOLOGIES

Tape Duplication
34310 9th Ave. S.
Campus Park, Ste. 107
Federal Way, WA 98003
(206) 874-2185
(206) 952-5055
Contact: Dean K Hart

CASSETTE WORKS

Tape Duplication
12 S. Raymond Ave.
Pasadena, CA 91105
(818) 796-1895
(800) 423-TAPE
Contact: Lauranda McKinney

CHAMPAIGN SOUND

PO Box 7003
San Jose, CA 95150
(408) 252-4536
Contact: Ted Champaign

CHIDVILAS FOUNDATION, INC.

Tape Duplication
PO Box 1510
Boulder, CO 80306
(303) 665-6611
Contact: Peter Hill

CHRISTIAN AUDIO TAPES

Tape Duplication
3005 W. Glendale Ave.
Phoenix, AZ 85051
(602) 246-4976
Contact: Rita Hauke

CIRCUIT RESEARCH LABS INC.

Mastering, Pressing, Tape Duplication
2522 W. Geneva Dr.
Tempe, AZ 85282
(800) 535-7648
Contact: Ray Updike

CLEAR LAKE AUDIO

CD Services
10520 Burbank Blvd.
North Hollywood, CA 91601
(818) 762-0707
Contact: Brian Levi, Jim Katsikides, Cathy Wyatt

COMMAND PRODUCTIONS

Tape Duplication
PO Box 2824
San Francisco, CA 94126
(415) 332-3161
Contact: Warren Weagant

RE COPSEY RECORDING

Tape Duplication
2021 Buena Vista Dr.
Camarillo, CA 93010
(805) 484-2415
Contact: Reese Copsy

COVENANT RECORDINGS INC.

Mastering, Tape Duplication
1345 S. Major St.
Salt Lake City, UT 84115
(801) 487-1096
Contact: Paul Lee

CREATIVE ARTS RECORDING CO.

Tape Duplication
2933 W. 23rd Ave.
Denver, CO 80211
(303) 455-2326
Contact: Roger Praevner
TAPE DUPLICATION
Duplicator: Nakamichi MR-2 43 (real time).
Method of Duplication: In cassette
Mastering Equipment: Nakamichi DMP-100 digital and MCI JH-110B 2-track 1/4" and 1/2".
Tape Used: Ampex, Agfa Magnetic.
Shell Used: Sharp, ICM.
Duplicating Speed: Real time.
Loading Equipment: King 760.
Rates: Call.

THE CREATIVE WORD

Tape Duplication
17885 B-2 Sky Park
Irvine, CA 92714
(714) 261-8273
Contact: Bryan Hill

DAVKORE CO.

Tape Duplication
1300-D Space Park Way
Mountain View, CA 94043
(415) 969-3030
Contact: Ray Kaiser
TAPE DUPLICATION
Duplicator: Electro-Sound, Magnetax, Sony
Capacity: 4,000/shift
Method of Duplication: In cassette, bin loop.
Mastering Equipment: MCI, Revox, Nakamichi
Tape Used: BASF, Agfa, Ampex
Shell Used: QCI, Shape.
Duplicating Speed: 32:1, 24:1
Loading Equipment: King 790.
Packaging Equipment/Fulfillment Services: Full service
Rates: Call for quote.
Other Services: Complete large run video duplication services.

DETROIT SOUND STUDIOS—MASTERING DIV.

Mastering, Pressing, Tape Duplication
PO Box 43609
Los Angeles, CA 90043
(213) 299-5002
Contact: F.H. Jackson

DIACOUSTIC LABORATORY

Mastering
22923 De Kalb Dr.
Calabasas, CA 91302
(818) 888-8010
Contact: Mickey Knight

DIGIPREP

CD Services
1425 N. Cole Pl.
Hollywood, CA 90028
(213) 461-1709
Contact: Warren Salyer, Dan Hersch

DIGITAL BROTHERS

Mastering, Tape Duplication, CD Services
1731 Bonaire Way
Newport Beach, CA 92660
(714) 645-9702
Contact: Ben

DIGITAL INTELLIGENCE SYSTEMS CORPORATION

Mastering, CD Services
2865 Pullman St.
Santa Ana, CA 92705
(714) 261-5654
Contact: Bill Cara
MASTERING
Cutting Lathes: D.I.S.C. CDM-1 compact disc laser mastering system.
Rates: Call.
Other Services: CD reference disc (one off's).
COMPACT DISC
Preparation/Manufacturing: Mastering & CD reference discs, CD mastering systems, stamper analyzer and CD analyzer for CD production quality control.

DUNCAN STREET STUDIOS

Tape Duplication
240 Duncan St.
San Francisco, CA 94131
(415) 285-9093
Contact: John Blakeley

THE DUPLICATOR

Tape Duplication
1404 Franklin St., #410
Oakland, CA 94612
(415) 547-1005
Contact: Glenn Davidson

ECHO RECORDING CO.

Tape Duplication
19 Bel Air Dr.
Orinda, CA 94563
(415) 254-2995
Contact: David or Maria Mears

EL MAR PLASTICS, INC.

821 E. Artesia Blvd.
Carson, CA 90746
(213) 327-3180
Contact: Maxine Hesse

EMI AMERICA RECORDS

Mastering
6920 Sunset Blvd.
Hollywood, CA 90028
(213) 461-9141 ext.307
Contact: Tina Hopkinson
MASTERING
Cutting Lathes: Scully Westrex lathe w/Capps computer
Console: Custom EMI Abbey Road mastering console
Tape Machines: Sony PCM-1630, DMR-4000 2-track digital w/Harmonia Mundi BW102 preview, Sony MCI JH-110M 2-track mastering, ATR 102
Monitor Speakers: Altec 604E w/Mastering Lab crossovers, Yamaha NS-10M, Augspurger room design
Signal Processing: Cybersonics HFL-2 and Westrex hi-frequency limiters
Engineers: Ron McMaster
Credits: Sheena Easton, Kenny Rogers, Peter Wolf, Talk Talk, Kajagoogoo, Stray Cats, George Thorogood, David Bowie, complete Blue Note catalog, Pet Shop Boys, Kate Bush
Rates: 12" lacquer, \$110, 7" lacquers, \$50, EQ and rundown, \$85/hr Other rates available upon request
Other Services: Simultaneous EQ tape copies, 1/4" or 1/2"; 15 ips or 30 ips, 2-track

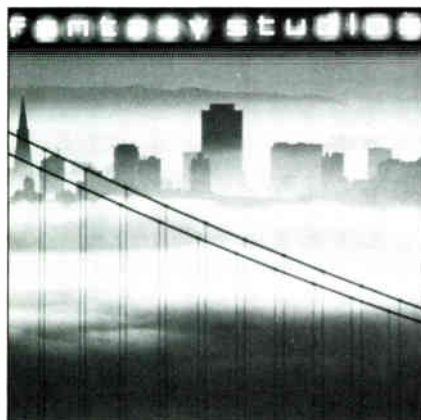

FANTASY STUDIOS MASTERING
Berkeley, CA

FANTASY STUDIOS MASTERING

Mastering, CD Services
10th & Parker Streets
Berkeley, CA 94710
(415) 549-2500
Contact: George Horn
MASTERING
Cutting Lathes: Neumann mastering system utilizing the Zuma Audio computer
Console: Sphere console
Tape Machines: Studer 1/4" and 1/2" tape machines, Mitsubishi X-80 2-track recorder
Signal Processing: Sontec
Engineers: George Horn, Phil De Lancia
Rates: Call for rates
Other Services: Mastering from Mitsubishi X-80 digital and

W E S T E R N**TAPE TO DISC****DIRECTORY**

from Sony 1630 digital Preparation of digital masters for compact disc manufacturing. Editing and equalization mastering from F1 format

FASTRAX, INC.
Tape Duplication
4033 Aurora Ave. N.
Seattle, WA 98103
(206) 632-8300
Contact: Candace Williams

FASTTRACK RECORDING STUDIO

Tape Duplication
4220 Broadway
Denver, CO 80216
(303) 292-2115
Contact: Wayne K. Gerbrandt

52ND STREET
Tape Duplication
1741 N. Ivar
Hollywoodwood, CA 90028
(213) 463-5252
Contact: Stu Yahm

FULLER SOUND/AV RECORDING

Tape Duplication
PO Box 65057
Los Angeles, CA 90039
(213) 660-4914
Contact: Mike Fuller



FUTURE DISC SYSTEMS
Hollywood, CA

FUTURE DISC SYSTEMS

Mastering, CD Services
3475 Cahuenga Blvd. W.
Hollywood, CA 90068
(213) 876-8733
Contact: Gary Rice, Kim Llorente
MASTERING
Cutting Lathes: Custom Ortofon and Neumann cutting systems.
Console: Automated mastering console, Sony digital editing system.
Tape Machines: Ampex, Studer, Mitsubishi, Sony
Monitor Speakers: Custom
Signal Processing: Sontec
Engineers: Steve Hall, Tom Baker
Credits: Madonna, Jermaine Jackson, Peter Cetera, Rod Stewart, The Jets, Quiet Riot.
Rates: Upon request.
Other Services: Complete analog and digital mastering services including digital editing for compact disc and cassette manufacturing.

THE GARAGE AUDIO AND VIDEO

Mastering, Tape Duplication
West Covina, CA
(818) 337-7943
Contact: Patrick Woertnik

GOLDEN TEMPLE ENTERPRISES

Tape Duplication
1605 S. Robertson Blvd.
Los Angeles, CA 90035
(213) 282-9974

GRABACIONES BAJA CALIFORNIA

Mastering, Tape Duplication
PO Box 1123
Calexico, CA 92231
1-(70)65-573479
Contact: Manuel Hurtado

BERNIE GRUNDMAN MASTERING

Mastering
6054 Sunset
Hollywood, CA 90028
(213) 465-6264
Contact: Lisa Smith, Denise Porter
MASTERING
Cutting Lathes: Scully Compudisc
Console: Custom designed
Tape Machines: Studer A80 mastering decks, ATR-102, Yamaha K2000, Mitsubishi X-86
Monitor Speakers: Tannoy custom.
Signal Processing: EMT plate, dbx compressors and de-essers, Harmonia Mundi.
Engineers: Bernie Grundman, Brian Gardner, Chris Bellman
Credits: Michael Jackson, Lionel Richie, Herb Alpert, Janet Jackson, Prince, George Harrison.
Rates: On request
Other Services: Complete preparation services for compact disc, from any digital source.

W.E. HARROD

Tape Duplication
9537 Cody Way
Stockton, CA 95209
(209) 951-6235
Contact: Willis E. Harrod

HAUKE LABS

Mastering
1825 E. Whitton Ave.
Phoenix, AZ 85016
(602) 266-8196
Contact: Chuck Hauke

HOERNER AUDIO PRODUCTIONS

Tape Duplication
PO Box 27090
Seattle, WA 98125
(206) 362-2611
Contact: Clint Hoerner
TAPE DUPLICATION
Duplicator: Otari DP-4050 C2 and Z3 Expanders
Capacity: 11 per pass, 800 C-90s per day, 4,000 C-90s per week
Method of Duplication: In cassette
Mastering Equipment: Tascam 58 40-4,32, 122 cassette w/Dolby or dbx, 520 mixer
Tape Used: Music quality: TDK ZD, Agfa 812, BASF, CSI; voice quality: CSI
Shell Used: TDK standard, custom mil-spec, Mark 10, Mag Media
Duplicating Speed: 15 ips, both sides in stereo at same time.
Packaging Equipment/Fulfillment Services: Shrinkwrap, inserts, custom labels and package
Rates: Vary with brand, quantity and length
Other Services: Audio mixdown and sweetening, VHS or Beta video duplication, audio and video recording studio, on location recording A/V, special effects equipment

HOLLYWOOD VAULTS, INC.

Mastering, Tape Duplication
742 N. Seward St.
Hollywood, CA 90038
(213) 461-6464
Contact: David Wexler

INTERSOUND INC.

Mastering, Tape Duplication
8746 Sunset Blvd.
Los Angeles, CA 90069
(213) 652-3741
Contact: Ahmed Agrama, Kent Harrison Hayes

JACKSON SOUND PRODUCTIONS LTD.

Tape Duplication
3897 S. Jason St.
Englewood, CO 80110
(303) 761-7940
Contact: Joe Jackson

JESTER SOUND & VIDEO

Tape Duplication
423 Kuhlman Dr.
Billings, MT 59105
(406) 248-5896
Contact: Bob Hale



KABA AUDIO
Novato, CA

KABA AUDIO
(FORMERLY KENNETH A. BACON ASSOCIATES)

Tape Duplication
24 Commercial Blvd., Ste. E
Novato, CA 94949

(415) 883-5041
(800) 231-TAPE (outside CA)
Contact: George Rosenfeld

TAPE DUPLICATION

Duplicator: 100-position, KABA 4-track real time system, KABA RTDS-4TM, KABA RTDS-4TS, Otari OM/C2/Z3 (5-slave), Alpha 2000M and Alpha 2000S (5 slave), bin system 16x/32x (5 slave)

Capacity: 2,000 real time and 2,000 high-speed per 8-hour shift (C-45).

Method of Duplication: In cassette, bin loop

Mastering Equipment: Otari MTR-12-I w/HxPro, Otari MX-5050 2 1/2" 2-track, 1/2" 4-track, Otari 1/2" 8-track, Nakamichi and Technics PCM.

Tape Used: BASF, Scotch, Sunkyong, Agfa, Ampex.

Shell Used: Elmar, Shape, Lenco, Filam, Quality, Sunkyong, Michelex.

Duplicating Speed: 1:1, 2:1, 8:1, 16:1, 32:1

Loading Equipment: TTL Model 515, Kronos-4.

Packaging Equipment/Fulfillment Services: ITI L-1B labeler,

Pack-all, shrinkwrap, Apex print-on-cassette

Rates: Call for catalog.

Other Services: Sales or lease of turnkey real time and high speed bin duplication systems featuring products of KABA, Otari, AEG, Lyric, Apex, Aphex, Tapex and Pack-all. Ampex, Agfa and Scotch mastering tape, complete cassette graphics and packaging, including books-on cassette packaging, custom labels and box liners, binders, fulfillment, 8-track recording studio, narration, location recording, pro equipment sales and service, editing supplies.

KDISC

Mastering, Pressing
26000 Springbrook Rd.
Saugus, CA 91350
(805) 259-2360
(818) 365-3991

Contact: Sharon Summerfield

KDISC MASTERING STUDIOS

Mastering, CD Services
6550 Sunset Blvd.
Hollywood, CA 90028
(213) 466-1323

Contact: Julie Gach

MASTERING

Cutting Lathes: Neumann.

Console: Custom consoles.

Tape Machines: Studer, Ampex.

Monitor Speakers: JBL custom, Cetec Gauss, Yamaha NS-10M.

Signal Processing: Sontec, API, Neve, Dolby, dbx
Engineers: John Golden, Ken Perry, Carol Hibbs, Bill Lightner
Credits: Peter Gabriel, Suzie & The Banshees, Billy & The Beaters, Wishful Thinking

Rates: Call for rates

COMPACT DISC

Preparation/Manufacturing: Sony PCM-1610 and 1630 mastering, editing, digital copies, compact disc prep

KM RECORDS, INC.

Mastering, Pressing
2980 N. Ontario St.
Burbank, CA 91504
(818) 841-3400
Contact: Jim Auchterlonie, Bill Riley

MASTERING

Cutting Lathes: VMS-70, SX-74, SAL 74-B

Console: Neumann SP78

Tape Machines: MCI JH-110 modified

Monitor Speakers: Custom, Yamaha NS-10

Signal Processing: EMT 140, API and other EQs

Engineers: Michele Stone, Jeff Sanders

Rates: Upon request

PRESSING

Presses: Toolex-Alpha Lened

Capacity: 15,000 per day

Vinyl Used: KC-569

Rates: Upon request

Other Services: In-house metal processing, printing of labels, jacket covers and liners, jacket fabrication, direct board printing cassette

LANE AUDIO & RECORDS (SONIC RESTORATIONS ONLY)

Mastering
Box 29171
Los Angeles, CA 90029
(213) 469-8007
Contact: Michael Lane

JAMES G. LEE RECORD PROCESSING

145 W. 154th St.
Gardena, CA 90248
(213) 321-2187
Contact: Edward Tobin, Jr

CASSETTE DUPLICATION SERVICE

24 HOUR TURNAROUND AVAILABLE



**So Simple
So Exact
So Affordable**

We specialize in short runs (1 to 1,000)

SUPERB SOUND REPRODUCTION
Our technicians are a unique blend of musicians and engineers who can deliver the sound that you demand. Each cassette is individually tested; each machine is calibrated daily.

TROUBLE-FREE OPERATION
Bauer Audio loads all their own cassettes with the most advanced equipment in the industry. You're assured jam free operation with low distortion and wide dynamic range.

PERSONALIZED SERVICE
Bauer Audio has a complete mastering facility to meet your individual needs. We can add special audio effects or improve old, noisy masters. Call Jim Bauer directly for any questions you may have on cassette recording or duplication techniques.

FAST, ON TIME DELIVERY AT COMPETITIVE PRICES
Bauer Audio delivers! Our reputation for on time delivery at realistic prices is unmatched in the industry. Contact us for our complete price schedule and **FREE SAMPLE TAPE.**

BAUER AUDIO

10735 BURBANK BOULEVARD
NORTH HOLLYWOOD, CALIFORNIA 91601
(818) 763-8606

HOURS: 9-5 MONDAY thru Friday Visitors, pickups and deliveries by appointment only.

BAUER AUDIO CAN DO IT ALL FOR YOU

REQUEST COMPLETE PRICE LIST AND DETAILS ON ALL OUR SERVICES.

CASSETTE DUPLICATION SAMPLE PRICE SCHEDULE

	5	12	30	60	100	250	500	1000	5000
REAL TIME (HIGH BIAS CHROME TYPE II)									
C-10	4.64	2.14	1.67	1.23	1.03	.98	.91	.86	.84
C-20	4.86	2.25	1.79	1.36	1.16	1.11	1.06	1.01	.96
C-30	5.15	2.35	1.94	1.51	1.31	1.26	1.21	1.16	1.11
C-40	5.30	2.45	2.14	1.71	1.51	1.46	1.41	1.36	1.31
C-50	5.66	2.70	2.33	1.90	1.70	1.65	1.60	1.55	1.50
C-60	5.95	3.02	2.54	2.11	1.91	1.86	1.81	1.76	1.71
C-70	6.71	3.70	2.79	2.36	2.16	2.11	2.06	2.01	1.96
C-80	6.93	3.90	2.99	2.56	2.36	2.31	2.26	2.21	2.16
C-90	7.15	4.12	3.22	2.79	2.59	2.54	2.49	2.44	2.39
SERMON CASSETTE SPECIAL (NORMAL BIAS TYPE 1)									
C-60	2.50	1.37	1.04	.89	.74	.68	.68	.67	.65
C-90	3.00	1.58	1.25	1.14	1.01	.86	.86	.83	.71

ONE STOP SERVICE

Bauer Audio offers a complete range of services:

- LABELS
- BOXES
- BOX INSERTS
- SHRINK WRAP

Give us a call—we'll handle it all for you. We are experienced and we care.

Too busy. Put us to your test. Satisfaction guaranteed.

Prices subject to change without notice or obligation.

Circle #160 on Reader Service Card

TERRY LESSIG SOUND**Tape Duplication**

1626 N. 7th St.
Phoenix, AZ 85006
(602) 255-0155

Contact: Terry W Lessig

TAPE DUPLICATION

Duplicator: Magnefax LB-72 bin loop mono, (25) Nakamichi MR-2 stereo.

Capacity: 2,500/day high-speed mono, 500/day real time.

Method of Duplication: In cassette, bin loop

Mastering Equipment: Otari MTR-10 w/HX-Pro.

Tape Used: BASF Chrome, LHD, LNS

Shell Used: Shape Mark 10, ips.

Duplicating Speed: 24:1 mono, real time stereo

Loading Equipment: TTL 515-B

Packaging Equipment/Fulfillment Services: Shrinkwrap, labels and inserts from camera-ready art

Rates: Call for quote

Other Services: Real time 1/4" tape duplication (2-track stereo) for broadcast syndication of spots or programs

LEW'S RECORDING PLACE**Tape Duplication**

1219 Westlake N., #115
Seattle, WA 98109
(206) 285-7550

Contact: Lew Lathrop

LISTEN TO LEARN TAPE LIBRARY**Mastering, Tape Duplication**

PO Box 47155
Phoenix, AZ 85068

(602) 266-TAPE

(800) 537-TAPE (outside AZ)

Contact: Michael Mathews

LOCATION RECORDING SERVICE INC**Mastering**

2201 W. Burbank Blvd.
Burbank, CA 91506

(213) 849-1321

Contact: Muriel Baker

MASTERING

Cutting Lathes: Neumann VMS-70, Neumann VG66, Neumann SX74

Console: (2) Neumann SP79, Neumann MT66

Tape Machines: Studer A80 MKII, PCM-F1

Monitor Speakers: UREI 811-A, Studer A68 amps.

Signal Processing: Sontec MES430 EQ, EMT240 plate reverb

Engineers: Bruce Kennedy, Erik Wolf, David Ellsworth, Stew Hillner, Kevin Gray

Credits: ABC Watermark, United Stations, Mutual, Westwood 1, MCA Radio, Radio International, Rick Dees Productions.

Rates: LP \$98.50/side, single \$32/side, rundown \$95/hr

Other Services: Complete printing services—labels, jackets, cue sheets, etc. Complete record productions, cassette bin loop mastering

LORAN CASSETTES AND AUDIO PRODUCTS**Pressing, Tape Duplication, CD Services**

4150 Riverside Dr., Ste. 207
Burbank, CA 91505

(818) 955-8577

Contact: Sandy Richman

TAPE DUPLICATION

Duplicator: Electro-Sound 8000, Harman Kardon (real time).

Method of Duplication: Bin loop

Tape Used: High quality Ferric and Chrome formulations

Duplicating Speed: Real time and 2:1

Loading Equipment: Mixal tape available for real time cassettes

Other Services: Complete production facility for art, printed components and duplication. Package design available.

COMPACT DISC

Preparation/Manufacturing: Complete compact disc production, fabrication of printed materials and package design.

MARTIN PRODUCTIONS**Tape Duplication, CD Services**

PO Box 46357
Seattle, WA 98146

(206) 243-9285

Contact: Jim Hess

TAPE DUPLICATION

Duplicator: KABA real time 24 units, Telex hi-speed, Recordex hi-speed.

Capacity: 2,500 per day

Method of Duplication: In cassette

Mastering Equipment: Dolby A, SR, B, C, dbx, Otari machine in tape, Nakamichi digital processor.

Tape Used: BASF

Shell Used: Shape MK10.

Duplicating Speed: Real time on music and hi-speed on voice only.

W E S T E R N**TAPE TO DISC****DIRECTORY**

MARTIN PRODUCTIONS
Seattle, WA

Loading Equipment: King custom load

Packaging Equipment/Fulfillment Services: Labeling, inserts, shrink.

Rates: \$35/hr. preparation per piece on duplication.

Other Services: Custom albums, printing

COMPACT DISC

Preparation/Manufacturing: Conversion of analog and digital masters for CD pressing, A to Z preparation to final CD product, minimum order 500 pieces.

MASTER CASSETTE**Tape Duplication**

2002 N. 25th Dr.

Phoenix, AZ 85009

(602) 269-2869

(800) 228-8919

Contact: Janita Cooper

MASTER DIGITAL, INC.**Tape Duplication, CD Services**

1749 14th St.

Santa Monica, CA 90404

(213) 452-1511

Contact: Paul Addis

TAPE DUPLICATION

Duplicator: Sony 16-bit digital, Nakamichi BX 300

Method of Duplication: Real time only.

Mastering Equipment: Studer B67, Sony PCM-1600, Ampex ATR-100, Nakamichi DMP-1000.

Tape Used: TDK SAX reference series, custom loaded to length

Shell Used: Shape MK10.

Duplicating Speed: Real time

Loading Equipment: King

Packaging Equipment/Fulfillment Services: Color stock, type-set and printed, cards and labels, shrinkwrap

Rates: \$3 and up.

Other Services: Video production, digital audio recording, compact disc mastering, video editing: one-inch and Beta-cam, ADO, Chyron, digital audio laybacks. Videophile duplication one-inch 3/4, VHS and Beta Hi-Fi.

COMPACT DISC

Preparation/Manufacturing: Full CD prep

MASTER TRACK PRODUCTIONS**Tape Duplication**

1524 W. Winton Ave.

Hayward, CA 94545

(415) 782-0877

Contact: Linda Rebusk

TAPE DUPLICATION

Capacity: 100,000 units/month

Method of Duplication: Bin loop

Mastering Equipment: Studer A80 MR.

Tape Used: BASF, Sunkyoung.

Shell Used: ICM.

Duplicating Speed: 16:1, 32:1.

Packaging Equipment/Fulfillment Services: On shell printing, overwrap, paper labels, full color inserts.

Rates: Call for detailed price lists.

Other Services: Complete 24-track recording studio.

THE MASTERING LAB**Mastering**

6033 Hollywood Blvd.

Hollywood, CA 90028

(213) 466-8589

Contact: Annie Butkiewicz

MATRIX ASSOCIATES INC.**CD Services**

881 Alma Real Dr.

Pacific Palisades, CA 90272

(213) 459-6913

Contact: Ed Koeppe, Rob Richstone

MCCUNE STUDIOS**Tape Duplication**

951 Howard St.

San Francisco, CA 94103

(415) 777-2700

Contact: Jim Draper

MISSION COMMUNICATIONS, INC.**Mastering, Tape Duplication**

100 E. Montecito Ave.

Sierra Madre, CA 91024

(818) 355-3346

Contact: Steve Haberth, Hugh Bell, Jr

MOBILE FIDELITY SOUND LAB**Mastering, Tape Duplication, CD Services**

1260 Holm Rd.

Petaluma, CA 94952

(707) 778-0134

Contact: Shawn Britton, Krieg Wunderlich

MOON VALLEY CASSETTE (WINTER SUN, INC.)**Tape Duplication**

10802 N. 23rd Ave.

Phoenix, AZ 85029

(602) 870-3987

Contact: Mark Bruno

TAPE DUPLICATION

Duplicator: Otari Model DP-1010 duplicating system using 1/4",

4-track DP-1310 master reproducer, Model DP-1510 slave

recorders and Model BL-1310 endless loop bin.

Capacity: 250,000 cassettes per year

Method of Duplication: Bin loop.

Mastering Equipment: Otari MX-5050 4-track, Otari MX-5050

2-track, TEAC Tascam 32-2.

Tape Used: BASF LHD, Agfa 8-11.

Shell Used: Shape Mark 10 clear, premium quality no-jam

5-screw shell.

Duplicating Speed: 16:1

Loading Equipment: TTL Mod. 515 cassette loader, Otari DP-2700

Packaging Equipment/Fulfillment Services: Art design, label/

insert printing and shrinkwrap services available.

Rates: Call for rates



MUSIC ANNEX, INC.
San Francisco, CA

MUSIC ANNEX, INC.**Tape Duplication**

970 O'Brien Dr., Menlo Park 94025

69 Green St.

San Francisco, CA 94111

(415) 328-8338 (Menlo Park)

(415) 421-6622 (San Francisco)

Contact: Keith Hatschek

TAPE DUPLICATION

Duplicator: Otari DP-80 w/Dolby HX-Pro master and five slaves.
 Capacity: 5,000 C-60 per shift.
 Method of Duplication: Bin loop
 Mastering Equipment: Otari MTR-10 w/Dolby HX-Pro 7 1/2 ips, 1/2"
 Tape Used: Agfa, BASF.
 Shell Used: Mag Media, Shape, ICM
 Duplicating Speed: 64:1, 480 ips master.
 Loading Equipment: King 790s.
 Packaging Equipment/Fulfillment Services: Apex (on-cassette printing) or paper labels
 Rates: Call or write for price lists.
 Other Services: Complete graphics, boxing, inserts, shrink-wrap and drop ship services. Client master may be either digital or analog



NATIONAL AUDIO VIDEO TRANSCRIPTS
 Denver, CO

NATIONAL AUDIO VIDEO TRANSCRIPTS
 Mastering, Tape Duplication
 21 Federal Blvd.
 Denver, CO 80219
 (303) 922-2197
 (800) 431-5954
 Contact: Candy Kissell
MASTERING

Tape Machines: Otari, Technics, Tascam, ADC
 Engineers: Mark Scardello, Russ Harrist
 Rates: Voiceover studio time: \$35/hr, editing time: \$20/hr
 Other Services: Video recording/post-production, editing, duplication 1", 3/4" VHS, Beta.
TAPE DUPLICATION
 Duplicator: (2) Magnefax bin loop systems, (2) KABA in-cassette stereo, 16 slaves, (12) Wollensak mono.
 Capacity: 250,000 C-60/month, 3 shifts
 Method of Duplication: In cassette, bin loop.
 Mastering Equipment: Otari MX-5050, Technics 1500 (reel-to-reel).
 Tape Used: Ampex, Agfa
 Shell Used: Kyrlic
 Duplicating Speed: Wollensaks. 30 ips, Magnefax: 90 ips/master, 45 ips slaves.
 Loading Equipment: (2) King 790, King 760
 Packaging Equipment/Fulfillment Services: ITI cassette labeler, automatic cassette boxing, shrinkwrapping (in-house).
 Rates: Ampex C-60 blank .59, Ampex C-90 blank .69, stereo dupes using Agfa 61 1/2" \$1.65 ea., quantity discounts.
 Other Services: Full-service video recording/production, post-production, duplication, 1", 3/4", VHS, Beta.

DOUG NOLTE ENTERPRISES
 Mastering
 443 N. Brimhall
 Mesa, AZ 85203
 (602) 969-6569
 Contact: Doug Nolte

NORTHWESTERN, INCORPORATED
 Tape Duplication
 1224 SW Broadway
 Portland, OR 97205
 (503) 226-0170
 (800) 547-2252 (outside CA)
 Contact: Robert M. Lindahl, Michael Lee Hellums

OPTICAL MEDIA INTERNATIONAL
 Mastering, Pressing, CD Services
 485 Alberto Way, Ste. 115
 Los Gatos, CA 95032
 (408) 395-4332
 (408) 395-6544 (FAX)

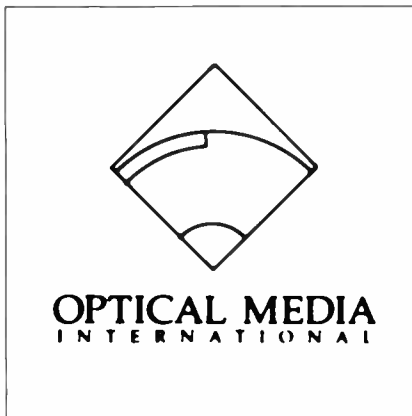

OPTICAL MEDIA INTERNATIONAL
 Los Gatos, CA

Contact: Allen Adkins
COMPACT DISC
 Preparation/Manufacturing: CD audio tape master preparation CD-audio tape premaster/encoding. CD-audio disc mastering services CD-audio disc pressing in any quantity 24-karat gold compact discs Complete services for all CD formats CD-Audio, CD-ROM, CD-I Call for price quote

PACIFIC CASSETTE LABORATORIES
 Tape Duplication
 20655 S. Western Ave., Ste. #116
 Torrance, CA 90501
 (213) 618-9267
 Contact: Michael Strange
TAPE DUPLICATION
 Duplicator: Computer-controlled Nakamichi ZX-9
 Capacity: Orders up to 5,000+
 Method of Duplication: In cassette
 Mastering Equipment: Sony PCM-F1 16/14-bit digital, MCI 1/2", Dolby B/C encoding
 Tape Used: Custom length TDK metal, SA, others by request
 Shell Used: TDK reference



PACIFIC CASSETTE LABORATORIES
 Torrance, CA

Duplicating Speed: 1 7/8 ips, real time
 Loading Equipment: King
 Packaging Equipment/Fulfillment Services: Complete packaging, labeling, J-cards, shrinkwrap
 Rates: Upon request
 Other Services: Please call

PACIFIC LUTHERAN UNIVERSITY, AUDIO SERVICES
 Mastering, Tape Duplication
 Tacoma, WA 98447
 (206) 535-7268
 Contact: Bob Holden, Jeffrey Bruton

PHANTASMA SOUND
 Tape Duplication
 7909 Fremont Ave.
 Ben Lomond, CA 95005
 (408) 336-2494
 Contact: Errol

You know how low-quality tape winds up, right?

Why be bothered with it? Count on United Group—manufacturers of expertly wound, highest quality *custom loaded* and *custom length* video and audio cassettes... and more!
 Authorized distributors of:

- AMPEX
- SCOTCH3/M
- CAPITOL
- TEAC/TASCAM
- TDK
- DISCWASHER
- BASF
- AUDIOLAB

Forget garbage forever!
 For information call or write:



Now at 6855 Vineland Avenue
 No. Hollywood, California 91605
 In California: 818/980-6700
 Toll Free: 1-800/247-8606 • From outside California: 1-800/433-4271

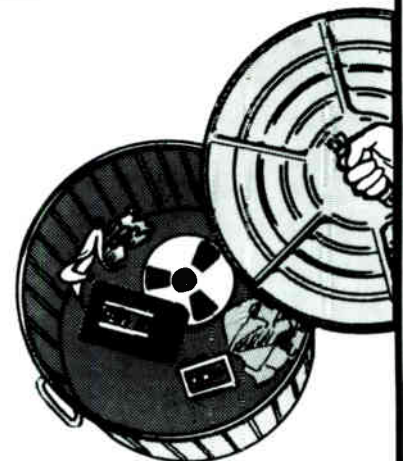



lowest prices
anywhere!

HIGHEST QUALITY TAPES

AMPEX AGFA BASF
3M SUNKYONG

Cassettes Loaded to any length
in most tapes

C-O's ■ Boxes

Labels Custom printed or blank

Dupl. Equip. & Supplies

ARCAL INC. (415) 369-7348
2732 Bay Rd., Redwood City, CA 94063

Circle #116 on Reader Service Card

Moonvalley Audiophile Quality
Cassette
Manufacturing

cassette

Hi-output/low-noise BASF-LHD
Tape in 5-screw Premium
Cassettes duplicated with
OTARI 16:1 bin loop equipment.

● **Audio Cassette Mastering**
● **Stereo Duplication**
● **Printing/Package Design**

Moonvalley Cassettes 10802 N. 23rd Avenue Phoenix, Arizona 85029
(602) 870-3987
A division of Wintersun, Inc.

Circle #167 on Reader Service Card

W E S T E R N

TAPE TO DISC

DIRECTORY

PHYLCO AUDIO
Tape Duplication
4697 Brooks St.
Montclair, CA 91763
(800) 525-0100
(714) 621-9561
Contact: Robert Deates, Gail Husa

TAPE DUPLICATION
Duplicator: Audio Tek GRT. (3) Telex
Capacity: 10,000 per shift
Method of Duplication: In cassette, bin loop
Mastering Equipment: Ampex, TEAC
Tape Used: BASF, IPS, Sunkyoung
Shell Used: IPS, Elmar
Duplicating Speed: 30 and 60 ips
Loading Equipment: (3) King.
Packaging Equipment/Fulfillment Services: Labeling, shrink-wrap.
Rates: Call for quote
Other Services: Custom loaded blanks, many grades Packaging individual and vinyl albums

PRECISION LACQUER
Mastering, CD Services
1008 N. Cole
Los Angeles, CA 90038
(213) 464-1008
Contact: Ralph Emerine

MASTERING
Cutting Lathes: Neumann DMM
Console: Neve DSP digital, NTP
Tape Machines: Ampex, Sony, Mitsubishi
Monitor Speakers: Flame-Thrower Mark 4
Signal Processing: Spring Bender Auxmassen
Engineers: Stephen Marcussen, Jay Willis
Credits: Streisand, Stevie Wonder, Pink Floyd, Yes, Dylan, JC Mellencamp, Tom Petty, The Mac
Rates: Sit down—have a cup of coffee—then call us

QUAD TECK STUDIOS
Mastering, Tape Duplication, CD Services
4007 W. 6th St.
Los Angeles, CA 90020
(213) 383-2155
Contact: Joani Waring

RADIOACTIVE RECORDS
Tape Duplication
170 SW 139th
Beaverton, OR 97006
(503) 626-2331
Contact: Mark Hannah



RAINBO RECORDS

RAINBO RECORDS AND CASSETTES
Santa Monica, CA

RAINBO RECORDS AND CASSETTES
Mastering, Pressing, Tape Duplication
1738 Berkeley St.
Santa Monica, CA 90404
(213) 829-3476

Contact: Jack G. Brown, Steven E. Sheldon

MASTERING
Cutting Lathes: All lacquers cut at EMI Capitol
PRESSING
Presses: 26 Lened automatics
Capacity: 60,000 12" per 24-hour day, 18,000 7"
Vinyl Used: Keycor KC 588
Rates: Call for current rates
Other Services: Labels, jackets, sleeves, packaging and drop shipping.

TAPE DUPLICATION
Duplicator: Electro-Sound 8000 w/HX Pro
Capacity: 30,000/24-hour day
Method of Duplication: Bin loop
Mastering Equipment: Otari
Tape Used: BASF
Shell Used: Michelex, Kyrac
Duplicating Speed: 32 1 or 64-1
Loading Equipment: King 790
Other Services: Apex printing, insert card and drop shipping.

COMPACT DISC
Preparation/Manufacturing: Packaging only

RAINBOW CASSETTE STUDIO
Tape Duplication
PO Box 472
Taos, NM 87571
(505) 776-2268
Contact: Judy Lujan

TAPE DUPLICATION
Duplicator: Gauss 2400 1" system w/Dolby HX Pro
Capacity: 1,000 cassettes/day
Method of Duplication: Bin loop
Mastering Equipment: Studer A80MR 1", MCI JH-110 1/4"
Tape Used: Agfa 662/962 Magnetite, Agfa 619/819 Ferric
Shell Used: Shape MK-10 5-screw
Duplicating Speed: 32-1 and 64-1
Loading Equipment: King
Packaging Equipment/Fulfillment Services: Apex on-cassette printing and shrinkwrap.
Rates: Available upon request

BILL RASE PRODUCTIONS, INC.
Tape Duplication
955 Venture Ct.
Sacramento, CA 95825
(916) 929-9181
Contact: Bill Rase

RECORD TECHNOLOGY, INC
Mastering, Pressing, Tape Duplication, CD Services
486 Dawson Dr.
Camarillo, CA 93010
(805) 484-2747
(805) 987-0508 (FAX)
Contact: Don MacInnis

RECORDING ASSOCIATES
Tape Duplication
5821 SE Powell Blvd.
Portland, OR 97206
(503) 777-4621
Contact: Jay Webster, Bob Stoutenburg

RECORDING, ETC.
Tape Duplication
633 Cowper St.
Palo Alto, CA 94301
(415) 327-9344
Contact: Dennis Reed, Ted Brooks

REELTIME TAPE DUPLICATION
Tape Duplication
125 Alena St.
San Rafael, CA 94901
(415) 459-7180
Contact: Tony Johnson

REX RECORDING CO.
Tape Duplication
1931 SE Morrison
Portland, OR
(503) 238-4525
Contact: Ken Bladow

ROCKY MOUNTAIN AUDIO/VIDEO PRODUCTIONS, INC.
Tape Duplication
4301 S. Federal Blvd., Ste. 108
Englewood, CO 80110
(303) 730-1100
Contact: Tim Skurdahl

TAPE DUPLICATION
Duplicator: Electro-Sound 8000

Capacity: 10,000/day
 Method of Duplication: Bin loop
 Mastering Equipment: Ampex, Sunkyong, Magnetic Media
 Shell Used: Magnetic Media
 Duplicating Speed: 32:1, 64:1
 Loading Equipment: King
 Packaging Equipment/Fulfillment Services: Shrinkwrap and automatic labeling
 Rates: On request
 Other Services: Video production and post-production, video duplication

ROCKY MOUNTAIN RECORDING
 Mastering, Pressing
 8305 Christensen Rd.
 Cheyenne, WY 82009
 (307) 638-8733
 Contact: Ray or Georgia Alexander

ROUGH CUT RECORDING
 Mastering, Pressing, Tape Duplication
 2525 E. 12
 Cheyenne, WY 82001
 (307) 638-9894
 Contact: Rich Creswell

RUTHER REMOTE RECORDING
 Tape Duplication
 108 N. Roosevelt
 Walla Walla, WA 99362
 (509) 522-0438
 Contact: Bud Ruther

SAKI MAGNETICS, INC.
 Mastering, Tape Duplication
 26600 Agoura Rd.
 Calabasas, CA 91302
 (818) 880-4054
 Contact: Trevor J. Boyer

SAWTOOTH MAGNETIC TAPE
 Tape Duplication
 329-A Ingalls St., PO Box 525
 Santa Cruz, CA 95061

(408) 423-1849
 Contact: Todd Thal
TAPE DUPLICATION
 Duplicator: Computer-controlled Studer 721
 Capacity: Orders up to 5,000 plus.
 Method of Duplication: In cassette
 Mastering Equipment: Studer A820 1/4", Studer A80 RC 1/2",
 Dolby A and SR, Sony PCM-F1, Beta and U-matic.
 Tape Used: BASF chrome
 Shell Used: Shape Mark 10
 Duplicating Speed: Real time exclusively
 Loading Equipment: AEG
 Packaging Equipment/Fulfillment Services: Complete packaging, labeling, J-cards and shrinkwrap.
 Rates: Upon request
 Other Services: Graphic arts department for J-card design.
 Please call

Santa Clara, CA 95054
 (408) 727-7620
 Contact: Lonnie Cory
TAPE DUPLICATION
 Duplicator: Electro-Sound, Infonics.
 Capacity: 10 slaves.
 Method of Duplication: In cassette, bin loop
 Mastering Equipment: Revox A700, Technics 1506, Ampex AG-440
 Tape Used: Agfa, Ampex.
 Shell Used: Magnetic Media, ICM.
 Duplicating Speed: 16:1, 32:1, real time.
 Loading Equipment: (4) King 790, Electro-Sound
 Packaging Equipment/Fulfillment Services: Tuck labeler, shrinkwrap
 Rates: Call
 Other Services: Real time duplication, location recording for conferences, seminars, etc

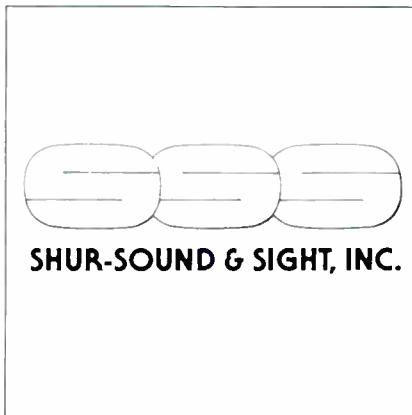

SHUR-SOUND & SIGHT, INC.
 Santa Clara, CA

SHUR-SOUND & SIGHT, INC.
 Tape Duplication
 3350 Scott Blvd., #5

SONIC ARTS CORP./THE MASTERING ROOM
 Mastering, Pressing, Tape Duplication
 666 Harrison St.
 San Francisco, CA 94107
 (415) 781-6306
 (415) 957-9471
 Contact: Kenneth Lee, Jr., Matt Venuti
MASTERING
 Cutting Lathes: Neumann, fully automated and computerized, VG66 amp w/Neumann SX-68 cutting head
 Console: Custom
 Tape Machines: Neumann, Telefunken, 3M, Inovonics, Ampex, featuring 1/2" 1/2-track mastering and PCM digital mastering
 Monitor Speakers: Altec 604 w/JBL woofers, Yamaha NS-10M.
 Signal Processing: Parametric and graphic EQ, Inovonics, Dolby A and dbx noise reduction, UREI and Inovonics limiters, AKG echo chamber, Sontec EQ.
 Engineers: Leo de Gar Kulka, Kenneth Lee
 Credits: Phillips, Warner Bros., Concord Jazz, Ralph Records, DDG, Catero and many local labels
 Rates: Available upon request
 Other Services: Half speed mastering, digital mastering
PRESSING
 Vinyl Used: Keyser, Teldec
 Rates: Call or write for brochure
 Other Services: Jacket, label and poster printing, colored

—CONTINUED ON NEXT PAGE

GET LISTED!

In Mix Directories

Mix Directories are the most complete guides to facilities and services for the audio and video industries. When production professionals need equipment, studios, or other services, they consult *Mix* first. To receive a questionnaire for a listing in any or all of the following Mix Directories, simply fill out and return the coupon or call the Directories Dept. at (415) 843-7901.

*Two-for-one! By listing in *Mix* magazine's monthly directories, you will receive the same listing FREE in the 1988 Annual Directory!

- MARCH '88: **STUDIOS OF THE SOUTHEAST**
(Deadline: December 14)
- APRIL '88: **VIDEO PRODUCTION & POST-PRODUCTION FACILITIES** (Deadline: January 2)
- MAY '88: **STUDIOS OF THE NORTHEAST**
(Deadline: February 3)
- JUNE '88: **REMOTE RECORDING & SOUND REINFORCEMENT FACILITIES**
(Deadline: March 3)

NAME _____

COMPANY _____

ADDRESS _____

CITY _____ STATE _____ ZIP _____

() _____

TELEPHONE _____

Mail to: **Mix Directories**
 2608 Ninth Street
 Berkeley, CA 94710

NOTE: Questionnaires for specific issues will be mailed five months prior to issue date.

vinyl, promotional buttons, stickers, matchbooks and T-shirts.
TAPE DUPLICATION
Mastering Equipment: 3M
Tape Used: Agfa PE 611
Shell Used: Data packaging
Packaging Equipment/Fulfillment Services: Album art reproduction, labels.
Rates: Call or write for brochure.

SOUND CONCEPTS

Tape Duplication
PO Box 1326, 175 W. 300 S.
Provo, UT 84603
(801) 375-7333
Contact: Michael K Jensen

SOUND INNOVATIONS

Tape Duplication
5520 Lake Otis Pkwy., Ste. 104
Anchorage, AK 99507
(907) 563-8273
Contact: Gardner W Wilcox, Bruce Graham



SOUND MASTER AUDIO/VIDEO RECORDING STUDIOS
North Hollywood, CA

SOUND MASTER AUDIO/VIDEO RECORDING STUDIOS

Mastering
10747 Magnolia Blvd.
North Hollywood, CA 91601
(213) 650-8000
Contact: Barbara
MASTERING
Cutting Lathes: Cybersonics w/Ortofon cutting amplifiers and head
Console: Cybersonics
Tape Machines: MCI, Ampex
Monitor Speakers: House
Signal Processing: Everything.
Engineers: Brian Ingoldsby, Ken Ingoldsby
Credits: Elton John, Olivia Newton-John, Joe Cocker, many others.
Rates: On request
Other Services: 24-track automated recording studio and full production video complex. Live sound reinforcement, remote recording, mobile video, plus underwater video

SOUND PRODUCTIONS

Tape Duplication
402 NE 72nd
Seattle, WA 98103
(206) 525-9999
Contact: Brian Bouchard

SOUND RECORDING COMPANY

Tape Duplication
W. 503 Indiana Ave.
Spokane, WA 99205
(509) 326-0222
Contact: Paul Carter

SOUNDINGS OF THE PLANET

Tape Duplication
PO Box 43512
Tucson, AZ 85733
(602) 883-1784
Contact: Dean Evenson

TAPE TO DISC

DIRECTORY

SOUTHLAND VIDEO VISION, INC.

Tape Duplication
3255 Cahuenga Blvd. W., #200
Hollywood, CA 90068
(213) 851-1190
Contact: Randal W Ridges, James Hardy

JAY STAGGS CASSETTE DUPLICATION

Mastering, Tape Duplication
7419 Florence Ave.
Downey, CA 90240
(213) 928-7516

STUDIO MASTERS

Mastering
8312 Beverly Blvd.
Los Angeles, CA 90048
(213) 653-1988
Contact: Larry Wood, Ferris Sloan

SUNKYONG INTERNATIONAL, INC.

Tape Duplication, CD Services
17106 S. Avalon Blvd.
Carson, CA 90746
(213) 327-5010
Contact: Mr. G I Lee

C/O SUPREME SIGNS/STEVE MCCAY
JINGLE PRODUCTIONS & CASSETTE DUPLICATION

Tape Duplication
801 Brundage Ln., Unit "T"
Bakersfield, CA 93304
(805) 322-9541
Contact: Steve McCay

TAPE ONE HAWAII, INC.

Tape Duplication
1520 Liona St., 2nd Floor
Honolulu, HI 96814
(808) 947-8802
Contact: Dwan H Hansen

TAPE SPECIALTY, INC.

Tape Duplication
13411 Salicoy St.
North Hollywood, CA 91605
(818) 786-6111
(213) 873-5400
Contact: Customer service

TAPES AGAIN

Tape Duplication
1135 Pearl St., #7
Boulder, CO 80302
(303) 447-8787
Contact: Mitch Rose

TIKI ENTERPRISES, INC.

Mastering, Pressing, Tape Duplication, CD Services
195 S. 26th St.
San Jose, CA 95116
(408) 286-9840
Contact: Gracie J O'Neal

HOWARD VALENTINE SOUND SERVICES

Mastering
6263 Leland Way
Hollywood, CA 90028
(213) 464-8888
Contact: Howard Valentine

VIDEO WEST

Tape Duplication
5 Triad Center
Salt Lake City, UT 84180
(801) 575-7442
Contact: Ronald G. Hansen

WARING F.D.S. LABS

Mastering, Tape Duplication, CD Services
4007 W. 6th St.
Los Angeles, CA 90020
(213) 383-2155
Contact: Hank Waring

WEA MANUFACTURING

Pressing, Tape Duplication, CD Services
3601 W. Olive Ave.
Burbank, CA 91106
(818) 953-2941
Contact: David A Grant

WORD OF FAITH TAPE

Tape Duplication
PO Box 1147
Azusa, CA 91702
(818) 969-4544
Contact: Ron Gibson

OUTSIDE U.S.

ACCUSONIC

Tape Duplication
70 Bathurst St.
Toronto, Ontario, Canada
(416) 368-1262
Contact: Paul Gallienne

ARSTON PZ

Mastering, Pressing, Tape Duplication, CD Services
Krakowskie Przedmiescie 13, Rm. 201
Warsaw, 00-071 Poland
26-50-51
Contact: Maria Wilk

BLC

Tape Duplication
20 A Callender St.
Toronto, Ontario, M6R 2H3 Canada
(416) 537-0968
Contact: Robert Rosen

B.M.G. ARISTA/ARIOLA

Mastering
Strathfield Plaza
Strathfield 2135
Sydney, Australia
(02) 764-3888
Contact: Bruce Sheldrick

CANATRON ELECTRONICS

Tape Duplication
4-35 Stafford Rd. E.
Nepean, Ontario, K2H 8V8 Canada
(613) 726-1660
Contact: D R Drake

CAPITOL RECORDS EMI CANADA

Tape Duplication
3109 American Dr.
Mississauga, Ontario, L4V 1B2 Canada
(416) 677-5050
(416) 677-5053
Contact: Hugh Wiets

CINRAM LTD.

Mastering, Pressing, Tape Duplication, CD Services
2255 Markham Rd.
Scarborough, Ontario, M1B 2W3 Canada
(416) 298-8190
Contact: J. Philosophie

PRESSING

Presses: (18) Alphas 12" and 17 SHT 7"
Capacity: 81,000 12"/day and 76,500 7"/day.
Vinyl Used: Keycor

TAPE DUPLICATION

Duplicator: (76) Electro-Sound 8000 and Gauss 2400
Capacity: 228,000/day
Method of Duplication: Bin loop

COMPACT DISC

Preparation/Manufacturing: 45,000/day, pre-mastering, mastering, pressing and packaging. Full service

DABEN ENTERPRISES LTD.

Tape Duplication
992 Hubrey Rd., Unit #5

London, Ontario, N6N 1B5 Canada
(519) 685-0075
Contact: Randy Wilson, Doug Sandercock
MASTERING
Console: Tascam M-600
Tape Machines: Tascam ATR-60/2T, MCI JH-110, Tascam 122 MKII
Monitor Speakers: JBL 4430, Yamaha NS-10, Fostex 6301
Signal Processing: Orban, dbx, Dolby, Lexicon, Yamaha.
Engineers: Dan Benn, David N. Chaulk, Randy Wilson.
Credits: Internationally recognized.
Rates: Rates available on request.

TAPE DUPLICATION
Duplicator: Tascam T2640MS, Tascam T26402S
Method of Duplication: In cassette
Mastering Equipment: Tascam, MCI, Sony
Tape Used: All types
Shell Used: All types
Duplicating Speed: Eight times
Loading Equipment: King Model 770 ECS modified by Concept Design (1987)
Packaging Equipment/Fulfillment Services: All services available on premises.
Rates: Rates available on request.
Other Services: Custom cassette manufacturing, custom labeling

DELTA TAPE MINISTRIES INC.

Tape Duplication
13-15531 24 Ave.
Surrey, BC, V4A 2J4 Canada
(604) 536-4808
Contact: Edward Becker

DISCOS GAS, S.A.

Mastering, Pressing, Tape Duplication
1201 Eje Central 100mts.,
G.A. Madero, 07700 Mexico D.F., Mexico
(525) 754-3055
Contact: Guillermo Acosta

E.M.A.C. SOUND RECORDING STUDIOS

Tape Duplication
343 Richmond St.
London, Ontario, N6A 3C2 Canada
(519) 667-3622
Contact: Robert Nation

ENREGISTREMENTS AUDIOBEC CANADA INC.

Mastering, Pressing, Tape Duplication
600 Ouest Port Royal W.
Montreal, Quebec, H3L 2C5 Canada
(514) 384-6667
Contact: J. Rabchuk

EVERGREEN AUDIO-VISUAL LIMITED

Tape Duplication
7170 Warden Ave., Unit 3
Unionville, Ontario, L3R 8B2 Canada
(416) 477-6322
Contact: L. Green

GREVILLE RECORDS

Tape Duplication
26 Wallace St., Albion
Brisbane, Australia
(07) 262-8422
Contact: Malcolm Jacobson, Bruce Jacobson

INTIMATE SOUNDS LTD.

Tape Duplication
6315 Metral Dr.
Nanaimo, BC, V9T 2L8 Canada
(604) 390-3421
Contact: Scott Littlejohn

KIRKLAND SOUND RECORDING

Tape Duplication
9 Summit Ave.
Kirkland Lake, Ontario, P2N 1M6 Canada
(705) 567-3847
Contact: B. May

LISTEN AUDIO PRODUCTIONS

Tape Duplication
308 Place D'Youville
Montreal, Quebec, H2Y 2B6 Canada
(514) 842-9725
Contact: Carole Akazawa

MAGRA INDUSTRIES LTD.

Tape Duplication
5722 St. Andre
Montreal, Quebec, H2S 2K1 Canada
(514) 272-8224
Contact: Serge Ruhlmann

MCCLEAR PLACE RECORDING STUDIOS

Mastering, Tape Duplication, CD Services
225 Mutual St.
Toronto, Ontario, M5B 2B4 Canada
(416) 977-9740
Contact: Lorraine Hume

OCEAN SOUND CORP.

1758 W. 2nd Ave.
Vancouver, BC, V6J 1H6 Canada
(604) 733-3146
Contact: Ken Morrison

PARK LANE STUDIOS

Mastering, Tape Duplication
12 Frobenstrasse
CH-4053 Basel, Switzerland
(04161)232-232
Contact: Thomas Buser

REP SOUND IMAGE RECORDING LIMITED

Tape Duplication
180 Sheldon Dr.
Cambridge, Ontario, N1R 6V1 Canada
(519) 623-2269
Contact: Ron Penner

ROAN SOUND PRODUCTIONS LTD.

Tape Duplication
1005 View St.
Victoria, BC, V8V 3L7 Canada
(604) 381-6151
(604) 385-0642
Contact: Ron Zahar

SUPRAPHON GRAMOPHONE RECORDS AND PUBLISHING HOUSE

Mastering, Pressing, Tape Duplication
112 99 Praha 1, Palackeche 1
Czechoslovakia
26-25-62
26-81-41
Contact: Dr. Pavel Smola

VICE VERSA S.C. LTD.

Mastering
R. Alves Guimaraes, 170
Sao Paulo, 05410 Brasil
(55-11)280-8111
Contact: Mr. Botelho

JOOP WESSELIUS GELUIDSTECHNIEK

Mastering, CD Services
187 Hogewoerd
2311 HL Leiden, The Netherlands
(+31)71-134217
Contact: J. Wesselius

—FROM PAGE 12, SESSIONS

ity equipped with an Otari DTR-900 32-track... **ETZ**, a Dallas new age group, dubbed their album from digital and edited it at **Goodnight Dallas Studios** with **Reuben Ayala**... **Pantheon Studios** in Scottsdale, AZ, worked on a new Ford Motors campaign, performed, arranged and produced by **Dennis Alexander**... At the new **Downtown Sound** in Dallas, **Dan Walker** was in programming keyboard sounds for the next **Duran Duran** album....

STUDIO NEWS

Producers Color Service (Southfield, MI) has added the AMS AudioFile to their audio post facilities... Mastering facilities at **A&M Studios**, **Atlantic Records**, **Capitol Recording**, **Editel**, **Masterdisk** and **Precision Lacquer** have recently retrofitted their Sony 1630 machines with Apogee Electronics' anti-aliasing filters... **Crow Recording Studio**, Seattle, has expanded with the addition of a computer-based MIDI room under the direction of **Steve Rice**... **Starlight Sound** in Richmond, CA, has gone through massive maintenance and equipment updates, adding the Atari 1040ST for sequencing, the Rockman sustainer, the Akai sampler, and more... **Future Disc Systems** (Hollywood, CA) took delivery of the tenth Harmonia Mundi

modular digital outboard rack delivered by Audio Intervisual Design to the L.A. area... **Axis Studios** in NYC has taken delivery of a 47-input Amek Angela console featuring a Disk Mix automation system and external patchbay... **Target Productions** of Boston has added a Synclavier... **Boutwell Studios** in Birmingham, AL, installed a new Sony/MCI MXP-3000 36-input automated mixing console... **Sunset Sound** has contracted with Amek Systems for delivery of an APC 1000 assignable console for their Los Angeles studio in January of 1988. The console has 56 inputs in a 64-input chassis with full GML moving fader automation, recall and reset systems... **Sheffield Audio/Video** of Baltimore upgraded its audio remote truck by installing a Neve 8068 MKII console; and the legendary **Apollo Theater** took delivery of a Neve V Series 48-input console with Neve 96. **Eleven Eleven Sound** in Nashville also purchased a Neve V... **Bench Recording** in Brooklyn, NY, has added a Roland D-50, a DX7 II, another REV7 and more... **London Bridge Studios** in Seattle has added a new Studer A-800 MkIII 24-track... The **Hit Factory** and **Power Station**, both in NYC, have retrofitted Sony 3324s with Apogee Filters... **Razor's Edge Recording** is a new 16-track facility in San Francisco that opened in October. The studio is equipped with a Tascam MS-16 one-inch recorder, a Yamaha 1608 console, and plenty of fine outboard gear. For more info call (415) 922-4382....

FEEDBACK

Dear Mix:

Re Rosanne Soifer's overview of the state of the musician's union (*Mix*, August '87): While providing Victor Fuentealba with a forum to bitch at managers and agents discouraging rock musicians from joining the union, and blaming the New York club scene as the musician's worst enemy, Ms. Soifer neglects to examine the fact that for years Local 802 made a tradition out of ignoring rock and roll and its players, a charge that has, in print, been acknowledged by the local's own treasurer, Barry Kornfeld.

Throughout the late '60s, the '70s and into this decade, the sordid concatenation of bloated, mediocre tuba players that made up Local 802's leadership consistently took the attitude towards rock musicians that you either play for scale or you don't play. Translation: eat steak or starve.

Russell Alexander's efforts, combined with a new administration elected in 1983, produced the short-lived "Rock/R&B Organizing Committee." But its demise can also be attributed less to an inherent inability to organize rock players than to the fact that for over a generation and a half there had been no role model for it in New York. You were on your own until you made it, in which case you'd better join up or you won't get your residuals and royalties.

You don't have to be an anti-unionist or even a congenital Republican to realize that Local 802—and any number of other locals across the country—are the architects of their own dwindling numbers.

Ms. Soifer raises some legitimate points in her piece, but without acknowledging the culpability of the urban good ol' boys who turned the union into a private and badly run club, she doesn't deliver the whole story.

Dan Daley
New York, NY

Dan Daley is a contributing editor of Mix. He has worked as a recording and performing artist for over 15 years.

Dear Mix:

As a tape recorder technician, I'm always interested in diving deeper into the murky mysteries of the magnetic media, but the graphs in Figures 1 and 2 of Greg Hank's "Analog Tape Recorder Electronics" (*Mix*, October '87) almost had me hanging up my tweaking tools in despair until I realized the error.

The x axis in Figure 1, which illustrates head gap loss, is labeled "Wavelength/Head Gap" instead of the correct "Head Gap/Wavelength." This also applies to the graph in Figure 2, which illustrates azimuth loss.

As it is printed, the hapless novice, struggling to understand head gap loss, would get confused into thinking that head gap loss occurs as the wavelength increases (as the frequency decreases) in proportion to the gap width. Instead the converse is true: head gap loss occurs at higher frequencies as the wavelength decreases to equal the gap width, and as the wavelength becomes smaller than the gap.

Robert Thomure
San Diego, CA

Dear Mix:

I greatly enjoyed Ben Harris' article on locking digital multi-track recorders. During a stint as an engineer with Sony, I had also been turned on to this powerful mode of operation by our clients. Ben is quite right in stating that electronic editing is the superior way to edit digital multi-track recordings, in terms of the integrity of the final product (no splicing tape, and continuous digital data throughout) and the power of the technique (fly anything anywhere, any number of times with no generation loss whatsoever).

I was quite interested, though, to

hear about the difficulties that Ben had in getting his setup going, and I thought your readers might like to hear how the same operation is performed with Sony PCM-3324s. Basically, it's a heck of a lot easier!

For one thing, no external synchronizer is necessary, as the PCM-3324s have the capability of performing their own highly precise lockup, with automatic punch-in and punch-out. This obviates about eight paragraphs of complication in Ben's situation, including all of the problems with servo-locking digital machines, and the timing reference problem. There is also no need to perform the operation of determining an exact offset between the machines, because the units use a dedicated "control track" that is transferred intact to the target machine. The offset is always, precisely "0," until the time comes to move tracks around, as Ben described.

I certainly don't want to make any blanket endorsement of one or the other of the major digital multi-track formats, but the use of a dedicated control track and the specific features that Sony's engineers designed in offer some distinct advantages in this application.

Gary Hall
Technical Manager
Gexco International

Dear Mix:

It was interesting to read about Bob Ludwig in the August issue. However, contrary to what he apparently believes, not a lot has changed over the last 25 years in the challenges of disc mastering technically, and the reliance of artists and producers on the opinions of mastering engineers. It is, and was, the last opportunity to save the final mix.

I take issue with Ludwig's statement "... mastering wasn't up to the state-of-the-art that it is now. *There were no*

MIX WORDS

© 1987 by Armand St. Martin

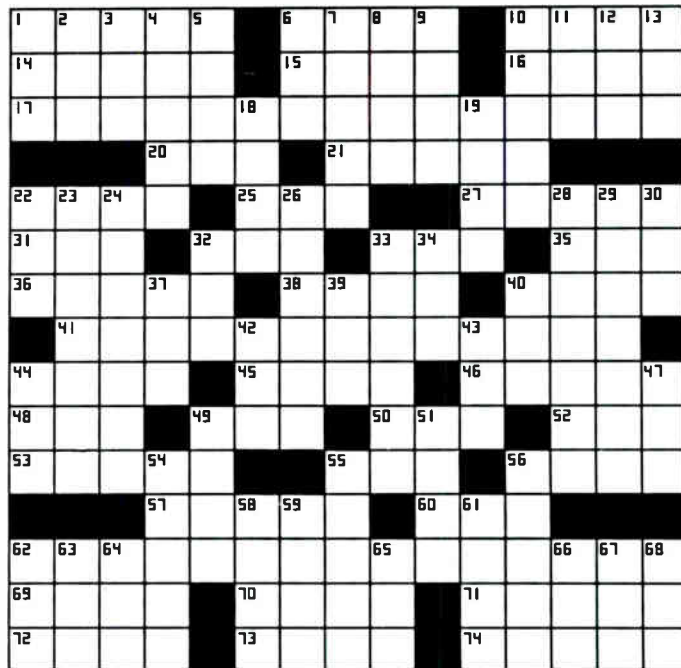

specialists in it back then." Oh come now Mr. Ludwig, surely you jest! There have been a great many other mastering people in this country and abroad, who have contributed greatly to our industry over the last 25 years. Many of these specialists were under far greater stress than their contemporary counterparts, I might add.

Jerome E. DeClercq
Largo, FL

Dear Mix,

Although installation of copy-guard chips in DAT recorders will knock out some mid-range frequencies, I think it will still become very popular with consumers who listen to heavy metal, because there is no F sharp and D flat anyway.

Also, I feel in time there will be no recording studios left on Long Island with Shoreham testing their current flow on our master tapes! Please send me information on isolation transformers, battery back-up supplies, surge protectors and 25 watt light bulbs for my mother's refrigerator and where I can purchase the anti-copy guard chip for my DAT recorder.

John Kutkowski, owner
JK's Underground Recording
E. Meadow, NY

AFTER TIME

ACROSS

1. Bothers
6. Confused
10. Type of dream
14. Worship
15. Computer screen
16. Israeli seaport
17. Element of the continuum
20. Word of discovery
21. Certain "observation" deck
22. Ancient god
25. "Annabel Lee" author
27. Enforcement part of a law
31. Can. prov.
32. Japanese coin
33. Chancellorsville was his great victory
35. Connection between notes
36. Binary information pieces
38. Shadow
40. French fellow
41. The "shapes in the sand," or a musical must
44. Lifeless
45. Run
46. Mister, in Mazatlan
48. French soul
49. Numerical prefix
50. Dutch commune
52. Prefix for self
53. Archaic tale
55. Amin to his pals
56. "Der "
57. Autumn cache item
60. Biological bag
62. Cases of "good timing"
69. Six or wolt
70. Summers, in Lyons
71. Our, in Orlean
72. A hail from a halyard
73. Aching
74. "F "

DOWN

1. Certain fighting fliers
2. Big little words

3. ___ Reed
4. Dashing movie man
5. Son of Adam
6. Put on the playlist
7. Musical form
8. Girl's name
9. Mime
10. Adhesive
11. Here, to Henri
12. Expert
13. Poetic nightfall
18. Optimism
19. Scale segment
22. Do a oo
23. Whenever
24. Occasionally
26. Prompt
28. Lasting
29. Break!
30. Attention getter
32. Wind dir.
33. Made sausages?
34. High note

37. Job for Bonaparte (abbr)
39. Past time
40. Regret
42. Sixty sixties, in Babylon
43. Halt a fly
44. Time-___
47. Way to go (abbr.)
49. High- or low-
51. Platter
54. Out of taste
55. Type of lining
56. L.A. denizen
58. Raw materials
59. Sunday section
61. "___ Misbehavin'"
62. Healing place
63. Word of agreement
64. Sarge
65. Process suffix
66. Japanese admiral and statesman
67. Latin lesson word
68. Aut. mo.

Solution to November Mix Words



STATEMENT OF OWNERSHIP, MANAGEMENT AND CIRCULATION

1. Name of the publication

2. Issue date for circulation data below

3. Issue frequency

4. Annual subscription price

5. Number of copies of this issue published

6. Total number of copies of this issue

7. Total number of copies of all issues published during the year

8. Total number of copies of this issue actually distributed

9. Total number of copies of this issue not distributed

10. Total number of copies of this issue not accounted for

11. Total number of copies of this issue not accounted for

12. Total number of copies of this issue not accounted for

13. Total number of copies of this issue not accounted for

14. Total number of copies of this issue not accounted for

15. Total number of copies of this issue not accounted for

16. Total number of copies of this issue not accounted for

17. Total number of copies of this issue not accounted for

18. Total number of copies of this issue not accounted for

19. Total number of copies of this issue not accounted for

20. Total number of copies of this issue not accounted for

21. Total number of copies of this issue not accounted for

22. Total number of copies of this issue not accounted for

23. Total number of copies of this issue not accounted for

24. Total number of copies of this issue not accounted for

25. Total number of copies of this issue not accounted for

26. Total number of copies of this issue not accounted for

27. Total number of copies of this issue not accounted for

28. Total number of copies of this issue not accounted for

29. Total number of copies of this issue not accounted for

30. Total number of copies of this issue not accounted for

31. Total number of copies of this issue not accounted for

32. Total number of copies of this issue not accounted for

33. Total number of copies of this issue not accounted for

34. Total number of copies of this issue not accounted for

35. Total number of copies of this issue not accounted for

36. Total number of copies of this issue not accounted for

37. Total number of copies of this issue not accounted for

38. Total number of copies of this issue not accounted for

39. Total number of copies of this issue not accounted for

40. Total number of copies of this issue not accounted for

41. Total number of copies of this issue not accounted for

42. Total number of copies of this issue not accounted for

43. Total number of copies of this issue not accounted for

44. Total number of copies of this issue not accounted for

45. Total number of copies of this issue not accounted for

46. Total number of copies of this issue not accounted for

47. Total number of copies of this issue not accounted for

48. Total number of copies of this issue not accounted for

49. Total number of copies of this issue not accounted for

50. Total number of copies of this issue not accounted for

51. Total number of copies of this issue not accounted for

52. Total number of copies of this issue not accounted for

53. Total number of copies of this issue not accounted for

54. Total number of copies of this issue not accounted for

55. Total number of copies of this issue not accounted for

56. Total number of copies of this issue not accounted for

57. Total number of copies of this issue not accounted for

58. Total number of copies of this issue not accounted for

59. Total number of copies of this issue not accounted for

60. Total number of copies of this issue not accounted for

61. Total number of copies of this issue not accounted for

62. Total number of copies of this issue not accounted for

63. Total number of copies of this issue not accounted for

64. Total number of copies of this issue not accounted for

65. Total number of copies of this issue not accounted for

66. Total number of copies of this issue not accounted for

67. Total number of copies of this issue not accounted for

68. Total number of copies of this issue not accounted for

69. Total number of copies of this issue not accounted for

70. Total number of copies of this issue not accounted for

71. Total number of copies of this issue not accounted for

72. Total number of copies of this issue not accounted for

73. Total number of copies of this issue not accounted for

74. Total number of copies of this issue not accounted for

I certify that the statements made by me above are correct and complete.

CLASSIFIEDS

Business Opportunities

DON HORN

David Foster is probably too busy with superstars so can you help this dedicated, hard working, athletic, young, all-American redheaded male pop singer? Entertainer w/ commercial appeal seeks to crack the top '40s w/long-term association/direction w/established proven record producer who has patience for breaking new acts. Tight but workable budget. Tenor to hi tenor, 2-octave range. In Confidence, Box 101, Seaford Harbor, NY 11783.

Employment Offered

Midwest-based National Radio Production facility needs PROD. ENGINEER w/management skills. Must have 5 years experience incl. documentaries and radio commercials. Send tape, resume, salary history and references to Classifieds, PO Box 2526, Berkeley, CA 94702.

One of the Southeast's leading music retail/pro-audio stores is looking for a service technician w/at least 2 yrs. experience w/multi-track tape recorders and/or keyboard synths. A knowledge of microprocessor-based systems is a must, as well as the ability to troubleshoot to the component level. 25-yr.-old co. w/good benefits and excellent service facility. Contact: Steve Stoeckel, Reliable Music, 650 E. Stonewall St., Charlotte, NC 28202. (704) 375-8662.

Equipment For Sale

New Used & Demo Soundcraft Neotek, Otari, Akai, Klark-Teknik, dbx, E-V, LEXICON. USED NEOTEK CONSOLES, microphone sale, over 200 mics in stock. E-V, AKG, Beyer, Sennheiser, etc. New E-V N-DYM mics in stock. Call Pyramid Audio Inc (312) 339-8014. **Call Us Last!**

SIDEREALKAP. The SiderealKap was designed from its inception to be the finest sounding capacitor available for audio today. Find out what the music lover's capacitor doesn't sound like. Free literature and price information upon request. Dealer inquiries invited. **SIDEREAL AKUSTIC,** 1969 Outrigger Way, Oceanside, CA 92054, (619) 722-7707.

Reliable Music

Serving the Southeast for 25 years offering an excellent selection of musical instruments pro sound and recording equipment in a "hands-on" environment. We have a progressive, experienced sales staff, factory-trained technicians, and our prices are competitive.



704/375-8662

Hours: Mon-Fri, 10:00 - 5:00 Sat 11:00 - 4:00
650 E. Stonewall Street, Charlotte, NC 28202

4-trk, 8-trk and MIDI studio gear. Best prices—courteous, knowledgeable staff. Most major lines of pro audio keyboard and studio equipment. Call our toll free wats line 1-800-354-7252 when you're ready. Mike, Bill, Terry or Marty.

**NEW, USED, DEMO SALE
RECORDERS, CONSOLES,
OUTBOARD EQUIPMENT**

Otari MTR-90I 24-trk w/locator,
Otari MX-70 8/16 8-trk, Tascam
16-trks, 2-trks, Soundcraft
200SEQ 20x4 mixer, Roland D-
50, S-50, D-550, S-550, Jambbox
4+, UREI 813C monitors, Yamaha
SPX-90II, NS-10M monitors,
REV5, 3/4" VCR, Sony ES-501
PCM, Fostex B16-D w/remote,
Scamp rack. . .

**E.A.R. PROFESSIONAL AUDIO
(602) 267-0600**

Pro Sound PA and High End audio equipment at cost or below. New, Used and Demo equipment available. Lowest prices. Call or write for list. Sound Equipment Company, Dept. M, 4132 Kincaid Drive, Raleigh, NC 27604. (919) 876-8432.

**USED EQUIPMENT
Bought & Sold**



**Summit
Audio
Inc.**
P.O. Box 1678
Los Gatos
CA 95031
408-395-2448

DO YOURSELF A FAVOR

If you're ready to buy any type of recording gear or musical instrument, do yourself a favor and call us before you buy. We have most name brands at some of the lowest prices you'll find anywhere. Call us before you buy, you won't regret it. (318) 234-5021.

World's Best Prices on quality used equipment. Super savings on ATR-100 and multi-track heads. We buy-sell-trade. Get on our mailing list and buy where the pros SAVE. **AUDIO VILLAGE,** PO Box 4692, Palm Springs, CA 92263, (619) 320-0728.

LEASE/BUY/SELL

Great prices and great service on over 200 lines including Otari, Harrison, Soundcraft, Tascam, JBL, Lexicon, AMS, Akai, Trident, KT, dbx and all the rest for the best in new or used. **AVC SYSTEMS (800) 323-0281,** in MN call (612) 729-8305.

**IF YOU'RE NOT USING IT
—SELL IT!**

Your national clearinghouse for used audio and video! Call for free copy of our latest listings, or to list your used gear free. The Bertech Organization Call toll free: (800) 992-2272 In Calif. call: (818) 909-0262 **THINK BERTECH FIRST!**

Westlake studio monitors, MegaMix console automation, Yamaha NS-10M reference monitors, Yamaha SPX90 effects processor, call Dick McCalley at (612) 929-4000.

LEASING

Specialists in
Audio Equipment

Rent or
Lease All
Brands

**WE TAKE
TRADE-INS!**

PMI, Inc.
567 N. Market St.
Wooster, OH 44691
(216) 262-1518

Southeast's largest broker has available quality, used recording equip. for sale—MCI & Harrison consoles, MCI & STUDER machines, QUANTEC QRS—steal at \$7K; LEXICON 224's—mics—all types of outboard equip. Lots & lots of MCI parts avail. Call for new list. Special: Dolby M-24H—\$8,000; EMT 251 w/250 prog.—Inquire. Randy, Bobby or Tim (615) 361-8429 or 361-6768. We are al-

ways looking for good used audio & video equip.

STUDIO FINANCING and leasing plans for qualified buyers. Quick service, 36-60 month terms. \$5K to \$200K—for information call Dick McCalley at (612) 929-4000.

19" Rack Mount Cabinets 6', steel, new, in cartons, beige, \$175 plus freight. (405) 755-6333.

**db ENGINEERING
THE ONLY CHOICE**

Otari MC5050B (used) exc.—\$1K, (2) Neumann U47 Tube mics—\$3K, Sony U-Matic VP-5000 (used)—\$1K, UREI 1176 LN (used)—\$350, Neve 36x24 w/Necam II—\$90K (in brand new cond). Many rare mics and processors. Specials on new items: Ashly, AKG, Aphex, Aries, Soundtracs, and many more. 1611 Mass Ave., Suite 204, Boston, MA 02115—(617) 262-0311.

MCI/SONY PRODUCTS

JH-24 recorder, MXP-3000 mixing console, ARR 5003 center track recorder, Sony PCM-3324 digital. Cash, lease or finance—Quick service call Dick McCalley (612) 929-4000.

TRIDENT TSM

40x32 mainframe console in exc. condition. (612) 872-0646—Steve (612) 824-8921.

**MCI 24-TRK—2-TRK HEADS
IN STOCK**

We stock tape heads 1/4" thru 2" & spare parts for most recorders (800) 553-8712 or (800) 325-4243 CA, (818) 994-6602, Telex: 754239, Sprague Magnetics, Van Nuys, CA.

AMEK 2500-48 CHANNEL, AMEK 2500-56 CHANNEL (Consoles can come w/ or w/o Mastermix automation). SYNCLAVER II FULL BLOWN SYSTEM, QLOCK 3.10 w/INTERFACE, OTARI MTR-20s, OTARI MTR-90 24-TRK (818) 980-4840—THOM.

**3M M-79 TAPE HEADS
IN STOCK 16- & 24-TRACK 2"**

We stock tape heads 1/4" thru 2" & spare parts for most recorders (800) 553-8712 or (800) 325-4243 CA, (818) 994-6602, Telex: 754239, Sprague Magnetics, Van Nuys, CA

OTARI MX-80 24-TRK. 3 MO. OLD \$23,950; NEUMANN "TUBE" U67 \$1,200; NEUMANN NEW KM-84 \$359 EA; RAMSA WRS-820 20 X 8/METER BRIDGE \$4,800; FOSTEX E-16 NEW \$5,400; OTARI MTR-12 6 MO. OLD \$6,950; TASCAM MS-16 W/LOCATOR, STAND,

BRIDGE \$7,500; NEUMANN TLM 170 "NEW" \$1,250. CALL OPUS FOR ALL YOUR EQUIP. QUOTES 312/336-OPUS (6787).

DAT

We have Digital Audio Tape decks and tape ready for delivery!!

PCM

We buy and sell all Sony PCM products. Call for info!!

Micro Seiki Turntables
SAEC Tonearms—Cartridges
LC-OFC wire—the best!!
Portable DATs available.

Audio Gallery (213) 829-3429
2718 Wilshire Bl., Santa Monica, CA 90403

VINTAGE TUBE MIKES

Call Bill Bradley
(312) 751-1216

"AMAZING"

LOW, LOW PRICES

INVENTORY REDUCTION SALE

- ✓ Quality Recording & Midi Gear
- ✓ Digital Reverb & PCM Processors
- ✓ P.A. Systems & Power Amplifiers
- ✓ Multitrack Recorders & Consoles
- ✓ All Equipment New & Warranted
- ✓ Major East Coast Audio Supplier
- ✓ Great Buys on Rare Equipment



TekCom
CORPORATION

Mastercard & Visa are Welcome

CALL 215-426-6700

(3) Studer A800 MKIII 24-trk. 1 year old machines w/autoloc stand. Take over or buy out lease. Call Bobby (212) 921-1711.

MIDI SAMPLING UNDER \$200

MIDI your Casio SK-1. New do-it-yourself kit for \$59.95 + \$3.00 S&H or let us do it for \$99.95 + \$6.00 S&H. See Aug. '87 Keyboard magazine, dealer inquiries invited. Call (404) 449-8536. Datastream, Inc.

APSI 2001 Record Console 20x4x4 w/16 inputs tape, 16 tape mon. Black face, fully modular 12 ch. w/parametric EQ. All diagrams. \$5,500. Board was \$12,000 new. LinnDrum Machine new \$800. (203) 732-5671, 795-1594.

LinnDrum II, never used \$1,000; Crown CX822VS, brand new \$1,500; Pultec HLF-3C \$350 ea.; Ursa Major Space Station \$850; Marshall 500Z time mod. \$500; Valley People Rack; (3) Gain Brain II, (1) Maxi Q \$850; dbx 155 \$300. Call Don (215) 776-1455 (eve.) (215) 432-0520 (day).

BUILDING AN AUDIO SUITE? NEED PA EQUIP?

DON'T BUY A THING... UNTIL YOU'VE HEARD MY PRICES on the brand you're looking for! Call David Wynn—American Audio Systems (612) 929-4000. Prices too low to afford an 800 number. Financing and/or leasing avail.

UNINTERRUPTIBLE POWER FOR COMPUTERS

An Uninterruptible Power System (UPS) is the only way to reliably power a computer. Systems that will power a PC and provide battery backup start at under \$400. We have systems that can make an entire studio immune to power blackouts and glitches. Please send us a list of the equipment that you would like to protect. ATLANTIC COMPUTER POWER, 3078 Fla. Blvd., Lake Park, FL 33410 (305) 626-7808.

Used Soundcraft 2400 Series 28/24/24 console, home studio use only—\$24,950; used Trident 80B 30/24/24—\$33,950 w/MasterMix automation add \$11,000. (813) 960-5100.

Otari MX-70 16-track w/remote 1" 30 or 15 ips, 8 months old—light use \$11,500 or best offer. (818) 241-9090.

AUTOMATION SYSTEM—Optifile disk-based console automation system. Uses SMPTE and retrofits to any console. 40 channel capacity, 32 VCAs installed. Only 1 year old, cost \$17K, sell for \$10K. (203) 269-4465.

NEOTEK ELITE 66 INPUT 50 OUT 8 months old, absolutely mint condition. Largest built in U.S. \$89K new—immed. avail. at \$65K. Includes Warranty. (203) 467-9038

Trident Series 75 console 28x24, 8 sends, 4-band EQ, EQ on monitors, 1½-yrs-old, exc. cond. \$18,500. Call (201) 653-6389 or 653-6729.

MIDAS CONSOLES

(1) Custom 38x8x4 Pro 5 House; (1) LS4 32x8x2 Pro 5 House; (1) Custom 16x8x4 Pro 5 Studio; (1) 30x10 6 blank Pro 4 monitor; EXCELLENT CONDITION. (705) 674-1450.

AVR GROUP

The widest selection of used gear. Otari MX5050B—\$1,200; Neumann U87 \$850; Otari Mark III—\$3,300; Neve 36x24 \$55K; Wheatstone 24x8—\$6K, Pultec MEQ—\$650; Tascam 48—\$3,000. All used equip. warranted and calibrated to factory specs or your \$ back. (617) 332-1441. Call for prices on new equip.

NOW—A solid oak, 16-space rack with ½" steel rails, sturdy metal casters for portability and a fully adjustable tilt for easy access. For more info, contact STUDIO WOODS INC., 20437 W. Outerdrive, Dearborn, MI 48124, (313) 563-8588.

PPG WAVE 2.3 (V.6 MIDI) synth w/WAVETERM A sampling computer. Original & custom libraries & Calzone cases. BEST OFFER. Call Sounds Unreel, (901) 278-8346.

MCI JH-416 console 24x24. Now in use at a home studio. Well-maintained, spare parts. Will accept ANY reasonable offer. Call Joe (301) 761-6159.

NEOTEK SERIES I 20 input x 8 out w/4 E Series Modules—\$11,000. Call (312) 935-2727.

AKAI MG-14D/ML14 multi-track recorder with auto-location system, brand new, never out of box \$4,400. Please call John at Studio Supply Comp. (615) 366-1890. Excellent buy.

3M-79 24-TRK RECORDER W/SELECTAKE; AUDITRONICS 501 CONSOLE 18x16; (2) UREI 529 1/3 OCTAVE EQ-CUT ONLY. CALL LEE (415) 359-1853.

(1) ½" Scully 4-track—\$2,200; (2) AG440 2-trk—\$1,900; (1) MCI 24-trk w/auto. loc. II—\$17,000; (1) 24 trks. of Dolby—\$12,000; (2) UREI 1/3 octave EQs—\$800; (1) EMT 140 tube plate—\$4,000. Contact: Rick or Eddie (803) 269-3961.

3M M56 2" 16-trk Rec. with remote and Selectake in exc. cond., \$8,000—(415) 348-1807. Cliff.

DATS IN STOCK!!!

Sony PCM 2000 and PCM 2500 Pro DATs in stock. Also demo equip. sale: Adams-Smith 2600 system, Rackmax mixer, Sentry 500 monitors ART DR1 & DR2 reverbs, Tannoy FSM studio monitor, Sony 2000 console. CSE Audio, 1200A Scottsville Rd., Rochester, NY 14624—(716) 436-9830.

MCI JH 500/56 mixing console. JH 50 auto., 8 groups, plasma, 1,008 pt. P.B., 8-echo return phase and extra VU meters, left and right prod. desk. \$79,500 o/b. Contact Dave Mancini—Care of Devonshire Rec. (818) 985-1945.

NEOTEK console Series II, NEW—not used or a demo. 28-input-mainframe. 28x24—\$22,000 and 16x24—\$15,000. Call George (213) 833-0130.

Sony PCM 2500 digital audio recorder \$4,995 or lease. (612) 929-4000.

(15) Sony APR 5002 2-trk recorders, factory re-conditioned at \$8,360. Now \$4,995. (612) 929-4000.

Exc. cond. Tascam 85-16B w/Remote Yamaha 2408 Console plus much more—\$12K, DX7FDII—\$1,750, TX-216—\$1,000, 5900—\$2,000. Call Rick (216) 456-2806 Today.

Equipment Rental

STAGE FRIGHT is cost-effective RENTALS for CHICAGO LAND.

KURZWEIL 250 EXPANDER and MIDI BOARD, expander has sound blocks A.B.C.D., also the E-MU SP-12 turbo drum machine, the new DX7-IIFD, Matrix-6, and K-3. MACINTOSH sound libraries for Kurzweil, SP-12 and DX7. Matrix 6 and K-3 libraries coming soon. Stage Fright Inc., PO Box 237, Dolton IL, 60419 (312) 849-3735.

DIGITAL DOMAIN

Sony 3324—\$750 per day, Focusrite EQ (6)—\$200 per day, Sony 3202—\$225 per day, Free cartage within 25 mi. of NYC (914) 639-1091.

AUDIO AFFECTS

STUDIO EQUIP. FOR HIRE
Technician on staff 7am-1am
Open 7 days a week
Digital Tape Machines,
Synclavier Systems,
Effects Processors, Reverbs
(213) 871-1104 (818) 980-4006

Design Fx Audio

DIGITAL AUDIO RENTALS

Specializing in digital tape machines, reverbs and effects processors. Technical consultation included.
(213) 838-6555
Outside CA (800) 441-4415
P.O. Box 491087
Los Angeles, CA 90049

On-Call 24 Hours



599 Eleventh Ave., NYC, 10036
(212) 582-4400

The Best That Money Can Rent

- Digital Multitrack
- Time Code Equip
- PA Equip
- Wireless Mikes
- Outboard Equip
- Mixing Consoles
- Walkie Talkies
- Video Playback

Instruction

14511 Delano
Los Angeles, CA 91411



818 994-9976

Recording
INSTITUTE

INSTITUTE OF COMMUNICATION ARTS. Commercial Music Performance, Audio Engineering/Prod., Video Prod./Sound Reinforcement, Music & Entertainment Bus., Communications, Electronic Music, Music Theory & Arrang. 2 Yr. Prog./P.T. Studies. 12-12840 Bathgate Way, Richmond, B.C. Canada (604) 278-0232.

The new fall 1987 *Mix* Bookshelf Catalog is now available! Write or call now for your free copy of the most comprehensive selection of books, tape courses, music software, SFX libraries, databases and more.

MIX BOOKSHELF
2608 Ninth Street
Berkeley, CA 94710

CALL TOLL FREE: (800) 233-9604
In California: (800) 641-3349

EDUCATIONAL VIDEOS

2/6/12 hour sound mixing/recording courses: \$39, \$119, \$239; 2 hour MIDI course \$39; Add \$5 shipping/handling for each course. Visa/MC/check. For brochure: RECORDING ASSOCIATION, 5821 SE POWELL, PORTLAND, OR 97206, (503) 777-4621.

Maintenance Services & Repair

TLM ELECTRONICS INC

343 MANVILLE RD
PLEASANTVILLE, NY 10570

Pro Audio Service

- Consoles • Multi-Trax
- Amplifiers • FX equip

- Repairs
- Modifications
- Performance Testing

(914) 769-6423

RCA MICROPHONES — Repair service on all models. Complete sound and cosmetic restoration. 35 yrs. experience with company. ENAK Microphone Repair, 420 Carew Avenue, Pitman, NJ 08071. (609) 589-6186.

NY TECHNICAL SUPPORT, LTD.

Factory Trained & Equipped
Ampex/API/MCI/Neve/Otari
Scully/SSL/Studer/3M/Trident
CALL GREG HANKS
Service/Design/Consults/Installs
35 Hardscrabble Hill
Chappaqua, NY 10514
(914) 238-4171

Music Products/Software

SOUND FX LIB. FOR EMU-II

Over 400 disks. \$2,500 or sold sep. Send for listing to: KEY EFFECTS, PO Box 8252, Calabasas, CA 91302. Send SASE.

SOUND IDEAS Effects Library. 125 Boxed Reels. 15 ips. Cross-referenced to over 13,000 entries. Comes with catalog and 3-ring binder. \$1,500 or BEST OFFER. SOUND VENDORS (818) 985-9774.

DISKS?
Exclusive library of over 400 disks: Emulator II, EMax, Oberheim DPX-1, Mirage, S-50
\$2000 per disk
Call or write for Specials:
Northstar Productions
13718 S.E. Ramona, Portland, OR 97236
(503) 760-7777

Recording Services

CD MASTERING & DIGITAL TRANSFERS
DIGITAL SERVICES
P.O. BOX 694
LYNBROOK, N.Y.
11563
(516) 872-2325

EVEN IF YOU DIDN'T RECORD AT REFLECTION, ALL IS NOT LOST—YOU CAN STILL MIX AT REFLECTION. We handle remix work from studios all over the country (and a few in Europe). You have heard our work on REM, Don Dixon, Marti Jones, Marshall Crenshaw, Let's Active, Tammy Faye Baker, and many others. 24-, 16- or 8-trk mix through Hard Disc Automated Sony 3000 board going to PCM-3202 Digital or APR-5000 1/2" Analog. IT'S NOT TOO LATE! Call us for rates and scheduling. (704) 377-4596 (Charlotte, NC).

DIGITAL REAL TIME

"Cassette Duplication Service"
Dolby A B C SR-digital to cassette, custom load BASF chrome Shape shells. Labels, inserts, custom packaging. Call (206) 243-9285, write: Martin Productions, Box 46357, Seattle, WA 98146.

Records & Tapes

ESP EASTERN STANDARD PRODUCTIONS
26 BAXTER ST. BUFFALO, N.Y. 14207

- AUDIO CASSETTE DUPLICATION High Quality Real Time
- VIDEO CASSETTE DUPLICATION All Formats
- CUSTOM PRINTING & PACKAGING Labels - Inserts - Shrink Wrap

CALL COLLECT For Free Brochure
(716) 876-1454

Disc Mastering and Record Production LPs, EPs, 45s—Plating, Labels, Pressing, Jackets.

DIGITAL NOW AVAILABLE! THE CUTTING EDGE

Box 217M
Ferndale, NY 12734
(914) 292-5965

REAL TIME

Best Quality Cassettes using Nakamichi decks only. Custom loaded Agfa or BASF Chrome. Label and insert printing, shrinkwrap, blank tapes. SUPERB QUALITY AT LOW PRICES

Uni-Sette, Inc. 1854 Fulton Ave., Sacramento, CA 95825. (916) 485-9534.

FACTORY DIRECT PRICES ON 3M TAPE & AMPEX TAPE

Discounts available.

We can & have saved you money! Call us—you'll like us. We're in the business, just like you. STUDIOWORKS is also a supplier of pro recording equipment. (800) 438-5921 & (704) 375-1053.

Super Low Prices on Agfa, BASF, Ampex and Mag Media, Bulk Cassettes and Accessories. Real-time and High Speed Duplication. Call or write for prices and brochure. TRAXX RECORDING PRODUCTS, 24 Crest Way KC, New Fairfield, CT 06812, (203) 746-3561.

CRYSTAL INC.
DUPLICATED CASSETTES
AS LOW AS 43¢ PLUS SET UP

FULL COLOR CASSETTE INSERTS
AS LOW AS \$53.00 PER 1000 ORDER OF TEN

FULL COLOR GLOSSY PRINTS
Suitable For Framing 23¢ EACH LOTS OF 1000

HIGH ENERGY CASSETTES
AS LOW AS
C-62: 28¢ and C-92: 34¢

FULL COLOR POSTERS OR BROCHURES
AS LOW AS \$195.00 PER 1000

FULL COLOR ALBUMS
58¢ EACH PLUS SET UP PER QUANTITY

PHONE TOLL FREE:
1-800-826-6540
TN: 615-843-0717
8002 Middle Valley Road, Hixson, TN 37343

PROFESSIONAL RECORDING SUPPLIES

We are a major wholesale Distributor of Ampex, Agfa & 3M reel to reel mastering tape (1/4" to 2"). We also stock broadcast video tape, assorted reels and boxes, splicing/leader tape, and pre-packaged cassettes. We load bulk cassettes in custom lengths using a variety of tape brands. Please call or write for our FREE catalog.

Advance Recording Products

7190 Clairemont Mesa Blvd., San Diego, CA 92111
(619) 277-2540
Inside CA: (800) 858-1061
Outside CA: (800) 854-1061
Visa/MC Accepted

ULTIMATE FIDELITY

The World's largest Nakamichi real time cassette duplication system. Full service packaging. 50 to 50,000 qty. Call toll free—in NO. CAL., (800) 327-AAPX outside CAL., (800) 323-AAPX or (707) 585-1132 —Call AAPEX today!

Best AGFA Prices!

2" Reel = \$105.
1/4" Bulk = \$9.50
WORLD CLASS TAPES
(313) 662-0669

CASSETTE COPIES TOMORROW

Top quality cassette duplication True speed thru high speed Custom printed labels & inserts Complete packaging. Call us for your immediate cassette needs. THE WAREHOUSE STUDIO 2071 Emerson St. #20, Jacksonville Florida 32207 Ph: (904) 399-0424

3M SCOTCH AUDIO TAPES

Prompt Service—Low Prices
1/4" pancakes, 1/4"-2" reels, accessories, Scotchcarts & cassettes.
Call or Write for Price List
R & M PRO AUDIO
1080 Pacheco, S.F., CA 94116
(415) 665-8480

Diskmakers

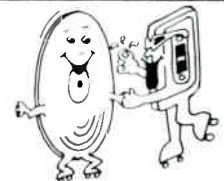

RECORD PRESSING CASSETTE DUPLICATION
SEND FOR OUR PRICE LIST
CALL TOLL FREE
1-800-468-9353
925 N. 3rd St., Phila., PA 19123

OUR 10TH ANNIVERSARY



IF YOU ARE LOOKING FOR A RELIABLE ENDLESS CASSETTE. YOU'VE FOUND IT YOUR ENDLESS SEARCH IS OVER

UP TO 120,000+ PASSES. HEAVY DUTY SELF-CLEANING TAPE SOUNDS BETTER LONGER

PLAYS VERTICALLY OR HORIZONTALLY. IDEAL FOR ON HOLD TELEPHONE MUSIC TALKING HOUSE RADIO TRANSMITTERS. POINT OF PURCHASE DISPLAYS. ETC

ALSO SPECIAL ENDLESS TAPE PLAYER AVAILABLE—CALL OR WRITE FOR PRICING INFORMATION

MANN ENDLESS CASSETTE INDUSTRIES
P.O. Box 1347 San Francisco, CA 94101
(415) 221-2000 EXT. 9

Neumann to Eventide, AKG to dbx. All in stock, ready to ship. UAR Pro Systems. 8535 Fairhaven, San Antonio, TX 78229. (512) 690-8888.

DISTRIBUTORS WANTED

Major manufacturer of bulk-loaded cassette blanks looking for distributors outside California. Standard and custom lengths. Send for confidential price list and samples on your letterhead. Phylco Audio, 4697 Brooks St., Montclair, CA 91763.

EUROPADISK, LTD.

Direct Metal Mastering

DMM U.S. Only Complete DMM Facility—

- Disk Mastering Suite
- Hi-Definition Plating
- State-Of-The-Art Pressing

For brochure & pricing, call or write

EUROPADISK, LTD.

75 Varick St., N.Y. 10013
(212) 226-4401

Studios For Sale

24-TRK STUDIO EQUIPMENT
Complete Package Includes: Harrison Console, Studer 24-trk, AMS, Eventide, Lexicon, UREI. Call Jim at (513) 681-8715.

48 TRK WORLD CLASS STUDIO
EXCEPTIONALLY BEAUTIFUL LOADED LARGE AND PRIVATE, W/house in residential, exclusive Alpine, NJ, nine minutes from NYC. \$1,950,000. BROKERS or AGENTS WELCOME. LANDCASTLE. (201) 767-8453.

FANTASTIC RECORDING STUDIO
MCI 16/24 trk, 8 trk. Additional equip. incl. Located in Midwest area. Studio designed and equip. 1st class. Realty and as package. Lease to own. (812) 446-0003. Write—1½ W. National Ave, Brazil, IN 47834. Attn: Warren Grey.

Miscellaneous

**TRACK SHEETS
BOX & REEL LABELS**

- Cassette Labels & Inserts
- Drum Machine Sheets
- Alignment Plaques
- Plus many other items

PRINTED WITH

Your Studio Name
Address & Phone

FREE CATALOG

of specialized forms for the
recording & music industries

STUDIOFORMS Co

186 Glen Cove Avenue, Suite 201/M-27
Glen Cove, NY 11542
(516) 671-1047

STAR'S CUSTOM CABLES

Audio & Video snakes, 16, 24 and 32 trks made to order. Custom P.B. & panels. Will install as desired & quality control guaranteed. (805) 251-6547. Call for estimates. Dolby

racks, outboard racks, PC board work, all done to your specs.

Rare & Hard-to-Find

Professional video supplies & accessories for recording, production & broadcasting at the best prices in America—the industry's most unique catalog!
Call or write now for your free copy:

Marker™

Technologies of America
145 Ulster Ave. Saugerties, NY (USA) 12477
800-522-2025 · in NY 914-246-3036

PUT THE MUSIC INDUSTRY AT YOUR FINGERTIPS!

- THE 1987/88 CALIFORNIA MUSIC DIRECTORY—\$33.45.
- THE 1987/88 MUSIC BUSINESS DIRECTORY—\$33.45.
- THE 1987/88 MUSIC RADIO DIRECTORY—\$33.45.

Special discount—All 3 for \$80.
Checks/M.O./VISA/MC to:
MUSIC INDUSTRY RESOURCES
Box 190, Dept. MIX
San Anselmo, CA 94960
(415) 457-0215—ORDER TODAY

—SOUND EFFECTS—

180 SOUNDS YOU REALLY NEED
5 STEREO LPs GROUPED BY
CATEGORY: \$89.95, POSTPAID.
EFX 2325 GIRARD S.
MINNEAPOLIS, MN 55405

SYNCLAVIER COPYIST

Synclavier Music Engraving
Lead sheets to complete orchestra scores. Full editing including corrections and transpositions. Write: Studio C, 2220 Broadridge Way, Stockton, CA 95209 (209) 477-5130.

How to Place a Mix Classified

Please print or type in CAPITAL LETTERS and lower case. There are 8 lines to the inch and approximately 24 CAPITAL letters per line or 32 lower case letters. \$80 per inch — 1" minimum. Additional lines \$10 per line. BOLD TYPE or Black Border \$10 per line. Gray screen \$15 extra. Logos or display advertising up to 4" will be charged at \$100/inch. Frequency discount rates available. Call for information. Payment by check, money order or charge must accompany ad. DEADLINE is the 15th of the month, 6 weeks prior to publication.

Categories Available (Check one.)

- | | | |
|---|--|---|
| <input type="checkbox"/> Acoustic Consulting | <input type="checkbox"/> Equipment Rentals | <input type="checkbox"/> Record & Tape Supplies |
| <input type="checkbox"/> Business Opportunities | <input type="checkbox"/> Equipment Wanted | <input type="checkbox"/> Recording Services |
| <input type="checkbox"/> Employment Offered | <input type="checkbox"/> Instruction | <input type="checkbox"/> Studios for Sale |
| <input type="checkbox"/> Employment Wanted | <input type="checkbox"/> Maintenance Services | <input type="checkbox"/> Miscellaneous |
| <input type="checkbox"/> Equipment for Sale | <input type="checkbox"/> Music Products/Software | |

Name _____

Address _____

Phone _____

I am paying by (Check one.): VISA MASTERCARD AMERICAN EXPRESS

Card #: _____ Expiration Date _____

Signature: _____

Check or Money Order #: _____ Amount Enclosed: \$ _____

Mail to:

Mix Classified, 2608 Ninth Street, Berkeley, CA 94710
(415) 843-7901

Ad Copy: _____

NEXT IN MIX

JANUARY '88

- Northwest Studios Directory
- NAMM Show Issue
- MIDI Rooms
- Music Software

FEBRUARY

- International Recording
- Directory: Independent Engineers and Producers
- Automation and Control Systems
- European AES Issue

AD CLOSING:

DECEMBER 7

MATERIALS DUE:

DECEMBER 15

MARCH

- Southeast Studios Directory
- Nashville Recording Supplement
- Studio Monitors

AD CLOSING:

JANUARY 7

MATERIALS DUE:

JANUARY 15

Only *Mix* has a BPA-audited circulation of over 44,000 copies each month!*

Call (415) 843-7901 for space reservations and complete advertising information.

*Source: Publishers' BPA statement of circulation for six months ending June, 1987 (average of qualified and non-qualified circulation).

ADVERTISERS INDEX

- | | | | |
|---------------|---|---------|--|
| 38 | A & R Record & Tape Manufacturing | 212 | JBL Professional |
| 151 | Aapex | 97 | Jensen Transformers, Inc. |
| 175 | Advance Recording Products | 151 | JRF Magnetic Sciences |
| 135 | Advanced Music Systems (AMS) | 176 | KABA Research and Development |
| 57, 124 & 137 | Akai/IMC | 142 | KCC Audio Video |
| 211 | Allen & Heath Brenell | 119 | K-disc Mastering |
| 92 | Alpha Audio | 118 | Keystone Printed Specialties Co., Inc. |
| 76 | Amek Consoles | 64 | Lake Systems |
| 50 | AMP Services | 146 | Lexicon, Inc. |
| 11 | Ampex Corporation | 120 | Lightning Music and Sound |
| 187 | API Audio Products, Inc. | 20, 116 | Loran Cassettes and Audio Products |
| 200 | Arcal, Inc. | 89 | Magnifax International |
| 121 | Aries | 128 | Manhattan Production Music |
| 56 | Sam Ash Music | 77 | Microsystems, Inc. |
| 159 | Associated Production Music (APM) | 111 | Midwest Custom Record Pressing Company, Inc. |
| 144 | Audio Engineering Associates (AEA) | 2-3 | Mitsubishi Pro Audio Group |
| 33 | Audio Logic | 140-141 | 1988 Mix Annual Directory |
| 100 | Audio Media Research (AMR) | 163 | Monster Cable |
| 111 | Audio Village | 200 | Moonvalley Cassettes |
| 85 | AudioLine Inc. | 81 | Moseley |
| 93 | B & L Sales, Inc. | 63 | Music Annex Duplication |
| 197 | Bauer Audio | 60 | NEOTEK Corporation |
| 52 | Beyer Dynamic | 9, 132 | Rupert Neve, Inc. |
| 18 | Biamp Systems | 17 | New England Digital (NED) |
| 37 | Bryston | 14-15 | Nimbus Records |
| 87, 183 | Burlington Audio/Video Tapes, Inc. | 36 | Northeastern Digital Recording, Inc. |
| 153 | C-T Audio Marketing, Inc. | 139 | Orban Associates, Inc. |
| 158 | Caig Laboratories, Inc. | 7, 181 | Otari Corporation |
| 174 | Capitol Magnetic Products | 99 | Peavey Electronics Corporation |
| 167 | Carver Corporation | 78 | Penn Fabrications (USA), Inc. |
| 115 | Carvin Corporation | 193 | Polyline Corporation |
| 92 | Cassette Works | 169 | Power Studio Supply & Distribution |
| 170 | CD Masters | 120 | Prodigital |
| 30 | Cetec Gauss | 192 | Producers' Tape Service, Inc. |
| 73 | Cipher Digital, Inc. | 83 | Professional Audio Services & Supply |
| 143 | Circuit Design Technology (CDT) | 130 | Progressive Tape Corporation |
| 91 | J.L. Cooper Electronics | 154 | Prosonus |
| 114 | CRL Audio | 191 | QCA Record Pressing |
| 117 | CST Manufacturing & Sales | 79 | Rainbo Records & Cassettes |
| 23 | D&R USA | 142 | RCA Test Tapes |
| 129 | DDA, Inc. | 125 | The Recording Workshop |
| 133 | DeWolfe Music Library, Inc. | 155 | Reliable Music |
| 66 | Dimension | 143 | Rhythm City |
| 185 | Diskmakers, Inc. | 105-107 | RolandCorp US |
| 122-123 | Dolby Laboratories, Inc. | 34 | Shape Optimedia, Inc. |
| 161 | EAR Professional Audio-Video | 31 | Shure |
| 162 | El Mar Plastics, Inc. | 43-47 | Sony Professional Audio |
| 67 | Electro-Voice | 155 | Sound Impressions, Inc. |
| 131 | E-mu Systems, Inc. | 164 | Sound Recorders, Inc. |
| 95 | Ensoniq | 51 | Soundcraft |
| 183 | Europadisk, Ltd. | 25 | Soundtracs |
| 125 | Eva-Tone, Inc. | 93 | Sprague Magnetics, Inc. |
| 165 | Focusrite US, Ltd. | 50 | Stoughton Printing Company |
| 149 | Forge Recording Studios, Inc. | 13 | Studer Revox |
| 59 | Fostex Corporation | 39 | Studio Consultants, Inc. |
| 175 | Frankford Wayne Mastering | 28 | Studiomaster, Inc. |
| 55 | Full Compass Systems | 41 | Tannoy North America |
| 133 | Full Sail Center for the Recording Arts | 19 | TASCAM |
| 54 | Fullersound, Inc. | 82 | Technetronics |
| 61 | Future Disc Systems | 77 | TeeVee Tunes |
| 157 | Gold Line/Loft | 65, 98 | Telex Communications, Inc. |
| 75 | Granny's House Recording Studios | 152 | Thoroughbred Music |
| 39 | Bernie Grundman Mastering | 88 | Trutone Records |
| 153 | Ian Communications Group, Inc. | 199 | The United Group |
| 89 | Imperial Tape Company | 152 | Valentino, Inc. |
| 104 | Institute of Audio Research | 68 | Valley International, Inc. |
| 149 | Institute of Audio-Video Engineering | 84 | Versadyne |
| 192 | Investment Technology, Inc. (ITI) | 130 | Vertigo Recording Services |
| | | 160 | Video Expo |
| | | 138 | Westlake Audio |
| | | 127 | Wireworks Corporation |
| | | 88 | World Records |
| | | 26-27 | Yamaha International |

EXIBIT

Designed for the Working Professional!
The Sigma Series offers you the Maximum Flexibility, in layout and design features that reflect the evolution of Sigma Engineering.

Built to the Highest Standards, to which AHB has established its reputation on... for over 14 years.

Performance

Sigma will satisfy your Current and Future needs in 16, 24 and 32 track recording as well as MIDI First Generation Recording and Sound Reinforcement Applications.

For more detailed information on the New AHB Sigma Console, Contact your Authorized AHB Dealer Today.

ALLEN & HEATH BRENELL

U.S.A.

Allen & Heath Brenell (USA) Ltd.

Five Connair Road

Orange, CT 06477 / (203) 795-3594

U.K.

Allen & Heath Brenell Ltd.

69 Ship St. Brighton, BN1 1AE England

Tel. (0273) 24928 / Telex 878235

CANADA:

CerrAudio/Toronto

(416) 361-1667



AHB SIGMA SERIES



TRUTH...

OR
CONSEQUENCES.

If you haven't heard JBL's new generation of Studio Monitors, you haven't heard the "truth" about your sound.

TRUTH: A lot of monitors "color" their sound. They don't deliver truly flat response. Their technology is full of compromises. Their components are from a variety of sources, and not designed to precisely integrate with each other.

CONSEQUENCES: Bad mixes. Re-mixes. Having to "trash" an entire session. Or worst of all, no mixes because clients simply don't come back.

TRUTH: JBL eliminates these consequences by achieving a new "truth" in sound: JBL's remarkable new 4400 Series. The design, size, and materials have been specifically tailored to each monitor's function. For example, the 2-way 4406 6" Monitor is ideally designed for console or close-in listening. While the 2-way 8" 4408 is ideal for broadcast applications. The 3-way 10" 4410 Monitor captures maximum spatial detail at greater listening distances. And the 3-way 12" 4412 Monitor is mounted with a tight-cluster arrangement for close-in monitoring.

CONSEQUENCES: "Universal" monitors, those not specifically designed for a precise application or environment, invariably compromise technology, with inferior sound the result.

TRUTH: JBL's 4400 Series Studio Monitors achieve a new "truth" in sound with

an extended high frequency response that remains effortlessly smooth through the critical 3,000 to 20,000 Hz range.

And even extends beyond audibility to 27 kHz, reducing phase shift within the audible band for a more open and natural sound. The 4400 Series' incomparable high end clarity is the result of JBL's use of pure titanium for its unique ribbed-dome tweeter and diamond surround, capable of withstanding forces surpassing a phenomenal 1000 G's.

CONSEQUENCES: When pushed hard, most tweeters simply fail. Transient detail blurs, and the material itself deforms and breaks down. Other materials can't take the stress, and crack under pressure.

TRUTH: The Frequency Dividing Network in each 4400 Series monitor allows optimum transitions between drivers in both amplitude and phase. The precisely calibrated reference controls let you adjust for personal preferences, room variations, and specific equalization.

CONSEQUENCES: When the interaction between drivers is not carefully orchestrated, the results can be edgy, indistinctive, or simply "false" sound.

TRUTH: All 4400 Studio Monitors feature JBL's exclusive Symmetrical Field Geometry magnetic structure, which dramatically reduces second harmonic

distortion, and is key in producing the 4400's deep, powerful, clean bass.

CONSEQUENCES: Conventional magnetic structures utilize non-symmetrical magnetic fields, which add significantly to distortion due to a nonlinear pull on the voice coil.

TRUTH: 4400 Series monitors also feature special low diffraction grill frame designs, which reduce time delay distortion. Extra-large voice coils and ultra-rigid cast frames result in both mechanical and thermal stability under heavy professional use.

CONSEQUENCES: For reasons of economics, monitors will often use stamped rather than cast frames, resulting in both mechanical distortion and power compression.

TRUTH: The JBL 4400 Studio Monitor Series captures the full dynamic range, extended high frequency, and precise character of your sound as no other monitors in the business. Experience the 4400 Series Studio Monitors at your JBL dealer's today.

CONSEQUENCES: You'll never know the "truth" until you do.



JBL Professional
8500 Balboa Boulevard
Northridge, CA 91329